

Popular Electronics

NOVEMBER 1991

THE DAT PACT



There's finally peace between the recording and electronics industries, but at what cost?

BUILD A REMOTE-CONTROLLED OUTLET

Add the convenience of remote-control operation to any AC-powered device

SCREEN-DUMP SCRIMMAGE

The easy way to get images from your computer's screen to paper

EXPERIMENTS IN GALVANISM

Fun experiments that demonstrate a basic electronics principle

A 1930'S-STYLE TRANSMITTER

Play cassette tapes and more through any AM radio



BUILD THE COUNTER-SURVEILLANCE MONITOR

Find hidden RF bugs with this simple-yet-sensitive circuit



A GERNSBACK PUBLICATION



#BXBDCH***** 5-DIGIT 60506
#60506DHMB97GAD06# FEB92 85
ROBERT DAHM RESP
997 GRAND AVE 072
AURORA, IL 60506



\$2.95 U.S.
\$3.75 CANADA

3 NEW
FactCards
IN THIS ISSUE

Electronics Paperback Books

GREAT PAPERBACKS AT SPECIAL PRICES

BP248—TEST EQUIPMENT CONSTRUCTION \$5.95. Details construction of simple, inexpensive, but extremely useful test equipment. AF Gen, Test Bench Ampl, Audio Millivoltmeter, Transistor Tester and six more.



BP267—HOW TO USE OSCILLOSCOPES AND OTHER TEST EQUIPMENT \$6.95. Mastering the oscilloscope is not really too difficult. This book explains all the standard controls and functions. Other equipment is also described.

BP265—MORE ADVANCED USES OF THE MULTIMETER \$5.95. Use these techniques to test and analyze the performance of a variety of components. Also see how to build add-ons to extend multimeter capabilities.



BP256—INTRO TO LOUDSPEAKERS AND ENCLOSURE DESIGN \$5.95. We explore the variety of enclosure and speaker designs in use today so the reader can understand the principles involved.

BP263—A CONCISE INTRO TO dBASE \$6.95. The dBASE series of programs are probably the best known database programs for microcomputers. This book is designed to help you get started working with them.



BP260—CONCISE INTRO TO OS/2 \$5.95. If you are a multitasking PC user and want to get the most out of your computer, then you must learn its OS/2 operating system. This book shows you just how to do that, quickly and easily.



BP249—MORE ADVANCED TEST EQUIPMENT CONSTRUCTION \$6.95. Eleven more test equipment construction projects. They include a digital voltmeter, capacitance meter, current tracer and more.



Digital Audio Projects

BP245—DIGITAL AUDIO PROJECTS \$5.95. Practical circuits to build and experiment with. Includes A/D converter, input amplifier, digital delay line, compander, echo effect and more.



BP247—MORE ADVANCED MIDI PROJECTS \$5.95. Circuits included are a MIDI indicator, THRU box, merge unit, code generator, pedal, programmer, channelizer, and analyzer.



BP257—INTRO TO AMATEUR RADIO \$6.95. Amateur is a unique and fascinating hobby. This book gives the newcomer a comprehensive and easy to understand guide to the subject.



PCP102—INTRODUCING DIGITAL AUDIO \$9.95. Covers all kinds of digital recording methods—CD, DAT and Sampling. Bridges the gap between the technician and the enthusiast. Principles and methods are explained.

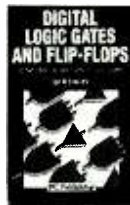

PCP107—DIGITAL LOGIC GATES AND FLIP-FLOPS \$10.00. Thorough treatment of gates and flip-flops for enthusiasts, student and technicians. Only a basic knowledge of electronics is needed.

BP251—COMPUTER HOBBYISTS HANDBOOK \$8.95. A wrapup of everything the computer hobbyist needs to know in one easy to use volume. Provides a range of useful reference material in a single source.



PCP108—COMPUTERS AND MUSIC \$9.95. Explains the basics of computers and music with no previous knowledge of computers needed. Covers types of music software and explains how to set up your own computer music studio.

BP195—INTRODUCTION TO SATELLITE TV \$9.95. A definitive introduction to the subject written for the professional engineer, electronics enthusiast, or others who want to know more before they buy. 8 x 10 in.

BP190—ADVANCED ELECTRONIC SECURITY PROJECTS \$5.95. Includes a passive infra-red detector, a fiber-optic loop alarm, computer-based alarms and an unusual form of ultrasonic intruder detector.

BP235—POWER SELECTOR GUIDE \$10.00. Complete guide to semiconductor power devices. More than 1000 power handling devices are included. They are tabulated in alpha-numeric sequence, by technical specs. Includes power diodes, Thyristors, Triacs, Power Transistors and FET's.

BP234—TRANSISTOR SELECTOR GUIDE \$10.00. Companion volume to BP235. Book covers more than 1400 JEDEC, JIS, and brand-specific devices. Also contains listing by case type, and electronic parameters. Includes Darlingtons transistors, high-voltage devices, high-current devices, high power devices.

BP99—MINI-MATRIX BOARD PROJECTS \$5.50. Here are 20 useful circuits that can be built on a mini-matrix board that is just 24 holes by ten copper-foil strips.

BP117—PRACTICAL ELECTRONIC BUILDING BLOCKS—Book 1 \$5.75. Oscillators, Timers, Noise Generators, Rectifiers, Comparators, Triggers and more.

BP184—INTRO TO 68000 ASSEMBLY LANGUAGE \$6.95. The 68000 is a great new breed of microprocessor. Programming in assembly language increases the running speed of your programs. Here's what you need to know.

BP179—ELECTRONIC CIRCUITS FOR THE COMPUTER CONTROL OF ROBOTS \$7.50. Data and circuits for interfacing the computer to the robot's motors and sensors

BP239—GETTING THE MOST FROM YOUR MULTIMETER \$5.95. Covers basics of analog and digital meters. Methods of component testing includes transistors, thyristors, resistors, capacitors and other active and passive devices.

BP97—IC PROJECTS FOR BEGINNERS \$5.50. Power supplies, radio and audio circuits, oscillators, timers, switches, and more. If you can use a soldering iron you can build these devices.

BP37—50 PROJECTS USING RELAYS, SCR'S & TRIACS \$5.50. Build priority indicators, light modulators, warning devices, light dimmers and more.

RADIO—100 RADIO HOOKUPS \$3.00. Reprint of 1924 booklet presents radio circuits of the era including regenerative, neutrodyne, reflex & more.

BP42—SIMPLE LED CIRCUITS \$5.50. A large selection of simple applications for this simple electronic component.

BP127—HOW TO DESIGN ELECTRONIC PROJECTS \$5.75. Helps the reader to put projects together from standard circuit blocks with a minimum of trial and error.

BP122—AUDIO AMPLIFIER CONSTRUCTION \$5.75. Construction details for preamps and power amplifiers up through a 100-watt DC-coupled FED amplifier.

BP92—CRYSTAL SET CONSTRUCTION \$5.50. Everything you need to know about building crystal radio receivers.

BP45—PROJECTS IN OPTOELECTRONICS \$5.50. Includes infra-red detectors, transmitters, modulated light transmission and photographic applications.

BP185—ELECTRONIC SYNTHESIZER CONSTRUCTION \$5.95. Use this book to learn how to build a reasonably low cost yet worthwhile monophonic synthesizer. You'll learn a lot about electronic music synthesis in the process.

CHECK OFF
THE BOOKS YOU WANT

ELECTRONIC TECHNOLOGY TODAY INC.
P.O. Box 240, Massapequa Park, NY 11762-0240

Name _____
Address _____
City _____ State _____ Zip _____

SHIPPING CHARGES IN USA AND CANADA

\$0.01 to \$5.00 \$1.50
\$5.01 to \$10.00 \$2.50
\$10.01 to 20.00 \$3.50
\$20.01 to 30.00 \$4.50
\$30.01 to 40.00 \$5.50
\$40.01 to 50.00 \$6.50
\$50.01 and above \$8.00

SORRY No orders accepted outside of USA & Canada

Number of books ordered

Total price of merchandise \$ _____
Sales Tax (New York State Residents only) \$ _____
Shipping (see chart) \$ _____

All payments must be in U.S. funds

Total Enclosed . \$ _____

P-1191

Popular Electronics®

THE MAGAZINE FOR THE ELECTRONICS ACTIVIST!

CONSTRUCTION ARTICLES

THE COUNTERSURVEILLANCE MONITOR	Vincent Vollono	27
<i>Locate and remove electronics eavesdropping devices with this simple, yet effective bug detector</i>		
BUILD A REMOTE-CONTROLLED OUTLET	John Yacono and Marc Spiwak	33
<i>Give yourself the gift of convenience with an infrared remote-controlled power outlet</i>		
BUILD A 1930'S-STYLE RADIO TRANSMITTER	Joseph C. Smolski	57
<i>Broadcast your own radio programs to any standard AM receiver with this easy-to-build low-power AM transmitter</i>		
THE SUPER-SIMPLE MUSIC CIRCUIT	Mike Giamportone	61
<i>Build a music synthesizer that's small enough to fit into your new or existing electronics projects</i>		

FEATURE ARTICLES

EXPERIMENTS IN GALVANISM	Stanley Czarnik	30
<i>Try these fun experiments that demonstrate a basic electronics principle</i>		
THE DAT PACT	Brian C. Fenton	38
<i>There is finally peace between the recording and electronics industry, but at what cost?</i>		
SCREEN DUMP SCRIMMAGE	Fred Blechman	64
<i>Get images from your computer screen to paper the easy way</i>		

PRODUCT REVIEWS

GIZMO		41
<i>Including: Sharp Multi-Use DAT Player/Recorder, Onkyo A/V Surround Integrated Amplifier, and more</i>		
PRODUCT TEST REPORT	Len Feldman	67
<i>Chinon Pocket 8 Camcorder</i>		
HANDS-ON REPORT		70
<i>EKI Mr. Circuit II Digital Magic Lab</i>		

COLUMNS

THINK TANK	John Yacono	18
<i>Shop equipment</i>		
CIRCUIT CIRCUS	Charles D. Rakes	71
<i>Power-control circuits, and more</i>		
ANTIQUÉ RADIO	Marc Ellis	74
<i>Safety for restorers: Part 1</i>		
COMPUTER BITS	Jeff Holtzman	76
<i>A classic updated</i>		
FUN SOFTWARE	Fred Blechman	78
<i>Mastering your computer's sound</i>		
HAM RADIO	Joseph J. Carr	80
<i>Build a bandsweeper</i>		
DX LISTENING	Don Jensen	82
<i>Something for everyone</i>		
SCANNER SCENE	Marc Saxon	84
<i>Modifications and more</i>		

DEPARTMENTS

EDITORIAL	Carl Laron	2
LETTERS		3
ELECTRONICS LIBRARY		4
NEW PRODUCTS		12
FACTCARDS		49
FREE INFORMATION CARD		51
ADVERTISER'S INDEX		96

Popular Electronics (ISSN 1042-170X) Published monthly by Gernsback Publications, Inc., 500-B Bl County Boulevard, Farmingdale, NY 11735. Second-Class postage paid at Farmingdale, NY and at additional mailing offices. One-year, twelve issues, subscription rate U.S. and possessions \$21.95, Canada \$28.84 (includes G.S.T. Canadian Goods and Services Tax Registration No. R125196280); all other countries \$29.45. Subscription orders payable in U.S. funds only. International Postal Money Order, or check drawn on a U.S. bank. U.S. single copy price \$2.95. © 1991 by Gernsback Publications, Inc. All rights reserved. Hands-on Electronics and Gizmo trademarks are registered in U.S. and Canada by Gernsback Publications, Inc. Popular Electronics trademark is registered in U.S. and Canada by Electronics Technology Today, Inc. and is licensed to Gernsback Publications, Inc. Printed in U.S.A.

Postmaster: Please send address changes to Popular Electronics, Subscription Dept., P.O. Box 338, Mount Morris, IL 61054-9332.

A stamped self-addressed envelope must accompany all submitted manuscripts and/or artwork or photographs if their return is desired should they be rejected. We disclaim any responsibility for the loss or damage of manuscripts and/or artwork or photographs while in our possession or otherwise.

As a service to readers, Popular Electronics publishes available plans or information relating to newsworthy products, techniques, and scientific and technological developments. Because of possible variances in the quality and condition of materials and workmanship used by readers, Popular Electronics disclaims any responsibility for the safe and proper functioning of reader-built projects based upon or from plans or information published in this magazine.

Larry Steckler

EHF, CET

Editor-In-Chief and Publisher

EDITORIAL DEPARTMENT

Carl Laron

Editor

Robert A. Young

Associate Editor

John J. Yacono

Associate Editor

Byron G. Wels, K2AVB

Associate Editor

Teri Scaduto

Assistant Editor

Kathy Terenzi

Editorial Assistant

Marc Splwak

Editorial Associate

Fred Blechman

Joseph J. Carr, K4IPV

Marc Ellis

Len Feldman

Jeffrey K. Holtzman

Don Jensen

Charles D. Rakes

Marc Saxon

Contributing Editors

PRODUCTION DEPARTMENT

Ruby M. Yee

Production Director

Karen S. Brown

Production Manager

Marcella Amoroso

Production Assistant

Janice Box

Editorial Production

ART DEPARTMENT

Andre Duzant

Art Director

Injae Lee

Illustrator

Russell C. Truelson

Illustrator

Jacqueline P. Cheeseboro

Circulation Director

Michele Torrillo

P-E Bookstore

BUSINESS AND EDITORIAL OFFICES

Gernsback Publications, Inc.

500-B Bi-County Blvd.

Farmingdale, NY 11735

1-516-293-3000

Fax: 1-516-293-3115

President: **Larry Steckler**

Customer Service/Order Entry

1-800-435-0715

7:30 AM - 8:30 PM EST

Advertising Sales offices listed on page 96

Cover photography by Diversified Photo Services

Composition by
Mates Graphics

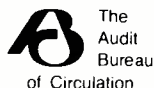

The
Audit
Bureau
of Circulation



The publisher has no knowledge of any proprietary rights which will be violated by the making or using of any items disclosed in this issue.

PAYING THE PIPER, AND HIS RECORD COMPANY

Conventional wisdom says that "there's no such thing as a free lunch." However, the way things are going, soon nothing at all will be free.

For instance, on page 38 is a story that details the recent agreement between the recording and electronics industries regarding digital-audio taping, and what it means to you. In essence, assuming the agreement is approved by Congress, a percentage of the price you pay for digital-audio taping hardware or blank tape will go toward royalties that, after administration expenses, will be disbursed to recording artists and companies. And you will have to pay those royalties no matter how or for what purpose you use your equipment.

The agreement was essentially the ransom that was paid by the electronics industry to allow consumers full access to the emerging digital-recording technologies such as DAT, DCC, and MD. Previously, the recording industries had refused to allow the distribution of software on digital-tape formats, which, in turn, restricted the growth of the technology. Of course, the ransom money itself will be paid by consumers like you and I.

Royalties were demanded despite the inclusion of the Serial Copyright Management System in every deck sold in this country. SCMS limits digital copying to one generation, which prevents a digitally copied tape from being used as a master.

To be fair, the agreement does finally clear the way for the new digital-recording media. And if the availability of pre-recorded software helps one or more of the formats gain public acceptance, prices of digital-recording gear can be expected to eventually drop.

In my opinion, however, using royalties in this context is self defeating. Previously, consumer surveys have shown that if someone liked a piece of music, they generally bought it and that most taping was done in the interest of location shifting. That is, recording a piece of music that the individual already owned so that it could be enjoyed elsewhere, such as in a car. Now, because of the new agreement, consumers may see home taping in a different light. Some of the individuals I've spoken to have taken the attitude "If I have to pay royalties, I'm going to make sure I get my money's worth!"

Carl Laron
Editor

COMPLIMENTS AND CORRECTIONS

Popular Electronics sure is doing its best to encourage hands-on learning (the best kind)! Every few years, a hobbyist magazine has a really first-rate article. Jonathan Connell's "Design Your Own Robot" (August 1991) is one. I've been disappointed countless times by articles that look good, but have little substance. This one is quite another kettle of fish!

In the same issue, I also liked Ron Johnson's article "All About Oscillators." However, his circuit for the Hartley oscillator omits one very important piece of information: L1 and L3 must be magnetically coupled. He did mention a tapped inductor, but anyone who builds this circuit with two separate inductors will discover variable coupling!

N.B.
Wellesley Hills, MA

ANTIQUÉ-RADIO IDENTIFICATION

I read with great interest Joseph

J. Carr's column on antique ham gear in the April issue of **Popular Electronics**. I am a collector of rare and unusual radios (mostly from the 1920's and 1930's).

Figure 2 in the article was labeled as a circa 1919-vintage receiver. In fact, what is pictured is a 1923 RCA Radiola III. It is a relatively inexpensive set as older radios go (\$50-\$150, depending upon condition). It is, however, a very interesting one.

A two-tube balanced amplifier was also available for those folks who wanted to run a horn speaker. Several years later, a combined set (receiver and amplifier) was offered. It came in one box with four tubes (WD-11 tubes) in it. It was the Radiola IIIA. The unit was also available in a small floor model.

J.A.
Los Altos, CA

LETTERS

HAVES & NEEDS

Help! I need schematics, a wiring diagram, a copy of the original manual, or all above for an old Crosley radio model 12-B1. Any help will be greatly appreciated. Thanks!

Christian Jacques
1326 Rue Beaudet
Thetford Mines, QC, Canada
G6G 6R7

I enjoy **Popular Electronics** very much—keep up the good work.

I'm starting a project that I hope some fellow readers might be able to help out with, by donating a transmitter to this cause. I'm a disabled Korean War veteran and I would like to have a portable radio station in the AM band, about 5 watts maximum. I plan to visit VA hospitals and local nursing homes and play old music, etc.,

and I would use the device like a wireless intercom through their existing power outlets. I have the turntable, cassette deck, and recordings of old shows done in the 1930's and 40's—everything but the transmitter. Please help me out with this. Thank you.

Ivan E. Bates
117 East Centennial
Boonville, AR 47601

What you are looking for is called a carrier-current transmitter; it places an AM signal on the AC power lines and allows you to "broadcast" private programs over short distances. We hope that one of our readers can come up with one for you. In the meantime, check out "Build a 1930's-Style Radio Transmitter" elsewhere in this issue. It may be all you need, especially in smaller nursing homes.—Editor

Train at HOME to be an Electronics Technician!

As the demand for computers and microprocessors in business, manufacturing and communications continues to grow, so does the need for qualified technicians. It's not unusual for experienced technicians to earn from \$30,000 to more than \$40,000 a year.* Now through Peoples College of Independent Studies you can train for this exciting field without interrupting your job or home life.

Choose From Five Programs of Study

- Electronics & Microprocessor Technology
- Industrial Electronics & Microprocessor Technology
- Communications Electronics with Microprocessor Technology
- Computer Servicing & Electronics Technology
- Specialized Associate Degree In Electronics Technology

Professional Equipment Is Included

Depending on the program you select, you'll perfect your skills using this advanced equipment, included in the price of tuition:

- IBM-Compatible Personal Computer
- Digital Multimeter
- Digital Logic Probe
- Elenco Oscilloscope
- Portable Cellular Telephone

(* Source: U.S. Bureau of Labor Statistics)



Exclusive Extras That Enhance Your Training

Peoples College introduces some training firsts to make your learning experience more complete:

- Accelerated Learning System — a scientifically proven study system that helps you learn faster and easier than ever before.
- Video Tutor Training Tapes — give you a permanent, visual record of informative lectures and close-up demonstrations.
- Experience Labs — professionally designed experiments that give you hands-on "bench" experience.
- Industry Certification Training Guide — provided with four of our programs. Prepares you for examinations you may take for your professional license or certification.

Easy Payment Plans — No Finance Charges

To help you get started on your education, Peoples College has reduced tuition rates and offers low monthly payment plans with no finance fees. So don't delay, call or write for more information today!

For COLOR CATALOG Mail Coupon or Call TOLL FREE 1-800-765-7247

Programs offered only in United States, Canada, Puerto Rico and Virgin Islands. No Obligation. No sales person will call.

Our programs are accredited by the Accrediting Commission of the National Home Study Council

YES! I would like to know more about your training programs. Send a catalog to:

Name _____

Address _____

City _____

State _____ Zip _____

Phone # _____

PEOPLES COLLEGE
OF INDEPENDENT STUDIES
233 Academy Drive • P.O. Box 421768
Kissimmee, FL 34742-1768
Member, D.L. Peoples Group E1191

ELECTRONICS LIBRARY

Wire & Cable for Electronics: A User's Handbook

by Neil Sclater

As wire and cable manufacturers have continuously improved their products, making electrical conducting equipment that is faster, smaller, and safer, the products have become increasingly application specific. It's gotten so that wires and cables are almost as complex as the systems they serve. This book, aimed at anyone who is involved in the manufacture, purchasing, sales, or distribution of wires and cable, explains the latest standards for the de-

sign, production, and maintenance of wire and cable assemblies. The book provides comprehensive coverage of the properties of conductor and insulation materials, system design and assembly techniques, and interchangeability requirements. Also discussed extensively are guidelines for using the latest wire and cable equipment, including single, paired, and special wires; flat cable and connectors; multiconductor and multipair cables; coaxial, triaxial, and twinaxial cables and conductors; process-control cable; and fiber-optic cable and connectors. Appendices provide fingertip access to international code designations and specifications, military specifications, UL and National Electrical Code definitions, and convenient conversion tables. Topics of current interest in the industry, such as corrosion prevention and environmental concerns, are also discussed.

Wire & Cable for Electronics: A User's Handbook costs \$29.95 and is published by TAB Books, Division of McGraw-Hill Inc., Blue Ridge Summit, PA 17294-0850; Tel. 1-800-822-8138.

CIRCLE 98 ON FREE INFORMATION CARD

EXPERIMENTAL ANTENNA TOPICS

by H.C. Wright

Nearly a century after Marconi's first demonstrations of radio communication, there is still a lot of research and experimentation going on in the field of antenna design and use. It's possible for the home experimenter to get in on the action, using inexpensive materials found around the home. This book shows readers how to make measurements and confirm principles using hand-made devices fabricated from common household throw-aways like cardboard, aluminum foil, cat-food tins, and plastic bottles. Only simple tools are required to build the devices, which include a dielectric-clad antenna, an interference-effects tester,

Experimental Antenna Topics

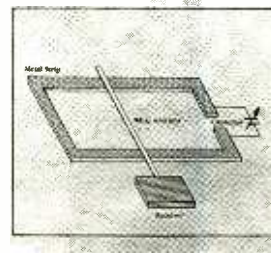

loop-and-frame antennas, and a sky-wave antenna. The projects are intended to encourage trial-and-error experimentation, which can lead to innovation and discovery.

Experimental Antenna Topics (order No. BP278) is available for \$8.45, including shipping and handling, from Electronics Technology Today Inc., P.O. Box 240, Massapequa Park, NY 11762-0240.

CIRCLE 97 ON FREE INFORMATION CARD

TVI-RFI SOLUTIONS INFORMATION PACKET

from Spi-Ro Manufacturing, Inc.

Spi-Ro offers an array of products designed to remove unwanted radio-, TV-, stray-, and harmonic-interference problems. This information packet contains fact-filled application notes, product listings, prices, and ordering information about products such as ferrite toroids, rods, and shielding beads. The products work on computers, modems, telephone lines, printers, amateur-radio equipment, power supplies, and power lines. Several kits are available, and discount prices are offered to technicians and experimenters.

The TVI-RFI Solutions Information Packet is free upon

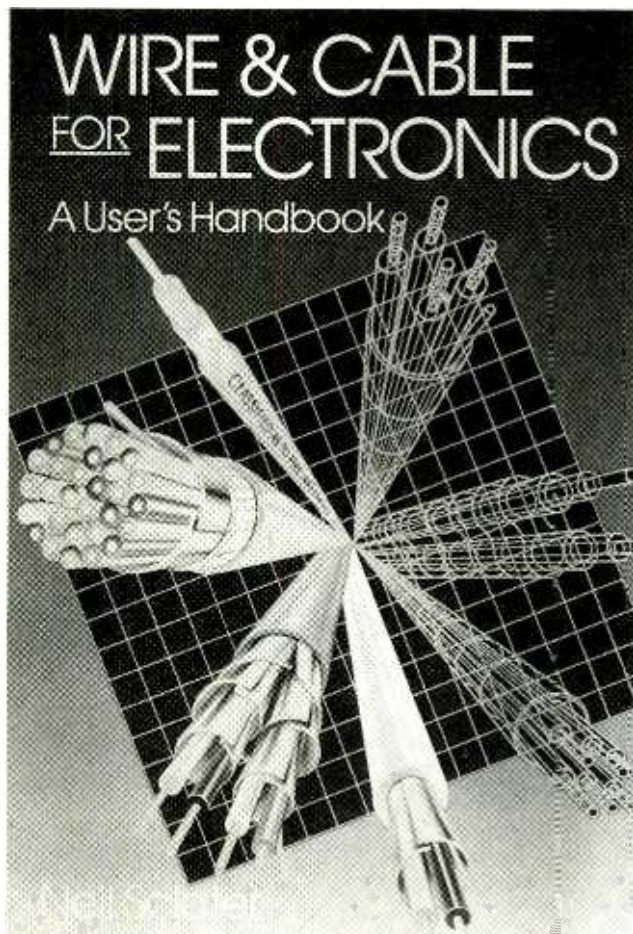

SELECT 5 BOOKS for only \$4.95 (values to \$111.75)



3628 \$26.95
Counts as 2



9290 \$36.00
Counts as 2



3371P \$16.95



3457 \$29.95
Counts as 2



3500 \$34.95
Counts as 2



1718 \$26.95
Counts as 2



2980P \$19.95



2790P \$14.95



3485 \$27.95
Counts as 2



3510 \$26.95
Counts as 2



2707P \$18.95



2800P \$16.95



2113P \$17.95



2883P \$18.95



2867P \$18.95

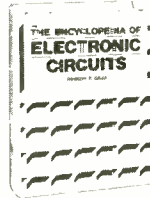

1928 \$60.00
Counts as 3



2925P \$4.95



3445 \$21.95



2995 \$25.95

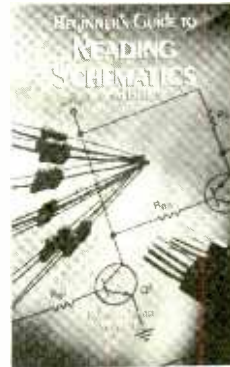

3632 \$18.95

Your most complete source for electronics books for over 25 years.



3414 \$39.95
Counts as 2



2887 \$16.95



2865P \$14.95



3258 \$28.95
Counts as 2

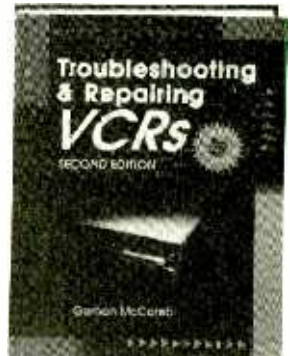

3777 \$32.95
Counts as 2



1367P \$24.95
Counts as 2



3241P \$16.95



2880P \$14.95

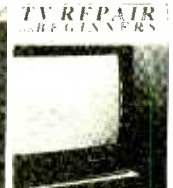

3527 \$29.95
Counts as 2



3672 \$28.95
Counts as 2

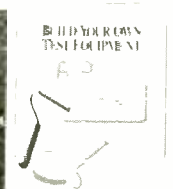

3475 \$27.95
Counts as 2

Membership Benefits • Big Savings. In addition to this introductory offer you keep saving substantially with members' prices of up to 50% off the publishers' prices. • **Bonus Books.** Starting immediately, you will be eligible for our Bonus Book Plan, with savings of up to 80% off publishers' prices. • **Club News Bulletins.** 15 times per year you will receive the Book Club News, describing all the current selections—mains, alternates, extras—plus bonus offers and special sales, with scores of titles to choose from. • **Automatic Order.** If you want the Main Selection, do nothing and it will be sent to you automatically. If you prefer another selection, or no book at all, simply indicate your choice on the reply form provided. You will have at least 10 days to decide. As a member, you agree to purchase at least 3 books within the next 12 months and may resign at any time thereafter. • **Ironclad No-Risk Guarantee.** If not satisfied with your books, return them within 10 days without obligation! • **Exceptional Quality.** All books are quality publishers' editions especially selected by our Editorial Board. (Publishers' Prices Shown)



ELECTRONICS BOOK CLUB

Blue Ridge Summit, PA 17294-0810

Please accept my membership in the Electronics Book Club and send the 5 volumes listed below, billing me \$4.95. If not satisfied, I may return the books within ten days without obligation and have my membership cancelled. I agree to purchase at least 3 books at regular Club prices during the next 2 years and may resign any time thereafter. A shipping/handling charge and sales tax will be added to all orders.

--	--	--	--	--

Name _____

Address _____

City _____

State _____ Zip _____ Phone _____

Valid for new members only. Foreign applicants will receive special ordering instructions. Canada must remit in U.S. currency. This order subject to acceptance by the Electronics Book Club. PE1191

All books are hardcover unless number followed by a P for paperback.

©1991 ELECTRONICS BOOK CLUB
Blue Ridge Summit, PA 17294-0810

request from Spi-Fo Manufacturing, Inc., P.O. Box 5000, Dept. PE, Lakeland, FL 33807-5500; Tel: 813-646-7925.
CIRCLE 81 ON FREE INFORMATION CARD

1991 CATALOG
 from EasyTech, Inc.

Dubbed "the electronic source book of the nineties," this 34-page catalog features a broad range of products for electronic hobbyists, amateur-radio operators, engineers, service technicians, students, and teachers. Included in its 34 pages are cables and connectors, semiconductors,



THE ELECTRONIC SOURCE BOOK OF THE NINETIES

switches, test equipment, soldering/desoldering equipment, books, batteries, PC-board design kits, cabinets and enclosures, tools, and power supplies. Color photographs accompany many of the product descriptions, and full specifications and pricing information is included.

The 1991 Catalog is free upon request from EasyTech, Inc., 2917 Bayview Drive, Fremont, CA 94538; Tel: 1-800-582-4044; Fax: 1-800-582-1255.
CIRCLE 82 ON FREE INFORMATION CARD

MORSE CODE: THE ESSENTIAL LANGUAGE Second Edition

by L. Peter Carron Jr., W3DKV

Although Morse code is no longer used as often as in the past, it remains a useful communications tool, and is used extensively by the maritime services, the military, and even as a backup system by American astronauts. Using the code is an exciting way to communicate, and understanding it means being fluent in another language. This book, published by

the American Radio Relay League (ARRL), provides a broad picture of Morse code, delving into the history of telegraphy, explaining the code itself, teaching how to receive and send code, describing the technology from the first transmitters to the latest advances,

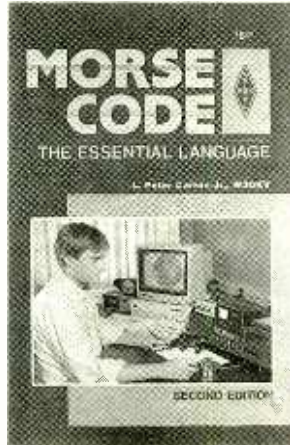

and discussing other versions of the code. In addition, the book covers high-speed operation, proper operating practices, and distress calls. Throughout the book, interesting anecdotes, photos, and illustrations accompany the easy-to-read text. The book also provides suggestions for related reading, lists of commonly used abbreviations, sources for equipment, and descriptions of related organizations and associations.

Morse Code: The Essential Language is available for \$6.00 plus \$3.00 shipping and handling from the American Radio Relay League, 225 Main Street, Newington, CT 06111.

CIRCLE 83 ON FREE INFORMATION CARD

1991 CATALOG
 from Rochester Electronics Inc.

More than 170 million discontinued and custom-packaged semiconductors are listed in this catalog, which also includes information concerning facilities, capabilities, electrical testing, quality conformance inspection processing, and quality assurance. Rochester supplies discontinued devices from AMD, Harris, Intel, Motorola, Texas Instruments, National/Fairchild, and other manufacturers. The inventory described in the catalog includes die, wafer, and original manufacturer mask sets. Linear, 54H, 54L,

RTL, DTL, TTL, ECL, CMOS, SUHL, Schottky, and many other product families are offered in a variety of standard and customer-specific packages.

The 1991 catalog is free upon request from Rochester Electronics, Inc., 10 Malcolm Hoyt Drive, Newburyport, MA 01950-4018; Tel: 508-462-9332; Fax: 508-462-9512.

CIRCLE 84 ON FREE INFORMATION CARD

DOS, WORDPERFECT & LOTUS OFFICE COMPANION

by Robert W. Harris

In the last decade, PC's have become an essential part of almost every office, and a few software programs have become firmly entrenched in offices everywhere. With the popularity of IBM-compatible computers, the DOS operating system has emerged as the leader. Lotus 1-2-3 is frequently the program of choice for spreadsheet analysis, and WordPerfect is one of the most popular word-processing programs on the market. A good working knowledge of those three programs should meet the

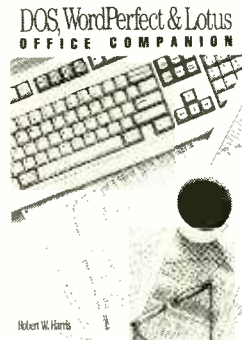

requirements of many businesses. Each of the three have in common sophistication, power—and complexity. This book is intended to teach beginning and intermediate PC users (who already have a basic knowledge of computers and software) to use the essential features of the three popular programs. Using a friendly, non-technical approach, the book puts the basic commands of DOS, Lotus 1-2-3, and WordPerfect at the user's fingertips. It discusses practical ideas and strategies, time-saving features, and handy shortcuts. Each

technique described in the book was chosen either because it solves a specific, common problem or because it saves time and effort. The book doesn't strive to turn its readers into expert users; its goal is to help readers become confident and productive users.

DOS, WordPerfect & Lotus 1-2-3 Office Companion costs \$19.95 and is published by Ventana Press, Inc., P.O. Box 2468, Chapel Hill, NC 27515; Tel: 919-942-0220; Fax: 919-942-1140.

CIRCLE 85 ON FREE INFORMATION CARD

HAMSTUFF: The Who-What-Where of Amateur Radio

edited by Walt Garrett, NOMAL

This comprehensive buyer's guide and directory contains information about more than 1000 vendors of ham-radio products

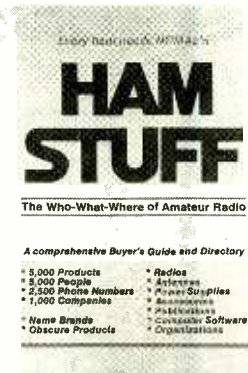

and services. It also contains descriptions of more than 5000 products, including radios, antennas, power supplies, accessories, personal and gift items, and other ham-related product categories. The book is divided into three main sections. The first is called "Stuff to Do" and includes chapters describing the basics of ham radio, licensing requirements, youth activities, and programs for disabled hams, along with information on membership organizations and publications. "Stuff to Buy," the second and by far the largest section, includes chapters on the entire range of amateur-radio equipment, including more than 5000 products arranged into chapters and sections by product type. The third section is the "HamStuff Index," which consists of 70 pages of vendor

Why take chances in today's job market?

Graduate as a fully trained electronics professional.

To get ahead and stay ahead in today's economy, you need the electronics training CIE has been providing its 150,000-plus successful graduates with for nearly 60 years.

Meet the Electronics Specialists.

When you pick an electronics school, you're getting ready to invest time and money. And your whole future depends on the education you receive in return. That's why it makes so much sense to go with number one... with the specialists... with CIE!

There's no such thing as a bargain education.

If you talk to some of our graduates, and we recommend you do, chances are you'd find a lot of them shopped around for their training. Not for the lowest priced, but for the best training available. They pretty much knew what was available when they picked CIE as number one.

Because we're specialists we have to stay ahead.

At CIE we have a position of leadership to maintain. Here are just a few of the ways we hang onto it...

Programmed Learning.

That's exactly what happens with CIE's Auto-Programmed Lessons®. Each lesson uses famous "programmed learning" methods to teach you important electronics principles. You explore them, master them completely before you start to apply them. You thoroughly understand each step before you go on to the next. You learn at your own pace.

And, beyond theory, some courses come fully equipped with electronics equipment to actually let you perform hundreds of hands-on experiments.

Experienced specialists work closely with you.

Even though you study at home, CIE's faculty and staff stand ready to assist via CIE's toll free number. And, each time you return a completed exam you can

be sure it will be reviewed, graded and returned with the appropriate instructional help, you get it fast and in writing from the faculty technical specialist best qualified to answer your question in terms you can understand.

Pick the pace that's right for you.

CIE understands people need to learn at their own pace. There's no pressure to keep up...no slow learners hold you back. If you're a beginner, you start with the basics. If you already know some electronics, you move ahead to your own level.

"Same Day" grading cycle.

When we receive your lesson, we grade it and mail it back the same day. You find out quickly how well you're doing!

State-of-the-art laboratory equipment.

Some courses feature the CIE Microprocessor

Training Laboratory. An integral part of computers, microprocessor technology is used in many phases of business, including service and manufacturing industries. The MTL gives you the opportunity to program it and interface it with LED displays, memory devices and switches. You'll gain all the experience

needed to work with state-of-the-art equipment of today and tomorrow.

New Courses!

CIE now offers two new career courses: Automotive Electronics and Computer Operation and Programming.

CIE offers you an Associate Degree.

One of the best credentials you can have in electronics — or any other career field — is a college degree. That's why CIE offers an Associate in Applied Science in Electronics Engineering Technology. And all CIE career courses earn credit toward your degrees.

Which CIE training fits you?

Beginner? Intermediate? Advanced? CIE home study courses are designed for ambitious people at all entry levels. People who have: No previous electronics knowledge, but do have an interest in it; Some basic knowledge or experience in electronics; In-depth working experience or prior training in electronics.

At CIE you start where you fit and feel comfortable where you start, then go on from there to your Diploma, Associate Degree and career!

Today is the day. Send now.

Fill in and return the postage-paid card attached. If some ambitious person has already removed it, cut out and mail the coupon below. You'll get a FREE CIE school catalog, plus complete information on independent home study. Mail in the coupon below or, if you prefer, call toll-free 1-800-321-2155 (in Ohio, 1-800-523-9109).



YES! I want to get started. Send me my CIE school catalog including details about the Associate Degree program. (For your convenience, CIE will have a representative contact you — there is no obligation.) AH20

Print Name _____

Address _____ Apt. _____

City _____ State _____ Zip _____

Age _____ Area Code/Phone No. (____) _____

Check box for G.I. Bulletin on Educational Benefits Veteran Active Duty

CIE CLEVELAND INSTITUTE OF ELECTRONICS, INC.
1776 East 17th Street • Cleveland, Ohio 44114 • (216) 781-9400

 A school of thousands.
A class of one.
Since 1934.

DIGITAL VIDEO STABILIZER ELIMINATES ALL VIDEO COPY PROTECTIONS



While watching rental movies, you will notice annoying periodic color darkening, color shift, unwanted lines, flashing or jagged edges. This is caused by the copy protection jamming signals embedded in the video tape, such as Macrovision copy protection. Digital Video Stabilizer: RXII completely eliminates all copy protections and jamming signals and brings you crystal clear pictures.

FEATURES:

- Easy to use and a snap to install
- State-of-the-art integrated circuit technology
- 100% automatic - no need for any troublesome adjustments
- Compatible to all types of VCRs and TVs
- The best and most exciting Video Stabilizer in the market
- Light weight (8 ounces) and Compact (1x3.5x5")
- Beautiful deluxe gift box
- Uses a standard 9 Volt battery which will last 1-2 years.

WARNING :
SCO Electronics and RXII dealers do not encourage people to use the Digital Video Stabilizer to duplicate rental movies or copyrighted video tapes. RXII is intended to stabilize and restore crystal clear picture quality for private home use only.

(Dealers Welcome)

To Order: \$59.95 ea + \$4 for FAST UPS SHIPPING

1-800-445-9285 or **516-568-9850**

Visa, M/C, COD M-F: 9-6 (battery not included)
SCO ELECTRONICS INC.

Dept CPE11581 W. Merrick Rd. Valley Stream NY 11580
Unconditional 30 days Money Back Guarantee

CIRCLE 15 ON FREE INFORMATION CARD

CABLE TV DESCRAMBLERS How You Can Save Money on Cable Rental Fees

Bullet Proof

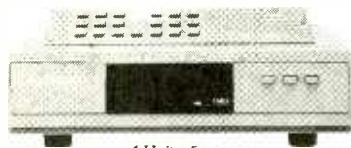

1 Unit 5+

**BEST Super Tri-Bi Auto/
Var. Gain Adjustment \$119.95...\$85**
Jerrold Super Tri-Bi ... \$109.95...\$79
Scientific Atlanta \$109.....\$79
Pioneer \$109.....\$79
Panasonic TZPC145... \$99.95...\$79
Stargate Converter..... \$95.....\$69
Digital Video Stabilizer. \$59.95...\$29
Wireless Video Sender..\$59.95...\$49.95

**US Cable'll Beat
Anyone's Price
Advertised in
this Magazine!**

**30 Day Money Back Guarantee
FREE 20 page Catalog**

Visa, M/C, COD or send money order to:

**U.S. Cable TV Inc. Dept. KPE11
4100 N. Powerline Rd., Bldg. F-4
Pompano Beach, FL 33073**

1-800-772-6244

For Our Record

I, the undersigned, do hereby declare under penalty of perjury that all products purchased, now and in the future, will only be used on Cable TV systems with proper authorization from local officials or cable company officials in accordance with all applicable federal and state laws. **FEDERAL AND VARIOUS STATE LAWS PROVIDE FOR SUBSTANTIAL CRIMINAL AND CIVIL PENALTIES FOR UNAUTHORIZED USE.**

Date: _____

Signed: _____

No Florida Sales!

CIRCLE 15 ON FREE INFORMATION CARD

names, addresses, and phone numbers.

HamStuff: The Who-What-Where of Amateur Radio is available through local ham-radio stores for \$19.95 or (with an additional \$3.00 for shipping and handling) directly from the publisher, GAI Systems Group, P.O. Box 5832, St. Louis, MO 63134; Tel: 314-831-6464; Fax: 314-895-3608.

**CIRCLE 86 ON FREE
INFORMATION CARD**

SPRING 1992 CATALOG from American Design Components

Geared to the various needs of computer buffs, hobbyists, students, and tinkerers, as well as manufacturers, engineers, and researchers, this 54-page catalog is filled with computers and computer-related parts and components at below-OEM prices. Included in its pages are components such as integrated circuits, crystals, fans, connectors, semiconductors, batteries, LED's, switches, and power supplies. Also featured are computer-related products such as disk drives, monitors,

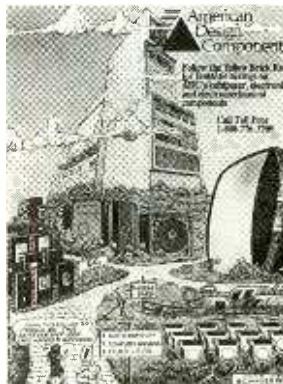

and add-on boards—plus complete computer systems for beginner's personal use right up to high-tech industrial use. Photographs accompany the product descriptions.

The Spring 1992 Catalog is available at no charge from American Design Components, 815 Fairview Avenue, Fairview, NJ 07022; Tel: 1-800-776-3700.

**CIRCLE 87 ON FREE
INFORMATION CARD**

FULL-LINE CATALOG from Hub Material Company

This detailed, fully illustrated buying guide contains 140

pages of electronic tools, test equipment, and supplies for the manufacture, assembly, and repair of electronics. A large selection of brand-name, competitively priced products includes test instruments, tool kits, soldering/desoldering systems, lamps and magnifiers,



anti-static products, and precision hand tools. To make it easy to find the products you need, the catalog features a table of contents, a comprehensive index, and color-coded product categories. Also featured are clear photographs and concise descriptions of the products, and easy-to-understand comparison tables of product features.

The Full-Line Catalog is free upon request from HMC, 33 Springdale Avenue, Canton, MA 02021, Tel: 617-821-1870; Fax: 617-821-4133.

**CIRCLE 88 ON FREE
INFORMATION CARD**

ADVANCED SHALLOW WATER TREASURE HUNTING: With the Fisher 1280-X Aquanaut Metal Detector

by Wallace L. Chandler

The author of this book has been using metal detectors for treasure hunting for more than 25 years, during which time he developed a specialty: shallow-water treasure hunting. In this book he shares his experience. He describes ways to modify metal detectors for improved performance, the best places to hunt, special search techniques, recovery tips, and safety precautions. In addition, he explains what to do with the coins, artifacts, and jewelry you unearth. A chapter called "Things I

Learned the Hard Way," is devoted to a discussion of legalities and provides tips on metal detecting in the water. In that chapter, too, the author debunks the "myth of the shrinking finger" (he claims that

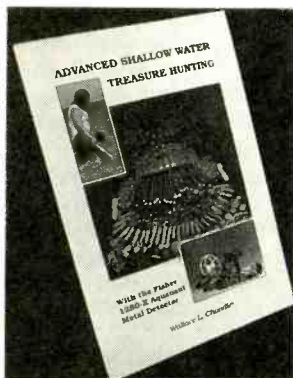

rings fall off in the water because they are too big to begin with, not because cold water makes fingers shrink). While the book was written specifically for owners of Fisher 1280-X Aquanaut Metal Detectors, most of the material that is covered in its 58 pages can be used by any shallow-water treasure hunter.

Advanced Shallow Water Treasure Hunting with the Fisher 1280-X Aquanaut Metal Detector costs \$6.00 (plus \$2.00 for shipping and handling on mail orders) and is published by Fisher Research Laboratory, Dept. PE, 200 West Wilmott Road, Los Banos, CA 93635; Tel: 209-826-3292; Fax: 209-826-0416.

CIRCLE 89 ON FREE INFORMATION CARD

1991 D.A.T.A. DIGEST LIBRARY

from D.A.T.A. Business Publishing

The latest edition of this five-volume set provides specifications, electrical parameters, sources, and substitutes for virtually every standard IC currently produced (more than 165,000). The books each cover a specific category—linear, memory, digital, interface, and microprocessor—of integrated circuits. The books' logical layouts let readers locate needed information using just a part number or a device's function. In addition, extensive cross-reference sections direct readers with limited information

to the necessary data for making component selection and replacement choices. A function index allows readers to locate device information by function or application; a part-number index, by part number; a discontinued parts numbers index references obsolete devices; device pinouts list electrical connections for each device; and technical sections allow comparisons by device characteristics. The books also provide a replacement/alternate source

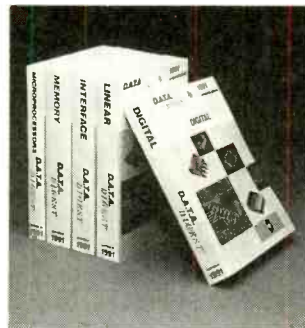

index and a manufacturers directory that includes part-

numbering schemes along with the names, addresses, and phone numbers.

Each D.A.T.A. Digest costs \$200; the complete five-book library costs \$900 (shipping and handling is additional). To order or for more information, contact D.A.T.A. Business Publishing, 15 Inverness Way East, P.O. Box 6510, Englewood, CO 80155-6510; Tel: 800-447-4666; Fax: 303-799-8082.

CIRCLE 90 ON FREE INFORMATION CARD

48 HOUR SHIPPING ELENCO & HITACHI PRODUCTS AT DISCOUNT PRICES 48 HOUR SHIPPING

Hitachi RSO Series

(Portable Real-time Digital Storage Oscilloscopes)

VC-6023 - 20MHz, 20MS/s	\$99/mo*
VC-6024 - 50MHz, 20MS/s	\$120/mo*
VC-6025 - 50MHz, 20MS/s	\$135/mo*
VC-6045 - 100MHz, 40MS/s	\$125/mo*
VC-6145 - 100MHz, 100MS/s	\$200/mo*

*Based on 24 months, except V-1150, VC-6045, VC-6145 (36 months)

Hitachi Portable Scopes

DC to 50MHz, 2-Channel, DC offset function, Alternate magnifier function

V-525 - CRT Readout, Cursor Meas.	\$1,025
V-523 - Delayed Sweep	\$995
V-522 - Basic Model	\$895
V-422 - 40MHz	\$795
V-223 - 20MHz delayed sweep	\$895
V-212 - 20MHz	\$425

LEASING AVAILABLE

For all Hitachi Scopes - Call for details

Hitachi Compact Series Scopes

This series provides many new functions such as CRT Readout, Cursor measurements (V-1085/1065/605), Frequency Cr (V-1085), Sweep-time Autotriggering, Delayed sweep and Trigger Lock using a 6-inch CRT. You don't feel the compactness in terms of performance and operation.

V-660 - 60MHz, Dual Trace	\$1,195
V-665 - 60MHz, DT, w/cursor	\$1,345
V-1060 - 100MHz, DT, w/cursor	\$1,425
V-1065 - 100MHz, DT, w/cursor	\$1,050/mo*
V-1085 - 100MHz, DT, w/cursor	\$1,225/mo*
V-1100A - 100MHz, Quad Trace	\$1,225/mo*
V-1150 - 150MHz, Quad Trace	\$1,115/mo*

20MHz Elenco Oscilloscope \$375

MO-1251

- Dual Trace Component Tester
- 6" CRT
- X-Y Operation
- TV Sync
- 2 P-1 Probs

FREE DMM with purchase of ANY SCOPE

SCOPE PROBES

P-1 65MHz, 1x, 10x \$19.95

P-2 100MHz, 1x, 10x \$26.95

Elenco 35MHz Dual Trace Good to 50MHz \$495

MO-1252

- High luminance 6" CRT
- 1mV Sensitivity
- 6KV Acceleration Voltage
- 10ms Rise Time
- X-Y Operation - 2 Axis
- Delayed Triggering Sweep
- Includes 2 P-1 Probes

All scopes include probes, schematics, operators manual and 3 year (2 yrs for Elenco scopes) world wide warranty on parts & labor. Many accessories available for all Hitachi scopes. Call or write for complete specifications on these and many other fine oscilloscopes.

Beckman TEST EQUIPMENT

All Models Available

Call for special price

Digital Capacitance Meter

CM-1550B

\$58.95

3 Ranges
1p/20,000pF
5% basic acy
Zero control w/ Case
Big 1" Display

Digital LCR Meter

LC-1801

\$125

Measures:
Colls 1uH-200H
Caps 1p-200uF
Res. 0.1-20M

Multimeter with Capacitance & Transistor Tester

SM-1500B

\$55

Reads Vols, Ohms
Current, Capacitors,
Transistors and
Diodes w/ with case

FLUKE MULTIMETERS

All Models Available

Call for special price

Quad Power Supply

XP-580

\$59.95

2-20V @ 2A
12V @ 1A
5V @ 3A
5V @ 5A

Fully regulated and short circuit protected

Triple Power Supply

XP-620

Assembled \$69

KH \$45

2 to 15V @ 1A,
2 to 15V @ 1A
(to 10 30V @ 1A)
and 5V @ 3A

All the desired features for doing experiments.
Features short circuit protection, all supplies

AM/FM Transistor Radio Kit with Training Course

Model AM/FM 108

\$26.95

14 Transistors + 5 Diodes
Makes a great school project

True RMS 4 1/2 Digit Multimeter

M-7000

\$135

.05% DC Accuracy
1% Resistance
with Freq. Counter
and Deluxe Case

Soldering Station

Temperature Controlled

SL-30 \$99

Digital Display
Temp Range:
300F-900F
Grounded Tip
Overheat Protect

Color Convergence Generator

SG-200

\$69.95

Finest in the industry
10 rock steady patterns

Four-Function Frequency Counters

F-100 120MHz \$179

F-1000 1.2GHz \$259

Frequency, Period, Totalize,
Self Check with High Stabilized Crystal Oven
Oscillator, 8 digit LED display

Digital Triple Power Supply

XP-765

\$269

0-20V at 1A
0-20V at 1A
5V at 5A

Fully regulated, Short circuit protected with 2 limit control, 3 separate supplies
XP-660 with Analog Meters \$195

GF-8016 Function Generator with Freq. Counter

\$249

Sine, Square, Triangle
Pulse, Ramp, 2 to 2MHz
Freq. Counter: 1 - 10MHz

GF-8015 without Freq. Meter \$179

Function Generator Blox

\$9600

\$28.95

Provides sine, triangle, square
wave from 1Hz to 1MHz
AM or FM capability

Learn to Build and Program Computers with this Kit

Includes: All Parts, Assembly and Lesson Manual

Model MM-8000

\$129.00

Starting from scratch you build a complete system. Our Micro-Master trainer teaches you to write into RAM, ROM and run a 8085 microprocessor, which uses similar machine language as IBM PC

Robotics Kit for above (MM8010) 71.95

WE WILL NOT BE UNDERSOLED!

UPS Shipping: 48 States 5%
(33 Min \$10 Max) Shipping
IL Res., 7% Tax FAX: 708-520-0085

Wide Band Signal Generators

SG-9000 \$129

RF Freq 100K-450MHz AM Modulation of 1KHz Variable RF output
SG-9500 w/ Digital Display & 150MHz built-in Counter \$249

MOVIT EDUCATIONAL ELECTRONIC ROBOT KITS

The MOVIT line is a series of computerized (and logic controlled) battery robot kits that can teach the basic principles of robotic sensing and locomotion. Each of the kits features pre-assembled PC boards, hardware and mechanical-drive systems that can be handled by almost anyone from ages 10 and up. Only basic hand tools are required for assembly. These fascinating robots allow you to experience and learn any one of the following features: sound sensor, remote control, infra-red sensor, wired control and/or programmable memory. The MOVIT line has provided the future with an innovative electronic educational kit. They are affordable robots that can entertain as well as educate. Now meet the family!

MV-912 Avioder Infra-red	\$45.95	MV-939 Medusa Sound Sensor	\$29.95
MV-915 Piper mouse Sound Sensor	\$45.95	MV-963 Line Tracker Infra-red	\$45.95
MV-916 Peppy Sound Touch	\$25.95	MV-966 Manta Sound/Touch	\$29.95
MV-931 Mr. Bootsman Arm Control	\$35.95	Y-01 Robotic Arm Robotic Control	\$45.95
MV-932 Catral Remote Control	\$45.95	BT-802 Grand Piano Electronic Piano	\$29.95
MV-936 S-Cargo Sound Sensor	\$45.95	BT-805 Roulette Digital Wheel	\$35.95

C & S SALES INC.

1245 Rosewood, Deerfield, IL 60015
(NIM) 292-7711 (708) 541-0710

15 Day Money Back Guarantee
2 Year Warranty
WRITE FOR FREE CATALOG

CIRCLE 6 ON FREE INFORMATION CARD

NEW PRODUCTS

Hand-Held Receiver

With continuous frequency coverage from 500 kHz to 1300 MHz, *Ace Communications' AR1000XC* hand-held radio allows reception of all broadcast bands, shortwave frequencies, military communications bands, and all public-service bands. AM or narrow FM reception modes, as well as FM broadcast and TV audio modes, are user-selectable at any frequency. The receiver features 26 front-panel keys that allow programming of 1000 total scan memory



channels. Pairs of upper and lower limits for bands to be searched can be stored in ten separate search-memory locations. All information is stored in permanent memory. Other features include selectable single-channel priority, keyboard lock-out, BNC antenna connector, and a backlit display for night use. The LCD readout offers 21 separate prompting annunciators to make the unit easier

to use. The compact AR1000XC measures $6\frac{7}{8} \times 2\frac{1}{2} \times 1\frac{1}{2}$ inches and weighs just 12 ounces. It comes with a 120-volt to 12-volt wall plug adaptor/charger, a DC cigarette-lighter charger, a flexible antenna, AA-size rechargeable batteries, and a carrying case.

The AR1000XC has a suggested retail price of \$429. For more information, contact Ace Communications, Monitor Division, 10707 East 106th Street, Fishers, IN 46038; Tel: 317-842-7115; Fax: 317-849-8794.

CIRCLE 101 ON FREE INFORMATION CARD

WIRELESS LIGHT SWITCH

Many homes have rooms with inconveniently placed light switches; some even have rooms with no light switches at all. *Heath Zenith* offers homeowners an easy way to add light switches to control plug-in lamps, using the *SL-6136 Reflex Wireless Switched Outlet*. The device is installed by plugging the receiver/outlet into any electrical outlet and then plugging the lamp into the receiver. After installing a 9-volt battery into the transmitter/switch, it can be installed on any surface in the room. The switch, which can be placed up to 50 feet away from the receiver, transmits radio-frequency signals that can pass through doors and around corners. Intended for indoor use only, the wireless switched outlet controls up to 500 watts of incandescent lighting. Besides incandescent lights, it can be used to control televisions and fans, as well as fluorescent lighting. Different RF channels are available so that more than

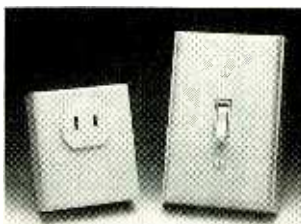

one wireless switched outlet can be used in the same house. The device also works with other Reflex indoor wireless-switch products that have the same channel code.

The SL-6136 Wireless Switched Outlet has a suggested retail price of \$29.97. For further information, contact Heath Zenith Reflex Brand Group, 455 River-view Drive, Benton Harbor, MI 49022.

CIRCLE 102 ON FREE INFORMATION CARD

COMPACT PRINTER BUFFER

To free up your PC during large printing jobs, the *Solectek Compact Buffer model CB256* provides temporary memory storage between the computer and printer. The buffer, which can be upgraded from 256K to 2MB, uses data-compression hardware to store up to twice as much data as conventional buffers. No software is required. The device is designed to work with any IBM-compatible computer and any parallel printer. The buffer accepts data up to



22KB/second, stores it in compressed form, and transfers it to the printer at the fastest printer receiving rate, including soft fonts. The streamlined buffer measures $5\frac{1}{2} \times 1\frac{1}{2}$ inches and comes with a standard 8-inch Centronics 36-pin ribbon cable. An outlet is required for the DC power adapter. The buffer is compatible with Solectek's printer-sharing devices.

The CB256 printer buffer has a suggested retail price of \$299.95. For additional information, contact Solectek Corporation, 6370 Nancy Ridge Drive, San Diego, CA 92121; Tel: 800-437-1518.

CIRCLE 103 ON FREE INFORMATION CARD

ACTIVE-DIFFERENTIAL PROBE

API's model SI-9000 is equally at home as an equipment-design aid in the laboratory, or as a safe, time-saving, troubleshooting tool in the field, or as a teaching aid in schools. The active-differential probe uses only one input channel of any general-purpose oscilloscope. Its built-in differential amplifier is internally powered with no adjustments required. The unit has switch-selectable



gains, high CMMR, DC to 15-MHz bandwidth, and a constant input impedance of 2 megohms, and 2.5 pF. It is useful with inputs as high as ± 700 volts and provides 2% accuracy for outputs as high as ± 3.5 volts across loads as low as 1000 ohms. Both inputs are protected against damage to ± 1000 volts. The SI-9000 can be used in monitoring, testing, designing, and troubleshooting applications.

The SI-9000 differential probe costs \$399. For more information, contact Avex Probes Inc., 1683 Winchester Road, Bensalem, PA 19020; Tel: 800-877-7623.

CIRCLE 104 ON FREE INFORMATION CARD

CLEANING TOOL

Equipped with a small bundle of glass fibers to reach tiny or hard-to-reach areas, the *Eliminator* brush removes corrosion from components, electronic equipment, and electrical contacts without damaging the metal. The glass fibers are less than two thousandths of an inch in diameter, but provide a cleaning force of hundreds of pounds per square inch. Three



glass-fiber cartridges are stored inside the Eliminator's handle. The multipurpose tool can also be used for deglossing parts before gluing, preparing parts for soldering, removing rust from precision tools, removing lay-out dye, and cleaning engraving.

The Eliminator cleaning tool

costs \$6.95. For additional information, contact *Pro Motorcar Products, Inc.*, 22025 US 19 N, Clearwater, FL 34625; Tel: 800-323-1090.

CIRCLE 105 ON FREE INFORMATION CARD

18-DISC CD PLAYER

For jukebox-style entertainment, *Pioneer's PD-TM1* three-magazine, multi-play CD changer is designed for continuous play of up to 18 discs. The

magazines allow "hands-off" operation and compatibility between the PD-TM1 and car multi-CD changers. The changer offers two-mode random play—random programmed play of all 18 discs and individual tracks and delete



Kepro Gets You Started! With Complete PCB Kits.

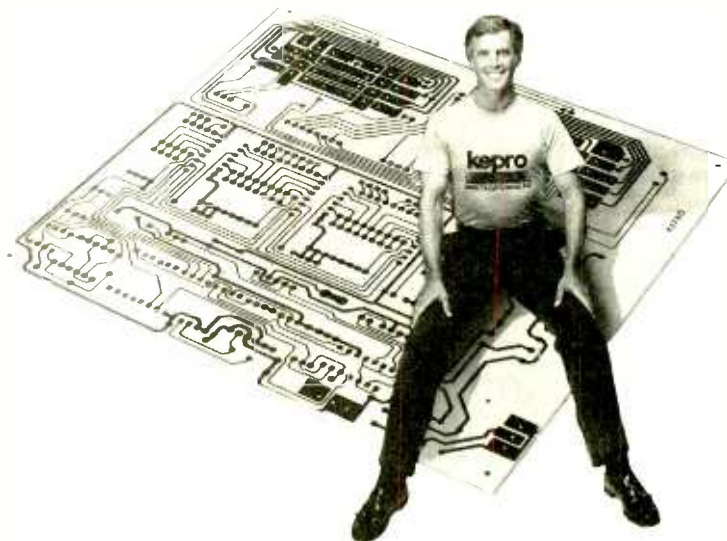

Get that electronic construction project started with professional-quality PCB's that you can make at home. Kepro makes it easy to produce your own etched circuit boards with all the quality materials and step-by-step instructions you'll need. Hobbyists really go for our complete kits for:

- Dry film photoresist
- Resist etched circuits
- Art layout
- Photo reversing
- Screen printing
- Nameplates
- And more

All Kepro products are easy to use and come with an unconditional guarantee. Call us for more information and to get your **FREE booklet** on how you can get started making your own PCB's with Kepro products.

1-800-325-3878
1-314-343-1630 (St. Louis)

kepro
Kepro Circuit Systems, Inc.

630 AXMINSTER DRIVE • FENTON, MISSOURI 63026-2992

CIRCLE 17 ON FREE INFORMATION CARD

Be an FCC LICENSED ELECTRONIC TECHNICIAN!



Earn up to \$30 an hour and more!

Learn at home in spare time. No previous experience needed!

No costly school. No commuting to class. The Original Home-Study course prepares you for the "FCC Commercial Radiotelephone License." This valuable license is your professional "ticket" to thousands of exciting jobs in Communications, Radio-TV, Microwave, Maritime, Radar, Avionics and more...even start your own business! You don't need a college degree to qualify, but you do need an FCC License.

No Need to Quit Your Job or Go To School This proven course is easy, fast and low cost! **GUARANTEED PASS**—You get your FCC License or money refunded. **Send for FREE facts now. MAIL COUPON TODAY!**

COMMAND PRODUCTIONS

FCC LICENSE TRAINING, Dept. 100
P.O. Box 2824, San Francisco, CA 94126
Please rush FREE details immediately!

NAME _____
ADDRESS _____
CITY _____ STATE _____ ZIP _____

SUPER LONG PLAY TAPE RECORDERS

12 Hour Model —
USES 120 TAPE
\$119.00*

Modified Panasonic Slimline, high quality AC-DC provide 6 continuous hours of quality recording & playback on each side of cassette for 12 hours total. Includes • Voice level control • Digital counter, etc. TDx - 120 Cassette Furnished.



PHONE RECORDING ADAPTER

Records calls automatically. All Solid state connects to your telephone jack and tape recorder. Starts recording when phone is lifted. Stops when you hang up.

\$28.50*

FCC APPROVED

VOX VOICE ACTIVATED CONTROL SWITCH

Solid state Self contained Adjustable sensitivity. Voices or other sounds automatically activate and control recorder, uses either recorder or remote mike.

\$28.50*

* Add for ship & handling. Phone Adapter & Vox \$2.00 each. Recorders \$5.00 each. Calif. Res. add tax. Mail order. VISA/MC, COD's OK. Money Back Guarantee. Quantity discounts available. Dealer Inquiries invited. Free Data.

AMC SALES INC. Dept. B 9335 Lubow Street
Box 928, Downey, CA 91204
Phones (213) 869-8219 1-800-926-2488
FAX (213) 923-1478
Mon-Fri 9-5 PAC TIME

CIRCLE 8 ON FREE INFORMATION CARD

play to eliminate unwanted tracks from the user-specified programming line-up. In addition, seven repeat modes include one track, all discs, programmed tracks, magazine highlight scan, delete, delete continue random, and continue random play. For added convenience, "last address play" with fade in allows listeners to begin disc playback from the last track played. Memory hold maintains programmed tracks and sets audio levels in memory for consistent sound. The PD-TM1 incorporates a one-bit digital-to-analog converter and eight-times oversampling digital filter.

The PD-TM1 18-disc CD changer has a suggested retail price of \$510. For further information, contact Pioneer Electronics (USA) Inc., 2265 East 220th Street, P.O. Box 1720, Long Beach, CA 90801-1720; Tel: 213-835-6177.

CIRCLE 106 ON FREE INFORMATION CARD

TRANSMOBILE CELLULAR PHONE

Providing an economical and versatile option to a hard-case transportable cellular phone, *Clarion's 5100CT-SP* "soft pack phone" quickly plugs into a car's cigarette lighter and, with an optional Ni-Cad battery pack, can also be used as a portable. The phone can be trickle charged if used with the battery and the cigarette-lighter con-



necter simultaneously. Convenience features include 50 speed-dial memories and five last-number stack memories. A memory autostore automatically stores a designated phone number into the next available empty memory location. With switchable auto answer, the 5100CT-SP automatically answers itself after three rings. A beeper can be set

to sound at one-minute intervals during a conversation, a handy reminder of elapsed time. A five-bar graph indicates signal strength. Other features include scratch-pad memory, memory search, electronic lock with 911 override, and microphone mute. The handset has large recessed buttons and an adjustable-angle LCD readout. The black leather case with shoulder strap is lightweight and comfortable to carry.

The 5100CT-SP has a suggested retail price of \$499.95. The optional battery pack costs \$79.95. For further information, contact Clarion Corporation of America, 661 West Redondo Beach Blvd., Gardena, CA 90247; Tel: 213-327-9100.

CIRCLE 107 ON FREE INFORMATION CARD

DMM PLUG-IN CARD

A plug-in card and software package from *Global Specialties* can be operated like any bench-top digital multimeter. The *PCI-DMM's* card provides all the usual functions of the



test instrument, and the software creates an easy-to-use front-panel emulation. The PC provides intelligence, data storage, and graphics facilities. Instead of using the buttons on a standard instrument, a mouse is used to point and operate the "buttons" on the computer screen. The resolution is 4.5 digits, and the functions include AC/DC volts, AC/DC current, resistance, capacitance, and decibels. Other features include relative or absolute measurements, short- or long-range averaging times, and automatic range selection. Instruments that are usually considered expensive add-ons—including a chart recorder and a data logger—come standard. Inputs are isolated to 500 volts DC and the board is equipped with self-resetting thermal fuses. In case of overload, the board will reset itself once the input is removed, eliminating the need to open up the cover of the PC.

The PCI-DMM digital multi-

meter plug-in card retails for \$795. For more information, contact Global Specialties, 70 Fulton Terrace, New Haven, CT 06512; Tel: 800-572-1028.
CIRCLE 108 ON FREE INFORMATION CARD

PORTABLE CAR ALARM

A portable security device from *Maxon Systems* is suitable for use in cars, vans, and other vehicles and requires no wiring or complex installation. The model *PAA-1B* motion-sensor alarm can be hung by its mounting bracket from the vehicle's window, and the window is



closed over the bracket. The electronics, including the motion- and vibration-sensing circuitry and the controls, hang inside the vehicle. The siren is located outside of the vehicle. When activated by motion or vibration, the unit emits a piercing, siren-like noise at 110 dB for 40 seconds, with a three-second rearm cycle. An eight-second arming delay allows the door to be closed without activating the unit. An audible "chirp" indicates that arming is complete and a clearly visible LED warns potential intruders that the unit is armed. A three-position sensitivity switch allows the *PAA-1B* to be set for different conditions. For instance, when the car is parked on a narrow street with a lot of traffic, the low-sensitivity setting would be used so that passing cars wouldn't trigger the alarm. The high-sensitivity setting would be used in quiet, open places. Because the 10-ounce unit can be mounted in seconds, it is suitable for travelers who want to protect rental cars or hotel rooms, and can be transferred from one vehicle to another.

The *PAA-1B* portable vehicle alarm has a suggested retail price of \$79.95. For more information, contact Maxon Systems, Inc., 8610 NW 107th Terrace, Kansas City, MO 64153; Tel: 800-922-9083.
CIRCLE 109 ON FREE INFORMATION CARD

CONDUCTIVE EPOXY KIT

For quick, solderless connection and conductive bonding applications in electronic design, prototype, and repair, the *2400 Circuit Works Conductive Epoxy Kit* provides a total of 12 grams of silver epoxy in two convenient: tubes for precise dispensing and easy handling. The epoxy is mixed at a non-critical, 1-to-1 ratio and provides a working bond in ten minutes at room temperature. It approaches maximum bond strength in 24 hours. Bonding performance can be accelerated by mild heat curing at less than 100°C. The material is particularly well suited for solderless connections and conductive bonding of heat-sensitive electronic components on conventional circuit boards, flex circuits, and membrane key pads. Other applications include



solderless surface-mount connections, circuit-board trace repair, static-discharge drains, shield bonding, and grounding. Each kit also includes complete instructions and a reusable stir applicator.

The *2400 Conductive Epoxy Kit* has a retail price of \$14.95. For additional information, contact Planned Products, 303 Potrero Street, Suite 53, Santa Cruz, CA 95060; Tel: 408-459-8088; Fax: 408-459-0426.
CIRCLE 110 ON FREE INFORMATION CARD

SURGE SUPPRESSOR

Specifically designed for local area network (LAN) applications, *Proxima's LAN Pro Model*

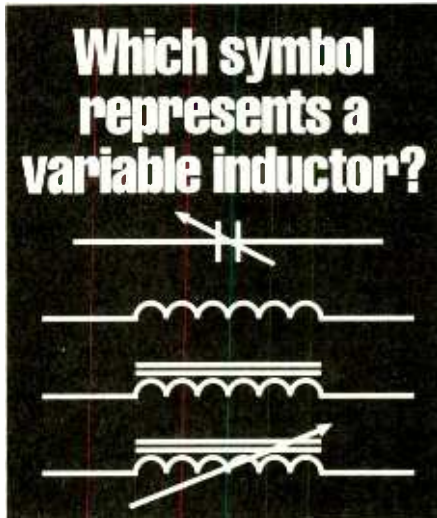

What is the principal disadvantage of neon lights?

What are out-of-phase signals?

Heath Video Courses speed your learning curve!

Learn basic electronics at home at your own pace with four, 60-minute video tapes. Know the variable inductor symbol. Recognize a PN junction. Understand oscillator fundamentals. Clearly SEE what most basic electronic books can only describe.

DC ELECTRONICS. Covers electron movement to troubleshooting and repairing a simple electronic circuit. **EV-3101-A.**

AC ELECTRONICS. Follow-up to DC Electronics. Covers the principles of AC, voltage and electrical measurement. Includes motors, generators and test instrument meter movements. **EV-3102-A.**

SEMICONDUCTORS. Complete the DC/AC videos and you're ready to learn how semiconductor devices are made, plus the principles of discrete devices, integrated circuits & optoelectronic devices. **EV-3103-A.**

ELECTRONIC CIRCUITS. Complete the basic course with amplifier configurations, biasing, coupling, audio amplifiers, closed-loop vs. open-loop operation and more. **EV-3104-A.**

An activity-filled workbook and explanation of how to solve each problem comes with each tape so you learn three ways — video, workbook and hands-on!

Order today!
Call Toll free,
24-hours a day.
1-800-253-0570.

VIDEO TAPES
\$44.95
EACH

We accept VISA, MasterCard, American Express and Heath Revolving Charge card. Use Order Code 601-062

Heath
 Benton Harbor, MI

Call for a FREE catalog 1-800-44HEATH.

Price does not include shipping and handling ED-238-R2 or applicable sales tax.

CIRCLE 11 ON FREE INFORMATION CARD

LEARN ELECTRONICS BY VHS VIDEO TAPE

BEGINNER PREPARATION SERIES

- BP-1 Schematic symbols and component appearance 19.95
- BP-2 Symbols and components practice 19.95
- BP-3 Component functions Unit 1 19.95
- BP-4 Component functions Unit 2 19.95

FUNDAMENTAL ELECTRONIC SERIES

- FE-1 AC-DC fundamentals 19.95
- FE-2 DC circuits and series parallel 19.95
- FE-3 AC circuits and reactance, impedance, resonance 19.95

BASIC ELECTRONICS SERIES

- BE-1 (PS-1) Power supply rectification and filtering 19.95
- BE-2 (PS-2) Power supply doublers and regulators 19.95
- BE-3 (AF-1) Amplifier fundamentals 19.95
- BE-4 (AF-2) Amplifier configuration and biasing 19.95
- BE-5 (AF-3) Amplifier coupling and stabilization 19.95
- BE-6 (AF-4) Amplifier circuits AF, VF, IF, RF 19.95
- BE-7 (OC-1) Oscillator circuits 19.95

Total purchase _____
 Shipping & handling \$7.00 _____
 TX add 8.25% tax _____
 Total amount _____

Name _____
 Address _____
 City _____ State _____
 Zip _____ Home phone _____ Work phone _____



Mail check or money order to
Enterprise Electronics
 P.O. Box 551327
 Dallas, Tx. 75355-1327

VideoText™ tapes are recorded on SP speed

LEARN to CLEAN/ MAINTAIN/ REPAIR CAMCORDERS



**EARN \$85
AN
HOUR!**

HUGE EXPANDING MARKET!

Work from your home - part time or full time! No prior experience needed - Average mechanical ability only requirement for your success! Over 15 million camcorders in use - Over 5 million expected to be sold in 1991 alone!

It is a fact that the vast majority of camcorder malfunctions (just like VCRs) are due to simple mechanical failure. We can show you how to easily fix those breakdowns and earn an average of \$85.00/hr while working at home!

Get In Now - Soon camcorders will be like VCRs, i.e., one in almost every home.

For a camcorder cleaning job you can earn \$65.00 for less than 30 minutes work.

For a camcorder repair job you can earn over \$100.00.

FREE INFORMATION PACKAGE call or write:
 Toll-Free 1-800-537-0589
 Viejo Publications, Inc.
 5329 Fountain Ave., Dept. PEC
 Los Angeles, CA 90029

CIRCLE 13 ON FREE INFORMATION CARD

S29LP surge and EMI/RF suppressor is backed with a "Lifetime Equipment Protection Policy." The company guarantees that any computer equipment that is damaged due to transients while properly connected to the LAN Pro will be repaired or replaced free of charge.

LAN Pro is designed to protect the high-performance hardware and high-speed data communications links that are typically found in LAN environments. Protection is accomplished by eliminating high-frequency noise and high-energy surges and spikes. An innovative high-frequency attenuator filter eliminates 99% of all EMI/RFI noise from 500 kHz to 100 MHz, which is particularly important for LAN communications that run between 2.5 and 20+ MHz. (Most other surge suppressors are designed to protect against lower frequency

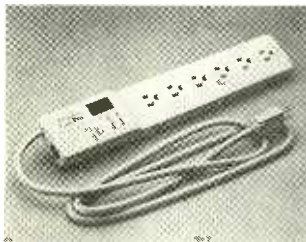

noise found on the 60-Hz power line.) Because local area networks are highly vulnerable to ground faults, the LAN Pro offers a polarity/ground fault indication.

The LAN Pro surge suppressor has a single-quantity list price of \$79.95. For more information, contact Proxima Corporation, 6610 Nancy Ridge Drive, San Diego, CA 92121; Tel: 619-457-5500.

**CIRCLE 111 ON FREE
INFORMATION CARD**

DIGITAL WATT METER/ MULTIMETER

To monitor and evaluate power losses from single-phase transformers and electrical equipment, *Extech's model 380660* digital wattmeter offers one-hand pushbutton operation. The handheld instrument also provides multimeter functions for measuring AC and DC volts and current. It measures true power from 0 to 2000 ohms with 1-ohm resolution or up to 6000 ohms with 10-ohm resolution.

The 380660 offers bipolar automatic switching, reverse polarity indication, and +30-count manual zero adjust in wattmeter mode and auto-zero in multimeter mode. The meter is



designed for easy use; the front panel has accessible and clearly labeled plug-ins for power and load. Other features of the unit include a 1/2-inch LCD readout and a built-in, fold-out stand. The meter comes complete with a 9-volt battery and a set of test leads.

The 380660 digital watt meter/multimeter has a suggested list price of \$149. For additional information, contact Extech Instruments Corporation, 335 Bear Hill Road, Waltham, MA 02154; Tel: 617-890-7440; Fax: 617-890-7864.

**CIRCLE 112 ON FREE
INFORMATION CARD**

CROSS-NEEDLE HF ANTENNA TUNER

The *MFJ-941E* combines a 300-watt PEP antenna that covers everything from 1.8 to 30 MHz, with a lighted cross-needle meter, an antenna switch, and a 4:1 balun. The cross-needle meter shows SWR, forward, and reflected power simultaneously. It reads forward/reflected power in 300/30 and 30/5-watt ranges. The meter lamp runs on 12 volts DC or, with the MFJ-1312 adapter, on 117 volts AC. The front-panel mounted antenna switch selects two coax lines, direct or through the tuner, and random wire/



balanced line or external double load. The tuner is housed in a black aluminum cabinet with a black brushed-aluminum front panel.

The MFJ-941E cross-needle HF antenna tuner has a retail price of \$109.95; the MFJ-1312 adapter costs \$12.95. For more information, contact MFJ Enterprises Inc., P.O. Box 494, Mississippi State, MS 39762; Tel: 601-323-5869 or 800-647-1800 for orders; Fax: 602-323-6551.

CIRCLE 113 ON FREE INFORMATION CARD

HEAVY-DUTY DMM'S

The *Techmaster* line of "ruggedized" digital multimeters from *A.W. Sperry Instruments* contains seven models: *DM-8100*, *DM-8200*, *DM-8300*, *DM-8400*, *DM-8500*, *DM-8600*, and *DM-8700 True RMS*. Each of the handheld DMM's are water resistant, drop-proof to ten feet and come in a bright safety-yellow casing with a combination tilt stand/hanger. The instruments offer 6KV transient-voltage protection and overload protection on all ranges. They each have an "auto-off" feature and provide audible continuity, diode test, and logic test. They

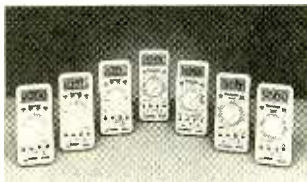

have current ranges to 20 amps AC/DC and meet IEC-348 Class I and UL-1244 standards. Other features offered by the *Techmaster* family of digital multimeters are analog bar graphs; 3½, 3¾, or 4½-digit LCD readouts; peak hold; data hold; and capacitance, transistor H_{FE} frequency, duty cycle, and direct-temperature measurement.

Prices for the *Techmaster* line of portable digital multimeters range from \$119.95 to \$189.95. For more information on the complete *Techmaster* line, con-

tact A.W. Sperry Instruments, Inc., 245 Marcus Boulevard, Hauppauge, NY 11788; Tel: 516-231-7050.

CIRCLE 114 ON FREE INFORMATION CARD

PROGRAMMABLE SOLDERING STATION

With tamper-proof temperature setting, quick heat-up time, and faster thermal recovery, Contact East's *Hakko 929* programma-



ble soldering station allows consistent, high-quality soldering with less dwell time on multi-layered boards and heavy ground planes. Its digital keypad can be used to set temperatures from 400°F to 899°F with an accuracy of $\pm 0.9^\circ\text{F}$. Once the temperature is set, unauthorized personnel cannot reset it without the programming card. The temperature-memory system allows the iron to be shut off and turned back on without having to reset the iron each time. The housing, iron, and cord are made of static-dissipative material. Resistance to ground is rated at less than 2 ohms and leak voltage is less than 0.6mV. The soldering station comes complete with the iron holder, a sponge, the programming card, and a 50-watt iron with an A1016 tip.

The *Hakko 929* programmable soldering station has a retail price of \$299.00. For further information about it, write or call Contact East, 335 Willow Street, North Andover, MA 01845; Tel: 508-682-2000. ■

CIRCLE 115 ON FREE INFORMATION CARD

Earn Your B.S. Degree in ELECTRONICS or COMPUTERS



By Studying at Home

Grantham College of Engineering, now in our 41st year, is highly experienced in "distance education"—teaching by correspondence—through printed materials, computer materials, fax, and phone.

No commuting to class. Study at your own pace, while continuing on your present job. Learn from easy-to-understand but complete and thorough lesson materials, with additional help from our instructors.

Our Computer B.S. Degree Program includes courses in BASIC, PASCAL and C languages — as well as Assembly Language, MS DOS, CADD, Robotics, and much more.

Our Electronics B.S. Degree Program includes courses in Solid-State Circuit Analysis and Design, Control Systems, Analog/Digital Communications, Microwave Engr, and much more.

An important part of being prepared to *move up* is holding the right college degree, and the absolutely necessary part is knowing your field. Grantham can help you both ways—to learn more and to earn your degree in the process.

Write or phone for our free catalog. Toll free, 1-800-955-2527, or see mailing address below.

Accredited by
the Accrediting Commission of the
National Home Study Council

GRANTHAM
College of Engineering
Grantham College Road
Slidell, LA 70460

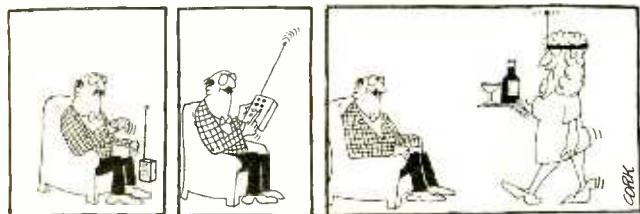

THINK TANK

By John J. Yacono

Shop Equipment

Nothing makes working on projects easier than having the right tools. Luckily, those of us interested in electronics can create all kinds of gadgets to make building and troubleshooting easier. Over the years, I've developed a bunch of handy devices that, even though they were easy to build, made jobs go quicker. This month I'd like to present a variety of such gizmos to make your work more straightforward and enjoyable.

LINE-MONITOR ADAPTER

The first circuit I'd like to present is a line-monitor adapter. Its incredibly simple schematic diagram is

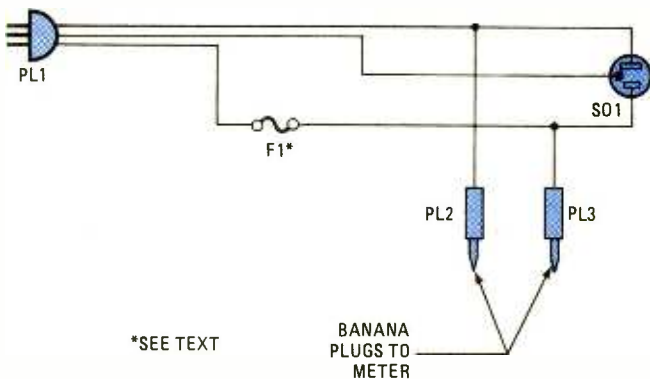

*SEE TEXT

Fig. 1. This AC line-to-multimeter adapter can make checking line voltage safer. You can use it to find taxing loads on your household wiring.

shown in Fig. 1. The little gimmick is just an extension cord outfitted with a fuse and banana plugs. It allows you to use your multimeter to monitor the line voltage from an AC socket with or without a load.

Using one of these simple devices is much safer than trying to hold probes in place. Since you don't have to hold the meter probes while trying to do something else, it's especially useful when performing a

job that requires three hands. It's particularly helpful for testing to see if a household circuit is being overtaxed. It can even allow you to determine which device on an AC line presents the greatest load so you can move that device to a different AC circuit.

The value of fuse F1 will depend on your meter. If your meter has a built-in fuse, you might want to leave out F1. However, if your meter is very old, it may not have a fused input; verify the presence of a fuse before dispensing with F1 in your design.

Provided that you have a meter that you seldom use laying around, you may wish to permanently install the circuit on the meter and use it as a full-time line monitor. It would make a useful addition to your shop.

A LINE BOOSTER

If you test your household voltage and find it somewhat low during certain times of the day, the simple device shown in Fig. 2 can bring it up again. The unit is actually an autotransformer made from a plain power-supply transformer. When wired properly, the transformer's secondary voltage is added to the line voltage before being sent to the socket. That boosts the line voltage by the value of the transformer's secondary voltage.

Once you wire up this project, check the input voltage (across the primary) and compare it to the output voltage (at the socket). If the output voltage is lower than the input voltage, switch the two secondary leads.

If you wish to leave a

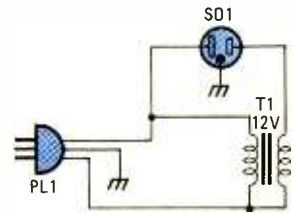

Fig. 2. When incoming AC power drops, you can bring the voltage back up with this booster circuit. It adds the transformer's secondary voltage to the AC line voltage.

particular device connected to the booster, you can add a switch to remove the transformer from the circuit when it's not needed. Although the secondary voltage of the transformer is shown as 12 volts, it can be any voltage that fits your needs; just make sure that the transformer you chose can handle the current your equipment requires. It can be made even more useful by housing it in the same cabinet as a multimeter augmented with the circuit in Fig. 1.

ISOLATION TRANSFORMER

One piece of equipment everyone who repairs electronic equipment should have is an isolation transformer. They provide power to a device while isolating it from the AC line. That pre-

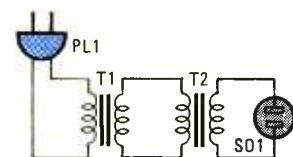

Fig. 3. "Safety first" is a good motto to follow when you play with electricity. You can follow that adage more closely with this homebrew isolation transformer.

Take Any **3** PROFESSIONAL BOOKS for only \$9⁹⁵

when you join the **ELECTRONICS ENGINEERS' BOOK CLUB**

values to \$21.40



9255 \$97.50
Counts as 3

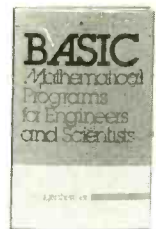

8225P \$19.95

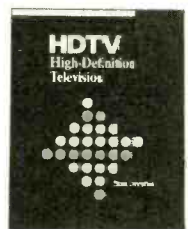

3272 \$24.95



9832 \$36.95



003957-7 \$49.95
Counts as 2



3557 \$29.95

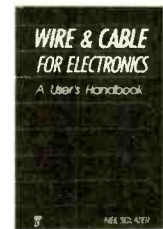

3787 \$29.95



3279 \$36.95
Counts as 2

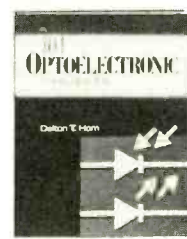

3205 \$24.95



9340 \$44.95
Counts as 2



3212 \$34.95

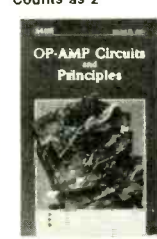

9401P \$19.95

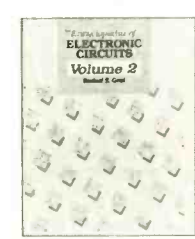

3138 \$60.00
Counts as 2



2672 \$49.50

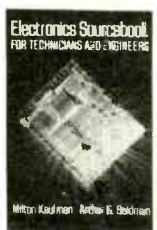

033559-1 \$29.95

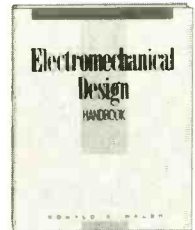

3102 \$49.95
Counts as 2

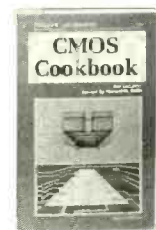

9244P \$18.95

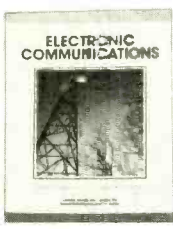

3365 \$34.95

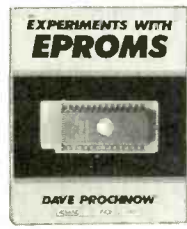

2962P \$17.95

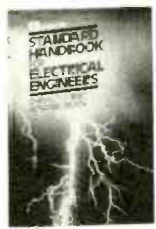

020975-6 \$99.50
Counts as 3



3199 \$52.00
Counts as 2



3321P \$16.95

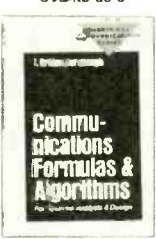

9354 \$39.95
Counts as 2

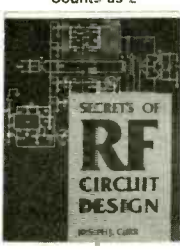

3710 \$32.95

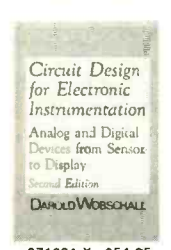

071231-X \$54.95
Counts as 2



3540 \$26.95

How the Club Works

YOUR BENEFITS: You get 3 books for \$9.95 plus shipping and handling when you join. You keep on saving with discounts of up to 50% off as a member.

YOUR PROFESSIONAL BOOKSTORE BY MAIL: Every 3-4 weeks, you will receive the Electronics Engineers' Book Club News describing the Main Selection and Alternates, as well as bonus offers and special sales, with scores of titles to choose from.

AUTOMATIC ORDER: If you want the Main Selection, do nothing and it will be sent to you automatically. If you prefer another selection, or no selection at all, simply indicate your choice on the reply form provided. You will have at least 10 days to decide. As a member, you agree to purchase at least 3 books within the next 2 years and may resign at any time thereafter.

BONUS BOOKS: Starting immediately, you will be eligible for our *Bonus Book Plan*, with savings of up to 80% off publishers' prices.

IRONCLAD NO-RISK GUARANTEE: If not satisfied with your books, return them within 10 days without obligation!

EXCEPTIONAL QUALITY: All books are quality publishers' editions especially selected by our Editorial Board. (Publishers' Prices Shown)

The Electronics Engineers and Designers Book Club and the Electronics and Control Engineers' Book Club have joined forces to bring you all the best titles from the most prominent electronics publishers.

ELECTRONICS ENGINEERS'

BOOK CLUB

Blue Ridge Summit, PA 17294-0860

YES! Please accept my membership in the ELECTRONICS ENGINEER'S BOOK CLUB and send the 3 volumes listed below, billing me \$9.95. If not satisfied, I may return the books within ten days without obligation and have my membership cancelled. I agree to purchase at least 3 books at regular Club Prices during the next 2 years, and may resign any time thereafter. A shipping/handling charge and sales tax will be added to all orders.

Name _____

Address _____

City _____

State _____ Zip _____ Phone _____

Valid for new members only. Foreign applicants will receive special ordering instructions. Canada must remit in U.S. currency. This order subject to acceptance by the Electronics Engineers' Book Club. PPIE1191

All books are hardcover unless number is followed by a "P" for paperback.
©1991 EEEG, Blue Ridge Summit, PA 17294-0860

AMAZING SCIENTIFIC & ELECTRONIC PRODUCTS

LASERS AND SCIENTIFIC DEVICES

VRL2K	3mw Vis Red Laser Diode System Kit	\$159.50
LLIS1K	Laser Beam "Bounce" Listener Kit	\$199.50
LHC2K	Visible Simulated 3 Color Laser Kit	\$44.50
LC7	40 Watt Burning Cutting Laser Plans	\$20.00
RUB4	Hi Powered Pulsed Drilling Laser Plans	\$20.00
LGU40	1 to 2mw HeNe Vis Red Laser Gun Assembled	\$199.00
LLS1	Laser Lite Show - 3 Methods Plans	\$20.00
SD5K	See in the Dark Kit	\$299.50
EML1K	Electromagnetic Coil Gun Kit	\$69.50
MCP1	Hi Velocity Coil Gun Plans	\$15.00
LEV1	Levitating Device Plans	\$10.00
EH1	Electronic Hypnotism Techniques Plans	\$10.00

HIGH VOLTAGE AND PLASMA DISPLAY DEVICES

HVM7K	75,000 Volt DC Variable Output Lab Source Kit	\$149.50
IOG3K	Ion Ray Gun Kit, project energy without wires	\$69.50
NIG9K	12V/115 VAC Hi Out Neg Ion Generator Kit	\$34.50
EMA1K	Telekinetic Enhancer/Electric Man Assembled	\$99.50
LGS5K	Lightning Display Globe Kit	\$54.50
BTC1K	Worlds Smallest Tesla Coil Kit	\$49.50
BTC3K	250KV Table Top Tesla Coil Kit	\$249.50
BTC5	1.5 Million Volts Tesla Coil Plans	\$20.00
JL3	Jacobs Ladder - 3 Models Plans	\$15.00
GRA1	Anti Gravity Generator Plans	\$10.00
PF520	Plasma Fire Saber Assembled	\$69.50
DPL20	Dancing Plasma to Music and Sounds Assembled	\$79.50

SECURITY AND PROTECTION DEVICES

ITM10	100,000 Volt Intimidator up to 20' Assembled	\$129.50
IPG70	Invisible Pain Field Blast Wave Gen Assembled	\$74.50
PSP4K	Phasor Sonic Blast Wave Pistol Kit	\$59.50
LIST10	Infinity Xmr, Listen in Via Phone Assembled	\$199.50
TAT30	Automatic Tel Recording Device Assembled	\$24.50
VWPM7K	3 Mi. FM Auto Tel Transmitter Kit	\$49.50
FV1K	3 Mi. FM Voice Transmitter Kit	\$39.50
HOD1K	Homing/Tracking Beeper Transmitter Kit	\$49.50

EASY ORDERING PROCEDURE TOLL FREE 1-800-221-1705
or 24 HRS ON 1-803-673-4730 or FAX IT TO 1-603-672-5406
VISA, MC, CHECK, MO IN US FUNDS. INCLUDE 10% SHIPPING. ORDERS
\$100.00 & UP ONLY ADD \$10.00. CATALOG \$1.00 OR FREE WITH ORDER.

INFORMATION UNLIMITED
P.O. BOX 716, DEPT. PE, AMHERST, NH 03031

LEARN VCR CLEANING/MAINTENANCE/REPAIR

EARN UP TO \$1000 A WEEK, WORKING
PART TIME FROM YOUR OWN HOME!



THE MONEY MAKING OPPORTUNITY OF THE 1990'S

IF you are able to work with common small hand tools, and are familiar with basic electronics (i.e. able to use voltmeter, understand DC electronics) . . . IF you possess average mechanical ability, and have a VCR on which to practice and learn. . . then we can teach **YOU** VCR maintenance and repair!
FACT: up to 90% of ALL VCR malfunctions are due to simple MECHANICAL or ELECTRO-MECHANICAL breakdowns!
FACT: over 77 million VCRs in use today nationwide! Average VCR needs service or repair every 12 to 18 months!
Viejo's 400 PAGE TRAINING MANUAL (over 500 photos and illustrations) and AWARD-WINNING VIDEO TRAINING TAPE reveals the SECRETS of VCR maintenance and repair—"real world" information that is NOT available elsewhere!
Also includes all the info you'll need regarding the BUSINESS-SIDE of running a successful service operation!

FREE INFORMATION
CALL TOLL-FREE 1-800-537-0589
Or write to: Viejo Publications Inc.
5329 Fountain Ave
Los Angeles, CA 90029 Dept. PE

CIRCLE 12 ON FREE INFORMATION CARD

vents you from grounding the device through your body or clothing while you're working with it. While isolation transformers are commercially available, they can be expensive.

Provided you have two identical power transformers laying around, you can have the safety but forego the expensive (see Fig. 3). In the circuit, T1 reduces the line voltage to the secondary voltage and isolates the rest of the circuit from the line voltage. The reduced voltage is sent to the secondary of T2. Transformer T2 boosts the voltage back up and passes it to the socket for use. The secondary rating of the transformers doesn't matter as long as they're identical. Like the line booster, the current capability of the transformers should match the needs of the load.

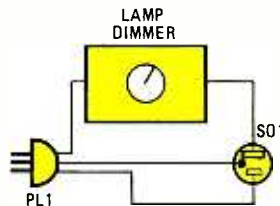

Fig. 4. Lamp dimmers can be used for more than just controlling lights. Just provide one with an AC line cord and a socket, and discover just how useful they can be.

APPLIANCE CONTROLLER

One last "hobbyist helper" is shown in Fig. 4. In that circuit, a common household lamp dimmer is placed in series with an AC line cord and socket. I originally built one of these to reduce the wattage on my soldering iron for delicate work. (I prefer irons on the heavy side, between 30 and 40 watts, but that's a bit much for light stuff.) After building it, I found it was also useful to vary the speed of constant-speed drills. Unfortunately, my wife also found it useful for her night-table lamp (guess I'll have to make another one).

If you decide to make one, be sure to use either wire nuts or solder and tape on all connections and mount it in a suitable enclosure.

Now let's see what interesting pieces of equipment you readers have sent in.

BATTERY SAVER

In the past, a lot of times when I would leave my shop I'd leave battery-powered test equipment turned on. After going through many batteries, I decided to install this handy circuit (see Fig. 5) in each piece of equipment to shut the unit off after a pre-

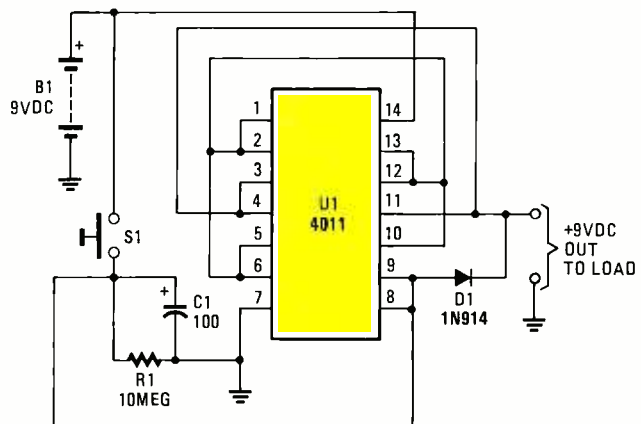

Fig. 5. This battery saver circuit can automatically turn off a small piece of test equipment after a desired period of time, allowing you to leave your shop worry free.

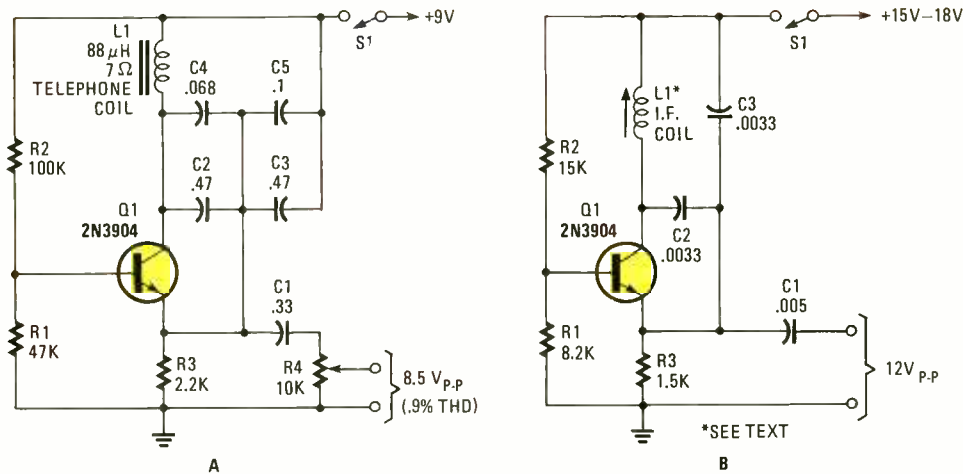

Fig. 6. Here are some simple oscillators. The one shown in A is excellent for testing audio circuits. The one in B would make a good RF receiver tester.

determined period of time. The circuit consists of a quad 2-input NAND-gate IC and three support components.

When S1 is depressed, capacitor C1 charges up to the battery potential. That supplies a logic-high to pins 8 and 9, which are the inputs of one NAND gate, so the output of that gate goes low. Since inputs of all the other gates are connected to that output, all their outputs go high. Those outputs are tied together and provide 9 volts to the battery-powered test equipment.

Once C1 has sufficiently discharged through R1 (after about 10 minutes), the output of the gate it feeds goes high, and all the other outputs go low, shutting down the test equipment. Diode D1 removes any remaining charge from C1.

The circuit draws very little current when it's in the "off" state, which preserves battery life. You can alter the values of C1 and R1 to extend or lessen its "on" time. If your test equipment requires more current or voltage, you could add a relay to the circuit, and connect the load to the required power via the relay.

—Bobby Triplett, Raleigh, NC

Nice going. I think any CMOS logic gate that can be configured for inversion might work in this circuit. When I give this one a try, I think I'll use a hex-inverter to see if I can get greater current output because of the extra gates. It'll make a neat experiment.

QUICK OSCILLATORS

Here are two oscillators that I've used for a long time. The circuit in Fig. 6A is designed to operate at 1 kHz. The circuit in Fig. 6B can be configured to operate at 100 kHz or 1 MHz, depending on whether you use a 455 kHz or 4.5 MHz IF coil, respectively.

The circuits can be built with almost any NPN transistor, but the bias to the transistor needs to be properly adjusted. To determine the proper bias, replace R1 with a potentiometer (10k ought to do) and connect the output of the circuit to an oscilloscope. Adjust the potentiometer for the best possible waveform. Measure the resistance setting of the potentiometer and replace it with the closest standard fixed-resistor value. Also, if you wish to experiment with different coils, remember to keep the resistance value of the coils low, otherwise the circuit will not oscillate.

Because of the high fre-

quencies involved, all wiring should be as short as possible, and the circuits should be housed in a metal enclosure. When I built mine, I housed each of them in an enclosure large enough to support a BNC and an RCA phone jack, plus binding posts. In that way, the circuit could be connected to a variety of equipment without the need for adapters.

—L.C. Pochop, Ontario, CA

I really like the fact that all the components are readily available. The low harmonic-distortion figure and the operating frequency of the 1-kHz oscillator make it great for testing audio equipment.

SINEWAVE CONVERTER

Here's one for the test bench. All of the triangle-wave-to-sinewave-converter circuits that I've ever seen rely on the logarithmic characteristics of either diodes or transistors. But, the waveforms that they generate are not dependable, since those devices have a high thermal sensitivity. My circuit (shown in Fig. 7) uses linear devices to provide a controlled, predictable output. The result is a very good sinewave approximation that is usable for most applications.

Referring to the sche-

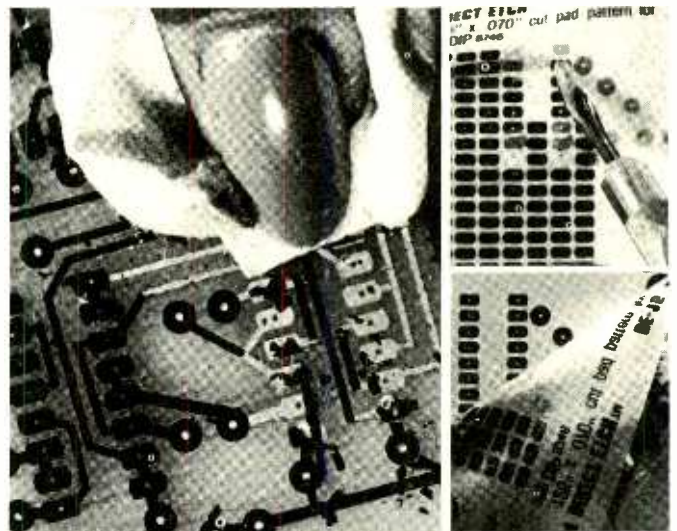

DIRECT ETCH™

NO MASTER • NO CAMERA • NO FILM • NO DEVELOPER

DIRECT ETCH dry transfers make quality circuit boards fast without formal artwork. A new Master Assortment includes over 4000 donuts from .050" to .250" and 118 trace lines from .014" to .125". It also contains all sizes of through hole and surface mount devices including DIP, TO, DIN, D and edge card connectors, SO, SOL, PLCC, flatpacks, SOT's, 2 terminal tubular and flat SMD's. The Master Assortment has 69 cut apart dry transfer sheets with complete instructions. Works with all common etchants.

DE-973 Master Assortment (69 pattern sheets) \$34.95 (Add \$2.00 shipping. NV and CA residents also add sales tax)

DATAK Corporation • 55 Freeport Blvd. • Sparks, NV 89431 21

matic diagram, U2 is the heart of a special circuit that emulates three functions: absolute value, voltage inversion, and frequency doubling. Its output supplies a bias current to U1. Op-amp U1 is a transconductance amplifier whose gain is linearly controlled by the bias current applied to pin 5. The change in gain shapes the triangle-wave input applied to U1 at pin 3 into a nice sinewave. The amplifier generates a current through R3, and the resulting voltage across that resistor is used as the output.

The circuit performs well from DC to well beyond 100 kHz. To use it, adjust potentiometer R5 for a ± 1 -volt sinewave and trim the ± 2 -volt triangle-wave input to obtain the best wave shape. For the highest precision, match diodes D1–D3, resistors R9 and R10, and resistors R6 and R7.

You can use a different supply voltage, but the cathode of D2 must be referenced to 5 volts above the negative supply rail. A voltage follower should be used at U1's output for higher drive requirements.

If you need a good ± 2 -volt triangle-wave generator, why not try the one that is shown in Fig. 8. It is similar to a classic function generator, but it has a design twist.

—Skip Campisi, South Bound Brook, NJ

Truly excellent. For those of you new to function generators, normally a triangle wave is generated by taking a squarewave and filtering out its high-frequency components. That has the effect of increasing the rise and fall times to yield a triangle wave. The circuit in Fig. 8 does that, but, unlike most circuits, the triangle-wave output is used as feedback to the square-wave generator.

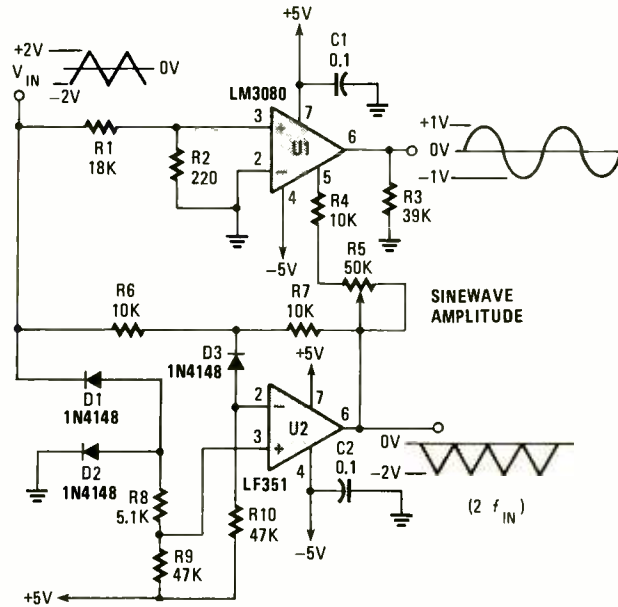

Fig. 7. Unlike most sinewave shapers, this circuit is temperature stable. It varies the gain of a transconductance amplifier to transform an input triangle wave into a good sinewave approximation.

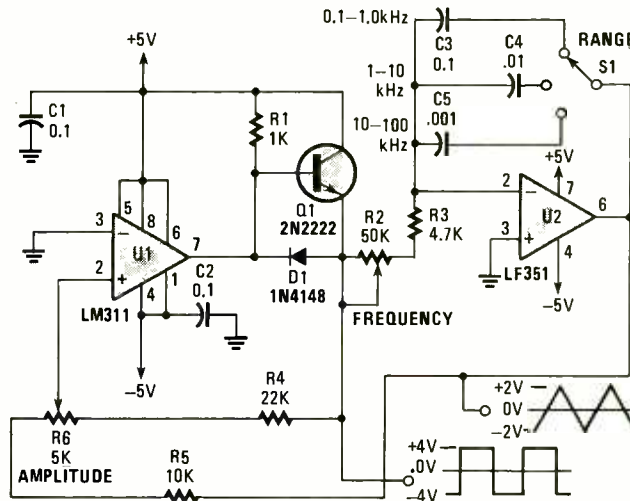

Fig. 8. If you need a source of triangle waves for the circuit of Fig. 7, this circuit will do. It consists of a squarewave generator whose output is filtered to produce triangle waves.

VOLTAGE PROBE

I used to work in a radar-manufacturing facility. As a part of the assembly process, a large amount of radar equipment had to be placed in a small room and wired together. All too often the quality-control group would tell the assembly personnel to fix something while the testing crew was putting a piece of equipment through its paces; so the assembly team never knew for sure whether a circuit to be repaired was

under power when they went to work on it.

To prevent accidents, simple voltage probes like the one shown in Fig. 9 were built and passed out to the employees. Although they cost less than 50 cents each to make, they can save lives. To test single-phase AC wiring, touch the negative probe to ground and poke the positive probe into the circuit to be tested. Three-phase wiring can be tested in a similar manner, but you should

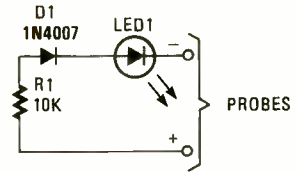

Fig. 9. This simple probe can save your life by warning you of live circuitry. It's ideal for times when more than one person is working on a device.

touch the positive probe tip to each leg (phase) of the circuit. The probe can also be used for DC circuits up to 50 volts.

The whole circuit can be fitted into an old surgical-knife container or felt-tip marker in such a way that the LED sticks out one end. The other end of the tube or marker could sport a probe made from a sharpened No. 40 bolt. A nut in the body of the probe can hold the bolt in place and provide a connection point for the wire to the LED assembly. You can use another bolt and tube for the other probe with a length of wire to connect the circuitry in the tubes. The tubes make excellent handles and hide the circuitry well.

—Jerry Penner, New Hamburg, Ontario

Straightforward and useful. I'd like to try a variation of the circuit (less the diode) with a tri-color LED. That way I could tell if the circuit was AC or DC, and it could tell me the polarity of the DC circuit in a colorful way during those times when I'm unsure.

Well that's all the room I have for this month. Please send all your best creations to me here at *Think Tank*, **Popular Electronics**, 500-B Bi-County Blvd., Farmingdale, NY 11735. As usual, all of you whose work appears here will receive the appreciation of your fellow readers, and a copy of the *Think Tank II* book. Have a safe and fruitful month. ■

5 sure steps to a fast start as a high-paid computer service technician

1. Choose training that's right for today's good jobs

Jobs for computer service technicians will almost double in the next 10 years, according to the latest Department of Labor projections. For you, that means unlimited opportunities for advancement, a new career, or even a computer service business of your own.

But to succeed in computer service today, you need training—complete, practical training that gives you the confidence to service any brand of computer. You need NRI training.

Only NRI—the leader in career-building, at-home electronics training for more than 75 years—gives you practical knowledge, hands-on skill, and real-world experience with a powerful 386sx/20 MHz computer you keep. Only NRI gives you everything you need for a fast start as a high-paid computer service technician.



1992 Good pay, too! 2002

Plus, now you train with and keep the latest in diagnostic hardware and software: the R.A.C.E.R. plug-in diagnostic card and QuickTech diagnostic software, both from Ultra-X. Using these state-of-the-art diagnostic tools, you learn to quickly identify and service virtually any computer problem on IBM-compatible machines.

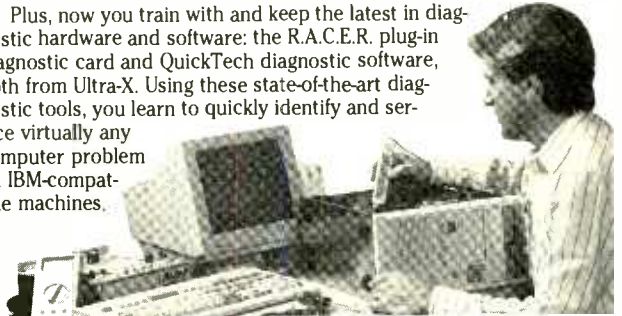

4. Make sure you've always got someone to turn to for help



Throughout your NRI training, you've got the full support of your personal NRI instructor and the entire NRI technical staff. Always ready to answer your questions and help you if you should hit a snag, your instructors will make you feel as if you're in a classroom of one, giving you as much time and personal attention as you need.

5. Step into a bright new future in computer service—start by sending for your FREE catalog today!

Discover for yourself how easy NRI makes it to succeed in computer service. Send today for NRI's big, full-color catalog describing every aspect of NRI's one-of-a-kind computer training, as well as training in TV/video/audio servicing, telecommunications, industrial electronics, and other growing high-tech career fields.

If the coupon is missing, write to: NRI School of Electronics, McGraw-Hill Continuing Education Center, 4401 Connecticut Avenue, NW, Washington, DC 20008.

R.A.C.E.R. and QuickTech are registered trademarks of Ultra-X, INC.

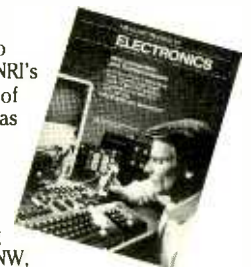

2. Go beyond "book learning" to get true hands-on experience

NRI knows you learn better by doing. So NRI training works overtime to give you that invaluable practical experience. You first read about the subject,

studying diagrams, schematics, and photos that make the subject even clearer. Then you do. You build, examine, remove, test, repair, replace. You discover for yourself the feel of the real thing, the confidence gained only with experience.

3. Get inside a powerful computer system

If you really want to get ahead in computer service, you have to get inside a state-of-the-art computer system. That's why NRI now includes the powerful new West Coast 386sx/20 MHz mini tower computer as the centerpiece of your hands-on training.

As you build this 1 meg RAM, 32-bit CPU computer from the keyboard up, you actually see for yourself how each section of your computer works. You assemble and test your computer's "intelligent" keyboard, install the power supply and high-density floppy disk drive, then interface the high-resolution monitor. But that's not all.

You go on to install a powerful new 40 meg IDE hard disk drive—today's most-wanted computer peripheral—included in your course to dramatically increase the data storage capacity of your computer while giving you lightning-quick data access.



NRI School of Electronics



For career courses approved under GI Bill
 check for details.

McGraw-Hill Continuing Education Center
4401 Connecticut Avenue, NW, Washington, DC 20008

CHECK ONE CATALOG ONLY

- | | |
|--|--|
| <input type="checkbox"/> Microcomputer Servicing | <input type="checkbox"/> Computer Programming |
| <input type="checkbox"/> TV/Video/Audio Servicing | <input type="checkbox"/> PC Software Engineering Using C |
| <input type="checkbox"/> Telecommunications | <input type="checkbox"/> Desktop Publishing & Design |
| <input type="checkbox"/> Industrial Electronics/Robotics | <input type="checkbox"/> Word Processing Home Business |
| <input type="checkbox"/> Basic Electronics | <input type="checkbox"/> Bookkeeping & Accounting |

Name _____

Address _____

City _____ State _____ Zip _____

Accredited Member, National Home Study Council

18-111

The Importance Of Setting Standards.

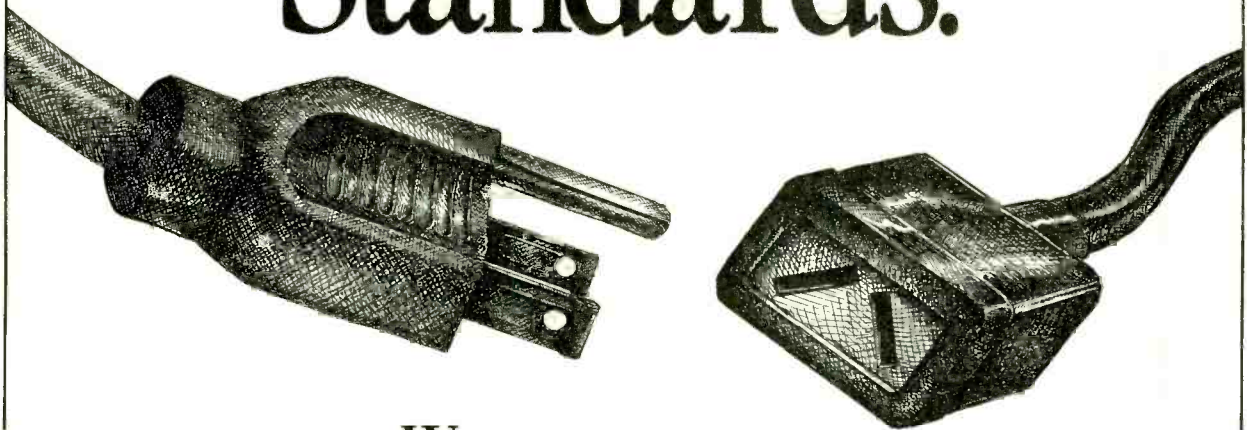

Without standardization in electronics, television wouldn't be seen, radio wouldn't be heard, computers wouldn't share information.

Fortunately the Electronic Industries Association (EIA) has been setting electronics standards since 1924 for everything from early tube radios to today's cellular telephones and stereo TV's.

Standards create *markets and jobs*. Today EIA, an internationally accredited standards making body, is helping to make HDTV a reality by working with the federal government and other industry organizations, to develop a timely, uniquely American transmission standard. For home automation,

EIA is also close to completing a standard which will permit all home electronic products to communicate with each other.

Our more than 1,000 member companies are manufacturers representing every facet of the American electronics industry—from defense to consumer products.

EIA is proud of the contributions it has made through its standards making process toward the growth and vitality of the U.S. electronics industries.

Setting the standard for more than 66 years.



ELECTRONIC INDUSTRIES ASSOCIATION

1722 Eye Street, N.W., Suite 300, Washington, D.C. 20006

The Countersurveillance Monitor

BY VINCENT VOLLONO

Many valuable ideas and information are lost from businesses and homes through electronic eavesdropping. In the business world, industrial espionage is due for the most part to the fact that whosoever gets their product to the market first is likely to reap huge profits as the others try to catch up. On the domestic side, with so many people now self employed and conducting business from a home office, the entrepreneur can become easy prey to those seeking to profit from the work of others.

You think domestic espionage is an unprofitable venture?... Think again! Consider that many of the video games and applications programs that you run on your home computer are written by hobbyists and hackers, and not by some computer scientist working for a large corporation that has vast sums of money to spend on security. And how many corporate mergers have been openly discussed in the informal surroundings of some CEO's home? But what is the small businessman or private individual to do when commercially available countersurveillance devices can run into the hundreds and even thousands of dollars?

That's where the *Countersurveillance Monitor* described in this article comes in. The Countersurveillance Monitor is a simple circuit that allows you to sweep for (detect) electronic eavesdropping devices (more commonly called bugs). The circuit contains no exotic parts and many of the components are so common that they may be found in your parts bin.

A Little Background. Electronic bugs are very small—perhaps as small as a postage stamp—radio-frequency (RF)

transmitters, that are secretly placed in a room that is to be monitored. Such transmitters emit an RF signal that can be picked up from distances of 1 mile away or more, depending upon the sensitivity of the receiver. The receiver is, of course, used to tune in the RF signals, thereby allowing the snooper to monitor any conversation taking place within the covered room.

Because most bugs are RF sources, almost any wideband receiver can be used as a bug detector. Our bug detector is essentially a highly sensitive, wideband receiver. When it detects an RF signal ranging from 1 to 2000 MHz it generates an audio output. The frequency of the audio output goes from a low growl for a weak signal to a high pitched squeal as the signal strength increases. In other words, the closer you get, the higher the pitch of the audio output. That allows you to sweep an area with the Monitor to determine the location of the transmitting device.

An important feature of the bug detector is its RF-gain stage; it is centered around a high-gain microwave transistor, which greatly improves sensitivity. By increasing the antenna length and setting the sensitivity control to its maximum level, extremely weak signals can easily be located. On the other hand, by reducing the length of the antenna and lowering the sensitivity setting, strong signals can be tracked down. Powered from a 9-volt transistor-radio battery, the circuit draws very little current, making for long battery life.

Circuit Description. Figure 1 shows a schematic diagram of the Countersurveillance Monitor. The circuit, built around a single integrated circuit (U1, an MC3403P quad op-amp), three transistors (Q1–Q3), and a few support components, receives its input from the

This simple-to-build, yet effective circuit can help you search out and remove electronic eavesdropping devices.



PARTS LIST FOR THE COUNTERSURVEILLANCE MONITOR

SEMICONDUCTORS

- U1—MC3403P quad op-amp, integrated circuit
 Q1—BFR90 or MFR901 NPN microwave transistor
 Q2, Q3—PN2222 general-purpose NPN silicon transistor
 D1—1SS99, ECG-112, or equivalent silicon diode

RESISTORS

(All fixed resistors are 1/4-watt, 5% units.)

- R1, R8—220-ohm
 R2, R10, R15—100,000-ohm
 R3—39,000-ohm
 R4, R21—470-ohm
 R5—1500-ohm
 R6—560-ohm
 R7—5000-ohm potentiometer
 R9—1-megohm
 R11–R13, R18—47,000-ohm
 R14, R16, R17, R19—10,000-ohm
 R20—100-ohm
 R22—22-ohm
 R23—4700-ohm
 R24—1000-ohm

CAPACITORS

- C1—.001- μ F, ceramic-disc
 C2–C7—.01- μ F, ceramic-disc
 C8—.0047- μ F, ceramic-disc
 C9—4.7- μ F, 16-WVDC, radial-lead electrolytic
 C10—10- μ F, 16-WVDC, axial-lead electrolytic

ADDITIONAL PARTS AND MATERIALS

- S1—SPST toggle switch
 B1—9-volt transistor-radio battery
 ANT1—Telescoping antenna
 SPKR1—8-ohm, 0.2-watt, 2 1/4-inch, speaker
 Perfboard materials, enclosure, battery connector, battery holder (optional), IC socket (optional), wire, solder, hardware, etc.

Note: The following items are available from Xandi Electronics (P.O. Box 25647, Tempe, AZ 85285-5647; Tel. 602-829-8152); A complete kit of parts (Kit No. XBD200K), containing all resistors, capacitors, semiconductors, and the potentiometer (enclosure not included), \$20.95; a pre-etched and drilled printed-circuit board only (part No. XBD200B), \$9.95. Contact them directly for shipping and handling charges. Arizona residents please add applicable sales tax.

d is used to drive Q3, which, in turn, drives the output speaker.

Construction. The Countersurveillance Monitor was assembled on a

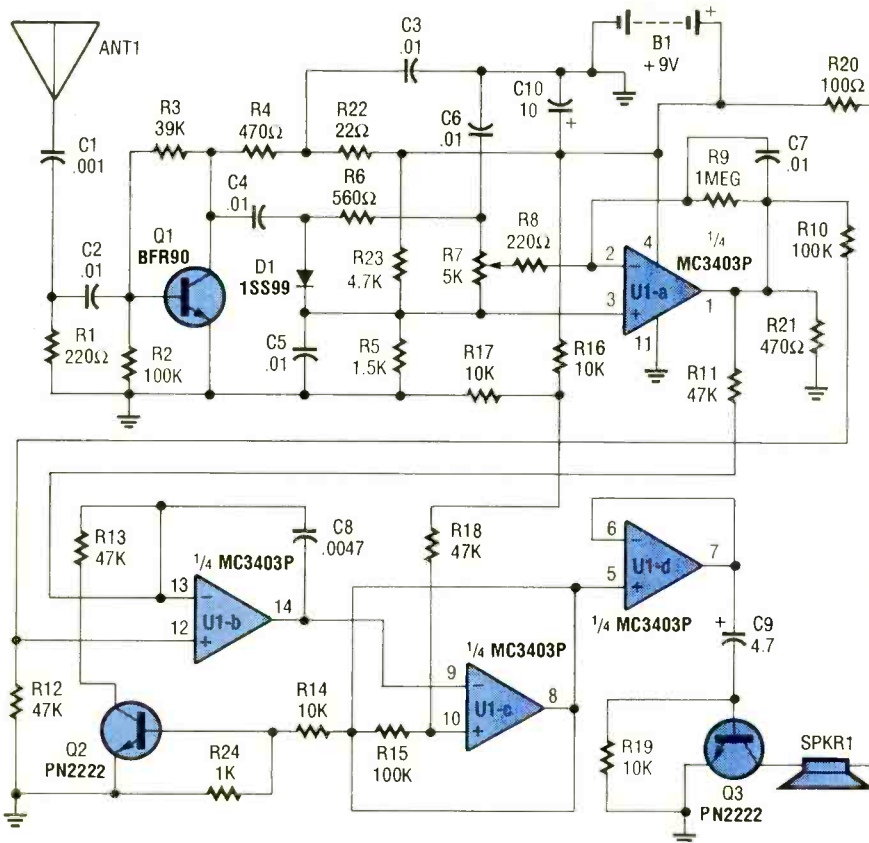

Fig. 1. The Countersurveillance Monitor is built around U1 (an MC3403P quad op-amp), three transistors (Q1–Q3), and a few support components.

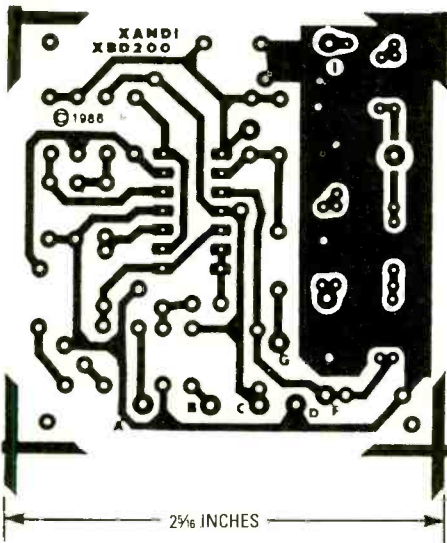

Fig. 2. This full-size template for the Countersurveillance Monitor's printed-circuit artwork is provided for those who wish to etch their own boards. For those not so inclined, a pre-etched and pre-drilled board, as well as the parts that mount on or connect to it, can be purchased from the supplier listed in the Parts List.

antenna (ANT1). That signal is fed through a high-pass filter, formed by C1, C2, and R1, which eliminates bothersome 60-Hz pickup from any nearby

power lines or line cords located in and around buildings and homes.

From the high-pass filter, the signal is applied to transistor Q1 (which provides a 10-dB gain for frequencies in the 1- to 2000-MHz range) for amplification. Resistors R2, R3, and R4 form the biasing network for Q1. The amplified signal is then AC coupled, via capacitor C4 and resistor R7's (the sensitivity control) wiper, to the inverting input (pin 2) of U1-a. Op-amp U1-a is configured as a very high gain amplifier. With no signal input from ANT1, the output of U1-a at pin 1 is near ground potential.

When a signal from the antenna is applied to the base of Q1, it turns on, producing a negative-going voltage at the cathode of D1. That voltage is applied to pin 2 of U1-a, which amplifies and inverts the signal, producing a positive-going output at pin 1. Op-amps U1-b and U1-c along with C8, R10–R18, and Q2 are arranged to form a voltage-controlled oscillator (VCO) that operates over the audio-frequency range. As the output of U1-a increases, the frequency of the VCO increases. The VCO output, at pin 8 of U1-c, is fed to the input of U1-d, which is configured as a non-inverting, unity-gain (buffer) amplifier. The output of U1-

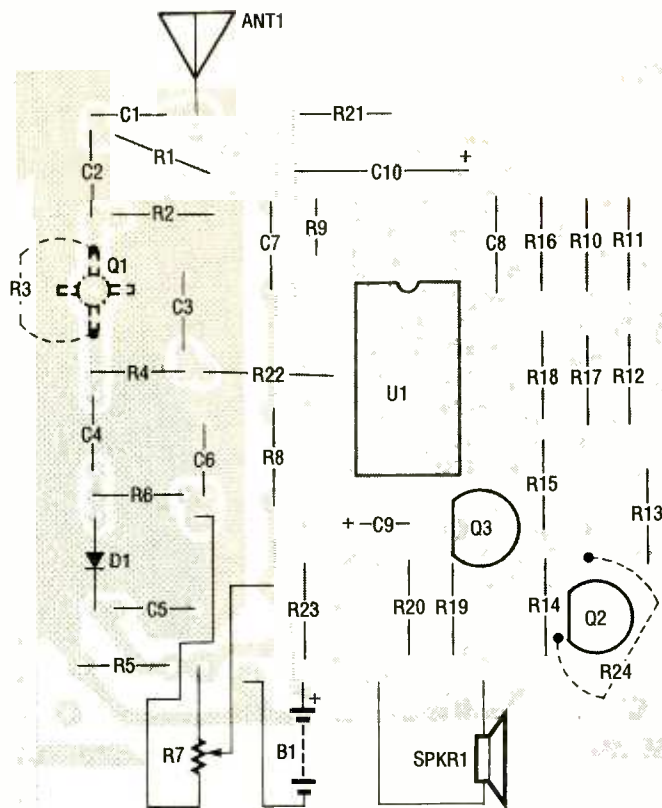

Fig. 3. Assemble the circuit's printed-circuit board using this parts-placement diagram as a guide. Note that transistor Q1, resistors R3 and R24 (all of which are shown as dashed lines) must be installed on the copper side of the board.

pre-etched, pre-drilled printed-circuit board that is available from the kit supplier listed in the Parts List. But, for those of you who'd prefer to etch your own board, a full-size template of the printed-circuit artwork is shown in Fig. 2. The circuit was designed to be housed in any plastic enclosure that's large enough to hold the circuit board, its 9-volt battery power source, a small speaker, potentiometer R7, and of course, switch S1.

Once you've etched or obtained the board and all the parts listed in the Parts List, construction can begin. Start by installing the passive components on the board, guided by Fig. 3. Once the passive components have been installed and checked for placement and orientation, install the semiconductors. The use of an IC socket for U1 is optional; however, if you decide not to use an IC socket for U1, be careful not to overheat the IC's terminals.

Note that transistor Q1 as well as resistors R3 and R24 (which are shown as dashed lines in Fig. 3) must be installed on the copper side of the board. Since Q1 is a microwave transistor, special care must be taken when installing it and its leads should be kept as short as possible. After that, attach a 9-volt bat-

tery connector and the off-board components to the board.

Circuit Checkout. Double-check your work for the common construction errors—misoriented components, solder bridges, misplaced components, etc.—particularly where the transistors and diode are concerned. Make sure that you have installed the resistors in the proper locations. When you are satisfied that all is well, connect a 9-volt battery and turn on the power. You should be able to adjust R7 to cause the speaker to make a siren-like sound. By rotating R7 counterclockwise, you should be able to make the pitch go higher or lower, turning it fully counterclockwise should stop the sound.

When using the unit to detect a bug, set the sensitivity low enough to avoid signals from nearby radio and TV stations. It may take some experimenting at first, but it should quickly become quite easy. When you get within a foot or two of an actual bug, there is no mistaking it for another signal—the audio pitch will be driven to its highest frequency. If you have problems with radio and TV signals, try adjusting the antenna to a shorter length and then setting the sensitivity control for greater

sensitivity to compensate for the reduction in antenna length. The Countersurveillance Monitor will also pick up other RF sources: microwave ovens, computers, etc., but those should cause you little concern. What you are looking for is that potted plant or lamp that has suddenly become an RF emitter.

Troubleshooting. In case of trouble, the first thing to do is make sure that the battery is connected properly and is in good working condition. If the power source and its connections are okay, you can check the circuit using an RF



The antenna and speaker for the Countersurveillance Monitor are held in place with silicone cement.

source—such as a cordless telephone, a signal generator, or a wireless FM microphone. Before you place the RF source near the antenna input of the Countersurveillance Monitor, connect a DC voltmeter from the cathode of diode D1 to ground. As you move the RF source closer to the antenna, the meter should read an increasingly more positive voltage.

Also make sure that the antenna's connecting cable is not shorted to ground (it is rather close to the circuit's ground plane). Also make sure that none of the component leads are left long; long leads can also cause grounding problems.

Once you get the Countersurveillance Monitor working, you can rest reasonably assured that the homefront is free of eavesdropping devices. And whenever there is a suspicion that perhaps someone is invading your privacy, you'll be ready to tackle your hunt-and-destroy mission!

In a book entitled "New Theory of the Pleasures," first published in 1767, Johann Georg Sulzer described the agreeable sensations that could be obtained when two coins, each made of a different metal, were wired together and placed on the tongue. About fifteen years earlier, he discussed an equivalent bimetallic effect and noted a taste similar to that of iron sulfate, although neither of the metals by itself gave any taste at all.

So, what was happening here? Sulzer suggested that the junction of the two metals "sets up a vibration in their particles, which, by affecting the nerves of the tongue, produces the taste in question." The effect, of course, was electrical; but Sulzer didn't know it; and, like

pear in his notebooks and carry the date November 6, 1780. Galvani had a large electrical machine on a table in his laboratory. On the same table there was a dissected frog with most of the animal cut away except for the legs, feet, and a bit of the "vertebral column" or spine. An assistant casually touched an exposed nerve with a metal scalpel. The muscles of the dead frog contracted and the preparation quivered. Immediately, Galvani was called over to see the mysterious movements for himself. He was "fired with incredible zeal" and became determined to bring to light "whatever might be concealed in the phenomenon."

It quickly became apparent that the activity occurred only when the elec-

Experiments In Galvanism

BY STANLEY A. CZARNIK

so many other occasional observations in the history of science, Sulzer's bimetallic reaction had to be "discovered" again.

The Doctor and the Frog. Luigi Galvani received his professional training in medicine and from 1775 on held various academic positions at the University of Bologna in Italy. Most of his early scientific activities were devoted to anatomical topics.

His first published work included a discussion of abnormal bone conditions. Later, he wrote several essays on the biology of birds. Finally, he turned to physiological studies and occupied himself with such things as Hallerian irritability and the effect of opiates on the nerves of frogs.

The first records of the experiments that were to make Galvani famous ap-

pear in his notebooks and carry the date November 6, 1780. Galvani had a large electrical machine on a table in his laboratory. On the same table there was a dissected frog with most of the animal cut away except for the legs, feet, and a bit of the "vertebral column" or spine. An assistant casually touched an exposed nerve with a metal scalpel. The muscles of the dead frog contracted and the preparation quivered. Immediately, Galvani was called over to see the mysterious movements for himself. He was "fired with incredible zeal" and became determined to bring to light "whatever might be concealed in the phenomenon."

The Experiments that Followed. It was clear to Galvani that the cause of the movements had something to do with electricity. What he now wanted to know was whether natural electricity, the kind that gathers in the sky during a thunderstorm, would have the same effect as the artificial variety generated by a machine.



So, he took his frogs and his wires up to the roof of his house. The animals were equipped with a simple antenna and grounded by dropping the nerve conductors down to the bottom of a well. The experiment went as expected. When lightning flashed, the frogs' legs moved. Sometimes, in fact, the contractions actually preceded the lightning. Galvani saw in that a kind of stormy weather warning device. Following the success of such experiments, he went on to expose his frog preparations to the aurora borealis; but no muscular movements were observed.

Galvani's house was furnished with a hanging garden surrounded by an iron lattice. Frog's legs were sometimes hung from the lattice by little bronze

*Learn the history of
"animal electricity"
and create simple
electrical cells
from some
groceries.*

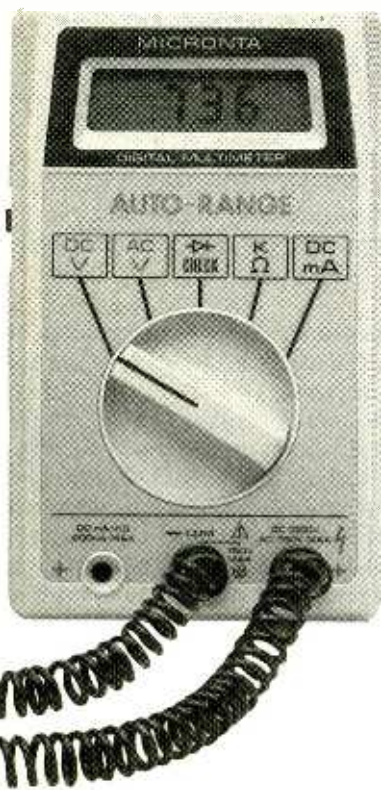

hooks attached to whatever was left of the spinal column. These dead body parts, too, tended to move around by themselves, and not only during storms, but also when the sky was perfectly clear. Reasoning on the basis of his earlier experiments, Galvani thought that atmospheric electricity must certainly be responsible. So, he watched and waited, inspecting the animals at various times and on various days, but nothing happened.

Finally, becoming a bit anxious and frustrated with the whole affair, the scientist tried scraping the bronze hook against the iron lattice. Galvani's manipulations completed the circuit and the frog muscles contracted in the usual manner. Did the bimetallic contacts have something to do with the contractions? To find out, Galvani took the preparation inside, laid it on an iron plate, and ran the hook fastened to the spinal column across the iron surface. The familiar muscular agitation appeared once again.

Galvani went on to experiment with a variety of different materials in place of the bronze and the iron. He found that some metals would cause the contractions to become stronger; others made them weaker. Poor conductors like glass, gum, resin, stone, and wood produced no muscular movements at all. He also found that the effect could be augmented by covering the frog nerves with metal foil. At the time, such a metallic covering was known as an armature. Two centuries earlier, William Gilbert installed steel armatures on lodestones to increase their magnetic strength, so it seemed a reasonable thing to try.

Animal Electricity. Galvani now began to think about where the electricity was coming from. The historical and philosophical developments antecedent to the problem are fairly complicated, but, to make a long story short, the scientist claimed that the electricity was a natural "animal electricity" held within the organism much like a static charge could be held within a Leyden jar.

Animal electricity, the discussion of which actually pre-dated Galvani's experiments, replaced the very old idea of "animal spirits," once described by Rene Descarte as "a very subtle fluid or rather a very pure and lively flame." The animal spirits had, in fact, become so pure, so subtle, so rarefied that many

thinkers wondered whether they had any reality at all. Electricity, animal or otherwise, was somewhat easier to comprehend. Furthermore, the new life force lent itself to some degree of manipulation and control within the confines of the laboratory.

Galvanism at Home. You don't need disembodied frog's legs to experiment with galvanic effects. Other sorts of organic matter will work just as well. You will be amazed at how easy it is to obtain various levels of voltage with simple household materials. For example, certain fruits and vegetables from the local supermarket. You'll also need a small collection of metal strips (see the Parts and Materials List for suppliers) and a sensitive voltmeter. If you are very new to electronics as a hobby and don't already have a good digital voltmeter, here's an excellent reason to get one. It's worth saying that the Micronta compact autoranging digital multimeter from Radio Shack works perfectly for the experiment.

Batteries from the Garden. Obtain a large, fresh lemon and place two narrow slits in the fruit about 1/4-inch wide and 1-inch deep. That can be done with a sharp knife of the appropriate size. The slits should be about 1-inch apart. Next, locate a strip of copper and a strip of zinc; the pieces need not be more than about 2-inches long. The pieces should be free of all surface oxidation.

When you're ready to begin the experiment, push the strips carefully into the slits in the lemon and connect your voltmeter to the metal pieces with a couple of alligator clips. The negative lead should go to the zinc; attach the positive lead to the copper. Your galvanic lemon cell will give you approximately 0.90 of a volt. Now, squeeze the lemon gently with your fingers. The voltage level will change!

Locate some magnesium ribbon and cut off a 2-inch strip. Magnesium oxidizes rapidly; so, make an extra effort to clean the piece thoroughly with some steel wool or fine sandpaper just before you use it. Remove the zinc electrode from your lemon cell and replace it with the magnesium strip. Once again, hook up the voltmeter. Believe it or not, your lemon cell equipped with copper and magnesium electrodes will give you at least 1.5 volts. Maybe even more!



A lemon cell can generate significant voltage if built with the right metal electrodes. Here one is shown connected to a voltmeter.



Galvani's original electro-physiological work in the late 18th century inspired a whole new wave of experimentation. Here, someone makes an attempt to generate animal electricity by sliding a pair of frog's legs across the tongue of a dead bull.

There are many other ways to obtain galvanic effects. For example, you can slice a lemon, place bimetallic bits directly on the moist electrolyte, and then touch the pieces with your voltmeter probes. To obtain the highest possible voltage level, the upper surface of the metal electrodes should be absolutely dry.

You can connect two or more lemon cells together for additional power. Let's try making a simple series system. Cut three strips of copper and three strips of zinc for a total of six. Now, attach two pieces of zinc to two pieces of copper with some narrow-gauge hook-up wire or magnet wire held in place with a few drops of solder. Cut three thick lemon slices and place them close together in

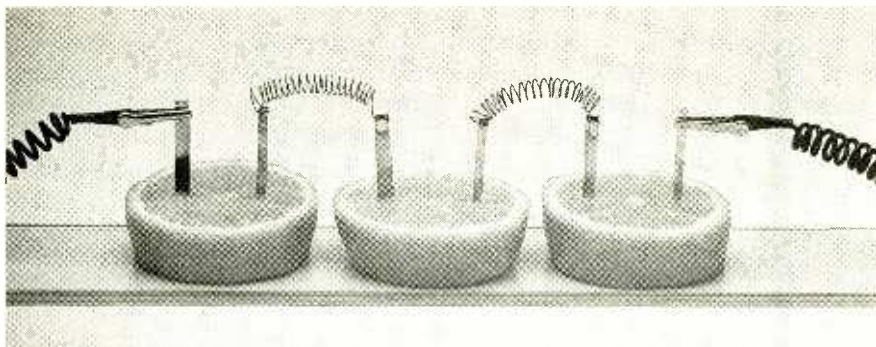

Your organic power cells can be wired together to form multi-cell batteries. Three lemons connected in series should give about 2.8 volts. The negative electrodes on the right side of each lemon slice are zinc; the positive electrodes on the left are copper.

PARTS AND MATERIALS LIST FOR EXPERIMENTS IN GALVANISM

Alligator clips
Copper strips
Digital voltmeter
Hook-up wire
Lemons (see text)
Magnesium strips
Zinc strips

The following materials are available from JerryCo, 601 Linden Place, Evanston, Illinois 60202: Two $\frac{1}{4} \times 10$ -inch copper strips (catalog number 10403), \$4.78 each. Two $\frac{1}{8} \times 10$ -inch magnesium strips (catalog number 10409), \$3.78. Two $\frac{1}{8} \times 12$ -inch zinc strips (catalog number 10406), \$3.78. The minimum order is \$12.50 and there is a flat \$4.00 fee for shipping and handling. The JerryCo catalog is fifty cents. The telephone number is 708-475-8440.

a row on an insulating surface, like a piece of glass. Connect the middle lemon to the other two with the bimetallic electrodes you just made. Complete the battery by placing the remaining strips into the appropriate

Further Reading

"Galvani and the Pre-Galvanian Electro-Physiologists," Hebbel E. Hoff, *Annals of Science*, Volume 1 (1936), pages 157-172.

"Animal Electricity," H.B. Steinbach, *Scientific American*, Volume 182 (February 1950), pages 40-43.

Commentary on the Effect of Electricity on Muscular Motion, Luigi Galvani, edited and translated by R.M. Green, Elizabeth Licht, 1953.

"Luigi Galvani," H.H. Skilling, *Science Digest*, Volume 35 (May 1954), pages 86-91.

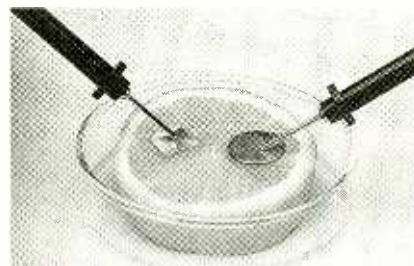

There are many ways to obtain the galvanic effect. Here, a bit of zinc and copper (in the form of a penny) are placed directly on a sliced lemon. To obtain the highest possible voltage level the upper surface of the metal electrodes should be absolutely dry.

lemons. Make sure that each slice has one copper electrode and one zinc electrode in it. Finally, hook up your voltmeter. If everything is connected correctly, the triple lemon power system should give you about 2.8 volts.

You can also try experimenting with different fruits and vegetables, like cucumbers, apples, onions, oranges, or whatever else you happen to have on hand. You will find that not all such batteries are created equal. Then try different electrode materials, like aluminum or iron.

Precautions. While these experiments are generally safe, there are a couple of precautions we should point out. First of all, there are certain chemical reactions going on between the metal electrodes and the juice inside the lemons. That, of course, goes for the other fruits and vegetables as well. So, as common sense would dictate, **do not eat your galvanic material when you're done experimenting—throw it away. Also, do not attempt to solder wire to magnesium ribbon.** Magnesium is a flammable material and it may catch fire if heat from a soldering iron or another source is applied to it. ■

Build a



REMOTE-CONTROLLED OUTLET

Here are two simple infrared remote-controlled outlets for lights, video, audio, or almost any AC-operated equipment.

BY JOHN YACONO AND MARC SPIWAK

It started out as a simple-enough wish: we wanted a remote-controlled window fan. As we got to thinking, we realized just about anything that you might plug into a wall could be made easier to use with a remote control. That's where the idea for the *Magic-Hand Remote-Controlled Outlets*, described in this article, came from.

Just think how versatile a remote-controlled outlet would be. You could turn on any lamp, fan, radio, television, etc., from wherever you are seated—score one for the couch potato! A remote-controlled outlet could even relieve you of having to crawl under the Christmas tree to turn the lights on and off. But, as you'll see, the Magic-Hand Remote can do much more.

What we'll describe in this article are two types of AC outlets that are turned on and off by infrared (IR) remote control. Each model has two AC sockets that work in unison so that two appliances can be plugged in and remotely controlled.

One version is based on two very basic circuits—an IR transmitter and

matching receiver—that can be built for under twenty dollars and take only one night to complete. A simple addition to the circuit enables it to control its two sockets "quasi-independently," or as a power controller, as you'll see.

This simple receiver lacks the ability to discriminate between its own transmitter and most other infrared remotes. For that reason, it is best used in areas isolated from other remotes. However, a more advanced transmitter/receiver pair that we'll present is selective and therefore, can be used side-by-side with any remote. The more "intelligent" Magic-Hand transmitter and receiver are not much more complex than the basic units; they require only one more chip each and some additional support components. As we'll explain, the full-blown unit can be expanded for multi-function capability, allowing it to independently control up to seven devices.

For times when you misplace the remote, or just can't find it in the dark, either model of the Magic-Hand can be controlled via any existing wall switch. That's particularly helpful when

you first enter a darkened room. Each receiver uses two project boxes: a large one to house most of the receiver circuitry and the AC outlets, and a small one for an IR sensor module. Each sensor is connected to its receiver via shielded multi-conductor cable. That allows you to place the sensor in a fairly unobtrusive location (a bookshelf, windowsill, etc.), while the larger case, and the AC line cords plugged into it, can be placed completely out of sight.

The handheld IR-transmitter circuits are housed in small project cases very similar in size to many other remote controls. They both can operate their receivers from a great distance (at least 15 feet). Let's take a look at how the circuits work.

The No-Frills Circuits. The basic remote-control transmitter is a very simple device, but with a little twist, as you'll soon see. At the heart of the circuit is a 555 oscillator/timer wired for astable operation (see Fig. 1). Its timing components are R1, R2, and C1. And now for the twist: By using the special voltage-control pin (pin 5), the timer can be

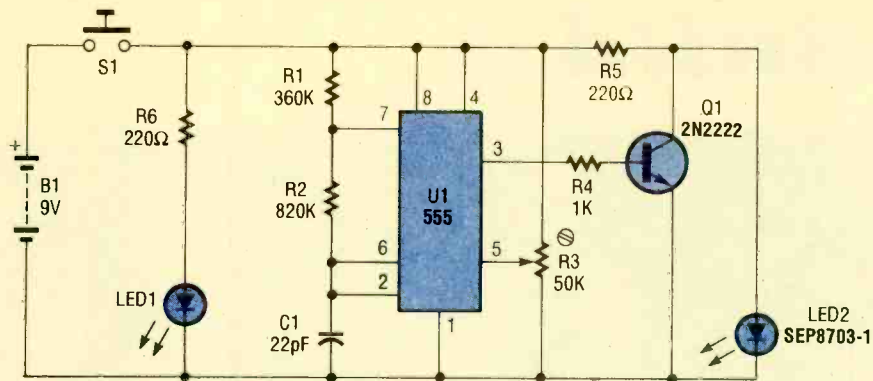

Fig. 1. This simple-looking transmitter makes a 555 timer jump through some amusing hoops: It provides a 50% duty cycle.

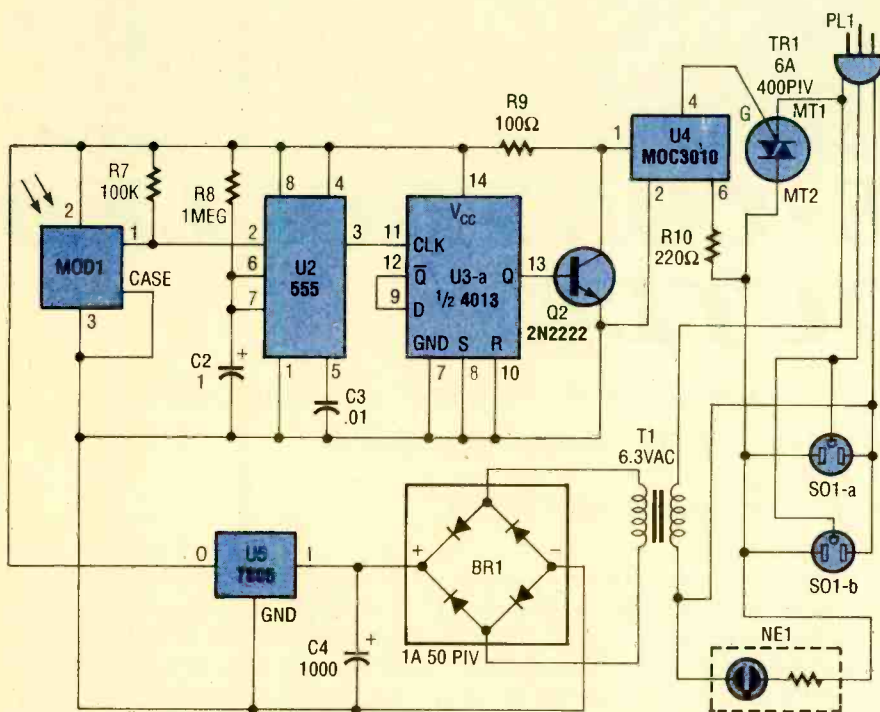

Fig. 2. The basic receiver contains a power supply, an infrared-detector module, a pulse stretcher, a toggling flip-flop, and power-control circuitry.

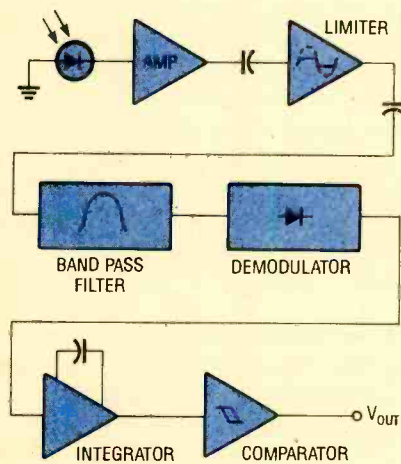

Fig. 3. The infrared detector module performs the task of detecting only the desired infrared signal and converting it into a logic-level signal.

operated with a 50% duty cycle! That's not possible with the typical astable configuration of a 555 because resistors R1 and R2 would determine the oscillator's high time, but only R2 would determine its low time. You can't make R1 zero because the 555 would short out the power supply each time it started to discharge C1. Thus, the high time would always be greater than the low time.

To obtain a 50% duty cycle, a voltage is applied to pin 5 via variable-resistor R3. The voltage at that pin controls the high time without affecting the low time. By properly setting that voltage (to approximately 4.89 volts), you can reduce the high time and overcome the affect that R1 has on the duty cycle.

Of course, altering the duty cycle in

PARTS LIST FOR THE NO-FRILLS MAGIC-HAND

SEMICONDUCTORS

- U1, U2—555 oscillator/timer, integrated circuit
- U3—4013 dual D-type flip-flop, integrated circuit
- U4—MOC3010 Triac-driver optoisolator/coupler, integrated circuit
- U5—7805 5-volt, 1-amp voltage regulator, integrated circuit
- Q1, Q2—2N2222 NPN general-purpose switching transistor
- BR1—1-amp, 50-PIV, full-wave bridge rectifier
- TR1—6-amp, 400-PIV Triac
- MOD1—Sharp GPIU52X infrared receiver/demodulator module (Radio Shack 276-137)
- LED1—Light-emitting diode (any color)
- LED2—SEP8703-1 wide-dispersion infrared-light-emitting diode

RESISTORS

- (All fixed resistors are 1/4-watt, 5% units unless otherwise noted.)
- R1—360,000-ohm
- R2—820,000-ohm
- R3—50,000-ohm multi-turn potentiometer
- R4—1000-ohm
- R5, R6—220-ohm
- R7—100,000-ohm
- R8—1-megohm
- R9—100-ohm
- R10—220-ohm, 1/2-watt

CAPACITORS

- C1—22-pF, ceramic-disc
- C2—1-μF, 15-WVDC, electrolytic
- C3—.01-μF, ceramic-disc
- C4—1000-μF, 15-WVDC, electrolytic

ADDITIONAL PARTS AND MATERIALS

- B1—9-volt transistor-radio battery
- PL1—AC power plug and line cord
- SO1—AC power socket
- S1—Normally-open momentary-contact pushbutton switch
- T1—6.3-volt, 500-mA power transformer
- NE1—120-volt AC/DC panel-mount neon lamp
- IC sockets, 3-conductor cable, perfboards, 3 cases, clear cabinet feet, wire, etc.

that manner also alters the frequency, so the values of the timing components had to be chosen to yield the right frequency with the voltage at pin 5 set at 4.89 volts. With R3 properly set, the output frequency is 40 kHz. Although you can use any 50k potentiometer for R3, using a multi-turn trimmer allows you to fine-tune the circuit for optimum operation and maximum range. When test-

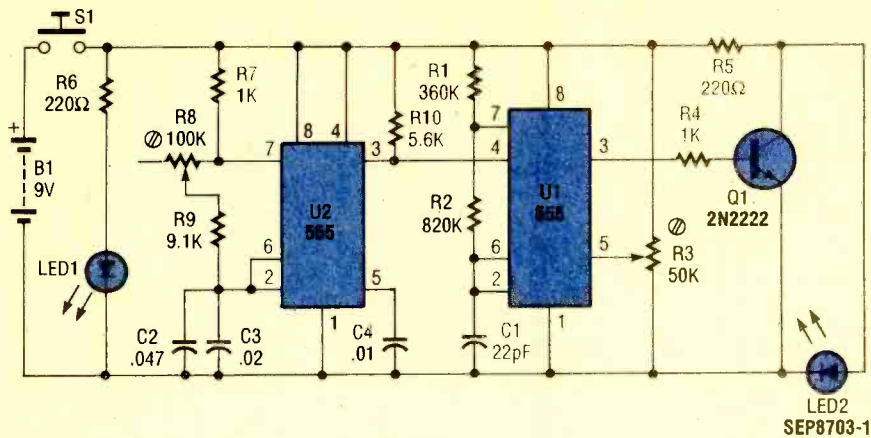

Fig. 4. This more-intelligent transmitter modulates the 40-kHz carrier at a frequency determined by R8.

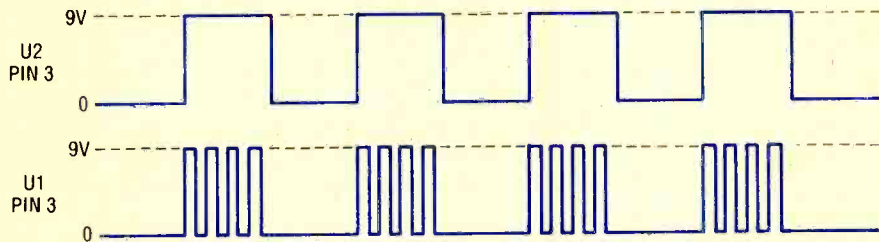

Fig. 5. The signal generated by U2 turns the 40-kHz carrier on and off, effectively modulating it by 100%. The result is a series of pulse bursts as shown by the bottom graph.

ing our prototype, the unit had at least a 15-foot range (we couldn't determine its maximum range because of our building's architecture!).

The rest of the circuit is straightforward. The oscillator's output switches Q1 on and off, which, in turn, shorts LED2 (an infrared emitter) at the oscillator frequency—in effect, it steals the power from the LED.

Often in home-brew IR transmitters, you'll see the LED in series with the switching transistor. That isn't really a good design because, depending on the value of the current-limiting resistor (R5 in our circuit), either the current through the transistor is too high, or the current through the LED is too low. That limits the transistor's life, or decreases the device's useful range, respectively. Furthermore, interaction between the LED and the transistor would prevent the LED from making nice sharp transitions from off to on and back again, also limiting the transmitter's effective range.

To operate our transmitter, the user must press S1, which applies power to the circuit and also lights the power indicator, LED1. The entire handheld unit is powered from a 9-volt battery.

The no-frills receiver circuit (see Fig. 2) contains more hardware, but its operation is easier to understand. The unit

receives its power from a 5-volt supply, consisting of PL1, T1, the bridge rectifier (BR1), C4, and U5. The 5-volt supply is always on.

When infrared light is received by MOD1—an infrared-detector module—it processes it to determine if it contains valid control signals (see Fig. 3). The infrared is first received by an IR photodiode. The signals present there are then amplified by a high-gain amplifier and AC-coupled to a limiter. The limiter chops the extreme highs and lows off the incoming signal and the result is a quasi-digital pulse train. The pulses are sent to a band-pass filter centered at 40 kHz with a bandwidth of ± 4 kHz.

The filter effectively attenuates noise and prevents false activation. The filtered signal is then demodulated and integrated to provide a continuous, but slightly varying, output for as long as a 40-kHz signal is detected. Next, a Schmitt trigger turns the integrated signals into clean logic transitions by ignoring the smaller variations in the integrator's output. The Schmitt-trigger output is sent to pin 1 of the module. Thus, that pin goes low only when a 40-kHz signal of proper amplitude is received by the photodiode.

Looking again at Fig. 2, you can see that those pulses are sent to pin 2 on a

555 timer. The timer is set up for mono-stable operation and pin 2 is the trigger. The 555 is used to provide bounce-free operation: If its trigger input is toggled a few times after it has begun outputting a timed pulse, the extra pulses are ignored. That's an important feature since the module might interpret a poor transmitter signal—due to a hand tremor, bouncing transmitter operation, low transmitter battery, or extreme transmitter distance or angle—as a train of pulses.

The 555 output is sent to a D-type flip-flop configured to toggle. When its Q output is high, Q2 shorts the input pins to the Triac-driver optocoupler, U4. That leaves the Triac driver off and the gate of TR1 receives no trigger voltage, so TR1 is off. When U3 is toggled, its Q output goes low, opening Q2 and activating the optocoupler. The Triac gate then receives current via R10 and U4, causing the Triac to turn on, completing the circuit to sockets SO1-a and SO1-b. Any device plugged into a socket will receive power.

Many newer houses (say less than eleven years old) contain AC outlets that are controlled by wall switches. If that is true of your house, don't worry—the receiver can be controlled by a wall switch for remote-free operation! By flipping the wall switch from off to on, you'll cause the circuit to trigger falsely, turning it on. If you flip the wall switch off and on again, the receiver's sockets will shut off and remain off. It's a good idea to leave the wall switch in the "on" position so that the receiver is always ready for remote operation later.

The Smart Magic Hand. We can add a touch of "intelligence" to the Magic-Hand system by modulating and demodulating the 40-kHz carrier. It is very easy to modulate the carrier by turning it on and off (often called 100% amplitude modulation). That can be accomplished by switching the 40-kHz astable located in the transmitter (U1) on and off at a certain rate. Put more briefly, if we want to send a 100-Hz signal on the 40-kHz carrier, we just have to turn the carrier on and off at 100 Hz.

Take a look at Fig. 4 to see how that's accomplished. Astable U1 turns the IR LED on and off at 40 kHz just as it did in the no-frills transmitter in Fig. 1. However, in this circuit U1 is turned on and off by U2, another astable oscillator. Thus the output from the IR LED is a burst of 40-kHz pulses that repeats at the operating frequency of U2 (see Fig. 5).

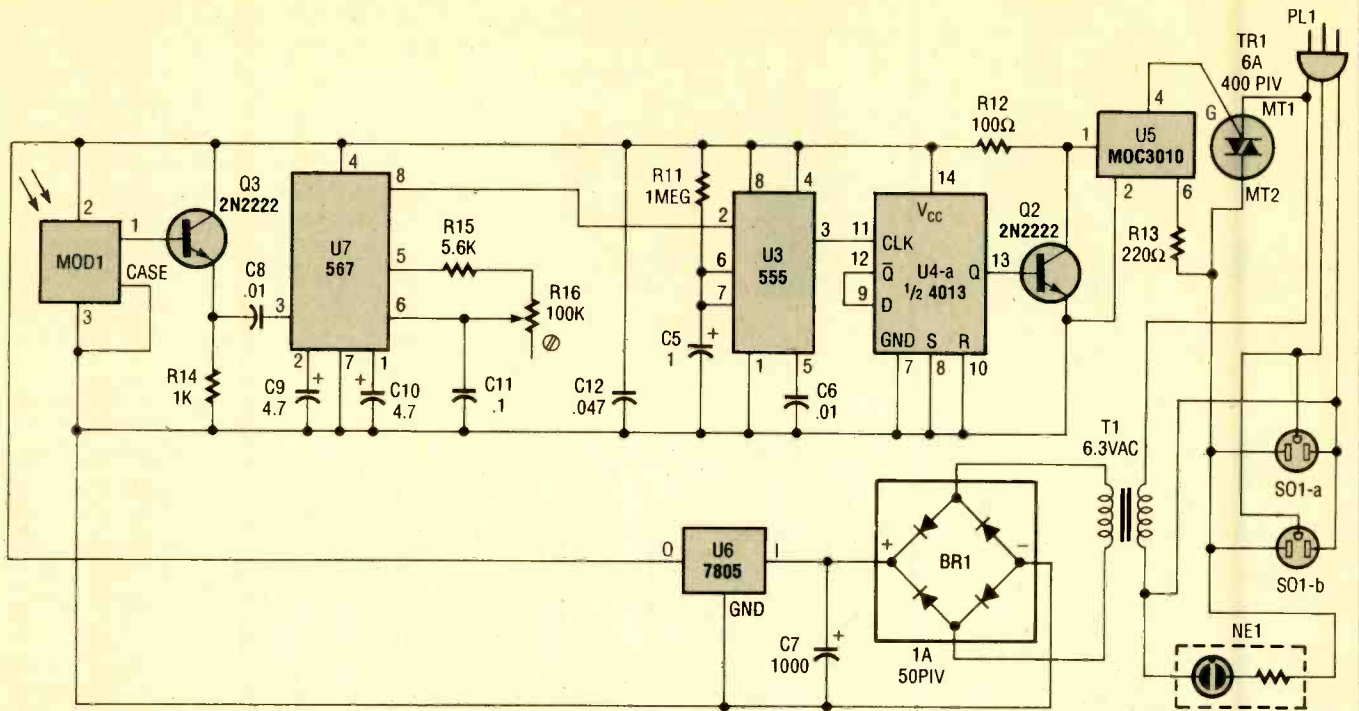

Fig. 6. Tone decoder U7 looks at the demodulated signal from the module to see if the incoming signal has intelligence of the right frequency. If it does, the rest of the circuit swings into action.

The frequency of U2 is determined by R7–R9, C2, and C3. Potentiometer R8 allows you to adjust U2's operating frequency from 98 to 1122 Hz. Over that range, the duty cycle of U2 only varies from 50.22 to 52.60%, respectively. We'll explain why adjusting the frequency might be necessary a little later.

The frequency range was chosen to cover the maximum range allowed by the IR module used in the receiver (see Fig. 6). The module can effectively decode intelligence from 100 to 1000 Hz as follows: When the module receives a series of 40-kHz bursts, its output goes low with each burst. That means the output changes in step with the intelligence that turned the carrier on and off in the transmitter (i.e., the module demodulates the 40-kHz carrier, giving you back the intelligence frequency generated by U2).

The demodulated intelligence is AC coupled to U7, a 567 tone decoder, via C8. Potentiometer R16 allows you to adjust the center frequency of the decoder to match the frequency of U2, and thus the intelligence. If the intelligence provided by Q3 is more or less equal to the center frequency of the decoder, the 567 activates U3. The rest of the circuit is exactly the same as the basic receiver in Fig. 2.

The advantage of this version of the remote-controlled outlet over the pre-

vious one is selectivity; not only must the receiver detect a 40-kHz signal, that signal must have intelligence of a specific frequency riding on it. Most IR-remotes modulate pulsed data on their carriers, but the pulsed data is not really periodic and shouldn't trigger the receiver. Even so, it is possible that a particular stream of data from some remote on the market may fool the receiver. That's why the intelligence frequency of the transmitter and receiver has been made adjustable. You can alter the frequency so that the receiver becomes insensitive to that remote.

Modifications. You can get the Magic-Hand to go an extra mile with some interesting modifications. For instance,

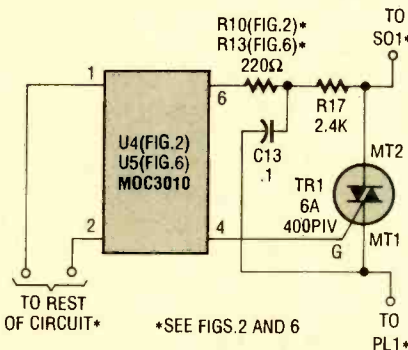

Fig. 7. The addition of an extra resistor and capacitor will permit the circuit to be used with inductive or "noisy" loads.

to turn on a highly inductive load, such as a whole-house fan or a pump, modify the receiver's Triac-trigger circuit as shown in Fig. 7. You need only add a resistor (R17) and capacitor (C12)—all of the other parts are in the original circuits of Figs. 2 and 6. The lag caused by highly inductive loads prevents the voltage and current on the AC line from going to zero at the same time. That can keep the Triac from turning off. The additional components are necessary to compensate for the phase lag and allow the Triac to shut down. That modification is only necessary for loads with very high inductive reactance.

You might have noticed that we didn't use the second flip-flop in the 4013. You can put it to good use if you wish to control two devices without the need for multi-function-remote circuitry (which we'll describe in a moment). Take a look at Fig. 8. Most of the components in that schematic diagram are already in both receiver units. The second socket (SO1-b) and its support components work just the same as SO1-a. The only difference is that its flip-flop receives its input from the other flip-flop; not from the 555. That permits you to turn on SO1-a with one press of the remote, SO1-b turns on with two presses, and both turn off with a fourth. You may wish to decrease the value of

PARTS LIST FOR THE INTELLIGENT MAGIC-HAND

SEMICONDUCTORS

- BR1—1-amp bridge rectifier
 Q1-Q3—2N2222 NPN switching transistor
 LED1—Light-emitting diode (any color)
 LED2—SEP8703-1 wide-dispersion infrared LED
 MOD1—Sharp GPIU52X infrared receiver/demodulator (Radio Shack 276-137)
 TR1—6-amp, 400-volt Triac
 U1-U3—555 timer, integrated circuit
 U4—4013 D-type flip-flop, integrated circuit
 U5—MOC3010 Triac-drive optocoupler, integrated circuit
 U6—7805 5-volt, 1-amp voltage-regulator, integrated circuit
 U7—LM567 tone decoder

RESISTORS

- (All fixed resistors are 1/4-watt, 5% units, unless otherwise noted.)
 R1—360,000-ohm
 R2—820,000-ohm
 R3—50,000-ohm multi-turn potentiometer
 R4, R7—1000-ohm
 R5, R6—220-ohm
 R8, R16—100,000-ohm trimmer potentiometer
 R9—9100-ohm
 R10—5600-ohm
 R11—1-megohm
 R12—100-ohm
 R13—220-ohm, 1/2-watt
 R14—1000-ohm
 R15—5600-ohm

CAPACITORS

- C1—22-pF ceramic-disc
 C2, C12—.047-μF ceramic-disc
 C3—.02-μF ceramic-disc
 C4, C6, C8—.01-μF ceramic-disc
 C5—1-μF, 15-WVDC, electrolytic
 C7—1000-μF, 15-WVDC, electrolytic
 C9, C10—4.7-μF, 15-WVDC, electrolytic
 C11—0.1-μF, NPO, ceramic-disc

ADDITIONAL PARTS AND MATERIALS

- B1—9-volt transistor-radio battery
 PL1—AC power plug and line cord
 SO1—AC power socket
 S1—Normally-open momentary-contact switch
 T1—6.3-volt power transformer
 NE1—Panel-mount neon lamp
 Perfboard material, enclosure, IC sockets, Shielded 2-conductor cable, clear cabinet feet, wire, hardware, etc.

C2 to shorten the pause time needed between presses.

That kind of operation is very useful if you wish to operate two devices at

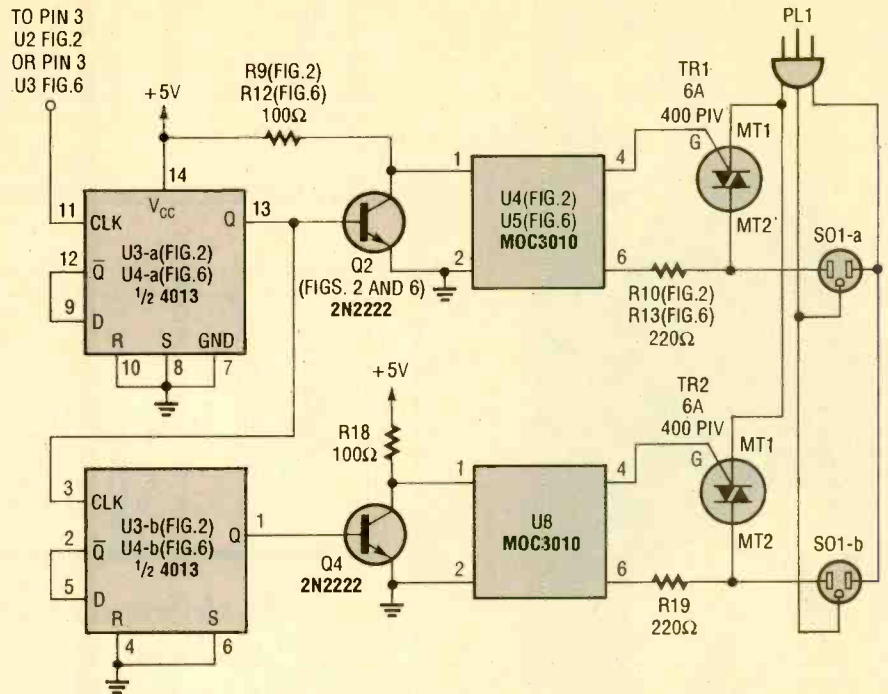

Fig. 8. With a few more components, the receiver can be made to operate two devices or power-control one.

once. For example, if you sometimes use one or two lamps in a room depending on the time of day. Or, perhaps you'd like to turn off up to two stereo components from your bed.

By further modifying the circuit of Fig. 8, you can also make the receiver a power controller for dimming a lamp or slowing a fan. You just have to replace TR2 with an SCR, and (dispensing with SO1-b) put the SCR's main terminals in parallel with TR1. One press of the transmitter and SO1-a will be at full power, another press and you'll get rectified AC for half-power operation, two more presses and the socket is off.

As we mentioned earlier, the intelligent Magic-Hand can be given multi-function capability. To do so, the transmitter must be capable of producing an intelligence frequency for each function or device that you wish to control. For each frequency you would need a momentary-contact DPDT pushbutton switch and a resistor. The switch would provide power to the circuit (in place of S1) and put a resistor in the circuit in the place of potentiometer R8. The resistor value (R_x) should be chosen to yield the frequency that you desire according to this equation:

$$f = 1/4.6431 \times 10^{-6} (19200 + 2R_x)$$

As mentioned before, the IR module can only reliably demodulate intelligence with a frequency between 100 and 1000 Hz. Other constraints on the

receiver require that you separate each intelligence frequency by 150 Hz. That means you can use a maximum of seven frequencies: 100, 250, 400, 550, 700, 850, and 1000 Hz.

The receiver must be modified to detect each intelligence frequency you wish to use (i.e., each device that you want to control). You'll need a 567 tone decoder, a 555 timer, a flip-flop, an optocoupler, a Triac, a socket, and their support components to form a detection circuit for each frequency. Each 567 should be connected to the emitter of Q3 via a 0.01-μF capacitor, and the only distinction between each detection circuit is the value of resistor that will replace R16. That resistance (which we'll denote R_x) determines the intelligence frequency (center frequency) that each decoder responds to according to the following equation:

$$f_o = 1/0.1 \times 10^{-6} (5600 + R_x)$$

Use that formula to select the resistor values according to whatever intelligence frequencies you'll be using.

Construction. The transmitter circuits were built on a small piece of perfboard using point-to-point wiring. The IR LED in each transmitter is mounted near one end of the circuit board. That places the IR LED right next to a hole drilled in the end of transmitter case when its circuit board is installed—just

(Continued on page 86)

The DAT PACT

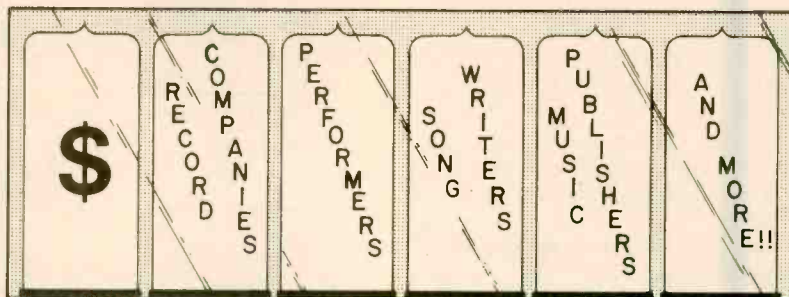
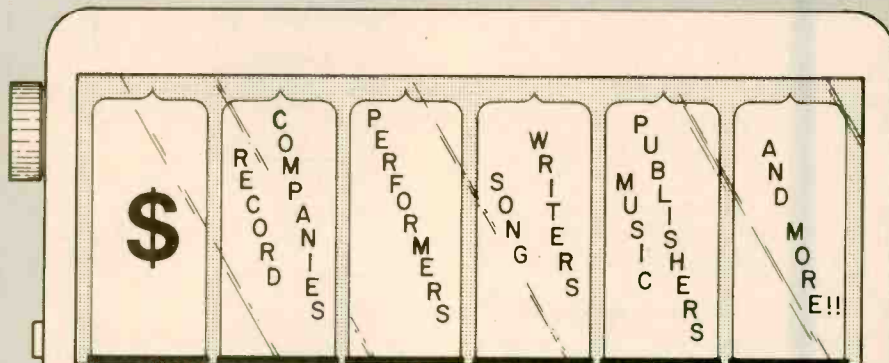

The electronics and music industries have reached an accord on home recording that could clear the way for new digital-recording technologies—but at what cost to consumers?

BY BRIAN C. FENTON

Just as we were ready to write off digital audio tape (DAT) as a mass-market failure, we were again reminded how difficult it is to predict the future of consumer electronics. After more than a decade of intra-industry fighting, the electronics manufacturers, recording companies, songwriters, music publishers, and performers have reached an agreement that could pave the way for DAT's entrance as a mass-market item. Ironically, DAT may owe its new shot at life to two new, competing digital formats, Philips' Digital Compact Cassette (DCC) and Sony's Mini Disc (MD), which were introduced earlier this year.

History Repeats? Although most consumers consider DAT to be new technology, that's hardly the case—it was introduced more than five years ago in Japan. Before DAT could be brought to the U.S., however, threats of lawsuits from the recording industry forced manufacturers to hold back. When Sony finally did introduce a DAT deck here in June of last year, they were promptly sued by the National Music Publishers Association. (That suit has been dropped as part of the recent agreement.)

After a slow start, the DAT format has finally caught on in Japan. Sales in the U.S., however, have been poor at best.

The recording companies, who were worried about the potential decrease in profits that might occur if consumers could make virtually perfect copies of copyrighted recordings, chose not to support DAT. Since no prerecorded software was available, consumers—more than satisfied with standard cassettes—saw little need to buy DAT decks despite their impressive hi-fi capabilities.

DAT is not the first electronic product to enter the market under the shadow of legal action. A similar situation arose in 1975 when Sony introduced their Betamax videocassette recorder. The movie industry was very worried about the potential competition of VCR's, and

the threat of financial losses brought about by home taping. Universal Studios and Walt Disney Productions sued Sony, alleging copyright infringement in 1976.

Although a U.S. District Court ruled in 1979 that home video taping for private use didn't constitute copyright infringement, the ruling was reversed by a U.S. Court of Appeals. Congress stepped into the controversy in 1981, introducing legislation that would overturn the Appeals Court decision. Later, a bill was introduced that would place royalty taxes on VCRs and blank video cassettes. Congress did not act on either bill.

In 1982, the U.S. Supreme Court was petitioned to resolve the home video-taping question. Initial hearings were heard in January 1983, and one year later, the Supreme Court ruled that home video taping does not constitute copyright infringement. Ironically, Hollywood now makes more money from the release of movies on videocassette than it does from theatrical releases!

Not a Good Answer? Despite the Supreme Court ruling, the video- and audio-recording industries continued to seek legislation that would impose royalties on cassette decks and VCRs as well as blank tapes. Bills were introduced in Congress that would impose royalties as high as 25% on recorders and at least 1 cent per minute on blank tape! Other alternatives were offered, including the requirement that anti-taping chips be built into recording decks. (Studies done on the anti-taping chip by the National Bureau of Standards concluded that it was not an acceptable solution because it seriously degraded the music quality.)

The introduction of DAT to the U.S. at the January 1987 Consumer Electronics Show got the recording industry even more worried, even though no company announced definite sales plans. A bill that would impose a 35% tariff on imported DAT recorders was introduced in Congress, but that also died.

Although Congress took no action on any of the bills introduced, the Recording Industry Association of America (RIAA) did—they threatened to file a lawsuit against any manufacturer who sold DAT in the U.S.

In an attempt to find out how serious a "problem" home taping was, the Office of Technology Assessment undertook a study and issued a report, *Copyright and Home Taping*, in 1989.

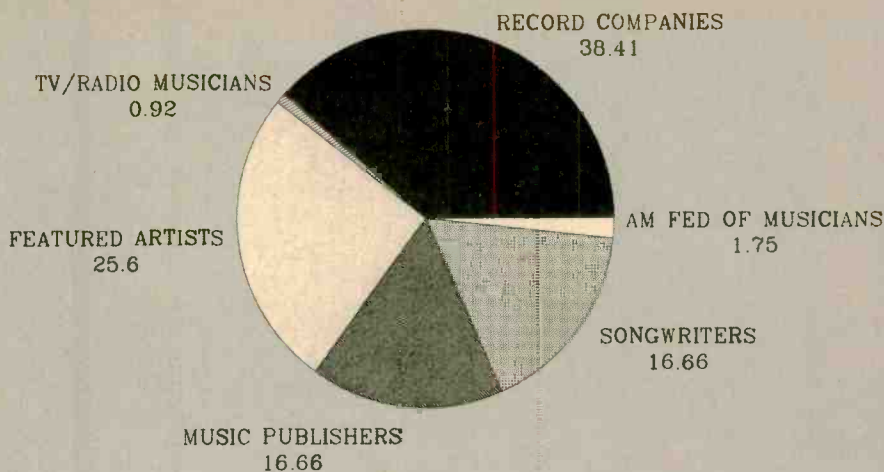

Although the royalty agreement spells out the percentages that each group should receive, we're cynical enough to assume that a good portion of the collected royalties will go to administering the collection and distribution of the funds. Payment to the record companies and artists will be made according to sales.

The report concluded that, even though "home taping may reduce the recording industry's revenues, a ban on home audio taping would be even more harmful to consumers and would result in an outright loss of benefits to society... In the billions of dollars." Some of the more interesting findings included:

- Almost three quarters (73%) of home taping "occasions" do not involve pre-recorded music. Instead, they include the taping of family members, lectures, band practices, answering-machine messages, etc.
- Most (72%) home-recorded tapes of copyrighted material were made from the tapers' own music collection. Another 9% (for a total of 81%) were made from material owned by other family members. The main reason for the taping was "place shifting." That is, home recorders made tapes of CD's so they could be played in a car's cassette player, *Walkman*, etc. The second most popular reason that home tapers made cassette copies was to make custom tapes with only the songs that they wanted, in the order they wanted them.
- About one quarter of pre-recorded purchases were made after the consumer heard the artist or recording on a home-made tape. (For example, a friend said, "Hey, listen to this song from this great new CD I just bought—you just gotta hear it!")
- If home tapers were not able to record, at least three quarters of home tapes would not be replaced by sales of prerecorded music.

After the report was issued, both

camp's went back into negotiations. The Digital Audio Tape Recorder Act of 1990, introduced in Congress early in the year, seemed to be the compromise that would finally "legitimize" the digital audio-tape recorder. Both sides realized that it was time to start working together. As the president of the RIAA testified before Congress, "Without our music, their products are worthless, but without their machines, no one can listen to our music."

The "DAT Act" called for the inclusion of SCMS, the Serial Copyright Management System, in all digital audio recorders. (See the sidebar elsewhere in this article.) The bill, if passed, still did not promise to be a definitive end to the home taping question (despite the Supreme Court's Betamax decision). The bill, in fact, said, "...this Act does not address or affect the legality of private home copying under the copyright laws."

In the eyes of the recording industry, the bill was a compromise that sought to preserve the status quo by making DAT home taping equivalent to analog home taping—that is, you can only make first generation copies. (Second-generation cassette recordings are substantially worse than the preceding generation.)

The "DAT Bill" turned out not to be the answer we all were waiting for because of opposition from other factions within the music industry. The National Music Publishers Association (NMPA); the Songwriters Guild of America (SGA); and the American Society of Composers, Authors, and Publishers (ASCAP)—who called themselves the "Copyright Coalition"—strongly opposed the bill

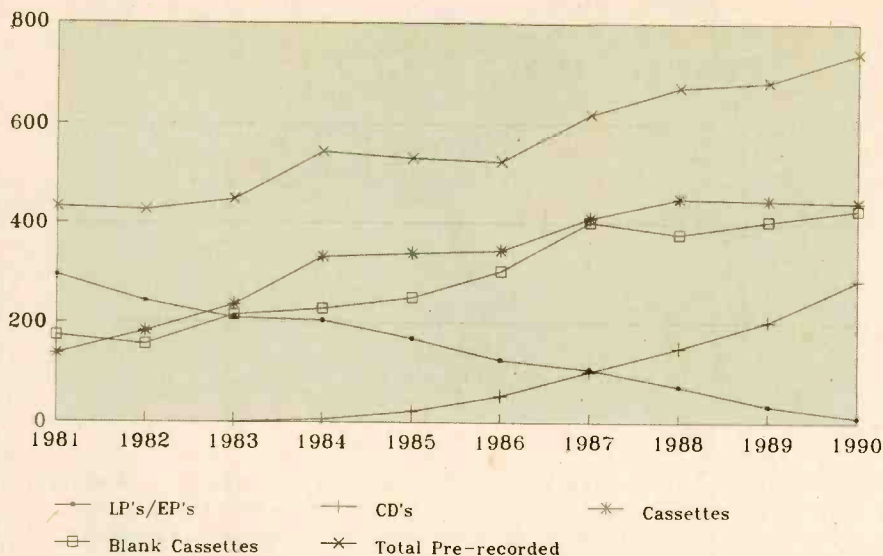

What's at stake? Shown here are sales, in millions of units, of various prerecorded media and blank cassettes over the last decade or so. Note that, although few things are easier than making a cassette recording, pre-recorded cassettes still outsell blank ones. Both far outsell CD's.

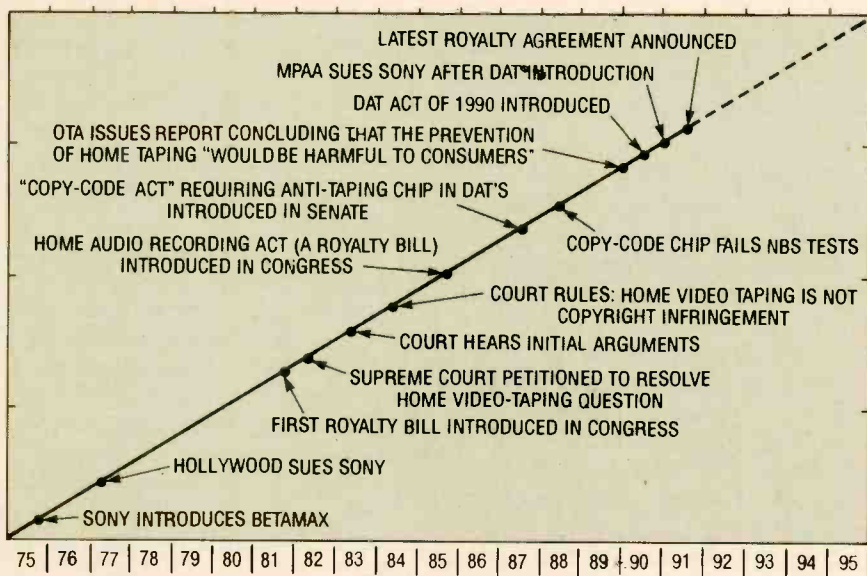

The long road: A brief history of the trials and tribulations of the digital audio tape recorder.

and instead wanted to continue to press for royalties. As a result, the bill died in subcommittee, and Congress took no action before it adjourned for the year.

Even without an official bill to "legitimize" it, DAT finally arrived in the U.S. in June of last year when Sony began officially importing and selling SCMS-equipped decks. Almost immediately, a class-action suit was brought against them by the NMPA. The suit was enough to keep other manufacturers from following Sony's lead, and although units from other manufacturers are now available (see Gizmo, elsewhere in this

issue, for a review of one such unit from Sharp), DAT sales fell far short of projections.

The Royalty Pact. Despite all the fighting, both sides knew that, without some sort of agreement, everyone had a lot to lose. The hardware manufacturers had the capability to produce new decks that they knew they could sell. The recording industry—though not admitting it publicly—knew that new formats are good for business. (Sales were virtually flat before the introduction of the CD in 1982.) Both sides were talking—in secret—in the spring

of this year.

The impetus for the talks was likely that the hardware manufacturers were not so much trying to clear the way for DAT as they were looking for a way to ensure that Digital Compact-Cassette and Mini-Disc recorders could enter the market without the same obstacles that hindered DAT. John Roach, Chairman of Tandy Electronics (which earlier had committed to introducing DCC to the U.S. in 1992) appears to have been instrumental in getting the two camps to come to agreement.

Like the agreement reached in 1990, the pact would require that all digital consumer recorders contain SCMS circuitry. For the first time, however, royalty payments would be required on the sale of all consumer digital recorders and on blank tapes. On recorders, the payment would be 2% of the manufacturer's price, with a minimum royalty of \$1, and a maximum of \$8 (\$12 for dubbing decks). On blank digital tapes, the royalty would be 3%.

The royalty payments would be collected by the U.S. Copyright Office and distributed—after deductions for the administrative overhead, of course—by the Copyright Royalty Tribunal into two unequal funds. One fund would be for the persons who own the copyright for the musical work, and the other for the copyright owners of the sound recording.

The total royalty pool would be divided up as follows: The record companies would get 38.41%; featured artists, 25.6%; songwriters, 16.66%; music publishers, 16.66%; the American Federation of Musicians (which represents non-featured musicians), 1.75%; and the American Federation of Television and Radio Artists (which represents non-featured vocalists), 0.92%. It is unclear to us whether there is any cap on the administrative overhead that can be collected by the various groups who must distribute the monies to the artists and copyright holders. Although no studies have shown that the more popular music is the most recorded, royalty distributions would be based on recording sales; that means that the largest-selling artists would receive the largest payments.

The pact marks the first time that the hardware manufacturers have agreed that the payment of royalties should be required for home taping. It also marks the first time that the recording industry has agreed that consumers can make

(Continued on page 89)

GIZMO

A CHRONICLE OF CONSUMER ELECTRONICS

VOLUME 4,
NUMBER 11

Dis, Dat, and De Other

RX-P1 MULTI-USE DAT PLAYER/RE-CORDER. From: Sharp Electronics Corporation, Sharp Plaza, Mahwah, NJ 07430-2135. Price: \$1499.

Just before this issue went to press (mid July), some major developments in the home digital-recording arena were announced. It seems that the Electronic Industries Association (EIA) reached a compromise with the Recording Industries of America (RIAA) and the nation's songwriters and performing artists, all of whom were concerned about loss of income if consumers were given the ability to dub near-perfect copies of CD's at home. The manufacturers, represented by the EIA, have agreed to add royalty payments to the cost of all recordable digital media and on any hardware that is capable of digital recording. One more hurdle remains: Congressional approval is needed to codify the royalty arrangements and to remove any question of the legality of audio taping by consumers. Legislation is to be introduced in Congress this fall. For more information on the EIA/RIAA agreement, see the article entitled "The DAT Pact," elsewhere in this issue.

The battle over royalties has been going on for several years now, with the recording industry fighting tooth and nail against DAT, and the EIA equally firm in their stance against royalties. Last year, the National Music Publishers Association sued Sony in an attempt to stop the sale of DAT players in America. (That suit was dropped as part of the new agreement.) And there have been almost no commercial releases of pre-recorded DAT tapes to go along with the units that have been introduced on the market. It's become quite obvious that without the support of the recording industry, new audio formats have little chance of succeeding.

There is some disagreement among insiders as to what effect the legislation (when passed) will have on the sales of digital audio tapes (DAT) and machines. One side believes that the accord was reached over the corpse of DAT, which, they believe, has lost any chance it might once have had to succeed as a mass-market item. The opposing point of view is that the agreement will give DAT the support it needs to get a foot in the door of the con-



CIRCLE 50 ON FREE INFORMATION CARD

sumer market and that, because there won't be any digital-recordable competition for a while (two recently announced formats, Philips' Digital Compact Cassette and Sony's Mini Disc won't be available until late next year), DAT will get a firm grasp on the market slots that DCC and MD were hoping to grab. Finally, there are those who believe that DAT seems to be slated strictly for the small market niche consisting of semi-professional and professional musicians and audiophiles, with DCC and MD standing poised to battle it out for mass consumer acceptance—especially if they are accompanied at their introductions with a broad selection of prerecorded material.

Between the uncertainty over the format's future and the lack of listening material—or perhaps for other reasons—consumers have shown little interest in DAT so far. We fully understand the hesitancy on the part of consumers. The idea of introducing (at the cost of at least \$1000) yet another format into our home system isn't tremendously appealing. Nor is the idea of shelling out \$10 to \$15 for a blank digital audio cassette tape that won't peacefully coexist with our personal players or car stereos. For years now, we've been maintaining a full library of LP's and then CD's for home listening, and maintained another collection of audio tapes for

(Continued on page 7)

TURN PAGE FOR CONTENTS

This month in GIZMO®

- Sharp RX-P1 Multi-Use DAT
Player/Recorder pg. 1
- Zirco PowerTrip Power Inverter . pg. 2
- PC Globe and PC USA pg. 3
- Cobra Pro-Lock Vehicle Security
System pg. 4
- Questech Transition 2000 Digital
Voice-Changing Telephone... pg. 5
- Onkyo A-SV810PRO A/V Surround
Integrated Amplifier pg. 6
- Car CD Player..... pg. 8
- Stereo Rack System pg. 8
- Cellular Phone Accessories pg. 9
- Laser-Disc Shields pg. 9
- Fax Machine pg. 10
- Handheld Color TV pg. 10
- Remote Control Light..... pg. 10
- Telecommunications Device
for the Deaf pg. 10
- Bookshelf Stereo..... pg. 11
- Radiation Monitor pg. 11
- Singalodeon K-8
Karaoke System pg. 11
- 60-Inch TV pg. 11
- Amplified Handset pg. 12
- Bang & Olufsen VCR..... pg. 12
- Game Boy Super Scrabble.... pg. 12
- Radar Detector pg. 12

Gizmo is published by Gernsback Publications, Inc., 500-B Bi-County Blvd., Farmingdale, NY 11735. Senior Writers: Chris F. O'Brian, Teri Scaduto. ©Copyright 1991 by Gernsback Publications, Inc. Gizmo is a registered trademark. All rights reserved.



CIRCLE 51 ON FREE INFORMATION CARD

Portable Power

PowerTrip POWER INVERTER. Manufactured by Zirco, Inc., 10900 W. 44th Ave., Wheat Ridge, CO 80033. Price: \$199.95

We sometimes worry about our love of electronic gizmos. There are so many that we "need" and can't live without that we sometimes fear that we're becoming addicted. One comforting thought is that we know we're not alone. Can you imagine living without your VCR?

When we have to leave our home for any length of time, we sometimes get a little anxious because we have to leave some of our gizmos behind. We soothe ourselves by remembering the timers we have running our lights, the VCR running itself in our absence, and we know that we can always call our answering machine if we get too worried.

We also find comfort in that we have so many portable gizmos that usually accompany us: our personal stereo, scanner, camcorder, etc. Unfortunately, some of the products that we just can't live without aren't as portable as we'd like them to be. That point was driven home the last time we left for a short vacation in our usual last-minute rush. We paid attention to our packing lists, and had everything that we thought we would need packed in our car, including the portable electronic equipment that usually accompanies us. But we weren't on the road for more than a couple of hours—passing our first "sights"—that we realized that we had forgotten something after all. We had forgotten to charge our batteries.

Batteries, especially those used with

camcorders, take time to charge, and you just can't rush it. We started to get used to the idea that we'd lose part of the complete vacation memories that we'd gotten accustomed to taping, editing, and using to create an "electronic scrapbook." Granted, it's not a life-or-death situation, and it's not something that would ruin a vacation, but it was enough to get us started off on the wrong foot.

Then we realized that all was not lost after all. Sitting in our car was a product that arrived just the week before: the PowerTrip from Zirco. PowerTrip is a power inverter, which converts the 12-volt direct current (DC) of your car's electrical system into the 110-volt alternating current (AC) that your household appliances need. You simply plug PowerTrip into your cigarette lighter, and then plug your favorite AC appliance into the socket on one end of the PowerTrip itself.

PowerTrip is quite small, roughly 3 x 4½ x 1½ inches, and weighs less than a pound. Despite its small size, it can handle a surprisingly large amount of power. No, you won't be able to power your refrigerator during the next blackout, but you will be able to run appliances up to 100 watts. That means that you won't be able to run that laser printer, but your laptop will work just fine. A small TV and VCR can easily be supported, to keep the kids in the back seat from asking "Are we there yet?" And, of course, it adds a whole new dimension to car camping.

The first question we had was what the effect of drawing all this power from our car battery was. Interestingly, not very much. A car's electrical system is capable of putting out considerable power, as it does every time the engine is started. But,

(Continued on page 8)

He's Got the Whole World on His Disk

PC GLOBE V 4.0 and PC USA V 2.0 ELECTRONIC ATLASES. From: PC Globe, Inc., 4700 South McClintock, Tempe, AZ 85282. Price: \$69.95 each.

What is largest country in the world? (The USSR) Which is the most populous? (China) The most densely populated? (Macau) Richest? (U.S.) Poorest? (Tuvalu). Where in the U.S. are you most likely to be a victim of violent crime (Washington D.C.). Least likely? (Utah).

Those geographical tidbits are just a small sample of what we found out after playing around for a few minutes with *PC Globe* and *PC U.S.A.*, two "electronic atlases" from *PC Globe, Inc.* Both programs turn your IBM PC or compatible computer into a colorful atlas and almanac.

Unlike traditional paper atlases, the information in *PC Globe* is flexible, so you can get to just the information you want, about the countries you want. You can do head-to-head comparisons between selected countries, or look at how one country compares with the rest of the world. The pull-down menus, although not perfect, make it easy to use the programs even if you're one of those people who refuse to read software manuals.

Let's say, for example, that you want to

get a rough idea of which countries produce the most radios and television sets. Using the keyboard or a mouse, you can opt to display that data on the world map. The map will then appear, showing the countries in different colors (or shades in the black-and-white mode) depending on their production.

Displaying data on the map is a valuable tool because it allows you to see trends that might not be as obvious if you saw the same data in a table. For example, displaying tourist arrivals and receipts on the map shows clearly that North America and Western Europe are where most tourists visit and spend their money. That might not be as obvious from poring over data in an almanac, where the data is probably presented alphabetically by country.

Displaying data on the map does have some disadvantages. First, country names are not displayed in the "map data" mode. It's especially frustrating because a "point-and-shoot" mode lets you scroll crosshairs around the screen and the country (or ocean, etc.) underneath the crosshairs is named—but not when you're displaying data. Another problem is that some countries are just too small to see! Take radio production, for example. Hong Kong leads the world, but you can't see that it's colored red to indicate its leading role. Even when you display only Asia, it's impossible to pick out that Hong Kong is the top producer.

Fortunately, choosing "Country Comparisons" from the pull-down menus lets you see the same data in bargraph and numerical form. You can choose to see data from the top ten or bottom ten countries (with or without data from the "active" country) or any eleven countries of your choice. *PC USA* has equivalent features for state statistics.

We were interested to find that the world's most densely populous country is one of which we've never heard, Macau. Needless to say, we didn't know where it was. We found it easily enough by choosing "Select Country" from the "World" menu. We then highlighted Macau from the list (although we could have typed it in if we chose to) and then clicked on "OK" to bring up the world map with a green square around Macau. We couldn't see its borders, but since the square was south of China, we called up the map of Asia from the "Region" menu. We still couldn't see it, despite the square, so we decided to call up the map from the "Country" menu. Macau, as it turns out, is three small islands at the mouth of the Pearl River in the South China Sea. Its area is a whopping six square miles, but its population is more than 400,000. (That's why it leads the world with a population density of more than 70,000 per square mile.)

We decided to find out a little more about tiny Macau, so we looked at the data for the "active country" and found out

(Continued on page 9)

PC Globe



Car Pro-Tection

PRO-LOCK MODEL VAS-110 PORTABLE VEHICLE SECURITY SYSTEM; from Cobra Electronics Group/Dynascan Corporation, 6500 West Cortland Street, Chicago, IL 60635. Price: \$119.95.

We live and work in a fairly low-crime area. Around here people lock their homes only at night, and their cars almost never. But the neighborhood has been plagued recently by a series of car break ins. Once or twice a month, every unlocked car parked out on the street is ransacked by intruders sometime during the night. We and the other victimized car owners are greeted the next morning with a bit of a mess—the contents of the glove compartments strewn all over the vehicles—but no major losses. Because all that's taken is loose change and an occasional pair of sunglasses (only the expensive, designer styles), we suspect the thieves are teenagers, picking up some easy spending money. The police can't do much about the problem. The victims' usual reaction is to lock the doors for a few nights following the break-ins (about as effective as closing the barn door after the cow has escaped). Within a week or so, we're all back to our standard, lax security habits—until the next time.

The problem didn't seem serious enough to warrant any drastic measures like buying a car alarm. After all, that would require either spending a precious weekend afternoon installing it, or paying a pro to do it for us—and then dealing with things like having to remember to arm it and being awakened at 3 AM by false alarms.

Then we were offered the chance to try out Cobra's Pro-Lock VAS-110 portable vehicle security system, which requires no installation but provides four-way protection with motion, shock, glass-breakage, and current sensors. The system consists of a padlock-shaped alarm unit with a flashing xenon strobe light and a matching, pocket-sized, key-chain transmitter. The Pro-Lock is intended to be placed on the car's dashboard, both for visual deterrence and because the alarm sounds louder when placed on a hard surface. The alarm is powered via the car's cigarette lighter using the supplied adaptor cord, with backup power provided by a 9-volt battery. (For those cars whose cigarette lighters don't work when the engine is turned off, alternate connection is possible by using the included fuse-clip adapter to bypass the lighter and go directly to the fuse block.) Completing the package are a couple of "theft-prevention" decals to be placed on the vehicle's windows.

The alarm is activated by first using an included key to turn the alarm on (a red LED lights to indicate power on). Then, after closing the doors, windows, trunk,



CIRCLE 53 ON FREE INFORMATION CARD

and hood, the remote control is used from outside the vehicle to arm the alarm. The red LED on the alarm unit will start flashing slowly and the alarm will "chirp" once to indicate that the alarm is armed. When motion, shock, glass breakage, or electrical current is detected, a piercing, 120-dB alarm sounds for two minutes, accompanied by the flashing red strobe light. If the alarm has been activated while you were away from the vehicle, you'll be able to tell because the LED will be flashing rapidly when you return. To disarm the unit, the button on the remote must be depressed; two "chirps" confirm that the unit is disarmed.

That's the only quick way to disarm the Pro-Lock. A thief can't simply pull the plug out of the lighter receptacle to shut up the alarm. When the DC power is disrupted, the back-up battery kicks right in. To remove the backup battery requires a tiny Phillips-head screwdriver, a good light source, and some manual dexterity, since the battery-compartment door is held in place with a tiny, recessed screw.

If your car has automatic cooling fans or delayed interior or exterior lights, you won't want to use the current-sensor feature, which activates the alarm when any type of electrical device is turned on in the vehicle (so that when a thief opens the car and the dome light goes on so does the alarm). That feature can be disabled by setting the current-sensor on/off switch, located inside the battery compartment of the main unit, to its off position.

There are nine other DIP switches inside the battery compartment, corresponding to nine switches inside the remote

control. Those can be used, if desired, to personalize your remote code. Each of the switches can be set in one of three positions; it doesn't matter how they are set as long as the switch positions in the remote control match those in the alarm unit.

We had a bit of trouble arming the unit at first (we're ashamed to admit). The problem turned out to be something not mentioned in the manual's troubleshooting guide. After years of using remote controls to operate our audio and video gear, we're accustomed to "point-and-shoot" action—a quick press of a button changes channels or tracks. The Pro-Lock remote requires the button to be depressed for at least a full second. That doesn't sound like much, but it was enough to foil our first attempts at arming the device!

When the button on the remote control is depressed for a full three seconds it serves as a "panic button" and activates the alarm whether it's armed or not. That feature could come in handy if the owner is threatened when returning to the car, or in other emergency situations. The remote control can activate the alarm from up to 100 feet away from the vehicle. For cars used by more than one driver, extra key-chain remotes are available from Cobra for \$20 apiece.

A sensitivity control allows you to select various motion/shock threshold levels, to prevent false triggering of the alarm from strong winds or passing cars. The sensitivity control is recessed into the side of the main unit, and can be adjusted using a small Phillips-head screwdriver. At the lowest setting, our Pro-Lock didn't acti-

(Continued on page 9)

You Rang?

TRANSITION 2000 DIGITAL VOICE-CHANGING TELEPHONE; from Questech International, Inc., 4951-B East Adamo Drive, Suite 238, Tampa, FL 33605. Price: \$79.95.

Have you ever picked up the phone and instantly regretted that the person on the other end recognized your voice? The caller might be your mother-in-law, your boss, that neighbor who always wants to borrow your expensive tools, your brother who always needs to borrow money, or an ex-wife or -husband. Some people avoid unwanted calls by using their answering machines to screen all calls (a practice that many others frown on as being rude).

Now there's a way to answer your phone, without the person on the other end knowing that *you* have picked up. The *Transition 2000* from *Questech International* is a digital voice-changing phone. Using an integrated digital signal processor, the phone has 16 different voice-masking levels. It lets men sound like women, children sound like adults, elderly people sound younger, and *vice versa*.

Dubbed "a telephone for the security conscious," the *Transition 2000* is aimed at three specific groups—latchkey kids, women living alone, and the elderly—who are frequent targets of prank calls, obscene calls, or telephone scams. None of those callers is likely to stay on the line

to harass a deep-voiced adult male.

The other potential market for a voice-changing phone is people who run small businesses from their homes with little or no support staff. The *Transition 2000* allows a man to answer his home-office line by saying, in a woman's voice, "Good morning. This is the Jones Company. How may I help you?" Once the caller has identified himself, Mr. Jones can decide whether he is "in" to take the call, or should have his "secretary" take a message.

We liked both suggested applications for a voice-changing phone. We also saw tremendous potential for playing tricks on unsuspecting friends and relatives. So we were anxious to put the *Transition 2000* to work.

The phone is a lightweight, single-line unit with only the most basic features—tone/pulse switch, ringer on/off switch, and last-number redial. Just below the keypad are three buttons—a red "normal/change" button flanked by two black keys used to change the keys lower or higher—and a red LED. When the LED is unlit, the phone lets your normal speaking voice pass through. Pressing the "normal/change" button allows you to adjust the voice level; the LED lights to indicate that you are in the voice-change mode. While in that mode, each press of the "low" (or "high") button deepens (or raises) the timbre of your voice. Pressing the "low" button is supposed to change a woman's voice to sound like a man's, or a child's to sound like an adult's. Similarly, pressing the "high" button should change a man's

voice into a woman's or an adult's voice into a child's.

To select the appropriate voice level for your needs, you simply pick up the handset, press the "normal/change" button, and press any number from 1 through 0 on the keypad. Then you have about 20 seconds or so to experiment with voice changing by pressing the high or low button, speaking into the phone, and listening to your altered voice through the earpiece of the handset, before the operator cuts in with a pre-recorded message ("We're sorry. Your call did not go through. Please hang up and try again."). In this case, however, the message should have said "We're sorry. Your voice sounds too silly to believe. Please hang up and try again."

In our tests, our voices ran the gamut from a deep drone like that of Lurch, the butler on the "Addams Family," to a Munchkin-like squeak. In between there were 14 other levels. The ones closest to normal sounded the most realistic but, to our ears, every voice level made us sound as if we were a computer—which is to be expected from digitization using a too-low sampling rate. What's worse, the digitized voices sound garbled. Although the manual suggests that you avoid using the extreme ends of the voice-change levels to get the clearest audible transmissions, every level produced some distortion. The extreme ends were totally unintelligible; the levels closest to normal simply sounded as if there was an extremely bad phone connection.

A call (using our regular office phone) to Questech revealed that the first production batch was seriously flawed. They had thought that all of those machines were out of circulation, and they promptly sent us a unit from a newer production batch.

The new *Transition 2000* we received worked just as it was supposed to. The distortion we noted before was almost nonexistent. Unfortunately, with no distortion, the digitization was even more obvious. But our changed voices were easily understandable, and our true ages and genders were unrecognizable.

Once you come up with an acceptable voice level for your purposes, you can set it in memory. That way you can recall the changed voice at any time by going into the change mode (so that, for example, your "secretary" always sounds the same), and revert to your own voice by simply pressing the "normal/change" button again to return to normal mode. Only one changed voice can be stored, so different family members may have trouble using the phone unless they can agree on a single setting.

Unfortunately, we weren't able to produce a voice on the *Transition 2000* that we felt was sufficiently realistic and clear to be acceptable for conventional business use. We still think the idea is a good one, and look forward to advances in the technology. ■



CIRCLE 54 ON FREE INFORMATION CARD



CIRCLE 55 ON FREE INFORMATION CARD

The Heart of Home Theater

A-SV810PRO A/V SURROUND INTEGRATED AMPLIFIER. Manufactured by Onkyo U.S.A. Corporation, 200 Williams Drive, Ramsey, NJ 07446. Price: \$1100.

As the home theater moves off the pages of glossy magazines and into the homes of real people, it usually travels a long and winding road to get there. The journey to home theater usually begins with the purchase of a hi-fi VCR or a laserdisc player, when the consumer realizes that even when renting the best movies, more than a TV—even a large-screen one—is needed to get the feeling of a movie theater. So the stereo system gets called into play to add “bigger” sound. Later, a surround-sound processor is added, along with a second pair of speakers.

Most people never make the most of their “home theater” system. Hooking up all that mismatched equipment can be daunting, and using it can be even more difficult for any family members who aren’t well versed in throwing all the right switches to pick the right inputs, and setting all the right levels to watch a movie.

These days, you can still build a home-theater system piece by unmatched piece using your stereo amplifier as a cornerstone. But now you have a better, easier, and more elegant option. You can build your home theater around an audio/video amplifier like Onkyo’s A-SV810PRO. Once all your components are properly connected, the amplifier serves as a convenient “command central.”

You can hook up quite a few home-theater components to the A-SV810PRO, which features Dolby Pro Logic decoding for Dolby Surround soundtracks, and digital signal processing (DSP) circuitry for ambience enhancement. The rear panel offers audio inputs for a CD, tuner, tape deck (record and playback), and turntable. Vid-

eo and audio connectors are provided for a laserdisc player, satellite (DBS), and three VCR’s (record and playback). All video connectors, with the exception of the third VCR connector, feature an S-video connector along with the standard phono jack for composite video. (Signals input via the S connector are output on both the S and standard video outputs.) A fourth video/audio input (also including an S-video connector) is included on the front panel, which makes it convenient to hook up a temporary source such as a camcorder.

The amplifier is large (about 18 × 6½ × 16½ inches) and heavy (almost 40 pounds). But that’s to be expected for a device that contains five power amplifiers. Three of the amps are rated at 85 watts (for left, center, and right channels) and two are rated at 35 watts (for the rear speakers), all into 8-ohm loads.

Setting up the audio/video amplifier is easy—the rear-panel connectors are all clearly labeled. Since the jacks include inputs for such equipment as videodisc players and satellite receivers, you, or whoever else uses the amplifier, will have an easy time; each input selected will be just what it says it is. (We would have liked, however, to have seen an input for a second audio tape deck. We had to connect our DAT deck to the third set of video connectors because our cassette deck was connected to the “Tape” connectors.)

Using the A-SV810PRO can be almost as easy as setting it up—in other words, it’s surprisingly simple for a complex piece of equipment that offers 10 sets of inputs, five sets of outputs, and controls up to six speakers. The first thing we noticed about the front panel of the unit is that it has so few buttons and knobs. Instead, it’s dominated by a large vacuum-fluorescent display (which includes a 10-character alpha-numeric readout that scrolls when it must display more than 10 characters) and a large motorized volume control. Sixteen pushbuttons and a display-dimmer control round out the front-panel complement.

As far as we could determine, it is possible to do *everything* from the front panel. So if you misplace your remote, or its

batteries run low, or if you’d just prefer to use the front panel, you’ll be able to make all necessary adjustments. (Onkyo deserves congratulations for that!) You’re not likely to use the front-panel controls too often, however, because the remote control is considerably easier to use, and a unique on-screen display gives you total control over all adjustments using the handheld remote.

The remote control, besides operating the A-SV810PRO, can also be programmed to operate a number of other devices you have connected to the amplifier. It comes pre-programmed to operate Onkyo equipment, but you can program it to control your existing VCR, CD player, and the like.

There are a number of ways to use the remote depending on which you find most convenient. Selecting a source, for example, can be as easy as pressing the “CD” button. You may decide instead to call up the on-screen menu, scroll to “Input Selector” and then scroll through the “jacks” displayed on the screen until you get to “CD.”

Why would you do that instead of pressing a single button? First, four cursor keys and an “Enter” key are all that you need to control *everything* using the on-screen menus—an important consideration if you want to use the remote control with one hand in the dark. A second reason is that if you want to select video from one source and audio from a second, the pictorial display makes it clear what you’re doing, because you can scroll through the video jacks and audio jacks separately if you want to.

Other choices on the main menu are “Rec Selector,” “Surround Mode,” “Surround Tuning,” “Tone control,” “Preset Memory,” and “Impulse Response.” In the “Rec Selector” menu, four choices are available. “Off,” “Source” (which routes the program being played to the audio tape deck and video recorder outputs), and “VDP-VIDEO” and “DBS-Video.” The latter two settings let you record something from your laserdisc or satellite receiver (or whatever else you have connected to the inputs) even if you’re watching something else.

The “Surround Mode” menu lets you scroll through the nine modes offered. Besides Dolby Pro Logic, there are Theater 1 and 2; Hall 1, 2, and 3; Live Concert; Jazz Club; and Disco. There is also a “Bypass” setting, which switches the digital processing out of the circuit for pure, unadulterated stereo reproduction.

Once you select the surround mode, you’ll want to call up the “Surround Tuning” menu, which gives you control over an assortment of parameters. For example, in the Dolby Pro Logic mode, you have 17 tuning parameters to adjust if you choose: The Pro-Logic mode can be switched between a normal mode and a 3-channel mode (if you don’t have surround-channel

speakers). The center mode can be switched between its normal mode, a "wide-band" mode, and a "phantom" mode (if you don't have a center-channel speaker). The delay time for the rear channel can be set to one of six values between 15 and 30 milliseconds. A pink-noise test tone, which lets you properly adjust sound levels can be selected to appear in any given speaker, or automatically rotate through the speakers. A "Pulse" setting is provided so that you can properly set the rear-channel delay. The center- and rear-channel levels can be adjusted, and the bass, midrange, and treble can be adjusted for the center, left and right, and rear channels. All of the settings can be stored in one of the 10 preset memories, and the memory can be instantly restored to the factory-preset settings.

From the tone-control menu, you can adjust the bass, midrange, and treble of the left and right, center, and rear channels, or all three channels at the same time. As with everything else we've been talking about, the on-screen graphics makes it easier than it sounds.

A separate main-menu selection lets you store, recall, or change the ten preset memories. Surround-tuning data, input settings, and volume settings can be stored.

The final main menu input is "Impulse Response," which gives you a graphical indication of how the digital signal processor is altering the reflection pattern and reverberations of the music. It's interesting and, perhaps, educational, but we feel that it's likely to end up being a little-used function.

Although the A-SV810PRO gives you incredible control over numerous parameters, and using the menu might sound complex, it's actually very easy to use. Using the front panel takes a little bit of getting used to, because the menus and submenus aren't shown graphically. That's especially apparent when adjusting the digital sound-field processor, where, in some modes, you can define the size and shape of the listening room, and even where your listening position is. All those adjustments are easy to do when you're looking at a picture, a little more difficult when you're not. We're thrilled nonetheless that you can fully adjust the amplifier from either the handheld remote or the front panel.

We were able to integrate the A-SV810PRO seamlessly into our system of diverse, mismatched components. It's DSP modes created pleasing, realistic effects (although the range of adjustments is so great that we *still* haven't gotten around to trying them all out). If you're looking for a foundation upon which you can build an impressive home-theater system, or if you're trying to find a way to bring your home theater up to the state of the art, then Onkyo's A-SV810PRO is a good bet. ■

DIS, DAT AND DE OTHER

(Continued from page 1)

listening on the road (or on the sidewalks). Granted, we *love* the idea of being able to make high-quality digital recordings of our favorite CD selections on a DAT machine. But a CD changer can be programmed to play a mix of songs on a home stereo—and if we couldn't play the DAT tape elsewhere, what's the advantage? So, while from a professional point of view we've been looking forward to getting our hands on a DAT player, as consumers, we've leaned toward the common attitude: "Let's wait and see."

Of course, electronics manufacturers haven't just been sitting on the sidelines, waiting for the dust to settle. Several companies have been actively marketing DAT players—including *Sharp Electronics*, whose *RX-P1* multi-use DAT player/recorder addresses some of those problems. The unit is packaged with accessories that allow it to be used as a portable tape player, a home-audio component, or as part of a car-stereo system. The custom tapes you make on your home system can go anywhere you go—and even be used once you arrive, hooked up to a friend's home stereo, for instance. The result of that innovative packaging, for consumers, is the feeling that they're getting a lot for the money—and that the initial monetary investment and the risk of buying into a new format are spread out and somehow lessened. Of course, the three-in-one set-up also allows that first-time DAT buyer to take advantage of skip-free listening to a digital source even when jogging or driving in pothole-ridden areas.

The basic unit is pocket-sized and weighs less than a pound. The tape door is on the top of the unit. (For anyone who isn't familiar with digital audio tapes, the tape itself is about half the size of an analog cassette tape, and the case is fully enclosed to prevent tape damage.) Record, play, pause, stop, fast-forward, and reverse controls are located on the front of the unit, along with an LCD readout that indicates track number, time, and other functions. Below the display is one jack for either headphones or the wired remote control and another for digital I/O. The power-in jack is found on the back of the unit. Slide switches for power and timer controls and a volume thumb-wheel are on the left side of the RX-P1.

For portable use, an AC adaptor/battery pack/charger attaches to the back of the unit, bringing the weight up to a hefty pound and a half. The included rechargeable batteries provide about an hour and a half of playback time, and charging takes eight hours, but you can use the RX-P1 as the batteries charge. The remote control, which provides the same operations as the front-panel buttons, is intended for portable use. You can keep the main unit in a

pocket and clip the tiny remote to your belt; the headphones can be plugged into the remote. To avoid inadvertently pressing operation buttons on the main unit when it's in a pocket, the timer switch on the side of the unit can be set to "key hold," temporarily disabling the front-panel buttons. A carrying case with removable strap and a pocket just big enough to hold a spare DAT tape is included.

The AC adaptor does double duty as an A/D converter; it is used when recording from analog sources and when the unit is hooked up to an analog amplifier or tape recorder (when the home stereo system doesn't include equipment with digital input/output jacks). The RX-P1 package comes with both a digital and an analog connecting cord to accommodate all set-ups.

There are a couple of options available for listening to the RX-P1 in your car. Both start out by setting the player in the cradle-like car-mounting unit, and securing it with a thumbwheel-driven screw. The mounting unit, which has shock-absorbing springs inside, can either be strapped to the cover of the center console between the driver and passenger seats or mounted to an included flexible gooseneck stand. The stand is designed to be bolted to the slide rail beneath the passenger seat and adjusted so that it is convenient to the driver. The mounting cradle can then be screwed on and off the stand as needed. At the back of the cradle is a jack for the power cord that plugs into the car's cigarette lighter, and a line that runs into the "tape adapter." The adapter looks just like a standard analog cassette tape and, when it is inserted into the car's tape player, transfers the DAT's audio output so that it can be read by the tape player's audio head.

Switching the RX-P1 between the home and car becomes a simple matter of unscrewing the thumbwheel from the AC adaptor and then doing the opposite with the car-mounting unit. Using it as a personal walkabout stereo becomes a little more complicated, because you must then disconnect the adapter from your stereo inputs and outputs.

One of the main advantages to digital recording is the convenience (the other, of course, is the superior sound quality). Digital recording allows you to set program markers on the recording for fast and easy track searches during playback. Adding a "Start ID" is as easy as hitting the record button in either the record or play mode. It can be erased by holding the record button down for two seconds. An "End ID" can also be recorded (by holding the fast-forward key for two seconds while in the record mode) to indicate the end of the program material on a tape.

The RX-P1 incorporates the Serial Copy Management System, or SCMS, to prevent bootlegging. (Part of the agreement reached between manufacturers and the re-

ording industry was that such a system must be included in every consumer digital-recording device.) SCMS permits first-generation copies to be made of compact discs, pre-recorded digital audio tapes, LP's, analog cassette tapes, and digital satellite broadcasts (as long as the broadcaster hasn't included a copy inhibition flag). Second-generation recordings are not possible, however. In other words, you cannot make a second digital recording from your original digital recording. (When digital recording is impossible, the LCD reads "no COPY.") Even digital tapes of analog sources like LP's and cassette tapes are copy-protected by the

SCMS circuitry. The exceptions are pre-recorded digital tapes and digital broadcasts that do *not* contain a copy inhibition flag; unlimited copies can be made of those sources, if you can find them. You can also, of course, make unlimited analog copies of digital recordings.

The RX-PI is a little inconvenient for home use because it lacks a wireless remote control. The side-mounted power switch is also a bit inconvenient for home use, although it's fine when it's used in a car. The buttons, in general, are a bit too small for comfort, except for portable operation, and the LCD is sometimes hard to read. But those design "flaws" are actu-

ally a result of the inevitable tradeoffs that are made to produce a product versatile enough to be "at home" anywhere.

Without question, the audio quality of the RX-PI is outstanding. DAT, of course, is touted for its ability to make master-quality copies of digital sources. The RX-PI doesn't do anything to make us think otherwise. Even though we didn't do any direct digital-to-digital recordings, we were unable to tell the difference between a CD and its DAT copy (made through its analog inputs) in blind A/B tests. Even when we knew which source we were listening to, we couldn't hear the difference. Now *that's* impressive. ■

PORTABLE POWER

(Continued from page 2)

of course, if you leave your lights on for a few hours, you'll end up with a dead battery. Using PowerTrip is something like leaving the lights on—with one important exception. PowerTrip will shut itself off if the car's battery voltage drops too low. Before that, it will sound an alarm to let you know that you're getting yourself in

trouble. It's easy enough to prevent that trouble from getting too serious: just start your car and let it run to charge the battery.

PowerTrip gets hot when you're running any considerable load. The case, which is made of heavy-gauge aluminum and has a heat sink along one edge, is designed to dissipate as much heat as possible. You have to help it by making sure the heat sink is exposed; keeping it on the carpet, near your heater, over the muffler, and in direct sunlight is asking for trouble.

The PowerTrip performed just as we hoped it would. In its first job, it powered our camcorder and then charged our camcorder battery without a hitch. None of the devices we tried subsequently—from lights, to laptops, to TV's—seemed to have any complaints about either the quality or the quantity of the power that the unit provided.

We however, do have a complaint: Now we have *yet another* gizmo we just can't leave home without!

ELECTRONICS WISH LIST

For more information on any product in this section, circle the appropriate number on the Free Information Card.

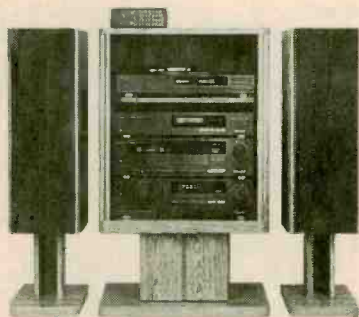

Sherwood Stereo Rack System

Stereo Rack System

It just seems as if the days of tower speakers and rack systems are gone. While it's true that bookshelf systems account for 60% of unit sales, they earn only a little more than half of what standard-size component systems account for in dollar sales. For those who favor the substance of full-size systems, *Sherwood* (Inkel USA Corporation, 14830 Alondra Blvd., La Mirada, CA 90638) offers the SS-2725R, an audio rack system that uses a conventional two-piece tower speaker system. The remote-controlled "Tri-Power Bass Servo" amplifier, which provides 125 watts per channel, has two video inputs, a loudness control, a headphone jack, a motor-driven volume control, power meters, and a five-band graphic equalizer. A top-loading, five-disc, carousel CD-changer; a double cassette deck with Dolby-B noise reduction and high-speed and synchronized dubbing; and a quartz PLL-synthesized tuner with 30 station presets round out the system. The vertical cabinet is available in oak finish or black-grain finish. Price: \$900.

CIRCLE 56 ON FREE INFORMATION CARD



Jensen Car CD Player

Removable Car CD Player

International Jensen's (25 Tri-State Office Center, Suite 400, Lincolnshire, IL 60069) CD 9500 car stereo receiver with CD player has an integrated handle, extractable mount bracket, and removable chassis for anti-theft security. The unit features multibeam laser tracking, shock and vibration protection, and a servo-controlled motor. The 20-watt-per-channel unit features two-channel preamp capability and separate bass and treble controls. The CD player offers such basic features as random play, track repeat, and 5- and 3-inch disc compatibility, and Jensen says that its front panel is designed to make it easier for the driver to reach frequently used controls. The AM/FM/FM2 Instaloc II tuner has up and down station seek, preset scan, and one-touch memory. Price: \$429.

CIRCLE 57 ON FREE INFORMATION CARD

CAR PROTECTION

(Continued from page 4)

vate even when we shook the unit around and dropped it on a carpeted floor. We kept it near the highest sensitivity level and weren't troubled by false alarms.

The alarm is intended not so much to notify car owners or passers-by to a theft-in-progress, but to make it so uncomfortable to be inside a vehicle while the alarm is sounding that a thief will leave immediately. The alarm is uncomfortably loud—particularly when it is placed on a hard surface in a small enclosed area, such

as the dashboard of a closed car, where the windshield reflects the sound back into the front seat—and notices both in the manual and on the device itself warn that “prolonged exposure to the siren within the vehicle may cause permanent damage to your hearing.” While performing tests in the Gizmo offices, we therefore took the precaution of muffling the device between a couple of pillows, which had the effect of reducing the noise from painful to simply annoying. Similarly, a crook with *chutzpah* might be able to muffle the alarm by placing it on the seat cushion and covering it with a rolled up jacket or shirt. We'd imagine, however, that the blaring siren

would deter most potential thieves from sticking around long enough to remove the radio, for instance.

Whether the Pro-Lock will scare off those sticky-fingered teenagers we've yet to find out. Fortunately for our neighbors, but unfortunately for Gizmo's research purposes, there haven't been any new strings of break ins in the neighborhood since we began testing it. (Perhaps we should have left a pair of Ray-Bans on the dashboard for bait.) But even if it didn't prevent any crimes during our test period, the Pro-Lock performed admirably in terms of easy setup and lack of false alarms. ■

WHOLE WORLD ON DISC

(Continued from page 3)

about Macau's age distribution, gross national product, and the makeup of the population in terms of the language they speak and the ethnic and religious groups to which they belong. We looked at the country's health statistics (including life expectancy, birth and death rates, infant mortality, hospital beds, etc.), major cities, natural resources, agricultural products, and what the major industries were.

We learned about Maccau's imports and exports, and much other data. We also found out that the country was an overseas territory of Portugal, even though its flag seemed to be the same as China. We couldn't tell much from our computer's rendition of Maccau's national anthem. PC USA offers an equivalent abundance of data, adding data on taxes, income by city, highway statistics, and the like.

PC Globe and PC U.S.A. won't replace paper atlases for everyone (although they will for some). Both programs contain a wealth of data, but like any paper atlas,

they leave out a lot of information. When we looked at state maps on our computers, we wanted to zoom in to see more and more details. We wanted to be able to “massage” the data and get it out in more formats than were available. (We couldn't find out, for example, which was the twelfth-most densely populated country). We had to keep reminding ourselves that these programs came on floppy disks, not CD-ROM's, and they do have their failings. But despite their shortcomings, they're fun, educational, and a “must have” for any family with a computer. ■

For more information on any product in this section, circle the appropriate number on the Free Information Card.

ELECTRONICS WISH LIST

Cellular Starter Kits

Eight custom-designed kits from *ORA Electronics* (9410 Owensmouth Avenue, Chatsworth, CA 91311) contain accessories needed by cellular-phone users. Each *Starter-Kit* includes a “Power Up” rechargeable battery; a “battery saver,” which allows you to power your portable telephone from your car's cigarette lighter; and a protective leather case. The kits are available for use with DiamondTel 99X, Mitsubishi 3000; Motorola 8000, Ultra Classic, or 9800XL; NEC P200 or P300; NovAtel PTR825; OKI 900; and Panasonic HP600/EBH30 portable cellular telephones. Prices: \$189.95 to \$199.95.

CIRCLE 58 ON FREE INFORMATION CARD



ORA Cellular Phone Accessories

Laser Disc Shields

To protect those expensive, high-tech laser discs from abuse and neglect, *Naki Industries* (8564 West Pico Blvd., Los Angeles, CA 90035) has come up with a low-tech solution: the *Laser Shield*. Each 12½ × 12½-inch Laser Shield is made of durable 3.0-gauge clear vinyl, double-welded on three sides. The original laser disc jacket slips into the Laser Shield, and all the writing on the front and back can be easily read. Laser Shields promise to keep discs and jackets in original condition without taking up any extra shelf space. Price: \$2.98.

CIRCLE 59 ON FREE INFORMATION CARD



Naki Laser-Disc Shields

ELECTRONICS WISH LIST

For more information on any product in this section, circle the appropriate number on the Free Information Card.



Toshiba Fax Machine

High-Performance Fax

Now that fax machines have become as essential as the telephone in offices, and have been gaining ground in home-based businesses, consumers have become more discriminating. *Toshiba America Information Systems Inc.'s* (Electronic Imaging Division, 9470 Irvine Blvd., P.O. Box 19724, Irvine, CA 92713-9724) *Model 4700* is aimed at small businesses and home offices with heavy transmission needs. With 256K of memory, it can store up to 15 pages for "broadcasting" applications (where faxes, once received, can be re-transmitted to other locations). Users can scan pages into memory and set the machine for automatic transmission later (to take advantage of lower phone rates, for instance), using simple menu-driven LCD programming. The fax can accommodate a paper roll that's 60% longer than most, reducing the need for frequent paper changes. However, if the paper does run out, when no one is there to attend to it, receptions (up to 15 pages) are stored in memory and can be printed later. The model 4700 also features 50 automatic dialing selections, including 12 one-touch numbers; an automatic paper trimmer; and a ten-page document feeder. A telephone handset and an answering machine are built in; and an automatic call router, which identifies and properly routes faxes and ordinary phone calls, eliminates the need for a separate phone line. Price: \$1299.

CIRCLE 60 ON FREE INFORMATION CARD

Handheld Color TV

Can't bear to miss that ball game (or soap opera while you're at the ball game)? You don't have to, if you have the *Model TV-1450* from *Casio* (570 Mt. Pleasant Ave., P.O. Box 7000, Dover, NJ 07801). The lightweight, portable TV features a high-resolution, 2.7-inch liquid crystal display. The unit has a telescoping rod antenna and offers viewing on TV channels 2 through 69. An external antenna jack allows users to connect the TV to a cable line or outdoor antenna. The TV-1450 runs on four "AA" batteries; with optional adaptors, it can also run on AC-line power and through a car cigarette lighter. Price: \$349.95.

CIRCLE 61 ON FREE INFORMATION CARD



Casio Handheld Color TV

Remote-Control Light

If you enjoy watching videos with the lights dimmed for that movie-theater effect, you've probably run into the problem of not being able to see the tiny keys on your remote control. *Recoton Corporation* (46-23 Crane Street, Long Island City, NY 11101) has come up with a sort of "night light" for remote controls. *The Illuminator* (model V646) mounts to one side of a remote control device via an adjustable, yet tightly fitting, cradle that holds the remote. It is powered by two "AA" batteries and uses twin 2.5-volt fuse, long-life lamps as its lighting source. The Illuminator is turned on and off with a thumb switch, and provides enough light to make the keys and labels legible. Of course, you're still on your own when it comes to *finding* the remote in the dark! Price: \$15.99.

CIRCLE 62 ON FREE INFORMATION CARD

Telecommunications Devices for the Deaf

We're all familiar with TAD's (telephone answering devices), but not many of us have seen TDD's (telecommunications devices for the deaf), which allow people to type messages back and forth over the phone. Two TDD's are now available from *AT&T Bell Laboratories* (Consumer Products Division, 5 Wood Hollow Road, 3L11, Parsippany, NJ 07054). The *TDD 2700* is an easy-to-use, lightweight unit with a flexible acoustic coupler for the telephone handset and a port for connecting to an external printer. A high-sensitivity switch helps eliminate errors in the incoming message caused by a noisy phone line. The *TDD 2930* (pictured) is an advanced model designed for people who need a portable TDD or a computer terminal. About the size of a videocassette tape, it has an 80-character display and a synthesized voice that tells a hearing person that a TDD is calling. The TDD 2930 is compatible with the ASCII computer format for using electronic mail, and its 32K memory (the equivalent of 10 typed pages) lets users store conversations, compose memos, and create a phone directory. Both models can be ordered by calling AT&T's National Special Needs Center at 1-800-833-3232 (TDD) or 1-800-233-1222 (voice). Prices: TDD 2700, \$249.99; TDD 2930, \$399.99.

CIRCLE 63 ON FREE INFORMATION CARD



AT&T Telecommunications Device for the Deaf

For more information on any product in this section, circle the appropriate number on the Free Information Card.

ELECTRONICS WISH LIST

Bookshelf Stereo

The completely separate components in *Fisher's* (21350 Lassen Street, Chatsworth, CA 91311-2329) *DCS-M44* bookshelf stereo system can be positioned in a vertical stack of four, or in two horizontal stacks of two components each with the speakers placed on their sides for a low-profile look. The system offers computer-controlled recording from CD to cassette, including automatic level set, edit-time programming, and fade-outs. Besides the CD player and double cassette deck, the *DCX-M44* features an AM/FM synthesized tuner with 12 AM and 24 FM presets and a 22-watts-per-channel amplifier that includes a 7-band equalizer with spectrum analyzer, matrix sound, and six sound presets to simulate the tonal qualities of different acoustic settings. Completing the system are a pair of two-way speakers with 5/4-inch bass drivers and a 64-function remote control. Price: \$899.95.

CIRCLE 64 ON FREE INFORMATION CARD

Low-Frequency-Radiation Monitor

The potential danger of low-frequency radiation—caused by power stations, power lines, and even computers—has been receiving increasing attention in the media over the past year or two. Exposure has been linked to increased risk of leukemia and other forms of cancer. So that individuals can monitor their own level of exposure (and that of their family), *Miller Technologies' Red Alert* (marketed by Certified Products Corporation, 2816 East 51st Street, Tulsa, OK 74105-1704) will alert users to the sources and intensity of low-level radiation at home and in the workplace. The multi-use meter also detects hidden and buried electrical lines, guarding against accidents when digging holes, tearing out walls, or remodeling. Price: \$69.95 (plus \$2 shipping and handling).

CIRCLE 65 ON FREE INFORMATION CARD

Karaoke Cassette System

You don't have to go to a club, bar, or restaurant to give your vocal chords a karaoke workout. *Lonestar Technologies, Ltd.* makes cassette-tape-based karaoke systems for home use. The top-of-the-line model is the self-contained *Singalodeon K-8* with satellite speakers. The K-8 also features a stereo dual-cassette deck with programmable music search system and continuous-play capability. Two professional-quality microphones have built-in windscreens, nine-foot cords, and separate controls to allow the user to adjust the voice/music balance on each. To make even the least talented singers find a key whose notes they can reach, the system provides pitch control. The K-8 also offers fully variable echo control and a five-band graphic equalizer. The satellite speakers and powerful, ported-duct woofer are driven by 15 watts of power, and can provide a surround-sound effect with proper placement. The unit's sync-dubbing feature allows the user to record background music and the singer's voice or song, and to copy tapes. Output jacks allow the user to hook up the K-8 to a stereo system, to take advantage of the stereo's power and fidelity. Price: \$299.95.

CIRCLE 66 ON FREE INFORMATION CARD

The Big Picture

A 60-inch rear-projection television from *Hitachi Home Electronics (America)* (401 West Artesia Blvd., Compton, CA 90220) provides 1000 lines of horizontal resolution, thanks to advanced lens and circuitry systems. The *UltraVision 60SX1K* also features a digital convergence system that provides precise color alignment, and pure green filters for color enhancement. Two remote controls come with the TV—an "easy" remote for commonly used functions and the "Genius II," a comprehensive, "learnable" remote that controls all Hitachi TV's, 30 brands of VCR's, and nine types of cable decoders. The "Insight 2901" on-screen display system allows the user to remotely control all audio and video adjustments, date/time memory, and station/channel memory with the help of on-screen prompts. The 60SX1K's audio portion incorporates a four-way surround system with Dolby Pro Logic and a 30-watts total built-in rear-channel amplifier. The entire package is surprisingly thin, measuring just over 28 inches front-to-back. Price: \$4399.95.

CIRCLE 67 ON FREE INFORMATION CARD

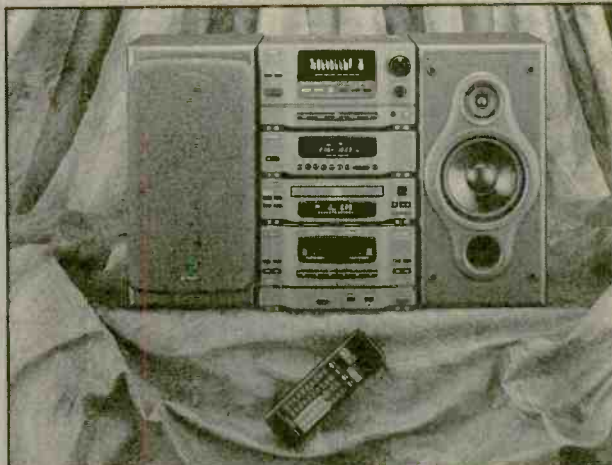

Fisher Bookshelf Stereo



Lonestar Singalodeon K-8 Karaoke System

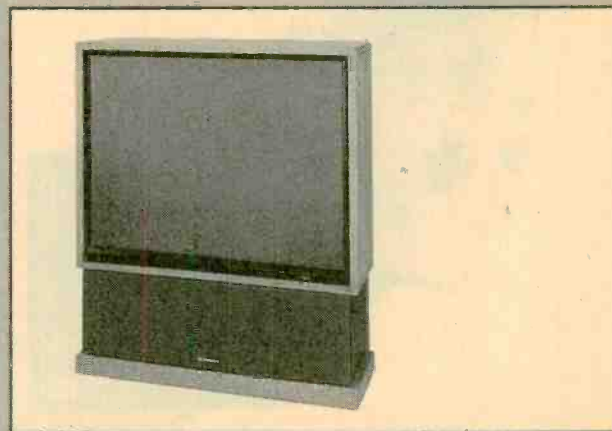

Hitachi 60-Inch TV

ELECTRONICS WISH LIST

For more information on any product in this section, circle the appropriate number on the Free Information Card.



Telefonix Amplified Handset

Amplified Telephone Handset

If your work environment is filled with the noise of heavy machinery (or your home is filled with screaming children), the *K/G 1000 amplified-receiver handset* from *Telefonix, Inc.* (P.O. Box 205, 2525 Greenfield Avenue, North Chicago, IL 60064) could make it a bit easier to hold a telephone conversation. The device suppresses local background acoustic noise to allow better hearing in noisy environments, and provides up to 25 dB of clear amplification of the received end of the call. To compensate for hearing impairments, the K/G 1000 emphasizes the upper voice-band frequencies. When incoming sound levels are excessive, the handset automatically reduces amplification. The unit works as a replacement for both modular K- (electret) and G- (carbon) type handsets. Price: \$59.95.

CIRCLE 68 ON FREE INFORMATION CARD

Looking Good

If you like to fill your home with *objets d'arts*, you might be interested to know that the Museum of Modern Art (MoMA) has selected *Bang & Olufsen's* (1150 Feehanville Drive, Mount Prospect, IL 60056) *Beocord VX 5000 VCR* for its Permanent Design Collection. Designed to be unobtrusive, the sleekly styled unit is just 3½ inches high and comes in white or charcoal gray. More than just another pretty face, the VX 5000 offers a full array of special effects, including picture-in-picture; a multi-picture function that can display 12 different channels simultaneously; strobe; and even a video "table of contents" at the beginning of a cassette. The MTS stereo VCR will accommodate several audio options, including simulcasts and high quality, extended-play audio-only recordings. The VX 5000 is also the first VCR sold in the U.S. to incorporate a special "multi port" socket that accepts a new type of cable converter that allows pay channels to be selected by the unit's remote control just as if they were normal channels. If only the cable companies would offer multi-port-compatible decoders, we'd all be happy. Price: \$2200.

CIRCLE 69 ON FREE INFORMATION CARD



Bang & Olufsen VCR

Radar Detector

An entry-level radar detector from *Maxon Systems Inc.* (8610 NW 107th Terrace, Kansas City, MO 64153), dubbed the *Expressway Series 10*, uses super-heterodyne X- and K-band circuits and can detect instant-on and pulse-type radar. The unit also has anti-falsing circuitry to minimize response to non-police microwave transmissions, which can trigger false alarms. A pulsating, amber alert light indicates how close the radar signal is; flashing becomes more rapid, as does the audio alert signal, as the distance narrows. The Expressway Series 10 also provides a two-position volume adjustment and a city/highway switch to further reduce false alerts in urban areas. Accessories include a spring visor clip, a straight power cord, Velcro-type fastener strips, and a spare fuse. Price: \$100.

CIRCLE 70 ON FREE INFORMATION CARD

Game Boy Scrabble

Hooked on handheld video games, but craving a bit of intellectual stimulation? *Milton Bradley Company* (443 Shaker Road, East Longmeadow, MA 01028) offers *Game Boy Super Scrabble* to meet both needs. The classic crossword game has been adapted for play by gamers ages 8 and up on the popular Game Boy handheld video game. You can compete against a friend or against the computer, which has five different levels and a 40,000 word vocabulary to verify plays. The display screen features the familiar letter rack, score panel, and a time clock. Price: about \$25.

CIRCLE 71 ON FREE INFORMATION CARD



Game Boy Super Scrabble



Build a 1930's Style Radio Transmitter

This single-tube AM transmitter allows you to re-live days long past by letting you broadcast your own program material to any standard AM receiver!

BY JOSEPH C. SMOLSKI

Dust off that old broadcast receiver and re-create the golden age of radio! Experience historic moments from the world of sports like Bobby Thompson's home run! Re-live the Hindenberg disaster, and other newscasts that rocked the world! Thrill to classic radio drama, like "The Shadow," "Jack Armstrong," and "The Lone Ranger!"

Impossible, you say? Not with this easy-to-build AM transmitter. You can put it together in one evening using common hand tools and readily available parts. Teamed with a cassette player, you can re-broadcast taped vintage-radio shows to Grandma's old console. Or, if you prefer, you can hook it up to any other high-level program source and broadcast it to any nearby (new or old) AM receiver.

Right Out of The 1930's. In the years immediately preceding World War II, manufacturers sold accessories—known as "phono oscillators" or "wireless record players"—for playing phonograph records through radio sets. Although those products must have seemed pretty "high-tech" at the time, they were nothing more than simple low-powered AM transmitters.

Most of those low-powered AM transmitters are gone now, but you can build one yourself at a very low cost. The unit, dubbed the *1930's Radio Transmitter*, described in this article is patterned closely after the phono transmitters of yesteryear. Its design makes only two concessions to the passage of time. A modern silicon rectifier is used in the power supply instead of a vacuum tube and a ferrite-core-oscillator coil is used

instead of an air-core coil. Air-core coils were typical of pre-war construction. The rest of the circuit is quite authentic, and it behaves exactly the way its fore-runners did some fifty years ago!

How It Works. Our AM transmitter is built around a single 12SA7 pentagrid converter, which was designed for broadcast-band receivers. Although never intended for transmitter service, it was nonetheless used in some phono oscillators. Introduced prior to World War II along with a host of other octal-based tubes, it quickly became standard in US-built, AC/DC operated radios, and it remained so through the early 1950's. The long-term popularity of that tube type accounts for the fact that it is still available today.

The 12SA7 was typically used in su-

perheterodyne receivers as a frequency converter. In that application, the 12SA7 worked like two separate tubes; a local oscillator and a mixer. Refer to Fig. 1A. The signal from the local oscillator was applied to grid 1, while the incoming RF signal was applied to grid 3 (the signal grid). Within the tube, the RF signal was mixed with the oscillator signal through a process called electron coupling. Electron coupling was accomplished via the electron stream, which is common to all the elements within the tube. The two signals would combine to produce a third signal, which oscillates at the desired IF.

The tube configuration used in the 1930's Radio Transmitter is similar. However, in the transmitter (see Fig. 1B), grid 1 is connected as a Hartley oscillator. The Hartley oscillator was used to generate a carrier. As shown, an audio signal (rather than RF) is applied to grid 3, and impressed on the carrier. That signal was then fed through the plate circuit and radiated into the air via the antenna.

Figure 2 shows a complete schematic diagram of the transmitter. A suitable signal is applied to the circuit via the AF IN terminals, and applied to grid 3 at pin 8 of V1. A Hartley oscillator, consisting of L1, C2, C3, C4, and R1, provides the carrier signal. The audio is impressed on the carrier and that combination is fed to the antenna via C1.

Power for the circuit is provided by T1, D1, and C8. Transformer T1 is a dual-secondary unit. One secondary winding of the transformer feeds a line-level voltage to a conventional half-wave rectifier, consisting of D1, the output of which is filtered by C8. The other winding of T1 provides 12.6 volts for V1's filament or heater.

Construction. Construction of the 1930's Radio Transmitter is a snap. Unlike most modern projects, it has no metal chassis, nor does it require a printed-circuit board. That means that there are no metal parts to drill, and you can forget about foil patterns and messy chemicals. The whole assembly is built on a piece of pineboard. That type of construction was used by radio manufacturers and experimenters alike during the 1920's. In fact, that type of construction continued to be used by experimenters long after it was replaced by metal in commercial products.

The first step in putting your transmitter together is cutting a 6½-inch length

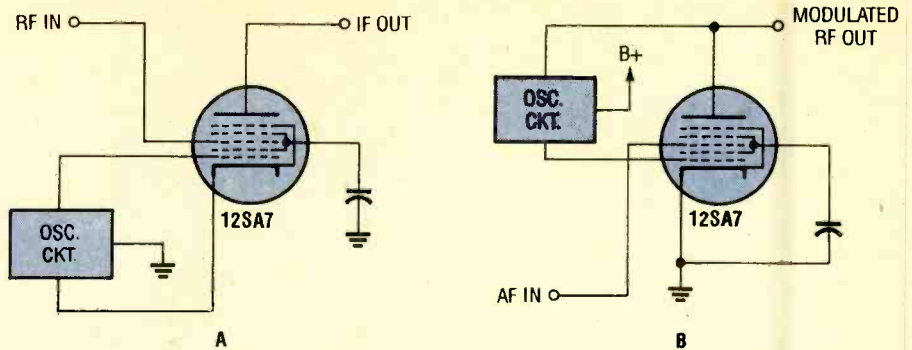

Fig. 1. The 12SA7, typically used in superheterodyne receivers, was configured as a frequency converter as shown in A. When used in a radio transmitter, however, the 12SA7 was configured as shown in B.

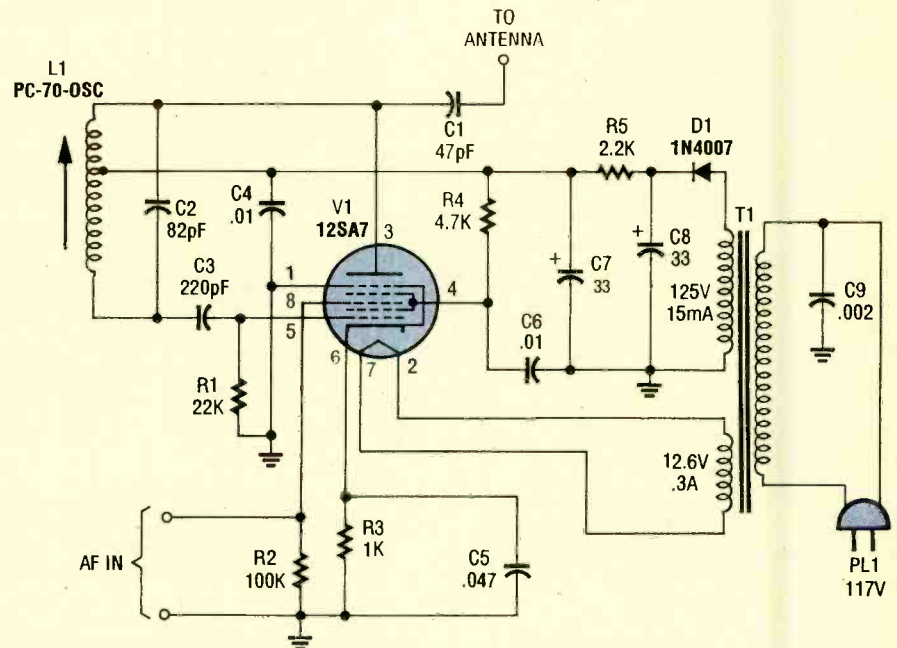

Fig. 2. Here's a complete schematic diagram of the transmitter. In that circuit, an audio signal is applied to grid 3 at pin 8 of V1 via the AF IN terminals, and is mixed with the output of a Hartley oscillator.

of 1- x 4-inch pinewood. The base board should then be sanded and coated with a wood finishing product like Minwax Puritan Pine, or a clear finish like polyurethane, before proceeding. Allow the finish to dry, and then move on to the electronics construction phase of the transmitter.

Before you begin wiring the transmitter, a word of caution is in order: Keep in mind that this circuit not only operates at much higher voltages than do solid-state circuits, but that it's also AC line powered. That means you *must* exercise care in its construction and caution during its operation. When operating the transmitter, it is especially important that no one comes in electrical contact with either side of the transformer primary. To that end, **be sure to sleeve the leads of C9, and cover any other conducting surface.**

In addition, the transmitter's plate-supply voltage can easily reach 160 volts or more. **So don't let your body touch the B+ supply and circuit ground at the same time.** If you are worried about shocks, you can house the entire transmitter inside some kind of protective enclosure. That's a particularly good idea if you have small children lurking about. Now back to our project.

Refer to Fig. 3 as a general layout diagram. Drill mounting holes in the baseboard. Since the circuit components will be connected to solder lugs held in place by sheet-metal screws, the holes should be drilled with a bit that is smaller than the hardware and should not go all the way through the base board. In essence, what you need are pilot holes. Drill two mounting holes for T1 at one end of the baseboard. Go

PARTS LIST FOR THE RADIO TRANSMITTER

RESISTORS

(All resistors are 1/2-watt, 5% units.)

- R1—22,000-ohm
- R2—100,000-ohm
- R3—1000-ohm
- R4—4700-ohm
- R5—2200-ohm

CAPACITORS

(All capacitors are 200-WVDC units, unless otherwise noted.)

- C1—47-pF, ceramic-disc
- C2—82-pF, ceramic-disc
- C3—220-pF, ceramic-disc
- C4, C6—.01- μ F, polyester film
- C5—.047- μ F, polyester film
- C7, C8—33- μ F, 250-WVDC, axial-lead electrolytic
- C9—.002- μ F, 1000-WVDC, ceramic disc

ADDITIONAL PARTS AND MATERIALS

- V1—12SA7-GT, vacuum tube
 - D1—1N4007 or similar 1-amp, 1000-PIV silicon rectifier diode
 - T1—Dual secondary (125 @ 15 mA/12.6V @ 0.3A) power transformer
 - L1—PC-70-OSC universal replacement BC-oscillator coil (Antique Electronic Supply)
- Wooden baseboard, 1/2-inch wooden spacer, #6 \times 3/8 inch pan-head sheet metal screws (10), #6 \times 1/4-inch pan-head sheet metal screws, #6 \times 1 1/2-inch, round-head wood screws, #6 ground lugs (8), Fahnestock clips (3), cable clamp (1), wire nuts (2), 8-inch bus wire, AC molded power plug with line cord, wire, solder, hardware, etc.

Note: A complete kit of parts (stock #K-488) for this project is available for \$19.95 + \$3.50 S&H from Antique Electronic Supply (6221 S. Maple Ave., Tempe, AZ 85283; Tel. 602-820-5411). AZ residents must add sales tax. Contact them directly for individual parts availability, cost, etc.

to the other end of the baseboard and drill four more holes; one for the antenna connection, two for the audio input (labeled ANT and AF IN, respectively in Fig. 3), and another for the terminating point of the ground bus.

With the board oriented as shown in Fig. 3 (with the antenna/AF inputs to the left), drill three holes in a triangular configuration in the area (near the top edge) where D1 is shown connected to solder lugs. Then go to the bottom edge of the baseboard, and drill another hole opposite the three solder-lug holes. Next return to the top of edge of the board and drill a 3/32-inch hole to a depth of about 1/4 inch (to the left of

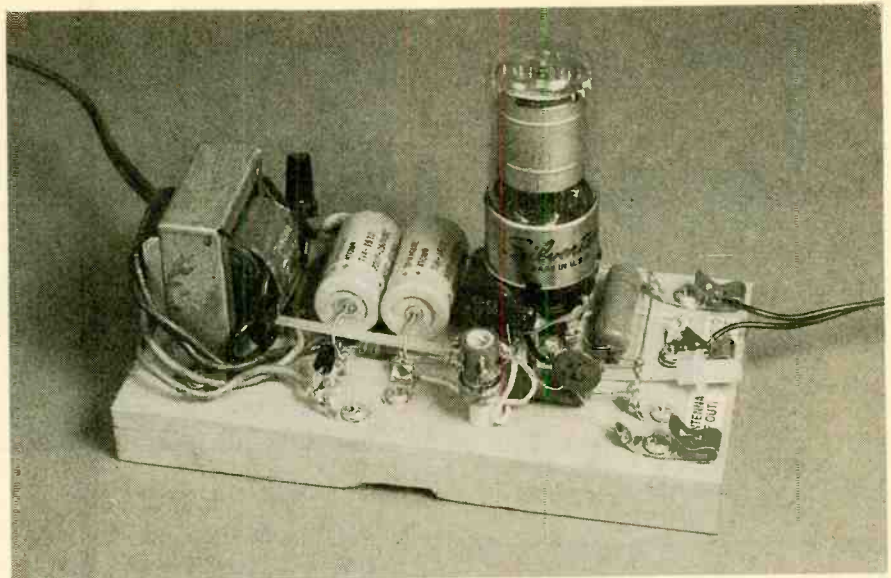

The Radio Transmitter, with its baseboard-mounted components, which is representative of the construction technique used during the 1920's, is patterned closely after the phono transmitters of yesteryear.

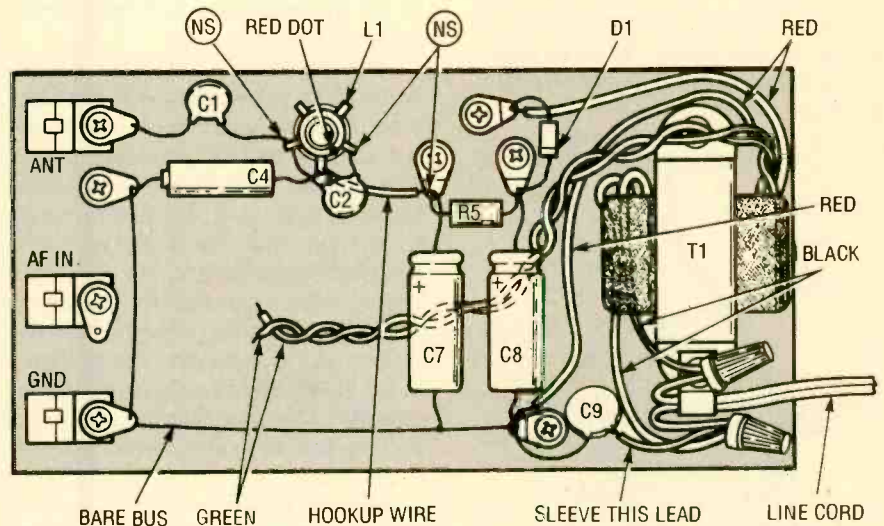

Fig. 3. This general layout diagram shows where many of the circuit components will be located. When wiring the circuit, the points labeled NS should not be soldered at this time as other components will be connected to those points later.

the three solder-lug holes) where L1 is located.

Once the drilling is complete, you can start mounting components, beginning with the #6 solder lugs and Fahnestock clips (which are spring-loaded wire clips). The Fahnestock clips are used for the audio-input, antenna-out, and ground connections. Secure the clips and solder lugs directly to the surface of the board with #6 \times 3/8-inch, pan-head sheet-metal screws. Next connect a bare bus wire as shown in Fig. 3. That wire will serve as a grounding point for the circuit components.

Now begin assembling the circuit guided by Fig. 2 and Fig. 3. Take your time and position each component as

shown in Fig. 3. It will make the final assembly much easier if you do. When the time comes to mount coil L1, carefully remove the metal clip from the coil form and insert that end of the form into the 3/32-inch hole that you drilled in the baseboard. Then connect and solder all of the parts shown in Fig. 3, except those marked "NS." Those are to be connected but *not soldered* until later. It is important to hold off on soldering those joints because you will be hooking more wires to those points in the next step of the assembly process.

Before you do any more wiring, get the board ready to accept the tube socket. Refer to Fig. 4. First cut a 5/8-inch diameter hardwood dowel to a length

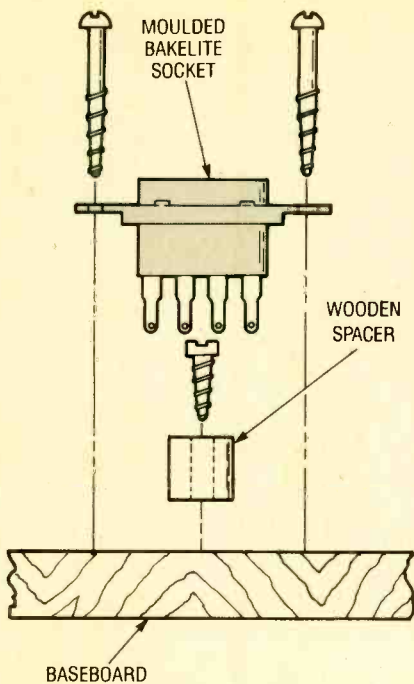

Fig. 4. Once the wiring outlined in Fig. 3 is complete, prepare the baseboard to accept the tube socket. The socket rests atop a 1/2-inch length of 3/8-inch diameter hardwood dowel.

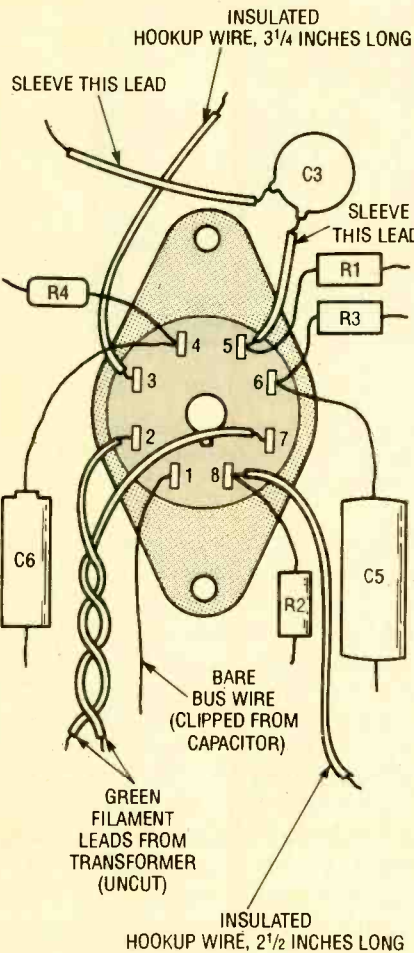

Fig. 5. Before mounting the tube socket on the board, wire C3, C5, C6, R1-R4, and the three connecting wires to the socket.

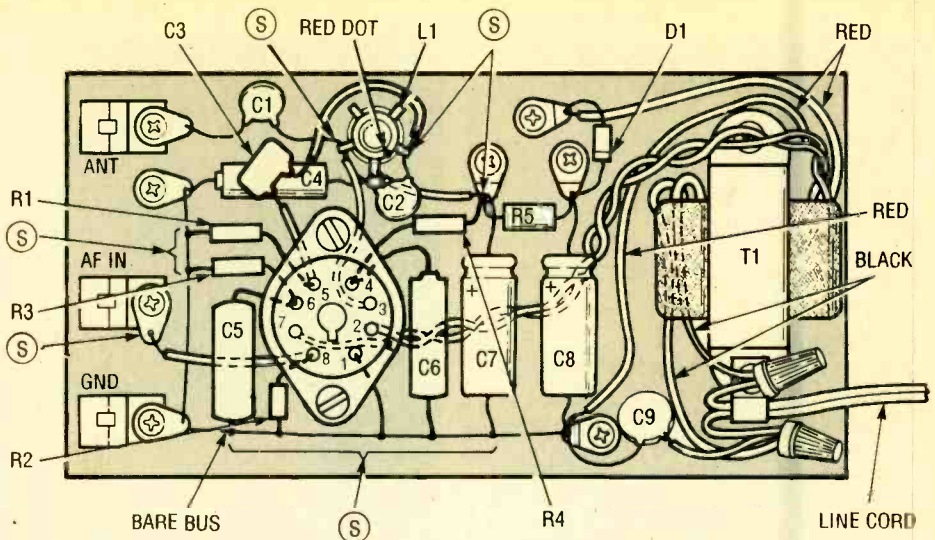

Fig. 6. Mount the tube socket, using two 1 1/2-inch, #6 round-head wood screws. After that, make all of the connections shown here to complete the transmitter.

of about 1/2-inch, and drill a hole straight through its center, large enough to pass a #6 sheet-metal screw. It is important to cut the ends square. It helps if you have a miter box.

The wooden dowel acts like a pedestal, and provides the necessary clearance between the socket terminals and the surface of the baseboard. The socket should be a molded bakelite type and not the phenolic wafer type. Screw the dowel section to the baseboard using a #6 x 3/4-inch sheet-metal screw. Rest the socket on top of the spacer with the keyway pointed in the same direction as shown in Fig. 5. Place two marks on the board directly under the holes in the metal saddle that surrounds the socket. Use those marks to locate two 3/32-inch pilot holes in the baseboard. When the time comes to mount the socket, two long screws in those holes will hold the socket securely on top of the wooden spacer.

Wiring the Tube Socket. It is much easier to wire the tube socket before it is mounted on the board than it is to do so afterward. For that reason, we'll now focus our attention on accomplishing that task. Begin by turning the socket upside down, so that its solder lugs are facing upward, and connect all of the leads shown in Fig. 5. Be sure the keyway is pointed in the direction shown, so that the parts that are to be connected to the socket subassembly line up properly with the parts on the baseboard.

Take your time, paying particular attention to lead length and position, especially if the components used to build the transmitter differ slightly in size

or shape from those pictured. Be absolutely sure that everything is hooked up to the right terminals. Connect and solder the filament leads from the power transformer last. Make certain that all of the connections on the tube socket are securely soldered before proceeding.

Final Assembly. If you have followed all of the instructions in sequence, you have already drilled the holes necessary to mount the tube socket and associated parts. Mount the tube socket (as shown in Fig. 6), using two 1 1/2-inch, #6 round-head wood screws. After you have mounted the sub-assembly, make all of the remaining connections (refer to Fig. 6). That will complete your transmitter. Check all of your wiring carefully before going on.

Testing Your Transmitter. First, plug the 12SA7 into its socket and connect a modulating source (AF voltage) to the AF IN terminals. You should be able to modulate the carrier with almost any high-level-audio source. The earphone output jack of a cassette tape player or the speaker terminals of almost any radio or record player should do just fine. If you have an audio oscillator, that is even better. When tuning in the transmitter for the first time, it's easier to pick out a continuous tone than it is to identify music or speech.

After hooking up whatever audio source is available, apply power to the circuit. After a brief warm-up period, adjust the transmitter. Tune an AM receiver to a quiet spot on the dial, somewhere between 1100 and 1600 kHz. Place the transmitter near the receiver's loop antenna. If it has no loop antenna,

(Continued on page 91)

The Super Simple Music Circuit

This music-synthesizing circuit is so small that it can easily be incorporated into your new electronics project or added to an existing one.

BY
MIKE GIAMPORTONE

Music is the art of sound. It is poetry in the Greek meaning. Most of us have, at one time or another, had the desire to add music to the electronic devices that we build or own... be it something as simple as a doorbell or something as complex as a radio-controlled mailbox alarm. The problem with pursuing such an undertaking lies in the design and implementation of such a circuit. However, the *Super Simple Music Circuit* (hereafter referred to as SSMC) described in this article can take the hassle out of adding a musical annunciator to an existing circuit or one that's still on the drawing board.

The SSMC is built around an LS3404 series melody chip. The LS3404-series melody chips are 8-pin, ion-implanted, monolithic, MOS chips, that require just a few external components. Those external components allow you to easily change the tempo, duration, and pitch of the tune played. The output of the LS3404 can directly drive a piezo-electric transducer, or the output can be fed to a single-transistor amplifier to drive a conventional speaker.

The chips in the series contain 31

popular melodies (see Table 1 for the available melodies), which are specified by a parts-number suffix. For example, the unit that plays Jingle Bells has the suffix 18, making its actual part number LS3404-18.

How it Works. Two circuits based on the LS3404 are shown in Fig. 1. The circuit in Fig. 1A is designed to drive a conventional 8-ohm speaker, while the one in Fig. 1B is configured to drive a piezo-electric transducer. Other than that, the operation of each circuit is the same.

With the momentary closing of S1, a short positive current passes through C5, applying a high to pin 8 (the power-on-reset, or POR, terminal) of U1, starting play. Briefly pressing S2, which momentarily interrupts power to the circuit, and causes the circuit to reset, playing the tune again from the beginning. The tune continues to play until interrupted again by S2 or until the entire tune is completed.

Resistor R1 and capacitor C1 (which are tied to pin 3) comprise an RC circuit that controls the duration and volume of the output tune. Another RC network,

comprised of R2 and C2 and connected to pin 4, governs the duration of U1's internal clock oscillator, which controls the tempo. The duration clock, along with U1's internal counter, determines the duration of each note. A third RC network (consisting of R3 and C3), attached to pin 5, controls the pitch or audio-frequency output of U1.

If the SSMC is to drive a conventional speaker, the circuit should be wired as shown in Fig. 1A, where the pin 1 output of U1 is fed to a 2N2222 (a general-purpose NPN transistor), which amplifies the output signal enough to drive an 8-ohm speaker. The value of resistor R5 determines the volume of the speaker output; decreasing its value increases volume, and vice-versa.

To configure the SSMC to drive a piezo-electric transducer, wire the circuit as shown in Fig. 1B, where pins 1 and 2 of U1 (the chip's push-pull outputs) feed a piezo-electric speaker; note that the transistor used to drive the speaker in the previous circuit has been eliminated.

Since S1, R4, and C5 are used only to restart the melody during or after the finish of the tune, those components

TABLE 1—MELODIES

Version	Song
3404-02	Christmas Medley
3404-03	"Somewhere My Love"
3404-04	"As Time Goes By"
3404-05	"Let Me Call You Sweetheart"
3404-08	"I'm In The Mood For Love"
3404-09	"Wedding March"
3404-10	"Happy Birthday I"
3404-11	"Zip-A-Dee-Doo-Dah"
3404-12	"Brahm's Lullabye"
3404-14	"Santa Claus Is Coming To Town"
3404-15	Christmas Angel Medley
3404-16	"We Wish You A Merry Christmas"
3404-17	"Walking In A Winter Wonderland"
3404-18	"Jingle Bells"
3404-19	"Joy To The World"
3404-20	"Love Makes The World Go Round"
3404-21	"My Favorite Things"
3404-22	"What The World Needs Now"
3404-23	"I'd Do Anything"
3404-24	"Hail To The Chief"
3404-25	"Thanks For The Memories"
3404-26	"Gonna Fly Now" (Rocky)
3404-27	"Lazy Crazy Hazy Days of Summer"
3404-28	"For He's A Jolly Good Fellow"
3404-29	"Pomp & Circumstance"
3404-30	"More"
3404-31	"Ain't She Sweet"
3404-32	"You Are The Sunshine Of My Life"
3404-33	Nursery Rhyme Medley
3404-34	"Happy Birthday II"
3404-35	Brahms/Mozart Lullabye Medley

can be eliminated from either version of the SSMC, if desired, without effecting the operation of the circuit. If the circuit is to be used in a prompt-specific application—such as doorbells, musical clocks, etc.—those components should be included in the circuit.

The SSMC draws less than 20 μ A at rest, 2.5 mA when driving a piezo transducer, and 50 mA when driving a speaker using the specified parts values. A 9-volt battery can power the SSMC for hours of uninterrupted music before needing a replacement; in standby, a 9-volt battery can power the circuit for months without need for replacement.

Assembly. Just about any construction technique is acceptable since the circuit is very forgiving and simple. It's recommended, however, that the circuit be assembled on a printed-circuit board to keep size to a minimum. Figure 2 shows a template of the full-scale foil pattern (which isn't much larger than a quarter) used by the author. Either version of the SSMC can be assembled on the same printed-circuit board.

Figure 3 shows the parts-placement diagram for both versions: the diagram

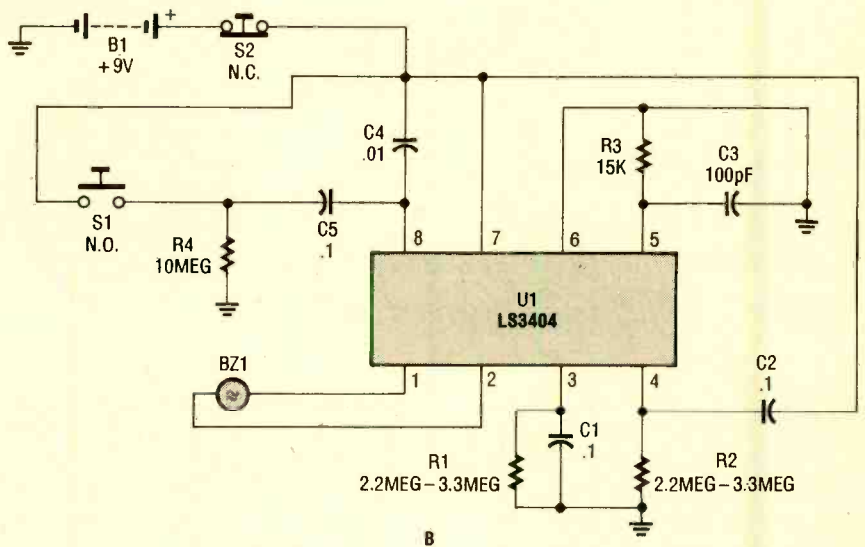
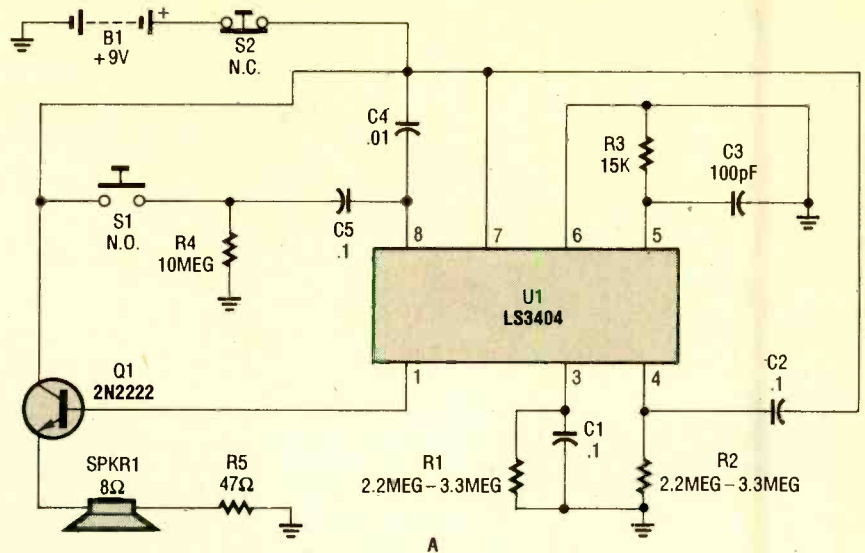

Fig. 1. The circuit in A is designed to drive a conventional 8-ohm speaker, while the one in B is configured to drive a piezo-electric transducer. Other than that, the operation of each circuit is the same.

in Fig. 3A being the speaker version and the one in Fig. 3B, the transducer version. Assemble your unit using the appropriate parts-placement guide. Assembly of the circuit can be easily accomplished in one evening.

Looking at Fig. 3A, notice that the ori-

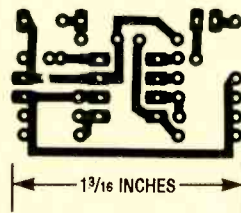

Fig. 2. This full-scale template of the SSMC's printed-circuit foil pattern isn't much larger than a quarter. Either version of the SSMC can be assembled using the same printed-circuit board.

entation of U1 and Q1 are the most critical part of assembling the speaker version. Begin construction by installing an 8-pin DIP socket at the U1 position; then install Q1 with the proper orientation. Insert U1 in its socket only after mounting all other components.

The piezo version of the circuit (see Fig. 3B) is the easiest to build, and contains the least number of support components. The cost for an entire piezo project could be as little as \$4! Once the circuit is completely assembled, check your work for construction errors, such as cold solder joints (characterized by the solder taking on a frosty look), solder bridges (and other shorts), misoriented components, etc.

Once you are satisfied that there are no construction-related problems, in-

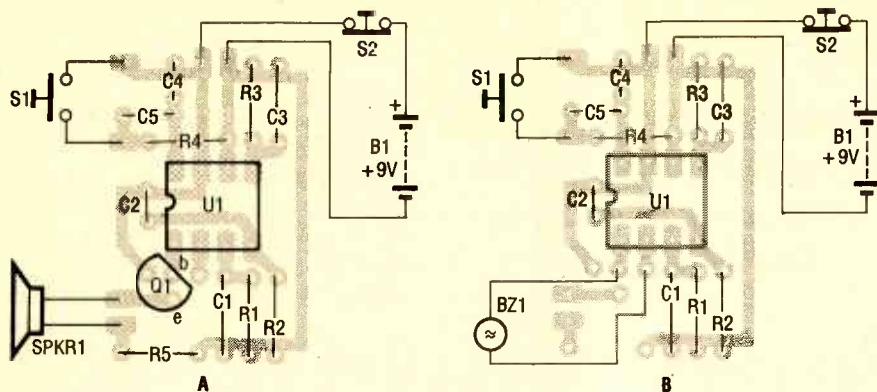

Fig. 3. The parts-placement diagram for the speaker version of the SSMC is shown in A, while B shows the transducer version. Assemble your unit using the appropriate parts-placement guide.

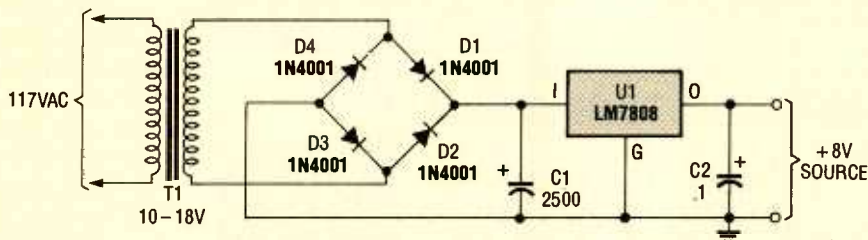

Fig. 4. As an alternative, the SSMC can be powered from a conventional power-supply circuit like the one shown here, or from a plug-in DC power pack. If you already have a power pack of a higher voltage rating or can only find one of a higher rating, its output can be fed to the filter/regulator portion of this circuit to provide the required power level.

stall the IC in its socket, and connect a 9-volt transistor-radio battery to the circuit. The circuit should begin to play a melody within seconds of applying power. If that does not occur, remove power and recheck your work. Start by examining the power source leads. Check to see that U1 is fully seated in its socket with the proper orientation.

If the circuit does play a melody as expected, check the operation of the reset circuit by closing S1. If the circuit does not reset, check the voltage at the C5/R4 junction. When S1 is pressed, the C5/R4 junction should initially be low (since C5 at first acts like a short, applying a short positive pulse to pin 8 of U1) and then gradually go high as C5 begins to charge. Once S1 is released, C5 should begin to discharge through R4. It may be necessary to experiment with the values of C5 and/or R4 to achieve the proper reset triggering.

Attuned to Your Liking. Modifying the circuit (and by extension, the pitch, tempo, and/or volume) to make the melody produced by the circuit more to your liking is a simple matter of changing either or both component values in any of the RC networks. Decreasing the value of R1 or increasing the value of C1, will slightly decrease

volume and speed up the tempo of the tune. Reducing the value R2 or C2, increases the tempo. Reducing the value of R3 lowers the pitch.

As stated earlier, decreasing R5's value increases the output volume of the circuit. Replacing R5 with a jumper wire provides the maximum output volume, but that also causes quite a drain on the battery, and causes distortion as the battery is worn down. One way to avoid that situation is to use a plug-in DC power pack or other power supply in place of the battery.

A suitable power-supply circuit is shown in Fig. 4. That power supply is a conventional circuit, consisting of a step-down power transformer, a full-wave bridge rectifier (D1-D4), a 1-amp fixed-voltage regulator, and a couple of capacitors for filtering the output voltage.

Note that although the author chose to use an LM7808, 8-volt regulator in his power-supply circuit, 9-volt units—such as Panasonic's AN7809 (available from Digi-Key)—or variable regulators (such as the LM317) can be used in that circuit to provide a 9-volt power source. Also, the four diodes that form the bridge rectifier can be replaced by a packaged bridge.

Whatever type of power supply you

PARTS LIST FOR THE SUPER-SIMPLE MUSIC CIRCUIT

RESISTORS

(All fixed resistors are 1/4-watt, 5% units.)
 R1, R2—2.2- to 3.3-megohm (see text)
 R3—15,000-ohm
 R4—10-megohm
 R5—47-ohm

CAPACITORS

C1, C2, C5—0.1- μ F, monolithic or ceramic-disc
 C3—100-pF, ceramic-disc
 C4—0.01- μ F, ceramic-disc

ADDITIONAL PARTS AND MATERIALS

U1—LS3404 melody synthesizer, integrated circuit
 Q1—2N2222 general-purpose NPN silicon transistor
 SPKR1—8-ohm, 100-mW speaker (optional, see text)
 B1—9-volt transistor-radio battery (optional, see text)
 BZ1—Piezo transducer (optional, see text)
 S1—Normally-open pushbutton switch (see text)
 S2—Normally-closed switch (see text)
 Printed-circuit board materials, enclosure, DIP socket, optional DC power pack or power supply (see text), battery connector (optional), wire, solder, hardware, etc.

Note: The following items are available from Thumb Electronics, PO Box 344, Marysville, MI 48040; LS3404 for \$2.00 each, plus \$1.50 shipping and handling for each order of up to 6 chips; six melody chip assortment for \$11 (shipping included). Iron-On resist patterns are available, 2 for \$1.00 with any order. Michigan residents, please add sales tax. For technical assistance, send a self-addressed-stamped-envelope to the above address.

use, make sure that the capacitors have a voltage rating of at least 2 to 2½ times the power supply's output voltage. For instance, if the output voltage of the supply is 9 volts, the filter capacitor should be rated for 22.5 volts or better. The closest standard electrolytic value is 25 volts. That same value should also be applied to the other capacitors in the project.

Applications. Uses for the circuit vary as much as the imagination: Some of the more obvious applications of the circuit include its use as a doorbell annunciator, in music boxes, or in a greet-

(Continued on page 91)

According to my dictionary, "scrimmage" means "a confused struggle." It seems to me that's also how you might describe getting decent screen dumps from an IBM compatible to your printer!

If you want to reproduce PC-compatible screens on your dot-matrix or laser printer for reports, presentations, articles, books, sales brochures, or whatever, you need to have some knowledge of the screen-dumping process and a good screen-dump program. This article will describe some of the fundamentals, and a few powerful programs, that will allow you to perform dumps with a minimum of confusion and effort.

Terminology. It seems like every time I start to write about a microcomputer topic, I have to stop and define some of the commonly used but frequently misunderstood words.

It's bad enough that many good "computerists" use regular words in odd ways, but they also tend to invent new words. For example, the other day I was reading an article that kept mentioning "parms." Huh? I finally figured out that the writer meant "parameters."

So, to make myself understood, let me give you a few of my definitions for some common terms. When I say "screen," or "display," I mean the image you see on your monitor (not the hardware). I'll identify monitors as either "monochrome" (usually white, green, or amber, with black used as a background or foreground) or "color" (anything with 3 or more colors.) I won't even get into the many different kinds of monitors. That topic would require another whole article!

I'll call a reproduction of the display on paper a "screen dump." If a screen dump shows only "alphanumeric characters" (english letters, numbers, and punctuation), I'll call it a "text

We present some helpful techniques and a few pieces of software that transform your monitor's graphics into printed images.

Screen Dump

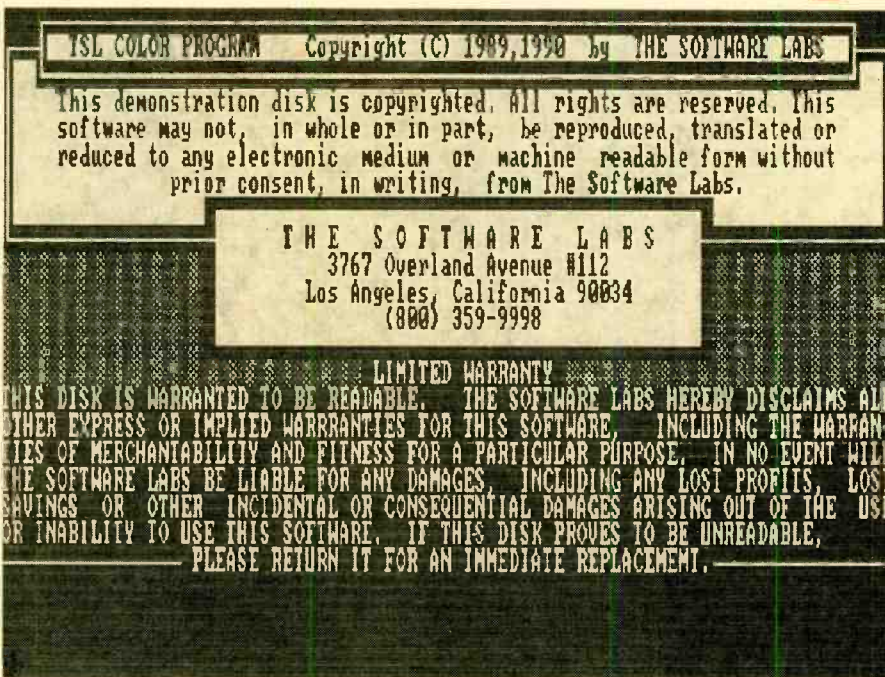

Scrimmage

BY FRED BLECHMAN

dump." If special characters that make up IBM's extended character set (such as symbols, borderlines, blocks, etc.) are to be dumped, I'll call the dump a "graphical-text dump." Keep in mind that such dumps can contain alphanumeric as well. If "graphics"—images that are plotted or "drawn" on the screen such as lines, circles, arcs, dots, special fonts—are to be sent to the printer, then we'll say you need a "graphics dump."

DOS Screen Dumps. It's relatively easy to send text dumps to just about any printer from an IBM PC compatible. Text files have an "extension" (the three characters after the dot in a filename) of TXT, DOC, or ASC. BASIC programs saved in ASCII with the SAVE"fil-

ename.ex", A command are also pure text files.

One method of dumping text files is particularly good to use while you're in DOS (and only in DOS) with your printer on and ready: You start by holding down the CTRL key and pressing the P key. The <CTRL-P> key combination puts your printer in "echo" mode. The ASCII code of anything that appears on your screen after you do that will be sent to the printer. Pressing those two keys again will turn off printer-echo mode.

The <CTRL-P> key combination is very useful when you want to both view and print text files at the same time. Any black characters on a bright background (called "reverse-video" characters) will be sent to the printer as normal characters.

Unfortunately, there are many printers that don't interpret all ASCII codes the same as a PC. Text characters are usually not a problem. However, to print graphic characters you'll need an IBM PC-

compatible printer (we'll examine why in a little while).

To see the content of a file before you attempt a dump you can use the DOS "TYPE" command. If it contains graphic characters you'll hear beeps and get garbage on your screen. Pure alphanumeric files will appear as normal text. Some word-processing files may also be readable, even if they contain some graphical characters.

Files that appear as pure alphanumeric on the screen, can be dumped to the printer by first using the <CTRL-P> key combination, then using the TYPE command, and following up with another <CTRL-P> once the entire file has scrolled by on your screen. (Just to let you know, <CTRL-PRTS> does the same thing as <CTRL-P>.)

Run-Time Screen Dumps. But sup-

```
ZDDDDDDDDDDDDDDDDDDDDDDDDDDDDDDDDDDDDDDDDDDDDDDDDDDDDDDDDDDDDDDDDDD>
ZDD4 TSL COLOR PROGRAM Copyright (C) 1989,1990 by THE SOFTWARE LABS CDD?
3 @DDDDDDDDDDDDDDDDDDDDDDDDDDDDDDDDDDDDDDDDDDDDDDDDDDDDDDDDDDDDDDDDDD 3
3 This demonstration disk is copyrighted. All rights are reserved. This 3
3 software may not, in whole or in part, be reproduced, translated or 3
3 reduced to any electronic medium or machine readable form without 3
3 prior consent, in writing, from The Software Labs. 3
3
3   | | | | | | | | | | | | | | | | | | | | | | | | | | | | | | | | | | | | | | | |
3 @DDDDDDDDDDDDDDDDDD T H E S O F T W A R E L A B S DDDDDDDDDDDDDDDDDDD
3 000000000000000000 3767 Overland Avenue #112 0000000000000000
3 000000000000000000 Los Angeles, California 90034 0000000000000000
3 000000000000000000 (800) 359-9998 0000000000000000
3 000000000000000000 00000000000000000000
3 00000000000000000000000000000000000000000000000000000000000000000000
3 THIS DISK IS WARRANTED TO BE READABLE. THE SOFTWARE LABS HEREBY DISCLAIMS ALL
3 OTHER EXPRESS OR IMPLIED WARRANTIES FOR THIS SOFTWARE. INCLUDING THE WARRANT-
3 TIES OF MERCHANTABILITY AND FITNESS FOR A PARTICULAR PURPOSE. IN NO EVENT WILL
3 THE SOFTWARE LABS BE LIABLE FOR ANY DAMAGES, INCLUDING ANY LOST PROFITS, LOST
3 SAVINGS OR OTHER INCIDENTAL OR CONSEQUENTIAL DAMAGES ARISING OUT OF THE USE
3 OR INABILITY TO USE THIS SOFTWARE. IF THIS DISK PROVES TO BE UNREADABLE,
3 DDDDDDDDDDDDDDDDD PLEASE RETURN IT FOR AN IMMEDIATE REPLACEMENT.DDDDDDDDDDDDDDD
```

Fig. 1. Simple print-screen style dumps of screens containing graphical characters do not come out properly on non-IBM compatible printers.

pose you're not in DOS but in the middle of a program and wanted to capture the screen image on paper. Most programs don't scroll information on the screen; instead it suddenly appears. For <CTRL-P> to work, the information must scroll onto the screen. Besides, most programs keep the printer-echo mode from working anyway.

As long as only alphanumeric are on the screen, you can press SHIFT and the PRTSC key. (Note: Some keyboards have a key labelled PRINT SCREEN instead; those keys seldom require shifting.) Whatever is on your monitor *at that moment* will be sent to your printer. Don't hold the keys down or you'll get multiple dumps.

To get a feel for the limitations of screen dumps, compare Figs. 1 and 2 with the image that appears (in a clearer form) at the beginning of this article. Figure 1 is a <SHIFT-PRTSC> style dump to a non-IBM-compatible dot-matrix printer. That printer, like many printers that have been around for three or more years, does not have the IBM graphical characters in its character generator. Therefore, graphical characters reproduce as whatever the printer does have in its character generator for those codes.

Figure 2 is an improvement, since the printer used (an Epson LX-810), like most modern printers, has the graphical characters in its character generator.

GRAPHICS.EXE. Up to now, our screen dumps have been limited to alphanumeric and graphic characters. That's fine for most applications, but you'll also need to get screen dumps of displays with graphical images (plots, line drawings, etc.—especially when multiple colors are used). Unfortunately, the IBM PC requires a program for such dumps.

Your DOS disk probably has a file

called GRAPHICS.EXE or GRAPHICS.COM. It is designed to provide screen dumps of CGA graphics. It's a memory-resident program and after it is loaded in, it is automatically activated with the <SHIFT-PRTSC> key combination.

Unfortunately, GRAPHICS will only work properly with IBM printers and close compatibles. Other printers may generate unwanted linefeeds or other anomalies. It also requires the presence of a color-graphics adapter board. If you want to dump displays from a monochrome system, GRAPHICS won't work.

If you have a color display card that will run CGA, and an IBM-compatible printer, GRAPHICS will be of some use to you. For the rest of you, hang in there—the good news is coming up!

GRAFPLUS. Several years ago, after hunting around for a graphics screen-dump program for the IBM PC—amazed that they weren't more common—I felt very frustrated that I couldn't get graphic screen dumps for my magazine articles and program documentation. Then I spotted a small classified

ad for GRAFPLUS and I bought the program in desperation. Despite its effectiveness, this "jewel" of a program, from Jewell Technologies (4740 44th Ave. S.W., Suite 203, Seattle, WA 98116; Tel. 1-206-937-1081), is almost unknown, since they don't advertise much. The latest version is 5.0. It sells for \$49.95 plus \$3 shipping (WA residents add local sales tax.) Specify 5.25-inch or 3.5-inch disk.

GRAFPLUS works with most close PC-compatibles and all of the common (and some uncommon) graphic cards and printers. In addition, support for new cards and printers is added in program updates. It even includes a program (EDITGRAF) so you can quickly and easily support other printers. You can also use EDITGRAF to change the scale of your printouts.

The clearly printed 62-page User's Manual is spiral-bound for ease of use. It is well written, easily understood by novices for typical use, and includes more detailed information for programmers who want to integrate graphic-screen dump capability into their programs. (Take a look at the sidebar entitled "Screen Dump Interrupts" for some information on that topic.)

The setup procedure of GRAFPLUS is menu driven, making it easy to install. Once you are familiar with the menu options, you can operate the program from the DOS command line instead of resorting to the menus. For example, from the DOS prompt, I simply type:

```
GRAFPLUS = #3
```

for dumping IBM PC screens to my Epson LX-810 printer. If you wish to put GRAFPLUS in memory on boot-up, you just have to add such a command line to your AUTOEXEC.BAT file.

Once in memory, the program stays out of the way waiting for the <SHIFT-

```
TSL COLOR PROGRAM Copyright (C) 1989,1990 by THE SOFTWARE LABS
This demonstration disk is copyrighted. All rights are reserved. This
software may not, in whole or in part, be reproduced, translated or
reduced to any electronic medium or machine readable form without
prior consent, in writing, from The Software Labs.
THE SOFTWARE LABS
3767 Overland Avenue #112
Los Angeles, California 90034
(800) 359-9998
LIMITED WARRANTY
THIS DISK IS WARRANTED TO BE READABLE. THE SOFTWARE LABS HEREBY DISCLAIMS ALL
OTHER EXPRESS OR IMPLIED WARRANTIES FOR THIS SOFTWARE. INCLUDING THE WARRANT-
TIES OF MERCHANTABILITY AND FITNESS FOR A PARTICULAR PURPOSE. IN NO EVENT WILL
THE SOFTWARE LABS BE LIABLE FOR ANY DAMAGES, INCLUDING ANY LOST PROFITS, LOST
SAVINGS OR OTHER INCIDENTAL OR CONSEQUENTIAL DAMAGES ARISING OUT OF THE USE
OR INABILITY TO USE THIS SOFTWARE. IF THIS DISK PROVES TO BE UNREADABLE,
PLEASE RETURN IT FOR AN IMMEDIATE REPLACEMENT.
```

Fig. 2. This print-screen style dump to an IBM-compatible printer worked well. However, the color backgrounds were removed which takes away from the graphical flare of the screen.

SCREEN DRUMP INTERRUPTS

Those who are more technically inclined may want to know exactly what happens inside the IBM PC when you press the <SHIFT-PRTS> key combination, especially when a screen-dump program is resident. The following explanation was provided by Warren C.R. Jewell, President of Jewell Technologies, and author of GRAFPLUS:

The 8088 microprocessor (CPU) used in the IBM PC has the capability to address one megabyte of memory. The first 640K is used as system memory, addressed in hexadecimal as 00000 to 9FFFF.

The first 1K of this is used for an "interrupt table" with 256 entries of four bytes each. The next 512 bytes are used by the BIOS and BASIC. DOS is loaded next, along with the CONFIG.SYS device drivers, system buffers, and so forth. Finally, COMMAND.COM is loaded and then the AUTO-EXEC.BAT (if it exists.) The computer then waits for operator input.

The memory above COMMAND.COM is available to the system as free memory (as reported if you run CHKDSK.) When you type a program name, for our example let's use GRAFPLUS, COMMAND.COM copies the contents of that file from disk into memory at a location beginning above the resident portion of DOS. The operating system then finds the start of the program just loaded and passes control to it.

At this point GRAFPLUS installs its various options, either through its menu and user inputs, or directly from its command line. It then terminates and stays resident, unlike most non-resident application programs. That is accomplished through DOS, which provides routines that allow a pro-

gram to "latch on" to the end of the resident portion of DOS. The free memory is then set past the end of the newly resident routine. Subsequent programs see the last resident program as part of DOS. That prevents subsequent programs from overwriting any that are already resident.

DOS provides two ways of terminating while staying resident (TSR), either by INT 27H or function call 31H. Function 31H is the preferred method, and that method also allows you to reserve more than 64K if you need to.

The 8088 CPU interrupt table uses two kinds of interrupts: hardware and software. In either case, an interrupt "vector" is supplied. Software interrupts supply the vector as part of the INT instruction, while hardware interrupts have the vector supplied by the Intel interrupt controller.

The vector is an 8 bit value (a byte) that is used by the CPU as an index into the "interrupt table." Upon receiving an interrupt instruction, the current instruction-pointer (IP) and code-segment (CS) registers, as well as the state of the CPU condition flags, are saved on the stack. The four bytes out of the table that correspond to the interrupt vector (from 00000 to 003FF) are fetched and used as the new IP and CS. The code activated by the interrupt is then executed, and when it has finished processing, an interrupt return instruction (IRET) is executed, restoring the IP, CS, and condition flags.

Interrupt 5 (INT 5) is the standard print-screen interrupt on PC-compatible computers. That means that when the <SHIFT-PRTS> key combination is pressed, the keyboard-handling code executes an INT

5 instruction. This causes the current CS, IP, and flags to be saved, and the vector at 00020 to be loaded as the new CS and IP.

In order to use this routine, which now has been left in memory, some provision must be made for the user to transfer control to it. In the case of GRAFPLUS, before it terminates it resets the INT 5 vector to point to the beginning of GRAFPLUS instead of the power-up location in the BIOS. By doing this, control is passed to GRAFPLUS when the <SHIFT> and <PRTS> key combination is pressed.

The vector at 00020 can either be changed with a direct memory write, or by using DOS function call 25H. Again, the DOS call is preferred. Once the <SHIFT-PRTS> combination has been pressed (or an INT 5 instruction has been executed by an application program) and until the screen dump is finished, GRAFPLUS has full control of the computer and executes like any other program. When it is complete it executes an IRET to return control back to the application program from where it came.

While it is executing, GRAFPLUS basically acts as a reformatter of data. From the parameters given by the user, GRAFPLUS knows the format of the data for both the video card and the printer. Therefore, it is only necessary for GRAFPLUS to read each of the pixels (dots) on the screen and arrange them in a manner that the printer can understand.

If there is a color image on the screen, then GRAFPLUS must interpret the color information and either produce a gray scale representation of the color, or format the data for output to a color printer. ■

PRTS> key combination. When it sees that combination, it jumps into action and sends a graphics dump to the printer regardless of the software you are using at the time.

For two-color printing (black on white) it prints using black dots on a white background—the opposite of the screen. You could also choose white dots on a black background. The dump in Fig. 3 was actually a color screen reproduced on a two-color printer. For such use GRAFPLUS prints each "color" in black and white in a different pattern. Although some combinations may be barely readable, you can change to the patterns that provide the best contrast.

If you have a color dot-matrix printer, GRAFPLUS will print in colors as well. It can also do sideways printing, and even crop off parts of the picture (such as prompts). If you want a straight text-screen dump instead of graphics, just quickly hit the <ESC> key after <SHIFT-PRTS>.

Pizazz Plus. After using GRAFPLUS for a few months, with great satisfaction, I discovered a newer entry into the screen-dump market—Pizazz. The latest version is called Pizazz Plus. Although at \$149 plus \$5 shipping and handling, Pizazz Plus is considerably more expensive than GRAFPLUS, it has many powerful features. It is available from Application Techniques, Inc. (10 Lomar Park Drive, Pepperell, MA 01463; Tel. 1-800-433-5201, or 508-433-5201).

Pizazz has great latitude in the way it represents colors on a two-color dot-matrix printer. It provides 30 assignable gray scales and patterns, so when a screen dump doesn't look quite right with GRAFPLUS, I can use Pizazz.

For example, Fig. 3 was made using the GRAFPLUS default patterns, and it lost much contrast in printing because of the screen colors. I could have left the program, altered the default patterns, started the program again, and tried the screen dump again, but altering defaults with Pizazz is easier.

Using Pizazz I changed all the colors to either black or white, and the printed result is shown at the beginning of this article.

Pizazz is designed to work with an IBM PC or 100% compatibles. It supports all the common graphic adapters and printers. Once Pizazz is installed in memory for a particular hardware configuration, you press the <SHIFT-PRTS> keys and the screen clears to present a main menu.

From the menu you can step through sub-menus to select from about 50 options that allow you to specify the way each color will be printed, define screen limits, width, height, margin, form feed, rotation, smoothing, density, number of copies, and other parameters—all just before the actual screen dump. You can also view the screen to be dumped to identify which colors are being changed; the target color blinks. Without leaving your current program, you can print the different screens.

(Continued on page 96)

PRODUCT TEST REPORTS

By Len Feldman

Chinon Pocket 8 Camcorder

Chinon America, Inc. (1065 Bristol Rd., Mountaintown, NJ 07092) calls their model C8-SC98 8mm camcorder the Pocket 8, and with good reason—this tiny unit measures a mere 3¾ inches wide by 4 inches in height and is only 7⅝ inches deep. While that's not shirt-pocket size, to be sure, it's certainly small enough to be tucked into a coat pocket!

Despite its diminutive size, this camcorder offers more than the typical "aim and

balance, record review, date and time display during recording, and the usual special effects during playback including still picture and fast search (at about 7 times normal play speed) in either direction. Also featured are auto-focus and auto-iris, and manual and macro (for extreme closeups) focus options are also available.

Accessories packed with the Pocket 8 camcorder include an AC adaptor, a shoulder strap, an audio/video cable, a 300-ohm/75-ohm adaptor, a VHF (RF) connecting cable, an RF adaptor, and a battery pack. Additional optional accessories available for the unit include a car battery cord, a carrying case, and an attachable light. Note that the last two items were included in the package supplied to us by Chinon, but are not listed in the owner's manual as available optional accessories.

CONTROLS

With so many features included in this tiny unit, Chinon cleverly elected to use a program-menu scheme to reduce the button count, and simplify using the camcorder. Pressing the mode and set buttons simultaneously causes the menu to appear in the electronic viewfinder. Then, by using the mode and set buttons individually, the wipe fade, gain, shutter speed, and white balance options can be scrolled through and selected.

The mode and set but-

tons, which also double as the fade and hold (freeze or still frame) controls, are located along the left side of the camcorder body. Also located there are the cassette compartment, the auto and manual focus buttons, a counter reset button, and a counter display button that lets you select between an elapsed-time, tape-length, or no counter display in the electronic viewfinder. A battery release switch is also found near the rear of this side surface. The right side surface of the camcorder houses the electronic viewfinder, a tally light, the record/pause switch, an input/output selector switch, the video input/output connector, a DC input connector, and the date/time button and its associated selector button. The battery pack, when used, is mounted on the rear surface of the camcorder.

Most of the top surface of the camcorder is devoted to VCR or playback controls. These include a play/still button, a stop button, fast-forward/search and rewind/search buttons, a camera/power-off/VCR-mode selector switch, the power zoom rocker switch, and the cassette-eject button. Play and power indicator lights are also found along the top surface of the camcorder. The underside of the camcorder contains a tripod mounting hole. There is also provision for retaining the lens cap when it is not covering the lens.

The AC adaptor supplied with the Pocket 8 cam-

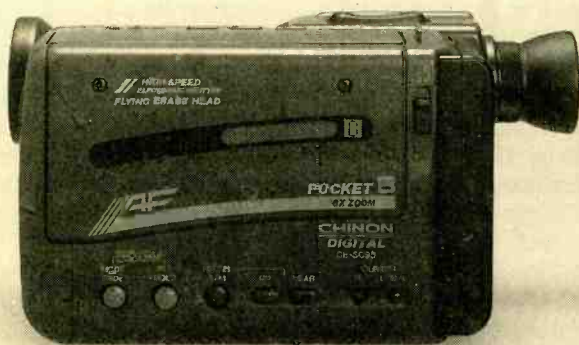

CIRCLE 120 ON FREE INFORMATION CARD

The Chinon Model C8-SC98 "Pocket 8" camcorder.

shoot" types that many other companies have been offering lately. It is equipped with a high-speed shutter (in addition to the normal 1/60th of a second mode, it offers shutter speeds of 1/500th and 1/1000th of a second); a flying erase head for clean, sharp edits and scene transitions; and even a "wipe fade" that offers 8 user-selectable fade-in/fade-out options. There's also a "gain up" mode that lets you shoot in lower than optimum light, an 8:1 power zoom lens, automatic white

corder is also used to recharge the battery pack and is therefore equipped with indicator lights that tell you the status of the battery being charged. Chinon has added a feature to the AC adaptor that many users of camcorders will particularly appreciate. A refresh switch allows the user to completely discharge the Ni-Cd battery prior to charging. That prevents a condition known as battery memory from preventing a full recharge or from shortening battery life. When the refresh switch is used, an indicator lights and remains on until the battery is completely discharged.

TEST RESULTS

APEL (the Advanced Product Evaluation Labs) determined that the minimum illumination required by this camcorder to produce a full-scale video signal was 4.8 lux, a bit lower than the 5 lux claimed by the manufacturer. However, with the gain option set to high, only 2.4 lux of illumination was needed to produce the same video output level. However, as is usually the case with such high-gain settings, the luminance (brightness signal) increased by about 3 dB. White balance, or the amount of chrominance or color that appears on a neutral object when the balance control is set for optimum was an acceptably low 7 IRE, while color contamination measured a very low 5 IRE, which is better than average for camcorders of this type.

Phase accuracy and chroma or color saturation were close to perfect. When examined on a vectorscope, the white spot fell very close to the center of the red target area and its distance from the center of the display showed that color-saturation levels were

TEST RESULTS—CHINON C8-SC98 CAMCORDER

Specification	Video Section	PE Measured
Minimum illumination		4.8 lux
White balance		7 IRE
Color contamination		5 IRE
Phase accuracy & color saturation		(See text)
Resolution		
Camera mode		350 lines
Record/play output		250 lines
Video signal-to-noise ratio		
Camera (chroma AM/luminance)		37.5/40.4 dB
Rec./play (chroma AM/luminance)		40.0/42.9 dB
	Audio Section	
Microphone maximum output		0.38 volts
	Additional Data	
Minimum focus distance		37 inches
Macro setting		¼ inch
Power requirements		9.5 watts
Weight (w/battery & cassette)		2¼ pounds
Dimensions (H x W x D, inches)		4 x 3¾ x 7¾
Suggested retail price:		\$1798.00

close to perfect as well. Since a solid-state CCD imaging device was used as the pickup in this camcorder, there was no evidence of streaking, lag, or image retention as the camera was quickly panned across scenes containing localized lights.

Horizontal picture resolution measured directly from the camera was a better-than-average 350 lines. That's somewhat better than broadcast quality, which is limited to about 330 lines of resolution. When measured via the complete record/play cycles, resolution decreased

to a still acceptable level of 250 lines. Video-chroma AM signal-to-noise ratio, when measured directly from the camera output, was about average at 37.5 dB. Strangely, it was actually a bit better when measured through the entire record/play cycle, increasing to an even 40.0 dB. Much the same thing held true for the luminance, or brightness. Measured via the camera output, APEL obtained a signal-to-noise reading of 40.4 dB, whereas when the measurement was made for the entire record/play cycle, the reading increased to a very

acceptable 42.9 dB.

APEL noted that the built-in microphone delivered a maximum audio-output signal level of 0.38 volts. The Chinon Pocket 8 has no provision for connecting an external microphone. Furthermore, since the internal microphone cannot be shorted out, there was no way to measure the audio signal-to-noise ratio of this unit. During our subsequent hands-on use of the camcorder, however, we did not find the residual noise level of the audio circuitry to be a problem.

HANDS-ON TESTS

The Chinon Pocket 8 camcorder was easy to use and we especially appreciated the control layout and the use of the menu program to increase the versatility and ease-of-use of the unit. Many small camcorders do not provide the user with a video/audio input capability. That capability means that the unit can be used for recording programs other than from the camera section, such as from the video and audio outputs of a VCR.

While Chinon lists the weight of this camcorder as being only 1.6 pounds, APEL noted (and so did we) that with the battery and cassette in place, the total weight of the unit was a bit more than 2 pounds. Nonetheless, we experienced no hand fatigue using the unit for extended periods of time, thanks to the excellent layout of the unit, its intelligently positioned center of gravity, and the ease with which it fits into one's hand. The zoom lens performed flawlessly and smoothly, as did all of the other diverse features of this unit.

For more information on the Chinon C8-SC98 Pocket 8 camcorder, contact the manufacturer directly, or circle no. 120 on the Free Information Card. ■

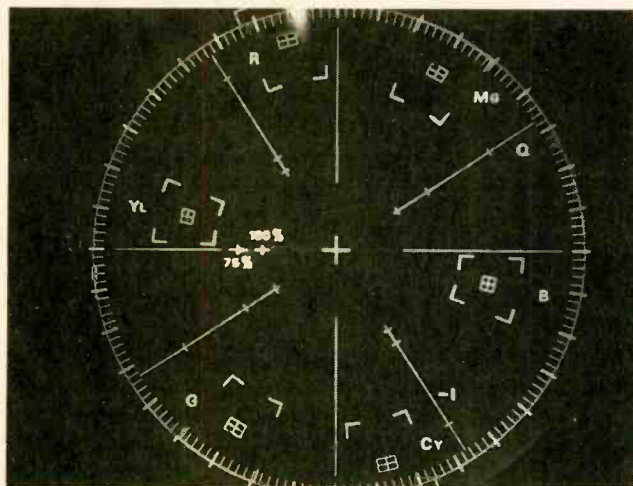

As shown by the location of the white spot in this vectorscope photo, the phase accuracy and color saturation of the Pocket 8 was close to perfect.



Give a Friend a Year of Electronics Fun this Christmas...

Does fighting the crowds at Christmas short-circuit your holiday fun? Don't blow a fuse this year. . . for the friend who shares your love of project-oriented electronics — or a youngster who may need only a spark to ignite a life-long interest — give a gift subscription to Popular Electronics.

. . . Because when you give him Popular Electronics, you're giving month after month of challenging construction projects — including complete plans for testing equipment, electronic worksavers for home and car, add-ons and modifications for hi-fi, computers, radio and TV.

He'll get the how-to he needs to build exciting, useful projects like these. . . a touch light dimmer. . . a traveler's theft alarm. . . an economy NiCd battery charger. . . a voice synthesizer. . . a wave form generator. . . the ultimate burglar alarm. . . a stereo graphic equalizer. . . and many, many more!

PLUS. . . testbench tips and techniques. . . circuit design. . . electronics fundamentals. . . book reviews, and new product news including our 12-page "Gizmo" section. . . regular columns on computers, scanners, dx'ing, ham and antique radio. . . the list goes on and on!

SAVE MONEY. . . A great gift to receive, Popular Electronics is also a great gift for *you* to give! The Special Holiday Rate saves you \$16.45 off the newsstand price on each gift. You can save another \$16.45 when you start or extend your own subscription at the same time. It's our "thank-you" for sharing Popular Electronics with a friend this Christmas.

Send no money, unless you prefer. We'll be glad to bill you in January, next year. Just take a brief moment to go over your gift list and make sure you haven't forgotten anyone who might appreciate the many benefits of Popular Electronics. Then write the names on the attached Gift Certificate and mail it back in the postage-paid reply envelope. . . we'll take it from there!

Your friends will receive a handsome gift announcement card signed with your name just before Christmas. And all through the new year they'll remember and appreciate your thoughtful gift!

So don't blow a fuse. . . take it easy and enjoy the holidays. Give Christmas gifts of Popular Electronics!

Popular Electronics[®]



EKI Mr.Circuit II Digital Magic Lab



CIRCLE 119 ON FREE INFORMATION CARD

A perfect springboard for the beginning electronics enthusiast.

Over 40 years ago, when my interest in electronics began, I learned by building simple circuits from construction projects in **Popular Electronics** and other magazines. I bought kits from Lafayette, Allied Radio, and Burstein-Applebee (all now long gone) and followed the pictorial drawings showing exactly where each part went. I didn't understand schematics at first, but by comparing the pictorial with the schematic for the same circuit I began to see the correlation. This was such an effective learning technique that less than a year later I was writing for the electronics magazines I used to just read!

There is probably no better way to learn anything mechanical or electronic than using a hands-on approach. EKI's recently introduced "Digital Magic Lab—Mr.Circuit II" (a follow-up to the phenomenally successful "Electronic Discovery Lab—Mr.Circuit I" used in schools throughout the country) can provide a painless introduction to digital electronics.

The Point of the Lab. The purpose of the Digital Magic Lab course is to teach digital technology and provide introductory hands-on experience by helping you build 30 different digital circuits with the supplied parts.

There are a number of reasons you

might benefit from the Digital Magic Lab. It might assist you with a career change into electronics. If you are already involved with electronics, they can provide hands-on training in conjunction with your current electronic study. If you are somewhat weak in digital technology, the lab can enhance your current knowledge. If you are a parent or grandparent, the lab could be a meaningful gift that will get your child or grandchild started in electronics.

Today, with computers and microprocessors found almost everywhere, an exposure to digital techniques is essential to anyone working with these devices. Students intending to follow an electronic career particularly need an early introduction to digital electronics.

Have you ever wondered exactly what's going on inside of most electronic devices these days? Have the terms "NAND logic gate," "truth table," and "Boolean Algebra" piqued your curiosity? Would you like to have a fighting chance to understand some of the computer and electronic articles you read? If your answer is "yes" to any of the above, the Digital Magic Lab will give you a good leap forward.

What's Covered. To work with the Digital Magic Lab, it is assumed that you have a basic understanding of analog

electronics, and a familiarity with resistors, capacitors, diodes, LED's, transistors, etc. (If that is not the case, you would be wise to start with the Mr. Circuit Lab I. It will get you up to speed with 30 simpler projects using a 300-hole solderless breadboard, a 48-page illustrated manual, and all the parts you'll need, except a 9-volt battery.)

The Digital Magic Lab aims at teaching about logic gates, how they are built, and how they work; the principles of Boolean Algebra; how to combine logic gates to build more complex devices like clocks, flip-flops, timers, etc.; the binary number system, and how binary and decade digital counting circuits work; digital displays, decoders, and multiplexers; schematic and pictorial diagrams; and laboratory breadboarding techniques. The Digital Magic Lab includes all the parts you'll need except for a 9-volt battery. In addition to an 840-hole solderless breadboard, the kit includes 36 resistors, 9 LED's, 1 transistor, 1 photocell, 1 potentiometer, 1 9-volt battery snap, 5 integrated circuits, 3 electrolytic capacitors, 3 disc capacitors, 3 diodes, 1 7-segment display, 1 pushbutton switch, and 50 solid wires. To make things even easier, the wires have their ends cut and trimmed off of insulation, so you don't even have to do that. A 555 timer, a 4011 quad 2-

(Continued on page 87)

CIRCUIT CIRCUS

By Charles D. Rakes

Power-control circuits, and more

Our first entry this month came about when a friend asked if I could come up with a more efficient way of supplying current to the glow plug in his model airplane engine when using a 12-volt car battery as the power source. After looking over his old power panel (that's the control panel, which distributes power for the glow plug; the electric starter; and electric fuel pump), it was obvious that the glow plug's current-limiting circuitry followed the path of maximum waste.

The current-limiting circuit consisted of a single high-wattage 2.5-ohm resistor connected in series with the glow plug and the 12-volt

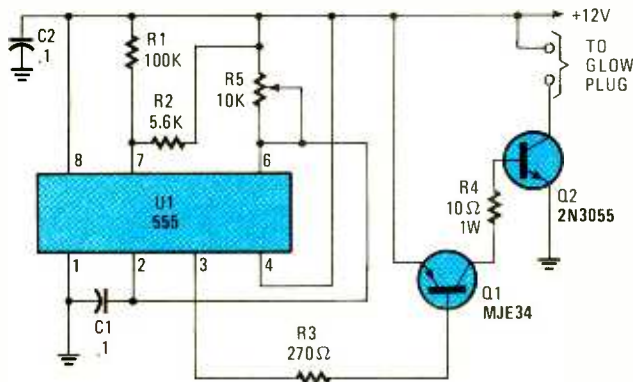

Fig. 1. In this circuit, a 555 oscillator/timer (U1), configured as an astable pulse generator, the output of which is fed to a single-transistor inverter (Q1), which feeds a power transistor (Q2).

battery to allow about 4 amps to flow through the glow plug. The energy wasted in heating the 2.5-ohm resistor is five times greater than what is needed to heat up the plug. That's about 40 watts of hot air. And when a fixed resistor is used as a current limiting device, there's no way to vary the current when the battery is low or to increase the current to overcome a flooded plug.

GLOW-PLUG POWER CONTROLLER.

The circuit in Fig. 1 cools the current-limiting components and solves the wasted-power problem. In that circuit, a 555 oscillator/timer (U1), configured as an astable pulse generator, produces a narrow negative-going pulsed output at pin 3 of U1. The circuit's frequency and pulse width are set by components C1, R1, R2, and R5. Potentiometer R5 controls the amount of current delivered to glow plug by varying the width of U1's output pulse.

The negative-going output of U1 is fed to the base

manufactures recommend 1.5 volts DC. When assembling the circuit, Q2 should be mounted on a 2 x 2-inch piece of aluminum (any thickness will do), which would serve as a heat sink. Potentiometer R5 should be connected so that when it's rotated to its clockwise position, it will be at its maximum resistance to produce a maximum output current.

DC-MOTOR CONTROLLER.

In many DC motor-control applications (when wasted energy isn't a factor), the simplest way to

PARTS LIST FOR THE GLOW-PLUG POWER CONTROLLER

SEMICONDUCTORS

- U1—555 oscillator/timer, integrated circuit
- Q1—MJE34 PNP silicon power transistor (Radio Shack 276-2027)
- Q2—2N3055 NPN silicon power transistor

RESISTORS

- (All fixed resistors are ¼-watt, 5% units, unless otherwise noted.)
- R1—100,000-ohm
 - R2—5600-ohm
 - R3—270-ohm
 - R4—10-ohm, 1-watt
 - R5—10,000-ohm potentiometer

ADDITIONAL PARTS AND MATERIALS

- C1, C2—0.1-μF, ceramic-disc capacitor
- Perfboard materials, enclosure, IC socket, heat sink material 12-volt power source, wire, solder, hardware, etc.

of Q1, which acts as an inverter, feeding a more powerful positive-going pulse to the base of Q2 (a 2N3055 power transistor). The pulsating collector current of Q2 is then fed to the glow plug. The 2N3055's on time is variable from about 8 to 16%, which gives the glow plug about the same power that it would receive from a 1 to 2-volt DC source. Most glow plug

control the speed of the motor is to place a high-resistance, high-wattage rheostat in series with the motor and power source. The only problem with that scheme is that as the load represented by the motor increases, the power that the rheostat must dissipate rises rapidly; and if a larger motor is used, the losses will even be higher.

Our next circuit uses a

PARTS LIST FOR THE DC-MOTOR CONTROLLER

SEMICONDUCTORS

U1—4001 CMOS quad 2-input NOR gate
 D1, D2—1N914 general-purpose silicon diode
 Q1—MJE34 PNP silicon power transistor
 Q2—2N3055 NPN silicon power transistor

RESISTORS

(All fixed resistors are 1/4-watt, 5% units.)
 R1—470-ohm
 R2—47-ohm
 R3—100,000-ohm potentiometer
 R4—500,000-ohm potentiometer

ADDITIONAL PARTS AND MATERIALS

C1—.01- μ F, ceramic-disc capacitor
 C2—470- μ F, 16-WVDC, electrolytic capacitor
 Perfboard materials, enclosure, heat sink material, IC socket, DC motor, 5-12 power source, wire, solder, hardware, etc.

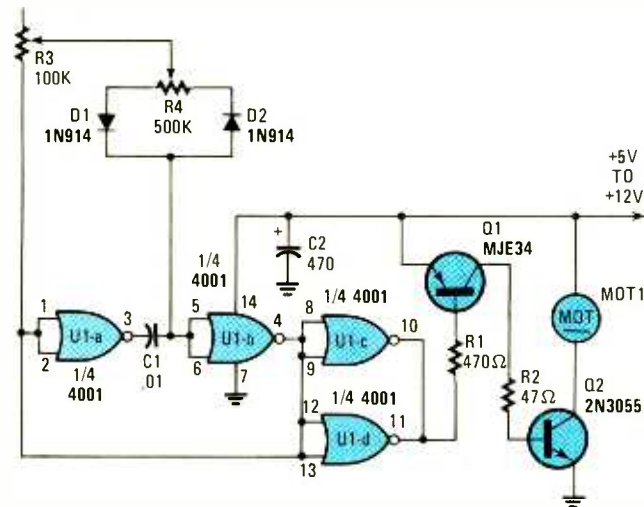

Fig. 2. This circuit uses a method similar to that used in the previous circuit to provide an efficient way of controlling the speed of a DC motor.

method similar to that used by the previous circuit to provide an efficient way of controlling the speed of a DC motor. The circuit in Fig. 2 eliminates the high-wattage losses of a rheostat-control system and allows a much larger motor or load to operate while using about the same amount of energy. That is to say, if a motor's normal speed is 500 rpm at 6-volts, then the motor's speed should be about the same if a twelve volt supply is used but switched on and off at a 50% rate. The average power to the motor is the same in both cases.

Now if the on/off time is varied, the speed of the motor will change accordingly. In Fig. 2, half of a 4001 CMOS quad 2-input NOR gate, U1-a and U1-b, is connected as a variable duty-cycle, astable oscillator. The oscillator's frequency is determined by the values of R4, R3, and C1. In that circuit, potentiometer R4 (which serves as a speed control) is used to vary the pulse width, while R3 sets the minimum width of the output pulse.

The output of the pulse of the oscillator is fed to U1-c and U1-d, which are configured as inverters and

connected in parallel with one another. The negative-going, parallel-connected outputs of those two gates are fed to the base of Q1 (an MJE34 PNP transistor). The output of Q1, at its collector, is fed to the base-emitter junction of Q2, turning it on for the duration of the pulse. When Q2 is turned on, the full battery voltage is applied to the motor for the same time period, causing it to rotate. By increasing Q2's on time, the energy supplied to the motor increases, causing the motor's speed to increase. Reducing Q2's on time slows the motor speed.

With the component values shown, the speed-control circuit can be used to operate 12-volt, 4-amp or less DC motors. The current capability of the circuit can be increased by decreasing the value of R2. By substituting a 22-ohm, 10-watt resistor, the 2N3055 can supply up to 8 amps to the motor. At such high current levels, Q2 should be equipped with an ample heat sink. If, in operation, Q2 becomes too hot, the sink isn't big enough. (Caution! You can get a nasty burn when taking the temperature of any hot operating component so

be very careful.) Transistor Q1 also must be mounted to a sufficient heat sink.

MOTOR-CONTROLLER MODIFICATION.

Larger motors can be operated by connecting several 2N3055's in parallel to share in the load current, as shown in Fig. 3. To avoid confusion, it should be noted that several of the components in Fig. 3—spe-

cifically, Q1, Q2, R1, and R2—are carried over from Fig. 2.

Figure 3 shows three 2N3055's (Q2-Q4) connected in parallel. That arrangement can be used to operate motors requiring up to 20 amps. Each of the paralleled transistors has a 0.1-ohm, 10-watt resistor (R5-R7) in its emitter circuit. By placing those resistors in the circuit, each power

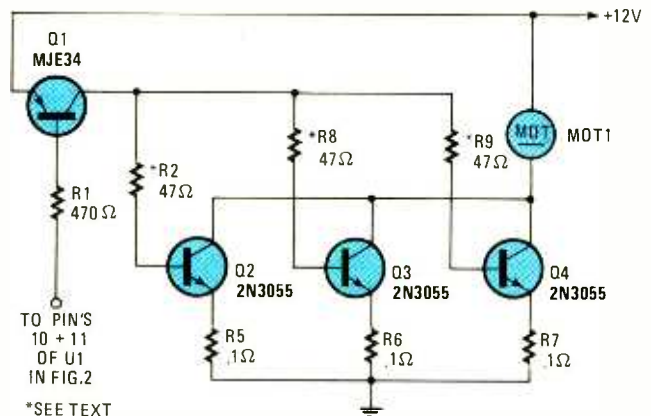

Fig. 3. The motor-controller modification outlined here can be used to operate motors requiring up to 20 amps. To avoid confusion, it should be noted that several of the components in the diagram (Q1, Q2, R1, and R2) are carry-overs from Fig. 2.

PARTS LIST FOR THE MOTOR-CONTROLLER MODIFICATION

Q2-Q4—2N3055 NPN silicon power transistor
 R2, R8, R9—47-ohm, 1-watt or 22-ohm, 10-watt resistor
 R5-R7—0.1-ohm, 10-watt resistor
 Perfboard materials, enclosure, heat sink, wire, solder, hardware, etc.

transistor is forced to share equally in the total load current. The values of R2, R8, and R9, which are connected to the bases of Q2-Q4, respectively, can be reduced as in the previous circuit to increase overall operating current. As was the case with the previous circuit, heat sinks should be mounted to the transistors.

To adjust the circuit, connect a 12-volt automobile stop or turn-signal lamp in place of the DC motor and apply power to the circuit. Set R3 to its mid position. Turn R4 to its counterclockwise position and the lamp should be off or on at a very low brilliance (if not, swap the fixed-resistance leads of potentiometer R4). Rotate R4 clockwise and the lamp should increase in brilliance.

Connect a DC voltmeter set to read 12 volts across the output of the circuit, return R4 to its counterclockwise position, and adjust R3 so that the meter just reads slightly up scale from its zero reading. Potentiometer R3 can be adjusted to give the motor a low idle speed or to set a minimum speed when R4 is fully counter clockwise.

ELECTRONIC COMBINATION LOCK.

Our next circuit, see Fig. 4, takes a few components, a dab of logic, and a pinch of electronic magic mixed together to produce an electronic combination lock. The lock requires that three pre-selected numbers (represented by switch positions) be picked in sequence to unlock the circuit. There is also a "failsafe" that shuts down the circuit if an incorrect digit is selected in the process. To further frustrate the would-be transgressor, once an incorrect digit has been entered, the circuit will not respond to any more code

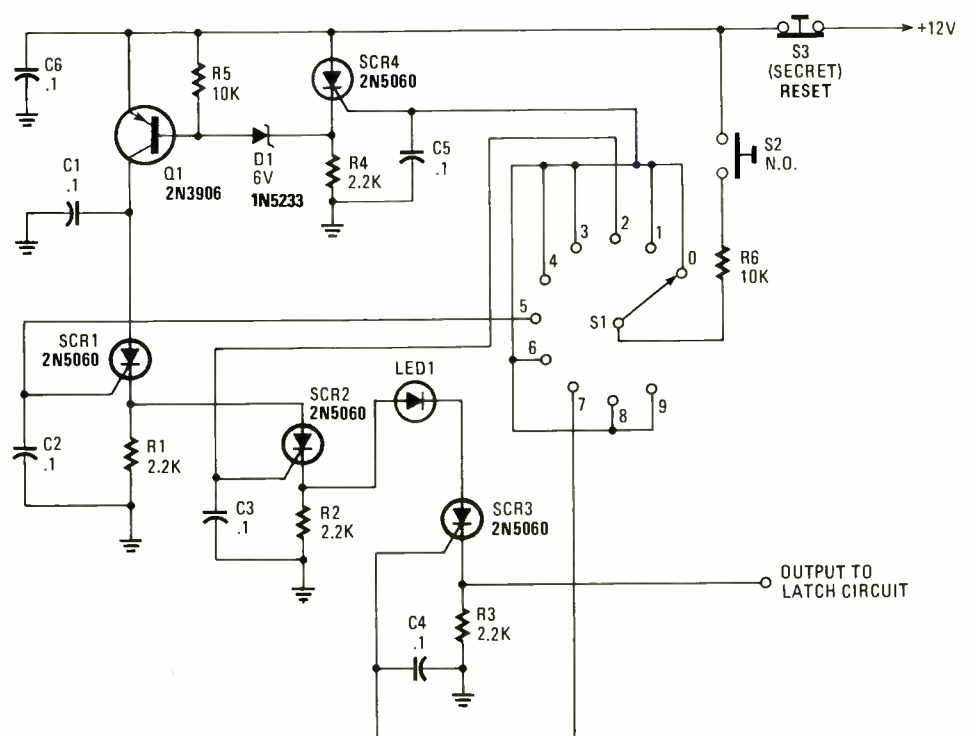

Fig. 4. The electronic combination lock requires that three pre-selected numbers (represented by switch positions) be entered in the correct sequence to unlock the circuit. The circuit also contains a "failsafe" that shuts down the circuit if an incorrect digit is entered in the process.

PARTS LIST FOR THE ELECTRONIC COMBINATION LOCK

SEMICONDUCTORS

D1—1N5233B, 1N753A, or similar 6-volt Zener diode
LED1—Light-emitting diode (any color)
Q1—2N3906 general-purpose PNP silicon transistor
SCR1-SCR4—2N5060 or similar silicon-controlled rectifier

SWITCHES

S1—SP10T rotary switch
S2—Normally-open pushbutton switch
S3—Normally-closed pushbutton switch

ADDITIONAL PARTS AND MATERIALS

C1-C6—0.1-µF, ceramic-disc capacitor
R1-R4—2200-ohm, ¼-watt, 5% resistor
R5, R6—10,000-ohm, ¼-watt, 5% resistor
Perfboard materials, enclosure, 12-volt power source, wire, solder, hardware, etc.

entries until a secret reset switch has been activated.

The lock's combination is not limited to just three numbers. The number of digits can be expanded simply by increasing the number of SCR latching circuits. A five-number code would require adding two more SCR's, and a few resistors and capacitors. The five-digit combination lock

would definitely be very difficult, if not impossible, to "open" without the correct number sequence. The circuit is very modifiable, making it easy to customize the electronic locking system.

The lock circuitry is built around a 10-position rotary switch (S1) that serves as the combination selector. Switch S1's wiper is con-

nected to the positive supply rail through a current-limiting resistor (R6) and a normally-open pushbutton switch (S2). With S1 set to position 5, closing S2 applies gate current to SCR1. That causes SCR1 to latch on, producing about 11 volts at its cathode. That 11 volts supplies operating power for SCR2, the second digit in the sequential code. Moving S1 to position 2 and pressing S2 causes SCR2 to latch on, producing about 10 volts at its cathode. The next SCR, SCR3, is latched on when S1 is placed in position 7 and S2 is activated. An annunciator (LED1) connected in series with SCR3's anode turns on whenever the correct combination (in this case 527) has been entered.

The failsafe is centered about Q1 (a PNP transistor), which operates as a voltage switch. The transistor supplies power to SCR1-SCR3 as long as SCR4 isn't activated. Transistor Q1 receives its bias from the current flow through the Zener diode D1 and R4. If, for example, S2 is closed (Continued on page 88)

ANTIQUE RADIO

By Marc Ellis

Safety For Restorers: Part 1

To the regular readers of this column who are waiting for a report on the successful completion of the Theremin project: Please sit tight for a bit longer! I'm still getting the bugs out of the volume-control circuit and will share the results as soon as I've made some definite progress. In the meantime, I'd like to talk about a subject I've been intending to bring to these pages for some time—safety for the restorer and user of antique radios.

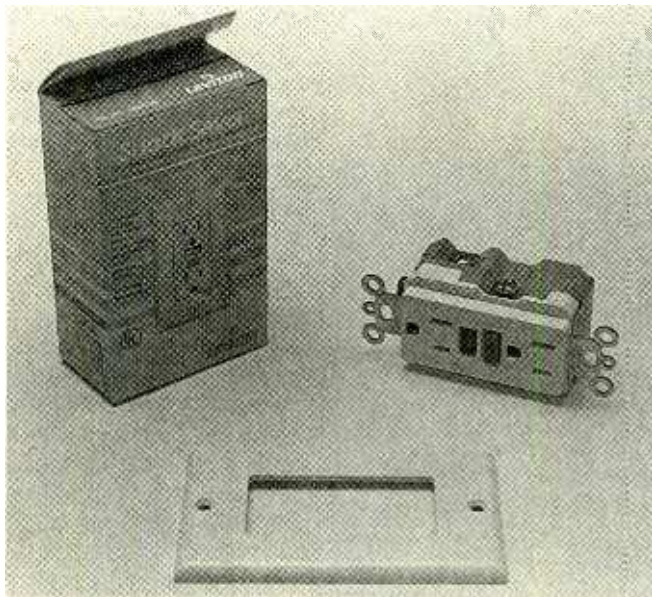

A ground-fault interrupter outlet kit replaces any standard wall outlet and enhances your shop's electrical safety.

Back in the March, 1991 issue, I ran a letter from reader D.K. Owens (Circleville, OH). Mr. Owens was concerned about the dangers lying in wait for inexperienced restorers of antique sets. He was particularly worried about the potentially lethal voltages and currents available from vintage power supplies. At the time, I strongly echoed Mr. Owens' warning and said that I'd like to devote a

future column to those all-important safety issues.

When you think about it for a minute, the importance of a good safety orientation for newcomers to the hobby can't be overestimated. Even many of those with a working knowledge of modern electronics circuitry may need help in this area. After all, most semiconductor circuitry is operated at very low voltages. And those voltages are obtained either from batteries or wall transformers; there's generally no direct connection to the very dangerous 117-volt household electrical system.

As a result, with the exception of such folks as TV repairmen and those who work on radio transmitters or specialized industrial equipment, the average modern experimenter or technician is free to test and tweak with power on and not give a thought to personal safety. But you definitely can't operate that way if you're working with antique-radio equipment—or any other tube gear. So, if you're new to the hobby and are not experienced in working with high-voltage circuits, here are some "street smarts" to help keep you out of danger.

BEWARE THE AC LINE!

People are generally aware that, lurking behind the familiar and innocuous-looking electrical outlets installed throughout their homes, lies enough raw power to severely hurt—or even kill—those who come in contact with it. They know that, under the right circumstances, a bad shock can

stop a person's heart. They also know that short circuits can be explosive in nature and easily capable of causing burns or setting fire to nearby combustible materials.

Yet familiarity breeds contempt, as the ancient saying goes. Most of us have made uneventful use of our household electrical power for so long that we just don't tend to think of the danger. But it's there nonetheless, especially for an electronics hobbyist in a typical concrete-floored basement workshop. The special danger comes from the fact that one of the two wires in every electrical power circuit is connected to ground.

We won't go into the reasons why the power companies ground one side of the line, but that feature is definitely built into the design of residential and commercial power systems throughout this country. As it happens, the ground conducts electricity almost as well as a metal wire, especially if it is damp. So does the concrete floor in your basement, which, of course, is in direct contact with the ground.

Imagine this: You're troubleshooting an old set at your workbench. The floor is a little damp because of a recent rain. Your shoes and socks are a little damp, too, because you've just been walking through some wet grass. Electrically speaking, then, your feet might just as well be hard-wired to one wire (the grounded one) of your shop's electrical power circuit.

The radio you're working on is shut off, so you're not

too concerned about getting a shock from the set's power supply. You're also using only one finger as you probe and prod at the set's wiring, so—even though the set is plugged in—you're not concerned about a shock from the AC line. After all, you can't get across the line if you only touch one connection at a time ... can you?

But eventually your finger comes in contact with one of the wires from the radio's line cord. That wire happens to be connected to the *ungrounded* side of the line, so your entire body—from your finger to your feet—is now across the 117-volt AC power line.

This time you're extremely lucky; the force of the shock knocks you back onto the floor out of contact with the set's wiring. You're a little shaky as you pick yourself up, but otherwise not too much harmed by the experience. Except for the fates, however, this could very well have been your last day on earth!

What's the moral here? Well, there are several ways in which you can protect yourself against such danger. First, if your shop is in a basement with a concrete floor, build a wood platform to stand on as you work—and it certainly wouldn't hurt to put a rubber mat on top of *that!*

Next, replace your workbench outlet with one that has a ground-fault interruptor. Such receptacles are available at electrical stores or large home centers. Installed according to instructions, they'll cut power to the outlet as soon as even the tiniest bit of current begins to flow from the outlet to your floor or other external ground.

Most GFI outlets (check your instruction sheet) can be electrically wired to standard outlets so that the latter also provide GFI pro-

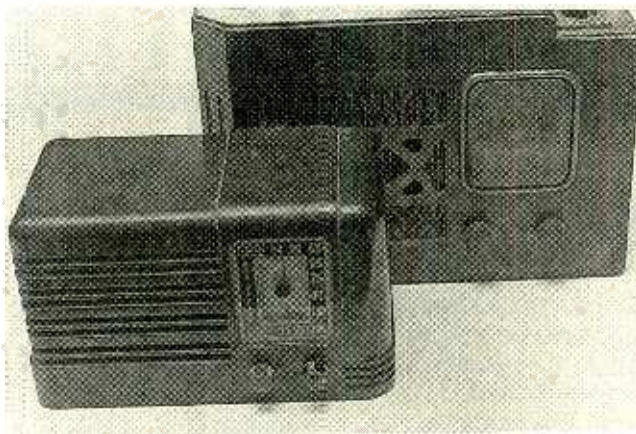

AC-DC sets are fun to collect and display, but dangerous to repair and operate. See text.

tection. And, in any case, the outlets on a good-quality, properly-wired power strip plugged into your GFI outlet should be GFI-protected as well.

Finally, *please* don't probe around in a plugged-in radio unless it's absolutely necessary. Whenever you can, conduct your tests with the plug removed from the wall. Another way of protecting yourself from such shocks is to use an *isolation transformer*, but we'll get to that in the next section.

THOSE TREACHEROUS AC-DC SETS

The AC-DC radio is one of my favorite collectibles. Born during the Depression, when designers were challenged to produce inexpensive broadcast sets to entertain folks who

couldn't afford to go out for their fun, such radios are masterpieces of minimalist design. During their heyday in the 1930's, 40's, and 50's, the sets were made in a variety of interesting plastic and wood cabinet styles very evocative of their eras. Because they're small, easy to display in bookshelves, and can be inexpensive, they're often purchased by newcomers to the hobby.

But those little radios are possibly the most dangerous small electrical appliances ever invented by man. The reason has to do with the fact that—for reasons of economy—such sets derive their operating voltages not from power transformers but directly from the AC line. As a result, one side of the line becomes part of the AC-DC set's ground system and, as

such, was generally connected directly to the metal chassis of the radio.

Depending on how the power plug is oriented when inserted into the receptacle, the chassis of an AC-DC set is either connected to the grounded side of the AC line, which makes it fairly safe, or to the ungrounded (or "hot") side of the line, which (per our earlier discussion) makes it quite dangerous indeed. I would never attempt to make tests on an AC-DC set plugged directly into a wall socket, even if I'd taken precautions such as those described in the previous section.

For one thing, there's still the possibility of receiving a nasty shock—or creating a dangerous short circuit—via test cables from such equipment as scopes or signal generators, both of which connect the chassis of the test equipment to that of the radio under test. If the scope or signal generator chassis is also connected to ground via a three-wire power cord, you can imagine the effect of touching the ground side of its test cable and the "hot" chassis of an AC-DC set at the same time—or of actually *connecting* the cable to the chassis.

The way around this problem is the one used by radio servicemen since the AC-DC set was invented. Never plug the radio directly into the line while it's on the test bench. Instead, power it via an isolation transformer.

The primary of the transformer is plugged into the line and the radio under test is plugged into the transformer secondary. The voltage at the secondary is the same as the line voltage, but there is no electrical connection between primary and secondary. Thus the chassis

(Continued on page 88)

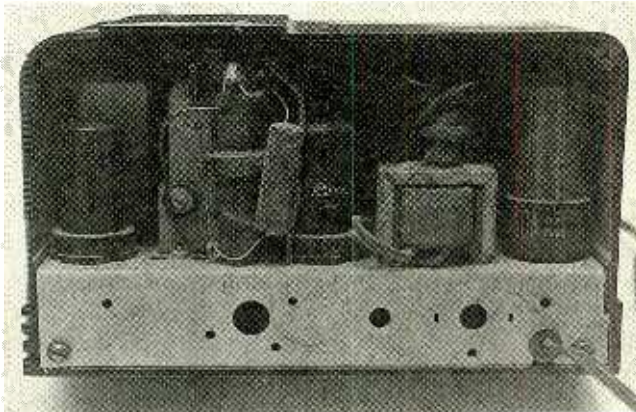

Is the back of your AC-DC missing? Many of them are. Install a replacement to protect users from accidental contact with metal parts that may be "hot."

COMPUTER BITS

By Jeff Holtzman

A Classic Updated

Seven or eight years ago, Borland released a little program called *SideKick* that forever changed the way we think about PC's. *SideKick* was the first terminate-and-stay-resident (TSR) program. (Actually, DOS' own PRINT program was the first TSR; through reverse engineering, it taught Borland and scores of other companies the required tricks.) Before *SideKick*, we used one program at a time on a PC. To move from one program to another, we exited the first and ran the second, and then maybe returned to the first. Then Borland showed us another way, and in the

40K of disk space and that could be loaded under your main application in about 70K of RAM. Any time you wanted access to a *SideKick* module, you'd press the hotkey and up it would pop.

Later Borland released an everything-including-the-kitchen-sink update called *SideKick Plus*, followed by a version for the OS/2 Presentation Manager. The recently released *SideKick 2.0* is the logical successor to the original program; SK2 also provides data compatibility with all previous versions.

WHAT IS IT?

The packaging proclaims that *SideKick* is "The World's Best PC Organizer." That means that SK2 is not trying to compete with PC Tools or Microsoft Works by trying to be all things to all people. Rather, its focus is on organizing your everyday life. To that end, SK2 provides all of the functions of the original, except the ASCII table. In addition, SK2 includes an address book and a fairly powerful telecommunications module. For efficient, secure access to data, everything is built on Borland's Paradox database engine.

The program runs under DOS, either as a TSR or in a stand-alone mode. As a TSR, it occupies about 40K of memory, swapping parts of itself in and out of RAM as necessary. The program will swap to EMS memory, if you have it, or to your hard disk if not. The program now requires about 3 megabytes of disk space.

You can run SK2 under Windows 3.0, but the alarm feature of the appointment

book does not seem to work. The overall operation of the program is very Windows-like, with robust mouse support, scrollable and resizable windows, dialog boxes with check boxes and radio buttons, etc.

Printer support is greatly improved; whereas SK1 really worked only with text-based printers, SK2 works with PostScript and LaserJet printers, as well as most common dot-matrix printers. Printouts created from the appointment and address books are quite attractive. In fact, they look almost as good as professionally designed forms.

However, the print routines have some annoying bugs. For example, SK2 claims to support page sizes for common time planners. In reality, the program prints in the upper left corner of an 8.5 x 11 inch page, so pre-cut time-planner pages (e.g., 5.5 x 8.5) lose part of the printout. In addition, there appears to be no way to force graphics mode printing to occur a page at a time.

GETTING ORGANIZED.

All modules have been beefed up substantially from SK1. For example, the Notepad allows as many as nine open files, each of which may contain 54K of text. Notepad now includes a spelling checker and a thesaurus, allows text attributes (bold, underline, italics), and can print with headers and footers.

The old Calendar has been reincarnated as the Time Planner, probably the most powerful module in SK2. The Time Planner provides two appointment-



The recently released *SideKick 2.0*, along with data compatibility with all previous versions, provides all of the functions of the original (except the ASCII table), plus an address book and a fairly powerful telecommunications module.

process redefined the industry.

The original *SideKick* was not an everything-but-the-kitchen-sink collection of programs. Rather, it was a small, extremely efficient collection of five functions: a Notepad, a Calculator, a Calendar, a modem-based telephone Dialer, and an ASCII table, all contained in a program that occupied

calendar like views (daily and monthly), a six-month display, and a time-usage display that helps you find free time for scheduling an appointment. You enter appointments in the daily view. Appointments can begin and end at any time, and you can force an alarm to sound ahead of time. Appointments can repeat at various intervals (daily, weekly, bi-weekly, monthly, monthly weekday, and yearly). You can also force SK to dial a voice or data call at a specified time.

SK2 maintains a To-Do list, also shown in the daily view. Each To-Do item has a priority (high, medium, low), a date due, and a date on which SK2 will start to warn you that the task is coming up. After you accomplish a task, you mark it as complete; SK2 also carries incomplete items forward from previous days. But, there is no way to sort the To-Do list, nor can you print a list of tasks accomplished.

The Time Planner provides several useful search features. You can search for a text string in the appointment book or in the To-Do list (e.g., "I know I made an appointment with Margaret, but can't remember when..."). You can also search for vacant appointment slots (e.g., "I need a two-hour appointment between 8:00 and 12:00 some time next week...").

Perhaps the most interesting new feature is the Time Planner's network support. Due to the use of the Paradox engine, multiple users can access the appointment book simultaneously without fear of corrupting

data. For example, assume that you want to schedule a meeting with several co-workers and that you all store your appointment books on a common network drive.

You could open each of their appointment books in turn, locate a mutually agreeable time slot, and schedule the meeting. If one of them happened to be working in the appointment book at the same time, his or her screen would be updated to reflect the new appointment. SK2 provides several security features that allow you to keep some appointments private, and that mark "unconfirmed" appointments with a special symbol.

Another interesting function allows you to merge two appointment books. For example, you normally keep your appointment book on the network so that your coworkers can schedule meetings with you. But then you go on a business trip, expecting to schedule more meetings, so you take a copy of your appointment book on your laptop. By the time you return, you've modified your laptop copy and your coworkers have modified your office copy. The merge feature allows you to view both copies on-screen side by side, and create a merged list. That's a nice touch.

SK1 included a basic calculator that also worked in hexadecimal and binary modes. SK2 includes four calculators (basic, business, scientific/engineering, and programming), each with scrolling "tapes" that you can edit, print, or save to disk.

VENDOR

SideKick 2.0 (\$99.95)
Borland Intl.
1800 Green Hills Road
P.O. Box 660001
Scotts Valley, CA 95067-0001
Tel. 408-438-5300

NEW FUNCTIONS.

The Address Book, also based on the Paradox engine, provides 14 fields for name, address, etc., including three phone-number

(Continued on page 85)

Protel Easytrax 2™

Outstanding value in Printed Circuit Board/CAD for your Macintosh and PC

Protel Easytrax 2 is a new, low-cost design package for PC and Macintosh users that includes everything required to produce professional quality Printed Circuit Board artwork.

Our easy-to-learn menu-driven design system breaks the 'expert barrier'-you'll be designing in minutes, not hours. Our comprehensive tutorials guide you through the program's extensive features that take the tedium out of board layout.

- Comprehensive library of Through-hole devices
- Gerber photoplotting and N/C drill tapes
- On-the-fly library components creation
- Intelligent Pad to Pad autorouting
- Switchable Metric/Imperial grid
 - Auto-panning
 - PostScript™ printing
- Powerful user-definable Macros
- Independent print/plot program
- Multi-layer boards of up to 32 X 32 inches.

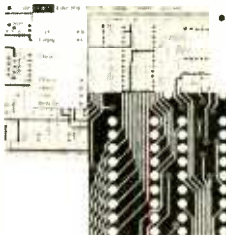

At Protel, we offer free technical support, 24-hour BBS, and 30-day money back guarantee. Prices start at

\$450

Free Evaluation Package
Toll Free: 800-544-4186

Protel Technology, Inc.

50 Airport Parkway, San Jose, CA 95110

Tel: 408-437-7771 Fax: 408-437-4913



CIRCLE 9 ON FREE INFORMATION CARD

GET THE LATEST ADVANCES IN ELECTRONICS

WITH A SUBSCRIPTION TO

Radio Electronics®



ENJOY THE WORLD OF ELECTRONICS EACH MONTH!

Now you can subscribe to the best electronics magazine. The only one that brings you articles on—electronics projects, technology, circuit design, communications, new products and much more.

Radio-Electronics looks to the future and shows you what new video, audio and computer products are on the horizon. What's more you'll find helpful, monthly department reports such as Video News, Equipment Reports, Hardware Hacker, Audio Update, IC Spotlight, Drawing Board. All designed to give you instruction, tips, and fun.

Radio-Electronics gives you exciting articles like:

- ✓ How to Choose the Right Battery
- ✓ Build a Solid State Disk Drive
- ✓ Build a Video Frame Grabber
- ✓ Microwave Technology
- ✓ VCR Repairs You Can Do
- ✓ The Sound Retrieval System
- ✓ Digital Circuit Simulation
- ✓ Display of the Future
- ✓ How to Fight Electrostatic Discharge
- ✓ Build R-E's Digital Dashboard
- ✓ Audio Amplifier Cookbook



FOR FASTER SERVICE CALL TODAY
1-800-999-7139

DON'T DELAY SUBSCRIBE TODAY!

Just fill out the order card in this magazine and mail it in today.

5PEL9

NOVEMBER 1991

FUN SOFTWARE

By Fred Blechman

Mastering Your Computer's Sound

At a recent IBM PC computer show I spotted a booth surrounded by more than the usual group of onlookers. All sorts of sounds were emanating from this area, so I went over to see what was happening. A computer retailer, Byte-Size Stores (136 W. Olive Ave, Monrovia, CA 91016), was demonstrating a space-flight simulator, a computer voice control system, and a MIDI music system—all using the Sound Master II board from Covox. This new board is so versatile that I've decided to make it the focus of this month's *Fun Software* column.



The Sound Master II from Covox lets you take complete control of your PC's sound functions. It features a MIDI (musical instrument digital interface), a voice-recognition system, and a sound and music generator.

Many of you will be interested in the technical details that follow, but don't feel overwhelmed if all you want is to use the sound already provided in existing software. The details are for those who want more information and are computer experimenters and computer-sound hobbyists.

While a detailed description can give you some facts, you'll really have to

hear the sounds this board can produce to believe it—especially if you have been depending on just your PC's built-in speaker!

DESCRIPTION

The Sound Master II, manufactured by Covox, Inc., is a full-featured sound card for IBM PC's and compatibles that plugs into any available 8- or 16-bit slot. It contains an audio pre-amplifier, sound digitizer, audio amplifier, MIDI (musical instrument digital interface), and an FM music synthesizer all on one 3/4-length card. The logic chips used are all CMOS for high noise immunity and low power consumption. Every function has alternate addresses so that two Sound Master II boards can be installed in a PC for stereo output.

A single-wire cable is included to connect the Sound Master's audio amplifier to the internal speaker port on your PC motherboard, if your PC has a chassis-mounted speaker. This reroutes all sound normally directed to the internal speaker to the Sound Master. Not only is the sound quality radically improved, but now you also have control of the amplified volume.

Two miniature 1/8-inch (3.5-mm) phone input jacks are provided. One is designed to accept Covox electret microphones (which need a small bias voltage to operate, as is provided by this input) or a line level output from a tape recorder or other audio source. The second jack is for typical off-the-shelf dynamic microphones.

The preamplifier uses a

two-stage transistor input with approximately 10dB of compression followed by a custom multi-pole linear-phase filter, with a frequency response of 20 Hz to over 5 kHz. This response can be extended with high-frequency pre-emphasis input equalization.

The input digitizer uses an 8-bit PCM (pulse code modulation), 25-kHz sample rate. The digitizer can be read directly using programmed I/O, or transferred to memory using DMA (direct memory access) for minimum CPU overhead. The DMA access rate can be micro-adjusted from 110 Hz to over 100 kHz by way of a 7.16-MHz reference frequency and a 16-bit divider. An extra 32-bit timer is available for other uses. I/O port ranges are 22x, 24x, 28x, or 2Cx (all hexadecimal). Two DMA channels, 1 or 3, are provided, and DMA terminal count can be on IRQ3, IRQ4, IRQ5, IRQ6, or IRQ7.

The output digitizer is 8-bit, using a custom hybrid circuit, with a custom linear-phase output filter. The DMA clocks, ports, channels, and IRQ's are the same as the input digitizer. The output digitizer is capable of playing back at a 44.1-kHz sample rate, the same as a compact disc.

The music synthesizer uses FM synthesis technology, with simultaneous voicing of 9 sounds, or 6 melody sounds and 5 rhythm (11 total). Both vibrato and amplitude-modulation oscillators are provided, and the synthesizer is 100% compatible with the AdLib card. Default ports are 388 and 389, with optional ports at 380 and 381 (both hexadecimal).

An industry-standard 6850 UART is used for the MIDI, with an opto-isolated input and a full-duplex, 8-bit, 1 start-bit, 1 stop-bit, 31.25K-baud format. This is 100% compatible with the IMA MIDI 1.0 standard. Interrupts (IRQ2, IRQ3, IRQ5, or IRQ7) are generated on MIDI input, with optional interrupt on MIDI out. The ports are 330 and 331, or 338 and 339 (all hex). A 6-foot cable is provided with a female DB-9 connector for the Sound Master, and the other end split out to two 5-pin DIN connectors for MIDI IN and MIDI OUT.

A 3.5mm output phone jack on the Sound Master II board provides 1 watt of capacitor-coupled output with less than 2% harmonic distortion into 8 ohms, using a knob to adjust output volume. Two external speakers, each mounted in a black 3 x 4 x 2.5-inch stylish cabinet, are included in the package. These permanent magnet mini-speakers are each capable of handling 5 watts, and come with a 3-foot shielded cable terminating in a 3.5mm phone plug to mate with the Sound Master II output jack. The Sound Master II output is monaural, so only one speaker is needed, but if you wish to simulate stereo, a mono-to-stereo adapter is included for you to plug in both speakers. This same adapter could also be used with a stereo headset.

OTHER FEATURES

The software programs included with Sound Master II allow you to record and playback directly to and from RAM memory or hard disk, up to the limit of available space. Sound data can be compressed in real time to just a fraction of the original PCM data rate. Also included are 2, 3, and 4-bit coding; silence; and a driver for playing back speech

recorded with the IBM Speech Adapter.

Software is included for real-time pitch changing, harmonizing, flanging, chorus, reverb, distortion, and other special effects. Sound can also be recorded and edited with a full-featured graphic waveform editor. You can cut, paste, copy, splice, invert, filter, move, save, adjust loudness, and manipulate any portion of a waveform. You can even create or edit digital sound files from other sound boards!

Complete "Voice Master Key" software is included with the Sound Master II board. Using a microphone (not supplied), you can add voice commands to virtually any software, such as spreadsheets, data bases, word processors, desktop publishing programs, and games. All you do is train the computer with your voice and assign key strokes to your commands. Now when you say the command, the keystrokes are instantly executed.

Also included is "PC-Lyra, The Musician's Sketch Pad." This graphics-based program uses a mouse or the keyboard for composing or editing musical compositions. You simply place the musical notes where you want them, or use a MIDI keyboard. Pull-down menus and full MIDI support are provided, and you can even print out your score. Thirty-eight popular jazz and classical music samples are included.

Three 5.25-inch 360K diskettes are included in the Sound Master II package. The programs and files cover sound recording and playback, audio special effects, a full working Version 2.7 of Voice Master Key voice recognition, a waveform editor, PC-Lyra music editor, a test program, and utility libraries. The diskettes are not copy protected.

The documentation consists of a nicely printed illustrated spiral-bound Owner's Manual and several files on the disks. The manual is in two sections. The first section (27 pages) covers the Sound Master II hardware and software. The second section (35 pages, including a 2-page index) is devoted to PC-Lyra, a music-composition program.

I found five documentation files on the three disks. One file tells you how to contact the Covox computer bulletin board with technical inquiries, three files document the voice recognition programs, and one file has some update information on PC-Lyra.

Sound Master II claims to be the world's most compatible monaural sound card, since it processes AdLib music, digital sound recording and playback, speech synthesis, and voice recognition; processes MIDI (Musical Instrument Digital Interface) signals; offers multimedia features; and includes versatile signal-processing software. The following software companies have products compatible with the Sound Master II: MicroProse, Broderbund, First Byte, Sierra OnLine, MusicWare, AdLib, Covox, Sega, SSI, Electronic Arts, Interplay, IBM, Infocom, California Dreams, Spectrum HoloByte, Lucasfilm Games, Virgin Mastertronic, GameTek, Activision, Digitek, Britannica Software, Dynamix, Accolade, Sir Tech, Origin, Data East, Access, and many, many more. Furthermore, Sound Master II is 100% compatible with the following products: Covox's VoiceMaster (\$189.95 internal, \$239.95 external), Speech Thing (\$79.95), and MIDI Maestro (\$189.95), as well as First Byte's Monologue text-to-speech synthesizer (\$149).

(Covox, Inc., 675 Conger St. Eugene OR 97402; Tel.

503-342-1271. IBM PC/XT/AT/286/386/486 or compatible, 256K RAM, DOS 3.0 or higher, and a spare 8- or 16-bit slot to accommodate the card. Not for use with the microchannel bus. \$229.95 + \$5 S&H)

CIRCLE 131 ON FREE INFORMATION CARD

NEW FUN SOFTWARE

Here are some recently announced programs that you can order from your regular software supplier. Suggested prices, where announced, are shown in parentheses.

MicroProse has announced Civilization, an IBM PC simulation that begins in 4,000 B.C. You must develop an entire civilization from a small nomadic tribe, balancing economics, politics, and defense using a computer-generated map. Watch out for Napoleon or Genghis Khan!

MicroProse also ventures into the past with Darklands, its first true fantasy role-playing game for the IBM PC. Set in 15th Century Medieval Germany, a time of violence and corruption, Darklands includes witches, saints, alchemists, noblemen, thieves, swordsmen, mercenaries, monks, and even dragons in caves.

High adventure comes alive with Dynamix's Heart of China (IBM, \$59.95). Travel the crowded streets of Hong Kong, brave a blinding storm in the Himalayas, and ride the fabled Orient Express with full-motion video, 256-color graphics, and stereo soundtrack (with VGA and a sound card.)

Electronic Arts' spectacular Chuck Yeager's Air Combat, reviewed in the last Fun Software column, is now available (IBM, \$59.95). Electronic Arts has also released IBM PC versions of Earl Weaver Baseball II (\$49.95), Commissioner's Disk II (\$29.95) and 1990

(Continued on page 88)

HAM RADIO

By Joseph J. Carr, K4IPV

Build a Bandsweeper Using the NE602

If you like working on the electronics bench, then this month's column is meant for you, for we will take a look at a simple sweep generator construction project. But first, a little background on why I wanted the circuit.

Over the years I've collected a few 455-kHz IF filters for receivers. There are a variety of such devices in my junkbox, and a few others were purchased recently. For example, I have a 455-kHz filter from an old (make that very old) Motorola VHF-FM mobile rig (it was originally in a taxicab, I believe). Several others are 455-kHz Collins mechanical filters that were

WHAT'S A SWEEP GENERATOR?

The reason for wanting a sweep generator was to examine the passband of these filters to see if they would be useful in a certain project. A sweep generator is a frequency-modulated oscillator that linearly changes frequency at a fixed rate in response to an input modulating signal. In ordinary FM, the modulating signal would be a sinusoidal AC waveform or speech, but in a sweep generator it is a linear sawtooth signal. When the sawtooth voltage is zero, as shown in Fig. 1, the RF signal from the oscillator is at f_1 . The frequency increases as a function of the sawtooth voltage amplitude until the sawtooth peaks at f_2 . When the sawtooth drops back to zero, the frequency of the sweep generator abruptly "flies back" to f_1 .

If we position the center frequency (f_c) of the generator at the center of the passband of the circuit or device being tested (usually called "device under test" or "DUT" for short) and make sure that f_1 and f_2 are outside the expected passband, then we can "map" the frequency response of the DUT. The same technique is also useful for ringing out any tuned circuit.

THE GENERATOR

Figure 2 shows the circuit diagram for a homebrew sweep generator. It is based on the Signetics NE602 IC (available from Digi-Key, 701 Brooks Ave South, P.O. Box 677, Thief River Falls, MN 56701-0677; Tel. 800-344-4539). It is an 8-pin DIP integrated circuit

that contains a double-balanced modulator and internal oscillator circuit. The RF signal is applied to either pin 1 or pin 2 (or across both in a push-pull configuration), while the oscillator components are attached to pins 6 and 7. The sum and difference frequencies (sans RF and local oscillator frequencies) appear at pins 4 and 5 (or across the two).

The NE602 was designed to be a frequency converter for a receiver front end. Therefore often overlooked is the fact that the NE602 also makes a dandy, well-behaved RF oscillator circuit. The technical literature on the NE602 says that it will work up to 200 MHz, and I've had one oscillating as high as the FM broadcast band (88-108 MHz). To make the local oscillator signal (pins 6 and 7) appear at the outputs of the NE602 (pins 4 and 5), bypass pin 2 to ground with a capacitor (C4 in Fig. 2), and ground pin 1 through a 10k resistor (R1).

The NE602 (U1) wants to see a DC power supply potential of 4.5 to 8 volts, and draws about 2.5 mA from the supply. In order to use the NE602 on +9 volts, it is necessary to insert a 1k resistor (R2) in series with the V+ terminal (pin 8) and the power supply. It is *not* recommended that the NE602 be operated from higher voltage DC power supplies. If you need to power it from +12 or higher supply voltages, then buy a 7809, 78L09, 78L05 or some other three-terminal IC voltage regulator to drop the voltage to within the acceptable range.

The chip's local oscillator is a voltage tuned Colpitts

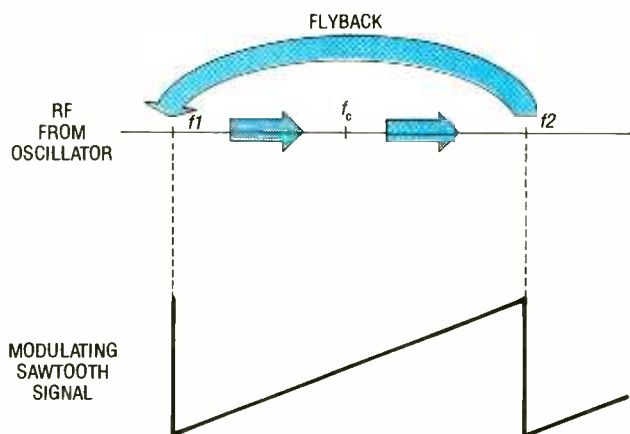

Fig. 1. In a sweep generator, when the modulating sawtooth's signal voltage is zero, the RF oscillator signal is at f_1 , and its frequency increases as the sawtooth voltage increases until the sawtooth peaks at f_2 . When the sawtooth drops back to zero the frequency abruptly "flies" back to f_1 .

filched from surplus receivers and sold at various hamfests.

I also recently purchased a small collection of those little ceramic filters used in modern AM broadcast radios. The selection included four 4-kHz and four 6-kHz bandwidth filters (centered on 455 kHz); the filters were made by Toko and purchased from Digi-Key.

oscillator centered on 455 kHz. The tuning inductor (T1) is a 455-kHz IF transformer used in transistor radios. For the capacitance values used in the circuit, select one with an inductance of 0.64 mH. Also make sure you choose one that has the tuning capacitor mounted external to the transformer, in a small recess in the bottom of the

device. Using a small screw driver, destroy the capacitor by crushing it and shaking out the debris. Make sure that it is completely removed.

(CAUTION: I wear prescription glasses when doing close work, and when I broke the capacitor some of the ceramic debris flew up and dusted my glasses. That was a powerful

PARTS LIST FOR THE FM SWEEP-FREQUENCY GENERATOR

RESISTORS

(All resistors are 1/4-watt, 5% units.)

- R1—1000-ohm
- R2—10,000-ohm
- R3—47,000-ohm

CAPACITORS

- C1—150-pF, ceramic-disc
- C2—.001- μ F, ceramic-disc
- C3, C4—0.15- μ F, ceramic-disc
- C5—.022- μ F, ceramic-disc
- C6—.01- μ F, ceramic-disc
- C7—68-pF, ceramic-disc
- C8—8–80-pF, PC-mount trimmer capacitor
- C9—100-pF, ceramic-disc

ADDITIONAL PARTS AND MATERIALS

- U1—NE602 low-power double balanced mixer, integrated circuit
 - D1—MV2107, NTE613, or similar, 22-pF varactor diode
 - T1—0.64-mH, 455-kHz IF transformer (Toko RMC-202313NO)
- Perfboard materials, enclosure, 9-volt power source, wire, solder, hardware, etc.

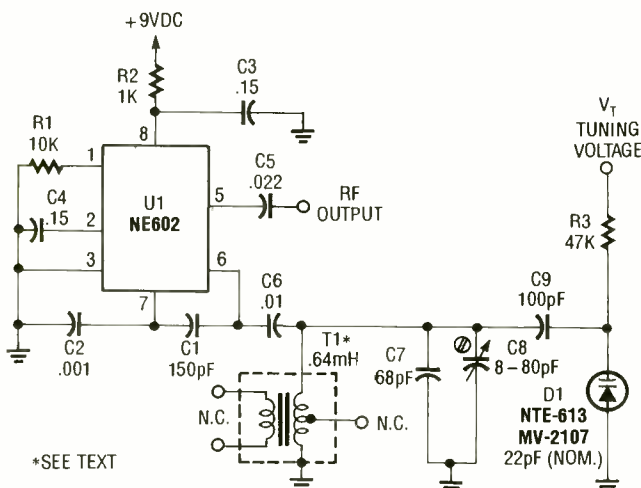

Fig. 2. Our homebrew sweep generator, the schematic diagram for which is shown here, is based on the NE602, an 8-pin DIP integrated circuit that contains a double-balanced modulator and internal oscillator circuit.

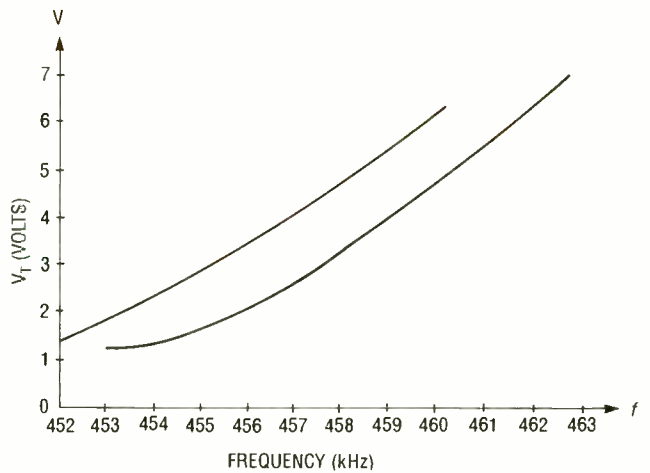

Fig. 3. Voltage-vs-frequency characteristic of the circuit in Fig. 2. The oscillating frequency of the sweep generator, as shown graphically here, is a function of the applied tuning voltage V_T . Note that the curves are not linear, but they are quasilinear in the 3.5- to 7-volt range.

reminder that there is a potential for eye damage when doing this type of work, so put on safety glasses or safety goggles before doing this job!)

A hallmark of any Colpitts oscillator, regardless of the active semiconductor de-

vice used (or vacuum tube, for that matter), is a capacitive voltage divider to provide the needed feedback. In Fig. 2 the feedback network consists of C1 and C2. The values shown are for a relatively low oscillat-

(Continued on page 92)

Make the most of your general coverage transceiver with Monitoring Times!

Every month Monitoring Times brings everything you need to make the most of your general coverage transceiver: the latest information on international broadcasting schedules, frequency listings, international DX reports, propagation charts, and tips on how to hear the rare stations. Monitoring Times also keeps you up to date on government, military, police and fire networks, as well as tips on monitoring everything from air-to-ground and ship-to-shore signals to radioteletype, facsimile and space communications.

ORDER YOUR SUBSCRIPTION TODAY before another issue goes by. In the U.S., 1 year, \$19.50; foreign and Canada, 1 year, \$26. For a sample issue, send \$2 (foreign, send 5 IRCs). For MC/VISA orders (\$15 minimum), call 1-704-837-9200.

MONITORING TIMES

Your authoritative source, every month.

P.O. Box 98
Brasstown, N.C. 28902

DX LISTENING

By Don Jensen

Something For Everyone

Responding to my earlier invitation to readers to write telling about their SW listening favorites, the Rev. Philip Bohlken, a Lutheran minister in Chattanooga, TN, writes, "My favorite shortwave station is the German-language service of *Deutsche Welle*. Listening to the station has improved my meager college German so that I can now carry on a conversation in that language. It's some-

It is heard

worldwide

Deutsche Welle

The Voice of Germany
The German short-wave service for the world

Postfach 10 04 44
5 Köln 1
Bundesrepublik Deutschland

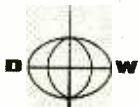

A program guide from Germany's shortwave voice, *Deutsche Welle*.

thing that I have always wanted to do. But it is a little like Mark Twain's first typewriter. He spent so much time explaining to people how he was able to get the machine to print that he got rid of the thing. When I speak with Germans visiting this country, I learn very little about them. I'm inundated with questions about how I learned to speak their language."

Rev. Bohlken says he enjoys **Popular Electronics** and *DX Listening*, but he'd

like to see more information about stations that broadcast in languages other than English. "Much of shortwave broadcasting is in other languages and it is very enriching to be able to listen in at least one other language."

Many SWL's understand only English, which is why this column does tend to emphasize English-language broadcasts. But it is also true that there are others in the hobby who know a second language, either (like Rev. Bohlken) because they've learned or are learning it in school, or because of their own ethnic heritage.

Noting that it's not always easy to find details on programming in other languages, he offers some listening tips for SWL's who can understand at least some German. "Naturally, there is *Deutsche Welle* from Cologne, Germany. I hear them from 1200 to 1600 UTC and from 1900 through 0000 to 1000 UTC (if I waken during the night). During the morning hours in the eastern U.S., my best frequencies are 15,275 or 17,860 kHz. Later in the morning at 1400 to 1600 UTC, I switch to 17,715 kHz. During the afternoons, try 15,275 or 17,860 kHz. At 2200 UTC, switch to 15,270 or 15,410. During the evening hours, I may switch to 6,100 kHz, depending on conditions. And at 0600 UTC, I go to 9,690 kHz.

"*Deutsche Welle* transmits four hours of German-language programming that's repeated over and over during the day, and targeting various parts of the world. If you are learning German, the repeated

broadcasts are helpful in getting a better grasp of something that you only half understood the first time.

Rev. Bohlken also reminds German-speaking SWL's that *Radio Berlin International*, the former *Voice of East Germany*, no longer exists. It was merged into *Deutsche Welle* when the two Germanys merged.

Other stations broadcasting in German include: *Swiss Radio International*, from 0430 to 0500 UTC on 9,650, 9,725 and 9,885 kHz. They also broadcast to North America from 0230 to 0300 UTC on 9,855 and 12,035 kHz. The *Voice of Free China*, Taiwan, broadcasts to Europe in German by way of a relay in Florida at 2100 to 2200 UTC on 9,852 kHz. *WYFR*, Family Radio (Florida), has its own German programming from 1700 to 1800 UTC on 15,566 kHz. Though directed to Europe, it is quite easy to receive here.

Radio Austria International broadcasts to the U.S. on 9,875 kHz at 0000, 0100, and 0200 UTC, with a half hour of German programming. *HCJB*, Quito, Ecuador, can be heard in German from 1830 to 1900 UTC and 2100 to 2130 UTC on 15,270 and 17,790 kHz. And on Saturdays, the *Christian Science Monitor* station on 15,610 kHz can be heard in German from 2000 to 2100 UTC; as well as on Sundays from 2115 to 2200 UTC."

There are other stations broadcasting in German, Rev. Bohlken says, most of them aimed at Europe from various parts of the world. But these are among the most easily heard in North America.

And let me again encourage the rest of you to write. Send your letters to *DX Listening, Popular Electronics*, 500-B Bi-County Blvd., Farmingdale, NY 11735. I'm looking forward to hearing from you.

DISCOVER DX'ING.

Discover DX'ing, subtitled "An introduction to TV-FM-AM DX'ing," is the title of an interesting little booklet written by John Zondlo, a veteran DX club editor and officer. It may come as something of an eye-opener to SWL's who think that DX'ing means short-wave only. Listening to AM medium wave—in other words, your regular everyday radio band—was the original DX'ing. DX'ing dates back to broadcasting's earliest days when everybody, it seemed, tried to tune into distant stations like KDKA, Pittsburgh, with their crystal sets.

There is still a sub-category of DX'ing hobbyists that try to pull in AM radio stations from distant points in the U.S. and Canada, to say nothing of foreign reception from Latin America, Europe, and even Asia and the Pacific. And although there are differences in DX'ing equipment and propagational factors that deliver long haul signals over many hundreds of miles, TV and FM DX'ing are other facets of the monitoring hobby.

As Zondlo notes, with a programmable scanner rather than a TV set, you might even pick up the VHF audio of Australian and New Zealand television channels. The 30-page booklet is available for \$5 from Discover DX'ing, Box 770228, Oklahoma City, OK 73177.

Incidentally, there are two hobby clubs in the U.S. that cater to those who tune the AM broadcast-band frequencies between 525 and

1620 kHz. One, the National Radio Club, is now more than 60 years old! Its bulletin, *DX News*, is published 30 times a year (weekly) during the winter DX season.

The NRC also has several auxiliary publications, including its very useful *AM Station Log* of broadcasting stations and a booklet on *Getting Started In Medium-wave DX'ing*. The club's annual membership fee is \$24 in the U.S. and \$25 in Canada. A sample bulletin is available for \$1. Write NRC, Box 118, Poquonock, CT 06064.

The International Radio Club of America (IRCA) similarly publishes a bulletin 34 times a year for members who are broadcast-band DX'ers. A sample of its publication, *DX Monitor*, costs \$1. Regular dues are \$25 a year in the U.S. and \$27 in Canada. Like NRC, IRCA also publishes other useful references for the AM radio monitor, including *A DX'er's Technical Guide*, the *Almanac*, and the *Foreign DX Reference*. The IRCA's address is 6059 Essex St., Riverside, CA 92504. Both clubs welcome beginning broadcast-band listeners.

DOWN THE DIAL.

As a switch from our usual lineup of shortwave listening tips, this month I'll pass along some AM-radio information from John Zondlo's *Discovering DX'ing*, which may help the newcomer to medium-wave DX'ing. As usual, all times are given in UTC (Coordinated Universal Time).

It is still possible, although extremely difficult, to hear AM stations from all 50 United States. Here are a few states that you can try for; some are easy catches while others are difficult (or next to impossible).

ALASKA—Tough to hear everywhere except on the west coast. From An-

chorage, try for KFQD (750 kHz), KBYR, (700 kHz), and KYAK (650 kHz) and KICY (850 kHz) in Nome. Propagation conditions must be ideal for listeners east of the Rockies to have a chance of hearing this state.

DELAWARE—Even in the east, it's a challenge to hear broadcasts from this state. Try WNRK, 1260 kHz (Newark) and WDEL, 1150 (Wilmington) at sunrise. Good luck!

GEORGIA—Atlanta's WSB (750 kHz) should be heard almost everywhere. Also try for WGST, 640 kHz (Atlanta); WEAM, 1580 kHz (Columbus); and WCNN, 680 kHz (North Atlanta).

IOWA—Another easy one with WHO, 1040 kHz (Des Moines) and KXEL, 1540 kHz (Waterloo).

MAINE—This is also a tough one, even for easterners. Go for WWGT, 1440 kHz (Westbrook); WABK, 1280 kHz (Gardiner); and WSKW,

1160 kHz (Skowhegan) at sunrise. Or try WGAN, 560 kHz (Portland) overnight.

NEW HAMPSHIRE—Another toughie. Try WFEA, 1370 kHz (Manchester) overnight or at sunrise. WKOS, 930 kHz, is also possible at sunrise.

OHIO—A cinch with clears—little or no interference on the frequency—are WLW (700 kHz) and WCKY (1530 kHz) in Cincinnati, and WWWE (1100 kHz) and WGAR (1220 kHz) in Cleveland.

TEXAS—With nearly 500 AM stations in the Lone Star state, there's plenty to hear! Your best bets are WOAI, 1200 kHz (San Antonio); WBAP, 820 kHz (Fort Worth); and KLIF, 1190 kHz; and KRLD, 1080 kHz (Dallas).

VERMONT—Another really difficult state, but try WSYB, 1380 kHz (Rutland) at sunrise and WVMT, 620 kHz (Burlington) overnight or at dawn. ■

Shortwave Listening Guidebook

by Harry Helms

The world is talking on shortwave radio, and here's the book that tells you how to listen in! In direct, nontechnical language, Harry explains how to get the most from your shortwave radio. Its 320 heavily illustrated pages are filled with practical advice on:

- antennas
- when and where to tune
- selecting the right radio for you
- accessories
- reception techniques



Learn how to hear the BBC, Radio Moscow, ham radio operators, ships at sea, even Air Force One! Includes hundreds of frequencies for stations around the world and the times you can hear them.

Only \$16.95 plus \$3.00 shipping (CA residents please include sales tax).

HighText
Publications, Inc.
7128 Miramar Road
Suite 15L, San Diego, CA 92121

SCANNER SCENE

By Marc Saxon

Modifications, and More!



Radio Shack's Realistic PRO-35 covers more than 20,000 frequencies. The direct-entry programmable radio stores 100 channels in ten memory banks.

All new from the Radio Shack Division of Tandy Corporation is the *Realistic PRO-35* handheld, direct-entry programmable with 100-channel coverage. The Realistic PRO-35 covers 29 to 54 MHz, 108 to 174 MHz,

and 406 to 512 MHz, giving it a total of more than 20,000 frequencies.

The channels can be stored in ten memory banks. A search mode makes it easy to discover new frequencies, and the monitor mode allows the

user to quickly store channels found during the search. A weather-band key provides instant reception of local 162-MHz NOAA weather-advisory frequencies.

The unit also has the standard features of selectable delays, lock-outs, and a priority channel. The channel memory will retain stored channels for an hour without a battery. The set comes with a backlit LCD readout, a detachable (BNC jack) antenna, and earphone jack, a belt clip, a rechargeable-battery pack, and an AC adapter/charger.

The retail price of the PRO-35 is \$229.95, and it's sold through Radio Shack's 7,000 retail outlets throughout North America.

HERE'S TO YOU!

Many states have agencies that regulate the sale of alcoholic beverages within their borders. That might include everything from raiding illegal "stills" to inspecting bars reported to be serving minors. From time to time we get requests for the frequencies used by those agencies. Many simply share the frequencies normally used by the state police in their jurisdictions. Those state alcohol-control agencies that do have their own assigned frequencies, according to our records, include: Florida on 45.06, 45.10, and 45.26; Georgia on 42.18; Mississippi on 154.905; Missouri on 154.7 and 154.83; Ohio on 45.10;

Pennsylvania on 45.30, 156.015, and 158.76; Texas on 154.905, 155.595, and 156.06; and Washington on 155.37 MHz. If any readers can offer additions or corrections to this information, we will be pleased to pass it along.

AVID READER

We received a fine letter from Frank L. Cox, Jr. (933 West 31st Street, 2nd Floor, Chicago, IL 60608). Frank is 39 years old, owns a Realistic PRO-2004, and has been a scanner buff for almost fifteen years. Being totally disabled for the past six years, he has plenty of time to devote to his hobby, and he's interested in everything that has to do with scanners. Frank wrote that he purchased the scanner frequency books offered by Radio Shack, but found them to be inadequate. Perhaps some active monitors in the Chicago area can send Frank some hot local frequencies to plug into his PRO-2004.

FE, FI, FO, FM

In the past, we have mentioned that reception in the 225- to 400-MHz VHF aeronautics band should be done with your scanner set for AM-mode operation (assuming that you have the ability to select that mode). Reader Morrie N., of Brooklyn, NY, writes to remind us that there are some military communications satellites operating in that band, and they usually use FM. While much of the communications are

scrambled, he advises that he has found an active NORAD (North American Aerospace Defense Command) unscrambled frequency using narrow-band FM (NFM) mode on 263.825 MHz. This is apparently a SATCOM downlink frequency. Assuming that one had a scanner antenna pointed in the general direction of the satellite, it should be possible to copy these communications on a scanner that will accept programming in this band. A preamplifier to help boost the incoming signal would probably help.

NIP & CLIP?

A letter from Curtis A. Waldrop, Newark, OH, is typical of several that we receive each week. Curtis owns a Regency 1016 scanner, and he points out that there are two areas of frequency coverage that this scanner doesn't accommodate: 54 to 136 MHz and 174 to 406 MHz. He knows that some scanners need nothing more than a diode lead being cut to add entire bands, and he is hoping that we can let him know if this can be done to his scanner to bring in the two bands, and, if so, what lead(s) should be cut?

Other readers write in with different model scanners, of course, and different bands they hope can be activated with no more than a slight clip at a strategic circuit point. Would that it were all so easy and convenient!

Scanners are designed to receive certain very specific bands. Some scanners, during their manufacture, have been rigged at the factory so that certain portions of their receiving coverage are locked out. That might, for instance, include two sub-bands between 800 and 900 MHz used by cellular phones that are locked out of a

scanner that was designed to receive the 800- to 900-MHz band. The factory locked the bands out by merely soldering a diode across two terminals of an IC.

By cutting one lead of that diode, the scanner's owner is doing nothing more than restoring a resident function of the scanner that had been disabled during the manufacturing process. Cutting the diode lead by no means adds any new features or functions that had not been there right from the start; it wouldn't be possible to do that.

For the most part, scanners are sold with the ability to receive all of the frequencies they are capable of receiving without the addition of an external converter. The one notable exception is that some scanners covering the 800-MHz band need a minor user modification to restore reception in the two cellular sub-bands. That said, it's reasonably safe to state that, although there are dozens of great modifications that can be done to enhance the function of some scanners, you aren't going to be able to clip anything and suddenly add coverage of the VHF or UHF aeronautics or TV bands, or the 800- to 900-MHz band, if those frequencies weren't part of the original design of your scanner.

Not that each and every scanner ever made is a candidate for any of the modifications known to be worthwhile. Some scanners that lend themselves to modification include Realistic PRO-34, PRO-2004, PRO-2005, PRO-2006, PRO-2021, PRO-2022; Bearcats BC-100XLT, BC-200/205XLT, BC760/950XLT; and Regency 1600, 4020, and 4030. Other models have not shown good results. Modifications for some of these scanners include in-

creasing memory channels, speeding up search/scan rate, adding signal-strength meters, adding fine tuning, etc.

The authoritative books on scanner modification are *Scanner Modification Handbook, Volumes 1 and 2*, by Bill Cheek, published by CRB Research Books, Inc., P.O. Box 56, Commack, NY 11725. You can request a free catalog showing these and other scanner-related publications. That catalog should also be of interest to Al Iloff (of Vallejo, CA) and the numerous other readers who have written asking where to get frequency guides. (Al, I used your name because your letter was on top of this week's big stack of requests for such information!)

If you have a question, comment, scanner loggings, or even a photo of your monitoring station, let us hear from you. We are at *Scanner Scene, Popular Electronics*, 500-B Bi-County Boulevard, Farmingdale, NY 11735. ■

COMPUTER BITS

(Continued from page 77)

fields, and a special code field. You can view the Address Book in a simulated Rolodex form, or as a traditional database table.

However, you cannot add, delete, or modify fields.

The Address Book provides several nicely formatted printouts, subject to the same page-size printout bugs listed above. One frustrating aspect of the Address Book is that you can only import data stored in the older SideKick formats, not standard formats (e.g., fixed-length or comma-delimited).

The other new function is SK2's telecommunications module, which provides basic terminal emulation (TTY, ANSI, VT100), a fairly

powerful script language for automating communications sessions, file capture of all session dialog, and XMODEM-based file transfers. Unfortunately, the program does not support more modern protocols such as YMODEM or ZMODEM.

CONCLUSION.

I've been searching for years for a way to get organized electronically. I've tried numerous products and approaches, but usually end up doing things the same old way. Early reports on SK2 gave me hope, but it turned out to be unjustified. The product has some good things, but it also has lots of excess baggage, and it lacks other features that I would find useful (e.g., a small spreadsheet).

SK1 came with several variations that allowed you to load just the modules you needed into memory, thus ensuring that you didn't waste RAM or disk space on unneeded features. SK2 isn't so frugal. It provides some nice new features in the Appointment and Address Books, but overloads the program in other areas (e.g., the spelling checker and thesaurus) so that disk requirements swell dramatically for marginally useful features.

However, I recognize that marginally useful to me might be extremely useful to someone else. Other than the printing bugs and lack of data-import facilities, I have no major complaints about SideKick 2.0. The overall operation of the program is smooth, it works well with a mouse, and the separate modules are well integrated, sharing both common keystrokes and data by means of a clipboard. I wish that SK2 provided a closer match to my needs—but maybe it'll do the trick for you. ■

Popular Electronics REPRINT BOOKSTORE

- | | |
|--|---|
| <input type="checkbox"/> 221 Popular Electronics (1991 back issues) \$4.00
Write in issues desired _____ | <input type="checkbox"/> 107 Radio-Electronics (1987 back issues) \$5.25
Write in issues desired _____ |
| <input type="checkbox"/> 220 Popular Electronics (1990 back issues) \$4.50
Write in issues desired _____ | <input type="checkbox"/> 106 Radio-Electronics (1986 back issues) \$5.50
Write in issues desired _____ |
| <input type="checkbox"/> 119 Popular Electronics (1989 back issues) \$4.75
Write in issues desired _____ | |
| <input type="checkbox"/> 118 Hands-On Electronics (1988 back issues) \$5.00
Write in issues desired _____ | |
| <input type="checkbox"/> 117 Hands-On Electronics (1987 back issues) \$5.25
Write in issues desired _____ | |
| <input type="checkbox"/> 116 Hands-On Electronics (1986 back issues) \$5.50
Write in issues desired _____ | |
| <input type="checkbox"/> EH91 Experimenters Handbook (1991) \$4.50 | |
| <input type="checkbox"/> EH90 Experimenters Handbook (1990) \$5.00 | |
| <input type="checkbox"/> EH88 Experimenters Handbook (1988-89) \$5.50 | |
| <input type="checkbox"/> EH87 Experimenters Handbook (1987) \$6.00 | |
| <input type="checkbox"/> HH91 Popular Electronics Hobbyist Handbook (1991) \$5.00 | |
| <input type="checkbox"/> HH90 Popular Electronics Hobbyist Handbook (1990) \$5.50 | |
| <input type="checkbox"/> HH89 Popular Electronics Hobbyist Handbook (1989) \$6.00 | |
| <input type="checkbox"/> 126 Radio-Electronics Annual 1986 \$6.00 | |
| <input type="checkbox"/> 211 Radio-Electronics (1991 back issues) \$4.00
Write in issues desired _____ | |
| <input type="checkbox"/> 210 Radio-Electronics (1990 back issues) \$4.50
Write in issues desired _____ | |
| <input type="checkbox"/> 109 Radio-Electronics (1989 back issues) \$4.75
Write in issues desired _____ | |
| <input type="checkbox"/> 108 Radio-Electronics (1988 back issues) \$5.00
Write in issues desired _____ | |

REPRINTS REPRINTS

- | | |
|--|--|
| <input type="checkbox"/> 169 Think Tank (133 Circuits) \$3.50 | <input type="checkbox"/> 169A Think Tank Vol. 2 \$3.00 |
| <input type="checkbox"/> 168 Fact Cards (#34-66) \$4.00 | <input type="checkbox"/> 168C Fact Cards (#67-99) \$3.50 |
| <input type="checkbox"/> 168D Fact Cards (#100-132) \$3.50 | <input type="checkbox"/> 167 Designing With IC's \$4.00 |
| <input type="checkbox"/> 166 Collected Works of Mohammed Ulyses Fips (62 pages, April Fools Collection) \$5.00 | <input type="checkbox"/> 165 How to Repair CD Disc Players \$5.00 |
| <input type="checkbox"/> 164 Modern Electrics (April 1908) \$3.00 | <input type="checkbox"/> 163 Receiving Satellite TV \$5.00 |
| <input type="checkbox"/> 162 Build Your Own Satellite TV Receiver \$5.00 | <input type="checkbox"/> 161 Descrambling (Feb. 1984) \$4.00 |
| <input type="checkbox"/> 161 Descrambling (Feb. 1984) \$4.00 | <input type="checkbox"/> 160 New Ideas - 42 Circuits \$3.50 |
| <input type="checkbox"/> 159 Low Frequency Receiving Techniques Building and using VLF Antennas \$5.00 | <input type="checkbox"/> 158 Electro Importing Co. Catalog (Circa 1918) \$5.95 |
| <input type="checkbox"/> 157 All About Kits \$2.00 | <input type="checkbox"/> 156 How To Make PC Boards \$2.00 |
| <input type="checkbox"/> 156 How To Make PC Boards \$2.00 | <input type="checkbox"/> 155 IBM Typewriter To Computer \$2.00 |
| <input type="checkbox"/> 155 IBM Typewriter To Computer \$2.00 | <input type="checkbox"/> 154 How To Repair VCR's \$3.50 |
| <input type="checkbox"/> 154 How To Repair VCR's \$3.50 | <input type="checkbox"/> 150 Pay TV Decoder (1981) \$3.00 |

To order any of the items indicated above, check off the ones you want. Complete the order form below. **include your payment**, check or money order (DO NOT SEND CASH), and mail to **Popular Electronics**, Reprint Department, P.O. Box 4079, Farmingdale, NY 11735. Please allow 4-6 weeks for delivery.

If you need a copy of an article that is in an issue we indicate is unavailable you can order it directly from us. We charge 50¢ per page. Indicate the issue (month & year), pages and article desired. Include payment in full, plus shipping and handling charge. Make checks payable to Gernsback Publications, Inc.

ARTICLE _____		
PAGES _____	MONTH _____	YEAR _____
TOTAL PAGES _____	@50¢ each	TOTAL PRICE _____

MAIL TO: **Popular Electronics**
Reprint Bookstore, P.O. Box 4079, Farmingdale NY 11735

All payments must be in U.S. funds

SHIPPING CHARGES IN USA & CANADA

\$0.01 to \$5.00	\$1.50	\$30.01 to 40.00	\$5.50
\$5.01 to \$10.00	\$2.50	\$40.01 to 50.00	\$6.50
\$10.01 to 20.00	\$3.50	\$50.01 and above	\$8.00
\$20.01 to 30.00	\$4.50		

SORRY — We only ship to USA & Canada

Total price of merchandise \$ _____
Sales Tax (New York State Residents only) \$ _____
Shipping Charge (see chart) \$ _____

Name _____ Total Enclosed \$ _____

Address _____

City _____ State _____ Zip _____

PE1191

REMOTE-CONTROLLED OUTLET

(Continued from page 37)

like most remotes. The hole in both transmitter cases is covered by clear self-sticking cushions like the kind used as "feet" on electronic gear. They act as lenses to disperse the IR radiation.

The power-on LED's are mounted standing on end so that they poke through the transmitter covers just ahead of the pushbuttons, which are mounted in a "thumb-friendly" position. The holes were drilled after each board was completed.

The main portion of the receiver circuits were also built on perfboard and the prototype was housed in a plastic enclosure. The outlets and neon lamps were mounted on the cover.

Before we continue, always remember to be careful when working with line current, as it can be hazardous. All the AC power connections, including those to the main terminals (MT1 and MT2) of the Triacs, should be made using heavy-gauge wire. The connections to MT1 and MT2 of the Triacs should first be tightly wrapped around the pins and then soldered to prevent the connections from melting under high current. Some heat-shrink tubing around the closely-spaced Triac pins is not a bad idea either. Although the Triac that was used in the prototype is a 6-amp, 400-PIV (peak-inverse voltage) unit, you can use a more powerful one should your application require it. A heat sink is a must for whatever Triac you use.

When building the main portion of either receiver circuit, remember to make solder points on the board for connection to the IR module, MOD1. As mentioned before, it is connected to the main circuitry via a 4-foot length of 2-conductor shielded cable (three conductors if you count the shield). The two center conductors connect to pins 1 and 2 of the IR module, and the shield wire connects to pin 3 and is also soldered to the module's case. *The case must be grounded in this fashion for proper operation.*

The IR module was mounted in its own case, with the detector lens butted against a small opening in the case so that IR light can be detected. The farther into the case the module is mounted, the more directional the unit becomes. A couple of dead AA batteries were secured inside the case as "dead weight" to keep it from sliding around too much.

HANDS ON REPORT

(Continued from page 70)

input NAND gate, a 4029 presetable binary decade up/down counter, a 4051 8-channel multiplexer/demultiplexer, and a 4511 binary to 7-segment decoder/driver are the IC's provided with the course.

The two-color heavily illustrated manual is 75-pages in length. The 8.5- by 11-inch staple-bound manual is arranged by lessons and experiments. Each experiment is actually a project, with the text broken up into introduction, procedure, and summary sections, with diagrams or formulas where needed. A schematic diagram, using conventional symbols, is provided, as well as a pictorial showing each part overlaid on the solderless breadboard. All of the component leads and suggested hole locations are clearly shown. Since the breadboard has reference locations for each hole, it is very difficult to go too far wrong.

Using the Course. About all you have to do to get started—after making sure to identify all the parts as illustrated in the manual—is to solder five wires. Three of the wires are soldered to the three terminals of the potentiometer, and the other two wires are soldered to two terminals on the switch. This is so they can be plugged into the breadboard. All other parts can plug directly

into the breadboard without additional leads.

The first few projects are simple enough, but later ones get fairly complex, involving three integrated circuits plus the 7-segment display. In many experiments, you move wires to different points to show different actions, with the text prompting you on what to observe.

Lesson 1 introduces you to the subject of digital electronics, pointing out that there are really only two types of electronic circuits: switching (or digital) and regulating (or analog). Lesson 2 describes logic circuits, truth tables, and timing diagrams.

Lesson 3 starts you off with an explanation of the solderless circuit-board contact arrangements. When that's out of the way, you start actually assembling circuits with the solderless breadboard. You put together an LED-based logic indicator and build AND, OR, NOT and YES (buffer), and NOR gates.

Lesson 4 of the course describes the various types of integrated circuits, pin numbering, and care and handling tips. Then you get to build a NAND gate, a two-gate clock, a two-gate timer, a basic memory circuit, and a typical 555 timer circuit.

Lesson 5 describes the decimal, octal, and binary numbering systems, as well as decimal-to-binary and binary-to-decimal conversions. Then you really get "down and dirty" by building twenty circuits: a binary counter, a decade counter, some dividers, a 7-segment

display circuit, a 7-segment decoder, a digital counter with display, an up/down counter with display, a multiplexer/demultiplexer, variable-speed up/down chasing lights, a logic probe, a one-shot touch pulse generator, a pulse train generator, a digital heads or tails game, a double-decision maker, a stop-action reaction tester, an on/off touch switch, a digital stepping touch switch, a photoelectric digital lap counter, a random-number generator, and digital die.

The appendix shows logic symbols, Boolean equations and truth tables for AND, OR, YES, NOT, NAND and NOR gates, as well as pinouts for each of the integrated circuits. A "troubleshooting guide" leads you through several steps to get your projects working in case you run into trouble.

Electronic Discovery Lab (Mr.Circuit I, \$19.85, Order # 1101L) and Digital Magic Lab (Mr Circuit II, \$36.85, Order #1201L) are available only from EKI, Inc., 16631 Noyes Ave., Irvine, CA 92714; Tel. 714/833-8711. Add \$3.50 per Lab for shipping, and CA residents add 6.5% sales tax. For more information contact EKI directly, or Circle 119 on the Free Information Card

EKI DIGITAL ELECTRONICS LAB Mr Circuit II

EXPERIMENT 13

EKI

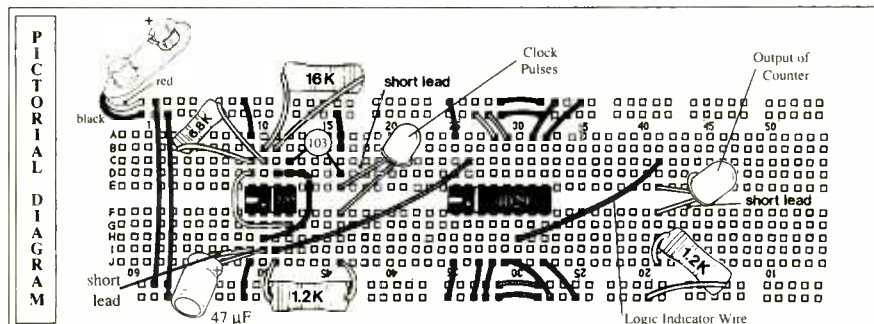
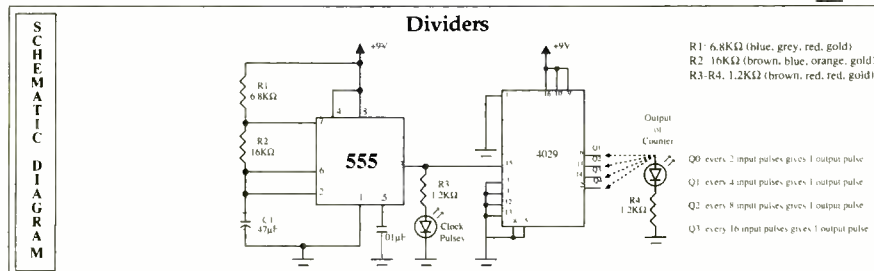

Copyright© 1990 by Electronic Kits International, Inc.

The manual has clear drawings of the circuits actually wired to the solderless breadboard as well as straightforward schematics.

ATTENTION! ELECTRONICS TECHNICIANS



EARN YOUR B.S.E.E. DEGREE

THROUGH HOME STUDY

Our New and Highly Effective Advanced-Placement Program for experienced Electronic Technicians grants credit for previous Schooling and Professional Experience, and can greatly reduce the time required to complete Program and reach graduation. No residence schooling required for qualified Electronic Technicians. Through this Special Program you can pull all of the loose ends of your electronics background together and earn your B.S.E.E. Degree. Upgrade your status and pay to the Engineering Level. Advance Rapidly! Many finish in 12 months or less. Students and graduates in all 50 States and throughout the World. Established Over 40 Years! Write for free Descriptive Literature.

COOK'S INSTITUTE OF ELECTRONICS ENGINEERING

4251 CYPRESS DRIVE
JACKSON, MISSISSIPPI 39212

NOVEMBER 1991

CIRCLE 7 ON FREE INFORMATION CARD

87

ANTIQUE RADIO

(Continued from page 75)

of the AC-DC set never becomes "hot," no matter how its power cord is oriented.

You can sometimes find isolation transformers at hamfest flea markets or in surplus-electronics catalogs. But even if you had to buy one new (less than fifty dollars for the 100-watt size appropriate for AC-DC sets), the investment is well worth it when you consider the risks involved in *not* using such a transformer.

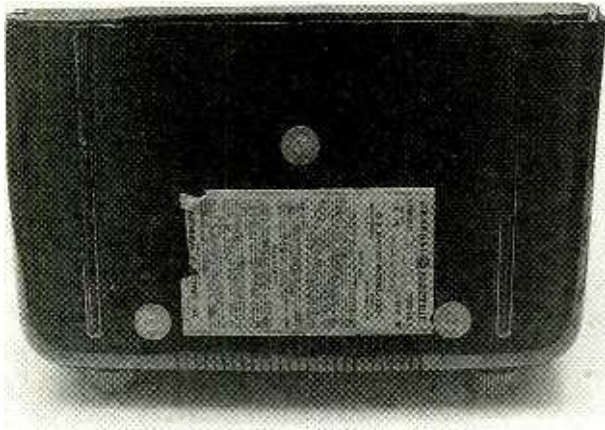

The metal screws holding the chassis to the cabinet are likely to be "hot" when the chassis is. Never touch them with the set plugged in, and never place the radio on a grounded object.

Please be very careful with an AC-DC set (easily identifiable by its lack of a power transformer) even off your workbench. Never use the volume or station controls if the knobs are missing; their shafts are hot when the chassis is hot. Also beware of the metal screws holding the chassis to the bottom of the cabinet. Never touch them while the set is in operation or locate the set so that the screws might contact a grounded object such as a radiator or water pipe.

If the back of the cabinet is missing, as is frequently the case, make a substitute out of hardboard or some other convenient material

(be sure to provide ventilation holes!) so that users will not be able to contact the chassis. And (need I say it?) never attempt to ground the radio for better reception unless there is a specifically-labeled ground connection.

DANGER: HIGH VOLTAGE!

Now that I've hit the key points regarding power-line safety, I find that I don't have enough space to deal with the other major shock hazard facing antique-radio restorers: the radio's high-voltage DC

plate supply (otherwise known as the "B" supply). In a large table model or console set, the B voltage could easily be as high as 350 volts—definitely not a value to be trifled with. And the power transformer for a radio with a 350-volt DC plate supply may very well deliver AC voltages in the 800- to 900-volt range. That is lethal stuff indeed.

Even the lower plate voltages used by AC-DC radios and battery sets are considered quite dangerous, so we'll continue with safety issues next month rather than returning to the Therman topic—giving full coverage to plate-supply dangers. ■

FUN SOFTWARE

(Continued from page 79)

MLBPA Player Statistics & Manager Profiles Disk (\$19.95), new sequels to the original award-winner.

Electronic Arts has just released Mario Andretti's Racing Challenge (IBM, \$49.95). Andretti not only endorses this game, but took an active part in its design. You are put in the driver's seat of sprint cars, modifieds, stock cars, prototypes, Formula One, and championship cars on 12 of the world's most exciting speedways. Also just released is Powermonger (IBM and Amiga, \$49.95), which casts you as the leader of a displaced tribe.

Many Electronic Arts affiliated labels have also been busy. From California Dreams comes Solidarity, a political simulation game (IBM and Amiga, \$59.95), and Wreck Hunters, where you command a crew of five in a high-tech submarine looking for sunken loot (IBM and Amiga). Three-Sixty has announced four new programs: Theater of War, a graphic/strategy game (IBM, \$49.95); ABC Wide World of Sports Winter Olympics 1992, a sports simulation game (IBM, \$49.95); and Patriot, a strategy/wargame simulation with super hi-res VGA (IBM, \$59.95). UBI Soft Entertainment has announced Battle Isle graphic/strategy and Pro Tennis Tour II sport-simulation games, each for IBM and Amiga for \$49.95. Strategic Simulations Inc. (SSI) has three new products: Ultimate Baseball, a sports-simulation game (IBM, \$49.95; Commodore 64, \$39.95); Gateway to the Savage Frontier, an AD&D/FRP adventure (IBM and Commodore 64, \$49.95); and Conflict in the Middle East, a strategy wargame (IBM and Amiga, \$59.95). ■

CIRCUIT CIRCUS

(Continued from page 73)

with S1 in position 1, SCR4 turns on. As the cathode voltage of SCR4 rises from zero to about 11, Q1's base bias is removed, causing it to turn off. That, in turn, cancels the voltage to the SCR, effectively deactivating the circuit. The lock remains deactivated until S3 is pressed. All unused switch positions are connected together and tied to the gate of SCR4 so that the failsafe is activated whenever an incorrect digit is entered.

Any three digits may be used for the combination, but it's best not to duplicate any number in the sequence. Make all three of the numbers different. The output of SCR3 can be used to drive a larger SCR or transistor to operate a solenoid-operated latch or similar locking device. To increase the number of digits in the combination just cascade additional SCR's in the manner that SCR2 is connected to SCR1, and take voltage from its cathode to power the next stage. The last SCR in the cascade can be used to operate the lock or latching device.

It looks like we're out of space for this month, so good circuiting until next time. ■

Lower the numbers and raise the odds.

Controlling your blood pressure can reduce your risk of heart disease.



 American Heart Association

THE DAT PACT

(Continued from page 40)

copies of copyrighted recordings for private, noncommercial use without the threat of copyright-infringement suits.

Analog tapes are not covered. Nor are video cassette recorders, even those with PCM (pulse-code modulation) digital-audio capabilities. The recording industry has agreed to stop pressing for royalties on the sale of blank analog cassettes. We expect, however, that the video industry—which has also pressed for royalty payments—is watching the action closely.

The royalty pact has the blessing of numerous groups, many of whom have rarely agreed in the past. Besides the EIA and the RIAA, the list includes the National Music Publishers Association (NMPA); the AFL-CIO Department of Professional Employees; the American Federation of Musicians (AFM); the American Federation of Television and Radio Artists (AFTRA); the American Society of Composers, Authors, and Publishers (ASCAP); Broadcast Music, Inc. (BMI); the National Academy of Songwriters (NAS); the National Association of Retail Dealers of America (NARDA); the National Consumers League (NCL); the Nashville Songwriters Association In-

ternational (NSAI); and the Songwriters Guild of America.

There's only one group that has still to be convinced: Congress. If the pact reached by the various organizations isn't put into law by Congress, things will be right back where they started. Without a law, it's likely that some manufacturers will refuse to pay royalties. That, of course, will lead to more lawsuits, questions, refusal by recording companies to support the new digital formats, and, ultimately, stalled sales.

Time, however, is tight. With the rollout of DCC due early in 1992, it is imperative to both sides that Congress act before the end of the year. As we go to press, no sponsors for a bill have come forward in either House. Congress, however, has historically resisted royalties because they raise the prices of electronic products. However, because previous adversaries are coming to Congress with a detailed pact—and, apparently, with no industry dissenters—it would seem that only consumer groups will fight any proposed legislation. So far, none has come forward to do so, despite the "definitive" study by the Office of Technology Assessment that showed that home taping did not hurt the recording industry. ■

SCMS—The Serial Copy Management System

SCMS is a system that allows DAT, DCC, Mini Disc, and other digital recorders to make direct, digital-to-digital copies of compact discs and other digital sources. It prevents, however, those copies from being copied digitally.

A DAT deck with SCMS reads coding information—including a "category code" and a copy-inhibit flag—from the digital subcode channels of the source material. If copies are not permitted, the deck will not record the source material. If they are, the deck will insert new subcodes in the recording, which will indicate whether future copies are permitted.

For now, DAT decks will be free to make unlimited analog copies from any source. Digital copies of those analog recordings, however, still can't be made after the first generation. It is still unclear whether digital-audio broadcasts (or cablecasts) will be recordable digitally.

Digital Compact Cassette decks and Mini Disc recorders will also contain SCMS, even though the audio encoding used in each of those formats makes it unlikely that second-generation recordings would sound very good even if they could be made. ■

**BLOOD
PRESSURE
PILLS ONLY
WORK IF YOU
TAKE THEM.**

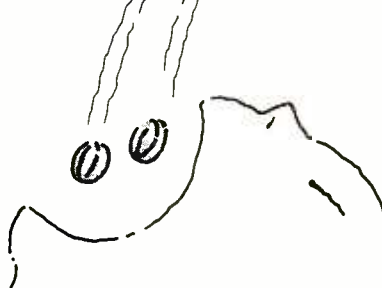

American Heart
Association



**RADON.
THE HEALTH
HAZARD IN
YOUR HOME
THAT HAS A
SIMPLE
SOLUTION.**

Call
1-800-SOS-RADON
to get your Radon
test information.



NOVEMBER 1991

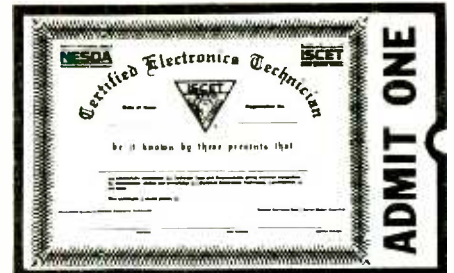

Your Ticket To SUCCESS

Over 28,000 technicians have gained admittance worldwide as certified professionals. Let your ticket start opening doors for you.

IS CET offers Journeyman certification in Consumer Electronics, Industrial, Medical, Communications, Radar, Computer and Video. For more information, contact the International Society of Certified Electronics Technicians, 2708 West Berry Street, Fort Worth, TX 76109; (817) 921-9101.

Name _____
Address _____
City _____
State _____ Zip _____

Send material about IS CET and becoming certified.

Send one "Study Guide for the Associate Level CET Test." Enclosed is \$10 (inc. postage).

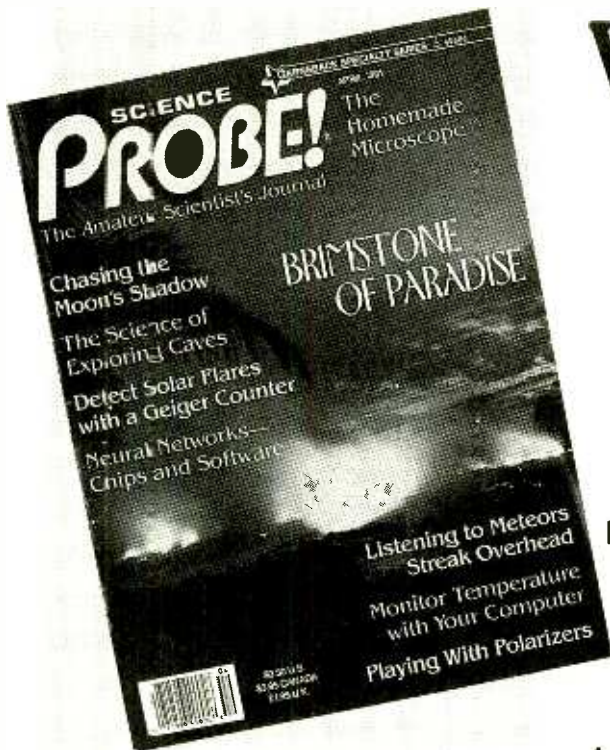

Welcome to . . .

SCIENCE PROBE!

The Amateur Scientist's Journal

Embark on an irresistible new journey into the realm of mystery, challenge, and exploration! The perfect magazine for the budding scientist, the serious amateur, the professional who would like to relax, and those who simply want to gaze at the stars.

Science PROBE! — the *only* magazine devoted entirely to Amateur Scientists! If you are fascinated by science in all its many forms . . . if you can't stay away from a microscope, telescope, calipers, or test tube — we invite you to share the wonders in every issue of **Science PROBE!** You will join a community of Amateur and Student Scientists who enthusiastically seek scientific knowledge or follow scientific pursuits for their own sakes and not merely as a profession.

Obtain your next issue of **Science PROBE!** by visiting a quality Newsstand, Convenience Store, or Supermarket or by reserving your personal copy through the mail by completing the coupon below.

From your very first issue of **Science PROBE!** you will be involved in a world of scientific facts, experiments, and studies pursued by amateur scientists who are university students, investors, academicians, engineers, or office workers, salesmen, farmers—whose *quest* is to probe into the mysteries of science and reveal them to all.

Plan to become a **Science PROBE!** reader!

Articles to appear in upcoming issues of **Science PROBE!** are:

- How an Amateur Mapped the Milky Way**
- Make your own Seismometer**
- Operate a Solar-powered Weather Station**
- Grow Crystals Automatically**
- Experiment with a Saltwater Aquarium**
- How to Keep a Science Notebook**

If you're fascinated by science in all its many forms, if you are compelled to experiment and explore, then **Science PROBE!** is your kind of magazine!

Science PROBE!
500-B Bi-County Boulevard
Farmingdale, NY 11735

Please forward my copy of **Science PROBE!** as soon as it comes off the press. I am enclosing \$3.50-U.S.A. (\$4.23-Canada-includes G.S.T.) plus \$1.00 for shipping and handling. Better still, please enroll me as a subscriber and send the next four (4) quarterly issues of **Science Probe.** I am enclosing \$9.95-U.S.A. (Canada: \$16.00—includes G.S.T.)

Next Issue Only Next Four Issues (1 Year)
Offers valid in the U.S.A. and Canada only. No foreign orders.

Name _____

Address _____

City _____ State _____ ZIP _____

All Orders payable in U.S.A. Funds only.

7PL13

**ON SALE AT QUALITY NEWSSTANDS, CONVENIENCE STORES AND SUPERMARKETS
GET YOUR COPY TODAY—\$3.50-U.S.A.—\$3.95-Canada**

SIMPLE MUSIC CIRCUIT

(Continued from page 63)

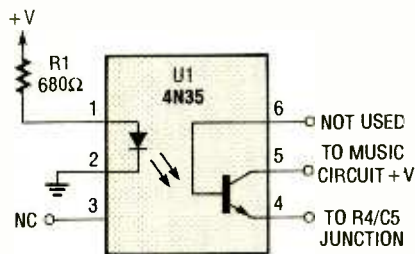

Fig. 5. Optoisolator/couplers, such as the one shown here, can replace S1, thereby allowing the SSMC to be triggered by some other electronic device. Other optoisolator/coupler units, containing various output devices, can also be used in the circuit depending on the intended application of the circuit.

ing card. To use the circuit in a greeting card, simply replace S2 or S1 with 2 conductors separated by some sort of thin insulating material (such as a piece of plastic). Then when the card is opened, the insulator is removed from between the two conductors, allowing them to touch and start the melody.

Other applications may require some other switching arrangement. For instance, to use the circuit as an automatic door annunciator, replace switch S1 with a normally-open magnetic alarm switch in such a way that when the door is opened, the switch contacts close, triggering the Super-Simple Music Circuit.

The circuit can also be used with a mechanical clock by attaching a small magnet to the back of to the minute hand, and a normally-open magnetic reed switch for S1 at, say, the 12 O'clock position. Then when the minute hand (with magnet attached) swings into the 12 o'clock position, the contacts of the reed switch close, triggering the circuit and playing a tune.

An optoisolator/coupler could be used in place of S1 to allow the Super-Simple Music Circuit to be triggered by some other electronic circuit (see Fig. 5), by connecting the output of the optoisolator/coupler in place of S1, and connecting the +V end of R1 to the desired trigger source.

Whatever the application, the Super-Simple Music Circuit's small size, low price, versatility, and ease of assembly will accommodate just about any of your music and project needs. Feel free to experiment with it, and, above all, have fun!

1930'S TRANSMITTER

(Continued from page 60)

bring the receiver's antenna lead near the transmitter. Turn the receiver's volume up high and then tune the transmitter slowly by adjusting the slug in L1 until you hear the modulating signal. If the signal is distorted, reduce the level of the modulation until the distortion disappears.

Once the transmitter and receiver are tuned to the same frequency, you can separate them and check signal propagation. You should not need to attach a radiating antenna to the transmitter. If necessary however, you may attach a short length of wire, up to six feet or so, to the ANT terminal of the transmitter to increase its range. Keep that lead as short as possible to avoid illegal radiation. Re-adjust L1's tuning slug with any change in antenna length.

Like many pre-war phono oscillators, this circuit covers the upper portion of the broadcast band. If you want to lower the frequency range over which the transmitter may be tuned, increase the value of C2. Conversely, if you wish to raise its operating range, you may do so by decreasing the value C2.

The number of uses you can find for this little "radio station" are limited only by your imagination. For example, you can use it to monitor what's going on in a nearby room without running wires. With two of them, you can set up communications. With a tone generator and a key, you can make it into a wireless code-practice oscillator. With some slight modifications, you can even make it into a CW (continuous wave) transmitter and send code! If you want to, you can change the value of C2 enough to shift the carrier frequency above or below the broadcast band. By doing that to the transmitter, and by using a suitable receiver, you can make it hard for anyone to intercept your transmissions.

Students can put this little device to good use, too. With some ingenuity, the circuit could become part of an award-winning science-fair project! If you have a working antique radio, you can transmit tape-recorded vintage-radio programs to your old set. Grandma was probably surprised enough when you got her relic radio running again. Imagine her face when you tune in a "live" broadcast from 40 or 50 years ago!

FUN WITH ELECTRONICS



◀ **160—COIL DESIGN & CONSTRUCTION MANUAL** \$5.95. How to make RF, IF, audio and power coils; chokes and transformers. Practically every possible type is discussed.

▶ **PCP113—THE PC MUSIC HANDBOOK** \$13.95. Learn the basics of computer music systems. For the professional musician, gifted amateur or just plain curious.



◀ **BP297—LOUDSPEAKERS FOR MUSICIANS** \$6.25. Loudspeaker design from the musician's point of view! All you need to know, and you should be able to design your own after reading this.

▶ **BP277—HIGH POWER AUDIO AMPLIFIER CONSTRUCTION** \$6.25. Here's background and practical design information on high power audio amplifiers capable of 300 ± 400 watts r.m.s. You'll find MOSFET and bipolar output transistors in inverting and non-inverting circuits.



◀ **BP302—A CONCISE USER'S GUIDE TO LOTUS 1-2-3 RELEASE 3.1** \$6.25. If you are a PC user and want to upgrade to Lotus 1-2-3 release 3.1, this book can teach you how to do that in the shortest and most effective way.

▶ **BP298—A CONCISE INTRODUCTION TO THE MACINTOSH SYSTEM AND FINDER** \$6.25. This introduction for those new to the Mac, this book also serves as a quick refresher for experienced owners that have not used the machine in some time.



MAIL TO: **Electronic Technology Today, Inc.**
P.O. Box 240
Massapequa Park, NY 11762-0240

SHIPPING CHARGES IN USA AND CANADA

\$0.01 to \$5.00	... \$1.50	\$30.01 to \$40.00	... \$5.50
\$5.01 to \$10.00	... \$2.50	\$40.01 to \$50.00	... \$6.50
\$10.01 to \$20.00	... \$3.50	\$50.01 and above	... \$8.00
\$20.01 to \$30.00	... \$4.50		

SORRY, No orders accepted outside of USA and Canada

Total price of merchandise \$	_____
Shipping (see chart) \$	_____
Subtotal \$	_____
Sales Tax (NYS only) \$	_____
Total Enclosed \$	_____

Name _____
Address _____
City _____ State _____ Zip _____

HAM RADIO

(Continued from page 81)

ing frequency. A good approximation for the values of these components is:

$$C1 = 100 \text{ pF} / \sqrt{f_{\text{MHz}}} \quad [1]$$

and

$$C2 = 1000 \text{ pF} / f_{\text{MHz}} \quad [2]$$

For my prototype, I used slightly different values from the calculated values because of what was in my junkbox, and the circuit worked fine. However, be aware that one of the symptoms of erroneous capacitor selection is that the circuit either won't oscillate, or will only oscillate at certain settings of the resonating coil and variable capacitor. If the C1/C2 values are selected correctly, and the design frequency is within the range of the device, then the circuit should oscillate throughout the entire ranges of resonant tank circuit inductor and capacitor components.

Four external capacitors are used to resonate the inductor; these form the required parallel resonant LC tank circuit. Capacitors C7 through C9 are ordinary NPO, ceramic-disc or silvered-mica capacitors. The fourth capacitor is actually a varactor diode (D1). A varactor diode has a junction capacitance that is a function of the reverse-bias voltage applied to the diode. The diode used for this project is the MV2109 (or NTE613 if you use replacement-line parts), which has a nominal capacitance of about 22 pF at a standard test voltage.

Because the capacitance of the diode is a function of the applied tuning voltage, the oscillating frequency of the NE602 will vary as V_1 is varied. Figure 3 shows the oscillating frequency as a function of the

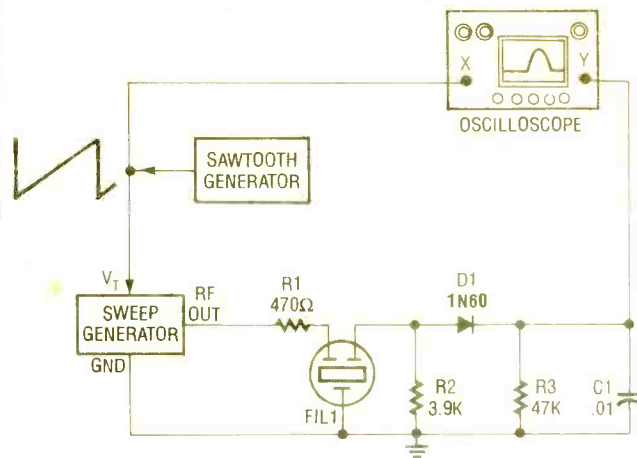

Fig. 4. This is the test set-up needed to measure the frequency response of a filter using the sweep generator. Note that the sawtooth generator feeds both the X (horizontal) input of an X-Y oscilloscope and the V_1 input of the sweep generator.

applied tuning voltage V_1 . Two curves were recorded at two different settings of C8. Note that the curves are not linear, but they are quasilinear in the 3.5- to 7-volt range; that is the range in which we want to operate.

Figure 4 shows the test set-up required to measure the frequency response of a filter. In this example, a 4-kHz bandwidth, ceramic AM filter is tested. It was terminated in the impedances recommended by the manufacturer (R1 and R2 in Fig. 4). A sawtooth generator is used to drive the V_1 input of the sweep-generator circuit, as well as the X-input (horizontal) of an X-Y oscilloscope (not all oscilloscopes have that feature, so check before buying—it's useful). The RF output from the filter is rectified by a germanium diode (D1) and filtered by R3/C1, before being applied to the Y-input (vertical) of the oscilloscope.

Figure 5 is the 455-kHz ± 10 -kHz signal from the sweep generator, clearly showing the swept action (note that on the right, the oscilloscope sync couldn't keep locked). Figure 6 shows the RF response (not rectified) of a tuned circuit

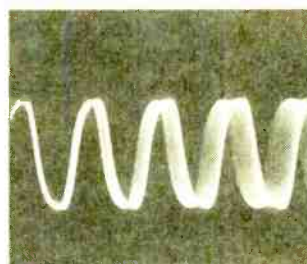

Fig. 5. Here is the 455-kHz, ± 10 -kHz, RF output of the sweep generator, clearly showing the swept action.



Fig. 6. Shown here is RF response (not rectified) of a 455-kHz IF transformer.

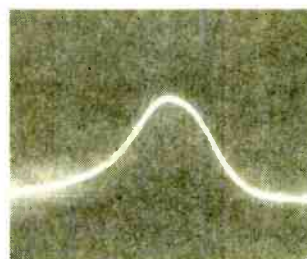

Fig. 7. Rectified response of a ceramic filter, as taken using the set-up in Fig. 4.

(another 455-kHz IF transformer), while Fig. 7 shows the rectified frequency re-

sponse of our ceramic filter.

My next chore will be to add a marker generator circuit so that the frequency-response curve can be calibrated. I calibrated the oscilloscope by noting the deflection as a function of a DC voltage applied to the inputs, but that is crude and not terribly accurate. A 455-kHz crystal oscillator mixed with the sweep signal would place a "pip" on the scope trace at f_c , while 1 kHz or 5 kHz signals would show the other calibration points.

The NE602 sweep generator can be operated at other frequencies by changing C1 and C2 according to Eqs. [1] and [2], and the resonant circuit components according to:

$$f = 1/2\pi\sqrt{LC} \quad [3]$$

where L is in henrys and C is in farads. Keep in mind that Eq. [3] is approximate because the capacitance term (C) must include an allowance for the effect of C1/C2, the input capacitance of the NE602, and stray capacitances caused by the wiring, wire board, and chassis or cabinet. You will invariably find the operating frequency too low if you use Eq. [3] exactly without making these allowances.

CONCLUSION

The NE602 makes a dandy sweep-generator circuit, and it can be used for both alignment of RF circuits and the testing or measurement of their frequency response characteristics. ■

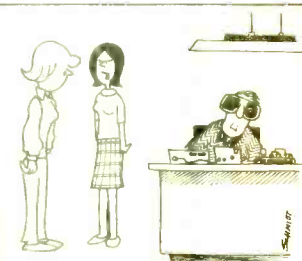

"He says they're safety glasses, but I think he puts them on whenever he wants a nap."

ELECTRONICS MARKET PLACE

FOR SALE

CABLE descrambler liquidation. Major makes and models available. Industry pricing! (Example: Hamlin Combo's, \$44 each... Minimum 10 orders). Call **WEST COAST ELECTRONICS**, 1 (800) 628-9656.

OLD radios, test eqpt, tubes, parts, schematics. Send SASE for list. **VICKERS**, 4244 SW 72 Ter., Davie, FL 33314.

OUR monthly picture flyer lists quality surplus parts at low prices. You'll like it. **STAR-TRONICS**, Box 683, McMinnville, OR 97128.

DESCRAMBLERS, cable TV converters, **lowest** prices, guaranteed, best quality, special Sacramento units, **CNC CONCEPTS INC.**, Box 34503, Minneapolis, MN 55434. 1 (800) 535-1843.

SAM'S photofacts. #11 thru 2520 while stock lasts. \$6.00 per set. Discounts for volume purchases. 1 (800) 274-2081 MC/Visa.

CLASSIFIED AD ORDER FORM

To run your own classified ad, put one word on each of the lines below and send this form along with your check to:

Popular Electronics Classified Ads, 500-B Bi-County Boulevard, Farmingdale, N.Y. 11735

PLEASE INDICATE in which category of classified advertising you wish your ad to appear. For special headings, there is a surcharge of \$11.00.

() Plans/Kits () Business Opportunities () For Sale
() Education/Instruction () Wanted () Satellite Television

Special Category: \$11.00

PLEASE PRINT EACH WORD SEPARATELY, IN BLOCK LETTERS.

(No refunds or credits for typesetting errors can be made unless you clearly print or type your copy.) Rates indicated are for standard style classified ads only. See below for additional charges for special ads. **Minimum: 15 words.**

1	2	3	4	5
6	7	8	9	10
11	12	13	14	15 (\$23.25)
16 (\$24.80)	17 (\$26.35)	18 (\$27.90)	19 (\$29.45)	20 (\$31.00)
21 (\$32.55)	22 (\$34.10)	23 (\$35.65)	24 (\$37.20)	25 (\$38.75)
26 (\$40.30)	27 (\$41.85)	28 (\$43.40)	29 (\$44.95)	30 (\$46.50)
31 (\$48.05)	32 (\$49.60)	33 (\$51.15)	34 (\$52.70)	35 (\$54.25)

We accept MasterCard and Visa for payment of orders. If you wish to use your credit card to pay for your ad fill in the following additional information (Sorry, no telephone orders can be accepted):

Card Number

Expiration Date

PRINT NAME

SIGNATURE

IF YOU USE A BOX NUMBER YOU MUST INCLUDE YOUR PERMANENT ADDRESS AND PHONE NUMBER FOR OUR FILES. ADS SUBMITTED WITHOUT THIS INFORMATION WILL NOT BE ACCEPTED.

CLASSIFIED COMMERCIAL RATE: (for firms or individuals offering commercial products or services) \$1.55 per word prepaid (no charge for ZIP code)...**MINIMUM 15 WORDS**, 5% discount for same ad in 6 issues within one year; 10% discount for 12 issues within one year if prepaid. **NON-COMMERCIAL RATE:** (for individuals who want to buy or sell a personal item) \$1.25 per word, prepaid...no minimum. **ONLY FIRST WORD AND NAME** set in bold caps at no extra charge. Additional bold face (not available as all caps) **30¢ per word additional**. Entire ad in boldface, \$1.85 per word. **TINT SCREEN BEHIND ENTIRE AD:** \$1.90 per word. **TINT SCREEN BEHIND ENTIRE AD PLUS ALL BOLD FACE AD:** \$2.25 per word. **EXPANDED TYPE AD:** \$2.05 per word prepaid. Entire ad in boldface, \$2.45 per word. **TINT SCREEN BEHIND ENTIRE EXPANDED TYPE AD:** \$2.55 per word. **TINT SCREEN BEHIND ENTIRE EXPANDED TYPE AD PLUS ALL BOLD FACE AD:** \$2.95 per word. **DISPLAY ADS:** 1" x 2 1/4"—\$205.00; 2" x 2 1/4"—\$410.00; 3" x 2 1/4"—\$615.00. **General Information:** Frequency rates and prepayment discounts are available. **ALL COPY SUBJECT TO PUBLISHERS APPROVAL. ADVERTISEMENTS USING P.O. BOX ADDRESS WILL NOT BE ACCEPTED UNTIL ADVERTISER SUPPLIES PUBLISHER WITH PERMANENT ADDRESS AND PHONE NUMBER.** Copy to be in our hands on the 18th of the fourth month preceding the date of issue (i.e.; Sept. issue copy must be received by May 18th). When normal closing date falls on Saturday, Sunday or Holiday, issue closes on preceding work day. Send for the classified brochure. Circle Number 49 on the Free Information Card.

CABLE TV DESCRAMBLERS ★ CONVERTERS ★ and ACCESSORIES.

**SAVE MONEY.
DON'T RENT!**

PANASONIC,
PIONEER, JERROLD, OAK,
SCIENTIFIC ATLANTA
AND MORE. LOWEST PRICES.
FREE CATALOG.
(800) 234-1006
CABLE READY COMPANY

CRIBSHEET laminated, of commonly used electronic formulas and symbols, \$3.00 to: **HUMEX**, 16365 Rhyolite Circle, Reno, NV 89511.

TOCOM and Zenith "test" chips. Fully activates unit. \$50.00. Cable descramblers from \$40.00. Orders 1 (800) 452-7090. Information (213) 867-0081.

CB RADIO OWNERS!

We specialize in a wide variety of technical information, parts and services for CB radios. 10-Meter and FM conversion kits, repair books, plans, high-performance accessories. Thousands of satisfied customers since 1976! Catalog \$2

CBC INTERNATIONAL
P.O. BOX 31500PE, PHOENIX, AZ 85046

HUGE 92 page communications catalog of short-wave, amateur and scanner equipment. Antennas, books and accessories too. Send \$1.00 to: **UNIVERSAL RADIO**, 1280 Aida Dr., Dept. PE, Reynoldsburg, OH 43068.

FREE CATALOG

FAMOUS "FIRESTIK" BRAND CB ANTENNAS AND ACCESSORIES. QUALITY PRODUCTS FOR THE SERIOUS CB'er. SINCE 1962
FIRESTIK ANTENNA COMPANY
2614 EAST ADAMS
PHOENIX, ARIZONA 85034

THE no-code ham radio operator's license is here. Pass first try guaranteed. \$4.85. **PINNACLE PRODUCTS**, PO Box 1756, Burlingame, CA 94011.

Quality Microwave TV Antennas

WIRELESS CABLE - IFTS - MMDS - Amateur TV
Ultra High Gain 50db(+) • Tuneable 1.9 to 2.7 Ghz.

- 36-Channel System Complete \$149.95
- 12-Channel System Complete \$114.95
- Call or write (SASE) for "FREE" Catalog

PHILLIPS-TECH ELECTRONICS
P.O. Box 8533 • Scottsdale, AZ 85252
(602) 947-7700 (\$3.00 Credit all phone orders)
MasterCard • Visa • CDD's • Quantity Pricing

LIFETIME WARRANTY

SATELLITE TV

FREE catalog — Do-it-Yourself save 40 — 60%. Lowest prices world wide, systems, upgrades, parts, all major brands factory fresh and warranted. SKYVISION, 2008 Collegeway, Fergus Falls, MN 56537. 1 (800) 334-6455.

CABLE converters all major brands Info & orders 1 (800) 782-0552. FREEWAY INC. s.m.p., PO Box 5036, Burnsville, MN 55337.

★★★★ PRESENTING ★★★★★
**CABLE TV
DESCRAMBLERS**
★★★★ STARRING ★★★★★
JERROLD, HAMLIN, OAK
AND OTHER FAMOUS MANUFACTURERS

- FINEST WARRANTY PROGRAM AVAILABLE
- LOWEST RETAIL/WHOLESALE PRICES IN U.S.
- ORDERS SHIPPED FROM STOCK WITHIN 24 HRS
- ALL MAJOR CREDIT CARDS ACCEPTED

FOR FREE CATALOG ONLY 1-800-345-8927
FOR ALL INFORMATION 1-818-709-9937

PACIFIC CABLE CO., INC.
7325 1/2 Reseda Blvd., Dept. 2008
Reseda, CA 91335

VC-2 board exchange and repair service, tracker V satellite receiver \$869.00. Call for phone quotes. We will not be undersold. SATELLITE TELEVISION, 120 W. Centennial, Muncie, IN 47303. (317) 288-0074 tech support 11-5 E.

SATELLITE TV and cable descrambling secrets. Surveillance transmitter plans. Send stamp for free catalog. COMMUNICATIONS ENGINEERING, 76 Boulevard, Hudson Falls, NY 12839.

SATELLITE TV — Do it yourself — Systems, upgrades, parts. Major brands discounted 40% — 60%. We'll beat everyone's price. L.J.H. Inc. Call LARRY, (609) 596-0656.

**CABLE DESCRAMBLERS
OAK M35B COMBO \$39.95**

Jerrold, Zenith, Hamlin, Sci. Atlanta, Pioneer & MORE! OUR PRICES ARE BELOW WHOLESALE!

CABLE+PLUS
14417 Chase St. #481-B Panorama City, CA 91402
1-800-822-9955 • Other Info. 1-818-785-4500
NO CALIF. SALES — DEALERS WANTED

PLANS & KITS

HOBBY/broadcasting/ham/CB/surveillance transmitters, amplifiers, cable TV, science, bugs, other great projects! Catalog \$1.00 PANAXIS, Box 130-H11, Paradise, CA 95967.

BUILD — five-digit, ohms, capacitance, frequency, pulse, multimeter. Board, and instructions \$9.95. BAGNAL ELECTRONICS, 179 May, Fairfield, CT 06430.

PLANS DC power supply +/-15VDC@1A. Function generator 1Hz to 1MHz sine square triangular DC outputs. Schematics assemblies PL's \$9.95 each. ELECTRICAL ENGINEERING CONSULTANTS, Box 232, Revere, MA 02151.

FM-stereo transmitter kit. Broadcast any audio signal, CD player, VCR to FM stereo radios throughout home/yard. PC board and components: \$22.00. TENTRONIX, 3605 Broken Arrow, Coeur d'Alene, ID 83814.

SURVEILLANCE transmitter kits tune from 65 to 305 MHz. Mains powered duplex, telephone, room, combination telephone/room. Catalog with Popular Communications, Popular Electronics and Radio-Electronics book reviews of "Electronic Eavesdropping Equipment Design," \$2.00. SHEFFIELD ELECTRONICS, 7223A Stony Island Ave., Chicago, IL 60649-2806.

DAZER personal protectors! Lasers! AM/FM/Infrared transmitters! Detectors! More! Kits/assembled. Catalog \$2.00. QUANTUM RESEARCH, 16645-113 Avenue, Edmonton, Alberta T5M 2X2.

**X-Y Scanner Kit
for your Laser**

- 2 Lissajous Oscillators
- 2 Audio Inputs 2 Galvo's
- Computer interface
- Fun to build and use !!

99⁰⁰
4 Lbs 900/20

Silicon Valley Surplus 1273 Industri-prkwy w bldg 460
415-582-6602 Hayward Ca. 94544-7025
CALL OR SEND FOR OUR FREE KIT CATALOG

REMOTE car starter plan. 30 pgs. Universal. Simple. Works! \$12.75 SCHLITZER, 414 Alva, Grand Prairie, TX 75051.

FREE cable and satellite descrambler plans. Send self addressed stamped envelope. MJH INDUSTRY, Box 531, Bronx, NY 10461-0208.

DESCRAMBLER kits. Complete cable kit \$44.95. Complete satellite kit \$49.95. Add \$5.00 shipping. Free brochure. No New York sales. SUMMIT PE, Box 489, Bronx, NY 10465.

CHRISTMAS star. Design for an 8 point sequencing star. Schematics, PCB layout and part sources included. \$10.00. CONTINUOUS CONCEPTS, PO Box 60414, San Diego, CA 92166. CA residents add 7% tax.

FREE CATALOG!
1-800-648-7938
JERROLD HAMLIN OAK ETC
**CABLE TV
DESCRAMBLERS**

- Special Dealer Prices!
- Compare our Low Retail Prices!
- Guaranteed Prices & Warranties!
- Orders Shipped Immediately!

REPUBLIC CABLE PRODUCTS, INC.
4080 Paradise Rd. #15, Dept. PELL
Las Vegas, NV 89109
For all other information (702) 362-9026

GERNSBACK — 1932, two tubes, plug-in coils, DX, shortwave radio. Free plan. BOB RYAN, PO Box 3039, Anaheim, CA 92803.

ROBOTICS — powerful, compact, inexpensive, Z80 based microcomputer perfect for robotic/micro-processor control applications. Plans/application notes \$5.50. ACS, 6220 Shallowford Rd. #152, Chattanooga, TN 37421.

SATELLITE TV descrambler. Build your own. Easy to follow instructions, parts list, circuit board and wiring diagram. Send: \$9.95. ABG ENTERPRISES, 27081C, Halifax, NS, Canada, B3H-4M8.

AUTOMOTIVE electrical system monitor IC controlled with case. Complete kit \$6.95. Assembled \$9.95. S&H \$3.00. NY residents add tax. V.R. ELECTRONICS CORP., PO Box 313, Flushing, NY 11365. (718) 357-9091.

SURVEILLANCE schematic book. Real equipment you can build! \$9.95, VHS, 815 Louisa Drive, Santa Rosa, CA 95404.

PC board etched and drilled for as low as \$.70 per square inch. (407) 767-8196 or fax (407) 767-5969. Or write JM ELECTRONICS, Box 150454, Altamonte Springs, FL 32715-0454.

SURVEILLANCE — countermeasures! Guaranteed lowest prices! Huge catalog \$5.00 (refundable). PROTECTOR, PO Box 520294-E, Salt Lake City, Utah, 84152.

**CABLE TV
"BOXES"**

**Converters-Descramblers
Remote Controls-Accessories**

- ★ Guaranteed Best Prices ★
- ★ 1 Year Warranty - C.O.D.'s ★
- ★ Immediate Shipping ★
- ★ FREE CATALOG ★

Call or Write
NAS/TRANS-WORLD CABLE CO.
3958 North Lake Blvd. • Suite 255
Lake Park, Florida 33403
1-800-442-9333
1-800-848-3997

RC lawn mower plans \$5.00. SCHNELL ENTERPRISES, 5809 Kircher Rd., Columbia, MO 65202.

CONTROL your world with your computer! Interface your computer with robotics projects, radio control, home security and more. Unlimited potential! Complete plans, schematics, programs, only \$12.95 check/m.o. ICDS, Dept-A, PO Box 265, Plainwell, MI 49080.

NINTENDO arcade housing. Simultaneous two player turbo. Authentic arcade style joysticks, buttons, sound. Includes cabinet blueprints, turbo circuit schematic, artwork and layout. \$19.95. Great Christmas surprise. CSI, Box 294475, Lewisville, TX 75029.

KITS, sound and light effects, games, unusual and high tech. Write for free catalog to JM ELECTRONICS, Box 150454, Altamonte Springs, FL 32715-0454.

BEST BY MAIL

Rates: Write National, Box 5, Sarasota, FL 34230

BUSINESS OPPORTUNITIES
EARN THOUSANDS DAILY READING BOOKS. Starter kit \$5.00. GHS, 163 E. Mill Rd., Long Valley, NJ 07853.

FINANCIAL
FAST****CASH****For Your Mortgage or Trust Deed. R&P Capital Resources 800-338-5815.
LOANS AVAILABLE! Business - Personal. No front fees. Easy qualify. (619)693-0498.

MONEYMAKING OPPORTUNITIES
MAKE \$2,000 MONTHLY At Home. Write to: Norton35, 1127 West Fairmont, Fresno, CA 93705.

OF INTEREST TO ALL
CITIZEN BAND RADIO DX. Details \$1.00. CBR, Box 212, Rochelle Park, NJ 07662.

WANTED

INVENTORS! Confused? Need help? Call IMPAC for free information package. USA/Canada: 1 (800) 225-5800. (24 hours!).

INVENTIONS/new products/ideas wanted: Call TLCI for free information/Inventors Newsletter 1 (800) 468-7200 24 hours/day — USA/Canada.

INVENTORS, circuit designer (MSEE) for hire. Affordable design, prototyping and fabrication. CIRCUITS, PO Box 80043, Valley Forge, PA 19485.

T.V. FILTERS

T.V. notch filters, phone recording equipment, brochure \$1.00. MICRO THinc., Box 63/6025, Margate, FL 33063. (305) 752-9202.

BUSINESS OPPORTUNITIES

YOUR own radio station! Licensed/unlicensed. AM, FM, TV, cable. Information \$1.00 BROADCASTING, Box 130-H11, Paradise, CA 95967.

EASY work! Excellent pay! Assemble products at home. Call for information (504) 641-8003 Ext. 5730.

BIG PROFITS **ELECTRONIC ASSEMBLY BUSINESS**

Start home spare time. Investment knowledge or experience unnecessary. **BIG DEMAND** assembling electronic devices. Sales handled by professionals. Unusual business opportunity.

FREE: Complete illustrated literature
BARTA PE-00 Box 248
Wainut Creek Calif 94597

MAKE \$50.00/hr working evenings or weekends in your own electronics business. Send for free facts. **MJPI INDUSTRY**, Box 531, Bronx, NY 10461.

MAKE \$75,000.00 to \$250,000.00 yearly or more fixing IBM color monitors. No investment, start doing it from your home (a telephone required). Information, USA, Canada \$2.00 cash for brochure, other countries \$10.00 US funds. **RANDALL DISPLAY**, Box 2168-H, Van Nuys, CA 91404, USA. Fax (818) 990-7803.

HOME assembly work available! Guaranteed easy money! Free details! **HOMEWORK-P**, Box 520, Danville, NH 03819.

\$ DISTRIBUTORS needed \$. New mini satellite antenna. Tremendous demand. 100% profit. No experience necessary. Serious inquiries only. 1 (800) 762-7952 Ex 774 24 hours.

HUGE profits best home businesses. Free details too 29 cent stamps. **RCF**, Box 177-P, Mastic, NY 11950.

MAKE \$\$\$! Become an American electronics dealer! Profit opportunities since 1965. Call Wayne Marks, 1 (800) 872-1373.

ANTIQUE RADIO CLASSIFIED
Free Sample!
Antique Radio's
Largest Circulation Monthly
Articles, Ads & Classifieds.
6-Month Trial: \$15. 1-Yr: \$27(\$40-1st Class).
A.R.C., P.O. Box 802-L8, Carlisle, MA 01741



EDUCATION/INSTRUCTION

VCR repair. Save money — make big profits! Learn how from *How to Keep Your VCR Alive*. "This detailed, step-by-step manual enables anyone with no previous knowledge or experience to fix most VCR problems easily, quickly, and inexpensively with a few simple tools." — *Small Press Review*. Highly recommended by *Popular Electronics*, *Modern Electronics*, *Popular Communications*, *Electronic Servicing*, *Videomaker*, *Library Journal*, and many other electronics and video magazines. "Far better than Viejo at 1/7 the cost." 400+ page book, with 724 illustrations, plus professional head-cleaning tool, \$24.95. Check B. Daltons and Waldenbooks. Or write **WORTHINGTON PUBLISHING**, PO Box 16691H, Tampa, FL 33687-6691. Or call 1 (800) 233-8277 toll-free for Visa or MC. Money-back satisfaction guarantee!

LEARN electronics & digital. Teach yourself with the Crash Course in Electronics Technology (\$21.95 plus \$2.50 S&H) and Crash Course in Digital Technology (\$19.95 plus \$2.50 S&H). Programmed self study texts. Good introduction, refresher or update. Both \$37.75 plus \$4.00 S&H. Send check or money order to **TSI**, 6050 NW 68th Street, Parkland, FL 33067.

VSWR, return loss, testing and troubleshooting guide. \$9.95. **MORGAN'S**, RD1, Box 1654, Moscow, PA 18444.

CABLE EQUIPMENT

CABLE TV secrets — the outlaw publication the cable companies tried to ban. HBO, Movie Channel, Showtime, descramblers, converters, etc. Suppliers list included. \$9.95. **CABLE FACTS**, Box 711-H, Pataskala, OH 43062.

FULL- OR PART-TIME JOB/BUSINESS:

Learn VCR repair!

Professional-level home study program. Master easy-to-learn, high-profit repairs *without* investing in costly high-tech instruments. Send or call today.

Free career kit: 800-223-4542

Name _____
Address _____
City _____ State _____ Zip _____

The School of VCR Repair, Dept. VM341
2245 Perimeter Park, Atlanta, GA 30341





ANNOUNCING:
AN END TO HIGH MONTHLY CABLE FEES!

All Jerrold, Oak, Hamlin, Zenith, Scientific Atlanta, Magnavox and all specialized cable equipment available for shipment within 24 hours. For fast service MC/VISA or C.O.D. telephone orders accepted. 60 Day Guarantee (Quantity Discounts) Send self-addressed Stamped envelope.

1-800-232-5017
C.O.D. ORDERS ACCEPTED

CABLE-TRONICS, INC.
1304 E. Algonquin Road Suite 501
Algonquin, Illinois 60102

GET OUT OF THE DARK.

Open your eyes and see just how many subjects are covered in the new edition of the Consumer Information Catalog. It's free just for the asking and so are nearly half of the 200 federal publications described inside. Booklets on subjects like financial and career planning; eating right, exercising, and staying healthy; housing and child care; federal benefit programs. Just about everything you would need to know. Write today. We'll send you the latest edition of the Consumer Information Catalog, which is updated and published quarterly. It'll be a great help, you'll see. Just write:

Consumer Information Center
Department TD
Pueblo, Colorado 81009

U S General Services Administration

SPECIAL FROM ETT

PCP101—PRACTICAL DIGITAL ELECTRONICS HANDBOOK ... \$9.95. Introduces digital circuits, logic gates, bistables and timers, as well as micro-processors, memory and input/output devices. Special section on digital test gear projects.



PCP102—INTRODUCING DIGITAL AUDIO ... \$9.95 Shows what is involved in the digital part of audio signals, particularly in the newest devices such as CD, DAT and sampling. Bridges the gap of understanding for the technician and enthusiast.



PCP103—PRACTICAL MIDI HANDBOOK ... \$9.95. Covers all MIDI based equipment you can use—keyboards, drum machines, sequencers, effects units, mixers, drum pads and guitars. Also a section on computer music that covers software and more.



PCP104—ELECTRONICS BUILD & LEARN, Second Edition ... \$9.95. You start by assembling a circuit demonstrator that is then used to build and investigate a variety of useful circuits including oscillators, multi-vibrators, bistables and logic circuits.



PCP105—MAKE MONEY FROM HOME RECORDING ... \$10.00. Now that you've spent all that money on all that recording gear, wouldn't it be nice to get some of it back? Well here's the book that can show you how.



PCP106—SYNTHESIZERS FOR MUSICIANS ... \$10.00. All current popular forms of synthesis explained; LA, additive, phase distortion, FM and sampling. Get the sounds you want from your synth. Written especially for musicians.



MAIL TO: **Electronic Technology Today, Inc.**
P.O. Box 240
Massapequa Park, NY 11762-0240

SHIPPING CHARGES IN USA AND CANADA

\$0.01 to \$5.00 ...	\$1.50	\$30.01 to 40.00 ..	\$5.50
\$5.01 to \$10.00 ..	\$2.50	\$40.01 to 50.00 ..	\$6.50
\$10.01 to 20.00 ..	\$3.50	\$50.01 and above ..	\$8.00
\$20.01 to 30.00 ..	\$4.50		

SORRY, No orders accepted outside of USA and Canada

Total price of merchandise	\$ _____
Shipping (see chart)	\$ _____
Subtotal	\$ _____
Sales Tax (NYS only)	\$ _____
Total Enclosed	\$ _____

Name _____
Address _____
City _____ State _____ Zip _____

NOVEMBER 1991

ADVERTISING INDEX

POPULAR ELECTRONICS magazine does not assume any responsibility for errors that may appear in the index below.

Free Information No.	Page		Page
8	AMC Sales	14	—
—	Amazing Concepts	20	11
—	Antique Radio Classified	95	—
—	Barta	95	—
6	C & S Sales	11	17
—	CBC International	93	—
—	CIE	9	—
—	Cable Plus	94	—
—	Cable Ready Company	93	9
—	Cable-Tronics	95	—
—	Command Productions	14	14
7	Cook's Institute	87	—
10	Datak Corporation	21	—
—	EIA	26	5
—	Electronic Tech. Today	91, 95	—
—	Electronic Tech. Today	CV2	15
—	Electronics Book Club	5	—
—	Electronics Engineers B.C.	19	—
—	Enterprize Electronics	16	16
—	Firestik II	93	12,13
	Grantham College	17	—
	Heathkit	15	—
	HighText Publications, Inc.	83	—
	ISCET	89	—
	Kepro Circuit Systems	13	—
	Monitoring Times	81	—
	NAS/TransWorld	94	—
	NRI Schools	25	—
	Protel Technology	77	—
	Pacific Cable	94	—
	People's College	3	—
	P.E. Reprint Bookstore	86	—
	Phillips Tech.	94	—
	Radio Shack	CV4	—
	Republic Cable	94	—
	SCO Electronics	10	—
	Silicon Valley Surplus	94	—
	The School Of VCR Repair	95	—
	US Cable	10	—
	Viejo Publications	16,20	—

ADVERTISING SALES OFFICE

Gernsback Publications, Inc.
500-B Bi-County Blvd.
Farmingdale, NY 11735
1-(516) 293-3000
President: Larry Steckler
Assistant to the President: Christina Estrada

For Advertising ONLY
516-293-3000
Fax 1-516-293-3115
Larry Steckler
publisher
Arlene Fishman
advertising director
Denise Haven
advertising assistant
Kelly McQuade
credit manager

Customer Service/Order Form
1-800-435-0715
1-800-892-0753
7:30 AM - 8:30 PM EST

SALES OFFICES

EAST/SOUTHEAST
Stanley Levitan, Eastern Sales Manager
1 Overlook Ave.
Great Neck, NY 11021
1-516-487-9357, 1-516-293-3000
Fax 1-516-487-8402

MIDWEST/Texas/Arkansas/Okla.
Ralph Bergen, Midwest Sales Manager
One Northfield Plaza, Suite 300
Northfield, IL 60093-1214
1-708-446-1444
Fax 1-708-559-0562

PACIFIC COAST/Mountain States
Marvin Green, Pacific Sales Manager
5430 Van Nuys Blvd, Suite 316
Van Nuys, CA 91401
1-818-986-2001
Fax 1-818-986-2009

SCREEN DUMP SCRIMAGE

(Continued from page 66)

Each screen dump takes several minutes, depending on the density selected (low, normal, high, or super) and the printer used. With a color printer you can choose from over 200 colors, and a program included with Pizazz prints a color-chart to show you the choices that are available.

The default values are well chosen, and I found that I usually only needed to specify reverse printing (black dots on a white background) and normal density for a darker printout than that provided by the low-density default draft mode.

Like all powerful programs, Pizazz Plus takes some getting used to, and the number of options makes it important that you read the 132-page illustrated manual, with its detailed 8-page Table of Contents and 4-page Index.

The Software Labs. Incidentally, I don't want to overlook mentioning the neat programs available from National Labs (3767 Overland Ave. #112, Los An-



LIMITED WARRANTY
THIS DISK IS WARRANTED TO BE READABLE. THE SOFTWARE LABS HEREBY DISCLAIMS ALL OTHER EXPRESS OR IMPLIED WARRANTIES FOR THIS SOFTWARE, INCLUDING THE WARRANTIES OF MERCHANTABILITY AND FITNESS FOR A PARTICULAR PURPOSE. IN NO EVENT WILL THE SOFTWARE LABS BE LIABLE FOR ANY DAMAGES, INCLUDING ANY LOST PROFITS, LOST SAVINGS OR OTHER INCIDENTAL OR CONSEQUENTIAL DAMAGES ARISING OUT OF THE USE OR INABILITY TO USE THIS SOFTWARE. IF THIS DISK PROVES TO BE UNREADABLE, PLEASE RETURN IT FOR AN IMMEDIATE REPLACEMENT.

Fig. 3. With some changes in shading, this GRAFPLUS black and white screen dump can provide you with a better feeling of what the actual screen looked like.

geles, CA 90034; Tel. 1-800-359-9998). For \$3.60 (including US postage) they will send you a 360K 5.25-inch sample disk with 44 useful programs and utilities, plus a copy of their 72-page catalog that gives detailed descriptions of hundreds of programs. Add \$1 for a 3.5-inch microdiskette, and \$10 for foreign shipping.

Caution. Some programs (like Microssoft's Flight Simulator) capture the keyboard and don't allow either GRAFPLUS or Pizazz to dump a screen to your printer. In such circumstances you can't get screen dumps unless you are an accomplished programmer that can get into the program and change something. ■

Never before has so much professional information on the art of detecting and eliminating electronic snooping devices—and how to defend against experienced information thieves—been placed in one VHS video. If you are a Fortune 500 CEO, an executive in any hi-tech industry, or a novice seeking entry into an honorable, rewarding field of work in countersurveillance, you must view this video presentation again and again.

Wake up! You may be the victim of stolen words—precious ideas that would have made you very wealthy! Yes, professionals, even rank amateurs, may be listening to your most private conversations.

Wake up! If you are not the victim, then you are surrounded by countless victims who need your help if you know how to discover telephone taps, locate bugs, or “sweep” a room clean.

There is a thriving professional service steeped in high-tech techniques that you can become a part of! But first, you must know and understand Countersurveillance Technology. Your very first insight into this highly rewarding field is made possible by a video VHS presentation that you cannot view on broadcast television, satellite, or cable. It presents an informative program prepared by professionals in the field who know their industry, its techniques, kinks and loopholes. Men who can tell you more in 45 minutes in a straightforward, exclusive talk than was ever attempted before.

Foiling Information Thieves

Discover the targets professional snoopers seek out! The prey are stock brokers, arbitrage firms, manufacturers, high-tech companies, any competitive industry, or even small businesses in the same community. The valuable information they filch may be marketing strategies, customer lists, product formulas, manufacturing techniques, even advertising plans. Information thieves eavesdrop on court decisions, bidding information, financial data. The list is unlimited in the mind of man—especially if he is a thief!

You know that the Russians secretly installed countless microphones in the concrete work of the American Embassy building in Moscow. They converted



**HAVE YOUR
VISA or MC CARD
AVAILABLE**

what was to be an embassy and private residence into the most sophisticated recording studio the world had ever known. The building had to be torn down in order to remove all the bugs.

Stolen Information

The open taps from where the information pours out may be from FAX's, computer communications, telephone calls, and everyday business meetings and lunchtime encounters. Businessmen need counselling on how to eliminate this information drain. Basic telephone use coupled with the user's understanding that someone may be listening or recording vital data and information greatly reduces the opportunity for others to purloin meaningful information.

The professional discussions seen on the TV screen in your home reveals how to detect and disable wiretaps, midget radio-frequency transmitters, and other bugs, plus when to use disinformation to confuse the unwanted listener, and the technique of voice scrambling telephone communications. In fact, do you know how to look for a bug, where to look for a bug, and what to do when you find it?

Bugs of a very small size are easy to build and they can be placed quickly in a matter of seconds, in any object or room. Today you may have used a telephone handset that was bugged. It probably contained three bugs. One was a phony bug to fool you into believing you found a bug and secured the telephone. The second bug placates the investigator when he finds the real thing! And the third bug is found only by the professional, who continued to search just in case there were more bugs.

The professional is not without his tools. Special equipment has been designed so that the professional can sweep a room so that he can detect voice-activated (VOX) and remote-activated bugs. Some of this equipment can be operated by novices, others require a trained countersurveillance professional.

The professionals viewed on your television screen reveal information on the latest technological advances like laser-beam snoopers that are installed hundreds of feet away from the room they snoop on. The professionals disclose that computers yield information too easily.

This advertisement was not written by a countersurveillance professional, but by a beginner whose only experience came from viewing the video tape in the privacy of his home. After you review the video carefully and understand its contents, you have taken the first important step in either acquiring professional help with your surveillance problems, or you may very well consider a career as a countersurveillance professional.

The Dollars You Save

To obtain the information contained in the video VHS cassette, you would attend a professional seminar costing \$350-750 and possibly pay hundreds of dollars more if you had to travel to a distant city to attend. Now, for only \$49.95 (plus \$4.00 P&H) you can view *Countersurveillance Techniques* at home and take refresher views often. To obtain your copy, complete the coupon below or call toll free.

RADIO-ELECTRONICS VIDEO OFFER **PE**
 500-B Bi-Country Blvd.
 Farmingdale, NY 11735

Please rush my copy of the Countersurveillance Techniques Video VHS Cassette for \$49.95 plus \$4.00 for postage and handling.

No. of Cassettes ordered _____
 Amount of payment \$ _____

Bill my VISA MasterCard
 Card No. _____
 Expire Date _____ / _____

Signature _____
 Name _____
 Address _____
 City _____ State _____ ZIP _____

All payments in U.S.A. funds. Canadians add \$4.00 per VHS cassette. No foreign orders. New York State residents add applicable sales tax.

PARTS PLACESM

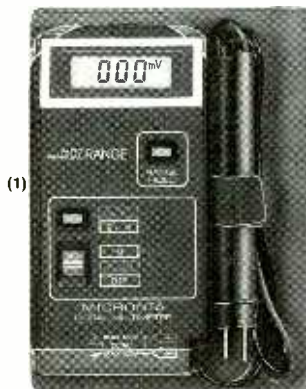

(1) **NEW! "Shirt Pocket" Multimeter.** Take it along! Features LCD display, autoranging with manual override, continuity sounder. Measures to 400 volts AC/DC and resistance. With fold-up vinyl case, manual and replaceable batteries. #22-169 27.95

(1)

(2) **NEW! Building Power Supplies.** Easy-to-understand, 96-page book explains linear and switching supplies. Includes complete plans for building five useful supplies with Radio Shack parts. #276-5025 4.95



(2)

(3) **Mini Audio Amplifier.** Great for computer voice/music synthesis, signal tracing and more. Has a built-in speaker, 1/8" headphone jack, 1/8" input jack and volume control. Put one on your bench today! #277-1008 11.95

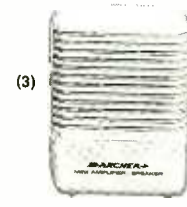

(3)

(4) **Digital Logic Probe.** LEDs and tone outputs reveal logic states instantly. It's the fast way to check operation and pinpoint problems in all types of digital circuits. #22-303 16.95



(4)

Parts Special-Order Hotline. Your local Radio Shack store stocks over 1000 popular electronic components. Plus, we can special-order over 10,000 items from our warehouse—linear and digital ICs, transistors and diodes, vacuum tubes, crystals, phono cartridges and styli, even SAMS[®] service manuals. Your order is sent directly to your Radio Shack store and we notify you when it arrives. Delivery time for most items is one week and there are no postage charges or minimum order requirements.

(1) **Shielded RS-232 Jumper Box.** Top-quality inline D-sub 25 adapter. Wire the included jumper wires and board to suit your need. #276-1403 9.95

(2) **Computer RS-232 Tester.** Dual-color LEDs monitor seven data/control lines to help you spot problems quickly. D-sub 25. Connects inline. #276-1401 14.95

(3) **Grounded-Tip Soldering Iron.** 15W. #64-2051 7.49

(4) **Vacuum-Type Desoldering Tool.** #64-2120 6.95

(5) **Locking Forceps.** 6" long. Stainless. #64-1866 4.95

(6) **Rosin Soldering Paste Flux.** 1 oz. #64-021 1.79

(7) **Lead-Free Solder.** 96% tin, 4% silver. 0.25 oz. #64-025 1.99

(8) **10-Amp Microwave Oven Fuses.** #270-1256 Pkg. of 2/1.29

(9) **2-Amp Fast-Acting Fuses.** #270-1275 Pkg. of 3/79c

(10) **5-Amp "Blade" Vehicle Fuses.** #270-1205 Pkg. of 2/89c

Computer/Printer/Business Machine AC Power Cords. 6 feet long.

(11) **Extension.** Just plug in to lengthen existing cord. #278-1259 4.99

(12) **With Space-Saving 90° CEE Connector.** #278-1260 5.99

(13) **With Straight CEE Connector.** #278-1257 3.99

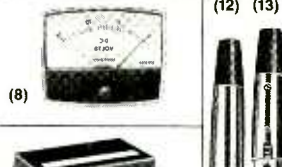
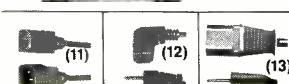
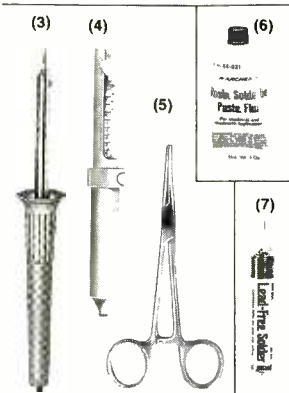
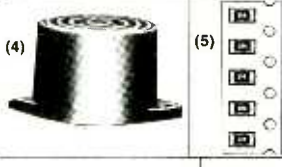
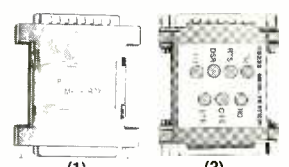
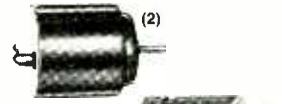

(1) **Voltage Regulator ICs.** Feature built-in overload protection and thermal shutdown. Great for custom projects. Maximum input: 35VDC. 7805. 5V. #276-1770 1.19
7812. 12V. #276-1771 1.19

(2) **Low-Voltage Motor.** Just the thing for science projects, robotics and solar power demos. Operates from 1 1/2 to 3VDC. About 1 1/2" long. #273-223 99c

(3) **High-Speed 12VDC Motor.** Up to 15,200 RPM, no load. About 2" long. #273-255 2.99

(4) **"Ding-Dong" Chime.** This IC and mini-speaker combo is ideal for a customer-entry alert or doorbell. Produces 80 dB sound pressure at 12VDC. Operates from 6 to 18VDC. #273-071 8.99

(5) **Surface-Mount Resistors.** 200-piece assortment of 15 popular values. Rated 1/8 watt, 5%. #271-313 Set 4.99

(6) **Metal Project Cabinet.** An attractive, easy-to-drill housing at a low price. 3 x 5 1/4 x 5 7/8". #270-253 6.79

(7) **Power Supply Project Case.** Vented 2 1/2 x 4 5/8 x 3 1/4" molded case. #270-287 3.99

(8) **0 to 15 DC Voltmeter.** Quality jeweled movement. #270-1754 7.95

(9) **Box/Board Combo.** Molded enclosure plus predrilled 2 x 3 1/8" board, labels and more. #270-291 4.99

(10) **Eight-Position Audio Phono Jack Board.** #274-370 1.69

(11) **1:1 Audio Transformer.** Z: 600-900Ω. #273-1374 3.59

(12) **Three-Pin XLR Mike Plug.** Metal body. #274-010 2.99

(13) **Three-Pin XLR Inline Socket.** #274-011 2.99

(14) **Three-Pin XLR Panel Socket.** #274-013 3.69

Since 1921 Radio Shack has been the place to obtain up-to-date electronic parts as well as quality tools, test equipment and accessories at low prices. Our 7000 locations are ready to serve you—NOBODY COMPARES

Prices apply at participating Radio Shack stores and dealers. Radio Shack is a division of Tandy Corporation

Radio Shack
AMERICA'S TECHNOLOGY STORESM

CIRCLE 5 ON FREE INFORMATION CARD