

Popular Electronics[®]

MARCH 1991

BUILD A LAVA LAMP

Have hours of psychedelic fun

DESIGN YOUR OWN SPEAKERS

The crossover network is the key

ELIMINATING INTERFERENCE

Get rid of the toughest problems

BUILD THE $\times 4$ LOGIC PROBE

A 4-channel probe for your bench

CELLULAR TELEPHONES

Learn how they work

CHEAP LINK

Move files between PC's

SHOOT THE CLASSIC MILK DROP

Take breathtaking photos like this one with our time-delay flash-trigger circuit

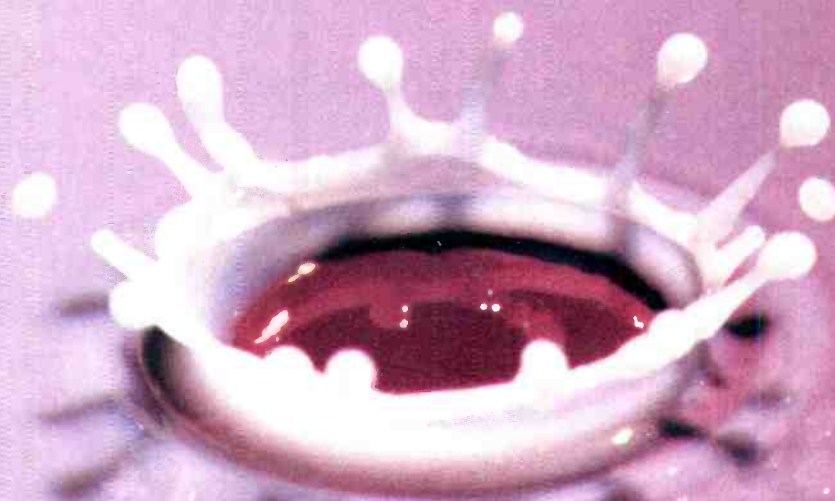

A
GERNSBACK
PUBLICATION

#2110***** 5-DIGIT 60506
#60506DHM997GADD6# FEB92 34
ROBERT DAHM RESF
997 GRAND AVE 064
AURORA, IL 60506

3 NEW
FactCards
IN THIS ISSUE

\$2.95 U.S.
\$3.75 CANADA



Never before has so much professional information on the art of detecting and eliminating electronic snooping devices—and how to defend against experienced information thieves—been placed in one VHS video. If you are a Fortune 500 CEO, an executive in any hi-tech industry, or a novice seeking entry into an honorable, rewarding field of work in countersurveillance, you must view this video presentation again and again.

Wake up! You may be the victim of stolen words—precious ideas that would have made you very wealthy! Yes, professionals, even rank amateurs, may be listening to your most private conversations.

Wake up! If you are not the victim, then you are surrounded by countless victims who need your help if you know how to discover telephone taps, locate bugs, or "sweep" a room clean.

There is a thriving professional service steeped in high-tech techniques that you can become a part of! But first, you must know and understand Countersurveillance Technology. Your very first insight into this highly rewarding field is made possible by a video VHS presentation that you cannot view on broadcast television, satellite, or cable. It presents an informative program prepared by professionals in the field who know their industry, its techniques, kinks and loopholes. Men who can tell you more in 45 minutes in a straightforward, exclusive talk than was ever attempted before.

Foiling Information Thieves

Discover the targets professional snoopers seek out! The prey are stock brokers, arbitrage firms, manufacturers, high-tech companies, any competitive industry, or even small businesses in the same community. The valuable information they filch may be marketing strategies, customer lists, product formulas, manufacturing techniques, even advertising plans. Information thieves eavesdrop on court decisions, bidding information, financial data. The list is unlimited in the mind of man—especially if he is a thief!

You know that the Russians secretly installed countless microphones in the concrete work of the American Embassy building in Moscow. They converted



**HAVE YOUR
VISA or MC CARD
AVAILABLE**

what was to be an embassy and private residence into the most sophisticated recording studio the world had ever known. The building had to be torn down in order to remove all the bugs.

Stolen Information

The open taps from where the information pours out may be from FAX's, computer communications, telephone calls, and everyday business meetings and lunchtime encounters. Businessmen need counselling on how to eliminate this information drain. Basic telephone use coupled with the user's understanding that someone may be listening or recording vital data and information greatly reduces the opportunity for others to purloin meaningful information.

The professional discussions seen on the TV screen in your home reveals how to detect and disable wiretaps, midjet radio-frequency transmitters, and other bugs, plus when to use disinformation to confuse the unwanted listener, and the technique of voice scrambling telephone communications. In fact, do you know how to look for a bug, where to look for a bug, and what to do when you find it?

Bugs of a very small size are easy to build and they can be placed quickly in a matter of seconds, in any object or room. Today you may have used a telephone handset that was bugged. It probably contained three bugs. One was a phony bug to fool you into believing you found a bug and secured the telephone. The second bug placates the investigator when he finds the real thing! And the third bug is found only by the professional, who continued to search just in case there were more bugs.

The professional is not without his tools. Special equipment has been designed so that the professional can sweep a room so that he can detect voice-activated (VOX) and remote-activated bugs. Some of this equipment can be operated by novices, others require a trained countersurveillance professional.

The professionals viewed on your television screen reveal information on the latest technological advances like laser-beam snoopers that are installed hundreds of feet away from the room they snoop on. The professionals disclose that computers yield information too easily.

This advertisement was not written by a countersurveillance professional, but by a beginner whose only experience came from viewing the video tape in the privacy of his home. After you review the video carefully and understand its contents, you have taken the first important step in either acquiring professional help with your surveillance problems, or you may very well consider a career as a countersurveillance professional.

The Dollars You Save

To obtain the information contained in the video VHS cassette, you would attend a professional seminar costing \$350-750 and possibly pay hundreds of dollars more if you had to travel to a distant city to attend. Now, for only \$49.95 (plus \$4.00 P&H) you can view *Countersurveillance Techniques* at home and take refresher views often. To obtain your copy, complete the coupon below or call toll free.

RADIO-ELECTRONICS VIDEO OFFER **PE**

500-B Bi-County Blvd.
Farmingdale, NY 11735

Please rush my copy of the Countersurveillance Techniques Video VHS Cassette for \$49.95 plus \$4.00 for postage and handling.

No. of Cassettes ordered _____
Amount of payment \$ _____

Bill me VISA MasterCard
Card No. _____
Expire Date _____ / _____

Signature _____
Name _____
Address _____
City _____ State _____ ZIP _____

All payments in U.S.A. funds. Canadians add \$4.00 per VHS cassette. No foreign orders. New York State residents add applicable sales tax.

Popular Electronics®

THE MAGAZINE FOR THE ELECTRONICS ACTIVIST!

CONSTRUCTION ARTICLES

BUILD A LAVA LAMP	Ralph Hubscher	31
<i>Lava lamps are as easy to build as they are fascinating to behold</i>		
SHOOT THE CLASSIC MILK DROP	James R. Bailey	40
<i>Capture breathtaking photographs with our time-delay, flash-trigger circuit</i>		
BUILD THE X4 LOGIC PROBE	John Yacono and Marc Spiwak	55
<i>Speed up your troubleshooting tasks with this four-channel logic tester</i>		

FEATURE ARTICLES

HOW TO DESIGN YOUR OWN SPEAKERS	Richard A. Honeycutt	34
<i>Explore the ins and outs of speaker crossovers, and learn to design your own speakers</i>		
ALL ABOUT CELLULAR TELEPHONES	Stephen J. Bigelow	58
<i>Read about the technology that lets you reach-out-and-touch someone while you're on the go</i>		
THE DIGITAL ELECTRONICS COURSE	Robert A. Young	64
<i>Getting familiar with analog-to-digital converters</i>		
ELIMINATING INTERFERENCE	Joseph J. Carr	67
<i>Here are some simple measures that you can take to eliminate or reduce radio-interference problems</i>		
THE CHEAP LINK FILE-TRANSFER SYSTEM	Fred Blechman	70
<i>An inexpensive way to move data between two computers, even when their disk formats are not compatible</i>		

PRODUCT REVIEWS

GIZMO		43
<i>Including: Canon EOS Rebel SLR Camera, Fisher Research Labs 1280-X Wader Metal Detector, Fisher FVC-880 8mm Camcorder, and more</i>		
HANDS-ON REPORT		73
<i>The Heathkit Most Accurate Clock</i>		
PRODUCT TEST REPORT	Len Feldman	76
<i>Pioneer CLD-1080 Laserdisc CD Player</i>		

COLUMNS

THINK TANK	Byron G. Wels	24
<i>Changing of the guard</i>		
ANTIQUÉ RADIO	Marc Ellis	78
<i>Mailbag time once more</i>		
COMPUTER BITS	Jeff Holtzman	80
<i>Indispensable software</i>		
FUN SOFTWARE	Fred Blechman	82
<i>Fun software that measures up</i>		
HAM RADIO	Joseph J. Carr	84
<i>Using digital frequency counters</i>		
DX LISTENING	Don Jensen	86
<i>Does the future of SW lie in SSB?</i>		
CIRCUIT CIRCUS	Charles D. Rakes	88
<i>Oscillator roundup</i>		
SCANNER SCENE	Marc Saxon	94
<i>A high-tech scanner</i>		

DEPARTMENTS

EDITORIAL	Carl Laron	2
LETTERS		3
ELECTRONICS LIBRARY		6
NEW PRODUCTS		14
ADVERTISERS INDEX		106

Popular Electronics (ISSN 1042-170X) Published monthly by Gernsback Publications, Inc., 500-B B-County Boulevard, Farmingdale, NY 11735. Second-Class postage paid at Farmingdale, NY and at additional mailing offices. One-year, twelve issues, subscription rate U.S. and possessions \$21.95, Canada \$26.95, all other countries \$29.45. Subscription orders payable in U.S. funds only. International Postal Money Order, or check drawn on a U.S. bank. U.S. single copy price \$2.95. © 1990 by Gernsback Publications, Inc. All rights reserved. **Hands-on Electronics** and **Gizmo** trademarks are registered in U.S. and Canada by Gernsback Publications, Inc. **Popular Electronics** trademark is registered in U.S. and Canada by **Electronic Technology Today, Inc.** and is licensed to Gernsback Publications. Printed in U.S.A.

Postmaster: Please send address changes to **Popular Electronics**, Subscription Dept., P.O. Box 338, Mount Morris, IL 61054-9932.

A stamped self-addressed envelope must accompany all submitted manuscripts and/or artwork or photographs if their return is desired should they be rejected. We disclaim any responsibility for the loss or damage of manuscripts and/or artwork or photographs while in our possession or otherwise.

As a service to readers, **Popular Electronics** publishes available plans or information relating to newsworthy products, techniques, and scientific and technological developments. Because of possible variances in the quality and condition of materials and workmanship used by readers, **Popular Electronics** disclaims any responsibility for the safe and proper functioning of reader-built projects based upon or from plans or information published in this magazine.

Larry Steckler

EHF, CET

Editor-In-Chief and Publisher

EDITORIAL DEPARTMENT

Carl Laron

Editor

Robert A. Young

Associate Editor

John J. Yacono

Associate Editor

Byron G. Wels, K2AVB

Associate Editor

Teri Scaduto

Assistant Editor

Kathy Terenzi

Editorial Assistant

Marc Spiwak

Editorial Associate

Fred Blechman

Joseph J. Carr, K4IPV

Marc Ellis

Len Feldman

Jeffrey K. Holtzman

Don Jensen

Charles D. Rakes

Marc Saxon

Contributing Editors

PRODUCTION DEPARTMENT

Ruby M. Yee

Production Director

Karen S. Brown

Production Manager

Marcella Amoroso

Production Assistant

Janice Box

Editorial Production

ART DEPARTMENT

Andre Duzant

Art Director

Injae Lee

Illustrator

Russell C. Truelson

Illustrator

Jacqueline P. Cheeseboro

Circulation Director

Michele Torrillo

P-E Bookstore

BUSINESS AND EDITORIAL OFFICES

Gernsback Publications, Inc.

500-B Bi-County Blvd.

Farmingdale, NY 11735

1-516-293-3000

Fax: 1-516-293-3115

President: **Larry Steckler**

Vice President: **Cathy Steckler**

Customer Service/Order Entry

1-800-435-0715

In IL 1-800-892-0753

7:30 AM - 8:30 PM EST

Advertising Sales offices listed on page 106

Cover photography by James R. Bailey

Composition by
Mates Graphics



The
Audit
Bureau
of Circulation



The publisher has no knowledge of any proprietary rights which will be violated by the making or using of any items disclosed in this issue.

A QUESTION OF BALANCE

Putting together an issue of **Popular Electronics** is somewhat akin to walking a circus tightrope: You have to watch your balance if you want to avoid a disastrous fall.

Just as in walking that tightrope, balance is the key to our success, or failure. Each issue we try to come up with a story lineup that looks at as many different aspects of the electronics hobby as possible.

Take this issue. As you leaf through its pages, you'll find articles covering audio, radio, photography, computers, communications, and more. And that's all in addition to our consumer-electronics reviews and the coverage given to the various specialized segments of our hobby in our regular columns.

But there is another important aspect to our search for balance: We try to balance the serious side of electronics with the fun side that any enjoyable hobby must have. For those of a more serious bent, there's the X4 Logic Probe—a four-channel logic tester that can make testing and troubleshooting digital circuits a lot easier.

And we haven't forgotten those who just wanna have fun: For you there's the Lava Lamp. That relic from the psychedelic 1960's is as much fun to build as it is to watch.

No matter what your interest in—or attitude toward—electronics is, we think you'll find something you'll like in this, and every issue of **Popular Electronics**.

Carl Laron
Editor

LETTERS

LIGHT DIMMER KIT

Ordering information for the light-dimmer circuit used in the "Electronic Novelty Light" (**Popular Electronics**, December 1990) was inadvertently omitted from the article. The light dimmer is available in kit form (Catalog # C4655) for \$5.95 from *The Electronic Goldmine*, P.O. Box 5408, Scottsdale, AZ 85261; Tel: 602-451-7454. The kit includes an etched-and-drilled PC board and all components, including an AC line cord and plug. The company requires a \$10.00 minimum order and has a flat \$3.00 fee for shipping and handling.—Editor

SSB/CW ADAPTER

I was in the process of converting an AM citizen band transceiver to the 10-meter band (a Radio Shack Navaho 23B that needed a BFO for SSB reception), when the May 1990 issue of **Popular Electronics** came out. The adapter for SSB/

CW was just the ticket. I added a product detector along with the adapter on the same 1½ by 3-inch board, and everything mounted with plenty of space. When I hooked up the product detector, I didn't use any particular precautions in lead length. I can assure you that it works!

I've been a reader of **Popular Electronics** for more years than I can remember, and have built various items through the years. The magazine makes a good reference library for electronics buffs like me.

B.U.

Ponoka, Alberta, Canada

PRODUCTS FOR THE BLIND

In reference to the letter in the

December issue of **Popular Electronics**, concerning visually-impaired people being frustrated by technology, I found a product years ago in a computer magazine that might be a small help. It's a low-tech, peel-and-stick bump that can be stuck on to the "home" buttons of calculators, PC keyboards, microwave ovens, and on things like the identical lock/unlock buttons on certain car doors. They are manufactured by Prodigy Products Company (864 Cambridge Road, Cleveland Heights, OH 44121, Tel: 216-381-0500). I bought a box-full and handed them out elderly relatives and blind friends, who give them rave reviews.

Moving up the high-tech ladder, I'd love to see some maker of telephone-answering machines tie the "messages" light

with an AC socket on the back. Blind folks could put a tiny fan, for instance, into such an outlet. I would love to plug in a 60-watt lamp for a message light that I could easily see, instead of peering dimly into the night-stand's gloom.

J.H.T.
Chicago, IL

HAVES AND NEEDS

I'm looking for an owner's manual for my Realistic *Comp-100* (Radio Shack catalog No. 20-110), which I purchased second-hand. Radio Shack no longer has information available on it. If anyone can help me with this I will gladly pay any copying and mailing costs.

Keith Tonn
P.O. Box 103
Coleman, WI 54112 ■

Train at Home to be an Electronics Technician!

Professional training and equipment can help you qualify for a dynamic, high-paying career in your spare time.

As the demand for computers and microprocessors in business and manufacturing continues to grow, so does the need for qualified technicians. It's not unusual for experienced technicians to earn from \$35,000 to more than \$40,000 a year.* Now there's a way you can train for this exciting field without interrupting your job or home life.

Choose From These Programs of Study

- Electronics & Microprocessor Technology
- Industrial Electronics & Microprocessor Technology
- Computer Servicing & Electronics Technology
- Specialized Associate Degree In Electronics Technology

You Get Professional Equipment For Professional Training

Depending on the program you select, you'll perfect your skills using this advanced equipment, included in the price of tuition:

(* Source: U.S. Bureau of Labor Statistics)

- IBM-Compatible Personal Computer
- Digital Multimeter
- Digital Logic Probe
- Elenco Oscilloscope

Exclusive Extras That Enhance Your Training

Peoples College introduces some training firsts to make your learning experience more complete:

- Accelerated Learning System — a scientifically proven study system that lets you learn faster and easier than ever before.
- Optional One-Week Seminar — available with our advanced programs. Conducted on our campus near Orlando, Fla. Not required for graduation, but a valuable opportunity to fine tune your skills with personal guidance.
- Video Tutor Training Tapes — give you a permanent, visual record of informative lectures and close-up demonstrations.
- Experience Labs — professionally designed experiments that give you hands-on "bench" experience.
- Industry Certification Training Guide — provided with three of our programs. Gives you first-hand insight into the examination you may take for your professional license.



For COLOR CATALOG Mail Coupon or Call TOLL FREE

1-800-765-7247

Programs offered only in United States, Canada, Puerto Rico and Virgin Islands. No Obligation. No sales person will call.

Our programs are accredited by the Accrediting Commission of the National Home Study Council



YES! I would like to know more about your training programs. Send a catalog to:

Name _____
Address _____
City _____
State _____ Zip _____

PEOPLES COLLEGE
OF INDEPENDENT STUDIES
233 Academy Drive • P.O. Box 421768
Kissimmee, FL 34742-1768
Member, D.L. Peoples Group E0391

CIRCLE 20 ON FREE INFORMATION CARD

AOR Scanners.

Great Performance. Great Service. Great Value.

Free Freight
25-Day Money-Back Guarantee
Toll-Free Service and Support
No Credit Card Surcharge
One Year Warranty



AR1000

\$499

1000 Channels. 8-600MHz, 805-1300MHz

Standard Features:

- Extremely compact size.
- Continuous coverage (except UHF TV 600-805)
- Antenna attenuator switch, 10db.
- Manual tuning knob.
- Earphone jack, 3.5mm.
- AM, FM and wide band FM tuning modes.
- Backlighted LCD display.
- 10 Scan Banks, 10 Search Banks.
- Selectable Priority Channel.
- Delay, Hold Features.
- Selectable Search Increments, 5-955KHz.
- Permanent memory backup.
- 4 AA Ni Cad batteries included.
- AC adaptor/charger.
- Carry Case.
- Cigarette Lighter Charger.
- Belt Clip.
- Earphone.

Options:

- External Speaker. Mobile Mount. MS190 \$19.50
- Extended Warranty. 2/3 yrs \$45/\$55

Specifications:

- Coverage: 8-600, 805,1300MHz
- Sensitivity: .35uV NFM, 1.0uV WFM, 1.0AM
- Speed: 20 ch/sec. scan. 40 ch/sec. search
- IF: 561.225, 58.075, 455KHz or 10.7MHz
- Increments: 5 to 955KHz selectable/ 5 or 12.5 steps.
- Audio: .4 Watts
- Power: Input 9 - 13.8 V. DC
- Antenna: BNC
- Display: LCD
- Dimensions: 6 7/8H x 1 3/4D x 2 1/2W. 12oz wt.

AR950

\$239

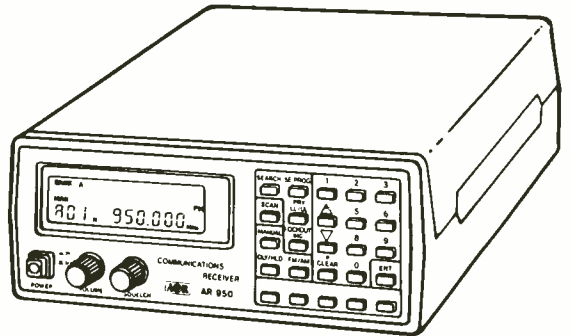

100 Channels. Low, Air, High, UHF & 800MHz.

Standard Features:

- Extremely compact size.
- Unrestricted 800MHz coverage.
- 100 channels permanent memory.
- Earphone Jack & Attenuator.
- Delay, Hold features.
- Channel 1 Priority.
- 5 Scan Banks, 5 Search Banks.
- Telescopic and Flexible Antennas w/ BNC connector.
- AC & DC Power cords w/ mtng hardware.
- One Year Limited Warranty.

Options:

- Base type antenna
- 25 to 1000MHz w 50' coax. AS300 \$59.95
- Mag Mnt Mobile Antenna. 15' coax. MA100 \$25.00
- Cigarette Lighter power adaptor. CP100 \$4.00
- External Speaker
- with mobile mount. MS100 \$19.50
- Extended Warranty. 2/3 yrs \$40/\$55

Specifications:

- Coverage: 27-54, 108-174, 406-512, 830-950MHz
- Sensitivity: .4uV Lo,Hi. .8uV Air. .5uV UHF. 1.0uV 800
- Scan Speed: 15 ch/sec.
- IF: 21.4MHz, 455KHz
- Increments: 10,12.5,25,30
- Audio: 1W
- Power: 12.8VDC, 200MA
- Antenna: BNC
- Display: LCD w/backlight
- Dimensions: 2 1/4H x 5 5/8W x 6 1/2D. 14oz wt.

We offer 100's of communications products.

AR3000

\$995

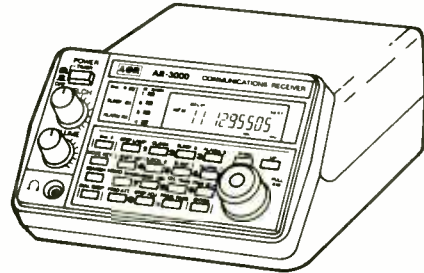

400 Channels. 100KHz to 2036MHz.

Standard Features:

- Extremely compact size.
- Continuous coverage
- Attenuation Programmable by Channel.
- Manual tuning knob.
- Tuning increments down to 50Hz.
- AM, FM, wide band FM, LSB, USB, CW modes.
- Backlighted LCD display.
- 4 Scan and Search Banks, Lockout in Search.
- 4 Priority Channels.
- RS232 control through DB25 connector.
- Delay, Hold Features.
- 15 band pass filters, GaAsFET RF amp.
- Sleep and Alarm Features.
- AC adaptor/charger. DC power cord.
- Telescopic Antenna.

Options:

Earphone.	EP200	\$2.00
External Speaker. Mobile Mount.	MS190	\$19.50
Extended Warranty. 2/3 yrs.		\$65/75
Mobile Mounting Bracket.	MM1	\$14.90
RS232 Control Package	SCS3	\$295.00
(software & cable) offers spectrum display and database.		

Specifications:

Coverage:	100KHz - 2036MHz
Sensitivity:	.35uV NFM, 1.0uV WFM, 1.0AM/SSB/CW
Speed:	20 ch/sec. scan. 20ch/sec. search
IF:	736.23, (352.23) (198.63) 45.0275, 455KHz
Increments:	50Hz and greater
Selectivity:	2.4KHz/-6db (SSB) 12KHz/-6db (NFM/AM)
Audio:	1.2 Watts at 4 ohms
Power:	Input 13.8 V. DC 500mA
Antenna:	BNC
Display:	LCD
Dimensions:	3 1/7H x 5 2/5W x 7 7/8D Wt. 2lb 10oz.

AR2500

\$499

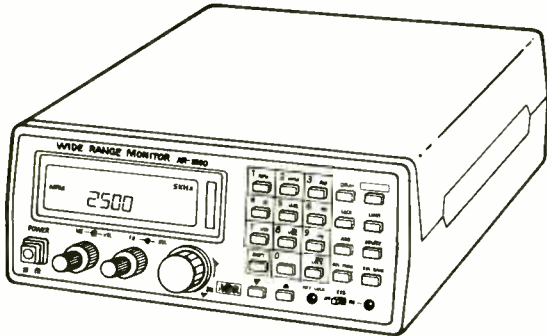

2016 Channels. 1 MHz to 1500 MHz

Standard Features

- Continuous coverage
- AM, FM, wide band FM, & BFO for SSB, CW.
- 64 Scan Banks.
- 16 Search Banks.
- RS232 port built in.
- Includes AC/DC pwr crd. Antenna, Mntng Brckt.
- One Year Limited Warranty.

Options:

Earphone.	EP200	\$2.00
External Speaker. Mobile Mount.	MS190	\$19.50
Extended Warranty. 2/3 yrs.		\$65/75
Mobile Mounting Bracket.	MM1	\$14.90
RS232 Control Package	SCS2	\$295.00
(software & cable) offers spectrum display and database.		

Specifications:

Coverage:	1 MHz - 1500MHz
Sensitivity:	.35uV NFM, 1.0uV WFM, 1.0AM/SSB/CW
Speed:	38 ch/sec. scan. 38 ch/sec. search
IF:	750.00, 45.0275, 5.5MHz 455KHz
Increments:	5,12,5,25 KHz
Audio:	1.2 Watts at 4 ohms
Power:	Input 13.8 V. DC 300mA
Antenna:	BNC
Display:	LCD, backlighted.
Dimensions:	2 1/4H x 5 5/8W x 6 1/2D Wt. 11lb.

To Order Call 1•800•445•7717

In All 50 States and Canada. 24 Hours a Day. Fax Orders: 1-800-448-1084, 24 Hours a Day.

ACE Communications Monitor Division 10707 E. 106th Street, Fishers, IN 46038

Int'l Voice# 317-842-7115. Int'l Fax# 317-849-8794.

Service and Support Lines: Mon-Fri 9a.m. to 9p.m., Saturday 10-4. EST

MasterCard, Visa, American Express, Checks, Approved P.O.'s. & C.O.D. (add 5.00)

Prices and specifications subject to change.

ELECTRONICS LIBRARY

Video Lighting and Special Effects

by James R. Caruso
and Mavis E. Arthur

One of the most effective ways to give any home video a professional look is to use lighting that enhances the mood and style of the production. This book provides a practical introduction to lighting, explaining in plain English the fundamental technological principles and exploring all the basic techniques needed to achieve the desired effects. More than 200 photographs and illustrations depict the do's and don'ts of video lighting, and step-by-step directions explain how to determine

Hands-on exercises walk the reader through first-time experiences such as observing light and shadows, determining lighting ratios, using filters, arranging basic lighting setups, and even how to light particular styles of films—a soap opera and a news broadcast.

In addition, the book demonstrates how to create more than 100 special effects. Inexpensive props—dry ice, miniatures, etc.—are used to add drama and realism to home video productions. As with the lighting directions, the special effects are presented clearly, with an emphasis on having fun while learning.

Video Lighting and Special Effects is available for \$24.95 from Prentice Hall, Englewood Cliffs, NJ 07632; Tel: 201-767-5937.

CIRCLE 99 ON FREE INFORMATION CARD

THE "TOP SECRET" REGISTRY OF U.S. GOVERNMENT RADIO FREQUENCIES: 25 to 470 MHz
by Tom Kneitel, K2AES

This is the seventh edition of the standard registry of VHF/UHF federal-agency frequencies, a popular reference source for scanner owners, and for the news media, law-enforcement agencies, the communications industry, and even federal-government agencies. The 240-page book provides frequencies, call signs, tactical ID's, locations, frequency usage, aircraft/ship rosters, and other fascinating information—such as agents' buzzwords and 10-codes, federal-vehicle license-plate codes, and the confidential codes used on State Department license plates to identify the nationality of foreign diplomats. It explains how to get the best results when monitor-

ing federal frequencies and how to discover new stations. Tom Kneitel also reveals some background information about how he managed to obtain some of the "top secret" listings.

The book covers approximately 80 agencies, including the FBI, Secret Service, Customs, DEA, ATF, CIA, NSA, U.S. Marshall, federal prisons, Department of State, national parks and forests, FAA, FCC, NASA, Coast Guard, ICC, FEMA, Fish & Wildlife, Immigration, Border Patrol, NORAD, NRC, and Veterans Administration, as well as all military services. In addition, it covers the UHF military-aeronautics band (225–400 MHz) at military and civilian airports and FAA facilities nationwide, and many 2–25-MHz frequencies are listed. Expanded coverage is given to Canadian listings.

The "Top Secret" Registry of U.S. Government Radio Frequencies is available for \$19.95 (plus \$2.00 for Book Class mailing or \$3.00 for First Class Mail, and \$1.50 sales tax for NY residents only) from CRB Research Books, Inc., P.O. Box 56, Commack, NY 11725.

CIRCLE 80 ON FREE INFORMATION CARD

AMERICAN COUNCIL OF INDEPENDENT LABORATORIES 1990–1991 DIRECTORY
from *The American Council of Independent Laboratories*

This guide to the leading independent testing, research, and inspection labs in the United States is a useful reference for anyone seeking third-party engineering or laboratory testing, research and development, or consulting services. It contains 348 full-page listings that provide key information about each company. In addition, com-

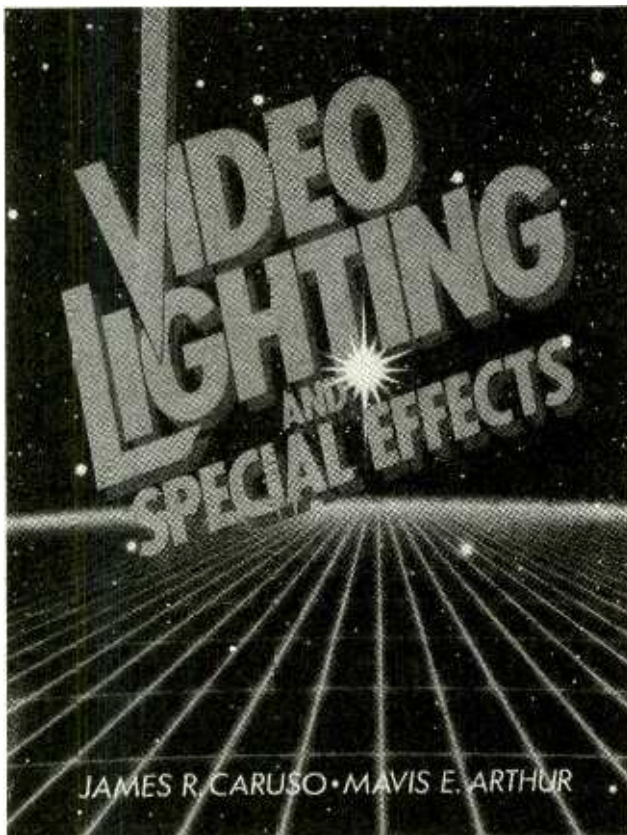

what to light, what type of light to use, how to place lights effectively, and how to prepare a "lighting plot"—a script for lighting your video production.

prehensive indexes containing more than 300 product/service categories and nearly 200 testing disciplines are geographically cross-referenced to 1000 facilities nationwide and abroad.

The American Council of Independent Laboratories 1990-1991 Directory is available for \$25.00 from ACIL, Inc., Attn: 1990-91 Directory, 1725 K Street, Washington, DC 20006; Tel: 202-887-5872.

CIRCLE 81 ON FREE INFORMATION CARD

GUIDE TO HIGH PERFORMANCE DMMs
from John Fluke Mfg. Co., Inc.

Introducing regular users as well as first-time buyers to the high-performance functions provided by today's digital multimeters, this booklet provides helpful selection criteria and information on how to get the most out of the instruments. Beginning with a description of a high-performance DMM, the text explains that it goes far



beyond the usual volts, ohms, and amps measurements. Sections are included on extended measurement capabilities, recording modes, special features, and accessories. To help match the technician and application with the best meter, there's a chapter on selecting true-rms and averaging meters.

Guide to High Performance DMMs is available at no charge from more than 600 distributor locations in North America or by

calling John Fluke Mfg. Co., Inc. (P.O. Box 9090, Everett, WA 98206-9090) at 800-44-FLUKE.

CIRCLE 82 ON FREE INFORMATION CARD

DOS: THE COMPLETE REFERENCE Second Edition
by Kris Jamsa

Providing the answers to all the most common questions users of DOS (through version 3.3) have, the second edition of this comprehensive reference contains essential information on both PC-DOS and MS-DOS. It is written for those who need an easy-to-understand overview of the disk-operating system, as well as for those who require advanced programming and disk-management techniques. To facilitate learning, each chapter begins with a discussion of specific applications followed by a list of related commands. Each chapter also includes review questions and answers. In addition to fundamental information needed to understand

how DOS and personal computers work, the book covers such subjects as international DOS concerns, EDLIN (the DOS line editor), customizing DOS, programming DOS, and Microsoft Windows. All of the routines in the book are available optionally on diskette, in a package that also includes utilities such as an on-line help feature that provides help for all of the DOS commands.

DOS: The Complete Reference (Second Edition) is available for \$26.95, and the diskette package for \$17.95 plus \$2.00 U.S. shipping and handling (\$5.00 foreign), from Osborne McGraw-Hill, 2600 Tenth Street, Berkeley, CA 94710.

CIRCLE 84 ON FREE INFORMATION CARD

PROCEEDINGS 1990
from Fine Tuning Special Publications

Fine Tuning, a non-profit organization of senior radio hobbyists (Continued on page 12)

Parts Express International Inc.

2-1/2" SANYO TWEETER
Paper cone with gold tone dust cap. 8 oz. magnet. 8 ohm. 1/2" ferro fluid voice coil. Power handling: 50W RMS, 70W max. Frequency response: 3K-20KHz.
#PD-271-020 \$1⁹⁵ \$1⁷⁵ 95c (1-9) (10-59) (60-up)

SUPER HORN TWEETER
Original piezo tweeter made by Motorola. SPL=94 dB 2.83V/1M. Response: 4KHz-27KHz. Handles approximately 50 watts.
#PD-270-010 \$5³⁰ \$4⁵⁰ \$3⁹⁵ (1-9) (10-79) (80-up)

2" DOME MIDRANGE
Textile dome midrange made by Philips. 8 ohm. SPL=90 dB 1W/1M. 30W RMS, 40W max. Response: 550-5KHz.
#PD-280-210 \$27³⁰ \$25⁷⁰ (1-3) (4-up)

Parts Express
340 E. First St., Dayton, Ohio 45402
Local: 1-513-222-0173
FAX: 513-222-4644

15" SUBWOOFER
Dual voice coil. 40 oz. magnet. 6 ohm imp. 100W RMS, 140W max. Response: 20-1.2KHz. Resonant frequency: 21Hz. SPL=93 dB 1W/1M.
PIONEER
#PD-290-190 \$54⁵⁰ \$49⁹⁰ (1-3) (4-up)

SUBWOOFER COVER
200W RMS crossover designed specifically for use with dual voice coil sub woofers. 12 dB per octave roll-off at 150Hz.
#PD-260-220 \$28⁸⁰ \$24⁴⁰

10" POLY WOOFER
Medium duty. 60W RMS, 80W max. 14 oz magnet. Response: 25-2.5KHz. fs=28Hz.
#PD-290-096 \$18⁵⁰ \$16⁹⁰ (1-3) (4-up)

TITANIUM COMPOSITE TWEETER
The advantages of both hard and soft dome technologies 8 ohm Ferro fluid cooled voice coil. SPL=90 dB 1W/1M. 50W RMS, 70W max. 4" round Polydax
Polydax #DTW100T125
polydax
#PD-270-047 \$27⁵⁰ \$24⁸⁰ (1-9) (10-up)

SPEAKER BUILDING BOOK
Revised edition of David Weems' best selling book. Learn to build low cost speakers that rival the high priced models.
#PD-500-021 \$16⁹⁵

CALL TOLL FREE 1-800-338-0531

12" CAST FRAME WOOFER
EMINENCE
12" woofer made in the USA by Eminence Paper cone and dust cap with treated cloth surround. 80 oz. magnet. 2-1/2" vented voice coil. 8 ohm. 170W RMS, 235W max. 40-4.5KHz response.
#PD-290-147 \$72⁹⁰ \$69⁵⁰ (1-3) (4-up)

Parts Express
FREE CATALOG

CIRCLE 6 ON FREE INFORMATION CARD

Join the Electronics and Control Engineers' Book Club®

TROUBLESHOOTING ELECTRONIC EQUIPMENT WITHOUT SERVICE DATA, Second Edition. By R.G. Middleton. 320 pp., illus. This indispensable new edition features all the information that made the first edition so successful, plus the latest developments in digital testing, phase checks, IC troubleshooting, and repair of VCRs, stereos, TVs, tape recorders, and much, much more. 585092-3 Pub. Pr., \$30.00 Club Pr., \$22.50

PRINTED CIRCUITS HANDBOOK, Third Edition. By C.F. Coombs, Jr. 960 pp., 556 illus. Here in one handy volume is all the information you need to design, manufacture, test, and repair printed wiring boards and assemblies. This new edition features ten all-new chapters, including three on SMT. 126/097 Pub. Pr., \$64.95 Club Pr., \$45.50

PRACTICAL ELECTRICAL WIRING, Fifteenth Ed. By H. P. Richter & W. C. Schwan. 672 pp., illus. The latest edition of the classic guide to electrical wiring. Updated to cover 1990 Code, this comprehensive reference explains the how and why of each operation—all without advanced mathematics. 523/932 Pub. Pr., \$32.95 Club Pr., \$24.95

MCGRAW-HILL ENCYCLOPEDIA OF ELECTRONICS AND COMPUTERS, Second Edition. S. Parker, Editor-in-Chief. 1,047 pp., 1,250 illus. Featuring 160 new and revised articles, this new edition treats the entire spectrum of applications, devices, systems, and theory in areas ranging from the flow of electricity to hardware, software, robotics, and IC fabrication. 454/99X Pub. Pr., \$79.50 Club Pr., \$54.95

COMMUNICATIONS RECEIVERS: Principles and Design. By Ulrich L. Rohde and T.N. Bucher. 608 pp., 402 illus. Everything you need to know if you design or work with communications receivers, from theory to practical design approaches. Coverage includes all types of receivers: shortwave, broadcast, radar, military, marine, aeronautical, and more. 535/701 Pub. Pr., \$64.95 Club Pr., \$44.50

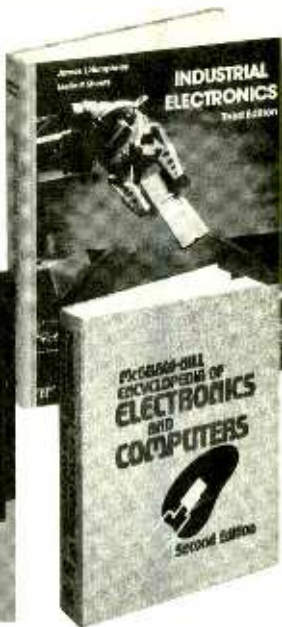
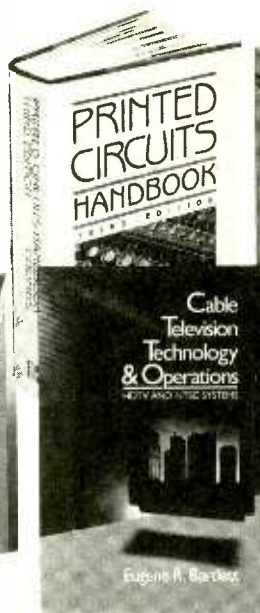

- your one source for engineering books from over 100 different publishers
- the latest and best information in your field
- discounts of up to 40% off publishers' list prices

New Members!
Take any one of these great professional books for only **\$289** as a premium with your first selection!

Spectacular values up to **\$197.90**

MCGRAW-HILL'S NATIONAL ELECTRICAL CODE HANDBOOK, Twentieth Ed. By J. F. McPartland & B. J. McPartland. 1,264 pp., 1,150 illus. The latest edition of this definitive sourcebook clearly and completely incorporates all new and reworked sections, including special requirements for conductor capacity, branch circuits, grounding, and more. 458/146 Pub. Pr., \$49.50 Club Pr., \$37.50

DESIGNING WITH FIELD-EFFECT TRANSISTORS, Second Ed. By Siliconix Inc., Revised by E. Oxner. 320 pp., illus. This on-the-job guide provides page after page of practical data, tables, examples, and design and specification strategies to help you capitalize on recent breakthroughs in MOSFET design. Coverage includes FET operating principles and procedures . . . step-by-step fabrication methods . . . how to bias FETs for desired performance . . . and much more. 575/371 Pub. Pr., \$39.95 Club Pr., \$29.95

PORTABLE ELECTRONICS DATA BOOK. By J. Douglas-Young. 360 pp., illus., softcover. A-to-Z coverage of all the essential facts, figures, and formulas you need in a format that's easy to use and easy to carry. Includes equations, algorithms, and BASIC programs in areas ranging from alternating current to waveguides and cavities. 585390-6 Pub. Pr., \$33.00 Club Pr., \$24.95

CABLE TELEVISION TECHNOLOGY AND OPERATIONS: HDTV and NTSC Systems. By E. R. Bartlett. 400 pp., illus. From practical troubleshooting to large-scale system upgrades, get step-by-step guidance on the design, manufacture, and maintenance of today's cable TV systems. 039/577 Pub. Pr., \$49.50 Club Pr., \$37.50

MOBILE CELLULAR TELECOMMUNICATIONS SYSTEMS. By W.C.Y. Lee. 442 pp., 215 illus. A to Z coverage of state-of-the-art cellular systems, from design to implementation and troubleshooting. Clearly explains spectrum efficiency, propagation models and prediction, interference treatment, and more. 370/303 Pub. Pr., \$62.95 Club Pr., \$44.50

EASY AutoCAD: A Tutorial Approach, Second Ed. By J. D. Hood. 296 pp., illus. Now you can teach yourself all the techniques you need to apply AutoCAD to all your drafting projects. Updated through Release 10, this best-selling tutorial takes you from booting up through three-dimensional drafting and advanced topics. 297/509 Pub. Pr., \$39.95 Club Pr., \$27.50

INTERNATIONAL ENCYCLOPEDIA OF INTEGRATED CIRCUITS. Edited by S. Gibilisco. 1,063 pp., illus. Instant access to over 1,000 ICs from the world over, with complete practical details on each circuit, including what it is, what it does, how it does it, and its relationship to other ICs and their uses. 585263-2 Pub. Pr., \$75.00 Club Pr., \$52.50

PRACTICAL ELECTRONIC TROUBLESHOOTING. By J. D. Lenk. 394 pp., illus. A clear, no-nonsense guide to identifying and correcting faults in industrial machinery, military equipment, and consumer products. Includes valuable pointers on using manuals and data sheets, localizing the problem, breakdowns in more than one circuit, and more. 585439-2 Pub. Pr., \$37.00 Club Pr., \$28.95

SURFACE-MOUNT TECHNOLOGY FOR PC BOARD DESIGN. By J.K. Hollomon, Jr. 504 pp., illus., softcover. Get a real working understanding of SMT. This up-to-date guide provides a proven, step-by-step approach to SMT design as it thoroughly covers components, methods, and techniques for maximizing quality, reliability, and profitability. 585235-7 Pub. Pr., \$49.95 Club Pr., \$36.50

ENGINEERING FORMULAS, Sixth Edition
By Kurt Gieck and Reiner Gieck
568 pp., 4 x 6, illus., 234/558

This new edition of the classic engineers' pocket guide has been fully updated to include new material on differential equations, integral and vector calculus, electrical engineering, and more. Logically arranged and just the right size, **ENGINEERING FORMULAS** is better than ever and it's yours **ABSOLUTELY FREE!**

Kurt Gieck
Reiner Gieck

Engineering Formulas
6th Edition

A \$25.95 Value—Yours ABSOLUTELY FREE when you join!

INDUSTRIAL ELECTRONICS, Third Ed. By J.T. Humphries and L.P. Sheets. 651 pp., illus. A clear, convenient guide to the components and systems used in modern industry. Included is an extensive collection of manufacturers' data sheets, along with many quick-access tables and charts. 585226-8 Pub. Pr., \$41.95 Club Pr., \$31.95

MORE C TOOLS FOR SCIENTISTS AND ENGINEERS. By L. Baker. 308 pp., illus. Now you can apply the C programming language to problems in statistics, graphics, mathematics, linear systems, and more. Coverage includes sparse systems, multivariate statistics, contour plotting, sorting . . . all presented in state-of-the-art algorithms. 033/587 Pub. Pr., \$29.95 Club Pr., \$22.95

DIGITAL FILTERS AND SIGNAL PROCESSING, Second Ed. By L.B. Jackson. 410 pp., illus. An acclaimed guide to signal processing theory, design methods, and implementation strategies. Using an intuitive approach, the author covers state-space representation, A/D and D/A conversion, the DFT, FFT, and much more. 585269-1 Pub. Pr., \$52.50 Club Pr. \$39.50

SWITCHGEAR AND CONTROL HANDBOOK, Second Ed. Edited by R. W. Smeaton. 1,056 pp., 789 illus. The only handbook that treats all aspects of switchgear control, including design, applications, safety, and maintenance. Updated to reflect the changes brought about by the use of computers, solid-state devices, and programmable controls. 584/494 Pub. Pr., \$85.00 Club Pr., \$59.95

ANTENNA APPLICATIONS REFERENCE GUIDE. Edited by R. C. Johnson and H. Jasik. 496 pp., 368 illus. and tables. Covers the major applications of antenna technology in all areas of communications and their design methods. Emphasizes important new applications such as earth station, satellite, seeker, aircraft, and microwave-relay antennas. 322/848 Pub. Pr., \$59.95 Club Pr., \$42.50

C: The Complete Reference, Second Ed. By H. Schildt. 823 pp., illus., softcover. This acclaimed reference is now updated to include the ANSI C standard and all new material on C++ programming. Now you'll have the answer to virtually any question on C at your fingertips. 881538-X Pub. Pr., \$28.95 Club Pr., \$21.95

AUDIO ENGINEERING HANDBOOK. Edited by K. B. Benson. 1056 pp., 722 illus. The ideal on-the-job reference for professionals who design, operate, and service audio equipment. It's a one-volume source of fundamental audio acoustics engineering information and practical how-to source book covering generation, transmission, storage, and reproduction of the audio signal. 047/774 Pub. Pr., \$86.95 Club Pr., \$59.95

Be sure to consider these important titles as well!

ASSEMBLY LANGUAGE PROGRAMMING FOR THE 80386. By J. N. Fernandez and R. Ashley. 265/752 Pub. Pr., \$24.95 Club Pr., \$18.95

LENK'S VIDEO HANDBOOK: Operation and Troubleshooting. By J. D. Lenk. 372/918 Pub. Pr., \$39.95 Club Pr., \$29.95

ESSENTIAL CIRCUITS REFERENCE GUIDE. By J. Markus & C. Weston. 404/623 Pub. Pr., \$59.95 Club Pr., \$47.50

THE PROGRAMMABLE LOGIC DEVICE HANDBOOK. By V. L. Burton. 585568-2 Pub. Pr., \$49.95 Club Pr., \$34.95

ENGINEERING FUNDAMENTALS FOR THE PROFESSIONAL ENGINEERS' EXAM, Third Ed. By L.M. Polentz. 503/931 Pub. Pr., \$39.50 Club Pr., \$27.95

DIGITAL BUS HANDBOOK. Edited by J. DiGiacomo. 169/233 Pub. Pr., \$64.50 Club Pr., \$48.50

COMPLETE GUIDE TO ACTIVE FILTER DESIGN, OP AMPS, AND PASSIVE COMPONENTS. By Z. H. Meiksin. 585454-6 Pub. Pr., \$35.00 Club Pr., \$27.50

PRINTED CIRCUITS DESIGN: Featuring Computer-Aided Technologies. By G. L. Ginsberg. 233/098 Pub. Pr., \$39.95 Club Pr., \$29.95

DIGITAL AND MICROPROCESSOR TECHNOLOGY, Second Ed. By P. J. O'Connor. 585184-9 Pub. Pr., \$42.00 Club Pr., \$33.50

ELECTROSTATIC DISCHARGE CONTROL: Principles and Practice. By O. J. McAteer. 448/388 Pub. Pr., \$59.50 Club Pr., \$44.50



Here's how the Club works to serve YOU:

■ IMPORTANT INFORMATION... WE MAKE IT EASY TO GET!

In our rapidly changing world, those who perform best are those who are best informed. Designed exclusively for the practicing engineer the Electronics and Control Engineers' Book Club provides you with information that is relevant, reliable, and specific enough to meet your needs. Each Club bulletin comes your way 14-16 times a year and offers you more than 30 books to choose from — the best and newest books from all publishers!

■ DEPENDABLE SERVICE... WE'RE HERE TO HELP!

Whether you want information about a book or have a question about your membership, our qualified staff is here to help. Just call us toll-free or write to our Customer Service. We also make sure you get only the books you want. All you do is simply tell us your choice on the Reply Card and return it to us by the specified date. If you want the Main Selection, do nothing — it will be sent to you automatically. (A small shipping and handling charge is added to each shipment.)

■ CLUB CONVENIENCE... WE DO THE WORK!

Beyond the benefit of timely information, Club membership offers many other benefits. For example, you get a wide choice of books that cannot be matched by any bookstore — anywhere. And all your books are conveniently delivered right to your door. You also get the luxury of 10 full days to decide whether you want the Main Selection. If you should ever receive a Main Selection you don't want because the Club bulletin came late, just return it for credit at our expense.

■ SUBSTANTIAL SAVINGS... AND A BONUS PROGRAM TOO!

In keeping with our goal to provide you with the best information at the greatest possible savings, you will enjoy substantial discounts — up to 40%! — on every book you buy. Plus, you're automatically eligible for our Bonus Book Plan which allows you savings up to 70% on a wide selection of books.

■ EASY MEMBERSHIP TERMS... IT'S WORTHWHILE TO BELONG!

Your only obligation is to purchase one more book — at a handsome discount — during the next 12 months, after which you enjoy the benefits of membership with no further obligation. Either you or the Club may cancel membership anytime thereafter.

MAIL THIS COUPON TODAY

McGraw-Hill Book Clubs Electronics and Control Engineers' Book Club®

P.O. Box 582, Hightstown, NJ 08520-9959

Please enroll me as a member and send me the two books indicated, plus ENGINEERING FORMULAS, 6/e. I am to receive one book for just \$2.89, the other at the discounted member's price, plus local tax, shipping and handling charges. I agree to purchase a minimum of one additional book during my first year of membership as outlined under the Club plan described in this ad. I understand that a shipping and handling charge is added to all shipments.

Your FREE Book	
234/558	
Write Code No. of the \$2.89 selection here	Write Code No. for the First selection here
<input type="text"/>	<input type="text"/>

Signature _____

Name _____

Address/Apt. # _____

City _____

State _____ Zip _____

This order subject to acceptance by McGraw-Hill. All prices subject to change without notice. Offer good only to new members. Foreign member acceptance subject to special conditions.

ECGB-041

MARCH 1991

Earn Your B.S. Degree in ELECTRONICS or COMPUTERS



By Studying at Home

Grantham College of Engineering, now in our 41st year, is highly experienced in "distance education"—teaching by correspondence—through printed materials, computer materials, fax, and phone.

No commuting to class. Study at your own pace, while continuing on your present job. Learn from easy-to-understand but complete and thorough lesson materials, with additional help from our instructors.

Our Computer B.S. Degree Program includes courses in the BASIC, PASCAL, and C languages — as well as Assembly Language, MS DOS, CADD, and more.

Our Electronics B.S. Degree Program includes courses in Solid-State Circuit Analysis and Design, Control Systems, Robotics, Analog/Digital Communications, and more.

An important part of being prepared to *move up* is holding the right college degree, and the absolutely necessary part is knowing your field. Grantham can help you both ways—to learn more and to earn your degree in the process.

Write or phone for our free catalog. Toll free, 1-800-955-2527, or see mailing address below.

Accredited by
the Accrediting Commission of the
National Home Study Council

GRANTHAM
College of Engineering
Grantham College Road
Slidell, LA 70460

ELECTRONICS BOOKS (Continued from page 7)

who specialize in shortwave broadcast (SWBC) DX'ing, has put together this collection of in-depth reviews, articles, and features for the SWBC DX'er. The book is intended as a reference tool for anyone who wants to increase their enjoyment of and expertise in the hobby. Every article is expertly written by leading radio hobbyists and thoroughly examined by a review panel of DX'ers. The result is a collection of highly informative pieces that are clear enough for beginners to understand, even though about half of the material is broadly technical in nature. Some of the articles include an extensive collection of modifications for the Sony ICF2010/2001D receiver, a guide to using major libraries as a DX'er's tool, in-depth features on DX'ing Central America and Africa's Sahara and Sahel regions, equipment reviews, and a 60-page study of tropical band propagation that challenges decades-old theories.

Proceedings 1990 is available for \$19.50 plus \$2.00 shipping in the U.S. (outside the U.S., \$3.00 surface book rate, which takes three to four months, or \$15.00) from *Fine Tuning Special Publications, c/o John Bryant, RRT #5 Box 14, Stillwater, OK 74074.*

**CIRCLE 85 ON FREE
INFORMATION CARD**

SPY TECH VIDEO CATALOG

from *Executive Protection Products, Inc.*

This "video catalog" features dozens of items available in the personal protection and security equipment field. Besides descriptions and prices, the videotape contains little-known details used by people in the protection and security business. Some of the devices shown include surveillance equipment, such as room monitors, and all kinds of listening and detection devices. Recorders, transmitters, bullet-proof vests, body wires, and microcameras are featured. The videotape comes with a printed catalog and a \$20.00 discount

coupon good for future purchases.

The Spy Tech Video Catalog is available for \$14.95 (postpaid) from *Executive Protection Products, Inc., 1325 Imola Avenue West #504, Napa, CA 94559.*

**CIRCLE 86 ON FREE
INFORMATION CARD**

PUBLIC ADDRESS LOUDSPEAKER SYSTEMS

by *Vivian Capel*

Although it is a critical part of any public-address installation, the loudspeaker system is often inadequate, resulting in poor intelligibility and unnatural sound reproduction. This book explains how the fault frequently lies with unsuitable microphones or poorly designed speaker systems, and shows

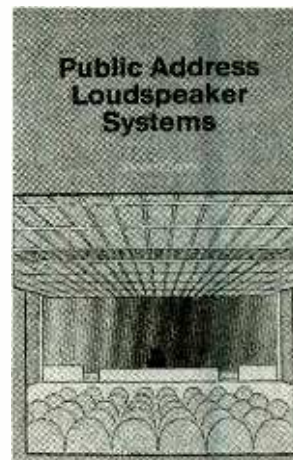

readers how the problem can be remedied. Various systems and their advantages and drawbacks are examined. The Line-Source Ceiling Array, or LISCA, is covered in detail, with full step-by-step construction and installation information. LISCA is a system that provides small-to medium-sized halls with clarity, even coverage, reduced feedback, natural source location, and a pseudo-stereo effect. The book also covers low-impedance matching, 100-volt systems, transmission lines, and how to design and install inductive hearing-aid loops.

Public Address Loudspeaker Systems (order number BP292) is available for \$8.95 (including shipping and handling) from *Electronics Technology Today*

Inc., P.O. Box 240, Massapequa Park, NY 11762-0240.

CIRCLE 97 ON FREE INFORMATION CARD

AutoLISP in Plain English: A Practical Guide for Non-Programmers (Third Edition)

by George O. Head

There are plenty of AutoCAD users out there who don't have any desire to become expert in AutoLISP, but just want to know enough to become more productive in their daily work. This book, revised and expanded for releases 10 and 11, gives readers the tools they need to begin using AutoCAD's powerful internal programming language. It provides detailed but easy-to-follow information on AutoLISP commands and how to use them and how AutoLISP works with AutoCAD's database. It provides tips and tricks for writing basic AutoLISP programs, and presents sample programs with line-by-line explanations. The book helps readers learn to write simple, useful AutoLISP programs to automate repetitive drawing tasks, create simple geometric constructions, and alter the drawing database to suit specific applications. A new chapter on file manipulation explains how to read and write files in AutoLISP.

AutoLISP in Plain English: A Practical Guide for Non-Programmers (Third Edition) is available for \$19.95 from Ventana Press, P.O. Box 2468, Chapel Hill, NC 27515; Tel: 919-942-0220; Fax: 919-942-1140.

CIRCLE 88 ON FREE INFORMATION CARD



"No, this is the whole kit—that's the kaboodle."

UNDERSTANDING PC SPECIFICATIONS

by R.A. Penfold

IBM PC and compatibles are popular choices for those who require a computer for business applications or for use at home—partially because of the wide selection of applications programs and hardware additions that are available for those PC's. But it's difficult for the uninitiated to determine which of those specifications best suit

their particular needs. Buying a PC that is inadequate for the required applications is just as wasteful as paying top dollar for one that does much more than is needed.

This book explains PC specifications in detail. It covers several important topics, including the differences between types of PC (XT, AT, 80386, etc.); math coprocessors; input devices such as keyboards, mice, and digitizers; memory; RAM disks; floppy-disk drive for-

mats and compatibility; hard drives, including interleave factors and access times; and all standard types of display adapters, including CGA, VGA, Hercules, and more.

Understanding PC Specifications (order number BP 282) is available for \$8.95 (including shipping and handling) from Electronics Technology Today Inc., P.O. Box 240, Massapequa Park, NY 11762-0240.

CIRCLE 97 ON FREE INFORMATION CARD

ELENCO & HITACHI PRODUCTS AT DISCOUNT PRICES

NEW! RSOs (Real-Time & Storage Oscilloscopes) From HITACHI **NEW!**

The RSO - its the new solution
View, Acquire, Test, Transfer and Document Your Waveform Data

4-Channel, 100MS/s Model	Introductory Price
100MS/s (25MS/s on 4 channels simultaneously), 100MHz, 4kw x 1ch., 2kw x 2ch., 1kw x 4ch	VC-6145 \$4,695.00
Compact, Full Feature Models	
40MS/s, 100MHz, 4kw x 1ch., 2kw x 2ch.	VC-6045 \$3,049.00
20MS/s, 50MHz, 2kw x 2ch.	VC-6025 \$2,295.00
Low Cost/High Value Model:	
20MS/s, 50MHz, 2kw x 2ch.	VC-6024 \$2,049.00
20MS/s, 20MHz, 2kw x 2ch.	VC-6023 \$1,749.00

RSOs from Hitachi feature such functions as roll mode, averaging, save memory, smoothing, interpolation, pretriggering, cursor measurements, potter interface, and RS-232C interface. With the comfort of analog and the power of digital.

V-212
\$435
DC to 20MHz
Dual Channel

Hitachi Portable Scopes
DC to 50MHz, 2-Channel, DC offset function, Alternate magnifier function

V-525 CRT Readout, Cursor Meas. \$1,025
V-523 Delayed Sweep \$995
V-522 Basic Model \$895

V-422 40MHz Dual Trace \$795

Compact Series Scopes

Delayed Sweep
Lightweight (13lbs)
2mv Sens
3 yr Warranty
Model V-1085 Shown

This series provides many new functions such as CRT Readout, Cursor measurements (V-1085/1065/665), Frequency Ctr (V-1085), Sweeptime Autoringing and Trigger Lock using a 6-inch CRT. You don't feel the compactness in terms of performance and operation.

V-660	60MHz Dual Trace	\$1,195
V-665	60MHz Dual Trace w/Cursor	\$1,345
V-1060	100MHz Dual Trace	\$1,425
V-1065	100MHz Dual Trace w/Cursor	\$1,695
V-1085	100MHz Quad Trace w/Cursor	\$2,045
V-1100A	100MHz Quad Trace w/Cursor	\$2,295
V-1150	150MHz Quad Trace w/Cursor	\$2,775

20MHz Elenco Oscilloscope \$375
MO-1251

- Dual Trace
- Component Tester
- 6" CRT
- X-Y Operation
- TV Sync
- 2 p-1 Probes

FREE DMM with purchase of ANY SCOPE

SCOPE PROBES
P-1 65MHz, 1x, 10x \$19.95
P-2 100MHz, 1x, 10x \$23.95

Elenco 35MHz Dual Trace \$495
Good to 50MHz
MO-1252

- High luminance 6" CRT
- 1mV Sensitivity
- 5KV Acceleration Voltage
- 10ns Rise Time
- X-Y Operation + Z Axis
- Delayed Triggering Sweep
- Includes 2 P-1 Probes

All scopes include probes, schematics, operators manual, and 3 year (2 yrs for Elenco scopes) world wide warranty on parts & labor. Many accessories available for all Hitachi scopes. Call or write for complete specifications on these and many other line oscilloscopes.

WE NOW CARRY COMPLETE LINE OF FLUKE MULTIMETERS Models

21F	83
23F	85
25F	87
27F	8050A
73	8060A
75	8062A
77F	+ More

CALL FOR SPECIAL PRICING

True RMS 1/2 Digit Multimeter M-7000

\$135

05% DC Accuracy
1% Resistance with Freq. Counter and derive case

10 Function Multimeter CM-365

\$65

AC + DC Voltage & Amps
Resistance to 2000MΩ
Diode, Logic, & Trans test
Capacitance to 200nF

Digital Capacitance Meter CM-1550

\$58.95

9 Ranges
1p1-20,000nfd
5% basic acy
Zero control with case

Digital LCR Meter LC-1801

\$125

Measures:
Coils 1uH-200uH
Caps: 1p1-200nF
Res. 0.1-20M

Function Generator B10x

\$96.00

\$28.95

Provides sine, triangle, square wave from 1Hz to 1MHz AM or FM capability

Triple Power Supply XP-620

Assembled \$65
KIT \$45

2 to 15V at 1A
-2 to -15V at 1A (or 4 to 30V at 1A) and 5V at 3A

Contains all the desired features for doing experiments. Features short circuit protection, all supplies.

Wide Band Signal Generators SG-9000

\$129

RF Freq 100K-450MHz
AM Modulation of 1KHz
Variable RF output

SG-9500 w/ Digital Display and 150MHz built-in Counter \$249

Soldering Station Temperature Controlled SL-30

\$99

Digital display
Temp range: 300F-900F
Grounded tip
Overheat protect

Color Convergence Generator SG-200

\$69.95

Finest in the industry
10 rock steady patterns

10MHz Oscilloscope S-3000

\$275

10MHz DC or AC
Triggered Sweep
Calibrated Vert & Hor
Reads Volts & Freq

Temperature Probe M-110CF

\$29.95

Semiconductor type
Range 58F-302F
Fits most digital multimeters

Autorange DMM M-5000

\$45

9 Functions
Memory and Data hold
1/2 % basic acc
3 1/2 digit LCD

AC Current Meter ST-1010

\$69.95

1000 Amps
Data & Peak hold
8 Functions
Deluxe Case

Decade Box #9610 or #9620

\$18.95

#9610 Resistor Box
47 ohm to 1M & 100K pot
#9620 Capacitor Box
47pF to 10MFD

Quad Power Supply XP-580

\$59.95

2-20V at 2A
12V at 1A
5V at 3A
-5V at 5A

Fully regulated and short circuit protected
XP-575 without meters \$39.95

LEARN TO BUILD AND PROGRAM COMPUTERS WITH THIS KIT!

INCLUDES: All Parts, Assembly and Lesson Manual

Model **MM-8000**
\$129.00

Starting from scratch you build a complete system. Our Micro-Master trainer teaches you to write into RAM, ROM and run a 6805 microprocessor, which uses similar machine language as IBM PC. You will write the initial instructions to tell the 6805 processor to get started and store these instructions in permanent memory as a 2016 C' P/ROM. Teaches you all about input and output ports, computer memory. Build your own keyboard and learn how to scan keyboard and display. No previous computer knowledge required. Simple easy to understand instruction teaches you to write in machine language.

ROBOTICS KIT FOR ABOVE (MM-8010) \$71.95

Digital Triple Power Supply XP-765

\$249

0.20V at 1A
0.20V at 1A
5V at 5A

Fully regulated, Short circuit protected with 2 limit control, 3 separate supplies
XP-660 with Analog Meters \$175

GF-8016 Function Generator with Freq. Counter

\$249

Sine, Square, Triangle
Pulse, Ramp, 2 to 2MHz
Freq. Counter: 1 - 10MHz

GF-8015 without Freq. Meter \$179

WE WILL NOT BE UNDERSOLD!
UPS Shipping: 48 States 5% (\$10 Max), IL, Res., 7% Tax

C & S SALES INC.
1245 Rosewood, Deerfield, IL 60015
(800) 292-7711 (708) 541-0710

15 Day Money Back Guarantee
2 Year Warranty Price subject to change
WRITE FOR FREE CATALOG.

CIRCLE 5 ON FREE INFORMATION CARD

NEW PRODUCTS

Tandy Personal Computer

Designed for business and home-office use, the Tandy 4020 SX is a 20-MHz, 80386SX-based PC with super-VGA graphics. Combining 32-bit performance with 16-bit hardware compatibility, it can be used as a stand-alone system or as a workstation on a network. Two megabytes of memory are standard, and the 4020 SX can be expanded to 16MB. Built-in super-VGA graphics provide photographic clarity with



256 colors in 640 × 400 resolution. The video memory is also expandable, to a maximum of either 256 colors with 640 × 480 resolution, or 16 colors with 1024 × 768 resolution.

The 4020 SX comes with a 1.44-MB 3½-inch floppy drive and a 16-bit SmartDrive IDE connector that makes it easy to add SmartDrive hard-disk drives without using a separate controller or an expansion slot. It also supports small computer device interface (SCSI) hard drives and tape-backup systems. Other

standard features include three 16-bit, full-size AT expansion slots; a 101-key enhanced keyboard; a socket for an optional 80387SX math coprocessor; one each serial, parallel, and mouse ports; a realtime clock with battery backup; and a 100-watt power supply. The computer has a small footprint and a unique hinged bay that swings open for easy access to expansion and device slots.

The Tandy 4020 SX personal computer sells for \$2,499 at more than 7,000 participating Radio Shack Computer Centers, Radio Shack Stores, and dealers nationwide. For more information, contact Radio Shack, 700 One Tandy Center, Fort Worth, TX 76102.

CIRCLE 102 ON FREE INFORMATION CARD

CORDLESS INFRARED HEADPHONES

A lightweight headset/receiver and an infrared transmitter/headset stand make up Arkon Resources' Arkon IR-500 Infrared headphone system. Designed for use with audio or video components, a microphone adapter is included for use with older television sets that don't have an audio-output/headphone jack. The headset, which is powered by two AAA batteries, features an on/off/volume control. The transmitter



provides a combination vertical/horizontal array for improved reception of the infrared signal throughout a wide coverage area.

The Arkon IR-500 Infrared headset system has a suggested retail price of \$99.95. For additional information, contact Arkon Resources, Inc., 11627 Clark Street, Suite 101, Arcadia, CA 91006; Tel: 818-358-1133; Fax: 818-303-6157.

CIRCLE 103 ON FREE INFORMATION CARD

MOBILE TRANSCEIVER

Part of Kenwood's line of super-compact FM mobile transceivers, the TM-241A features wide-band receiver coverage, from 118 to 173.995 MHz. Its transmit frequency range is 144 to 148 MHz, and the unit can be modified for MARS and CAP operation (permits required). The compact unit is easy to install, and the RC-20 remote-control option allows custom installation for a professional look.



Other features include 20 full-function memory channels, multiple scanning functions, and a large LCD readout with four-step dimmer control. It comes with a mounting bracket, a DC cable, fuses, and a multi-function DTMF microphone.

The TM-241A FM mobile transceiver has a suggested retail price of \$469.95. For more information, contact Kenwood U.S.A. Corporation, Communications & Test Equipment Group, 2201 East Dominguez Street, Long Beach, CA 90810.

CIRCLE 104 ON FREE INFORMATION CARD

(Continued on page 18)

CIE Gives You The Training You Need to Succeed... At Your Own Pace...& In Your Own Home!

Discover Your Career Potential In The
Fast-Growing Field Of High-Tech Electronics!

If you're anxious to get ahead...and build a *real* career...you owe it to yourself to find out about the Cleveland Institute of Electronics!

CIE can help you discover *your* career potential in the fast growing field of high-tech electronics. A career that will challenge and excite you every day...reward you with a powerful feeling of personal accomplishment...and deliver a level of financial security you may have only dreamed of before!

As the leading school in home-study electronics, CIE has helped over 150,000 students in the U.S.A. and over 70 foreign countries get started in this exciting field. To find out how CIE could be helping *you*...read on...then send for a CIE catalog TODAY!

A Growing Need For Trained Professionals!

The career opportunities shown here are only a few of the challenging, high-paying careers you could enjoy as an electronics technician.

You could be the "brains" behind the scenes of an exciting TV broadcast...trouble-shoot life-saving medical equipment...design exotic new aeronautics systems...CIE's job-oriented programs offer you the quickest possible path to the career of your dreams! And CIE also features military and union re-training, to build on what you already know.

Dozens Of Fascinating Careers To Choose From!

Even if you aren't sure which career is best for you, CIE can get you started with core lessons applicable to *all* areas of electronics. As you advance, CIE makes job opportunities available to you through the bimonthly school paper, *The Electron*.



Data Communications



Automotive Electronics



Avionics



Computer-Assisted Manufacturing



Consumer Electronics



Military Electronics

Personal Training From A Renowned Faculty.

Unlike the impersonal approach of large classroom study, CIE offers you one-on-one instructional help 6 days a week, toll-free. Each CIE lesson is authored by an independent specialist, backed by CIE instructors who work directly with you to answer your questions and provide technical assistance when you need it.

Practical Training... At Your Own Pace.

Through CIE, you can train for your new career while you keep your present job. Each course allows a generous completion time, and there are no limitations on how fast you can study. Should you already have some electronics experience, CIE offers several courses which start at the intermediate level.

"State-Of-The-Art" Facilities & Equipment.

In 1969, CIE pioneered the first electronics laboratory course, and in 1984, the first Microprocessor Laboratory. Today, no other home study school can match CIE's state-of-the-art equipment. And all your laboratory equipment is included in your tuition cost. There is no extra charge—it's yours to use while you study at home and on the job after you complete your course!

Earn Your Degree To Become A Professional In Electronics!

Every CIE course you take earns you credit towards the completion of your Associate in Applied Science Degree, so you can work towards your degree in stages. And CIE is the only school that awards you for fast study, which can save you thousands of dollars in obtaining the same electronics education found in four-year Bachelor's Degree programs!

Send For Your Catalog Today!



CIE World Headquarters

Cleveland Institute of Electronics, Inc.
1776 East 17th St., Cleveland, Ohio 44114

YES! Please send me your independent study catalog (For your convenience, CIE will have a representative contact you—*there is no obligation.*)

Print Name _____

Address _____ Apt # _____

City/State/Zip _____

Age _____ Area Code/Phone No. _____

Check box for G.I. Bill bulletin on educational benefits: Veteran Active Duty

Mail This Coupon Today!

AHO3

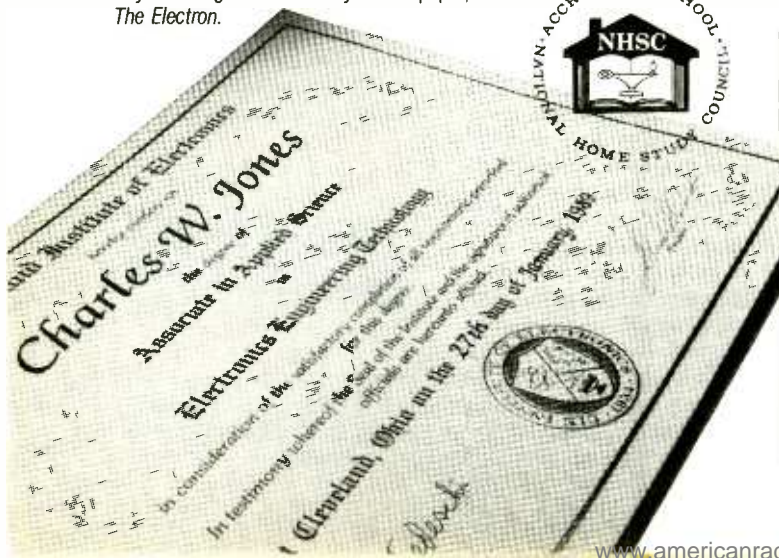

MARCH 1991

Courteous Service • Discount Prices • Fast Shipping

ALL ELECTRONICS

P.O. Box 567 • Van Nuys, CA 91408

** New ** FLASH UNIT

This NEW compact flash unit comes from a U.S. manufacturer of cameras. Unit operates on 3 Vdc and measures 2 1/2" X 1 1/4". Ideal for use as a strobe, warning light or attention getter. Complete with instruction on how to wire.
CAT# FSH-1 \$3.75 each 10 for \$35.00

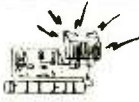

Special New Reduced Price PHOTOFLASH CAPACITOR

Rubicon CE photoflash capacitor. 0.79" dia. X 1.1" high. These are new capacitors that have been prepped with 1.4" black and red wire leads soldered to the terminals.
210 Mfd 330 Volt CAT# PPC-210
\$1.25 each • 10 for \$11.00 • 100 for \$100.00
Large quantities available. Call for pricing.



FLASHING L.E.D.

Diffused L.E.D. with built in flashing unit. PULSE RATE: 3 Hz @ 5 Volt/20 ma. Unit continually flashes when 5 Volts is applied. Operates between 4.5 Volts and 5.5 Volts. T 1 3/4 size. IDEAL AS AN INDICATOR

RED CAT# LED-4
GREEN CAT# LED-4G
YELLOW CAT# LED-4Y
\$1.00 each • 10 for \$9.50 • 100 for \$90.00



HEAVY-DUTY NICKEL CADMIUM "C" BATTERY

Yuasa 1800C Special purchase of new, rechargeable nickel-cad batteries. 1.2 volts, 1800 mA.H.
PRICE REDUCED ON 10 OR MORE.
CAT# HDNCB-C
10 pieces for \$42.50 (\$4.25 each)
100 pieces for \$375.00 (\$3.75 each)



POWER SUPPLIES

5Vdc 3 AMP

ACDC Electronics #5N3-1 New, prepped power supply with wires and connectors soldered to the inputs and outputs. Open frame style. 4.94" X 4.03" X 2". Input: 115 Vac. UL and CSA listed. Regulated.
CAT# PS-53 \$10.00 each

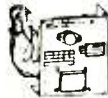

12 Vdc 5 AMP

ACDC Electronics # 12N5 or equiv. Input: 100-240 Vac (wired for 115 Vac)
Output: 12 Vdc @ 5 amps. Open frame style. 7" X 4 3/4" X 3" high. Regulated.
CAT# PS-125 \$37.50 each

24 Vdc 2.4 AMP

Power-One Inc. #HC-24-2.4 Input: 115/230 Vac (wired for 115 Vac)
Output: 24 Vdc @ 2.4 amps. Open frame style. 5.62" X 4.87" X 2.50" CSA listed.
CAT# PS-2424 \$30.00 each

TOLL FREE ORDER LINES

1-800-826-5432

CHARGE ORDERS to Visa, MasterCard or Discover

TERMS: Minimum order \$10.00. Shipping and handling for the 48 continental U.S.A \$3.50 per order. All others including AK, HI, PR or Canada must pay full shipping. All orders delivered in CALIFORNIA must include state sales tax (6 %, 6 1/2 %, 7 %). Quantities Limited. NO C.O.D. Prices subject to change without notice. Call Toll Free, or clip this coupon

FREE 60 Page Catalog
Containing over 4,000 ITEMS
ALL ELECTRONICS CORP.
P.O. Box 567 • Van Nuys, CA • 91408

Name _____
Address _____
City _____ PC391 State _____ Zip _____

CIRCLE 9 ON FREE INFORMATION CARD

NEW PRODUCTS

(Continued from page 14)

SOLDERING-IRON CONTROLLER

To change any fixed-temperature soldering iron into a fully adjustable one, M.M. Newman Corporation has introduced the Dial-Temp soldering-iron controller. The compact device plugs into a 117-VAC wall outlet and accepts any three-prong



fixed-temperature iron ranging from 15 to 1600 watts. The dial on top is used to adjust temperatures from 150°F to full heat.

The Dial-Temp soldering-iron controller has a list price of \$29.95. For further information, contact M.M. Newman Corporation, 24 Tioga Way, P.O. Box 615, Marblehead, MA 01945; Tel: 617-631-7100; Fax: 617-631-8887.

CIRCLE 105 ON FREE INFORMATION CARD

AUTOMATIC VOLTAGE REGULATORS

A line of automatic voltage-regulating power conditioners from Perma Power protect computers and peripherals from more than 95% of power-line problems—including over-voltage, under-voltage, spikes, surges, and RFI/EMI noise. Each of the three regulators in the AVR Series features an advanced tap-changing design that provides accurate voltage regulation ($\pm 5\%$ of 117 VAC), and compensates for input voltages as low as 93 VAC and as high as 143 VAC. Five levels of regulation are provided. The units are always connected to the load, providing continuous clean



power even during switching intervals, to eliminate data errors or accidental re-booting that can occur when a load is disconnected from the power line during switching. The AVR Series regulators provide 99% efficiency, with quiet and quiet operation, regardless of the amount of power being drawn.

Three sizes are available: 600, 1200, and 1800 watts. The 1200- and 1800-watt units feature a system of front-panel LED voltage indicators and a warning buzzer that sounds when dangerously high or low voltages are sensed. They also monitor the power-line wiring for inadequate grounding and/or reverse polarity, and LEDs warn if either condition is present.

Models AV 600, AV 1200, and AV 1800 have suggested user prices of \$149.00, \$249.00, and \$339.00, respectively. For additional information, contact Perma Power Electronics, 5601 West Howard Avenue, Chicago, IL 60648; Tel: 312-763-0763; Fax: 312-763-8330.

CIRCLE 106 ON FREE INFORMATION CARD

ROMAN-NUMERAL DIGITAL CLOCK KIT

Displaying hours, minutes, and seconds in Roman numerals, Landis Electronics digital clock kit makes a unique timepiece. The display uses 177 bright-red LEDs that can be easily seen in daylight or darkness, and its case is hand-finished mahogany. The kit includes all necessary parts, including the



power supply, low-power CMOS logic, LEDs, a double-sided PC board, and the case. Complete

instructions are provided, and the clock can be assembled in a couple of evenings.

The *Roman-Numeral Digital Clock* costs \$89.95 in kit form (or \$139.00 fully assembled and tested), plus \$6.00 shipping and handling. For additional information, contact Landis Electronics, 207 Oak Street, Norton, MA 02766.

CIRCLE 107 ON FREE INFORMATION CARD

TVRO-ANALYSIS/ ANTENNA-AIMING SOFTWARE

Tailored for use by professionals and dealers as well as technically-oriented TVRO owners, *TVRO System Analysis and Satellite Locator Version 1.1* can be instrumental in system analysis and antenna aiming. The software, from *Baylin Publications*, includes a system-configure screen that can be used to set a number of factors that refine program operation—including the cutoff angle above the horizon below which satellites cannot be detected; and the noise-weighted, the pre-emphasis, the peak-to-peak conversion, and the video-noise bandwidth factors, which vary between NTSC, PAL, and SECAM broadcasts. The analysis section is useful for



predicting performance when viewing signals from a weak satellite, and accurately calculates picture quality from user-entered system parameters such as LNB noise temperature, satellite EIRP, and antenna diameter. The user is prompted to enter 10 required parameters and then choose one of those to be varied while the others are held constant. The variables are used to calculate slant distance, path loss, antenna gain, and other factors. The antenna-aiming section calculates azimuth and elevation angles, and range to all satellites within "view" of a

TVRO. The names and latitudes of all C and Ku-band broadcast satellites worldwide are listed. The software is available on either a 5/4- or 3/2-inch diskette.

TVRO System Analysis and Satellite Locator Version 1.1 costs \$49.95 plus \$2.00 shipping and handling. For more information, contact Baylin Publications, 1905 Mariposa, Boulder, CO 80302.

CIRCLE 108 ON FREE INFORMATION CARD

TWO-WAY LOUDSPEAKER

Design Acoustics' PS-8C two-way loudspeaker uses a ferro-cooled one-inch tweeter with a crossover point at 2,800 Hz, for superior power-handling capacity. An eight-inch woofer yields an accurate frequency response down to 50 Hz. The company recommends using the speaker



with amplifiers delivering up to 200 watts per channel. The PS-8C comes in a choice of oak or black ash finishes.

The PS-8C loudspeaker has a suggested price of \$189.95 per speaker. For additional information, contact Design Acoustics, division of Audio-Technica U.S., Inc., 1225 Commerce Drive, Stow, OH 44224; Tel: 216-686-2600.

CIRCLE 109 ON FREE INFORMATION CARD

EMI FILTER MODULE

Providing an easy, effective way for users to eliminate the problems of stray electromagnetic interference (EMI) in signal cables running between poorly filtered equipment, *Coilcraft's EMI Filter Module* has two DB-9-type connectors (one male and one female) and plugs between an RS-232 cable and an input or output port.

DIGITAL VIDEO STABILIZER ELIMINATES ALL VIDEO COPY PROTECTIONS



While watching rental movies, you will notice annoying periodic color darkening, color shift, unwanted lines, flashing or jagged edges. This is caused by the copy protection jamming signals embedded in the video tape, such as Macrovision copy protection. Digital Video Stabilizer: RXII completely eliminates all copy protections and jamming signals and brings you crystal clear pictures.

WARNING :
SCO Electronics and RXII dealers do not encourage people to use the Digital Video Stabilizer to duplicate rental movies or copyrighted video tapes. RXII is intended to stabilize and restore crystal clear picture quality for private home use only.

(Dealers Welcome)

- FEATURES:**
- Easy to use and a snap to install
 - State-of-the-art integrated circuit technology
 - 100% automatic - no need for any troublesome adjustments
 - Compatible to all types of VCRs and TVs
 - The best and most exciting Video Stabilizer in the market
 - Light weight (8 ounces) and Compact (1x3.5x5")
 - Beautiful deluxe gift box
 - Uses a standard 9 Volt battery which will last 1-2 years.

To Order: \$49.95 ea + \$4 for FAST UPS SHIPPING
1-800-445-9285 or **516-568-9850**
Visa, M/C, COD M-F: 9-6 (battery not included)
SCO ELECTRONICS INC.
Dept. CPE 3 581 W. Merrick Rd. Valley Stream NY 11580
Unconditional 30 days Money Back Guarantee

CIRCLE 17 ON FREE INFORMATION CARD

CABLE TV DESCRAMBLER How You Can Save Money on Cable Rental Fees

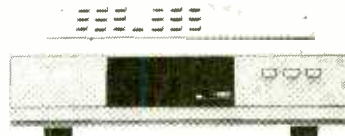

	1 Unit 5+
Jerrold SB w/Tri-Bi.....	\$99...\$70
SuperTri-Bi (TBM).....	\$109...\$75
Jerrold 450 combo.....	\$189...\$139
Scientific Atlanta.....	\$109...\$75
SA 8536.....	\$250...\$195
Pioneer.....	\$109...\$79
Oak KN12 (w/VS).....	\$109...\$65
Hamilin MLD 1200.....	\$89...\$59
Tocom.....	\$169...\$129
Stargate converter.....	\$89...\$69
Panasonic TZPC145.....	\$99...\$79

**US Cable will
Beat Anyone's
Price
Advertised in
this Magazine!**

30 Days Money Back Guarantee
Free 16 page Catalog

Visa, M/C, COD or send money order to:
US Cable TV Inc. Dept. KPE3

4100 N. Powerline Rd., Bldg F-4
Pompano Beach, FL 33073

1-800-445-9285

For Our Record

I, the undersigned, do hereby declare under penalty of perjury that all products purchased, now and in the future, will only be used on Cable TV systems with proper authorization from local officials or cable company officials in accordance with all applicable federal and state laws. FEDERAL AND VARIOUS STATE LAWS PROVIDE FOR SUBSTANTIAL CRIMINAL AND CIVIL PENALTIES FOR UNAUTHORIZED USE.

Date: _____

Signed: _____

No Florida Sales!

CIRCLE 18 ON FREE INFORMATION CARD

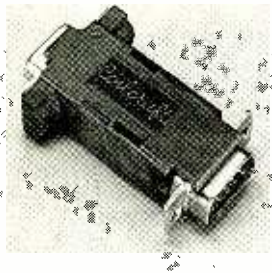

Common-mode magnetics filter all lines including the frame ground, attenuating EMI as much as 19 dB over the critical 30–300-MHz range. Data signals are left completely undisturbed.

The EMI Filter Module costs \$25.95 plus shipping. For further information, contact Coilcraft, 1102 Silver Lake Road, Cary, IL 60013; Tel: 708-639-6400.

CIRCLE 110 ON FREE INFORMATION CARD

OPTO-ISOLATION MODULE

Providing a communications link from one port to the other with no electrical connections, *Telebyte Technology's model 268 Opto-Isolation Module* acts as a filter to block unwanted electrical disturbances. Isolation is important in systems that use different power sources, have noisy signals, or operate at different ground potentials. Non-isolated devices provide a path for RF noise and allow voltage spikes to appear on data lines, increasing the chance of data errors and system faults.

The model 268 provides two full-duplex, optically isolated signal paths, one dedicated to

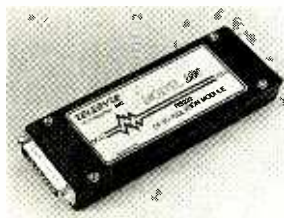

TD and RD Data and the other for a control signal pair. Internal jumpers select any proper combination of CTS, RRTS, DCD, or DTR. The module also uses micro-power DC-to-DC convert-

ers that generate the required operating voltages. Two sets of those circuits, one for each port, ensure that the module will work even if only TD and RD are connected. The model 268 can be plugged directly into a terminal or similar device.

The model 268 opto-isolation module costs \$126, with significant discounts available for quantity. For further information, contact Telebyte Technology, Inc., 270 East Pulaski Road, Greenlawn, NY 11740; Tel: 800-835-3298 or 516-423-3232; Fax: 516-385-8184 or 516-385-7060.

CIRCLE 111 ON FREE INFORMATION CARD

HIGH-RESOLUTION VGA CARD

Providing graphics resolution comparable to those of the IBM 8514/A and adapters based on the Texas Instruments TIGA interface specification, a VGA card from *Definicon* is dubbed *CAD RACE* (Resolution And Color Enhanced). The board allows the AutoCAD user to achieve equivalent high-resolution lines and colors on standard, low-cost VGA monitors.

CAD RACE uses an intelligent RAMDAC (digital/analog converter) for anti-aliasing, a

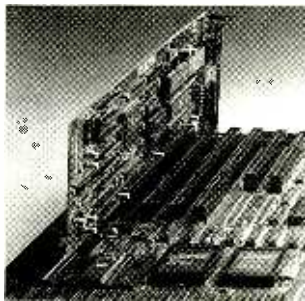

technique used to smooth the jagged edges of lines, circles, and other non-rectangular objects drawn on the CRT screen. The board produces flicker-free, near-photographic-quality graphics in true color. A software-based Display List Processing feature allows AutoCAD users to re-draw three to ten times faster than under standard AutoCAD operation. In addition to AutoCAD releases 9 and 10 and AutoCAD 386, the CAD RACE supports any soft-

ware—including specialized applications like desktop publishing as well as general-use programs—that observes the requirements of the IBM 8514/A high-resolution graphics board.

The CAD RACE VGA board with one megabyte of on-board memory (the standard configuration for CAD uses) costs \$495. For further information, contact Definicon International, 181-B West Orangethorpe, Placentia, CA 92670; Tel: 714-961-0438; Fax: 714-961-9052.

CIRCLE 112 ON FREE INFORMATION CARD

440-MHz ANTENNA TUNER

The *MFJ-924* 440-MHz tuner with built-in SWR/wattmeter handles power up to 200 watts, and its compact (8 × 2½ × 3-inch) size and wide impedance-matching range make it well-suited for mobile and/or base operation. The UHF tuner also features SO-239 input and output connectors and a wing-nut post for ground. The built-in



SWR/wattmeter displays power on 30- or 300-watt scales and SWR.

The The MFJ-924 antenna tuner, including a one-year unconditional guarantee, has a suggested price of \$69.95. For more information, contact MFJ Enterprises, Inc., P.O. Box 494, Mississippi State, MS 39762; Tel: 601-323-5869 or 800-647-1800; Fax: 601-323-6551.

CIRCLE 113 ON FREE INFORMATION CARD

TOOL MAGNETIZER/DEMAGNETIZER

Bondhus Corporation's Wiha 40010 tool magnetizer/demagnetizer has a powerful permanent magnet on one side to magnetize tools and small parts, and the other side demagnetizes items. The device



comes in a compact (2.1 × 2 × 1.1-inch), shatter-proof plastic box. Tools are magnetized or demagnetized simply by sliding them through the box.

The Wiha 40010 magnetizer/demagnetizer has a suggested list price of \$7.65. For further information, contact Bondhus Corporation, 1400 East Broadway, Monticello, MN 55362; Tel: 800-328-8310 or 612-295-5500.

CIRCLE 114 ON FREE INFORMATION CARD

DIGITAL-NOISE ABSORBERS

Designed to reduce electromagnetic interference (EMI) caused by digital circuits in CD players and DAT recorders, *TDK's NF-C09B* digital-noise absorbers are compact, passive filters that snap easily onto signal cables and power cords up to 9mm in diameter. A high-density ferrite core absorbs high-frequency energy to eliminate the high-range distortion



associated with EMI. The sonic effects are heard as increased clarity and reduced distortion when the digital-noise absorber is attached to the CD player's interconnect cables, as close as possible to the source deck.

The NF-C09B digital-noise absorbers cost \$10.00 for a package of two. For additional information, contact TDK Electronics Corporation, 12 Harbor Park Drive, Port Washington, NY 11050.

CIRCLE 115 ON FREE INFORMATION CARD

**NOW! AT-compatible computer, 20 meg hard drive,
and new diagnostic hardware and software!**

Learn to troubleshoot and service today's computer systems as you build a fully AT-compatible micro

Train the NRI way — and learn to service all computers as you build your own fully AT-compatible micro, now with 1 meg RAM, 20 meg hard drive, and exciting new diagnostic hardware and software!

Jobs for computer service technicians will almost double in the next 10 years according to Department of Labor statistics, making computer service one of the top 10 growth fields in the nation.

Now you can cash in on this exciting opportunity—either as a full-time industry technician or in a computer service business of your own—once you've mastered electronics and computers the NRI way.

NRI's practical combination of "reason-why" theory and hands-on building skills starts you out with the fundamentals of electronics, then guides you through more sophisticated circuitry all the way up to the latest advances in computer technology. You even learn to program in BASIC and machine language, the essential language for troubleshooting and repair.

Get real-world skills as you train with and keep a powerful AT-compatible computer system plus popular Microsoft® Works software

Only NRI gives you hands-on training with the finest example of state-of-the-art technology: the powerful new West Coast 1010ES computer. As you assemble this fully IBM PC/AT-compatible computer from the keyboard up, you actually see for yourself how each section of your computer works.

You assemble and test your computer's "intelligent" keyboard, install the power supply and 5-1/4" floppy disk drive, then interface the high-resolution monitor.

Your hands-on training continues as you install a powerful 20 megabyte hard disk drive—today's most-wanted computer peripheral—now included in your course to dramatically increase the data storage capacity of your computer while giving you lightning-quick data access.

Plus you now work with today's most popular integrated software package, Microsoft Works, learning to use its word processing, spreadsheet, database, and communications utilities for your own personal and professional applications. But that's not all.

NEW! Training now includes Ultra-X diagnostic hardware and software for quick, accurate troubleshooting

Now you train with and keep the latest in diagnostic hardware and software: the extraordinary R.A.C.E.R. plug-in diagnostic card and QuickTech diagnostic software, both from Ultra-X. Using these state-of-the-

Your NRI computer training includes all this: Discovery Lab®, digital multimeter and digital logic probe; AT-compatible computer with 1 meg RAM, 1.2 meg floppy drive, and high-resolution monitor; 20 meg hard drive; MS-DOS, GW-BASIC, and Microsoft Works software; R.A.C.E.R. plug-in diagnostic card and QuickTech diagnostic software



art tools, you learn to quickly identify and service virtually any computer problem on XT, AT 80286/80386, and compatible machines.

You discover how to use the R.A.C.E.R. diagnostic card to identify individual defective RAM chips, locate interfacing problems, and pinpoint defective support chips. Plus you learn to use your QuickTech software to test the system RAM and such peripheral adapters as parallel printer ports, serial communications ports, video display memory, floppy drives, and hard disk drives.

Only NRI gives you such confidence-building, real-world experience. Only NRI gives you both the knowledge and the professional tools to succeed as today's in-demand computer service technician.

No experience needed, NRI builds it in

With NRI training, you learn at your own convenience in your own home. No classroom pressures, no night school, no need to quit your present job until you're

ready to make your move. NRI starts you with the basics, building on that foundation step by step until you have the knowledge and skills you need for success.

And all throughout your training you've got the full support of your personal NRI instructor and the entire NRI technical staff, always ready to answer your questions and help you achieve your training goals.

FREE catalog tells more

Send today for NRI's big, free catalog that describes every aspect of NRI's innovative computer training, as well as hands-on training in other growing high-tech career fields.

If the coupon is missing, write to: NRI School of Electronics, McGraw-Hill Continuing Education Center, 4401 Connecticut Avenue, NW, Washington, DC 20008.

IBM and AT are registered trademarks of International Business Machines Corporation R.A.C.E.R. and QuickTech are registered trademarks of Ultra-X, Inc.

SEND CARD TODAY FOR FREE NRI CATALOG

NRI Schools

McGraw-Hill Continuing Education Center
4401 Connecticut Avenue, NW, Washington, DC 20008



✓ CHECK ONE FREE CATALOG ONLY

- | | | |
|--|--|--|
| <input type="checkbox"/> Microcomputer Servicing | <input type="checkbox"/> Computer Programming | <input type="checkbox"/> PC Software Engineering Using C |
| <input type="checkbox"/> TV/Video/Audio Servicing | <input type="checkbox"/> PC Systems Analysis | <input type="checkbox"/> Industrial Electronics & Robotics |
| <input type="checkbox"/> Automotive Servicing | <input type="checkbox"/> Electrician | <input type="checkbox"/> Building Construction |
| <input type="checkbox"/> Telecommunications | <input type="checkbox"/> Desktop Publishing & Design | <input type="checkbox"/> Small Engine Repair |
| <input type="checkbox"/> Security Electronics | <input type="checkbox"/> Locksmithing | <input type="checkbox"/> Word Processing Home Business |
| <input type="checkbox"/> Electronic Music Technology | <input type="checkbox"/> Bookkeeping & Accounting | <input type="checkbox"/> Paralegal |
| <input type="checkbox"/> Basic Electronics | <input type="checkbox"/> Fiction/Nonfiction Writing | <input type="checkbox"/> Air Conditioning, Heating & Refrigeration |

For career courses
 approved under GI Bill
check for details.

Name (please print) _____ Age _____

Address _____

City/State/Zip _____ Accredited Member, National Home Study Council 18-031

ponent values can be changed to accommodate whatever task you have for the circuit.

—Jerry Mercks, Huntsville, AL

Good Jerry, and thank you. I'm sure this circuit could easily be adapted to any sump pump and with a little imagination, to lots of other applications.

PILOT LIGHT

Many electronic circuits need an indication that they're under power; for most AC circuits, a neon lamp is the device of choice (it will operate on anything above 70 volts or so). In this era of semiconductors, it's hard to find the necessary operating voltage for a neon lamp. However, a bidirectional tri-color LED can be used if a capacitor is connected in series with the LED to limit the current through the LED. Refer to see Fig. 2.

The reactance of a capacitor depends on the

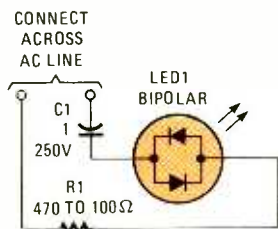

Fig. 2. This simple power-indicator configuration, built around an LED and a capacitor, can take the place of neon pilot lamps in AC circuits.

frequency of the line and the unit's capacitance. We can put a 1- μ F, 250-WVDC capacitor, which has a reactance of 2,650 ohms at 60 Hz, in series with an LED to limit the current through the unit to 43 mA. The impedance of the LED is low compared with the reactance of the capacitor, so nearly all the impedance will be due to the capacitor with the added advantage

of no energy loss caused by the capacitor.

The power of the LED is $1.175V \times 0.43A = 75mW$ compared to an NE-2 at 58 mW or an NE-2H at 250 mW, which is not so bad! For 230 volts, we can use a 0.47- μ F, 400-WVDC capacitor to do the job.

Just remember that you're dealing with a high-voltage circuit and observe the necessary precautions for safety's sake. Since some capacitors can be shorted by line transients, add a 47- Ω 100-ohm 1/4-watt resistor in series as a fuse, just to be on the safe side.

—Juan J. Martinez, Mexico, DF

Thanks, Juan. A handy circuit indeed. We like getting mail from you, as my boss collects stamps. Those Mexican stamps are mighty colorful, too.

SELF-TEST INTERFACE

By, I wanted an interface circuit that would allow me to connect my Franklin 1200 computer to my Ford Bronco II's EEC-IV Self-Test readout. I'm sure that by applying the principles outlined here, other applications will become self evident. See Fig. 3.

The self-test codes are sent via a series of 1/2-second pulses (+ 12 volts to 0 volts) to indicate digits with 2 and 4 second delays separating digits and codes. Of course, the Ford service manual is required for any use of this information. Not knowing what's in the Ford "black box" I elected to use a transistor to drive a reed relay, thereby limiting the current draw to 1 mA or less.

The relay contacts simulate pushing a button on the game paddle and a program I wrote deciphers the pulses and prints out the code with a brief description. The LED and S1 activate the self test and indicate the circuit is armed and ready to go when the

Safety, Security, Convenience, Entertainment and Energy Management

Home Automation from Heath, the catalog that has it all...

Enter the world of Home Automation. Remote lighting and appliance controls. Security alarms and lighting. Automated thermostats. Video monitoring systems. Whole-house security systems. They're all yours in the Heath Home Automation Catalog. To receive your FREE copy, call today toll-free.

1-800-44-HEATH
(1-800-444-3284)

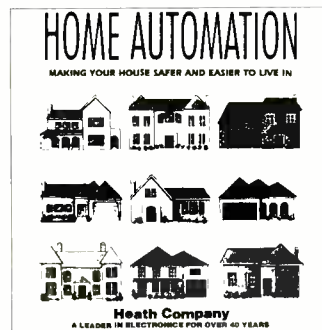

Heath Company
Marketing Dept. 107-034
Benton Harbor, MI 49022

CL-807

CIRCLE 8 ON FREE INFORMATION CARD

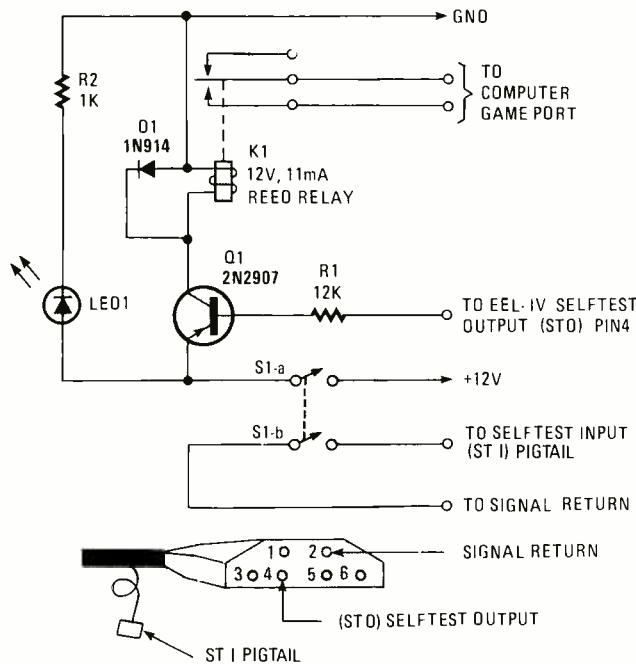

Fig. 3. This circuit when placed between the vehicle's EEC-IV Self-Test read-out and a Franklin 1200 computer acts as an interface.

Bronco key is turned on. Diode D1 protects Q1 from any inductive kick caused by the relay.

I prepared a wiring harness—consisting of 1/4-inch male push connectors and alligator clips for battery

connections—to mate with the connector on the Bronco.

Rather than open the computer each time to use the DIP plug as with the game paddle, I cut the game cable and inserted 8-pin DIN jack and plugs.

—Bob Lovdahl, Anchorage, AK

Good shot, Bob! And readers, if you have a use for an interface such as this, check the service manual for your own car and see if you can adapt Bob's circuit.

help! Take the box back and show that it's the other button that lights the light. You press it, and Bingo!

Okay, now that I let the bunny out of the bag, I'm lying low to escape all the people who couldn't light the light!

—Christopher Dunn, Chicago, IL

Chris, score one for our side! I'm sure our readers are going to have lots of fun with this one.

RELAY ACTUATOR

I've seen relay actuators using a single, normally-open pushbutton switch and a 4069 hex inverter, but here's an even simpler circuit (see Fig. 5).

Switch S1 is a normally-open pushbutton switch (ON), while S2 is a normally-closed pushbutton switch (OFF or reset). Pressing S1 completes the circuit to activate and latch the relay. The only way to de-actuate the relay is to press switch S2.

Because the normally-

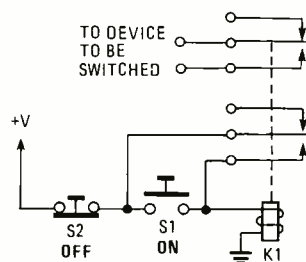

Fig. 5. Using two switches (one a normally-open pushbutton and the other a normally-closed pushbutton), this simple circuit can be used to replace others that use more complicated and expensive hardware.

open contacts of the relay are being used, the relay should be a double-pole, double-throw type.

—Ian Skinner, Victoria, B.C., Canada.

Sometimes, Ian, we electronics types do things the hard way, I like your circuit for its simplicity and obvious low cost.

MORE MAGIC

I saw the magic light box in your November, 1990 column, and it brought back a rush of memories. I made a few of those things for my own use.

Starting with all switches off or open (see Fig. 4), explain that only one switch will light the light. Show (by pressing the switch) that the left-most switch won't do it, nor will the right-most switch turn on the light. It's always the center button. Press it and the light will turn on.

You can now press the center button several times, showing that it turns the light on and off. The left and right buttons do nothing. Press them to turn the light off, and hand the box to a friend. He'll press the center button, to no avail. Tell them they now have a 50/50 chance with one of the other buttons. They'll press one, again, no

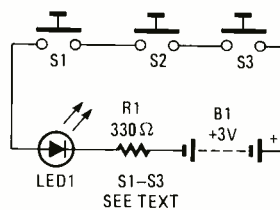

Fig. 4. The magic light circuit is nothing more than three push-to-make, push-to-break switches, an LED, and two AA batteries connected in series. All three switches must be on in order to light the LED.

Protel Easytrax 2™

Outstanding value in Printed Circuit Board/CAD for your Macintosh and PC

Protel Easytrax 2 is a new, low-cost design package for PC and Macintosh users that includes everything required to produce professional quality Printed Circuit Board artwork.

Our easy-to-learn menu-driven design system breaks the 'expert barrier'—you'll be designing in minutes, not hours. Our comprehensive tutorials guide you through the program's extensive features that take the tedium out of board layout.

- Comprehensive library of Through-hole devices
- Gerber photoplotting and N/C drill tapes
- On-the-fly library components creation
- Intelligent Pad to Pad autorouting
- Switchable Metric/Imperial grid
- Auto-panning
- PostScript™ printing
- Powerful user-definable Macros
- Independent print/plot program
- Multi-layer boards of up to 32 X 32 inches.

At Protel, we offer free technical support, 24-hour BBS, and 30-day money back guarantee. Prices start at

\$450

Free Evaluation Package
Toll Free: 800-544-4186

Protel Technology, Inc.
50 Airport Parkway, San Jose, CA 95110
Tel: 408-437-7771 Fax: 408-437-4913



DISCOVER THE LATEST ADVANCES IN ELECTRONICS . . . FROM TAB

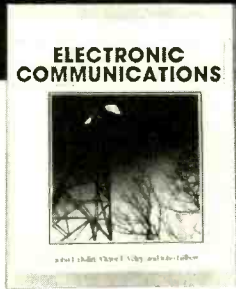

ELECTRONIC COMMUNICATIONS
by John J. Dulin, Victor F. Veley,
and John Gilbert
Both a professional reference and a study guide for the aspiring technician, this is a well-illustrated introduction to the theoretical and practical aspects of modern electronic communications.
688 pp., 566 illus. #3365H \$34.95

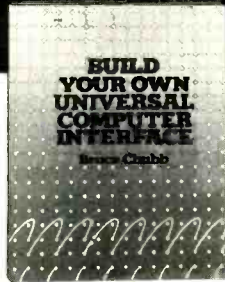

BUILD YOUR OWN UNIVERSAL COMPUTER INTERFACE by Bruce Chubb
Build electronic interfacing circuits that will enable your microcomputer to control external devices: your home security system, laboratory experiments, and much more.
285 pp., 224 illus. #3122P \$19.95

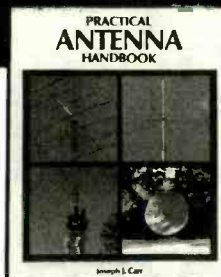

THE PRACTICAL ANTENNA HANDBOOK by Joseph J. Carr
Build antennas for any application, including radio and TV antennas, antennas for emergency communications, antennas for shortwave listeners, mobile and vehicular antennas, and more. You get 22 BASIC computer programs for designing antennas on your PC.
416 pp., 354 illus. #3270H \$32.95

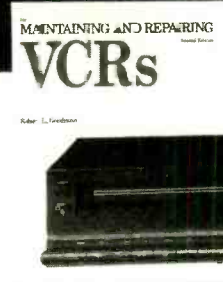

MAINTAINING AND REPAIRING VCR'S—2nd Ed. by Robert L. Goodman
Maintain and repair VHS HQ machines, 8mm, and camcorders using the money-saving troubleshooting tips in this guide. You get full coverage of the mechanical systems and electronic circuits plus illustrated service data.
352 pp., 370 illus. #3103H \$27.95

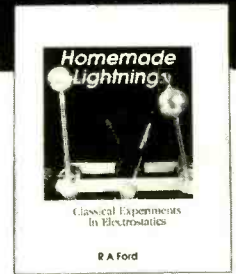

HOMEMADE LIGHTNING: Creative Experiments in Electricity by R. A. Ford
This book weaves a mixture of scientific history, electronics theory, and hands-on projects, offering you the chance to demonstrate for yourself some of the greatest electrostatic discoveries of the past 150 years.
160 pp., 163 illus. #3576H \$23.95

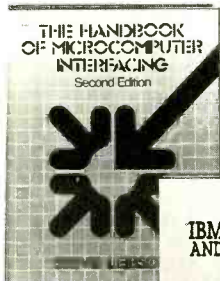

THE HANDBOOK OF MICROCOMPUTER INTERFACING—2nd Ed. by Steve Leibson
Put your computer to work controlling everything from household appliances to amateur radio equipment. This practical guide tells you how to attach peripherals from any manufacturer—even how to construct your own practical interface circuits.
339 pp., 338 illus. #3101H \$29.95



BUILD YOUR OWN 80386 IBM® COMPATIBLE AND SAVE A BUNDLE by Aubrey Pilgrim
This guide gives you easy-to-follow instructions for assembling an 80386 computer that will accommodate OS/2 or MS-DOS 4.0. Or, upgrade a PC/XT/AT or compatible to an 80386.
232 pp., 84 illus. #3131H \$26.95



GORDON McCOMB'S TIPS AND TECHNIQUES FOR THE ELECTRONICS HOBBYIST by Gordon McComb
This easy-to-use volume contains all the information you need to build, test, and use common electronic devices. Drawings, schematics, and illustrations show you exactly how to proceed. Includes 16 test equipment and hobby accessory projects.
300 pp., 180 illus. #3485H \$27.95



GORDON McCOMB'S GADGETEER'S GOLDMINE! 55 Space-Age Projects by Gordon McComb
An extraordinary collection of thoroughly tested space-age contraptions! Use this book to build a computer-controlled intelligent robot, Geiger counter, Tesla coil, Jacob's ladder, and much more!
400 pp., 274 illus. #3360H \$29.95



PRACTICAL TRANSFORMER DESIGN HANDBOOK—2nd Ed. by Eric Lowdon
Build power, impedance, and current transformers for all your equipment and project needs! Lowdon offers you valuable illustrated guidance on all aspects of transformer design and construction.
400 pp., 288 illus. #3212H \$34.95



THE COMPLETE SHORTWAVE LISTENER'S HANDBOOK—3rd Ed. by Hank Bennet, Harry L. Helms, and David T. Hardy
This "bible of shortwave" offers you the latest in equipment, innovations, and operating practices. Features include: a frequency listing for major and minor stations worldwide, SWL terminology, abbreviations, signals, and equipment jargon, and more.
304 pp., 96 illus. #2655P \$17.95

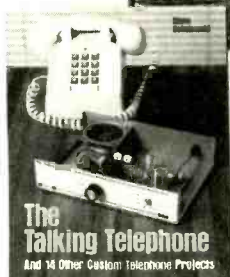

THE TALKING TELEPHONE—and 14 Other Custom Telephone Projects by Steve Sokolowski
This guide gives you a wealth of practical, easy-to-follow plans for inexpensive-to-assemble devices. Build pleasant-sounding ringers, a late-night telephone guard, hold buttons, LED displays, a code-protected dialing system, off-hook detectors, and even talking phones that read back dialed numbers.
352 pp., 328 illus. #3571H \$25.95

TO ORDER, Call Toll Free: 1-800-822-8158
(in PA, AK, and Canada call direct 1-717-794-2191)
FAX Orders: 1-717-794-2080, or mail coupon to:
TAB BOOKS, Blue Ridge Summit, PA 17294-0840

Please send me the book(s) below:

No. _____	Price _____	No. _____	Price _____
No. _____	Price _____	No. _____	Price _____

Please add applicable state and local sales tax.

Check or money order enclosed made payable to TAB BOOKS.

Charge my VISA MasterCard American Express Please Print

Acct. No. _____ Exp. _____

Signature _____

Name _____

Address _____

City/State/Zip _____

Orders subject to credit approval. Prices subject to change.

Satisfaction Guaranteed—If you are not completely satisfied, return the book(s) for a complete refund.

PE31

The Importance Of Setting Standards.



Without standardization in electronics, television wouldn't be seen, radio wouldn't be heard, computers wouldn't share information.

Fortunately the Electronic Industries Association (EIA) has been setting electronics standards since 1924 for everything from early tube radios to today's cellular telephones and stereo TV's.

Standards create *markets and jobs*. Today EIA, an internationally accredited standards making body, is helping to make HDTV a reality by working with the federal government and other industry organizations, to develop a timely, uniquely American transmission standard. For home automation,

EIA also is close to completing a standard which will permit all home electronic products to communicate with each other.

Our more than 1,000 member companies are manufacturers representing every facet of the American electronics industry—from defense to consumer products.

EIA is proud of the contributions it has made through its standards making process toward the growth and vitality of the U.S. electronics industries.

Setting the standard for more than 66 years.



ELECTRONIC INDUSTRIES ASSOCIATION

1722 Eye Street, N.W., Suite 300, Washington, D.C. 20006

Build a LAVA LAMP

Watching the hypnotic motion of a Lava Lamp is fun, but did you ever wonder how one works? Here's the answer, and a guide that shows you how you can build one yourself.

BY RALPH HUBSCHER

While hiking in the mountains this past summer, I stopped at a small restaurant for a spot of refreshment. I wound up with more, however; I left with an idea.

The owner had a unique decorating scheme, but what caught my attention were the decorative, table-lamp like devices that occupied each table in the establishment. They consisted of a cylinder-shaped bottle with a very short neck. In it, one red liquid moved leisurely up and down in a second, colorless liquid. The bottle was mounted on a stand and illuminated, and a decorative roof-like cap hid the bottle cap.

The red liquid bulged, formed bubbles and balls which rose very slowly and changed shape. Near the surface they sometimes coalesced with other balls, but always sank, only to go through the routine again. It was quite a spectacle and, like watching fish in an aquarium, you could look for hours.

Of course, the lamps were versions of the "Lava Lamp" that was so popular in the late 1960's and early 1970's. But as that psychedelic age faded, so did the lamp's popularity. Eventually, they were consigned to the farthest corners of closets or dark recesses of musty curio shops.

While Lava Lamps have made a bit of a comeback of late, why buy something when building one presents more of a challenge, and a lot more fun? I

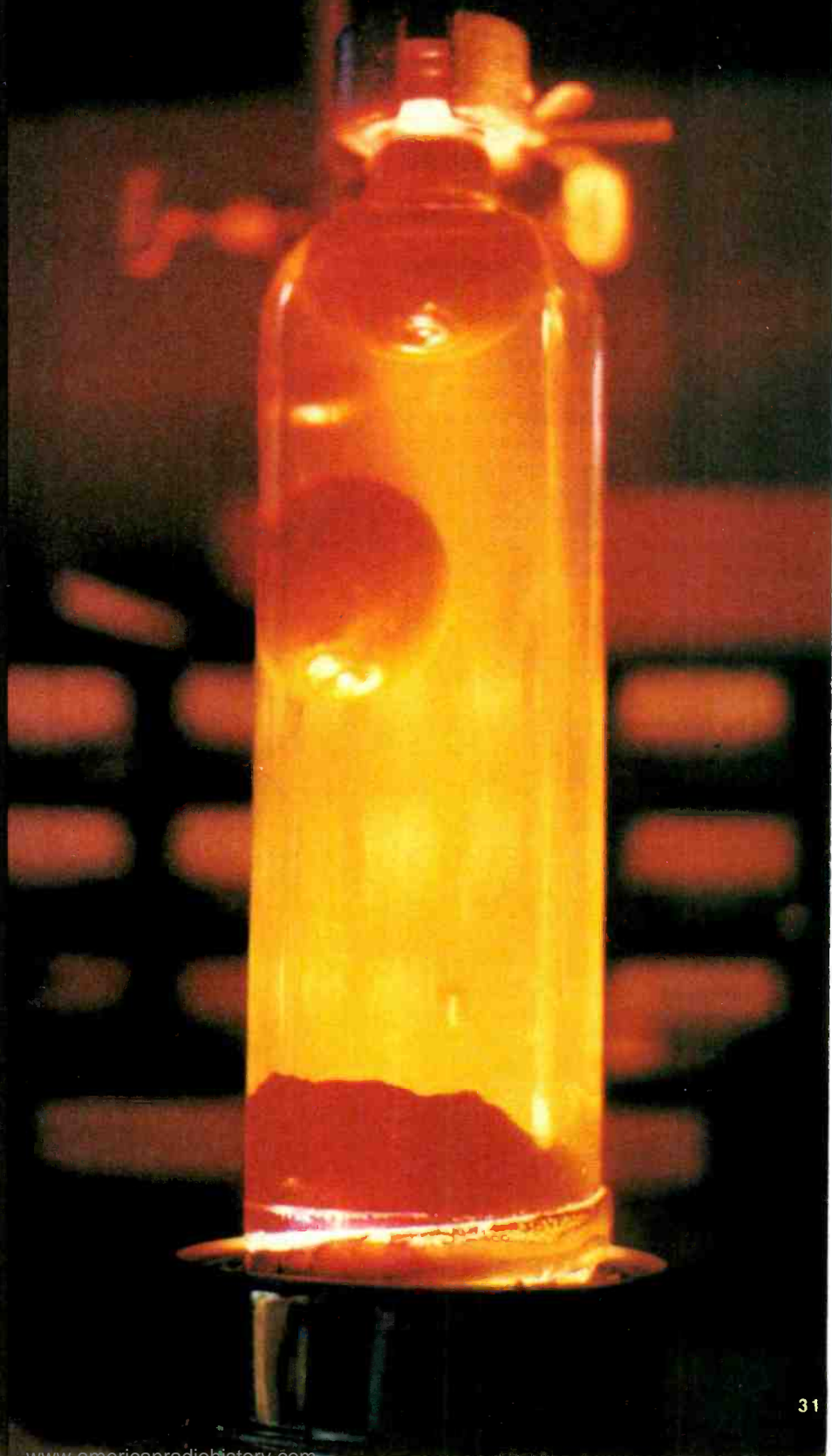

decided that I'd try to figure out how they were made and build my own.

What's Inside a Lava Lamp?

Examining the lamp, a few facts became clear. Obviously two immiscible fluids had been poured together, one of them dyed for contrast, and heat was applied at the bottom to make the bottom liquid warm up and expand. When expanded, that liquid's specific gravity is lower, and therefore it tends to move upward to where it is cooler. Once the liquid reaches the top of the container, it cools off, becomes heavier again, and starts sinking towards the bottom and the source of heat. The source of heat is the light bulb that illuminates the vessel containing the two fluids.

The first thing that must be determined is the nature of the liquids. I started out assuming the transparent fluid was water. The second fluid looked like SAE 50 motor oil, but oils float on water while this liquid sank, so it had to be something else. I remembered reading about some imported devices of this type and that they contained poisonous and dangerous chlorinated hydrocarbons. I looked through the Handbook of Chemistry to get alternate ideas, and made a list of requirements.

Assuming fluid 1 is water, the second fluid should:

- be insoluble in water, so the liquids remain separate
- be heavier than water, but not too heavy, in order to just sink
- not be emulsifiable in water so that it separates rapidly
- be non-flammable (for safety)
- be compatible with water (some substances will react)
- be stable in air (an air bubble remains on top)

WARNING!! This article deals with and involves subject matter and the use of materials and substances that may be hazardous to health and life. Do not attempt to implement or use the information contained herein unless you are experienced and skilled with respect to such subject matter, materials and substances. Neither the publisher nor the author make any representations as for the completeness or the accuracy of the information contained herein and disclaim any liability for damages or injuries, whether caused by or arising from the lack of completeness, inaccuracies of the information, misinterpretation of the directions, misapplication of the information or otherwise.

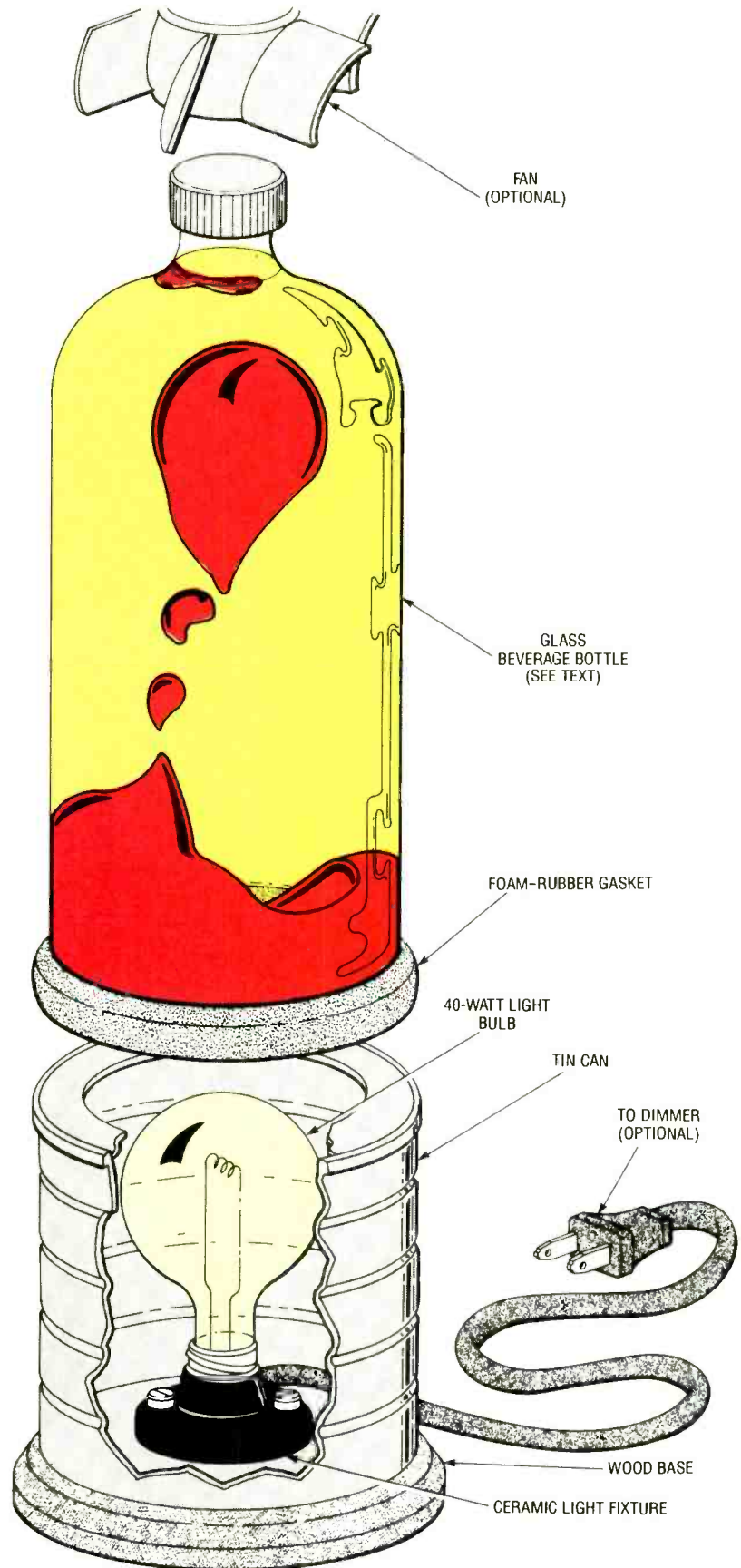

Fig. 1. Here are the major components of the Lava Lamp. Heat from the light bulb warms the benzyl alcohol in the glass container, causing bubbles to rise to the top, where they cool and eventually drift downward again.

- not be very poisonous (in case of breakage)
- not be chlorinated (in case of breakage)
- have a high boiling point (in case of breakage)
- be somewhat viscous so as to form "oily" bubbles
- be reasonably priced
- have a greater coefficient of expansion than water

That list of requirements is quite demanding. In fact, as any chemists out there will quickly realize, it eliminates about 999 out of 1000 possible compounds. After a thorough search, I came up with five chemicals which might be worth a try, but none of them were without a question mark. The list can be found in Table 1.

MATERIALS LIST FOR THE LAVA LAMP

- Benzyl alcohol
- Water
- Table salt
- Glass beverage bottle, 10-inches or taller
- Tin can, pint-size or larger
- Plywood (see text)
- Foam rubber, 1/4-inch (approximate) thickness
- Ceramic light fixture
- Light bulb, 40 watts
- Rubber grommet, AC plug with line cord, small fan (optional, see text), light dimmer (optional, see text), hardware, etc.

PARTS LIST FOR THE LIGHT DIMMER

- TR1—ECG 5603, NTE 5603, 2N6071, or equivalent Triac
- D1—ECG 6408, NTE 6408, or equivalent Diac
- R1—3000-ohm, 1/4-watt, 5% resistor
- R2—500,000-ohm potentiometer
- C1—0.1- μ F, ceramic-disc capacitor
- SO1—AC socket
- PL1—AC plug with line cord
- F1—5-amp fuse
- S1—SPST switch
- Wire, solder, hardware, etc.

Looking that list over, I decided to try benzyl alcohol. That substance, as well as the rest of the chemicals mentioned in this article, can be obtained through just about any reasonably stocked chemical supply house (check your local telephone book). Although benzyl alcohol is a little more soluble in water than the rest of the chemicals that are

TABLE 1—CHEMICAL CHARACTERISTICS

Chemical	Specific Gravity	Boiling Point (°C)	Solubility in Water
Benzyl alcohol	1.043	204.7	slightly soluble
Cinnamyl alcohol	1.04	257.5	slightly soluble
Diethyl phthalate	1.121	298	insoluble
Ethyl salicylate	1.13	233	insoluble
Nitrobenzene	1.205	210.9	very slightly soluble

TABLE 2—SALT CONCENTRATIONS

% Salt	Specific Gravity
1	1.0053
2	1.0125
4	1.0268
5	1.0341
6	1.0413

listed in Table 1, it seemed to work well so I stayed with it.

Before we proceed, some words of caution are in order: **While benzyl alcohol is a relatively harmless chemical, all chemicals are poisonous to one degree or another—you can kill yourself with salt. Of course, you must not drink it and skin contact should be avoided, if possible. Further, if benzyl alcohol should get into your eyes, wash it out with plenty of water while you hold your eye open using both hands, and then call a physician immediately! Finally, breathing benzyl alcohol should be avoided, (although it has such a high boiling point that hardly any of it evapo-**

rates). By the way, the oxidation products of benzyl alcohol—beuzaldehyde and beuzoic acid—are used as food additives, specifically as artificial almond flavoring and as a preservative, respectively.

A suitable red oil-soluble dye was found quickly. An old red felt pen was cut up (without spillage) and the dye-containing felt strip in it was placed in a jar with some benzyl alcohol. The dye was an excellent choice. It was stable in air and light, and insoluble in water—just perfect.

The red-dyed benzyl alcohol was then poured into a heat-resistant beaker, water was added, and the blend was heated on a hot plate. Nothing happened! Apparently, the specific gravities of the two liquids were too far apart and the liquids simply stayed where they were originally. I decided to try adding sodium chloride (table salt) to the water to increase its specific gravity. Table salt's affect on the specific gravity of water is shown in Table 2.

My initial tests showed that 5% and 6% salt concentrations were too high—the benzyl alcohol just floats to the top when heated and stays there. But a 4.8% salt solution worked fine. To get that concentration, I dissolved 48 grams of salt and filled up a container to 1 liter.

I now had all the components for my Lava Lamp. Benzyl alcohol (specific gravity 1.043 g/cm³) settles on the bottom of the vessel filled with a 4.8% salt-water (brine) solution (specific gravity approximately 1.032g/cm³). When the vessel is heated, the benzyl alcohol expands enough to become lighter than the brine and red bubbles rise to the top. There, the bubbles cool off, become heavier than the brine again, and sink. The cycle then repeats.

Construction Details. The first step is to find a suitable vessel. Use a glass beverage bottle shaped roughly as
(Continued on page 102)

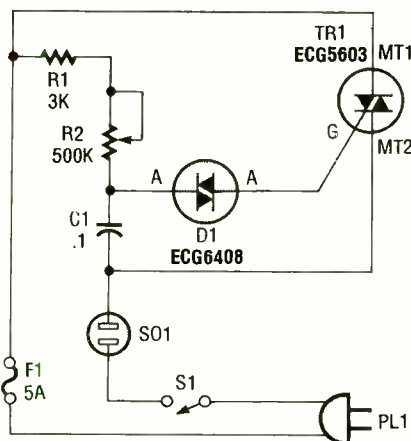

Fig. 2. Using a light dimmer is one way to control the amount of heat applied to the Lava Lamp. Nearly any dimmer circuit, including the one shown here, can be used.

I know a young man who had inherited some speakers from his girlfriend and decided that they would make a great addition to his car's stereo system. Shoving all the empty Coke cans aside, he squeezed the boxes into his back seat (which they filled). Naturally any speaker *that* big must be able to handle lots of power, so he didn't hesitate to connect the leads to his 200-watt power booster. Almost immediately after cranking the volume up until no lyrics were distinguishable, a "pop" occurred. It was barely audible over the music, but after that the speakers didn't sound so good.

squawker, because of its sound quality if used alone. For some reason, the name didn't appeal to Madison Avenue. Since the introduction of the third speaker, four- and five-way systems have been introduced, though, as Paul Klipsch pointed out, "with no resulting additions to the nomenclature."

What these systems really needed was a crossover network. The job of a "crossover" is to split the electrical energy among the various speakers. A woofer is fed through a low-pass filter that, as you might guess, passes low frequencies and rejects highs. The tweeter is fed through a high-pass filter

are more sensitive to high frequencies than to lows, low-frequency sounds (and signals) must be endowed with more energy to be heard. The extra power given to the lows can be easily handled by a woofer, since it has a characteristically high mass, but it could damage smaller midrange and tweeter drivers.

The final reason is to improve the frequency response as much as possible. Many drivers have very irregular response, sometimes with large peaks in response outside their desired frequency range. For example, many woofers have large peaks at around 1500 to

Explore the ins and outs of speaker crossovers and learn how to custom design your own speakers.

How to Design Your

He opened up one of the speaker cabinets and exclaimed "Hey, what's this fuzzy stuff all over the inside of my speaker cabinet, and why doesn't the little speaker work?" Well, the fuzzy stuff was the remains of a crossover capacitor whose voltage rating had been seriously exceeded. By exploding, it had in fact nobly saved the tweeters. Whether they were worth saving is another question.

The capacitor was used as a simple "crossover network" (commonly called just a crossover.) In this article we'll explore why crossovers are used and how you can design one of your own to suit your specific needs. Hopefully by the end, you'll be able to avoid the catastrophe my young friend experienced.

Why Use Crossovers? It was discovered very early that a wide range of frequencies can be reproduced more effectively if that range is split up among several different speakers, each optimized for its particular portion of the range. The first generation of speakers taking advantage of the concept contained a woofer for low frequencies and a tweeter for highs. Next, a midrange driver was added. That driver was sometimes called a

that rejects low frequencies. If one or more midrange speakers are used, they are fed through band-pass filters that pass only a certain band of frequencies, rejecting higher and lower ones. Usually, a band-pass filter is just a high-pass filter followed by a low-pass filter, so there are really only two types of circuits that we need examine.

There are three reasons why a crossover is needed: The first is simple efficiency—why waste high-frequency power by applying it to a speaker that can't reproduce highs?

The second, and more important reason, is to protect the midrange and tweeter from damage. Since our ears

3000 Hz. A crossover can ensure that energy above, say, 1200 Hz will be delivered to a midrange or tweeter, but not to the woofer.

The Simplest Crossover. A crossover usually consists of very simple circuitry. The simplest crossover network uses no low-pass filter at all, and only a capacitor for the high-pass filter. Such a network is shown in Fig. 1. My friend's freebie speakers were of this kind. A capacitor's reactance is inversely proportional to frequency, according to the formula:

$$X_C = \frac{1}{2\pi fC}$$

where f is the frequency and C is the capacitance in farads. Since reactance limits the alternating current, and capacitors have a high reactance at low frequencies, the capacitor does not allow much low-frequency current to flow to the tweeter. The so-called "crossover frequency" is the frequency at which the capacitive reactance equals the tweeter's impedance. Thus we can find the needed capacitor value by substituting the tweeter impedance Z_T into the previous equation and solving for C as follows:

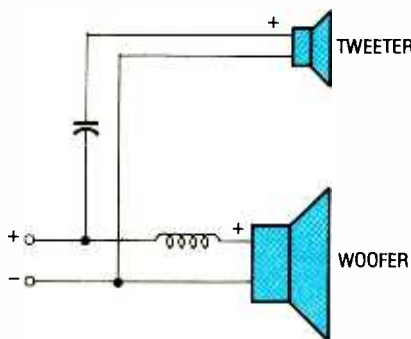
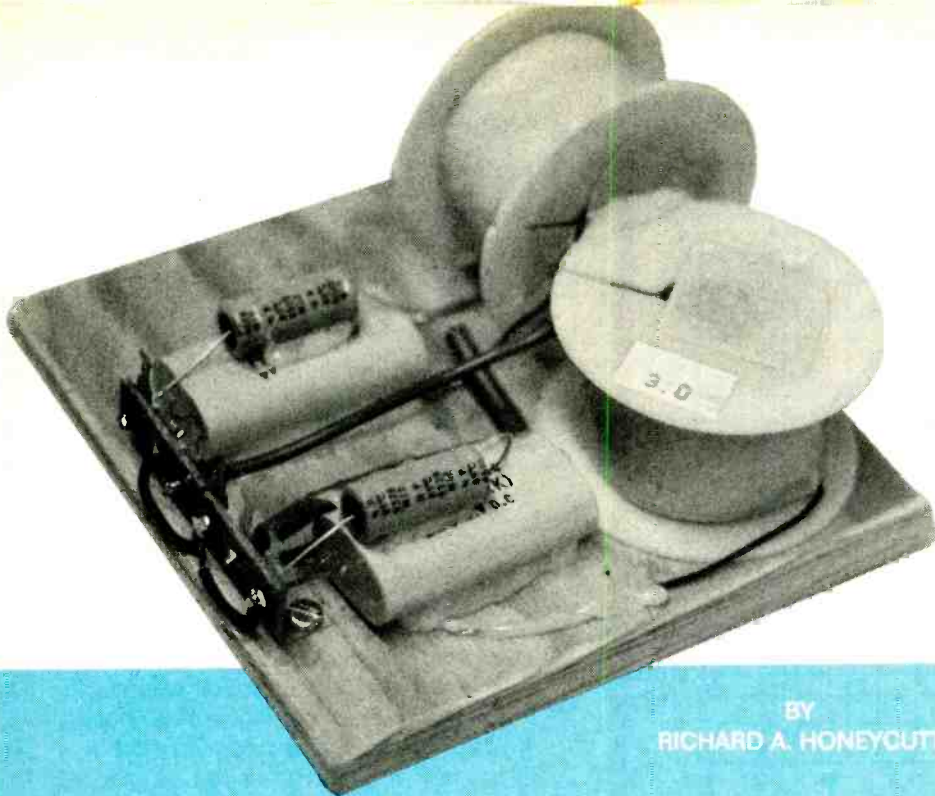

Fig. 1. A simple capacitive crossover can protect a tweeter from damage.



BY
RICHARD A. HONEYCUTT

Own Speakers

$$C = \frac{1}{2\pi f Z_T}$$

You can use this equation to find the size capacitor you need, or you can use the graph shown in Fig. 2.

There is a "gotcha", though, even in this simple design, and we may as well deal with it now. Speaker impedance is not constant with frequency. Therefore, your "8-ohm" speaker may have an impedance of 10 or 12 ohms or more at the crossover frequency. Thus you must determine the speaker's impedance at that frequency.

Fortunately, there's an easy way to measure the speaker's impedance. All you need is a signal generator, a voltmeter, and an ammeter. If you don't have an ammeter you can use a 1k resistor and a voltmeter instead.

The test setup with the ammeter is shown in Fig. 3A. After wiring up the circuit, you adjust the audio generator to produce the desired crossover frequency, and read the voltage and current from the meters. The impedance will be the voltage divided by the current.

The setup without the ammeter is shown in Fig. 3B. You adjust the audio generator as before and read the volt-

ages as shown. To determine the impedance divide the value of the voltage across the speaker (V_s) by the resistor voltage (V_r) and multiply by 1000.

We are not quite through yet: When you go looking for capacitors at your local electronic emporium, you'll find that you need to know more than just the value. There's a voltage rating to be reckoned with, too. The rating you choose will determine the maximum power that your system can handle. The voltage can be calculated by using:

$$V = \sqrt{2PZ}$$

where P is the maximum power your amplifier can produce, and Z is the highest speaker impedance into which the amplifier can produce full power (usually 8 ohms for home stereos and 4 ohms for car units). Alternatively, you can read the voltage from Fig. 4. I always buy at least 100-WVDC capacitors, allowing a theoretical maximum of a 600-watt amplifier. That provides a comfortable safety margin.

Another choice you'll have is the type of capacitor. The cheapest way to go is to use a non-polar electrolytic. Standard electrolytics, including Tantals, require a DC polarizing voltage, but a

non-polar electrolytic has two standard units inside, connected "back-to-back" (i.e. the two positive leads connected together).

Many smaller stores have only polarized units, especially in values above about 2 μF but you can make a non-polar capacitor by wiring two polarized capacitors back to back as mentioned. Each capacitor must have twice the capacitance that you want the non-polar unit to have.

While electrolytic capacitors can be used in crossovers, they do have a tendency to soak up some of the speaker's power at high frequencies, so that you don't get maximum performance from the tweeter. The technical name for that fault is "dielectric absorption."

Polyester film capacitors, or better yet, polypropylene film units, have almost no dielectric absorption in the audio range. The difference between electrolytics and film capacitors is audible, unless you've sacrificed your hearing to too much loud stuff.

They are available in values up to about 12 μF and they can be wired in parallel to obtain larger values. (Capacitor values add when capacitors are wired parallel to one another.) In fact, if the values you need are over 6 μF , it's often cheaper to buy smaller capacitors and parallel them than to buy a single large unit.

Adding a Low-Pass Filter. If you choose to add a low-pass filter for the woofer, it can be just a simple coil (or inductor). A coil's reactance is proportional to the frequency it handles:

$$X_L = 2\pi f L$$

where L is the inductance in henrys. Putting a coil in series with the woofer causes the woofer to get progressively less power as the frequency is increased. The correct coil inductance can be found by using:

$$L = \frac{Z_W}{2\pi f}$$

where Z_W is the woofer impedance at the crossover frequency. Alternatively, you can use the chart in Fig. 5. The circuit with the coil added is shown in Fig. 6.

Coils can be bought at many electronics stores and from mail-order houses. Again, you have some choices

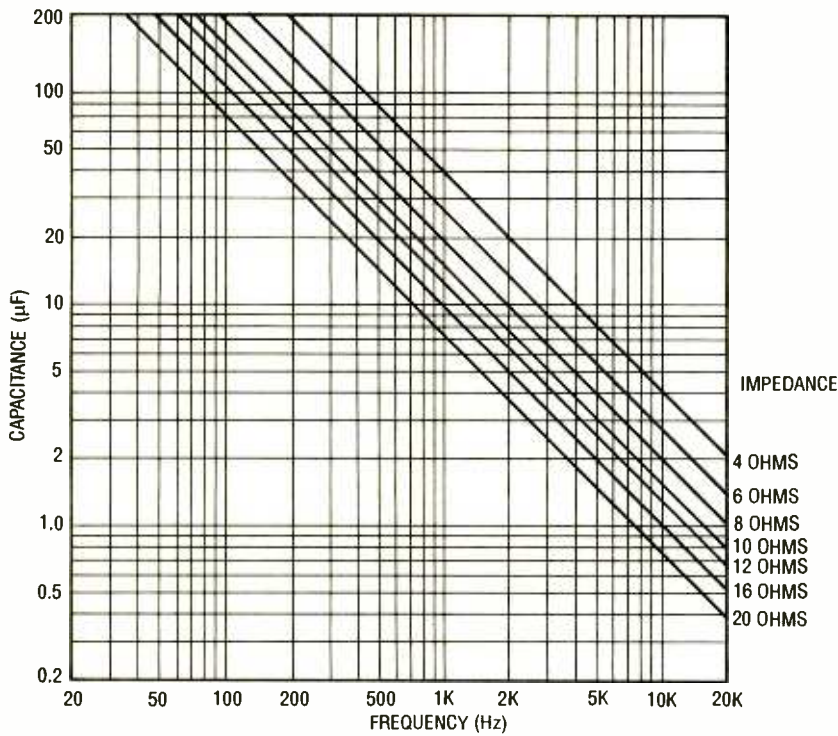

Fig. 2. Select capacitor values for two-way speaker systems from this easy-to-use graph.

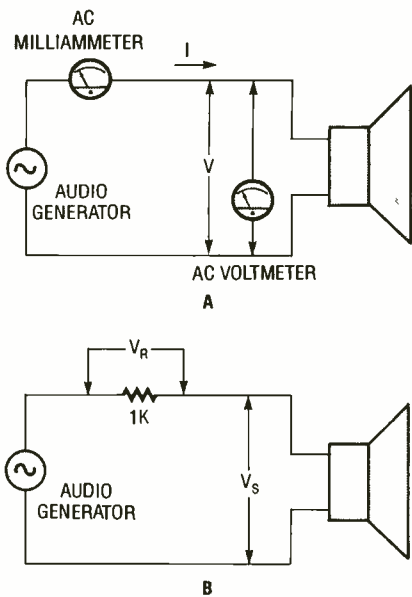

Fig. 3. Measuring speaker impedance is easy. You only need a signal generator, a voltmeter, and an ammeter (A). If you don't have an ammeter, you can use a resistor and voltmeter instead (B).

be under 1% or so, as long as you do not exceed the rated power. However, at excessive power levels, an iron-core coil will make your system sound really raunchy.

Your other choice is to use an air-core coil. They do not introduce distortion, but unless large enough wire is used to wind them, they can degrade your system's damping factor. (For a discussion

of damping factor, check out a copy of Howard Tremaine's *Audio Cyclopaedia*, published by Howard W. Sams, from your local library.) Figure 7 indicates the minimum wire gauge that is suitable for coils of various inductances, assuming a nominal 8-ohm speaker. For a 4-ohm speaker, use coils wound with wire three sizes larger. The graph is based on a coil resistance that is not over 5% of the speaker's DC resistance (e.g. 0.3 ohm for an 8-ohm speaker with a 6-ohm DC resistance).

Unlike the capacitor (unless you're really adventurous), a coil is a component that you can make from scratch. Being able to "roll your own" is only an advantage if you can't find the value you need; it may not be a good way to save money. You see, copper "magnet wire" for winding coils costs roughly one-fifth as much when bought in 50-lb bails as it does when bought a pound at a time. So a coil maker can sell you a prewound, tested coil at a healthy profit while still charging you no more than you would have to pay for the wire alone, unless you have a friend who's into motor rewinding. (Those are the guys who buy most of the 50-lb bails.) How to wind crossover coils is a subject for another article, though.

The frequency response of a simple coil-and-capacitor crossover network is shown in Fig. 8. Notice that at frequencies a little beyond the crossover frequency, the response falls off at a rate of 6-dB-per-octave (an octave is a dou-

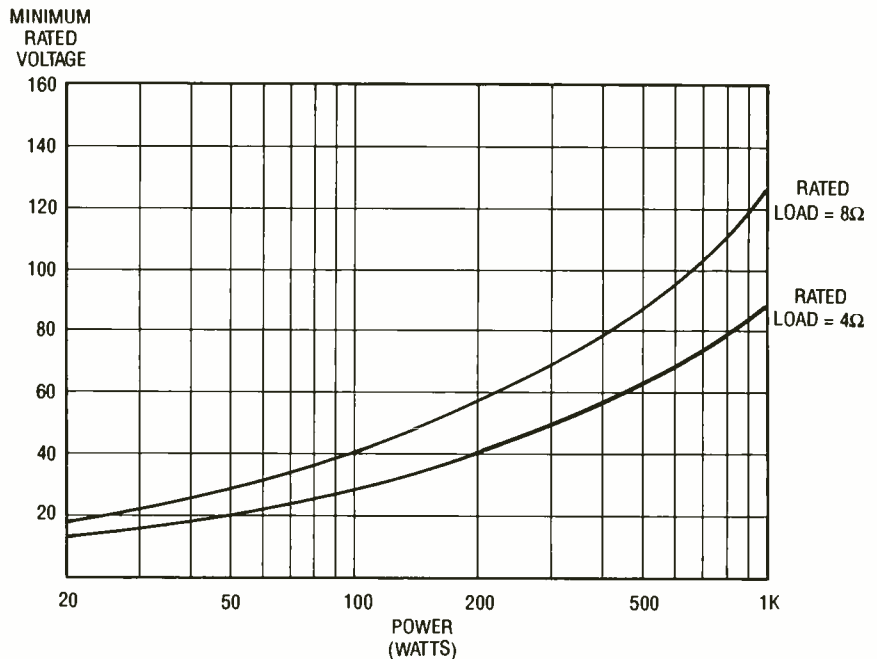

Fig. 4. You can determine the capacitor voltage rating if you know your amplifier's maximum output power by using this graph.

POPULAR ELECTRONICS to make, the first of which is whether you want to use an iron- or air-core coil. Iron-core coils are commonly available because it takes fewer turns of wire to make them. Unfortunately, the magnetic characteristics of iron are not very linear, so those coils introduce some distortion. However, in a well-designed iron-core coil the distortion will usually

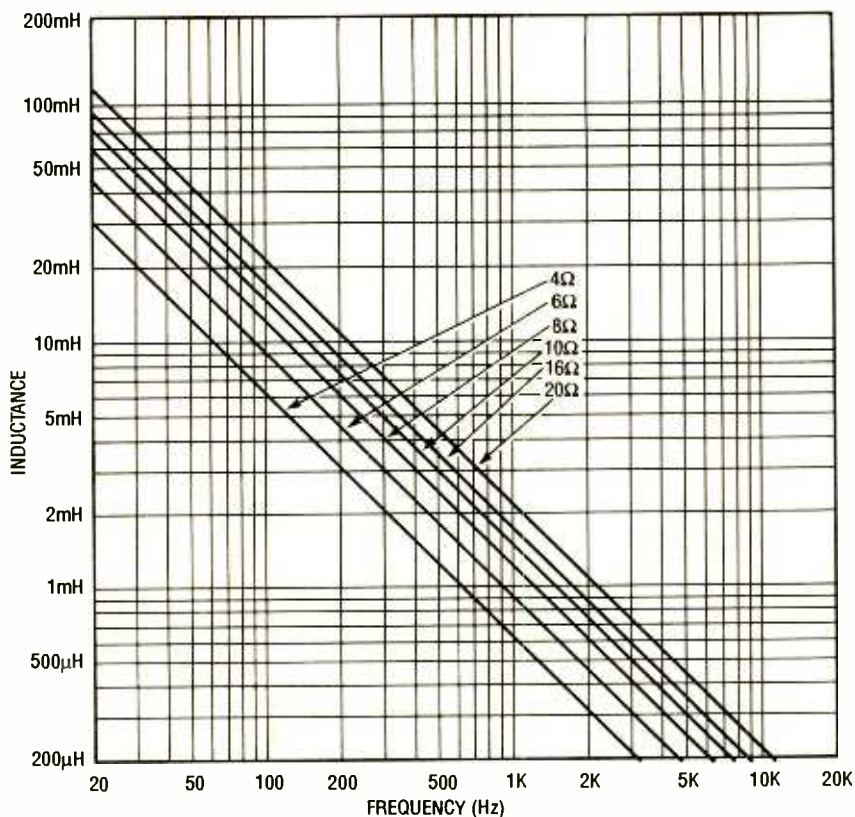

Fig. 5. Inductors can be selected from this graph if you know the frequency and load requirements of your speaker system.

bling or halving of frequency). That is characteristic of "first-order filters," which are filters that have only one reactive device (whether it's a coil or capacitor). Since the woofer's low-pass filter has only the coil, and the tweeter's high-pass filter has only the capacitor, each is a first-order filter, and this is a first-order network.

Adding a Midrange. We could add a midrange speaker to our system, using another coil and capacitor as shown in Fig. 9. The additional components form a band-pass filter. The values of the components can be determined from:

$$C1 = \frac{1}{2\sqrt{2}\pi f_H Z_T}$$

$$C2 = \frac{f_H - f_L}{\pi Z_{ML} f_M^2}$$

$$L1 = \frac{Z_{MH}}{4\pi(f_H - f_L)}$$

$$L2 = \frac{\sqrt{2}Z_W}{2\pi f_L}$$

where the various impedances are indicated by a subscript: W for woofer, T for tweeter, and M for midrange, and L and H denote the values at the low and

high crossover-frequencies, respectively. (For example, two impedances are needed for the midrange driver: Z_{ML} at the low crossover frequency, and Z_{MH} at the high frequency.) The frequency f_M is the "geometrical center frequency" of the midrange section, and it is given by $f_M = \sqrt{f_H f_L}$. A peculiar feature of many 3-way crossovers is that they boost the midrange about 2 dB above the woofer and tweeter. That is no real problem, but it does mean that the midrange should be made about 2 dB less sensitive than the other two speakers (more on that later).

A Two-way, Second-Order Crossover. Figure 10A shows a 2-way second-order crossover network and Fig. 10B contains its response curves. Notice that at frequencies a little distance from the crossover frequency, each of its curves falls off at a rate of 12 dB per octave. The first-order filter's response is also shown (dashed lines) for comparison.

You might be wondering why you would want to use a second-order filter, since it requires twice as many components. There are two possible reasons: In high-power systems, the woofers can often stand 200 watts or more. Tweeters, however, can only handle a

small fraction of that power. Thus it becomes very important to cut off the high-energy low frequencies as sharply as possible.

For example, let's say a first-order system is built with a crossover frequency of 1000 Hz, and a 100-watt, 500-Hz sine-wave is fed into the system. The tweeter will have to handle about 50 watts. With a second-order crossover, the tweeter would only have to handle about 25 watts.

The second reason for using a higher-order crossover is that whenever two speakers are reproducing the same frequency at roughly the same levels,

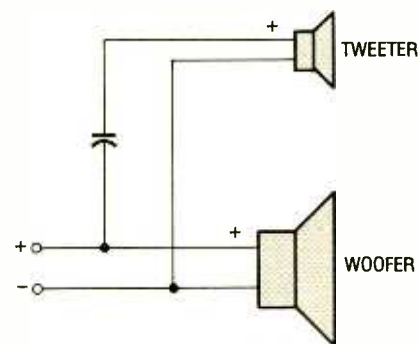

Fig. 6. This is a simple two-way first-order crossover. It prevents the woofer from receiving a significant amount of high-frequency energy.

there will be interference between them, reinforcing some frequencies and cancelling others. By using a higher-order crossover, you can reduce the range of frequencies in which such overlap is possible. To choose the values for a 2-way second-order crossover, use these equations:

$$C1 = \frac{1}{4\pi Z_T f_H}$$

$$C2 = \frac{1}{4\pi Z_W f_L}$$

$$L1 = \frac{Z_T}{\pi f_H}$$

$$L2 = \frac{Z_W}{\pi f_L}$$

Notice that the tweeter in Fig. 10A is connected with opposite polarity than the one in Fig. 6. This is necessary because of the phase shift introduced by the second-order network. In order for the woofer and tweeter to pump air in phase at the crossover frequency (where they're both working), they have

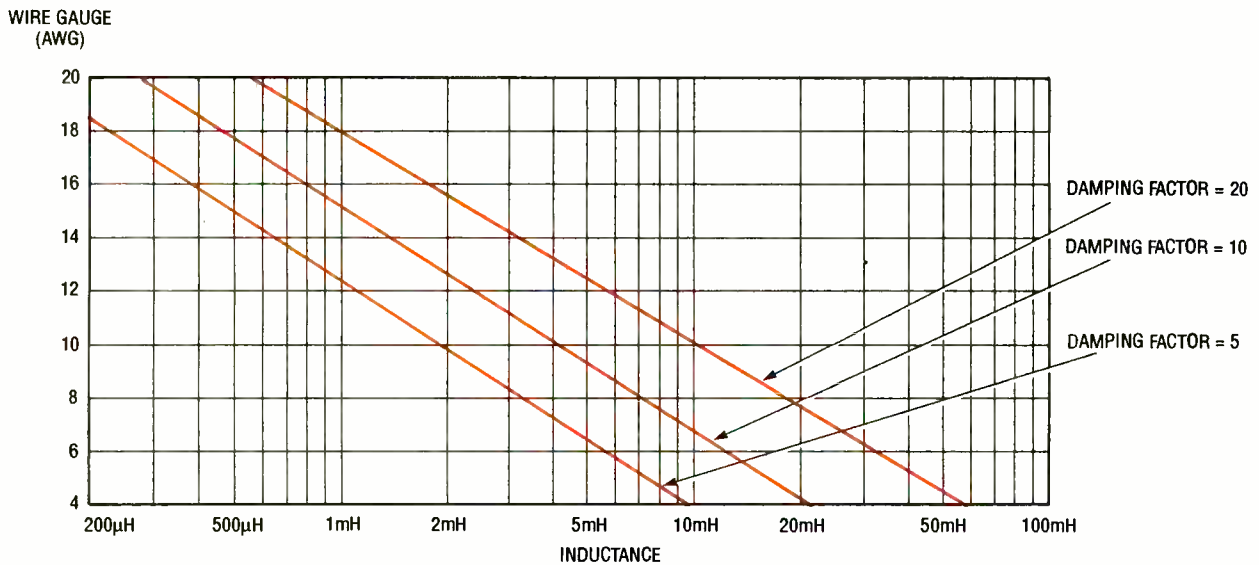

Fig. 7. The wire size of an inductor is important. It restricts the dampening capability of the drivers.

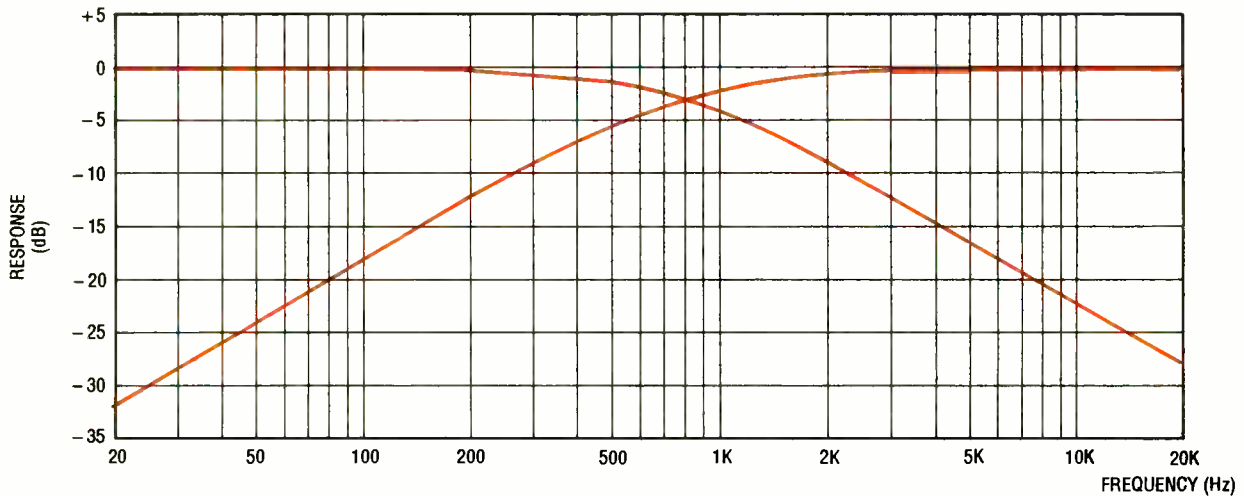

Fig. 8. This is the typical response of a first-order two-way crossover network. Note the shape decline in response beyond the crossover frequency.

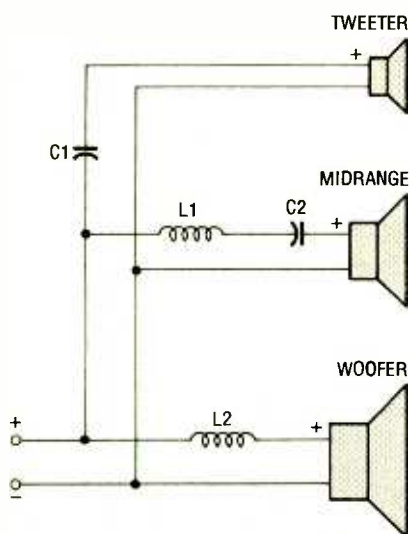

Fig. 9. This three-way first-order crossover can greatly enhance the sound quality of a speaker system.

to be connected as shown. Otherwise, their outputs will cancel and produce a response dip at the crossover point.

A Three-Way, Second-Order Crossover. Figure 11 shows a 3-way second-order crossover network. Note the tweeter is wired with the same polarity as the woofer, but now the midrange is reversed. Calculate the parts value as follows:

$$C1 = \frac{1}{4\pi Z_T f_H}$$

$$C2 = \frac{f_H - f_L}{2\sqrt{2}\pi Z_{ML} f_M^2}$$

$$C3 = \frac{1}{2\sqrt{2}\pi Z_{MH}(f_H - f_L)}$$

$$C4 = \frac{1}{4\pi Z_W f_L}$$

$$L1 = \frac{Z_T}{\pi f_H}$$

$$L2 = \frac{Z_{MH}}{\sqrt{2}\pi(f_H - f_L)}$$

$$L3 = \frac{Z_{ML}(f_H - f_L)}{\sqrt{2}\pi f_M^2}$$

$$L4 = \frac{Z_W}{\pi f_L}$$

A Practical example. As an example, let's see what components we would need to make a typical speaker system. We'll use a 12-inch woofer and a horn tweeter with stated impedances

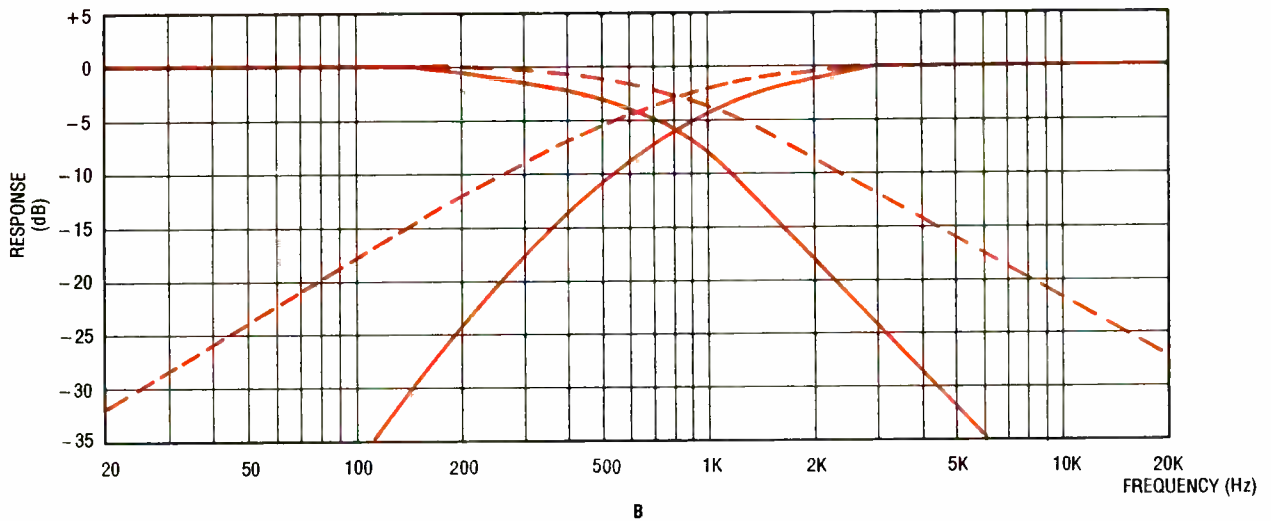
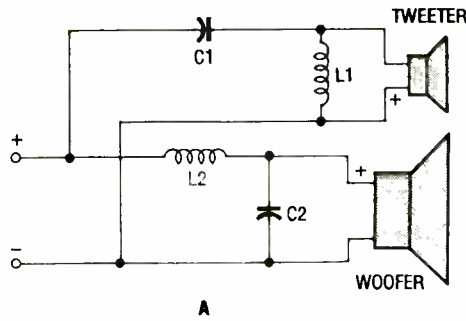

Fig. 10. A two-way second-order network is a more frequency-selective circuit (A). As you can see the response declines at 12 dB per octave (B).

of 8 ohms. We'll choose a 2-kHz crossover frequency. Measuring the actual speaker impedances, we find that Z_W is 20 ohms and the Z_T is 9 ohms at 2 kHz. If we only use a simple capacitor crossover, the capacitor's value would be:

$$C = \frac{1}{2\pi f Z_T} = \frac{1}{2 \times \pi \times 2000\text{Hz} \times 9\Omega} = 8.8\mu\text{F}$$

Moving on to a two-way first-order crossover will require adding a coil whose inductance is:

$$L = \frac{Z_W}{2\pi f} = \frac{20\Omega}{2 \times \pi \times 2000\text{Hz}} = 1.6\text{mH}$$

If we decide to improve performance and increase tweeter protection by using a second-order network, we'll cut the capacitor value in half and double the inductor value. Thus we will need two 4.4- μF capacitors and two 3.2-mH coils.

Perhaps, after looking more closely at the response curves for our woofer and tweeter, we decide that our system could be improved if we used a mid-

range speaker also. We decide on crossover frequencies of 500 and 4,000 Hz. Measuring impedances, let's say we find that the woofer presents 18 ohms at 500 Hz, the midrange has 8.9 ohms at 500 Hz and 12.6 ohms at 4,000 Hz, and the tweeter has a load of 9.8 ohms at 4,000 Hz. Plugging those numbers into the equations for a second-order, three-way network, we find:

$$f_M = \sqrt{4000\text{Hz} \times 500\text{Hz}} = 1414\text{Hz}$$

$$C1 = \frac{1}{4\pi Z_T f_H} = \frac{1}{4 \times \pi \times 9.8\Omega \times 4,000\text{Hz}} = 2\mu\text{F}$$

$$C2 = \frac{f_H - f_L}{2\sqrt{2} \times \pi Z_{ML} f_M^2} = \frac{4000\text{Hz} - 500\text{Hz}}{2\sqrt{2} \times \pi \times 8.9\Omega \times (1414\text{Hz})^2} = 22.1\mu\text{F}$$

$$C3 = \frac{1}{2\sqrt{2} \pi Z_{MH} f_H - f_L} = \frac{1}{2\sqrt{2} \times \pi \times 12.6\Omega \times (4,000\text{Hz} - 500\text{Hz})}$$

$$= 7\mu\text{F}$$

$$C4 = \frac{1}{4\pi Z_W f_L} = \frac{1}{4 \times \pi \times 18\Omega \times 500\text{Hz}} = 8.9\mu\text{F}$$

$$L1 = \frac{Z_T}{\pi f_H} = \frac{9.8\Omega}{\pi \times 4,000\text{Hz}} = 0.78\text{mH}$$

$$L2 = \frac{Z_{MH}}{\sqrt{2} \pi (f_H - f_L)} = \frac{12.6\Omega}{\sqrt{2} \times \pi \times (4000\text{Hz} - 500\text{Hz})} = .9\text{mH}$$

$$L3 = \frac{Z_{ML} (f_H - f_L)}{\sqrt{2} \pi f_M^2} = \frac{12.6\Omega \times (4000\text{Hz} - 500\text{Hz})}{\sqrt{2} \times \pi \times (1414\text{Hz})^2} = 1.2\text{mH}$$

$$L4 = \frac{Z_W}{\pi f_L} = \frac{18\Omega}{\pi \times 500\text{Hz}} = 11.4\text{mH}$$

Many years ago, I built a three-way speaker system using prime-quality
(Continued on page 100)

Shoot the Classic Milk Drop



Build a time-delay, flash-trigger circuit that lets you capture shots that would be next to impossible otherwise.

BY JAMES R. BAILEY

If you are like me, you have been amazed at the simple, yet classic beauty of the familiar "milk drop" photos. They are among the thousands of well-known images created by famed inventor and educator, Dr. Harold Egerton. Now, you can shoot your own "classic" using your own camera and flash, coupled with this easy-to-make time delay flash trigger.

How It Works. The schematic diagram for the time delay circuit is shown in Fig. 1. The circuit is built around a single 4093 quad 2-input NAND Schmitt trigger. Two gates from that quad package (U1-a and U1-b) are configured as a set-reset flip-flop, which is triggered by a phototransistor (Q1). As long as Q1 is illuminated by a beam of light, one input of U1-a is held high. When the beam is interrupted, say by a falling milk drop, the input to U1-a is pulled low via resistor R1.

That causes U1-a's output to go high, thereby forcing U1-b's output low. At that point, C2 (which in conjunction with R2 and R3, determines the length of the time delay) begins to discharge through R2 and R3. The actual delay time in seconds is given by:

$$t_d = C \times (R2 + R3)$$

When C2 has discharged sufficiently, U1-b's output goes high, triggering SCR1 and firing your flash. Now C1 begins to charge through R4, which takes about a half second. When that time has elapsed, U1-d's output goes low, reset-

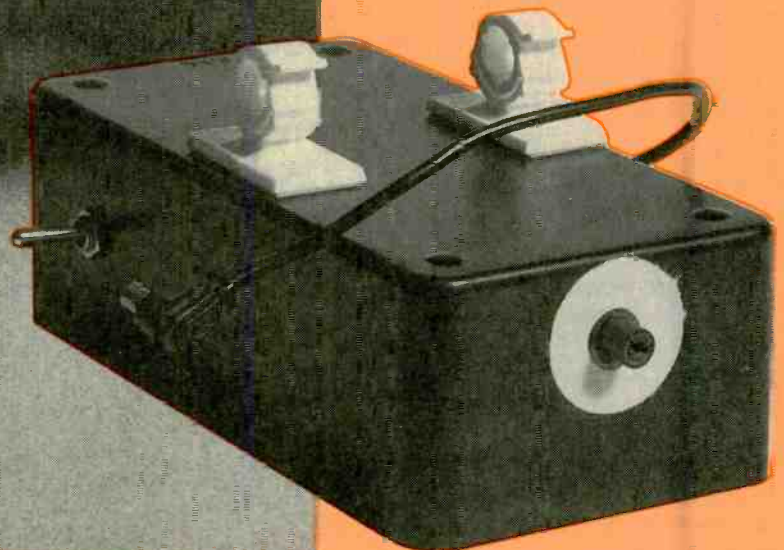

ting U1-a and U1-b to their initial state. Capacitor C2 then quickly recharges through D1, so that it's ready for the next shot. The half-second delay produced by C1 prevents double exposing your shots.

Construction. The author's prototype of the trigger-delay circuit was built on a printed-circuit board (see Fig. 2) measuring 1½ by 2½ inches. After etching your circuit board, install the components using Fig. 3 as a guide. Be careful when handling U1. It's a CMOS device and can be damaged by static discharges. Also, when installing C1 and C2, be sure to observe the proper polarity.

Mount the phototransistor, Q1, near one end of the circuit board. The lead nearest to the flattened edge of the phototransistor is the collector, and should be connected to the +9-volt bus (as shown). Before installing Q1 bend the ends of its leads to form a 90° angle to line up with a hole that will be drilled in one end of the circuit's enclosure (more on that in a moment). Just about any phototransistor will work for Q1. Both infrared and visible light types are acceptable.

You'll need a short length of black plastic tubing to fit over Q1 to help keep it lined up with the hole. The author used a section cut from an old disposable ballpoint-pen housing. A hole about ¼ inch was drilled in the sealed upper end of the pen housing to allow light to get to Q1. Be careful not to make the hole too large; if you do, a drop of milk may be too small to block all the light.

GE C106D SCR's come both with and without heat-sink tabs. For this project the tab is unnecessary, so you can cut it off if desired to prevent shorting. You can also use Teccor T106D's. Do not substitute any other SCR for SCR1; either version of the 106D is inexpensive and have been used successfully on many flash and control projects.

Next prepare the enclosure that will house the time-delay circuit by drilling holes for S1, R2, Q1, and the flash cord. The author's circuit was housed in an enclosure measuring about 5¼ by 2½ by 1½ inches. The author drilled a hole in one end of the enclosure for Q1. That hole should be small enough to fit Q1's plastic tubing snugly. Cement the tubing in place.

Drill a hole in the side of the enclosure for the flash sync cord. For the sync cord, cut the male end off of a pho-

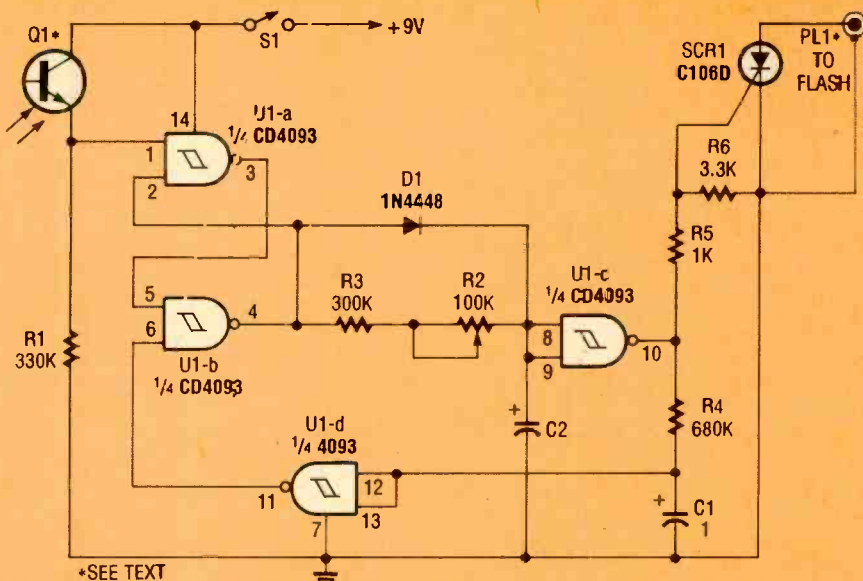

Fig. 1. The time-delay trigger circuit is built around a single 4093 quad 2-input NAND Schmitt trigger. Two gates from that quad package (U1-a and U1-b) are configured as a set-reset flip-flop.

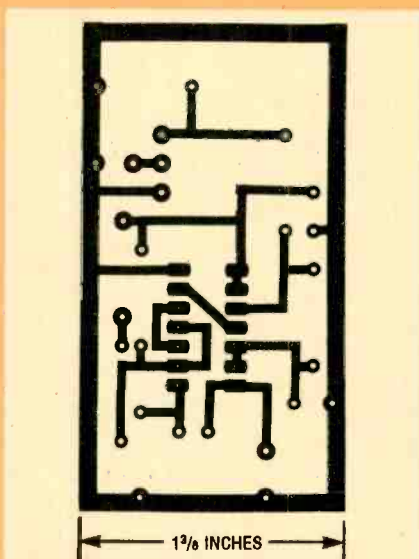

Fig. 2. The author's prototype unit was built on a printed-circuit board measuring 1½ by 2½ inches.

tographic extension cord. Use the female end and the wire for this project.

Attach two adhesive-backed plastic cable clamps to the bottom of the case along the centerline. They are used to attach the delay unit to the ringstand. Cut a disc about ⅝-inch in diameter from a white, self-adhesive label. Make a hole in the center to fit around the photocell opening in the case. Mount the disc around the hole. The disc will serve as a target for lining up to take your splash photos.

Testing. Before mounting the circuit board in the enclosure, attach the battery and make sure that the circuit is

functioning correctly. Temporarily solder the sync cord to the appropriate points on the circuit board. The white or center lead goes to the anode of SCR1. The black lead or outer conductor goes to ground. A few flashes have negative-polarity sync circuits; if that is the case with your unit, it will be necessary to reverse those connections.

To determine if the sync cord is properly connected for your flash unit, plug the sync cord into your flash unit. If your flash unit has a variable-power "manual" setting, set it to minimum power for the quickest recycle time. Turn the flash unit on, but leave the delay turned off for the moment. Connect a voltmeter across the anode and cathode of SCR1. The anode should be positive and the cathode negative. The voltage is unimportant and is likely to be any-

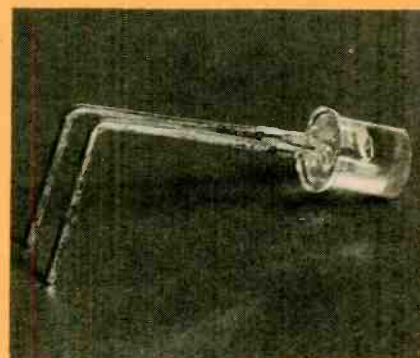

Just about any phototransistor (infrared or visible light type) is fine for Q1. Before installing Q1, bend the ends of its leads to form a 90° angle (as shown here) so that it lines up with the hole in the end of the enclosure.

PARTS LIST FOR THE TIME DELAY FLASH TRIGGER

SEMICONDUCTORS

U1—CD4093 quad 2-input, NAND Schmitt-trigger, integrated circuit
 Q1—NPN phototransistor, see text
 SCR1—C106D or T106D silicon-controlled rectifier
 D1—1N4448 or similar fast-recovery silicon diode

RESISTORS

(All fixed resistors are 1/4-watt, 5% units.)

R1—330,000-ohm
 R2—100,000-ohm potentiometer
 R3—300,000-ohm
 R4—680,000-ohm
 R5—1000-ohm
 R6—3300-ohm

ADDITIONAL PARTS AND MATERIALS

C1, C2—1- μ F, 35-WVDC, Tantalum capacitor
 S1—SPST toggle switch
 Perfboard materials, 5/16" \times 2 3/8" \times 1 1/2-inch plastic enclosure, cable clamps, 9-volt transistor-radio battery and connector, sync cord, knob, wire, solder, hardware, etc.

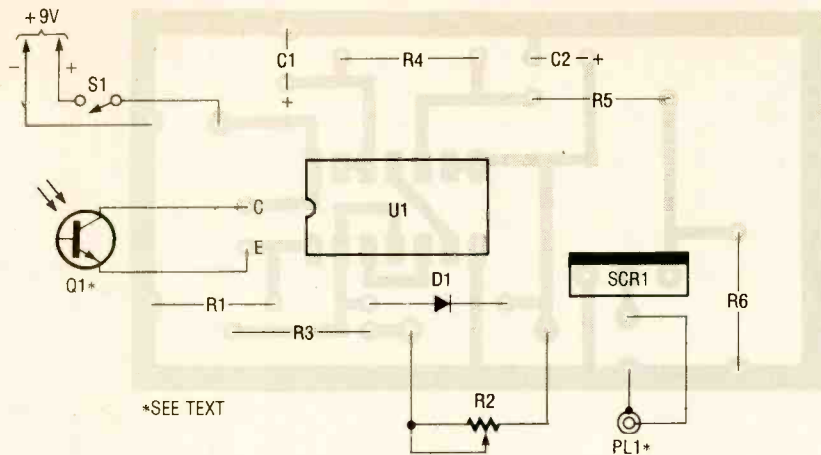
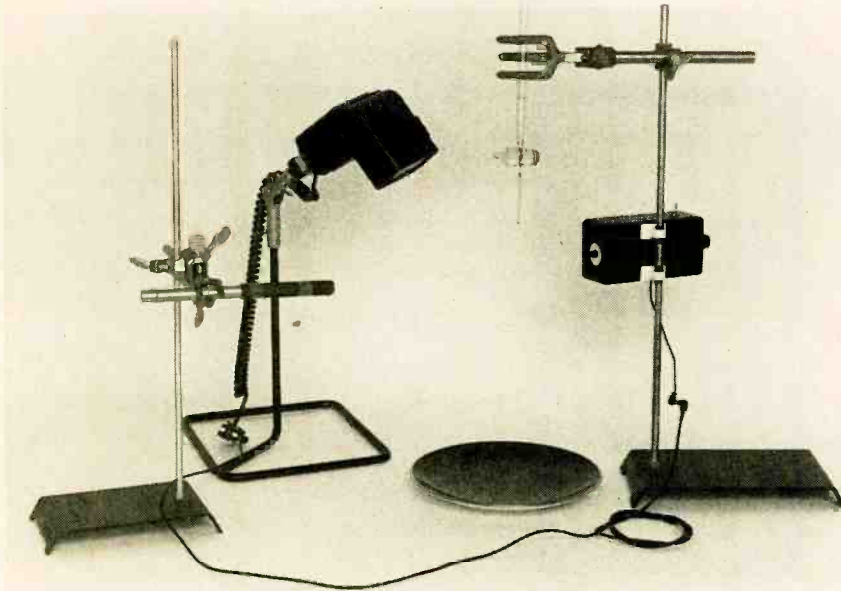

Fig. 3. Install the components using this figure as a guide. Be careful when handling U1. It's a CMOS device and can be damaged by static discharges. Also, when installing C1 and C2, be sure to observe the proper polarity.



Here is the author's set up. Two adhesive-backed plastic cable clamps were used to attach the time delay trigger circuit to the ringstand.

where from 2 to 250 volts—depending on the design of the flash. If the anode is negative with respect to the cathode, unsolder the sync cord leads from the board and reverse the connection.

Attach a 9-volt battery to the battery connector and turn on the power switch. Make sure no direct light is shining on Q1. The flash should fire every second or so. Rotating R2 should change the time interval between flashes. If the flash does not fire, check the battery to make sure it's fresh. Shine a bright pen light on Q1 and the flashing should stop. Briefly interrupt the beam with a pencil or other object and the flash should fire a moment later.

If a fresh battery fails to make the

flash fire, momentarily place a short across the sync cord to see if the flash is working. It should fire each time you short out the sync cord. Assuming the flash is working, check the following voltages: with Q1 lit, pin 1 should be at 8.5 volts and 0 volts when dark; pin 3 should be at 0 volts with Q1 lit; pin 4 at 8.5 volts with Q1 lit; pin 10 at 0 volts with Q1 lit; pin 11 at 8.5 volts with Q1 lit. With the exception of pin 1 of U1, the voltages should alternate between the high and low readings with Q1 dark.

If the voltages do not check out, then SCR1 is probably defective, otherwise suspect U1 or that a capacitor is installed backwards.

Once you have everything working,

temporarily disconnect the sync cord from the printed-circuit board, feed it through the hole in the enclosure, and reconnect it to the circuit board at the point indicated in Fig. 3. Insert Q1 into its tubing and secure the circuit board to the bottom of the enclosure with double-sided foam adhesive tape. Mount S1 and R2 to the enclosure.

Add a piece of insulating cardboard or foam over the circuit board to isolate it from the battery, which will lay above it in the case. Close up the enclosure, and install a knob on the shaft of R2.

Taking the Photo. The ideal source for falling milk drops is a glass laboratory burette. Mount it on a ring stand with its tip about eleven inches above the table. Place a dark or brightly colored dinner plate below the burette. Clip the delay box onto the ring stand (see photos). Position the photocell so that it is about 1/2 inch below the tip of the burette. Fill the burette with either milk or half milk/half water.

Support a pen light about a foot away from the delay box and aim it at the photocell. Tape a black paper hood around the pen light to confine the beam. It should light the ring around the photocell. Connect your flash to the delay and set it for minimum

(Continued on page 101)

GIZMO®

MARCH 1991

VOLUME 4,
NUMBER 3

A CHRONICLE OF CONSUMER ELECTRONICS

X Marks the Spot

FISHER M-SCOPE 1280-X WADER. Manufactured by Fisher Research Laboratories, Dept. P-E, 200 West Wilmott Road, Los Banos, CA 93635. Price: \$549.95 with 8-inch coil and \$559.95 with 10½-inch Spider Coil (pictured).

We've never needed an excuse to head down to the beach. And while we enjoy basking in the summer sun, there's something to be said for a brisk fall day on an almost deserted beach, and those still-too-cold-for-bathing-suits spring afternoons that offer a glimpse of the summer to come, and even a bundled-up winter stroll along the shore. Actually, even in season we tend to prefer the beach in early morning or late afternoon—before or after the burning rays and heavy crowds. Time spent on an empty beach is both calming and exhilarating, and has a way of putting everyday life into perspective.

Very often during the off-season and off-hours, we've noticed solitary figures pacing off the sand with metal detectors. We'll admit, we always thought they were a bit, well, strange.

Then we came across a couple of issues of *Fisher World Treasure News*, a free newsletter for treasure hunters, rather sporadically published by *Fisher Research Laboratories*. Headlines such as "\$75,000 Coin Cache Found on U.K. Farm," "How I Found Gold in Downtown Houston," "Beach Hunters Strike it Rich," "2,600 Year Old Weapons Hoard Unearthed in South Wales," and "Guthrie Gold Find Sets Metal Detector History" piqued our imaginations. We were spending time strolling the beaches anyway. Why not try to supplement our incomes as we soothed our souls?

We contacted Fisher, the oldest manufacturer of metal detectors. The company's founder, Gerhard Fisher, designed and patented the first aircraft radio direction finder in the 1920's (and received an enthusiastic response from Albert Einstein



CIRCLE 50 ON FREE INFORMATION CARD

for his invention). Upon learning that the direction finders were fouled up when planes flew over highly conductive, mineralized areas, Dr. Fisher realized that a portable prospecting instrument based on the same principle could be developed. Despite Einstein's opinion that it wasn't very useful, the "Metallscope"—a bulky, awkward device consisting of two flat wooden boxes containing copper coils, five vacuum tubes, and a handful of other components—was patented by Fisher in 1937.

Today's metal detectors are used by mining companies, law-enforcement agencies, public utilities, archaeologists, and professional and amateur treasure hunters (proving that even Einstein was occasionally wrong). Modern detectors are, of course, lighter and more sophisticated than those of yesterday. They come in a variety of different styles, and with features to suit all sorts of treasure-hunting situations. The 1280-X is what's called a VF/TR or Voice Frequency/Transmit-Receive type of detector. It detects metal by transmitting a 2.4 kHz signal (a voice frequency) into the ground. Any metal will disturb the electromagnetic field of the transmitted signal, which the detector senses as it receives a reflected signal. Not

all detectors use the same frequencies or even the same type of signal. We'll leave out some confusing details about the other types, and talk more about the Wader later.

It was a balmy Indian summer day when we decided on the *1280-X Wader*, a metal detector that would allow us to search not only the shore line, but also under the water. A less expensive version of the underwater 1280-X Aquanaut—used by divers, archaeologists, and professional treasure hunters—the Wader is completely submersible except for its headset. (We could have opted for metal detectors intended for gold prospecting, or for searching in grassy areas (which the Wader also handles)—but we'd prefer to spend time on the beach and not risk our suburban neighbors' wrath by digging up their lawns.)

The 1280-X metal detector consists of a fiberglass shaft that telescopes from 33 to 49 inches, with a search coil at one end (ours came with the 8-inch coil), an adjustable arm rest at the other, and a control box attached to a padded hand grip in the middle. Virtually no assembly is required; most of the setup involves adjustments for the user's height and arm length. The front (top) panel of the control box has an LED

(Continued on page 7)

TURN PAGE FOR CONTENTS

This Month In GIZMO®

Fisher Research Labs 1280-X Wader Metal Detector.....	pg 1
Radio Shack EC-340 Desktop and EC-339 Pocket Rolodex™ Directories.....	pg 2
Canon EOS Rebel SLR Camera	pg 3
Lightwave Technologies Lester the Cordless Mouse.....	pg 4
Fisher FVC-880 8mm Camcorder.....	pg 5
Seiko TR-1700 Japanese-English Translator.....	pg 6
Bearcat Scanner.....	pg 9
Executive Headphone.....	pg 9
Portable Calculator.....	pg 9
Two-Line Phone/Clock Radio...	pg 9
Car Stereo With CD Changer Controller.....	pg 10
Timekeeper Answering Machine.....	pg 10
Word Processor.....	pg 10
Wrestling Game Boy Cartridge	pg 10
Audio Shelf System.....	pg 11
Auto-Reverse Cassette Deck...	pg 11
FonFax Switcher.....	pg 11
Pro Bridge 500.....	pg 11
Alarm Light.....	pg 12
A/V Re-Broadcast System.....	pg 12
Super Subwoofer.....	pg 12
Zenion Screen ELF.....	pg 12

Gizmo is published by Gernsback Publications, Inc., 500-B Bi-County Blvd., Farmingdale, NY 11735. Senior Writers: Chris F. O'Brian, Teri Scaduto. © Copyright 1990 by Gernsback Publications. Gizmo is a registered trademark. All rights reserved.



CIRCLE 51 ON FREE INFORMATION CARD

Number, Please?

RADIO SHACK EC-340 DESK-TOP AND EC-339 POCKET ROLODEX™ DIRECTORIES. Manufactured by Radio Shack, Division of Tandy Corporation, Fort Worth, TX 76102. Price: \$149.95 (desktop) and \$99.95 (pocket).

We hate dialing information for phone numbers. It's a matter of principle: Phone rates are high enough without our handing over an additional fee each time we dial 411. Unfortunately, we frequently find ourselves in situations where we don't have access to the number we need—trying to change a doctor's appointment during working hours, for instance, we'll discover that his number is listed in our phone book at home, but not on file in the office. Or we'll have to make an after-hours business call to the west coast from home, and realize the number is on our desk at work.

Some meticulous record-keepers manage to keep one or two (or more) phone directories up to date, and even bring one along when travelling, but we don't fall into that category. That stack of business cards we bring back from each press conference often ends up staying in a side pocket of a briefcase, and when a friend or relative changes addresses, the new one tends to get stuck up on the refrigerator instead of entered into each of our several telephone directories. And even those changes or additions that are made to one directory are rarely transcribed to the others. We end up dialing 411 much too often, and our phone bills reflect it.

Because we aren't inherently neat or well organized, neither are our phone-number files. Our desktop phone directories combine barely legible hand-scrawled cards, haphazardly clipped-on business

cards, and scraps of paper covered with quickly jotted names and numbers. If we scroll through too fast, things go flying. All the crossed-out entries in our personal phone books reflect how frequently our friends tend to relocate. Those books also hold notes about new restaurants to try, scraps containing "new" addresses, business cards that never made it to the office—all held together with rubber bands.

It's no wonder we were anxious to try a new method, like using a combination of electronic Rolodexes from Radio Shack. The desk-top model EC-340 and the pocket-sized EC-339 each have 64K memory, and phone-directory entries can be transferred between them in a matter of seconds. You still have to input the information once, but then it's a simple thing to copy them to the other Rolodex. Information is typed in—keeping it all legible—and there's no place for stray business cards and scraps of paper to accumulate.

The EC-340 is designed to resemble a miniature PC, with a large LCD readout perched atop a Rolodex-style scroller, and a row of "function" choices spanning the top of its QWERTY-style keypad. Those functions let you do much more than just keep track of addresses and phone numbers (which fall under "business-card file" category.) Instead of all those scraps of paper, you can use the "letters-to-write" and "call sheet" categories to store reminders of who you need to get in touch with; entries can be made manually or by making an "internal transfer" of the appropriate information from the business card file. "Reminder notes" provides a place for you to manually input and store appointments and other things you'd prefer not to forget. Pressing "monthly calendar" displays a calendar of the current month; pressing the forward or reverse

(Continued on page 7)

Picture Perfect

CANON EOS REBEL AUTOMATIC SLR CAMERA. Manufactured by: Canon U.S.A. Inc., One Canon Plaza, Lake Success, NY 11042. Price: \$299 (body); \$180 (35-80-mm zoom lens); \$300 (80-200-mm zoom lens).

We have fond memories of our first foray into photography. Our Kodak Brownie box camera was easy to use, even for children. Loading the film was the most difficult part. The rest was easy—just point and shoot. The result? Pretty good snapshots, mostly of people squinting into the sun.

While the composition could have been better, the quality of the pictures was good. Images were rarely out of focus—the fixed-focus lens made sure of that, as long as we followed the cardinal rule of keeping at least four feet from the subject. The camera fit us perfectly, although our needs were not very sophisticated.

As we grew older, however, we began to understand and appreciate some of the more subtle things a camera could do, and wanted to try to get results that weren't possible with a fixed-focus camera. We graduated to a 35-mm range-finder camera that gave us control over the focus, shutter speed, and lens opening or aperture. An electronic light-meter let us know if our shots would be over- or underexposed. We were impressed by the results, and were ready to begin being a little more artistic.

With the adjustable shutter speed, we could blur the image to show speed, or get stop-action shots if we wanted. With the adjustable aperture, we could control the depth of field to remove a distracting background from a portrait shot, or keep everything in focus in a landscape scene. Granted, it took a while to learn, and each picture required a little setup time, but the results were usually worth it.

Once we mastered the techniques, the range finder's two drawbacks became apparent. First was the inability to switch

lenses, which meant that we couldn't get those wide-angle shots. Second was the lack of a TTL, or through-the lens, viewfinder. Usually, the picture we got was the picture we wanted. But unless you're looking through the lens, you can't really be sure.

As you might have guessed, we graduated to a 35-mm SLR, or single-lens reflex, camera that gave us pretty much everything we wanted—complete control over focusing, aperture, and shutter speed, and the ability to try different lenses. It even had a semi-automatic aperture-priority mode in which, once the aperture is set, the camera determines and sets the shutter speed for proper exposure. That made taking a good picture easy and quick—for those who had mastered the camera's complexities. For some non-technical types, the SLR camera was too complicated for point-and-shoot picture taking. It seemed that any camera we found that gave us the control we required for "real photography" was over-qualified for such basic tasks as taking candid snapshots under the Christmas tree or on vacation.

As silly as it might sound, we found that the only solution that let us take creative pictures while also letting even the low-tech family members in on the picture-taking action was to keep an Instamatic on hand for snapshots. Now, however, we've found that just as electronics has made our lives easier in so many other ways, it's made picture taking easier as well.

That fact was driven home to us by the *Canon EOS Rebel*, the latest entry in Canon's EOS line of auto-focus SLR's. The camera is extremely easy to use, even for beginners. Yet it allows serious photographers to take full control for creative photographs.

Even loading film into the EOS Rebel is simple: you just insert a roll of film and close the camera back. The film is wound onto what is normally called the take-up spool. As each picture is shot, the film is rewound back into the film canister or cassette. The advantages are twofold: The camera's LCD always shows the number of frames *left to shoot*, and if you accidentally open the camera back in the middle of shooting a roll of film, all of the exposed frames will be safely stored in the film cassette.

Like most recent cameras, the Rebel automatically sets itself for the proper film speed by reading the DX codes (those black and silver squares on the side of the film cassette) so that it's impossible to forget to set the proper speed. It is possible, however, to *purposely* set the camera to the incorrect speed for special effects.

Four Programmed Image Control (PIC) and five auto-exposure (AE) modes let beginners take what Canon's advertisements say are not mere snapshots, but pho-

(Continued on page 8)

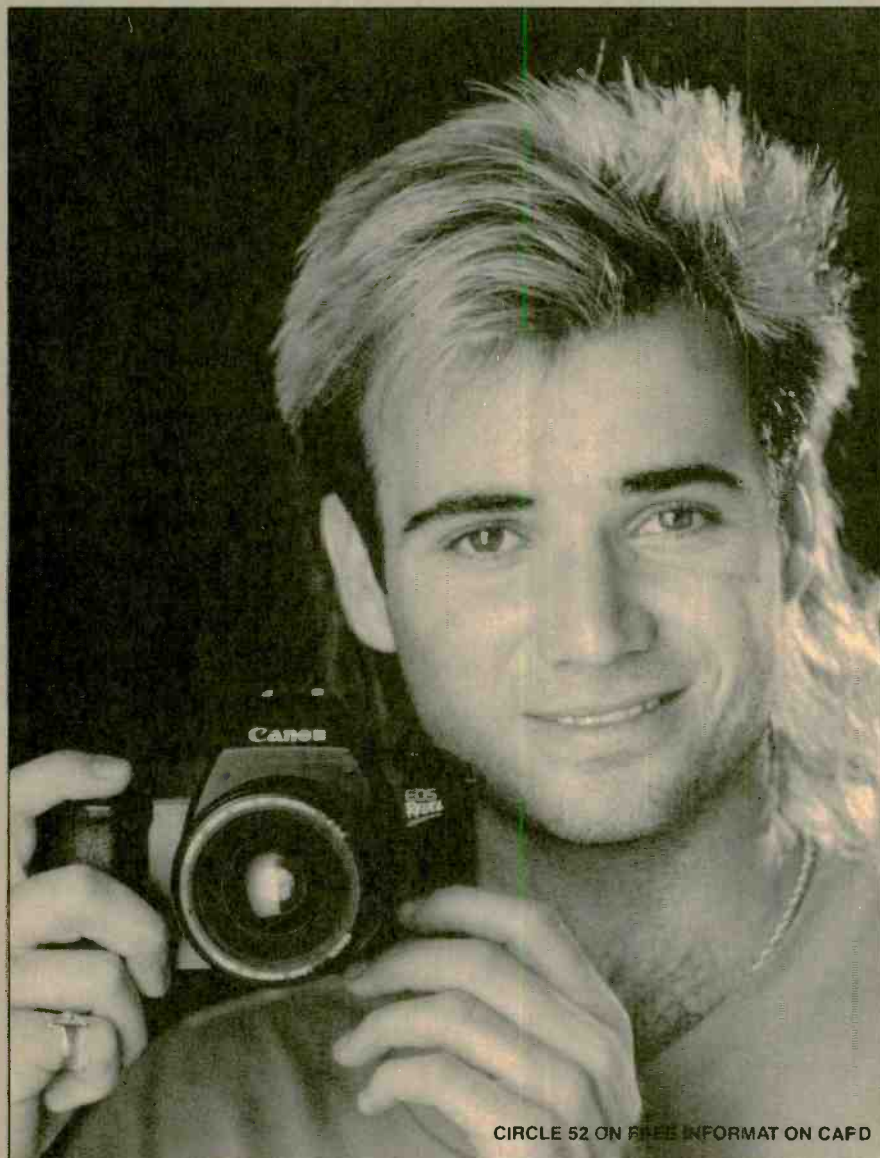

CIRCLE 52 ON FREE INFORMATION CARD

Mouse Without A Tail

LESTER THE CORDLESS MOUSE. Manufactured by: Lightwave Technologies, Inc., Mundelein, IL 60060-0599. Price: \$129.95.

Until the 1980's, a mouse was simply a rodent. But then Apple introduced their Macintosh, and it became a computer-input device. We weren't crazy about the idea. We were just coming around to the IBM PC, and still defending CP/M as a viable computer operating system. The mouse, to us, was for "sissies" who didn't know anything about computers.

We always preferred to work from the command line—it's quicker. We realize, however, that the graphical user interface is popular, and it's now entrenched even in the MS-DOS world of IBM PC's and clones. We like Windows 3.0 (the industry-standard graphical user interface for MS-DOS computers)—especially since it lets us quickly exit to the standard DOS prompt.

When our graphics applications required a mouse, we decided on a trackball instead of a standard mouse. We liked it because it doesn't take up that much room on the desktop—or we should say that it always takes up the same amount of room. After using the trackball for a while, we decided that it wasn't much of an improvement. We realized that it wasn't the amount of room the mouse required that bothered us. It was the mouse's tail—the wire that connects the mouse to the computer's bus or serial port. It always seemed to get in the way, or get buried underneath papers.

Still, the trackball seemed to work reasonably well, and it seemed to us to be a more natural way of moving a pointer on the computer screen. It had one feature that we didn't like, however—it was too tall. Even with long fingers, it was not very comfortable to use while keeping one's wrist on the desktop. Unfortunately, while it's possible to make trackballs with lower profiles, they're not going to feel very natural. That's because a natural feel requires a larger roller ball, and the size of the ball limits how small the unit can be.

A mouse, on the other hand, typically has a ball less than an inch in diameter, as compared to the cue-ball size of a typical trackball. A mouse could be easily made smaller, but then it would lose its natural feel.

The latest entrant into the mouse game is Lester, the Cordless Mouse. We wondered why anyone would call a mouse Lester. Well, Lightwave Technologies must have worked a long time to come up with the name, which is actually an acronym for Light-Emitting Static-Tracking

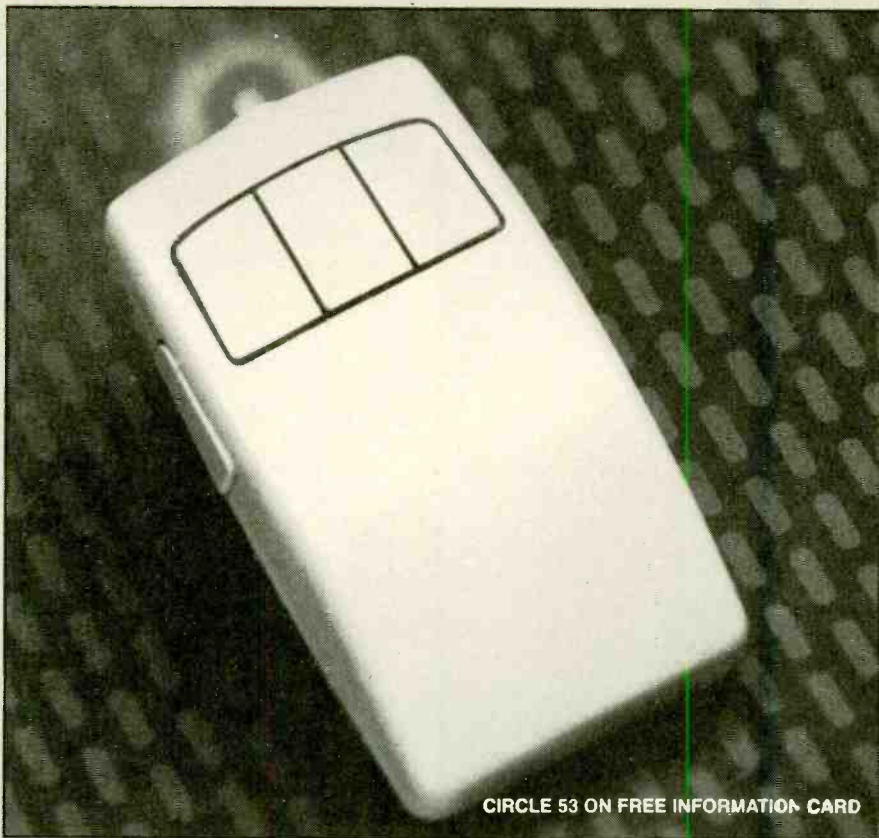

CIRCLE 53 ON FREE INFORMATION CARD

Extended-Range technology. It doesn't make any sense to us, either: After all, a static mouse doesn't need to be tracked, and we found that the maximum range for reliable operation was about six feet—but we couldn't read our monitor from that distance anyway.

We tested Lester on an AT-clone computer, although a Macintosh version is also available. Installation is reasonably easy, even for inexperienced users.

Lester consists of two units: the wireless mouse, and an infrared-receiver unit that is wired to the computer's serial port. (That's right, the mouse isn't *completely* wireless.) Although the receiver unit has a 9-pin connector on the end of its cable, the package includes a 9-to-25 pin adapter, along with a second adapter that converts the 9-pin connector to the Mouse Port connector used on IBM's PS/1 and PS/2 computers. The hand unit, of course, needs no installation—except for loading the two "AAA" batteries that power the transmitter. (The receiver is powered from the serial port.)

As with any other mouse, software installation is also required. But that, too, is quite simple—as simple as typing "MOUSE," or adding one line to your AUTOEXEC.BAT file (which runs automatically each time you boot your computer). You can select several options; for example, MOUSE 2 installs Lester on COM2, the computer's second serial port.

Lester is compatible with the Microsoft mouse and the Mouse Systems mouse.

While Microsoft is the default mode, switching is as simple as entering the command MOUSE 3, which installs the mouse in the Mouse Systems mode. Is it really compatible? Yes. In fact, after we installed the hardware, we ignored the software to see whether everything we had configured for our trackball would run. It did, without problems.

We did, of course, want to try out the supplied drivers as well. One of the things we liked was the "Intelligent Sensing Circuit" that determines automatically the type of mouse for which your software is configured, and configures Lester to operate in that mode. So if you prefer using one of your software packages with a three-button (Mouse-Systems-compatible) mouse, while you prefer a two-button (Microsoft-compatible) mouse for the rest, you can set it up once to work that way, and never have to think about it again.

Using Lester was a pleasure. Its movements caused the cursor or pointer to track accurately, and the infrared link added no perceptible delay. The default sensitivity seemed comfortable and natural. But if you prefer smaller mouse movements to result in larger cursor movements or vice versa, it's a simple matter to adjust Lester's sensitivity with a software command from 10 to 1200 dpi, or dots per inch. (The default is 300 dpi.)

We found, however, that Lester's "variable tracking feature" gave us enough flexibility that we never needed to adjust the
(Continued on page 8)

Fuzzy Logic, Clear Picture

FISHER FVC-880 8mm CAMCORDER.
Manufactured by: Sanyo Fisher Corp.,
21350 Lassen Street, Chatsworth, CA
91311-2329. Price: \$1299.95.

When we first heard of the *Fisher FVC-880*, with its unusual horizontal configuration and "Fuzzy Logic" circuitry, we figured that it was just another case of camcorder designers staying up all night to come up with something just a little different to make their camera stand out in a crowded market. This camcorder does just that. Its horizontal design gives it a unique look—and a unique feel. It's held in a way that resembles using binoculars or a still camera. And, although it's a very light camera—1.7-pounds without the battery—it's easy to hold steady when two hands are used. Its thin line allows it to fit easily in a briefcase, and its small size means that it can be carried in a purse or even a fanny pack.

While its looks certainly are the first thing you'll notice, what really does set the FVC-880 apart from all of its competition is the inclusion of "Fuzzy Logic" circuitry, which adds a degree of artificial intelligence to the control of auto-focus and auto-iris operation. Rather than making focusing and iris adjustments on a strict "yes/no" digital basis, fuzzy logic is said to add a "maybe" to its list of options.

In theory, a fuzzy-logic focusing system should react in a more "human-like" man-

ner. For example, if the subject on which you're focusing moves out of the center of the scene, a standard auto-focus camcorder will focus on the new scene that's in the center, while the intended subject becomes blurred. Although other digital focusing schemes can break the scene into more than one zone to allow for quicker auto focusing, they can't always be sure of the correct object on which to focus. For example, two off-center objects at different distances might cause the camcorder to oscillate back and forth between the two items. Fuzzy logic, however, is supposed to be able to determine the most logical object on which to focus. It does that by monitoring the signal output from each of the six segments into which the focusing area is broken, and always focusing on the strongest signal.

Unfortunately, the strongest signal does not always correspond to the object on which you want to focus. We found that when it made the right choice, focusing was quick and accurate. Unfortunately, the fuzzy logic didn't always make the right choice. For example, when our subject went into the shadows, the camcorder would shift focus to a different part of the scene—even when our subject was at the center of the screen. At least it stuck to its choice; the FVC-880 never fell into the oscillating-between-subjects trap.

Fuzzy logic is also used to handle the camcorder's automatic exposure. In theory, it can keep the subject properly exposed even in difficult lighting conditions, for example, shooting a subject indoors in front of a brightly lit window, or in the shade on a bright, sunny day. We found that it did a good job evaluating the light-

ing conditions, and we rarely had to manually adjust the iris.

None of the other camcorders we've used has a horizontal design, and when we first saw pictures of the FVC-880 we were skeptical. Why, we wondered, would anyone want to use a camcorder that required the use of two hands? All video cameras were designed for one-hand shooting, with the opposite hand required only to adjust lesser-used functions. From the photographs we saw, however, we didn't realize how small the FVC-880 is. When we picked up the actual camcorder, we were surprised to find that it was quite comfortable to use. Most of the time, in fact, we were able to operate the camcorder using only our right hand. Although it got tired relatively quickly, we had expected it to be worse, because the weight of the camera should have been creating maximum torque on the hand holding it. A small ridge on top of the camcorder lets the right hand get a firm, comfortable grip on the unit (although we did get complaints from users with small hands).

Two-handed operation, of course, was even more comfortable. Actually, it's essential, because important controls must be controlled by the left hand.

Besides fuzzy logic, the FVC-880 provides the standard array of features that we've come to expect. For example, it offers a 6× variable-speed zoom with macro-focus capability, six selectable shutter speeds from 1/100 to 1/4000 second, title insertion, a flying erase head for cleaner edits, scene search for in-camera editing, and a 4-lux low-light rating. The camera comes equipped with a 1000-mAh battery, a charger/AC adapter, an RF adapter/antenna switch, and an IR remote control.

So how do the features that set the FVC-880 apart from the camcorder crowd stack up? Although we liked the horizontal design, there are a few improvements we'd like to suggest. First, we'd like to be able to reach the main power button with the right hand. We'd also prefer some of the other controls, perhaps the power zoom, to be controlled by the right hand. (Of course, left-handed users, who will find using the FVC-880 difficult enough, would probably not like that idea.)

As for whether we like fuzzy logic, well, we can't give a straight "yes" or "no" answer—we'll have to say "maybe." While we thought it handled the auto exposure quite well, we were somewhat less impressed by its auto-focus operation. Even though the auto focus performed quite well in some situations, we found ourselves switching to manual operation more than we do when using other camcorders. We should remember, however, that this is the first time that fuzzy-logic technology has been applied to a camcorder. We're looking forward to advances in the years to come.



CIRCLE 54 ON FREE INFORMATION CARD



Kotoba Kodougu (Language Gizmo)

SEIKO INSTRUMENTS TR-1700 JAPANESE-ENGLISH TRANSLATOR. Manufactured by: Seiko Instruments USA, Inc., Consumer Products Division, 2990 W. Lomita Blvd., Torrance, CA 90505. Price: \$89.99.

Perhaps it's our nationalistic arrogance. Maybe it's the short-sightedness of our school systems. We're not sure. But like most Americans, we don't speak any language other than our native tongue. OK, *nous parlons Francais un petit pue*. But only what we can remember from a couple of years' worth of high-school French classes.

Since we're not so arrogant to assume that everyone knows some English, we're usually hesitant about leaving the safety of New York to go somewhere where they speak languages we don't understand. Recently, however, we had the opportunity to visit Japan—a country about which we knew nothing, save for our familiarity with the output of their consumer-electronics and automotive industries. Although we were somewhat apprehensive, we carried with us a little security: *Seiko Instruments' TR-1700* English-Japanese, Japanese-English translator. All we would have to do is type in what we wanted to say in English, and the translation would pop up immediately on the 16-character LCD, letting us communicate freely with people in Japan. At least that's the theory. In practice, things weren't always so simple—but we'll get to that.

Since we like to travel light, we were happy that the translator is only slightly

larger than a credit card, though thicker (about six cards thick). We knew that the "manual"—actually a 10 × 14-inch sheet of paper, printed on one side—wouldn't take up much space in our luggage either.

The TR-1700's front panel features a 36-key membrane keyboard. The letter keys are arranged alphabetically—which makes it frustratingly difficult to use for those of us who know how to type—and the eight command keys form the last two columns of the 9 × 4-key keyboard.

To turn the translator on, you hit either the J-E or E-J key. The appropriate mode shows up on the display, and the translator is ready for your input. After you type in the input, hitting the TRAN key brings up the appropriate translation. For example, if you wanted to know how to say "Thank you" in Japanese, you would hit E-J, then type in "thank you" and hit TRAN; the display would show "arigatou."

If there is more than one appropriate translation, a comma appears after the first choice. For example, the translation for "Thanks" first shows "arigatou," with the comma indicating that another choice is available. Hitting the "TRANS" key a second time brings up the word "kansha" followed by a period to indicate that it's the last translation available.

Since we really don't like keyboards that are alphabetically arranged, and since membrane keyboards are also difficult to use, we are happy that shortcuts are available. For example, rather than enter the words "Thank you," we could enter "THA" and then enter one of the SRCH keys to search forward or backward alphabetically through the words, "than, thank, thankless, thanks, thanks to," and finally, "thank you." The search keys also come in handy for those of us who can't spell too well. If a word isn't recognized, a suggestion will appear in the display followed by a question mark. For example, if you entered "THANC," the TRAN key would bring up "thank?" to the display.

Then you could either hit the translate key again, or use the search keys to scroll to the appropriate word.

The translator is also a calculator. Hitting the CALC key changes the function of the alphabet keys to the numbers and functions shown in the upper-right corner of each key in a small gold-colored box. It's a standard 4-function calculator with memory, and one added feature: currency conversion. Since we were not used to thinking in terms of the Japanese *Yen*, we found the conversion feature particularly convenient.

While converting one currency to another was quite simple, converting from one language to another was quite another story. The first problem with the translator is that it converts words, not phrases. For example, if you want to find out how to say "How do I get to Tokyo?" you would have to enter each word separately. And since many words have more than one translation ("how" has three) you can't be sure if you're picking the right one. To add to the problem, the word "do" in English can be used many different ways. The translator, which gives two Japanese equivalents, doesn't let you know what meaning it is translating. A third problem is that the two languages are quite different. Even if you translate all of the words correctly, you have no way of knowing what order they go in, or if they're the appropriate words to ask the question. You'd probably have better luck simply saying "Tokyo?" and looking confused.

There are, however, some multiple-word translations available. Some examples are "Keep in mind," "make an effort," and "salve for itch." At least we didn't have to worry about getting poison ivy and not being able to find calamine lotion in Japan!

Going from Japanese to English is even more difficult. People generally speak too fast for the translator to be useful, and of course, spelling presents another problem. The TR-1700's spelling system requires you to enter words using a phonetic system called *Romanji*. Each vowel sound is consistent. The "ee" sound is always represented by the letter "i" and so on. It sounds easy, but it isn't necessarily so. For example, we all know how to say goodbye in Japanese: *sigh-oh-nar-ah*. But in order to translate it, you'd have to spell it correctly, or at least come close to *sayounara*.

Although we've been pointing out a lot of situations in which we had difficulty with the translator, we were impressed with it nonetheless. Its vocabulary of more than 12,000 words in each language rarely left us at a loss for words. And the ability to search through the vocabulary allowed us to learn new words while sitting on a bus or in the back of a taxi. However it wasn't suitable for translating on the fly, and we're glad we had a companion who spoke both languages fluently as we toured Japan. ■

X MARKS THE SPOT

(Continued from page 1)

that flashes when a target is detected or during battery tests, and three controls—power/volume, discrimination, and battery test/sensitivity—that we'll discuss later. Eight "AA" batteries are housed in the rear of the control box and provide 45–75 hours of use; a NiCd battery pack with a 110-volt recharger and a 12-volt recharger is optional. The control box can be detached and worn clipped to a belt, removing the weight for added comfort during land or shallow water use. (Because of the possibility of wires becoming snared on underwater objects, Fisher recommends leaving the control box on the shaft when diving.)

We didn't have to consider that recommendation. Unfortunately, the weather was less than cooperative, and the day that our metal detector arrived heralded the onset of cold weather. While that didn't keep us off the beach, it did discourage us from venturing more than knee-deep into the ocean with our Wader.

Dressed for the cold (the headphones do keep one's ears warm!)—but with pants legs rolled up for wading—and armed with our metal detector, we walked slowly across the sand, moving the Wader back and forth in front of us. We looked a bit, well, strange.

The Wader is a "motion-discriminate all-metal ground-balance" detector. "Ground balance" refers to the instrument's ability to balance out the effects of the minerals in the earth, "all-metal" means that it accepts all types of metal targets, and "discriminate" translates to the unit's ability to eliminate junk targets such as bottle caps and tin foil. "Motion" means that to activate the instrument's metal-detecting, ground-balance, and discrimination features the coil must be kept moving. The higher the front-panel discrimination knob is set, the less junk is detected.

The other front-panel controls are used to adjust sensitivity and volume, test the batteries, and turn the power on and off. Sensitivity refers to the depth at which buried objects can be detected; in general, the higher the sensitivity, the deeper the machine can detect. Sensitivity decreases as the discrimination is increased. The batteries are tested using the same knob, clicked in and out of the "battery test" position. Fully charged batteries are indicated by a loud tone and a strong LED signal; weak ones generate a faint tone and dim light. The volume control lets you keep the beeps at a comfortable level of loudness while searching. We mistakenly kept turning it higher as minute after minute passed without our finding any treasure; the result was an ear-piercing beep at the first coin we located.

Patience—not one of our virtues—is an

important character trait for successful metal detecting. Not only can it save your eardrums, but searching is a slow, methodical process, not a fast-paced adventure. According to the manual (which is a delightful surprise to anyone accustomed to the barely legible booklets included with most electronic devices), the best way to use the Wader is to walk slowly, swinging it in an arc with the coil parallel to the ground, and overlapping your sweeps by at least 50% to be sure not to miss anything. The manual is filled with pointers for "detectorists" of all levels—particularly helpful for novices—including easy text explaining how to search for, pinpoint, and recover targeted objects and plenty of illustrations for added clarity (along with advice on how to be a responsible, law-abiding treasure hunter).

On our first treasure-hunting expedition, we kept the discrimination level low to get a feel for how the Wader responded to various objects. In the course of about an hour, we unearthed a hair clip, several bottle caps and flip tops, a few beer cans, a large nail, a cigarette box (the foil lining registered), and four quarters. As the manual indicated, there were different sounds for the various types of objects. The smaller pieces of junk produced weak or intermittent audible signals, and would have been ignored had we used the recommended level of discrimination.

Experience is also an important plus in metal detecting, although the controls provided by the Wader, and the instructions in its manual, give even the unexperienced detectorist an edge. With time, we've been told, one learns to determine by the strength of the signal whether an object is worth digging for, and becomes more adept at pinpointing the spot to excavate. In fact, by the end of our first "treasure hunt" we got pretty good at hearing the difference between junk and the good stuff. We still had problems in the water (besides numb toes), because the shifting sands and waves set off weak but frequent beeps—another situation where experience is said to pay off. We won't find out for sure until next year, when the water starts to warm up.

For our second beachcombing expedition, however, Indian summer had turned into winter, with wind chills in the teens. It's almost impossible to be patient in those conditions, and our find proved it—one 1974 Lincoln penny.

So, we didn't strike it rich. (At the rate we're going it will take quite a few more trips before we make back the price of the Wader.) But those expeditions will be pleasurable. Carrying the Wader doesn't detract from a walk on the beach—it's very lightweight, and you can still hear the sound of the surf while wearing the headphones. And, in the back of our minds lies the possibility of a big find, which can be almost as much fun as the discovery itself. In fact, we might be hooked. ■

NUMBER PLEASE?

(Continued from page 2)

keys displays future or past months. The final function key, labeled "morning review," recalls and scrolls through the information you've stored in the "letters to write," "call sheet," and "reminder notes" categories. In addition, the EC-340 provides basic calculator and currency-conversion functions, on-screen instructions, and a "privacy" option to safeguard confidential information.

The EC-339 handheld unit provides all of the same features, except the Rolodex knobs for scrolling, in a compact package. Measuring just $2\frac{1}{2} \times 4\frac{1}{4} \times \frac{5}{8}$ -inch when folded, the EC-339 fits easily into a purse or pocket. It's encased in metal—heavier than a typical, inexpensive pocket calculator, and able stand up to some abuse in overcrowded briefcases.

Typing in the data is fairly easy on the desk-top EC-340. Pressing the "enter" key brings up a menu that prompts you to press one of the function categories. Pressing "business-card file" calls up a screen with prompts that show you exactly where you're supposed to type in last name (first), first name (second), company name, phone, fax, address, city, state, and zip code. After that, you have an "unlimited" amount of space in which to type extra information—home phone number, birthday, other names at that company, or any other information you deem important. With most of the memory in each of the Rolodexes (60K) allocated to the business card file, you have plenty of space. While the keys are a bit small and closely spaced, their typewriter-style setup simplifies the process. Typing on the tiny EC-339 keyboard is a bit trying, but not impossible. The manual provides quite clear instructions; the on-screen instructions are a bit more confusing, but come in handy for refreshing your memory about how a specific feature is used.

Once you have some names and numbers listed in the business-card file, it's equally easy to access the information. By typing the first few letters in the name of the person or company that you need, the instrument will find the name for you. Or you can use the roller to scroll alphabetically through each of the entries, forward or backward.

What we liked best about the Radio Shack Rolodexes was that once we'd input the information from a stack of recently acquired business cards to the EC-340, it took just seconds to transmit that data to the EC-339 (or vice-versa, although we highly recommend inputting on the larger keyboard!). Almost before you know it, the last record sent is displayed on the screen, indicating that the transfer is complete. It's also possible to transfer one business-card record at a time. The transfer capability allows even disorganized

people to keep two or more phone directories up to date—or at least at the same stage of almost up to date.

The calendar, calculator, and various reminder files are helpful features, and the currency converter is particularly convenient on the portable EC-339. Of course, being lazy as well as disorganized, we would have liked to be able to transfer information from the other categories as well—particularly the morning review.

While we're on the negatives, we might as well point out that the screen, though large, can be difficult to read. A contrast control would help, as would the ability to tilt the screen to avoid conflict with ambient lighting. We had a couple of other minor complaints. The security code—a feature we appreciate because we store our long-distance carrier's calling card number on our EC-339—must be reactivated before you turn the unit off to be in effect the next time you use the directory. However, there is no way to manually turn the unit off—it shuts itself off automatically when 3½ minutes have passed without a key being pressed—making it easy to forget to reactivate the security mode. When an entry is changed on one unit, and transferred to the other, it doesn't overwrite the old entry. Instead, a new entry is created, and you must remember to erase the original one. Of course, the most important potential source of trouble is that, if you don't remember to type in information, it won't be there when you need it.

Those drawbacks didn't detract from the convenience of finally having the numbers we need at our fingertips whether we're at home, in the office, or on the road. And while they cost the equivalent of quite a few phone calls to 411, the EC-340 and EC-339 do more than provide the right numbers—they also offer the satisfaction of having gadgets to show for our dollars, instead of higher phone bills. ■

PICTURE PERFECT

(Continued from page 3)

tographs. The idea is that choosing the correct one of those nine modes virtually ensures a high-quality photograph.

The four PIC modes give you the ability to get some artistic effects without a lot of thought. In Portrait mode, the camera automatically sets itself for a shallow depth of field to eliminate distracting foregrounds and backgrounds. For example, if you focus on a subject's face, the background and foreground will be blurred, and won't distract from the subject. The Landscape mode does the opposite, automatically setting the exposure for maximum depth of field. The Close-up mode tries to make macro photography easier by also automatically setting the exposure to ensure the largest possible area of acceptable focus. In Sports mode, the rebel always maintains the fastest shutter speeds

to keep up with fast-moving action, and the camera is put into its continuous-wind mode. In addition, the camera offers an "AI servo AF" mode that continually keeps moving subjects in focus.

The first auto-exposure, or AE, mode is called Green Zone AE. For someone who doesn't want to think about any camera settings, it's the ideal place to start. The Rebel automatically selects the best combination of shutter speed and aperture value for the existing light conditions—and even for the lens you're working with. If the shutter speed is slow enough to make it difficult to hold the camera steady, a small lightning bolt-like icon will blink in the viewfinder to prompt you to use a flash. We found the Green Zone an excellent way to get familiar with the camera, and the results were, without exception, good pictures.

In the Shutter-Priority AE mode, you must select the shutter speed you wish to use. If you want to freeze fast-moving action, for example, you would select a fast shutter speed. The camera will automatically select the aperture you need for correct exposure. If you select a shutter speed that will cause the picture to be underexposed or overexposed, the aperture setting will start blinking in both the viewfinder's LED and in the LCD panel on top of the camera to prompt you to set a different shutter speed.

In the Aperture-Priority AE mode, you select the aperture you want to use so you can control the depth of field. The camera will automatically pick the shutter speed for correct exposure. All exposure information is displayed in the viewfinder and the LCD panel, and the shutter speed will blink to show an under- or overexposed condition.

An Intelligent Program AE mode gives some creative control to the photographer while maintaining virtually all-automatic operation. If the selected shutter/aperture combination doesn't suit your needs, it can be easily adjusted with the Electronic Input Dial, a small wheel behind the shutter button. Turning the wheel in one direction opens the lens and speeds up the shutter, while turning it in the other direction does the opposite. It is impossible to adjust the exposure incorrectly. This mode cannot be used with a flash.

A Depth-of-Field auto-exposure mode lets you choose a point in the foreground and a point in the background to be the limits of your depth of field. Everything outside those set points will be out of sharp focus. Let's say, for example, you want a picture of a sports fan in a crowded stadium. You could eliminate the distraction created by fans in front of and behind your subject with a narrow depth of field. The process requires three steps once the camera is set to the proper mode. First, you place the focus mark (in the center of the viewfinder) on the first point and press the shutter button halfway, and repeat for the

second point. When the points are set, you simply recompose the picture, check the exposure settings, and shoot.

In the past, we stayed away from AF/AE cameras because we wanted full control over our photographs. We found that Canon's EOS Rebel gave us full control, while letting us take some of the more artistic shots—and in less time than we normally would require. Interestingly, even though completely manual operation is possible, we hardly used it. The various automatic modes were too much fun. We also appreciated the Rebel's light weight—it's the lightest 35-mm AF SLR camera on the market—and the surprisingly small size of the motorized 35-80 and 80-200 zoom lenses. And we liked how the camera would emit a small beep when the image was in focus—even in the manual-focus mode. Most important, however, was the consistently high quality of the pictures we took under a wide range of conditions. ■

MOUSE WITHOUT A TALE

(Continued from page 4)

sensitivity any other way. A fourth button, on the left side of the mouse, activates the variable tracking. If you move the mouse slowly with the side button depressed, the cursor will move across the screen in small steps. But if you move the mouse quickly with the side button depressed, the cursor will move in much larger steps. The fourth button also serves as a "wake-up call" for Lester, who, rather thoughtfully, turns himself off after about 10 minutes to conserve battery power.

Lester comes equipped with a utility program to test the mouse. A menu-maker program lets you create mouse-activated menus for software that doesn't normally allow for mouse control.

The review package we received also included a few extra goodies: a mouse pad, a mouse pocket, and a color paint program. At first, we wondered why anyone would want to use a mouse pad. After all, one of the advantages of a cordless mouse is that you don't have to worry about its placement: a mouse pad seemed at first to defeat the purpose. However, after using Lester for a while on our Formica-topped desk, we found that the mouse didn't always track accurately. It seems that a little dust or dirt would cause the roller ball to slide instead of roll. The foam mouse pad eliminated that problem. The mouse pocket, a small plastic holder with a double-stick foam pad, sat unused in the box. We're not that neat. The paint program, called Visualizer, is a good introductory graphics-generating program, but it's certainly no match for a program such as *PC Paintbrush*.

We're not sure whether it's Microsoft Windows 3.0 or Lester, but we're beginning to like using a mouse. Maybe Apple had the right idea all along. ■

For more information on any product in this section, circle the appropriate number on the Free Information Card.

ELECTRONICS WISH LIST

Yuppie Headphones

If you need to buy a gift for a "mobile executive," for whom open-foam headphones just won't provide the right image, *Philips Consumer Electronics* (One Philips Drive, P.O. Box 14810, Knoxville, TN 37914-1810) would suggest their model *SBC3172A01* portable (foldable) headphones. They're designed specifically for use with CD players, CD-Video, and DAT decks and provide a frequency-response range of 10-28,000 Hz. The headphones have a black-anthracite metal finish with silver graphics, a leather-coated adjustable headband, and cushioned earpads. The semi-open-back acoustic system lets in some ambient sound. The *SBC3172A01* folds into a sturdy carrying case for protection while traveling. Price: \$54.95.

CIRCLE 56 ON FREE INFORMATION CARD



Philips Executive Headphone

Portable Calculator

To keep your numbers tallied at home, work, school, or in transit, *Canon U.S.A., Inc.'s* (One Canon Plaza, Lake Success, NY 11042) *BS-121* portable calculator runs on either batteries or solar power. The 12-digit LCD readout adjusts for easy viewing, and the calculator has a retractable stand. Time-saving functions include pre-selection of decimal points, a double-zero key, a delta percent key to simplify profit calculations (mark up/mark down), and the ability to store cumulative results in memory. Price: \$29.95.

CIRCLE 57 ON FREE INFORMATION CARD

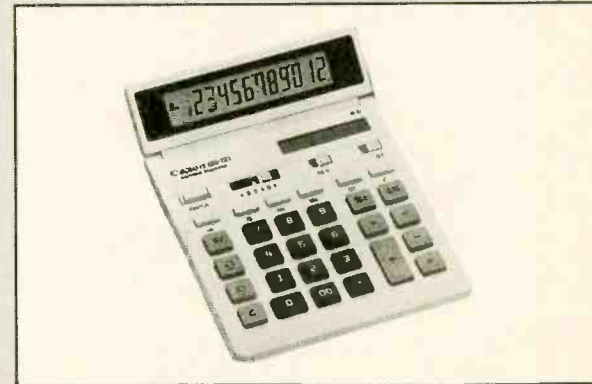

Canon Portable Calculator

Two-Line Phone/Clock Radio

Those whose working days seem to last 24 hours will be able to juggle phone calls after turning in for the night with *Soundesign's* (Harborside Financial Center, 400 Plaza Two, Jersey City, NJ 07311) model *7474* clock-radio/telephone with two-line capability. "Business-like" functions include conference calling, hold, a 14-number programmable memory, separate ringers for each line, on-hook dialing, and automatic radio mute. The time is displayed on a bright-red LED readout. The phone's keypad and function buttons are positioned on the back of the handset, away from the tuning, volume, and selector controls for the AM/FM clock radio. Price: \$89.99.

CIRCLE 58 ON FREE INFORMATION CARD



Soundesign Two-Line Phone/Clock Radio

Programmable Scanner

One member of *Uniden America Corporation's* (4700 Amon Carter Blvd., Ft. Worth, TX 76155) line of base scanners is the 16-channel *BC 177XL*. The fully programmable scanner receives 11 bands, including aeronautical, and offers such features as WX search, priority, programmable band search, lock out, and selectable scan speed. Other features include an LCD frequency readout, memory backup, and track tuning. Price: \$229.95.

CIRCLE 59 ON FREE INFORMATION CARD



Uniden Bearcat Scanner

ELECTRONICS WISH LIST

For more information on any product in this section, circle the appropriate number on the Free Information Card.



Sharp Word Processor

Personal Word Processor

Some people just can't justify the expense of a PC, even though their typewriters no longer meet their writing needs. With 50K of user memory, the *PA-W1410* word processor from *Sharp Electronics Corporation* (Sharp Plaza, Mahwah, NJ 07430-2135) fills the gap. The word processor has an 80-character × 16-line, backlit, high-definition LCD readout and an MS-DOS-compatible 3½-inch floppy-disk drive with 720K storage capacity so you can take text files home from work or create files at home. A dictionary/thesaurus is built in, as are software programs for editing, mail merge, file formats, "desktop-publishing" page and line formatting, and basic (indent, centering, tab, etc.) typing functions. Disk-drive management software is also built in. The word processor also features proportional spacing, two-line correction memory, three pitches, and a keyboard cover. Price: \$799.99.

CIRCLE 60 ON FREE INFORMATION CARD



Cobra Timekeeper Answering Machine

Phone-Answering Machine

We like to know not just *who* calls us when we're out, but *when* they call. But even people who have gotten used to talking to answering machines often neglect to include the time and date in their messages unless specifically prompted to by the outgoing message. Someone in *Cobra Electronics Group's* design department must have had the same gripe, and came up with the *Timekeeper AN-8537* to deal with it. The beeperless answering system includes time/day voice identification, along with a voice-prompt system that provides digitally synthesized spoken messages to help the user during answer mode, playback, and remote use. The Timekeeper also has a digital call counter, extension-phone control, and a micro-cassette-tape system with switchable musical or beep tones after the outgoing announcement. Price: \$109.95

CIRCLE 61 ON FREE INFORMATION CARD



Blaupunkt Car Stereo With CD Changer Controller

A Little Bit of Country

Even if your tastes run more toward Mozart than the Oak Ridge Boys, the *Nashville CM 40* FM/AM cassette receiver with CD changer controller from *Blaupunkt* (Mobile Communications Division, 2800 South 25th Avenue, Broadview, IL 60153) should meet your car stereo needs—particularly if your car has a "three-hole dashboard." The Nashville is designed to simplify the addition of a CD changer system in a three-hole dash. (It is compatible with Blaupunkt's CDC 01 changer.) The CD-remote features make it easy to switch from disk to disk and track to track, and to activate track-mix, cue, pause, play, review, and scan functions. The radio, which can be played while rewinding or fast forwarding tapes on the auto-reverse cassette player, has 18 FM, six AM, and six "TravelStore" presets. A built-in amplifier can drive two or four external speakers. Security Code Protection disables the radio until the secret four-digit code is entered; a flashing red LED on the front panel lets would-be thieves know that the system is armed. Price: \$399.95.

CIRCLE 62 ON FREE INFORMATION CARD



Hal Wrestling Game Boy Cartridge

Game Boy Wrestling

Many parents we know don't care to have their kids spending hours playing video games, or glued to the TV screen watching professional wrestling. Now the kids can drive their parents to new heights of despair by doing both at once, with *Hal Wrestling* for the Nintendo Game Boy. *Hal America Inc.* (7873 S.W. Cirrus Drive, 25-F, Beaverton, OR 97005) promises that players can experience the "thrills, spills, pins, and holds" of big-time wrestling for themselves. The game can be programmed for one-on-one or four-man team wrestling with a field of athletes that includes "King Sampson," "The Big Crusher," and "The Death Monster." Players can pit themselves (or their four-man team) against the computer (or its four-man team), or against another player. Price: \$28.95.

CIRCLE 63 ON FREE INFORMATION CARD

For more information on any product in this section, circle the appropriate number on the Free Information Card.

ELECTRONICS WISH LIST

Audio Shelf System

Sansui USA Inc. (P.O. Box 625, Lyndhurst, NJ 07071) claims that the "Robot" CD-changer in its MC-3000 audio system is the world's smallest. The five-disc Robot has dual digital-to-analog converters, 4x oversampling, 16-track random programming, and four-way repeat play. Rather than using a cartridge or a carousel mechanism to change discs, a robot-like arm lifts the top disc from the storage well and moves it to a second well for play, and then to a third well when play is complete. The MC-3000's mini components—20-watts-per-channel AM/FM stereo receiver, dual auto-reverse cassette deck with Dolby B and C noise reduction, and two-way speakers—can be set up vertically or horizontally to fit on a shelf or tabletop. The audio system comes with a remote control. The receiver has five preset equalizer settings (flat, rock, jazz, classic, and cinema), and provides inputs for VCR sound and "mic mixing" with a separate level control for adding live sound. Price: \$849.95.

CIRCLE 64 ON FREE INFORMATION CARD

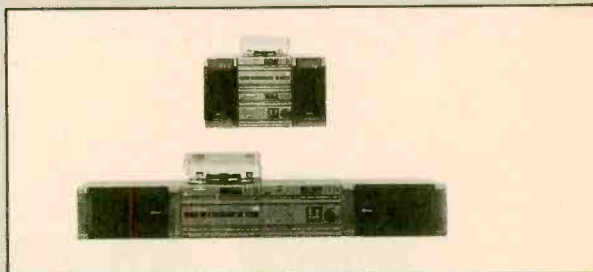

Sansui Audio Shelf System

Phone/Fax Switcher

To keep your wires from getting crossed, D1 International, Inc. (95 East Main Street, Huntington, NY 11743) suggests using their model CE-PF01 FonFax Switch, which automatically directs incoming calls to your telephone or fax machine. Outgoing calls are not affected, and, on incoming calls, the caller is spared from hearing the high-pitched fax signal. Built-in "barge-in protection" eliminates the possibility of a phone call interrupting fax operation or vice versa. The CE-PF01 can be used with an answering machine and a front-panel control can be used to manually switch calls from phone to fax or fax to phone. If the power goes out, the unit automatically switches to telephone mode. Price: \$179.95.

CIRCLE 65 ON FREE INFORMATION CARD

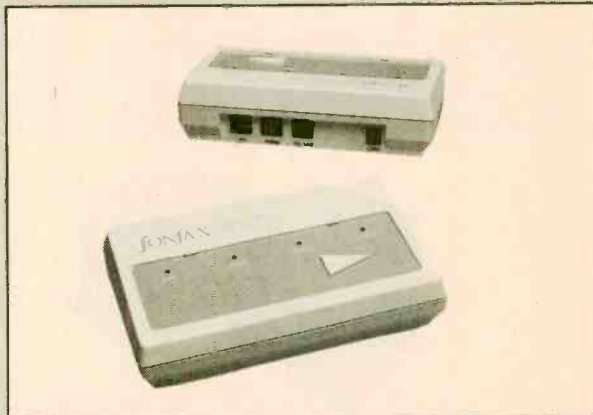

D1 International FonFax Switcher

Computerized Bridge

You no longer need three friends for a serious game of bridge. A computerized bridge game from Saitek Industries Ltd. (2291 West 205th Street, Suite 101, Torrance, CA 90501), dubbed Pro Bridge 500 has advanced levels for serious club players and a built-in "coaching" feature for beginners and those looking to improve their game. It gives hints, suggests which cards to play, and allows the player to take back a bid or a card. Both rubber and duplicate bridge can be played in the player's choice of five major bidding systems with 11 bidding conventions. The 128K program allows the Pro Bridge 500 to act as a partner or an opponent with other players, or to play against itself in "autoplay" mode. The laptop-style game measures 9 x 9 x 1 1/2 inches when folded shut for easy portability. Price: \$399.

CIRCLE 66 ON FREE INFORMATION CARD

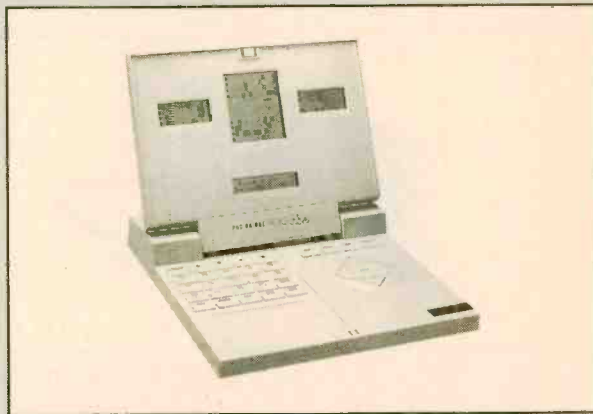

Saitek Pro Bridge 500

Integra Auto-Reverse Cassette Deck

Onkyo's (200 Williams Drive, Ramsey, NJ 07446) TA-R500 is the first auto-reverse cassette deck in their "Integra" line. It features a three-motor drive system with dual flywheels for stable tape transport, an isolated transformer to eliminate hum, a silent tape-transport system, and Onkyo's proprietary "Accubias" system that lets the user fine-tune the recording bias. The TA-R500 is compatible with Onkyo's "Remote Interactive" and, when connected to one of the company's receivers, becomes part of their room-to-room remote system, which allows remote operation of the tape deck from other rooms. Price: \$450.

CIRCLE 67 ON FREE INFORMATION CARD



Onkyo Integra Auto-Reverse Cassette Deck

ELECTRONICS WISH LIST

For more information on any product in this section, circle the appropriate number on the Free Information Card.



A/V Re-Broadcast System

It's not a good idea to leave the kids playing unsupervised in the yard, or even napping indoors while you work in the garden. Now you can keep an eye on the kids remotely, using the *POW-R-MAX Video Commander* from *Midland Consumer Products* (1690 North Topping, Kansas City, MO 64120) and a video camera. The system includes a small transmitter, into which the video source is plugged, and one (or more) receiver, which is plugged into a TV. The Video Commander can also be used to rebroadcast signals from a VCR, satellite system, camcorder, monitor camera, or computer to one (or more) remote TV locations within a 100-foot range. Filters reduce interference in metropolitan areas, and the transmission system delivers clear sound and pictures without the need for fine-tuning by the user. Price: Not available.

CIRCLE 68 ON FREE INFORMATION CARD



M&K MX-2000 Subwoofer

Super Subwoofer

M&K Sound Corporation (10391 Jefferson Blvd., Culver City, CA 90232) has introduced a subwoofer for people who are *really* into bass. The *MX-2000* features a 300-watt RMS power amplifier, dual 12-inch high-performance subwoofer drivers, and an innovative harmonic-distortion-reduction technique that uses a "push-pull" driver configuration. That configuration—in which one driver is mounted conventionally and the other is inverted, so that each cone is always in the exact opposite position in its travel relative to the other—is also said to increase efficiency and reduce cabinet vibration and the resultant sonic coloration. The *MX-3000* has a 36-dB/octave low-pass filter above 125 Hz, and the upper rolloff point can be set anywhere between 50 and 125 Hz. (A high-pass filter is available separately.) Price: \$1695.

CIRCLE 69 ON FREE INFORMATION CARD



Lee Marketing Alarm Light

Alarm Light

Walking and jogging might be good for your health, but doing so alone at night can be dangerous. To provide some peace of mind for people who find themselves frequently running into scary situations, *Lee Marketing Company* (210 Easy Street, Suite 17, Mountain View, CA 94043) has come up with the *Alarm Light*. The pocket-size device does double duty as a flashlight and an alarm. When the carrying strap is disconnected from the device, the alarm is activated. Price: \$9.99.

CIRCLE 70 ON FREE INFORMATION CARD



Zenion Screen ELF

Monitor-Radiation Neutralizer

Medical studies have indicated an array of harmful effects caused by spending hours in front of video terminals. *Zenion Industries Inc.* (5430 Commerce Blvd., Rohnert Park, CA 94928) has introduced the *Screen ELF* (Electronic Limiter of Field Radiation), a silent device that generates a continuous flow of negative ions (anions) across a CRT screen to offset the potentially dangerous positive ions (cations) created by the high voltage required to illuminate the screen. "The unit creates a "wall" of anion-enriched air that neutralizes the cations in the air around the screen and continuously replenishes the air within a six-foot area. According to Zenion, the ELF "can reduce headaches and other symptoms within hours of installation." Needless to say, those symptoms don't include eyestrain (the cause of most VDT-induced headaches) or the effects of electromagnetic radiation emanating from the VDT. Price: \$99.95.

CIRCLE 71 ON FREE INFORMATION CARD

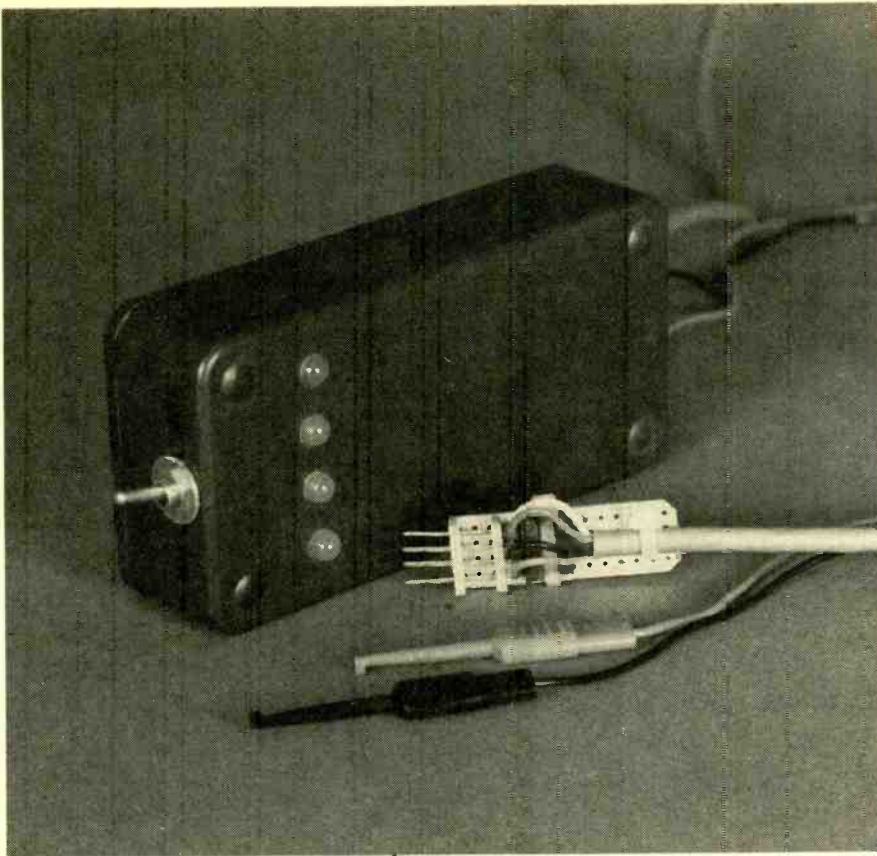

Build the × 4 Logic Probe

Our hand-held four-channel probe can indicate whether each of four test points is high, low, toggling, or open!

BY MARC SPIWAK AND JOHN YACONO

Let's face it: the more test instruments you have on your workbench, the quicker (in general) each job will get done. You may not need every instrument for every job, but you'll always find yourself in need of that one thing you don't have. And, while special-purpose instruments are often the only thing that can be used for a particular job, general-purpose instruments can come in handy for a wide variety of tasks. That's why we've developed the *x4 Logic Probe*, a 4-channel logic indicator.

The *x4 Logic Probe* is built around four dual-color LED's, each of which can indicate one of four conditions: high, low, pulsing, or high impedance (or unconnected). The way in which they do that is simple. To begin with, each LED case actually contains two LED's: a red one and a green one. They are biased opposite each other, so the LED appears green when current flows in one direction, and red in the other. And the unusual thing is that when you apply an AC signal or square wave, an orange-like color is generated...to be somewhat more accurate, it looks like a half-ripe tomato. The amount of red or green depends on the duty cycle of the signal.

So there we have our four conditions.

A ripe tomato (red) can be a high, a green one can be a low, a half-ripe (orange-like) indicates a changing signal, and, of course, an unlit one indicates no connection. The only difference between the prototype and the version presented here is that in the prototype red was used to indicate a low (and green for a high). That's because the original plans for the unit involved monitoring certain points in a circuit for a low, and red is easier to see. But you can set up yours however you like.

Another detail on the prototype are the four probe tips, which are designed to monitor four IC pins at once. We'll discuss the details concerning the probe tips in a little while, but keep in mind that you can use whatever you like, such as micro clips, alligator clips, a DIP clip, bare wires, etc. Also remember that, while the prototype contains four LED's, the circuit is easily expandable so you can build a unit with as many as you like.

TTL vs. CMOS. Before we discuss the design of the circuit, a little exploration into TTL and CMOS logic levels is in order. It'll help explain how the *x4 Logic Probe* deals with both types of devices.

As you may know, TTL chips typically operate with 5-volt supplies, and their logic-level voltages are rigidly defined (0 to 0.8 volts is a low and 2 to 5 volts is a high). CMOS circuits, on the other hand, can be run at various voltages, so their logic levels are determined by percentages of the supply voltage (0 to 30% is a low and 70 to 100% is a high).

When we set out to design the probe we wanted it to be able to test both families of logic (and "tri-state CMOS," which we'll discuss later), as well as voltages not associated with IC's. To test CMOS circuits, the probe would have to be connected to the power supply for the D.U.T. (device under test) so it can determine what voltages are valid highs and lows; as you'll see, it does that with a voltage-divider network that provides voltages at 30 and 70%. That being true, the probe might as well be powered from the supply for the D.U.T., and as long as the probe contains all CMOS chips (as it must to test CMOS devices) that's fine.

However, a problem arises when we want to test TTL logic. The probe's CMOS gates will operate fine at the 5 volts from the D.U.T.'s power supply but, if they were set up only for CMOS, they would assume that valid lows range from 0 to 1.5 volts (30% of 5 volts) and valid highs

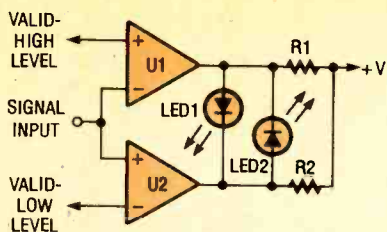

Fig. 1. The $\times 4$ Logic Probe is based on this strangely symmetric circuit. In the actual circuit, LED1 and LED2 are replaced by a single dual-color LED.

run from 3.5 (70% of 5 volts) to 5 volts. If the probe was allowed to operate that way, a lazy pin on a chip—one not going low enough—might not be detected. Also, acceptable logic highs between 2 and 3.5 volts could not be detected, leading you to suspect that a good chip is bad.

One obvious, but very inelegant, solution is to reduce the 5-volt supply to a

value such that 2 volts is a high (70%) and 0.8 is a low (30%). That can actually be done by operating the probe at 3 volts, but its ground must be 0.1 volts lower than that of the D.U.T. To produce such an offset would require the use of a negative or switching power supply, programmable regulators, a two-pole three-throw switch, and a menagerie of support components. As you'll see, our design went a different route.

Under the Hood. The best way to go was to use gates that could be "programmed" to go high or low at specific voltage levels. A voltage comparator is the perfect gate for such operation. For the less familiar, a comparator output is high when its non-inverting input is at a higher potential than its inverting input. It's low when the reverse is true.

Take a look at the circuit in Fig. 1. The non-inverting input (+) of U1 is tied to

the lowest acceptable voltage representing a high. The inverting input (-) of U2 is tied to the highest voltage that can represent a low. Their remaining inputs are tied together to receive the input logic. If the input level is higher than the voltage at the non-inverting input of U1, U1's output goes low; remember, if the inverting input is higher than the non-inverting input, a comparator's output goes low.

Simultaneously, U2's output is idle at a high output. That means current will flow through R2 and light LED2, which is now forward biased. If the input signal is lower than the voltage at the inverting input of U2, U2 goes low and U1 is high. That lights LED1. If the voltage at the input is in the intermediate range (which can be achieved with a little extra circuitry that overcomes the internal biasing of the comparators) both LED's will be off.

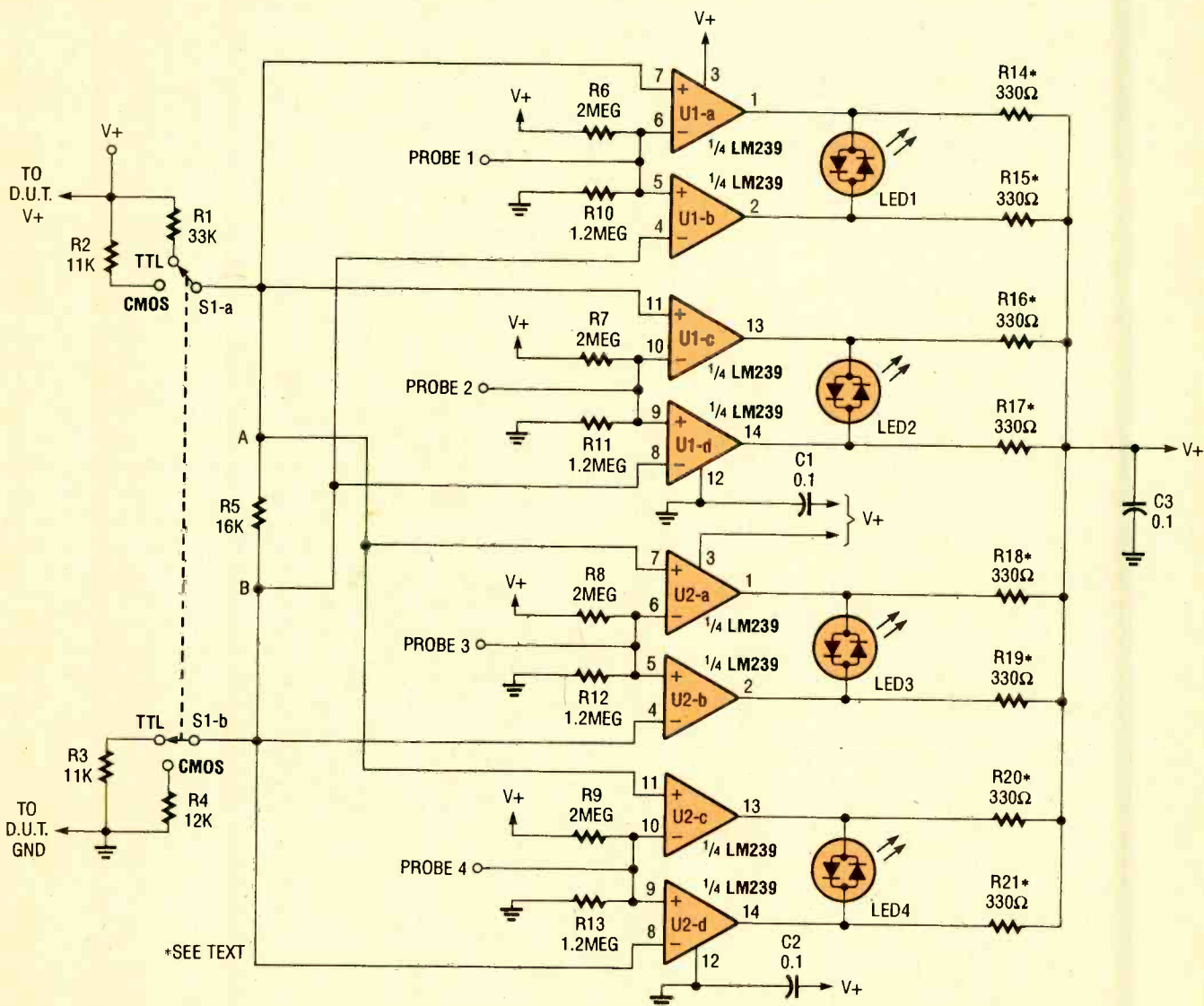

Fig. 2. The resistor networks (R1/R2 and R3/R4, respectively) to the left program the comparators with the proper voltage levels.

Now, if LED1 and LED2 are replaced by dual-colored LED's, and the circuit is multiplied by four, we come up with the circuit you see in Fig. 2.

Resistors R1-R4 "program" the comparators for the right high and low voltage levels. Switch S1 allows the user to select a resistor network that sets either TTL- or CMOS-compatible voltage levels. Resistors R6-R13 bias the probe inputs to prevent the probe from indicating a high for open circuits. When a probe tip is on an open IC pin, the corresponding LED will be off.

That's an important feature for three reasons: it allows you to detect failing pins or chips without power, it can keep you from incorrectly suspecting a chip because you misaligned the probe, and it will allow you to test tri-state chips. Tri-state chips have three logic levels (states): high, low, and high impedance. When testing such IC's, an off LED tells you its corresponding pin is in a high-impedance state. What all that means is that a single dual-colored LED will tell you if a pin is high, low, alternating, or even high-impedance/malfunctioning.

One thing should be mentioned about the alternating indication: Many computer circuits send out pulses that are too brief to light an LED or too brief for you to see them. Such test points may appear continuously high or low because of their lopsided duty cycle. It is assumed that the probe will not be used on such overwhelmingly fast cir-

cuits without other test equipment to check for such possibilities.

However, for "hobbyist-speed" circuits, the probe shines in this capacity. It will emit the half-ripe tomato color for duty cycles close to 50%. Its easy to see alterations in current for duty cycles from 30 to 70% even at respectable frequencies, although the color varies. During the initial testing of the dual-color LED's, it was a lot of fun adjusting the duty cycle of an input signal to modulate the LED's color from red to orange to yellow to green.

By the way, if you want to add more LED's to the project, it's a simple matter of adding another LM239 for every two LED's added (two comparators from each quad IC are needed for each LED). Just connect the non-inverting and inverting inputs of the additional comparators to points A and B in Fig. 2 (non-inverting to A and inverting to B). It's also possible to build the unit with only two LED's and one LM239, but when four LED's can be incorporated into such a small package, it doesn't make much sense not to take full advantage of the circuit.

By the way, if LM239's are hard to come by, LM339's are a good substitute. Our first prototype unit used LM339's, which were replaced with LM239's because of their current-handling capability. If you consider that overkill, LM339's will work fine. Also, the resistor network, R14-R21, can be replaced by discrete 330-ohm, 1/4-watt, 5% units if desired.

Construction. The $\times 4$ Logic Probe was built on a small piece of perfboard using wire-wrap techniques. Once the size of the cabinet was chosen, the components were first test-fitted on the board before any assembly began. Keep in mind the location of S1 when laying out your own unit to provide it with some clearance.

The only thing that complicated the otherwise simple job of wire-wrapping the circuit was the compactness we desired. That meant working in close quarters. If you don't need the unit to be as small as the prototype, or if you are using more than four LED's, use a bigger piece of perfboard and a larger cabinet to make your job easier. You might want to make a table-top version with a long cable for the "business end."

A piece of four-conductor wire was used to connect the unit to the special four-tip probe. The probe was assembled from scraps of perfboard and

four probe-tips from a wire-wrap IC socket (see photos). Each pin slides through holes in two pieces of perfboard glued to a third piece. The wire from the cable keeps the pin from sliding out of the end, and a rubber block gives each pin a certain amount of give to ensure a secure seating on the test IC's pins.

If you like, you can avoid the probe entirely and put micro clips on the ends

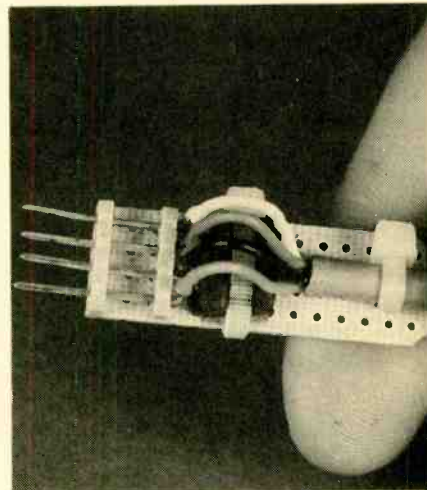

Here is the probe tip, which was designed to make it quick and easy to check up to four IC pins at once.

of the test leads. That way, the unit might be a little more versatile. Micro clips were used for the power leads, but use anything that suits your needs.

Set-Up and Use. The probe needs only to be connected to the power supply of the D.U.T., and used like any other logic probe. However, some general testing rules are in order at this point.

When testing a suspect IC, if the V+ pin is high-impedance or low and gate outputs are low, the IC is not getting power. A foil trace, solder joint, or IC socket are likely suspects. If the ground pin is high impedance or high, the device has no ground, so again check the foil trace, solder joint, or IC socket. If the V+ pin is high, but all the chip's output pins are low, the gates are lacking internal power and the chip is probably shot. If all the outputs are high, but the ground is low, the gates aren't getting ground, and again the chip is shot.

Because the probe has four indicators, it is ideally suited to testing 2- and 3-input gates. You can monitor a gate's inputs and the resulting output simultaneously to make sure it's functioning properly. Because of features like that, you can expect a decrease in the time you spend testing IC's. ■

PARTS LIST FOR THE $\times 4$ LOGIC PROBE

SEMICONDUCTORS

U1, U2—LM239 (or LM339, see text), integrated circuit
LED1-LED4—Dual-colored LED

RESISTORS

(All resistors are 1/4-watt, 5% units unless otherwise specified.)

R1—33,000-ohm
R2, R3—11,000-ohm
R4—12,000-ohm
R5—16,000-ohm
R6-R9—2-megohm
R10-R13—1.2-megohm
R14-R21—330-ohm, 16-pin. DIP resistor network (Digi-key 761-1-R330 or similar), see text

ADDITIONAL PARTS AND MATERIAL

C1-C3—0.1- μ F. polyester capacitor
S1—DPDT toggle switch
Micro-clips, 4-conductor wire, perfboard, IC sockets, wire-wrap wire, solder, hardware, etc.

Cellular telephones, once considered the exclusive tools of busy salesmen and fast-paced executives, are becoming almost as commonplace as conventional telephones. That's because they are not all "car-bound" devices as many people think. Transportable phones (which can be removed from an automobile much like a cordless phone) have opened up an entirely new world of opportunity for people who must communicate directly from work sites such as inspectors, craftsmen, architects, and reporters. Instant communication also comes in handy for families that must keep in touch. With constant improvement and expansion of the cellular network, as well as the falling costs of cellular phones, it may not be long before we all "go mobile."

This article will describe some of the basic theories and operations of cellular telephones and the cellular network. It will also mention a variety of costs that are incurred with cellular phones and discuss the typical problems that can be encountered.

The Cellular Approach. In its simplest sense, a cellular telephone is little more than a low-power, computer-controlled two-way radio. It transmits and receives FM (frequency-modulated) signals in the UHF (Ultra-High Frequency) band in much the same way as any other radio set. There are, however, several important differences that distinguish cellular sets from conventional radios. Before we dive right into cellular-phone operation, let's look at the functioning of the older two-way radio-type phone. (Refer to the sidebar entitled "A History of Mobile Telephones.")

Early mobile communication used conventional two-way radios to establish a radio link between a car and a centrally located base-station transmitter/receiver that connected the local service area to the telephone company's central office (or CO). The car required a large, powerful transmitter (often higher than 50 watts) to maintain a clear link with the base station. Even then, the service area was limited to less than 30 miles from the base. Beyond 25 miles, the signal quality—both transmitting and receiving—would begin to de-

grade. Once you moved beyond the maximum range, there would not be enough power to maintain the link and the conversation would be terminated. That frustrating limitation restricted the use of mobile communication to the area around the base station providing the mobile service. The technique was also highly susceptible to interference from nearby mobile-service areas.

The cellular concept redefines radio communication using a clever and innovative technique: instead of using a single, high-power transmitter to cover a wide service area, the region covered is divided into many smaller zones called "cells" (see Fig. 1). Each cell site is equipped with a low-power transmitter and receiver. The cellular transmitter in the phone also operates at a much lower power (usually less than 2 watts). Low-power operation limits each cell to a working range of only a few miles, but as the car travels and the signal strength changes, a computer determines which cell in the network will provide the best signal. At the point when another cell will provide a better signal your conversation is automatically switched over to the new cell site. That action maintains the highest signal quality across the entire breadth of the network.

A cellular switching office (SO) connects and controls every cell site in the network. It is the SO that determines how to best handoff your conversation between cells, as well as interconnects the network to the telephone company central office (CO). Ultimately, the CO connects the network to the destination telephone.

The cellular approach offers an array of advantages over conventional radio. First, low-power transmitters are smaller, lighter, and consume much less power. Low-power also virtually eliminates the interference problems associated with regular radio. So cellular telephones operate efficiently, quietly, and occupy little space—so much so that many cellular phones can now be removed from a car and carried into business or industrial work areas as mentioned before. Also, small cell areas guarantee a strong, clear signal at all times since the conversation is handed off to an adjacent cell well





Nowadays, with the popularity of cellular phones on the rise, it probably won't be long before you reach out and touch someone while you're on the go. Read about the technology that's already making that possible for many.

before any signal degradation begins. Finally, a network can be expanded almost indefinitely by simply adding cells and tying them into the network's switching office.

Perhaps the most remarkable feature of the modern cellular telephone network is the "transparency" of its operation. The user is usually unaware of the many functions occurring in the various parts of the network. For many, it's no more complicated than just picking up the phone.

Telephone Components. In spite of its various buttons and controls, the cellular telephone itself is actually a very straightforward mechanism. Although the size, shape, and circuit complexity will vary with each model, every cellular telephone can be broken down into four major sections (see Fig. 2): the power supply, the handset, the control module, and the antenna. Let's look at each of these sections in more detail, starting with the power supply.

can be found on boats, buses, trains, at work sites, etc. Smaller transportables generally make use of nickel-cadmium (NiCd) batteries, while larger transportables may use gelled electrolyte batteries (or gel-cells). Gel-cells are preferred because they offer a much better working life than NiCd cells, and they will not spill acid like your car's battery.

The cellular telephone is almost always controlled from the handset assembly. Many telephones have some sort of alphanumeric display, as well as control keys and the dial pad on the handset. Of course, it also houses the microphone and receiver earpiece. The handset is connected to the control module through a multi-conductor cable that handles both audio and the keypad's control signals. A liquid-crystal display is often used to show the telephone's status, the number that is dialed, or any errors that might occur.

The control module is the workhorse portion of the cellular telephone and

All about CELLULAR TELEPHONES

BY STEPHEN J. BIGELOW



Since cellular telephones are designed as a means of mobile communication, power is almost exclusively provided by batteries. The choice of battery will often depend on the particular telephone and its application. For permanent automobile installations, the telephone is wired directly into the car's electrical system so the telephone can draw energy directly from the car's battery.

Transportable cellular telephones do not rely on the car's battery since they are intended to be taken anywhere—inside or outside the car. Transportables

performs a variety of critical functions. It houses the transmitter circuit that delivers modulated control and voice signals to the antenna. The receiver circuit demodulates incoming voice and data signals designated for your particular telephone. The transmitter and receiver circuits are basically the same as any other two-way radio. However, they are supervised by the telephone's control-logic circuit. In small cellular models, the functions of the control module are often incorporated into the handset.

The control logic contains a micro-

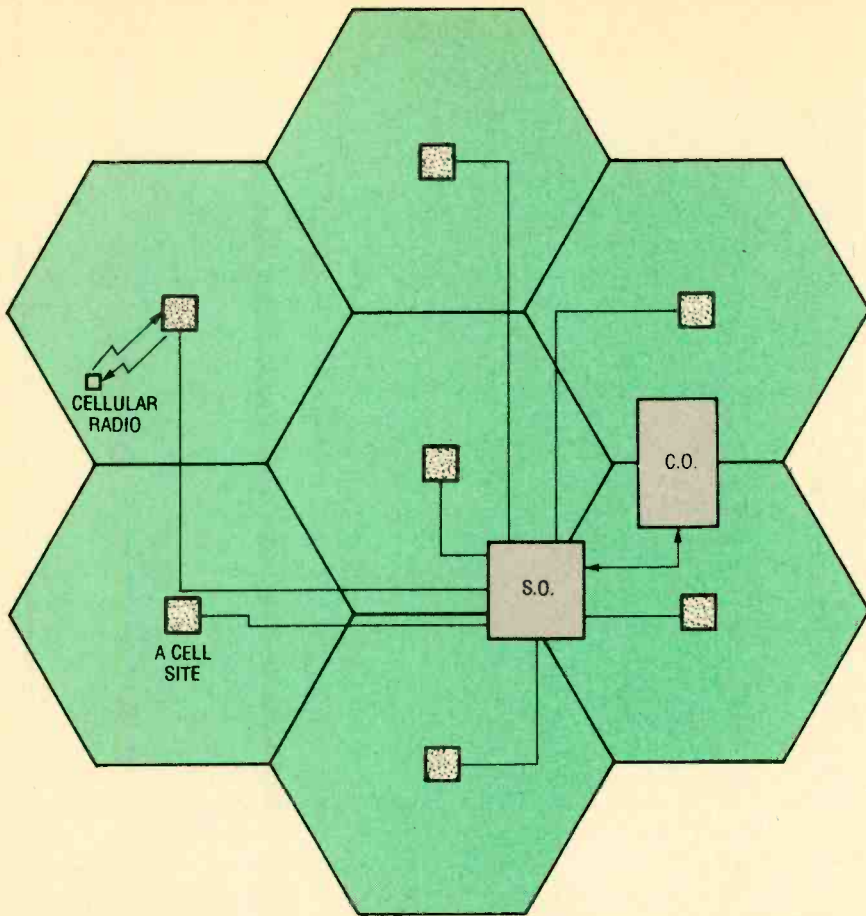

Fig. 1. This is a diagram of the cells that make up a cellular network. The areas that each cell site could cover actually overlap. The lines dividing the cells show the areas each cell services before a call switches between cell sites.

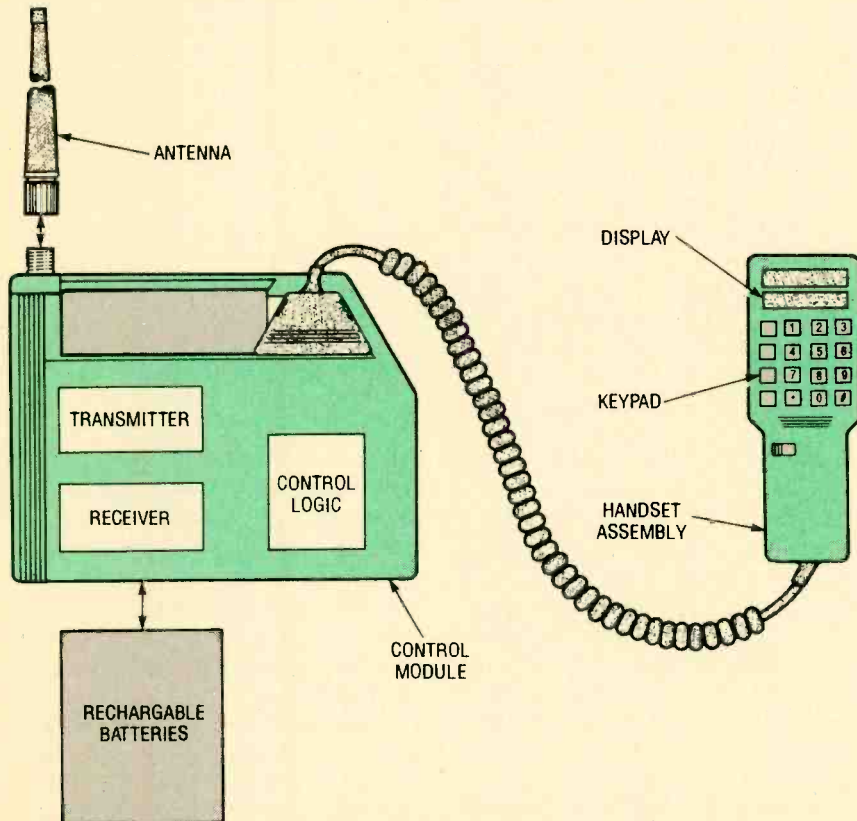

Fig. 2. Here's a block diagram of a typical cellular telephone. The control logic is really the brains behind the machine.

computer that oversees the operations of the cellular telephone. The control logic encodes the control signals from the dial pad and sends them to the transmitter, which then relays them to the network along with any modulated audio.

Any command or status signals from the network that reach the receiver will be decoded by the logic and shown on the handset display if appropriate. The control logic also adjusts the telephone's output power to optimize the signal that reaches the cell site, as well as coordinate the handoff of the conversation between cell sites. Batteries are housed inside or along the side of the control module.

There are a variety of antenna structures that are commonly used in cellular telephones. The choice depends on the type of telephone that is used (permanent or portable) and the desired location of the antenna.

Permanently installed cellular telephones usually use an antenna that is mounted somewhere on the car's body. Those antennas are easy to spot—they usually have a built-in coil in the middle (see Fig. 3A). The "pigtail" acts to increase the efficiency of the antenna by improving its radiating capacity. Beware of variations in the types of external antennas. Roof-mounted, trunk-mounted, and glass-mounted antennas are each designed slightly differently to optimize the radiation properties of each type. Therefore, a roof-mounted antenna may not work well if it is mounted on the trunk, and so on. Be sure to mount the desired antenna in the proper location.

Transportable telephones, on the other hand, use flexible (or "rubber duck") antennas which are small and discrete (Fig. 3B). Although flexible antennas do not perform as well as their externally mounted counterparts, their size and flexing quality make them ideal for telephones that are on-the-go.

Never underestimate the importance of a quality antenna. The antenna is responsible for emitting your transmitted signals and picking up any signals directed to you. Now that we have examined the sections of a typical cellular telephone, let's take a look at the overall cellular system.

Cellular System. The cellular telephone itself is only a small (but important) part of a large and complex communications network that can span entire regions of the country. All

networks, regardless of their particular costs and services, are made up of five important components: the user (with the cellular telephone), cell transceivers, the cellular switching office, the telephone company central office, and the destination telephone. Each segment must operate properly for the network to be effective.

Cellular-telephone users subscribe to a network that is operating in their desired area. That's almost always done during the initial purchase and installation (if necessary) of the telephone. At that time, it is programmed with a telephone number and serial number. A security code may also be available as an option on some models. The new phone number is registered with the cellular-service carrier who will provide your service (and your monthly bill). Once your phone is programmed, you will have normal access to the network, and you may send or receive calls at any time. Just remember that you must be within range of a cell site in order to use the network.

Cellular service will only be available where there are cell sites to link the user to the network. A network cell site is usually very easy to recognize (see Fig. 4). In suburban or rural areas, they are most often located at higher elevations (on hills or mountains) to provide the widest possible area of coverage. Urban or

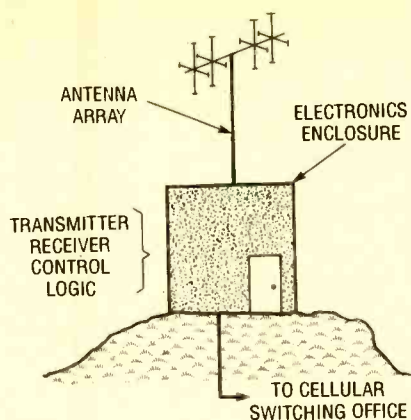

Fig. 4. If you look around in your area you may encounter something that looks like this. It is a typical cell site.

metropolitan cell sites are often placed on high buildings.

Cells consist of a small building that houses the transmitter, receiver, and control circuits to monitor and direct the cell's operation. A complex array of directional antennas is mounted to the building. Each element in the array consists of both a receiving and transmitting antenna. That allows simultaneous two-way communication to take place. Modern cells are designed to accommodate up to 45 two-way conversations at a time. Each conversation uses a pair of frequencies (one for transmit, one for receive).

Due to the low-power nature of cellular-telephone transmissions, frequency pairs can be simultaneously used by non-adjacent cells without interference. Control signals and voice channels are sent to the cellular switching office by underground or overland cables. If the cell site is within visual range of the SO, it may use a short-range microwave link to connect the cell to the SO. It is the SO that manages the operations of the network.

The switching office is the nerve center of the entire network. It connects each cell together to form a pattern of coverage across a region. The SO accepts the voice and data signals from each cell. It also sends voice signals from the telephone company central office to the appropriate cells, along with any command data necessary to coordinate the cell's operation. The SO controls the handoff of conversations between cells. Ultimately, all of the conversations on the network are channeled through the SO and connected to the central office.

The central office belongs to the telephone company that provides stan-

dard phone service in the network area. The cellular SO requests a telephone line from the CO in much the same way as any other telephone. Effectively, the cells and switching office merely provide a communications path and control link between your cellular phone and the CO. The CO, in turn, is connected directly to each of the conventional telephones in its local area.

The destination phone, simply stated, is the phone number that you are calling from your cellular phone. In many cases, it will be a conventional telephone connected to the central office. However, it may also be another cellular telephone. That is accomplished when the CO tries to connect the destination phone. It will re-route your call back to the SO, which will treat the new signals from the CO as an incoming call for another cellular phone (more on system operation in the next section). Since CO's are connected together with their own network throughout the country and the world, it is possible for a cellular phone user to reach a conventional phone just about anywhere in the world. Let's look at how the network operates.

System Operation. Using the cellular telephone to place a call is very similar to placing a call from a standard phone. Many cellular phones add just one extra step: Dial the desired telephone number on the dial pad as you would on any other phone (the dial pad is usually located on the handset) and press a send key (or equivalent). If you don't press the send key, the number will remain in the phone's memory waiting until you do. That will allow you to enter the desired number whenever you are stationary (at a stoplight, etc.), but make the call whenever you are ready simply by pressing the send button.

The send key tells the phone to connect to the nearest cell and establish a communications link to the SO and CO. Once the cellular phone confirms that a link has been established, it will automatically dial the number you've entered. The entire process may take no longer than 5 seconds. You will probably never hear the dial tone from the CO because the phone will dial the number the moment it senses a connection.

Although you may not hear dial tone, you will hear the busy or ringback signals from the CO to indicate the sta-

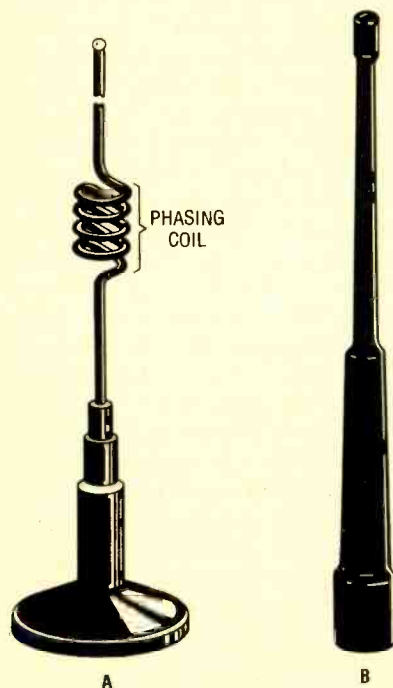

Fig. 3. Shown here are drawings of an external-type car antenna with a pigtail (A), and a flex-type ("rubber-duck") antenna (B).

tus of the destination phone. If the called party picks up, the conversation will take place normally (as long as you stay within the region covered by the network).

When you are ready to hang up, you simply replace the cellular handset into its cradle, or press a termination key such as an end key. Either action tells the cell and the rest of the network that you wish to disconnect. You must be sure to hang-up in the proper fashion. Remember that you are charged for the time that you are connected to the network, so even if the other party has already hung up, you will still be running up your bill. You'll also tie up a useful channel for someone else.

Another phone (either a conventional phone or a cellular phone) will call your number in much the same way as they would any other telephone. The central office determines that the number belongs to your cellular phone and activates a line to the switching office. The SO searches for the cell with your phone, then alerts you to the incoming call by causing your phone to ring.

The communications link is established when you lift the cellular handset. The network is contacting you so there is no need to press a send button. After you lift the handset, simply carry on a normal conversation. Keep in mind that you must pay for connection time to the cellular network—even when receiving calls—so be very sure to replace the handset in the cradle, or press the end button to disconnect.

Roaming. Part of the appeal of cellular telephones is their ability to keep you in touch from "anywhere." The problem is that no single cellular network can provide coverage everywhere—networks are only just so big. To improve the coverage of cellular service, many adjacent networks enter into joint agreements that allow their subscribers to use the facilities of other networks while traveling. Switching between networks is called "roaming," and can greatly enhance the coverage area of cellular services.

If you travel outside of your local area into an adjacent network, you will still be able to place and receive calls within the "cooperative network." Most cellular phones use a "roam" indicator to show when the phone is being used within another network. Be aware that you may be charged a "roaming toll" for the use of cooperative networks.

A History of Mobile Telephones

Mobile communication can trace its roots back as far as the early 1920's when the Detroit Police Department first installed two-way radios in their police cars. Although the radios ("state-of-the-art" technology at the time) were large, cumbersome, and difficult to use, they proved indispensable. For the first time in history, a group of individuals scattered across a wide area could communicate and coordinate their activities from remote locations. The idea caught on, and mobile communication was on its way.

Radio technology improved through the next two decades, and the first public mobile telephone service opened in St. Louis, Missouri in the late 1940's. The system had its share of drawbacks. A mobile operator had to dial the desired number and connect the destination phone to the "radio-telephone." Full duplex communication (speak and listen simultaneously) was impossible. It operated by the push-to-talk, release-to-listen technique. Further, the few areas that offered these services were usually very busy.

By the late 1960's, the radio-telephone network had grown and become more organized. Additional advances in radio technology had made the systems more reliable and easier to use. The introduction of full duplex service and automated dialing were both big advances. In spite of the improvements, the systems were still heavily congested with voice traffic, and had an absolute working range of no more than 30 miles to a single control station. There had to be a better way.

The initial proposal for a working "cellular" communication network reached the FCC in the early 1970's. Although the basic concept of a cellular system was around since the first public mobile telephone service, it was only in the 1970's that the computer and control technologies had developed enough to consider a practical network.

By the end of the 1970's, a prototype cellular network was implemented in Chicago. It was a hit. AT&T assumed a leading role to develop the new cellular technology. The first full-fledged cellular network went online in Washington D.C. in 1984.

At this time, cellular services are available in just about every urban center and many suburban areas across the United States. It is only a matter of time until cellular service is available in all parts of the country. ■

Costs. The single greatest expense associated with a cellular telephone is the purchase cost plus installation. Although there are cellular rental and leasing opportunities available from just about any cellular phone dealer, many first-time users are taking advantage of dropping cellular costs and purchasing them outright. The cost for a new cellular telephone can range from \$500 to more than \$1000 depending on the functions and features available

on each model. There are advantages and disadvantages to buying, renting, and leasing.

Renting is the most versatile, but by far the most expensive, means of obtaining a cellular phone. You can rent for any period of time—a day, a week, a year—as long as you like. Turn in the phone at any time for any reason. If it fails, just bring it back and get another. You are not responsible for its maintenance or upkeep (unless, of course, you should lose the phone or abuse it beyond normal expected wear-and-tear).

Leasing is a cross between renting and buying. The main differences between renting and leasing are: 1) A lease is a legal commitment to rent a certain phone for a fixed period of time, where a rental period can be flexible; 2) When a lease expires, you will usually own the phone; 3) If the phone breaks during the lease period, a temporary replacement will be loaned to you until the original phone is repaired. Since a lease commits you to pay over a fixed time period, the overall cost of leasing is normally lower than renting, but is still greater than purchasing the phone.

Buying is perhaps the most popular means of obtaining a cellular phone for long-term use. The single, one-time purchase price of the phone can be very appealing when compared against monthly rental or leasing costs. However, as a piece of personal property, it carries the same responsibilities and problems as other personal items. You are responsible for its insurance and repair (although extended warranties and service contracts are often available).

Once the phone is installed, you will have to consider some of the charges that will be billed to your account each month. The "monthly charge" is the most common fixed cost. It is very similar to the monthly charge found on all conventional phone bills. That fee pays for your regular access to the network. It will vary a little from network to network depending on the one you choose.

The "airtime charge" often makes up the bulk of all variable charges. Airtime is charged whenever your cellular telephone is connected to the network regardless of whether you are placing or receiving a call. As you can see, you will save money by keeping calls short and to the point.

Toll charges are exactly the same as conventional telephones. Remember

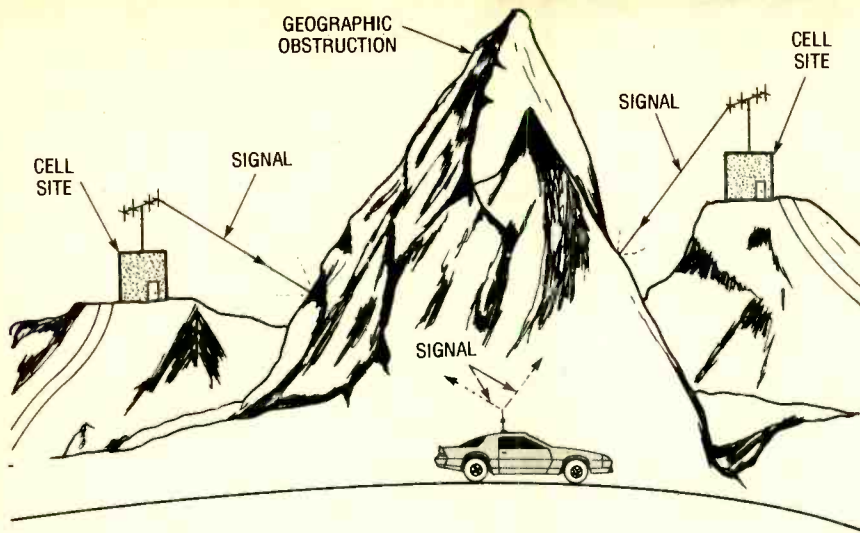

Fig. 5. A geographic dead zone can be caused by large hills or mountains interfering with cellular reception.

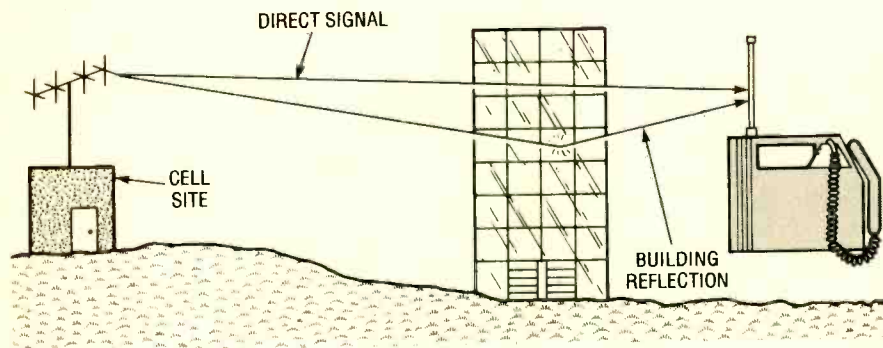

Fig. 6. In urban areas dead-zones are often caused by large man-made structures interfering with reception, or canceling out the signal through destructive interference with reflections.

that when you place a call, you are ultimately using the telephone company's facilities, so you will be charged normally for any toll calls that you make. Local calls do not carry a toll charge. If you receive an incoming toll call, the caller will be billed the toll charge.

Service charges cover any special services that you may have on your account such as call waiting or call forwarding. Federal, state, and local taxes are billed to your account depending on your utilization of the network.

Problems. Although cellular telephones are generally convenient and reliable instruments, they do have their operational limitations. From time to time, you may encounter situations where your phone will not work properly.

Since cellular phones rely heavily on UHF-radio communications, they can experience the same limitations as other radio equipment. Drop off can occur whenever there is a severe mo-

mentary loss of radio-signal strength. That seriously degrades the conversation, sometimes causing it to cut out briefly. It is very similar to a "bad connection" in a conventional phone.

Drop offs happen because of the poor transmission conditions that exist in wide, low-lying rural areas, around large bodies of water, or in areas that are heavily wooded. Drop offs can also take place in urban areas that have many large buildings in close proximity, under bridges, or around other large structures. That's because UHF radio waves are easily reflected and scattered by objects. Large buildings or natural barriers (like hills and mountains) are notorious for this. More obstructions to the radio signal increase the probability of interference.

Unfortunately, there is no way to tell whether or not a particular area is prone to drop off until you are actually there and it is happening, but cellular networks are designed to tolerate short drop offs without disconnecting your con-

Cellular Phone Glossary

Access Charge—A fixed monthly fee charged to your cellular-phone account for subscription to the local network and its services.

Advanced Mobile Phone System (AMPS)—AT&T's official name and inter-connection standard for cellular service.

Carrier—A company which provides cellular services.

Cell—The area serviced by a permanent cellular transmitter/receiver station (cell station).

Central Office (CO)—Telephone-company switching facilities which connect the standard telephone network to the cellular switching office.

Channel—In cellular communication, it is a frequency pair used for full duplex communication between a cellular phone and a cell site. More than 600 channels are allocated for cellular use.

Connect Time—The length of time that a cellular phone is connected to a cell site. (It is not the length of a conversation.)

Dead Zone—Due to natural or man-made interference, an area where cellular signals will not travel.

Drop Off—A brief signal loss due to natural or man-made interference.

Electronic Service Number (ESN)—The serial number of a cellular phone recorded in its permanent digital memory.

Handoff—The transfer of a conversation from the control of one cell site to another as the phone moves.

Multipath interference—A cause of dead zones. A type of radio interference where a direct signal is combined with one or more reflections of the same signal.

Numeric Assignment Module (NAM)—The cellular phone's permanent memory chip which contains its ESN and its assigned phone number.

Phasing Coil—The "pigtail" section in many car-mounted antennas.

Roaming—The use of cellular services outside of the local network. Many adjacent networks have roaming agreements.

Service Area—The area of cellular coverage provided by a carrier.

Switching Office (SO). Cellular switching facilities that control the network cells and interface to the CO

versation. If you encounter frequent or prolonged drop offs, the network may interpret that loss of signal to mean that either you or the other party has hung up. Whenever you experience drop offs, you may either cut the conversation short and call back later, or simply forewarn the other party that you may get cut off at some point, and that you will call back if that happens.

Effectively, dead zones occur for the same reasons as drop offs—the radio waves are obstructed. A dead zone, however, covers an area much larger than a drop off, perhaps several miles. No cellular service will be available

(Continued on page 106)

THE DIGITAL ELECTRONICS COURSE

GETTING FAMILIAR WITH A/D CONVERTERS

Analog signals are often used to control digital circuits, but before that can happen they must be digitized to provide data that logic circuits can understand.

BY ROBERT A. YOUNG

The process of converting an analog voltage into an equivalent digital signal (analog-to-digital conversion, commonly referred to as A/D conversion or ADC) is somewhat more complicated than D/A conversion. Over time several methods of A/D conversion—simultaneous, counter, electromechanical, etc.—have been developed.

Simultaneous Conversion. Simultaneous conversion (probably the simplest of all methods of A/D conversion) uses a number of comparators in its design. The analog signal to be digitized serves as one input to each comparator; the other input to each comparator is connected to its own reference voltage, as shown in Fig. 1. In our example, the reference voltages are $+V/4$, $+V/2$, and $3/4(+V)$, where $+V$ is the maximum signal voltage the circuit can handle.

If the analog input exceeds the reference voltage to any comparator, that comparator's output goes high. That means there are four voltage ranges that can be detected and effectively discerned by our circuit: If all comparator outputs are low, the analog in-

The Digital Microprocessor Course is reprinted here with the permission of the Electronic Industries Association/Consumer Electronic Group (EIA/CEG). The complete parts kit is available from EIA/CEG. For further information, contact EIA/CEG Product Services Department, 1722 Eye Street, NW, Suite 200, Washington, DC 20006; or call 202/457-4986.

put signal must be between 0 and $+V/4$. If the output of U1 is high, and U2 and U3 are low, then the input must be between $+V/4$ and $+V/2$. If U1 and U2 are high while U3 is low, the input must be between $+V/2$ and $3/4(+V)$. Finally, if all comparator outputs are high, the input signal must be between $3/4(+V)$ and $+V$.

The three comparator's outputs can be fed into a coding network that converts their combined output into a two-bit digital value. The bits of the coding network can then be fed to a register for storage and final output.

In order to gain a clear understanding of simultaneous A/D conversion, let's look at the three-bit converter shown in Fig. 2. Note that seven comparators—allowing the input to be divided into eight ranges—are required to convert the analog input into a 3-bit digital signal. The simultaneous A/D converter is quite straightforward and relatively easy to understand. However, as the number of bits in the digital number increases, the number of comparators

increases very rapidly. Because of that, simultaneous conversion becomes too expensive where larger numbers are involved. So other methods are used for numbers more than three or four bits wide.

The Counter Method. The counter method of A/D conversion uses only one comparator and a variable reference voltage, which is applied to the comparator. Such a converter contains a simple binary counter, from which the digital output values (and the device's

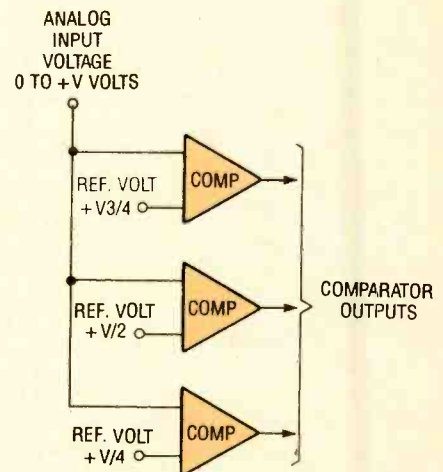

Fig. 1. Simultaneous conversion requires a number of comparators in its design. The analog signal to be digitized serves as one input to each comparator, the other input to each comparator is a standard reference voltage.

*Our gratitude is extended to the EIA/CEG for the creation of this course, especially to the consultants who brought it to fruition: Dr. William Mast, Appalachian State University; Mr. Joseph Sloop, Surry Community College; Dr. Elmer Poe, Eastern Kentucky University.

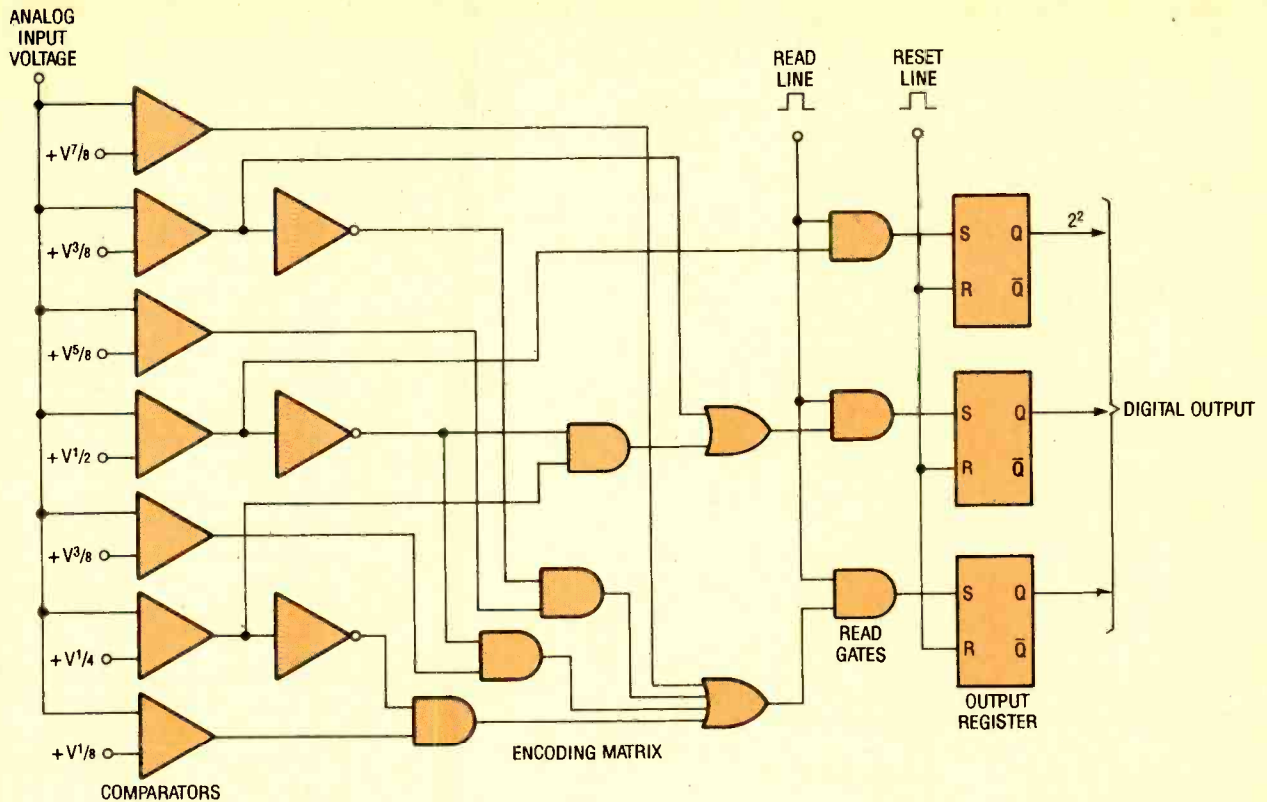

Fig. 2. Seven comparators—allowing the input to be divided into eight ranges—are required to convert an analog input to a 3-bit digital signal.

name) are derived. The counter must be an n -bit counter, where n is the desired number of output bits.

At first, the counter output is not sent to the outside world. Instead, the digits it produces are only available to a D/A converter inside the chip via a series of level amplifiers. That converter is a standard binary ladder (like that described in the D/A Converter exercise last month).

When a clock signal is applied to the counter input, it causes the output of the binary ladder to appear like the staircase waveform shown in Fig. 3A.

That staircase is used as the reference voltage needed for the comparator (see Fig. 3B). When the reference voltage approximately matches the ana-

log input, the comparator signals the control circuitry.

When that happens, the control circuitry pauses the counter by interrupt-

PARTS LIST FOR THE A/D CONVERTER EXERCISE

- U1—ADC0804 8-bit analog-to-digital converter, integrated circuit
- LED1-LED8—Jumbo light-emitting diode
- R1-R8—270-ohm, 1/4-watt, 5% resistor
- R9—10,000-ohm, 1/4-watt, 5% resistor
- R10—100,000-ohm, trimmer potentiometer
- C1—150-pF, ceramic-disc capacitor
- S1—SPST switch
- Breadboard, voltmeter, logic probe, +5-volt power source, wire, etc.

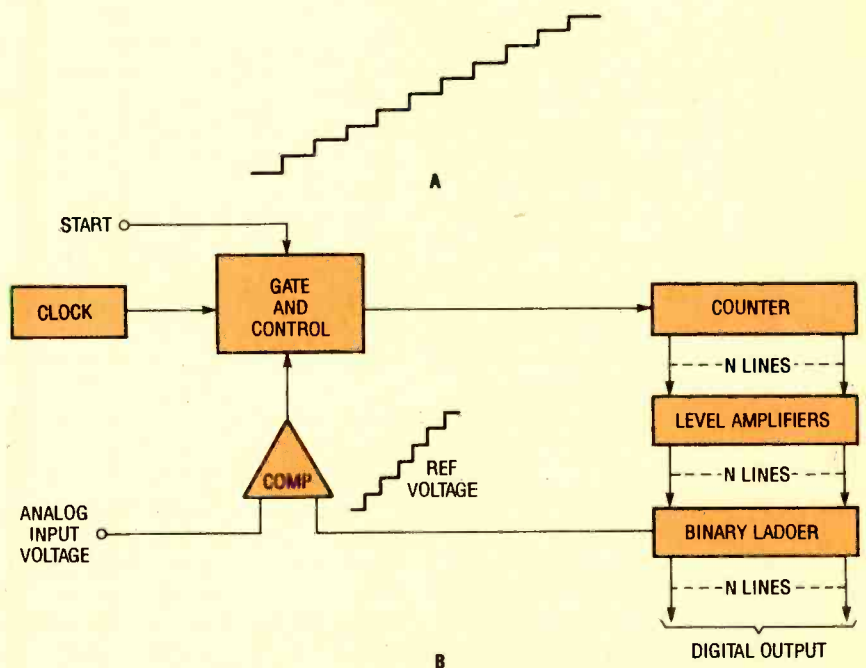

Fig. 3. If a clock signal is applied to the counter input, the output of the binary ladder is the staircase waveform shown in A. The block diagram for a counter-type A/D converter is shown in B.

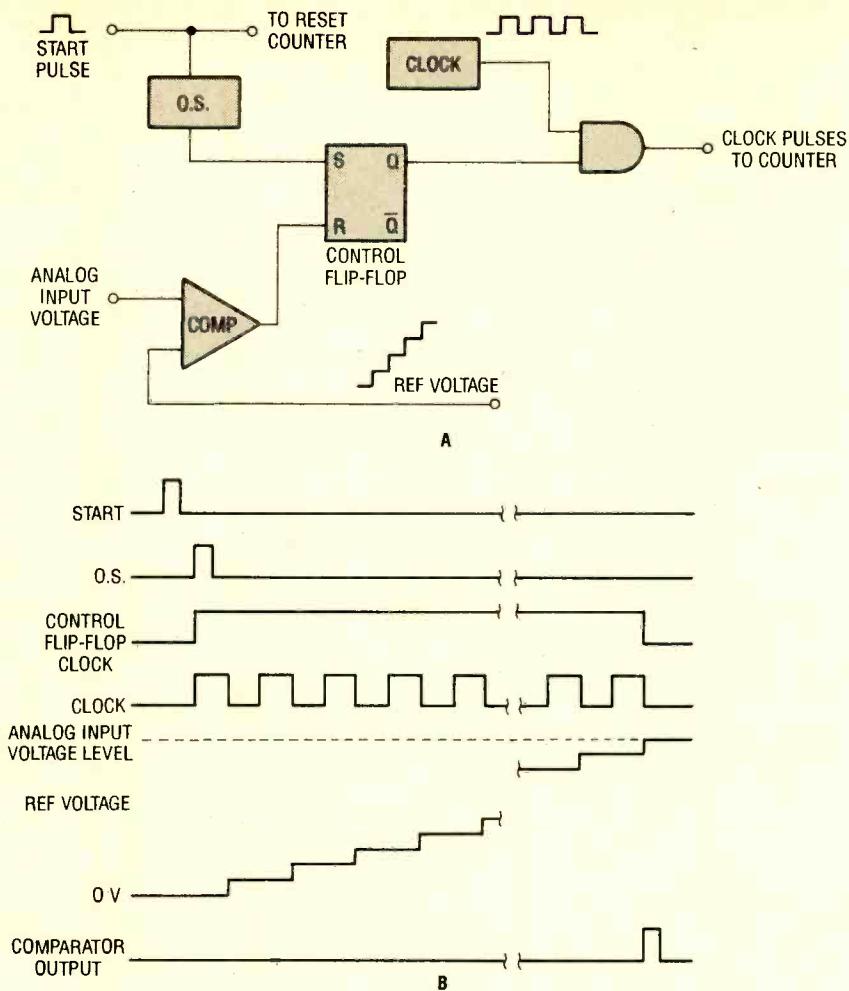

Fig. 4. In A we show a control circuit that could be used with the converter shown in Fig. 3B. The waveforms for one conversion are shown here in B.

ing the clock signal. It then allows the counter's current digital value to appear at the chip's output pins via registers. The control circuit then waits for a start signal to coax it into getting the next value. Upon receiving the start signal, it resets the counter to zero and allows clock pulses to reach the counter.

The circuit can be considered a closed-loop control system: An error signal is generated at the comparator output by taking the difference between the analog input and the feedback signal (the staircase reference voltage).

The error is detected by the control circuit, and the clock advances the counter so that the error signal is reduced by increasing the feedback voltage. When the error is reduced to zero, the feedback voltage is equal to the analog input. At that point, the control circuit stops the counter, and the system stops. Although this type of A/D converter offers high resolution and is much

simpler than the simultaneous method, it requires a longer conversion time. Because the counter advances one count for each cycle of the clock, the clock determines the maximum conversion rate.

Figure 4A shows a portion of the control circuit that can be used in the converter shown in Fig. 3B. The waveforms for one conversion are shown Fig. 4B. The positive edge of the START pulse is used to reset the counter and to trigger the one-shot (denoted O.S.). The one-shot's output sets the control flip-flop, which allows the clock to advance the counter via an AND gate.

A delay between the counter's RESET pulse and the beginning of the clock pulses ensures that all the flip-flops in the counter are reset before the count begins. Once the reference voltage equals the analog input voltage, the comparator output resets the control flip-flop and stops the count.

An obvious method for speeding up the process is to eliminate the need to

reset the counter each time a conversion is made. If that were done, the counter would not begin at zero each time, but instead would begin at the value of the last conversion and attempt to alter its value to match the current signal level. However, that means that the counter would have to be capable of counting either up or down. There is also the need for additional logic circuitry, since we must decide whether to count up or down by examining the output of the comparator.

An A/D converter that uses an up-down counter—called a continuous A/D converter—is shown in Fig. 5A. A waveform typical of that converter is shown in Fig. 5B. There are a variety of other methods for digitizing analog signals—too many to discuss in detail in this article—but let's look at a few.

Other Converter Configurations.

The Successive-Approximation method is the process by which an analog voltage is approximated one bit at a time beginning with the MSB (most-significant bit). Each conversion takes the same time and requires one conversion cycle for each bit. So the total conversion time is equal to the number of bits multiplied by the time required for one conversion cycle (normally one clock cycle).

Another method for reducing the total conversion time of a simple counter converter is to divide the counter into sections—that configuration is called a "section counter." To understand how the total conversion time might be reduced by the section method, assume we have a standard eight-bit counter. If the counter is divided into two equal counters of four bits each, we have a section converter.

The converter sets the section containing the four least-significant bits (or LSBs) to all 1's and then advances the other section until the ladder voltage exceeds the input voltage. At that point, the four LSBs are reset and advance until the ladder voltage equals the input voltage. Such converters are often used in digital voltmeters.

Electromechanical A/D conversion is another very important method; it involves the translation of the angular position of a shaft into digital information. A common application of that technique is in large radar installations, and many other aircraft and aerospace applications, where the azimuth and

(Continued on page 98)

AM-band, VHF, and shortwave receivers in particular often produce audio signals that are a terrible mess of weird squawks, squeals, and other objectionable noises. Today, the growing number of electronic devices is making the cacophony louder and messier than ever before. Fortunately, many of the interference problems that you might experience can be fixed, or at least reduced significantly in severity.

Interference is usually produced by one of two sources: local radio- and TV-station signals and other electronic devices. Signals from AM, FM, and TV stations are quite powerful, and can be troublesome for receiver owners in their immediate vicinity. Unfortunately, in many areas of the country, residences are located quite close to such stations—in a few areas even shortwave stations are located near homes. Let's discuss the problems caused by local transmitters first.

Radio-Station Interference. Typical problems from local transmitters include blanketing, desensitization, harmonic generation, and intermodulation. Let's define each of these in turn.

First we'll deal with blanketing. Blanketing occurs when a very strong local signal completely washes out radio reception all across the band. It generally affects only the band that the signal is found in. The offending signal can either be received throughout the band, or at numerous discrete points.

Another problem is desensitization. Desensitization appears as severely reduced receiver sensitivity due to the presence of a strong local signal. Desensitization can occur across a wide frequency range and is not restricted to a single band. You might not hear the offending signal on your receiver unless it's tuned to the station's frequency.

Yet a third problem is harmonic generation. If the signal is strong enough to drive the RF amplifier of the receiver into nonlinearity, then the receiver may internally generate harmonics of the strong signal. For example, if you live close to a 780-kHz AM broadcast-band signal source, and the receiver overloads from its transmissions, then you might be able to pick up the signal at twice the frequency (1,560-kHz), three

times the frequency (2,340-kHz), and so on up throughout the shortwave bands. Note that the radio station is not generating harmonics (which would violate FCC regulations). The receiver is just responding inappropriately to the received signal.

Last, there's the possibility of intermodulation. This problem occurs when two signals of different frequencies (say, f_1 and f_2) mix together to produce a third frequency (f_3). The two initial frequencies involved might be (and probably are) the assigned fundamental

operating on 21,390 kHz (in the 15-meter band). Both stations are operating normally, but at least one is close enough to overload your receiver and produce nonlinearity in the RF amplifier. When the second harmonic of 10,120 kHz (i.e. 20,240 kHz) mixes with the 21,390-kHz signal, one resulting frequency is:

$$21,390 - 20,240 = 1,150 \text{ kHz}$$

which is right in the middle of the AM-broadcast band.

If there are many signals generated

BY
JOSEPH J. CARR

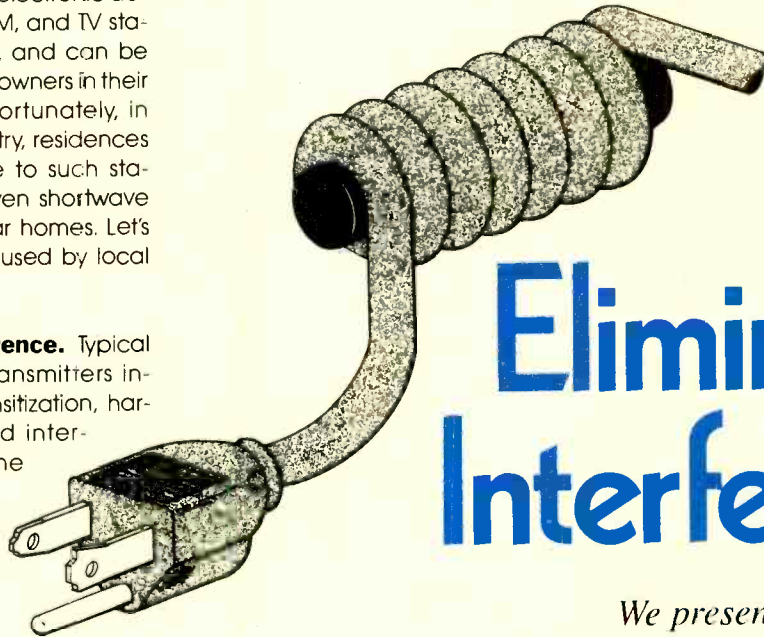

Eliminating Interference

We present a guide to reducing or eliminating interference to any RF receiver.

frequencies of legitimate radio stations, or their harmonics. The third signal is sometimes called a "phantom signal." The frequencies mix due to nonlinearity in some component in the receiver or antenna. The nonlinearity can be due to receiver overload, improper receiver design, or some other source (legend has it that rusted downspouts and corroded antenna connections can act as nonlinear PN junctions). As they say in the new science of Chaos Theory: "...nonlinearity can arise throughout nature in subtle ways."

The possible values for the new frequency can be found from:

$$f_3 = mf_1 \pm nf_2$$

where m and n are integers, although not all possibilities are likely to occur in any given situation. Suppose one local ham is operating on 10,120 kHz (in the new 30-meter band), and another is

in your locality, an extremely large number of possible intermodulation combinations can arise. In my hometown there is a hill, right in the middle of a densely populated residential neighborhood, on which there are two 50-kilowatt FM-broadcast stations; a 5-kilowatt AM-broadcast station; scores of VHF and UHF landmobile-radio base-station or repeater transmitters; and an assortment of paging systems, ham operators, a medical telemetry system, and the microwave towers of an AT&T long-lines relay station—all within a city block or two. Only a few unassisted radio receivers work well in that neighborhood!

There are two approaches to overcoming these problems. First, either reject or somehow selectively attenuate the offending signal (or one of the signals in the case of an intermodulation problem). That is done using a wave-

trap placed between the antenna and the rig. Second, add a passive pre-selector to the front-end of the radio receiver between the antenna line and the antenna input of the receiver.

Wavetraps. Let's discuss three wavetrap circuits that can be used from the AM band up through VHF/UHF frequencies. The circuit in Fig. 1 is an LC wavetrap based on inductors and capacitors. There are two forms of LC resonant circuit shown in Fig. 1. In series with the signal path is a parallel resonant circuit (L2/C2). Such circuits have a very high impedance at the resonant frequency, so they will attenuate signals of that frequency trying to pass through the line between J1 and J2. A pair of series resonant circuits are shunted across the line on both ends of the signal path. Series resonant LC circuits have a low impedance at the resonant frequency, and a high impedance at all other frequencies, so they shunt only the offending signal to ground.

The wavetrap of Fig. 1 can be built using either fixed inductors and variable capacitors, or vice-versa. It can be built either for one fixed frequency, or as a variable wavetrap that can be tuned from a front-panel knob to attenuate the offending signal.

Figure 2 shows the circuit of a similar type of wavetrap, but this one is built with varactor diodes. They are used as variable capacitors because their junction capacitance varies with the applied reverse-bias voltage. Thus the circuit is tuned by properly setting V_T . In the circuit of Fig. 2, only series resonant circuits are used.

Wavetraps built from LC circuit elements are useful well into the VHF re-

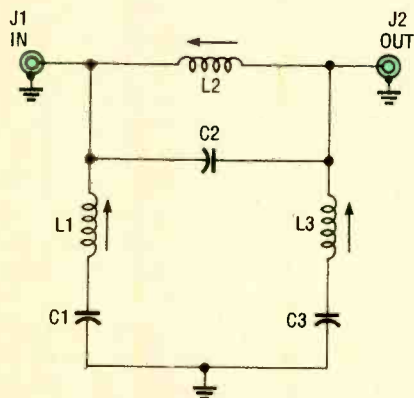

Fig. 1. This is a wavetrap using one series resonant and two parallel resonant tank circuits.

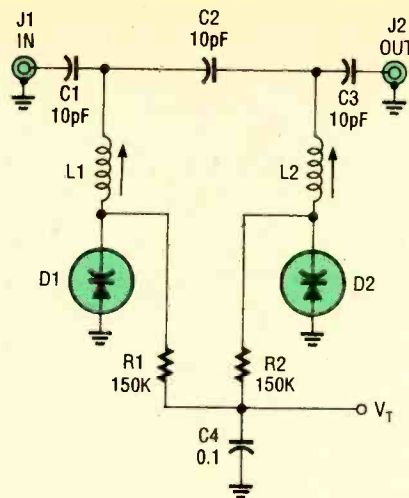

Fig. 2. This voltage-tuned wavetrap takes advantage of the variable junction capacitance of the two varactor diodes.

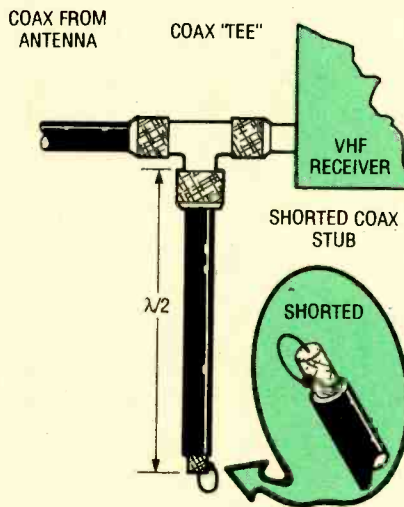

Fig. 3. This half-wavelength shorted-stub form of wavetraps can be used to attenuate a specific frequency. The length of the stub determines the frequency.

gion. In fact, many video and other electronics stores sell wavetraps similar to the one in Fig. 1 that are built especially for the FM-broadcast band (88 to 108 MHz). Those are good sellers because nearby FM-broadcasting stations are frequent sources of interference to VHF television receivers.

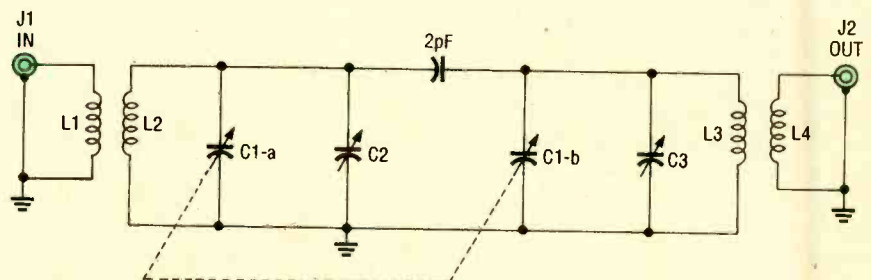

Fig. 4. This passive LC preselector circuit is handy because, unlike wave traps, it is variable.

Another VHF/UHF wavetraps is shown in Fig. 3. That type of wavetraps is called a half-wavelength shorted stub. One of the properties of a transmission line is that it will reflect the load impedance every half wavelength along the line. When the end of the stub is shorted, a "virtual" short-circuit will also appear every half wavelength along the line. The stub length determines the frequency that is shorted. The length of the stub can be found from:

$$L = 492V/f$$

where L is in feet and f is in megahertz. The V term is the velocity factor of the transmission line. For common coaxial lines the value of V ranges from 0.6 (for cable with a polyethylene inner insulation) to 0.82 (for cable with polyfoam insulation).

For example, assume that we need to eliminate the signal from a local FM broadcaster at 88.5 MHz. The shorted stub is made from ordinary coax ($V=0.66$), and must have a length of:

$$(492)(0.66)/88.5 = 3.669 \text{ feet}$$

(or 44-inches).

The half-wavelength shorted stub is connected in parallel with the antenna input on the receiver. In the case shown in Fig. 3, the stub is connected to the receiver and antenna transmission line through a coaxial "tee" connector. Of course, although UHF connectors are shown, the actual connectors that you use must match your receiver and antenna. Also, it is possible to use 300-ohm twinlead for the stub rather than coax, provided it is used as the transmission line as well.

The other approach to solving the problem is to use a passive preselector ahead of the receiver. Again, the pre-selector is inserted directly in the transmission line between the receiver's antenna input and the antenna. Figure 4 shows a typical circuit for this type of preselector. The tuning is controlled by resonant pairs $C1-a/L2$ and $C1-b/L3$,

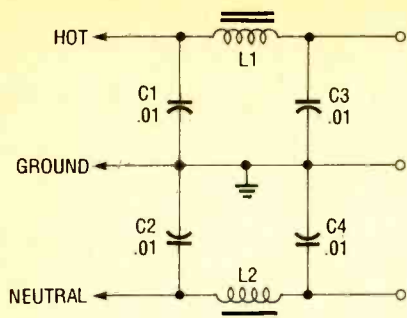

Fig. 5. An LC line-noise EMI filter can effectively prevent noise produced by TV's, VCR's, computers, and other pieces of electronic gear from reaching your household wiring.

which are trimmed by C2 and C3, respectively. The circuit should be built in a closed, shielded metal box.

The Russians, VCR's, and TV's. The world is a terrible place for sensitive radio receivers: a lot of pure crud (in addition to the programming material itself!) comes over the airwaves from a large variety of electronic devices. There are also some renegade transmitters out there. For example, in the HF shortwave spectrum you will occasionally hear a "beka-beka-beka" pulsed signal that seems to hop around quite a bit. It will suddenly appear on your favorite listening frequency, and then go to another. That signal is an "over the horizon backscatter" (OTHB) radar system in the USSR. It is called the "Russian Woodpecker" by North American SWL's and hams. Unfortunately, the very nature of the pulsed signal causes it to spread out over several megahertz—wiping out large segments of the spectrum. That's a problem you can do little about, so let's look at some interfering signals that we can affect.

A lot of homes are equipped with light dimmers. These devices are based on Triacs that cut the AC sinewave off twice per cycle, which produces a harmonic-rich sharp waveform. These devices can cause your receiver to produce a sound similar to "frying eggs" well into the shortwave band.

If you suspect a light dimmer is causing interference confirming your diagnosis is simple: turn off the light. If the noise stops when the light is turned off, then the dimmer is at fault.

Although it is possible to install LC line-noise filters at the dimmer, that approach is not always feasible. It would be better to either remove the dimmer and replace it with an on-off switch, replace the dimmer with a special model that is designed to suppress ra-

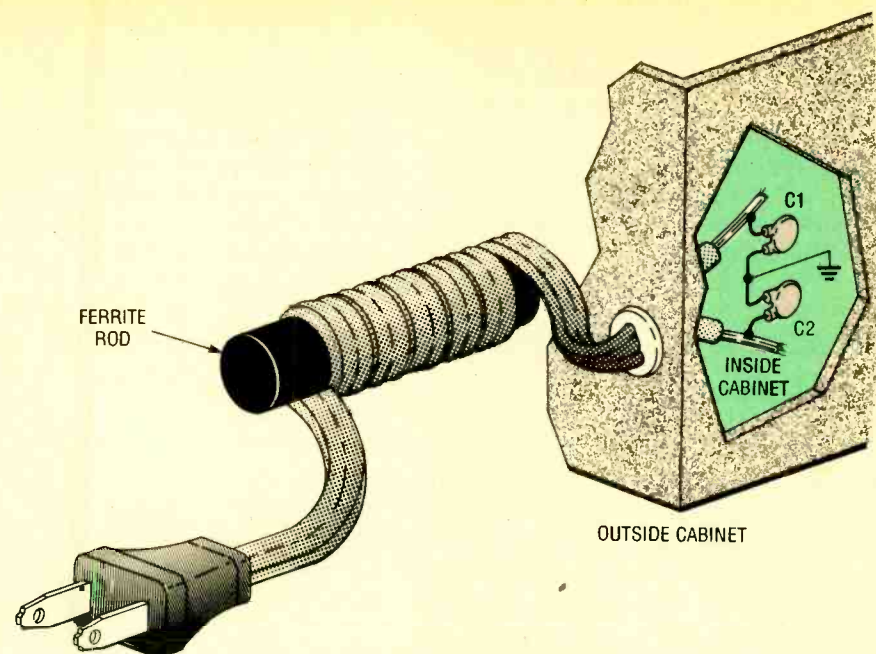

Fig. 6. This ferrite-rod line-cord EMI filter is another effective means of keeping noise from entering your home's wiring.

dio noise, or keep the light turned off when using the receiver.

Another radiation source is the common videotape recorder (or VCR). All VCR's contain a number of radiation-producing circuits, including a 3.58-MHz color-subcarrier oscillator. Don't get me wrong, they are magnificent entertainment products, and I own one, but I also own SW- and ham-radio receivers and can always tell when a popular movie is on TV: Lots of people tape the movie (legalities notwithstanding), so I receive a load of trash at around 3.58-MHz (right in the middle of the 80-meter amateur-radio band) till the movie is over.

Your TV can also be the cause of poor radio reception. A TV set contains at least two major interference producers: a 60-Hz vertical-deflection system and a 15,734-kHz horizontal-deflection system. The horizontal system includes a high-powered amplifier driving a high-voltage "flyback" transformer and a deflection yoke. As you tune up and down the shortwave band, you will hear "little birdies" caused by the horizontal-deflection signal every 15,734-kHz, which are the harmonic signals of the TV's horizontal signal.

One quick solution to interference from VCR's and TV's is a line-noise filter. Those "EMI filters" should be placed in the power line coming from the offending device. They work much of the time because the power line of the VCR or TV acts as the greatest radiator of the interference. The EMI filter should be in-

stalled as close as possible to the body of the offending device.

The filter in Fig. 5 uses LC elements to form a low-pass filter network that is placed in series with the AC power line. Most readers should consider buying a ready-made line filter from a distributor (even Radio Shack offers models suitable for most applications). **Homebrew EMI filters are potentially dangerous if built incorrectly.** If you still want to make your own filter, it should be placed inside a heavy-duty metal cabinet. Also make sure you use capacitors and inductors that are rated for continuous application of AC power.

Another possible solution is the filter shown in Fig. 6, which can be made for any appliance that has ordinary zip lead as the power cord. The wire should be wrapped around a 3/8 to 1/2-inch ferrite rod (Amidon Associates, 12033 Otsego Street, North Hollywood, CA 91607), and then taped to keep it in place. The filter should be mounted as close as possible to the TV or VCR chassis. The optional bypass capacitors (C1 and C2), which are placed inside the equipment cabinet should be .01- μ F, 1600-WVDC ceramic discs.

Many communities today are wired for cable-TV. Cable systems transmit a large number of TV, FM-broadcast, and special-service signals along coaxial-transmission lines. They operate on frequencies of 54-MHz to 300-MHz in 36-channel systems and 54-MHz to 440-MHz in 55-channel systems. Whenever
(Continued on page 101)

Are you having this problem: You have two IBM PC's or compatibles. Machine A has one or two 5.25-inch drives, and machine B has one or two 3.5-inch drives? You might even have a hard-disk drive on one or both. You can get all kinds of software on 5.25-inch floppy disks for use on ma-

Many articles have been written about adding drives, so I won't cover that topic here.

Second, you could get a friend with both size drives in the same machine to make 3.5-inch copies of your 5.25-inch diskettes, or vice versa. You must be sure the target format is readable in your

in about 50 feet of each other, you could use another method, which is none of those things: simply wire the two computers directly together and use a high-speed transfer program on each machine. That requires the proper cable and dedicated software. This article will describe how to do that, and

If you have a couple of computers at home you can connect them to form a more powerful workstation. Read how to inexpensively break down the walls between them so they can communicate and share files.

BY FRED BLECHMAN



The Cheap-Link File-Transfer System

chine A, but you can't move it into machine B. Perhaps machine B is a laptop, and you've saved some work on a 3.5-inch disk or the hard drive, and you'd like to transport the work into machine A. You can try to put the two machines as close to each other as possible, but osmosis won't work.

You have at least four alternatives: You could add a disk drive to one machine. That is expensive (about \$150 for an external drive, power supply, and perhaps a new controller board and cables). Further, you'll find yourself stepping gingerly through a minefield of compatibility problems (switch settings, software drivers, cables, etc.) However, if you already own the hardware and know what you're doing, that might be the most "convenient" arrangement.

machine: A 1.44MB 3.5-inch micro-diskette can not be read by a 3.5-inch 720K drive, and a 1.2MB 5.25-inch diskette can not be read by a 360K 5.25-inch drive. This method requires a friend with the right equipment, who is also willing to give you his time and effort. A local computer store might offer you the courtesy of using its equipment to make disk conversions.

Third, you could transfer files between computers with two modems, two phone lines, and a communication program on each machine. That is slow and cumbersome, but about the only practical method if the two machines are not near each other.

Those three methods are either expensive, clumsy, slow, or all of the above. But if the two machines are with-

how it can be done for only \$25-\$40.

Expensive Link. There are several commercial packages available to implement the last method. They provide special cables and software, and run in the \$100-\$150 range.

LapLink III (Traveling Software, 18702 North Creek Parkway, Bothell, WA 98011; Tel. 206-483-8088. Suggested list price: \$149.95) consists of a six-headed cable and special software. Each end of the cable has three connectors: one to mate with a DB-25 (25-pin) serial port, one for a DB-9 (9-pin) serial port, and one for a Centronics-type 36-pin parallel port. I haven't personally used it, but all the reports I've read have been very positive. If you are willing to spend the money, LapLink III is certainly an option.

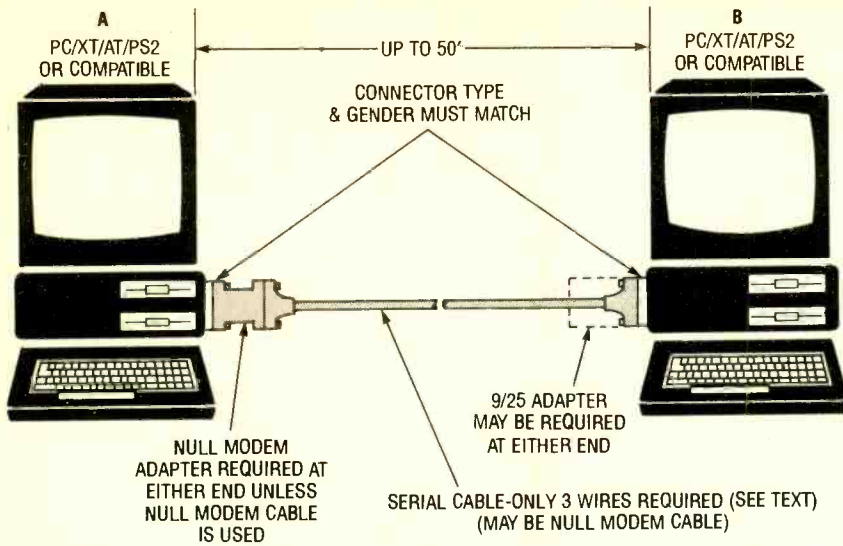

Fig. 1. To connect a couple of computers you can use a null-modem cable or a null-modem adapter with a null-modem cable. By selecting the hardware wisely you can connect DB-25 equipment to DB-9 equipment.

Fastlynx (Rupp Corporation, 835 Madison Ave., New York, NY 10021; Tel. 212-517-7775. Suggested list price: \$149.95) is another option. Two cables are provided. One cable has the DB-9 and DB-25 serial connectors on each end; the other cable has Centronics parallel connectors on each end. The serial cable and special software provided can transfer at 200,000 bits per second (bps), while the parallel transfer can handle a blazing 500,000 bps. If a character, with error checking, uses about ten bits, then 500,000 bps is about 50,000 characters per second! (Note: The term "baud" is frequently used in place of "bits per second." While not identical, the differences are not significant for this application.)

There are others (Brooklyn Bridge and PC Link are two names that come to mind) that provide cables and software to allow you to tie two IBM PC-compatible machines together to transfer files. Most offer features in addition to file transfer, such as reading directories and basic DOS functions. They work fine, but may provide far more than you need. The cables are intended to mate with most common connectors. Since you only have a specific set of connectors, you don't need most of the cabling. The manufacturers, because of competition, add more and more features (and confusion) to their products.

Don't get me wrong; if you have a requirement to transfer many large files very often, the software provided with these packages is powerful. However, if

your needs are modest, you may be paying for overkill.

Cheap Link. Over the years I've dealt with over a dozen different microcomputers, and have transferred programs and files between them in various ways. Trust me—it can either be easy, or a nightmare. I think I've come up with the ideal combination of hardware and software that will let you transfer files between PC compatibles at 115,200 bps, without problems, and it won't devastate your budget.

You will primarily be dealing in two areas: hardware and software. The hardware is the biggest potential problem, but I've reduced that down to some relatively simple instructions for you to follow. The software could be a problem, but not if you use the program I recommend.

Hardware. The first step to linking com-

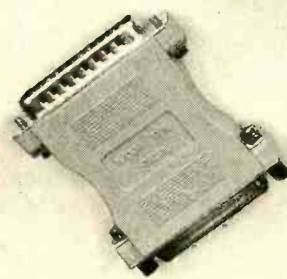

A null modem adapter is easy to use. Just put it in the signal path and it's ready to go.

puters is to look at the rear of your two computers. They must each have a serial port (usually referred to as "RS-232" or "RS-232C") and the ports must both be IBM PC-compatible serial ports.

Incompatibility may not be physically obvious, since serial (and parallel) ports on many different types of computers use a similar connector. For example, the DB-25 connectors on a TRS-80 Model I, III, 4, 4P, or 4D are not IBM compatible. The Sanyo MBC-55X also uses a DB-25 connector for its serial port, and although it is an MS-DOS machine, the serial port is not IBM PC-compatible.

Generally speaking, determining if your serial port is IBM PC compatible is not difficult. If your computer runs most IBM PC programs, it probably has a serial port, and it should work fine with Cheap Link.

Second, you should determine the type of connectors you will need. Typically, the PC serial-port connector is a 25-pin DB-25 or a 9-pin DB-9. Furthermore, it is usually the male gender—it has pins rather than holes. The holes are considered "sockets" in this context. Usually these connectors are referred to as DB-25P and DB-9P (the "P" stands for "pin"). The mating connectors are DB-25S and DB-9S (the "S" stands for "socket"), respectively.

You can get those connectors already attached to cable. Such cabled connectors often have the suffix of "M" for "male" and "F" for "female." There does not seem to be a hard and fast rule for using F and M rather than S and P, so be familiar with all these suffixes.

One last thing to consider is the wiring of the cable. In this respect there are two basic kinds of cable: straight-through and null-modem. A straight-through cable connects the pins or sockets on one end to the same pins and sockets on the other end. A null-modem cable swaps some of the wires around.

You do need to interchange some of the wires to connect two computers together, so a null-modem cable is called for. However, the wire swapping can take place inside a small box called a "null-modem adapter" placed in line with a straight-through cable.

Null-modem adapters are useful because they not only switch wires around, but they can alter connector type (and sometimes gender) as well (see Fig. 1). They allow you to use cheap (\$5 to \$10) straight-through cable sporting either DB-9 or DB25 connectors and both ends. Less common, but available,

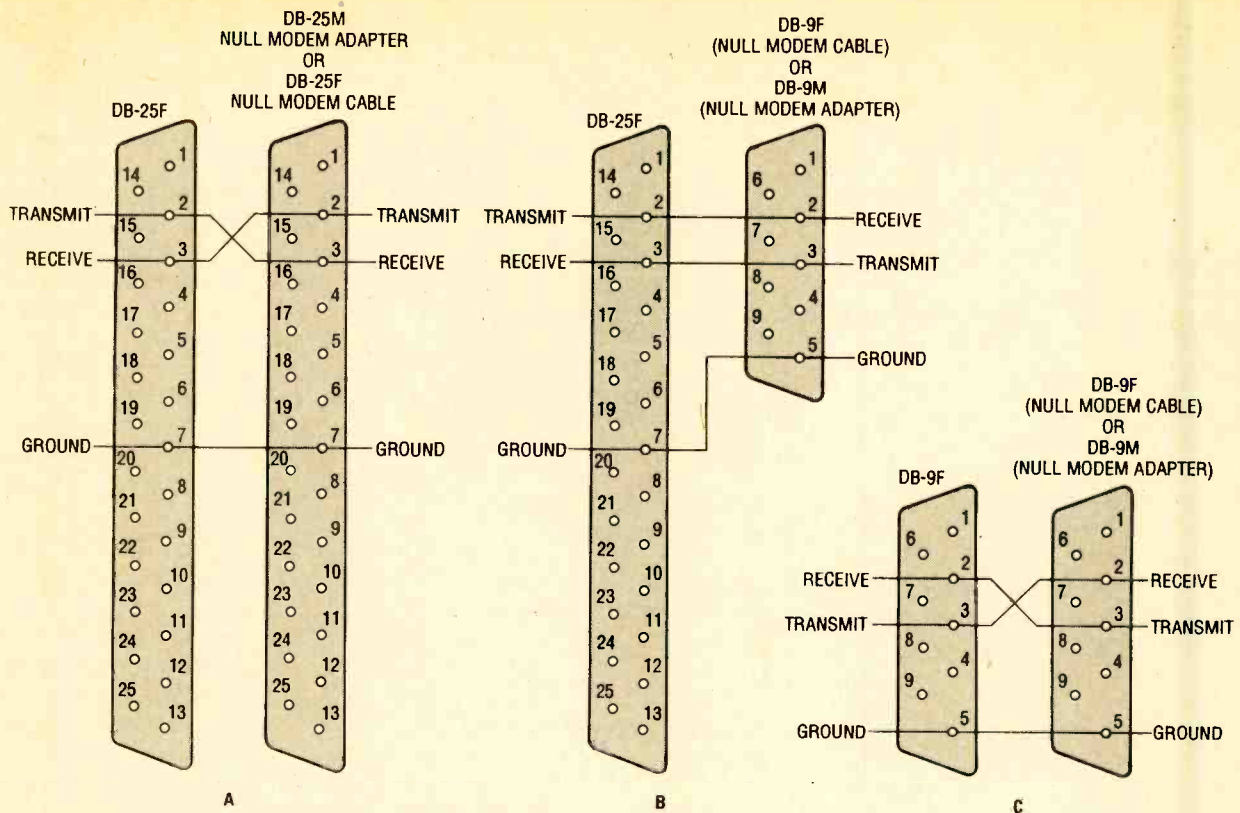

Fig. 2. Switching pins 2 and 3 on a DB-25 straight-through cable (A) turns it into a simplified null-modem cable. On a DB-25 to DB-9 adapter/null-modem cables (B) the connections don't need to be swapped. However, they do for a DB-9 to DB-9 hook up.

is a straight-through cable with a DB-25F on one end, and a DB-9F on the other end. Obviously, only nine wires are connected and a null-modem adapter is still required.

At this point it's a good idea to discuss the wires required by Cheap Link. Without getting into the details of how an RS-232 interface works, there are many wires normally used for data transmission and control. However, Cheap Link uses only three wires: "transmit," "receive," and "ground."

The trick to wiring a null-modem cable or adapter is to know which pin is for transmitting, which is for receiving, and which one is ground. When a DB-25 connector (regardless of gender) is used, the standard convention is to use pin 2 to transmit data, pin 3 to receive data, and pin 7 as the signal ground. With a DB-9 (again ignoring gender), pin 2 is receive, pin 3 is transmit, and pin 5 is ground. Don't ask me why they both don't use the same pin designations—they easily could have, but they don't!

Regardless of both gender and the number of pins, the transmit pin from one computer must be connected to the receive pin of the other computer, and vice versa. If you don't swap the

transmit and receive connections, both computers will try using the same wire to transmit data, and they both will try to receive from the same wire. If you stop to think about it, that can't possibly work. That's where a null-modem adapter or cable comes in—it swaps the wires so the transmissions of one computer are received by the other, and vice versa.

Normally, a null-modem adapter has a male connector at one end and a female at the other, so gender is not effected, and it is bi-directional. If you buy a null-modem adapter, just stick it in line with the serial cable and that takes care of your hardware.

DB-25 null-modem adapters are very common, and sell for \$2-\$7. You may have difficulty finding a DB-9 null-modem adapter. If this is the case, get one or two DB-9/DB-25 cables as needed and a DB-25 null-modem adapter.

You can save almost the entire cost of cables and adapters by making your own custom cable that does two things: mates with the serial connectors for machines A and B, and uses three wires to carry transmit, receive and ground in the null-modem configuration. Figures 2A, 2B, and 2C show you the typical

configurations. Note that the connector on one end is male or female, depending on whether you are making a null-modem cable or a gender-preserving adapter.

Incidentally, you can buy so-called null-modem cables, but be careful! In my experience, since they look exactly like regular cables, they may be mislabelled and not actually swap the transmit and receive wires (as well as various other differences provided by some null-modem hardware). My suggestion, if you don't make your own cables, is to use a straight-through cable and a null-modem adapter, or check the connector-to-connector pin wiring with an ohmmeter before buying a so-called null-modem cable.

Sometimes, especially on laptops and portables, space considerations have forced the manufacturer to use a special socket. If this is the case, you may have to obtain the mating connector from the manufacturer, or use a cable they supply.

Cheap Software. In researching this article, I tried at least a dozen different programs to transfer files. Some were
(Continued on page 102)



THE HEATHKIT MOST ACCURATE CLOCK



CIRCLE 119 ON FREE INFORMATION CARD

Most clocks are fairly accurate, but when you need to know the correct time to within a few milliseconds, then the Heathkit Most Accurate Clock is for you.

The concept of time has been around for thousands of years. The sun was probably what started it all. People noticed that the sun was not in view all of the time, and that's what gave us night and day. They also knew that the sun's position changed throughout the day.

Since then, man has continually found new ways to increase the precision of timekeeping—from sundials, to hourglasses, to mechanical clocks, to quartz crystals. As technology advances, so does the need for precise timekeeping. As an example, it would be impossible to run a computer on a wind-up mechanical clock; you couldn't possibly derive accurate microsecond pulses from such a timepiece, let alone even smaller increments.

So what's more accurate than a quartz crystal? The answer is an atomic clock or, to be more precise, an atomic oscillator. The only problem is that you could never afford one, let alone get your hands on one. You're probably wondering why anyone would need such an accurate clock. Some potential uses are for satellite navigation; certain ham-radio applications; and services that inform the government, the military, and the public of the correct time. It's also good for all of the major information services to be synchronized with each other.

Closely related to time is frequency. Frequency is the number of oscillations that take place over a certain period of time. An accurate frequency is always needed to calibrate instruments that are used to measure frequency. Even accurate frequency sources drift over time, and that's why they need calibrating in the first place. So, an extremely accurate frequency is needed for calibration purposes. What would be the sense of calibrating a frequency counter against an inaccurate source?

The Next Best Thing. If you happen to require such accurate timekeeping or a calibration frequency, yet can't get your hands on an atomic clock, you can get help from the National Bureau of Standards (NBS). They maintain all standards of physical measurement, including length, mass, time, and temperature. With regard to measuring time, they do have an atomic clock. The NBS broadcasts the time of day along with various other messages from their two shortwave radio stations: WWV in Colorado and WWVH in Hawaii. Both stations broadcast 24 hours a day on 5, 10, and 15 MHz.

The one problem with most clocks is that you can't accurately set the time by ear. And that's where the Heathkit Most Accurate Clock comes into play. Along with voice announcements, WWV and WWVH send out a time code

on a 100-Hz subcarrier that is made up of BCD (binary-coded decimal) pulses. The Most Accurate Clock (available as a kit or an assembled unit) contains circuitry that deciphers the time code and automatically sets itself to the NBS time—you never have to set the time. When locked onto WWV, the clock is accurate to 10 milliseconds or better. (For the sake of discussion, when we refer to WWV, we are referring to either WWV or WWVH, depending on which of the two shortwave stations you can receive better.)

Maintaining Accuracy.

To keep the display as accurate as possible, the clock must receive the time code as often as possible. For times when reception may be poor, the clock contains its own internal crystal-controlled oscillator that is under microprocessor control. However, the microprocessor not only maintains accuracy during periods of bad radio reception, but it also trims the speed of the internal oscillator according to how the clock's time has drifted as compared to the NBS signal. Therefore, both the clock speed and a 3.6-MHz reference output (available from a BNC connector on the back panel) become more and more accurate each time a valid time code is received. If the clock is not updated each day, the tenths-of-a-second digit will dim.

The accuracy of the clock oscillator is approximately ± 10 -parts-per-million (ppm). That improves after warm-up and after the clock has been updated by WWV for several days. The oscillator may fluctuate slightly during extreme temperature variations.

It's possible that some of the code bits may be lost due to a fading signal, so the clock is designed to detect errors in the code. It does that in the following manner: One "frame" of data is decoded and stored in memory. The next frame is stored and compared with the first one. If the two don't differ by exactly one minute, then the first frame is discarded and the process repeats itself until three successful decodes have been made. The clock will then correct its time and trim the internal oscillator.

To enhance the reception of the WWV signal, the receiver circuit can choose from the 5-, 10-, and 15-MHz carrier frequencies. The microprocessor scans each band to determine which has the strongest signal. The clock will then try to lock onto that signal.

Features. Not only does the clock display the time to tenths of a second, it also contains a built-in speaker so you can listen to the audio portion of the signal—WWV has a male voice announcement, and WWVH a female. As mentioned, an extremely accurate 3.6-MHz reference-frequency output is available from a BNC connector at the rear of the cabinet.

DIP switches on the bottom of the cabinet allow you to adjust the clock for many variables. You can select from 24 time zones, lock out any channels that don't come in well, correct for propagation delay of the WWV signal, automatically correct for daylight saving time, switch between a 12- or 24-hour display, and display the Universal Coor-

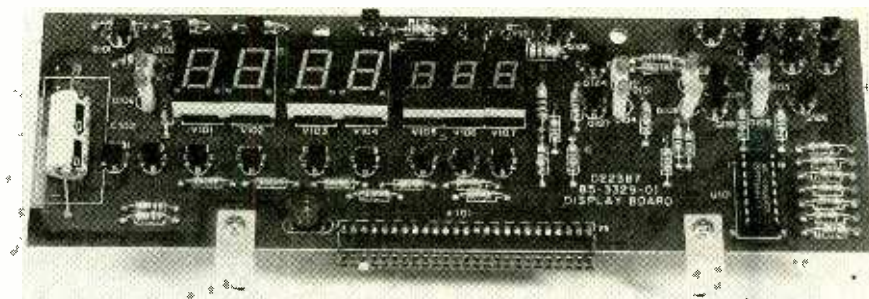

The display board is the Most Accurate Clock's human interface.

minated Time (UTC, originally Greenwich Mean Time, GMT).

You can also set the clock to display "UTC 1" time. UTC 1 time (the true navigator's scale related to the Earth's angular position) compensates for the fact that the Earth has a slight wobble on its axis and that its rotation around the sun is not perfectly circular. To overcome the slight inaccuracy produced by those factors, UTC 1 time data contains extra 0.1-second increments up to ± 0.7 second. When the UTC 1 correction approaches 0.7 second from UTC time, the NBS will issue a leap second to compensate for the difference. Leap seconds are usually scheduled to occur on June 30th or December 31st.

The clock can communicate the time to computers via the GCA-1000 RS-232C Output Accessory. It is available as a separate parts pack if you are building the unit, but is included in the pre-assembled unit. Time and date data is transmitted to a computer through an RS-232C interface in ASCII format. The RS-232 output features selectable baud rate, stop bit, and year information. There is an automatic mode that will transmit data to the computer continuously and a normal mode that requires a signal from the computer before data is transmitted. The year data is set by a DIP switch on the accessory, and must be changed each year. An interfacing software package is also available.

On the left side of the clock cabinet is a switch that allows you to turn the 7-digit display on and off. That feature can conserve a lot of power, and comes in handy if you are powering the clock from a 12-volt battery; it can also be powered from 117/220 VAC. When the 12-hour mode is selected, the appropriate AM/PM LED indicator will light. Those indicators are off when the clock is in the 24-hour mode.

When the clock is initially powered up, the 7-digit display is blank. The digits stay off until the clock is set by WWV signals. Three LED's on the front panel are used to indicate which WWV channel (5-, 10-, or 15-MHz) the receiver is tuned to. Initially, each LED lights for approximately 3 seconds while the receiver scans to determine which channel has the best signal. When the receiver determines which channel has the best signal, it locks onto that signal for approximately 16 seconds. The appropriate LED will then stay lit indicating the current channel.

Once WWV is received, the Data LED flashes once every second, except for the first second of each minute. Each flash varies in duration from short, to medium, to long. The flash of the LED lags the seconds update by 0.2 seconds.

Whenever the receiver detects a WWV 1000-Hz tone burst, the Capture LED lights. If the microprocessor determines that the WWV information is in-

Prices

- GC-1000-H Most Accurate Clock kit—\$249.95
- GCW-1000-H Assembled unit (includes RS-232 interface accessory)—\$380.00
- GCA-1000-1 RS-232 Interface Accessory—\$49.95
- GCA-1000-3 Heath/Zenith Interfacing Software—\$49.95
- GCA-1000-4 Technical Manual—\$24.95
- GCA-1000-5 Tuned Dipole Outdoor Antenna—\$99.95
- GCS-1000-1 Combination (includes GC-1000-H kit and GCA-1000-4 manual)—\$259.95

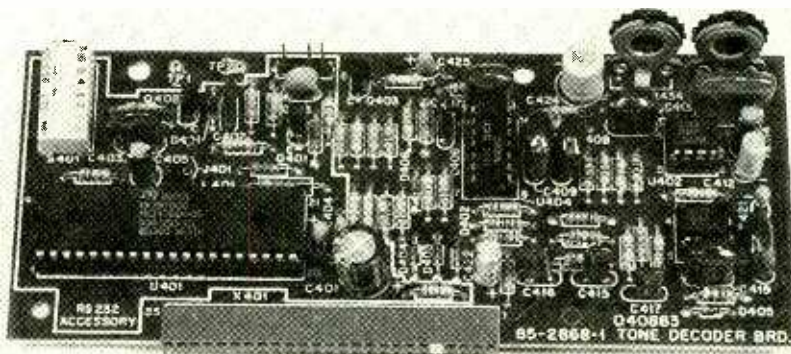

The tone-decoder board also houses the RS-232 interface circuitry.

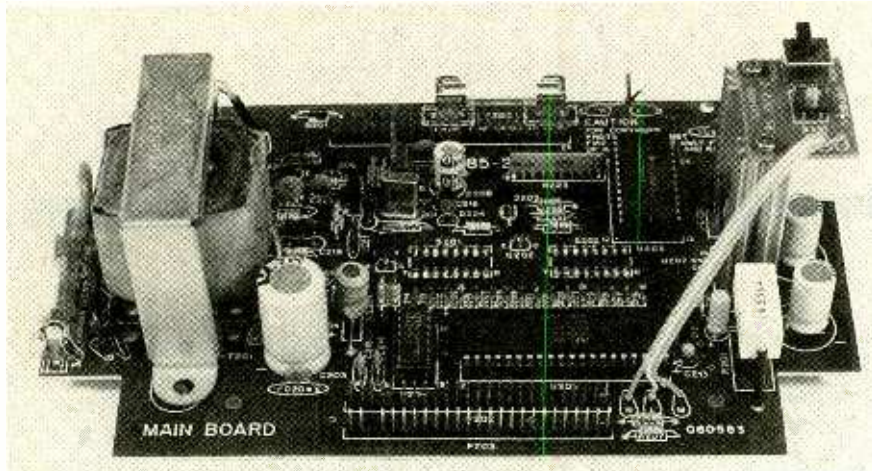

The main board is used to interconnect all of the other boards.

valid, the Capture LED is turned off. The receiver then proceeds to look for the strongest channel again.

A Hi-Spec LED lights for about 10 minutes each time the clock is updated. When the Hi-Spec LED is lit, the accuracy of the clock is within 10 milliseconds of WWV time.

The clock features a female BNC connector for an external antenna in case the built-in telescoping antenna is inadequate. Heathkit sells a highly-suitable tuned-dipole outdoor antenna as an accessory for the Most Accurate Clock.

A volume control for the internal speaker is provided, and the audio can also be shut off completely. There are two modes of volume operation: automatic and normal. In the automatic mode, the microprocessor turns the audio on only when the Hi-Spec LED is on. In the normal mode, the automatic control of the audio is defeated. You can vary the volume level in both modes.

Building the Kit. You now know about all of the clock's features, especially if you intend to buy an assembled unit. So let's talk about building the unit from a kit.

Most people build kits because they enjoy it and it also gives them something to do. In that respect, the GC-1000-H really delivers. Literally hundreds of parts must be installed on the boards which, by the way, are double-sided, plated-through, silkscreened, and generally of excellent quality—as are all of the parts. The unit contains three boards that connect to a main or “motherboard,” much like an IBM PC or clone. They are a display board, a receiver board, and a tone-decoder board. The RS-232 Interface Accessory is a separate package of parts that

mount on the tone-decoder board.

The one major problem in building kits is that you can wind up with an expensive disaster. However, Heathkit sees to it that there's virtually no chance of having any problems with the assembly. For example, the receiver board is extremely intricate, and would require extensive alignment procedures. Therefore, the receiver board is supplied completely assembled, tested, and aligned to save you the trouble.

Another good disaster-prevention measure is the excellent documentation provided in the assembly manual. It covers the assembly, testing, and calibration of the unit, in addition to all of the technical aspects of the clock. It's clear that the instructions were thoroughly gone over before printing; there are no contradictions or ambiguities. For those who wish even further documentation, a technical manual is available that includes expanded circuit descriptions, schematics, disassembly and alignment procedures, and IC data charts.

The kit comes with exactly the number of parts you need, and all parts for a given step are packaged together. That serves as a good safety check; you shouldn't have any parts left over after a particular step, and the last part installed should match its description in the text. If that's not so, then you did something wrong.

During the assembly procedure, certain steps should be followed to choose between receiving either WWV in Colorado or WWVH in Hawaii, and to select between 117- or 220-VAC operation. Being in New York, the unit we built was set up for WWV reception, set for approximately a 2000-mile propagation delay, and for 117-VAC operation.

After everything is assembled and vi-

sually checked, the boards can be quickly connected together. A few ohmmeter checks must be made, and then it's on to the testing and calibration procedures. Testing involves putting the unit in the “test” mode, where all display digits and LED indicators are checked. The testing of our unit went smoothly, and took all of about three minutes. Calibrating the unit involves setting only two potentiometers, and no test instruments are required.

If everything has gone well, the clock is ready to roll. All that is required before plugging it in is to set the DIP switches according to your particular time zone and preference of 12- or 24-hour format, daylight saving time, etc.

The Moment of Truth. The manual says that, after being plugged in, the clock should *typically* take from 4 to 30 minutes to set itself, and that the display will be blank until it is set. I was quite nervous, as the display was blank for about 45 minutes. I thought that perhaps the external antenna was going to be needed. Then, all of a sudden, the correct time was shown on the display.

The unit works exactly as advertised. It will scan each band until data is detected, as indicated by the Data LED. If the clock is receiving data, the Capture LED soon lights. If the Capture LED stays on long enough, the clock resets itself and the Hi-Spec LED lights for about 10 minutes. The only problem is that you will never see the display adjust itself, as the adjustments are made in increments that are too short for the eye to detect—but as long as the Hi Spec LED is lit, you can rest assured that the time is accurate to within 10 milliseconds. As proof of its accuracy, a quartz watch drifted nearly 10 seconds from the Most Accurate Clock in one week.

Using the built-in antenna, the clock has a tendency to reset itself several times in the morning and in the evening, with an occasional reset here and there. However, there's generally not much activity during the daytime. The audio portion of the WWV signal is audible most of the time. Although it is not absolutely necessary, the external antenna greatly improves WWV reception; it is needed only when the clock does not reset itself at least once a day.

Pricing for the Most Accurate Clock can be found elsewhere in this article. For more information contact Heathkit (Heath Company, Benton Harbor, MI 49022) directly or circle no. 119 on the free information card. ■

PRODUCT TEST REPORTS

By Len Feldman

Pioneer CLD-1080 Laserdisc/CD Player

Videodiscs are finally becoming popular with American consumers. After years of confusion, multiple formats, and a shortage of desirable software, the laser videodisc is coming into its own. Chief among the proponents who steadfastly refused to count the laser videodisc out—even when sales were minimal—is Pioneer Electronics (USA) Inc. (2265 E. 220th St., P.O. Box 1720, Long Beach, CA 90801-1720). Their latest videodisc player reflects the many years of

desired order. Multi-speed playback (of CAV, or constant angular-velocity discs) is also possible in either the forward or reverse direction, at up to nine speeds. Still-frame playback and frame advance or reverse are also available. Six repeat-play modes are also available: memory repeat, one-chapter repeat, one-side repeat, section repeat, program repeat, and, for discs that incorporate a table of contents (TOC), random repeat. For discs containing a TOC, the player can automatically select and program chapters that can be played within a specified time—a useful feature when dubbing to tape.

Similarly, when playing a digital-audio CD, up to 24 tracks can be selected and played in any order. All tracks on a disc can be played in random order.

The six repeat-play modes available for CD's include memory repeat, one-track repeat, all-tracks repeat, section repeat, program repeat, and random repeat. As for laserdiscs, for CD playback an auto program-editing feature selects and programs tracks that can be played back within a specified time—useful when dubbing audio programs to an analog or digital-audio tape (DAT) deck.

Other features of this player include a "last memory" function, automatic disc discrimination, and compatibility with all types and sizes of laser videodiscs and digital-audio CD's, including 12- and 8-inch

laserdiscs, 5-inch CD's and CDV's and 3-inch CD's. (CDV discs contain 5 minutes of video with audio, followed by 20 minutes of digital audio-only programming.)

CONTROLS

Most of the features associated with this multi-format disc player are accessible either by means of the supplied infrared remote-control unit or at the front panel of the player itself. The front panel is equipped with a power switch at the extreme left; adjacent to that switch are a stereo-headphone jack and its level control. The disc tray and access door occupy much of the upper section of the panel, while further to the right are an open/close button, a stop button, and a play/pause button.

Below those basic controls are forward- and reverse-scan buttons, forward- and reverse-skip buttons (for skipping chapters or tracks of a disc in either direction), a random-play button, and an intro-scan button (that, when pressed, causes the player to play the first 8 seconds of each chapter or track of a disc). An edit button initiates the program-edit feature discussed earlier. That feature selects chapters or tracks so that their total playing time becomes the time specified using numbered buttons located nearby; those are the same numbered buttons that are used for random track or chapter programming of the player.



Pioneer's CLD-1080 Combination Laserdisc/CD player

experience that the company has had in this product category.

To begin with, if you still haven't purchased a compact-disc (CD) player and are also interested in playing back laser videodiscs on your TV set, you're in luck. The CLD-1080 plays both CD's and laserdiscs. That makes a great deal of sense, for while the electronics needed to decode digital-audio data and analog video signals differs, the optical system needed for both formats is essentially the same.

The unit's videodisc functions include the ability to select any of up to 24 "chapters" from a disc and to play them back in any

When the player is used with a TV to play videodiscs, a display button can be used to bring up a variety of information on the TV's screen. That information includes elapsed time from the beginning of the disc, remaining total time, remaining track time, elapsed time of the track, and total time of the disc. Another small pushbutton switches between disc play and VHF TV when the player is connected to the TV via the set's VHF-antenna input. However, best picture reproduction is of course obtained via the set's audio/video inputs, if available.

A display area on the front panel provides a wide variety of information concerning the status of the player. That information includes track or chapter numbers, frame number or time, remaining or total time, section-repeat indication, edit-feature indication, program-play indication, random-play indication, CX (noise-reduction) indication (when such noise-reduction is present on a videodisc), pause or play indications, and digital-sound indication (when the audio portion of a videodisc is available in digital format).

The hand-held infrared remote-control unit supplied with the CLD-1080 duplicates just about all of the control functions found on the front panel. There are even power-on/off and eject buttons on the remote so that the unit can be turned on and off without having to get up from your viewing or listening chair! Of course, you would still have to move up to the player to change, insert, or remove CD's or videodiscs.

The rear panel of the player is equipped with two sets of stereo-audio and video output jacks. That arrangement would permit you to connect audio and

TEST RESULTS—PIONEER CLD-1080 LASERDISC/CD PLAYER

Specification	APEL Measured
Video Section	
Frequency response	
At 0.5 MHz	-0.78 dB
At 2.0 MHz	-1.20 dB
At 3.58 MHz	-0.98 dB
At 4.2 MHz	-0.98 dB
Video S/N ratio (chroma AM, PM, Lum.)	43.2 dB, 35.3 dB, 44.6 dB
Max. deviation, stairstep linearity	-3%
Analog Audio Section	
Output level, 1 kHz (CX on/off)	1.46/0.52 volts
THD @ 75% modulation (CX on/off)	0.75%/0.65%
Signal-to-noise ratio (CX on/off)	81.8/59.2 dB
Digital Audio Section	
Output level (1 kHz)	2.02 volts
S/N (de-emphasis in/out)	107.1/106.6 dB
Separation, 1 kHz (left/right)	108.7/107.2 dB
THD @ 0 dB (20 Hz, 1 kHz, 10 kHz)	0.003/0.0027/0.0065%
Linearity error (0 dB to -50 dB)	-0.04 dB
Frequency response (20 Hz to 20 kHz)	+0.01 dB to -0.33 dB
Compact Disc Section	
Output level (1 kHz)	2.015 volts
S/N ratio	107.3 dB
Separation, 1 kHz (left/right)	112.2/106.4 dB
THD (17 Hz, 1 kHz, 10 kHz)	0.003/0.0027/0.0066%
Linearity error (0 dB to -50 dB)	0.01 dB
Frequency response (17 Hz to 20 kHz)	+0.01, -0.32 dB
Additional Data	
Power requirements	28 watts
Random access time (Ch. 1 to Ch. 47)	4.2 seconds
Scan time (Ch. 1 to Ch. 2)	1.0 second
Dimensions (H x W x D, inches)	4¾ x 16½ x 16¼
Weight	16¾ lbs.
Suggested price:	\$600.00.

video signals to your TV monitor as well as to a separate audio or audio/video integrated amplifier or receiver. The unit also offers the standard coaxial VHF-TV input and output jacks and a slide switch that lets you select either a Channel-3 or -4 output. A CD-deck synchro jack on the rear of the panel is intended for use when synchronizing recording between the player and certain compatible Pioneer audio-cassette decks. Overall system control can also be performed (via another output-jack connection) when this player is combined with an optional Audio/Video Control Center that can provide centralized control of certain other Pioneer products.

THE TEST RESULTS

As in previous video product test reports, all lab measurements were made

by Advanced Product Evaluation Laboratory (APEL). Results of their measurements, along with the sample actually tested, were then sent to our lab for further subjective testing and hands-on use of the product. The video frequency response of the player was measured using a multiburst test signal. From that test, APEL determined that response extended out to, and beyond 4.2 MHz—the highest video frequency in the NTSC TV transmission system that's used in the U.S. At 4.2 MHz, response was down only 0.98 dB.

APEL used a vectorscope to display the relative phase angles and intensity of the various color bars found in the standard color bar pattern. That test revealed that color purity or accuracy was excellent, with almost perfect color-bar reproduction and saturation levels. We

confirmed this in our own lab by playing some standard color-bar signals.

Chroma (color) signal-to-noise ratios were about average, measuring 43.2 dB for AM chroma noise and 35.3 dB for PM (phase modulated) chroma noise. The signal-to-noise ratio with respect to the luminance (brightness) signal was a better than average 44.6 dB. Stairstep linearity (the ability to reproduce varying shades of gray, from black to white) was never off by more than 3% for any one of the test "steps."

Both the analog- and the digital-audio sections of the player were measured for the videodisc player. For the analog section, distortion at 1 kHz varied from 0.65% to 0.75%, depending upon whether or not the CX noise-reduction system was engaged. Without CX, audio signal-to-noise ratio for the analog-audio section was 59.2 dB, with CX it jumped to an extremely excellent 81.8 dB.

Digital-audio measurements revealed why more and more videodiscs are being issued with digital-sound tracks. Signal-to-noise ratio for the digital-audio section ranged from 106.6 to 107.1 dB, depending upon whether or not de-emphasis was used. Channel separation hovered around the 108 dB mark! Total harmonic distortion at 1 kHz measured an inaudibly low 0.0027%, while frequency response for the digital-audio section was flat from 20 to 20,000 Hz, staying within +0.01 dB and -0.33 dB!

While the CD-player section measurements and digital-audio for the video-section measurement should theoretically be identical, APEL took the trouble to separately test the player in terms of its CD performance. Signal-to-

(Continued on page 96)

ANTIQUÉ RADIO

By Marc Ellis

Mailbag Time Once More

In last month's column, we all but completed our series on the "Cunningham Special" tube tester—a unit specifically intended for vintage tubes not handled by most commercial testers available today, even the older ones. I had hoped to run the last installment this month, but haven't quite finished building my own version of the Cunningham Special. Look for the conclusion in the next column,

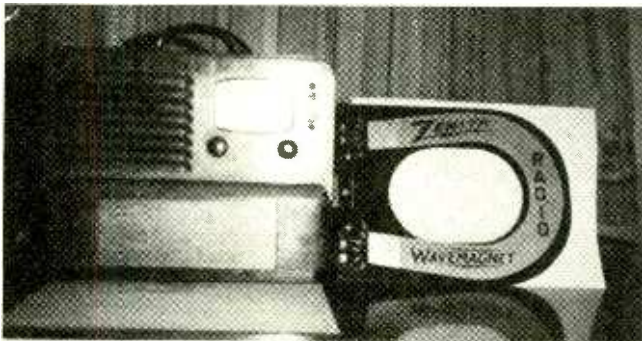

Kent A. Ponton sent along this shot of his latest garage-sale find, a wood-cabinet Zenith portable (model T197604), complete with wavemagnet antenna.

when I should be able to show you some pictures of the instrument. Test data and operating instructions will also be provided at that time.

But for now, let's take a long-delayed look into the mailbag. It's been several months since we've been able to find time for doing that, and some of the letters have been waiting quite a while for attention!

SCHEMATICS AND INFO NEEDED

Here's a group of readers looking for schematics and/or service information for various radios. If you can help, please write the person involved: *RCA model 3-BX-671* and *Capehart-Farnsworth model 88P66NL* (Mark Bender, 4555 Pine St.,

Unit 4-J, Riverside, CA 92501-4036); *Stewart-Warner chassis 91-82* (Victor Zebuda, 38 Lloyd Ave., Lynbrook, NY 11563); *Trav-Ler Radio Corp. model 5015* (Jim Fritschie, 9449 Hoffman Way B301, Thornton, CO 80229); *RCA Victor model 110* (Rick Dreyer, Savoy Electronics, Inc., 1175 Northeast 24 St., Ft. Lauderdale, FL 33310); *RCA Victor model 97K2* (Todd R. Ames, 8381 West Main Rd., Westfield, NY 14787); *Pilot Wasp* (especially information on identifying coils with faded color codes and on constructing replacements for missing coils) (Kevin Adams, 145 Hillcrest Ave., Apt. 2007, Mississauga, Ontario, Canada L5B 3Z1); *Atwater Kent model 20* (Barry Mac Kintner, 320 Washington Ave., Cicero, IN 46034). *Crosley 3R3* (M. Velsler, 43 Charing Rd., Nepean, Ontario, Canada K2G 4G2).

A couple of readers want to build crystal sets for their grandchildren and are looking for schematics and parts, or possibly kits, for such radios. They are Charles A. Hall (26327 Governor Ave., Harbor City, CA 90740) and Harry A. Razen (1288 Vermeer Dr., Nokomis, FL 34275). By the way, Charles writes that he is an old-time ham from the days of spark transmitters.

About 25 years ago, James P. Rodgers (8074 Park Villa Circle, Cupertino, CA 95014) tossed out all of his receiving tube manuals. Now he's retired, into restoration of old tube gear, and needs replacements. Larry Fullner (4808 NE 74, Seattle, WA 98115) can use information on building electronic replacements for auto radio vibrators (6- and 12-volt;

positive- and negative-ground). Philip Taylor (14 Willow Walk, Canewdon, Rochford, Essex SS4 3QH, England) needs manuals for the *Pilot Wasp* and *National SW5*.

PARTS AND PIECES

Here are some readers who are seeking parts or other items to complete their sets. Once again, contact the appropriate person if you can help! Ken Bryant (341 Wilson Dr., Unit 8, Milton, Ont., L9T 3Y9 Canada) would like to obtain a replacement or substitute for a *Plessey Type 1214* non-synchronous 12-volt vibrator. The unit is needed to repair an English auto radio—vintage unknown. Glinda Fagin (570 Haskill Basin Rd., Whitefish, MT 59937) needs a 6J8G tube to put an old Philco back in service.

William Lapinsky (2634 Lone Pine Rd, Palm Beach Gardens, FL 33410) seeks a *Stromberg Carlson No. 14 Cone Speaker*, or equivalent, for his *Stromberg Carlson 636-A* receiver. Cynthia J. Davies (R.R. 1 Site 2 Comp 48, Shady Rest Park, Westbank B.C. V0H 2A0, Canada) enjoys listening to 78's on her *Wilcox-Gay Recordio*, but now she'd like to record a few discs herself. Can anyone come up with a stylus or two that will fit the Recordio's cutting head?

Bill Stayduhar (394 Hoffman Rd., Reserve Twp., Pittsburgh, PA 15212) accidentally broke the dial glass on his *Zenith 10S155* and is anxious to get his hands on another one. Joao-Manuel Mimoso (R. Augusto Costa [Costinha] Lotte 48-2-A, P-1500 Lisboa, Portugal) seeks various parts for an

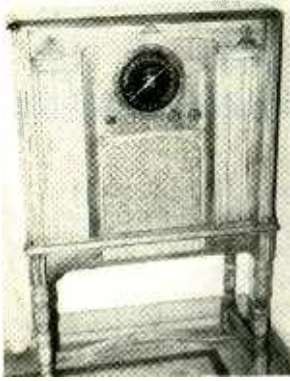

This cabinet now houses a large Howard radio (see text), but Joao-Manuel Mimoso would like to know what set was originally installed. Can you help?

Atwater Kent model 82 and a Zenith Transoceanic (model unspecified). He also has a beautiful console cabinet that was modified to accept a Howard radio (see photo), and would like to know what set it originally housed.

SERVICE AND RESTORATION PROBLEMS

Jonathan T. Nadenicek (304 N. Kiwanis #214, Sioux Falls, SD 57104) is restoring an Atwater Kent model 60, and would like to correspond with someone who shares his problems: namely, finding ways to restore the cabinet's wood-grain finish and to replace the tangle of rubber-covered wires (with deteriorating insulation) surrounding the area where the line cord enters the cabinet.

Jonathan could also use service data and a schematic for the set.

First-time restorer Timothy J. Hummer (RD#1 Box 33, Pittsfield, PA 16340) needs service data for an Atwater Kent model 44. He'd also like a little help and advice from someone familiar with that radio, and would particularly like to hear from someone who can replace the speaker cone—which was damaged in a flood.

Robert Grant (5775

Bishop, Detroit, MI 48224) likes to collect and repair tube-type portable radios. But he's baffled by a problem with one of his recent acquisitions, a Motorola model 52B1U. While intended to be a broadcast-band-only radio, it picks up strong shortwave signals that interfere with the BC reception. Bob has noticed a similar problem on inexpensive modern transistor radios. Any ideas on how to correct that?

William Ellis (1420 New Hope Rd., Atlanta, GA 30331) seeks to correspond with someone about a problem he has with the tuning capacitor of a National model NC98.



Worden A. Young would like information about the value (see text) of his "Tom Thumb Transistor Pocket Radio," which is complete with original owner's guide.

If you're qualified to repair antique radios and live in Louisiana (preferably the New Orleans area), contact Greg Hingle (Rt. 2, Box 584, Port Sulphur, LA 70083). Two Detroit-area radio owners are also looking for qualified servicemen: Mr. and Mrs. C. William Maxwell (6058 Canmoor, Troy, MI 48098) have an ailing Majestic Model 25; Terry R. Livermore (c/o DMB&B Licensing Group 1725 N. Woodward Ave., Bloomfield Hills, MI 48303) needs someone to work on a Zenith model 9S367.

WHAT ARE THEY WORTH?

Michael S. Sage (9036-E Arbogate Dr., Charlotte, NC 28273) is inquiring about the value of the following three radios: Wilcox-Gay Recordio model A-85 (which has AM/SW radio; plays and records 78's); Philco model 50-326; and Zenith AM/FM model H724U. Although Mike didn't say so, I assume that he'd be willing to part with those sets for the right offer. Worden A. Young (3409 Hagar Drive, Tarawa Terrace, NC 28543) sent along a photo of his "Tom Thumb Transistor Pocket Radio," along with the accompanying owner's guide. He's interested in finding out its original selling price, approximately how many were manufactured, and its current worth.

Bryan Harris (221 Cole St., Clovis, CA 93612), an 11-year-old newcomer to the antique-radio hobby, would like to know how much it would take to acquire a Philco 90B in good condition. Kent A. Ponton (155 East Baker St., Manteno, IL 60950) is also a newcomer to the antique-radio hobby. Kent sent a shot of his recent garage-sale discovery: a wood-cabinet Zenith portable (model T197604), complete with wavemagnet antenna. Kent replaced the defective line cord, restored the cabinet, and did some cosmetic cleaning. Now the set looks and works great, and he'd like a little background information about it—including its value.

GETTING IN TOUCH

I receive many letters from readers who are new to the field of antique-radio collecting or restoring, and would like to get in touch with basic information about available literature, parts, tubes, and services. This issue of the mailbag includes such letters from

Bruce Carling (Gaithersburg, MD), Salah Al-Noman (Sharjah, U.A.E.) and R.E. Thomas (Queens Village, NY).

Besides reading this column regularly, I'd advise serious newcomers to take two steps. First, write to Antique Electronic Supply (6221 S. Maple Ave, Tempe, AZ 85283) for a copy of their 1991 catalog. The A.E.S. catalog, which is updated yearly, contains 28 pages of otherwise hard-to-find tubes, parts, restoration supplies, literature, and other items of interest to antique-radio enthusiasts. Second, contact *Antique Radio Classified* (P.O. Box 2, Carlisle, MA 01741) for a free sample copy. The monthly publication is loaded with ads from people who'd like to buy or sell antique-radio items or who offer products, services, or information for the radio restorer. *Antique Radio Classified* also runs regular book reviews, lists of recent auction prices, articles on collecting and restoration topics, and photos of interesting pieces. Current annual subscription prices (U.S.) are \$24.00 by second-class mail and \$36.00 by first-class.

Those fine sources will give you an excellent orientation to the information base you'll need for participation in the hobby. And from them you'll learn about other sources that will help you still further. Follow up on those systematically and you'll soon be quite well-informed!

By the way, Mr. D.K. Owens (478 Sycamore Dr., Circleville, OH 43113) writes that he's concerned about the safety of inexperienced folks working around antique radios. He makes the excellent point that the high voltages and currents available from old-time power supplies are potentially lethal, and that

(Continued on page 96)

COMPUTER BITS

By Jeff Holtzman

Indispensable Software

Suppose you were stranded on a desert island and could have only one application software package—which would you choose? My choice would be a program called GrandView. Although GrandView has occasionally been categorized as a Personal Information Manager (PIM), it's really an outline processor with a very strong built-in word processor. I've been using successive versions of this program since it first appeared; the latest version polishes an already shining product.

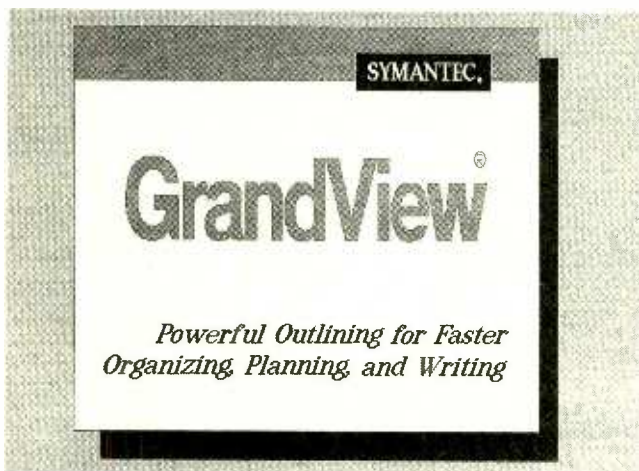

GrandView combines the best features of ThinkTank and PC Outline (a shareware program) into a single program. Version 1.0 was released in 1988; an update was subsequently released in 1989; Version 2.0 came out during the summer of 1990.

HISTORY

GrandView is really the offspring of two early outline programs: ThinkTank and a shareware program called PC Outline; the latter has been upgraded several times and is still available through shareware distributors.

ThinkTank was originally produced by a company called Living VideoText; Symantec subsequently purchased rights to the program, hired the author of

PC Outline (John Friend), who combined the best features of both programs to produce GrandView. Version 1.0 was released in 1988; an update was subsequently released in 1989; Version 2.0 came out during the summer of 1990.

OUTLINING

As children, most of us are taught to outline subjects before preparing reports. The process consists of taking a topic, breaking it into subtopics, breaking the subtopics into sub-subtopics, etc., then writing text to fill in each subdivision in the hierarchy. I don't know about you, but I hated it! The method seemed artificial, forced, and difficult to carry out because it was hard to reorganize an outline once the basic structure was laid out. So when outliners first hit the PC scene in the mid 1980's, I was skeptical. However, an early version of PC Outline quickly converted me.

The reason was that structuring an outline was no longer a rigid process. If, during the course of research or writing, a new structure seemed warranted, just press a few keys and you've got it. Gradually, as I became adept with the tool, I learned that outlining was not intellectually restricting but, in fact, quite the opposite. It was liberating to know that I could record ideas, thoughts, notes, etc., in whatever order they popped into my head, all the while knowing that with the press of a few keys, I could bring order to a random mass of data.

Just how do you bring order to chaos using an outline program? First get the data into the program,

separating each distinct concept into a separate headline. Then stare at the data until you start to see how several items might fit together. Then think of an appropriate title for the group as a whole, add a new headline with that title, and subordinate the sub-items to the main one.

For example, using GrandView, you can cursor through a list of headlines, marking each one you want to bring under the new head by pressing <F2>. Then move the cursor to the new headline and execute the "Gather" command; GrandView will then bring the elements together under the new main head.

Suppose that after creating several major headlines and subordinating a few data items to each, you still have quite a few uncollected items and feel lost—the electronic version of not being able to see the forest for the trees. Simply hide some of the details. Move to each of the main heads you've already created and press the gray minus (<->) key; doing so prevents the display of any subordinate details. Then focus on the remaining items and find ways to group them together.

After grouping most of the subordinate details, you may find several that don't seem to fit anywhere. What I usually do is create a headline labeled "Misc" where I store the stuff that doesn't fit anywhere else. As the project progresses, I occasionally look at the items under Misc to see if I can find a new place to put them. Eventually all the "misfits" fall into place.

ORDER

After organizing the raw data into outline categories, it's usually necessary to rearrange the order of the main headlines, as well as the subordinate headlines within each headline. That type of movement is easy: place the cursor on the headline you want to move, press a <SHIFT> key, and then use the arrow keys to move in the desired direction. Of course when you move a headline, all of its subheadlines move with it.

If you want to focus your attention on a specific headline (and its sub-heads), you can hoist it. Hoisting a headline hides all other headlines at the same level or higher, making it seem as if that headline were the entire outline. Another command allows you to expand or contract the entire outline a specified number of levels—main heads only, main and first-level subheads, and so on.

TEXT

Each head and subhead may have an arbitrary amount of text associated with it. You enter the text using word processor functions equal to any mid-range product. The word processor includes just about everything you would expect, including macros, sorting, headers and footers, a spelling checker, search and replace, support for a wide range of printers (including LaserJet and PostScript devices), page preview, etc.

You can format text using bold, italic, and underline, and set up formatting by outline level so that, for example, higher outline levels print in a larger typeface. GrandView automatically numbers and formats outline entries by level; you can specify both the numbering style and the amount of indentation per

level, as well as fonts and special effects. For final polishing, you can export an outline in several popular formats (WordPerfect, WordStar, ASCII, etc.).

THE BIG PICTURE

GrandView has many features, and it takes time to learn how to use them all. However, Symantec has done a first-rate job of easing the process via their tutorial and reference materials. The printed documentation is excellent; GrandView also includes an on-line help system, and a subsidiary help system to which you can add your own notes.

GrandView allows you to open as many as nine outlines simultaneously, each in its own separate on-screen window. You can move and size windows, and even save a window group and load it later. The program will also run in a memory-resident mode, in which case it uses only 20K of memory. However, you'll need EMS memory or a fast hard disk to do so.

GrandView also has several features designed for business users: a category view that provides an alternate view of outline data, a calendar function for simple scheduling, and the ability to export outlines to business presentation programs. And GrandView runs just fine under Windows 3.0.

If you're a student or if your business requires sifting and organizing large quantities of information, give GrandView a try. I'd rather be shipwrecked with it than with any other tool of its kind. ■

VENDOR

GrandView 2.0 (\$295)
Symantec Corporation
10201 Torre Avenue
Cupertino, CA 95014-2132
Tel. 408-253-9600

Be an FCC LICENSED ELECTRONIC TECHNICIAN!



Earn up to \$30 an hour and more!

Learn at home in spare time. No previous experience needed!

No costly school. No commuting to class. The Original Home-Study course prepares you for the "FCC Commercial Radiotelephone License." This valuable license is your professional "ticket" to thousands of exciting jobs in Communications, Radio-TV, Microwave, Maritime, Radar, Avionics and more...even start your own business! You don't need a college degree to qualify, but you do need an FCC License.

No Need to Quit Your Job or Go To School
This proven course is easy, fast and low cost! **GUARANTEED PASS**—You get your FCC License or money refunded. **Send for FREE facts now. MAIL COUPON TODAY!**

COMMAND PRODUCTIONS
FCC LICENSE TRAINING, Dept. 100
P.O. Box 2824, San Francisco, CA 94126
Please rush FREE details immediately!

NAME _____
ADDRESS _____
CITY _____ STATE _____ ZIP _____

AMAZING NEW Pocket Reference

480 pages of tables, maps, formulas, and conversions and it fits in your shirt pocket (3.2" x 5.4" x 0.6")!

\$9.95*



* Plus \$2.00 shipping & handling. Colorado residents add 5% tax.

Small sample of contents

Air Tool CFM vs PSI	Radio Alphabet
Battery Charging	TEN Radio Codes
Tire Manufacturer Codes	Telephone Area Codes
Lumber Sizes & Grades	Lost Credit Card Phones
Concrete & Mortar	Sound Intensities
Element Tables	Wind Chill Factors
Computer ASCII Codes	Frequency Spectrum
IBM® PC Error Codes	Geology Mineral Tables
IBM® Interrupts-I/O Map	Glues and Solvents
30288 Hard Disk Types	Bolt Torque Tables
Printer Control Codes	Wood Screw/Nail Sizes
Electric Wire Size vs Load	Math Formulas & Tables
NEMA Motor Frames	Plane/Solid Geometry
Wire & Sheet Gauges	Copper/Steel/PVC Pipe
Resistor/Capacitor Colors	Rope, Cable and Chain
Pilot Lamp Specs	Tap-Die-Drill Sizes
Fuse & Battery Specs	Sand Paper & Abrasives
RF Coil Winding Data	Weld Electrode & Solder
Wire Size vs Turns/inch	3200 Conversion Factors

Money Back Guarantee—If not completely satisfied, return book postage prepaid, in mint condition for a 100% refund!

Sequoia Publishing Inc.
Dept 918, P.O. Box 620820
Littleton, CO 80162

CIRCLE 12 ON FREE INFORMATION CARD

FUN SOFTWARE

By Fred Blechman

Fun Software That Measures Up

Fasten your seat belt, tighten your shoulder harness, plug in your G-suit, cinch up your helmet, and prepare yourself for a unique challenge—flying a high-tech Russian Su-25 “Stormovik” ground-attack aircraft against terrorists determined to initiate World War III!

But wait! Before you slam that throttle forward, take a few minutes to read about some new entertainment programs. This update by no means covers all the new programs, but does include some of those from major distributors.



Stormovik puts you at the controls of a Soviet Su-25 attack helicopter and pits you against international terrorists bent on starting World War III.

WHAT'S NEW

Two factors have influenced the increase in the number of good entertainment software in the marketplace. The primary factor is that microcomputer-equipment speed, color, and graphics capability have greatly improved. In the IBM PC world, the 80286/80386 machines with VGA graphics running 20 MHz or faster allow sophisticated programming with fast, colorful, smoothly animated screens that result in more authentic simulations and arcade action.

The second factor in the growth of “fun software” is that distribution has been improved by cooperative marketing. Some larger software manufacturers, like Electronic Arts and MicroProse, have added “affiliated labels”—smaller companies that produce their own products, but distribute them through the larger company. This offers economies in advertising and order processing for direct telephone sales, as well as having the products more widely available on retail store shelves.

You should be able to find the following products through software stores and mail-order advertisers, usually at reduced prices, or you can call the number shown for direct purchase at the suggested retail price.

Electronic Arts (1-800-245-4525): Budokan: The Martial Spirit (martial arts), Amiga \$49.95; 688 Attack Sub (US or Soviet submarine simulation), Amiga \$49.95; Escape From Hell (adventure roll-playing), IBM \$49.95; Earl Weaver Baseball Player Stats (1989 player statistics for 26 teams), IBM and Amiga \$19.95; Startlight (space fantasy roll-playing adventure), C64/128 \$39.95; and Ferrari Formula One (high-speed driving simulation), C64/128 \$29.95.

The following are affiliated-label programs available from Electronic Arts:

Strategic Simulations: DragonStrike (ride the back of a dragon in air combat), IBM and Amiga \$49.95; Storm Across Europe (recreation of World War II on a grand strategic scale), IBM and Amiga \$59.95; C64/128 \$39.95; Renegade

Legion: Interceptor (science fiction strategy based on FASA board game), IBM \$59.95; and Countdown to Doomsday (first Buck Rogers computer game), IBM and Amiga \$49.95, C64/128 \$39.95, clue book \$12.95.

California Dreams: Street Rod (customize and drag race), IBM and Amiga \$39.95, C64/128 \$29.95.

Strategic Studies Group: Fire King (action/adventure), IBM \$39.95, C64/128 \$29.95.

Three-Sixty: Sands of Fire (WWII North Africa tank simulation), IBM \$44.95; Armor Alley (arcade combat with helicopters, paratroopers, tanks, missiles, and infantry), IBM \$39.95, Macintosh \$49.95; MegaFortress (B-52 nuclear mission simulation based on the “Flight of the Old Dog” novel), IBM and Amiga \$49.95; Das Boot (WWII German U-boat simulation), IBM, Amiga, and Atari ST \$49.95; and The Blue Max (WWI air combat, eight aircraft), IBM, Amiga, and Atari ST \$49.95.

Cinemaware/Spotlight Software: Brainblaster (two action and strategy games: Xenon 2 and Bombuzal), IBM, Amiga, and Atari ST \$39.95.

Miles Computing: Questmaster, The Prism of Hehuetotol (graphic adventure), IBM and Apple IIGS \$39.95, C64/128 and Apple \$34.95.

Sega Enterprises: Altered Beast (arcade game), IBM and C64/128 \$39.95, Amiga and Atari ST \$49.95.

MicroProse (1-800-879-PLAY): Silent Service II (WWII submarine simulation), IBM \$59.95; Knights of the Sky (WWI dogfighting), IBM \$59.95; Covert Action (role-playing techno-thriller adventure/simulation), IBM \$59.95; and LightSpeed (interstellar role-playing

DX LISTENING

By Don Jensen

Does The Future Of SW Lie In SSB?

Is single sideband the future of shortwave broadcasting? That's a question that may well be answered within the next several years. Single sideband (SSB) is a mode of transmission that, for years, has been popular with commercial two-way communications services and amateur-radio operators. But, how does SSB work and how does it differ from normal amplitude-modulated (AM) broadcasts?

An ordinary AM signal is made up of a powerful carrier and two sidebands—upper and lower—that are "mirror images" of each other, and constitute the program material.

Then, for no explicable reason, he also loads the porker's twin brother (the other sideband) aboard, and begins trundling his barrow down the lane.

With an AM signal, the carrier is, in a sense, wasted energy. But it is needed by an ordinary radio to give the listener undistorted audio sound. But because both sidebands carry the same programming information, only one is really needed. For Farmer Brown it takes a lot of effort to move his two hogs. How much easier it would be, he thinks, if he didn't have to push the heavy cart and the second animal. That won't work for Brown, but it is just what SSB allows—eliminating the second sideband and the carrier. In SSB, all or most of the AM carrier and one of the two sidebands are dispensed with.

For the international broadcaster, the advantages of SSB are obvious. Without the need to transmit a powerful carrier, the station saves substantially on electrical energy, which translates into a cost savings. A 30-kilowatt SSB transmitter will have about the same effectiveness, in terms of reaching a distant audience, as a regular 100-kilowatt AM transmitter.

For the listener, there's a plus as well. With only one transmitted sideband, the signal takes up only half of the band space. That means that stations aren't crowded as close together and will, hopefully, cause less interference to each other.

The main disadvantage of SSB shortwave-broadcasting is that normal AM-only receivers won't work

satisfactorily. The receiver itself must be specifically designed to insert a substitute carrier to replace the one not transmitted. And the substitute carrier must have exactly the same frequency as the one that has been eliminated at the transmitter. It requires a very stable receiver because any drift in frequency, either at the transmitter or the receiver, would cause serious distortion. And tuning is much more critical. Many SWLs have good quality communications receivers that perform well with SSB signals. But older or inexpensive shortwave radios won't.

Single-sideband transmissions have been under consideration by many major SW stations, particularly since 1987, when the delegates to the World Administrative Radio Conference (WARC) recommended that international broadcasters switch to SSB-mode transmissions in the 1990's. But the idea has run into resistance, particularly from third-world countries, because of the high cost of upgrading transmitters and the high cost to the average listener who will need SSB-capable receivers.

That recommendation is expected to be reviewed at the next WARC conference, set to convene in Spain in 1992, or at a follow-up conference devoted exclusively to shortwave that is scheduled for the following year. In the meantime, one international station, HCJB, the *Voice of the Andes*, in Quito, Ecuador, is pushing

*Credits: Mike Hardester, Okinawa; John Carson, OK; Carl Davis, Newfoundland, Canada; North American SW Association, 45 Wildflower Road, Levittown, PA 19057

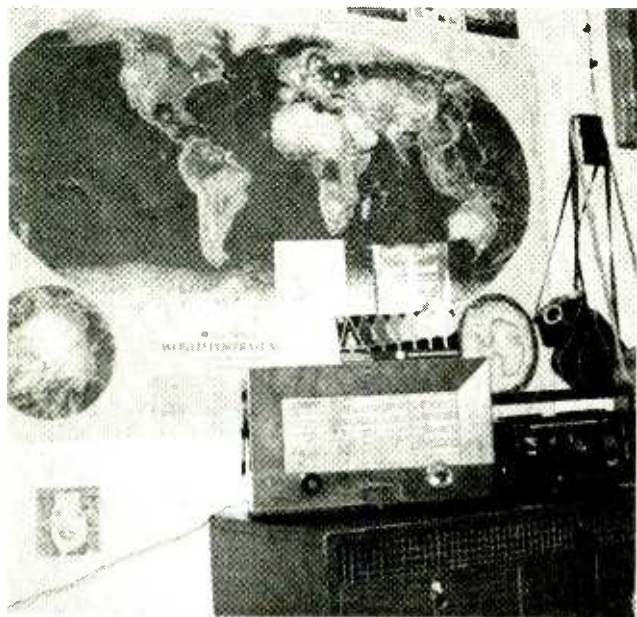

This SW listening post belongs to Canadian Carl Davis, a faithful reader of DX Listening.

A rather simplistic, rustic example may help you to understand the concept. A farmer wishes to take his pig to the fair, hoping to win a blue ribbon. How does he go about it? He gets his wheelbarrow (the AM signal's carrier) and into it he loads his pig (one of the two sidebands of program-

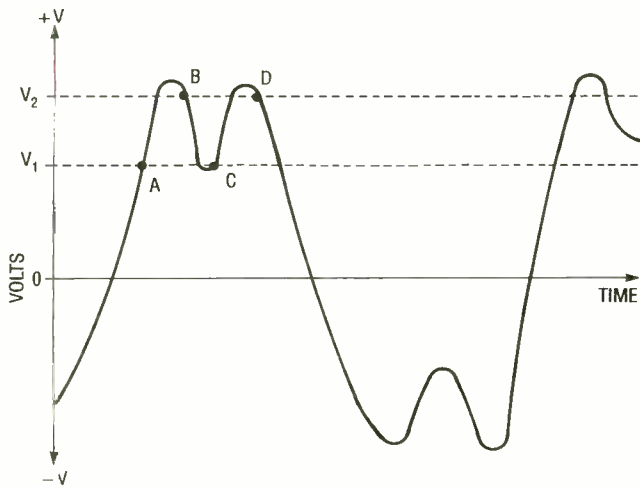

Fig. 2. If the input signal crosses the trigger window too many times per cycle (as this harmonically-distorted signal does), the counter is triggered twice for each input cycle, and therefore gives a reading that's twice the frequency of the actual input signal.

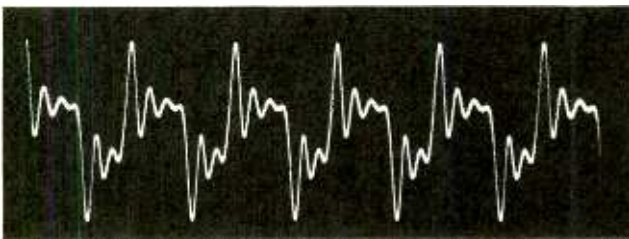

Fig. 3. Noisy or modulated signals (like this one taken from an old RF signal generator) cause unpredictable counts. Because of this signal's highly irregular amplitude, it offers plenty of opportunity to cross the threshold limits many times per cycle.

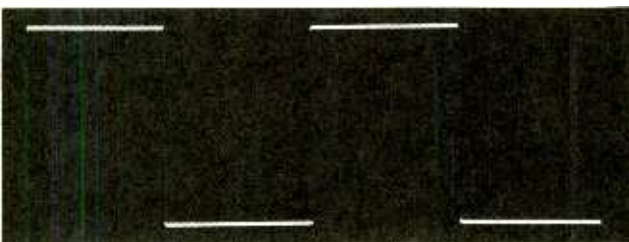

Fig. 4. This square-wave signal was applied to an oscilloscope and RF-frequency counter from an audio-range function generator.

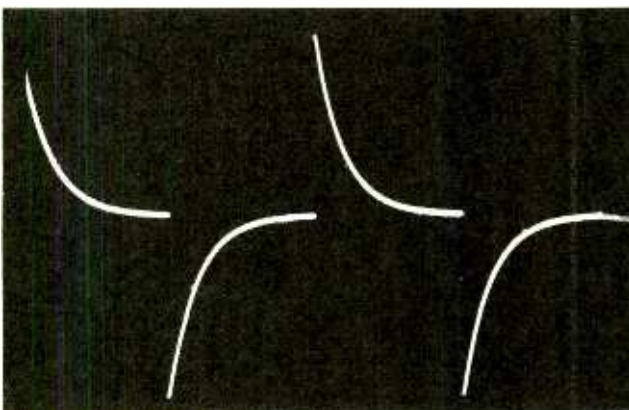

Fig. 5. When the square-wave signal in Fig. 4 was applied to an RF-frequency counter, which used capacitive coupling (to eliminate the DC component of the input signal), the signal was differentiated, creating two pulses for one, causing double counting.

that was exactly twice the actual input frequency. Here's why: My particular counter is designed principally as an RF counter, while the square wave's frequency was low audio. Since the input of the counter was capacitor coupled (to eliminate DC components on input signals), the square wave was differentiated, producing the signal shown in Fig. 5.

One thing that this discussion should tell you immediately is that the carrier frequency of modulated ham rigs cannot be properly measured with a simple DFC. Some sophisticated DFC's can strip off the modulation, but for most instruments, the modulation will foul up the reading. To combat that possibility, use a low-power output setting in CW mode in order to measure the frequency. Either that, or set the rig to AM and be very quiet while taking the reading. Single-side band (SSB) rigs may (but probably won't) produce enough carrier to trigger the counter. If not, then use the Carrier Injection control, if one is available.

Another problem seen on some counters is simple overload. The input-signal level will be quite high when the whip antenna on the DFC is extended full length, and placed near the transmitter antenna or dummy load (yes, dummy loads do leak some signal). If problems are seen, try reducing or increasing the signal to a point where proper triggering occurs. One can have both too little or too much signal, so be careful. Too much signal can burn out the front-end of the counter, so, again, be careful to follow the directions of the counter manufacturer.

It shouldn't be necessary to mention this, but many counters are burned up by

one particularly dumb stunt, so I will: **Under no circumstance should the output of the transmitter be connected to the input of the counter.** Even a 30-watt mobile rig can burn out the counter's front-end in quick order. I actually saw that happen at a club display at an ARRL Atlantic Division Convention in the early 1960's (when DFC's cost \$4,000 and up!). The guy connected the output of a Collins 32V2 HF ham transmitter directly to the high-impedance input of the counter. Sigh!..the DFC bellied up with a quick puff of smoke.

The only exception to the admonition to not connect the transmitter to a counter is the specific case where the counter is a through-line model. That type of instrument has a 50-ohm transmission-line section between an input and output jack so that the counter can be left connected in-line while the transmitter is operating. The actual signal for the DFC is taken from a small "gimmick" or coupling link that samples the signal. The actual, full-power signal is not applied to the counter input—only a small sampling of the total power level is used.

The digital frequency counter is probably the best way to measure frequency. It's certainly the easiest method, for the answer is usually unambiguous and needs no interpretation. And, when anomalous results occur, it is usually fairly easy to figure out what is happening, and deal with it.

Note: One easy way to examine the signal for such anomalies is to use an oscilloscope. Like digital counters, the costs of new scopes of more-than-basic capability are now quite low. Watch this column in the future for information on the oscilloscope and how it is used in ham radio. ■

HAM RADIO

By Joseph J. Carr, K4IPV

Using Digital Frequency Counters

Federal Communications Commission regulations don't require hams to know their exact operating frequency (at least not in most cases), but they do require that we observe the edge of the band (or sub-band if you are not an Extra Class licensee) in which we are operating. Therefore, we need to be able to measure the operating frequency of our transmitters when we work close to the edge of the dial—the

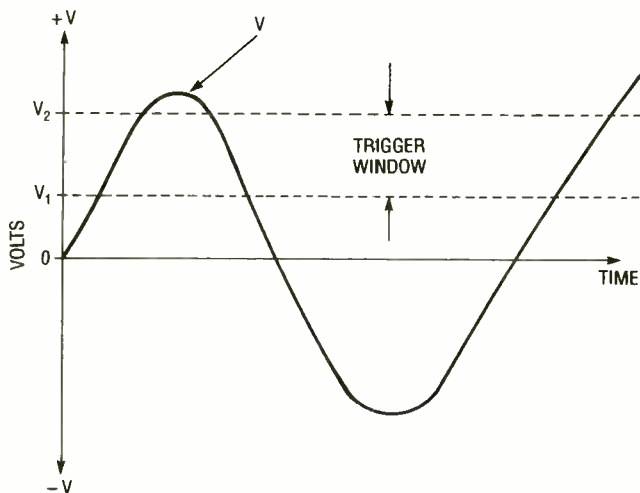

Fig. 1. Here's the input signal/trigger window for a properly functioning counter. The trigger window limits are V_1 and V_2 . To trigger properly, the input signal must first cross V_1 in a positive-going direction, and then cross V_2 in a negative-going direction.

dial frequency on the rig is not always accurate (in fact, it is rarely accurate unless the unit has a built-in frequency counter).

FREQUENCY MEASUREMENTS

There are many different ways to measure frequency, but digital-frequency counters are the current "best way" to measure the operating frequency of a radio transmitter. Once the exclusive play-toy of well-financed (with strong emphasis on the word

financed) two-way radio shops, engineering laboratories, industrial-production testers and government-lab technicians were the only people who could afford such instruments. But today, most amateurs who can afford an HF ham rig can also afford a decent digital-frequency counter.

Why are such instruments so popular? Perhaps it's because of their ease of operation. Just press the microphone button (or the telegraph key) and the operating frequency of your transmitter pops up on the digital display for all to see. What could be simpler? But, if it's so simple, then why do we frequently get the wrong answer? In fact, when the answer is wrong, it's so ridiculously wrong that a child could see the error.

Why does that happen? Perhaps, just perhaps, digital-frequency counters (DFC's) are—dare we commit heresy—not perfect. In fact, digital-frequency counters are far from perfect, especially the simpler, low-cost types. But understanding the sources of counter errors can keep you from making mistakes.

ERROR SOURCES

Erroneous readings result because the input circuit of a digital-frequency counter is a triggered circuit. Such circuits contain built-in hysteresis over a certain trigger window that conditions the signal. The input signal must cross two thresholds, in the right order, only once per cycle. Figure 1 shows the basic scenario. The input signal is a semi-AC waveform that has both positive and negative excursions with little or no DC-offset component.

The trigger window limits are V_1 and V_2 , and are set by the design of the counter (some counters have adjustable trigger windows). To trigger properly, the input signal must first cross V_1 in a positive-going direction, and then cross V_2 in a negative-going direction, so the counter can trigger properly.

But what if the input signal either fails to cross both trigger window limits, or if it crosses too many times per cycle (as when the signal is noisy)? Consider the signal in Fig. 2, for example. That signal is a sine wave with severe harmonic distortion. The signal crosses the trigger thresholds (V_1 and V_2) twice per cycle (at points A, B, C, and D), so it would be erroneously read as twice the frequency of the actual input signal.

OTHER PROBLEM SOURCES

Figure 3 shows the output from an older RF signal generator that has a problem. The signal amplitude is highly irregular, and offers plenty of opportunity for the signal to cross the threshold limits many times per cycle. When that photograph was taken from my oscilloscope, the signal generator was set to 600-kHz CW, but the digital-frequency counter read (in sequence) 690, 1214, 420, and 2,202 during the time it took for the Polaroid film to develop (about 45 seconds). Who could believe that reading.

Figures 4 and 5 illustrate another type of problem. Figure 4 shows the square-wave output of an audio-range function generator, which, when applied to my DFC, generated a read out

adventure/simulation), IBM \$59.95.

The following companies—Paragon Software and Mindcraft—also distribute their products through MicroProse.

Paragon Software: Megatraveler 1: The Zhodani Conspiracy (role-playing adventure/combat), IBM \$59.95; Space 1889 (sailing ships that fly through space), IBM \$49.95; X-Men II (Marvel Comics adventure), IBM \$39.95; and The Amazing Spider-Man (comic adventure), IBM \$34.95, Amiga and Atari ST \$39.95.

Mindcraft: Magic Candle II (fantasy adventure), IBM and Apple II \$49.95, C64/128 \$39.95.

Accolade (408-985-1700): Test Drive III: The Passion (exotic-car driving simulation), IBM \$59.95

Spectrum HoloByte (415-522-0107): Flight of the Intruder (flight simulation based on the book and movie; the book is included), IBM \$59.95; Stunt Driver (stunt driving and racing simulation), IBM \$49.95; and Falcon 3.0 (combat flight simulator, replaces Falcon AT), IBM \$69.95.

Virgin Mastertronic (714-833-8717): SPOT, The Computer Game (board-like strategy game), IBM \$39.99.

And now, pilots man your planes!

STORMOVIK

It's 1991, and many military leaders and industrialists in the USSR and the U.S. have seen their power base collapse as the superpowers pursue a course of peace and disarmament. Using American and Soviet military weaponry, they begin conducting random terrorist raids to destroy relations between the nations of NATO and the Warsaw Pact during German unification. The object: get all nations to accuse

each other of these attacks and start World War III!

You are assigned to the Red Guard Strike Force, an elite aerial assault team that reports directly to the Supreme Soviet. You fly the battle-proven Sukhoi Su-25, NATO codename FROG-FOOT, but here called "Stormovik" (which means "ground attack aircraft" in Russian).

Pitted against terrorist-controlled Soviet and American weapons and vehicles, you fight a three-year war against terrorism. As you complete successful missions, you are promoted and gain access to better weapons as the missions become more complex. The final desperate mission is to save the Soviet President himself from the terrorists!

Based on the actual Su-25 (which was used in Afghanistan against the rebels), Stormovik is one of the most realistic flight simulators I've tested. Running on a 12-MHz AT with VGA, the action is fast, with screen updates so smooth that it's almost like watching a movie. Vivid 3D polygon graphics in up to 256 colors add to the realism.

In fact, this program is so realistic that I believe this is the first time I've actually experienced vertigo with a computer flight simulator! I was flying at night or in fog, with no visual horizon, when I found myself frequently in a graveyard spiral (nose-down turn) without realizing it until I checked the artificial horizon. Flying on instruments is easy with Stormovik, since it is very stable. However, it is so sensitive to joystick-control movement that if you don't constantly scan your attitude and direction instruments, or spend too much time looking through the heads-up display, you can easily find yourself in a

(Continued on page 99)

LEARN VCR CLEANING/MAINTENANCE/REPAIR EARN UP TO \$1000 A WEEK, WORKING PART TIME FROM YOUR OWN HOME!



Secrets Revealed!
NO Special Tools or Equipment Needed.
EARN UP TO \$60 AN HOUR AND MORE!

THE MONEY MAKING OPPORTUNITY OF THE 1990'S

IF you are able to work with common small hand tools, and are familiar with basic electronics (i.e. able to use voltmeter, understand DC electronics) . . .

IF you possess average mechanical ability, and have a VCR on which to practice and learn . . . then we can teach YOU VCR maintenance and repair!

FACT: up to 90% of ALL VCR malfunctions are due to simple MECHANICAL or ELECTRO-MECHANICAL breakdowns!

FACT: over 77 million VCRs in use today nationwide! Average VCR needs service or repair every 12 to 18 months!

Viejo's 400 PAGE TRAINING MANUAL (over 500 photos and illustrations) and AWARD-WINNING VIDEO TRAINING TAPE reveals the SECRETS of VCR maintenance and repair—"real world" information that is NOT available elsewhere!

Also includes all the info you'll need regarding the BUSINESS-SIDE of running a successful service operation!

FREE INFORMATION
CALL TOLL-FREE 1-800-537-0589
Or write to: Viejo Publications Inc.
5329 Fountain Ave
Los Angeles, CA 90029 Dept. PE

CIRCLE 13 ON FREE INFORMATION CARD

AMAZING SCIENTIFIC & ELECTRONIC PRODUCTS

LASERS AND SCIENTIFIC DEVICES

VRL2K	3mw Vis Red Laser Diode System Kit	\$159.50
LLIS1K	Laser Beam "Bounce" Listener Kit	\$199.50
LHC2K	Visible Simulated 3 Color Laser Kit	\$44.50
LC7	40 Watt Burning Cutting Laser Plans	\$20.00
RUB4	Hi Powered Pulsed Drilling Laser Plans	\$20.00
LGU40	1 to 2mw HeNe Vis Red Laser Gun Assembled	\$199.00
LLS1	Laser Lite Show - 3 Methods Plans	\$20.00
SDSK	See in the Dark Kit	\$299.50
EML1K	Electromagnetic Coil Gun Kit	\$69.50
MCP1	Hi Velocity Coil Gun Plans	\$15.00
LEV1	Levitating Device Plans	\$10.00
EH1	Electronic Hypnotism Techniques Plans	\$10.00

HIGH VOLTAGE AND PLASMA DISPLAY DEVICES

HVM7K	75,000 Volt DC Variable Output Lab Source Kit	\$149.50
IGG3K	Ion Ray Gun Kit, project energy without wires	\$69.50
NIG9K	12V/15 VAC Hi Out Neg Ion Generator Kit	\$34.50
EMA1K	Telekinetic Enhancer/Electric Man Assembled	\$99.50
LG5K	Lightning Display Globe Kit	\$54.50
BTC1K	Worlds Smallest Tesla Coil Kit	\$49.50
BTC3K	250KV Table Top Tesla Coil Kit	\$249.50
BTC5	1.5 Million Volts Tesla Coil Plans	\$20.00
JL3	Jacobs Ladder - 3 Models Plans	\$15.00
GRA1	Anti Gravity Generator Plans	\$10.00
PFS20	Plasma Fire Saber Assembled	\$69.50
DPL20	Dancing Plasma to Music and Sounds Assembled	\$79.50

SECURITY AND PROTECTION DEVICES

ITM10	100,000 Volt Intimidator up to 20' Assembled	\$129.50
IPG70	Invisible Pain Field Blast Wave Gun Assembled	\$74.50
PSP4K	Phasor Sonic Blast Wave Pistol Kit	\$59.50
LIS10	Infinity Xmt, Listen in Via Phone Assembled	\$199.50
TAT30	Automatic Tel Recording Device Assembled	\$24.50
VWPM7K	3 Mi. FM Auto Tel Transmitter Kit	\$49.50
FMV1K	3 Mi. FM Voice Transmitter Kit	\$39.50
HOD1K	Homing/Tracking Beeper Transmitter Kit	\$49.50

EASY ORDERING PROCEDURE TOLL FREE 1-800-221-1705
or 24 HRS ON 1-603-673-4730 or FAX IT TO 1-603-672-5406

VISA, MC, CHECK, MO IN US FUNDS. INCLUDE 10% SHIPPING. ORDERS \$100.00 & UP ONLY ADD \$10.00. CATALOG \$1.00 OR FREE WITH ORDER.

INFORMATION UNLIMITED
P.O. BOX 716, DEPT. PE, AMHERST, NH 03031

ahead with its own tests of single-sideband broadcasting.

Last year, HCJB bought four German-made Siemens 30-kW SSB transmitters from the Swiss telecommunications agency, which had used them for aeronautical communications since the 1960's. Though 30-years old, their design is still considered quite modern.

In HCJB tests, the amount of carrier added at the transmitter has varied from 5 to 50 percent. The station subsequently settled on a 20-percent carrier insertion. That means that, from a partial standpoint, listeners without a receiver capable of tuning SSB will note considerable distortion in music programming, but should find speech more or less understandable. For SWL's with SSB-capable radio receivers, the results will be fine and the audio will sound louder than signals from normal 100-kW AM stations.

Those HCJB SSB transmitters feed rhombic and ground-plane antennas; the former is capable of broadcasting on frequencies between about 15 and 26 MHz and the latter only on the 11-meter band.

At the time that this column was written, the shortwave frequencies used for SSB transmissions were 21,458 and 25,950 kHz, in use on a 24-hour-a-day basis. HCJB programming on its regular, high-powered AM transmitters continues as usual on its other frequencies.

HCJB indicates that the SSB tests will continue, changing frequencies and schedules, with programs beamed to various parts of the world. The station's engineers solicit reception reports from SWL's regarding the quality of the SSB signals received. Reports may be sent to HCJB, Cas-

illa 691, Quito, Ecuador, South America.

BACKTALK

This is the place for your questions and comments about SWL'ing. Your letters are always welcome. Write to *DX Listening*, **Popular Electronics**, 500-B Bi-County Blvd., Farmingdale NY 11735.

This month, Carl R. Davis of St. John's, Newfoundland, sent both a photo and a question. The photo shows Carl's listening post where, he notes, he has heard some 47 different short-wave outlets, including *Radio New Zealand* and *Radio Portugal*. Carl writes, "I'm looking for the address of *Radio Norway International* so I can write for time and frequency schedules."

Okay, Carl, send your inquiry to Radio Norway International, N-0340, Oslo 3, Norway. Here's a tip: Look for their rather abbreviated English programming, "Norway This Week," on Sunday mornings at 1600 UTC on 21,705 kHz or at 1700 UTC on 17,765 kHz.

DOWN THE DIAL

Here are a few SW stations that listeners have been reporting:

COSTA RICA—7,375 kHz. *Radio For Peace International* transmits in SSB from this Central American country. Look for its broadcast of a UN English program, "Caribbean Magazine" at 0630 UTC.

JAPAN—3,377.5 kHz. NHK, the national shortwave station at Osaka, which is run by the same outfit that operates the widely heard *Radio Japan* international service, is one of the few broadcasters regularly using an SSB transmitter. This one programs in Japanese for domestic audiences, although reception may be possible on the North American west coast at around 1100 UTC.

Make the most of your general coverage transceiver with *Monitoring Times!*

Every month *Monitoring Times* brings everything you need to make the most of your general coverage transceiver: the latest information on international broadcasting schedules, frequency listings, international DX reports, propagation charts, and tips on how to hear the rare stations. *Monitoring Times* also keeps you up to date on government, military, police and fire networks, as well as tips on monitoring everything from air-to-ground and ship-to-shore signals to radioteletype, facsimile and space communications.

ORDER YOUR SUBSCRIPTION TODAY before another issue goes by. In the U.S., 1 year, \$18; foreign and Canada, 1 year, \$26. For a sample issue, send \$2 (foreign, send 5 IRCs). For MC/VISA orders (\$15 minimum), call 1-704-837-9200.

MONITORING TIMES

Your authoritative source, every month.

P.O. Box 98
Brasstown, N.C. 28902

STATEMENT OF OWNERSHIP, MANAGEMENT AND CIRCULATION Required by 49 U.S.C. 1432		
1A Title of Publication	1B PUBLICATION NO.	2 Date of Filing
POPULAR ELECTRONICS	07432968	12/4/90
3 Frequency of Issue	3A No. of Issues Published Annually	3B Annual Subscription Price
MONTHLY	12	\$21.95
4 Complete Mailing Address of Known Office of Publication (Street, City, County, State and ZIP+4 Code) (Not Printer):		
500-B BI-COUNTY BLVD. FARMINGDALE, NY 11735		
5 Complete Mailing Address of the Headquarters of General Business Offices of the Publication (Not Printer):		
500-B BI-COUNTY BLVD. FARMINGDALE, NY 11735		
6 Full Names and Complete Mailing Addresses of Publisher, Editor, and Managing Editor (This box MUST NOT be blank):		
LARRY STECKLER 500-B BI-COUNTY BLVD. FARMINGDALE, NY 11735		
Editor (Name and Complete Mailing Address):		
CARL LARON 500-B BI-COUNTY BLVD. FARMINGDALE, NY 11735		
Managing Editor (Name and Complete Mailing Address):		
7 Owner (If owned by a corporation, its name and address must be stated and also immediately thereunder the names and addresses of stockholders owning or holding 1 percent or more of total amount of stock. If not owned by a corporation, the names and addresses of the individual owners must be given. If owned by a partnership or other unincorporated firm, its name and address, as well as that of each individual must be given. If the publication is published by a single individual, his name and address must be stated. (This box must be completed))		
Full Name Complete Mailing Address		
GERSHACK PUBLICATIONS, INC. 500-B BI-COUNTY BLVD. FARMINGDALE, NY		
LARRY STECKLER 500-B BI-COUNTY BLVD. FARMINGDALE, NY		
8 Known Bondholders, Mortgagees and Other Security Holders Owning or Holding 1 Percent or More of Total Amount of Bonds, Mortgages or Other Securities (If none, so state)		
Full Name Complete Mailing Address		
9 For Completion by Nonprofit Organizations Authorized to Mail at Special Rates (49 USC 3685 only): The purpose, function, and nonprofit status of this organization and the exempt status for Federal income tax purposes (Check one)		
<input type="checkbox"/> Has Not Changed During Preceding 12 Months <input type="checkbox"/> Has Changed During Preceding 12 Months <input type="checkbox"/> (If changed, publisher must submit explanation of change with this statement)		
10 Extent and Nature of Circulation (See instructions on reverse side)		Average No. Copies Each Issue During Preceding 12 Months
Actual No. Copies of Single Issue Published Nearest to Filing Date		
A Total No. Copies (Net Press Run)	161,143	163,200
B Paid and/or Requested Circulation	38,518	35,048
1 Sales Through Dealers and Carriers, Street Vendors and Counter Sales		
2 Mail Subscriptions (Paid and/or requested)	43,673	49,974
C Total Paid and/or Requested Circulation (Sum of 10B1 and 10B2)	82,191	85,022
D Free Distribution by Mail, Carrier or Other Means (Samples, Complimentary, and Other Free Copies)	5,935	5,543
E Total Distribution (Sum of C and D)	88,125	90,565
F Copies Not Distributed	12,482	13,549
1 Office use, left over, unsold/returned copies after printing		
2 Return from News Agents	60,535	59,086
G TOTAL (Sum of E, F1 and F2 should equal net press run shown in 10A)	161,143	163,200
11 I certify that the statements made by me above are correct and complete		
Signature and Title of Editor, Publisher, Business Manager, or Owner		
LARRY STECKLER, Editor		

PS Form 3526, Feb. 1989

(Use instructions on reverse)

CIRCUIT CIRCUS

By Charles D. Rakes

Oscillator Round-Up

With spring just around the corner, it's a great time for *Circuit Circus* to run an electronic marathon to see how many "user friendly" circuits we can cram into our allotted space. So here we go.

TTL CRYSTAL OSCILLATOR

Our first circuit came about when a project we were working on required a low-cost crystal oscillator that would produce both a

and its surplus availability. If the required frequency happens to be one of the popular computer or industrial standards, the price is likely to be very low, but if a special non-standard frequency is required, be prepared to pay a much higher price. In any case, it would be difficult to build a circuit that performs as well as this one for less money.

Two gates of a 7400 quad two-input NAND gate make up the actual oscillator circuit, with a crystal

generated at the junction of C1 and XTAL1. The impedance at that point is extremely high and can not supply a direct output signal. Transistor Q1, configured as an emitter-follower amplifier, offers a high input impedance to the sine-wave signal and a low output impedance to an external load.

The circuit will kick start even the most stubborn crystals and can operate with crystal frequencies of less than 1 MHz to over 10

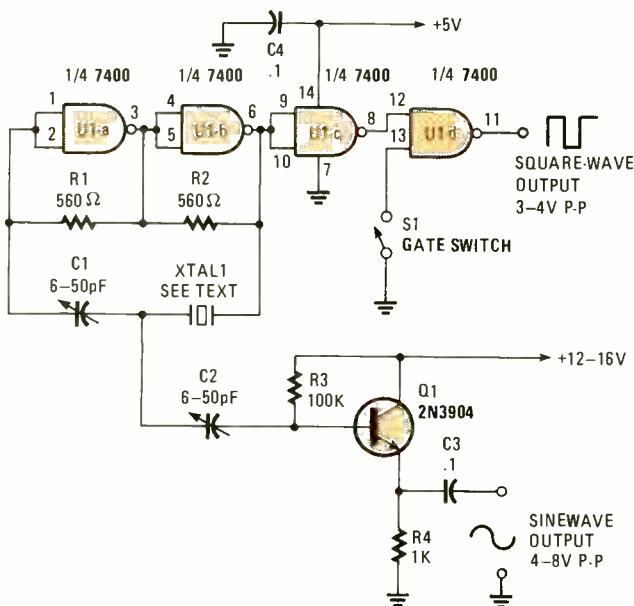

Fig. 1. Two gates (U1-a and U1-b) of a 7400 quad 2-input NAND comprise the actual oscillator circuit, with feedback controlled by a crystal (XTAL1) and a variable capacitor (C1). Gate U1-c is used to buffer the output of the oscillator, while U1-d is used to turn the output on and off.

square- and a sine-wave outputs. Frequency stability, low cost and a small parts count were the three major design criteria to be considered. The TTL crystal oscillator circuit shown in Fig. 1 fills the bill.

With TTL IC's and 2N3904 transistors going for pennies, the cost of the oscillator primarily depends on the crystal's frequency

and a variable capacitor functioning as the feedback network between the input of gate U1-a and the output of gate U1-b. Gate U1-c operates as a buffer between the oscillator and output stage, U1-d. Switch S1 serves as a manual gate control to turn the square-wave output of U1-d at pin 11 on and off. With S1 open, as shown, the square-wave appears at the output, and when closed it is turned off. The switch may be replaced with a logic gate to electronically control the output.

A near perfect 6- to 8-volt peak-to-peak sine wave is

generated at the junction of C1 and XTAL1. The impedance at that point is extremely high and can not supply a direct output signal. Transistor Q1, configured as an emitter-follower amplifier, offers a high input impedance to the sine-wave signal and a low output impedance to an external load. The circuit will kick start even the most stubborn crystals and can operate with crystal frequencies of less than 1 MHz to over 10

PARTS LIST FOR THE TTL CRYSTAL OSCILLATOR

RESISTORS

(All resistors are 1/4-watt, 5% units.)

R1, R2—560-ohm

R3—100,000-ohm

R4—1000-ohm

ADDITIONAL PARTS AND MATERIALS

U1—7400 quad two-input NAND gate, integrated circuit

Q1—2N3904 general-purpose NPN silicon transistor

C1, C2—6-50-pF, trimmer capacitor

C3, C4—0.1-μF, ceramic-disc capacitor

S1—SPST toggle switch

XTAL1—Crystal (see text)

Perfboard materials, enclosure, 5-volt power source, wire, solder, hardware, etc.

TWO-TRANSISTOR CRYSTAL OSCILLATOR

Our next item, see Fig. 2, is a two-transistor, crystal-oscillator circuit that works

SELECT 5 BOOKS

for only \$4⁹⁵

(values to \$129.70)
and get a **FREE Gift!**

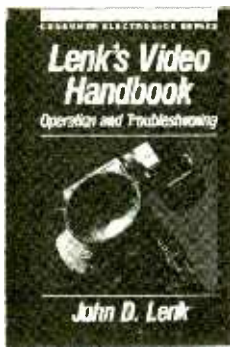
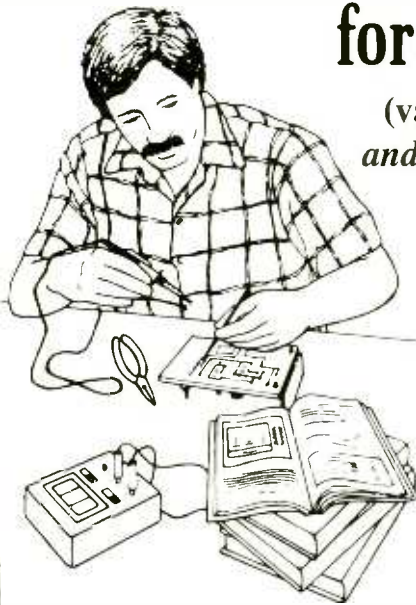

10018 \$39.95
Counts as 2



2803P \$17.95



2867P \$18.95

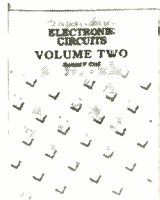

3138 \$60.00
Counts as 3



2800P \$16.95



3329 \$29.95
Counts as 2



3275 \$36.95
Counts as 2

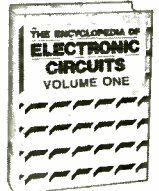

1938 \$60.00
Counts as 3



2987P \$16.95



3219 \$27.95
Counts as 2



3157P \$15.95



1604P \$17.95

Your most complete source for electronics books for over 25 years.

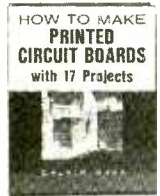

2898P \$15.95



1532P \$14.95

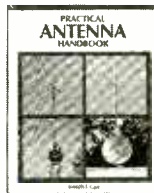

3270 \$32.95
Counts as 2



3241P \$16.95

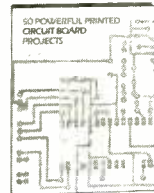

2972 \$23.95

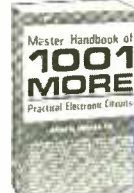

804P \$21.95
Counts as 2



2613P \$17.95



3260 \$22.95



3283 \$25.95
Counts as 2



3307 \$26.95
Counts as 2



3374P \$16.95

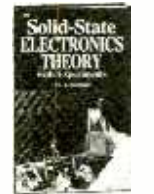

2926 \$25.95



3321P \$16.95



1197P \$15.95



3258 \$27.95
Counts as 2

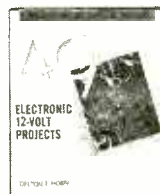

3265 \$22.95

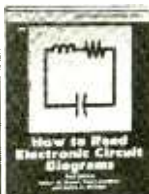

2830P \$14.95



FREE when you join!

15 Easy Electronic Projects From Delton T. Horn
Projects you can build—some unique, some old favorites—from the author's vast treasury of electronics know-how.

A \$7.95 Value!



Membership Benefits • Big Savings. In addition to this introductory offer, you keep saving substantially with members' prices of up to 50% off the publishers' prices. • **Bonus Books.** Starting immediately, you will be eligible for our Bonus Book Plan, with savings of up to 80% off publishers' prices. • **Club News Bulletins.** 15 times per year you will receive the Book Club News, describing all the current selections—mains, alternates, extras—plus bonus offers and special sales, with scores of titles to choose from. • **Automatic Order.** If you want the Main Selection, do nothing and it will be sent to you automatically. If you prefer another selection, or no book at all, simply indicate your choice on the reply form provided. You will have at least 10 days to decide. As a member, you agree to purchase at least 3 books within the next 12 months and may resign at any time thereafter. • **Ironclad No-Risk Guarantee.** If not satisfied with your books, return them within 10 days without obligation! • **Exceptional Quality.** All books are quality publishers' editions especially selected by our Editorial Board.

PE391

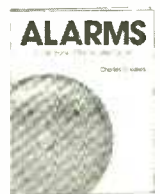

2996P \$13.95



3205 \$24.95



3355 \$26.95
Counts as 2

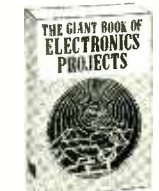

1367P \$24.95



2925P \$9.95



2331P \$16.95

A shipping/handling charge and sales tax will be added to all orders

©1991 ELECTRONICS BOOK CLUBSM

If card is missing, use this address to join:
ELECTRONICS BOOK CLUB, Blue Ridge Summit, PA 17294-C810

All books are hardcover unless number is followed by a "P" for paperback. (Publishers' Prices Shown)

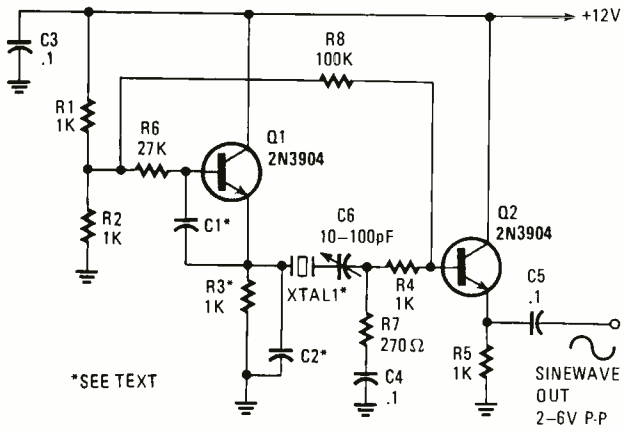

Fig. 2. Built around two general-purpose transistors, this oscillator produces a sine-wave output of from 2 to 6 volts peak-to-peak.

PARTS LIST FOR THE TWO-TRANSISTOR CRYSTAL OSCILLATOR

RESISTORS

(All resistors are 1/4-watt, 5% units.)

- R1-R5—1000-ohm
- R6—27,000-ohm
- R7—270-ohm
- R8—100,000-ohm

CAPACITORS

- C1, C2—See text
- C3, C5—0.1- μ F, ceramic disc
- C6—10- to 100-pF, trimmer

ADDITIONAL PARTS AND MATERIALS

- Q1, Q2—2N3904 general-purpose NPN silicon transistor
- XTAL1—See text
- Perfboard materials, enclosure, 12-volt power source, wire, solder, hardware, etc.

great, costs little, and uses no coils or chokes. Here again, the cost depends mainly on the crystal used, as the total cost of the other components (provided that you have a full junkbox to raid) should be no more than a couple of dollars.

Transistor Q1 and the few surrounding components make up the oscillator circuit. The ground return for the crystal is routed through C6, R7, and C4. At the junction of C6 and R7, which is a fairly low impedance point, the RF is fed to an emitter-follower amplifier, Q2. The shape of the waveform at the C6/R7 junction happens to be a near perfect sine wave. The output, at the emitter of Q2

varies in amplitude from about 2- to 6-volts peak-to-peak, depending on the crystal's Q and the values used for capacitors C1 and C2.

The values of C1 and C2 determine the frequency range that the circuit will cover. For crystal frequencies below 1 MHz, C1 and C2 should be 2700 pF (.0027 μ F). For frequencies of 1 MHz to about 5 MHz, use 680-pF capacitors; and for 5 MHz up to about 20 MHz, use 200-pF capacitors. You might try experimenting with values of those capacitors to obtain the best looking output waveform. Also, the setting of capacitor C6 will influence both the output level and waveform shape.

METAL DETECTOR

The next entry is one of my favorite gadgets—a simple two-transistor metal detector—which you can put together in an evening or two and enjoy using for hours on end. The circuit (see Fig. 3) probably won't lead you to a pot of gold, or any other treasure for that matter. But it can help locate wiring in the walls or pipes in the floor, and will cost you next to nothing to build. And if you happen to have a youngster under

foot with nothing to do, this circuit just might be the one gadget that will get junior outdoors and into a fun hobby.

In Fig. 3, transistor Q1 (a 2N3904 NPN device) is connected in a simple LC-oscillator circuit with the values of L1, C3, C4, and C9 determining the circuit's operating frequency. The oscillator's output is fed through C1 and R4 to a 455-kHz ceramic filter. When the oscillator is tuned to the filter's center frequen-

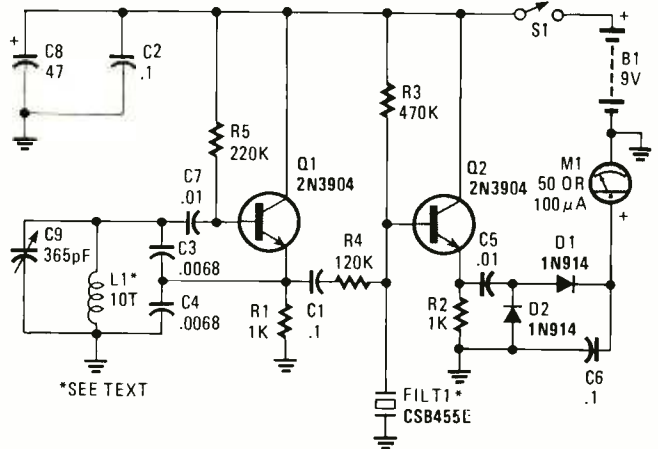

Fig. 3. The metal detector is little more than a simple oscillator circuit (built around Q1), whose output is fed to a meter (M1), causing it to deflect to about mid-scale. When the sense coil (L1) is brought near metal, the oscillator frequency changes, and that change causes the meter needle to move either up or down the scale depending on the type of metal detected.

PARTS LIST FOR THE METAL DETECTOR

RESISTORS

(All resistors are 1/4-watt, 5% units.)

- R1, R2—1000-ohm
- R3—470,000-ohm
- R4—120,000-ohm
- R5—220,000-ohm

CAPACITORS

- C1, C2, C6—0.1- μ F, ceramic-disc
- C3, C4—0.0068- μ F, 50-WVDC polystyrene
- C5, C7—0.01- μ F, ceramic-disc
- C8—47- μ F, 16-WVDC, electrolytic
- C9—365-pF variable (see text)

ADDITIONAL PARTS AND MATERIALS

- Q1, Q2—2N3904 general-purpose, NPN silicon transistor
- D1, D2—1N914 general-purpose, small-signal silicon diode
- L1—Search loop (see text)
- F1—455-kHz crystal-filter (Murata CSB455E or similar)
- B1—9-volt transistor-radio battery
- M1—50- to 100-mA meter (see text)
- Perfboard materials, enclosure, wire, solder, hardware, etc.

cy, the filter acts like a parallel tuned circuit and produces a high level 455-kHz signal at the junction of R3 and R4. The 455-kHz signal is fed to the base of Q2, which is configured as an emitter follower. The output of Q2 (taken from its emitter) is then converted to DC by D1, and from there, is applied to M1 (a 50- to 100- μ A meter).

With the oscillator operating at, or very near the filter's center frequency, the meter will read somewhere in the vicinity of mid-scale. But when any metal object larger than a BB is brought near the loop, the meter's reading will either increase or decrease, depending on the type of metal. The circuit will detect a penny two inches away or a "D"-cell battery at about five inches in open air.

The search loop is wound on a small diameter form that's best suited for locating smaller objects at close range, but a larger loop may be built to detect larger objects located at greater distances. A plastic end cap for a 4-inch PVC sewer pipe (which can be purchased at just about any plumbing-supply shop) can be used as the coil form for the search loop.

The search loop should be ten close-wound turns of number-26 enamel-coated copper wire wound around the bottom of the end cap and taped firmly in place. The electronics can be built on perfboard and should be housed in a metal cabinet.

Capacitor C1 can be any variable capacitor that you happen to find in your junkbox or one removed from an old broadcast-radio receiver. The 50- μ A meter movement can come from an older volt-ohm meter or from some other piece of retired gear. Several different 455-kHz ceramic filters were tried in

the circuit and all seemed to work just fine. If you can't locate a ceramic filter, just send an S.A.S.E. (self-addressed, stamped envelope) to me at "Circuit Circus," **Popular Electronics Magazine**, 500-B Bi-County Blvd., Farmingdale, NY 11735 and I'll send you one.

The loop should be located at least one foot away from the locator's cabinet, separated by a non-metal support. A wood dowel rod is a good choice. Run a twisted pair of unshielded wires between the loop and the circuit board.

If for some reason you don't get a meter reading when turning C9 through its rotation, it could be that the oscillator just isn't tuning to the filter's frequency. A frequency counter can be connected to the emitter of Q1 to see what signal (if any) is present. Or, if a counter isn't available, use a standard BC receiver and tune to the oscillator's second harmonic. If the oscillator is operating at 500 kHz, tune your radio to 1 MHz and you should hear the carrier. If the oscillator's frequency is too high, add capacitance across C9. If the frequency is too low, decrease C3 and C4.

Also if the meter won't quite make it to full scale, R4 can be reduced in value; if the needle bangs full scale, R4 can be increased.

Through a little experimenting, you'll soon determine the best method to use in tuning the locator for detecting the size and type of desired metal objects. The circuit is more sensitive when the tuning is adjusted so that the meter is at about half scale when no metals are present; at that setting, the circuit will indicate ferrous and non-ferrous metals by causing the meter to increase with one and decrease with the other. ■

ATTENTION! ELECTRONICS TECHNICIANS



EARN YOUR B.S.E.E. DEGREE

THROUGH HOME STUDY

Our New and Highly Effective Advanced-Placement Program for experienced Electronic Technicians grants credit for previous Schooling and Professional Experience, and can greatly reduce the time required to complete Program and reach graduation. No residence schooling required for qualified Electronic Technicians. Through this Special Program you can pull all of the loose ends of your electronics background together and earn your B.S.E.E. Degree. Upgrade your status and pay to the Engineering Level. Advance Rapidly! Many finish in 12 months or less. Students and graduates in all 50 States and throughout the World. Established Over 40 Years! Write for free Descriptive Literature

COOK'S INSTITUTE OF ELECTRONICS ENGINEERING

CI 4251 CYPRESS DRIVE
JACKSON, MISSISSIPPI 39212

CIRCLE 15 ON FREE INFORMATION CARD

SUPER LONG PLAY TAPE RECORDERS

12 Hour Model —
USES 120 TAPE
\$119.00*

Modified Panasonic Slimline, high quality AC-DC provide 6 continuous hours of quality recording & playback on each side of cassette for 12 hours total includes • Voice level control • Digital counter, etc. TDK — 120 Cassette Furnished.



PHONE RECORDING ADAPTER

Records calls automatically. All Solid state connects to your telephone jack and tape recorder. Starts recording when phone is lifted. Stops when you hang up. **\$28.50*** FCC APPROVED



VOX VOICE ACTIVATED CONTROL SWITCH

Solid state Self contained Adjustable sensitivity. Voices or other sounds automatically activate and control recorder. Uses either recorder or remote mike. **\$28.50***



*Add for ship & hdg Phone Adapter & Vox \$1.50 ea
Recorders \$4.00 ea Cal Res. add tax. Mail order. VISA
M/C COD's OK Money Back Guarantee Qty. disc.
avail. Dealer inquiries invited, Free data.

AMC SALES INC. Dept B 9335 Lubec St.
Box 928. Downey, CA 90241
Phone (213) 869-8519
FAX (213) 923-1478

CIRCLE 10 ON FREE INFORMATION CARD

SCANNER SCENE

By Marc Saxon

A High-Tech Scanner

Versatility is what the AOR model AR3000 scanner is all about. The state-of-the-art scanner is essentially a full-spectrum receiver that covers from 100 kHz straight through to 2036 MHz (2.036 GHz) without any gaps. Within that stupendous range, it operates in AM, SSB, NFM, WFM, and CW modes. It scans at 20 cps, and has fine-tuning increments down to 50-Hz accuracy. It can be manually tuned, or frequencies



With a scanning range of 100 kHz to 2036 MHz, and an optional frequency-logging and -analysis system, AOR's model AR3000 is truly a state-of-the-art scanner.

may be entered from the keyboard. The AR3000 has 400 memory channels, four priority channels, and four search-and-scan banks with lockout in the search mode.

Selectivity ratings are 2.4 kHz/–6 dB for SSB; 12 kHz/–6 dB for NFM/AM. Sensitivity is rated at 0.35 μ V for NFM modes; 1 μ V for WFM, SSB, AM, and CW modes. The circuitry includes no less than fifteen bandpass filters, and a GaAsFET RF amplifier.

There is an especially in-

teresting optional feature available for the AR3000—a computer-driven frequency-logging and -analysis system that consists of control software and serial-interface hardware. Two basic types of analysis and logging functions are offered in the package. First, the tabular method lists active stations by frequency, signal strength, date, and time, and even brings up a tape recording of the audio portion of the radio transmission. Second, the spectrum-analyzer type display shows received signals on a computer monitor as vertical spikes along a horizontal baseline, with the height of the spikes representing the relative strength of the signals. Those images can also be printed out on a dot-matrix or laser printer. Tabular data also can be output as hard copy or stored to disk. The RS232C interface allows for remote operation and future expansion capabilities. A transfer rate of 4800 baud is supported.

The basic AR3000 scanner carries a manufacturer's suggested retail price of \$995, with the optional data-logging and -analysis package adding an extra \$295. Both come from Ace Communications, Monitor Division, 10707 East 106th Street, Indianapolis, IN 46356. Their toll-free number is 1-800-445-7715. Ask them for more information.

HERE'S AN ODD ONE!

A letter from Darrel Tackett, Barberton, OH, said that not long ago he purchased a Regency R-4030 hand-

held scanner (a Bearcat BC-200XLT clone). It worked fine, but Darrel thought that perhaps the case might be developing minor cracks so he sent it back to Uniden. They said not to worry; there were no cracks, just some marks left from the mold. But they changed some parts, replacing R-215 and "MJAL," and realigned the unit.

Now, Darrel reports, he can't pick up certain stations unless he uses an outside antenna. He used to be able to copy them without the scanner's rubberized whip. He thinks the sensitivity of the set was definitely reduced by Uniden's efforts and can't understand why they felt the need to replace parts and realign a piece of equipment that had been working perfectly. He wants to know what to do next.

It's been said before, but not often enough: "If it ain't broke, don't fix it." Uniden probably thought that they were doing you a favor, but if they performed procedures you didn't request and lowered the capabilities of the scanner, then complain! Send it back and explain the situation, asking them to restore the unit's function to its status when you originally sent it in for them to (only) examine cracks in the case.

We discussed Darrel's letter because it is certainly not the first problem of its kind to be brought to our attention. The best bet, under similar circumstances, would be to specify that you don't want any electrical repairs or adjustments made to the equipment.

GALVESTON, GALVESTON!

A comprehensive listing of Galveston, TX frequencies was furnished to us by William J. Reagan of that city. We noted that the Galveston Police Department have Channel 1 on 460.20 MHz, Channel 2 on 460.30 MHz, Channel 3 on 460.225, and Channel 4 on 460.35 MHz. The Police Department supervisors are on 145.85 MHz, while the Fire Department uses 151.115 MHz. Listen for the Sheriff's Beach Patrol on 154.80 and 155.255 MHz. EMS operates on 155.055 MHz.

GOOD PICKINGS

We hardly recommend this as a method of getting electronics equipment, but G.B. of Everett, WA, tells us that the day before Christmas he happened to be passing by the dumpster in the back of a Radio Shack store. There he spied a used scanner that had been disposed of by the store. It needed some minor repairs—the set (and display) became intermittent after a few minutes of operation. Not bad for free, he feels, and the unit provided a good challenge to refurbish and repair. Since then, he's gone back several times and found assorted other items that were defective to some extent that the store had disposed of.

DOT'S NICE

You get used to hearing voice transmissions on a scanner, but a letter we received from Dr. E.M. Hurley of Mill Neck, NY, questions some CW that he hears about every half hour on 155.655 MHz, along with police transmissions. He can't copy code, so he can't tell us what the messages are about. But he wonders if we can tell him why those stations would use Morse code to send messages to police officers.

He asks, "Is it to maintain secrecy?"

Our guess is that what's being monitored aren't actual messages so much as the FCC-assigned call sign, transmitted automatically at regular intervals to satisfy federal identification requirements. That type of ID is used by quite a few stations in various services around the country. We also have heard on occasion automatic station ID's sent out in the form of a computer voice, which sometimes announces the licensee name and station location along with the station's assigned call sign.

Todd Marshall, who hails from Arizona, tells us that he enjoys monitoring the Border Patrol communications systems. He would like to know if any of their frequencies are more heavily used than others in connection with catching smugglers. We would suggest trying 165.875 and 165.975 MHz as possibilities, Todd.

WRITE TO US

We are always at your service here, and look forward to hearing your questions and ideas. Our address is *Scanner Scene*, **Popular Electronics**, 500-B Bi-County Blvd., Farmingdale, NY 11735. We look forward to hearing from you, and to seeing you again next month! ■

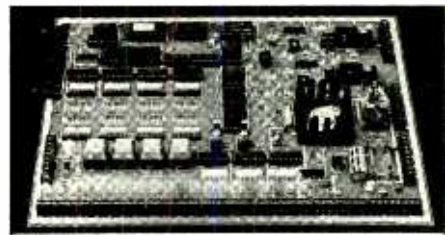
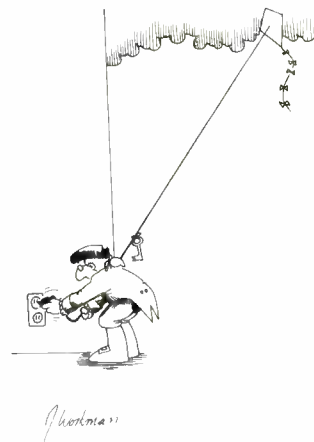

Knight Patrol™ Talking Home Alarm Kit

A high end alarm system at an affordable price!

Features include:

- ◆ State of the art PCF 8200 Speech Synthesizer
- ◆ 21 Sensor Zones, 2 Arming Circuits
- ◆ 2 Five Watt Audio Amplifiers
- ◆ Auxiliary Alarm
- ◆ Real Time 24 Hr. Clock
- ◆ A 10A & 3A Relay Circuit for Sirens, etc.
- ◆ Alert/Sleep Monitoring Modes (verbal status)
- ◆ Trigger Memory (verbal status)
- ◆ Self Diagnostics & Performance Monitoring
- ◆ Microprocessor Controlled
- ◆ Pleasant Female Voice
- ◆ Expandability & so much MORE!

Available as a kit or pre-assembled. Send \$3 for full-line catalog. A complete line of peripherals is also available. Complete circuit board kit \$220.00 + \$10.50 S & H. (CA residents add 6.75% tax) Complete systems starting from \$440.00. Instructional video tape (VHS \$9.95 + \$2.50 S & H)

Paladin Electronics

19425 B Soledad Cyn Rd
Suite 333 Dept PE
Contra Costa County, CA 94531

"We protect your castle"



CIRCLE 14 ON FREE INFORMATION CARD

There are two kinds of heart attack victims.

The quick and the dead.

When you're having a heart attack, getting to the hospital quickly can mean the difference between life and death. If you feel the symptoms, don't take chances—get to the hospital. New life-saving therapies are now available. But they have to be given early. For more information write us at: American Heart Association, 7320 Greenville Avenue, Box 14, Dallas, TX 75231.

*You can help prevent heart disease.
We can tell you how.*



**American Heart
Association**

This space provided as a public service.

PRODUCT TEST REPORT

(Continued from page 77)

noise ratio in the CD-player mode was 107.3 dB, while separation ranged from 106.4 dB to 112.2 dB, depending upon which channel (left or right) was measured. Distortion at the maximum recorded level was identical to that measured for the digital-audio

various modes and applications. Especially useful is a function chart on the back cover of the manual. It summarizes which functions are possible while playing each type of disc. For example, the chart shows that frame number search is possible with CAV videodiscs but not with CLV (constant linear velocity) ones. Conversely, time-number search is shown to

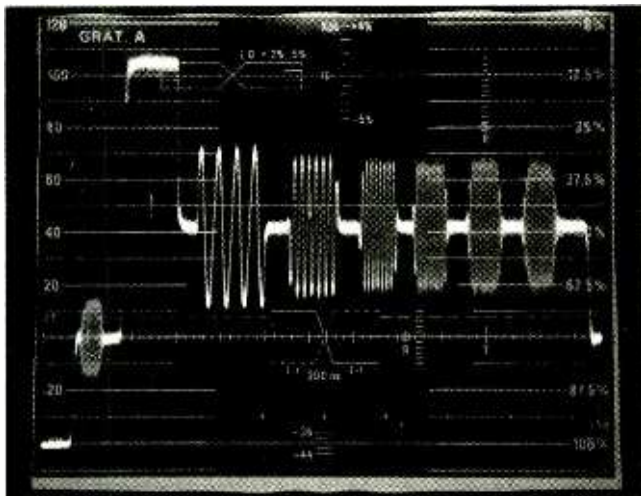

The video frequency response was measured using a multiburst test signal. At 4.2 MHz, the frequency response was down only 0.98 dB.

section when playing a videodisc, or 0.0027%.

Frequency response was essentially flat from 17 Hz to 20 kHz, staying within +0.01 dB and -0.32 dB.

Additional detailed measurements can be found elsewhere in this article. APEL pointed out in their report to us that all published specifications supplied by Pioneer in their owner's manual were either met or exceeded.

HANDS-ON TESTS

Both APEL and we were impressed with the extremely fast access time achieved by the laser pickup of this player. This was true whether we played CD's or laser videodiscs. The 40-page owner's manual is extremely well written, with excellent step-by-step instructions and diagrams for operating the player in its

be possible with CLV discs (and with digital-audio compact discs) but not with CAV discs, while still-step and multi-speed play is possible with CAV discs but not with CLV discs (and, of course, not with CD's).

If you've previously stayed away from videodisc players because you felt that there wasn't enough software available to make the format worthwhile, you'd best take another look at what's happened recently. There are literally thousands of individual videodiscs available and they contain the best in motion pictures, popular and classical concerts, and much more.

For more information on the Pioneer CLD-1080 Combination Laserdisc/CD player, contact the manufacturer directly, or circle No. 120 on the Free Information Card. ■

ANTIQUE RADIO

(Continued from page 79)

hobbyists whose experience with radio has been limited to low-voltage transistor sets might not approach the old equipment with enough respect. On top of that, high-voltage may appear at unexpected places, such as the adjustment screws of older IF transformers.

I'd like to devote a future column to safety concerns such as those, but in the meantime, let me strongly echo Mr. Owens' statements. If you're a beginning antique-radio repair technician, proceed with extreme caution!

Mr. Owens is willing to correspond with newcomers needing technical advice. Just include a S.A.S.E. for your reply. He also has a good collection of radio schematics; enclose \$1.00 per request to cover copying costs.



Reader Norm Lehfeltdt shows off his 1939-vintage Philco wireless turntable, which here sits atop a Philco model 37-116 console.

SHOW'N TELL TIME

Norm Lehfeltdt (757 Guerrero St, San Francisco, CA 94110) sent along a photo of his Philco wireless turntable (circa 1939). He used it to make me a tape dub of some Theramin music from an old 78 record. That'll be discussed in a later issue, when I get into the results of

the "Theremin contest." But for now, Norm would like to hear from anyone who can supply servicing information or anything else Philco may have published on the turntable. He's especially interested in locating a good original, or approved replacement, cartridge to replace the temporary one he now has installed.

And while we're talking about wireless Philco devices, I should mention a note I received from George H. Fathauer, the senior member of the father-and-son team that operates Antique Electronic Supply. George was responding to a question asked in a mailbag column some time back by reader Doug Robertson. Doug was curious about a label on his Philco model 41-226, which indicated that the set was built for TV sound and FM reception "the wireless way," when used with a Philco "picture receiver" or "FM converter."

Speaking from his experience as a Philco dealer during 1939-1942, the period during which Doug's set was manufactured, George doubts that the FM and TV accessory products were ever developed. The label was just part of a sales pitch aimed at overcoming the resistance of customers who were delaying radio purchases until TV or FM receiving equipment became available.

Nick Tonkin (Vancouver, WA) located a chrome-plated Philco intercom speaker/mike similar to the one first described in the December, 1988 column. In answer to your questions, Phil, the connecting cable in mine is cut short, but appears to be ordinary zip cord. I think the cable is original because it enters the unit through a neatly fitted strain-relief/grommet that's an integral part of the wire. Like yours, my unit has



Newly replaced red-plastic side pieces glow in the dark, providing a final touch of authenticity to George Rutkay's restored Seeburg "trashcan" jukebox.

a 1/4-inch hole in the bottom of the front cover's rim. I never noticed the opening until you called attention to it, and have no idea what it's for. Possibly some kind of a port to improve acoustical quality?

Reader George Rutkay (Brampton, Ontario, Canada) has made further progress on the restoration of his Seeburg model 148ML "trashcan"-style jukebox (see June, 1990). George accidentally discovered a jukebox-restoration shop in the basement of a small-town restaurant at which he happened to stop for lunch. The proprietor was able to recommend a source for the red-plastic side pieces needed to restore the "trashcan" to its original appearance. George proudly enclosed a shot of his box. The source: "The Jukebox Junction," Box 1081, Des Moines, IA 50311.

Some months ago, Edward G. Rountree (Route 1, Norris City, IL 62869) wrote that he had two complete coil sets for the Pilot Super Wasp, and would be interested in selling at the right price. Unfortunately, I wasn't able to publish the letter as soon as I got it, so this lead may now be a dead end. But if you need the coils, it's certainly worth a try! I'd suggest enclosing a S.A.S.E. with your inquiry. ■

Popular Electronics REPRINT BOOKSTORE

- | | |
|---|--|
| <input type="checkbox"/> 221 Popular Electronics (1991 back issues) \$4.00
Write in issues desired _____ | <input type="checkbox"/> 107 Radio-Electronics (1987 back issues) \$5.25
Write in issues desired _____ |
| <input type="checkbox"/> 220 Popular Electronics (1990 back issues) \$4.50
Write in issues desired _____ | <input type="checkbox"/> 106 Radio-Electronics (1986 back issues) \$5.50
Write in issues desired _____ |
| <input type="checkbox"/> 119 Popular Electronics (1989 back issues) \$4.75
Write in issues desired _____ | |
| <input type="checkbox"/> 118 Hands-On Electronics (1988 back issues)
Write in issues desired _____ \$5.00 | |
| <input type="checkbox"/> 117 Hands-On Electronics (1987 back issues)
Write in issues desired _____ \$5.25 | |
| <input type="checkbox"/> 116 Hands-On Electronics (1986 back issues)
Write in issues desired _____ \$5.50 | |
| <input type="checkbox"/> EH91 Experimenters Handbook (1991) \$4.50 | |
| <input type="checkbox"/> EH90 Experimenters Handbook (1990) \$5.00 | |
| <input type="checkbox"/> EH88 Experimenters Handbook (1988-89) \$5.50 | |
| <input type="checkbox"/> EH87 Experimenters Handbook (1987) \$6.00 | |
| <input type="checkbox"/> HH91 Popular Electronics Hobbyist Handbook (1991) \$5.00 | |
| <input type="checkbox"/> HH90 Popular Electronics Hobbyist Handbook (1990) \$5.50 | |
| <input type="checkbox"/> HH89 Popular Electronics Hobbyist Handbook (1989) \$6.00 | |
| <input type="checkbox"/> 126 Radio-Electronics Annual 1986 \$6.00 | |
| <input type="checkbox"/> 211 Radio-Electronics (1991 back issues) \$4.00
Write in issues desired _____ | |
| <input type="checkbox"/> 210 Radio-Electronics (1990 back issues) \$4.50
Write in issues desired _____ | |
| <input type="checkbox"/> 109 Radio-Electronics (1989 back issues) \$4.75
Write in issues desired _____ | |
| <input type="checkbox"/> 108 Radio-Electronics (1988 back issues) \$5.00
Write in issues desired _____ | |

REPRINTS REPRINTS

- | | |
|--|---|
| <input type="checkbox"/> 169 Think Tank (133 Circuits) \$3.50 | <input type="checkbox"/> 169A Think Tank Vol. 2 \$3.00 |
| <input type="checkbox"/> 168 Fact Cards (#34-66) \$4.00 | <input type="checkbox"/> 168C Fact Cards (#67-99) \$3.50 |
| <input type="checkbox"/> 168D Fact Cards (#100-132) \$3.50 | <input type="checkbox"/> 167 Designing With IC's \$4.00 |
| <input type="checkbox"/> 166 Collected Works of Mohammed Ullyses Fips (62 pages, April Fools Collection) \$5.00 | <input type="checkbox"/> 165 How to Repair CD Disc Players \$5.00 |
| <input type="checkbox"/> 164 Modern Electrics (April 1908) \$3.00 | <input type="checkbox"/> 163 Receiving Satellite TV \$5.00 |
| <input type="checkbox"/> 162 Build Your Own Satellite TV Receiver \$5.00 | <input type="checkbox"/> 161 Descrambling (Feb. 1984) \$3.00 |
| <input type="checkbox"/> 160 New Ideas - 42 Circuits \$3.50 | <input type="checkbox"/> 159 Low Frequency Receiving Techniques Building and using VLF Antennas \$5.00 |
| <input type="checkbox"/> 158 Electro Importing Co. Catalog (Circa 1918) \$5.95 | <input type="checkbox"/> 157 All About Kits \$2.00 |
| <input type="checkbox"/> 156 How To Make PC Boards \$2.00 | <input type="checkbox"/> 155 IBM Typewriter To Computer \$2.00 |
| <input type="checkbox"/> 154 How To Repair VCR's \$3.50 | <input type="checkbox"/> 150 Pay TV Decoder (1981) \$3.00 |

To order any of the items indicated above, check off the ones you want. Complete the order form below, include your payment, check or money order (DO NOT SEND CASH), and mail to **Popular Electronics**, Reprint Department, P.O. Box 4079, Farmingdale, NY 11735. Please allow 4-6 weeks for delivery.

If you need a copy of an article that is in an issue we indicate is unavailable you can order it directly from us. We charge 50¢ per page. Indicate the issue (month & year), pages and article desired. Include payment in full, plus shipping and handling charge. Make checks payable to Gernsback Publications, Inc.

ARTICLE _____

PAGES _____

MONTH _____

YEAR _____

TOTAL PAGES _____

@ 50¢ each

TOTAL PRICE _____

MAIL TO: Popular Electronics

Reprint Bookstore, P.O. Box 4079, Farmingdale NY 11735

All payments must be in U.S. funds

SHIPPING CHARGES IN USA & CANADA

\$0.01 to \$5.00	\$1.25	\$30.01 to 40.00	\$5.00
\$5.01 to \$10.00	\$2.00	\$40.01 to 50.00	\$6.00
\$10.01 to 20.00	\$3.00	\$50.01 and above	\$7.50
\$20.01 to 30.00	\$4.00		

SORRY — We only ship to USA & Canada

Total price of merchandise \$ _____
 Sales Tax (New York State Residents only) \$ _____
 Shipping Charge (see chart) \$ _____

Name _____ Total Enclosed \$ _____

Address _____

City _____ State _____ Zip _____

PE391

DIGITAL COURSE

(Continued from page 66)

elevation information are determined from shaft position.

A/D Converter Exercise. The majority of measurements, such as light, sound, heat, humidity, etc., yield analog voltages. In order to use such information with digital circuits, that information must be transformed into logic signals. A circuit capable of performing that conversion is the ADC0804, a TTL-compatible CMOS 8-bit successive-approximation A/D converter that provides an 8-bit binary output. The ADC0804 has a built in clock generator (whose frequency is set by an external RC network), several flip-flops, a binary ladder/decoder, a comparator, a successive-approximation register, an 8-bit shift register, output latches, and more.

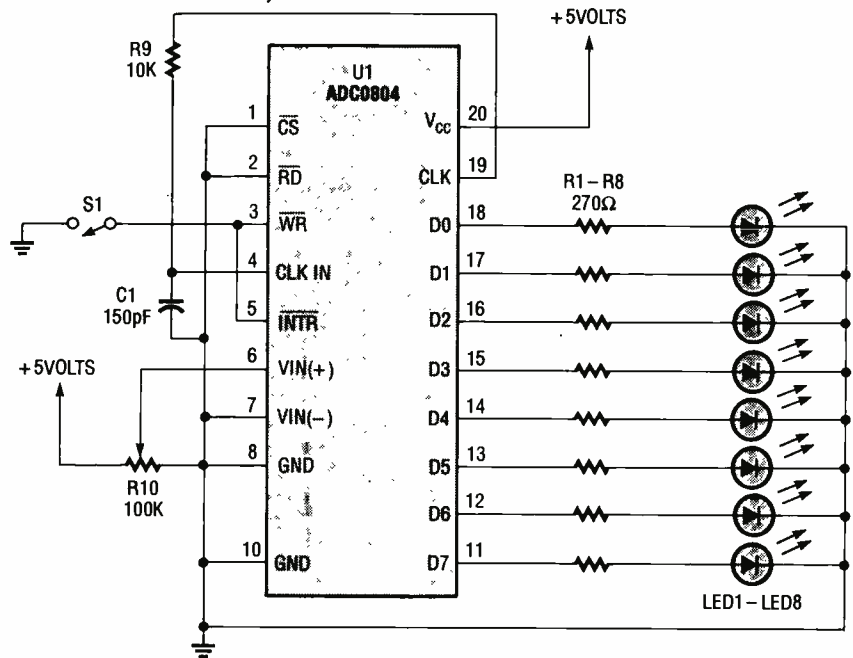

Fig. 6. The ADC0804 is set up in the free-running mode to provide an 8-bit output.

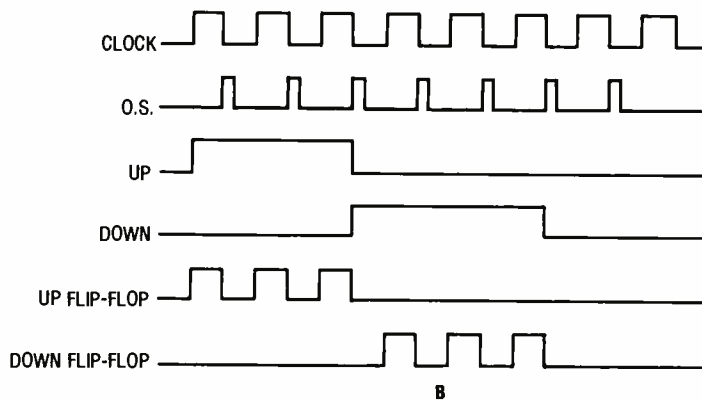
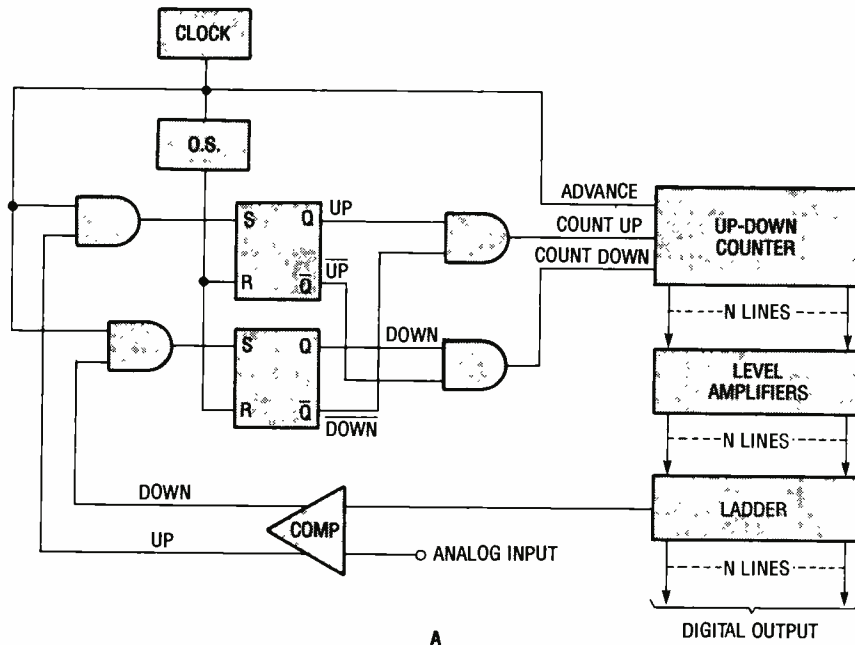

Fig. 5. A continuous A/D converter (A) and its associated waveforms (B).

Figure 6 shows the ADC0804 set up to provide an 8-bit digital output based on an analog voltage derived from potentiometer R10. The ADC0804 is set up in the free-running mode by connecting the RD and CS pins to ground. In that mode the IC will continually perform AD conversions. (By the way, switch S1 must be momentarily closed to ensure the start-up of the conversion process.)

Breadboard the circuit in Fig. 6, and apply power (in this case, +5 volts from the previously breadboarded power supply). Monitor the analog input voltage of U1 at pin 6 (V_{in}) using a voltmeter. Adjust R10 so that the analog input to the converter at pin 6 is 2.5 volts. If no activity is detected, momentarily close S1. With an analog input of 2.5 volts, what is the digital output, as indicated by the LED's?

Record the analog input and digital output for several settings of R10. Remove power from the circuit. Calculate the analog voltage value from the digital outputs by first changing the digital value into a decimal number. Then divide the decimal number by 256, and multiply the resulting value by the reference voltage (+5 volts) or in mathematical terms:

$$V_{in} = \text{ADC output} \times 5/256$$

How does your calculated output value compare with the known analog input value? How accurately do your calculations reflect the analog input voltages?

FUN SOFTWARE

(Continued from page 83)

completely different attitude than you "feel." That's vertigo, and is quite common in real flying when you have no horizon or ground reference.

If you've ever dreamed of rumbling through the skies, soaring, swooping, and diving with your guns thundering and missiles blazing, you'll love Stormovik. You'll feel the terror of trying to elude heat-seeking or radar-directed missiles, and experience the elation of blasting an enemy barge or tank. Or you could get "killed" and watch your own funeral, or be sent on guard duty for performing badly on a mission. Or you could get a medal and promotion.

While you don't need to have a fast computer, VGA graphics, or a hard drive to fly Stormovik, you are well advised to have all of these. Screen updating is choppy on a slow machine, CGA only offers four colors, and floppy drives cause significant delays when you perform some optional functions (like looking at a map of your operating area to see where you are). Besides, if using floppies, you'll go out of your mind swapping disks.

If you are using a joystick, be sure to calibrate it carefully, using the supplied JTUNER.EXE program, before jumping into Stormovik. With the joystick properly calibrated (which will probably involve adjustment of the stick's trim controls), you'll have a solid, stable, responsive aircraft. An improperly calibrated joystick will cause constant stick pressure on your part to prevent turning, diving, or climbing. Calibrating your joystick before flight has the same effect as trimming a real aircraft while in flight; all

control forces are neutralized.

Before you try flying Stormovik, spend an hour or two reading the excellent 64-page staple-bound 8.5-inch by 6.5-inch manual. Heavily illustrated, and with detailed descriptions of all aircraft instruments, displays, controls and armament, the manual contains a wealth of information. It is also an interesting blend of well-written fact and fiction.

My advice is to read through the manual, try flying Stormovik, then return to the manual to clear up the confusion you will certainly have on your first flights. I spent several hours flying Stormovik and still kept discovering new features. For example, in addition to looking forward through the cockpit windscreen, there are eleven other viewpoints, most with zoom capability!

Although the three 360K 5.25-inch floppy disks supplied are not copy protected, you'll need a Russian-English Dictionary, scattered through the pages of the manual, to find a random password. If you need them, two 720K 3.5-inch disks are available for an extra \$7.50.

There are plenty of missions! Each of the three combat years has ten different missions, as well as a practice session. Once you select the year (from a 1991, 1992, or 1993 Pravda newspaper screen), and select a mission for that year, you are presented with a mission summary and a mission map showing your takeoff airfield, your target, and your landing field. Then you arm your aircraft, selecting from an enormous collection of weaponry (or choose the default weapons already slung on your aircraft's ten wing hard-points), and you find yourself sitting on the run-

way, engine idling, ready for takeoff.

Firewall the throttle, lift off, raise your wheels, and set your course to the first waypoint. You can roll, loop, Immelmann, and make tight turns with ease. This plane is a real pleasure to fly! The HUD (head-up display) shows considerable information, but you also have a "full panel" of instruments (except for a turn-ball indicator.) Speed is in kilometers-per-hour and altitude is in meters. I was able to push this crate up to 980 km/h and pull 6 g's in a tight turn.

Effective sound and music is provided throughout the program, and enhanced sound is available if you have a Tandy machine, or AdLib or CMS sound boards installed in your computer.

Some of the panel instruments are difficult to read, but the HUD is very clear.

When you have a horizon, there is no problem controlling the aircraft, but you have no control of whether your mission will be flown at night or bad weather, so instrument flying may be necessary. Your Stormovik is loaded with weapons of many types, and you can use radar targeting. You'll have to keep on your toes to avoid enemy infrared and radar-guided missiles.

Everything considered, Stormovik (when used with a hard drive, VGA, and a 286 or better machine) is among those at the top of my list of flight simulators.

(Distributed by Electronic Arts, 1820 Gateway Drive, San Mateo, CA 94404, Tel. 800-245-4525 M-F 8AM-5PM Pacific Time. Retail Price: IBM PC/Tandy/Compatibles, \$49.95. Color-graphics board required.)

CIRCLE 132 ON FREE INFORMATION CARD

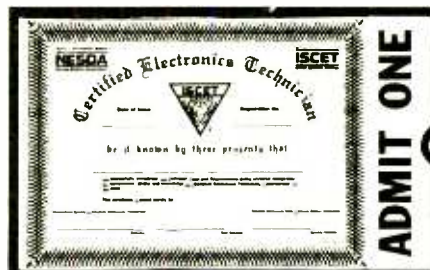

Your Ticket To

SUCCESS

Over 25,000 technicians have gained admittance worldwide as certified professionals. Let your ticket start opening doors for you.

ISCT offers Journeyman certification in Consumer Electronics, Industrial, Medical, Communications, MATV, Radar, Computer, and Video. For more information, contact the International Society of Certified Electronics Technicians, 2708 West Berry St., Fort Worth, TX 76109 • (817) 921-9101.

Name _____
Address _____
City _____
State _____ Zip _____

Send material about ISCT and becoming certified.

Send one "Study Guide for the Associate Level CET Test." Enclosed is \$10 (inc. postage).

SPEAKERS

(Continued from page 39)

components and well-designed, well-built crossovers and cabinets. The system sounded harsh at the top end, however. Measurements using sine-wave signals did not reveal the problem. After quite a lot of head-scratching, I determined that the problem was tweeter resonance. I was crossing from the midrange into the tweeter at 2500 Hz using a second-order crossover. The tweeter's resonant frequency was 1600 Hz. What was actually happening was that the tweeter was receiving enough energy at 1600 Hz to make the voice coil move far beyond its linear range. As a result, the tweeter was producing a lot of distortion whenever the music had frequencies around 1600 Hz. Figure 12 shows a notch-filter circuit that can be added to the crossover across the tweeter's resonant frequency. The design equations are:

$$C_N = \frac{1}{2\pi R_E Q_{es} f_s}$$

$$L_N = \frac{Q_{es} R_E}{f_s}$$

$$R_N = R_E + \frac{Q_{es} R_E}{Q_{ms}}$$

where R_E is the speaker's DC resistance, Q_{es} and Q_{ms} are the electrical and mechanical Q's of the speaker, and f_s is the speaker's resonant frequency.

Those characteristics should be available from the speaker's manufacturer, but you can measure R_E using a digital multimeter, for yourself. You can also find f_s by using the test setup shown back in Fig. 3. Adjust the signal generator's frequency for the lowest current (voltmeter-ammeter method) or the highest voltage across the resistor (resistance-voltmeter method). "Guess" values of Q_{es} and Q_{ms} would be about 1.2 and 0.7, respectively, for typical dome tweeters. Fortunately, guessing wrong on the Q's will not seriously affect the circuit's operation.

The notch-filter circuit can also be used with the midrange driver, but it is seldom needed there unless a dome-type midrange is used. Cone and horn midrange units usually have very well-damped resonances that don't cause problems.

If a second-order network is better

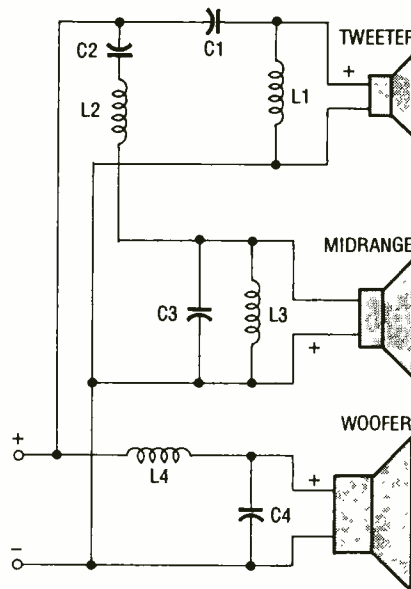

Fig. 11. A three-way second-order crossover has a pretty impressive name but it's pretty easy to build. Note the reversed midrange polarity.

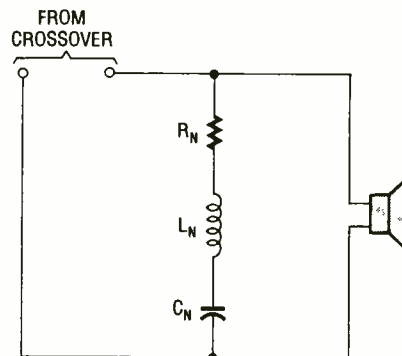

Fig. 12. A notch filter like this one can be used to stop annoying resonance.

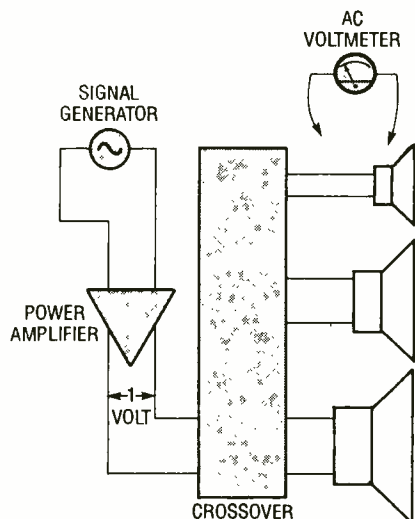

Fig. 13. This crossover test setup is easy to arrange and use. Be sure your power amplifier is supplying no more than one volt before connecting the crossover.

than a first-order one, wouldn't a third (or fourth or fifth) be better still? Perhaps marginally so, but each time you add an inductor in series with a speaker, you add some resistance and reduce the damping factor, so there's a point of diminishing returns. Many designers believe that if you need more than a second-order crossover, you should use an active circuit; once again, active crossovers are a subject for another time.

Selecting Drivers. We've left one of the most important concerns for last: how do you choose a woofer, midrange, and tweeter that will sound good together? First, you make sure that the three have overlapping responses. Preferably, you will have published response curves at your disposal that you can use to verify this, but at least you can check the stated response specifications. Then you can place the crossover frequencies in the middle of the overlaps. (It should go without saying that you don't want speakers with published response curves that have serious humps or dips in the middle.)

Second, the woofer and tweeter should have the same sensitivity ratings (given in dB at 1 watt from a distance of 1 meter). As mentioned earlier, the midrange should be 2 dB less sensitive than the woofer and tweeter, because three-way crossover networks actually have a 2-dB gain in their midrange section.

Finally, all three speakers should be rated for at least the minimum power you plan on using. Midrange and high-frequency speakers often have two power ratings: an actual power rating and a "system" power rating. As an example, a tweeter rated for use in a 100-watt system may have an actual power rating of about 6 watts, provided that a second-order crossover of 300 Hz or higher is used.

Building and Testing. When you build a crossover network, mount the components on a plywood board that can be screwed to the inside of the speaker cabinet, preferably with some sponge weatherstrip underneath the board to suppress rattles. You can mount the components using hot-melt glue or silicone "bathtub caulk." Always mount adjacent coils at right angles to each other to prevent magnetic interaction.

Once you have built the crossover network, it pays to make a few mea-

surements before you hook up the stereo for a sound check. Figure 13 shows a test setup that you can use to make the test. What you're trying to verify is that the crossover works as expected.

While slowly varying the frequency from one half to two times the low crossover frequency, measure the AC voltage at the woofer terminals. That voltage should start dropping just below the crossover frequency, and should drop rapidly above it. Do the same with the midrange. It should have a low voltage at half the lower crossover frequency, rising as the frequency increases, then leveling out above the crossover frequency. Check the midrange and tweeter sections in the same way, but this time varying the frequency from half to twice the upper crossover frequency. Any wiring errors you may have made can be discovered by these tests. (I once blew an amplifier by mis-wiring a crossover network so that it presented too low an impedance to the amp; a 15-minute test is cheap insurance.)

If you are really interested in crossover design, there has been a lot of valuable work published in the *Journal of the Audio Engineering Society* in the last few years. Much of this is summarized in Vance Dickason's *Loudspeaker Design Cookbook*, published by the Marshall Jones Company of Francestown, N.H. There's also some good info in Badmaieff/Davis', *How to Build Loudspeaker Enclosures*, published by Howard Sams.

Well, I guess you're wondering about my young friend and his girl's ex-speaker system. Once he found out what the problem was, he decided to use a simple capacitive crossover like the one that was originally in the system, but he did buy 100-volt capacitors. Then he decided to add midrange units. He wasn't very good with a saber saw. Oh well ■

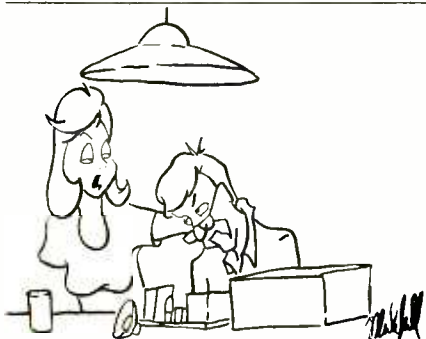

"Why can't you be obsessed with cars like a normal man?"

ELIMINATING INTERFERENCE

(Continued from page 69)

a large number of signals get together in one system, intermodulation is a possibility, and that means signals outside of the official spectrum can be generated. The problem is that signals leak out of the cable TV system, and interfere with your receiver. The only thing that you can do legally is to complain to the cable operator and insist they eliminate the interference. Fortunately, the FCC is your ally: by law, the operator must keep the signals home!

Other Culprits. It is likely that most American homes today are equipped with microwave ovens. They use a magnetron tube to produce several-hundred watts of microwave power on a frequency of approximately 2,450-MHz. The high voltage applied to the magnetron is typically pulsating DC. It is that pulsating DC that causes "hash" in radio receivers. Although better-quality microwave ovens are equipped with EMI filters, many are not. However, most manufacturers or servicers of microwave ovens can install EMI filters inside the oven. Alternatively, one of the EMI filters we've shown can be used.

The proliferation of personal computers has greatly increased the amount of noise in the radio spectrum. The noise is caused by the digital pulses generated by their internal circuits. Older machines, which use internal clock frequencies of 1 to 4.77 MHz (like the original IBM-PC), wipe out large portions of the AM and shortwave bands. If you doubt that, try using an AM radio near a computer! Later-model computers (XT-turbo, AT, etc.) use higher clock frequencies (e.g. 8, 10, 12, 16, 25, or 33 MHz), and they can wipe out the VHF bands—including the FM-broadcast band—as well.

Most of the noise produced by the computer is radiated through the power line or from the keyboard cable. In the latter case, make sure that a shielded keyboard cable is used. Power-line noise can be stopped by using the EMI filters discussed earlier.

Printers or, more commonly, printer cables are another source of noise. If the cable between the computer and the printer is not shielded, then replace it with a shielded version. Otherwise, you might want to consider a ferrite clamp-on filter bar such as the Amidon 2X-43 or equivalent. ■

CLASSIC MILK DROP

(Continued from page 42)

power as before. Place it near the pen light and aim it downward toward the plate.

Your camera should have a macro-focusing lens with at least a 100-mm focal length. The falling milk splashes, and the longer focal length will keep the lens surfaces at a relatively safe distance. Load the camera with ISO/100-speed film.

Turn off the room lights and open the burette slightly to allow one drop to fall about every one to two seconds. Move the burette until you see the shadows of the falling drops cross the photocell. The flash should fire as each drop passes. Adjust the delay knob until you see



This milk crown—a drop of milk actually splashing off a solid surface—is but one example of an action that requires split-second timing to capture on film.

the "crown" splash. Your vision persistence will hold the image long enough to see the splash clearly.

Once you have the delay set to your liking, simply set your camera's shutter to "B" and open it just long enough to record the next splash. Set the aperture as small as possible for maximum depth of field. Don't let more than a thin layer of milk accumulate in the plate. Too much milk makes the "crowns" less spectacular. To get a cone-shaped splash, make the milk deeper.

Timing is quite important to catch the splash. Since the tolerance of electrolytic capacitors tends to be pretty wide, you may need to make R3 a bit larger or smaller to get the proper time delay. Otherwise, you can raise or lower the height of the burette until you see the splash. ■

LAVA LAMP

(Continued from page 33)

shown in Fig. 1. It should be about 10-inches high, although the taller the bottle the better. Fill it partially with brine, add about 150 milliliters of benzyl alcohol (dyed red), and then fill the bottle up with brine. Leave about 1-inch of air on top to buffer expansion; note that the bubble size is influenced by the amount of air space.

Open a 1 pint (or larger) tin can, remove the lid completely, and remove the contents. Clean the can thoroughly and cut (or drill and file) a hole in the bottom. That hole should be as large as possible, but a metal lip must remain; that lip will be used to support the beverage bottle chosen when the can is inverted. Be sure to remove any sharp edges from the hole before proceeding.

Cut a circular piece of wood, about 4-5-inches in diameter, from a piece of scrap plywood of suitable size. Mount a ceramic light fixture at the center of the board. Drill a hole in the side of the can (toward the open, top end) that's large

enough for a power cord. Fit the hole with a grommet, feed a length of power cord through the hole, and connect the wire to the terminals on the fixture. Screw a 40-watt bulb into the fixture. Invert the can (open end down), place it over the fixture and bulb, and center it. Glue the can to the board using epoxy cement.

Create a gasket from a thin piece of foam rubber and place it on the can's lip. The gasket's function is to keep light from escaping around the bottom of the bottle. Place the bottle on the can assembly, plug in the light source, and soon your lamp should be bubbling away.

Improvements. If your bottle is tall enough, or you don't have the lamp running all the time, your Lava Lamp may work well exactly as described. However, the key to the lamp's operation is the temperature within the bottle. It is best to operate the unit at the lowest temperature possible since at lower temperatures, separation appears to be best and sticking to the walls is reduced. And if things get too warm, after a while the benzyl alcohol will simply

accumulate at the top. That's particularly likely to happen if the bottle is too short.

There are a couple of ways of combating this. One is to use a cooling fan at the top. Another is simply to turn off the lamp and let things cool down. But perhaps the best approach is to use a simple lamp-dimmer circuit to regulate the temperature. One suitable circuit is shown in Fig. 2, but just about any lamp dimmer could be used. With the lamp dimmer, the unit can be turned on at full brilliance to get things warmed up, and then the wattage can be reduced to the point where things run continuously.

If the lamp doesn't get things going fast enough to suit you, almost instant warming up can be had by means of a hot-air blower or hair drier. The hot air should be directed only toward the red layer of benzyl alcohol that sits on the bottom when the lamp is cool.

If available, a trace of antioxidant, such as BHT or BHA, can be added. In some of my experiments, I used some fluorescein sodium, a pink dye that gives the salt water a beautiful greenish color that contrasts even better with the red. ■

CHEAP LINK

(Continued from page 72)

regular communication programs, but they were either too complicated, too slow, or, more commonly, both.

Several were shareware programs available from bulletin boards and public domain vendors. Of those I tried, I was shocked at the complexity and poor documentation of some of them. One had great documentation, but I couldn't get the program to work. Another required special drivers and modification of your CONFIG.SYS file.

I only found one free public-domain program from such sources that worked at high speed and was relatively easy to use. However, the documentation was outdated and incorrect for the version, and I had to do considerable head-scratching to make it work. Then I found it only transferred a single file at a time, and had to be reloaded on both computers for each file. That made it unacceptable to me.

I was close to giving up when I contacted Bob Jack, who wrote my favorite telecommunications program, OPUS 6/7 (Sanyo MBC-55X) and OPUS 8 (IBM PC). Because of its simplicity, I had pret-

ty much decided to recommend OPUS 8 for this article even though it was limited to modem speeds.

But Bob told me he no longer sold OPUS 8. However, when I explained my frustration with finding a simple transfer program, Bob told me about a program he wrote a couple of years ago. It was designed exclusively for file transfer, using its own proprietary protocol, and would not support modem use. When he told me he sold it for under \$20, I had him send me a copy.

This program, called by the unlikely name of Saffron, is heads and shoulders above all the others I tried. It is incredibly easy to use, and transfers any file (program or data) at 115,200 baud (about 15,000 characters per second).

Furthermore, Saffron allows you to have either machine act as the "master" or "slave" at any time. You can perform the various file-management functions on any drive on either machine from either machine—all at blinding speed.

Saffron version 3.0's documentation (on the disk) is only 15 sheets, many of them partly blank, and the program is so intuitive that you probably won't need the documentation after brief familiarization with Saffron's capabilities.

There is only one program file (instead of the half-dozen or more with most other programs I tried), and no installation is required.

I tested Saffron on all possible matings of my four PC-compatible machines (PC/AT, PC/XT, Toshiba T1000 laptop, Microgold Voyager 286/12 laptop) using three-wire cables. On the T1000 I had to use its Chad program with color-on-color mode 2 to see the reverse-video highlighted selections. Except for having to set a sync bit (a program option) at 15,200 bps for a slow 4.77MHz XT, Saffron worked with all its default settings. For this application, the program is a winner!

Saffron is available only directly from Bob Jack Software, 8371 White Road, Burbank, OH 44214. Phone: 216-948-2059. It is supplied on a 360K, 5.25-inch diskette for \$19.95, postpaid. Add \$2 for both a 5.25-inch and a 720K 3.5-inch microdiskette. (Ohio residents add local sales tax.)

Other programs may require a full null-modem adapter or cable with more than three wires. If you follow the steps we've laid out for determining what you need, you should have no problem setting up your own PC-to-PC file-transfer system. ■

ELECTRONICS MARKET PLACE

FOR SALE

DESCRAMBLERS. All brands. Special: Combo Jerrold 400 and SB3 \$165.00. Complete cable descrambler kit \$39.00. Complete satellite descrambler kit \$45.00. Free catalog. **MJH INDUSTRY**, Box 531, Bronx, NY 10461-0208.

CABLE descrambler liquidation. Major makes and models available. Industry pricing! (Example: Hamlin Combo's, \$44 each... Minimum 10 orders). Call **WEST COAST ELECTRONICS**, 1 (800) 628-9656.

PRINTED circuit boards etched & drilled. Free delivery. **K & F ELECTRONICS, INC.**, 33041 Groesbeck, Fraser, MI 48026. (313) 294-8720.

ELECTRONIC parts kits, security products. Free catalog. No minimum orders. **WELSH ELECTRONICS**, 620 Olive Lane, Ambridge, PA 15003-2458.

CB RADIO OWNERS!

We specialize in a wide variety of technical information, parts and services for CB radios. 10-Meter and FM conversion kits, repair books, plans, high-performance accessories. Thousands of satisfied customers since 1976! Catalog \$2.

CBC INTERNATIONAL
P.O. BOX 31500PE, PHOENIX, AZ 85046

CABLE descramblers (Jerrold) from \$40.00. Tocom VIP test chip. Fully activates unit. \$50.00. Call (213) 867-0081.

SECRET scanner frequencies: Directories list federal, police, surveillance, bugging, channels. Big free catalog. **CRB**, Box 56-PE, Commack, NY 11725.

FANTASTIC Books! "Gadgets Goldmine" \$17.50. "Homemade Holograms" \$14.50. "Build Your Own Laser, Phaser, Ion Ray Gun" \$17.50. "Robot Builders Bonanza" \$16.50. "Active Filter Cookbook" \$15.50. "Video Scrambling/Descrambling" \$18.50. "Satellite TV Handbook" \$16.50. Softbounds, postpaid. **Satisfaction Guaranteed!** Catalog \$1.00, free with order. **INDUSTRIAL MICRO**, Box 596-E, Logan, Utah 84321. (801) 753-2321.

CB DX 1990's, get more out of your radio. **CBR**, Box 212, Rochelle Park, NJ 07662. Free catalog.

FREE programs!! Free disks!! Choose game, utility, or business. And we will send you an IBM compatible program free. On 5-1/4" 360K or 3-1/2" 720K disk. You choose category, we choose program. Also get our electronics surplus/closeouts catalog and rental/shareware catalogs on another disk free! Just send \$2.00 (refundable for shipping!) **BEACH RADIO**, PO box 548, Boston, MA 02112-0548.

STOP unwanted use of long distance with simple telephone product. Free details. **PO BOX 504**, Plattsburgh, NY 12903.

LEARNING electronics troubleshooting? Basic electronics simulations and problems program can help. PC/MSDOS \$32.95 EES-PE3, POB 1391, Lubbock, TX 79408.

CONVERTERS all major brands info + orders 1 (800) 782-0552 **FREEWAY INC.** (s.m.p.), PO 5036, Burnsville, MN 55337. No MN sales.

PRINTED circuit boards — etched, drilled, tin plated. Single sided \$1.25/sq. inch. Free shipping. **CHELCO ELECTRONICS**, 61 Water Street, Mayville, NY 14757. (716) 753-3200.

FREE Catalog: Save hundreds on sought after electronic, electro mechanical, and computer related hardware and components — including hard-to-find items. Call toll free: 1 (800) 776-3700. **AMERICAN DESIGN COMPONENTS/Dept.** 114-031, 315 Fairview Avenue, Fairview, NJ 07022.

HUGE 88 page communications catalog of short-wave, amateur and scanner equipment. Antennas, books and accessories too. Send \$1.00 to: **UNIVERSAL RADIO**, 1280 Aida Drive, Dept. PE, Reynoldsburg, OH 43068.

FREE CATALOG

FAMOUS "FIRESTIK" BRAND CB ANTENNAS AND ACCESSORIES. QUALITY PRODUCTS FOR THE SERIOUS CB'er. SINCE 1962

FIRESTIK ANTENNA COMPANY
2614 EAST ADAMS
PHOENIX, ARIZONA 85034

IBM PC video digitizer, connects through printer port. 640 by 480 resolution. 256 gray levels \$89.98. Demo disk \$3.00. **COLORBURST**, Box 3091, Nashua, NH 03061.

FREE lists, new merchandise, discounted prices! **New York surplus electronics warehouse now open to the public!** Electronics, computer products, fans, motors, power supplies, switches, transformers, speakers, semiconductors, etc. **ELECTRONIC COMPONENTS TRADING CORP.**, 44 V Jefryn Blvd., Deer Park, NY 11729. 1 (800) 942-9439, NY (516) 242-7733.

REMOTE car starter. Complete devices, or plan. Plan includes auto, device schematics, PCB template, parts/suppliers list, diagrams, instructions, photos. \$19.90. 414 Alva Dr., Grand Prairie, TX 75051. (214) 642-0338.

CABLE TV DESCRAMBLERS! BARGAIN HEADQUARTERS!



- JERROLD™ • TOCOM • HAMLIN
- OAK • ZENITH
- SCIENTIFIC ATLANTA

6 month warranty! We ship C.O.D.!
Lowest retail/wholesale prices!

FREE CATALOG:
Global Cable Network
1032 Irving St. Suite 109
S.F., CA 94122
NO CALIFORNIA SALES!!!

ORDER TODAY! 800-327-8544

WANTED

INVENTORS! Have an idea? Call **IMPAC** for free information package. US/Canada: 1 (800) 225-5800 (24 hours!).

HAVE a new idea? Invention? Call **THE "CONCEPT NETWORK"** for free confidential kit at 1 (800) 835-2246 ext. 197 US/Canada 24 Hrs. day.

NEED help with your electronic project, schematic or PCB artwork? Write to **TOP SECURITY**, PO Box 5275, Flint, MI 48505.

MITCHELL transistor radios models 1101, 1102 and 1103. Any condition. **JEROME ROACH**, 8640 East Florence Ave., Downey, CA 90240.

AUTOMATION

\$460 Dual stepper motor kit connects to PC. \$700 XY positioning table plus other low cost automation products. Perfect for engineers and educators. **ARRICK ROBOTICS** (817) 571-4528.

CABLE TV CONVERTERS WHY PAY A HIGH MONTHLY FEE?

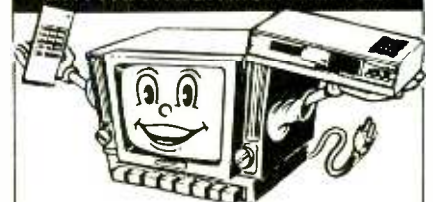

All Jerrold, Oak, Hamlin, Zenith, Scientific Atlanta, Magnavox and all specialized cable equipment available for shipment within 24 hours. For fast service MC / VISA or C.O.D. telephone orders accepted (800) 648-3030 60 Day Guarantee (Quantity Discounts) 8 A.M. to 5 P.M. C.S.T. **CLOSED WEEK-ENDS.** Send self-addressed Stamped envelope (60¢ postage) for Catalog

MIDWEST ELECTRONICS INC.
P.O. Box 5000
Suite 311 (PE)
Carpentersville, IL 60110

No Illinois Orders Accepted.

HOW-TO MANUALS

NEW! How to pay for college full-size manual by former university financial aid counselor, M. Educ.! Completely comprehensive steps, explanations, tips, definitions, equations. Finally, the straight inside story. Courageously truthful planning resource. Maximize free money efficiency. Unparalleled. Educate someone you love. Protect high school sophomores, juniors, seniors now with information that will prevent financial panic in their college freshman year. Perfect turning point gift! Avoid crippling official information flaws, national aid delivery crisis, college academic jeopardy due to financial aid uncertainty. **Your financial, academic survival edge!** Crucial timetable, updates. Order today! **Full money-back guarantee.** \$22.95 plus \$3.00 handling, shipping. **SMITH PUBLICATIONS**, Box 5448, 2143 Melrose Court, Norman, OK 73070.

Quality Microwave TV Antennas

WIRELESS CABLE - IFTS - MMDS - Amateur TV
Ultra High Gain 50db(+) • Tunable 1.9 to 2.7 Ghz

- 36-Channel System Complete \$149.95
- 12-Channel System Complete \$114.95
- Call or write (SASE) for "FREE" Catalog

PHILLIPS-TECH ELECTRONICS
P.O. Box 8533 • Scottsdale, AZ 85252
(602) 947-7700 (\$3.00 Credit all phone orders)
MasterCard • Visa • CDD's • Quantity Pricing

LIFETIME WARRANTY

SATELLITE TV

FREE catalog — Do-it-yourself save 40—60% lowest prices world wide, systems, upgrades, parts, all major brands factory fresh and warranted. **SKY-VISION INC.**, 2008 Collegeway, Fergus Falls, MN 56537. 1 (800) 334-6455.

LPTV transmitters, attention Mexico & Latin America, for communities outside USA and Canada, low power TV transmitters to serve TV to towns, from satellite dishes. Call (62) 150199 (Mexico). Write: **ELECTRONICA SONORA**, 252 Grand Ave., Nogales, AZ 85621.

INSTALL CATV quality outlets/SMATV system amplifier schematics, coax handling techniques: send \$5.00 for informative booklet. **D. SCHWEIGART**, POB 1352, Wellsville, NY 14895.

*****PRESENTING*****
**CABLE TV
 DESCRAMBLERS**
 ***** STARRING *****
JERROLD, HAMLIN, OAK
 AND OTHER FAMOUS MANUFACTURERS

- FINEST WARRANTY PROGRAM AVAILABLE
- LOWEST RETAIL/WHOLESALE PRICES IN US
- ORDERS SHIPPED FROM STOCK WITHIN 24 HRS
- ALL MAJOR CREDIT CARDS ACCEPTED

FOR FREE CATALOG ONLY 1-800-345-8927
 FOR ALL INFORMATION 1-818-709-9937

PACIFIC CABLE CO., INC.
 7325 1/2 Reseda Blvd., Dept. 2000
 Reseda, CA 91335

CABLE EQUIPMENT

CABLE TV secrets — the outlaw publication the cable companies tried to ban. HBO, Movie Channel, Showtime, descramblers, converters, etc. Suppliers list included. \$9.95. **CABLE FACTS**, Box 711-H, Pataskala, OH 43062.

T.V. FILTERS

T.V. notch filters, phone recording equipment, brochure \$1.00. **MICRO THINC.**, Box 63/6025, Margate, FL 33063. (305) 752-9202.

Motion Control System → \$59.00



Includes Computer, Monitor, Keyboard, Power supply, 4 Motors, and Software.
 Call or Send for **Free Robotics Catalog**

Silicon Valley Surplus 415 261-4506 4222 E. 12th St. Oakland Ca. 94601 Serving you since 1983 8 am to 4 pm PST

EDUCATION/INSTRUCTION

MAGIC! Four illustrated lessons plus inside information shows you how. We provide almost 50 tricks including equipment for four professional effects. You get a binder to keep the materials in, and a one-year membership in the International Performing Magicians with a plastic membership card that has your name gold-embossed. You get a one-year subscription to our quarterly newsletter, "IT'S MAGIC!" Order now! \$29.95 for each course + \$3.50 postage and handling. (New York residents add applicable state and local sales tax). **THE MAGIC COURSE**, 500-B BiCounty Blvd., Farmingdale, NY 11735.

\$60.00 — \$80.00 per hour! Thousands of customers! Exciting new book tells how to start in computer repair/rental from home. Send \$9.95 now to: **INSTITUTE OF BUSINESS**, Dept PE3, PO Box 743024, Dallas, TX 75374.

BEST BY MAIL

Rates: Write National, Box 5, Sarasota, FL 34230

FINANCIAL

11.88% CREDIT CARDS. Why pay high interest? \$2/mo. 1-900-535-9800 X545.

IT PAYS YOUR DRINKS? 900% profit possible with super novelty. Sample \$20.00 + \$2.00 SH. Imorex(PE), Box 8300-103, Dallas, TX 75205.

FREE LOANS! VISA! Credit repair! Box 5408(PE), Corpus Christi, TX 78465.

"MONEYMAKING DEVICE!" INCREASES mileage 27%, reduces pollution 85%. 100% guaranteed, \$2.00/mo. 1-900-535-9800, Ext-544.

PLANS & KITS

CATALOG: hobby/broadcasting/HAM/CB: Cable TV, transmitters, amplifiers, surveillance devices, computers, more! **PANAXIS**, Box 130-H3, Paradise, CA 95967.

BUILD — five-digit, ohms, capacitance, frequency, pulse, multimeter. Board, and instructions \$9.95. **BAGNALL ELECTRONICS**, 179 May, Fairfield, CT 06430.

SURVEILLANCE transmitter kits! Four models of each; telephone, room, combination telephone, room transmitters tune from 65 to 305 MHz. Catalog with **Popular Communication's** and **Popular Electronics** book reviews of "Electronic Eavesdropping Equipment Design," \$1.00. **SHEFFIELD ELECTRONICS**, 7223A Stony Island Ave., Chicago, IL 60649-2806.

CABLE DESCRAMBLERS OAK M358 COMBO \$39.95

Jerrold, Zenith, Hamlin, Sci. Atlanta, Pioneer & MORE! OUR PRICES ARE BELOW WHOLESALE!

CABLE+PLUS

14417 Chase St. #481-B Panorama City, CA 91402
 1-800-822-9955 • Other info. 1-818-785-4500
 NO CALIF. SALES — DEALERS WANTED

VIDEOCIPHER II manuals. Volume 1 — Hardware, Volume 2 — Software — either \$34.95. Volume 3 — Projects/Software, Volume 5 — Documentation or Volume 6 — Experimentation \$44.95 each. Volume 7 — 032/Hacking \$54.95. Volume 4 — repair — \$99.95. **VC Primer** — \$9.95 **Scanner Hacker's Bible** — \$34.95. **Cable Hacker's Bible** — \$34.95. **Clone Hacker's Bible** — \$34.95. Catalog-\$3.00. CODs: (602) 782-2316. **TELECODE**, PO Box 6426-PE, Yuma, AZ 85366-6426.

MINIATURE FM transmitters! Tracking transmitters! Voice disguisers! Bug detectors! Phone devices! More! Available as kits or assembled and tested! Catalog \$2.00 (refundable): **XANDI ELECTRONICS**, Box 25647, Dept. 32B, Tempe, AZ 85285-5647.

**CABLE TV
 "BOXES"**

Converters — Descramblers
 Remote Controls — Accessories

- ★ Guaranteed Best Prices ★
- ★ 1 Year Warranty — C.O.D. ★
- ★ Immediate Shipping ★
- ★ FREE CATALOG ★

Call or Write
TRANS-WORLD CABLE CO.
 12062 Southwest 117th Court, Suite 126
 Miami, Florida 33186
 1-800-442-9333



SURVEILLANCE — countermeasures! Guaranteed lowest prices! Huge catalog \$5.00 (refundable). **PROTECTOR**, PO Box 520294-E, Salt Lake City, Utah 84152.

KITS — Alarms, games and test equipment. Send \$1.00 for catalog. **RAKJAB**, PO Box 1875, Apopka, FL 32704.

LASER lighting entertainment systems and accessories. Create 3-dimensional laser light shows with these professional secrets! Electronic and mechanical designs for all budgets! \$20.00 **MILLINIUM**, 229 McAfee, Thousand Oaks, CA 91360.

DAZER II Personal protection device! Plans \$8.00. Lasers! Transmitters! Detectors! More! Kits or assembled! Catalog \$2.00. **QUANTUM RESEARCH**, 16645-113 Avenue, Edmonton, Alberta T5M 2X2.

SURVEILLANCE — Audio/video/infra-red/laser equipment. Industrial or private. 500 item catalog \$7.00. **SECURITY SYSTEMS**, 3017F Hudson, New Orleans, LA 70131.

AC/DC VOLTAGE **KELVIN 200**
 AC/DC CURRENT
 RESISTANCE DIODE TEST
 LOW BATTERY Warning
 ACCURACY +/- 0.5%
 CONTINUITY TEST/BUZZER
 TRANSISTOR CHECKER
 CAPACITANCE CHECKER

Stock No 990091
\$39.95

7 Fairchild Ave., Plainville, NY 11803
 (516) 349-7620 1(800) 645-9212



STEREO power meter. 3 color, 10 step LED or incandescent to 100/W each. Fun attention getter. Inexpensive, build any size. Plans PCB layout \$5.00. **CACTUS CREATIONS**, Box 901055, Palmdale, CA 93590.

NEW devices: proximity switch, static snooper, personal defender, laser supplies, bug snooper, PC interfaces and more. Catalog \$2.00. **BAUER**, 35 Soucy, Delson, Quebec, J0L 1G0.

BUILD a light activated motion sensor. Chimes when triggered. Similar units sold for \$45.00. Great project! Fun! Educational! Easy to build! Plans \$2.00. Plans and kit \$8.50. **FUN PROJECTS**, Box 284, Brookings, SD 57006.

PARABOLIC microphone for under \$60.00. Detailed plans and sources. Send \$6.00 to: **PARAPLANS**, POB 511, Crab Orchard, WV 25827.

PRO-2004/2005/2006 Owners! Restore cellular telephone, add-on S-meter, add 6,400 channels, increase scanning speed, auto tape record, etc! Manual includes 10 modifications with detailed instructions and schematics. Only \$8.95 from the **ENGINEERING WORKSHOP**, PO Box 4176, Fullerton, CA 92634-4176.

THE JOY OF PROGRAMMING!

Algorithm

THE PERSONAL PROGRAMMING NEWSLETTER

► features how-to projects for beginners and experts: fractals, moiré patterns, ecological simulations, black holes, sand-piles, wallpaper for the mind and much more!

► Write today for a free sample issue to:

Algorithm - Special Order Department
 P.O. Box 29237, Westmount Postal Outlet
 785 Wonderland Road South
 London, Ontario, CANADA N6K 1M6

BUILD from easy-to-follow schematics: audio mixers/equalizers (stage, studio, business, home, basic to sophisticated), feedback controllers, active filters, guitar super-fuzz box, loudspeaker enclosures (including car/van), power supplies, more. vSSE reliability. Send \$5.00 for descriptions. Reasonable prices. **VON SPRECKEN SOUND ENGINEERING**, Dept.A, Box 1315, Clinton, MS 39060.

DIGITAL answering machines. No power supply, cassettes. Compact, easily used through phone. Very flexible plus much more. Many more products. Assembled, kits, Plans \$15.00 or send \$1.00 to **PERFORMANCE ELECTRONICS**, Avondale, CON.BAY, NFLD, Canada, A0A 1B0.

SHORTWAVE — 1933. One-tube. Plug-in coils. DX radio. Free plans. **BOB RYAN**, PO Box 3039, Anaheim, CA 92803.

MIDI and music accessories, plans, kits, and assembled, catalog \$1.00, **M-SEQ**, Box 231233, San Diego, CA 92194.

FREE catalog. Kits and electronic parts. Low, low prices. Fast delivery. **CAL WEST SUPPLY**, 31320 Via Colinas, Suite 105, Dept. A, Westlake Village, CA 91362.

ASTONISHING, rare technical devices, information, projects, and plans. Most unusual and comprehensive catalog of its kind! \$3.00. **P.A.R. RESEARCH**, 3404 Hillcrest Rd., Harrisburg, PA 17109.

ANTIQUE RADIO CLASSIFIED

Free Sample!

Antique Radio's

Largest Circulation Monthly.
Articles, Ads & Classifieds.

6-Month Trial: \$13. 1-Yr: \$24 (\$36-1st Class).
A.R.C., P.O. Box 802-L5, Carlisle, MA 01741



DESCRAMBLER secrets for hotel pay-per-view movies. Easy and works. Send \$5.00 cash/M.C., to **DESCRAMBLER SECRETS**, Dept. PE, Box 416, Rutland, MA 01543.

HOW to use surface mount techniques. Build ultra miniature projects. Included free, two sets plans. Infra red remote control, and light display. Send \$15.00 to **CHARLIE'S VIDEO**, Dept. SMT, PO 7782, LaSierra, CA 92503.

KITS, over 100 electronic kits sound effects visual effects. Write for free catalog: **JM ELECTRONICS**, PO Box 150454, Altamonte Springs, FL 32715-0454.

STOP! Don't let the gas pump cut into your standard of living. Alcohol fuel, easy to produce, \$1.17 per gallon. Plans \$5.00. **PROSPECTS UNLIMITED**, 620 Dick Road, Suite 383, Depew, NY 14043.

BUILD 35' free standing tilt-over tower. Plan book \$8.95 plus \$1.00 S&H. Build metal lathe, metal shaper, milling machine, drill press, brake, engines, etc. Large SASE for book list. **GINGERY TOOL**, PO Box 75, Fordland, MO 65652-0075.

ETCH your own printed circuit boards using the photographic method. The only inexpensive step by step process that guarantees professional results. A book that every serious electronics hobbyist should have. Send \$12.95 to **ETCHING INFO**, PO Box 8064, Westfield, MA 01086-8064.

RECEIVER plans, kits. Simple to sophisticated. Thorough explanations included. All bands. Catalog and sample schematics \$3.00. **PREMIER ENTERPRISES**, 3850 Plymouth Blvd., Suite 104, Plymouth, MN 55446.

Cable TV Descramblers



If you find a better deal,
we'll better our deal.

*Jerrold *Tocom *Hamlin *Oak
*Scientific Atlanta *Zenith
Ask about our extended warranty program.

COD, Visa, M/C welcome.
Free Call - Free Catalog.

Video Tech **800-562-6884**
2702 S. Virginia St., Ste. 160-304
Reno, NV 89502.

MAKE \$\$\$! Become an American electronics dealer! Profit opportunities since 1965. Call **WAYNE MARKS**, 1 (800) 872-1373.

WHY rent? Homes for \$1.00, repos. Gov't give away programs! For information (504) 649-0670 ext. R-5730.

HOT opportunity! Start your own electronics business. 1990 wholesale directory lists overseas sources. \$4.95. **ANKH TECHNOLOGY**, Box 4124, Dept.-P, Ann Arbor, MI 48106.

CUSTOM DESIGN SERVICE

REGISTERED professional electrical engineer will design your product. Specializing in microprocessor based designs. For a free estimate, send your proposal to: **LEPRECHAUN TECHNOLOGIES**, PO Box 64371, Lubbock, TX 79464.

FREE CATALOG!
1-800-648-7938
For all information 1-702-362-9026
JERROLD HAMLIN OAK ETC.
CABLE TV
DESCRAMBLERS
• Compare our low Low Retail Prices!
• Guaranteed Prices & Warranties!
• Orders Shipped Immediately!
REPUBLIC CABLE PRODUCTS INC.
4080 Paradise Rd. #15 Dept. PE-90
Las Vegas, NV 89109

NAS
CABLE BOXES
FREE CATALOG
1-800-848-3997
Jerrold • Scientific Atlanta
Many Others
1 Year Warranty • COD's

BUSINESS OPPORTUNITIES

YOUR own radio station! AM, FM, TV, cable. Licensed/unlicensed. **BROADCASTING**, Box 130-H3, Paradise, CA 95967.

MAKE \$50/hr working evenings or weekends in your own electronics business. Send for free facts. **MJPI INDUSTRY**, Box 531, Bronx, NY 10461.

MAKE \$2000.00/week — reclaiming pure gold from scrap computers. Free report! (worth \$25.00) 1 (900) 246-2323 (\$2.00 min.).

LET the government finance your small business. Grants/loans to \$500,000. Free recorded message: (707) 448-0270. (KJ8)

EASY work! Excellent pay! Assemble products at home. Call for information (504) 641-8003 Ext. 5730.

SAVE \$. Learn to clean VCR's. Instructional tape \$39.95. VCR maintenance tapes also available. **TELEVISION DYNAMICS**, PO Box 2893, Ann Arbor, MI 48106. MasterCard and Visa accepted. (313) 663-6886.

TEST EQUIPMENT

FACTORY direct test equipment. Function generators, frequency counters and security devices. Call for free brochure. **APPLIED ELECTRONIC RESEARCH INC**, Hollywood, FL. (305) 987-9785.

BUY BONDS

SPECIAL FROM ETT SAVE \$\$ TODAY

□ **2617T—BUILD A REMOTE-CONTROLLED ROBOT** regular \$9.95 **SPECIAL \$8.95.** Foot-proof instructions for putting together your own full-size working robot at a fraction of the commercial cost.



□ **2645T—117 PRACTICAL IC PROJECTS YOU CAN BUILD** regular \$10.95 **SPECIAL \$9.95.** Dozens of fully tested ready-to-build circuits you can put together from readily available, low-cost IC's.

□ **BP53—PRACTICAL ELECTRONICS CALCULATIONS AND FORMULAE** regular \$6.95 **SPECIAL \$5.95.** Six basic sections: Units and Constants, Direct Current Circuits, Passive Components, Alternating Current Circuits, Networks and Theorems, Measurements.



□ **2706T—BUILDING METAL LOCATORS** regular \$9.95 **SPECIAL \$8.95.** A treasure hunter's project book. Build your own high-quality metal detector for a fraction of the factory-built cost.

□ **BP234—TRANSISTOR SELECTOR GUIDE** regular \$10.00 **SPECIAL \$9.00.** Offers a range of selection tables compiled so as to be of maximum use to all electronics engineers, designers and hobbyists.



□ **ETTCAT—ELECTRONIC TECHNOLOGY TODAY INC. CATALOG** \$2.00. 36-pages list a wide variety of electronics books. Included with catalog is a coupon good for \$3.00 off your first purchase.

MAIL TO: **Electronic Technology Today, Inc.**
P.O. Box 240
Massapequa Park, NY 11762-0240

SHIPPING CHARGES IN USA AND CANADA

\$0.01 to \$5.00	...	\$1.25	\$30.01 to \$40.00	\$5.00
\$5.01 to 10.00	...	\$2.00	\$40.01 to \$50.00	\$6.00
\$10.01 to \$20.00	...	\$3.00	\$50.01 and above	\$7.50
\$20.01 to \$30.00	...	\$4.00		

SORRY, No orders accepted outside of USA and Canada

Total price of merchandise	\$	_____
Shipping (see chart)	\$	_____
Subtotal	\$	_____
Sales Tax (NYS only)	\$	_____
Total Enclosed	\$	_____

Name _____
Address _____
City _____ State _____ Zip _____

ADVERTISING INDEX

POPULAR ELECTRONICS magazine does not assume any responsibility for errors that may appear in the index below.

Free Information No.	Page
10	AMC Sales 93
19	Ace Communications 4
9	All Electronics 18
—	Amazing Concepts 83
—	Antique Radio Classified 105
5	C&S Sales 13
—	CB City 103
—	CIE 17
—	Cable Plus 104
—	Command Productions 81
15	Cook's Institute 93
—	Elec. Industry Association 30
—	Electronic Tech. Today .. CV2, 105
—	Electronics Book Club 91
—	Firestik II 103
—	Global Cable Network 103
—	Grantham College 12
8	Heathkit 25
—	Iscet 99
—	Kelvin 104
—	McGraw Hill Book Club 8
—	Midwest Electronics 103
—	Monitoring Times 87
—	NRI Schools 23
11	Protel Technology 26
—	Pacific Cable 104
14	Paladin Electronics 95
6	Parts Express 7
20	People's College 3
—	P.E. Reprint Bkst. 97
—	Phillips Tech. 103
7	Radio Shack CV4
—	Republic Cable 105
17	SCO Electronics 19
12	Sequoia Publishing 83
—	Tab Books 29
—	Silicon Valley Surplus 104
—	Trans World 104
—	Video Tech 105
18	U.S. Cable 19
13	Viejo Publications 83

CELLULAR TELEPHONES

(Continued from page 63)

while in a dead zone (which may extend for several miles). If you enter a dead zone while conducting a conversation, the call will be cut off and disconnected. You will probably experience a series of worsening drop offs before entering a dead zone and losing the connection.

Dead zones can be natural, due to the geography of the region you are traveling through (see Fig. 5). The great majority of dead zones are encountered around mountains, in valleys, and near large bodies of water.

Urban areas can also have dead zones, although they are less common. Urban dead zones develop when radio signals reflect from large buildings and re-combine with the original cell signals to create destructive interference patterns (see Fig. 6). This phenomenon is commonly referred to as "multipath interference."

Conclusion. The demand for cellular communications has grown tremendously in the last few years. Networks across the country now service millions of subscribers. This growing trend will almost certainly continue as network services improve and expand, and as cellular telephones themselves become smaller, more reliable, and less expensive.

Cellular phones are every bit as easy to use as conventional phones. With the exception of a few extra keystrokes, you can send and receive calls from your local network, or a cooperative net-



Here are two views of the Diamond Tel 90X cellular telephone. Photo provided through the courtesy of the Mitsubishi Corporation.

work while roaming, just as you would from your own phone.

Even though the initial investment and monthly costs of owning and operating a cellular phone are much higher than those of a standard telephone, the benefits one provides many personal and professional applications can easily justify the extra cost.

It will not be long before we have cellular telephones that can fit in our shirt pockets. They may soon become standard equipment in some production automobiles. The future will see cellular service available in public transportation such as ferries, buses, and railways. With the costs of cellular phones dropping rapidly, and the quality and coverage of service improving almost daily, cellular phones may soon become an indispensable tool in our everyday lives.

ADVERTISING SALES OFFICE

Gernsback Publications, Inc.
 500-B Bi-County Blvd.
 Farmingdale, NY 11735
 1-(516) 293-3000
 President: **Larry Steckler**
 Vice President: **Cathy Steckler**

For Advertising ONLY
 516-293-3000
 Fax 1-516-293-3115

Larry Steckler
 publisher
Arline Fishman
 advertising director
Denise Haven
 advertising assistant
Christina Estrada
 advertising associate
Lisa Strassman
 credit manager

Customer Service/Order Entry
 1-800-435-0715
 In IL 1-800-892-0753
 7:30 AM - 8:30 PM EST

SALES OFFICES

EAST/SOUTHEAST
Becky Akers
 Pattis/3M
 310 Madison Ave., Suite 1804
 New York, NY 10017
 1-212-953-2121
 Fax 1-212-953-2128

MIDWEST/Texas/Arkansas/Okla.
Ralph Bergen
 540 Frontage Road—Suite 339
 Northfield, IL 60093
 1-312-446-1444
 Fax 1-312-446-8451

PACIFIC COAST/Mountain States
Marvin Green
 5430 Van Nuys Blvd., Suite 316
 Van Nuys, CA 91401
 1-818-986-2001
 Fax 1-818-986-2009

Electronics Paperback Books

GREAT PAPERBACKS AT SPECIAL PRICES

BP248—TEST EQUIPMENT CONSTRUCTION \$5.95. Details construction of simple, inexpensive, but extremely useful test equipment. AF Gen, Test Bench Ampl, Audio Millivoltmeter, Transistor Tester and six more.

Test Equipment Construction



BP267—HOW TO USE OSCILLOSCOPES AND OTHER TEST EQUIPMENT \$6.95. Mastering the oscilloscope is not really too difficult. This book explains all the standard controls and functions. Other equipment is also described.

How to Use Oscilloscope and Other Test Equipment



BP265—MORE ADVANCED USES OF THE MULTIMETER \$5.95. Use these techniques to test and analyze the performance of a variety of components. Also see how to build ad-ons to extend multimeter capabilities.

More Advanced Uses of the Multimeter



An Introduction to Loudspeakers and Enclosure Design

BP256—INTRO TO LOUDSPEAKERS AND ENCLOSURE DESIGN \$5.95. We explore the variety of enclosure and speaker designs in use today so the reader can understand the principles involved.

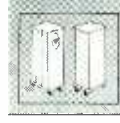

BP263—A CONCISE INTRO TO dBASE \$6.95. The dBASE series of programs are probably the best known database programs for microcomputers. This book is designed to help you get started working with them.

A Concise Introduction to dBASE

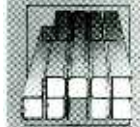

BP260—CONCISE INTRO TO OS/2 \$5.95. If you are a multitasking PC user and want to get the most out of your computer, then you must learn its OS/2 operating system. This book shows you just how to do that, quickly and easily.

A Concise Introduction to OS/2



BP249—MORE ADVANCED TEST EQUIPMENT CONSTRUCTION \$6.95. Eleven more test equipment construction projects. They include a digital voltmeter, capacitance meter, current tracer and more.

More Advanced Test Equipment Construction



Digital Audio Projects

BP245—DIGITAL AUDIO PROJECTS \$5.95. Practical circuits to build and experiment with. Includes A/D converter, input amplifier, digital delay line, compander, echo effect and more.



BP247—MORE ADVANCED MIDI PROJECTS \$5.95. Circuits included are a MIDI indicator, THRU box, merge unit, code generator, pedal, programmer, channelizer, and analyzer.



An Introduction to Amateur Radio

BP257—INTRO TO AMATEUR RADIO \$6.95. Amateur is a unique and fascinating hobby. This book gives the newcomer a comprehensive and easy to understand guide to the subject.



PCP102—INTRODUCING DIGITAL AUDIO \$9.95. Covers all kinds of digital recording methods—CD, DAT and Sampling. Bridges the gap between the technician and the enthusiast. Principles and methods are explained.

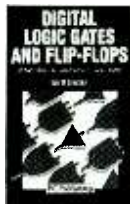

PCP107—DIGITAL LOGIC GATES AND FLIP FLOPS \$10.00. Thorough treatment of gates and flip-flops for enthusiasts, student and technicians. Only a basic knowledge of electronics is needed.

BP251—COMPUTER HOBBYISTS HANDBOOK \$8.95. A wrapup of everything the computer hobbyist needs to know in one easy to use volume. Provides a range of useful reference material in a single source.



PCP108—COMPUTERS AND MUSIC \$9.95. Explains the basics of computers and music with no previous knowledge of computers needed. Covers types of music software and explains how to set up your own computer music studio.

- BP195—INTRODUCTION TO SATELLITE TV**... \$9.95. A definitive introduction to the subject written for the professional engineer, electronics enthusiast, or others who want to know more before they buy. 8 x 10 in.
- BP190—ADVANCED ELECTRONIC SECURITY PROJECTS**.....\$5.95. Includes a passive infra-red detector, a fiber-optic loop alarm, computer-based alarms and an unusual form of ultrasonic intruder detector.
- BP235—POWER SELECTOR GUIDE**.....\$10.00. Complete guide to semiconductor power devices. More than 1000 power handling devices are included. They are tabulated in alpha-numeric sequence, by technical specs. Includes power diodes, Thyristors, Triacs, Power Transistors and FET's.
- BP234—TRANSISTOR SELECTOR GUIDE**.....\$10.00. Companion volume to BP235. Book covers more than 1400 JEDEC, JIS, and brand-specific devices. Also contains listing by case type, and electronic parameters. Includes Darlingtons transistors, high-voltage devices, high-current devices, high power devices.
- BP99—MINI-MATRIX BOARD PROJECTS**.....\$5.50. Here are 20 useful circuits that can be built on a mini-matrix board that is just 24 holes by ten copper-foil strips.
- BP82—ELECTRONIC PROJECTS USING SOLAR CELLS**.....\$5.50. Circuits with applications around the home that are powered by the energy of the sun. Everything from radio receivers, to a bicycle speedometer, to timers, audio projects and more.
- BP117—PRACTICAL ELECTRONIC BUILDING BLOCKS—Book 1**.....\$5.75. Oscillators, Timers, Noise Generators, Rectifiers, Comparators, Triggers and more.
- BP184—INTRO TO 68000 ASSEMBLY LANGUAGE**.....\$6.95. The 68000 is a great new breed of microprocessor. Programming in assembly language increases the running speed of your programs. Here's what you need to know.

- BP239—GETTING THE MOST FROM YOUR MULTIMETER**..... \$5.95. Covers basics of analog and digital meters. Methods of component testing includes transistors, thyristors, resistors, capacitors and other active and passive devices.
- BP97—IC PROJECTS FOR BEGINNERS**.....\$5.50. Power supplies, radio and audio circuits, oscillators, timers, switches, and more. If you can use a soldering iron you can build these devices.
- BP37—50 PROJECTS USING RELAYS, SCR'S & TRIACS**.....\$5.50. Build priority indicators, light modulators, warning devices, light dimmers and more.
- RADIO—100 RADIO HOOKUPS**.....\$3.00. Reprint of 1924 booklet presents radio circuits of the era including regenerative, neutrodyne, reflex & more.
- BP42—SIMPLE LED CIRCUITS**.....\$5.50. A large selection of simple applications for this simple electronic component.
- BP127—HOW TO DESIGN ELECTRONIC PROJECTS**.....\$5.75. Helps the reader to put projects together from standard circuit blocks with a minimum of trial and error.
- BP122—AUDIO AMPLIFIER CONSTRUCTION**.....\$5.75. Construction details for preamps and power amplifiers up through a 100-watt DC-coupled FED amplifier.
- BP92—CRYSTAL SET CONSTRUCTION**.....\$5.50. Everything you need to know about building crystal radio receivers.
- BP45—PROJECTS IN OPTOELECTRONICS**.....\$5.50. Includes infra-red detectors, transmitters, modulated light transmission and photographic applications.

BP179—ELECTRONIC CIRCUITS FOR THE COMPUTER CONTROL OF ROBOTS \$7.50. Data and circuits for interfacing the computer to the robot's motors and sensors.

CHECK OFF THE BOOKS YOU WANT

ELECTRONIC TECHNOLOGY TODAY INC.
P.O. Box 240, Massapequa Park, NY 11762-0240

SHIPPING CHARGES IN USA AND CANADA

\$0.01 to \$5.00	..	\$1.25
\$5.01 to 10.00	..	\$2.00
\$10.01 to \$20.00	..	\$3.00
\$20.01 to \$30.00	..	\$4.00
\$30.01 to \$40.00	..	\$5.00
\$40.01 to \$50.00	..	\$6.00
\$50.01 and above	..	\$7.50

SORRY No orders accepted outside of USA & Canada

Number of books ordered

Name _____
Address _____
City _____ State _____ Zip _____

Total price of merchandise \$ _____
Sales Tax (New York State Residents only) \$ _____
Shipping (see chart) \$ _____

All payments must be in U.S. funds

Total Enclosed .. \$ _____

RADIO SHACK PARTS PLACE SM

YOUR SOURCE FOR PROJECT AND REPAIR ESSENTIALS

PARTS HOTLINE

Your nearby Radio Shack store has a huge selection of popular electronic components. Plus, we can special-order 10,000 items from our warehouse—ICs, tubes, semiconductors, phono cartridges and styli, even SAMS® manuals. Service is fast and there's no minimum order or postage charge.

BATTERY HOTLINE

In addition to our large in-store stock, Radio Shack can now supply almost any currently manufactured consumer-type battery—for cordless phones, computer memory, camcorders, transceivers, pagers and more. No postage charge!

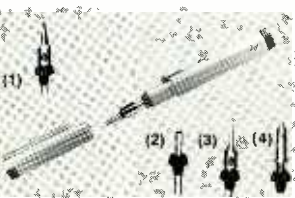

Bright Krypton Bayonet-Style Lamps for Flashlights. Use in place of standard lamps for super brightness. For example, K4 replaces standard PR4. Each 79¢

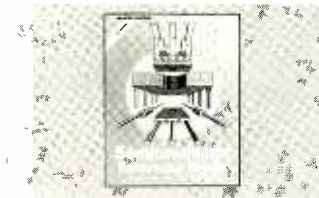

1991 Semiconductor Reference Guide. A "must" for electronics building and repair. This new edition gives you a 95,000-item semiconductor substitution guide plus detailed data on Radio Shack ICs, SCRs, LEDs, diodes, transistors and optoelectronics. #276-4014 3.99



Bench/Portable LCD Digital VOM. Our best multimeter! Displays transistor gain directly and has diode-check, memory and continuity functions. Autoranging or manual modes. Measures to 1000VDC, 750VAC, 10 amps AC/DC and resistance. #22-195 99.95

4-in-1 Soldering Tool. Operates anywhere on standard butane lighter fuel. Refills in seconds. #64-2161 29.95
 (1) 1.0 mm Tip. #64-2163 9.95
 (2) Blow Torch Tip, #64-2168, (3) Heat Blower, #64-2169, (4) Hot Knife, #64-2170 available on special order Each 9.95

Type	Volts	mA	Cat. No
K4	2.33	480	272-1169
K1	2.4	600	272-1156
K2	2.4	830	272-1157
K3	3.6	800	272-1158
K15	4.8	700	272-1162
K12	6.0	650	272-1163
K18	7.2	700	272-1164

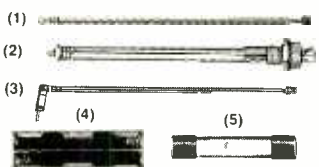

Replacement Rod Antennas. For cordless phones, radios, portable stereos, walkie-talkies and your own custom projects. 16 styles in stock!
 (1) 30 1/2". #270-1401 2.99
 (2) 13". #270-1407 2.79
 (3) 23 5/8". #270-1417 3.49

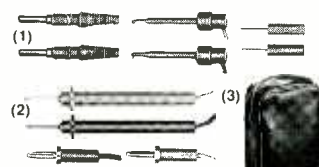

(1) Mini-Clip Test Leads. 48" long. Mini test clip at one end, banana plug at the other. Includes pin-type plug adapters. #278-1160 Pair/3.99
 (2) Test Probes With Coiled 6-Ft. Leads. #278-750 Pair/4.99
 (3) Deluxe Soft Carrying Case. Perfect for multimeters. #22-149 7.95

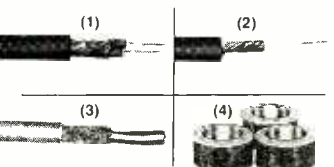

(1) Dual Mike Cable. For balanced hookups. 30 ft. #278-1281 19.95
 (2) Super-Flex Mike Cable. Extra-supple. 30 ft. #278-1282 14.95
 (3) 4-Conductor Double-Shielded Cable. 30 feet. #278-777 7.95
 (4) Magnet Wire Assortment. 22, 26, 30 gauge. #278-1345 4.99

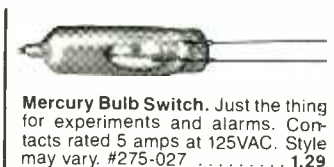

Mercury Bulb Switch. Just the thing for experiments and alarms. Contacts rated 5 amps at 125VAC. Style may vary. #275-027 1.29

Battery Holders. Ideal for projects, for replacement or for building external power packs. Our store near you has 15 different styles in stock!
 (4) Holder for 8 "AA" Cells. 9V-type snap connector. #270-407, 1.29



Six-Outlet Power Strip With Spike Protector. Noise filter, breaker. Rated 15A. #61-2780 29.95

Replacement Fuses. For appliances and vehicles. Over 60 values in stock!
 (5) 10-Amp Fuse for Microwave Ovens. #276-1256 Pkg. of 2/1.29

Surface-Mount Resistors. 200-piece assortment! Popular values, rated 1/8 watt, 5%. #271-313, Set 4.99

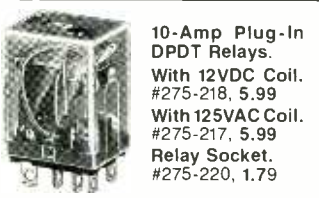

10-Amp Plug-In DPDT Relays.
 With 12VDC Coil. #275-218, 5.99
 With 125VAC Coil. #275-217, 5.99
 Relay Socket. #275-220, 1.79



Piezo Speaker. Only 1 3/32"-dia. by 5/64" thin. This high-efficiency device can be driven by ICs. 500 Hz to 20 kHz. 1200 ohms. #273-091 2.49

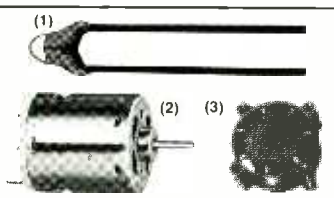

(1) Precision Thermistor. Range: -50 to +110°C. #271-110 1.99
 (2) High-Speed 12VDC Motor. Up to 15,200 RPM at no load. About 2" long (with shaft). #273-255 2.99
 (3) 12VDC Brushless Micro Fan. Ideal for cooling mobile equipment and hum-sensitive circuits. 4.6 CFM. 150 mA. #273-244 17.95

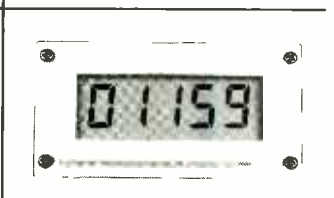

Electronic Counter Module. Pre-wired! Great for a traffic or event counter. Counts up to 99,999. Advanced (or reset) by external switch closure or digital circuit. Accepts count rate up to 7 Hz. Has 1/2" liquid crystal display. Requires "AA" battery. Low current drain—only 4 µA. With data. #277-302 16.95

Since 1921 Radio Shack has been the place to obtain up-to-date electronic parts as well as quality tools, test equipment and accessories at low prices. Over 7000 locations to serve you—NOBODY COMPARES

Prices apply at participating Radio Shack stores and dealers. Radio Shack is a division of Tandy Corporation

Radio Shack
 AMERICA'S TECHNOLOGY STORE™

CIRCLE 7 ON FREE INFORMATION CARD