

Make Tuning Coils For Any Application

Popular Electronics

APRIL 1990

THE MAGAZINE FOR THE ELECTRONICS ACTIVIST!



BUILD A REACTION TIMER

Use it as a game of skill, or as a training device to help you improve your reflexes

BUILD A CUSTOM SECURITY SYSTEM

An expandable, adaptable, user-programmable alarm system that can be used to protect your home, car, and more

REVIVING A RELIC

Get top-of-the-line SW performance with one of yesterday's workhorses

TRANSFORMERLESS POWER SUPPLY

High-current capacity, high-voltage output, and no transformer is needed

BUILD THE DITHERIZER

Improves the quality of digitized music and speech

A "SOUND" INSTALLATION

There are lots of ways to install a mobile radio; this isn't one of them!



A GERNSBACK PUBLICATION



\$2.50 U.S.
\$2.95 CANADA

3 NEW
FactCards
IN THIS ISSUE

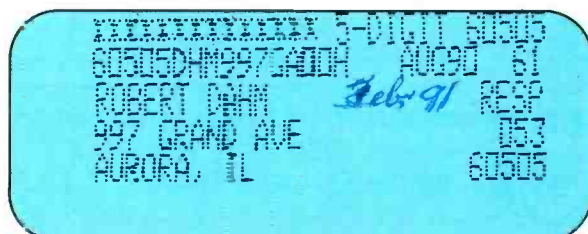

DAMARK

INTERNATIONAL, INC.

ORDER TODAY!!
1-800-729-9000
 THE "GREAT DEAL" CATALOG

PACKARD BELL
America grew up listening to us. It still does.
**PACKMATE 286 COMPUTER W/
 VGA COLOR MONITOR**

- 80286 micro-processor (operates at 12 MHz).
- One 3-1/2" 1.44 MB floppy drive.
- One 5-1/4" 1.22 MB floppy drive.
- 30 MB hard drive.
- 1 MB RAM on motherboard expandable to 3 MB.
- Includes VGA 14" color monitor & VGA card.
- IBM compatible.
- AT compatible.
- 8 expansion slots.
- Dual FDD/HDD controller.
- 2 half height drive cavities exposed.
- 1 half height drive cavity enclosed.
- 2 serial ports.
- 1 parallel port.
- System configuration in CMOS with battery back-up.
- 101 key keyboard.
- Includes MS DOS 3.3 & GW BASIC.
- 145W Universal power supply.
- Zero wait state.
- Socket for 80287 co-processor on motherboard.
- **One Year Warranty!**

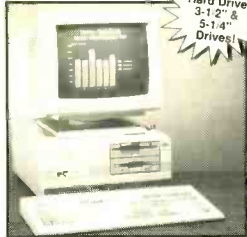

30 MB Hard Drive!
 3-1/2" & 5-1/4" Drives!

FACTORY NEW! FACTORY PERFECT!

Mfg. Sugg. Retail: **\$3,449.00**

DAMARK PRICE:
\$1499

Item No. B-1861-132142
 Insured Ship/Hand.: \$39.00

**Leading Edge 386 FULL 32-BIT
 COMPUTER & VGA
 COLOR MONITOR**

- 100% IBM compatible.
 - 32-bit 80386 microprocessor.
 - 8/16 MHz speed (switchable).
 - 40 MB—22 milli-second hard drive with integral 1:1 interleave controller.
 - 1 MB RAM expandable to 8 MB.
 - One 5.25" 1.2 MB floppy disk drive.
 - Four 16-bit expansion slots.
 - Two 8-bit expansion slots.
 - One 16-bit VGA video adaptor with 256K memory expandable to 512K, displays up to 1024 x 768 resolution.
 - 1 Centronics parallel port.
 - 2 RS-232C serial ports.
 - 80387 math coprocessor socket.
 - Includes software: MS-DOS 3.3, & GW-BASIC.
 - Zero wait state.
 - Supports all VGA/EGA/CGA/MDA/Hercules modes.
 - Dim.: 15.5" x 15.9" x 6.1".
- VGA Color Monitor:**
- 14" high res. tilt swivel monitor.
 - IBM compatible.
 - .31 mm dot pitch.
 - Analog input signal.
 - Resolution: 640 x 480.
 - **Full 20 Month Factory Warranty!**
 - **Factory New!**
 - **Factory Perfect!**



Mfg. Sugg. Retail: **\$3,295.00**

DAMARK PRICE:
\$1999

Item No. B-1861-133967
 Insured Ship/Hand.: \$39.00

**IMSI HAND-HELD IMAGE
 SCANNER with Software**

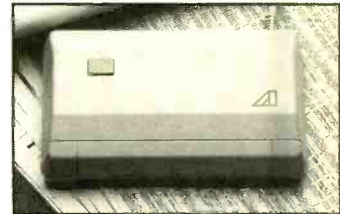

- Scanning maximum width: up to 4" wide.
- 100/200 dpi resolution.
- Scans at approximately 1" per second.
- Quickly reads signatures, logos, photos, news columns, and clip art.
- Display bar charts in 2-D or 3-D.
- Scanner, controller, and IMSI Graphic Presentation software.
- 3 dithering patterns for grey scale effects.
- Scanned images look as sharp and clear as originals.
- Works w/ major graphic & desktop publishing software.
- Uses red LED & CCD light sensors.
- IBM compatible.
- 13 different graph types with unlimited combinations.
- Requires IBM or 100% compatible computer and a hard drive.
- Dim.: 5.75"Wx 1.5"H x 3.3"D.
- **One Year Warranty!**
- **Factory New!**
- **Factory Perfect!**

Mfg. Sugg. Retail: **\$299.00**

DAMARK PRICE:
\$99

Item No. B-1861-134270
 Insured Ship/Hand.: \$5.00

**XEROX 635 DIABLO WIDE CARRIAGE
 DAISYWHEEL PRINTER WITH
 DUAL BIN AUTO SHEET FEEDER**

- Print speed: 55 CPS.
 - 255 typestyles & 15 foreign language daisywheels with 10, 12, 15 pitch and proportional spacing.
 - 100% IBM compatible.
 - Auto paper loading.
 - Full word processing capabilities.
 - Max print line width is 13.2" and paper width is 16.5".
 - Letter quality printer.
 - Prints 132 columns at 10 CPI.
 - 158 columns at 12 CPI.
 - 197 columns at 15 CPI.
 - Snap in IBM/Centronics interface cartridge (with cable) for instant compatibility with most microcomputer systems.
 - Quiet operation: noise level only 56 dBa.
 - Can operate on 110/220 VAC 50/60 Hz.
 - Printer weight: 30 lbs.
- Dual Bin Sheet Feeder features:**
- Diablo F52 dual bin sheet feeder w/ 240 sheet capacity.
 - Drop in installation.
 - Model #: 635.
 - **90 Day Warranty!**
 - **Factory New & Perfect!**



Mfg. Sugg. Retail: **\$1,890.00**

DAMARK PRICE:
\$399

Item No. B-1861-135350
 Insured Ship/Hand.: \$39.00

**SCHLAGE KEPSAFER PLUS Wireless
 Security System**

- Keepsafer Plus security system—wireless!
- Advanced control console.
- When away from home, set exit and entry delay on selected entrances (up to 40 seconds).
- Leave and return without sounding alarm.
- 5 alarm modes.
- Handheld remote control.
- 6 transmitters with batteries.
- 6 sets of sensors.
- Back-up Power Supply Unit. Insures continuous operation up to 6 hours if power supply fails. Recharges automatically when AC power is on.
- Easy installation—only a screwdriver is needed!
- Main unit dim.: 13"W. x 8"H. x 2-1/2"D.
- **One Year Warranty!**
- **Factory New & Perfect!**



Mfg. Sugg. Retail: **\$499.95**

DAMARK PRICE:
\$149

Item No. B-1861-114462
 Insured Ship/Hand.: \$9.50

**DOUBLE PLAY "...WATCH TWO TELEVISION
 CHANNELS AT ONCE!"**

- Provides same high-tech capabilities of TVs costing \$1000.00 or more!
- View a program on smaller screen while watching another on the bigger screen.
- Scan channels on smaller screen without interrupting main program.
- Switch programs back & forth from smaller to bigger screen.
- Move small picture to any corner of TV.
- Freeze frame function on smaller screen.
- Wireless remote that controls Double-Play functions.
- Enlarge smaller picture to full size by remote.
- Easy to install.
- For use with your current TV.
- *VCR required.
- Includes cables/connectors.
- Includes 2 AAA batteries for remote control.
- Model #: DP5000.
- **90 Day Warranty!**
- **Factory New!**
- **Factory Perfect!**



Mfg. Sugg. Retail: **\$279.95**

DAMARK PRICE:
\$99

Item No. B-1861-133488
 Insured Ship/Hand.: \$7.50

**FOR FASTEST SERVICE
 CALL TOLL FREE
 1-800-729-9000**
 CUSTOMER SERVICE: 1-612-566-4940



QTY	DESCRIPTION	ITEM #	S/H/I	PRICE

DELIVERY TO 48 U.S. CONTINENTAL STATES ONLY

SUB TOTAL

in MN add 6% Sales Tax

Total S/H/I

GRAND TOTAL

B-1861

NAME _____
 ADDRESS _____
 CITY _____ ST _____ ZIP _____
 PHONE _____

Check/Money Order VISA SIGNATURE _____
 MasterCard Discover CARD NO. _____ EXP. DATE _____

Send To: **DAMARK INTERNATIONAL, INC., 6707 Shingle Creek Parkway, Minneapolis, MN 55430**

Popular Electronics®

THE MAGAZINE FOR THE ELECTRONICS ACTIVIST!

CONSTRUCTION ARTICLES

BUILD A REACTION TIMER	John Wannamaker	33
<i>Use it as a game of skill or to improve your reaction time.</i>		
THE DITHERIZER	Jerry Penner	37
<i>Give digitized audio the ambiance of the original analog signal.</i>		
THE VERY VERSATILE CODE ALARM	Mike and Karen Giamportone	39
<i>Protect your valuables with this easy-to-build-and-program digital alarm.</i>		
TRANSFORMERLESS DC POWER SUPPLIES	Ralph Hubscher	45
<i>A variable-voltage/current power supply without a cumbersome transformer.</i>		

FEATURE ARTICLES

RESTORING A CLASSIC SHORTWAVE RECEIVER	Joseph J. Carr	61
<i>If you can't afford a modern SW receiver, get almost-as-good performance from one of yesterday's workhorses.</i>		
A "SOUND" INSTALLATION	Fred Stock	64
<i>There's more than one way to install a mobile antenna; this isn't one of them.</i>		
THE BOZART 911 STEREO SPEAKER		67
<i>A hands-off report just for April.</i>		
FIBER-OPTIC COMMUNICATIONS	Alvin G. Sydnor	68
<i>How and why we'll all soon be talking on a beam of light.</i>		
AN INTRODUCTION TO DIGITAL ELECTRONICS	Joseph J. Carr	71
<i>Learn about the basic building blocks of digital electronics.</i>		
THE DIGITAL ELECTRONICS COURSE	Robert A. Young	77
<i>Light-controlled monostable applications.</i>		

PRODUCT REVIEWS

GIZMO		49
<i>Including: Cyrus One 25-Watt Integrated Audio Amplifier, QuickShot Studio 4 Sound Mixing System, and much more.</i>		
HANDS-ON REPORT		79
<i>Audio Technica ATH-909 Stereo Headphones.</i>		
PRODUCT TEST REPORT	Len Feldman	80
<i>Yamaha TX-1000U AM/FM Stereo Tuner.</i>		

COLUMNS

THINK TANK	Byron G. Wels	22
<i>How to win friends...</i>		
ANTIQUA RADIO	Marc Ellis	82
<i>Wireless receiving—1912-style.</i>		
COMPUTER BITS	Jeff Holtzman	88
<i>Pushbutton computing.</i>		
CIRCUIT CIRCUS	Charles D. Rakes	90
<i>Infrared communications links.</i>		
HAM RADIO	Joseph J. Carr	92
<i>Winding your own adjustable coils.</i>		
DX LISTENING	Don Jensen	94
<i>DX fare from our northern neighbors.</i>		
SCANNER SCENE	Marc Saxon	96
<i>High-performance, low-tech scanner.</i>		

DEPARTMENTS

EDITORIAL	Carl Laron	2
LETTER BOX		4
ELECTRONICS LIBRARY		6
NEW PRODUCTS		14
FACTCARDS		47
FREE INFORMATION CARD		65
ADVERTISER'S INDEX		107

Popular Electronics (ISSN 1042-170X) Published monthly by Gernsback Publications, Inc., 500-B Bi-County Boulevard, Farmingdale, NY 11735. Second-Class postage paid at Farmingdale, NY and at additional mailing offices. One year, twelve issues, subscription rate U.S. and possessions \$21.95, Canada \$26.95, all other countries \$29.45. Subscription orders payable in U.S. funds only. International Postmaster: Order or check drawn on a U.S. bank. U.S. single copy price \$2.50. © 1990 by Gernsback Publications, Inc. All rights reserved. **Hands-on Electronics** and **Gizmo** trademarks are registered in U.S. and Canada by Gernsback Publications, Inc. **Popular Electronics** trademark is registered in U.S. and Canada by Electronics Technology Today, Inc. and is licensed to Gernsback Publications. Printed in U.S.A.

Postmaster: Please send address changes to Popular Electronics, Subscription Dept., P.O. Box 308, Mount Morris, IL 61054-9932.

A stamped self-addressed envelope must accompany all submitted manuscripts and/or artwork or photographs if their return is desired should they be rejected. We disclaim any responsibility for the loss or damage of manuscripts and/or artwork or photographs while in our possession or otherwise.

As a service to readers, Popular Electronics publishes available plans or information relating to newsworthy products, techniques and scientific and technological developments. Because of possible variances in the quality and condition of materials and workmanship used by readers, Popular Electronics disclaims any responsibility for the safe and proper functioning of reader-built projects based upon or from plans or information published in this magazine.



Editorial

Larry Steckler

EHF, CET

Editor-In-Chief and Publisher

EDITORIAL DEPARTMENT

Carl Laron

Managing Editor

Robert A. Young

Associate Editor

John J. Yacono

Associate Editor

Byron G. Wels, K2AVB

Associate Editor

Teri Scaduto

Assistant Editor

Kathy Terenzi

Editorial Assistant

Robert A. W. Lowndes

Editorial Associate

Marc Spiwak

Editorial Associate

Joseph J. Carr, K4IPV

Marc Ellis

Jeffrey K. Holtzman

Don Jensen

Charles D. Rakes

Marc Saxon

Contributing Editors

PRODUCTION DEPARTMENT

Ruby M. Yee

Production Director

Karen S. Tucker

Production Manager

Marcella Amoroso

Production Assistant

ART DEPARTMENT

Andre Duzant

Art Director

Russell C. Truelson

Technical Illustrator

Injae Lee

Assistant Illustrator

Jacqueline P. Cheeseboro

Circulation Director

Michele Torrillo

P-E Bookstore

BUSINESS AND EDITORIAL OFFICES

Gernsback Publications, Inc.

500-B Bi-County Blvd.

Farmingdale, NY 11735

1-516-293-3000

Fax: 1-516-293-3115

President: **Larry Steckler**

Vice President: **Cathy Steckler**

Advertising Sales Offices listed on page 105

Cover photography by
Diversified Photo Services

Composition by
Mates Graphics
and
Magtype

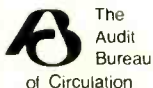

The publisher has no knowledge of any proprietary rights which will be violated by the making or using of any items disclosed in this issue.

THE LEGEND OF FIPS

April has always been a special time here at Gernsback Publications. In years-gone-by it was the month when our founder, Hugo Gernsback, would assume his alter ego—Mohammed Ulysses Fips. Writing as Fips, and with tongue firmly in cheek, Hugo would describe some fascinating yet “impossible” device, and poke some gentle fun at some of the hype and fads of the day.

His Fips articles were very special on two counts: First, they were so cleverly written that, were it not for the “April 1” line with which each story ended, undoubtedly some enterprising readers would have spent countless hours attempting to duplicate the project.

Second, each story was firmly rooted in technology. In fact, many of the things described actually came to be. The transistor, miniature radios, picture phones, and computer-based electronic servicing were just some of the developments that Hugo accurately predicted through his humor.

Hugo is no longer with us, but his spirit lives on. Each April, we try to add a little extra fun to our hobby. We hope you enjoy this year’s efforts as much as we enjoyed bringing them to you. It’s our way of honoring the legend of Mohammed Ulysses Fips.

Carl Laron
Managing Editor

Radio Shack Parts PlaceSM

START SPRING PROJECTS TODAY AT RADIO SHACK

Special-Order "Hotline"



- No Minimum Order
- No Postage Charge

Your Radio Shack store manager can special-order a wide variety of parts and accessories from our warehouse—vacuum tubes, ICs, microprocessors, phono cartridges and styli, crystals, even SAMS Photofacts®. No minimums, no postage charge. Just fast, direct delivery to the Radio Shack store near you.

Electronic Counting Module

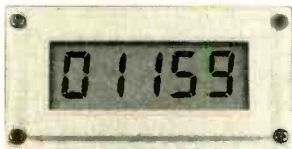

Prewired! Heart of a Traffic/Event Counter

16⁹⁵

Counts up to 99,999. Advanced (or reset) by external switch closure or digital circuit. Count rate up to 7 Hz. Features 1/2" LC display, panel-mount escutcheon and holder on back for required "AA" battery. Long battery life—draws only 4µA. 2 1/16 x 1 3/8 x 1 1/8". With data. #277-302

Computer/Peripheral Connectors

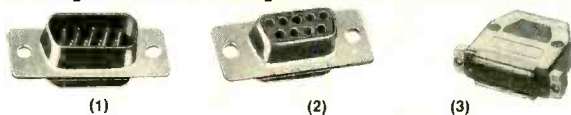

Solder-Type D-Subs. Metal shield plus gold-plated pins and terminals for highest reliability.

Fig.	Description	Cat. No.	Only
1	D-Sub 9 Male	276-1537	.99
2	D-Sub 9 Female	276-1538	1.99
3	Shielded Hood	276-1513	1.49

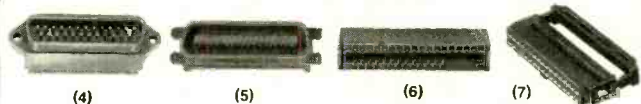

Solderless IDC-Type Connectors

Fig.	Description	Cat. No.	Each
4	D-Sub 25 Male	276-1559	3.99
5	D-Sub 25 Female	276-1565	3.99
6	36-Pos. Male Printer	276-1533	4.99
7	34-Pos. Card-Edge	276-1564	1.99
	34-Pos. Header	276-1525	2.49

Super Adhesive

3⁴⁹

Works When Others Fail

Forms a secure bond to most plastics, metals, ceramics and wood. Twin-plunger dispenser eliminates measuring and waste. #64-2305



Shunt Box

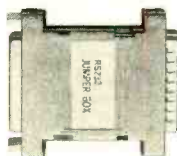

Top-quality, shielded male-to-female RS-232 adapter. Wire included jumpers and board to suit your need. #276-1403 ... 9.95

Chime & Buzzers



- (1) "Ding-Dong." #273-071 ... 8.99
- (2) Two-Tone. #273-070 ... 9.95
- (3) Miniature Electronic Buzzers.

DC Voltage	Cat. No.	Each
1 1/2 to 3	273-053	2.19
6	273-054	2.19
12	273-055	2.19

Strobe Tube



Super Bright! Long Life!

Perfect for photo replacement or hobby projects and experiments. Trigger: 4 kV. Anode: 200V min. With circuit data. #272-1145 ... 3.29

Shielded Cables



Our Best!

- (1) Oxygen-Free Copper A/V Cable. 6 feet, 6 mm dia. #278-1271 ... 5.95
- 8 mm Diameter. #278-1272 ... 7.59
- (2) Dual Mike Cable. For balanced hookups. 30 ft. #278-1281 ... 19.95
- (3) Super-Flex Mike Cable. Extra-supply. 30 ft. #278-1282 ... 14.95

Resistor Buys

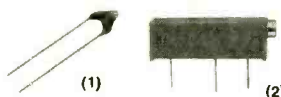

- (2) Precision Thermistor. Resistance changes in proportion to temperature. -50 to +110° C. #271-110 ... 1.99
- (2) 15-Turn Trimmer Pots. 3/4 watt. 1k, #271-342. 10k, #271-343. 20k, #271-340 ... Each 1.49

Tantalum Caps

Low As **59¢** Each

High capacity in a tiny package.

µF	VVDC	Cat. No.	Each
0.1	35	272-1432	59
0.47	35	272-1433	59
1.0	35	272-1434	59
2.2	35	272-1435	69
10.0	16	272-1436	79
12.0	16	272-1437	1.19

Service Chems

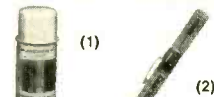

- (1) Color-TV Tuner/Control Cleaner. #64-2320 ... 3.19
- (2) Precision Lubricator. Needle-tip applicator reduces spills and waste. #64-2301, 1.69

Etch Your Own Boards

9⁹⁵

Extra Etchant and Pens Available



Everything You Need For Two PC Boards

Archer® PC Board Kit includes two 4 1/2 x 3" copper-clad boards, resist-ink pen, solvent, etchant, layout strips/circles, tank, special 1/16" drill bit and instructions. #276-1576

Autoranging Probe DVM

39⁹⁵



Measures to 400 volts AC/DC and resistance. It's really handy for tight spaces. Data hold freezes display and lets you remove tester for easy reading. Has continuity sounder, low-battery indicator. Overload protected. Ready to use with batteries, manual, case. #22-165

"Pro" Soldering Station

39⁹⁵

Solder Better, Faster!



Selectable 15/25-watt power, grounded tip to protect sensitive components. Tip-cleaner pad. Ironclad replacement and surface-mount tips available. UL listed AC. #64-2057

Over 1000 items in stock! Binding Posts, Books, Breadboards, Buzzers, Capacitors, Chokes, Clips, Coax, Connectors, Fuses, Hardware, ICs, Jacks, Knobs, Lamps, Multitesters, PC Boards, Plugs, Rectifiers, Resistors, Switches, Tools, Transformers, Transistors, Wire, Zeners, More!

Prices apply at participating Radio Shack stores and dealers

Radio Shack

A DIVISION OF TANDY CORPORATION

CIRCLE 14 ON FREE INFORMATION CARD

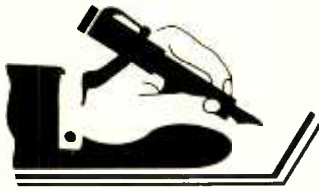

Letters

LOCATING ENCLOSURES

Builders of the "Audio Sweep/Burst Generator" (**Popular Electronics**, February 1990) might have difficulty finding the recommended Radio Shack enclosure, which does not appear in their latest catalog. Instead, they can try Dick Smith Electronics (173 East Broadway, P.O. Box 468, Greenwood, IN 46142; 317-888-7265) enclosure #DS RXRE2G for \$9.95. It has ABS top and bottom shells with aluminum front and rear panels.

Anyone who orders a PC board for the generator will receive a panel-layout template for both enclosures. The PC board can be raised above the bottom with long 4-40 machine screws so that wire leads from the panel controls can be tack-soldered directly to the foil side as the article suggests.

A variation of computer virus, perhaps computer "plague," is taking its toll as mail-order houses abandon long-stocked components for higher profit items. By the time the author of a construction article sees his work in print, one or more sources for supplies might have to be discontinued. Sorry, folks, it's a sign of the times.

John Wannamaker

THE IC IS EXTRA

Thanks to everyone at **Popular Electronics** for doing a superb job on my article "Build the Sonic Emulator" (February, 1990). However, I want to clear up an ambiguity in the ordering information. The basic kit, offered for \$30 plus \$2.50 for S/H does *not* include the Reticon IC (U4). That IC must be ordered separately at the prices listed in the article. I hope that mix-up will not cause anyone any inconvenience.

Chadwick Pryson

THE MICROPROCESSOR OF THE 90'S?

Regarding the Editorial in the January 1990 issue: In January 1980 I was using a Heathkit H89 CP/M computer with 64K memory. It ran WordStar, MBASIC, SuperCalc, and dBASE II. I would *love* to have a pocket organizer that has more computational capabilities than my old H89!

Seriously, though, I agree with your perception that the next ten years will have to produce something special to out-do the microprocessor. My vote for that "something"

is the prospect of mixed-mode analog-digital semicustom arrays and Application-Specific IC's (ASIC). A number of companies are working on that new technology.

In order to integrate in a small package a lot of analog functions along with digital logic, designers will need a low parts count, just as VLSI chips from companies such as Chips and Technology have made available PC add-on boards with so much power. For high-performance or high-power, mostly analog applications, bipolar technology probably will be used. For mostly digital or low-power applications, CMOS probably will be used. Both array-based and standard-cell technology are being developed. The prospect of combining both analog and digital functions on one piece of silicon, while retaining the performance advantages of both IC technologies, will be an exciting challenge.

Regarding the "Editor's Note" in the "Letters" column of the same issue, concerning the LED chaser schematic error where the dot was missing at the junction where the two lines cross: We use the military standard where no connections can be made where two lines cross on a schematic. If a circuit junction exists, one of the lines must be broken and a jog made in the drawing. That way, there is never any problem with missing dots, since a connection is never made at crossing lines. I hope this is helpful.

C.H.

Tinton Falls, NJ

Using the military standard would eliminate missing dots as a source of errors in schematics, and we did consider using it at one time. However, it proved to be impractical for us to do so for logistic reasons, especially in larger, more complicated schematics.

*Incidentally, while it's not a pocket "organizer" in the strict sense of the word, take a look at the Atari "Portfolio" computer reviewed in the February 1990 issue of **Popular Electronics**. That palm-top, pocket-sized computer offers all of the usual organizer features including a calculator; a diary, which includes an appointment calendar with programmable alarms; and an address and telephone directory. But it also features 128K of RAM (expandable to 640K) and built-in software including a Lotus 1-2-3-compatible spreadsheet, a word processor, and an operating system that uses MS-DOS-compatible commands.—Editor*

DIGITAL DILEMMA

I've been following the "Digital Electronics Course" for several months, and I ran into a problem. On page 105 in the January 1990 issue of **Popular Electronics**, under the heading "Exercise," the reader is directed to build the circuit in Fig. 6A, with the hint that a logic circuit containing four variables has a total of 16 combinations. I'm not sure what I'm being asked to do. I see two separate circuits in Fig. 6A (one on each side of the equation), each with two inputs (variables). That should

make four possible input combinations for each circuit, making a total of eight combinations between the two circuits in Fig. 6A. Any help you can give will be appreciated, as I am just beginning to learn about digital circuits. Thanks.

W.C.C.

Mechanicsburg, PA

You are absolutely right: There are no four-input circuits shown, and the number of variables is in fact two to the second power (2²), or 4 (4² appeared due to a typographical error).

In the exercise you are being asked to verify that the two circuits are functionally equivalent. And, speaking of equivalents, note that the two truth tables in Fig. 6B do not agree (another typo). In the first truth table, the output column reads, from top to bottom: 1, 0, 1, 0. It should read: 1, 1, 1, 0, as in the second truth table in the figure.—Editor

CLOSED-CAPTION COMMENTS

As a reader who had a closed-caption decoder in my home where it is used by my deaf son, I was particularly interested in the description of the National Captioning Institute's newest decoder in the "Innovations 89" article in the November 1989 issue of **Popular Electronics**.

I'm writing to stress the point that innovations in electronics for the hearing impaired are valued only insofar as emphasis by the creators of captions is placed on language. Over the years, I have noticed a frustrating lack of attention given to the details of language by those who write captions for TV programs. Not only are words often completely misspelled, but even the gist of the caption does not always relate to what the characters are actually saying. I have often had to interpret a sentence (or would-be sentence) for my son while he is watching a captioned program.

Without greater attention paid to the accuracy of the written language, the whole purpose of captioning will be lost to those reading them on the screen. There is little excuse for translating what a spoken word sounds like when the caption is written for the viewer. Quite often words are not spelled exactly as they sound. If, for example, the word "home" is written as "hom" or "homb" in the captioned text, it could confuse the hearing-impaired viewer—and constant abuse of English in captioning could diminish that viewer's respect for the correct use of the language. Most of us who have hearing-impaired family members would like them to use English properly in whatever they write or even attempt to say.

Finally, I'd like to comment that I find it ironic that profanity is usually spelled correctly when it is flashed on the screen in a captioned program.

S.J.K.

Buena Park, CA

CHRISTMAS CONFUSION

I was looking over the schematic for the "Christmas Tree Lighting System" (**Popular Electronics**, December 1989)—I like to pick out any bugs before I build a project. In the Parts List under "Capacitors" C5 is listed. I cannot find C5 in the diagram. Has it been left out of the schematic diagram or is the Parts List in error?

Also, in the schematic Fuse 1 is listed as 4 amps, but the Parts List states that Fuse 1 is a 5-amp, 250-volt, 3-AG fuse. Could you please clear up the confusion?

D.L.

Laval, Quebec

Although it snuck into the Parts List somehow, there is no C5 in the project. Also, fuse F1 is a 4-amp, 250-volt, 3-AG fuse. Sorry for the mix-up.—Editor

HAVES AND NEEDS

HELP! I am desperately seeking a band-select switch for my beloved *Realistic DX-160*. The receiver not only has great sentimental value but, frankly, is the best I can afford. I've tried Radio Shack to no avail, and checked with several sources in your advertising pages. I don't have a schematic, so I can't describe the switch in "pole/throw" terms, but I would deeply appreciate any help from you or your readers.

By the way, thanks for publishing circuits for those of us on low budgets, who get most of their parts by scrounging through cast-off electronic devices!

Warren W. Wright
93 York Street
Stoughton, MA 02072

I'm trying to locate an old *Timex 2068* computer. I've searched everywhere, and can't find one to buy that is in good condition. I'm willing to pay postage, too. Perhaps another reader has one to sell, or knows of one. Any help in finding that computer would be greatly appreciated.

Pierre Le Ber
8332 Casgrain
Montreal, Quebec
Canada, H2P 2K8

VLF DETECTOR

A friend told me that **Popular Electronics** recently published an article on a very low-frequency detector (or receiver). He couldn't remember what issue it was in. Can you help me find the article?

N.H.
Prescott, AZ

The article you are looking for is "Build the Whistler VLF Receiver" in the July, 1989 issue. That article also looks at some of the mysterious signals heard in the 3-30-kHz VLF band.—Editor

CABLE-TV

WE'LL MATCH OR BEAT ANYONE'S
ADVERTISED RETAIL OR WHOLESALE PRICES!

BONANZA!

ITEM	1 UNIT	10 OR MORE
HAMLIN MCC 3000 36 CORDED REMOTE CONVERTER (Ch 3 only)	29.00	18.00
PANASONIC WIRELESS CONVERTER (our best buy)	98.00	79.00
STAR GATE 2000	88.00	69.00
JERROLD 400 COMBO	169.00	119.00
JERROLD 400 HAND REMOTE CONTROL	29.00	18.00
JERROLD 450 COMBO	199.00	139.00
JERROLD 450 HAND REMOTE CONTROL	29.00	18.00
JERROLD SB ADD ON	99.00	63.00
JERROLD SB-ADD ON WITH TRIMODE	109.00	75.00
M-35 B COMBO UNIT (Ch 3 output only)	99.00	70.00
M-35 B COMBO UNIT WITH VARISYNC	109.00	75.00
MINICODE (N-12)	99.00	62.00
MINICODE (N-12) WITH VARISYNC	109.00	65.00
MINICODE VARISYNC WITH AUTO ON-OFF	145.00	105.00
ECONOCODE (minicode substitute)	69.00	42.00
ECONOCODE WITH VARISYNC	79.00	46.00
MLD-1200-3 (Ch 3 output)	99.00	62.00
MLD-1200-2 (Ch 2 output)	99.00	62.00
ZENITH SSAVI CABLE READY	175.00	125.00
INTERFERENCE FILTERS (Ch 3 only)	24.00	14.00
EAGLE PD 3 DESCRAMBLER (Ch 3 output only)	119.00	65.00
SCIENTIFIC ATLANTA ADD-ON REPLACEMENT DESCRAMBLER	119.00	85.00

CALL FOR AVAILABILITY

Quantity	Item	Output Channel	Price Each	TOTAL PRICE

California Penal Code #593-D forbids us from shipping any cable descrambling unit to anyone residing in the state of California.

Prices subject to change without notice.

SUBTOTAL	
Shipping Add \$3.00 per unit	
COD & Credit Cards — Add 5%	
TOTAL	

PLEASE PRINT

Name _____

Address _____ City _____

State _____ Zip _____ Phone Number () _____

Cashier's Check Money Order COD Visa Mastercard

Acct # _____ Exp. Date _____

Signature _____

FOR OUR RECORDS:

DECLARATION OF AUTHORIZED USE — I, the undersigned, do hereby declare under penalty of perjury that all products purchased, now and in the future, will only be used on cable TV systems with proper authorization from local officials or cable company officials in accordance with all applicable federal and state laws. FEDERAL AND VARIOUS STATE LAWS PROVIDE FOR SUBSTANTIAL CRIMINAL AND CIVIL PENALTIES FOR UNAUTHORIZED USE.

Dated: _____ Signed: _____

Pacific Cable Company, Inc.

7325½ RESEDA BLVD., DEPT. # P-4 • RESEDA, CA 91335
(818) 716-5914 • No Collect Calls • (818) 716-5140

IMPORTANT: WHEN CALLING FOR INFORMATION
Please have the make and model # of the equipment used in your area. Thank You

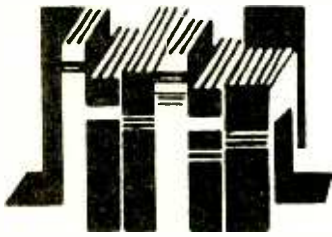

Electronics Library

To obtain additional information on the books and publications covered in this section from the publisher, please circle the item's code number on the Free Information Card

ELECTRONIC AND COMPUTER PARTS

from American Design Components

Aimed at cost-conscious manufacturers, engineers, students, and electronics and computer hobbyists, this catalog's emphasis is on value. The 36-page brochure contains a wide selection of electronic components, including semiconductors, batteries, IC's, switches, power supplies, fans, connectors, and LED's. Computer-related products in-



clude complete computers as well as add-on boards, disk drives, monitors, keyboards, and printers. Also included are "plasma-neon" kits, lasers, infra-red viewers, and stepper motors for robotics.

The Electronic and Computer Parts catalog is free from American Design Components, 815 Fairview Avenue, Fairview, NJ 07022; Tel. 1-800-776-3700.

CIRCLE 81 ON FREE INFORMATION CARD

SURFACE MOUNT TECHNOLOGY Materials, Processes, and Equipment

by Carmen Capillo

First used in the 1960's in defense and aerospace applications, surface-mount technology (SMT) is now finding widespread use in many commercial applications, from computers and communications equipment to consumer and medical electronics. This

book provides a detailed guide to designing, fabricating, and testing printed-circuit boards using surface-mount technology for superior packaging densities, circuit performance, and automation efficiency.

The book traces the development of SMT, explains how it differs from both through-hole and hybrid technology, evaluates its strengths and weaknesses, and explores both present and future applications. A broad range of topics are discussed, including passive, discrete, and active types of surface-mount components; how to design surface-mount PC boards, from construction guidelines to reliability; and the entire process of manufacturing surface-mount assemblies. Practical approaches to cleaning surface-mount assemblies; surface-mount testing; and such reflow soldering methods as vapor phase, dual wave, hot



bar, and laser reflow are also provided.

Surface Mount Technology: Materials, Processes, and Equipment is available in hardcover for \$44.95 from McGraw-Hill Book Company, 11 West 19th Street, New York, NY 10011; Tel. 1-800-2-MCGRAW.

CIRCLE 96 ON FREE INFORMATION CARD

VIDEO CAMERAS AND CAMCORDERS

by Marvin Hobbs

Not simply another consumer guide, this book is geared toward service technicians and engineers. It contains the theory and circuit technology for video cameras and camcorders, and explores the broad range of video-camera applications.

Broadcast and consumer video cameras and camcorders are covered in two separate sections. A third section is devoted to closed-circuit and non-TV applications, including surveillance, image analysis, and still video. While consumer equipment is covered in the greatest detail, there is sufficient information on broadcast equipment and other video-camera applications to give the technician an insight into the variety of work available in the field.

The amply illustrated book contains detailed examples of many specific cameras,

and a thorough discussion of new developments in the field—including the electronic shutter, luminance resampling, S-VHS, and 8mm hi-band. The new servicing method for determining whether the problem lies in the camera or the camcorder, called fault isolation, is also covered.

Major emphasis is placed on solid-state imagers, which have been incorporated into the latest consumer video camcorders and are penetrating all other video-camera and camcorder applications as well. Detailed information regarding the processing of signals from solid-state imagers is provided.

Video Cameras and Camcorders costs \$37.00 in hardcover. It is available from Prentice Hall, Englewood Cliffs, NJ 07632.

CIRCLE 99 ON FREE INFORMATION CARD

BOB GROVE'S SCANNER AND SHORTWAVE ANSWER BOOK

by Bob Grove

Question: Where can hams and DX'ers find the answers to shortwave or scanner questions? Answer: In the pages of this handy reference book. Whether the question involves what is the best equipment on the market, how to reduce interference, how to protect equipment from lightning damage, where to get parts and repairs, or what coaxial cable to use, the answer is here.

Hundreds of questions, culled from eight years of letters sent to *Monitoring Times* by its readers, are answered in the book. Amateur-radio enthusiasts will find themselves referring to it again and again—when they have trouble calculating world time zones or are trying to figure out kilohertz, megahertz, and meter band, for example. Puzzling antenna problems (How high must it be? Can the same one be used for shortwave and scanner reception? Does an antenna tuner help reception?) are all solved, along with hundreds of other dilemmas, idiosyncrasies, quandaries, and queries.

Bob Grove's Scanner and Shortwave Answer Book is available for \$12.95 (plus \$2.00 shipping in the U.S.) from Grove Enterprises, P.O. Box 98, Brasstown, NC 28902; Tel. 704-837-9200.

CIRCLE 82 ON FREE INFORMATION CARD

ELECTRONICS ENGINEER'S REFERENCE BOOK: 6th Edition

edited by F.F. Mazda

While retaining the basic format that has proven so successful with previous editions of this well-respected volume, the fast-paced changes in electronics technology necessitated revisions in much of the material. The comprehensive book is still di-

vided into five basic subject areas—techniques, physical phenomena, materials and components, electronic design, and applications. In the first, the mathematical and electrical techniques used in the analysis of electronic systems are examined. Physical phenomena, including electricity, light, and radiation, are given detailed coverage in the second section. Basic electronics components and materials described in the third section cover the whole spectrum of devices, from resistors to microprocessors. A range of design techniques—from linear to digital circuits, at all power levels—are explored in the next section, which includes chapters on electronic circuit design and instrumentation. Finally, applications such

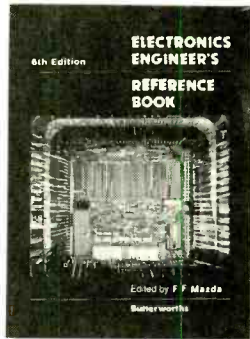

as communication satellites, ISDN, fiber optics, LAN, radar, computers, video recording, and medical electronics are covered.

A lot of material is included in the book's 63 chapters, without skimming on details. The hefty reference guide's type is small and closely spaced, though legible, and ample illustrations complement the text. The book is fully referenced and extensively indexed, making it easy to extract the information you need.

The Electronics Engineer's Reference Book: 6th Edition costs \$125.00 in hardcover. It is available from Butterworths, 80 Montvale Avenue, Stoneham, MA 02180.

CIRCLE 83 ON FREE INFORMATION CARD

ELECTRONIC KITS AND PARTS

from Ballco Inc.

The 22-page *Fall/Winter Electronics Catalog* from Ballco has a selection of standard and hard-to-find parts, as well as kits for all project builders of all skill levels—from beginner to engineer. Kits are available for automotive, audio, telephone, sports, and test-equipment projects. A digital measuring system with optional add-on modules is also offered. Each kit is fully documented

with step-by-step instructions, schematics, and theory of operation.

The Fall/Winter Electronics Catalog is free upon request from Ballco Inc., P.O. Box 1078, Snellville, GA 30278-1078; Tel 404-979-5900.

CIRCLE 84 ON FREE INFORMATION CARD

DESIGNING WITH FIELD-EFFECT TRANSISTORS: Second Edition

Siliconix, Inc.
revised by Ed Oxner

This thorough exploration of both basic and advanced circuit design using field-effect transistors (FET's) includes in-depth explanations of the advantages of their use in integrated circuits, detailing how FET's can be applied most effectively and successfully. Written for electronics and electrical engineers who are involved with circuit design, the book provides full coverage of FET theory, operation, and applications. Topics covered range from basic operating principles to static and dynamic parameters, and from a step-by-step look at the fabrication process to examinations of design techniques for low- and high-frequency circuits.

(Continued on page 12)



EMINENCE



MOTOROLA

Polydax



PIONEER

1-800-338-0531

3-WAY 100W CROSSOVER

12 dB/octave rolloff. 800Hz, 5000Hz crossover points. 8 ohm. 100 watts RMS.



#260-210 **\$12.50** (1-9) **\$9.95** (10-up)

SPEAKER CONTROL PANEL

Panel with 50 watt L-pads for tweeter and midrange and built-in LED power meter. 5" x 2 1/2" 100 watt version available



#260-235 **\$14.50** (1-5) **\$12.90** (6-up)

12" POLY WOOFER

Super duty, 40 oz. magnet. 100 watts RMS, 145 watts max. 4 and 8 ohm compatible (8 ohm). 2" voice coil. fs = 25 Hz. QTS = .166, VAS = 10.8 cu ft. Response: 25-1500 Hz. Net weight: 9 lbs. Pioneer #A30GU40-51D



#290-125 **\$36.80** (1-3) **\$34.50** (4-up)

WALNUT SPEAKER CABINET KIT

Super quality, genuine walnut veneer cabinet. Kit includes: routed and mitred top, sides, and bottom in unfinished 3/4" walnut veneer. Cut your own custom holes in the front and rear to match your drivers. 15" x 24" x 11". Volume: 1.9 cubic feet.



#260-350 **\$22.50** (1-3) **\$19.95** (4-up)

PIONEER HORN TWEETER

Mylar dome. 2.93 oz. barium ferrite magnet. 8 ohm. Response: 1800-20000 Hz. 35W RMS, 50W max. fs = 2000 Hz, SPL = 106 dB. Pioneer #AHE60-51F



#270-050 **\$6.50** (1-9) **\$5.90** (10-up)

12" SUB WOOFER

Dual voice coil sub woofer. 30 oz. magnet, 2" voice coils. 100 watts RMS, 145 watts max. fs = 25 Hz. 6 ohm (4 and 8 ohm compatible). SPL = 89 dB 1W/1M. Response: 25-700 Hz. QTS = .31, VAS = 10.3 cu. ft.. Pioneer #A30GU30-55D. Net weight: 6 lbs.



#290-145 **\$39.80** (1-3) **\$36.80** (4-up)

15" THRUSTER WOOFER

Thruster by Eminence. Made in USA. Poly foam surround, 56 oz. magnet. 2-1/2", 2 layer voice coil. 150 watts RMS, 210 watts max. 4 ohm. fs = 23.5 Hz. QTS = .33, VAS = 17.9 cu ft. SPL = 94.8 dB 1W/1M. Net weight: 15 lbs.



#290-180 **\$43.50** (1-3) **\$39.80** (4-up)

GRILL FRAME KIT

With this kit you can make speaker grill frames up to 30" x 40". Kit includes 4 corner pieces, 2 "T" brackets, and 7 frame bars. Grill mounting kit included.



#260-333 **\$8.50** (1-9) **\$7.80** (10-up)

18" EMINENCE WOOFER

MADE IN USA
100 oz. magnet, 3" voice coil. 250 watts RMS, 350 watts max. 8 ohm, 30 Hz resonant frequency. 22-2700 Hz response. Efficiency: 95 dB 1W/1M. Paper cone, treated accordion surround. Net weight: 29 lbs.



#290-200 **\$98.90** (1-3) **\$89.50** (4-up)

TITANIUM COMPOSITE TWEETER

Titanium is deposited on a polymer dome to combine the advantages of both hard and soft dome technologies. 8 ohm Ferro fluid cooled voice coil. fs = 1200 Hz. SPL = 90 dB 1W/1M. 50 watts RMS, 70 watts max. 4" round. Polydax part #DTW100T125.



#270-047 **\$27.50** (1-9) **\$24.80** (10-up)



340 E. First St., Dayton, Ohio 45402
Local: 1-513-222-0173
FAX: 513-222-4644

* 15 day money back guarantee *\$15.00 minimum order *We accept Mastercard, Visa, Discover, and C.O.D. orders *24 hour shipping *Shipping charge = UPS chart rate + \$1.00 (\$3.00 minimum charge) *Hours: 8:30 am - 6:00 pm EST, Monday - Friday *Mail order customers, please call for shipping estimate on orders exceeding 5 lbs.

CIRCLE 13 ON FREE INFORMATION CARD

www.americanradiohistory.com

Take any one of these HANDBOOKS ELECTRONICS and CONTROL

- your one source for engineering books from over 100 different publishers
- the latest and best information in your field
- discounts of up to 40% off publishers' list prices



322/910

Publisher's Price \$119.50

ANTENNA ENGINEERING HANDBOOK, Second Edition

Edited by R. C. Johnson and H. Jasik

- 1,408 pages, 946 illustrations
- covers all types of antennas currently in use with a separate chapter devoted to each
- provides detailed data on physical fundamentals, operating principles, design techniques, and performance data
- up-to-the-minute information on antenna applications
- a must for those involved in any phase of antenna engineering

Publisher's Price \$78.00

STANDARD HANDBOOK OF ENGINEERING CALCULATIONS, Second Edition

By T. G. Hicks

- 1,468 pages, 793 illustrations, 499 tables
- puts more than 1,100 specific calculation procedures at your fingertips
- every calculation procedure gives the exact, numbered steps to follow for a quick, accurate solution
- virtually all procedures can be easily programmed on your PC or calculator
- uses USCS and SI units in all calculation procedures

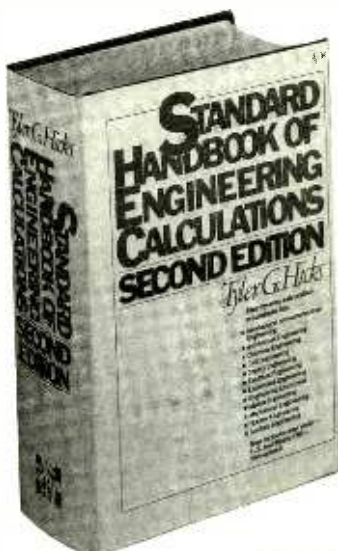

287/35X



047/790

Publisher's Price \$99.95

TELEVISION ENGINEERING HANDBOOK

Edited by K. B. Benson

- 1,478 pages, 1,091 illustrations
- packed with all the technical information today's engineer needs to design, operate, and maintain every type of television equipment
- extensive coverage of receivers, broadcast equipment, video tape recording, video disc recording, and the latest technological advances
- provides television system and industry standards for the U.S. and other countries
- the most comprehensive book on the subject of television engineering

for only \$14.95 – when you join the ENGINEERS' BOOK CLUB



404/461

Publisher's Price \$94.95

MODERN ELECTRONIC CIRCUITS REFERENCE MANUAL

By J. T. Markus

- 1,264 pages, 3,666 circuit diagrams
- a handy, desktop reference with 103 chapters organized by "family" grouping
- filled with predesigned and use-tested circuits to save you production time and money
- includes concise summaries of all the recent applications notes, journal articles, and reports on each circuit, efficiently organized and indexed for the practicing engineer



4 reasons to join today!



1. Best and newest books from ALL publishers! Books are selected from a wide range of publishers by expert editors and consultants to give you continuing access to the best and latest books in your field.

2. Big savings! Build your library and save money, too! Savings range up to 40% off publishers' list prices.

3. Bonus books! You will automatically be eligible to participate in our Bonus Book Plan that allows you savings up to 70% off the publishers' prices of many professional and general interest books!

4. Convenience! 14-16 times a year (about once every 3-4 weeks) you receive the Club Bulletin FREE. It fully describes the Main Selection and alternate selections. A dated Reply Card is included. If you want the Main Selection, you simply do nothing – it will be shipped automatically. If you want an alternate selection – or no book at all – you simply indicate it on the Reply Card and return it by the date specified. You will have at least 10 days to decide. If, because of late delivery of the Bulletin you receive a Main Selection you do not want, you may return it for credit at the Club's expense.

As a Club member you agree only to the purchase of two additional books during your first year of membership. Membership may be discontinued by either you or the Club at any time after you have purchased the two additional books.

Publisher's Price \$92.00

STANDARD HANDBOOK FOR ELECTRICAL ENGINEERS, Twelfth Edition

Edited by D.G. Fink and H.W. Beaty

- 2,416 pages, 1,388 illustrations, 430 tables
- the essential reference for all electrical engineers
- ranges from basic circuits and measurements to advanced topics, such as power distribution and telecommunications
- fully updated to cover all recent advances and developments
- written and compiled by 115 contributors – all experts in their fields

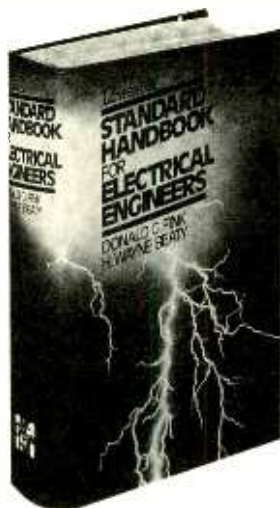

209/758

FOR FASTER SERVICE IN ENROLLING CALL TOLL FREE 1-800-2-MCGRAW

McGraw-Hill Book Clubs
Electronics and Control Engineers' Book Club®
P.O. Box 582
Hightstown, NJ 08520-9959

Please enroll me as a member of the Electronics and Control Engineers' Book Club® and send me the book I have chosen for only \$14.95 plus local tax, postage and handling. I agree to purchase a minimum of two additional books during my first year as outlined under the Club plan described in this ad. Membership in the club is cancellable by me or McGraw-Hill any time after the two book purchase requirement has been fulfilled. A shipping and handling charge is added to all shipments.

I wish to order the following book:

- ANTENNA ENGINEERING HANDBOOK (322/910)
- MODERN ELECTRONIC CIRCUITS REFERENCE MANUAL (404/461)
- STANDARD HANDBOOK FOR ELECTRICAL ENGINEERS, 12/e (209/758)
- TELEVISION ENGINEERING HANDBOOK (047/790)
- STANDARD HANDBOOK OF ENGINEERING CALCULATIONS (287/35X)

Signature _____

Name _____

Address/Apt. # _____

City/State/Zip _____

This order subject to acceptance by McGraw-Hill. Offer good only to new members. Foreign member acceptance subject to special conditions

ECGB-029

FREE!

New Catalog of Hard-To-Find Precision Tools



Jensen's new catalog is jam-packed with more than 2,000 quality items. Your single source for hard-to-find precision tools used by electronic technicians, scientists, engineers, schools, instrument mechanics, laboratories and government agencies. This popular catalog also contains Jensen's world-famous line of more than 40 tool kits. Call or write for your free copy today!

JENSEN TOOLS INC. 7815 S. 46th Street
Phoenix, AZ 85044
(602) 968-6231

CIRCLE 10 ON FREE INFORMATION CARD

Be an FCC LICENSED ELECTRONIC TECHNICIAN!



No costly School. No commuting to class. The Original Home-Study course prepares you for the "FCC Commercial Radiotelephone License". This valuable license is your "ticket" to thousands of exciting jobs in Communications, Radio-TV, Microwave, Computers, Radar, Avionics and more! You don't need a college degree to qualify, but you do need an FCC License. **No Need to Quit Your Job or Go To School** This proven course is easy, fast and low cost! **GUARANTEED PASS**— You get your FCC License or money refunded. **Send for FREE facts now. MAIL COUPON TODAY!**

COMMAND PRODUCTIONS

FCC LICENSE TRAINING, Dept. 203
P.O. Box 2824, San Francisco, CA 94126

Please rush FREE details immediately!

NAME _____
ADDRESS _____
CITY _____ STATE _____ ZIP _____

Electronics Library

(Continued from page 7)

The original book, written by the applications engineering staff at Siliconix, Inc., has been updated by Ed Oxner to include full coverage of such developments as small-signal DMOS (double-diffused MOSFET)

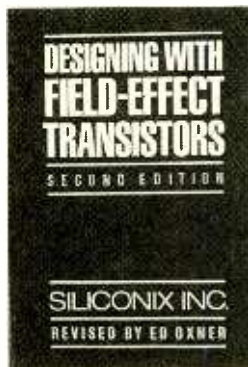

technology and the process of using the power FET as a high-speed switch.

Designing with Field-Effect Transistors: Second Edition costs \$39.95 in hardcover. It is available from McGraw-Hill Book Company, 11 West 19th Street, New York, NY 10011; Tel. 1-800-2-MCGRAW.

CIRCLE 96 ON FREE INFORMATION CARD

THE VIDEO MAGALOG

from Interstate/Florida, Inc.

This catalog of special-interest and how-to video tapes contains more than 2,000 video titles in a wide range of subject areas. The 144-page, magazine-style catalog includes videos on sports, fitness, education, business, art, beauty and fashion, family fun, pets, finance, personal motivation, home, parenting, art, music, and computers. A certificate worth \$2.95 off your first order is included with the catalog.

The Video Magalog is available for \$2.95 plus \$1.00 shipping and handling (FL residents must add appropriate sales tax) from Interstate/Florida, Inc., 2165 Sunnydale Blvd., Suite D, Clearwater, FL 34625.

CIRCLE 85 ON FREE INFORMATION CARD

IBM PERSONAL COMPUTER TROUBLESHOOTING & REPAIR for the IBM PC, PC/XT, and PC AT

by Robert C. Brenner

Written in a style simple enough for novices to follow, yet detailed enough to be helpful to experienced technicians, this book helps readers to locate and correct most failures on IBM PC, XT, and AT comput-

ers. An in-depth description of each of those systems, with illustrations and charts, explains how each computer works and forms the basis of understanding how to extend its operational life.

All the major subsystems are explored, with block diagrams to provide an overview of personal computer signals and circuitry. The book explains how and why computer failures occur, and how to use preventative maintenance to avoid them. Readers are encouraged to use the information presented to develop their own diagnostic hardware and software tools. Throughout the book, diagnostic techniques are discussed with an emphasis on how to isolate and analyze problems and how to decide on the proper corrective action. Advanced troubleshooting and malfunction-repair techniques are explained in full detail.

IBM Personal Computer Troubleshooting & Repair for the IBM PC, PC/XT, and PC AT costs \$24.95. It is available from Howard W. Sams & Company, 4300 West 62nd St., Indianapolis, IN 46268; Tel. 800-428-SAMS.

CIRCLE 95 ON FREE INFORMATION CARD

LOU SANDER'S GOLD MINE Game Tips for Commodore Users

by Louis F. Sander

More than 1200 game-winning formulas, as well as the most comprehensive list of game sources currently available, are included in this book. Tips and tricks for succeeding at more than 500 computer games—including such favorites as "Break-thru," "Defender of the Crown," "Gunship," "The Last Ninja," and "Legacy of the Ancients"—are offered. While most of the strategies and pointers originated with Commodore and Amiga owners, many of them are equally effective with Apple, IBM, Atari, Macintosh, and other game versions.

Lou Sander's Gold Mine: Game Tips for Commodore Users is available for \$19.95 from TAB Books Inc., Blue Ridge Summit, PA 17294-0850; Tel. 1-800-233-1128.

CIRCLE 98 ON FREE INFORMATION CARD

ISDN, DECnet, AND SNA COMMUNICATIONS

edited by Thomas C. Bartee

The new age of communications—heralded by the expansion of computer-to-computer systems, PC networks, local area networks (LAN), and leased-line dedicated networks, combined with the development of advanced voice facilities—is explored in this book. A broad view of the subject is taken, with the international political implications

given full consideration along with detailed explanations of the technical aspects. The integrated services digital network (ISDN), systems network architecture (SNA), and Digital Equipment Corporation's digital-network architecture (DECnet) are given in-depth treatments, along with packet-switched networks and other major telecommunications networks.

Taking a global approach, the book offers a look inside international and national standards committees and major computer and communications companies. With each chapter written by an expert in the field, the book provides "inside" information on the potential and limitations of digital communications, the standards process; the newly emerging field of communications management; the structures, operations, and impact of circuit, message, and packet switching; and the politics of communications. The book examines areas of potential controversy, including national-defense postures, information flows across national boundaries, the right to personal privacy, and compatibility between competing networks.

ISDN, DECnet, and SNA Communications is available in hardcover for \$39.95 from Howard W. Sams & Company, 4300 West 62nd St., Indianapolis, IN 46268; Tel. 800-428-SAMS.

CIRCLE 95 ON FREE INFORMATION CARD

PC BOARD CATALOG

from Capital Circuits, Inc.

This brochure describes Capital Circuits' services as well as their product line. The products include single, double, and multi-layer PC boards; Teflon boards; flexible boards; and surface-mount technology products. Among the services offered are photo reduction, first article inspection, subcontracting capabilities for design and assembly, and data transfer by modem.

The PCB Buyer's Brochure is available from Capital Circuits, Inc., 7845-J Airport Road, Gaithersburg, MD 20879; Tel. 301-990-6715.

CIRCLE 86 ON FREE INFORMATION CARD

MAGNETIC RECORDING HANDBOOK: TECHNOLOGY AND APPLICATIONS

edited by C. Denis Mee and Eric D. Daniel

The editors' previously published three-volume set entitled *Magnetic Recording* has been updated, expanded, and combined in this one comprehensive volume. Providing state-of-the-art information for anyone involved in the development of computer, video, audio, and instrumentation technology, the book examines dozens of im-

portant topics, including recent developments in the magnetic-recording field.

More than 20 specialists have written about their areas of expertise. Their combined contributions cover everything from error correction, coding, and magneto-optical recording to the analog and digital applications of magnetic-recording technology. Also discussed are advances in rigid and flexible disks, new materials and designs for magnetic media and heads, and magnetic tapes for computer storage and video recording.

Magnetic Recording Handbook: Technology and Applications, is available in hardcover for \$94.50 from McGraw-Hill Publishing Company, 11 West 19th Street, New York, NY 10011; Tel. 1-800-2-MCGRAW.

CIRCLE 96 ON FREE INFORMATION CARD

AN INTRODUCTION TO AMATEUR RADIO

by I.D. Poole

Amateur radio has attracted a broad base of enthusiasts around the world. This British book, written for those who are new to the hobby, covers a wide variety of topics that fall under the far-reaching amateur-radio heading.

Beginning with a short historical overview, the book provides the beginning ham

with a comprehensive but easy-to-follow introduction to the hobby. Basic aspects, in-

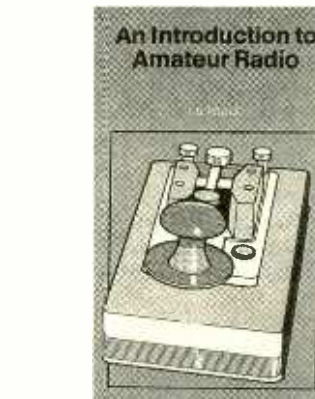

cluding operating procedures, callsigns, jargon, Morse code, and setting up a station, are explained in complete detail. Technical topics include discussions of propagation, transmitters, receivers, and antennas. The book is illustrated and contains several handy charts and lists.

An Introduction to Amateur Radio costs \$7.75, including shipping. It is available from Electronics Technology Today, Inc., P.O. Box 240, Massapequa Park, NY 11762-0240.

CIRCLE 97 ON FREE INFORMATION CARD

MORE THAN TIME



Most Accurate Clock by Heathkit®

Discover the world's most accurate time piece plus a large assortment of other electronic products in your **FREE Heathkit Catalog**. It's filled with both kit and ready-to-use home theater components, weather stations and amateur radio products, along with kit laptop computers and a wide variety of self-study courses for the novice or seasoned electronics enthusiast. Order your **FREE Heathkit Catalog** today. Time's a wasting!

1-800-44-HEATH
(1-800-444-3284)

Send to: **Heath Company, Dept. 107-884**
Benton Harbor, Michigan 49022

Name _____

Address _____

City _____

State _____

Zip _____

CIRCLE 22 ON FREE INFORMATION CARD

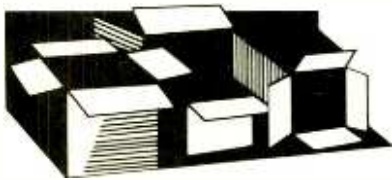

New Products

To obtain additional information on new products covered in this section from the manufacturer, please circle the item's code number on the Free Information Card

BENCH POWER SUPPLY

A general-purpose bench power supply from B&K-Precision, the model 1646, has an output that is variable to 16 volts. The DC power supply, with its 10-amp capacity and well-regulated output, is suited for a servicing, testing, and engineering applications in the electronic, electrical, laboratory, and manufacturing fields. The 1646 has excellent regulation and low-ripple characteristics. Coarse- and fine-voltage controls are provided for convenient, precise voltage settings. Two large, front-panel-mounted meters allow simultaneous monitoring of voltage and current. Two current ranges are provided for the highest possible resolution. The power supply offers automatic mode selection between constant-voltage and constant-current operation; the selected mode is indicated by front-panel LED's. In constant-voltage applications, a current limit can be preset. The 1646 automatically switches to constant-current mode if variations in the load cause the current to reach the preset value. Its design includes automatic overload and short-circuit protection; reverse polarity and over-voltage protection are also provided. To supply additional voltage or current requirements, two



1646 power supplies can be connected in series or in parallel, as the output terminals are fully isolated.

The model 1646 DC bench power supply has a user price of \$489.00. For further information, contact B&K-Precision, Maxtec International Corporation, 6470 West Cortland Street, Chicago, IL 60635.

CIRCLE 100 ON FREE INFORMATION CARD

HOME-SECURITY SYSTEM

It takes only minutes to install X-10's Protector Plus Supervised Home Security System (SS5400)—without tools, wiring, or programming. The system simply plugs in, and door/window sensors are easily mounted with heavy-duty self-adhesive strips. During setup, the system randomly selects a unique internal code for each sensor to identify the door or window being protected. A single button on a hand-held remote control is used to arm and disarm the system. Battery backup assures that the Protector Plus works even when the power fails.

The starter system consists of four units. The base receiver has a loud built-in siren and zone-status indicator lights. The remote control is used for controlling lights as well as for arming and disarming the system. It also has a delay switch to give the homeowner enough time to get in and out of the house without triggering the alarm. Any two keys pressed simultaneously will trip the "panic alarm." One door/window sensor and



one lamp module—which permits a light to flash when the system is tripped—complete the basic starter package.

As many as 16 doors or windows can be protected by adding more sensors; each is supervised to let the homeowner know if there is a problem with it. The system will not arm if a door or window is open or if one of the sensors has not "reported in." If a door or window is opened when the system is armed, the siren sounds and all the lights connected to the lamp modules flash on and off. The lights will keep on flashing until the homeowner turns them off, but the siren automatically stops after four minutes. The Protector Plus is completely compatible with X-10 Powerhouse timers and home-control interfaces; by combining various components, lights and appliances can be pro-

grammed to turn on and off automatically when no one is home.

The Protector Plus Supervised Home Security System starter set has a suggested retail price of \$115.00. For further information, contact X-10 (USA) Inc., 185A Legrand Avenue, Northvale, NJ 07647.

CIRCLE 101 ON FREE INFORMATION CARD

MUSIC KEYBOARDS

Featuring "one-finger ad-lib" and 16-bit digital sound, four new keyboards from Kawai allow anyone to play like a pro. Midsize models MS210, MS510, and MS710, and the full-sized 49-key FS610 (pictured) each contain 17 notes in the ONE FINGER AD-LIB region of the keyboard. When one of those notes are pressed, the keyboard plays a phrase that complements the selected rhythm. For example, when starting with a disco-rhythm accompaniment, each one of those 17 notes will play a different ad-lib



melody that is appropriate to disco songs. When the rhythm is switched to, say, a march, the phrases will also change to suit the style of a march. All of the various rhythms offered on the keyboard have their own set of 17 phrases. Experienced players can also instantly add any of up to 408 musical riffs as they play.

The MS210, MS510, MS710, and FS610 carry suggested retail prices ranging from \$99.00 to \$199.00. For more information, contact Kawai America Corporation, 2055 East University Drive, Compton, CA 90224.

CIRCLE 102 ON FREE INFORMATION CARD

COMPACT STEREO SYSTEM

Consisting of a compact-disc player, a cassette deck, a turntable, and an AM-FM radio, Soundesign's model 6988-46 provides a full range of listening options in a small package. The front-loading CD player has three-beam, one-laser pick-up and custom play controls including skip/fast forward and skip/fast backward for easy program selection. The repeat switch can be used to select and replay one song or an entire disc. The model 6988-46 records directly from the tuner, CD player, turntable, PH/AUX/TV input, or with optional microphones. The cassette deck features automatic level

(Continued on page 16)

9 Reasons you'll really enjoy The Modern Electronics Manual



Look how easy it is to make your own printed circuits now

1. Select the board layout you want
2. Place it on top of a photo sensitive copper baseboard and expose to sunlight, spotlight or incandescent bulb
3. Etch away unwanted material in bath solution to create your printed circuit
4. Attach components and solder to board
5. Plug it in and use it



1. Filled with practical, useful projects

Over 400 pages of how-to information that's easy-to-follow and makes projects faster, easier and more enjoyable. Now you can build your own electronic components in wide range of areas—from telecommunications to stereos, computers, radio and TV.

2. Circuit layouts on acetate—Save you time and effort

Here's how to eliminate the most time consuming step of almost any project—fabricating the printed circuit you need. The Manual gives you the board layout in black on a clear acetate. Just place the acetate over a photosensitive PC copper baseboard, expose it to light, develop it, and you have your own printed circuit board specially crafted for each project.

3. Save money by doing things yourself

Build things for the home and office that make your life easier and more pleasant, and give you more efficiency. Learn when to call the repair man and

when you can fix it yourself. Save unneeded service calls.

4. Sources of supply

Your Manual gives you listings of firms that sell electronic components through stores and through the mail.

5. Professional "hints and kinks"—tips, & new techniques

Professional techniques are explained in detail, step-by-step. You learn the easy shortcuts as well as the pitfalls to look out for.

6. Keep on top of what's new

Advances in electronics occur rapidly today, so we send regular updates to give you insight into new technologies and how you can work with it.

7. Trouble-shooting techniques

Build your understanding from the ground up. Learn the technology

and how it works, then the applications, the maintenance and repair procedures.

8. Well-organized, easy to access information

The FREE, sturdy 3-ring Binder with Index Tabs organizes material so you find what you need quickly.

9. Publisher's Moneyback Guarantee

There's absolutely no risk in taking a look at **The Modern Electronics Manual**. You pay nothing unless you are completely satisfied it's for you. If you have paid already you will receive a full 100% of your money back.

No Risk Trial Certificate

Just return the coupon below and we'll send you the Manual to look over in the comfort of your home or office. Take the time it deserves to examine it carefully and then decide.

Send for your no risk look today.

Here are just some of the subjects covered:

Electronic components and their characteristics
 Hand tools for electronic kit building
 Electronic component handling
 Electrical soldering techniques
 Sources of electronic components and supplies
 Printed circuit board layout techniques
 Making printed circuit boards
 Surface mount technology
 Electrical safety
 Basic radio
 Basic TV
 Solid state darkroom timer
 Electrical surge protection
 Amplifier for your Walkman
 Basic telephone
 Telephone testing set
 Cellular telephone
 Night light that turns on when telephone rings

Introduction to Satellite TV
 Facsimile fundamentals
 Guide to using computer bulletin boards
 Short wave radio
 Digital logic fundamentals
 A DOS tutorial
 BASIC programming tutorial
 Video display adapters for PCs
 Laser printing
 Installing accessory cards in your PC
 Installing a hard/fixed disk drive
 Managing data on your hard drive
 Electrical desoldering techniques
 Audible voltage continuity tester
 General diagnostic techniques
 Ground fault-interrupter
 Cost effective function generator
 Double sided printed circuit boards
 Soldering iron idler
 Improving antenna reception performance



To order your Manual right away, call 1-800-222-WEKA

The Modern Electronics Manual

97 Indian Field Road, Greenwich, CT 06830

YES, send me **The Modern Electronics Manual** for only \$69.95 (plus \$4.50 for shipping and handling). Enclosed is my check or credit card number and signature. I understand if I am not completely delighted I can return the Manual at any time and receive a complete 100% refund.

Bill me Payment enclosed Charge my Visa MasterCard
 Acct. No. _____ Exp. Date _____

Signature _____

Name _____

Address _____

City, St, ZIP _____

All orders must be signed to be processed.

If I elect to keep the Manual, I understand I'll also receive supplements 4 to 5 times a year at 25¢ per page to ensure my Manual remains completely up to date. I'll be billed with each separate supplement and can return them unpaid if I'm not satisfied. I can also cancel further supplements at any time.

Put Professional Knowledge and a
COLLEGE DEGREE
 in your Technical Career through
HOME STUDY

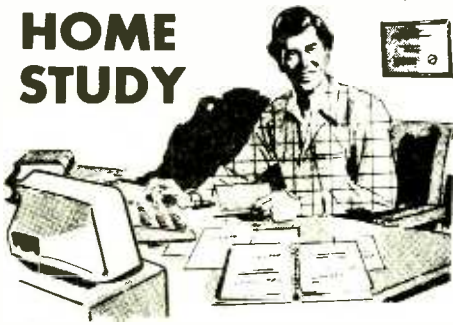

Add prestige and earning power to your technical career by earning your Associate or Bachelor degree through directed home study.

Grantham College of Engineering awards accredited degrees in **electronics and computers.**

An important part of being prepared to *move up* is holding the right college degree, and the absolutely necessary part is knowing your field. Grantham can help you both ways—to learn more and to earn your degree in the process.

Grantham offers two degree programs—one with major emphasis in **electronics**, the other with major emphasis in **computers**. Associate and bachelor degrees are awarded in each program, and both programs are available completely by correspondence.

No commuting to class. Study at your own pace, while continuing on your present job. Learn from easy-to-understand lessons, with help from your Grantham instructors when you need it.

Write for our free catalog (see address below), or phone us at toll-free 1-800-955-2527 (for catalog requests only) and ask for our "degree catalog."

Accredited by
 the Accrediting Commission of the
 National Home Study Council

GRANTHAM
 College of Engineering
 10570 Humbolt Street
 Los Alamitos, CA 90720

New Products

(Continued from page 14)

control, built-in synchro-start for use when recording CD's onto tape, and auto stop in both record and playback modes.

The unit's amplifier/tuner section includes an AM/FM stereo radio, a three-band graphic equalizer, and rotary-thumbwheel tuning. A semi-automatic, two-speed turntable sits on top of the tuner. It features a bi-directional cue/pause control, tone-arm

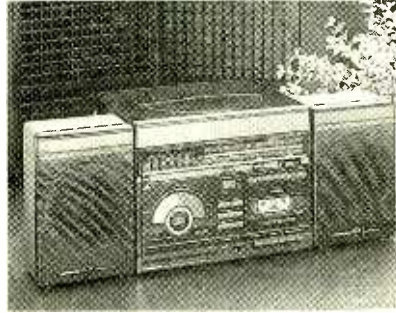

lock, ceramic cartridge, and a black dust cover. A pair of five-inch, wide-range speakers rounds out the system.

The model 6988-46 compact stereo system has a suggested retail price of \$269.95. For more information, contact Soundesign Corporation, Consumer Electronics Division, Harborside Financial Center, 400 Plaza Two, Jersey City, NJ 07311.

CIRCLE 103 ON FREE INFORMATION CARD

DIAGNOSTIC MODULE

Consisting of a hardware/firmware add-on board that contains diagnostic codes, *Total Power's LOGIMER* is a diagnostic system designed to simplify the troubleshooting and repair of IBM PC/XT/AT, 80286, 80386, and compatible-system boards. It comes with three ROM chips and plugs into any slot on the computer, allowing a series of tests to be performed with little supervision.

LOGIMER can make more than 1000 individual tests in less than one minute. Particularly useful are its capacity for detect-

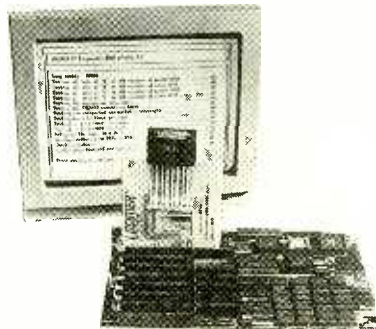

ing intermittent breakdowns and its capability to take over (using its two-digit alphanumeric display) in the event of a computer-screen blackout. The device can also carry out loop tests, making 100 loops of 1000 tests for up to 64 hours of looping. On-screen instructions make the device easy to use without frequently referring to the manual, which is also included.

The LOGIMER in-circuit diagnostic module costs \$399.00. For further information, contact Total Power International, Inc., 418 Bridge Street, Lowell, MA 01850.

CIRCLE 104 ON FREE INFORMATION CARD

SATELLITE DISHES

Yuppies are often more than upwardly mobile—they also tend to move around a lot from place to place. To simplify their lives, *Dixee Paper Products* has begun shipping disposable satellite dishes and cups to selected markets across the country. It is no longer necessary for the relocating yuppie to uproot, disassemble, crate, and ship his satellite antenna when he packs up and

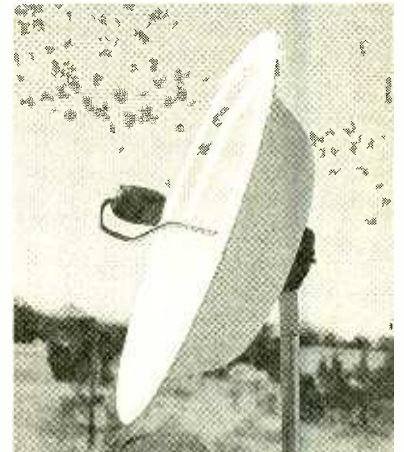

moves from one town to another. All he has to do is crumple up the old dish—which is made of lightweight, plastic-impregnated cardboard for weather resistance—throw it away, and buy a fresh dish (or cup, for smaller Ku-band installations) upon arriving at his new locale. Dixee disposable paper satellite dishes come in 6-, 8-, 10- and 12-foot sizes, in plain or floral pattern.

Prices for the disposable satellite dishes start at \$195.00. For further information, contact Dixee Paper Products, 1224 Suwanee Drive, South of the Border, SC 29536.

CIRCLE 4/1 ON FREE INFORMATION CARD

8mm CAMCORDER

The *Canovision 8 E30* is a fully automatic 8mm camcorder from Canon that is compact, light, and easy to use. Designed for users who want point-and-shoot simplicity,

the E30 automatically sets the focus, exposure and white balance when the power is turned on. No adjustment is required before recording.

The 2.4-pound (without battery pack) camcorder features Canon's "180° Flexigrip," a combination grip and electronic viewfinder that rotates 180 degrees for comfortable shooting at almost any camera angle. Each button on the compact E30 is dual-function, performing both recording and



playback operations. A wireless remote control can also be used for both recording and playback functions, including zooming and fades.

Other features include a 9-54mm f/1.4 6x power zoom lens; macro focusing for sharp close-up shots; auto backlight compensation; a two-field auto metering system to determine the precise exposure ratio; a built-in titler; and automatic dating function. The electronic viewfinder provides an extensive information display to monitor camera functions including manual camera settings, white-balance lock, interval or self timer, low-battery charge, and tape end. The BP-E77K battery pack, included with the camcorder, supplies power for 45 minutes of continuous recording.

The Canovision 8 E30 has a suggested retail price of \$1,199.00. For additional information, contact Canon U.S.A., Inc., One Canon Plaza, Lake Success, NY 11402.

CIRCLE 106 ON FREE INFORMATION CARD

10-METER YAGI ANTENNA

For novice and experienced hams who want to enjoy the DX opportunities of the 10-meter band, the *Cushcraft Ten-3* is a three-element Yagi that combines high performance with ease of use and durability. The

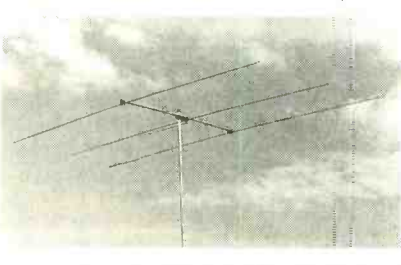

antenna offers 8-dB forward gain and a front-to-back ratio of 25 dB; it is power rated for 2000-watts P.E.P. The Ten-3 has an 8-foot boom and takes a mast size of 1 1/2 to 2 inches, which makes it easy to install on a simple mount with only a light rotator. The "reddi-match" system provides 50-ohm feed for a standard PL259 connector. It is easy to assemble from precision-manufactured components, by following the detailed instructions. All tubing used in the antenna is heavy-wall hard-drawn, bright-finish aluminum.



The Ten-3 10-meter Yagi has a suggested retail price of \$125.00. For additional information, contact Cushcraft Corporation, P.O. Box 4680, 48 Perimeter Road, Manchester, NH 03108.

CIRCLE 107 ON FREE INFORMATION CARD

SOLDERING STATION

Exceeding Department of Defense standards, *Royal Soldering Systems' Thematic T300, T3050, T5000, and T5050* soldering

HITACHI SCOPES AT DISCOUNT PRICES

Digital Storage Scopes  VC-6025 20MS/S 50MHz Bandwidth 2K Word Memory Capacity \$2349.00		 V-212 \$435 List \$595 Save \$160		 V-1060 \$1,359 List \$1595		<ul style="list-style-type: none"> • DC to 100MHz • Dual Channel • Delayed Sweep • CRT Readout • Sweep Time • Autoranging • Trigger Lock • 2mV Sensitivity
<p>Advanced storage functions create new dimensions in scopes such as one shot observation, flicker free display, bright display for even high speed event, trace observation for low speed event, hard copy by plotter and data output to computer.</p> <p>VC-6045 100MHz 40MS/S 4K Word Memory cap (call)</p> <p>All Hitachi scopes include probes, schematics, and Hitachi's 3 year worldwide warranty on parts and labor. Many accessories available for all scopes.</p>						
V-422 40MHz	D.T. 1mV sens.	DC Offset	Vert Mode	Trigger, Att Mag	LIST \$940	SAVE \$200
V-423 40MHz	D.T. 1mV sens.	Delayed Sweep	DC Offset	Att Mag	\$1,025	\$825 \$200
V-425 40MHz	D.T. 1mV sens.	DC Offset	CRT Readout	Cursor Meas	\$1,070	\$849 \$221
V-460 60MHz	D.T. 2mV sens.	Delayed Sweep	CRT Readout	Cursor Meas	\$1,295	\$1,145 \$150
V-1065 100MHz	D.T. 2mV sens.	Delayed Sweep	CRT Readout	Cursor Meas	\$1,895	\$1,670 \$225
V-1100A 100MHz	Q.T. 1mV sens.	Delayed Sweep	CRT Readout	DVM Counter	\$2,450	\$2,095 \$355
V-1150 150MHz	Q.T. 1mV sens.	Delayed Sweep	Cursor Meas	DVM Counter	\$3,100	\$2,675 \$425

ELESCO PRODUCTS AT DISCOUNT PRICES

20MHz Dual Trace Oscilloscope  \$375 MO-1251 • 6" CRT • Built in component tester • TV Sync	FREE DMM with purchase of ANY SCOPE SCOPE PROBES P-1 65MHz, 1x, 10x \$19.95 P-2 100MHz, 1x, 10x \$23.95	35MHz Dual Trace Oscilloscope  \$495 MO-1252 • High luminance 8" CRT • 1mV Sensitivity • 6KV Acceleration Voltage • 10ns Rise Time • X-Y Operation + Z Axis • Delayed Triggering Sweep
Top quality scopes at a very reasonable price. Contains all desired features. Two 1x, 10x probes, diagrams and manual. Two year guarantee.		

PRICE BREAKTHRU on Auto Ranging DMMs 3 to choose from: MDM-1180 \$24.95 MDM-1181 \$27.95 MDM-1182 \$29.95 • 3 1/2 LCD Display • 27 Functions • Auto Manual Ranges • Audible Continuity • Data Hold (MDM-1182) • 1% Accuracy (MDM-1181)	True RMS 4 1/2 Digit Multimeter \$135 M-7000 • 0.5% DC Accuracy • 1% Resistance with Freq. Counter and deluxe case	Multimeter with Capacitance and Transistor Tester \$55 CM-1500 Reads Volts, Ohms, Current, Capacitors, Transistors and Diodes with case	Digital Capacitance Meter CM-1550 \$58.95 9 Ranges 1pf-20,000fd 5% basic accy Zero control with case	Digital LCR Meter LC-1801 \$125 Measures Coils 1uH-200uH Caps. 1pf-200uF Res. 0.1-20M
Bench DMMs M-3500 \$125 3 1/2 digit M-4500 \$175 4 1/2 digit 3% accy 0.5% accy	AC Current Meter ST-1010 \$69.95 1000 Amps Data/Peak Hold 8 Functions Deluxe Case	Solderless Breadboards 9430 1,100 pins \$15 9434 2,170 pins \$25 9436 2,960 pins \$35 All have color coded posts	AC Clamp-On Current Adapter ST-265 \$25.00 • 0-100A AC Works with most DMM	

Soldering Station Temperature Controlled SL-30 \$99 Digital display Temp range 300F-900F Grounded tip Overheat protected	Color Convergence Generator SG-200 \$69.95 Finest in the industry 10 rock steady patterns	10MHz Oscilloscope S-3000 \$275 10MHz DC or AC Triggered Sweep Calibrated Vert & Hor Reads Volts & Freq	Temperature Probe M-110CF \$29.95 Silicon diode type Range -56F-302F Fits most digital multimeters	Autoranging DMM M-5000 \$45 9 Functions Data Hold 1% basic acc 3 1/2 digit LCD
Wide Band Signal Generators SG-9000 \$129 RF Freq 100K-450MHz AM Modulation of 1KHz Variable RF output SG-9500 with Digital Display and 150MHz built-in Freq Ctr \$249	TRIPLE POWER SUPPLY XP-620 Assembled \$65 KIT \$45 Contains all the desired features for doing experiments. Features short circuit protection on all supplies	Function Generator Blox \$28.95 Provides sine tri, saw wave from 1Hz to 1MHz AM or FM capability	Decade Blox #9610 or #9620 \$18.95 #9610 Resistor Blox #9620 Capacitor Blox 47pf to 10MFD	
Digital Triple Power Supply XP-765 \$249 0-20V at 1A 0-20V at 1A 5V at 5A Fully Regulated, Short circuit protected with 2 Limit Cont., 3 Separate supplies XP-660 with Analog Meters \$175	Quad Power Supply XP-580 \$59.95 2-20V at 2A 12V at 1A 5V at 3A 5V at 5A Fully regulated and short circuit protected XP-575 without meters \$39.95	LEARN TO BUILD AND PROGRAM COMPUTERS WITH THIS KIT! INCLUDES: All Parts, Assembly and Lesson Manual  MODEL MM-8000 \$129.00 Starting from scratch you build a complete system. Our Micro Master trainer teaches you to write into RAMS, ROMS and run a 8085 microprocessor, which uses machine language on a 64K PC. You will write the actual instructions to tell the 8085 processor to get started, and store these instructions in permanent memory in a 2816 EPROM. Teaches you all about input and output ports, computer timers. Build your own keyboard and learn how to scan keyboard and display. No previous computer knowledge required. Simple, easy to understand instruction teaches you to write in machine language.		

WE WILL NOT BE UNDERSOLD!
 UPS Shipping: 48 States 5% (\$10 Max) IL Res., 7% Tax

C & S SALES INC.
 1245 Rosewood, Deerfield, IL 60015
 (800) 292-7711 (708) 541-0710

15 Day Money Back Guarantee
2 Year Warranty
WRITE FOR FREE CATALOG

CIRCLE 15 ON FREE INFORMATION CARD

New Products

stations provide a tip-to-ground resistance of 0.58 ohms, tip-to-ground leakage of 0.70 mV, and $\pm 3^\circ\text{F}$ idling temperature. The units are designed to increase the user's control over the soldering process and minimize the risks of thermal and electrostatic discharge shock.

Those specifications, along with other features, make the soldering stations attractive to commercial and other non-military users as well as military users. Heat-up time is 20 seconds, and recovery time after solder is 10 seconds. A 24-volt DC power supply protects the soldering iron from transient voltage and switching-spike damage. Tip-to-ground connection requires little main-



tenance, thanks to a design that provides an air-tight connection that resists oxidation for the life of the tip. The outer barrel cover screws on and locks the tip between the shoulder and a tapered spike that penetrates the end of the copper tip core.

Each unit simultaneously displays both setpoint and actual tip temperature. The stations each come with a soldering iron, a power unit with iron holder, sponge and tray, ground lead, and user's manual. Analog and digital models of the 115-volt single-iron station are available, with either a T300 (40-watt, 3mm) or a T500 (60-watt, 5mm) tip.

The analog T3000 115-volt unit with T300 tip has a list price of \$259.00; the same unit with a T500 tip, model T5000, costs \$269.00. Digital stations, the T3050 115-volt with T300 tip and the T5050 with T500 tip, cost \$359.00 and \$369.00, respectively. Replacement tips cost \$5.75 for the T300 and \$5.95 for the T500. For more information, contact Royel Soldering Systems Inc., 744 Salem Street, Glendale, CA 91203.

CIRCLE 108 ON FREE INFORMATION CARD

SURGE PROTECTOR

A six-outlet surge-protector/power strip from *Belkin Components* is designed to protect sensitive computer equipment from high-voltage surges of up to 76 joules, which insures that the AC current supplied to the devices is at a safe level. The *SurgeMas-*



ter features a 6-foot power cord, six switched outlets, triple MOV protection, an illuminated on/off switch, a surge-protection indicator light, and a 15-amp resettable circuit breaker. The unit is UL rated at 400 volts. Packaged in a neutrally colored, high-impact plastic case, the *SurgeMaster* can be wall mounted.

The *SurgeMaster* surge protector/power strip has a suggested list price of \$29.95. For more information, contact *Belkin Components*, 14550 South Main Street, Gardena, CA 90248; Tel. 800-2-BELKIN.

CIRCLE 109 ON FREE INFORMATION CARD

NiCd BATTERIES

The *Sunpak RB* series from *ToCAD* consists of three rechargeable nickel-cadmium batteries that fit today's most popular 8mm camcorders and video lights that accept NP-series batteries. All three batteries—the 1100-mAh *RB-55*, the 1500-mAh *RB-77*, and the 2200-mAh *RB-77S*—use Sanyo NiCd cells. The cells are precisely matched in voltage and amperage characteristics to assure consistent, long-lasting



performance. Four-point spot welding on each battery terminal provides precise connection between each battery cell, guaranteeing maximum current flow through each cell for the life of the battery. For safety and to prevent overcharging, a thermal circuit-breaker system automatically

stops charging when a critical heat level is reached.

The *RB-55*, *RB-77*, and *RB-77S* NiCd batteries have suggested retail prices of \$69.96, \$89.95, and \$119.95, respectively. For more information, contact *SUNPAK/ToCAD America, Inc.*, 401 Hackensack Avenue, Hackensack, NJ 07601.

CIRCLE 110 ON FREE INFORMATION CARD

FINGER WARMER

Concert pianists customarily play for half an hour or more to limber up their fingers before a performance. And even in these days of universal central heating, keyboardists of all sorts—pianists, typists, computer programmers—still need a way to get their fingers up to speed on those chilly winter mornings.

The solution for the 1990's is *Cleveland Microwave's* microwave finger warmer, model 5199. The unit consists of a small box containing a power supply and Gunn-diode microwave-generating circuitry. Two small clip-on dish antennas attach easily to any sort of keyboard, and direct a beam of

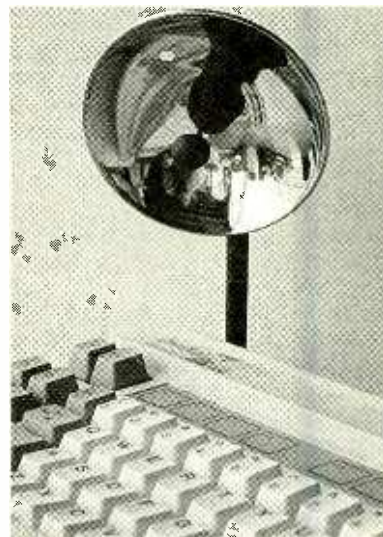

gentle microwaves straight into the area to be heated. With the 5199, lengthy limbering-up and warm-up times can be reduced to just five or ten seconds, increasing productivity and accuracy. A hi-low switch on the unit permits it to double as a coffee warmer, and to be used for heating up light lunches and small pizzas. Dishes are available in silver, black, and eggshell finishes.

The model 5199 microwave finger warmer has a suggested list price of \$149.95. For more information, contact *Cleveland Microwave*, 911 Scorched River Drive, Cleveland, OH 44101. ■

CIRCLE 4/1 ON FREE INFORMATION CARD

Discover Your Career Potential In The Fast Growing Field Of High-Tech Electronics!

CIE Gives You The Training You Need to *Succeed...*
At Your Own Pace...& In Your Own Home!

If you're anxious to get ahead...and build a *real* career...you owe it to yourself to find out about the Cleveland Institute of Electronics!

CIE can help you discover *your* career potential in the fast growing field of high-tech electronics. A career that will challenge and excite you every day...reward you with a powerful feeling of personal accomplishment...and deliver a level of financial security you may have only dreamed of before!

As the leading school in home-study electronics, CIE has helped over 150,000 students in the U.S.A. and over 70 foreign countries get started in this exciting field. To find out how CIE could be helping *you*...read on...then send for a CIE catalog TODAY!

A Growing Need For Trained Professionals!

The career opportunities shown here are only a few of the challenging, high-paying careers you could enjoy as an electronics technician.

You could be the "brains" behind the scenes of an exciting TV broadcast...trouble-shoot life-saving medical equipment...design exotic new aeronautics systems...CIE's job-oriented programs offer you the quickest possible path to the career of your dreams! And CIE also features military and union re-training, to build on what you already know.

Dozens Of Fascinating Careers To Choose From!

Even if you aren't sure which career is best for you, CIE can get you started with core lessons applicable to *all* areas of electronics. As you advance, CIE makes job opportunities available to you through the bimonthly school paper, *The Electron*.



Data Communications



Automotive Electronics



Avionics



Computer-Assisted Manufacturing



Consumer Electronics



Military Electronics

Personal Training From A Renowned Faculty.

Unlike the impersonal approach of large classroom study, CIE offers you one-on-one instructional help 6 days a week, toll-free. Each CIE lesson is authored by an independent specialist, backed by CIE instructors who work directly with you to answer your questions and provide technical assistance when you need it.

Practical Training... At Your Own Pace.

Through CIE, you can train for your new career while you keep your present job. Each course allows a generous completion time, and there are no limitations on how fast you can study. Should you already have some electronics experience, CIE offers several courses which start at the intermediate level.

"State-Of-The-Art" Facilities & Equipment.

In 1969, CIE pioneered the first electronics laboratory course, and in 1984, the first Microprocessor Laboratory. Today, no other home study school can match CIE's state-of-the-art equipment. And all your laboratory equipment is included in your tuition cost. There is no extra charge—it's yours to use while you study at home and on the job after you complete your course!

Earn Your Degree To Become A Professional In Electronics!

Every CIE course you take earns you credit towards the completion of your Associate in Applied Science Degree, so you can work towards your degree in stages. And CIE is the only school that awards you for fast study, which can save you thousands of dollars in obtaining the same electronics education found in four-year Bachelor's Degree programs!

Send For Your Catalog Today!

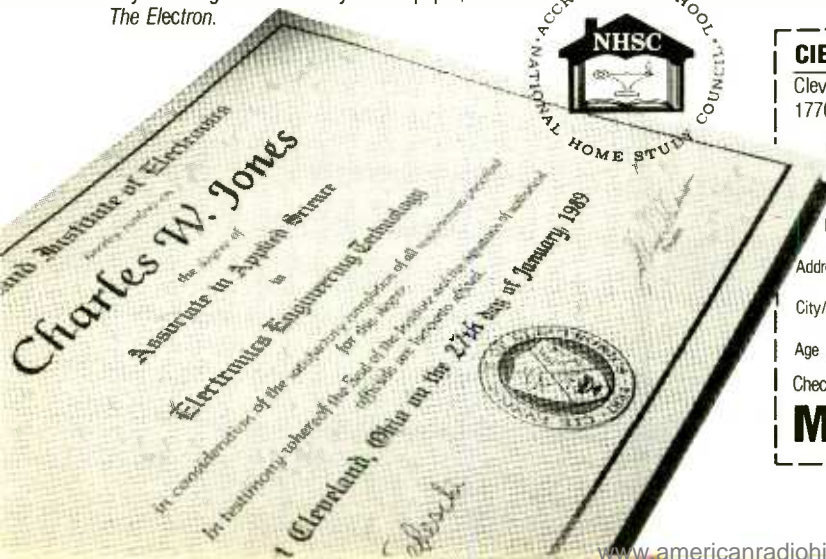

CIE World Headquarters

Cleveland Institute of Electronics, Inc.
1776 East 17th St., Cleveland, Ohio 44114

AHO-145

YES! Please send me your independent study catalog (For your convenience, CIE will have a representative contact you—there is no obligation.)

Print Name _____

Address _____ Apt # _____

City/State/Zip _____

Age _____ Area Code/Phone No. _____

Check box for G.I. Bill bulletin on educational benefits: Veteran Active Duty

Mail This Coupon Today!

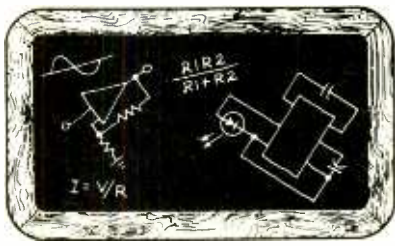

Think Tank

By Byron G. Wels, K2AVB

HOW TO WIN FRIENDS...

Alrigh, the answer is *three* times. No matter what you pull out the first two times (and it might or might not be a pair) the third time is the charm. By the time you've pulled out three of them, you're sure to have a pair.

Meanwhile, I got a letter from one of our readers, Tom Allston, of Amarillo, TX. He tells of the three friends that decided to go to the Consumer Electronics Show, in Chicago. It was a spur-of-the-moment decision, and they showed up in the Loop with no room reservations. Now you know how crowded Chicago gets during a show, right? Finally, they found a hotel with only one room left, and decided to share the room while it was still available.

The desk clerk explained that the room would cost \$30 for the night (some hotel, huh?) so each of them put up ten dollars. Later, the manager realized that he had overcharged them, that the room should only have been \$25. He gave the bellhop five single dollar bills and told him to take it up and reimburse the guests.

On the way, the bellhop wondered how he was going to split five dollars among the three men, and to simplify things, he put two of the dollar bills in his own pocket. At the door, he gave each of the men a dollar back. So each man paid \$9. for the room, a total of \$27. The bellhop got two bucks, for a total of \$29. Now where did that extra dollar go?

Don't blame me! If you think you've solved it, write to me with the answer, and I'll give you the right answer next month. Can you wait? And hey Tom, thanks a whole bunch.

Now I'm going to lay some great news on you. Remember the *Think Tank* book? Well, *Volume II* is now available and ready for sale. It's even better than the first volume was, and that one was sold out and reprinted many, many times. And if you still haven't gotten *Volume I* as yet, we've got lots of those left too. Here's how to order: *Volume I* (#169) costs \$3.50. *Volume II* (#169A) is

only \$3.00. Order both at the same time and you'll save fifty cents. The price for both books is \$6.00. Please include \$2.00 for postage and handling charges, and New York State residents please add applicable sales tax. Order from **Popular Electronics**, 500-B Bi-County Blvd., Farmingdale, NY 11735.

Now, let's take a look at what the mail bag has to offer this month.

Solenoid Tester. You'll find this circuit (see Fig. 1) to be a great help in checking solenoids and relays. Inductor T1 is a discarded coil from a solenoid that acts as the secondary of a step-down transformer. When a solenoid is activated, it has current flow in its coil. When T1 is placed on the solenoid, it picks up this current flow. Diodes D1 and D2 rectify and double the output, while C1 and C2 filter the output. Transistor Q1 is used as a switch, that when forward biased, causes LED1 to light. Resistors R1 and R2 are used to absorb excessive current flow. A piece of iron is added to T1 to assist in the pick up of current.

The unit is a very simple circuit that can be point-to-point wired on a section of perfboard and mounted in a small plastic tube.

—Manny Valco, Stony Point, NY

There's a copy of the Think Tank book on its way to you. I hope you'll enjoy it.

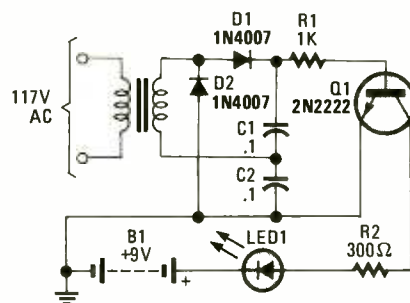

Fig. 1. The circuit shown here is a great help in checking solenoids and relays. An inductor acts as the secondary of a step-down transformer, picking up induced current from the solenoid coil.

555 Controller. While designing a complex system, I required several timed output pulses to occur at disproportionate intervals. My first choice was to use a 555 timer to provide the necessary output delays. But the 555 timer always initiates the timing phase on power-up. That wasn't acceptable for my application. I had two choices. Drop the timer and look for other circuits, or do some head-scratching and come up with a fix.

I found that a positive voltage applied to the trigger pin of the timer just before initialization provided the desired condition: No output. I used an RC network (see Fig. 2) using a ¼-watt resistor and an electrolytic capacitor at pin 8 (V_{DD}) of the device. It worked like a charm. However, the results were not

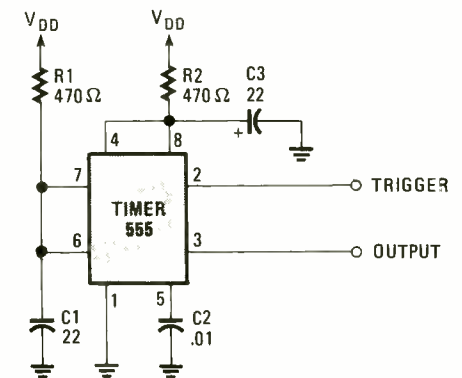

Fig. 2. The 555 Controller circuit produces timed output pulses that occur at disproportionate intervals.

always repeatable. It worked with some units and didn't with others. I increased the capacitance and learned that a 22-µF capacitor and a 470-ohm resistor provided consistent results.

The 555 timer is available in both CMOS (low power/high speed) and bipolar version. In either event, the circuit can be powered from 12-volt DC source. The supply voltage is a determining parameter of the time delay output. Because of the characteristics of the two versions of 555, if one is substituted for the other, it will be necessary to recalculate the values of the RC components.

—Daniel R. O'Geary, Albuquerque, NM

Thanks, Dan. That's a clip-and-save for sure. And it's what our hobby is all about. If you can't find what you want, make it. I sent you a copy of our Think Tank I book, which I know will keep you happy for awhile.

(Continued on page 24)

SELECT 5 BOOKS for only \$4.95

(values to \$130.70)
and get a **FREE Gift!**

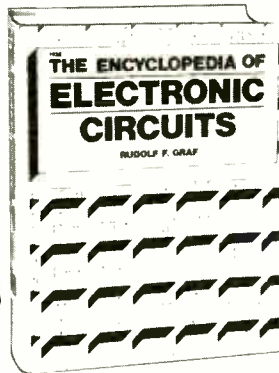

1938P \$29.95
Counts as 2

Electronics projects . . . ideas . . . the latest technology
all at up to 50% off publishers' prices!

Membership Benefits • Big Savings. In addition to this introductory offer, you keep saving substantially with members' prices of up to 50% off the publishers' prices. • **Bonus Books.** Starting immediately, you will be eligible for our Bonus Book Plan, with savings of up to 80% off publishers' prices. • **Club News Bulletins.** 14 times per year you will receive the Book Club News, describing all the current selections—mains, alternates, extras—plus bonus offers and special sales, with scores of titles to choose from. • **Automatic Order.** If you want the Main Selection, do nothing and it will be sent to you automatically. If you prefer another selection, or no book at all, simply indicate your choice on the reply form provided. As a member, you agree to purchase at least 3 books within the next 12 months and may resign at any time thereafter. • **Ironclad No-Risk Guarantee.** If not satisfied with your books, return them within 10 days without obligation! • **Exceptional Quality.** All books are quality publishers' editions especially selected by our Editorial Board.

©1990 ELECTRONICS BOOK CLUB, Blue Ridge Summit, PA 17294-0810
All books are hardcover unless number is followed by a "P" for paperback. (Publishers' Prices Shown)

FREE when you join!

15 Easy Electronic Projects From Delton T. Horn

Projects you can build—some unique, some old favorites—from the author's vast treasury of electronics know-how.

ELECTRONICS BOOK CLUBSM

Blue Ridge Summit, PA 17294-0810

Please accept my membership in the Electronics Book Club and send the 5 volumes listed below, plus my FREE copy of *Delton T. Horn's All-Time Favorite Electronic Projects* (3105P), billing me \$4.95 plus shipping and handling charges. If not satisfied, I may return the books within ten days without obligation and have my membership cancelled. I agree to purchase at least 3 books at regular Club prices (plus shipping/handling) during the next 12 months and may resign any time thereafter.

Name _____
 Address _____
 City _____
 State _____ Zip _____ Phone _____
 Signature _____

Valid for new members only. Foreign applicants will receive special ordering instructions. Canada must remit in U.S. currency. This order subject to acceptance by the Electronics Book Club. PE490

CIRCLE 19 ON FREE INFORMATION CARD

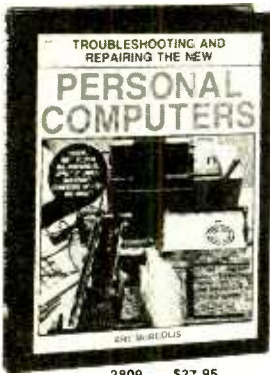

2809 \$27.95
Counts as 2



3205 \$24.95



1532P \$14.95



2613P \$15.95



2883P \$16.95



2867P \$17.95

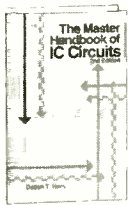

3185 \$34.95
Counts as 2

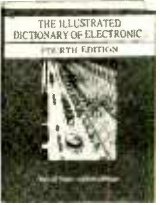

2900P \$24.95
Counts as 2



2826P \$15.95

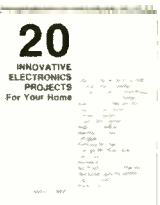

2947P \$13.95

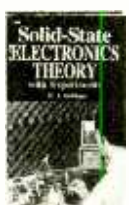

2926 \$25.95



3155 \$19.95



2898 \$23.95



1897P \$14.95



1604P \$17.95



2831P \$15.95

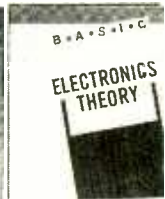

3195 \$28.95
Counts as 2

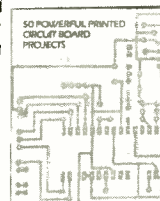

2972 \$23.95

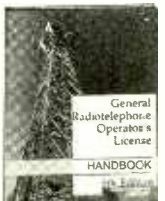

3156 \$23.95

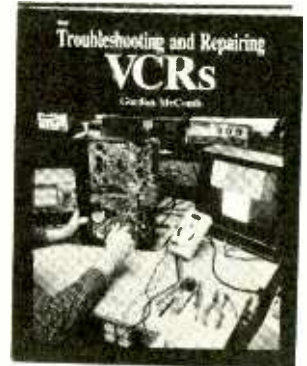

2960 \$27.95
Counts as 2



2707 \$26.95
Counts as 2



2987P \$16.95



2980P \$19.95



2887 \$16.95



3241 \$24.95
Counts as 2



2912P \$14.95

FISHER m-SCOPE

FREE Metal Detector Catalog

Models for underwater Treasure Hunting, beachcombing, relic hunting and gold nugget prospecting. High performance, lightweight, easy to use. The very latest from the world's oldest and proudest name in metal detectors. Write:

FISHER RESEARCH LABORATORY
 1005 I Street, Dept. PE, Los Banos, CA 93635
 Ph. (209) 826-3292, FAX (209) 826-0416

FISHER m-SCOPE

CIRCLE 11 ON FREE INFORMATION CARD

PROFESSIONAL QUALITY WEATHER STATION NOW AFFORDABLE ENOUGH FOR HOME USE!

The new WeatherPro weather station uses state-of-the-art technology to give you full monitoring capability at an incredibly low price. The WeatherPro includes a weather computer, remote precision wind direction vane, wind speed sensor, external temperature probe, mounting hardware and 40' of cable—all for only \$179!

- WIND SPEED
- TEMPERATURE
- WIND DIRECTION
- TEMPERATURE HI/LO
- RAINFALL (OPTIONAL)*
- WIND GUST
- WIND CHILL
- TIME
- AUTO SCAN
- 1 YEAR WARRANTY

• 14-DAY MONEY-BACK GUARANTEE

DIGITAL WEATHERPRO
 WEATHER STATION: ONLY \$179!
 ORDER TODAY: 1-800-678-3669, PE
 M-F 7AM-5:30 PM Pacific Time

*Automatic-empting electronic rain gauge. \$49.95
 Add \$5.00 for shipping. CA residents add sales tax.
 Fax 1-415-732-9188 • M/C and VISA

DIGITAL®
 3465 DIABLO AVE, HAYWARD, CA 94545

THINK TANK

(Continued from page 22)

Meter Tester. This unit uses switches and resistors to provide a number of current ranges. It allows you to test most of the meters available at surplus outlets, and without damaging the sensitive movements when you have no idea of internal resistance or full-scale current of the unit.

Here's how it works. In Fig. 3, M1 is a multimeter set to measure current, and M2 is the meter-under-test. Starting with S1 set at the maximum resistance and S2 open, decrease the resistance setting of S1, fine tuning with R12, until M2 reads full scale. Then read M1. It will tell you the full-scale current for the unknown meter. As the meters are connected in series, the same current flows through both.

Now close S2 and adjust R14 and R15 until M2 reads exactly mid-scale and M1 reads the same current as determined earlier to be the maximum current for M2. Half the current is flowing in M2 and half is going through R14 and R15. The voltage drop is the same across the meter and R14 and R15, because they're in parallel. That means that the sum of the resistance of R14 and R15 is the same as the internal resistance of meter M2.

If the internal resistance of M2 is less than 470 ohms, set R14 at maximum resistance and close S3. Readjust R14.

Both R14 and R12 should be linear-taper potentiometers.

This circuit will work for a majority of meters. A few have internal resistances of several thousand ohms. Switch S3 could be replaced by a rotary switch and resistor arrangement similar to S1 to extend the meter's range. You could have ranges from 500 ohms to 3000 ohms, for example.

—Ed Stiles, Tucson, AZ

Thanks Ed. Nice job, and a useful circuit. Seems our readers are always interested in test equipment, and as they come in, we're happy to share them with you.

Quake Detector. After Stockton, CA was mildly rattled in the October 17 earthquake, I decided to come up with a way to provide a warning in the event of a tremor. After watching my chandelier swing, I developed this circuit (see Fig. 4). We were studying switching transistors in electronics school so it tied in nicely with our class theory.

The circuit is a simple transistor switch. Any movement closes the switch, triggering the transistor from cutoff to saturation, causing a current to flow through the buzzer and LED. That provides both a visual and audible warning, hopefully alerting sleeping persons in the early seconds of an earthquake and perhaps providing a few additional critical seconds to obtain proper cover. It can be hung from a chandelier

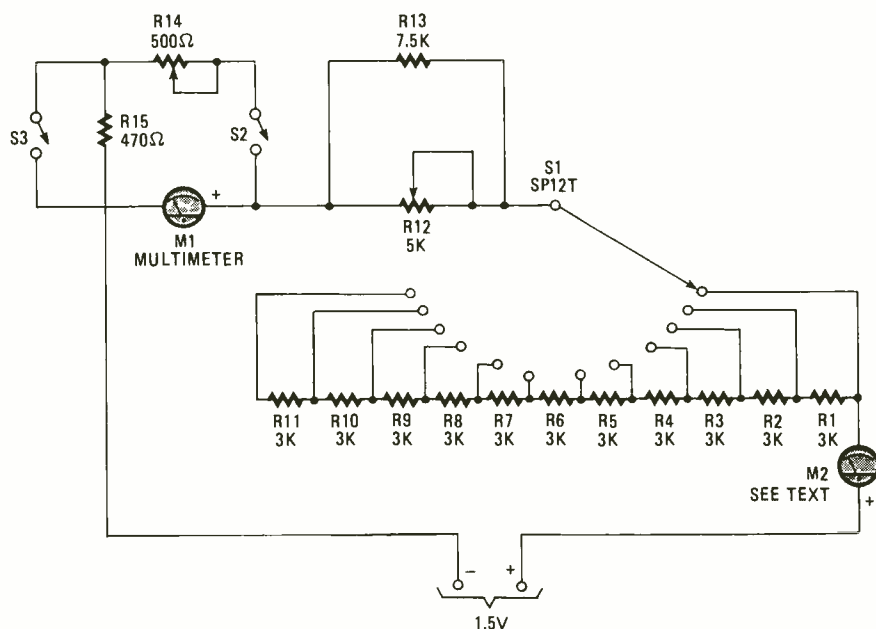
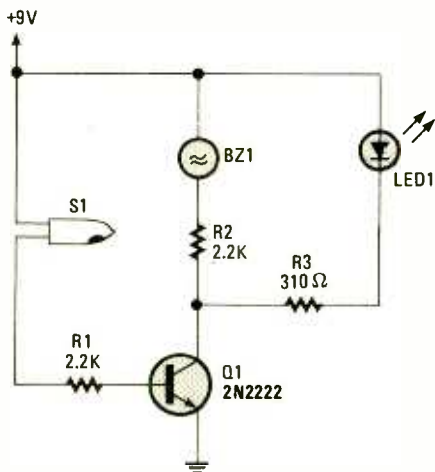

Fig. 3. The Meter Tester uses switches and resistors to provide a number of current ranges, thereby allowing you to test most of the meters available at surplus outlets without damaging their sensitive movements even though you have no idea of the full-scale current requirement of the unit.



LED1 IS A DUAL LED FOR EXTRA BRIGHTNESS
RESISTORS ARE 1/2 WATT

Fig. 4. The Quake Detector circuit is really a simple transistor switch, in which tremor detection is accomplished via a mercury-switch sensor.

or by itself from a ceiling where it can swing freely. It can also be used as a motion detector on a door, etc. I built my own unit on a small piece of perfboard. It turned out to be more sensitive than I had planned, and it can be

crudely adjusted by changing the angle of the switch. Leave the leads long enough when soldering so that you can bend the switch to the desired angle.

I noticed that there are very few female entries in the *Think Tank*. Hopefully, I'll be starting a trend. Come on, women readers! Let's speak up!

—Annette Mathews, Stockton, CA
Good for you Annette! And I'll echo Annette's words. Come on, women of electronics...let's hear from you!!!

Risetime Tester. This circuit (see Fig. 5) is used to test the risetime of digital encoders. The output of such encoders is produced by a mechanical wiper moving across a conductive surface. That movement results in a slow risetime as each pulse is created. My tester is designed to check each pulse for a minimum 5 ms risetime without using a scope. In a production environment, it is easier to teach a worker to check for a green or red light than it is to train him to use a scope. Our customer required that the pulse must rise to a 2.5-volt level within a 5-ms time frame.

The encoder to be tested is put into a frame and its shaft coupled to a small

motor. When the motor is turned on it rotates the encoder's shaft so that each pulse has the same on and off times. When the first pulse reaches pin 8 of the comparator, it rises above pin 9's reference voltage, causing pin 14 to go low, which then fires the 555. Its time constant is set for 5 ms. The pulse closes both of the 4066's switches for that amount of time.

If the voltage level input to the top comparator's pin 4 rises above the 2.5-volt threshold, the output of the comparator pin 2 goes low and fires the top 555 which turns on the green LED indicating a good risetime. However if the voltage level input to the top comparator does not rise above the threshold, pin 2 remains high. That high is fed to the lower comparator at pin 6, which will be above the fixed reference voltage at pin 7. That comparator's output then goes low and fires the bottom 555 to turn on a red LED to indicate a bad risetime for that pulse. Finally, when the pulse being tested goes to the low state, the first comparator's output pin 14 returns to the high state and is ready to receive the next pulse to be tested.

I used the 555's so the user had time

Train at Home to be an Electronics Technician!

Professional training and equipment can help you qualify for a dynamic, high-paying career in your spare time.

As the demand for computers and microprocessors in business and manufacturing continues to grow, so does the need for qualified technicians. It's not unusual for experienced technicians to earn from \$35,000 to more than \$40,000 a year.* Now there's a way you can train for this exciting field without interrupting your job or home life.

Choose From These Programs of Study

- Electronics & Microprocessor Technology
- Industrial Electronics & Microprocessor Technology
- Computer Servicing & Electronics Technology
- Specialized Associate Degree In Electronics Technology

You Get Professional Equipment For Professional Training

Depending on the program you select, you'll perfect your skills using this advanced equipment, included in the price of tuition:

- Zenith Data Systems eaZy Personal Computer
- Digital Multimeter
- Digital Logic Probe
- Elenco Oscilloscope

Exclusive Extras That Enhance Your Training

Peoples College introduces some training firsts to make your learning experience more complete:

- Accelerated Learning System — a scientifically proven study system that lets you learn faster and easier than ever before.
- Optional One-Week Seminar — available with our advanced programs. Conducted on our campus near Orlando, Fla. Not required for graduation, but a valuable opportunity to fine tune your skills with personal guidance.
- Video Tutor Training Tapes — give you a permanent, visual record of informative lectures and close-up demonstrations.
- Experience Labs — professionally designed experiments that give you hands-on "bench" experience.
- Industry Certification Training Guide — provided with three of our programs. Gives you first-hand insight into the examination you may take for your professional license.



For COLOR CATALOG Mail Coupon or Call TOLL FREE
1-800-366-3113

No Obligation. No sales person will call.

Our programs are accredited by the Accrediting Commission of the National Home Study Council

YES! I would like to know more about your training programs. Send a catalog to:

Name _____
Address _____
City _____
State _____ Zip _____

PEOPLES COLLEGE
OF INDEPENDENT STUDIES
233 Academy Drive • P.O. Box 421768
Kissimmee, FL 34742-1768
Member, D.L. Peoples Group PE490

(* Source: U.S. Bureau of Labor Statistics)

DIGITAL VIDEO STABILIZER ELIMINATES ALL VIDEO COPY PROTECTIONS



While watching rental movies, you will notice annoying periodic color darkening, color shift, unwanted lines, flashing or jagged edges. This is caused by the copy protection jamming signals embedded in the video tape, such as Macrovision copy protection. Digital Video Stabilizer: RXII completely eliminates all copy protections and jamming signals and brings you crystal clear pictures.

- FEATURES:**
- Easy to use and a snap to install
 - State-of-the-art integrated circuit technology
 - 100% automatic - no need for any troublesome adjustments
 - Compatible to all types of VCRs and TVs
 - The best and most exciting Video Stabilizer in the market
 - Light weight (8 ounces) and Compact (1x3.5x5")
 - Beautiful deluxe gift box
 - Uses a standard 9 Volt battery which will last 1-2 years.

WARNING :
SCO Electronics and RXII dealers do not encourage people to use the Digital Video Stabilizer to duplicate rental movies or copyrighted video tapes. RXII is intended to stabilize and restore crystal clear picture quality for private home use only.

(Dealers Welcome)

To Order: \$49.95 ea + \$4 for FAST UPS SHIPPING
1-800-445-9285 or **516-694-1240**
Visa, M/C, COD M-F: 9-6 (battery not Included)
SCO ELECTRONICS INC.
Dept. CAQ 581 W. Merrick Rd. Valley Stream NY 11580
Unconditional 30 days Money Back Guarantee

CIRCLE 25 ON FREE INFORMATION CARD

CABLE TV DESCRAMBLER



	1 Unit	10 +
Jerrold S.B.	\$74	\$55
Jerrold SB w/Trimode.....	\$90	\$70
Oak N-12 (w/VS).....	\$89	\$65
Scientific Atlanta.....	\$109	\$75
Pioneer.....	\$109	\$75
Panasonic converter.....	\$98	\$79
73 channel converter.....	\$79	\$59

We Beat Anyone's Price!
30 Days Money Back Quaranty
Free Catalog

Visa, M/C, COD or send money order to:
US Cable TV Inc. Dept. KAB
4100 N.Powerline Rd., Suite F-4
Pompano Beach, FL 33073

1-800-445-9285

Please have make and model number of the equipment used in your area ready.

No Florida Sales!

It's not the intent of US Cable TV Inc. to defraud any pay TV operator and we will not assist any company or individual in doing so.

CIRCLE 26 ON FREE INFORMATION CARD

THINK TANK

to see them turning on the LED's. To calibrate the unit, feed a 1 kHz or faster pulse into the circuit and view pin 3 of the first 555 on a scope. Adjust R4 until a 5-ms pulse is displayed. To test for a good risetime, feed a 1-Hz or slower pulse to the input. The green LED should light. To test the red LED, feed a 1-Hz or slower pulse into the top of two 10k resistors set up as a voltage divider. Connect the middle of this divider to the input and the bottom to ground. This cuts the pulse amplitude in half causing it to fail the test and light the red LED.

—Jim Abare, Rochester, NH

Good for you Jim. That represented a great deal of effort, and we want you to know that it is appreciated.

Hot-Part Finder. Very often, you have to feel around a prototyping board for hot components. Between crowded components and rats-nest wiring, you can often do more damage with a finger than you mean to. This circuit (see Fig. 6) is the easy way to handle that problem.

It's an audible temperature probe

whose output rises in frequency when its tip is placed in contact with a warm component. I used a Radio Shack thermistor (part 271-110), which is coupled to an NPN transistor, to control the frequency of a 555 timer. The circuit must operate on 9 volts or temperature sensitivity will be lowered. By the same token, you can't use lower-value capacitors. And believe it or not, the circuit only works when the transistor is connected *backwards* as shown in the diagram! You'll also be interested to know that if the supply voltage drops below three volts, the entire circuit works in reverse.

It's probably obvious that I have no training in electronics.

—Thomas I. Stuart, Cambridge, Ontario, Canada

Tom, I searched all through our stock, trying to find a copy of our Think Tank book that was bound backwards, but no luck. You'll have to settle for a normal one. Listen guy, you've got a big jump on James Clerk Maxwell, Alessandro Volta, and Thomas Edison. Those guys never even heard of an IC!

Tone-Burst Oscillator. This little circuit

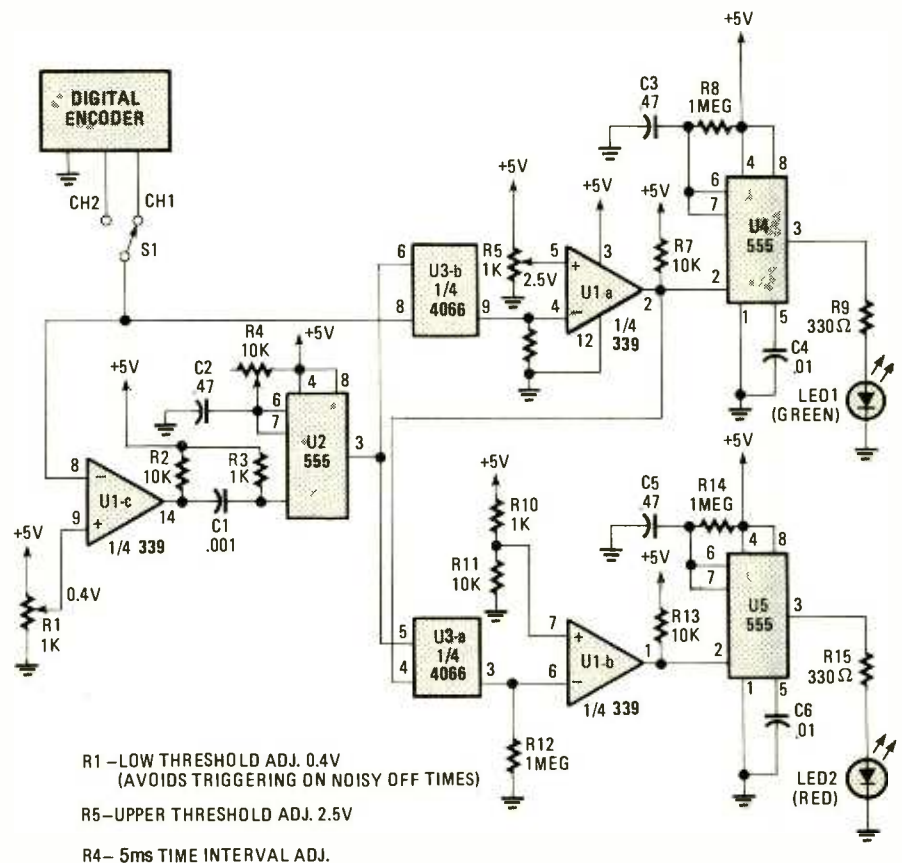

Fig. 5. The Rise-time Tester can be used to check the risetime of digital encoders without the use of a scope.

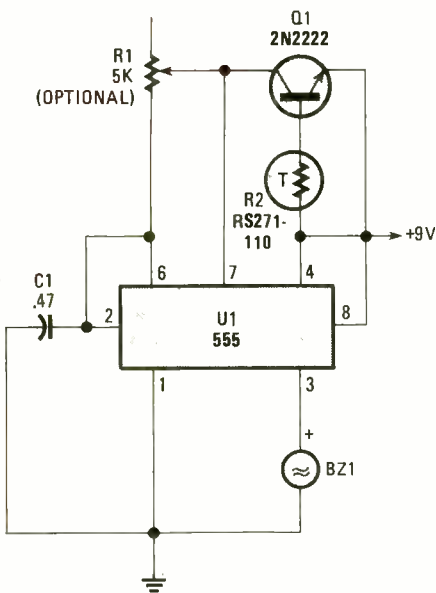

Fig. 6. The Hot Part Finder is an audible temperature probe whose output rises in frequency when its tip is placed in contact with a warm component.

(see Fig. 7) is used as a building block in a lot of projects. I've used it as a tone-burst oscillator to drive a piezo element directly, with a transistor to ring a bell, and I've even used it to modulate an FM transmitter to make it beep. It is comprised of one quad NAND gate, two resistors, and two capacitors. The first two gates are used as the "burst" oscillator and the third and fourth gates

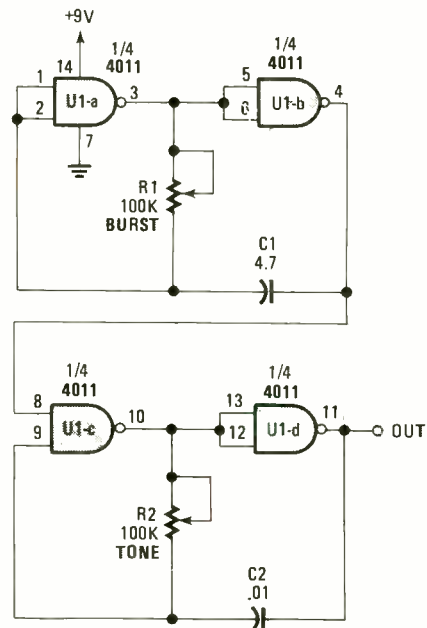

Fig. 7. The output of the Tone-Burst Oscillator can be used to drive a piezo element directly, or using a transistor-driver circuit, to ring a bell; it can also be used to modulate an FM transmitter.

serve as the "tone" oscillator. The burst oscillator is much slower than the tone oscillator and is used to pulse the tone oscillator on and off.

In circuits where size is not important, I use adjustable resistors for the two resistors so that I can set the tone and burst intervals to my liking. The same circuit will work with a hex inverter (4049B) and will produce a bit more in the way of drive. The only difference is that a diode has to be used to connect the two oscillators.

Jerry Baumeister, Jones, OR

Good, circuit Jerry. I'm sure it's one that our readers will reference often.

BBS Protector. The attached circuit (see Fig. 8) describes my solution to the typical problem with multi-user bulletin boards. The device protects the BBS from users who initiate a 250K download, and head off to bed. An interactive line is detected and the modem's DTR control is cycled, dropping the user off-line and readying the system for the next caller. All without the CPU overhead of a monitoring program.

★ QUALITY PARTS ★ DISCOUNT PRICES ★ FAST SHIPPING

ALL ELECTRONICS CORP.

<p>12 VOLT DC MINI FAN Howard Industries 5-15-15-15 Operates on 12 Volt, 0.10 amp, 1.0 watt Compact plastic housing 2.35" square X 1.275" thick 9 blade fan. Two 9" gage leads CAT# CF-121 \$9.00 each</p>	<p>LED CHASER KIT Build this variable speed led chaser 10 leds flash sequentially at whatever speed you set them for. Easy to build kit includes pc board, parts and instructions Ideal for special lighting effects, costumes, etc. Operates on 3 to 9 volts. PC board is 5" X 2.25". A great one hour project CAT# AEC \$6.50 each</p>	<p>STEPPER MOTOR Aurpax# AB2743-M4 Brand new 12 volt dc stepper motor 35 ohm coil 7.5 degrees per step. 2.25" diameter, 0.93" long excluding shaft. 0.22" dia shaft 0.75" long. 2 hole mounting flange, 2.675" mounting centers. 6 wire leads CAT# SMT-5 \$10.00 each</p>	<p>RECHARGEABLE BATTERY PACK (USED) Four AA nickel cadmium batteries connected in series to make a 4.8 volt pack. Batteries are in a 2 X 2 configuration with a 2 pin connector attached. The four batteries can be separated into single AA size solder tab nickel cadmium batteries or resoldered into other configurations. SPECIAL SALE PRICE NOW \$3.00 per pack + 10 packs for \$25.00 CAT# NCB-41AAU</p>
<p>TIL-99 PHOTO TRANSISTOR TO-18 case with window. For wide angle viewing applications. Specially and mechanically compatible with TL-31B. CAT# TL-99 \$1.00 each - 10 for \$9.00</p>	<p>NICKEL-CAD BATTERIES (RECHARGEABLE) AAA SIZE \$1.50 each 1.2 volts 180 mAh CAT# NCB-AAA AA SIZE \$2.00 each 1.25 volts 300 mAh CAT# NCB-AA AA SIZE \$2.25 each WITH SOLDER TABS CAT# NCB-AA C SIZE \$4.25 each 1.2 volts 1200 mAh CAT# NCB-C D SIZE \$4.50 each 1.2 volts 1200 mAh CAT# NCB-D</p>	<p>0-30 MINUTE AUTO- SHUTOFF TIMER Sanyo Seiko Mfg # TMC35M7B9 120 Vac 50 Hz. 10 amp contacts UL listed. Turn shaft to turn on lights or other electrical devices. Bell rings and circuit breaks after specified amount of time. Ideal for any device that needs to shut off automatically. 2.92" X 1.9" X 2.54" behind face plate. 1/4" half-round shaft. CAT# TMC-30 \$3.00 each</p>	<p>LED'S BAREWARE JUMBO CAPSULED 11-364 size RED CAT# LED-1 10 for \$1.50 - 100 for \$13.00 GREEN CAT# LED-2 10 for \$2.00 - 100 for \$17.00 YELLOW CAT# LED-3 10 for \$2.00 - 100 for \$17.00 FLASHING LED with built in flashing circuit operates on 5 volts. RED CAT# LED-4 10 for \$6.50 GREEN CAT# LED-5 10 for \$6.50 BI-POLAR LED Light RED one direction GREEN in other. Two leads CAT# LED-4 2 for \$1.70 LED HOLDER Two piece holder. CAT# LED-10 10 for \$6.00</p>
<p>TIL-31B PHOTO DIODE TO-18 case with window. Infrared emitting photo diode. CAT# TL-31B \$1.00 each - 10 for \$9.50</p>	<p>SWITCHES ITT PUSH BUTTON ITT MDPL series 3/4" X 1/2" grey rectangular key cap. S.P.S.T. NO Push to close. RATED: 0.1 amp switching 0.25 amp carry current. P.C. mount. CAT# PB-8 \$6.50 each - 10 for \$60.00 100 for \$50.00</p>	<p>PHOTO FLASH CAPACITOR Rubycon FPKX 200 mfd. 330 volts 0.79" diameter X 1.11" high Solder loop terminals CAT# PPC-200 \$3.25 each 10 for \$30.00 - 100 for \$275.00</p>	<p>L.E.D. FLASHER KIT Two L.E.D.'s flash in series when a 9 volt battery is attached. This kit includes a p.c. board, all the parts and test comp. to make a simple flasher circuit. A quick and easy project for anyone with basic soldering skills. CAT# LEWNT \$1.75 per kit</p>
<p>SPDT PUSHBUTTON Merquardt 1843 Rated 8 amps @ 125/250 Vac. Stack plastic pushbutton Switch body. 92" X 94" X .85" CAT# PB-18 \$1.85 ea. - 10 for \$15.00 ea.</p>	<p>XENON TUBE 1/8" long. Replaces with 3/16" red and black leads. Ideal for electronic flash or strobe projects. CAT# FLT-3 2 for \$1.00</p>	<p>22/44 PIN CONNECTOR 156" pin spacing, 0.200" between double rows, gold contacts, P.C. mounting SPECIAL Same as AMP# 2-530655-6 CAT# EBC-1G \$1.00 each - 10 for \$8.00</p>	<p>LOOK WHAT \$1.00 WILL BUY 20 ASSORTED 1/4 WATT RESISTORS Black, red, yellow, green and carbon film CAT# GRE \$1.00 per assortment 20 ASSORTED 1/2 WATT RESISTORS Black, red, yellow, green and carbon film CAT# GRABE \$1.00 per assortment 50 ASSORTED DISC CAPACITORS Most are cut (D.C. leads). Some to 500 volts CAT# GRABD \$1.00 per assortment 15 VALUES OF ELECTRICALS Contains both axial and radial styles from - mfd CAT# GRABPC \$1.00 per assortment</p>
<p>PUSHBUTTON SWITCH GCThermal 35-420 S.P.S.T. normally open momentary pushbutton switch. Radial plastic actuator. 0.57" diameter. Chrome base 0.68" diameter. Threaded bushing mounts in .50" diameter hole. Rated 3 amp @ 250Vac. Solder loop terminals CAT# PB-20 \$1.00 each</p>	<p>RELAYS 5-8 VDC S/P REED RELAY Enclosed "Blue Boy" BBS ADSA10 5-8 Vdc. 300 amp coil S.P.S.T. nor- mally open reed relay. 1.5 20P X 3" 0.6 amp contacts. S/P configuration. CAT# RRLT-S/PS \$1.10 each - 10 for \$10.00</p>	<p>ELECTRONIC GAME BOARD The inner workings of an electronic Scrabble game. Operates on 6 Vdc. 8 digit alpha-numeric readout, 45 button keypad, 14 transistors, 2 I.C.'s, 1 photo element and other goodies. Top and bottom row of keypad buttons are function keys, middle 3 rows are alphabetic. No instructions available. # X 4.45 CAT# BT-4 \$1.75 each 10 for \$15.00</p>	<p>LOOK WHAT \$2.00 WILL BUY 15 AMP SNAP-ACTION SWITCH 1 piece of a 15 amp 125,250 Vac normally open switch. Body is 1 3/4" X 5/8" X 5/8" Button extends 3/16" above switch body. CAT# GRABM \$2.00 per assortment 20-42 TRANSISTORS 20 assorted TO-18 plastic case transistors. Various types of NPN and PNP. Some house numbered. Various mounting CAT# GRABTR \$2.00 per assortment SWITCHES 10 assorted slide toggle, rotary, pushbutton and rotary switches. Our choice CAT# GRABSW \$2.00 per assortment</p>
<p>WALL TRANSFORMERS ALL PLUG DIRECTLY INTO 100 VAC OUTLET 8 VDC VOLTAGE RELAY Armacore REL-25V Miniature SPDT dual coil latching relay. 8 Vdc. 170 ohm coils. 1 amp. TTL compati- ble. UL and CSA recognized. 0.787" X 0.364" X 0.364" CAT# LRLV-SDC \$2.50 each</p>	<p>12 VOLT D.C. COIL S.P.D.T. Onvone GDE-16C 4 amp contacts 250 ohm coil Sugar cube size. 8 1/4" X 4 1/4" X 4 1/4" High P.C. mount with pins on 1/8" spacing. CAT# RLX-787 \$1.50 each</p>	<p>TELEPHONE ISOLATING TRANSFORMER Multi Products International A194-HO-101 Primary: 800 ohm Secondary: 600/600 ohm 0.77" X 0.61" X 0.62" High 6.0 C.P.M. on 0.187" centers. Primary Inductance: 200 mH. at 1kHz. 1 volt. CAT# TCTX-1 \$1.25 each - 10 for \$11.00</p>	<p>OPTO SENSOR U shaped package with mounting ears. 1/2" opening 3/4" mounting ears CAT# OSU-4 500 each 10 for \$4.50 - 100 for \$40.00</p>
<p>SERVO MOTOR 3 Vdc servo with continuous torque. Ideal for robotics or remote control model experimentation. Resizes typical. 140 degrees Pot connected to motor varies from either 500 to 3000 ohms. 1.5" X 0.88" X 1.68" 0.37" diameter rubber wheel attached to motor shaft can be used as a capacitor or can be easily removed. Prepiped with cap screws, chassis and wire leads CAT# SVQ-2 2 for \$1.00</p>	<p>AC LINE CORDS Black, GR, 182, SPT-2 15 AMP POLARIZED PLUG CAT# LPLC 2 for \$1.00 100 for \$85.00</p>	<p>NON POLARIZED PLUG CAT# LPLC 2 for \$1.00 100 for \$85.00</p>	<p>POLARIZED PLUG CAT# LCP-1 900 each 100 for \$80.00</p>

CALL OR WRITE FOR OUR FREE 60 PAGE CATALOG OVER 4000 PARTS!

ORDER TOLL FREE 1-800-826-5432

MAIL ORDERS TO: ALL ELECTRONICS P.O. BOX 567 VAN NUYS, CA 91408

INFO: (818)904-0524 FAX: (818)781-2653

MINIMUM ORDER \$10.00 QUANTITIES LIMITED CALIF. ADD SALES TAX USA: \$3.50 SHIPPING FOREIGN ORDERS INCLUDE SUFFICIENT SHIPPING. NO C.O.D.

CIRCLE 5 ON FREE INFORMATION CARD

THINK TANK

An active carrier-detect enables the device. An idle transmission line allows C1 to charge. As the voltage across C1 (and thus the voltage applied to the inverting input of U1 at pin 2) rises above the reference set at pin 3 of U1 by R4, the output of U1 goes low. That activates relay K1, which in turn disconnects the user. Transistor Q1 discharges C1 when the line is disconnected and the carrier goes low. An active transmission line keeps the charge on C1 low through Q2.

Resistor R4 sets the idle-time limit from 1 to 5 minutes. Monitoring the host's TX terminal, as opposed to RX, prevents trips during periods where the host is processing and minimal user input is required. The device has been used at 3/12/2400 baud for the last 5 months.

—Dave Bean, Allenstown, NH

Dave we don't get too many computer-oriented ideas, and if I'm not mistaken, this is the first! Congratulations and welcome!

Broadband RF Amplifier. Byron, thanks to your constant pestering in your column, I finally did-up the enclosed circuit as one of my favorites. It's an all-purpose broadband RF amplifier, and has a usable gain of up to 100. I used it for many years as a preamp ahead of an old tube receiver. Currently, it's in use as a preamp in front of a station monitor scope.

The circuit (see Fig. 9) is simple and inexpensive. I built it entirely from junkbox parts. Just make sure it's built using good RF practice, such as short leads and make sure you include all the bypass capacitors. There are a few things you should be aware of, how-

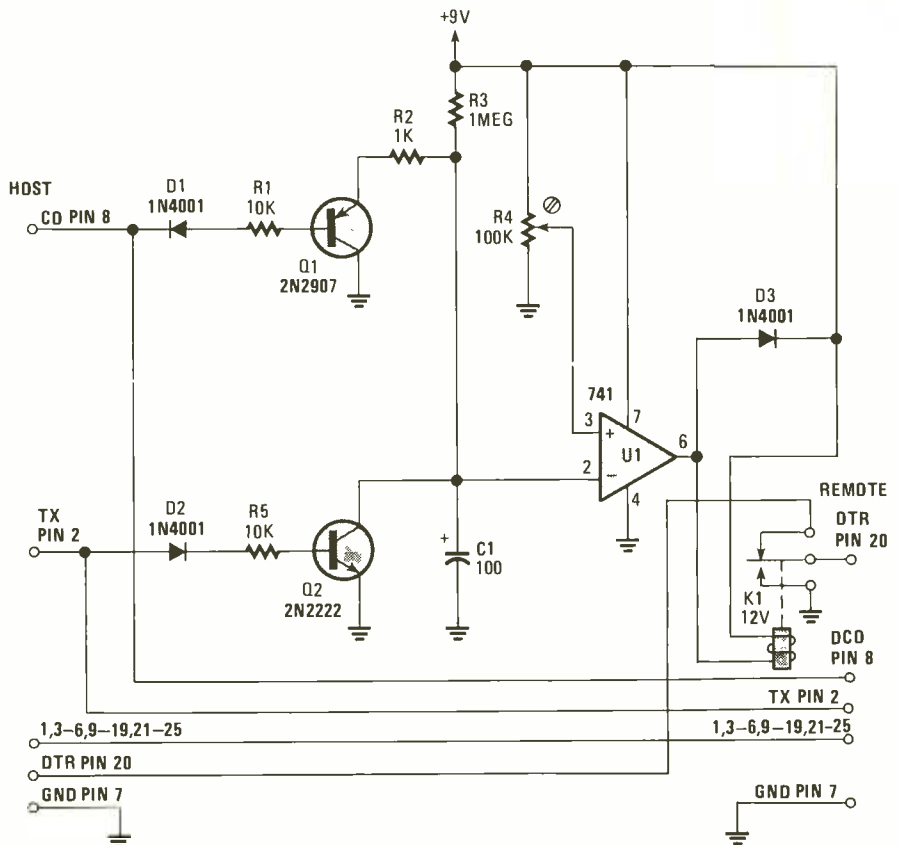

Fig. 8. The BBS Protector circuit is designed to save BBS's from users who initiate a 250K download, and head off to bed. An active carrier detect enables the circuit. When an inactive line is detected, the modem's DTR control is cycled, dropping the user off line and readying the system for the next caller.

ever: Q1 and Q2 are NPN transistors such as the MPS918. Mylar capacitors are recommended for all bypasses, and use an LC network at jack J1 to use the unit as a receiver preselector. As you can see, Q1 is a common-emitter stage, and Q2 is an emitter follower.

By, if you like this circuit, please send me a Fips book, or if they are gone, whatever.

—Howard Krause, Ann Arbor, MI

They are Howard, but I'm sending you a copy of the original Think Tank book. I think some of the projects there will keep you busy for awhile!

Okay guys, I figure that's just about enough to fill the space allocated to us for this month. You can earn a free copy of the *Think Tank* book too. Just send your pet circuits (along with detailed explanations) to: *Think Tank*, **Popular Electronics**, 500-B Bi-County Boulevard, Farmingdale, NY 11735. See you next month!

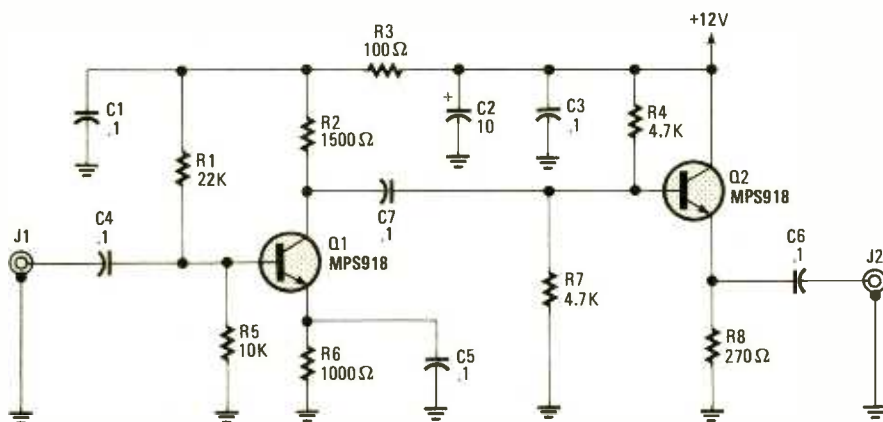

Fig. 9. The Broadband RF Amplifier is simple, inexpensive, and can be built entirely from junkbox parts. The only precaution that you should take is to make sure that lead lengths are kept as short as possible, and that Mylar units be used as bypass capacitors as indicated.

Support
research.



American Heart
Association

5 sure steps to a fast start as a high-paid computer service technician

1. Choose training that's right for today's good jobs

Jobs for computer service technicians will almost double in the next 10 years, according to the latest Department of Labor projections. For you, that means unlimited opportunities for advancement, a new career, or even a computer service business of your own.

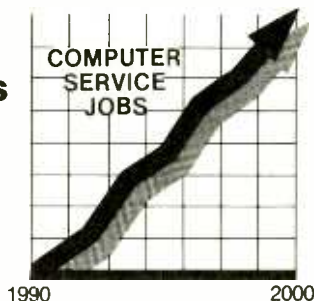

But to succeed in computer service today, you need training—complete, practical training that gives you the confidence to service any brand of computer. You need NRI training.

Only NRI—the leader in career-building, at-home electronics training for more than 75 years—gives you practical knowledge, hands-on skill, and real-world experience with a powerful AT-compatible computer you keep. Only NRI starts you with the basics, then builds your knowledge step by step until you have everything you need for a fast start as a high-paid computer service technician.

computer while giving you lightning-quick data access.

By getting inside this powerful computer, you get the confidence-building, real-world experience you need to work with, troubleshoot, and service today's most widely used computer systems.



4. Make sure you've always got someone to turn to for help



Throughout your NRI training, you've got the full support of your personal NRI instructor and the entire NRI technical staff. Always ready to answer your questions and help you if you should hit a snag, your instructors will make you feel as if you're in a classroom of one, giving you as much time and personal attention as you need.

5. Step into a bright new future in computer service—start by sending for your FREE catalog today!

Discover for yourself how easy NRI makes it to succeed in computer service. Send today for NRI's big, 100-page, full-color catalog describing every aspect of NRI's one-of-a-kind computer training, as well as training in robotics, TV/video/audio servicing, electronic music technology, security electronics, and other growing high-tech career fields.

If the coupon is missing, write to: NRI School of Electronics, McGraw-Hill Continuing Education Center, 4401 Connecticut Avenue, NW, Washington, DC 20008. AT & IBM are registered trademarks of International Business Machines Corp.



2. Go beyond "book learning" to get true hands-on experience

NRI knows you learn better by doing. So NRI training works overtime to give you that invaluable practical experience. You first read about the subject,

studying diagrams, schematics, and photos that make the subject even clearer. Then you do. You build, examine, remove, test, repair, replace. You discover for yourself the feel of the real thing, the confidence gained only with experience.

3. Get inside a powerful computer system

If you really want to get ahead in computer service, you have to get inside a state-of-the-art computer system. That's why NRI includes the powerful new West Coast 1010 ES computer as the centerpiece of your hands-on training.

As you build this fully IBM AT-compatible micro from the keyboard up, performing key tests and demonstrations at each stage of assembly, you actually see for yourself how every section of your computer works.

You assemble and test your computer's 101-key "intelligent" keyboard, install the power supply and 1.2 meg 5¼" floppy disk drive, then interface the high-resolution monitor. But that's not all.

You go on to install a powerful 20 megabyte hard disk drive—today's most-wanted computer peripheral—included in your training to dramatically increase the data storage capacity of your



NRI School of Electronics

McGraw-Hill Continuing Education Center
4401 Connecticut Avenue, NW, Washington, DC 20008

For career courses approved under GI Bill
 check for details.

<input type="checkbox"/> CHECK ONE CATALOG ONLY <input type="checkbox"/> Computers and Microprocessors <input type="checkbox"/> Robotics <input type="checkbox"/> TV/Video/Audio Servicing <input type="checkbox"/> Telecommunications	<input type="checkbox"/> Security Electronics <input type="checkbox"/> Electronic Music Technology <input type="checkbox"/> Digital Electronics Servicing <input type="checkbox"/> Computer Programming <input type="checkbox"/> Basic Electronics
--	--

Name _____

Address _____

City _____ State _____ Zip _____

Accredited Member, National Home Study Council 18-040

Table with columns for Part, Price, and various resistor and capacitor values under the heading 'INTEGRATED CIRCUITS'.

Table with columns for Part, Price, and various resistor and capacitor values under the heading 'INTEGRATED CIRCUITS'.

Table with columns for Part, Price, and various resistor and capacitor values under the heading 'SILICON TRANSISTORS'.

Table with columns for Part, Price, and various resistor and capacitor values under the heading '1 AMP SILICON RECTIFIERS'.

Table with columns for Part, Price, and various resistor and capacitor values under the heading '5% CARBON FILM RESISTORS'.

Table with columns for Part, Price, and various resistor and capacitor values under the heading '5% WIREWOUND RES. RESISTORS'.

Table with columns for Part, Price, and various resistor and capacitor values under the heading 'PANASONIC SU SERIES'.

Table with columns for Part, Price, and various resistor and capacitor values under the heading 'MINIATURE ALUMINUM ELECTROLYTIC CAPACITORS'.

Table with columns for Part, Price, and various resistor and capacitor values under the heading 'DISC CAPACITORS'.

Table with columns for Part, Price, and various resistor and capacitor values under the heading 'TANTALUM CAPACITORS'.

Table with columns for Part, Price, and various resistor and capacitor values under the heading 'PANASONIC V SERIES'.

Table with columns for Part, Price, and various resistor and capacitor values under the heading 'SILICON TRANSISTORS'.

Table with columns for Part, Price, and various resistor and capacitor values under the heading '1% METAL OXIDE FILM RESISTORS'.

Table with columns for Part, Price, and various resistor and capacitor values under the heading 'MINIATURE ALUMINUM ELECTROLYTIC CAPACITORS'.

Table with columns for Part, Price, and various resistor and capacitor values under the heading 'DISC CAPACITORS'.

Table with columns for Part, Price, and various resistor and capacitor values under the heading 'POLYMER CAPACITORS'.

Table with columns for Part, Price, and various resistor and capacitor values under the heading 'QUARTZ CRYSTALS'.

Table with columns for Part, Price, and various resistor and capacitor values under the heading '7400 TTL 7400 CMOS'.

Table with columns for Part, Price, and various resistor and capacitor values under the heading '7400 TTL 7400 CMOS'.

Table with columns for Part, Price, and various resistor and capacitor values under the heading 'DISC CAPACITORS'.

Table with columns for Part, Price, and various resistor and capacitor values under the heading 'TANTALUM CAPACITORS'.

Table with columns for Part, Price, and various resistor and capacitor values under the heading 'DISC CAPACITORS'.

Table with columns for Part, Price, and various resistor and capacitor values under the heading 'DISC CAPACITORS'.

Table with columns for Part, Price, and various resistor and capacitor values under the heading 'DISC CAPACITORS'.

Table with columns for Part, Price, and various resistor and capacitor values under the heading 'DISC CAPACITORS'.

Table with columns for Part, Price, and various resistor and capacitor values under the heading 'DISC CAPACITORS'.

Table with columns for Part, Price, and various resistor and capacitor values under the heading 'DISC CAPACITORS'.

Circle 12 on Free Information Card. The Dig Key volume discount and service charges are simple to apply. Most items sold by Dig Key may be combined for a volume discount...

Build a REACTION Timer

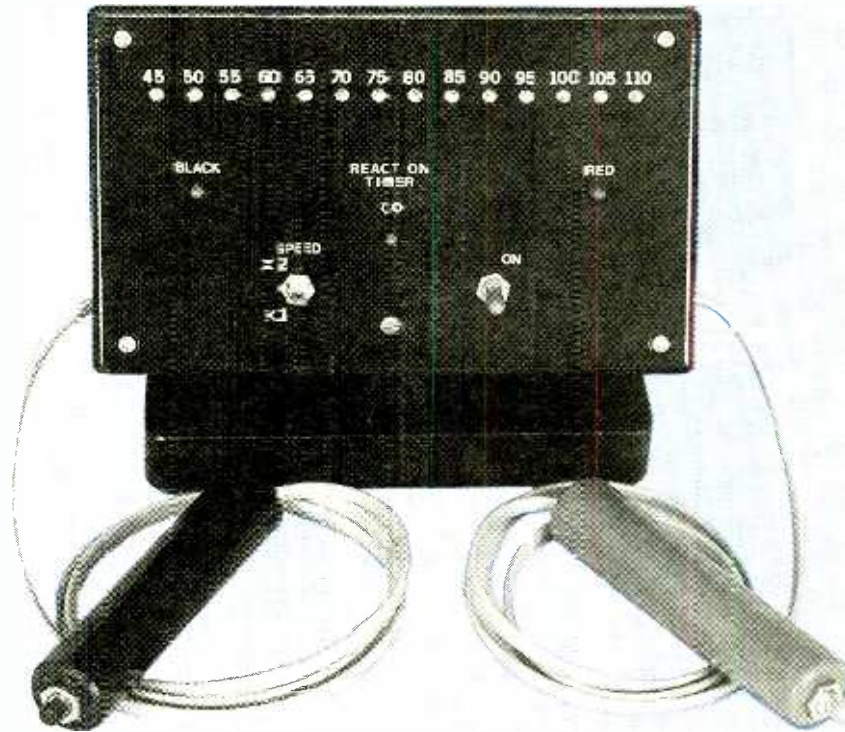

Has time begun to take its toll on your reflexes? Is your reaction time equal to or better than your teenager's? Now you can find out with this easy-to-build circuit.

BY JOHN WANNAMAKER

Who reacts the fastest, you or a teenager? Will one beer on an empty stomach slow you down? Can you improve your reaction time with practice? Here's a way to find out by measuring how quickly you can press a pushbutton switch in response to a flash of light...not unlike the guy behind you when the stoplight turns green.

With the *Reaction Timer* you can play against yourself by trying to beat your old record, or you can play against an opponent. You'll be timed to within five milliseconds by a sequentially flashing row of LEDs, or if you are as old as the author, ten millisecond intervals may be selected. There's a 110-millisecond maximum on the fast range and twice that on the slow range. If you can't stop

on a lit LED within 0.22 seconds, you should have doubts about driving—and we don't mean to say that your driving will be safe even if you do better than that when you're loaded.

Two can play, and each player has a switch to press. The first to press locks out the other, with one of two LEDs lighting to indicate the winner. The winning time is indicated by where the sequencing LED's stop. On the fast range, where the lights flash at 5 millisecond intervals, the timing given above each LED will be the maximum and you could have actually been almost 5 milliseconds faster than that. But you've only got to be a nanosecond or so faster than your opponent to be declared the winner.

The enclosure to house the timer may be almost anything you're willing to

look at, although it has to be big enough to house the 2 × 5 inch printed-circuit board, an on/off switch and a range switch. The player's switches may be mounted on the unit or extended to hand-held units, perhaps a bit more fair to players who favor the same arm. The author's prototype has the switches mounted in the ends of wooden dowels, which were painted so that either black or red player may be declared the winner.

The unit automatically cycles when it's turned on and about every six or seven seconds the go light is lit for one second as the cue for the players. The winner has about six seconds to enjoy his triumph before the go light turns on again and all the old information is wiped out. The player's buttons only op-

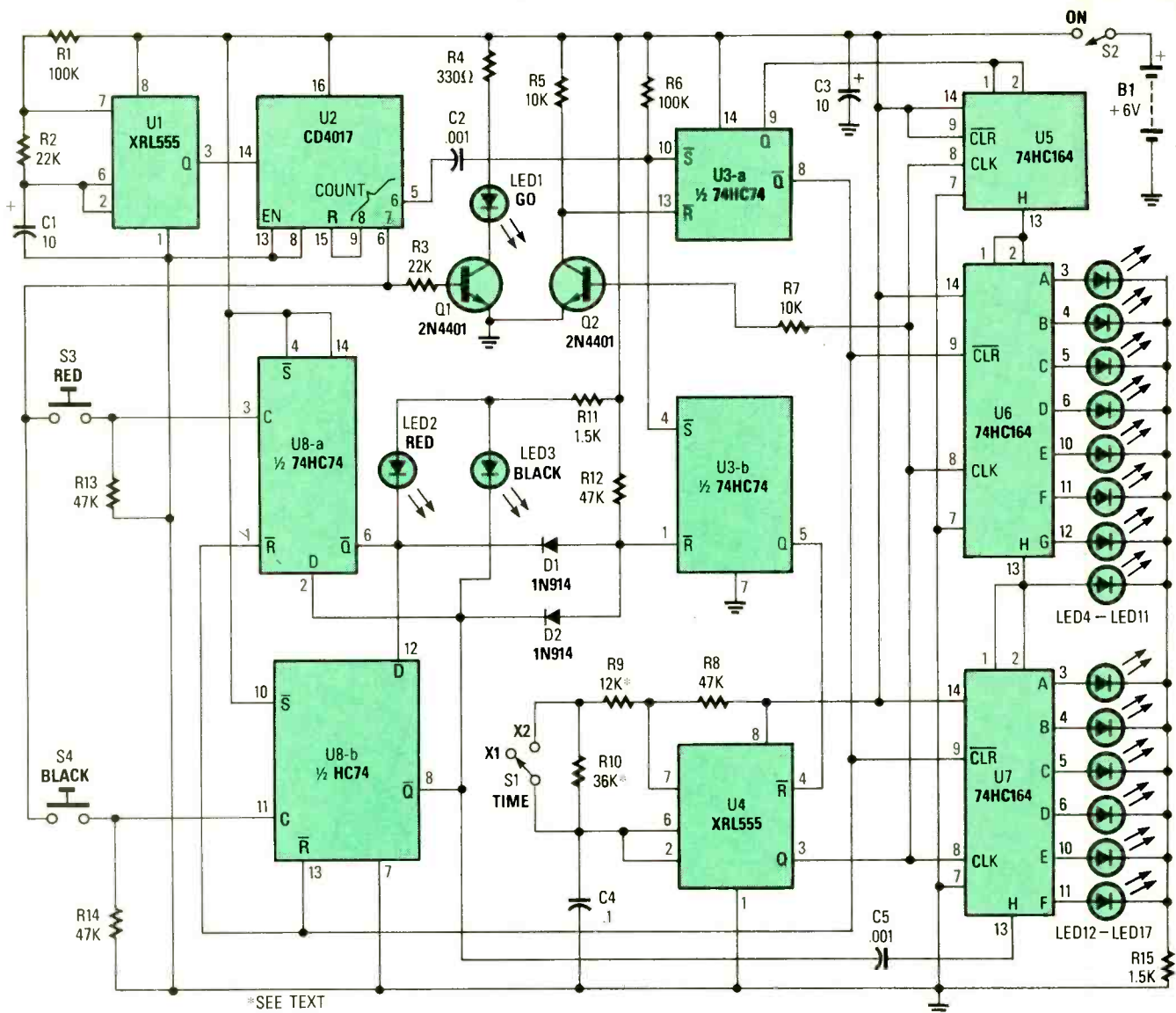

*SEE TEXT

Fig. 1. Although the Reaction Timer may appear to be rather complicated, it is just the opposite, consisting of a couple of 555 timers, some flip-flops, and a few counters. The rest of the circuit is made up of a wide assortment of support components.

erate during the time that the GO light is lit, which minimizes having to scrub a game due to nervous twitching.

Theory of Operation. The object is to enter a single "one" into the input stage of three cascaded shift registers when the GO LED lights and shift it down the line by clocking the registers with pulses that are five milliseconds apart. Each memory in the register lights its LED as it receives that one piece of information. When the player presses his/her switch, he/she stops the clocking oscillator.

Figure 1 is a schematic diagram of the Reaction Timer. A low-power 555 timer, U1, furnishes pulses at one second intervals into U2, a decade counter with one-of-ten decoded outputs. The eighth count is fed back as a premature reset to shorten the cycling. At the end of the sixth count (or the begin-

ning of the seventh), the GO LED is energized through transistor Q1. At the same time, a D flip-flop (U3-a), acting as an RS memory, is set and its Q output goes high while the \bar{Q} output goes low. The \bar{Q} output wipes out any old information from the previous game. The Q output places a high ("one") on serial-input pins, 1 and 2, of the first shift register, U5.

At the same time that U3-a is set, U3-b is set. Its Q output goes high and enables U4, another low power 555 timer, that produces pulses at either five or ten millisecond intervals, depending on the setting of the TIME ($\times 1/\times 2$) switch, S1. The positive-going edge of the first pulse from U4 clocks all shift registers and the high from the Q output of U3-a gets locked into the first memory of the series of shift registers. The same clocking pulse is slightly delayed in resetting U3-a, via transistor Q2, and the input to

the shift register for all clock pulses to come will be zero volts. With only one bit being shifted, there is a savings in battery power since only one LED at a time will be lit.

Integrated-circuit U5 has no indicator LED's for its eight bits since it shifts its "one" into the first memory of U6 in 45 milliseconds and no one is fast enough to be concerned with the actual lapsed time thus far. The eight memories of U6, and six of the memories in U7, light their LED in turn as clocking continues.

The first player to press his/her push-button causes the voltage at the clock input (pin 3 or 1) of either U8-a or U8-b to go high and enter the data from the \bar{Q} output of the other D flip-flop. Both \bar{Q} outputs would initially be high and the first to clock in that high causes his/her \bar{Q} output to drop low and the opponent

can only clock in a low, which does nothing.

As soon as the \bar{Q} output of either U8-a or U8-b goes low, it resets U3-b via either D1 or D2. That disables the 555 timer, U4, which stops producing clocking pulses to the shift registers. The shift-register LED that happens to be lit at that time remains lit to indicate the reaction time. In about six seconds the sequence repeats, wiping out the old data as a first priority. If neither player resets U3-b, the last shift register memory (unused) does the job and maintains sync.

The IC's are CMOS and have little drive current for the LED's necessitating the use of high-brightness LED's. Those rated at more than 50 mcd (microcandels) at 30 mA or less are adequate for all but the go light. The high-efficiency types often have a viewing angle of only a few degrees and the go light must be seen more easily. It should be a diffused type. Check it for a wide viewing angle.

The timing of the one-second pulse generator (U1) is not critical and the values given will be close if the timing capacitor, C1, is not too far off. Lower the value of the 100k resistor attached to pin 7 if you want to speed things up. The timing components for U4 are more critical if you want an accurate (to within 1%) measurement.

Construction. Figure 2 is a template for the printed-circuit board on which the Reaction Timer was assembled. The pattern can be copied and used to etch your own printed-circuit board. After etching the board and obtaining the parts, begin assembly by installing sockets at all IC locations indicated in Fig. 3.

Next install all the jumper connections (denoted J in Fig. 3), and then the resistors followed by the capacitors. Watch the orientation of the polarized capacitors. After installing the passive components, move on to the semiconductors. Start with the diodes, and then the transistors, but do not install the IC's in their respective sockets just yet.

Connect lengths of hook-up wire to the points labeled S1, S2, and LED1-LED3. Connect S2, an SPST toggle switch, in series with a 4-unit "AA" battery holder, and then connect that assembly to the appropriate wires coming from the board. The switch should be in series with the positive side of the power source. Install another SPST toggle switch to the circuit for S1.

Note that S3 and S4 are of the push-

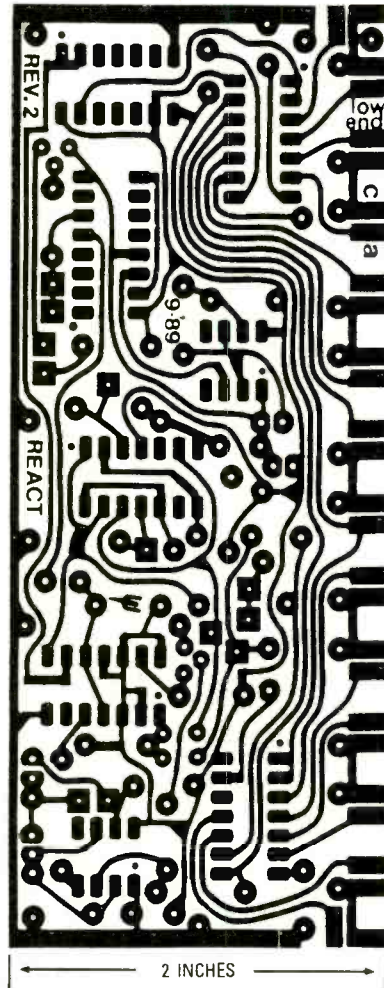

Fig. 2. The Reaction Timer was assembled on a printed-circuit board, a template for which is shown here.

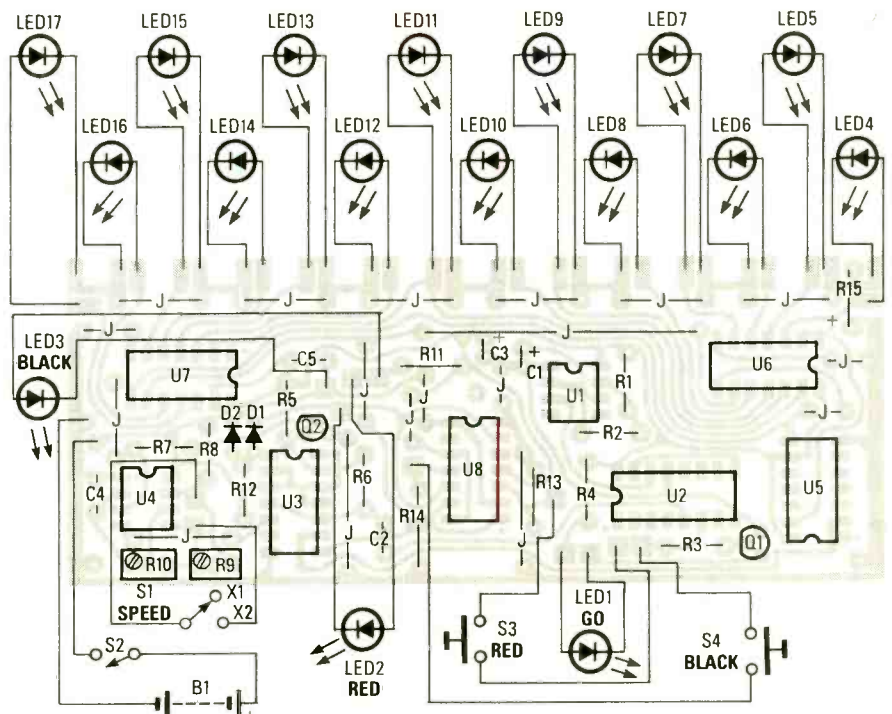

Fig. 3. When assembling the Reaction Timer it's a good idea to install IC sockets at all IC locations, followed by the jumper connections (denoted J), then the resistors and capacitors.

button variety, and are used to transmit your response to the circuit board. In the author's prototype, those units were mounted to the ends of drilled-out wooden dowels and were connected to the board via lengths of quad telephone-extension wire.

Finally, solder 14 LED's directly to the wide foil areas along the long edge of the board. Starting from the left (or the right) side of the board, connect the LED's anode to the first pad, and the cathode to the next. The next LED should be connect opposite in orientation to that of the previous one; e.g., anode faces anode and cathode faces cathode. The LED's at the extreme ends must have one lead bent to be soldered along the shorter edge.

Although resistors R9 and R10 are shown as fixed resistors in the schematic, they should be replaced with 50k multiturn trimmer potentiometers for more accurate timing. If trimmer potentiometers are used, adjust the output frequency of U4 to 200 Hz via R9 while S1 is closed, then open S1 and adjust R10 for the same frequency.

Next prepare the enclosure that will house the project. The author's prototype unit was housed in a plastic enclosure that measures 6¼ x 4¾ x 2 inches. Several holes were drilled in the front panel (or cover plate) to accommodate the off-board components and the 14 timing LED's connected to the edge of the printed-circuit board.

PARTS LIST FOR THE REACTION TIMER

SEMICONDUCTORS

- U1, U4—XRL555 or similar low-power oscillator/timer, CMOS integrated circuit
 U2—4017 decade counter/divider, integrated circuit
 U3, U8—74HC74 dual high-speed, D flip-flop, CMOS, integrated circuit
 U5—U7—74HC164 high-speed 8-bit serial-in/parallel-out shift register, CMOS, integrated circuit
 Q1, Q2—2N4401 general-purpose NPN silicon transistor
 D1, D2—1N914 general-purpose, small signal diode
 LED1—Wide-angle, diffused light-emitting diode
 LED2—LED17—LN28CAL Panasonic light-emitting diode

RESISTORS

- (All resistors are ¼-watt, 5% units, unless otherwise noted.)
 R1, R6—100,000-ohm
 R2, R3—22,000-ohm
 R4—330-ohm
 R5, R7—10,000-ohm
 R8, R12—R14—47,000-ohm
 R9, R10—50,000-ohm, square upright, multitrack trimmer potentiometer
 R11, R15—1500-ohm

CAPACITORS

- C1, C3—10-μF, 16-WVDC, radial-lead electrolytic
 C2, C5—0.001-μF, ceramic-disc
 C4—0.1-μF, ceramic-disc

ADDITIONAL PARTS AND MATERIALS

- S1, S2—SPST miniature toggle switch
 S3, S4—Normally-open, momentary-contact, pushbutton switch
 B1—Four "AA" batteries
 Printed-circuit materials, enclosure, IC sockets, battery holder, wire, solder, hardware, etc.

Note: A printed-circuit board for the Reaction Timer is available from John Wannamaker (Rt. 4 Box 550, Orangeburg, SC) for \$10.95 (money orders only) postage-paid. Residents of Canada please add \$0.25. South Carolina residents please add 5% sales tax. Send S.A.S.E. for free parts-source listing.

The front-panel holes for the timing LED's (LED4 through LED17) were spaced about ⅜-inch apart.

The LED's, when pushed through the holes in the front panel, help to hold the printed-circuit board in place (see photo). The board is then securely braced using a strip of aluminum from the board to the front panel of the en-

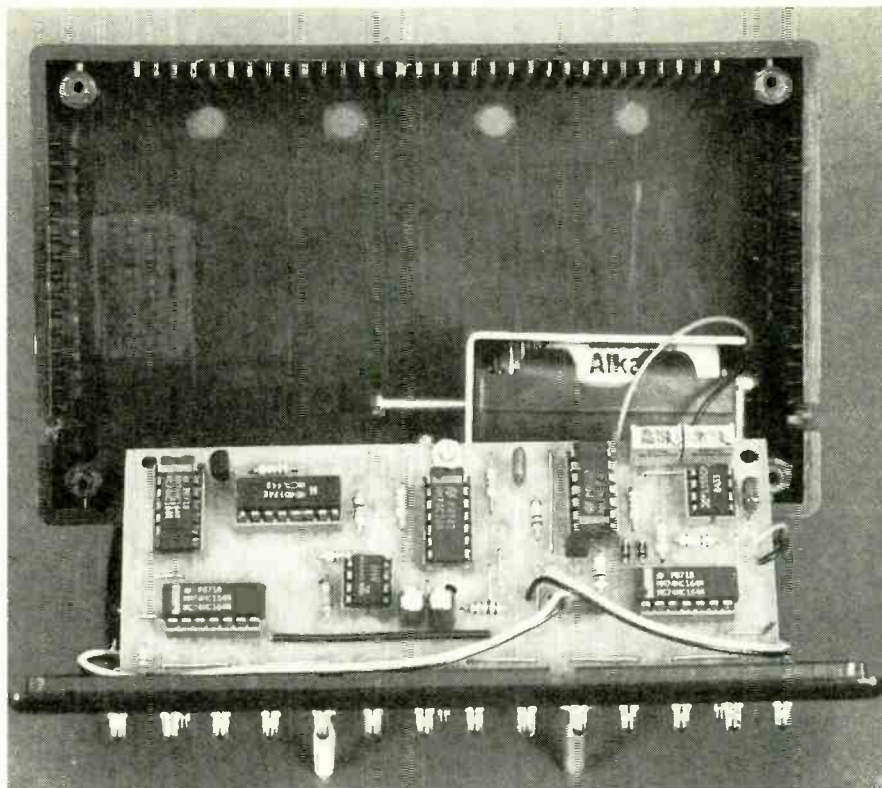

The Reaction Timer's printed-circuit board was mounted to the front panel of the enclosure using the timer LED's for support and an aluminum strip as a brace.

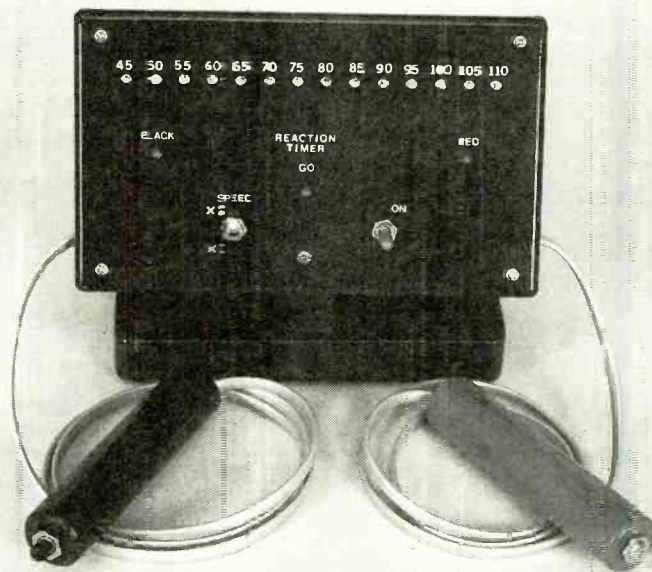

In the author's prototype, switches S2 and S3 were mounted on drilled-out wooden dowels and connected to the board via modular-telephone wire.

closure. Five additional holes must be drilled in the front panel of the enclosure for LED1—LED3, as well as S1 and S2. Finally slots were etched out on the sides of the enclosure through which the wires to switches that hold S3 and S4 leave the enclosure.

Before applying power, check your work for construction errors. Assuming that you find none, power up the circuit

and give it a try. Set S1 to the $\times 2$ position and flip S2 to the on position. The two player LED's should light, promptly followed by the sequencing of LED4 through LED17. After a short delay, LED1 should light, followed by the sequencing of LED4 through LED17. If your circuit performs as described, your project is nearly complete. All that's left to do is seal the circuit in its enclosure. ■

The "Ditherizer"



Give digitized audio the ambiance of the original analog signal by placing this circuit between the source and the output device

BY JERRY PENNER

That digitation sounds terrible." "I did the best I could...I used the highest sample rate possible, and made sure the analog input was wound right up, but not clipping."

"It still sounds terrible. Hear that aliasing?"

"You mean that high-pitched ringing?"

"That's it. That's what you get when the input frequency is higher than half the sampling frequency."

"What can be done about it?"

"Two things. One is to filter the input to make sure no frequency that's higher than half the sampling frequency gets through."

"What's the second?"

"Dither the analog input."

"Like in video?"

"Yep, same idea."

That was the start of the *Ditherizer*. Limiting the input frequency looked too daunting to try: The filtering would have to be changed for each sample rate and the thought of recalculating the component values for each change did not fill me with joy. Therefore, dithering the input seemed to be the only practical way to go.

The *Ditherizer* was originally developed for use with the Commodore Amiga, but since the *Ditherizer* is an analog device, it can be used with any computer or digitizer. The circuit con-

nects between the the signal source's output and the digitizer's input and mixes a pink-noise output with the signal to be digitized. Pink noise is a wide-band acoustic noise in which the amplitude is inversely proportional to the frequency. That is, the lower the frequency, the greater the noise amplitude (volume), and vice versa. To round things out, an amplifier stage is also included in the circuit to boost the signal amplitude if it isn't high enough. The gains in "fidelity" that can be achieved with the *Ditherizer* are absolutely amazing.

The Theory. Video dithering is a method of making a picture file look more realistic. The color values for each pixel have a random number added to or

subtracted from them. That provides a deviation that gives the effect of texture as opposed to a smooth, monocolored area. The more dithering added, the more deviant the final output. The same is true for audio. The more random noise added to the input, the more deviant the output.

Since an A/D converter splits an analog wave into steps, a sinewave may resemble Fig. 1A; add a bit of dithering and the output may resemble Fig. 1B. Dithering crosses each step several times instead of just once. That gives a digitized output that is more pleasing to the ear and can even turn an unrecognizable digitization into something that is more pleasant to listen to.

Through the mere act of dithering, a 1 bit, 10-kHz sample went from absolute

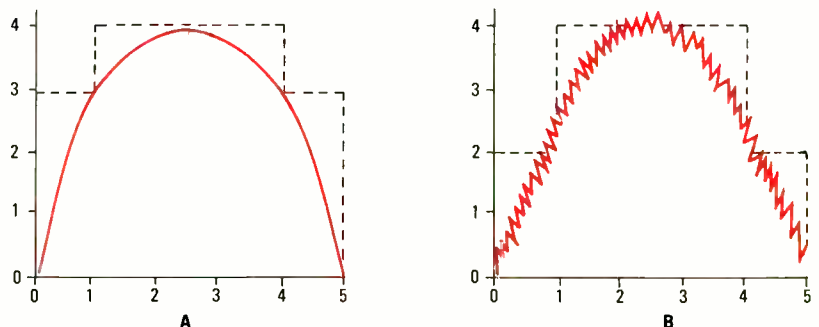

Fig. 1. An A/D converter splits an analog wave into steps so that a sinewave may resemble the waveform shown in A; add a bit of dithering and the output may resemble the waveform shown in B.

garbage to recognizable in a university lab. The magic number for noise input is about 70% of 1 bit. Therefore, if your input is 8 bits and the input signal is 2 volts peak-to-peak (p-p), the noise level needed is:

$$V_{\text{noise}} = V_{\text{inp-p}}/2^n \text{ bits} \times 0.7$$

$$V_{\text{noise}} = 2 V_{\text{p-p}}/2^8 \times 0.7$$

$$V_{\text{noise}} = 2/256 \times 0.7$$

$$V_{\text{noise}} = 5.5 \text{ mV}$$

About the Circuit. Looking at the circuit in Fig. 2, you will see that C1–C3, Q1, Q2, and R1–R4 make up the pink-noise generator. Transistor Q1 is connected as a reverse-biased diode junction, and is used to generate a white-noise (random noise) signal. That signal is capacitively coupled to the base of Q2 via C1. Transistor Q2 amplifies the noise signal. The output of Q2 is fed across C2, which removes (filters out) the higher frequencies to simulate pink noise more closely.

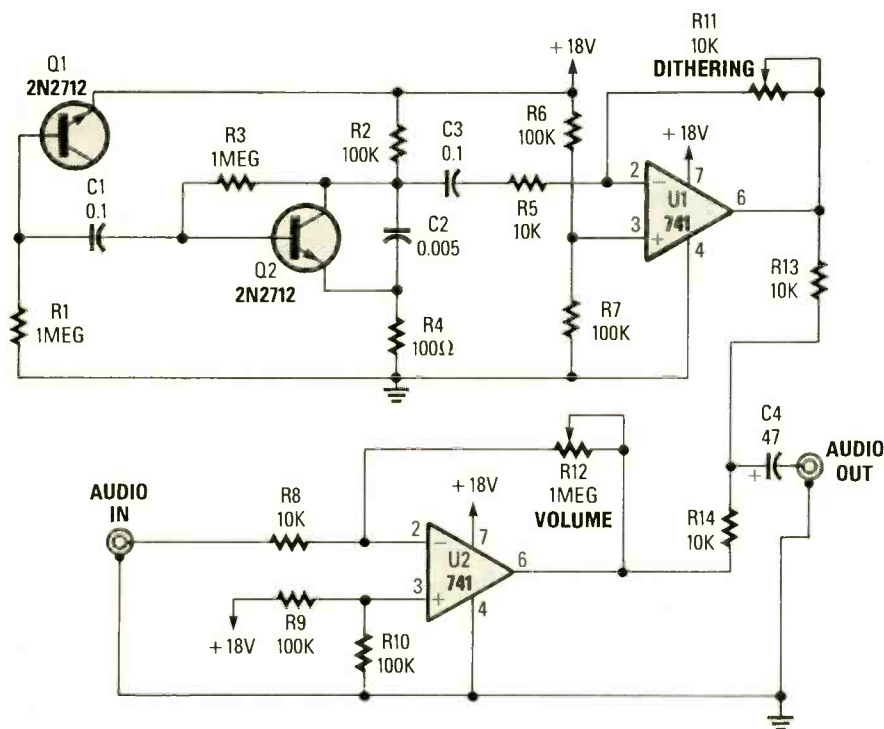

Fig. 2. In the dithering circuit, a bipolar transistor (Q1) generates a white-noise signal that is capacitively coupled to the base Q2 of via C1, which in turn amplifies the noise signal and feeds it to C2, which removes (filters out) the higher frequencies to simulate pink noise more closely.

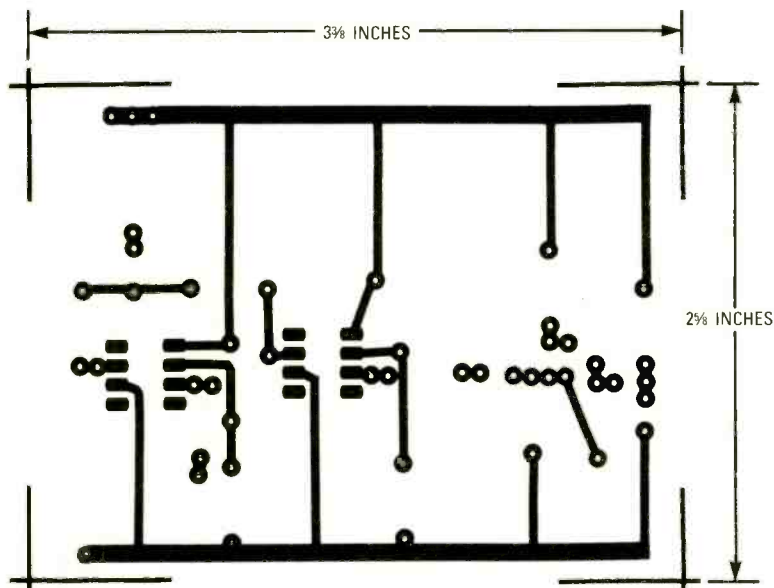

Fig. 3. It is recommended that the Ditherizer be assembled on a printed-circuit board; a template for that board is shown here.

PARTS LIST FOR THE DITHERIZER

SEMICONDUCTORS

U1, U2—741 op-amp, integrated circuit
Q1, Q2—2N2712, general-purpose NPN silicon transistor

RESISTORS

(All fixed resistors are 1/4-watt, 5% units.)

R1, R3—1-megohm
R2, R6, R7, R9, R10—100,000-ohm
R4—100-ohm
R5, R8, R13, R14—10,000-ohm
R11—10,000-ohm, audio-taper potentiometer
R12—1-megohm, audio-taper potentiometer

CAPACITORS

C1, C3—0.1-µF, ceramic-disc
C2—0.005-µF, ceramic-disc
C4—47-µF, 35-WVDC, miniature radial-lead electrolytic

ADDITIONAL PARTS AND MATERIALS

Printed-circuit materials, enclosure, IC sockets, 9-volt transistor-radio battery (2), battery connectors and holder, phono jack (2), knobs, wire, solder, hardware, etc.

Components C4, U1, U2, and R5–R14 make up the audio-amplifier/noise-amplifier/mixer circuit. The output from the noise generator is high enough for our purposes and only needs buffering. The filtered pink-noise signal is fed through C3 and R5 to the inverting input of U1, which produces an amplified and inverted image of the input signal.

Op-amp U2, along with resistors R12 and R8 are configured to give a maximum gain of 100, eliminating the need for a preamp stage in front of the digitizer as well. The output of U1 and U2 combine at the junction formed by R14 and C4, and are fed to the circuit's output jacks.

Construction. It is recommended that the Ditherizer be assembled on a printed-circuit board. A template for the Ditherizer's printed-circuit board is shown in Fig. 3. After etching a board from the pattern provided and collecting the parts, construction can begin.

Start by installing IC sockets at the positions indicated in Fig. 4. Then install all components in the circuit. Make sure that all polarized components are mounted with the proper orientation. Use RCA-type phono jacks for the audio input and output.

Only one special consideration is
(Continued on page 104)

THE VERY VERSATILE CODE ALARM

Protect your valuables from would-be burglars and car thieves alike with this easy to build and program digital-lock security system

BY MIKE AND KAREN
GIAMPORTONE

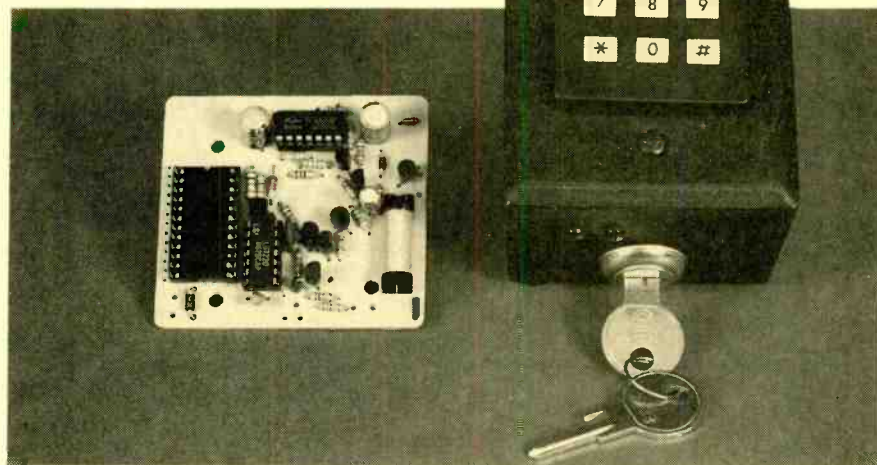

It's dark, very dark outside when all of a sudden your car's horn starts to blare, waking you up from your sleep. You go to the bedroom window to find your car's headlights flashing, horn still blaring and you see someone scampering away to an awaiting car, which then speeds off.

You immediately call the police. While you're waiting for the police to arrive, your car's alarm shuts off and resets itself. When the police arrive, you take them out to the car to inspect it, showing them the alarm system (which you've built at a cost of around \$30.00). The same alarm—the *Versatile Code Alarm*—that just discouraged the attempts of a would-be car thief could be used to protect your home, boat, or garage. And it can do more than just beep horns or turn on lights.

The Versatile Code Alarm has separate adjustable enter and exit delays and automatic alarm reset; it consumes minute amounts of energy, is controlled by a 1-digit code you select for arming, and a 4-digit code for disarming. In addition, it can be disarmed via a key switch when necessary or preferred; it has a tamper circuit to keep prying eyes out of the enclosure; a flashing red LED to show that the alarm is "armed," and a green LED to show when all circuits are ready and doors are closed.

The whole package fits in an enclosure measuring about 3-inches wide by 4-1/2-inches long, and is inexpensive

to build and install. With one or two evenings of construction and one for installation, your total investment will make it well worth building.

Circuit Description. Figure 1 shows the schematic diagram for the Versatile Code Alarm. The circuit is built around an LS7220 digital lock (U1), a 4001 quad 2-input NOR gate (U2), accompanied by assorted support components. The circuit is powered from a 12–14-volt DC source (either battery or AC derived).

When power is applied to the circuit, U1 self-arms, turning on LED1 (a green LED) to show the status of the circuit.

With the circuit armed, pin 13 of U1 goes low, biasing Q2 on. With Q2 turned on, a bias voltage is applied to the base of Q3, turning it on. With Q3 biased on, power is delivered to the base of Q4 and the +V input of U2. With Q4 turned on, a positive voltage (through S2, S3, and Q6) is fed to the pin-2 input of U2, forcing its pin-3 output low. That low is applied to the gate of SCR1, keeping it turned off. With the SCR turned off, a logic high is applied to pins 8 and 9 of U2, forcing its pin-10 output low. That low is applied to the base of Q5, keeping it turned off. With Q5 turned off, no power is applied to the relay (K1), keeping it off, and preventing the alarm from sounding.

Now, if S2 or S3 were to open, removing +V from Q6, pin 2 of U2 would be pulled low via Q4, forcing the pin-3 output of U2 to go high. The high output of

U2 at pin 3 is applied to the gate of SCR1, triggering it into conduction. With the SCR conducting, pins 8 and 9 of U2 are pulled low, forcing U2's pin-10 output high. That high is then applied to the relay, causing its contacts to close, thereby activating the sounder.

If, instead, S4 or S5 were to close, the bias voltage at the base of Q6 would be shorted to ground, again pulling pin 2 of U2 low via Q4. And again pin 3 of U2 would be forced high, causing the SCR to conduct, triggering the relay, which in turn would cause the alarm to sound.

Switch S6 (the TAMPER SWITCH) is an extra measure of protection. If the would-be thief tries to defeat the alarm system by wrecking its circuitry, the contacts of S6 would close when the alarm's cover is removed. With the contacts of S6 closed, a positive voltage is applied to the base of Q5, turning it on, energizing the relay and causing the alarm to sound. The SCR will conduct (and thus the alarm will continue to sound) as long as the current through the SCR remains above the rated holding current (I_{H}) of the unit.

Even if the TAMPER SWITCH were quickly reopened, the alarm would sound after a delay because the short pulse produced as a result of momentarily closing S6 feeds a trigger voltage to the gate of the SCR, causing it to conduct, thereby energizing the relay. The entry delay starts as soon as the TAMPER SWITCH is closed.

Zener diode D1 is used to regulate

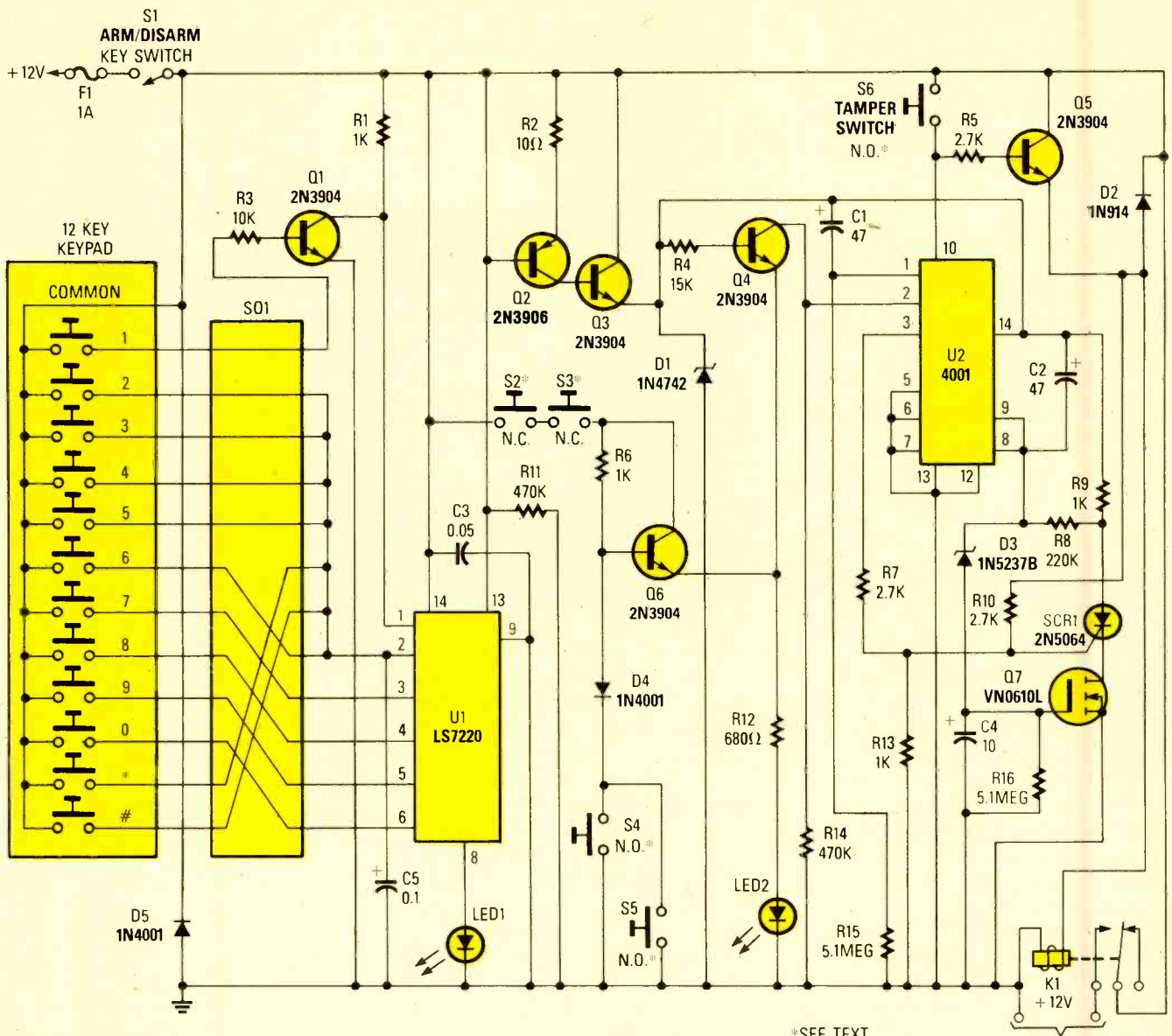

*SEE TEXT

Fig. 1. The Versatile Code Alarm is built around an LS7220 digital lock (U1), a 4001 quad 2-input NOR gate (U2), accompanied by assorted support components.

the voltage applied to U2 to 12 volts. Capacitor C1 provides the exit delay, while C2 provides the entry delay. With the values shown for C1 and C2, the entry and exit delay times are about 12 seconds. Capacitor C4 determines how long the alarm sounds; with the value shown, the alarm sounds for about 40 seconds before resetting.

Capacitor C4 charges via D3, an 8.2-volt Zener diode connected to the positive supply rail through Q3. Diode D3 provides enough time to allow Q7 to reverse bias fully and not lock pins 8 and 9 into an intermediate state. If not for that unit, SCR1 and Q7 would not turn fully off. A MOSFET was selected for Q7 because its low-power attributes make a long delay with a small capacitor possible.

Transistor Q7 is switched off as C4 is discharged through R16, thus opening the SCR1 circuit, causing conduction through the SCR to cease. Doing so also makes pins 8 and 9 go high and pin 10 go low, turning off Q5 and K1.

The circuit can be disarmed by pressing the proper digit on the keypad only in the right sequence. When the proper disarm code is entered, pin 13 of U1 goes high and reverse biases Q2, removing base bias from Q3. That removes power from the rest of the circuit.

When the proper arm code is entered via the keypad, a positive voltage is applied to the base of Q1, causing it to turn on, pulling pin 1 of U1 low, forcing pin 13 low, and once again powering up the rest of the circuit. All other keys if pressed would require re-entering of

the code. Those keys are all tied to pin 2 of U1.

Diode D2 protects the circuit from spikes caused when the relay is switched off. Diode D4 prevents current from a dome-light circuit from biasing Q6 while the auto's doors are closed, but either S2 or S3 is open, but will allow a dome-light switch to ground the base of Q6, turning it off and starting the delay for the alarm.

Construction. Begin by cutting a piece of single-sided, unetched copper-clad printed-circuit material to about 2½ × 2¾ inches, and etching the board using the pattern in shown in Fig. 2. A simple way to transfer the pattern to the printed-circuit material is to use Meadowlake Corp's TEC-200

coated film. To use it, copy the printed-circuit board pattern onto the film in a dry toner, plain-paper copier. Then

place the print ink-down on the printed-circuit material and iron the copied image onto the printed-circuit

material. The ink from the copier becomes the etch-resist. (Printed-circuit board patterns all ready to be ironed on are offered in the Parts List).

Before dunking the board into the etchant, make sure that all traces and pads have been transferred. If there are any inconsistencies in the transferred pattern, they can be corrected by going over the affected areas with a permanent marker. The results are excellent. After etching, drill the component-mounting holes in the board. Also drill the three board-mounting holes to $\frac{5}{32}$ inch.

Once all the board holes have been drilled, the printed-circuit board can be used as a guide to mark and drill holes in the enclosure for board mounting. The author's prototype unit was housed in a Mason electrical box (Part C100) with a matching blank cover plate (Part C340), which are available from most building-supply outlets.

Begin preparation of the enclosure by labelling (on the inside) the upper and lower removable, cover-mounting plates, as top and bottom, respectively. Remove the mounting plates and cut as shown in Fig. 3. Enlarge one of the threaded intake holes of the enclosure to $\frac{3}{4}$ inch to accommodate the key switch. Above that hole and slightly to the left, the tamper switch will be mounted.

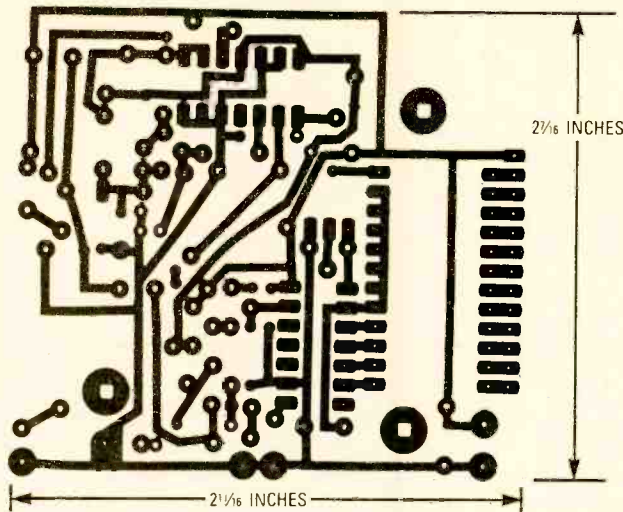

Fig. 2. The Versatile Code Alarm was assembled on single-sided printed circuit board; the template for that board is shown here.

PARTS LIST FOR THE VERSATILE CODE ALARM

SEMICONDUCTORS

- U1—LS7220 digital-lock, integrated circuit
- U2—4001 quad 2-input NOR gate, integrated circuit
- Q1, Q3—Q6—2N3904 general-purpose NPN silicon transistor
- Q2—2N3906 general-purpose PNP silicon transistor
- Q7—VN0610L N-channel power MOSFET
- SCR1—2N5064 0.8-amp, 200-PIV silicon-controlled rectifier
- D1—1N4742A 12-volt, 1-watt, Zener diode
- D2—1N914 general-purpose, small-signal diode
- D3—1N5237B 8.2-volt, $\frac{1}{2}$ -watt, Zener diode
- D4, D5—1N4001, 1-amp, 50-PIV, rectifier diode
- LED1—Jumbo green light-emitting diode
- LED2—Jumbo red light-emitting diode

RESISTORS

(All resistors are $\frac{1}{4}$ -watt, 5% units, unless otherwise noted.)

- R1—1000-ohm, $\frac{1}{2}$ -watt
- R2—10-ohm
- R3—10,000-ohm
- R4—15,000-ohm
- R5, R7, R10—2700-ohm
- R6, R9, R13—1000-ohm
- R8—220,000-ohm
- R11, R14—470,000-ohm
- R12—680-ohm
- R15, R16—5.1-megohm

CAPACITORS

- C1, C2—47- μ F, 25-WVDC, radial-lead electrolytic

- C3—0.05- μ F, ceramic-disc
- C4—10- μ F, 25-WVDC, radial-lead electrolytic
- C5—0.1- μ F, 25-WVDC, Tantalum

SWITCHES

- S1—SPST key switch (RS 49-515 or similar)
- S2, S3, S6—Normally-closed, pushbutton switch, see text
- S4, S5—Normally-open, pushbutton switch, see text
- K1—Normally-open, SPST 12-volt, 1-amp reed relay
- F1—1-amp fuse

ADDITIONAL PARTS AND MATERIALS

- 12-key keypad (part KL0025 or KL0026)
- Printed-circuit materials, enclosure, IC sockets, 12-14 volt DC source, siren (or other signalling device), paint (optional) wire, solder, hardware, etc.

Note: An iron-on printed-circuit pattern is available from Mike Giamporone, 7330 Duce Rd., Yale, MI 48097 for \$1.00 (money order only) and an S.A.S.E. For technical assistance send an S.A.S.E. with description of the problem to the above address.

The LS7220 (U1) is available from Belco Electronics (194 Myrtle, Elemhurst, IL 60126, Tel. 312-544-3303 or 312-530-1105). The company requires no minimum purchase.

Keypads and the LS7220 are available from Tory Sales, 336 Boulevard, Hasbrouk Heights, NJ 07604, Tel. 201-288-5656 (the company requires a 201-288-5656 (the company requires a \$25 minimum purchase.)

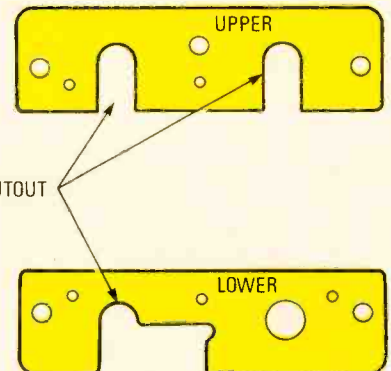

Fig. 3. The electrical junction box used by the author as an enclosure has inner mounting plates that must be slightly modified, as outlined here.

With the lower mounting plate just lying in place, position the tamper switch so that the lever comes through the cutout notch in the plate. Drill two holes through the enclosure's bottom end, so that the switch lever is fully collapsed when the cover is secured to the enclosure and fully extended with the cover removed. Do not fasten the switch or mounting plate at this time. Lay the bare, printed-circuit board with

the foil side down and the pad for the 24-pin DIP socket towards the upper mounting plate in the enclosure.

Center the printed-circuit board, then mark and drill the $\frac{5}{32}$ -inch mounting holes through the enclosure. Put threaded plugs (which are supplied with the electrical box) in the enclosure's threaded holes as needed, leaving one open for the wires that go to the various switches and power source to exit the enclosure. Screw the upper (inside) mounting plate to the back of the upper end of the cover plate. Center the mounting plate and mark the positions of its two $\frac{5}{16}$ inch holes on the cover plate. That's where the LED's will mount in the cover plate. Drill the cover-plate LED holes to $\frac{1}{4}$ inch. Using the mounting instructions from the keypad. Here are several keypads the can be used in the alarm circuit's construction. All are essentially the same, and the only requirement is that the one you choose not be the matrix type.

Cut and drill the cover plate as needed, and then remove all burrs from the enclosure and the cover plate with a file or sandpaper. Do not mount the keypad yet. Clean, then paint all outside surfaces with wrinkle black paint (available at most auto-parts stores). Follow the instructions on the can for a nice finish. Don't forget to paint the cover-plate and keypad-mounting screws. Let everything dry and warm up the soldering iron.

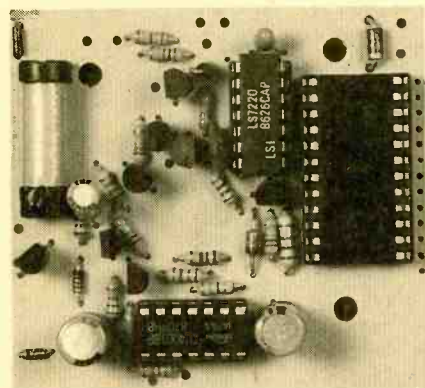

Here is the fully assembled printed-circuit board. The circuit, while using relatively few components, provides features that rival those found on commercially available units.

Printed-Circuit Assembly. Start out by installing 3 DIP sockets at the positions indicated in Fig. 4. Installing the sockets first helps to locate the proper positions for the other components. Mount transistor Q2 (the 2N3906 PNP

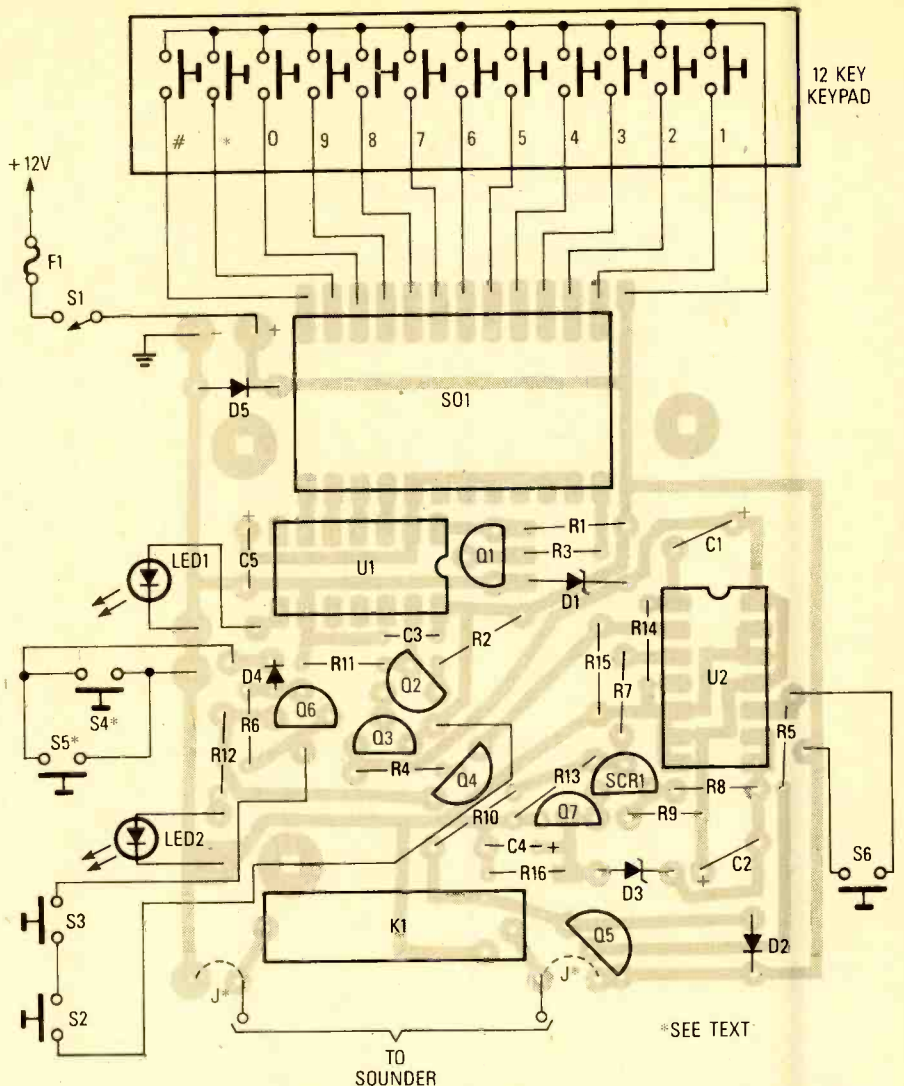

Fig. 4. Install the board-mounted components using this diagram as a guide. Pay close attention to the orientation of the polarized components.

unit), noting proper orientation. Then install SCR1 and Q7 (the MOSFET), followed by Q1, Q3, Q4, Q5, and Q6 (all 2N3904 NPN units). Note: D5 is vertically mounted. If you do not require that the alarm shut off and reset after 40 seconds, eliminate R16, C4, D3, and Q7. But you must install a jumper between where Q7's source and drain terminals would have gone. That allows SCR1 to conduct directly to ground.

Install the capacitors, again noting each unit's orientation; mount C4 elevated at least $\frac{1}{4}$ inch off the board. Mount the remaining components in place. If you are going to ground a horn relay, alarm, or light relay through the circuit, install a jumper wire at the ground end of relay K1. If you intend to power some device through the circuit, install the jumper connection just above relay K1.

Next connect the LED's through hook-up wire to the board. When soldering

the LED's to their wires, be sure to put heat shrink tubing over the positive lead and larger heat shrink tubing over both wires, then solder the wires to the LED's and slide the tubing over the joints.

Now we come to the installation of the keypad, which will require a little patience. Start by deciphering the pinout on the keypad and marking the pins on the back of the keypad to show the actual key represented by each pin. The pins may be numbered; however, the numbering may or may not represent the corresponding key. The keypad can be mounted with screws and small nuts, or by heating an old screw-driver tip on your stove and melting pins over to fasten it securely to the dried cover plate. We do not recommend using a soldering iron to melt plastic, it may ruin the tip.

Shorten the keypad pins as needed. Solder either a 13 conductor (12 keys and one common) ribbon cable to the keypad or separate 22-26 gauge wires

to each pin. Solder the other ends of the keypad wires to the printed-circuit board. After checking the wiring, silicone rubber may be applied to the pin/wire joints to insulate and strengthen the connection.

Arm/Disarm Code Selection. The first step in establishing the arm/disarm code is to select a four-digit disarm code and a single-digit arm code. Note that each number can be used no more than once. The arm/disarm code is programmed in to the circuit via jumper connections installed in the 24-pin DIP socket. Use 22-gauge solid copper wire for the code jumpers.

Measure and cut off the length of wire need to make the connection (plus a little extra). Strip about 3/16-inch of insulation from the ends of the jumper

wire, and push one end into position 24 of the 24-pin DIP socket and the other end to the corresponding pin hole for the digit you chose for arming the alarm. If you take a close look at SO1 in Fig. 1, you'll note that the author used keypad position 1 as his arming code.

The next jumper is installed from pin 13 of SO1 to the last digit of your disarming code (in this instance 0). Jumper pin 14 of SO1 to the 3rd digit of the disarm code, pin 15 to 2nd digit, and pin 16 to your first digit of the disarm code with these jumpers. Be sure all jumpers are fully in the pin holes. Again referring to Fig. 1, the author's disarm code was selected to be "7-8-9-0." All unused keypad switches can be jumped to any of the unused socket positions since all of them are tied to pin 2 of U1.

If, when entering the disarm code,

the wrong digit is pushed, you must start the code over. The circuit provides 5040 possible 4-digit combinations.

Switch/Sounder Selection. All normally-closed sensor switches (S2 and S3 in Fig. 1) used in the alarm must be wired in series with each other. All normally-open sensor switches (represented by S4 and S6 in Fig. 1) must be wired in parallel. More normally-open and/or normally-closed switches can be added to the circuit as required.

With the key switch mounted in the enclosure, connect wires between it and the printed-circuit board. If you eliminate any of the normally-closed sensor switches, jumper wires must be installed in their place to complete the circuit. But if your installation does not require normally-open switches, no ad-

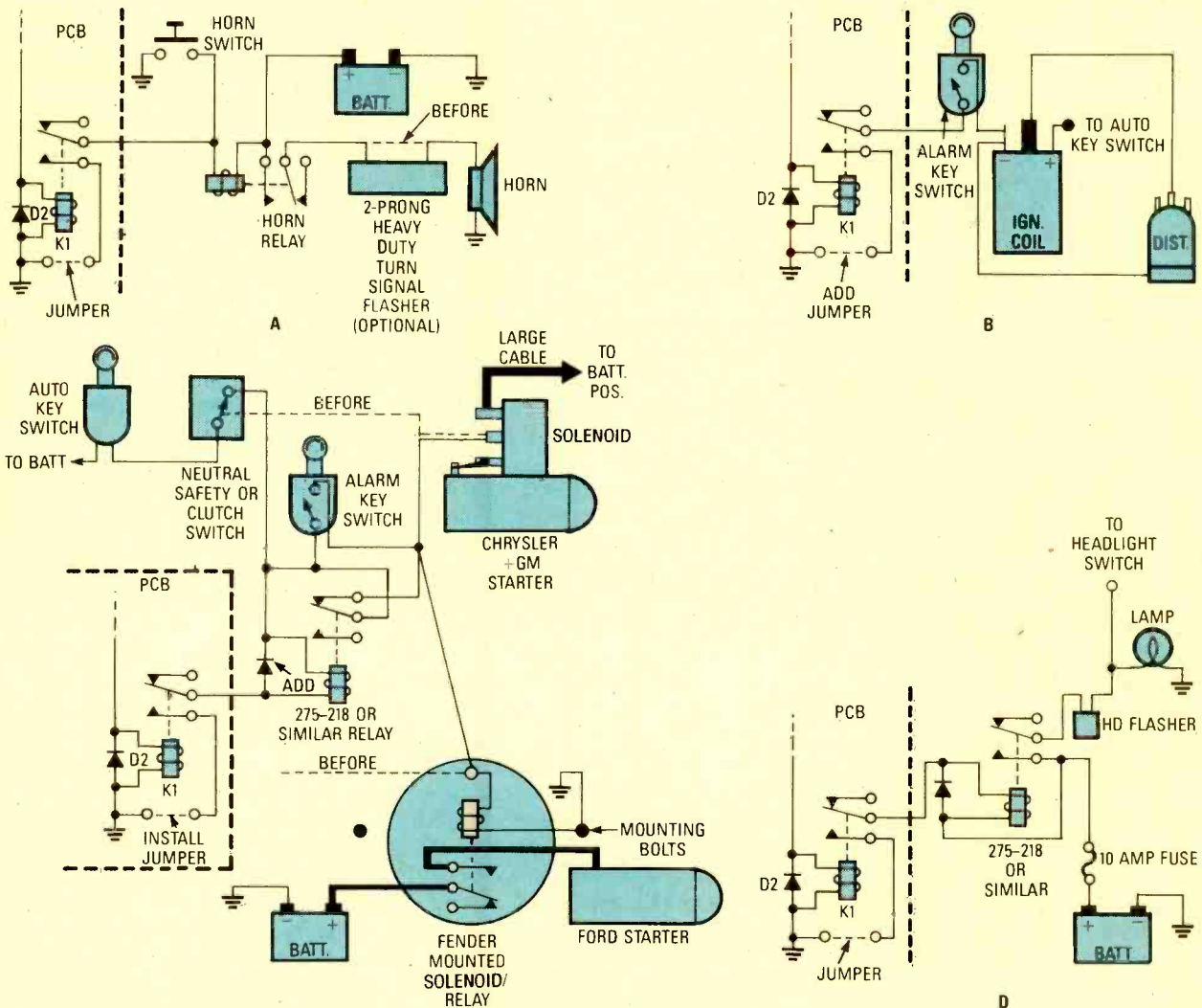

Fig. 5. There are several ways in which the alarm can be installed. The installation scheme in A show how to use the vehicle's existing horn as the alarm sounder; B shows an installation wherein the Versatile Code Alarm is wired to automatically cut engine power if the car is started while the alarm is still armed; C shows how to install the alarm to function as a no-start (ignition defeat) switch; and D shows how to tie the alarm circuit into the vehicle's headlamp flasher.

ditional jumper connections are required. The switches needed for your particular installation can most likely be purchased from electronic suppliers, who also sell a wide selection of sirens to suit your needs.

Among the switches that might be used are existing dome-light switches, door switches, pin switches for auto's (hood and trunk); pressure mats, smoke or heat sensors, window foils, glass-break detectors, motion detectors, etc. for the home. In automotive applications, the alarm can be configured to kill the engine or prevent starting. In the home, it can also be used to trigger house and/or yard lights.

As for the alarm sounder/annunciator, an existing auto horn, a separate siren, lights, a bell, or a buzzer may be used. But if you use a 117-volt AC siren, remember that it must be totally isolated from the printed-circuit board.

Circuit Board Installation. In the author's prototype, the printed-circuit board was installed in its enclosure mounted on 1-inch nylon spacers using three #6 screws and nuts. Slide the printed-circuit board assembly into the enclosure with the 24-pin DIP socket at the upper end of enclosure. Fasten the printed-circuit board to the enclosure securely. Cut off excess screw length as needed from the back of enclosure. Be sure that the printed-circuit board traces do not touch the enclosure.

Solder wires to S6 (the tamper switch) and mount it to the enclosure. The switch used in the author's prototype is a three-terminal—common, normally-open, and normally-closed—unit. Connect your wires to the common and normally-closed terminals. That may appear to contradict what's shown in Fig. 1, but remember, as the tamper switch, its control lever is to be held down by the enclosure's cover plate, keeping the switch open until the cover is removed.

Bend the tamper switch's lever arm as needed to adjust its on/off point. Carefully install the IC's in their respective sockets. Next you must decide how the circuit, which draws between 30 and 70 mA, is to be powered. Of course, if the circuit is to be used in an automotive application, it will be impossible to power it from household current. But for home installations, there are choices to make. For instance, you can power the circuit from an AC-derived DC power supply, a battery, or a combination of the two. For the latter two possibilities, you might even consider

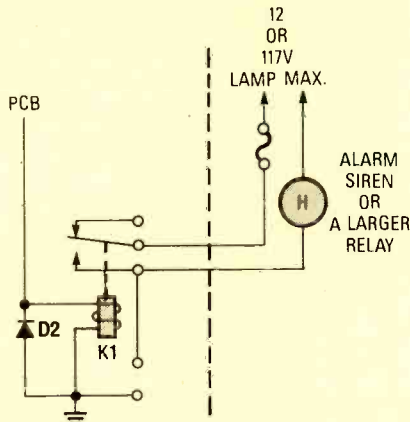

Fig. 6. If your installation requires that the alarm sounder be electrically isolated from the printed circuit board, use this connection scheme. Note that the jumper connection that is present in the previous connection schemes has been eliminated.

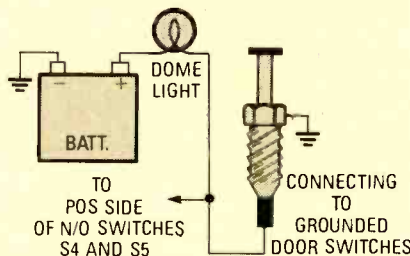

Fig. 7. You can also tie the alarm circuit into a hood- or trunk-light circuit to take advantage of existing switches.

connecting a trickle charger across the battery. That would give continuous security even during power outages. Plug-in 12-volt DC power supplies work just fine.

Installation. Before we go into installation details, it is appropriate that we caution you on neatness; a sloppy installation could render even the best alarm system useless. Concealment is another consideration. In some applications you may wish to have just the control panel (keypad and LED annunciators) visible.

The control panel can be mounted on a wall, on the dashboard, or in a console with the rest of the circuit hidden away. If you plan to use the alarm in an ignition-disable configuration, it will be necessary to reduce the value of C2 (the entry-delay component) to perhaps 10 μ F to reduce time allowed to disarm the alarm or drive away.

Figure 5 shows several ways that the alarm can be installed. In each diagram, the alarm's key switch is wired as a failsafe. The key switch can turn off or disconnect the alarm, so that you don't have to give the code to a neighbor, strangers servicing the vehicle, or use

the disarm code in the presence of a stranger. The key switch also removes the ground (in the ignition-defeat installation), thereby allowing the vehicle to start or run in case of an alarm-system failure.

When using the vehicle's existing horn as the alarm sounder, simply tap into the horn relay's wire going to the horn switch, as shown in Fig. 5A. If on your auto all the doors are connected to the dome light, it is necessary to tie into one dome-light switch wire only, because they are all connected together at the dome bulb.

Figure 5B shows an installation wherein the Versatile Code Alarm is wired to automatically cut engine power (after a delay) if the car is started while the alarm is still armed. Engine power, of course, can thereafter be restored by disarming the alarm via the key or disarm code.

Figure 5C shows how the alarm circuit is installed in the vehicle as a no-start (ignition defeat) switch. In that configuration (as in commercial units that perform the same function), the auto engine is rendered inoperative while the alarm circuit is engaged.

Figure 5D shows how to tie the alarm circuit into the vehicle's headlamp flasher. If you are going to turn on flashing headlamps, or use a no start or auto kill hookup, you'll need a heavy duty relay. You may wish to devise your own way of flashing on/off your siren or lights, but, we've found that a two-prong, heavy-duty, turn-signal flasher installed between the relay and a medium load, like your existing horn or headlights, works just fine.

Figure 6 shows how to connect the alarm sounder so that it is electrically isolated from the printed circuit board. Note that the jumper connection that is present in the previous connection schemes has been eliminated. You may also want to tie into a hood or trunk light circuit to take advantage of existing switches (see Fig. 7).

There are other security schemes that can be incorporated into the your installation; for instance, hood-locking pins controlled via a solenoid that could be made to engage (lock down the engine compartment) whenever the alarm is armed, as is available in some of the commercial units.

No matter which installation scheme you use, a little time and effort (coupled with some careful thought) can turn the Versatile Code Alarm into a valuable asset. ■

Transformerless

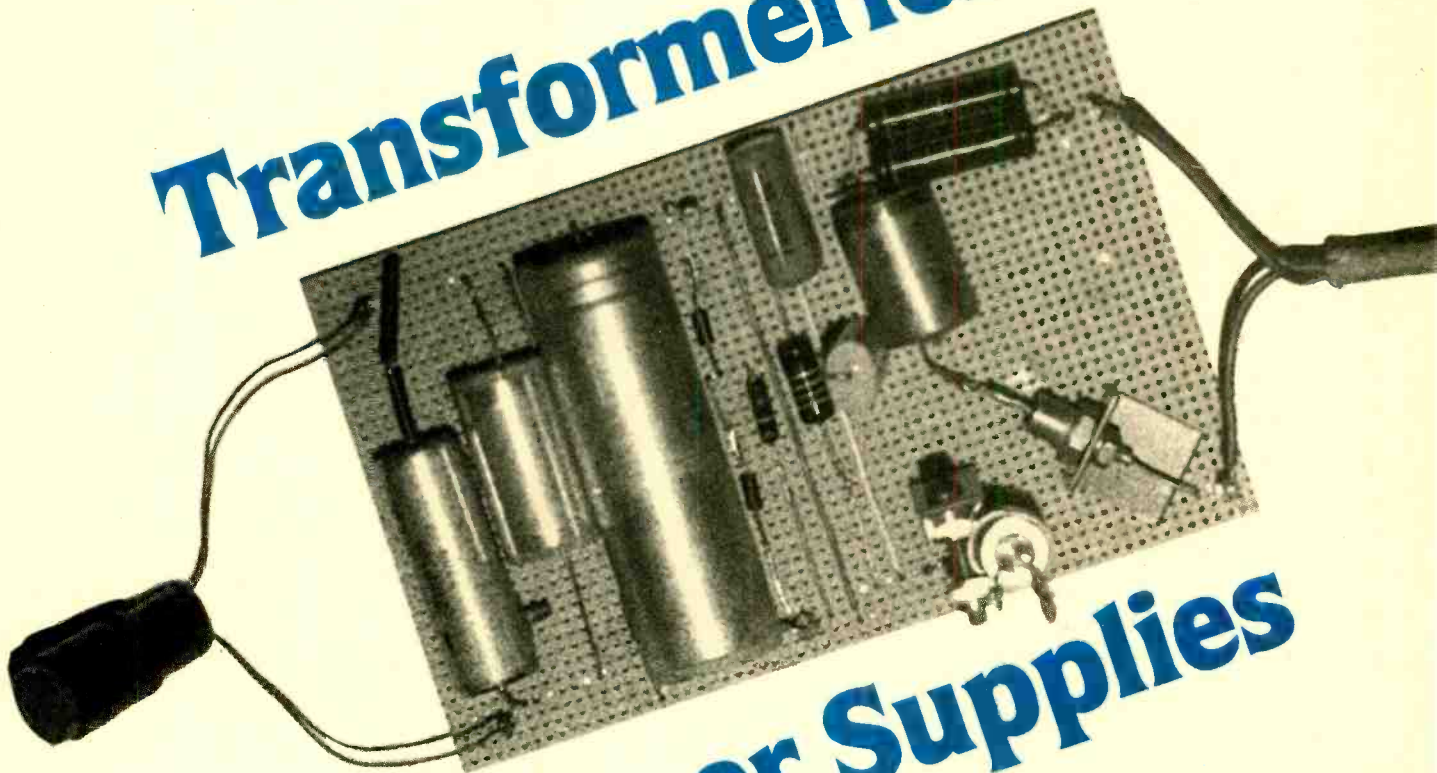

DC Power Supplies

BY RALPH HUBSCHER

While the transformer is still a key part of most power-supply designs, it is possible to build a useful power supply without one...and we'll show you how!

The transformer has been with us for quite a while, and has lent itself nicely to several applications. For instance, it is handy for raising or lowering AC voltages, and has been used widely for adjusting impedances or separating individual stages in multi-stage systems.

It's hard to imagine that the transformer will ever become obsolete. But haven't you wondered whether such a heavy, cumbersome piece of equipment might not be some day replaced by something more modern (or, at least smaller)? Any transformer replacement is not likely to be a tiny chip because when sizable currents flow, heat must be dissipated (often sizable amounts of heat), so surface and bulk become mandatory.

But if it is a power supply that you seek, certainly one can be built without a transformer—hence the basis of this article; the *Transformerless Power Supply*. **It should be mentioned, however,**

that such a power supply poses a greater shock hazard than do those that incorporate a transformer into their designs, since the circuit operates at line (117-volts AC) potential. As such, a great deal of caution should be observed when building and using such a supply.

About the Circuit. Figure 1 is a schematic diagram of the Transformerless Power Supply. Switch S1 places one of a bank of non-polarized electrolytic "scoop" capacitors (C2–C7) across the AC line, allowing it to charge. (I call them scoop capacitors because they sort of scoop the AC to the SCR.) The SCR (SCR1) is configured so that it only fires (conducts) during positive excursions of the AC waveform. When the SCR fires, it acts as a conventional diode, allowing the charge from the scoop capacitor to flow through it to the output filter capacitor (C9) and out to the load.

As you can see, the whole thing is really quite simple. The balance of the circuitry serves support functions such as ensuring that the SCR fires only during the positive half-cycles of the AC waveform. The Zener diode (D1) is placed in the circuit to regulate the voltage available at the output. Resistor R1 essentially acts as a "slo-blo" fuse, with some "olefactory and visual indicators." That is, if excessive current flows, the resistor will become discolored and begin to smell even before it goes up in smoke. That will give you plenty of time to pull the plug. Capacitor C1 acts as an AC resistor.

The voltage and current available at the output is determined by the value of the scoop capacitor selected and the size of the load. If you check Table 1, you'll see that voltages of 3.2 to 43.5 volts DC were measured with a 100-ohm, 20-watt load connected across the output of the circuit. Currents ranged from 31 to 322 mA.

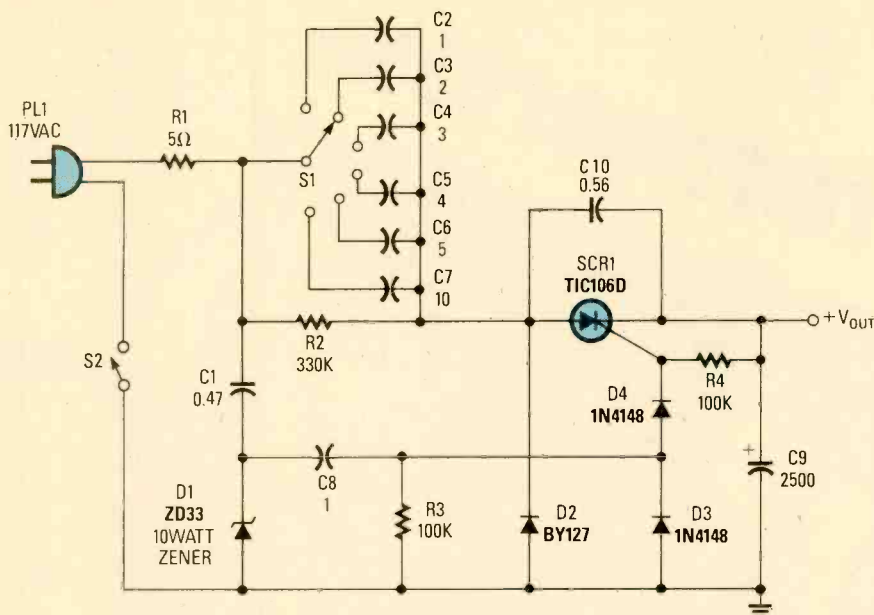

Fig. 1. The Transformerless Power Supply is made up of relatively few, readily available components. The output voltage level (and the amount of available current, see Table 1) can be varied by rotating switch S1.

TABLE 1—OUTPUT CURRENT/VOLTAGE AT SPECIFIED LOADS

Capacitance (μF)	Load					
	100 Ohms		200 Ohms		1000 Ohms	
	V_{OUT} (V)	Current (mA)	V_{OUT} (V)	Current (mA)	V_{OUT} (V)	Current (mA)
1	3.2	31	6.0	29	25	24
2	6.4	61	11.2	54	41	41
3	9.0	87	16.1	78	52	52
4	11.8	113	20.7	100	61	61
5	15.5	147	24.7	120	67	67
6	17.8	169	28.8	140	68	68
7	18.5	176	31.9	155	69.4	68
8	20.3	195	36.8	173	70	71
9	22.8	220	41.0	193	70	71
10	24.9	238	42.0	204	71	71
11	27.1	259	44.9	219	—	—
14	33.0	317	52.7	257	—	—
20	43.5	422	65.8	322	—	—

If you want to supply a specific DC voltage or current to meet the requirements of a specific piece of equipment, check the device's resistance. Connect an equivalent resistor across the output of the Transformerless Power Supply. Also connect a voltmeter to the output and switch through the scoop capacitors until you get the voltage needed. It is possible to raise voltage and/or current further by going to an

even larger scoop capacitor. However oil-capacitors beyond 10- μF , 200-volts AC are large. Zener diodes and SCR's also need larger heat sinks when pushed into the 20-watt region. The power supply described herein is not exactly small to begin with and it should not be expanded into a range where it becomes obvious that it will take up more space than the transformer/rectifier power supply that it is to replace.

PARTS LIST FOR THE TRANSFORMERLESS POWER SUPPLY

SEMICONDUCTORS

- SCR1—TIC106D or similar, 8-amp, 400-PIV, silicon-controlled rectifier
 D1—ZD33, ECG5142 or similar, 33-volt, 10-watt Zener diode
 D2—BY127 or similar, 3-amp, 1000-PIV silicon rectifier diode
 D3, D4—1N4148 or 1N914, small signal, silicon diode

RESISTORS

(All resistors are 1/4-watt, 5% units, unless noted)

- R1—5-ohm, 10-watt
 R2—330,000-ohm
 R3, R4—100,000-ohm

CAPACITORS

- C1—0.47- μF , 200-WVDC, ceramic-disc
 C2—1- μF , 200-WVDC, non-polarized electrolytic
 C3—2- μF , 200-WVDC, non-polarized electrolytic
 C4—3- μF , 200-WVDC, non-polarized electrolytic
 C5—4- μF , 200-WVDC, non-polarized electrolytic
 C6—5- μF , 200-WVDC, non-polarized electrolytic
 C7—10- μF , 200-WVDC, non-polarized electrolytic
 C8—1- μF , 50-WVDC, non-polarized electrolytic
 C9—2500- μF , 70-WVDC, electrolytic
 C10—0.56- μF , 400-WVDC, ceramic-disc

ADDITIONAL PARTS AND MATERIALS

- S1—SP5T rotary switch
 S2—SPST toggle switch
 PL1—117-volt AC molded power plug with line cord
 Perfboard materials, enclosure, wire, solder, hardware, etc.

Note that the switched scoop capacitors (C2–C7) must be non-polarized types, meaning that they can be foil capacitors or oil-filled capacitors. They cannot be standard electrolytics because such capacitors would heat up and may explode. AC motor-starting capacitors will do the job. In place of the specified SCR (a TIC106D 5-amp 400-PIV unit) equivalent SCR's, such as the T6N400 (AEG) or others, can be used. They must be mounted on heat sinks.

The Zener diode regulates the voltage supplied to C9. For test purposes and for applications requiring only a few milliamperes, a ZPD30 (30-volt Zener) or a combination of two ZPD15 (Continued on page 104)

GIZMO

A CHRONICLE OF CONSUMER ELECTRONICS

APRIL 1990

VOLUME 3,
NUMBER 4

25 Watts, No Sweat

CYRUS ONE 25-WATT INTEGRATED AUDIO AMPLIFIER. Manufactured by: Mission Electronics USA, Inc., 18303 8th Avenue, Seattle, WA 98148. Price: \$549.

For our money, one of the greatest cars ever manufactured was the MG-TF that came into this country for a brief couple of years around 1954. That little two-seat roadster was, perhaps, the archetype for all British sports cars. It was far from a luxury car, even for those days. The wood-framed(!) MG didn't even have roll-up windows—you had to stop and put up side curtains when you wanted that sort of protection from the elements. And a heater, as we recall, was an option (although everyone had one). The engine was a straightforward and easily accessible four-cylinder 1250-cc. (later, 1500-cc) design that always started, no matter what the weather. And for handling, the MG could not be equaled. It cornered like nobody's business, and even on snow and ice you always knew what was going on underneath you—you never, ever needed chains or even snow tires. It was a simple and honest car, and a joy to own and drive.

What's this paean to long-lost days of motoring doing here in *Gizmo*? Well, we recently had the opportunity to use for a while an amplifier manufactured in Britain by *Mission*, known best to date in this country for its loudspeakers. In design and performance this amplifier, the *Cyrus One*, reminded us a lot of our old MG. It is very plain, almost utilitarian, but it does the job it is supposed to, and does it well.

The *Cyrus One* is rated at 25 watts per channel. (There's also a *Cyrus Two* with an output of 50 watts per channel, boostable with an accessory power supply to 70.) "Big deal," you say, "I have a boom box with more output than that!" But wait—this is a solid 25 watts that the amplifier can *always* be depended upon to provide, under any conditions.

You see, it is a fact of audiophile life that speaker impedances vary all over the place according to the frequency of the signal



CIRCLE 50 ON FREE INFORMATION CARD

being fed to them. Thus, the impedance of a system whose rating is nominally eight ohms may drop as low as two ohms when reproducing certain sounds. That change in load is reflected to the amplifier, whose output is (theoretically) a constant wattage. That being the case, then (according to Ohm's law) when the load changes downward by a factor of four, four times the current that would be output into eight ohms must be delivered. That's a lot, especially at high volume levels, and many amplifiers are incapable of keeping up with the demands made as a result of such impedance changes. Their output and the dynamics of the music they are reproducing suffer, and the result is a "constricted" sound.

The power supply in the *Cyrus One*, though is designed to deliver up to 35 amps, no matter what! We put the amp through some pretty demanding exercises, including portions of the Charles Dutoit recording of Holst's *The Planets* and the Telarc recording of Tchaikovsky's *1812 Overture*—the one that once destroyed one of our woofers when the cannons went off. What a pleasure it was to listen to that material through the *Cyrus*! Even at the crescendos, there was no sense of audio

constriction, or of the amplifier straining. Such phenomena tend to make us cringe a little inside, but the *Cyrus One* allowed us to "just relax and let the music flow," as it has sometimes been put. It truly seemed to be an effortless performance on the part of the amplifier, and you could tell it. And 25 watts—an *honest* 25 watts—is nothing to sneeze at, believe us. The *Cyrus One* really delivers as promised.

Now for the "MG" part. The charcoal-gray front of the *Cyrus One* presents you with a not-very-impressive view—at least you could get an MG in colors like red and British Racing Green, with a little chrome here and there. On the *Cyrus One*, you see three knobs and a power switch. Two of the knobs are source selectors for listening and recording; the third is a large (the same size as the other two knobs) volume control with detents. A ring-type knob around the one for volume adjustment controls balance, but only to the degree of a 5-dB cut in either channel. No more. If your situation requires more than that, you'll have to make the fix otherwise. There's also a paddle-type power switch with a small red LED **POWER ON** indicator alongside it.

(Continued on page 4)

TURN PAGE FOR CONTENTS

This month in GIZMO®

Cyrus One 25-Watt Integrated Audio Amplifier	pg. 1
Casio TS100-IV World Time/Temperature Watch	pg. 2
Sharp UX-100 Facsimile	pg. 3
QuickShot Studio 4 Sound-Mixing System	pg. 5
Tele-Receptionist Electronic Secretary	pg. 6
Radio Shack HTX-100 10-Meter SSB-CW Amateur-Radio Transceiver	pg. 7
Remote Control	pg. 8
S-VHS Editing VCR	pg. 8
A/V Center	pg. 9
Cassette Deck	pg. 9
Communications Receiver	pg. 9
Portable Videogame	pg. 9
Basketball Game	pg. 10
Laptop Computer	pg. 10
Mobile preamp/equalizer	pg. 10
Round Radio	pg. 10
Harmon Kardon CD Player	pg. 11
Miniature Speaker System	pg. 11
Multi-Mode VCR/TV	pg. 11
VCR Head Cleaner	pg. 11
Car Stereo	pg. 12
Computer Monopoly Game	pg. 12
Sansui CD Player	pg. 12
Radar Detector	pg. 12
Videodisc Player	pg. 12

Master of Time and Space ... and Temperature

CASIO TS100-IV WORLD TIME/TEMPERATURE WATCH. Manufactured by: Casio, Inc., 570 Mt. Pleasant Ave., P.O. Box 7000, Dover, NJ 07801. Price: \$64.95.

It used to be that watches just told time. Then for a while they did almost everything else, too, including showing TV pictures and playing games and melodies. The wrist-TV is gone as, thankfully, seem to be most of the game- and music-playing watches (the mating calls of their descendants, though, can still be heard in public places such as movie theaters and concert halls, usually shortly before or after the hour). What we have these days are generally quieter watches. Their uncommunicative nature, though, belies a multiplicity of functions.

Serious clock- (or watch-) watchers, you may have observed, are never content with knowing the current time. They want to know, as well, what time it's going to be, and what time it was five minutes or an hour ago. Or even what time it was yesterday at this time. That's why they're always looking at their wrists, and then up at the wall, and then back at their wrists again. If there's no clock around, they read other peoples' watches upside-down. While knowing the precise time is important to him, the big thing in a watch-watcher's life is knowing what time it *isn't*. If his watch can tell him something else that isn't, as well, he's that much the happier. Casio's TS100-IV World Time/Temperature watch may be the answer to a watch-watcher's prayer. It tells not only what time it is—and was, and will be—but the temperature as well. It does some other things, too.

You cycle through the watch's modes by pushing a button (one of four) at the lower left of the watch's black plastic body. In the first mode you come to after the normal timekeeping one, the time display that fills the lower half of the LCD is replaced by what looks like another time display except that it lacks colons. It's a temperature display, and we'll come back to it. What interests us here is that in the upper right quadrant of the display, next to a world map, is now the three letter abbreviation for a city (it appears that many of these abbreviations derive from the three-letter combinations used to identify airports: LAX for Los Angeles, SIN for Singapore, and so forth). Below that appears the time in that city, or more properly, in the entire



CIRCLE 51 ON FREE INFORMATION CARD

time zone it represents. There are 23 such cities built into the watch. (You figure out which time zone is not included!) The time is shown only to the nearest minute, but that's probably close enough for most people. Pushing the upper-right or lower-right button allows you to cycle backward or forward through the time zones. Time, by the way, can be displayed in either 12- or 24-hour format, and there's an indicator for Daylight Savings.

The mode you come to after the one for world time/temperature is another temperature one, and after that comes an alarm display—displays, actually, since this watch allows you to set not one, not two, but *five* daily alarm times! After the alarm(s) you come to a presettable countdown timer with alarm, and then an up-counter (stopwatch) that can keep track of two separate events and whose display reads to a hundredth of a second. (Well, why not?) After that you get back to the regular timekeeping mode.

Now, when you get tired of seeing what time it *is/was/will be*, and how long it has been/will be between now and last/next time, you can go to one of the temperature modes and watch that for a while. Beneath the LCD is an inset silver button, which is the cap of a thermistor. Every two minutes—precisely on the even minutes (you can tell because the temperature display, which you can elect to show in place of the day of the week in the upper right-hand corner, winks)—the watch shoots a tiny blast of current through the thermistor, measures the resistance it encounters, and from that calculates the device's temperature which it displays—in degrees Fahrenheit or Celsius, of course. There's also a somewhat hard-to-read linear scale that gives you a rough idea of the tem-

(Continued on page 4)

Gizmo is published by Gernsback Publications, Inc., 500-B Bi-County Blvd., Farmingdale, NY 11735. Senior Writer: Josef Bernard. Contributing to this issue: Joan Chernok, Leah King, Elvira Segura-Langton, Mike Wilson. ©Copyright 1990 by Gernsback Publications. Gizmo is a registered trademark. All rights reserved.

The A Bare Fax

SHARP UX-100 FACSIMILE. Manufactured by: Sharp Electronics Corp., Sharp Plaza, Mahwah, NJ 07430-2135. Price: \$1299.99.

Well, it doesn't look as though the personal computer is going to become a fixture in every home as was once expected. Microprocessors, yes; computers, no. What we do see happening, though, is the proliferation of home and office facsimile devices. Not only do people *like* fax machines right off—which is a reaction rare among first-time computer users, terror being the more usual one—but they may even prove useful in every-day situations. (We have a strong suspicion that the current fax mania is due largely to the fact that people think fax works by magic—you put the paper in at your end and it squeezes through the phone wire and comes out the other. It's probably the thrill of working magic that accounts for fax's popularity more than its supposed superiority to overnight mail services.)

A popular scene in science-fiction stories of days gone by involved coming to the breakfast table and finding a freshly printed copy of your own newspaper, personalized to include only the topics in which you were interested. With a fax machine and a little computer (whoops!) technology, that scenario has already become a reality in some circles. And fax could very easily come to replace the mailman, and other deliverers of paper, as well. A telephone without a fax machine might be as rare in the future as is a telephone without pushbuttons, today.

Fax machines, however, are not cheap (so far); list prices start above \$1000. Those prices are inflated, of course, and fax machines can be found discounted for \$600 or so. That puts them in the same class of affordability as personal copiers, which are now found in many home-office situations. If you can justify the expense—or just like to watch the magic happen—you can have your own fax pretty easily.

Which brings us to the subject of this report, the *Sharp UX-100* facsimile. By cutting back on the frills that might be considered indispensable in an office situation, Sharp has produced a light-duty machine intended for home or very-small-business use.

The purpose of facsimile is to transmit or receive in a hurry material that has to be seen to be believed. (In other words, a picture is worth a thousand words.) The UX-100 does that, and does it well. It offers three modes of resolution: standard, fine, and halftone. Either one of the first two can be programmed as the default mode. The standard mode is the "15-second" one quoted in ads; the others take

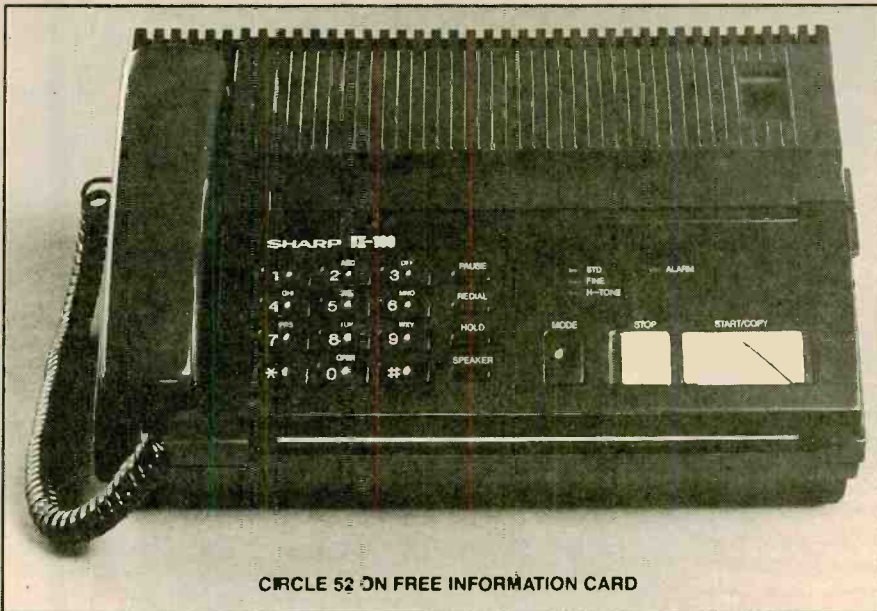

CIRCLE 52 ON FREE INFORMATION CARD

longer because as more detail is transmitted more time is required. The halftone mode can reproduce sixteen shades of gray (counting, of course, black and white) at a resolution of 196 dots-per-inch—better than many magazine photographs. A fax consisting of mixed text and pictures is a little difficult (but not impossible) to read when that mode is used, but the images come through very well, indeed.

When not engaged in faxing, the UX-100 can double as a photocopier. That assumes, of course, that you will be satisfied with copies produced on thermal paper and that you will restrict yourself to copying only things that can be ingested by the unit—in other words, single pages. Books, magazines, hands, or other three-dimensional objects won't fit into the slot. Sharp does supply, though, a carrier sheet that can be used to run documents much smaller than the standard 8½ × 11 sheet size through for copying or faxing.

Despite its position at the bottom of Sharp's facsimile-machine line, the UX-100 is more than a bare fax. It does include a few convenience features. Among them are a five-page document feeder and a built-in phone. The phone itself has a few nice touches, such as on-hook dialing (you can listen to the dialing and answering process through a built-in speaker) and a HOLD button. While the phone offers a last-number-redial feature, there is no other memory—you cannot recall frequently used fax numbers with the touch of a key or two. That's a strange omission, since it is not a particularly expensive feature to realize these days. Also included is the ability to add a 22-character answer-back message (such as "This is Gizmo") and your fax-line phone number on each outgoing page. There's no provision for time-and-date stamping, however.

On the back of the unit are two RJ-11 modular phone jacks. One accepts the ca-

ble that connects it to the phone jack in your wall. The other is intended for ... well, we're not sure what its purpose is. According to the manual—which is, we understand, starting to undergo a badly-needed rewriting—that jack is for an extension phone. Why you would want to use an extension phone with a unit that already has a phone built in, or would wish to run a length of cable from that jack to a phone in another room, we don't know. Furthermore, the manual states that an extension phone should not be used (or won't work) in certain of the unit's auto-answer modes. There is a single passing reference to an "answering machine" function in connection with that jack. We called Sharp about it, since it would have been nice to have a phone, a fax, and an answering machine all on a single line. It turns out that an answering machine *should* (and in our case did) work from that jack. It also turns out, however, that some machines won't—and it seems that Sharp, being overly cautious, simply made the assumption, on the part of the user, that *none* would.

The machine also has a *Touch Tone*-sensitive system that allows you to switch from voice to fax by pressing two keys. That is usable, according to the manual, from the extension phone plugged into the jack in question, permitting you to pick up a call on the extension, and then switch over to the UX-100 to receive a fax. It turns out, though, that, subject to the whims of your local phone system, that function can also be called from other phones in your home or office that are on the same line as the fax, even though not connected directly to it, and maybe even from a remote phone. Theoretically, at least, that would permit you to instruct a caller, via your answering machine, to leave you a voice message and then punch two digits on his phone and leave a fax. It worked for us, providing a sophistication of operation we

would not have expected in a bare-bones machine.

Among the features the UX-100 does not offer are such things as the ability to auto-feed more than five pages at a time, to place calls unattended (say, late at night to take advantage of lower phone rates), or to cut its roll of thermal paper into sheets at the end of each page. You have to do the tearing manually. Thoughtfully, though, the machine prints a dotted line at the end of each page to guide you in your tearing, in case you don't rip off each page as it comes in and so wind up with a long scroll. We also missed having some kind of indication that the fax connection, once having been established, was still in effect. There are sometimes long pauses when nothing happens and you begin to wonder whether the other machine (or your own, for that matter) has hung up on you. There are some who, without that kind of reassurance, would hang up and try again ... in the middle of a perfectly normal fax session! We feel, though, that none of these omissions—except, maybe, the last—is serious in a machine intended for personal rather than heavy-duty day-in and day-out business use.

On one more point, though, we must take Sharp to task. While the print mechanism and user keypads seem to be well constructed (the keypad uses real pushbutton switches, not the membrane type, and has a very good positive feel) the plastic case and associated parts are unacceptably flimsy. Our review unit came through with one of the hinges on the paper-roll cover broken, and we had a difficult time making the wire support of the document feeder stay in its plastic clips. If, though, you need only a light-duty machine, that factor may not disturb you. After all, the UX-100 does what a fax machine is supposed to do, and it does it pretty well. ■

CYRUS ONE

(Continued from page 1)

At the rear of the unit are jacks for the banana plugs used for speaker connection (Mission supplies screw-on plugs for your speaker cable) and RCA-type input jacks. The Cyrus One can accept moving-coil or moving-magnet phono cartridges. The manual supplied with the amplifier needs a good going over, but if you have attained the level where you can appreciate the capabilities of the Cyrus One, you'll encounter no difficulties with the instructions.

The Cyrus One has no bass, treble, loudness, or other contouring controls. Nor does it have a CD-DIRECT switch. Many amplifiers and receivers of recent manufacture incorporate such a switch, which permits you to bypass all the extra signal processing (bass, treble, loudness, etc.) and conduct the signal from the CD player to the amp by the most direct route, to reduce distortion and attenuation. The

Cyrus One doesn't need a switch for that purpose, since it was designed using what Mission terms "straight-line signal paths" and has nothing to bypass—*everything* is "CD direct" ... or "tuner direct" or "phono direct." If you want some sort of compensation you'll have to add an equalizer in one of the tape loops, although we suggest you avoid doing so.

What impressed us most—and it was an overwhelming impression—about this amplifier was the effortless way in which it performed. Most amplifiers, even those with a few dB of "dynamic headroom," start to strain when called upon to show their stuff in a pinch. You can almost see them wince and try to cover their heads as they struggle to keep up with the demands of the music. The end result is a kind of musical muttering (which your amplifier does to fool you into thinking it's delivering its full output) that all too frequently muddies the sonic waters.

You can tell that the Cyrus One doesn't have that problem. No matter what we asked it to reproduce—the last movement of Beethoven's *Ninth Symphony*, the crescendo with the organ in the *Mars, Bringer of War* movement of *The Planets*—ours took it all in stride, without ever breaking into a sweat. While the cabinet got a little warm after a bit of that treatment, it was barely so, and the amp ran much cooler than most others would have. To be honest, we were scared (for our speakers) to open the Cyrus One up all the way—the output with the volume control near its midpoint was about as much as we could stand.

The availability of ample power whenever it was needed, coupled perhaps with the unit's "straight-line signal path" design, allowed us to hear things on our CD's that we hadn't been aware, or had barely suspected, were there. Our speakers delivered highs we hadn't known they were capable of reproducing, and the same can be said for the other end of the spectrum. Our old amp just mumbled when called upon to reproduce these sounds; the Cyrus One delivered! We should add that the availability of power does not necessarily equate with volume of sound. Even at relatively low listening levels, the difference between the Cyrus and our more conventional amplifier was apparent: at higher ones it was extraordinary.

Mission's amplifier is certainly not for everybody. But then, neither was the MG in its day. If you wanted a car to take the kids to school and run down to the supermarket, you bought a Chevrolet. If you wanted handling (and just plain fun), you bought an MG. It wasn't fancy and it didn't do a lot but what it did, it did very well. If you want plenty of controls and flashing lights, buy an amplifier from the Orient. If you want sound reproduction that will make you weep for joy, try the Cyrus One. ■

CASIO WATCH

(Continued from page 2)

perature and is always displayed, no matter what mode you are in.

Because the thermistor is built into the body of the watch, the temperature it measures is largely dependent on that of the watch case. For that reason, you can switch between OFF-WRIST and ON-WRIST modes. The first gives you a straight temperature reading while the second supposedly factors in a correction component for your body temperature, which would, of course, affect the watch temperature. You have to make sure the thermistor gets plenty of air; otherwise, if it gets trapped under your shirtsleeve for example, the readings that will be displayed will be considerably off.

Since this is a *world* watch/thermometer, it also displays the temperatures in those 23 cities whose times it can show. Unfortunately, it's not as easy to know what temperature it is in, say, Bangkok at 11 in the morning as it is the time, so Casio has provided the next best thing. Built into the watch's ROM is high-temperature/low-temperature data for each of the cities for each month of the year, as compiled from information gathered during the years 1982–1986. That time-like mode—without the colons—that we mentioned earlier shows you high temperature, low temperature, and month, with the time thrown in as a bonus.

And, hold on, there's one more function to go. The next stop on the "mode cycle" after the "high-temperature/low-temperature" one brings you to a large two-digit temperature display. At the upper right of the display is the word "LOC" (local) and the time rounded off to the nearest previous hour (9:00, 10:00, 11:00, etc.). This watch, see, records the temperature in a 24-hour log every hour on the hour. You can cycle backward or forward again through the last 24 hours to see how it varied. As a new temperature is recorded, it erases the previous entry.

The TS100-IV has a couple of other neat, if less spectacular, features. If you hold any of the buttons down, an auto-repeat function comes into play, allowing you to run through times or temperatures, or anything else, without having to push that button repeatedly. In addition, while you cycle through the watch's modes by pressing the lower-left button, if you stop in any mode and do anything there by pressing another button, the next press of the MODE button brings you back to the timekeeping display. That had us puzzled for a while, but we finally figured it out. Finally, this watch is waterproof, or as Casio puts it "water resistant." Ours supposedly would keep running down to a depth of 100 meters (300 feet). We didn't get that far, but it did hold up nicely in the shower. ■

A Little Mix-Up

QUICKSHOT STUDIO 4 SOUND MIXING SYSTEM. From: Bondwell Industrial Company, Inc., 47485 Seabridge Drive, Fremont, CA 94538. Price: \$79.95.

What do you give a teenage niece for a birthday present? A good question, and one that has caused us much anguish over the years. A few years ago we got lucky and sent her a batch of blank audio cassettes. No complaints were heard and we repeated the gift the next year. The year after that, seeking a change, we tried something different and got a rather lukewarm response. We've gone back to tapes. We have no idea what she does with them all, but they seem to make her happy.

We presume that we are not alone in our experience and that millions and millions of blank cassettes wind up in the hands of adolescents every year. And, presumably, those kids use all of that tape to record music—from the radio, from their friends' records and tapes, maybe even live, for all we know—to play back on their own personal portable tape systems. Lucky kids have—or have parents who have—dubbing decks, with everything they need to make high-speed copies of friends' tapes. Other kids are not so fortunate, and may have to be satisfied with their parents' single-well Nakamichi Dragon and a second recorder to make the dub.

Sensing that burgeoning area of kiddie deprivation, the *QuickShot* division of Bondwell (that name is now reserved for the company's higher-end electronics products, such as computers) has leapt to fill the gap with a kid-size mixing deck it calls the *Studio 4*. (There's also a monophonic version, the *Studio 2*, for about twenty dollars less.) It's not fancy, and it's certainly not going to replace Dad's Nakamichi, but it has stuff that kids will appreciate more than they would a self-aligning azimuth mechanism, or automatic bias settings with manual fine tuning.

Mostly, kids don't care too much about those things. The *Studio 4* gives them what they'd rather have: stuff like sound effects, a microphone, and built-in speakers so they can sing along with the music or play disk jockey when they're not busy ripping off other kids' tapes. And, of course, there's a stereo tape deck.

To begin at the beginning, the *Studio 4* operates from four "D"-size dry cells (not included). That, together with the shoulder strap that is included, makes it eminently portable and allows the kids to take their noise anywhere their intuition tells them it will cause the most nuisance. For stay-at-homes, there's a 6-volt wall-plug DC converter.

The tape section of the *Studio 4* does what's required of it, and nothing more.



CIRCLE 53 ON FREE INFORMATION CARD

There's no noise reduction, and the record/playback electronics seem set for good old Type I, low-bias, ferric-oxide formulations. We doubt the kids will care. There's also no output jack; you can listen through the 2½-inch speakers built into the sides of the unit, or through the open-ear headphones that come with it. (Thank you for that, *QuickShot!*) Watch out for those headphones, though—the way the cord is cut it will strangle you if you have an average-size head and don't open up the phones all the way before trying to put them on. Because of the unit's lack of output jacks, if the kids want to listen to their mixdowns on higher-end equipment they'll have to remove the tape to another deck and feed in the audio from there.

Speaking of mixdowns, there are five slide-pot controls on the face of the cabinet. The first four of those faders control, from left to right, the levels of the microphone, the auxiliary input (which is where you plug in the "playback" tape deck when making copies), the effects generator, and the built-in tape deck. The mike input and the effects are monophonic. The right-most pot is a master level control that adjusts the overall level of the mix. There is a crude SOUND LEVEL indicator that seems to be built around a small incandescent bulb that's either on or off. If you set the level just so, you can make it flicker. The slide pots are functional over only about the bottom quarter of their range. After that they're "full on" and moving them further serves no purpose. The portion of their travel over which they have any effect is so small as to render them extremely sensitive (over that limited range) and very tricky to use.

We suspect that the part that kids will most enjoy about the *Studio 4* is its effects generator. Eight sound effects are available, each controlled by a single button. Those effects are labeled: SCAN UP, SCAN DOWN, JET, BOMB, ROCKET, LAZER [*Sic*], GUN, and ALARM. None of them sounds the way its label would lead you to believe—the jet sounds more like a World War II buzz bomb (and when used in short bursts, like a Bronx cheer)—but they are lots of fun to interject into the music.

We didn't measure the *Studio 4*'s signal-to-noise ratio, but our initial impression was that it was only about 16 dB or so. Tapes made and played back on the unit were very, very noisy—they sounded as though they had been made while standing under a waterfall. Remember, this unit is "optimized" for ferric-oxide formulations and lacks noise reduction, to boot.

Curiously, when we played one of the noisy tapes on our big cassette deck the noise, while still noticeable, appeared to be much less than we originally thought. It's our guess that the *Studio 4*'s electronics and its itty-bitty speakers have a lot to do with the phenomenon. Anyway, given the type of material that will probably be recorded—chamber music is certainly far down the list—we suspect that the flaw will never even be noticed.

Despite ourselves, we were kind of impressed with the *Studio 4*. It's the sort of toy we would have coveted in our youth—these days we set our sights higher, on bigger and more expensive ones. We do have some reservations about the price/value ratio, but they certainly built in enough potential for fun! Wish they'd thought to include a pan pot. ■



CIRCLE 54 ON FREE INFORMATION CARD

"I'm Sorry, He's Gone to China for the Afternoon"

TELE-RECEPTIONIST ELECTRONIC SECRETARY. Manufactured by: News Media Services, Inc., 1615 N. Wilcox Ave., P.O. Box 4110, Los Angeles CA 90078. Price: \$379.

One of the signs that you're getting somewhere in the business world is that you no longer have to answer your own phone. It impresses people when they know you can pay someone to do that for you, to screen your calls, and take messages. Not everyone can afford that luxury, though. For many small businesses—one or two-person operations, for example—it's more important to pay the rent. For those who would hire a receptionist if they could, but can't, there's now an electronic solution.

Tele-Receptionist is the product of a small company called *News Media Services*. The idea behind the device is a clever one. The unit contains circuitry to digitize speech and to store it in its internal 256k bytes of solid-state memory. Entering a one- or two-digit number from the built-in keypad calls up a particular phrase or message—a total of up to 48 seconds' worth can be stored, depending on the version—and plays it back. If the phrases

you store are of the proper kind, and your fingers are nimble enough, you can make your *Tele-Receptionist* answer the phone for you, screen your calls, and (appear to) take messages.

The unit is small, about 5¼ by 6 inches square, and is intended to sit on a desk alongside or near your telephone. You plug it into a modular phone jack (a cable for that purpose is attached) in parallel with the phone you normally use. Power comes from a small wall-plug AC transformer, also supplied. There's no power switch or POWER ON indicator, a style that seems to be growing into a trend, and of which we do not approve—you should always know in what state your Gizmos, big or little, are. (The same disaffection holds regarding those wall-plug transformers and AC-to-DC converters, which are always on, always run hot, and present a continual ... but that's for another time.) A built-in, and rather inaccessible, battery in the *Tele-Receptionist* can keep your stored messages alive for a number of years (in case, we guess, you accidentally kick the wall-plug transformer out of its socket) and *that* circuit for some reason has a switch.

Programming the *Tele-Receptionist* is not particularly difficult once you get the hang of it. The first thing you have to do is plug a phone into the modular jack provided on the unit's back panel. That jack is used only during programming, and sits empty and idle the rest of the time. Taking the phone off-hook does two things—it provides one step in the programming-enabled process, and it lets you use the phone's mouthpiece as the speech-input device. That's the only way you can get

your data in, so you'd better use the best-sounding phone you can get your hands on. The quality of the stored digitized speech is not up to even phone-company standards, and it needs all the help it can get. (You may want to include an apologetic message that says something like, "I'm sorry for the way I sound, a steam-roller ran over the phone this morning.")

Pressing the FLASH and I keys on the keypad, followed by the two digits representing the message number you assign, sets the unit up for recording. Then, for as long as you hold down the 0 key, it will store the message you—or somebody with a sweeter voice than yours—speak into the phone connected at the rear. You recall a message by pressing its two-digit memory number, at which time it is played instantaneously—one of the benefits of using random-access memory instead of a system such as tape.

To help you add to the illusion that someone is answering your phone for you, there's a button on the keypad marked RING. After you have the canned voice say, "Hold on, I'll see if he's in his office," you can press that button a couple of times to give the party at the other end the feeling that he's hearing your intercom buzzing. You can't record that effect; it has to be provided anew each time.

A typical session might go like this (the voice of the *Tele-Receptionist* is shown in bold type):

Ring, ring, ring ...

Mr. Firefly's office.

May I speak with Mr. Firefly, please?

One moment, I'll see if he's in (you push the RING button) ... ring, ring ... I'm sorry, Mr. Firefly seems to be out of the country at the moment. Can he call you back?

Yes, please. Ask him to call ...

You never have to pick up the phone, but can monitor the conversation through the unit's tiny built-in speaker and press the appropriate-response buttons.

For some reason, the *Tele-Receptionist's* built-in programming tells it to hang up ten seconds after it has delivered a message if nothing else happens. Good for saving on line charges, we suppose, but potentially a source of embarrassment. Fortunately, you are allowed to program what is called a "hold time" for each message. That is the length of time that will be allowed to pass (and the amount of time, presumably, that a caller has to speak his piece) before hangup occurs. Periods can range from a long 99 seconds down to one second, the last being the equivalent, we guess, of slamming the phone down into the cradle.

The *Tele-Receptionist* also has an AUTO ANSWER mode, in which it will answer the phone after a specified number of rings (between two and nine), deliver one of your programmed messages, and then

(Continued on page 8)

QST ("Attention all radio amateurs")

RADIO SHACK HTX-100 10-METER SSB/CW AMATEUR RADIO TRANSCEIVER. Manufactured by: Radio Shack, One Tandy Center, Fort Worth, TX 76102. Price: \$259.

You may never see this again—a piece of ham-radio equipment reviewed in *Gizmo!* However, there are several circumstances that make a look at such a product right now especially appropriate. The first is the manufacturer: *Radio Shack*, a company that is becoming increasingly involved in two-way communications. Of course, Radio Shack has been selling CB equipment for years, but a look at the current catalog shows not only that, but also such items as two-way marine radios and cellular telephones. Not to mention the *HTX-100* ten-meter amateur-radio transceiver.

The ten-meter amateur band, spanning the frequencies between 28 and 30 MHz, is generally considered to be the highest of the amateur HF (high-frequency) bands. Its characteristics vary from hour to hour, season to season, and even year to year (more about that shortly). At its worst, ten meters is strictly for local, ground-wave, communications whose effective range is perhaps 30 miles at best—much like what's theoretically expected on the neighboring Citizens' Band down at 27 MHz. At its best, ten meters' propagation characteristics make it a DX-er's (long-distance aficionado) dream. When ten meters is "open" you can work the world with just a couple of watts and a wet noodle, as more than one ham has been heard to note.

One of the conditions that governs the effectiveness of ten-meter communications is the 11-year sunspot cycle. As the cycle approaches its peak—that is, as the number of sunspots increases—so does DX on ten meters. The band opens early in the morning and stays open for a good part of the day, and there is a frenzy of activity in what is in other years a completely dead part of the RF spectrum. This year will see us at about the peak of the current sunspot cycle, and quite a peak it is expected to be, too—promising perhaps the best conditions since the beginning of amateur radio. Conditions are certainly expected to be at least as good as those of 1957-58, when they were, well, fantastic. This is a good time to be up on ten meters.

The final reason is that now, after many years, holders of Novice Class licenses, the easiest class to obtain, have both CW (Morse code) and phone (voice) privileges

on ten meters. To many a beginning ham, that, with band conditions being the way they are, is equivalent to opening the gates of Paradise. Novices are not known for their financial well being, and the availability of a "rig" at the price of the HTX-100 makes Paradise that much more attainable for them.

We (as well as most of the rest of the amateur-radio community, we suspect) were initially aghast when we saw a ten-meter transmitter/receiver in the Radio Shack catalog—*Radio Shack*, where Chicken Banders (one of the nicer names by which CB'ers have sometimes been known in the ham community over the years) buy their stuff. There has been animosity between hams and CB'ers right from the start of the Citizen's Band service—first because CB took away what had formerly been the amateur-radio 11-meter band, and second because in its heyday (and probably even today, in some places) CB was notorious for sloppy and illegal operating procedures. A number of people who chose to use the CB frequencies thought nothing of doing so with amateur-radio equipment (illegal), too much power (illegal), and without a license (illegal). Some of those operators even decided that the CB frequencies were not enough for them and encroached on ham territory—the bottom of the ten-meter band. Little wonder that CB got such a bad reputation in so many circles (and in the confusion some of it was even passed on to undeserving hams)! Seeing a ham rig suddenly pop up in Radio Shack stores all over the country probably made a lot of hams suddenly very suspicious.

You don't need a license to own or listen to a piece of amateur-radio equipment, but you do need one to transmit with it. (We checked with several local Radio Shack

stores and were told that we would not have to show them a license to purchase the HTX-100.) However, Radio Shack has tried to cover itself against misuse of the unit—and it seems a sincere effort, not just another token attempt at discouraging illegal operation—with warnings and precautions in its catalogs and in the instruction manual for the transceiver itself. There's even a sticker warning against transmitting without a license affixed to the top of the HXT-100's case. Let's hope the efforts work.

Now for the rig itself. It's not fancy, but it seems to do the job and even contains a few "luxuries." For instance, the tuning on the SSB/CW rig is digitally synthesized, allowing you to dial up a specific frequency with ease, and the tuner contains ten memories that you can use to store often-used frequencies. There's also a scuech control to cut interstation and no-signal noise—something no real ham would be caught dead using. Iest he miss a weak station as he was tuning past! We suspect that the design for the HTX-100 was derived from that for a CB transceiver, and that is one of the things that drifted over from there.

The rig's wideband output stage requires no tuning to resonance; all you have to do is find a clear frequency and let loose. Output power is switchable between 5 watts and 25 watts. Metering is provided by a string of five red bar LED's—the more of them that are lit, the greater the signal strength of the station to which you're listening, or the higher your output power. Calibration is in S-units only; the power reading is arbitrary. A small, bottom-mounted speaker provides adequate, albeit somewhat tinny, audio.

Tuning is accomplished with a large—relatively speaking—knob, or from a cou-



CIRCLE 55 ON FREE INFORMATION CARD

ple of buttons marked UP and DOWN on top of the microphone that's supplied with the rig. You can tune in increments of 0.1, 1.0 or 10 kHz, selectable in rotation by pressing a switch marked STEP, or in giant leaps of 500 kHz. If you are in the MEMORY mode, having chosen one of the ten locations as a starting point, you can tune continuously from the front-panel knob, but the UP and DOWN buttons then serve only to walk you through the memories, not up or down the band as you would expect.

We had some difficulties in adjusting to that incremental tuning system, perhaps because we're accustomed to one that feels more like an analog one. We found the 0.1-kHz steps to be too small and the 10-kHz ones to be too large. The 1.0-kHz steps seemed to get us where we wanted to go at about the right speed, but at the risk of coming to rest a few hundred hertz away from the exact frequency we wanted to be on. That then required switching to either 0.1-kHz steps or, most of the time, using the receiver's RIT (receiver incremental tuning) control, which is analog. We found ourselves passing by signals that might have been interesting because it was too much of a nuisance to stop and fine-tune them into intelligibility.

While the receiver has an RF GAIN control to prevent very strong signals from overloading it, there was no way provided to control the audio level of the outgoing signal. That did not prove to be a source of

difficulty—we just watched the RELATIVE OUTPUT meter and adjusted our distance from the mike or voice level accordingly. We generally got good reports on our audio, although one station, when prodded, replied that it sounded like it was "almost on the edge" of distorting.

A final comment on the HTX-100: Until we got it, we didn't know it was a mobile rig intended to be powered by your automobile (Radio Shack includes a fused four-foot cable for that purpose, as well as a mounting bracket). If you run it as a fixed station, you need to come up with a 12-volt supply capable of outputting at least six amperes (if you're going to use the rig in its 25-watt capacity). The largest power supply that Radio Shack sells puts out 2.5 amps—perhaps you can run three of them in parallel. We were lucky—we had a big homebrew 10-amp supply lying around.

For the Novice—or even for the ham who has spent his operating life so far up on line-of-sight VHF and has just now decided to see what it's like to talk to stations over the horizon—the HTX-100 could be the start of something big. Sure, it lacks a lot of the conveniences that are common on lots of ham equipment these days—dual-slope IF filters, notch filters, variable-bandwidth AM and CW filters, digital signal processing, and other such doodads—but it does have what you need to get on the air ... and, after all, that's what counts. ■

TELE-RECEPTIONIST

(Continued from page 6)

hold the line for up to 99 seconds. If you are frequently far enough away from the phone that it takes you a bit of time to get to it, you can use that feature to answer for you and request the caller to wait for you to arrive.

You can also use it to turn the device into a short-term answering machine, perhaps to tell callers that you've gone for a short walk and will be back in ten minutes, or whatever. That can save wear and tear on your regular answering machine. Just remember two things: Set the Tele-Receptionist to answer after fewer rings than your regular TAD requires, and educate your callers to the fact that they'd better try again in a little while because they can't leave you messages that way. Incidentally, there's no switch for enabling or disabling the AUTO ANSWER feature—you have to reprogram the Tele-Receptionist to do so, a slight inconvenience.

News Media Services also suggests that you can use the Tele-Receptionist as a family message exchange by leaving a phone plugged into its rear-panel jack all the time and using this phone to program messages for Mom, Dad, Junior, etc. Each member of the family can have his own set of message numbers reserved for him so he knows which ones to check. We'll stick with pencil and paper. ■

ELECTRONICS WISH LIST

For more information on any product in this section, circle the appropriate number on the Free Information Card.



Hitachi S-VHS Editing VCR

Editing VCR

The *Studio Edit VT-S730A* is an S-VHS VCR from Hitachi (401 W. Artesia Blvd., Compton, CA 90220) with a number of features to facilitate tape editing. Besides using the S-VHS format and VHS Hi-Fi sound for state-of-the-art video and audio recording and reproduction, the unit includes such editing enhancements as a jog-and-shuttle dial, title and date recording, tape-time-remaining bar display, double VCR control, and a feature called "synchro edit," which enables synchronized operation of two VCR's during transfers. All functions, including jog-and-shuttle and assembly editing, can be controlled from the unit's remote control, which also contains instruction sets for controlling late-model TV's made by ten other manufacturers. Price: \$1199.95.

CIRCLE 56 ON FREE INFORMATION CARD



Mitsubishi Remote Control

Minimalist Remote Control

Owners of Mitsubishi (5757 Plaza Drive, P.O. Box 6007, Cypress, CA 90630-0007) TV's up to four generations old—the TV's, not the owners, that is—now have available to them a remote control whose size and shape—about that of a fat ballpoint pen—offer convenience and transportability in a simple-to-use package. The company's PRM-1 "pen" remote operates the basic functions—power, volume, and channel selection—of all Mitsubishi televisions. Intended as an alternative to its full-featured remotes, the PRM-1 provides users with the convenience of simple remote-control operation, perhaps as a "second" remote, at an affordable price. Power is provided by a pair of replaceable "N"-size batteries. Price: \$24.95.

CIRCLE 57 ON FREE INFORMATION CARD

For more information on any product in this section, circle the appropriate number on the Free Information Card.

ELECTRONICS WISH LIST

Olde-Time Cassette Recorder

As the first step in developing an entire single-well cassette-deck line, *Vector Research* (1230 Calle Suerte, Camarillo, CA 93010) has announced the introduction of the *VCX-255*. This model, says Vector, reflects an old-school, hi-fi-enthusiast mentality. The *VCX-255* features an aluminum front panel, a RECORD BALANCE control, and has a FINE BIAS adjustment for "tweaking" of the bias current to match it to the tape being used. The mechanical-assist soft-touch mechanism is said to use heavier-than-usual flywheels and a special high-torque motor, reminiscent of the early days of hi-fi. Price: \$179.

CIRCLE 58 ON FREE INFORMATION CARD

A/V System

Kenwood Electronics (2201 E. Dominguez St., Long Beach, CA 90810) has put just about everything you could conceivably need in an A/V system all together in its *Spectrum 7080AV* package. The *DA-128* integrated amplifier puts out 125 watts per channel, and includes a seven-band graphic equalizer and dual video-sound inputs. The *KT-58* digitally synthesized tuner allows for 20 station-presets and offers both manual- and automatic-tuning modes. A *KX-68W* dual-well cassette deck makes possible high-speed dubbing with full logic computer-controlled tape movement and Dolby B noise reduction. A CD player, Kenwood's *DP-48 CD*, offers 4x oversampling with dual 16-bit D-to-A converters. A 27-inch *KMT-3327* video monitor provides over 500 lines of horizontal resolution. The video receiver offers MTS stereo and SAP decoding, as well as a simulated-stereo mode and has an S-video input. Finally, a pair of *JL-980AV* three-way speaker systems offer a power-handling capacity of 180 watts. Price: \$2550.

CIRCLE 59 ON FREE INFORMATION CARD

Portable Color Videogame

"A complete traveling arcade" is the way *Atari* (1196 Borregas Blvd., Sunnyvale, CA 94088-3427) describes its *Atari Portable Color Entertainment System*. The one-pound portable unit, which is slightly larger than a videocassette, has a built-in 3.5-inch color LCD screen with a resolution of 160 by 102 pixels. The screen can display up to 16 colors at a time, chosen from a palette of 4096 colors. Controls include an eight-way joystick that moves the main character of a game in all directions, as well as two FIRE buttons and five "function" buttons. The images on the screen can be rotated 180 degrees to allow both left- and right-handed players to play at their best. Games feature four-channel sound, and there is a headphone jack so that players can enjoy all the sound effects without disturbing others nearby. A unique feature of the system is its capability to provide each player with a first-person view of the action. For example, in a two- (or more) player auto-race game, if the second car is approaching the lead car, the lead car becomes proportionally larger on the second player's screen. When the second car actually passes the first, the first car then sees the second car ahead of it. Each driver views the race track from the perspective of his car. Up to eight units can be linked by connecting cable for increased competition and multi-player challenges. Price: Under \$150.

CIRCLE 60 ON FREE INFORMATION CARD

Portable Communications Center

SWL's, and anyone else with an interest in global communications—and a fat wallet—will want to get their hands on *Sony's* (One Sony Drive, Park Ridge, NJ 07656) *CRF-V21 Visual World Band* radio. The 21-pound portable operates from rechargeable batteries or from house current and covers "a vast range" of long- and short-wave frequencies. Among its numerous features are: 350-station memory, a clock/eight-event programmable timer, priority tuning to avoid missing broadcasts, an LCD spectrum monitor, and a built-in thermal printer that can output radio fax and RTTY messages, or satellite images, unattended. The printer can also provide hard copy of any of the many displays (station activity graphs, scan settings, options, etc.) of which the LCD is capable. An 8-pin mini-DIN connector outputs data in RS-232C format for use with computers. Price: \$6500.

CIRCLE 61 ON FREE INFORMATION CARD



Vector Research Cassette Deck

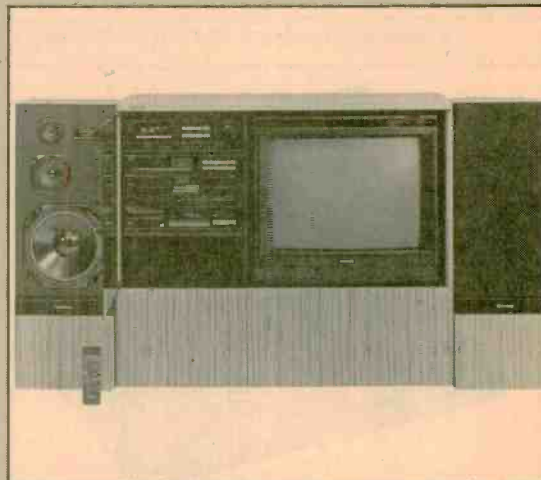

Kenwood A/V Center



Atari Portable Videogame

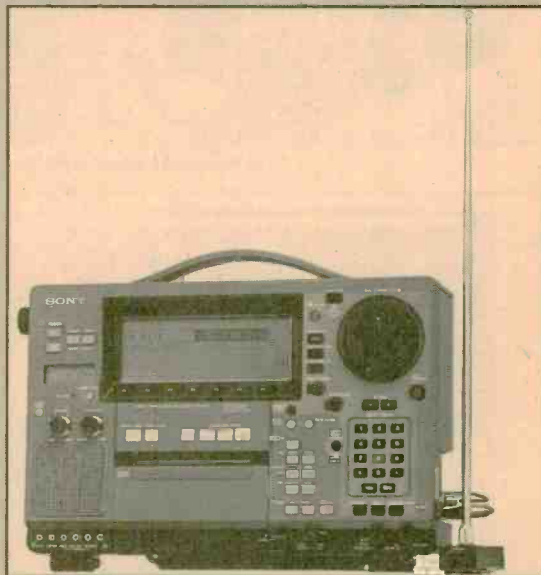

Sony Communications Receiver

ELECTRONICS WISH LIST

For more information on any product in this section, circle the appropriate number on the Free Information Card.



Alphasonik Mobile Audio Preamp/Equalizer



Bondwell Laptop Computer



Fun Products Round Radio



Express Yourself Basketball Game

Mobile Audio Preamp/Equalizer

With features not usually found on car-stereo preamp/EQ combos, the P-2 preamplifier/equalizer from *Alphasonik Inc.* (701 Heinz Ave., Berkeley, CA 94710) is designed for ruggedness and reliability. The 1/2-inch-high unit features five adjustable EQ controls, which permits it to operate in a fashion similar to that of a parametric equalizer. Each band of equalization has switches that allow for 12 different center frequencies and work in 1/3-octave increments. The preamplifier section of the P-2 has a front-rear fader, balance, and volume controls. Inputs for tape and CD, each with adjustable sensitivity controls, are available on the back panel. The device uses a switching power supply to isolate the chassis ground from the audio ground and to improve dynamic headroom by allowing the use of higher voltages. A switch on the volume control can be used to control the entire audio system. Front-panel backlighting is switchable between amber and green to match that of your car. Price: \$300.

CIRCLE 62 ON FREE INFORMATION CARD

Lightweight Laptop

Weighing only 8.5 pounds and measuring just 13 × 12.2 × 2.2 inches, the B310 laptop computer from *Bondwell Industrial Co.* (47485 Seabridge Drive, Fremont, CA 94538) is said to be one of the smallest, lightest, and most powerful 80286-based laptops on the market. The B310 uses a low-power 12-MHz 80C286 microprocessor running with no wait states to yield performance equivalent to that of a 16-MHz AT. The computer includes a high-contrast, non-glare, supertwist LCD display; a megabyte (expandable to 2 Mb) of RAM; a 1.44-Mb, 3.5-inch disk drive; and a 40-Mb, 25-ms hard-disk drive using a 1-to-1 interleave factor for speed. Two serial ports, one parallel port, and a real-time clock are built in. Operation is from a removable rechargeable battery pack or from the AC adapter included with the unit. Software supplied with the computer includes MS-DOS 3.3 and GW BASIC 3.22. A soft carrying case and spare rechargeable battery pack are among the accessories offered as optional extras. Price: \$3695.

CIRCLE 63 ON FREE INFORMATION CARD

Round Radio

Looking for the next wave in radios? How about *Switch-It*, an AM/FM receiver in a clear-plastic spherical shell with speaker and headphone adapter, and multi-colored internal components? The strap—by which you suspend the radio from around your neck—doubles as an antenna. The radio, which its marketer, *Fun Products* (2397 Shattuck Avenue, Suite 201, Berkeley, CA 94704) calls a "Boom Ball," operates for about 40 hours from two "AAA"-size cells and is the size of a racketball. According to its manufacturer, *Switch-It* took three years to develop. Price: \$39.95.

CIRCLE 64 ON FREE INFORMATION CARD

Electronic Basketball

When things get slow at the office, here's something that will pick them up without contributing a single thing to productivity or profits. *Hero Hoops* is an indoor basketball game that includes a 90-second LED timer and score keeper. Its manufacturer, *Express Yourself* (1800-A Associates Lane, Charlotte, NC 28217), is the same company that recently brought you a noisy little gadget for frustrated drivers called the *Revenger*. A built-in speaker in the *Hero Hoops'* backboard produces a constant background of cheering, as well as comments ("Score," "Two points," "Good shot") each time a basket is made. There's a RESET switch, as well as a MUTE button for those occasions when the boss suddenly walks in. Price: \$119.95.

CIRCLE 65 ON FREE INFORMATION CARD

For more information on any product in this section, circle the appropriate number on the Free Information Card.

ELECTRONICS WISH LIST

Bit Stream CD Player

With an entirely new system of digital-to-analog conversion called "bit-stream conversion," *Harman Kardon's* (240 Crossways Park West, Woodbury, NY 11797) *HD760* CD player uses pulse-width modulation to achieve what is said to be an unprecedented level of accuracy and clarity as well as minimizing harmonic distortion. Within the player, the 18-bit parallel output of a digital filter is converted to a serial data stream at four times the sampling frequency. That single-file string of bits is then converted to a digital waveform, the length of whose pulses is determined by the density of the bits in the serial stream. That pulse-width-modulated waveform is then integrated by an analog circuit to produce a signal compatible with conventional analog equipment. The process is said to eliminate most of the nonlinearities introduced by conventional D-to-A converters. The *HD7600* also has an optical digital output whereby the D-to-A conversion process is bypassed and a digital signal is conveyed directly to an amplifier for conversion (and amplification) there, thus avoiding the potential for induced distortion and extraneous noise. Price: \$700.

CIRCLE 66 ON FREE INFORMATION CARD

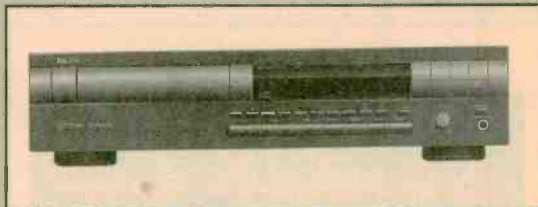

Harman Kardon CD Player

Multi-Mode TV/VCR

Videotapes in the VHS format made using the PAL or SECAM standards used by most of the world, as well as NTSC-format tapes, can be played and viewed on the *Multicombo*, a combination VCR and TV receiver from *Ten-Lab* (11054 Mississippi Ave., Los Angeles, CA 90025). The all-in-one unit contains a VCR capable of playing NTSC and PAL tapes in color—and SECAM-format ones in black-and-white—and a 20-inch NTSC color receiver for displaying them. The system also features a wireless remote control, 155-channel tuner, on-screen programming display, and sleep timer. Price: \$1345.

CIRCLE 67 ON FREE INFORMATION CARD



Ten-Lab Multi-Mode VCR/TV

Miniature Speaker System

Design Acoustics (1225 Commerce Drive, Stow, OH 44224) has a new high-performance speaker system, the *PS 3*, whose small size simplifies placement for pinpoint imaging. The system consists of three units: two very small ($7\frac{1}{16} \times 4\frac{1}{16}$ -inches) satellite speakers and a separate compact subwoofer. The subwoofer, which uses a six-inch driver, is finished on all sides, removing potential hindrances to placement for aesthetic reasons. It can even be placed under or behind furniture without compromising its performance. Price: \$599.

CIRCLE 68 ON FREE INFORMATION CARD

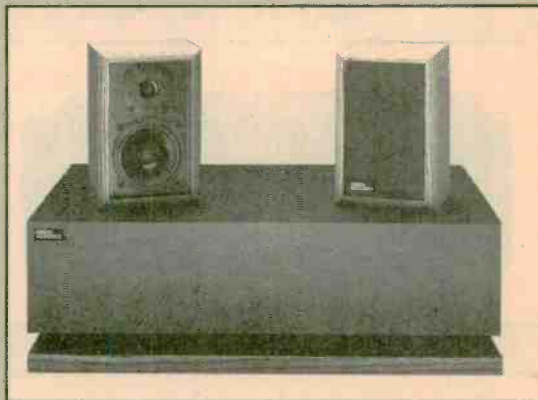

Design Acoustics Speaker System

VCR Head Cleaner

The *Double Shot with Dirt Alert* is a VCR head cleaner with a twist—every thirty days it flashes a light at you to remind you that it's time (based on an average of one hour's usage a day) to use it again. This wet cleaning system from *Advanced Video Dynamics* (289 Great Valley Parkway, Malvern, PA 19355) is designed so that residue-free freon solvent from a built-in reservoir is dispensed onto a non-abrasive cleaning tape not only at the beginning of the clean cycle, but also midway through it. That results in a wet ... dry ... wet ... dry action said to be especially effective in removing contaminants from the VCR head mechanism. The device, which comes with its own battery, is good for thirty uses, or 2½ years if used as specified. Price: \$29.95.

CIRCLE 69 ON FREE INFORMATION CARD



Advanced Video Dynamics VCR Head Cleaner

ELECTRONICS WISH LIST

For more information on any product in this section, circle the appropriate number on the Free Information Card.



Pioneer Videodisc Player

Low-Price Videodisc Player

With a suggested retail price of \$500, Pioneer's (2265 E. 220th St., P.O. Box 1720, Long Beach, CA 90801-1720) LD-870 laserdisc player brings the benefits of videodiscs—among which are improved resolution, high-quality sound, and the availability of many movies in their original, uncropped, screen formats—within the reach of most consumers. The player is designed to provide 425-line horizontal resolution with a 46-dB signal-to-noise ratio. It can play both 12- and 8-inch discs and features noise-cancellation circuitry and other devices to enhance picture quality. The player, which comes with a wireless remote control, also generates a full-screen display showing the disc's table of contents and uses a visual calendar to display the programming and play status of up to eight seconds of each track. Price: \$500.

CIRCLE 70 ON FREE INFORMATION CARD

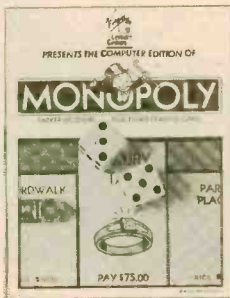

Virgin Mastertronic Monopoly Game

IBM Monopoly

The best-selling board game of all time, *Monopoly*, is now available on disk for IBM-type computers from Virgin Mastertronic International (18001 Cowan, Suites A & B, Irvine, CA 92714). The fully authorized (by Parker Brothers, its originator) game is an exact replica of the original classic. Up to eight players—human, computer, or some of each—can participate, although a full house might make it somewhat crowded around the screen. Looking at the other side of the coin, if you're all alone but feel the urge to play, your computer can be your opponent. Price: \$39.95. (Do not pass go, do not collect ...)

CIRCLE 71 ON FREE INFORMATION CARD



Profile Car Stereo

Pull-Out Car Stereo

One of five pull-out DIN-chassis car-stereo receivers/cassette players in a series, Profile's (11155 Knott Avenue, Suite 1, Cypress, CA 90630) Model DIN-910 helps foil thieves by being easily removable from its mount. When not in place, the unit's rechargeable battery can maintain its memory for station presets and keep the clock running for up to a week. Other features include an amplifier section rated at 25 watts per channel, a loudness control, and a power-antenna activator. There's also a front-panel jack for connecting a portable CD player. The AM/FM receiver has 18 station presets, while the auto-reverse cassette player includes Dolby noise reduction and metal-tape capability. Price: \$319.95.

CIRCLE 72 ON FREE INFORMATION CARD

Digital Radar Detector

A Motorola 56000 microprocessor is at the heart of Cincinnati Microwave's (One Microwave Plaza, Cincinnati, OH 45249-9502) new *Escort* radar detector. The powerful CPU is the basis for a digital signal-processing (DSP) system that digitizes and analyses 50,000 signal samples per second to find and isolate radar signals too weak to be detected by conventional technology, and to perform other signal-enhancement functions. The detector also contains a theft-deterrent system that sees to it that the unit stops working unless the owner inserts an electronic "key" after each 150 hours of use. Price: \$295.

CIRCLE 73 ON FREE INFORMATION CARD

One-Bit CD-Player

The CD-X711 compact-disc player from Sansui (1250 Valley Brook Avenue, Lyndhurst, NJ 07071) features four of that company's 1-bit digital-to-analog converters to produce what Sanyo calls "the most realistic analog signal yet achieved in CD reproduction." The novel system provides a slight, but measurable, improvement in quality when compared with 18- or 20-bit $8 \times$ oversampling ones. To ensure purity of sound, special attention has been paid to eliminating all possible sources of noise—including providing a shut-off switch for the unit's fluorescent display. In addition to the usual analog outputs, the player also has two sets (coaxial and optical) of digital outputs. Other features include 20 tracks of programmability, variable-time music scan, auto spacing, and timer start. Price: \$1100.

CIRCLE 74 ON FREE INFORMATION CARD



Cincinnati Microwave Radar Detector



Sansui CD Player

Restoring A Classic

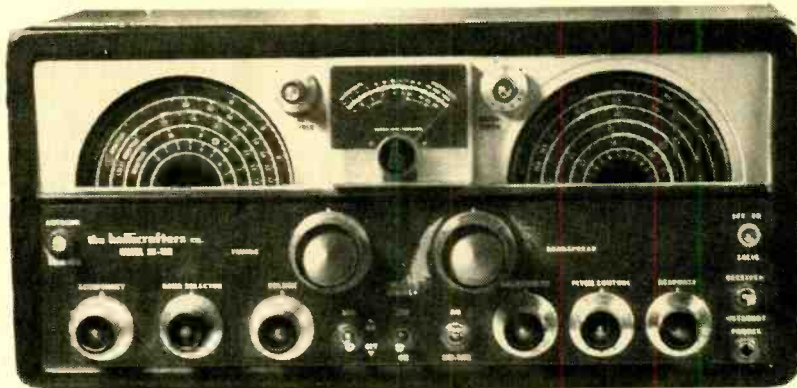

Shortwave Receiver

If you can't afford a modern SW receiver, take heart; a visit to a local hamfest and a little revamping can get you a rig to be proud of.

BY JOSEPH J. CARR

Modern shortwave receivers are a delight to behold, and they work even better than they look. But they also cost an arm and a leg, so for many people a modern shortwave receiver is simply beyond their means. But reworking an old unit is an alternative that can allow you to get at least a decent shortwave-communications receiver, if not one of the best military, commercial, or amateur-radio receivers of only a few years ago. That idea might also appeal to those who (like myself) like antique and classic radios.

Where to Buy. So where are all of those receivers of yesteryear? They are, for the most part, still owned by people who bought them new and then used them for years before retiring the old warhorses in favor of a smart new solid-state receiver from Japan. I find a lot of older communications receivers at hamfests and other amateur-radio get-togethers. They are also advertised in both national ham magazines and (more often) in local ham newsletters. At the last hamfest I attended, there were quite a number of decent used receivers in the "tailgating" section. I bought a Standard C-6500 for the nephew of a friend of mine (who is an

EI2 amateur from Ireland) for a low price that I am sure my friend didn't believe. One reason for the good deal, I suspect, is that I got to the hamfest at the crack of dawn instead of later in the morning.

What to Buy? The receivers that are the most desirable are those that were serious shortwave-communications or shortwave-listening receivers. Look for brands such as Hallicrafters, Hammarlund, Collins, National, and RME. There were other brands, but those just mentioned were probably the most popular.

Also, look for surplus military and naval receivers of the World War II and

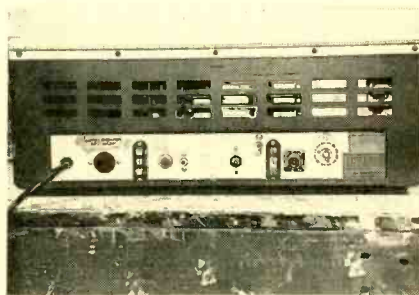

Look on the rear panel of the receiver for indications of added or removed connectors. Such alterations are sometimes a bad sign.

Korean War eras. Nomenclatures to look for include BC-342, BC-348, BC-779, BC-1039, R-388, R-390, and R-392. There were a number of other military radios, so don't restrict yourself to those listed here.

Information on specific receivers can be found by looking at old issues of amateur-radio publications in the library. At one time, *The ARRL Radio Amateur's Handbook* had an advertising section in the back. Those old ads are still on the shelves or on microfilm at many local libraries.

Another source of information on older receivers, at least those made prior to 1951, is Morgan E. McMahon's book *A Flick of the Switch 1930-1950* (Vintage Radio, Box 1331, North Highlands, CA 95660). Although the book is on antique broadcast radios, they have a section on amateur-radio receivers.

Trudging through the hot swelter of a summer hamfest last year (no mean trick with my bulk and a heel spur), I found my own antique treasure of a shortwave receiver. I admit that saving money was not my driving ambition, I was there because I'm an old-radio buff. Sitting on the tailgating table of one of the local amateur-radio clubs was a nice looking Hallicrafters SX-100 shortwave receiver. I'd owned its little

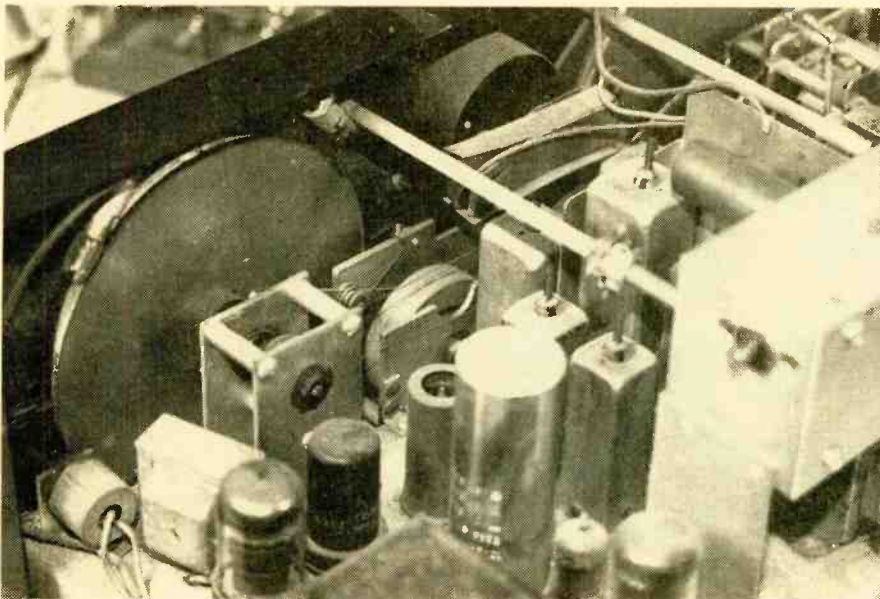

A broken dial mechanism may seem like a small matter to repair or replace, but repairing a dial cord can be a very difficult job. Check that item carefully before purchasing a radio.

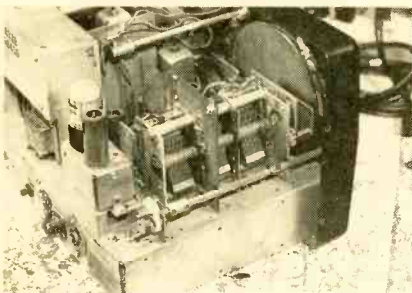

Take a close look at the main tuning capacitor, preferably before you make a purchase. That component, cannot be easily repaired or replaced.

brother, the SX-99, back in 1959 as a novice. I bought the SX-99 from a pawnshop, putting down \$5 from my paper route and then paying for it a few dollars at a time on "lay-away" until I'd completed the purchase. But an SX-100...well, an SX-100 was way beyond my means. At that time, the SX-100 was among the best general-coverage receivers used by hams and SWL's. In fact, the first time I saw an SX-100 was in the pages of **Popular Electronics** in the same column that I now conduct. So my purchase was based on sheer nostalgia, but I nonetheless wanted it to work properly; there is no room in my ham shack for non-working equipment!

Preliminaries. When looking over the receiver that you intend to purchase, make a few preliminary observations. First, operate all of the controls looking for binding, scratchiness, or other signs

of disrepair. Also look for missing knobs, torn-up or missing controls, and other signs of abuse. Sometimes a lot of internal injuries show up as little anomalies when viewed from the outside. For example, a banged up tuning capacitor (a nearly impossible defect to fix) may be indicated only by a little binding as you tune the radio through its range.

Look on the rear panel of the receiver for signs of alteration. Added or removed connectors are sometimes a bad sign. Some possible exceptions to that rule are SO-239 UHF coaxial antenna connectors added to, or replacing,

the terminal-strip connector normally used on receivers of that era. Another possible exception is an RCA phono connector added to accommodate a Q-multiplier device. Those units were external regeneration devices that improved selectivity. They were popular in the 1950's as after-market add-ons. The Heathkit QM-1, for example, was extremely popular.

In the case of my SX-100 receiver, a required octal jumper plug on the rear panel was missing. That was remedied by salvaging the octal base from a burned-out tube from my junk box. Those octal plugs are still available in some parts outlets, but for many people it might be necessary to obtain the schematic and internally wire the unit to conform with the required shorting pattern without using a plug.

Another preliminary is to inspect the innards of the receiver, if at all possible. In the case of many receivers of the 1940's and 1950's there was a hinged lid on the top of the cabinet to make that easy. Among those was the SX-100, so it was easy to peer into the receiver from outside. Look for obviously missing parts such as tubes, IF transformers, and the dial mechanism. Retrofitting the dial may seem like a small matter, but a dial cord that is either busted, or about to break, can be a real dog to replace. It isn't one of the more fun jobs in rebuilding old radios!

Also take a close look at the main tuning capacitor. That component and the bandswitch, are probably the only two components that cannot be re-

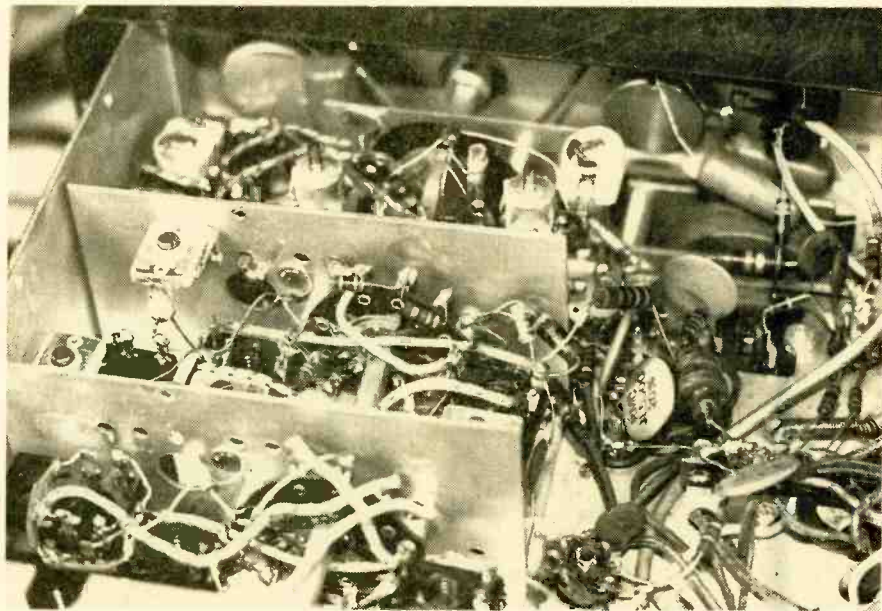

If a bandswitch is broken, it is unlikely that you will be able to fix it. If the switch is merely intermittent, then a little cleaning should do the trick.



Use your nose to check how the transformer smells. A pungent odor could mean trouble. Also look for brown or black, tar-like material in its vicinity in case the transformer leaks.

paired, replaced, or worked around. If either of those components is shot, then the whole project is in serious jeopardy. If a bandswitch is broken, then it is unlikely that you will be able to fix it. If the switch is merely intermittent, then clean it with contact cleaner. Some technicians also like to use the eraser of a thin pencil to gently remove the dirt from the switch contacts. That trick, however, is dangerous unless you are pretty sure of what you are doing.

Also use contact cleaner on all of the switches and potentiometers on the radio receiver. Spray the cleaner as directed on the label, and then operate the switch or control vigorously several times to work the cleaner into its inwards.

Tuning Trouble. The main tuning capacitor should rotate easily without binding as you tune slowly through its range. If the plates are bent, or if there is foreign matter between them, then there will be either binding or scratchy tuning. My receiver showed a funny—or perhaps not-so-funny—defect, but I was able to fix it.

The problem manifested itself in several ways: scratchy tuning; loud tunable oscillations (shreiks like a banshee!); abrupt, large changes in frequency while tuning; and the receiver would suddenly go dead except for a little scratching while tuning. Before we take a closer look at the cause of those particular symptoms, let's review what the tuning capacitor is and how it works.

The rotor plates of most tuning capacitors are grounded to the chassis of the receiver through the capacitor's mounting plate. The electrical connection of rotor to capacitor frame is accomplished through one or more brass or steel "U" or "finger" clips. Those clips straddle the rotor shaft at the mounting plate.

The problem with my receiver was that the clip was no longer making good electrical contact between the rotor shaft and the mounting plate. Corrosion ("crud" as it is sometimes called in high-tech circles) had built-up around the spring-clip contact points and under the rivet. Repairing that problem is relatively simple: clean the corrosion from beneath the clip. I used a relay burnishing tool to slip between the end of the clip and the mounting plate. Those tools are very thin pieces of spring steel that look very much like a feeler gauge.

Diagnosing the problem with a shorted capacitor is easy. Sometimes you will hear a scratching sound as the tuning capacitor is tuned across the band. That is a good indication of a short in the capacitor. However, the scratching could also be due to the spring clip used to ground the rotor. One way to tell whether or not the capacitor is shorted and where that short occurs in the rotation of the capacitor is to use an ohmmeter. Although both analog and digital ohmmeters can be used, analog meters are a little easier to use in this application.

Set the ohmmeter to its highest resistance scale. Disconnect the capacitor from the circuit, and then connect it across the probes of the ohmmeter. Slowly tune the capacitor through its entire range while watching the ohmmeter. If there is a positional short, then the ohmmeter will flick downscale when the short is located. A good eye and a strong magnifying glass may be needed to see which of the many pairs of plates are actually shorted, but the problem should be visible.

There are two ways a capacitor can be shorted: foreign matter (including dust or metal particles) can fall inside the plate assembly, or the plates can be bent. Foreign matter can often be dislodged by a quick blast or two from a source of dried, compressed air. Electronics supplies stores, and some auto-parts stores, sell small cans of dried, compressed air just for that purpose. You usually have to buy a nozzle attachment for the can, although I've seen one type with a plastic nozzle fitted to it like an aerosol can.

Bent plates are another matter. If a bent plate is close to the surface, then small needle-nose pliers will be useful in bending the plate back to its original shape. Otherwise, you may have to use a small tool such as a burnishing tool to gently work the plate into the correct

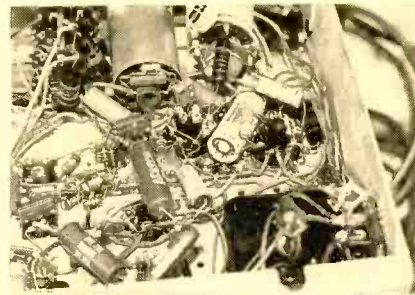

Be sure to check all the electrolytic capacitors. If an electrolytic has a paper body, then look for discoloration, especially if it appears to be from a liquid,

shape and position. Do not use a file or other cutting tool. The file will leave filings that will further short the plates together.

Another problem that affected my capacitor was that the lubricant in the ball-bearing race of the front mounting plate was dried out. Ordinary spray-on contact cleaner (or liquid alcohol) can be used to clean out the old lubricant. If you use contact cleaner, don't press the button on the aerosol can very hard. In order to keep from spraying fluid all over the capacitor—or more importantly, between the plates—you should use a quick, delicate *spritz*. A cotton swab (such as a Q-Tip) can be used to clean out the old lubricant and cleaning fluid. Once the bearing race is cleared, refill it with a dab of white lubricant (such as Lubriplate). Use a toothpick as an applicator. Be careful to prevent the lubricant from getting between the plates (work clean).

Other Problem Areas. The power transformer is probably the next area of concern. One of the best pieces of test equipment for a transformer, at least when you are inspecting it prior to purchase, is your own nose. Sniff around the area of the power transformer. A pungent odor may indicate that the power transformer is burned out. If you can, inspect the chassis around the transformer and look for oozing deep-brown or black, tar-like material. That is an almost sure sign of problems.

Finally, inspect the other components on the underside of the chassis. Look for paper capacitors that have the wax plugs popped out. In fact, it is my policy to replace paper capacitors regardless of whether or not they appear to be bad. Also look for discolored or burned resistors, and frayed wires.

Special attention should be paid to both the tubular and chassis mounted
(Continued on page 100)

A "Sound" Installation

There's more than one way to install a mobile antenna, but this isn't one of them.

BY FRED STOCK

It was a slow day at the warehousing center in a Los Angeles suburb. A single truck was being loaded at one end of a long dock, which was surrounded by a two-story building on three sides. On the parapet along the second-story offices I sat waiting for a meeting to break up. I was a mobile radio technician, and was there to repair a piece of base-station equipment in the owner's office.

Below me, a yard man drove into the staging area with a brand-new shiny white tow-truck—one of those huge rigs used to rescue tractor-trailer trucks along the freeways. The fellow popped out of the cab in a black tee-shirt and blue jeans and hoisted a tool bag up onto the roof of the cab. Then he climbed up himself. I wondered what he was up to, and he apparently hadn't seen me, so I slipped back from the railing a bit and just watched.

It soon became evident he was installing a citizens-band radio and a roof-mount antenna. His mounting method was unique, if not unusual; here's the best I can recall it:

First, he grabbed a black-ink marker and looked at the cab, and immediately marked a circle about an inch in diameter on the white roof. It didn't appear to be far from center. Then he took a nail and a rectangular hammer, and with a mighty blow, marked the spot very close to the middle of the circle. Then with an awl and another whack, he finally made a hole in the top.

Next a flat-blade screwdriver was hammered into the hole and twisted to make it larger. That was when he discovered another layer of sheet metal about an inch under the top.

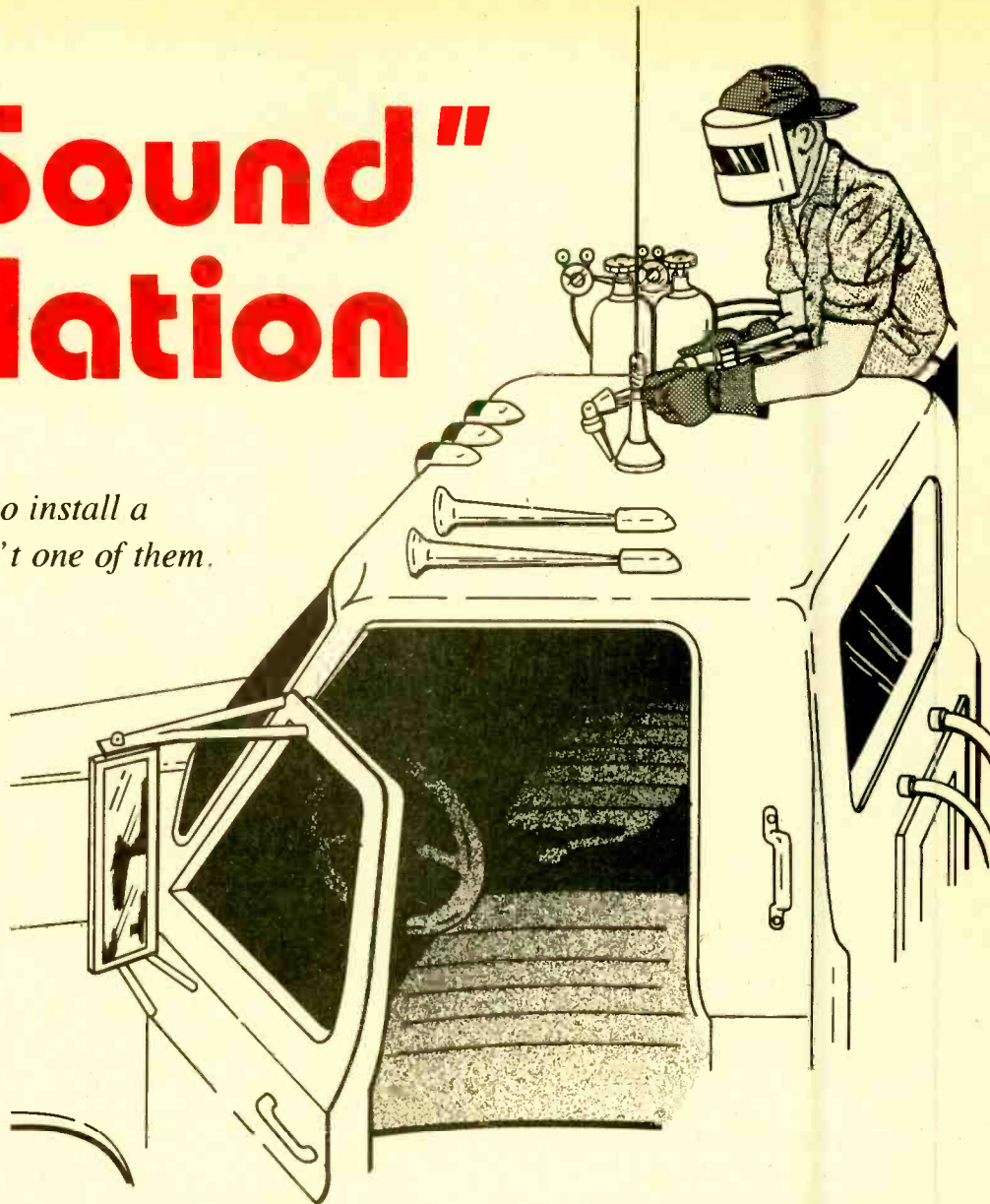

"What the...," he remarked, grabbing the awl again. Soon the screwdriver blade went completely down into the cab. He seemed very proud of himself.

That was the moment the boss's meeting ended, and his guests left through the door at the opposite side. The owner came toward the glass door, and, putting my index finger to my lips, I signaled with a "Shhhhh," sound and waved him out onto the parapet. He silently joined me in reconnaissance.

Below, the "technician" had taken tin snips, and carefully cut the hole out near the edges of his black circle, which is about where the top layer was now receding into the opening. He busily crawled into the cab and cut the inner layer of metal to roughly match. Then he jumped back on the roof to measure his success.

He grabbed the base-loaded antenna, still attached to its cable and mounting hardware. He held it over the hole, and discovered it would now go

completely through both layers of the roof. It landed standing at attention on the front seat with the tip of it protruding through the roof next to a PL259 connector Scotch-taped to the raw end of the cable. Some dilemma.

But, being a pro, he had the answer. Over to the junkbox in the mechanic's corner. Yes! Here it is, a whole box of washers. Now back to the roof of the truck, with a welder's mask, wire brush, and red and black cables. He found a washer that would fit the three-quarter inch mounting assembly. He carefully brushed it shiny, apparently wanting to do his best. Then he brushed the remaining bits of white paint around the cut-out, and spot welded the washer in place. Ah, perfect!

Next, back to the tool bag for a tube of sealant, the kind used to repair leaks around a windshield. That would keep the openings around the washer from leaking water. Good thinking!

(Continued on page 103)

THE BOZART 911 STEREO SPEAKER

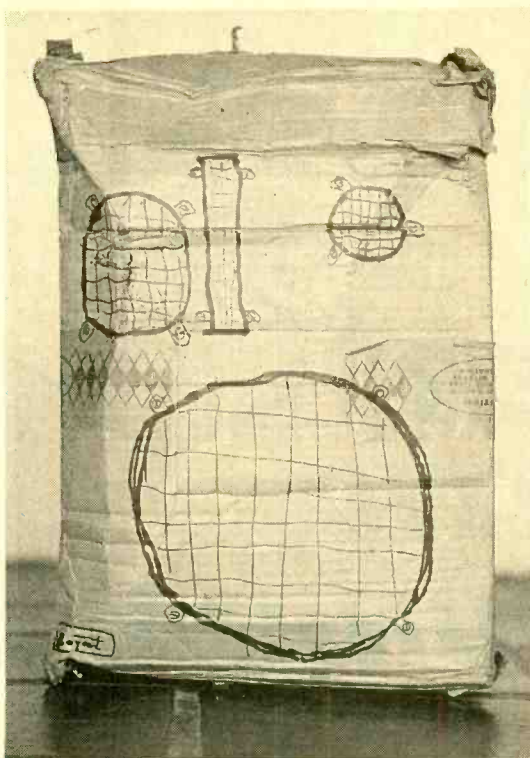

Stereo sound from a single speaker brings hope to those with only a half-vast living space.

Our magazine has presented a lot of audio equipment over the years—amplifiers, speakers, surround-sound processors, etc. Of late we have been particularly intrigued by developments in surround sound and some of the experiences we've had with it were incredible, to say the least. A leading innovator in this field has been *Bozart* (The Gully, Farmingham, MA 01707), and when the phone call came from them inviting us to try a new stereo speaker system, the *Model 911*, we jumped at the opportunity.

Before we begin to discuss the 911's unique qualities, it is best to quickly review a history of stereophony and surround sound. Early stereophonic sound systems, such as the one used for Walt Disney's *Fantasia* in 1940, used an array of as many as eight speakers arranged in a row in front of the listener, each speaker reproducing a segment of the orchestra that had been picked up by a dedicated microphone and recorded on its own soundtrack. It was eventually determined that just two mikes and two speakers, however, could faithfully reproduce the same soundstage, and that is the system that is largely in use today.

The first motion-picture surround-sound systems also used as many as eight channels of sound fed to speakers arrayed in front of, to the sides of, and behind the listener. Quadraphonic

sound, briefly popular in the 1970's, used four channels and four speakers, Processes such as Dolby Surround can be reproduced faithfully with as few as three speakers—two in front of, and one to the rear of, the listener.

Bob Carver's Sonic Holography also produces a type of surround sound, using just two speakers. While true front-and-back differentiation is not possible with this system, under good conditions sounds can appear to come from beyond the bounds of the soundstage set by the speakers themselves, and even to emanate from an arc partially encircling the listener. It was Carver's achievement that inspired the engineers at Bozart: "If," they said, "Carver can get surround sound out of just two speakers, why can't we get stereo out of one?" And that was the beginning of the the *Model 911*.

Principles of Operation. In its initial efforts to produce stereophonic sound from a single speaker, Bozart tried a number of techniques, among them multiphase, single-phase, and stacked arrays; multiported ducts; and multiported ducts. Recognizing, finally, that the answer lay not so much in the enclosure as in the drivers, Bozart redefined its goals, took aim, and careened off in a new direction.

Designing a speaker that could do the job was no simple task. Bozart tried

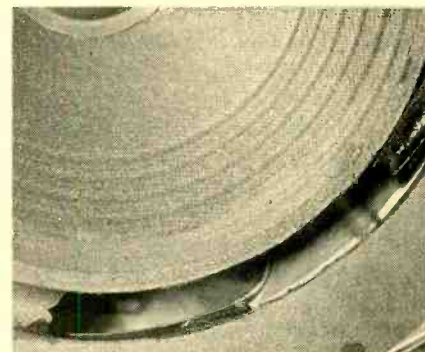

Some of Bozart's early driver designs did not work out too well. Here's some evidence of that taken from their labs.

literally dozens of designs, including polyphasic, polyhedral, and polyhedonic ones, but the results were nil. Indeed, they were sometimes disastrous, as can be seen from one of the photos, which shows a damaged driver. The photograph, taken from the Bozart archives, was slipped to us by a disgruntled employee during one of our visits to the Bozart facilities. We were also told by that employee that such violent destruction was not uncommon in the early Bozart designs and the resultant increase in insurance premiums is in part responsible for the 911's suggested base price of \$18,000.

Recognizing, finally, that the answer lay not just in the enclosure or drivers, but in the crossover network as well, *(Continued on page 108)*



FIBER OPTIC COMMUNICATIONS

What is light? What is its nature? Questions like those have inspired intense curiosity in human minds for thousands of years. Ancient scholars had very little concrete knowledge of the nature of light. They surmised that light was composed of many particles emitted from the source; it was even conjectured that perhaps the eye itself emitted the particles of light that illuminate objects.

Surprisingly, those scholars did establish some theories about light that are still held today, including the ideas that light travels in a straight line, that it is reflected from a mirror at the same angle it arrives at, and that a beam of light is "bent," or refracted, when it passes from air into a transparent material such as water or glass.

Early Experimentation. In 1666 Sir Issac Newton demonstrated that white light could be decomposed into its seven spectral colors by passing it through a prism, then recomposed again by passing the dispersed light through an inverted prism. He concluded that white light was really a mixture of light components, each capable of stimulating the eye to produce the sensation of a color.

Newton's experiments added support to the popular theory that light was made up of tiny particles traveling at an extremely high speed, which would explain both the straight-line behavior of light and refraction.

If light consisted of high-speed particles, some questions arose that remained unanswered. Why, for example, was one color of light refracted more than another, or why didn't the crossing of two beams of light cause the streams of particles to collide, thus distorting the individual paths of the beams?

It was in 1678 that a Dutch physicist, Christian Huyghens, theorized that light was composed of waves whose color depended on wavelength. The theory would explain the variation in refraction of different colors of light, since it was reasonable to assume that waves of different lengths would have varying degrees of refraction. From Huyghens' theory, it could be explained that two beams of light don't interfere with each other just as sound waves are able to cross without becoming distorted.

In spite of being able to answer questions that could not be explained by the "particle theory," Huyghens' theory did not explain why light waves did not travel around objects as did sound and water waves, or how light waves could travel through a vacuum. So, if light consisted of waves, what was the medium being "waved" in space? The answers to those mysteries were slow in coming despite much determined investigation.

In 1818, French physicist Augustin Fresnel presented some concepts that were so insightful that they are used in microwave-communications technology today. Fresnel's wave theory

stated that if an obstacle within a beam of light is small enough, light waves will definitely "bend" around it, the obstacle's size must be close to the wavelength of light for this "diffraction" to take place. If the object is large with respect to the wavelength of light, the light not obstructed by the object will travel straight and cast a sharply defined shadow without diffraction.

Along with many attempts to find out more about the nature of light were studies attempting to determine light's speed. Galileo Galilei was the first to attempt to measure the speed of light. Although his principle of measuring light at increasingly greater distances would have worked, he did not have the necessary mechanical devices to make accurate measurements. More than 300 years later, a German-American physicist, Albert Michelson, was able to measure the speed of light in a vacuum and found it to be 186,284 miles per second. It was not until 1963 that refinements in technique enabled scientists to determine the speed of light to be 186,281.7 miles per second ($2,998 \times 10^8$ meters/second).

The Ether and Electromagnetism.

While scientists were still gathering increasing amounts of information on light, some of the old questions still remained. The question of how light, if it consisted of tiny waves, could travel through the vacuum of space was particularly disturbing. Was there an "ether"

Most communications systems require a transmitter, a transmission medium, and a receiver. Fiber-optic systems use a light-emitting transmitter and a light-sensitive receiver. A glass or plastic fiber is the transmission medium!

BY ALVIN G. SYDNOR

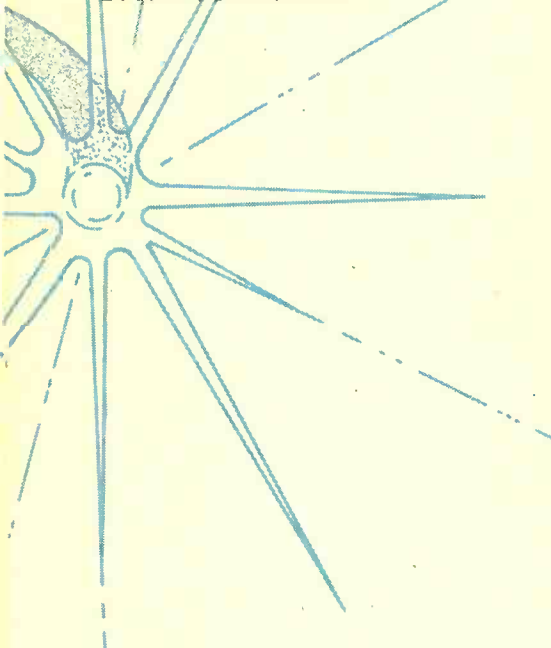

each field further and further from the source of the first field. That's what Maxwell termed "electromagnetic radiation." Maxwell calculated that the velocity of an electromagnetic wave was equal to the speed of light, and he speculated that visible light was only part of a greater spectrum, much of whose wavelengths are not visible to the eye.

In spite of the new theories and speculations, the question of the ether's existence was not satisfied. It was in 1900 that German physicist Max Planck proposed that radiation consisted of discrete units that he called "quanta." The energy contained in one quanta was in inverse proportion to its wavelength. The latter theory implied that some colors of light would contain a greater amount of energy than others.

It was Albert Einstein who theoretically verified the existence of Planck's quanta while working out an explanation for the photoelectric effect. He called the packets of energy "photons." That, however, was not to be a step back to the particle theory of light; Einstein proposed that the photon not only had properties of a particle, but of a wave as well. Either one group of properties or the other was exhibited depending on the situation. The theory made the ether unnecessary; light could travel through the vacuum of space due to its particle-like properties.

The Full Spectrum. Research into the nature of light has given birth to new

terms. In the measurement of the length of light waves, for example, it has been found that the wavelength of red light is around 0.000075 centimeter. Because numbers such as that are difficult to work with, a more convenient unit called the "angstrom" was adopted. One angstrom equals a hundred millionth of a centimeter. Thus, the red wavelength is 7,500 angstroms.

Another unit that is used in connection with the measurement of light waves is the micron. That unit of measurement is equal to one millionth of a meter, or 10^4 angstroms. As an example, violet light waves are in the 0.38 micron range.

The visible-light frequency spectrum appears within the confines of a larger spectrum as shown in Fig. 1. The immensity of the frequency spectrum of light—which includes not only visible light but also infrared, ultraviolet, and x-ray—allows us to transmit information such as voice, radio, television, and data signals.

Lasers and LED's. Recent advances in semiconductor technology have produced two light sources that can be used for communications purposes: the light-emitting diode (or LED) and the laser.

As we know, if slides of P- and N-type semiconductor materials are joined to form a diode junction, the free electrons from the N-type material combine with the available holes in the P-type material over a thin portion of the

beyond the earth's atmosphere that enabled the passage of light from the sun and other stars? Many scientists thought so.

In time, Michael Faraday proposed the concepts of lines of force and related it to magnetic-field strength. Subsequent mathematical descriptions of those fields by James Maxwell supplied new insight into the nature of light. The relationship between electricity and magnetism described by Maxwell essentially implied that electric and magnetic fields must coexist. It is also true that a change in a magnetic field brings about a corresponding change in its complimentary electric field, and vice versa. The concept can be further extended by proposing that a varying magnetic field can create a varying electric field, which in turn can create a varying magnetic field, and so on with

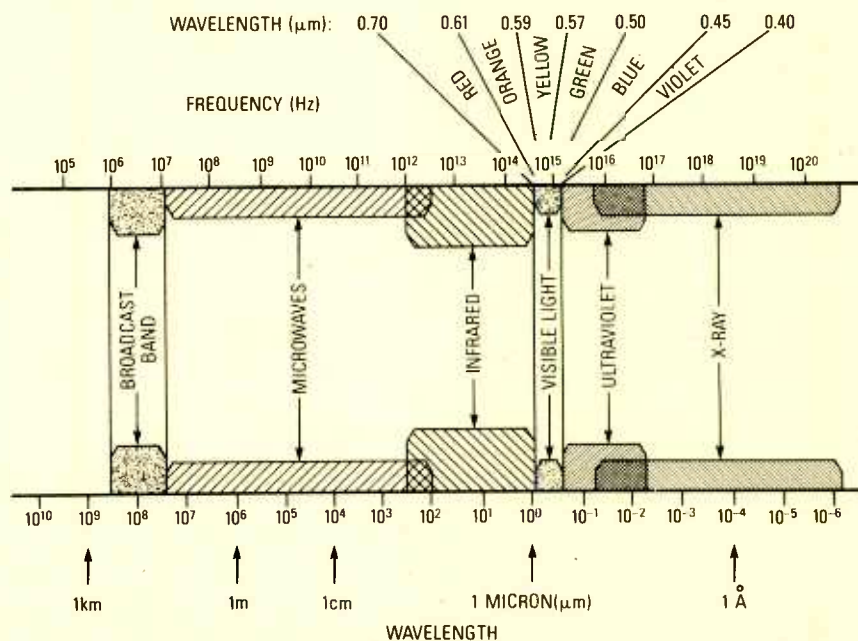

Fig. 1. The full spectrum of light extends beyond the visible. It contains the infrared, ultraviolet, and x-ray frequencies, too.

junction (the depletion layer). When a voltage is applied so that the P material is more positive than the N material, it causes current to flow, thus forward-biasing the semiconductor.

In the case of an LED, any forward-biasing current through the P-N junction causes electrons to be temporarily "pumped" to a higher energy level, but as each electron falls to a more stable state, it releases energy in the form of light whose color (or wavelength) depends on the semiconductor material. As an example, an LED made of gallium arsenide (GaAs) will emit light in the infrared portion of the frequency spectrum, while one made of gallium arsenide phosphide (GaAsP) will produce visible red light.

The Fiber Medium. Just as it is possible to send Morse-code like signals over a distance by using a flashlight, it is also possible to send signals with an LED, but at a much faster rate. But why the push toward optical communications? Some of the advantages of optical data transmission are the larger bandwidth available, its freedom from crosstalk and other types of interference, its low cost, and its light weight. In addition, information can be transmitted much faster at optical frequencies than at lower frequencies. Which brings us to the key element of communications: the transmission medium.

In any optical system the signal medium is most certain to be one of several types of hair-thin glass fibers. Such an optical fiber is actually a tiny waveguide that conducts optical waves using the principle of total internal reflection. We'll discuss the specifics of internal reflection as we look at each class of optical fiber, since each type uses the principle in a slightly different fashion.

Fibers usually come in three "flavors:" single-mode step-index, multimode step-index, and multimode graded-index. A single-mode fiber (see Fig. 2A) can only function efficiently by working in conjunction with the coherent light from a laser. That's because its core, which is the portion of the fiber used for transmission, is so thin it will only support one group of in-phase waves.

However, the emission from an LED is "multimode incoherent light," which means that the light emitted is not uniform in intensity or phase. It is possible to make an LED produce coherent light by turning it into a semiconductor laser, which produces a very intense light of a

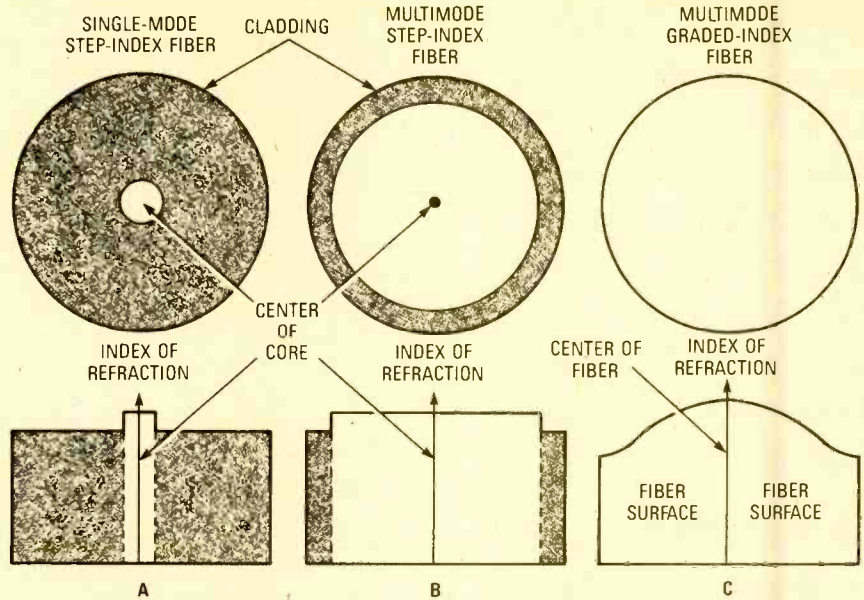

Fig. 2. These are the three most popular types of optical fiber. The single-mode step-index fiber (A) can only be used with laser light. The multimode step-index fiber (B) has an outer layer (cladding) that reflects light back into the fiber should it try to escape. The multimode graded-index fiber (C) requires no cladding because it has a refractive index that changes with distance from the core.

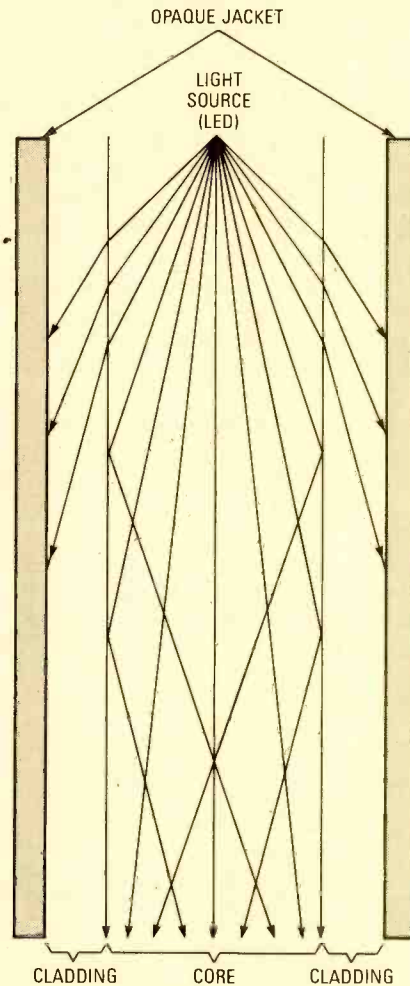

Fig. 3. Incoherent light rays from an LED are confined to the core of a multi-mode step-index cable because of the change in the refractive index at the cladding boundary.

certain wavelength and uniform phase (when the laser is operated in what's called its "fundamental mode"). Unfortunately, semiconductor lasers that can operate at room temperature for long periods of time are not yet commercially available. However, recent improvements in crystal-growing techniques promise to make them a commercial reality in time.

On the other hand, multimode fibers (see Figs. 2B and 2C) may be used with incoherent-light sources such as LED's. Incoherent light rays spread out as they travel along a multimode fiber. In a step-index fiber (see Fig. 3), when they reach the cladding (an outer layer of transparent material that has an index of refraction that is lower than the core) some of them pass through and get absorbed by the opaque jacket. The rest get reflected back and continue moving down the fiber core.

The graded-index optical fiber (Fig. 2C) also consists of two materials with differing refractive indices, but they're mixed together in such a way that the index of refraction decreases with distance from the fiber's axis. That causes the light rays to gradually "bend" back and forth across the axis of the fiber in a sinusoidal manner (see Fig. 4).

Optical Attenuation. As in any communications system, the transmitted signals in an optical fiber must span the distance to the receiver and arrive
(Continued on page 99)

Digital electronics has moved from the outskirts to the forefront of our hobby. Here's your chance to learn about or refresh your knowledge of some of the basic elements of that technology.

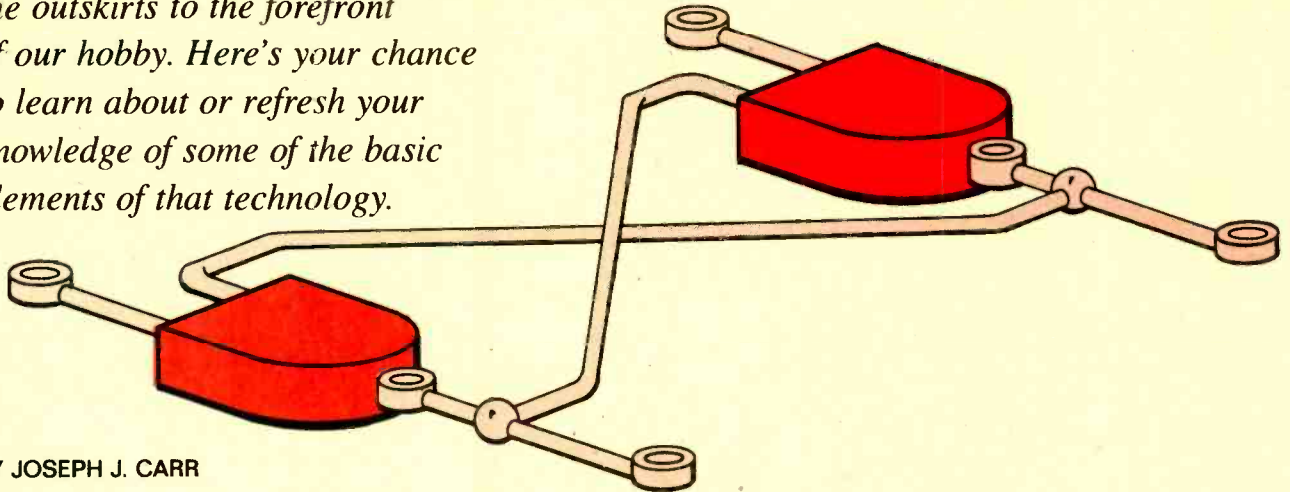

BY JOSEPH J. CARR

An Introduction to Digital Electronics

You don't have to be too old to remember when digital electronics was the province of a few esoteric specialists who worked in forsaken realms of electronics. Everyone in those days "knew" that analog electronics was "real" electronics. But times changed; Digital electronics eventually became easily accessible to all because of the introduction of integrated-circuit logic elements.

The costs of digital technology also have dropped precipitously over the years. The old **Popular Electronics** was at the forefront in introducing digital IC chips to the public. In fact, the magazine was the breakthrough publication when it came to digital circuits. But there was one fly in the digital ointment back then: price. This author can recall paying \$5 for a NAND-gate chip in 1967, and nearly \$14 for a 7490 BCD-output decade counter. Today the 7490 is less than a buck.

Another change in digital-circuit project building is the ease of obtaining the chips. At the dawn of the digital revolution one could only purchase parts from specialized industrial distributors who disdained the "no-volume" electronic-hobbyist market. Today, both mail-order and local sources stumble over each other to bring you the chips you need, in the quantity you want, and at competitive prices.

Reliability has improved over the past

two decades as well. At one time, a large digital project was unreliable by default. But today, chips hold up well and projects can be expected to last a long time. Even green chips, which by definition have no factory burn-in, perform as well as many high-reliability devices.

In this article we will take a look at the most fundamental building blocks of digital electronics: gates and flip-flops. All larger digital circuits, whether a simple BCD counter like the 7490 or a large-scale integration (LSI) microprocessor chip, ultimately boil down to

a very few, different forms of digital-logic gates. We will learn about those basic-circuit elements below.

Logic Families. Digital-logic families are devices using the same technology, and the same general circuit elements, that are designed so that it is easy to interface them using only electrical conductors (e.g. wires and printed-circuit traces). The interfacing chore is thus eliminated because we don't need to worry about matching signal levels and impedance values. The two modern digital-logic families consist of the tran-

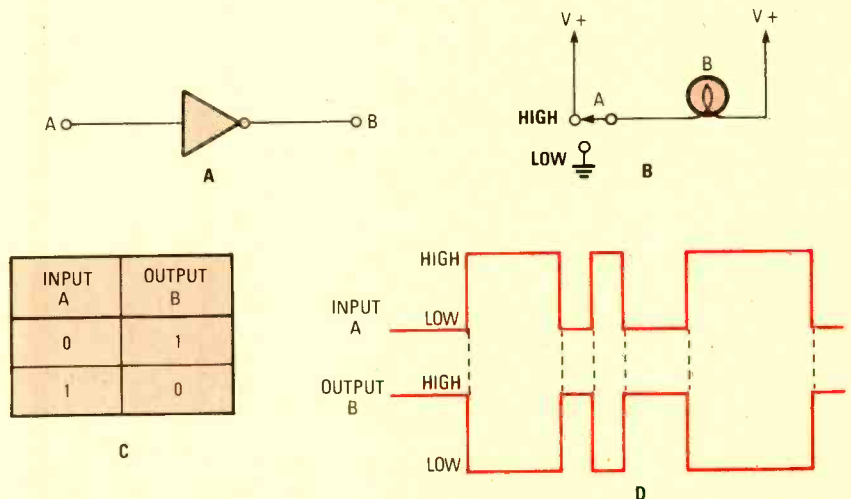
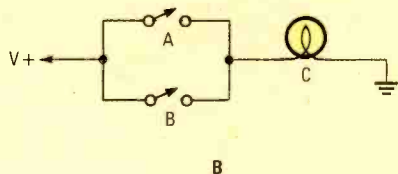
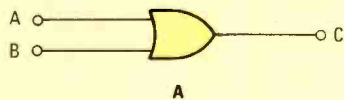

Fig. 1. The inverter or NOT-gate's schematic symbol is given in A. The circuit in B will mimic the gate's operation whose truth table is given in C. Typical waveforms for the device are shown in D.



INPUT A	INPUT B	OUTPUT C
0	0	0
0	1	1
1	0	1
1	1	1

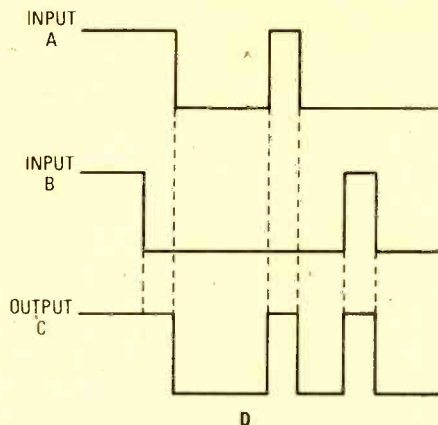

Fig. 2. The two-input OR-gate (A) can be simulated by the circuit in B to yield the results shown in C. When operating in a circuit it acts as shown in D.

sistor-to-transistor logic (TTL) and complementary metal-oxide semiconductor (CMOS) devices. The TTL devices are based on NPN/PNP bipolar transistors, while the CMOS devices are based on field-effect transistors (MOSFETs).

You can recognize the CMOS devices by their "4xxx-series" part numbers (e.g. 4049). TTL devices carry part numbers of 74xx (e.g. 7490) or 74xxx (e.g. 74161). Military TTL devices are sometimes seen in hobbyist parts suppliers as industrial surplus. Those devices carry the same number as the civilian version, except that the first "7" is replaced with a "5." In other words, a 5490 is a 7490 that's been "drafted".

Digital Vs. Analog. Digital electronics differs from analog electronics in the nature of the signals processed. In an analog circuit, a signal can have any value within a certain range. For example, suppose we have an operational amplifier connected for analog operation. Further, suppose that the output voltage can swing from -12 to +12 volts DC. In an analog circuit, the output voltage can take on any value between -12 volts and +12 volts; no values are forbidden.

In digital circuits, on the other hand, the signals can take on only one of two permissible values—all other values are forbidden. Because only two values are permitted, we say those circuits are binary in nature. The two levels are often called 1 and 0 (or logical-1 and

logical-0), true and false, or high and low. In this article, we will use high and low to denote the different states, except for a few cases where 1 and 0 seem particularly appropriate.

The two families of digital devices use different voltage levels for high and low. For example, the TTL family uses +2.4 to +5 volts for high, and 0 volts to +0.8 volts for low. In the CMOS family, on the other hand, it is possible to use anything

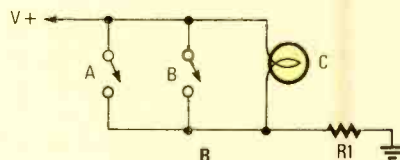
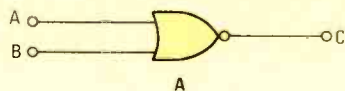

INPUT A	INPUT B	OUTPUT C
0	0	1
0	1	0
1	0	0
1	1	0

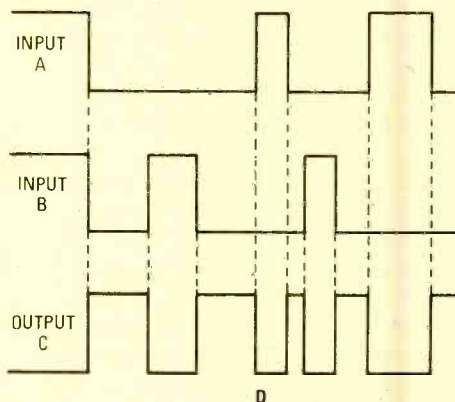

Fig. 3. The NOR-gate circuit symbol (A) is the same as the OR gate but with a circle at the output indicating inversion. It is functionally equivalent to the circuit in B. Its truth table output is just the inverse of the OR gate's. Shown in D are some typical waveforms for the gate.

from -15 to 0 volts for low, and 0 to +15 volts for high. In general, one of two situations are standard in CMOS circuits. Either low is zero and high is +5 volts (when TTL compatibility is needed), or low is a negative voltage and high is a positive voltage of the same value.

The terms "positive logic" and "negative logic" sometimes confuse people who are just learning digital electronics. In positive-logic systems, a high will be a more positive voltage than a low. In negative-logic systems, a low will be more positive than a high.

Gates. The most basic digital elements are gates. All digital circuits can be formed from only three of such basic elements: the NOT gate, AND gate, and OR gate. Although those three gates can do it all, we also include the NOR, NAND, and XOR gates among the basic elements.

While discussing each gate, we'll show you its schematic symbol, an equivalent circuit made of switches that operate a lamp, and its truth table (in which 1=high and 0=low). Finally, we'll present a *wavetrain* example. You might want to examine the wavetrain examples in order to gain insight on how these gates work in dynamic circuits.

Inverters. Inverters, also called NOT gates, get their name from the fact that

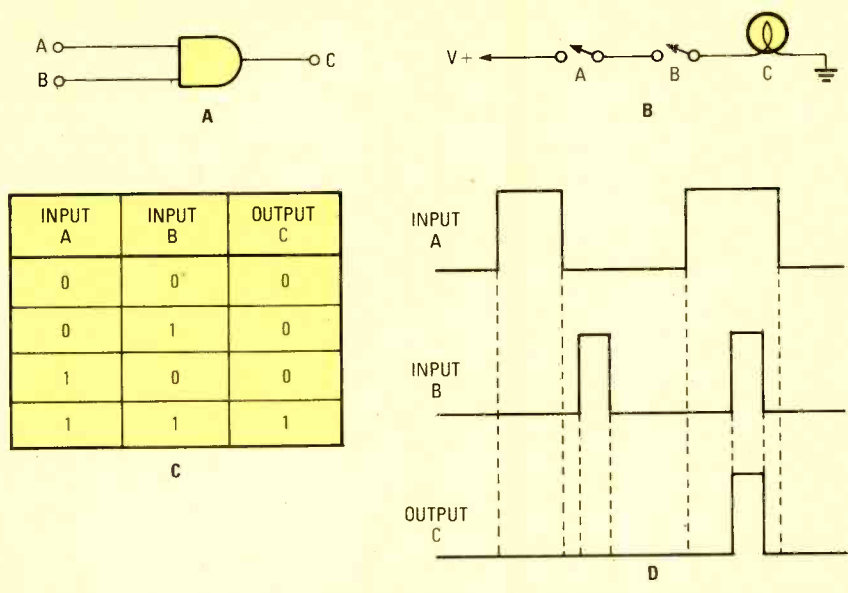

Fig. 4. The AND-gate's circuit symbol (A) should not be confused with the OR-gate's. A simple equivalent circuit can be constructed out of two switches and a lamp, as in B. It produces the truth table given in C. Typical waveforms for the device are given in D.

they produce an output that is opposite of the input. A high input yields a low output and vice versa. The letter "A" is an expression that represents the input, so "A" can equal a high or a low. In like fashion, the letter "B" represents the output.

An inverter is represented by a triangle on its side with a circle at the output (the apex; see Fig. 1A). Whenever a circle appears at any lead (input or output) of a digital circuit it indicates inversion, as we'll see with some of the other gates.

We can sometimes get better insight into a circuit's behavior by looking at a simple equivalent circuit. In Fig. 1B we have a simple DC circuit that represents the operation of an inverter. Switch S1 selects either a high signal (V+) or a low signal (ground or 0 volts) as the input to the circuit. The lamp indicates the output—it's on for a high output and off for a low output. When the switch is in the HIGH position, both sides of the lamp have the same potential so the lamp is not illuminated. That indicates a low output. When the switch is in the low position, the lamp receives both ground and V+ so the lamp lights to indicate a high output.

The truth table for the NOT gate is shown in Fig. 1C. If the input is A and the output is B, we find that a low input produces a high output, and a high input produces a low output.

That circuit action is shown in Fig. 1D. In this case, the input is A, while the output is called B or \bar{A} . The line above the input or output in logic notation in-

dicates that the signal is the opposite of whatever the "unbarred" signal is. For example, if A is high, then \bar{A} is low. We can use that notation to indicate the relationship between the input and the output:

$$B = \bar{A}$$

That is an expression used in Boolean algebra, which is the mathematics of digital logic.

OR Gates. An OR gate (Fig. 2A) produces a high output if at least one input

is high. So if A, B, or both A and B are high, then the output is high. Another, perhaps simpler, way to put that is to say both inputs must be low to get a low output.

Figure 2B shows a simple equivalent circuit for the OR gate. The lamp (output) is on (high) if either switch A or switch B is high. That's why they're called OR gates.

A truth table for the OR gate is shown in Fig. 2C. What it says is that the output is low only when all inputs are also low, and a high on any or both inputs produces a high output.

The circuit action of those rules is shown in a practical form in Fig. 2D. Both inputs receive a series of pulses, and the change in output reflects the operation of the gate in response to those input levels.

NOR Gates. The NOR gate is a gate made by combining an OR gate with an inverter. (Note the circle on the output terminal in Fig. 3A.) The gate might be considered a NOT-OR gate. The NOR gate produces a low output if any or both inputs is high.

An equivalent switch circuit for the NOR gate is shown in Fig. 3B. As long as both switches are open, the lamp is on, but if either switch is closed then the lamp is turned off. The truth table for that type of circuit is shown in Fig. 3C, which can be summarized by the following rules: The NOR output is high if, and only if, both inputs are low (i.e., the output is low if any input is high.)

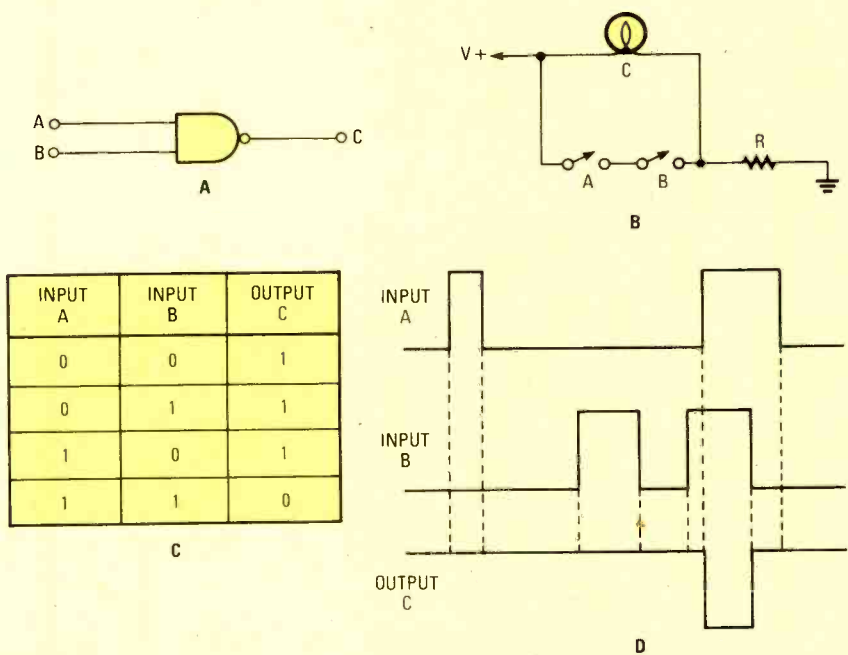
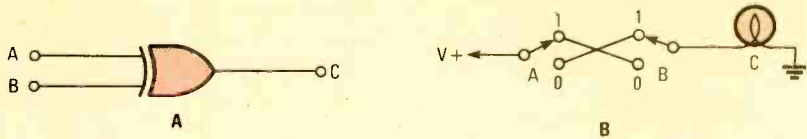
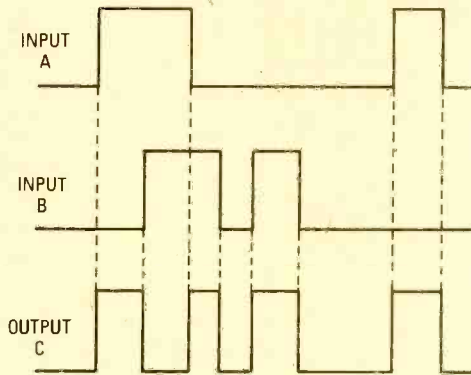

Fig. 5. Here we present the NAND-gate circuit symbol (A), an equivalent circuit (B), its truth table (C), and some typical waveforms (D).



INPUT A	INPUT B	OUTPUT C
0	0	0
0	1	1
1	0	1
1	1	0

C



D

Fig. 6. The XOR-gate (A) requires a more complex equivalent circuit, as shown in B. It generates the unique truth table given in C. The graphs in D are characteristic of its behavior.

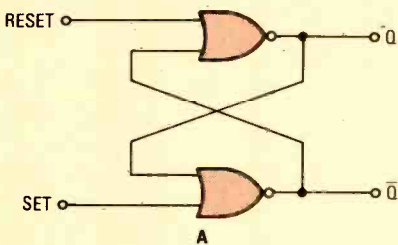

A

SET INPUT	RESET INPUT	Q OUTPUT	Q-bar OUTPUT
0	0	(NO CHANGE)	
0	1	0	1
1	0	1	0
1	1	(DISALLOWED)	

B

Fig. 7. The circuit for NOR-logic R-S flip-flop is shown in A; its truth table is given in B.

As in the case of the OR gate, those rules are presented in a more dynamic form in Fig. 3D.

AND Gates. The AND gate (see Fig. 4A) produces a high output if and only if both inputs are high. The AND-gate equivalent switch circuit is shown in Fig. 4B. The lamp is turned on only if both switch A and switch B are closed.

The truth table of Fig. 4C can be summarized as follows: The output will be low if either input is low (i.e., the output will be high only if all inputs are high). Those rules are summarized for real-time circuits by the timing diagram in Fig. 5D.

NAND Gates. The NAND gate (see Fig. 5A) is another gate made by combining an AND gate with an inverter. An equivalent circuit is shown in Fig. 5B; if either switch is open the lamp is turned on, and will only go off if both switches are closed. The rules of operation are given in the truth table (see fig. 5C), and can be summarized as follows: The output is high if one or both inputs are low, which is to say the output is low only if both inputs are high. As in our previous cases, a dynamic example of those rules is given in Fig. 5D.

XOR Gates. The last basic gate that we will consider is the Exclusive-or (XOR). That gate (shown in Fig. 6A) is a little unusual, but it has a lot of different applications. An equivalent circuit for the XOR gate is shown in Fig. 6B. The switching circuit has two SPDT switches cross-connected as shown. The truth table (Fig. 6C) reveals some interesting behavior: If both inputs are low, then the output is low. If both inputs are high, then the output is again low. If one input is high, and the other is low, then the output is high.

In other words, a low output occurs anytime that both inputs are at the same level (regardless of whether they're high or low). That behavior is displayed in Fig. 6D.

Flip-Flops. Once an electronics buff progresses beyond an understanding of elementary digital-logic gates, it's time to tackle the next order of circuit

organization—flip-flop circuits. A flip-flop is a one-bit memory device made of basic gates, although it is rarely thought of as such in this day of 256KB and 1MB dynamic-memory chips. But flip-flops are still commonly used in digital electronics, both in computers and

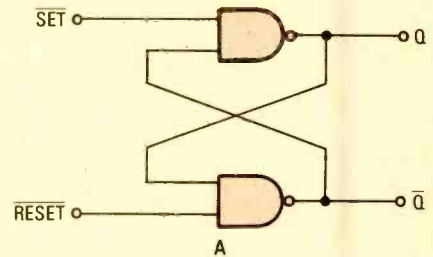

A

SET INPUT	RESET INPUT	Q OUTPUT	Q-bar OUTPUT
0	0	(NO CHANGE)	
0	1	1	0
1	0	0	1
1	1	(DISALLOWED)	

B

Fig. 8 The circuit for a NAND-logic R-S flip-flop appears in A; its complementary truth table is given in B.

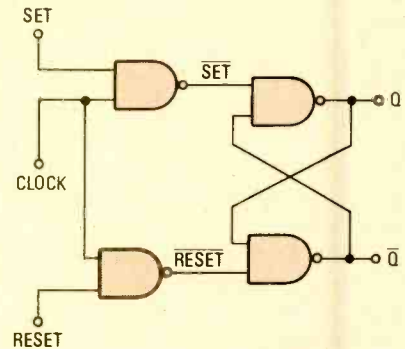

Fig. 9. The R-S flip-flop is asynchronous—it is not time-dependent and will operate whenever a valid input is applied unless a clock control input is provided.

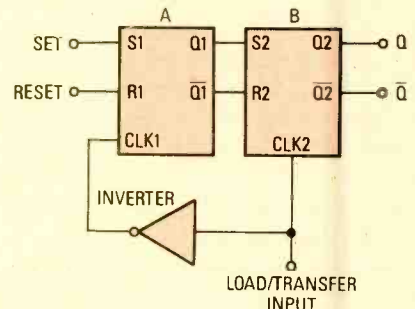

Fig. 10. The master/slave flip-flop circuit consists of two clocked R-S flip-flops, designated here as A and B. The circuit is configured so that the outputs of A drive the inputs of B. The two clock lines are driven out of phase from a common clock, through the load/transfer input.

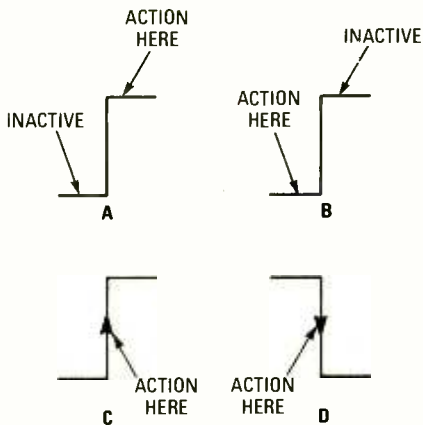

Fig. 11. In a level-triggering flip-flop, the circuit action happens when the level is either high—positive-level triggering, as in A—or low—negative-level triggering, as in B. Edge triggering occurs when the input signal is in transition from either low-to-high (at the positive edge) or high-to-low (at the negative edge) as illustrated in C and D, respectively.

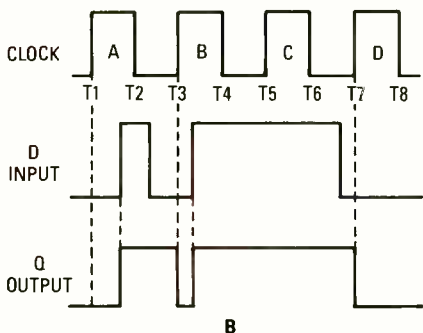
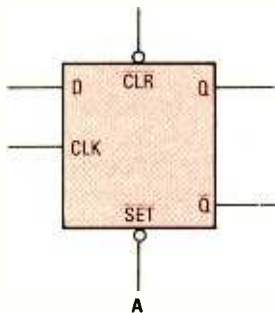

Fig. 12. The type-D flip-flop (A) is a one-bit data latch. It will transfer the data on the D input line only when the clock line is active. A time chart (B) shows how the Q output switches with the D input and clock pulses.

in circuits that have little or nothing to do with computers.

Some flip-flops have two outputs called Q and Q-not (or \bar{Q}). The Q output is the main output, while \bar{Q} is said to be a complimentary output. That is, when Q is high, then \bar{Q} will be low, and when Q is low, then \bar{Q} will be high. Also, when an input line on a schematic diagram is shown with a small circle at the flip-flop body, then that input is active when low.

Otherwise, the input is active when high.

R-S Flip-Flops. The R-S, or “Reset-Set,” flip-flop is a flip-flop circuit that has two inputs: set and reset. When the reset input is made active, the Q output is forced low (if a \bar{Q} output is available, then it is forced high). The set input has just the opposite effect: an active input signal forces the Q output high and the \bar{Q} output low.

There are two forms of R-S flip-flop: NOR-logic and NAND-logic. The NOR-logic R-S flip-flop circuits are configured with two-input NOR-gates such as in the 7402 devices. The NAND-gate circuits are built using two-input NAND-gates such as in the 7400 chips.

The NOR-logic flip-flop circuit is shown in Fig. 7A, while the truth table is shown in Fig. 7B. The NOR logic circuit uses active-high inputs. In other words, a low on both inputs at the same time will result in no output change. But if either input is made high, while the other is low, then the result will be an output-state change.

Which state occurs depends upon whether it was the set or reset input that was made active. The condition of both inputs being simultaneously high is disallowed because the results will be unpredictable.

The NAND logic circuit (Fig. 8A) uses two-input NAND gates instead of NOR gates to form a flip-flop. They act just the opposite of NAND-gate flip-flops (compare Fig. 8B with Fig. 7B)

There are two R-S flip-flop chips available in the CMOS family of devices. The 4043 is a quad NOR-logic R-S flip-flop (“quad” because four R-S flip-flop’s are in the same package). Similarly, the 4044 device is a quad NAND-logic R-S flip-flop.

Clocked R-S Flip-Flops. One of the problems inherent in the design of the R-S flip-flop is that noise on the inputs can trigger an output transition. Also, the R-S flip-flop is asynchronous—it is not time-dependent and will operate wherever a valid input is applied. A solution to those kinds of problems is the clocked R-S flip-flop circuit of Fig. 9.

The two gates on the right form a NAND gate logic R-S flip-flop in the same manner as in Fig. 8A. The inputs of that flip-flop are controlled by the outputs of the other two NAND gates. As long as the clock input remains low, the outputs of both left gates are locked high, so the R-S flip-flop cannot operate. However, if the clock-input goes high, then the inputs of the R-S flip-flop will respond to the inputs applied to the set or reset inputs.

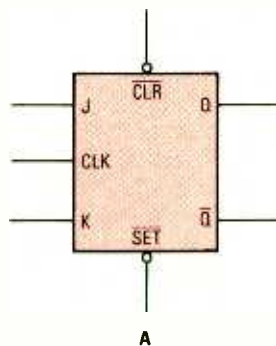

PRECLEAR	PRESET	OUTPUT Q
0	0	DISALLOWED
0	1	0
1	0	1
1	1	NORMAL FOR CLOCKED OPERATION

J	K	CLK	OUTPUT Q
0	0	[Clock Pulse]	NO CHANGE
0	1		0
1	0		1
1	1		FLIPS TO THE OPPOSITE STATE

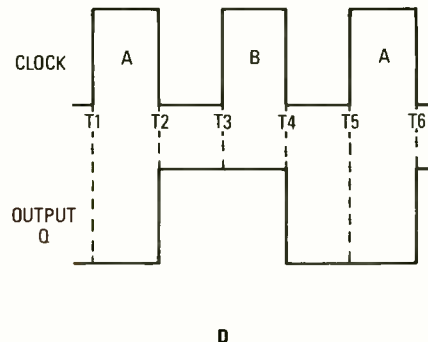

Fig. 13. The J-K flip-flop (A) can be operated in either of two modes: direct and clocked. The logic truth table for the direct mode is shown in B. The truth table for clocked operation of the J-K flip-flop is shown in C. Its activity in a binary-division application is shown in D.

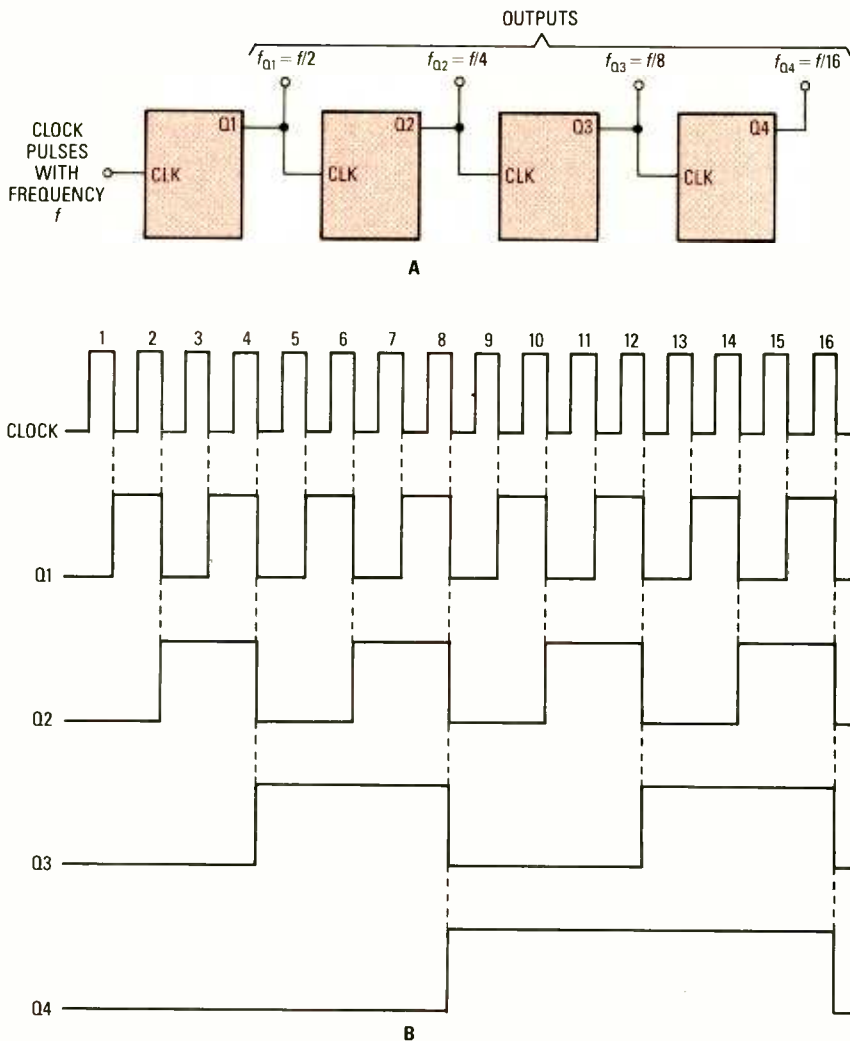

Fig. 14. Shown in A is a four-bit binary counter made from 4 J-K flip-flops. The timing diagram for the circuit is shown in B.

Master-Slave Flip-Flop. The so-called "master-slave" flip-flop, also called the load/transfer flip-flop, is shown in Fig. 10. That circuit consists of two clocked R-S flip-flops, A and B as shown. The circuit is configured such that the outputs of the left flip-flop drive the inputs of the right one. The two clock lines are driven out of phase with one another but from a common clock line, now called the load/transfer, or the L/T input.

If the L/T line is high, then the clock of the A flip-flop is low and the B one is high. Under that condition, B is active, and A is inactive. Whatever levels appear on the outputs of A are automatically transferred to the outputs of B by virtue of CLK2 being high. But when the L/T line goes low, B is disabled (but its outputs remain the same) and A is enabled. Any changes on the S and R inputs are reflected on the $Q1/\overline{Q1}$ outputs of A. When the L/T line goes high again, those new levels are transferred

to the outputs of B. The master-slave flip-flop is used where noise or synchronization is a problem.

In some flip-flops we see a difference between various types of clock triggering. Figures 11A and 11B show the difference between positive- and negative-level triggering. In level triggering, the circuit action happens when the level is either high (positive-level triggering) or low (negative-level triggering). Edge triggering occurs when the input signal is in transition from either low-to-high (called positive-edge triggering), as in Fig. 11C, or high-to-low (called negative-edge triggering), as shown in Fig. 11D.

Type-D Flip-Flops. The type-D flip-flop, also sometimes called a one-bit data latch, is a digital element that will transfer the data on the D input line (Fig. 12A) *only* when the clock (CLK) line is active. In most type-D flip-flops, the clock is active when high, so that rule

translates into: the data level on the D input is transferred to the Q output when the CLK line is high. Thus, the type-D flip-flop is said to "latch" the data on the D input for one clock cycle.

Put another way: While the CLK line is high, the Q output state follows the D input. All transitions occurring at the D input are inverted and sent to the Q output. A high input produces a low output, and a low input produces a high output.

Figure 12B shows a timing diagram of how the type-D flip-flop works. There are four clock pulses shown: A, B, C, and D. They are shown as a periodic square-wave pulse train, but they need not be that regular. The CLK line could be connected to a line that only goes high occasionally.

Assume the Q output is initially low. At time T1 the CLK goes high and the D input is low. Thus, the Q output will remain low at this time. However, note that while pulse A is still high the D input makes an abrupt transition to high. At this point, the Q output snaps high and remains there after pulse A expires at time T2. If the D input had dropped low again, the Q output would have followed. Examine the remaining pulses for the relationship between the output and input levels relative to the clock signal.

Examples of type-D flip-flop include the 7474 dual edge-triggered TTL flip-flop, and the 4013 CMOS device. The 7475 is a TTL quad-latch device, but it has only two clock-inputs. Each clock input is connected to a pair of flip-flops. When both clock lines are connected together the 7475 operates as a four-bit data latch.

J-K Flip-Flops. The J-K flip-flop (Fig. 13A) can be operated in either of two modes: direct and clocked. The logic truth table for the direct mode is shown in Fig. 13B. The direct inputs of the device (clear and set) are active when low. For direct operation the J and K inputs are normally tied to the inactive state, which in this case is low. The circuit action depends on those inputs, and the clock input is irrelevant (in the "don't care" state). Note that all four possible combinations of clear- and set-input states are shown.

When both set and clear are low, the J-K flip-flop does not know what to do, so that state is disallowed. The results are unpredictable when it occurs, so avoid that combination of inputs. When

(Continued from page 101)

THE DIGITAL ELECTRONICS COURSE

LIGHT-CONTROLLED MONOSTABLE APPLICATIONS

Comparator and timer circuits are both very useful by themselves, but when combined they can perform complex and interesting operations. This month we present you with just such a circuit.

BY ROBERT A. YOUNG

In the last two exercises, we looked at the 324 op-amp and the 555 oscillator/timer individually. This time we'll combine the basic monostable multivibrator with a comparator circuit. Combining the two into a practical application will serve to reinforce your understanding of the two circuits.

Light-Controlled Monostable.

Figure 1 shows a 555 monostable multivibrator (from the last lesson) combined with a pair of light-controlled comparators (from two lessons ago) to form a circuit that can be used to turn on the entrance lights of one's home for a predetermined length of time, and at the end of that period turn them off.

Note that pin 7 of U1-b is connected to pin 4 (reset) of U2. Recall from the previous exercise that in order for a timing cycle to be initiated, pin 4 must be held high. If pin 4 is held low at the time that a negative-going trigger pulse is applied to pin 2 of the 555, no timing cycle is initiated. Also recall that the LDR's have a dark resistance of about 0.5 megohm and a full-light resistance of about 100 ohms.

During the daytime, strong light strikes

R5 (we are only concerned with R5 since it is the only LDR that has any affect on the circuit), therefore its resistance is low, say about 100 ohms. Because R6 has a resistance many times that of R5, the voltage drop across it is far greater—about 4.98 volts for R6, as opposed to .02 volt for R5. Now, with the values shown for R1 and R3, less than half of the supply voltage,

about 1.02 volt, is applied to inverting input of U1-b.

With the inverting input of U1-b at a higher potential than its non-inverting input, the output of U1-b goes low. That low is applied to pin 4 (reset) of U2, inhibiting it, so the application of a negative-going trigger pulse at pin 2 does not initiate a timing cycle. But as sundown approaches, the resistance

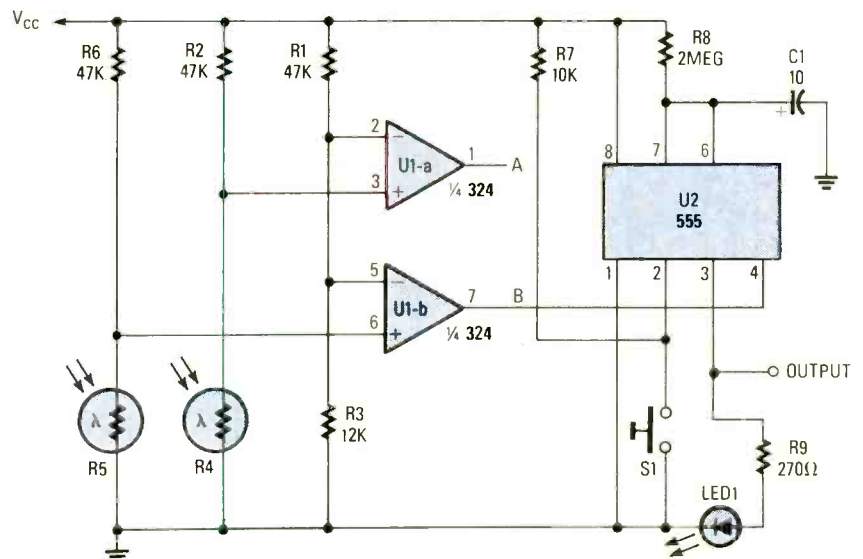

Fig. 1. The light-controlled monostable was produced by combining a 555 monostable multivibrator with a pair of light-controlled comparators. The circuit can be used to enable or disable the operation of the load device, depending on the time of day. During the daylight hours, the timer (U2) is disabled, and so produces no output. However, during the nighttime hours, U2 is enabled by the output of U1-b, so that pressing S1 initiates a timing cycle, which activates LED1 for a time determined by R8 and C1.

*Our gratitude is extended to the EIA/CEG for the creation of this course, especially to the consultants who brought it to fruition: Dr. William Mast, Appalachian State University; Mr. Joseph Sloop, Surry Community College; Dr. Elmer Poe, Eastern Kentucky University.

of R5 increases toward its maximum value of about 0.5 megohm.

As the resistance of R5 increases, and hence the voltage drop across it also increases, the output of U1-b becomes less negative. When the resistance of R5 crosses the 47k mark, the output of U1-b swings positive, removing the inhibit signal applied to pin 4 of U2. Pressing S1 at that point initiates a timing cycle, producing an output at pin 3 of U2, which would, in turn, trigger the device or circuit that follows. For instance, the output of U2 at pin 3 might be fed to the base of a transistor, which could be used to activate a relay and thereby turn on an AC lamp.

That task can also be handled by an optocoupler with a Triac driver (also called a bilateral trigger) to fire a Triac, which would apply power to an AC load.

Light-Controlled Timer Circuit. The circuit shown in Fig. 2 is basically the same as that shown in Fig. 1, with the exception that the switch (S1) connected to pin 2 of U2 in Fig. 1 has now been replaced by the output of U1-a. Such a circuit can be strategically placed so the entry lights can be turned on automatically by the beam from your automobile's headlights. The light sensors (R4 and R5) must be located so that your automobile's headlights shine on R4, but not on R5.

Under no-light (nighttime) conditions, U1-b and its associated components perform as before. Resistor R4, now at its maximum dark resistance, causes a

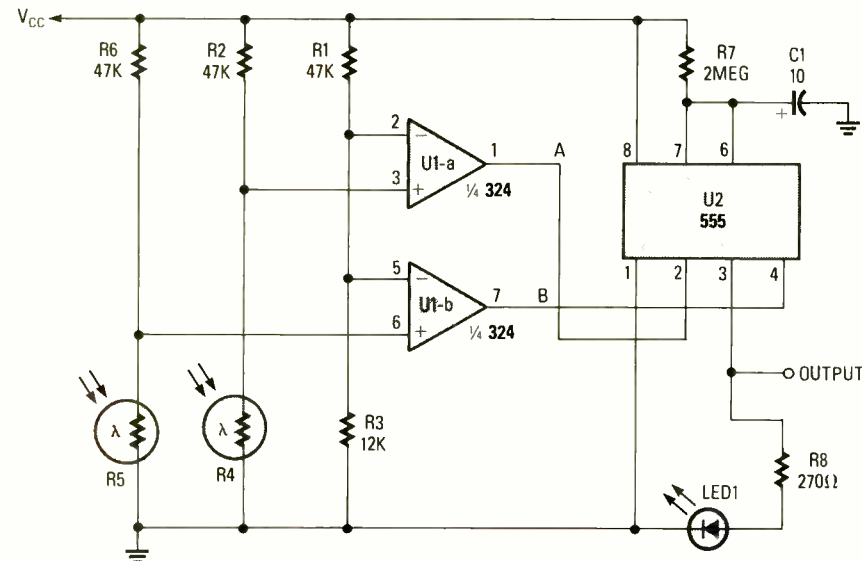

Fig. 2. This light-controlled timer circuit is basically the same as that shown in Fig. 1, with the exception that S1, formerly connected to pin 2 of U2 in Fig. 1, has now been replaced by the output of U1-a. Such a circuit can be strategically placed so the entry lights can be turned on automatically by the beam from your automobile's headlights.

The Digital Microprocessor Course is reprinted here with the permission of the Electronic Industries Association/Consumer Electronic Group (EIA/CEG). The complete parts kit is available from EIA/CEG. For further information, contact EIA/CEG Product Services Department, 1722 Eye Street, NW, Suite 200, Washington, DC 20006, or call 202/457-4986.

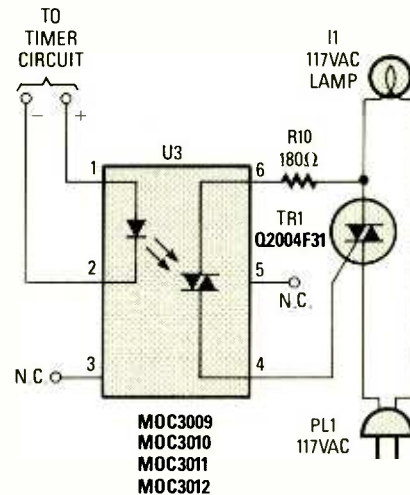

Fig. 3. The circuits in Figs. 1 and 2 can be combined with this circuit (which contains optocoupler U3 with Triac-driver output) to control AC power to the load device.

voltage (about 4.5 volts) close to the supply voltage to be applied to the non-inverting input of U1-a, producing a high output at pin 1. That high is fed to pin 2 of U2. Since the 555 requires a negative-going pulse to initiate a timing cycle, the positive voltage applied to pin 2 has no effect on the circuit.

PARTS LIST FOR THE LIGHT-CONTROLLED MONOSTABLE EXERCISE

RESISTORS

(All resistors are 1/4-watt, 5% units unless otherwise specified)

R1, R2, R6—47,000-ohm

R3—12,000-ohm

R4, R5—Light-dependent resistor (0.5-ohm dark resistance, 100-ohms light resistance)

R7—10,000-ohm

R8—2-megohm

R9—270-ohm

ADDITIONAL PARTS AND MATERIALS

U1—LM324 quad low-power, op-amp, integrated circuit

U2—555 oscillator/timer, integrated circuit

LED1—Jumbo light-emitting diode (any color)

S1—SPST switch

Breadboard, +5-volt power source, wire, etc.

When a light is shined on R4, its resistance decreases, and hence the voltage applied to the non-inverting input of U1-a. As the voltage drop across R4 decreases, the output of U1-a becomes less positive. When the resistance of R4 drops below 47k, the output of U1-a goes negative. That negative-going pulse is applied to pin 2 of U2, initiating a timing cycle. The output of the circuit can then be used to drive some power-control circuitry.

Power-Control Circuits. Figures 3 and 4 show two AC control circuits that can be added to the circuit in Figs. 1 and 2 to control an entrance lamp. The circuit in Fig. 3 uses an optocoupler (U3) with a Triac-driver output to trigger TR1. The output of U2 (see Fig. 2) at pin 3 is tied to pin 1 of U3, and pin 2 of U3 is tied to ground. When the output of U2 goes high, U3's internal LED is forward-biased, causing it to light.

Light radiation from the LED striking the light-sensitive area of U3's internal Triac-driver (called a bilateral switch or a Diac) causes it to conduct, delivering a trigger voltage, derived from the AC line through R9, to the gate of TR1. That triggers the Triac on for one half of the AC cycle. As the AC signal collapses toward zero crossing (*i.e.*, when the signal swings from positive to negative, or *vice versa*), the Triac turns off only to be re-triggered by a negative-going voltage for the other half of the AC cycle.

The action of the Triac and its trigger
(Continued on page 103)



AUDIO-TECHNICA ATH-909 STEREOPHONES



*Low-priced, high quality stereo headphones
that deliver comfort and CD-grade audio performance!*

In this high-tech world of camcorders, CD players, computers, VCR's, etc., it is surprising to discover that consumers are still concerned about the quality of more basic audio equipment, like a stereo headset. What is more surprising is the quality of currently available products.

One such headset caught the eye of this reviewer in an audio store while attempting to listen to a new FM tuner without disturbing the other customers. I picked up a pair of Audio-Technica (1221 Commerce Dr., Stow, OH 44224) ATH-909 Stereophones, which was on display to promote high-fidelity headset sales. Its presence appeared to do just that.

Surprise was not the word to describe this reviewer's reaction to the audio quality that he heard from that moderately priced headset. A sample was obtained from Audio Technica, and from its examination and testing, the following *Hands-on Report* was born.

Human Engineering. The ATH-909 Stereophone is a bit unusual in appearance. When placed on the head, you may have some difficulty adjusting the headband the first time, because of its novel operation. It doesn't have separate earpieces that slide up and down in relation to the headband. Instead, the headband consists of two pieces: an upper headband (made from stiff plastic) that is a mount for the earpieces and a second soft-pliable

plastic headband beneath it. The soft lower band rests on the wearer's head while the hard, upper band does not touch the head at all.

Each earpiece pivots, so the slightest pressure will ensure good audio coupling between the ears and headset while making a comfortable fit. The open-back design of the earpiece delivers solid bass response and allows them to be comfortably worn for long periods of time with no sense of fatigue or isolation from the user's surroundings.

Specifications and Facts. The ATH-909 Stereophones is fabricated from quality molded-plastic parts and electronics. An earpiece was removed from the headband, the cloth cushion gently pried off, and a felt donut wafer was removed to facilitate inspection. Each plastic-earpiece shell is sturdy and acts as a mount for a single 44-mm diameter driver. There's nothing shoddy about its construction.

The total weight of the ATH-909 Stereophones without the cord is 6.9 ounces. The lower headband conforms to the head shape of the wearer, evenly distributing the headset's weight along the breadth of the scalp.

A single 30-ohm driver in each earpiece includes a high-flux samarium-cobalt magnet to drive the 1¾-inch diameter cones. The company's claimed frequency response of 20–20,000 Hz with very low distortion is apparently valid.

The earpiece wires flow from the bottom of each earpiece to meet at a juncture 14 inches from the headset and then continue on to a ¼-inch stereo phone plug. The cord is 3 meters long (about 2 inches short of 10 feet) and extremely flexible, permitting motion by the wearer without ungainly tugging by the cord. The cord is extremely light and flexible—it's not coiled and didn't tangle during the testing period.

Listening Test. The ultimate test for a headset is its ability to reproduce sound for a critical listener who is aware of the nuances and instruments used to make the original recordings. Thus, a variety of familiar recordings were played ranging from a voice solo to a complete orchestration of a popular classical piece.

Solid sound reproduction of the RCA *Dirty Dancing* soundtrack CD was heard on the ATH-909 Stereophone. The voices sounded genuine without screeching highs. And the headset was comfortable to wear.

Listening to Van Halen's *OU812* (Warner Bros.) CD on the ATH-909 Stereophone revealed limitations of the original source that were transferred to the CD. That spoke well of the fidelity of the headset. A lesser headset would have smeared the original recording. Nevertheless, the string instruments and keyboard-synthesized strings were as exciting as a live concert.

(Continued on page 108)

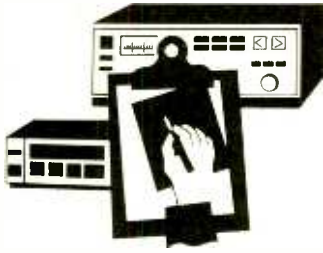

Product Test Reports

Yamaha TX-1000U AM/FM Stereo Tuner

By Len Feldman

While standards for FM broadcasting have remained essentially unchanged since 1961 (that was when the FCC authorized FM-stereo broadcasting), various manufacturers of audio equipment continue to strive to deliver the best possible sound from an FM program source. Delivering good sound from FM involves more than just good frequency response, low distortion, and good sensitivity. With more stations crowding the FM dial, (especially in densely populated metropolitan areas) it's increasingly important for a good tuner to be able to separate one station from another. Narrowing the IF (Intermediate-Frequency) bandwidth of the tuner accomplishes that purpose, but is often accompanied by higher distortion levels and poorer stereo separation. The solution is to have two levels of bandwidth: wide and narrow. That's what *Yamaha* has done in their superb new *TX-1000U* tuner. Beyond that, they have even automated the selection of wide or narrow, allowing the tuner's circuitry to determine which of those two modes is needed for a particular station signal.

You can store up to 24 station frequencies for instant recall. In setting up those two-dozen presets, information concerning the choice of antenna input (the tuner features two indepen-

dent antenna inputs), IF bandwidth (wide or narrow mode), and several other parameters are stored along with the frequency of the preset signal, providing optimum reception every time the station is recalled.

In addition to the presets, you can tune the tuner manually or have it search for the next acceptable signal on the AM or FM dial. An interesting added feature is the ability to memorize station signals by name instead of frequency, if you choose to do so. In other words, when you want to assign a preset for a signal you like, you can identify that signal by using up to four letters rather than its frequency, which you may be more likely to forget. Fortunately, a backup power system ensures that all of that programming is retained, even in the event of a brief power outage.

Yamaha has developed a remarkable tuning system for this tuner, which they call "computer servo lock tuning." That system provides two different tuning modes, each optimized for different signal conditions, and both controlled by a microprocessor. The microprocessor discriminates between different reception conditions and selects the appropriate tuning mode. If the station has a strong, high quality signal, an "infinite resolution" FM-stereo tuning cir-

cuit is activated for maximum audio quality. With a weak, poor-quality signal, a PLL (phase-locked loop) locks on to the broadcast frequency to ensure the best possible reception.

This tuner has many other features, including a remote control. Some of the others will become evident as we discuss the front-panel controls and their functions.

The Controls. A power switch is found at the left end of the front panel. Below it are eight numbered buttons used to store and recall presets. Each button can really be thought of as three buttons, since successive pushing of another button nearby determines whether the first button corresponds to preset number 1, number 9, or number 17, etc. A display window near the upper right end of the panel shows preset numbers, frequency of selected stations, IF mode (wide or narrow) in use, signal strength, tuning mode, presence of a stereo signal, auto/manual tuning status, which antenna input is in use, whether stereo blending has been selected (to reduce noise for weak-signal stereo reception), whether an RF-attenuator button has been depressed (to attenuate overly strong signals that might overload the front end of the tuner), and whether a "station lock" function has been activated to lock in the required frequency. In short, looking at this elaborate display pretty well tells you everything you want to know about the current status of the tuner.

What looks like a rotary tuning knob is located at the extreme right of the panel. In fact, that control only moves slightly clockwise or counterclockwise, serving either to change tuned-to frequencies in either direction or to call up letters of the alphabet on the display when you want to store favorite stations by call letters rather than by frequency.

Secondary controls are hidden from view until you tip a movable section forward, disclosing several additional controls. Included on that swivel-panel section are the wide and narrow-IF selectors, the FM/AM band selector, tuning-mode buttons, antenna-input selector buttons, the blend on/off button, the RF-attenuator button, the station-display button (frequency/letters), the station-lock button (which, incidentally, also deactivates the tuning knob so that it won't accidentally be used to detune a station), and the memory button that's used to store station frequencies in the various presets. If you

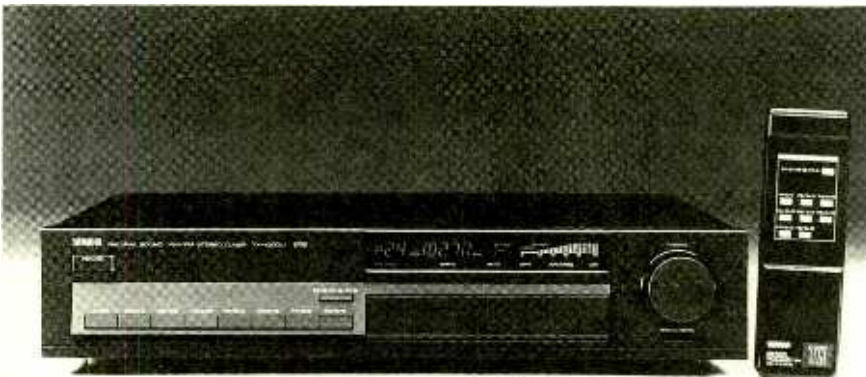

CIRCLE 119 ON FREE INFORMATION CARD

The Yamaha TX-1000U AM/FM Stereo Tuner

primarily use the presets instead of the tuning dial, and if each preset has been memorized together with its optimal reception modes, there is little need to access those secondary controls at all. That's why they can be hidden behind the panel for a less cluttered front-panel look.

The rear panel is equipped with two 75-ohm connectors for the two FM-antenna inputs, a 300-ohm AM antenna input, and a pair of output jacks. Accessories supplied with the tuner include an AM loop antenna that comes with a small clamp that can serve as a stand, so that the loop can be posi-

tioned atop the tuner and oriented for best AM reception. A 75-ohm/300-ohm transformer is supplied as well, in case your FM antenna lead-in is of the 300-ohm variety.

The Test Results. We tested the FM-
(Continued on page 98)

YAMAHA TX-1000U STEREO TUNER—PUBLISHED SPECIFICATIONS AND ACTUAL PERFORMANCE

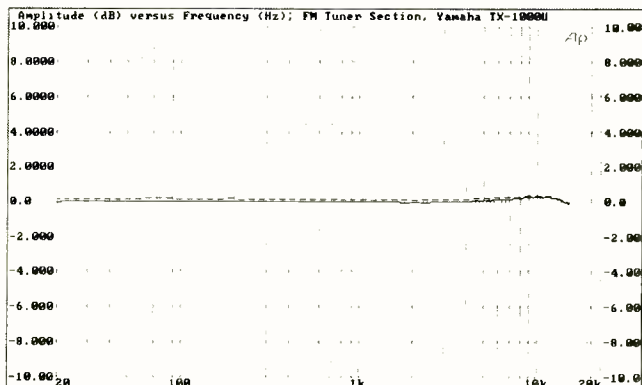

The unit's frequency response was nearly flat, deviating by no more than 0.2 dB from 20 Hz to 15 kHz.

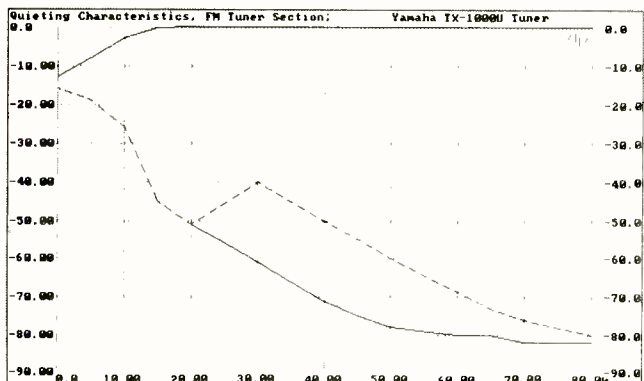

The 30-dB quieting point was reached with an input of only 10.3 dBf. The upper solid line in the chart is the audio reference level, the lower solid line is mono, and the dashed line is stereo.

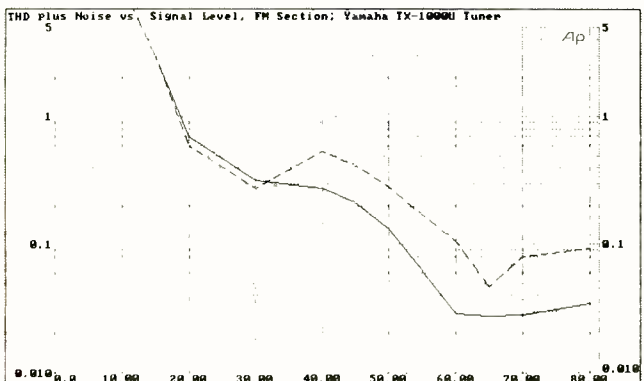

This graph shows distortion plus noise versus signal level in the wide-IF mode. The solid line is mono; the dashed line is stereo.

Specification	Manufacturer's Claim FM Tuner Section	PE Measured
Usable Sensitivity (30 dB quieting)	10.3 dBf	10.5 dBf
50 dB Quieting		
Mono	15.3 dBf	18.0 dBf
Stereo	37.2 dBf	40.0 dBf
Signal/Noise Ratio		
Mono	98 dB (See text)	82 dB
Stereo	90 dB	80 dB
Distortion, 1 kHz		
Mono (wide)	0.02%	0.028%
Stereo (wide)	0.03%	0.045%
Stereo Separation, wide	68 dB @ 1 kHz	60 dB
Frequency Response (20 Hz–15 kHz)	± 0.5 dB	± 0.2 dB
Image Rejection	95 dB	98 dB
I.f. Rejection	115 dB	>100 dB
Spurious Rejection	110 dB	>100 dB
AM Suppression	70 dB	68 dB
Capture Ratio	1.2 dB (Wide)	1.5 dB
Selectivity	90 dB (Narrow)	Confirmed
AM Tuner Section		
Usable Sensitivity	100 μV/m	90 μV/m
Selectivity	32 dB	34 dB
Signal-to-Noise Ratio	52 dB	55 dB
Image rejection	40 dB	38 dB
Distortion	0.3%	0.28%
Frequency Response (70 Hz–3.8 kHz)	N/A	± 6 dB
General Specifications		
Audio Output (FM/AM)	500 mV/150 mV	
Power Requirements	120V AC 60 Hz, 15 W	
Dimensions (W × H × D, inches)	17 ¹ / ₈ × 3 ³ / ₄ × 14 ⁷ / ₁₆	
Weight	13 lbs. 7 oz.	
Price	\$549.00	

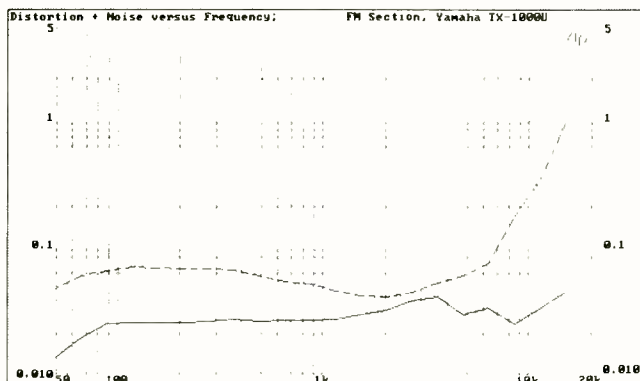

In the wide-IF mode, distortion and noise measured only .032% in mono (solid line) and .07% in stereo (dashed line) at 6 kHz.



Antique Radio

WIRELESS RECEIVING—1912-STYLE

By Marc Ellis

If you are one of the many readers who have been waiting for a report on the results of powering up the *Pilot A.C. Super-Wasp*, I'm going to have to ask you to be patient just a little bit longer. As you know, I accidentally ruined the wire-wound resistor that was to be used as the voltage-divider/bleeder for the Wasp's power supply, and couldn't come up with another one in time to try out the Wasp for last month's column. The parts-procurement problem being what it is today, I'm still not ready.

Having tried all of the local parts sources, and even driven out twenty miles to shop at a small hamfest that happened to be scheduled a few weeks ago, I still came up empty-handed. If this had been strictly a personal project, I would have now put the partly completed power supply on the shelf—indefinitely if necessary—until I could locate the resistor in a surplus catalogue or hamfest flea market.

However, since folks out there in reader-land are watching and waiting, I've taken the drastic step of ordering new material from one of the last of the full-line mail-order parts dealers. (And, being the frugal—if not downright cheap—soul that I am, don't think it didn't break my heart to come up with the twenty-five buck minimum order!) With any luck, we should be ready to get back the to Super-Wasp next

month, and I hope you all appreciate the sacrifice!

Tuning In With The Radio Boys. So, without the Wasp to work on, let's continue with the new story I began last month. I've been trying to paint a picture of what it must have been like for a young experimenter to get started in radio (or "wireless," as they called it then) in the early decades of this century when the medium was still new. In the March issue, we followed our experimenter as he set up a typical spark-transmitter "starter set." Then we talked about the steps he would have most likely taken later to improve it. This month, we'll do the same thing for the receiving apparatus.

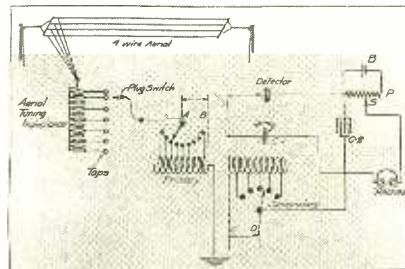

Another early receiver schematic shows a loose coupler hookup. The battery (B) and potentiometer (P) supply bias for the detector. This set makes use of a separate inductor coil for tuning the antenna circuit.

To set the stage, here's a short passage from *The Radio Boys' First Wireless* by Allen Chapman (copyright 1922 by Grosset & Dunlap). The scene is the barn workshop of radio enthusiast Dr. Amory Dale, church pastor in the small town of Clontonia. Dr. Dale is giving a talk to a group of the local boys on how to set up a radio receiver, and he has just demonstrated a simple crystal set:

"... You can see how many things I've used that any one of you can find about the house, such as tinfoil, curtain poles, curtain rings, wood for the box,

and so on. The wire needed for your tuning coil and your aerial can be obtained for less than a dollar. The detector, including the crystal, can be got for another dollar. An excellent receiver (Note: Here the Doctor is referring to an earphone or telephone receiver.) can be bought for two dollars. A few minor things will be needed at perhaps five or ten cents each. Altogether, the cost of the set can be brought within five dollars."

So even factoring in the several-hundred-percent difference between the value of 1920's and 1980's money, almost any interested young person with a talent for scrounging could eventually scrape together the makings of a decent radio receiver. Not only could the youngster obtain all the necessary parts for little more than pocket change, but he wouldn't need the assistance of a graduate electronics technician to assemble them into a working radio. Though the technology of the era was primitive, it was—at least—accessible to almost everyone.

Don't be too quick, then, to feel superior to the radio enthusiasts of that by-gone time or smile at their rudimentary circuits and homely materials. The state of the art was such that any scientifically minded person could easily understand it. Basement and attic experimenters could, and often did, make significant contributions to that art—sometimes using those contributions as the basis for illustrious careers in research or industry.

Thus, the neighborhood experimenter of the 1910's and '20's found an excitement and stimulation in the hobby of a type that can't be matched today. And as he magically plucked signals from the air—some of them from hundreds of miles away—he was looked on with awe and respect by his family and friends. Such a home-grown wizard might very well feel sorry for the electronic hobbyists of the 1980's, who have a much smaller chance of making a similar impact!

The Simplest Receiver. Actually, putting together a "starter" receiver could be even simpler than Dr. Dale made it out to be. If you'd already acquired your crystal detector and earphone, it was possible to get a taste of radio receiving without even taking the time to wind the coil. All you had to do was connect one earphone lead and the antenna to one terminal of the crystal detector and then connect the other

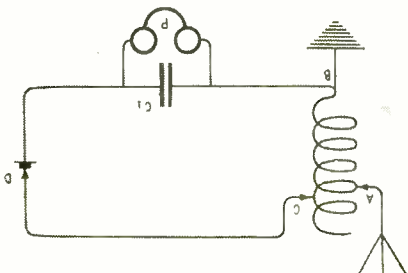

This schematic from an early wireless text shows the "autotransformer" method of isolating an antenna/ground circuit from the phones (P) and the detector (D).

Enter A World Of Excitement with a Subscription to Popular Electronics®

Get the latest electronic technology and information monthly!

Now you can subscribe to the magazine that plugs you into the exciting world of electronics. With every issue of Popular Electronics you'll find a wide variety of electronics projects you can build and enjoy.

Popular Electronics brings you informative new product and literature listings, feature articles on test equipment and tools—all designed to keep you tuned in to the latest developments in electronics. So if you love to build fascinating electronics, just fill out the subscription form below to subscribe to Popular Electronics... It's a power-house of fun for the electronics enthusiast.

EXCITING MONTHLY FEATURES LIKE:

- CONSTRUCTION**—Building projects from crystal sets to electronic roulette
- FEATURES**—Educational training on digital electronics, Ohm's Law, Antennas, Communications, Antique Radio, Simplified Theory
- HANDS-ON-REPORTS**—User test comments on new and unusual consumer products
- SPECIAL COLUMNS**—Think Tank, Circuit Circus, Computer Bits, DX Listening, Antique Radio, Amateur, Scanner Scene

PLUS: ALL OUR GREAT DEPARTMENTS!

You'll get 12 exciting and informative issues of Popular Electronics for only \$18.95. That's a savings of \$11.05 off the regular single copy price. Subscribe to Popular Electronics today! Just fill out the subscription order form below.



FOR FASTER SERVICE CALL TODAY
1-800-435-0715

IN ILLINOIS 1-800-892-0753 (7:30AM-8:30PM)

EASTERN STANDARD TIME

Popular Electronics® SUBSCRIPTION ORDER FORM

P.O. Box 338, Mt. Morris IL. 61054

YES! I want to subscribe to Popular Electronics for 1 Full year (12 Issues) for only \$18.95. That's a savings of \$11.05 off the newstand price.

Payment Enclosed Bill me later

Please charge my: Visa Mastercard

Acct. #

Signature _____

Exp. Date _____

PLEASE PRINT BELOW:

NAME _____

ADDRESS _____

CITY _____

STATE _____

ZIP _____

Allow 6 to 8 weeks for delivery of first issue. U.S. Funds only.
In Canada add \$5.00 Postage. All Other Foreign add \$7.50 Postage.

APEDO

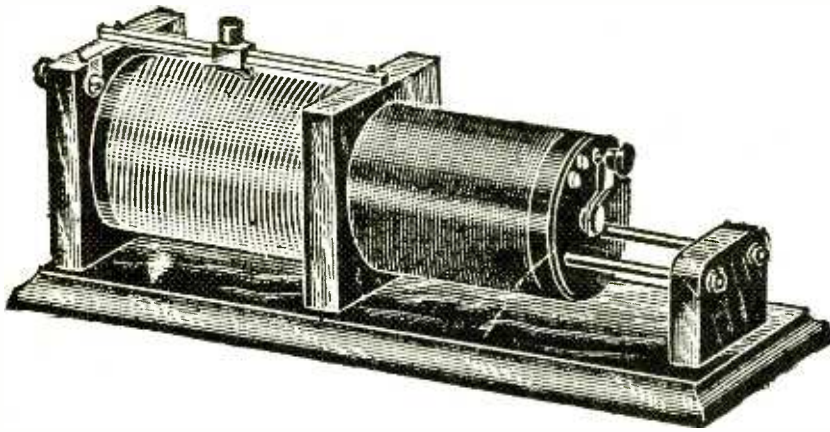

A typical loose coupler uses a slider to tune the outer (primary) coil and a tap switch to tune the inner (secondary) coil. Note the two rails on which the secondary could be moved in and out.

and Rotary Slid- cted by us stands de Detector Stand

It
de

1/2
over
ed
As
ed
he
not
ite
ry

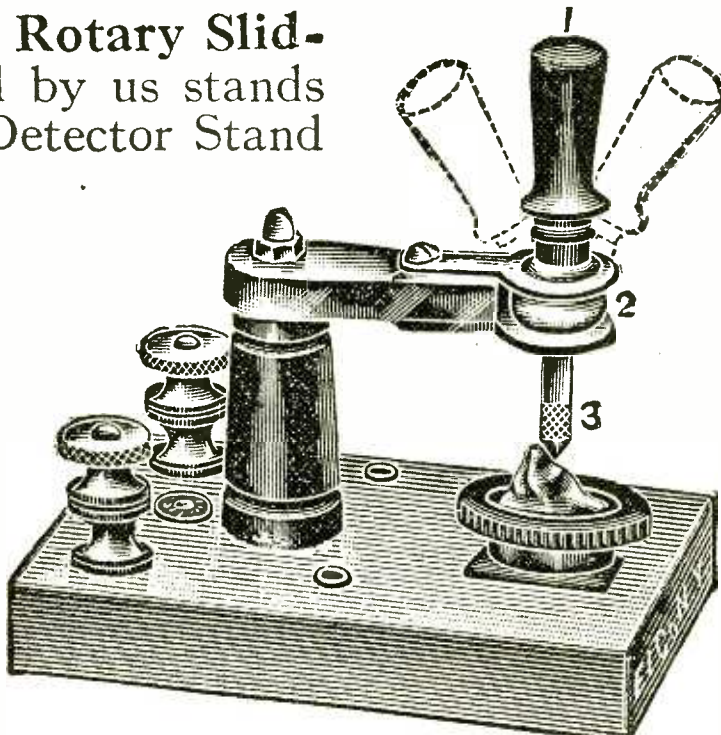

A first-class detector stand of the period featured nickel-plated brass hardware and a marble base. The contact arm had a nifty ball-joint mounting for easy adjustment.

earphone lead and the ground to the other terminal.

Listening intently to the earphone, you'd next touch the "cat's whisker" (usually a stiff phosphor bronze wire) to various locations on the crystal until you'd found the "sensitive spot" that would enable you to hear radio signals. Of course, without the coil, there was no way of tuning the receiver. You simply heard anything that was on the air at the time and within the range of your simple apparatus (though frequencies that were closest to the natural resonance of your antenna and ground system would be favored).

The fact that your little set had no selectivity wasn't really much of a problem. There didn't need to be much concern for separating interfering stations. In fact, most times you'd feel lucky to pick up anything at all!

My own first experience with "building" a radio involved just such a set. And even though the event took place over 45 years ago, I still vividly remember my excitement on first trying out the hook-up. Since it was the mid 1940's and not the early 1920's, there was plenty on the air to hear. What I got was a jumble of local broadcast stations, but they sounded just wonderful to me!

Coils and Sliders. Of course, even with the sparsely populated radio spectrum of the 1920's, no serious receiver would be complete unless it could be tuned to specific frequencies, so that stations of interest could be selected and unwanted ones tuned out. Accomplishing that meant adding tuned circuits.

In more modern practice, a tuned circuit usually contained a fixed coil, or inductor, associated with a variable capacitor. Tuning adjustments were then made with the capacitor. But in the early days of radio, tuning capacitors were expensive and not in common supply. So most amateurs used a variable inductor, which could be easily built in a home workshop.

The variable inductor was made by winding a coil of insulated wire on a cylindrical form (like the curtain pole mentioned by Dr. Dale). One or more sliding contacts were then arranged so that they could travel the length of the coil, touching the coil turns at different locations. (Dr. Dale somehow made his sliding contacts out of metal curtain rings.) The insulation of the coil wire was removed (by burning or sanding) along the path traveled by the slider so that the slider could make electrical contact with the coil turns.

Using the slider, different numbers of coil turns could be cut in and out of the circuit, providing a more-or-less continuously variable inductance. And if the coil was wound to the correct specifications, its inductance would be such that the desired frequencies could be tuned using only the inherent capacity of the circuit wiring; a separate fixed capacitor would not be required.

Getting Sharp Tuning. If you had a basic detector-and-earphone setup such as the one described earlier, and desired to improve it by adding a tuned circuit, you could most easily do it with a single-slide inductor coil. All you had to do was break the antenna lead and place the inductor in series with it, connecting one of the free wires to one end of the inductor coil and the other wire to the slider.

You could now tune the receiver to a desired frequency by moving the slider to the correct position on the coil. But there was a big disadvantage to that system. The presence of the detector and earphone in the antenna/ground pathway degraded the performance of the tuned circuit, reducing both selectivity and sensitivity. To obtain really

ke
pe
re
is
al
ac
th
wi
m

co
be
pc
bi
IN

satisfactory performance, the signal flowing in the antenna/ground pathway (including the tuned circuit) had to be isolated from that flowing through the phones and detector.

Many different circuit arrangements were devised to cope with that problem, and we couldn't possibly cover them all here. But a solution frequently used by amateurs involved the use of a two-slide inductor coil. One end of the coil winding was tied to ground and to one side of a series-connected detector/earphone circuit. The other end of the circuit was hooked to one of the sliders, and the antenna was connected to the second one.

Now the radio-frequency signal could flow from the antenna, through the tuning coil, to ground, unimpeded by the earphone/detector circuit. The signal also flowed through the earphone/detector circuit, but not by direct electrical connection. Instead it was transferred by inductive coupling (also known as "transformer action") between the coil windings. The sensitivity and selectivity of such a hookup were much better.

The Loose Coupler. A receiver with such a two-slide inductor was tuned by adjusting both slides for maximum volume of the desired signal. One slide tuned the antenna/ground circuit to resonance with the signal; the other one tuned the earphone/detector circuit to resonance with the antenna/ground circuit. But there was a problem associated with that hookup. Changing the positions of the slides also affected the degree of *coupling* (energy transfer) between the two circuits.

With coupling that was too tight (allowing too great an amount of energy transfer), both the selectivity and sensitivity of the set would suffer. On the other hand, coupling that was too loose wouldn't put a strong enough signal into the detector/earphone circuit—thus reducing sensitivity.

Remember that those early experimenters had no vacuum-tube amplifiers to boost signal strength. That meant that they had to use every other trick in the book to increase the sensitivity of their receivers. And one of those "tricks" involved arranging for separate control of the coupling and tuning functions.

A number of different circuits were worked out to accomplish that—some involving multiple-slide tuners. Again, we can't even begin to cover all of the

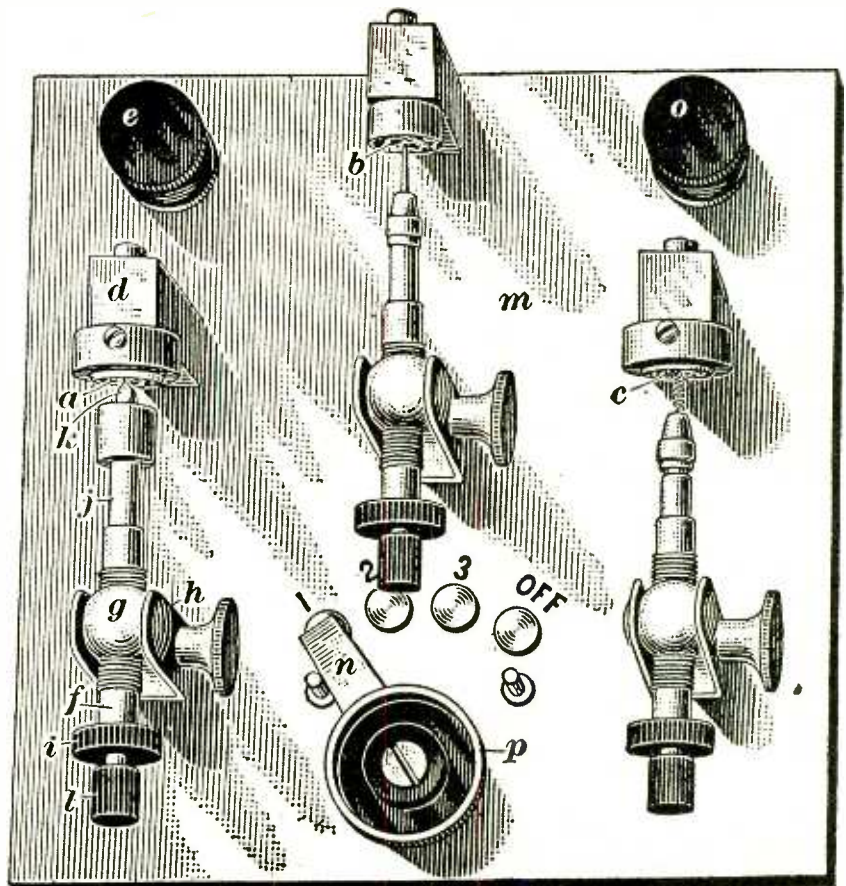

Here's a three-way detector panel for those who wanted to keep their options open. The user could switch between (left to right) silicon, carborundum, and galena detectors.

variations here. But the most common and well-known solution was to make use of a "loose coupler" (otherwise known as an inductively coupled receiving transformer). If you had one of those, you were really going first class.

The primary and secondary windings of the loose coupler were mounted concentrically, and the secondary was mounted on rails so that it could be slid inside the primary or set at some partly-in/partly-out position. By adjusting the position of the secondary, any degree of coupling could be obtained—regardless of the frequency to which the coils were tuned.

Frequency control of the antenna circuit was often accomplished by a slider set up on the transformer primary. But because it had to slide *within* the primary, the secondary could not be tuned in that way. The sliding secondary was often equipped with a tap switch on its face plate, allowing coarse adjustment of the inductor in the local circuit. Fine tuning was handled with a variable capacitor connected across the secondary winding.

Biased Detectors. Before concluding this whirlwind tour through the

colorful world of 1910's and 1920's receiving circuits, I have to mention the important subject of crystal detectors that required battery power. Many of you may blink at that because you're used to thinking of crystal radios as being "free-power" devices.

But during the early days of radio, experimenters discovered that certain materials that were already fair detectors (carborundum crystals being a good example) became much more effective in their action if a small electrical current was passed through them. The polarity of the current was important; it had to flow in the direction in which the crystal normally conducted electricity. In modern terms, I guess you would say that the crystal had to be *forward biased*. Receivers that made use of detectors operating on that principle were equipped with bias batteries (about 4 volts) along with potentiometers to adjust current flow for best results.

I'll Be Back Next Month. Next time, with any luck, I'll give you my long-delayed report on how the Super-Wasp behaved under power at that time. I hope to see you all then. ■



Computer Bits

PUSHBUTTON COMPUTING

By Jeff Holtzman

Some revolutions explode on the scene, permanently affecting the way the world works. Others kind of sneak up on you but have an even more profound affect. Electronic publishing is one of the latter.

What is electronic publishing? I don't know; I don't think anyone else does either, not yet. The reason is that electronic publishing is evolving rapidly now, affecting fields as diverse as word processing, advertising, video production, music production, education, corporate training, commercial databases, on-line communications, traditional paper-based publishing, and more. And it's affecting media ranging from paper to magnetic disk to optical disk (CD-ROM) to digital audio tape (DAT) to PC's.

Of course PC's, all 30 million of them at last count, are the cause of that revolution. PC's are getting more powerful in terms of their raw processing and storage capacities. They're also becoming

more powerful because of their increasing "connectedness" to the outside world. Faxes, modems, scanners, speech boards, video-capture boards—all allow us to capture and convert data into a form the PC can deal with. And laser printers and high-resolution video displays allow processed information to be output in a form that we can deal with.

All those devices, and the software that supports them, deal with information in an electronic form. The dispersal of information in any form is publishing; ergo, electronic publishing. If you start thinking about it, it seems that just about any PC activity you come up with is publishing—and the experts won't disagree with that assessment.

Of course, traditional paper-based products will be with us for a long while. But as time goes on, they'll be considered options in the spectrum of publishing technologies. When someone has some information to publish, it won't be

a question of finding a printing plant. Rather, up-front planning will force people to ask questions like: What is the best way to present this information? Tape? Disk? Paper? Would it benefit from live video or audio? Would it benefit from still photographs or line art? Will the "document" consist of a linear presentation, or will the "reader" want to jump around it at random?

PC Publishing. One likely medium for new publishing ventures is the PC. It's low-cost, ubiquitous, and it has a user-interface (no matter how faulty it is) that millions understand. A likely tool for PC publishing is a significant new product for PC's called HyperPAD. Like the hit Macintosh program called HyperCard, HyperPAD provides an attractive, intuitive environment for designing screens, for linking them to each other and to external programs, for creating data-entry forms, for creating and running Pascal-like "scripts," and more. Unlike the Mac program, HyperPAD runs in character mode, so what you lose in graphic subtlety, you gain in speed (and color).

It's hard to say just what HyperPAD is, because it combines a number of what we normally think of as mutually exclusive tools into one powerful environment. And that environment functions for both product development and end-user usage.

What can you use HyperPAD for? You can use it as a DOS "shell" from which you run application programs, and in which you can manage your hard disk. Linking applications to HyperPAD is easy, but the built-in file-manager is somewhat weak.

Actually, the file manager is one of several HyperPAD "pads," or applications built from HyperPAD scripts. Other built-in pads include a phone book, an idea pad, a game pad, a calculator, a scheduler, a note pad, and more. The overall effect is a visually oriented Side-Kick-like desktop organizer.

You activate a pad or run an external application by "pressing a button," either by clicking on the button with a mouse, or by using the TAB key to highlight the desired button and then pressing <ENTER>.

Special buttons on HyperPAD's home pad allow you to quickly add a new external program or pad. Creating your own pads requires a bit more work, depending on the complexity of what you want to do.

You can create surprisingly sophisti-

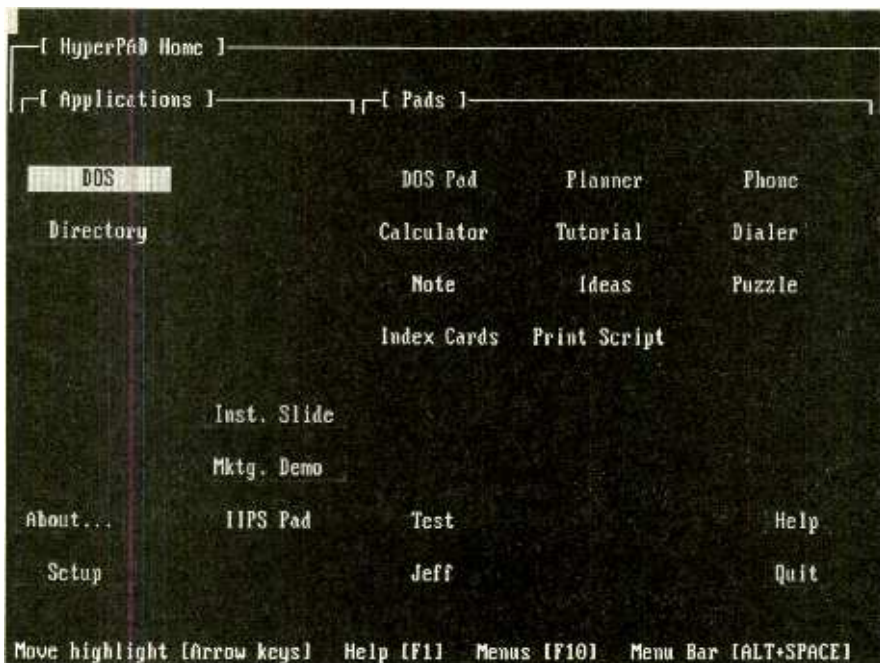

HyperPAD brings pushbutton computing to the PC world. If this program turns out to be as popular as HyperCard is for the Mac, it will revolutionize the way many people use their PC's.

cated pads without ever getting into writing scripts. For example, assume you wanted to create a database listing your record collection. You could do so by copying one of the pre-existing databases (the phonebook), and then modifying the screen layout and fields as needed.

Screen design is quite easy; HyperPAD's painting and line-drawing tools are quite intuitive. Defining fields is also quite easy, and involves no complex formatting specifications or anything of that sort. Just invoke the new field (using a drop-down menu), size it using the mouse, and you're all set! Any given field can contain letters, numbers, or a combination of the two, and you can search and sort a pad (i.e., a database) based on field contents. The maximum size of a field is 30,000 characters; the maximum size of a pad is limited by available disk space. You can optionally set text to wrap automatically in a multi-line field.

HyperPAD is not designed to compete with dBASE or any large database package; it's really designed for relatively small databases that don't depend heavily on validating input data.

There are other uses for HyperPAD. One potentially hot area is in interactive PC-based training. Say, for example, that you wanted to create a self-running tutorial teaching people how to use WordPerfect. You would go through WordPerfect and capture the screens (using a utility that comes with HyperPAD) you want to illustrate. Then you'd import those screens into HyperPAD, convert menu items into buttons (a simple process), link the screens, annotate them—and that's it. Of course, you could also create original screens for marketing demos and the like.

Inside HyperPAD. Like Microsoft Windows and the OS/2 Presentation Manager, HyperPAD is built around an object-oriented message-passing system. If you just deal with HyperPAD at the level of interactive-screen design, you'll never have to come to grips with what that means. But if you want to do anything fancy, you'll have to learn

about message passing and about HyperPAD's script language, which has a syntax like Pascal and many high-level programming statements like modern versions of BASIC.

The idea behind message passing is this: Most of the time, the system sits dormant waiting for an action to occur. (Actions include pressing keys or mouse buttons, and selecting menu items.) When an action does occur, a message is sent through a well-defined hierarchy, and any object in that hierarchy can intercept that message, do something in response to it, and optionally pass it or another message along for objects higher in the hierarchy to act on.

Fields and buttons are at the lowest level; then comes the page those items are located on, followed by the pad of which that page is a part, then the Home pad, and then HyperPAD itself. You can write a "handler" that responds to a specific message, and put that handler at any level in the hierarchy. A very specific handler would go in a low level (field or button); a more general one would go in a high level (page or pad).

For example, you could create a context-sensitive help system. Depending on what was highlighted and where the user was when he or she pressed <F1>, a different help screen would pop up. You'd implement it by writing specific handlers for each field and button, generic handlers for each page, and one for the pad as a whole.

The script language is called PadTalk; it contains Pascal-like control structures (do while, do until, for, if then else, etc.). It also contains many statements for controlling, screen, printer, mouse, modem, and keyboard. The language presently doesn't have PEEK and POKE statements for getting at memory, nor does it have INP and OUT statements for getting at I/O ports. It's also somewhat weak on formatted output, and the script editor is poor. But you can use your own editor and import ASCII files as scripts.

Present weaknesses aside, there's still a lot of power in HyperPAD. If this product takes off in the PC world the way HyperCard did in the Mac world, it's going to change the way many people think about computers, publishing, and about creating applications.

It's also worth mentioning that HyperPAD is a heck of a lot of fun to use and work with. And that's what makes life with PC's worthwhile. ■

AMAZING NEW Pocket Reference

480 pages of tables, maps, formulas, and conversions and it fits in your shirt pocket (3.2" x 5.4" x 0.6")!

\$9.95*



* Plus \$2.00 shipping & handling. Colorado residents add 5.6% tax.

Small sample of contents

Air Tool CFM vs PSI	Radio Alphabet
Battery Charging	TEN Radio Codes
Tire Manufacturer Codes	Telephone Area Codes
Lumber Sizes & Grades	Lost Credit Card Phones
Concrete & Mortar	Sound Intensities
Element Tables	Wind Chill Factors
Computer ASCII Codes	Frequency Spectrum
IBM® PC Error Codes	Geology Mineral Tables
IBM® Interrupts-IO Map	Gloves and Solvents
80286 Hard Disk Types	Bolt Torque Tables
Printer Control Codes	Wood Screw/Nail Sizes
Electric Wire Size vs Load	Math Formulas & Tables
NEMA Motor Frames	Plane/Solid Geometry
Wire & Sheet Gauges	Copper/Steel/PVC Pipe
Resistor/Capacitor Colors	Rope, Cable and Chain
Pilot Lamp Specs	Tap-Die-Drill Sizes
Fuse & Battery Specs	Sand Paper & Abrasives
RF Coil Winding Data	Weld Electrode & Solder
Wire Size vs Turns/Inch	3200 Conversion Factors

Money Back Guarantee—If not completely satisfied, return book postage prepaid, in mint condition for a 100% refund!

Sequoia Publishing Inc.
Dept 905, P.O. Box 620820
Littleton, CO 80162

CIRCLE 9 ON FREE INFORMATION CARD

ATTENTION! ELECTRONICS TECHNICIANS

EARN YOUR
**B.S.E.E.
DEGREE**



THROUGH HOME STUDY

Our New and Highly Effective Advanced-Placement Program for experienced Electronic Technicians grants credit for previous Schooling and Professional Experience, and can greatly reduce the time required to complete Program and reach graduation. No residence schooling required for qualified Electronic Technicians. Through this Special Program you can pull all of the loose ends of your electronics background together and earn your B.S.E.E. Degree. Upgrade your status and pay to the Engineering Level. Advance Rapidly! Many finish in 12 months or less. Students and graduates in all 50 States and throughout the World. Established Over 40 Years! Write for free Descriptive Literature.

COOK'S INSTITUTE
OF ELECTRONICS ENGINEERING

CI 4251 CYPRESS DRIVE
JACKSON, MISSISSIPPI 39212

CIRCLE 18 ON FREE INFORMATION CARD

VENDOR INFORMATION

HyperPAD (\$99.95)
Brightbill-Roberts
120 E. Washington Street
Suite 421
Syracuse, NY 13202
(315) 474-3400

CIRCLE 118 ON FREE INFORMATION CARD

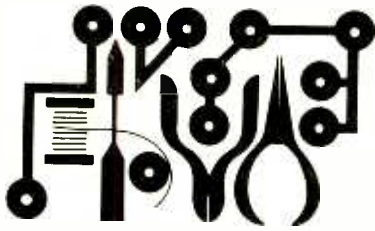

Circuit Circus

By Charles D. Rakes

INFRARED COMMUNICATIONS LINKS

This month we are going to spend our time together exploring and experimenting with a number of circuits that use light as the medium to convey information from one location to another. Remote-control applications probably lead the pack when it comes to using light to convey data from point "A" to point "B," and that's where our circuit odyssey begins.

The most popular frequency range used for remote-control applications is in the 900-nanometer band, better known as the infrared region of the light spectrum. That's the region where the majority of the *InfaRed* (IR) LED's and phototransistors peak in output and sensitivity.

The simplest IR remote-control scheme is one that uses a switched (on/off) IR-light source for the transmitter and a photo-sensitive pickup device with a switched output for the receiver. Such remote-control systems work as long as the receiver is not exposed to any other IR-light source. The receiver can't tell the difference between the sun's IR radiation (or any other IR-rich light source) from the transmitter's output. The usefulness of such a simple system is extremely limited.

Infrared Transmitter. Our IR remote-control scheme avoids the ambient infrared-radiation problem by using a modulated light source for the transmitter and a tuned detector in the receiver circuit. Although such a scheme keeps the receiver from responding to IR-light sources other than the one that is intended, it does not keep the IR detector from seeing the other IR sources.

If the IR detector is not shielded from strong IR emitters, the detector can be saturated and will not respond to the transmitter's signal. Protection from that predicament is easily added by placing the phototransistor in an opaque enclosure and allowing light to enter from only one direction.

The transmitter, shown in Fig. 1, is built

PARTS LIST FOR THE INFRARED TRANSMITTER

SEMICONDUCTORS

- U1—567 phase-locked loop, integrated circuit
- Q1—2N3904 general-purpose, NPN silicon transistor
- LED1—Infrared-emitting diode (Radio Shack 276-143A)

RESISTORS

- (All resistors are 1/4-watt, 5% units, unless otherwise noted.)
- R1, R2—1000-ohm
- R3—100-ohm 1/2-watt
- R4—25,000-ohm potentiometer

CAPACITORS

- C1—C4—0.1- μ F, ceramic disc
- C5—680-pF, ceramic disc
- C6—47- μ F, 16-WVDC, electrolytic

ADDITIONAL PARTS AND MATERIALS

- S1—SPST normally-open pushbutton switch
- Printed circuit or perfboard materials, enclosure, IC sockets, 9-volt battery and battery holder, wire, solder, hardware, etc.

around a 567 PLL (Phase-Locked Loop), which is used to modulate the IR-light transmissions. Transistor Q1, a 2N3904 NPN unit, serves as the driver for a high-output IR LED (LED1). The PLL is connected as a VFO (Variable-Frequency Oscillator), which produces a square-wave output at pin 5. That output supplies drive current to the base of Q1, which in turn switches the LED on and off at the oscillator's frequency. The IR LED's maximum current is limited to a safe value by R3.

Infrared Receiver. The receiver circuit shown in Fig. 2 mates nicely with the transmitter circuit in Fig. 1. In the Fig. 2 circuit, the modulated IR signal is detected by phototransistor Q3, which toggles between saturation and cutoff in time with the incoming signal. The AC component of the signal present at the collector of Q3 is passed through C2 to the base of Q1 for additional amplification.

Afterwards, that now boosted signal is fed to U1, another 567 PLL, which is configured as a decoder circuit and is tuned to the same frequency as the PLL in the transmitter. When the signal at the pin-3 input of U1 is on frequency and above 50 millivolts, the output of U1 at pin 8 of U1 is pulled to ground, lighting LED1.

Transistor Q2 monitors the DC portion of the received IR signal (including all of the desired and undesired IR radiation hitting the phototransistor) to help in alignment and to keep the undesired IR

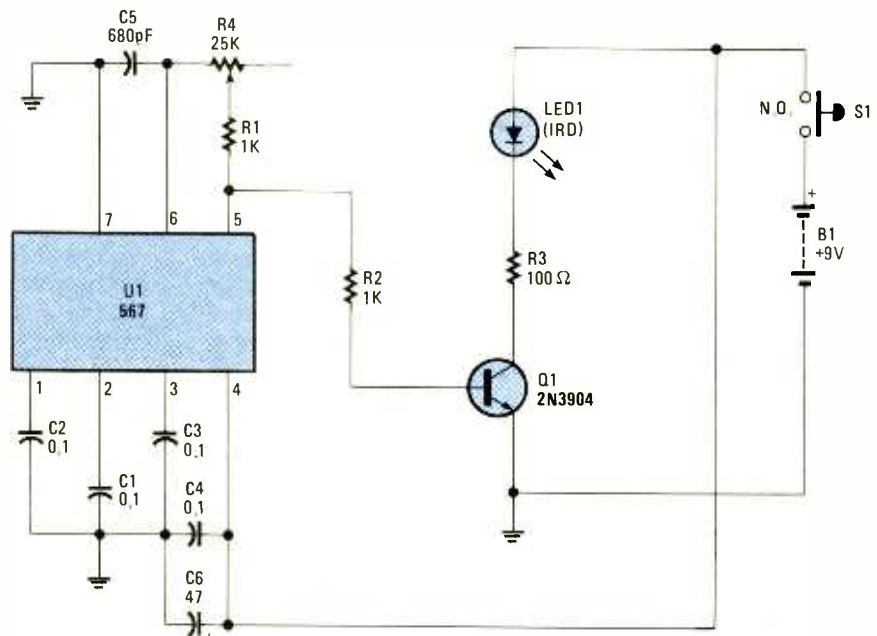
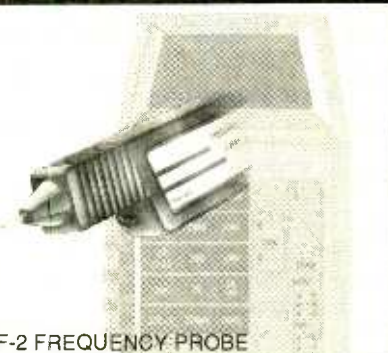

Fig. 1. The Modulated IR Transmitter avoids ambient IR-radiation problems by producing a modulated-light transmission.

PROBES MEASURE FREQUENCY



F-2 FREQUENCY PROBE

and show the value on the display of your 3 1/2 or 4 1/2 DVM.

Two models:

F-20, range 2 KHz to 20 MHz. Accuracy $\pm .005\%$
F-2, range 200 Hz to 2 MHz. Accuracy $\pm .05\%$

Priced from about \$49.95 U.S.

These instruments are tested, proven and made in North America.

I.M. INSTRUMENT Brantford Canada
CORPORATION (519) 756-3770

CIRCLE 21 ON FREE INFORMATION CARD

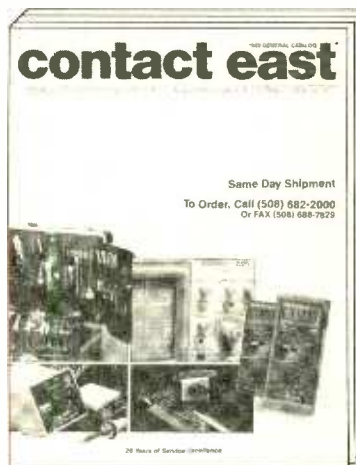

FREE CATALOG TEST INSTRUMENTS & HARD-TO-FIND TOOLS

Packed with over 10,000 quality products for testing, repairing, and assembling electronic equipment. A full selection of test instruments, power protection equipment, precision hand tools, tool kits, soldering supplies, and much more. Products are shown in full color with detailed descriptions and pricing. All products come with a 100% satisfaction guarantee. SAME-DAY shipment program.

In a hurry to receive your catalog?

Call (800) 225-5370

In Massachusetts call (508) 682-2000

Contact East, Inc., Dept R452
335 Willow Street, Andover, MA 01845

CIRCLE 24 ON FREE INFORMATION CARD

APRIL 1990

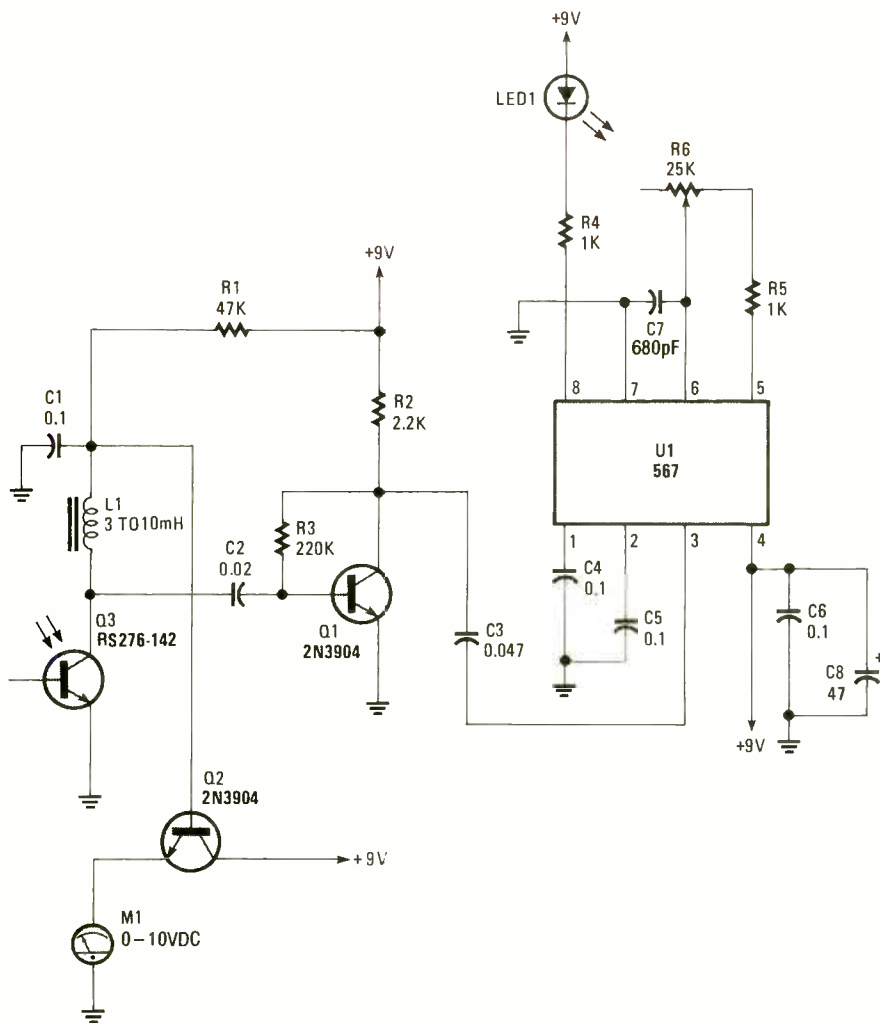

Fig. 2. This Modulated IR-Receiver circuit mates nicely with the transmitter circuit in Fig. 1. Here the modulated IR signal is detected by Q3, which toggles between saturation and cutoff in time with the incoming signal.

PARTS LIST FOR THE INFRARED RECEIVER

SEMICONDUCTORS

- U1—567 phase-locked loop, integrated circuit
- Q1, Q2—2N3904 general-purpose, NPN silicon transistor
- Q3—Infrared phototransistor (Radio Shack 276-142)
- LED1—Light-emitting diode (any color)

RESISTORS

- (All resistors are 1/4-watt, 5% units, unless otherwise noted.)
- R1—47,000-ohm
 - R2—2200-ohm
 - R3—220,000-ohm
 - R4, R5—1000-ohm

- R6—25,000-ohm potentiometer

CAPACITORS

- C1, C4, C5, C6—0.1- μ F, ceramic-disc
- C2—.02- μ F, 100-WVDC, Mylar
- C3—.047- μ F, 100-WVDC, Mylar
- C7—680-pF, ceramic-disc
- C8—47- μ F, 16-WVDC, electrolytic

ADDITIONAL PARTS AND MATERIALS

- M1—0-10-volt DC meter
- L1—3- to 10-mH RF choke
- Printed-circuit or perfboard materials, enclosure, IC sockets, 9-volt battery and battery holder, wire, solder, hardware, etc.

light from saturating Q3. The DC-carrier voltage decreases as the intensity of the IR light increases, so a low voltage indicates that a really strong signal is hitting Q3.

As long as the voltage at the collector of Q3 stays above 2 volts, the receiver operates just fine; but if the

ambient IR hitting the phototransistor is too intense, the voltage can drop to a point where the transmitter's signal will not be detected.

An optocoupler can be substituted for LED1, thereby allowing just about anything to be turned on or off with the
(Continued on page 102)



Ham Radio

By Joseph J. Carr, K4IPV

WINDING YOUR OWN ADJUSTABLE TUNING COILS

Hams have always enjoyed building their own electronic projects. Although some pundits bemoan the "appliance operator" of today, my mail and personal contacts tell me that there are still a lot of activists out there who build projects. In fact, it may be that the readers of this column are even more interested in projects than most other hams because they come from the high-quality audience that is the **Popular Electronics** readership.

Inductors (L) and capacitors (C) are used in a large variety of RF-tuning circuits in electronic projects. The resonant frequency is the frequency to which the LC combination is tuned to, and is found from:

$$f = 1/(6.28\sqrt{LC})$$

or, if either the inductance (L) or capacitance (C) is known, then the other variable can be found by solving for the unknown. The equations for doing that are:

$$C = 1/(39.5F^2L)$$

and

$$L = 1/(39.5F^2C)$$

For all three equations, L is in henrys, C is in farads, and frequency is in hertz.

Capacitors are easily obtained in a wide variety of values. But variable or tuning inductors are either unavailable, or are available only in other people's ideas of what you need. As a result, it is difficult to find the kinds of parts that we need for our electronic and amateur-radio hobbies. In this article we will take a look at how to make your own slug-tuned variable inductors, RF transformers, and IF transformers.

Tuning inductors can be either air-core or ferrite/powdered-iron core coils. The air-core coils are not usually adjustable unless clumsy taps are provided during the winding of the coil. However, the ferrite and powdered-iron core coils are adjustable if the core is adjustable.

Figure 1 shows a basic "slug-tuned" coil form. The form is made of plastic, phenolic, fiberglass, nylon, or ceramic materials and is internally threaded. The windings of the coil (or coils in the case of RF/IF transformers) are wound onto the form. The equation for calculating the inductance of a single-layer coil is found in any good radio book, but is not needed for our purposes. We have a simpler way. The tuning slug is a ferrite or powdered-iron coil core that mates with the internal threads in the coil form. A screwdriver slot or hex hole in either end (or both) allows adjustment. The inductance of the coil depends on how much of the core is inside the coil windings.

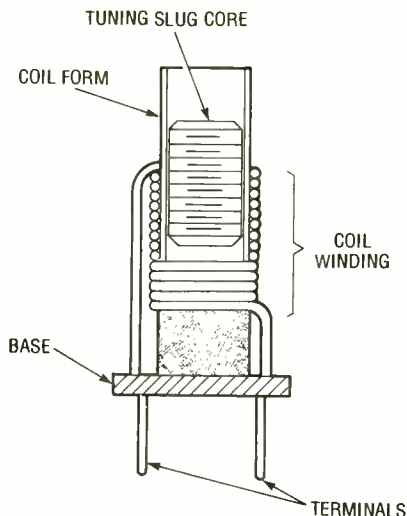

Fig. 1. Here's a cross-section view of a typical slug-tuned coil. The coil form can be made from plastic, phenolic, fiberglass, nylon, or ceramic materials and is internally threaded.

Amidon Associates Coil System. It was once difficult to obtain coil forms to make your own inductors. But Amidon Associates, Inc. (12033 Otsego Street, North Hollywood, CA 91607; Tel. 818-760-4429; Technical Assistance Tel. 714-630-8621) makes a series of slug-tuned inductor forms that can be used to make any value coil that you are

likely to need. Figure 2A shows a cross section of an Amidon form, while Fig. 2B shows an exploded view. Table 1 shows the type numbers, frequency ranges (in MHz), and other specifications for that company's coil forms.

Three sizes of coil form are offered. The L-33-X are 0.31-inch square and 0.40-inch high; the L-43-X are 0.44-inch square and 0.50-inch high; and the L-57-X are 0.56-inch square and 0.50-inch high. The "X" in each type number indicates the type of material, which in turn translates to the operating-frequency range (see Table 1). Now, let's see how the coil forms are used.

In my experiment to test the coil forms, I decided to build a 15-MHz WWV converter that reduced the WWV frequency to an 80/75-meter band frequency. Thus, I needed a tuned circuit that would tune 15-MHz. It is generally a good idea to have a high capaci-

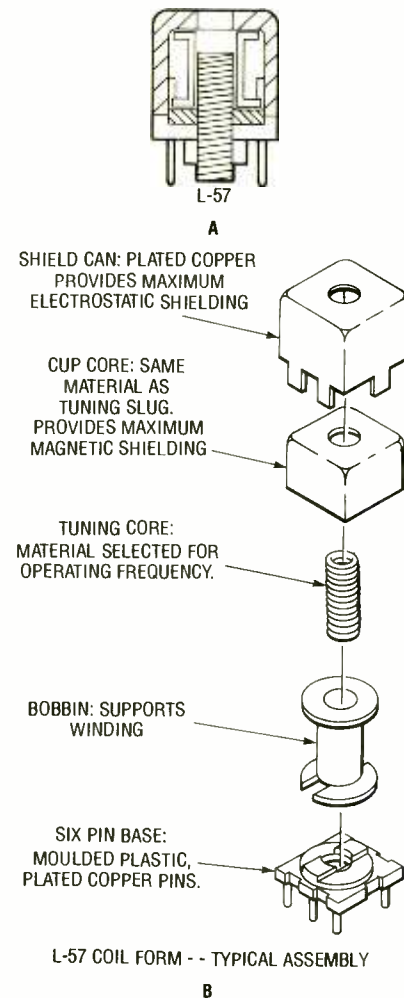

Fig. 2. Amidon Associates make a line of coil forms that make winding your own tunable inductors easy. A cross-section of an Amidon form is in A; an exploded view of a coil form is shown in B.

TABLE 1
AMIDON COIL FORM SPECIFICATIONS

Part Number	Frequency Range (MHz)	A _l Value	Ratio	Q _{max}
L-33-1	0.30-1.0	76	1.7:1	80
L-33-2	1.00-10	68	1.5:1	90
L-33-3	0.01-0.5	80	1.8:1	70
L-33-6	10-50	60	1.5:1	100
L-33-10	25-100	54	1.4:1	120
L-33-17	50-200	48	1.3:1	130
L-43-1	0.30-1.00	115	1.6:1	110
L-43-2	1.00-10	98	1.6:1	120
L-43-3	0.01-0.5	133	1.8:1	90
L-43-6	10-50	85	1.4:1	130
L-43-10	25-100	72	1.3:1	150
L-43-17	50-200	56	1.2:1	200
L-57-1	0.30-1.0	175	3:1	—
L-57-2	1.00-10	125	2:1	—
L-57-3	0.01-0.5	204	3:1	—
L-57-6	10-50	115	2:1	—
L-57-10	25-100	100	2:1	—
L-57-17	50-200	67	1.5:1	—

tance-to-inductance ratio in order to maintain a high "Q" factor, so I selected a 56-pF/NPO capacitor for the tuned circuit. That value was selected because it is in the right range to allow for a high C/L ratio and because a dozen or so were in my junkbox. With the value of capacitance selected, I was able to calculate the required inductance, which turned out to be about 2-μH.

Next, I needed to calculate the number of turns (N) required to make my inductor. To calculate that, I used the following equation:

$$N = 100\sqrt{L/[0.9A_l]}$$

Where L is the required inductance in microhenrys (μH). The A_l factor is a function of the properties of the core material and is specified in microhenrys-per-100 turns; its value can be found in the appropriate column of Table 1.

For my inductor I selected an L-57-6 (which covers the correct frequency range); that coil form has an A_l value of 115-μH/100-turns. Plugging that value into the preceding equation, I found that I need 14 turns of wire.

The coil should be wound using fine-gauge wire; because the forms are small, I recommend using the No. 32 wire, though any gauge between 26 and 32 will work fine. Ideally, Litz wire is used, but that type of wire is both hard to find and difficult to solder. For most projects, ordinary enamel-coated "magnet wire" will suffice. A razor knife (such as X-acto) and soldering-iron can be used to remove the enamel from the ends of the wire.

Winding the coil can be a bit of an art if your vision needs augmentation as much as mine. But using tweezers, needle-nose pliers, and a magnifying glass on a stand made the task relatively easy. Figure 3 shows the method for winding a coil with a tapped winding. BOBBIN

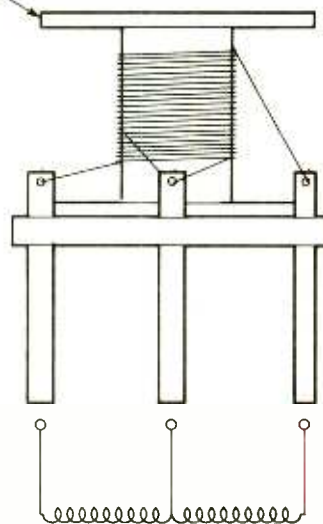

Fig. 3. To wind a tapped coil, secure the wire to the left-hand post, tightly wind the coil to the tap, loop the wire around the center post, and then wind the balance of the coil. Finish up by securing the wire to the right-hand post.

Anchor one end of the wire with solder on one of the end posts, and use this as the reference point. In my case, I wanted a 3-turn tap on the 14-turn coil so I wound three turns and then looped the wire around the center post. After that point was soldered, the rest of the coil

(Continued on page 97)

20156

ELECTRONIC COMPONENTS

Whether you order 1 part or all 20,156... MOUSER stocks to meet your needs and can... ship today!!

MOUSER also makes it easy to do business.

Try us! Call for your FREE CATALOG today

(800) 992-9943

MOUSER ELECTRONICS

Sales & Stocking Locations Nationwide

CIRCLE 23 ON FREE INFORMATION CARD

NEW SUPER LONG PLAY TAPE RECORDERS

12 Hour Model — \$119.00*
USES D-120 TAPE

Modified Panasonic Slimline, high quality, AC-DC Recorders provide 6 continuous hours of quality recording & playback on each side of cassette for a total of 12 hours.
Built-in features include:
• Voice level control • Digital counter, etc. TDK DC 120 Cassette Furnished



PHONE RECORDING ADAPTER

Records calls automatically. All Solid state connects to your telephone jack and tape recorder. Starts recording when phone is lifted. Stops when you hang up. \$28.50*
FCC APPROVED



VOX VOICE ACTIVATED CONTROL SWITCH

Solid state. Self contained. Adjustable sensitivity. Voices or other sounds automatically activate and control or remote mike. \$28.50*
Add for ship & hdlg. Phone Adapter & Vox \$150 ea. Recorders \$4.00 ea. Cal. Res. add tax. Mail order, VISA, MIC, COD's OK. Money Back Guarantee. Qty. disc. avail. Dealer inquiries invited, Free data.
AMC SALES INC., Dept. B 9335 Lubec St., Box 928 Downey CA 90241 Phone (213) 869-8519



CIRCLE 6 ON FREE INFORMATION CARD

APRIL 1990

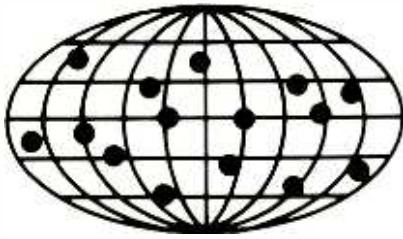

DX Listening

By Don Jensen

DX FARE FROM OUR NORTHERN NEIGHBORS

After last month's look at the *Voice of America*, it seems like the right time to pay a little attention to its Canadian counterpart, *Radio Canada International*. Understandably, it also puts a blockbuster signal into North America and it surely is one of the first of several shortwave stations a brand new SWL will tune across.

Like the VOA, Canada's international shortwave broadcaster dates back to WWII. In 1942, the Canadian government authorized its creation and within a year, two 50,000-watt shortwave transmitters were being built at Sackville, Nova Scotia, near the Atlantic coast. Today, Sackville remains RCI's major transmitter location.

The station's first broadcasts were aired Dec. 16, 1944, and those programs were beamed to Canadian troops stationed in Europe. In the years that followed, Canadian shortwave added 13 language services to its original English, French, and German programming. Later, however, a half-dozen of the language services were dropped for budgetary reasons.

English programs directed at Canada's neighbor to the south, the U.S., began in 1964, and the station has been popular with listeners here ever since.

Radio Canada's International Service improved its coverage in 1967 as a result of an agreement with the BBC to relay programming from transmitters in England. In 1972, the name was changed to Radio Canada International and, not long afterward, construction of five 250-kilowatt shortwave transmitters at Sackville was completed.

Agreements were also reached with other international broadcasters to relay RCI programming from their overseas transmitter locations. Those relay broadcasts include those from Germany, Portugal, Japan, Austria and, most recently, China.

Radio Canada International's news broadcasts, "The World at Six" and "As It Happens," (2100-2200 UTC) have been

called the best on shortwave by one listener publication.

Among SWL fans, RCI's weekly program, "Shortwave Listeners Digest" is popular. The broadcast, hosted by Ian McFarland, has been on the air since 1977, during which time it has been renamed and lengthened from five minutes to about 25 minutes.

"SWL Digest" features information on the latest shortwave equipment and communications technology, plus listening tips and features. Your "DX Listening" columnist can be heard with a bi-monthly feature called "Don Jensen's Journal" on that program.

You can get on Radio Canada International's schedule-mailing list by writing to PO Box 6000, Montreal, Quebec, Canada, H3C 3A8. With the spring mailing, you will receive a blank do-it-yourself QSL card. Return it with a reception report of your listening to RCI. Provided

your information is accurate, it will be returned to you stamped "Verified."



If you haven't already come across RCI's programs, some frequencies to try include 5,960, 6,050, 6,140, 7,295, 9,555, 9,635, 11,775, 11,855, 11,955, 15,225, 15,260, 15,325, 17,875, and 21,675 kHz, at various times of the day and night.

Moose in a Muffler. So maybe it's not a moose. Even *Radio Sweden* isn't really sure of the species that serves as its cartoon mascot these days. Right now, Radio Sweden is offering its listeners special T-shirts featuring its new antlered mascot, which it cautiously describes as a "moose/elk character." The shirts, with the multi-colored cartoon printed on white cotton, comes in sizes from small to double-extra-large. The price is \$13 in U.S. funds, payable by international money order or internationally negotiable check (contact your bank or post office). The address is Radio Sweden, S-105, Stockholm, Sweden.

Radio Sweden's shortwave broadcasts can be heard around the world, with English programming beamed to North American listeners during our afternoons (1500 UTC on 17,880 and 21,610 kHz) and evenings (0330 UTC on 9,695 and 11,705 kHz). The programs offer information about Sweden and other Nordic countries—Denmark, Finland, Norway, and Iceland—with re-



BROADCAST SCHEDULE D89 SEPT. 24, 1989 - MARCH 24, 1990

Address: Radio Sweden S-105 10 Stockholm, Sweden 
Telephone: national (08) 784 74 00, internat. +46 8 784 74 00 
Telefax: RRSWE S 11738
Telefax: national (8) 667 62 83, internat +46 8 667 62 83
Published by Radio Sweden, Stockholm
Ansvarig utgivare: Hans Wachholz (responsible under Swedish press law)
Printed by AB Grafiska Gruppen, Stockholm 1989

While even *Radio Sweden* isn't sure what species its mascot belongs to, the adorable creature is now available on a T-shirt.

Tune in!
Lyssna till oss
Hör Schweden
Emissions en Français
Sintonize a Suécia
Sintonicenos!
Слушайте нас
Kuulake meid!
Klausies Zviedriju!

BROADCAST SCHEDULE D89 SEPT. 24, 1989 - MARCH 24, 1990

ports on Swedish views of international events and news from Sweden of interest to the world.

"Sweden Calling DX'ers," the oldest program of its kind in the world, is directed especially to shortwave-listening fans and includes the latest information on when and where to tune in many of the SW stations around the globe. It is included as part of the Radio Sweden program block, which can be heard in the U.S. and Canada on Monday night and Tuesday afternoon.

The SWL information is submitted by a network of some 1,500 contributors worldwide. The "Sweden Calling DX'ers" program also offers several free publications, "The Beginner's Guide to DX'ing" and "Communications in Space." Listeners can write to the same address as above.

Feedback. Your letters, with questions and comments about shortwave DX'ing, or with information on what you've been hearing, including the frequencies and times, are welcome! Write to me at "DX Listening," **Popular Electronics**, 500-B Bi-County Blvd., Farmingdale, NY 11735

I have a letter from David M., who writes from California:

"I've been reading your column for a while now but have not found the answer to one question.

"A friend of mine recently moved to Saipan, Northern Marianas Islands in the Pacific. News coverage there is pretty limited, so I suggested he might want to listen to the BBC or the Voice of America on shortwave.

"The trouble is, I don't know how to find a schedule of English-language news programs that are broadcast to that part of the world. For that matter, I don't know how to find a schedule of programs broadcast to North America. Can you help me out?"

David, first of all, your friend on Saipan might want to look in his own backyard first. The *Christian Science Monitor* owns and operates KYOI, a shortwave station located at Agingan Point, right on Saipan. It relays the CSM World Service programs that originate at their studios in Boston. A local phone call should result in information on KYOI's current frequencies and times.

*CREDITS: Harold Levison, PA; Dan Sheedy, CA; Norman Bobb, MN; Daniel Sampson, WI; Joseph Kremer, IN; Ed Chickorek, NJ; Rufus Jordan, PA; North American SW Association, 45 Wildflower Rd., Levittown, PA 19057.

Also, the *British Broadcasting Corp.*, a fine source for news, beams its English-language World Service to the Pacific area from 0600 to 0030 UTC, which, in Saipan's time, is 4 p.m. to 10:30 a.m. the next morning. As of this writing, he may wish to try frequencies such as 9,740, 11,750, or 15,360 kHz during his afternoon and evening hours, and 7,145 or 9,570 kHz during his early mornings. The frequencies change with the seasons; detailed schedule information is available from the BBC, World Service, Bush House, London WC2B 4PH, England.

Those Pacific-area transmissions are relayed by BBC transmitters at Singapore. World Service news is aired on each hour, with longer and more detailed reports broadcast several times daily.

Voice of America English broadcasts to the Pacific are transmitted from stations in California and the Philippines between 1000 and 1200 UTC (8 to 10 p.m. Saipan time). Frequencies to try include 11,715 and 15,425 kHz. Program-schedule information is available by writing to the Voice of America, Washington, DC 20547.

Down The Dial. Here are some shortwave catches being reported lately. What are you hearing?

Canada—6,160 kHz, The *Canadian Broadcasting Corp.*, in addition to its *Radio Canada International*, operates several domestic shortwave outlets for Canadian listeners. One of those is CKZU in Vancouver, British Columbia, on Canada's west coast. Try this one around 0800 UTC.

Guam—11,700 kHz, KSDA, *Adventist World Radio*, and 11,805 kHz, KTWR, *Trans World Radio* are two religious stations operating from this U.S. territory. You can hear an English ID from KSDA at 0800, after a Chinese program. Look for KTWR in English around 1000 UTC.

New Zealand—15,485 kHz, *Radio New Zealand*. Noted around 0430 UTC, returned to a frequency used several years ago.

Paraguay—6,025 kHz, *Radio Nacional* is one of only a couple of active shortwave stations in this seldom-heard Latin American country. You may find this one here or in parallel on 9,735 kHz, all in Spanish.

U.S.—5,950 kHz, Taiwan's *Voice of Free China* in English, relayed by U.S. shortwaver WYFR in Florida, is a solid signal during the evening hours around 0200 UTC, with news and commentary, Chinese cultural programs, and music. ■

AMAZING SCIENTIFIC & ELECTRONIC PRODUCTS

PLANS PARTS ARE IN STOCK		
GRA1	ANTI GRAVITY GENERATOR	\$10.00
LCT	40 WATT BURNING CUTTING LASER	\$20.00
RUB4	HI POWER PULSED DRILLING LASER	\$20.00
STC5	1 MILLION VOLT TESLA COIL	\$20.00
MCPI	HI VELOCITY COIL GUN	\$15.00
LLS1	LASER LIGHT SHOW 3 METHODS	\$20.00
EH1	ELECTRONIC HYPNOTISM TECHNIQUES	\$8.00
EML1	LOWER POWERED COIL GUN LAUNCHER	\$8.00
JL3	JACOB LADDER 3 MODELS	\$10.00
SD5	SEE IN THE DARK	\$10.00
LEV1	LEVITATION DEVICE	\$10.00

KITS ASSISTANCE PROGRAM AVAILABLE		
FMV1K	3 MILE FM VOICE TRANSMITTER	\$34.50
PFS1K	HAND CONTROLLED PLASMA FIRE SABER	\$49.50
NIG7K	HI FLUX NEGATIVE ION GENERATOR	\$34.50
PG5K	PLASMA LIGHTNING GLOBE	\$49.50
LHC2K	VISIBLE SIMULATED 3 COLOR LASER	\$44.50
HOD1K	HOMING/TRACKING BEEPER TRANSMITTER	\$44.50
LGU6K	2.5 MW HAND-HELD VISIBLE LASER GUN	\$249.50
STC3K	250,000 VOLT TABLE TOP TESLA COIL	\$249.50
IGG2K	ION RAY GUN, project energy without wires	\$129.95
TKE1K	TELEKINETIC ENHANCER/ELECTRIC MAN	\$79.50
VWPM7K	3 MILE AUTO TELEPHONE TRANSMITTER	\$49.50

ASSEMBLED	ASSEMBLED IN OUR LABS	
LIST10	INFINITY XMTR Listen in via phone lines	\$199.50
IPG70	INVISIBLE PAIN FIELD BLAST WAVE GENERATOR	\$74.50
ITM10	100,000 VOLT INTIMIDATOR UP TO 20'	\$99.50
TAT30	AUTOMATIC TELEPHONE RECORDING DEVICE	\$24.50
PSP40	PHASOR SONIC BLAST WAVE PISTOL	\$89.50
DNE10	ALL NEW 26" VIVID COLORED NEON STICK	\$74.50
LGU20	5 TO 1MW VISIBLE RED HeNe LASER GUN	\$199.50
BL510	100.00 WATT BLASTER DEFENSE WAND	\$89.50

EASY ORDERING PROCEDURE - TOLL FREE 1-800-221-1705 or 24 HRS ON 1-603-673-4730 or FAX IT TO 1-603-672-5406
VISA, MC, CHECK, MOIN US FUNDS. INCLUDE 10% SHIPPING. ORDERS \$100.00 & UP ONLY ADD \$10.00. CATALOG \$1.00 OR FREE WITH ORDER.

INFORMATION UNLIMITED
P.O. BOX 716, DEPT. P.N., AMHERST, NH 03031

Get A Complete Course In

ELECTRONIC ENGINEERING

8 volumes, over 2000 pages, including all necessary math and physics. 29 examinations to help you gauge your personal progress. A truly great learning experience.

Prepare now to take advantage of the growing demand for people able to work at the engineering level.

Ask for our brochure giving complete details of content. Use your free information card number, or write us directly. **\$99.95**, Postage Included. Satisfaction guaranteed or money refunded.

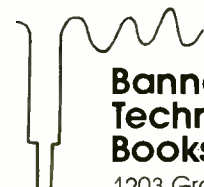

Banner Technical Books, Inc.
1203 Grant Ave.
Rockford, IL 61103

CIRCLE 16 ON FREE INFORMATION CARD



Scanner Scene

By Marc Saxon

A HIGH-PERFORMANCE, "LOW-TECH" SCANNER

Regency Electronics, which is now a part of *Uniden Corp. of America*, recently introduced the model *INF-50*, one of a new series of scanners aimed squarely at the person who is looking for good performance with a minimum of controls to deal with. They hope that those qualities will remove any "high-tech" phobias that have prevented some people from getting into scanners.

The Regency *INF-50* scans (approximately) 33 to 47 MHz, 151 to 162.60 MHz, 453 to 460.60 MHz, and 473 to 512 MHz. While that certainly isn't the world's most all-encompassing scanner-frequency coverage, it's adequate to provide basic public safety, weather, and emergency scanning on the most heavily used bands. Regency even saves the user the trouble of programming anything; it's been factory programmed with the various frequencies used in each state. The user need only select a state code and the *INF-50* scans all appropriate police, fire, or emergency channels for that state, at a rate of 60 to

100 channels per second. Weather-channel access is available at the touch of a button.

The user may lock out as many as 32 channels, and a three-second delay can also be switched on and off. The *SCAN* and *HOLD* keys cause the unit to begin scanning and to stop scanning when you want to stay within a channel for a while. The *INF-50* comes with a telescopic antenna. It operates from 12 VDC, but can be powered from household power with an AC adaptor.

For those who would like to hear much of the action, but aren't interested in the nuts and volts, this is probably a good place to begin. The manufacturer's suggested retail price is \$179.95. It comes from Regency Electronics, 4700 Amon Carter Blvd., Fort Worth, TX 76155.

Higher and Higher. From the looks of the incoming mail, there appears to be an enormous amount of interest in 800 MHz and above, where so many public safety, industrial, and other services are

going, in accordance with the latest developments in communications technology. Probably as a result of being popularized by cellular-telephone use of the 869- to 894-MHz segment of that band, the 800-MHz band has become very fashionable for many other communications services. Now, 866 to 869 MHz has been set aside for a new public-safety (police, fire, local government, etc.) band, and the FCC is under heavy demand from other potential users for licenses.

Nationally, 866.0125 MHz has been designated as the frequency where units of one agency or department can initiate contact with bases or mobile units of other agencies, such as when mutual aid is required during situations such as a police pursuit or chase, or a major fire. After contact is made on that channel, the units clear that frequency and switch over to one of five designated national working channels. Those frequencies are 866.0125, 866.5125, 867.0125, 867.5125, and 868.0125 MHz. At the very least, it sounds like the contact channel, 866.0125 MHz, is going to be the one that everybody will want to monitor.

Two topics are continually brought up in our mail in relation to that band. The first is a misconception that *all* communications in the 800-MHz band are those pesky "trunked" systems that we described here in the last issue of **Popular Electronics**.

Actually, that isn't true. While some are trunked, the majority are simplex and repeaters such as you're used to dealing with in the regular VHF and UHF bands. So there aren't any special considerations or problems for receiving that band—assuming you have the proper equipment for it, since only some of the scanners currently available cover 800-MHz frequencies.

That brings up the next most-often-asked family of questions, those relating to scanning on the 800-MHz band without shelling out the cash for a new scanner and ditching existing equipment. We have mentioned converters in the past, and that's made many readers ask how they work—and *if* they work.

How they work is basic. Let's take, for example, the *GRE America Super Converter I* (for desktop scanners) and *II* (for handheld scanners). These units plug into the scanner's antenna connector, then the scanner antenna plugs into the converter. The converter is powered from an internal 9-volt bat-



Simplicity is the word for the plain-faced but hard-working model INF-50 scanner from Regency Electronics.

tery, or from your own external 9-VDC power source.

Your scanner need only be able to pick up or search for new frequencies in all or part of the 406- to 512-MHz band. When you switch on the converter, it picks up all signals between 806- and 912-MHz, then shifts them downward 400 MHz in frequency and feeds them into your scanner so they can be copied. So, if you wanted to receive 866.0125 MHz, you'd switch on the converter and punch up 466.0125 MHz on your scanner. If you wanted to search/scan 866 to 869 MHz, you'd flip on the converter and let your scanner move through 466 to 469 MHz. Nothing could be easier. When you switch off the converter, the unit is bypassed, leaving you with normal 406- to 512-MHz reception with no noticeable signal loss.

The two GRE America units were used as examples because they are popular, widely available, reasonably priced (the manufacturer's suggested retail price is less than \$95 for the handheld model, and even less expensive for the desktop model), and because both have proven themselves to be nicely manufactured and excellent performers. Check the catalogs; this certainly appears to be a viable approach to scanning this vibrant band that is worth monitoring.

Speaking of the 800-MHz band, we received a letter from Milo C. Delucchi, WA6RZR, of Seattle, WA, noting that when his *Realistic PRO-34* handheld scanner operates between 851.1125 to 868.9375 MHz it picks up a lot of cellular activity. Inasmuch as those frequencies aren't allocated for cellular car-phone use, it would appear that the reception mentioned consists of the IF image offset (21.4 MHz) of transmissions that are actually taking place between 829.72 and 847.5375 MHz, since those are the cellular mobile-unit transmitting frequencies. That sort of image reception isn't at all uncommon on frequencies in the 400- and 800-MHz bands for several different makes and models of scanners; that information can come in handy when trying to monitor frequencies that have been blocked-out on your scanner at the factory.

That's all we have room for this month. Until next time, let's hear from you with your questions, frequency discoveries, photos, and comments. Our address is: *Scanner Scene*, **Popular Electronics**, 500-B Bi-County Boulevard, Farmingdale, NY 11735. We hope to hear from you soon!

HAM RADIO

(Continued from page 93)

was wound and then anchored at the remaining end post. A dab of glue will keep the coil windings from moving.

If you want to make an RF/IF transformer, then there will be two windings. Try to separate the primary and secondary windings if both are tuned. If one winding is not tuned, then simply wind it over the "cold" (i.e. ground) end of the tuned winding.

The Amidon coil forms are tight, but do have sufficient space for very small ceramic-disc capacitors inside. The 56-pF capacitors that I selected fit nicely inside the shielded can of the coil, so I placed it there. Thus, I basically had made a 15-MHz IF transformer.

I tested the coil and found that the slug tuned it to 15-MHz with a nice tolerance on either side of the design resonant frequency. It worked!

Although slug-tuned inductors are sometimes considered a bit beyond the hobbyist or ham, that is not actually true. The Amidon Associates, Inc. L-series coil forms are easily used to make almost any inductor that you are likely to need. ■



One tree can make
3,000,000 matches.



One match can burn
3,000,000 trees.



A Public Service of This Magazine
© The Advertising Council

LEARN VCR CLEANING/MAINTENANCE/REPAIR

EARN UP TO \$1000 A WEEK, WORKING
PART TIME FROM YOUR OWN HOME!



Secrets
Revealed!

NO Special
Tools or
Equipment
Needed.

EARN UP TO \$80
AN HOUR AND
MORE!

THE MONEY MAKING OPPORTUNITY OF THE 1990'S

IF you are able to work with common small hand tools, and are familiar with basic electronics (i.e. able to use voltmeter, understand DC electronics) . . .

IF you possess average mechanical ability, and have a VCR on which to practice and learn . . . then we can teach **YOU** VCR maintenance and repair!

FACT: up to 90% of ALL VCR malfunctions are due to simple MECHANICAL or ELECTRO-MECHANICAL breakdowns!

FACT: over 77 million VCRs in use today nationwide! Average VCR needs service or repair every 12 to 18 months!

Viejo's **400 PAGE TRAINING MANUAL** (over 500 photos and illustrations) and **AWARD-WINNING VIDEO TRAINING TAPE** reveals the **SECRETS** of VCR maintenance and repair—"real world" information that is **NOT** available elsewhere!

Also includes all the info you'll need regarding the **BUSINESS-SIDE** of running a successful service operation!

FREE INFORMATION

CALL TOLL-FREE 1-800-537-0589

Or write to: Viejo Publications Inc.
3540 Wilshire BL. STE. 310
Los Angeles, CA 90010 Dept. PE

CIRCLE 8 ON FREE INFORMATION CARD

Make the
most of your
general
coverage
transceiver
with
*Monitoring
Times!*

Every month *Monitoring Times* brings everything you need to make the most of your general coverage transceiver: the latest information on international broadcasting schedules, frequency listings, international DX reports, propagation charts, and tips on how to hear the rare stations. *Monitoring Times* also keeps you up to date on government, military, police and fire networks, as well as tips on monitoring everything from air-to-ground and ship-to-shore signals to radioteletype, facsimile and space communications.

ORDER YOUR SUBSCRIPTION TODAY before another issue goes by. In the U.S., 1 year, \$18; foreign and Canada, 1 year, \$26. For a sample issue, send \$2 (foreign, send 5 IRCs). For MC/VISA orders (\$15 minimum), call 1-704-837-9200.

MONITORING TIMES

Your authoritative source,
every month.

P.O. Box 98
Brasstown, N.C. 28902

APRIL 1990

PRODUCT TEST REPORT

(Continued from page 81)

tuner section first. Its audio-frequency response was among the most uniform we have ever measured, deviating from flat response by no more than 0.2 dB at any frequency from 20 Hz to 15 kHz. The claimed signal-to-noise ratio of 98 dB in mono and 90 dB in stereo is beyond the measurement capability of any test equipment we know of, including our own state-of-the-art FM generator. We did, however, measure a S/N ratio of 82 dB in mono and 80 dB in stereo for strong signal inputs, and those are superb readings by anyone's standards. The 30-dB quieting point was reached with input-signal levels of only 10.3 dBf, as claimed, however, calling that the usable sensitivity, as Yamaha did, is a misnomer, since usable sensitivity is defined as that point where both noise and distortion combined are 30 dB below the reference output level. In both the wide- and narrow-IF modes, that point was reached with an input-signal level of around 14 dBf; not the lowest we have measured for high-quality tuners, but certainly acceptable.

The advantage of the wide-IF mode became evident when we measured distortion for strong signals. In the wide-IF mode, distortion plus noise was a mere 0.028% in mono and 0.045% in stereo for a 1-kHz test signal. Contrast that with the narrow-IF mode readings under the same conditions, which were 0.1% in mono and 0.35% in stereo; still good results, but nowhere near as good as in the wide mode. Much the same held true at other audio frequencies tested. For example, at 6 kHz, distortion plus noise measured only 0.032% in mono and 0.07% in stereo when the tuner was operated in the wide-IF mode. When operated in the narrow-IF mode (as you might have to do if nearby station frequencies interfered with the signal you were trying to receive), distortion plus noise rose to 0.29% in mono and to 0.55% in stereo.

The only time performance in the narrow-IF mode was better than that in the wide mode was when we measured FM-stereo separation, and the results obtained are still very puzzling. Where normally we would expect separation to be poorer in the narrow-IF mode, it actually turned out to be better, at least at middle audio frequencies. Specifically, at 1 kHz we measured stereo separation of 55 dB in the wide-IF mode, but separation actually increased to just over 60 dB when we switched to the narrow-IF operating mode. Results were somewhat more like what we would have expected them to be at higher frequencies. Separation measured 48 dB at 10 kHz in the wide-IF mode, but decreased somewhat to 43.5 dB at that frequency when using the narrow-IF mode. All in all, however, stereo separation was excellent regardless of which operating mode was used. The blend control, as expected, reduced stereo separation to no more than about 11 dB at mid-frequencies and to even less at high frequencies, but it also performed its task of reducing noise for weak-signal stereo reception very admirably.

Secondary specifications were measured and are compared with the manufacturer's claims in the chart that can be found elsewhere in this report. In most cases, claims were easily met or exceeded. Since our equipment cannot measure selectivity or the various rejection values in excess of 100 dB, we will have to take Yamaha's word for the specifications that exceed that value.

As for AM-section performance, we checked the manufacturer's published

specifications and, on the whole, found them to be fairly accurate. We noted, however, that, like most other manufacturers, Yamaha did not quote frequency response for the AM-tuner section of this otherwise well executed design. We were not surprised, however, to find that the -6-dB roll-off points occurred at around 75 Hz and at 3.8 kHz. That's hardly what you would call high-fidelity, but it is actually somewhat better than what we encounter with most tuners' and receivers' AM sections. There is now a move afoot to induce both broadcasters and receiver manufacturers to pay more attention to the quality of AM-radio broadcasts and reception and, hopefully, in the not-too-distant future we'll find tuners that have extended response to at least 7.5 kHz.

The Hands-On Tests. We found it easy enough to program our favorite stations into the numbered presets of the tuner. Having twenty-four available preset numbers may be a bit much for most users, but of course you don't have to use all of them. For that matter, you don't have to use any of the presets if you don't want to. Manual tuning worked well, as did the automatic-tuning mode. We especially liked the graphic displays; they really let us know how matters stood as far as operation of the tuner was concerned. "Dialing-in" station call letters proved to be a bit tedious, since you have to scan through the alphabet, using the dual-function tuning knob to dial-up the call signs letter-by-letter. Still, since for most people that would be a one-time operation, it may be worth the effort.

Connected to our reference multiple-element directional outdoor antenna, we picked up no fewer than 56 stations. Ten of those required the use of the narrow-IF mode to reduce adjacent-channel interference. About a dozen of the weaker stations benefited from the use of the blend control, which, despite its effect upon stereo separation, still afforded an adequate stereo perspective.

Admittedly, you could buy an entire integrated stereo receiver for what this tuner costs. But, for those of us who are serious about FM (and are fortunate enough to have a couple of good stations in our listening area), the \$549.00 list price may well be justified.

For more information, contact Yamaha (6722 Orangethorpe Ave., Buena Park, CA 90620) directly, or circle No. 119 on the Free Information Card. ■

HOT BOOKS FOR HOBBYISTS



2617T—BUILD A REMOTE-CONTROLLED ROBOT FOR UNDER \$300....\$9.95. Fool-proof instructions for putting together your own full-size robot



62 HOME REMOTE CONTROL AND AUTOMATION PROJECTS....\$12.95. A fascinating collection of projects to make your life safer, more convenient, and more fun

BUILD A REMOTE-CONTROLLED ROBOT....FOR UNDER \$300

2617T—If you're fascinated by the home robots increasingly available on today's market ... but are stopped by their price tags ... here's your solution. Build your own home robot—and a full size unit at that—for less than \$300. No advanced electronics or computer skills are needed to put together "Questor", a robot butler especially designed to be both affordable and easy-to-build.—Order your copy for \$9.95 plus \$2.00 shipping.

62 HOME REMOTE CONTROL AND AUTOMATION PROJECTS

2735T—A device that automatically dims the lights when you turn on your stereo ... an automatic guest greeter ... sensors that keep your air-conditioning at ideal levels automatically ... voice-operated transmitters, door and window controllers and more. Complete instructions, wiring diagrams, and show-how illustrations for each device. \$12.95 plus \$3.00 shipping.

Send 40-page catalog—FREE with order.

I've included \$2.00 Send catalog and coupon good for \$2.00 on first order.

Electronic Technology Today
P.O. Box 240
Massapequa Park, NY 11762

FIBER OPTICS

(Continued from page 70)

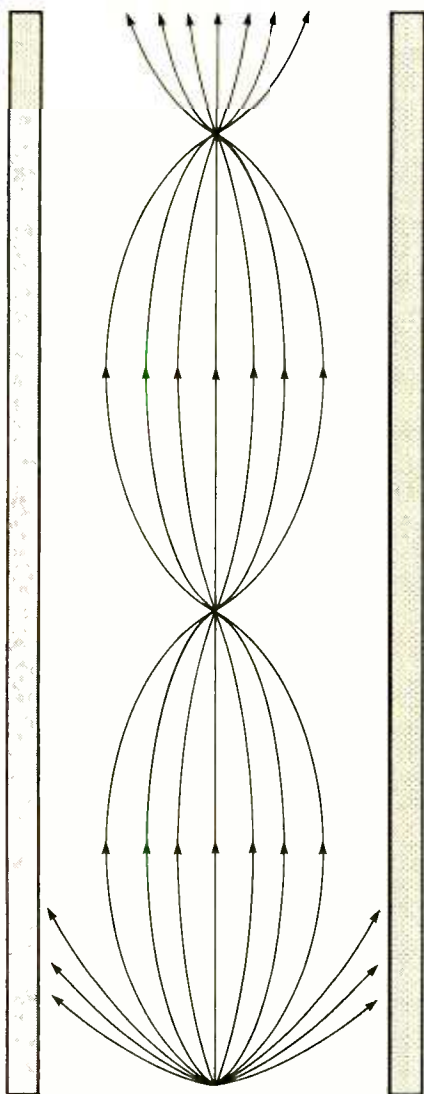

Fig. 4. Light rays travel in sinusoidal paths when sent through a self-focusing or graded-index fiber. That's because as a light ray moves away from the core, the progressive change in refractive index gradually reflects the light back.

there in an acceptable enough condition so that they can be detected with a certain degree of reliability. The maximum range of a system largely depends on the type of light sources and light detection used, and on the purity and construction of the optical fiber.

If digital signals are what we wish to transmit, they would appear as bursts or flashes of light occurring over time. It is necessary that the receiver be able to distinguish succeeding bursts of light from one another in order to recover the encoded information. That means the flashes must have a reasonable intensity and they must be spread apart

over time. Two things that interfere with that are attenuation and differential delay (the broadening of signals in time).

Attenuation rears its ugly head at the moment light enters the fiber. That's because the extent to which a multimode fiber can accept and transmit light depends greatly upon the angle at which the light rays enter the fiber. The angle must be less than the critical acceptance angle of the particular fiber being used. In general, only about 4% of the light initially emitted by the LED is sent down the optical fiber!

Once inside the fiber, the attenuation of light is mainly due to absorption and scattering. Absorption loss is caused by the presence of impurities such as iron, copper, nickel, and cobalt. Those materials are usually trapped in the glass from which the optical fiber is made. In a good-quality fiber, the total amount of metallic-ion impurities should not be more than one part per million.

Power loss due to scattering is caused by imperfections in the core material and by irregularities in the region where the core interfaces with the cladding. "Rayleigh Scattering," for instance is caused by the existence of tiny dielectric inconsistencies in the glass. Because those perturbations are small with respect to the waves being propagated, the light scatters in all directions.

Optical fibers must have a very high transparency in order to provide efficiency over a long distance. As an example, for some given intensity of light, an optical fiber might convey the energy a distance of 1,000 meters at some acceptable level. When we compare that to ordinary window glass or water, the energy would be carried only about 5 meters or 1 meter, respectively.

Differential Delay. The degradation of light by differential delay (also known as pulse broadening or spreading) is a more significant problem than scattering. The cause of pulse broadening has to do with the angle at which a ray from a light source enters the fiber also. The rays that enter a multimode fiber parallel to the fiber axis travel the shortest distance to the receiver. Those entering at various angles must be reflected back and forth by the cladding, and thereby travel a longer distance to the receiver, so they get there a little later, just like an echo. The "spread" in arrival times at the receiver causes the pulse to appear to last longer. If a pulse is stretched long enough, it will overlap

the beginning of the next pulse and obscure the data.

One way to minimize the problem is to get the light rays to travel as close to the core as possible. That means the difference in refractive index between the core and cladding must be kept small, thus also keeping the critical acceptance angle small. One way to do that is to use a graded-index optical fiber because they concentrate light in a small region at their core.

Another approach to eliminating differential delay is by using a single-mode step-index fiber. Since the light source for such a fiber must be a laser, all the light will (at least initially) be in phase. Such cables have the potential for carrying much more information than other designs, but unfortunately, they are difficult to manufacture and hard to handle in the field as well.

Optical communications technology has progressed to the point where optical systems are packaged as integrated optical circuitry (IOC). They are analogous to electronic integrated circuits, but IOC components consist of microscopic lasers, optical switches, and laser modulators. Perhaps that is a sign of the many things to come. ■

FIBER OPTIC KITS

Low cost kits ideal for all situations requiring immunity from electrostatic, electromagnetic, and RF interference. Also eliminates ground loop problems.

Experimenter's Kit 1 meter data link with matched LED and phototransistor. Includes fiber and data sheets.

IFO-108 \$9.95

Educational Kit Same as above, plus printed circuit boards and electronic components to build a complete optical link. Assembly and tutorial information included.

IFO-104 \$24.95

Project Kit Includes the book "Fiber Optic Communications, Experiments, & Projects" by Waldo T. Boyd with necessary optic components and fiber to complete 8 experiments and 5 projects. An ideal tool to gain theoretical and hands-on experience in fiber optic data communications.

IFO-106 \$54.95

Fiber Optic Lab Manual & Hardware Kit 7 Experiments + Final Project covers all the principles of fiber optics suitable for schools & science projects.

IFO-107 \$49.95

**CALL FOR
FREE CATALOG**

Components, Kits, Tools & Sockets.

Sintec Company

28 8th St., Frenchtown, NJ 08875

1-800-526-5960

Visa/MasterCard accepted

EIA COURSE

(Continued from page 78)

circuit continues as long as the output of U2 is high. After a period set by C1 and R7 in Fig. 2, the output of U2 goes low, removing the forward-biasing voltage from U3's internal LED, causing it to go out. That, in turn, deactivates U3's internal Diac, discontinuing trigger signals to the gate of TR1, so that at the next zero crossing TR1 turns off.

The circuit in Fig. 4 performs the same function as the one in Fig. 3, but does it in a slightly different way, using different components. In this circuit, the output of U2 in Fig. 2 is tied to the base of Q1 in Fig. 4. As long as the output of U2 is low, Q1 remains off, keeping the relay de-energized. But when a timing cycle is initiated, the output of U2 (Fig. 2) goes high, turning on Q1. That in turn completes the relay circuit, energizing it. That causes its contacts to close applying AC power to lamp I1.

Light-Controlled Monostable Exercise. The following exercise uses the two circuits that we assembled in the previous two exercises. If the circuits

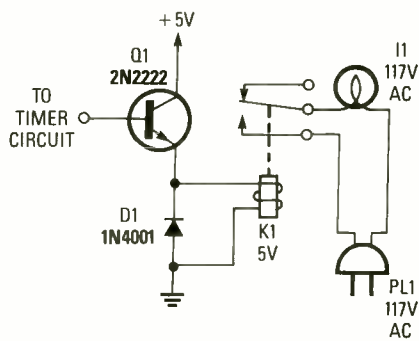

Fig. 4. This circuit, like the one in Fig. 3, can be used to control AC power to the load device.

have been disassembled, then now is the time to reassemble them; if not, connect them together as shown in Fig. 1. You'll also need a logic probe to monitor the output of the circuit. It will also be necessary to insert a switch from pin 2 of U2 to ground, and to remove R7 from the circuit.

Apply power to the circuit, leaving the LDR's (R4 and R5) uncovered to simulate daylight conditions. When S1 is pressed, the output indicator, LED1, should remain dark. Now cover R5, to simulate nighttime conditions. When

switch S1 is pressed, LED1 should turn on and remain on for a period determined by the R8/C1 combination.

After completing the first exercise, power down the circuit, and rewire it to form the one shown in Fig. 2. All that's required is to remove S1 from the circuit and connect the output of U1-a (pin 1) to pin 2 of U2. After doing so, restore power to the circuit and cover both LDR's (R4 and R5) to simulate nighttime conditions; momentarily uncover R4 to simulate light from an automobile headlamp. The output indicator (LED1) should turn on and remain on for a period set by the values of R8 and C1.

Uncover R5 during a timing cycle to simulate daylight. The output indicator should remain off regardless of the condition of R4. While you have the circuit built, it would be a good time to do some experimenting of your own. Should you decide to merge one of the AC control circuits shown in this exercise (or any others for that matter), **do not** assemble them on the breadboard. They should be built on a small per-board, which can then be connected to the circuit via an appropriate shielded conductor. ■

Managing to Get Ahead



Test yourself with this sample question:

Which one of the following questions may you ask a prospective employee in a job interview?

- (1) Do you own or rent your home?
- (2) Are you married?
- (3) Are you able to work overtime?
- (4) Have you ever been arrested?
- (5) All of the above?

Now wouldn't you like to test yourself against the real thing?

If you've got the experience and knowledge it takes to get the job done, you can get certified in professional service management. The Certified Service Manager exam is offered through NESDA for owners or service managers with a minimum of 4 years of experience.

For a practice test and more information about CSM Certification, write to NESDA, 2708 W. Berry St., Fort Worth, TX 76109-2356, or phone (817) 921-9061.

(ANSWERS: # 3)

Employers

Willing workers available now at as little as 1/2 your usual cost.

This is your chance to get help you've needed, but thought you couldn't afford.

No business too large or too small. Call your private industry council or write **National Alliance of Business**, P.O. Box 7207, Washington, D.C. 20044

A Public Service of
This Publication



SHORTWAVE RECEIVER

(Continued from page 63)

electrolytic capacitors. If an electrolytic capacitor has a paper body, then look for discoloration, especially if it appears to be from a liquid. On all electrolytic capacitors, look for signs of oozing around the seals at the ends. Look for liquid, grayish-tan powder, or corrosion around the end-caps of the capacitor. That indicates that the capacitor needs to be replaced.

Conclusion. If the receiver does not work after you've tried all of the things mentioned, then test the tubes and replace any of them that are bad. If the receiver still does not respond, then ordinary radio troubleshooting is needed. Schematics are sometimes hard to find, but in every case where I've rebuilt a radio, I found the schematic either in Sams Photofacts, by advertising in local ham magazines, or by asking people in my ham club and dealers who've been in business a long time. Rebuilding an older receiver is a viable alternative to buying a more costly modern unit, and it can yield a decent shortwave receiver and a whole lot of fun! ■

DIGITAL ELECTRONICS

(Continued from page 76)

the clear input is low and the set input is high, then the Q output immediately goes to the low state and the \bar{Q} output is high. But when the set input is low and the clear input is high, the opposite action takes place: Q = high and \bar{Q} = low. Now note the action when both set and clear are high: the J-K flip-flop is set up for clocked operation and a different set of rules applies.

The truth table for clocked operation of the J-K flip-flop is shown in Fig. 13C. The J-K flip-flop is a negative-edge triggered device. That is, the circuit's output transitions only occur during the high-to-low transition of the clock (CLK) line. If both J and K inputs are low, then there will be no change in the output state during clock transitions. But if J is low and K is high, then a clock transition forces Q low and \bar{Q} to high. Similarly, when J is high and K is low, the opposite occurs: Q goes high and \bar{Q} goes low.

When both J and K are high, the Q output will flip to the opposite state when the negative-going clock transition occurs.

A depiction of that is shown in Fig. 13D. There it would appear that the input frequency is being divided in half. At time T1 the clock is positive-going, so no change occurs. But at time T2, there is a negative-going change, so the output snaps from low to high. The next negative-going transition occurs at T4, so the output line snaps low again. The result is that two input pulses (A and B) must be applied to the clock line to create one complete output pulse, therefore:

$$f_{in} = 2f_{out}$$

If J-K flip-flops are connected in cascade, as in Fig. 14A, then the outputs form a binary-division chain. In the four-bit case shown, the input frequency of the clock is f , while frequency at the Q1 is $f/2$, at Q2 it is $f/4$, at Q3 it is $f/8$, and at Q4 it is $f/16$. An example series of clock pulses and the resulting outputs are shown in 14B.

Conclusion. The family of gates are very useful electronic devices. Clearly understanding the rules governing each one allows the experimenter to use them in both traditional and non-traditional circuit applications. Use your imagination, and you will be able to solve a remarkable variety of electronics problems. ■

WATCH ^{FOR} THIS ISSUE ON SALE MARCH 1

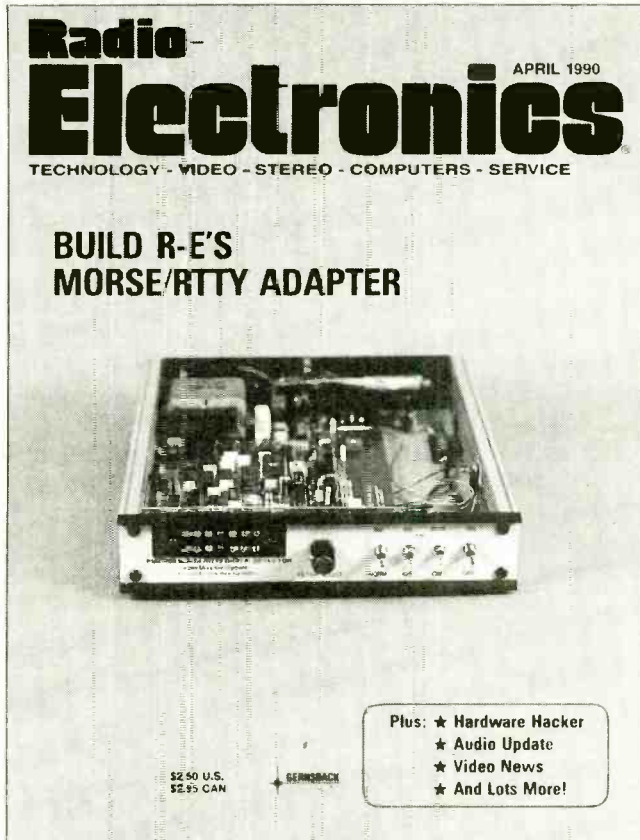

Radio-Electronics APRIL 1990
TECHNOLOGY - VIDEO - STEREO - COMPUTERS - SERVICE

**BUILD R-E'S
MORSE/RTTY ADAPTER**

Plus: ★ Hardware Hacker
★ Audio Update
★ Video News
★ And Lots More!

\$2.50 U.S.
\$2.75 CAN

GERMACK

OUR APRIL ISSUE FEATURES:

BUILD R-E'S MORSE/RTTY DETECTOR

Display Morse code and radioteletype signals on your computer—even if you don't know a dit from a dah.

BUILD A CAPACITANCE ADAPTER

Turn your voltmeter into a capacitance meter with this easy-to-build circuit.

GLITCHES ON THE POWER LINE

A look at what causes glitches and what you can do to protect your equipment.

AUDIO AMPLIFIER COOKBOOK

Practical IC audio power amplifier circuits for automotive applications.

COMPUTER DIGEST

How to secure your hard disk from unauthorized snooping.

**PLUS: Hardware Hacker
Audio Update
Hardware Reviews**

**Software Reviews
Video News
And lots more!**

CIRCUIT CIRCUS

(Continued from page 91)

simple remote-control system. Any well-regulated DC supply ranging between 5 to 9 volts at about 25 milliamps or more can be used to power the receiver circuit.

The transmitter's circuit can be built on perfboard and housed in a small plastic enclosure with the IR diode protruding from one end. A simple lens system can be added to either or both units to concentrate the IR energy for greater operating range.

The operating frequency of the transmitter and receiver is variable from about 50 kHz to over 200 kHz allowing a single transmitter to control a large number of receivers in the same general location. The transmitter's frequency-control potentiometer, R4, can be replaced with a number of fixed-value resistors and an equal number of normally open pushbutton switches in an arrangement like that shown in Fig. 3. Values for the resistors should be selected to suit the application.

Now that we're able to send on/off control signals using an IR carrier, why

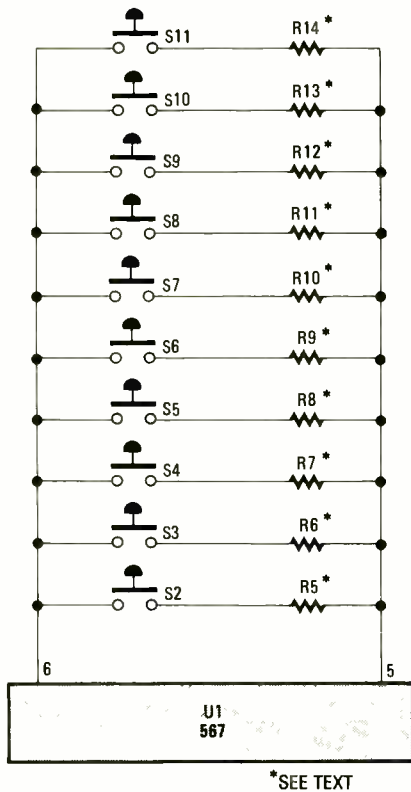

*SEE TEXT

Fig. 3. The transmitter's frequency control (R4 in Fig. 1) can be replaced with a number of fixed-value resistors and an equal number of normally-open pushbutton switches in an arrangement like that shown here.

not convey a more complex signal like audio? The 567 PLL is capable of demodulating an FM signal and providing a linear output at pin 2. With a 10% frequency deviation, the demodulated audio output will be about 200 millivolts. That's plenty of audio to drive a 386 low-power audio amplifier without the need of a preamp stage.

Frequency Modulator. All that's needed now is a simple method of frequency modulating our IR transmitter. There are two ways to vary the frequency of the 567's internal oscillator. One way to accomplish that task is to vary the frequency-setting capacitor that's connected between pin 6 and the circuit's ground; the other is to vary the value of the frequency setting resistor that's connected between pins 5 and 6 of the PLL.

The circuit in Fig. 4 produces an effect similar to frequency modulation (FM) by varying the voltage at pin 6 of the PLL using an audio signal. That works fine as long as the audio level at the collector of Q1 remains below 2 volts peak-to-

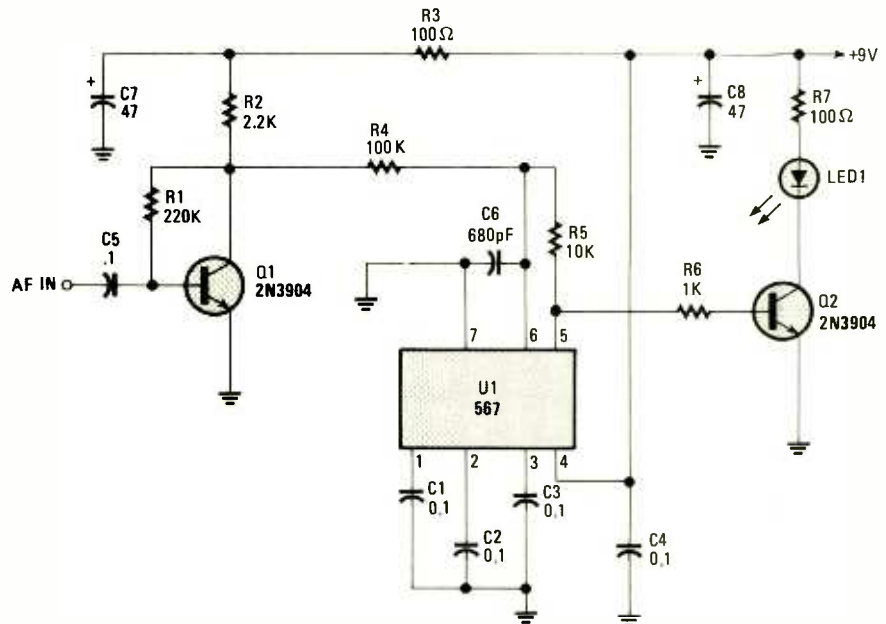

Fig. 4. This circuit produces an effect similar to frequency modulation (FM) by varying the voltage at pin 6 of the PLL using an audio signal.

peak. If the audio signal goes beyond the 2-volt level, the frequency shift will be too wide from the receiver's PLL input bandwidth and the audio will then distort.

Frequency-Modulated IR Receiver.

The FM receiver circuit in Fig. 5 is similar to the remote control receiver in Fig. 2, with a low-power IC amplifier added to drive the speaker. The demodulated

PARTS LIST FOR THE FREQUENCY MODULATOR

SEMICONDUCTORS

- U1—567 phase-locked loop, integrated circuit
- Q1, Q2—2N3904 general-purpose, NPN silicon transistor
- LED1—Infrared emitter (Radio Shack #276-143A)

RESISTORS

- (All resistors are 1/4-watt, 5% units.)
- R1—220,000-ohm
- R2—2200-ohm
- R3, R7—100-ohm
- R4—100,000-ohm
- R5—10,000-ohm
- R6—1000-ohm

CAPACITORS

- C1—C5—0.1- μ F, ceramic-disc
- C6—680-pF, ceramic-disc
- C7, C8—47- μ F, 16-WVDC, electrolytic

ADDITIONAL PARTS AND MATERIALS

- Printed-circuit or perfboard materials, enclosure, IC sockets, 9-volt battery and battery holder, wire, solder, hardware, etc.

audio is fed from pin 2 of U1 to the input of U2 (a 386 low-power audio amplifier) at pin 3. If a volume control is desired, replace R7 with a 10k potentiometer.

Connect a mike or a low-level audio source to the audio input of the IR FM transmitter and aim the infrared-emitting diode toward the receiver's phototransistor. Tune the receiver (using R9) toward the transmitter's frequency until the receiver's LED lights. If everything is

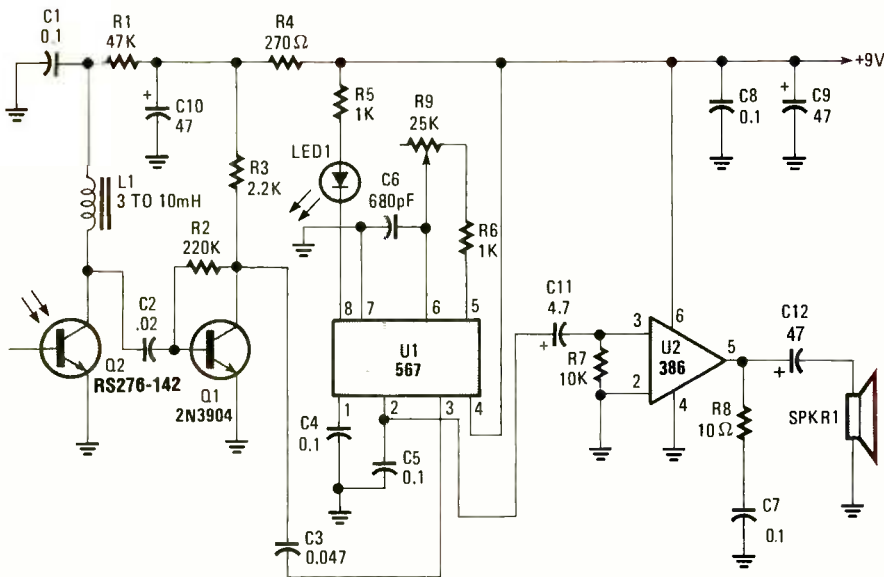

Fig. 5. The Modified Frequency-Modulated IR Receiver is similar to the remote-control receiver in Fig. 2. In this circuit the demodulated audio is fed from pin 2 of U1 to the input of U2 (a 386 low-power audio amplifier) and is used to drive an 8-ohm speaker.

PARTS LIST FOR THE FREQUENCY-MODULATED IR RECEIVER

SEMICONDUCTORS

- U1—567 phase-locked loop, integrated circuit
- U2—386 low power audio-amplifier, integrated circuit
- Q2—Infrared phototransistor (Radio Shack 276-142)
- Q1—2N3904 general-purpose NPN silicon transistor
- LED1—Light-emitting diode (any color)

RESISTORS

- (All resistors are 1/4-watt, 5% units, unless otherwise noted.)
- R1—47,000-ohm
 - R2—220,000-ohm
 - R3—2200-ohm
 - R4—270-ohms
 - R5, R6—1000-ohm
 - R7—10,000-ohm
 - R8—10-ohm
 - R9—25,000-ohm potentiometer

CAPACITORS

- C1, C4, C5, C7, C8—0.1-μF, ceramic-disc
- C2—.02-μF, 100-WVDC, Mylar
- C3—.047-μF, 100-WVDC, Mylar
- C6—680-pF, ceramic-disc
- C9, C10, C12—47-μF, 16-WVDC, electrolytic
- C11—4.7-μF, 25-WVDC, electrolytic

ADDITIONAL PARTS AND MATERIALS

- SPKR1—4-inch 8-ohm speaker
- L1—3- to 10-mH RF choke
- Printed-circuit or perfboard materials, enclosure, IC sockets, 9-volt battery and battery holder, wire, solder, hardware, etc.

working, there should be a quieting sound in the speaker. Speak into the mike and the receiver should respond. If no audio comes out and the receiver's LED is on, the trouble is probably in the audio circuitry.

The operating range depends on the sensitivity of the phototransistor used in the receiver and the radiant-power output of the IR emitter. The distance between the transmitter and receiver can be increased by using a lens to concentrate the IR energy. Also, you can experiment with the receiver's input circuitry by adding an additional gain stage between Q1 and the 567, or try using an LC-tuned circuit in place of the RF choke (L1).

We've once again come to the end of the space allotted to us for the month. But be sure to join us again next time for another discussion on electronic circuitry. Until then, may the flow be with you. ■



"SOUND" INSTALLATION

(Continued from page 64)

By this time the owner and I are shaking our heads, and quietly walking back into the office to work on his company's radio system.

A short while later, having finished the repair job, I packed my tools and quietly walked toward the door, where I joined the boss, still observing, still apparently unobserved.

By now, our doctoral candidate had inserted the antenna, sprayed a little white lacquer over the washer and sealant, and the weld spatters, and climbed into the cab. There he was busily doing something along the roof-line. The boss looked at me, hooked a one-sided grin, and said, "This ought to be interesting." We walked down the stairwell to the bay and over to the truck. I noticed he had installed the connector on the end of the cable, but I saw no evidence of a soldering iron or a crimping tool. There was plenty of friction tape wrapped around the heel of the connector, however. He was attaching the antenna cable to the roof of the cab with something black which resembled chewing-gum wads, then spritzing it with lacquer. The owner peered into the truck, and asked, "What cha' doin', Don?"

"Puttin' in a CB for the yard."

"Do you think it'll work?"

"Bet my job on it," Don replied.

"Okay, that's a deal." The boss glanced at me with that lopsided grin as we walked away.

The radio was lying on the rubber mat under the seat, held in place with a "bungie" cord. The black lead was wrapped around a tech-screw in the back wall, without a lug. The red lead was under the foot-carpet and ran off to some point in the dashboard.

A few moments later Don proudly announced he was ready for a test, and handed the owner a CB handheld with a telescoping antenna. The boss, Don, and I walked to the truck, where Don proudly picked the mike out of the ash tray, flipped the ignition key, and keyed the mike.

"FFFFffffffpp-cghcgh," the radio announced, as a little puff of blue smoke came out around the heat sink at the back. Don looked crushed. "What the...?"

"Gee, Mr. Clouster, what was that 'FFFFppch' sound," I inquired?

"That was the sound of a job opening up," he replied. ■

TRANSFORMERLESS SUPPLY

(Continued from page 46)

diodes (15-volt, 500-mW Zener) in series will do.

For higher currents, a 10-watt Zener (such as the ZX33 type or two ZX15 types in series), with heat sinks, should be used.

Putting It Together. The Transformerless Power Supply can be assembled on perfboard (not experimenter's board, which is very similar). Component interconnections can then be accomplished using point-to-point wiring. Because the circuit provides no isolation from the AC line, any jumper connections that are required should be made using heavy (16-gauge or larger) insulated wire.

Assemble the circuit guided by Fig. 1, and make all component connections as the parts are installed. Connect wires to the appropriate points on the board for connection to the off-board components. You'll need seven wires for switch S1 (one for the wiper, and the remaining six for the switch contacts), plus two additional wires to be brought out to the output terminals (+V and ground). Be careful when wiring the po-

WARNING

This article deals with and involves subject matter and the use of materials and substances that may be hazardous to health and life. Do not attempt to improve or use the information contained herein unless you are experienced and skilled with respect to such subject matter, materials and substances. The publisher makes no representations as to the accuracy of the information contained herein and disclaims any liability for damages or injuries, whether caused by inaccuracies of the information, misinterpretations of the directions, misapplication of the information, or otherwise.

larized components (D1-D4 and SCR1).

Once you've finished interconnecting the circuit elements, check your work for the common construction errors—cold solder joints, misconnected components, etc. Afterward, if you are satisfied that the circuit is correctly assembled, apply power to the circuit (and stand back).

If you own (or have access to) a variable transformer, use it to slowly bring the voltage applied to the circuit up to full line level, while being mindful of any abnormal odors emanating from the circuit components. If you notice a

strange smell coming from the circuit, quickly remove power from the circuit, and recheck your work. If, on the other hand, at full line voltage you notice no problem, remove power from the circuit, disconnect the circuit from the variable transformer, and plug the Transformerless Power Supply's power cord directly into an AC outlet.

Once again apply power to the circuit, and with a multimeter (set to read voltage) connected across the output of the circuit, monitor V_{out} as switch S1 is rotated. Changing the setting of S1 should cause a change in output voltage level. If all is okay, mount the circuit in an **insulated**, plastic enclosure of your own choosing. Mount the off-board components at any convenient location on the front panel of the enclosure, close up the enclosure, and your power supply is ready for use.

By the way, **an enclosure is not optional.** Because of the high voltages in the circuit, it is important to keep curious fingers away. **Place the circuit in an insulated enclosure even if it's only to be used for experiments.**

As mentioned before, a transformer is not easily replaced, but the contraption shown here is not a "Rube Goldberg" either. It has its merits. ■

THE DITHERIZER

(Continued from page 38)

necessary with this circuit—the power supply must supply pure DC with no trace of ripple. Because of that, the use of batteries is recommended. Since the

output is a high-impedance type, a pair of 9-volt batteries should last months, even without an on/off switch.

Testing. Testing the circuit is relatively easy since there's nothing to calibrate. Plug the Ditherizer into your digitizer

and the digitizer to your computer. Turn the audio volume control (R12) all the way down and the dithering control (R11) all the way up. If you take a sample now, you should get low-level pink noise. Now turn R11 down and R12 up, plug a source into the AUDIO IN jack (J1) and take a sample. You should get a normal input without dither.

To set dithering, turn R12 down and adjust R11 while sampling. With no audio, input-resistor R11 should be set so that the sample bounces up and down from the center by 1 bit each way. Now adjust R12 until the desired audio amplitude is reached. Sampling may now be done. The final result will be a clearer, more understandable, and pleasing digital sample.

"Not bad, eh?"

"No, not bad. What did you do?"

"I dithered the input."

"The horns and bells sound so much clearer. Where did you get your Ditherizer?"

"I built it from a magazine article." ■

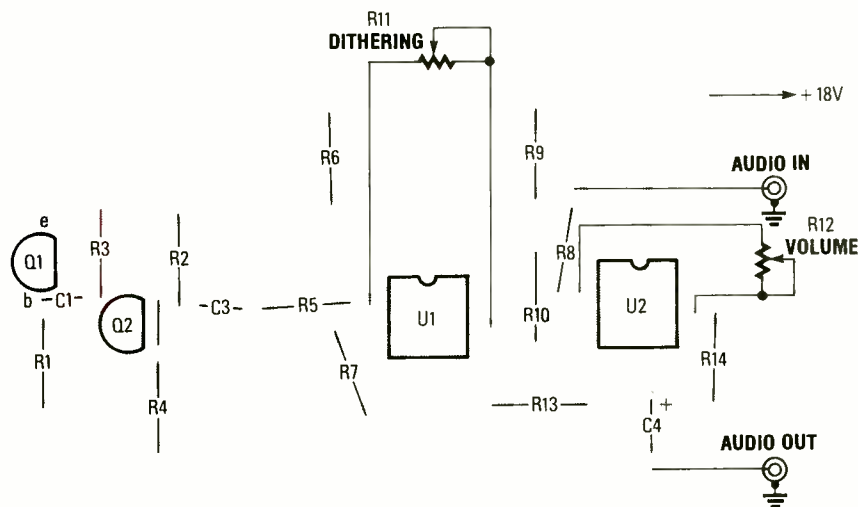

Fig. 4. Start by installing IC sockets at the positions indicated in this parts-placement diagram. Then install all components in the circuit with the proper orientation.

BUY BONDS

ELECTRONICS MARKET PLACE

FOR SALE

DESCRAMBLERS. All brands. Special: Combo Jerrold 400 and SB3 \$165. Complete cable descrambler kit \$39.00. Complete satellite descrambler kit \$45.00. Free catalog. **MJH INDUSTRY**, Box 531, Bronx, NY 10461-0531

LISTEN to the world! Huge catalog of shortwave receivers, antennas, accessories, plus radioteletype and facsimile decoding equipment. Send \$1 to: **UNIVERSAL RADIO**, 1280 Aida Drive, Dept. PE, Reynoldsburg, OH 43068

SURPLUS ELECTRONICS. New giant wholesale catalog. Hundreds of incredible bargains. \$2. Box 840, Champlain, NY 12919.

LASER Listener II, other projects. Surveillance, descrambling, false identification, information. Plans, kits, other strange stuff. Informational package \$3.00 refundable. **DIRIJO/BOND ELECTRONICS**, Box 212, Lowell, NC 28098

LASER components! New surplus tubes, power supplies, optics. Build a working laser for under \$75.00. Free plans with order. \$1.00 (refundable) brings list. **FUNDSERV**, 1546A Peaceful Lane, Clearwater, FL 34616.

CABLE TV DESCRAMBLERS!



BARGAIN HEADQUARTERS!

• JERROLD • TOCOM • HAMLIN
• SCIENTIFIC ATLANTA • ZENITH

Oak M35B ONLY \$60
6 month warranty! We ship C.O.D.
Lowest retail/wholesale prices!

FREE CATALOG:
Global Cable Network
1032 Irving St, Suite 109
S.F., CA 94122

ORDER TODAY! 800-327-8544

1,000,000 videomovies/soundtracks LPs! Video catalogue—\$1.00. Soundtracks—\$1.00. **RTS/PE**, Box 750579, Petaluma, CA 94975.

ALARM equipment wholesale prices call or write for free information. **ALARM CLUB**, 8186 Center, Suite G, LaMesa, CA 92042. (619) 589-2582.

TUBES: radio, TV, send self addressed stamped envelope for list. **LEE DICKINSON**, 478 Main Street, Cromwell, CT 06416.

12 HOUR standard cassette recorders, voice activated. Free brochure. **PRODUCTIVE PRODUCTS**, Box 930024, Norcross, GA 30093.

DESCRAMBLERS — for free catalog, contact **CABLE CONNECTION**, 1304 E. Chicago Street, Suite 301, Algonquin, IL 60102. (708) 658-2365.

SURVEILLANCE — privacy control — debugging — protection. (Kits — assembled). Large new catalogue \$5.00. **TRI-TRON**, 2209F Lapalco, Harvey, LA 70058.

SECURE-64 programmable security system using your Commodore-64. Write **B.R.V.**, 14732 Currency, Baton Rouge, LA 70817. (504) 296-5227.

CB RADIO OWNERS!

We specialize in a wide variety of technical information, parts and services for CB radios. 10-Meter and FM conversion kits, repair books, plans, high-performance accessories. Thousands of satisfied customer since 1976! Catalog \$2.

CBC INTERNATIONAL
P.O. BOX 31500PE, PHOENIX, AZ 85046

SECURITY chain alarms \$9.95. NUAGE, PO Box 777, Battleground, WA 98604. Washington residents add tax.

PRO-2004/5 owners: search with auto-store. Information **SASE. KEY RESEARCH**, PO Box 5054E, Cary, NC 27511.

CLASSIFIED AD ORDER FORM

To run your own classified ad, put one word on each of the lines below and send this form along with your check to:

Popular Electronics Classified Ads, 500-B Bi-County Boulevard, Farmingdale, N.Y. 11735

PLEASE INDICATE in which category of classified advertising you wish your ad to appear. For special headings, there is a surcharge of **\$11.00**.

() Plans/Kits () Business Opportunities () For Sale
() Education/Instruction () Wanted () Satellite Television
() _____

Special Category: \$11.00

PLEASE PRINT EACH WORD SEPARATELY, IN BLOCK LETTERS.

(No refunds or credits for typesetting errors can be made unless you clearly print or type your copy.) Rates indicated are for standard style classified ads only. See below for additional charges for special ads. **Minimum: 15 words.**

1	2	3	4	5
6	7	8	9	10
11	12	13	14	15 (\$23.25)
16 (\$24.80)	17 (\$26.35)	18 (\$27.90)	19 (\$29.45)	20 (\$31.00)
21 (\$32.55)	22 (\$34.10)	23 (\$35.65)	24 (\$37.20)	25 (\$38.75)
26 (\$40.30)	27 (\$41.85)	28 (\$43.40)	29 (\$44.95)	30 (\$46.50)
31 (\$48.05)	32 (\$49.60)	33 (\$51.15)	34 (\$52.70)	35 (\$54.25)

We accept MasterCard and Visa for payment of orders. If you wish to use your credit card to pay for your ad fill in the following additional information (Sorry, no telephone orders can be accepted.):

Card Number _____

Expiration Date _____

PRINT NAME _____

SIGNATURE _____

IF YOU USE A BOX NUMBER YOU MUST INCLUDE YOUR PERMANENT ADDRESS AND PHONE NUMBER FOR OUR FILES. ADS SUBMITTED WITHOUT THIS INFORMATION WILL NOT BE ACCEPTED.

CLASSIFIED COMMERCIAL RATE: (for firms or individuals offering commercial products or services) \$1.55 per word prepaid (no charge for ZIP code)...**MINIMUM 15 WORDS.** 5% discount for same ad in 6 issues within one year; 10% discount for 12 issues within one year if prepaid. **NON-COMMERCIAL RATE:** (for individuals who want to buy or sell a personal item) \$1.25 per word, prepaid....no minimum. **ONLY FIRST WORD AND NAME** set in bold caps at no extra charge. Additional bold face (not available as all caps) **30¢ per word additional.** Entire ad in boldface, \$1.85 per word. **TINT SCREEN BEHIND ENTIRE AD: \$1.90 per word. TINT SCREEN BEHIND ENTIRE AD PLUS ALL BOLD FACE AD: \$2.25 per word. EXPANDED TYPE AD: \$2.05 per word prepaid.** Entire ad in boldface, \$2.45 per word. **TINT SCREEN BEHIND ENTIRE EXPANDED TYPE AD: \$2.55 per word. TINT SCREEN BEHIND ENTIRE EXPANDED TYPE AD PLUS ALL BOLD FACE AD: \$2.95 per word. DISPLAY ADS:** 1" x 2 1/4"—\$205.00; 2" x 2 1/4"—\$410.00; 3" x 2 1/4"—\$615.00. **General Information:** Frequency rates and prepayment discounts are available. **ALL COPY SUBJECT TO PUBLISHERS APPROVAL. ADVERTISEMENTS USING P.O. BOX ADDRESS WILL NOT BE ACCEPTED UNTIL ADVERTISER SUPPLIES PUBLISHER WITH PERMANENT ADDRESS AND PHONE NUMBER. Copy to be in our hands on the 15th of the fourth month preceding the date of issue (i.e.; Sept. issue copy must be received by May 15th). When normal closing date falls on Saturday, Sunday or Holiday, issue closes on preceding work day. Send for the classified brochure. Circle Number 49 on the Free Information Card.**

MICROWAVE TV RECEIVERS 1.9 to 2.7 GHz



2 CH Compact Dish System - \$77.95
 5 CH Dish System - \$93.95
 12 CH Yagi (Rod) System - \$123.95
 30 CH Dish System - \$163.90 Yagi - \$183.90
SUN MICROWAVE INT'L. INC. Send \$1.00 for
 P.O. BOX 34522 catalog on these
 PHOENIX, AZ 85067 and other fine
 (602) 230-0640 video products.
VISA/MC/COD QUANTITY DISCOUNTS LIFETIME WARRANTY

CABLE descrambler liquidation. Major makes and models available. Industry pricing! (Example: Hamlin Combo's, \$44 each... Minimum 10 orders). Call **WEST COAST ELECTRONICS**, (800) 628-9656.

NEURAL network chip learns reflex actions in real time, \$75.00. **ACCOTECH**, 1126 Apple Valley Road, Accokeek, MD 20607. (301) 292-4124.

IBM software. Large selection of programs. \$3.00 per disk. For free catalog send SASE to: **BY-TEHEAD**, Dept. E, Box 597, Dundee, IL 60118.

FREE CATALOG

FAMOUS "FIRESTIK" BRAND CB ANTENNAS AND ACCESSORIES. QUALITY PRODUCTS FOR THE SERIOUS CB'er. SINCE 1962

FIRESTIK ANTENNA COMPANY
 2614 EAST ADAMS
 PHOENIX, ARIZONA 85034

PLANS & KITS

CATALOG: hobby/broadcasting/HAM/CB: Cable TV, transmitters, amplifiers, surveillance devices, computers, more! **PANAXIS**, Box 130-H4, Paradise, CA 95967.

BUILD this five-digit panel meter and square wave generator including an ohms, capacitance and frequency meter. Detailed instructions \$2.50. **BAGNALL ELECTRONICS**, 179 May, Fairfield, CT 06430.

VIDEOCIPHER II manuals. Volume 1 — hardware, Volume 2 — software — either \$32.45. Volume 3 — projects/software — \$42.45. Volume 4 — repair/software — \$97.45. Volume 5 — Documentation — \$42.45. Volume 6 — Experimentation — \$42.45. **Clone Hacker's Bible** — \$32.95. **Cable Hacker's Bible** — \$32.45. CODs: (602) 782-2316. 0100-032 software available. Catalog \$3.00. **TELECODE**, Box 6426-PE, Yuma, AZ 85366-6426.

REMOTE CONTROL KEYCHAIN



Complete w/mini-transmitter and +5 vdc RF receiver
 Fully assembled including plans to build your own auto alarm
 Quantity discounts available

\$24.95 Check, Visa or M/C
 Add \$3 shipping

VISITECT INC. /Dept. P (415) 872-0128
 PO BOX 5442, SO. SAN FRAN., CA 94080

DETECTION — Surveillance, debugging, plans, kits, assembled devices. Latest high-tech catalog \$5. **DETECTION SYSTEMS**, 2515 E. Thomas, #16-864J, Phoenix, AZ 85016.

CLOSEOUT "TV Frequency Standard" April 1988 R-E, kit/antenna coil \$55.00, finished units \$200.00; Dot-Bar generator kit \$35.00; Matchbox FM transmitter kit \$15.00; **PERSHING TECHNICAL**, Box 1951, Fort Worth, TX 76101.

ELECTRONIC kits! Tracking transmitters! Voice disguisers! Bug Detectors! Surveillance items! More! Catalog \$1.00. **XANDI ELECTRONICS**, Box 25647, 32MM, Tempe, AZ 85285-5647.

SURROUND sound stereo speaker system: four, three — way pyramid shaped enclosures form fit upper corners of room producing a fantastic new listening experience. Plans \$5.00. **SURROUND SOUND STEREO SYSTEMS**, Box 347, Fairfax, CA 94930.

Motion Control System 159⁰⁰

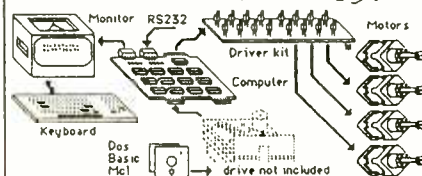

Includes Computer, Monitor, Keyboard Power supply, 4 Motors, and Software 15 day refund policy! Call or send for details and FREE robotics Catalog

Silicon Valley Surplus 415-261-4506
 Open 8am to 4pm PST Mon - Fri
 Freight & tax are extra
 We gladly ship cod cont USA
 4222 E. 12th St. Oakland ca 94601

STRESSED out? Relaxation technique easily learned with the aid of a simple electronic device. Not hypnosis! Plans \$9.95. **BLUE CHIP ENGINEERING**, Dept. 42, PO Box 1100, Walnut, CA 91789.

SHORTWAVE — 1933. One-tube. DX radio. Free plans from **BOB RYAN**, PO Box 3039, Anaheim, CA 92803.

CONNECT your IBM/Apple computer to the outside world. Set of manuals for 10 experiments \$16.00. Specify IBM or Apple. **TECH-LINK, INC.**, 520 Lorena SW, North Canton, Ohio 44720.

PC/XT — selectively boot from A: or B: drives — 5 1/4" or 3 1/2." Easy to build inexpensive switching device. Plans \$5.00. **REUTER ENGINEERING, INC.**, PO Box 24514, Mpls, MN 55424.

PROJECT supplies — tools — motors — casting — etc. Catalog \$1.00. **INVENTORS HARDWARE**, Box 8460-P, Anaheim, CA 92812.

NEW HE NE LASER TUBES \$35



Dealer Inquiries Invited.
 Free Catalog!

MEREDITH INSTRUMENTS: 6403 N. 59th Ave.
 Glendale, AZ 85301 • (602) 934-9387
 "The Source for Laser Surplus"

CABLE TV CONVERTERS IN STOCK

Stocking all types of converters — Panasonic, Jerrod, Tocom, Pioneer, Scientific Atlanta, Zenith, Oak, Hamlin, Eagle, and others brands available.

Call or write for **FREE CATALOG**
 10 am - 5:30 pm Eastern, Mon. - Fri.

VIDEO-LINK Enterprises, Inc.

520 GLENBROOK RD., STE. 202
 STAMFORD, CT 06906
 Orders 1-800-622-9022
 Catalog & info: 203-975-7543

EDUCATION/INSTRUCTION

MAGIC! Four illustrated lessons plus inside information shows you how. We provide almost 50 tricks including equipment for four professional effects. You get a binder to keep the materials in, and a one-year membership in the International Performing Magicians with a plastic membership card that has your name gold-embossed. You get a one-year subscription to our quarterly newsletter, "IT'S MAGIC!" Order now! \$29.95 for each course + \$3.50 postage and handling. (New York residents add applicable state and local sales tax). **The Magic Course**, 500-B BiCounty Blvd., Farmingdale, NY 11735.

LEARN IBM PC assembly language. 80 programs. Disk \$5. Book \$15. **ZIPFAST**, Box 12238, Lexington, KY 40581-2238.

F.C.C. Commercial General Radiotelephone License. Electronics home study. Fast, inexpensive! "Free" details. **COMMAND**, D-178, Box 2824, San Francisco, CA 94126.

OUTSTANDING educational software for IBMs & compatibles! Wide variety. Rush \$2.00 — (complete information) **D.L.S.**, PO Box 1393, Federal Station, Worcester, MA 01601, #D401.



TUBES - 2000 TYPES DISCOUNT PRICES!

Early, hard-to-find, and modern tubes. Also transformers, capacitors and parts for tube equipment. Send \$2.00 for 24 page wholesale catalog.

ANTIQUE ELECTRONIC SUPPLY
 688 W. First St. • Tempe, AZ 85281 • 602/894-9503

BUSINESS OPPORTUNITIES

YOUR own radio station! AM, FM, TV, cable. Licensed/unlicensed. **BROADCASTING**, Box 130-H4, Paradise, CA 95967.

LET the government finance your small business. Grants/loans to \$500,000. Free recorded message: (707) 448-0270. (KJ8).

EASY work! Excellent Pay! Assemble products at home. Call for info. (504) 641-8003 Ext. 5730.

MAKE \$50/hr working evenings or weekends in your own electronics business. Send for free facts. **MJPI INDUSTRY**, Box 531, Bronx, NY 10461.

SIMPLE electronic home assembly & more! High earnings! Details \$1.00 (refundable) to **RESEARCH CENTRAL**, Box 12691, Dept. PE10, Wichita, KS 67277-1269.

General Technics
 Quality Computer Systems
GT (516) 981-9473
 Save hundreds of dollars assembling
 Your own IBM Compatible Computer
Complete AT Computer System \$675
 Amber Monitor, 512k Memory, 101 Enhanced Keyboard, 1.2m Flappy Drive
 12 mhz 80286 Mother Board, Hard/Flappy Controller Card, Instruction Manual
FREE CATALOG
 P.O. Box 2676, Lake Ronkonkoma, NY 11779

WANTED

BUYING 1950's and 1960's audio equipment, mono and stereo, especially tube electronics. **PAUL**, (313) 737-0429.

SATELLITE TV

FREE catalog — Do-it-yourself save 40—60% **Lowest prices** world wide, Systems, upgrades, parts, all major brands factory fresh and warranted. **SKYVISION INC.**, 2008 Collegeway, Fergus Falls, MN 56537. 1 (800) 334-6455.

BEST BY MAIL

Rates: Write National, Box 5, Sarasota, FL 34230

OF INTEREST TO ALL

NEW! WATERWATCH! NO battery change. Runs on tap water. Radiopene! Earphone AM radio and pen! Send \$11.50 each to: F&A Enterprises, Box 1203, Dearborn, MI 48121.

HAWAIIAN DESIGNS! CATALOG \$3.00. "Tiki", Box 3249, Mililani, HI 96789.

FINANCIAL

HAVING CREDIT PROBLEMS? For our **National Credit Guide** rush \$27.95 to: DM Manuals, 3377 Wilshire Blvd., Dept. 1022, Los Angeles, CA 90010. 30 Days Money Back Guarantee!

HOME WORKERS NEEDED. Make money. 900 directories, addresses. \$10.00. Nationals, RT. #3-M, Waseca, MN 56093.

NEED CREDIT? \$1,500 + Gold Card. No deposit. No turn downs. Visa available. 1(602)420-1486.

PERSONAL/MISCELLANEOUS

LONELY? FREE SINGLES Lists! \$1.00: Publishing, Box 24618(PE), Detroit, 48224.

DEALERS WANTED
BURGLAR ALARMS ■ FIRE ALARMS
INTERCOM ■ CLOSED CIRCUIT TV
PROFESSIONAL EQUIPMENT □ WHOLESALE PRICES
 495 (Irretrievable) For Catalog of Newest
 Electronic Technology
MONEY BACK IF NOT MORE THAN SATISFIED
ACS ENTERPRISES
 2531 Jefferson NE, Albuquerque, NM 87110
 1 800 545 6286

STEPPER MOTORS

CONTROL stepper motors with your computer \$59.95. Includes motor, driver, software, documentation. Information package \$1.00. **ARRICK ROBOTICS**, Box 1574, Hurst, TX 76053. (817) 571-4528.

SOFTWARE

FREE software for IBM and compatibles! Info \$1.00. **BLUE CHIP ENGINEERING**, Dept. 42, PO Box 1100, Walnut, CA 91789.

CABLE TV "BOXES"
Converters — Descramblers
Remote Controls — Accessories
 ★ Guaranteed Best Prices ★
 ★ 1 Year Warranty — C.O.D.'s ★
 ★ Immediate Shipping ★
 ★ FREE CATALOG ★
Call or Write
TRANS-WORLD CABLE CO.
 12052 Southwest 117th Court, Suite 126
 Miami, Florida 33186
 1-800-442-9333



FREE CATALOG!
1-800-648-7938
 For all information 1-702-362-9026
JERROLD HAMLIN OAK ETC.
CABLE TV
DESCRAMBLERS
 • Compare our low Low Retail Prices!
 • Guaranteed Prices & Warranties!
 • Orders Shipped Immediately!
REPUBLIC CABLE PRODUCTS INC.
 4080 Paradise Rd. #15 Dept. PE-90
 Las Vegas, NV 89109

LCD DIGITAL COUNTER

FOUR digits, multipurpose, battery operated. Plans \$10.00 parts kit without circuit board \$45.00 add \$3.00 shipping, handling. For kit only chassis not included. Money orders, certified checks only. **W.P. ELECTRONICS**, 59 Oriole Street, Gardner, MA 01440-2105. Allow 6-8 weeks for delivery.

DIGITAL CAR DASHBOARDS

BUILD yourself complete electronic dashboards. Informational package: \$2.00 (refundable). **MODERN LABS**, 2900-F Ruisseau, Saint-Elizabeth, QC, J0K 2J0, Canada.

T.V. FILTERS

T.V. notch filters, surveillance equipment, brochure \$1.00. **D.K. Video**, Box 63/6025, Margate, FL 33063. (305) 752-9202.

CABLE T.V. CONVERTERS
WHY PAY A HIGH MONTHLY FEE?

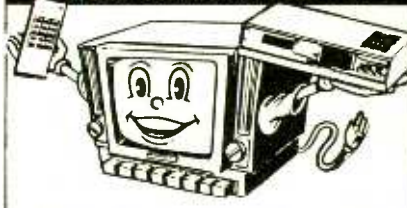

All Jerrold, Oak, Hamlin, Zenith, Scientific Atlanta, Magnavox and all specialized cable equipment available for shipment within 24 hours. For fast service MC/VISA or C.O.D. telephone orders accepted **(800) 648-3030** 60 Day Guarantee (Quantity Discounts) 8 A.M. to 5 P.M. C.S.T. **CLOSED WEEK-ENDS**. Send self-addressed Stamped envelope (60¢ postage) for Catalog.

MIDWEST ELECTRONICS INC.
 P.O. Box 5000
 Suite 311 (PE)
 Carpentersville, IL 60110
 No Illinois Orders Accepted

ANTIQUE RADIO CLASSIFIED
Free Sample!
 Antique Radio's
 Largest Circulation Monthly
 Articles, Ads & Classifieds.
 6-Month Trial: \$11. 1-Yr: \$20 (\$30-1st Class).
A.R.C., P.O. Box 802-L3, Carlisle, MA 01741



ADVERTISING INDEX

POPULAR ELECTRONICS magazine does not assume any responsibility for errors that may appear in the index below.

Free Information No.	Page		Page
—	ACS Supply	107	10
6	AMC Sales	93	—
5	All Electronics	27	—
—	Amazing Concepts	95	—
—	Antique Electronic Supply	106	—
—	Antique Radio Classified	107	—
16	Banner Technical Books	95	23
15	C & S Sales	17	—
—	CB City	105	—
—	CIE	21	—
—	Command Productions	16	13
17	Communications Electronics	CV4	—
24	Contact East	91	14
18	Cook's Institute	89	—
—	Damark International	CV2	25
12	Digi Key	32	9
—	Digital	24	—
19	Electronics Book Club	23	20
—	Electronic Tech. Today	98	—
11	Fisher Research	24	—
—	Firestik II	106	26
—	General Technics	106	—
—	Global Cable Network	105	8
—	Grantham College	16	—
22	Heathkit	13	—
21	I.M. Instrument	91	—
—	Jensen Tools	16	—
—	McGraw Hill Book Club	8	—
—	Meredith Instruments	106	—
—	MetraByte	38	—
—	Midwest Electronics	107	—
—	Monitoring Times	97	—
—	Mouser	93	—
—	NESDA	100	—
—	NRI Schools	31	—
—	Pacific Cable	5	—
—	Parts Express	7	—
—	People's College	25	—
—	Radio Shack	3	—
—	Republic Cable	107	—
—	SCO Electronics	26	—
—	Sequoia Publishing	89	—
—	Silicon Valley Surplus	106	—
—	Sintec	99	—
—	Sun Microwave Int'l	106	—
—	Trans World	107	—
—	U.S. Cable	26	—
—	Video-Link	106	—
—	Viejo Publications	97	—
—	Visitect	106	—
—	Weka Publishing	15	—
—	Windjammer	CV3	—

ADVERTISING SALES OFFICE

Gernsback Publications, Inc.
500-B Bi-County Blvd.
Farmingdale, NY 11735
1-(516) 293-3000
 President: **Larry Steckler**
 Vice President: **Cathy Steckler**

For Advertising ONLY
516-293-3000
Fax 1-516-293-3115
Larry Steckler
 publisher

Arline Fishman
 advertising director
Denise Haven
 advertising assistant
Christina Estrada
 advertising associate
Lisa Strassman
 credit manager

SALES OFFICES

EAST/SOUTHEAST
Becky Akers
 Patis/3M
 310 Madison Ave., Suite 1804
 New York, NY 10017
 1-212-953-2121
 Fax 1-212-953-2128

MIDWEST/Texas/Arkansas/Okla.
Ralph Bergen
 540 Frontage Road—Suite 339
 Northfield, IL 60093
 1-312-446-1444
 Fax 1-312-446-8451

PACIFIC COAST/Mountain States
Marvin Green
 5430 Van Nuys Blvd., Suite 316
 Van Nuys, CA 91401
 1-818-986-2001
 Fax 1-818-986-2009

BOZART 911

(Continued from page 67)

Bozart lurched off in a different, new direction.

Bozart's research into crossovers eventually resulted in the development of the intricate MC², or Multiphasic Complex Crossover. The device is sometimes referred to by its in-house code name "BIPA," for Bozart Incoherent-Phased Array (which early-on gave rise to the phrase, "You bet your sweet BIPA...") and provided the key that unlocked the secret of single-speaker stereo. By feeding half the stereo signal into each end of the network, and arranging the wires just so, a pair of 3rd, 4th, and 12th-order overdrive signals is derived that can be recombined and used to drive the halves of a bifurcated-voice-coil speaker.

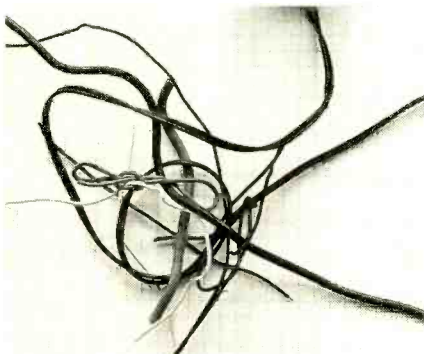

This version of Bozart's BIPA crossover network shows its not a run-of-the-mill filter bank. This is the kind of quality you can only get from an industry leader.

The BIPA crossover so obfuscates the signal with aphasical information that the simplest thing that the ear—being frequency-, time-, phase-sensitive, and much, much more—can figure out to do with it, short of dropping the matter entirely, is to perceive it as stereo and leave it at that.

Construction. The premium-priced, top-of-the-line Bozart 911-4, which is the one we reviewed since we didn't have to worry about paying for it, contains four separate drivers: a tweeter, a wheedler, a barfer and a huge 19-inch ferrofluid-cooled subgrumbler. A one-gallon can of ferrofluid is supplied with each Bozart 911-4 (two-quart cans with the 911-3 and 911-2), and the listener is encouraged to pour a small amount over the subgrumbler during heavy workouts to carry away some of the heat generated. Extra ferrofluid can be ordered directly from Bozart. Bozart

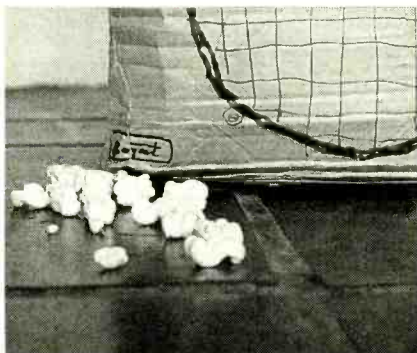

There is only one source in the world for the material that Bozart uses to fill its enclosures, and that is one of the company's most closely guarded secrets.

strongly cautions you against buying just any brand of ferrofluid from street vendors, since in many instances that has proven to be nothing more than brake-, transmission-, or cerebro-spinal fluid with the word "ferro" crudely lettered over the container's original markings.

In addition to a standard four-way crossover to divide frequencies as equitably as possible among the four drivers, the 911-4 contains several BIPA crossovers, in sealed lead boxes, to generate the disphasic signals required. A quad-amped version of the system with BIPA networks in the amplifiers was considered by Bozart, but due to meltdown problems in the amplifiers' output stages resulting from too many phases, it was abandoned. The slight distortion added by the BIPA network is said to be nearly unnoticeable amidst all the other auditory brouhaha.

Bozart has also paid special attention to the 911-series enclosures. Conventionally, materials such as wood, sand, concrete, sawdust, ceramic, and adobe bricks are used to impart rigidity to the enclosure; that discourages the box from resonating and "coloring" the sound. Bozart, on the other hand, prefers some degree of resonance and vibration—"It adds to the confusion," said one Bozart engineer with whom we spoke.

To that end, all Bozart 911 speaker systems are assembled in a special double-wall corrugated-board container. The box material vibrates almost—but not quite—in synchrony with the speaker drivers, adding to the cacophony and thus even more to the perceived stereophony. Sound coloration can be controlled somewhat by modifying the proprietary damping material used within the case, and by changing the ink used to print the "grill

cloth" on it. The enclosure also doubles as a shipping container, helping to keep down the already astronomical cost of the system. And perhaps best of all, hookup and operating instructions are printed right on the speaker, eliminating the need for a separate manual that can get lost.

Listening Tests. After all we had heard about it, we were somewhat skeptical about listening to the Bozart. However, taking courage in hand we connected our amplifier as directed to the 911 using the special cables provided with it and positioned the unit as instructed: in the bathroom, equidistant from all the tiled surfaces we could locate and measure from. Bozart says that this placement benefits bass response (the "boom-box" effect, they call it) and further enhances the work of the BIPA network.

We put the test CD Bozart supplied us into our player, and assumed our favorite listening position. After the initial cracklings and poppings had died away, and the fire department had cleaned up as best it could and gone home, we were pleasantly surprised the next day to discover that...

(Continued on April 1) ■

HANDS-ON REPORT

(Continued from page 79)

Of course, no examination of a headset would be complete without a listening of Tchaikovsky's *1812 Overture* (CBS) played by the New York Philharmonic, Leonard Bernstein conducting. Taken from a CD made from newly remixed, original-session tapes, the gunfire heard on the ATH-909 Stereophone was realistic and crisp. Played as loud as the ear could endure for a few minutes, the sound did not break up the bass—it remained solid and with no apparent second-harmonics.

The listening session was the clincher—the Audio-Technica ATH-909 Stereophone rated a published review, and a recommendation for **Popular Electronics** readers to give the headset their personal, critical examination at their local audio store.

The Audio-Technica ATH-909 Stereophone is a winner in its class. Priced at a suggested retail of \$79.95, the Stereophone will be a welcome addition to any audiophile's listening chamber. For more information circle No. 120 on the Free Information Card. ■

East of the sun. West of the moon. Windjammer.

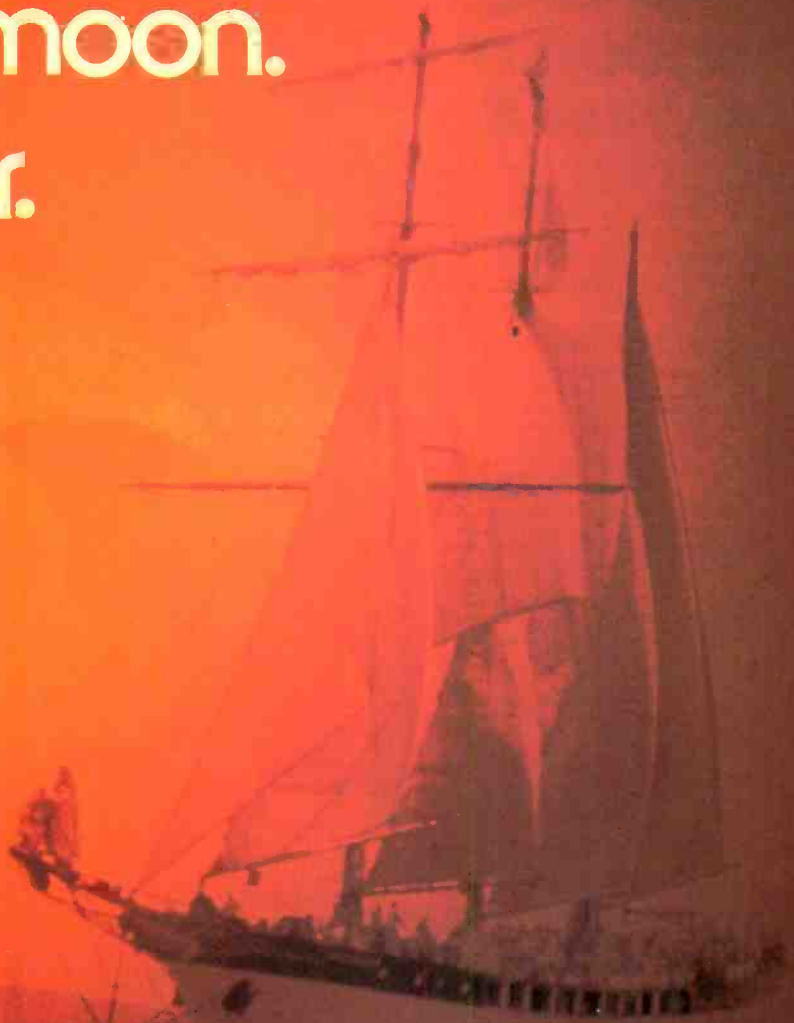

A place to live your fantasies.
A place to free your soul.

To cozy up to the Caribbean sun.
To dance among a thousand stars
to the rhythms of steel drums.
To play on sparkling white and
pink sand beaches.
To discover the underwater
paradise of the reefs.
To find a new friend and share the
intimacies of a sensuous night.

To come alive and live.
To remember for a lifetime.

6 days and 6 nights. From \$625.

Reservations toll free
1-800-327-2600
In Florida 305/373-2090.

**Windjammer
Barefoot Cruises**

Pos: Office Box 120,
Miami Beach, Florida 33119.



Cap'n Mike, rush me my free, full color 'Great Adventure' booklet and show
me the way to Paradise for 6 days and 6 nights from \$625.
Windjammer Barefoot Cruises,
P.O. Box 120, Dept. 1642 Miami Beach, Fla. 33119.
Name _____
Address _____
City _____
State/Zip _____

uniden®

\$12,000,000 Scanner Sale

Uniden Corporation of America has purchased the consumer products line of Regency Electronics Inc. for \$12,000,000. To celebrate this purchase, we're having our largest scanner sale in history! Use the coupon in this ad for big savings. Hurry...offer ends March 31, 1990.

★ ★ ★ MONEY SAVING COUPON ★ ★ ★

Get special savings on the scanners listed in this coupon. This coupon must be included with your prepaid order. Credit cards, personal checks and quantity discounts are excluded from this offer. Offer valid only on prepaid orders mailed directly to Communications Electronics Inc., P.O. Box 1045 - Dept. UN19, Ann Arbor, Michigan 48106-1045 U.S.A. Coupon expires March 31, 1990. Coupon may not be used in conjunction with any other offer from CEI. Coupon may be photocopied. Add \$12.00 for shipping in the continental U.S.A.

COUPON

COUPON

COUPON

- Regency TS2-T \$259.95
- Regency R1600-T \$239.95
- Regency R1099-T \$99.95
- Regency RH806B-T \$419.95
- Regency RH256B-T \$294.95
- Bearcat 200XLT-T2 \$229.95
- Bearcat 100XLT-T \$184.95
- Bearcat 800XLT-T2 \$229.95
- Uniden HR2510-T \$229.95
- Uniden HR2800-T \$274.95
- Uniden PRO500D-T2 \$29.95

★ ★ ★ VALUABLE COUPON ★ ★ ★

Bearcat® 760XLT-T

List price \$499.95/CE price \$244.95/SPECIAL 12-Band, 100 Channel • Crystalless • AC/DC Frequency range: 29-54, 118-174, 406-512, 806-956 MHz. Excludes 823.9875-849.0125 and 868.9875-894.0125 MHz. The Bearcat 760XLT has 100 programmable channels organized as five channel banks for easy use, and 12 bands of coverage including the 800 MHz band. The Bearcat 760XLT mounts neatly under the dash and connects directly to fuse block or battery. The unit also has an AC adaptor, flip down stand and telescopic antenna for desk top use. 6-5/16" W x 1 1/4" H x 7 3/4" D. Model BC 590XLT-T is a similar version without the 800 MHz band for only \$194.95. Order your scanner from CEI today.

NEW! Regency® Products

- R4030-T Regency 200 ch. handheld scanner \$254.95
- R4020-T Regency 100 ch. handheld scanner \$189.95
- R4010-T Regency 10 channel handheld scanner \$114.95
- R1800-T Regency 100 channel mobile scanner \$244.95
- P200-T Regency 40 channel CB Mobile \$38.95
- P210-T Regency 40 channel CB Mobile \$56.95
- P220-T Regency 40 channel CB Mobile \$79.95
- P300-T Regency 40 channel SSB CB Mobile \$137.95
- P400-T Regency 40 channel SSB CB Base \$174.95
- PR100-T Regency visor mount radar detector \$54.95
- PR110-T Regency "Passport" size radar detector \$114.95
- PR120-T Regency "micro" size radar detector \$144.95
- MP5100XL-T Regency 40 Ch. marine transceiver \$139.95
- MP510XL-T Regency 60 Ch. marine transceiver \$159.95
- MP6000XL-T Regency 60 Ch. marine transceiver \$209.95
- MP2000XL-T Regency handheld marine trans. \$189.95

Regency® RH256B-T

List price \$799.95/CE price \$299.95/SPECIAL 16 Channel • 25 Watt Transceiver • Priority The Regency RH256B is a sixteen-channel VHF land mobile transceiver designed to cover any frequency between 150 to 162 MHz. Since this radio is synthesized, no expensive crystals are needed to store up to 16 frequencies without battery backup. All radios come with CTCSS tone and scanning capabilities. A monitor and night/day switch is also standard. This transceiver even has a priority function. The RH256 makes an ideal radio for any police or fire department volunteer because of its low cost and high performance. A 60 Watt VHF 150-162 MHz. version called the RH806B-T is available for \$429.95. A UHF 15 watt, 16 channel version of this radio called the RU156B-T is also available and covers 450-482 MHz. but the cost is \$454.95.

★ ★ ★ Uniden CB Radios ★ ★ ★

The Uniden line of Citizens Band Radio transceivers is styled to compliment other mobile audio equipment. Uniden CB radios are so reliable that they have a two year limited warranty. From the feature packed PRO 810E to the 310E handheld, there is no better Citizens Band radio on the market today.

- PRO310E-T Uniden 40 Ch. Portable/Mobile CB \$83.95
- PRO30E-T Uniden 40 Ch. Remote mount CB \$104.95
- PRO500D-T Uniden 40 Channel CB Mobile \$38.95
- KARATE-T Uniden 40 channel rescue radio \$53.95
- GRANT-T Uniden 40 channel SSB CB base \$166.95
- MADISON-T Uniden 40 channel SSB CB mobile \$244.95
- PC122-T Uniden 40 channel SSB CB mobile \$119.95
- PRO510XL-T Uniden 40 channel CB Mobile \$38.95
- PRO520XL-T Uniden 40 channel CB Mobile \$56.95
- PRO530XL-T Uniden 40 channel CB Mobile \$79.95
- PRO540E-T Uniden 40 channel CB Mobile \$97.95
- PRO640E-T Uniden 40 channel SSB CB Mobile \$137.95
- PRO710E-T Uniden 40 channel CB Base \$119.95
- PRO810E-T Uniden 40 channel SSB CB Base \$174.95

★ ★ ★ Uniden Radar Detectors ★ ★ ★

Buy the finest Uniden radar detectors from CEI today.

- TALKER-T2 Uniden talking radar detector \$144.95
- RD7-T Uniden visor mount radar detector \$99.95
- RD9-T Uniden "Passport" size radar detector \$114.95
- RD9XL-T Uniden "micro" size radar detector \$144.95
- RD25-T Uniden visor mount radar detector \$54.95
- RD500-T Uniden visor mount radar detector \$74.95

Bearcat® 200XLT-T

List price \$509.95/CE price \$239.95/SPECIAL 12-Band, 200 Channel • 800 MHz. Handheld Search • Limit • Hold • Priority • Lockout Frequency range: 29-54, 118-174, 406-512, 806-956 MHz. Excludes 823.9875-849.0125 and 868.9875-894.0125 MHz. The Bearcat 200XLT sets a new standard for handheld scanners in performance and dependability. This full featured unit has 200 programmable channels with 10 scanning banks and 12 band coverage. If you want a very similar model without the 800 MHz band and 100 channels, order the BC 100XLT-T for only \$189.95. Includes antenna, carrying case with belt loop, ni-cad battery pack, AC adapter and earphone. Order your scanner now.

Bearcat® 800XLT-T

List price \$549.95/CE price \$239.95/SPECIAL 12-Band, 40 Channel • No-crystal scanner Priority control • Search/Scan • AC/DC Bands: 29-54, 118-174, 406-512, 806-912 MHz. Excludes 823.9875-849.0125 and 868.9875-894.0125 MHz. The Uniden 800XLT receives 40 channels in two banks. Scans 15 channels per second. Size 9 1/4" x 4 1/2" x 1 1/2". If you do not need the 800 MHz band, a similar model called the BC 210XLT-T is available for \$178.95.

Bearcat® 145XL-T

List price \$189.95/CE price \$94.95/SPECIAL 10-Band, 16 Channel • No-crystal scanner Priority control • Weather search • AC/DC Bands: 29-54, 136-174, 406-512 MHz. The Bearcat 145XL is a 16 channel, programmable scanner covering ten frequency bands. The unit features a built-in delay function that adds a three second delay on all channels to prevent missed transmissions. A mobile version called the BC560XLT-T featuring priority, weather search, channel lockout and more is available for \$94.95. CEI's package price includes mobile mounting bracket and mobile power cord.

President® HR2510-T

List price \$499.95/CE price \$239.95/SPECIAL 10 Meter Mobile Transceiver • Digital VFO Full Band Coverage • All-Mode Operation Backlit liquid crystal display • Auto Squelch RIT • Preprogrammed 10 KHz. Channels Frequency Coverage: 28.0000 MHz to 29.6999 MHz. The President HR2510 Mobile 10 Meter Transceiver made by Uniden, has everything you need for amateur radio communications. Up to 25 Watt PEP USB/LSB and 25 Watt CW mode. Noise Blanker. PA mode. Digital VFO. Built-in S/R/F/Mod/SWR meter. Channel switch on the microphone, and much more! The HR2510 lets you operate AM, FM, USB, LSB or CW. The digitally synthesized frequency control gives you maximum stability and you may choose either pre-programmed 10 KHz. channel steps, or use the built-in VFO for steps down to 100 Hz. There's also RIT (Receiver Incremental Tuning) to give you perfectly tuned signals. With receive scanning, you can scan 50 channels in any one of four band segments to find out where the action is. Order your HR2510 from CEI today.

NEW! President® HR2600-T

List price \$599.95/CE price \$299.95/SPECIAL 10 Meter Mobile Transceiver • New Features The new President HR2600 Mobile 10 Meter Transceiver is similar to the Uniden HR2510 but now has repeater offsets (100 KHz.) and CTCSS encode.



BC760XLT
800 MHz.
mobile scanner
SPECIAL!

★ ★ ★ Uniden Cordless Telephones ★ ★ ★

- XE750-T Uniden Cordless Phone with speaker \$99.95
- XE550-T Uniden Cordless Phone \$79.95
- XE300-T Uniden Cordless Phone \$69.95

★ ★ ★ Extended Service Contract ★ ★ ★

If you purchase a scanner, CB, radar detector or cordless phone from any store in the U.S. or Canada within the last 30 days, you can get up to three years of extended service contract from Warrantech. This service extension plan begins after the manufacturer's warranty expires. Warrantech will perform all necessary labor and will not charge for return shipping. Extended service contracts are not refundable and apply only to the original purchaser. A two year extended contract on a mobile or base scanner is \$29.99 and three years is \$39.99. For handheld scanners, 2 years is \$59.99 and 3 years is \$79.99. For radar detectors, two years is \$29.99. For CB radios, 2 years is \$39.99. For cordless phones, 3 years is \$34.99. Order your extended service contract today.

OTHER RADIOS AND ACCESSORIES

- BC55XLT-T Bearcat 10 channel scanner \$114.95
 - BC70XLT-T Bearcat 20 channel scanner \$159.95
 - BC175XLT-T Bearcat 16 channel scanner \$156.95
 - R2066-T Regency 60 channel scanner \$149.95
 - R1099-T Regency 45 channel scanner \$109.95
 - TS2-T Regency 75 channel scanner \$269.95
 - UC102-T Regency VHF 2 ch. 1 Watt transceiver \$114.95
 - BPS5-T Regency 16 amp reg. power supply \$179.95
 - BP205-T1 Ni-Cad batt. pack for BC200/BC100XLT \$39.95
 - B8-T 1.2 V AA Ni-Cad batteries (set of eight) \$17.95
 - FBE-T Frequency Directory for Eastern U.S.A. \$14.95
 - FBW-T Frequency Directory for Western U.S.A. \$14.95
 - RFD1-T Great Lakes Frequency Directory \$14.95
 - RFD2-T New England Frequency Directory \$14.95
 - RFD3-T Mid Atlantic Frequency Directory \$14.95
 - RFD4-T Southeast Frequency Directory \$14.95
 - RFD5-T N.W. & Northern Plains Frequency Dir. \$14.95
 - ASD-T Airplane Scanner Directory \$14.95
 - SFR-T Survival Radio Frequency Directory \$14.95
 - TSG-T "Top Secret" Registry of U.S. Govt. Freq. \$14.95
 - TTC-T Tune in on telephone calls \$14.95
 - CBH-T Big CB Handbook/AM/FM/Freeband \$14.95
 - TIC-T Techniques for Intercepting Communications \$14.95
 - RRF-T Railroad frequency directory \$14.95
 - EEC-T Embassy & Espionage Communications \$14.95
 - CIE-T Covert Intelligence, Elect. Eavesdropping \$14.95
 - MFF-T Midwest Federal Frequency directory \$14.95
 - A80-T Magnet mount mobile scanner antenna \$35.95
 - A70-T Base station scanner antenna \$35.95
 - A1300-T 25 MHz-1.3 GHz Discone antenna \$109.95
 - USAMM-T Mag mount VHF ant. w/ 12' cable \$39.95
 - USAK-T 3/4" hole mount VHF ant. w/ 17' cable \$35.95
- Add \$4.00 shipping for all accessories ordered at the same time. Add \$12.00 shipping per radio and \$4.00 per antenna.

BUY WITH CONFIDENCE

To get the fastest delivery from CEI of any scanner, send or phone your order directly to our Scanner Distribution Center. Michigan residents please add 4% sales tax or supply your tax I.D. number. Written purchase orders are accepted from approved government agencies and most well rated firms at a 10% surcharge for net 10 billing. All sales are subject to availability, acceptance and verification. All sales on accessories are final. Prices, terms and specifications are subject to change without notice. All prices are in U.S. dollars. Out of stock items will be placed on backorder automatically unless CEI is instructed differently. A \$5.00 additional handling fee will be charged for all orders with a merchandise total under \$50.00. Shipments are F.O.B. CEI warehouse in Ann Arbor, Michigan. No COD's. Most items listed have a manufacturer's warranty. Free copies of warranties on these products are available by writing to CEI. Non-certified checks require bank clearance. Not responsible for typographical errors.

Mail orders to: Communications Electronics, Box 1045, Ann Arbor, Michigan 48106 U.S.A. Add \$12.00 per scanner for U.P.S. ground shipping and handling in the continental U.S.A. For Canada, Puerto Rico, Hawaii, Alaska, or APO/FPO delivery, shipping charges are two times continental U.S. rates. If you have a Discover, Visa, American Express or Master Card, you may call and place a credit card order. 5% surcharge for billing to American Express. Order toll-free in the U.S. Dial 800-USA-SCAN. In Canada, dial 800-221-3475. FAX anytime, dial 313-971-6000. If you are outside the U.S. or in Michigan dial 313-973-8888. Order today. Scanner Distribution Center™ and CEI logos are trademarks of Communications Electronics Inc. Sale dates 9/1/89 - 3/31/90 AD #090189-T Copyright © 1989 Communications Electronics Inc.

For credit card orders call
1-800-USA-SCAN

COMMUNICATIONS ELECTRONICS INC.

Consumer Products Division
P.O. Box 1045 □ Ann Arbor, Michigan 48106-1045 U.S.A.
For orders call 313-973-8888 or FAX 313-971-6000

CIRCLE 17 ON FREE INFORMATION CARD

www.americanradiohistory.com