

# Computers

NOVEMBER 1984 \$1.95

& E L E C T R O N I C S

**FACEOFF:**  
**IBM'S UPDATED PCjr**  
**VERSUS APPLE'S IIC**



**MATRIX PRINTERS:**  
**LATEST ADVANCES**  
**AND BUYER'S GUIDE**

**MICRO SOFTWARE FOR**  
**PERSONAL INVESTING**

**MICROCOMPUTER BASED**  
**VIDEO PROCESSING**



# Silent/Scribe®

Go Quietly.



In these modern times, you have to go all out to stay ahead of the competition. And going with our up-to-date Silent/Scribe printers can help keep you there; because Silent/Scribe quietly goes about your business reports, letters, charts and graphs, while you quietly go about your business.

Unruffled. Undisturbed. And assured that the letter you signed on the first day of the month and the final monthly report will both have

the same crisp high-quality look.

All Silent/Scribe printers feature snap-in long life ribbon cartridges, easy-to-use controls, and Logic/Card® interfacing to fit virtually any computer.

And they come in a variety of models to fit your specific needs and budget.

Call us today and discover how going quietly can quickly get you ahead.

Outside California: (800) 4-ANADEx  
In California: (800) 792-9992

© Copyright 1984 Anadex, Inc

Circle No. 13 on Free Information Card



**Anadex** ... *When you know printers.*

ANADEx, INC. • 1001 Flynn Road • Camarillo, CA 93010 • Tel: (805) 987-9660 • TWX: 910-494-2761  
ANADEx, LTD. • Weaver House, Station Road • Hook, Basingstoke, Hants RG27 9JY, England • Tel: Hook (025672) 3401 • Telex: 858762 ANADEx G

# GUARANTEED HEAD

## LOWEST APPLE & IBM PRICES

### OUR INCREDIBLE GUARANTEE

If you find that any item you purchased through The Micro Exchange™ was available at the time of your purchase at a lower nationally advertised price, send us appropriate proof of the lower price, including sales tax, shipping, and other charges, within 21 days of your purchase, and we will refund the purchase price and the merchandise is yours!

Call toll-free today to join...

# THE MICRO EXCHANGE™

A Service of MicroVision, Inc.

**1-800-34M-ICRO**  
(In Florida Call: 1-800-35M-ICRO)

Ask for operator 23

### Earn More Than You Spend

You'll want to tell all your friends and associates about the guaranteed savings at The Micro Exchange™. And for every new member you refer, we'll thank you by paying you \$10 cash! Not only will you easily cover the cost of your membership, but you can even earn hundreds of dollars more through this unlimited offer.

### Hardware, Software, You Name It.

We'll furnish you with virtually everything you need for your IBM and Apple system, including products from these leading manufacturers:

- Amdek • Apple • Ashton-Tate • AST • BPI • Broderbund
- CDC • Digital Research
- Dow Jones • Epson • Hayden
- Hayes • IBM • IUS • Lotus
- MicroPro • Microsoft • NEC
- Peachtree • Quadram • Rana
- Software Publishing • Tandon
- Teac • Tecmar • Visicorp

**MicroVision, Inc.**  
8663 Baypine Road, Dept 23  
Jacksonville, Florida 32216  
904 737-8400

Yes, I want to be guaranteed that I'm purchasing my hardware and software at the absolute lowest prices in America.

Charge my  Visa  Master Card  Check or Money Order enclosed

Credit Card No. \_\_\_\_\_ Expiration Date \_\_\_\_\_

Name \_\_\_\_\_

Address \_\_\_\_\_

City \_\_\_\_\_ State \_\_\_\_\_ Zip \_\_\_\_\_

Telephone (\_\_\_\_\_) \_\_\_\_\_

Signature \_\_\_\_\_

### What's the catch?

Yes, there is a catch. The guaranteed lowest prices in America on hardware and software for your IBM and Apple computer are now available only to members of The Micro Exchange™. But, the good news is it costs only \$25 to join, and you can earn that back *plus much more!*

### Computerized Bidding

The Micro Exchange™ is linked by computer with a nationwide network of suppliers who are eager to bid on your order. Through bidding, we're able to purchase products for you at prices which are guaranteed to be the lowest in America. Simply call the toll-free number, available to members only, with the makes and model numbers of the items you wish to purchase. We'll handle the transaction and arrange for the delivery of your merchandise right to your doorstep. All done quickly and efficiently so we keep you as a satisfied member of The Micro Exchange™.

# "MANAGING YOUR MONEY"<sup>TM</sup> is, simply, the finest personal financial management program on the market."

PERSONAL SOFTWARE MAGAZINE, JULY, 1984.

"The first fully-integrated financial program that really makes a computer for the home worth the money."

SEYMOUR MERRIN  
COMPUTER WORKS OF CT.

"MANAGING YOUR MONEY is the most complete home finance package I've seen. It's also about the most easy-to-use software package I've ever encountered."

KEN USTON'S ILLUSTRATED  
GUIDE TO THE IBM PC.

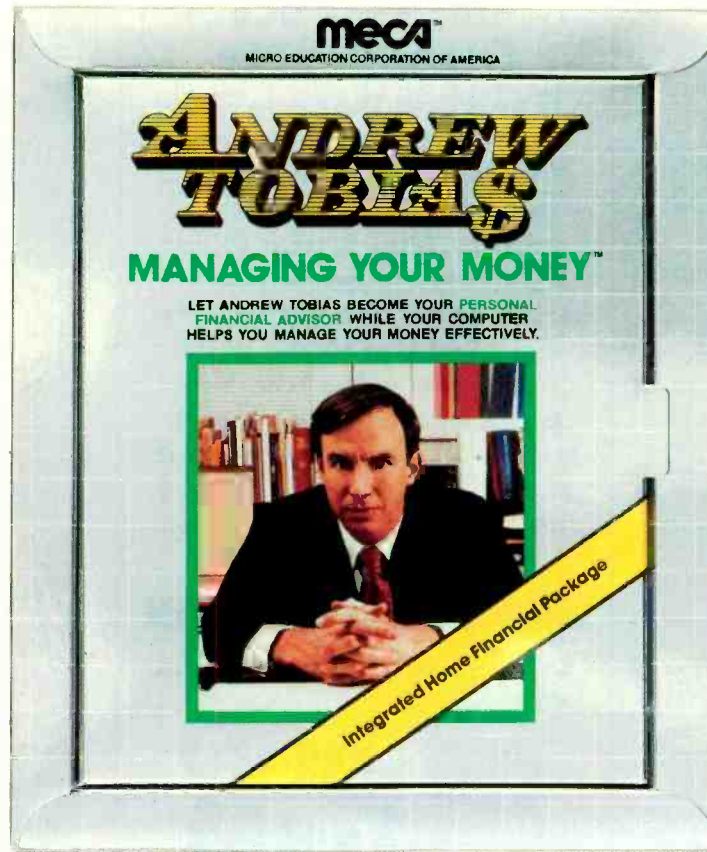

Disk version for IBM PC, XT, Compaq and now for PCjr with 256K. Cartridge version available for PCjr at IBM authorized dealers.

Andrew Tobias' new program "can explain the most complex personal financial dilemmas with impressive clarity and frequent twists of wit."

FORBES,  
APRIL 9, 1984.

"You'd expect MANAGING YOUR MONEY to be difficult to use and full of financial jargon. It isn't."

COMPUTE'S PC & PCjr,  
MAY, 1984.

**The only financial software you'll ever need. The easiest financial software you'll ever use.**

It's seven programs in one. It prepares your budget and balances your checkbook. It calculates your net worth. It helps manage your stock portfolio. It calculates your taxes. It estimates your life insurance needs. It analyzes loans and helps you do retirement planning. It reminds you of important dates. No need for a big, bulky manual. With MANAGING YOUR MONEY<sup>TM</sup> all the help you need is constantly on-line, on the computer. And everything is integrated so you only need to enter data once.

Other fine software products from MECA



For Atari, Apple and IBM.



For IBM.

**meca**<sup>TM</sup>  
Software that makes your  
personal computer worth having.<sup>TM</sup>

© 1984 • MICRO EDUCATION CORPORATION OF AMERICA • 285 RIVERSIDE AVENUE, WESTPORT, CT 06880 • (203) 222-1000

Circle No. 69 on Free Information Card

Available where fine software is sold.

# Computers & ELECTRONICS

## Features

### 50 Faceoff: The Apple IIc vs IBM's New PCjr

By Peter Costa & Josef Bernard  
Which mid-priced computer is for you?

### 54 Advanced Matrix Printers

By Ed Teja  
Greater speed and resolution in high-end products.

### 60 Get More Impact from Your Printer

By Jaine Saffir  
Software permits you to take advantage of graphics and downloadable fonts.



### 65 Buyer's Guide to Matrix Printers

### 68 Personal Investing: From Bits to Riches

By Howard Young  
You can use data and techniques formerly available only to professionals.

### 74 You Can Get There from Here

By John Smith-Richardson  
Ways to get seemingly incompatible hardware and software to work together.

### 80 Video Processing

By Louise Melton  
Sophisticated tools for capturing and manipulating video images.



COVER PHOTO BY ROBERTO BROSAN

## Reviews

### 32 Epson LQ-1500

By Al Burawa

### 33 Toshiba P1351

By Ed Teja

### 38 Panasonic Sr. Partner

By Robin Webster



### 44 Ideaware

By Lee D. Zimkind

### 48 Andrew Tobias Managing Your Money

By Evelyn Boorman

## Columns

### 10 Bits & Bytes

By Sol Libes

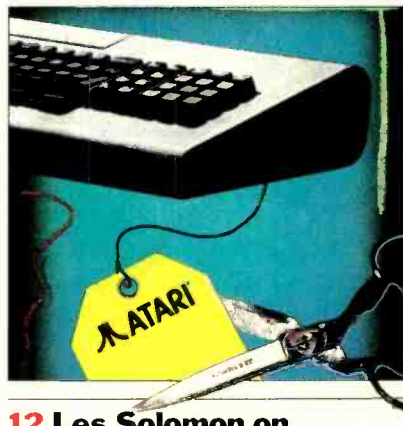

### 12 Les Solomon on Computer Hardware

"Tle wtugo fmt."

### 14 The Computer Scientist

By Forrest M. Mims, III  
Random numbers.

## Departments

### 4 Editorial

By Seth R. Alpert  
On reading reviews.

### 6 Letters

### 109 Computer Mart/ Electronics Classified

### 114 Advertisers' Index

COPYRIGHT © 1984 BY ZIFF-DAVIS PUBLISHING COMPANY. All rights reserved. Computers & Electronics (ISSN 0032-4485) November 1984, Volume 22, Number 11. Published monthly by Ziff-Davis Publishing Co., at 3460 Wilshire Blvd., Los Angeles, CA 90010. Richard P. Friese, President; Selwyn Taubman, Treasurer; Bertram A. Abrams, Secretary. One year subscription rate for U.S. and Possessions, \$16.97; Canada, \$21.97; all other countries, \$23.97 (cash orders only, payable in U.S. currency). Second Class Postage Paid at Los Angeles, CA 90052 and at additional mailing offices. Authorized as second class mail by the Post Office Dept., Ottawa, Canada, and for payment of postage in cash. POPULAR ELECTRONICS including ELECTRONICS WORLD trademark registered. Indexed in the Reader's Guide to Periodical Literature. Ziff-Davis also publishes Boating, Car and Driver, Cycle, Flying, Popular Photography, Skiing, Stereo Review, Electronic Experimenter's Handbook, and Tape Recording & Buying Guide. POSTMASTER: Send address changes to COMPUTERS & ELECTRONICS, Circulation Dept., P.O. Box 2774, Boulder, CO 80302. Please allow at least eight weeks for change of address, enclosing, if possible, an address label from a recent issue. PERMISSIONS: Material in this publication may not be reproduced in any form without permission. Send requests for permission to Jean Lamensdorf, Rights and Permissions, Ziff-Davis Publishing Co., One Park Ave., New York, NY 10016.

# SETH R. ALPERT EDITORIAL ON READING REVIEWS



ONE of the services provided by this magazine is publishing reviews of new software and hardware. Boiled down, these articles are the opinions of reviewers retained by the magazine to evaluate products and report back to the readers. We in the business like to believe that our reviews are important and have an effect on how well or poorly a product fares commercially. Perhaps this is true; but perhaps it isn't.

As editor of this magazine, I would like to assume that our reviews do have some effect, even if they are not the absolute determinants of a product's fate. Having been in such a situation often enough myself, I know that many of you read reviews to help you decide whether a particular product merits your purchasing consideration. Many others of you read reviews just to keep abreast of the field, because you are curious about how good a product that you have seen advertised really is. After all, someday you, or a friend, or your company may want to buy the thing.

Given the attention reviews receive, it might be interesting to hear the opinion of someone who reads reviews for a living on how to best make use of them. In an issue in which we do a head-to-head comparison of Apple's IIc and IBM's upgraded PCjr, I think these comments will have particular relevance.

One of the facts that I bear in mind when I read a review is that most people in computing seem to have very strong likes and dislikes. There is something

about this field that makes zealots out of otherwise reasonable people. For example, programmers often have favorite languages that they support with an enthusiasm bordering on fanaticism.

There are many reasons for this diversity of opinion about programming languages. For one thing, I think that people tend to gravitate toward a language that is the easiest for them to use, that is, to one that best suits their own thought patterns. Also, different languages are suited to different tasks, so the kinds of systems that programmers work on color their thinking. Finally, learning a new language is a lot of work, and it is much more sensible to try to get the rest of the world to do things the way you do than to switch.

Of course, all the above points about programmers and languages can be equally well made about any micro user and his choice of software or hardware. My point is that everyone differs and everyone has an opinion. Keeping that simple observation in mind will help you to make the best use of reviews.

Despite what anyone would have you believe about the objectivity of reviews, the love or hate that a particular reviewer has for a product is just one person's opinion. And that person's criteria for evaluating a product may differ entirely from your own. Even a publication like *Consumer Reports*, whose primary purpose is to publish unbiased reviews, is colored by opinion, namely, their opinion of how a particular type of product should be evaluated.

When you see an opinion in a review, remember that what matters to you may differ from what matters to the reviewer. The best reviews provide you with many facts about a product. Armed with those facts, you can form your own opinion about the product.

The opinions in a review do have a purpose, and I hate reading reviews without them. Opinions are interesting and fun to read. All I am saying is that you should try to avoid succumbing to the temptation that we all feel, to just look for "the answer" and not have to do any thinking. Life would be much easier if it were possible to make absolute evaluations of products, but it just doesn't work that way. ◇

## WORLD'S LARGEST COMPUTER MAGAZINE **Computers** & ELECTRONICS

WILLIAM S. DAVID *Publisher*

SETH R. ALPERT *Editor*

PETER COSTA *Executive Editor*

LESLIE SOLOMON *Technical Director*

JOHN R. RIGGS *Managing Editor*

ROBERT LASCARO *Art Director*

JOSEPH DESPOSITO *Technical Editor*

JOSEF BERNARD *Technical Editor*

CHARLES A. MILLER *Staff Editor*

DANIEL GLADSTONE *Senior Copy Editor*

ANDRE DUZANT *Technical Illustrator*

JEFF NEWMAN *Editorial Assistant*

AMY MADWED *Assistant Art Director*

**Contributing Editors:** Sol Libes, Forrest M. Mims, III, Barbara E. McMullen, John F. McMullen

**Editorial and Executive Offices**  
One Park Avenue, New York, N.Y. 10016.  
212-503-3500

### Advertising Sales Offices

#### Eastern

Ken Lipka, 1 Park Ave., New York, N.Y. 10016.  
212-503-5029

Linda M. Holbrook, 160 State St., Boston, MA  
02109. 617-367-7190

#### Midwestern

Robert Vanek, Suite 1400, 180 N. Michigan Ave.,  
Chicago, IL 60601. 312-346-2600

#### Western

Janet Bish, 11 Davis Dr., Belmont, CA 94002. 415-  
598-2290

Anne Abeln, 3460 Wilshire Blvd., Los Angeles, CA  
90010. 213-387-2100

#### Southeastern

Mark Browning, PO Box 81306, 2511 Carroll Ave.,  
Atlanta, GA 30366. 404-455-3430.

### Computer Publications Division

Kenneth Koppel	General Manager
Eileen G. Markowitz	Senior Vice President
Jerry Schneider	Vice President, Licensing & Special Projects
Herbert Stern	Vice President, Creative Services
Jonathan D. Lazarus	Vice President, Editorial Director
Carole Mandel	Vice President, Circulation
Peter J. Blank	Creative Director
Roni Sonnenberg	Marketing Manager

### Ziff-Davis Publishing

**President** Richard P. Friese; **President Consumer Magazine Division** Albert S. Traina; **Executive Vice President, Marketing and Circulation** Paul H. Chook; **Senior Vice President** Phillip T. Heffernan; **Senior Vice President** Sidney Holtz; **Senior Vice President** Edward D. Muhlfeld; **Senior Vice President** Philip Sine; **Vice President** Baird Davis; **Vice President** George Morrissey; **Vice President** Rory Paris; **Vice President** William L. Phillips; **Treasurer** Selwyn Taubman; **Secretary** Bertram A. Abrams

**Editorial correspondence:** COMPUTERS & ELECTRONICS, 1 Park Ave., New York, NY 10016. Editorial contributions must be accompanied by return postage and will be handled with reasonable care; however, publisher assumes no responsibility for return or safety of manuscripts, art work, or models submitted.

The publisher has no knowledge of any proprietary rights which will be violated by the making or using of any items disclosed in this issue.

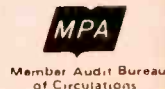

# THE ONLY COMPUTER THAT MAJORS IN EDUCATION.

It doesn't take an advanced degree to know that teaching computers in a school isn't the same as using a computer in business.

But most computers are designed for businesses or homes, not for schools.

Acorn has designed a computer especially for schools.

It's called The British Broadcasting Corporation Microcomputer System.

Simple to use, it can handle everything from basic applications to creating sophisticated networks. So it won't become obsolete the minute a student becomes advanced. In fact, no other similar sized or priced computer exceeds Acorn's built-in expansion capabilities. But Acorn's Micro is more than a computer. It's a total learning system designed by and for educators. Consisting of educator endorsed software, lesson plans and teacher workbooks. We call it schoolware, because it gives teachers and students everything they need for learning.

You can even learn about Acorn's Micro on our toll-free teacher hotline. And at special Acorn Learning Centers at computer dealers around the country.

Doing our homework has already made Acorn's Micro one of the biggest selling microcomputers in Britain. And led to its selection by the British government for use in its nationwide computer literacy program.

So if you're interested in a computer that will do well in school, take a lesson from the British and learn more about Acorn's Micro.

For more information, write Acorn Computers Corporation, 400 Unicorn Park Drive, Woburn, Massachusetts 01801, or call toll-free 1-800-225-8001 (in Massachusetts, call 617-935-1190).

Circle No. 10 on Free Information Card  
© 1984 Acorn Computers Corporation

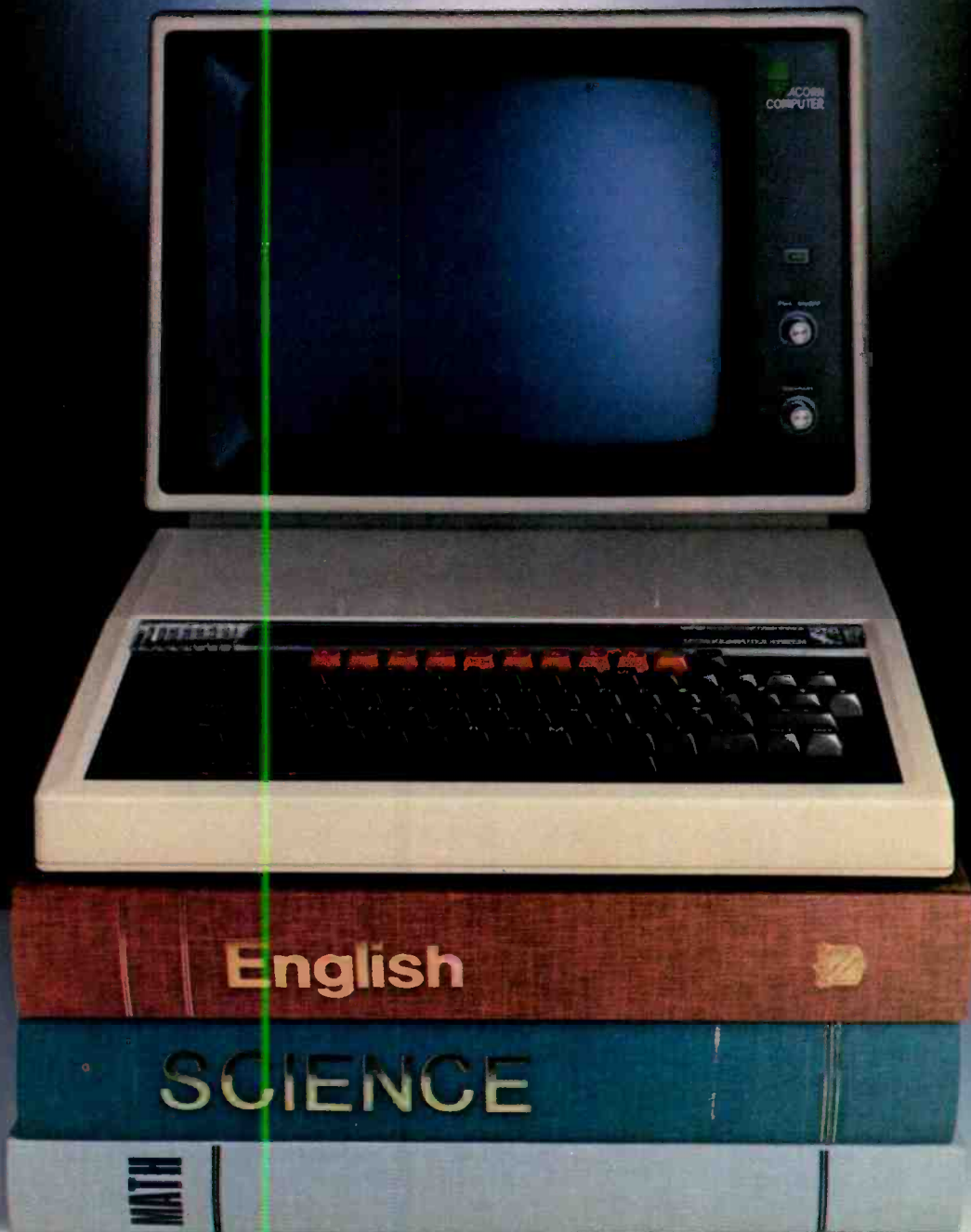

# LETTERS

## Watching the ps and qs

I found Bob Margolin's article on VDTs and vision interesting and informative. The one area in which the article was a little hesitant was in the discussion of typefaces or the styles of letters. Since this is my area, I thought I could clarify matters somewhat for your readers.

Margolin is correct in stating that it is traditionally believed that Roman typefaces—those with serifs at the ends of the letters—are more readable than sans serif styles. There are two reasons for this. One is that the serifs help define the baseline of the line being read, helping the eye to differentiate between lines and move smoothly along. The second is that the individual letterforms are more highly refined and appear more individual than those in many sans serif alphabets.

Familiarity is definitely a factor in readability; as sans serifs have become more widely used, we have become more

accustomed to reading them and experience little or no difficulty. The problem with reading the letters on some monitors is not that they are "simple, no-frill characters" but that they are crude. The concept of "saccades" is a new one on me, and contradicts the legibility research I am familiar with. To my knowledge, we recognize words by their shapes and the patterns the letters and the white spaces within and between them form. The characters formed by many monitors and terminals are so crude that the resulting word shapes are actually different from those we are used to. The worst are those where the letters with descenders—p, q, y, g, j—do not actually descend below the baseline, but are "bounced" so that the whole letter fits within the space allowed for the other letters. If you have ever tried to read text on that type of monitor, I'm sure you can recall how different the words look.

Incidentally, it is because of word

shapes and patterns that **TEXT IN ALL CAPITALS IS HARDER TO READ THAN CAPITALS AND LOWER-CASE. CAPITALS FORM ENTIRELY DIFFERENT WORD SHAPES AND PATTERNS FROM LOWER-CASE LETTERS.** You can imagine, then, how much more difficult it is to read text on computers that use all capitals, and crudely formed capitals at that.

—REID NEUBERT  
Mill Valley, CA

## Manufacturers of "Real World Interfaces"

The following are the manufacturers of the products mentioned in "Real World Interfaces" (C&E, September 1984).

*Switcheroo series of computer controlled switches*

Knowles & Hazlett/BRI  
326 Third Ave.  
Pittsburgh, PA 15222

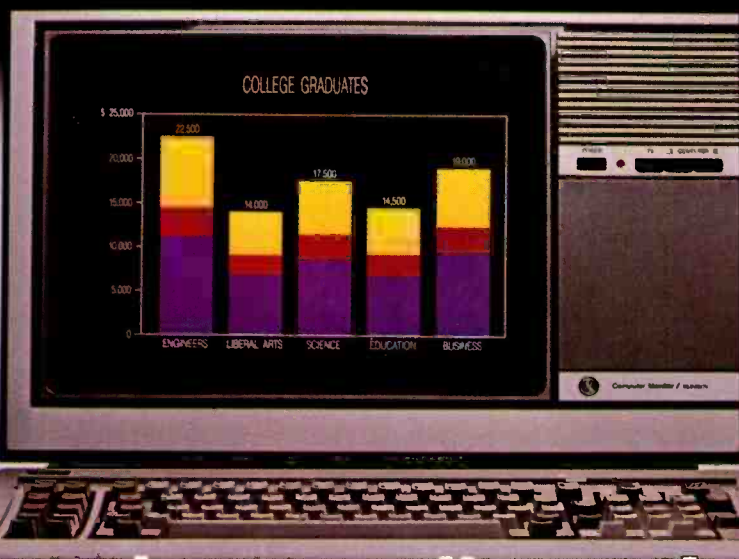

## The computer monitor so ingenious,

If you're torn between buying a dedicated monitor and making do with your regular TV, there's a smarter alternative. The General Electric Monitor/TV.

### First and foremost, it's a computer monitor.

Compatible with all major computer brands, it combines these advanced features to sharpen text and graphics and deliver a display that's easy-on-the-eyes: Direct and split video inputs; 320-line resolution via a comb filter, plus a computer grade, .5mm-pitch Neovision™ picture system.

For the name of your nearest dealer, call The GE Answer Center™ Information Service, 1-800-626-2000.



412-391-6707  
*A16, A32, and R16 T/B boards for  
Apple II, II+, IIe*

Rogers Labs  
2710 So. Croddy Way  
Santa Ana, CA 92704  
714-751-0442

*CDFR motor controller*

Vantec  
15445 Ventura Blvd.  
Suite 10-281  
Sherman Oaks, CA 91413  
818-993-1073

*ADC-1 data acquisition system and  
controller*

Remote Measurement Systems  
PO Box 15544  
Seattle, WA 98115  
206-525-3369

*SmartHome-1 security system and  
appliance controller*

CyberLynx  
4828 Sterling Dr.  
Boulder, CO 80301

303-444-7733  
*Starbuck 8232 data acquisition and  
control system*

Starbuck Data  
PO Box 24  
Newton Lower Falls, MA 02162  
617-237-7695

*AOM-12 D/A converter and AIM-12  
A/D converter*

Dual Systems  
2530 San Pablo Ave.  
Berkeley, CA 94702  
415-549-3854

*Home Automatic Weather Station*

Vaisala  
2 Office Tower Pk.  
Woburn, MA 01801  
800-227-3800

*Analog interface board A/D and D/A  
converter system*

Computer Continuum  
301 15th Ave.  
San Francisco, CA 94118  
415-752-6294

*Data acquisition and control devices for  
Apple II, II+, IIe*

Lawson Labs, Inc.  
5700 Raibe Rd.  
Columbia Falls, MN 59912  
406-387-5355

*DT2808 A/D and D/A board for IBM  
PC*

Data Translation  
100 Locke Dr.  
Marlboro, MA 01752  
617-481-3700

*PCVision frame grabber, video digitizer  
and display module*

Imaging Technology  
600 W. Cummings Pk.  
Woburn, MA 01801  
617-958-8444

*Series 500 measurement and control  
cards*

Keithly DAS  
349 Congress St.  
Boston, MA 02110  
617-423-7780



**it even runs this kind of program.**

**Secondly, it's a first class TV.**

Flip a switch and these same advanced electronics give you an outstanding TV, with a high-contrast picture and rich, true colors.

And you get all this for about the same price as an ordinary monitor. Another piece of ingenuity we thought you'd appreciate.

**We bring good things to life.**



Simulated Monitor/TV Picture

 IS A TRADEMARK OF GENERAL ELECTRIC CO. © 1984

**Picture a computer under \$1000  
that runs over 1000 of the best programs  
written for the IBM PC.**

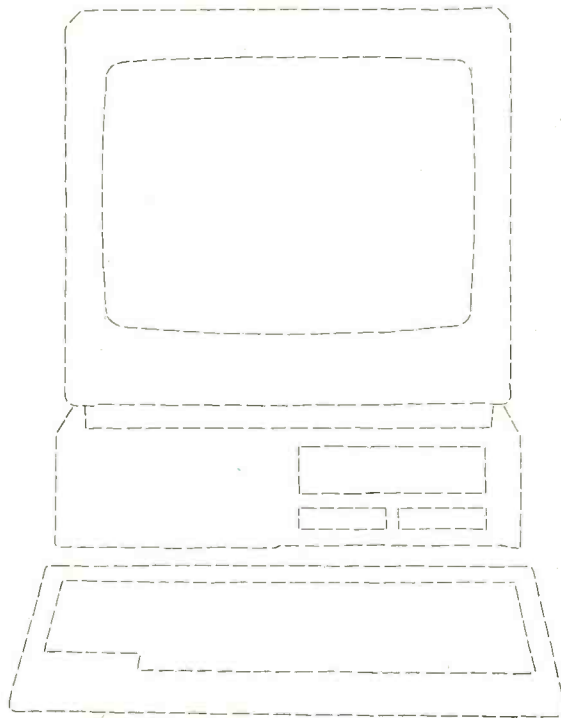

# Now picture this.

There's a lot that's new about PCjr and it's all good news for you.

PCjr now has a lower price. A new typewriter-style keyboard.

A new option that can give user memory a dramatic boost.

And new business and personal programs to add to its fast-growing library of up-to-date programs.

All of which can make PCjr the most useful computer a little money can buy.

It comes standard with 128KB of user memory — twice the memory of its most popular competitor. An advanced 16-bit processor. And a double-sided diskette drive that can store over twice as much information as most single-sided drives.

With all these features, PCjr can run over a thousand of the most popular programs written for the IBM PC. And with the new optional 128KB Memory Expansion Attachment,

it can run over a thousand more.

PCjr also runs a growing number of powerful cartridge programs. They work faster than



diskettes, and don't take up a bit of user memory. The three newest examples being Lotus 1-2-3,™ the fascinating PCjr ColorPaint and Managing Your Money™ by financial expert Andrew Tobias.

As its library of software keeps growing, PCjr keeps growing, too. By leaps and bounds. Because IBM designed it with 13 ports for add-on options. And a modular construction that will accept new capabilities down the road. Even those that haven't been invented yet.

All this in a computer that weighs a mere 10 pounds.\*

Takes up just a bit over a square foot of desk space. And costs less than \$1,000†, without monitor.

Picture yourself with a PCjr. Try one out and see what's new at an authorized IBM PCjr dealer or IBM Product Center.

For the name of the store nearest you, call 1-800-IBM-PCJR. In Alaska and Hawaii, call 1-800-447-0890.



Right now, PCjr can run the powerful Lotus 1-2-3™ on diskette (with Lotus 1-2-3 PCjr Installation Kit and additional memory). The new cartridge version, requiring no additional memory, will be available this fall.



Managing Your Money™ by Andrew Tobias, new on cartridge for PCjr, is a comprehensive personal financial advisor and manager.



Turn your screen into a canvas. The new cartridge program, PCjr ColorPaint, lets you create with the added dimension of color.



The new PCjr Memory Expansion Attachment can give memory a quick lift to 256KB. Or, along with a PCjr Power Expansion Attachment, all the way to a hefty 512KB.

### More computer for your money.

See how PCjr compares with other computers at its price.

Memory	Software
User Memory (RAM): 128KB (expandable to 512KB)	Runs over 1,000 programs written for the IBM PC
Permanent Memory (ROM): 64KB	Runs both diskette and cartridge programs
<b>Diskette Drive</b>	<b>Display</b>
Double-sided, double density	40- and 80-column
Capacity: 360KB	Resolution:
	4-color: 640h x 200v
	16-color: 320h x 200v
<b>Processor</b>	<b>Expandability</b>
16-bit 8088	Open architecture
<b>Keyboard</b>	Optional 128KB Memory Expansion Attachment(s)
Typewriter-style	13 ports for add-ons, including built-in serial interface
Detached; cordless	
<b>Warranty</b>	
1-year limited warranty	



PCjr's new typewriter-style keyboard adds a nice touch to business, home or educational computing.

# IBM PCjr

Growing by leaps and bounds.

Circle No. 32 on Free Information Card

Little Tramp character licensed by Bubbles Inc., s.a.

Managing Your Money is a trademark of MECA. 1-2-3 and Lotus are trademarks of Lotus Development Corporation.

\*Weight does not include power pack and monitor.  
†IBM Product Center price.

# SOL LIBES BITS & BYTES



## Apple Juice

► Now that Apple and Computerland have gotten back together again, the Apple distribution picture is expected to change. Computerland decided not to renew its distribution agreement with Apple two years ago, feeling its IBM PC business more than made up for the loss of the Apple business. The market, however, has changed radically of late, with Apple's aggressive marketing of the Mac, Apple IIc and Apple IIe. In the meantime, the IBM PC market appears to be saturated and many Computerland stores are finding themselves competing directly with IBM on sales to large accounts.

The result is that Apple has gained some increased distribution (many of the Computerlands continued to sell Apples, buying them directly from Apple). The stores now will receive a discount about 10% greater than the one they received buying directly from Apple. Moreover, they won't have to pay the 8% royalty to Corporate, which made it difficult to make a profit selling Apples and which encouraged many Computerlands to drop them.

The independent stores and smaller chains are now in a poorer competitive position vis-a-vis Computerland, which places additional pressures on the smaller retailers, many of whom are already struggling to compete in a marketplace largely dominated by the large chains. One chain, CompuShop (50 outlets) has already reacted by dropping Apple from its shelves.

## Rumors & Gossip

► Rumors are circulating that Apple might license Macintosh technology to

one or two manufacturers to establish the Mac as an industry standard like the IBM PC. Apple also reports it will have doubled its Mac production by year-end to 80,000 a month. We also hear that Apple may be working on a color version of the Mac. . . . Texas Instruments is expected to begin sampling its token ring local area network chip set. Production is likely to begin by mid-1985, and systems will be introduced by late 1985 or early 1986. Since this chip set, most likely, is the one IBM will use for its PC LAN system, its introduction time will determine when we can expect to see IBM's PC LAN products. . . . Look for AT&T to drop the price of its Sceptre home videotext terminal sharply in an attempt to stimulate the home videotext marketplace. The unit currently sells for \$600. Its price, no doubt, has deterred acceptance of videotext, which has been available in selected areas for over 4 years. The price will probably drop to around \$300. . . . Digital Research (producer of CP/M) appears to be developing a graphics-based interface product for IBM's new 80286-based PC, code-name Crystal, under contract to IBM and a similar product for AT&T. . . . IBM, we hear, is developing its own integrated software product for the PC based on its Query-By-Example relational database language used on its large mainframes. It is expected to include graphics, spreadsheet and electronic mail facilities and to require 512K of RAM. Observers think it will use a desktop metaphor similar to that on the Apple Lisa. . . . Data General entered the kneetop computer market with a machine similar to the Hewlett-Packard portable with a 25-line × 80-column

LCD display, 3.5" disk drive, 128K RAM and IBM PC compatibility. . . . Digital Equipment Corp. is said to be close to announcing local-area-network capability for its Professional 350 desktop unit running a Unix-like operating system.

## Who Tarries at Atari Is Kaput

► With Jack Tramiel, former Commodore president, taking over Atari from Warner Communications, a hurricane of rumors is flying. Here are some of the more reliable ones.

With the purchase of Atari, Tramiel got 100,000 64K Atari 800XL computers for \$80 each. Rumor is that he will drop the retail price from the current \$239 to \$159 to undercut the Commodore 64, which lists for \$199. At the same time, Jack is trying to cut manufacturing expenses by moving production from Taiwan to less costly Hong Kong. With the machine reportedly costing \$130 to make, Warner lost money on each unit sold; meanwhile Commodore is making C64s for \$90 each. Sounds like a repeat of the TI vs Commodore story.

Since taking over Atari July 1st, Tramiel has dismissed nearly 1000 workers, including most executives and most of the manufacturing staff in Taiwan. He has restaffed top management with former employees from Commodore. Tramiel declared that his aim is for Atari "to be number one—nothing less" and that he will keep only those employees "who work frugally."

The 16K Atari 600XL computer and 7800 video game player (introduced only last May) have reportedly been dropped. The price of the 2600 video game player

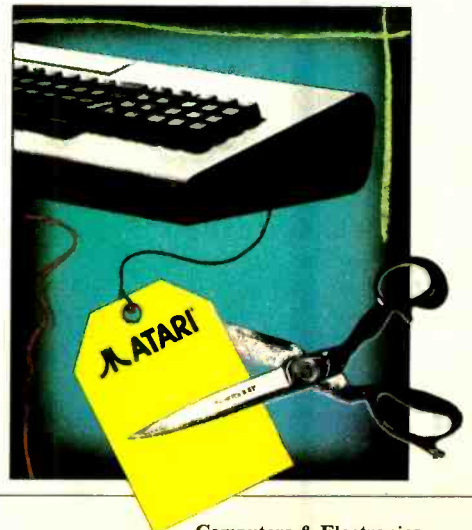

ILLUSTRATIONS BY CARL WESLEY

is expected to decrease about \$30.

Tramiel may be announcing a 16-bit machine early next year, to be shipped by mid-1985. A 32-bit machine may follow next summer, with initial deliveries by year-end. These machines, which are expected to compete with the present IBM PC and Apple Macintosh in price, will be distributed by mass merchandisers. Speculation is that the 16- and 32-bit machines will list for \$1000 and \$1500, respectively.

### Hard Times for Software

► Many home computer software companies appear to have fallen on hard times, cutting prices, laying off personnel, merging with larger companies and, in many cases, closing their doors. The marketplace appears to be reaching saturation, which is causing heavy inventory returns and obsolescence.

For example, *Readers Digest* recently closed its software division, Sirius Software filed for Chapter 11, Datasoft was bought out by Gillete, and Datamost is negotiating with its creditors. What's more, Human Engineered Software, Parker Brothers and Electronic Arts have laid off significant segments of their workforces.

Most companies are attempting to ride out what they hope is a seasonal lull by reducing the number of titles offered, dumping returned merchandise via liquidators and cutting prices. There are predictions that there will be many more failures, mergers and acquisitions. Venture capital is scarce for new software startups.

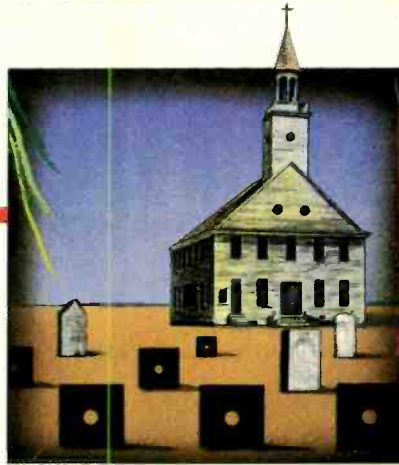

With sales of home computer systems dropping from 7 million last year to an estimated 3 million this year, it appears that software companies are in for a protracted weak marketplace. The sharp drop in home computer sales became evident in April and May and has continued well through the summer. The remaining companies are hoping that the coming Christmas season will pull them out of the red.

### Gloom at Sinclair

► It is over a year since Timex stopped marketing the Sinclair ZX-81 and 2068 (alias, Sinclair Spectrum) in the U.S. Now there are reports that Sinclair is having problems on its home turf—England. There are reports that the Spectrum is experiencing quality control problems. One English magazine reports a 25% return rate to dealers. Sinclair counters that it is instituting more rigorous quality control.

Sinclair promised to start shipping its new \$500 QL (Quantum Leap) system in February. It uses the Motorola 68008 (a 68000 32-bit micro with 8-bit I/O). Sinclair started taking prepaid orders from customers several months early. First shipments of QL did not leave the fac-

tory until the late spring and then only to the early customers; dealers will not get their systems until year-end.

Further, early customers are reporting problems with their QLs. Sinclair has acknowledged them and provided these early customers with a hotline to the factory and an assurance that they will receive ROM upgrades. There have also been complaints that such a powerful system still relies on cassettes for storage. As one British magazine reviewer commented, "by comparison...even the Commodore 64 disk drives are fast." Sinclair has responded by saying that a disk system for the unit is under development.

The QL was due to go on sale in the U.S. this fall. However, considering the problems Sinclair is experiencing in the U.K., I suspect that we will not see the unit here until next year.

### Random News

► The International Personal Robot Congress and Exposition, which will meet in the U.S. in 1986, is planning a robot Ping-Pong contest. I expect that it will be similar to the robot mouse contest held by the IEEE several years ago. Robot builders wishing more information on the contest should write to John Billingsly, Department of Electrical and Electronic Engineering, Portsmouth Polytechnic, Angelse Rd., Portsmouth, UK. . . . Microsoft reported that it finished its eighth fiscal year of operation with record revenues of \$100 million; an increase of 100% over the previous year. The company now has 608 employees. ◊

### New and Noteworthy

► As predicted months ago in this column, IBM introduced a more powerful version of its PC. The company announced the new PC/AT on the third anniversary of the August 1981 introduction of the PC. The new computer is based on the new Intel 80286 microprocessor (a true 16-bit device). It supports up to 3M bytes of RAM (the PC supports 512K maximum), 1.2M-byte floppies (PC supports only 360K-byte units), a 20M-byte hard disk (PC/XT has a 10M-byte unit) and a new version 3.0 of PC-DOS. The basic model (\$3995) comes with 256K bytes of RAM and a single floppy; the expanded model (\$5795) has 512K bytes of RAM, floppy and hard disk drives and parallel/serial I/O card. The PC/AT keyboard cor-

rects the earlier PC keyboard problems.

IBM also announced it will introduce, in the first quarter of 1985, a PC local area networking system to link together up to 72 PCs with a PC/AT functioning as a file server. A broadband coaxial cable LAN system, it transmits at 2M bits/sec and costs about \$700 per station. IBM's LAN is thus slower and more expensive than some of the systems (e.g. Ethernet) that have been on the market for some time. In fact, it is really an interim system: IBM will introduce a token-passing LAN in another two years.

Also to be available in the first quarter of 1985 will be PC/Xenix, a three-user version of Microsoft's multi-user, multi-tasking operating system based on Unix

System III. Note that Xenix and several other Unix versions for the PC/XT have been available, from other suppliers, for a long time. Many of these versions run faster, support more users, and cost less.

Overall, the PC/AT appears to be a "ho-hum" upgrade of the PC/XT. It leaves opportunities for PC-compatible makers to bring out AT-Compatibles with better performance. For example, consider that the 80286 can directly address up to 16M bytes of memory, that most small multi-user systems have more than three users, and that 20M bytes of disk space is really not adequate for a three-user Xenix system. However, with the IBM name on it and the largest dealer and sales organization in the world, the PC/AT should do well.

LES SOLOMON ON

# COMPUTER HARDWARE

## TLE WTUGO FMT

No, the title of this column is not written in Martian, or any other strange language—it is in English, written with a normal word processor working on a perfectly good computer.

This linguistic aberration started when I sat down at my word processor and began to write a column. Everything on screen looked fine. However, when the column was finished, and I tried printing the text, everything came apart at the seams—the English was converted to gibberish.

find out which bit is stuck, and how does it get stuck?

But first, a little background. There are not too many standards in the computer field, but one that we do have (it came into existence long, long ago, before the advent of the microcomputer, when Teletypes ruled the communications medium) is called ASCII (American Standard Code for Information Interchange). It is understood by all computers and allow them to intercommunicate regardless of which microprocessor, operating system, or language

other hand, if B3 is stuck low, the code for capital E (1000101) will produce capital A (1000001).

So there is your clue on stuck bits. If you play with the ASCII code, you will see how a change in one bit can produce erroneous looking output, even though the system is working fine.

Now the title of this column—"Tle Wtugo Fmt"—is the bit-3-stuck-high version of what I typed, The Stuck Bit. If bit-3 were stuck low, the name of this column would have been Pha Spqck Bip.

A stuck bit can be caused by a short in an IC connected to a data line. That particular data line remains high or low (in whatever state the IC shorted into) regardless of what data is passed along the line. Although there are several other ways to get into this predicament, probably the most common is a faulty data-carrying IC with an internal short.

In my particular case, it turned out that the bit-3 line in the UART driving the serial port shorted to the +5V line—the printer was fine. Since the same UART also feeds the modem, it's a good thing I found this problem before I went on line.

Now, of what value is all this to a person whose greatest concession to hardware is plugging the system into a wall socket, inserting a diskette, or changing the paper in the printer?

Well, since the labor charges for servicing are usually far greater than the price of the parts used, anything you can do to reduce the labor charge means money in your pocket.

If you run into the gibberish problem, either on the CRT screen or in hard copy, consult your friendly ASCII chart and experiment with various letters and symbols and see what comes out on either the video terminal or printer. It should not take you long to determine if a bit is stuck high or low, and if it is, which bit it is.

The service technician can then save an hour or so of diagnostic time when you point out that bit-x in the printer/modem/video terminal/etc. is stuck either high or low. A little judicious thought can isolate the problem to the faulty peripheral so you don't have to drag the complete system down to the shop. ◇

B7	0	0	0	0	1	1	1	1		
B6	0	0	1	1	0	0	1	1		
B5	0	1	0	1	0	1	0	1		
B4	0	0	0	0						
B3	0	0	0	1						
B2	0	0	1	0						
B1	0	0	1	1						
	0	1	0	0						
	0	1	0	1						
	0	1	1	0						
	0	1	1	1						
	1	0	0	0						
	1	0	0	1						
	1	0	1	0						
	1	0	1	1						
	1	1	0	0						
	1	1	0	1						
	1	1	1	0						
	1	1	1	1						

NUL	DLE	SP	0	@	P	.	p
SOH	DC1	!	1	A	Q	a	q
STX	DC2	II	2	B	R	b	r
ETX	DC3	#	3	C	S	c	s
EOT	DC4	\$	4	D	T	d	t
ENQ	NAK	%	5	E	U	e	u
ACK	SYN	&	6	F	V	f	v
BEL	ETB	'	7	G	W	g	w
BS	CAN	(	8	H	X	h	x
HT	EM	)	9	I	Y	i	y
LF	SUB	*	:	J	Z	j	z
VT	ESC	+	:	K	[	k	{
FF	FS	,	<	L	\	l	
CR	GS	-	=	M	]	m	~
SO	RS	.	>	N	^	n	~
SI	US	/	?	O	_	o	DEL

ASCII CODE

My name was printed as Lewlme, the digits 12345 came out as 56745, and the word "computer" came out as "gomtutev." It was then I realized that a headache was about to start.

Being hardware oriented, I determined that since the CRT readout was correct, the printer must be at fault (when you are a hardware person, such fantastic logical deductions come easy). Well I changed printers—but still got gibberish hard copy.

Since everything else seemed to be working normally, the peculiar change in text from English on the CRT screen to gibberish on the printer led me to believe that a "stuck bit" was at fault. Now, what is a stuck bit, how do you

they are using. For example, ASCII allows communication between micros and mainframes.

In this code, shown in the accompanying table, all of the required alphanumeric and symbols required for human communication and the symbols required for machine communication can be encoded in a binary form using combinations of seven bits from 0000000 to 1111111. In the table, B1 (bit 1), the least significant bit, is on the right, while B7 (bit 7), the most significant bit, is on the left.

The table shows that the code for the capital letter A is 1000001. Note that if B3 is stuck high, 1000001 becomes 1000101—the data for capital E. On the

# What's the best recommendation you can make when you're asked about business graphics?

## The Business Professional Plotter from Hewlett-Packard — The 6-Pen HP 7475A

Today, business professionals are more aware of the vital importance of business graphics to their success. Tomorrow, they may ask for your recommendation. Here's some important information that will help. Tell them ...

### Make a first impression that lasts

Truly impressive graphic presentations can create a first impression of quality and professionalism that lasts and lasts. The way you present your information can be equally as important as the information you're presenting. And that's where the HP 7475A Business Professional Plotter lets your professionalism shine through.

### Standards unsurpassed in the plotter business

The technical standards of the HP 7475A have no equal for producing quality graphics. With a resolution of one-thousandth-of-an-inch, curved lines are smooth, not jagged, and straight lines are consistently straight. Its exceptional repeatability (the ability of a pen to return *precisely* to a given point) assures that intersecting lines and circular shapes will meet *exactly*.

### Compatible with almost any personal computer in your office and supported on today's most popular graphics software packages

The HP 7475A quickly "makes friends" with most of the personal computers you may already have in your office, including IBM®, Apple™, and Compaq™—as well as a host of HP computers. You even have a choice of many off-the-shelf software packages, such as Lotus 1-2-3™ and Symphony™, that give you "first-day" productivity with the HP 7475A.

### Your Choice: 2 media sizes

While most professional business applications will be satisfied with standard 8½ x 11" paper or transparencies, the HP 7475A adds the capability of plotting on larger 11 x 17" media, too.

### The cost? Surprisingly affordable

The HP 7475A Business Professional Plotter is an amazingly affordable \$1895. When you consider the high cost of having your graphics prepared by an outside service, you'll find the return on your investment is almost immediate.

1-2-3 and Symphony are trademarks of Lotus Development Corporation

Circle No. 34 on Free Information Card

## Another choice: HP's low-cost, high performance Personal Computer Plotter

For the "business on a budget," you may also want a look at our 2-pen Personal Computer Plotter, the HP 7470A. Its low-cost (only \$1095) is as remarkable as the quality of its plots. With many of the same features as the HP 7475A, the HP 7470A plots on media up to 8½ x 11!" It stores and caps two-pens, and you can easily change the pens for multi-color plotting.

### Send for your FREE "Better Presentations Package" today!

For a FREE sample plot, overhead transparency, and more details, mail the coupon below. We'll also enclose a list of graphics software packages you can use right "off-the-shelf."

For the name of your nearest Hewlett-Packard dealer, call toll-free 800-547-3400.

1101404



YES! I want to make the most informed business graphics recommendation I can. Please send me your FREE "Better Presentation Package," so I can learn more about the HP 7475A Business Professional Plotter and the HP 7470A Personal Computer Plotter. I understand I will receive this valuable package without cost or obligation.

Name \_\_\_\_\_ Title \_\_\_\_\_

Company \_\_\_\_\_

Address \_\_\_\_\_

City, State & Zip \_\_\_\_\_

Phone Number ( ) \_\_\_\_\_

My computer is \_\_\_\_\_

Send to: Hewlett-Packard, 16399 W. Bernardo Drive,  
San Diego, CA 92127-1899  
Attn: Marketing Communications

11404 CXX

FORREST M. MIMS III

# THE COMPUTER SCIENTIST

## RANDOM NUMBERS

**D**OES your computer have a random number feature? Do you ever use it?

Even if you have never used your machine's ability to generate random numbers, some of the commercial software you've purchased—especially games and specialized statistics packages—might have. Therefore, you may find it useful to know that the "random" numbers generated by your computer are *not* perfectly random. Since they are *nearly* random, they are more properly called *pseudo-random* numbers.

In this column I'll cover several ways to use your computer's random number generator. I'll also describe some simple hardware and software methods that may produce numbers having more randomness than those given by your computer's built-in firmware.

### Probability Theory

Life abounds with situations in which the probable outcome of an event can be predicted mathematically. Like a flipped coin, many situations have only one of two possible outcomes. For example, a seed may or may not sprout, an egg may or may not hatch, and a newly hatched bird is either male or female.

Other situations may have *many* possible outcomes. For example, a seed may fall in thousands of different places, and a bird may choose to build its nest in any of hundreds of suitable trees.

In all such instances, the likelihood of a particular outcome can be assigned a particular *probability*. While the probability of a flipped coin landing with its

head side up is  $\frac{1}{2}$ , the likelihood of a tadpole maturing into a frog, though also an event having one of two outcomes, is considerably less predictable.

Based upon elementary logic and their own observations of flipped coins and

thrown dice, mathematicians have devised formulas that permit the probability of a particular outcome of an event to be predicted. Such formulas, which are collectively known as *probability theory*, are widely used with varying degrees of success by statisticians, economists, sociologists, biologists, military strategists and, of course, gamblers.

Computers are widely used to perform probability studies. Ironically, one of the first large scale computers, the ENIAC, almost fell victim to the discouraging results of a probability study regarding the chances for the machine's success.

Since ENIAC used some 18,000 vacuum tubes and since each tube had a limited life, the study predicted ENIAC, which was not yet completed, would operate at most only a few minutes before a tube would require replacement. Fortu-

(Continued on page 20)

Fig. 2. Two practical random number generator circuits.

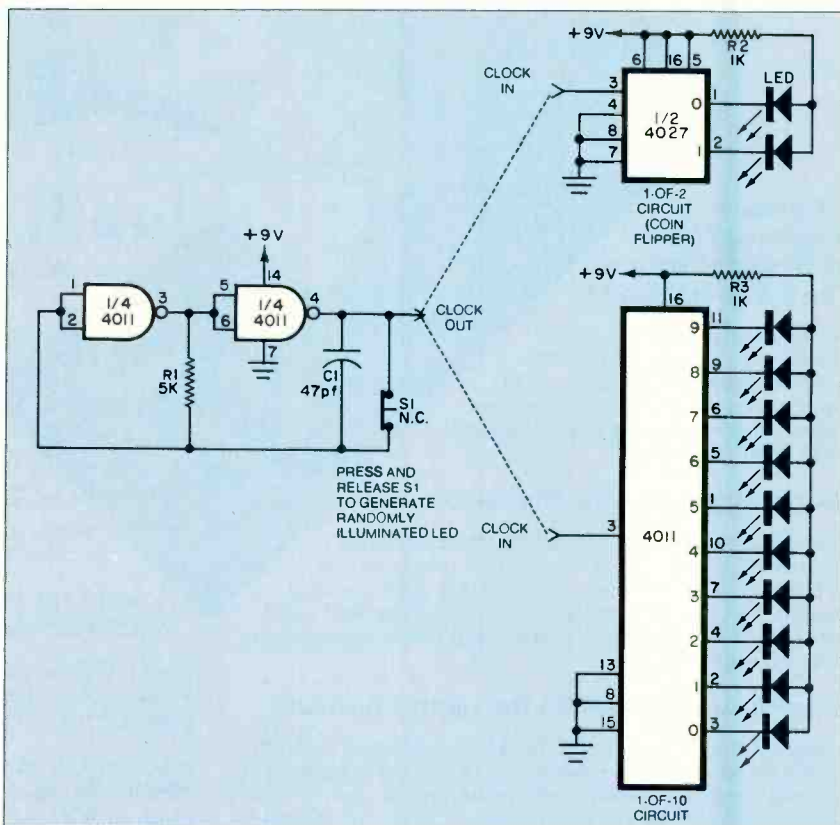
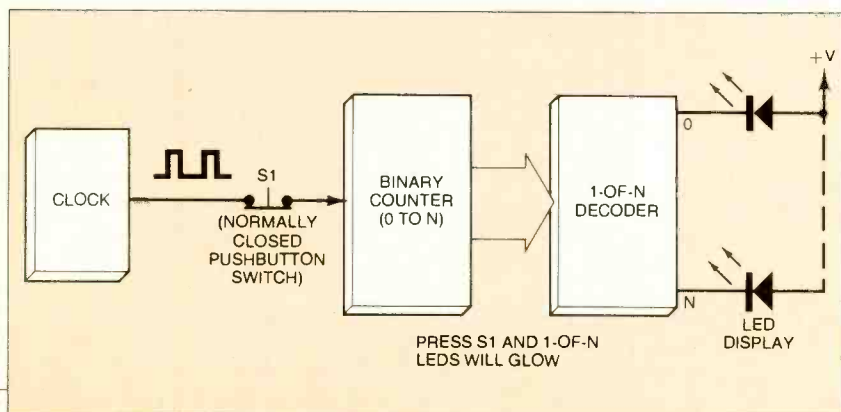

Fig. 1. Block diagram of a random number generator circuit.





# BASF QUALIMETRIC™ FLEXYDISKS. A GUARANTEED LIFETIME OF OUTSTANDING PERFORMANCE.

*BASF Qualimetric FlexyDisks feature a unique lifetime warranty,\* firm assurance that the vital information you enter on BASF FlexyDisks today will be secure and unchanged tomorrow. Key to this extraordinary warranted performance is the BASF Qualimetric standard... a totally new set of criteria against which all other magnetic media will be judged.*

*You can count on BASF FlexyDisks because the Qualimetric standard reflects a continuing BASF commitment to perfection in magnetic media. One example is the unique two-piece liner in our FlexyDisk jacket. This BASF feature traps damaging debris away from the disk's surface and creates extra space in the head access area for optimum media-head alignment. The result is a guaranteed lifetime of outstanding performance.*

*For information security that bridges the gap between today and tomorrow, look for the distinctive BASF package with the Qualimetric seal. Call 800-343-4600 for the name of your nearest supplier.*

Visit BASF at Comdex/Fall  
Booth 1372

\*Contact BASF for warranty details.

Circle No. 33 on Free Information Card

ENTER TOMORROW ON BASF TODAY.

© 1983 BASF Systems Corp., Bedford, MA



**BASF**

**Wouldn't you like to have a  
new skill you could call your own?  
Learn TV, audio, and video servicing  
with at-home training from NRI.**

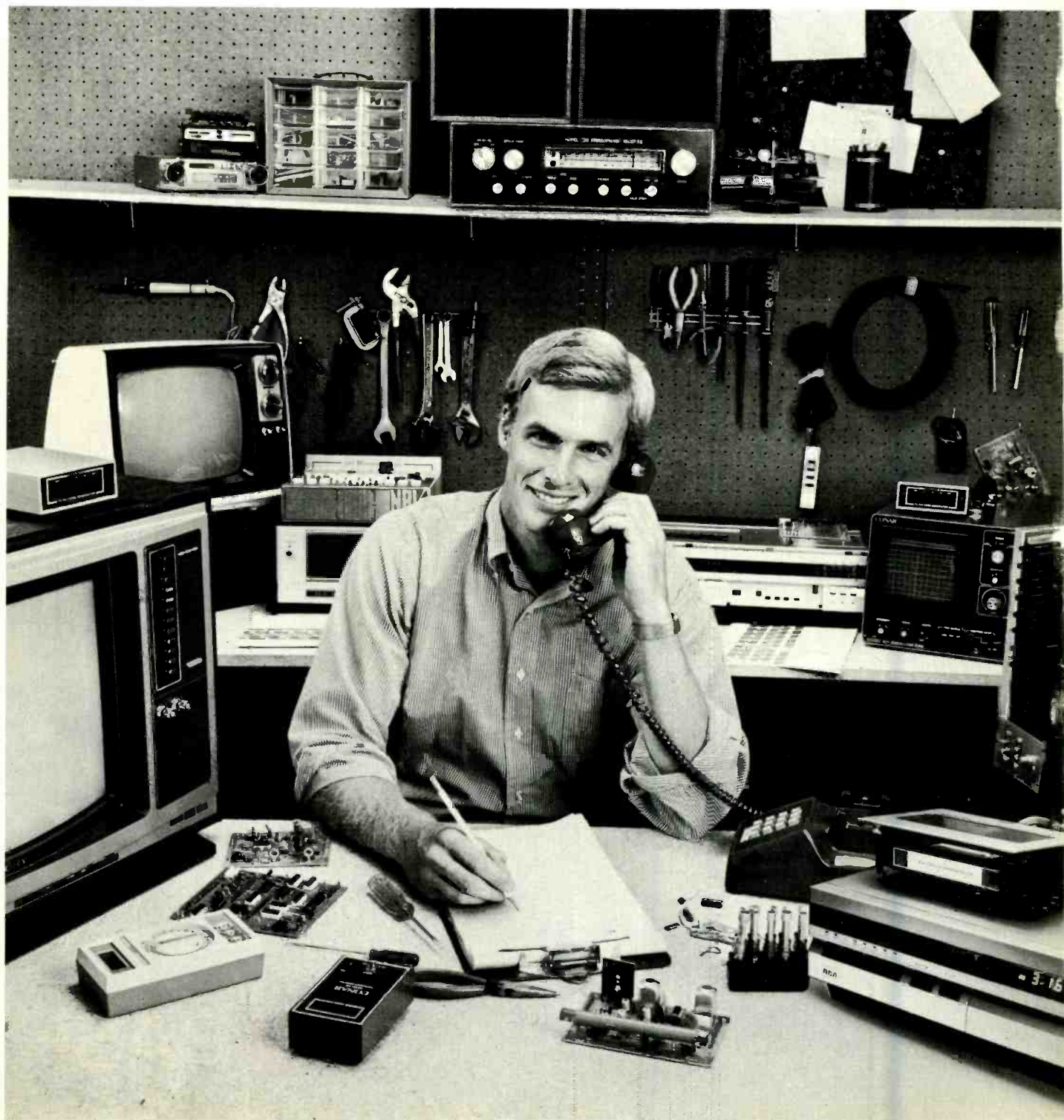

You can learn to service and repair TVs, stereos, electronic musical instruments and amplifiers, car and portable radios, record and tape decks, videocassette recorders and disc players, almost any kind of electronic equipment on the market. And you can learn to do it at home, in your spare time, without quitting your job or wasting time and gasoline on night school. NRI will train you, as it has over a million and a quarter others, with effective methods proven over 69 successful years.

### Hands-On Training

NRI training is practical training all the way. Throughout your course, you'll perform hands-on experience projects that make theory come to life and give you real understanding.

### Includes Both 25" TV And VCR, Plus DMM And More

As part of your training, you'll build your own 25" Heath/Zenith color TV, a state-of-the-art unit with infrared remote tuning, programmable channel selection, and the incredible space phone for remote calling. You also get a front-loading, remote-controlled videocassette recorder to play your videotaped lessons and learn about servicing this complex instrument.



Practical training on a real state-of-the-art TV, VCR or stereo, using professional equipment

You'll learn troubleshooting techniques using a professional 3½-digit digital multimeter. You'll use it when assembling your TV to check demonstration circuits you build on the NRI Discovery Lab, and in your professional work. It's the equipment and training you need for success.

### Exclusive NRI Training On Videotape

In addition to profusely illustrated lessons, you get NRI Action Videocassettes . . . videotaped lessons that show you graphic presentations of electronic systems, vivid closeups of servicing techniques and professional "shortcuts" to study and replay as often as you want.

### Training For Success

NRI not only prepares you to become a top technician, we get you ready for independence. NRI Video/Audio servicing gives you a great new way to earn

extra money doing part-time servicing for appliance and department stores—building a good-paying, new career with an electronics firm . . . or even starting your own business. You can start small, even part-time in your basement or garage, make the most of your opportunities to grow into a successful businessman.

### Free Catalog . . . Mail Card Today

Send the postage-paid card for our free 104-page color catalog describing our courses in full, showing all equipment, lesson outlines, and career opportunities. It also shows other exciting courses like Microcomputers, Electronics Design, Industrial Electronics, Digital Electronics, and more. Mail the postage-paid card today for your copy. And

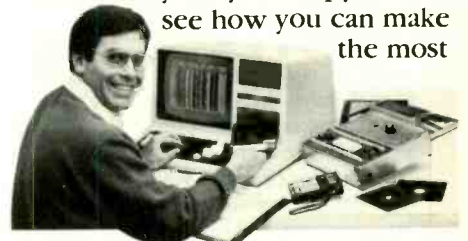

see how you can make the most of your talent. If card has been removed, please write to:



**NRI Schools of Electronics**  
 McGraw-Hill Continuing Education Center  
 3939 Wisconsin Avenue  
 Washington, DC 20016

We'll give you tomorrow.



# Computer Scientist

(Continued from page 14)

nately, this prediction proved too pessimistic and ENIAC, when completed, did manage to operate much longer than a few minutes per session.

## Random Numbers

What is a random number? A number is considered random if the likelihood of its occurrence is the same as that of any other number in a given set.

Many sets contain only two numbers. If each of its faces is assigned a number, a flipped coin falls in this category. A cubical die has a set of six numbers, while the cardboard spinner of a board game may have a dozen or more numbers.

Some applications require that a number be selected randomly from hundreds or even millions of possibilities. For example, the Selective Service System once staged lotteries to select candidates for military induction. Capsules containing numbers were mixed in a revolving drum and picked from the drum.

Generating a sequence of random numbers is not as simple as one might expect. Even the well-known example of the flipped coin, the source of countless yes-or-no decisions, can defy the expected odds. For example, while experimenting with a computerized coin toss simulator program to be described, I decided to compare the program's results with those of a real coin.

Accordingly, for five dollars I hired my 8-year-old daughter, Vicki, to flip a coin 1000 times and to record the results. She selected a nickel, randomly of course, from her change collection and went to work. Several hours later, she presented me a tally sheet giving the results for 1327 tosses. Instead of the expected closely matched number of heads and tails, Vicki reported 645 heads and 682 tails.

Frankly, I was delighted, since the coin toss program produced more predictable results. However, as any student of probability would quickly point out, outside factors may have influenced the test with the nickel.

Perhaps one side was more worn than the other. Or maybe Vicki inadvertently developed a flipping pattern that favored tails. The latter possibility came to mind when I totaled the results on the back side of the tally sheet. These flips, which were made a few hours after those on the

**TABLE I—FREQUENCY OF OCCURRENCE OF THE FIRST 1000 RANDOM NUMBERS BETWEEN 1 AND 10.**

Random Number	Adam	CoCo	Model-100	PC-3	PCjr
1	98	112	91	107	93
2	113	107	106	82	100
3	116	90	104	103	90
4	99	95	96	113	101
5	89	102	103	99	124
6	80	100	112	89	101
7	100	104	91	104	112
8	101	97	102	104	96
9	100	91	107	100	96
10	104	102	88	99	93
<b>Standard Deviation:</b>	10.37	6.93	8.03	8.86	10.27

front side of the sheet, gave a closely matched 140 heads and 142 tails.

## Random Number Hardware Circuits

Before looking at computerized random number generators, let's quickly review a couple of simple circuits I've used to generate random numbers. Later I'll show you how to implement both circuits in software.

Figure 1 is a block diagram that illustrates the operating principle of both circuits. In operation, a clock oscillator sends a rapid stream of pulses to a binary counter. Pressing the normally closed pushbutton switch S1 opens the pulse stream and freezes the counter. Since the oscillator sends a million pulses to the counter each second, it's virtually impossible for operator bias to alter the results.

Figure 2 shows typical circuits. The clock oscillator is made from two cross-connected CMOS gates in a 4011 gate package. The coin flipper version uses a 4027 flip-flop as a 0...1...0...1-of-2 counter. The 1-of-10 version uses a 4017 decoded counter.

You can quickly build either or both circuits on a plastic, solderless breadboard. Be sure to handle the CMOS chips carefully since they can be damaged by static electricity. For more information about these and other random number hardware circuits, see *The Forrest Mims Circuit Scrapbook* (McGraw-Hill, 1984, pp. 125-126, 128).

## Computerized Random Numbers

Both circuits in Fig. 2 can be easily simulated with any personal computer. Later, I'll give some examples, but first let's look at the random number generator function built into most computers.

Often an algorithm permanently stored in ROM generates the random numbers. If a random number function isn't built-in, it can be programmed by the machine's user.

Many random number algorithms are available. One recommended by Hewlett-Packard in the owner's manual for its HP-97 programmable calculator squares a user-specified four digit number (known as a *seed*) and then extracts the four center digits. This becomes a pseudo-random number. A second pseudo-random number can be generated by squaring the first number and extracting its four middle digits. The procedure can be repeated any number of times, under program control, to generate a series of pseudo-random numbers.

Another algorithm for generating random numbers was developed by Don Malm as part of a Hewlett-Packard HP-65 Users' Library program and is described in the standard applications manual for the HP-41C family of programmable calculators (see the Arithmetic Teacher program). This generator takes the fractional part of  $(9821 \times \text{seed number} + 0.211327)$ . Subsequent random numbers are generated by using the previous random number as the seed for the next calculation.

It's important to keep in mind that the sequence of "random" numbers produced by these and other algorithms is not necessarily purely random since the sequence will eventually repeat itself. There is, however, nothing obvious in a printout of computer-generated random numbers to indicate the numbers are anything but random.

Pseudo-random numbers are adequate for many, but not all, purposes. Knuth gives a test for randomness in

**AND NOW THE GAME BEGINS**

**PERSONAL COMPUTER**  
*The Game*

**BUSINESS EDITION**

# INTRODUCING THE AT&T



1	2	3	4	5	6	7
1						
2						
3						
4						
5						
6	REGION	1984	1985	1986	1987	1988
7		(\$M)	(\$M)	(\$M)	(\$M)	(\$M)
8						
9	NORTHEAST	8868.0	9256.0	9812.0	9875.0	10120.0
10	MID-ATLANTIC	6290.0	7125.0	6980.0	7336.0	7820.0
11	SOUTHEAST	6940.0	7536.0	7421.0	8120.0	8820.0
12	CENTRAL	5970.0	6666.0	6230.0	7030.0	7426.0
13	WEST	4620.0	5629.0	5534.0	6177.0	6690.0
14	NORTHWEST*	3640.0	4299.0	3870.0	4170.0	5290.0
15	SOUTHWEST	8321.0	8080.0	8502.0	9802.0	10801.0
16						
17	TOTAL	44439.0	49397.0	47469.0	52524.0	56177.0
18						
19						
20						
						*INCLUDES ALASKA AND HAWAII
VALUE:						
Enter a formula						
RL3C6				97% Free		PRINT

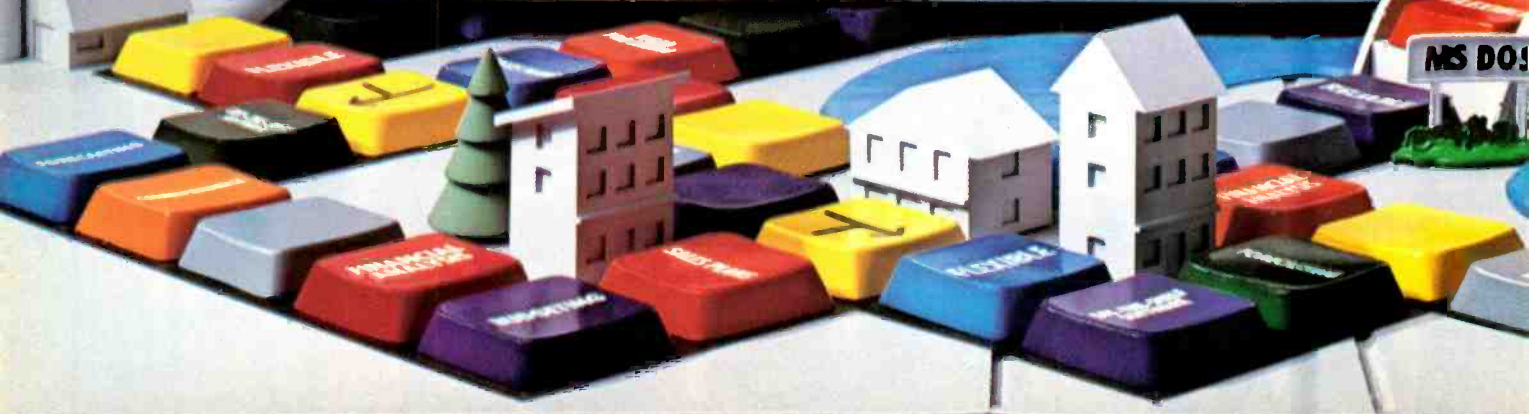

# PERSONAL COMPUTER.

The personal computer game is ready for business—and now it's your move. To win the game your company needs a fast, flexible, reliable personal computer that enables you to call the shots.

Go directly to the new AT&T Personal Computer.

The AT&T Personal Computer is more than just a superior piece of hardware. Behind it is a commitment to a better way of managing information and communications. One that can pay off handsomely in increased productivity and profits.

Because our AT&T PC is designed to be flexible enough to meet all your business needs—today and in the future.

Whether you use it as a stand-alone workstation or as a team player in a fully integrated system, you'll find our PC a high-performance machine. And a hard-working addition to your office.

Its fast processing and high-resolution graphics will help make any computer task a computing pleasure. In addition, you can expect more standard features. More expansion slots. More options for future growth.

## OFF-THE-SHELF SOFTWARE DOES THE JOB

Driven by the MS-DOS\* operating system, the AT&T PC runs the most popular off-the-shelf software for a wide range

of business applications. Financial analysis. Forecasting. Budgeting. Word processing. Inventory. The AT&T PC does it all.

And its flexibility means that when it's time to expand, our PC will actually make your computer growing pains painless.

With our unique PC Interface it can be linked to the more sophisticated, higher capacity world of the UNIX\*\* System V Operating System—the AT&T Computer “brain” that is emerging as the operating system standard for multi-user, multi-tasking machines.

## THE AT&T TRADITION CONTINUES

Some things about our PC cannot be measured in bits and bytes, but are of immeasurable value.

For instance, the unmatched service and support of AT&T. The built-in reliability—and outstanding quality—of our products. The century-long tradition of technological innovation and personal attention to detail.

Think about it. Then make your move—to the AT&T Personal Computer, from AT&T Information Systems.

To get in on the game, call your AT&T Account Executive, visit an Authorized AT&T PC Dealer, or call 1 800 247-1212.

**AT&T INFORMATION SYSTEMS.  
WHEN YOU'VE GOT TO BE RIGHT.**



\*MS-DOS is a trademark of Microsoft Corporation.  
\*\*UNIX is a trademark of AT&T Bell Laboratories.  
©1984 AT&T Information Systems



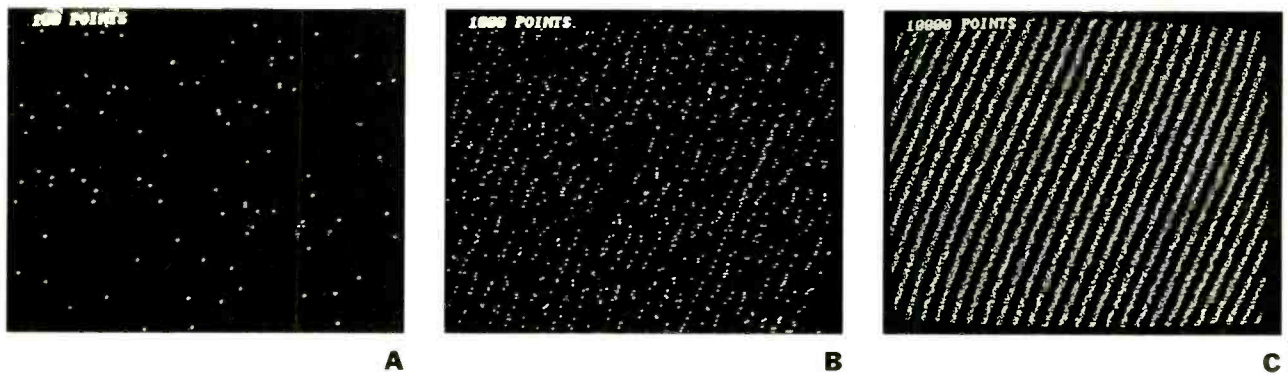

Fig. 3. Dots plotted at "random" (RND) coordinates of a PCjr.

*The Art of Computer Programming* (Addison-Wesley, 1978). Another way to estimate the randomness of a computer or calculator random number algorithm is to write a program that tallies the occurrence of each random number in a series of many. If the numbers are genuinely random, their totals, while not necessarily equal, should be closely matched.

Table I lists the results of such a program for several popular personal computers. It's important to note that if the program for each computer is run again and again, unless the random number generator is *reseeded*, the resulting sequences of random numbers will be identical to those in the table.

The results in the table were obtained by the program listed below. Line 30 must be revised in accordance with the individual computer's random number feature (Model 100 version shown). To change the sequence of random numbers, insert a RANDOM or RANDOMIZE statement in the program.

The Radio Shack PC-3 TRS-80 Pocket Computer will give a different sequence of numbers each time the program is run unless the computer is switched off between runs. Incidentally, to use this program with the PC-3 it's necessary to insert LET after each THEN in lines 70-160. Change line 30 to read X=RND(10).

```

10 INPUT "NUMBER OF
SAMPLES"; N
20 K=K+1
30 X=INT(RND(1)*10)

```

```

40 GOSUB 70
50 IF K=N THEN 180
60 GOTO 20
70 IF X=1 THEN A=A+1
80 IF X=2 THEN B=B+1
90 IF X=3 THEN C=C+1
100 IF X=4 THEN D=D+1
110 IF X=5 THEN E=E+1
120 IF X=6 THEN F=F+1
130 IF X=7 THEN G=G+1
140 IF X=8 THEN H=H+1
150 IF X=9 THEN I=I+1
160 IF X=0 THEN J=J+1
170 RETURN
180 PRINT "1 =" ; A,
    "6 =" ; F
190 PRINT "2 =" ; B,
    "7 =" ; G
200 PRINT "3 =" ; C,
    "8 =" ; H
210 PRINT "4 =" ; D,
    "9 =" ; I
220 PRINT "5 =" ; E,
    "10 =" ; J
230 END

```

A more dramatic verification of randomness results from a simple routine that places dots on a computer's monitor or draws them on an x-y plotter at randomly selected coordinates. If the coordinates are perfectly random, the dots will appear uniformly distributed over the screen. The dots may appear organized or clumped ("hot spots") and some areas may have comparatively few dots ("cold spots") if the coordinates are pseudo-random.

Here's a program for the PCjr that plots dots in medium resolution mode at random coordinates across the screen of a monitor:

```

05 'PCjr RANDOM DOTS
10 CLS:KEY OFF
20 SCREEN 1,0:COLOR 1
30 INPUT "ENTER NUMBER
OF POINTS: ",N
40 CLS
50 S=S+1:LOCATE 1,1
60 IF S=N THEN PRINT
    N;"POINTS"
70 IF S=N THEN 70
80 X=INT(RND*(320+1))
90 Y=INT(RND*(200+1))
100 PSET (X,Y)
110 GOTO 50

```

Lines 80 and 90 activate Junior's random number function, RND(x). Since the numbers returned are decimal fractions between 0 and 1, it's necessary to add a correction factor to obtain random numbers corresponding to the available range of coordinate values. Since the program above selects Junior's medium resolution mode, the correction factor multiplies the decimal random number times 320 and 200. It then assigns as x and y coordinates the integer portion of the products.

What happens when this program is run? Figure 3 is a series of three screen photographs showing dots plotted at "random" coordinates on the monitor of a PCjr. The 100 dots in (A) appear uni-

Fig. 4. Dots plotted at "randomized" (RANDOMIZE TIMER) coordinates.







# Show your colors.

## The new Epson® JX-80™ 7-color printer.

Say more faster. With greater clarity and comprehension. And with a lot more impact. Say it in color.

### Join the color revolution.

The revolutionary JX-80 gives you seven vivid colors to breathe life into charts and give soul to text.

But that's just for starters.

The JX-80's exclusive SelecType control panel makes choosing and mixing any of nine popular typefaces (the JX-80 prints 144 different faces in all) as easy as pushing a few

buttons on the printer.

### Color it hot.

The JX-80 prints graphics or text in black and white at speeds of up to 160 characters per second exactly like our legendary FX-80™ dot matrix printer. So, like all Epson printers, it's supported by virtually all software and personal computers. Switch to color, however, and the JX-80 is supported by all popular color software such as Lotus® Symphony.™

And of course, the JX-80 is backed by the one-year Number One Warranty, and priced right.

See your nearby Epson dealer. Get the full story in black and white.

And yellow and cyan and magenta and violet and green and orange...

Number one. And built like it.

**EPSON®**  
EPSON AMERICA, INC.

2780 Lomita Boulevard • Torrance, CA 90505 • Call (800) 421-5426 for the Epson dealer in your area. In California call (213) 539-9140.

Epson is a registered trademark, and JX-80 and FX-80 are trademarks of Epson America, Inc. Lotus and Symphony are trademarks of Lotus Development Corporation.

## Computer Scientist

formly sprinkled across the screen. The 1000 dots in (B), however, reveal the emergence of what appear to be several linear patterns of dots. Finally, the 10,000 dots in (C) reveal that the supposedly randomly selected coordinates are distributed primarily in a series of linear bars spread diagonally across the screen.

Remember, unless it's reseeded, a firmware-based random number function will always give the *same* sequence of random numbers. Some computers include a RANDOM or RANDOMIZE statement that permits the internal random number generator algorithm to be reseeded manually or under program control. Reseeding a random number generator is much like shuffling a deck of cards.

The PCjr's RANDOMIZE TIMER statement is particularly useful in this regard. It uses the last two digits (00 to 59 seconds) in Junior's internal clock as the seed for the next random number calculation.

The screen photographs in Fig. 4 show dots plotted on the screen of a PCjr loaded with the previous listing with the following line added 75 RANDOMIZE TIMER. The 100 dots in (A) appear uniformly distributed. Among the 1000 dots in (B), however, are numerous "holes," in which dots are not found. Even after the 10,000 dots have been

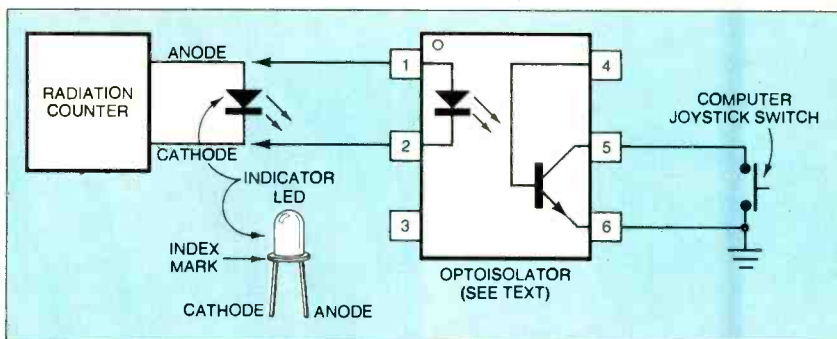

Fig. 5. Interfacing a radiation meter to a joystick "fire" switch.

Incidentally, since each pair of randomly generated coordinates springs from a seed determined by Junior's clock, a different pattern of dots is produced each time the amended program is run.

### Coin Toss Programs

As I noted above, many events in nature have exactly one of two possible outcomes. Random number generators that permit a computer operator to select the range of numbers to be generated can be easily used to develop *coin toss* programs that give random sequences of two digits or characters (e.g., heads or tails, 0 or 1, etc.).

The following PCjr program gives any specified number of coin flips and, when complete, displays the total number of heads and tails:

```
ELSE 40
100 LOCATE 1,1
110 PRINT "HEADS =";Y;
    "AND TAILS =";Z
```

When asked to provide 1000 coin flips, this program will give 474 heads and 526 tails each time it's run on a PCjr. Other computers may give different results.

The program will provide different and more random results if this line is inserted: 45 RANDOMIZE TIMER. A run of 1000 flips gave 510 heads and 490 tails, 10,000 flips gave 4998 heads and 5002 tails.

It's interesting that this program provides results more random than those obtained by my daughter's coin toss experiment. And at 37 seconds per 1000 tosses, it's certainly much faster.

### Interactive Random Number Generators

The circuits in Fig. 2 can be easily simulated with any personal computer that runs BASIC. With it you can generate random numbers *without* using the computer's built-in random number generator.

For example, here's a simple coin toss routine:

```
10 FOR N=1 TO 2
20 IF INKEY$="F" THEN
    PRINT N;
30 NEXT N
40 GOTO 10
```

This routine counts from 1 to 2 thousands of times each second. If the F key (for *Flip*) is pressed, the current count is displayed on the monitor. The program will return random numbers up to any number you specify in line 10. For instance, to simulate the 1-of-10 random number circuit in Fig. 2, change line 10 to FOR N=1 TO 10.

Many variations of this program are possible. For example, the FOR-NEXT loop can be replaced by a line that increments a loop counter each cycle of a continuous loop. When the count equals a

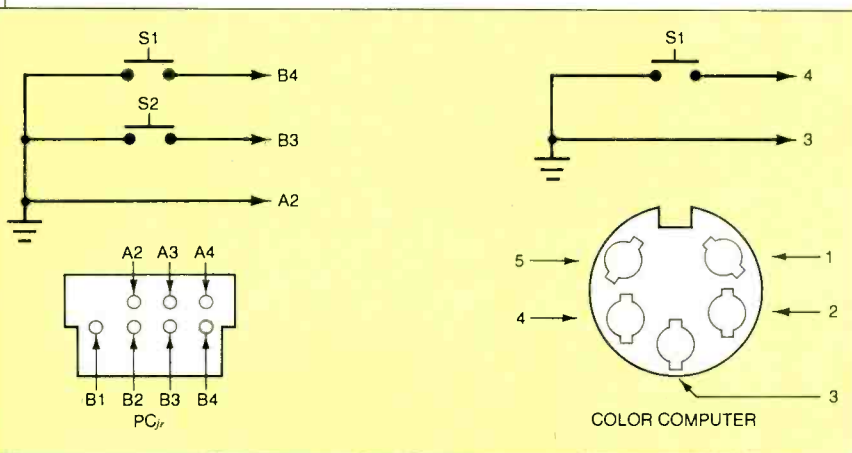

Fig. 6. Joystick connector ports for PCjr and Color Computer.

plotted in (C), small holes and regions having small concentrations of dots still remain. If they're not obvious, you can see them by squinting your eyes.

Do the holes indicate a significant degree of nonrandomness? Not if a test I performed by sprinkling sugar on a black sheet of paper is valid. The sugar formed a pattern very much like Fig. 4C, holes and all.

```
10 'COIN TOSS ROUTINE
20 CLS:KEY OFF
30 INPUT "NUMBER OF
    TOSSES";N
40 S=S+1
50 X=INT(RND*(2))
60 PRINT X;
70 IF X=0 THEN Y=Y+1
80 IF X=1 THEN Z=Z+1
90 IF N=S THEN 100
```

# The one-stop, microcomputer shopping center

## Heath/Zenith... Two great names in one all-service store.

A computer purchase is the beginning of a long-term partnership between you and the people you buy from. Your ongoing need for software, peripherals, accessories and add-on circuit boards requires a partner who will stand by you with a growing line of products to meet your needs. Heath/Zenith will be that strong partner for you. Look at what we have to offer.

## A fine selection of microcomputers.

The H/Z 100 series computers run 8- or 16-bit software. They have massive storage, flexible expansion capability and they include the MS-DOS operating system. Our desktop and portable 150 Series PC's are IBM compatible. They come with a standard 128 KB user memory and are loaded with enhanced features. All models are available in kit or fully factory assembled and tested.

## Your headquarters for add-on boards.

We have a full line of "Heath checked" boards for IBM and Heath/Zenith PC's. Decide what your computer should do; we've got boards like AST SIX-PAK PLUS\* and Access 1-2-3 Modem to do it at the right price. Those "Best of Breed" boards come with complete instructions and our own 90 day money-back guarantee.

\*MS is a registered trademark of Microsoft Corp. IBM is a registered trademark of International Business Machines Corp. SIX-PAK PLUS is a registered trademark of AST Research, Inc.

## A full range of printers, peripherals and furniture.

Trust us to match your computer to the compatible drive, printer or modem that works best. And to keep both operator and computer at maximum efficiency, we carry a full line of functional, comfortable computer furniture.

## The best software a store can stock.

The right software is as important as the computer itself. We offer the latest versions of best-selling management tools, word processing, accounting, data base management and home education software. And we make sure our software is up to date and competitively priced.

## We will teach you.

We have the education experience to help you understand your purchase before you buy. So, you can get more than a computer; you can get the knowledge to make it work at full potential.

## Or, you can teach yourself.

Gain true mastery over the computer. Master the software! Heathkit/Zenith

Educational Systems self-paced, self-study courses can help you learn all about a programming language or operating system. Learn what you want, when you want. Another reason why Heath/Zenith is the Strong Partner you can depend on.

## Service and support.

Prompt, professional service and assistance is available nationally through Heathkit Electronic Centers,\*\* Zenith Data Systems for commercial users, or through Heath factory servicing and phone-in technical assistance.

Complete, integrated computer hardware and software, designed to serve and grow with you - that's what to look for in a strong partner. And with Heath/Zenith you get it all...in one stop.

## Make one stop at your Heathkit Electronic Center.

71 stores throughout the U.S. and Canada. Consult your telephone white pages for locations.



# Heath ZENITH

your strong  
partner in  
microcomputers

**Heath/Zenith**  
Heath  
Company

Circle No. 24 on Free Information Card

\*\*Units of Veritechnology Electronics Corporation CP-232

## Computer Scientist

previously specified maximum random number, the loop counter is reset to 1.

Furthermore, some applications might require that the random number be selected when a switch some distance from the keyboard is pressed. In this case the program above can be modified to sample the status of a joystick trigger button during each cycle of the loop.

Here's a PCjr coin toss routine that incorporates both these modifications as well as others and returns 0 or 1 each time a joystick trigger button is pressed:

```

10 'PCjr COIN TOSS
20 CLS:KEY OFF
30 N=0:STRIG ON
40 X=STRIG(1)
50 N=N+1
60 IF N=2 THEN N=-1
70 IF X=0 THEN 40
   ELSE 80

```

Incidentally, the program will not return a random number each time the trigger button is closed. Can you explain why?

### A "Nuclear Powered" Coin Flipper

The timing of many natural events is predictable; the timing of other natural events, such as the emission of alpha particles by the radioactive substances, is unpredictable and, therefore, random.

A manually actuated random number routine like the previous one (PCjr Coin Toss) can also be triggered by the random emission of a radioactive particle. Simply interface a radiation counter with one of the joystick trigger buttons of a suitable computer.

Recently I interfaced a Radiation Alert (TM) Monitor 4 radiation meter to both a PCjr and a Color Computer. Though many other radiation meters

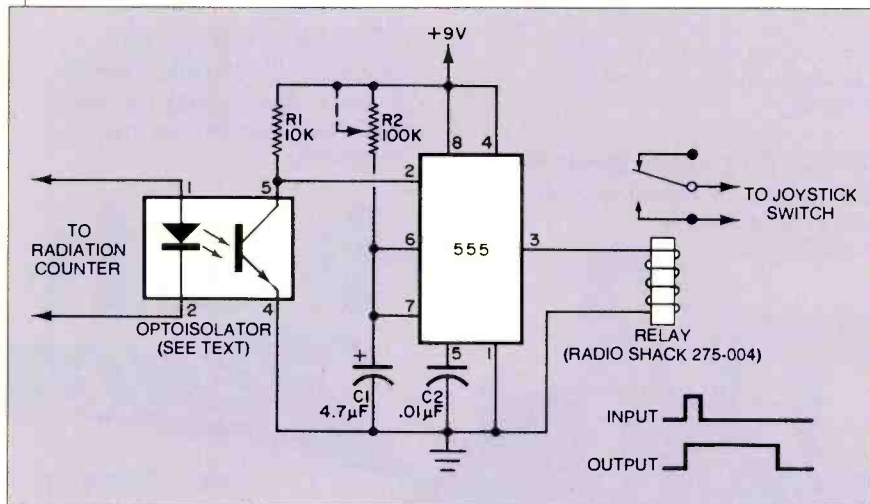

Fig. 7. Pulse stretcher for a joystick switch.

```

80 IF X=-1 THEN 90
   ELSE 40
90 IF N=0 OR N=1 THEN
   PRINT N;
100 X=STRIG(1)
110 IF X=-1 THEN 100
   ELSE 40

```

This program can be adapted for any computer having joystick trigger (or "fire") buttons. For instance, the status of the two joystick buttons that can be connected to Radio Shack's Color Computer are automatically poked into memory address 65280. To read the status of the buttons, include this line in your program: S=PEEK(65280). If the left button is pressed, S will equal 125 or 253, and if the right button is pressed, S will equal 126 or 254. If neither button is pressed, S will equal 127 or 255.

can also be used, at \$149.50 (plus \$5 for postage and handling) the Monitor 4 is among the most economical. It's available from Solar Electronics International (156 Drakes Lane, Summertown, TN 38483).

Figure 5 shows how a standard LED-phototransistor opto-isolator (G.E. H11A1 or similar) can be used to interface the Monitor 4 to a joystick trigger switch. The red indicator LED in the Monitor 4 flashes each time a radioactive particle passes through the Monitor 4's Geiger tube. Therefore, when the LED in the opto-isolator is connected directly across the indicator LED, the phototransistor in the opto-isolator is momentarily switched on each time a particle is detected.

Before an opto-isolator can be con-  
(Continued on page 105)

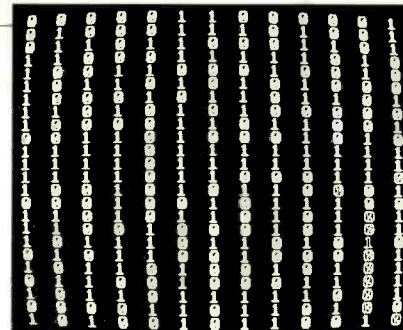

Fig. 8. Random 0s and 1s generated by a coin toss program controlled by a radiation meter.

### Listing 1. Manually triggered random number generator.

```

10 'MANUALLY TRIGGERED RND
   NUM GENERATOR
20 'COPYRIGHT 1984 BY FORREST M.
   MIMS
30 'RETURNS PSEUDO-RANDOM
   NUMBERS WHEN
40 'JOYSTICK TRIGGER PRESSED.
50 'TALLIES AND PRESENTS
   DISTRIBUTION
60 CLS
70 INPUT "NUMBER OF TOSSES"; Q
80 STRIG ON
90 FOR N=0 TO 9
100 S=STRIG(1)
110 IF S=0 THEN 160
120 IF S=-1 THEN GOSUB 270
130 T=STRIG(1)
140 IF T=-1 THEN 130
150 Z=Z+1:IF Z=Q THEN 180
160 NEXT N
170 GOTO 90
180 CLS:LOCATE 1,1
190 PRINT "1 = ";A;"2 = ";B;"3 = ";C
200 LOCATE 2,1
210 PRINT "4 = ";D;"5 = ";E;"6 = ";F
220 LOCATE 3,1
230 PRINT "7 = ";G;"8 = ";H;"9 = ";I
240 LOCATE 4,1
250 PRINT "0 = ";J
260 END
270 PRINT N;
280 'TALLY SUBROUTINE
290 IF N=1 THEN A=A+1
300 IF N=2 THEN B=B+1
310 IF N=3 THEN C=C+1
320 IF N=4 THEN D=D+1
330 IF N=5 THEN E=E+1
340 IF N=6 THEN F=F+1
350 IF N=7 THEN G=G+1
360 IF N=8 THEN H=H+1
370 IF N=9 THEN I=I+1
380 IF N=0 THEN J=J+1
390 RETURN

```

Fig. 9. Random digits generated by a program controlled by a radiation meter.

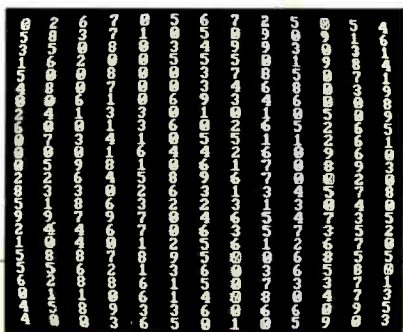

# 100 MHz scope, counter, timer, multimeter: All one integrated system.

**100 MHz dual time base scope.** 3.5 ns risetime; sweeps from 0.5 s to 5 ns/div; alternate sweep;  $\pm 2\%$  vertical/horizontal accuracy; vertical sensitivity to 2 mV/div @ 90 MHz.

**9-digit fluorescent display.** Digitally accurate readouts accompany the CRT waveform. Error messages and prompts also appear on the display.

**Dc volts and ac coupled true RMS volts.** Measured through the Ch 1 scope input.

**Gated measurements.** Use the scope's intensified marker to measure frequency, period, width and to count events within specified portions of the signal.

**Auto-ranged, auto-averaged counter/timer.** Frequency, period, width, delay time,  $\Delta$ -time, plus totalize to more than 8 million events —with 7 digits plus exponent displayed.

**Auto-ranged DMM.** Use floating DMM side inputs with up to 5000-count resolution. Get precise readouts of average dc and true RMS voltage. Measure resistance from milliohms to gigohms.

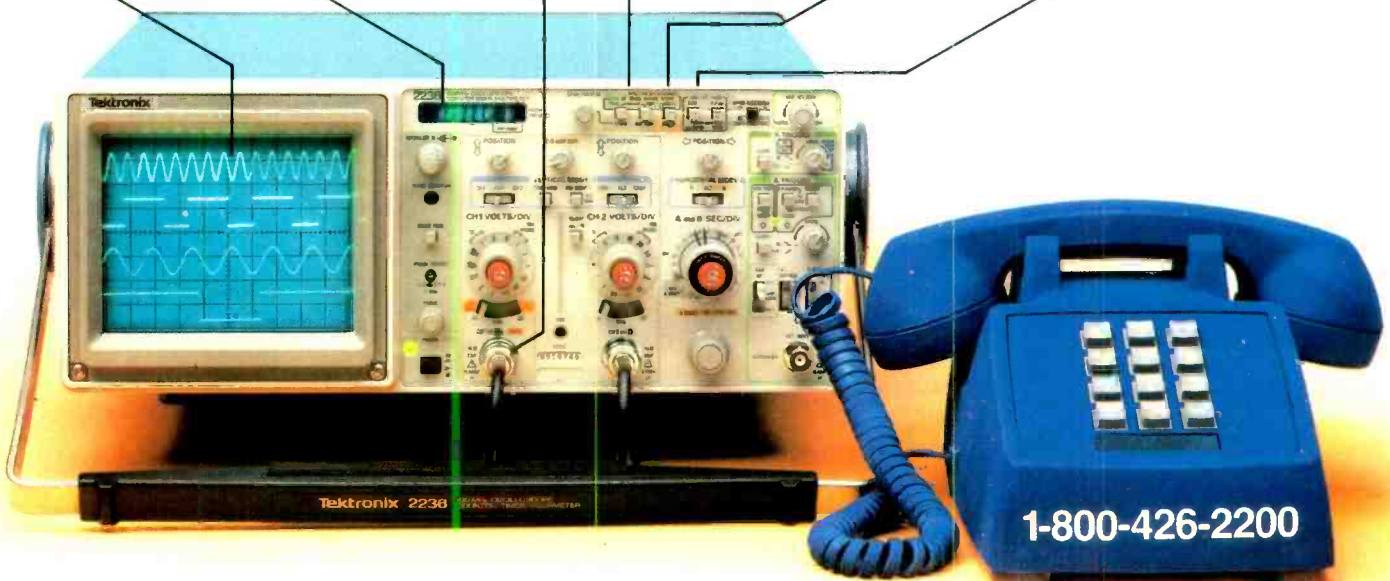

**Now make measurements faster, easier, with greater accuracy and user confidence.** The Tek 2236 makes gated counter measurements, temperature, time, frequency, resistance and voltage measurements push-button easy. You see results concurrently on the 9-digit numeric readout and CRT display.

Its complete trigger system includes pushbutton trigger view, plus peak-to-peak auto, TV line, TV field, single sweep and normal modes.

At just \$2650\*, the 2236 includes the industry's first 3-year warranty on all parts and labor, including the CRT.

**Integrated measurement system. 3-year warranty. 15-day return policy. And expert advice. One free call gets it all!** You can order, or obtain literature, through the Tek National Marketing Center. Technical personnel, expert in scope applications, can answer your questions and expedite delivery. Direct orders include operating and

service manuals and worldwide service back-up.

**Call toll-free:  
1-800-426-2200,  
Extension 109.**

In Oregon, call collect:  
(503) 627-9000, Ext. 109.  
Or write Tektronix, Inc.  
P.O. Box 1700  
Beaverton, OR 97075

**Tektronix**  
COMMITTED TO EXCELLENCE



*Hayes. Leading the way with quality telecomputing systems for the personal computers that businesses use most.*

When it comes to communicating—computer to computer—Hayes says it best. All you need is a Hayes Smartmodem (it's like a telephone for your computer) and Smartcom II® software, to get you into all the right places.

In no time at all, and with no assistance at all, you can create, send and store files, and automatically log on to information services. The communication possibilities are endless!

---

*Introducing our new Smartcom II.  
More connection capabilities.  
More convenience.*

---

Now Hayes goes even further to streamline your communications and optimize your connections.

Smartcom II software is currently available for more than 16 personal computers (with even more to come). That means you can communicate,

Smartcom to Smartcom, with an IBM PC, DEC Rainbow 100, HP 150, TI Professional Computer\* and others.

And that's not all! Smartcom II also emulates the DEC VT100 and VT52 terminals, now in widespread use in many businesses. This feature lets your personal computer "pretend" it's a DEC terminal, opening the door to a vast installed base of DEC minicomputers!

---

*We stand on protocol.*

---

In addition to the popular Hayes Verification protocol, the new Smartcom II also includes the XMODEM protocol, ensuring accurate transmission to a wide range of personal computers and mainframes at information services. By matching the protocol (or "language") of a remote computer to yours, Smartcom II can transmit information error-free, regardless of interference on the phone lines.

*"When I got this computer I thought my problems were over. Then it dawned on me I needed to talk to the PC in sales and the TI in accounting. What I needed was the right modem and software, so I went with the leader!"*

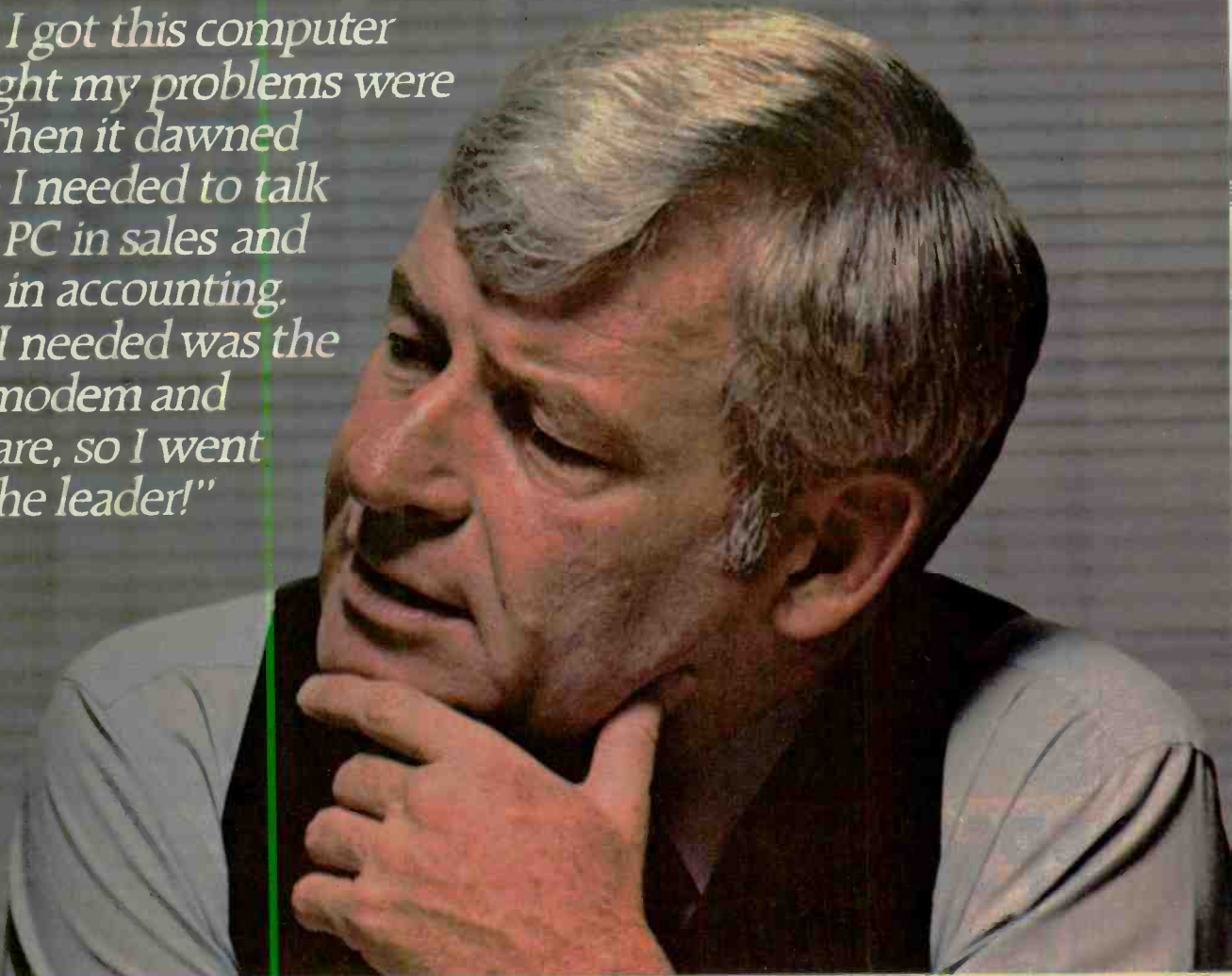

---

***Voice to data—in the same call!***

With Smartcom II, you can easily switch from voice to data transmission (and back again), all in the same phone call. This saves you time and money, since you don't have to hang up and dial again.

---

***Your Hayes telecomputing system works—totally unattended.***

Smartcom II makes telecomputing simple, even when you're not there. It allows your Smartmodem to receive a message for you when you're out, and leave it on your disk or printer. And you can tell Smartcom II to "save" the messages you've created during the day, and automatically send them at night, when phone rates are lowest.

---

***Get your hands on the leader.***

With an unsurpassed record of reliability, it's a small wonder Smartmodem

is such a smart buy! Smartmodem 300™ (the first of the Smartmodem series) dials, answers and disconnects calls automatically. Smartmodem 1200™ and Smartmodem 1200B™ (it plugs into an expansion slot inside an IBM PC or compatible), provide high-speed, high-performance communications for businesses of all sizes.

And when Smartmodem is purchased with Smartcom II, you have the most dependable telecomputing system available for your personal computer.

Everything we do at Hayes is designed to make communications easier for you. Feature-rich, direct-connect modems. Menu-driven software. Concise documentation. And a customer service organization, second to none!

See your dealer right now for a hands-on demonstration of Smartmodem and our latest version of Smartcom II. From the telecomputing leader, Hayes.



# Hayes

**Hayes Microcomputer Products, Inc.**  
5923 Peachtree Industrial Blvd.  
Norcross, Georgia 30092 404/441-1617.

Circle No. 8 on Free Information Card

# HARDWARE REVIEWS

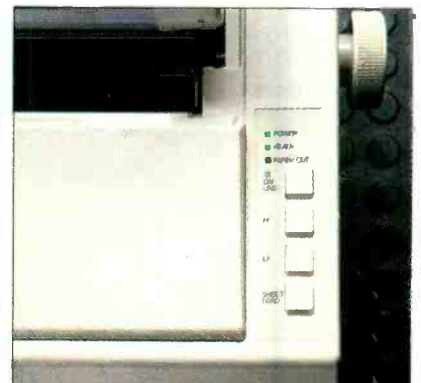

## EPSON LQ-1500 PRINTER

*Near letter  
quality and Epson  
compatibility*

**BY AL BURAWA**

**E**PSON, whose name is synonymous with high-quality medium-priced dot matrix printers, has added a new model to its line—right at the top. Called the LQ-1500, it's designed to provide fast draft and near-letter-quality printing as well as graphics.

Standard features include a 24-pin printhead, a plastic sheet guide for feeding cut sheet paper, a 15" platen, and full compatibility with Epson's FX series of printers. Suggested list price of the LQ-1500 is \$1395, but you'll have to spend at

least another \$95 for a Centronics (parallel) interface. Also available are RS-232 (\$150) and IEEE-488 (\$150) interfaces. Other options include a tractor feed for \$60 and a single-bin sheet feeder for \$499. A double-bin sheet feeder is expected to be available by this issue's publication date; cost is \$839.

### Basic Features

Because it has a footprint of approximately 24" × 14½" and a weight of almost 31 lb, plan on setting aside a large area for this printer on your computer desk or placing it on a separate printer table. The overall effect of size and weight gives one a feeling of confidence in the LQ-1500's ability to do just about any printing job.

Frequently used operator controls and status indicators are located on a panel at the top right of the printer. In addition to the usual on/off LINE, LINE-FEED and FORM-FEED buttons, there is a SHEET-LOAD button, which opens the paper bail, gravity feeds cut-sheet paper into position, and power feeds the paper into the printer. The entire operation is automatic once SHEET LOAD is pressed.

### Selecting Print Functions

The printer can be programmed through software or various switches in

a pair of DIP-switch assemblies. These switches are easy to reach through a slot in the plug-in parallel interface module at the rear of the printer. In the smaller DIP-switch network, one switch enables and disables a 2K buffer; a second, the paper-out detector; and the third, the automatic line feed. The functions addressed by the second DIP-switch network include: selection from among eight international character sets; selection of 11" or 12" form length; turning on and off "skip over perforation;" turning on and off the bell; selection of draft or letter-quality printing; and selection of fixed or non-fixed SLCT IN signal. The serial interface unit has other switches for setting data transfer (baud) rate and protocols.

The printer has three basic character sets—draft, letter-quality, and proportionally spaced—which are made up of 96 regular (Roman), 96 italic, and 31 international characters. Additionally, there are pica, elite, micro, and expanded formats, emphasized, double-strike, and emphasized-double-strike densities that can be used with each of the three basic character sets.

Text is printed at a zippy 200 characters per second in the draft mode and about 67 cps in the letter-quality mode.

*(Continued on page 102)*



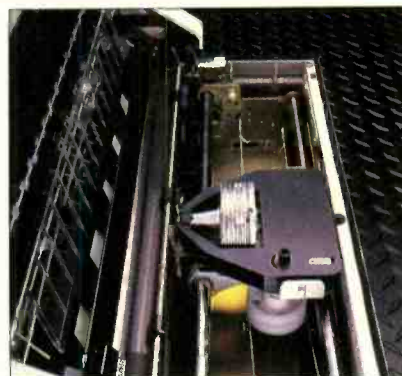

# TOSHIBA P1351

*Top-of-the-line  
printer uses  
24-pin head*

**BY ED TEJA**

**T**OSHIBA'S P1351 belongs to a class of printers that is setting new standards for quality and performance in the dot matrix arena. It gives you extremely readable printouts at 160 cps (10 cpi) or 192 cps (12 cpi) and letter-quality output at 78 cps (10 cpi) or 93 cps (12 cpi). At \$1895, the P1351 might seem priced a bit steeply for microcomputer systems, but before you agree, take a look at what you get for your money.

### Basic Features

The P1351 has a solid feel that assures you it won't slide all over the table while printing. It weighs 42 lb and measures 21.7" W × 15" D × 5.9" H. An attrac-

tive unit, it looked right at home next to the Toshiba T-200 computer that I used to test it out. The printer comes with either a serial (RS-232C) or parallel (Centronics) interface (the evaluation unit had a parallel interface). However, if you need or want both, the dealer will install the other interface at no extra charge.

### Selecting Fonts

The printer's firmware contains three distinct fonts. Two are high-quality and one is high-speed (draft-quality). A DIP switch on the inside of the front panel (you lift the paper cover to get access to it) lets you select font and character pitch (10 or 12 cpi). Both high-quality fonts produce print quality that looks extremely good. They are typewriter-like fonts, one darker than the other.

The output of the darker font (it looks a bit like double strike) on bond paper is difficult to tell from daisywheel-printed output. On quality paper the dots tend to bleed together, forming lines rather than groups of dots. Who could ask for more? It is difficult to describe print quality, but the output of the current crop of 24-wire printers is exceptional, and Toshiba's P1351 is right up there with the best.

The ballistic print wires create interlaced dots that are only 8 mils in diameter. In fact, if you use the printer to pro-

duce graphics, it can place 180 by 180 dots on each inch of the paper.

To help you take advantage of its graphics capability, the P1351 comes with 31 graphics characters stored in firmware that make it even easier to draw pretty pictures.

The manufacturer claims that the printhead will last for 200 million impressions. If a single pin gets messed up, it can be replaced.

If speed is more important than print quality, you can flip the switches to select the high-speed font. At 192 cps, the printer produces an odd-looking, but extremely readable draft-quality printout. The lower-case "r" looks out of place, and the left-hand quotation marks curve awkwardly to the left, but for proof copies and memos it is completely satisfactory.

You aren't restricted to the fonts that Toshiba has put into firmware, either. You can download nearly any font to accommodate special typeface needs. In fact, Toshiba provides software for this purpose, as noted in the feature article on dot matrix printers in this issue. Emulation is even better than flattery.

To make it easy to get the printer up and running, it features emulation of the Qume Sprint 5 daisywheel printer. The

*(Continued on page 103)*

PHOTOS BY BOB LORENZ

**Learning electronics  
is no picnic.**

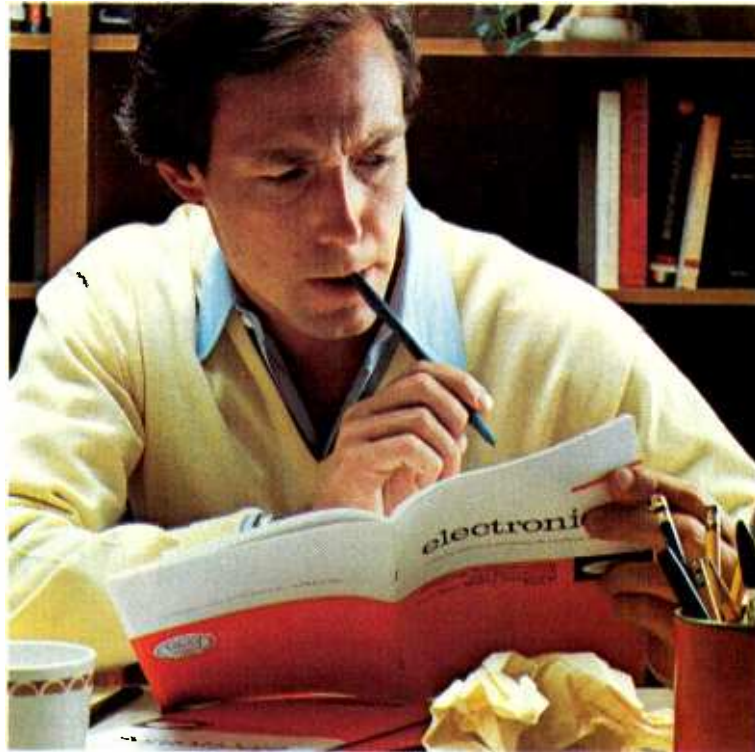

**At any level it takes  
work and a few  
sacrifices. But with  
CIE, it's worth it.**

Whoever said, "The best things in life are free," was writing a song, not living a life. Life is not just a bowl of cherries, and we all know it.

You fight for what you get. You get what you fight for. If you want a thorough, practical, working knowledge of electronics, come to CIE.

You can learn electronics by spending some hard-working time at home. Or, would you rather go bowling? Your success is up to you.

At CIE, you *earn* your diploma. It is not handed to you simply for putting in hours. But the hours you do put in will be on your schedule, not ours. You don't have to go to a classroom. The classroom comes to you.

### Why electronics training?

Today the world depends on technology. And the "brain" of technology is electronics. Every year, companies the world over are finding new ways to apply the wonders of electronics to control and program manufacturing, processing...even to create new leisure-time products and services. And the more electronics applications there are, the greater the need will be for trained technicians to keep sophisticated equipment finely tuned and operating efficiently. That means career opportunities in the eighties and beyond.

### Which CIE training fits you?

Beginner? Intermediate? Advanced? CIE home study courses are designed for ambitious people at all entry levels. People who may have:

1. No previous electronics knowledge, but do have an interest in it;
2. Some basic knowledge or experience in electronics;
3. In-depth working experience or prior training in electronics.

You can start where you fit and fit where you start, then go on from there to your Diploma, an Associate Degree if you want it, and career.

### Many people can be taught electronics.

There is no mystery to learning electronics. At CIE you simply start with what you know and build on it to develop the knowledge and techniques that make you a specialist. Thousands of CIE graduates have learned to master the simple principles of electronics and operate or maintain even the most sophisticated electronics equipment.

### CIE specializes in electronics.

Why CIE? CIE is one of the largest independent home study schools that specializes in electronics. Nothing else. CIE has the elec-

tronics course that's right for you.

Learning electronics is a lot more than memorizing a laundry list of facts about circuits and transistors. Electronics is interesting! It is based on recent developments in the industry. It's built on ideas. So, look for a program that starts with ideas and builds on them. Look to CIE.

### Programmed learning.

That's exactly what happens with CIE's Auto-Programmed<sup>®</sup> Lessons. Each lesson uses famous "programmed learning" methods to teach you important principles. You explore them, master them completely, before you start to apply them. You thoroughly understand each step before you go on to the next. You learn at your own pace.

And, beyond theory, some courses come fully equipped with electronics gear (the things you see in technical magazines) to actually let you perform hundreds of checking, testing, and analyzing projects.

### Experienced specialists work closely with you.

Even though you study at home, you are not alone! Each time you return a completed lesson, you can be sure it will be reviewed, graded, and returned with appropriate instructional help. When you need additional individual help, you get it fast and in writing from the faculty technical specialist best qualified to answer your question in terms you can understand

### CIE offers you an Associate Degree.

One of the best credentials you can have in electronics — or any other career field — is a college degree. That's why CIE gives you the opportunity to earn an Associate in Applied Science in Electronics Engineering Technology. Any CIE career course can offer you credit toward the degree...more than half of the number needed in some cases.

You can also prepare for the government-administered FCC (Federal Communications Commission) Radiotelephone License, General Class. It can be a real mark in your favor...government-certified proof of your specific knowledge and skills.

### Today is the day. Send now.

Fill in and return the postage-free card attached. If some ambitious person has removed it, cut out and mail the coupon. You'll get a FREE school catalog plus complete information on independent home study. For your convenience, we'll try to have a CIE representative contact you to answer any questions you may have.

Mail the card or the coupon or write CIE (mentioning the name and date of this magazine) at: 1776 East 17th Street, Cleveland, Ohio 44114.

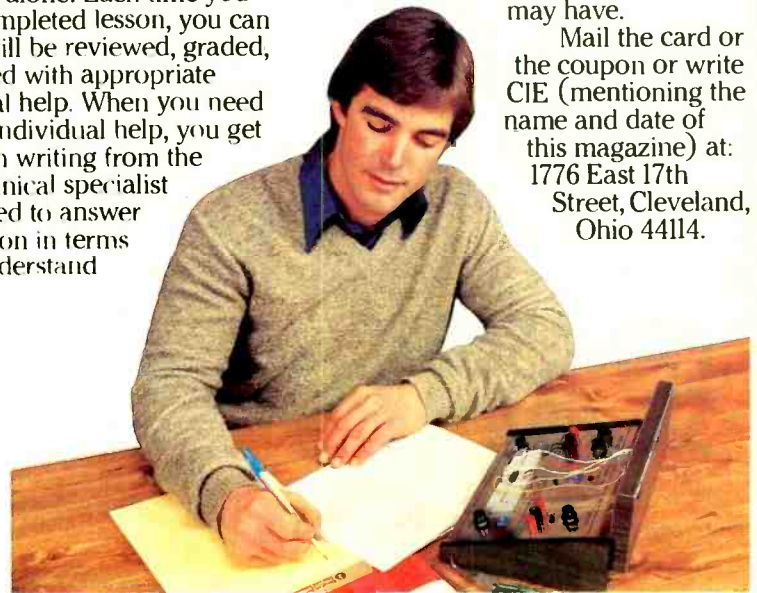

## CIE

Cleveland Institute of Electronics, Inc.

1776 East 17th Street, Cleveland, Ohio 44114

Accredited Member National Home Study Council

YES I want to learn from the specialists in electronics — CIE. Send me my FREE CIE school catalog including details about the Associate Degree program... plus my FREE package of home study information.

Print Name \_\_\_\_\_

Address \_\_\_\_\_ Apt. \_\_\_\_\_

City \_\_\_\_\_ State \_\_\_\_\_ Zip \_\_\_\_\_

Age \_\_\_\_\_ Area Code/Phone No. \_\_\_\_\_ / \_\_\_\_\_

Check box for G.I. Bill bulletin on Educational Benefits:  Veteran  Active Duty

**MAIL TODAY!**



## PANASONIC SR. PARTNER

*A new entry in  
the transportable  
compatibles  
sweepstakes*

**BY ROBIN WEBSTER**

**T**HE Panasonic Sr. Partner, a recent entrant in the transportable computer market, is designed to appeal to users who want a high degree of IBM PC compatibility in a luggable package. What's unique about the Sr. Partner is that the standard model comes with an integral printer and other features that are usually regarded as options on other computers.

Standard items on the Sr. Partner include: 256K of RAM (originally 128K,

but recently upgraded); built-in color graphics capability; integral thermal printer; and RS-232 serial port. Software packages bundled with the machine are VisiCalc; GWBASIC; WordStar; and PFS Graph, Report, and File. A single-disk system has a suggested retail price of \$2145; a dual-disk system sells for \$2595.

### The Basic Machine

The Sr. Partner measures  $8\frac{1}{2}'' \times 13\frac{3}{16}'' \times 8\frac{1}{4}''$  and is quite neat in appearance. There are no sharp corners, and the system casing (aluminum sheet) is a cream/beige color. Panasonic has placed the carrying handle on one side of the case so that it hangs down vertically when carried. (Usually, the handle is on the front or back of the case so that it can be flipped down to act as a tilt stand for the machine.) I didn't find the Panasonic arrangement particularly useful—in fact, there seems to be a good chance of smashing the machine against anything higher than a dachshund while carrying it. A separate flip-down metal stand is located along the lower front edge of the

computer to tilt it up about 15°.

One of the ads for the Sr. Partner seemed to suggest (visually) that it can be carried around with a spring in your step. This is not so! The machine weighs 32 to 33 lb, depending on the number of drives installed and can therefore cause you to list heavily to one side if you attempt to walk at anything more than a measured stride. Other luggable machines that provide the same carrying experience are the Compaq (33 lb), the IBM Portable (30 lb), and the Eagle portable (32.5 lb).

The Sr. Partner consists of only two separate parts: the system unit and the clip-on keyboard. The 83-key, IBM-style keyboard snaps onto the front of the system unit during transport, and is removed by depressing plastic latches on either side. Interestingly, Panasonic has designed the keyboard cable to be detachable.

Whenever you pack up the Sr. Partner, you must first unplug the 8-pin connector from the back edge of the keyboard and then let the coiled cable retract under its own power into the system unit. A special plastic stopper is attached to the end of the keyboard cable, which is used to keep it safely tucked away. It is a much better idea than just sandwiching the cable between the front of the computer and the keyboard as with some other systems, but it does mean that you have to reconnect it every time you want to start work.

Although the keyboard layout is exactly the same as the IBM PC's, there are some subtle differences. The return key, for example, is about twice the size of the IBM's. Keyboard feel is quite different though—somewhat bouncy—and keys don't produce audible feedback when pressed.

The Sr. Partner's 9" green display is placed just left of center in the system unit. Since the machine comes with a color graphics board as standard (and therefore produces color input whether you can make use of it or not), text on the monochrome screen is not really crisp. Also, multi-colored images put up on the monochrome screen can look somewhat washed out for the same reason. It's not the ideal situation for extended word processing work.

Since I had an IBM RGB monitor on hand, I tried it with the Sr. Partner. Immediately after attaching the monitor I knew something was wrong. While I could discern colored text on a colored background, the image was badly distorted by image "ghosting" and "snow," the kind of effect you can reproduce by

*(Continued on page 40)*



# LAST NIGHT, 39 MUSICIANS HAD A COMPU SERVE CONFERENCE, SO DID 31 M.D.S, 49 SPORTS FANS AND 640 APPLE POLISHERS, AND NO ONE HAD TO LEAVE HOME.

## The Electronic Forum, Cheaper than Long Distance and Much More Rewarding.

Every night on the CompuServe Information Service, professional and social groups discuss a wide range of subjects. From what's new in medical technology to what's nouvelle in continental cuisine.

And every day more computer owners who share a common interest are discovering this exciting new way to exchange ideas and even transfer hard copy data.

And besides electronic forums, they leave messages for each other on our national bulletin board, "talk" informally on our CB simulator, and communicate via CompuServe's electronic mail.

But best of all, in most cases, CompuServe subscribers get all of these state of the art communications options, plus a world of on-line information and entertainment for the cost of a local phone call plus connect time.

To become part of this flexible communications network, all you

need is a computer, a modem and CompuServe. CompuServe connects with almost any personal computer, terminal, or communicating word processor.

To buy a Starter Kit, see your nearest computer dealer. To receive our informative brochure or to order direct, call or write:

## CompuServe

Consumer Information Service, P.O. Box 20212  
5000 Arlington Centre Blvd., Columbus, OH 43220

**800-848-8199**

In Ohio call 614-457-0802

Circle No. 60 on Free Information Card

An H&R Block Company

# Panasonic

using a badly shielded hair dryer next to a TV set, only worse.

After investigating the matter, I found out that the Sr. Partner supplied for the review was of a slightly older design than current production models. The older model used four resistors on the RGB port that were set to handle signals (logical lows and logical highs) within a fairly narrow range when compared to the normal IBM PC setup. The newer models have been fitted with more specific resistors that resolve the problem. These are available to current users of the older models as a retrofit.

Immediately to the right of the display are the two floppy disk drives (only one installed with the standard machine). Each drive holds 320K, and each writes and reads data in IBM standard 9 sectors per track, double-sided/double-density format. The drives are mounted vertically, and instead of the more familiar flip-down disk retainers, they use special spring-locked catches. The idea is that you insert the floppy disk until you feel a slight click, then you push the spring-loaded catch over the disk entrance. I experienced some problems with this disk retaining mechanism. At random intervals the disk would not stay put when I inserted it, or it would pop out of place as I tried to close the catch. It got to the point where it became a bit of a nuisance. There's no simple way around the situation—you just have to keep trying until it works.

All the I/O connectors and system controls are placed along the rear of the machine. These include the on/off switch, the fuse, the power cord connector, the RGB monitor port, the brightness control, both a parallel (Centronics) and a serial (RS-232C) port, and a cut-out in the casing through which an optional system board can protrude. There is no reset button. In transit, this back



## Specifications

**Product:** Sr. Partner  
**Supplier:** Panasonic Industrial Co. Div. of Matsushita Elec. Corp. of America  
 1 Panasonic Way  
 Secaucus, NJ 07094  
**Price:** \$2595  
**Dimensions:** 18½"W × 13¾"D × 8¼"H  
**Weight:** 33 lb  
**Operating System:** MS-DOS 2.11  
**Features:** 8088 CPU, 256K RAM, RS-232 port, color graphics, dual 5¼" floppy drives, integral thermal printer, VisiCalc, WordStar, PFS File, PFS Report, PFS • Graph, GWBASIC

area is protected by a clip-on cover, which also serves to retain the power cord in a specially hollowed-out bay.

Having the screen brightness button on the back of the machine is inconvenient. Certainly, you should not need to alter the brightness every time you use the system; but having to lean over the machine, with your face angled to see the screen and your arm searching for the brightness switch is more like something you would do in an aerobics class than during a word processing session.

## Inside the Sr. Partner

Gaining access to the inside of the Sr. Partner is not just a case of removing four Phillips head screws and tugging away. First, you must remove the top cover of the integral thermal printer and disconnect a multi-pin connector you find underneath (four screws). Secondly, you must remove the back of the system casing (five screws). Finally, you must turn the system on its face—with the keyboard in place—and lift the main casing off.

The innards of the Sr. Partner are quite cramped, but well put together. There is a lot of formed aluminum sheeting in the construction, and each of the floppy drives is adequately surrounded by its own aluminum cage to reduce r-f interference.

The Sr. Partner uses the Intel 8088 microcomputer. The standard 256K RAM memory is split up so that 128K is on the motherboard and the other 128K is on a separate RAM board that is placed into one of the two expansion slots. Installing more RAM chips on the 128K board (another 256K can be added) is fairly difficult, however, since the board is hard to get to.

The expansion slots are obscured by an aluminum sheet that doubles as a re-

*(Continued on page 98)*

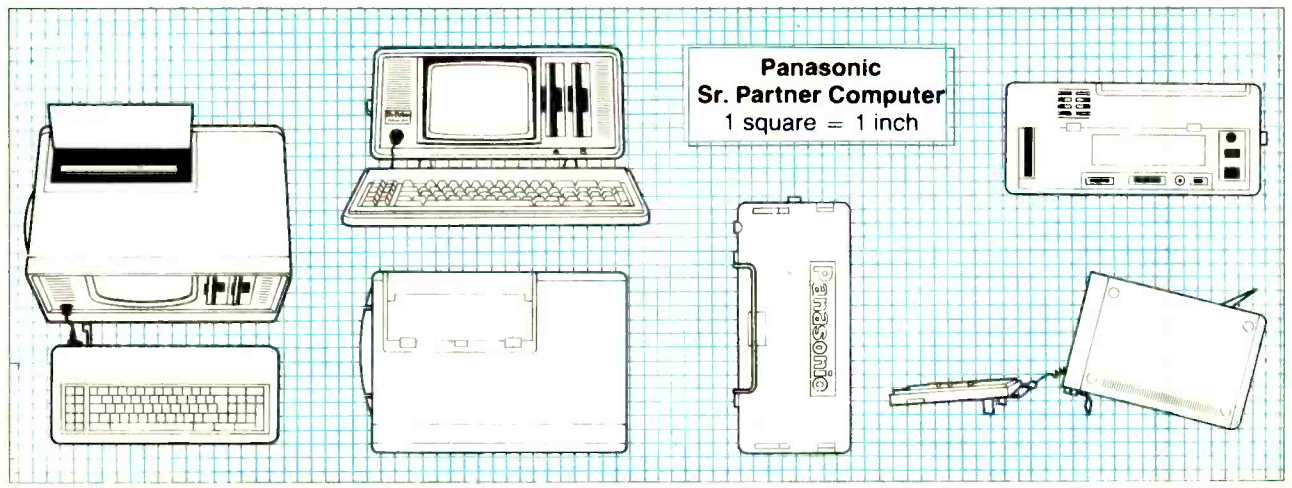

## Compare the TRS-80 Model 4!

	TRS-80	Apple IIe	IBM PCjr
CPU With One Drive	1299.00	995.00	999.00
Monitor	Included	229.00	129.00
Second Drive	Included		Not Avail.
RS-232 Interface	Included		Included
Printer Interface	Included	90.00	99.00
80-Column Video	Included	125.00	Included
DOS and BASIC	Included	Included	140.00
Numeric Keypad	Included	99.00	Not Avail.
Reference Manuals	Included	60.00	Included
Hard Disk Available	Yes	Yes	No
Ext. Drives Available	Yes	Yes	No
<b>Total</b>	<b>1299.00*</b>		<b>1367.00*</b>



# THE BEST BUY IN DESKTOP COMPUTERS...PERIOD.

Compared to the Apple IIe and the IBM PCjr, Radio Shack's Model 4 is more than just a good value at \$1299: it's more computer.

Only the Model 4 (26-1069) comes with two disk drives. Apple wants over \$300 more for their second drive; IBM doesn't offer one. The Model 4 comes with an 80-column screen. The Apple IIe doesn't. The Model 4 can expand with external drives and hard disks, something IBM can't do.

## We Invite Comparison!

Feature	TRS-80	Apple IIe	IBM PCjr
CPU With One Drive	1299.00	995.00	999.00
Monitor	Included	229.00	129.00
Second Drive	Included	329.00	Not Avail.
RS-232 Interface	Included	139.00	Included
Printer Interface	Included	90.00	99.00
80-Column Video	Included	125.00	Included
DOS and BASIC	Included	Included	140.00
Numeric Keypad	Included	99.00	Not Avail.
Reference Manuals	Included	60.00	Included
Hard Disk Available	Yes	Yes	No
Ext. Drives Available	Yes	Yes	No
<b>Total</b>	<b>1299.00*</b>	<b>2066.00*</b>	<b>1367.00*</b>

Come see the Model 4 and our huge selection of off-the-shelf software. And ask about quantity discounts that make the Model 4 even more affordable for businesses and schools.

**Radio Shack**<sup>®</sup>  
**The Technology Store**<sup>™</sup>

A DIVISION OF TANDY CORPORATION

## Send me a new 1985 Computer Catalog.

Mail To: Radio Shack, Dept. 85-A-301  
 300 One Tandy Center, Fort Worth, Texas 76102

NAME \_\_\_\_\_

ADDRESS \_\_\_\_\_

CITY \_\_\_\_\_

STATE \_\_\_\_\_ ZIP \_\_\_\_\_

PHONE \_\_\_\_\_

\*Manufacturers' pricing as of 7/6/84. Model 4 prices apply at Radio Shack Computer Centers and at participating Radio Shack stores and dealers. Apple is a registered trademark of Apple Computer. IBM is a registered trademark of International Business Machines Corp.

# Introducing the new United they stand.



Programs in IBM's Assistant Series are like actors in a play. Alone, each gives an outstanding performance. Together, they've been directed to act well as a troupe. (In the software world, this interaction is called "integration.")

Just as actors can easily perform on different stages, these programs can easily work on different IBM personal computers — from PCjr to larger systems like PC/XT.

## ***How integrated software works.***

Want to get your facts and figures in order? Start with IBM Filing Assistant. Then, to print the facts in tabular form, add IBM Reporting Assistant. To write about what you've been working on (and make sure the spelling's accurate), use IBM Writing Assistant — the word processing program. Want to put a chart in the middle of your text? Use IBM Graphing Assistant. It takes data directly from IBM Filing Assistant to turn numbers into pictures. When it's time to think ahead with schedules and forecasts — get IBM Planning Assistant,\* the spreadsheet program. The finishing touch? IBM Assistant Solutions. They

Little Tramp character licensed by Bubbles Inc., s.a.

\* Available early next year.

\*\* Prices apply at IBM Product Centers



# *IBM Assistant Series. Divided they stand.*

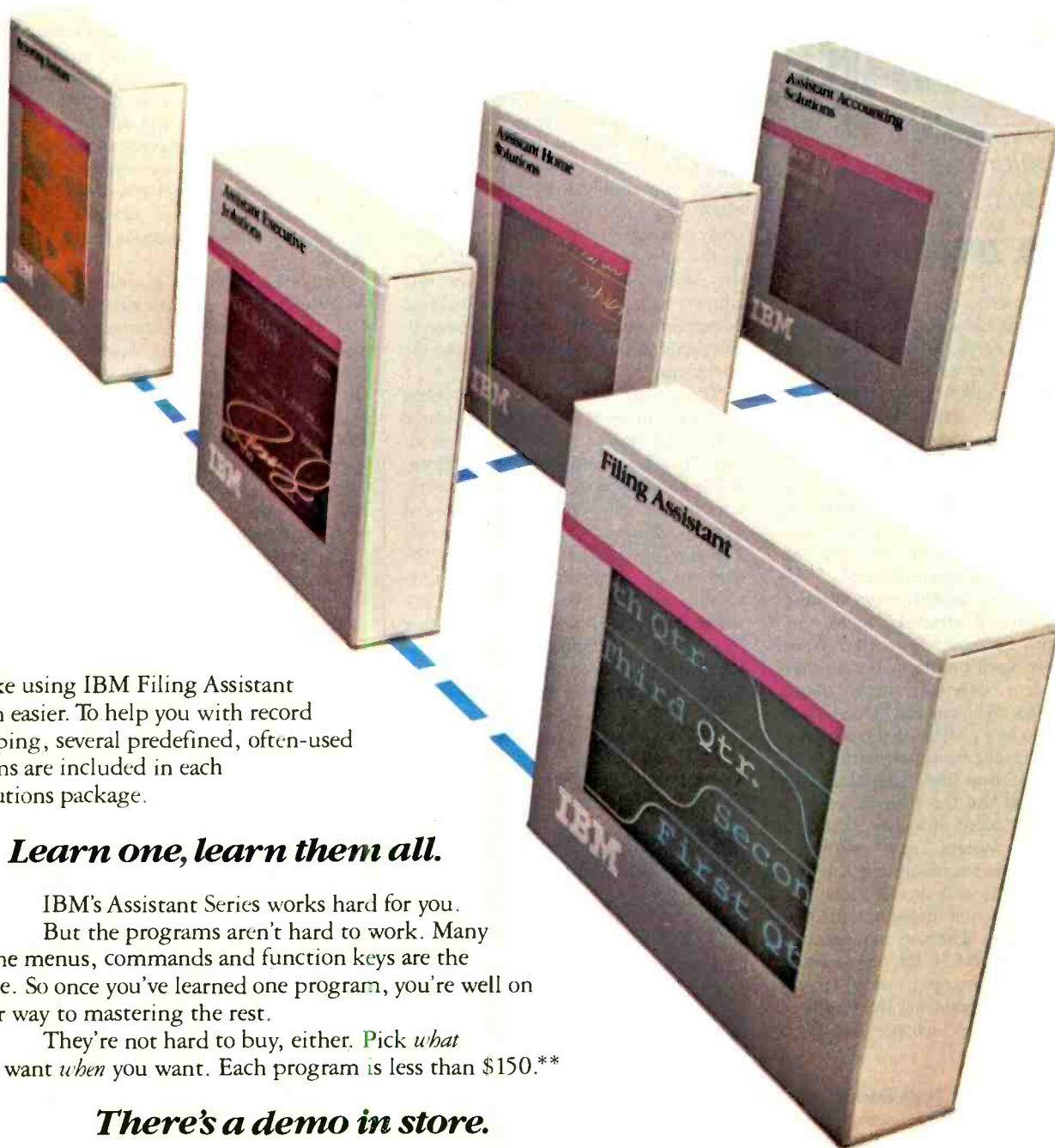

make using IBM Filing Assistant even easier. To help you with record keeping, several predefined, often-used forms are included in each Solutions package.

## ***Learn one, learn them all.***

IBM's Assistant Series works hard for you.

But the programs aren't hard to work. Many of the menus, commands and function keys are the same. So once you've learned one program, you're well on your way to mastering the rest.

They're not hard to buy, either. Pick *what* you want *when* you want. Each program is less than \$150.\*\*

## ***There's a demo in store.***

We've shown you how affordable the new IBM Assistant Series is. But we can't show you how easy. Your dealer can. Simply ask for a demonstration. For the authorized IBM Personal Computer dealer or IBM Product Center near you, call 800-447-4700. In Alaska or Hawaii, 800-447-0890.

The IBM logo, consisting of the letters 'IBM' in a bold, sans-serif font with horizontal stripes.

**Personal Computer Software**

Circle No. 41 on Free Information Card

# SOFTWARE REVIEWS

## IDEAWARE

*Idea processor  
uses micro as  
electronic note pad*

**BY LEE D. ZIMSKIND**

EVERYONE has a different way of storing ideas and facts. Some use index cards. Others write notes on the backs of envelopes or on grubby slips of paper. Still others try to keep everything in their heads. Whatever the method, most of us get ideas or information that we need to organize for easy recall. If your recall system has ever broken down, fear no more. Help has arrived in the form of a new class of personal computer programs that are best described as "thought processors." All of these aim to provide easy storage, classification and retrieval of ideas.

The Idea Processor from Idea Ware, Inc., is one such program. It's an integrated system for the management of text and graphics. Who needs it? One type of buyer might be a professional who does a lot of writing and wants help with the organization of ideas and material. Such a person would use the Idea Processor's medium-duty word processor, text data management system, and integrator, which links other software applications, such as graphics and spreadsheets. The Idea Processor is not meant to replace or compete with a database management system, such as dBASE III, or a graphics or spreadsheet program; rather, it provides a tool for organizing the results of these programs and incorporating them into presentations.

### Cardfile and Text Editor

The program's word processor is split into a cardfile and text editor. The cardfile is used for creating, storing, and editing notes, ideas, quotations or other information you may later want to retrieve. Each card may contain up to 8000 characters (about 1500 words) and may be indexed with up to ten keywords. Cards are stored in "drawers," and as many as eight drawers are stored in a cabinet. When you're using the cardfile, you see menus displayed near the bottom of the screen. From them you can select options to open and close cabinets

and drawers or retrieve, edit, type, add and delete cards. You invoke functions either by placing the cursor on the option and hitting the return key or by typing the option's first letter.

You use the text editor for manipulating text files. When you enter the edit mode, you supply a file name, and a blank screen or the beginning of a previously created file with that name appears on the screen. You can read cards from the cardfile while working in the text editor—without affecting the current document. Alternatively, it is easy to edit cards and incorporate them into the document.

You can use the same word processing functions in either cardfile or editor mode. The bottom line of the screen always displays the function-key options. A line above that shows the current status—on or off—of the insert, word wrap, boldface and underline functions. The top line of the screen shows the name of the document file. One shortcoming involves the status lines: nowhere do you see a reading of the cursor location. It is particularly annoying in a long document to be unsure what line or page you're currently working on.

### Word Processing Features

The word processor has all the usual features: forward and backward search

features: forward and backward search and replace; global search and replace, moving, copying and deleting blocks of text. It also has some advanced features, such as superscripting and subscripting. You can back out of an error easily, too: You can "undelete" an erroneously deleted line or block of text. An edited version of a document is automatically stored with a BAK extension when it's saved.

I was especially pleased with the macro feature—it's one of the easiest to use I've encountered. The cursor control and scrolling capabilities, however, are only adequate. I found little logic behind the implementation. For example, CTRL + HOME is used for moving to the far left of the cursor's line and CTRL + TAB to the far right. These keys, unfortunately, are widely separated on the standard IBM PC keyboard, and the tab key is left of the home key.

The greatest shortcoming of the word processor is the lack of user control over the appearance of the document or card on the screen. There is no facility for setting line width or paragraph indentation while editing, although you can set conventional tabs (there are no decimal tabs). This shortcoming is mitigated somewhat by the extensive formatting features and the facility for reviewing the

*(Continued on page 97)*

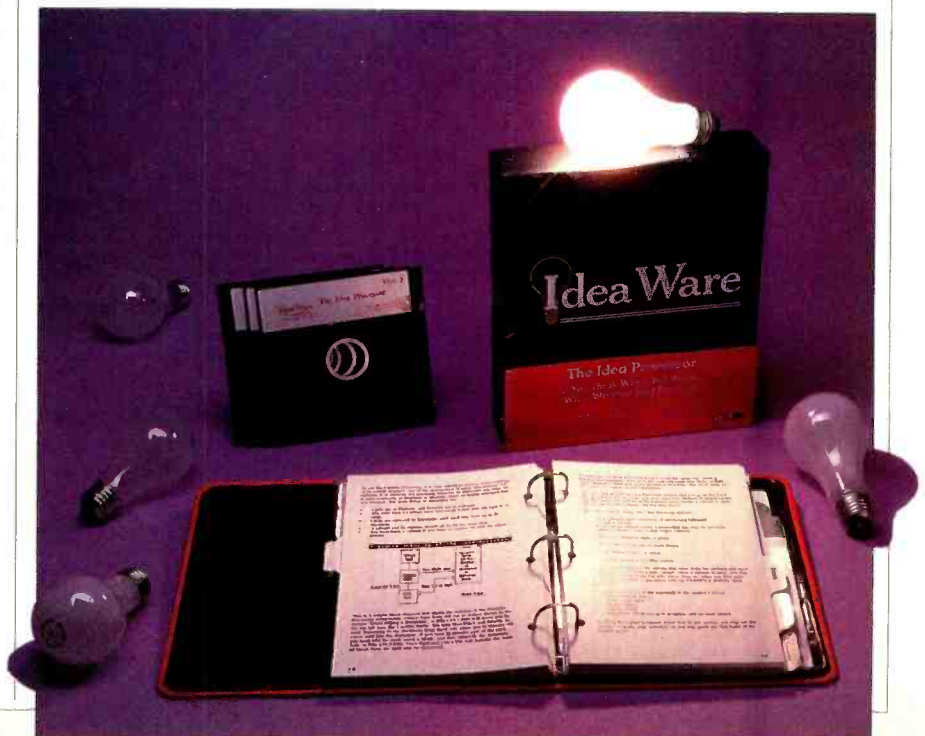

PHOTO BY STEVE BORNS



**In the Air Force no idea is too far out.**

Air Force engineers are designing tomorrow's technology today. It takes imagination to dream new dreams and skills to bring those dreams to life.

If you're an electrical or aerospace engineer, or plan to be, the Air Force gives you a chance to push your skills to the limit and learn new ones. And while you're growing,

you'll be helping your country grow stronger, too.

For more information, mail in the card or call toll-free at 1-800-423-USAF (in Calif. 1-800-232-USAF). Better yet, send your resume to HRS/RSAANE, Randolph AFB, TX 78150. We're waiting for your ideas.

**AIM HIGH AIR FORCE**

# ANDREW TOBIAS MANAGING YOUR MONEY

Proving that personal productivity software can offer real benefits

BY EVELYN BOORMAN

**M**OST people don't relish balancing their checkbooks at the end of each month. And only masochists look forward to doing personal income tax returns. Now, thankfully, there's a program that can help with these and other tasks and make managing your personal finances almost fun. It's called, aptly, *Managing Your Money* (from Micro Education Corporation of America, or MECA). It's a powerful yet easy-to-use package that runs on the IBM PC, PC/XT or PCjr.

The program helps you maintain your financial records, manage an investment portfolio, do budgeting, create a personal balance sheet and estimate (and prepare) your federal income taxes. It was developed with the help of Andrew Tobias, author of *The Only Investment Guide You'll Ever Need* and *The Invisible Bankers*. (He wrote the user requirements and text, a technical staff did the programming.) Tobias's lucid, entertaining style shows up throughout the prompts and help screens. In fact, some of the messages resemble short book chapters, advising on both the software and money management.

The program is menu-driven. Anytime you get stuck you press the ESC key for help, which explains why the user's guide is minuscule (a welcome relief if you want to get up and running right away). Most of the information you need for using the package is on the disk, in an

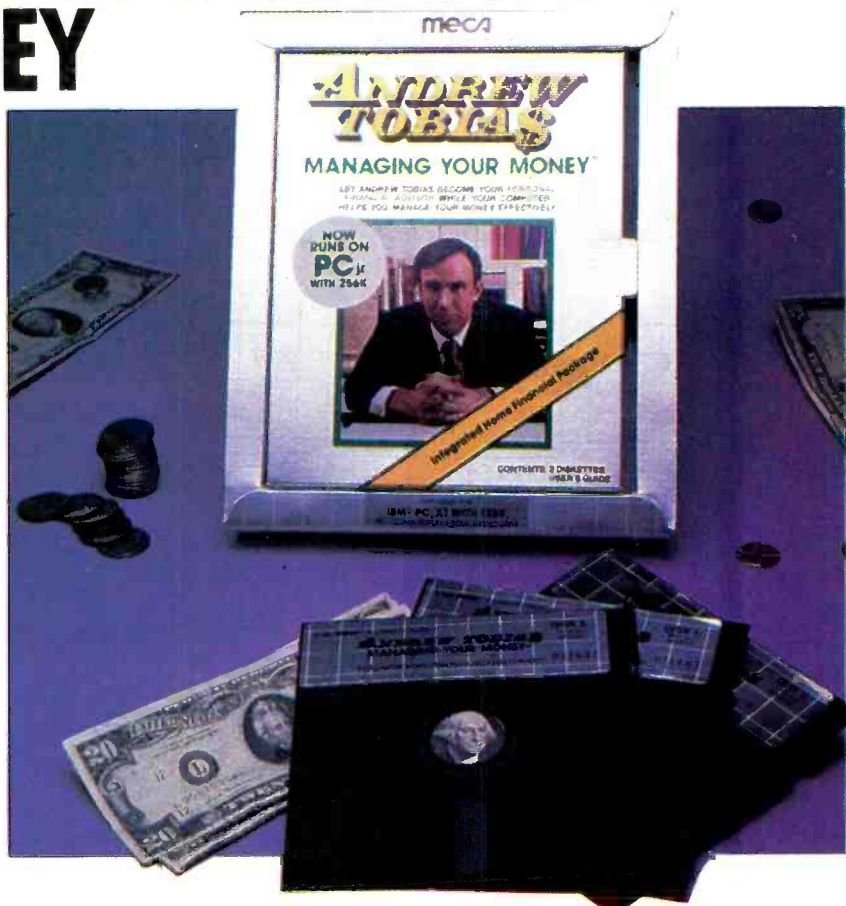

online introduction, or available from the help screens. For practice, the program disks contain sample bank accounts and portfolios to experiment with. One the program's more useful features is an online index, which provides brief descriptions of terms you find in the program and where they are.

The program is made up of seven modules: "Budget and Checkbook," "Income Tax Estimator," "Portfolio Manager," "Your Net Worth," "Financial Calculator," "Insurance Planning," and "Reminder Pad."

The Budget and Checkbook module is

the principal record-keeping section for checking, savings, cash, or charge accounts. You can set up several accounts within each category. A special option transfers entries between accounts.

With the Budget and Checkbook module you can set up budget categories, divided into income and expenses. For instance, "groceries" would be a budget expense category. You may set up as many budget categories as you want (depending on the amount of memory you have). And each category can have a tax classification—for example, you can set up a category for salary, another for contributions, employee business expenses, etc. You have to input your monthly budget amounts; actuals are summarized from individual transactions. You can display your projected net cash flow and your cash position by month or compare your monthly budget versus actuals for any category. You can also project period totals by budget category.

Here's how a typical transaction works: To log a payment, you first

(Continued on page 84)

## MACHINE HANDLING CAPABILITY

Machine Capacity	Unreconciled Checks and Budget Categories	Portfolio Items	Reminders	Asset/Liability Categories
128K	100	100	200	250
192K	350	300	1000	1050
256K	600	500	1800	1850
320K	850	700	2600	2650
384K*	1100	900	3400	3450
448K*	1350	1100	4200	4250
512K*	1600	1300	5000	5050

\*Requires PC/XT

PHOTO BY STEVE BORNIS

# Take your family beyond computers



## Enter the fascinating world of the home robot

HERO JR is a friendly, dynamic home companion robot. He'll wake you in the morning, guard your home at night, and entertain throughout the day with small talk, songs, and games.

Buy HERO JR assembled, ready to roll out of the box. Or, build him from a simple "We Won't Let You Fail" kit. Either way, you don't need to know anything about robots. His built-in personality is fully pre-programmed. A flip of the switch turns him into your personal robot. Let him move on his own or direct him with a wireless remote control.

Slip in a new cartridge for more pre-programmed phrases, games and actions. And, with his RS-232 interface, optional HERO JR BASIC and a personal computer, you can write your own programs.

There's a lot to learn...and even more to enjoy! So, for less than the cost of a home computer, introduce your family to the wonders of robotic living.

See HERO JR at Heathkit Electronics Centers\* in major cities across the U.S. and Canada. Consult your telephone white pages for the store nearest you.

**OR SEND TODAY FOR MORE INFORMATION!**



Mail this coupon today. Get your...

**FREE Heath Catalog.**

Full color, full information on HERO JR plus over 500 other fascinating electronic kits.

Mail to: HEATH COMPANY  
Dept. 010-238  
Benton Harbor, MI 49022

Name \_\_\_\_\_

Address \_\_\_\_\_

City \_\_\_\_\_

State \_\_\_\_\_ Zip \_\_\_\_\_ RO-118

## Heath®/Zenith®

Heath  
Company

Circle No. 26 on Free Information Card \*Units of Vertechonology Electronics Corporation.

# FACE

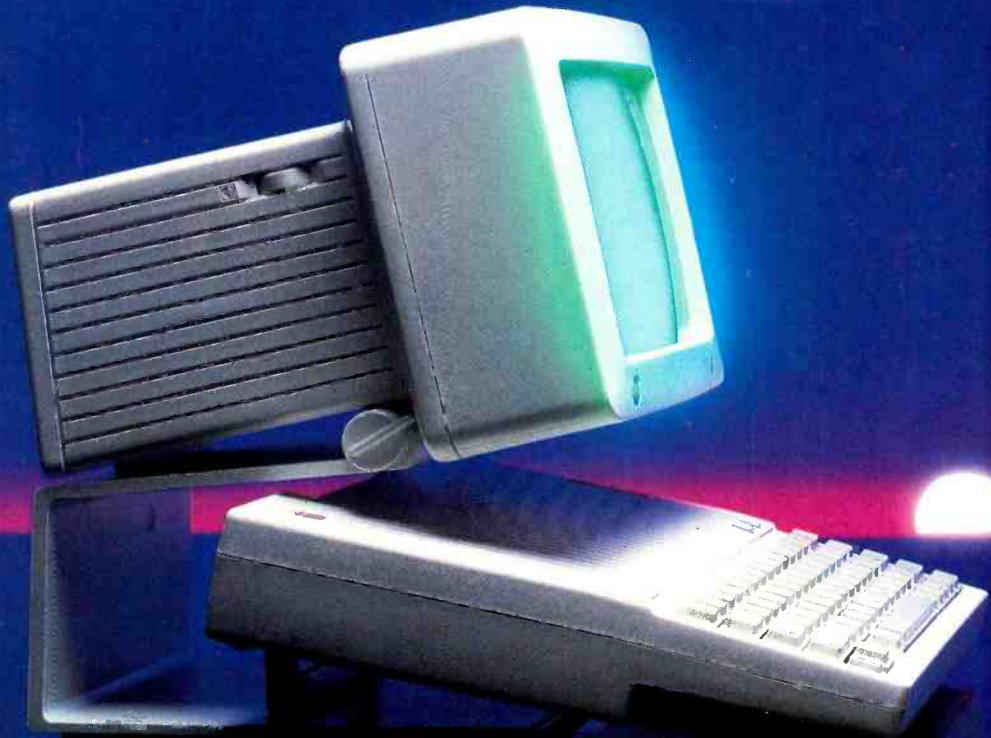

## THE APPLE IIc VS

*Which of these midpriced computers is right for you?*

**BY PETER COSTA & JOSEF BERNARD**

**I**BM and Apple are fighting for the hearts and minds of future computer buyers with aggressive advertising campaigns to promote their two hot "little" machines, the IBM PCjr and the

Apple IIc. Both micros appeal to the vast middle market of potential computer users who are looking for full-featured personal computers, but ones priced below the heavy desktop models.

The race has quickened with IBM's revamping of the jr. Because of disappointing initial sales and much loud criticism of the jr's "Chiclet" keyboard, IBM has retrofitted the jr with a new typewriter-style keyboard (see below) and increased the jr's memory capacity. These enhancements may help the jr claim some of the territory that is sought by the Apple IIc.

But few analysts are willing to predict who will win the contest for this lucrative middle ground. Microcomputers, like automobiles, succeed or fail in the marketplace for reasons that often are based on emotion rather than logic. Tell a sports car owner that his dream machine is a multi-thousand-dollar mistake because it is hard to repair and expensive to maintain, and he'll counter with a catalog of features about handling, acceleration and personal style.

So it is with most micro owners. Even Osborne I users will find something positive to say to vindicate their purchase of

PHOTOS BY ROBERTO BROSAN



# IBM'S NEW PCjr

the mini-screen, now-extinct portable. Apple lovers and IBM devotees are the same: They're emotionally involved. With that in mind, let's examine the IIC and the *jr* and try to compare their features.

Perhaps most striking is the difference in appearances. The IIC, designed by a European firm, has rounded corners and smooth lines and looks as if it could pass a wind tunnel test for aerodynamic flow. The *jr* looks like a boxy Model T, with the rectangle as its basic aesthetic building block. This look is reinforced by additional units and ROM cartridges that are

also rectangular. The IBM design philosophy seems to favor function over form and few of their machines break with tradition: They are nearly all uninteresting boxes with keyboards.

In a comparison of monitors, the IIC appears to be the clear aesthetic winner, with its monochrome unit, perched on a swivel stand. Our monitor mounting bolt, though, had the unnerving tendency to loosen up with use, causing the monitor to drop downward in a gravity-loving Newtonian arc.

The color monitor for the *jr* is apparently intended to sit on top of the com-

puter (as you see it here and in the IBM ads) but using it in this manner may not be feasible. The *jr* manual cautions against using a video display closer than 6" to the computer, stating that doing so may cause the computer to function erratically. And, in our tests we found it did—we experienced repeated disk errors until we removed the monitor and set it to one side of the computer. That solved the difficulty, but also wasted a lot of desktop real estate.

*Peter Costa is Executive Editor and Josef Bernard is a Technical Editor of COMPUTERS & ELECTRONICS.*

# CHIP FOR CHIP

BY MARK MOERDLER

**A**t the heart of the PCjr and the Apple IIc are, respectively, the 8088 and the 65C02 microprocessors. Because the architectures and capabilities of these microprocessors influence the construction and performance of the two computers, we will attempt to point out the major differences between them.

Key aspects of the design of any microprocessor include word size, maximum addressable memory size, and processor speed. Other, less important, issues we will not consider: interrupt-handling mechanisms, stack mechanisms, number and kinds of registers, instruction sets, and available coprocessors.

The 65C02 is classified as an 8-bit mi-

croprocessor because both the data bus and the microprocessor work with only 8 bits at one time. The 8088 also has an 8-bit data bus. However, internally, the registers, arithmetic-logic unit (ALU), and control logic handle 16-bit data. Due to this difference in data width, the 8088 is called a hybrid, or an 8/16, machine. The ability of the 8088 to handle 16 bits internally allows it greater precision and speed when dealing with any data, especially numbers. While an 8-bit machine can only handle at one time integers as large as 255, a 16-bit machine can handle integers as large as 65,535. The limitations of an 8-bit unit can be overcome by special-purpose number-handling software, but at the expense of

poorer performance.

One must not be misled into believing that the 8088 is a 16-bit machine. The 8088 is able to receive over its data bus only 8 bits while internally it can handle 16 bits. Therefore, it takes two 8-bit bytes to receive the full 16 bits. The 8088 chip designers attempt to alleviate this data bottleneck by creating a 4-byte (1 byte = 8 bits) instruction queue within the 8088. Thus the high-speed memory allows the microprocessor to receive outside data as fast as possible while allowing the processor to work as soon as sufficient data is accessible.

The 8088 lies somewhere between the 65C02 and a standard 16-bit machine in handling data. It can handle 16-bit

## Hardware Considerations

The IIc features built-in 80-column capability (switchable to 40 columns), an integrated 1/3-height disk drive and a connector for an external drive. Unlike its predecessors, the IIc is "slotless" and is expandable only through ports in the back of the machine for a serial printer, plotter, modem, mouse, hand controls and joystick. There is, however, no facility at present for expanding its memory beyond 128K.

The PCjr, which also can display either 80 or 40 columns and contains a single disk drive, is, in many respects, more expandable than the IIc. While the jr has no provision for a second IBM disk

drive, second drives are available from outside sources. There are also slots for two ROM cartridges; much software that might otherwise be available only on disk may show up for the jr in cartridges.

In display resolution, the jr has the edge over the IIc. While the latter's high-resolution color graphics mode is just a trifle coarser than the jr's medium-resolution mode, the jr adds a high-resolution color graphics mode. This mode, while providing only two colors, is comparable to the IIc's—monochrome—graphics mode. It should be noted though, that while the IIc's resolution is slightly inferior to that of the jr, the

number of colors available from it is somewhat—although not significantly—larger in comparable modes.

If disk capacity is important to you, the jr wins by a margin of greater than 2:1. It can store 320K on its single drive; the IIc's maximum is 140K. Of course, the fact that a second drive is available from the manufacturer for the IIc but not for the jr is an important consideration. This not only doubles the IIc's external storage capacity, but also facilitates making copies of disks and doing other operations. If you expand the jr's memory, there is software available that will let you partition a section of that memory to act as a RAM disk, in effect

**Photo below shows the relative sizes of the Apple IIc and IBM PCjr. The former occupies less desk space. On the opposite page, upper left, are a trio of keyboards: the IIc, the IBMjr's old "Chiclet" style, and the new**





words like a 16-bit machine but receives data 8 bits at a time like an 8-bit machine.

Both the 65C02 and the 8088 have 16-bit address busses. However, the 8088 augments its bus with a hardware segmentation scheme and segmentation registers, which allows the chip to access 1 megabyte of read-write memory. The 65C02, without additional memory-handling hardware, is thus limited to 64K of direct memory access. In the Apple IIc, the memory limitation is overcome by the use of additional software and hardware. Larger memory is achieved at the cost of degraded performance.

The PCjr has a 4.77-MHz clock, while the Apple IIc runs only at 1.02 MHz.

The difference might suggest that the PCjr should run nearly five times as fast as the Apple IIc. In fact that conclusion might be inaccurate for these reasons:

1) Different operations take different numbers of processor cycles, depending on the architecture. Thus a specific instruction may require more cycles in the 8088 than in the 65C02.

2) The PCjr employs a screen refreshing method that steals one out of every four cycles from the processor. The PCjr uses the same memory for the screen as for programs.

3) As stated earlier, differences in the size of the data affect the processor speeds.

On the average, the 8088 in the PCjr is

roughly twice as fast as the Apple IIc's 65C02 for equivalent instructions.

The points we have mentioned seem to imply that the PCjr has more horsepower under the hood than the Apple IIc, but it is not that simple.

The processor is not usually the device that slows microcomputer performance; rather, the disk drive, memory, printer and screen update speeds do. Also, a great deal of a microprocessor cycle time is spent in the operating system, whose efficiency can alter the results the user observes. Lastly, most programs are written in high-level languages that are not efficient and can rob a computer of any advantages inherent in its microprocessor. ◊

giving you the equivalent of a second drive, but that is not something you can stick in your briefcase and take home with you.

The jr uses DOS 2.1, the latest version of PC-DOS (except for DOS 3.0, which is intended primarily for the new PC AT). The IIc can run regular Apple DOS, Pascal, or Apple's new ProDOS. It's difficult to say which is the best, since once you are accustomed to an operating system it becomes hard to see its limitations. The DOS from IBM has a few more features (like time-and-date stamping of files), but most people will probably not come into close contact with any of the operating systems in the

normal course of running their applications programs.

To make ProDOS easier to use, Apple has available a "front end" called AppleWorks that acts as a buffer between the computer user and the operating system. Learning to use PC-DOS requires wading through pages and pages of manuals, and, perhaps, even referring to books on the subject written by people outside IBM.

The jr has a number of connectors on its rear panel for peripherals such as a video monitor, a TV receiver, and a serial device (e.g., a printer, mouse, or external modem). If the optional direct-connect modem is installed, it too is

accessible from the rear panel.

While neither computer is truly bus-oriented, at least part of the jr's bus structure is brought out to the world, hidden behind a panel on the computer's right side. When this panel is removed, additional memory (up to three 128K modules, for a total of 512K), a parallel printer interface, or a speech digitizer can be added. If more than one module is added, an auxiliary power supply module must also be used. This type of expandability, which allows for a certain amount of flexibility in putting together a system to meet your requirements, is a definite plus in the jr's favor. Note, how-

(Continued on page 93)

**typewriter-style introduced for the IBMjr. Photo at upper right, shows the add-on expansion modules for the IBMjr. At the bottom are rear views of the IIc (left) and the jr (right) showing peripheral ports.**

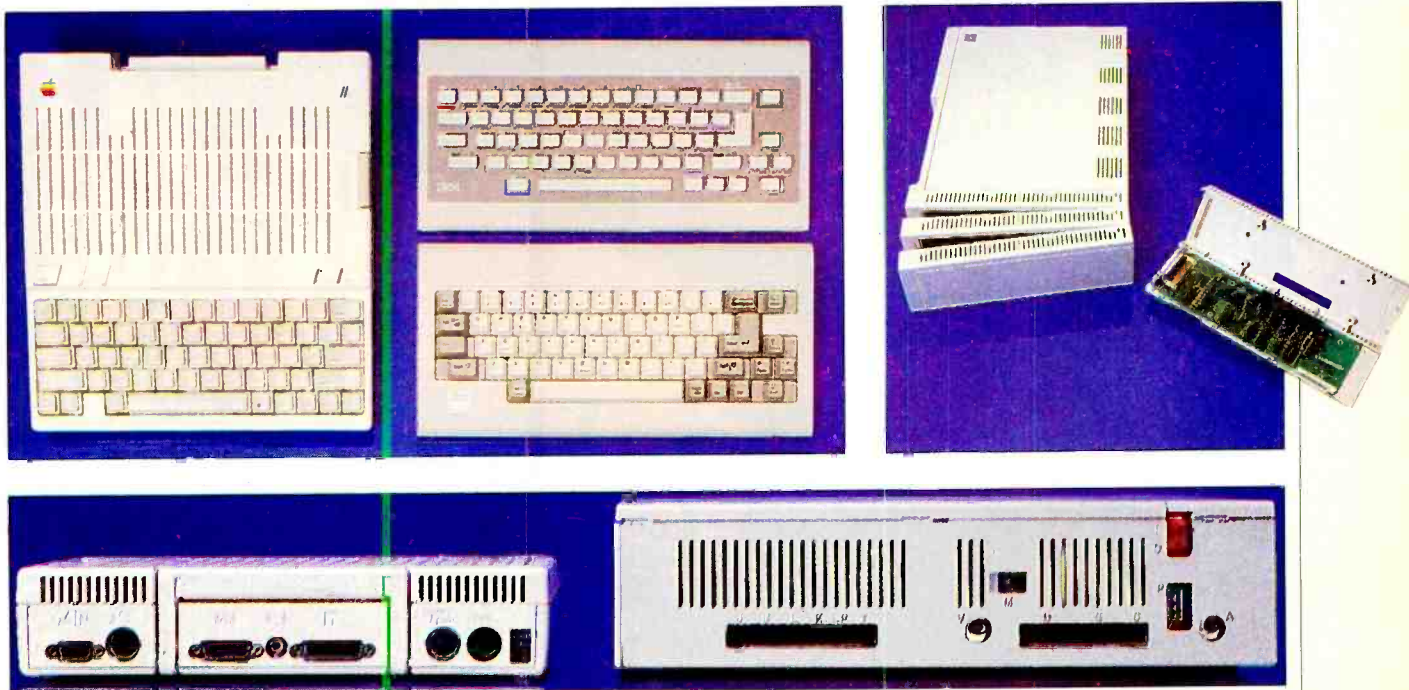

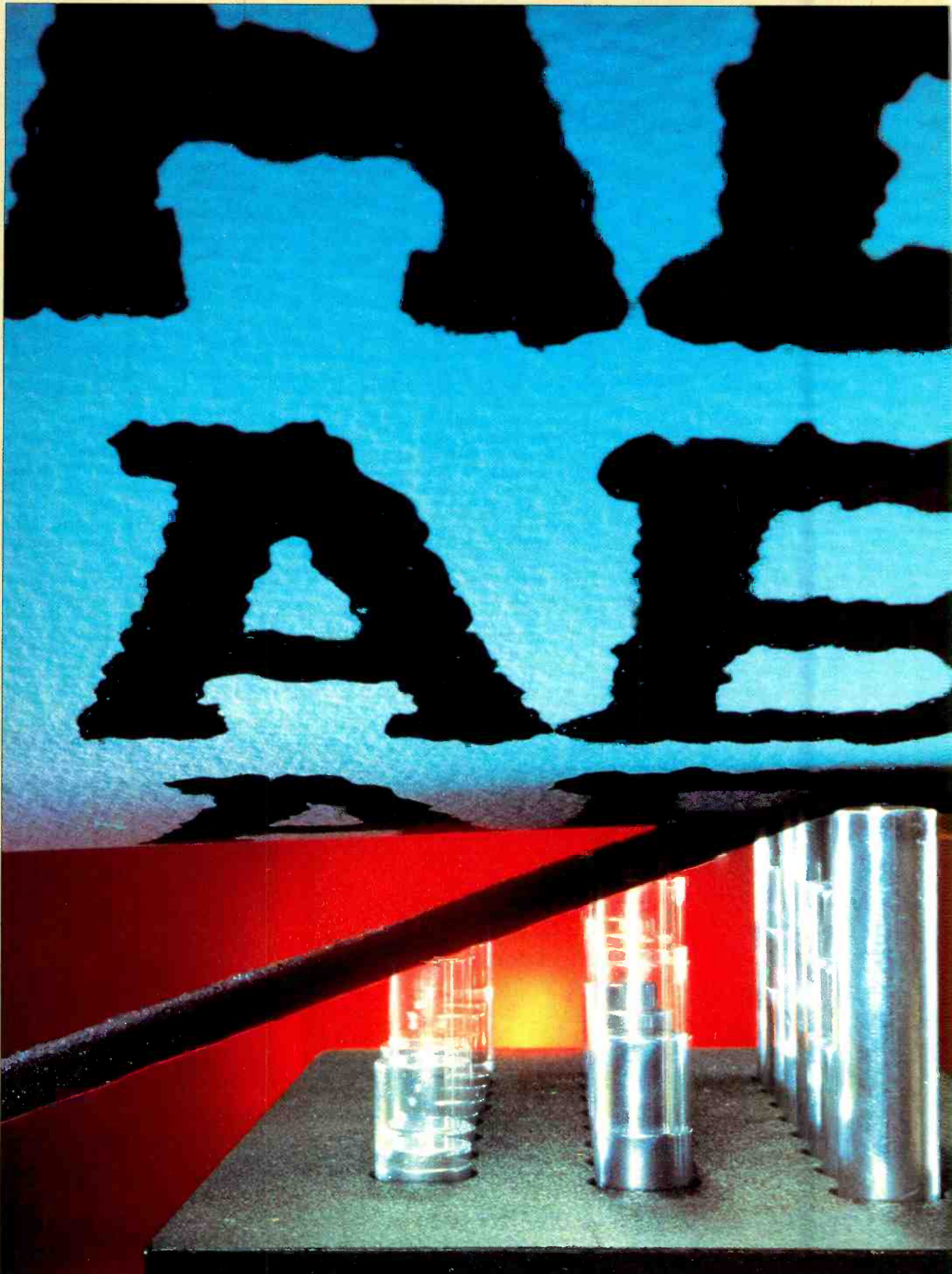

PHOTO BY BARRY BLACKMAN



# ADVANCED MATRIX PRINTERS

*New technology brings greater speed  
and resolution to high-end products*

**BY ED TEJA**

**D**OT matrix impact printers, the stalwarts of microcomputer hardcopy, have come a long way during the past few years, especially in terms of their output speeds and letter-quality typefaces. But selecting one can be difficult because there is a large variety to choose from—some cost a few hundred dollars, others as much as \$3000.

What makes one dot matrix printer cost substantially more than another? Sophisticated printhead design, speed, and computing capability are the features that raise the price. High-quality dot matrix printers can produce formed characters almost as well as office typewriters; they can accept add-on accessories, such as sheet feeders, which allow users to load stacks of cut paper into the printer; they can emulate expensive daisywheel printers; and they are very reliable. But the bottom line for top-of-the-line printers is the speed at which letter-quality copy is produced.

#### **Defining the Character Cell**

What's a reasonable way to compare the print quality of one printer with its competitors without trying them all out? One criterion is the density of the dots within the dot matrix character cell that the printer produces. The more dots within the print cell, the closer together they will be, and the more fully formed will the character be. But there are no industry-wide standards. No particular dot density equals any particular letter or font quality; comparing manufacturers' data sheets, however, will give some idea of the ranges for each quality level.

There are, after all, obvious limits to the quality of the type you can produce with a 5×7 matrix. You can call the font "near-letter quality" all you want, but the characters won't have true descenders (the parts of the characters below the line). A height of seven dots just isn't enough to describe a character accurately.

ly. Describing is exactly what the dots do: They sketch a character, and the reader's eye fills in the spaces between the dots.

The character cell stays about the same size for all printers, as long as the pitch (the number of characters per inch) stays constant. A 10-pitch (or 10 cpi) character cell printed at 12 cpi will look better. The reason? You have the same number of dots printed in a smaller area, which leaves less space between dots. So when you compare print samples, be sure they are printed at the pitch you intend to use for correspondence.

The greater the density of dots within a character cell, the easier a character should be to read. At Dataproducts, for example, print qualities are assessed as data processing quality (low), text quality (for first drafts), and letter quality (for business use). The lowest-quality characters are formed out of a character cell nine dots by nine dots (18×9 on some special models, such as the Model 8050); text quality uses a 24×9-dot cell; letter quality requires 36×18 dots.

Anadex's top-of-the-line WP-6000 furnishes letter-quality output with an 18-wire printhead which makes a 58×18-dot cell at 125 cps. The unit comes with built-in Diablo 630 (daisywheel) emulation and sells for \$2700. If you've already configured your application for the Diablo, you can plug in the Anadex and print without modifying software.

For less critical applications, the firm offers less dense printouts, such as a 17×18 dot matrix. Anadex calls this intermediate quality the "dual-pass correspondence mode." (You'll see references to high-quality, but not highest-quality, letters in various manufacturers' lines as "memorandum" quality.)

Mannesmann Tally's Model MT-440L (\$2695) outputs an 18×40 dot matrix that the firm calls correspondence quality. The printer can produce the

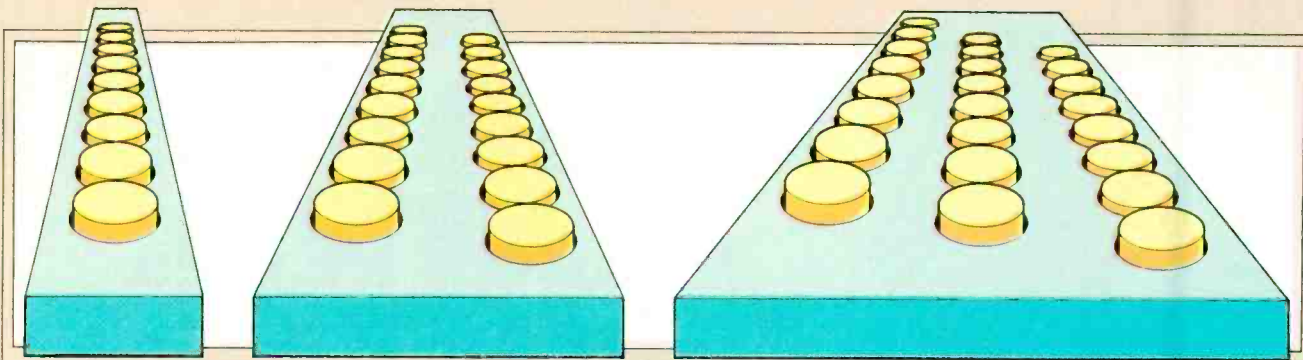

The printheads shown magnified above contain, from left to right, 9 pins, 18 pins, and 24 pins.

character cell at both 10 and 12 cpi and print it at 110 cps.

Printek, Inc., calls its Model 930 the Executive Printer and lists its 80 cps, 36 × 18 dot printout as executive-quality letter mode. The \$1995 printer has Diablo emulation and both serial and parallel interfaces. Single- and dual-bin sheet feed are optional.

#### From Gutenberg to Ballistics

There are two basic approaches to arranging enough dots on paper to form high-quality printed characters: you can use a simple head with a design that has a few print wires, or pins, and make multiple passes over each character cell, or you can use a printhead with a lot of wires (say, 18 or 24 wires) and make a single pass. The complex printhead works exactly the same way as the simple printhead, but the wires are arranged to print overlapping dots. Nearly all of the printheads used today are based on the same ballistic design. Invented by a small California company called Hydra, the basic design was immediately copied by nearly all printer manufacturers. The idea behind the ballistic head is that if

you carefully control the firing of a wire at the ribbon (to print a dot on the paper), the wire should strike at a consistent velocity. You gain control over the darkness of the dot (and thus print quality) at the same time you keep the wire from shredding the paper. A well-designed head controls each wire individually.

A typical printhead intended for high-quality printing (such as the 18-wire Anadex printhead) shown above, has multiple rows of print wires that are slightly offset. This arrangement lets the printer produce two vertical rows of dots on a single pass of the head. The wires of one row interleave with the wires of the next row, yielding dots that overlap slightly. The characters look more fully formed and less like a traditional dot matrix output.

A number of theories estimate how many wires the ultimate printhead should have. Still, you'll find printers that promise high-quality output using from nine to 24 print wires. There is a tradeoff between design complexity and cost that sets limits to the number of wires. And having more wires isn't necessarily better, anyway.

A printhead with a single vertical row of nine wires can do an excellent job, but it will have to make more print passes over each character line to do so than a head with two rows of nine wires. It is the number of rows that determines the number of passes required—the number of wires determines the total character matrix. A nine-wire printhead, for example, might require as many as two to four passes to produce letter-quality printout; an 18-wire head would be able to produce exactly the same quality in one or two passes.

The more passes the head must make, the longer it takes to print a page. The trade-off seems to be between more expensive and complex head design or slower print speeds (due to the need for multiple passes). Two printers that use nine-pin printheads are the Datasouth DS-220 and the Smith-Corona D-300. They produce near-letter-quality print at speeds of 40 cps and 33 cps, respectively.

The C. Itoh Model 8600 and the Anadex WP-6000 both use printheads that have two rows of nine wires each. While the 8600 produces letter-quality

The DS-220 creates letter-quality print in two passes of the printhead; the Epson LQ-1500 does it in one pass.

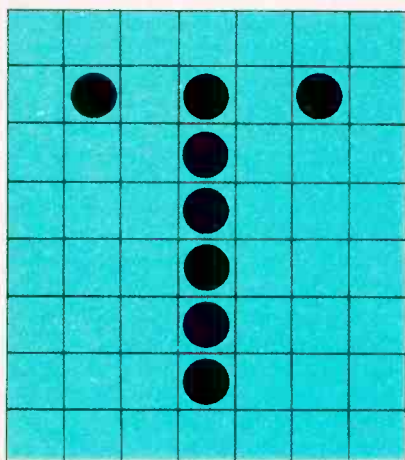

The Datasouth DS-220 9-pin head

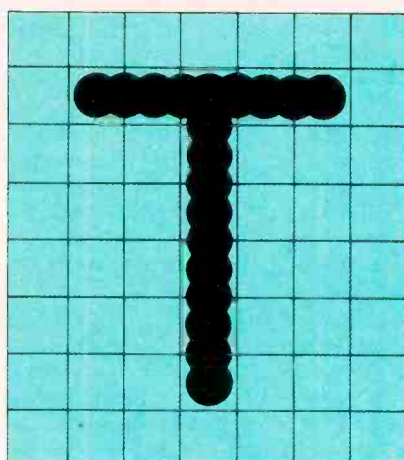

The Datasouth DS-220 9-pin head

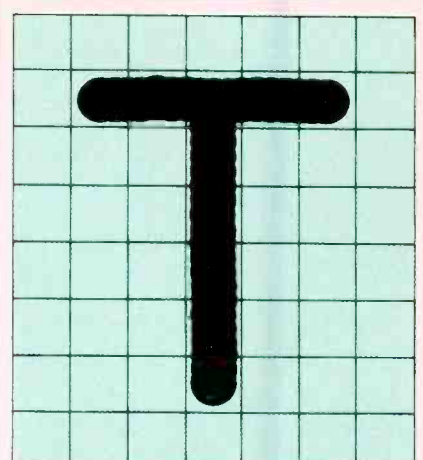

The Epson LQ-1500 24-pin head

output at 60 cps, the WP-6000 hums along at 125 cps.

Toshiba America, Inc., uses a 24-wire printhead in its P1351 printer. (See a detailed review in the hardware section of this issue.) The \$1895 unit accepts downloadable fonts that give it a variety of extremely readable fonts at 100 cps (draft quality at 160 and 192 cps). The downloadable fonts come on three diskettes: the Toshiba Font Disk (\$49.95); Fonts America (\$49.50); and Greentree Software (\$34.95). The versatility of the 24-wire printhead allows the printer to output Gothic, Italic, and Courier typefaces as well as Graph 10 and 12 (elite) graphics characters.

If price is a problem, Toshiba now offers a second 24-pin dot matrix printer—the P1340. This letter-quality printer costs only \$995. What you lose, compared to more expensive units, is print speed. The P1340 prints its best output at 54 cps, yet it can do drafts at 120 cps.

A competitor in the 24-pin printhead design is Epson America, Inc. with its LQ-1500 printer. This printer, which is reviewed elsewhere in the magazine, can produce letter quality output at 67 cps.

On the bottom of the facing page are the results of one and two passes of the nine-pin head of a Datasouth DS-220 printer and the result after one pass of the 24-pin head of Epson's LQ-1500.

**Drawing Crazy Patterns**

Nearly all high-resolution printers offer one additional feature, at no extra charge—good (but not exceptional) graphics. The dot matrix printer's approach to characters is, after all, a graphics one, and the printer only understands characters as sets of dots. So it's fairly easy to output graphics by sending a bit-for-bit image of the screen to the printer.

The Anadex WP-6000, for example, features two modes of dot-addressable graphics: at 72x72 and 144x144 dots/in. Although the printer is primarily a multimode word printer, it does a credible job of reproducing screen images on paper.

Not all graphics images are created on-the-fly, however. For convenience, many printers feature preprogrammed sets of block-graphics characters (that you can use to create images). The Panasonic KX-1092 features 64 characters, and you can download as many as 256 more.

For business applications many print-

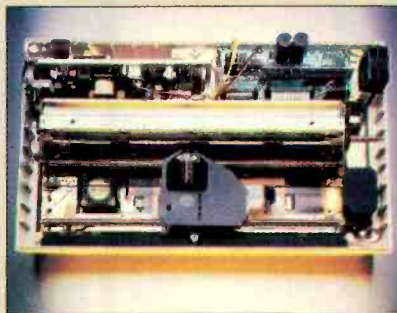

Star Micronics Radix 15 draft-quality print sample

Star Micronics Radix 15 near-letter quality print sample

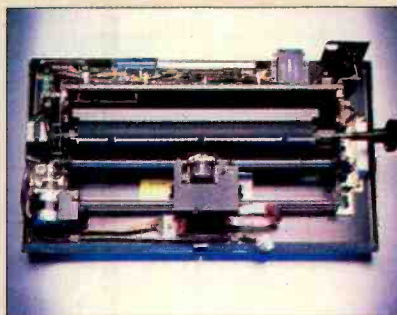

Smith-Corona D-300 draft-quality print sample

Smith-Corona D-300 near-letter quality print sample

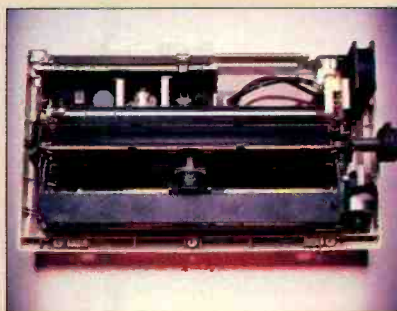

NEC Pinwriter P3 draft-quality print sample

NEC Pinwriter P3 near-letter quality print sample



C. Itoh 8600 draft-quality print sample

C. Itoh 8600 near-letter quality print sample



Anadex WP-6000 data processing quality print sample

Anadex WP-6000 Helvetica letter quality print sample

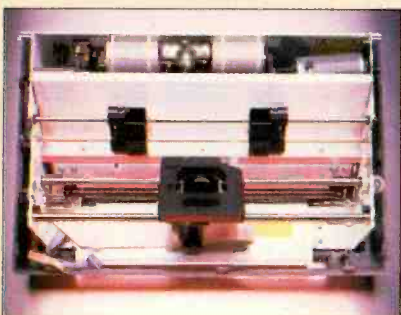

Datasouth DS-220 draft-letter quality print sample

Datasouth DS-220 near-letter quality print sample

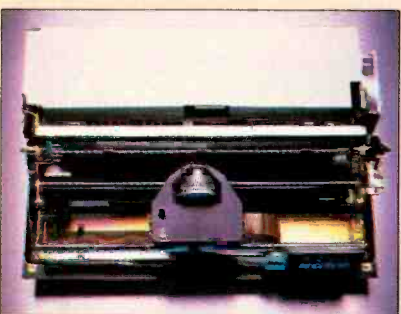

Toshiba P1351 draft-quality print sample

Toshiba P1351 near-letter quality print sample

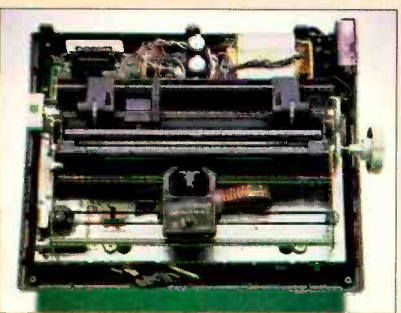

Panasonic KX-P1093 draft-quality print sample

Panasonic KX-P1093 near-letter quality print sample

ers are now offering a specialized set of graphics characters—bar codes. Data-products' Model 8070, for example, has included in its preprogrammed repertoire several standard bar code types, including Code 39, UPC, Interleaved 2-of-5 and Codabar. A programmable character generator lets you create new bar codes or other block-graphics characters to meet special needs.

**Printer Accessories**

Not everything you may need to make a printer useful comes as a standard feature. For the computer to "talk" to the printer, you'll need some kind of interface. The trend currently is to provide a parallel interface, such as a Centronics-compatible connection, as a standard component of the printer. If you want a serial connection, you'll have to pay extra. Because more and more buyers need only parallel interfaces, manufacturers can cut costs by omitting the serial interface whenever possible. Anadex's VP of marketing, Ken Mathews, estimates that only about half of all printer users want serial interfaces. For Anadex's B series printers, therefore, you'll need to specify option S to get a serial interface. This kit includes a serial interface pc board, interface cable and connector, mounting hardware and documentation. The kit costs \$100.

NEC's P2 and P3 Pinwriters use plug-in interface modules. There are presently three available: RS-232C, Centronics parallel, and IBM PC. Should you change computers, these printers can adapt very easily.

Pay close attention to the type of paper handling that comes with the printer. Some printers have a pin feed mechanism, some have tractor feed, and some have friction feed. Some even have a combination of these. Today's tractor and pin feed mechanisms handle the paper so smoothly that the printer can even back the paper up to add the fine details in graphics mode. If tractor feed is not standard with your printer, you may have to pay as much as \$200 for the option.

If you need to feed many individual sheets of paper into the printer, you'll want to consider a sheet feeder option. Printek's ASF-1, for example, has a single feed bin that holds over 200 sheets of 20-lb paper; the Model ASF-2 has two bins. Attached to the firm's Model 930 printer, the sheet feeders handle forms up to 14" long. But these aren't cheap. The single-bin ASF-1 costs \$699; the double-bin ASF-2 costs \$995. However, if you have occasion to do a lot of printing on letterhead or other cut paper



**The 24-pin printhead used in Toshiba printers.**

stock in quantity, you'll find them a tremendous asset.

#### Measuring Reliability

The newest printers provide a good measure of reliability, even when they are required to print almost constantly during a business day. Improved components, such as stepper motors, which control paper position, and better printhead design enable these units to carry heavy workloads. Although the printers do more than ever before, the designs are actually simpler. The printers have fewer parts. As a result, you can get more comprehensive warranties and improved reliability specifications.

But how do you measure reliability? Two criteria are generally applied: MTTF (mean time to failure) and MTBF (mean time between failures). The first tells you approximately how

long you will be able to run the printer before a breakdown occurs. The second roughly indicates frequency of repair.

Most of the printers we've mentioned have good reliability estimates. Print-heads, in particular, have improved to the point that their reliability is measured in millions of impressions. Toshiba's 200 million is a low estimate. The firm plans on it doing much better.

#### Adding Color

One of the more recent innovations in dot matrix technology is color printing. Color adds highlighting, lets you emphasize certain features in a drawing or words in text. Okidata's Pacemark 2410 uses a two-color ribbon (red and black), in the same manner as a typewriter. Normally, however, color is produced using four-color ribbons.

From Anadex, the Model DP-9725B Color Scribe (\$1625), is intended to invade IBM PC territory. It comes with two sets of device drivers on diskette: One allows the printer to emulate the IBM PC color printer; the other, the Epson color printer. The Color Scribe prints in draft, enhanced and dual-pass correspondence modes at 240 to 60 cps.

The Model 5500 printer, which is to come from Juki Industries in early 1985, will produce near-letter-quality correspondence in seven colors. The seven colors include four "dumb" colors and three "smart" ones. The dumb colors are the four ribbon colors—magenta, cyan, yellow and black—you obtain by shifting the ribbon to the desired position with positioning commands. To get the

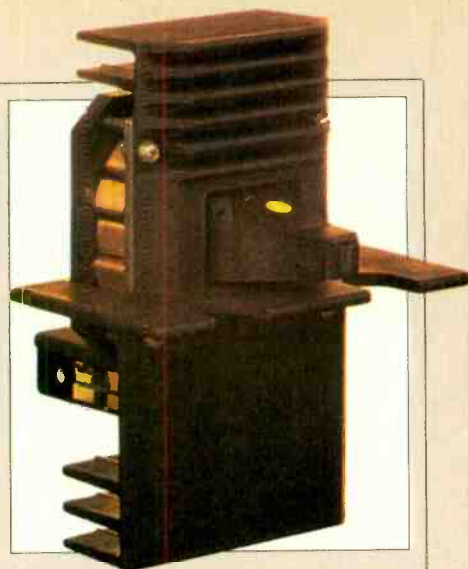

**The Anadex WP-6000 uses this 18-pin printhead.**

additional, smart, colors (green, orange or violet) you direct the printer to interlace dots automatically from the four ribbon colors. Specifying smart colors (sometimes referred to as automatic color mixing) requires you to know something about how colors combine. The simple design and smooth operation of the 5500 might be worth waiting for. No price was available as of this writing, but Juki products tend to be situated at the lower end of the price range.

Epson's OEM division has introduced a seven-color dot matrix printer, the JX-80, that features 160 cps printing in a 9x9 dot matrix (18x18 in double strike mode). The printer sells for \$450 (in *Continued on page 86*)

*Ed Teja has written frequently for COMPUTERS & ELECTRONICS on microcomputers and related subjects.*

## PRINTER PRODUCT TRENDS

**T**HERE was a time when the standard computer printer was slow, prone to paper jams, and limited to black and white. Anything more was an expensive option. New printer models, however, are becoming "feature-rich" and are giving you more for your dollars, according to David R. Bothwell, vice president and general manager of Dataproducts Corporation's operations in Milford, NH, where the company manufactures medium-speed dot matrix printers. He says better paper handling, high speed options and color are becoming standard rather than optional features.

Bothwell continues: "Graphics capability is pretty much standard now, so are variable print modes. We're seeing a move to interchangeable fonts (type faces), which are often used for foreign language capabilities.

"For instance, we've offered color graphics printing and changeable fonts with our P-series printers for more than three years. Those features are now standard in some models of our new 8000-series."

Bothwell says that because of demand, manufacturers can more easily justify investing in enhanced production techniques like automated assembly and robotics. Increased demand and production volume have also reduced base material costs. Manufacturers are now able to install EPROM (electronically programmable read-only memory) chips in printers, instead of the ROMs that had been usual.

The EPROM chips allow a greater variety of features to be incorporated in the printer. It makes the printer "smarter," able to change type fonts, for instance, or to print page 1 of a letter, print page 2,

then address and stuff the envelope.

Bothwell says that manufacturers are installing 18-wire heads instead of the conventional nine-wire heads. This change can increase the speed of the printer or sustain speed while enhancing print quality. "The change is application driven," he says. "More and more PCs are being used for word processing, and this type of flexibility is demanded by PC users."

Bothwell sees the need for a variety of printer types to accomplish a variety of applications. "There's a marketplace for each technology... including daisy-wheels, dot matrix, and nonimpact printers. . . . Each has its limitations and its advantages."

Meanwhile the technology advances: "In the nonimpact field, for instance, the barriers—like the need for special paper—are starting to erode." ♦

# GET MORE IMPACT FROM YOUR PRINTER

*Software permits you to take  
advantage of graphics and  
downloadable fonts*

**BY JAINE SAFFIR**

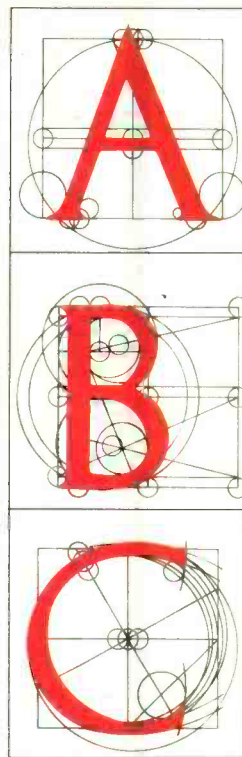

**D**OT matrix printers allow your computer to do things that no other type of printer can, in particular, graphics—either images dumped from the screen or characters and alphabets for which no conventional print elements exist. And as important as a good printer is to a system, it is software that ultimately determines what and how well you can do graphics.

By combining the right software and dot matrix printer you can output anything from a pie chart to a still life and caption it in almost any font you can imagine. The type of software you require will depend on your needs.

Graphics software can loosely be divided into four categories:

1. Drawing
2. Typesetting
3. Business
4. Utilities

These categories are not mutually exclusive; a drawing program, for example, may be capable of typesetting, and almost all graphics packages contain a few utilities. Still, each type of software contains routines unique to the job it was designed to handle, which makes dedicated packages a lot easier to use.

You can produce a bar chart with just about any good drawing package, but business programs will also accept numerical data and automatically scale the graphs.

Graphics software designers face the same challenge as the people who design

word processors, databases, or any other type of software; they have to balance friendliness against flexibility. The more versatile the program, the more time you have to spend learning how to use it. A completely menu-driven program just cannot offer the same flexibility as one that provides a library of routines and commands you can incorporate in your own programs.

These conflicts are particularly obvious with graphics programs because there are really no rules governing or limiting what you can do.

## **Drawing Programs**

Before you can get any output, you must have some input. The most versatile graphics software is for drawing. It allows you to use your computer like pencil and paper to create designs and artwork.

You can change the size of a "brush," select color palettes, and call up built-in routines to draw circles or other shapes, even to add characters in a variety of fonts. Some packages will allow you to move images you've created around the screen until they're just where you want them.

Farther up the ladder are programs that let you create 3D hidden-line figures and put graphics routines into your own programs. Programs like these, however, are much more demanding. They give you tools that are powerful but which must be learned to be used.

Most of the programs will accept input from a variety of devices and will

save the pictures you create on disk for later editing prior to display or printing.

## **Typesetting**

The capability to do graphics gives you control over every dot that appears on the computer's display and ultimately on a printout. Since printed letters and numbers are only arrays of dots, there's no reason why you have to limit yourself to a single nondescript typeface. While your printer probably contains a few fonts in its firmware that you can access with control codes, its ability to do graphics means you can print documents in any typeface you want.

While all the good drawing packages have font editors built into them, some programs are specifically aimed at typesetting. Entirely menu-driven software like Broderbund's *Printshop* is a good program for making greeting cards, letterheads, signs, and so on. It's hard to imagine anything easier to use, and the results are impressive. You can design graphic elements and also format printed greeting cards for folding.

A much more powerful program is *Fontrix* from Data Transforms. It's a true typesetter with a wide range of fonts available and with screen editing functions that permit you to create your own fonts. *Fontrix* allows you to use either the keyboard or any one of a variety of peripheral devices for input.

Data Transforms encourages users of *Fontrix* to design their own fonts by offering to pay a fee if it decides to include them on its distribution disk. You not



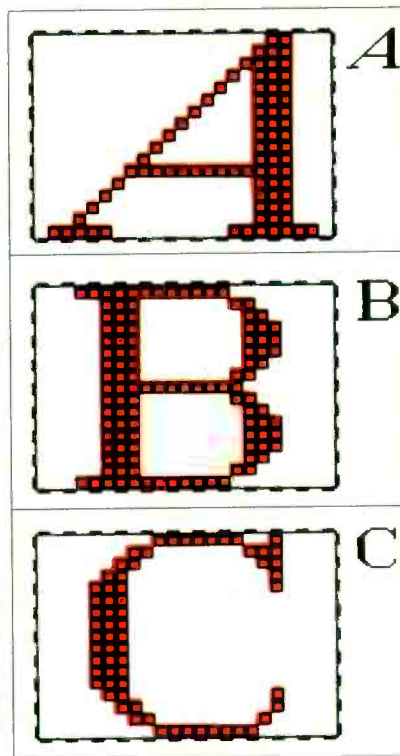

only get a great program, but you also can get paid for learning how to use it!

The strength of a program like *Fontrix* is evident when you realize that a font can be a lot more than just a set of letters. The font editor can be used to design graphic elements and icons, each of which can be assigned to a different key on the keyboard. With your keyboard customized, producing an image on the screen becomes as easy as positioning the cursor and pressing the right key.

*Fancy Font*, from Softcraft, takes the idea of typesetting a step further. You can edit and print the text files you generate with your word processor to include any combination of the fonts that come with the program. The program also has a font editor with which you can redesign characters or create a new set of your own.

Dot matrix printers are usually a lot slower when they print graphics whose definitions are stored in the computer's memory than when they print straight text using a built-in character generator. One way to speed them up is to design a graphics set and download it to your printer as an alternate character set. The price you'll pay for the increase in speed is the loss of the ability to see the images on the screen, but it's a good way to combine text and graphics on the same page.

There are a number of programs that let you create your own alternate charac-

ter sets. Since character formatting varies from printer to printer, make sure you get the right program for your printer. Check with the printer manufacturer for recommendations.

Several printer manufacturers offer either their own or a third party's software for use with their printers.

Okidata produces *Personal Touch*, a font editor and downloader designed specifically for its printers. It comes with several character sets on the disk and walks you through the process of creating your own. C. Itoh has a package called *PC Itoh Utilities* for use with its ProWriter series of printers that permits screen dumps and allows the creation of custom character sets. For its P1351 printer, Toshiba makes available three font packages; one of its own and two from outside suppliers.

#### Business Graphics

Most graphics software on the market is designed for use in business. These packages translate numeric information that might ordinarily be shown in tables to more readily intelligible forms: bar charts, pie charts, graphs, and other sorts of presentation graphics. It is much easier to make an important point or to spot trends through pictorial representations of data than it is by sifting through the numbers themselves.

Although you can undoubtedly create

the same types of images using other software, dedicated business packages contain features that relieve you of much of the creative burden. Such packages can automatically create graphs and charts from data contained in spreadsheets or other databases, automatically scale graphs, and merge text with graphics. (Business graphics software is discussed in detail in "Painting a Good Business Picture" in the May 1984 issue of *COMPUTERS & ELECTRONICS*.)

Since this sort of material is usually intended to be included in reports for presentation to others, the quality of the printed output is important. It should be of near-letter quality. A color printer (see below) might help in making complex graphs more intelligible.

#### Utilities

Once you've created an image on your display, you want to print it out . . . and here is where a good graphics utility can be invaluable. Such a utility can solve the problem of hardware incompatibility, give you powerful tools to manipulate your image, and, in general, let you do things with your graphics that go beyond the capabilities of the program you used to create it in the first place. Utilities can help you in three areas:

1. Printing
2. Presentation
3. Programming

Geometric Analysis of Roman capital letters on opposite page is from the book *A Constructed Roman Alphabet*, by David Lance Gomes. Drawing of a fifteenth century scholar in his scriptorium is from the Bettmann Archives. Letters above right illustrate a computer generated font.



Printed using Anadex with Printographer.

By designing your own font, you can

**USE A DOT MATRIX**

printer to mix your text

with any kind of graphic you're

capable of producing. A font

can be an alternate character set or

anything YOU want it to be!!!

Printed using Okidata with Fontrix.

## RESOLUTION, SOFTWARE, AND COMPATABILITY

**T**HE biggest problem in printing graphics is compatibility—making the software work with the hardware. With text, on the other hand, the firmware in the printer forms a character when it receives the ASCII code for that character. What makes the operation possible is the second letter in the acronym ASCII—the “S” for “Standard.” When you get into graphics, however, the whole idea of standards goes out the window.

If you examine the printhead on a dot matrix printer, you'll see that it's nothing more than a row of pins stacked one on top of another. Firing one of these pins produces a dot on the paper.

In just the same way that letters are produced on your video display, the printer uses a character generator ROM to fire certain combinations of pins, one vertical row at a time, to produce the letters on the page.

Graphics printing can be thought of as

using an alternate character set. The characters may come from the printer's ROM or directly from the computer. The number of possible row patterns depends on the number of pins in the printhead. By having your computer tell the printer which patterns to print and in what order, you can capture on paper any image you create on the screen.

Incompatibility is a problem because there are no standard ASCII codes for dot patterns. Each printer manufacturer has its own. A further complication is that different printer models from the same manufacturer often use different graphics codes.

This state of affairs underscores what must be obvious. Before you spend money for graphics software, make sure it's compatible with your hardware. There are few things more frustrating than spending hours creating an image on the screen that comes out of your printer looking like Martian hieroglyphs. ◇

### Printing Utilities

Most programs used to create graphics include drivers for several printers along with installation procedures to configure the program to match your computer hardware. But there are a lot of hardware combinations possible, and there's a good chance that your favorite graphics software won't support either your old hardware or that new printer you've been thinking about buying.

Good utility packages, such as the *Printographer* from Roger Wagner Publishing or *Paper Graphics* from Penguin Software, contain drivers for almost every printer you can name and get updated as new hardware appears on the market.

In addition to solving the compatibility problem, such programs let you crop, magnify, zoom, add text, and manipulate your image before it's printed. The features contained in these programs make them worthwhile even if your graphics software already supports your hardware.

### Presentation Utilities

Presentation utilities can help you make your printouts more effective with

Some printer drivers produce better results than others from the same material.



# THE ONE GIFT SUITABLE FOR ALL OCCASIONS

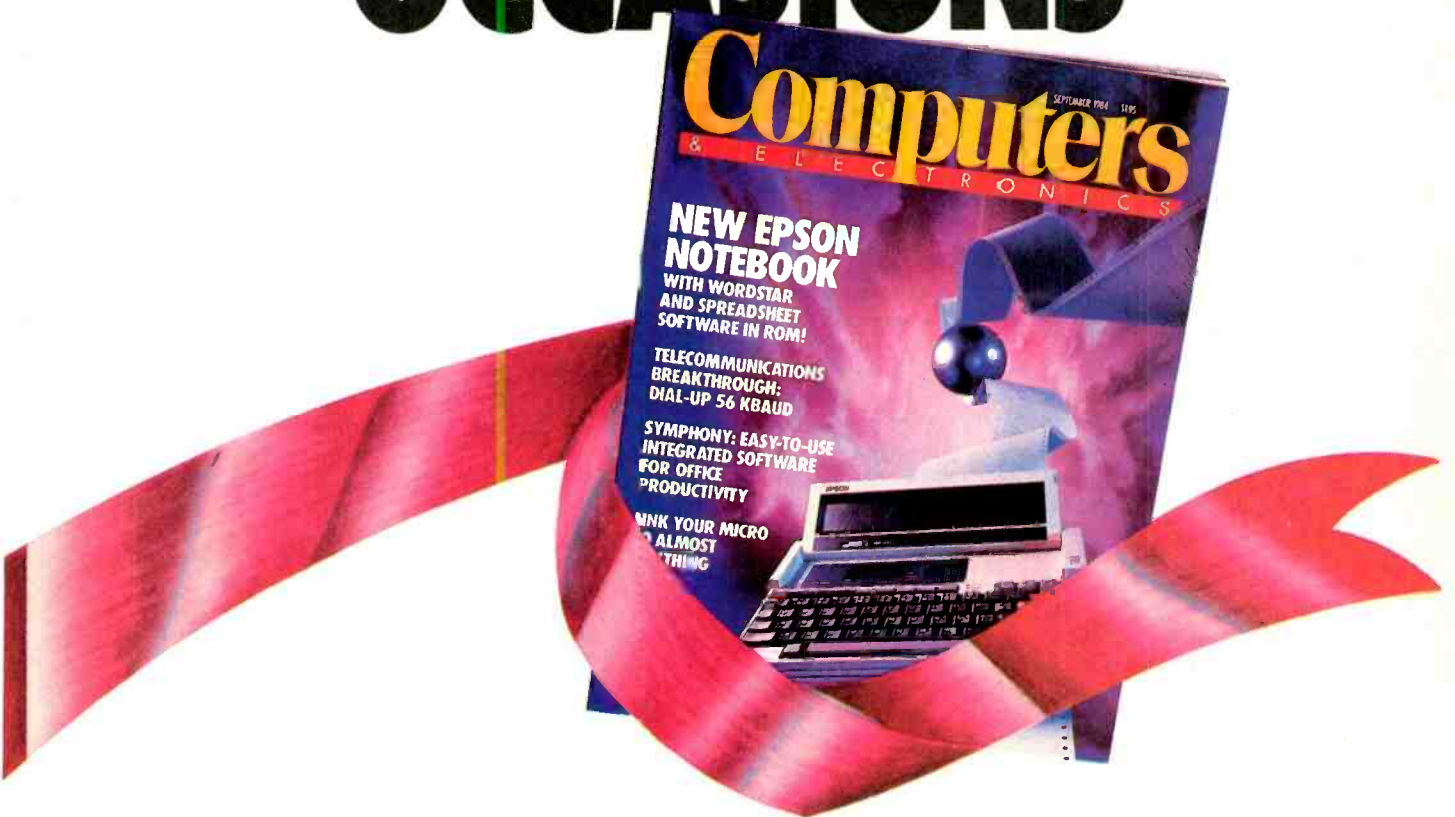

Give a friend a new gift every month with COMPUTERS & ELECTRONICS ! It's a great way to tell them that you're thinking about them, while you provide them with hours and hours of useful information, facts and ideas!

When you give COMPUTERS & ELECTRONICS as a gift subscription you're giving in-depth product evaluations, previews on the technology of tomorrow, interviews with computer designers and developers, and a fresh look at the microcomputer industry and its trends!

This is a perfect gift for birthdays, promotions, graduation, the holidays and a reminder that you're always thinking about them!

An attractive signed gift card will be sent in your name with every gift you order!

**FOR FAST SERVICE PHONE TOLL FREE 1-800-852-5200**  
or use the attached Gift Order Card!

CE4Z049

charts, special typefaces, and elaborate images.

*Press 'N Plot*, from the American Programmers Guild, has features especially to help anyone working with business graphics. You can merge text and graphics to be printed on the same page and use name-and-address files to do Mail-Merge-type operations.

A graphics printer can even be invaluable for apparently nongraphic jobs. *Printstar*, from Microstar, will let you rotate your spreadsheets 90 degrees and print them vertically! Anyone who has ever wanted to squeeze "just one more column" into a spreadsheet printout will appreciate this package.

To take full advantage of a graphics printer means using a lot of control characters or escape sequences to tell the printer exactly what to do. Remembering which codes do what can often be as much work as creating the graphic itself. A program like *Printerface*, from Datadon, can make the entire printer set-up procedure absolutely painless. By calling up the file for your printer, you can select the features you want, and *Printerface* will write an executable file that can set your printer up any way you want. You can save different files for different jobs so that initializing your printer will be no more difficult than typing a one-word command.

**Programming**

Creating original graphics software can be a tedious, and even forbidding, process if the only tools you have are the ones provided in your operating system. The task is particularly difficult if you want to use specialized input devices

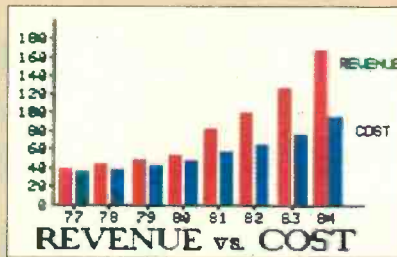

**Shifting banded ribbon up or down produces different colors.**

that are not widely supported.

Koala Technologies manufactures the Koala Touch Pad and the Gibson Light Pen, both ideally suited to creating screen graphics, but the amount of software that supports them, particularly the light pen, is limited. Fortunately, Koala also offers the *Programmer's Tool Kit*, a series of routines you can include in your own programs to take advantage of the Koalpad's unique capabilities. A similar product has been promised for the Gibson Light Pen.

Apple's new mouse for its II series comes with *MousePaint*, a drawing program similar to the Macintosh's. You can choose drawing modes such as FILL, SPRAY CAN, TEXT, CUT AND PASTE and others using the mouse to select the appropriate icon on the screen. If you're into programming, the mouse manual has all the information you'll need to use the mouse in your own routines.

**Color**

Color can give graphic images a lot of life but take a lot of money. Some computers, like the IBM PC, require the addition of an expensive peripheral card and color monitor before they'll do any color graphics at all.

If you do decide to add color to your

graphics and have a way of displaying them on the screen, you're still faced with the problem of printing them. Dot matrix printers with color options are now slowly appearing on the market. Surprisingly, their prices are not much higher than those of comparable single-color printers.

The Anadex 9725B is a good example of the new crop of color printers. It overstrikes a four-color ribbon to produce 15 different colors in both text and graphics modes. Color changes can be made via software, and the printer can even shift colors in mid-line.

**There's No Perfect Product**

When you work with graphics you'll discover that producing the images you want takes time, effort, and the combined use of several different programs. No single program will satisfy all your needs.

Even though your printer may be supported by the drawing program you use, there may be a utility program with a better-written printer driver that produces better-looking output. The process of creating a graphic, from electrons to ink, involves the combined effort of brain power, hardware, and software. To

*(Continued on page 100)*

**Note:** Two printers were used to produce the graphics in this article. The black and white illustrations were done on an Okidata Microline 93 and the color examples were printed on an Anadex 9725B. The software used to generate and print the graphics was run on an Apple II+ and is listed under each of the examples.

**Shifting ribbon up or down on the Anadex 9725B brings different bands of colored ink into position before printhead.**



*Jaine Saffir is a free-lance author who specializes in writing about computer software.*



**"False Color" King Tut produced using Anadex and Printographer.**

# BUYER'S GUIDE TO MATRIX PRINTERS

**T**HE chart on the following pages lists high-quality dot matrix printers. A representative printer was chosen from each company appearing on the list. If the company produces more than one printer that could qualify for the list, only the top-of-the-line model was chosen in most cases. Color dot matrix printers were not considered.

If a particular printer model comes in two carriage sizes, the wide carriage version is described. If a printer cannot produce at least a correspondence quality typeface, it is not included.

Some of the column headings may

need further clarification as follows:

Under the heading Speed, LQ (letter quality) also includes near letter quality typefaces; Correspondence includes memo quality; and Draft includes EDP quality. Ratings for letter-quality speed are for the pica (10 pitch) mode; correspondence and draft ratings are for pica in most cases.

Graphics density lists the highest resolution the printer is capable of.

The Interface column lists interfaces in the following way: If a printer includes two interfaces as a standard feature, the interfaces are separated by a

comma; if the purchaser can choose one or another interface, they are shown in the list separated by a slash (/); if the interface is available as an option, it is shown in parentheses.

All printers on the list have a friction feed capability. Under the tractor feed column, "Yes" indicates that a printer includes either tractor, pin or sprocket feed as a standard feature. If tractor feed is an option, the price is shown. Under Sheet Feeder, the price represents the cost of a single-bin feeder.

Paper entry is classified as rear (r), front (f), or bottom (b). ◇

## PRINTER MANUFACTURERS' ADDRESSES

### Anadex, Inc.

9825 De Soto Ave.  
Chatsworth, CA 91311

### Antex Data Systems

2630 California St.  
Mountain View, CA 94040

### Brother (Dynamax)

Suite 2800  
333 S. Hill St.  
Los Angeles, CA 90071

### Canon U.S.A., Inc.

One Canon Plaza  
Lake Success, NY 11042

### Centronics Data Computer Corp.

1 Wall St.  
Hudson, NH 03051

### C. Itoh Digital Products, Inc.

Suite 220  
19750 S. Vermont Ave.  
Torrance, CA 90502

### Computers International, Inc.

3540 Wilshire Blvd.  
Los Angeles, CA 90010

### Cromemco, Inc.

280 Bernardo Ave.  
Mountain View, CA 94043

### Dataproducts

6200 Canoga Ave.  
Woodland Hills, CA 91365

### Datasouth Computer Corp.

4216 Stuart Andrew Blvd.  
Charlotte, NC 28210

### Diablo Systems, Inc.

PO Box 5030  
Fremont, CA 94537

### Digital Equipment Corp.

146 Main St.  
Maynard, MA 01754

### Digital Matrix Corp.

105 Filley St.  
Bloomfield, CT 06002

### Epson

3415 Kashiwa St.  
Torrance, CA 94537

### Facit, Inc.

Data Products Division  
235 Main Dunstable Rd.  
Box 828  
Nashua, NH 03061

### Florida Data Corp.

600D John Rodes Blvd.  
Santa Clara, CA 32935

### Fujitsu America, Inc.

2945 Oakmead Village Ct.  
Santa Clara, CA 95051

### Genicom Corp.

One General Electric Dr.  
Waynesboro, VA 22980

### Hewlett-Packard Co.

3000 Hanover St.  
Palo Alto, CA 94304

### Integral Data Systems, Inc.

Rt. 13  
Milford, NH 03055

### Legend Peripheral Products (Cal-Abco)

14722 Oxnard St.  
Van Nuys, CA 91401

### Mannesmann Tally

8301 South 180th St.  
Kent, WA 98032

### NEC Home Electronics, Inc.

Personal Computer Division  
1401 Estes Ave.  
Elk Grove Village, IL 60007

### North Atlantic/Qantex

60 Plant Ave.  
Hauppauge, NY 11788

### Okidata Corp.

532 Fellowship Rd.  
Mt. Laurel, NJ 08054

### Panasonic Industrial Co.

One Panasonic Way  
Secaucus, NJ 07094

### Philips Peripherals, Inc.

Unit 12 S  
385 Oyster Point Blvd.  
San Francisco, CA 94080

### Printek, Inc.

1517 Township Rd.  
Benton Harbor, MI 49022

### Radio Shack

1500 One Tandy Center  
Ft. Worth, TX 76102

### Santec Corp.

9 Columbia Dr.  
Amherst, NH 03031

### Smith-Corona

Consumer Products Division  
SCM Corp.  
65 Locust Ave.  
New Canaan, CT 06840

### Star Micronics, Inc.

Suite 2309  
200 Park Ave.  
New York, NY 10166

### Texas Instruments, Inc.

PO Box 225012,  
Mail Station 57  
Dallas, TX 75265

### Toshiba America, Inc.

Information Systems Division  
2441 Michelle Dr.  
Tustin, CA 92680

# BUYER'S GUIDE TO MATRIX PRINTERS

Manufacturer	Model	Price (\$)	Printhead (# pins)	Speed (cps)			Matrix
				Draft/	Corr/	LQ	
Anadex	WP-6000	2700	18	230	170	125	58x18
Antex Data Systems	ADS-2000	495	9	165	---	40	9x9/--/17x17
Brother	DM40	1395	24	160	---	80	18x7/16x13
Canon	PW-1156A	895	9	160	---	27	11x9/--/23x18
Centronics	240	1495	24	160	---	80	7x18/--/30x16
C. Itoh	8600	1295	18	180	90	60	9x9/--/--
Computers International	Daisywriter Matrix 24	1995	24	240	160	80	9x24/13x23/37x24
Cromemco	3032CQ	1295	9	150	---	60	9x11/--/16x35
Dataproducts	8050	1695	9	200	110	35	18x9/24x9/36x18
Datasouth	DS-220	1995	9	220	100	40	9x7/9x15/18x48
Diablo	32CQI	995	9	150	---	60	9x11/--/16x36
Digital Equipment Corp.	LA50	695	9	100	50	--	9x7/13x9/--
Digital Matrix	Durawriter Plus	1500	9	180	90	45	9x9/18x9/--
Epson	LQ-1500	1395	24	200	---	67	9x17/--/37x17
Facit	4512	995	9	140	---	25	9x9/--/18/17
Florida Data	OSP-130	3995	8	600	195	100	4x8/4x8/8x8
Fujitsu	DPL24	1995	24	288	160	80	9x24/13x24/36x24
Genicom	3304	2490	18	300	200	100	4x9/5x9/9x18
Hewlett-Packard	HP2934A	2895	12	200	67	40	9x12/36x24/--
Integral Data Systems	Prism 132	1995	9	200	150	--	18x9/24x6/--
Legend Peripheral Products	CP VII	1195	18	180	---	90	7x9/--/13x17
Mannesmann Tally	MT440L	2695	9	400	110	--	9x7/18x40/--
NEC	P3	1250	18	180	90	30	9x7/13x9/21x18
North Atlantic/Qantex	7065	1995	8	300	125	65	9x5/9x12/18x24
Okidata	Microline 93	899	9	160	80	40	9x9/--/9x17
Panasonic	KX-P1093	899	9	160	80	31	9x9/9x9/17x18
Philips Peripherals	GP 300L	2855	18	300	---	80	9x9/--/18x25
Printek	930	1995	18	200	---	80	9x9/--/36x18
Radio Shack	DMP-2100	1995	24	160	---	100	24x18/--/24x36
Santec	5700	3600	7	400	350	180	--/--/24x84
Smith-Corona	D-300	795	9	140	---	33	9x8/--/17x16
Star Micronics	Radix 15	995	9	200	---	50	9x9/--/18x18
Texas Instruments	TI-855	936	9	150	---	35	9x9/--/32x18
Toshiba	P1351	1895	24	160	---	78	16x11/--/24x24

(1) See text on previous page.

(2) Centronics optional for \$95. RS232 optional for \$150.

# DOT MATRIX

Graphics Density	Buffer Size	Interface Std (Opt) (1)	Tractor/pin feed	Sheet feeder	Carriage	Paper Entry (3)	Noise Level (dBa)	Proportional Printing
144x144	4.5K	Cent,RS232	\$100	\$500	Wide	b,r	60	Yes
1920 dots/line	1.92K	Cent(RS232)	Yes	No	Narrow	r	16	Yes
180x180	16K	Cent	Yes	\$250	Wide	r	65	Yes
240 dots/in.	2K	Cent(RS232)	Yes	No	Wide	r	60	Yes
180x180	132	Cent(RS232)	Yes	\$280	Wide	r	62	Yes
120x240	2K	Cent/RS232	-	No	Narrow	r	60	Yes
1224x8 dots/line	4K	Cent/RS232	Yes	\$595	Wide	r	55	Yes
--	2K	RS232	Yes	No	Wide	r,f,b	n.a.	No
168x84	5K	Cent,RS232	Yes	Std.	Wide	r,f,b	65	Yes
144x144	2K	Cent,RS232	Yes	No	Wide	f,b	74	No
240 dots/in.	2K	Cent	No	No	Wide	r,f,b	57.8	Yes
72x180	2K	RS232	Yes	No	Narrow	r	n.a.	Yes
72x72	3.39K	Cent,RS232	Yes	No	Wide	f,b	60	No
240 dots/in.	2K	(2)	\$60	\$499	Wide	r	65	Yes
72x100	2K	Cent,RS232	Yes	No	Wide	r	65	Yes
120x384	512	RS232(Cent)	Yes	Std.	Wide	r	59	Yes
180x180	4K	Cent(RS232)	Yes	\$1400	Wide	r	60	Yes
144x144	512	RS232(Cent)	Yes	\$845	Wide	r	62	Yes
90x90	2K	RS232	Yes	No	Wide	r	63	No
84 dots/in.	3.4K	Cent,RS232	Yes	\$149	Wide	r,b	63	No
20x23	1K	Cent(RS232)	Yes	No	Wide	f	50	Yes
100x72	2K	Cent/RS232	Yes	\$1170	Wide	r,b	59	No
240x216	3.5K	Cent/RS232	\$175	\$430	Wide	r	62	Yes
144x144	4.7K	Cent,RS232	Yes	Std.	Wide	f,b	60	Yes
72x72	256	Cent(RS232)	Yes	No	Wide	r,b	67	No
216x240	2K	Cent,RS232	Yes	No	Wide	r,b	62	Yes
144x144	3K	RS232(Cent)	\$210	\$817	Wide	r	53	Yes
144x144	768	Cent,RS232	Yes	\$699	Wide	r	60	No
180x180	132	Cent	\$169.95	\$995	Wide	r	60	Yes
960x288	2K	Cent,RS232	\$200	\$1100	Wide	r	55	No
120 dots/in.	2K	Cent,RS232	Yes	No	Wide	r	63	Yes
240x144	16K	Cent,RS232	Yes	No	Wide	r	60	No
144x144	256	Cent,RS232	\$59	\$499	Narrow	r	62	Yes
180x180	4K	Cent/RS232	\$195	\$1095	Wide	r	65	No

# PERSONAL INVESTING: FROM BITS TO RICHES

*Anyone with a personal computer can use data and techniques formerly available only to professionals*

**BY HOWARD YOUNG**

**M**icrocomputer technology is helping tame the bulls and bears on Wall Street. Armed with investment analysis software and instant access to stock market data via telecommunications, investors are better equipped to make financial decisions.

Only three years ago, investors who used microcomputers numbered in the thousands; today, there are tens of thousands. Many use microcomputers daily to monitor their portfolios. Others generate charts on their stocks, access databases to get stock prices, and perform sophisticated analysis on the information they've gathered. Still others use electronic databases to gather fundamental information on corporate finances, new products or changes in management.

## **Accessing a Database**

Most investors who do their own analysis gather information from a financial database such as the Dow Jones News/Retrieval Service, Warner Computer, CompuServe, The Source, or Remote Computing. These databases include price (high/low and close), volume, and a wide range of other information for most listed stocks, going back a year or more. They also contain information similar to that found in corporate financial reports.

## **Technical Analysis: Market Indicators**

The most popular software programs now used are for technical analysis (see sidebar). They put emphasis on reading the "language of the market," rather than on the fundamentals of earnings, profits, or dividends. Technically minded investors and traders follow dozens of data patterns that link stock (or market) price movement, for example, to the number of new highs or new lows daily or to the number of traders buying puts and calls. With new software, investors

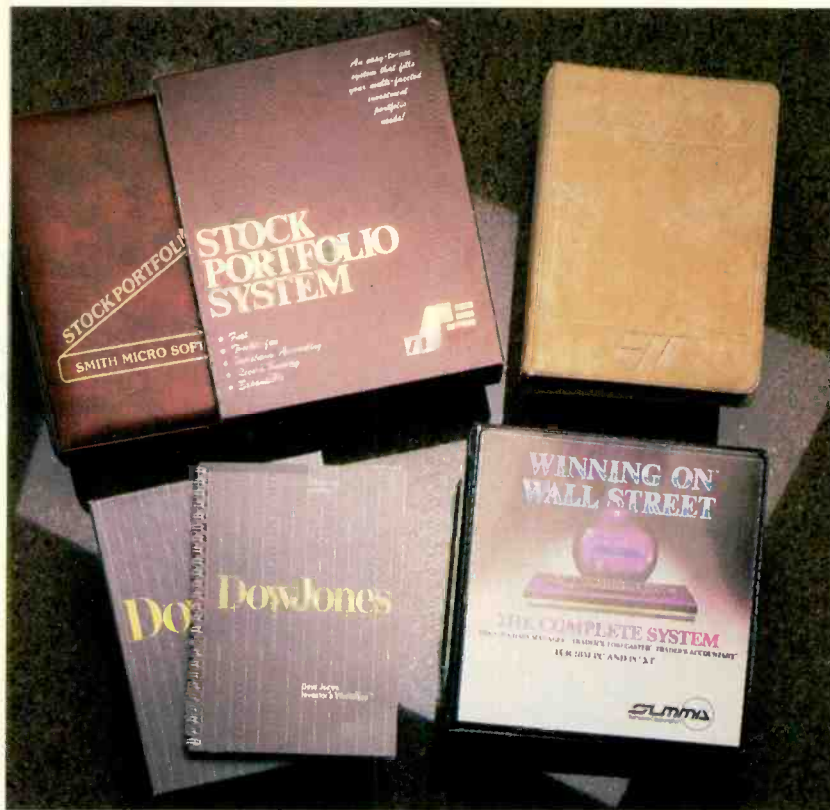

PHOTO BY RICK BARRICK

*Tickertape courtesy American Stock Exchange; computer courtesy J. M. Sposato; stocks and certificates courtesy American Banknote Co.*







A sampling of investment software

are devising their own indicators and doing their own research based on these.

Stockmarket newsletter advisors frequently base their predictions of the course of the Dow Jones Industrial Average (or other broad market indicators like Standard & Poor's and Value Line) on "smaller gauge" technical indicators. Now, investors can gather data and indicators (for instance, is the market going up or down?) with a new software package, the Market Trend Analysis System, produced by Personal Equity Computing, Inc. It enables the investor to track 87 different indicators, organized into three groups: technical, psychological and fundamental. This versatile program allows the user to spot where a major technical indicator is out of synch with one of the broader markets. For technical analysts, such a discrepancy is a major guide for assessing market direction.

The system also features a buy/sell monitor to alert the use of market turn-arounds. However, as with all such automatic buy/sell signals, you must decide whether you agree with the investment concepts and strategies underlying the signal. In other words, there is no substi-

## GLOSSARY

**Simple Moving Average (SMA)** A mean or average equaling the total set of data divided by the total number of observations. The moving average is compiled by dropping the oldest data as the newest is added. Thus, a 10-day SMA would include the sum of the data for the first 10 days, divided by 10. On the 11th day, that day's new data would be added and the first day's would be dropped.

**Trendlines:** Lines connecting a series of points representing the price of the stock to indicate the direction the stock is moving.

**Oscillators:** Indicators that measure a stock's volume as a signal of whether it is overbought or oversold. One example is an index compiled from a comparison of price and volume to calls, based on the theory that the number of shares traded peaks before the price of the stock does.

**Covered Call Writing:** Name given to the strategy by which one sells a call option on the shares of the underlying stock that one owns.

## FUNDAMENTAL VERSUS TECHNICAL ANALYSIS

BY CHARLES A. MILLER

**T**HE professionals who analyze and forecast stock performance are generally of two types: fundamentalists and technical analysts.

Fundamentalists believe that a company's financial condition and performance are the main determinants of how well its stock will do. Fundamental analysis, therefore, involves using all the information about a company that can be gleaned from annual or quarterly reports (among other sources) to determine its prospects. The information may include such data as a company's earnings, its sales, assets, product line and management, and such external factors as competition and GNP. It won't necessarily include the price movement of the stock.

Technical analysis takes anything and everything else into account. It's concerned with stock price, volume, timing and trend for a given company as well as for other companies in the same industry and the market as a whole. Strictly speaking, this approach to market theory holds that previous price movements, properly interpreted, can predict future price patterns. What's more, a

technical analyst might factor in the weather or the political atmosphere. More realistically, the analyst would take into account the volume of trading in a stock or the volatility of its price, that is, whether the price has shot up or down frequently. Technical analysts also look at broad spectrums—movement of composite prices and indices, for instance.

One of the tools technical analysts might use, for instance, is a chart of the past prices of a company's stock. Searching carefully to spot trends or variances from trends in the market, they might find a price breakthrough or abnormal price movement. For example, if a price stays within a three-point range for a long time and then breaks out of that range, either higher or lower, it might signal the onset of a trend.

Because the technical analysts are in many ways statisticians and data analysts, computers play a major role in their world. Many of the programs listed in the accompanying table help bring that world into the hands of personal computer users. ◇

tute for using one's own judgment to make the final investment decision.

### Technical Analysis of Stocks: Charting Programs

Software programs that permit investors to chart stocks and analyze stock prices and volume are among the best sellers in investment software. The most common kind allows a user to download price/volume information automatically from a database into a stock-charting program. Investors can then generate charts and plot any length of moving average or trendline. When prices go above or below moving averages or when moving averages cross one another, technicians interpret the actions as buy or sell signals.

Among the popular charting programs are the Market Analyzer, the Technical Investor, the Technical Analyst and Winning on Wall Street. These programs have features such as four-window screens that enable the investor to view simultaneously four different stocks (or different aspects of the same stock in the Technical Investor program). One feature, Autoplot, lets the investor set up a series of commands to

process many stocks automatically. The program plots designated trendlines of the market and prints out desired charts automatically.

Many of the software packages make it easy to do operations such as plotting moving averages, trendlines, volume and oscillators with a few keystrokes.

### Options Software

With the advent of options on stock market indices, it is now possible to speculate on the Dow Jones or another major index. While playing the options market can bring returns almost as great as Atlantic City jackpots, the risks are nearly as high. Those risks and the suspicion that options are terribly complicated (which is true only for the more complex professional strategies) may explain why many investors hesitate to enter this market. Their reluctance is unfortunate. With new options software, the investor can use conservative strategies to protect market profits or at least minimize losses.

To aid newcomers, most of the manuals that accompany the options software instruct the user in the basics of options trading. In addition, some on-line

systems (two-way telecommunications systems, such as those linking brokerage houses and clients, or database and users) provide guidance and assistance, performing most of the selection chores. For traders who are active in the market, the online systems (such as Wall Street Online) will pick underpriced and overpriced options and execute complex analyses to show the user the best buys.

Some of the packages, such as Soap, developed by H & H Scientific, lead the user through a maze of trading strategies and make the rapid calculations necessary for timely decision-making. Less expensive, but nonetheless comprehensive, programs have been developed by Calcugram, Mehrstens and Star Value. Investors can use their software to estimate profit from covered calls, a simple options technique by which the investor can sell a call against an owned stock.

### Following the Tape

Many investors and traders used to call their brokers frequently to find out

*Howard Young is the editor of Financial & Investment Software Review, 11 Hanover Square, New York, NY 10005.*

## QUOTREK

**I**NFORMATION—getting it while it's hot—is the key to trading in stocks and commodities. While most investment news services run "behind the ticker" from 5 to 15 minutes, a new system, QuoTrek, sends traders almost instantaneous price data from the major stock and commodity exchanges and NASDAQ's computer system.

The heart of QuoTrek is a pocket-size FM radio receiver equipped with an alphanumeric keyboard and a 40-character LCD display. Except for an antenna that telescopes out the top, the 12-oz device resembles an ordinary pocket computer or programmable calculator.

But it is not a calculator of any kind. The radio is pretuned to a local FM station that transmits digitized stock and commodity data on its subcarrier—the same subcarrier used by other FM stations to transmit Muzak to restaurants and banks. (The subcarrier cannot be picked up by a standard FM radio.)

Once received, the information is fed to a microprocessor with 40 programmable memory registers and one direct-access display memory. An investor programs the memory registers simply by punching in the standard trading symbols on the keyboard: IBM for IBM, MGM for MGM Studios, etc. Users can

either scroll through the programmed memories item by item in their portfolios or manually program their QuoTreks for stocks not stored in memory registers.

### Data Transmission and Decoding

About every 2 minutes the FM station providing the QuoTrek service transmits a "loop" of data on approximately 8000 stocks and commodities; the loop includes the last sale, the high, the low, up/down tick, open and total volume. The QuoTrek receiver's microprocessor strips off the information on up to 40 selected stocks (the user's portfolio) and stores it in the symbol-keyed memories. A user who wants to see the data on a particular stock without scrolling through the portfolio can simply enter the trading symbol. Getting data that is not in one of the 40 memories, however, can take up to 2 minutes because the manual memory must wait for the data to be received.

### Where the Data Comes From

While it all looks simple and easy at the receiver end, much advanced communications technology goes into getting the data from the stock exchange(s) to the user almost instantaneously.

The data from the exchanges is gath-

ered by RCA, whose own computers select either a satellite or surface link—whichever is optimal at that time—to QuoTrek's central computers located in California. The central computers—VAX 11-750 and 11-730s—process the "raw" data into a compressed database on more than 8000 stocks and commodities. The processed data is fed to a memory stack whose output is read as a data "loop" that is uplinked to the Westar IV

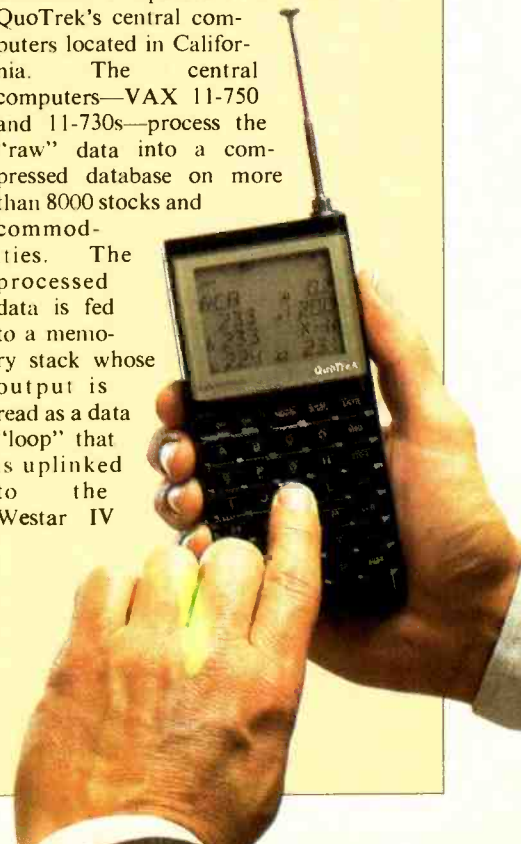

(Continued on page 86)

## Personal Investing

the price of their stocks. Tape-addicted traders would camp at their brokers' office to watch the electronic stock tape flash price and volume information. Now they can watch the ticker tape or obtain stock prices on their own computer screen—anytime. With a dedicated line from Western Union and the telephone company and a \$100 monthly fee, investors can now use a ticker software program.

Most of these programs provide features previously available only in brokers' offices. One of the earliest systems developed by Max Ule is called Tickertec. Two new software packages, Windows on Wall Street and Pro-Monitor add indicators that can be used to determine which way particular stocks (or the market as a whole) are headed. These systems help the user identify stocks that may be candidates for takeovers and watch for breakouts in stocks. They can even ring alarm bells or buzzers to warn when a stock has reached a preset level. One of the most comprehensive systems is produced by Computrac. It covers most of the technical indicators followed by active investors and traders.

### Fundamental Analysis

Fundamental data on corporations

are available either on-line, via electronic databases, or off-line, via disks sent monthly by publishers as part of their software packages. Two such publishers are the leading providers of stock market information and advice: Standard and Poor's and Value Line. These companies also provide software packages that enable investors to analyze the data. With this software, investors can search for corporations with low PEs, for example, or use other, more sophisticated criteria.

Software and database access provided by other publishers generates detailed reports on a corporation or facilitates comparisons among corporations. One of the largest database search-and-screening programs is Micro-Scan (from Isys Corp.), with which an investor can analyze up to 1400 stocks in 99 industries, with 54 variables for each stock.

Micro-PMS (from Boston Co.) provides a monthly subscription to data disks listing over 40 items for each stock in the database. It also helps investors select stocks by enabling them to scan a database of 1500 stocks based on numerous criteria.

Information about the activities of corporate insiders, including who owns the corporation, is provided from finan-

cial databases by Disclosure (updated by Disclosure Co.). The user is able to analyze the data in a variety of formats.

Several databases provide access to the large financial library of Media General (Medgen). From this source, the fundamentalist can obtain a substantial amount of the information necessary to analyze a company's fortunes.

A recent move by the Securities and Exchange Commission may also prove to be a boon in this area. It recently announced that corporations will be able to send their financial reports to Washington electronically and that this information will be made available to the public shortly thereafter. An individual investor, by accessing the data via microcomputer, will be able to make judgments about a company's finances and stock position at the same time the professionals do.

### Downloading Data into Spreadsheets

A spreadsheet provides a multicolumn format of figures that can be manipulated individually, in pairs, or in any combination desired and by any number of simple or complex formulas. Such spreadsheets as Lotus 1-2-3 enable the

(Continued on page 86)

## S&P's STOCKPAK II

BY BARBARA E. AND JOHN F. McMULLEN

IT'S one thing to have a program that makes it easy to analyze securities, but quite another to get the data itself. Standard & Poor's Stockpak II system gives you both. With Stockpak II you get an analysis program and monthly data (current to the last trading date of each month).

The program was written for S&P by Stock Market Software, which previously developed "On Balance Volume Charting," a system for the Apple II. Stockpak II lets you examine 127 pieces of fundamental and market information on over 1500 securities and perform comparisons by graphs and reports. You can also screen securities to select only those that meet certain criteria.

When you boot the system you're presented with a six-item menu:

1. *Look Up Information on One Company.* When you choose this option, you're asked for the ticker symbol of the security you want to check. You can then browse through three display pages of information on that security. Page 1 contains raw data (for example, price, sales information); page 2 provides performance ratios calculated using both

preprogrammed and user-defined formulas; and page 3 is a graphic display of the security's earnings and price data.

2. *Compare information on Several Companies.* This option compares securities graphically.

3. *Screen a Database Diskette.* This allows you to select every security from the database that meets either predefined or user-generated criteria. You can then enter automatically selected securities into the comparison graphics feature mentioned above.

4. *Prepare a Report.* A useful option that allows you to produce printed reports in predefined or user-generated formats. You can use securities that you've entered manually or those that were selected through the screening process.

5. *Access Support Functions.* A house-keeping option that allows you to change the various system parameters, report formats, selection criteria, etc.

6. *Exit Stockpak II.*

We found that the system performed these functions with reasonable speed and little difficulty. The documentation provided is not voluminous, but does

contain sufficient information for you to learn the program rapidly. It also provides clear definitions for the data and ratio information displayed.

The service is marketed on a subscription basis, and the price varies according to the type of service you want:

12 months of 1500

NYSE issues . . . . . \$245.00

12 months of 800 ASE . . . \$245.00

12 months of 2300 OTC . \$490.00

12 months of 1500 selected issues including 1200 NYSE, 100 ASE, and 200 OTC issues incorporating the S&P 500) . . . . . \$245.00

There is also an initial subscription charge of \$30.00. Standard & Poor's says that the majority of individual subscribers use the 1500 selected-issues subscription. Users may transfer services during the subscription period or may drop the service entirely with full credit for the unused portion.

At this price, the Stockpak service is well worth the attention of anyone having even a passing interest in fundamental analysis of securities. Stockpak II is published by Standard & Poor's, 25 Broadway, New York, NY. 212-208-8000. ◇

# INVESTMENT SOFTWARE

Vendor	Product	Hardware	Price/Fee
<b>C.D. Anderson</b> 300 Montgomery St. Suite 440 San Francisco, CA 94104 800-822-2222	<b>Desktop Broker</b> Online trading system	All computers (Modem)	Initial fee is \$95; other fees vary
<b>Anidata</b> 7200 Westfield Ave. Pennsauken, NJ 08110 609-663-8123	<b>Market Analyst</b> Consists of 3 modules: technical analysis; portfolio management; and news, views and quotes	Apple II, II+, IIe, (64K); IBM PC (128K)	\$495
<b>ATS Software, Inc.</b> 90 John St. New York, NY 10038 212-227-5731	<b>Oscar</b> Online option trading and analysis	IBM PC, PC/XT (128K, modem)	\$300/month
<b>The Boston Co.</b> One Boston Place Boston, MA 02106 617-722-7939	<b>Micro PMS</b> Program can scan a database of 1500 stocks for criteria selected by user	Apple II, IIe, III, 64K; IBM PC, PC/XT (Two disk drives)	\$595
<b>Bristol Financial Systems, Inc.</b> 23 Bristol Place Wilton, CT 06897 203-834-0040 203-762-9191	<b>Window on Wall Street</b> Integrated set of computer programs designed to analyze, display and store information from the New York Stock Exchange floor. Real-time ticker on screen	IBM PC (320K, two disk drives)	\$75/Demo kit
<b>Calc Shop, Inc.</b> PO Box 1231 W. Caldwell, NJ 07007 201-228-9139	<b>Opval</b> Forecasts fair prices and deltas for options	Apple II, IIe or III (with emulator) IBM PC, PC/XT	\$250
<b>CompuServe</b> 5000 Arlington Centre Blvd. Columbus, OH 43220 614-457-8650	<b>CompuServe Information Service</b> Financial database	All computers	Rates vary
<b>Compu Trac, Inc.</b> 1021 9th St. New Orleans, LA 70115 504-895-1474	<b>Compu Trac Programs</b> An extensive, growing system of software allowing for automatic data collection from many databases; programs allow you to analyze stocks, the broader markets, index futures, commodity futures	Apple II (Hayes micromodem) IBM PC, PC/XT (Two disk drives)	\$1947 initial fee; \$200 annual maintenance  \$1900 initial fee; \$300 annual maintenance
	<b>Intra Day Analyst</b> Tracks stocks and commodities on a real-time basis and allows for instant analysis using many formulas, as well as graphing of the results	Apple II+ or IIe  IBM PC	\$1575 initial fee; \$250 annual maintenance  \$1600 initial fee; \$250 annual maintenance
<b>Decision Economics, Inc.</b> 14 Old Farm Rd. Cedar Knolls, NJ 07927 201-539-6889	<b>Stockcraft</b> Portfolio management, technical analysis and optimized trading strategy program	Apple II+, IIe, III (Emulator, two drives)	\$118
<b>Dow Jones &amp; Co.</b> PO Box 300 Princeton, NJ 08540 609-452-2000 800-257-5114	<b>Market Analyzer</b> Performs technical analysis on the high/low/close and volume data for stocks on any of the Dow Jones indexes	Apple II+, IIe, III (emulation mode); IBM PC (color graphics card); TI professional	\$349
	<b>Market Microscope</b> Database for use in screening industry groups and stocks. Price-alert routine data on your disk on stocks that have reached critical buy/sell levels	Apple II, II+, IIe, III (two disk drives, modem); IBM PC, PC/XT	\$349
	<b>Market Manager Plus</b> Portfolio management program	Apple II series, III (two disk drives and printer); IBM PC (asynchronous communications card)	\$249
	<b>News Retrieval Service</b> Financial database	All computers (Modem)	Rates vary

(Continued on page 90)

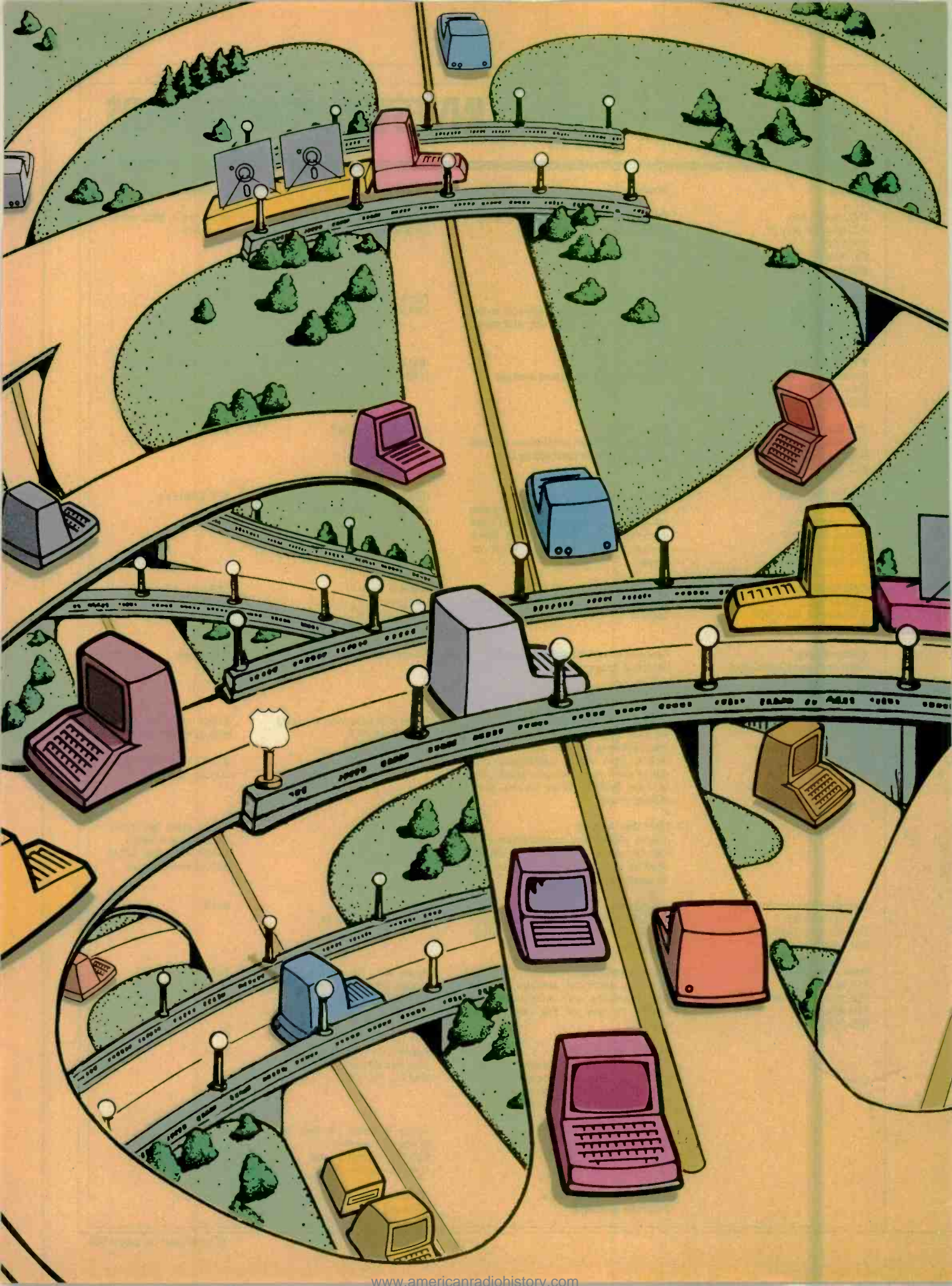

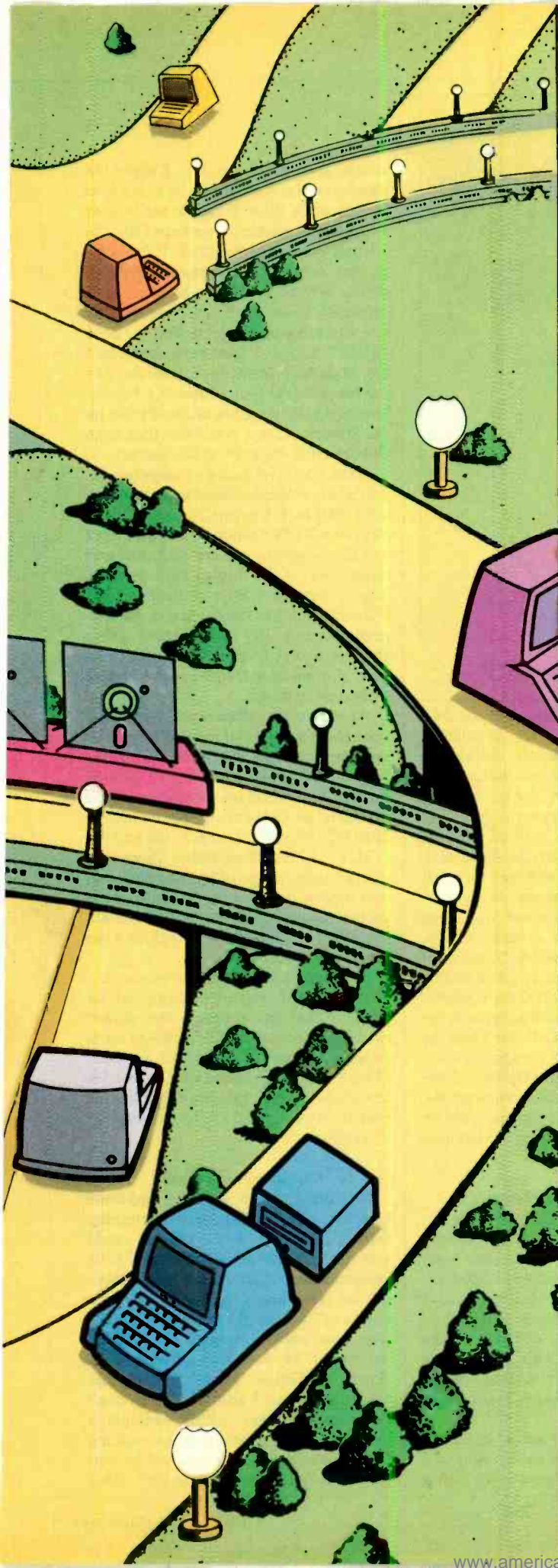

# YOU CAN GET THERE FROM HERE

*Ways to get seemingly incompatible hardware and software to work together*

**BY JOHN SMITH-RICHARDSON**

**T**HERE'S an old story about a farmer who, after failing at several tries to give directions to a traveler, gives up. The story ends with the punch line: "Nope. I guess you can't get there from here!" Sometimes, with the plethora of microprocessors, disk formats, terminal types, etc., around these days, that phrase seems to be particularly appropriate.

For example, let's assume you got into personal computing back in the early days with a Radio Shack TRS-80 Model I. Your company started using *Scriptit* for its correspondence, and for business records used a then-available commercial database or one you wrote yourself using *BASIC*. That stuff has for many years delivered outstanding service, but your company has grown and so have your computing needs. If you're typical of many—if not most—business users, your new personal computer will be an IBM-workalike, and it's not going to accept or run the data and programs from your Radio Shack computer(s).

Or maybe you're an accountant or a field engineer, and you found the Osborne 1 was the perfect answer to bringing the computer to your clients. Unfortunately, Osborne folded, and your clients aren't using the Osborne computer when they upgrade their own computerized services. However, you find the Osborne computer is still the perfect portable for you, and you would like to continue using it even though your clients are now using PCs, Kaypros, or any of ten other inexpensive computers—everything except the Osborne. You must either rewrite all your records and spreadsheets or find some way to adapt the Osborne to the modern computers.

Fortunately, you do not have to discard either your old equipment or its software. There are many programs and hardware accessories designed to permit the interchange of software between various computers. If you like to use the Osborne 1 or a Kaypro 2x at your client's office, by all means do so, for there are programs that will allow the PC back at your home office to read the data from the Osborne and Kaypro disks.

While most format-interchange software allows one kind of computer to read text or data files from other computers or operating systems, some actually permit the user to run a program from another computer; and if running the program directly isn't feasible, there are hardware devices that permit an IBM PC to emulate a CP/M-80 or an Apple II or II+ computer. (Yes, your PC can "come up" in CP/M or Apple DOS.)

## **Copying Other Formats**

At the bottom of the scale of software interchange products

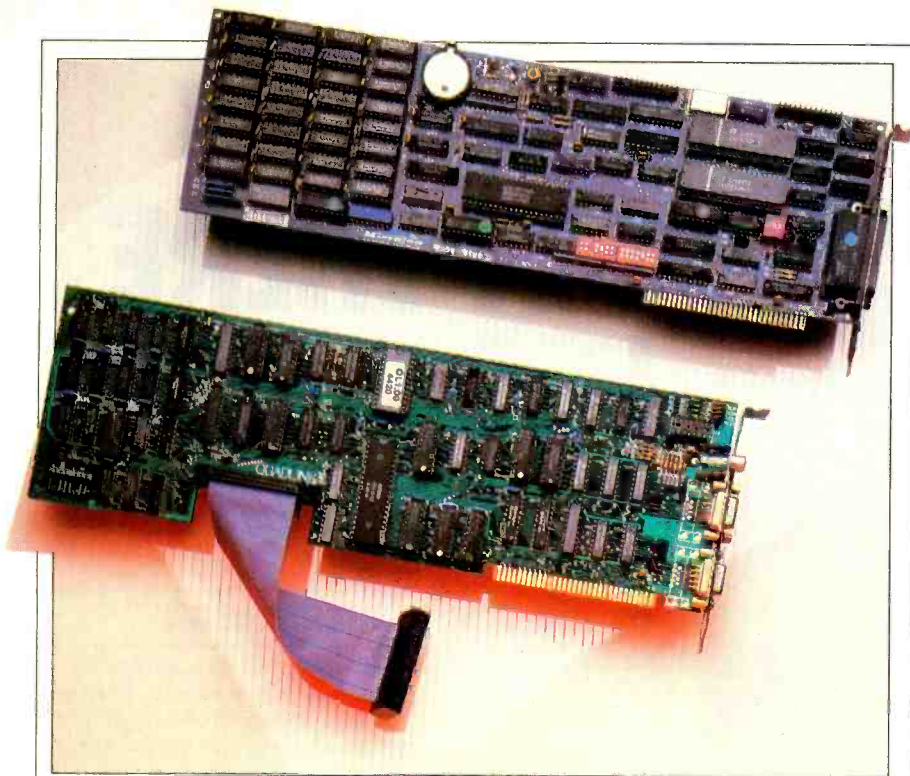

**Baby Blue II (above) and Quadlink (below) boards for the IBM PC.**

are the programs that translate the text or data files on "foreign" disks to the format of the host computer and vice versa.

To use them you load a translator program into the host computer. A menu allows you to select a foreign disk format for drive B, into which you load the foreign disk. A disk formatted for the host computer is loaded into the A drive. The translator program then copies the text or data files on drive B to drive A. As a general rule, the translator software will also work the other way around, copying text and data from a disk in host drive A to a disk formatted for a foreign computer in drive B. While this kind of interchange software is generally effective and usually attractive because of its moderate price, it often has limitations the user doesn't discover until after the software is paid for.

First, the text and data must be ASCII files. They can be data files, word processing texts, even BASIC programs, but almost without exception they must be in ASCII format. The few programs we tried that were supposed to convert binary files or tokenized statements didn't work reliably, and we will not cover them here.

Also, translation software frequently requires preformatted disks. If, for example, you are going to transfer a PC WordStar text file to a Kaypro formatted disk, the foreign disk may have to be preformatted on a Kaypro computer.

One of the better examples of translator software we had a chance to use is *Crossdata*, which translates files either

way between CP/M and MS- or PC-DOS. Unfortunately, while it offers a broad selection of computer formats, it lacks two of the major ones: Osborne single density and Zenith Z-100. Another effective interchange program is *Filetran*, which comes in three different versions. Filetran was originally intended for the Osborne 1, and two different versions covered just about all the 5 1/4" disk formats in common use (and some not-so-common ones). A new version, for the PC, accommodates 22 different double-density formats. But not all formats are available on all three versions. For example, one version translates between a single-density Osborne 1 and the PC, but the PC version does not accommodate the single-density Osborne 1 format. If you have a specific requirement, check directly with the Filetran people; they'll tell you which version you should order.

#### **Run-Time Capability**

Transferring data and text files between disk formats is one thing. Actually running a foreign program on your computer is something entirely different. Presently there are two notably effective run-time programs available. One is bundled with Kaypro computers, the other is "thrown in" with Montezuma Micro's CP/M, an aftermarket version of CP/M 2.2 for the Radio Shack TRS-80 Model 4 computer.

Run-time translator software causes one of your disk drives to function as a host for a foreign format. In other

words, if you are using a Kaypro 2x computer, the A drive will be in Kaypro format while drive B can be set to read and write in another—perhaps Osborne 1 single-density or Zenith Z-100. As far as the computer is concerned, both drives are hosts. And, because both drives are hosts, the Kaypro can *directly run* any software program that is "pure CP/M" and not hardware dependent (i.e., it doesn't directly access memory or use specific I/O port addresses). For example, if your program originally ran on the Osborne 1, you could run that same Osborne disk directly on the Kaypro.

If the CPUs of the two computers involved are incompatible (for example, an 8-bit Z80 in a Kaypro 2x and a 16-bit 8088 in a TI Professional) and you can't run the program, you can still read and write *data* to the foreign disk directly. You can set drive B to emulate an IBM PC drive and then use the text or data directly from a PC disk without going through a disk-to-disk translation process. You can also transfer text and data from disk to disk.

As with most software and hardware, once there's an initial breakthrough the marketplace soon fills with even better products. Kaypro provides 12 foreign formats for several such well-recognized products as Osborne, Xerox, TRS-80, IBM PC, Morrow, Zenith Z-100 and the NEC PC-8100a. Montezuma Micro covers the same range of standard models and throws in a number of not-so-well-known names, such as Lobo Max-80, Cromemco Z-2, LNW, Eagle II, and the Hurricane Compactor.

If even this list doesn't impress you, there's a software package called *Compat* that can program the second drive of a number of CP/M-based computers to emulate any of 82 formats! (There is also a version of *Compat* for certain S-100-bus disk controller boards that allows you to add 5 1/4" drives to an 8" system.)

#### **Custom Keyboards**

Not all keyboards are alike, and some lack keys that are essential for running certain programs. For instance, could you use most of your software if your computer lacked an ESCAPE key? Probably not. That key is frequently used as a "bail-out" key to get you out of otherwise inescapable situations. It is also the "attention" key for much software. Consider the TRS-80 Model 4 computer (and the Models I and III). They don't have ESCAPE keys, which presents a mountain-sized problem when running CP/M. The problem is resolved by employing a "key translator" as part of the



## Product Sources

### Baby Blue II \*

Microlog  
222 Route 59  
Suffern, NY 10901  
\$995.00

### Compat

Mycroft Labs., Inc.  
PO Box 6045  
Tallahassee, FL 32314  
\$95.00

### Crossdata

Award Software, Inc.  
236 N. Santa Cruz Ave.  
Los Gatos, CA 95030  
\$99.00

### Filetran

Business Micro Products, Inc.  
3128 Hagar Lane, Unit B  
Glenwood Springs, CO 81601  
\$99.00

### Montezuma Micro CP/M for TRS-80 Model 4

Montezuma Micro  
PO Box 32027  
Dallas, TX 75232  
\$199.95

### ProKey

RoseSoft  
4710 University Way NE  
Suite 601  
Seattle, WA 98105  
\$129.95

### Quadlink

Quadram Corp.  
4355 International Blvd.  
Norcross, GA 30093  
\$680.00

### Remote Control

Kensington Microwave Ltd.  
251 Park Ave. South  
New York, NY 10010  
\$180.00

### Talisman

Disco-Tech Div. of  
Morton Technologies, Inc.  
600 B St.  
Santa Rosa, CA 95402  
\$125.00

\* 256K configuration

CP/M for the Model 4. For example, Montezuma Micro's CP/M 2.2 makes the Model 4's UP-ARROW key function as an ESCAPE key for CP/M.

While there are several programs available that permit the user to reprogram any key, none is as effective at terminal emulation as one called *Talisman*. It can automatically simulate any common keyboard configuration on most host terminals or computers and can be made to load a configuration automatically along with an applications program. A program like *Talisman* is particularly useful for adding function keys to terminals and computers that have none.

*Talisman* can turn almost any terminal into almost any other model terminal. For example, if your software was written using the screen and cursor control codes for a Televideo 920 and you are using a Lear-Siegler ADM-3A, you can redefine your ADM-3A so it behaves like a Televideo and still run that software. As is typical of keyboard-reconfiguration software, *Talisman* also lets you reprogram individual keys to output an entire string rather than a single character. This capacity is useful for complex word processing commands, for telecommunications logons, and for headings for letters or invoices.

While *Talisman* is supplied with overlays for emulations of almost every conceivable terminal and computer used with CP/M programs, it's possible that somewhere out there is one that's not included. A phone call to Disco-Tech (the producer of *Talisman*) will get you the emulation you need.

### Reconfiguring IBM

Theoretically, software for IBM workalikes needs no configuration because the IBM keyboard is a "standard." True enough, but "standard" is not synonymous with "great," or even with "good." The fact is, the IBM keyboard has some well-known bugs. Among the most glaring is a left SHIFT key in the wrong place for U.S. typists and a lack of cursor positioning keys independent of the numeric-entry keys—one set of keys is used for both functions. Word processing would be a lot easier for most

typists if the SHIFT key were restored to its usual position by swapping it with the "vertical line/backslash" key; and independent cursor-positioning and numeric-entry keys would make life a lot easier for users of spreadsheets and numeric databases. Also, some less dextrous typists find it extremely difficult to enter control codes, which require two keys—CONTROL and something else. IBM's three-key reset and the second-tier ASCII code generation (ALT plus a keypad key) are almost impossible for such people.

But almost all PC keyboard problems can be resolved with ProKey, a software package specifically for the PC and PC-compatibles. ProKey can customize any key or combination of keys to represent any other key(s) or function(s)—up to 300 individual functions—or to represent a string of up to 12,000 characters. While much of ProKey's power lies in areas beyond the scope of this article, for "getting there from here" ProKey can be set to auto-load functions such as: 1) a shift-key swap—interchanging the left SHIFT key with the "vertical line/backslash" key; 2) moving either the numeric keypad or the cursor positioning functions to the alpha keys so it's not necessary to use the NUMLOCK key to switch between the two; and 3) stacking the printer control codes or graphics onto single keys.

ProKey can even set up the control functions for operating one key at a time. For example, it can program the keyboard so pressing CONTROL automati-

Just a few of the ways to get there from here.



## You can get there

cally programs the keyboard to send a CONTROL and whatever key is pressed next. The ALT key can be programmed the same way, so that a reset would be accomplished by pressing the CONTROL, ALT and DELETE in sequence rather than simultaneously. The same can be done for any applications software that requires multikey combinations, such as those found in word processors and databases. Complete customized ProKey keyboard configurations can be stored and AUTOEXEC'd with their associated applications software. In short, any PC keyboard configuration or string representation problem can be resolved with ProKey.

### Computer Emulation

To do a thorough computer emulation takes hardware. Two plug-in boards are now available for the PC: the *Quadlink* and the *Baby Blue II*. The first is an Apple emulator; the second allows you to run 8-bit CP/M software.

The Quadlink is an emulator for the Apple II, Apple II+ and Apple-compatible computers. It uses the IBM PC's disk drives and color/graphic monitor adapter. The board permits either PC or Apple foreground operation at the touch of a key. A composite video output from the Quadlink board is used for both the PC and Apple displays. The Quadlink is fully self-contained; it's a stand-alone 6502 computer with 64K of RAM. The remaining hardware supports the keyboard, three screen display modes, and screen and disk interfaces. While a "real" Apple computer has 48K of RAM and 16K of ROM (the first 16K), this board uses software to create an image of the Apple ROM in the first 16K of RAM.

A special software package, called *The Filer*, that comes with the Quadlink board contains several utilities as well as Apple DOS 3.3 and FPBASIC (Floating Point BASIC), otherwise known as Applesoft BASIC. The setup software switches the PC between normal operation and the Apple emulation. The screen presentation is in the conventional Apple format when the Quadlink selects Apple emulation. When the computer is toggled for PC operation, it is in PC format.

Since both computers are independent except for sharing use of the display, you can actually run two programs at the same time and have either one as the foreground (screen) presentation. More important, the Quadlink board allows the exchange of text and data files between Apple-format and PC-format disks, and it permits a single computer to

be used for developing programs for both the PC and Apple computers.

The Quadlink does have its limitations, though. It cannot run software from the Apple IIe or any protected software that uses half-tracking because the PC's disk drives cannot half-track. And, while the board worked successfully when the computer was configured with

---

**The operative term  
is "sometimes."  
Sometimes it's  
almost 100%  
successful;  
sometimes  
barely 10%**

---

IBM or Quadram plug-in adapters, it didn't when the hardware was non-IBM or non-Quadram; sometimes a program ran properly; sometimes it didn't. If you have a need to run specific Apple II or Apple II+ software on a PC, the best thing is to check with Quadram to see whether it will run. Even better, try it out somewhere. Quadram is very open and honest about the limitations of its Quadlink, and they gave good telephone support, but the final determination of compatibility is with the user.

### It Really is CP/M!

Baby Blue II is an intelligent multi-function board for a PC's long expansion slot. It also contains a complete CP/M emulator—in this instance a 64K Z80-based CP/M-80 Version 2.2 computer. The Baby Blue II emulator can directly run any transportable CP/M program, which means any program that is not hardware dependent. It can also write CP/M text and data files directly to a PC format disk. In certain instances a PC-DOS command must be used in place of the usual CP/M resident commands. For example, you must use PC-DOS commands for renaming and erasing files and for viewing the directory. Similarly, the manufacturer suggests that the PC commands COPY and CHKDSK be substituted for CP/M's PIP and STAT. There are a few other quirks, such as a lack of CP/M's normal line editing support and the need to press RETURN when it would not normally be required by CP/M, but in general the conversion works very well.

As a general rule, CP/M programs ran without problems when there were

no differences between CP/M and PC-DOS functions. The greatest difficulty was finding CP/M software on PC-formatted disks—and that proved to be a challenge.

Our Baby Blue II came with a disk format conversion utility that only supported five CP/M computers: NEC PC-8001, IMS-5000, DEC VT-18X, Heath/Zenith Soft Sected and CP/M-86. These are not the five all-time CP/M best-sellers. In fact, except for the Heath/Zenith format we could not locate any CP/M-80 software in the other formats, even though the Baby Blue II documentation claims that "Most vendors now offer their CP/M software already on PC-DOS formatted diskettes, in what is often called the 'Baby Blue format'." Not one dealer in our area had ever heard of a "Baby Blue format" or could provide any CP/M software in the other formats. We had to resort to subterfuge and use a format-conversion program in a rather unorthodox way.

For the average user, finding software ready to run on the Baby Blue II will not be simple. So-called "computer hackers"—and other computer science types—will have it easier because the Baby Blue II comes with extensive technical documentation, much of it beyond the comprehension of the applications-oriented user. But if you can get the disk formats untangled, it works great.

### Remote Control

*Remote Control* is the name of a software package for the IBM PC that performs an unusual emulation. It turns the PC into an enhanced version of the Radio Shack TRS-80 Model 100 or NEC PC-8201A lap computers. Although intended primarily to allow one of those lap computers to take over control of the PC (either by modem or through direct connection), it also contains emulations of their TEXT and TELCOM programs. If you do much of your work on a lap computer and like its word processing and communications facilities, Remote Control allows you to move that work over to a PC and continue it in a familiar environment. There's no need to learn the intricacies of a new word processor or communications package. You get all the features you're familiar with, plus a number of useful additions to the original programs. A full review of this package will appear shortly in COMPUTERS & ELECTRONICS.

(Continued on page 96)

*Jaine Saffir is a free-lance author who specializes in writing about computer software.*



# Creative Computing

the #1 magazine of computer applications and software

December 1983  
Vol. 9, No. 12  
\$2.50

**Programming Techniques**

CREATIVE COMPUTING

VOL. 9, NO. 12

DECEMBER 1983

**In-Depth Evaluations:**

- Kaypro 10
  - Casio FX-700P
  - Quadlink
  - Koalaplod
  - Pixy Plotter
  - Percom TI Disk Drive
  - Apple Mechanic
  - The Tool
  - DiversiDOS
  - XEdit
  - Memory / Shift
  - MULE
  - Witness and Planetfall
  - Games for TS 1000
  - Arcademic Learning Series
  - Spacediscs
  - Controller Update
- High Precision Functions in Basic
- CBasic Clinic
- Basic Debugging
- Input Line Editor
- Plotting Tutorial
- Preventive - Maintenance Primer

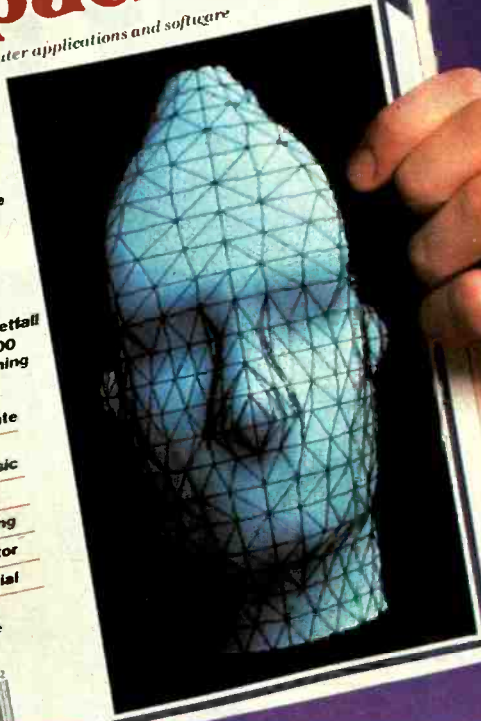

# SOFTWARE TO STIMULATE

Stimulate your mind every month with the #1 magazine of computer applications and software... CREATIVE COMPUTING! There is no other magazine like CREATIVE COMPUTING... WE TALK YOUR LANGUAGE!... Any make... any model... whether it's Apple, IBM, Radio Shack, TI, Mattel, Atari, Commodore... CREATIVE COMPUTING has monthly departments and articles you can use! You will receive a continuing education on *everything* related to personal computing with intriguing and useful applications for your personal computer. This is a magazine that will help you get more out of your computer—versatility, function and enjoyment—in easy-to-read and fully illustrated articles!

**Subscribe to CREATIVE COMPUTING today and save up to 26%!**

**YES**

**creative computing**

P.O. Box 5214, Boulder, Colorado 80322

CC82060

Please enter my subscription to CREATIVE COMPUTING for:

- |  |  |   |
|--|--|---|
| <input type="checkbox"/> 8 issues<br>for \$13.97.<br>I SAVE 16%! | <input type="checkbox"/> 1 year (12 issues)<br>for \$19.97.<br>I SAVE 20%! | <input type="checkbox"/> 2 years<br>for \$36.97.<br>I SAVE 26%! |
|--|--|---|



Mr/Mrs/Ms \_\_\_\_\_ (please print name in full)

Company \_\_\_\_\_

Address \_\_\_\_\_

City \_\_\_\_\_ State \_\_\_\_\_ Zip \_\_\_\_\_

Check one:  Payment enclosed  Bill me later

Charge my:  American Express  Visa  MasterCard

Card No. \_\_\_\_\_ Exp. Date \_\_\_\_\_

Savings based on full one-year subscription price of \$24.97.  
Please add \$5 per year in Canada, \$10 per year in all foreign countries.  
Please allow 30 to 60 days for delivery of first issue.

# VIDEO PROCESSING

*Sophisticated tools for capturing and manipulating video images are reaching the microcomputer market*

**BY LOUISE MELTON**

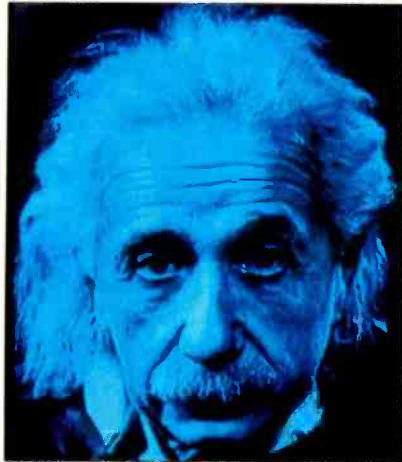

**T**HE human eye is a remarkable instrument. It can perceive faint movements in a dimly lit room or follow the slant of sails in blazing sunlight. But, remarkable as it is, it does have limitations. Through time, humans have devised instruments to overcome some of the eye's shortcomings—we can see inside cells with microscopes and distant galaxies through telescopes. Other limitations have been overcome by modern technologies, from radar to television. Computers are only the latest addition to this arsenal.

For more than 15 years, scientists have been using video processing for everything from enhancing and analyzing television images of Saturn's rings to counting missile silos on grainy aerial photographs. But until now video processing has been the exclusive property of NASA, well-funded university research labs and the Defense Department—those capable of paying \$100,000 and more for hardware. Because of the high cost of equipment (primarily main-frame computer systems and massive storage devices) video processing applications have had to be major projects to

justify the cost.

Just in the last year, video processing products ranging in price from \$495 to \$25,000 have been introduced. While they can't duplicate the \$100,000 systems, they are still powerful and exciting. And they're just the beginning.

Today, thanks to these dramatic reductions in price, due mainly to advances in microcomputer design, signal processing and dense storage technology, video processing is exploding into virtually every area. Medical imaging, robotics, graphic design and security are the earliest beneficiaries of the new lower costs. Office automation, communications, and commercial and retail applications are following fast.

Like a lot of new technology, low-cost video processing systems are coming from new companies that are getting new products to market quickly. Cromemco, Inc., the California-based microcomputer manufacturer started in 1975 by Harry Garland and Roger Melen of Stanford University, is the oldest and largest company producing small video processing hardware and software systems.



The other three low cost systems developers are less than three years old.

Vice President Richard Govatski of Memotech Corp. points out that the term "low-cost" is strictly relative. He says that people who already own a fully expanded Memotech 8-bit MTX personal computer, "can add video processing for under \$7000. But you have to keep in mind the total system cost is around \$18,000. It's possible to do some limited image processing for under \$10,000—but not much under. It's still not a toy for the hobbyist or for general purpose computing. For the near future, microprocessor-based video processing is going to be used primarily in dedicated applications."

Govatski predicts that the proliferation of microprocessor-based video processing applications will depend on the third-party applications-software, developers of the same group that played a big part in the proliferation of business and graphics software.

Ron Massa, an electrical engineer and national sales manager at Imaging Technology in Woburn, MA, agrees. He feels that applications software will be written



by third-party OEMs (original equipment manufacturers) who have expertise in specific industrial and scientific areas.

More software is probably being written for Imaging Technology systems than for all the other major players put together. Imaging Technology has the most versatile and impressive array of products and capabilities—including the recently introduced \$3000 PC Vision system for the IBM PC. The company's video processors are purchased in volume by systems integrators for use primarily with Digital Equipment Corporation's 16- and 32-bit systems. The company is also developing low-cost VLSI versions of its high-end systems.

Chorus Data Systems in Merrimack, NH, produces PC-Eye, a \$495 hardware/software package that users can hook up to their IBM PCs. While other companies concentrate on board-level products and video processing systems software, Chorus Data Systems packages consumer products, and has agreements with retail distributors.

#### **Pictures Are Data**

Computer image processing springs

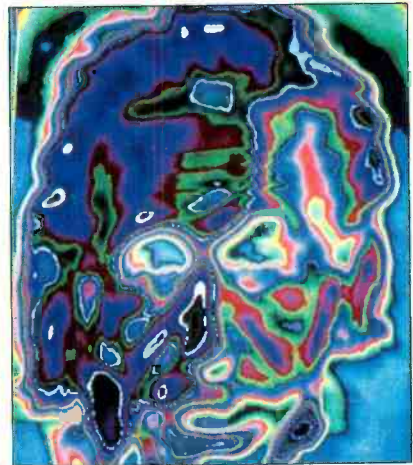

largely from the space program. NASA and the Jet Propulsion Laboratory in Pasadena, CA, used video cameras, computers and communications equipment on board spacecraft to send pictures back from our neighbors in the solar system. Starting in the early 1960s with the Ranger 7 through the more recent Pioneer and Voyager probes, scientists have developed increasingly sophisticated image processing techniques.

Enhancing an image makes it easier for a human being (or a machine) to see more detail. Except in the graphic arts, enhancement rarely has an aesthetic purpose—the idea is not to make images prettier, rather more useful. Enhancement can be as simple as adjusting contrast or as complex as modifying image elements to reduce noise or geometric distortion. For example, averaging is a technique routinely used to clean up pictures from space. The image processor compares multiple frames of an image of, say, the Martian desert, eliminating

*Louise Melton, a free-lance author based in New England, specializes in advanced technologies.*

## Video Processing

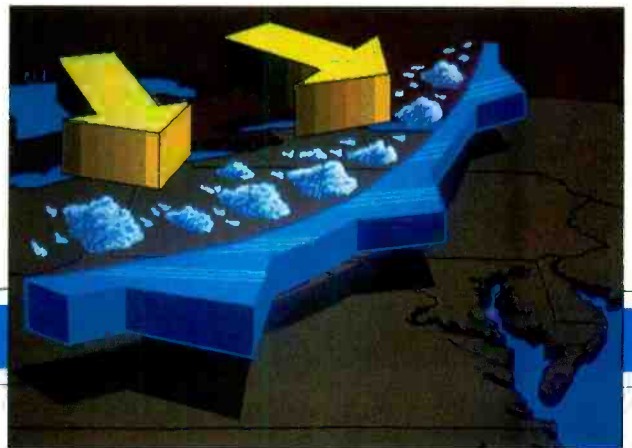

**Illustration by Scott Harris, left, demonstrates airbrush and shades generator. Airplane map, right, has arrows and clouds added by artist Ron Clowney.**

those that have extraneous, false information, such as that caused by radio interference from a solar flare.

*Extraction and analytical opinions* enable users to measure objects, recognize patterns, and output image data in numerical or graphic formats.

The marriage of video and computers maximizes the strengths and minimizes the limitations of each. Video signals are analog—messy, complicated, ungovernable waves of information. Computers take in digital signals—precise, quantitative, mathematical. Convert analog signals into digital signals and you've domesticated them. The first of the four major functions that define video processing therefore is *digitizing*. Video images are made up of dots of light arranged in a grid. Image components include the relative brightness of each dot—called a *pixel* or picture element—and its *xy* coordinate position on the grid. Digitizers are essentially A-to-D converters that take their input from television cameras, electron microscopes, radar, infrared detectors, or X-ray devices and translate the brightness

and position of each pixel into a numeric equivalent.

After the image is digitized, it must be stored—the second function of an image processor. Storage can be in an on-board buffer memory or in the storage devices supported by the host CPU.

Third, the image must be output. We most often think of output as a display of some kind, such as monochrome or color televisions, RGB monitors, videotext terminals, computer display screens or special high-resolution display devices. Extracted data may also be output as histograms, scatter plots or other graphic representations.

The fourth function of an image processor is, of course, the actual processing, which may be performed by internal processors or, via an interface, with host computer. Most often, ROM on a dedicated board holds the logic that performs operations such as subtracting one image from another, or shifting brightness levels throughout an image by a predetermined factor, or retaining only those pixels within a certain range of intensity.

How detailed the image is, and how much information the computer can therefore garner from it, depends on *resolution*. The higher the number of pixels on the grid, the clearer the image input and output. The application determines the resolution necessary—and the cost of the system. Higher resolution takes more memory and more processing power and time. At the top end of image processing systems are what Imaging Technology's Massa calls "the real exotic Landsat stuff, 4000 by 4000 resolution, a million bucks each." Systems capable of producing images of  $1024 \times 1024$  pixels are common in scientific applications. At the low end are  $256 \times 256$  resolution systems adequate for, say, simple edge detection devices used in robotic vision.

Another factor that contributes to cost is the range of gray scale the system accommodates. Gray scale is determined by the number of bits used to represent a pixel's brightness. One bit is sufficient to tell the computer that a pixel is black or white. Six bits—sufficient for most current applications—provide 64

**Below left is noisy image of a silicon wafer generated by a scanning electron microscope. At center, noise is eliminated by image averaging; at right, texture is accentuated by phase contrast.**

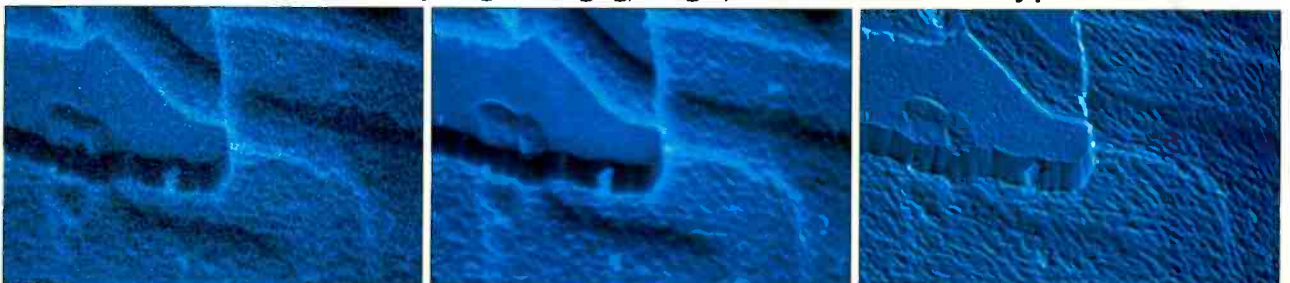

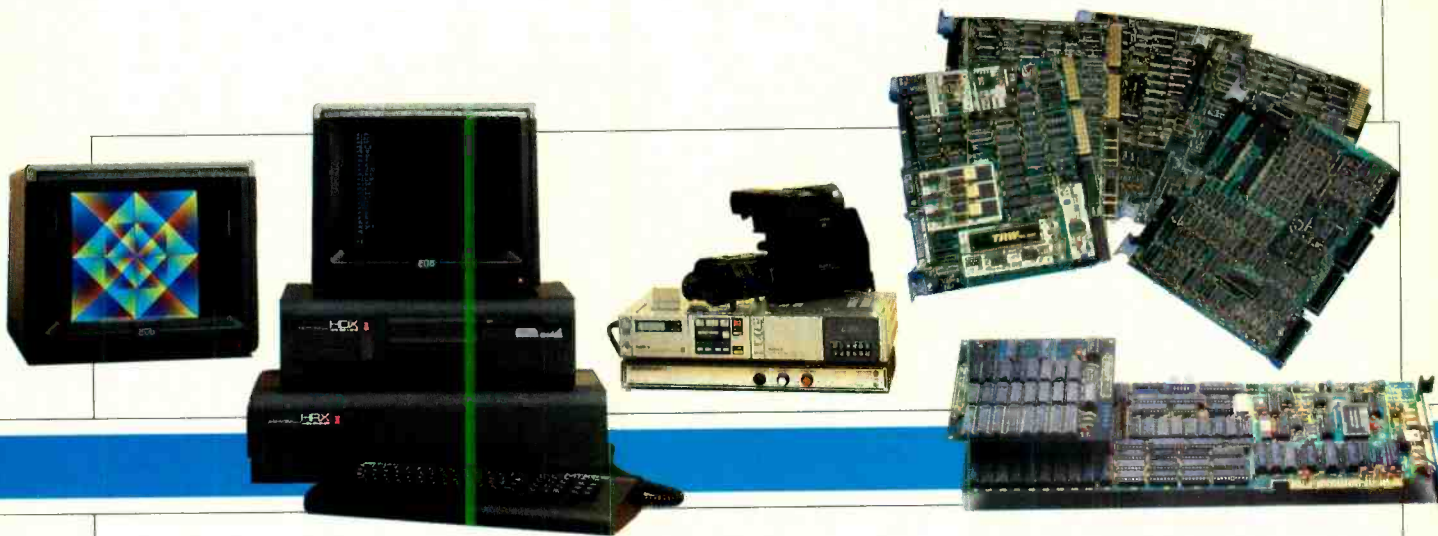

**At left, Memotech's HRX image-processing computer in a typical configuration. At right, Imaging Technology's series of plug-compatible modules.**

different levels of gray. Until recently only very sophisticated systems in the \$100,000 range offered more—8 bits and 128 gray levels. VLSI-based 8-bit systems that will sell for a quarter of that cost are now being developed.

What about color? Like very high resolution and broad gray scales, color is not necessary in the great majority of applications. In fact, 90% of image processing is done in black and white. As Imaging Technology's Massa says, "Color looks nice, but the computer can care less, and it just makes the system very expensive. It's gray level that the computers are looking for in processing data—and you actually get better resolution with black and white."

In applications where direct input of conventional video signals is not necessary, color can be handled by using three boards to process red, green, and blue separately. For special applications, the user can assign color definitions to only those pixels that are of a certain intensity. The technique is called *pseudo-color*. This process can be used to create the illusion of true color or simply to high-

light certain areas of interest on an image. Pseudo-color is particularly useful in infrared image analysis—displaying wear in friction-stressed machinery or demonstrating how poorly insulated houses shed heat during cold winter nights.

#### Capability Determines Cost

Video processing is characterized by a wide range of system costs and capabilities. Special equipment, such as frame grabbers, flash digitizers, slow scan video acquisition systems and true, full-function video processors all use the same basic technology. The real difference is how much of the image the system can acquire and how fast. The clerk in the variety store who puts your kid's video image on a T-shirt or kitchen towel is using a very low resolution, non-real-time image acquisition and digitizing system.

Flash digitizer chips convert an entire frame of video information from analog to digital in real time—that is, at video speed,  $1/30$  s. Frame grabbers such as Imaging Technology's and PC Vision prod-

ucts and Memotech's HRX add-on are combinations of flash digitizer chips and buffering boards so that the video speed input doesn't overcome the processor's RAM.

Adding arithmetic logic units and resident lookup tables to a frame grabber allows for video processing. If processing is done by the host CPU, it is limited to the CPU's processing speed and has to be done off-line.

Imaging Technology's high-end board systems use the host CPU only for power, system initialization and user interface. All image processing is done on very high speed ALU boards. Data is transferred at 10 MHz over a unique video bus.

Video processing can therefore be added to a real-time, multitasking, interactive system without the enormous CPU overhead usually associated with the process.

In many applications, acquiring the entire image may not be necessary. Video sampling systems trade real-time, full-image acquisition for lower memory

(Continued on page 94)

**Photo at left, made on an optical microscope, shows edge enhancement of original image of a silicon wafer shown at center. At far right is a high-pass filtered image of a fruit fly.**

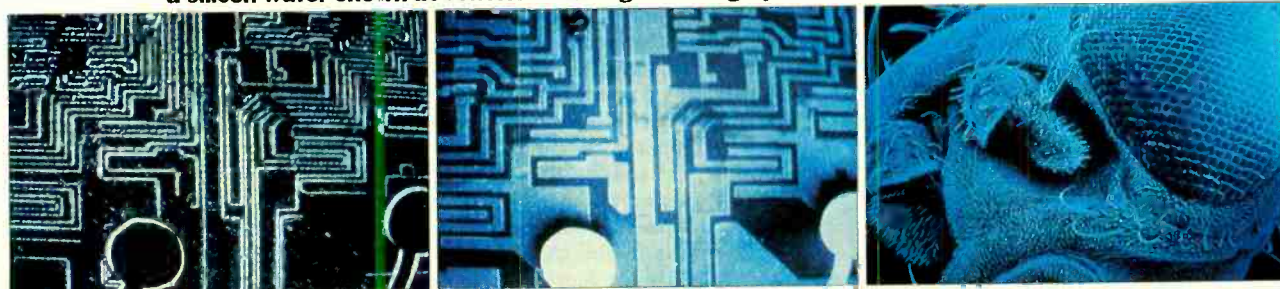

BOTTOM ROW OF PHOTOS COURTESY IMAGING TECHNOLOGY INC.

## Andrew Tobias (Continued from page 48)

choose the appropriate account. You then record the check number, date, payee, amount, and, if you wish, the payee's address, a memo, and the transaction fee. Next you allocate the amount to a budget category. You can split up the amount over several categories.

What about recurring transactions, such as rent payments? An "automatic" feature handles these conveniently. You can set up fixed transactions, specifying the amounts, payees, dates, etc., and even designate the budget allocations. Then, whenever you wish to record a payment, you enter the payment date and check number and select the transaction from your list. For your electricity bill, you would define a variable-amount transaction. For a fixed-rate, level-payment mortgage, you would specify the loan terms and the budget categories to be used for the principal, interest, and escrow portions of the payment.

If you like, you can use an integrated check-writing routine—you have to purchase the checks separately with a mail order form in the manual. I had one quibble with this feature, however. When the program writes a check, the payment amount is not spelled out in words.

The program includes a convenient bank statement reconciliation routine. You see only unreconciled transactions on the detailed account listing, because reconciled transactions are automatically archived (that is, removed from memory and stored in a datafile) to free up working memory.

At the end of the year, the system archives all the transactions. You can call up any of a number of predefined reports based on the archived data (e.g., a month's or year's transactions by budget category or by account). You can also customize a report with the program's simple—that is, limited—report writer.

The Budget and Checkbook numbers feed into the Income Tax Estimator (using the tax classification of each budget category). You may override any of these numbers to do "what-if" estimations (what if I make \$80,000 more than I thought I would this year?). This module prepares summarized versions of Form 1040, and several commonly used schedules, such as A through E, G and W. Some simple tax formulas built into the program can be modified to stay current with tax rules.

You can manage your investments just as easily. Your actual and, if you wish, hypothetical, investments are maintained in the Portfolio Manager module. Each asset placed in a portfolio has a symbol, name, type (e.g., common

stock, bond, real estate, metals/collectibles), number of units, purchase date, and other attributes—and you can define special codes for further classification.

The program lets you unsell a sold asset, update one asset or every asset with the same symbol (e.g., all occurrences of an asset with the symbol IBM), or sell all or part of one. The software does not access any online quote system, so stock and bond prices must be updated manually.

The program handles short sells, stock splits, and stock dividends. It has a handy financial reminder that automatically notifies you if a position is within a designated number of days of going long-term (yes, you can take advantage of the new tax law by redefining long-term as six, rather than twelve, months) or if a specified price objective or predetermined stop-loss has been met.

---

### Program handles short sells and stock splits

---

Detailed appreciation and yield reports can be created using intricate selection criteria, such as all common stock purchased after March 1, 1984 and recommended by Jim Smith. Simple capital gains and commission analyses and some graphics are also part of the package. There is, however, no facility for tracking and analyzing assets over time nor routines for any sophisticated investment analysis.

Sold assets can be archived periodically as well as at year end. And again, you can use the limited report-generator to define your own reports on the archived data or use predefined reports. One supplied report shows gain/loss results by portfolio or asset.

Bank accounts, loans, actual (not hypothetical dream-machine, Mai-Tai-on-the-yacht) investments, and other data from the various modules flow into the Net Worth program, which maintains your personal balance sheet. You can define additional individual or aggregate assets and liabilities at any level. Thus, your personal balance sheet can be as detailed or simplified as you wish.

Managing Your Money's Financial Calculator computes compound interest, current yield and yield-to-maturity on bonds, loan amortizations, after-tax cash flows and internal rates of return. One section of the module analyzes rental property. It handles up to two mort-

gages, either straight-line or ACRS depreciation, and anticipated sale date and price. One problem: I'm disappointed that the input assumptions in this module tend to be oversimplified. There are fixed—rather than variable—cash flows for present value calculations, and fixed-rate loans for all analyses.

This module also maintains your loans, transferring their outstanding balances to the liability section of the Net Worth module. I was frustrated by the lack of accommodation for loans held, which are, of course, assets, not liabilities.

You can also do retirement planning with the program. You use account balances from the Budget and Checkbook module and a few simplified assumptions to compute available funds at retirement.

The Insurance Planning program estimates your life expectancy, the amount of life insurance you should carry, and the annual premium for that amount of term life insurance. The module also contains an organizer for your insurance policies. The cash values on your whole life policies automatically go to the Net Worth module.

The Reminder Pad is a convenient tickler system for remembering birthdays, appointments and other important dates. When you start the program, the reminder displays events that will take place within a designated number of days. The reminder self-destructs if it's a one-time reminder or hibernates until the following year if it's an annual occurrence.

The program also has a built-in calculator with five memory registers. The calculator does standard arithmetic operations, exponents, roots, and date arithmetic (adding 1235 days to 2/15/84). With a couple of keystrokes, data can be transferred back and forth between the cursor position and the calculator line.

Other useful features: If you head down an errand path, you're presented with clear error messages and afforded graceful error recovery. The program gives you the option to save or not save your latest activity to disk. The print routines always let you back up without printing or stop once printing has begun. And there are warning messages showing the number of additional transactions that can be added before memory is full.

Managing Your Money is a powerful, complete, easy-to-use system to manage your personal finances. It's a joy to use and deserves to be in every household that has a personal computer. ♦



# Not Dow Jones.

THE SOURCE INVESTOR SERVICES -- MR. WYATT: THIS IS TO CONFIRM YOUR ONLINE PURCHASE OF 500 SHARES WESTINGHOUSE AT \$25 5/8 UNIT. YOUR CONFIRMATION TIME: 10:52:25. YOUR PORTFOLIO VALUE: \$42,817.56

# Not MCI Mail.

VIA SOURCEMAIL -- DEAR BOB: I FOUND YOUR NAME IN THE SOURCE MEMBER DIRECTORY. COULD YOU PLEASE JOIN OUR WEEKLY COMPUTER CONFERENCE ON PC APPLICATIONS FOR ARCHITECTS? HOWARD -STC 301

# Not CompuServe.

THE SOURCE/MICROSEARCH -- THIS IS THE REVIEW YOU REQUESTED ABOUT SYMPHONY SOFTWARE. TITLE: A SYMPHONIC PERFORMANCE. AUTHOR: ANDERSON, DICK. PUBLICATION: PC WORLD (JUL 1984) TEXT FOLLOWS:

# Only The Source.

Before you read this, read the computer screens above.

Because what you see there will tell you more about The Source than a magazine-full of copy.

And those are just a handful of the hundreds of innovative features you'll discover on America's first telecomputing service.

No wonder industry experts have hailed The Source as "ahead of its time" and "The most potent information pipeline."

And this year, we're giving them even more to boast about.

We've added another *dozen* major features, yet reduced our membership price to just \$49.95.

We've also published an information kit

that explains just how powerful a resource The Source is.

For your free copy, call (800) 336-3366. Or mail the reader card at the back of this magazine.

Then, the next fascinating screen you read might be your own.

Online trading provided by Spear Securities, Inc., an independent brokerage firm. The Source is a servicemark of Source Telecomputing Corporation, a subsidiary of The Reader's Digest Association, Inc. The Source services are offered in participation with Control Data Corporation. ©Source Telecomputing Corporation, 1984  
1616 Anderson Road, McLean, VA 22102

INFORMATION NETWORK  
**The Source**<sup>SM</sup>

The most powerful resource any personal computer can have.

Circle No. 54 on Free Information Card

CEGA114

## Matrix Printers (Continued from page 59)

quantities of 1000 or more) and comes with an optional 15×18 near-letter-quality font.

Another color printer, the Prowriter 1570 from C. Itoh, produces seven-color printouts. Using a 24-wire printhead, the unit prints its best quality at 130 cps, and provides label-printing quality at 180 cps. It prints 13×18 dot matrix characters (21×18 compressed) and handles both friction and tractor-feed paper. It features a built-in daisywheel emulator, which converts daisywheel printer control codes into comparable dot matrix control codes, thus permitting the use of software whose special features are enabled only through daisywheel printer drivers.

These are but a few examples of color printers. Nearly every manufacturer is, or soon will be, furnishing a model that gives you four-color output. Consider color as a nice addition in a business or engineering system, but think for a while before spending the extra money for any other application.

Some problems of dot matrix color printers might also give you reason to pause. There is a lack of software that takes advantage of their features. Without software to support your specific printer, you may find yourself unable to transfer the color on your display to the paper in your printer. Also, if you compare the output of your dot matrix color printer to that from a color ink jet or thermal transfer model, you may feel that you've gotten the short end of the quality stick.

### The Right Printer for the Job

Ultimately, the printer you buy depends on the job you want it to do. Whether or not you need a 24-wire printhead racing back and forth along the paper or color printing is something you must decide.

Prices are falling on printers right now and should continue to drop as technology makes the component parts less expensive. But options such as tractor feeds and sheet feeders are likely to maintain their price and add as much as 50% to the cost of a printer.

Don't worry about getting perfect quality if you're paying for perfect quality. In many applications, you don't need both print speed and quality. If you do, be sure to check the printer's output rate for its best price. You will be satisfied with just one; if the other, rest assured that a printer can produce excellent quality if it has enough time, or it will print if you're not particularly concerned with how the output looks. ◇

## Quotrek (Continued from page 71)

equatorial satellite.

A Westar IV transponder downlinks the data to participating FM stations that transmit the data at 4800 baud on one of their subcarrier channels. At 4800 baud it takes the stations more than 2 minutes to transmit the "compressed" data on 8000 stocks and commodities; hence, the 2-minute loop length.

The loop or interval between quotes for a particular company is 2 minutes if there are no trades. The instant a trade takes place RCA transmits the data to the central computers, where it is processed and immediately inserted into the output of the memory stack. Instantaneously, the data is uplinked to the satellite and transmitted by the participating FM stations. If the stock or commodity has been programmed into the QuoTrek receiver, the memory register updates its information as soon as it receives the data. With manual programming, getting the new data can take slightly over 2 minutes if the QuoTrek was programmed right after the transmission of the update was transmitted because the trading data is now in the 2-minute loop. Of course, another trade will cause an instantaneous update.

Prior to the markets' opening each day, QuoTrek broadcasts the previous day's closing prices and volume for each listing. The loop for this listing takes approximately 45 seconds. Mixing "live" (real-time) data with the previous day's listings increases the loop length to a maximum of 2.25 minutes.

Although QuoTrek is so far available only in San Francisco, Los Angeles, Chicago and New York, it is feasible anywhere the local FM station is under Westar IV's "footprint."

Because in most instances an FM station's subcarrier uses approximately 10% of the station's total output power, the subcarrier's signal is not received reliably over as large an area as the main (program) channel. The QuoTrek receiver is rated to work up to 30 to 40 miles from an FM station. A reception indicator is built into the QuoTrek to ensure error-free reception. Sufficient signal strength for reliable data reception is indicated by the letters OK on the LCD display. If the OK is not displayed, the

## Personal Investment (Continued from page 72)

user to input, say, stock prices for GM for a 60-day period, and then compute a 10-day moving average based on those prices or perform other operations that automatically act upon one, several, or many other columns simultaneously. ◇

user simply moves the antenna or the QuoTrek itself until the OK appears.

CMOS circuits provide the nonvolatile memory that retains the data last entered if the received signal isn't sufficient for reliable updating or if the QuoTrek is turned off.

QuoTrek comes with a rechargeable battery pack, a combination charger/ac adapter and a leather carrying case. The cost is \$495 for the unit and approximately \$45 for a month of service. Eventually, traders will be able to buy and sell stocks by entering symbols on a keyboard and transmitting them by telephone to a broker's computer. They even may be able to transmit messages to other QuoTrek users. To this end, connections for a miniature, integrated modem are already in place along the bottom edge of the QuoTrek. While subscribers cannot use the message system yet, QuoTrek's developer, Dataspeed, can transmit onto the LCD its own messages. For example, it can inform the user that a trial period is active or expiring.

### For PC Users

As of this writing, Dataspeed was preparing to introduce a radio-modem system called Modio to be connected to IBM-compatible personal computers. Modio will receive QuoTrek information via FM radio and enter it into the personal computer. The PC will be transformed into a desktop stockbroker's terminal, displaying and processing real-time prices, highs, lows, up-down ticks, etc. Using the same technology as QuoTrek, Modio will track up to 150 stocks and sound an audible alarm if activity in a particular stock increases or a specific price is reached.

The computer's own software will be able to supplement Modio's capabilities and track or chart any of the 150 stocks, producing printouts or graphic displays. Because the Modio will receive data through the FM radio, there will be no telephone line charges until the user decides to make a trade.

For additional information write to Dataspeed, Inc., 1900 S. Norfolk St., Suite 150, San Mateo, CA 94403. ◇

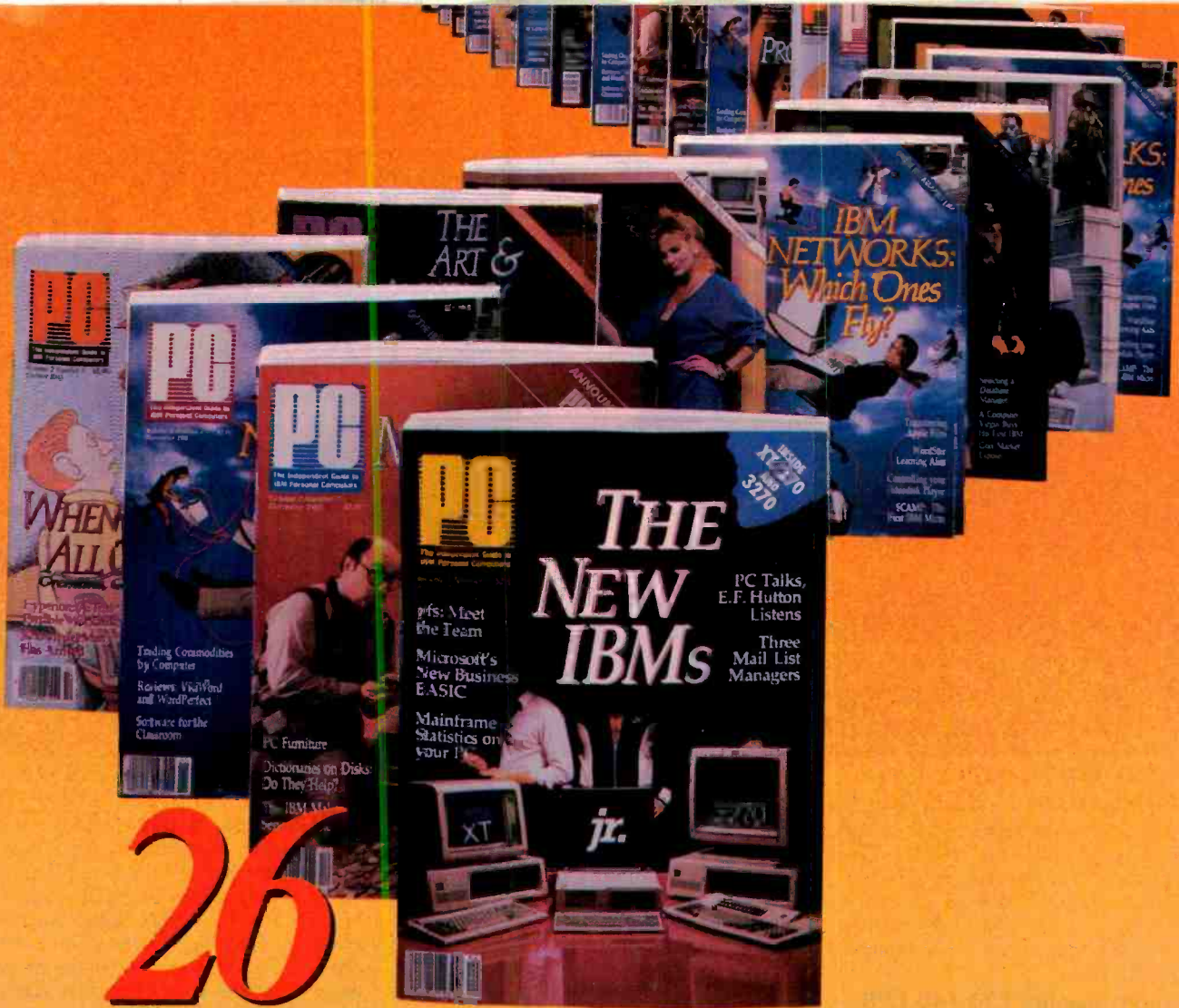

26

# REASONS TO SUBSCRIBE TO

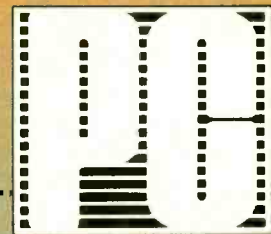

...because PC goes on-sale every-other-Tuesday, bringing you the latest innovations and applications as they *happen!*

When you subscribe to PC, you'll receive the most up-to-date facts and technological breakthroughs that affect your PC, every-other-week! YES! PC will be delivered to your door at unbelievable savings!

You'll begin to develop a library of professional insights including the latest coverage of newly released hardware and peripherals. You'll find timely information on innovations in programming, applications and networking. You'll communicate with professional users like yourself and get reviews of new software packages, some before they even hit the shelves!

You can subscribe to PC, The Independent Guide to IBM Personal Computers for as little as \$1.00 an issue! Use the attached coupon at right TO SUBSCRIBE TODAY!

**GET THE MOST UP-TO-DATE INFORMATION FOR YOU AND YOUR PC EVERY-OTHER-WEEK, WITH PC!**

**26** SUBSCRIBE TO

P.O. BOX 2443 • BOULDER, CO 80322

**26**

**YES**, Please enter my subscription to PC for:

- 20 issues for \$21.97. LESS THAN \$1.10 A COPY!
  - 40 issues for \$39.97. LESS THAN \$1.00 A COPY!
- Full one-year subscription price \$34.97. Single copy price \$2.50.

Mr./Mrs./Ms \_\_\_\_\_ please print name in full

Company \_\_\_\_\_

Address \_\_\_\_\_

City \_\_\_\_\_ State \_\_\_\_\_ Zip \_\_\_\_\_

Check one:  Payment enclosed  Bill me later

Charge my:  American Express  Visa  MasterCard

Card No. \_\_\_\_\_ Exp. Date \_\_\_\_\_

Add \$2 per issue for postage to Canada and all other foreign countries. Please allow 30 to 60 days for delivery of first issue.

PC8Z078

# FANTASTIC COMPUTER PRINTER SALE!!!

## COM-STAR T/F

Tractor  
Friction  
Printer

only \$ **169\*\***

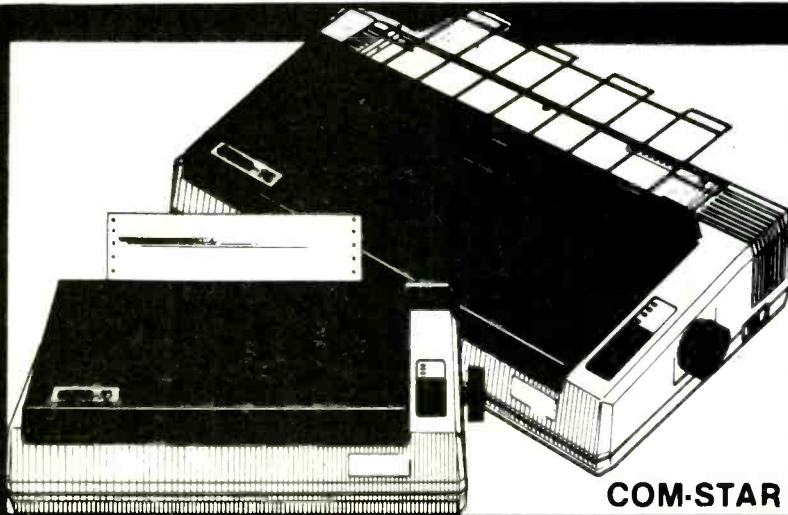

• **Lowest Priced, Best Quality, Tractor-Friction Printers in the U.S.A.**

- **Fast 80-120-160 Characters Per Second** • 40, 46, 66, 80, 96, 132 Characters Per Line Spacing
- **Word Processing** • **Print Labels, Letters, Graphs and Tables** • **List Your Programs**
- **Print Out Data from Modem Services** • **"The Most Important Accessory for Your Computer"**

### \*\* DELUXE COMSTAR T/F 80 CPS Printer — \$169.00

This COMSTAR T/F (Tractor Friction) PRINTER is exceptionally versatile. It prints 8½" x 11" standard size single sheet stationary or continuous feed computer paper. Bi-directional, impact dot matrix, 80 CPS, 224 characters. (Centronics Parallel Interface).

### Premium Quality 120-140 CPS 10" COM-STAR PLUS+ Printer \$249.00

The COM-STAR PLUS+ gives you all the features of the COMSTAR T/F PRINTER plus a 10" carriage, 120-140 CPS, 9x9 dot matrix with double strike capability for 18x18 dot matrix (near letter quality), high resolution bit image (120 x 144 dot matrix), underlining, back spacing, left and right margin settings, true lower decenders with super and subscripts, prints standard, italic, block graphics and special characters. It gives you print quality and features found on printers costing twice as much!! (Centronics Parallel Interface) (Better than Epson FX80). List \$499.00 **SALE \$249.00**

### Premium Quality 120-140 CPS 15½" COM-STAR PLUS+ Business Printer \$349.00

Has all the features of the 10" COM-STAR PLUS+ PRINTER plus 15½" carriage and more powerful electronics components to handle large ledger business forms! (Better than Epson FX 100). List \$599 **SALE \$349.00**

### Superior Quality 140-160 CPS 10" COM-STAR PLUS+ IBM IBM Pers/Bus Printer \$369.00

Has all the features of the 10" COM-STAR PLUS+ PRINTER! It is especially designed for all IBM personal computers! 140-160 CPS HIGH SPEED PRINTING 100% duty cycle, 2K buffer, diverse character fonts, special symbols and true decenders, vertical and horizontal tabs. A RED HOT IBM personal business printer at an unbelievable low price of \$369.00 (centronics parallel interface) List \$699 **SALE \$369.00**

### Superior Quality 160-180 CPS 10" COM-STAR PLUS+ HS Business Printer \$369.00

The Super Com-Star+ High Speed Business Printer 160-180 CPS has a 10" carriage with all the Com-Star+ features built in! The 15½" High Speed Business Printer is especially designed with more powerful electronics to handle larger ledger business forms! Exclusive bottom feed! (Centronics parallel interface) 15½" printer is also compatible with IBM Personal/Business Computers! 15½" Printer List \$799.00 **SALE \$469.00**

**Olympia**

### Executive Letter Quality DAISY WHEEL PRINTER \$379.00

This is the worlds finest daisy wheel printer **Fantastic Letter Quality**, up to 20 CPS bidirectional, will handle 14 4" forms width! Has a 256 character print buffer, special print enhancements, built in tractor-feed (Centronics Parallel and RS232C Interface) List \$699 **SALE \$379.**

• **15 Day Free Trial - 1 Year Immediate Replacement Warranty**

#### PARALLEL INTERFACES

For VIC-20 and COM-64 — \$49.00 For Apple computers — \$79.00 Atari 850 Interface — \$79.00 For ALL IBM Computers — \$89.00

Add \$14.50 for shipping, handling and insurance. Illinois residents please add 6% tax. Add \$29.00 for CANADA, PUERTO RICO, HAWAII, ALASKA, APO-FPO orders. Canadian orders must be in U.S. dollars. WE DO NOT EXPORT TO OTHER COUNTRIES.

Enclose Cashiers Check, Money Order or Personal Check. Allow 14 days for delivery, 2 to 7 days for phone orders, 1 day express mail! VISA—MASTER CARD—We Ship C.O.D. to U.S. Addresses Only

## PROTECTO

### ENTERPRIZES (WE LOVE OUR CUSTOMERS)

BOX 550, BARRINGTON, ILLINOIS 60010  
Phone 312/382-5244 to order

COM-STAR PLUS+  
Print Example:

**ABCDEFGHIJKLMN OPQRSTUVWXYZ  
ABCDEFGHIJKLMN OPQRSTUVWXYZ 1234567890**

NEW 128K —MEGA BYTE DUAL DISK DRIVE—80 COLUMN

# COMPUTER SYSTEM SALE!

HOME • BUSINESS • WORD PROCESSING

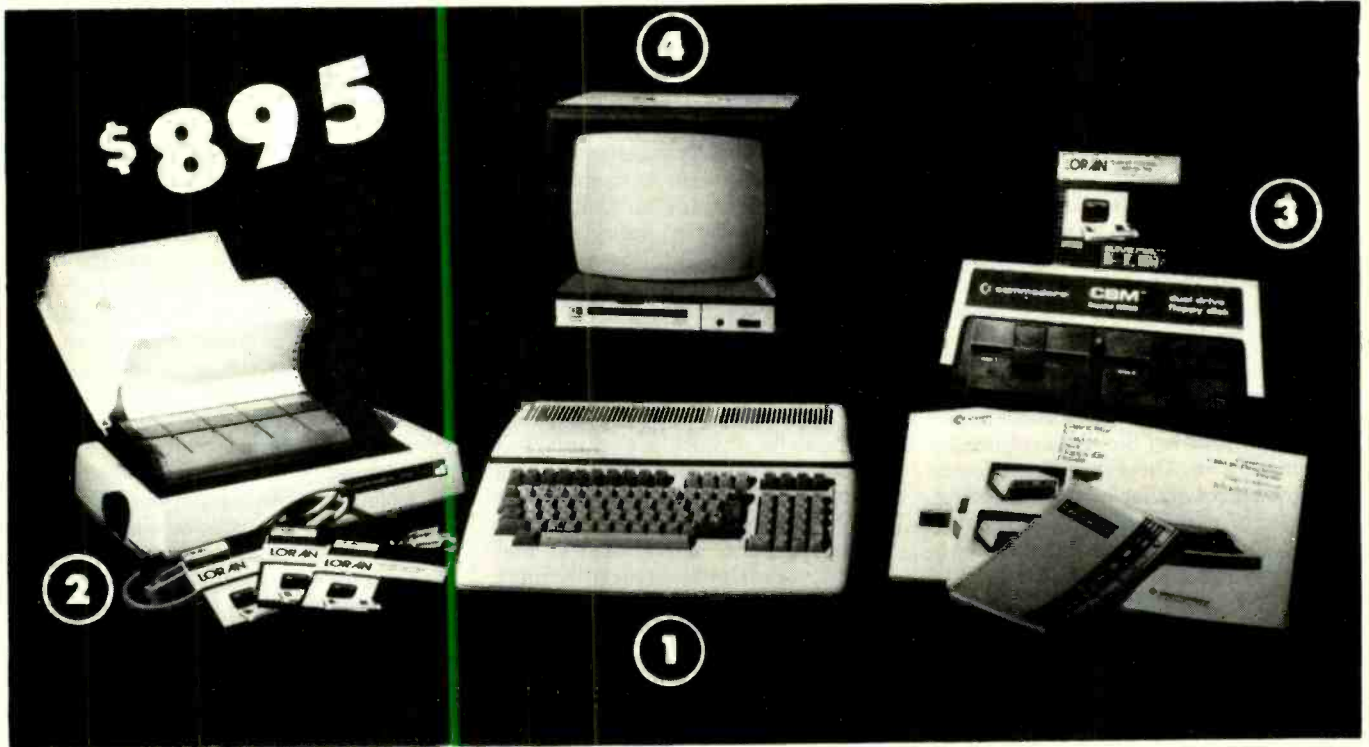

LOOK AT ALL YOU GET FOR ONLY **\$895.**

- |  |            |           |
|--|------------|-----------|
| ① B128 COMMODORE 128K 80 COLUMN COMPUTER           | LIST PRICE | \$ 995.00 |
| ② 4023 - 100 CPS - 80 COLUMN BIDIRECTIONAL PRINTER |            | 499.00    |
| ③ 8050 DUAL DISK DRIVE (over 1 million bytes)      |            | 1795.00   |
| ④ 12" HI RESOLUTION 80 COLUMN MONITOR              |            | 249.00    |
| • BOX OF 10 LORAN LIFE-TIME GUARANTEED DISKS       |            | 49.95     |
| • 1100 SHEETS FANFOLD PAPER                        |            | 19.95     |
| • ALL CABLES NEEDED FOR INTERFACING                |            | 102.25    |

**TOTAL LIST PRICE \$3717.95**



**PLUS YOU CAN ORDER THESE BUSINESS PROGRAMS AT SALE PRICES**

	LIST	SALE		LIST	SALE
Professional 80 Column Word Processor	\$149.95	\$99.00	Payroll	\$149.95	\$99.00
Professional Data Base	\$149.95	\$99.00	Inventory	\$149.95	\$99.00
Accounts Receivable	\$149.95	\$99.00	General Ledger	\$149.95	\$99.00
Accounts Payable	\$149.95	\$99.00	Financial Spread Sheet	\$149.95	\$99.00

**PRINTER REPLACEMENT OPTIONS**

(replace the 4023 with the following at these sale prices)

	LIST	SALE
☛ Olympia Executive Letter Quality Serial Printer	\$699.00	\$399.00
☛ Comstar Hi-Speed 160 CPS 15 1/2" Serial Business Printer	\$779.00	\$499.00
☛ Telecommunications Deluxe Modem Package	\$199.00	\$139.00

**15 DAY FREE TRIAL.** We give you 15 days to try out this SUPER SYSTEM PACKAGE!! If it doesn't meet your expectations, just send it back to us prepaid and we will refund your purchase price!!

**90 DAY IMMEDIATE REPLACEMENT WARRANTY.** If any of the SUPER SYSTEM PACKAGE equipment or programs fail due to faulty workmanship or material we will replace it IMMEDIATELY at no charge!!

Add \$50.00 for shipping and handling!!  
 \$100.00 for Alaska and Hawaii orders.  
 WE DO NOT EXPORT TO OTHER COUNTRIES  
 Enclose Cashiers Check, Money Order or Personal Check. Allow 14 days for delivery, 2 to 7 days for phone orders, 1 day express mail!! We accept Visa and MasterCard. We ship C.O.D. to continental U.S. addresses only.

**PROTECTO ENTERPRISES** (WE LOVE OUR CUSTOMERS)  
 BOX 550, BARRINGTON, ILLINOIS 60010  
 Phone 312/482-5244 to order

## Personal Investment

(Continued from page 86)

sheets. Then performing a host of analytical functions is possible.

Dow Jones is currently selling Spreadsheet Link, a program to access information from its vast database and analyze it using such spreadsheets at Lotus 1-2-3, Multiplan, or Visicalc. Summa Corp. and Warner Computer have recently introduced programs to link all major financial database and major spreadsheet programs.

### Stock Market Games

Stock market games let investors have fun while testing their investment skills—before they put real money into the market. A simple stock market game, Millionaire, put out by Blue Chip Software, simulates market investing. It allows a player to compress 77 weeks of stock trading into a 2-hour exercise, realistically tracking the results of investment decisions. There are different levels of investment available, some including the use of margin. Their tycoon game provides market simulation for commodities, precious metals, foreign currency, the S&P index and T-bills. Like Millionaire, Tycoon can generate completely new market environments for trading and investing.

A more specialized game, based on Point and Figure (P&F) charting (a technique used to obtain buy/sell signals), is Beat the Street (from MEA software). It has 11 years of price history for 175 stocks, with other stockprice histories available. The object is to make lots of money by buying or selling one of the 175 stocks at an optimum point, as determined from the P&F graph generated on the screen.

Another interesting game, available

from Flexible Software, is Portfolio. Reminiscent of Monopoly, it features an electronic game board and can be played by up to four people. Players, put in charge of a multimillion dollar portfolio, make money by managing these corporate funds successfully. The game allows for such activities as watching a ticker tape and evaluating rumors.

### Portfolio Management

Investors who want to keep track of their portfolios on disk for analysis and tax purposes will find many portfolio packages on the market. For the individual, the portfolio programs available are simple, well-organized and easy to use; a few, such as Plain Vanilla (Iris Communications, Inc.) are inexpensive. These portfolio packages generally perform the basic accounting functions, including daily updates of stock prices, gain/loss statements as often as required, and tax reports for strategic analysis or the IRS. Software packages, such as the Personal Investor, provide elegant screens that are truly user-friendly. Some of the more widely sold software, including the Market Manager from Dow Jones, enable investors to keep track of their positions every day and prepare necessary tax reports quickly. Most of the programs in this category also keep investors current on the returns they are receiving from their investments. Changes or updates of the portfolio are easy to make.

### Trading Via Computer

Investors and traders are accustomed to hearing a voice at the other end when they call a brokerage house to buy or sell. With the widespread use of the microcomputer, however, a number of bro-

kerage firms now allow investors to execute stock transactions directly through their computers.

First to install such systems were the discount brokers, among them C.D. Anderson of San Francisco and Fidelity Brokerage of Boston. Both firms use a system developed by Trade-Plus that allows the investor to place an order as well as obtain information on stocks. Customers may even place orders in the evening or on weekends. Other features include an interactive portfolio system that allows investors to follow all their stocks and other financial instruments—the software constantly update clients' holdings. In addition, Fidelity will shortly allow its customers to make on-line fund switches among its family of funds.

Investors can also obtain up-to-date information on their accounts from other brokerage firms that have developed electronic systems. Huttonline (from E.F. Hutton), for instance, allows the customer to see all account positions at the previous day's close of business and to review transactions for the previous 45 days.

Investors who are familiar with the workings of the microcomputer and who are willing to follow the instructions provided by the excellent manuals (which come with many of the financial and investment programs) will find that they can make better investing decisions by using the software. It will soon be possible for anyone—with the time and the discipline—to use the microcomputer for collecting and analyzing data with a speed, efficiency and effectiveness not previously available even to the market professional. ◇

## Investment Software

(Continued from page 73)

	<b>Spreadsheet Link</b> Data downloaded from any of Dow Jones financial databases, such as Current Quotes, Historical Quotes, Media General Financial Services, Disclosure II or Corporate Earnings Estimator and transferred into VisiCalc, Lotus, and MultiPlan spreadsheets	IBM PC, PC/XT; Apple II series	\$249
	<b>Investor's Workshop</b> Portfolio management program	Apple II series	\$149
<b>Fidelity</b> 82 Devonshire St. 136D Boston, MA 02109 800-343-8722	<b>Investor's Express</b> Allows you to do trades, get quotes, list portfolio	All computers (Modem)	Initial fee, \$95; \$15/mo service charge; connect charge, \$40/hr (prime time) \$.10/hr (nonprime time) Apple: \$250 IBM: \$350
<b>H&amp;H Scientific</b> 13507 Pendleton St. Ft. Washington, MD 20744 301-292-2958	<b>Stock Option Analysis Program (Soap)</b>	Apple II, II+, IIe; IBM PC, PC/XT	\$350
	<b>Stock Option Scanner (SOS)</b> Stock option analysis package	Apple II, II+, IIe; IBM PC, PC/XT	\$350
<b>Investor's Software</b> Box N Bradenton Beach, FL 33510	<b>The Evaluation Form</b> Fundamental method of stock selection	Apple II series; TRS-80, II, III, 4; CP/M computers; Altos; Eagle	\$100

(Continued on page 92)

THE MOST COMPLETE COMPUTER INFORMATION RESOURCE

# THE NEW ENCYCLOPEDIA OF COMPUTER SCIENCE AND ENGINEERING

IS YOURS FOR ONLY **\$2.95!**

WHEN YOU JOIN THE LIBRARY OF COMPUTER AND INFORMATION SCIENCES

You simply agree to buy 3 more books—at handsome discounts—within the next 12 months.

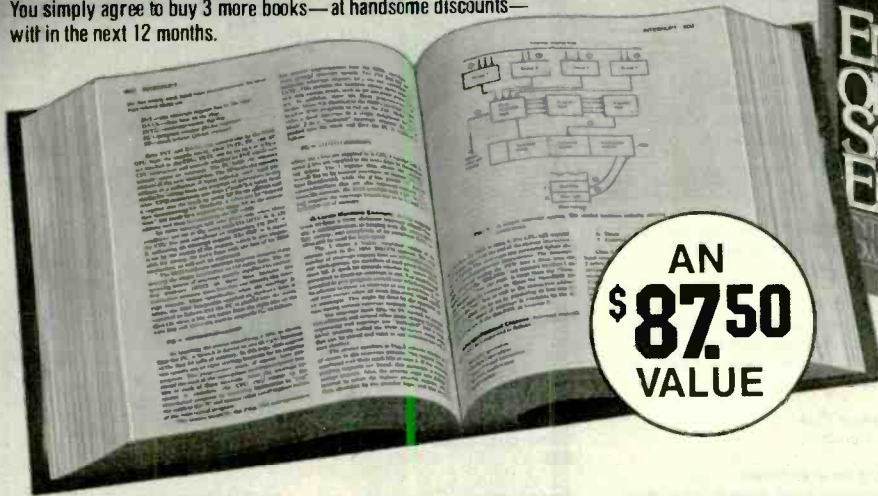

Thoroughly revised, updated and reorganized.

AN **\$87.50** VALUE

## This up-to-date Second Edition contains:

- Over 1,670 pages of revised, expanded, and updated text
- 550 articles on virtually every aspect of the computer sciences
- Written by 301 distinguished authorities
- Profusely illustrated with over 500 photos, and over 250 diagrams, graphs and charts

Indispensable to consultants, business people, data processing professionals, and enthusiasts, the ENCYCLOPEDIA OF COMPUTER SCIENCE AND ENGINEERING is a veritable data base of information on:

- Hardware
- Software
- Programming languages
- Artificial intelligence
- Computer applications
- Personal computing and much more!

The Encyclopedia is organized to make finding and using its wealth of information an ease. Articles are alphabetically arranged and are cross-referenced to related articles and to specific subject matter. The clear and expanded appendices include abbreviations, acronyms, special notation and terminology, as well as numerical tables, the mainstay of applied technologies. A complete 5,000-term index contains

references to sub-categories, doubles as a computer science dictionary, and is an invaluable tool for locating specific information.

**Praise For the First Edition:** Called "Impressive... comprehensive... well done" by *Datamation*, and "... a real treasure cache" by *Business Management*, the new Second Edition promises to eclipse *Computer Management's* statement on the original of "There isn't another book like it." Send for your free 10-day trial.

**The Library of Computer and Information Sciences** is the oldest and largest book club especially designed for the computer professional. In the incredibly fast-moving world of data processing, where up-to-date knowledge is essential, we make it easy for you to keep totally informed on all areas of the information sciences. In addition, books are offered at discounts up to 30% off publishers' prices. Begin enjoying the club's benefits today!

**MEMBERSHIP BENEFITS:** In addition to getting the Encyclopedia of Computer Science and Engineering for only \$2.95, when you join, you keep saving substantially on the books you buy. Also, you will immediately become eligible to participate in our Bonus Book Plan, with savings up to 70% off the publishers' prices. At 3-4 week intervals (16 times per year) you will receive the Book Club News, describing the coming Main Selection and Alternate Selections, together with a dated reply card. If you want the Main Selection, do nothing and it will be sent to you automatically. If you prefer another selection, or no book at all, simply indicate your choice on the card, and return it by the date specified. You will have at least 10 days to decide. If, because of late mail delivery of the News, you should receive a book you do not want, we guarantee return postage.

## The Library of Computer and Information Sciences

(the oldest and most respected computer book club in the world)  
Riverside, New Jersey 08075

7-CR4

Please accept my application for trial membership and send me the Encyclopedia of Computer Science and Engineering (44904) for \$2.95. I agree to purchase at least three additional Selections or Alternates over the next 12 months. Savings range up to 30% and occasionally even more. My membership is cancelable any time after I buy these three books. A shipping and handling charge is added to all shipments.

**No-Risk Guarantee:** If you are not satisfied—for any reason—you may return the Encyclopedia within 10 days and your membership will be canceled and you will owe nothing.

Name \_\_\_\_\_

Name of Firm \_\_\_\_\_  
(If you want subscription sent to your office)

Address \_\_\_\_\_ Apt \_\_\_\_\_

City \_\_\_\_\_

State \_\_\_\_\_ Zip \_\_\_\_\_

(Offer good in Continental U.S. and Canada only. Prices slightly higher in Canada.) Computer & Electronics 11/84

# Investment Software

(Continued from page 90)

<p><b>Iris Communications, Inc.</b> Suite 750 660 Newport Center Dr. Newport Beach, CA 92660 800-523-2004</p>	<p><b>Plain Vanilla</b> Stock market portfolio system</p>	<p>Apple II series; IBM PC, PC/XT</p>	<p>\$80</p>
<p><b>Isys Corp.</b> 50 Church St. Fourth Floor Cambridge, MA 02138 617-491-6221</p>	<p><b>Micro-Scan</b> Database on disk; updated monthly</p>	<p>Apple II series (128K, two disk drives) IBM PC, PC/XT</p>	<p>Price varies \$6000-\$100,000 annually</p>
<p><b>Knowledgeware Systems</b> 4114 Wildwood Dr., NE Ham Lake, MN 55303 612-784-4789</p>	<p><b>Stock Mizer</b> Technical analyses and portfolio management; handles 30 stocks; does graphs of price volume, moving averages</p>	<p>IBM PC, PC/XT</p>	<p>\$130</p>
<p><b>PBL Corp.</b> PO Box 559 Wayzata, MN 55391 612-473-8998</p>	<p><b>Personal Investor</b> Portfolio management program</p>	<p>Apple II, II+, IIe IBM PC, PC/XT</p>	<p>\$145 \$195</p>
<p><b>Personal Equity Computing, Inc.</b> PO Box 2105 Ocean, NJ 07712 201-922-4726</p>	<p><b>Market Trend Analysis System</b> Tracks market movement using 87 indicators</p>	<p>IBM PC, PC/XT (128K RAM)</p>	<p>\$300</p>
<p><b>Savant Corp.</b> Savant Software PO Box 440278 Houston, TX 77244 800-231-9900</p>	<p><b>One-Minute Market Analyst</b> Buy/sell signals based on analysis of technical indicators</p>	<p>IBM PC</p>	<p>\$495 (\$595 with 18 months of data; '60 for quarterly updates)</p>
<p><b>Smith Micro Software</b> PO Box 7137 Huntington Beach, CA 92615 714-964-0412</p>	<p><b>The Technical Investor</b> Charting module allows user to choose up to four independently controlled miniscreens, each capable of plotting any of the charts available</p>	<p>IBM PC (128K)</p>	<p>\$395</p>
<p><b>Spiral Enterprises</b> 308 Crown Rd. Willow Park, TX 76086 817-441-8901</p>	<p><b>Stock Portfolio System</b></p>	<p>Apple II series, III (128K) IBM PC</p>	<p>\$185</p>
<p><b>Standard &amp; Poor's</b> 25 Broadway New York, NY 10005 800-852-5200 X7 212-208-8000</p>	<p><b>SMAS</b> Moving average system operates on databases; provides detailed buy, hold, and sell signals</p>	<p>TRS80 models I, III, 4 (48K, two disk drives)</p>	<p>\$173</p>
<p><b>Star Value Software</b> 12218 Scribe Dr. Austin, TX 78759 512-837-5498</p>	<p><b>Stockpak II</b> Provides monthly database disk; covers 4500 companies with over 100 information items on each company in database</p>	<p>Apple II series; IBM PC</p>	<p>Varies with type of subscription</p>
<p><b>Summa Software Corp.</b> PO Box 2046 Beaverton, OR 97095 503-644-3212</p>	<p><b>Optionvue Plus</b> Options program</p>	<p>IBM PC/XT and compatibles; Demo disk, including manual, \$35</p>	<p>\$495</p>
<p><b>Trade*Plus</b> PO Box 60970 Palo Alto, CA 94306 800-952-9900</p>	<p><b>Winning on Wall Street</b> A decision-support system; fully integrated into three-module systems: Trader's Data Manager, Trader's Forecaster and Trader's Accountant</p>	<p>Apple II series; IBM PC, IBM PC/XT</p>	<p>\$700 for the system</p>
<p><b>Max Ule &amp; Co., Inc.</b> 6 E. 43rd St. New York, NY 10017 212-986-1660</p>	<p><b>Switchboard</b> Communications and file transfer program; accesses databases and links to spreadsheet, word processing and investment programs</p>	<p>IBM PC, IBM PC/XT (192K, two disk drives, modem, double-density disks)</p>	<p>\$150</p>
<p><b>Value Line</b> 711 Third Ave. New York, NY 10017 212-687-3965</p>	<p><b>Trade*Plus</b> Online portfolio database</p>	<p></p>	<p>Billed through brokerage firm</p>
<p><b>Wall Street On-line</b> 76 Beaver St. New York, NY 10005 212-514-5700</p>	<p><b>Tickerscreen</b> Stock ticker bulletin board</p>	<p></p>	<p></p>
<p><b>Warner Computer Systems</b> 605 Third Ave. New York, NY 10158 212-986-1919</p>	<p><b>Value/Screen</b> System allows selection of stocks from Value Line database of 1650 stocks that satisfy up to nine different criteria from the 32 available</p>	<p>Apple II, II+, IIe; IBM PC, PC/XT</p>	<p>\$495 (includes monthly update)</p>
<p><b>Warner Computer Systems</b> 605 Third Ave. New York, NY 10158 212-986-1919</p>	<p><b>Wall Street On-line</b> Stock, option and commodity databases</p>	<p>(Modem)</p>	<p>Rates vary</p>
<p><b>Warner Computer Systems</b> 605 Third Ave. New York, NY 10158 212-986-1919</p>	<p><b>The Warner Connector</b> Accesses Dow Jones database for technical and fundamental analysis</p>	<p>(Modem)</p>	<p>\$20</p>
<p></p>	<p><b>Spreadsheet Analyzer</b> Program downloads in DIF format from Warner's database to spreadsheet program</p>	<p>IBM PC (Modem)</p>	<p>\$495</p>



## Faceoff

(Continued from page 53)

ever, that a special utility (supplied by IBM) is required to allow you to make use of memory in excess of 128K.

Probably the greatest change in the new PCjr is its keyboard. The old "Chiclet" type with the hard-to-read legends has been replaced by one with real keys that can be used by a touch typist. In a much-publicized move, IBM has made this new keyboard available free of charge to owners of jrs with the old style one. The cordless infrared arrangement has been retained and seems to function as well as the original.

The Apple IIc's keyboard is an integral part of the computer. It, too, is suitable for touch typing and offers, as does the jr's, upper and lower case. In what is probably a bid for the educational market, Apple has included a switch that turns the QWERTY keyboard into one using a supposedly more efficient Dvorak layout. The keytops are removable so they can be arranged to accommodate whichever layout is in use.

The CPU in the IIc is a 65C02 8-bit CMOS microprocessor running at 1.02 MHz, an enhanced version of the Apple II's 6502. The jr uses the same 8088 found in the larger PC, with a 4.77-MHz clock. This does not mean, though, that the jr is four or more times faster than the IIc (see page 52).

The number crunching power of both machines is impressive. The jr in many applications may not be faster than the IIc, despite its so-called 16-bit CPU—while the jr's 8088 has a 16-bit internal structure, all its dealings with the rest of the system and with the outside world are 8-bit operations. In similar "painting" programs, the IIc actually seemed somewhat speedier, perhaps, due in part to how the software was written but also due to the extreme efficiency of the 6502 family for certain types of operations.

But despite its somewhat awkward appearance and construction, the jr is probably a better computer in terms of hardware simply because it has expansion capabilities the IIc lacks.

### Portability

The Apple IIc has a handle and is designed to be portable. (The handle also serves to elevate the rear of the computer and to permit air to enter it for ventilation.) The jr has no handle and is not really intended to be portable, although a carrying case is available for it.

The IIc can be powered by either an external supply that requires 120 V ac (house current) or directly by 9-20 V dc. This latter capability means that it may obtain its power from a car's cigarette lighter receptacle. The jr will operate

only from 120 V ac. The ac-to-dc conversion is done externally for the IIc, internally for the jr.

Even though Apple has given the ac power supply that comes with the IIc a contoured look, you still get the feeling that it should be powering an electric train rather than a computer. IBM uses a similar-sized unit for the 128K jr, but adds a second heavy black transformer to power its add-on modules. None of the power supply units are particularly lightweight.

As of this writing, the IIc uses a video display, but Apple is working on an 80-column by 25-line LCD screen that should be available about the time you read this. A battery pack is already being marketed by a third party vendor. These features could make it truly portable.

### Software

Both computers have broad software bases, and there are probably comparable programs for the basic 128K versions of both. In fact, the 128K Apple can probably run more sophisticated programs than a 128K jr.

Why? Is the 8-bit computer more powerful than the 16-bit one? Not necessarily, but for some reason 8088 programs seem to take for granted the availability of lots and lots of memory, and the result is a sort of "software sprawl." Programs for 8-bit computers are *tight!*

However, the jr will find favor with a number of users simply because it can run a number of such popular programs as Lotus 1-2-3, which, because of microprocessor incompatibility and memory requirements, cannot be used on the IIc.

### Documentation

The user manuals provided with the IIc are a joy to read. They are colorful, imaginative and clearly written. The jr documentation is comprehensive but often dull. It seems that IBM does not devote as much effort as Apple to make the support materials user friendly. In fact, many of the manuals for the IBM add-ons are boring, dense and a bit reminiscent of IRS tax manuals. But the major jr book, "The Guide To Operations" manual, in general is readable and fairly straightforward.

Documentation, as any micro owner painfully knows, is very important, especially in the target market where there are so many computer novices. Apple seems to understand; IBM seems to agree but apparently only grudgingly.

### Which One?

Which of the two computers will benefit you the most? To a great degree, that

depends on who you are. The determination will rest primarily on the software available for each.

Apple has long known that if it could get its products into the educational system and have millions of students learning about computing using Apples, these same students (and their teachers) would later buy Apples for home use. Consequently, there is a large amount of educational software for the Apple.

IBM, increasingly aware of the value of this strategy, has introduced a reading program for the primary grades called "Writing to Read." The program helps teach children how to read by having them type words and parts of words representing speech sounds on a jr or PC.

The company, some educators believe, may also be reaching for the educational market with the jr and its optional speech synthesizer. In addition to having its own vocabulary of 196 words in ROM, the device can record about 18 seconds worth of speech in digital form (from an accessory microphone) and is programmable from BASIC. It could easily find use in language laboratories or other learning reinforcement applications.

As of this writing, however, Apple continues to dominate the schools—especially at the K-9 level. IBM is increasing its penetration of high schools, but so is Apple. In the light of recent events, many analysts believe that it is at school that the major battle of the war for the educational market will be won.

On the other hand, if you principally use computers in business, your choice will probably be—whether you consciously make it or not—the PCjr, again because of the software factor.

While there is undeniably much business software available for the Apple, any *new* business software, with very few exceptions, will be written for the PC family of computers. And, while that software is aimed at the PC/XT/AT market, the jr, with its expanded memory, will be able to run most of it. If you use a PC at work, you'll probably want a jr at home.

Of the two computers, the IIc is the better looking and more sturdily constructed. The software available for it makes it the better suited for home and personal use, especially in a family with school age children. But the PCjr, with its expanding software base and the support of the world's largest computer company, is probably the choice for those who wish or need to remain in the software mainstream. Regardless, considering their prices, one cannot go wrong in buying either machine. ◇

## Video Processing (Continued from page 83)

requirements and cost. In a personnel database that includes photos with employee records, for example, real-time image acquisition would be expensive and pointless. Chorus Data PC-Eye is, according to Chorus' co-founder Bruce Monk, "intended for things which can be frozen in time—still pictures. It captures only every tenth frame and something like 50 lines of information per frame in  $\frac{1}{3}$  second, whereas a true frame grabber would get all 512 lines of video." The digitized image is fed directly into the host CPU's main memory or graphics adapter card for processing. PC-Eye can also use an IBM PC's display screen rather than an additional video monitor in most applications.

Cromemco's SDD (Super Dazzler Digitizer) also doesn't use flash digitizer chips. Unlike the PC-Eye image acquisition system, which samples on a fixed basis, the SDD does image processing as the image is being captured. It takes the system 2 or 3 s to acquire a frame because it only takes in information as it needs it for specific operations.

### Operations Algorithms Critical

The capabilities of a video-processing product are largely a matter of trade-offs based on price/performance. The real heart of any system is its software. As Imaging Technology's Massa says, "Anybody can stuff components on a board. But where are the equations? That's the real soup that makes the whole thing work. That's proprietary stuff. Top secret. That's what makes it a difficult technology to copy. It took years to write those equations." At Imaging Technology the operations algorithms were written largely by Rashid Beg, vice president of engineering. Beg founded the company with fellow Canadian Robert Wang in 1982 because, as Massa says, "They knew really powerful image processing could be done with microprocessors and nobody was doing it."

Complex and mathematically elegant operations algorithms like Beg's are responsible for the excitement video processing is causing at trade shows and among systems integrators. Components are what a system is. Algorithms dictate what the system does.

There are basically four types of video processing operations. *Pixel point processing* enables the user to address and manipulate pixels independently in order to do enhancements and change contrasts. *Pixel group processing* involves manipulating the spatial relationships between pixels. *Frame processing* deals with an entire image and may include both pixel point and pixel group process-

ing. *Geometric operations* allow the user to enlarge and reduce images or rotate and position them on a screen.

### First Step by Robotics

Microprocessor-based vision systems are found in industrial robots and automated inspection systems. Historically, they were the initial step that led to the development of the powerful processing software we have today.

According to Massa, "In the early 1970s there was an explosion in robotics and automated assembly systems based on minicomputers and, later, on micros. With that explosion came a great need to develop low-cost image processing as eyes for the robot, to do automatically what people were doing—visual inspection, where high reliability is important. By the late 1970s and early 1980s, image processing really began to take off because of the increasing number of applications—primarily in inspection." Massa cites a 1981 report by International Data Corporation, an independent industry research organization, that forecast a total market for image processing at around \$80 million in 1982, increasing to a \$550 million annual market by 1987.

"I think that the market has grown considerably more than that because of the use of microprocessors," Massa says. "My guess is that it's as much as a \$300-\$400 million market currently, and by the end of 1987, it will probably be higher than \$600 million."

Automated inspection can be as simple as image subtraction, as when the computer compares an image of an electronics board coming down an assembly line to a stored image of a perfect board. Where it is possible to "step" the inspection line (so that the object under scrutiny pauses under the camera), low-end sampling devices are adequate. Says Massa, "We have some customers who were inspecting only at the end of the line. By doing process inspection so that they could make necessary changes in their equipment as things were going through, they increased their yields from 10 or 20% to 50 or 80%."

More complex inspection systems, such as those developed for automobile assembly plants by Machine Vision International and Synthetic Vision Systems, use combinations of operations to perform a variety of inspection and robot positioning tasks.

Security, simple surveillance and monitoring systems comprise the second major application for low-cost video processing equipment. Bruce Monk of Chorus Data says, "It's practical now to [have a camera that is linked to an image

processing system] look at a control panel to read gauges, note combinations of lights on and lights off and then automatically dial a telephone number to set off an alarm if necessary." So in a power plant, a petrochemical factory or a scientific experiment with a lot of instrumentation, you don't have to have an expensive human inspector. And you don't have the cost and hassle of wiring a computer up to all those devices.

According to Memotech's Govatski, the success and spread of security applications will open up more and more archiving applications for video systems. "Within a few years," he says, "we are going to be storing images in computers as routinely as we now store data."

Medical imaging is a third major—and growing—application. Because much of the state-of-the-art medical instrumentation in use today is based on microprocessors, adding video processing digitizer and logic boards and software is taking place very rapidly. Adding video processing to ultrasound scanners and video X-ray systems, for example, allows the physician to select particular frames (or parts of frames) for enhancement and to store them as part of a computerized database along with other pertinent data. Scanning electron microscopy products from Bausch and Lomb and diagnostic eye care systems being developed by Cooper Vision employ Imaging Technology video processing boards.

Graphic arts is also becoming an important market for video products. Dramatic visual effects are generating a lot of excitement in the industry, but it's the cost benefits that are selling systems. Among the huge stack of sales leads Memotech picked up at a recent trade show were greeting card companies, billboard studios, ad agencies, cartographers and print producers of all kinds. "Dummy layouts for artwork and storyboards are very labor intensive and time consuming," Govatski says. "The greeting card companies put out a tremendous amount of material every year. They're very interested in being able to bring up a real-time picture of some scene or photograph, play with it by manipulating the color, combining images, superimposing text and graphics—and then printing out hard copy of the result as a dummy."

Microprocessor-based video systems can provide simple productivity improvements, for example, by allowing the graphic artist to alter in minutes the gray scales in a photograph. The same process formerly had to be done painstakingly in a darkroom using silkscreen

# YOUR LINK TO THE FUTURE OF MICROCOMPUTING

*New hardware that will change the way you do business*

*Novel applications of existing technology*

*Who are the leaders and what are they doing?*

*Technologically advanced—User literate*



## COMPUTERS & ELECTRONICS

is your state-of-the-art link to technology and innovations of micro-computing. No other magazine ties you into the developments and the developers of the future of microcomputing quite like COMPUTERS & ELECTRONICS.

Your subscription to COMPUTERS & ELECTRONICS brings you the latest developments in hardware, software and peripherals—and the impact these products will have on you, today, and in the future! You'll have an open forum with the developers of new worlds of technology and processing! You'll be an active part of today, while blazing new paths towards tomorrow!

Open your link to the future of microcomputing the way you want it—the way you need it!

**SUBSCRIBE TO  
COMPUTERS & ELECTRONICS  
AND SAVE UP TO 32%!**

**Computers**  
& ELECTRONICS

P.O. Box 2774  
Boulder, Colorado 80322

**YES!** I want a direct link to the future of microcomputing.

Please send me COMPUTERS & ELECTRONICS for:

8 issues for \$8.97.  1 year for \$12.97.  2 years for \$22.97.  
I SAVE 21%! I SAVE 24%! I SAVE 32%!

Savings based on full one-year (12 issue) subscription price of \$16.97.

Mr./Mrs./Ms. \_\_\_\_\_ please print full name

Company \_\_\_\_\_

Address \_\_\_\_\_

City \_\_\_\_\_ State \_\_\_\_\_ Zip \_\_\_\_\_

Check one:  Payment enclosed  Bill me later  
Charge my:  American Express  Visa  MasterCard

Card No. \_\_\_\_\_ Exp. Date \_\_\_\_\_

Add 40¢ an issue in Canada. Add 70¢ an issue in all other foreign countries.  
Please allow 30 to 40 days for delivery of first issue.

CE4Z031

## Video Processing

masks. Linked with special cameras that produce 35-mm transparencies, video processing is reducing the cost of commercial slide production from \$50-\$75 a slide to around \$5 and improving the quality of the image at the same time.

The broadcast industry is, of course, an old hand at video processing. The vivid and colorful video montages that swoop out at us nightly are the products of video processing. Until the last few years, only the big networks and major-market stations could afford the equipment to do the best video processing and special video effects.

Colorgraphics Systems, Inc., based in Madison, WI, is this country's largest supplier of broadcast graphics systems. Some 80% of all the television stations in the country use Colorgraphics's LiveLine systems to generate weather, news and sports graphics. The basic system is built around Cromemco microcomputers and, at \$50,000, is about half the cost of comparable earlier generations of equipment. In April 1983, Colorgraphics introduced the ArtStar video processing hardware and software package as a \$7000 add-on. ArtStar uses Cromemco's SDD board. It takes standard NTSC signals and allows the studio graphic artists to capture and manipulate video images not only of people and props, but also of radar patterns from weather information network services. Algorithms developed by Colorgraphics give the artist some 256 colors to play with and emulate the visual effects of airbrush, chalk and other media as well as picture surface textures ranging from hard bristol board to rough canvas.

### The Future

According to Richard Daly, vice president of research and development at Colorgraphics, the merger that is now taking place between advanced computer graphics techniques and video processing will have a profound effect on the broadcasting industry. The production of TV ads using integrated graphics and video processing techniques, he says, is a huge and lucrative marketplace just waiting for low-cost video processing.

Video is even cheaper than film, and images are easier and less costly to manipulate than writing all the software that turns bits into objects with color, depth, texture and motion. According to Daly, "The only thing holding back the widespread use of video processing in the production of television commercials has been the quality of the image. Products coming up from the low end are now solving those problems and creating systems that are compatible with exist-

ing studio equipment."

On the basis of these new systems and on its own unique expertise integrating graphics and video, Daly's company is expanding from broadcasting into the graphic arts market. "I foresee this technology being an important part of the processing chain that brings work from the original scene to the final viewer," Daly says. He predicts that an integrated print production system including automated typesetting, video processing, graphics, designer interface and machine output of four-color printing plates will be available within a year.

Bringing together text, graphics and images promises to create new products for office automation. However, as Memotech's Govatski points out, wider use of video processing in the office awaits better hard-copy output devices. "The ink jet printers now entering the market are a real improvement over the older dot matrix technology," he says, "but we're looking for even more improvement."

### High-Communications Bandwidth

Bruce Monk at Chorus Data Systems sees a future for video processing in the office, based primarily on communications. "We have to make computers productivity tools," he says. "So we ask, 'How do you make this product closer to the human?' A lot of people are looking at things in voice recognition. That's good. In some applications, that's definitely the way to go. But voice is not the high-communications bandwidth for humans—*vision* is.

"There is a lot of printed material that is not suited to computer entry via keyboard, mouse, or digitizer tablet—a lot of visual information out there that could be telecommunicated."

Chorus Data Systems is working on a telecommunications product tentatively being referred to as Video Mail. Suppose someone in an office in San Francisco wants to send a sketch, a set of plans or a photograph to someone in an office in Philadelphia. "It's not like video teleconferencing," Monk says, "where you want to send moving images in real time. With the proper compression of the image and with the 56K baud lines that are now being offered, you could send images—not as economically as facsimile perhaps—but at quite reasonable rates. And facsimile is limited to text and line art—no gray scale, no color."

Melen at Cromemco thinks that, in the retail or commercial market, video processing will be widely used in catalogs and in point-of-sale systems. "Mitsubishi Rayon in Japan has a

Cromemco-based system," he says, "that allows the customer to design a kitchen. You display pictures of kitchens, combine the images with images of faucets, cabinets and other items you wish to include. And when you've put together the design you want, the computer prints out a bill of materials."

More interesting than faucets and kitchen cabinets, however, is the potential video presents as a data capture medium for input to artificial intelligence systems. Melen says, "I think intelligent, interactive imaging expert systems form an important technical direction of the future." He cites existing AI systems like MYCIN, a medical diagnostic system, as candidates for interfacing with video processors. If such a system could "look" at an X-ray, a blood sample or an ECG pattern directly, a great deal of the expense and time involved in routine diagnostics could be saved.

The future for video processing may parallel other electronics technology—systems will grow smaller, more powerful and less expensive, spreading outward into more and more applications.

Given the rapid pace of development, does that mean that we'll have four-color picture phones with zoom and windowing capabilities at home within a few years? No, probably not. But it is likely that most computers with a practical purpose will have vision.

*[A good source for information on the more detailed aspects of video processing operations and video processing technology in general is Gregory A. Baxes' Digital Image Processing: A Practical Primer (Prentice-Hall, 1984).]* ♦

## You Can Get There

(Continued from page 78)

### Summing Up

By using the means we've discussed, you can sometimes make what is otherwise incompatible software and hardware work together. The operative term is "sometimes." Sometimes it's almost 100% successful, sometimes barely 10%—and you often won't know until you give it a try. We evaluated a considerable amount of various "interchange" and translator software in preparing this article, and a large portion of it barely worked. The interchange and translator products that appeared to live up to their manufacturers' claims are the ones we included here. We found enough of them to demonstrate that there are ways around most of the theoretical incompatibility problems associated with computers. The farmer was wrong. You really *can* get there from here! ♦



## CALCULATOR SAVINGS



HP-11C Programmable	\$64.99	82160A HP-IL Module	\$69.99
HP-12C Financial	\$69.99	82161A Cassette Drive	\$59.99
HP-15C Programmable	\$99.99	82162A HP-IL Printer	\$59.99
HP-18C Hexadecimal	\$99.99	82164A RS-232 Interf.	\$49.99
HP-41CV Alpha Progrm	\$189.99	82166A HP-IL Modem	\$59.99
HP-41CX Extnd Functn	\$259.99	22198A 80 col Video Int.	\$269.99
82104A Card Reader	\$149.99	2225B HP-IL Think Jet	\$419.99
82143A Printer	\$299.99	9114A HP-IL Disk Drv	\$49.99
82153A Wand	\$99.99	82180A Extnd Functions	\$59.99
HP-97 Desk Progrmb	\$99.99	82181A Extnd Memory	\$59.99
HP-71B Computer	\$419.99	HP-41 System Case	\$49.99
82700A Card Reader	\$124.99	Port-X-Tender to 10 ports	\$129.99
82401A HP-IL Interface	\$107.99		
82420A 4K Mem for 71B	\$59.99		
HP-75C Computer	\$699.99		
HP-75D Computer	\$329.99		
82700A 8K Mem for 75	\$149.99		

Call for Low Prices on all Accessories and Software

TI	TI-66 Advanced Programmable, 500 steps	\$39.99
	TI-55-II Scientific Calculator w/ Statistics	\$4.99
	LCD-Programmer Hexadecimal Converter	\$9.99
Brother	BP-30 Type-A-Graph Typewriter/4-Color Graph Maker	\$239.99
Canon	TYPESTAR-5 Portable Electronic Typewriter	\$169.99
	TYPESTAR-6 Portable Electronic Typewriter 2K Memory	\$249.99

Sharp	EL-7050 Graphwriter 4-color Printing Calc	\$79.99
	EL-7001 Memowriter with 40 word memories	\$9.99
	EL-5500 II Handheld Computer/Calculator	\$79.99
	PC-1250A Pocket-size BASIC Computer	\$9.99
	PC-1261 Two-line 10K Pocket Computer	\$159.99
	PC-1500A Expandable 8K Handheld Computer	\$79.99
	CE-125 Printer/Minicassette for 1250A/1261	\$39.99
	CE-126P Cassette Interface/Printer for 1250A/1261	\$79.99
	CE-150 Cassette Intf/Pttr for 1500A	\$79.99
	CE-158 RS-232C & Parallel Interface for 1500A	\$159.99
	CE-161 16K Memory Expan with Battery Back-up	\$39.99

Case	FX-700P Handheld Computer, 1568 steps	\$59.99
	FA-3 Cassette Adapter for FX-700P	\$4.99
	FP-12 20-column printer for FX-700P	\$9.99
	FX-98 Credit card Solar Scientific Calculator	\$4.99
	FX-451 Scientific Calculator with Hexadecimal	\$29.99
	FX-720P Expandable Handheld Computer	\$79.99
	FX-750P Expandable 4K Handheld Computer	\$109.99
	SL-800 Film Card	\$2.99

Use cashier's check, postal money order, VISA, or M/C. Personal checks take five weeks to clear. Add shipping, 1% of your order (\$3.95 minimum). East of Mississippi extra \$1.50. CA res add 6%. Subject to availability. USA prices.

**tam's**  
INCORPORATED

Tam's Inc, Dept CE-11  
14932 Garfield Ave.  
Paramount, CA 90723  
(213) 633-3262

Circle No. 42 on Free Information Card

## PRINTERS

QUALITY BRANDS...  
...DISCOUNT PRICES

- ANADEK
- BROTHER
- C-ITOH
- EPSON
- JUKI
- OKIDATA
- SMITH-CORONA
- TOSHIBA
- TRANSTAR

CALL OR WRITE FOR THE PRINTER & PRICE TO MEET YOUR NEEDS.  
YOUR SATISFACTION GUARANTEED.

**CRAFTSMAN CORPORATION**

3116 BAY to BAY — BOX 18966  
TAMPA, FL 33679

**813/831-5681**  
IN FLORIDA

ALL OTHERS 1-800-237-4044  
VISA & MASTERCARD ACCEPTED

Circle No. 7 on Free Information Card

## Panasonic Sr. Partner

(Continued from page 40)

reach and obscured by ribbon cabling. Setting DIP switches with their miniature rocker controls can be tough at the best of times, trying to do it on a "long-distance" basis is even worse.

### IBM Compatibility

The Sr. Partner uses MS-DOS version 2.11 as its operating system and therefore offers essentially the same features as PC-DOS. Indeed, looking at a directory of the Sr. Partner's system disk gives the impression that you are using an IBM PC. Files such as: COMMAND.COM; BASICA.COM; and EDLIN.COM are all there. The only difference is the varying size when compared to the IBM equivalents.

The Sr. Partner BASICA file runs to 55,280 bytes in size, whereas the IBM version is only 25,984 bytes. The Sr. Partner's EDLIN file is 8110 bytes in size, whereas the IBM PC's is 4608 bytes.

As a first step in testing its compatibility, I formatted a disk using the Sr. Partner's format program and then placed the disk in an IBM PC. The IBM system couldn't detect any difference and was able to write and read data from the "foreign" disk without error. Placing the disk back in the Sr. Partner's B, I loaded

create a default system file prior to my entering data, an error message proclaiming "End of file found unexpectedly" or "Index file cannot be opened" appeared. I could never get beyond this point. With dBASE II itself, I could create a file and set up its structure, but I could not enter data because of the EOF error message. However, both Friday! and dBase II worked perfectly on the Sr. Partner when I booted it off the IBM's system disk.

I was pleased that other programs, such as Microsoft's Flight Simulator, worked perfectly on the Sr. Partner.

Overall, I would rate the Panasonic machine as IBM compatible, given that you have an IBM DOS disk around for those programs that need its company. But do expect the machine to stumble when it encounters software that makes direct calls to the IBM ROM or uses some exotic protection scheme; if the software doesn't find what it's looking for, it will curl up and go to sleep.

### The Thermal Printer

Fitted snugly into the top of the Sr. Partner (hidden when necessary by yet another clip-down cover) is the thermal printer. It operates at varying speeds, depending on the print mode you have set, but it seems capable of about 50 characters per second.

Thermal printers are extremely quiet in operation and the Sr. Partner's is no exception. In fact, you occasionally have to peer down into the printer just to reassure yourself that everything is going OK. From the documentation, it would appear that you must use Panasonic's own thermal printer paper, which comes in 8 1/2" rolls perforated every 11". Paper feed is managed by a few rubber rollers rather than sprockets.

Generally, I found that the printer worked very well and produced good quality output in black characters. Without the printer, the Sr. Partner would be yet another transportable—with it, the system becomes quite impressive. The printer can print in 80-column mode or a compressed-font 132-column mode. Double-width text, compressed text, underlined text and graphics output are available to the user. Compressed text is very useful if you wish to print out worksheets from your favorite spreadsheet program. The graphics mode can be used to reproduce screen-generated graphs and charts. Unfortunately, all the above printer features must be specially configured by the user via BASIC using Epson MX 80 printer commands (unless the software supports these functions). If you wanted compressed text output, you

## Some programs generated gremlins like "End of File" or "Divide Overflow"

an IBM format WordStar (version 3.30). There were no unpleasant surprises, and the Sr. Partner completed every WordStar task that I asked of it. I was also able to print out documents—created with the IBM WordStar disk—on the Sr. Partner's thermal printer.

Not surprisingly, the Sr. Partner objected with the message "divide overflow" when I tried to run the IBM BASICA program. I could, however, run the Sr. Partner's BASICA on the IBM with no apparent trouble at all. The Sr. Partner would also boot off an IBM PC-DOS system disk (version 2.11).

The first problem occurred when I tried to run dBASE II and the dBASE offshoot, Friday!, under the Sr. Partner's MS-DOS 2.11 system disk. Both Friday! and dBASE loaded normally. But actually doing something with them caused problems. Just as Friday! was about to

would first initialize the printer by executing the BASIC statement:

```
LPRINT CHR$(15)
```

If you wanted to produce underlined output you would use the BASIC statement:

```
LPRINT CHR$(27);
CHR$(45); CHR$(1)
```

Here's a point where Panasonic could have helped the user a bit. Instead of just adopting the Epson printer conventions,

## Is there a memory map in there?

it would have been nice to provide a menu-based program from which the various printer output options could be quickly chosen.

### Documentation

Only the Operations/DOS manual was provided with the review machine, so I can only make somewhat limited comments about the Sr. Partner's documentation. What there was to see was quite good in that it was professionally printed and contained within a three-ring binder. Enough technical data is provided so that even the more sophisticated user can find something of interest—although I would still like to know if there's a memory map in there somewhere.

### Conclusion

The Panasonic Sr. Partner does not add anything exciting to the growing list of compatibles other than an integral printer and a pretty good list price of \$2145 for a one-drive, 256K machine. But it is highly IBM compatible, its appearance is pleasant, and it comes with a "free" bundle of popular software.

You'll probably want to attach a larger monitor to the machine and have access to a better quality printer at your workplace. Also you'll need to spend about \$60 on an IBM DOS disk if you want to use software that requires it.

Originally the machine was sold for \$2495, but that had to change when IBM dropped its microcomputer prices. The fact that Panasonic reacted with a price cut indicates that it intends to play in the major league and not just be among the products left "on the bench." ◇

"The MDC-550 is more computing machine for the dollar than any other personal computer on the market."  
Byte August 1984

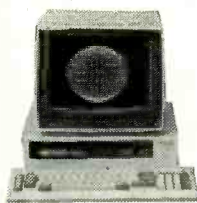

We have the lowest prices for the Sanyo 550's and more free software\*

\*Our prices this month are at least \$10 less than any bona-fide advertised price in this magazine for Sanyo 550's, 555's, 550-2's, 555-2, and our new 720K "dash fours". Plus in addition to Sanyo's regular software bundle we include two free disks with games, graphics, diagnostics, and more. Low prices aren't the only reason we've sold more Sanyo computers than any other dealer in the United States. To find out why these "under \$1,000" MS-DOS machines are the best value in microcomputing call or write for our free brochure.



## Columbia

Still the best compatible buy. Prices include MS-DOS 2.1, Basic 2.0, CP/M 86, Perfect Writer, Speller, Calc, and Piler, Fast Graphs, T.I.M. IV Data Base Management System, ATI Tutorial Disks, Home Accountant Plus, Space Commanders, and nationwide Bell and Howell Service.  
1600-1V ..... \$1799 VP's ..... \$1799  
1600-4V (with 10 Megabytes) ..... \$3239

COMPUTERS	
Sanyo 1150	\$1299
Sanyo 4050	\$1799
Zenith 151-52	\$2244
Apple Macintosh	call

PRINTERS	
Tally Spirit 80	\$259
Oki 82 w/Ok Writer	\$419
Okidata 92	Same
Okidata 93	\$350 OFF
Epson	call
Toshiba 1351	\$1299
Gemini 10X	\$258
Power Type	\$338
Radix 15	\$699

300/1200 MODEMS	
Password	\$309
Mark XII	\$249

**Scottsdale Systems Ltd.**  
617 N. Scottsdale Road, Suite B, Scottsdale, Arizona 85257  
(602) 941-5856  
Call 8-5 Mon.-Fri. **Our 5th Year**

We participate in arbitration for business and customers through the Better Business Bureau.

### SERVICE/ORDERING

**TELEMARKETING ONLY:** If you plan to visit please call first for an appointment. Prices listed are for cash and include 3% discount. We sell on a Net 30 basis to Fortune 1200 companies and universities. No C.O.D.'s or A.P.O.'s. P.O.'s add 2%. Visa, Mastercard add 3%. Az. residents add 6%. Prices subject to change, product subject to availability. Personal/company checks take 3 weeks to clear. All items listed are new with manufacturer's warranty, 0-20% restocking fee for returned merchandise. Shipping extra-products are f.o.b. point of shipment. Software is not warranted for suitability. Registered trademarks: Teletideo-Teletideo Systems, Inc.; Unix-AT&T Technologies, Inc.

## AMAZING DEVICES

**PERSONAL DEFENSE AND PROPERTY PROTECTION UTILIZE SPACE AGE TECHNOLOGY. CAUTION THESE DEVICES CAN BE HAZARDOUS AND MAY SOON BE ILLEGAL**

**PHASORS**

**POCKET PAIN FIELD GENERATOR — IPG50**  
Assembled ..... \$64.50  
IPG5 Plans \$8.00 IPG5K Kit/Plans \$44.50

**PHASOR PAIN FIELD CROWD CONTROLLER — PPF10**  
Assembled ..... \$250.00  
PPF1 Plans \$15.00 PPF1K Kit/Plans \$175.00

**BLASTER** — Provides a plasma discharge capable of puncturing a can  
BLS10 Assembled ..... \$89.50  
BLS1 Plans \$10.00 BLS1K Kit/Plans \$69.50

**SHOCKER/PARALYZING DEVICE** — Very intimidating and effective 5 to 10 feet  
SHG60 Assembled ..... \$99.50  
SHG6 Plans \$10.00 SHG6 Kit/Plans \$69.50

**RUBY LASER RAY GUN** — Intense visible red beam burns and welds hardest of metals. **MAY BE HAZARDOUS.**

**RUB3 All Parts Available for Completing Device \$15.00**  
**CARBON DIOXIDE BURNING, CUTTING LASER** — Produces a continuous beam of high energy. **MAY BE HAZARDOUS.**

**LC5 All Parts Available for Completing Device \$15.00**  
**VISIBLE LASER LIGHT GUN** — produces intense red beam for sighting, spotting, etc. Hand held complete

**LGU3 Plans \$10.00 (Kit & Assembled Units Available)**  
**IR PULSED LASER RIFLE** — Produces 15-30 watt infra-red pulses at 200-2000 per sec.

**LRG3 All Parts & Diodes Available \$10.00**  
**BEGINNERS LOW POWER VISIBLE LASER** — Choice of red, yellow, green — provides an excellent source of monochromatic light

**LHC2 Plans \$5.00 LHC2K Kit \$34.50**

**SECRETARY**

**SNOOPER PHONE** — Allows user to call his premises and listen in without phone ever ringing

**SNP20 Assembled \$89.50**  
**SNP2 Plans \$9.00 SNP2K Plans/Kit \$59.50**

**LONG RANGE WIRELESS MIKE** — Miniature device clearly transmits well over one mile. Super sensitive, powerful

**MFT1 Plans \$7.00 MFT1K Plans/Kit \$49.50**

**WIRELESS TELEPHONE TRANSMITTER** — Transmits both sides of phone conversation over one mile. shuts off automatically

**VWPM5 Plans \$8.00 VWPM5K Plans/Kit \$39.50**

**TALK & TELL AUTOMATIC TELEPHONE RECORDING DEVICE** — Great for monitoring telephone use

**TAT20 Assembled \$24.50**  
**TAT2 Plans \$5.00 TAT2K Plans/Kit \$14.50**

Our phone is open for orders anytime. Technicians are available 9-11 a.m. Mon-Thurs for those needing assistance or information. Send for free catalog of hundreds more similar devices. Send check, cash, MO, Visa, MC, COD to **INFORMATION UNLIMITED**  
DEPT Q1 P.O. Box 7th Amherst, N.H. 03031 Tel: 603 673 4730

## LEARN PROGRAMMING



### MASTER COMPUTERS IN YOUR OWN HOME

Now you can write programs and get a computer to do just what you want. Get the most out of any computer, and avoid having to pay the high price of pre-packaged software.

### LEARN AT YOUR OWN PACE IN YOUR SPARE TIME

Our independent study program allows you to learn about computers, operations, applications and programming in your spare time, at home. Our instructors provide you with one-on-one counseling.

### LEARN EVEN BEFORE YOU DECIDE ON A COMPUTER

Everything is explained in simple language. You will enjoy learning to use a computer—EVEN IF YOU DON'T OWN ONE. Learn to program on any personal computer, IBM, APPLE, COMMODORE, TRS, TI and more.

### BE YOUR OWN COMPUTER EXPERT

Programming is the best way to learn to use computers, and we can show you the best—and most economical—way to learn programming! Send today for your free information package. No obligation. No salesman will call.

**halix** CENTER FOR COMPUTER EDUCATION  
INSTITUTE 1743 South Vermont Ave., Los Angeles, California 90006

HALIX CENTER FOR COMPUTER EDUCATION Dept. 140  
1743 SO. VERMONT AVE., LOS ANGELES, CA 90006

YES! Send me information on how I can learn about computers and programming at home!

Name \_\_\_\_\_ Age \_\_\_\_\_

Address \_\_\_\_\_

City \_\_\_\_\_ State/Zip \_\_\_\_\_

I already have a computer available

Make \_\_\_\_\_ Model \_\_\_\_\_

## More Printer Impact (Continued from page 64)

be sure, there's no easy solution.

Whatever your graphics needs are, the first rule is to approach the marketplace

with a good deal of caution and do a lot of looking around before you pull out your wallet. If you play your cards right and

select the products that best fit your requirements, you'll find yourself thinking in disbelief, "Did my printer do that?" ◇

### SOURCES OF PRINTER SOFTWARE

Manufacturer	Product	Price	Computer or Operating System	Comments
<b>Function: Drawing</b>				
Digital Research PO Box 579 Pacific Grove, CA 93950	DR Draw	\$195.00 \$195.00	IBM CP/M	CP/M version is only available for certain terminals.
Koala Technologies 3100 Patrick Henry Dr. Santa Clara, CA 95052	Micro Illustrator	\$99.95 (incl. in KoalaPad price)	Apple, Atari, IBM, Commodore	
	PenPainter PenAnimator PenDesigner	\$250.00 (incl. in light pen price)	Apple	
Apple Computer 20525 Mariani Ave. Cupertino, CA 95014	Mousepaint	\$149.00 (incl. with Apple-Mouse II)	Apple	
Accent Software 3750 Wright Pl. Palo Alto, CA 94306	The Graphic Solution	\$149.95	Apple	An excellent manual makes it easy to draw and animate graphics.
Penguin Software PO Box 311 Geneva, IL 60134	Complete Graphics System Graphics Magician	\$79.95 \$59.95 \$39.95 \$49.95 \$49.95	Apple Apple Atari IBM Commodore	Drawing package with many editing tools. Menu-driven animation program with utilities
<b>Function: Typesetting</b>				
Data Transforms 616 Washington St. Suite 106 Denver, CO 80203	Fontrix	\$75.00 \$125.00	Apple IBM	Design your own font or choose from a predefined library. Completely menu driven.
Broderbund Software 17 Paul Dr. San Rafael, CA 94903	Printshop	\$49.95	Apple	Create greeting cards and posters. Comes with colored paper and envelopes.
Okidata 532 Fellowship Rd. Mt. Laurel, NJ 08054	Personal Touch	\$49.95	Apple	Onscreen design aid to create alternate fonts for Okidata printers.
Softcraft Suite 400 222 State St. Madison, WI 53703	Fancy Font	\$180.00	CP/M, IBM	Prints standard text files in a variety of fonts. You can create your own font as well.
<b>Function: Business</b>				
VisiCorp 2895 Zanker Rd. San Jose, CA 95134	VisiTrend/ VisiPlot	\$99.00	Apple, IBM	Does some statistical operations on data and plots projected and actual data.
Software Publishing 1901 Landings Dr. Mountain View, CA 94043	PFS Graph	\$125.00 \$175.00 \$140.00	Apple II Apple III IBM	Produces graphics that can be integrated with other software from the same company.
Digital Research PO Box 579 Pacific Grove, CA 93950	DR Graph	\$195.00	IBM, CP/M	Menu-driven software. The CP/M version only available for selected terminals.
IBM PO Box 1328-W Boca Raton, FL 33432	IBM Graphing Assistant	\$149.00	IBM	One member of IBM's integrated business software series.
Peachtree Software 3445 Peachtree Rd., NE Atlanta, GA 30362	Business Graphics System	\$295.00 \$125.00	IBM Osborne 1 (CP/M)	Produces a wide range of graphics. The CP/M version only works for selected terminals.
Okidata 532 Fellowship Rd. Mt. Laurel, NJ 08054	Okigraph II	\$65.00	Apple	Designed specifically for Okidata printers.
Redding Group 609 Main St. Ridgefield, CT 06877	GrafTalk GrafLib	\$450.00 \$400.00	IBM, CP/M IBM, CP/M	Can be used from a menu or directly. Programming modules for business graphics.



Manufacturer	Product	Price	Computer or Operating System	Comments
Gutenberg Software 47 Lewiston Rd. Scarborough, Ontario Canada M1P 1X8	Gutenberg, Jr.	\$90.00	Apple	A word processor that uses the HiRes screen to create and display text and graphics.
<b>Function: Utilities</b>				
Roger Wagner Pub. 10761 Woodside Ave. Santee, CA 92071	Printographer	\$39.95	Apple	Versatile printing utility supports the new color dot matrix printers.
Koala Technologies 3100 Patrick Henry Dr. Santa Clara, CA 95052	Programmer's Tool Kit	\$39.95	Apple	Tools for programming using the KoalaPad.
	Graphics Exhibitor	\$39.95	Commodore Apple	Create, display, and print graphics.
Datacon Assoc. 2210 Wilshire Blvd. Suite 651 Santa Monica, CA 90403	PrinterFace	\$95.00	IBM, CP/M (Anadex, Toshiba)	Menu-driven utility simplifies setups for printers. Remembers control codes.
		\$59.00	All others	
Microstar 6 Admiral Dr. Suite 384 Emeryville, CA 94608	Printstar	\$95.00	IBM	Modify or create fonts and print spreadsheets vertically to get more on a page.
Penguin Software PO Box 311 Geneva, IL 60134	Cat Graphics	\$34.95	Apple	Powerful programming routines for graphics.
	Transitions	\$49.95	Apple	Complete control for slide show production.
	Paper Graphics	\$49.95	Apple	Printing utility for more than 85 printers.
American Programmers Guild 55 Mill Plain 17-5 Danbury, CT 06811	Press 'N Plot	\$149.00	IBM	Merges graphics and text. Supports a wide variety of software, printers and plotters.

Now available to everyone!

Computer Publishing Society  
a unit of the  
Computel System presents...

Subscribe now—and become an official member! A subscription to Computel brings all of these exciting entitlements for the duration of the membership:

**Computel™**  
PUBLISHED MONTHLY

**ONE YEAR SUBSCRIPTION: \$14.00**  
CANADIAN: \$18.00 FOREIGN: \$24.00  
(SAMPLE COPY: \$1.00) (BACK ISSUE: \$2.00)

- The Membership Print Certificate—an honorable-looking medallion worth framing, created by the Computel staff to signify membership to the Computel System!
- Hundreds of WHOLESALE and below-wholesale priced electronic gift items available for your own personal use or for use with the Computel Merchandise Distribution Plan—a marketing technique you can use in a business of your own!
- Group discounts when buying computer systems, supplies, and components with the other members of the Society, from huge closeouts and factory shutdowns that we are constantly seeking as they occur!
- Discounted prices on computer hardware and software purchased through the Society at affiliated outlets around the world!
- A comparison of the computer systems and equipment on the market BEFORE you make an investment, through Computel's advisory panel of members whose dedication in your locality will assist you on where to buy and where to get help!
- A multi-national magazine bulletin board for students, Computer Enthusiasts, Computer Hackers, Phone Phreaks, management, and any party so interested—spanning the world of Computers, Electronics, and Communications, joining the hobby and profession in a spectacular display of creativity you won't want to miss!
- FREE advertising in Computel for members who wish to trade or sell their equipment, leave messages, or just want to find out what's going on with other members—we can print any message you send in, and forward all replies!

SEE HOW EASY IT IS TO BECOME PART OF THE COMPUTEL SOCIETY?  
... 24 hours a day... 7 days a week  
JUST DIAL OUR TOLL-FREE NUMBER AND HAVE YOUR CREDIT CARD NUMBER READY. GET IT WHILE IT'S HOT—THE PUBLICATION FOR YOU!

**1 800 6-COMPUTEL**  
CALLS OUTSIDE CALIFORNIA  
**1 800 5-COMPUTEL**  
CALLS WITHIN CALIFORNIA

- ORDER THESE GREAT REPORTS BY MAIL OR BY PHONE TODAY!
- The History of Computing ..... \$14.95
  - The History of the Telephone ..... \$16.95
  - The Phone Phreaks' Guide to Computers ..... \$19.95
  - Telephone Engineering Course ..... \$24.95
  - Computer Repair—Do it Yourself and SAVE! ..... \$24.95

ALL 5 REPORTS PLUS A SUBSCRIPTION TO COMPUTEL: \$88.00.

Computel Publishing Society  
6354 Van Nuys Blvd., 161-CG/Van Nuys, CA 91401-2696

Don't miss out—subscribe now!

Put Professional Knowledge and a  
**COLLEGE DEGREE**  
in your Electronics Career through

**HOME STUDY**

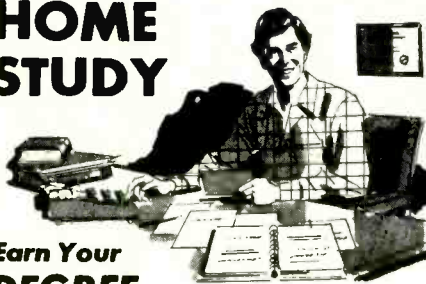

**Earn Your DEGREE**

No commuting to class. Study at your own pace, while you continue your present job. Learn from Grantham easy-to-understand lessons, with help from your home-study instructors.

You can earn your B. S. Degree in the Grantham electronics degree program, offered by independent home study and accredited by the NHSC Accrediting Commission.

Our free bulletin gives details. Write for *Bulletin E-84*.

Grantham College of Engineering  
2500 So. LaCienega Blvd.  
P. O. Box 35499  
Los Angeles, California 90035

**SLASH YOUR DISKETTE COST BY 50%!**



Make use of the back of your 5 1/4" Diskettes and SAVE.

- **NIBBLE NOTCH** tools make it easy
- Adds the precise notch where it's needed.
- Doubles diskette space or MONEY BACK.

**NIBBLE NOTCH I**

Cuts square notch for Apple, II, II+, IIe, III, Franklin and Commodore.

only **\$14.95**

add \$1.50 each P&H / (\$4.50 each foreign P&H)

**DISK OPTIMIZER® SYSTEM**  
SOFTWARE FOR APPLE, II, II+, IIe, III & Franklin

- 469% FASTER Than Similar Programs!
- Certifies your "new" disk 100% Error Free
- Removes Bad Sectors • Adds 36th Track
- Performs Disk Drive Speed Check
- Adds DOS and More

only **\$24.95** each

add \$1.50 each P&H / (\$4.50 each foreign P&H)

— OR BUY BOTH —

only **\$29.95**

add \$2.50 each set P&H / (\$6.50 foreign P&H)

SATISFACTION GUARANTEED OR YOUR MONEY BACK

\*Florida Residents Add 5% Sales Tax\*

**ORDER TODAY!**

CALL TOLL FREE 1-800-642-2536

OR SEND CHECK OR MONEY ORDER TO:

**NIBBLE NOTCH**  
**COMPUTER PRODUCTS**

DIVISION OF CORTRAN INTERNATIONAL  
4211 NW 75th TERRACE, DEPT. 8 4  
LAUDERHILL, FL 33319

PAT. PEND. ALL TRADEMARKS ARE ACKNOWLEDGED

Circle No. 5 on Free Information Card

## Epson LQ-1500

(Continued from page 32)

Character matrices come in three formats:  $9 \times 17$  dots in the draft mode,  $15 \times 17$  dots in the letter-quality mode,  $37 \times 17$  dots in the proportionally spaced mode. Text is printed bidirectionally (with logic seeking) in all text modes, including letter quality, and each line is printed in a single pass.

In the graphics mode, three printing densities are available. In single-density, there are 60 dots per horizontal inch, while in double- and quadruple-density, the dots per inch increase to 120 and 240, respectively.

### User Comments

It is difficult to evaluate a fine-quality printer like the Epson LQ-1500 without making comparisons to other printers on the market in its price range or with the same or similar features. When I reviewed the Texas Instruments Model TI-855 dot matrix printer earlier this year, I was very impressed with its unusual flexibility in selecting type styles.

Although the LQ-1500 may lack the flexibility of the TI-855 and the undeniable crispness of the printed characters that can be hammered out by even a cheap formed-character printer, it does have several features that recommend its purchase. It is *fast* in all text modes. It comes standard with a 15" platen to han-

dle full-width accounting forms. It is relatively quiet, although not as quiet as a few of the more expensive printers. Moreover, it is built like a battleship. And it preserves virtually all the escape codes of Epson's previous MX and FX series of printers; you don't need to learn a whole new sequence of codes or reconfigure software if you are trading up from a previous Epson model.

The LQ-1500's print compares very

well to output from true formed-character printers and is on a par with output from the TI-855 printer. Though I did not attempt to print out graphics of any kind with the LQ-1500, I performed extensive tests of the text modes. Working with a word-processing package, I tried a wide variety of type styles and formatting routines. Some of the copy generated in the compressed mode, using proportional spacing and near-letter quality density was, indeed, almost up to professional standards.

I was especially pleased with the speed at which this printer delivered near-letter-quality text. The speed was two to three times faster than what I have been used to for formed-character printers selling for less than \$1000 and noticeably faster than formed-character printers costing up to \$4000.

### Conclusions

I heartily recommend the LQ-1500 to anyone who needs a constant-use workhorse printer for high-speed draft printing, reasonably high-quality letter writing, a wide range of graphics, and mixed text and graphics printing. The LQ-1500 is easy to set up with almost any computer on the market today. It is speedy, relatively quiet, and churns out beautiful copy. What more can you ask?  $\diamond$

### Specifications

**Product:** LQ-1500

**Manufacturer:** Epson America, Inc.,  
3415 Kashiwa St.,  
Torrence, CA 90505

**Dimensions:** 23.8"W  $\times$  14.3"D  $\times$   
5.1"H

**Weight:** 30.8 lb

**Suggested Retail Price:** \$1395

**Features:** 24-pin printhead, letter-quality at 67 cps, draft quality at 200 cps, FX-80 compatible

**Options:** Centronics (parallel) interface \$95, RS-232 (serial) interface \$150, IEEE-488 interface \$150, Tractor feed \$60, Single-bin sheet feeder \$499, Double-bin sheet feeder \$839

**Software:** Facelift \$29.95

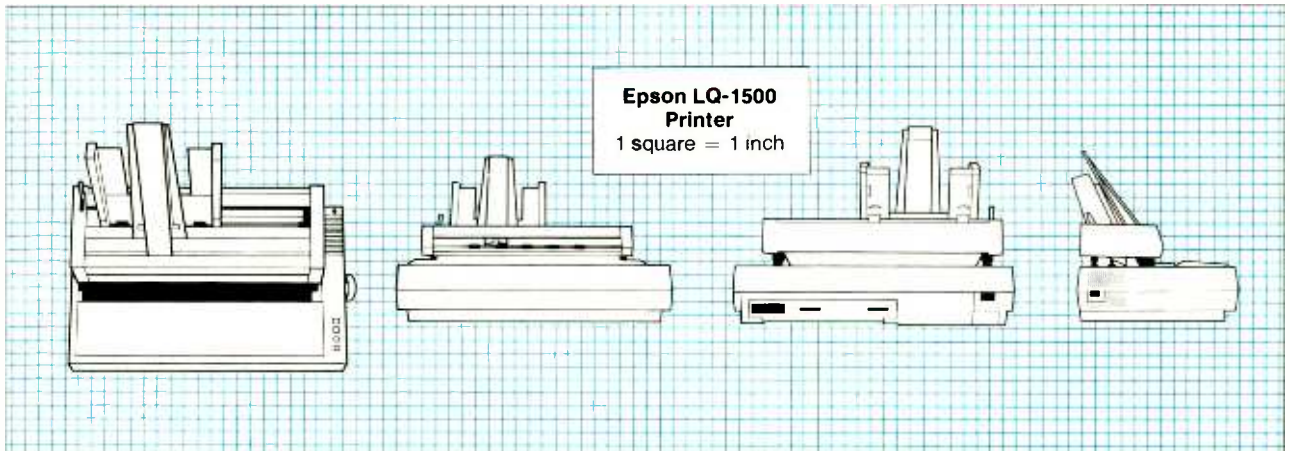

## Toshiba P1351

(Continued from page 33)

printer intercepts daisywheel commands and converts them to dot matrix commands. You can take advantage of the excellent print quality that the 24-wire printhead can provide without having to know anything about the way in which the printer forms characters.

A quick reinstallation of WordStar, with the Sprint 5 as the output device, got the printer going with no problems. The only trouble I had was with the serial protocol; if you don't turn the serial

protocols off when using the parallel printer, WordStar will wait forever for acknowledgment of a nonexistent serial transmission. And it's easy to turn off by answering "none" to the protocol question after the printer selection.

### Paperfeed Options

A friction-feed roller is the standard means of feeding the printer. As an option, you can get a very good tractor-feed mechanism (\$195) that handles the pa-

per quite gently. The directions make installation of the tractor feed more complex than it needs to be, however.

For handling single pages, Toshiba has its own special sheet-feeder assembly that replaces the tractor-feed mechanism. The feeder (\$1095) installs easily and works quite smoothly.

### User Comments

Toshiba's P1351 does all the good things that a printer should do. It pro-

duces letter-quality output at 78 cps and is relatively easy to use due to its emulation capability. With the sheet feeder added, you have a truly sophisticated piece of equipment. When I first used the sheet feeder, each page was lower than it should have been. A minor adjustment fixed it.

Though the cost of the P1351 may be a fairly large share of the cost of an entire computer system, I think it is a high-quality product of significant value. ♦

<b>Specifications</b>	<b>Features:</b> 24-pin printhead, letter-quality print at 78 cps (10 pitch) and 93 cps (12 pitch), draft print at 160 cps (10 pitch) and 192 cps (12 pitch). RS-232 or Centronics interface (both on request), Qume Sprint 5 emulation
<b>Product:</b> Toshiba P1351	<b>Options:</b> Tractor feed (\$195) Sheet feeder (\$1095)
<b>Manufacturer:</b> Toshiba America, Inc. Information Processing Systems Div. 2441 Michelle Dr. Tustin, CA 92680	
<b>Dimensions:</b> 21.7" x 15" x 5.9"	<b>Software:</b> Toshiba Font Disk (\$49.95), Fonts America (\$49.50), Greentree Software (\$34.95)
<b>Weight:</b> 42 lb <b>Suggested Retail Price:</b> \$1895	

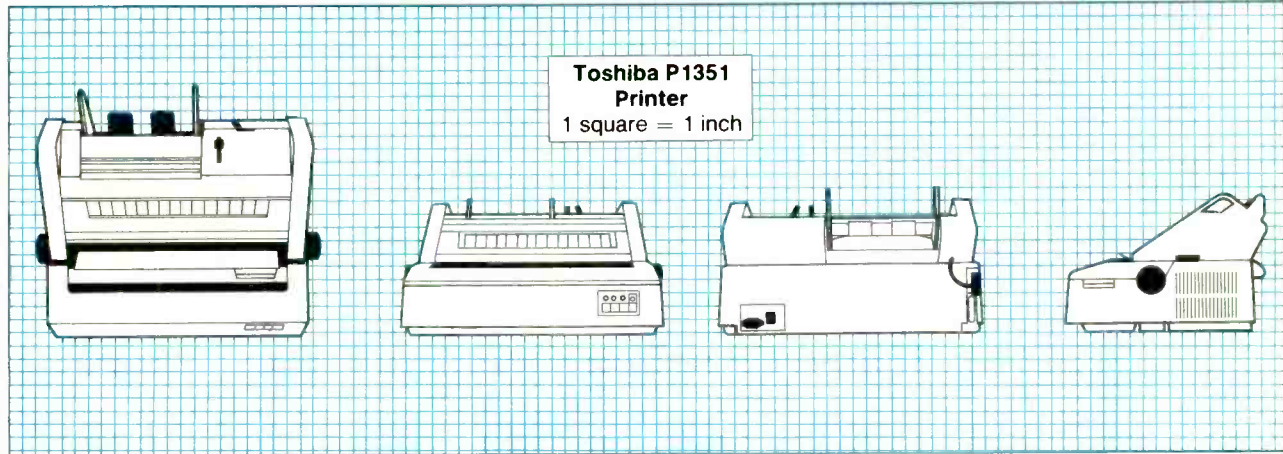

**Toshiba P1351  
Printer**  
1 square = 1 inch

**QUALITY COMPONENTS - NOT MAIL ORDER "SECONDS"** ★ Send \$1.00 postage and handling for FREE COMPLETE CATALOG which includes coupon for \$1.00 OFF purchase

**ARIES ZERO INSERTION FORCE SOCKETS**

cam actuated, true zero insertion - tin plated solder tail pins - capable of being plugged into dip sockets, including wire wrap.

Stock No.	No. of Pins	1-9	10-49	50
11055	24	4.98	\$4.35	\$3.93
11056	28	5.15	4.50	4.05
11057	40	6.81	5.95	5.35
11058	64	12.02	10.50	9.45

**IC-COOLERS** from UNITRACK™ dissipate over 2 watts of heat from IC's, producing longer life and better performance. Just push IC-Kooler on heat is collected from top and bottom of IC and dissipated. Won't shake loose!

Stock No.	No. in IC	Price
22225	14	\$ .29
22226	16	.29
22228	18-20	.29

**WILD ROVER**  
Touch switch capsule. Operating motion is 0.05" without the use of a levered arm. Extremely fast on and off with low noise. Normally open - rated 115 VAC, 1.6 amp/30 milliohm resistance - 615 radius by .160 thick

Stock No.	1-9	10 & Up
12098	\$1.42	\$1.28

**SCREW MACHINED SOCKET PINS**, loose, packaged in bags of 100. Stock No. 11310 is solder tail with gold collet (tin shell). Stock No. 11311 is wire wrap with gold collet gold shell.

Stock No.	Description	1 Bag	5 Bags	10 Bags
11310	Bag of 100 solder tail pins	4.95	4.45	\$3.95
11311	Bag of 100 wire wrap pins	11.95	10.75	9.50

**3 X 4 Elastomeric Keyboards**  
Each keyboard has a p.c. board, elastomeric pad with contacts, ABS bodies and double shot molded keys. Max rating: 12 VDC @ 20mA.  
Contact Res. less than Stock Operating Key Price  
500 ohms/Bounce: less 11291 120x40g 2.05:5mm \$4.95 \$4.50  
11292 80x40g 1.5x:5mm 3.95 \$3.50

**TI WIRE WRAP SOCKETS**  
Tin plated phosphor bronze contact - 3 wrap

Stock No.	No. of Pins	1-99	499	500
11301	8	\$4.0	\$3.6	\$3.0
11302	14	.59	.54	.45
11303	16	.64	.58	.48
11304	18	.73	.66	.55
11305	20	.99	.90	.75
11306	22	1.12	1.02	.85
11307	24	1.25	1.14	.95
11308	28	1.52	1.38	1.15
11309	40	2.05	1.86	1.55

**TI LOW PROFILE SOCKETS**  
Tin plated copper alloy 688 contact pins with gas tight seal

Stock No.	No. of Pins	1-24	25-99	999
11201	8	\$1.0	\$0.9	\$0.8
11202	14	.14	.13	.12
11203	16	.16	.15	.14
11204	18	.18	.17	.15
11205	20	.20	.18	.16
11206	22	.22	.20	.18
11207	24	.24	.22	.20
11208	28	.28	.26	.25
11209	40	.40	.37	.33

**SUB CUB I and SUB CUB II** are high quality, complete LSI Counter Modules with LCD readout. Modules plug in p.c. board. (Stock No. 51071). Complete function evaluation kit (Stock No. 51070) contains: p.c. board, 4.5V battery and variable frequency oscillator to supply train of count pulses. Stock No. 51070 has LATCH, RESET and TEST functions (3 buttons). P.C. board unplugs for bread-board work.

**SUB CUB I**

**SUB CUB II**

**8 Digit LSI Counter Modules with LCD Readouts and Associated Mounting Assemblies** 51070

Stock No.	Description	Price
51071	Complete Function Evaluation Kit (includes batteries but does not include display counter)	7.50
51072	only SUB CUB I display counter module only	18.00
51073	only SUB CUB II display counter module only	24.00
51074	Panel Bezel	12.00
51075	Evaluation Kit for SUB-CUB II (does not include SUB-CUB II counter module) DATA SHEET	.25

**SINGLE ROW SOCKETS**  
Strip of 25 collet sockets/pins mount odd-center components easily. Gold plated contacts.

Stock No.	1-24	25	50
10240	\$1.70	\$1.50	\$1.30

Both styles breakable to any number of contact positions wanted.

Strip of 40 pins with single beam sockets. Tin plated contacts.

Stock No.	1-99	100	500	1000
10850	\$1.09	\$0.90	\$0.82	\$0.72

**OPCOA**  
Single Digit Displays - Common Cathode

Stock No.	Color	1	100
12082	Red	\$1.12	\$ .99
12085	Green	1.84	1.63
12087	Yellow	1.92	1.70
12089	Orange	2.08	1.84

Right Angle Socket for Above Displays

Stock No.	1	100
11010	\$1.24	\$ .99

**OPTEL LCD's with pins**

Stock No.	Description	1	10
47005	3 1/2 dig. 5"	\$ 5.95	\$ 5.50
47006	4 dig. 5"	5.95	5.50
47007	4 dig. 7"	11.90	11.00

Stock No. 47006

Stock No. 47007

**The Battery Just Wrap™ Tool**  
New battery powered tool wraps insulated wire around .025" square posts without need for pre-cutting and pre-stripping. Complete with bit and 100 ft. 30 AWG wire.

Stock No.	Description	Price
13340	Battery just-wrap tool with bit and 100 ft. 30 AWG wire	\$59.95
13341	Replacement bit	10.35
13342	100 ft. blue replacement wire	7.54
13343	100 ft. white replacement wire	7.54
13344	100 ft. yellow replacement wire	7.54
13345	100 ft. red replacement wire	7.54

**MICRO Charts** - colorful 8 1/2" x 11" charts eliminate the need to stumble through manuals and summaries. Fully decoded - instant access - totally comprehensive - gives pin outs, cycle times, buy notes, etc.

Stock No.	Reference	Price
23010	Z80 CPU	\$5.95
23011	8080/8085A	5.95
23012	6802 (85XXX)	5.95
23013	9548 and relatives	5.95
23014	54/7400 TTL Pinouts	5.95
23015	Basic Algorithms	5.95
23016	8086/8088	5.95
23017	How to generalize from a sample	5.95
23018	Wordstar	5.95

**PIN FORMING TOOL**  
puts IC's on their true row to row spacing. One side is for 300 centers. Flip tool over for devices 600 centers. Put device in tool and squeeze.

**ONE TOOL DOES 8 THRU 40 PINS!**

Hand Tool	Price
11059	\$12.95
10200	\$14.95

NEW! ANTI-STATIC MODEL

**OK MACHINE AND TOOL**

**IC INSERTION/EXTRACTION KIT**  
Includes DIP IC extractors and inserters to accommodate all IC's from 14 to 40 pins. Tools that engage conductive surfaces are CMOS safe and include grounding lugs. Stock No. 13306 \$41.34

**SOCKET WRAP ID**

13295	14 pin	\$1.95
13296	16 pin	1.95
13297	18 pin	1.95
13298	20 pin	1.95
13299	22 pin	1.95
13300	24 pin	1.95
13301	28 pin	1.95
13302	40 pin	1.95
13303	96 pin	1.95

\$1.95 per pack

**THERMOPROBE: Identifies Dead Components - Replaces Volt Meters!**  
Identify dead components which do not emit heat. Just point thermistor probe within 1/16" of board - move over components and see which are dead.

Stock No.	Price
22300	\$21.95

**Scotchflex™ Breadboard Systems Basic kit**  
comes with 24 various Dual Sockets, 40 various Plug Strips, wire and tools. Kit can be used with any of the six boards.

Stock No.	Description	Price
03500	Basic Kit	\$79.95
03511	Basic board, 4.5 x 5.5	19.50
03506	Intel SBC-8010 Board, 12 x 6.75	64.95
03507	Motorola M-6800 Board, 9.75 x 6	42.95
03508	S-100 Board, 10 x 5.3	36.95
03509	Z-80 Board, 7.7 x 7.5	39.95
03510	Eurocard Board, 6.3 x 3.9	21.95

**PARTIAL LISTING ONLY - PLEASE CALL OR WRITE FOR FREE CATALOG.**

**STATIC RAMS**

2114	1024 x 4 (450ns)	8/9.95
2114-25	1024 x 4 (200ns)	8/10.95
2114L-2	1024 x 4 (250ns) (LP)	8/13.95
TMM2016-200	2048 x 8 (200ns)	4.15
TMM2016-150	2048 x 8 (150ns)	4.95
TMM2016-100	2048 x 8 (100ns)	6.15
HM6116.4	2048 x 8 (200ns) (cmos)	4.75
HM6116.3	2048 x 8 (150ns) (cmos)	4.95
HM6116LP-4	2048 x 8 (200ns) (cmos) (LP)	5.95
HM6116LP-3	2048 x 8 (150ns) (cmos) (LP)	6.95
HM6264	8192 x 8 (150ns) (cmos)	39.95

**DYNAMIC RAMS**

4116-250	16384 x 1 (250ns)	8/7.95
4116-200	16384 x 1 (200ns)	8/12.95
4116-150	16384 x 1 (150ns)	8/14.95
4164-200	65536 x 1 (200ns) (5v)	9/44.95
4164-150	65536 x 1 (150ns) (5v)	9/49.00
TMS 4164-15	65536 x 1 (150ns) (5v)	8.95

**EPROMS**

2708	1024 x 8 (450ns)	3.95
2716	2048 x 8 (450ns) (5v)	3.95
2716-1	2048 x 8 (350ns) (5v)	5.95
TMS2532	4096 x 8 (450ns) (5v)	5.95
2732	4096 x 8 (450ns) (5v)	4.95
2732-250	4096 x 8 (250ns) (5v)	8.95
2732-200	4096 x 8 (200ns) (5v)	11.95
2732A	4096 x 8 (250ns) (5v) (21vPGM)	9.95
2732A-2	4096 x 8 (200ns) (5v) (21vPGM)	13.95
27128	16384 x 8 (300ns) (5v)	24.95

5v = Single 5 volt supply 21vPGM = Program at 21 Volts  
**SPECTRONICS CORPORATION**  
 EPROM ERASER PE-14, 9 chip capacity 83.00

**8000**

8039	5.95
8080	3.95
8085	4.95
8087	175.00
8088	29.95
8155	6.95
8748	24.95

**8200**

8203	39.95
8205	3.50
8212	1.80
8216	1.75
8228	3.49
8237-5	21.95
8243	4.45
8250	10.95
8251	4.49
8253	6.95
8253-5	7.95
8255	4.49
8255-5	5.25
8259	6.90
8259-5	7.50
8275	29.95
8279	8.95
8282	6.50
8284	5.50
8286	6.50

**Z-80**

Z80-CPU	3.95
Z80-PIO	3.95
Z80A-CPU	4.49
Z80A-CTC	4.95
Z80A-PIO	4.49
Z80A-SIO/O	12.95
Z80B-CPU	9.95

**6500**

6502	4.95
6522	6.95
6502A	6.95

**6800**

6802	7.95
6809E	14.95
6821	2.95
6845	14.95
6850	3.25
6883	22.95

**DISK CONTR**

1771	24.95
1791	24.95
1793	26.95
2791	54.95
2793	54.95

**INTERFACE**

8T28	1.89
8T97	.89
DM8131	2.95
DP8304	2.29
9334	2.50
9368	3.95

**CLOCK CHIPS**

MM5369	3.95
MM58167	12.95
MSM5832	3.95

**DATA ACQ**

ADC0804	3.49
ADC0809	4.49
ADC0817	9.95

**SOUND CHIPS**

76488	5.95
AY3-8910	12.95

**CRYSTALS**

32.768 khz	1.95
1.0 mhz	3.95
1.8432	3.95
2.0	2.95
2.4576	2.95
3.276	2.95
3.579545	2.95
4.0	2.95
5.0	2.95
5.0688	2.95
6.0	2.95
6.144	2.95
8.0	2.95
10.0	2.95
10.738635	2.95
14.31818	2.95
15.0	2.95
16.0	2.95
17.430	2.95
20.0	2.95

**74LS00**

74LS00	.24	74LS157	.65
74LS02	.25	74LS158	.59
74LS03	.25	74LS161	.65
74LS04	.24	74LS163	.65
74LS05	.25	74LS164	.69
74LS08	.28	74LS165	.95
74LS09	.29	74LS169	1.75
74LS11	.35	74LS173	.69
74LS14	.59	74LS174	.55
74LS20	.25	74LS191	.89
74LS21	.29	74LS193	.79
74LS27	.29	74LS194	.69
74LS30	.25	74LS195	.69
74LS32	.29	74LS221	.89
74LS33	.25	74LS240	.95
74LS38	.35	74LS241	.99
74LS42	.49	74LS242	.99
74LS47	.75	74LS243	.99
74LS51	.25	74LS244	1.29
74LS73	.39	74LS251	.59
74LS74	.35	74LS257	.59
74LS75	.39	74LS258	.59
74LS76	.39	74LS259	2.75
74LS85	.69	74LS260	.59
74LS86	.39	74LS266	.55
74LS90	.55	74LS273	1.49
1N751 5.1v zener	.25	74LS92	.55
1N759 12v zener	.25	74LS93	.55
2N2222	.25	74LS107	.39
PN2222	.10	74LS109	.39
2N2905	.50	74LS112	.39
2N2907	.25	74LS122	.45
2N3055	.79	74LS123	.79
2N3904	.10	74LS125	.49
2N3906	.10	74LS126	.49
1N4004	10/1.00	74LS132	.59
1N4148	25/1.00	74LS133	.59
		74LS136	.39
		74LS138	.55
		74LS139	.55
		74LS148	1.35
		74LS151	.55
		74LS153	.55
		74LS154	1.90
		74LS156	.69

**DISCRETE**

KBP02 Bridge	.45
1N751 5.1v zener	.25
1N759 12v zener	.25
2N2222	.25
PN2222	.10
2N2905	.50
2N2907	.25
2N3055	.79
2N3904	.10
2N3906	.10
1N4004	10/1.00
1N4148	25/1.00

**LINEAR**

TL084	2.19
LM301	.34
LM307	.45
LM311	.64
LM317T	1.19
LM319	1.25
LM324	.59
LM339	.99
LF351	.60
LM353	1.00
LM358	.69
LM380	.89
LM386	.89
LM393	1.29
TL497	3.25
NE555	1.30
NE558	3.44
NE564	2.95
LM565	.99
LM566	1.49
LM567	.89
NE592	.98
LM723	.50
LM741	.35
LM1303	1.95
MC1408LB	2.95
LM1458	.59
LM1488	.69
LM1489	.69
XR2206	3.75
XR2211	5.25
CA3146	1.85
LM3914	3.95
75150	1.95
75154	1.95
75188	1.25
75189	1.25
7805T	.75
7808T	.75
7812T	.75
7815T	.75
7805K	1.39
7812K	1.39
78H05K	9.95
78L05	.69
78L12	.69
7905T	.85
7912T	.85
79L05	.79
79L12	.79

**74S00**

74S00	.32	74S86	.50
74S02	.35	74S112	.50
74S04	.35	74S124	2.75
74S05	.35	74S138	.85
74S08	.35	74S157	.95
74S10	.35	74S175	.95
74S11	.35	74S240	2.20
74S20	.35	74S280	1.95
74S32	.40	74S287	1.90
74S74	.50	74S288	1.90

**7400**

7400	.19	7447	.69
7402	.19	7473	.34
7404	.19	7474	.33
7405	.25	7475	.45
7406	.29	7476	.35
7407	.29	7486	.35
7408	.24	7490	.35
7410	.19	7492	.50
7411	.25	7493	.35
7414	.49	74121	.29
7416	.25	74123	.49
7417	.25	74132	.45
7420	.19	74151	.55
7425	.29	74154	1.25
7430	.19	74157	.55
7432	.29	74164	.85
7438	.29	74168	1.00
7442	.49	74192	.79
7445	.69	74193	.79

**CMOS**

4001	.25	4069	.29
4011	.25	4070	.35
4013	.38	4071	.29
4015	.39	4081	.29
4016	.39	4093	.49
4017	.69	14411	11.95
4020	.75	4511	.85
4024	.65	4518	.89
4027	.45	4520	.79
4040	.75	4553	5.79
4042	.69	4584	.75
4046	.85	74C00	.35
4049	.35	74C04	.35
4050	.35	74C74	.35
4051	.79	74C925	5.95
4066	.39	74C926	7.95

**ORDER TOLL FREE**

**800-538-5000**  
**800-662-6279**  
 (CALIFORNIA RESIDENTS)

**D-SUBMINIATURE CONNECTORS**

DB09P	Male 9 Pin D-Sub	\$2.08
DB25P	Male 25 Pin D-Sub	2.50
DB25S	Female 25 Pin D-Sub	3.25
DB25SR	Female 25 Pin Right Angle PC	4.42
GREY HOOD	for DB25 Connectors	1.25

**IDC CONNECTORS**

IDS26	26 Pin Ribbon Socket	2.43
IDS34	34 Pin Ribbon Socket	3.15
IDS50	50 Pin Ribbon Socket	4.65
IDE34	34 Pin Ribbon Edge Card	3.25
IDP16	16 Male Pin Dip Plug	1.65
RC50	50 Conductor Ribbon Cable	1.38/ft.

**JUMBO LEDS**

RED	.10	.09
GREEN	.18	.15
YELLOW	.18	.15

**MOUNTING HARDWARE**

.10 EA. 100/ .09 EA.

**DISPLAYS**

MAN 72	CA. 3"	.99
MAN 74	CC. 3"	.99
FND-357	CC. 3.75"	1.25
FND-500	CC. 5"	1.49
FND-507	CA. 5"	1.49

**ELCOMP**

Hardware Handbook  
 Mfr's Specs: LOGIC,  
 MEMORY, MPU's & more  
**800 pgs \$14.95**

**CAPACITORS**

10pf	56pf
22pf	82pf
27pf	100pf
33pf	220pf
47pf	.001uf

**MONOLITHIC**

.01uf-mono	50V	.14
.047uf-mono	50V	.15
.1uf-mono	50V	.18
.47uf-mono	50V	.25

**ELECTROLYTIC**

1uf	25V	.14
47uf	35V	.18
470uf	25V	.30
2200uf	16V	.60

**AXIAL**

1uf	50V	.14
22uf	16V	.14
47uf	50V	.20
220uf	25V	.30
COMPUTER GRADE		
44,000uf	30V	3.95

**BARGAIN HUNTERS CORNER**

**FLOPPY SALE**

**FD200-8 FOR \$-100 \$195.00**

## Computer Scientist (Continued from page 28)

nected, it's necessary to solder a pair of wires to the Monitor 4's LED. Remove the three screws (one is inside the battery compartment) that hold the back of the case in place and find where the LED is soldered to the circuit board. Then carefully remove the plastic coating from around the two solder connections and solder an insulated wire to each connection. Wrapping wire is a good choice.

Use caution when operating the Monitor 4 and making the connections: If you damage the device, you may void its warranty. Avoid touching the circuitry since CMOS circuitry can be damaged by static electricity. Also, use a battery-powered soldering iron.

Incidentally, the red LED will *not* flash when the opto-isolator is connected. That's because the voltage drop of the infrared emitter in the opto-isolator is lower than that of the red LED.

The phototransistor side of the opto-isolator can be connected directly to a joystick connector. Figure 6 shows the pin connection for the PCjr and the Color Computer.

Alternatively, you can do as I've done and install a miniature phone jack in a joystick enclosure and connect its terminal directly across the selected trigger switch. The opto-isolator is then connected to a two-wire cable plugged into the joystick. This method is particularly useful with the PCjr since this machine uses hard-to-find connectors.

When the Monitor 4 is interfaced to a computer loaded with a program like PCjr Coin Toss and switched on, the monitor will *not* display a new random number each time a particle of natural background radiation is detected. That's because the pulses produced are very brief and tend to occur when the program is performing housekeeping chores rather than when it is sampling the status of the joystick switches.

The solution to this problem is to increase the number of particles by placing a radioactive substance near the Monitor 4 radiation detector. A thorium-impregnated lamp mantle or a polonium-210 source from a Static-Master IC200 static eliminating brush works well.

Even though these radioactive sources are from radiation-safe commercial products, you must use caution when handling them. (I covered the general subject of measuring radiation in this magazine in September 1983.)

Figure 7 shows a circuit that stretches the pulse from the Monitor 4 to increase the odds that a single pulse will give a random number. If R2 is a potentiometer, the duration of the stretched pulse can be easily varied.

Figure 8 shows a screenful of 0's and 1's generated by the coin toss program given above under the control of a Monitor 4 and a polonium alpha emitter.

Listing 1 shows one way to generate and tally random numbers from 0 to 9 under the control of a PCjr joystick trigger button. Figure 9 shows a screenful of random numbers produced under the control of a Monitor 4. Incidentally, since Listing 1 is fairly slow, an excessive

radiation count rate will simply give a continual sequence of 0-9 counts.

### Going Further

There's much more that could be said about random numbers and computerized methods for generating them. Unfortunately, it will not fit in this column. Therefore, I'll leave to you the adventure of continuing this trek through unpredictable outcomes. ◇



# Active



**The One Stop Electronic Shop!**

**Call Toll FREE 1-800-343-0874**

**In the United States:**

#### Mail Orders

P.O. Box 8000  
Westborough, Mass.  
01581  
(Mass) (617) 366-0500

#### Boston

133 Flanders Road  
Westborough, Mass.  
01581  
(617) 366-9684

#### Seattle

13107 Northup Way  
Bellevue, Wash.  
98004  
(206) 881-8191

**In Canada:**

#### Montréal

5651 Rue Ferrier  
Montréal, Québec  
H4P 1N1  
(514) 731-7441

#### Ottawa

1023 Merivale Road  
Ottawa, Ontario  
K1Z 6A6  
(613) 728-7900

#### Toronto

14 Carlton Street  
Toronto, Ontario  
M5B 1K5  
(416) 977-7692

#### Calgary

3220-5th Ave. N.E.  
Bay 2  
Calgary, Alberta  
T2A 5N1  
(403) 235-5300

#### Downsview

86 St. Regis Cr. N.  
Downsview, Ontario  
M3J 1Y8  
(416) 630-0400

#### Vancouver

3070 Kingsway  
Vancouver, B.C.  
V5R 5J7  
(604) 438-3321

**Visit your nearest Active store, call, write or circle  
the Reader Service Card for your copy of Active's new catalog.**

**7400**

\*Number of Pins per I.C. for easy Socket purchases

Part No.	*Pins	Price	Part No.	*Pins	Price	Part No.	*Pins	Price
SN7400N	14	29	SN7472N	14	39	SN74156N	16	59
SN7401N	14	29	SN7473N	14	39	SN74157N	16	59
SN7402N	14	29	SN7474N	14	39	SN74158N	16	59
SN7403N	14	29	SN7475N	16	49	SN74159N	16	59
SN7404N	14	35	SN7476N	16	49	SN74160N	16	59
SN7405N	14	29	SN7477N	14	39	SN74161N	16	59
SN7406N	14	29	SN7478N	14	39	SN74162N	16	59
SN7407N	14	29	SN7479N	14	39	SN74163N	16	59
SN7408N	14	29	SN7480N	14	39	SN74164N	16	59
SN7409N	14	29	SN7481N	14	39	SN74165N	16	59
SN7410N	14	29	SN7482N	14	39	SN74166N	16	59
SN7411N	14	29	SN7483N	16	49	SN74167N	16	59
SN7412N	14	29	SN7484N	14	39	SN74168N	16	59
SN7413N	14	29	SN7485N	14	39	SN74169N	16	59
SN7414N	14	29	SN7486N	14	39	SN74170N	16	59
SN7415N	14	29	SN7487N	14	39	SN74171N	16	59
SN7416N	14	29	SN7488N	14	39	SN74172N	16	59
SN7417N	14	29	SN7489N	14	39	SN74173N	16	59
SN7418N	14	29	SN7490N	14	39	SN74174N	16	59
SN7419N	14	29	SN7491N	14	39	SN74175N	16	59
SN7420N	14	29	SN7492N	14	39	SN74176N	16	59
SN7421N	14	29	SN7493N	14	39	SN74177N	16	59
SN7422N	14	29	SN7494N	14	39	SN74178N	16	59
SN7423N	14	29	SN7495N	14	39	SN74179N	16	59
SN7424N	14	29	SN7496N	14	39	SN74180N	16	59
SN7425N	14	29	SN7497N	14	39	SN74181N	16	59
SN7426N	14	29	SN7498N	14	39	SN74182N	16	59
SN7427N	14	29	SN7499N	14	39	SN74183N	16	59
SN7428N	14	29	SN7500N	14	39	SN74184N	16	29
SN7429N	14	29	SN7501N	14	39	SN74185N	16	29
SN7430N	14	29	SN7502N	14	39	SN74186N	16	29
SN7431N	14	29	SN7503N	14	39	SN74187N	16	29
SN7432N	14	29	SN7504N	14	39	SN74188N	16	29
SN7433N	14	29	SN7505N	14	39	SN74189N	16	29
SN7434N	14	29	SN7506N	14	39	SN74190N	16	29
SN7435N	14	29	SN7507N	14	39	SN74191N	16	29
SN7436N	14	29	SN7508N	14	39	SN74192N	16	29
SN7437N	14	29	SN7509N	14	39	SN74193N	16	29
SN7438N	14	29	SN7510N	14	39	SN74194N	16	29
SN7439N	14	29	SN7511N	14	39	SN74195N	16	29
SN7440N	14	29	SN7512N	14	39	SN74196N	16	29
SN7441N	14	29	SN7513N	14	39	SN74197N	16	29
SN7442N	14	29	SN7514N	14	39	SN74198N	16	29
SN7443N	14	29	SN7515N	14	39	SN74199N	16	29
SN7444N	14	29	SN7516N	14	39	SN74200N	16	29
SN7445N	14	29	SN7517N	14	39	SN74201N	16	29
SN7446N	14	29	SN7518N	14	39	SN74202N	16	29
SN7447N	14	29	SN7519N	14	39	SN74203N	16	29
SN7448N	14	29	SN7520N	14	39	SN74204N	16	29
SN7449N	14	29	SN7521N	14	39	SN74205N	16	29
SN7450N	14	29	SN7522N	14	39	SN74206N	16	29
SN7451N	14	29	SN7523N	14	39	SN74207N	16	29
SN7452N	14	29	SN7524N	14	39	SN74208N	16	29
SN7453N	14	29	SN7525N	14	39	SN74209N	16	29
SN7454N	14	29	SN7526N	14	39	SN74210N	16	29
SN7455N	14	29	SN7527N	14	39	SN74211N	16	29
SN7456N	14	29	SN7528N	14	39	SN74212N	16	29
SN7457N	14	29	SN7529N	14	39	SN74213N	16	29
SN7458N	14	29	SN7530N	14	39	SN74214N	16	29
SN7459N	14	29	SN7531N	14	39	SN74215N	16	29
SN7460N	14	29	SN7532N	14	39	SN74216N	16	29
SN7461N	14	29	SN7533N	14	39	SN74217N	16	29
SN7462N	14	29	SN7534N	14	39	SN74218N	16	29
SN7463N	14	29	SN7535N	14	39	SN74219N	16	29
SN7464N	14	29	SN7536N	14	39	SN74220N	16	29
SN7465N	14	29	SN7537N	14	39	SN74221N	16	29
SN7466N	14	29	SN7538N	14	39	SN74222N	16	29
SN7467N	14	29	SN7539N	14	39	SN74223N	16	29
SN7468N	14	29	SN7540N	14	39	SN74224N	16	29
SN7469N	14	29	SN7541N	14	39	SN74225N	16	29
SN7470N	14	29	SN7542N	14	39	SN74226N	16	29

**MICROPROCESSOR COMPONENTS**

Part No.	*Pins	Price	Part No.	*Pins	Price		
0765CA	40	195	1103	1024x1	300ns	1.49	
2651	40	9.95	4027	16	4096x1	1.99	
1M55501	40	19.95	4116N-2	16	384x1 (150ns)	1.39	8/10.95
MCS5002	40	6.49	4116N-4	16	384x1 (200ns)	1.15	8/9.95
6809	40	9.95	4116N-4	16	384x1 (200ns)	89	8/9.95
6809E	40	9.95	416AN-150	16	65.536x1 (150ns)	5.19	8/4.95
8031	40	6.49	416AN-200	16	65.536x1 (200ns)	4.95	8/4.95
IN80303N	40	14.95	416AN-200	16	65.536x1 (200ns)	35	8/11.95
IN80303N	40	14.95	MM5270	22	2048x1 (385ns)	4.95	8/4.95
IN8040N-6	40	14.95	MM5271	22	4096x1 (385ns) MK4096	4.95	8/4.95
IN8070N	40	9.95	MM5272	22	4096x1 (210ns)	3.95	8/4.95
IN8073N	40	9.95					
PR685A	40	14.95					
8086	40	24.95					
8088	40	19.95					
8155	40	19.95					
8237	40	15.95					
8237-5	40	19.95					
8748	40	39.95					

**Z80, Z80B, Z80C, Z8000 SERIES**

Part No.	*Pins	Price	Part No.	*Pins	Price
Z80	40	19.95	Z8000	40	19.95
Z80-CTC	40	3.49	Z8000-1	40	19.95
Z80-DART	40	3.49	Z8000-2	40	19.95
Z80-DMA	40	12.49	Z8000-3	40	19.95
Z80-DMA	40	12.49	Z8000-4	40	19.95
Z80-DMA	40	12.49	Z8000-5	40	19.95
Z80-DMA	40	12.49	Z8000-6	40	19.95
Z80-DMA	40	12.49	Z8000-7	40	19.95
Z80-DMA	40	12.49	Z8000-8	40	19.95
Z80-DMA	40	12.49	Z8000-9	40	19.95
Z80-DMA	40	12.49	Z8000-10	40	19.95
Z80-DMA	40	12.49	Z8000-11	40	19.95
Z80-DMA	40	12.49	Z8000-12	40	19.95
Z80-DMA	40	12.49	Z8000-13	40	19.95
Z80-DMA	40	12.49	Z8000-14	40	19.95
Z80-DMA	40	12.49	Z8000-15	40	19.95
Z80-DMA	40	12.49	Z8000-16	40	19.95
Z80-DMA	40	12.49	Z8000-17	40	19.95
Z80-DMA	40	12.49	Z8000-18	40	19.95
Z80-DMA	40	12.49	Z8000-19	40	19.95
Z80-DMA	40	12.49	Z8000-20	40	19.95
Z80-DMA	40	12.49	Z8000-21	40	19.95
Z80-DMA	40	12.49	Z8000-22	40	19.95
Z80-DMA	40	12.49	Z8000-23	40	19.95
Z80-DMA	40	12.49	Z8000-24	40	19.95
Z80-DMA	40	12.49	Z8000-25	40	19.95
Z80-DMA	40	12.49	Z8000-26	40	19.95
Z80-DMA	40	12.49	Z8000-27	40	19.95
Z80-DMA	40	12.49	Z8000-28	40	19.95
Z80-DMA	40	12.49	Z8000-29	40	19.95
Z80-DMA	40	12.49	Z8000-30	40	19.95
Z80-DMA	40	12.49	Z8000-31	40	19.95
Z80-DMA	40	12.49	Z8000-32	40	19.95
Z80-DMA	40	12.49	Z8000-33	40	19.95
Z80-DMA	40	12.49	Z8000-34	40	19.95
Z80-DMA	40	12.49	Z8000-35	40	19.95
Z80-DMA	40	12.49	Z8000-36	40	19.95
Z80-DMA	40	12.49	Z8000-37	40	19.95
Z80-DMA	40	12.49	Z8000-38	40	19.95
Z80-DMA	40	12.49	Z8000-39	40	19.95
Z80-DMA	40	12.49	Z8000-40	40	19.95

**6500/6800/68000 SERIES**

Part No.	*Pins	Price	Part No.	*Pins	Price
MCS6020	40	4.95	68000	40	19.95
MCS6020	40	4.95	68000-1	40	19.95
MCS6020	40	4.95	68000-2	40	19.95
MCS6020	40	4.95	68000-3	40	19.95
MCS6020	40	4.95	68000-4	40	19.95
MCS6020	40	4.95	68000-5	40	19.95
MCS6020	40	4.95	68000-6	40	19.95
MCS6020	40	4.95	68000-7	40	19.95
MCS6020	40	4.95	68000-8	40	19.95
MCS6020	40	4.95	68000-9	40	19.95
MCS6020	40	4.95	68000-10	40	19.95
MCS6020	40	4.95	68000-11	40	19.95
MCS6020	40	4.95	68000-12	40	19.95
MCS6020	40	4.95	68000-13	40	19.95
MCS6020	40	4.95	68000-14	40	19.95
MCS6020	40	4.95	68000-15	40	19.95
MCS6020	40	4.95	68000-16	40	19.95
MCS6020	40	4.95	68000-17	40	19.95
MCS6020	40	4.95	68000-18	40	19.95
MCS6020	40	4.95	68000-19	40	19.95
MCS6020	40	4.95	68000-20	40	19.95
MCS6020	40	4.95	68000-21	40	19.95
MCS6020	40	4.95	68000-22	40	19.95
MCS6020	40	4.95	68000-23	40	19.95
MCS6020	40	4.95	68000-24	40	19.95
MCS6020	40	4.95	68000-25	40	19.95
MCS6020	40	4.95	68000-26	40	19.95
MCS6020	40	4.95	68000-27	40	19.95
MCS6020	40	4.95	68000-28	40	19.95
MCS6020	40	4.95	68000-29	40	19.95
MCS6020	40	4.95	68000-30	40	19.95
MCS6020	40	4.95	68000-31	40	19.95
MCS6020	40	4.95	68000-32	40	19.95
MCS6020	40	4.95	68000-33	40	19.95
MCS6020	40	4.95	68000-34	40	19.95
MCS6020	40	4.95</			

**QUALITY** - Name brand products from nationally recognized manufacturers  
**SERVICE** - Computerized order processing and inventory control  
**SAVINGS** - Volume Discounts • OEM Quality Pricing • Toll Free 800 Number

### INTEGRATED CIRCUITS

Part No.	Description	Pin	Price
LM741CN	741CN	14	1.00
LM742CN	742CN	14	1.00
LM743CN	743CN	14	1.00
LM744CN	744CN	14	1.00
LM745CN	745CN	14	1.00
LM746CN	746CN	14	1.00
LM747CN	747CN	14	1.00
LM748CN	748CN	14	1.00
LM749CN	749CN	14	1.00
LM750CN	750CN	14	1.00

### 1% Metal Film Resistors

Part No.	Description	Price
1000	1000	1.00
1001	1001	1.00
1002	1002	1.00
1003	1003	1.00
1004	1004	1.00
1005	1005	1.00
1006	1006	1.00
1007	1007	1.00
1008	1008	1.00
1009	1009	1.00

### TEXAS INSTRUMENTS I.C. SOCKETS

Low cost • Temperature Coefficient: 100 ppm/°C  
 Dielectric Withstanding Voltage: 500V  
 Standard resistor values from 10 to 100M ohm  
**STANDARD RESISTOR VALUE TABLE**

Standard Resistor Value	Part No.
10	10
100	100
1000	1000
10000	10000
100000	100000
1000000	1000000
10000000	10000000
100000000	100000000
1000000000	1000000000

### DISC CAPACITORS

Part No.	Description	Price
1000	1000	1.00
1001	1001	1.00
1002	1002	1.00
1003	1003	1.00
1004	1004	1.00
1005	1005	1.00
1006	1006	1.00
1007	1007	1.00
1008	1008	1.00
1009	1009	1.00

### NEW! KIT DISC CAPACITORS

Price includes capacitor, disc, and mounting hardware.  
**ASSORTMENT OF 15**  
 Price: \$35.95

### PARANOID RESISTOR TARIUM CAPACITORS

Price includes capacitor, disc, and mounting hardware.  
**ASSORTMENT OF 15**  
 Price: \$54.95

### 5% Carbon Film Resistors

Part No.	Description	Price
1000	1000	1.00
1001	1001	1.00
1002	1002	1.00
1003	1003	1.00
1004	1004	1.00
1005	1005	1.00
1006	1006	1.00
1007	1007	1.00
1008	1008	1.00
1009	1009	1.00

### WIRE WRAP I.C. SOCKETS

Standard profile  
 Underneath for wire wrap  
 Price includes capacitor, disc, and mounting hardware.

### TEXAS INSTRUMENTS GOLD EDGEBOARD CONNECTORS

Price includes connector, disc, and mounting hardware.  
**ASSORTMENT OF 15**  
 Price: \$35.95

### PARANOID RESISTOR TARIUM CAPACITORS

Price includes capacitor, disc, and mounting hardware.  
**ASSORTMENT OF 15**  
 Price: \$54.95

### NEW! KIT DISC CAPACITORS

Price includes capacitor, disc, and mounting hardware.  
**ASSORTMENT OF 15**  
 Price: \$35.95

### PARANOID RESISTOR TARIUM CAPACITORS

Price includes capacitor, disc, and mounting hardware.  
**ASSORTMENT OF 15**  
 Price: \$54.95

### 4110 Nsec 16,384x1 D Ram

Part No.	Description	Price
1000	1000	1.00
1001	1001	1.00
1002	1002	1.00
1003	1003	1.00
1004	1004	1.00
1005	1005	1.00
1006	1006	1.00
1007	1007	1.00
1008	1008	1.00
1009	1009	1.00

### Silicon Transistors

Part No.	Description	Price
1000	1000	1.00
1001	1001	1.00
1002	1002	1.00
1003	1003	1.00
1004	1004	1.00
1005	1005	1.00
1006	1006	1.00
1007	1007	1.00
1008	1008	1.00
1009	1009	1.00

### EDGEBOARD CONNECTORS

Part No.	Description	Price
1000	1000	1.00
1001	1001	1.00
1002	1002	1.00
1003	1003	1.00
1004	1004	1.00
1005	1005	1.00
1006	1006	1.00
1007	1007	1.00
1008	1008	1.00
1009	1009	1.00

### PARANOID RESISTOR TARIUM CAPACITORS

Price includes capacitor, disc, and mounting hardware.  
**ASSORTMENT OF 15**  
 Price: \$54.95

### NEW! KIT DISC CAPACITORS

Price includes capacitor, disc, and mounting hardware.  
**ASSORTMENT OF 15**  
 Price: \$35.95

### PARANOID RESISTOR TARIUM CAPACITORS

Price includes capacitor, disc, and mounting hardware.  
**ASSORTMENT OF 15**  
 Price: \$54.95

### SILICON RECTIFIERS

Part No.	Description	Price
1000	1000	1.00
1001	1001	1.00
1002	1002	1.00
1003	1003	1.00
1004	1004	1.00
1005	1005	1.00
1006	1006	1.00
1007	1007	1.00
1008	1008	1.00
1009	1009	1.00

### EDGEBOARD CONNECTORS

Part No.	Description	Price
1000	1000	1.00
1001	1001	1.00
1002	1002	1.00
1003	1003	1.00
1004	1004	1.00
1005	1005	1.00
1006	1006	1.00
1007	1007	1.00
1008	1008	1.00
1009	1009	1.00

### EDGEBOARD CONNECTORS

Part No.	Description	Price
1000	1000	1.00
1001	1001	1.00
1002	1002	1.00
1003	1003	1.00
1004	1004	1.00
1005	1005	1.00
1006	1006	1.00
1007	1007	1.00
1008	1008	1.00
1009	1009	1.00

### PARANOID RESISTOR TARIUM CAPACITORS

Price includes capacitor, disc, and mounting hardware.  
**ASSORTMENT OF 15**  
 Price: \$54.95

### NEW! KIT DISC CAPACITORS

Price includes capacitor, disc, and mounting hardware.  
**ASSORTMENT OF 15**  
 Price: \$35.95

### PARANOID RESISTOR TARIUM CAPACITORS

Price includes capacitor, disc, and mounting hardware.  
**ASSORTMENT OF 15**  
 Price: \$54.95

### 3 AMP SILICON RECTIFIER

Part No.	Description	Price
1000	1000	1.00
1001	1001	1.00
1002	1002	1.00
1003	1003	1.00
1004	1004	1.00
1005	1005	1.00
1006	1006	1.00
1007	1007	1.00
1008	1008	1.00
1009	1009	1.00

### EDGEBOARD CONNECTORS

Part No.	Description	Price
1000	1000	1.00
1001	1001	1.00
1002	1002	1.00
1003	1003	1.00
1004	1004	1.00
1005	1005	1.00
1006	1006	1.00
1007	1007	1.00
1008	1008	1.00
1009	1009	1.00

### EDGEBOARD CONNECTORS

Part No.	Description	Price
1000	1000	1.00
1001	1001	1.00
1002	1002	1.00
1003	1003	1.00
1004	1004	1.00
1005	1005	1.00
1006	1006	1.00
1007	1007	1.00
1008	1008	1.00
1009	1009	1.00

### PARANOID RESISTOR TARIUM CAPACITORS

Price includes capacitor, disc, and mounting hardware.  
**ASSORTMENT OF 15**  
 Price: \$54.95

### NEW! KIT DISC CAPACITORS

Price includes capacitor, disc, and mounting hardware.  
**ASSORTMENT OF 15**  
 Price: \$35.95

### PARANOID RESISTOR TARIUM CAPACITORS

Price includes capacitor, disc, and mounting hardware.  
**ASSORTMENT OF 15**  
 Price: \$54.95

### AMP CHAMP CONNECTORS

Part No.	Description	Price
1000	1000	1.00
1001	1001	1.00
1002	1002	1.00
1003	1003	1.00
1004	1004	1.00
1005	1005	1.00
1006	1006	1.00
1007	1007	1.00
1008	1008	1.00
1009	1009	1.00

### EDGEBOARD CONNECTORS

Part No.	Description	Price
1000	1000	1.00
1001	1001	1.00
1002	1002	1.00
1003	1003	1.00
1004	1004	1.00
1005	1005	1.00
1006	1006	1.00
1007	1007	1.00
1008	1008	1.00
1009	1009	1.00

### EDGEBOARD CONNECTORS

Part No.	Description	Price
1000	1000	1.00
1001	1001	1.00
1002	1002	1.00
1003	1003	1.00
1004	1004	1.00
1005	1005	1.00
1006	1006	1.00
1007	1007	1.00
1008	1008	1.00
1009	1009	1.00

### PARANOID RESISTOR TARIUM CAPACITORS

Price includes capacitor, disc, and mounting hardware.  
**ASSORTMENT OF 15**  
 Price: \$54.95

### NEW! KIT DISC CAPACITORS

Price includes capacitor, disc, and mounting hardware.  
**ASSORTMENT OF 15**  
 Price: \$35.95

### PARANOID RESISTOR TARIUM CAPACITORS

Price includes capacitor, disc, and mounting hardware.  
**ASSORTMENT OF 15**  
 Price: \$54.95

## SERVICE CHARGES VOLUME DISCOUNT

0.00 - 9.99 Add \$2.00 0.00 - 99.99 NET  
 10.00 - 49.99 Add \$3.00 100.00 - 249.99 Less 10%  
 50.00 - 99.99 Add \$4.00 250.00 - 499.99 Less 15%  
 100.00 - 249.99 Add \$5.00 500.00 - 999.99 Less 20%  
 250.00 - 499.99 Add \$6.00 1000.00 - 2499.99 Less 25%  
 500.00 - 999.99 Add \$7.00 2500.00 - 4999.99 Less 30%  
 1000.00 - 2499.99 Add \$8.00 5000.00 - 9999.99 Less 35%  
 2500.00 - 4999.99 Add \$9.00 10000.00 - 24999.99 Less 40%  
 5000.00 - 9999.99 Add \$10.00 25000.00 - 49999.99 Less 45%  
 10000.00 - 24999.99 Add \$11.00 50000.00 - 99999.99 Less 50%  
 25000.00 - 49999.99 Add \$12.00 100000.00 - 249999.99 Less 55%  
 50000.00 - 99999.99 Add \$13.00 250000.00 - 499999.99 Less 60%  
 100000.00 - 249999.99 Add \$14.00 500000.00 - 999999.99 Less 65%  
 250000.00 - 499999.99 Add \$15.00 1000000.00 - 2499999.99 Less 70%  
 500000.00 - 999999.99 Add \$16.00 2500000.00 - 4999999.99 Less 75%  
 1000000.00 - 2499999.99 Add \$17.00 5000000.00 - 9999999.99 Less 80%  
 2500000.00 - 4999999.99 Add \$18.00 10000000.00 - 24999999.99 Less 85%  
 5000000.00 - 9999999.99 Add \$19.00 25000000.00 - 49999999.99 Less 90%  
 10000000.00 - 24999999.99 Add \$20.00 50000000.00 - 99999999.99 Less 95%  
 25000000.00 - 49999999.99 Add \$21.00 100000000.00 - 249999999.99 Less 98%  
 50000000.00 - 99999999.99 Add \$22.00 250000000.00 - 499999999.99 Less 99%  
 100000000.00 - 249999999.99 Add \$23.00 500000000.00 - 999999999.99 Less 99.5%  
 250000000.00 - 499999999.99 Add \$24.00 1000000000.00 - 2499999999.99 Less 99.8%  
 500000000.00 - 999999999.99 Add \$25.00 2500000000.00 - 4999999999.99 Less 99.9%  
 1000000000.00 - 2499999999.99 Add \$26.00 5000000000.00 - 9999999999.99 Less 99.95%  
 2500000000.00 - 4999999999.99 Add \$27.00 10000000000.00 - 24999999999.99 Less 99.98%  
 5000000000.00 - 9999999999.99 Add \$28.00 25000000000.00 - 49999999999.99 Less 99.99%  
 10000000000.00 - 24999999999.99 Add \$29.00 50000000000.00 - 99999999999.99 Less 99.995%  
 25000000000.00 - 49999999999.99 Add \$30.00 100000000000.00 - 249999999999.99 Less 99.998%  
 50000000000.00 - 99999999999.99 Add \$31.00 250000000000.00 - 499999999999.99 Less 99.999%  
 100000000000.00 - 249999999999.99 Add \$32.00 500000000000.00 - 999999999999.99 Less 99.9995%  
 250000000000.00 - 499999999999.99 Add \$33.00 1000

# Computer Mart

RATE: Ads are "by 3". 1 insertion: \$935.00. 6 insertions: \$900.00 ea. 12 insertions, \$865.00 ea. Closing date: 1st of the 2nd mo. preceding cover date. Send order and remittance to Computer Mart, Computers & Electronics, 1 Park Ave., N.Y., N.Y. 10016. Direct inquiries to: Lois Price (212) 503-5115. For Customer Service (212) 503-5115. For Customer Service, call (212) 503-4506.

## COMMODORE 64 INTERFACING BLUE BOOK

Written by a college professor in a friendly and informative style, this book is a gold mine of practical information on how to build a variety of useful interfaces for your computer. Over 30 projects including cassette interface, printer interface, expansion bus, light pen, RS-232 interface, more user ports, thermometer, speech synthesizer and two other voice projects. A/D and D/A converters, 5 telephone interfaces including a sophisticated voice mail project, motor controllers, AC power control, logic analyzer, capacitance meter, spectrum analyzer, home security system and many more. \$16.95 postpaid. Foreign orders add \$3 for AIR MAIL shipping.

## VIC 20 INTERFACING BLUE BOOK

30 hardware interfacing projects for the VIC 20. Similar to the 64 book above. See what your VIC can do with a little interfacing. \$14.95 postpaid.

**microsignal**  
Dept. B, P.O. BOX 22  
MILLWOOD, NY 10546

Thanks to YOU . . . We're Growing  
with YOU and your Computer . . .  
**LEO ELECTRONICS, INC.**  
P.O. Box 11307  
Torrance, CA. 90510-1307  
Tel: 213/212-6133 800/421-9565  
TLX: 291 985 LEO UR

We Offer . . . **PRICE . . . QUALITY**  
**PERSONAL SERVICE**

64K UPGRADE			
9 Bank (IBM PC)	\$43.65	(150ns)	
	\$41.85	(200ns)	
4164 (150ns)	\$4.85 ea.		
(200ns)	\$4.65 ea.		
8 Bank (other PC)	\$38.80	(150ns)	
	\$37.20	(200ns)	
4164 (150ns)	\$4.85 ea.		
(200ns)	\$4.65 ea.		
256K "Mother Saver" Upgrade			
256K (150ns)	\$36.00 each		
6116P-3	\$4.40	2732	\$3.95
2716	\$3.20	2764	\$7.00
TMS-2716	\$4.95	27128	\$24.00

We accept checks, Visa, Mastercard or Purchase Orders from qualified firms and institutions. U.S. Funds only. Call for C.O.D. California residents add 6 1/2% tax. Shipping is UPS. Add \$2.00 for ground and \$5.00 for air. All major manufacturers. All parts 100% guaranteed. Pricing subject to change without notice.

**Marymac**  
INDUSTRIES

800-231-3680

**Pan American**  
ELECTRONICS

800-531-7466

## Radio Shack TRS-80's

People you Trust to give you the very best!



- Lowest Price
- Reliable Service
- Quality Products

22511 Katy Fwy., Katy (Houston) Texas 77450  
(713) 392-0747 Telex 774132

CIRCLE NO. 120 ON FREE INFORMATION CARD

## NEW!

### SURGE-STOP

Give any circuit 4500 AMPS of surge protection by just plugging it in! . . . . . **\$9.95**

### Surge Suppressor,

With EMI/RFI filtering, 6 plug switched- 15 Amp circuit breaker . . . . . **\$29.95**

### Build Your Own 68000 System

with 128KB, 3-RS232 ports for about . . . . . **\$250**

FREE CATALOG

**Digatek Corporation**

2723 W. Butler Dr., Suite 7  
Phoenix, AZ 85021  
602-995-8371

CIRCLE NO. 119 ON FREE INFORMATION CARD

## ICs PROMPT DELIVERY!!!

SAME DAY SHIPPING (USUALLY)

DYNAMIC RAM			
256K	150 ns	\$35.77	
64K	200 ns	4.87	
64K	150 ns	4.87	
64K	120 ns	5.59	
16K	200 ns	1.21	
EPROM			
27256	32Kx8	300 ns	\$49.97
27128	16Kx8	250 ns	26.50
2764	8Kx8	250 ns	7.97
2732	4Kx8	450 ns	5.40
2716	2Kx8	450 ns	3.60
STATIC RAM			
5565P-15	150 ns	\$35.97	
6264LP-15	150 ns	35.97	
6116P-3	150 ns	6.36	

Open 6 1/2 days, we can Ship via Fed-Ex on Sat.

MasterCard, VISA or UPS CASH COD

**Factory New, Prime Parts** **µP**

**MICROPROCESSORS UNLIMITED**  
24,000 South Peoria Ave  
BEGGS, OK 74421

Prices shown above are for July 30, 1984

Please call for new discount & current prices. Prices subject to change. Please expect higher prices on some parts due to world wide shortages. Shipping and insurance extra. Cash discount prices shown. Small orders received by 6 PM CST can usually be delivered to you by the next morning, via Federal Express Standard Air. \$3.99

CIRCLE NO. 118 ON FREE INFORMATION CARD

## ★MICROCOMPUTER★

# BUSINESS SOFTWARE

MEDICAL MGMT...  
DENTAL MGMT...  
INSURANCE AGENT  
LEGAL BILLING.....  
PROPERTY MGMT..  
AND MUCH MORE !

UNIVAIR INTERNATIONAL  
9024 St. Charles Rock Road  
ST. LOUIS, MISSOURI 63114

(314) 426-1099

CIRCLE NO. 96 ON FREE INFORMATION CARD

## BUILD YOUR OWN COMPUTER!!!

68000 BASED MULTI-BUS COMPATIBLE KIT

### 4 BOARD SET INCLUDES:

- 1 6 SLOT MOTHER BOARD
- 1 CPU CARD
- 1 I/O with UFD 765 FLOPPY CONTROLLER
- 1 128K RAM CARD

SCHEMATICS PARTS LIST & ASSEMBLY DRAWINGS

KT 1001 COMPUTER KIT (FLATBOARDS ONLY)	\$189.99
KT 1004 COMPUTER KIT (UNTESTED BOARDS, POPULATED)	\$399.99
KT 1002 COMPUTER KIT (DOCUMENTATION ONLY)	\$35.00
KT 1003 PAL FOR RAM BOARD	\$16.99
KT 1005 CP/M FOR KIT (INCLUDES BIOS)	\$350.00

WE CARRY A COMPLETE LINE OF ELECTRONIC COMPONENTS SEND FOR A FREE CATALOG!!!



**NICORN ELECTRONICS**  
10010 CANOGA AVE. UNIT B-8  
CHATSWORTH, CALIF. 91311  
(818) 341-8833

CIRCLE NO. 116 ON FREE INFORMATION CARD

## GREAT DISKETTES Super Low Prices BIG NAME, NO NAME

You've used these diskettes a hundred times...and never knew their name. They're used by many of the major software manufacturers...and now you can buy them.

**\$119** ea. 5 1/4" SSDD Qty. 50  
**\$159** ea. 5 1/4" D5DD Qty. 50

5 1/4" SSDD-96TPI \$1.89 ea. 5 1/4" D5DD-96TPI \$2.14 ea

\*\*\* LIFETIME WARRANTY! \*\*\*

These are bulk packed diskettes with white Tyvek sleeves. No user identification labels or write-protect tabs are included.

Shipping: 5 1/4" DISKETTES—Add \$3.00 per 100 or fewer diskettes  
Payment: VISA or MASTERCARD accepted. COD orders only, add \$3.00 handling charge. Taxes: Ill. residents only, add 8% sales tax.

WE WILL BEAT ANY NATIONALLY ADVERTISED PRICE ON THE SAME PRODUCT AND QUANTITIES!

For orders only: 1-800-621-6827  
(In Illinois: 1-312-944-2788)  
(All other calls: 1-312-944-2788)  
Hours: 9AM-5PM Central, Mon.-Fri.

**DISK WORLD, Inc.**

Suite 4806 • 30 East Huron Street • Chicago, Illinois 60611

**DISK WORLD!**

Home of **BIG NAME, NO NAME DISKETTES**

CIRCLE NO. 97 ON FREE INFORMATION CARD



# ELECTRONIC COMPONENTS



**FREE CATALOG**  
160 PAGE

Catalogs Mailed Outside USA Send \$2.00

**MANUFACTURERS OF QUALITY ELECTRONIC COMPONENTS**

OVER 15,000 DIFFERENT ITEMS IN STOCK!

**MOUSER ELECTRONICS**  
11433 WOODSIDE AVE., SANTEE, CA 92071  
PHONE: (619) 449-2222 TWX: 910-331-1175

CIRCLE NO. 98 ON FREE INFORMATION CARD

# TOTAL CONTROL

For the **Timex-Sinclair Computer**



**I/O**  
16 lines IN 16 lines OUT  
**Real Time Clock/Calendar**  
with Buttons, Back up  
**Analogue to Digital Converter**  
4 Channels, 8 Bit  
**8K Non-Volatile RAM**  
RAM as EPROM  
**Compatible with**  
ZX Spectrum, TS 1000 & TS 1500

Built & Tested \$174.95  
Bare Board \$49.95

TERMS: Check or Money Order  
Call Res. Add 8%  
SHIPPING: inside U.S. \$5.00  
Outside U.S. \$10.00

**JK AUDIO**  
P.O. Box 3295  
Escondido, CA 92025 0580  
(619) 741-5132

CIRCLE NO. 101 ON FREE INFORMATION CARD

# MULTI-CHANNEL current carrier transceiver 2-WAY COMMUNICATION with any BSR type device

- Switch selectable for 8 channels transmit & 3 channels receive OR 3 channels transmit & 8 channels receive + 1 channel for on/off cmd.
- Switch selectable for any of the 16 BSR 'house codes' A thru P.
- To transmit a BSR signal, take the assigned TTL input port high momentarily.
- Upon receiving a BSR 'on' signal, the TTL output port goes high and stays high until reset by BSR 'off' signal.
- An interrupt driven Z-8 micro, complete with power supply (requires 24 vac ct @ 200 ma) on a 4.5" card with 44 pin connector, \$187.00.
- Optional RS-232 interface capable of sending and receiving all 256 channels, \$49.00.

**HYDRUS CORPORATION** dept. C  
(214) 350-8766  
6218 Cedar Springs Rd Dallas, Texas 75235

CIRCLE NO. 104 ON FREE INFORMATION CARD

Now we can make any computer sing as well as talk, for only \$219.



As featured in Garcia's Circuit Cellar, BYTE Magazine, September, October 1982.

## Microvox.

MICROVOX is a completely self contained professional voice quality text-to-speech synthesizer. MICROVOX may be easily interfaced to any computer, modem, RS-232C serial or parallel output device.

- 6502 Microprocessor based text-to-speech algorithm
- SC-01A phoneme based speech synthesizer
- 64 crystal controlled inflection levels
- 3000 character buffer
- RS-232C and parallel port interfaces
- On board power supply
- Music and sound effects capability

MV01 Microvox Assembled & Tested ..... \$299.00  
MV02 Microvox, complete kit ..... \$219.00

To Order: Call Toll Free 1-800-645-3479  
In N.Y. 1-516-374-6793  
**MICROMINT, INC.**  
561 Willow Avenue  
Cedarhurst, NY 11516

CIRCLE NO. 99 ON FREE INFORMATION CARD



# SAVE MORE THAN EVER ON 3M Scotch® DISKETTES

SALE PRICES ON 5 1/4" DISKETTES  
Prices good thru 9/30/84.

\$149 ea. 5 1/4" SSDD      5 1/4" DSDD \$195 ea.  
Qty. 20      **LIFETIME WARRANTY!**      Qty. 20

5 1/4" SSDD-96TPI \$2.19 ea      5 1/4" DSDD-96TPI \$2.75 ea  
8" SSDD \$2.05 ea      8" SSDD \$2.50 ea  
8" DSDD \$3.10 ea

All diskettes are boxed in 10's with Tyvek sleeves, reinforced hubs on 5 1/4" user identification labels and write-protect tabs  
Shipping: 5 1/4" DISKETTES—Add \$3.00 per 100 or fewer diskettes  
8" DISKETTES—Add \$4.00 per 100 or fewer diskettes    Payment: VISA and MASTERCARD accepted. COD orders only add \$3.00 handling charge. Taxes: Illinois residents only add 8% sales tax  
**WE WILL BEAT ANY NATIONALLY ADVERTISED PRICE ON THE SAME PRODUCT AND QUANTITIES!**  
For orders only: 1-800-621-6827  
(In Illinois: 1-312-944-2788)  
(All other calls: 1-312-944-2788)  
Hours: 9AM-5PM Central, Mon-Fri  
**DISK WORLD, Inc.**  
Suite 4806 • 30 East Huron Street • Chicago, Illinois 60611

**DISK WORLD!**      Authorized Distributor Information Processing Products      **3M**

CIRCLE NO. 102 ON FREE INFORMATION CARD

# TOROIDAL POWER TRANSFORMERS

— Small size • Low noise • Easy mounting —

Made in U.S.A.  
Custom sizes: 15VA-3,000VA at 50/60 Hz  
40 standard transformers with 117V-60Hz primaries in stock for 20VA, 40VA, 70VA, 100VA, 150VA, 340VA, 600VA  
Call or write for data sheets

Size	Secondaries** Volts/Amps	Price Each		
		1	2-4	5-24
40VA	2x8.5V/2.35A	\$26.10	\$22.00	\$19.60
OD 2.8"	2x12V/1.67A	26.10	22.00	19.60
H 1.3"	2x15V/1.33A	26.10	22.00	19.60
Wt. 1.1 lbs	2x18V/1.10A	26.10	22.00	19.60
	2x24V/.83A	26.10	22.00	19.60
	Multivoltage**	31.60	27.30	24.60
100VA	24V/4.15A	\$29.10	\$24.80	\$22.10
OD 3.7"	2x8.5V/5.8A	30.00	25.70	23.00
H 1.4"	2x12V/4.15A	30.00	25.70	23.00
Wt. 2.2 lbs	2x15V/3.3A	30.00	25.70	23.00
	2x18V/2.8A	30.00	25.70	23.00
	Multivoltage**	37.00	32.50	29.50
340VA	220V/1.55A	\$48.20	\$41.10	\$36.20
OD 4.5"	2x24V/7.08A	49.10	41.90	37.10
H 2.3"	2x30V/5.67A	49.10	41.90	37.10
Wt. 5.3 lbs	2x33V/5.15A	49.10	41.90	37.10

\* Dual secondaries may be used separately, in parallel or in series.  
\*\* For 5V and 12V or 5V and 15V regulated DC.  
Terms: VISA, MASTERCARD, COD or money orders—UPS charges added.

301-464-2100      TOROID CORPORATION OF MARYLAND  
6000 Laurel-Bowie Rd., Bowie, MD 20715-4037

CIRCLE NO. 105 ON FREE INFORMATION CARD

# 20 PROGRAMS on 2 cassette tapes

for 16K  
TS1000,  
TS1500,  
& ZX81  
only  
\$19.95.



\*for TS2068, C-64, VIC-20, ATARI, TI99/4A, CoCo & MC-10 only \$29.95  
Save money, learn about the exciting world of home computing and have fun doing it with the new HOME-PAC™  
The HOME-PAC™ with 21 page user manual covers educational, graphics, recreational, home finance and utility applications.  
Great tool for learning to program in BASIC. Programs are listable and manual includes section on modification tips.

**10 DAY MONEY BACK GUARANTEE**  
Please add \$2.00 shipping and handling to order.  
**Simplex Software, Dept CE2**  
62 Crestview Drive  
Willingboro, NJ 08046  
MC, VISA & Checks Accepted  
Orders & Inquiries State Computer Type  
Dealer Inquiries Invited

CIRCLE NO. 100 ON FREE INFORMATION CARD



**DRIVE DIAGNOSTIC TEST MENU**  
D = Drive Select      H = Head Select  
C = Clamp Center      S = Speed  
R = Radial      P = Position Error  
A = Azimuth      I = Index Time  
W = Write Data      V = Verify Data  
X = Exit to DOS

## FLOPPY DISK DRIVE DIAGNOSTIC

Do it yourself and save time and money. No special training needed.

All tests made WITHOUT REMOVING DRIVES. Additional equipment not needed. Our kit also includes users guide that shows how to do the drive adjustments.

OUR DRIVE DIAGNOSTIC WILL HELP YOU PREVENT COSTLY DATA ERRORS.

APPLE II® DRIVE DIAGNOSTIC ..... \$119  
KAYPRO® DRIVE DIAGNOSTIC ..... \$119  
**Sheepshead Software™**  
P.O. Box 486  
Boonville, CA 95415  
(707) 463-1833

Phone orders Mon.-Sat., 9 a.m. to 9 p.m., Pacific Coast Time.  
MASTER VISA Card or C.O.D. add \$2.  
Call, add 6%. UPS Blue Label add \$5.

CIRCLE NO. 103 ON FREE INFORMATION CARD

# EPROM PROGRAMMER KIT - MODEL 1409

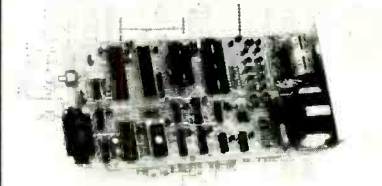

- Programs, lists, reads and verifies 2508, 2516, 2532, 2564, 2758, 2716, 2732A, 2764, 27128, 68732, 68764, 68766, 8741, 8748, H, 9, H
- RS-232 interface, supports XON-XOFF and/or hardware handshaking (RTS, CTS, DTR)
- Auto baud rate select (300-9600 baud)
- Accepts keyboard entry with line editing capability, ASCII, INTEL, MOTOROLA, or HEX files
- User friendly monitor for easy I/O debugging
- On board power supply

• 1409-1: P.C. board, X-former, software (4KEPROM) & documentation: ..... \$89.50  
• 1409-2: 1409-1 + full set of parts: ..... \$199.50  
• 1409-3: Assembled and tested unit: ..... \$299.50  
• Communication software for IBMPC, APPLE, CPM, TRS80: \$35.00

**B&C MICROSYSTEMS**  
6322 Mojave Dr., San Jose, CA 95120  
Tel. (408) 997-7685, Tx. 4995363

CIRCLE NO. 106 ON FREE INFORMATION CARD

## COMMODORE-64 & VIC-20

**MULTIPLEXED  
DIGITAL  
VOLTMETER**  
Only \$79

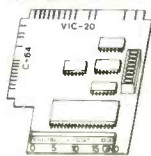

### FEATURES

- 16 Channel A/D converter (0-5V range)
- High accuracy (1/2% of full scale)
- Simple to use (one BASIC statement)
- Plugs into either VIC-20 or C-64

Great for engineering experiments, Science Fair projects, household monitoring of temperatures, solar intensity, position sensing, etc.

Get professional results, inexpensively!  
It's a safe learning tool for the student.

Send check or money order or request our free brochure.

**DRIVER ELECTRONICS**  
797 Overhill Drive  
Hayward, CA 94544

California residents add 6% sales tax.

CIRCLE NO. 106 ON FREE INFORMATION CARD

**DO NOT WAIT ANY LONGER, BIG SAVINGS ON SYSTEM PROTECTION**

Computer breakdowns can be prevented. Heat, humidity and voltage spikes can be devastating. Our Early Warning Indicator, monitors the humidity and system temperature, giving you time to save your system. The Surge Suppressor we offer will protect your system against voltage spikes/surges, "best buy anywhere". Unit contains four sockets, on/off switch, indicator light, circuit breaker, 6' cord and three MOV's for common mode and differential mode protection. Rating is 15 amps.

Early Warning Indicator 2 for \$9.95 + shipping  
Surge Suppressor 2 for \$39.95 + shipping

Terms: Check, Money Order or COD (add \$3.00 for COD)  
California residents add 6 1/2% sales tax

Electro Systems Research, Inc.  
P.O. Box 1268  
Temecula, CA, 92390  
1-314-678-5699

CIRCLE NO. 108 ON FREE INFORMATION CARD

## DRIVE CONTROL UNIT



Turns off  
8 inch Drives  
when not being accessed  
Save Drive, Save Media, Quiet Operation. Easily installed. Thousands are in use. For Shugart 800/850, Siemens 100/200, CDC Qume DT8, Remex 4000 Kit \$29.95 Assembled and Tested \$49.95  
Call or send for literature package  
VISA, MASTERCARD, COI Accepted

**OPTRONICS** 716-377-0369  
TECHNOLOGY 2990 Atlantic Ave.  
Penfield, NY 14526

## Eprom Eraser & Programmer

At Unbeatable Prices

LA6A EPROM ERASER \$44.90



LA6T EPROM ERASER \$59.50

MP32KB PROGRAMMER \$169.00



MP-100 PROGRAMMER \$389.50



PA12 AC ADAPTER \$4.75



Erases up to 8 chips in 15 minutes. This unit utilizes a high-intensity shortwave (253.7nm) ultra violet tube for the erasing process. A conductive foam pad placed inside the chip drawer prevents electrostatic, as well as physical damage to the chips.

Same as above plus an electronic timer with LED time interval indicator.

The MP32KB is a self-contained stand alone unit which requires no additional system or software for operation. Specially designed for simple and easy operation, it can program most single 5V EPROMs: 2716, 2732, 2732A, 2532, and more. A single press key allows the users to PROGRAM, VERIFY, LOAD, READ, and KEY in with binary keypad. A parallel I/O port allows users to connect MP32KB to any computers for data transfer.

A stand alone unit, this advance programmer has 64K internal buffer and on board expandability to 128K. It can program most EPROMs available today from 16K to 512K at any Vpp. The hexadecimal keypad and display with color coded panel are designed to minimize operational errors. With built-in parallel I/O and Remote ports, the MP-100 can be easily connected to any computers for data transfers or to any host computers as a remote programmer (optional RS232). A large conductive foam padded compartment stores more than 10 PROMs or Jump® modules.

Wall plug power adapter for MP32KB and MP-100 PROM Programmers.

Mail orders: Please add \$3.00 handling NJ residents: Please add 6% sales tax

**ANGO ELECTRONICS CORPORATION**  
Box 112, Harrison, NJ 07029  
212-685-6336

## COMPUTER CONTROL YOUR HOME

SAVE ENERGY - IMPROVE SECURITY  
USING YOUR HOME COMPUTER

This clear, easy to understand book provides detailed information on the fundamentals of using your home computer to monitor and control home energy systems, greenhouses, sprinkler systems and home security systems.

Includes: fundamental background information for developing hardware and software interfaces to your home computer.

Send \$14.95 plus \$1.50 for shipping and handling for each softcover copy of "COMPUTER CONTROL YOUR HOME" by Alan Hale, Associate Professor of Computer Science, Eastern Washington University to:

**TUCANA PRESS**  
Post Office Box 330  
Cheney, Washington 99004

Allow 6 to 8 weeks for delivery.

CIRCLE NO. 109 ON FREE INFORMATION CARD

## Votrax SC-01A SPEECH SYNTHESIZER



\$32 each  
( \$24 in  
hundreds )

Order in Ones or Thousands

The SC-01A Speech Synthesizer is a completely self-contained solid state device. This single chip phonetically synthesizes continuous speech of unlimited vocabulary.

Computer interfaces and text-to-speech algorithms also available for product development.

Micromint is the largest U.S. distributor of the SC-01A. Call us for a price quote.

Call 1-800-645-3479, in N.Y. 1-516-374-6793

**MICROMINT INC.**  
561 Willow Avenue  
Cedarhurst, NY 11516



Add \$2.00 for shipping & handling

CIRCLE NO. 111 ON FREE INFORMATION CARD

## FANTASTIC LOW PRICES ON BASF QUALIMETRIC DISKETTES

- LIFETIME WARRANTY •
- PLASTIC STORAGE CASES •

5 1/4" DSD \$139 ea.  
5 1/4" SSDD \$189 ea.  
Qty. 20 5 1/4" DSDD Qty. 20

All BASF Diskettes include a PLASTIC DISK CADDY, Tyvek sleeves, reinforced hubs, user identification labels and write-protect tabs.

Shipping: 5 1/4" DISKETTES—Add \$3.00 per 100 or fewer diskettes. Payment: VISA or MASTERCARD accepted. COD orders only, add \$3.00 handling charge. Taxes: Ill. residents only, add 8% sales tax.

WE WILL BEAT ANY NATIONALLY ADVERTISED PRICE ON THE SAME PRODUCT AND QUANTITIES!

For orders only: 1-800-621-6827

(In Illinois: 1-312-944-2788)

(All other calls: 1-312-944-2788)

Hours: 9AM-5PM Central, Mon.-Fr.

**DISK WORLD!, Inc.**

Suite 4806 • 30 East Huron Street • Chicago, Illinois 60611

**DISK WORLD!** Authorized Reseller Information Processing • BASF Media

CIRCLE NO. 10 ON FREE INFORMATION CARD

## COMPUTER MAGAZINE PROGRAMS TYPED AND MAILED ON DISK

FROM ONLY \$8.25 PER MONTH

Including disk and postage  
WE TYPE FOR:

**C64 ★ ATARI ★ APPLE**

We are a typing service. Price includes all the programs from 3 top magazines for your computer. Programs are typed, run tested, and mailed to you on disk as soon as possible each month.

**AMTYPE CORPORATION**

7 DAYS TOLL FREE

1 (800) 521-3200

CIRCLE NO. 110 ON FREE INFORMATION CARD

## PUBLIC DOMAIN SOFTWARE

Lots of it available in these formats:

- Single sided formats
- Actrix (SSDD)
- Cromemco CDOS (SSDD)
- Cromemco CDOS (SSSD)
- Cromemco w/Inl Term CPM
- DEC VT180 (DD)
- Health w/Magnolia (DD)
- IBM PC (CP/M-86 SSDD)
- Kaypro II
- LOBO MAX-80 (DD)
- MS-DOS/PC-DOS (Ver. 1)
- MS-DOS/PC-DOS (Ver. 2)
- Morrow MD2
- NEC PC-8001A
- Osborne 1 (DD)
- Osborne 1 (SD)
- Superbrain (40 Trk SS)
- Superbrain (JR)
- TI Professional (DD)
- TRS-80 I (Omikron CP/M)
- TRS-80 Mod III (MM CP/M)
- Xerox 820 (SD)
- Xerox 820-II (DD)
- Zenith Z-90 (48 tpi SS)
- Double sided formats
- Actrix (DSDD)
- Cromemco CDOS (DSDD)
- Cromemco CDOS (DSSD)
- Cromemco w/Inl Term CPM
- Datavue (DSDD)
- EPSON QX-10
- Hewlett Packard HP-125
- IBM PC (CP/M-86 DSDD)
- IMS 5000
- Kaypro 4/10
- MAGIC Computer
- MS-DOS/PC-DOS (Ver. 1)
- MS-DOS/PC-DOS (Ver. 2)
- Morrow MD3
- NEC PC-8801A
- Olivetti Attache
- Sanyo Superbrain (OD)
- TelesVideo
- Toshiba T100
- Zenith Z-100 (DD)

Over 200 disks, most formats \$12 per disk. Send \$2 for PD catalog. Sample disk \$8.

Sheepshead Software™

P.O. Box 486  
Boonville, CA 95415

CIRCLE NO. 112 ON FREE INFORMATION CARD

## TS1000 ZX81



### 3-Color Keyboard Symbols with Conversion Instructions

- Plastic TS1000-ZX81 keyboard symbols in Black, Red and Blue. Opaque background. Will fit all standard-size keys. Adhesive backing for easy application.
- Simple illustrated instructions will show you how to convert a cheap (about \$20) surplus keyboard to a full-size TS1000/ZX81 console. "...as easy as stringing wire on a fence."
- Do's and Don'ts for selecting a surplus keyboard.
- Bonus for the "pro" - Schematic Diagram of Computer.

**MULE Electronics \$12\***

Dept. 310  
444 Lincoln Blvd.  
Venice, California 90291

\*Add \$1.50 P&H. California residents add 6.5% tax. Money-back guarantee, of course.

### COMMODORE 64\* PROGRAM EXPANDER BOARDS

PLUGS INTO BACK OF COMPUTER. PLACE MOST USED PROGRAMS ON EXPANDER BOARD—TURN THE SWITCH ON TO THE PROG. YOU WANT, PRESS RESET BUTTON TO START PROGRAM. KEEPS ALL YOUR FAVORITE PROGRAMS AT YOUR FINGERTIPS.

	PRE-TESTED ORDER#	GUARANTEED TO WORK	RETAIL COST
4 PROGRAM EXPANDER BOARD	DE111744	\$39	
6 PROGRAM EXPANDER BOARD	DE154116	\$49	
8 PROGRAM EXPANDER BOARD	DE110278	\$59	

For 1 to 999 ordered—ADD POSTAGE & HANDLING CHARGES. 1000up—Postage is incl.  
NO. DE111744 ADD \$2.00 Per Unit  
NO. DE154116 ADD \$3.00 Per Unit  
NO. DE110278 ADD \$4.00 Per Unit\*\*

BACKSHELL FOR 12/24 CARDAGE CONNECTOR—USER PORT COVER FOR VIC-20\* & COM. 64\*  
1,000-29,999=80¢Ea. 30,000-59,999=75¢Ea.  
60,000-99,999=65¢Ea 100,000UP=65¢Ea.\*\*  
FOR HARDWARE ADD 20¢ PER UNIT

\*\*TERMS: 30% DOWN & BALANCE COD. ALLOW 6 wks. DELIVERY. KS. Residents ADD 3% SALES TAX. WITH APPROVED CREDIT ONLY! DEALER & DISTRIBUTOR PRICE LIST AVAILABLE UPON REQUEST.

\*COMMODORE 64 and VIC-20 is a trademark of Commodore Bus. Machines, Inc. CALL OR SEND YOUR ORDER TODAY TO:  
DYNAMIC ELECTRONICS INC. (316)264-8636  
1621 S. SENECA WICHITA, KS. 67313

### COMMODORE 64\* PROGRAM EXPANDER BOARDS

CIRCLE NO. 114 ON FREE INFORMATION CARD



## NEW GUITAR CHORD COMPUTER

Quick. Think of 3 ways to play a D flat 9th chord. Give up? The GUITAR CHORD COMPUTER shows you all three in less than 10 seconds. Virtually every guitar player can use one of these. Here's what it will do: CHORDS Major, Minor, Dominant, Augmented, and Diminished; SCALES Major, Harmonic Minor, Melodic Ascending and Melodic Descending; ALTERNATES/INVERSIONS 3 and 4 alternates are shown for most chords (Easiest to play is displayed first); TRANSPOSE Up or down by half-steps. 6th, 7th, 9th CHORDS Displayed at the touch of a button. Play better and easier guitar in minutes. Order yours today! No. GC-2 Guitar Chord Computer \$59.95 (plus \$2.50 postage & handling) Ask for your free catalog.

CHARGE TO VISA OR MC TOLL-FREE  
1-800-654-8657 9AM to 5PM CST MON-FRI

**RAIA Electronics, Inc.**

1020 W. Wilshire, Oklahoma City, OK 73116 (405)843-9626

CIRCLE NO. 113 ON FREE INFORMATION CARD

NOW USE BOTH SIDES  
OF YOUR DISKETTE!

## DISKETTE HOLE PUNCH

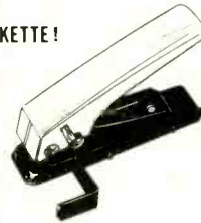

NO GUESSWORK  
WITH HOLE GUIDE

and EDGE GUIDE

PUNCH OUT IS ALWAYS IN THE RIGHT POSITION

Available for IMMEDIATE Shipment

only \$9.50 add \$1.50 shipping



N.P.S. Inc.  
Dept. D



(215) 884-6010

1138 BOXWOOD RD. JENKINTOWN, PA 19046

A 24 HR ANSWER MACHINE

CIRCLE NO. 115 ON FREE INFORMATION CARD

## DISCOUNT COMPUTER EQUIPMENT

LOWEST PRICES on Printers, Disk Drives, Software, and Other Computer Equipment!  
EPSON, Star Micronics, Okidata, Tandon, TEAC, & Many Others.

For a free catalog call

**918/825-4844**

918 825-4844

**AMERICAN Small Business COMPUTERS**

1150 W. 10th St. Muskogee, OK 74401

## FREE CATALOG!

Just let us know and we'll mail you a FREE *Creative Computing* Catalog—16 pages filled with books, buyer's guides, magazines, and more!

To get your FREE catalog, write to: *Creative Computing* Catalog, Dept NA1X 39 East Hanover Ave., Morris Plains, NJ 07950.

# Computers & Electronics Marketplace

**CLASSIFIED RATES:** Per Word, 15 Word Minimum. **COMMERCIAL:** \$5.00. **PERSONAL:** \$3.00. **EXPAND-AD®:** \$7.50. Ads set in all bold type @ 20% premium. Ads set with background screen @ 25% premium. **DISPLAY:** 1" x 2 1/4", \$605.00. 2" x 2 1/4", \$1,165.00. 3" x 2 1/4", \$1,675.00. **GENERAL INFORMATION:** Frequency rates and prepayment discounts available. Payment must accompany order except credit card—Am. Ex., Diners, MC, VISA (include exp. date)—or accredited ad agency insertions. Copy subject to publisher's approval; must be typewritten or printed. First word set in caps. Advertisers using P.O. Boxes MUST supply permanent address and telephone number. Orders not acknowledged. They will appear in next available issue after receipt. Closing date: 1st of the 2nd month preceding cover date (e.g., Mar. issue closes Jan. 1). Send order & remittance to: Classified Advertising, **COMPUTERS & ELECTRONICS** Magazine, 1 Park Avenue, New York, NY 10016. To Charge your ad to a major credit card, call Lois Price at (212) 503-5115. For Customer Service, call (212) 503-4506.

### FOR SALE

GOVERNMENT and industrial surplus receivers, transmitters, snooper scopes, electronic parts, Picture Catalog 25 cents. Meshna, Nahant, Mass. 01908.

RECONDITIONED TEST EQUIPMENT \$1.00 for catalog. WALTER'S TEST EQUIPMENT, 2697 Nickel, San Pablo, CA 94806, (415) 724-0587.

ELECTRONIC CATALOG. Over 4,500 items. Parts, & components. Everything needed by the hobbyist or technician. \$2.00 postage & handling (United States Only), refundable with first \$15.00 order. T & M Electronics, 472 East Main St., Patchogue, NY 11772. (516) 289-2520.

POLICE CODE UNSCRABLERS, lets you hear the coded messages of Police, Fire and Medical channels; plus other scanner accessories, satisfaction guaranteed. DNE Inc., Rt. 7, Box 257-A, Hot Springs, AR 71901. (501) 623-6027.

PRINTED CIRCUIT BOARDS, your artwork. Quick delivery. Reasonable. Atlas Circuits, Box 892, Lincolnton, NC 28092. (704) 735-3943.

CABLE TV CONVERTERS & EQUIPMENT. Plans and parts. Build or buy. For more information send \$2.00: C & D ELECTRONICS INC., P.O. Box 21, Jenison, MI 49428.

FREE Catalog of special function IC's and quality components. Goldsmith Scientific, Box 318M, Commack, New York 11725.

FREE! 1984 CATALOGUE. 1001 bargains. Speakers-parts-tubes-video cassettes—record changers—tape recorders—kits. EVERYTHING IN ELECTRONICS. Write: McGEE RADIO & ELECTRONICS, 1901 McGee Street, Kansas City, MO 64108-1891.

TV & RADIO TUBES, 59¢ each. Send for free catalog. Cornell, 4213 University, San Diego CA 92105.

12 SATELLITE DISH AND POLAR MOUNT. Total weight 125-lbs. For \$189.00. For information send \$4.95 (Refundable u.p.) to: Satellite Operational Systems, P.O. Box 2002, Titusville, FL 32781.

CABLE TV products. Jerrold, Hamlin and Oak, send \$3.00 to ADDITIONAL OUTLET CORP., 1041 W. Commercial, Ft. Lauderdale, FL 33309.

HARD TO FIND lightbulbs thousands types buy, sell. Jetco, P.O. Box 8755, Newport Beach, CA 92658.

LOWEST POSSIBLE PRICES ANYWHERE! Computers Hardware—Software—Printers, Audio, Video, Car Stereo. ELECTRIFIED DISCOUNTERS, 996 Orange Ave., West Haven, CT 06516. MC/VISA. (203) 937-0106.

## RADAR JAMMER!



- Causes speed radar guns to read out either: — a percentage of your true speed, or whatever speed you dial in
- Activated by your Escort and most other detectors
- Especially effective against instant-on radar
- Operates on both X and K bands (not FCC approved)
- MONEY-BACK GUARANTEE**, if not satisfied.

WARNING: The device described in this literature is not legal for use against police radar.

Complete literature & plans package, send \$14.95 to:

**Phillips Instrument Design Co. Inc.**

9513 S.W. Barbur Blvd. # 109 C Portland, OR 97219

VISA and M/C order line: (503) 626-6764

## MICROWAVE ANTENNA SYSTEMS

Freq 2.1 to 2.6 GHz • 34 db Gain •  
**COMPLETE SYSTEMS** (as pictured)  
 Commercial 40' Rod Style \$99.95  
 Parabolic 20' Dish Style 89.95

**LIFETIME WARRANTY**  
 PARTS AND LABOR

CALL OR WRITE FOR KITS • PARTS  
 • INDIVIDUAL COMPONENTS

We Repair All Types Down  
 Converters & Power Supplies

**Phillips-Tech  
 Electronics**  
 P.O. Box 34772  
 Phoenix, AZ 85067  
 (602) 967-6972

Special Quantity Pricing • Dealers Wanted

## WERSI electronics ORGAN & PIANO KITS

### ALPHA DX 300



fully  
**DIGITAL  
 RS 232  
 Interface**

For Free Sound Info  
 Call 1-800-233-3865  
 or write WERSI USA  
 Dept. M3 P.O. Box 5318  
 Lancaster, PA 17601

THE WORLD LEADER

## A SINGER'S DREAM!



### REMOVES VOCALS FROM RECORDS!

Our **VOCAL ELIMINATOR** can remove most or virtually all of a lead vocal from a standard stereo record and leave most of the background untouched! Record with your voice or perform live with the backgrounds. Used in Professional Performance yet connects easily to a home component stereo system. Not an equalizer! We can prove it works over the phone. Write or call for a free brochure and demo record.

Write to: **LT Sound, Dept. CE, PO Box 338**  
 Stone Mountain, GA 30086  
 In Georgia Call (404) 493-1258

**TOLL FREE: 1-800-241-3005 — Ext. 37**

Telephone Audio Coupler connects between your recorder auxiliary input and phone line modular jack. (T adapter included). Play back or record messages. Uses improved broadcast engineering techniques. \$14.95 plus \$2.00 p&h. Info \$1.00. Columbus Music Company, 2514 13 Street, Columbus, NE 68601.

**FREE BROCHURE!** Largest selection of computer oriented T-shirts and caps. Must see! Computer Graphics, Box 4055, Lutherville, Maryland 21093.

**SATELLITE TV RECEIVER BREAKTHROUGH!** Build your own system and save! Instruction manuals, schematics, circuit boards! Send stamped envelope: XANDI, Box 25647, Dept. 22C, Tempe, AZ 85282.

**AUTOMOBILE MUSICAL DOOR** open indicators, automatic glovebox/trunk lights, purse alarms and many more electronic devices. Catalogue \$1.00 (refundable w/purchase). P.W. Cornelius (Dept. B), 118 Auden Drive, Greensboro, NC 27406.

**CABLE CONVERTERS, MICROWAVE T.V. antennas**, all types of cable T.V. accessories and kits. HMR SALES, 221 East Camelback #1, Phoenix, AZ 85012. (602) 993-0398.

**FREE CATALOG.** 99¢ KITS. Audio, video, TV, computer parts. Allkit, 434 West 4th St., West Islip, NY 11795.

**PRINTED CIRCUIT BOARDS.** Double sided with plated through holes or single sided. No set up charge. **Caudill Inc., 205 East Westwood Ave., Highpoint, NC 27262. (919) 884-0229.**

## COMPUTER EQUIPMENT/PARTS

SAVE 90% Build Your Own Minicomputer. Free Details. Digatek, 2723 West Butler Dr., Suite 20C, Phoenix, AZ 85021.

**FREE 64 PAGE COMPUTER CATALOG** crammed full of thousands of the best buys and lowest prices around! **A.P. COMPUTER PRODUCTS**, Dept. CC, 214A East Main, Patchogue, NY 11772. (516) 698-8636.

**USED COMPUTER** terminals, printers, modems, cables, surplus electronic parts. Specials: CRT's \$20.00, Hardware Modems as-is \$15.00. Catalog \$1.00. Roudure Company, "The Computer Room" CE, P.O. Box 35566, Dallas, TX 75235, (214) 630-4621.

**REPLACEMENT RIBBONS** for computer printers and word processors. Fantastic saving! Thousands in stock. Quick delivery. Call/write: 1 (800) 292-6272. National Computer Ribbons, 114 Elbank Ave., Baltimore, MD 21239.

**SANYO 550-1, Blow-out price-\$817; 555-2, 360K-\$1190; Plus freight.** Order Sanyo computers available. **SMS Dist. Center, Box 1904, Fargo, ND 58107. Rebtable price sheet \$5.00.**

**AMBER REPLACEMENT CRT's** (picture tubes) for IBM PC, Radio Shack, TeleVideo, DEC, Kaypro and many more monitors. Made with European Amber phosphor, high-lead glass, anti-glare tech, high-res gun, etc. Finest quality. Replace your CRT (a 20 minute job) and eliminate eye fatigue, improve appearance. Free literature. ALSO, anti-radiation, anti-glare terminal shields. Langley-St. Clair Instrumentation Systems, 132 W. 24th St., NY, NY 10011. (800) 221-7070.

**COMPUTER DISPLAY ENHANCER.** Increases Clarity. Call for details. \$49.50. VISA accepted. Components Corp., Denville, NJ 07834. (201) 627-0290.

**DISKS 99¢ each, 20 minimum.** 5 1/4" for Apple, TRS80, Commodore, etc. Top makers, guaranteed! Promotional offer, limited quantities. Order by phone with MC/VISA. **ERM, 27 Water St., Wakefield, Mass. 01880. (617) 246-3550.**

**MINIATURE COMPUTER CLOCK \$4.95.** Golf, Football etc. **FREE!** catalog. U.S. shipping \$2.00 (Dealers Wanted) **C.R.E. Wholesale, Box 361, North Sale Lake, Utah 84054.**

## COMPUTER SOFTWARE

**FREE VIC-20 and COMMODORE 64 USERS GROUP MEMBERSHIP** with software purchase. Why pay to belong to a users group when you don't have to? Benefits: Newsletter, extensive club library, discounts, contests, questions hot-line and more! Free details—(803) 797-1533. **Lords of Basic, P.O. Box 459, Dept. 102 Ladson, SC 29456.**

**TS 1000, T199/4A, VIC-20 Software.** Turns Programs into Profits; Catalog: **Midwest Software, 9922 Harwich, Crestwood, MO 63126.**

**RENT PUBLIC DOMAIN SOFTWARE.** It's not copyrighted, no fees to pay. Copy hundreds of useful business, utility and game programs from our rental libraries onto your own computer at home! **SASE NATIONAL PUBLIC DOMAIN LIBRARY, 1062 Taylor, Vista, CA 92083. (619) 941-0925.**

**DISCOUNT Computer—Software, Wargames, Video cassettes.** FREE catalog. **Wizard Entertainment, Box 509, Saugus, CA 91355.**

**DISCOUNT SOFTWARE/HARDWARE-30% minimum below retail.** Apple II/III+, Atari 400/800/XL, T1-99/4A, VIC-20, Commodore 64, IBM/PC. Gemini-10X \$275.00, Okidata 92P \$445, Epson RX-80 F/T \$380.00. Flight simulator II \$37.50, Zork I/II/III \$26.50 each. T1 extended basic \$77.50. Direct connect printer interface; T1 \$85.00, Atari \$69.50. Send \$1 (stamps okay) for extensive software/hardware catalog. Specify computer system. **Multi-Video Services, Box 246, East Amherst, NY 14051. (716) 688-0469 (5-9 P.M.).**

**FREE Commodore-64/T199-4A/TRS80-COCO/TRS80-MC10/VIC-20/TIMEX program!** Send stamps! **eZRA EZRA Company, Box 5222-CN, San Diego, California 921005.**

**SOFTWARE CLEARANCE:** TS1000 programs from Timex for \$1.99. Atari programs like Jawbreaker \$8.95. VIC20 and Apple programs at below cost prices. FREE catalog. **Megatrack Computers, PO Box 940, Jackson Heights, NY 11372. (212) 927-1104.**

**COMMODORE 64/VIC 20 Games/educational software.** Over 400 titles! Write for FREE catalog! **American Peripherals, 12 Bangor St., Lindenhurst, NY 11757.**

**Ti-99/4A, C-64 TIMEX 16K-48K, VIC, IBM, OWNERS.** 5 fun programs for \$2.00! Get Baseball, Etching-Sketch, Black-jack, Dungeon, Galactic Patrol. Specify your computer. **CHIPMUNK SOFTWARE, 634 Littlecroft, Upper-Darby, PA 19082.**

**Ti-99/4A Softwares** for personal, home entertainment, and business applications. Write for free catalog to: **Micro-Biz Hawaii, Dept. P 98-1409D. Kaahumanu St., Aiea, Hawaii 96701.**

**FREE SOFTWARE.** Earn "BONUS BUCKS" for FREE Software, Books and Supplies. Catalog \$1.00 (refundable with order). Specify model. **Computer Discount Center Inc., Dept. CE, PO Box 1548, Springfield, VA 22151.**

## PHONE LISTENING DEVICE

Record telephone conversations in your office or home. Connects between any cassette or tape recorder and your telephone line. Starts automatically when phone is answered. Records both sides of conversation. Stops recorder when phone is hung up.

19<sup>95</sup> ea. Qty discounts available

**WIRELESS MIC** (super powerful)

10 times more powerful than other mics. Transmits up to 1/4 mile to any FM radio. Easy to assemble kit 15V battery (not incl.) Call (305) 728-1000 or send \$19.95 + \$1 shipping per item to **USI Corp., P.O. Box CE-2052, Melbourne, FL 32901. COD's accepted.** For catalog of transmitters, voice scramblers and other specialty items, enclose \$2 to USI



**CABLE TV EQUIPMENT.** Notch filters for "Beeping" Channels. Information \$1.00. **Goldcoast, Box 63/6025 CE, Margate, Florida 33063 (305) 752-9202.**

**Computer/Satellite modulators, CCTV cameras, monitors, MATV, Kits.** Free video catalog. **Phone (402) 987-3771. Dealership available. ATV Research, 13-CE Broadway, Dakota City, NE 68731.**

**MICROWAVE ANTENNAS COMPLETE WITH WARRANTY** from the original manufacturer. Three styles Daisey, Parabolic, and Yaggi. We also repair all down converters and power supplies. **S.A.P. 3531 W. Glendale Ave., Phoenix, Arizona 85021. (602) 973-9117.**

**CABLE T.V. EQUIPMENT, JERROLD HAMLIN, OAK, all types.** We also have Jerrold SB-3 in kit form. All parts and instructions included. Dealer inquiries invited. **S.A.P. 3531 W. Glendale Ave., Phoenix, Arizona 85021. (602) 973-9117.**

**FOR SALE BY OWNER.** Listing of microcomputers and peripherals for sale by owner. IBM-PC, IBM-XT, Portable, Apple, many others for complete listing send \$26.00 to: **JEGAL CORP., Box 244, Wyckoff, New Jersey 07481.**

**FREE FLYER!** IC's, resistors, capacitors, jacks, etc., plus SSM music synthesizer/audio IC's, power amp modules, analog delay IC's, computer books, and more. Also plans for analog delay/chorus unit! **PGS Electronics, Route 25, Box 304 Terre Haute, IN 47802.**

**CABLE TELEVISION FACTS AND SECRETS.** Now you can get the informative publication that CATV companies have been unsuccessfully trying to get banned for 15 years. **Movie Channel, HBO and Showtime converters, etc. Send \$8.75 to: CABFAX, P.O. Box 091196, Bexley, Ohio 43209.**

RENT SWAP your SOFTWARE. FREE catalog. SUPER LIBRARY. Box 27125, Orlando, FL 32867.

USED SOFTWARE free catalog, buy, sell, all computers, Software Exchange Incorporated, Box 485, Hales Corners, Wisconsin 53130.

COMPUTER TRAINING through disks/tutorials, IBM, Apple, Sanyo, etc. Hardware, Software, Work Stations. Rye Data, Box 210E, Mountain St, Haliburton, Ont. K0M 1S0 Canada. (705) 457-2774.

ELECTRONICS made easy for Apple II users with Mentor, the proven theoretical circuit package. Excellent learning aid too, \$174.95. Kormeyer Electronic Design, Inc., 5701 Prescott, Lincoln, NE 68506. (402) 483-2238.

BBS PROGRAM, for C64, 1541 Drive, Automodem. \$79.95. Atlasware, 4120 Lakeland, Robbinsdale, MN 55422. Dealers wanted!

MOOD graphics, TI-99/4A, brilliant colorful action, sets mood for parties, romance. Several screens, XBasic, cassette \$12.95. Novelty Software, Box 286, Karlstad, MN 56732.

EXCITING NEW CARTRIDGES for your VCS! New LCD games too! FREE catalog: DIGITEK ELECTRONICS, Dept-AA 1025 Jefferson, Suite 270, Santa Clara, CA 95050.

DIRECT manufacturing company offering for VIC and Commodore owners LIGHTPENS \$18.95, and BATTERY BACKUP \$79.95, Creative Electronics, P.O. Box 4253, Thousand Oaks, CA 91360, (805) 492-1506.

TRY BEFORE YOU BUY!!! TI-99/4A Users save money by renting software from the SOFTWARE USERS EXCHANGE, Dept. E, P.O. Box 49, New Cumberland, PA 17070. Free Brochure!

VIDEO TITLE EDITOR—create custom titles and messages on any videotape. Full color control. Blank-out commercials. \$29.95. Specify disk/tape. Specify any Atari/VIC 20/Com 64. Videoware, 19777 West 12th Mile Rd., Suite 180, Southfield, MI 48076.

5¼" Floppies. SSDD MAXELL MD-1, \$179; DYSAN 104/1D \$1.99; D3DD Maxell MD-2 \$2.39; DYSAN 104/2D \$2.69. Shipping \$3.75 ON ANY SIZE ORDER. Sold in 10 packs. VISA, MC. 1-(800) 245-6000. Tapeworld, 220 Spring St., Box 361, Butler, PA 16001.

DISCOUNT SOFTWARE/HARDWARE—20% to 30% below retail. Apple, Macintosh, Atari, Commodore, IBM PC, TI-99/4A. Gemini 10x \$279. Epson RX80 \$280, TI extended BASIC \$82, Macintosh BASIC \$105. No hidden charges—only 3% shipping. Send \$1 for extensive catalog. Over 1000 titles. Specify computer. Multi Video Services, P.O. Box 246, East Amherst, NY 14501. (716) 688-0469 (5-9 pm).

THE MATHEMATICIAN is a complete math package for the IBM, HP and TS1000 with nearly the power of PROTRAN, a program available for mainframes, but very easy to use. Do your homework. Comes with documentation, hardcopy for easy conversion to any other computer and program. Requires 32K. 3½ inch HP disk version available. Cassette \$19.95. Aereo disk \$24.95. Russell Reeve, 825N 750E, Bountiful, UT 84010.

COMMODORE 64 OWNERS! Rent software with option to buy. Low prices and no membership fee. Hundreds of brand name programs. Call or write for free catalog to Centisble Software, P.O. Box 263, Stevensville, MI 49127. (616) 465-6632.

MAKE FOREIGN languages fun! Apple, PC, 64. Free catalog. Gessler Educational Software, Suite T, 900 Broadway, NYC 10003, (212) 673-3113.

## ENERGY

SOLAR ELECTRIC PANELS at drastically reduced prices! Off-spec and surplus modules from major manufacturers. Up to 50% off list. Styles, outputs vary. Call FREE for details—(800) 638-8304. Major Credit Card welcome.

## COMPUTER REPAIRS

DISK DRIVES ALIGNED AND REPAIRED. 5¼-SS-\$50, 5¼-DS & 8"-SS-\$60, 8"-DS-\$80; includes \$20 in parts. Most home and personal computers repaired. Dealers/users invited, MICROAIDE INC. (201) 283-1910.

## COMPUTER HARDWARE

COMPLETE COMPUTER schematic. Z80 or 8080 system 24"x36" sheet notes. \$10.50. Schematic, 1443S 680 E. Orem, UT 84058.

\*SUPER SAVERS\* Apple Compatible Floppy \$165, ½ ht. \$175, Hard Disk 10mb \$1395, Monitor 12" Amber or Green \$115. Internal 10mb Hard Disk for IBM \$1095, Floppy JA551-2 \$174. Oztech, (800) 222-6697, California (408) 980-9987.

BUILD A FLAT BED PLOTTER for the Commodore 64 or Vic 20. Plans and programs \$49.00; Kit \$169.00; Assembled \$249.00. MAXI-PLOT, 839 Sea Foam, Houston, Texas 77062.

## COMPUTER PUBLICATIONS

"DISK DRIVE MANUAL"—Drive Alignments, Preventive Maintenance, Diagnostics, Troubleshooting, Repairs—Without Special, Expensive Software, Equipment. Comprehensive. \$19.90. Brochure \$1. Williams, M.S.E.E., 2011 Crescent, Alamogordo, NM 88310.

## TIMEX/SINCLAIR

AERCO will continue to provide high performance disk, printer, and other Interfaces for ALL MODELS of Timex/Sinclair computers. Box 18093, Austin, TX 78760, (512) 451-5874.

Timex 2068 programs. Wall street: Biorhythms: Disassemblers: Star Trek and many more. \$10 each. SAE plus \$1 for comprehensive list. C. Dos-Santas, P.O. Box 9521, Fountain Valley, CA 92728.

FASTFILE, professional data base management system 100% machine code—Add, Edit, Sort, Delete, Query, Analyze, LPrint—Best filing program for ZX81/TS100 or money back. Write for more information or send \$19.95 plus \$2.00 postage/handling for cassette and manual: Tom Cole, 1314 Speight #15, Waco, TX 76706. Texans add 5% tax.

TIMEX/SINCLAIR QUALITY SOFTWARE. Free price list. WMJ Data Systems, 4 Butterfly Dr., Hauppauge, NY 11788.

## COMMODORE 64

600 + COMMODORE 64 SOFTWARE TITLES! Bonanza Catalog \$2.00 (refundable). SKELGRAF, 4415 Basswood, Bellaire, Texas 77401.

VOICE SYNTHESIZER FOR COMMODORE 64. Unlimited vocabulary, easy to use, completely assembled. FREE INFORMATION FFSA 3812, North, Northwood Peoria, IL 61614.

## CABLE T.V.

CHANNEL 3—60db notch filter, 66 5MHz \$32. Crosley, Dept. 607, Box 840, Champlain, NY 12919.

CABLE TV SECRETS, the Informative Publication the Cable Companies Tried to Ban. HBO, Movie Channel, Showtime converters, etc.—\$8.95. CABLE FACTS, Box 711-PE, Pataskala, Ohio 43062.

CABLE TV CONVERTERS and modulators. Commercial types. BEST PRICES. Catalog \$2.00. Professional Video Inc., 4670 Hollywood Blvd., Hollywood, CA 90027.

## PLANS AND KITS

Communicate for miles with other computers with no license radio link. Study package with full details, sources. \$8.00 refundable. Broadcast Technical Services, 11 Walnut St., Marshfield, MA 02050.

PROJECTION TV ... CONVERT your TV to project 7 foot picture ... Results comparable to \$2,500 projectors ... Total Cost less than \$30.00 ... PLANS AND 8" LENS \$19.95 ... Illustrated information FREE. Macrocoma-CCX Washington Crossing, Pennsylvania 18977. Creditcard orders 24 Hours, (215) 736-3979.

ROBOT FACE LOOKS, TALKS, BLINKS, SMILES. MOUTH MIMICS SPOKEN OR RECORDED MESSAGES. EASILY BUILT. COMPLETE PLANS, \$6.95. MCR, Box 24857, ROCHESTER, NY 14624.

## MAILING LISTS

COMPUTER SHOW ATTENDEES N.Y., N.J.: 15,000 NAMES. \$30/M. P/S labels. For info, (201) 297-2526.

FREE MAILING LIST analysis. Details. GOC-9N, Box 1107, Stuart, FL 33494. (305) 334-5205.

## WANTED

GOLD, electronic, circuit board scrap, silver, platinum, tantalum, mercury. Ores, metals assayed. Samples evaluated. Wholesale Terminal, toll free 1-800-932-1010, (617) 326-3442 in Mass.

## TUBES

TUBES: "Oldies", Latest. Supplies, components, schematics. Catalog Free (stamp appreciated). Steinmetz, 7519-PE Maplewood, Hammond, Ind. 46324.

TUBES-RECEIVING, Industrial and Semiconductors Factory Boxed. Free price sheet including TV, radio and audio parts list. TRANSELETRONIC, INC., 1365 39th St., Brooklyn, NY 11218. Telephone: (212) 633-2800. Toll free: (800) 221-5802. Ask for Abe.

TV & RADIO TUBES, 59¢ each. Send for FREE CATALOG. Cornell, 4213 University, San Diego, CA 92105.

7,000,000 TUBES. World's largest inventory. Free catalog. UNIT ELECTRONICS, Dept. CE, P.O. Box 213, Elizabeth, NJ 07206.

## PERSONALS

MAKE FRIENDS WORLDWIDE through international correspondence, illustrated brochure free. Hermes-Verlag, Box 110660/Z, D-1000 Berlin 11, W. Germany.

ORIENTAL SINGLES seeking cultural exchange, friendship, sharing, marriage. WRITE: CHERRY BLOSSOMS, Box 1021P, Honokaa, Hawaii 96727.

CORRESPONDENCE TO ASIA FOR LASTING RELATIONSHIP. Free information. AAWS-CE, Box 2777, Orcutt, CA 93455-0777.

MATHEMATICAL INSIGHTS: Easily understood illustrated booklet (also for computers) discovers new formulas from traditional concepts. ORDER TODAY! MONEY BACK GUARANTEED. \$1.00. Michael Gilbert, Box 2376, El Paso, TX 79952.

FREE: WORLD'S LARGEST PARTNER PHOTO CATALOG for friendship and marriage. Personalized introductions. INTERCONTACT, Box 12, Toronto, Canada M4A 2M8.

PENFRIENDS foreign, USA. For free information, send name, address: PAPYRUS, 580C HWY. 67, Florissant, MO 63031.

BEAUTIFUL PHILIPPINE LADIES seeking nice friendship, marriage! Photos, details—\$1.00. Transcor-C&E-C, Box 2321, Manila, Philippines 2801.

## INSTRUCTION

UNIVERSITY DEGREES BY SPECIAL EVALUATION of existing credits and Job Experience. Fast, inexpensive. Call (614) 863-1791. Or write: EVALUATION, Box 13151-A11, Columbus, Ohio 43213.

REPAIR ELECTRONIC ORGANS—Revised home study course covers all current makes and models. Free booklet. Niles Bryant School, P.O. Box 20153, Sacramento, CA 95820.

LEARN WHILE ASLEEP! HYPNOTIZE! Astonishing details, strange catalog free! Autosuggestion, Box 24-ZD, Olympia, Washington 98507.

MEDICAL ELECTRONICS TECHNOLOGY, home study. Troubleshoot medical instruments. WTI, P.O. Box 3124, Fresno, CA 93650-3124.

HANDLE YOUR OWN LEGAL AFFAIRS—Be a Paralegal. Accredited Attorney Instruction. Home Study. FREE CATALOG. Southern Career Institute, Drawer 114CE-2158, Boca Raton, FL 33427. (305) 368-2522.

EARN \$800+WEEK! Get your "F.C.C. Commercial Radiotelephone License" at home. "Free" details. COMMAND, D-100, Box 2223, San Francisco 94126.

**Get Your 2-Year ASSOCIATE DEGREE in ELECTRONICS TECHNOLOGY**

No previous experience necessary... Train at home in spare time for exciting opportunities in fast-growing space-age industries... Automation, Aerospace, Cable-TV, Electronic Circuitry, Computers, and much more. No need to quit your job. Instructors are as close as your telephone... *we pay the bill.* Send for free facts, color brochure. No salesman will call. COS Electronics Center, Dept. P084F, Scranton, PA 18515 021A

LEARN TOUCH TYPING IN ONE EVENING—Computer or typewriter—complete home study kit \$6.50. Check or MO to TOUCHTYPE, 1043 Heathstone, Cincinnati, OH 45231.

UNIVERSITY DEGREES! Economical home study for Bachelor's, Master's, Doctorate. Prestigious faculty counsels for independent study and life experience credits. Free information—Richard Crews, M.D. (Harvard), President, Columbia Pacific University, 1415 Third St., Dept. 2D5N, San Rafael, CA 94901; Toll Free (800) 227-1617; Ext. 480; California: (800) 772-3545, Ext. 480.

**FOR INVENTORS**

INVENTIONS, IDEAS, NEW PRODUCTS WANTED! Industry presentation/national exposition. Call free 1-800-528-6050—Arizona, 1-800-352-0458, X831.

PATENT AND DEVELOP your invention. FREE PATENT INFORMATION. Richard L. Miller, P.E., 3612-E, Woolworth Building, New York, NY 10007, (212) 267-5252.

**INVENTORS! IDEAS HAVE VALUE!**

Ever think of an idea, forget it and see it later on the market? Many people don't forget, act quickly and are rewarded by American Industry. Write down your idea! We offer free disclosure registration and initial consultation regarding your idea's potential value. Call or write without delay for your free information package.

AMERICAN INVENTORS CORPORATION  
82 Broad St., Dept. CE  
Westfield, MA 01086  
413-568-3753

A Fee Based Marketing Company  
Offices Coast to Coast

**BUSINESS OPPORTUNITIES**

MECHANICALLY INCLINED individuals desiring ownership of Small Electronics Manufacturing Business—without investment. Write: BUSINESSES, 92-K11 Brighton 11th, Brooklyn, New York 11235.

ERASE DEBTS with little-known law—create wealth!! Details FREE—Wealth Kit, No. EE11, Billings, NY 12510.

BORROW \$300-\$30,000 INTEREST FREE! Keep indefinitely! Free Details. Write: American, 1601 Main, Plainfield, Indiana 46168.

BUMPER STICKER PRINTING DEVICE. Cheap, simple, portable. Free details. Bumper, POB 22791 (PE), Tampa, FL 33622.

FREE CATALOGS. Repair air conditioning, refrigeration. Tools, supplies, full instructions, Doolco, 2016 Canton, Dallas, Texas 75201.

BORROW \$30,000 without interest! All eligible. Repay anytime. Free details! Infohouse-CE, 808 Post, San Francisco, CA 94109.

\$360 WEEKLY/UP. MAILING CIRCULARS! No quotas. Sincerely interested, rush stamped envelope: Marketing International, Box 15967-E9, San Diego, CA 92115.

BE A COMPUTER PIONEER! Time-based/A.I./consumer software & development, now with Timex, Commodore & Sinclair QL applications. For business and personal software. PROGRAMMERS INQUIRE. TIMESTAR, PO Box 3521, Greenville, DE 19807.

PROJECTION TV ... MAKE \$\$\$'s assembling Projectors ... Easy ... Results comparable to \$2,500 projectors. Your total cost less than \$20.00. PLANS, 8" LENS & Dealers information \$17.50 ... Illustrated information FREE ... Macrocoma-CC, Washington Crossing, Pennsylvania 18977. Creditcard orders 24 Hours (215) 736-2880.

MULTI-CHANNEL microwave antennas. Highest quality, low prices, dealers welcome. D.T. compact \$38.00; P.T.-1 \$48.00; SR-1 \$65.00; D.T. Grid \$69.00; PTS-33 \$75.00. All units complete! Daisy Tenna, Box 42010, Phoenix 85080. 1(800) 874-9033.

"COMPUTER ILLITERATE TO \$33,000 + PROGRAMMER IN ONE YEAR." How I did it—complete details. Send \$8.95 to: R.B.P., 3063 Sugar Lane, Vienna, VA 22180.

MAIL ORDER OPPORTUNITY! Start profitable home business without experience or capital. Information free. Mail Order Associates, Inc., Dept. 502, Montvale, NJ 07645.

\$300.00 a month spare time income with your computer! Free details. DIGATEK CORPORATION. 2723 West Butler Drive, Suite 20B, Phoenix, AZ 85021.

REVEALING. 40 page, info pack, on how to start your own COMPUTER hardware/software MAIL ORDER/RETAIL business. Send \$10 to: JPI, PO Box 7033, Huntington Beach, CA 92615.

SELL YOUR PROGRAMS in our software catalog. FREE information. Russelt Winthrop Book CO., PO Box 45727, Seattle WA 98145.

HOW TO GET RICH with your microcomputer. Super opportunities. \$9.00. Satec, Box 02038, Columbus, OH 43202.

**REAL ESTATE**

500 OFFICES ... 45 STATES! 30,000 listing on computer, 16,000 under \$50,000! Free printouts and regional catalogs! UNITED FARM AGENCY, 612-EP West 47th, Kansas City, MO 64112. Ph: 1-800-821-2599, in MO 1-800-892-5785.

**INSURANCE**

SAFWARE. If your computer is important to you, insure it! SAFWARE provides full replacement of hardware, media and purchased software. As little as \$35.00 a year for comprehensive coverage including fire, theft, power surges, earthquake, water damage, auto accident. Call 8 to 8 Mon. through Sat. SAFWARE, The Insurance Agency, Inc., 2929 North High Street, Columbus, OH 43202. (800) 848-3469 (nat). (614) 262-0559. (OH).

**EMPLOYMENT OPPORTUNITIES**

ELECTRONICS/AVIONICS EMPLOYMENT OPPORTUNITIES. Details FREE. Aviation Employment Information Service, Box 240E, Northport, New York 11768.

COUNSELORS NEEDED, millions want credit! Fantastic earnings! No experience! Be 1st! Equal Opportunity Foundation, Box 10323, Marina Del Rey, CA 90285.

**BOOKS & MAGAZINES**

**SATELLITE TV VIEWERS**  
Get the most complete weekly listings.  
Send \$1 for sample copy.

**Satellite TV Week**

"P.O. Box 308Z, Fortuna, CA 95540"  
800-358-9997 (U.S.) • 800-556-8787 (Calif.)  
707-725-2476 (all others)

*Interested in home satellite TV?*

Learn how it works, what services are available, how to buy a system and more through the new booklet *Tuning In To Satellite TV*. Clip out this coupon and send it with your name and address, and \$1.00 for postage and handling to:

**Tuning In To Satellite TV**  
CommTek Publishing Company  
P.O. Box 2228, Dept. J  
Hailey, ID 83333

FAMILY TREE CLIMBERS COMPUTER APPLICATION GUIDE \$24.95; Quarterly magazine \$20/year. Posey International, PO Box 338, Oren, Utah 84057.

PUBLISHERS' OVERSTOCKS, BARGAIN BOOKS 2,000 titles, all subjects! Free catalog: Hamilton, Box 15-D, Falls Village, CT 06031.

ELECTRONIC SYSTEMS NEWSLETTER is a monthly publication written especially for the electronics hobbyist/experimenter. Fascinating projects, new ideas, sources. Free details. AF Publishing, Dept. CE, PO Box 524, So. Hadley, MA 01075.

**MISCELLANEOUS**

COMPUTER LOVERS GIFT CATALOG. Chocolate computers, diskette ties, computer clocks, jewelry and wallets. Write: SweetWare, 516 Shelburne Road, Dept. A South Burlington, VT 05401. (802) 862-1344.



**THE MASTER DIRECTORY  
OF PRODUCTS FOR THE  
IBM PC, PC XT, PCjr  
AND MOST COMPATIBLES!**

AVAILABLE AT YOUR  
LOCAL NEWSSTAND AND  
COMPUTER STORE.

**ADVERTISERS INDEX**

RS no.	ADVERTISER	PAGE no.
10	Acorn Computers Corp. ....	5
50	Active Electronics .....	105
13	Anadex, Inc. .... Cover 2	
	AT&T .....	21-23
33	BASF .....	15
	Classified Advertising .....	108-114
	Cleveland Institute of Electronics, Inc. ....	34-37
60	CompuServe .....	39
67	Computel Publishing Society .....	101
7	Craftsman Corp. ....	98
14	Digi-Key Corp. ....	107
	Epson America, Inc. ....	25
	General Electric .....	6-7
	Grantham College of Engineering .....	101
	Halix Institute .....	99
8	Hayes Microcomputer .....	30-31
24	Heath Co. ....	27
26	Heath Co. ....	49
34	Hewlett-Packard .....	13
32	IBM Corporation .....	8-9
41	IBM Corporation .....	42-43
	Information Unlimited/ Scientific Systems .....	99
12	Inmac .....	97
21	Jameco Electronics .....	106
22	JDR Microdevices .....	104
23	J & R Music World .....	97
20	Leading Edge .....	Cover 4
	MacMillan Book Club .....	91
69	Meca .....	2
	Micro Exchange .....	1
2	Microstuf, Inc. .... Cover 3	
	NRI Schools .....	16-19
5	Nibble Notch Computer Products .....	101
40	Protecto .....	88-89
	Radio Shack .....	41
	Scottsdale Systems .....	99
36	Sintec .....	103
54	Source, The .....	85
42	Tam's Inc. ....	98
	Tektronix .....	29
	United States Air Force .....	45-47

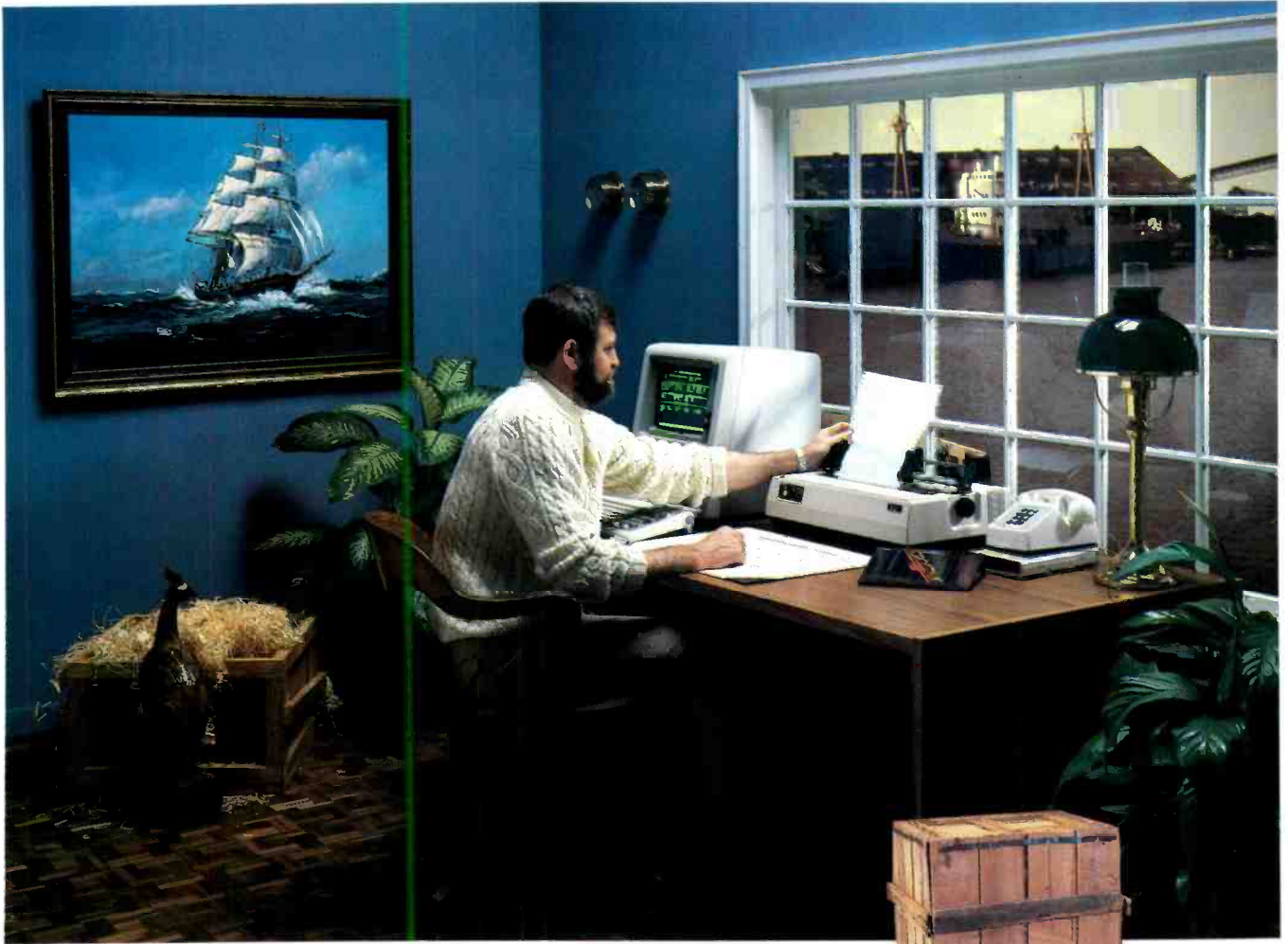

## International Connections

With the industry's most popular data communications program, the world is at your command.

An import/export office in New Jersey can instantly check the London market for current dollar exchange rates ... send Hong Kong an updated production schedule ... print-out the week's sales results from the Dallas branch.

There's virtually no limit to how far you can reach with your microcomputer, ordinary telephone lines, and CROSSTALK.

Even if your own business and personal needs are closer to home, you'll appreciate CROSSTALK's compatibility with a wide user base ... smart terminal characteristics ... total modem control ... and the ability to capture data at a high speed for later off-line editing. CROSSTALK has extras you may not find in other programs. Data capture to memory buffer (and on-line display). Protocol error-checking file transfer. Modem/telephone hangup, and display of elapsed time of call. Command file power and flexibility. Remote takeover and operation. And much more.

There is a CROSSTALK version for almost every CP/M, CP/M-86, or IBM DOS based microcomputer system. See your dealer, or write for a brochure.



# CROSSTALK™

**MICROSTUF®**

1000 Holcomb Woods Parkway / Roswell, Georgia 30076

CROSSTALK is a trademark of Microstuf, Inc.. CP/M and CP/M-86 are trademarks of Digital Research, Inc.. IBM is a trademark of International Business Machines, Inc.

Circle No. 2 on Free Information Card

[www.americanradiohistory.com](http://www.americanradiohistory.com)

## THE GREAT UNKNOWN

The great new personal color computer that nobody knows about.

Yet.

It's the next step in the evolution of personal computer technology, not just another copy of the IBM® PC.

The Leading Edge Personal Color Computer is far faster (50%) and compatible with all industry-standard software (like Flight Simulator, Lotus 1-2-3, Leading Edge™ Word Processing, dBASE II, Nutshell,™ etc.); comes standard in color with 256K (expandable to 640K). Includes all the software you need to get up and running instantly (MS-DOS and GWBasic); and it's fully covered by a mind-boggling full-year warranty backed by a nationwide network of service centers—yet sells for far less than computers that give you far less: \$2,995 complete. (\$3,995 with 10 Megabyte Hard Disk).

The Leading Edge Personal Color Computer.

Always buy the best, regardless of cost. Even if it's cheaper.

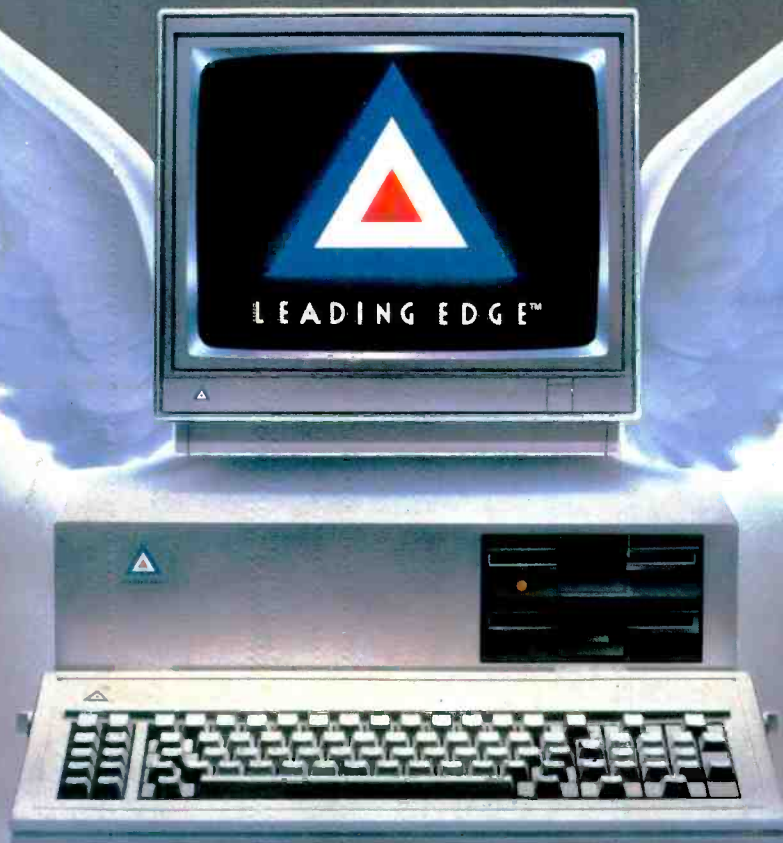

LEADING EDGE PRODUCTS, INC.  
LEADING EDGE PC DIVISION, 235 TRENOR STREET, CANTON, MA 02021, 800-343-6833, (617) 828-8150  
SOFTWARE DIVISION, 21 HIGHLAND CIRCLE, NEEDHAM HEIGHTS, MA 0294, 800-343-3436, (617) 439-1655  
FORTUNE DIVISION, 235 TRENOR STREET, CANTON, MA 02021, 800-354-0554, (617) 828-8150

IBM is a registered trademark of International Business Machines Corporation.

Circle No. 29 on Free Information Card

[www.ami.com/aviationhistory.com](http://www.ami.com/aviationhistory.com)