

WORLD'S LARGEST COMPUTER MAGAZINE

Computers & ELECTRONICS

JUNE 1984

\$1.95

**Now!
HP
Puts
1-2-3,
MS-DOS
In The
8.5 lb. 110**

**Apple's
Portable
New Iic**

**Forrest
Mims
Reviews
PCjr**



Chameleon, Morrow MD11

Choosing a Local Area Network

MRS EDNA DAHM
997 GRAND AV
ROSA
IL
*****S-DIGIT 60506
390736 DHM 09970093 P41D SEPR
14024 14278

Introducing the MTX 512

A World Apart from the Ordinary.

It begins with the sense of touch.

With the sleek black metal housing. Cool to the touch. Cool to the advanced circuitry and components contained within.

And the solid feel of people-sized keys set up in a field that gives you room to work and space in which to think.

But the difference only begins with what you see and feel. Where it ends...well, that's really up to you.

In a very practical sense, the only limits you'll experience with the MTX512 are those you choose to accept.

64K To 512K RAM – A Look On The Inside

Take a close look at the MTX512.

We could tell you it offers the greatest performance and versatility of any micro in its price range, but we think you're smart enough to draw your own conclusions.

The design is elegant in its simplicity. Remarkable for the power and complexity it represents. 64K RAM built in, with total expansion to 512K. And that doesn't include 16K of video RAM controlled by its own processor.

Speaking of video, keep in mind this is no ordinary monochromatic, single screen system. The MTX starts off where other micros end up. Delivering vivid screen capabilities with 256 x 192 pixels that crisply define interference-free high resolution graphics. 16 brilliant colors that can be displayed simultaneously. In a format powered by 32 easily movable, user-defined graphics characters. Graphics capabilities you'd find impressive in a system that gives you a single screen to work in. With the MTX, you have eight.

Yes, eight.

Eight definable windows to operate independently or in tandem. And still maintain full screen capabilities. Thus, you can manipulate spread sheets on the MTX and see the impact of changing variables in graphics at the same time. Eight separate windows on the world. We call them Virtual Screens. You'll call them extraordinary.

Far from ordinary as well are the built-in system outputs that come standard on the MTX. The Centronics parallel printer port. The two industry-standard joystick ports. The uncommitted parallel I/O port. The Cassette port with 2400 baud. Separate TV and Video Monitor Ports. The 4-channel sound hifi output. We've even installed a ROM cartridge port for word processing and other dedicated programs.

Interactive Languages And Routines – A Look At The Way All Micros Will One Day Perform

Forget the way all other micros perform. This is the way they should.

Interactively.

With the MTX, you can create and manipulate programs using four different languages in dynamic interaction, all coordinated through the FRONT PANEL DISPLAY. Interweaving elements as you would in creating a symphony.

And take a serious look at the languages housed in the MTX's 24K ROM. MTX BASIC, a more powerful form of BASIC that allows you to use all standard BASIC programs. MTX GRAPHICS, with straight forward commands, eliminates the tedium and difficulty of creating complex graphics programs. NODDY, an 11-command "easy learn" language that can transform real world programming into a child-friendly activity. And MTX ASSEMBLER, which enables sophisticated programming in assembly language. Something else the advanced programmer will appreciate is our ASSEMBLER/DISASSEMBLER, tied to BASIC, which provides unprecedented display and keyboard access to Z80 CPU storage locations, memory and program.

If you're hungry for more, PASCAL and FORTH are also available as add-on ROM packs.

On the keyboard side of things, you'll find a number of operator-oriented features that speed up and ease up the operation of the MTX. The separate numeric pad with quadri-directional cursor control and full editing functions. The eight dual function keys.

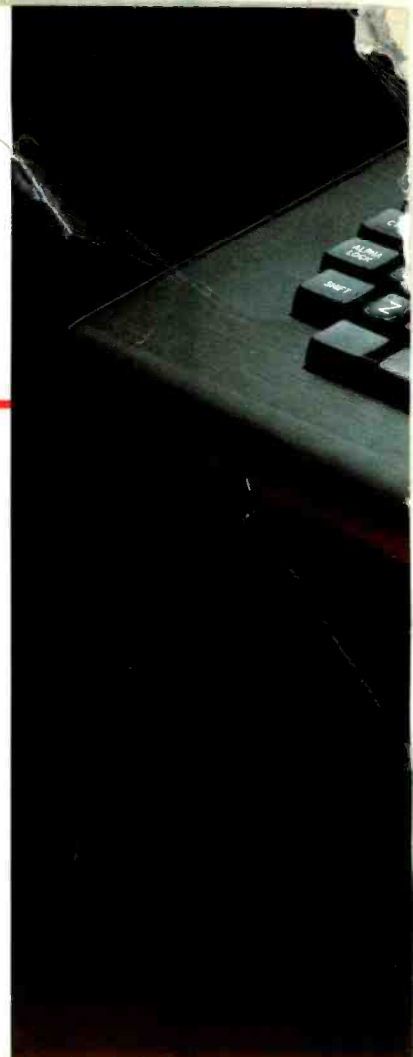



The auto repeat function on all alpha-numeric keys. Add to this such programmer-saving features as the use of abbreviated BASIC commands, a built-in syntax verifier, automatic cursor-honing to errors, auto-line numbering and automatic scrolling, and you begin to see the MTX not only opens a lot of doors that other micros leave closed, but speeds you through them as well.

The 160 Megabyte Connection – A Look At The System

To build a good system, quality must be designed in at every level.

We designed the MTX and its complete line of system peripherals using proven, standard components. Striking a strategic balance between power, versatility and dependability. Our Z80A processor, running at 4MHz, gave us the high performance characteristics we were striving for, plus the ability to expand into the MTX Hard Disc, MTX Silicon and Floppy Disc CP/M operated systems. Systems that could provide up to 160 megabyte storage capacity. More power than you'll probably ever need, unless you take full advantage of the MTX's impressive system capabilities.

Systems hookup is as simple as every other MTX procedure. By merely plugging in the twin RS232C Serial interfaces and the Node software, sold optionally, you're ready to create a disc-driven interactive communications network (OXFORD RING®) that can link up to 255 units.

Software? You'll never worry about software availability with the MTX. Dozens of MTX-dedicated programs have already been created, supplementing the vast landscape of CP/M applications software currently available. And advance word of the MTX's technical capabilities has precipitated an MTX software "push" on the part of many leading software manufacturers.

Word Processing For \$999 – A Look At A Great Deal

Look first at the capabilities, then at the price.

This is word processing the way it should be. Quick. Easy. Professional. A package that includes the MTX512; the powerful New Word™ word processing ROM cartridge; and the Memotech DMX80 correspondence quality printer.* An exceptional value!

And that brings us to the bottom line.



A Look At The Price

There's a very simple equation that covers the pricing of the MTX512.

The more engineering you put in a system, the less it will cost to produce. As you've already seen, the MTX is a pure product of advanced, innovative engineering.

Which is why we can sell it for \$595**

And why we can confidently back it up with a full one-year warranty.

Make no mistake. When you turn this page, you'll be returning to a world very different from this one.

A world in which all microcomputers will suddenly seem very different.

Suddenly very ordinary.

For more information about the MTX512, or to find out the location of the MTX dealer nearest you, contact Memotech Corporation, 99 Cabot Street, Needham, MA 02194; or phone (617) 449-6614

MEMOTECH CORPORATION

CP/M is a trademark of Digital Research, Inc.
New Word™ is a trademark of New Star Software, Inc.
*DMX80 correspondence quality printer suggested retail price \$395.
**Suggested retail price.

All the hits your computer is missing.



If you thought you'd never find fun games for your hardworking home computer, happy days are here. Because now ATARISOFT™ has all the great hits... Pac-Man¹, Donkey Kong² by Nintendo³, Centipede⁴, Defender⁵, Joust⁶, Jungle Hunt⁴, Moon Patrol³, Pole Position⁵, Galaxian¹, Ms. Pac-Man¹, and Battlezone¹.

And we've got them for all the hit computers ... Apple, IBM, Commodore 64, Vic-20, Colecovision^{*}, and TI 99/4A. We've got Pac-Man, Centipede and Defender for Intellivision too.

So dust off your joystick and ask your dealer for all the ATARISOFT hits. It's the software your hardware's been waiting for.

ATARISOFT™

All the hits your computer is missing.

ATARISOFT products are manufactured by Atari, Inc. for use with various computers and video game consoles. ATARISOFT products are not made, licensed or approved by the manufacturer(s) of these computers and video game consoles. *Donkey Kong and Battlezone not available on Colecovision. 1. Trademarks of Bally Mfg. Co. Sublicensed to ATARI, Inc. by Namco-America, Inc. 2. Trademarks and © Nintendo 1981, 1983. 3. Trademarks and © Williams 1980, 1982, manufactured under license from Williams Electronics. 4. Trademark and © of Taito America Corporation 1982. 5. Engineered and designed by Namco Ltd., manufactured under license by ATARI, Inc. Trademark and © Namco 1982. Atari® © A Warner Communications Co. © 1984 ATARI, Inc. All rights reserved.

Circle No. 9 on Free Information Card

www.americanradiohistory.com

Computers & ELECTRONICS

Features

50 You Can Take It With You

By Peter Costa
Hewlett-Packard's HP-110 is an 8.5-lb battery-powered lap computer with Lotus in ROM.

52 An Apple To Go

By Peter Costa
Apple's new IIc: a slim transportable with built-in disk drive.

54 What Makes Junior Run?

By Forrest M. Mims, III
A review of the IBM PCjr.

59 IBM Software for the PCjr

By J. Smith-Richardson
A look at the products available for the low-end personal computers.

64 Encryption Deciphered

By Carl Nicolai
Encoding locks your data away from anyone not possessing the key.

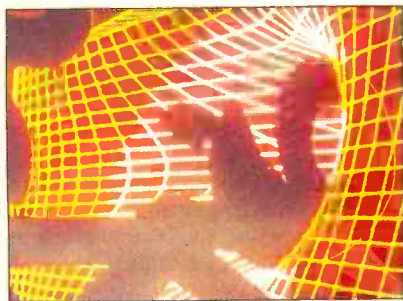

68 Computer Security in the Micro Age

By Larry Dietz
The risks faced by corporations who use personal computers.



COVER PHOTO BY TRUMAN MOORE

72 Choosing a Local Area Network

By TJ Byers
A guide to selecting the LAN best suited to your needs.

Reviews

30 The Chameleon Plus

By Charles P. Rubenstein

32 Hard Copy With A Flair

By Al Burawa

34 Morrow's New Hard Disk MD11

By Michael Guttman

42 TK! Solver

By Lee D. Zimskind
Equation solving power for your micro.

46 NewWord

By Michael McCarthy
The latest in sophisticated, powerful word processing software.

Columns

8 Bits & Bytes

By Sol Libes

16 Les Solomon on Computer Hardware

How Many Bits?

22 The Computer Scientist

By Forrest M. Mims, III
Computer Aided Drafting.

80 Guest Column

By Barbara and John McMullen
Compatibility and Portability.



Departments

4 Editorial

By Seth R. Alpert
An Ethical Question.

6 Letters

82 New Products

112 Computer Mart/ Electronics Classified

126 Advertisers' Index

COPYRIGHT © 1984 BY ZIFF-DAVIS PUBLISHING COMPANY. All rights reserved. Computers & Electronics (ISSN 0032-4485) June 1984, Volume 22, Number 6. Published monthly by Ziff-Davis Publishing Co., at 3460 Wilshire Blvd., Los Angeles, CA 90010. Richard P. Friese, President; Selwyn Taubman, Treasurer; Bertram A. Abrams, Secretary. One year subscription rate for U.S. and Possessions, \$15.97; Canada, \$20.97; all other countries, \$23.97 (cash orders only, payable in U.S. currency). Second Class Postage Paid at Los Angeles, CA 90052 and at additional mailing offices. Authorized as second class mail by the Post Office Dept., Ottawa, Canada, and for payment of postage in cash. POPULAR ELECTRONICS including ELECTRONICS WORLD trademark registered. Indexed in the Reader's Guide to Periodical Literature. Ziff-Davis also publishes Boating, Car and Driver, Cycle, Flying, Popular Photography, Skiing, Stereo Review, Electronic Experimenter's Handbook, and Tape Recording & Buying Guide. POSTMASTER: Send address changes to COMPUTERS & ELECTRONICS, Circulation Dept. P.O. Box 2774, Boulder, CO 80302. Please allow at least eight weeks for change of address, enclosing, if possible, an address label from a recent issue. Permissions. Material in this publication may not be reproduced in any form without permission. Send requests for permission to Elizabeth Amado, Rights and Permissions, Ziff-Davis Publishing Co., One Park Ave., New York, NY 10016.

WORLD'S LARGEST COMPUTER MAGAZINE
Computers
& ELECTRONICS

WILLIAM S. DAVID *Publisher*
SETH R. ALPERT *Editor*
PETER COSTA *Executive Editor*
LESLIE SOLOMON *Technical Director*
JOHN R. RIGGS *Managing Editor*
JAMES KIEHLE *Art Director*
ROBERT LASCARO *Associate Art Director*
A. W. BURAWA *Senior Editor*
JOSEPH DESPOSITO *Technical Editor*
JOSEF BERNARD *Technical Editor*
ANDRE DUZANT *Technical Illustrator*
CARMEN VELAZQUEZ *Production Editor*
JEFF NEWMAN *Editorial Assistant*
AMY MADWED *Art Assistant*

Contributing Editors: Sol Libes, Forrest M. Mims, III, Barbara E. McMullen, John F. McMullen

Editorial and Executive Offices
One Park Avenue, New York, N.Y. 10016.
212-725-3500

Advertising Sales Offices

New York

Tom Ballou 212-725-3578/Ken Lipka 212-725-3580

Midwestern

Robert Vanek, Suite 1400, 180 N. Michigan Ave.,
Chicago, IL 60601. 312-346-2600

Western

Joe Mesics, J.E.M. Associates, 1905 Pierce St., San
Francisco, CA 94115. 415-563-3230

Anne Abeln, Ziff-Davis Publishing Co., 3460
Wilshire Blvd., Los Angeles, CA 90010. 213-387-
2100

Southeastern

Mark Browning, PO Box 81306, 2511 Carroll
Ave., Atlanta, GA 30366. 404-455-3430.

**Consumer Computers & Electronics
Magazine Division**

Larry Sporn *President*
Jeff Hammond *Vice President, Marketing*
Carole Mandel *Vice President, Circulation*
Eileen G. Markowitz *Vice President,*
General Manager
Jerry Schneider *Vice President, Licensing*
& Special Projects
Herb Stern *Vice President, Creative*
Jonathan D. Lazarus *Editorial Director*
Peter J. Blank *Creative Director*

Ziff-Davis Publishing

President Richard P. Friese; **President Consumer
Magazine Division** Albert S. Traina; **Executive
Vice President, Marketing and Circulation** Paul
H. Chook; **Senior Vice President** Phillip T.
Hessman; **Senior Vice President** Sidney Holtz;
Senior Vice President Edward D. Muhlfield; **Senior
Vice President** Philip Sine; **Vice President**
Baird Davis; **Vice President** George Morrissey;
Vice President Rory Parisi; **Vice President** Wil-
liam L. Phillips; **Treasurer** Selwyn Taubman; **Sec-
retary** Bertram A. Abrams

Editorial correspondence: COMPUTERS & ELEC-
TRONICS, 1 Park Ave., New York, NY 10016. Editor-
ial contributions must be accompanied by return
postage and will be handled with reasonable care;
however, publisher assumes no responsibility for re-
turn or safety of manuscripts, art work, or models
submitted.

The publisher has no knowledge of any proprietary
rights which will be violated by the making or using of
any items disclosed in this issue.



Member Audit Bureau
of Circulations

SETH R. ALPERT EDITORIAL

AN ETHICAL QUESTION

HAVE you ever wondered why people don't photocopy books? Because it is too expensive and inconvenient and the end product is far less desirable than the original. My point is that genuine self-interest rather than any sense of morality or fear of punishment keeps people from illegally copying books.

Consider, however, the case of personal computer software. Unprotected software is easy to copy and very much more expensive to purchase than it is to steal. Moreover, the replica is indistinguishable from the original.

My concern here is copying by individuals for personal use. I think most people recognize the immorality and criminal intent of the big thieves—the pirates and corporate copiers who extensively duplicate both programs and documentation. Their assault on the copyright laws represents a serious problem for the software makers and their attorneys.

Copying by individuals in the privacy of their own homes is a different, less blatant act. Although most people recognize its illegality, surprisingly few admit its immorality. I am reminded of public attitudes about speed limits. Most of us know what the limits are, admit that obedience to them is in the public interest, and keep our excesses to a mere 10 to 15 miles an hour over the posted speed. Similarly, people often feel they are showing great self-restraint by doing only a little bit of illegal copying.

After all, the reasoning seems to go, how can something that easy and that private be wrong? We are conditioned to this attitude by many things in our society: by the freedom of consenting adults and, more relevantly, by the freedom to tape broadcasts off the air and the all too human foible of readily adopting others' ideas as our own. I have even heard the rationale that those who copy software are no more immoral than companies that charge high prices for products that cost essentially nothing to manufacture!

Of course, illegal copying hurts everyone. The damage to the software industry is the obvious loss of revenue. In my

view, lower revenue for the industry hurts end users as well, because a thriving commerce is essential to generating new and more capable products. Some also claim that reduced revenues lead to higher retail prices—although I am not convinced. Software prices seem to me to be more a function of market forces like supply and demand and healthy competition.

By far the most unfortunate side effect of software companies' copyright protection problem is the adoption of copy protection schemes to foil would-be thieves. Anyone who really wants to can



quickly defeat such schemes, or buy a program that does so. What copy protection generally does achieve is a loss of utility for the average user. In particular, legitimate copying, such as for backup or transfer to a hard disk, is frustrated.

Those are the fundamental issues with respect to copying of software by individuals. While the legal and business issues are clear, the moral issues seem to be less so to many people. I would be very curious to hear from readers about this controversial subject.

Will software copyright infringement by individuals ever cease to be an issue? Only if it is no longer in people's self-interest. This would require software to be priced much like a hard-cover book, or for the industry to develop technology that makes copying difficult or impossible. ◇



You're traveling through 140° terrain
at 300 rpm.

Only one disk guarantees safe passage through the torrid zone of drive heat. Maxell.

A lifetime warranty. And manufacturing standards that make it almost unnecessary.

Consider this: Every time you take your disk for a little spin, you expose it to drive heat that can sidetrack data. Worse, take it to the point of no return. Maxell's unique jacket construction defies heat of 140°F. And keeps your information on track.

And Maxell runs clean. A unique process impregnates lubricants throughout the oxide layer. Extending media and head life. How good is Gold?

Maxell's the disk that many drive manufacturers trust to put new equipment through its paces. It's that bug-free.

So you can drive a bargain. But in accelerated tests, Maxell floppys lead the industry in error-free performance and durability. Proving that if you can't stand the heat you don't stand a chance.

maxell®
IT'S WORTH IT.



Maxell Corporation of America, 60 Oxford Drive, Moonachie N.J. 07074 201-440-8020

Circle No. 30 on Free Information Card

LETTERS

No Fooling

With regard to your interview with Arktronics co-chairman Robert Kotick in the April issue (p 54), was that an "April-fool" thing or not? I won't try to repeat all of Mr. Kotick's statements that I found hard to swallow but, tell me, how does a 20-year-old student with no full-time job finance a company for three months using a credit card? With regard to saving memory space by creating their own language, isn't it easier just to program in machine language?

—JOHN R. STEVELEY
Bellevue, WA

Well, it's June now, and using a high-level language to generate machine code makes it much simpler to port a program from one type of computer to another. As far as the other matter goes, some people have a better line of credit than others.—Ed.

Digital Signal Processors

I am a graduate student at Southern Methodist University, in the Department of Electrical Engineering. I was very interested in the article "High-Speed Signal Processors" in the April 1984 issue of C&E. Is there any way to get more information about this, such as more details on the TMS320, other articles about the subject, or books that I can refer to?

—CHIEN-CHIH CHEN
Dallas, TX

Information on the TMS320 is available free of charge from the Texas Instruments Publication Center, PO Box 401560, Dallas, TX 75240. You should ask for Pub. #SPRV001, "TI Digital Signal Processor," and Pub. #SPRY002, "TI Signal Processing Products and Technology."—Ed.

16 or 32 Bits?

In your article about the latest product from Apple's constantly enlarging orchard ("Macintosh: Big Step, Small Footprint," March, p 42), the author repeatedly referred to the MC68000 as a "32-bit microprocessor." I feel that this could be a bit misleading to the general public. Although the MC68000 does have seventeen 32-bit registers (8 data, 7 address, 2 stack pointers) and one 32-bit program pointer internally, it communicates externally via a 16-bit data bus. All of the MC68000 documentation from Motorola refers to it as a "16-bit microprocessor." Nowhere is it called a "32-

bit microprocessor." Hence, is Macintosh then a 32-bit computer? I think not unless someone has redefined how we classify computers. I have been led to believe that the number of processor data lines classifies the computer. That seems fair to me and most of the computer professionals I work with.

However, I must say, Macintosh, in the young, dependable tradition of Apple is another winner; but let's call it what it is—in a "word," an Apple.

—MIKE MAJOWICZ
Redmond, WA

Les Solomon deals with these questions in his column "Computer Hardware" in this issue.—Ed.

Real-Time Audio Analyzer

In the March issue of your magazine, I read with great interest the article "Microcomputers in the Recording Studio," by Martin Porter. He mentioned an application for the Apple II machine as a real-time audio analyzer, marketed by Eventide Clockworks. I am an Apple II user and a musician with interest in a sound company and have been searching for just such an application source. Could you please furnish me with an address and phone number for Eventide.

—JOE SEAWRIGHT
Greenwood, MS

Eventide Clockworks is at 1 Alsan Way, Little Ferry, NJ 07643. Telephone: 201-641-1200.—Ed.

Microwriter Availability

I was interested in the review of the Microwriter, by Fred Blechman, in your April issue. This product isn't new. I ran across reviews of it some years ago, and it piqued my interest then. When I wrote to the developer in England, I was told that they were only going to market the unit in Great Britain, had no immediate plans for U.S. distribution, and "thank you very much."

Mr. Blechman's article told me a great deal about the product and has good photos and illustrations. I'm still interested and might even pay \$500 for it. One thing the article did not say is whether the Microwriter is now available in the U.S. and, if so, through whom.

—T.T. THOMAS
Albany, CA

You can obtain a Microwriter from Microwriter USA, Inc., 251 E. 61 St., New York, NY 10010.—Ed.

Enter CompuServe's Electronic Mall™ and shop at your convenience in these exciting departments.

The Micro Mart
The Department Stores
The Travel Agent
The Book Bazaar
The Record Emporium
The Photo Booth
The Software Shop
The Financial Market
The Magazine Kiosk
The Gardening Shed
The Newsstand

A sample of the companies participating in CompuServe's Electronic Mall™ includes:

Amdek
American Airlines
American Express
AST Research
Bantam
CBS Publishing
CDEX
Colonial Penn
Commodore
Computer World
Digital Equipment
dilithium Press
800 Software
Heath
Hertz
E.F. Hutton
Inmac
Innovative Software
Magazine Supply House
Manufacturer's Hanover Trust
McGraw-Hill
Metropolitan Life
Microsoft
Miracle Computing
Misco
Newsnet
Official Airline Guide
Pan American Electronics
Peachtree Software
Practical Peripherals
Program Store
Professional Color Labs
RCA Record Clubs
Record World
Sears
Select Information Exchange
Sim Computer Products
Software Advisor
Stark Brothers
Supersoft
Max Ule
Vanguard
VisiCorp
Ziff-Davis

Merchants and manufacturers who want to participate in the Electronic Mall™ may contact: Stephen A. Swanson, L.M. Berry & Co., P.O. Box 6000, Dayton, OH 45401, (513) 296-2015.



BY THE YEAR 2000, THE WORLD MAY CATCH UP WITH THE WAY COMPU SERVE'S NEW ELECTRONIC MALL™ LETS YOU SHOP TODAY.

Introducing the first computer shopping service that brings you convenience, savings and enjoyment.

Here's your chance to expand the practical uses of your personal computer.

Sign up for CompuServe and shop in our new Electronic Mall. It's easy to use. It tells you more about the products you're buying. It lets you order faster. And it's totally unique.

CompuServe's new Electronic Mall™ offers you all these shopping innovations.

– It's enormous! So it gives you in-depth information on thousands of goods and services, and lets you buy even hard-to-find merchandise. – Its unique "Feedback" service lets you ask the merchants themselves specific questions. – It's incredibly efficient in ordering the products and services you want

– Its special discount opportunities make it economical, purchase after purchase. – And its name-brand merchants assure you of top-quality merchandise.

Make the CompuServe Electronic Mall 15-Minute Comparison Test.

What you can do in 15 minutes shopping the Electronic Mall way.

- Call up on your computer screen full descriptions of the latest in computer printers, for instance.
- Pick one and enter the order command.
- Check complete descriptions of places to stay on your next vacation.
- Pick several and request travel brochures.
- Access a department store catalog and pick out a wine rack, tools, toys... any thing!
- Place your order.

What you can do in 15 minutes shopping the old way.

- Round up the family and get in the car.

The Electronic Mall, a valuable addition to the vast world of CompuServe.

CompuServe's Consumer Information Service brings you shopping information, entertainment, personal communications and more.

You can access CompuServe with almost any computer and modem, terminal or communicating word processor.

To receive your illustrated guide to CompuServe and learn how to subscribe, call or contact...

CompuServe

Consumer Information Service
P.O. Box 20212
5000 Arlington Centre Blvd.
Columbus, OH 43220

800-848-8199

In Ohio call 614-457-0802

Circle No. 60 on Free Information Card

An H & R Block Company

SOL LIBES BITS & BYTES



Rumors & Gossip

► Look for Radio Shack to introduce an 8-line by 80-column version of their popular Model 100 kneetop portable this month. The old model displayed only 8 lines by 40 columns. There are rumors of a 16-line by 80-column version for very early next year. Also, there may be an IBM PC compatible knee-topper. . . . IBM is expected, this summer, to introduce version 3.0 of the PC-DOS operating system for the IBM PC. It should be multitasking and have windows. Rumors are that IBM developed it and has forsaken Microsoft. This is expected to create problems for IBM PC compatible makers. . . . Gold Star Co., Ltd., in Korea, may be making the new AT&T 32-bit supermicro. . . . Kaypro is expected this summer to introduce a notebook-size battery-operated portable. When attached to a "base station" containing CRT and disk drives, it will be compatible with the IBM PC. An IBM PC compatible transportable is also expected. . . . Apple is rumored again to be making hard disk drives in-house. These are said to be 10- and 20-byte half-height drives. . . . Microsoft is supposedly readying a business software package for the PC (e.g. general ledger, et al.). . . . TI is expected to bring out shortly a new version of its handheld computer that uses cassette storage instead of the wafer tape drives it originally promised for the unit. . . . Look for IBM to introduce a new graphics card for the IBM PC with 600 × 400 dot-addressable graphics in 8 and 16 colors. This is better resolution than the Macintosh. . . . Lastly, there are rumors that AT&T is negotiating a joint venture with Apple Computer for a low-cost

desktop personal computer system. It is expected to involve either the Macintosh or Lisa-II.

Commodore to Make IBM PC Compatible System

► In a real about-face, Commodore has changed its mind and decided to postpone, indefinitely, its Z8000-based business computer and go instead with an 8088-based IBM PC compatible. The new business-oriented system is expected this fall. To shorten development time and cut costs, Commodore acquired rights to a PC clone called the Hyperion from Bytec-Comterm, Montreal, Canada. And Commodore is negotiating with Intel to manufacture its own 8088 microprocessor chips. If Commodore uses the same marketing tactics in the PC-compatible business marketplace that it used in the home computer marketplace, we can expect to see significant price cutting and company attrition next year.

Commodore has not been successful in selling personal computers to business



owners, probably because of its poor relations with computer stores. Commodore continues to sell its B256 business-oriented system. However, it has admittedly not done well.

Sinclair Discloses CPU Marketing Plans

► Timex's decision to withdraw from the home computer market has apparently ended the retail marketing of Sinclair computers in the U.S. However, Sinclair has announced that it plans to market its new 68008-based QL computer system via mail-order in the fall at \$499. The unit will include 128K of memory, two 100K tape drives and a full-travel keyboard. Sinclair had originally marketed its popular ZX-81 computer via mail order before entering into a retail marketing agreement with Timex. And, it continued to maintain an office in Boston.

Two More Drop Out of U.S. Home Computer Market

► Following in the footsteps of Texas Instruments and Mattel, Timex has withdrawn from the home computer business, after suffering significant losses, estimated at almost \$100 million. Timex is rumored to have over 200,000 Model 1000 computers in stock and having trouble moving them out at even liquidation price. They actually ceased production of the unit in August of 1983. Timex 1000's have been selling recently in some drug stores for less than \$10. Timex had reportedly sold a million 1000's but sales dwindled during the second half of '83. The newer 1500 and 2068 models, selling for over \$100 have had lackluster sales.

Matsushita's Panasonic division, which had been marketing its JR-200 \$269 home computer in the U.S. has decided to throw in the towel indicating that it cannot compete in a very price-sensitive market. Two weeks prior, another Japanese vendor, Tomy, also withdrew from the U.S. home computer market. And NEC Home Electronics has indicated that it is considering yanking its PC-6000 home computer and putting its marketing efforts behind its kneetop portable computer.

While on the subject of poor business in the home computer market—Coleco Industries reported, in March, that it lost \$35 million in the last quarter due to disappointing sales of the Adam home computer system. It reported a \$9-million loss for the year, which would have been much worse had it not done so well selling Cabbage Patch dolls. Coleco had boasted it would produce a half-million

dams before year-end but was only able to ship 95,000 systems. There are rumors that Coleco is considering discontinuing the system.

And Victor Technologies Inc. declared bankruptcy, being in the hole for about \$30 million. It is ironic because the company, founded by computer pioneer Chuck Peddle, introduced a computer at about the same time as the IBM PC which was clearly superior to the PC with far better graphics, four times the disk storage space, Selectric-type keyboard, plus other extras. Unfortunately, Chuck, who is a terrific system designer (he created the 6502 microprocessor and Commodore PET computer) could not compete against the marketing power of IBM.

PCjr Getting Cool Reception

► Initial reports are that there is no shortage of IBM PCjrs on dealers shelves despite IBM's still shipping only limited quantities to dealers. IBM is reportedly spending \$40 million in an effort to sell 500,000 PCjrs this year. That works out to \$80 per machine and therefore may be IBM's largest single expense on the product.

Some dealers are expressing the view that the Apple IIe, which costs significantly less, presents a better value and estimates are that Apple will sell more than 750,000 IIe's, up from 600,000 last year. Many purchasers are unfavorably comparing the PCjr to the new Apple Macintosh, since a comparably equipped PCjr is not much lower in cost and lacks many of the Mac's features and performance.

Many criticize the PCjr's keyboard with its funny feel, keys that are far apart, and hard-to-read labels. Yet IBM says it hasn't gotten any complaints from users. Others find the machine too expensive as a home machine and lacking the power needed for an office machine. Thus IBM has its work cut out for it in trying to sell the machine. Of course, the best thing it has going for it are the three letters on its front—IBM.

PC-Compatible Prices Expected to Drop

► IBM's standard PC and PC transportable are still limited in availability while supplies of the XT and PCjr appear to have caught up with demand. Industry experts are predicting that IBM's supply of PCs will catch up with demand this fall. That is expected to put pressure on the PC-compatible makers to reduce prices and bring out products with more competitive features.

Thus it is expected that the market-

place will see prices on the PC-compatibles drop between 10% and 20% by year-end while companies introduce new compatibles with enhanced features. The PC-compatible makers are working feverishly to lower the manufacturing costs of existing products and economize on future designs. This generally means moving assembly and manufacturing to the Far East and Mexico. Design costs are being reduced by integrating functions in custom ICs to reduce parts count.

New enhanced designs are mainly expected to emphasize notebook-size portable PC compatibles. Units with 16-line by 80-character LCD displays are expected to become available late this year, with full 25-line displays next year.



IBM, CBS & Sears Plan Videotext Venture

► IBM, CBS Inc. and Sears Roebuck & Co. have announced a joint venture into the home videotext business. Each will hold an equal share in the partnership and the venture will be staffed by employees from each governed by a committee of representatives from each company. Expected to take a few years to bring to fruition, it will bring two-way electronic services into the home and compete with a similar venture from AT&T. This new system would be different from the AT&T system in that users will be able to have their own personal computers while the AT&T system requires purchasing a \$600 terminal.

Videotext will allow the sending of words and pictures to a home video screen. Thus it is expected that Sears will sell insurance, financial and real estate services and also be responsible for marketing, billing and customer support. IBM will make the personal computers and CBS will operate the videotext.

IBM has been marketing a corporate videotext system based on its Series 1 minicomputer system. CBS had previously participated in a year-long test of videotext with AT&T. There is one videotext system currently in operation in southern Florida. The potential for videotext however is still uncertain.

Networking News

► The Jolly Blue Giant has introduced what it calls a "cluster program" or, in other words, a local area networking system, allowing up to 64 PCs, XTs and PCjrs to be interconnected. Messages can be sent from one machine to another, and hard disks and printers can be shared. A typical configuration to link together five machines would cost a little over \$2500 including interfaces and cables, but not including the personal computers.

Japan's Posts and Telecommunications Ministry is currently studying possible standards for communications between personal computers and teletext systems. Nippon Electric Co., has developed a networking system using the ac power line and transmitting data at 9600 bps.

Anti-Software Piracy Fund Formed

► The "Software Protection Fund" has been formed to aid in the combating of an "explosion" of illegal software copying. The SPF's goal is to "frustrate" software piracy, particularly by large companies or "national account type" users, by professional resellers, by home users and hobbyists, software rental firms, and companies that "aid and abet" by marketing software copying devices and software.

The SPF organizers include Ashton-Tate, Lotus Development Corp., Sorcim and Microsoft Corp. The group, which already has \$500,000 in contributions, expects to work closely with ADAPSO (Association of Data Processing Service Organizations) to influence government copyright law legislation. It will also "educate" to discourage copying and pursue enforcement of legal rights against pirates.

Lotus recently filed a \$10 million copyright infringement suit against a company that it accused of copying its Lotus 1-2-3 and distributing it to its local offices. The company did not try to resell the copies.

Random News

► A black market traffic in Apple Macintosh computers was nipped in the bud by Notre Dame University officials who discovered a student offering to buy other students' systems and resell them off-campus at a discount. Notre Dame is one of 24 schools selling Macs to students, faculty and staff up to 60% off list. However, it is unlikely that schools can stop the resale of Macs to outside people or companies and a resale market in Macs is expected to flourish.

How to move with and take your

Introducing the IBM *Portable* Personal Computer.

It's a complete PC. In a case. With a handle.
And a welcome addition to the family.

The IBM *Portable* Personal Computer is
the first IBM PC system you can pick up and
take with you. Across town or across the
hall. Or put away easily for another day.

It's a powerful system, with 256 KB of
user memory (expandable to 512 KB)
and a slimline double-sided 5¼"
diskette drive (and room for
another). Plus a built-in



modern times PC with you.



9" monitor with easy-to-read amber characters. Text and graphics capability. And an 83-key keyboard.

All fitted into a sturdy, transportable case that's easy to handle. And park.

The IBM® of portable personal computers. Make no mistake about it, this is a true IBM PC.

Which means it is part of the same dependable family as the IBM Personal Computer, the IBM PC/XT and the new IBM PCjr. And that means you can use many IBM Personal Computer Software

programs to help you reach your goals.

All this and five expansion slots, ready to accept expanded memory, printers and other useful IBM Personal Computer options. Which should keep you rolling far into the future.

Pick one up at a store near you. You can see the new IBM *Portable* Personal Computer at any authorized IBM PC dealer or IBM Product Center.

To find the store nearest you, call 1-800-447-4700. In Alaska or Hawaii, call 1-800-447-0890.

IBM®

Circle No. 41 on Free Information Card

LES SOLOMON ON

COMPUTER HARDWARE

HOW MANY BITS?

HERE seems to be a bit of mystery when it comes to determining just how many bits a particular microprocessor has. In one ad you will read that a particular device is 16-bit; in another ad the same processor will be called 32-bit; while a third takes a firm neutral stand and proclaims the CPU as being a 16/32-bit processor. Just what is the criteria for an 8-, 16-, or 32-bit CPU? As we shall see, the answer is similar to that old story about the blind men and the elephant.

Let's take a brief look at some popular CPUs and I'll tell you my version.

The 8088 as used by IBM and clones has an 8-bit data bus and 20 address lines that can directly communicate with 1,048,576 bytes of memory. And it contains thirteen 16-bit registers. Although many machines that use the 8088 are called "16-bit" machines, the CPU manufacturer calls the 8088 the "8-bit version of the 16-bit 8086." This is because the 8088 has only 8 data lines, even though it has 16-bit registers.

The 8086 is identical (even to the instruction set) to its 8088 sibling except that it has 16 data lines. Since the 8088 has an 8-bit data line, it requires two clock cycles to grab the same amount of data that the 16-bit data-line 8086 can in one clock cycle. Thus, the major difference between the two processors is speed.

Another CPU, the 16-, 16/32-, or 32-bit 68000 (again, the number of bits depends on who is talking) features 16 data lines, 24 address lines that can directly address 16,777,216 bytes of memory, and seventeen 32-bit registers. Some have called this processor a 16-bitter because it has 16 data lines; others call it a 32-bitter because it has 32-bit registers; and others play it safe and call it 16/32 bits. Regardless, one of the major advantages of this CPU is that it has a symmetrical and compact instruction set in which a few general-purpose instructions (which can have many options) can generate large amounts of op code.

There are several other processors for which the number of bits may be in question. These include the 6809 and the

Z8000 series, each of which has its own interesting characteristics.

Is there really an answer to "how many bits"? Yes, there is, and it depends on whether you are a hardware or software person.

If software is your concern, then register size rather than number of data lines is the determining factor. In the software universe, a CPU that manipulates data in 16-bit hunks is a 16-bit machine, while a CPU that manipulates data in 8-bit hunks is an 8-bit device.

If hardware is your thing, then CPU interfacing (those ubiquitous data lines)



with the real world is what matters. Microprocessors that grab data 8 bits at a time are classified as 8-bit machines (the 8088 is in this family), while those that grab 16-bit chunks are 16-bit machines (the 8086 and 68000 fit this category).

But why 32 bits? Did this come about because someone felt that, since 8 bits are good, then 16 bits are twice as good, and 32 bits even better. And, if so, where do we stop?

The 32-bit approach started several years ago when far-sighted microcomputer engineers realized that the day was approaching when microcomputers would take over from minicomputers. For the microcomputer to be able to port software to and from a mainframe (as opposed to just plain communicating with the mainframe), it has to grab data 32 bits at a clip.

Although the 68000 and 16000 CPUs exist in a 32-bit software environment, they are still not in the real 32-bit world. A true 32-bit CPU should also have a 32-bit data path. (This means 32 data lines, which might result in a large and unwieldy IC package.) However, the 68000 and 16000 both have only 16 data lines. Thus, despite how we feel about software, they are still 16-bit CPUs.

However, the 68020, a true 32-bit processor that includes 32 data lines is standing in the wings awaiting an introduction this summer. This new true 32-bit CPU, along with the NS32032 32-bit version of the 16000 will introduce us to the real world of 32-bit computing.

BDOS Error in My Memory

Back in my March column, "Those Were the Days," in which I reminisced about the first days of microcomputers, I made the dreadful mistake of placing Albuquerque, New Mexico (repeat New Mexico), in the "Arizona" desert. Obviously, I must have been daydreaming when I wrote that. The proofreader also missed it; but, according to my mailbox, it was not overlooked by a bunch of proud New Mexicans.

They also jumped on me for saying "downtown Albuquerque," and my suggesting that the Rio Grande was a mere foot deep. I have been reminded by several readers that the Rio Grande at that point is three feet deep.

People, believe me, over the years I have spent many happy days and nights in Albuquerque—after all, it was there that I first met Forrest Mims and Ed Roberts; and it was there that the Altair was born. So Albuquerque holds a dear place in my heart.

Yes, I know about the Sandia Mountains. In fact, it was on one of those windy mountain tops, that Ed Roberts and I discussed the newly developed computer and tried to figure out what uses it could have. At that time, we did not know what kind of a tiger we had by the tail—though we suspected that it was a tiger.

In the same column, I also mentioned

ILLUSTRATION BY YVONNE BUCHANAN

what I thought was the start of MITS in Forrest Mims's trailer. Well, I just heard from Ed Roberts—the creator of the first 8080 microcomputer (Altair) and its associated bus structure now called S-100 or IEEE-696.

Ed tells me that MITS actually started in his garage and that there were four equal partners—Stan Cagle, Forrest Mims, Bob Zaller, and Ed Roberts. After the failure of the Opticom infrared communicator (POPULAR ELECTRONICS, November 1970), he purchased the complete stock of MITS and started over again with calculators.

Ed states that the name Altair bus was changed to S-100 to keep competitors from advertising the MITS product. According to Ed, "To this day, I am still frustrated by the theft of my design. I certainly have not had any objection to anyone using the design, nor did we attempt to stop such use by applying patent laws or charging royalties. All that was ever asked was that the bus be called by its correct name; that is, the Altair bus. Incidentally, think of how much money we could have made if we had charged royalties for the use of the bus."

I, for one, disagree with Ed. If it were left up to me, I would call it the "Roberts bus," since without Ed, where would we be without our microcomputers now?

About QWERTY

I guess we have all wondered, when we first came across the term QWERTY keyboard, where the name came from. Obviously, it derives from the first six letters across the third row of keys.

In a recent article in *Scientific American* ("The Skill of Typing," February 1984), Timothy A. Salthouse cleared up the mystery of how it all started. In the early 1870s, the keys on typewriters tended to jam, even at moderate typing speeds. The QWERTY layout was selected so that the weakest fingers of each hand operated the most used keys. Thus the typist was slowed down, and probably the most maladaptive man-machine interface ever was invented.

Now for another mystery. Under optimal conditions (highly practiced people and a minimal number of stimulus-response alternatives), the average latency or delay between the presentation of the stimulus and the pressing of a button is approximately 250 milliseconds. The paradox of typing is that a latency of 250 ms yields a typing rate of 48 words/min (assuming five keystrokes/word). Yet, keyboard speeds twice that rate are fairly common and no one knows why. As they say, reading is fun. ♦



PREVENT THE DISASTER OF HEAD CRASH AND DROPOUT.

The war against dust and dirt never ends. So before you boot-up your equipment, and everytime you replace a cassette, disk or drive filter, be sure to use Dust-Off II; it counteracts dust, grit and lint. Otherwise you're flirting with costly dropouts, head crashes and downtime.

Dust-Off II is most effective when used with Stat-Off II. Stat-Off II neutralizes dust-holding static electricity while Dust-Off II blasts loose dust away. There's also the Dual Extender and Mini-Vac for vacuuming dust out of hard-to-reach places.

Photographic professionals have used Dust-Off brand products consistently on their delicate lenses and expensive cameras for over ten years. They know it's the safe, dry, efficient way to contaminant-free cleaning.

Cleaning not provided by liquid cleaners.

Dust-Off II's remarkable pinpoint accuracy zeroes in on the precise area being dusted. And you have total control—everything from a gentle breeze for



Stat-Off II neutralizes dust-holding static electricity from media and machines.

delicate computer mechanisms to a heavy blast for grimy dirt.

Don't let contamination disrupt your computer operation.

Stock up on Dust-Off II—the advanced dry cleaning system,

at your local computer or office supply dealer.

Or send \$1.00 (for postage and handling) for a 3 oz. trial size and literature today.



Dust-Off II

The safe dry cleaning system

Falcon Safety Products, Inc., 1065 Bristol Road, Mountainside, NJ 07092

Circle No. 25 on Free Information Card

FORREST M. MIMS III

THE COMPUTER SCIENTIST

COMPUTER AIDED DRAFTING

WHILE a student at Texas A&M University in the mid 1960s, I began keeping what has become a series of laboratory notebooks. About ten years ago, I showed one of these to David Gunzel, Radio Shack's publications director. Dave liked the drawings in it and concluded Radio Shack should publish a hand-lettered and illustrated book of electronic circuits modeled after my notebooks.

It took several years to convince the appropriate people that the project was viable. Eventually, Gary Burkhart, then Radio Shack's electronics parts buyer, asked me to write the hand-lettered book that became *Engineer's Notebook*. That book and its sequel have sold well over half a million copies. More recently, Dave Wolf, Gary's successor, has assigned several other hand-lettered books, including *Getting Started in Electronics*.

You might wonder why hand-lettered books are so popular in today's era of total automation. Perhaps the books appear friendlier than the traditional circuit books with their monotonous rows of type and starkly drawn, neat-as-a-pin illustrations.

In any event, producing and publishing a hand-lettered book is no simple task. Though many steps are involved, the toughest is the actual handwork. A single page can take several agonizing hours or more to produce. This chore is made even more onerous by the word processing equipment resting on the desk as I work. Why a book must be hand-lettered in the computer age is the question my aching fingers keep asking.

Unfortunately, the word processor cannot be moved out of sight. Its display reveals the text, carefully entered into its memory some weeks before, to be copied by hand onto each page. How's that for a technological time warp?

Computer-Aided Drafting

Printing and illustrating books by hand has intensified my interest in computer-aided drafting (CAD). Just as printing presses, typewriters and copy

machines long ago put most scribes, copyists and calligraphers (yours truly excepted) out of business, CAD is changing the drafting industry. Today, the drafting table and its shiny metal and plastic implements are being rapidly replaced by graphics tablets, joysticks, light pens and computer-controlled, x/y pen plotters.

Contrary to the popular view, producing a drawing with CAD equipment doesn't necessarily save time. The advantage of CAD comes when corrections, revisions or additional copies are required. Simply by recalling from the CAD system's memory the parameters of the original drawing, corrections and

Until recently, CAD systems were very expensive, generally costing from \$50,000 to \$100,000 or even more. Now, thanks to personal computers and more competition in the software and peripherals businesses, CAD is rapidly becoming more affordable. Today it's possible to purchase economical, quality CAD software for systems designed around the Apple IIe, the IBM PC family and other machines.

As shown in Fig. 1, a typical CAD system includes a computer, two disk drives, color monitor, x/y pen plotter, printer and one or more pointing devices. Of these, the pointing device(s) is second in importance only to the soft-

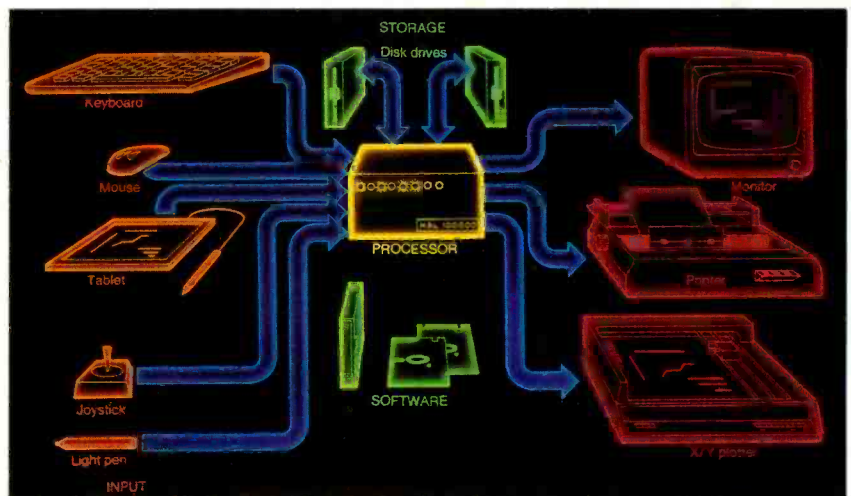

Fig. 1. Ingredients of a computer-aided drafting (CAD) system.

even major changes can be made much faster than the old-fashioned way. In other words, CAD does for drawings what word processing does for writing.

CAD has other advantages, too. Since drawings are digitized, they can be electronically transferred next door or across the country. Furthermore, automated equipment doesn't make smudges or spill ink. It's relatively easy to use. And it stimulates creativity since the user can easily revise and experiment with new ideas displayed on the system's monitor before committing the final design to paper.

ware driving the system.

Briefly, light pens provide the best hand-eye coordination, but they can be fatiguing to use. Joysticks and mice are not as natural as the graphics tablet, but tablets lack the proximal feedback of the light pen. And cursor control thumbwheels and keys are awkward and time-consuming to use.

In short, it is essential that the prospective CAD user understand that, in spite of manufacturer's claims, there is no single "perfect" or "ideal" pointing device. If possible, CAD users should experiment with various pointing de-

COMPUTERS ARE CREATING JOBS FOR UNTRAINED PEOPLE





Bound for glory.

The Epson® Line has a printer for all reasons.

Epson is the best-selling name in printers for small computers the world has ever seen.

Because we make the right printer for virtually every computer. And every job.

Something for everybody.

Our reliable, affordable RX™ Series printers, for instance, are perfect for the small business or home user. Our FX-80™ and wide-carriage FX-100™ provide all the speed, graphics capability and features anyone could ask

for. And our new LQ-1500™ is an astonishing breakthrough for business—it switches effortlessly between letter quality and high speed draft printing.

What's more, any printer you buy in the U.S. with the Epson name on it is guaranteed for a full year. Which is four times longer than the guarantee on most printers.

Get on board.

No matter what kind of computer you own, or what job you intend for it, your printer should be an Epson.

Because we build a better printer, price it fairly, guarantee it longer, and give you the one thing you don't always get from a printer company.

A choice.

Number one. And built like it.

EPSON
EPSON AMERICA, INC.

3415 Kashiwa Street, Torrance, California 90505 • Call (800) 421-5426 for the Epson dealer in your area. In California call (213) 539-9140.

Epson is a registered trademark of Epson Corporation. RX, FX-80, FX-100 and LQ-1500 are trademarks of Epson America, Inc.

Circle No. 26 on Free Information Card

www.americanradiohistory.com

COMPUTERS ARE CREATING JOBS FOR NRI-TRAINED PEOPLE.

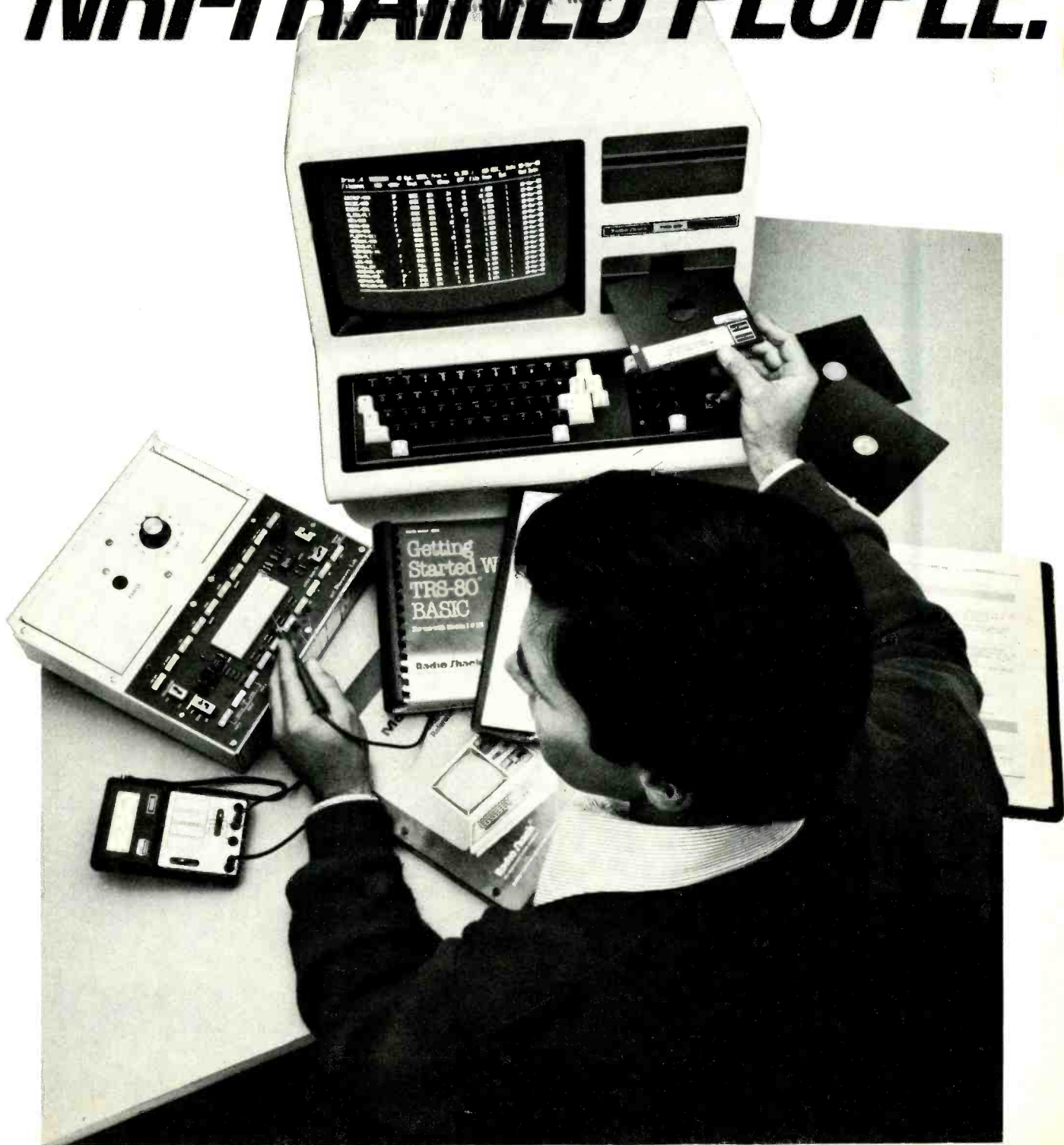

IF YOU'RE SERIOUS ABOUT MAKING MONEY IN MICRO-COMPUTERS, NRI IS SERIOUS ABOUT SHOWING YOU HOW.

The U.S. Department of Labor projects job openings for qualified computer technicians will soon double. International Resource Development, Inc., estimates a 600% increase in these jobs in a decade. And most of these will be new jobs, created by the expanding role of computers.

NEVER HAS THERE BEEN A FASTER-GROWING FIELD OF TECHNOLOGY.

Many people are afraid of losing their jobs to computers, but thousands of jobs will be created for those who are prepared to meet the challenge.

With NRI training, you'll be prepared. You can have a profitable, exciting future as an expert who can handle the operational, programming and technical aspects of all kinds of microcomputers and micro-processors.

LEARN IN YOUR SPARE TIME.

NRI trains you in your own home, at your convenience...no classroom schedule to meet, no need to quit your job. As a class of one with complete course materials and the backing of a staff of professional electronics instructors, you'll get extraordinary hands-on training on the latest model in the most popular line of microcomputers: the new TRS-80™ Model 4, with disk drive for greater memory capacity. The TRS-80 Model 4 complete with advanced features

TRS-80 is a trademark of the Radio Shack division of Tandy Corp.



Your NRI course will include the new TRS-80 Model 4 with Disk Drive or the TRS-80 Color Computer with NRI Computer Access Card...plus a professional LCD multimeter, NRI Discovery Lab and hundreds of demonstrations and experiments. It's all yours to keep.

that are built right in...features that are offered as options on other microcomputers. Designed to perform diverse personal and business functions and to accept the most software, the TRS-80 Model 4 is a great computer to learn on...and it's yours to keep, along with the disk drive!

LEARN HOW TO USE, PROGRAM AND SERVICE STATE-OF-THE-ART MICROCOMPUTERS.

Through your carefully designed NRI course, you'll get a wealth of practical experience. You'll build circuits...from the simplest to the most advanced ...with your NRI Discovery Lab.® You'll use a professional 4-function LCD digital multimeter for analysis and troubleshooting.

With NRI training, you'll explore your computer's memory and input/output ports. You'll even write programs, control the circuits designed and built. You'll perform hundreds of experiments, a full-time faculty ready to help you personally.

When your NRI training is complete, you'll be a computer technician, ready for your first job — servicing, testing or programming all types of microcomputers — in a rewarding and challenging new career.

THE CATALOG IS FREE. THE TRAINING IS PRICELESS.

Send the postpaid card today for your FREE 104-page catalog. It's a valuable guide to opportunities and training in the high-tech revolution.

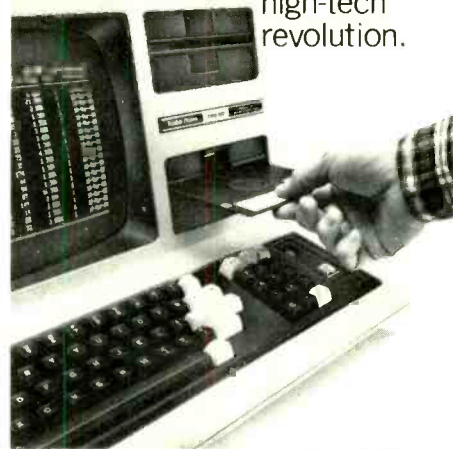

For greater computer memory capacity, a double density disk drive is included.

You'll see how easily you become part of the growing high-tech world of microcomputers.

If the card has been removed, please write to us today.



NRI School of Electronics
McGraw-Hill Continuing Education Center
3939 Wisconsin Avenue
Washington, D.C. 20016

We'll give you tomorrow.

Computer scientist

...the ones they prefer. For
...few of the principle points
...see the article "A Few Quick
...COMPUTERS & ELECTRONICS
...1984).

Low-Cost CAD Systems

Sophisticated computer-aided drafting systems include a wide range of image drawing, manipulation and editing



Fig. 2. FutureNet's DASH-1 electronic circuit design workstation.

features. Representative instructions that give a good idea about these features include *zoom, pan, save, preview, line, draw, scale, text* and many others. In past years CAD systems possessing a full selection of such features cost up to \$100,000 or even more.

The advent of low-cost personal computing has been accompanied by the development of low to moderately priced CAD systems that duplicate many of the functions of their more expensive predecessors. As I noted above, some of these systems consist of software packages designed to operate with such popular personal computers as the Apple II/IIe and the IBM PC family. Others are sold as "turnkey" systems complete with software, computer, disk drives, plotter and one or more pointing devices.

Some of these new CAD systems are dedicated to a single task such as the generation of electronic circuit diagrams. Among the most important of these is FutureNet's DASH-1, a software/hardware package that converts the IBM PC into an electrical engineer's schematic-drawing workstation.

DASH-1, which is shown in Fig. 2, includes software, a proprietary graphics controller, 3-button mouse and a C. Itoh Model 1550 dot-matrix printer (136 ×

144 dots per inch resolution). The package, which can be interfaced without modification directly with an IBM PC, sells for under \$6000.

DASH-1 includes, within its software library outline, images of most TTL integrated circuits and the most popular microprocessor and memory chips. Also included are symbols for transistors, diodes, resistors, potentiometers, inductors, capacitors and many other com-

mon electronic parts. New symbols and even circuit subsections can be added to the library by the user.

Drawings are created or revised by means of the mouse and a set of 16 control commands. Entire drawings or fragments can be saved on disk for later retrieval, editing, revision and correction.

While DASH-1 is very good at what it does, it can only draw circuit diagrams and print parts lists. Non-dedicated CAD systems have much more versatili-

ty since they can draw—in addition to electronic circuits—surveys, floor plans, plant layouts, piping diagrams and, in short, anything a human draftsman can draw.

Figure 3 shows the A-CADS/1, a turnkey, non-dedicated CAD system sold by Andromeda Systems Inc. (9000 Eton Avenue, Canoga Park, CA 91304). This system is designed around a Digital Equipment Corporation LSI-11/23 computer. The complete package, which sells for under \$24,000, includes computer, floppy disk drive, Winchester drive, monitor, graphics tablet, joystick and pen plotter.

The A-CADS/1 software includes a library of images with arcs, circles, ellipses, polygons and both solid and broken lines, any of which can be selected in any combination and placed anywhere on the monitor's screen.

Images being drawn are stored in a portion of the computer's memory designated as the *User Work Area (UWA)*. The UWA stores in a 32-bit register three-dimensional coordinates for each point entered into the system. This means, for instance, that if the user unit is one inch, the A-CADS/1 coordinate system can define any point within a cubic mile to a precision of 0.0001 inch! The UWA also keeps track of up to 16 pen selections per drawing.

Andromeda Systems' A-CAD/1 provides virtually unlimited drawing and drafting possibilities. But it is much more expensive than several recently announced CAD software packages designed to work with personal computers and low cost plotters and digitizers.

Among the most impressive of these new packages is Robographics CAD-1, a product of Chessell Robocom Corporation (111 Pheasant Run, Newtown, PA 18940). Designed to operate in conjunc-

Fig. 3. Andromeda Systems A-CAD/1 computer drafting system.



tion with an Apple II or IIe, the CAD-1 package sells for \$1095 and includes software, precision joystick controller and an interface module that plugs into the Apple's game port. CAD-1 will directly drive a Robographics plotter, and software drivers for other popular plotters can be obtained at prices ranging from \$250 to \$400.

I recently had an opportunity to try the CAD-1 system and found it has many features identical to those of much more costly CAD systems. For example, here's how you draw a line:

First, use the joystick to move the cursor to any desired origin. Lock the cursor in place by pressing a button on the controller. Then move a second (or *dynamic*) cursor to any desired point. As the dynamic cursor is moved, a line of dots connects it to the origin so you can preview any desired line. Since the dotted line expands and contracts as the cursor is moved, it's called a *rubberband*.

Finally, press a second button on the controller when the desired end-point has been selected. A solid line will in-

Up to 192 individual symbols and complete drawings can be stored on a single floppy disk. This means the total storage capacity of the user library is limited only by your diskette budget. Images can be retrieved from disk *without* the need for keystroke commands thanks to a graphic index feature that places on the screen miniature versions of each stored image.

When compared to earlier systems and expensive CAD work stations, CAD-1 is a very affordable package. Nevertheless, in view of the declining trend in software prices and the upsurge of interest in CAD systems for personal computers, it's likely software packages with capabilities similar to those of CAD-1 will one day be available for a few hundred dollars.

Another strong possibility is the arrival of economical, desktop CAD workstations complete with software and a graphics tablet, joystick or other pointing device. A hint of what is possible is provided by Amiga Corporation, a Santa Clara, CA company that makes joystick

A Touch of CAD

If you have not had the opportunity to try out a real CAD system, you can get a hint of what it's like to draw lines on a monitor's screen if you have access to a computer equipped with a joystick. Here are some simple routines for several popular computers that will get you started.

Adam. Here's an ultra-simple joystick drawing routine for the Adam:

```
10 HGR2
20 HCOLOR = 3
30 X = PDL ( 1 )
40 Y = PDL ( 3 ) / 1.34
50 HPLLOT X , Y
60 GOTO 30
```

This routine tells Adam to enter its high resolution mode, retrieve the joystick coordinates and mark a point on the screen at their junction. Moving the joystick handle causes a line of points to be drawn. Both joystick values and the horizontal resolution extend from 0 to 255. Line 40 divides the vertical joystick axis by 1.34 since the vertical resolution extends only from 0 to 191 ($256/192 = 1.33 \dots$).

Since Adam's joystick is an 8-position, rate-mode device, straight and angular lines are easily drawn. But a rate joystick doesn't allow you to move the line instantly to any point on the screen as does an absolute joystick.

This routine places Adam in its graphics mode. Therefore only three or four rows of text can be placed along the bottom of the monitor's screen. To review the program or make revisions or corrections, first type TEXT and hit the RETURN key. This will switch the entire screen from graphics to the text mode.

Incidentally, SmartBASIC, the primary language of Coleco's Adam, is a derivative of Applesoft BASIC. Therefore, this routine might also work with the Apple II or IIe.

PCjr. The PCjr uses Microsoft BASIC. Here's a routine that gives the current coordinates of the joystick plugged into the left joystick port on the back of the machine:

```
10 X=STICK ( 0 ) :
   Y=STICK ( 1 )
20 PRINT X , Y
30 GOTO 10
```

This routine allows you to draw on the screen of the PCjr's monitor

```
10 CLS
```

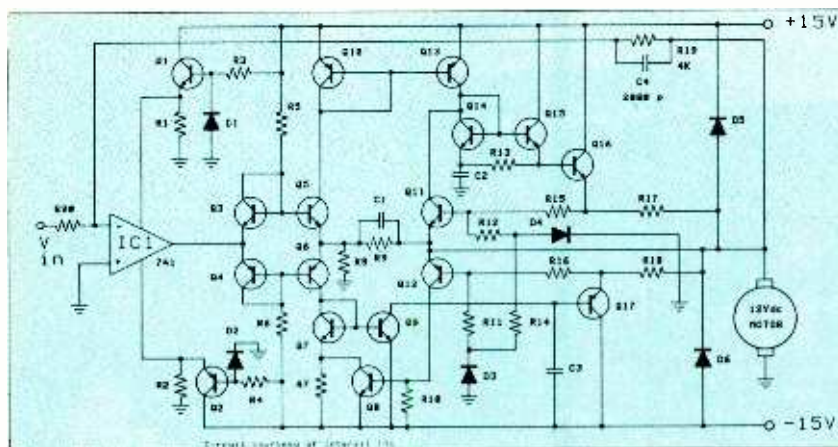

Fig. 4. A typical drawing produced with Robographics software.

stantly connect the origin and the end-point.

CAD-1 includes many powerful drawing and editing functions. Images can be cross-hatched and selectively painted in any of 16 separate colors. Lines can be broken or continuous. Vertical or horizontal labels and text can be entered in various sizes and rotations.

Isometric drawings can be easily produced with the help of angle and grid lock commands that restrict the movement of the cursor along preset vectors. Portions of drawings can be enlarged to fill the entire screen by means of a zoom command. The magnified drawing can then be revised or corrected. A reverse-zoom feature reduces the complete screen image to any user-defined size.

assemblies for video games.

Amiga is developing "Lorraine," a 16-bit graphics station complete with 128K bytes of RAM, a slot for removable memory cartridges and a single disk drive. While these specifications resemble those of IBM's PCjr, Lorraine, which the company claims will run major 16-bit operating systems, has a palette of 3616 colors and the ability to remove hidden lines. Moreover, Amiga expects the system will sell for *less* than \$1000.

Though Lorraine is *not* a CAD system, it nicely illustrates how economical some sophisticated graphics stations have become. No doubt we can soon expect to see a similar development of economical yet sophisticated CAD work stations.

Build your own IBM compatible - and save hundreds of dollars.

HEATH PROUDLY ANNOUNCES THE NEW HS-151 DESKTOP AND HS-161 PORTABLE COMPUTERS.

The world's largest library of PC software has IBM's name on it. But if that's not the name you want on your computer, you don't have to be left out anymore. Now you can run that software on a new machine that feels superior and friendly.

Superior, because it performs. Friendly, because you can build this complex computer from a simple kit.

Can you do it? 85% of our first-time customers ask the same. And the answer is 100% yes. You can.

In fact, you should build it. There's no better introduction to computers in general and the Heath PC's in particular. So, glance at the clear, simple steps that can lead to your own PC. And imagine the fun you'll find along the way.

EVEN OPENING THE BOX IS A PLEASURE!



Getting your PC kit is exciting... and reassuring. Because, as soon as you open it, you'll know it's been designed by experts. Even the box works well. Everything is packed in sections so you build from one organized section at a time. Parts stay stored in the box until needed.

Except for some very simple tools, we include everything. You'll find a soldering guide for mistake-free work. Even an extra circuit board for practice soldering.

PROCEED ONE STEP AT A TIME. BUILD CONFIDENCE... AND AN ADVANCED COMPUTER... FROM A SIMPLE KIT.



The two main circuit boards come to you as they are shown here. Pre-assembled. They're not only completed...they're also factory-tested so

you know they work. And you don't have to bother with complicated testing equipment.

If all of that is done, then what's to build? We do ask you to build some of smaller boards, plus

install any optional memory you've ordered. Then you'll connect the sockets and wiring harnesses between components.

You'll build the chassis from pre-formed subassemblies. The keyboard is already assembled; just put the cover on. Then, finally, bolt the power supply in place. We help you by writing the world's best instruction manuals. And we illustrate those manuals

because one picture may be worth all the words needed to explain a dozen steps. The simpler the better.

The process is exciting because each finished step is its own reward. And every step brings you nearer your completed computer.

EXPERT ADVICE AND TROUBLE-SHOOTING ARE JUST A PHONE CALL AWAY.

You are never alone in this process. If there is ever any question, call our Service Line. You'll reach a trained consultant whose specialty is talking sense, not jargon.

Your computer will work. Our entire business depends on that. And we'll do whatever's necessary to make our simple pledge come true: "We Won't Let You Fail."



**A LITTLE WONDER,
AND A LOT OF PRIDE...**

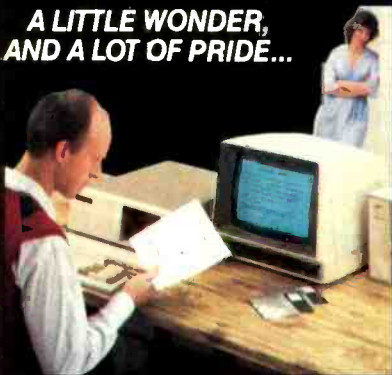

Then the moment of truth. Plug it in. Slide in the included test disk. Odds are the only problem will be contain-

ing the pride you feel when your new computer comes to life.

**YOU'VE BUILT IT. YOU'LL
KNOW HOW TO USE IT.**

You now possess the highest quality personal computer...with up to 320K RAM, a professional keyboard and dual 360K disk drives.

Your machine is truly complete. It's color capable and MS-DOS* is included.

And, because it's IBM compatible, your new machine can work with all that's worthwhile in software. Better yet, with the money saved by building a kit, think of all the peripherals and software you can buy!

*MS-DOS is a registered trademark of Microsoft Corporation.

**FOR COMPUTING
ON THE GO...
THE HS-161
PORTABLE.**



The HS-161 has the same features as the HS-151. Amber Monitor included. Convenient keyboard folds up, two disk drives fold down.

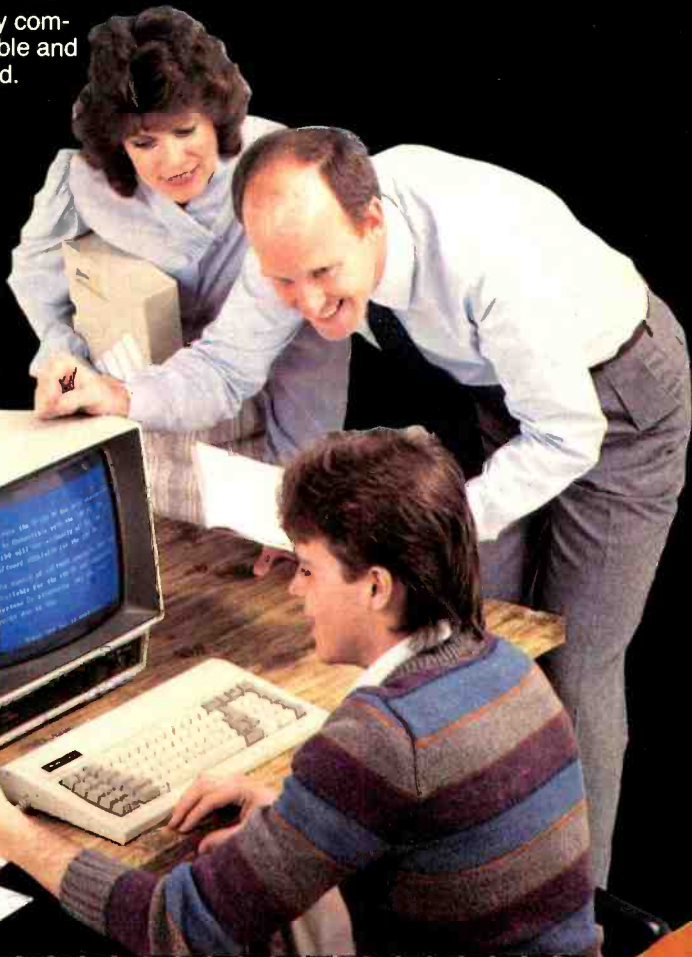

HS-151 Desktop PC with standard floppy disk drive or optional hard disk.

**Get more information
on the most rewarding
personal computers...**

Heathkit[®]
Heath
Company



Get your **FREE**
HEATHKIT CATALOG

Mail this coupon to:
Heath Company, Dept. 01G-184
Benton Harbor, MI 49022

Name _____

Address _____

City _____

State _____ Zip _____

CP-229

Circle No. 24 on Free Information Card

Computer Scientist

```

20 SCREEN 1
30 COLOR 1
40 X=STICK(0):
   Y=STICK(1)
50 A=X*2.9:B=Y*1.66
60 PSET(A,B)
70 GOTO 40
  
```

The PCjr's joystick is an analog type that provides absolute-mode operation. Therefore, the dots placed on the screen follow the position of the stick. Rapid movements of the stick will exceed the program's cycle time and widen the gap between dots.

If the PCjr with which you try this routine is equipped with a standard IBM joystick, you'll be able to experiment with its thumbwheels. While intended for calibrating the joystick's center-return position, the thumbwheels can be used to make drawings in the vicinity of the center of the screen.

TRS-80 Color Computer. Many of the PCjr's commands are strikingly similar to those of Radio Shack's Color Computer. The joystick coordinates of the Color Computer, however, extend only from 0 to 63. Here's a low resolution joystick drawing routine for this machine:

```

10 CLS(0)
20 H=JOYSTK(0):
   V=JOYSTK(1)
30 IF V>31 THEN V=V-32
40 SET(H,V,3)
50 RESET(H,V)
60 GOTO 20
  
```

Unlike the previous routines, when the joystick handle is moved, this program erases the point previously set on the screen. This is done since low resolution points are four times the size of high resolution points. Omit line 50 to draw a line of these large, rectangular points.

Some CAD systems provide an on-screen digital readout of the cursor's coordinates.

You can easily add this capability to the previous routine by inserting the following lines:

```

15 PRINT @ 0, JOYSTK(0);
16 PRINT @ 5, JOYSTK(1);
60 GOTO 15
  
```

Note that line 60 is changed to reflect the new lines. When the revised program is run, the x and y coordinates indicating the position of the joystick's handle will appear in two small windows near the upper left corner of the monitor's screen.

Most personal computers have two joystick ports. To simultaneously view

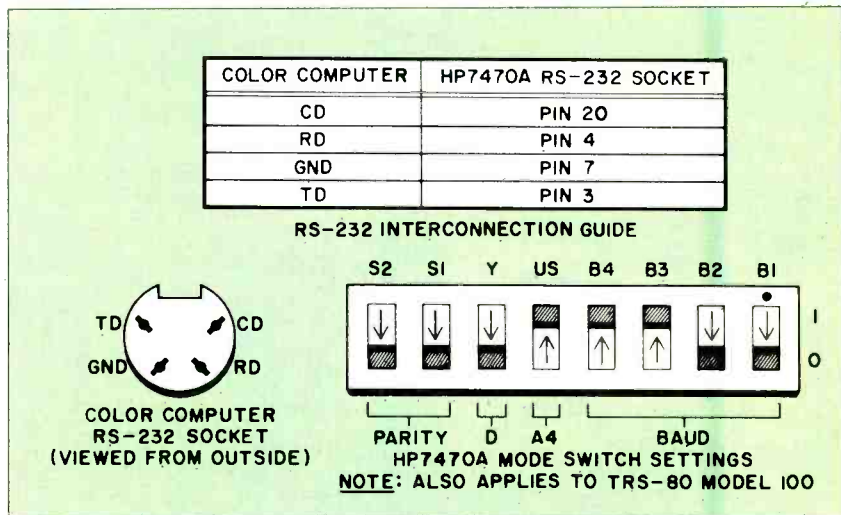

Fig. 5. RS-232 interfacing between a CoCo and HP7470A plotter.

the x and y coordinates of two joysticks connected to the Color Computer, load and run this routine:

```

10 CLS
20 PRINT @0, JOYSTK(0);
30 PRINT @5, JOYSTK(1);
40 PRINT @10, JOYSTK(2);
50 PRINT @15, JOYSTK(3);
60 GOTO 20
  
```

Do-It-Yourself CAD

If you have access to a pen plotter and a compatible computer, you can easily devise and experiment with programs that perform rudimentary CAD functions. The program that follows, for example, is for the Color Computer equipped with a joystick and the HP-7470A pen plotter:

```

05 'JOYPLOT
10 CLS(0)
15 PRINT @ 0, JOYSTK(0);
20 PRINT @ 5, JOYSTK(1)
30 H=JOYSTK(0):
   V=JOYSTK(1)
40 IF V>31 THEN V=V-32
50 SET(H,V,3)
60 RESET(H,V)
70 P=PEEK(65280)
80 IF P=126 THEN 110
90 IF P=254 THEN 110
100 GOTO 15
110
PRINT#-2, "SC0, 70, 0, 35;
SP1; PA"H, V"; PR, 0, 0, PD,
2, 0, 0, 2, -2, 0, 0, -2, PU; "
120 GOTO 15
  
```

This program places the Color Computer in its resolution mode and draws a

cursor on the screen to indicate the position of the joystick's handle. The cursor is erased and a new one is formed when the joystick handle is moved. This creates the impression that the cursor follows movements of the joystick's handle.

When the joystick's fire button is pressed, the plotter's pen advances to the designated point and draws a rectangle to simulate the appearance of the cursor. Cursor images can be drawn anywhere on the plotter's paper.

This program, which can be revised for the PCjr, illustrates how an image can be drawn by a plotter anywhere on a sheet of paper completely under joystick control. Though line 110 defines the image as a bar-shaped replica of the on-screen cursor, any shape that can be programmed in HPGL (Hewlett-Packard Graphics Language), the plotter's language, can be drawn. Since the plotter has a resolution of 0.001", images can be drawn on paper having much finer detail than those displayed on the monitor's screen.

For this program to work, the Color Computer and HP-7470A plotter must be able to communicate with one another over their common RS-232 ports. Figure 5 shows the necessary connections and switch settings. Incidentally, don't be concerned if the plotter's error light begins blinking. Probably because of the Color Computer's limited RS-232 port, the HP-7470 will frequently indicate the presence of an error condition even though it continues to function normally.

If you don't have access to either or both Color Computer and HP-7470A plotter, the program can be modified for other equipment. Line 110 is the only line that sends instructions to the plot-

(Continued on page 105)

Tek's best-selling 60 MHz scopes: Now 25 ways better for not a penny more!

Now Tek has improved its 2213/2215 scopes with brighter displays. Greater accuracy. And more sensitive triggering. At no increase in price.

The 60 MHz 2213 and dual time base 2215 have been the most popular scopes in Tektronix history. Now, Tek introduces an "A" Series update with more than 25 specification and feature enhancements — things you have asked for such as single sweep — all included at no added cost.

A brighter display and new vertical amplifier design provides sharp, crisp traces.

That makes the 2213A/2215A a prime candidate for tasks like TV troubleshooting and testing, where fast sweeps are typical.

New features include 10 MHz bandwidth limit switch, separate A/B dual intensity controls (2215A only), and power-on light: additions customers have suggested for



1-800-426-2200



giving these scopes the final measure of convenience.

Triggering, sweep accuracy, CMRR and many more major specifications are better than ever.

Check the performance chart: not bad for scopes already considered the leaders in their class!

The price: still \$1200* for the 2213A, \$1450* for the 2215A. Or, step up to the 100 MHz 2235 for just \$1650*! You can order, obtain literature, or get expert technical advice, through Tek's National Marketing Center.

Direct orders include operator manuals, two 10X probes,

15-day return policy, world-wide service back-up and comprehensive 3-year warranty.

Talk to our technical experts.

**Call toll-free:
1-800-426-2200
Ext. 184.**

In Oregon call collect:
(503) 627-9000 Ext. 184.

Specification enhancement	2213/2215 "A" Series	2213/2215
CRT brightness	14 kv accel. potential	10 kv accel. potential
Vertical accuracy	3%, 0° to 50°C	3%, +20° to 30°C
Chop rate	500 kHz	250 kHz
Input capacitance	20 pF	30 pF
CMRR	10 to 1 at 25 MHz	10 to 1 at 10 MHz
Channel isolation	100:1 at 25 MHz	Not specified
A Trigger sensitivity (int)	0.3 div at 5 MHz	0.4 div at 2 MHz
TV triggering	1.0 div compos. sync	2.0 div compos. sync
Sweep accuracy (in 10X)	4%, 15° to 35°C	5%, 20° to 30°C
Delay jitter	20,000 to 1 (2215A) 10,000 to 1 (2213A)	10,000 to 1 (2215) 5,000 to 1 (2213)
Holdoff Range	10:1	4:1

*Price FOB Beaverton, OR
All scopes are UL Listed and CSA approved. 3-year warranty includes CRT and applies to 2000 family oscilloscopes purchased after 1/1/83

At CIE, you get electronics career training from specialists.



If you're interested in learning how to fix air conditioning, service cars or install heating systems— talk to some other school. But if you're serious about electronics... even earning an Associate Degree... come to CIE — The Electronics Specialists.

Why trust your education and career future to anything less than a specialist?

You shouldn't. And you certainly don't have to.

If you talked to some of our graduates, chances are you'd find a lot of them shopped around for their training. They pretty much knew what was available. And they picked CIE as number one.

Be sure to shop around. Because, frankly, CIE isn't for everyone.

There are other options for the hobbyist. If you're the ambitious type—with serious career goals in electronics—take a close look at what we've planned for you at CIE. **What you should look for first.**

Part of what makes electronics so interesting is it's based on scientific discoveries—on ideas! So the first thing to look for is a program that starts with ideas and builds on them!

That's what happens with CIE's Auto-Programmed® Lessons.

Each lesson takes one or two principles and helps you master them—before you start using them!

How practical is the training?

This is the next big important question. After all, your career will be built on what you can do—and on how well you do it.

Here are ways some of CIE's career courses help you get your "hands-on" training...

With CIE's Personal Training Laboratory...

you learn and review the basics—perform dozens of experiments. Plus, you use a 3-in-1 precision Multimeter to learn testing, checking, analyzing!

When you get your own 5MHz, solid-state

oscilloscope, you take some real professional steps. You use it as a doctor uses an X-ray machine—to "read" waveform patterns...lock them in...study, understand and interpret them!

When you get your Digital Learning Laboratory, you'll

be into digital theory—essential training today for anyone who wants to keep pace with the state of the art of electronics. With CIE's Digital Lab, you'll be applying in dozens of fascinating ways the theory you've learned. For example, you'll compare analog and digital devices. You'll learn to make binary to decimal conversions and to work with semiconductor devices and circuits. You'll see how digital equipment is vital to today's exciting, growing fields such as security... where digital theory provides the brains for space-age alarm and protective devices.

You'll build your Microprocessor Training Laboratory, a working microcomputer—from "scratch." You'll also learn how to program and interface it with displays, memories, switches, and more.

Earn An Associate Degree from CIE.

One of the best credentials you can have in electronics—or any other career field—is a college degree. That's why CIE gives you the opportunity to earn an Associate in Applied Science

in Electronics Engineering Technology. Any CIE career course can offer you credit toward the degree...more than half of the number needed in some cases.

You can also prepare for the government-administered FCC (Federal Communications Commission) Radiotelephone License, General Class. It can be a real mark in your favor... government-certified proof of your specific knowledge and skills.

Shop around...but send for CIE's free school catalog first!

Mail the card. If it's gone, cut out and mail the coupon. If you prefer to write, mention the name and date of this magazine. We'll send you a copy of CIE's FREE school catalog—plus a complete package of independent home study information! For your convenience, we'll try to have a representative contact you to answer your questions.

Mail the card or coupon—or write: CIE, 1776

East 17th St.,
Cleveland,
OH 44114.

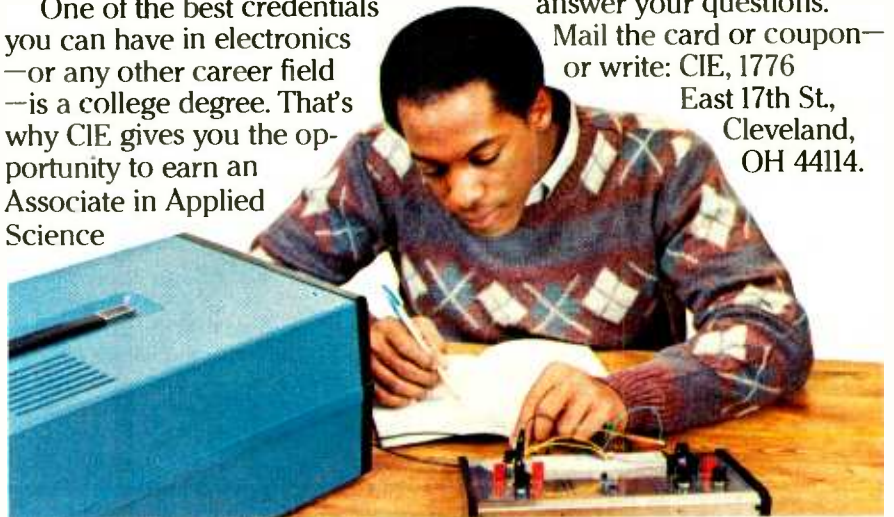

CIE Cleveland Institute of Electronics, Inc.

1776 East 17th Street, Cleveland, Ohio 44114

Accredited Member National Home Study Council

YES... I'm shopping around for the right kind of career training in electronics—and CIE sounds well worth looking into. Please send me my FREE CIE school catalog—including details about the Associate Degree program—plus my FREE package of home study information!

Print Name _____

Address _____ Apt. _____

City _____ State _____ Zip _____

Age _____ Area Code/Phone No. _____

Check box for G.I. Bill information: Veteran Active Duty

MAIL TODAY!

PE-13

HARDWARE REVIEWS

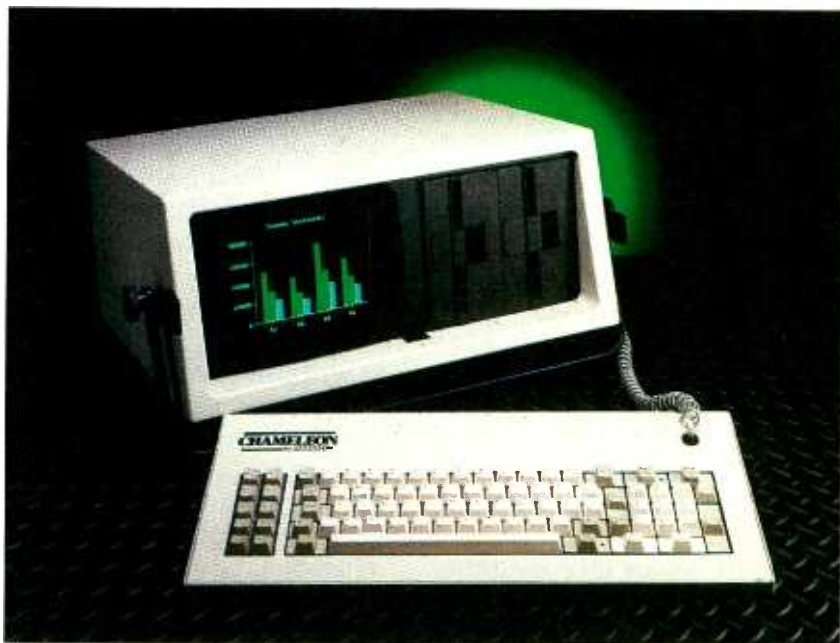

THE CHAMELEON PLUS

Seequa's upgraded IBM compatible portable had double-sided drives and 256K RAM

BY CHARLES P. RUBENSTEIN

MANY of the so-called new microcomputers coming onto the market are really either portable versions of standard configurations, or upgraded versions of older models. The Seequa Computer Corporation's new Chameleon Plus (suggested retail price, \$2895) falls into the latter category. Like the original Chameleon, the Chameleon Plus is a dual-processor system; its 8088 and Z80 processors offer users access to both the 16-bit world of MS-DOS and CP/M-86 and the 8-bit world of CP/M-80. The Chameleon Plus, however, comes with standard double-sided disk drives and 256K RAM, improvements that should make

this transportable IBM PC compatible a strong competitor in the computer-clone market. It also has going for it a wide range of hardware options that can transform this Chameleon to suit the many tasks a portable computer might be asked to do.

Hardware Construction

The Chameleon Plus's electronics are carefully laid out on four printed circuit boards: a 12 $\frac{1}{2}$ " \times 17" main board that lies across the top of the unit, a CRT electronics board, and two power-supply boards located directly behind the CRT display screen. About half of the integrated circuits on the main board are socketed for easy repair and upgrading to enhanced systems. In addition to the two processors; the unit contains 16K of ROM (8K for the monitor, 8K for the character generator) upgradable to 48K, 256K of 9-bit dynamic RAM upgradable externally to over 700K, 4K video RAM, and 17 PAL (programmable array logic) circuits.

Fifteen empty sockets allow for user/dealer upgrades, such as the addition of an 8087 math coprocessor, four 8K ROMs, and ICs for the optional peripheral ports. Cutouts have been made on a recessed rear panel for the following ports: an IEEE standard 488 GPIB talker/listener controller and transceiver system, a second Serial RS-232

analog/digital converter, RGB color monitor, and an external IBM-style expansion bus chassis. Upgrading the Chameleon Plus could be a simple matter of adding a couple of ICs and a cable or two. However, it may also require the reprogramming of a PAL.

The Chameleon Plus seeks to imitate Big Blue's innards as closely as possible by including hardware for a separate DMA controller (8237), a programmable interval timer (8253), a programmable interrupt controller (6845), a multi-protocol serial I/O controller with dual full-duplex transceivers (UART-like 8274), and a double-sided, double-density floppy disk controller (μ PD765). These implement the standard DB25 serial RS-232C port, and a Centronics-type parallel port, which are located behind a movable panel in the rear of the unit. The parallel port connector is a DB25 connector using IBM pinouts. (Unfortunately, Seequa provides no technical documentation that indicates the pinouts of either the serial or parallel ports.) The full power of the floppy disk controller is available through disk format conversion programs such as Crossdata (Award Software, 236 North Santa Cruz Ave., Los Gatos, CA 95030).

Because the cost of random access memory has recently dropped, while its storage capacities have increased, manufacturers now routinely package 128K or 256K of dynamic RAM with their

portable computers. Not to be outdone in this regard, Chameleon Plus has 256K of *parity-checked* bytes. Thus, under its cover are four banks of nine (not eight) 64K × 1-bit dynamic memory chips. In reading from and writing to memory, this extra bit is used to check the parity of the stored byte.

The Chameleon Plus is housed in an instrument-like cream-colored case that measures about 8" × 18¼" × 16" and weighs 31 lb. Attached to the sides of the case is a black metal handle for transporting the closed unit. When the system is in use, the handle folds under it, tilting the screen to a viewing angle of about 10°. You must be careful, however, to avoid pinching your fingers when moving the handle from its in-use position to its transporting position.

A movable panel at the rear of the computer allows access to the detachable ac line cord, the fuse, the keyboard connector socket, the brightness control, and various I/O connectors. (None of the connectors is identified.) There is no reset switch at the back of the Chameleon. To recover from most software hangups, you can press the SHIFT, ALT, DEL keys simultaneously. (Although no mean feat for one-handed programmers, this is quite effective and avoids scraped forearms from reaching into the back to reset.) If a serious hangup occurs, you can always make a cold start by turning the unit off and then on again.

Unlike the manufacturers of several other portables, Seequa seems to have made an effort to avoid vent slots and exposed connectors. Even the fan, which is mounted inside the computer, cannot begin circulating air until the movable panel at the rear is opened. I can't help being annoyed, however, with the designers of this movable panel. There seems to be no way to justify a 4" × 4" metal panel hinged to open *down* onto the desk with cables hanging out over it.

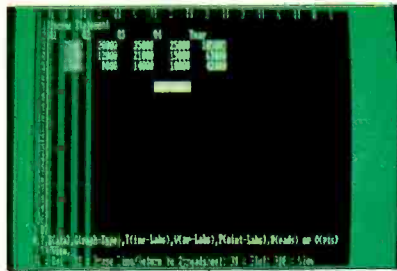

(Figs. 1 and 2) Only SuperCalc³ protected fields are illegible.

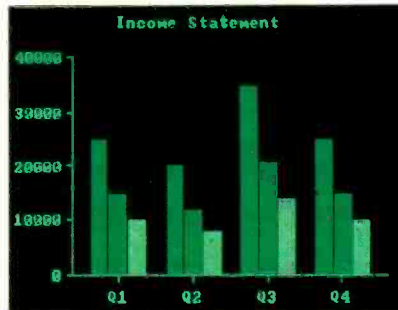

This panel should be redesigned so that it opens to the side, or is removable, and is not such an eyesore.

The Keyboard

Sometimes I wonder if the designers of portable computer keyboards all attended the same seminar, for they all seem to connect the keyboard to the console with unshielded modular telephone wire. The Chameleon Plus's keyboard uses a six-pin cord that can't be detached from the keyboard without opening the unit. Its standard 3' coiled cord can extend to 6', easily accommodating the extra 20" required to reach around the side and plug into the rear. This can be a problem in systems with shorter cords.

The full-featured, 83-key keyboard duplicates the IBM PC keyboard layout. All keys produce a single character when pressed lightly and repeat the

character when fully depressed. When a key is pressed, a speaker in the rear of the console emits a chirping sound. (No instructions are provided for disconnecting this feature if it is not desired.) The 10 function keys are used alone, and in conjunction with the SHIFT, ALT, and CTRL keys to produce up to 40 key functions. There are two keys with LEDs: a caps lock key and a key that toggles the numeric keypad between numbers (LED on) and cursor control.

Standard keyboard encoding is performed on this Keytronic-manufactured keyboard using an 8748 dedicated microcomputer with on-chip 2K ROM for serial coding of the keys. I was unable to locate any program or documentation on reconfiguring or revising the codes for either the number pad or function keys. The keys are configured for use with Perfect Software products.

The Display Monitor

The 9"-diagonal screen adequately displays 24 lines of 80 characters each. (The manufacturer claims that 25 lines are possible, but I have seen no more than 24 plus space at the bottom of the screen.) The characters are readable, but there is a blurring of the horizontal dots that make up the 8 × 8 matrix on the display, a product of the Clinton Taiwan Corporation. Lowercase letters such as g, q, and y are provided with descenders. The monochrome display resolution is an impressive 640 × 200 pixels. If a color monitor is used, the resolution will be 320 × 200 pixels.

There is an 8K ROM labeled FONT inside the console, which led me to expect built-in graphics and special characters. If an advanced set of multiple characters is available, however, it is inaccessible, for the documentation provides no information about it.

(Continued on page 94)

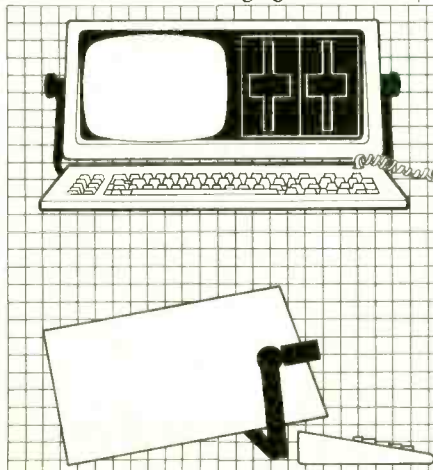

Specifications
 Chameleon Plus Computer
 Mfr: Seequa Corp.
 8305 Telegraph Rd.
 Odenton, MD 21113
 Operating system: MS-DOS 1.25
 Dimensions: 8"H × 18¼"W × 16"D
 Weight: 31 lb
 Price: \$2895

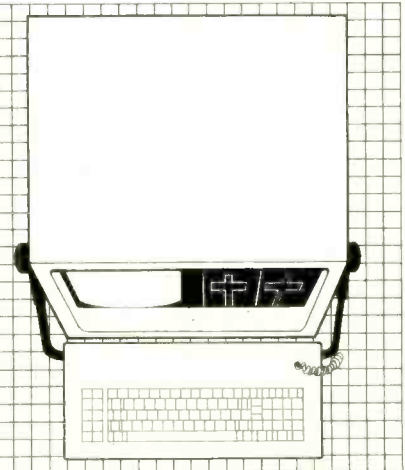
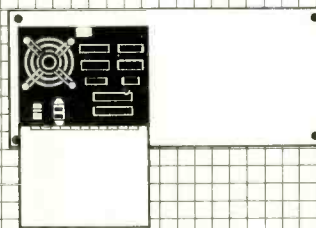

HARD COPY WITH A FLAIR

Texas Instruments' TI-855 dot-matrix printer gives new meaning to the term flexibility

BY ALEXANDER BURAWA

CONSIDERING the state of current printer technology, the announcement of a new dot-matrix impact printer that can create copy in both draft- and letter-quality modes is hardly an occasion to break out the champagne. Many recently introduced matrix printers have this capability. But few in its price range offer the combination of print quality, throughput, and flexibility available in the Texas Instruments Model 855. We have used this printer for several months in a real-life office environment and conclude that the TI Model 855 sets new standards for printer design and flexibility.

The Model 855 is likely to be all the printer you will ever need unless you require camera-ready copy. For high-speed throughput, where print quality is of only secondary importance, the Model 855 can breeze along in its draft mode at 150 cps for hours on end. But if you need letter-quality copy, this printer can hammer it out in a wide variety of fonts at about 35 cps. Throughput in the letter-quality mode may not be very fast, but it equals or surpasses that of top-quality true formed-character printers selling for \$2000 and more. And with its built-in, user-selectable/programmable RS-232 serial and Centronics parallel inputs, the printer is compatible with virtually all personal computers on the market.

The Model 855 features a replaceable 9-wire printhead, a 256-character buffer, and friction feed for handling cut-sheet and roll paper for a base price of \$935 (\$995 with optional adjustable tractor feeder). A built-in ROM gives the printer both draft-quality character and mosaic graphics printing capability; and dot graphics capability for providing hard copy of screen graphics is also featured. Finally, and perhaps most importantly,

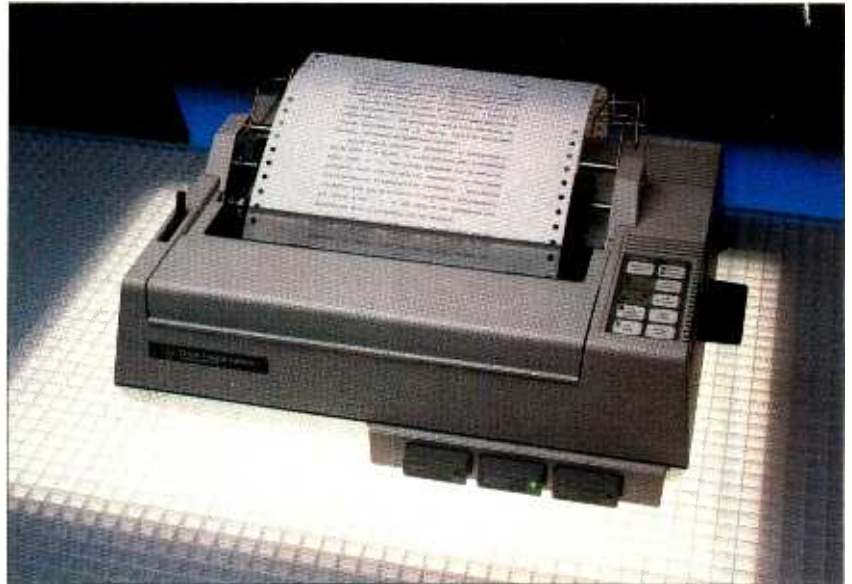

the Model 855 has three front-panel slots for plugging in a choice of solid-state ROM font modules that emulate daisy-wheel or thimble print elements.

Currently available options for the Model 855 printer include about a dozen different character-font ROM modules that sell for around \$40 each, a 4K RAM buffer expansion module, a drop-in design-it-yourself character font RAM module, a drop-in fanfold paper feeder, a roll-paper holder, a stacking tray for fanfold paper, and cables for specific makes and models of computers.

Control Panel

The Model 855 printer is designed for simple operation and features a touch-type membrane control panel for selecting various printing options and a collection of red and green LEDs that indicate mode and function selections.

On power-up, the printer performs a self-diagnostic, during which all LED

indicators in the control panel area and in each plugged-in font module light up. When the diagnostic procedure is complete (and the system passes muster), only those LEDs that indicate the default settings on the panel and the LED in the module plugged into slot 1 remain on. The default settings put the printer into the DRAFT mode and set character spacing to 10 pitch, line spacing to 1, and form length to 66 lines. Any option can be easily changed by pressing various combinations of switches.

One control panel switch, labeled MODULE SELECT, permits selection of any one of the ROM font modules plugged into the three slots. When a cartridge is enabled, its built-in green LED is on.

Another switch offers a choice of either draft- or letter-quality printing, while a CHAR SPACING switch offers a choice of pitches. Each preprogrammed ROM font module has a default pitch of 10, 12, 12.5, or 15 built into it that can be

This is a sample of printing using the Courier WP font cartridge in standard draft mode

This is a sample of printing using the Courier WP font cartridge in quality mode

This is a sample of printing using the Courier Italic WP font cartridge in standard draft mode

This is a sample of printing using the Courier Italic WP font cartridge in quality mode

This is a sample of printing using the Prestige Elite font cartridge in quality mode, compressed.

Printed samples illustrate the difference between draft- and letter-quality modes. The compressed letter quality at the bottom is obviously more professional.



Control panel for selecting modes and print options.

easily overridden using the CHAR SPACING switch.

A LINE SPACING switch offers a choice of 6 lines per inch (lpi) or 8 lpi in single-space mode, or 3 or 4 lpi in double-space mode. The FORM LENGTH and LINE FEED switches are used to reprogram the form length from the printer's default of 66 lines. To accomplish this, you first press the ON LINE switch to take the printer off-line. Then you press the FORM LENGTH switch to enter the programming mode and press the LINE FEED switch as many times as required for the new form length. Finally, pressing FORM LENGTH terminates programming mode and pressing ON LINE puts the printer back on-line.

Print Options

The Model 855 is very flexible due to its ability to accommodate up to three



Front-panel slots accept up to three ROM modules for selecting a variety of character fonts for printed text.

preprogrammed character-font ROM cartridges. Once installed in the printer's slots, ROM cartridges can be individually switched in and out as needed during a printing session. Selection and deselection can be accomplished either by pressing a switch on the printer's control panel or, more practically, if many font changes are to be made in the text of a document, by embedding appropriate control codes in the applications software. This ability to instantaneously change fonts while the printer is in operation makes the TI 855 more convenient to use than true formed-character printers, which require that printing be suspended to remove one printing element and replace it with another.

Although the Model 855 printer has only three font cartridge slots, more than three font cartridges can be used in a single document simply by embedding wait commands in the file, deselecting

the cartridge slot, installing the desired cartridge, and manually selecting the newly installed cartridge. The procedure sounds more complicated and time-consuming than it really is, since it can be accomplished in less time than it takes to explain it or to change a printwheel.

With no cartridge plugged into any of the printer's slots, the Model 855 can still hammer out copy with its built-in character set ROM, though only in the draft-quality mode. The internal draft-mode ROM differs from that normally used in most other dot-matrix printers on the market in that it offers only standard Roman characters. While most dot-matrix printers can print italics from their built-in character-set ROMs, the Model 855 requires the use of a font cartridge. The internal character ROM does provide 10-, 12-, and 17-pitch characters and variable line spacing. Plug-

(Continued on page 95)

Specifications
 Model 855 Printer
 Mfr: Texas Instruments Inc.
 12501 Research Blvd., Box 2909
 Austin, TX 78769
 Dimensions: 17"W x 13"D x 5"H
 Price: \$936 (\$995 with tractor)



Specifications

Model MD11 Desktop Computer
Mfr: Morrow
600 McCormick St.
San Leandro, CA 94577
Dimension: 16.7"W × 11.3"D × 5.3"H
Price: \$2995
Specifications: Z80 CPU; 128K RAM; 5¼", 11M (formatted) hard disk system; 5¼" half-height, double-sided, double-density floppy drive; two RS-232C serial and one Centronics parallel ports; QWERTY keyboard plus 14-key numeric pad, four cursor keys, nine user-definable function keys; 12" diagonal green screen; 80 × 24-character display.

MORROW'S NEW HARD DISK MD11

Powerful Z80 system offers 11-Mb hard disk, 128K RAM and CP/M 3.0

BY MICHAEL GUTTMAN

IN the stampede to jump onto the IBM PC-compatible bandwagon, many consumers may overlook some of the excellent values available in 8-bit computers that run the CP/M operating system. Among the best known of these is the line of desktop computers offered by Morrow Designs. And perhaps one of the best buys in the marketplace is this company's new Model MD11, which includes an 11M hard disk system, 128K of RAM, a full-fea-

tured video terminal, and an impressive array of bundled software. The exciting news is the system's low price—only \$2995 complete.

Clearly, the MD11 is very price competitive with other hard disk desktop computers. But how does it stack up in terms of features and performance? To find out, we used the MD11 over a three-month period with a variety of applications software, including word processing, database management, accounting, and programming packages. What we found pleased us.

Inside the Computer

Like earlier Morrow computers, the MD11 is based on the Zilog Z80 microprocessor. However, while most Z80-based desktop computers are limited to 64K of RAM, Morrow takes advantage of the Z80's memory banking feature to access the entire 128K of RAM supplied with the MD11. To support this feature, Morrow chose the CP/M 3.0 operating system (also popularly known as CP/M Plus), which is an upgrade of the more familiar CP/M 2.2.

The real power behind the MD11 is its 5¼" half-height hard disk system, which has a 12.76M unformatted capac-

ity and provides 11.0M of real storage after formatting. The system has a maximum transfer rate of 625K bps (bits per second) and an average random access time of 95 milliseconds. Included with the hard disk system is a half-height, double-sided, double-density 5¼" floppy disk drive for loading and unloading programs and data to and from the hard disk. The disk controller can support a second hard disk system and/or floppy drive, which are optionally available from Morrow. Additional disk units require their own separate power supply and enclosure.

Extra hardware and software support are provided to further improve the performance of the hard disk system. Key to this support is Morrow's proprietary version of controlled memory access (CMA), which uses the CPU to transfer information directly from the disk to main memory and bypasses the CPU registers. In addition, Morrow's CP/M 3.0 uses the upper 64K of RAM as a "disk cache" system that stores the most recently used and active disk sectors in RAM to cut down on actual disk accesses. These features provide the MD11 user with exceptionally fast response from the hard disk system.

(Continued on page 40)

A TRS-80[®] Color Computer 2 Makes Learning Child's Play

Our TRS-80 Extended BASIC Color Computer 2 is an exciting learning tool that entertains while it educates. Just hook it up to any TV and you have a valuable home learning system in your living room. With the excellent line of programs developed by The Children's Television Workshop, the creators of Sesame Street[®], children are encouraged to

play constructively and learn actively through the use of vivid color graphics and engaging sound effects. And since the level of difficulty and pacing of the game are under the player's control, your child will progress in his or her unique way. The first series of programs for ages 3 thru 6 uses the popular Sesame Street characters to encourage practice of basic preschool skills. Choose *Grover's Number Rover[™]*, *Ernie's Magic*

Shapes[™], *Big Bird's Special Delivery[™]* or *Cookie Monster's Letter Crunch[™]*.

The second series for ages 7 thru 10 focuses on problem solving through cooperation with others. This series includes *Taxi[™]*,

Star Trap[™] and *Peanut Butter Panic[™]*. Each program costs only \$19.95.

You also get an informative manual for both child and parent to help you get the most from each

program. The only "extras" you'll need are a pair of joysticks and a cassette recorder. Come into your

nearest Radio Shack Computer Center, participating Radio Shack store or dealer today and ask for a demonstration

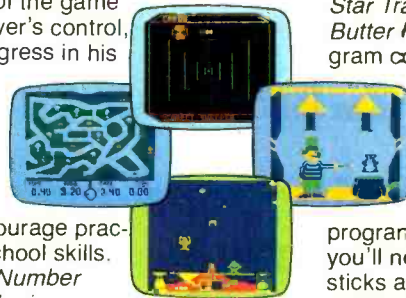

16K Extended BASIC
Color Computer 2

19995
26-3027

USE YOUR



SM

Radio Shack[®]
The Technology Store[™]

A DIVISION OF TANDY CORPORATION

Prices apply at participating Radio Shack stores and dealers. TV, cassette recorder and joysticks sold separately. Programs ©1983 Children's Computer Workshop, Inc. All rights reserved. Muppet characters are trademarks of Muppets, Inc. Sesame Street is a registered trademark of Children's Television Workshop. All other titles are trademarks of Children's Computer Workshop, Inc. CitiLine is a service mark of Citicorp.

Send for a free TRS-80 Computer catalog.

Mail To: Radio Shack, Dept. 84-A-685
300 One Tandy Center, Fort Worth, TX 76102

NAME _____
ADDRESS _____
CITY _____
STATE _____ ZIP _____
TELEPHONE _____

In Computer Electronics...

NTS INTRONIC™ HOME TRAINING GIVES YOU THE EDGE

The competition for High-Technology careers is strong, and the rewards are great. Give yourself the edge you need by training with NTS.



NTS INTRONIC home training provides you with a special kind of "Hands-On" experience that prepares you better, develops your skills faster. You advance as quickly as you wish, working with actual circuits, diagrams, schematics, and state-of-the-art hardware. There are a dozen different NTS programs in electronics to help you develop and reach your potential. They range from basics to advanced areas in several fields. And the ALL-NEW NTS course catalog spells it all out. It's free, and does not obligate you in any way. Send for it today.

A GROWTH INDUSTRY

High-Technology is a growth industry. The evidence is clear, and most observers predict a steady expansion due to a relatively strong flow of investment capital into computers, electronics and precision instruments. Sales of computers alone will reach an estimated ten million units this year. This means challenges and new

employment opportunities, especially in servicing and maintenance. Computer servicing skills can best be learned by working directly on field-type equipment. NTS electronic hardware is selected and developed especially for the training program with which it is associated. You learn by doing, by assembling, by performing tests and experiments, covering principles of computer electronics, microprocessor troubleshooting, and circuitry.

MICROCOMPUTERS

NTS offers three programs in computer electronics. You will receive training covering solid-state devices, digital logic circuitry, and the fundamentals of the computer itself. Instruction includes micro-control technology and detailed operation of microcomputers. These courses will prepare you for entry-level in many facets of the computer industry such as field service and customer engineering as well as programming. In addition to written texts your course includes the NTS/HEATH disc-drive computer which you assemble as part of the training process. The assembly and use of the computer will serve to reinforce practical application of principles.

MICROPROCESSOR TECHNOLOGY

The field of industrial and microprocessor technology encompasses the application of electronic microprocessor control principles. Your course takes you from fundamentals of digital electronics and associated circuitry through the application of the microprocessor as a control device. You will learn how to move and manipulate instructions and information. The microprocessor trainer included in your course is a microcomputer system designed as a practical tool for learning the use of software and hardware techniques utilized in the linking of microprocessors to various systems.

DIGITAL ELECTRONICS

The NTS Compu-Trainer is a fascinating solid-state device which you will build in order to perform over ninety logic circuit experiments. These experiments serve to emphasize an area of electronics which is essential to the understanding of state-of-the-art control equipment; they are also extremely important to those wanting to pursue a career in computer servicing. Separate courses involving the Compu-Trainer are also available in Microcomputer Servicing and Digital/Analog Electronics.

ROBOTICS & VIDEO TECHNOLOGY

Other NTS courses cover a wide range of specialization. In Robotics, the NTS/Heath Hero I is included to train you in robotic applications in

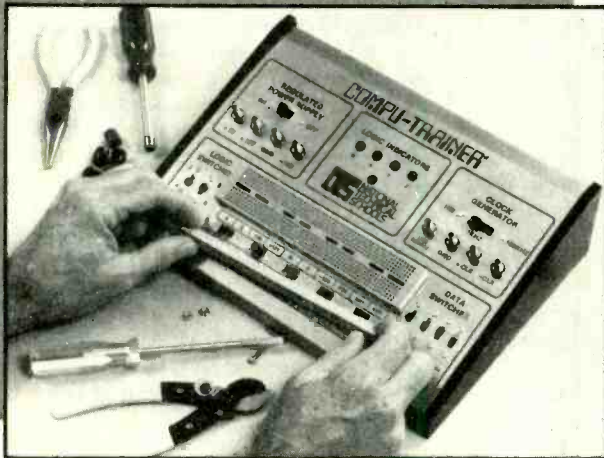

NO OBLIGATION NO SALESMAN WILL CALL

NTS NATIONAL TECHNICAL SCHOOLS

TECHNICAL TRADE TRAINING SINCE 1905
Resident and Home-Study Schools
4000 So. Figueroa St., Los Angeles, CA 90037

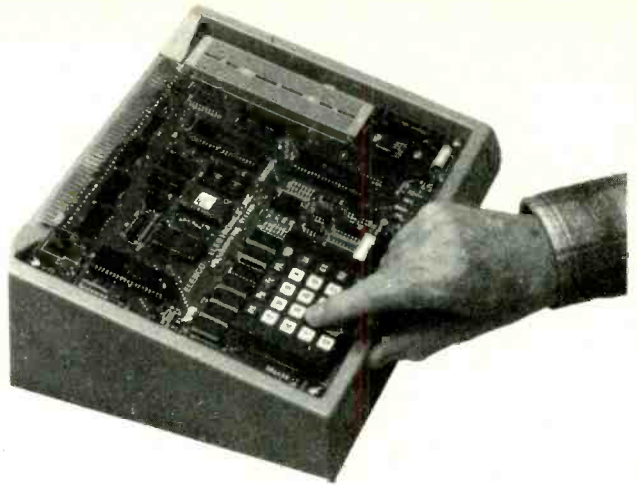

manufacturing processes. In Video technology, a new course features the advanced NTS/Heath Z Chassis "Smart Set" color TV with computer space command remote control and space phone. This is an excellent program for those interested in a career in video servicing with microcomputer basics.

EARN CEU CREDITS

America's industrial giants are turning more and more frequently to home study as an effective way to upgrade employee skills. You benefit from the experience NTS has gained in its 79 years as a leader in technical training. The skills and experience gained in the building of kits and test equipment provide you with training that cannot be duplicated. And, depending on the program you select, you can earn up to 30 CEU credits for successful completion. Complete details included in the catalog.



Use the mail-in card or fill out and mail the coupon. Indicate the field of your choice. (One, only please.) FREE full color catalog will be sent to you by return mail.

NATIONAL TECHNICAL SCHOOLS Dept. 205-064

4000 South Figueroa Street, Los Angeles, CA 90037

Please send FREE color catalog on course checked below:

- | | |
|---|---|
| <input type="checkbox"/> Robotics | <input type="checkbox"/> Computer Electronics |
| <input type="checkbox"/> Digital Electronics | <input type="checkbox"/> Video Technology |
| <input type="checkbox"/> Auto Mechanics | <input type="checkbox"/> Home Appliances |
| <input type="checkbox"/> Air Conditioning/Solar Heating | |

Name _____ Age _____

Address _____ Apt. _____

City _____ State _____

Zip _____ Phone () _____

- Check if interested ONLY in classroom training in Los Angeles
 Check if interested in G.I. Bill Information.

Morrow MD11

Physical Characteristics

The MD11 consists of a main unit and a video terminal. In the main unit are the hard and floppy disk systems, Z80 processor, memory, and related components. This unit is relatively compact and lightweight, measuring 16.7" W × 11.3" D × 5.3" H and weighing just over 22 lb.

All hookups to the main unit are made via connectors mounted on the rear of the cabinet. Each connector is clearly labeled for easy installation. The power switch is also located on the rear panel—a bit awkward to reach—but the RESET button for reinitializing the system is located on the front panel.

Also contained inside the main unit is a 12-cfm 2 $\frac{1}{4}$ " cooling fan. The fan is relatively quiet, but still emits an audible hum that might annoy some users. The unit's power supply is rated at 100 watts, 117 volts.

The Terminal

The terminal that comes with the MD11 computer has a 12" diagonal nonglare green screen and can display up to 80 columns by 24 lines of text. Each displayable character is formed in a 9 × 12 matrix, giving the screen an effective resolution of 700 × 300 pixels. The standard ASCII character set is augmented by 64 graphics characters. The terminal supports all combinations of reverse video, underlining, and half-intensity display.

A 6' coiled cord connects the detached keyboard to the video display monitor unit. The QWERTY-style keyboard has 91 keys, including a 14-key numeric pad, four cursor control keys, and nine user-definable function keys.

Manufactured to Morrow's specifications by Zenith, this terminal closely resembles Zenith's own Z-29 terminal. One particularly nice feature is the terminal's screen-saver time-out, which automatically turns off the display when no activity is detected after about 10 minutes and restores it as soon as any key is pressed or a character is received from the computer.

Morrow provides additional support for the terminal in the form of a software feature that allows the user to redefine the function keys or any other keys. With this feature, the user can store sets of commands or commonly used text to be brought up whenever desired. This is particularly useful in word processing and programming, which require many repetitive functions.

Communications

The MD11 has as standard features two RS-232C serial ports and one Centronics-style parallel port. One serial port is intended for the terminal, while the other serial port and the parallel port can be used for printers, modems, or any other peripherals. Morrow provides an easy-to-use program called "Setup" that allows the user to reconfigure these ports to meet the specifications of other peripherals.

A third serial port can be optionally connected into the system through another RS-232C connector or configured to connect to an on-board RS-422 connector. The RS-422 connector can run in high-speed synchronous serial mode or be configured to support mainframe-compatible communications modes,

The exciting news is the system's low price— only \$2995 complete

such as bi-synch, HCLC, and SDLC. This gives the MD11 the ability to be used with a mainframe terminal port to transfer data to and from a host computer. However, Morrow does not currently offer software to support this function.

The Software

Bundled with the MD11 is an array of software that includes a word processor, spelling checker, spreadsheet, database manager, bookkeeping system, and two programming languages. In addition, the CP/M 3.0 operating system offers a number of useful features not found in earlier versions of CP/M.

The NewWord word processor, reviewed elsewhere in this issue, is practically a carbon copy of the well-known WordStar word processor. Morrow allows buyers to substitute WordStar 3.0 for NewWord. But based on our experience, no advantage is to be gained by making the substitution. NewWord is actually easier to learn, and it comes with an excellent manual. It also includes all the features of WordStar's MailMerge, which is usually an expensive option with WordStar. For those users who customize their word processor, NewWord comes with an easy-to-under-

stand, menu-driven installation program.

The spreadsheet offered with the MD11 is the well-known Supercalc. The database manager is Personal Pearl, which has long been standard with the Morrow line and is now gaining a popular following elsewhere. Pearl is one of the easiest database programs to learn and use. It will also produce reports in the NewWord (WordStar) format for inclusion in documents and Supercalc format for spreadsheets.

The MD11 also comes with Quest Bookkeeper II, a simplified version available only through Morrow of a full accounting system sold by Quest. This package also includes a general ledger with financial statements, accounts receivable, and cash disbursements.

Programming languages supplied with the MD11 include Microsoft BASIC and Pilot. Morrow has used Pilot to program a menu-driven control system that guides the novice user from start-up to power-down. Called Co-Pilot, it eliminates the need to know anything about the operating system for first-time users of the MD11. With Pilot, a more experienced user can easily modify Co-Pilot to add new applications to the menus to customize a "turnkey" system for novice users.

The CP/M 3.0 operating system merits some comment. If you have used earlier versions of CP/M, the 3.0 version will seem like a breath of fresh air. Among the many enhancements made in this upgraded version are the ability to call programs from a common logical disk and/or user area; redirect console and printer input and output to and from files; show sorted directories and perform date and time stamping; and provide on-line assistance using a help command. In addition, CP/M 3.0 comes with a comprehensive and well-written set of manuals that are a real treat after the cryptic documentation supplied with earlier versions of CP/M. All programs from these versions should run under CP/M 3.0, with the exception of those that directly call the BIOS.

Morrow's standard implementation of CP/M for the MD11 places drive A on the hard disk and drive B on the floppy. Morrow provides a "virtual drive" feature that permits the floppy to be temporarily reassigned to drive C, D, or E. It also provides a trap for CP/M's read/write disk error, allowing the user to recover from certain operational errors without crashing a running program.

A "Backfield" program is provided
(Continued on page 110)



The Computer Book Club®

Recognized as the authoritative source for micro users!

Superior Performance, Practical Price!

More programs, projects, ways to use your micro for home, hobby, education, and business!

Select 5 Books for Only \$2⁹⁵



1496
List \$17.95



1050
List \$13.95



1710
List \$19.95



1062
List \$14.95

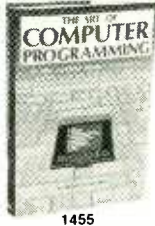

1455
List \$16.95



1423
List \$10.95 (paper)



1276
List \$15.95



1567
List \$18.95



1295
List \$16.95

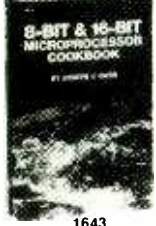

1643
List \$19.95



1513
List \$19.95

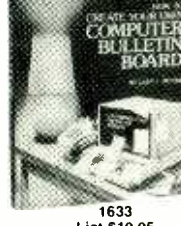

1633
List \$19.95



1205
List \$16.95



1673
List \$13.95



1160
List \$14.95

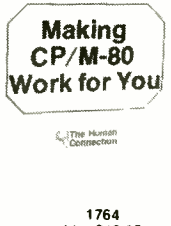

1764
List \$16.95



1479
List \$19.95



1556
List \$21.95



1389
List \$15.95



1506
List \$7.95 (paper)



1640
List \$21.95

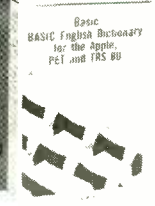

1521
List \$17.95



Free guide to BASIC Statements & Commands

Plus FREE For Joining



7 very good reasons to join The Computer Book Club®

- **Big Savings.** Save 20% to 75% on books sure to increase your computer know-how
- **No-Risk Guarantee.** All books returnable within 10 days without obligation
- **Club News Bulletins.** All about current selections—mains, alternates, extras—plus bonus offers. Comes 13 times a year with hundreds of up-to-the-minute titles you can pick from
- **"Automatic Order."** Do nothing, and the Main selection will be shipped automatically! But . . . if you want an Alternate selection—or no books at all—we'll follow the instructions you give on the reply form provided with every News Bulletin
- **Bonus Books.** Immediately get a Dividend Certificate with every book purchased and qualify for big discounts of 60% to 80%
- **Extra Bonuses.** Take advantage of added-value promotions, plus special discounts on software, games, and more
- **Exceptional Quality.** All books are first-rate publisher's editions selected by our Editorial Board and filled with useful, up-to-the-minute information

The Computer Book Club®

P.O. Box 80, Blue Ridge Summit, PA 17214

Please accept my membership in The Computer Book Club® and send the 5 volumes circled below, plus my FREE copy of *BASIC Statements, Commands and Functions*, billing me \$2.95 plus shipping and handling charges. If not satisfied, I may return the books within ten days without obligation and have my membership canceled. I agree to purchase 3 or more books at reduced Club prices (plus shipping/handling) during the next 12 months, and may resign any time thereafter.

1050 1062 1160 1195 1205 1276 1295 1389 1423
1455 1466 1473 1479 1496 1506 1513 1521 1533 1556
1567 1607 1633 1640 1643 1673 1710 1712 1764

Name _____ Phone _____

Address _____

City _____

State _____ Zip _____ PECC-684

Valid for new members only. Foreign applicants will receive special ordering instructions. Canada must remit in U.S. currency. This order subject to acceptance by The Computer Book Club®

SOFTWARE REVIEWS

TK! SOLVER

Equation solving power not found in spreadsheet packages

BY LEE D. ZIMSKIND

TK!Solver (TK stands for "Tool Kit") from Software Arts, Inc., creators of VisiCalc, represents an alternative to traditional programming for the solution of systems of equations. The user can build his own model by specifying a system of equations or he can use one of the TK!SolverPacks, which contain solutions for common problems in particular disciplines. TK!Solver and TK!SolverPacks are available for most professional desktop computers, including those made by IBM, Digital, Wang, Texas Instruments, Grid, Eagle, Zenith, and Apple. The program was tested by us on IBM PC and Eagle computers for this review.

The TK!Solver package contains a manual, a program diskette, a backup diskette (the program is copy protected), and a useful quick reference card. A reference poster in color that can be placed near the computer is also supplied.

The manual is divided into two parts. First, there is the instruction manual which, when used in conjunction with some sample models included on the program diskette, leads the reader through the building and use of several models using progressively more sophisticated features of the package. The manual is easy to follow and attempts, fairly successfully, to explain to a general audience non-trivial mathematical concepts such as iteration. The second part is a reasonably easy-to-use reference manual.

A technical support phone number is provided, should a user run into difficulties that he cannot solve by referring to the manuals.

The basic concept of the program is that there are "sheets" containing various kinds of information required to solve the problem in question. When the program is started up, two blank "sheets" appear on the screen—one for the "rules," or equations, and one for the "variables."

For any equation specified in the rule

sheet, the variables used in the equation are automatically listed in the variable sheet. The latter contains information about each variable: a field for assigning input value, an output field where the result is shown if the variable is calculated, the units (feet, volts, liters, etc.) of the input or output, a comment field, and a status field.

In the simplest models, the user defines the equations in the rule sheet, inputs the known values on the variable sheet, and types "!" to solve the problem. Error messages are generated if the system of equations is either over- or under-defined. If the input is insufficient to fully solve the system of equations, the program will solve these equations that are satisfied, and inform the user which equations have not been solved.

The program is capable of creating lists of solutions based on lists of inputs for one or more variables; that is, it can handle single-subscribed variables. Solving equations containing multi-subscribed variables is somewhat more cumbersome.

One nice feature of TK!Solver is its unit-conversion capability. Variables can be input in one form (feet, for example) and converted to another (say, meters) automatically as long as the conversion has been specified in a unit sheet. The units used for output can also be specified.

Solutions are displayed on the variable sheet or on a table sheet. The user

can specify horizontal or vertical display of a table of values. The display width is user-defined, but the accuracy to which a value is displayed cannot be controlled. That means that decimal points are not necessarily aligned in columns. The tables can be output to a printer or displayed on the screen.

Primitive graphing capabilities exist. Any sets of values in two lists can be used for X and Y coordinates. Multiple functions can be plotted on the same graph using different characters.

Lists created by TK!Solver can be stored in DIF format, which is compatible with VisiCalc. Similarly, properly created VisiCalc files in DIF format can be used to create lists that can be used by TK!Solver.

What Makes it Different?

The capabilities described so far, with the exception of unit conversion, are similar to those available in any good spreadsheet program. The major factor that differentiates TK!Solver from these is that it is easier to specify models where the known components or input variables differ from one use of the model to another.

With TK!Solver, no variable is pre-specified as input or output, and it is easy to solve equations for variables on either side of the equality. Software Arts refers to this feature as "backsolving." For example, in order to solve problems related

The package contains a manual and program and backup diskettes.



to loans, a user would first enter the equations defining the relationship between principal, periodic payments, term of the loan, and interest rate. Then he could supply input for any three of the items, and TK!Solver would calculate the value of the unknown.

The other feature that makes TK!Solver unique is its capability to solve equations using an iterative method. Iteration is a commonly applied practice in everyday life, best exemplified by the adage: "If at first you don't succeed, try, try, again."

An artist uses the principle of iteration when he mixes colors: to make purple, he combines red and blue, tests the result, adds a little more of one color or the other, tests it again, and continues in this manner until just the right shade of purple is obtained.

In mathematics, the iterative process consists of first making a guess as to the solution of a problem and then using the guess and performing a mathematical manipulation to obtain a new estimate or guess that is nearer to the correct solution. This process is continued until an answer is obtained.

There are, of course, instances when this procedure fails to provide an answer to a problem—usually when the first guess is poor, or when no single solution exists to solve simultaneously all the equations in a system.

TK!Solver makes it very easy to use the iterative process. The user supplies the first guess and the maximum number of iterations (number of guesses) desired. The program does the rest, stopping when a solution is obtained, or the specified number of iterations is exceeded without a solution being found. The instruction manual gives a good description of the iterative process, along with examples.

TK!SolverPacks

Software Arts has used the TK!Solver program to develop models for solving problems in particular fields, and has packaged them in TK!SolverPacks. So far, three TK!SolverPacks are available: Financial Management, Mechanical Engineering, and Introductory Science.

If the Financial Management package is indicative of the other applications, they are geared toward the professional, rather than the casual user. Some of the topics included in the package are: compound interest, level debt service, present value calculations, bond swap analysis, convertible debt analysis, financial statement analysis, and cost of equity capital. A good feature of the

TK!SolverPacks is that the models can be modified by the user to suit particular situations. (Of course, you can create models for your own applications from scratch.)

Other TK!SolverPacks currently under development include Building Design and Construction, Electrical Engineering, and Statistics. In addition, the McGraw-Hill Book Company's Professional and College divisions will soon be producing a major series of TK!SolverPacks.

Software Arts also publishes a journal called TK!SATN for users of the TK!Solver family of products. Modeled after a similar production for VisiCalc users, it contains useful hints, tips, and tutorials for the TK!Solver user.

Observations

Although speed is not TK!Solver's best feature, the program does run toler-

ably quickly. A simple model can be solved in a few seconds. In general, the speed with which a model can be solved is dependent upon the complexity of the model and the method of solution chosen (obviously, the iterative process takes longer). In fact, it often takes longer to load a model than it does for it to be solved.

One annoying thing about the implementation of TK!Solver we used, Version 1.2, is that DOS cannot be resident on the program diskette, and thus the program cannot be made self-loading. DOS has to be loaded, the DOS disk removed, and the TK!Solver disk inserted in the drive. Perhaps this will be rectified in the future.

In summary, TK!Solver is convenient for solving simple systems of equations. It can also be used for more complicated models, but will require effort on the part of the user to learn and understand all its facilities. ◊

WHAT IS A MATHEMATICAL MODEL?

IN the physical world, models of various kinds are encountered every day. An architect constructs a scale model of a building before it is built. Children build and play with model airplanes or cars. All these models are concrete and specific.

A mathematical model is more abstract. In general, it consists of one or more equations that define a relationship between variables. Mathematical models are generally used in a business or scientific environment when it is desirable to be able to see the result of varying one or more of the inputs.

For example, the equation defining the area of a rectangle:

$$\text{Area} = \text{Length} \times \text{Width}$$

remains valid regardless of how the shape of the rectangle changes.

The relationships between principal, interest, rate, time, and total paid for a loan using simple interest calculations is most easily expressed using two equations:

$$\begin{aligned} \text{Interest} &= \text{Principal} \times \text{Rate} \times \text{Time} \\ \text{Total Payment} &= \text{Principal} + \text{Interest} \end{aligned}$$

In scientific and engineering work, mathematical modeling is invaluable. Not only can it eliminate much of the considerable expense of trial-and-error prototyping, it can also permit the simulation of situations or conditions (such as those found in outer space) that are impossible to duplicate at any expense. ◊

OVERVIEW

Product: TK!Solver

Vendor: Software Arts, Inc.
27 Mica Lane
Wellesley, MA 02181

Price: \$399. TK!SolverPacks \$100 each.

Operating systems: IBM PC and XT (and compatibles), DEC Rainbow 100 and Professional 350, Wang Professional, TI Professional, Grid Compass, Canon AS-100, Eagle 1600, Toshiba T300, Zenith Z-100, Apple IIe.

System Requirements: One 5 1/4" disk drive, 128K RAM.

TK!Solver is a satisfactory performer. If you need a 'calc program this is not for you, but if you make extensive use of mathematical models—whether for financial, engineering, or other purposes—then this is a program to which you should give serious consideration. The price is reasonable for what you get.

CE...your best source for diskettes

For you the diskette buyer, it's a jungle out there. There are so many different brands to choose from, you need to go on a safari to find a good brand at a reasonable cost. Fortunately, CE has already hunted for the best diskettes and offers you an excellent choice at a CE price. To save you even more, CE also offers bulk product where 100 diskettes are packed in the same box without envelopes or labels. Since we save packaging costs, these savings are passed on to you. Diskette envelopes are also available from CE. These super strong and tear resistant Tyvek® envelopes are only \$15.00 per 100 pack. Use order # TE-5 for a 100 pack of 5 1/4" diskette envelopes.

Quantity Discounts Available

Our diskettes are packed 10 disks to a carton and 5 or 10 cartons to a case. The economy bulk pack is packaged 100 disks to a case without envelopes or labels. Please order only in increments of 100 units for quantity 100 pricing. With the exception of bulk pack, we are also willing to accommodate your smaller orders. Quantities less than 100 units are available in increments of 10 units at a 20% surcharge above our 100 unit price. **Quantity discounts** are also available. Order 300 or more disks at the same time and deduct 1%; 500 or more saves you 2%; 1,000 or more saves 3%; 2,000 or more saves 4%; 5,000 or more saves 5%; 10,000 or more saves 6%; 50,000 or more saves 7%; 100,000 or more saves 8%; 500,000 or more saves 9% and 1,000,000 or more disks earns you a 10% discount off our super low quantity 100 price. Almost all our diskettes are immediately available from CE. Our efficient warehouse facilities are equipped to help us get you the quality product you need, when you need it. If you need further assistance to find the flexible diskette that's right for you, call the appropriate manufacturers compatibility hotline telephone number listed at the bottom of this ad. Dealer inquiries invited.

Buy your diskettes from CE with confidence

To get the fastest delivery of your diskettes, phone your order directly to our order desk and charge it to your credit card. Written purchase orders are accepted from approved government agencies and most well rated firms at a 10% surcharge for net 10 billing. For maximum savings, your order should be prepaid. All sales are subject to availability, acceptance and verification. All sales are final. All prices are in U.S. dollars. Prices, terms and specifications are subject to change without notice. Out of stock items will be placed on backorder or substituted for equivalent product at no extra cost to you unless CE is instructed differently. A \$5.00 additional handling fee will be charged for all orders with a merchandise total under \$50.00. All shipments are F.O.B. CE warehouse in Ann Arbor, Michigan. COD terms are available, in U.S. UPS areas for \$5.00 extra, and are payable with cash or certified check.

For shipping charges add \$8.00 per 100 diskettes and/or any fraction of 100 8-inch diskettes, or \$6.00 per 100 diskettes and/or any fraction of 100 5 1/4-inch mini-diskettes for U.P.S. ground shipping and handling in the continental U.S. UPS 2nd day air rates are three times continental U.S. rates. For Canada, Puerto Rico, Hawaii, Alaska, or APO/FPO delivery, shipping charges are three times continental U.S. rates.

Mail orders to: Communications Electronics, Box 1002, Ann Arbor, Michigan 48106 U.S.A. If you have a Visa or Master Card, you may call and place a credit card order. Order toll-free in the U.S. Dial 800-521-4414. In Canada, order toll-free by calling 800-265-4828. If you are outside the U.S. or in Michigan dial 313-973-8888. Telex anytime 810-223-2422. Order today. Copyright ©1984 Communications Electronics™ Ad #050184

**COMMUNICATIONS
ELECTRONICS™**

Computer Products Division

818 Phoenix □ Box 1002 □ Ann Arbor, Michigan 48106 U.S.A.
Call TOLL-FREE 800-521-4414 or outside U.S.A. 313-973-8888

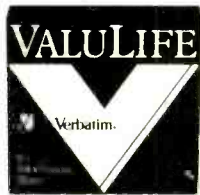

**Verbatim
diskettes** for as low as
\$1.79 each

**3M
diskettes** for as low as
\$1.84 each

**Memorex
diskettes** for as low as
\$1.84 each

**TDK
diskettes** for as low as
\$2.09 each

**Fuji
diskettes** for as low as
\$2.99 each

Verbatim Part #	CE quant. 100 price per disk (\$)	3M Part #	CE quant. 100 price per disk (\$)	Memorex Part #	CE quant. 100 price per disk (\$)	TDK Part #	CE quant. 100 price per disk (\$)	Fuji Part #	CE quant. 100 price per disk (\$)
-----	-----	8SSSD	1.94	3062	1.94	F1-S	2.69	FD1S-128N	2.99
-----	-----	-----	-----	3015	1.94	-----	-----	-----	-----
-----	-----	8SSDD	2.39	3090	2.39	-----	-----	-----	-----
-----	-----	8DSDD	2.89	3102	2.89	F2D-S	3.29	FD2D	4.59
-----	-----	-----	-----	-----	-----	-----	-----	-----	-----
-----	-----	8DSDD-1024	2.89	3104	2.89	F2D-S1024	3.29	FD2D-1024	4.59
-----	-----	-----	-----	-----	-----	-----	-----	-----	-----
28820	1.79	5SSDD-RH	1.84	3481	1.84	M1D-S	2.09	MD1D	2.99
-----	-----	-----	-----	-----	-----	-----	-----	-----	-----
28821	2.54	5DSDD-RH	2.59	3491	2.59	M2D-S	2.84	MD2D	3.19
-----	-----	-----	-----	-----	-----	-----	-----	-----	-----
28823	3.44	5DSDD-96RH	3.49	3501	3.49	M2DX-S	3.89	MD2D-96TPI	4.49
-----	-----	-----	-----	6100	3.74	-----	-----	-----	-----

Lifetime warranty

For more info on Verbatim call
800-538-8589
In California 408-245-4400

Lifetime warranty

For more info on 3M call
800-328-9438
In Minnesota 612-736-9524

5 year warranty

For more info on Memorex call
800-448-1422
Monday-Friday 9am-4pm ET

Lifetime warranty

For more info on TDK call
800-645-6571
In New York 516-625-0100

Lifetime warranty

For more info on Fuji call
800-223-6535
In New York 212-736-3335

Circle No. 19 on Free Information Card

www.americanradiohistory.com

NewWord

A powerful challenger to WordStar

BY MICHAEL MCCARTHY

I LOVE WordStar, but I've found something I like even more. It's called *NewWord*.

NewWord is powerful and sophisticated word processing software, offering most of the capabilities of more costly, dedicated free-standing systems.

Indeed, many people (including me) believe that a general-purpose micro coupled with a product like this is a much better buy than a dedicated word processing system, because you can use the overall system for so many more things than just word processing.

And, within limits, you can run NewWord on the machine of your choice with the terminal and printer that best suit your needs.

But I digress.

How does NewWord differ from the dozens of other word processors?

Briefly, simpler text editors generally tend to rely on the buffered electronic typewriter philosophy of a decade ago. They may have more features—and they certainly are a big advance over pure typewriters—but in general they don't make serious attempts to exploit the inherent strengths of many of today's microcomputers.

In contrast, NewWord goes beyond typewriter philosophy. Instead, it fully acknowledges that the subsystems of a microcomputer—main memory, disk storage, keyboard, video display and printer—collectively represent an electronic medium that can and should be exploited.

When this is done, entirely new capabilities emerge which together represent a completely novel way of managing text.

Here's what I mean:

First, NewWord is designed to handle not only simple business or personal correspondence, but also much larger, more complex bodies of text. For example, legal documents and technical manuals both tend to be lengthy, and there are significant advantages in being able to maintain them as single files. (This makes it easy, say, to search for all instances of a particular name or term and then to change them all to something else, automatically.)

With NewWord, your text is not lim-

ited to what can be stored in a memory-resident buffer. Instead, text can grow to the point where it overflows memory. When this happens, NewWord automatically manages the shuffling of portions of the text in and out of memory. (In practice, to edit a long file you need about twice as much free space on disk as the size of the file you plan to modify.)

On the other hand, NewWord also allows you to assemble documents from separate files, some of them containing "boiler plate" text. This lets you produce highly customized form letters, contracts and the like, all automatically.

Second, NewWord has extensive print formatting capabilities (including formal support of microjustification for supported dot-matrix and letter-quality printers). It shows you on your terminal screen what things will look like when they're printed, even while the text is being created. Justification, margin con-

The developers of NewWord have identified weaknesses in WordStar and fixed them

trol and so on are automatic and visible.

This greatly reduces the number of trial print runs you have to make to get a printed document or boiler plate skeleton to come out looking the way you want it to. (And if your printer is unavailable for some reason, you can still bring a document along to a near-final state.)

Third, NewWord automatically handles such issues as lines of text that fit just fine on your 132-column printer but are too wide for display on your 80-column terminal.

Fourth, NewWord makes it easy for you not only to create formatted documents but also (and more importantly) for you to *change* their layout.

Fifth, NewWord works just as well with program source files as with English text. (For example, in programming applications you typically don't want automatic justification of text. These issues are exactly the reverse of what you usually want when creating English text.)

Sixth, NewWord recognizes that the "right" way for a text editor to behave varies not only with the job at hand but

also with the individual person using the software, the equipment on which it is being run, and so forth. NewWord therefore contains extensive facilities for customizing the software to a broad range of personal tastes or user requirements.

We could go on and on, but instead, let's summarize. What makes NewWord unusual is its bundling of all these capabilities into a single well-documented package. Thus you don't need one editor for correspondence, another for programming, a third for creating contracts, and a fourth for working with the output of a spread-sheet processor. You only need NewWord.

Knowledgeable readers by now probably will have said to themselves: "Isn't he describing WordStar?" The answer is "yes, but" because NewWord has all the capabilities of WordStar, and more.

Technical specifications comprise just one of the many dimensions of a software product. Here are some others:

- Price
- Getting on the Air
- Support
- Reliability
- Documentation
- Performance
- Ease of use

All of these are important, and some of them (for example, support and ease of use) are more important to computer newcomers than are the technical specifics.

In a nutshell, NewWord seems to have everything that WordStar + Mail-Merge has—and more. If you like WordStar and have been thinking about upgrading to Version 3.3, you would do well to consider switching to NewWord instead.

What if you're not now a WordStar user? In that case you'd better read the "Ease of Use" section of this review. Learning to use this kind of editor is nearly as difficult as learning to fly a helicopter, but it's worth it if you plan to spend a lot of time pushing characters around on a CRT screen.

NewWord is intended as a "drop-in" replacement for WordStar + Mail-Merge. Its publisher, Rocky Mountain Software Systems, says in its advertising, "There's only one main difference: price."

Price

Well, price certainly is one difference: The entire NewWord package lists for \$249, including the equivalent of Mail-Merge. This contrasts with a typical *discounted* price of \$370 or so for

10th
YEAR

creative computing's COMPAQ SWEEPSTAKES

10th
YEAR

WIN A \$2,995 Compaq Portable in creative computing's 10th Anniversary Sweepstakes

Join us in celebrating our first ten years of publishing the #1 magazine of computer applications and software... enter CREATIVE COMPUTING's AN-NIVERSARY SWEEPSTAKES!

You could win a COMPAQ Portable microcomputer, bringing you all of the features of a desk-top PC with the portability of an electric typewriter! Full function keyboard, Systems Box housing the CPU chassis, 9" phosphor screen and slots for two disk drives makes the COMPAQ a wonderful foundation for a major system! Use over 95% of all IBM PC software to create and develop new programs!

One lucky reader will win the COMPAQ, *but you can be a winner every month with CREATIVE COMPUTING!*

OFFICIAL RULES NO PURCHASE NECESSARY

1. On an Official Entry Form or a 3" x 5" piece of paper, hand-print your name, address and zip code. Enter as often as you wish, but mail each entry separately to CREATIVE COMPUTING'S COMPAQ SWEEPSTAKES, P.O. Box 5212, Boulder, Colorado 80322. Entries must be received no later than July 31, 1984, and the drawing will be held by August 31, 1984. All entries become the property of CREATIVE COMPUTING, which reserves the right to reprint the name and address of the winner.

2. The winner will be selected in a random drawing from among all entries received, under the supervision of the publishers of CREATIVE COMPUTING, whose decision will be final. Only one prize will be awarded in this Sweepstakes. Winner will be notified by mail and may be required to execute affidavit of eligibility and release. Odds of winning will depend on the number of entries received. CREATIVE COMPUTING will arrange delivery of prize. Taxes are the responsibility of the winner. Any manufacturer's claims or warranties will apply, but CREATIVE COMPUTING makes no claims or warranties with regard to any prizes. Prize is not transferable. No substitutions for prizes.

3. Sweepstakes open to all residents of the U.S., its territories and possessions, except employees (and their families) of CREATIVE COMPUTING Magazine, its affiliates, and its advertising and promotion agencies. Void where prohibited or restricted by law.

4. For winner's name, send a stamped self-addressed envelope to CREATIVE COMPUTING'S COMPAQ SWEEPSTAKES, Circulation Department, One Park Avenue, New York, N.Y. 10016.



Get the latest news about microcomputers, unbiased and in-depth hardware and software reviews, and innovative business, education and recreation applications every month!

Mail in your complete Official Entry Form now, and you could win the COMPAQ Portable!

**SUBSCRIBE TODAY AND
SAVE UP TO 33%!**

10th
YEAR

OFFICIAL ENTRY FORM creative computing's

10th
YEAR

COMPAQ SWEEPSTAKES

CREATIVE COMPUTING • P.O. BOX 5212, BOULDER, COLORADO 80322

YES! Enter my name in CREATIVE COMPUTING'S COMPAQ SWEEPSTAKES and start my subscription to CREATIVE COMPUTING for:

- | | | |
|--|---|---|
| <input type="checkbox"/> One year (12 issues) for \$19.97—SAVE 20% | <input type="checkbox"/> Two years for \$36.97—SAVE 26% | <input type="checkbox"/> Three years for \$49.97—SAVE 33% |
|--|---|---|

Savings based on full one-year subscription price of \$24.97.

- NO, I don't wish to subscribe now, but tell me if I've won CREATIVE COMPUTING'S COMPAQ SWEEPSTAKES.

Mr./Mrs./Ms. _____ please print name in full CC 8H179

Address _____

City _____ State _____ Zip _____

Check one: Payment enclosed Bill me later

Charge my: American Express Visa MasterCard

Card No. _____ Exp. Date _____

Offer valid in U.S., its territories and possessions only. Please allow 30 to 60 days for delivery of first issue.

NewWord

WordStar + MailMerge, which together have a list price of \$645.

So if you don't now own WordStar but have been considering buying it, NewWord is certainly less costly.

However, be aware that NewWord's support of terminals and printers is not yet as extensive as WordStar's. If your equipment is not listed in the NewWord "install" program's menus, then your dealer, or you, or a consultant, may have to do some low-level customizing. (For example, my ADDS Viewpoint is supported by NewWord, but my IBM 3101 isn't. WordStar supports both of them.)

If you are now a user of WordStar 3.0, your choice is between buying NewWord and purchasing an upgrade to both WordStar 3.3 and MailMerge 3.3. (That's right, you need both of them. You can't run MailMerge 3.0 with WordStar 3.3)

I believe NewWord is the better buy provided your equipment is supported directly or you have access to the customization talent.

Getting On the Air

As an experienced WordStar user, I was able to put NewWord to work immediately, without referring to the user manual at all.

You have to call Rocky Mountain to get the software "unlocked" before you can install it, but this is a toll-free call and the folks who take the call are friendly and helpful. They led me step-by-step through the procedure, which was simple (though somewhat intimidating). With NewWord unlocked, I ran the installation procedure cold, referring only to the READ-ME text file on the distribution disk. Again this presented

no difficulties.

Having installed NewWord, I began to use it to write a draft of this review. Here's what I noticed right away: The procedural differences between operating NewWord and operating WordStar are minor and generally self-evident. I felt at home immediately, and I was productive immediately. (But some of the differences felt like NewWord bugs to me at first.)

Would your experiences be the same? "Yes" if you know WordStar, "No" if you don't. (And see Ease of Use if you don't.)

The second thing I noticed was an impression forming as the body of text grew and I began to make changes: NewWord seemed to be *faster-and-less annoying* than Wordstar, at least when it came to reforming paragraphs. And this became my consistent experience in working with NewWord: It's faster and friendlier than WordStar. It's more powerful, too.

Now, I find this amusing because, while I am a great fan of WordStar, I know people who loathe WordStar. They say it's too slow.

This comment had me mystified because I have been using WordStar for almost two years and hadn't once thought of it as slow. (On the other hand, my system has a hard disk, which covers a multitude of performance sins.) Nevertheless, when I began reforming paragraphs with NewWord, it did seem faster—and at that point the text was short enough to fit in memory so that NewWord wasn't making any disk accesses. Interesting. So then I tried the feature which many WordStar nonusers find the most agonizing, a global search-and-replace. And it was obvious that NewWord had WordStar beat by a considerable margin. Suddenly, I too could only think of WordStar as slow.

"Hmmm," I said to myself. "That's fine, but readers deserve facts as well as opinions. How about quantifying the performance differences?" So I began to run some experiments on text files, doing the kinds of things one buys a powerful text editor for—search and replace, reforming text to fit changed margins, printing with special effects, etc.

The results of these experiments will be presented later, but the bottom line is this: in many useful respects, NewWord is *much* faster than WordStar.

Internally both word processors seem to work at much the same speed. When a command calls for screen updating, however, NewWord runs rings around the competition.

(Continued on page 96)

SPEED COMPARISONS

Measurements were made on a Molecular Computer Supermicro-8 using a 4-MHz Z80A running a CP/M 2.2 lookalike operating system. This computer has a Tandon 8" floppy drive and a Priam hard disk. Times (in seconds) are floppy-based, with hard disk times given in parentheses.

I took a near-final version of this review and ran it through several representative word processing operations. Here are the measured results:

Operation	NewWord 1.28	WordStar 3.3
Load program, open document text file	34 (13)	30 (15)
Replace all occurrences of "the" with "xxx" using ^QA command	78 (68)	237 (228)
Go from back of file to front of file using ^QR	11 (6)	5 (4)
Replace all "xxx" with "the", but follow with immediate "go to back of file" (that is, ^QA followed by ^QC to inhibit screen updates)	19 (13)	10 (9)
Automatically reform all paragraphs	197 (182)	250 (249)
Save file and exit	10 (3)	13 (8)
Print resulting file	219 (212)	233 (224)

OVERVIEW

Product:	NewWord
Vendor:	Rocky Mountain Software Systems 1280-C Newell Ave. Suite 1055 Walnut Creek, CA 94596
Price:	\$249
Operating system(s):	CP/M-80, MS-DOS, PC-DOS
Minimum system requirements:	CP/M-80: 64K, 1 8" or 2 5/4" drives MS-DOS, PC-DOS: 96K, 2 5/4" drives

NewWord is a powerful word processor that is the equal of—and in some respects, better than—WordStar. It is also less expensive than WordStar, especially when you consider that it has the equivalent of MicroPro's MailMerge built in. While somewhat complex to learn and master, it should be given serious consideration by those in the market for a word processor with all the "bells and whistles." Those considering upgrading an older version of WordStar should also look at NewWord before making a decision.

COMPUTER MAIL ORDER

commodore

**SX-64
PORTABLE**

\$839



CBM 8032.....\$599
CBM 4032.....\$599

CBM 12880\$769.00
CBM 64K Memory Board\$269.00
8032 to 9000 Upgrade\$269.00
2031 LP Disk Drive\$299.00
8050 Disk Drive\$99.00
8250 Disk Drive\$1199.00
4023 Printer\$379.00
8023 Printer\$569.00
6400 Printer\$1399.00
Z-RAM\$499.00
Silicon Office\$699.00
The Manager\$199.00
Soft. ROM\$125.00
VisiCalc\$159.00

PROFESSIONAL SOFTWARE
Word Pro 2 Plus\$159.00
Word Pro 3 Plus\$189.00
Word Pro 4 Plus/5 Plus each\$279.00
InfoPro\$179.00
Administrator\$399.00
Power\$79.00

FRANKLIN

ACE 1000 Color Computer CALL
ACE Family Pack System CALL
ACE PRO PLUS System CALL
ACE 1200 DMS CALL
NOT file EXPENSIVE

APPLE IIe STARTER PACK
64K Apple IIe, Disk Drive & Controller, 80 Column Card, Monitor II & ODS 3.3
COMPLETE.....CALL

**PRINTERS
AXIOM**

AT-846 Atan Interface\$99.00
AT-100 Atan Interface Printer\$239.00
GP-100 Parallel Interface\$199.00

BMC

401 Letter Quality\$589.00
BK-80 Dot Matrix\$269.00

C.ITOH

Gonila Banana\$209.00
Prowriter 8510P\$379.00
Prowriter 1550P\$679.00
A10 (18 cps)\$569.00
F10-40\$999.00
F10-55\$1499.00

EPSON

MX-80FT, MX-100, RX 80, RX 80FT
FX 80, FX-100, LQ-1500 CALL

OKIDATA

82, 83, 84, 92, 93, 2350, 2410 CALL

SMITH CORONA

TP-1000\$399.00
Tractor Feed\$119.00

SILVER REED

500 Letter Quality\$449.00
550 Letter Quality\$569.00
770 Letter Quality\$899.00

STAR

Gemini 10X\$299.00
Gemini P15X\$399.00
Delta 10\$449.00
Radix 10\$599.00
Radix 15\$699.00
Serial Board\$75.00

TRANSTAR

120P\$499.00
130P\$699.00
315 Color\$499.00

CBM 64.....\$199
VIC 20.....CALL

MSD-1 Disk Drive\$379.00
MSD-2 Disk Drive\$599.00
C1541 Disk Drive\$259.00
C1530 Datasette\$69.00
C1520 Color Printer/Plotter\$169.00
M-801 Dot Matrix/Parallel\$219.00
C1526 Dot Matrix/Serial\$279.00
C1702 Color Monitor\$259.00
C1311 Joystick\$4.99
C1312 Paddles\$11.99
C1800 VIC Modem\$59.00
C1650 Auto Modem\$89.00
Logo 64\$49.00
Pilot 64\$39.00
Word Pro 64 Plus\$59.00
Parallel Printer Interface\$49.00
CalcResult 64\$65.00
CalcResult Easy\$39.00
Corlewriter 64\$75.00
Quick Brown Fox\$49.00
Vidtex Telecommunications\$34.95

**APPLE/FRANKLIN
DISK DRIVES
MICRO-SCI**

A2\$219.00
A40\$299.00
A70\$319.00
C2 Controller\$79.00
C47 Controller\$89.00

RANA

Elite 1\$279.00
Elite 2\$369.00
Elite 3\$569.00

ZENITH

PC Compatible Computers
150 Series (Desktop & Portable) CALL

**SOFTWARE FOR
ATARI, APPLE/FRANKLIN,
CBM & IBM**

ELECTRONIC ARTS

Hard Hat, Mack [AT/AP/CBM/IBM]\$29.95
Archon [AT/AP/CBM/IBM]\$32.95
One On One [AP ONLY]\$32.95
Cut & Paste Word [AT/AP/CBM/IBM]\$42.95
Pinball Construction [AT/AP/CBM/IBM]\$32.95

INFOCOM

Zork 1, 2, 3 [AT/AP/CBM/IBM]\$29.00
Deadline [AT/AP/CBM/IBM]\$32.95
Enchanter [AT/AP/CBM/IBM]\$32.95
Planetfall [AT/AP/CBM/IBM]\$32.95
Witness [AT/AP/CBM/IBM]\$32.95
Starcross [AT/AP/CBM/IBM]\$29.00

ATARISOFT

PacMan [IBM/AP]\$29.99
PacMan [CBM/VIC]\$37.99
Centipede [IBM/AP]\$29.99
Centipede [CBM/VIC]\$37.99
Dig Dug [IBM/AP]\$29.99
Dig Dug [CBM/VIC]\$37.99
Donkey Kong [IBM/AP]\$29.99
Donkey Kong [CBM/VIC]\$37.99
Defender [IBM/AP]\$29.99
Defender [CBM/VIC]\$37.99
Robotron [IBM/AP]\$29.99
Robotron [CBM/VIC]\$37.99
Star Gate [IBM/AP]\$29.99
Star Gate [CBM/VIC]\$37.99

CONTINENTAL SOFTWARE

Home Accountant [AT/AP/CBM]\$49.00
Home Accountant [IBM PC]\$68.00

**HOME
COMPUTERS**

ATARI®



600XL.....\$199
800XL.....\$299
1200XL.....CALL
1400XL.....CALL

PERCOM

AT 88-S1\$369.00
AT 88-A1\$259.00
AT 88-S1PD\$449.00
AT 88-DDA\$119.00
RFD 40-S1\$449.00
RFD 40-A1\$269.00
RFD 40-S2\$699.00
RFD 44-S1\$539.00
RFD 44-S2\$869.00

RANA

1000\$329.00

INDUS

GT Drive\$379.00

TRAK

AT-D2\$389.00

KOALA PAD

Atari\$75.00
Apple\$85.00
IBM\$95.00
CBM 64\$75.00

WICO CONTROLLERS

Joystick\$21.99
3-way Joystick\$22.99
Famous Red Ball\$23.99
Power Grip\$21.99
BOSS Joystick\$34.99
ATARI/VIC TrakBall\$54.99
Apple Trak Ball\$15.99
Apple Adapter\$37.99
Apple Analog\$37.99

MODEMS

ANCHOR

Volksmodem\$59.00
MARK II\$79.00
Mark VII (Auto Ans/Auto Dial)\$119.00
Mark XII (1200 Baud)\$299.00
TRS 80 Color Computer\$99.00
9 Volt Power Supply\$9.00

HAYES

Smartmodem 300\$209.00
Smartmodem 1200\$499.00
Smartmodem 1200B\$449.00
Microcom IIe\$269.00
Microcommodem 100\$299.00
Smart Com II Chronograph\$199.00

NOVATION

J Cat\$99.99
Smart Cat 103\$179.00
Smart Cat 103/212\$399.00
Auto Cat\$219.00
212 Apple Cat II\$399.00
Apple Cat 212 Upgrade\$249.00
Cat\$139.00
D Cat\$149.00
PC Cat 1-2-3\$399.00
Apple Cat II\$229.00

ZENITH

ZT-1\$309.00
ZT-10\$339.00
ZT-11\$399.00

1010 Program Recorder\$74.00
1020 Color Printer\$249.00
1025 Dot Matrix\$349.00
1027 Letter Quality\$309.00
1030 Direct Connect Modem\$119.00
1050 Disk Drive\$399.00
CX30 Paddle\$12.00
CX40 Joystick each\$8.00
CX77 Touch Tablet\$4.00
CX80 Trak Ball\$48.00
CX85 Keypad\$105.00
488 Communicator II\$229.00
4003 Assembler Editor\$47.00
4011 Star Raiders\$33.00
4012 Missile Command\$29.00
4013 Asteroids\$29.00
5049 VisiCalc\$159.00
7097 Logo\$79.00
7101 Entertainer\$69.00
7102 Arcade Champ\$75.00
8026 Dig Dug\$33.00
8030 ET Phone Home\$33.00
8031 Donkey Kong\$39.00
8033 Robotron\$35.00
8034 Pole Position\$39.00
8036 Atan/Writer\$79.00
8040 Donkey Kong Jr\$39.00
8043 Ms PacMan\$39.00
8044 Joust\$39.00

**MEMORY BOARDS
for ATARI 400/800**

Axlon 32K\$59.00
Axlon 48K\$99.00
Axlon 128K\$299.00
Intec 32K\$59.00
Intec 48K\$85.00
Intec 64K\$99.00
Intec Real Time Clock\$29.00
Atan 853-16K\$49.00

MONITORS

AMDEK

300 Green\$149.00
300 Amber\$159.00
310 Amber\$169.00
Color 1\$279.00
Color 1 Plus\$299.00
Color 2 Plus\$419.00
Color 3\$349.00
Color 4\$699.00

BMC

12" Green\$79.99
12" Green Hi-Res\$119.99
9191-13" Color\$249.99

GORILLA

12" Green\$88.99
12" Amber\$95.99

NEC

JB 1260 Green\$109.99
JB 1201 Green\$149.99
JB 1205 Amber\$159.99
JC 1215 Color\$269.00
JC 1216 RGB\$429.99

PRINCETON GRAPHICS

HX-12\$529.00

TAXAN

12" Green\$119.00
12" Amber\$129.00
Taxen 1 RGB\$279.00

SAKATA

SC-100\$269.00

USI

Pi 1, 9" Green\$99.99
Pi 2, 12" Green\$119.99
Pi 3, 12" Amber\$149.99
Pi 4, 9" Amber\$139.99
1400 Color\$269.99

ZENITH

ZVM 122 Amber\$109.00
ZVM 123 Green\$99.00
ZVM 135 Color/RGB\$469.99

east

800-233-8950

In PA call (717)327-9575, Dept. 40607
Order Status Number: 327-9576
Customer Service Number: 327-1450
477 E. 3rd St., Williamsport, PA 17701

canada
Ontario/Quebec

800-268-3974

Other Provinces 800-268-4559
In Toronto call (416)228-0868, Dept. 40607
Order Status Number: 828-0868
2505 Dunwin Drive, Unit 3
Mississauga, Ontario, Canada L5L1T1

west

800-648-3311

In NV call (702)588-5654, Dept. 40607
Order Status Number: 588-5654
P.O. Box 6689
Stateline, NV 89449

MasterCard

VISA

No risk, no deposit on C.O.D. orders and no waiting period for certified checks or money orders. Add 3% (minimum \$5) shipping and handling on all orders. Larger shipments may require additional charges. NV and PA residents add sales tax. All items subject to availability and price change. Call today for our catalog. **CANADIAN ORDERS:** All prices are subject to shipping, tax and currency fluctuations. Call for exact pricing in Canada.

Circle No. 11 on Free Information Card

www.americanradiohistory.com



YOU CAN TAKE IT WITH YOU!

The HP-110 from Hewlett-Packard offers MS-DOS, Lotus 1-2-3, terminal emulation, and word processing in an 8.5-lb battery-powered package

BY PETER COSTA

Hewlett-Packard's new disk-less HP110 portable is an awesome kneetop machine. It combines the latest in CMOS technology with an array of powerful software permanently stored in ROM, all for under \$3000.

MS-DOS, Lotus 1-2-3, MemoMaker (HP's document-text editor), a Personal Applications Manager (a simplified menu command system for MS-DOS) and a terminal emulator are permanently etched in ROM. Because there are no balky mechanical disk drives to break down or unreliable floppy disks to suffer amnesia, the bundled software is virtually indestructible. You cannot accidentally erase, write over or lose it. Coupled with the 384K of ROM is a substantial 272K of continuous, static RAM—enough memory to store nearly 170 pages of double-spaced text.

The HP portable uses MS-DOS Version 2.11 as its operating system and therefore is compatible with a large range of already available software with few modifications.

According to Hewlett-Packard, the HP110's "solid-state RAM disk" makes the machine 200 times faster than a floppy disk system. For example, the HP110 is ready to use Lotus in about five seconds compared to the 75 seconds a disk system requires to load 1-2-3.

And because software is stored in ROM, one can use RAM for storing data, not programs. Not only does this allow the user to store larger data files without having to resort to an external disk drive, but execution speeds on the HP110 are also increased because the software is already loaded on the so-called electronic disks in the HP110. (Electronic disks are sections of memory designed as high-speed mass storage devices.)

There are two electronic disks in the portable: drive A and drive B. Drive A is the RAM disk. It can be configured (partitioned) so that part serves as a peripheral disk to store data and programs while the balance serves as system memory. RAM is preserved as long as the battery pack contains a charge and the RAM disk is not affected by resetting the computer. Drive B is the ROM disk. It is permanent and not affected by resetting the computer or by a discharged battery.

External disk drives are labeled sequentially starting with the drive C designation. Other drives, for example, would be labeled D, E, F, G, etc. As many as eight single disk drives or four dual drives can be connected.

CMOS 8086

The soul of this machine is a CMOS

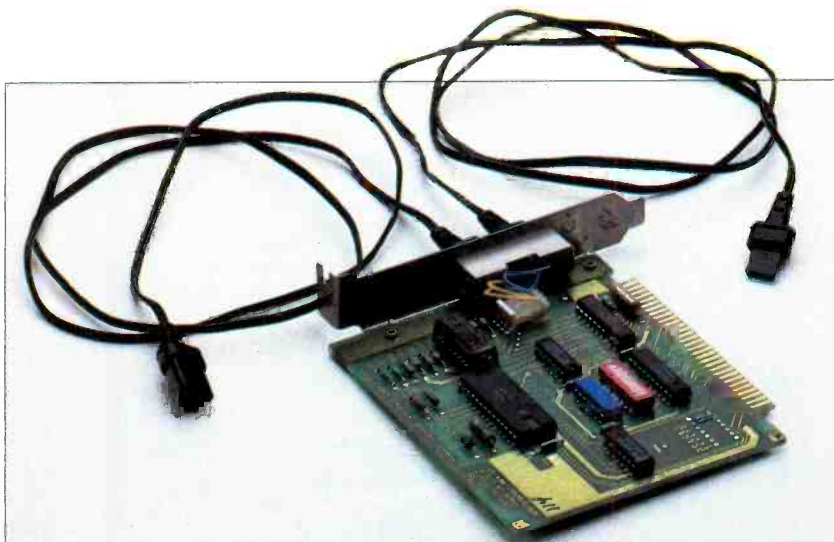

HP's Interlink card and cables.



The HP110 can access desktop disk drives.



Portable trio: HP110, ThinkJet, disk drive.

8086, a true 16-bit microprocessor that sprints through spreadsheets at a number-crunching 5.33 megahertz. (A complete review of the HP110 will appear in a future issue of C&E.)

The HP110 is powered by three 2-volt, semipermanently installed lead-acid batteries. HP chose lead-acid cells

because it believes the output from them is more linear and therefore more predictable than nickel cadmium batteries. Also, lead-acid cells do not suffer from the memory quirks that nickel cadmium cells do on recharging, HP claims.

The 6-volt, 2.5-Ah battery pack is
(Continued on page 88)

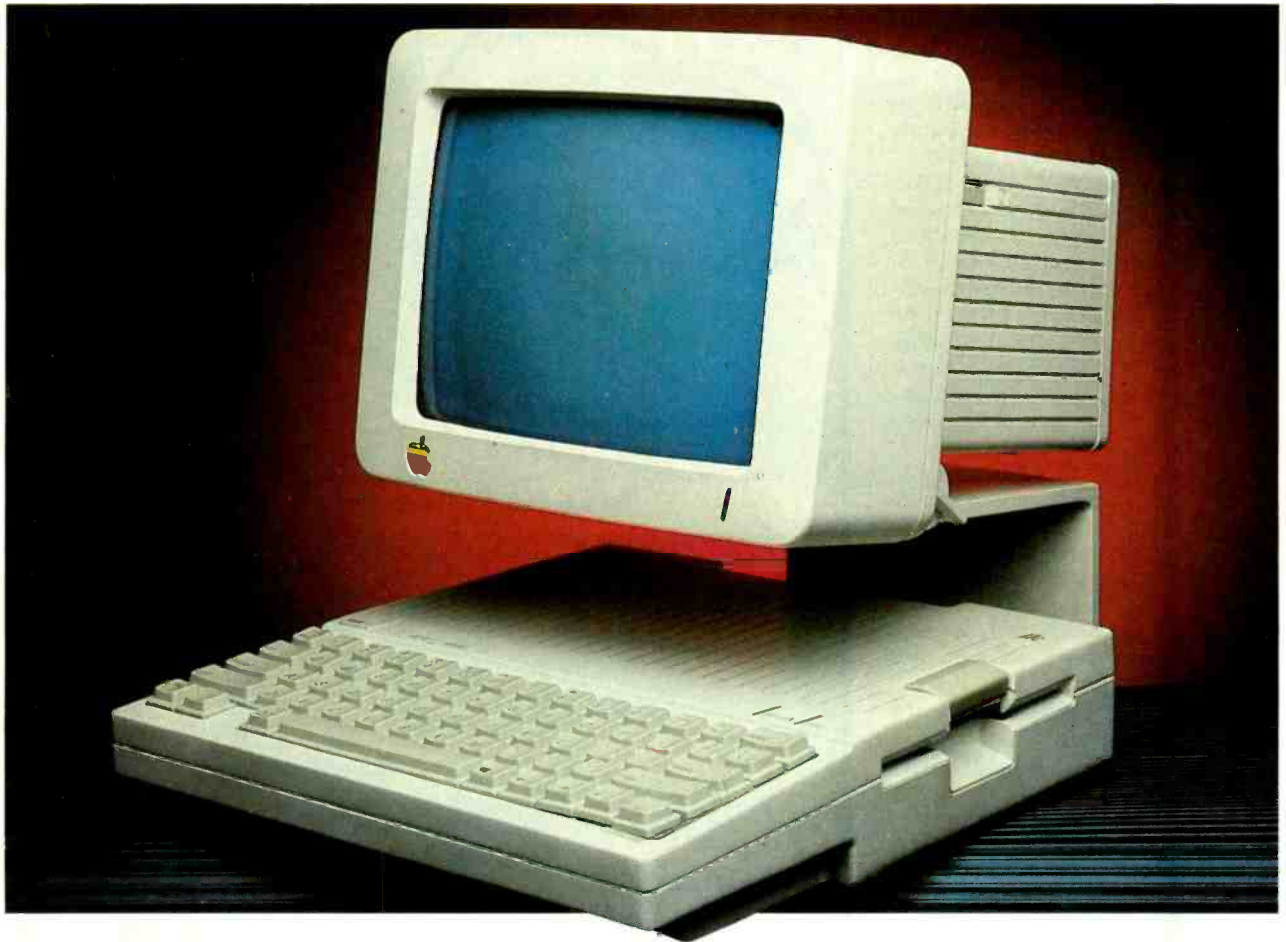

AN APPLE TO GO

The Apple IIc is a slimmer, lighter version of the IIe with an integrated disk drive

BY PETER COSTA

ON the theory that you can improve even a best-selling product, Apple has taken its very popular IIe, slimmed it down, doubled its memory, added a built-in disk drive and launched it into the transportable-universe.

But Apple's new, under \$1300 machine, called the IIc, despite obvious improvements over the IIe has some limitations. Currently, it is still tethered to an ac power cord, but by the fall of this year, it will be retrofitted with an 80-by-24 liquid crystal display and an outboard

battery pack. Both items are being designed by third-party vendors.

The IIc as presently constructed can run off the 12-V dc from a car's cigarette lighter, but this will only be useful when the LCD becomes available. Nevertheless, despite the IIc's reliance on house current, Apple lovers will admire the sleekness, the modular, plug-in expandability and the small footprint of the 7.5-lb IIc.

Underneath the streamlined, aerodynamic-looking cover beats a cold, calculating CMOS heart. The IIc uses a 65C02 eight-bit microprocessor—the CMOS version of the venerable 6502. There are more than 500 million 6502s in use and Apple first used the 6502 in its

machines as early as 1976.

The 65C02 runs at a 1-MHz clock rate in the IIc and performs up to 500,000 eight-bit operations per second.

The IIc comes with an impressive 128K of RAM, more than twice that of the IIe, and 16K of ROM. Permanently stored in ROM are Applesoft BASIC, disassembler, and a machine language monitor program. Operating systems available for the IIc are ProDOS and DOS 3.3. SuperPILOT, Logo, FORTRAN, Pascal and a 6502 assembly language are also available.

Apple is introducing an integrated software package as an option for the IIc called Appleworks which contains a word processor, a database and a spread-

Peter Costa is Executive Editor of Computers & Electronics.

TOP PHOTOS BY BOB LORENZ

sheet. The IIc comes with six "training" disks to introduce the user to the software.

There is a built-in, half-height 5¼" disk drive and a controller for a second disk drive (or slot 6 equivalent in the IIe). The IIc was designed as a "slotless" machine with expansion capabilities being implemented through plug-in ports in the rear of the computer. The IIc is a very compact 12" × 11½" × 2½" machine with a built-in speaker for audio output. There is a volume control knob and a headphone jack on the left side of the IIc for those who want to use ear-phones instead of the speaker.

The top of the IIc includes a 63-key, full-travel keyboard that generates upper- and lowercase letters and all 128 characters in the ASCII character set including control characters. There is also a conveniently located reset key, a 40/80 column switch for a television set or video monitor, a power-on light, a light that indicates when the disk drive is active, and a keyboard switch that converts the QWERTY keyboard to a DVORAK keyboard. (On export models of the IIc, the keyboard switch will be used to alternate between English and second-language key characters.)

Because Apple worries about the powerful IIc cannibalizing IIe sales, it is planning to lower the price of the IIc for the educational market. Apple believes the IIe will still be the computer of choice for the K-12 educational market, even though the IIc is more transportable and has so many built-in features.

Apple said its philosophy behind the IIc is to have a machine that is easy to use and install, is transportable and has excellent software compatibility with the IIe model.

More than 2000 IIc's per day are being manufactured at the Apple plant in Dallas and international models are in



full production at their plant in Cork, Ireland.

Designing A 'Cuddly' IIc

Apple's commitment to improving the aesthetics of their machines can be seen in the new look of the IIc. Apple insisted that their new transportable be what they called the "cuddliest" and "warmest" of any machine they had ever produced.

To meet that goal, Apple hired the German design firm, Frogdesign, the group that designed the Sony Walkman, and asked them to come up with new styling for the IIc. The German design group smoothed out all curves and edges on the IIc to make them conform to human proportions. They also slimmed down the unit and incorporated a series of long, ventilation slots which gives the unit a sense of speed and dynamic motion.

(Continued on page 102)



Engineering chief Peter Quinn holds Apple IIc's only board (above). Robert Gemmill describes vent slots (right). Far right are ports on back and mouse.

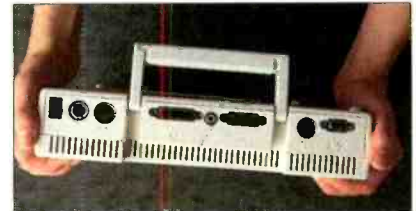
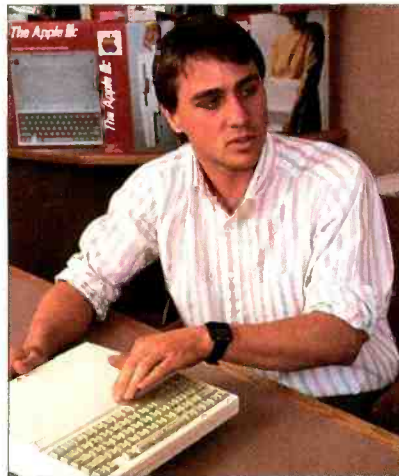

TOM KELLER

WHAT MAKES JUNIOR RUN ?

*A review of the IBM PCjr,
with a particular look at the
electronics of its keyboard.*

BY FORREST M. MIMS III



AFTER a few months of perplexed hesitation, I have become the proud owner of a brand new IBM PCjr. Several factors contributed to my initial concern, primarily the Junior's high price, its toy-like keyboard, and the near-simultaneous arrival of Apple's Macintosh.

So why did I buy a PCjr? As the ads for PC-compatible hardware and software in this and other computer magazines quickly reveal, like it or not, IBM has become the *de facto* standard for high-level personal computers. While not totally compatible with the PC, the PCjr is essentially a scaled-down version of its bigger brother. In short, PCjr gives its owner many of the capabilities of the PC for about half the price.

Another reason why I bought a PCjr is that nearly every detail of the machine's hardware is exceptionally well documented. The computer itself, festooned with more than a dozen external sockets and connectors, is ripe for expansion.

Though Macintosh's Lisa-like design makes for a much friendlier, more approachable machine, Mac was not designed with makers of hardware add-ons in mind. That role is filled for Apple by its best-selling Apple IIe. Indeed, if any comparison can be made between IBM and Apple, it is that IBM makes nothing that compares with Mac. On the other hand, Junior represents a high-level, direct competitor to the Apple IIe.

Forrest M. Mims, III, is a contributing editor to C&E and the author of many books in the computers and electronics field.



IBM PCjr



everyone other than IBM for fully six months before the machine was actually unveiled to the public? The frenzy of media hype culminated in a page-one feature in *The Wall Street Journal*. When Junior was actually shown to the media, however, many in the press expressed dismay over its keyboard and single disk drive.

By now, you have probably read a

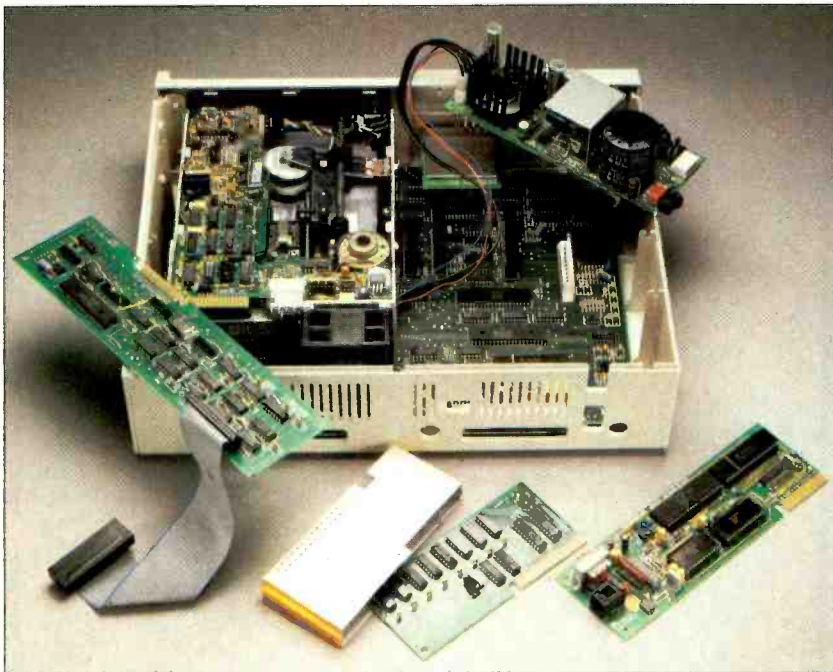

At top, subassemblies are shown installed in internal expansion slots; lower photo shows units before assembly.

The Negatives

Junior is overpriced and it has a few annoying flaws. Its keyboard is a disaster. The machine uses nonstandard connectors. IBM charges an extra \$65 for the DOS diskette and manual, even with the expanded machine with built-in disk drive. And the disk drive will not operate properly if the video monitor is placed on top of the computer where it belongs. As a note supplied with the machine reads: "This problem can be easily solved by moving your [video] display away from the IBM PCjr."

These objections notwithstanding, Junior is a powerful, expandable addition to the PC family. You can be sure that hundreds of thousands of PCjrs will be snapped up by computerists eager to jump onto the IBM bandwagon.

Hands-On Tour

Remember how PCjr was hyped by

good deal about these objections. Significantly, because of the delay between Junior's announcement and its actual availability in stores, most reviews until now have been based upon little or no hands-on experience. With this in mind, let us take a close-up tour of PCjr's hardware.

IBM actually offers two versions of PCjr. The entry-level machine, which retails for \$669, consists of three separate units: a cordless keyboard, an outboard power transformer, and an electronics assembly housed in a cabinet called the *system unit*. Within the system unit is an 8088 microprocessor (the same used in the PC), 64K of RAM, a cassette interface, a complex sound generator, and a versatile video/graphics subsystem.

An enhanced version of the PCjr (the one I purchased) is available for \$1269. This version adds to the entry-level machine a single half-height, double-sided, double-density 5¼" floppy disk drive, a disk drive controller card, and an additional 64K of RAM.

The entry-level system can easily be upgraded to an enhanced system at a later date for about \$620. The machine's built in BASIC programming language can be made more powerful by means of a plug-in ROM called Cartridge BASIC for an additional \$75, and a \$199 modem card can be installed within the computer.

The system unit measures 13.9" × 11.4" × 3.8" and weighs a scant 5.5 lb (8.25 lb with disk drive installed). It is much smaller and lighter than you might expect. Even though it has no handle, you can hold Junior in one hand. Part of the reason for this light weight is IBM's liberal use of plastic. The entire cabinet is made of the stuff, and even the colorful circuit board, which is attached along its back edge to the bottom of the cabinet by four screws, is secured in place by plastic clips.

The major reason why the system unit is so light in weight, however, is that IBM has chosen to make the machine's hefty, almost brick-size power supply a separate entity. Since a press release for the PCjr described the 2.8-lb transformer as a "desktop" unit, one can only speculate as to why IBM did not put it where it belongs: in a slightly larger system unit cabinet.



Internal expansion slots.

As for the existing cabinet, its top can be easily popped off by gently twisting a dime inserted into each of three slots along its back edge. With the top removed, access is provided to the entire circuit board and the connectors for the optional modem, disk drive controller, and 64K of expansion RAM.

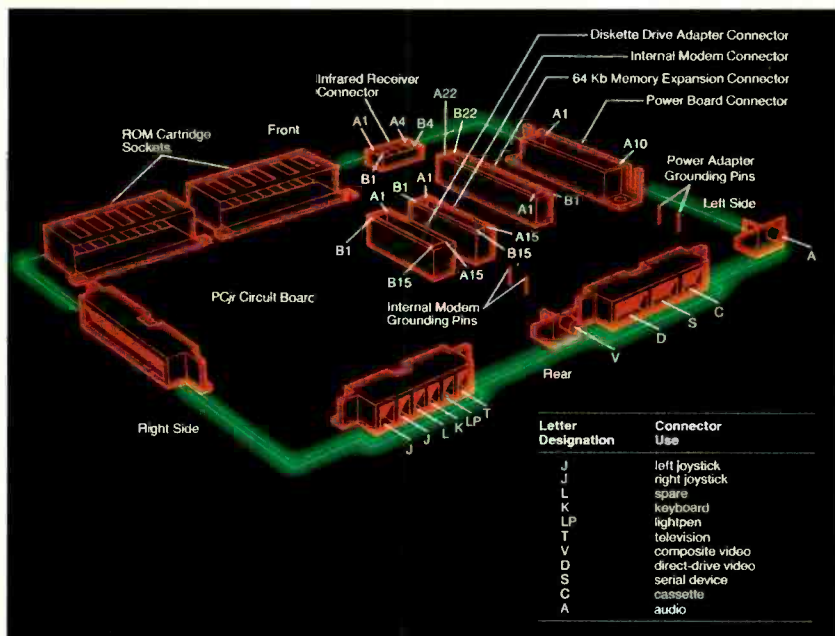

Fig. 1. Expansion and interfacing connectors and sockets.

Junior's plethora of external and internal connectors and sockets is summarized in Fig. 1. All back-panel connectors and the I/O Expansion Connector are Berg-type sockets that are soldered directly to the system unit's pc board by means of wire standoffs. While these sockets save space and are easier for the factory to install than cabinet-mounted connectors, at least two of them present special drawbacks. The serial output connector, for instance, is *not* a standard 25-pin D-type RS-232 socket. To be able to link the PCjr with a printer, plotter, or other standard serial interfaced peripheral, you have to spend \$25 for an IBM adapter cable.

Likewise, the IBM color monitor cable is not compatible with Junior's direct-drive video connector. You'll need a \$20 adapter cable to use your IBM computer with your IBM color monitor!

One thing you will not need is a special cable to use the PCjr with IBM's monochrome monitor, for the simple reason that Junior will not work with that monitor! Curiously, my Junior works fine with a Texas Instruments color monitor and a Zenith monochrome monitor connected by means of a standard phono plug cable.

Don't feel left out of the connector game if you don't own a compatible monitor and want to use a television set instead. You'll need a \$30 connector to use Junior with your TV.

My first reaction to this need for special connectors, one reinforced by the sales staff at the independent dealer from which I bought my Junior, was that IBM is trying to make money by selling adapter cables to hapless PCjr customers. However, now that I have opened my machine and seen first-hand the utter

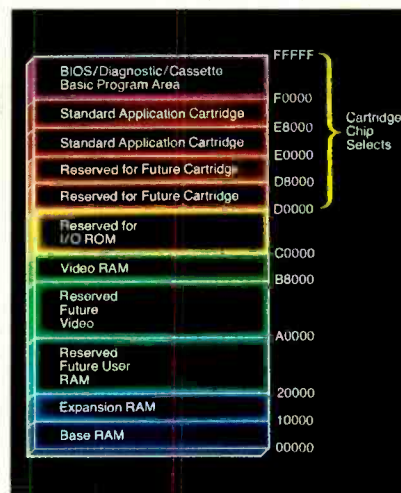

Fig. 2. The memory map.

simplicity of the Berg-type sockets, it seems as though connector choice was governed more by manufacturing considerations than by any effort to make money from adapter sales. In any event, IBM has not enhanced its reputation among users who have had to buy adapters for Junior's nonstandard RS-232 and direct-drive video sockets.

Nonstandard or otherwise, Junior's connectors provide ample access to the system's hardware. Standard features include sockets for a lightpen and two joysticks. The latter two ports are designed to accept analog-type joysticks that contain 100,000-ohm potentiometers. (In a future installment of "The Computer Scientist," a regular column in this magazine, I will give a detailed description of Junior's joystick ports and tell how to use them for other purposes.)

As you can see in the Fig. 2 memory map, IBM has reserved 512K of memory space for "future use." Outside vendors have already begun to take advantage of this by offering memory boards for expanding total system RAM out to 640K, the maximum allowed by the disk operating system. Add-on floppy-disk drives and controllers are also available.

The Cordless Keyboard

Anyone who has complained about Junior's toy-like keyboard has a strong case. Its blocky keys might be just fine for children and first-time computer users, but experienced computerists and touch typists can only wonder why IBM has shortchanged its machine—and its customers—with an inferior keyboard. Did IBM's marketing strategists want to keep the PCjr from competing with the company's PC? Or did their accountants insist on preserving profit margins at all

Keyboard details and, top center, IR transmitter LEDs.

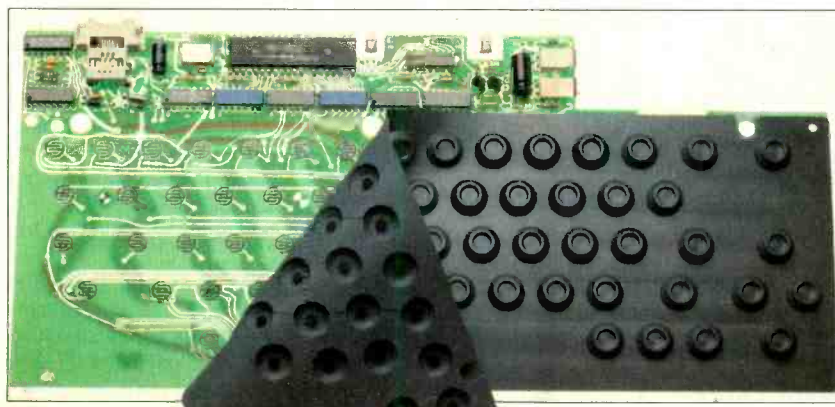

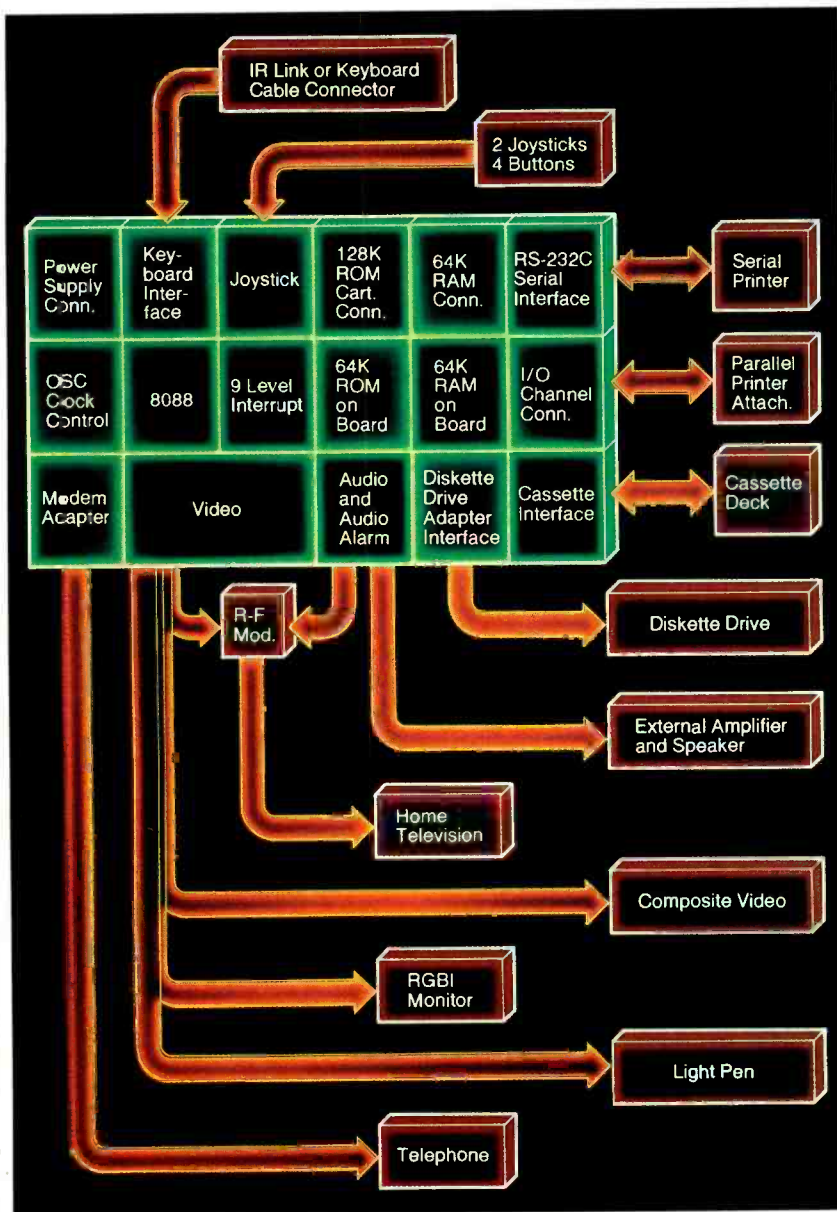

Junior's internal organization and peripheral interfacing.

costs, even to the extent of crippling the product with an inferior keyboard?

If you have not tried out a PCjr, you might be wondering why all this fuss is being made about its keyboard. There are at least three major keyboard deficiencies. First, the keys lack the sculpted design almost universally used even with much less expensive keyboards. Second, the keys are hard to press and feel spongy. Finally, the key legends are placed *above* (or *below*) the keys instead of on the keytops where they belong.

Some criticism has also been directed at the keyboard's light weight (22 oz with battery), its lack of separate function keys and a numeric keypad, and its need for batteries (which are unneces-

sary when the keyboard cord is used).

IBM defends the placement of the key legends by explaining that the keyboard is designed for efficient use with overlays. That explanation does not wash with hunt-and-peck typists, like yours truly, who must be able to see the legends to type 40 words per minute. It is tough to see the legends when they are blocked by your fingers!

My negative feelings about the keyboard were enhanced by the professional appearance and feel of the keyboard included with Coleco's Adam, a much more affordable system brought to market about two months before the PCjr. My son owns an Adam, and we have both concluded that the people at IBM

responsible for the PCjr keyboard could learn valuable lessons in keyboard design and esthetics from the Adam.

Several sales people for independent computer dealers have told me that PCjr's inferior keyboard design has cost them sales. They are probably correct. In fact, I decided to buy my Junior only after learning that professional-quality keyboards were being readied for market by a couple of outside vendors.

Though the human engineering of Junior's keyboard leaves much to be desired (at least it has a programmable "clicker"), its cordless operating mode represents an important step forward. Some reviewers have criticized the infrared link between keyboard and computer as "gimmicky." Apparently, they have not fully analyzed the possibilities an infrared link provides. Of course, the most obvious advantage such a link offers is that the system works without a dangling cord.

Even more interesting is the opportunity to gain access to Junior via the system unit's infrared receiver behind a small aperture on the front panel. One can envision pocket-size instruments that send sequences of prestored keystrokes when a single button is pressed. Other possibilities include wireless telemetry, intruder detection, and remote control.

In short, the keyboard's infrared link, though not its keys, offers the potential for several truly innovative applications. For a detailed explanation of the operation of the infrared link, see the accompanying box.

The Disk Drive

The right front side of Junior's system unit, in the enhanced version, is occupied by the horizontally mounted, half-height floppy-disk drive. Directly below the drive are two slots for removable ROM cartridges (more about these later).

IBM has been criticized for its decision to have the PCjr support only one disk drive, but this objection can be countered in part by the computer's pair of ROM cartridge sockets. After all, plug-in solid-state software modules do not take up RAM space, and they eliminate loading time. This leaves as the major objection to a single-disk system the extra time required to make backup diskettes.

The drive's 360K storage scheme allows PCjr diskettes to be interchanged with the PC and PC-XT. Manufactured by Qume, the drive is only slightly slower than those supplied with the PC and

PC-XT. Along with its controller board, the drive can easily be installed by the user in the driveless starter version of Junior.

At least three companies have announced add-on drives for the Junior. Since the fully expanded Junior lacks the capacity to power an additional drive and controller, these add-on products include self-contained power supplies.

The Cartridge Slots

The cartridge slots partially compensate for the lack of a second drive in the PCjr. Each slot can accept a cartridge with up to 32K bytes of ROM.

Storing programs in cartridges is more difficult, time-consuming, and expensive than storing programs on diskettes. One probable result is a reduction in software pirating, which is exactly why many companies are expected to offer cartridge software for the Junior. In the meantime, however, the variety of cartridge software titles for Junior will be rather scarce.

PCjr's Technical Reference manual includes a complete description of the hardware and software considerations for the cartridge ROM system. One feature every PCjr user should be aware of is the automatic system reset that occurs whenever a cartridge is either plugged in or removed when the computer is operating. Should this occur, *all* data stored in RAM will be irretrievably lost. It is essential, therefore, to save whatever important data is in RAM *before* inserting or removing a ROM cartridge.

You can see how the reset feature works by examining the top side of the edge connector on the Cartridge BASIC ROM. The end of the left-most copper foil conductor, which is one of two of the cartridge's ground connections, forms an L that crosses over the position of the missing adjacent conductor. This L is called the *cartridge reset tab* since it shorts the socket's reset connection to ground whenever a cartridge is inserted into a slot.

The Power Supply

Junior's external power transformer reduces 104-to-127-volt-ac line power to a more manageable 17 volts ac. Junior's power supply card, which is located along the left side, of the system unit, converts the incoming 17 volts ac into direct current by means of a rectifier network and a filter capacitor. Standard voltage regulator chips transform the dc into +5, +12, and -6 volts.

(Continued on page 98)

IBM SOFTWARE FOR THE PC jr

What you can do with the wide range of currently available products for IBM's low-end personal computer

BY JOHN SMITH-RICHARDSON

THE IBM PCjr has generated a great deal of interest in the micro-computer community, and deservedly so. It is a moderately priced computer that can serve the needs of home as well as small business users. Software available from IBM alone spans a broad spectrum of interests. There are arcade games, elementary-level educational software, home/family applications packages for word process-

ing and budget management, and a few products from the IBM PC and XT software collection.

PCjr runs under the PC-DOS Version 2.10 operating system, the same one used for the IBM PC and XT computers; hence, some software written for the PC and XT will also run on the PCjr. What determines which of the PC and XT software packages can be used on the PCjr? It's the PCjr's built in limitations of

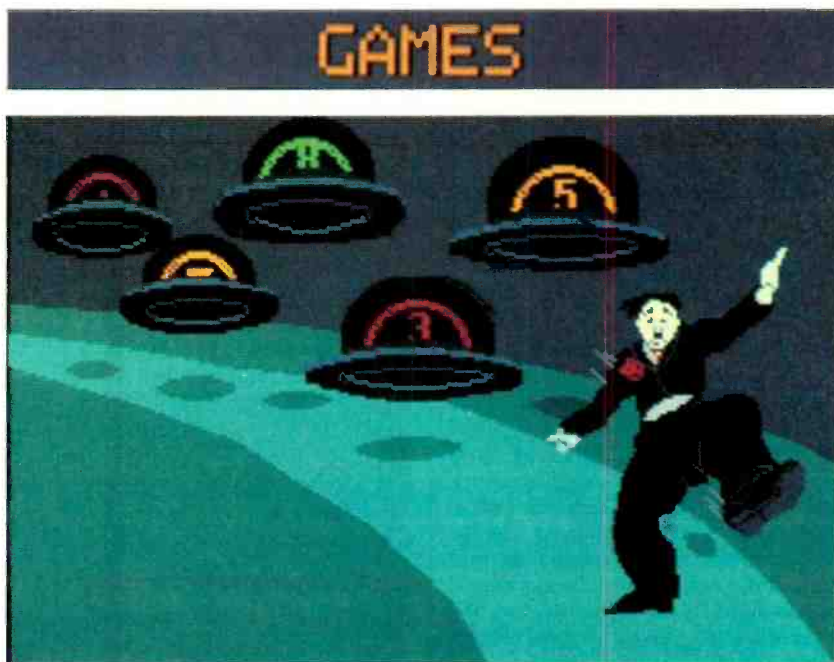

COMPUTER GRAPHIC ILLUSTRATIONS BY LINDA GOTTFRIED
COURTESY OF IN TIME DESIGN STUDIO

Software for PCjr

HOME AND FAMILY



128K RAM and one disk drive. Of the 128K RAM, 16K is used for the PCjr's video display and approximately 24K for PC-DOS, leaving a maximum of 88K for the applications software. Presently, little PC and XT software will run in 88K. (Eventually, add-on products for PCjr should become available to solve this problem.) Using as a base the PC and XT software that will operate, IBM has been able to flesh out a line of software for the PCjr that covers many diverse interests and applications.

Games

The arcade games that we looked at were in cartridge format. The PCjr has two cartridge ports and either can be used. Unlike other computers that utilize cartridges, the PCjr does not have to be powered down before inserting one; it automatically does a reset whenever a cartridge is inserted or removed.

If there is one outstanding quality of the IBM games, it's the spectacular use of color. As a general rule it is bright, eye-catching, and certain to keep the attention of youngsters. The sound effects are excellent, too. While many games have the usual "beep," "boinnng," and "boop" sound effects associated with personal computer arcade games, some have much more sophisticated sounds. ScubaVenture, an undersea treasure hunt, has polyphonic "underwater" sounds that echo and hiss much in the manner we have come to expect from Disney cartoon features.

Unfortunately, the games available for PCjr vary in playing quality and presentation. Some are dull, others exciting. Additionally, the games we reviewed did not even use high-resolution graphics! Characters, animals and other figures were the barest approximations of what they really look like. The graphics are reminiscent of the arcade games of a few years back. Also, joystick control varies from game to game. Some, such as Crossfire, have the almost instantaneous response we expect from arcade games. Others, such as Mouser, have a relatively long joystick delay, which makes much of the game dependent on chance rather than skill.

For users without joysticks, the keyboard control layout can be an important consideration. For example, while Crossfire is an exciting game with joysticks (one of the best action games for any home computer), for the user without joysticks its keyboard control layout

MineShaft graphics are not high resolution.

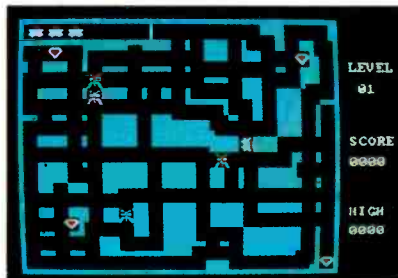

defies logic in that it does not employ what is the almost universal "diamond"-key pattern for *up*, *down*, *left*, *right*. You reach for a *down* key where you expect it to be and it's not there.

Essentially, there is no consistency of quality among the PCjr games although all make exciting use of color. And speaking of color, PCjr offers users some help in adjusting the colors on their displays.

When the computer is first turned on, it goes through a 9-second start-up procedure that checks RAM and displays the IBM logo. Below the logo, across the bottom of the screen, are 16 color bars used for adjusting the color and tint controls of the associated TV monitor—which is generally an ordinary color TV set. (If a black and white TV or monochrome monitor is used, the color bars provide a grey scale for adjustment of the contrast and brightness controls.) If the start-up logo "times out" before the color adjustments are optimized, it can be recycled by turning the main power switch off and then on again. Since much of an arcade game's excitement and interest is derived from the color display (it's pretty dull in black and white, worse in green-screen), an extra recycle or two is worthwhile to insure optimum color.

Educational Software

The educational software from IBM is disk-based, but the programs we obtained also required that the optional cartridge BASIC—an enhancement to the built-in ROM BASIC—be plugged in at the same time. If the cartridge is not installed, a screen prompt reminds the user it is required.

In general, the quality of educational software available for *all* personal computers varies greatly. Some are very good—consistent with grade-level school concepts. Others are nothing more than games that use explosions of color and sound in an attempt to create an excitement that isn't really there.

Advancing through the castle of Adventures in Math.



Worse, some of the educational software for preschoolers requires at least an eighth grade reading level just to follow the instructions! As one might expect, educational software from IBM corresponds to what's generally available in the marketplace.

For the Bumble software, IBM rates an A+. The Bumble Games (ages 4-11), which teach graphic skills, and Bumble Plot (ages 8-13), which develops geometric skills, conform closely to grade-level instruction in the elementary schools. The use of concepts, color, and sound effects is first rate; especially the sound effects, which are complex but not overwhelming.

On the other hand, the Juggles' Butterfly software, which teaches reading and math readiness skills (ages 3-6) has somewhat of a Sesame Street approach: jumpy, erratic visuals and bing-bong sound effects from the era of "pong" games. Unfortunately, the software requires a reading skill greater than the age group for which the visual material is intended. Furthermore, for a good part of the action there are no screen instructions at all! Finally, the software is supplied with a chintze paper keyboard overlay that's folded into the packaging. Unfolded, it doesn't lie flat, gets in the way of the fingers when keying, and tends to tear easily. Worse, there are two keyboard overlay paper strips that the user must cut out with scissors! Considering the cost of the package, the user should not be required to cut strips of paper.

What's surprising about the difference in quality between the Bumbles and Juggles software is they both originate from the same source—The Learning Company.

Two educational programs for which there is no indication of the original publisher are Monster Math and Adventures In Math, and once again we have the good and the not-so-good. Though neither package is age-rated, they appear to fit somewhere in the 8-11 age group.

HomeWord uses icons to select WP functions.

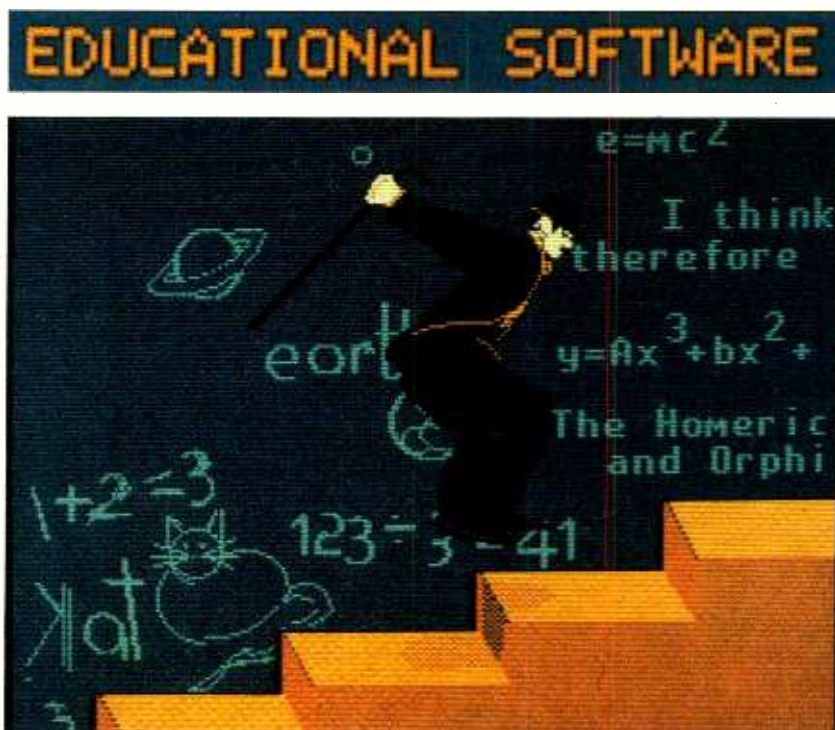
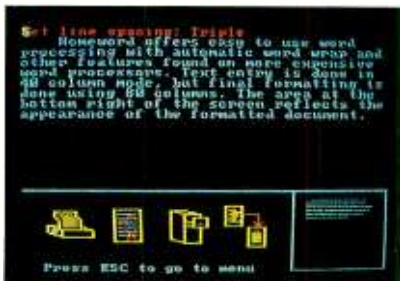

Monster Math has very good medium-resolution graphics and conventional "beep-boop" musical sound effects for six levels of skill involving the four functions of addition, subtraction, multiplication and division. It's the usual material available for just about every home computer. Adventures in Math is a different story. Using absolutely superb graphics and better than average sound effects, it integrates four-function (+, -, *, /) arithmetic with a lively adventure game. The math problems are presented in a somewhat unusual and challenging manner, and even the adults who used the program had a lot of fun with it. This one can really raise the sweat on a student's brow.

Home/Family Software

In the home/family software area, we examined HomeWord (word processing), and Home Budget Jr. (budget management), both of which appear to be in the same performance/price range as the computer itself. Both are also most likely representative of the level of software that will be developed for the PCjr by IBM and third-party vendors.

HomeWord, from Sierra On-Line, Inc., is a self-contained disk package (the BASIC cartridge isn't required). It is in many ways what one would expect of high-performance software intended for home use, primarily in the area of documentation. Most professional software packages include pounds of documenta-

tion, the heavier the better. While it is one thing for people who earn their living with word processors to spend weeks learning the intricacies detailed in 350 pages of documentation, home users rarely have the time, patience, or inclination to fight through pounds of documentation or remember an endless number of control codes.

HomeWord neatly sidesteps the excess documentation problem by using icons for the various word processing functions. Icons are small on-screen pictographs representing the various program functions: A file cabinet denotes a *file*, a printer means *print*, etc. The functions can be selected simply by positioning the cursor on the desired icon and pressing ENTER. If sub-menus are necessary, a new group of icons appears. The icon sub-menu selection is repeated until the desired function is attained. Through icon selection it's possible to use HomeWord with only a cursory reading of the documentation, which is only 70 pages to begin with.

HomeWord's functions can also be accessed through the keyboard. An experienced user who finds the icons distracting can simply turn them off and access all functions by pressing the appropriate key(s).

A keyboard overlay defining the function codes simplifies use of HomeWord,

J. Smith-Richardson is a free-lance author on computers and electronics.

WHY PAY MORE?

BUY AT DEALER PRICES

30 DAY SATISFACTION GUARANTEE

(ALL ITEMS 100% APPLE & FRANKLIN COMPATIBLE)



ZEUS 2001 — \$999.00 NOW \$549⁰⁰

ZEUS 3005 (Detachable Keyboard) \$599⁰⁰

APPLE + CP/M + 64K

- * 8 Expansion Slots
- * 89 Function Keys
- * Numeric Key Pad
- * Color Graphics
- * Auto Repeat Keys
- * Built-in Cooling Fan
- * Expandable To 128K
- * Break + Pause Keys
- * Runs Apple and CP/M Software



DISK DRIVE* — \$275.00 NOW \$169⁰⁰

- * 35 Track SS-DD
- * Shugart Mechanism
- * Caset + Reliable
- * 90 Day Warranty

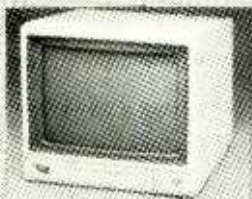

YANJEN MONITOR — \$179.00 NOW \$119⁰⁰

- * 20 MHZ
- * Amber or Green
- * 1,000 Lines At Center
- * Super High Resolution

ACCESSORIES

(100% COMPATIBLE TO APPLE AND FRANKLIN)

	WAS	NOW
1. Disk Drive Interface Card	\$159.00	\$ 59.00
2. TEAC Slimline Disk Drive	\$285.00	\$219.00
3. Z-80 CP/M Softcard	\$199.00	\$ 79.00
4. 80 Column Card	\$299.00	\$ 99.00
5. 16K RAM Card	\$159.00	\$ 59.00
6. 128K RAM Card	\$499.00	\$199.00
7. RS-232 Serial Interface	\$169.00	\$ 79.00
8. Integer Card	\$149.00	\$ 49.00
9. Communication Card	\$149.00	\$ 79.00
10. Parallel Printer Interface	\$159.00	\$ 49.00
11. 16K To 64K Buffer Printerface	\$289.00	\$139.00
12. Epson Printer Card	\$149.00	\$ 34.00
13. Prowriter Printer	\$595.00	\$389.00
14. Super 5 Printer	\$499.00	\$299.00
15. T.V. Interface	\$ 35.00	\$ 15.00
16. Modem Apple Cat II (with S.W.)	\$369.00	\$249.00

works or runs on ours

DISCOUNT COMPUTERS

3500 S. Orange Ave., Suite #102
Orlando, Fla. 32806

(305) 425-7770

Ask About Our \$3.00 Phone Credit

IBM Software

but once again it's a paper overlay that interferes with the keys because it doesn't lie flat. The overlay should consist of two separate pieces of rigid plastic—the same kind of material used by third-party vendors who provide plastic overlays for the PC and XT. (The paper overlay isn't going to last long; ours was cracking in the center after only three uses.)

The whole concept of HomeWord is intriguing: A relatively high-performance word processor capable of being used in the home by older children (ages 11 and up should have no difficulty with it) without the need for tutorials or hours of training, yet suitable for some business applications. While HomeWord is no WordStar, it is doubtful whether anyone ever sat down to WordStar and created a brand-new document in 15 minutes.

Home Budget, Jr, a scaled-down version of the PC and XT Home Budget software package, attempts to do the same thing as HomeWord; but, for many potential users, it may miss the mark. The program, which is disk-based, also requires the BASIC cartridge. It provides for 47 separate accounts and 4000 entries, and will keep running totals, classifications for taxes, and the usual kind of information generally associated with a check file. But the problem is that it is not as flexible as a check file. Only one word can be used to describe an account ("Sales Tax") is not permitted, it must be "Salestax"), charge account entries cannot be broken down conveniently, and much information retrieval is slower than using a record book you can get free at an H&R Block tax service center.

Typical of data files written in BASIC, it runs slowly. Also, the program is menu driven; one menu flows into a sub-menu, which flows into yet another sub-menu, etc. This makes it easy to use, but it's a slow process. Storing records in a record book or on file cards is faster in many instances, even with calculations done by hand using a pocket calculator.

Essentially, Home Budget, Jr is representative of "budget managers" for other, much less expensive home computers. It does not fit into the PCjr's overall concept of high-quality software for a high-performance home computer that is fundamentally compatible with the PC and XT, and which Mom, Pop and the older children might use on the job and in school.

Finally, we come to the regular disk-based PC and XT software that runs more or less normally on the PCjr. There is Multiplan, VisiCalc, PFS:File,

PFS:Report, Time Manager, and others. Though we didn't test all of these, there's no reason they shouldn't run as expected, other than for the inconvenience of having one disk drive instead of two and possibly a 40-column screen (TV set). If a monochrome monitor is available, the software can be configured for 80 columns. For business software the loss of color is more than offset by the convenience of an 80-character display, particularly when using a modem to access a database or information provider such as The Source.

One of the "serious" programs we tried out was the disk-based Personal Communications Manager, a communications package specifically intended for information access and electronic mail. When used with the PCjr's internal modem, it provides for auto-dial and auto-answer. Set-up and operation are menu driven. After set-up, the package can be used with only rare attention to the documentation.

About the only technical problem we ran across was that the software dropped the first two incoming characters when autodialing an information provider through Uninet. Unfortunately, the loss of the first two characters resulted in a clean screen; and, so far as we knew, the software or the modem wasn't working. It took a while before we realized there was no difficulty with the modem's connection.

Documentation

Just as the quality of PCjr software is inconsistent, so is the quality of the documentation. For Bumble and HomeWord, it is excellent. But for some of the others, there are serious problems. Documentation for game and educational software is too light and stretched out. By the time one wades through all the fluff, the point of the documentation is lost.

Business applications documentation is long and drawn out. It often gets down to the most insignificant details concerning a self-evident function, and then "bails out" on a primary set-up procedure by either not showing even one single example, or referencing another chapter in the book.

Admittedly, whatever strengths and shortcomings there are in the PCjr's software and documentation are echoed throughout the industry. But we expect more from IBM. Obviously, the Bumble and HomeWord software proves we can expect more from the PCjr and get more. In our opinion, there just isn't enough

(Continued on page 101)

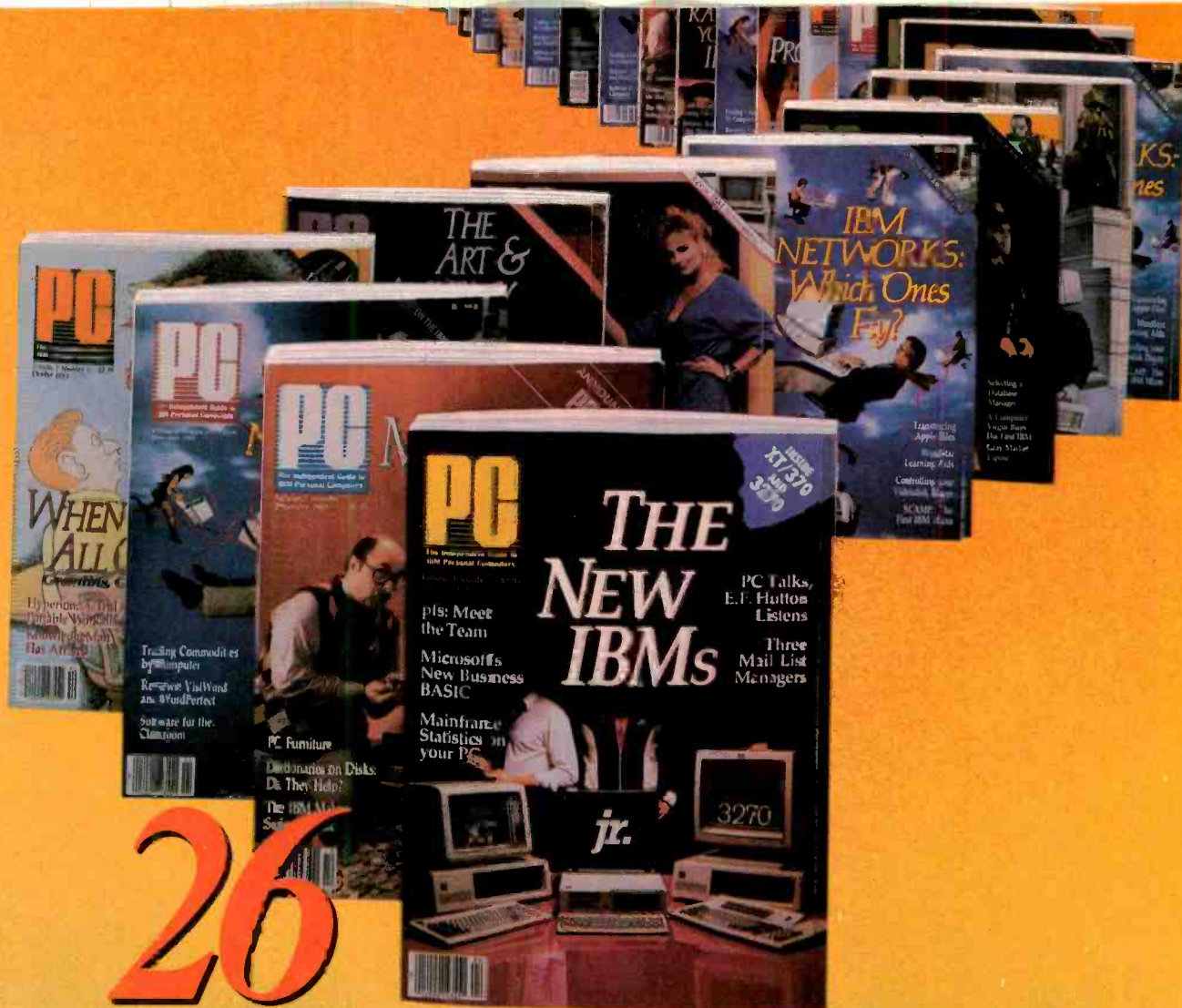

26

REASONS TO SUBSCRIBE TO

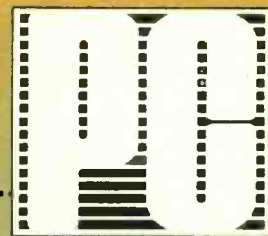

Your subscription will bring you 26 big issues every year of the most up-to-date facts and technological breakthroughs that affect you and your IBM or compatible personal computer. 26 big issues of *PC* delivered to your door AT UNBELIEVABLE SAVINGS!

Every other week you'll get a library of professional insights including latest coverage of newly-released hardware and peripherals. You'll find timely information on innovations in programming, applications and networking. You'll communicate with professionals and peers like yourself and get reviews of new software packages, some before they even hit the shelves.

You can subscribe to *PC*, The Independent Guide To IBM Personal Computers for as little as \$1.02 an issue! Use the attached card or coupon at right TO SUBSCRIBE TODAY!

GET THE MOST UP-TO-DATE INFORMATION FOR YOU AND YOUR PC WITH *PC*, 26 TIMES A YEAR!

26 SUBSCRIBE TO

26

P.O. BOX 2443 • BOULDER, CO 80322

YES, Please enter my subscription to *PC* for:

26 issues (one year) for only \$29.97...**LESS THAN \$1.16 A COPY!**

52 issues for only \$52.97...**LESS THAN \$1.02 A COPY!**

Full one-year subscription price \$34.97. Single copy price \$2.50.

Mr./Mrs./Ms. _____ please print name in full

Company _____ PC BH872

Address _____

City _____ State _____ Zip _____

Check one: Payment enclosed Bill me later

Charge my: American Express Visa MasterCard

Card No. _____ Exp. Date _____

Add \$52 a year for postage to Canada and all other foreign countries. Please allow 30 to 60 days for delivery of first issue.

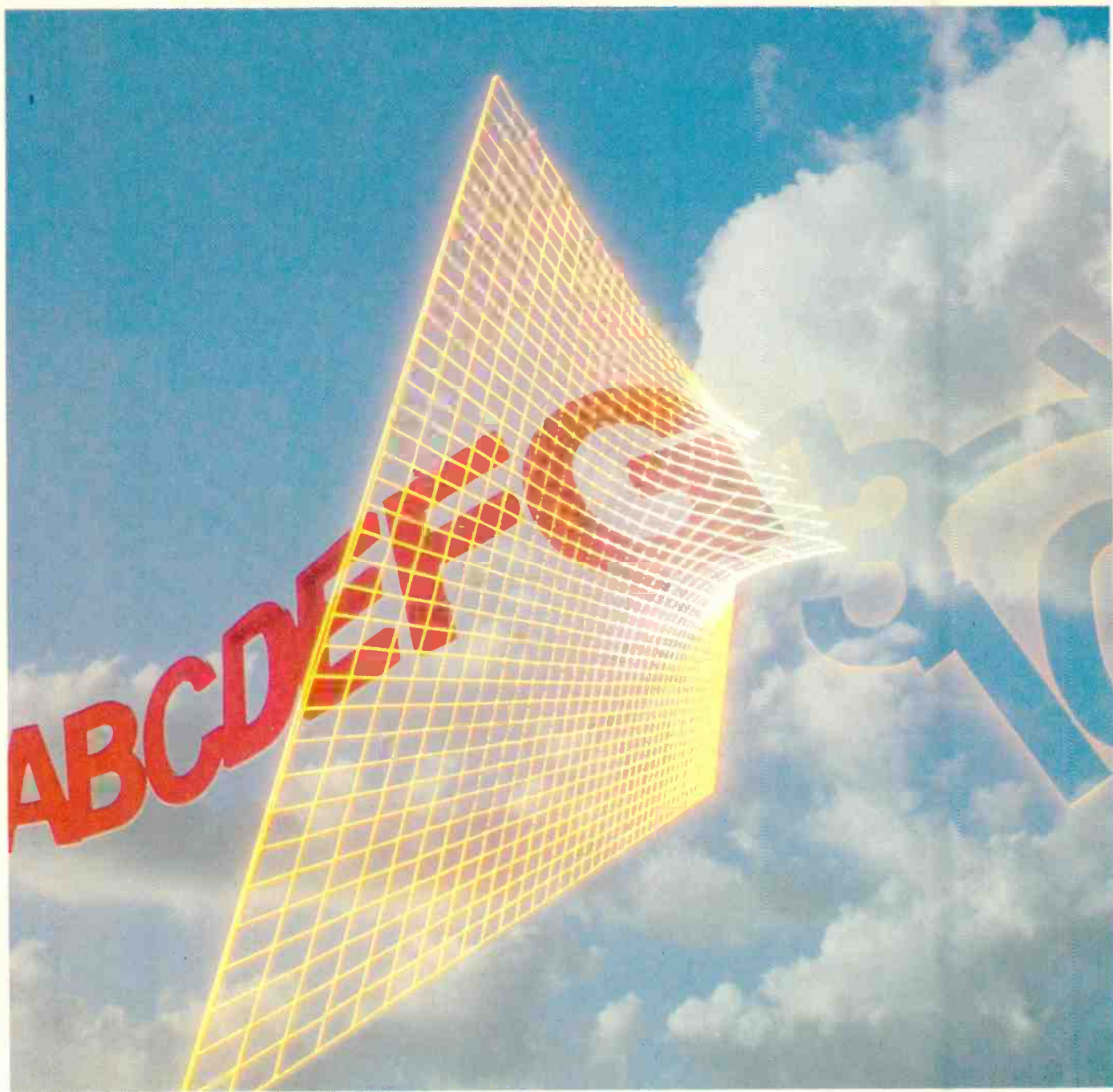

ENCRYPTION

Encoding locks your data away from anyone not possessing the key

BY CARL NICOLAI

CRYPTOGRAPHY—the use of codes and cyphers to protect information from prying eyes—has always been considered a “black art” ranking with alchemy, astrology, and witchcraft. Early scientists used codes and cyphers to protect their secrets, and “crypto” was a tool of smugglers, spies, and governments. Empires have been won or lost as successful codes have been

used and unsuccessful ones broken. After years of being held “top secret” by the government, cryptography is moving rapidly out of the closet and into the business world. The code books, cypher wheels and clanking machines of World War II crypto have now been replaced by the silent electronic boxes of the computer revolution.

As stacks of paper are turned into

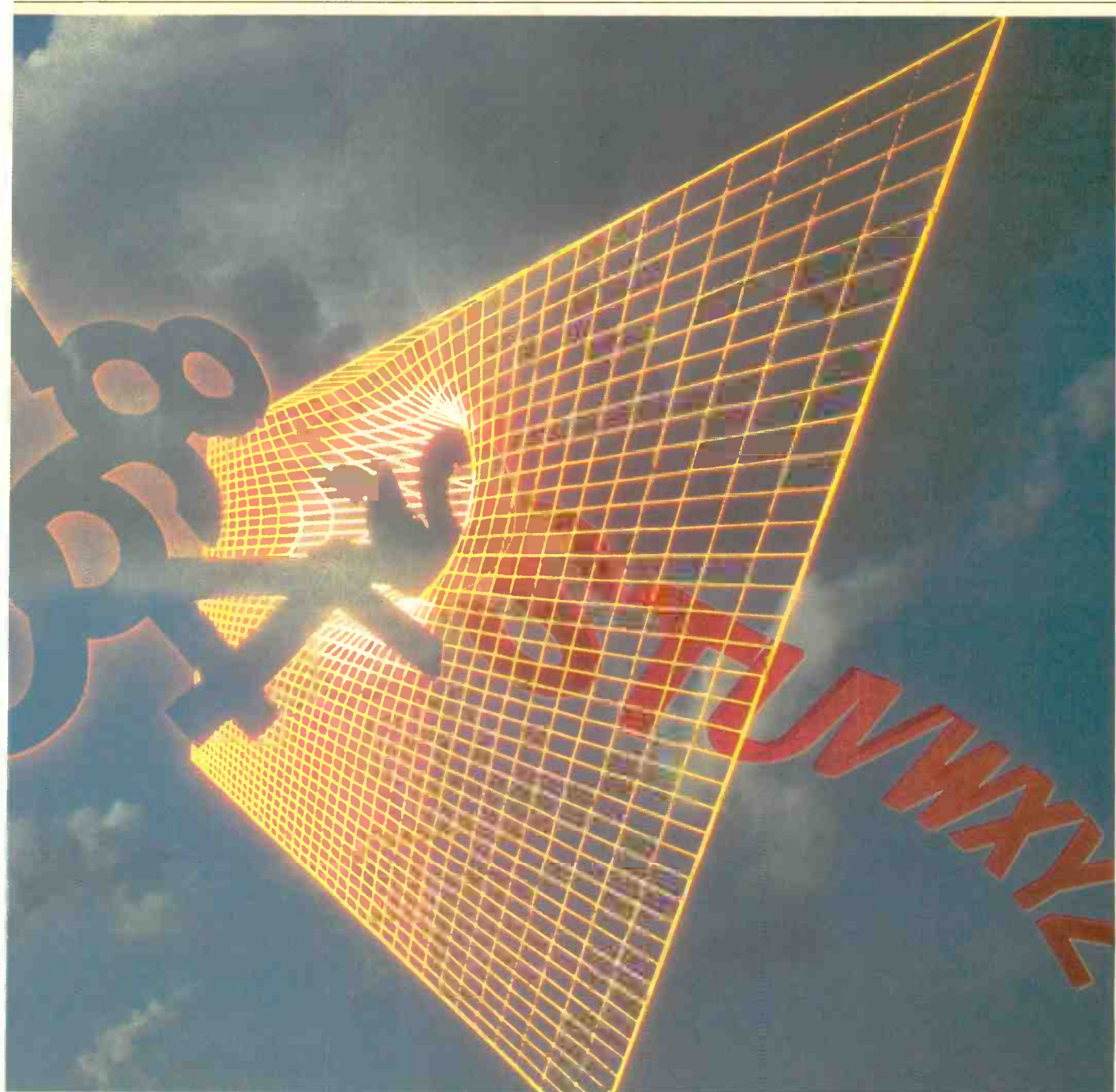

DECYPHERED

streams of electrons, the protection of information located in computers and transmitted electronically becomes increasingly important. As more people acquire computers and the modems used to communicate between them, that in-

Carl Nicolai is president of Cryptext Corporation and the inventor of non-deterministic cryptography.

formation becomes harder to protect. It has always been easy for computer wizards and "hackers" to break into computers. Today there are more of them, some just "having fun" breaking into a system, some with the intent to steal or modify data for profit.

It is estimated that by 1992 there will be 24.4-million personal computers used by businesses in this country. Many en-

gineering firms already have two computers or computer terminals per user.

Although corporate vice presidents once shunned working at terminals, now they cannot function without them. It's often more efficient for an executive to compose his own correspondence on a word processor than it is for him to dictate to a secretary.

Along with the widespread use of

Encryption Decyphered

computers comes the threat of unauthorized interception of vital corporate and personal data. This is a particular concern when information about someone else is being used, transmitted, or stored. A lawyer, for example, would be as legally negligent for the interception of private data should he not protect it as he would be if he were to leave his office and his file cabinets unlocked. This legal responsibility for personal data extends to doctors, insurance companies, police departments, and indeed to anyone who compiles and stores confidential information about another person with the assistance of a computer.

Consider the example of an attorney who is handling a case away from his home office. He finds that he is missing a critical piece of confidential information needed to finish the task. Before the days of computers, he would have retained a

hand courier to bring him the required papers. Today he can transport the information to his remote location by using a terminal and accessing a database on his office computer. But without encryption that information can be easily intercepted.

Encryption allows him to use a briefcase-size microcomputer to download the critical information in coded form from his office computer to his out-of-town location. He then supplies the key to the decryption system in his briefcase terminal, and has the documents in hand without having risked a breach of the confidentiality of the file.

The mail is another area in which encryption will be increasingly used. Today there are over 100,000 people who have access to an electronic mail system. As conventional paper mail costs increase and handling efficiencies de-

crease, people—and particularly businesses—will shift to electronic mail. Since people have always been concerned about the privacy of their mail, encryption is certain to be used to protect it from unauthorized tampering.

Banks now use electronic funds transfer (EFT) to move large amounts of currency from one branch or account to another. And EFT is not only being used by banks, but also by point-of-sale terminals and automatic pay systems. Just as the pay envelope containing cash has now been replaced by the paycheck, in the near future the paycheck itself will no longer be used and wages will be automatically credited to your bank account. This cannot be accomplished with any degree of security without the use of encryption.

Optical character readers (OCRs) and bar-code readers are rapidly converting all written literature to electronic "data banks" that can be used by anyone with a terminal or microcomputer and a modem. Here, too, security is a necessity.

There is a growing concern today among programmers that the law will not, or cannot, protect their programs from theft. Every time someone invents a method to protect a disk from being copied some equally clever person markets a product for copying it.

It is possible to build a computer with a physically sealed microprocessor and ROM in it. If this is done, programs can be stored on a disk in encrypted form, then decrypted and run within this sealed environment. This method of program protection allows a user to make as many backup copies of his program as he likes, but to run them only on the sealed and electronically-serial-numbered computer.

Video discs have made it feasible to store billions of bits of information on a single medium. There is no reason why such a storage system cannot contain thousands of programs. You could buy the basic disk for a few dollars, and then use only the programs you wanted by phoning in your Visa or MasterCard number and receiving the key to decrypt the desired programs. (A scheme similar to this is already used for some floppy-disk-based software.) In fact, cable TV could be used to constantly circulate millions of computer programs or other types of information constantly, to be accessed by an authorized user by entering a key to decrypt them.

Sometimes it is desirable to release large amounts of information simultaneously to many people. The information could be sent in encoded form over a

Double encryption uses two different methods for encyphermment.

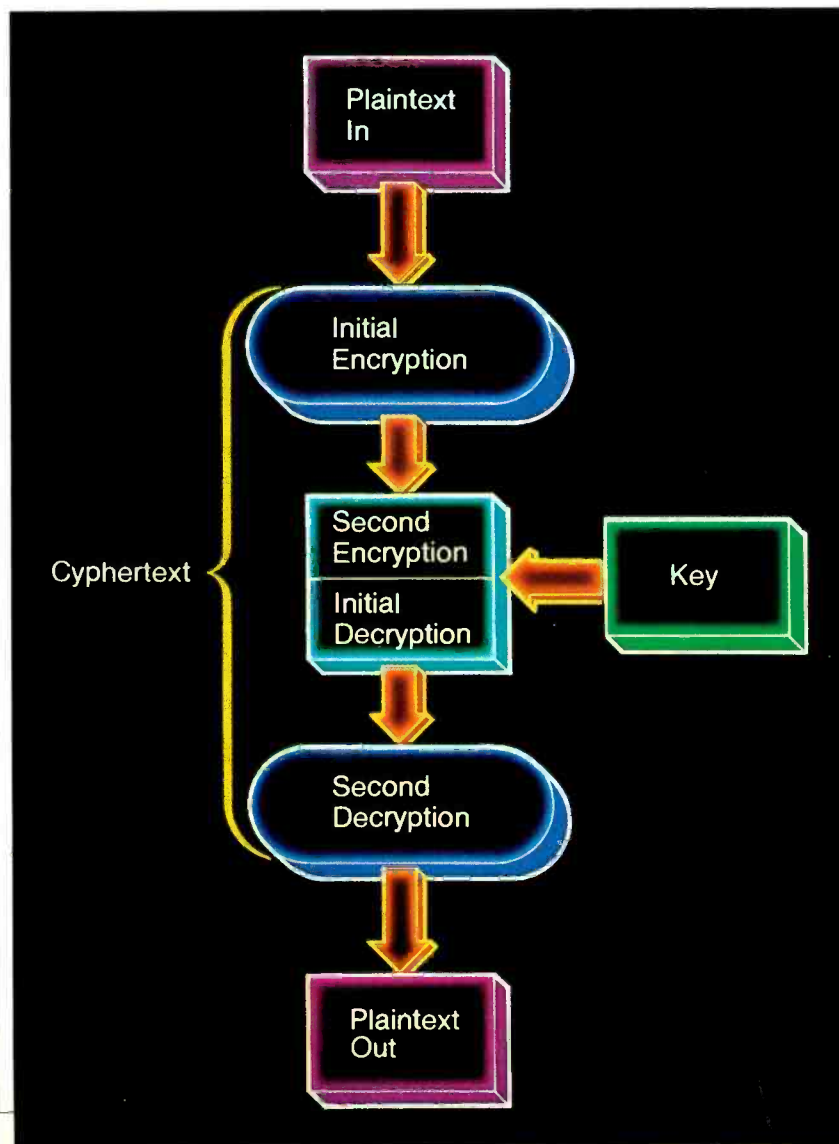

period of several weeks by a variety of methods, and then at the proper moment the key needed to decrypt it could be issued.

Recently there has been a lot written about how multinational companies and countries interrelate. Companies in allied countries and, even our own corporations, often commit industrial espionage against one another in the usual course of business.

The USSR can be considered as a country whose interests and philosophies are essentially opposed to ours. From a business standpoint, however, the Soviet Union is one huge corporation whose methods of doing business have little restriction on the use of dirty tricks against the competition. These people are obviously "bad guys" against whom we have to protect ourselves. In another sense, though, they are merely another company trying to find out information about the competition.

Whoever our business—or political

Cryptography is moving rapidly out of the closet and into the business world

—competitors are, it is necessary for us to protect our secrets from them. Encryption of sensitive information can provide at least a partial solution to the problem.

Satellite communications, while providing fantastic capabilities for transmitting information, has also opened the way for various forms of information abuse. This abuse can be committed by other companies, one's own government, or criminals trying to subvert the system for illicit profits. The use of encryption can prevent the abuses of modern communications technology from disrupting normal business activity.

There has been a real need for data and computer security for several years but many businessmen do not yet perceive this, and so are wide open when it comes to protecting their data. Any company whose computer has an auto-answer modem has left its secrets open to thousands of "hackers" with micro-computers. The recent arrest by the FBI of several high school students for electronic "breaking-and-entering" further underscores the need for security.

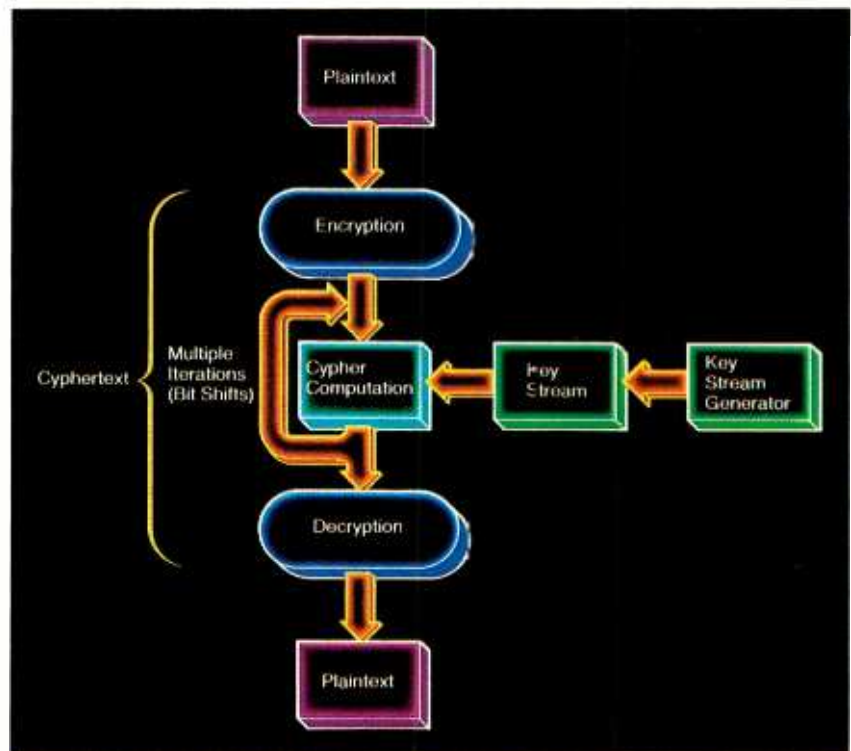

Recirculating block cypher adds security to the DES.

Electronic Security

Today there are several systems that can be used to prevent unauthorized access to information stored in, or transmitted by, computer.

The first is *password protection*. Passwords are used to identify a particular user. The trouble comes when the password is found experimentally or falls into the wrong hands. A determined "hacker" can find or create a "back door" to allow himself continuing access to a computer, and sometimes only complete modification of that computer's operating system can close the loophole.

The second method is the *dial-back modem*. This device answers the phone, identifies the user and then hangs up and calls him back. The chief problem is that the user must call from a known phone number, thus restricting his mobility.

The third system is to use *encryption*. When used for access control, only someone who has the same encrypting/decrypting equipment and the same key can have access to the computer. Encryption also ensures that a telephone tapper (listening to a communications satellite will qualify you these days) receives only a meaningless jumble of characters. When encryption is used to protect files within a computer system those files can be made safe against even the efforts of the company's own programmers.

There are many problems that face the

potential user of encryption. Foremost is the cost of the equipment. It's hard to justify protecting a terminal that has access to a computer when the cost of the protection device is more than that of the terminal itself. Crypto, to be widely used, must be low cost, and to be low cost many units have to be manufactured. This chicken-and-egg problem will only be resolved when the demand for products increases substantially.

Cryptography

Probably the greatest problem that faces the potential user is that the field of cryptography is extremely complicated. Terms like "affine," "primitive polynomial," and "NP complete," confront the novice. Many times manufacturers of cryptographic systems use "specmanship" (one-upping the competition by presenting what appear to be better specifications) and further confuse the issue. This problem is further compounded by the lack of adequate definitions for crypto systems.

Let's start out by describing the most modern systems. There exist two primary types of crypto systems today: **single key** (sometimes called **private key**) systems, and **two key** (sometimes called **public key**) systems.

In a single-key system, the same key is used to encrypt and decrypt the information. A two-key system uses different keys for encryption and decryption.

(Continued on page 90)

COMPUTER SECURITY IN THE MICRO AGE

The widespread use of personal computers exposes corporations to a new set of risks

BY LARRY DEITZ

THE proliferation of personal computers in the 1980s has impacted almost all large businesses, some small businesses, and—according to Software Access International, Inc., of Mountain View, CA—about 11% of U.S. households. As a consequence, the availability of computer power has become a fact of American business life. Terminals, mainframes, minicomputers and microcomputers are considered as much a part of the office environment as the telephone and the typewriter.

For the most part, personal computers have been viewed as productivity tools—a way for people to do their jobs better, faster, and more accurately. Businesses have responded to personal computers in a big way. Fortune 500 companies are projected to account for the majority of small computer purchases over the next three to five years. Small business is also moving to computerize, with some industries approaching it faster than others. The end result is that

Lawrence Dietz is president of The Alec Group, specializing in microcomputer security and vertical market analysis.

more corporate information is being kept in electronic form than ever before.

Along with increased reliance on data stored in computers comes an increased risk of that data being damaged, lost, or—worse—stolen. There are two major classes of threats to computer resources: intentional and unintentional. Unintentional hazards include accidental erasure of data, data-entry mistakes, and damage resulting from weather and other acts of God.

Intentional ones can be as simple as having data looked at by someone not authorized to do so. More serious are such things as a bank employee's taking "just a little bit" from a number of accounts (called "salami slicing" in computer crime jargon).

Harm can come from any number of sources. Current or former employees may have something to gain by tampering with the company computer(s). The motivations behind these activities can include embezzlement, use of computer facilities for private business, and/or revenge by disgruntled employees.

Confidential or proprietary information is confidential no matter where it is



Computer Security

stored. If a word processor has confidential memos typed on it, then certain safeguards such as passwords, encryption, media labeling, physical segregation, or other means should be employed to safeguard that information. Confidential information must also be protected in personal computers, mainframes, minicomputers, and office files. It is the nature of the information that dictates the level of protection, not the location.

Each business has to assess its own vulnerabilities and the nature of its personnel. Dishonesty is not limited to any particular size company, or any individual industry. Anybody can get hurt. Just as most companies would never leave the front door to the office unlocked during the Christmas vacation, they should also never leave the door to the computer's memory ajar.

In this article we'll point out some key areas of concern in the realm of microcomputer security, and bring to your attention some products that try to meet these challenges.

Beware

In many cases, management is still trying to figure out what to do with its new personal computers. There is the feeling that these devices can help in different areas, and most companies are less than three years into integrating small computers into their information universe. Consequently, line management is more concerned with results than with security. As more instances of computer misuse and abuse are made public, the awareness level of such problems will rise. But *now* is the time to wise up!

Corporate management must use reasonable means to safeguard its assets, and information is one such asset. Consequently, managers will have to devote more effort to protecting information. Potential litigation concerning such things as loss of data, illegal copying, inaccurate figures, and privileged information that shows up where it is not supposed to will force managers to institute safeguarding measures.

The courts will look to the value of the assets involved, the gravity of the loss or damage or improper disclosure, the likelihood of such incidents recurring, and what measures might have been taken to prevent them from ever having taken place and their cost.

While each case will turn on its own facts, the fiduciary responsibilities placed on managers include the safeguarding of information, electronic or otherwise.

Information Integrity

One of the most important, yet least understood, hazards arising in the use of personal computers concerns data integrity during uploading and downloading. One form of *uploading* is the transfer of data from a small computer—such as one located in a branch sales office—to a large one such as the mainframe at corporate headquarters. *Downloading* is the reverse: the transfer of information from a mainframe to a smaller unit.

(Continued on page 101)

COMPUTER SECURITY SOURCES

HERE'S a listing of just a few of the hardware and software systems on the market that can make your programs and data more secure. Write to the manufacturers at the addresses shown.

Encryption

The Encryptor: High-speed DES boards for IBM PC, Apple, and S-100 CP/M computers. **Jones Futurex**, 9700 Fair Oaks Blvd., Suite G, Fair Oaks, CA 95628. \$250-400.

Microslave: Plug-in board for IBM PC (also available as Transcryptor in outboard configuration) using RSA, DES and proprietary algorithms. **Cryptext Corp.**, PO Box 425, Northgate Station, Seattle, WA 98125. \$658-945.

The Protector: Hardware and software for IBM PC, S-100 CP/M systems, and in outboard configuration, using RSA and other algorithms. **Merritt Software, Inc.**, PO Box 1504, Fayetteville, AR 72702. \$175-\$2000.

μPSYPHER: Software DES encryption for CP/M, MP/M, and MS-DOS (PC-DOS) systems, and for the Wang PC. **Prime Factors**, 6529 Telegraph Ave., Oakland, CA 94609. \$100 (CP/M and MP/M); all others \$150.

Disk Protection

CopyLock: Disk duplication equipment offering protection of programs for the IBM PC, TRS-80 and other computers. System works by putting a "fingerprint" on disks. Software is useless unless fingerprint is found. Systems start at \$12,000. **Formaster**, 1983 Concourse Dr., San Jose, CA 95131.

Data-Lock: Password file protection for CP/M program or data files. **Southern Computer Systems, Inc.**, 2304 12th Ave. North, Birmingham, AL 35234. \$95.

The Key: Hardware for IBM PC and others that sends a software-verifiable key from keyboard to computer. Protected software won't run unless key is received. **Staff Computer Technology Corp.**, 10457 Roselle St., Suite J, San Diego, CA 92121. \$60 (in OEM quantities of 100).

Data Reclamation

dataCURE: Software for CP/M-80 systems permits reclamation of data lost because of physical or electrical damage

(disk must be protected *before* damage occurs). **Colorado Online**, 50 Balfour Lane, Ramsey, NJ 07446. \$99 (\$109 for 5¼" formats).

Disk Doctor: Software for CP/M-80 and CP/M-86 for salvaging data from damaged disks. **Supersoft, Inc.**, PO Box 1628, Champaign, IL 61820. \$100.

Norton Utilities: Includes routines for IBM PC and PCjr to recover erased files and scrambled data and to recover from damaged disks. **Peter Norton**, 2210 Wilshire Blvd., #186, Santa Monica, CA 90403. \$80.

Disk Backup

BackRest: Hard-disk backup program for CP/M-80, TurboDOS, CP/M-86, and MS-DOS (PC-DOS). Multi-user versions available. **StoK Software, Inc.**, 17 W. 17th St., New York, NY 10011. \$99.95.

FileDriver: Hard-disk backup utility for CP/M-80, MP/M, and TurboDOS. **Dunbar-Ridge Corp.**, Software Publishers, 102 Sterling Ct., Syosset, NY 11791. \$85 (\$90 for 5¼" formats).

In addition to the above, you should also investigate areas such as power-line conditioners, anti-static mats and sprays, anti-theft devices for computers, and special insurance that is available. ◇

IS YOUR COLOR FADING AWAY?

ADD MORE COLOR TO YOUR COLOR COMPUTER WITH



Have you been looking for the magazine to make your Color Computer more colorful... versatile and fun?! It's here... in full color... with bright new ideas, programs and games—The COLOR COMPUTER Magazine, the magazine for TRS-80 Color Computer users and owners! Every issue of The COLOR COMPUTER Magazine brings you a new “users manual” and program guide each month! You'll get:

- Programs for home and business... adults and kids!
- Software and Hardware reviews on the best (and least expensive) ways to upgrade your system!
- Games of skill, chance and luck!
- Sound and music synthesizing tips!

- How-to articles for the “Do-It-Yourselfer”!

You'll also find current listings of new products, directories and compatible peripherals for your Color Computer!

ADD “LIVING COLOR” TO YOUR HOME COMPUTER AND SAVE UP TO 41% WITH The COLOR COMPUTER Magazine!

YES!



I want to make my Color Computer more versatile! Please enter my subscription to The COLOR COMPUTER Magazine for:

- One year for \$17.97. I SAVE 28%!
- Two years for \$31.97. I SAVE 36%!
- Three years for \$43.97. I SAVE 41%!

Savings based on full one-year (12-issue) subscription price of \$24.97.

Mr./Mrs./Ms. _____ please print name in full TR 8H112

Company _____

Address _____

City _____ State _____ Zip _____

Check one: Payment enclosed Bill me later

Charge my: American Express Visa MasterCard

Card No. _____ Exp. Date _____

Please allow 30 to 60 days for delivery of first issue.

Add \$8 per year for Canada and all other foreign countries.

THE COLOR COMPUTER MAGAZINE—P.O. Box 2597—Boulder, CO 80322



COMPUTER GENERATED ILLUSTRATION BY BILL BRAMBLE

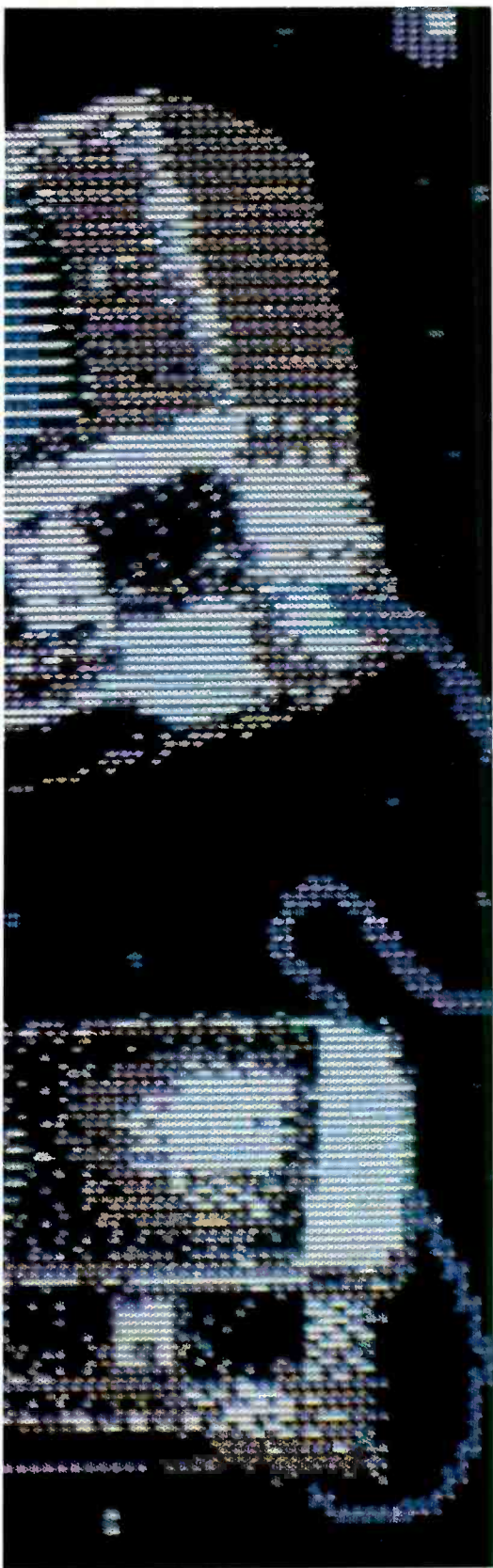

CHOOSING A LOCAL AREA NETWORK

A guide to selecting the LAN best suited to your needs

BY TJ BYERS

ARE you in the market for a local area network? Do you *need* one? Many of us do, and often without even being aware of it. How do you know if you need a LAN? Simply by asking yourself these few questions.

Do you find yourself constantly running around the office exchanging floppy disks with other workers? Do you spend more time milling around the letter-quality printer than you ever did standing at the water cooler? Do you schedule your coffee breaks to coincide with terminal access more often than not? If you answered yes to any of the above questions, your office is a prime candidate for a local area network.

A local area network permits you and your co-workers to share limited office resources, like that letter-quality printer. It also allows you to communicate and share data with other personal computer users—without ever leaving your desk or shuffling floppies. And best of all, it lets you take your coffee breaks when you want to, not when you *have* to.

Unfortunately, the recent influx of LANs has created as many problems as it has solved. There are just too many unanswered questions about networking and how it applies to you. Much of the confusion centers around the lack of networking standards.

In an effort to help you untangle the web of confusion surrounding local area networks, **COMPUTERS & ELECTRONICS**

TJ Byers is the author of the book "Introduction to Local Area Networks," to be published this fall by Prentice-Hall.

has assembled the accompanying buyer's guide. The guide compares a number of networks according to their protocols, operating specifications, special features, and relative prices.

In addition to the listing, we are providing an in-depth, discussion of the two current *de facto* network standards, Ethernet and Arcnet. These two protocols have done much to enhance LAN acceptance. We will also explain why broadband networks, like WangNet, can make those seemingly outrageous performance claims; you may find it surprising. Let's first look at Ethernet.

Ethernet

Ethernet was developed by Xerox at its Palo Alto facility. Through a combination of vigorous mass media campaigns and low licensing fees, Xerox has earned the honor of becoming one of two *de facto* standards for local area networks.

Ethernet has achieved this status by supporting one of the most sophisticated network contention schemes around. In a working network, it must be decided which station, or node, has use of the network and for how long. Ethernet solves this problem using a form of Carrier Sense Multiple Access network contention with Collision Detection, or CSMA/CD. (See "Electronic Ties that Bind" in the March 1984 issue of **COMPUTERS & ELECTRONICS**.)

Basically, it works as follows. When a node has a message it wishes to send over the network, it first listens to the LAN for activity. If the network is silent, the

Local Area Networks

node begins transmitting. If the network is busy, on the other hand, the station listens and waits for the network to clear. Once the conversation ends, the waiting node seizes control of the network and transmits its message.

In the event that two stations happen to be waiting for the same conversation to end, they will access the LAN at the same time. This results in a collision of data bits, none of which make any sense to anybody listening. In fact, a collision is more likely to occur just after the completion of a successful transmission than at any other time.

Inside the Ethernet controller is a receiver that monitors the transmission as it is sent. The moment the controller detects an overlapping of pulses caused by a collision, it stops the transmission. The competing node does likewise. An **abort pattern** is then broadcast over the LAN, informing all nodes on the network that

waiting period before it will transmit. And there the LAN sits, quietly waiting for something to happen.

The first node to time out listens to the network. Naturally, it finds it clear and proceeds to send its message. Should two stations happen to time out at the same moment, another collision results. This recycles the process and forces the LAN back into the holding pattern. Competing nodes then take new numbers and the process of network contention begins again. Eventually, one node will be successful in its attempts.

Ethernet claims that its protocol allows as many as 1000 nodes to share the network efficiently. The more nodes sharing the network, though, the greater the chances of a collision occurring.

Ethernet Framing

In an Ethernet network, information

transmitter, and generally lets everybody know a message is on its way. The preamble is a 64-bit word consisting of 62 alternating 1s and 0s, followed by a 11 ending (10101 . . . 01011).

The first of the two address fields is a 6-byte number representing one of three address destinations. It can be the address of an individual station for which the message is intended, or the address of a group of stations. Ethernet also contains a special code that allows the transmitting node to broadcast a message to every station on the network.

The second address field contains the address of the originating node. The type field is a 2-byte directive used to identify the user protocol associated with the frame.

The data field contains the actual message. The length of this field is not fixed, and may be adjusted to accommodate the information involved. However, the

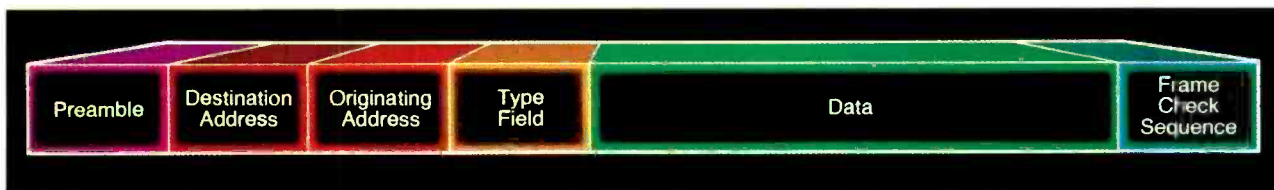

Fig. 1. In the Ethernet network, information is contained in a frame made up as shown here.

a collision has occurred. The receiving station(s), prompted by the abort command, dumps its registers of any data received just prior to or during the collision.

The network then goes into a holding pattern. Each node wishing to send a message loads itself with a random number that represents a time period—a

is transmitted and received in a package called a **frame**. An Ethernet frame contains a **preamble**, two **address fields**, a **type field**, the **data field**, and a **frame check sequence**, in that order. A graphic representation of an Ethernet frame can be seen in Fig. 1.

The preamble is an opening statement that synchronizes the receiver to the

message must not be shorter than 46 bytes, nor longer than 1500 bytes.

To ensure data fidelity, all fields (excluding the preamble) are subjected to processing by an error-detecting algorithm. The result of this calculation is entered into the field check sequence. When the frame is analyzed by the receiver, it performs the same calculation and compares its answer to the number contained in the field check sequence. If they match, the data is considered valid.

An Ethernet controller from 3COM.

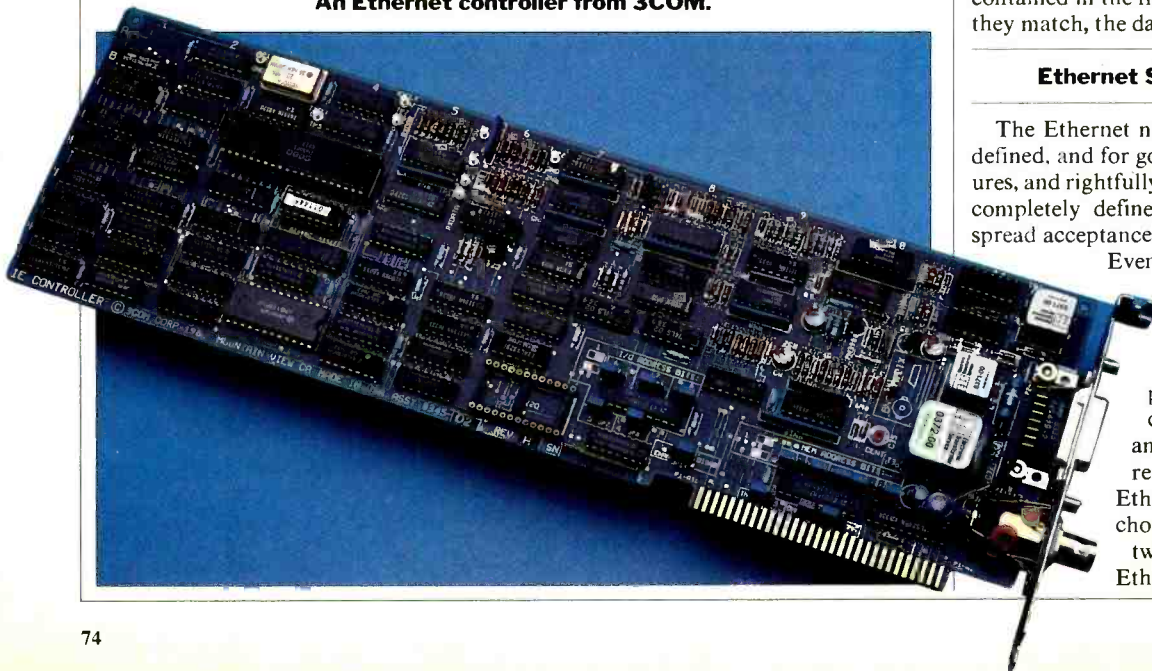

Ethernet Specifications

The Ethernet network is very rigidly defined, and for good reason. Xerox figures, and rightfully so, that, if a system is completely defined, it will find widespread acceptance.

Even the hardware of the network is specified, down to the nuts and bolts. The network must be plumbed with coaxial cable of a certain size and impedance. In this respect, however, Ethernet does offer a choice. There are actually two acceptable types of Ethernet coax, the newer

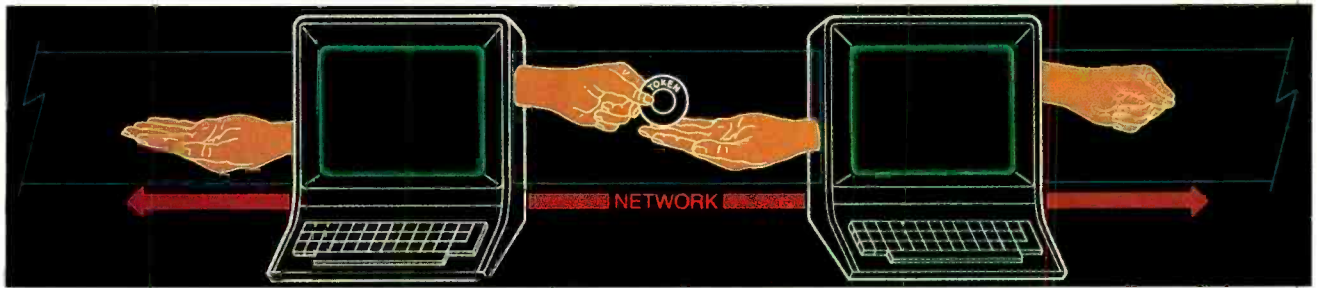

Fig. 2. Token passing. Access to the network is determined by possession of the token.

entry being a thin coax for smaller networks.

The length of the cable is also precisely stated. It is to be no longer than 2.5 kilometers (1.55 miles). Nodes are added to the cable with an Ethernet tap. The tap is a needle-like clamp that pierces the outer shield of the coax and makes contact with the inner conductor. In this

interchangeable.

More than likely, though, you will find competitive networks don't use the Ethernet framing structure. In fact, many vendors think their protocols are superior to Ethernet in some respects—and they may be right. After all, protocol efficiency is really related to the task at hand, and a protocol can be tailored

ABOUT THE TABLE

(see page 76)

ONCE you've decided you need a network, you are faced with the problem of selecting one that suits your needs. To assist you in your search, the overleaf chart has been compiled. Interpreting the information, however, requires the following explanations.

Maximum Nodes: This number represents the maximum number of nodes the network was designed to support.

Gateway: A gateway is a bridge that links one LAN to another. Not all gateways are defined equally. Sometimes the gateway requires a protocol translator or software. Other times, it is nothing more than a communications link, not unlike a modem.

Software: This listing indicates whether or not LAN includes networking software.

Dedicated file server: In some networks, a dedicated file server is required. This means that one node, like an IBM XT, must be dedicated to serving as a file controller. If a dedicated server is required, a "yes" appears in this column. If, on the other hand, a file server can participate in other duties, it is considered "shared" and you will see a "no."

Print spool: A print spool is actually a buffer of some sort that allows you to feed a low-speed peripheral, like a printer, at network speeds. It does this by storing the data in memory and metering out the stored bits as the peripheral demands them.

Minimum system: Lists the price of the smallest system you can get by with when building the network. In most cases, the vendor offers a starter kit, which contains everything you need to network two or three CPUs together. If such a kit is offered, the price is listed.

Additional stations: Lists the price of each additional node added to the network once you have made the initial investment. These prices are somewhat qualified though, because not every network lets you add a single node at a time. Sometimes they come in multiples. When this is the case, the minimum number of additional nodes is listed in next to the price. ◇

Ethernet tap uses an insulated coax-piercing fitting.

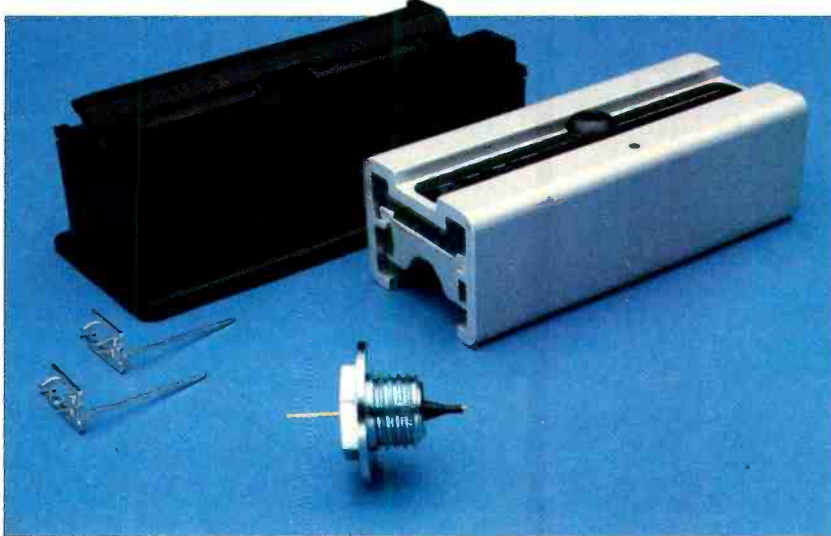

way, nodes can be added to and removed from the network with no break in the system.

The coaxial tap is fed into an Ethernet transceiver, also precisely defined, and to an Ethernet controller. The controller contains all the instructions necessary for proper framing and network control. Each node has its own controller.

Ethernet-Like Systems

Many networks are based on the Ethernet principle of collision sensing and detection (CSMA/CD), and they often compare their performance to Ethernet standards. In some cases, like that of the Ungermann-Bass Net/One, the network is Ethernet compatible and protocols between them are directly

interchangeable. Ethernet, on the other hand, takes a more universal approach.

Another difference you will find from network to network is speed. While Ethernet hums along at 10 MHz, most CSMA networks operate at 1 MHz. This is not necessarily a handicap, though, as the sidebar on data rates will tell you.

Arcnet

Arcnet is the second network to become a standard. Developed and licensed by Datapoint, Arcnet is a token-passing network. Datapoint likes to refer to it as a *modified* token-passing scheme.

Token passing differs considerably from the CSMA/CD contention protocol previously reviewed. Unlike CSMA,

Local Area Networks

A REPRESENTATIVE SAMPLE OF LANS

Network	Vendor	Computers Supported	Protocol	Data Rate (b/s)	Maximum Nodes	Network Medium	Gateway	Software	Dedicated File Server	Printer Spooler	Minimum System	Additional Stations
Desnet	The Destek Group 830 C.E. Evelyn Ave. Sunnyvale, CA 94086	IBM PC/XT S-100 RS-232C IEEE 488 RS-422	Broadband CSMA/CD	2M	256/ channel	coax/ fiber optics	yes	yes	yes/no	yes	\$1250	\$750
Dynasty	DY-4 Systems Inc. 888 Lady Ellen Pl. Ottawa, Ontario, Canada K1Z 5M1	IBM PC/XT Dynasty Onon	CSMA/CD	1M	64	twisted pair	yes	yes	yes	yes	\$1890	\$500
ELAN	Tecmar Inc. 23600 Mercantile Rd. Cleveland, OH 44122	IBM PC/XT	Ethernet	10M	1024	coax	yes	yes	no	yes	\$1695	\$1695
EtherLink	3Com, 1390 Shorebird Way Mountain View, CA 94043	IBM PC/XT	Ethernet	10M	1024	coax	no	yes	yes	yes	\$3005	\$795
G/Net	Gateway Communications Inc. 16782 Red Hill Ave. Irvine, CA 92714	IBM PC/XT	CSMA/CD/CA	1.43M	255	coax	yes	yes	yes/no	yes	\$1995	\$595
IDEAnet	IDEAssociates, Inc. 7 Oak Park Dr. Bedford, MA 01730	IBM PC/XT	CSMA/CD	800K	20	coax	no	yes	no	yes	\$1640	\$545
IDEAshare	IDEAssociates, Inc.	Any RS-232C port	Parallel network	19.2K	4	multi-wire cable	no	yes	yes	yes	\$395 (software)	\$195- \$295
LAN/1	3M Corp., PO Box 33600 St. Paul, MN 55133	Any RS-232C port	Broadband Arcnet	2.5M	255/ channel	coax	no	yes	no	no	\$5700	\$1400(2)
LocalNet 20	Sytek, Inc., 1225 Charleston Rd. Mountain View, CA 94043	Any RS-232C port	Packet-switched broadband	19.2K	24,000	coax	yes	yes	no	no	\$5680	\$1090(2)
MacLink	Davong Systems Inc. 217 Humbolt Ct. Sunnyvale, CA 94806	MacIntosh	SDLC loop	1M	64	coax	yes	yes	yes	yes	NA	NA
MultiLink	Davong Systems Inc.	IBM PC/XT	Arcnet	2.5M	255	coax	no	yes	no	yes	\$2375	\$595
Net/One	Ungermaun-Bass, Inc. 2560 Mission College Blvd. Santa Clara, CA 95050	any RS-232C IEEE 488, or parallel port	Broadband CSMA/CD Ethernet	5M	300/ channel	coax fiber optics	yes	yes	yes	no	\$9600	\$3400(6)
Net/One Personal Connection	Ungermaun-Bass, Inc. 2560 Mission College Blvd. Santa Clara, CA 95050	IBM PC/XT	Ethernet	10M	1024	coax	yes	yes	no	yes	\$2290	\$895
NET/PLUS	Interlan Inc., 3 Liberty Way Westford, MA 01886	Any RS-232C port	Ethernet	10M	1024	coax	yes	yes	no	no	\$2900	NA
NetWare/S	Novell, Inc. 1170 N. Industrial Park Dr. Orem, UT 84057	IBM PC/XT Victor 9000 TI PC	Star network	500K	24	multi-wire cable	yes	yes	yes	yes	\$13,135	\$250
NetWare/X	Novell, Inc.	IBM PC/XT	CSMA/CD	1.43M	64	coax	yes	yes	yes	yes	\$2995	\$250
Omninet	Corvus Systems 2029 O'Toole Ave. San Jose, CA 95131	IBM PC/XT Apple IIe, TI PC DEC Rainbow	CSMA/CD	1M	64	coax	yes	yes	yes	yes	\$2095	\$495
PC Cluster	IBM	IBM PC/XT	CSMA/CD	375K	64	coax	no	no	no	no	\$1898	NA
PCnet	Orchid Technology 44790 Westinghouse Dr. Fremont, CA 94539	IBM PC/XT	CSMA/CD	1M	256	coax	no	yes	no	yes	\$1490	\$695
	AST Research Inc. 2372 Morse Ave. Irvine, CA 92714											
	Santa Clara Systems 1860 Hartog Dr. San Jose, CA 95131											
PerComNet	Percom Data Corp. 11220 Pagemill Rd. Dallas, TX 75243	IBM PC/XT	Token passing	1M	254	2-twisted pairs	no	yes	yes/no	yes	\$1695	\$595
PLAN 4000 PLAN 3000	Nestar Systems, Inc. 2582 Bayshore Rd. Palo Alto, CA 94303	IBM PC/XT Apple II/III	Arcnet	2.5M	255	coax	yes	yes	yes	yes	\$12,780	\$595
Pro/Net	SWI International Systems 7741 E. Gray Rd. Scottsdale, AZ 85260	IBM PC/XT Apple IIe	CSMA	3.3M	127	4-twisted pairs	yes	yes	no	yes	\$994	\$298
Radio Shack Arcnet	Radio Shack One Tandy Center Fort Worth, TX 76102	Radio Shack Model 12, II	Arcnet	2.5M	255	coax	no	yes	yes	no	\$1300	\$399
Soft/Net	Autocontrol, Inc. 11411 Dorsett Rd. St. Louis, MO 63043	IBM PC/XT	CSMA	1M	255	coax	no	yes	no	yes	\$1695	\$250
10-NET	Fox Research, Inc. 7005 Corporate Way Dayton, OH 45459	IBM PC/XT	CSMA/CA	1M	Software defined	twisted pair	no	yes	no	yes	\$695	\$695
Token/Net	Concord Data Systems 303 Bear Hill Rd. Waltham, MA 02154	any RS-232C or parallel port	Token-passing broadband	5M	1000/ channel	coax	yes	no	no	no	\$3483	\$350
WangNet	Wang Laboratories, Inc. One Industrial Ave. Lowell, MA 01851	Wang PC	Broadband Arcnet	2.5M	255/ channel	dual coax	yes	yes	yes	yes	\$1350	\$1350(4)
XLAN	Complex Systems, Inc. 4930 Research Dr. Huntsville, AL 35805	Any RS-232C port	CSMA	1M	64 nodes; 192 terminals	twisted pair	no	no	no	no	\$2995	\$1450(3)
X/Net	XComp, Inc., 7560 Trade St. San Diego, CA 92121	IBM PC/XT	CSMA/CD	2.5M	255	twisted pair	yes	yes	no	yes	\$995	\$490

FROM THE PUBLISHERS OF 

A LIBRARY OF SOFTWARE PROGRAMS FOR THE IBM PC™...
PC DISK
 MAGAZINE

...The low-cost and efficient way to build a library of software programs!



These are some of the programs and applications you will have at your fingertips to expand your IBM PC:

Now you can build a library of software programs with amazing ease and at amazing savings! Imagine, adding to your home a library of utilities, sub-routines, games and data files for as little as \$3 per program! PC DISK MAGAZINE, a new concept for your IBM PC gives you this and much more!

Every issue you get is a thoroughly tested, ready-to-run floppy disk with up to 8 programs, accompanied by a fully illustrated user manual.

ALL YOU HAVE TO DO IS INSERT THE FLOPPY DISK AND GO!

Subscribe today and save up to \$60 for your order of PC DISK MAGAZINE! Send us the full payment by check, money order or credit card and save an additional 10%.

ACT NOW...SAVE MONEY AND BEGIN YOUR SUBSCRIPTION TO PC DISK MAGAZINE TODAY!

Product Specifications:

- Programs will run on IBM PC, PC XT, PCjr, and most compatibles under PC-DOS and MS-DOS versions 1.1, 2.0, and 2.1, requiring a minimum of 64K under DOS 1.1 and 128K under DOS 2.0 and 2.1.
- Most programs will be written to run on monochrome and color display; however, some games and utilities may be developed for color display only. (Monitor vs. TV recommended)
- Most programs will be written in advanced BASIC; however, some machine language and compiled code may be used.
- All disks are fully tested and guaranteed to run. Damaged or faulty disks will be replaced at no charge.
- All programs and documentation are copyrighted by Ziff-Davis Publishing Company. All rights or reproduction in all forms and media strictly observed. We guarantee full satisfaction!



BUSINESS AND FINANCE AIDS: Advanced pie, bar and line chart graphics...compute loan payment tables...calculate the Present Value and Internal Rate of Return for investments...Visicalc® templates for Real Estate, Lease/Purchase and Tax Shelter Analysis.



HOME/PERSONAL PROGRAMS: Income tax return helper...maintain mailing lists...personal cash flow analyzer...speed reading training...SAT test preparation aids...games of dexterity, skill and MORE!

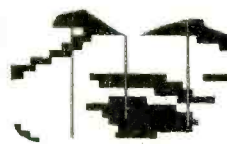

UTILITIES AND DIAGNOSTICS: Print graphics and screen images...simulate a conversational terminal...sort files...transfer files to or from another computer...diagnose and correct problems!

ALL THIS FOR AS LITTLE AS \$3 PER PROGRAM!

SAVE OVER \$60 ON PC DISK MAGAZINE

PC DISK MAGAZINE
 P.O. Box 5930, Cherry Hill, NJ 08034

PD8H575

YES, I want to begin to build my library with PC DISK MAGAZINE for:

- 3 issues for \$84. Save over \$20!
- 6 issues for \$149. Save over \$60!
- 1 issue for \$34.95—SPECIAL OFFER!

Mr./Mrs./Ms. _____

Address _____

City _____

State _____ Zip _____

Payment Enclosed \$ _____

Charge My: American Express Visa MasterCard

Card No. _____ Exp. Date _____

Deduct an additional 10% when you pay by money order, check or credit card! (Offer valid in U.S. only.)

Bill me later. Does not apply to Special One Disk offer.

Please allow 30 to 60 days for delivery of first issue. Canadian and foreign orders shipped Air Printed Matter; add \$5 per issue and include payment in U.S. funds with order.

Local Area Networks

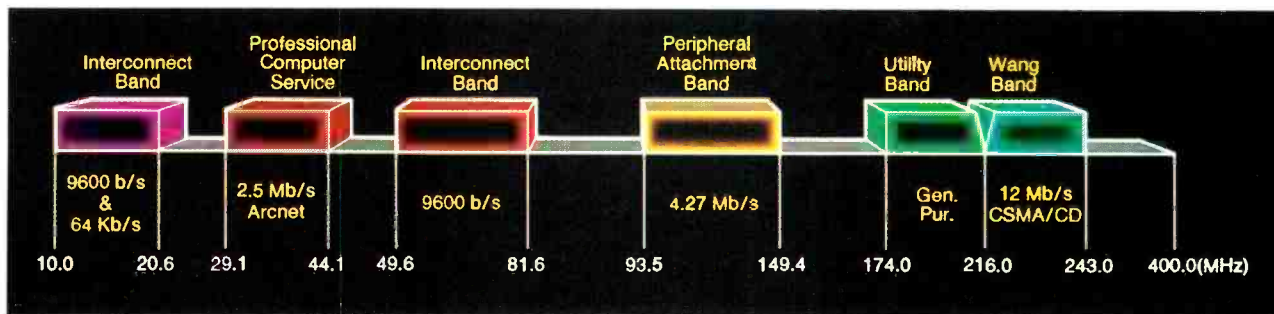

Fig. 3. Allocation of frequencies in the 390-MHz-wide communications band used by WangNet.

which allows everyone access to the network at all times, token passing permits only one user at a time access to the network.

Network use is determined by an electronic tag called a **token**. The token gives the station in possession of it the right to transmit on the network. Only one node at a time can be in possession of the token.

As illustrated in Fig. 2, the token is given to the first node on the network, and allows that node use of the network for a prescribed amount of time. Once the station is finished sending its message, or its time expires, the token must be relinquished to the next station in line.

For instance, let's say that station 19 has the token. When it's finished with it, it gives it to node 53 (if so programmed). This gives station 53 access to the network.

Should station 53 have nothing to say, however, it simply passes the token to the next node. And so the token goes around the network, giving every station access to the LAN as its turn comes up. The last node on the line returns the token to the first and the cycle begins over again. During the token-passing process, all nodes listen to the network.

Datapoint claims its Arcnet token-passing protocol is actually more efficient than a multiple-access network, like Ethernet, because it eliminates the idle time resulting from collisions.

Arcnet Network Reconfiguration

In a CSMA environment, like Ethernet, nodes can be added and deleted at will. The presence or absence of a node has no effect whatsoever on the performance of the network.

In a token passing network, however, this is not so. If you add a new node to a token passing scheme, you must add its address to the roster of destinations for the token; otherwise, access to the network will never be granted to the new kid on the block. Network access re-

quires that the new node *receive* the token.

Arcnet solves this problem with a unique network-reconfiguration scheme. When a new station is added to the network, it broadcasts a reconfiguration burst-pattern. What this does is erase the token's destination address from every node on the network.

After the reconfiguration burst occurs, each workstation starts a timeout period. The length of each node's timeout is determined by its address. The node with the highest address number times out first, and gains possession of the token.

It is then the duty of that node to start the token-passing process. It does so by broadcasting the address of the lowest known workstation and asking if anyone listening can answer the call and accept the token. If not, it proceeds to the next address and makes a similar query. When a recipient is found, the token is passed. The forwarding address is then

stored in the memory of the initiating node.

Each subsequent station receiving the token goes through the same procedure, beginning with its address plus one and looking for the next station on the line. When the token returns to the highest-numbered node, the reconfiguration is complete. Once reconfigured, the network can go back to work.

To prevent the loss of a token during normal operation, Arcnet requires that the node passing the token monitor the LAN for activity. If the network remains silent for more than 78 microseconds after the token is passed, the originating node assumes that the token has been lost and reclaims possession of it. A search is then made to find a station capable of accepting the token.

To illustrate the point, let's assume that workstation 19 has a token and passes it along to station number 53. Now, if node 53 has been taken off the

(Continued on page 103)

Fig. 4. Broadband network frequency conversion as used in LocalNet 20.

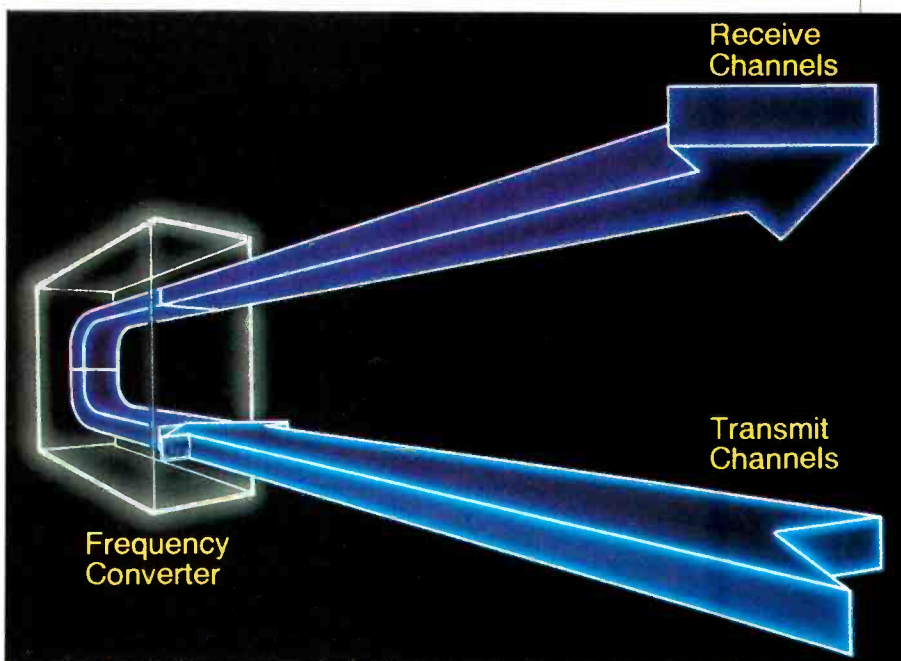

TOP OF ITS CLASS



- ▶ APPLE BUSINESS GRAPHICS
- ▶ FINE ARTS GRAPHICS
- ▶ LISADRAW
- ▶ REVIEWS
 - 128K MEMORY BOARDS
 - WORD JUGGLER
 - OLIVETTI INK JET PRINTER
 - KOALA PAD
 - CREATOR
 - SENSIBLE SPELLER
- ▶ TRANSFERRING SOFTWARE TO THE APPLE
- ▶ LEARNING LOGO



A+ ...THE MARK OF EXCELLENCE
 ...THE PINNACLE OF SUCCESS
 ...THE HEIGHT OF ACHIEVEMENT

Finally there is a magazine written exclusively for Apple II series and Macintosh users that can be called **A+**. If you're looking for ways to expand the use of your Apple... if you're a doctor or lawyer and you want to computerize your practice... if you're a student and you need an Apple to organize your workload... or if you want to know more about games, **A+** is the *magazine for you!*

Business and Finance Applications, Product Reviews, Apples at Work, Apples and Learning and That's Entertainment are just a sampling of the features you'll find in **A+** month after month!

A+ ... TOP OF ITS CLASS.



The Independent Guide for **apple** Computing

AM 8H260

YES, I want to save up to 33% on A+. Please enter my subscription for:

- | | | |
|--|---|---|
| <input type="checkbox"/> One year (12 issues) for \$19.97
I Save 20%! | <input type="checkbox"/> Two years for \$36.97
I Save 26%! | <input type="checkbox"/> Three years for \$49.97
I Save 33%! |
|--|---|---|

Savings based on full one-year subscription price of \$24.97.

Mr/Mrs/Ms _____ (please print name in full)

Company _____

Address _____

City _____ State _____ Zip _____

Check one: Payment enclosed Bill me later

Charge my: American Express Visa MasterCard

Card No. _____ Exp. Date _____

Add \$12 a year in Canada and all other foreign countries. Please allow 30 to 60 days for delivery of first issue.

A+ P.O. Box 2964 Boulder, Colorado 80322

BARBARA AND JOHN McMULLEN GUEST COLUMN

COMPATIBILITY AND PORTABILITY

COMPAQ Computer Corporation's latest offering, the Compaq Plus Computer, is a superb machine. We make that statement without fear of contradiction after exercising the computer for slightly over a month and utilizing much of the popular IBM PC business software (e.g. Lotus 1-2-3, MultiMate, dBase II, VersaForm, and so on). We also took the Compaq Plus on business trips, and found that it travelled very well on airlines. The computer is as fully IBM PC compatible as the first product from Compaq Computer Corporation, the Compaq Portable Computer and performs equally well. In addition, the Compaq Plus includes a built-in 10M-byte hard disk. Suggested list price for the system, which includes hard disk, 128K RAM, one 320K disk drive, built-in 9" green-phosphor monitor and attached keyboard, is \$4995.00. (Suggested list prices of other configurations in the Compaq line are shown in Table I).

Though we've had a strong positive reaction to the Compaq Plus, that doesn't mean that the computer will be a success in the marketplace. After all, as we have seen many times, excellent technical performance does not always translate into outstanding sales. (Witness such fine machines as the Corvus Concept and Sage. Although technically superior to the IBM PC, these computers have obviously not gained the popular acceptance that the PC has.) We do think, however, that the Compaq Plus will be successful, and for the same reasons that the Portable was: compatibility, portability and marketing. To properly understand these factors, let's examine each in more detail.

Compatibility

Compaq Computer Corporation had, as one of its initial design goals, "full" compatibility with the IBM PC. There

Barbara E. McMullen and John F. McMullen are contributing editors for COMPUTERS & ELECTRONICS.



The Compaq Plus includes a 10M-byte hard disk and 9" monitor.

are many definitions of compatibility—usually formulated by vendors to achieve their own goals. Some people might think that WordStar, running under the CP/M operating system, or VisiCalc, running on an Apple II, are compatible with the same program running on an IBM PC because they operate

Perfect intrinsic compatibility with the IBM PC is impossible

in a similar manner. While these systems might be considered "operationally" or "functionally" compatible, they certainly could not be considered "fully" compatible. You cannot put your Apple VisiCalc program and data diskettes into

your IBM PC and have anything happen. The disk format, operating system, and internal processing chips, are quite different in IBM PCs and Apples.

Other firms provide more than operational compatibility. They may have compatible data formats, which enables a data file created on one machine to be read on another. (It appears that the Tandy 2000 is format compatible with the IBM PC. This does not mean that the version of MultiPlan that runs on the IBM PC will run on the 2000, but it does mean that the Tandy version of MultiPlan will read data created on the PC using MultiPlan.)

The final level of compatibility is the one in which most people are interested. At this level, one computer (such as the Compaq) can properly run software written for another machine (such as the IBM PC). Furthermore, the user should not have to make modifications to the software or use complicated procedures to get it to run. It is for this final level of

compatibility that Compaq (and Columbia and Corona and many others) have striven.

Perfect intrinsic compatibility with IBM PC is impossible to achieve. IBM uses a proprietary method of loading Microsoft's BASIC programming language (MBASIC) that comes with the system. The PC contains the "kernel" of BASIC in read-only memory (ROM). Enhancements to this kernel are contained on DOS diskettes that may be obtained from IBM. Expansions to the built-in BASIC are called BASIC.COM and BASICA.COM (BASICA represents Advanced BASIC) on the DOS diskette. When a computer user wishes to run a BASIC program—lets call it MYPRG.BAS—he or she types BASICA MYPRG. The system responds to this input by:

1. loading BASICA from the diskette (this load procedure, unique to the IBM PC, recognizes the existence of the BASIC kernel in ROM and loads the disk-based extension as a supplement to the ROM-resident kernel);
2. loading the user's BASIC Program, MYPRG;
3. executing the user's program.

The loading and execution of a BASIC program on the Compaq (and other compatibles) differ in that the BASIC interpreter loaded from diskette is the full implementation of BASIC and not an extension. On the Compaq, full BASIC on diskette is called BASICA, thus no change in procedures is required when loading programs. (On some other machines, such as the Corona, the full BASIC on diskette is named GWBASICA. While this BASIC, also from Microsoft, is equivalent to BASICA, the difference in names causes some difficulty with BASIC programs that run automatically on system startup. These programs are invoked by AUTOEXEC.BAT files which contain the entry BASICA MYPRG within the file. The user of a system that comes with GWBASICA must utilize a text editor to change those commands to GWBASICA MYPRG.)

Compaq also provides a method that allows the same program diskette to be used on both Compaq and IBM PC. Using this method, the user copies the file called BASICA.EXE from the Compaq DOS master diskette to the user's program diskette. The only time this procedure (which is described in Appendix B-1 of the Compaq Portable Computer Operators Guide and in Section 4-6 of the Compaq Operations Guide) will not work is when there is no room on the program diskette for the file to be copied. In those cases, the user must main-

tain two program diskettes—one for the Compaq and one for the PC.

In deciding to strive for a final product as close to perfect compatibility as possible, Compaq decided that the standards embraced by IBM would become industry standards and that, to be successful in the marketplace, adherence to these standards was mandatory. To its credit, Compaq is considered throughout the industry as the most compatible of compatibles. Compaq works very hard at maintaining this position. It ensures that any device or program that works on the PC also works on the Compaq. Although other manufacturers may profess the same degree of compatibility, too often when calling firms to inquire why a certain piece of software does not properly work on the manufacturer's unit, we've been told "Well, it should." Similar calls to Compaq, how-

True portables are quiet, small and can be carried by a 10-year-old

ever, resulted in: "We have found this difficulty and are now working with the producer/manufacturer to correct it." And we have seen that the device or program eventually becomes usable on the Compaq.

We should also mention that one pays a price for attempting to attain full compatibility. In doing so, the manufacturer commits itself to emulating not only the virtues of the model, but also its deficiencies. Compaq has chosen this path of total compatibility. Others have not. Hyperion has not emulated all of the deficiencies of the IBM keyboard; it has built a keyboard with the shift key in the right place and put the function keys on top. Tandy has chosen a faster chip for its TRS-80 Model 2000. In Hyperion's case, the change is essentially cosmetic; but not in Tandy's. Tandy's change has precluded it from utilizing all software available for the PC. It must count on convincing software producers that the market for Model 2000 products is significant enough to warrant production of software useable by the 2000. Hyperion's decision to offer an improved keyboard was not of the same magnitude and does not have the same effect.

Compaq's decision to be exactly com-

patible is by far the safest route available but—though it may appear to be merely sacrificing performance for such safety—the decision has broader implications. While we prefer the layout of the Hyperion, and would choose that design if it were our only computer, we certainly do not want the third, fourth and fifth computers in our office to have a layout different from that of our first two computers (which are IBMs). These systems must be completely interchangeable. The differences in such designs lead us into a consideration of the marketing strategy of various compatible manufacturers. These points will be discussed in more depth later in the article. For the present, we will say simply that Compaq saw itself co-existing with IBM, whereas companies like Hyperion saw their marketplace as inhabited by users who would decide to purchase their computer in lieu of IBM's.

Portability

Portable, like *compatible*, means different things to different people. Webster's dictionary defines *portable* as "capable of being carried or moved." Under this definition, the Compaq Portable and Plus computers would be correctly classified as *portable*. We, however, maintain that a truly *portable* computer is:

1. easily carried by anyone over age 10 in reasonably good physical condition.
2. of a size and weight that would not interfere with also carrying a handbag or briefcase.
3. useable in an environment conducive to reading a book or magazine, such as an airline seat, a library, an automobile's passenger seat, a doctor's waiting room, a conference room, or a park bench.

With these definitions, Compaq computers are not really portables. They are "transportables," or computers that are easily moved (with the use of an airline cart) from office to home, or office to hotel. They function equally well in any of these locations. The true portables are the "briefcase" computers—the TRS 80 Model 100 and the Convergent Workslate, for example—which are small and battery operated.

To make this distinction is not meant to demean the Compaq or any of the other 20-to-30-lb transportables; it merely points out certain differences between machines described as portables. One should not muddy the waters by grouping them all together. We make extensive use of both our TRS-80 Model 100 and our Compaq. The Model 100 has

(Continued on page 86)

NEW PRODUCTS

33M HARD DISK STORAGE SYSTEM

The I² DiskSystem from Interface Inc. provides 33.3M of formatted storage for the IBM PC under PC-DOS 2.0 and for PC-workalike computers. Included with the 5 $\frac{1}{4}$ " hard-disk system is a cabinet, power supply, cable, connector, and I/O adapter. The system records 640 tracks per inch and has an average access time of 40 ms. It features a full sector buffer (512 bytes) and has a microprocessor-based architecture with error correction of 32 bits. It measures 15 $\frac{1}{4}$ " D \times 8 $\frac{1}{4}$ " W \times 5 $\frac{1}{2}$ " H. \$2795. Address: Interface Inc., 7630 Alabama Ave., Canoga Park, CA 91304.

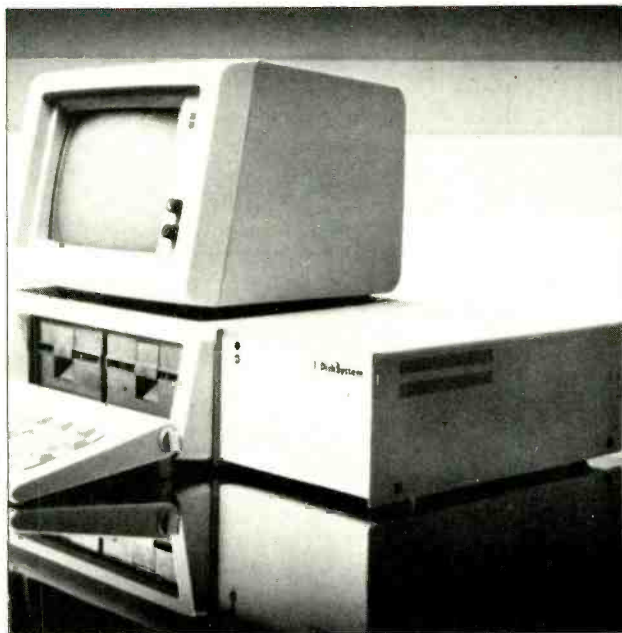

REMOVABLE HARD-DISK SYSTEM

Hard_Disk is a removable-medium 5M hard-disk system from Digital Electronic Systems for Apple II and IBM PC computers. The removable 5M-byte-capacity disk PAK utilizes thin-film technology. Operation of the system is transparent to current Apple and IBM software and is claimed to introduce no decrease in available user memory. The software is capable of supporting up to 900M on either computer. An interface card allows an IBM PC Hard_Disk to operate on an Apple II. \$1295. Address: Digital Electronic Systems, Inc., 107 Euclid Ave., Mountain Brook, AL 35213.

SOFTWARE SOURCES

Courseware Package. CLAS is a courseware package from Tough Technologies for Apple II+ and IIe; IBM PC, PC-XT, and PCjr; Commodore C-64; and Acorn computers. It functions as a teaching tool for any subject. Its streamlined authoring procedures allow instructors to create lessons in their own personal teaching style. All text is typed free-form, and editing procedures are simple. Up to 30 problem sets can be offered with each lesson. Questions can take the form of true/false, multiple choice, short answering, or matching. If desired, questions can be presented in a different order each time the lesson is used. CLAS uses sound to give feedback when a response is made to a question. A student help feature, review of problem areas, and summary of student performance at the end of the lesson are provided. Requirements: Apple computer with 48K of RAM; DOS 2.0 or 2.1 for IBM computers. \$89.95. Address: Tough Technologies, 609 S. Escondido Blvd., Suite 101, Escondido, CA 92025.

Relational Database Manager. R:base 2000 is a single-user relational database management system for use in small personal computers like the IBM PCjr. It was developed for the individual who has limited database management requirements. The package provides basic information management features like file organization and management, search and sort capabilities, and easy-to-use prompts and commands. Simple commands enable the first-time user to easily define formats and files for information storage and retrieval. The system can manage more than 65,000 records. R:base 2000 can run in computers that use MS-DOS, PC-DOS, CTOS, and BTOS operating systems. Requirements: 128K of RAM. Address: Microrim Inc., 1750 112 Ave. NE, Bellevue, WA 98004.

SPEECH INPUT DEVICE

The IntroVoice II speech input device from Voice Machine Communications is claimed to work with any existing Apple II applications software, with a claimed recognition accuracy exceeding 98%. The system allows commands and data to be fed into the computer by voice or in combination with the keyboard. Sequences in which

words or phrases are joined (syntax) can be easily defined. The product offers an unlimited vocabulary in subsets of 160 words or phrases. Other features include voice-controlled correction, repeat, and voice on/off switching. The board contains a 16-channel audio spectrum analyzer, 16K of RAM, and 8K of ROM. Address: Voice Machine Communications, Inc., 1000 S. Grand Ave., Santa Ana, CA 92705.

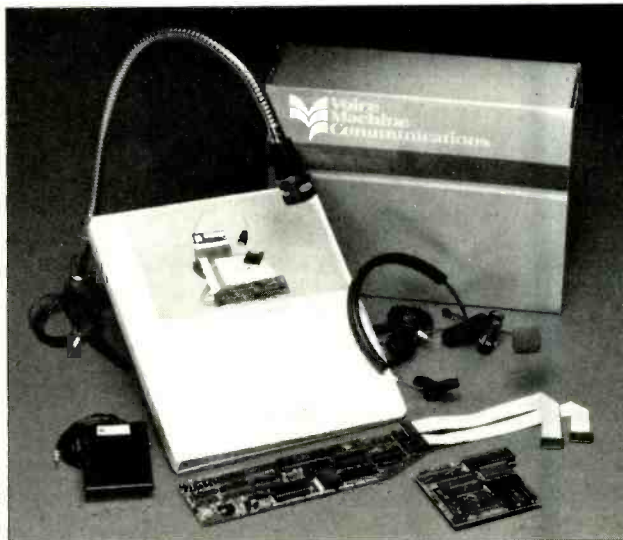



PERSONAL DATA-BANK WRISTWATCH

Seiko is marketing an alarm chronograph with data storage and retrieval system and calculator capabilities. The Data 2000 consists of two elements—an LCD quartz alarm chronograph and a check-book-size data entry keyboard. The watch snaps into the keyboard to become a full-function calculator for data input. The watch is capable of storing 200 lines of 10 characters each in its own built-in memory. When worn separate from the keyboard element, the watch is capable of displaying four lines of text at a time and can scroll through all 200 lines of data.

Circle No. 83 on Free Information Card



ADVANCED PORTABLE COMPUTER

The PC Traveler from Strategic Technologies is a high-performance portable microcomputer that uses advanced technologies. The attache-case-size computer features a 9 1/4" diagonal plasma display with 80 x 25-character display and a true 16-bit 80186 microprocessor. Other features include 256K of RAM (1M addressable); 32K of ROM; dual 360K half-height 5 1/4" floppy-disk drives; and a custom-designed IBM PC-compatible detached keyboard. Also built in is an 80-cps full-function printer capable of printing 80- and 132-characters per line on cut-sheet, fanfold, and roll paper. The printer supports multiple print fonts, character sets, and dot-addressable graphics. Complete communications capability is optional. \$4495.

Circle No. 85 on Free Information Card



EMERGENCY AC POWER SYSTEM

Powermark's Automatic Power Systems provide up to three hours of emergency ac power to protect computer equipment against memory loss, data-entry errors, and hardware problems associated with brownouts, voltage sags, and momentary power outages. Unlike conventional uninterruptible power systems, the Powermark system operates in a standby mode when ac power is stable, switching to emergency power only when line power drops

to a threatening level. Transfer from ac-line to inverter power is typically 4 ms. The devices are rated to deliver 300 VA at 60 Hz and feature short-circuit protection. Address: Powermark, Inc., 3855 Ruffin Rd., San Diego, CA 92123.

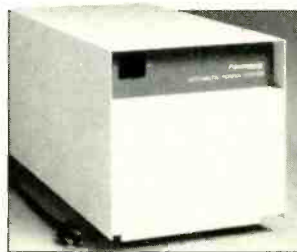

300- AND 1200-BAUD MODEMS

Apple's Modem 300 and Modem 1200 are auto-dial, auto-answer modems designed to fit under a standard telephone instrument. Both are fully compatible with all Apple II, Apple III, Macintosh, and Lisa computers. The modems are command compatible with Hayes Smart Modems and work with a variety of communications software packages. Apple Modem 300 operates at 300 or 110 baud, while Apple Modem 1200 is designed to operate at 1200 or 300 baud. Each modem comes with a menu-driven terminal program for dialing such information services as CompuServe and The Source. \$225 for Apple Modem 300; \$495 for Apple Modem 1200.

Circle No. 84 on Free Information Card

40M HARD-DISK SUBSYSTEM

CompuPro is marketing a 40M hard-disk subsystem with built-in 8" floppy disk drive for IEEE 696/S-100

bus-compatible microcomputers. The Model H40 subsystem features a Quantum Model Q540 5 1/4" hard-disk system, CompuPro's Disk 3 DMA controller, and CP/M-80 and CP/M-86 operating

systems. The double-sided, double-density, 2.4M-capacity Qume Trak 842 floppy drive accepts single- or double-density, single- or double-sided media. \$5495.

Circle No. 86 on Free Information Card



NEW PRODUCTS

LOW-COST MODEM

Anchor Automation's Volksmodem is an inexpensive modem that is claimed to interface with virtually every personal computer on the market. The Volksmodem features 300-baud operation, plug compatibility with any wall telephone jack, full/half-duplex switch, voice/data switch for use without having to disconnect the modem, low-power CMOS circuitry for up to two years of operation on a single 9-volt battery, and originate and answer operating modes. Five adapter



cables are optionally available for connecting to computers, including RS-232 DCE male, RS-232 DTE male, RS-232

DCE female, TRS-80 Color Computer, and Atari. \$79.95; \$12.95 each adapter cable.

Circle No. 87 on Free Information Card

POWER LINE CONDITIONER

Gould Power Conversion has introduced a larger version of its Personal Conditioner for IBM PC computers. Rated at 400 VA, the Model PC-400 is expressly designed to provide voltage-regulated, transient-free power to a fully configured IBM PC-XT with built-in hard-disk system and printer. Unlike transient surge suppressors that only clip high-voltage spikes, the



Personal Conditioner filters out noise of any amplitude and assures precise voltage and pure sine-wave power for equipment that draws up to 3.33 A at 117 V ac. \$349. Address: Gould Inc., Power Conversion Div., 2727 Kurtz St., San Diego, CA 92110.

KEYBOARD EXTENDER

Bytes & Pieces has developed the Keyboard Extender, an extension cable that adds up to 5 feet to the length of the cable that tethers the IBM PC to its keyboard. The cable is plug-in compatible with the IBM PC. \$19.95. Address: Bytes & Pieces, 550 N. 68 St., Wauwatosa, WI 53213.



MOBILE COMPUTER

Wildcat is a new Apple-compatible mobile computer from Wholesale Technology. Specifically designed to be used in road vehicles, boats, and aircraft, it offers 6502 and Z80 microprocessors for Apple II and CP/M 2.2 software compatibility. Standard features include: 64K of RAM; system ROM; detached keyboard with numeric keypad and separate cursor-control keys;

5 1/4" floppy-disk drive; upper/lower-case display capability; composite-video color and monochrome and RGB outputs; 40 x 20 line text display; 16-color 40 x 40 and 6-color 280 x 192 graphics or 280 x 162 graphics and four text lines. Built in are a dual-disk interface, speaker, two games I/O ports, and serial and parallel printer ports. \$1099. Address: Wholesale Technology, Inc., 1530 S. Sinclair, Anaheim, CA 92806.

SOFTWARE SOURCES

Relocating Cross Assembler. XMACZ80 from Allen Ashley enables PC-DOS/MS-DOS microcomputers to serve as development stations for the Zilog Z80 microprocessor. This software system includes a relocating macro assembler, linking loader, absolute macro assembler, text editor, cross-reference generator, hex file converter, and off-loading facilities. Programs developed under XMACZ80 must be off-loaded to the target processor for test. A user-configurable downloader is provided. Availability is on 5 1/4" and 8" media. \$250. Address: Allen Ashley, 395 Sierra Madre Villa, Pasadena, CA 91107.

Database Manager. Superbase 64 from Precision Software offers an unlimited number of databases, with up to 15 files per database, for Commodore C-64 computers. The number of records per file is limited only by disk drive capacity. Each record can hold up to 1108 characters, with a maximum of 127 fields. The system includes search and sort capabilities, using B+ tree indexing. An easy-to-use programmable interface that comes with the program permits creation of customized applications packages within the Superbase 64 environment. Requirements: C-64 computer and a Commodore Model 1541 disk drive or any large Commodore disk drive, including a hard-disk system. \$99. Address: Precision Software (USA), Inc., Suite 1100, 820 Second Ave., New York, NY 10017.

NEW PRODUCTS

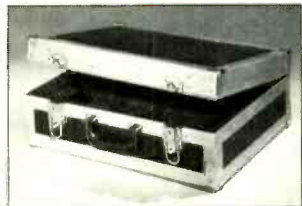

COMPUTER CARRYING CASES

The Computer Case Company has a line of compact carrying cases for the IBM PC and PCjr and Apple Lisa and Macintosh computers. The Trav-L-Cases are built of scuff-resistant vinyl-clad plywood and contain a minimum thickness of 1" of interior foam padding to protect the computers during transportation. Metal protection on edges and corners and locks are provided. **Address:** Computer Case Co., 5650 Indian Mound Ct., Columbus, OH 43213.

INTELLIGENT PRINTER INTERFACE

Texprint's Print-It! Model 2 is an Apple II series and Apple-workalike computer/printer interface card that handles both serial and parallel printers. The card features 64K of program ROM and 202 graphics, 25 text, and 9 format modes. It supports 40- and 80-column text, even using the Videx card; standard and alternate fonts; color and black-and-white printing; low-, high-, double-high- and double-low-resolution graphics; text formatting; "dumb" card emulation; and automatic selection of proper print format. On-board switches are available to provide compatibility with virtually all available printers. \$149. **Address:** Texprint, Inc., 8 Blanchard Rd., Burlington, MA 01803.

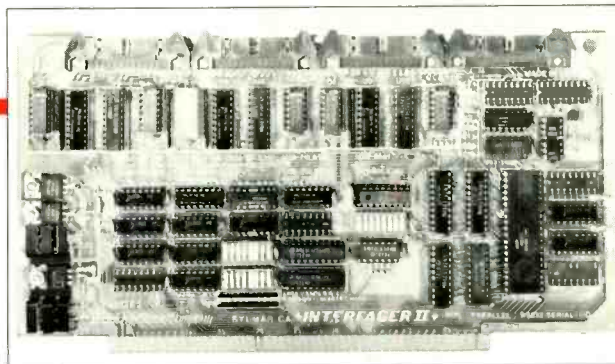

3P+S PORT BOARD

A multipurpose interface for IEEE 696/S-100 bus systems from Vector Electronic provides three full-duplex parallel I/O channels, an RS-232C serial port, and a selectable-rate timer on a single board. Each of the No. 8800GF2 board's parallel data channels has eight TTL latched-input lines and eight tristate output lines with 24-mA drivers. Parallel data transfer rates up to 10 MHz are supported. A selectable interrupt timer offers fixed 50 to 19,200 interrupts per second (reducible

by factors of 2, 4, or 8 by jumper placement). The serial port provides RS-232C ± 12 V or optically isolated internal or external current source 20-mA signals with choice of DTE or DCE operation. Character codes can be 7 or 8 bits long, with odd/even/no-parity selection and one or two stop bits, with transmission rate of 50 to 19.2K baud, including a 143.5-baud rate for Selectric typewriters. \$325 standard version, \$399 certified version. **Address:** Vector Electronic Co., Inc., 12460 Gladstone Ave., Sylmar, CA 91342.

HIGH-RESOLUTION DIGITIZER

Pencept's new Penpad for the IBM PC and workalike computers recognizes hand-printed characters and doubles as a high-resolution digitizer for pin-point graphics. It can be used to send drawings, special commands, and cursor controls to the host computer and can double as a touch-pad or mouse. The mouse mode is called by operating a push-button switch built into Penpad's pen. The product consists of a $15\frac{7}{8}'' \times 16\frac{7}{8}'' \times \frac{1}{2}''$ pad assembly with $11'' \times 11''$ writing area, a ball-point pen that is electrically connected to the tablet, and an add-in circuit board that fills one full slot in the IBM PC or PC-XT. It features four modes of operation: keyboard, mouse, digitizer (with 200-dot-per-in. resolution), and character. Penpad comes with several software utilities that make it easy to use with most off-the-shelf software. \$995.

Circle No. 88 on Free Information Card

COMPUTER WITH BUILT-IN LAN

Santa Clara Systems is offering what is claimed to be the first IBM-compatible personal computer with built-in local area network (LAN). The PCterminal functions as an intelligent terminal in an IBM

PC network (PCnet) and is compatible with IBM PC and PC-XT computers. An optional floppy-disk drive allows users to run programs locally, as well as on the network. PCterminal has a video display monitor, typewriter-style keyboard, 8088 CPU, 64K (expandable to

256K) of RAM, serial and parallel ports, four expansion slots, connection for a disk drive, and PCnet networking capabilities. It runs under PC-DOS and the company's SCS-DOS version of MS-DOS. \$1295. **Address:** Santa Clara Systems, 1860 Hartog Dr., San Jose, CA 95131.

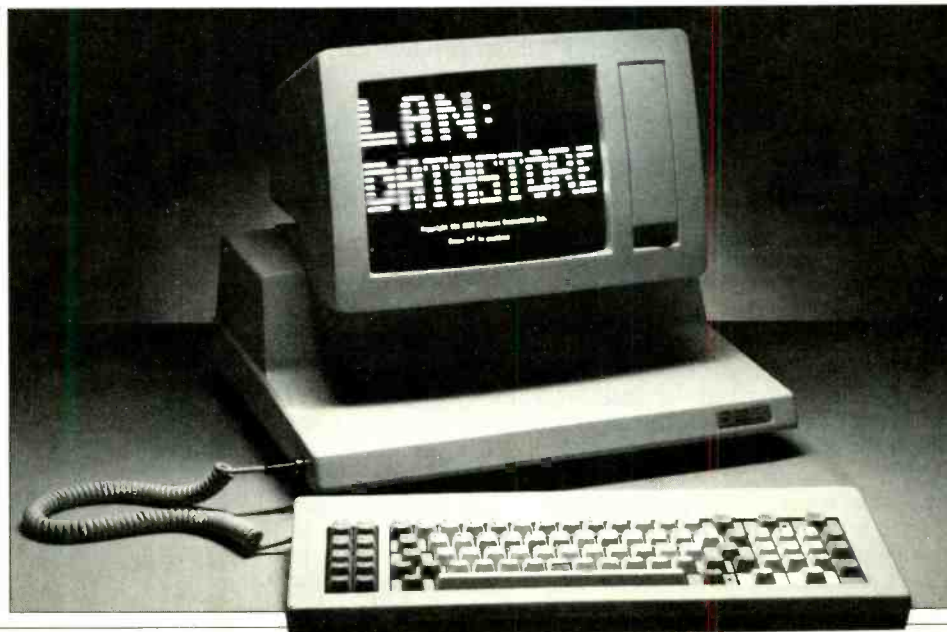

Compatibility and Portability

(Continued from page 81)

32K, a built-in modem, an eight-line LCD display and no disk drives. The Compaq Plus (with an AST Six-Pack Plus installed), has, on the other hand, 640K, full 25-line monitor, 320K floppy disk drive and 10M-byte hard disk—clearly, two different animals. We use the Model 100 on the airplane and the Compaq in the hotel or office.

Traveling with Compaq is a pleasure. On airlines the computer is no trouble at all; it either fits under a seat or, on some airlines, in an overhead compartment. The only difficulty we have experienced is on some smaller airplanes where, under the forward seat, there is not enough room for both the computer and your feet. (This presents no problem for us as the two of us always travel together and can put our feet under one seat, leaving the other for the computer—a little more difficult if you don't know the person seated next to you!) Some more adventurous souls have allowed their computers to be checked on as baggage and have had no problems. We are not psychologically ready to hand our \$5000 computer over to the same people that dent our Samsonite. The power of the Compaq's portability really shows up when, at an office or hotel, you set up the computer and find that it works fine. You can continue writing the same analysis report in

TABLE I—PRICES OF COMPAQ CONFIGURATIONS

- 128K Compaq Portable with one 320K disk drive, built-in 9" green-phosphor monitor and attached keyboard: \$2995.
- 256K Compaq Portable with one 320K disk drive, built-in 9" green-phosphor monitor and attached keyboard: \$3590. (Second 320K disk drive for Portable computer: \$595.)
- 128K Compaq Plus with one 320K disk drive, 10-million character fixed disk, built-in 9" green phosphor monitor and attached keyboard: \$4995. (128K memory upgrade for Compaq Plus: \$495. Upgrade of Compaq Portable to Compaq Plus: \$2500.)

puters might service 14 users who can bring a computer, when needed, to their own desks. We cringe at the amount of money being spent in organizations that use large, bulky and usually ugly rolling units that move PCs around. Certainly, a portable such as the Compaq makes sense if plans are to move it from desk to desk.

Marketing

Since the inception of the firm, Compaq's marketing strategy has dif-

proposes "something that's as good as the PC . . . and maybe even better," simply because he does not offer IBMs. The advice of Sears or Computerland personnel to consider the Compaq line for office or travel does not seem to be negatively selling against IBM. Rather, the feeling is that the salesperson is responding to the purchaser's unique needs. If portability is important for the purchaser, then the Compaq line should be considered. If, on the other hand, portability is unimportant, the purchaser will be directed to the IBM PC.

This marketing approach, while very successful, should not lead prospective purchasers to view a Compaq as non-competitive with IBM. The Compaq machines provide a viable alternative, even if portability is *not* a prime consideration. An IBM PC configuration with the same power as a comparable Compaq, will generally be more expensive and obviously less mobile, particularly when comparing the PC-XT with the Compaq Plus. IBM encourages you to never move the XT; Compaq says you can drop the Plus on the floor. Our office is a mix of PC's (vanilla and XT's) and Compaqs (Portables and Pluses) tied together through a Corvus Omninet Network. In this environment, the IBMs and Compaqs work equally well, but the Compaqs have the added advantage that, at a moment's notice, they can be packed up and taken away.

A Quality Product

All of the planning and understanding of the marketplace evidenced by Compaq would, however, have gone for naught had Compaq not produced a quality product. But it did, and the company became a huge success. On October 25, 1983, Compaq simultaneously introduced the Compaq Plus and announced that it had filed registration with the Securities and Exchange Commission for a preliminary to a public offering. It also disclosed that it had shipped more than 28,000 units in the first nine months of 1983 (including approximately 6700 in Sept. 1983) and had for that period revenues of \$58,978,000. When Compaq subsequently went public, the offering was quite satisfying to its original investors. *Time* magazine, in its January 23, 1984 cover story on venture capital firms, pointed out that the initial \$2.5 million investment in Compaq by the Sevin-Rosen Capital Management Fund (the principal investor in both Compaq and Lotus Development Corp.) was worth \$40 million on the day of public

(Continued on page 88)



Power cord access is through side panel.

Anchorage that this morning you began in New York.

Though the ability to use a computer on trips is important to some, it is not the only benefit of transportability. Many more people use a computer both at home and in the office, and Compaq provides a way for them to do this effectively with one computer. Another often overlooked benefit of transportability is the ease with which one can move computers within an office. This can result in a more judicious use of funds within an organization. For example, three com-

ferred from the rest of the manufacturers who produce compatibles. While other firms, such as Columbia and Corona, have presented their products as alternatives to the IBM PC, Compaq has really put forth its products as PC supplementals. This approach, which allows the PC user to run the same programs at home, on the road, or in the office, has resulted in Compaqs being marketed by the same independent dealers who market PC. Thus, looking to buy, a prospective purchaser does not confront—as he would in a non-IBM dealer's—someone who

TO KEEP UP WITH TODAY'S TECHNOLOGY

...YOU HAVE TO KNOW WHERE TO TURN.



When you turn to *Computers & Electronics*, you're reading the world's foremost publication covering the microcomputer industry — where last night's discovery is today's technology. *Computers & Electronics* is your direct link to state-of-the-art information in:

Microcomputer Developments

Whether you're investing \$300 or \$3000, turn to *Computers & Electronics* first. You'll find candid test reports of all major new microcomputers... from the Commodore 64 to the Apple™ IIe to the IBM-PCXT. And you'll discover which unit has the power, software and expansion capability to meet your specific needs. At your specific budget.

New Peripherals and Software

Micro programs and add-ons are increasing almost geometrically. Let *Computers & Electronics* sort it all out for you.

You'll get features like a buyer's guide to printers. A preview of the first workable economical thesaurus program that runs on virtually any CP/M-based system. Advance looks at new products like a joystick for Visicalc®...disk drive assemblies...a color monitor for the IBM-PC.

Increase Your Computer Science I.Q.

Computers & Electronics will enlighten you with easy-to-understand discussions of computer fundamentals. Such as the series on learning 16-bit microcomputer technology and an in-depth look at the structure of CP/M.

You'll also delve into the future with articles like Super Chip: next-generation personal computers with double the performance at a lower price.

• Windowing Software
• New Tools Of Art



Plenty of Hands-On Action, Too

With expert input from *Computers & Electronics*, and your own electronics savvy, you'll find dozens of ways to experiment with...upgrade...and increase the versatility and performance of your system.

For example, with less than \$3 and very little time, you can add a feature to your keyboard that lets you automatically repeat a character by holding down a key. Or you might want to build a circuit that lets you match a 600-baud CoCo to a 300-baud printer.

Heard about the important new electrically-erasable PROMs? *Computers & Electronics* will keep you filled in on the improved memory chips as they're produced — how they work, how to wire them, what applications to use them for.

Get Every Issue...PLUS Savings up to 37%!

If you're not getting every informative issue of *Computers & Electronics*, there's a gap in your knowledge — and enjoyment — of today's high-speed, high-tech revolution. And now's the best time to subscribe, while this introductory offer is in effect: One year (12 big issues) for just \$12.97, with long-term savings available up to 37%!

So keep up with what's happening. Turn to the special postpaid order card or the coupon below...now!



**DON'T MISS ONE
INFORMATIVE ISSUE.
SUBSCRIBE NOW AND
SAVE UP TO 37%!**

WORLD'S LARGEST COMPUTER MAGAZINE
**Computers
& ELECTRONICS**

P.O. Box 2774
Boulder, CO 80322

YES! Keep me tuned in with *Computers & Electronics* for the term I've checked below:

- One year (12 issues) just \$12.97 — I save 24%!
- Two years just \$22.97 — I save 32%!
- Three years just \$31.97 — I save 37%!

(Savings based on full one-year subscription price of \$16.97)

Mr. /Mrs. /Ms.

(please print full name)

CE 45150

Address

Apt.

City

State

Zip

CHECK ONE: Payment enclosed. Bill me later.

Please charge my credit card: American Express MasterCard Visa

Card No.

Exp. Date

Add \$5 a year in Canada; all other foreign add \$8 a year. Please allow 30-60 days for delivery of first issue.

Compatibility and Portability

(Continued from page 86)

offering. (Benjamin M. Rosen, one of the principals in Sevin-Rosen is now chairman of Compaq.)

What do we mean when we say that Compaq produces a quality product? Before closing this discussion, let's look at the machines we're speaking about:

- The Portable and Plus look exactly alike except, of course, that the Plus has a hard disk on the right side.
- Their keyboards are exactly the same as the PC keyboard.
- The Plus weighs approximately 31 lb and the Portable (with two floppy disk drives) approximately 1 lb more.
- Both machines initially have five expansion slots. Using its own video card and a Centronics parallel interface card, Compaq has filled two slots on these machines. The hard disk controller on the Plus takes up an additional slot leaving three slots on the Portable and two on the Plus for external expansion.
- The video circuitry within the machines allows the very sharp 9" black-and-green monitor to serve as both a text and graphics monitor. Additionally, the Compaq has its own character set, which is more readable than the standard IBM. Compaq feels that its video circuitry is

unique and has applied for a patent in this area.

- Compaq has attained its high degree of hard disk reliability with a 3½" hard disk (rather than the usual 5¼"). The smaller size leaves room for more impact-proof material to protect the drive. While we agree with Compaq's design decision, we are aware of an individual who replaced the Compaq assembly with a 5¼" 20M-byte hard disk and has had no problems (as yet). It is his feeling that the Compaq case itself provides sufficient impact-proofing for a properly mounted Winchester.

- The Plus that we purchased has been extremely sensitive to temperature. Whenever we left it in an unheated room, it refused to boot until we had warmed it up. Once warmed, it worked fine.

For those interested in hardware compatibility, we have plugged an AST 6 Pack Plus, Quadram Quadboard, Corvus Omninet Server, Microsoft Mouse, VisiOn Mouse and Quadram Quadlink interfaces into the systems and have had no problems. The installation of such cards, however, brings us to one of our only annoyances with the system. Compaq does not provide technical doc-

umentation, schematics or instructions for installing such peripherals. Only through trial and error does one find that, to install peripherals, one must just loosen (not remove) the screws that fasten the inner impact case. You find this out *after* you find out how to pry open the case and *before* you find that the system board switches are in the opposite position from the PC and that, to allow proper access to the switches on the Plus, the hard disk controller card must be removed from its slot.

When we compare the lack of technical documentation for the Compaq with the technical reference and hardware maintenance manuals available for the PC and the technical information furnished with the Columbia VP, we get even more annoyed. Nevertheless, small annoyances aside, we give top rating to the Compaq computers for compatibility, performance and reliability.

We have purchased Compaqs as well as IBMs and have absolutely no regrets or misgivings about those purchases. For the future, we will choose Compaqs over all compatibles presently on the market and, in most cases, also over the IBM PC. ◇

Hewlett-Packard Model 110

(Continued from page 51)

rechargeable and provides 16 hours of continuous use on a full charge. It takes approximately 12 hours to recharge the battery pack using the battery charger/eliminator that comes with the HP110. Continuous memory will be retained for as long as one year while the portable is

CMOS CIRCUITRY

How did Hewlett-Packard get so much computing power in so little a space? By using only CMOS circuitry and custom-designed ICs.

The HP 110 has four printed circuit boards which hold nearly 100 CMOS chips: A main logic board on which reside the CPU, RAM and ROM; an I/O board with RS232; an LCD board; and a battery board.

Hewlett-Packard custom designed their own RAM, ROM and LCD controller and used what they call a "Kitchen sink bar" (it has everything but the kitchen sink on it) to control most of the other functions.

There are more than 16 million silicon-based inside the HP110; but because of the CMOS design, even when running full bore the HP110 consumes less than a watt of power. ◇

off, so there is little probability of losing data.

An 80-character by 16-line liquid crystal display is used to view data and its contrast may be lightened or darkened by keyboard commands. The display tilts in a nearly 180-degree continuous arc to allow for user visual preference and ambient lighting conditions. Unfortunately, the HP110 does not support an external video monitor. For those who are accustomed to the gray tones of an LCD this should not pose much of a problem, but for those used to high-resolution monitors, an LCD can be very frustrating.

The portable employs a typewriter-style 75-key keyboard with eight special functions keys. The keyboard will not win any design awards. Rather, it looks much like the rough-and-tumble keyboards of the old manual typewriter days. There is something very durable and functional about the way the keyboard looks, however, and the key travel feels good and permits rapid typing.

A true lap computer, the HP110 weighs a compact 8.5 lb and measures 13" wide by 10" deep by 2⅞" high. It is certainly small enough to fit inside most briefcases; and since you need no floppies, you may even have room for

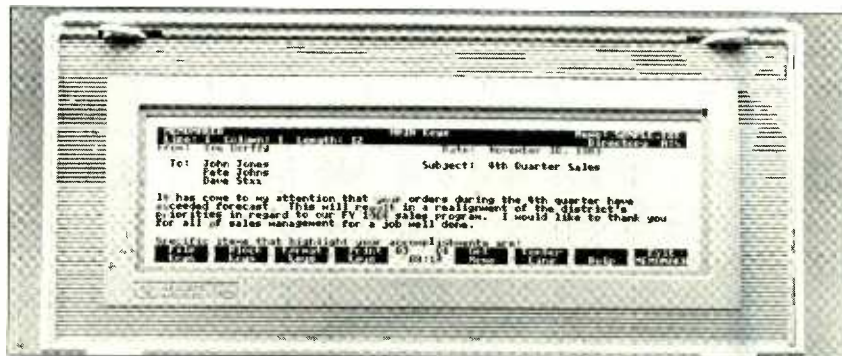

HP110's LCD with menu function commands.

your favorite sci-fi novel as well as the printouts of your work.

Built into the portable is a 300-baud modem that provides full-duplex, asynchronous operation. The modem also features automatic dialing (pulse or tone) or manual dialing, ring detect and automatic answer.

Connecting Peripherals

Serial peripherals can be connected to the HP110 using the built-in serial port cables for use with the port: one for printers and plotters, the second for connecting modems—if you wish to use an external modem.

The portable can interface with desktop computers like the IBM PC, Compaq and others and use the desktop's peripherals through HP's Interlink, which consists of a plug-in card for the desktop computer, software and cables. For example, the HP110 can drive a desktop's hard disk, plotter or printer simply by connecting two cables and the plug-in card.

HP also offers a companion battery-powered disk drive, the HP9114A. In addition to the vast solid-state "disk drives," the HP110 will drive as many as eight external HP disk drives. HP's battery-powered drive is a 3½" 700K drive and will be one of the first 3½" drives to

use double-sided media. It will have a 6-to-8-hour duty cycle per full charge. It rotates at 600 rpm and sports a 497-milisecond average access time. It will cost around \$700 and shipping will begin around June 15.

One interesting feature designed into the HP110 portable is a "fuel gauge"—a continuous display that tells the user by means of a two-digit number what percentage of battery power remains.

In addition, when the battery voltage drops below a predetermined level, a low-battery indicator is displayed in the lower left corner of the LCD. At this point, the user has from 1½ to 2 months of memory. If the battery is not charged

HP110—KING OF THE KNEETOPS

BY SETH R. ALPERT

RECENTLY I got to spend some time with Hewlett-Packard's new dream machine, the HP110. Aside from the obvious—its incredible compactness and portability—this machine has a lot to be said for it. Specifically, there are the silicon disks, the speed of the 8086 processor and the ROM-based software. In addition, the 110 feels substantial and solid despite its small size and weight.

Let me try to put the speed issue into perspective. Obviously, because of the 110's silicon disks anything that normally utilizes disk I/O happens with seemingly magic quickness. This includes starting up applications and loading or saving text or worksheet files. For example, a 33K worksheet file is loaded by the ROM-resident 1-2-3 in about 16 seconds. Also, CPU-intensive work like recalculating a large spreadsheet model seems significantly faster than on 8088-based machines that I have used, including the IBM PC. On the other hand, operations that don't really depend on disk access or computation run about as they do elsewhere. For example, Wordstar operations that are display intensive are about as slow as on other machines.

One of the fascinating things about speed, of course, is that one immediately acclimates to whatever is available. Thus, after a few hours at the 110's keyboard, its speed began to feel ordinary. Going back to my existing MS-DOS machine, however, will likely prove painful for a while.

Regarding the built-in software, the two HP proprietary applications are functional but unexciting. The terminal emulation program, simply called Terminal Emulation, uses menus to set com-

munications parameters and to create upload and download procedures between the micro and host. These do get the job done competently, but they are less convenient to use than other communications software. Also, while 300 baud is adequate, it seems unfortunate that a machine that is so fast in all other respects does not have a 1200-baud modem. However, this is a relatively minor quibble, and for those who really want 1200 baud, an outboard modem can be used.

The ROM-based word processor, called MemoMaker, is adequate for the preparation of simple text files—memos, just as the name implies. A full-blown word processor it is not. MemoMaker reads and writes files that are Wordstar compatible.

Of course, the big seller here is 1-2-3. This machine is a financial analyst's dream. All the power of the best-selling spreadsheet is there, including the graphics. And boy, is it fast.

One minor limitation is the 16-line display. I found the number of lines to be only a slight inconvenience. Those who really need to see as large a view of what they are doing as possible or who must have color should note that they will not be able to use a monitor with the 110 even when at the office. Too bad.

As for the display quality, this LCD suffers from the same problems as its brethren elsewhere. That is, you need good lighting and a properly adjusted viewing angle to be able to work comfortably. Actually, I sat at the keyboard for several hours putting the beast through its paces and found the screen to be easy on the eyes. Be aware that reactions to LCD's vary significantly be-

tween individuals.

Then there's Interlink. Available from HP, this combination of software and an add-on board for a disk-based MS-DOS machine gives you the ability to snatch data and programs from the disk drives that you already have in another machine. In fact, any of the desktop's peripherals are accessible to the 110 through Interlink, including printers and the display. Unfortunately, the display is treated as a virtual printer, so you cannot use Interlink effectively to run the 110 with a monitor. As an example, one possible application of Interlink if you have access to a PC with Wordstar would be to use MemoMaker while you're on the road and save the serious word processing for when you get back to the office. This would save you from having to chew up memory with Wordstar. Portable disk drives are not available. Hence, if you are going to add your own application to the HP110 such as a heavy duty word processor, you'd better remember that it will reside on drive A, the RAM disk. This means that large programs (Microsoft Word for example) won't really fit on the machine. In fact, in this operating mode it is simply amazing how quickly the 272K of memory disappears. My advice for those who want to run a large application besides Lotus is to wait until the disk drive is available and get one. Until then, those with access to an Interlink-compatible MS-DOS machine can utilize the disk-based machine's drives when not traveling with the 110.

To summarize, I really enjoyed using the HP110. It is an exciting breakthrough in lap-size portable computers. ♦

HP110

during this time, normal operations are automatically halted including any currently executing program, beeper output, display output or interlink operation.

Also included is a real-time clock that keeps the date and time even when the unit is turned off. The clock is used to set time and date within MS-DOS, so your files are properly time and date stamped. The clock can also be set to turn the portable on and run a program automatically. For example, the HP110 can turn itself on in the middle of the night when the telephone rates are less expensive, autodial, and dump its data into a mainframe.

The portable is compatible with the HP150 in that it can switch data files back and forth. But because of its 16-line display, there are some programs with which it is not compatible. Microsoft BASIC, Pascal and FORTRAN and dBase II will be available for the HP110 soon.

As a companion to the HP110 (and the HP150), Hewlett-Packard has introduced ThinkJet, a portable ink-jet printer that costs \$495. ThinkJet prints at 150 characters per second, uses an 11×12 dot-matrix and weighs about 6 lb. Any paper may be used with the printer. The ink cartridge has a 500-page capacity and the battery life is rated at being able to print 200 pages. It will support full graphics, 192-by-96 or 96-by-96 dots per inch. A Centronix interface is available as well as the HP-Interlink interface.

The three portable devices—HP110, disk drive, and printer—together weigh only about 20 lb.

The HP110 can be operated in a fairly broad range of temperature regimes—32 to 113 degrees F—but HP does not recommend leaving the unit in the trunk of a car or accompanying Rocky as he works out in a meat cooler.

Hewlett-Packard claims the portable meets stringent FCC standards regarding electrical emissions and it certified that it passes Class B parts 15 and 68 regulations. The HP110 is also UL listed and CSA certified.

The plastic case which houses the HP110 is shock tested to an enviable 100 g's of force on all six sides which makes it almost suitable even for rides with New York City cab drivers.

In sum, the HP110 portable with its ROM loaded with Lotus 1-2-3, a word processor and terminal emulator, seems to have everything but Dilithium Crystals and Vulcan logic gates. So if you want a truly powerful portable with few compromises, ask Hewlett-Packard to beam one down to you. ◇

Encryption

(Continued from page 67)

The best known single-key system today is the data encryption standard, or DES. Originally IBM's Lucifer system, the DES was jointly refined by IBM and

the National Security Agency (the U.S. government agency responsible for—among other things—making and breaking codes and cyphers), and approved by

TWO-KEY ENCRYPTION

IN 1976 three mathematicians (Martin Hellman, Whitfield Diffie, and Ralph Merkle) working at Stanford University developed a method of cryptography in which the encryption key can be different from the decryption key. Knowledge of one of the keys does not yield the other. The system is analogous to having a box with a lock on it that can be locked by one type of key but can only be unlocked by another type of key.

This system became known as **two-key**, or public-key, cryptography. The term "public-key" refers to the fact that one of the keys can be published in a directory and distributed publicly without invalidating the integrity of the encrypted information.

If one person wanted to send another a private message, he could look up his public key in the directory and encrypt a message with it. Once encrypted even the originator would not be able to decrypt the cyphertext. When the cyphertext was received, the secret key corresponding to the recipient's public key would be used to restore the message to its original form.

In 1977 an MIT Group headed by Ron Rivest amplified upon the work of the Hellman group and developed what has become the most widely used two-key system. Known as the RSA (Rivest, Shamir, Adleman) system, this example of two-key cryptography derives its security from a problem that has been studied in mathematics for a long time.

The RSA system relies on the difficulty of factoring a large number that is the product of two large primes (prime numbers can only be evenly divided by themselves and by 1). It is much easier to prove that a large number is prime than it is to *find* the prime numbers that were multiplied to create a larger number.

The RSA algorithm has the advantage that it can be used to double-encrypt a message, first with a secret key and then with a public key. The result is a cyphertext that must first be decrypted with the recipient's secret key and then with the sender's public key. In this way the recipient has a message that can only be read by him and could have only been sent by one other person. This process is known as authentication and can be used to sign contracts electronically even though the two people have never met.

As an example of RSA, consider a

message consisting of the number 64 (ASCII "A") and raise it to the 123rd power while reducing it modulo 11797 (that is, finding its remainder when divided by 11797). The resultant number, 5362, is the cyphertext, or encrypted information. Raising that number, 5362, to the 187th power mod 11797 yields the original plaintext of 64.

The modulus (11797) can be published, along with one of the exponents (say, 123), allowing anyone to encrypt a message. The secret exponent (187) can be derived only by knowing the factors of the modulus. (11797 has the factors 47 and 251).

If the original primes that make up the modulus are on the order of 100 digits, a 200-digit number results when the two are multiplied. The problem for the code breaker is to find the factors of the modulus so that given one of the exponent keys the other can be derived. This process is easy when the modulus is small, but the difficulty approximately doubles each time the size of the modulus is increased by three digits.

As recently reported in an issue of *Time* magazine, a powerful Cray 1 computer has been used to factor a 69-digit prime number. The number:

```
1326861043989
7205317760857
5506090561429
3539359890335
2580289146945
9697
```

which can be expressed as 2 to the 251st power minus 1, has been curious to mathematicians because the number 251 is itself prime. The factoring took 32.2 hours.

It is reasonable to assume that within the next 20 years machines will be developed that can factor 10,000 times faster than the Cray 1, and that the difficulty of factoring doubles with every three added decimal digits. In the original MIT publication (MIT/LCS/TM-82, April 1977) the RSA group recommended that the previous assumptions, RSA based on a 200-digit number would require over 500,000 years to break 20 years from now. Since it is always easier to multiply numbers than to factor them, the security of RSA can always be increased by using a larger modulus. This is why we describe the RSA algorithm as "computationally secure." ◇

HARNESS THE FULL POTENTIAL OF YOUR HOME COMPUTER

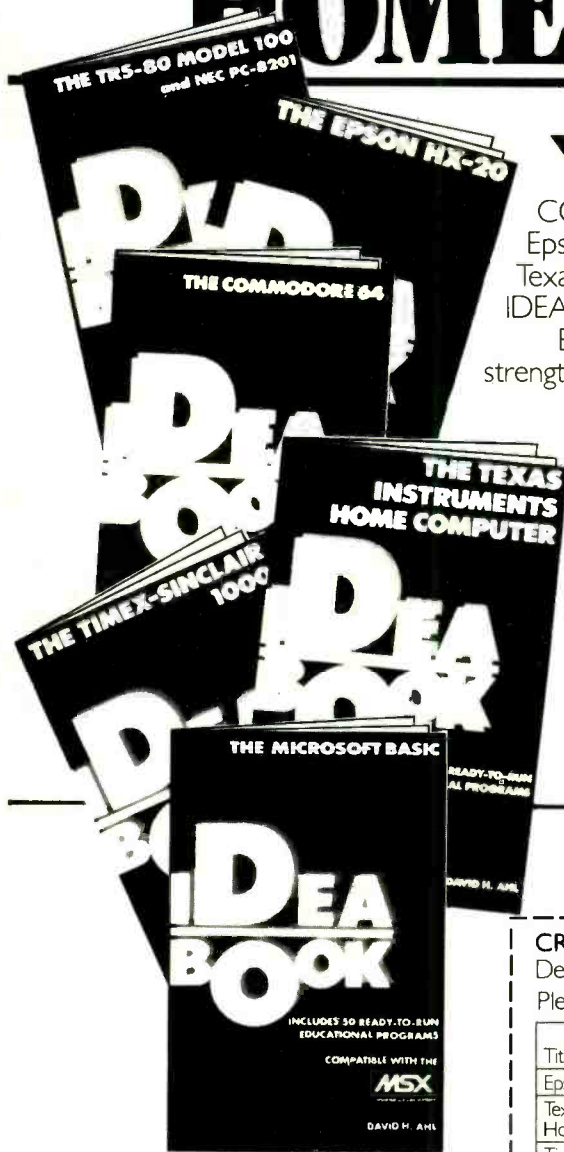

**ONLY
\$8.95
EACH**

You can increase your knowledge and harness all the power your home computer system has to offer with CREATIVE COMPUTING PRESS' IDEABOOKS. If you're an owner of an Epson HX-20, TS 1000, TRS-80 Model 100, Commodore 64, Texas Instruments or work with Microsoft Basic, you'll find an IDEABOOK written for you!

Each IDEABOOK helps you discover your computer's hidden strengths and overcome its weaknesses! As soon as you open to chapter one, you'll begin to get more out of your system with:

- 50 tested, ready-to-run programs that will help you solve everyday problems in math, science and business.
- Problem solving formulas with repetitive trials, convergence, recursion, compounding, probability, simulations, geometry, science and drill and practice.
- Ways to identify any shortcomings and targeted applications that are best suited for your system.

Supplement your user manual with the IDEABOOK that's just right for you! Gain the knowledge and confidence you need to make the most of your system—ORDER YOUR COPY TODAY!

**For faster delivery, PHONE TOLL FREE
9 am-5 pm E.S.T.: 1-800-631-8112 (In NJ only: 201-540-0445)**

Also available at your local bookstore or computer store.

CREATIVE COMPUTING PRESS

Dept. NT7F 39 East Hanover Avenue, Morris Plains, NJ 07950

Please send me the following books:

Title	Book No.	Qty.	Price Each	\$2.00 Postage & Handling Each	Total Price
Epson HX-20 Ed.	3S		\$8.95		
Texas Instruments Home Computer Ed.	3R		\$8.95		
Timex-Sinclair 1000 Ed.	3P		\$8.95		
TRS-80 Model 100 Ed.	4A		\$8.95		
Microsoft Basic Ed.	67-4		\$8.95		
Commodore 64 Ed.	68-2		\$8.95		
CA, NJ and NY State residents add applicable sales tax					
Total Amount Due					

Payment Enclosed \$ _____ Outside USA add \$3.00 per order.

Purchase orders \$50 minimum.

Charge My: American Express Visa Mastercard

Card No. _____ Exp. Date _____

Mr./Ms./Mrs. _____ (print full name)

Address _____

City/State/Zip _____

Please send me a Free Creative Computing Press Catalog.

Circle No. 4 on Free Information Card

Encryption

the National Bureau of Standards for non-classified government data.

The DES is a **block cypher** system with a block size of 64 bits. That is, the information is encrypted in blocks 64 bits (eight bytes) long. It uses a key 56 bits long. The DES can be used as a **key stream** system if cypher feedback—encryption in which the key stream is subtly modified each time it is used—is employed. (A key stream is the information used as a key, or to generate a key.) The American Banking Association has approved the DES for use in electronic funds transfer in its cypher-feedback mode.

The best known two-key (or public key) system utilizes the RSA algorithm developed at MIT by a group headed by Ron Rivest. (See accompanying sidebar). RSA derives its security from the difficulty of factoring very large prime numbers. It works by raising the numeric representation of a message—a large number—to a high power and then reducing it modulo another number.

(This process can be explained as follows: Call the large number raised to a high power x , and divide it by another number, y . This divisor is referred to as the *modulus*. Note that the modulus must be smaller than the number it divides. The result is a whole number, n , and a remainder, r . In modular arithmetic what counts is only that remainder, r . For example, $5 \text{ mod } 2$ is 1, the remainder obtained when 5 is divided by 2.)

The **cyphertext**, or encrypted number, is converted to the **plaintext**, or original number, by raising it to a second large power and reducing by the modulus. Breaking the system is equivalent to factoring the modulus—the divisor—which is chosen to be the product of two large primes. With a modulus greater than 512 bits this would require thousands of years even with today's fastest computers. Thus RSA is considered to be computationally secure because the factoring of a composite of two large primes is a problem of known—and extreme—difficulty.

Other Systems and Applications

There are many other types of cypher systems available. In general it is difficult to determine their adequacy. The best assurance a user can have about a system is that it has been openly published, analysed by many cryptographers, and is uniquely keyable by a number consisting of more than 120 bits.

For even higher security **superencipherment** is used. Superencipherment

is encrypting several times using two or more unrelated crypto systems. De-

crypting a superencyphered message requires applying the appropriate decod-

THE ONE-TIME PAD

THE one-time pad is totally secure because each part of the cyphertext produced using it has an equal probability of containing any possible pattern. The first step in the construction of a one-time pad is to generate truly random numbers. Consider flipping a coin to obtain the following sequence, with heads being represented by a 1 and tails by a 0:

10011011 00110110 00101101
10011001 01010001 11010010

This sequence becomes the **key stream**—the source from which the key is derived.

If we represent the characters by their ASCII (American Standard Code for Information Interchange) code in binary form, the message:

Test 1

Becomes:

T	e	s
01011110	01100101	01110011
t		l
01110100	00100000	00110001

The next task is to exclusive-or (XOR) the key stream with the plaintext. In the XOR function if both bits are either 1 or 0 the result is 0. If the bits are different the result is 1:

A	B	A XOR B
0	0	0
1	0	1
0	1	1
1	1	0

Using the "Test 1" example shown above, the result of XORing the text with the key stream is as shown in Fig. A.

The plaintext can be recovered by XORing the cyphertext with the key stream as shown in Fig. B.

The truly random key stream can be replaced by a pseudo-random number generator. A number generator is called pseudo random if its output appears random, but is in fact, controlled by a formula. The key for the generator is the place the generator starts. If the pseudo-random generator is cryptographically secure, then the cyphertext produced will be secure. Many types of generators have been devised, and the best include combinations of mathematically unre-

lated types. The following generator is called a feedback shift register generator:

Initial state	1000	The first bit of the shift register is
	1100	XORed with the last bit. The four bits
	1110	are shifted right with the last bit
		disappearing.
	1111	The XORed bit is added to the left.
	0111	
	1011	
	0101	
	1010	
	1101	
	0110	
	0011	
	1001	
	0100	
	0010	
	0001	
	1000	

Note that there are 15 unique states (or 2 to the n minus 1, where n equals the number of bits in the shift register) and that the all-0 state is excluded. If the generator were keyed to this state then it would only output 0s. This generator can be keyed with four bits; it can also be broken with the same four bits. This form of generator (called a linear generator) must be very long, and be combined (XORed) with other types of generators in order to be secure.

Although the national DES has been criticized for being insecure because of its short key-length (56 bits), one mode of using the DES has generally been evaluated as fairly secure. This mode is called the **one-bit cypher-feedback mode**. In the one-bit cypher-feedback mode a shift register is originally set to a given pattern. After that a single bit of the DES key stream is XORed with the plaintext to produce a cyphertext. The cyphertext bit is then placed in the shift register which is shifted to accommodate it. The new information in the shift register is passed through DES, and the leftmost bit is used to encrypt the next plaintext bit. In this way the DES forms a type of key-system generator. ♦

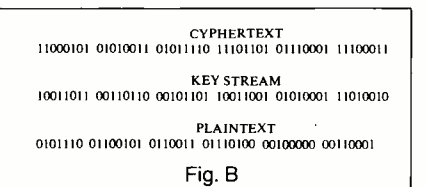
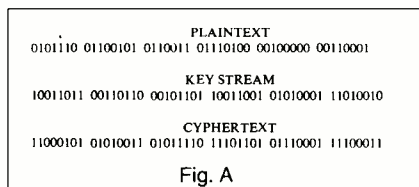

ing schemes in the reverse order in which they were used for encryption.

An important design consideration for crypto systems is that the security should rest with the key and be independent of knowledge of how the encryption algorithm operates. Crypto keys must be managed as carefully as the combination to the company safe, or the keys to a locked file cabinet. In addition to keeping information private there are other uses for cryptography.

One way crypto can be used is to prevent a message from being tampered with, or "spoofed." Large block cyphers are excellent for this purpose, as changing even a single bit in the block can result in a change in any part of the entire block.

Another new use is for authentication. Using two-key encryption (see the sidebar on this subject), a secret key and a public key can be used to encrypt a message. The resulting cyphertext must first be decrypted with the recipient's secret key, and then with the sender's public key. This combination of keys is unique and specifically identifies both the sender and the recipient, and makes it possible to validate electronic signatures.

GLOSSARY

Algorithm: A procedure or formula for solving a problem or attaining a particular end.

Block cypher: An encoding scheme that operates on information in groups of a predetermined size. The DES uses a block cypher length of 64 bits.

Cryptography: Applied cryptology.

Cryptology: The study of making and breaking codes and cyphers.

Cypher: A method of rendering a message unreadable by altering and/or rearranging the information contained in it.

Cypher feedback: Recirculating a key or cypher.

Cyphertext: The encrypted information.

Decrypt: To return an encrypted message to intelligible form.

DES: The National Bureau of Standards' data-encryption standard.

Encrypt: To render a message unintelligible, as by the use of a cypher.

Key: The information used to encrypt or decrypt a message.

Modulus: A divisor used in modular arithmetic. 15 modulo, or mod, 2 is 15 divided by two. In modular arithmetic, only the remainder (1 in this case) is considered.

Plaintext: The information before encryption or after decryption.

Preshuffling: The process of using one method to encrypt information prior to its being encrypted by another. This provides additional security.

RSA: A type of two-key cryptographic system deriving its security from the difficulty of factoring large prime numbers.

Single-key cryptography: A system using the same key to both lock and unlock information.

Supercypher: To encrypt twice using two unrelated methods.

Two-key cryptography: A system using one key for encryption and a different key for decryption. Knowledge of one key does not reveal the other.

RATED #1 FOR SERVICE & RELIABILITY

CALL TOLL FREE
800-221-8180
IN NEW YORK STATE
CALL (212) 732-8600

J&R MUSIC WORLD

23 PARK ROW
NEW YORK CITY,
NEW YORK
10038

THIS MONTH'S SUPER SPECIALS

ATARI 800XL



• Home Computer
• 64K RAM/256 Colors
• Built-in High-Level BASIC

\$259⁹⁵

ATARI 800XL HOME COMPUTER

• 156K RAM Built-in Basic
• Expandable to 64k

\$159⁹⁵

ATARI SOFTWARE

ATARI 1010 Program Recorder \$74.95
ATARI 1050 Disk Drive \$359.95
ATARI 850 Interface Module \$69.95
MICRO PERK: 64K Exp. Exp. \$119.95

ATARI 5200 GAMEWARE

ATARI CX2020 Centipede \$34.95
ATARI CX2010 Invaders to Pro \$79.95
ATARI CX4018 Pilot Home Package \$64.95
DATA-SOFT ZAXXON Cassette \$69.95

ATARI 5200 GAMEWARE

ATARI CX2699 1az \$27.95
ATARI CX2675 Ms. Pac Man \$29.95
ATARI CX2676 Centipede \$27.95
ATARI CX2681 Joust \$27.95
ATARI CX2688 Pole Position \$24.95
PARKER 5300 Frogger \$22.95

ATARI 5200 GAMEWARE

ATARI CX5209 Ramparts Base \$37.95
ATARI CX5240 Joust \$27.95
ATARI CX5206 Galaxian \$27.95
ATARI CX5217 Pole Position \$27.95

MODEMS

ATARI 1030 Direct Connect \$119.95
ATARI 130 Acoustic Modem \$139.95
VIC 1600 Modem for VIC 20 \$59.95
VIC 1650 Acoustic Modem \$59.95

ANCHOR AUTOMATION Volkswindem

Universal Tractor Cable \$59.95
Special Cable for Apple Texas Inst. \$12.95
Atari or IBM \$12.95
ANCHOR AUTOMATION MK-III \$49.95
RS232 Comp. Hayes Compatible \$49.95

SANYO MBC555

• 128K Color Computer
• Double Disk Drives
• Software Pak

\$1249⁹⁵

SANYO MBC550 128K Single Drive \$819.95

SANYO MBC1100 320K Drive \$1199.95

MONITORS

VIC C1702 14" Color \$249.95
NEC C1202A 12" Color \$259.95
TAXAN 415 12" High Vision III \$299.95
TAXAN 100 12" Green Screen \$129.95
TAXAN 210 12" 800L Composite \$289.95
AMDEK 300A 12" Amber Screen \$159.95
AMDEK 300C 12" Green Screen \$159.95
AMDEK COLOR 14" 13" Monitor \$299.95
ZENITH ZM172 12" Amber \$119.95
PANASONIC DT1600 10" Color \$269.95
PANASONIC DT1300D 13" Color \$349.95
PANASONIC DT1100 10" or 12" \$199.95

APPLE IIc



• Starter System
includes
Monitor
80 Col. Card
Drive & Controller

\$1279⁹⁵

APPLE SOFTWARE

BARRON'S EDU. S.A.T. DISK \$69.95
CONTINENTAL HOME ACCT. DISK \$44.95
EINSTEIN COMPILER DISK \$79.95
BROCKBUND BANK STREET WRITER
(Word Processor) Disk \$39.95

EAGLE PC2 PERSONAL COMPUTER

• 128K RAM
• 2 Drives
• 17" Screen
• IBM Compatible
• MS-DOS, CP/M 85

\$2589⁹⁵

DISC DRIVES

CONCORD PERIPHERAL DRIVES
CONCORD C221 M For Atari
170K 10 1/2 \$289.95
CONCORD C322 P For Commodore 64
Double-Disk 5.25 Drive \$399.95
CONCORD C121 For Apple II 16K \$219.95
CONCORD C130 For Apple II Controller
Set for 10 1/2 & Drives \$59.95

RANA 1000 For Atari 180K

RANA ELITE - 1 For Apple II
With Controller Card \$319.95
RANA ELITE 1 For Apple II \$249.95

FREE GIANT CATALOGS

288 PAGE GIANT AUDIO
VIDEO COMPUTER
CATALOG: Complete
Buying Source

80 PAGE GIANT VIDEO
CATALOG: With over 7000
Video Cass. CED, & Laser
Disc Movies

64 PAGE GIANT SOURCE & CASSETTE CATALOG: Complete List of
the most Popular Artist and Titles

23 PARK ROW, DEPT. CES, NYC, NY 10038

HOW TO ORDER BY MAIL. FOR PROMPT AND CERTAIN SHIPMENT SEND MONEY

ORDER: CASH, CHECK, CASHIER'S CHECK, MASTERCARD, VISA, INSURE CARD
NUMBER. Interbank No. expiration date and signature. **DO NOT SEND CASH.** PER
SONAL AND BUSINESS CHECKS MUST CLEAR OUR BANK BEFORE PROCESSING \$25

MINIMUM ORDER: Shipping, handling & insurance charge is 5% of Total Order
with a \$5.95 minimum. We ship to CONTINENTAL U.S. Alaska, Hawaii, Puerto
RICO, AND CANADA ONLY (Canadian Dollars, add 15% shipping, with a \$9.95
minimum charge) For shipments by air, please double these charges. SORRY,
NO C.O.D.'s. New York residents please add SALES TAX. ALL MERCHANDISE
SHIPPED BRAND NEW, FACTORY FRESH, AND 100% GUARANTEED. WE ARE NOT
RESPONSIBLE FOR ANY TYPOGRAPHICAL ERRORS.

WRITE OR CALL for FREE 288 PAGE AUDIO / VIDEO / COMPUTER CATALOG

Circle No. 23 on Free Information Card

inmac
PERSONAL COMPUTER
SUPPORT
CATALOG

CALL TOLL FREE
FREE COPY

Inmac makes it easy to make your computer work harder.

- Choose from over 1500 products, all specially selected to help you get more out of your computer.
- **One-stop shopping.** Paper, connectors, cables, more. Many exclusive Inmac products, too.
- **Easy ordering.** Mail, phone or TWX. Verbal P.O.'s welcome.
- **Lower shipping costs.** All 9 Inmac distribution centers are fully stocked, so your order can be shipped from the nearest center.
- **45-day risk-free trial.** Full refund if not completely satisfied.
- **Guaranteed quality.** Most guaranteed for one year, some guaranteed for life.

1-800-547-5444.*

inmac

Please send me a free copy of Inmac's Personal Computer Support Catalog.

Inmac Catalog Dept.
2465 Augustine Drive
Santa Clara, CA 95051

NAME _____

COMPANY _____

ADDRESS _____

CITY _____

STATE _____

ZIP _____

PHONE _____

*In California, call 1-800-547-5447 for your free catalog.

235105

Circle No. 10 on Free Information Card

Chameleon

(Continued from page 31)

The Disk Drives

Though the original Chameleon could not read double-sided IBM disks, its big brother, the Chameleon Plus, is equipped to handle the job. The dual MPI model 52S drives on the Chameleon Plus are 5¼" double-sided and double-density, thus allowing for a full 360K bytes of storage on each drive and a total of over 640K of on-line storage. The LED lights up when the drives are in use, then turns off to indicate that you can remove the disk. As in most portables, both drives are activated even if only one is being used.

A few seconds after you insert an MS-DOS disk, the Chameleon Plus comes to life as an IBM PC compatible system using standard MS-DOS disk formats. Without a disk in the drive, the cold boot implements the Chameleon Monitor Version 2.14 after about 20 seconds. The monitor commands include B (Boot Disk), G (Go), and V (which toggles to a 40-column screen display).

Software

The Chameleon Plus comes with bundled software, including Perfect Writer, Perfect Speller, Perfect Calc, and two 8088-processor MS-DOS 1.25 (Version 1.02) system disks. (GW BASIC and CONDOR can be obtained by mailing in a certificate.) Since the Chameleon Plus is first and foremost IBM PC compatible, all of its bundled software is MS-DOS based.

The disk operating system is exceptionally fast. Microsoft BASIC version 5.28, (included with the MS-DOS system disk) loads in about 3 seconds! Although touted as IBM PC BASIC compatible, BASIC86 does not support some of the more common IBM BASIC keywords, such as CLS; SOUND; KEY; KEY OFF; BEEP; WAIT; DEFSTR; and LOCATE.

A smart terminal simulator program called CTERM is included on the BASIC disk. CTERM allows the transmission and reception to disk of files via the serial RS-232 port and creates a 4K transmit buffer and a 64K receiver buffer. The serial port driver routines are included as an alterable SERDRV.OBJ file. I had no trouble using this program with a null modem to talk to other computers or communicate over phone lines using a modem.

The Z80-processor CP/M-80 Version 2.2 (Rev 1.0) system disk is available from Seequa as an option for \$150. The disk includes the standard Digital Re-

search CP/M-80 utility programs and is documented by the regular CP/M-80 manuals. Unfortunately, you cannot run your CP/M-80 programs on the system unless you purchase PC-DOS (version 2.00 or up) and the Crossdata program (\$99). To run on the Chameleon Plus, CP/M-80 programs must be written onto CP/M-86 formatted disks. Another drawback is that, in the CP/M-80 mode, you do not have access to any of the nearly 200K bytes not used by the operating system. This differs from machines such as the Kaypro 4 Plus 88, which uses the extra memory as a RAM disk.

It seems to me that what the world needs is a 16-bit microcomputer system that allows *coprocessing* with an 8-bit Z80. The Chameleon Plus, an MS-DOS machine, will not even read a directory

The Chameleon Plus seeks to imitate Big Blue's innards as close as possible

from the CP/M-80 disk in the normal mode (or vice versa). To implement the CP/M-80 system, you must reboot the system using the CP/M disk. There is a DSKMAINT program included that formats a disk (CP/M-86 format), copies the system, or copies an entire disk. I also was able to make a backup of the CP/M disk while in MS-DOS.

Documentation

A significant problem with the Chameleon Plus, as with many other systems, is that the documentation and upgrade instructions are inadequate. Approximately 7½ lb of software documentation is provided: typeset Perfect Writer and Perfect Calc manuals, about 50 pages of "Read-Me-First" materials covering the basics of running the various programs, and two small looseleaf binders containing a User's Manual and CP/M-80 documentation. The user's manual consists of photocopies of the Microsoft MS-DOS manual, the Microsoft BASIC86 Interpreter User's Guide, the Microsoft BASIC86 Reference Manual, and the Chameleon manual itself.

The documentation contains no hardware/software configuration information specific to the Chameleon Plus. There is no I/O port evaluation and no

DB25 connector pinouts for the standard RS-232 serial or Centronics parallel ports. There's no indication of where the Chameleon-specific BIOS and ROM routine entry points are. In short, there's hardly any technical information for the more sophisticated user who wants to write custom software, or for the user wishing to have someone else write programs for the system.

IBM Compatibility

Seequa appears to have aimed at making the Chameleon Plus as compatible with the IBM PC as possible. I had little trouble booting PC-DOS 2.0 or running SuperCalc3, Lotus 1-2-3, or Microsoft Word, as set up for the IBM PC. I could not run IBM BASIC or BASICA programs, however, including most of the public-domain software available through IBM PC user groups.

Another major limitation of the Chameleon Plus is that it does not fully implement the PC ROM as far as graphics are concerned. SuperCalc3 and Lotus, for example, both use protected fields for backgrounds in their spreadsheets and superimpose the user's data on top of these fields. In both programs the user graphics and data themselves are very clear and well presented, and there is no problem in printing either program. However, protected background graphics are distorted and letters break up (Fig. 1). Graphics produced with either of the programs are not affected (Fig. 2).

Conclusions

The Chameleon Plus is a transportable IBM PC clone that runs most PC software *without modification*. It is designed to allow customization and hardware upgrading, although the exact means and documentation for this are not provided. The CP/M-80 portion of the system should, perhaps, have been modified to enable the Z80 to take advantage of the Chameleon Plus's capabilities, possibly in a coprocessor or multiprocessing environment.

There is a real need for much more Chameleon-specific hardware and software documentation than is supplied. The use of PALs to configure the machine might make reconfiguration difficult without dealer assistance, which is often not reliable and not always freely given. There is an extension chassis that allows the use of PC compatible circuit cards, but I think if you really need that much compatibility with the IBM PC you would be better off with an actual PC or PC portable. ◇

TI 855 Printer

(Continued from page 33)

ging any of the optional font ROM cartridges into the printer automatically disables the built-in ROM and transfers control to the preprogrammed cartridge.

Any print option can be selected directly from the printer's control panel. To print out a simple document in which only a single font is to be used, such as a letter, all print options can be preset via the control panel switches, obviating the need to embed escape codes in the document file.

For complex printing tasks that require more than one font, it is more practical to embed appropriate escape codes in the document file. With proper coding, anything a word-processing program is capable of providing can be printed out by the Model 855 printer.

It's a wonder that this printer has come to market at a price that doesn't break the \$1000 barrier

Optional font cartridges currently available offer a variety of popular Roman and italics fonts that can be used in either the DRAFT or the QUALITY mode. Some include proportional spacing, while all can be used to generate justified text and a variety of pitches within the same document. Additional type fonts are likely to be added to the list in the near future.

If you require a special font not available from TI's library, you can design it yourself with the optional RAM font module.

Other Features

Inside the printer is an 8-position DIP switch for presetting certain parameters. Two positions permit selection of either 7 or 8 data bits and odd or even parity. A third position enables and disables the automatic line-feed feature, while the fourth position permits selection of the WP (word processing) or DP (data processing) mode.

In its word processing mode, the printer accepts the code set used for Diablo formed-character printers. Its data processing mode allows the printer to accept the code set used in Epson series

dot-matrix printers.

The final four positions of the DIP switch permit selection of either Centronics-compatible parallel interface (which is the configuration to which the printer is set at the factory) or standard RS-232 serial interface with various protocols and baud rates. Connection to the printer in either case is through the same DB-25 connector on its rear apron.

The optional drop-in fanfold paper tractor requires neither tools nor electrical connections for installation. Once in place, it uses a rather unusual scheme to move the paper around the platen and past the printhead. Instead of pulling the paper out of the printer after printing, as most tractors do, it *pushes* the paper under the platen and to the printhead. By using the push-feed scheme, the tractor makes it possible to print on the first line of any sheet of paper, rather than having to skip a sheet to begin printing as conventional pull-type tractors do.

One concern of a prospective buyer might be how much space on a computer desk will have to be reserved for the Model 855 printer. Since this is a standard letter printer that can be adjusted to handle paper up to 8½" wide (without tear-off perforations for fan-fold paper), its footprint is in the median range, measuring roughly 16" wide by 13" deep. This is only slightly larger than the Epson MX-80's footprint, though its height of 5½" (6" with tractor installed) is about 1½" taller than the MX-80.

Closing Comments

The TI Model 855 printer is not exactly quiet in operation, although it is a lot less noisy than other impact dot-matrix printers we have used. In the months we have had it up and running, we have had not one complaint about its performance, which was in fact flawless. The convenience and flexibility it offers have to be experienced to be appreciated. And considering all that the printer is capable of doing in formatting text, using different ROM font cartridges, it is a wonder that it has come to market at a price that does not break the \$1000 barrier.

Having used a number of late-model printers from various manufacturers, all offering a letter-quality mode, we have decided to make our next printer purchase a TI Model 855—mostly because of its ability to conveniently accommodate different plug-in ROM font cartridges. As an aside to this, it is interesting to report that several people who have seen the Model 855 in operation in our offices have already placed orders for this printer. ♦

REDUCES DISKETTE COST 50%!

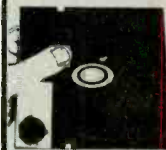

Make use of the back of your 5¼" Diskettes and SAVE.

- **NIBBLE NOTCH** tools make it easy

- Adds the precise notch where you need it.

- Doubles diskette space or MONEY BACK.

NIBBLE NOTCH I

Cuts square notch for Apple, II, II+, IIe, III, Franklin and Commodore.

only **\$14.95** each
add \$1.50 each P&H / (\$4.50 each foreign P&H)

NIBBLE NOTCH II

Cuts square notch and ¼" inch round "index hole." For use with computers other than those shown above.

only **\$21.90** each
add \$2.50 each P&H / (\$6.50 each foreign P&H)

SATISFACTION GUARANTEED OR YOUR MONEY BACK

Florida Residents Add 5% Sales Tax

ORDER TODAY!

SEND CHECK OR MONEY ORDER TO:

NIBBLE NOTCH
COMPUTER PRODUCTS

DIVISION OF CORTIAN INTERNATIONAL

4211 NW 75th TERRACE, - DEPT. 83
LAUDERHILL, FL 33319

PAT. PEND. ALL TRADEMARKS ARE ACKNOWLEDGED

Circle No. 1 on Free Information Card

NO PREVIOUS EXPERIENCE NECESSARY

BECOME YOUR OWN COMPUTER EXPERT

LEARN HOW TO USE A COMPUTER

Now you can LEARN EVERYTHING you ever wanted to know about microcomputers, applications, operations and programming. UNDERSTAND computer talk and WRITE professional BASIC programs. Use and modify any of thousands of readily available home or business programs for your own special needs. Programs like: word-processing, data base management, bookkeeping, mailing lists, graphics and hundreds more!

LEARN AT YOUR OWN PACE IN YOUR SPARE TIME
Our guided independent study program allows you to learn at your own pace. In your spare time, in the privacy of your own home. No classes to attend. And our expert instructors will provide you with one-on-one counseling.

LEARN EVEN BEFORE YOU DECIDE ON A COMPUTER
Everything is explained in clear easy-to-understand language. You will enjoy learning to use a computer—EVEN IF YOU DON'T OWN ONE. Learn to program from the first lesson, programs that will run on any personal computer you choose: IBM, APPLE, COMMODORE, TRS, TI and more.

LEARN AT HOME. TAKE IT TO WORK
Programming is the best way to learn to use computers and we can show you the best and most economical way to learn programming!

Send today for your free information package. No salesman will call.

halix
INSTITUTE

CENTER FOR COMPUTER EDUCATION
1743 So. Vermont Ave., Los Angeles, CA 90006

HALIX INSTITUTE CENTER FOR COMPUTER EDUCATION
DEPT. 44-6
1743 SO. VERMONT AVE.
LOS ANGELES, CA 90006

YES! Send me information on how I can learn about computers and programming at home!

Name _____ Age _____

Address _____

City _____ State/Zip _____

I already have a computer available.

Make _____ Model _____

NewWord

(Continued from page 48)

Support

Support being important with a complex product like NewWord, I decided to test it. I called Rocky Mountain with a question about NewWord. They put me through to a support person who answered my question politely and straightforwardly. (And there was no way she could have known I was a reviewer.)

The question: "Why doesn't NewWord show my bolded text in bold on the screen as the manual says it should?"

The answer: "Because it (NewWord 1.18) has a bug. The bug will be fixed in the next release, due out in about three weeks."

"Oh really", I said. "What's your update policy?"

"We're still defining it" I was told, "But you'll be able to buy the update for a modest price." (I was given a tentative price that is considerably lower than what it would cost you to upgrade from WordStar+ Mailmerge 3.0 to WordStar+ Mailmerge 3.3. Even more important, the promised update arrived three weeks later and the bug in fact has been fixed. NewWord 1.28 displays highlighted text like this, intensified on the screen.)

Fine, that was one call. What happens if you have several questions over time? Well, NewWord comes with 90 days of no-charge telephone support (although, of course, you pay for the calls). After that, you can either get your questions answered by mail until the end of the first year, or you can pay an hourly rate of \$45 for telephone support. Rocky Mountain also offers a continuing telephone support contract for \$50 per month.

The folks at Rocky Mountain have certainly done their marketing homework. They're selling a better product at a dramatically lower price. They support it, they promise to update it, and they promise to make the updates affordable. I believe them.

Reliability

I found NewWord to be very reliable. This is remarkable in any new product, especially in high-performance industrial-grade software like NewWord. The developers, Newstar Software Inc., have done an outstanding job.

Nevertheless, in writing this review, I encountered what at first seemed like several minor bugs in NewWord. They proved instead simply to be minor differences between the command structure of

NewWord and that of WordStar. None of these differences prevented me from getting the work done; and, had I actually read the NewWord documentation, I'm sure I would not have had any difficulty at all.

Bugs aside, software functions only in the context of an overall computer system, and all systems fail, sooner or later. Recognizing this, the NewWord developers have included an important reliability aid which helps reduce the chances of your losing a text file because of a system crash. When you do a "save-and-resume" with NewWord, your file is saved and then re-opened *with the cursor position unchanged*. WordStar doesn't do this. When I do a save-and-resume on WordStar, I have to try to remember to make a note of where I was, and then I have to search the text for that place. This takes time, and anyway I'm on a very reliable hard disk system, so it doesn't seem worth it, and I don't do it—and once in a while I get hurt. My system software and hardware are both very reliable, but . . .

My local power company has "pulled the plug" on me four times in the last year. One of those times I was in the middle of a very intricate edit. It took me four hours to recover, because I had lost the habit of save-and-resume-ing frequently. On the other hand, with NewWord I can save the entire review on my hard disk right *now*—I counted off 15 seconds till I was able to resume—because it's no trouble at all. This simple feature of NewWord will make you willing to do save-and-resume operations, encouraging you to back up your current work on disk as you go.

Of course, equipment failure isn't the only thing that can cost you a file. Suppose you're creating one from scratch (so there isn't a .BAK File). You haven't done a save, and by mistake you just did "delete block (of text)" when you meant "move block." With WordStar you're out of luck.

With NewWord, you simply do ^U, which unerases the whole thing. (The size of the "unerase buffer" is an installation option. I keep it set to 2000 bytes which is a little more than a screenful of text.) Incidentally, these are just two of the many examples of where the developers of NewWord have identified weaknesses in WordStar and taken steps to fix them.

Here's another example: In edit mode, NewWord's BACKSPACE key functions just like the DELETE/RUBOUT key. WordStar doesn't do *this* either. (Unless you know how to customize it or you have a keyboard macro processor.)

Documentation

Because I know WordStar very well, it's hard for me to judge; but NewWord comes with what looks like very good documentation.

NewWord has a training manual, oriented toward computer novices, which take you step by step through installation and basic word-processing operations. With those skills in place, the manual gives you increasingly advanced training until, after 200-plus pages, you will be a reasonably capable user. At that point you are ready for NewWord's "Encyclopedia" (their term), another 200-plus pages of comprehensive (and well-written) reference material.

Also, by then you will have formed a strong set of preferences about how NewWord ought to operate. The "Nuts and Bolts" section of the manual tells you how to customize NewWord in a variety of ways to suit your tastes.

In general, all of this customization can be done through NewWord's "install" program, including the setting of many options which would have to be done through low-level patches on WordStar. You can still resort to patches if you want. For example, my own preference is to have normal text displayed intensified, with highlighted text displayed as dim. Sufficient information was given in "Nuts and Bolts" to allow me to locate the pair of NewWord instructions that control this issue, and to interchange them so as to make NewWord work the way I prefer. This kind of modification calls for strong assembly language skills, along with a low-level reference manual for the terminal to be used, but it can be done.

Beginners will benefit greatly from the considerable NewWord documentation which exists online in the form of messages, reminders, explanations, and the like. WordStar has this also, but its messages tend toward "computerese," while NewWord's messages mostly are in English. And while I'm thinking about it, one of WordStar's most annoying messages is its demand that you press ESCAPE every time you cancel an operation. NewWord doesn't require this. It simply cancels, as you asked, leaving you ready to enter another command.

Performance

What I found concerning performance is presented in the sidebar. As you can see, NewWord is typically either faster than WordStar or of comparable performance.

NewWord also has a subtle performance feature that is referred to as the "fullness gauge." This lets you see at a glance how close you are to overflowing working memory with your text.

In what sense is this a performance feature? Well, neither WordStar nor NewWord is bothered by such overflow, but you will be, if you are editing a lengthy document on a floppy-based system. This is because search times suddenly stretch out as pieces of the text get "swapped" in and out of memory automatically.

By monitoring the fullness gauge you are encouraged to break your text into separate files, each able to fit into working memory. And because NewWord incorporates the equivalent of MailMerge right in the foundation product, printing these individual files as a single document becomes easy.

Ease of Use

I thought that the documentation would make NewWord easier to learn than WordStar, but I'm not so sure. The NewWord approach assumes that you'll

be looking at your CRT (or anywhere but at the keyboard) all the time. To be productive you must know where everything is, and you have to find your way around by feel.

In short, this kind of word processor presumes you know how to touch-type—and if you believe that you can't learn to touch-type then this kind of text editor probably is not for you.

With NewWord and WordStar, when you hold the CONTROL key down, every letter key has command meaning. Many commands involve pairs of such "control characters," and a few involve three consecutive keystrokes. With typeahead, seemingly independent separate multi-key commands interact.

Both NewWord and WordStar presume that you have developed "muscle memory" for where these controls are and what they do. The choice of keys for these controls is not always logical and hardly ever mnemonic. Instead, you have to keep at it until their locations and functions become reflexive, Zen-like, requiring no conscious attention on your part.

All this takes some getting used

to—hours until you feel like you know what's going on, days till you feel comfortable, and months till you stop reaching for the manual. But if you're any kind of textsmith, then the investment is worth it. Because nobody has yet figured out a better approach to managing a broad variety of text, all the way from memos to novels to system program source files.

For years, WordStar has been the "Big Daddy" of microcomputer text editors. Now, NewWord is vying for that title.

Conclusion

In comparison with WordStar, NewWord is lower-priced, offers more features, is faster, and is better-supported.

Although somewhat tricky for a novice to learn, NewWord offers significant advantages to the already experienced user of WordStar, or to anyone who has been considering moving up to WordStar.

If I had fewer ingrained WordStar habits, then I would switch to NewWord for both writing and programming. ◇

WE'LL BACK YOU UP!

ATTENTION COMMODORE 64 OWNERS

If you own a disk drive then you'll need "The Clone Machine". Take control of your 1541 drive.

NEW IMPROVED WITH UNGUARD.*

Package includes:

- 1.) Complete and thorough users manual
- 2.) Copy with one or two drives
- 3.) Investigate and back-up many "PROTECTED" disks
- 4.) Copy all file types including relative types
- 5.) Edit and view track/block in Hex or ASCII
- 6.) Display full contents of directory and print
- 7.) Change program names, add, delete files with single keystroke
- 8.) Easy disk initialization
- 9.) Supports up to four drives



"Dad should've made a back-up with the Clone Machine."

\$49⁹⁵



CALL (201) 838-9027

Dealers & Distributors
Inquiries Invited

MICRO WAVE

1342 B Rt. 23
Butler, N.J. 07405

Circle No. 34 on Free Information Card

"POWER FAILURE PROBLEMS"

**BLACKOUTS!
BROWNOUTS!
DIPS!
YOUR SOLUTION...**

LINE-SAVER™

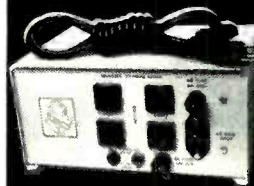

STANDBY UNINTERRUPTABLE POWER SYSTEM

SAVE YOUR DATA from power "blackouts," "brownouts" or line "dips."

PROTECT YOUR DATA from "transient voltages, spikes and EMI/RFI line noise."

LINE-SAVER™ stands-by to switch 240 Watts-VA of power to your micro-computer. Its heavy duty internal sealed battery provides up to 40 minutes of back-up power; more than enough to SAVE your data and shut down your system if line power does not return.

LINE-SAVER™ provides constant protection for your system from damaging voltage surges, spikes and conducted line noise.

LINE-SAVER™ constantly monitors the AC line and itself, with a unique visual and audible three staged ANNUNCIATOR that provides you at-a-glance status.

LINE-SAVER™ is compact in size and utilizes the latest PWM technology to make it compatible with virtually every microcomputer system today.

LINE-SAVER™ is low in cost. **\$485.00**

Call or write today for free literature

AEGIS®
Power Conditioning
Equipment

ORDER TODAY

Out of State
Toll Free Order Number
1-800-524-0400
In-State Order No.
215-837-0700



MasterCard

VISA

KALGLO®

6584 Ruch Rd., Dept. LCE
Bethlehem, PA 18017

DEALER & OEM
INQUIRIES INVITED

Add \$10.00 for shipping & handling • COD's add \$3.00
PA Res. add 6% sales tax

Circle No. 58 on Free Information Card

What Makes Junior Run?

(Continued from page 58)

All three voltages are available at the external I/O connector. However, before you decide to power external circuits from the I/O connector, read what the Technical Reference manual says on page 2-135: "The amount of power available on the I/O connector for a machine that is fully configured with internal features is 400 mA of +5 V dc, 0 mA of +12 V dc and 0 mA of -6 V dc." In other words, unless your add-on circuit uses low-power CMOS ICs, you are limited to a maximum of several TTL chips.

Sound and Color

Though PCjr is generally viewed as a scaled-down version of the IBM PC, it has superior sound, graphics, and color capabilities. You can verify this for yourself by spending a few minutes with the "Exploring the IBM PCjr" demonstration diskette that accompanies the computer's Guide To Operations. What follows is intended merely to whet your appetite. You will have to refer to the machine's documentation for complete explanations.

Cordless keyboard is among its most innovative features

Let's cover Junior's sound effects first. Like the PC, Junior includes a piezoelectric alerter that beeps under program control or when you do something wrong, like operating the keyboard when too little infrared energy is striking the receiver. Junior also includes a Texas Instruments SN76496N complex sound generator (CSG) chip. The sounds this chip produces are channeled under program control to an audio connector on the back of the system unit.

The CSG chip generates up to three separate frequencies, which can be mixed to produce chords. The chip also includes a white-noise generator whose output can be amplitude modulated and blended with that of the tone generators. By careful selection and mixing of the outputs from these four generators, an incredible variety of sounds can be produced. The sound possibilities include organs, gunshots, explosions, trains, race cars, sirens, whistles, and virtually any of the ear-benders emitted by full-size video arcade games.

The beauty of including an SN76496N in the PCjr is that almost any imaginable sound sequence the chip is

capable of producing can be obtained under total software control. The relevant PCjr BASIC statements are SOUND, NOISE, and PLAY. SOUND is followed by parameters that specify frequency, duration, and volume. NOISE is followed by parameters that specify either periodic or white noise, volume, and duration. PLAY is a powerful statement provided in Cartridge BASIC for ordering the PCjr to play the tune specified by an appended character string of musical notes. This character string can include lengths, pauses, tempo, volume, and other parameters.

Apparently, Junior will not be limited to sound generated by its built-in hardware. Pin B30 of its I/O expansion connector is designated AUDIO IN.

PCjr's sound-effects capabilities will keep creative programmers busy for hours at a time. True, creating impressive-sounding effects will require careful planning and lots of trial and error. But as a hardware guy who has spent many hours building single-function sound-effects circuits, I assure you that the keyboard control provided by PCjr is immeasurably faster and infinitely superior to making uncertain changes in a hardware circuit.

Junior's color graphics are at least as impressive as its sound effects. If you are a Radio Shack Color Computer fan, you will be happily surprised to find that many of the CoCo's graphics statements, plus a few new ones, are available with PCjr.

Unlike the PC's graphics system (obtained with an expansion card you have to buy for \$244), Junior is supplied with built-in video graphics capabilities. Furthermore, the circuitry contained on the PC graphics card has been reduced in the Junior to a Motorola 6845 CRT controller chip, LSI5220 video gate array, 2K character-generator ROM, and a few associated chips.

The character-generator ROM stores 256 characters and symbols in a 7 × 7 pixel (plus one line descender) format. In addition to the standard 96-character ASCII set, the characters include symbols for games (16), word-processing (15), and business-graphics (48). Also included are 16 Greek symbols, 48 foreign-language characters, and 15 scientific-notation symbols.

Junior can display either 25 40-character lines (for low-resolution video monitors and television sets) or 25 80-character lines (for high-resolution monitors). Sixteen foreground and background colors are available for each character, as is single-character blinking.

Three dot-addressable graphics display modes are also available: low resolution (160 × 200), medium resolution (320 × 200), and high resolution (640 × 200). Any of 16 colors can be used in all three modes. All 16 colors can be used in the low- and medium-resolution modes, while two or four colors can be used in the high-resolution mode.

The sound-effects capabilities will keep creative programmers busy for hours at a time

Since its entire 128K of RAM can be used to store image pages, Junior can be operated as a dedicated graphics machine. This permits development of "slide shows," animation, and instant help, menu, and instruction screens.

Hardware Accessories

In addition to the internal disk drive and controller, modem, and 64K RAM board, IBM offers several extra-cost external hardware accessories for the PCjr. Up to two joysticks, each selling for \$40, can be plugged into Junior's rear panel. A parallel printer port, for \$99, plugs into the I/O expansion connector on the right side of the system unit. IBM also sells a high-resolution color monitor for \$680 and a variety of impact and nonimpact dot-matrix printers.

Thanks to Junior's numerous connectors and its thorough technical documentation, IBM has guaranteed the computer's attractiveness to outside hardware vendors. Therefore, you can expect to see many additional hardware accessories in the near future.

Should You Take One Home?

If you want IBM compatibility and ample hardware accessibility, and can afford its price, you should give serious consideration to buying the IBM PCjr. However, if you are more interested in a hassle-free computer with highly approachable, almost intuitive software, have a look at Apple's Macintosh.

Finally, don't feel left out if the PCjr is beyond your means. The BASIC used in Radio Shack's Color Computer provides a highly effective subset of PCjr's BASIC. ♦

THE INFRARED CONNECTION

THOUGH PCjr's keyboard has drawn a lot of justifiable criticism, its cordless operating mode is among the computer's most innovative features. Not everyone agrees with this assessment. In fact, some writers have labeled the infrared link a useless gimmick.

True, it is necessary to keep books and other objects from blocking the system unit's receive aperture. The keyboard's signal cannot always reach the computer when you operate the keyboard from your lap. And interference in the form of undesirable keystroke crosstalk can occur between nearby PCjrs. But IBM has foreseen these potential problems and offers an optional cable to obviate them. The infrared link, though, provides a new measure of operating convenience, and the system unit's infrared receiver provides an entirely wireless, optical port for external peripherals.

How It Works

There is little fundamental difference between Junior's keyboard transmitter and an infrared remote controller for a TV set. Both devices send an encoded train of pulses to a photodetector diode that transforms the optical energy in the pulses into a photocurrent. The photocurrent is amplified and sent to pulse-shaping and detection circuitry.

Junior's transmitter consists of a pair of near-infrared emitting diodes that project invisible beams from apertures at the rear of the keyboard. The keyboard has no power switch and is always in a powered-down standby mode. When a key is pressed, a CMOS version of Intel's 8048 microprocessor scans the keyboard to locate the closed key. The microprocessor then generates an appropriate scan code which is sent to a pair of A13 Darlington driver transistors. The transistors act as switches that forward-bias the two infrared-emitting diodes with a carrier frequency of about 40 kHz.

Up to 16 key closures can be stored in the Junior's keyboard buffer. When no keys are pressed and when the buffer is empty, the microprocessor again enters its low-power standby mode.

When the optional cable is used, the infrared transmitter in the keyboard is disabled and battery power is removed. In addition, the system unit's infrared receiver is disabled, thus permitting operation without the fear of interference from nearby infrared keyboards.

The scan codes sent by the keyboard are *not* in standard ASCII format. Instead, they are compatible with scan codes for the IBM PC and PC-XT at the BIOS interface level. All keys can operate in a typematic mode by sending a string of characters when the key is held down. When invalid combinations of three or more keys are simultaneously pressed, the keyboard sends a hex 55 scan code that tells the computer to disregard all the invalid keys.

The drawing below shows the serial data format transmitted by the keyboard. Each bit occupies one of two slots in a 440-microsecond window. Note that the cable signal is a square pulse, while the infrared signal is a 40-kHz burst.

If inadequate signal amplitude from the keyboard arrives at the receiver, the computer beeps when any key is pressed. Otherwise, expect a transmission range of at least 20 feet.

Interference (and beeping) can be caused by bright fluorescent lamps. However, a bright incandescent flashlight pointed directly into the receiver port caused no problems, perhaps because Junior uses an ac-coupled photodiode that is linear to incident light over a several-decade range. In other words, the keyboard signal passes on through while the dc light level is blocked.

A Detective Story

For this report, I wanted very much to give the wavelength emitted by Junior's

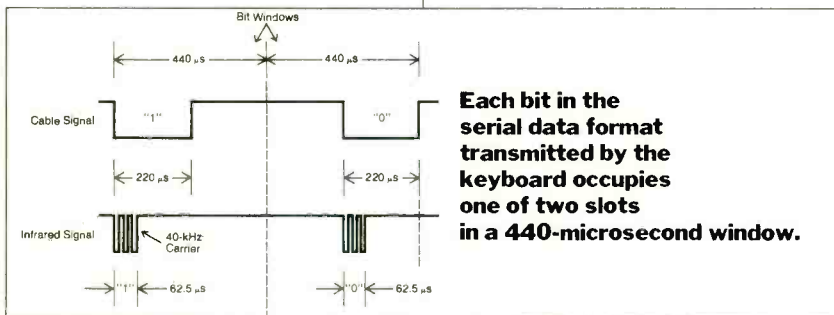

DON'T BLAME THE SOFTWARE!

Our Isolators eliminate equipment interaction, clean up interference, curb damaging power line spikes and lightning bursts.



ISO-1 ISOLATOR

3 isolated sockets; quality spike suppression; basic protection. . . \$81.95

ISO-3 SUPER-ISOLATOR

3 dual isolated sockets; suppressor; commercial protection. . . . \$122.95

ISO-17 MAGNUM ISOLATOR

4 quad isolated sockets; suppressor; laboratory grade protection. . \$213.95

ESP® Electronic Specialists, Inc.

171 S. Main, Natick, MA 01760 (617) 655-1532

Toll Free Order Desk 1-800-225-4878
MasterCard, VISA, American Express

Circle No. 51 on Free Information Card

Put Professional Knowledge and a
COLLEGE DEGREE
in your Electronics Career through

**HOME
STUDY**

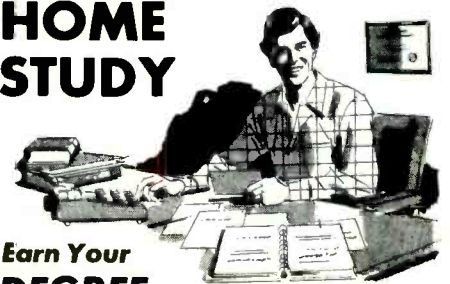

**Earn Your
DEGREE**

No commuting to class. Study at your own pace, while you continue your present job. Learn from Grantham easy-to-understand lessons, with help from your home-study instructors.

You can earn your B. S. Degree in the Grantham electronics degree program, offered by independent home study and accredited by the NHSC Accrediting Commission.

Our free bulletin gives details. Write for *Bulletin E-84*.

Grantham College of Engineering
2500 So. LaCienega Blvd.
P. O. Box 35499
Los Angeles, California 90035

How to teach your kids about the IBM PC.

Now you can teach your children how to use your PC without bogging them down in the user manual...without spending hours demonstrating the simplest functions...and without fear that they'll break your PC because they don't know how to use it properly.

You can do it with the PC edition of *Computers for Kids*—a BASIC learning text whose Sinclair, Apple, and Atari editions have already introduced thousands of children and parents to computers.

Computers for Kids teaches children age 8 and older to write their own programs in less than an hour—without the necessity for previous knowledge of algebra, variables, or computers. And there's a special section that keeps parents and teachers on the same successful command path.

Starting off with an easy-to-understand explanation of how to use the IBM PC, your kids will progress quickly to flow charts and simple print programs...to loops, graphics, and other programming concepts that show the young user how to make the PC do exactly what he wants—in non-technical language that makes life easier for both of you.

Take it from Donald T. Piele, Professor of Mathematics at the University of Wisconsin (Parkside): "*Computers for Kids* is the best book available for introducing children to the IBM PC. And it's a perfect tool for adults who are learning about computers and programming *with* their children."

So do your children a favor. Do yourself a favor. Order the PC edition of *Computers for Kids* today!



Here are just a few of the useful and exciting topics covered in *Computers for Kids*:

- What is a computer?
- Flowcharting
- Running the IBM PC
- Getting Ready to Program
- PRINT and Variables
- GOTO, INPUT and RND
- IF-THEN and FOR-NEXT
- Graphics Programs
- Sample Programs
- Glossary of Statements and Commands
- Notes for Teachers and Parents

Creative Computing Press

Dept. ND8B 39 East Hanover Avenue, Morris Plains, NJ 07950

Send me _____ *Computers for Kids*, PC edition, at \$5.95 plus \$1.50 postage and handling each. #12K

PAYMENT ENCLOSED \$_____. Residents of CA, NJ and NY State add applicable sales tax. Outside USA add \$3.00 per order.

CHARGE MY: (Charge and phone order \$10 minimum)
 American Express MasterCard Visa

Card No. _____ Exp. Date _____

Signature _____

Mr./Mrs./Ms. _____ (please print full name)

Address _____ Apt. _____

City/State/Zip _____

Send me a FREE *Creative Computing Catalog*.

Junior

keyboard. Alas, a call to Advanced Input Devices, the company that manufactures the keyboard unit for IBM, elicited no such information. I was told that the information was proprietary and that IBM did not permit the release of any information about it.

Considering the vast quantity of information about Junior's hardware in the Technical Reference manual, I was surprised by this response. But since the keyboard is the only circuit not provided in the manual, either IBM or its vendor must surely want to safeguard information about the keyboard unit.

As for the wavelength of the infrared diodes, the only two reasonable possibilities are silicon-compensated gallium arsenide (GaAs:Si) diodes that emit energy at about 950 nm (nanometers) and aluminum gallium arsenide (AlGaAs) diodes that emit at 880 nm.

It was a simple matter to determine which is used in the PCjr by connecting first a GaAs:Si diode and then an AlGaAs diode to the input of an audio amplifier. Since these diodes operate well as detectors of radiation emitted by identical diodes, I quickly determined the answer to the wavelength question. The AlGaAs diode provided a very small signal when a key was pressed, but the GaAs:Si diode produced a very strong signal.

I am surprised that Junior's keyboard does not use 880-nm emitters. They are at least twice as powerful and considerably faster than the 950-nm emitters IBM selected. In a future installment of "The Computer Scientist," I will explore this and other PCjr keyboard topics in more detail, perhaps by trying 880-nm emitters in my Junior's keyboard. In the mean time, try the "Radar" program in the listing. And have fun with your new PCjr! ♦

"RADAR" PROGRAM

```

10 CLS
20 SCREEN 1:COLOR 1
30 PRINT "RADAR"
40 PRINT ""
50 PRINT "COPYRIGHT 1984 BY FORREST M. MIMS, III"
60 PRINT ""
70 PRINT "THIS PROGRAM CONVERTS PCjr INTO"
80 PRINT "AN INFRARED RADAR."
90 PRINT ""
100 PRINT "FIRST, SECURE THE Z KEY IN THE"
110 PRINT "DOWN POSITION WITH TAPE."
120 PRINT ""
130 PRINT "THEN PLACE THE KEYBOARD ON TOP"
140 PRINT "OF THE CONSOLE SO THE BACK OF"
150 PRINT "THE KEYBOARD FACES THE SAME DIRECTION"
160 PRINT "AS THE FRONT OF THE CONSOLE."
170 PRINT ""
190 PRINT "PCjr WILL NOW BEEP TO INDICATE"
200 PRINT "THE PRESENCE OF AN OBJECT"
210 PRINT "UP TO SEVERAL FEET AWAY."
220 PRINT ""
230 PRINT "PRESS ANY KEY TO BEGIN."
240 IF INKEY$="" THEN 240
250 AS=INKEY$
260 IF AS="Z" or AS="z" THEN BEEP
270 IF AS="Z" or AS="z" THEN PRINT "OBJECT DETECTED!"
280 IF AS="" THEN PRINT "ALL CLEAR."
290 GOTO 250
300 END
    
```

IBM Software (Continued from page 62)

software around that is the equal of Bumble and HomeWord.

Conclusions

Although IBM has put its imprimatur on certain software products for the

Computer Security (Continued from page 70)

There are some very real dangers involved in uploading, most of which are functions of intermediate management layers in an organization. For example, a branch sales manager in St. Louis may send his sales forecast to his regional manager in Chicago. The regional manager may feel the forecast is too conservative, and change it. He then transmits the revised forecast to corporate headquarters.

The corporate data-processing group melds all the forecasts received from all the regional managers into one corporate figure. This figure (and all those derived from it) is then circulated to all divisions. Obviously, the information that flows from headquarters is not accurate because of the changes made in Chicago by the regional manager. Unfortunately, technology has not yet found a way to detect and correct this sort of innovative bookkeeping.

Line management is responsible for policy, and it would be up to the national sales manager in this example to indicate to his regional managers that forecasts (and other such matters) are not to be tampered with. Where input is critical, some type of validation is necessary. Whether this is accomplished through an editing piece of software, or off-line by responsible management, depends on the nature of the individual company and the facts at hand. Regardless, managers should check on the audit trail of any information sent through multiple layers or locations within an organization.

Care must be taken to develop two parallel and independent audit trails. One should be the traditional type, where debits equal credits, or batch totals check, or entry counts equal the number of documents, etc.

The other audit trail should be through data-processing. Somewhat akin to a chain of possession of evidence, it should record any changes to data and can include such items as new entries, and total changes. A new tally should be generated any time a file is read or written. This not only facilitates any data-processing auditing, but can also serve to validate the authenticity of records.

In the case of downloading, the prob-

lems are not so much those of data integrity as of proper use. Once corporate (or other) data is passed to micros at the local level, someone must be responsible for the appropriate safeguarding and distribution of that information. A good maxim to keep in mind is "safeguard information according to its value, not its location."

Concerns for Small Business

Where a small business depends on a microcomputer for its livelihood, care must be taken to guard against the loss of data. Computers and blank disks can be easily replaced; replacing lost data is much more difficult. Adequate backup is perhaps the most critical issue facing a small business.

With the usually hectic day-to-day pace of a small business, it is sometimes difficult to find the time needed to perform essential backup operations. It is up to the owner or company president to ensure that the backup procedure is routinely performed on a daily or weekly basis, as required. It is also a good idea to keep a set of duplicate software and data off premises, ideally in a secure and fire-proof location.

While it may not be necessary to plan for every contingency, the staff should know which records are most important, and plans should be made to remove these first in the event of an emergency. It is a good idea to have a contingency plan for removing disks and other magnetic media to safety in the event of fire, flood, or other disaster.

And, while it is not absolutely necessary, it is useful to know where equipment can be found to process the business's records in the event of a problem with its own computer system.

Another important factor for small businesses is to make sure that more than one person knows how to operate its computer system. A backup operator is not a luxury—it is a *necessity*. It is also a wise idea for one or more of the owners or officers to understand the workings of this company's system. Checks and balances are important even in small companies. Technology cannot take the place of common-sense management. ◇

CABLE TV

CONVERTERS

Largest Selection
of Equipment Available
\$ Buy Warehouse Direct & Save \$



36 channel
converter
\$45.95

36 channel
wired remote
converter
only
\$89.95



Send \$2 for complete catalog
of converters and equipment

Quantity Discounts • Visa • Master Charge
Add 5% shipping—Mich. residents add 4% sales tax

C&D Electronics, Inc.
P.O. Box 21, Jenison, MI 49428
(616) 669-2440

CALCULATOR SAVINGS

**hp HEWLETT
PACKARD**

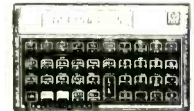

HP-11C Programmable	\$74.99		
HP-12C Financial	99.99		
HP-15C Programmable	99.99		
HP-16C Hexadecimal	99.99		
HP-41C Alpha Progrmb	149.99		
HP-41CV Full Memory	209.99	82160A HP-IL Module	\$94.99
HP-41CX Extnd Functn	259.99	82161A Cassette Drive	347.99
82104A Card Reader	149.99	82162A HP-IL Printer	347.99
82143A Printer	299.99	82164A RS-232 Interic	249.99
82153A Wand	99.99	92198A 80 col Video Int	269.99
HP-71B Computer	419.99	7470A HP-IL Plotter	899.99
82400A Card Reader	Call	82180A Extnd Functns	59.99
82401A HP-IL Interface	107.99	82181A Extnd Memory	59.99
82420A 4K Mem for 41B	59.99	82182A Time Module	59.99
71B Application Pacs from	64.99	82183A Extnd I/O	59.99
HP-75C Computer	739.99	HP-41 System Case	49.99
82700A 8K Mem for 75C	149.99	Port-X-Tender to 10 pts	129.99

Call for Low Prices on all Accessories and Software

Ti CC-40 Compact 6K Expandable Computer	\$199.99
CC-40 Solid State Software	from 49.99
TI-55-II Scientific Calculator w/ Statistics	34.99
LCD Programmer Hexadecimal Converter	59.99
BA-55 Advanced Handheld Financial	49.99
TI-5310 Desk Printing Financial	109.99

Sharp EL-7050 Graphwriter	69.99
EL-7100 Memowriter	59.99
PC-1500 Advanced Handheld Computer	139.99
PC-1500A Advanced 8K Handheld Computer	179.99
CE-150 Cassette Interic/4-color Printer Plotter	179.99
CE-151 4K Memory for 1500/A	39.99
CE-155 8K Memory Expansion Box for 1500/A	79.99
CE-158 RS-232C & Parallel Interface for 1500/A	179.99
CE-159 8K Memory Expan with Battery Back-up	99.99
CE-161 16K Memory Expan with Battery Back-up	149.99
PC-1500/A ROM Software Modules	49.99

Casio FX-700P Handheld Computer 1568 steps	\$69.99
FA-3 Cassette Adapter for FX-700P	34.99
FP-12 20-column printer for FX-700P	59.99
FX-98 Credit card Solar Scientific Calculator	24.99
FX-450 Scientific Calculator with Hexadecimal	29.99
FX-191 Scientific Scaler	44.99
PF-8000 Data Bank	64.99
SL-800 Film Card	22.99

Use cashier's check, postal money order, VISA, or M/C. Personal checks take five weeks to clear. Add shipping 1% of your order (\$3.95 minimum). East of Mississippi extra 11.50 CA. res. add 6%. Subject to availability. USA prices.

ORDER **800-421-5188** Outside
TOLL-FREE Information line (213) 633-3262 CA, AK, HI

tam's
INCORPORATED

Tam's Inc, Dept CE-4
14932 Garfield Ave.
Paramount, CA 90723
(213) 633-3262

Apple IIc (Continued from page 53)

They also gave the IIc a new paint job, choosing an off-white color which they call "Apple Fog."

Apple is also introducing a printer which will be compatible with the IIc. It is called the Scribe and will cost under \$300. The Scribe is a serial interface, dot-matrix printer with full graphics capability. Its ribbon will print 35 pages before needing to be replaced and it will print in four colors.

The Scribe is a uni-directional machine with a printing speed of 20 to 25 lines per minute. There is no ventilation blower in the Scribe and the less than 50-dB noise it generates when printing is hardly noticeable even in a quiet office.

The printer has a 96 ASCII character set with 25 European characters available. The character pitch can be set at either 10 cpi for text or 17 cpi for draft material. The Scribe sits on a plastic shelf

with paper fed from underneath the machine. Plain paper can be used and the paper tray holds up to 100 sheets.

The IIc has an array of ports to which peripheral devices can be connected. The back of the IIc has seven ports and a main power switch. The ports are: a 9-pin D-type connector for hand-controls or a mouse; a 5-pin DIN connector for a modem; a 15-pin D-type connector for video expansion; an RCA-type jack for a video monitor; a 19-pin D-type connector for a second disk drive; a second 5-pin DIN connector for serial input and output for a printer or plotter; and a 7-pin DIN connector for 15-volt power input.

The engineers at Apple were particularly concerned about heat problems with the IIc. A disk jacket begins to melt at about 52° C (125° F), Apple said, and with the internal disk drive and no blow-

er, it was necessary to drill holes in the printed circuit board of the IIc. (The IIc employs one main pc board.) But Apple says it has the heat problem under control and claims that the IIc will operate at a relatively cool 12° over ambient room temperature while dissipating about 30 watts.

Apple estimates the following costs for IIc peripherals: a flat LCD panel, under \$600; a 9" green phosphor monitor with stand, under \$250; an external drive, under \$400; the Scribe thermal transfer dot-matrix printer, under \$300; a mouse, under \$100; and carrying case, under \$40.

To summarize, the Apple IIc is a powerful, sleek machine that offers compact versatility. With the promised-by-fall battery pack and LCD, the IIc should command a large share of the transportable market. ◇

FIRST IMPRESSIONS OF THE IIc

BY JOE DESPOSITO

I'm a hard-core Apple user. I've got a II+ at home, a IIe in the office and have borrowed my brother's Macintosh while he's off on a business trip. So when I heard that we were getting an early production model IIc in the office, I was delighted. But my initial reaction to Apple's latest product was that it was not what I was expecting.

To begin with, although you can conveniently tote the 7.5-lb unit around by its handle, the IIc has neither battery power nor a built-in display. Happily, both options will be available later this year. Another surprise was that, like the IBM PCjr, the IIc has an outboard power supply about the size of a pound of butter.

After a few minutes with the IIc, I understood Apple's approach. Here is a computer that you can buy at your local computer store (or even at a mass-market store), take home, and have up and running as fast as you can plug in a cable and power core and insert a disk into the drive. What a novelty! Last year, when I attached drives to my brand new IIe, I wondered how people without any mechanical aptitude were going to deal with the clamps that attach to the rear of the computer. I guess other people were wondering, too, and have done something about it.

So between my initial surprise and subsequent reappraisal, I think I can give a fair description of what it's like to use an Apple II computer without having to

open it up and install printer and disk-drive interface cards into slots one and six. My first test of the machine was compatibility. Would I be able to use AppleWriter IIe as well as other programs in my library of II+ and IIe software? Could I squeeze in a game of "Hard-Hat Mack" during lunch time? The answer is yes. Of the programs I tried, the only one that shows any incompatibility at all is AppleWriter IIe, and it is minimal. The status line along the top breaks up slightly, and occasionally the cursor changes from a block to an apple or bell. I had no problem writing and editing, however or saving to disk. I did not hook a printer up to the IIc because it uses a nonstandard interface (which I didn't have): but I took the disk from the IIc, popped it into the IIe and printed out files without any problems.

The keyboard is not like those found on other Apple Computers, but it is fine for typing. If you press very hard on the keys, two things happen: the letter repeats and the keyboard gives about one-sixteenth of an inch. Although this is distressing to see, it doesn't appear to have serious implications as far as normal typing is concerned.

Though the IIc can be used with any monitor, there is a contoured 9" diagonal monitor made for it. The monitor sits on an angled stand rather than on the computer itself.

The IIc has one built-in, single-sided, single-density disk drive. The side-locat-

ed half-height drive is very convenient. The drive uses spring pressure to aid in closing the latch and ejecting the disk. The problem is that the spring was a bit stiff on this early production model, but Apple will probably work this out. If you want to upgrade to a dual-drive system, the second drive will have to be an outboard one. (There's a connector at the rear of the unit for a second drive.)

The IIc has something that no other II-series product has—built-in serial (two) and RGB outputs. However, none uses a standard connector, so be prepared to buy special cables for whatever you plan to do. You'll need a cable for printing, another for communications, and one for connecting to an RGB monitor. A composite video output is also available with a standard RCA connector. The IIc lacks a parallel output, which means that your printer must accept serial input.

There is no applications software bundled with the IIc. However, the unit comes with six tutorial disks that should help the novice become accustomed to the machine rather quickly.

After coming to terms with the IIc, I think I understand what Apple is trying to accomplish with it. Here is a computer that includes as standard the features that most people want. It's ready to go right out of the package and should attract many new users. It is a good strategy and it will be interesting to see how it works for Apple. ◇

Local Area Network

(Continued from page 78)

network or shut down, it can't acknowledge receipt of the token. This becomes apparent to node 19 when the 78-microsecond timing period expires. Node 19 now takes charge of the token and increments the destination address by one, to 54. And the token is given to node 54. Failure of station 54 to respond to the token forces node 19 to increase the destination code to 55.

This process continues until, finally, a node is found that can accept the token and acknowledge its presence. This new address is permanently installed in station 19, and each time it receives the token thereafter, it forwards it to the new address.

Should station 53 come back on line, it can regain token status by scrambling the network with a reconfiguration burst.

Arcnet Specifications

Unlike Ethernet, Arcnet is a somewhat looser network in some respects. That is, not all parameters and components are so strictly defined or enforced. This was done intentionally, to allow users some flexibility.

First of all, no network medium is specified. In an Ethernet network, you must use Ethernet-grade coaxial cable—and nothing else. Although most Arcnet vendors also use coax, they aren't compelled to. With Arcnet you can use coax, pairs of wires or even fiber optics! Any workable medium is acceptable.

This freedom not only allows you to construct a network to meet specific needs, but it also enables you to make use of an existing wiring system. Which, of course, can translate into dollars saved.

Another case in point is the Arcnet protocol. Although Arcnet does provide framing guidelines, the user is not forced into using them religiously. Changes can be made, provided you maintain Arcnet's opening statement for the beginning of a frame. Davong, for one, had opted to change its packet protocol to the transportable Xerox Network System's XNS.

Broadband Networks

Local area networks, as a whole, fall into two distinct categories. Most networks are of the **baseband** design. In baseband, the digital signal is placed directly onto the network wires. The same thing happens when you connect your stereo system to a speaker through a pair of wires. The signal travels through the

wires, or the LAN, at its original frequency. This is a baseband network.

The second type of LAN is the broadband network. Broadband can best be compared to cable TV. For each program there is a separate channel.

Let's say that computer A wants to talk to computer B. It can do so by establishing contact on, for example channel 2. Now if computers C and D also wish to talk, they can do so by placing their conversation on channel 3. In other words, both conversations can go on at the same time over the same cable, much like television signals travel through CATV.

This is achieved by a technique called **frequency multiplexing**. What that means is that every channel is assigned a base frequency called a **carrier**. The carrier is a radio frequency many times greater than the frequency of the signal we wish to pass through the channel, and each channel has its own specific frequency, which is different from all other channels.

To talk on channel, the carrier is modulated. Several modulating techniques are in common use, most of them probably familiar to you. There are amplitude

modulation (AM), frequency modulation (FM), frequency shift keying (FSK), and many others. With television, the carrier is modulated with picture and sound information. In a broadband LAN, the carrier is modulated by digital pulses.

In most broadband networks, channels are assigned specific duties. Let's take WangNet, for example. Wang uses a 390-MHz-wide communications band extending from 10 MHz to 400 MHz. The bandwidth is divided up into segments, as illustrated in Fig. 3.

Each segment is a LAN channel, and each channel has a particular function to perform. The utility band, for instance, is reserved for video communications such as teleconferencing. The Wang band serves Wang business computers.

The band of interest to most of us, though, is the Professional Computer Service band. It uses a 15-MHz segment of the 390-MHz WangNet frequency spectrum, beginning at 29 MHz and extending to 44 MHz. Within this band are five individual channels each 3MHz wide. Wang has designated these channels as its personal computer communication channels. Each channel can be

DATA RATES

THE unfortunate part of comparing LANs is that we must often use statistical guidelines that have little to do with network performance. So the reader is advised to take more than a casual look at the numbers in the buyer's guide on page 76.

Network efficiency vs. data rates is a good example of this possible misinterpretation. An examination of the buyer's guide reveals that Ethernet, with a listed 10-MHz data rate, is four times faster than its competitor, Arcnet. Does this mean that Ethernet is four times better than Arcnet. Hardly so.

Data rates express the *maximum* rate that a network can throughput data. While the data rate is a nice number, it has little to do with the real world of networking. The actual data rate is controlled by your system.

For instance, it is impossible to take full advantage of Ethernet's speed when feeding data to a 19,200-baud printer. Even with a printer spooler, the mechanical nature of the printer slows things down. Modems, with their 300-to-1200-baud rates, are another source of congestion.

Hard-disk files, network bridges, video displays, and the CPUs themselves all impose restrictions that further limit network speed. A 1-MHz LAN is just as fast as a 10-MHz LAN when your data rates are ultimately governed by a 100-kilobaud file server.

Furthermore, even the above precaution isn't enough. Even when networks are seemingly comparable, there are marked differences in performance. These differences are created by software overhead. Let's face it, not every program is a gem, and in the infant world of local area networks, there's a considerable amount of difference in program execution speeds, which directly affects network performance.

If you take PCnet, for example, and challenge it to a benchmark test with an Omninet network, you will soon discover that, even though the advertised data rates of both are identical, Omninet is able to perform the test faster. This doesn't make PCnet bad, just different.

As networking matures, and stricter standards are implemented, you will find data rate figures will be more meaningfully presented than they are today. ◇

Local Area Network

used for a local area network capable of supporting up to 255 nodes.

WangNet Protocol

Broadband networking channels are faced with the same network contention problems plaguing baseband networks. In other words, who has use of the network—or channel in our case—and for how long?

For its Professional Computer Service, Wang has adopted the Arcnet token-passing protocol. It works the same way, with each node on the network (channel) given a chance at the LAN when the token is passed to it. Even the 2.5-MHz data rate and framing protocols have been maintained intact. The only difference is that the 2.5-MHz Arcnet signal is multiplexed onto a carrier frequency.

Wang could just as easily have opted for a different protocol, though. In fact, it uses a CSMA/CD protocol for its Wang band.

Some broadband networks are even

A NOTE TO PC USERS

HERE is a special message for users of the IBM PC and IBM PC compatibles.

Not all the LANs listed in the chart on page 76 that claim to operate with IBM PCs and IBM XTs can do so. It is often the case that you will have to remove expansion boards, such as serial interface boards you already have in service. Not because you need the expansion slot for the network, but because certain interrupt functions overlap, creating confu-

sion within the machine.

Also be forewarned, that some networking implementations will not work with all IBM PC compatibles. This is particularly true when the networking program makes calls to IBM's BIOS (Basic Input/Output System) ROM chip. This chip is proprietary, and not available in compatible models (although in some instance most of the BIOS chip functions may be emulated by the system software). ◇

convertible. Ungermann-Bass' Net/One, for example, provides protocols for both an Ethernet baseband LAN and a frequency-multiplexed broadband LAN.

Network Turnaround

Although a broadband network can support more than one LAN at a time through channel separation, it doesn't come without a problem. The problem is crosstalk.

When piping radio frequencies through a coaxial cable, it is desirable to have all the signals flow in the same direction. If you take a length of coax and inject a signal into each open end, a predictable phenomenon occurs. Where the two signals meet, an interference pattern is set up, not unlike the merging ripples you see when two stones are cast into a pond of water.

The waves interact with each other, resulting in a distortion of the original signal, including harmonic overtones. This is totally unacceptable for a digital—or any other—communications link.

If, however, the waves are traveling in the same direction, they have no opportunity to mix. This can be demonstrated by throwing two stones into the same pond at the same spot.

To avoid signal mixing, broadband LANs force unidirectional data flow by dividing the node into distinct transmit and receive ports. Through the transmit port it is possible only to talk, but not to listen. Likewise, the receiver port has no voice.

Broadband networks achieve this division in two different ways. WangNet uses two separate cables for its LAN. One is outgoing, the other is incoming.

Another common technique, which eliminates the hassle of having to install dual coaxial cables and permits the use of a single one, is to divide the transmit and receive functions into two widely separated bands. Let's examine LocalNet 20, by Sytek. It is such a network.

The LocalNet 20 uses two 36-MHz-widebands for its transmit and receive functions. The frequencies from 70 MHz to 106 MHz are used to transmit information. All nodes feed the coax at these frequencies when talking, and all data on all channels flows in one direction through the cable.

At the end of the cable is a frequency converter. It takes the incoming transmitted frequencies and converts them into higher frequencies. The new frequencies occupy the 226-to-262-MHz portion of the radio spectrum. This new 36-MHz-wideband is retransmitted over the network cable in the *opposite* direction.

The receivers in the LAN are tuned to this band, and all nodes intercept their messages on these frequencies. Consequently, a memo sent by you on the 70-MHz channel is converted and returned to you at 226 MHz. These two frequencies are spaced far enough apart that the little bit of interference they generate is not significant enough to disturb the network. Figure 4 illustrates the concept very well.

Epilogue

Local area networks have made quite an impact on the computer community, and will become even more prevalent. Not only have they reduced the drudgery commonly associated with working with computers, they have made them more efficient, as well. ◇

AMAZING DEVICES

PHASORS

PERSONAL DEFENSE AND PROPERTY PROTECTION UTILIZE SPACE AGE TECHNOLOGY.
CAUTION THESE DEVICES CAN BE HAZARDOUS AND MAY SOON BE ILLEGAL

POCKET PAIN FIELD GENERATOR — IPG50
Assembled \$59.50
IPG5 Plans \$7.00 IPG5K Kit/Plans \$39.50

PHASOR PAIN FIELD CROWD CONTROLLER — PPF10
Assembled \$250.00
PPF1 Plans \$15.00 PPF1K Kit/Plans \$175.00

BLASTER — Provides a plasma discharge capable of puncturing a can.
BLS10 Assembled \$79.50
BLS1 Plans \$10.00 BLS1K Kit/Plans \$59.50

SHOCKER/PARALYZING DEVICE — Very intimidating and effective
SHG60 Assembled \$99.50
SHG6 Plans \$10.00 SHG6 Kit/Plans \$79.50

LASERS

RUBY LASER RAY GUN — Intense visible red beam burns and welds hardest of metals. **MAY BE HAZARDOUS**

RUB3 All Parts Available for Completing Device \$15.00

CARBON DIOXIDE BURNING, CUTTING LASER — Produces a continuous beam of high energy. **MAY BE HAZARDOUS.**

LC5. All Parts Available for Completing Device. \$15.00

VISIBLE LASER LIGHT GUN — produces intense red beam for sighting, spotting, etc. Hand held complete.

LGU3. Plans \$10.00 (Kit & Assembled Units Available)

IR PULSED LASER RIFLE — Produces 15-30 watt infra-red pulses at 200-2000 per sec.

LRG3. All Parts & Diodes Available \$10.00

BEGINNERS LOW POWER VISIBLE LASER — Choice of red, yellow, green — provides an excellent source of monochromatic light.

LHC2 Plans \$5.00 LHC2K Kit \$29.50

SECURITY

SNOOPER PHONE — Allows user to call his premises and listen in without phone ever ringing

SNP20 Assembled \$89.50
SNP2 Plans \$9.00 SNP2K Plans/Kit \$59.50

LONG RANGE WIRELESS MIKE — Miniature device clearly transmits well over one mile. Super sensitive, powerful

MFT1 Plans \$7.00 MFT1K Plans/Kit \$39.50

WIRELESS TELEPHONE TRANSMITTER — Transmits both sides of phone conversation over one mile. shuts off automatically.

VWPM5 Plans \$8.00 VWPM5K Plans/Kit \$34.50

TALK & TELL AUTOMATIC TELEPHONE RECORDING DEVICE — Great for monitoring telephone use.

TAT20 Assembled \$24.50
TAT2 Plans \$5.00 TAT2K Plans/Kit \$14.50

Our phone is open for orders anytime. Technicians are available 9-11 a.m. Mon-Thurs for those needing assistance or information. Send for free catalog of hundreds more similar devices. Send check, cash. MO, Visa, MC, COD to: **INFORMATION UNLIMITED**
DEPT Q1, P.O. Box 716, Amherst, N.H. 03031 Tel: 603-673-4730

Computer Scientist (Continued from page 24)

ter. SC, the HPGL *scale* command, establishes a scale that matches the joystick coordinates. SP1 selects pen 1. PA moves the pen to the point specified by the corrected joystick coordinates (H and V). Finally, the plot relative (PR) command specifies the relative coordinates that define the cursor's shape.

Although not all computers have joystick ports, most are equipped with cursor control keys. These keys can be used to draw lines or position a shape anywhere on the monitor.

For example, the next program converts Radio Shack's TRS-80 Model 100 notebook computer into a computerized *Eich-A-Sketch*. The Model 100 has a built-in RS-232 interface that works well with the HP-7470A plotter so long as a *null modem* is used (or switch the wires between pins 2 and 3 of one of the RS-232 connectors). The program includes several HPGL instructions that provide a hard copy of whatever is drawn on the Model 100's display. Here's the program:

```
05 ' TRACE
10 CLS
15 COM ON: OPEN "COM:48
  N2E"FOR OUTPUT AS 1
20 Y=32: X=120
30 PRINT #1,
  "SC0,239,0,63;"
40 PRINT #1,
  "SP1;PA"X,Y";PD;"
50 AS=INKEY$
60 IF INKEY$=CHRS(28)
  THEN 100
70 IF INKEY$=CHRS(29)
  THEN 200
80 IF INKEY$=CHRS(30)
  THEN 300
90 IF INKEY$=CHRS(31)
  THEN 400
95 GOTO 60
100 X=X+1:GOTO 1000
200 X=X-1:GOTO 1000
300 Y=Y-1:GOTO 1000
400 Y=Y+1:GOTO 1000
1000 PSET (X,Y)
1010 PRINT #1,
  "PA"X,Y";"
1020 GOTO 60
```

If you like, you can condense this program by merging lines 100, 200, 300 and 400 with, respectively, lines 60, 70, 80 and 90. Lines 15, 30, 40 and 1010 establish communications with the plotter and can be omitted if you haven't access to one. Use the plotter switch settings shown in Fig. 5.

Going Further

I'll continue this discussion of computer-aided drafting in the next installment of "The Computer Scientist."

We'll find out how to use an inexpensive graphics tablet. Then we'll develop software for digitizing rough drawings placed over the tablet so they can be transferred by a plotter into publication-quality images.

In the meantime, if you would like to know more about computer-aided drafting, you might want to read *Introduction to CAD* by Donald D. Voisinet (McGraw-Hill, 1983). This book, pro-

vides a concise summary of the most common operating modes of major commercial CAD systems. (The book may also be listed under the title *Introduction to Computer-Aided Drafting*.)

Incidentally, if you enjoy hardware projects, stay tuned. I plan to describe in forthcoming columns several interesting circuits that function independently but can be connected to a computer for a visual display of various data. ◇



Active



1984 Mail Order Catalog

The One Stop Electronic Shop!

Call Toll FREE 1-800-343-0874

In the United States:

Mail Orders

P.O. Box 8000
Westborough, Mass.
01581
(Mass) (617) 366-0500

Boston

133 Flanders Road
Westborough, Mass.
01581
(617) 366-9684

Seattle

13107 Northup Way
Bellevue, Wash.
98004
(206) 881-8191

In Canada:

Montréal

5651 Rue Ferrier
Montréal, Québec
H4P 1N1
(514) 731-7441

Ottawa

1023 Merivale Road
Ottawa, Ontario
K1Z 6A6
(613) 728-7900

Toronto

14 Carlton Street
Toronto, Ontario
M5B 1K5
(416) 977-7692

Calgary

3220-5th Ave. N.E.
Bay 2
Calgary, Alberta
T2A 5N1
(403) 235-5300

Downsview

86 St. Regis Cr. N.
Downsview, Ontario
M3J 1Y8
(416) 630-0400

Vancouver

3070 Kingsway
Vancouver, B.C.
V5R 5J7

(604) 438-3321

Visit your nearest Active store, call, write or circle
the Reader Service Card for your copy of Active's new catalog.

CIRCLE NO. 50 ON FREE INFORMATION CARD

4164

64K DYNAMIC 200 NS

\$595

TMM2016

2KX8 STATIC 200 NS

\$415

STATIC RAMS

2101	256 x 4 (450ns)	1.95
5101	256 x 4 (450ns) (cmos)	3.95
2102-1	1024 x 1 (450ns)	.89
2102L-4	1024 x 1 (450ns) (LP)	.99
2102L-2	1024 x 1 (250ns) (LP)	1.49
2111	256 x 4 (450ns)	2.49
2112	256 x 4 (450ns)	2.99
2114	1024 x 4 (450ns)	8/9.95
2114-25	1024 x 4 (250ns)	8/10.95
2114L-4	1024 x 4 (450ns) (LP)	8/12.95
2114L-3	1024 x 4 (300ns) (LP)	8/13.45
2114L-2	1024 x 4 (200ns) (LP)	8/13.95
TC5514	1024 x 4 (650ns) (cmos)	2.49
TC5516	2048 x 8 (250ns) (cmos)	9.95
2147	4096 x 1 (55ns)	4.95
TMS4044-4	4096 x 1 (450ns)	3.49
TMS4044-3	4096 x 1 (300ns)	3.99
TMS4044-2	4096 x 1 (200ns)	4.49
MK418	1024 x 8 (250ns)	9.95
TMM2016-200	2048 x 8 (200ns)	4.15
TMM2016-150	2048 x 8 (150ns)	4.95
TMM2016-100	2048 x 8 (100ns)	6.15
HM6116-4	2048 x 8 (200ns) (cmos)	4.75
HM6116-3	2048 x 8 (150ns) (cmos)	4.95
HM6116-2	2048 x 8 (120ns) (cmos)	8.95
HM6116LP-4	2048 x 8 (200ns) (cmos)(LP)	5.95
HM6116LP-3	2048 x 8 (150ns) (cmos)(LP)	6.95
HM6116LP-2	2048 x 8 (120ns) (cmos)(LP)	10.95
Z-6132	4096 x 8 (300ns) (Qstat)	34.95
HM6264	8192 x 8 (150ns) (cmos)	49.95

LP = Low Power Qstat = Quasi-Static

EPROMS

1702	256 x 8 (1us)	4.50
2708	1024 x 8 (450ns)	3.95
2758	1024 x 8 (450ns) (5v)	5.95
2716	2048 x 8 (450ns) (5v)	3.95
2716-1	2048 x 8 (350ns) (5v)	5.95
TMS2516	2048 x 8 (450ns) (5v)	5.50
TMS2716	2048 x 8 (450ns)	7.95
TMS2532	4096 x 8 (450ns) (5v)	5.95
2732	4096 x 8 (450ns) (5v)	4.95
2732-250	4096 x 8 (250ns) (5v)	8.95
2732-200	4096 x 8 (200ns) (5v)	11.95
2732A-4	4096 x 8 (450ns) (5v) (21vPGM)	6.95
2732A	4096 x 8 (250ns) (5v) (21vPGM)	9.95
2732A-2	4096 x 8 (200ns) (5v) (21vPGM)	13.95
2764	8192 x 8 (450ns) (5v)	6.95
2764-250	8192 x 8 (250ns) (5v)	7.95
2764-200	8192 x 8 (200ns) (5v)	19.95
TMS2564	8192 x 8 (450ns) (5v)	14.95
MCM68764	8192 x 8 (450ns) (5v) (24 pin)	39.95
MCM68766	8192 x 8 (350ns) (5v) (24 pin)(pwr dn.)	42.95
27128	16384 x 8 (300ns) (5v)	29.95

5v Single 5 Volt Supply 21vPGM Program at 21 Volts

CRYSTALS

32.768 khz	1.95
1.0 mhz	3.95
1.8432	3.95
2.0	2.95
2.097152	2.95
2.4576	2.95
3.2768	2.95
3.579545	2.95
4.0	2.95
5.0	2.95
5.0688	2.95
5.185	2.95
5.7143	2.95
6.0	2.95
6.144	2.95
6.5536	2.95
8.0	2.95
10.0	2.95
10.738635	2.95
14.31818	2.95
15.0	2.95
16.0	2.95
17.430	2.95
18.0	2.95
18.432	2.95
20.0	2.95
22.1184	2.95
32.0	2.95

CMOS

4000	29	4528	1.19
4001	25	4531	.95
4002	25	4532	1.95
4006	89	4538	1.95
4007	29	4539	1.95
4008	95	4541	2.64
4009	39	4543	1.19
4010	45	4553	5.79
4011	25	4555	.95
4012	25	4556	.95
4013	38	4581	1.95
4014	79	4582	1.95
4015	39	4584	.75
4016	39	4585	.75
4017	69	4702	12.95
4018	79	74C00	.35
4019	39	74C02	.35
4020	75	74C04	.35
4021	79	74C08	.35
4022	79	74C10	.35
4023	29	74C14	.59
4024	65	74C20	.35
4025	29	74C30	.35
4026	1.65	74C32	.39
4027	45	74C42	1.29
4028	69	74C48	1.99
4029	79	74C73	.65
4030	39	74C74	.65
4034	1.95	74C76	.80
4035	.85	74C83	1.95
4040	.75	74C85	1.95
4041	.75	74C86	.39
4042	.69	74C89	4.50
4043	.85	74C90	1.19
4044	.79	74C93	1.75
4046	.85	74C95	.99
4047	.95	74C107	.89
4049	.35	74C150	5.75
4050	.35	74C151	2.25
4051	.79	74C154	3.25
4053	.79	74C157	1.75
4060	.89	74C160	1.19
4066	.39	74C161	1.19
4068	.39	74C162	1.19
4069	.29	74C163	1.19
4070	.35	74C164	1.39
4071	.29	74C165	2.00
4072	.29	74C173	.79
4073	.29	74C174	1.19
4075	.29	74C175	1.19
4076	.79	74C192	1.49
4078	.29	74C193	1.49
4081	.29	74C195	1.39
4082	.29	74C200	5.75
4085	.95	74C221	1.75
4086	.95	74C244	2.25
4093	.49	74C373	2.45
4098	2.49	74C374	2.45
4099	1.95	74C901	.39
14409	12.95	74C902	.85
11C90	13.95	74C903	.85
95H90	7.95	74C905	10.95
2513-001 UP	9.95	14412	12.95
2513-002 LOW	9.95	14419	7.95
		14433	14.95
		4502	.95
		4503	.65
		4508	1.95
		4510	.85
		4511	.85
		4512	.85
		4514	1.25
		4515	1.79
		4516	1.55
		4518	.89
		4519	.39
		4520	.79
		4522	1.25
		4526	1.25
		4527	1.95

★ ★ ★ ★ HIGH-TECH ★ ★ ★ ★

HM6264 8K x 8 STATIC RAM

- Fast—150 ns • +5V Supply
 - 28 Pin—Compatible w/2764 EPROM
 - Low Power CMOS (TTL Compatible)
 - 200 mW Operation/.01 mW Standby (LP)
- HM6264P-15 \$39.95 HM6264LP-15 \$49.95

★ ★ ★ ★ SPOTLIGHT ★ ★ ★ ★

- ★ Computer managed inventory — virtually no back orders!
- ★ Very competitive prices!
- ★ Friendly staff!
- ★ Fast service — most orders shipped within 24 hours!

DYNAMIC RAMS

TMS4027	4096 x 1 (250ns)	1.99
UPD411	4096 x 1 (300ns)	3.00
MM5280	4096 x 1 (300ns)	3.00
MK4108	8192 x 1 (200ns)	1.95
MM5298	8192 x 1 (250ns)	1.85
4116-300	16384 x 1 (300ns)	8/11.75
4116-250	16384 x 1 (250ns)	8/7.95
4116-200	16384 x 1 (200ns)	8/12.95
4116-150	16384 x 1 (150ns)	8/14.95
4116-120	16384 x 1 (120ns)	8/29.95
2118	16384 x 1 (150ns) (5v)	4.95
MK4332	32768 x 1 (200ns)	9.95
4164-200	65536 x 1 (200ns) (5v)	5.95
4164-150	65536 x 1 (150ns) (5v)	6.95
MCM6665	65536 x 1 (200ns) (5v)	8.95
TMS4164-15	65536 x 1 (150ns) (5v)	8.95

5V single 5 volt supply

UARTS

AY3-1014	6.95
AY5-1013	3.95
AY3-1015	6.95
PT1472	9.95
TR1602	3.95
2350	9.95
2651	8.95
IM6402	7.95
IM6403	8.95
INS8250	10.95

GENERATORS

MC14411	11.95
BR1941	11.95
4702	12.95
COM5016	16.95
COM8116	10.95
MM5307	10.95

BIT-RATE

MC14411	11.95
BR1941	11.95
4702	12.95
COM5016	16.95
COM8116	10.95
MM5307	10.95

FUNCTION

MC4024	3.95
LM566	1.49
XR2206	3.75
8038	3.95

MISC.

UPD7201	29.95
TMS99532	29.95
ULN2003	2.49
3242	7.95
3341	4.95
MC3470	4.95
MC3480	9.00
11C90	13.95
95H90	7.95
2513-001 UP	9.95
2513-002 LOW	9.95

CLOCK CIRCUITS

MM5314	4.95
MM5369	3.95
MM5375	4.95
MM58167	12.95
MM58174	11.95
MSM5832	3.95

KEYBOARD CHIPS

AY5-2376	11.95
AY5-3600	11.95
AY5-3600 PRO	11.95

6800

68000	49.95
6800	2.95
6802	7.95
6803	19.95
6808	13.90
6809E	14.95
6809	11.95
6810	2.95
6820	4.35
6821	2.95
6828	14.95
6840	12.95
6843	34.95
6844	25.95
6845	14.95
6847	11.95
6850	3.25
6852	5.75
6860	7.95
6875	6.95
6880	2.25
6883	22.95
68047	24.95
68488	19.95

6500

6502	4.95
6504	6.95
6505	8.95
6507	9.95
6520	4.35
6522	6.95
6532	9.95
6545	22.50
6551	11.85

8000

8035	5.95
8039	5.95
INS-8060	17.95
INS-8073	49.95
8080	3.95
8085	4.95
8085A-2	11.95
8086	24.95
8087	CALL
8088	29.95
8089	89.95
8155	6.95
8155-2	7.95
8156	6.95
8185	29.95
8185-2	39.95
8741	29.95
8748	24.95
8755	24.95

8200

8202	24.95
8203	39.95
8205	3.50
8212	1.80
8214	3.85
8216	1.75
8224	2.25
8226	1.80
8228	3.49
8237	19.95
8237-5	21.95
8238	4.49
8243	4.45
8250	10.95
8251	4.49
8253	6.95
8253-5	7.95
8255	4.49
8255-5	5.25
8257	7.95
8257-5	8.95
8259	6.90
8259-5	7.50
8271	79.95
8272	39.95
8275	29.95
8279	8.95
8279-5	10.00
8282	6.50
8283	6.50
8284	5.50
8286	6.50
8287	6.50
8288	25.00
8289	49.95

Z-80

Z80-CPU	3.95
Z80-CTC	3.95
Z80-DART	10.95
Z80-DMA	14.95
Z80-PIO	3.95
Z80-SIO/0	11.95
Z80-SIO/1	11.95
Z80-SIO/2	11.95
Z80-SIO/9	11.95

2114 450 NS

8/\$995

2114 250 NS

8/\$1095

74LS00

Table listing various 74LS00 logic chips with their respective prices.

74S00

Table listing various 74S00 logic chips with their respective prices.

VOLTAGE REGULATORS

Table listing various voltage regulators with their respective prices.

7400

Table listing various 7400 logic chips with their respective prices.

SOUND CHIPS

Table listing various sound chips with their respective prices.

BYPASS CAPS

Table listing various bypass capacitors with their respective prices.

EPROM ERASERS SPECTRONICS CORPORATION

Table listing various EPROM erasers with their respective prices.

INTERFACE

Table listing various interface components with their respective prices.



DATA ACQUISITION

Table listing various data acquisition components with their respective prices.

CONNECTORS

Table listing various connectors with their respective prices.

EXAR

Table listing various EXAR components with their respective prices.

INTERSIL

Table listing various Intersil components with their respective prices.

9000

Table listing various 9000 series components with their respective prices.

LINEAR

Table listing various linear components with their respective prices.

RCA

Table listing various RCA components with their respective prices.

TI

Table listing various TI components with their respective prices.

BI FET

Table listing various BI FET components with their respective prices.

DIP SWITCHES

Table listing various DIP switches with their respective prices.

CENTRONICS

Table listing various Centronics components with their respective prices.

LED LAMPS

Table listing various LED lamps with their respective prices.

LED DISPLAYS

Table listing various LED displays with their respective prices.

MICRODEVICES AT MICROPRICES

© Copyright 1984 JDR Microdevices

Circle No. 22 on Free Information Card

Morrow MD11

(Continued from page 40)

with the system for the purpose of using the floppy to back up data on the hard disk. The program is supposed to support a full backup, partial backup, or archival backup of changed files only. It is also supposed to store the files in a packed format that greatly decreases the number of floppy disks required for the task. We cannot comment on how this program works, because Backfield was not available when we tested the MD11.

Finally, the MD11 comes with a handy disk format emulator that supports a number of foreign formats, including Kaypro, Osborne, Televideo, and Xerox. This utility permits data to be transferred to and from these machines and also allows the user to obtain software that may not be available in the Morrow format. As is the case with all such transferred programs, of course, software specially modified from generic CP/M to utilize the special features of other machines may not run when transferred to the MD11.

Getting Acquainted

One of the acid tests of a new product is the ease with which it can be gotten up and running. Our impression of the MD11 is very positive in this respect. Assembly requires only connecting the terminal to the main unit and the keyboard to the terminal. After power-up, the system begins initializing. In a conversational style, you are asked what type of printer you are using, after which the system proceeds to configure all resident software to properly interface with the printer. The procedure takes about five minutes to complete.

After configuration, you are immediately brought to the main Co-Pilot menu. All the software available is clearly listed, and each can be chosen with a single keystroke. To make things even easier, Co-Pilot selects a suitable user area on the hard disk for each application so that each has its own directory. Upon exiting an application, the main Co-Pilot menu reappears.

Since the Pilot language is interpretive, each time Co-Pilot takes over, the interpreter and the Co-Pilot source files must be reloaded. This causes a relatively short but noticeable delay. Experienced users may want to deactivate Co-Pilot by changing the "profile.sub" command file that CP/M 3.0 uses to initiate the system.

New users should always remember to run the "park" program supplied by Morrow to park the hard disk heads before power-down. Failure to do this might cause disk damage if the main unit

of the computer were to be jostled while not powered up.

Operation and Performance

Overall, we are pleased with the performance of the MD11. In more than three months of use we have encountered no operating problems. (A second MD11 we received about five weeks prior to writing this review also operated flawlessly under extensive use.) Similarly, we encountered no problems with any of the available software, and we were delighted with the many extra features CP/M 3.0 provides.

The star of the show, of course, is the hard disk system. Although we have not executed any formal benchmarks, the system seems to outperform other such systems we have used, all costing several times as much. Many applications seem to run almost as if there is no need to access the disk, even with disk-intensive operations. This is probably attributable to the disk cache and the well-known performance of Morrow's disk controller cards.

We also have some good things to say about the new terminal that Morrow has introduced with all of its desktop computers. The keyboard's feel is excellent, and the high-resolution 12" screen, with its well-formed characters, should be a relief to anyone who has had to suffer with the small screens and/or poor-quality character sets all too prevalent with low-cost computers.

The software included at no extra cost with the system is generally first-rate. Not only will a new computer user save a good deal of money with the software supplied with the MD11, but he can be assured that the software will work properly in his particular system configuration without having to perform complicated customizing procedures. We might add that the documentation included is more than adequate. The Morrow User's Guide, the NewWord manual, and the CP/M Plus User's Guide are particularly well-written and well-organized.

Buying Considerations

Naturally, the MD11 is not for everyone. Prospective buyers should note that the MD11 currently offers no compatibility with the IBM PC and MS-DOS operating system, other than through modem communications or through some networks that support both CP/M and MS-DOS. According to recently released literature, however, Morrow is planning to introduce in the near future

both an add-on 16-bit 8088 board with 256K of RAM for running MS-DOS and a network that will support Morrow and other computers running under MS-DOS.

The Morrow terminal that normally comes with the MD11 supports some excellent character graphics, but it does not support color or bit-addressable graphics and cannot be modified to do so. If a buyer needs such graphics, he can buy the MD11 without the terminal for \$400 less and invest in one of the many excellent color graphics terminals that interface easily with the MD11. In addition, Digital Research's GSX graphics control package for CP/M is available.

If a buyer already owns a terminal, he can probably use it with the MD11. Morrow provides a terminal configuration utility to support almost any ASCII-type video terminal with RS-232C communications interface.

Virtually all software written for earlier versions of CP/M will run under Morrow's CP/M 3.0 operating system. In general, any incompatibility should be limited to software that makes direct BIOS calls, such as special CP/M extensions and utility tools like Power! or custom system configuration software supplied for a particular computer by its manufacturer. CP/M business programs, however, should work fine without modification and even gain some advantage from the additional program memory space (62K TPA) available under CP/M 3.0.

Anyone who wishes to use Quest Bookkeeper II with the MD11 should know that this system, as configured, does not contain a payroll or inventory module and that the cash disbursements module works on a cash and not an accrual basis. These and other accounting modules are available at additional cost directly from Quest. Furthermore, use of Bookkeeper beyond one accounting period requires a license from Quest, which currently charges a support fee of \$37.50 per company.

Conclusions

Our overall opinion of the MD11 is that it is an excellent system and a very attractive buy for anyone who requires or desires the extra speed, versatility, and storage capacity that a hard disk system has to offer. Morrow is to be commended for an exceptional job of integrating hardware and software for a price only slightly higher than many best-selling floppy-disk-based systems currently on the market. From where we stand, the MD11 looks like a winner. ◇

RS232 ADAPTER FOR VIC-20 AND COMMODORE 64



The JE232CM allows connection of standard RS232 printers, modems, etc. to your VIC-20 and C-64. A 4-pole switch allows the inversion of the 4 control lines. Complete installation and operation instructions included.

Plugs into User Port • Provides Standard RS232 signal levels • Uses 6 signals (Transmit, Receive, Clear to Send, Request to Send, Data Terminal Ready, Data Set Ready).
JE232CM \$39.95

VOICE SYNTHESIZER FOR APPLE AND COMMODORE

NEW!



Over 250 word vocabulary - affixes allow the formation of more than 500 words • Built-in amplifier, speaker, volume control, and audio jack • Recreates a clear, natural male voice • Plug-in user ready with documentation and sample software • Case size: 7 1/4" L x 3 3/4" W x 1-3/8" H

APPLICATIONS: • Security Warning • Telecommunication • Teaching • Handicap Aid • Instrumentation • Games

The JE520 VOICE SYNTHESIZER will plug right into your computer and allow you to enhance almost any application. Utilizing National Semiconductor's DIGITALKER™ Speech Processor IC (with four custom memory chips), the JE520 compresses natural speech into digital memory, including the original inflections and emphases. The result is an extremely clear, natural vocalization.

Part No.	Description	Price
JE520CM	For Commodore 64 & VIC-20	\$114.95
JE520AP	For Apple II, II+, and IIe	\$149.95



JE664 EPROM PROGRAMMER

8K to 64K EPROMS — 24 & 28 Pin Packages

Completely Self-Contained — Requires No Additional Pins for Operation • Programs and validates EPROMs • Checks for properly erased EPROMs • Emulates PROMs or EPROMs • RS232C Computer interface for erasing and program loading • Loads data into RAM by keyboard • Changes data in RAM by keyboard • Loads RAM from an EPROM • Compares EPROMs for content differences • Copies EPROMs • Power Input: 115VAC, 60Hz, less than 10W power consumption • Enclosure: Color-coordinated, light tan panels with milled end pieces in mocha brown • Size: 15 1/4" L x 8 1/4" W x 3 1/8" H • Weight: 5 1/2 lbs.

The JE664 EPROM Programmer erases and programs various 8-bit VROM EPROMs from 8K to 64K (8K memory capacity). Data can be entered into the JE664's internal 8K x 8-bit RAM in five ways: (1) from a ROM or EPROM, (2) from an external computer via the optional JE665 RS232C BUS, (3) from its panel keyboard. The JE664's RAMs may be accessed for erasure purposes from the panel's test socket to an external microprocessor. In programming and erasure, the JE664 allows for examination, change and validation of program content. The JE664's RAMs can be programmed quickly to all 1's (or any value), allowing unneeded addresses in the EPROM to be programmed later without necessary of "UV" erasing. The JE664 displays DATA and ADDRESS in convenient hexadecimal (alphanumeric) format. A "DISPLAY EPROM DATA" button changes the DATA readout from RAM word to EPROM word and is displayed in both hexadecimal and binary code. The front panel features a convenient operating guide. The JE664 Programmer includes one JM15A Jumper Module (as listed below).

JE664-A EPROM Programmer \$995.00
Assembled & Tested (Includes JM15A Module)

JE665 — RS232C INTERFACE OPTION — The RS232C Interface Option implements computer access to the JE664's RAM. This allows the computer to manipulate, store and transfer EPROM data to and from the JE664. A sample program listing is provided in MBASIC for CPM computers. Documentation is provided to adapt the software to other computers with an RS232C port (9600 Baud, 8-bit word, odd parity and 2 stop bits).

FOR A LIMITED TIME A SAMPLE OF SOFTWARE WRITTEN IN BASIC FOR THE TRS-80 MODEL I, II, & III WILL ALSO BE PROVIDED.

JE664-ARS EPROM Prog. w/ JE665 Option \$1195.00
Assembled & Tested (Includes JM15A Module)

EPROM JUMPER MODULES — The JE664's JUMPER MODULE (personality Module) is a plug-in Module that pre-sets the JE664 for the proper programming outputs to the EPROM and configures the EPROM socket connections for that particular EPROM.

JM15A Jumper Module No.	EPROM	Programming Voltage	EPROM MANUFACTURER	PRICE
JM58A	2708	25V	AMD, Motorola, Mic, Intel, TI	\$14.95
JM15A	2716, 2765/16 (It)	25V	AMD, Hitachi, Mosaid, NEC, TI	\$14.95
JM15B	1702/16 (3-15V)	5V - 15V - 12V	Motorola, TI	\$14.95
JM22A	2765/32	25V	Motorola, TI, Intel, AMD	\$14.95
JM27B	2732	25V	AMD, Fujitsu, NEC, Hitachi, Intel, Mitsubishi, National	\$14.95
JM27C	2732A	21V	Fujitsu, Intel	\$14.95
JM44A	MC680764, MC680764	21V	Motorola	\$14.95
JM49B	2764	21V	Intel, Fairchild, Oki	\$14.95
JM49C	1702/564	25V	TI	\$14.95

HI-TEK 14-KEY NUMERIC KEYPAD
Great keypad for many home and business computer applications • SPST switching • Mounted on PC board • Size 5" L x 3" W x 1 1/2" H • Color: Grey • Weight: 1 lb. • Spec available
K-14 \$9.95

MICRO SWITCH ASCII Encoded Keyboards
Large selection of keyboards • Half effect switching • Some have parallel interfaces • Some have serial interfaces • All have status LEDs and a minimum of 68 keys • Some with numeric keypad capabilities, cursor controls, or both • Styles may vary • Weight: 2 lbs. • No specs available
KB-MISC \$9.95

Mitsumi 54-Key Unencoded Matrix All-Purpose Keyboard
SPST keyswitches • 20 pin ribbon cable connection • Low profile keys • Features: cursor controls, control caps (lock, function, enter and shift keys) (Color: keycaps) grey • Wt. 1 lb. • Pinout included
KB54 \$14.95

71-Key ASCII Cherry Keyboard
7 bit parallel ASCII with strobe • 11 key numeric keypad • SPST mechanical keyswitches • 15/30 card-edge connector • Features: escape, control, cursor controls, plus 10 add'l. special function keys • Color: white • Weight: 2 lbs. • Spec included
KB1801 \$29.95

87-KEY ASCII Cherry Keyboard
12-key numeric keypad • Cursor keypad • SPST mechanical keyswitches • 40-pin header connector • Colors: main and numeric keypad—orange • Cursor keypad—yellow • Weight: 2 lbs. • Spec included
KB8600 \$34.95

106-KEY 8-BIT SERIAL ASCII KEYBOARD
The terminals were designed to be daisy chained around a central host computer and used as individual work stations • Half effect switching • numeric and cursor keypad • 10 user definable keys • 50" interface cable with 9-pin sub-miniature connector • 7 LED function displays • Security lock • N-key roll-over • Automatic key repeat function • Color: (case) white • White/black name-(key caps) grey and blue • Weight: 6 1/2 lbs. • Data included.
KB139 \$59.95

POWER SUPPLIES
TRANSACTION TECHNOLOGY, INC.
5VDC @ 1 AMP Regulated Power Supply
Output: +5VDC @ 1.0 amp (also +30VDC regulated) • Input: 115VAC, 60 Hz • Two-tone (black/beige) self-enclosed case • 6 foot, 3-conductor black power cord • Size: 6 1/2" L x 7" W x 2 1/4" H • Weight: 3 lbs.
PS51194 \$14.95

Power/Mate Corp. REGULATED POWER SUPPLY
Input: 105-125/210-250 VAC at 47-63 Hz • Line regulation: ±0.05% • Three mounting surfaces • Overvoltage protection • UL recognized • CSA certified
Part No. Output Size Weight Price
EMA5/6B 5V@3A/6V@2.5A 4 7/8" L x 4" W x 2 1/2" H 2 lbs \$29.95
EMA5/6C 5V@6A/6V@5A 5 1/4" L x 4 1/2" W x 2 1/2" H 4 lbs \$39.95

NEW!
ASTEC SWITCHING REGULATED POWER SUPPLY
Apple III Power Supply • Multiple outputs for bench top uses and other applications • Input: 115VAC, 50-60 Hz @ 3.0 amps • Output: +5VDC @ 1.0 amp, -12VDC @ 1.0 amp, -12VDC @ 1.0 amp, +24VDC @ 2.5 amp, -24VDC @ 2.5 amp • Size: 15" L x 3 3/4" W x 2 1/2" H • Weight: 2 1/2 lbs.
AS1155 \$39.95

POWER SUPPLY +5VDC @ 7.6 AMP, 12VDC @ 1.5 AMP SWITCHING
Input: 115VAC, 50-60Hz @ 3 amp/230VAC, 50Hz @ 1.5 amp • Fan volt/power supply select switches (115/230VAC) • Output: 5VDC @ 7.6 amp, 12VDC @ 1.5 amp, 8 foot black power cord • Size: 11 1/4" L x 13 1/4" W x 3 1/4" H • Weight: 9 lbs
PS94VDS \$39.95

KEPCO/TDK 4-OUTPUT SWITCHING POWER SUPPLY
Ideal for clock drive needs of CRT terminals, microcomputers and video games • Input: 115/230VAC, 50/60Hz • Output: -5V @ 5 Amp, -12V @ 1.8 Amp, +12V @ 2 Amp, -12V @ 0.5 Amp • UL recognized • CSA certified • Size: 7 1/2" L x 6-3/16" W x 1 1/4" H • Weight: 1 1/2 lbs.
MRM 174KF \$59.95

4-CHANNEL SWITCHING POWER SUPPLY
Microprocessor, mini-computer, terminal, medical equipment and process control applications • Input: 30-250VAC, 47-640Hz • Output: +5VDC @ 5A, -5VDC @ 1 A, +12VDC @ 1A, -12VDC @ 1A • Line regulations: ±0.2% • Ripple: 30mV p-p • Load regulation: ±1% • Overcurrent protection • Adj: 5V main output • 10% • Size: 6 1/4" L x 1 1/4" W x 4-15/16" H • Weight: 1 1/2 lbs.
FCS-604A \$69.95 each

Switching Power Supply for APPLE II, II+ & IIe
Can drive four floppy disk drives and up to eight expansion cards • Short circuit and overload protection • Fits inside Apple computer • Fully regulated +5V @ 5A, +12V @ 1.5A, -5V @ 5A, -12V @ 5A • Direct plug-in power cord included • Size: 9 1/4" L x 3 3/4" W x 2 1/4" H • Weight: 2 lbs.
KHP4007 \$79.95

\$10.00 Minimum Order — U.S. Funds Only
California Residents Add 6% Sales Tax
Shipping — Add \$3.00 plus \$1.50 Insurance
Send S.A.S.E. for Monthly Sales Flyer!

Spec Sheets — 30¢ each
Send \$1.00 Postage for your FREE 1984 JAMECO CATALOG
Prices Subject to Change

MasterCard **Jameco ELECTRONICS** VISA

1355 SHOREWAY ROAD, BELMONT, CA 94002
8/64 PHONE ORDERS WELCOME — (415) 592-8097 Telex: 176043

NEW!
Bright 4-digit 0.5" high display • 10 minute snooze alarm
• AM/PM indicator
• Automatic display dimmer

The JE750 Clock Kit is a versatile 12-hour digital clock with 24-hour alarm. The clock has a bright 0.5" high blue-green fluorescent display. The display will automatically dim with changing light conditions. The 24-hour alarm allows the user to disable the alarm and immediately re-enable the alarm to activate 24 hours later. The kit includes all documentation, components, case and wall transformer. Size: 6 1/4" L x 3 3/4" W x 1 1/4" D.
JE750 Alarm Clock Kit \$29.95

DISK DRIVES AND SUPPLIES

5 1/4" APPLE™ Direct Plug-In Compatible Disk Drive
Uses Shugart SA390 mechanics • 143K formatted storage • 35 tracks — compatible with Apple controller • Complete with connector and cable — just plug into your disk controller card • Size: 6 1/2" L x 3 1/4" W x 8-9/16" D • Weight: 4 1/2 lbs.
ADD-514...\$195.95

+5VDC @ 6 Amps
+12VDC @ 4 Amps
-12VDC @ 0.5 Amps
Microcomputer Power Inc. Regulated Power Supply

Perfect for computer or disk drive systems • Supply has AMP connectors for direct connection to two 5 1/4" disk drives • Cooling fan • Input: 100/115/200/230VAC, 47-63Hz • Output (above) • Weight: 9 lbs.
CP167 \$59.95

INDUSTRIES Protect Yourself... DATASHIELD® Surge Protector
Eliminates voltage spikes and EMI-RFI noise before it can damage your equipment or cause data loss • 6 month warranty • Power dissipation (100 microsecond) 1,000,000 watts • 6 sockets • 6 foot power cord • Normal line voltage indicator light • Brown out/black out reset switch • Weight: 2 lbs.
Model 100 \$69.95

Protect Yourself... DATASHIELD® Back-Up Power Source
Provides up to 30 minutes of continuous 120 VAC 60Hz power to your computer system (load dependent) when you have a black out or voltage sag • Output rating: 200 watts • Six month warranty • Weight: 19 lbs.
Model 200 (PC200) \$349.95

IBM MEMORY EXPANSION KIT COMPAQ COMPATIBILITY

SAVE HUNDREDS OF \$\$\$ BY UPGRADING MEMORY BOARDS YOURSELF!

Most of the popular memory boards allow you to add an additional 64K, 128K, 192K, or 256K. The IBM64K Kit will populate these boards in 64K byte increments. The kit is simple to install. Just insert the nine 64K RAM chips in the provided sockets and set the two groups of switches. Directions are included.

IBM64K (Nine 200ns 64K RAMs) \$49.95

TRS-80 MEMORY EXPANSION KIT

TRS-80 to 16K, 32K, or 48K
**Model 1 = From 4K to 16K Requires (1) One Kit
Model 3 = From 4K to 48K Requires (3) Three Kits
Color = From 4K to 16K Requires (1) One Kit
**Model 1 equipped with Expansion Board to 48K Two Kits Required — One Kit Required for each 16K of Expansion —
TRS-16K3 *200ns for Color & Model III \$12.95
TRS-16K4 *250ns for Model I \$10.95

TRS-80 Color 32K or 64K Conversion Kit

Easy to install kits comes complete with 8 ea. 4164-2 (200ns) 64K dynamic RAMs and conversion documentation. Converts TRS-80 color computers with D, E, F, and M-C circuit boards to 32K. Also converts TRS-80 color computer to 64K. Flex-DOS or OS-9 required to utilize full 64K RAM on all computers.
TRS-64K2 \$44.95

UV-EPROM Eraser

8 Chips — 51 Minutes
1 Chip — 37 Minutes
Erases 2708, 2716, 2732, 2764, 2516, 2532, 2564. Erases up to 8 chips within 51 minutes (1 chip in 37 minutes). Maintains constant exposure distance of one inch. Special conductive foam liner eliminates static build-up. Built-in safety lock to prevent UV exposure. Compact — only 9.00" x 3.70" x 2.60". Complete with holding tray for 8 chips.
DE-4 UV-EPROM Eraser \$79.95
UV-11E Replacement Bulb \$16.95

Computer Mart

RATE: Ads are " by 3". 1 insertion: \$935.00. 6 insertions: \$900.00 ea. 12 insertions, \$865.00 ea. Closing date: 1st of the 2nd mo. preceding cover date. Send order and remittance to Computer Mart, Computers & Electronics, 1 Park Ave., N.Y., N.Y. 10016. Direct inquiries to (212) 725-4215.

COMMODORE 64 INTERFACING BLUE BOOK

Written by a college professor in a friendly and informative style, this book is a gold mine of practical information on how to build a variety of useful interfaces for your computer. Over 30 projects including cassette interface, printer interface, expansion bus, light pen, RS-232 interface, more user ports, thermometer, speech synthesizer and two other voice projects. A/D and D/A converters. 5 telephone interfaces including a sophisticated voice mail project, motor controllers, AC power control, logic analyzer, capacitance meter, spectrum analyzer, home security system and many more. \$16.95 postpaid. Foreign orders add \$3 for AIR MAIL shipping.

VIC 20 INTERFACING BLUE BOOK

30 hardware interfacing projects for the VIC 20. Similar to the 64 book above. See what your VIC can do with a little interfacing. \$14.95 postpaid.

microsignal
Dept. B, P.O. BOX 22
MILLWOOD, NY 10546



Best Prices On TRS-80 Computers

Our 6th year of discounts
Ed or Joe McManus
Fgt. Prepaid. Save Tax.
Toll Free 800-231-3680
Marymac Industries, Inc.
22511 Katy Fwy., Katy
(Houston) Tx 77450
1-713-392-0747
Telex 774132

See us in the Wall Street
Journal every Tues. Wed. Thurs.

SAVE 90%

IBM Machine with a 40% plus in performance-8086 based system with 128KB memory two RS232 Ports plus a Centronics Port for ~\$235 Upgradable!

CPMachine-4MHz Z80A based 64KB memory, two RS232 Ports for ~\$120.00

16/32 bit commercial workhorse a 68000 based, 128KB memory three RS232 Ports for ~\$265 Expandable!

Floppy Interface \$60. 25 x 80 CRTs \$200, Software, Boards ROMs, Parts and MORE!

FREE CATALOG

DIGATEK CORPORATION
SUITE 7
2723 West Butler Drive
Phoenix AZ 85021

Why waste money on a Commodore, Atari, TI, etc. when a system with a future costs less?

CIRCLE NO. 100 ON FREE INFORMATION CARD

EPROM Eraser \$44.90 EPROM Programmer \$159.

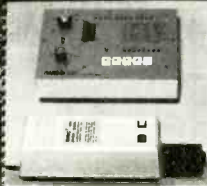

ERASER

- contains same features as competitors' but cost less than one half their price
- erases up to 9 chips
- 6.4 mA/cm² on chips
- chip drawer prevents UV exposure to users
- long life UV tube
- erase time from 15 min

PROGRAMMER

- ★ PROGRAMS & COPIES: 2516, 2532, 2716, 2732, 2732A.
- ★ 4K INTERNAL RAM BUFFER STORAGE CAPACITY.
- ★ NO PERSONALITY MODULE REQUIRED.
- ★ POWER CAN BE REMOVED FROM ZIF SOCKET WHEN LOADING EPROMS.
- ★ BINARY ADDRESS AND DATA DISPLAY.
- ★ INDEPENDENT UNIT -- VERIFIES, PROGRAMS, INPUTS DATA FROM BINARY KEYBOARD, LOADS DATA FROM EPROM TO RAM, AND CHANGES ANY BIT OF DATA.
- ★ FULL 90-DAY GUARANTEE ON ALL PRODUCTS FOR ANY DEFECTS IN MATERIALS AND WORKMANSHIP.

ANGO ELECTRONICS CORP. 212-685-6336
P.O. BOX 112 HARRISON, NJ 07029 TLX: 42131 ARTISTI

MasterCard Mail orders: Please add \$3 handling charge N.J. residents: Please add 6% sales tax VISA

CIRCLE NO. 96 ON FREE INFORMATION CARD

MODULES FOR TIMEX-Sinclair



MODEM

- 2 FREE HOURS COMPUSERVE
- NOW BOTH ORIGINATE AND ANSWER
- Send & Receive Programs by Phone
- Copy Information into Memory. Print it. Review It. Save It On Tape. Send Text From Memory.
- Use Timex 2040 Printer or Any RS-232 Printer.
- RS-232 Printer Port Provided.
- No extra Memory Required. But with 64K Memory You Can Store Up To 60 Full Screens.
- ADAPTABLE TO THE NEW 2068

BYTE-BACK CO. Rt. 3 Box 147 Brodie Rd.
Leesville, S.C. 29070 Ck COD VISA M/C AM EXP
Ph. 803-532-5812 Add \$4.95 shipping to all orders
10 day money back guarantee plus 90-day warranty

CIRCLE NO. 98 ON FREE INFORMATION CARD

GENERAL INSTRUMENT SP0256-AL2 Speech Synthesizer

UNLIMITED VOCABULARY EASY INTERFACE TO ANY COMPUTER

\$25.00 each plus \$2.00 shipping
The General Instrument ALLOPHONE speech processor is a single chip LSI device that synthesizes continuous speech of unlimited vocabulary. Not to be confused with limited (stored) vocabulary speech chips like the JPO-56-017. Documentation includes program listings, interfacing, etc., for use with Apple, VIC-20, Commodore 64 and TRS-80. Also general info for use with other systems!

PARTIAL KIT ALSO AVAILABLE
Includes CHIP, P board, hard to find components, documentation, etc.
Apple \$4. Commodore 64 \$40.
VIC-20 \$40. TRS-80 (I-111) \$40.
plus \$3.00 shipping

SEND CHECK OR M.O. to:
SILICON SCIENCE, INC.
4710 Wellington Blvd.
Alexandria, La. 71305
Call (513) 442-7735 for 2ISA or VISA

CIRCLE NO. 101 ON FREE INFORMATION CARD

PRINTER STAND or DESK

- Size: 27h x 24d x 27" w.
- Black Painted Steel
- Sh. Wt. 75 Lbs.
- Shipped Freight Collect
- Use Order No. 2A70585



\$39.95



FAN CONTROL Controls Speed Of AC MOTORS!

ONLY **\$3.88** 3 for \$10.00
Muffin Fans, Caravel Fans, Blowers, ETC... Good for 115/220-VAC up to 6 amps stall current. Control rated at 1.6 amps. Size: 1 1/4 x 2 x 1" Shaft mounting. Use Order No. 3BS0269.

BNF Enterprises

119r FOSTER St.
Peabody MA 01960
(617) 531-5774

40 Page Catalog
Customer Pays All Shipping Charges.

CIRCLE NO. 97 ON FREE INFORMATION CARD

20 PROGRAMS on 2 cassette tapes

for 16K TS1000, TS1500, & ZX81 only **\$19.95**

*for TS2068 C-64, VIC 20, ATARI, TRS COLOR & MC-10 only \$29.95

Save money. learn about the exciting world of home computing and have fun doing it with the new HOME-PAC™
The HOME-PAC with 21 page user manual covers educational, graphics, recreational, home-finance & utility applications.

10 DAY MONEY BACK GUARANTEE

Please add \$2.00 shipping and handling to order.

SIMPLEX SOFTWARE

220 N. Centre St., Dept. CEI
Merchantville, NJ 08109
MC, VISA & Checks Accepted
Orders & inquiries state computer type

CIRCLE NO. 99 ON FREE INFORMATION CARD

got a COMMODORE 64 OR TIMEX SINCLAIR COMPUTER ?

GET STARTED WITH BOSS DISCOUNT SOFTWARE

GAMES, BUSINESS, EDUCATION, TUTORIAL

WRITE FOR FREE CATALOG

EULYN ENTERPRISES
4N 650 RIDGEWOOD
BENSENVILLE, IL., 60106
(312) 543-4225

CIRCLE NO. 102 ON FREE INFORMATION CARD



LEO ELECTRONICS, INC.
 8921 S. Sepulveda # 208
 Los Angeles, CA. 90045
 (213) 641-3101 (800) 421-2418
 TLX: 664-688 Interline LSA

**PRICE!
 QUALITY!
 SERVICE!**

RAMS			
4116 (150ns)	1.35	16K UPGRADE	
4116 (200ns)	1.25		
4164 (150ns)	4.95	64K UPGRADE	
4164 (200ns)	4.75		
6116P-3	4.40		
EPROMS			
2708	3.00	2532	4.50
2716	3.20	2732	3.95
TMS2716	4.75	2764	7.00

TERMS: Check, Visa, Mastercard. Call for C.O.D. U.S. Funds only. California residents add 6% sales tax. SHIPPING: Add \$2.00 for Ground and \$5.00 for Air. ALL MAJOR MANUFACTURERS ALL PARTS 100% GUARANTEED. Pricing subject to change without notice.

**Radio Shack TRS-80™
 Computers**

At Guaranteed Savings



from
Pan American Electronics

1117 Conway Ave
 Dept CE
 Mission, Texas 78572
 Ph 512/581 2766
 Telex 767339



Full Line
 Computers
 Printers &
 Peripherals

CALL TOLL FREE
 800-531-7466

CIRCLE NO. 103 ON FREE INFORMATION CARD

It's simple. . . .
CALL & SAVE MONEY

1-800-841-0860

**UP TO 20% DISCOUNT
 COMPUTERS
 MONITORS • PRINTERS
 CALL FOR BEST PRICES**



MICRO MANAGEMENT SYSTEMS
 TELEMARKET DEPT. # 12
 2803 THOMASVILLE RD. EAST
 CAIRO, GEORGIA 31728
 GA. & INFO 912-377-7120

CIRCLE NO. 104 ON FREE INFORMATION CARD

MICROSETTE

5 1/4-inch DISKETTES

- Single or double sided, all double density (SSDD, DSDD).
- Soft sector, reinforced hub

ITEM	10 PACK	50 PACK
SSDD	\$25.00	\$100.00
DSDD	\$35.00	\$150.00

CASSETTES

- Error-free computer grade

C-10	7.50	32.50
C-20	9.00	39.00
C-60	11.00	50.00
C-90	15.00	70.00

UPS SHIPPING INCLUDED
 In Continental USA
 CA Customers add taxes

MICROSETTE CO.
 475 Ellis St., Mtn. View,
 CA 94043 (415) 968-1604

CIRCLE NO. 105 ON FREE INFORMATION CARD

**TRS-80
 COMPUTER
 DISCOUNTS**

- Factory Direct
- Best Prices Anywhere
- No Out-of-State Taxes
- 100% Radio Shack Warranty
- Free Price List
- Authorized TRS-80

**SCOTT TASSO
 ASSOCIATES**

175 North Delsea Drive
 Vineland, N.J. 08360
 800-257-0426
 NJ 609-691-7100

CIRCLE NO. 106 ON FREE INFORMATION CARD

**COMPUTER
 FURNITURE**

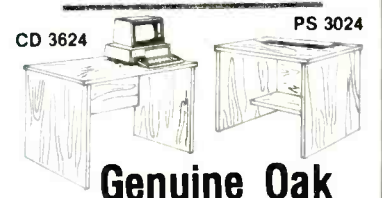

Genuine Oak

Veneer \$89.95 Each

Completely Finished — Ready for Use
 Excellent for Student, Home or Office

Send name and address with check or money order for \$89.95 per unit. Specify model no. Add \$15.00 for castors. Include \$10.95 for prompt shipping. Mail to: C.F.M.

P.O. Box 520652 • Salt Lake City, UT 84152



MONEY BACK GUARANTEE

A Division of
 Timeless Computer Furniture Manufacturers

CIRCLE NO. 107 ON FREE INFORMATION CARD

BUILD YOUR OWN COMPUTER!!

68000 BASED MULTI-BUS COMPATIBLE KIT

4 BOARD SET INCLUDES:

- 1. 6 SLOT MOTHER BOARD
- 1. CPU CARD
- 1. 0.5MB JRD-YES FLOPPY CONTROLLER
- 1. 128K RAM CARD

SCHEMATICS PARTS LIST & ASSEMBLY DRAWINGS

KT 1001 COMPUTER KIT (FLATBOARDS ONLY)	\$ 189.99
KT 1004 COMPUTER KIT (UNTESTED BOARDS POPULATED)	\$ 899.99
KT 1002 COMPUTER KIT (DOCUMENTATION ONLY)	\$ 35.00
KT 1003 PAL FOR RAM BOARD	\$ 16.99
KT 1005 CP-M FOR KIT (INCLUDES BIOS)	\$ 350.00

WE CARRY A COMPLETE LINE
 OF ELECTRONIC COMPONENTS.
 SEND FOR A FREE CATALOG!!!



NICORN ELECTRONICS
 1000 CANYON AVE. UNIT 8 B
 CHATSWORTH, CALIF. 91311
 (818) 341 8833

CIRCLE NO. 107 ON FREE INFORMATION CARD

**SALES
 POWER**

Computers & Electronics not only sells itself at a nice profit, it helps sell the hardware and software in your store too. Because it goes home with customers and continues to influence buying decisions long after you're closed for the day. Let's talk now.

**CALL COLLECT:
 (212) 725-7679**

Or write:
 Ziff-Davis Publishing
 One Park Avenue
 New York, NY 10016



Minimum order, 10 copies. We pay all shipping costs

maxell®

Floppy Discs

CALL NOW — TOLL FREE

1-800-328-DISC

Dealer inquiries invited. C.O.D.'s and charge cards accepted.

All orders shipped from stock, within 24 hours. Call toll FREE.



NH

North Hills Corporation

3564 Rolling View Dr.
 White Bear Lake, MN 55110

1-800-328-DISC

MN Call Collect 1-612-770-0485

SAVE MORE THAN EVER ON 3M Scotch® DISKETTES

LIFETIME WARRANTY!

\$185 ea. 5 1/4" SSDD (744) **\$235** ea. 5 1/4" DSDD (745)→

Qty. 20 Qty. 20

5 1/4" SSDD—96TPI (746)	\$2.60 ea.
5 1/4" DSDD—96TPI (747)	\$3.25 ea.
8" SSDD (740)	\$2.05 ea.
8" SSDD (741)	\$2.50 ea.
8" DSDD (743)	\$3.10 ea.

Shipping: 5 1/4" DISKETTES—Add \$3.00 per 100 or fraction thereof. 8" DISKETTES—Add \$4.00 per 100 or fraction thereof. OTHER ITEMS: Shipping charges as shown in addition to diskette shipping charges. Payment: VISA or MasterCard. COD orders only, add \$3.00. Taxes: Illinois customers, please add 8%.

Hours: 9 AM-5 PM Central Time
For fast service call
Nationwide: 1-800-621-6827
In Illinois: 312-944-2788

DISK WORLD!
*Suite 4806 • 30 East Huron Street • Chicago, Illinois 60611

Authorized Distributor
Information Processing Products **3M**

AMAZING AVOIDER™

THE AVOIDER, THE INTELLIGENT ROBOT YOU BUILD YOURSELF

You'll think the 21st century is here!

\$59.95

Infra-red from The AVOIDER's electronic sensor detect obstacles in its path. Just like full-size robots, Japanese-made AVOIDER walks and turns thanks to electronic controls. Plus—all circuits and moving parts of the 4 1/2" x 4 1/2" x 5" robot are visible through the impact-resistant clear acrylic body. Build this intelligent robot from a complete kit of quality-made precision parts with easy-to-follow instructions. No fancy tools needed!

IDEAL STARTER KIT FOR INTELLIGENT MACHINE ENTHUSIASTS—FUN, EDUCATIONAL, GREAT FOR GIFTS.

ORDER NOW! Not available in any store. Supplies limited.

YES! Rush me _____ AVOIDER kits so I can build my own intelligent robot(s)

Name _____

Address _____

City _____ State _____ Zip _____

Check _____ money order enclosed for \$ _____
(Include \$2.50 handling charge)

Allow 3-4 weeks for delivery

Send to S. M. Robotics, 759 Boylston St., Chestnut Hill, MA 02167

CIRCLE NO. 108 ON FREE INFORMATION CARD

TimeEPROMmer



S-100

EPROM PROGRAMMER REAL TIME CLOCK

All the best features for EPROM Programming and a Real Time Calendar Clock for S-100

- All Eprom types from 2708 to 2764
- ZIF Socket, Port Addressable
- Comprehensive Menu driven software including Source
- Socketted Lithium Battery backup

Call or send for literature package
VISA, MASTERCARD, COD Accepted
Assembled and Tested \$295, Kit \$195

OPTRONICS TECHNOLOGY 716-377-0369
2990 Atlantic Ave.
Penfield, NY 14526

ICs PROMPT DELIVERY!!!

SAME DAY SHIPPING (USUALLY)

DYNAMIC RAM		
256K	200 ns	\$59.90
64K	200 ns	5.87
64K	150 ns	5.99
64K	120 ns	7.50
16K	200 ns	1.15
EPROM		
27128	300 ns	\$22.50
2764	250 ns	9.25
2732	450 ns	8.50
2716	450 ns	3.60
2532	450 ns	4.75
STATIC RAM		
6264P-15	150 ns	\$42.00
6264LP-15	150 ns	44.00
6116P-3	150 ns	6.56

MasterCard VISA or UPS CASH COD **JIPCO**
Factory New, Prime Parts
MICROPROCESSORS UNLIMITED
24,000 South Peoria Ave.
BEGGS OK 74421 (918) 267-4961

Prices shown above are for March 15, 1984. Please call for current & volume prices. Prices subject to change. Please expect higher prices on some parts due to world wide shortages. Shipping and insurance extra. Cash discount prices shown. *Small orders received by 6 PM CST can usually be delivered to you by the next morning via Federal Express Standard Air. \$3.99

CIRCLE NO. 109 ON FREE INFORMATION CARD

Scotch® DISKETTES

Call Toll-Free
1-800-328-DISC for prices and information. Dealer inquiries invited. C.O.D. and charge cards accepted.

All orders shipped from stock, within 24 hours. Call toll FREE

North Hills Corporation
3564 Rolling View Dr.
White Bear Lake, MN 55110
1-800-328-DISC
MN Call Collect 1-612-770-0485

CIRCLE NO. 110 ON FREE INFORMATION CARD

ELECTRONIC COMPONENTS



MOUSER ELECTRONICS
160 PAGE CATALOG

MANUFACTURERS OF QUALITY ELECTRONIC COMPONENTS
OVER 15,000 DIFFERENT ITEMS IN STOCK!

MOUSER ELECTRONICS
11433 WOODSIDE AVE., SANTEE, CA 92071
PHONE: (619) 449-2222 TWX 910-331-1175

CIRCLE NO. 110 ON FREE INFORMATION CARD

Now available for the computer experimenter!

COMPUTER CONNOISSEUR'S DELIGHT!
ONLY \$6.00 EACH. ASSORTMENT OF SIX FOR \$26.50

OVER A THOUSAND COMPUTER PROGRAMS! TOO MANY TO LIST HERE. LEARN HOW TO RECEIVE VERY USEFUL PUBLIC DOMAIN MATERIAL SUCH AS: "SHOW", "SWEEP", "DO", "LIST", "MODEM", "D", "SORT", "MERGE", ETC. UNIQUE GAMES—VERSIONS OF DONKEY KONG, SPACE INVADERS, ADVENTURE, STAR TREK, ETC.—WILL ENHANCE SYSTEMS WITH UNSOPHISTICATED GRAPHIC CAPABILITIES AND ALLOW YOU TO PLAY THEM ON ALMOST ANY COMPUTER. MATHEMATICS, ASTROLOGY, ASTRONOMY TOO!

UNPUBLISHED MATERIAL

The one you've all been waiting for

Computel
PUBLISHED MONTHLY

ONE YEAR SUBSCRIPTION \$14.00 (SAMPLE COPY \$2.00)

COMPUTEL—the complete SOURCE for everyone. You can now do the things you've only heard about, right in the privacy of your own home. Indispensable reference to preteaks and hackers. Learn how to get all kinds of computer programs FREE. Get the inside story of big business systems—their quirks and flaws—and remain up to date with vital occurrences within the computer industry. Computel is a publication designed for everyone who has an intense curiosity of computer systems, containing a wealth of hard to find information, codes, and numbers. Published monthly.

161 **Compertel Publishing Society** CPS
6354 VAN NUYS BLVD. / VAN NUYS, CA 91401

CIRCLE NO. 111 ON FREE INFORMATION CARD

Now we can make any computer sing as well as talk, for only \$219.

As featured in Garcia's Circuit Cellar, BYTE Magazine, September, October 1982.



Microvox.

MICROVOX is a completely self contained professional voice quality text-to-speech synthesizer. MICROVOX may be easily interfaced to any computer/modem RS-232C serial or parallel output device.

- 6502 Microprocessor based text-to-speech algorithm
- SC-01A phoneme based speech synthesizer
- 64 crystal controlled inflection levels
- 3000 character buffer
- RS 232C and parallel port interfaces
- On board power supply
- Music and sound effects capability

MV01 Microvox Assembled & Tested \$299.00
MV02 Microvox, complete kit \$219.00

To Order: Call Toll Free 1-800-645-3479
In N.Y. 1-516-374-6793

MICROMINT, INC.
561 Willow Avenue
Cedarhurst, NY 11516

CIRCLE NO. 112 ON FREE INFORMATION CARD

★MICROCOMPUTER★ BUSINESS SOFTWARE

MEDICAL MGMT...
DENTAL MGMT...
INSURANCE AGENT
LEGAL BILLING.....
PROPERTY MGMT..
AND MUCH MORE !

UNIVAIR INTERNATIONAL
9024 St. Charles Rock Road
ST. LOUIS, MISSOURI 63114
(314) 426-1099

CIRCLE NO. 113 ON FREE INFORMATION CARD

HAPPY HANDS OFFERS DISCOUNTS ON ALL TRS-80 COMPUTERS

- * Free Shipping in U.S.
- * NO Tax on Out of State Orders
- * Lowest Prices

Call Toll Free:
1-800-545-9019

or write:
**HAPPY HANDS
P.O. Drawer I
Ruidosa, N.M. 88345**

CIRCLE NO. 114 ON FREE INFORMATION CARD

COMMODORE 64* PROGRAM EXPANDER BOARDS

PLUGS INTO BACK OF COMPUTER. PLACE MOST USED PROGRAMS ON EXPANDER BOARD—TURN THE SWITCH ON TO THE FROG. YOU WANT, PRESS RESET BUTTON TO START PROGRAM. KEEPS ALL YOUR FAVORITE PROGRAMS AT YOUR FINGERTIPS.

PRE-TESTED GUARANTEED TO WORK

4	PROGRAM EXPANDER BOARD	\$39	RETAIL COST
ORDER #	DEI11744		
6	PROGRAM EXPANDER BOARD	\$49	RETAIL COST
ORDER #	DEI54116		
8	PROGRAM EXPANDER BOARD	\$59	RETAIL COST
ORDER #	DEI10278		

FOR 1 TO 999 ORDERED—ADD POSTAGE & HANDLING CHARGES. 1000UP—Postage as incl. NO. DEI11744 ADD \$2.00 Per Unit NO. DEI54116 ADD \$3.00 Per Unit NO. DEI10278 ADD \$4.00 Per Unit**

BACKSHELL FOR 12/24 CARDAGE CONNECTOR—USER PORT COVER FOR VIC-20* & COM. 64* 1000-29,999=80¢EA. | 30,000-59999=75¢EA. 60,000-99,999=65¢EA. | 100,000UP=65¢EA.** FOR HARDWARE ADD 20¢ PER UNIT

**TERMS: 30% DOWN & BALANCE COD. ALLOW 6 Wks. DELIVERY. KS. Residents Add 3% SALES TAX. WITH APPROVED CREDIT ONLY! DEALER & DISTRIBUTOR PRICE LIST AVAILABLE UPON REQUEST.

*COMMODORE 64 and VIC-20 is a trademark of Commodore Bus. Machines, Inc. CALL OR SEND YOUR ORDER TODAY TO:
**DYNAMIC ELECTRONICS INC. (316)264-8636
1621 S. SENECA WICHITA, KS. 67313**

COMMODORE 64* PROGRAM EXPANDER BOARDS

CIRCLE NO. 115 ON FREE INFORMATION CARD

-Fast ANALOG I/O BOARD

For Commodore 64, TRS80 Color, Apple, Timex, & most any computer with a memory port. 8 channels A/D & 8 channels D/A. 1.6 µS A/D convert time. 8 bit res. Easy to program. Box & cable available. **\$220.**

Software for Commodore 64 & Board

SCOPE
Dual trace. 256 samples taken at rates from 3 to 72000 Hz. Trigger & cursor. Disk & printer utilities. Averaging. Usable subroutines.

F.F.T.
128 spectrum lines. Displays 0 Hz to 1/2 sample freq. Mag & phase done in 1 sec! Needs CPM card.

Scope & FFT on disk w/manual **\$85.**
Similar software for TIMEX on EPROM **\$85.**
Please call or write for **FREE CATALOG.**

Computer Continuum
301 Sixteenth Avenue
San Francisco, CA 94118 (415) 752-6294

SPEECH SYNTHESIS **NEW!** SAVE \$\$ ONLY **\$59** **KIT**

TRS 80
**ZX81
TIMEX
VIC20
APPLEII**

• UNLIMITED VOCABULARY \$69
• AMPLIFIER & SPEAKER BUILT IN
• INPUT FOR EARPHONE MUSIC UNITS

SMART EARS! **SPEECH RECOGNITION** **\$99**

FOR ABOVE LISTED COMPUTERS & OTHERS (SOME NEED I/O)

Hugely successful Speech Recognition System, complete with microphone, software and full instructions BUILT-TESTED & GUARANTEED

MUSIC SYNTHESIS

STEREO+16 LINE CONTROL PORT
PLAY 3 PART MUSIC, EFFECT DRUMS ECT.
I/O PORT TO CONTROL ROSSIGNI, 999KIT
HOME TO CHURCHY EAR ECT BUILT \$59

AUDIO VISION 1279 N. NORMANDIE LOS ANGELES, CA 90027

SPEECH CHIP SX-01 \$36
ADD \$3 SHIPPING (CA. RES. 4.5% TAX)
(213) 6608217

CIRCLE NO. 116 ON FREE INFORMATION CARD

GREAT DISKETTES
Super low prices
SYNCOM

The low priced, high quality diskette with a LIFETIME WARRANTY. Packed in polybags of 10 with Tyvek envelopes, labels and reinforced hubs.

One of the best buys we've seen. **LIFETIME WARRANTY**

\$139 ea. 5 1/4" SSDD **\$185** ea. 5 1/4" DSDD

QTY 20 QTY 20

OTHER GREAT VALUE:

DISKETTE 70—Holds 70 5 1/4" diskettes in dust free safety **\$14.95 ea. + \$3.00 Shpg.**

DISK CADDIES—Flip up style holds 10 5 1/4" diskettes **\$1.65 ea. + 20 Shpg.**

Shipping: 5 1/4" DISKETTES—Add \$3.00 per 100 or fraction thereof. OTHER ITEMS: Shipping charges as shown in addition to diskette shipping charges. Payment: VISA or MC COD orders only, add \$3.00. Taxes: Illinois customers, please add 8%.

Nationwide: 1-800-621-6827
In Illinois: 1-312-944-2788
Minimum Order: \$35.00
WE WILL BEAT ANY NATIONALLY ADVERTISED PRICE!
DISK WORLD!
Suite 4806 • 30 East Huron Street • Chicago, Illinois 60611

SYNCOM

POWER LINE PROBLEMS?

SPIKE-SPIKERS™... The Solution!

Minimize equipment damaging spikes and conducted RF noise to or from sensitive equipment. Transient surge protection plus low pass RFI hash filtering. All units 120V 15A.

MINI II \$44.95
Wall Mount
3-stage filter
2 sockets

QUAD II \$59.95
Wall mount. Dual 3-stage filter
4 sockets & light

DELUXE \$79.95
Dual 5-stage filtered ckt. 8 switch sockets
main switch, fuse, light

Kalgio Electronics Co., Inc. Order Factory Direct
65 84 Ruch Rd. Dept. C E **215-837-0700**
Berthlehm, PA 18017

Out of State **1-800-524-0400**

DEALERS INVITED
PA Res. Add 6% • COD add \$3.00 + Shipping

CIRCLE NO. 117 ON FREE INFORMATION CARD

SALES POWER

Microsystems not only sells itself at a nice profit, it helps sell the hardware and software in your store too. Because it goes home with customers and continues to influence buying decisions long after you're closed for the day. Let's talk now.

CALL COLLECT: (212) 725-7679

Or write:
**Ziff-Davis Publishing
One Park Avenue
New York, NY 10016**

Minimum order: 10 copies. We pay all shipping costs.

TOTAL CONTROL
For the
**Timex-Sinclair
Computer**

JK AUDIO

Built & Tested \$174.95
Bare Board \$49.95

I/O
16 lines IN 16 lines OUT
Real Time Clock/Calendar
with Battery Back up
Analog to Digital Converter
4 channel 14 bit
8K Non-Volatile RAM
RAM in EPROM
Compatible with
ZX-80 ZX-81 TS 1000 & TS 1500

TERMS: Check or Money Order
Call Res. Add 6%
SHIPPING: Inside U.S. \$5.00
Outside U.S. \$10.00

P.O. Box 3295
Escondido, CA 92025-0580
(619) 741-5132

CIRCLE NO. 118 ON FREE INFORMATION CARD

**Vobrax SC-01A
SPEECH SYNTHESIZER**

\$42 Each (\$32 in hundreds)

Order in Ones or Thousands

The SC-01A Speech Synthesizer is a completely self-contained solid state device. This single chip phonetically synthesizes continuous speech of unlimited vocabulary. Computer interfaces and text-to-speech algorithms also available for product development. Micromint is the largest U.S. distributor of the SC-01A. Call us for a price quote.

Call 1-800-645-3479, in N.Y. 1-516-374-6793

MICROMINT INC.
561 Willow Avenue
Cedarhurst, NY 11516

Add \$2.00 for shipping & handling

CIRCLE NO. 119 ON FREE INFORMATION CARD

Computers & Electronics Marketplace

CLASSIFIED RATES: Per Word, 15 Word Minimum. **COMMERCIAL:** \$5.00. **PERSONAL:** \$3.00. **EXPAND-AD:** \$7.50. Ads set in all bold type @ 20% premium. Ads set with background screen @ 25% premium. **DISPLAY:** 1" x 2 1/4", \$605.00. 2" x 2 1/4", \$1,165.00. 3" x 2 1/4", \$1,675.00. **GENERAL INFORMATION:** Frequency rates and prepayment discounts available. Payment must accompany order except credit card—Am. Ex., Diners, MC, VISA (include exp. date)—or accredited ad agency insertions. Copy subject to publisher's approval; must be typewritten or printed. First word set in caps. Advertisers using P.O. Boxes MUST supply permanent address and telephone number. Orders not acknowledged. They will appear in next available issue after receipt. Closing date: 1st of the 2nd month preceding cover date (e.g., Mar. issue closes Jan. 1). Send order & remittance to: Classified Advertising, **COMPUTERS & ELECTRONICS** Magazine, 1 Park Avenue, New York, NY 10016. To Charge your ad to a major credit card, call Lois Price at (212) 725-4312.

FOR SALE

GOVERNMENT and industrial surplus receivers, transmitters, snooper scopes, electronic parts. Picture Catalog 25 cents. Meshna, Nahant, Mass. 01908.

BUILD AND SAVE, TV EARTH STATION, DETECTIVE ELECTRONICS, Video Recorders, Color Cameras, advanced Telephone Projects. BROADCAST Electronics, 50 page color catalog of unusual electronic projects AIR MAILED \$3.00, with 3 hour audio cassette dramatization of our catalog \$5.00. Don Britton Enterprises, PO Drawer G, Waikiki, Hawaii 96815.

RECONDITIONED TEST EQUIPMENT \$1.00 for catalog WALTER S TEST EQUIPMENT, 2697 Nickel, San Pablo, CA 94806, (415) 724-0587.

ELECTRONIC CATALOG Over 4,500 items Parts, & components Everything needed by the hobbyist or technician \$2.00 postage & handling (United States Only), refundable with first \$15.00 order. T & M Electronics, 472 East Main St., Patchogue, NY 11772, (516) 289-2520.

PRINTED CIRCUIT BOARDS, your artwork Quick delivery Reasonable. Atlas Circuits, Box 892, Lincolnton, NC 28092 (704) 735-3943

POLICE CODE UNSCRABLERS, lets you hear the coded messages of Police Fire and Medical channels, plus other scanner accessories, satisfaction guaranteed. DNE Inc., Rt 7 Box 257-A, Hot Springs, AR 71901 (501) 623-6027.

CABLE TV CONVERTERS & EQUIPMENT. Plans and parts. Build or buy. For more information send \$2.00: C & D ELECTRONICS INC., P.O. Box 21, Jenison, MI 49428.

FREE FLYER! IC's, resistors, capacitors, jacks, etc., plus SSM music synthesizer/audio IC's, power amp modules, analog delay IC's, computer books, and more. Also plans for analog delay/chorus unit! PGS Electronics, Route 25, Box 304 Terre Haute, IN 47802

Worlds Most Remarkable Radar Jammer!



Philips Instruments
Causes speed radar guns and devices to read out your choice of either a percentage of your true speed when in automatic mode (example: Your speed: 75 mph, auto mode set for 75%, speed displayed—57 mph), or the speed that you dial in when in manual mode. Transmits only in the presence of speed radar, or by manual override. Operates on both X and K bands. WARNING: The device described in this literature is not legal for use against police radar, and is not FCC approved.

For complete literature and plan package, send \$14.95 to
Philips Instrument Design Co., Inc.
9560 S.W. Barbur Blvd. Suite # 109 CE
Portland, Oregon 97219
VISA OR M/C ORDERS ONLY (503) 626-6764

MICROWAVE ANTENNA SYSTEMS

Freq. 2.1 to 2.6 GHz + 34 db Gain + COMPLETE SYSTEMS (as pictured)
Commercial 40" Rod Style \$89.95
Parabolic 20" Dish Style \$79.95

TWO YEAR WARRANTY PARTS AND LABOR
CALL OR WRITE FOR KITS + PARTS + INDIVIDUAL COMPONENTS
We Repair All Types Down Converters & Power Supplies

Philips-Tech Electronics
P.O. Box 34772
Phoenix, AZ 85067
(602) 957-6972

Special Quantity Pricing = Dealers Wanted

MasterCard VISA COD'S

CABLE TV
Buy Direct & Save

SUPER SPECIALS

40 CHANNEL CONVERTER \$29.95
Advanced Solid State design and circuitry allows you to receive mid & super band channels. Restores programming to VCR Recorders

36 CHANNEL REMOTE CONTROL CABLE CONVERTER \$69.95

JERROLD 400 THE ULTIMATE CABLE TV CONVERTER

60 CHANNEL INFRARED REMOTE CONTROL \$129.95

Send \$5 for Complete Catalog

DIRECT VIDEO SALES
P.O. BOX 1329
JEFFERSONVILLE, INDIANA 47130
CALL 1-812-282-4788

NEW! MULTI-CHANNEL MICROWAVE

Complete Antenna Systems from \$69.95

Full 800 Mhz Range
Tune 1.9-2.7 Ghz
Includes all ITFS Channels

DEALERS WANTED

COD's and Credit Card Orders call TOLL FREE
1-800-247-1151

GALAXY ELECTRONICS
6009 N. 61 Avenue
Glendale, AZ 85301
1-602-247-1151

GOLD STAR
SILVER STAR
STAR II
TELE STAR

BUILD AND SAVE, TV EARTH STATION, DETECTIVE ELECTRONICS, Video Recorders, Color Cameras, advanced Telephone Projects. BROADCAST Electronics, 50 page color catalog of unusual electronic projects AIR MAILED \$3.00; with 3 hour audio cassette dramatization of our catalog \$5.00. Don Britton Enterprises, PO Drawer G, Waikiki, Hawaii 96815.

FREE! 1984 CATALOGUE. 1001 bargains. Speakers-parts-tubes-video cassettes—record changers—tape recorders—kits. EVERYTHING IN ELECTRONICS. Write: McGEE RADIO & ELECTRONICS, 1901 McGee Street, Kansas City, MO 64108-1891.

TV & RADIO TUBES, 59¢ each. Send for free catalog. Cornell, 4213 University, San Diego CA 92105.

PRINTED CIRCUIT BOARDS, QUICK PROTOTYPES production, design, reflow solder. Send print or description for quote to: KIT CIRCUITS, Box 235, Clawson, MI 48017.

SATELLITE TELEVISION COMPLETE SYSTEMS. \$2.00 for catalog. Write: Sunspur Sales, P.O. Box 32245 A-6, Fridley, MN 55432

Telephone Listening Device

Record telephone conversations in your office or home. Connects between any cassette or tape recorder and your telephone or telephone LINE. Starts automatically when phone is answered. Records both sides of phone conversation. Stops recorder when phone is hung up. This device is not an answering service.

Each \$19.95
Qty. Disc Avail.

Super Powerful Wireless Mic

10 times more powerful than other mics. Transmits up to 1/4 mile to any FM radio. Easy to assemble kit. 15V battery (not incl.)
Call (305) 725-1000 or send \$19.95 + \$1.00 shipping per item to USI Corp., P.O. Box CE-2052, Melbourne, FL 32901. COD's accept. For catalog of transmitters, voice scramblers and other specialty items, enclose \$2.00 to USI Corp.

CABLE TV SECRETS, the informative publication the cable companies are trying to ban. HBO, Movie Channel, Showtime converters, etc. Send \$8.95 to: CABLE FACTS, Box 711-PE, Pataskala, Ohio 43062.

GEARMOTORS \$35.00. 12VDC(6-36) 60 RPM 1/6 HP. Instructions. Also speed controls. Drives robots, antenna doors, gates, carts. Sepac, 625 NW 41 Street, Seattle, WA 98107.

RF MODULATORS for SATELLITE TELEVISION, MICRO-COMPUTERS CCTV, Also monitors, cameras, kits. FREE VIDEO CATALOG. Phone (402) 987-3771. Dealers Welcome. ATV RESEARCH, 13-P Broadway, Dakota City, NE 68731.

12 SATELLITE DISH and POLAR MOUNT. Total weight 125-lbs. For \$189.00. For information send \$4.95 (Refundable u.p.) to: Satellite Operational Systems, P.O. Box 2002, Titusville, FL 32781.

CABLE TV products. Jerrold, Hamlin and Oak, send \$3.00 to ADDITIONAL OUTLET CORP., 111 E. Commercial Blvd., Ft. Lauderdale, FL 33334.

PRINTED CIRCUIT ARTWORK, DESIGN/LAYOUT Quality, prompt SOMMER/CIRCUIT DESIGN, P.O. B. 635, Wooster, OH 44691 VISA/MC (216) 263-6930

PAY-TV RECEPTION, HBO, Showtime, Cinemax How-To! Book \$4.95 Diptronics, Box 80(B6), Lake Hiawatha, NJ 07034.

FREE 1984 COMPUTER FURNITURE CATALOG. Over 20 manufacturers. Never a shipping charge. Visa/MC. Interior Design Systems, 3641-CE St. Mary's Place NW, Washington, D.C. 20007.

ALARM EQUIPMENT—Burglar, Holdup, Fire, Medical. We prewire. Easy installation! Wholesale prices. Fast police notification service—Nationwide; Catalog \$1.00 U.S. DETECTION, 109 21st South, Birmingham, Alabama 35233.

HARD TO FIND lightbulbs thousands types buy, sell. Jetco, P.O. Box 8755, Newport Beach, CA 92658.

RECONDITIONED FAX, G-2, hand-operation, with paper. \$385.00 C&F USA per unit. For more information write: Mashinno Machine Co., Ltd., Minami-Hanahata 3-7-13, Adachi-ku, Tokyo 121, Japan

DESIGN AND BUILD YOUR COMPUTER. Your hardware, software, language. Not a kit or course. Complete details \$1.00 RFS 828 Wood St., Statesville, NC 28677.

CABLE TV EQUIPMENT, Notch filters for "Beeping" Channels. Information \$1.00. Goldcoast, Box 63/6025 CE, Margate, Florida 33063 (305) 752-9202.

SECRET TECHNICAL INFORMATION concerning electronic investigative techniques and countermeasures. Catalog \$3.00. A.T.I.S., 61 Gatchell, Buffalo, NY 14212.

FREE CATALOG! UTILITIES, games, amateur radio software for VIC-20, Commodore 64, TI/99/4A. RAK Electronics, Box 1585, Orange Park, FL 32067.

COMPUTER EQUIPMENT/PARTS

SAVE 90% Build Your Own Minicomputer. Free Details. Digatek, 2723 West Butler Dr., Suite 20C, Phoenix, AZ 85021.

FREE 64 PAGE COMPUTER CATALOG crammed full of thousands of the best buys and lowest prices around! A.P. COMPUTER PRODUCTS, Dept. EC, 214A East Main, Patchogue, NY 11772. (516) 654-8811.

USED COMPUTER terminals, printers, modems, cables, surplus electronic parts. Specials: CRT's \$20.00, Modems \$20.00, Modems \$35.00, Catalog \$1.00. Rondure Company, "The Computer Room" PO Box 35566 Dallas, TX 75235. (214) 630-4621.

48K APPLE COMPATIBLE COMPUTER: US \$380.00 and hundreds of programs. Details US \$1.00. Reliant, PO Box 33610, Sheungwan, Hong Kong.

COMPUTERS, CLONES, DRIVES, monitors, expansions, software bargain prices—directory of manufacturer's in Taiwan. Hong Kong, \$4.00. Multitek, Box 25, Allentown, PA 181205.

WANT A PLEASANT SURPRISE? Call or write for quotes: Atari, Commodore, Timex, T.I., Corona (IBM work-alike), Amdek, Gemini, Apple & IBM accessories, Hayes, More. **GET SURPRISED! HARDWARE SOFTWARE ANYWARE CO.,** 10 Coles Street, Brooklyn, NY 11231, (212) 596-3592.

SANYO COMPUTERS, stereos, equipment cost plus 10%. Rebateable price sheet \$5.00. SMS Dist. Center, Box 1904, Fargo, ND 58107.

COMPUTER SOFTWARE

FREE VIC-20 and COMMODORE 64 USERS GROUP MEMBERSHIP with software purchase. Why pay to belong to a users group when you don't have to? Benefits: Newsletter, extensive club library, discounts, contests, questions hot-line and more! Free details—(803) 797-1533. Lords of Basic, P.O. Box 459, Dept. 102 Ladson, SC 29456.

DISKETTE FORMAT CONVERSIONS/DOWNLOADING, from \$5.00. Port-A-Soft, 423 #800 N, Orem, UT 84057. 801/226-6704.

TI-99/4A PROGRAMMERS: Affordable Software! Catalog, only \$1. PROGRAMS SOFTWARE, 1435 Burnley Square North, Columbus, Ohio 43229.

TS 1000, ZX81, TI 99/4A, VIC-20 SOFTWARE. Send for FREE Catalog: Midwest Software, 9922 Harwich, Crestwood, MO 63126.

TI-99/4A SOFTWARE BARGAIN! Complete library of 100 programs. Only 50¢ each! Free catalog. Exchange, PO Box 46, Sterling, VA 22170.

TI-99/4A CASSETTE CABLES \$16.71 (Extended Basic, Logo, Mini-memory \$88.11 each!), PHP1250 Drive \$210.94. CSC, Box 1361, Bloomington, IL 61702-1361. (309) 828-3251.

RENT PUBLIC DOMAIN SOFTWARE. It's not copy-righted, no fees to pay. Copy hundreds of useful business, utility and game programs from our rental libraries onto your own computer at home! SASE NATIONAL PUBLIC DOMAIN LIBRARY, 1062 Taylor, Vista, CA 92083. (619) 941-0925.

TI-99/4A SOFTWARE: Programs for astronomy, Mathematics, Finance, Education. Send 40¢ for catalog East-bench Software, 1290 Cliffside Drive, Logan, UT 84321.

TI-99/4A "99-CALC" Electron C Spreadsheet Program in Extended Basic, 16K. Cassette and Instructions \$20.00 p.p. P.C. Barnes, 24631 Via San Fernando, Mission Viejo, CA 92692.

MULTI-LINGUAL, educational and other software, FREE CATALOGUE. The Professor, 959 N.W. 53rd St., Ft. Lauderdale, FL 800-222-1399.

PRESCHOOL MATHEMATICS PROGRAM. Commodore 64 Disk, \$9.00. DATA DAY PRODUCTS, P.O. Box 285, Concordia, MO 64020.

DISCOUNT Computer—Software, Wargames, Video cassettes. FREE catalog. Wizard Entertainment, Box 509, Saugus, CA 91355.

TI-99/4A SOFTWARE BARGAIN! Programs only 50¢ each. Complete library. (100 programs \$49.95, 120 programs \$59.95, 140 programs \$69.95). FREE CATALOG! Exchange, P.O. Box 46, Sterling, VA 22170, (703) 435-2789.

TI-99/4A extended basic and joystick needed. Six games, money back if dissatisfied. Cassette \$27.95. Henry Straub, RD #5, Cadiz, Ohio 43907.

COMMODORE 64 Educational package. Eng, Math, Science, 104 programs on 8 discs. \$39.95. Millsons, Box 180, Kennewick, WA 98544.

VIC-20: COMMODORE 64 engineering solutions. Moment of inertia—cassette \$12.75. Triangle Solutions—Cassette \$9.95. + Others. RIDOUT, PO Box 2647, Roswell, NM 88201.

FREE Commodore—64/TI99-4A/VIC-20/Timex/TRS80-COCO programs! Send stamps! Ezra Ezra Company, Box 5222-CJU, San Diego, California 921005.

TI-99/4A OWNERS. Get your free catalog of new, exciting, low cost software. D.E., Box 690, Hicksville, NY 11801.

HARD TO FIND SOFTWARE/HARDWARE for Apple II/E, Macintosh, Atari, TRS-80, TI 99/4A, Vic20, Commodore 64, IBM PC/JR, AHOS, Sinclair, DEC, NEC, S-100, Northstar, Kaypro, to over 33% off. Over 3000 items, hard disk/printers, business/educational software/650 games, \$1000 off NEC Spinwriter 7710-\$2085. Amdek Color I-\$289, PFS: file-\$84, Lotus 1-2-3-\$329, Flight Simulator II-36.50, Zaxxon-\$27. Free Flyer. Send \$2.00 for extensive 84 catalogue, stamps okay, or call (714) 962-0112. For specials specify computer. JP Instruments & Computers, PO Box 7033, Huntington Beach, CA 92615.

SOFTWARE BARGAIN! VIC-20, Commodore 64, Apple, Atari, TI. 10 adventure filled, colorful game programs for \$2.00. (Spritewrite, lasertrace, Timplex, Gladiator, etc.) + secrets of arcade programming. Specify Computer, Program Brokers, PO Box 1796, MHFS, NY NY 10016.

DISCOUNT SOFTWARE/HARDWARE—30% minimum below retail. Apple II/II+, Atari 400/800/XL, TI-99/4A, Vic-20, Commodore 64, IBM/PC. Gemini-10X \$275.00, Okidata 92P \$445, Epson RX-80 F/T \$380.00. Flight simulator II \$37.50, Zork I/II/III \$26.50 each. TI extended basic \$77.50. Direct connect printer interface; TI \$85.00, Atari \$69.50. Send \$1 (stamps okay) for extensive software/hardware catalog. Specify computer system. Multi-Video Services, Box 246, East Amherst, NY 14051. (716) 688-0469 (5-9 P.M.).

COMPUTER PUBLICATIONS

"DISK DRIVE MANUAL."—Drive Alignment, Speed Adjustment, Maintenance, Repair—Without Special Software, Equipment. Comprehensive, 15,000+ words. \$15. Brochure \$1. CONSUMERTRONICS, 2011 Crescent, Alamogordo, NM 88310.

MICRO MOONLIGHTER NEWSLETTER—our third year of home computer business resources! Sample \$3.00. Dept. CC, 4121 Buckthorn Court, Lewisville, TX 75028.

COMPUTER CLUBS

Commodore—64 software 40% off, Free Programs, Newsletter, Rent Software, more! Membership \$12.00 yearly. CCAE, PO Box 784C, Bronx, NY 10473. (212) 409-0717.

COMPUTER GRAPHICS

AVL computer graphics & programming systems. Slide, Motion, Overhead, Video, & Audio equipment & supplies. Rentals & Staging. Custom Graphics. Slides & Presentations. NEW ORIENT MEDIA-IL. 1-(800) 223-9473, 1-(312) 428-6000.

COMPUTER FURNITURE

BUILD YOUR OWN COMPUTER WORKSTATION. Under \$20. Fast, easy, without elaborate tools! Free details. Easy-Made, Box 31636, Seattle, WA.

COMMODORE 64

VIC 20/C64 DATASETTE SCHEMATICS, PARTS LISTS, layouts. All versions \$7.95 COMPUCLINIC 766 Tower Ave., Cedarburg, WI 53012.

TIMEX/SINCLAIR

TREE FORTH for the 2K+ Sinclair User—\$49.95. Multitasking forth for ZX81 and TS1000. Free information. Contact: Softmagic Corp., 1213 West High Street, Bryan, Ohio, 43056. (419) 636-4531.

AERCO will continue to provide high performance disk, printer, and other interfaces for ALL MODELS of Timex/Sinclair computers. Box 18093, Austin, TX 78760. (512) 331-0719.

C.B. EQUIPMENT

CB MODIFICATIONS, conversions, books, plans, kits, repairs. Catalog \$2. CBCI, Box 31500PE, Phoenix, AZ 85046. (602) 996-8700.

CABLE T.V.

CHANNEL 3—60db notch filter, 66.5MHz \$32. Crosley, Dept. 607, Box 840, Champlain, NY 12919.

PLANS AND KITS

MICROPROCESSOR CONTROLLED. Six voice polyphonic synthesizer plans. \$15.00. Syntron 1075 1/2 Mill Rd., Helena, Mt 59601.

HBO CONVERTER. Complete instructions and schematic. Send \$4.00 and SASE. Electrographics, 630 Sullivan, Deltona, Florida 32725.

PROTECT COMPONENTS FROM THEFT, install easy to make security device. Send \$5.50 for plans. Vanguard Security Co., P.O. Box 35101, Detroit, MI 48235.

AUTOMATIC FIRE JOYSTICK VIC 20/64, Atari, etc. Simple assembly for less than \$5.00. Send SASE for information or \$2.00 for complete plans. Dyas, PO Box 1567, Media, Pennsylvania 19063.

MAILING LISTS

COMPUTER SHOW ATTENDEES N.Y., N.J.: 15,000 NAMES. \$30/M. P/S labels. For info, (201) 297-2526.

FREE MAILING LIST analysis. Details. GOC-4N, Box 1107, Stuart, FL 33494. (305) 334-5205.

3,100+ computer stores with telephone numbers. Intelligent Tool Company, PO Box 44047, Las Vegas, NV 89104. (702) 459-8428.

WANTED

GOLD, electronic, circuit board scrap, silver, platinum, tantalum, mercury. Ores, metals assayed. Samples evaluated. Wholesale Terminal, toll free 1-800-932-1010, (617) 326-3442 in Mass.

AUTHORS! Major publisher of popular how-to computer books seeks manuscripts. Send sample chapters, outline, to: Acquisitions Compusoft Publishing, 535 Broadway, El Cajon, CA 92021.

DONATIONS OF COMPUTER EQUIPMENT needed by Tax Exempt non-profit for vocational training program. J-CAP, P.O. Box #148, Central Station, Jamaica, New York, 11435.

GOVERNMENT SURPLUS

IS IT TRUE YOU CAN BUY JEEPS FOR \$44 THROUGH THE U.S. GOVERNMENT? Get the facts today! Call (312) 742-1142 Ext. 4649.

TUBES

TUBES: "Oldies". Latest. Supplies, components, schematics. Catalog Free (stamp appreciated). Steinmetz, 7519-PE Maplewood, Hammond, Ind. 46324.

HUGE INVENTORY! Thousands of types. Wholesale prices. FREE CATALOG! ETCO Electronics, DEPT. 290, Plattsburgh, NY 12901.

TUBES-RECEIVING, Industrial and Semiconductors Factory Boxed. Free price sheet including TV, radio and audio parts list. TRANSLATERONIC, INC., 1365 39th St., Brooklyn, NY 11218. Telephone: (212) 633-2800. Toll free: (800) 221-5802. Ask for Abe.

TV & RADIO TUBES, 59¢ each. Send for FREE CATALOG. Cornell, 4213 University, San Diego, CA 92105.

PERSONALS

UNIVERSITY DEGREES BY MAIL! Bachelors, Masters, Ph.Ds. Free revealing details. Counseling, Box 317-EP6, Tustin, California 92680.

MAKE FRIENDS WORLDWIDE through international correspondence. Illustrated brochure free. Hermes-Verlag, Box 110660/Z, D-1000 Berlin 11, W. Germany.

FREE: WORLD'S LARGEST PARTNER PHOTO CATALOG for friendship and marriage. Personalized introductions. INTERCONTACT, Box 12, Toronto, Canada M4A 2M8.

INSTRUCTION

UNIVERSITY DEGREES BY SPECIAL EVALUATION of existing credits and Job Experience. Fast, inexpensive. Call (614) 863-1791. Or write: EVALUATION, Box 13151-A6, Columbus, Ohio 43213.

REPAIR ELECTRONIC ORGANS—Revised home study course covers all current makes and models. Free booklet. Niles Bryant School, P.O. Box 20153, Sacramento, CA 95820.

F.C.C. COMMERCIAL RADIOTELEPHONE LICENSE. Home Study. Fast, Inexpensive! Free details. COMMAND, D-100 Box 2223, San Francisco 94126.

UNIVERSITY DEGREES BY MAIL! Bachelors, Masters, Ph.D.s . . . Free revealing details. Counseling, Box 317-PE6, Tustin, California 92680.

LEARN WHILE ASLEEP! HYPNOTIZE! Astonishing details. strange catalog free! Autosuggestion, Box 24-ZD, Olympia, Washington 98507.

MEDICAL ELECTRONICS TECHNOLOGY, home study. Troubleshoot medical instruments. WTI, P.O. Box 3124, Fresno, CA 93650-3124.

FOR INVENTORS

INVENTIONS, IDEAS, NEW PRODUCTS WANTED! Industry presentation/national exposition. Call free 1-800-528-6050—Arizona, 1-800-352-0458 X831.

PATENT AND DEVELOP your invention FREE PATENT INFORMATION. Richard L. Miller, P.E., 3612-E, Woolworth Building, New York, NY 10007, (212) 267-5252.

BUSINESS OPPORTUNITIES

MECHANICALLY INCLINED individuals desiring ownership of Small Electronics Manufacturing Business—without investment. Write BUSINESSES, 92-K6 Brighton 11th, Brooklyn, New York 11235

ERASE DEBTS with little-known law—create wealth!! Details FREE—Wealth Kit, No EE6, Billings, NY 12510.

ONE MAN CRT FACTORY. T.V.'s, Business machines, Monitors, Scopes, VDT's. \$3.00 rebuilding nets \$100-\$500 each tube. Higher profits overseas. New/used. FACTORY, 1909 Louise, Crystal Lake, IL 60014. (815) 459-0666.

BORROW \$300-\$30,000 INTEREST FREE! Keep indefinitely! Free Details. Write: American, 1601 Main, Plainfield, Indiana 46168.

BUMPER STICKER PRINTING DEVICE Cheap, simple, portable. Free details. Bumper, POB 22791 (PE), Tampa, FL 33622.

FREE CATALOGS. Repair air conditioning, refrigeration. Tools, supplies, full instructions. Doolin, 2016 Canton, Dallas, Texas 75201.

ELECTRO MECHANICAL ASSEMBLERS ASSOCIATION is looking for assemblers interested in working at home. Potential \$600 per week. Write for application. Enclose \$3.00 for processing. EMMA, Dept. CE, Box 9186, Columbus, MS 39705

BORROW \$30,000 without interest! All eligible. Repay anytime. Free details! Infohouse-CE, 808 Post, San Francisco, CA 94109.

EARN EXTRA INCOME with your microcomputer. Super opportunities! Free details. Scitec, Box 02038, Columbus, OH 43202

START YOUR OWN Microcomputer based mail order business. Free info. Bark Research, 21 Foxanna Dr. CE Hershey, PA 17033.

BE A COMPUTER BROKER/CONSULTANT if you are good with micros, then your advice is needed. Book tells all to get you started as a broker/consultant in your own home. Where to buy. How to get clients. Cash in on fast growing area of micros. \$5.00. ETC Marketing, P.O. Box 5205, Hacienda, CA 91745

\$360 WEEKLY/UP. Mailing Circulars! No quotas. Sincerely Interested, rush stamped envelope: Commission Mailing, Box 15967-E6, San Diego, CA 92115.

MAKE MONEY REPRESENTING MAJOR US corporation. Write: SRS, 600 Valley Road, #E63, Warrington, PA 18976.

COMPUTERS GET IN ON THE GROUND FLOOR. Full details on how to start a MAILORDER home business or RETAIL STORE selling COMPUTER SOFTWARE/HARDWARE. First information pack of its kind, with east/west distributor list, sample pricing, ad placement, obtaining resale number. No technical experience or capital necessary. Info pack \$10.00. JPI, P.O. Box 7033, Huntington Beach, CA 92615.

REAL ESTATE

500 OFFICES... 45 STATES! 30,000 listings on computer, 16,000 under \$50,000! Free printouts and regional catalogs! UNITED FARM AGENCY, 612-EP West 47th, Kansas City, MO 64112. PH: 1-800-821-2599, in MO., 1-800-892-5785.

EMPLOYMENT OPPORTUNITIES

GOVERNMENT JOBS—Thousands of vacancies must be filled immediately. \$17,634 to \$50,112. Call 716-842-6000, Ext 3900.

ELECTRONICS/AVIONICS EMPLOYMENT OPPORTUNITIES. Details FREE. Aviation Employment Information Service, Box 240E, Northport, New York 11768.

BOOKS & MAGAZINES

SATELLITE TV VIEWERS
Get the most complete weekly listings
Send \$1 for sample copy.



P O Box 308, Fortuna, California 95540
800-358-9997 (U.S.) • 800-556-8787 (Calif.)
707-723-2476 (all others)

MICROWAVE TECHNOLOGY BOOK: learn to build local microwave receivers, satellite TV, police radar and much more. Send \$5.00 plus 75¢ for postage and handling to: Tom Howell Productions, POB 32357, Washington, DC 20007.

MUSICAL ELECTRONICS & HOME RECORDING. Schematics and "how-to," bi-monthly \$12.00/year. Sample issue \$2.50. Polyphony, Box 20305, Oklahoma City, OK 73156.

WORLD'S LARGEST COMPUTER MAGAZINE
Computers
& ELECTRONICS

ADVERTISERS INDEX

RS no.	ADVERTISER	PAGE no.
8	Acorn Computers Corp.	Cover 4
50	Active Electronics	105
9	Atari	2
	C & D Electronics	101
	Classified Advertising	112-118
	Cleveland Institute of Electronics, Inc	26-29
19	Communications Electronics	44-45
60	CompuServe	6-7
39	The Computer Book Club	41
11	Computer Mail Order	49
14	Digi-Key Corp.	108-109
2	Discount Computers	62
25	Dust-Off II/Falcon Safety Products	13
51	Electronic Specialists	103
26	Epson America, Inc.	15
	Grantham College of Engineering	103
	Halix Institute	95
24	Heath Co.	22-23
41	IBM Corporation	10-11
	Information Unlimited/ Scientific Systems	104
10	Inmac	93
21	Jameco Electronics	111
22	JDR Microdevices	106-107
23	J & R Music World	93
58	Kalglo Electronics Co., Inc.	97
30	Maxell	5
	Memotech Corp.	Cover 2, 1
5	Micro Craft Corp.	Cover 3
34	Micro-Ware	97
	National Technical Schools	36-39
1	NRI Schools	16-19
	Nibble Notch Computer Products	95
	Radio Shack	35
42	Tam's Inc.	101
	Tektronix	25

*****CLASSIFIED ADVERTISING ORDER FORM*****

1	2	3	4	5
6	7	8	9	10
11	12	13	14	15 (MINIMUM)
16	17	18	19	20
21	22	23	24	25
26	27	28	29	30
31	32	33	34	35
36	37	38	39	40
41	42	43	44	45
46	47	48	49	50

Please refer to heading on first page of this section for ad placement information

COMMERCIAL: \$5.00. PERSONAL: \$3.00. EXPAND-AD®: \$7.50.

OF WORDS _____ # OF INSERTIONS _____

PAYMENT ENCLOSED \$ _____

CHARGE You will be billed monthly American Express Diners Visa MasterCard-Interbank # _____

Account # _____ Exp. Date _____

SIGNATURE _____

PRINT NAME _____

ADDRESS _____

CITY _____ STATE _____ ZIP _____

CE-684

DIMENSION. THE MOST POWERFUL, MOST COMPATIBLE PERSONAL COMPUTER YOU CAN BUY.

(CRT not included)

Introducing the capability the world has been waiting for. A single personal computer able to handle Apple,[®] IBM,[®] TRS-80,[®] UNIX[™] and CP/M[®] based software.

The Dimension 68000 Professional Personal Computer does it all. It actually contains the microprocessors found in all of today's popular personal computers. And a dramatic innovation creates the environment that lets these systems function merely by plugging in the software.

Add to this the incredible power of a 32 bit MC68000 microprocessor with up to 16 megabytes of random access memory.

Dimension has the power of a mainframe at a personal computer price. It's obviously the best value you can find. For more information ask your dealer or call us at (214) 630-2562 for the name of your nearest dealer.

dimension™

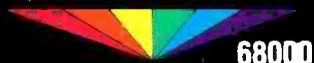

68000

A product of
Micro Craft Corporation
4747 Irving Blvd., Suite 241
Dallas, Texas 75247. ©1983

Circle No. 5 on Free Information Card



Apple is a registered trademark of Apple Computer, Inc.; IBM is a registered trademark of International Business Machines Corporation; TRS-80 is a registered trademark of Radio Shack, a Tandy Corporation company; UNIX is a trademark of Bell Laboratories, Inc.; CP/M is a registered trademark of Digital Research Corporation.

www.americanradiohistory.com

DEALER INQUIRIES INVITED

THE ONLY COMPUTER THAT MAJORS IN EDUCATION.

It doesn't take an advanced degree to know that teaching computers in a school isn't the same as using a computer in business. But most computers are designed for businesses or homes, not for schools. Acorn has designed a computer especially for schools. It's called The British Broadcasting Corporation Microcomputer System. Simple to use, it can handle everything from basic applications to creating sophisticated networks. So it won't become obsolete the minute a student becomes advanced. In fact, no other similar sized or priced computer exceeds Acorn's built-in expansion capabilities. But Acorn's Micro is more than a computer. It's a total learning system designed by and for educators. Consisting of educator endorsed software, lesson plans and teacher workbooks. We call it schoolware, because it gives teachers and students everything they need for learning. You can even learn about Acorn's Micro on our toll-free teacher hotline. And at special Acorn Learning Centers at computer dealers around the country. Doing our homework has already made Acorn's Micro one of the biggest selling microcomputers in Britain. And lead to its selection by the British government for use in its nationwide computer literacy program.

So if you're interested in a computer that will do well in school, take a lesson from the British and learn more about Acorn's Micro.

For more information, write Acorn Computers Corporation, 400 Unicorn Park Drive, Woburn, Massachusetts 01801, or call toll-free 1-800-225-8001 (in Massachusetts, call 617-935-1190).

© 1984 Acorn Computers Corporation

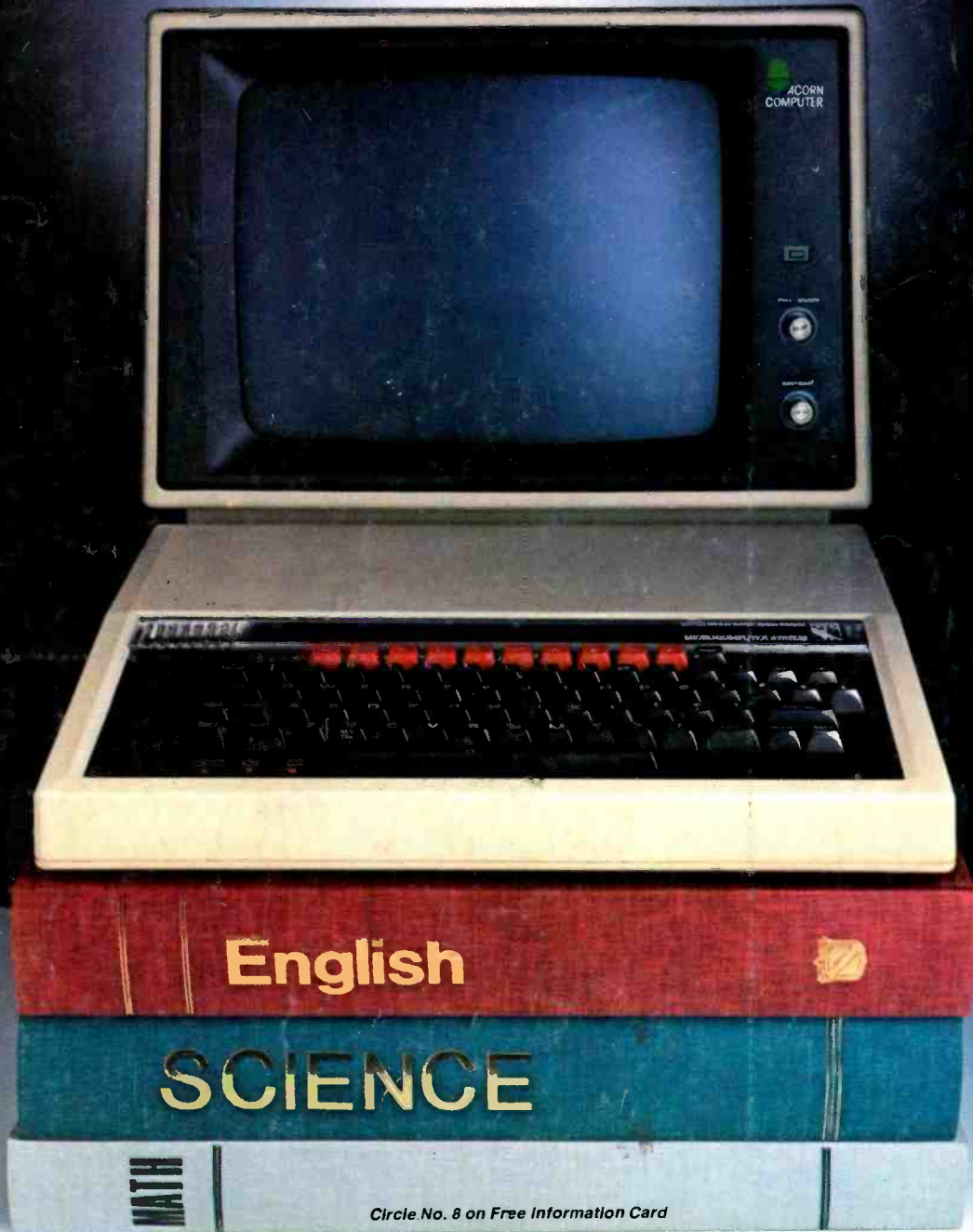

Circle No. 8 on Free Information Card