

Computers & Electronics

OCTOBER 1983

Customize Your Computer with EEPROMs
What Makes Game Cartridges Tick
Heath/Zenith's New 8/16-Bit Desktop Computers

**PROTECTING
COMPUTERS
FROM
POWER-LINE
DISTURBANCES**

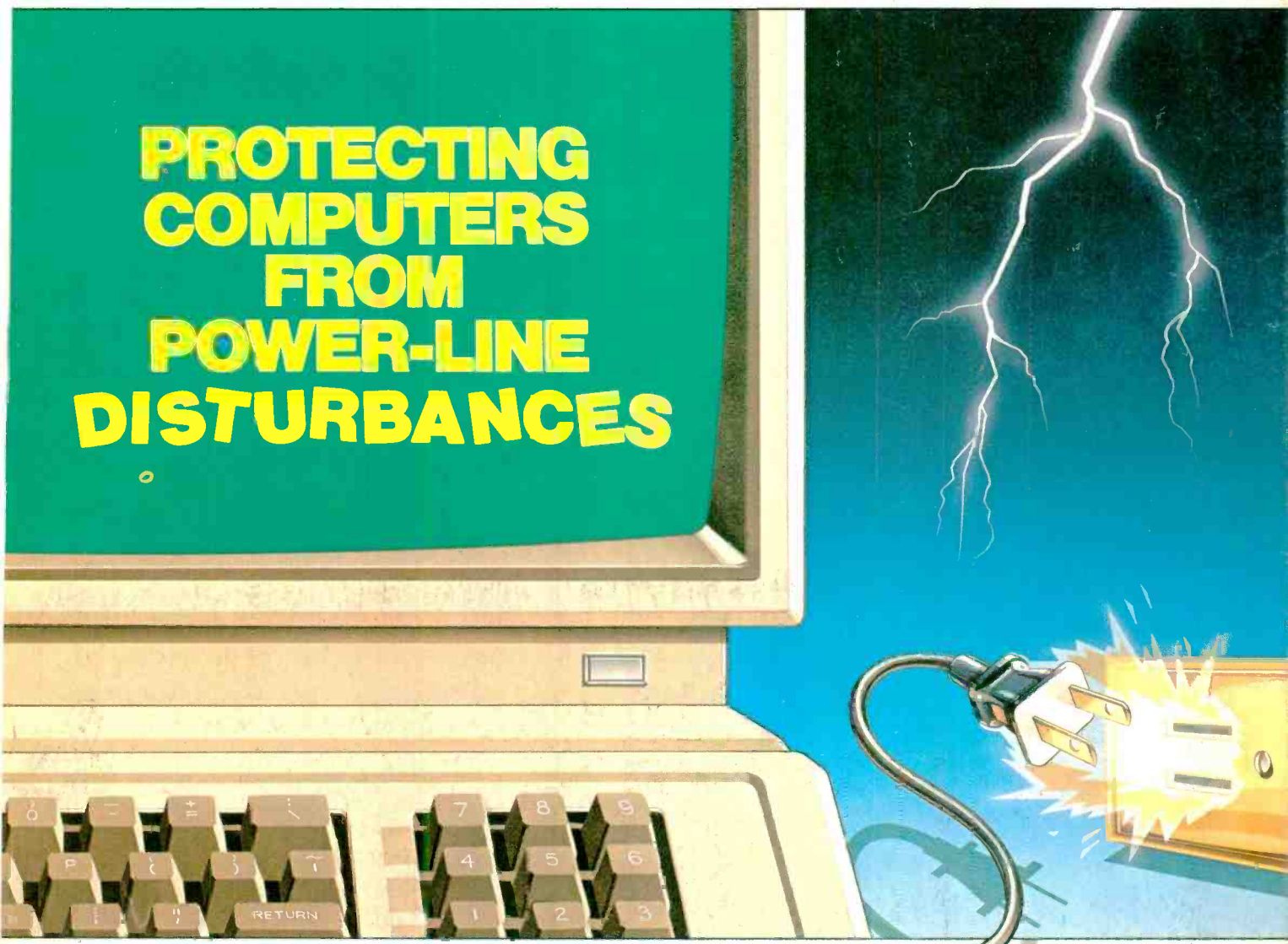

Also in this Issue:

ong's 5Mb Hard Disk

s 19" Color Monitor/TV Receiver

390636 DHM 09976093 R44D SEP84
G063AF1004
MRS EDNA DAHM
997 GRAND AV
DIPORA
IL 60506
10#99
0

CRYSTAL UNIFORMITY
 ADVANCED BINDER
 REFINED LUBRICANT
 IMPROVED JACKET
 INTENSIFIED CALENDERING

THE GOLD STANDARD

You can wait for industry standards to mandate improved performance. Or you can have it now on Maxell. The Gold Standard.

The refinements of The Gold Standard, from oxide particles to lubricant to jacket, are uniquely Maxell. And therefore, so are the benefits.

Our unique, uniform crystals assure dense oxide packing. So you begin with an original signal of extraordinary fidelity. A signal we safeguard in ways that leave industry standards in our wake.

An advanced binder bonds oxides to the base material preventing time and money-wasting dropouts. Calendering then smooths the surface for a read/write signal that stays

clear and accurate. And lubricants reduce friction between head and disk for a longer media and head life. To house it, we then constructed a new jacket heat-resistant to 140° F to withstand drive heat without warp or wear. And

created the floppy disk that leads the industry in error-free performance and durability.

All industry standards exist to assure reliable performance. The Gold Standard expresses a higher aim: perfection.



maxell
 IT'S WORTH IT.

Computer Products Division, Maxell Corporation of America, 60 Oxford Drive, Moonachie, N.J. 07074 201-440-8020
 Circle No. 30 on Free Information Card

Your own telephone can become a 24-hour-a-day lifeguard!

The SENSAPHONE Transforms Your Telephone Into a Full-Time Monitor, Whether You're Home Or Not.

TALKS TO YOU — IN CLEAR ENGLISH

Your Sensaphone uses a standard built-in modular telephone connector. Instead of plugging your phone into the wall, plug it into the Sensaphone, then in turn plug the Sensaphone into the wall. Total time: 10 seconds.

Once installed, the Sensaphone does its job and reports its findings in clear English. For example —

- If you aren't home and a problem occurs, it calls anyone you've designated and reports that problem, **in English**, then arranges to quit calling once the message is acknowledged.
- If you want to know what time it is, your Sensaphone tells you — **in English**.
- If you want to know the current temperature in the room, your Sensaphone tells you — **in English**.
- If the backup batteries (which hold the "memory" if you have a power failure) are low, your Sensaphone tells you so — **in English**.
- If you call in from the outside to learn how things are, your Sensaphone reports on all conditions — **in English**.

YOU MAY NOT BELIEVE IT AS YOU READ THIS, BUT YOU'LL BELIEVE WHEN YOU PLUG IT IN. YOUR MONEY BACK IF WE'RE EXAGGERATING.

Read This Section Carefully: Your SENSAPHONE Will Do All This —

1. You can call in from any phone in the world. SENSAPHONE will report every monitored condition to you.
2. You can listen to room sounds in your home or office through the powerful built-in microphone, from any phone in the world.
3. It reports **specific** unusual sounds, such as a smoke alarm's ringing or buzzing, or a burglar alarm.
4. It monitors and reports on any three other conditions of your choice (basement water level; door or window opening; water heater; appliance on).

MADE IN U.S.A. by Gulf & Western

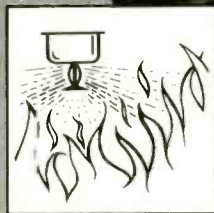

Senses and reports problems in the home.

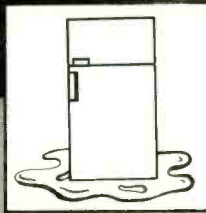

Calls for help so food won't spoil.



Monitor your home from any phone in the world.

5. (Get this!) If one of the pre-programmed problems occurs, it automatically calls you or anyone you designate, then states in English what the problem is. If the first person called doesn't answer, SENSAPHONE calls up to four numbers in rotation until someone answers and acknowledges receiving the call.
6. It monitors your household or office electricity, so if your refrigerator or lights go out, it reports the problem.
7. If room temperature rises above the number you preset, or falls below it, Sensaphone tells you so.
8. An automatic dialer calls any of eight numbers with one-button dialing.
9. It tells you the correct time, in English, including whether the time is a.m. or p.m.
10. It tells you the exact room temperature, on request.

The Sensaphone **\$249.95**
two for \$229.95 each
A FANTASTIC GIFT IDEA!
add \$3.50 per total order for shipping

WE ABSOLUTELY GUARANTEE!

Plug your home or office phone (or both) into the Sensaphone. Use it for up to 30 days. If for any reason you decide you don't want to keep it, return it for a 100% refund.

For fast delivery on credit card orders, call toll-free 24 hours a day, 7 days a week:

1-800-443-0100

Ask for Extension 111

Or send check or money order. Please add \$3.50 per total order for shipping.

The **Sensaphone** is another electronic marvel from

NEW HORIZONS

Dept. CE10, 5-31 Fiftieth Avenue
Long Island City, NY 11101

Circle No. 17 on Free Information Card

Computers & Electronics

OCTOBER 1983

VOLUME 21, NUMBER 10

FEATURE ARTICLES

- 34 PROTECTING YOUR COMPUTER FROM POWER LINE DISTURBANCES**
Francis J. Stifter/The causes and cure of computer "crashes" and data errors.

- 44 THE NEW HEATH/ZENITH 8/16-BIT DESKTOP COMPUTER**

- 52 HOW TO "PEEK" INTO A ROM CARTRIDGE**
Hardy McGoff/A technique for listing the contents of VIC-20 plug-in programs.

- 56 A DC MOTOR SPEED CONTROLLER/Mike Coppola**

- 66 MULTIPLE-CHARACTER GENERATION/Randy Carlstrom**

- 68 HEX/ASCII/DECIMAL CONVERSION CHART/Les Solomon**

- 70 LIGHT CHASER**
Fernando Viesca/A microprocessor controller for light shows.

- 76 SYNONYMS FOR WORD PROCESSING**
Ernest E. Mau/The electronic thesaurus.

- 79 KEYBOARD ENCODING SCHEMES**
Ralph Tenny/A guide to computer keyboard operation and solving interface problems.

- 85 BAUD-RATE MATCHING FOR COCO/S. E. Harding**

- 88 ADD EEPROM TO YOUR COMPUTER/Michael Keryan**

- 90 DAVONG 5-Mb WINCHESTER HARD DISK SYSTEM/Stephen Walton**

EQUIPMENT REVIEWS

- 95 JVC TELSTAR 19" MONITOR/RECEIVER**



COLUMNS

- 14 COMPUTER VIDEO GAMES**

- 18 BITS & BYTES/Sol Libes**

- 22 LES SOLOMON ON COMPUTER HARDWARE**

- 24 COMPUTER SOURCES**

- 30 ENTERTAINMENT ELECTRONICS/Len Feldman**

- 99 THE ELECTRONICS SCIENTIST/Forrest M. Mims, III**

DEPARTMENTS

- 4 EDITORIAL/Art Salsberg**
AT&T and the Seven Dwarfs.

- 6 LETTERS**

- 12 NEW PRODUCTS**

- 86 TIPS AND TECHNIQUES**

COVER ART BY DENNIS MUKAI

COPYRIGHT © 1983 BY ZIFF-DAVIS PUBLISHING COMPANY. All rights reserved. Computers & Electronics (ISSN 0032-4485) October 1983, Volume 21, Number 10. Published monthly by Ziff-Davis Publishing Co., at One Park Ave., New York, NY 10016. Richard P. Friese, President; Selwyn Taubman, Treasurer; Bertram A. Abrams, Secretary. One year subscription rate for U.S. and Possessions, \$15.97; Canada, \$20.97; all other countries, \$23.97 (cash orders only, payable in U.S. currency). Second Class Postage Paid at New York, N.Y. 10016 and at additional mailing offices. Authorized as second class mail by the Post Office Dept., Ottawa, Canada, and for payment of postage in cash. POPULAR ELECTRONICS including ELECTRONICS WORLD trademark registered. Indexed in the Reader's Guide to Periodical Literature. Ziff-Davis also publishes Boating, Car and Driver, Cycle, Flying, Popular Photography, Skiing, Stereo Review, Electronic Experimenter's Handbook, and Tape Recording & Buying Guide. POSTMASTER: Send address changes to COMPUTERS & ELECTRONICS, Circulation Dept. P.O. Box 2774, Boulder, CO 80302. Please allow at least eight weeks for change of address, enclosing, if possible, an address label from a recent issue. Permissions. Material in this publication may not be reproduced in any form without permission. Requests for permission should be directed to Elizabeth Amado, Rights and Permissions, Ziff-Davis Publishing Co., One Park Ave., New York, NY 10016.

It writes, rates, creates, even telecommunicates. Costs less, does more- the Commodore 64.



When Commodore introduced the 64, the industry suddenly realized that there would be a

computer in every home, school and business years before anyone ever dreamed.

That's because Commodore 64 halved the price of high technology: while you can compare the 64's capabilities with those of any sophisticated business PC, you can compare its price with that of an average television.



What can you do with it? Create with its high resolution Sprite Graphics. Add a printer and type with it. Add a disk drive to use

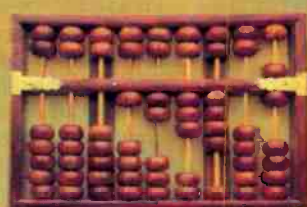

spread sheets and other financial programs. Learn and play music through your home sound system on the 64's professional quality music synthesizer.

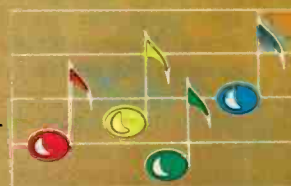

Add a modem, and hook up with the vast computer networks through your telephone. In short, the Commodore 64 is the ultimate personal computer, at a price you can afford.

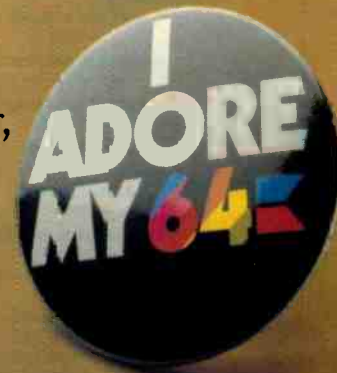

COMMODORE 64

Circle No. 29 on Free Information Card



EDITORIAL



AT&T and the Seven Dwarfs

BLESS you, Tom Carter. Fifteen years ago you won the right for any of us to connect non-Western Electric devices to AT&T telephone lines, though doing so meant we had to pay the local telephone company a monthly fee for a special interface when connecting "foreign" devices. It took another ten years for our speedy FCC to come up with interface design standards and certification procedures for independently manufactured equipment. As a result, we can now simply plug in a certified modem, phone-answering machine, or whatever, to our telephone line without paying Ma Bell additional money for a Data Access Arrangement.

In the interim, AT&T was broken up by the Justice Department, dividing its

22 Bell System operating companies into seven independent regional companies that will provide local telephone services. Now that this cozy alliance has been destroyed, clear sailing is ahead, right? Wrong!

AT&T, though divested of its local telephone companies, retains its long-distance lines, Bell Labs' R&D facilities, and Western Electric's factories, adding a competitive marketing arm, American Bell, Inc. (a name that will be changed), and a cellular radio service operation, Advanced Mobile Phone Service. It still has a lock on satellite dial-up circuits for interstate use, and wants to charge a fee to independent modem makers for information on timing specifications that it changes at will. It still owns the Unix operating system, too, which is expected to gross \$5-billion+ in the micro area alone in a few years. And it will soon enter the small computer market with a bevy of machines that employ Unix.

The seven dwarfs can be tough, too, though no longer part of the AT&T monolith. For example, it seems that at least one of the seven telephone companies—Southwestern Bell (serving Arkansas, Kansas, Missouri, Oklahoma, and some of Texas)—has cast its eyes on the burgeoning use of telephone lines for data communications as a good source of additional revenue. It has swept any modem connected to its network into the business category at an information terminal rate that's about 500% higher than the standard phone rate. This has taken place in Oklahoma, where the Oklahoma Modem Users

Group (OMUG) is slugging it out with its newly organized telephone company.

Clearly, this tariff is regressive. It promises to stifle growth of small computer hardware and software since the ability to send and receive data by phone lines is a leading attraction of microcomputers. Moreover, a decrease in use of normal voice telephone lines would reduce the company's income.

This unconscionable penalty was initiated in a different age . . . many years before the birth of the microcomputer, at a time when AT&T and the phone companies were a monopolistic entity. Data communication through normal phones was not widespread and, certainly, not employed in homes. Is there any doubt that the tariff should be rescinded and that home users should not pay a business service rate? Don't you think the six other dwarfs are watching this brouhaha to see if they, too, can enjoy windfall profits?

For a running update on what's happening in the Oklahoma modem battlefield, you can get a recorded message about it from the local user's group at 405-360-7462. To discuss this problem, SYSOP Robert Brave said he'd be pleased to hear from any of our 600,000 readers who reach him at 405-364-9564.

Computers & Electronics

formerly Popular Electronics

WILLIAM S. DAVID
Publisher

ARTHUR P. SALSBERG
Editorial Director

LESLIE SOLOMON
Technical Director

JOHN R. RIGGS
Managing Editor

JAMES KIEHLE
Art Director

ALEXANDER W. BURAWA
Senior Editor

JOSEPH DESPOSITO
Technical Editor

JOSEF BERNARD
Technical Editor

ANDRE DUZANT
Technical Illustrator

CARMEN ROBLES
Production Editor

JEFF NEWMAN
Editorial Assistant

Contributing Editors:

Walter Buchsbaum, Len Feldman
Glenn Hauser, Julian Hirsch
Forrest Mims

Editorial and Executive Offices
One Park Avenue
New York, New York 10016
212 725-3500

Sales Offices

New York Office
Tom Ballou 212 725-3578
Ken Lipka 212 725-3580

Midwestern

Suite 1400, 180 N. Michigan Ave.,
Chicago, IL 60601 312 346-2600
Sales: Robert Vanek

Western

J.E.M. Associates
Francisco Bay Office Park
1750 Montgomery Street
San Francisco, CA 94111 415-989-4643
Joe Mesics

Representation in Japan

J.S. Yagi
Iwai Trading Co., Ltd.
603 Ginza Sky Heights Bldg.
18-13, Ginza 7-Chome
Tokyo, Japan 104

Consumer Computers & Electronics Magazine Division

Larry Sporn President
J. Scott Briggs Vice President, Marketing
Carole Mandel Vice President, Circulation
Eileen G. Markowitz Vice President,
General Manager
Peter J. Blank Creative Director

Ziff-Davis Publishing Company

Richard P. Friese President
Albert S. Traina President, Consumer
Magazine Division
Paul H. Chook Executive Vice President
Marketing and Circulation
Senior Vice Presidents

Phillip T. Heffernan Vice Presidents
Sidney Holtz
Edward D. Muhlfield
Philip Sine
Baird Davis
George Morrissey
Selwyn Taubman Treasurer
Bertram A. Abrams Secretary

Editorial correspondence: COMPUTERS & ELECTRONICS, 1 Park Ave., New York, NY 10016. Editorial contributions must be accompanied by return postage and will be handled with reasonable care; however, publisher assumes no responsibility for return or safety of manuscripts, art work, or models submitted.

The publisher has no knowledge of any proprietary rights which will be violated by the making or using of any items disclosed in this issue.



Free Timex Computer, Software and Free Timex Watch

Just in time for back to school...

Timex technology and the buying power of Communications Electronics will put you in the challenging, fascinating arena of home electronics for much less than you thought possible. As you grow in your computer expertise and needs, you can be secure knowing your TIMEX SINCLAIR 1000 Computer is expandable with a complete line of accessories. You won't outgrow your T/S 1000 Computer — it grows with you!

In addition to the accessories, Timex offers a full range of software for the T/S 1000 Computer. Cassette programs designed especially for your computer open the magical microprocessor doors to home management, business applications, educational aids and computer games. If your computer is used in business, it may be fully tax deductible.

Of course, as you become more skillful in using the T/S 1000 Computer, you'll find that you can create your own programs — tailored, as you wish, to your own specific requirements. The extensively detailed instruction manual that comes with the T/S 1000 Computer gives complete information on how to do your own programming.

Behind you and your TIMEX SINCLAIR 1000 Computer is proven Timex technology and reliability. It doesn't end with the unique design of this sensational computer. Timex wants you to enjoy and grow with it. When something isn't clear or if you're having trouble operating your computer, just dial **800-24-TIMEX** — you'll be in touch with the Timex Technical Support Group. They're ready to answer all your questions.

Join the home computer technology generation at an amazingly low cost.

Receive your TIMEX T/S 1000 personal home computer and your TIMEX quartz watch absolutely free when you purchase the following:

- The Timex T/S 1016 16K Ram Pack
- The Timex T/S 2040 Printer
- And your choice of six of the following software cassettes:

1. College Cost Analyzer	10. Coupon Manager
2. Home Improvement Planner	11. IRA Planner
3. Organizer	12. Stock Option Analyzer
4. Money Analyzer 1	13. Geometry 1
5. Algebra 1	14. Statistics
6. Mixed Game Bag II	15. Power Pack 1
7. Fortress of Zorlac	16. Grimm's Fairy Trails
8. Gambler	17. Presidents
9. Supermaze	18. Cube Game

When you order, you will receive this complete package: T/S 1000 Computer, Ram Pack, Printer, choice of six Timex software cassettes, and as an extra bonus, a coupon for a free Timex quartz watch. But wait, there's more. If you order before October 31, 1983 from CE, Timex will also give you a coupon that's good for an additional six free software cassettes from a choice of over seventy titles (Frogger™ excluded). The additional value of this bonus software is worth up to \$116.70. Therefore, if you act now, you can get this complete package worth up to \$461.20 for only \$199.00 plus \$10.00 for U.P.S. shipping and handling in the continental U.S.A.

Order at no risk.

All Timex products carry CE's 31 day money back guarantee. If for any reason you are not completely satisfied with this special offer, return everything within 31 days and we will give you a full refund (less shipping and handling charges). All Timex computer products come with a **ninety day warranty**. Should anything go wrong with your Timex products, simply mail it to Timex and they will promptly repair or replace it. Dealer and educational inquiries welcome.

Mail orders to: Communications Electronics™, Box 1002—Dept. CE-10, Ann Arbor, Michigan 48106 U.S.A. If you have a Visa or MasterCard, you may call and place a credit card order. Order toll-free in the U.S. Dial 800-521-4414. In Canada, order toll-free by calling 800-265-4828. Telex anytime 810-223-2422. If you are outside the U.S.A. or in Michigan dial 313-973-8888. Michigan residents add tax. The demand will be great for this fantastic limited time offer, so be sure to order today.

Order Toll-Free 800-521-4414

T/S1000 is a registered trademark of Timex Corp. Copyright© 1983 Communications Electronics™

TIMEX *sinclair* 1000

Free!

Timex Sinclair 1000 Computer
a \$49.95 value



Free!

6 Timex Software Cassettes
up to a \$116.70 value



Free!

Timex Watch
Choose your watch from 5 styles
up to a \$49.95 value



Free!

Timex T/S 1016 16K Ram Pack



Free!

Timex T/S 2040 Printer



Free!

Choice of 6 Software Cassettes



COMMUNICATIONS ELECTRONICS™

Computer Products Division

818 Phoenix □ Box 1002 □ Ann Arbor, Michigan 48106 U.S.A.
Call TOLL-FREE 800-521-4414 or outside U.S.A. 313-973-8888



FREE!! Computer, Watch & Software Cassettes

• **YES, Please send my free Timex computer, software and watch with the purchase of a Ram Pack, Printer and choice of six cassettes for only \$199.00** (plus \$10.00 for shipping/handling in the continental U.S.A. For Canada, Puerto Rico, Hawaii, Alaska, or APO/FPO delivery, shipping is \$25.00).

• **Mail To:** Communications Electronics™
Box 1002—Dept. CE-10
Ann Arbor, Michigan 48106 U.S.A.

• List selection of cassettes by number: 1 ___ 2 ___ 3 ___ 4 ___ 5 ___ 6 ___

• Credit Card # _____ Exp. _____

• Name _____

• Address _____

• City _____ State _____ Zip _____

• Telephone _____

• Note: For additional product information call **800-24-TIMEX**.

• To order call **800-521-4414** or **313-973-8888** CE-10

Circle No. 19 on Free Information Card

Here's why we're Number One.

When it comes to logic probes, more people buy Global Specialties. Because no one can match us for value. Our four logically-priced probes—including our remarkable new 150 MHz ECL—deliver more speed, accuracy, flexibility and reliability than others costing considerably more! So why compromise? Discover for yourself why we're the number-one logical choice!



Standard LP-1, \$50.00*, with memory—captures pulses to 50 nsec, 10 MHz, guaranteed.
Economy LP-2, \$32.00*, to 50 nsec, 1.5 MHz.
High-speed LP-3, \$77.00*, with memory, guaranteed to 10 nsec (6 nsec, typical), 50 MHz!
New ECL LP-4, \$150.00*, the new industry standard—with memory, guaranteed to 4 nsec (2 nsec, typical), 150 MHz!

GLOBAL SPECIALTIES CORPORATION

70 Fulton Terr. New Haven, CT 06509 (203) 624-3103. TWX 710-465-1227
 OTHER OFFICES: San Francisco (415) 648-0611. TWX 910-372-7992
 Europe: Phone Sallron-Walden 0799-21682. TLX 817477
 Canada: Len Finkler Ltd. Downsview, Ontario

Call toll-free for details
1-800-243-6077

During business hours

*Suggested U.S. resale. Prices, specifications subject to change without notice.
 © Copyright 1981 Global Specialties Corporation

Circle No. 46 on Free Information Card

LETTERS

SOLID-STATE DISKS

Having read the article "Solid-State Disks," in your June issue, I thought you might be interested in knowing about another alternative produced by our company. This is the Solidrive 525. It utilizes bubble memory and is thus non-volatile without battery backup. There are two versions: one with removable media and a hostile-environment cartridge for remote data load program load and data collection; the other unit has nonremovable media and is intended for truly portable use. Interfacing was designed around the concept of direct replacement of floppy disks; and internal DIP switches allow selection of SDSS, SDDS, DDSS, DDDS, all at 5¼ or 8 inch. While prices represent a premium, we have experienced considerable interest due to total lack of media wear, and complete non-volatility.—*Les Horn, Targa Electronics Systems Inc., Ottawa, Can. K1G 3H9.*

TRULY PORTABLE COMPUTERS

We were interested in Les Solomon's column in your August issue ("A 'Truly Portable' Sinclair/Timex") in which he recommended the use of our SX-70 battery packs. A better, although not "free," means of achieving his aim does exist. We sell a more powerful battery in the same flat format, called a P100 Polapulse™ Powerpack. It is widely available.

In addition, we have a "P100 designers kit," which includes five P100 batteries and a plastic battery holder that allows easy connection and battery change. This is available from us at \$16.75, plus applicable sales tax, post-paid (Part #604155, Polaroid Battery Div., 784 Memorial Dr., Cambridge, MA 02139). I have glued this holder to the bottom of my Sinclair ZX-81 with four larger rubber feet added in the corners to accommodate the pack. I also added an on/off switch directly wired to the holder and diode into the computer. It works beautifully.

Incidentally, the contacts on the battery are aluminum and any attempt to solder wires will be harmful to the end cell.—*Frederic S. Cohen, Polaroid Corp., Commercial Battery Div., Cambridge, MA.*

ADD-ONS FOR TIMEX/SINCLAIR

After reading your magazine for about eight months, I can say I have enjoyed every issue and want to congratulate you on your excellent work. I especially liked the construction articles for the Timex/Sinclair personal computer ("Talk Can Be Cheap" in February and "Upgrading Timex/Sinclair Video" in

May).—*Justin Dunker, Bronx, NY.*

The T/S 1000 keyboard is so small it's practically unusable. Is there some way I can couple some other inexpensive keyboard to the T/S 1000 the way Les Solomon described adding a video monitor in his column in the March issue?—*William Knight, Burbank, CA.*

There are a host of full-size keyboards available that can be added to the Timex/Sinclair. For example, Suntronics, 12621 Crenshaw Blvd., Hawthorne, CA 90250 has one with true typing capabilities for \$69.95 that can be installed in about five minutes.

MIMS IS THE WORD

The information Forrest Mims gave about thermoelectric modules in the July "Electronics Scientist" was very interesting. Perhaps the makers of my "CupCake" coffee warmer will go high-tech with thermoelectric modules so that I could flip the unit over to keep lemonade cool in the summer. Thanks for a good read.—*James H. Tolsod, Chicago, IL.*

UNIX, THE EASY WAY

In my article on Unix (p. 43, September 1983), there are two typographical errors that should be pointed out. On page 46, at the bottom of the first column, the sentence should read "With all these attributes going for it, Unix seems like an *ideal* (not *idea*) system. And just across the page, at the bottom of the third column, the Pixel AP/100 should have been the Pixel 80/AP.—*David Fiedler.*

STANDARDS EFFORTS

Regarding your Editorial on standardization ("Shades of De Gaulle") in the July issue, the new (and fast-growing) technology for "Tele-Delivery" of PC software is a good example. Softyme Inc. (a joint venture with Tymshare Inc.) is willing to lead the requisite standardization efforts. However, there is no appropriate ANSI/IEEE committee.

Considering the various delivery means (dial phone, CATV, satellite, DTS, Videotext, etc.) and the different contents (software, games, documents, data files, etc.) a joint effort might be most appropriate.

Perhaps if you let people know of our willingness to lead this effort, we might be able to get something going now—in time to benefit both vendors and users. The Fall Comdex meeting could be the kickoff.—*Richard A. Davis, Office of the President, Softyme, 329 Bryant St., San Francisco, CA 94107.*



ALL MINI DISKS COME ERROR FREE.

THE HARD PART IS MAKING SURE THEY STAY THAT WAY.

A disk is built with certain safeguards. That's why most disk makers offer guarantees that the product you receive comes to you error free.

We at Memtek Products are concerned that the minidisk remains error free. *Every* time you use it. After exposure to dust, cigarette smoke, fingerprints, even wear caused by your computer. And so, we have built safeguards around the disk, as well.

Memtek Products' latest innovation... acknowledgment of a real world beyond the laboratory.

The hub ring. Designed to prevent our minidisks from jamming in your machine. Rigid. Durable. Reinforced.

The coating. A critically-controlled coating of high-energy magnetic oxide particles that covers the disk's surface, which is then micro-polished to improve head to disk contact, preventing dropouts, lowering head abrasion.

The lubrication system. A constant lubricant protects both the disk surface and the drive head from wear.

The sleeve. Comes with a soft liner that protects the disk while gently cleaning the surface.

The guarantee.

We'll replace, free, any minidisk if it fails to accurately store and retrieve data due to a defect in materials or workmanship for up to 5 years from date of

purchase. Simply mail the disk back.

The Memtek lineup.

Premium, double and quad density minidisks as well as 10- and 15-minute computer cassettes and a 5 1/4" disk drive head cleaner.



WE PLAY FOR KEEPS™

New from NRI...
Industrial Electronics
with color computer.

**Get a head start in the emerging technologies
with practical training in control systems,
instrumentation, robotics, optoelectronics, and lasers.
Exclusive computer-aided instruction!**

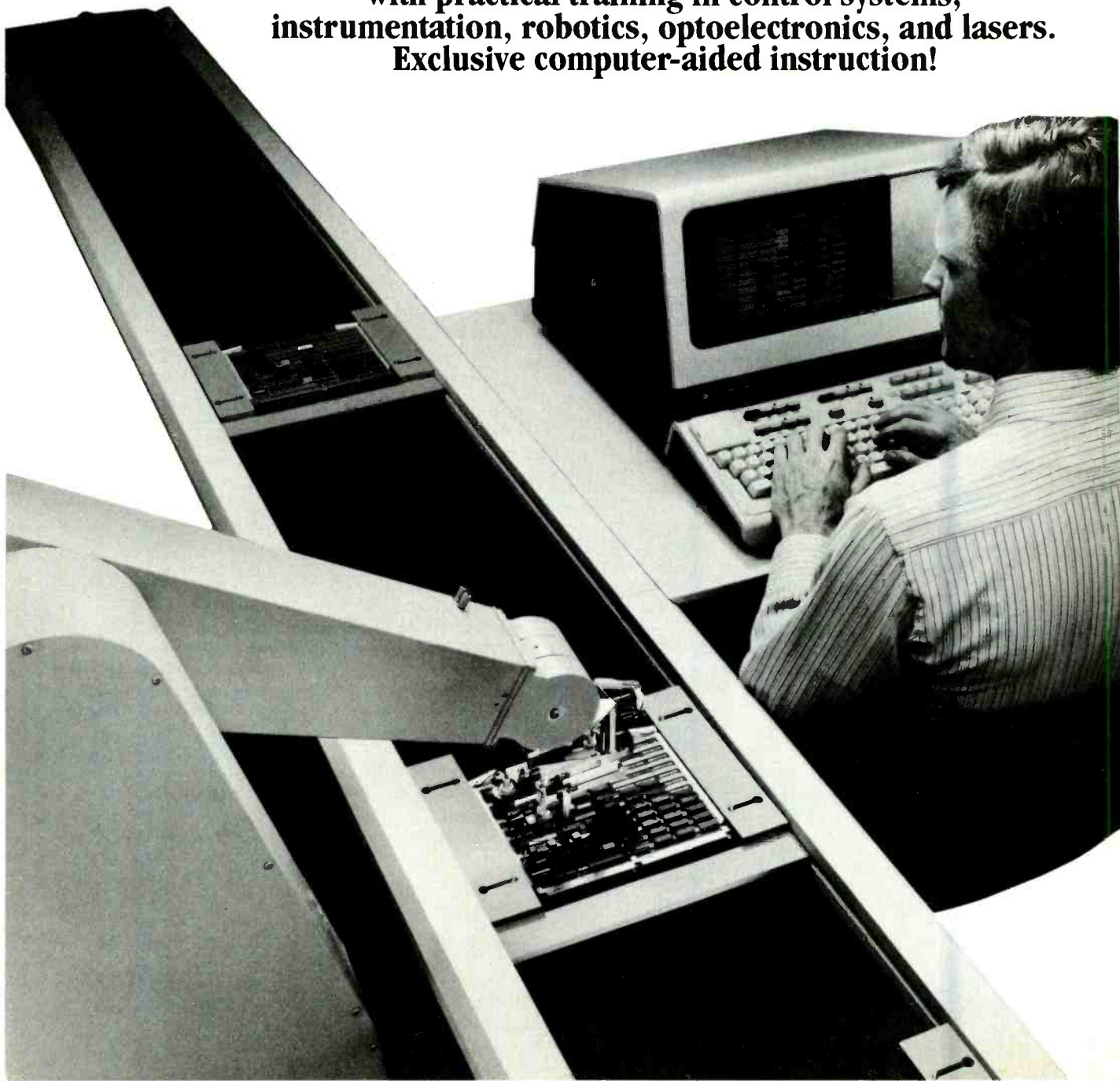

Here's the training that gets you into the heart of American industry's rebirth. Over \$5 billion a year will be spent in automation alone...\$2.3 billion in computerized control systems...\$600 million in industrial robots and robotics is only just getting underway! To help meet the soaring demand for people to operate, maintain, repair, and design these control systems, NRI has created the only complete training in Industrial Electronics for Instrumentation and Control Technicians.

Learn on Your Own Computer

NRI training is more than lessons...it's experiences. You learn by doing, using the TRS-80™ color computer to learn about control systems, programming, and troubleshooting. It comes with special computer-aided instruction programs to speed learning, is expandable for business and personal computing, and is yours to keep. And that's just the beginning.

NRI's exclusive Discovery Lab® is designed to interface with your computer and special breadboarding card so you build demonstration circuitry, "see" inside your computer, and follow its operation. You also get profes-

(TRS-80 is a trademark of the Radio Shack division of Tandy Corp.)



Your training includes the TRS-80 color computer, the NRI Discovery Lab, interfacing breadboard, digital multimeter, frequency counter, computer-assisted training programs, audio instruction tape, and 46 profusely illustrated lessons.

sional quality instruments, including your own digital multimeter and CMOS frequency counter. You'll use them during your hands-on training, keep them to use in your work.

No Experience Needed

Your NRI training is thorough and complete. Starts you with the fundamentals, builds step-by-step up to the most advanced concepts. You learn about automatic control and feedback systems, control motors, numerical control systems, lasers and optoelectronics, robotics, microprocessors, instrumentation, computer peripherals, and much more. NRI keeps you up with technology to

make the most of the big demand for control and instrumentation technicians.

Send for Free Catalog

Send the postage-paid card for NRI's big electronic careers catalog. There's no cost or obligation, and no salesman will call. In it, you'll find complete lesson plans, equipment descriptions, and career opportunities in this exciting field. You'll also get information on almost a dozen other electronic courses including Microcomputers, Electronic Design, TV/Audio/Video Servicing, Digital Electronics, and more. Act today and get on with your future. If card has been used, write to us.



NRI Schools
McGraw-Hill Continuing
Education Center
3939 Wisconsin Ave.
Washington, D.C. 20016

We'll give you tomorrow.

NEW PRODUCTS



16-LINE LCD DISPLAY PORTABLE COMPUTER

"Workslate" from Convergent Technologies of Santa Clara, CA, is designed to provide computing power without requiring the user to know anything about computers. The 8½" × 11" × 1" CMOS-design, battery-powered machine employs an electronic worksheet that supports entry of words, numbers and formulas organized in rows and columns that can be altered and manipulated at any time through its typewriter-style keyboard and numeric keypad. No language such as BASIC is used. The LCD shows 16 lines by 46 characters, while a 64K ROM contains a proprietary operating system, and 16K of RAM gives the equivalent of 12 pages of typewritten information. \$895.

Circle No. 83 on Free Information Card

APPLE "FREEZER" FOR PRINT DUMP

Practical Peripherals' "Snapshot" board permits processing interrupts to be generated at any time and provides printout of a particular screen for Apple II (Revision C and later) computers. Virtually any text or graphics can be printed. \$119.

Circle No. 84 on Free Information Card

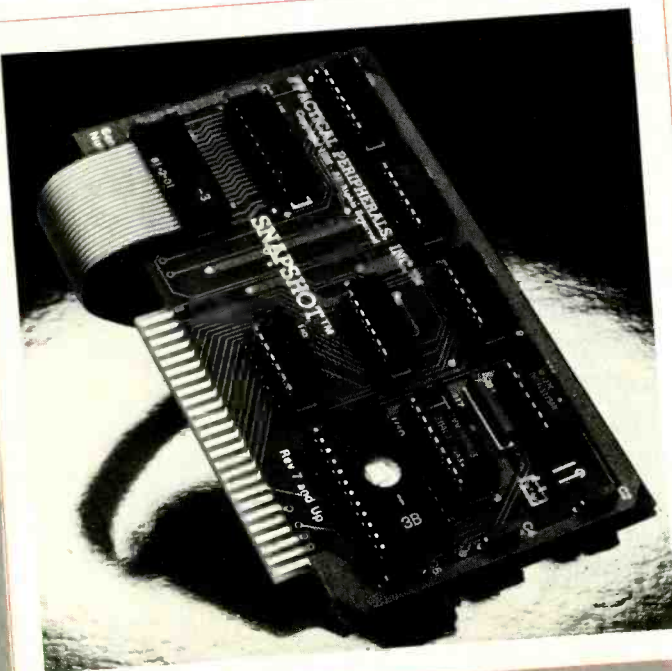

ENHANCEMENT BOARD FOR IBM PC

Easitech's "Easiboard" provides the IBM PC or XT personal computers with 11 separate functions on a single plug-in card. It contains an Easisort data sorter; Easispool printer buffer/spooler; three Easidisk high-speed solid-state electronic disk emulators; Easitime and Easidate computerized clock and calendar; Easiswap switcher for two printers; communications port for modem or printer; and memory expansion from 64K to 245K of RAM. An extensive "Easimaster" software package is included. \$325 standard version; \$395 and \$595 with added memory.

Circle No. 85 on Free Information Card

FLOPPY-DISK RESTORER

The "Bit Scrubber" from Techstar, Inc., restores used and noisy floppy disks to original magnetic condition. It can be employed with any size floppy from micro to 5¼" to 8" and single-sided, single-density to double-sided, quad-density. \$49.95 plus \$4.00 S/H. Address: Techstar, Inc., 8651 NW 56 St., Miami, FL 33166.



Computers & Electronics

INTELLIGENT STAND-ALONE MODEM

A microprocessor-based Bell 212A-type modem "Info-Mate," from Cermetek, is designed to fit under a standard telephone instrument and features auto dial, auto answer, auto speed select, auto polarity select, and auto/manual selection of pulse or tone dialing. The 300/1200-baud device automatically adapts to the host's communication parameters. Single commands select the function desired. Nonvolatile memory stores up to 52 32-digit numbers or log-on messages. \$595.

Circle No. 86 on Free Information Card



MEMOTECH'S NEW Z80-BASED MICRO



Memotech, known for its Timex/Sinclair add-ons, has announced a new 3-voice/16-color MXT512 computer that is Z80-based, has 80K of user RAM (expandable to 512K) and Oxford BASIC interpreter with logo-type commands in ROM. Using optional disk drives, the selected operating system is CP/M. Keyboard has eight user-definable keys that can be shifted to access up to 16 functions, auto repeat, u/lc character set, and 26 graphics and user-definable characters.

Circle No. 87 on Free Information Card

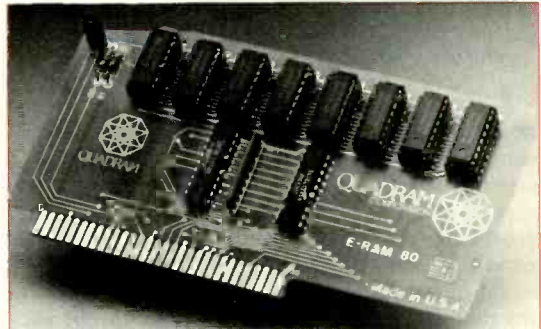

DUAL DISPLAY FORMATS FOR APPLE

Quadram's eRAM 80 is a low-cost enhancement card designed to double the text displayed on the Apple IIe screen and improve memory. Can be switched between 40- and 80-column format with 64K or 63K of RAM. \$159.

Circle No. 88 on Free Information Card

CP/M CAPABILITY FOR ACE COMPUTERS

The Ace 80 plug-in module, from Franklin Computer Corp, permits Ace 1000 users to run both Apple II and CP/M programs. Includes a Z80 operating at 6 MHz and 64K of supplementary RAM. Provides a 40-column window that can be scrolled to view 80-column pages.

Circle No. 89 on Free Information Card

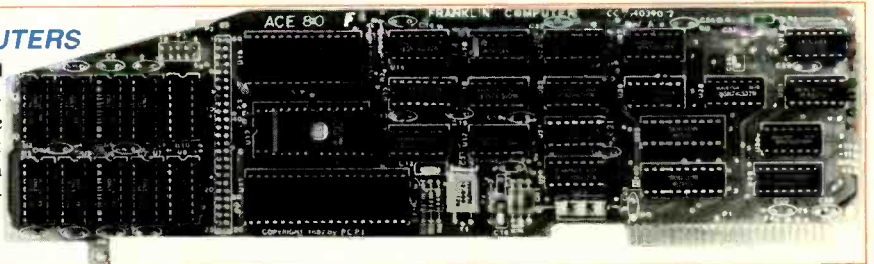

COMPUTERIZED CASSETTE DECK

Tandberg's Model TCD 3014 stereo cassette deck combines advanced audio design and user-friendly computer control. Includes three heads, four motors, Dolby B and C, peak-indicating meters, etc. An 8-bit CPU and 32K EPROM control all transport functions.

Circle No. 90 on Free Information Card

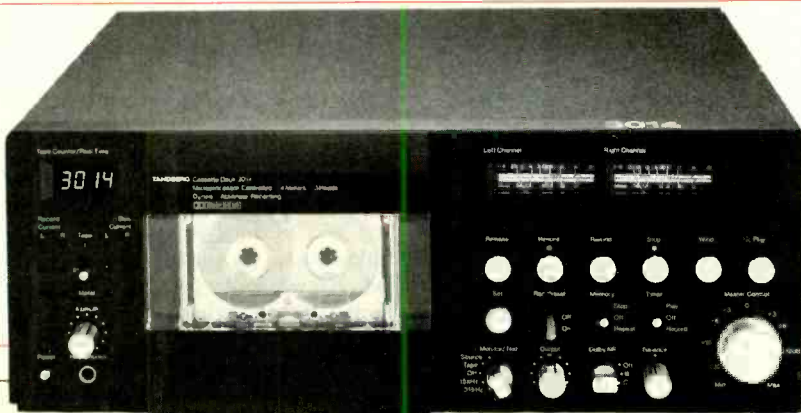

COMPUTER VIDEO GAMES

Hands-On Reviews of Recently Released Game Software

CLIPPER: Around the Horn in 1850

Diskette for Atari 400/800
P.D.I. (Program Design, Inc.), 93 East Putnam Ave., Greenwich, CT 06830, 203-661-8799. \$29.95 (disk), \$24.95 (cassette).

Graphics ★★★★★
Gameplay ★★★★★
Sustained Interest ★★★★★+
Type: Joystick strategy game
Memory Required: 32K Disk/24K Cassette plus Atari BASIC

Every so often we run across a truly imaginative and thoroughly enjoyable computer game that makes us run out of superlatives. This is one of those rare gems that is both exciting and thought-provoking. It's definitely not a twitch-game, but you still need a steady hand on the tiller (joystick) to keep your Clipper ship afloat and on course in spite of ocean squalls, navigation mistakes (yours), lack of wind for the sails, mutiny, sickness and death of crew members, finding yourself shorthanded, and running short of provisions.



You start from New York in 1850 (or so), and the object of the game is to get your Clipper ship around the Horn and safely to San Francisco with its cargo intact. You get paid a certain amount of money (from \$15 to \$50 a ton) for safe delivery, so naturally you want to carry as much cargo as you can.

Faced with a choice of 10 different ships, there's a strong tendency to pick the biggest one (with the greatest cargo capacity), but be careful! You have to hire enough crew not only to handle this ship safely, but also enough extra hands to fill in for crew members down with dysentery, scurvy and other seafarers' diseases, and to stand in for mutinous

crew members whom you're forced to put into irons.

You also have to load enough supplies. One barrel of provisions will last one seaman for 19 days, according to the game's rules. If you don't have enough food and provisions, you can put into port later to get new supplies—provided you still have enough in your ship's treasury. Doing this takes valuable days to change course, and this too, uses up more provisions. The money in the ship's treasury is used to buy provisions and to pay the crew's wages. If either provisions or money run short, you may be faced with a mutiny.

Like some other PDI disk programs, this one comes with an audio track on a separate cassette, which, when played through the Atari's cassette system, stops the action of the game while crewmen sing sea chanties, start a mutiny, or simply threaten you (the Captain). Other sound effects add to this nice touch of realism.

The display consists of the helmsman's view, with a wheel that turns when you move the joystick, and a very unclippershiplike display of information you need to run the ship. It looks almost like the dashboard of an automobile and includes percent of sail in use, position in longitude and latitude, ship heading in degrees and speed, and wind direction and speed. A little circular cutout navigation aid shows the best heading for the ship for speed with a given wind direction.

The wind shifts constantly so you find yourself trying to tack to take best advantage of Mother Nature's power plant. A map in the back of the instruction booklet helps you guide your ship, and you can switch to an on-screen map display any time you want to see the actual ship's position in the game.

If you don't make it to San Francisco (chances are you won't the first couple of times), the game ends with a newspaper article on the screen describing the ship and the fact that it's missing and feared lost at sea with all hands—or words to that effect.

The perils you face on the trip include mutiny, illness, storms, hitting land or ice, and uncharted submerged reefs. To help you along, you can read the ship's log any time by pressing the joystick firing button. The log shows the ship's position, wind direction and speed, present heading and speed, days out of New York, days of provisions left, amount of money in treasury, tons of cargo on board, and the manning report—able hands, men in irons, and men infirmed.

This is one of the best of the current crop of thinking games, and it should be both educational and engrossing for many of those evenings ahead. We highly recommend it.

APPLE CIDER SPIDER

Diskette for Apple II/II+ /IIfx
Sierra On-Line, Inc., Sierra On-Line Bldg., Coarsegold, CA 93614,
209-683-6858. \$34.95

Graphics ★★★★★
Gameplay ★★★★★
Sustained Interest ★★★★★
Type: Joystick/keyboard action game
Memory Required: 48K



This game is one of those easy-to-learn, difficult-to-master types such as Apple Panic and On-Line's own Cannonball Blitz. The premise is simple: a spider has dallied around a cider mill past daybreak and the mill has begun a new day; now it's up to you to guide the spider through a succession of moving conveyor belts and apple crushers to the safety of the attic. There are three different screens to master as the spider makes its trip through the mill. Although it's fairly easy to direct this animated arachnid to the attic in level 0 (the so-called teddy bear mode), levels 1 through 6 pose a greater problem.

Frogs, birds and wasps complicate matters at the higher levels. However, the three screens leading to the attic remain the same. This took away some of my enthusiasm for the game, since I had already reached the ultimate goal (the attic) at the lowest level. But one of the options, which is two players, renewed my interest. I found that having another person there to challenge me at the higher levels was the remedy for my ennui.

The game can be played with a joystick (which can be switched between two players) or at the keyboard. A selection of functions is available, among which are toggle sound, restart a game, switch levels in the game, and pause the game. The top ten high scores are stored on the disk.

There is one disturbing aspect to the

After you ask what it can do for you now, ask what it can do for you later.

If you're about to buy a personal computer, you need to consider two basic issues: What your needs are now, and what they're likely to be a few years from now.

That's why the HP-86 has to be your best choice. It's got the software and the hardware to go the distance.



The HP-86
Personal Computer.

Dow Jones/News Retrieval Service, or a number of other nationwide information sources.

When the time comes for more, consult our 450-page software catalog. Chances are, you'll find what you're looking for.

Software for today and tomorrow.

Save \$255* on the Personal Productivity Pac. Here's a good way to get started. With software that, if bought separately, would cost you \$750** We're offering it at the reduced price of \$495** You'll get VisiCalc® PLUS, the world-famous electronic spreadsheet for "what-if" planning. (The "PLUS" is a Hewlett-Packard bonus: extra programs

to quickly turn your spreadsheet into bar graphs, line graphs, or pie charts.) Plus WORD/80, for word processing. And FILE/80, for record keeping without paperwork. CP/M® Buy this plug-in module, and you'll extend your HP-86 system to accept many popular programs written under the CP/M operating system — programs such as WordStar™ and dBASE II.™

Graphics Presentations. When combined with the HP 7470A plotter, our graphics software lets you produce professional-quality pie and bar charts, line graphs, text pages, and overhead transparencies. And you can do it all in color.

Data Communications. If you decide you want it, an optional accessory lets you access The Source, the

*Software savings are based on suggested U.S. list prices and may vary.
**Suggested retail price. May vary outside U.S.
VisiCalc is a registered trademark of VisiCorp.
CP/M is a registered trademark of Digital Research, Inc.
WordStar is a registered trademark of MicroPro.
dBASE II is a registered trademark of Ashton-Tate.
PGO2320 209E

Hardware that expands with your needs.

While your computer's ability to expand depends largely on software, naturally, the hardware must keep up. That's why the HP-86 system has a modular design. So you can add a printer or plotter as easily as you hook up a tape deck to your stereo. And operate up to 14 peripherals at once, if you wish.

When you find yourself facing lengthy problems or spreadsheet analyses, simply add more memory — up to 640K bytes.

As you demand more of your HP-86, you'll find that it keeps up. Whether you need a broad range of hardware, software, or peripherals, the HP-86 makes expansion easy, giving you a hard-working system tailored to help solve your specific problems.

If you need more good news, try this: The basic system is only \$2820** (128K computer/keyboard, 12" monitor and single 3½" disc drive).

Get a hands-on demonstration of the system that works for you now, and will still be working for you later.

For the authorized HP dealer or HP sales office nearest you, call TOLL-FREE 800-547-3400 and ask for operator 96. M-F, 6 a.m.-6 p.m. PST.

Personal computers & calculators
for professionals on the move.



Circle No. 65 on Free Information Card

game. As you play, you begin to realize that there is only one path that can be travelled to get to the attic. During the game, the spider jumps from shelf to shelf or climbs up a line to reach its destination. However, seemingly good jumps or attempts to attach to a line are for naught if you are not travelling the "chosen" path. This I learned to live with.

Its weak points notwithstanding, the game is fun and has that unique power of injecting just enough frustration to keep the player coming back for more. I think you'll find that, once the spider lures you into its game-playing web, it will be difficult to escape.

ARACHNOID

ROM cartridge for VIC-20
UMI (United Microware Industries, Inc.),
3503 "C" Temple Ave., Pomona, CA
91768. 714-594-1351. \$44.95.

Graphics ★★★

Gameplay ★★★★★

Sustained Interest ★★★★★

Type: Joystick action game

Memory Required: Resident RAM

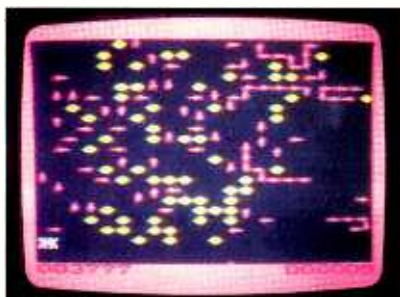

Arachnoid is cut from the same piece of cloth as Atari's Centipede and UMI's previous VIC game, "Video Vermin." They're all exciting, twitch-type action games that work even better with a track-ball controller than with a joystick.

The hero of this piece is a spider who has just laid a nest of eggs that must be protected against marauding insects such as ants, gnats, flies and wasps. Using the joystick as a cursor controller, you first select your poison (your principal adversaries) with ants at the lowest difficulty levels from 1 to 5, and wasps at the highest from 16 up to anybody's guess.

In the process of shooting invading ants or whatever, your spider also spins a sticky web which can trap further invading pests. But scavenging gnats and flies can open the web at strategic points, forcing you to keep on your many toes.

The game keeps track of the highest

score during any play session, and we found it to be as good graphically and certainly just as engrossing as Video Vermin. It gets extremely high marks on playability and player involvement.

NIGHT STRIKE

ROM cartridge for Atari 400/800
TG Products, 1104 Summit Ave., Suite
110, Plano, TX 75074. 214-424-8568.
\$44.95.

Graphics ★★★

Gameplay ★★★★★

Sustained Interest ★★★★★

Type: Joystick action game

Memory Required: Resident ROM

This is a plug-in from a new software company, and the pre-production sample we tested came without any instructions. Even so, the gameplay is very straightforward and easy to figure out. It's a classic shoot-em-up, but without any space invaders.

The scenario looks like London during the Blitz. There are waves upon waves of bombers dropping bombs (of all things), and occasional V-1 buzz-bomb (colored blue so you can spot them more easily) which have an annoying tendency to seek out the good guy. This happens to be your mobile anti-aircraft cannon mounted on tank treads so you can move horizontally to get the best firing position and to get out of the way of those V-1s when they drop toward you.

You're also in danger of getting hit by bombs from very low-flying bombers which seem to skim the rooftops. The graphics are pretty decent with a lot of colorful skyline-silhouetting reds and oranges.

You get a total of three mobile anti-aircraft cannons which come rolling out from the left of the screen. You can move the cannon horizontally and change the angle of fire. You get a free cannon at 10,000 points—at 100 points per enemy aircraft you hit, plus bonus points earned for good percentages of hits vs. ammunition used.

MATCHBOXES

Diskette for Atari 400/800
Broderbund Software, Inc., 1938 Fourth
St., San Rafael, CA 94901. 415-456-
6424. \$34.95

Graphics ★★★★★

Gameplay ★★★★★

Sustained Interest ★★★★★

Type: Joystick memory and guessing game

Memory Required: 32K

You are faced with 36 blank boxes, behind which are hiding 18 pairs of animated pictures of some kind (everything

from jumping dinosaurs to puffing railroad trains), and it's up to you to match up pairs. You get to uncover two boxes each turn and try to remember what is hiding where. Match up a pair successfully, and you get another turn plus points.

There are several variations of the game, including versions where uncovered boxes reveal a portion of letters making up a secret word. Guess the word correctly and you're the winner, regardless of how many boxes you matched up correctly.

In the pure matchup variation, you go instead for high score by outguessing your opponent on the identity of the boxes. It's brain-taxing fun, and after each game, the computer scrambles up the locations of the various hidden objects for the next round of play.



Playing against another person with an exceptionally good memory can be very frustrating. This is one game where you can play solo against the computer and win almost every time since the computer is programmed to have a very poor memory. This gives us lowly humans much more than a fighting chance. It's a great game for all ages, and an excellent memory-building tool.

SHAMUS

ROM cartridge for the VIC-20
HES (Human Engineered Software) 71
Park Lane, Brisbane, CA 94005. 415-
468-4110, \$39.95

Graphics ★★★

Gameplay ★★★

Sustained Interest ★★★★★

Type: Joystick action game

Memory Required: Resident ROM

It's inevitable! When you translate a successful game from Atari 800 disk format into a plug-in ROM for the VIC, something gets lost in the translation. The original (Atari) version is a great favorite, and Shamus lovers may find this version a little too slam-bam-thank-you-Ma'am, and too difficult for beginners.

Does that make it less than worthwhile? We think not, because the basic Shamus game is still there; the graphics

are somewhat simplified, and you seem to be much more susceptible to the predatory Shadow, but the mazes are in place, and like the original, with practice, you can get better.



Shamus is a space-age detective with super Shivs in unlimited supply which he uses to take out the Shadow's many henchmen who are continuously shooting at him in the Shadow's castle. The maze leads Shamus to such treasures as keys to unlock doors and otherwise get at the Shadow in his lair. Try it; you'll like it! But it can be habit-forming.

FOURTH ENCOUNTER

ROM cartridge for VIC-20
 Thorn EMI Video, 1370 Ave. of the Americas, New York, NY 10019, 212-977-8990. \$39.95.

Graphics ★★★★★
Gameplay ★★★★★
Sustained Interest ★★★
Type: Joystick action game
Memory Required: Resident ROM

After a couple of possibly misguided attempts, Thorn has finally come up with a really super game cartridge for the VIC. Fourth Encounter is an excellent, high-speed action game that reminds us a little of Activision's "Megamania" for the Atari 2600 game machine. That's high praise indeed, for like Megamania, this cart provides you with lots of action of the sweaty-palm variety.

You have the very familiar ground-based shooter (cannon, or what-have-you) which you can move horizontally. You are attacked by descending swarms of hostile aliens. The first wave looks like a bunch of gigantic killer bees. Finish them all off and you're "awarded" the next wave—some difficult-to-describe blue boxes with rotating eyeballs inside. The third wave consists of attacking spaceships complete with laser cannons. Watch out! We haven't been able to get past this wave yet, so what else is in store is hard to say.

But this is definitely on the must list of new plug-in games for the VIC. It's a real winner, even when you lose!

How to tame your data.

To soothe the savage information beast, a businessperson could use the IBM Personal Computer XT.

Because with XT's 10-million-character fixed disk drive and IBM data management software *specifically* designed to complement the hardware, you can whip thousands of names and numbers into more manageable shape.

(Helping you get a better shot at the lion's share.)

Use IBM PFS:FILE* to generate a "form" on the screen. Customize it by putting pertinent data in the blank spaces provided.

Then use IBM PFS:REPORT to sort, organize, search, update, store and print the facts with ease.

To learn more about how the IBM Personal Computer XT can help you more efficiently handle many high-volume applications, visit your authorized IBM Personal Computer retail dealer.

IBM



The IBM Personal Computer A tool for modern times

For more information on where to buy the IBM Personal Computer, call 800-447-4700. In Alaska or Hawaii, 800-447-0890.
 *PFS is a registered trademark of Software Publishing Corporation

Circle No. 41 on Free Information Card

Rumors & Gossip

► **Commodore** is expected to drop the "list" price of the model 64 to under \$200 and introduce a stripped-down 64 with a suggested retail price of under \$150 for the Christmas season. Also look for a 16K version of the VIC-20. Rumors abound that Commodore will soon do away with its P-series of computers and introduce a \$100 low-capacity disk drive . . . **International Telephone and Telegraph (ITT)** is rumored readying a personal computer entry at its Qume division . . . **Spectravideo** is reportedly coming up with a lap-size portable computer that's a souped up version of the Tandy 100 at, naturally, a lower cost . . . Watch for a new home-oriented computer to be introduced by **IBM**, possibly as soon as October. The unit is expected to be upward compatible with the PC and sell for between \$500-600. It will probably be a "transportable" machine, slim and lightweight, and will include a disk drive and 64K of RAM, but no expandability.

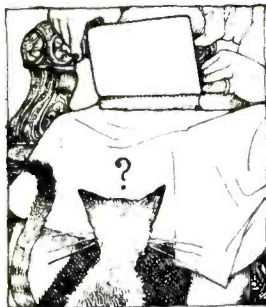

Word is that they have already begun talking to mass merchandisers about the product. The problem is how to market the product without upsetting their current dealer organization and yet enter the larger home computer market . . . **Apple** is also expected to introduce a similar machine at about the same time . . . **Compaq** is rumored readying two new versions of its machine. One will have a hard-disk drive in place of one of the floppies. The other will have a 25-line by 80-character flat-panel display (plasma type) instead of the CRT. Thus, it should be considerably smaller and lighter than the current unit—and more expensive! Compaq is also expected to go public sometime soon . . . **Microsoft** is expected to release a version of Xenix, its Unix version for the XT, very soon. Xenix is a real-time, multiuser, multitasking operating system that is currently popular on large minicomputers . . . However, **IBM** is expected to release a new operating system for the PC and XT that was developed in-house and is upward compatible with its larger mainframes . . . Look for **Tandy (Radio Shack)** to release an IBM PC compatible machine and undercut the market in price.

Apple Doings

► **Apple Computer** is continuing to wage its battle against Apple II clones. The latest are three lawsuits filed against **Jade Computer Products**, Hawthorn, CA; **Cosmic Computers Unltd**, Diamond Bar, CA; and **Ironsides Computer Corp.**, Reseda, CA. Apple is charging them with copyright and patent infringement as well as unfair competition. Apple claims that all three companies are selling computers and software that are virtually identical to the Apple II.

In the meantime, the shortage of IIs that existed in the first four months of the year is no more. In fact, Apples are now in abundant supply, triggering a price war. The Apple IIe system, which includes a monitor and display, lists for \$1995 and is now being offered by some discounters for as low as \$1599. Apple has already established 135 of its 1500 dealers to carry the Lisa and all of them have already received demo

units, with customer shipments expected by late summer. Apple expects to increase its Lisa dealer base to about 300 by this time next year. The company is relying on its own national accounts sales force for most Lisa sales. Apple is also expected to do a large OEM business with the Lisa.

Latest in the Price Battle

► I could hardly believe my eyes, but there was the ad in my local paper . . . the **Timex 1000/Sinclair ZX-81** on sale for \$29.97 . . . how much lower can it go? Then the same store advertised the **Commodore 64** for \$199.97 and there are reports of prices as low as \$194.99. And the **VIC-20**, **Atari 400** and **TI-99/4** are fighting it out at the \$69 level.

Price erosion has even begun on the more expensive machines. For example, I recently saw a newspaper ad for the **Osborne 1** computer for \$988. And there are special discounts being offered on the **Apple IIe** when bundled with peripherals and software so that the effective street price of the machine is now well below \$1000.

Japanese Computer Standard

► Fourteen Japanese and one American company have reportedly agreed to adopt a computer standard, developed by **Microsoft**, for the home computer market where the Japanese have as yet had no success in penetrating the U.S. marketplace. It would allow for software plug-in module compatibility and is referred to as **MSX**. The standard requires a Z80-based CPU, **TI 9918** graphics controller, a **General Instruments** sound chip, 64K of RAM, 32K of ROM (containing **Microsoft BASIC** and a minimal operating system), a quadrature joystick, and an **NEC** cassette interface.

The companies include **Canon**, **Fujitsu**, **General Corp.**, **Hitachi**, **Mitsubishi**, **Pioneer**, **Sony**, **Toshiba**, **Sanyo**, and **Matsushita**. The one U.S. company is **Spectravideo**. **Digital Research**, developer of **CP/M**, has also stated that it is developing a standard.

The New War in Software

► Manufacturers and retailers had hoped to make their money on selling software at full suggested retail price while discounting the computers to near cost. However, now the price war appears to have spread to software as manufacturers are bundling more and more of it with the basic machine. Further, manufacturers are beginning to drop prices on software in the same way they dropped prices on hardware. **Commodore**, for example, has recently begun selling game software at \$10 that previously sold in the \$20-35 range, and business-oriented software such as spreadsheets and database programs in the \$50-100 range where previously they sold for several hundred dollars.

Software is now merchandised in much the same manner as audio records and tapes. There are specialized software stores and software has even begun springing up on the racks of drug stores. Over 50% of all software distribution is now done through distributors (a la records and magazines) and no longer from manufacturer to dealer. This percentage is expected to increase.

(Continued on page 20)

Look at what the best modem has been reduced to.

Our engineers have come up with some state-of-the-art LSI technology and a whole new modem.

It's smaller. J-Cat is about 1/5th the size of an ordinary modem. Easy to stick-on, tuck-in, put anywhere you want.

It's better. J-Cat does the things you need for professional performance. No fussing to get it into the right answer or originate mode; it does it automatically. LED's show you status; and audio "beeps" tell you when you reach a busy signal, detect a carrier, get a dial tone, etc.

And you can hook it into any modular RJ11C phone jack.

It costs less. If you've shopped around, you know a modem with close to these features costs \$250 or more. Our LSI technology has let us do the right thing with the price, too. Suggested retail—\$149.

Smaller is definitely better. See your dealer. He has them right now.

The Novation **J-CAT**[™]



J-CAT FEATURES:

- Direct Connect, FCC Part 68 Registered
- Auto Answer
- Auto Search (Originate or Answer Mode)
- Disconnect/Test Key
- Connect/Break Key
- Self-Test
- Audio Line Status Indicator
- Dialtone/Busy Status at Serial I/O Connector
- Off Hook Control at Serial I/O Connector
- Compatible With EIA-RS232C or TTL Interfaces
- Low Power
- And it's from Novation, the world's leader in personal communications.

Novation



(800) 423-5419

In California:
(213) 996-5060

20409 Prairie Street, Box 2875
Chatsworth, CA 91311

Circle No. 75 on Free Information Card

Bad Times Hit the PC Business

► Texas Instruments has disclosed that, as yet, it has never made a profit in the personal computer business. This follows a similar statement made by Atari earlier this year. Actually, TI has never been truly successful in consumer electronics. Its efforts in digital watches and calculators were also serious disappointments.

Atari, whose market share of the game business has slipped from 80% to about 40%, is going through a "consolidation" and "reorganization." During the past year it has eliminated some 2000 jobs in the U.S. and shifted manufacturing to the Far East, Puerto Rico, and Ireland.

TI ordered a two-week "vacation" for all its consumer group employees, has closed all of its retail stores, and is expected to have a new round of price cuts (which will intensify the current price war even further). It is estimated that TI currently has over 200,000 computers in dealers' stock, another 200,000 units in its own warehouses and a similar quantity in parts for production. Thus, there are predictions that TI will soon begin dumping these units on the market at substantially reduced prices.

In the meantime, Apple and IBM are reported talking to mass merchandisers about marketing new stripped-down versions of the IIe and PC. They are both trying to work out marketing plans that will not upset their current dealer organization and yet allow them to enter the larger home computer segment of the marketplace.

Software Market Skyrockets

► Personal computer software sales for this year are expected to top \$2.3 billion, up from \$1.2 last year . . . and it is expected to increase to \$11 billion by 1987. About 40% of personal computer owners buy computer games and spreadsheet programs, while only about 20% buy word-processing and accounting software. Educational software is purchased by about 12%, database by 11%.

In terms of applications programs, the number-one seller so far is Visicalc with close to a half-million copies sold at a rate of over 20,000 per month. Lotus 1-2-3 and Multiplan are second, shipping close to 15,000 each a month, while SuperCalc is selling close to 7000 copies per month. WordStar is the leader in word processing, shipping about 15,000 per month, with Applewriter a close second with nearly the same numbers, while Easywriter is shipping about 7000 per month. The leading database program is PFS with close to 15,000 units being shipped per month. DBase II is second, shipping about 7000 per month. BPI and Peachtree are the leaders in accounting packages, each one selling close to 10,000 copies per month.

Today the key to success in marketing software is the software wholesaler/distributor (two years ago they were almost nonexistent). Retailers now buy almost half of their software from wholesalers, a quarter from the publishers, and a quarter from computer manufacturers. The leading wholesalers are Micro-D and Soft Sell.

The latest trend in software retailing is the software store. Several chains are already in existence. By 1986-87 it is expected that there will be close to 2000 software stores in operation.

The software business is very profitable. For example, Visicorp is currently grossing an estimated \$2 million a month from Visicalc for a yearly revenue of well over \$20 million. Visicorp will this year pay Software Arts, the author of Visicalc, nearly \$7 million in royalties, and should show a profit, before taxes, of \$4 million.

Who are the largest software publishers? Radio Shack leads with estimated sales for '84 of \$60 million. Apple, Visicorp, and Microsoft are next with \$30+ million. Micropro, Atari, IBM, TI, and Digital Research are in the \$20+ million range.

Who's Shipping What?

► Monthly shipping rates of machines: Apple IIe—40,000, IBM PC and XT—20,000+, PC-compatibles—5-10,000 and growing rapidly, CP/M systems—40,000 units (from almost 100 vendors), TRS-80—15,000 units. All the 68000-based machines taken as a group amount to less than 10,000 per month. The Timex 1000, Commodore VIC-20, and TI-99/4 are all being shipped at a rate of about 100,000+ per month . . . all three have shipped over a million units.

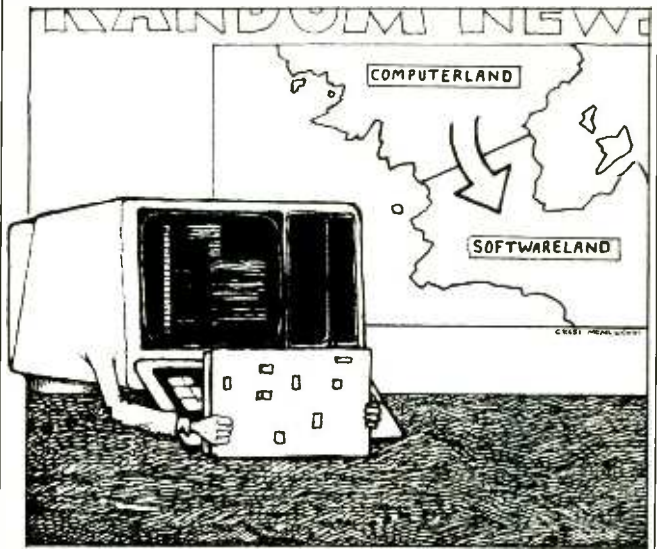

Random News

► **Fortune Computer Systems**, the first company to introduce a 68000-base Unix system, will announce a loss for the second quarter ending in July. They attribute it to a drop in orders and delays in software shipments . . . **Shugart** is expected to introduce a 12" optical-disk drive later this year with a one-gigabyte storage capability. Price is expected to be close to \$10,000 . . . **Digital Equipment Corporation** has disclosed that it will abandon production of 36-bit minicomputers in favor of its 32-bit machines . . . **Computerland** has filed a suit against Softwareland to stop it from using the suffix "land" in its name . . . **Computers International**, Los Angeles, CA is reportedly at work on a 100-cps daisywheel printer . . . **Tandon Corp.**, the disk-drive manufacturer, will enter the personal computer market with a system sold under a private label by Atari . . . **Romox**, Campbell, CA has demoed a reprogrammable game cartridge with the expectation that customers will bring their old Romox game cartridges back to their dealers to have them reprogrammed with new games at \$10 each.

Quotation of the month:

"By 1984 the personal computer industry will be larger than the minicomputer industry and by 1986 will surpass the mainframe computer industry. The personal computer software industry is already larger than the minicomputer industry."—*Portia Issacson, Future Computing*

MEMOTECH

The Complete Range

Fifteen months ago Memotech developed the first 64K Memopak, designed to maximise the capabilities of the Sinclair ZX81. Since then, using the ZX81 as a starting point, we've gone on to produce a comprehensive range of Memopaks, adding 16K and 32K memory expansions, utilities packages comprising a Word Processor, Z80 Assembler and Spreadsheet Analysis, plus Communication Interfaces, High Resolution Graphics and a professional quality Keyboard. To complete our range of Timex add-ons, we are now introducing the MEMOPAK RS232 Serial Interface.

RS232 Interface

The RS232 is an all-purpose interface which allows the Timex not only to output to suitable serial printers, but can link up with numerous types of peripheral or even other processors. The Interface has two main modes of operation: BASIC mode allows you to use the range of functions supplied in the RS232 EPROM within an ordinary BASIC program, and TERMINAL mode allows you to use your Timex as a terminal to another processor. The EPROM functions offered permit the user to send, receive and convert bytes between Z80 code and ASCII, as well as check the status of numerous control flags. Received or transmitted data can appear simultaneously on the screen, and received data may be printed simultaneously.

\$99.95 cable \$19.95

Memopak Centronics I/F

The BASIC commands LPRINT, LLIST and COPY are used to print on any CENTRONICS type printer. All ASCII characters are generated and translation takes place automatically within the pack. Reverse capitals give lower case. Additional facilities allow high resolution printing.

\$74.95 cable \$19.95

Memopak HRG

This pack breaks down the constraints imposed by operating at the Z80 character level and allows high definition displays to be generated. All 248 x 192 individual pixels can be controlled using simple commands, and the built in software enables the user to work interactively at the dot, line, character, block and page levels.

\$99.95

Memocalc

The screen display behaves as a 'window' on a large sheet of paper on which a table of numbers is laid out. The maximum size of the table is determined by the memory capacity, and with a Memopak 64K a table of up to 7000 numbers with up to 250 rows or 99 columns can be specified.

\$49.95

Memotext

Text is first arranged in 32 character lines for the screen with comprehensive editing facilities. On output the user simply chooses the line length required for printing and the system does the rest. Used with the Memopak Centronics Interface, the Word Processor makes available printout with 80 character lines, upper and lower case and single and double size characters.

\$49.95

Memopak Memory Extensions

For those just setting out on the road to real computing, these packs transform the Timex from a toy to a powerful computer. Data storage, extended programming and complex displays all become feasible. Further details available on request.

16K Memopak \$49.95
32K Memopak \$99.95
64K Memopak \$149.95

Z80 Assembler

The Assembler allows you first to code and edit a source program in the Z80 language, and then assemble it into machine code. You can now write flexible and economic programs. The Editor mode allows you to code directly in the right format, manipulate individual lines and control the exact placing of source and machine code. Routines may be merged or listed (even to a commercial printer using our Centronics Interface). The assembler mode handles all standard Z80 mnemonics, numbers in hex or decimal, comments and user-selected labels.

\$49.95



Memotech Keyboard

The Memotech plug-in Keyboard plus buffer pack takes the effort out of data entry for Timex users. The Keyboard has a light professional touch and is housed in an elegant aluminum case. The simple plug-in system means that you are not obliged to open up your Timex, use a soldering iron or invalidate your Timex warranty.

Keyboard Buffer Pak

The Buffer Pak performs a "housekeeping" function for the Keyboard, interfacing directly with the port of your Timex.

\$99.95 - (keyboard & buffer included)

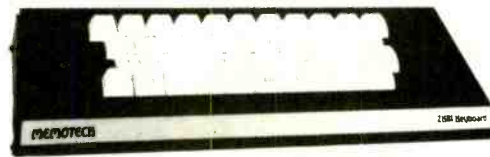

Note! All Memotech products carry a 6 mo. warranty. 80 column dot matrix printer packages available at a substantial savings from Memotech.

Order at no risk (10 day money-back guarantee): Call 1-800-662-0949 (Colorado 1-303-986-1516). Or send your name, address, phone number and a check/money order/Visa or MasterCard number with expiration date to: Memotech Direct Sales Division, 7550 W. Yale Avenue, Denver, Colorado 80227. Shipping/Handling \$4.95; Colorado Residents add applicable sales tax.

LES SOLOMON ON COMPUTER HARDWARE



By Hook,
Crook,
or Flip-Flop

WHEN people drop in to play games on my computer, they often boast about how "expert" they are in video arcade games. Since most of the games on my computer keep a record of the highest scores, it is fun to watch their faces when, after trying the game for some time, they find it almost impossible to beat my scores. Obviously, they suspect that I am doing something a trifle shady.

However, because I have neither the skill, time, nor inclination to play those games long enough to improve my hand-eye coordination to become an expert high scorer, I do the next best thing—I cheat.

OK, you are probably thinking, he gets into the software and fixes things the way he likes. Unfortunately, the games are on diskette, in machine language, and are protected by complex software encoding schemes. So, if I want to "cheat," I start with the hardware. Actually, I prefer to call what I do "problem solving" rather than cheating.

I start by making a couple of assumptions. First, the game software "knows" that the pushbutton on the controller fires the "gun" (or whatever) used in the game; and, second, the score increments when the "bullet" (laser beam, missile, etc.) hits the target.

We surmise that the scores are kept down by the fact that the targets are moving very fast, and that the software writers know that there is a limit to how fast a normal person can operate the trigger.

Before we go any further, I should tell you that there is one catch to the game-improvement technique to be discussed. In some games the weapon is actually a "machine gun" whose rate of fire is soft-

ware fixed. This type of game cannot be tinkered with very easily.

Also, in this example, the Apple II is used simply because I have one. However, the technique can be applied to almost any other system.

The only part of the game that we can get to is the game controller—actually the pushbutton on the controller that acts as the weapon "trigger." What we have to do is what the old western gunfighters did to get a lot of shots off fast—learn how to "fan" our gun.

To effect the change, first check the schematic of the system to find out how the pushbutton is wired into the circuit. In the case of the Apple II, one side of the pushbutton is connected to +5 volts and the other side to one end of a 680-ohm resistor, whose other end is connected to the system ground. The pushbutton/resistor junction is connected to an input on a TTL chip. When the switch is open, this input is pulled to ground via the 680-ohm resistor. The computer software "reads" the TTL chip associated with this input and, since the input is logic 0, it "knows" that the weapon has not been fired. In Apple parlance, the memory at -16287 (\$C061) is less than 128.

When the user depresses the controller pushbutton, the switch closure places +5 volts on the input of the TTL chip forcing it to a logic 1. The software "reads" this as "weapon fired" and "fires" the "bullets." In the Apple, the memory at -16287 now contains a number greater than 128.

So far, everything is honest. However, this does not increase our score. To do this, let's get to the "problem solving" stuff.

Break out the soldering iron and build a variable-frequency pulser using a 555 timer. You can copy any standard 555 oscillator circuit. The pulse repetition rate of the pulser should be variable from a few to several tens of pulses per second. There is no "magic" number so a variable source should be used. In operation, when the oscillator "turn-on" pushbutton (which may be the switch that applies the voltage) is depressed, the output should be a series of pulses.

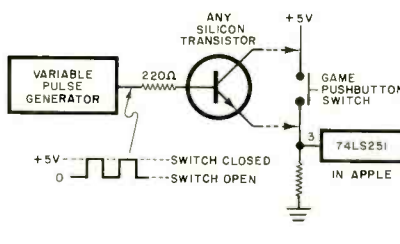

A simple transistor can have either a high or low collector-to-emitter resistance depending on the polarity of the signal applied to its base with respect to the emitter. (This is the pulse stream being fed to it by the 555 oscillator.) In this way, a transistor can be made to emulate a high-speed mechanical switch.

In the case of the Apple, an npn transistor is wired so that the collector is connected to the side of the pushbutton switch tied to +V, and the emitter to ground via the resistor side of the switch. Applying a positive-going signal (with respect to the emitter) from the 555 pulser to the base will "close" the electronic switch. When the positive signal is removed from the base, the electronic switch is open. What we have done, in essence, is to parallel the slow, manually operated pushbutton switch with a relatively high-speed electronic switch. The computer doesn't care how the TTL input changes state, mechanically or electronically, as long as it changes. And TTL logic can change states much faster than a human can operate a mechanical switch.

All you have to do now is run the game, and fire the "weapon" using the controller pushbutton to get the "feel" of the game. Release the controller pushbutton and operate the 555 "fire" pushbutton. The on-screen weapon should fire much faster with the rate determined by the multivibrator control. Adjust this potentiometer for the optimum firing speed for the particular game. Adding the switch will not affect the game—only your score.

Now, when no one is around to watch your spectacular gamesmanship, run up a couple of great scores and make sure that they are recorded on the game diskette. Then remove the electronic switch from the controller pushbutton to return it to normal use. If anyone should ask if you have been cheating by doctoring the software, you can tell them the truth. Just explain that you are a good game player who knows how to use the system hardware.

On any system other than Apple, you must clearly identify exactly how the mechanical pushbutton is wired in as far as voltage polarities are concerned. Keep in mind that, besides npn transistors, there are also pnp types and FETs that can be used as electronic switches. The FET can be used where there are no dc voltages to be switched since it can "look" like a nonpolarized electronic switch having a very low "on" resistance and a very high "off" resistance.

Now that you have the idea, go run up some interesting game scores. ♦

Where's Your **ELECTRONICS** Career Headed?

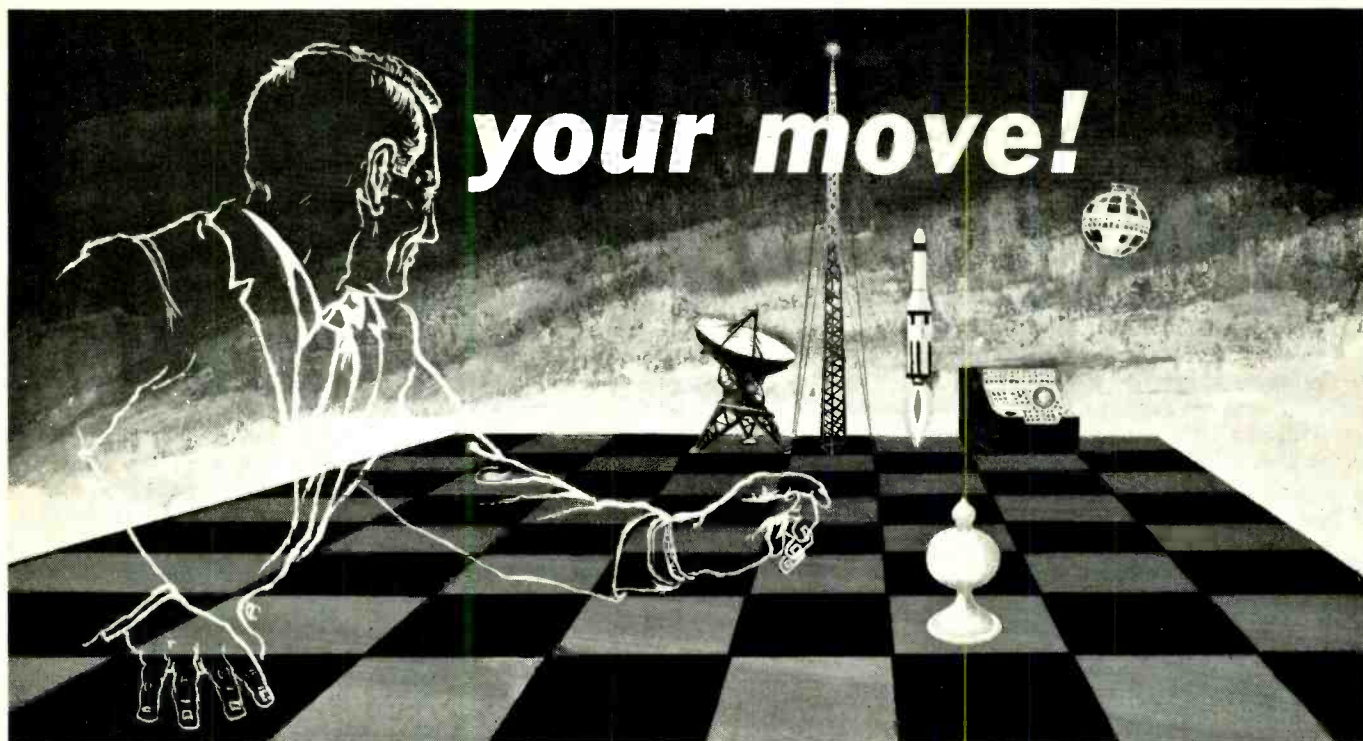

The Move You Make Today Can Shape Your Future

Yes it's your move. Whether on a chess board or in your career, you should plan each move carefully. In **electronics**, you can *move ahead* faster and further with a

B. S. DEGREE

Put professional knowledge and a **COLLEGE DEGREE** in your electronics career. Earn your degree through independent study at home, with Grantham College of Engineering. No commuting to class. Study at your own pace, while continuing your present job.

The accredited Grantham non-traditional degree program is intended for mature, fully employed workers who want to upgrade their careers . . . and who can successfully study electronics and supporting subjects through

INDEPENDENT STUDY, AT HOME

Free Details Available from:

Grantham College of Engineering
2500 South La Cienega Blvd.
P. O. Box 35499
Los Angeles, CA 90035

Independent Home Study Can Prepare You

Study materials, carefully written by the Grantham staff for independent study at home, are supplied by the College, and your technical questions related to those materials and the lesson tests are promptly answered by the Grantham teaching staff.

Recognition and Quality Assurance

Grantham College of Engineering is accredited by the Accrediting Commission of the National Home Study Council.

We are located at 2500 S. LaCienega Blvd., Los Angeles, California, but for faster response please use our mailing address: P. O. Box 35499, Los Angeles, CA 90035.

Grantham College of Engineering ET-10-83
P. O. Box 35499, Los Angeles, CA 90035

Please mail me your free catalog which explains your B.S. Degree independent-study program.

Name _____ Age _____

Address _____

City _____ State _____ Zip _____

Hardware

New Computer. The Sord M68 personal computer features both an 8- and 16-bit CPU. The 16-bit device is a 68000 operating at 10 MHz, has 256K bytes of RAM (with parity), and a real-time clock formed from an HD146818 with battery backup. The RAM can be expanded to one megabyte or, with 256K dynamic RAM chips, to 4 megabytes. In the 16-bit mode, the 8-bit CPU becomes the I/O processor. The 8-bit



mode uses a Z80A operating at 4 MHz, 64K bytes of RAM and 4K bytes of ROM. The system is fitted with two 5¼" mini-floppies having 1.2M bytes capacity. The separate keyboard is typewriter style, and has a numeric keypad. The computer supports two RS232C serial ports, one Centronics-compatible parallel port, and an IEEE-488 GPIB I/O bus. External storage options include 5¼" and 8" floppies, a 5¼" hard and two 8" hard disks. Both monochrome and color video monitors are available. **Address:** Sord Computer of America, Inc., 200 Park Ave., NY, NY 10166 (212-878-6789).

Super Floppy. The Model 320 Super Minifloppy provides 3.33 megabytes of storage capacity and a 3-ms track-to-track performance in a half-height 5¼" minifloppy format. It uses 192 tpi double-sided recording. A proprietary track-following servo maintains head positioning. A brushless dc motor and on-board microprocessor are provided and no preventive maintenance is required. Formatted specifications include 2.62M bytes/disk, 1.31M bytes/surface, 8192 bytes/track, and 256 bytes/sector. Transfer rate is 500K bits/s. Rotational speed is 360 rpm, recording density is 9908 bpi, flux density

is 9908 fci, track density is 192 tpi. There are 160 cylinders, 320 tracks, two read/write heads, and the encoding method is MFM. \$333. **Address:** Drivetec, 2140 Bering Dr., San Jose, CA 95131 (408-942-1515).

Another Super Floppy. The Amlyn 5460 5M-byte minifloppy disk drive is compatible through an interface with the Shugart SA460 but appears as five SA460 drives to the controller and software. This is because the 5460 uses a package containing five 5¼" single-sided diskettes having a formatted capacity (512 byte sectors) of 4.1M bytes, 819.2K bytes/surface, 5120 bytes/track, and a transfer rate of 250K bits/second. Adjacent track-to-track time is 3 ms, with an average access time of 95 ms. The physical dimensions are 3.25"H, 5.75"W, 8"D, and a flush depth of 10.45". **Address:** Amlyn Corp., 2450 Autumnvale Drive, San Jose, CA 95131 (408-946-8616).

IBM PC Storage Product. The Quick Disc is a semiconductor memory that appears to the IBM PC as an additional disk drive. It may be configured for a permanent storage file, or as a cache buffer in combination with existing Winchester and floppy drives. In the cache mode, frequently referenced sectors from the disk are retained in buffers allowing rapid access (512 bytes/0.0015 second) for each reference after the first. Typical performance is claimed to be 120 times faster than a Winchester and 200 times more than a floppy drive. The models range from 128K bytes to 4M bytes and it either fits on top of the PC or can be located up to 100 feet away. **Address:** CTC Electronics, 2237 Colby Ave., Los Angeles, CA 90064 (213-477-4283).

IEEE-488 for Apple. The APL-488CT requires a single slot in an Apple III and provides full IEEE-488 Standard 1978 instruments and peripheral controlling capabilities. It is SOS driver compatible, allowing PRINT # and INPUT # statements to control the bus function. All high-level languages are supported. Data rates are to 50K bytes/second, the diskette contains the SOS driver file, and the system supports IEEE-488 subsets C1 C2 C3 C4, and C25. \$495. **Address:** Innovative Peripheral Systems, 4060 Morena Blvd., San Diego, CA 92117 (619-270-8600).

Super Diskette. Called the Isomax and developed by the Spin Physics unit of Eastman Kodak Co., this 5¼" floppy

diskette can store up to 10 megabytes using perpendicular recording. It operates at up to 40,000 flux changes/inch and track densities from 96 to 200 tpi. The isotropic cobalt-enhanced magnetic particles allow up to 100,000 flux changes/inch. Several companies are presently experimenting with using this new floppy diskette.

Drive Tester. The Model 1024 handheld, floppy disk drive tester can be used to check out micro, 5¼", and 8" drives without the use of a computer. The indicators show track, write protect status, track 00, ready, index pulses, sector, separated data and clock (single density), and the presence of clock and data (dual density). Controls allow for write data frequency, provide data to drive, provide write enable to drive, step head to track 00, reset track counter to 00, step head away from track 00, control speed of stepper motor, enable motor/head load, and select the side in dual-sided drives. Size is 3.5" × 6.5" × 1.6"; weight, 8 oz. \$199. **Address:** Teaco, Inc., PO Box E, Michigan City, IN 46360 (219-874-6234).

QX-10 Modem. The CR-103 Communicator modem is a 300-baud modem for the Epson QX-10 computer. It offers automatic answering, automatic dialing, and one-key redial. Also includes a speaker for audio monitoring the phone

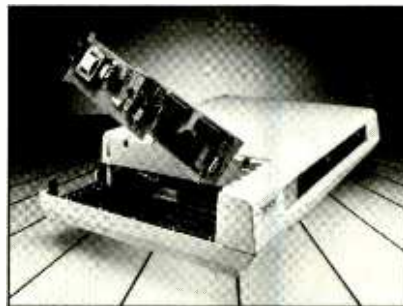

line. Tandem dialing allows using the modem with MCI or Sprint phone systems. It also features an 18-second automatic disconnect, touch-tone, pulse dialing, and loop-back testing for self-test. \$159.95. **Address:** Comrex Int. Inc., 3701 Skypark Drive, Torrance, CA 90505 (213-373-0280).

Sinclair/Timex Work Station. The Control Center is a desk-type work station for Sinclair/Timex computers. It includes an on/off switch, and accommodates all brands and sizes of RAM packs. Software tapes can be stored in special pockets and openings are pro-

vided for both printer and cassette deck hookups. It is 35/8" high, 20" long, and 14 1/2" wide, and is constructed from high-impact molded polystyrene. It will accommodate a 13" video monitor angled for optimum display. \$29.95. **Address:** Timeworks Inc., 405 Lake Cook Rd., Building A, Deerfield, IL 60015 (312-291-9200).

Software

IBM-PC Tutor. Your Personal Computer Tutor is an interactive tutorial that teaches the basic skills required to operate the IBM PC. The tutorials consist of modules covering such topics as Introduction to the Computer, How to Use the Keyboard, Information Storage, DOS commands, How the Computer Works, What is Software, and so forth. The seven tutorials are fully interactive and there is a question and answer section at the end. They appear in color when a color monitor is used. The program requires DOS and 64K and will work with IBM "look alikes" such as Columbia and Compaq. Three games are included that will support color. **Address:** TexaSoft Inc., 3415 Westminister, Suite 100, Dallas, TX 75205 (Tel: 214-369-0795).

Apple Forth. FORTH-79 Ver. 2 is available for Apple II/II+/IIE machines. Other formats supported include CP/M 1.4 and 2.x, Micropolis Mod II, Vector Graphics, NorthStar, Cromemco, Heath/Zenith, Osborne I, Kaypro II, Xerox 820, and TRS-80 Model II. FORTH-79 meets all provisions of the FORTH-79 Standard and standard programs are portable. Base system includes a screen editor, macroassembler, string package, 32-bit integer arithmetic, and over 200-page tutorial and reference manual. Floating point available for all formats, HIRES for Apple and NorthStar Advantage. \$99.95 to \$139.95. **Address:** MicroMotion, 12077 Wilshire Blvd., #506, Los Angeles, CA 90025 (Tel: 213-821-4340).

TRS-80 to IBM PC. The files transfer program allows transferring files from a TRS-80 Models II, 4, 12 and 16 to an IBM PC or XT. Included is a communications program for the PC as well as a means of connecting two systems. The file transfer will work with any file in ASCII, embedded control codes, compressed binary formats, encrypted data bases, high-level languages, spreadsheet

data, word processor files, etc. File concatenation is provided. Baud rates supported are 110 to 9600. **Address:** Personal Computer Products, 1400 Coleman Ave., Suite C-18, Santa Clara, CA 95050 (408-988-0164).

Hard Disk Utilities. The BAKUP Package is a set of machine-language programs for Z80-based computers using CP/M 2.2. The package includes utilities for making backup copies of hard disk files on floppies, automatically fragmenting files too large for one disk into separate disks, and a utility for restoring files archived on floppy disks back to the hard disk. It also provides a method to determine the archive status of files and to display an extended disk directory of the archive status of all files. Another utility provides for verified disk-to-disk file copying capabilities. Several other useful utilities are provided. \$50. **Address:** Computer Dynamics, Inc., 105 S. Main St., Greer, SC 29651 (803-877-7471).

TRS-80 Graphics. Draw is a graphics and text editing package that requires the use of a TRS-80 Model III and a Grafyx Solution Board (allows 98,304 points in a 512 x 192 matrix). The



cursor is moved with arrow keys and one-letter commands. You can set, clear, or complement points, lines, circles, or boxes. The point size can be changed as desired, or reverse or shifted video is allowed. Sections of the screen can be filled with patterns. The finished picture can be saved on disk/tape or printed. \$39.95. **Address:** Micro Labs Inc., 902 Pinecrest, Richardson, TX 75080 (214-235-0915).

New Apple DOS. ProDOS provides increased compatibility between Apple II and Apple III computers. It uses the hierarchical file structure, file-naming conventions, and data formats of the Apple III SOS. Both files and data media are interchangeable between the two Apples. It also frees the Apple II from the physical limitations of the 143K-byte Apple II drive, and can recognize

any storage device using Apple protocol. The Unix-like file structure allows managing larger numbers of files on larger storage devices. ProDOS supports interrupt-driven processing and will also support the upcoming AppleNet local area network. **Address:** Available from most local Apple dealers or Apple Computer Inc., 20525 Mariani Ave., Cupertino, CA 95014.

VIC Programs. The MicroBase is a data base and mailing label/report generator for the VIC-20/64. It allows up to 12 fields per record, up to 80 characters per field, and up to 176 characters per record. Fields can be sorted by alpha, numeric, or character match parameters. It can also print mailing labels, reports, etc. \$29.95 for cassette, \$34.95 for diskette. **Address:** Arfon Micro, 111 Rena Dr., Suite C, Lafayette, LA 70503 (318-988-2478).

TRS-80 Info System. Exec-1 for the TRS-80 Model 2, 12 or 16 is an information system consisting of a mailing list of names, addresses, and telephone information; a letter/memo for printing memos and letters; a record inventory utility; a check management system with tax code; a stock security system; a personal finance application; and an appointment manager. \$199. **Address:** Micro Architect Inc., 6 Great Pines Ave., Burlington, MA 01803 (617-272-5658).

IBM PC Telephone Communication. The PC-to-PC 4800 Baud is software that allows users of IBM PC's to communicate at 4800 baud over voice-grade telephone lines. This is about one type-written page per second. An automatic error recovery feature ensures that any data transmission errors will be immediately detected and corrected. The use of this system requires both transmitting and receiving PC's to incorporate this firm's software and PC Express integrated software/hardware communications package. \$350. **Address:** Intelligent Technologies International Corp., 151 University Ave., Palo Alto, CA 94301 (415-328-2411).

Wordprocessor Graphics. Wordplot incorporates graphic data in a word-processor text file. It edits the data, produces a grid, automatically scales the data, and then creates a word-processor compatible text file. It is available for the IBM PC, TRS-80, and Apple IIe. **Address:** ATC Software, RT 2, BX 448, Estill Springs, TN 37330 (205-837-4718). ◇

NTS Electronics

Learn Robotics, Microcomputers, Microprocessors, Digital Video, Test Equipment and more with NTS INTRONIC™ home training. Courses include state-of-the-art equipment, lessons and texts to make your hands-on programs exciting and down-to-earth practical.

HERO 1 is included in two courses, one basic and one advanced. You'll cover principles of industrial electronics, microprocessor troubleshooting, fundamentals of mechanics, and robotic applications in industry. You'll learn analog and digital skills, radio control, fluidic, pneumatic and servo-mechanisms, as well as computer interfacing and robotic programming. HERO 1, complete with arm, gripper and speech synthesis board, is a fully self-contained electro-mechanical robot—the featured unit in the most exciting training programs ever offered in home study.

NTS Intronic Training is a carefully developed and tested learning system providing a thorough intergration of advanced electronic hardware with modern lesson texts. The relationship between theory and practical applications is made clear through the hands-on experience of building and assembling kits of state-of-the-art equipment. Courses include a wide variety of test instruments, both digital and analog, as well as other units not shown here. And, depending on the NTS program you select, you can earn up to 30 CEU credits for successful completion. Our full-color catalog has complete details. NTS has taught industrial skills for over 78 years—a record that has no equal.



Training.....

FIRST WITH TOMORROW'S TECHNOLOGY

1. **Advanced "Z Chassis" NTS/HEATH "Smart Set"** with computer space command remote control and space phone. Originate or receive telephone calls through this set and the number appears on the screen-store your police and other emergency numbers into memory which may be recalled and auto-dialed at any time. Traditional and incomparable picture quality. Unit has Quartz Controlled Tuning, 178 channel capacity, remote antenna switch accessory for reception of VCR, VDR, Broadcast, Cable, Video Games, and Personal Computer Input (no cable change) plus computer-controlled color. Featured in all-new Video Technology Course.

2. **NTS/HEATH HN89A Microcomputer** is included in two programs. This famous and reliable unit features Floppy Disc Drive, 48K Memory on Board, CRT Terminal with its own Z-80 Processor, and standard keyboard as well as Numerical Input Keyboard. The growing importance of computer knowledge and skills have made these programs increasingly significant. The experience gained in assembling these kits is invaluable in the understanding of computer troubleshooting skills.

3. **NTS Microprocessor Trainer** is included in our Industrial and Microprocessor Technology Course. It is a portable unit, contained in a convenient high-impact carrying case. Hardware/Firmware includes Monitor Operating System-Expandable User Memory-User Experimental On-Board Section-Breakpoint Editor-Single Step Trace-Cassette I/O.

NO OBLIGATION

NO SALESMAN WILL CALL



TECHNICAL TRADE TRAINING SINCE 1905
Resident and Home-Study Schools
4000 So. Figueroa St., Los Angeles, CA 90037



Use the mail-in card or fill out and mail the coupon. Indicate the field of your choice. (One, only please.) FREE full color catalog will be sent to you by return mail.

NATIONAL TECHNICAL SCHOOLS Dept. 205-103
4000 South Figueroa Street, Los Angeles, CA 90037

Please send FREE color catalog on course checked below:

- | | |
|---|---|
| <input type="checkbox"/> Robotics | <input type="checkbox"/> Computer Electronics |
| <input type="checkbox"/> Digital Electronics | <input type="checkbox"/> Video Technology |
| <input type="checkbox"/> Auto Mechanics | <input type="checkbox"/> Home Appliances |
| <input type="checkbox"/> Air Conditioning/Solar Heating | |

Name _____ Age _____

Address _____

Apt. _____ City _____

State _____ Zip _____

Check if interested in G.I. information.

Check if interested ONLY in classroom training in Los Angeles

A New Approach To Tape Azimuth Alignment

By Len Feldman

HAVE you ever wondered why commercial prerecorded cassette tapes don't always sound as good on your cassette deck as the tapes you record yourself on the same deck? Many experts place the blame on poor high-speed tape duplication, which, indeed, can be part of the problem. Frequently, however, the real fault is poor orientation of the playback head with respect to the recorded tracks on the tape.

At the very slow 1 $\frac{7}{8}$ -ips speed at which cassette tapes travel past the deck's heads, the longitudinal tape length occupied by a single alternation of a high-frequency signal is extremely small. One full cycle (two alternations) of a 20-kHz signal, for example, takes only 0.00005 second to pass the head. In this extremely short time, the tape has actually traveled only $0.00005'' \times 1.875''$, or $0.0000938''$. That's only 93.8 millionths of an inch! It's obvious that a tape head wouldn't have to be tilted very far from perfect perpendicularity to the direction of tape travel for the head gap to cover the entire length of a single 20-kHz cycle. Should this occur, the positive- and negative-going alternations of the cycle (or, more correctly, the two patterns of magnetization on the tape) would cancel each other and no 20-kHz output would be available from the playback head. An exaggerated representation of this condition is illustrated in Fig. 1.

The Table details how much attenuation (reduction in signal amplitude) would occur during playback of a cassette tape when head azimuth error varies from as little as 3 minutes of arc (0.05°) to as much as 15 minutes of arc (0.25°) for frequencies between 1 and 20 kHz. As you can see from the entries in the Table, once frequencies begin to become attenuated, the decrease is more and more rapid with increasing frequency.

If the record and playback heads in a cassette deck are misaligned with respect to each other by as little as 0.2°, a 10-kHz signal will be attenuated by slightly greater than 3 dB. For the same degree of misalignment, a 15-kHz signal will be down by 7.77 dB, while a 20-kHz signal will be attenuated a full 18.6 dB!

Needless to say, proper head alignment is of critical importance at the higher frequencies.

Which Head to Align? Tape head azimuth alignment isn't new. For years, professional open-reel tape decks have had facilities that permit users to periodically adjust the record head with respect to the fixed, factory-aligned playback head. However, only a few manufacturers of three-head cassette decks provide the same facilities in their products. (With cassette decks that have common record/play heads, azimuth alignment isn't a problem, since the same head both records and plays back the tape and is by definition properly aligned. The problem arises only when playing back tapes recorded on other decks.)

Nakamichi was first to provide the user with adjustable record-head azimuth alignment facilities and the first to introduce a deck that performed the adjustment automatically. In both cases, only recording head azimuth was made adjustable, with playback head azimuth fixed at the factory, using a precision reference. This guarantees that tapes recorded on the deck could be played back with correct azimuth alignment on the same deck. Tapes recorded on any other deck with correct alignment could also be played back with no loss in signal information.

Tapes recorded without correct azimuth alignment—unfortunately true of many commercially prerecorded tapes—will suffer the degree of high-frequency attenuation discussed above. The plot thickens with auto-reverse cassette decks. If you were to attempt to play a tape on such a deck, even if the record head is perfectly aligned with the

play head during the forward pass of the tape, when the tape moves in the opposite direction it follows a slightly different path and adjustable record head azimuth doesn't solve the problem.

From the foregoing, the obvious solution to the azimuth problem is to have the playback—not the record—head adjust automatically. This could be accomplished in much the same manner as Nakamichi uses in its automatic record head azimuth alignment system, using a 400-Hz tone recorded in-phase on both tracks. During playback, the phases of the right and left channel output signals are compared and any difference is fed to a circuit that automatically adjusts the record head until both signals are in-phase. The drawback is that there's no universal effort to have these test signals on all tapes to be played back. Furthermore, this approach doesn't take into account misalignments that occur during playback from one end of the tape to the other; such changes wouldn't be corrected by the Nakamichi test-tone/phase-comparison system.

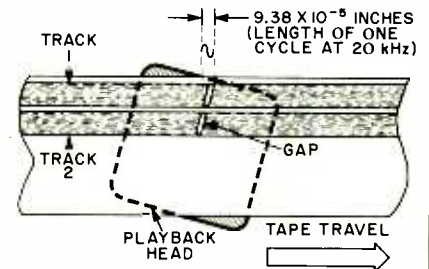

Fig. 1. With severe azimuth error, high frequencies on tape can be totally cancelled by tilted tape playback head.

ATTENUATION OF HIGH FREQUENCIES AS A FUNCTION OF AZIMUTH ERROR

Azimuth Error

(minutes)	3	6	9	12	15
(degrees)	0.05	0.10	0.15	0.20	0.25

Frequency (kHz)

	Loss (dB)				
1	0.00	-0.01	-0.02	-0.03	-0.04
2	-0.01	-0.03	-0.06	-0.11	-0.18
4	-0.03	-0.11	-0.26	-0.46	-0.73
6	-0.06	-0.26	-0.59	-1.05	-1.67
8	-0.11	-0.46	-1.05	-1.91	-3.07
10	-0.18	-0.73	-1.67	-3.07	-5.03
12	-0.26	-1.05	-2.45	-4.59	-7.77
15	-0.40	-1.67	-3.97	-7.77	-14.6
17	-0.52	-2.17	-5.27	-10.8	-25.5
19	-0.65	-2.75	-6.85	-15.3	—
20	-0.73	-3.07	-7.77	-18.6	—

A New Approach. Because Nakamichi was the pioneer in cassette-deck azimuth adjustment, it seems only natural that this company should once again devise a unique and realistic solution to the problem. In a recently introduced cassette deck dubbed the "Dragon," the company introduced the revolutionary Nakamichi Auto Azimuth Correction (NAAC) system, which promises to solve the problem once and for all. The key element of the NAAC system is a unique playback head that "reads" two signals from *each* track.

Under the Nakamichi NAAC system, no special test signals are used; rather, actual *program material* signals are used. Hence, the phase difference between the signals in the left and right channels cannot be compared, since the two channels don't carry identical program information, let alone in-phase signals. Within the same channel, however, if two gap/coil combinations read the contents of a given channel, the signals will be identical and, if azimuth alignment is perfect, *in-phase*.

Operation of the NAAC system is illustrated in Fig. 2. A dual-core playback head "reads" two signals from the same track. One signal corresponds to information on the upper half of the track, the other to information on the lower half. Each signal is then passed through a bandpass filter, which selects the portion of the spectrum that's most appropriate for phase comparison.

Because very-low-frequency signals won't differ appreciably in phase, even if azimuth is off, they cannot be used as a sensitive phase-comparison indicator. Nor will very-high-frequency signals meet the proper criteria, since they might appear to be in-phase when, in

fact, they could be out-of-phase by one or more complete cycles.

The filters represented in Fig. 2 were designed to avoid the frequency extremes but to provide sufficient bandwidth to ensure a high probability of in-band signal with normal program material. It's important at this point to emphasize that Nakamichi's NAAC system operates with actual *musical program* material, read by the split head during playback of *any* tape, whether recorded on the same or any other cassette deck. Since no special test signals are needed for system operation, NAAC is virtually universal in application.

Having been filtered, the signals pass through squaring circuits and then through a precision phase comparator that extracts any phase error that exists between them. Any error signal generated at the output of the phase comparator is amplified and used to drive a servo motor that readjusts orientation of the *playback* head until the error disappears.

The system is designed so that when power is first applied to the cassette deck, the playback head automatically orients to a normally correct position, as it might be in a standard fixed-head cassette deck. As soon as any program material is read by the two-part playback head, the NAAC system comes into play and continuously tracks azimuth status and readjusts head orientation for as long as a tape is being played. When program material lacks information in the frequency range of the phase-comparator circuit, playback head orientation "freezes" in the last adjusted position until new program material is sensed.

More Details. Development of NAAC made it possible for Nakamichi to design an auto-reverse transport function into the Dragon that optimally plays back tapes in both directions. The system guarantees full frequency-response reproduction from any tape that has the potential to deliver such reproduction, regardless of whether the tape was recorded on the Dragon or any other cassette deck.

In the interesting technical paper concerning development of the NAAC system and other features incorporated into the Dragon, Nakamichi points out that errors in response, such as those caused by incorrect azimuth, are further accentuated when sliding-band noise-reduction systems (Dolby B and C and even linear-companding systems like the dbx) are used. With such noise-reduction systems becoming increasingly popular, it becomes even more important that proper azimuth be maintained. Nakamichi's solution to the problem is, as usual, a most sophisticated and inventive one.

Future Outlook. Interestingly, even as the audio industry is about to enter the digital age, researchers are still working on improving the analog cassette deck. This is very reassuring, since the cassette deck is the one analog component likely to survive as a program source even after digital discs have supplanted conventional LPs. Hopefully, the lead taken by Nakamichi in optimizing tape head azimuth alignment will be emulated by other manufacturers of high-quality cassette and even open-reel decks—even if this means signing a licensing agreement with the inventors of the NAAC system. ◊

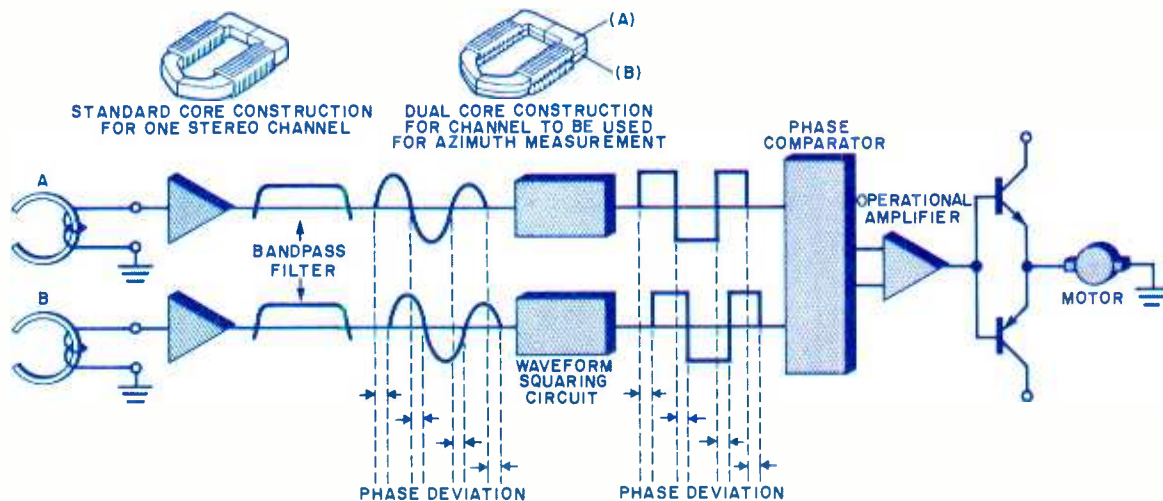

Fig. 2. Block diagram of automatic playback head azimuth correction system.



Inside Apple

Vol. 1, No. 3

Apple's new Monitor II. A sight for sore eyes.

If you've been using a TV as a monitor, perhaps you can get a friend to read this for you:

Apple's brand new Monitor II will improve your vision.

It features all the latest ergonomic improvements in monitor technology.

For example:

Studies have shown that the leading cause of eye fatigue for computer users is lack of contrast between the displayed characters and their background.

So we designed the Monitor II around a high contrast green phosphor CRT that provides an extremely dark background. That means you can read text at a lower brightness. And that means you can be more productive — working longer and more comfortably.

Toward that same end, we also gave Monitor II a tilt screen. So you can angle it perfectly for your working position, without scooting your chair around or sitting on phone books.

And we made that screen antireflective to reduce glare from ambient light.

Monitor II also features a high bandwidth video amplifier and a high tolerance linearity circuit. The former keeps characters from smearing

on the screen and eliminates the annoying "ghosts" left by a fast moving cursor. The latter keeps characters crisp, legible and prevents "keystoning" right up to the edges of the display. Both add up to superior display of 80-column text and extremely

accurate graphics.

Designed as the perfect system partner for the Apple® IIe Personal Computer, Monitor II requires no monitor stand. It's a perfect fit, aesthetically as well as technically. So it's pleasing to the eye even when it's turned off. See for yourself.

At your local authorized Apple dealer.

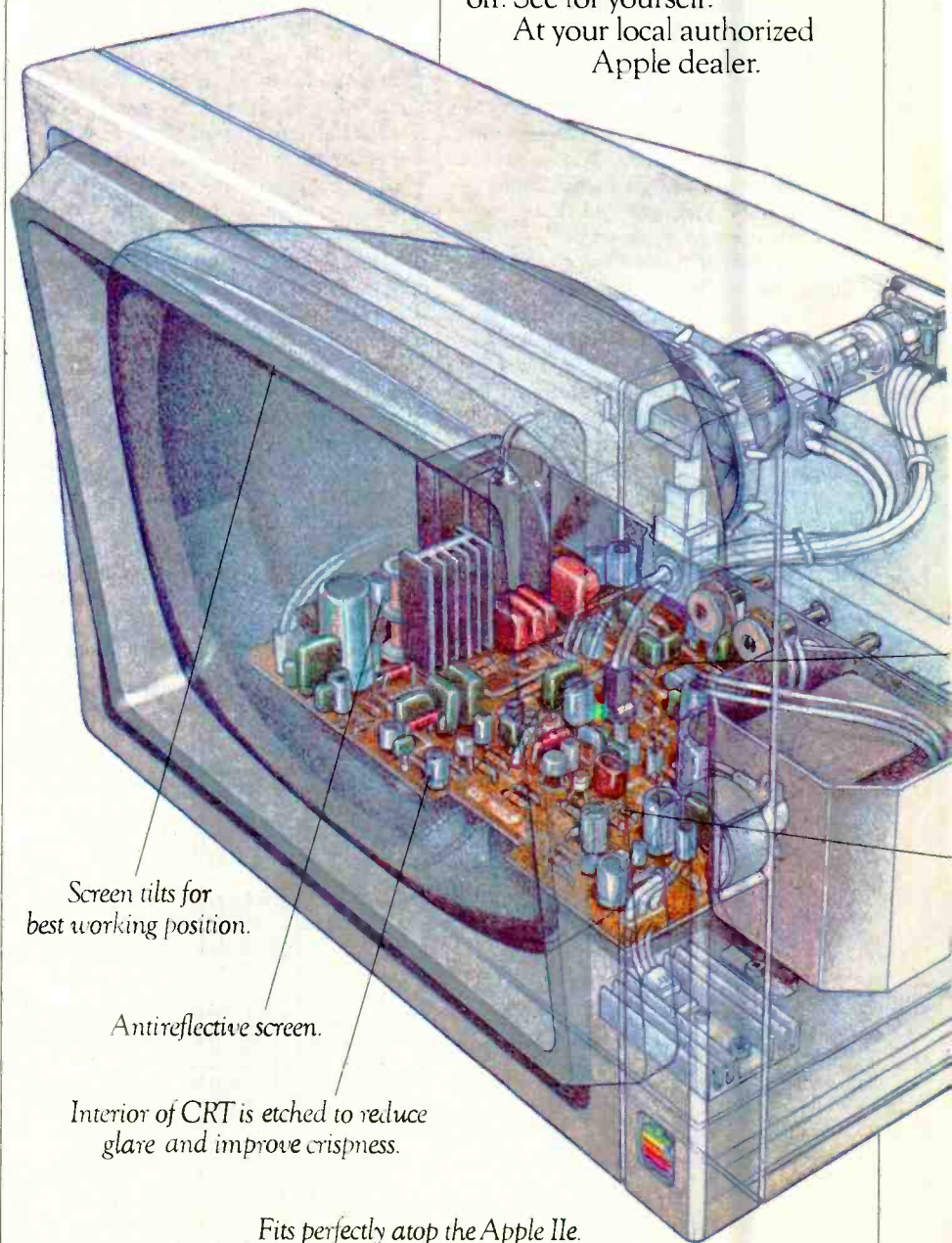

Screen tilts for best working position.

Antireflective screen.

Interior of CRT is etched to reduce glare and improve crispness.

Fits perfectly atop the Apple IIe.

Now Apple plots color.

Since color graphics are becoming ever more important in business, we've been hearing more and more calls for a color plotter as reliable as an Apple.

Here it is:

Apple's new Color Plotter can generate all kinds of presentation graphics, engineering drawings or anything else you have to illustrate in up to eight brilliant colors.

And it can perform its art on any size paper up to 11" x 17". Or, with optional transparency pens, it can draw right on transparent film for overhead projection.

Measuring just 4.8"H x 16"W x 12"D, it's the smallest four-color, wide bed color plotter you can buy — about half the size of conventional flatbed plotters. So it takes up less space on your desk and can easily be

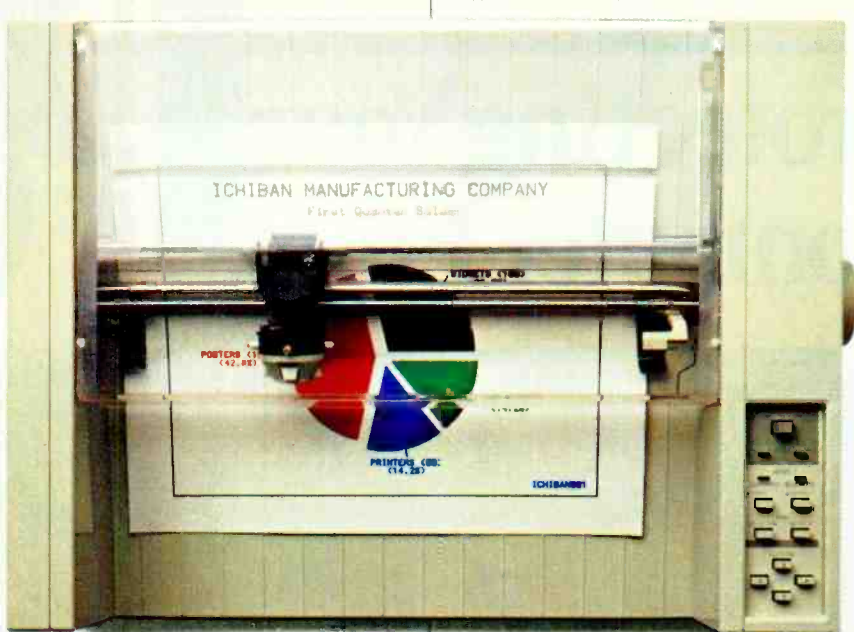

moved to someone else's desk.

There are two color plotter accessory kits to choose from to assure a perfect marriage with your Apple II or IIe, or Apple III.

Each kit comes with eight color pens — red, blue, green, black, burnt orange, gold, violet and brown. Plus a starter package of plotter paper. Plus all the manuals, documentation and cables appropriate to

your particular kind of Apple. So you can get up and coloring right away.

Apple also offers a complete selection of 24 different pen packages — so you can choose whatever colors you need in a variety of widths for a variety of applications and media types.

As you might expect, all of the above is available at many of our authorized Apple dealers.

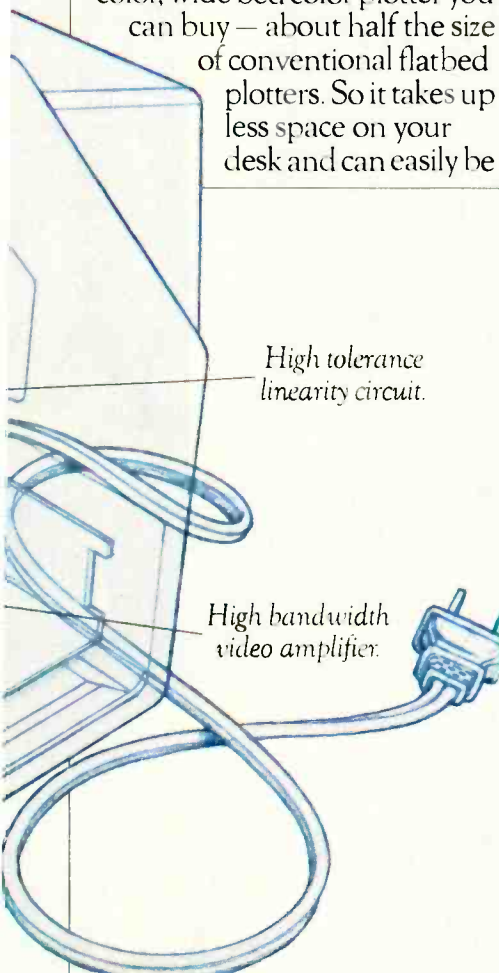

Carry on with AppleCareSM Carry-In Service.

No matter how long you've owned your Apple system, you can now get a long term service contract at a very reasonable cost.

AppleCare Carry-In Service is a service plan that will cover most Apple-branded components in your system for one full year.

It covers an unlimited number of repairs and is honored by over 1500 authorized Apple dealers nationwide.

Apple-trained technicians assure you of the highest quality service, fast — in most cases less than 24 hours.



AppleCare Carry-In Service is ideal for anyone who needs to know ahead of time the cost of maintenance for their system.

So check out the details — you'll find it's the lowest cost health plan an Apple can have.

Protecting Your Computer From POW



THE QUICK BROWN FOX
JIMPEZ 04 THE LAKY DUK

POWER-LINE

Disturbances

How ac line surges, brownouts, spikes, and noise can cause computer "crashes" and data errors

*By Francis J. Stifter**

AC power line problems haunt the personal computer user in many subtle ways. Program difficulties are sometimes the result of programmer ineptitude, but they can also be traced to ac power irregularities. For example:

- That ingenious game that you've just created develops bugs after a few perfect copies have been printed for the computer club. A computer error? More likely, it's caused by interaction over the power line between the printer and computer.
- Your computer had major repair work a few months ago, but it seems some minor chip fails every couple of weeks. Poor computer design? Probably not. Damage from a high-voltage spike may have destroyed some components immediately, while degrading others to the point where they failed when the next minor power spike occurred.
- On a hot day, even with an air conditioner running, your computer "acts up." Heat-sensitive equipment? Unlikely. Heavy air conditioning loads accompanying summer heat often give rise to brownouts—evidenced by temporary low voltage conditions and increased power-line disturbances.

Most computer manufacturers design their equipment to operate with the ac power normally supplied by your friendly neighborhood utility. However, abnormal power conditions occur on occasion, causing grief, despair and sadness in computer country. In this article, some of the most common power-related computer problems will be

examined and ways of alleviating them will be shown.

Power Line Noise and Hash. Computer "glitches," as contrasted to outright equipment damage, are usually caused by electrical system noise—which travels under many different guises. On TV receivers, power line noise is frequently (and erroneously) called "snow." On radios, it is sometimes called "static." Electrical noise is also often referred to as "hash," "power glitches," or "power pollution." Hash was a term used in the early days of radio and audio to describe continuous, dense noise, and it is still used by some engineers and technicians for particularly oppressive noise conditions.

Electrical noise is impressed on the power lines in several ways. These noise sources can be classified as RFI (radio frequency interference), EMI (electromagnetic interference), and conducted interference. Regardless of the source or the mechanism through which the interference is impressed on the line, the net effect on computer behavior spells trouble.

Power-line noise can scramble the output of a computer, whether it's to a disk drive, printer, or other peripheral. Figure 1 shows what might happen if such noise got mixed in with the output to a printer.

The reason for the garbled characters is that the binary representation of characters is nothing but a string of 0s and 1s and changing just one of those digits to the other one changes the character. For example, the binary representation



*President
Electronic Specialists, Inc.

"I built this 16-bit computer and saved money. Learned a lot, too."

Save now by building the Heathkit H-100 yourself. Save later because your computer investment won't become obsolete for many years to come.

Save by building it yourself. You can save hundreds of dollars over assembled prices when you choose the new H-100 16-Bit/8-Bit Computer Kit – money you can use to buy the peripherals and software of your choice.

H-100 SERIES COMPUTER SPECIFICATIONS:

USER MEMORY:
128K-768K bytes*

MICROPROCESSORS:
16-bit: 8088
8-bit: 8085

DISK STORAGE:
Built-in standard
5.25" disk drive,
320K bytes/disk

KEYBOARD:
Typewriter-style,
95 keys, 13
function keys,
18-key numeric pad

GRAPHICS:
Always in graphics mode.
640h/225v resolution;
up to eight colors
are available**

COMMUNICATIONS:
Two RS-232C Serial
Interface Ports and
one parallel port

DIAGNOSTICS:
Memory self-test
on power-up

AVAILABLE SOFTWARE:
Z-DOS (MS-DOS)
CP/M-85
Z-BASIC Language
Microsoft BASIC
Multiplan
SuperCalc
WordStar
MailMerge
Data Base
Manager
Most standard
8-bit CP/M
Software

*128K bytes standard. **Optional.

The H-100 is easy to build – the step-by-step Heathkit manual shows you how. And every step of the way, you have our pledge – "We won't let you fail." Help is as close as your phone, or the nearest Heathkit Electronic Center.

And what better way to learn state-of-the-art computing techniques than to build the world's only 16-bit/8-bit computer kit? To run today's higher-speed, higher-performance 16-bit software, you need an H-100. It makes a significant difference by processing more information at faster speeds.

Dual microprocessors for power and compatibility. The H-100 handles both high-performance 16-bit software and most current Heath/Zenith 8-bit software.

Want room to grow? The H-100's standard 128K byte Random Access Memory complement can be expanded to 768K bytes – compared to a 64K standard for many desktop computers.

And the industry-standard S-100 card slots support memory expansion and additional peripheral devices, increasing future upgradability of the H-100.

High-capacity disk storage, too. The H-100's 5.25" floppy disk drive can store 320K bytes on a single disk. The computer also supports an optional second 5.25" and external 8" floppy disk drives. And an optional multi-megabyte internal Winchester disk drive will be available in the near future.

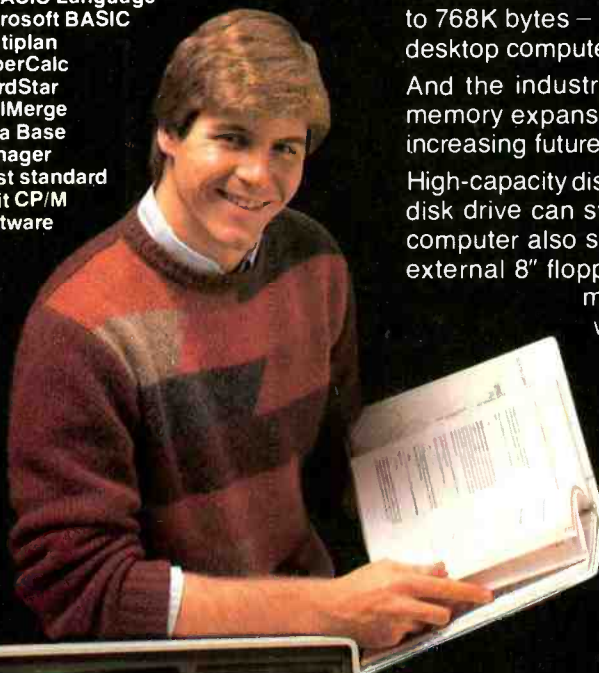

*The H-100 gives me the
for my computer dollar!*



Critical circuits are pre-assembled, making the H-100 easier and faster to build!

Want beautiful high-resolution graphics? You can create extensive charts, drawings, graphs and symbols to meet your needs — using the H-100's bit-mapped graphics and its 640 x 225 pixel video display.

The H-100 gives you total communications flexibility. Three interface ports let you plug in dot-matrix and letter-quality printers, as well as other peripherals.

Compare the H-100's exceptional capabilities with other desktop computers:

COMPUTER:	Heathkit H-100	IBM Personal Computer	Apple II
MICROPROCESSORS:			
16-bit:	8088	8088	—
8-bit:	8085	—	6502
RANDOM ACCESS MEMORY:			
Minimum:	128KB	16KB	128KB
Maximum:	768KB	576KB	256KB
FLOPPY DISK STORAGE:			
Per Diskette:	320KB	320KB	140KB
Maximum Internal:	640KB***	640KB	140KB
8" Floppy Support:	Standard	—	—
EXPANSION SLOTS:	Five S-100 (four available)	Five (three available)	Eight
I/O PORTS:			
Parallel:	1	Optional	—
Serial:	2	Optional	—
VIDEO DISPLAY:			
Line Columns:	25 x 80	25 x 80	24 x 80
Pixels Colors:	640 x 225 (8 colors)	640 x 200 (2 colors) 320 x 200 (4 colors)	560 x 192 (16 colors)
OPERATING SYSTEMS:	CP M-85, Z-00S (MS-00S)	CP M-8E, PC-00S (MS-DOS), UCSD P-System	Apple SOS

Information current as of 6/31/82. *** External disk storage available soon.

Learn by building. When you build and operate the H-100, you learn more about this sophisticated computer system and its unique 16-bit/8-bit software capabilities.

Learn from outstanding documentation. One of the most important parts of any computer system is documentation — and Heathkit documentation is among the industry's best. Our instruction and operating manuals are fully detailed, in the world-famous Heathkit tradition.

Learn by doing. Many of our software programs come with a complete set-up and operating manual. More complete than most other software documentation, each manual not only tells you what the program will do — it shows you the easiest way to accomplish each task.

We back you all the way. With Heathkit computer products, technical assistance and expertise is as close as your telephone — or the nearest Heathkit Electronic Center.† Complete technical assistance and service is available at over 60 locations nationwide.

Buy from a leader. When you choose a Heathkit computer, you get the backing and reliability of the world's leader in quality electronic kits for over 50 years! You can count on us for quality, service, reliability and value — at kit prices that give you more computer for your dollar!

See the H-100 in action. Visit your nearby Heathkit Electronic Center, which

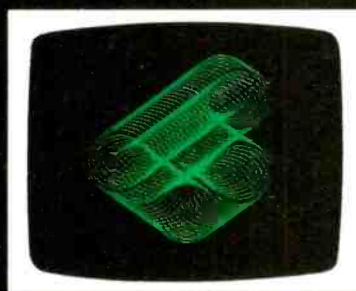

Always in graphics mode, you can control each of the H-100's 144,000 screen dots! (Color graphics optional)

has the world's first 16-bit/8-bit computer kit, peripherals and software programs on display. See your telephone white pages for the nearest store location. Or mail the coupon today for a FREE, full-color Heathkit computer catalog.

CLIP COUPON AND MAIL TODAY TO: Dept. 310-104
Heath Company, Dept. 310-104
Benton Harbor, MI 49022

Please send my FREE Computer Catalog, with details on the new 16-bit/8-bit H-100 Computer Kit, today!

Name _____

Address _____

City _____ State _____

CP-218R Zip _____

† Heathkit Electronic Centers are units of Veritechnology Electronics Corporation. Heath Company and Veritechnology Electronics Corporation are subsidiaries of Zenith Radio Corporation. Prices, product availability and specifications are subject to change without notice.

Heathkit
Heath
Company

Circle No. 28 on Free Information Card

www.americanradiohistory.com

in the ASCII system for the letter A is 100 0001 (65 decimal, or 41 hex). If a noise spike changed the binary to 100 1001, the character would be an I (73 decimal, 49 hex). Thus, noise that gets into a computer system can easily be interpreted as data and becomes confused by the system with the data that was originally there.

Of course, noise can introduce an unwanted bit anywhere in the processing train. Commands may be modified, intermediate computations may be affected, or instructions from an incorrect memory address may be retrieved. Errors can be trivial or serious; they may merely be a nuisance in a game situation or they may gravely affect a company's payroll figures.

Noise typically enters a computer through its power supply. A bare bones power supply system is shown in Fig. 2. Ac power is applied to the primary

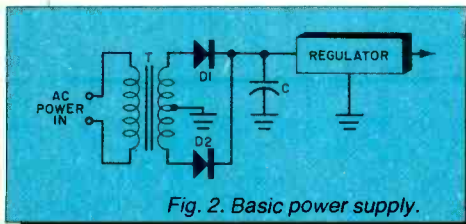

Fig. 2. Basic power supply.

winding of transformer *T*. The secondary voltage is rectified by diodes *D1* and *D2*, and a high-value electrolytic filter capacitor, *C*, is used to smooth the ripple. Rectified, filtered dc voltage is passed through a regulator, holding voltages to values required by the computer circuits. A portion of any noise impressed on the power line's sinewave voltage will pass through the transformer and rectifiers when they conduct. Electrolytic capacitors used for filtering have a very large series inductance, effectively rendering the capacitor useless for filtering high-frequency noise. Regulators, being low-frequency devices, may pass some of this noise directly through to the microcomputer's dc supply system. Once there, an occasional noise pulse may alter the state of a logic circuit, creating a computer error.

Modern computers have input-noise filtering and spike suppression, so most power-line noise is attenuated sufficiently to prevent logic errors. However, computers located in severe-noise environments may encounter some interference. Unfortunately, some homes contain enough appliances, typewriters, and tools to also qualify as severe environments. Offices and factories are even more likely to present a severe power pollution environment.

Radio frequency interference (RFI) that adversely affects computers can be

caused by CB radios, police or taxi radios, broadcast radio and TV stations, or other broadcasting services. RFI can also originate from medical diathermy equipment, neon or arc type lights, and welding shops. Spherics, such as lightning or electrical discharge between clouds of sand or snow, also generate considerable RFI. Motors, electric switches, and other devices that interrupt current usually generate RFI, although only very large motors or power station switching gear generate enough radio frequency energy to pose interference problems for computers.

Acting as antennas, the power company's lines pick up the r-f interference and conduct the energy in all directions. Some of this interference ultimately finds its way to the wall socket behind your computer desk. Any radio-frequency energy that passes through the computer's input filter and transformer may be responsible for changing logic states in the computer circuits.

RFI below about 6 or 8 MHz (which includes the entire AM broadcast band and extends well beyond it) can directly affect computer logic gates, while higher frequencies can easily be detected by any of the many diodes found in a computer and then enter logic circuits to create errors.

Electromagnetic interference (EMI) is created when magnetic fields envelope the ac power lines. Perhaps the greatest source of EMI is lightning and other spherics, where large magnetic fields set up by the discharge current generate considerable EMI on power lines. Other EMI sources are welders, electric staplers, and solenoid-operated equipment such as vending machines and time clocks. Once on the power lines, electromagnetically created interference is conducted throughout the system, gradually diminishing in strength as it travels from its source.

Conducted interference is noise applied directly to power lines by appli-

ances, tools, motors, and other electrical devices. The noise is conducted from these sources throughout the wiring of the room, office, building, and neighborhood. The noise level is gradually attenuated as the noise is conducted away from the interference-generating source, but it may still be troublesome hundreds of feet away.

Power company transformers usually attenuate noise voltages considerably, so that noise is likely to be confined to the area where it is produced, within the bounds of local transformers. Noise at an extremely high level, such as that from welders, power company switchgear, or spherics, may still retain sufficient energy to create interference after passing through several transformers.

So-called "clean" or "dedicated" lines, brought out from a circuit-breaker box and up to a computer, usually do little more than add some additional power-line length for noise to travel. Actual interference reduction by a dedicated line is minimal unless the line is connected to the power-transmission lines through a separate "dedicated" transformer. Such an installation is very expensive. Dedicated lines are useful,

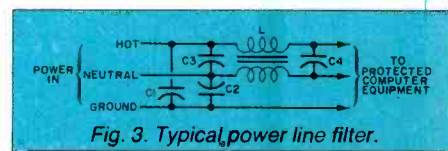

Fig. 3. Typical power line filter.

though, in isolating computer equipment from the damage that can be caused by low-voltage situations or no-voltage (as in the case of a circuit breaker opening) situations. Operating a computer from the same line that's used by an air conditioner or electric heater should be avoided.

Interaction between system components occasionally causes computer errors. Disk drives, dot-matrix printers, or impact printers may generate sufficient noise to cause errors; since they

Fig. 1. Example of what happens when noise scrambles computer output.

MEGABYTE COMPUTER CLUB		
MEMBERSHIP LIST		12/31/82
AADVARD, A.A.		DUES OWED \$5.00
123 RAM WAY		
ANYWHERE, NY 01023		

MEGABYTE COMPUTER C/UB		
MEMBERSHIP LYST		12/31/x2
QADVARK, A.A.		TUES OWED 45.00
1r3 RAM WAY		
ANYWHERE, NY p1023		

"Radio Shack's TRS-80® Model 100 is an amazing machine."

—Byte Magazine, Page 34, May 1983

"When I consider the unheard-of abilities contained in this small, under \$1000 package, I must rate the Model 100's performance "excellent."

—InfoWorld, June 27, 1983

"It is the first portable computer we've seen that's both practical and affordable."

—Popular Computing, May 1983

"It can do all of the things that one of the new integrated systems on much larger machines can do."

—Computers & Electronics, May 1983



The Computer That's Taking America by Storm is Radio Shack's \$799 Micro Executive Workstation™

More and more people are finding it easy to make friends with our TRS-80 Model 100 portable computer. Maybe it's things like a full-size keyboard, a built-in modem and an 8-line by 40-character display. Or is it? *Byte* magazine said, "On top of the impressive collection of hardware that makes up the Model 100 is an equally impressive collection of software." Indeed, the TRS-80 Model 100 is the *only* computer with five built-in programs. Use it as a personal word processor, address book, appointment calendar, telephone auto-dialer and communications terminal.

And *Basic Computing* says Model 100's BASIC language "... gives perhaps the most accurate transcendental mathematical functions in any computer." In its May, 1983 issue,

Money magazine said "... the Model 100 is so packed with goodies that it could well become the machine of the year. Just the fact that someone who knows absolutely nothing about computers can sit down ... and in less than 10 minutes be writing letters on it puts it in a class all its own." Read enough? Then get your own TRS-80 Model 100 at your nearest Radio Shack Computer Center or participating store or dealer!

NEW! 1984 TRS-80 CATALOG! Send for your free copy.

Mail to: Radio Shack, Dept. 84-A-676
300 One Tandy Center, Fort Worth, Texas 76102

Name _____
Company _____
Address _____
City _____ State _____ Zip _____
Telephone _____

Prices apply at participating Radio Shack stores and dealers

Radio Shack®
The biggest name in little computers®
A DIVISION OF TANDY CORPORATION

Reprinted with permission from: *Basic Computing*, May 1983, pp. 41-42, ©80-Northwest Publishing, Inc.; *Byte Magazine*, May, 1983 pp. 14-34; *Computers & Electronics*, May 1983 pp. 51-55, ©Ziff-Davis Publishing Company; *InfoWorld*, June 27, 1983, pp. 66-69, Copyright 1983 by Popular Computing/Inc., a subsidiary of CW Communications, Inc.; *Money*, May 1983, pp. 154-158, ©Time, Inc.; *Popular Computing*, May 1983, pp. 86-165.

The New Heath/Zenith 8/16 Bit Desktop Computer

- 16-bit/8-bit dual microprocessors!
- S-100/IEEE 696 expansion bus!
- Dual 320K-byte 5¼" floppy disk drives!
- 128K RAM expandable to 768K!
- 640 × 225 pixel video screen!
- Color capable!
- Two serial/one parallel I/O ports
- High-power switching supply

That's what Zenith Data Systems highlighted in its initial announcement of a new series of personal desktop computers. It was exciting news, and about time! After all, how long could ZDS and its sister operation, Heath, run with their workhorse 8-bit-CPU H/Z-89/90 desktop models in today's volatile computer world? There's a limit to how many refinements can be made to a 1979 model, you know—a single built-in soft-sector disk drive here, and additional serial port there, a green-phosphor screen option, etc. Enough already!

The arrival of a tan/earth-brown-encased ZF-120-22 Zenith machine was therefore almost cause for an editorial party. This was obviously ZDS's and Heath's new flagship computer. Will it run IBM PC software? Will it also handle the mountain of software both HDOS and CP/M, used in its older computer models? Is its graphics capability truly HiRes? How readily can expansion and enhancement be made? And where is the kit version (it came a few months later) that can save one almost \$1000 against a \$3599 factory-wired cost?

Here is a report on our experiences with the two models that answer the foregoing questions and likely many others that you have.

Distinguishing Features. Though the H/Z-120 computers examined here feature monochrome 12"-diagonal green-phosphor screens, you can also choose amber or white at the same price (make mine amber, please). A color monitor can be added as a second display, requiring the addition of two sets of color video RAM chips to get RGB output signals. (Another H/Z model, a low-

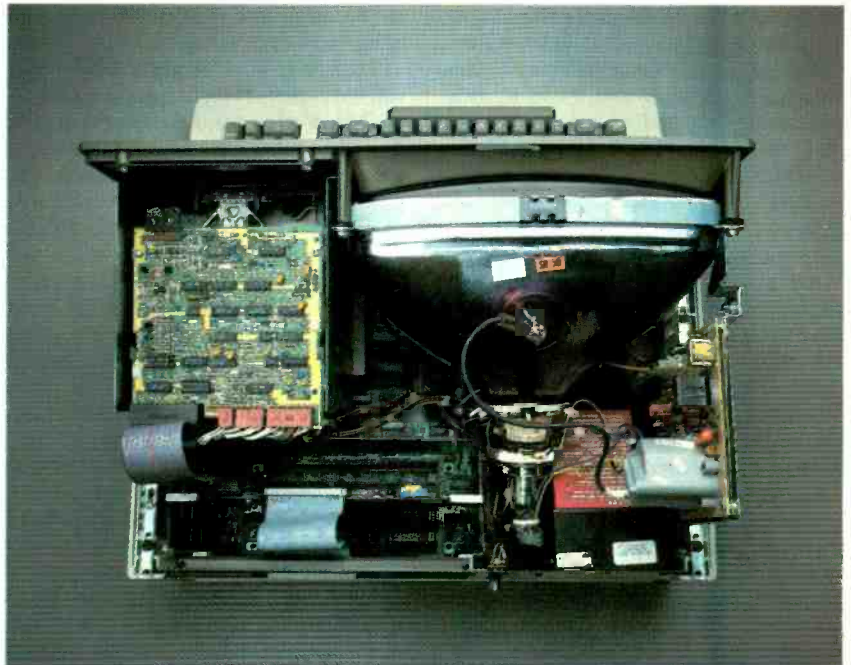

View of the interior of the H/Z 120.

profile one without a built-in CRT, is available, too, should one want color only at the onset.)

The Heathkit version is a clone of the ZDS model with two exceptions. (1) Whereas the Zenith model comes supplied with two built-in disk drives, the standard Heath has one drive with provisions for an optional built-in second one. Drives are soft-sector, naturally, and are dual-density, dual-side types. (2) The kit version meets the more stringent FCC Class-B r-f interference standards for home use, whereas the factory-assembled Zenith has a Class-A designation for commercial environment locations. The kit's lower r-f radiation was largely achieved by spraying conductive paint on the inside sections of the case, a manufacturing procedure that I was told would soon be applied to the ZDS machines.

Most desktop personal computers nowadays use either the manufacturer's own bus design or an adaptation of a

popular bus structure for system expansion with optional special-purpose hardware. In the H/Z-100 series, the means of expansion is the popular S-100 (standardized as the IEEE 696) bus. Five slots are built into the computer, but only four are usually available for expansion, since one must be occupied by the floppy disk drive controller card, while another slot would be used for a hard-disk controller if one uses a Winchester drive. Into the remaining unused slots can be plugged any combination among hundreds of expansion or enhancement off-the-shelf S-100 boards: I/O port, digital vocalizer, A/D and D/A, and other special-purpose S-100 cards.

Inside the cabinet is a powerful collection of hardware, starting with the 8085 8-bit and 8088 16-bit microprocessors. The system can address up to 1M byte of memory, including 768K of user-addressable RAM. Three banks of 64K of RAM each (192K total) are re-

served for the red, green, and blue video banks for full-color display operation. Sockets are provided on the computer's main board to expand on-board RAM from the 128K supplied to 192K. Further memory expansion is via plug-in memory cards.

The three I/O ports supplied (two serial and one 8-bit Centronics parallel) make it possible to connect into the system a variety of printers, modems, plotters, etc. A fourth light-pen input port is not presently supported with software.

An integral 12" diagonal-measurement white, green, or amber CRT in the all-in-one systems displays alphanumeric and other characters on-screen in a 5 x 9 matrix. The character set is "soft" programmed, giving the user the opportunity to dynamically redefine it as desired, and alternate character sets are available with software.

One of the nicer features built into the machine is its bit-graphics capability.

With this feature, one can display high-resolution (225 lines of 640 dots) monochrome and, optionally, full-color graphics in two and three dimensions. Each of the 144,000 screen pixels is individually addressable and can be assigned any one of eight possible colors. Furthermore, text and graphics can be mixed on the same screen. Installing the color video RAM option also enables the built-in CRT screen to display up to eight levels of intensity.

The professional-style QWERTY keyboard has the usual special-character and special-function keys required for computing. It also has a HELP key that's used by some software to guide the user through the helpful "menus" and a LINE FEED key that moves the cursor down one line, without generating a carriage return, for continuing entry beyond the 80-column width of the video display in software that doesn't have automatic wrap. Additionally,

there are insert/delete character (I/D CHAR) and insert/delete line (INS/DEL LINE) editing keys.

Located on the numeric keypad to the right of the main keyboard are the cursor control keys (HOME, left, right, up, and down). Their functions are available directly, instead of having to use a shift key to access them.

With one drive slot empty in the H-120 kit, the buyer has the option of filling it with a second identical Tandon TM-100 320K-byte floppy drive or an 11M-byte mini-hard-disk drive. The drive controller, based on a popular Western Digital design, is capable of handling up to two 5¼" and two external 8" floppy drives. The wired Zenith system has a model available with the built-in Winchester drive in place of the second floppy for an additional \$2000.

Rounding out the system's basic hardware is a hefty and highly efficient switching power supply that's capable



**Learning electronics
is no picnic.**

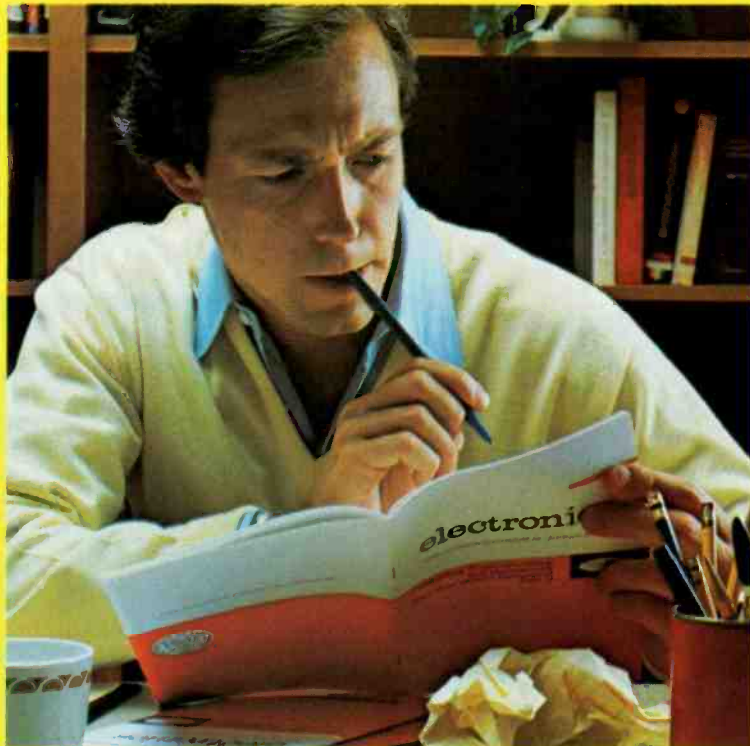

**At any level it takes
work and a few
sacrifices. But with
CIE, it's worth it.**

Whoever said, "The best things in life are free," was writing a song, not living a life. Life is not just a bowl of cherries, and we all know it.

You fight for what you get. You get what you fight for. If you want a thorough, practical, working knowledge of electronics, come to CIE.

You can learn electronics by spending some hard-working time at home. Or, would you rather go bowling? Your success is up to you.

At CIE, you *earn* your diploma. It is not handed to you simply for putting in hours. But the hours you do put in will be on your schedule, not ours. You don't have to go to a classroom. The classroom comes to you.

Why electronics training?

Today the world depends on technology. And the "brain" of technology is electronics. Every year, companies the world over are finding new ways to apply the wonders of electronics to control and program manufacturing, processing...even to create new leisure-time products and services. And the more electronics applications there are, the greater the need will be for trained technicians to keep sophisticated equipment finely tuned and operating efficiently. That means career opportunities in the eighties and beyond.

Which CIE training fits you?

Beginner? Intermediate? Advanced? CIE home study courses are designed for ambitious people at all entry levels. People who may have:

1. No previous electronics knowledge, but do have an interest in it;
2. Some basic knowledge or experience in electronics;
3. In-depth working experience or prior training in electronics.

You can start where you fit and fit where you start, then go on from there to your Diploma, an Associate Degree if you want it, and career.

Many people can be taught electronics.

There is no mystery to learning electronics. At CIE, you simply start with what you know and build on it to develop the knowledge and techniques that make you a specialist. Thousands of CIE graduates have learned to master the simple principles of electronics and operate or maintain even the most sophisticated electronics equipment.

CIE specializes in electronics.

Why CIE? CIE is one of the largest independent home study schools that specializes in electronics. Nothing else. CIE has the elec-

tronics course that's right for you.

Learning electronics is a lot more than memorizing a laundry list of facts about circuits and transistors. Electronics is interesting! It is based on recent developments in the industry. It's built on ideas. So, look for a program that starts with ideas and builds on them. Look to CIE.

Programmed learning.

That's exactly what happens with CIE's Auto-Programmed® Lessons. Each lesson uses famous "programmed learning" methods to teach you important principles. You explore them, master them completely, before you start to apply them. You thoroughly understand each step before you go on to the next. You learn at your own pace.

And, beyond theory, some courses come fully equipped with electronics gear (the things you see in technical magazines) to actually let you perform hundreds of checking, testing, and analyzing projects.

Experienced specialists work closely with you.

Even though you study at home, you are not alone! Each time you return a completed lesson, you can be sure it will be reviewed, graded, and returned with appropriate instructional help. When you need additional individual help, you get it fast and in writing from the faculty technical specialist best qualified to answer your question in terms you can understand.

CIE offers you an Associate Degree.

One of the best credentials you can have in electronics—or any other career field—is a college degree. That's why CIE gives you the opportunity to earn an Associate in Applied Science in Electronics Engineering Technology. Any CIE career course can offer you credit toward the degree...more than half of the number needed in some cases.

You can also prepare for the government-administered FCC (Federal Communications Commission) Radiotelephone License, General Class. It can be a real mark in your favor...government-certified proof of your specific knowledge and skills.

Today is the day. Send now.

Fill in and return the postage-free card attached. If some ambitious person has removed it, cut out and mail the coupon. You'll get a FREE school catalog plus complete information on independent home study. For your convenience, we'll try to have a CIE representative contact you to answer any questions you may have.

Mail the card or the coupon or write CIE (mentioning the name and date of this magazine) at:
1776 East 17th
Street, Cleveland,
Ohio 44114.

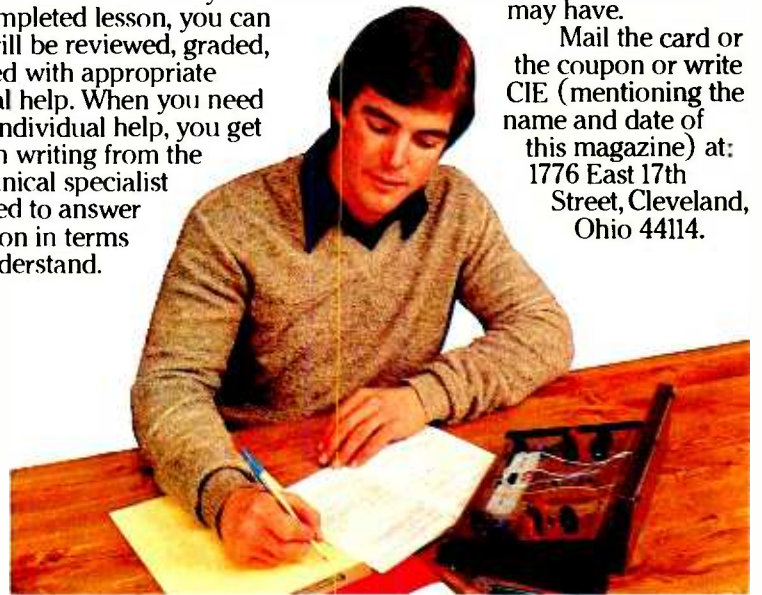

CIE Cleveland Institute of Electronics, Inc.
1776 East 17th Street, Cleveland, Ohio 44114
Accredited Member National Home Study Council

YES...I want to learn from the specialists in electronics—CIE. Send me my FREE CIE school catalog...including details about the Associate Degree program... plus my FREE package of home study information.

Print Name _____

Address _____ Apt. _____

City _____ State _____ Zip _____

Age _____ Area Code/Phone No. ____ / _____

Check box for G.I. Bill bulletin on Educational Benefits: Veteran Active Duty

MAIL TODAY!

PE-96

of delivering more than enough power to drive the computer and any extra S-100 cards that might be installed in it. The system's cooling fan is built into the power-supply module.

Software. With the exception of a "Customer Demonstration Disk," no software is included in the H/Z-120's basic price. For our evaluation, we used an 8/16-bit software package consisting of CP/M-85 operating system (standard 8080 CP/M tailored to take full advantage of all the features of the 8085 microprocessor), a Z-DOS operating system for the 16-bit 8088 processor, an MBASIC interpreter programming language for CP/M, a Z-BASIC interpreter for Z-DOS, and a Microplan electronic spreadsheet.

Z-DOS is a version of Microsoft's MS-DOS operating system written for Heath/Zenith computers and is similar to the PC-DOS operating system used in the IBM Personal Computer. Though the two operating systems have the same origin and are basically the same in terms of features, IBM software is not compatible with the 100 Series computers and vice-versa. During our use tests, we were able to DIR (directory) some disk software written for the IBM PC as well as for other computers written under MS-DOS. We were unable to RUN any of them, however.

MBASIC, from Microsoft, is an enhanced disk BASIC programming language that has become more or less standardized. Z-BASIC, also by Microsoft, offers more power in terms of graphics and color selection.

Manuals. Supplied with the H-120 computer is a very impressive set of user manuals. The least technical is the Z-100 User's Manual in looseleaf binder. Contained in its 300 or so 8½" × 11" pages is a superficially technical overview of system operation, written with the beginner and nonprogrammer in mind but containing much information useful to experienced computer users who are new to 100 Series computers. With this manual comes a 5¼" soft-sectored "Customer Demonstration Disk" on which are programs, written under Z-DOS and Z-BASIC, that demonstrate the computer's graphics artwork and mixed text and business graphics capabilities.

The User's Manual, basically Z-DOS oriented, includes sections devoted to CP/M-85 and programming languages (including BASIC). One of 12 appendices details configuring procedures for customizing the system for different printers (a greatly simplified procedure

that takes less than two minutes to perform with most popular printers). Another gives step-by-step details for converting software written for Heath's H-89 computer for use in the 100 Series.

For more serious users who have hardware and software experience, Heath also provides the Z-100 Technical Manual, which is divided into separate Hardware, Appendices, and Boot ROM Source Listings volumes.

Kit Assembly. Although the H-120 is a complex electronic device, it's a very easy kit to assemble and get up and run-

The remaining work basically involves installation of the various boards and subassemblies on the chassis, mounting the disk drive(s) and video display tube, etc. All subassemblies interconnect via factory-prepared cables.

Assembly time is brief, considering the complexity of this computer and our previous experience in assembling the much less complex Heath H-89 computer. Our assembly time of about 10 hours included about two hours spent in locating and rectifying a fault on the disk drive controller card. Normally, troubleshooting a card as complex as



Three I/O ports are on the rear.

ning. Very little electronic assembly is required. The extremely complicated main board, on which are located virtually all of the main computer circuit devices (8085 and 8088 CPUs, support chips, first 128K bytes of user RAM, sockets for the 192K option, S-100 expansion bus and drivers, I/O port electronics, and more) comes factory assembled and tested.

Similarly, the video logic board comes assembled and tested, with empty sockets to accommodate the two additional 64K banks of RAM required to provide color capability. Finally, the power supply with built-in cooling fan is a preassembled drop-in module with even the power-distribution cable connectors installed.

What's left for the kit builder to do consists of assembling the video deflection board, disk drive controller card, and a small calibration board that's used for setting up the drive controller.

the drive controller is a task best left to Heath factory service, but our working Zenith Z-120 computer helped us localize a faulty IC.

We're impressed by how well all the mechanical elements in this kit fitted together. Not once did we have to force parts into alignment for insertion of hardware. And the quality of the mechanical parts was excellent throughout. In particular, the bottom plate, which supports the entire computer, is made of heavy-gauge steel and has captive nuts that simplify mounting of subassemblies. The only tools required for assembly were soldering iron, longnose pliers, diagonal cutters, a couple of screwdrivers, and a hex driver set.

User Comment. Powerful, fast, versatile, and attractive-looking, the Zenith computer system is first and foremost a small-business or professional machine. Moreover, the machine is ideally suited

for customized applications. The Heathkit model, in turn, with more than half the machine pre-built by Heath and with a substantial price advantage, should appeal to technical enthusiasts and technical training institutions.

Heath/Zenith went its own way with this design. It's not a clone of some other successful or popular design, nor a simple upgrade of a model in its line. "Doing it my way" has its pitfalls, though. Not being at all software or hardware compatible with the popular IBM PC—the ports, interrupts, disk controller, and video are all different—Heath/Zenith offers alluring alternatives. The many S-100/IEEE 696 hardware additions available, the traditionally fine software support given by Heath/Zenith and third-party suppliers, and the vastly superior video capability of the H/Z computers give these desk-toppers a strong identity all their own.

Having an 8085 alternate processor is also a positive factor since owners of software for H/Z-89 8-bit computers can use much of their existing software immediately. I say "much of" simply because such portability is limited to software that was developed with 8080-CPU code for the Z-80 CPU-based older computers. Software that took advantage of the Z-80's additional instructions cannot be used, however. Thus, you can use H/Z-89 Wordstar, Mail-Merge, SuperCalc, D-Spool, CBASIC, Pearl 3, and a host of other software you might own on soft-sectored disks. But you couldn't use H/Z's 8-bit Condor, RTTY, or Peachtree accounting packages.

There is a considerable amount of 16-bit software immediately at hand, though, so that in most cases one shouldn't feel deprived. For example, Peachtree alone has 16 accounting packages designed for H/Z-100 Series computers. I can quickly count 24 database management packages, too (including Condor and Personal Pearl). There are many word-processing and spelling editors, also, for 16-bit operation. These include Wordstar, Peachtext, Spellbinder, Magic Spell, SpellStar, Spelgud, and others. Spreadsheets include Multiplan, SuperCalc, and ScratchPad, among others. Add software packages for communications, graphics, entertainment, languages (Forth, Fortran, and C compiler), engineering, education, real estate, medical management, legal, utilities, an IBM3270 emulator, et al., and you'll realize that one's choice is very wide indeed. Lotus 1-2-3 is probably available at this writing, too, adding to the more than 230 16-bit software packages ready

to run. (Heath, by the way, offers Peachtree 5000 word-processing, financial-planning, and data-management software to registered H-100 or H-120 kit owners for only \$275—a \$125 price reduction.) The list grows daily, and gaps will likely all be filled.

The H/Z-100's "footprint" is remarkably small: 380¼" sq in., only about 11% more than an H/Z-89's. So if space is a consideration, the all-in-one design is an important attribute. One does give up the comfort of a detachable keyboard that could be easily moved about for typing and viewing position adjustments, though.

If you are graphics oriented, the H/Z-100 must be considered a leader in its power class. By reprogramming, you can double its already high resolution to 500 lines by 640 pixels for TV-quality

monochrome pictures.

The functional keyboard was a pleasure to use. Notable are the extra-large reverse-L shape of the RETURN key, the automatic repeat, and the placing of the cursor controls on unshifted keys in the numeric keypad cluster. The keyboard layout and the "feel" of the keys are areas where the H/Z-100s shine.

Not to be overlooked is Zenith's "on-site" service policy and Heath's "hold-your-hand" assistance with any difficulties you might encounter whether hardware or software—now and seemingly forever.

In sum, the H/Z-100 computer systems are exceptionally fine in most respects, with its few shortcomings balanced by very attractive design innovations. —Alexander W. Burawa

Circle No. 91 on Free Information Card

TECHNICAL SPECIFICATIONS

Microprocessors:	8085 (8-bit); 8088 (16-bit).
Clock Rate:	5 MHz for both 8085 and 8088.
User RAM Supplied:	128K bytes, with sockets on board for additional 64K
Maximum Working Memory:	Approx. 1M byte assigned as 768K user RAM, three banks of 64K video RAM (192K total) for color option, and 64K ROM (8K actually used).
I/O Ports Supplied:	Two RS-232C serial communications, one Centronics standard parallel printer, and one light pen.
Serial Port Features:	110-to-38,400-baud transmission rate; asynchronous full- or half-duplex or synchronous operation; odd, even, or no parity; 1, 1.5, or 2 stop bits.
Video Display:	12" diagonal-measurement integral monochrome white, green, or amber CRT, selected at time of purchase, with H-120.
Text Display Format:	24 lines by 80 columns, plus 25th line for user information; characters formed in 5 × 9 matrix, definable to other values using software.
Character Set:	128 characters, upper- and lower-case.
Cursor:	Blinking, underline, or reverse video; relative or direct addressing.
Graphics Display Format:	640 × 225 (144,000) individually addressable pixels in noninterlaced mode, 640 × 512 (327,680) pixels in optional interlace mode.
Displayable Colors:	Red, green, blue, magenta, cyan, yellow, white, black; requires optional video RAM and optional RGB video monitor. Video RAM option can display up to eight levels of intensity on monochrome video monitor.
Keyboard Features:	Typewriter-style QWERTY layout with full-size, full-travel keys; HELP, LINE FEED, and text-editing keys; 13 user-programmable keys; separate numeric keypad with HOME, left, right, up, down cursor-control key functions available directly (no keyboard SHIFT operation required for access); automatic repeat at 11 characters per second, plus fast repeat at about 3 × normal auto-repeat speed; defeatable audible key click.
Disk Drive Supplied:	Single or dual Tandon Model TM-100 48 TPI, 6-ms step-rate, 320K-byte capacity soft-sectored, double-sided, double-density 5¼" drives.
Controller:	Western Digital design S-100 (IEEE 696 Standard) card; supports up to two internal 5¼" and two external 8" floppy-disk drives simultaneously.
Expansion Bus:	Five 100-contact S-100 (IEEE 696 Standard) slots; one occupied by disk drive controller card and four available to user.
Power Supply:	Factory-assembled switching type with built-in cooling fan.
Size:	13.5"H × 19.5"W × 19.5"D.

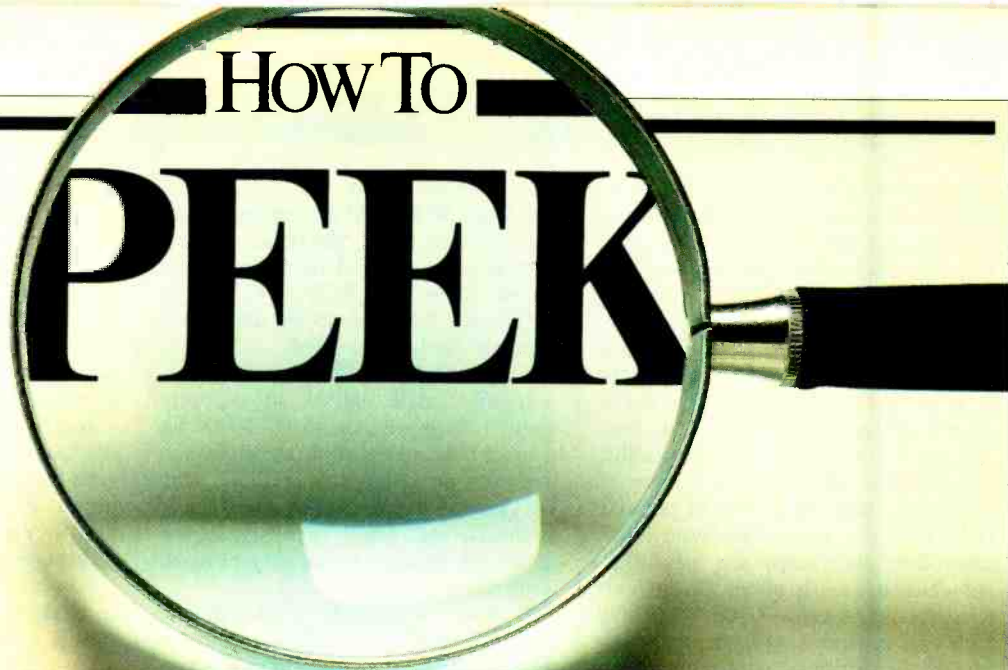

HOW TO PEEK INTO A ROM CARTRIDGE

Here's a simple technique for listing the contents of VIC-20 plug-in programs

By Hardy McGoff

ALTHOUGH there are many books on machine language programming, listings of professional programs (such as those that reside in ROM cartridges) are hard to come by. A first-hand look at published works is probably as valuable as learning programming techniques. Here's a way to look into cartridge ROMs for the VIC-20, and disassemble the machine language programs.

VIC Modification. In the operating system of the VIC there is a power-up routine that checks to see how much memory is available and if any ROM is present. If ROM is present, the routine checks locations \$A000-A001 (40960-40961 decimal) for a program entry address. The ASCII characters AOCBM appear at locations \$A004-A008. When these characters are recognized by the computer, the ROM program is booted in. If there is no expansion RAM or ROM present, "3583 Bytes Available" appears on the screen.

To examine the contents of a ROM cartridge, it should be placed in the slot on the VIC-20 after power-up. Normally, this is not a recommended procedure since you could damage the cartridge. To solve this problem, a separate power switch can be inserted into the 5-V line on the VIC-20 cartridge port. To install the switch (a pushbutton type is recommended), remove the three screws on the underside of the VIC keyboard and

then remove the top of the computer. Once inside, look to the right rear and you'll see the expansion port, which is a 22/44-pin edge connector (see the VIC Reference Manual and Fig. 1). Cut the +5-V wire lead (pin 21) and install *S1* directly into the circuit. Mount the switch on the top of the keyboard under the power light. This allows the +5-V supply to the cartridge to be turned on and off. Be sure to put some spaghetti insulation (any kind will do) on the soldered leads to avoid any shorts. Alternately, if you have an expansion board such as the "Supermother" (Compu-scope, Inc., 4105 Blimp Blvd., Tillamook, OR 97141), switches are already in place on the board.

Now you can power up, engage the cartridge with *S1*, and the auto start se-

quence will not function. (Once powered up, the initialization routine will not be recalled.) All that's left to be done is to load a disassembler program from disk or cassette, run it, start at location \$A000 (40960 decimal), and the contents of ROM will appear on your screen.

Disassembly. There are many methods of viewing memory locations. Ideally, you would want a program that disassembles the machine language code to mnemonics. If you don't have access to a disassembler, Table I is a short program you can try.

This program prints out the machine code for the ROM in hexadecimal notation. This code can be disassembled by hand if you wish. You'll need a reference source for 6502 assembly language programming, though, such as Lance Leventhal's book, *6502 Assembly Language Programming* (Osborne/McGraw-Hill, Inc.). Using the reference, you can translate the hex code into mnemonics, values, and addresses. For example, two consecutive bytes may be

40985 A9
40986 01.

The numbers 40985 and 40986 are the decimal addresses of the memory locations; A9 is the hexadecimal representation of the LDA assembly language instruction (for the 6502 MPU); and 01 is a hex value. The lines are an instruction that tells the computer to load the accu-

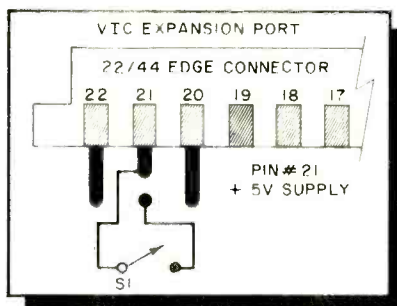

Fig. 1 How to install the switch on the wire going to pin 21 of the expansion port.

mulator with the hex value 01.

Before disassembling the program you will want to know at what memory location it begins. If you type SYS40960, you'll find that nothing happens (the SYS command will begin executing a machine language program starting at the memory location given.) This is because the entry code for the program resides at locations \$A000-A001 (40960-40961 decimal). \$A000 is the LSB (Least Significant Bit) of the program entry address and \$A001 is the MSB (Most Significant Bit). So to find the starting address type the following: PRINT PEEK (40960)+256*PEEK(40961), then press RETURN and an address will be displayed. Do a SYS to that address and the cartridge program will slam onto the screen even with the disassembler program still in memory. To exit the program hit, S/ and power down. Or, if you have a reset switch, just hit S/, then reset, and you're back to normal.

This information should be of considerable help to struggling young program writers since machine language programming sometimes seems to be shrouded in a cloud of mystery. At least now you can study the techniques of the professionals for fun or fortune. ◇

Table I

PROGRAM FOR PEEKING INTO A VIC CARTRIDGE

```

5 REM ***CARTRIDGE PEEKER***
10 PRINT "VIC CARTRIDGE PEEKER":PRINT
15 PRINT "F1=WAIT F3=CONTINUE"
20 FOR X=0 TO 2000:NEXT X
25 X=40960
30 P=PEEK(X)
35 M=INT(P/16)
40 L=P-(M*16)
45 IF M<10 THEN M=M+48:GOTO 55
50 M=M+55
55 IF L<10 THEN L=L+48:GOTO 65
60 L=L+55
65 PRINT X;CHR$(M)CHR$(L):K=PEEK(197)
70 IF K=39 THEN 85
75 IF X=49152 THEN END
80 X=X+1:GOTO 30
85 PRINT "WAITING"
90 K=PEEK(197):IF K=47 THEN 30
95 GOTO 90
    
```

READY.

New! A solid wood Work Center as efficient as your computer

The Exeter, the complete computer work center, and also a tall, handsome cabinet which conceals work clutter! Finished cabinet is antique (dark) pine. 62" h x 32" w x 25 1/4" d. Also available unfinished in kit form.

- Fits most computers — IBM, Apple, TRS 80, etc.
- Paper tray below printer
- Pull-out shelves for computer keyboard and printer
- Adjustable/removable shelf for CRT

Call toll-free: 1-800-258-4720

In New Hampshire: 1-800-552-0320

Visa, MasterCard, American Express

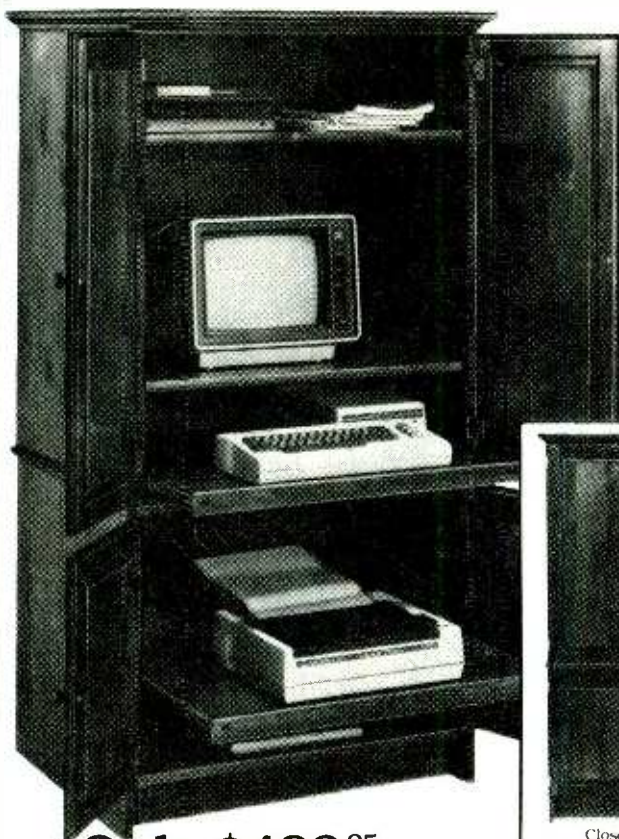

Only \$499.⁹⁵ plus shpg

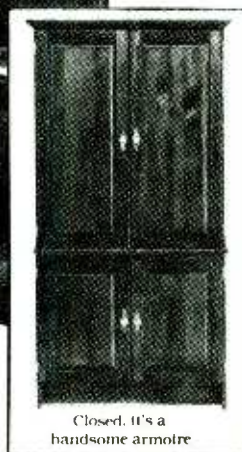

Closed, it's a handsome armoire

Yield House®

Quality pine furniture for over 35 years
Dept. CE30 North Conway, N.H. 03860

- Please send the Exeter Computer Work Center. Enclosed is \$499.95 plus \$50.00 shipping. (Requires minor assembly)
- Please send the easy-to-build unfinished Exeter kit. Enclosed is \$349.95 plus \$35.00 shipping.
- Please send free additional information.

Name (please print)

Address

City

State

Zip

Circle No. 74 on Free Information Card

Introducing A 16-Bit
Microprocessor System
Designed To Expand
Your Knowledge.



Here's How You Can Learn 16-Bit Technology. And Graduate To One Of Today's Most Powerful And Advanced Microcomputers.

Now you can master 16-bit technology with an all-new Advanced Microprocessor course. And build hands-on experience with the only 16-bit microcomputer specifically designed for the hobbyist, working engineer and student.

Advanced Microprocessor Course

This all-new self-study course (EE-8088) provides in-depth coverage of 16-bit, state-of-the-art technology.

You will gain a thorough understanding of microprocessors from this 1200 page course. In 10 easy-to-understand units, starting with microcomputer basics, you'll cover all phases of 16-bit microprocessing. Assembly language. Program writing. Addressing modes. Dynamic and static RAM. And hardware interfacing.

And by using your 16-bit Trainer/Learning Computer for hands-on experiments (over 60 included), you'll gain actual circuit interface and software programming experience with an 8088 microprocessor system.

Trainer/Learning Computer

A unique combination of design features makes this versatile microprocessor system much more than a "teaching machine." Use it as a trainer with the Advanced Microprocessor course. Use it as an experimental design computer. And use it to run a wide variety of 16-bit software—including Z-Dos, Multiplan, Z-Basic, Condor File Manager, and much more.



In its most basic form, the Trainer/Learning Computer is a 16-bit,

cassette-based microcomputer.

Its unique design features access ports and solderless breadboards to allow you to build interfaces, design and modify circuits, or simply experiment with the inner workings of the microprocessor system.

The basic system has an 8088 processor, 32K ROM (including assembler, editor and debugger) and 16K RAM.

The unit also features a serial I/O printer port, cassette interface and a detached 95-key keyboard (including 16 function keys and a numeric keypad) which generates a full ASCII character set. It's available either in kit form or factory assembled.

And you can take advantage of the system's H/Z-100 computer design heritage by easily upgrading it to a disk-based, 16-bit microcomputer that will run H/Z-100 series software and many other forthcoming programs.

Fully Upgradeable

The powerful upgrade package and variety of accessories allow you to make the basic 16-bit system more powerful and versatile. You can add 128K or 192K bytes

of RAM. Floppy disk controller. 48TPI double-sided, double-density, single or dual floppy disk drive. Bit-mapped video graphics or full-color graphics. Two RS-232 ports. Programmable timer. And a Centronics-compatible printer port.

Learn on it. Design with it. Use it as a 16-bit computer.

It's the only 16-bit microprocessor system specifically designed to integrate theory with a hands-on understanding of how 16-bit computers work. And it's from Heathkit/Zenith Educational Systems, the world-leader in problem-solving courses, trainers and accessories to help you learn state-of-the-art technology.



Heathkit[®]
Heath
Company

A subsidiary of Zenith Radio Corporation

Circle No. 24 on Free Information Card



Get more information in the
**FREE
HEATHKIT CATALOG**

Mail to: Heath Company, Dept. 010-104
Benton Harbor, MI 49022

Name _____

Address _____

City _____

State _____ Zip _____

ED-199

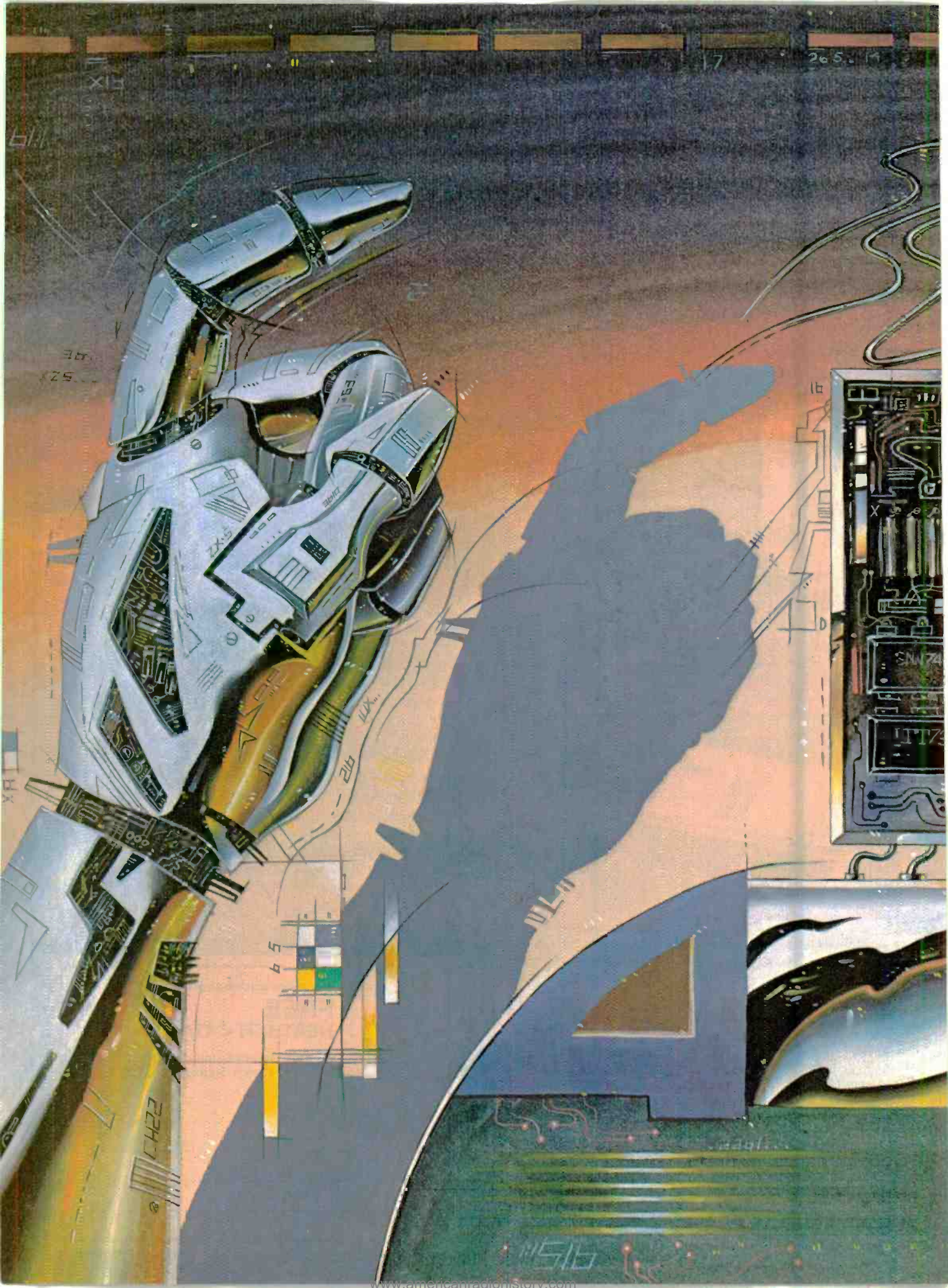

ADC MOTOR SPEED CONTROLLER

Circuit uses a pulse-width modulated amplifier to maintain constant motor speed for, say, robot motive power and other applications that require high efficiency

By Mike Coppola

CONTROLLING the speed of dc motors has always been somewhat of a problem when the operating efficiency of the system is of key importance. In such cases, a high-efficiency motor drive circuit is imperative. To maintain a relatively constant motor speed (as in a battery-operated robot), the circuit should have voltage feedback to increase the current delivered to the motor under loaded conditions, while current feedback could be included to protect the system from over-current conditions.

The circuit should also be designed so that the motor can be controlled from full stop to full speed, using a 0-to-5-V linear control signal. This leaves open the possibility of interfacing to other circuits, including computers.

Since high-efficiency amplifier is needed to control the dc motor, a study of amplifier classes is in order.

Classes of Amplifiers. The most common types of amplifiers are classes A, B, AB, C, and D. In the basic class-A amplifier shown in Fig. 1, a specific quiescent current I_B is always present in the base of the transistor. This base current results in a collector current (I_C) of $I_B \times B$, where B is the current amplification factor of the device. With the amplifier not processing any signals, there will be

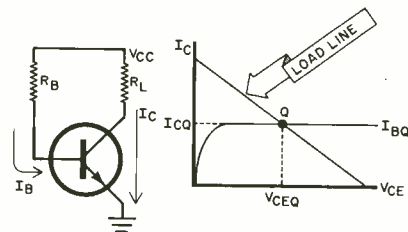

Fig. 1. Basic class-A amplifier.

some collector current flowing. However, this is wasted power since there is no demand for work to be done. Varying the base current varies the collector current, and causes the Q point to shift on the load line. As I_B decreases, the voltage across the device (V_{ce}) increases.

According to Kirchhoff's Law, which states that the sum of the voltages around a loop must be zero, we can see that any voltage not dropped across the load ($V_{cc} - V_{rL}$), must be dropped across the device (V_{ce}). Therefore, not only is power being dissipated in the load, but power is also being dissipated as heat in the device ($V_{ce} \times I_c$). This mode of operation is very inefficient. In fact, the maximum operating efficiency for a class-A amplifier is 50%—unacceptable for our purposes.

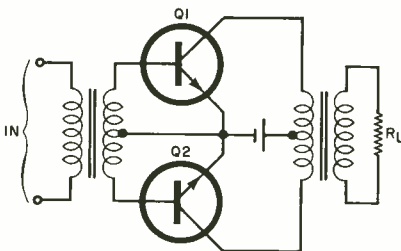

Fig. 2. Class B uses two transistors.

The class-B amplifier, shown in Fig. 2, has a greater operating efficiency than a class A. In this case, the two transistors are biased at cutoff, eliminating the inefficiency of quiescent current. One half of an input signal causes one transistor to conduct and the other to be reverse-biased. The other half of the input signal causes the opposite to hap-

pen. Unfortunately, any voltage still not dropped across the load is dropped across the device. As in class-A operation, any power not dissipated in the load is wasted as heat. The maximum efficiency of this amplifier is 78.5%, which is better but still an unacceptable design.

From the brief review of class-A and B amplifiers, we can see that in any amplifier configuration, inefficiency is present when the difference in power supply voltage and load voltage is dropped across the device (assuming some current flow). Any amplifier configuration in which the device is operated in the linear region cannot be used since maximum efficiency is a mandatory requirement. Since classes AB and C also operate in this manner, they can be eliminated as possibilities for this design. Therefore, exit classes A, B, AB, C, and enter class D—the switching amplifier.

The active device in a class-D amplifier is never operated in the linear region as it is either in cutoff or saturation, as shown in Fig. 3. If the device is in saturation, the voltage across it is theoretically zero (maximum current) and no power is dissipated. When the device is

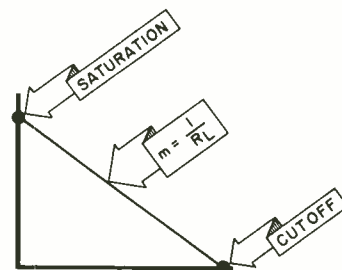

Fig. 3. Load line for class D.

reverse biased, there is maximum voltage but no current (theoretically) and no power is dissipated. Thus, the class-D configuration can be looked at as a simple on/off switch.

In Fig. 4A, the switch is open (cut-off); there is no current flow in the device; and as a result, no power dissipation. In Fig. 4B, the switch is closed (saturation). Maximum current is flow-

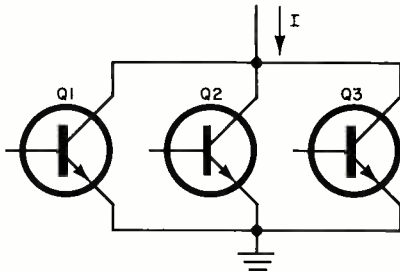

Fig. 4. Class D analogy to a switch.

ing (determined by R_L), and there is zero voltage across the device. Again, no power is dissipated in the device.

By this simple representation we can see that all the power being dissipated is in the load, and we have achieved a maximum theoretical efficiency of 100%. The actual efficiency is less, of course, due to certain characteristics of the semiconductor switching device. We expect the voltage across a closed switch to be zero. In actuality there is some small voltage across the device in the saturated state (V_{sat}), just as there is some leakage current through the device in the cutoff state. However, this type of amplifier suits our needs.

The Control Voltage. The next step will be to choose a method of controlling the switching amplifier with a 0-to-5-V signal. The design is such that a control signal of 0 V corresponds to an open switch while 5 V corresponds to full power through the load. A question may be raised on how a switching amplifier can provide currents linearly between 0 and several amperes. Consider the output of a +12-V class-D amplifier, shown in Fig. 5.

In Fig. 5A the switcher is turned on for 50 ms, and off for 50 ms. Since the duty cycle is 50%, the average voltage over 100 ms interval is 50% of 12 V, or 6 V. In Fig. 5B, the duty cycle is 25% and the average voltage is 0.25 x 12 or 3 V.

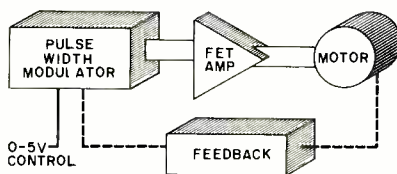

Fig. 5. Output waveforms of class D.

In this manner, the average dc voltage is determined by varying the duration of the pulse width. The speed of a dc motor can, therefore, be controlled by modulating the pulse width. A typical pulse-width modulation block diagram is shown in Fig. 6.

The output of the pulse-width modulator (PWM) is fed to the input of the class-D switching amplifier. It is important that the rise and fall times of the switching waveform be as low as possible, since this will result in the switching devices' being operated in the linear region for only the duration of these times. If switching times are considerably shorter than the on or off times, then power dissipation in the devices will be minimized.

A zero control voltage will result in a 0% duty cycle, and consequently no output from the amplifier. A 5-V control signal will result in a 100% duty cycle and full output from the amplifier.

Devices. The final step is to investigate the devices that will accomplish the actual power switching. As mentioned earlier, the devices are theoretically switches; and, unfortunately, semiconductor devices are not ideal. What is needed are devices having low on resistance, resulting in low V_{sat} and low leakage currents. These two factors reduce the power dissipated in the devices

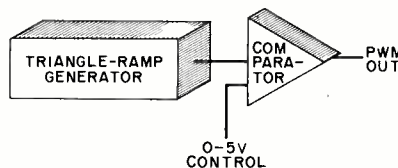

Fig. 6. Typical PWM block diagram.

during the on and off cycles. Since it may be necessary to parallel devices to obtain the required constant-current capability, another important factor in selecting the devices is the ease with which paralleling can be accomplished.

Investigating the two main types of devices that would suit this application, bipolars and MOSFETs, we find that the main disadvantages of bipolars are their inherent "current hogging" characteristics. The current in a bipolar generates heat. The buildup of heat results in a lowering of internal resistance, which leads to an increase in current flow. This phenomenon, known as "thermal runaway," is characteristic of bipolars in general.

Consider the simplified circuit shown in Fig. 7. Assume all three transistors are operating, and sharing current, I. Now assume that Q1 heats up and passes more current than Q2 or Q3. With more current, it heats more, and will soon "run away" and self-destruct.

If Q1 destructs in the shorted state, the load circuit will likely be damaged. If Q1 fails in the open state, then Q2 and Q3 will be forced to handle the current originally meant for all three. This is what is meant by "current hogging." Soon Q2 or Q3 will also run away, causing another device failure. This process will continue until all the devices have self-destructed or the circuit fails.

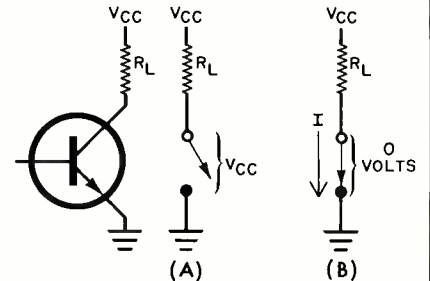

Fig. 7. Simplified amplifier circuit.

Another circuit could be added to prevent this; but the addition of such circuitry would require extra power, thus reducing the efficiency of the system. Also, bipolars are current-operated devices requiring current-drive circuitry. A good engineering rule states that the less the component count in the design, the more reliable and efficient the system.

MOSFETs are particularly suited for this design. Especially those known as VFETs and HEXFETs. The main advantage of using these FETs is their high-impedance, voltage-operated gate, low on resistance, low leakage current, and negative temperature coefficient. An amplifier employing VFETs/HEXFETs can be driven directly from the output of the PWM circuit (comparator voltage output) since the high input impedance (> 100 kilohms) of these devices eliminates preamplifier loading problems. The low on resistance (typically less than 1 ohm) and low leakage current assure a minimum dissipation in the device during on and off times. Of main importance is their negative temperature coefficient, allowing ease of paralleling. As a VFET/HEXFET heats up, it draws less current, forcing other devices to share the current until the first cools. Thus, paralleled FETs are self-stabilizing due to this characteristic. A simplified block diagram of the complete system is shown in Fig. 8.



Fig. 8. Block diagram of the system.



We train specialists from the ground, up.

It takes a lot of special people to keep the Air Guard in the air. And not all are at the controls of a Phantom Jet.

Most serve in vital support positions. Positions requiring the very highest level of expertise. So when you join the Air Guard, you're trained by the best in the business. By top professionals in avionics, munitions loading, environmental support, and Tactical Air Command and Control. You can also get expert training in hundreds of other areas essential in defending America's skies. Training which can be just as important in launching your civilian career.

So if you're a special person looking for a specialty, check out the Air National Guard. For information, mail the attached coupon. Or call toll-free 800-638-0936.*

*In Alaska, Hawaii, New Jersey, Puerto Rico, Guam and the U.S. Virgin Islands, consult your local directory.

We Guard America's Skies.



Complete and mail to:

Air National Guard, P.O. Box 6000, Clifton, N.J. 07015.

MALE
 FEMALE

NAME (Please Print) _____

ADDRESS _____ APT _____

CITY _____ STATE _____ ZIP _____

AREA CODE: PHONE _____

OCCUPATION _____

BIRTH DATE _____

PRIOR MILITARY SERVICE YES NO

BRANCH _____ RANK _____ AFSC/MOS _____

Circle No. 15 on Free Information Card

A2CPTR**103NP

Controller

tion, partially eliminating the need for external protection circuitry. To avoid heat dissipation, all four are mounted on aluminum heat sinks. The gates are tied together and connected to the output of the PWM. The sources are grounded and the drains tied together and connected to the negative side of the motor. Wire of sufficient gauge is used to permit heavy current drain. To help eliminate the problem of inductive voltage spikes from the motor, a free-wheeling diode is used across the armature. Higher current capability can be obtained by paralleling more FETs.

Construction. Since there is nothing critical, the circuit of Fig. 11 can be constructed on perforated board using point-to-point wiring, or a small pc board can be designed and fabricated. If the feedback circuits (or one of them) shown in Fig. 12 are desired, then it too can be fabricated as desired.

Current-sense resistor *R11* (Fig. 12) is connected to the positive terminal of motor *M1* with diode *D1* located near the motor and connected across its terminals. Paralleling the FETs is straightforward. Connect drain to drain, gate to gate, and source to source. Capacitors

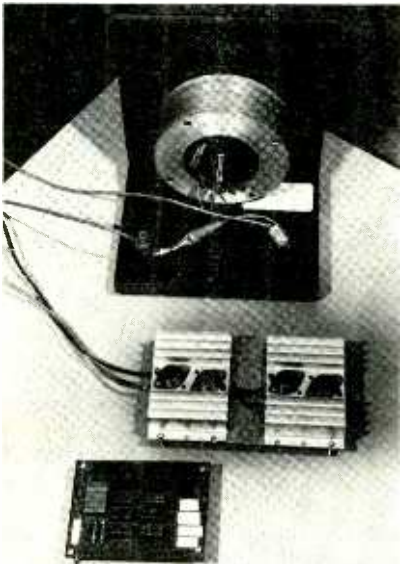

Complete system with power amplifiers on heat sinks.

C6 and *C7* of Fig. 12 are power-supply filters that serve to filter out any unwanted noise that may have been picked up in the run from the bipolar supply to the circuit. Don't forget to use proper-size conductors for the current level.

Finally, equivalents can be substituted for most parts. A 741 op amp can be substituted at the sacrifice of switching speed, which is extremely important. The same goes for the comparator, but with a sacrifice in speed and output current. Any n-channel VFET can be used

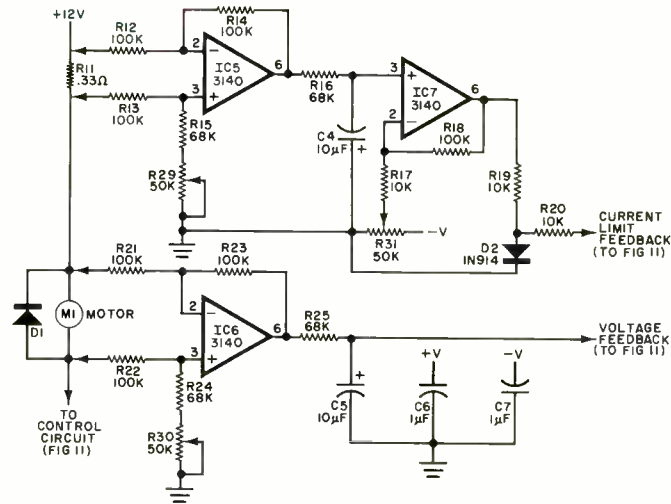

Fig. 12. Current-limit and voltage feedback circuits.

for *Q1-Q4* as long as its current ratings are observed and total paralleled on resistance is low (under 0.5 ohm). Another function generator could be used in place of that suggested for *IC1* but resistor values for the buffer stage (*IC2*) may have to be changed. All potentiometers should be of the multiturn type for better accuracy and resolution.

Setup and Calibration. The first step in getting the circuit working is balancing the differential amplifiers *IC5* and *IC6* of Fig. 12. Remove *IC7* from the circuit and disconnect both the voltage and current feedback leads. Apply a sine wave of approximately 700 Hz (5-to-10 V p-p), to the current-sense differential amplifier input (*R12* and *R13*). Connect a scope to the output of *IC5* (pin 6) and adjust *R29* for a minimum signal. Repeat the procedure for the voltage feedback amplifier. Apply the same signal to *R21* and *R22* (not on the op-amp side) and adjust *R30* for a minimum signal on the output of *IC6* (pin 6).

Set the control voltage to 0 V (obtaining a control voltage will be discussed in the conclusion), and connect a scope to the output of function generator *IC1* at pin 4 (Fig. 11). Adjust *R26* for a frequency of approximately 700 Hz. Using the oscilloscope, observe the output of buffer *IC2* (pin 6) and adjust *R27* so that the bottom peak of the amplified triangle wave is on a 1-V dc reference. Connect the voltage feedback lead(s) and set the control voltage to 5 V. Using the scope, observe the gate signal of the FETs (output of comparator *IC3* at pin 7) and adjust *R28* for a pulse-width duty-cycle transition from 99% to 100%. (The pulse just goes to a straight dc level.) At this point, the circuit should be operating correctly except for the current feedback. A 0-V control sig-

nal should result in 0% duty cycle and a 5-V control signal should result in a 100% duty cycle. Note that *R27* controls the 0% point, and *R28* controls the 100% point. If you load the motor down, note that the pulse width increases to compensate for loading.

To set the current limit, replace *IC7*, connect the scope to the output of this amplifier (pin 6), adjust *R31* so that the output of the amplifier is at V+. Potentiometer *R31* controls the level at which the circuit will current limit. Notice that as you load the motor the dc level at pin 6 of *IC7* will drop toward ground, and the circuit will current limit when this level drops below 0 V. In adjusting *R31*, adjust the dc level at no load. The closer to ground this level starts at, the sooner it will go into current limit. To set the duty cycle, load the motor to the current level desired and adjust *R31* so that the pulse width shrinks. You can demonstrate the operation by loading the motor gradually. At the preset current level you will notice the pulse width decreasing.

Conclusion. The efficiency of the amplifier discussed in this article was measured to be greater than 95% at current levels up to 5 A. (No measurements were made for efficiency above that.) The FETs ran extremely cool, even at current levels over the rated 10 A. The control voltage can be derived from a potentiometer setup or, in the case of a robot, one for each wheel. This project provides the necessary feedback for the motor to maintain speeds when climbing up hills, yet protect itself if the robot attempts to walk through some immovable object. In addition to this, optically encoded speed information can be processed by a computer to allow the machine to turn. There's no limit now! ◇



Predictable.

A flawless future is in sight with 3M diskettes.

When it comes to keeping track of precious data, predictable means reliable. Being able to count on every diskette, every time. At 3M, reliability is built into every diskette. We've been in the computer media business for over 30 years. And we've never settled in. We're constantly improving and perfecting our product line, from computer tape and data cartridges to floppy disks.

3M diskettes are made at 3M. That way, we have complete control over the entire manufacturing process. And you can have complete confidence in the reliability of every 3M diskette you buy.

Look in the Yellow Pages under Computer Supplies and Parts for the 3M distributor nearest you. In Canada, write 3M Canada, Inc., London, Ontario. If it's worth remembering, it's worth 3M diskettes.



3M hears you...

Circle No. 48 on Free Information Card

www.americanradiohistory.com

3M

Now, the most significant advance in DECTM software ever!

Announcing DIGITAL REVIEW...the monthly magazine exclusively for your DEC microcomputer.



HARDWARE: Each and every month, you'll get all the latest technological developments—minicomputers... microcomputers... peripherals... telecommunications—and what they mean to you.



PROGRAMMING: All the latest in programming techniques with special features devoted exclusively to traditional and new software applications.

COMPUTER GRAPHICS: Color visual tools for the financial analyst, the laboratory technician, and the physics major. DIGITAL REVIEW reports on the latest innovations and how you can use them in your field.



WORD PROCESSING: You'll learn the newest techniques that will make your office as efficient and as cost-effective as possible.

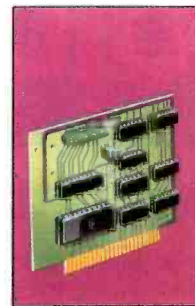

SOFTWARE: Whether it's the newest in operating systems... or advances in computer networks, DIGITAL REVIEW keeps you up-to-date... and spotlights releases that are changing the way businesses conduct their business.

I/O FEEDBACK: A chance for you—the user—to network your application needs and ideas.





Save up to 36%!

Now, through this Special Introductory Offer, you can save up to 36% when you subscribe to **DIGITAL REVIEW**.



digital
review

P.O. Box 2989
Boulder, CO 80322

YES! I want to subscribe to Digital Review for:

One year (12 issues) for \$24.97—I save 16%!

Two years for \$43.97—I save 27%!

Three years for \$57.97—I save 36%!

Savings based on full one-year subscription price of \$29.97
Add \$13 for Canada and all other foreign countries.

CHECK ONE: Payment enclosed Bill me
Charge my: American Express MasterCard VISA

Account No. _____ Exp. Date _____

Name _____

Address _____ **8H039**

City _____ State _____ Zip _____

Please allow 30 to 60 days for delivery of first issue.

Would you like to receive special offers from qualified users of our mailing list? Yes No

Now 60 MHz or 100 MHz Tek quality is just a free phone call away!



Tek has expanded its best-selling 2200 scope line up to 100 MHz. And brought it all as close as your phone. Tek's revolutionary, reduced-component architecture brings unprecedented quality, reliability and affordability to the 60 MHz 2213 and 2215, and now, the 100 MHz 2235.

All three of these lightweight (13.5 lb.) scopes feature 2 mV/div vertical sensitivity and 5 ns/div sweep speeds, plus a complete trigger system for stable triggering on digital, analog or video waveforms.

Scopes with a comprehensive 3-year warranty*... probes... and expert advice. One free call gets it all! You can order, or obtain literature, through the Tek National

	2213	2215	2235
Bandwidth	60 MHz	60 MHz	100 MHz
No. of Channels	2	2	2 + Trigger View
Alternate Sweep	—	Yes	Yes
Vert/Trig B/W Limit	—	—	Yes—20 MHz
Single Sweep	—	—	Yes
Accuracy: Vert/Horz	3%	3%	2%
Delay Jitter	1:5,000	1:10,000	1:20,000
Trigger'g Sensitivity	0.4 div at 2 MHz	0.4 div at 2 MHz	0.3 div at 10 MHz
Input R-C	1M Ω -30pf	1M Ω -30pf	1M Ω -20pf
Variable Holdoff	4:1	4:1	10:1
Price	\$1200†	\$1450†	\$1950†

Marketing Center. Technical personnel, expert in scope applications, will answer your questions and expedite delivery. Direct orders include operating and service manuals, two 10X probes, 15-day return policy, and worldwide service back-up.

**Call toll-free:
1-800-426-2200,
Extension 79.**

In Oregon, call collect:
(503) 627-9000, Ext. 79.

†Price F.O.B. Beaverton, OR.
*3-year warranty includes CRT and applies to 2000 family oscilloscopes purchased after 1/1/83. Scopes are UL Listed, CSA and VDE approved.

Tektronix®
COMMITTED TO EXCELLENCE

Circle No. 82 on Free Information Card

HEX/ASCII/DECIMAL CONVERSION CHART

By Leslie Solomon

THERE are occasions when certain pieces of software require the insertion of alphanumerics (or other elements of the ASCII character set) into a program and one needs to know the hexadecimal or decimal equivalents. Other times, a computerist might want to know just what ASCII characters are represented by a group of hex or decimal numbers. The chart shown here provides an aid in converting hex and decimal numbers into their equivalent ASCII codes and vice versa.

Each box in the chart illustrates a

character and gives its decimal equivalent. The hex equivalent is found by the numbers of the rows and columns of the boxes. That is, to determine the ASCII equivalent of a hex byte, locate the row by its most significant byte (MSB), then move to the column under the least significant byte (LSB). The desired ASCII code is found at the intersection.

For example, assume the hex byte is 41. Proceed down the MSB to 4, then move to the right to the LSB of 1. The ASCII code there is A. The decimal equivalent is 065.

This approach can be used in reverse to determine the hex equivalent of an ASCII character. For example, to find the hex for lower-case g, locate this character on the chart. Note that it is at the intersection of MSB 6 and LSB 7. So the hex byte is 67. The decimal equivalent is 103.

The upper group of boxes shows where the control codes fit as indicated by the carets pointing up. The chart also identifies the first 33 nonprinting codes and explains what the abbreviations stand for. ◇

		LSB															
		0	1	2	3	4	5	6	7	8	9	A	B	C	D	E	F
MSB	0	NUL ^ 000	SOH ^ 001	STX ^ 002	ETX ^ 003	EOT ^ 004	ENQ ^ 005	ACK ^ 006	BEL ^ 007	BS ^ 008	HT ^ 009	LF ^ 00A	VT ^ 00B	FP ^ 00C	CR ^ 00D	SO ^ 00E	SI ^ 00F
	1	DLE ^ 016	DC1 ^ 017	DC2 ^ 018	DC3 ^ 019	DC4 ^ 020	NAK ^ 021	SYN ^ 022	ETB ^ 023	CAN ^ 024	EM ^ 025	SUB ^ 026	ESC ^ 027	FS ^ 028	GS ^ 029	RS ^ 030	US ^ 031
	2	SP 032	!	"	#	\$	%	&	'	()	*	+	,	-	.	/
	3	0	1	2	3	4	5	6	7	8	9	:	;	<	=	>	?
	4	@	A	B	C	D	E	F	G	H	I	J	K	L	M	N	O
	5	P	Q	R	S	T	U	V	W	X	Y	Z	[]	^	_	
	6	,	a	b	c	d	e	f	g	h	i	j	k	l	m	n	o
	7	p	q	r	s	t	u	v	w	x	y	z	{	}	~	DEL	

NUL = null
 SOH = start of heading
 STX = start of text
 ETX = end of text
 EOT = end of transmission
 ENQ = enquiry
 ACK = acknowledge
 BEL = bell
 BS = backspace
 HT = horizontal tab
 LF = line feed

VT = vertical tab
 FF = form feed
 CR = carriage return
 SO = shift out
 SI = shift in
 DLE = data link escape
 DC1 = direct control 1
 DC2 = direct control 2
 DC3 = direct control 3
 DC4 = direct control 4
 NAK = negative acknowledge

SYN = synchronous idle
 ETB = end transmission block
 CAN = cancel
 EM = end of medium
 SUB = substitute
 ESC = escape
 FS = form separator
 GS = group separator
 RS = record separator
 US = unit separator
 SP = space

New from McGraw-Hill

CRAM COURSE IN MICROCOMPUTERS

Now, save time, money and confusion as you learn how to choose and use the personal computer that's right to handle your problems. McGraw-Hill's new Cram Course in Microcomputers is for Executives, Managers, and Professionals looking for the competitive edge but not exactly sure where to begin.

Now you've got to perform. You've got to catch up with the computer age fast. Personal computers are already sitting on thousands of executive desks . . . forecasting, analyzing, communicating. In thousands of small businesses . . . doing payroll, billing, inventory. And in thousands more homes . . . doing taxes, budgets, teaching, and entertaining.

Strip away all the advantages of a microcomputer system and there's still one fact you just cannot ignore—with a personal computer on your desk, you're making an immediate, positive statement about yourself and your commitment to improving your managerial and personal efficiency (by as much as 30%, according to some experts). You're placing yourself on the fast track for growth and promotion.

Easy Audio / Tutorial System

The McGraw-Hill Microcomputer Program will show you how to make the most of this incredible opportunity. Quickly, conveniently and inexpensively, through audio cassette tapes and vividly clear, integrated text, you'll get full understanding of the advantage of having a personal computer.

You'll learn just what a computer can do, how it does it, and what's required to make it happen. You'll know how to select the computer that's best for you, without paying too much for excess capacity or committing the probably greater mistake of paying too little for a computer inadequate for your needs.

How to Pick a Computer

First, you have to know how to identify your computing needs, and we show you that in detail. Then, we'll show you how to match your needs against such name brands as IBM, Osborne, Xerox, and Apple. And to do it objectively, without having to depend on the dubious "expertise" of a salesman.

You do it all with the McGraw-Hill Cram Course in Microcomputers, the personal program that comes to you. As you listen to professional presentations on audio cassette tapes, interact with self-teaching drills and demonstrations, you'll become thoroughly comfortable with what formerly seemed to be impossible technical complexities and incomprehensible jargon. Because you control this program, you can



Put the power of a personal computer to work for you immediately!

PROGRAM OUTLINE

What a small computer can do for you
• Matching a computer to the job you want it to do for you • Comparing small computers
• What kind of software • How much memory • What kind of chip • What kind of storage • Strategies for getting started
• Follow-up services • Survey of off-the-shelf software • The office of the future.

PLUS YOU GET ALL THIS

- 6 subject modules
- 6 audio cassette tapes
- 200-page, illustrated text
- Handsome leather-grain vinyl binder
- Datapro's latest computer comparison report (\$29.95 retail)

repeat whatever's necessary or skip quickly through anything you already know.

We show you what to expect and what has to be done to perform with speed and efficiency functions like bookkeeping, bill paying, inventory control, word processing, analyzing and forecasting.

From the Leader in Business Publishing

It took McGraw-Hill's unique experience as the world's largest educational and business publisher to create this practical, useful, one-of-a-kind program. It starts you at the beginning. No need for any experience with computers, no need to even own one. It's the drama of a seminar

and the depth of a book, combined into a single, personal learning program.

15-Day Free, No-Risk Examination

This program is something you have to see and experience for yourself to appreciate. And you can do it without risk or obligation. Just order by coupon or call toll free and we'll send the complete Cram Course in Microcomputers to you to examine free for 15 days. If you're not absolutely satisfied that this is exactly what you need, just pack everything back in the box and return it. We'll cancel your charge or return your payment immediately.

**TO ORDER MAIL COUPON OR CALL TOLL FREE
AND USE YOUR VISA, MASTERCARD, OR AMERICAN EXPRESS
Call 1-800-323-1717 . . . Ask for Operator 51 . . . Order Program No. 3540-103
(In Illinois, call 1-800-942-8881)**

**McGraw-Hill's New Cram Course in Microcomputers
NO RISK, FREE EXAMINATION ORDER FORM**



Mail to: McGraw-Hill Continuing Education Center
3939 Wisconsin Avenue, NW, Washington, DC

YES, without risk or obligation, please send me the Cram Course in Microcomputers for a FREE, 15-DAY EXAMINATION. The cost is just \$95.00 plus \$4.75 for shipping and handling. I may return the program within 15 days for a full refund or cancellation of credit card charges.

Name _____ (Please Print)

Street Address _____

City/State/Zip _____

- If sending check or money order, fill out this coupon and mail together in envelope.
(D.C. residents add 6% sales tax.) Payable in U.S. funds only.
- Charge to my: VISA MasterCard American Express

Card No. _____ Expiration Date _____

Signature _____ Date _____

(Credit Card charges not valid unless signed)

3540-103

Light Chaser

A Microprocessor Controller for Light Shows

Spectacular, multi-pattern effects can be achieved by changing software

By Fernando Viesca

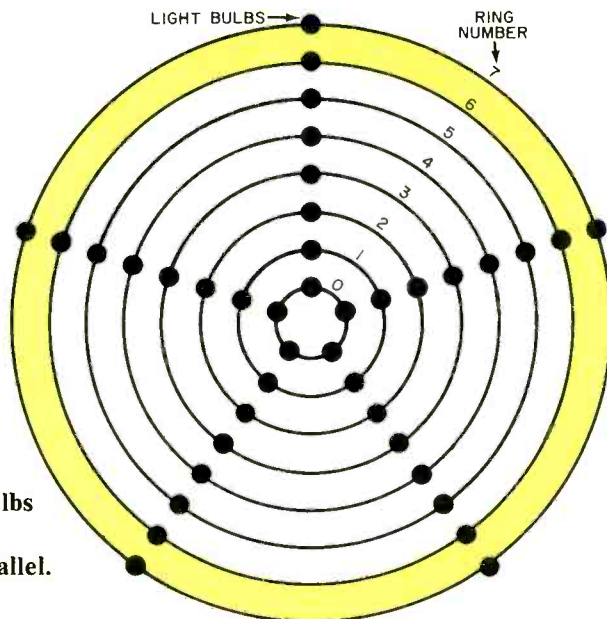

Fig. 1. All the bulbs in one ring are connected in parallel.

ANYONE who has gone to a discotheque has been amused by the striking visual effects achieved with the movement of light. Lately, exotic light sources such as lasers have been in use. But the workhorse, and perhaps the light show most used, is the light chaser. Basically, the light chaser controls a string of light bulbs in a given sequence. By arranging the lamps in arrays or figures, a pleasing effect of movement is created. The bright lamp bulbs appear to chase the dark bulbs, and thus the name "light chaser."

Historically, light chasers were first used in theater displays to attract attention. In those pre-digital days, the chasers relied almost exclusively on electro-mechanical devices. By means of bands and pulleys, an electric motor drove a cam full of switches, which, in turn, energized a bank of relays. In operation, the accompanying noise resembled a

LIGHT CHASER



hailstorm on a tin roof. Let's take a look at how electronics could be used to create a nonmechanical light chaser.

Suppose we have a star pattern light-bulb array such as that shown in Fig. 1. All bulbs in the same ring are connected in parallel so that, when power is applied to that ring, all five bulbs will light. Assume that the light pattern desired starts with the center ring (ring 0) glowing, followed by each succeeding ring glowing until all eight rings of light are lit. At this point, we want the entire array to blink twice, turn off, then start the pattern over again.

To perform this relatively simple sequence, all that is needed is a clock, several flip-flops, some gates, and eight light-bulb drivers capable of handling each rings.

If you decide to alter the light pattern to make the array expand and contract, you soon discover that even such a simple change involves large hardware changes. If you decide on more extensive pattern changes, the electronic design becomes very complicated. A microprocessor, however, simplifies the circuitry. Using one of these ubiquitous semiconductor devices allows extensive pattern modifications—even multi-pattern designs, with no hardware modifications. All that has to be done is to program the microprocessor.

Although the software (Listing 1) was written for the 1802 microprocessor, if the principles are understood, the flowchart shown in Fig. 2 can be implemented on any microprocessor.

Flowchart Description. The Initialize block defines which register will act as the data pointer, sets a memory byte on which the length of the time interval between memory readout processes will be written, and sets the high-order byte for the memory area of the sequence (data). This particular block is written for the 1802's unique addressing modes, so it may be deleted or modified for other microprocessors.

The Data Pointer block points to the first data word to be read.

To Output a Byte using an 1802, a single instruction fetches a data word, enables an output port, and increments the data pointer. In this case, output port #3 is enabled. In other processors, it is necessary to read from memory into the accumulator, then write to the output port.

The Input Time Interval features a single instruction that enables input port #3 and writes the data word at the memory location pointed by data point-

er B. If fixed time delay is desired, delete the EB,6B instructions at addresses 1A and 1B of Listing 1, and use a Load Immediate (F8) instruction followed by the time byte. If the input port is used, the time delay can be set by switches. The switches need not be debounced.

In the Decrement Time Interval block, the data from the input port is decremented by one and tested for zero. This allows the processor to create a loop whose only function is to slow down the memory reading to a level acceptable for the eye. Since the speed of the sequence is proportional to the input word, it will change with the input after the current loop reaches zero. After the predetermined time has expired and register E reaches zero, the original data pointer is restored.

“By arranging lamps in arrays or figures, a pleasing effect of movement is created.”

In the End of Sequence, the fetched byte is masked with an exclusive-OR instruction and tested. Remember, XOR will yield zeros only if the byte under test and the masking byte are identical. If not zero, then the byte under test is data and program operation is resumed. If zero, then this byte means the end of the sequence. The data pointer is restored to the first data word, and the sequence starts over.

Program Implementing. Listing 2 shows a short program starting at address 0026 (called from the main program of Listing 1). Where a ring is to be illuminated, write a 1 at the ring number; and where a ring is to be dark, mark a 0 at that point. The resulting 1s and 0s are then coded into hex to be used by the computer. This listing shows how easy it is to change the lighting sequence simply by changing a 1 or a 0 as desired, then changing the hex code fed to the processor.

The end-of-sequence byte (77H at address 0033 in Listing 2) may be any hex value, but care must be taken so that the value selected appears only at the end of the sequence. If this value appears elsewhere in the data, the program will end sooner than expected—ignoring any

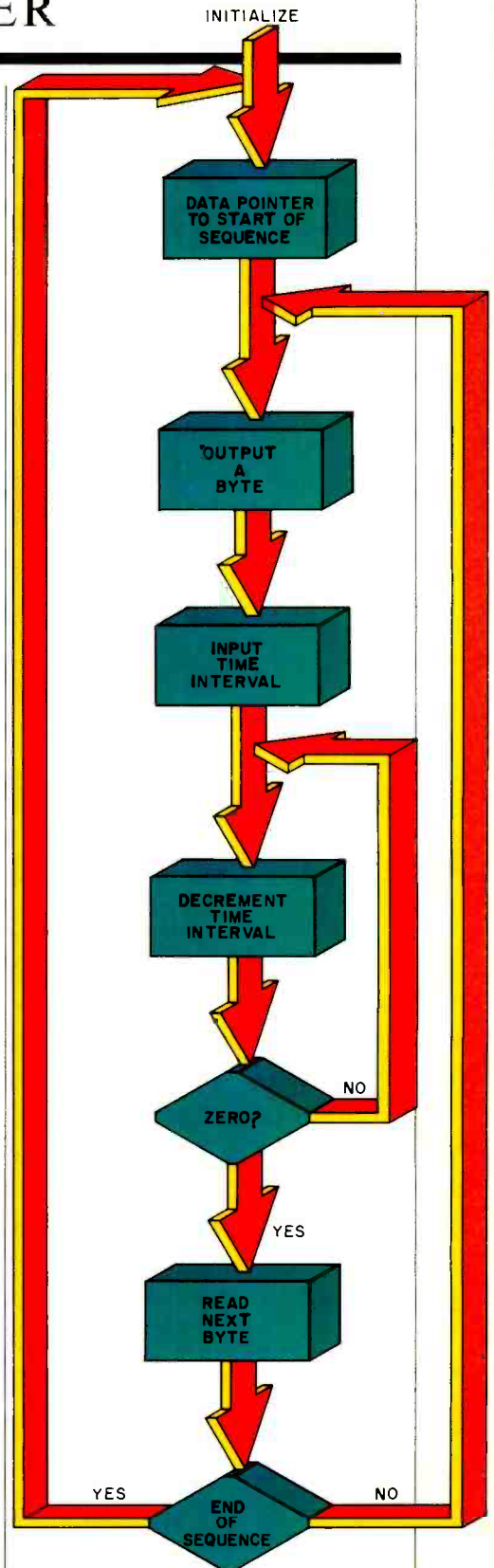

Fig. 2. The basic flowchart can be implemented on any microprocessor.

A NEW BREAKTHROUGH

**SAVE UP TO 50%
WITH OUR CHARTER
SUBSCRIPTION
OFFER!**



Introducing **A+**, the Most Significant Advance in Apple History!

It's here! Big, bold and bursting with page after page of the latest in hardware, software, programming—and more! **A+** is the monthly magazine written exclusively for your Apple microcomputer. Each issue gets you involved with a host of fascinating features, probing updates, unique departments—and reaches to the depths of your imagination to challenge you with daring new strategies and adventures!

Here's just a sampling of what **A+** is all about:

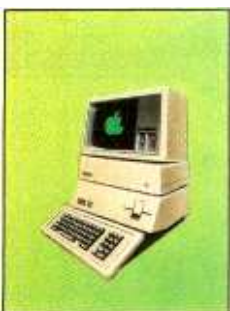

HARDWARE: From the latest advances in telecommunications and networking...to new ways to augment memory and access a wider variety of peripherals with greater ease...each issue of **A+** gets you involved.

SOFTWARE: What's new on the market and how you can make your system more powerful...plus full reviews and programming information.



UTILITIES AND DIAGNOSTICS: In addition to language utilities, **A+** helps you troubleshoot problems... makes you faster and more efficient...with utilities ranging from record processing to data transfer.

BUSINESS AND FINANCE AIDS: Software for financial forecasting and analysis...general accounting programs...financial news retrieval services...and business graphics so you can see just where your money is going.

GAMES: Take the **A+** challenge—with hoards of innovative brain teasers...from games to help you learn spelling and arithmetic...to games that provide fun and adventure!

FOR YOUR APPLE™



PROGRAMMING TOOLS: Speed up program development with Apple text editors, testing and debugging aids and data base management systems. Since your Apple can speak many languages—from Cobal to Basic and Pascal—**A+** gives you a wide range of utilities for each language so you can create your own exciting programs.



HOME / PERSONAL PROGRAMS: covers it all...from basic processing...to helping you draw with Apple graphics...to speed reading...music theory and composition... even a course on cooking with your Apple... and then how to monitor your diet easily and accurately...along with many educational programs to learn math, science, and geography.

DATA FILES: Let **A+** probe new data base management systems so you'll be able to organize, store and retrieve information in ways you never thought possible.



YOUR TURN: Speak up with your ideas and innovations and network with other Apple users near and far.

Plug into Savings of Up to 50% with Our Limited Time Charter Offer, Good Until Nov. 30, 1983

YES! I want to subscribe to **A+** for:

- One year (12 issues) only \$15.49—38% off
- Two years only \$26.49—47% off
- Three years only \$37.49—50% off

Savings based on full one-year subscription price of \$24.97.

Name _____ **8H070**

Address _____

City _____

State _____ Zip _____

Check One: Payment enclosed. Please bill me.

Please charge my: MasterCard VISA American Express

Card No. _____ Exp. Date _____

Would you like to receive special offers from qualified users of our mailing list? YES NO

MAIL TO: **A+**, P.O. Box-2964, Boulder, CO 80322

LIGHT CHASER

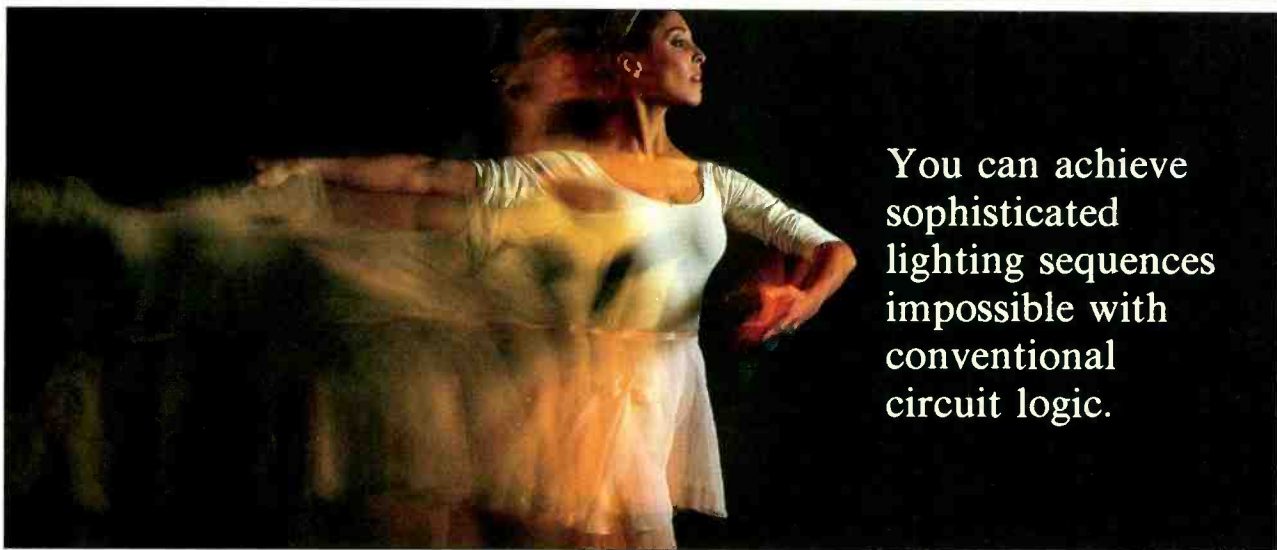

You can achieve sophisticated lighting sequences impossible with conventional circuit logic.

further data. Be careful to use equal values for this byte and the masking byte in the main program—the instruction right after the XOR-immediate instruction at address 014 of Listing 1. The rings do not light up at address 033 since this is where the program restores to address 0026. Although address 0033 contains 77H, it should be thought of as 0000 0000 since no lamps are lit. Following these guidelines, a simple se-

quence can be written and run. If desired, the hex code of Listing 2 can be changed to try another, different, sequence.

Hardware. The interface circuit shown in Fig. 3 can be used if the computer output port is latched and buffered.

When an output bit goes high, the associated transistor (*Q1* through *Q8*) turns on. Current then flows through

the LED portion of the associated optocoupler which, in turn, causes the light-sensitive triac to turn on. When this occurs, the associated power triac operates to allow line current to pass through socket *SO1* and the protective fuse. The optional red LED and its current-limiting resistor provide proof that the transistor has turned on.

Once the power triac is turned on, any lamp that is plugged into *SO1* will

LISTING 1

Address	NME	Hex	Comments
0000	SEX'C'	EC	Main program data pointer
01	LDI	F8	Memory byte for time interval data pointer
02		00	
03	PHI'B'	BB	
04	LDI	F8	
05		25	
06	PLO'B'	AB	
07	LDI	F8	Memory area for sequence data pointer
08		00	
09	PHI'C'	BC	
0A	LDI	F8	
0B		26	
0C	PLO'C'	AC	
0D	NOP	C4	
0E	OUT'3'	63	Output
0F	NOP	C4	
10	NOP	C4	
11	BR	30	To time routine
12		1A	
13	LDX	F0	
14	XRI	FB	Test if next byte equals masking byte
15		77	To output, sequence continues
16	BNZ	3A	To start of sequence
17		0D	
18	BR	30	
19		0A	
1A	SEX'B'	EB	Time routine data pointer
1B	INP'3'	6B	Input time
1C	PHI'E'	BE	
1D	DEC'E'	2E	Decrement

1E	GHI'E'	9E	
1F	NOP	C4	If not zero,
20	BNZ	3A	continue loop
21		1D	
22	SEX'C'	ED	Restore and branch
23	BR	30	to the main programs
24		13	

LISTING 2

Address	Ring #	Hex Code	Comments
0026	0000 0000	00	start, all off
0027	0000 0001	01	first ring on
0028	0000 0011	03	next ring on
0029	0000 0111	07	next ring on
002A	0000 1111	0F	next ring on
002B	0001 1111	1F	next ring on
002C	0011 1111	3F	next ring on
002D	0111 1111	7F	next ring on
002E	1111 1111	FF	all rings now on
002F	0000 0000	00	all rings off
0030	1111 1111	FF	all rings on
0031	0000 0000	00	all rings off
0032	1111 1111	FF	all rings on
0033	0111 0111	77	end of sequence

LISTING 3

000D	OUT 3	63	OUT low byte
000E	SEQ	7B	Set Q
000F	OUT 3	63	Out, high byte
0010	REQ	7A	Reset Q

LIGHT CHASER

operate. The use of an opto-coupler isolates the computer output port from possibly damaging voltage spikes on the power line.

Using the parts specified in Fig. 3 and proper heat sinking, 500 W/channel can be supplied. With all rings on, 4000 W are required, thus the correct wire gauges must be used. Note that two types of opto-couplers are specified for *OCI*. The MOC3030 features zero voltage switching, which reduces r-f noise on the power line. This opto-isolator should be used when more than 60 W per channel is being switched.

16-Bit Output. If a spectacular or complex light pattern is desired, then a 16-channel output (and an extra 8-input power controller) are required. The following uses output ports 3 and 4.

The trick is to place the low-order byte in an even-memory address, and the high-order byte in an odd address. In Listing 1, at address 00F, substitute a 64 (OUT 4) instruction for the C4 (NOP) currently there. The low byte will then appear at output port 3 and the high byte at output port 4. Since the time required by the computer to execute these instructions is too short for the human eye to detect, the program appears as a single 16-bit output.

If you are using an RCA VIP computer, which has a single output port, a software trick is required. Change Listing 1 to reflect the changes in Listing 3.

Note that the Q line is set after the first output instruction. The Q line also enables a pair of quad latches (Fig. 4) to capture the low-order bytes, then resetting immediately to enable a second pair of latches.

Other Possibilities. Many other light-chaser options are available. They include:

(1) Dual output. With a 16-bit output, two independent 8-bit sequences can run simultaneously. Hardware-software is identical, but program 1 is stored in odd addresses and program 2 in even addresses. Though the sequences are independent, they do bear a timing relationship, so for best visual effect they should be located away from each other.

(2) Strobe lights, black lights, projectors. If the Q line is not used, it can be tied to a transistor/optocoupler/Triac arrangement as shown in Fig. 3. Change the software to set Q for about 3 or 4 complete sequences, and then reset for 3 or 4 complete sequences. Thus, slow changing loads can be controlled.

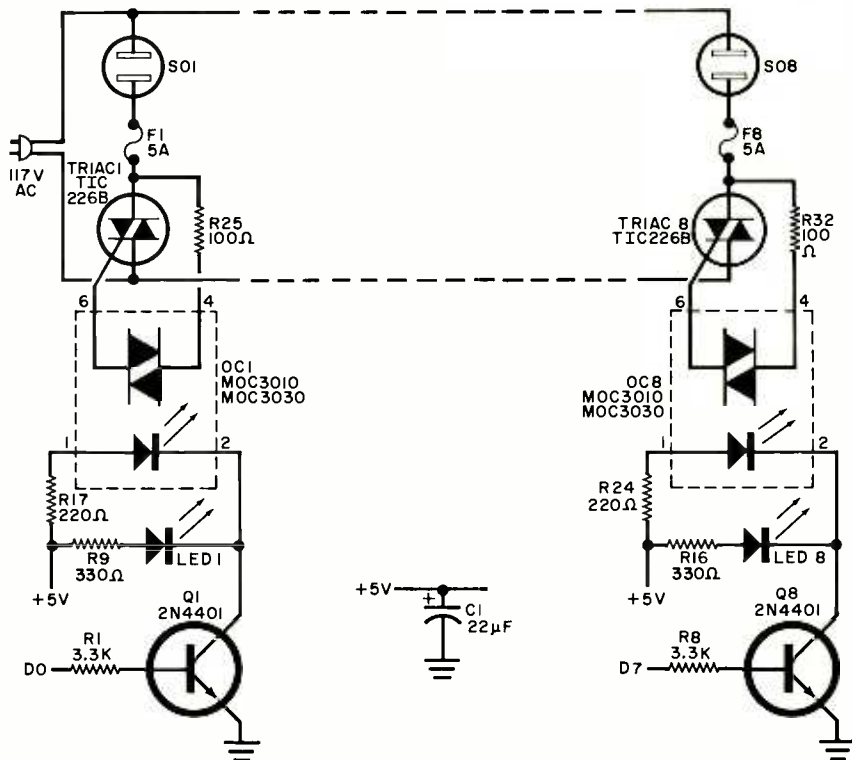

Fig. 3. Using parts shown in this interface 500 W/channel can be supplied.

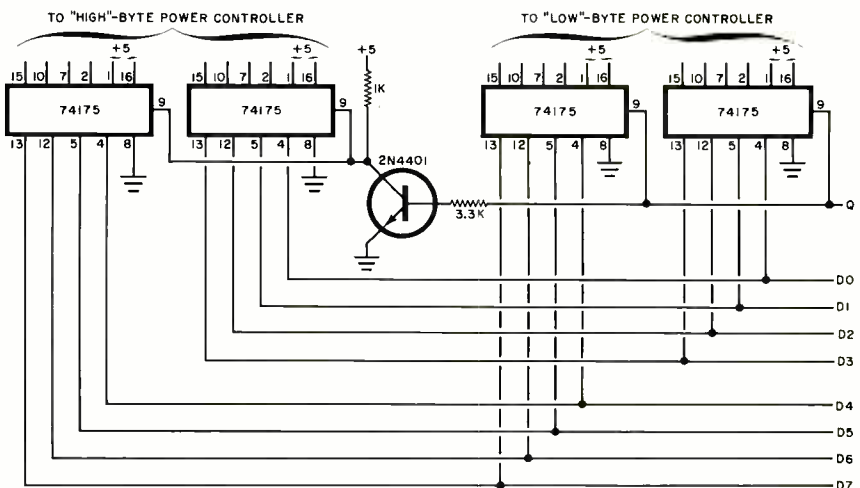

Fig. 4. Circuit for a 16-channel interface.

(3) Program change. The 1802 has four software-testable flags: EF1, EF2, EF3, and EF4. These flags can be connected to switches and tested by software. The tests then change the data pointer's address to a different sequence. Before using any flag, however, check that it will not interfere with the computer's operating system.

Summing Up. Your light chaser's capabilities can grow with your skill. With patience, you can write very sophisticated sequences that are next to impossible to build with conventional circuit logic. You can also modify them with a minimum of expense and effort. Computer programming has come a long way from mechanical devices! ♦

Synonyms for Word Processing

The Electronic Thesaurus runs on CP/M and provides synonyms for 5000 words

By Ernest E. Mau

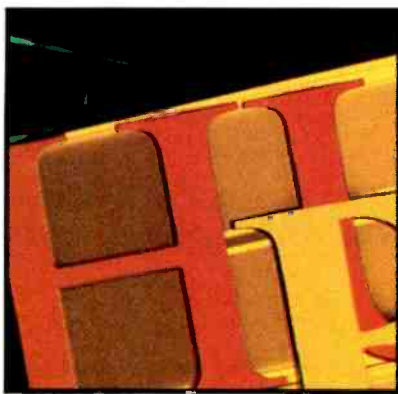

As a professional writer and reviewer, I've used many different word processors, spelling proofreaders, and card-file management systems. I've also used, in conjunction with my work, a bibliography management program, a footnoting program, a style and grammar proofreader, and packages that prepare document indexes and tables of contents. About the only thing I had been lacking was an automated method of looking up synonyms while I wrote at the keyboard. (I've always had to pause and refer to one or more books.) Now Dictronics Publishing, Inc. has filled that last gap with its delightful new program called The Random House Electronic Thesaurus®.

The concept of a computerized thesaurus isn't new. However, Dictronics appears to be the first to market a workable and economical thesaurus program that's not specific to a particular brand of hardware. The Random House Electronic Thesaurus runs on virtually any CP/M-based system, with or without a word processor. If used directly from

the operating system without a word processor, it's a fast and convenient tool. Just run the program, type the word being sought, and view the list of synonyms a few seconds later. By itself, that's not particularly impressive, and the program doesn't really show its advantages until operated under the control of a word processor such as WordStar.

The Electronic Thesaurus works differently than most enhancements to WordStar. Instead of being run outside the processor, installation of Electronic Thesaurus modifies the processor to add a new key (command) function. The escape key is activated as the thesaurus control command. Literally at the touch of a button, Electronic Thesaurus provides synonyms for 5000 of the most used and overused English words, drawing from a master thesaurus containing 60,000 synonyms. In displaying the synonyms, it even identifies the specific parts of speech, though it doesn't attempt to group synonyms by



degrees of meaning and doesn't provide antonyms.

Electronic Thesaurus is so easy to use, it's almost unnerving. With the text displayed on the screen, you just position the cursor anywhere in a word or on the space following a word, tap the escape key twice, and the list of synonyms is displayed at the top of the screen. Text is moved down automatically to make room for the list of synonyms. To abort back to the unchanged document, you just press the return key. To select any synonym, just use the space bar and backspace (or regular whole-word cursor movement keys) to

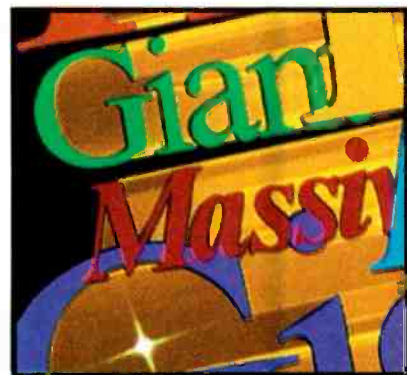

move forward or backward a word at a time until positioned on the desired one, and then press the key one more time.

Behold! The original text word is replaced by the synonym automatically. Talk about user friendliness! Since you don't type the replacement word, you eliminate the chance of a typographical or spelling error. The whole process is neat, clean, and takes less than 10 seconds. Try looking up a synonym in a reference book and entering it with manual editing in 10 seconds!

If the original word is not among the 5000 preselected key words, the program indicates that at the top of the screen and provides its best guess about a possible alternate. The suggested alternate is surrounded with other keywords both preceding and following (alphabetically) the best guess. From this point, you can either terminate the search by pressing the return key or position the cursor on an appropriate alternate keyword. By pressing the escape key with the cursor on an alternate, the synonyms for that word are displayed. If the escape key is pressed again, the synonym under the cursor is inserted into the original text.

Throughout, Electronic Thesaurus is an attractive, easy-to-use package, but it does have some limitations. Perhaps the most noticeable and potentially most troublesome is that there's no provision for altering, expanding, or customizing the thesaurus. The user is tied to Dictronics' particular keyword and syn-



onym selections and has no way to build the thesaurus into a tool specific for his or her applications. Perhaps this won't be a major problem to many users, but writers in specialized fields such as technical, scientific, or medical communication could find it confining. A Dictronics' representative has indicated that the nature of the library compression technique and the indexing method probably preclude a user-update or user-modification module. However, they do plan to market expanded libraries, which may or may not alleviate the problem, but which will work only for those users having sufficient storage space on a diskette.

Another somewhat disturbing feature is that the thesaurus is not fully cross-referenced. A particular key word may give a list of synonyms, but there's a high probability that the synonyms are not key words themselves and cannot be used to get back to the original. As a result, synonym searching often

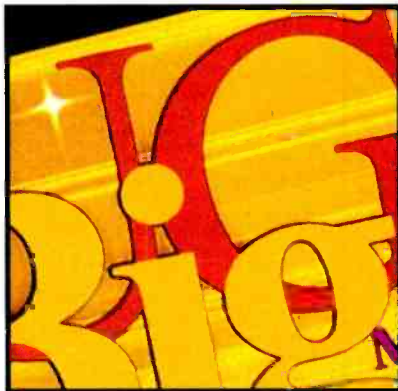

goes in one direction only. To illustrate how this works, one listed synonym for the word *writing* is *authoring*. However, one cannot go the reverse way to find *writing* as a synonym for *authoring*. In fact, neither the root word *author* nor any other derivative of that word is included in the acceptable key words.

The statement that *Electronic Thesaurus* provides 60,000 synonyms for 5000 words sounds like a great many references. While it is a substantial number, it's certainly not excessive and

may not even be adequate for professionals who earn their livings writing. Remember that only 5000 key words can be looked up, and that is the number of greatest concern. If all 60,000 synonyms could have been cross-referenced to provide a true 60,000-word thesaurus, it would have made the program far more versatile and useful.

Another area may be of concern, although it relates to inconsistencies in the English language and is not a flaw in the program. Simply stated, the program does not handle word endings automatically. These include *s* for plurals, *ed* for past tense, *ing*, and others. Most often, the program operates by looking up and substituting root words. Consider the word *stated*. Looking it up, *Electronic Thesaurus* indicates it's not listed, but the alphabetically closest word is *state*. Using that as an alternate results in a list of 38 synonyms, one of

BEHOLD!

The original text word is replaced by the synonym automatically. Talk about user friendliness!

which is *express*. Selecting that as an acceptable synonym, *express* is substituted for *stated* in the text, but the editing functions must be used to add the *ed* ending to obtain *expressed*. Had the program been designed to duplicate endings, the often erratic behavior of English probably would have generated more misspellings than correct spellings.

The program I tested did have a minor bug, but Dictronics is aware of it and may be able to fix it before this review is published. Using line lengths greater than 80 columns under WordStar 3.0 causes lines to extend beyond the right edge of the screen, often splitting words midway until the screen is scrolled horizontally. As a result, only part of a word is on the screen at one time. When this happens, positioning the cursor on the visible portion and allowing part of the word to remain invisible results in an improper thesaurus search. The program only registers those letters that can be seen, omitting any extension beyond the right screen edge. It doesn't happen at the left edge, so positioning the cursor in the space immediately following the desired word always causes a correct search whether the whole word can be seen or not.

A couple of other points are worthy of mention. The early releases of the

program let some Z80 code slip through. Thus, these versions won't run on 8080/8085 microprocessors. Again, Dictronics personnel are making the appropriate changes to eliminate that processor-specific code. Also, the program will not work with ANSI (American National Standards Institute) terminals using numerically coded cursor commands. However, since most popular terminals for small computers are not ANSI types, the problem should be minimal.

For people using SpellStar, memory conflicts in the modified WordStar will prevent subsequent use of that proofreader. There are two ways around this. One is to purchase some other spelling proofreader. The other is to have the system disk also contain an unmodified copy of WordStar so that the modified version can be exited and the unmodified version entered when it's time to do the spelling check.

Overall, the minor problems with *Electronic Thesaurus* certainly don't harm its appeal or usefulness to the average word-processing user. Though there is some room for later improve-



ments, the program functions well. It's a pleasure to use and has proven valuable even in my own specialized endeavors. At \$150, including a copy of *The Random House Thesaurus* (pocket edition), I consider it a worthwhile investment. If someone is in the habit of using reference books, the time saved can easily offset the cost of the software.

The roster of compatible computer systems and word processing software is expanding quickly. The initial release of *Electronic Thesaurus* is designed for a CP/M operating system (or equivalent) with a minimum 56K memory and WordStar. It's expected that the software soon will be available for the IBM Personal Computer, Apple II (with CP/M), TRS-80, and others. Word processors will include Peachtext, Scripsit, EasyWriter, etc. (Interested potential users should contact Dictronics Customer Service, PO Box 367, Tijeras, NM 87059 to determine if a particular system is compatible.) ◊

COMPUTER MAIL ORDER

TeleVideo

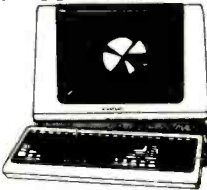

TERMINALS

910	\$559.00
912	\$689.00
920	\$739.00
925	\$719.00
950	\$929.00
970	CALL

COMPUTERS

800A	\$1099.00
802	\$2699.00
803	\$1949.00
802H	\$4695.00
806/20	\$4999.00
816/40	\$9199.00
1602	\$3399.00
1603	CALL

MODEMS

HAYES

Smart	\$219.00
Smart 1200 (1200 Baud)	\$519.00
Chronograph	\$199.00
Micromodem 100	\$309.00
Micromodem II	\$279.00
Micromodem II (with term)	\$299.00
Smart Com II	\$99.00
Smart 1200B	\$469.00

NOVATION

J-Cat	\$119.00
Cat	\$144.00
D-Cat	\$159.00
103 Smart Cat	\$189.00
Apple Cat II	\$279.00
103/212 Smart Cat	\$439.00
212 Apple Cat II	\$609.00
Apple Cat II 212 Upgrade	\$309.00

ANCHOR

Mark I (RS-232)	\$79.00
Mark II (Atari)	\$79.00
Mark III (T. I. 99)	\$109.00
Mark IV (CBM-PET)	\$125.00
Mark V (Osborne)	\$95.00
Mark VI (IBM-PC)	\$179.00
Mark VII (Auto Ans/Auto Dial)	\$119.00
Mark VIII	\$269.00
TRS-80 Color Computer	\$99.00
9 Volt Power Supply	\$9.00

ZENITH

ZT1 Terminal	\$369.00
--------------	----------

FRANKLIN



CALL

ACE 1000 Color Computer
ACE 1100 Drive & Cover for ACE 1000
ACE 1200 Computer with Disk Drive
ACE PRO PACK

ACE 1000. Disk Drive.
80 Column Card. ACECalc &
ACEWriter II

MICRO-SCI Apple & Franklin

A2	\$249.00
A40	\$349.00
A70	\$459.00
C2 Controller	\$79.00
C47 Controller	\$89.00

RANA

Elite I (Apple/Franklin)	\$279.00
Elite II (Apple/Franklin)	CALL
Elite III (Apple/Franklin)	CALL

EAGLE



II-E-1	\$1369.00
II-E-2	\$1649.00
II-E-3	\$2399.00
II-E-4	\$3199.00
PC-E	\$1579.00
PC-1	\$2399.00
PC-2	\$2799.00
PC-XL	\$3599.00
1620	\$3599.00
1630	\$5499.00
1640	\$6499.00
Cyma Software	CALL

Commodore



CBM 8032

\$599

CBM64 \$219
VIC 20 \$99

CALL ON

Executive 64 Portable

1520 Color Printer/Plotter	\$169.00
1525 80 Column Printer	\$219.00
1526	\$319.00
1530 Datasette	\$69.00
1541 Single Disk Drive	\$249.00
1600 VIC Modem	\$59.00
1650 AD/AA Modem	\$89.00
1701 14" Color Monitor	\$249.00
Pet 64	\$569.00
Pet 4032	\$599.00
CBM 8032	\$599.00
Super Pet	\$999.00
B128-80	\$769.00
BX256-80	\$969.00
2031	\$299.00
4040	\$649.00
8050	\$949.00
8250	\$1199.00
9060	\$1999.00
9090	\$2199.00
4023	\$379.00
6400	\$1399.00
64K Upgrade	\$269.00
Spell Master	\$149.00
Z-Ram	\$549.00
Silicon Office	\$749.00
The Manager	\$209.00
Soft Rom	\$129.00
Jinsam	CALL
Call Result 64	\$139.00

PROFESSIONAL SOFTWARE

Word Pro 2 Plus	\$159.00
Word Pro 3 Plus	\$189.00
Word Pro 4 Plus	\$279.00
Word Pro 5 Plus	\$279.00
InfoPro	\$179.00
Administrator	\$399.00
Power	\$79.00
Word Pro 64 Plus	\$65.00

CARDCO for VIC 20/64

Light Pen	\$32.00
Cassette Interface	\$29.00
Parallel Printer Interface	\$69.00
3 Slot Expans. Interface (20)	\$32.00
6 Slot Expans. Interface (20)	\$79.00

ATARI HOME COMPUTERS

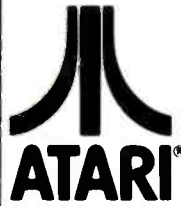

ATARI 600XL	\$149
ATARI 800XL	\$269
ATARI 1200XL	CALL
ATARI 400	CALL
ATARI 800	CALL

PERCOM

DISK DRIVES FOR ATARI

AT88-S1	\$369.00
AT88-A1	\$299.00
AT88-S2	\$569.00
AT88-S1 PD	\$469.00
AT88-S2 PD	\$669.00
AT88-DDA	\$139.00
AT44-S1	\$579.00
AT44-S2	\$969.00
TEXAS INSTRUMENTS DRIVE	
TX 99-S1	\$349.00

RANA

1000 Atari Disk Drive	\$319.00
-----------------------	----------

PRINTERS

EPSON

MX80 FT. MX100. RX80.	
FX80. FX100	CALL

OKIDATA

82. 83. 84. 92. 93	CALL
--------------------	------

STAR

STX 80	\$169.00
Gemini 10X	\$299.00
Gemini 15	\$479.00
Serial Board	\$75.00

SMITH CORONA

TP-1	\$469.00
TP-2	CALL
Tractor Feed	\$119.00

C. ITOH

Gorilla	\$209.00
Prowriter 8510P	\$379.00
Prowriter 1550P	\$689.00
Starwriter F10-40P	\$1149.00
Printmaster F10-55P	\$1569.00
Tractor Feed	\$199.00

DAISYWRITER

2000 Letter Quality	\$1149.00
2500. NEW	CALL
Tractor Feed	\$109.00

DIABLO

620	\$949.00
630	\$1769.00

IDS

Call for ALL Configurations on
IDS PRISM PRINTERS.

NEC

8023	\$399.00
8025	\$729.00
3510	\$1449.00
3530	\$1499.00
3550	\$1799.00
7710/7730	\$1999.00

BMC

401 Letter Quality	\$699.00
--------------------	----------

MONITORS

AMDEK

300G	\$149.00
300A	\$159.00
310A	\$169.00
Color I	\$279.00
Color I plus	\$299.00
Color II	\$399.00
Color III	\$349.00
Color IV	\$999.00

USI

Pt. 1. 9" G	\$99.00
Pt. 2. 12" G	\$119.00
Pt. 3. 12" A	\$159.00
Pt. 4. 9" A	\$139.00
1400 Color	\$299.00

ZENITH

ZVM 122A	\$119.00
ZVM 123G	\$109.00

BMC

12" Green	\$85.00
9191 13" Color	\$299.00

TAXAN

12 N Green	\$129.00
12 A Amber	\$139.00

PANASONIC

TR 120 Hi-res. Green	\$149.00
CT 160 Dual Mode Color	\$279.00

NEC

JB 1260	\$119.00
JB 1201	\$149.00
JC 1212	\$299.00
JC 12-202	\$299.00
JC 1203	\$469.00

GORILLA

12" Green	\$89.00
-----------	---------

TIMEX
SINCLAIR \$49⁹⁵
1000

= WEST = = EAST =
1.800.648.3311 = 1.800.233.8950



In NV call (702)588-5654. Dept. 1007. Order Status #: 588-5654
P.O. Box 6689. Stateline. NV 89449

In PA call (717)327-9575. Dept. 1007. Order Status #: 327-9576
477 E. Third St., Williamsport. PA 17701



No risk, no deposit on C.O.D. orders. Pre-paid orders receive free shipping within the UPS continental United States with no waiting period for certified checks or money orders. Add 3% (minimum \$5.00) shipping and handling on all C.O.D. and credit card orders. Larger shipments may require additional charges. NV and PA residents add sales tax. All items subject to availability and price change. We stock manufacturer's and third party software for most all computers on the market. Call today for our catalog.

Circle No. 11 on Free Information Card

Keyboard Encoding Schemes

A guide to computer keyboard operation and solving interfacing problems

THE primary human-to-computer interface is a keyboard, a collection of individual keys, each of which has a particular symbol on its face and a unique binary value (code) used by the computer to identify that particular key. Different ways to produce these codes are explored here.

Except for special custom-made models, most keyboards have one contact closure per key. All standard keyboards use one of two wiring arrangements. The circuitry common to most small calculator keyboards, where all keys share a single common terminal or the keys are arranged in groups, with each group having a different common terminal, is shown at Fig. 1A. The most ver-

By Ralph Tenny

satile keyboard will have two isolated terminals for each key using the arrangement shown in Fig. 1B. This approach is rare in small keyboards, but is quite common to large models.

Almost without exception, keys on a keyboard "bounce"—that is, the key makes several very short intermittent contacts as it is depressed. Fig. 1C shows a typical keyboard contact circuit and the waveform resulting from key bounce. Most digital systems are fast enough to read each bounce and record the assumed single closure event as a *series* of key openings and closings. To

prevent entry errors, any key encoding scheme must also include some method to mask or eliminate the bounce effect.

Many methods of keyboard encoding have been devised, and the best one for a particular keyboard will depend on a number of factors. Two of the most important considerations in choosing an encoding method are the number of keys, and the type of switch contacts involved. That is, the fully isolated keys (Fig. 1B) can be used in most encoding schemes, while those keyboards whose keys share a common terminal (Fig. 1A) are limited in their applicability to some encoding schemes. The type of code to be produced by each key will also be a factor in deciding how to do the encod-

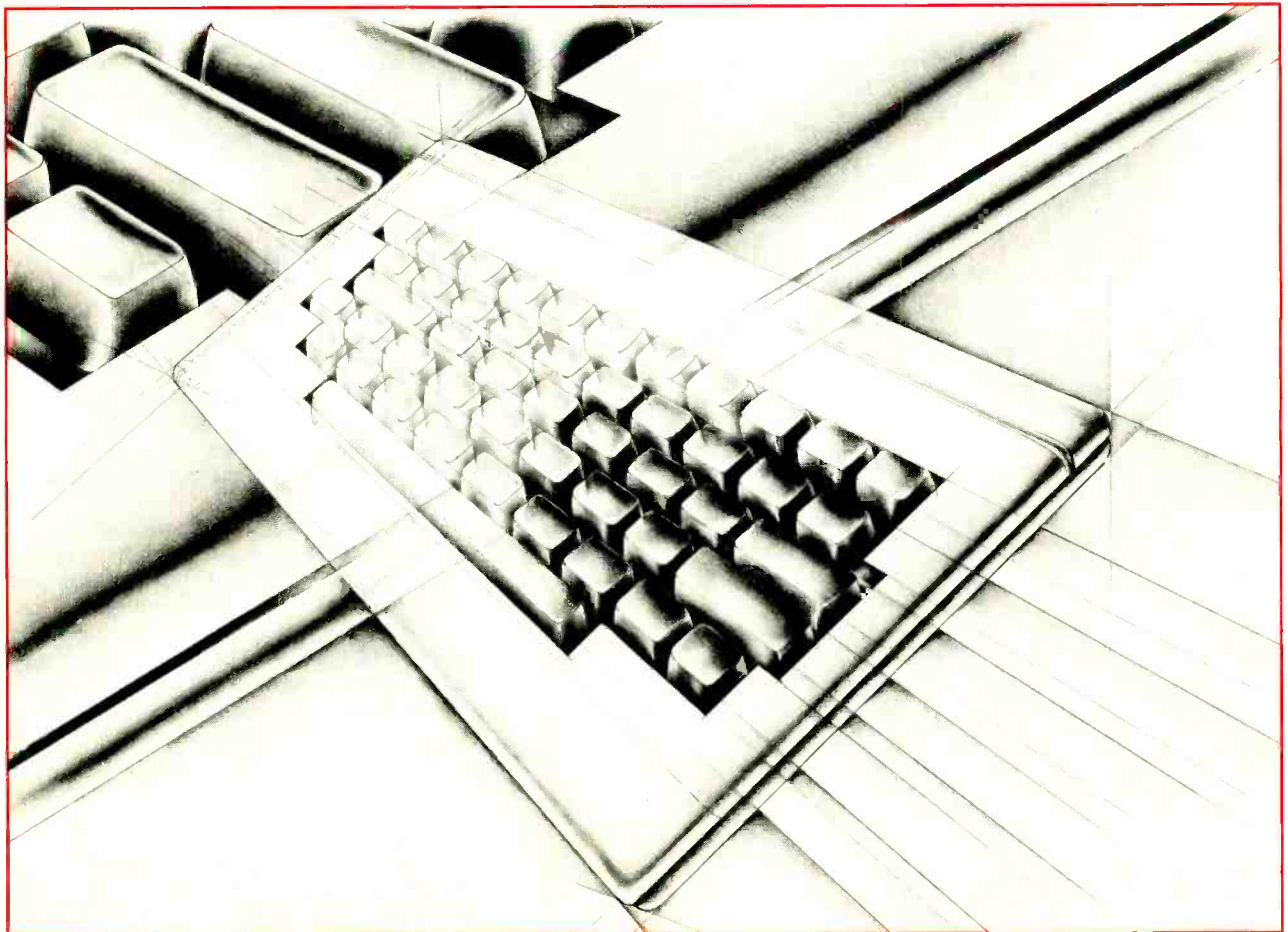

Keyboard Encoding

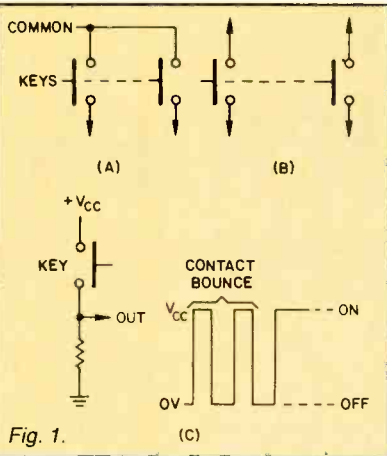

Fig. 1.

BITS		BITS	
KEY	0 1	KEY	0 1 2
1	0 0	1	0 0 0
2	0 1	2	0 0 1
3	1 0	3	0 1 0
4	1 1	4	0 1 1
(A)		5	1 0 0
		6	1 0 1
		7	1 1 0
		8	1 1 1
		(B)	

Fig. 2.

ing. In general, simple codes can be produced by simple schemes, as long as the number of keys to be encoded is small. Special codes, or a large number of keys, require complex encoding schemes.

If the key code is to be unique for each key, then the number of keys involved determines how many binary bits will be needed to define each key. For example, Fig. 2A shows that two bits will encode four keys. Another bit (3 bits total) will allow a total of eight keys to be defined as shown at Fig 2B. In other words, n bits will encode 2^n keys.

Decoding. For straight binary coding of a small number of keys, NAND gate encoding as shown in Fig. 3 may be used. (We will cover key 0 shortly.) The complexity will jump very rapidly with an increase in the number of keys needed, however. In Fig. 3, two 2-input NAND gates sufficed for four keys, but it takes three 4-input NAND gates for eight keys (3-bit code) and four 8-input gates for 16 keys (4-bit code). As a rule of thumb, it takes one gate for each bit to be encoded, with half as many inputs per gate as the maximum number of gates that can be encoded by that num-

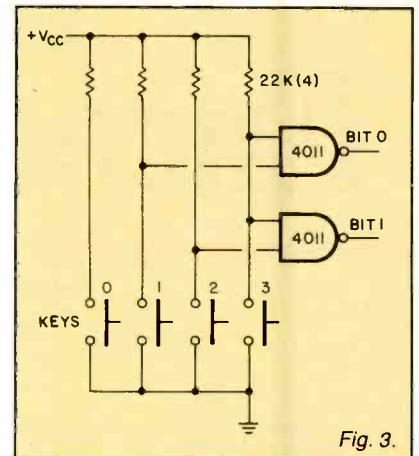

Fig. 3.

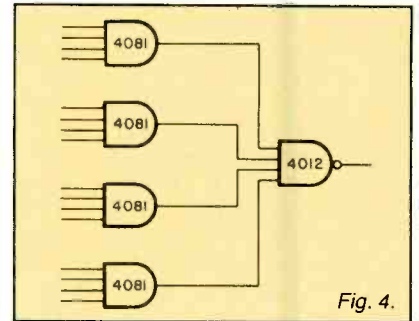
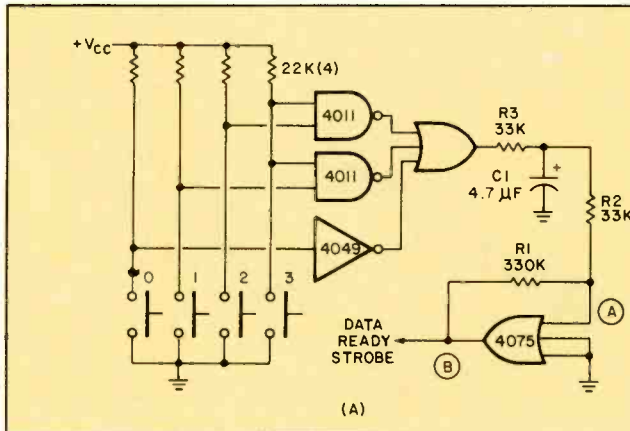
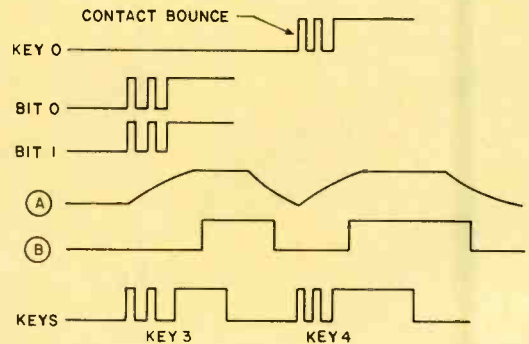

Fig. 4.



(A)



(B)

Fig. 5.

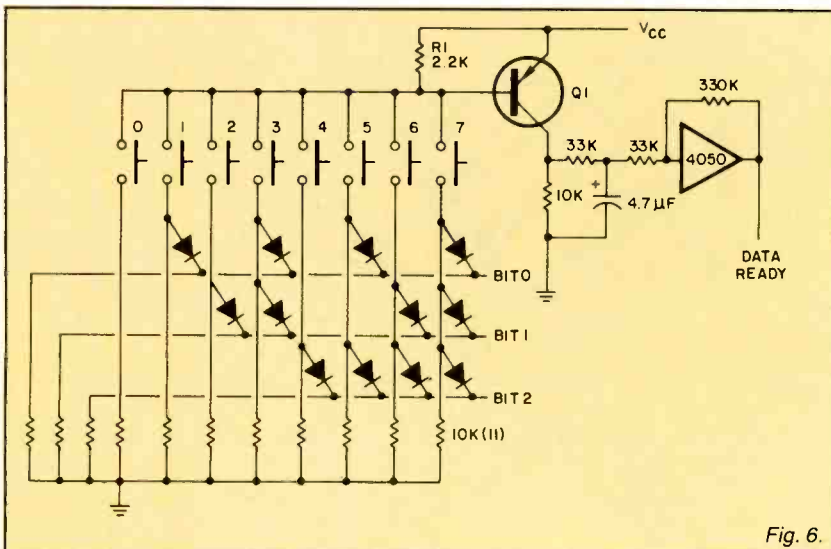
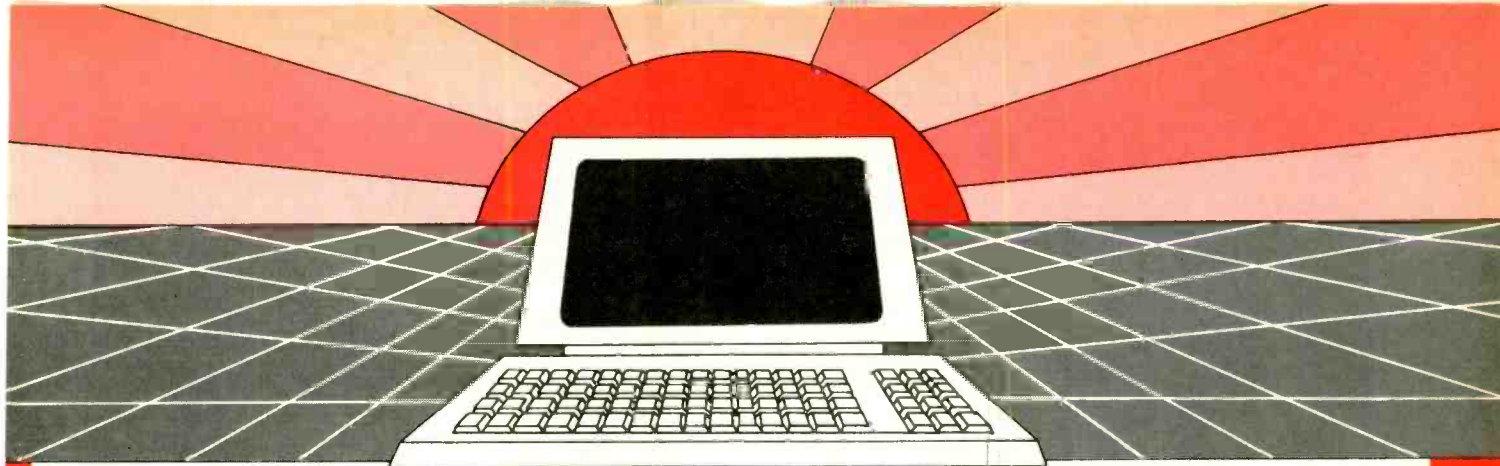

Fig. 6.

ber of bits. For example, 5 bits will encode 32 keys, but each gate needs 32/2 or 16 inputs. Since this type of gate does not exist, it can be made up as shown in Fig. 4.

Note in Fig. 3 that, although the four keys were properly encoded, no output will result if key 0 is pushed. Also, there is no key-debouncing circuitry. To sense the operation of key 0, add an inverter as shown in Fig. 5A. If the three outputs are summed in an OR gate, an output is obtained for each key closure. By feeding this output to a delay circuit built with another OR gate, a delayed pulse will occur after key bounce has stopped.

For those not familiar with the delay circuit of Fig. 5A, it works this way. Resistor $R3$ and capacitor $C1$ delay the incoming signal from the OR gate as shown in Fig 5B. Resistor $R1$ provides



DISCOVER THE MAGAZINE THAT HELPED LAUNCH THE MICROCOMPUTER INDUSTRY

Incredible as it may seem, *Popular Electronics* helped launch the microcomputer industry. Back in 1975, we published plans for building the first powerful microcomputer based on the 8080 cpu. These plans generated incredible excitement—and started the world thinking about personal computing.

Since then, we've added more coverage of personal computing. Today, so much of the magazine is devoted to microcomputers that we've changed our name to...

Computers & Electronics

Computers & Electronics continues the *Popular Electronics* tradition of helping our readers experience the advances of the future—today. We do it with clearly written, in-depth articles explaining each innovation... plans for building useful, money-saving projects incorporating the newest technology... reviews of the latest mass-produced equipment. Whether it's microcomputer equipment, audio, video, or personal electronics, *Computers & Electronics* will make it possible for you to enjoy the newest, the most sophisticated, the most innovative technology around.

Helpful buying guides

Computers & Electronics compares and contrasts computers and other electronics gear in meaningful buyer's guide articles. We discuss features and options, what to look for, and how to get the best value. Recent buyer's guides have covered computer printers, pocket computers, sophisticated telephones, video cassette recorders and high-tech audio cassettes.

World-famous test reports

In every issue of *Computers & Electronics* you'll find our famous in-depth test reports. We take a new product, test it and analyze the results. Recently we've tested the Radio Shack TRS-80 Model III, the IBM Personal Computer, and the Sinclair ZX-81. Microcomputers by Apple, Atari, Hewlett-Packard, Intelligent Systems and Netronics. Plus an interactive data terminal, software,

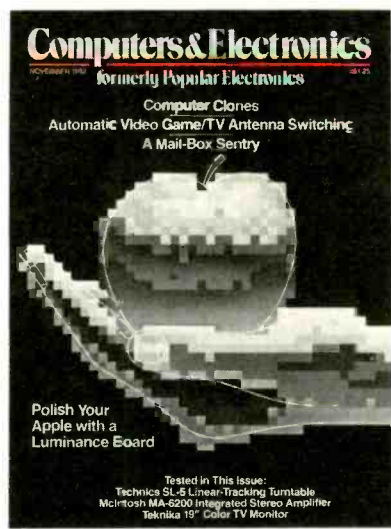

and a variety of audio, video and testing equipment.

Innovative construction projects

If you're a do-it-yourselfer, you'll love the construction projects in *Computers & Electronics*. Not only did we bring the world the first successful microcomputer kit, but also projects for building the first low-cost modem. The first computer keyboard integrated with the computer (SOL).

The first low-cost voice synthesizer. The first low-cost logic analyzer. The first 1802-based microcomputer (ELF). The first low-cost function generator. The first gas-lase communicator (awarded a place in the Smithsonian Institution). The first low-cost color graphics computer module. An interface to transfer narrow line listings from your TRS-80 Pocket Computer to either a printer or CRT screen....

As you can see, our construction projects, while not necessarily complex (thanks to multifunction IC chips), will keep you at the forefront of technological development—at remarkably low cost. And in the future, we'll be bringing you construction projects to help you make your microcomputer more useful—whether it's an enhancement, an application, or a merging of technology with external controls and products.

Get the leader in the field— at up to 33% off!

Computers & Electronics is the world's most widely read computer and personal electronics magazine. Now you can subscribe at big savings: up to 33% off. At our New Subscriber rates, a one-year subscription is only \$12.97. Take advantage of this offer—complete and return the coupon or postage-paid reply card today!

Computers & Electronics P.O. Box 2774, Boulder, Colorado 80322

YES! Send me one year (12 issues) of *Computers & Electronics* at \$12.97—I save 19%.
 I prefer two years for \$22.97—I save 28%.

 Make that three years for \$31.97—I save 33%.

Savings based on full one-year subscription price of \$15.97

Mr./Mrs./Ms. _____ (Please print full name) 4S077

Address _____ Apt. _____

City _____ State _____ Zip _____

CHECK ONE Payment enclosed Bill me later.

Offer valid in U.S. and possessions only. Please allow 30 to 60 days for delivery of first issue.

Keyboard Encoding

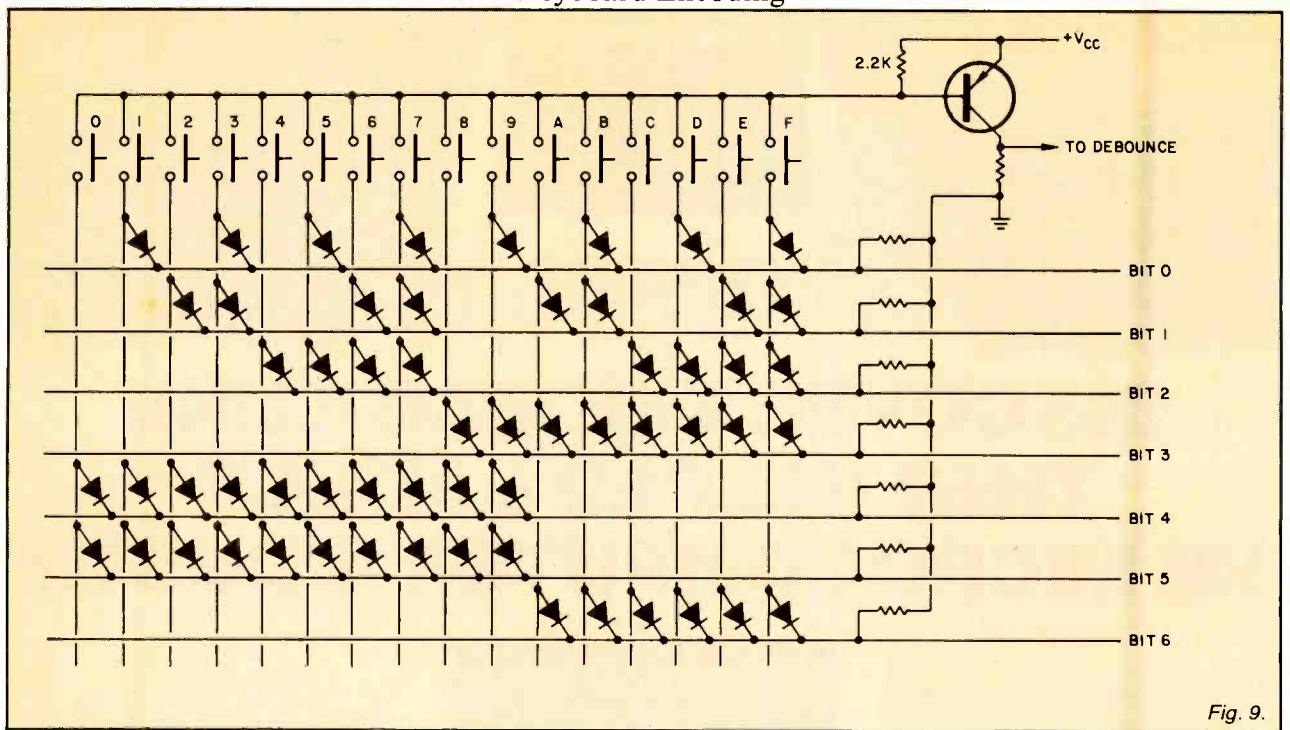

Fig. 9.

HEX	ASCII
0	30
1	31
2	32
3	33
4	34
5	35
6	36
7	37
8	38
9	39
A	41
B	42
C	43
D	44
E	45
F	46

Fig. 7.

	2^6	2^5	2^4	2^3	2^2	2^1	2^0
31H	0	1	1	0	0	0	1
46H	1	0	0	0	1	1	0

Fig. 8.

positive feedback which aids the slow-rising waveform at point A, so that the output pulse from the delay circuit has a normal logic risetime. When the output at B changes, this can signal the external circuitry that key data is available at the NAND gate outputs. It should be noted that this encoding scheme, like most simple systems, offers no protection against pushing two keys at once. It is also well suited for the switch types of Fig. 1A.

A common encoding scheme for small keyboards uses diodes to produce

the appropriate codes as shown in Fig. 6. Any key closure will be sensed by $Q1$, which turns on to produce a positive step at its collector as any key draws current through $R1$ and the individual bit lines. The encoding is accomplished by the diode connections, which are arranged to produce binary values for each key. This encoding scheme is also well suited for nonisolated keyboards.

Suppose that ASCII code (Fig. 7) is required from the circuitry of Fig. 6.

From Fig. 7 we see that the numbers 0 through 9 are 30 through 39 in hexadecimal code while A through F are 41 through 46 hex. Fig. 8 shows the binary bit pattern for 31 and 46 hex, and Fig. 9 shows that each key must pull up the 2^4 and 2^5 bit lines for 0 through 9, or the 2^6 bit line for A through F. Thus, by adding appropriate diodes, the 16-key calculator-type keyboard can produce almost any custom code despite the shared common terminal.

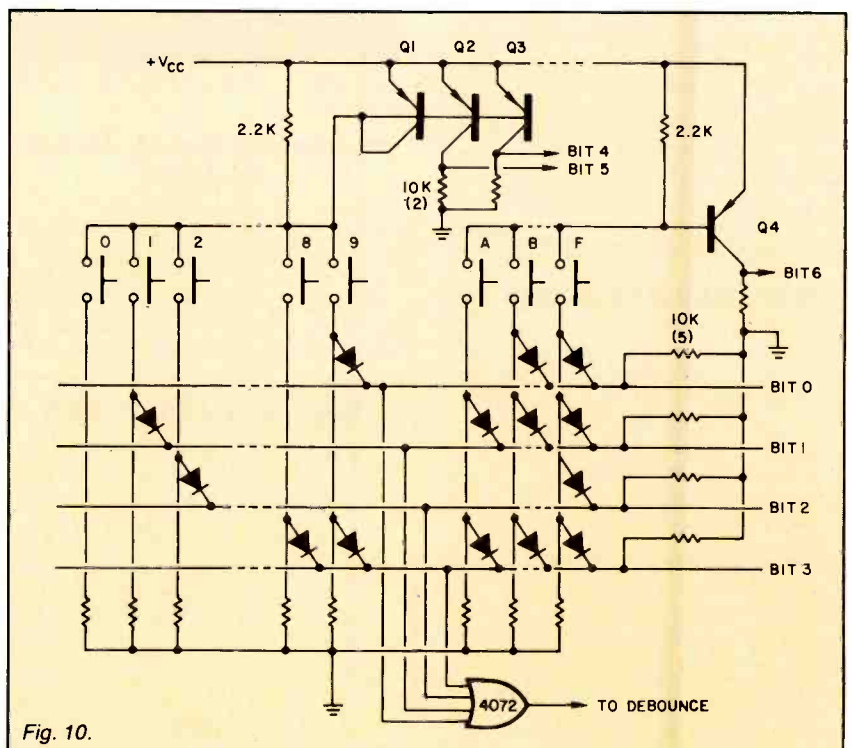

Fig. 10.

Keyboard Encoding

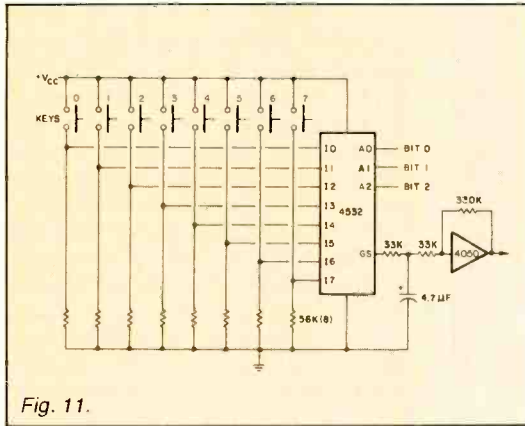

Fig. 11.

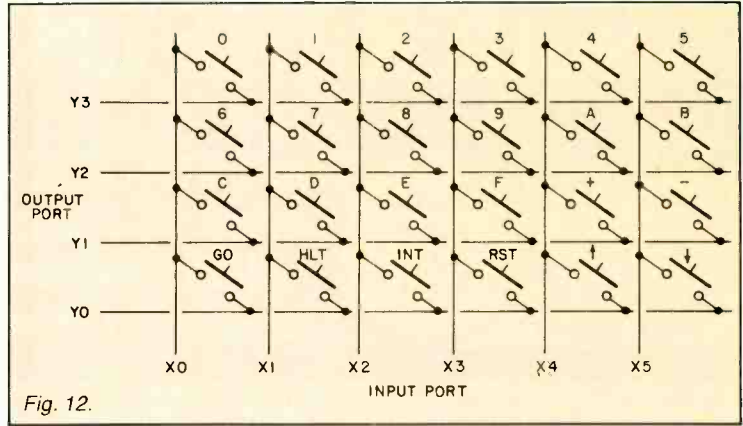

Fig. 12.

If the isolated-contact type keyboard is available, Fig. 9 can be simplified as shown in Fig. 10. Note that a number of keys have been omitted for clarity, and that only four bit lines need to be diode encoded. Instead, a number of transistors sense groups of keys in the same manner as *Q1* in Fig. 6. The odd connection between *Q1*, *Q2*, and *Q3* is called a current mirror—it causes the same current to flow in the collectors of *Q2* and *Q3* as is flowing in the collector of *Q1*. This allows all the bit lines to have the same "1" voltage. Note that this type of circuitry can be expanded to any reasonable number of keys. Similarly, any special codes can be produced using relatively few parts.

A third method of binary coding a few keys (eight, for example) uses a priority encoder such as the 4532 shown in Fig. 11. This IC produces the octal code (3-bit binary code) corresponding to the closed key. Although this approach simplifies key encoding, debouncing is still necessary. The Group Strobe (GS) signal is output when any key is depressed, and is delayed (as usual) to produce a Data Ready strobe. Expansion and special codes can be done with sense transistors as in Fig. 10.

The scanned matrix is a commonly used method of encoding a large number of keys. The basic concept of Fig. 12 is formed from an X-Y matrix of lines with the isolated-type keys connected at each intersection. In a form which uses the least hardware, the Y lines are tied to an output port of a computer and the X lines are on an input port. Software writes a "1" to each output line in turn, and checks for an input. Suppose that input bit X4 goes high during the time that output bit Y3 is on—this means that key "4" is closed. The software searches for line 34 to find that the "4" key is pressed then performs its designed software function. Key debouncing is done by reading the input, delaying a certain length of time, and verifying the previous reading. The software scan for 64 keys requires 16 I/O lines.

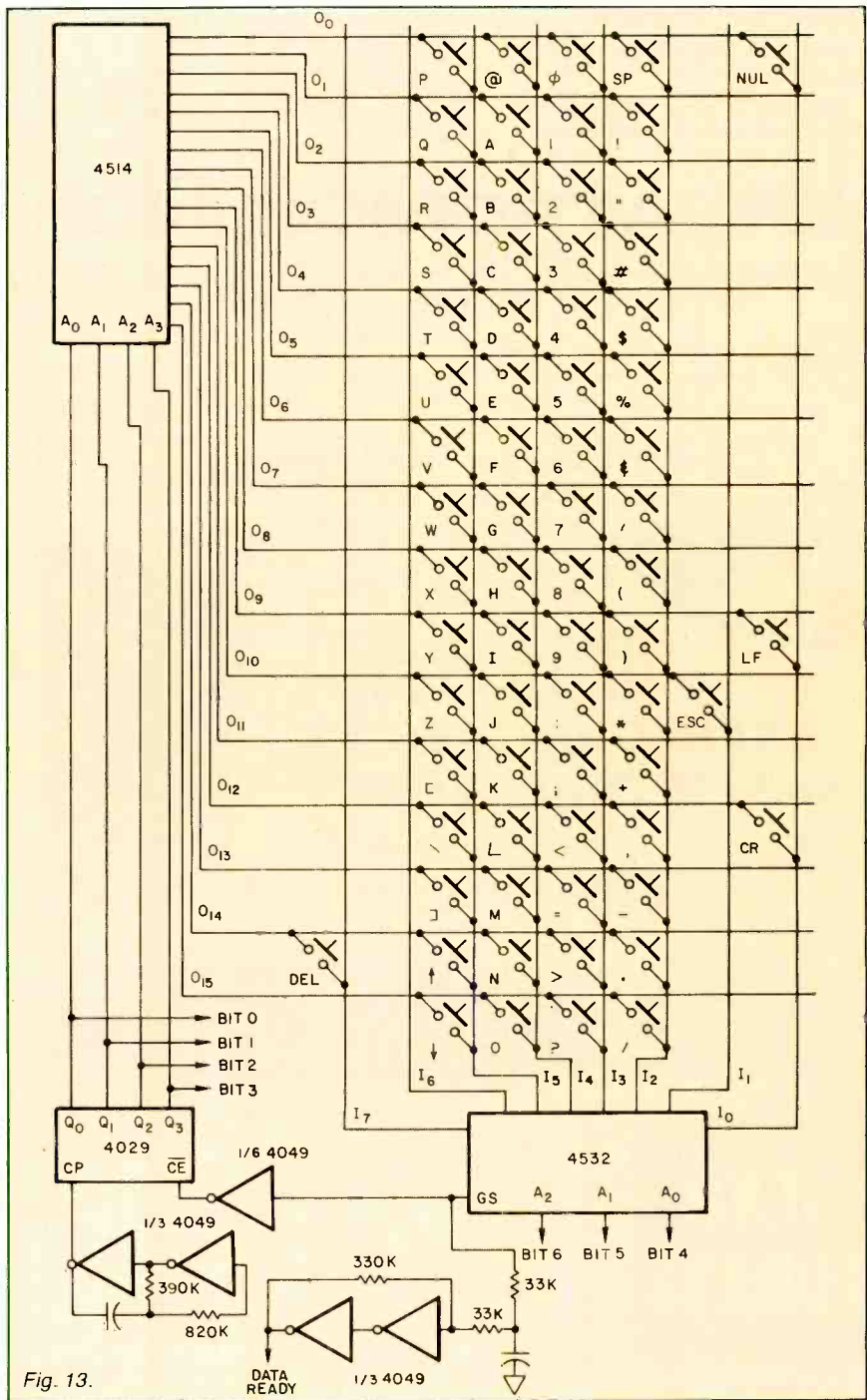
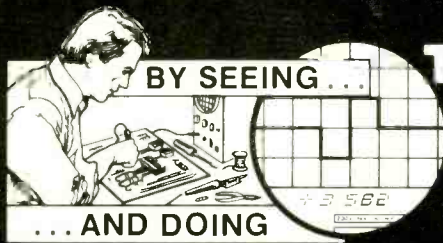

Fig. 13.

CONQUER THE CHIP



BY SEEING ...

... AND DOING

The **PRACTICAL**
way to master
electronics in
your own home

- Build a modern oscilloscope.
- Recognize and handle current electronic components.
- Read, draw and understand circuit diagrams.
- Carry out 40 experiments on basic electronic circuits used in modern equipment.
- Build and use digital electronic circuits and current solid state chips.
- Learn how to test and service every type of electronic device used in industry and commerce today. Servicing of radio, T.V., Hi-Fi and microprocessor/computer equipment.

LERNATRONICS, INC.

Associated Schools

UNITED KINGDOM FRANCE SPAIN MOROCCO SINGAPORE MALAYSIA CHINA SRI LANKA AUSTRALIA
P.O. Box 1240 • Pompano Beach, Fl 33061

NAME _____
ADDRESS _____
CITY _____
STATE _____ ZIP _____

Free Color Brochure • No Obligation!

A strictly hardware approach to the scanned matrix is shown in Fig. 13. Here 16 lines (00 to 015) are sequentially enabled as a 4029 binary counter drives a 4514 1-of-16 decoder. If any key is closed, the GS output of priority encoder 4532 disables the counter's clock input and signals the computer that data is ready. With 4 bits from the counter and 3 bits from the priority encoder, a 7-bit data word is generated. By proper arrangement of switches and data lines, the circuit in Fig. 13 produces ASCII code for each key. Note

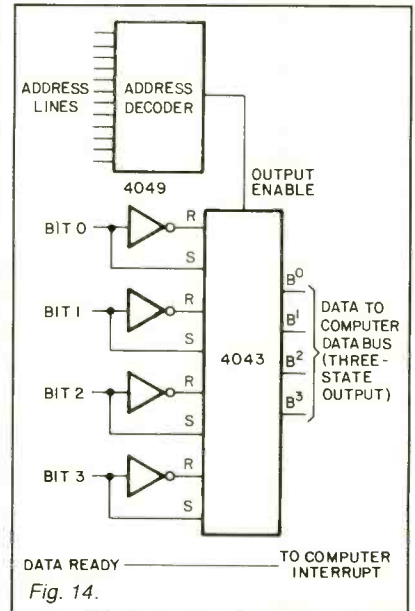

this matrix will encode 128 keys and not all possible key locations are filled. Note also that this circuit inherently rejects any key depression except the first one recognized—called key lockout—and that the delay circuit additionally provides good noise immunity.

For a top-level approach to key encoding, a number of companies produce special encoder IC's using the matrix principle. These devices perform all encoding, debounce, and key lockout functions using only a few external components. In addition, some such ICs will accept a second key closure while the first input is being processed.

No computer interface has been shown with any other schemes, but the normal approach will be to use a dedicated port. Alternatively, Fig. 14 shows the major components of a memory-mapped keyboard port: data latches with three-state outputs and an address decode network to enable the outputs at the proper time.

In the final analysis, the number of and type of keys, the number of I/O lines, the condition of the junk box and the size of one's purse are all inputs to the solution of a keyboard interfacing problem. ♦

FREE

McIntosh STEREO CATALOG and FM DIRECTORY

Get all the newest and latest information on the new McIntosh stereo equipment in the McIntosh catalog. In addition you will receive an FM station directory that covers all of North America.

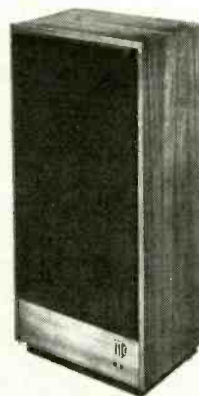
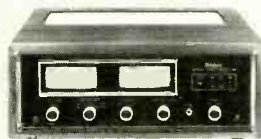

**SEND
TODAY!**

McIntosh Laboratory Inc. CE
East Side Station P.O. Box 96
Binghamton, N.Y. 13904-0096

NAME _____
ADDRESS _____
CITY _____ STATE _____ ZIP _____

If you are in a hurry for your catalog please send the coupon to McIntosh.
For non rush service send the Reader Service Card to the magazine.

CIRCLE NO. 31 ON FREE INFORMATION CARD

Baud-Rate Matching for CoCo

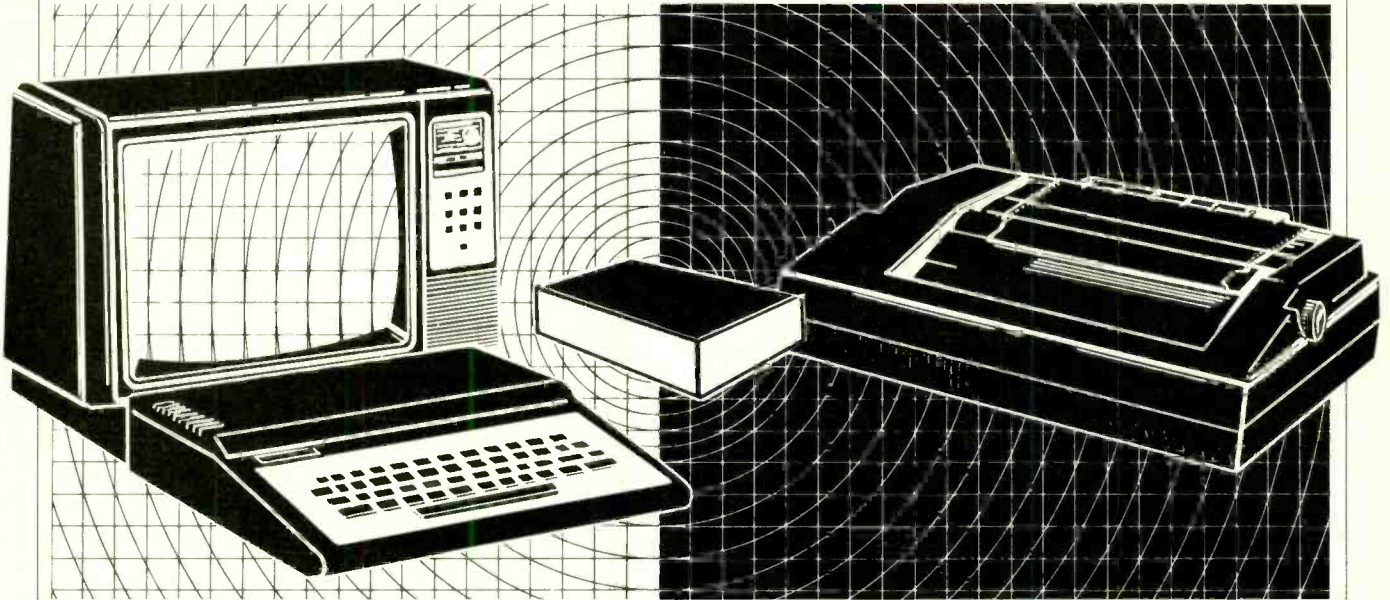

How to match a 600-baud TRS-80 Color Computer to a 300-baud printer the hardware way

By S. E. Harding

BAUD-RATE matching is an imperative when trying to interface a peripheral with a computer. In most cases, either a hardware or software switch is provided to make this adjustment on one or both devices. However, such a switch is not always provided, and the problem then arises of how to match baud rates so that a particular peripheral can be used.

In the interface to be described, the computer was a TRS-80 Color Computer having an output port operating at 600 baud, with a printer operating at 300 baud. Both of them had conventional RS232C ports. The schematic is shown in Fig. 1.

Circuit Operation. Operation of the baud-rate changer is based on a UART (Universal Asynchronous Receiver Transmitter) formed by IC2. Such a UART contains two halves—a receiver that accepts serial data and converts it to parallel data, and a transmitter that accepts parallel data and converts it to serial data. Both halves of the UART are controlled by a clock whose frequen-

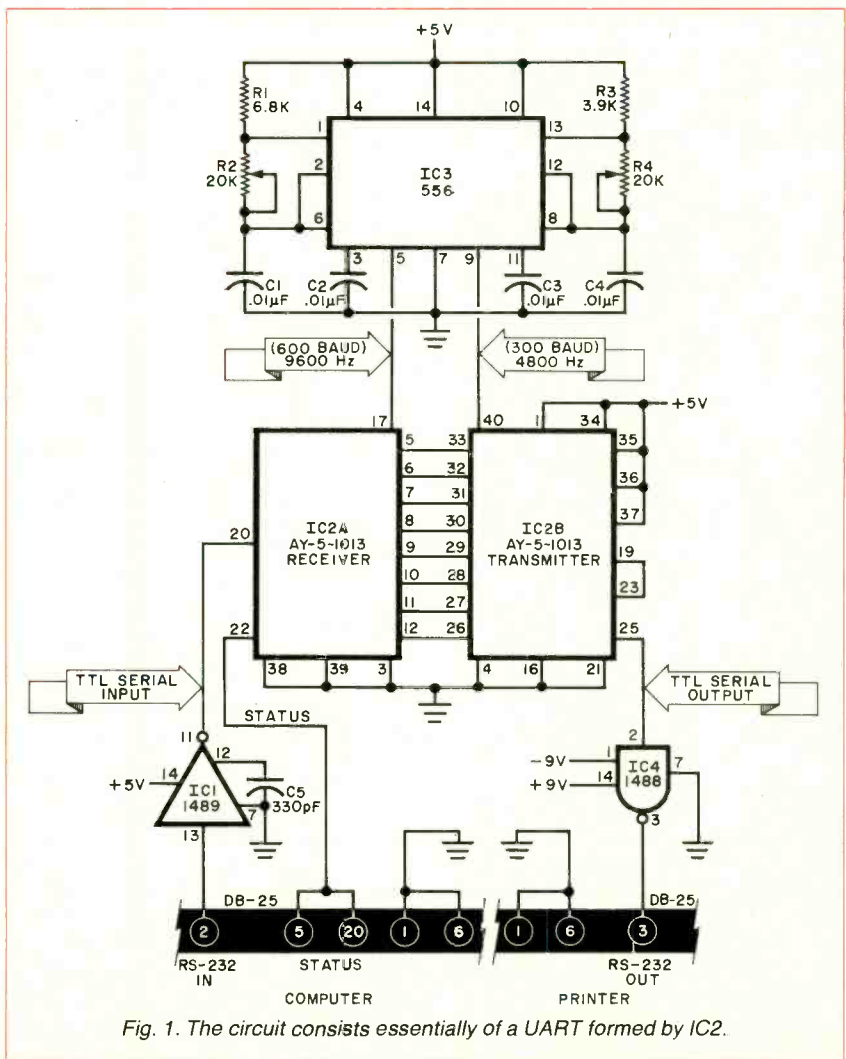

Fig. 1. The circuit consists essentially of a UART formed by IC2.

cy is 16 times the required baud rate. Thus, with the receiver operating at 600 baud, its clock must be 16 times 600 or 9600 Hz. The transmitter operating at 300 baud needs a 4800-Hz clock. Note that in Fig. 1, the 8-bit output of the receiver is directly connected to the 8-bit input of the transmitter via pins 5 through 12 and 26 through 33. Both halves of the UART are programmed to a common format via pins 34 to 39.

The incoming RS232 data signals from the computer are fed to pin 13 of *IC1* (one element within a quad RS232 receiver). This IC converts the positive and negative voltage swings of the RS232 mode into the +5 volts and ground of a conventional TTL level signal required by the UART. The TTL serial input is fed to *IC2A* pin 20.

When the buffer within the receiver is full (it contains an 8-bit byte), a load-OK signal appears at pin 22 of *IC2A* to inform the computer that it is time to send another character. This is called "handshaking."

The parallel data word from the receiver buffer appears on pins 5 through

PARTS LIST

C1, C4—0.01- μ F, 25-V mylar capacitor
 C2, C3—0.01- μ F, 25-V disc capacitor
 C5—330-pF disc capacitor
 IC1—1489 quad RS232 receiver
 IC2—AY-5-1013 UART
 IC3—556 dual timer
 IC4—1488 quad RS232 driver
 R1—6.8-kilohm, resistor
 R2, R4—20-kilohm, pc potentiometer
 R3—3.9-kilohm, 1/4-W resistor

12 which are directly coupled to the parallel input buffer of the transmitter half via pins 26 through 33. As the transmitter clock beats away, the 8 bits within the transmitter buffer are clocked out at 4800 Hz (300 baud), and after passing through one element within quad RS232 driver *IC4*, they appear as RS232 level data signals for transmission to the printer. In some cases, a capacitor of not less than 330 pF may be required at the output of *IC4* (pin 3) to

limit the slew rate to values within RS232 specifications.

Construction. The circuit is not tricky and can be built using any form of construction, from point-to-point wiring to a small pc board or even a prototyping board.

A power supply capable of delivering the required +5 volts for the TTL logic and the bipolar +9 and -9 volts for the RS232 levels at *IC4* is required. These are all low-current loads, so any type of power supply can be used.

Connections to the computer/printer are left up to the user. Fig. 1 shows the standard DB-25 connections used by RS232 ports. However, any method of interconnection can be made.

Before using the circuit, make sure the clock pulses at pin 5 of *IC3* appear at a 9600-Hz rate adjustable via *R2*, and at pin 9 there should appear the 300 baud (4800 Hz) signals adjusted by *R4*. A frequency counter can be used to adjust these two controls. Once adjusted, the potentiometers should be locked in place to avoid accidentally changing the baud rate. \diamond

TIPS & TECHNIQUES

KEEPING COMPONENTS SAFELY

To save time when building an electronic kit, it's a good idea to systematically arrange and label each component before beginning. One of the best ways to do this is with a plastic foam block like those available in hardware and lumber stores (Fig. 1). (For components that

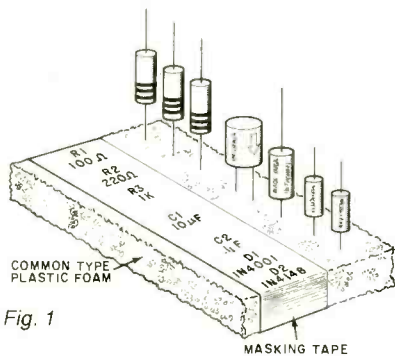

Fig. 1

are easily damaged by static discharge, such as MOS ICs and MOSFETs, you must use black conductive plastic foam (Fig. 2) which can be bought in an electronics store. If you can't find this special type, use white plastic foam wrapped in aluminum foil instead.)

Divide the components into groups (resistors, capacitors, transistors, etc.). Then secure masking tape along the foam block. As each component is placed on a block,

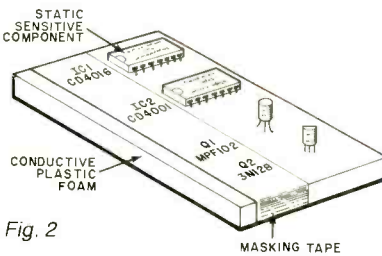
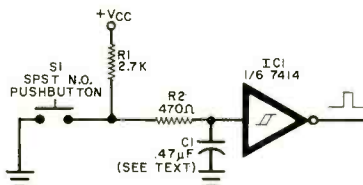

Fig. 2

check off the component on the parts list or schematic. Then, using a felt pen, write the component's value and identification number on the tape alongside it—Noel Boutin, Quebec, Can.

DEBOUNCING A CIRCUIT

When a pushbutton is used to clock a circuit such as a counter or shift register, some form of debouncing must be used to prevent extraneous clock pulses. You can debounce a circuit by using a single-pole double-throw pushbutton to toggle a bistable latch (that is, a crosscoupled pair of NAND gates). However, the spdt



pushbutton can be expensive, particularly when a large number is needed (for example, if you are building a hex keyboard).

The debouncing circuit shown here allows the use of inexpensive, normally open spst pushbuttons (commonly available for \$0.25 to \$0.50 each). A hex Schmitt-trigger/inverter package, *IC1*, allows up to six pushbuttons to be debounced with one IC. Any unused gates can be used as standard TTL inverters elsewhere in your circuit. Capacitor *C1* is typically 0.47 μ F—either a ceramic disc or electrolytic can be used. However, if your pushbuttons are of the "low-bounce" variety, then a 0.1- μ F ceramic disc will suffice.—Jim Ericksen, Windsor, CT.

HIGH-MELTING-POINT SOLDER

You can waste a great deal of time trying to desolder high-melting-point solder like that found in old TV sets, with a low-wattage iron, just heat the joint to be desoldered to the melting point of electronic solder. Then apply the electronic solder to the joint until it has completely melted and combined with the original solder at the joint. The electronic solder fuses with the high-melting point solder to lower its melting point to where it can be desoldered by a low-wattage iron.—Ted C. Huff, Imperial, MO.

Now electronics technicians can get into VCR Servicing quickly and easily

Learn professional VCR servicing at home or in your shop with exclusive videotaped demonstrations

Today, there are more than 10 million VCRs in use, with people standing in line to have them serviced. You can bring this profitable business into your shop with NRI professional training in VCR servicing. This top-level training supports the industry's claim that the best technicians today are those who service VCRs.

Integrated Three-Way Self-Teaching Program

In one integrated program, NRI gives you a study guide, 9 instructional units, 2 hours of video training tapes accompanied by a 32-page workbook that pulls it all together. At home or in your shop, you'll cover all the basic concepts of video recording, mechanical and electronic systems analyses, and the latest troubleshooting techniques. Your workbook and instructional units also contain an abundance of diagrams, data, and supplementary material that makes them valuable additions to your servicing library.

The "How-To" Videotape

Your NRI Action Videocassette uses every modern communications technique to make learning fast and easy. You'll enjoy expert lectures and see animation and video graphics that make every point crystal-clear. You'll follow the camera eye into the heart of the VCR as step-by-step servicing techniques are shown. Both electronic and mechanical troubleshooting are covered . . . including everything from complete replacement and adjustment of the recording heads to diagnosing micro-processor control faults.

Plus Training On All The New Video Systems

Although your course concentrates on VCRs covering Beta, VHS, and 3/4" U-Matic commercial VCRs, NRI also brings you up to speed in other key areas. You'll get training in capacitance and optical video disc players, projection TV, and video cameras. All are included to make you the complete video technician. There's even an optional final examination for NRI's VCR Professional Certificate.



Covers Beta and VHS systems with actual instruction on videotape.

The Best Professional Training

This exclusive self-study course has been developed by the professionals at NRI. NRI has trained more television technicians than any other electronics school! In fact, NRI has consistently led the way in developing troubleshooting techniques for servicing virtually every piece of home entertainment equipment as it appears in the marketplace.

Satisfaction Guaranteed . . . 15-Day No-Risk Examination

Send today for the new NRI Self-Study Course in VCR Servicing for

Professionals. Examine it for 15 full days, look over the lessons, sample the videotape. If you're not fully satisfied that this is the kind of training you and your people need to get into the profitable VCR servicing business, return it for a prompt and full refund, including postage. Act now, and start adding new business to your business.

Special Introductory Offer

This complete VCR training course with two hour videotape is being offered for a limited time only, on orders received from this ad, at our low introductory price of \$179.95. Save \$20 by acting now!

NRI Training For Professionals
McGraw-Hill Continuing Education Center
3939 Wisconsin Avenue Washington, DC 20016

YES! Get me started in profitable VCR servicing. Rush me my NRI self-study course in VCR Servicing for Professionals. I understand I may return it for a full refund within 15 days if not completely satisfied.



NRI Training For Professionals
McGraw-Hill Continuing Education Center
3939 Wisconsin Avenue
Washington, DC 20016

PLEASE SPECIFY TAPE FORMAT DESIRED VHS BETA

Name (please print) _____

Company _____

Street _____

City/State/Zip _____

Enclosed is my check money order for \$179.95 (D.C. residents add 6% tax) Make check payable to NRI

Charge to VISA MasterCard _____

Interbank Number _____

Card Number _____ Expiration Date _____

Signature _____

(required for credit card sales)

2601-103

ADD

EEPROM TO YOUR COMPUTER

SEVERAL memory devices involving new technologies have become available in the last few years. Among them are the electrically alterable read-only memory (EAROM), the electrically erasable programmable read-only memory (EEPROM), and the nonvolatile random access memory (NOVRAM), all of which show great promise for replacing conventional memory chips in certain applications. They have the attributes of the ideal memory: they are fast, random access; they don't "forget" everything when power is lost; and they can be reprogrammed without removing them from their sockets in the computer.

Since they are several times more expensive than conventional memory chips, the use of these new memory devices is not widespread in current circuit designs. Owing to their advantages, however, and the likelihood that prices will be reduced (as is historical in this industry), it's appropriate to get a leg up on this technology. Therefore, let's examine such a chip, using as an example the X2816A by Xicor, Inc., which is extremely easy to interface. The X2816 is a 2K X 8 (2048-byte) EEPROM that runs on a single 5-volt power supply. The chip requires no external latches or data preconditioning and can be used like RAM. Since it has the same basic pinout as the popular 2716 EPROM, 2316 ROM, and 6116 RAM, the X2816 can be placed in sockets for any of these chips, with only minor rewiring required for the control signals. The chips are ideal for the new 2716 EPROM/6116 RAM boards now available for a number of computers.

About the Chip. The pinout of the X2816 is shown in Fig. 1. Three input pins control the action of the read and write cycles: chip enable (\overline{CE}), output enable (\overline{OE}), and write enable (\overline{WE}). A low signal to \overline{CE} switches the chip from the low-current (less than 40 mA) standby mode to the active (100 mA) mode. This \overline{CE} line must be brought low

*Electrically erasable
PROMs are fast, random
access, don't forget
when power is lost,
& easily reprogrammed*

By Michael Keryan

to either read or write to the chip.

To read data from the chip, the \overline{OE} line is brought low (while \overline{WE} is held high). To write data to the chip, the \overline{WE} line is brought low (while \overline{OE} is held high). The data input/output lines are inhibited in the other possible states of the control lines. To summarize, \overline{OE} can be considered as a read pin and \overline{WE} a write pin. A low pulse to one of them results in a read or write cycle, provided the \overline{CE} is also low. These operation modes are shown in the Table.

The X2816 has on-chip latches, a timing-pulse generator, and a high-voltage pulse generator used for the write cycle. The write cycle takes up to 10 milliseconds to complete, but once triggered (by \overline{CE} and \overline{WE} low and \overline{OE} high), the cycle is

OPERATION MODES OF THE X2816

Control Lines			Mode of operation
\overline{CE}	\overline{OE}	\overline{WE}	
H	L	L	Low-power standby
H	L	H	Low-power standby
H	H	L	Low-power standby
H	H	H	Low-power standby
L	L	L	Inhibit
L	L	H	Read cycle, data = output
L	H	L	Write cycle, data = input
L	H	H	Inhibit

automatic. Therefore, the X2816 can be used as RAM, but the chip should not be accessed until at least 10 milliseconds after a write cycle has been initiated. When not writing to the chip, the read access time is similar to conventional memory chips (300 nano-seconds or less). The chips contain write-protection circuitry for power-up/power-down transitions and glitches on the \overline{WE} pin. They are designed for 10,000 write cycles.

Wiring the EEPROM. In many cases, normal 6116 CMOS static RAM chips can be replaced by X2816 EEPROMs with no changes required to the wiring. The pin-outs of the X2816 and 6116 are identical. As shown in Fig. 2A, the memory read line is brought to \overline{OE} , the memory write line is brought to \overline{WE} , and the chip enable line is brought to \overline{CE} . For new circuitry using the Z80, 8085, 8080, etc., the interfacing is straightforward. CPU chips such as the 6502, 6809, 6800, etc., usually use a single read/write line (R/\overline{W}) that is high on a read cycle and low on a write cycle. In this case, the \overline{OE} input can be derived by inverting the R/\overline{W} line connected to the \overline{WE} input, as shown in Fig. 2B. In any case, when using the EEPROM as RAM, you will probably want to address it outside of the normally used contiguous block of workspace RAM, to protect it from being written to indiscriminately. This can be accomplished either by hardware (decoders address it away from the other RAM) or software techniques (setting the boundaries of the workspace RAM to exclude the EEPROM).

A simple method of adding EEPROM to a TRS-80 is shown in Fig. 3. This basic addressing scheme is used to add either RAM or EPROM addresses in address space \$3000 to \$37DF. Note that the last 32 bytes of the EEPROM will not be used. The Disable switch allows the EEPROM to be write-protected, and the LED lights when the EEPROM can be written to.

When used to replace EPROM or ROM in an existing circuit, some part has to be changed to allow the chip to be active on both the read and write cycles. Normally, EPROM and ROM chips are enabled only on read cycles. After defeating the read-only access, wire the \overline{OE} and \overline{WE} as previously explained.

To "burn" the chip, merely write data to a valid address by using the BASIC POKE statement, or use a machine language or assembly program to move or store data in the desired address. If more than one byte will be written, the program must provide for the approximate 10 milliseconds dead time after each write cycle. Waste-time loops can easily be added to both BASIC and assembler programs. An alternate method is to verify each byte prior to writing the next byte; the data lines will be in an open state during the internally timed write cycle. However, since reading data from an open-state data bus will result in a certain data byte (dependent on type of computer, usually \$00 or \$FF), when writing this certain data byte be sure to insert a software timing loop.

Applications. The EEPROM can be used in just about any application where conventional EPROM or ROM is now used. The difference is that now you will be able to easily change the code. Use an EEPROM for a character generator, bootstrap programs, input/output drivers, new utility programs, to fix bugs in your BASIC-in-ROM, etc. It can also be used in applications that were impossible to do before. Use it to download program or data files from EEPROM to RAM and then save the updated data back to EEPROM; that is, a disk emulator with non-volatile memory. Remember, the 10,000 write cycle lifetime will allow daily updates for over 25 years.

For more information on EEPROMs, write to Xicor, Inc., 851 Buckeye Court, Milpitas, CA 95035. Ask for application note #104 and a data sheet for the X2816A, which is currently priced at about \$35 for single units. Other EEPROM manufacturers include General Instruments, Hitachi, Intel, National, Motorola, and Seeq. Seeq also has a 5 volt-only EEPROM available. ◊

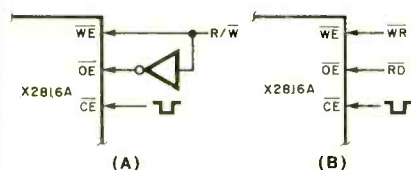

Fig. 2. Interfacing to the X2816 depends on the type of CPU used.

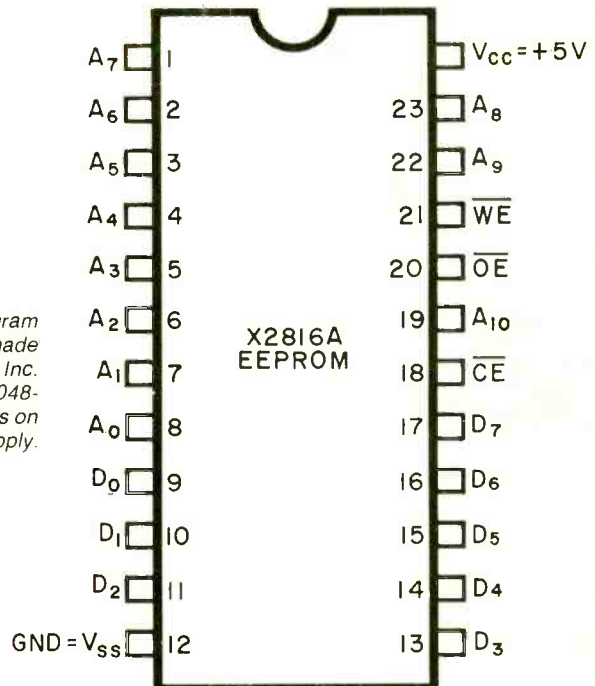

Fig. 1. Pinout diagram of the X2816A, made by Xicor, Inc. It is a 2K X 8 (2048-byte) EEPROM that runs on a single 5-volt supply.

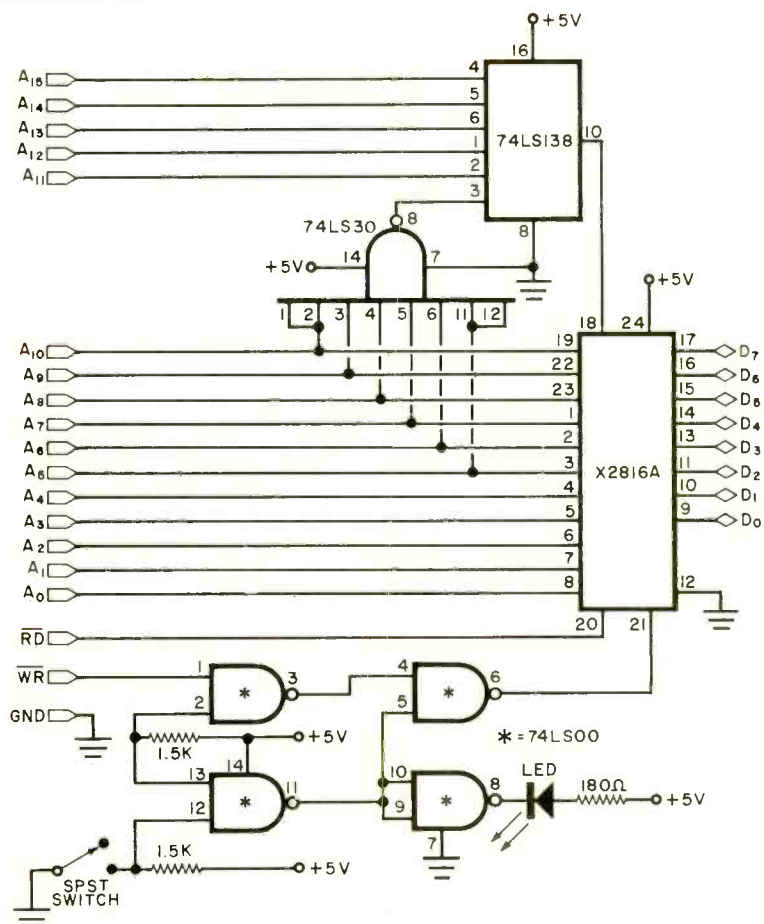

Fig. 3. A simple method of adding EEPROM to a TRS-80.

Davong 5-megabyte Winchester Hard Disk System



By Stephen Walton

SOME ten years ago, IBM introduced two new data storage devices: a 14" rigid-disk system called a "Winchester" and an 8" floppy-disk drive, both designed for large-scale computers. It took only three years for the flexible disk system to evolve into a less costly, smaller size. Made by Shugart Associates, the floppy quickly revolutionized the small computer market. With powerful desktop microcomputer systems widespread, hard disk drives are now taking the same route, aimed at users who handle a lot of data for, say, a mailing list or other large data base, accounting, etc.

Davong Systems, Sunnyvale, CA, is among the many companies taking aim at the micro market with Winchester hard disk systems for IBM PC, Osborne 1, and Apple II, IIe, and III computers. A 5-megabyte external single-drive system for an IBM PC was chosen for examination. It is priced at \$1995. Here are my experiences with its installation and operation.

Hardware. The sealed hard-disk subsystem is divided into three major assemblies: the Tandon Wintech TM501 four-head Winchester technology drive, the controller (interface) board, and the subsystem's 3-ampere power supply, which is in a separate cabinet.

The drive itself occupies about the same amount of space as a standard 5¼" floppy unit. It can either be mounted in the IBM unit in place of one of the 5¼" floppy drives or it can be purchased in its own enclosure. Since the disk is not removable, it is in a sealed box with no door. An activity light indicates when the drive is in use.

The controller board occupies a single expansion slot, and is supplied with a clip-in card guide to hold it in place.

Besides its connection to the bus (through the expansion slot), the board requires three cable connections to the drive and one to the power supply.

The fused power supply measures 3½" × 5" × 11¼" and weighs eight pounds. Its fan is somewhat louder than that of the PC system.

Hardware Installation. Davong indicates that its controller board has to be installed in expansion slot J5, which is on the far right. The reason for this is that the cables coming from the board are bulky enough (when you include the size of their connectors) to interfere with the placement of another board to the right of it.

My floppy controller, though, is the Maynard Electronics unit, which has a parallel-printer interface. Owing to cable lengths and the parallel port, it could not easily be moved out of slot J5. I found it easier to give the Davong controller two slots, though it meant removing my Asynchronous Communications Adapter for the duration. I put the controller board into the far-left slot, leaving the next one empty.

With no change in the number of floppy drives in the system, no alteration of the system-board switch settings was needed. And, after connecting all the cabling with power off, I was ready to power up—Winnie and peripherals first, then the PC.

Software Installation. Davong's installation software is supplied on a non-bootable diskette. I copied the files onto a DOS 1.1 system diskette (I had an early Davong version; Multi-OS, which is DOS 2.0 compatible, is now available) and used the most general of them, INST5xx.COM. This program leads you smoothly through the installation process, asking questions as it goes—and if you should ever falter, it can be

interrupted with Control-C. The questions cover:

- Capacity of the hard disk (5 megabytes, formatted in my case)
- Whether double-sided drivers are to be used (at a slight cost in the size of the DOS)
- Whether to use one of several standard volume (disk subsection) divisions of Winchester's storage space or some custom configuration.
- If a standard division is to be used, which one. (See box.)
- Whether to do a complete media check (which is time-consuming, but recommended).

With a hard disk, volume letters are used to reference hard disk areas. I chose the standard volume division that provides for three volumes on the hard disk—A: and B: of 2.4 megabytes each, and C: the same size (320K bytes) as a double-sided floppy. My floppies became D: and E:. I okayed full media verification, and found it to be a go-away-for-a-while process, taking almost 25 minutes for the 5-megabyte drive.

When I came back, I found I was on my new, giant-size A: drive, with DOS on my floppy modified to give me the next best thing to booting directly from the hard disk. Bringing up the system with the modified diskette in my first floppy drive takes me directly to Volume A: on the Winchester where my AUTOEXEC.BAT file can be executed. Everything proceeds normally then.

Operating Impressions. I remember what it was like when I first changed from using cassettes for mass storage to floppy disks. Going from floppies to the Winchester is nearly that impressive.

To put it another way, it's like moving out of a studio apartment into a twelve-room house. There's a lot of space and you think you'll never have enough furniture to fill it.

Is Your Cordless Phone Obsolete? YES — If It Doesn't Have a 1500-Foot Range! NEW HORIZONS Smashes the Distance Barrier with These Advanced Phones

The SuperFone 650 with TRUE TOUCHTONE®

Most cordless phones will work in Touchtone areas, but the phone itself won't generate a Touchtone signal.

The SuperFone 650 is a true Touchtone. From your pool, patio, or neighbor's home, you can use MCI, Sprint, PABX, or a computer code.

Range is 1500 feet, minimum. Users report 1800 and 2000 feet. That's approaching half a mile. SuperFone 650 is a radiophone, not a gadget, and that's why the signal is crisp and strong even at distances that would leave most phones with nothing but a frustrated hiss.

A secret code system lets you choose from 512 combinations. No other signal can interfere. Change the code whenever you like.

Speakerphone, Intercom Features

The base station is a speaker phone. The base and unit have complete intercom capability, which means one person can roam the yard or warehouse and be in constant touch with the base.

A privacy button lets you hear the party on the other end of the line without his hearing you.

Automatic recall of the last number is a real convenience.

A security switch makes it impossible for anyone but you to make outgoing calls.

What else? A volume control for the speaker, a call button to page the base from the cordless phone, and sound fidelity so good we challenge anyone to tell the difference between SuperFone 650 and a corded phone.

How much for all this? \$239.95.



The Mini-SuperFone 620 — State-of-the Art Electronics

The SuperFone 620 is no bigger than a pack of cigarettes. It's the smallest high-performance phone in the world. But it has a 1500 foot range.

It also has private "security codes" — 512 of them. In fact, except for the speakerphone, paging system, and Touchtone® capability, it has all the features of its big brother, the SuperFone 650 — including incredible sound quality.

The SuperFone 620 is yours for \$159.95.

TRIPLE THE RANGE OF ANY CORDLESS PHONE!

The SuperAntenna will give your cordless phone, regardless of make or model, three times the range it has now.

If the range is 700 feet, it'll leap to over 2,000. If it's 1500 feet (the range of the phones on this page), it could be as far as one mile!

Easy to install. Only \$79.95 complete. Add \$4.50 for shipping.



The Tote & Talk Is a Decorator Cordless Phone with 1500-Foot Range and a 10-Phone-Number Memory

This extended-range cordless phone is absolutely gorgeous. Don't be misled by its beauty: it has a brain!

The Tote and Talk (made by Universal) is programmable. You can put ten of your most-called numbers into its memory, including a last-number redial. Then, by pushing two digits you'll be able to dial any of those numbers.

Tote & Talk has a full intercom between the base station and the remote unit, including a call button on each unit. It has the "Mute" privacy key, so you can hear the other party without his hearing you.

You'll be proud to display this phone. Put it on a countertop or hang it on the wall. The rich brown vinyl inset-panel matches any decor.

How much for this long-range decorator cordless phone? \$209.95 (if you don't need the 10-memory capability, it's even less — \$189.95).



The SuperFone 650, with True Touchtone dialing — \$239.95 (two for \$219.95 each)

The SuperFone 620, with 1500-Foot Range — \$159.95 (two for \$149.95 each)

The Tote & Talk with 10 Memories — \$209.95 (two for \$199.95 each)

The Tote & Talk without Memory Feature — \$189.95 (two for \$179.95 each)

The SuperAntenna, TRIPLES the Range of Any Cordless Phone — \$79.95

Please add \$4.50 per total order for shipping.

For instant service, if you have a VISA or MasterCard, call toll-free 24 hours a day, seven days a week:

800-443-0100

Ask for Extension 111

WE ABSOLUTELY GUARANTEE!

Use ANY of these wonder-phones, or the SuperAntenna, for up to 30 days. For any reason you decide not to keep them, return them for a 100% refund.

New marvels are what you expect from

NEW HORIZONS

Dept. CE10, 5-31 Fiftieth Avenue
Long Island City, NY 11101

Circle No. 53 on Free Information Card

In practice, your software "furniture" can catch up with you faster than you expect. It looks as though you have room for everything on the Winnie, so you move it in—no more wasting your life commuting between floppies! You can have everything you use in your software development or your data processing application all handy at once. It feels positively liberating.

That impression lasts for quite a while, but then one day you realize that, with all the utilities and program modules you've accumulated, your five megabytes is down to a couple of hundred K. Shortly thereafter you find that you don't even have enough room to assemble your latest monument to the art of programming. Don't get me wrong, though. Five megabytes is a lot of room—you just have to learn to use it wisely.

Speed is the other advantage you immediately recognize, though the hard disk doesn't give you as great an edge as you may first think. What the hard disk does, it does faster than a floppy: but you soon give it a lot more to work on than any floppy is ever burdened with. Once you've really loaded up a Winnie-volume's directory, things tend to slow down again.

I did an informal benchmark using a PC BASIC program of 28,160 bytes in ASCII form, compiling and linking it first on the hard disk, where source program, compiler, linker and library were all on the same volume. Then I repeated the process using floppies, where the source file (and, subsequently the object and executable files) were on one drive, and everything else on the other. To make the linking more challenging, I used the compiler's "/O" option, which creates stand-alone (and consequently large) programs that can be used without the runtime package. The hard disk volume was already loaded up a bit—some 112 files totaling 1.1 million bytes.

Compiling using the floppies took 1

minute, 53 seconds; linking, 2 minutes, 2 seconds. The hard disk times were: 1 minute, 29 seconds to compile; 1 minute, 9 seconds to link. That's a noticeable, but not blistering, difference.

Yes, my word processor finds its overlays (up near the top of the directory) faster on the Winchester. Any given disk operation is speedier. But it's a lot of them on one job that can—and will—slow you down.

Pitfalls. Where's the dividing line between prudence and paranoia? It depends on what each may cost you in your particular situation. I had reason to thank myself at least once for keeping backup copies of what was on the hard disk.

Davong's documentation does tell you that you have to use its version of FORMAT.COM, even for floppies, once the hard-disk system is working. I read documentation as carefully as anyone does—which is to say, often too hastily and sometimes too late. I needed a fresh floppy, and blithely used the regular DOS FORMAT utility on my diskette, which was in the E: drive, and which fact I indicated to FORMAT.

Well, my whole A: hard-disk volume got blown away. I have to admit, though, that was my fault, and not Davong's. One must always read the documentation first! [Editor's note: Davong says this possibility has been eliminated in Davong's Multi-OS.]

One concern that is common to all hard disk users and crucial if the equipment has nonremovable media, is reliability. Another, specific to the PC environment, is heat.

First reliability. In all the time I used the Davong subsystem, I never saw *any* indication of a soft error anywhere on the recording media. Quality control must be much improved since my first acquaintance with hard disks (not so many years ago chronologically, but way back in terms of technology). The

media diagnostics ran squeaky-clean, and my own daily use only confirms their results.

The process of backing up data to some removable mass-storage medium (sometimes tape or a hard-disk cartridge; floppies in my case) is essential for the prudent, ongoing use of a hard disk. Using the BACKUP and RESTORE utilities supplied by Davong, I ran into a slight problem: BACKUP proceeded without a hitch, but RESTORE reported a "critical error" and warned that the data involved might not be reliable. Indeed it was not. The file, fortunately, was ASCII, and I could tell by examining it that it was indeed "garbaged." (It was truncated, with the tail of a different file grafted to it.) As a result of that experience, I would tend to rely on individual backup (via the DOS COPY function) of really important files, at least until Davong's backup utilities ensure that what's written can later be read reliably.

As for heat, the case of my PC's system unit never gets perceptibly warmer than room temperature when I'm using just floppies. When the Davong power supply is on, the top of the system unit is definitely warm, despite my external-as-possible installation of the subsystem and the fact that its power supply is in a separate external case. There's a lot of hearsay and folklore about thermal failures of PC's when used with hard disk systems, especially internally-mounted ones, and it's said that such failures happen sooner when the power hungry 8087 co-processor is also resident. But, even though I had a toasty-warm system unit, I had no problem that could be attributed to imminent thermal failure of my system.

Compatibility. I have used the Davong Winchester with the Baby Blue CPU Plus and CP/M software, with a program that remaps the PC keyboard (by modifying DOS) to make it touch-type like a Selectric typewriter, and with a wide range of orthodox PC software. There were no compatibility problems.

Some copy-protected software will always have to be loaded from a floppy, although data files can usually reside on a hard-disk volume. And, while there is a way to bring up such programs and use them freely on the Winchester (though the trick does not defeat copy protection), I have not tested the subsystem with copy-protected programs.

All my pre-Davong hardware worked unblinkingly with the Davong system installed, including the non-IBM Maynard Electronics floppy-controller-

STANDARD VOLUME CONFIGURATIONS

Option	Volume size	Max. directory entries	Default name
1	100% of hard disk	1024 files	IBM DOS A
2	50% of hard disk	512 files	IBM DOS A
3	50% of hard disk	512 files	IBM DOS B
	40% of hard disk	512 files	IBM DOS A
	20% of hard disk	512 files	IBM DOS B
	20% of hard disk	512 files	IBM DOS C
	20% of hard disk	512 files	IBM DOS D

All options include the equivalent of one floppy disk.



The Computer Book Club®

Your source for software and books at substantial savings!

More programs, more projects, more ways to use your micro for home, hobby, and business!

Select any 6 books for only \$2.95 when you join (values to \$128.70)



1295 List \$16.95



1398 List \$16.95



1269 List \$21.95



1455 List \$15.95



1111 List \$15.95

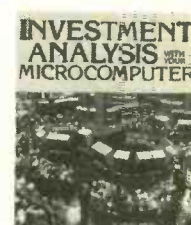

1478 List \$19.95



1195 List \$13.95



335 List \$14.95



1333 List \$16.95

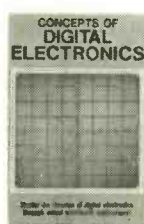

1331 List \$17.95

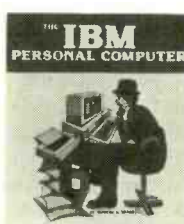

1496 List \$17.95



1535 List \$16.95



1160 List \$13.95



1205 List \$16.95



1062 List \$14.95



1478 List \$19.95



1276 List \$15.95



1251 List \$16.95



1199 List \$18.95



1389 List \$15.95



1521 List \$17.95



1533 List \$17.95



1637 List \$26.95



1513 List \$19.95



1473 List \$19.95

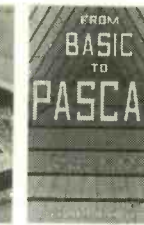

1466 List \$17.95

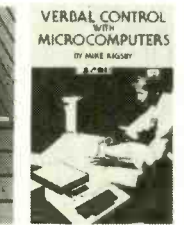

1468 List \$18.95



1050 List \$13.95



1396 List \$14.95

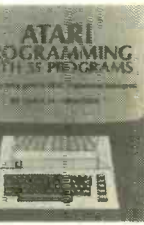

1465 List \$21.95

7 very good reasons to try The Computer Book Club® Blue Ridge Summit, PA 17214

- **Reduced Member Prices.** Save 20% to 75% on books sure to increase your computer know-how
- **Satisfaction Guaranteed.** All books returnable within 10 days without obligation
- **Club News Bulletins.** All about current selections—mains, alternates, extras—plus bonus offers. Comes 13 times a year with dozens of up-to-the-minute titles you can pick from
- **"Automatic Order."** Do nothing, and the Main selection will be shipped automatically! But... if you want an Alternate selection—or no books at all—we'll follow the instructions you give on the reply form provided with every News Bulletin
- **Continuing Benefits.** Get a Dividend Certificate with every book purchased after fulfilling membership obligation, and qualify for discounts on many other volumes
- **Extra Bonuses.** Take advantage of added-value promotions, plus special discounts on software, games, and more
- **Exceptional Quality.** All books are first-rate publisher's editions filled with useful, up-to-the-minute information.



The Computer Book Club®

Blue Ridge Summit, PA 17214

Please accept my membership in The Computer Book Club® and send the 6 volumes circled below, billing me \$2.95 plus shipping and handling charges. If not satisfied, I may return the books within ten days without obligation and have my membership cancelled. I agree to purchase 4 or more books at reduced Club prices (plus shipping/handling) during the next 12 months, and may resign any time thereafter.

- 335 1050 1062 1111 1160 1195 1199
 1205 1251 1276 1295 1333 1369 1389 1396
 1398 1455 1466 1468 1473 1478 1479
 1485 1496 1513 1521 1531 1533 1535 1637

Name _____ Phone _____

Address _____

City _____

State _____ Zip _____

Valid for new members only. (Orders outside U.S. or Canada must be prepaid in International Money Orders in U.S. dollars. Canada must remit in U.S. dollars.) This order subject to acceptance by The Computer Book Club® PECC-1083A

cum-parallel-port. I removed my async board only because I needed two slots width of space to accommodate the Davong controller in my situation. (The three remaining slots are filled by the Maynard board, the Baby Blue and an IBM color/graphics board.)

Utilities Supplied. BACKUP and RESTORE let you write out or reread all or part of a specified hard-disk volume at a time, with the files involved optionally (and customarily) described by the contents of an ASCII file and allowing backups to be incremental—covering only those files changed since the last backup. A negative "skip these" option for describing groups of files is something that DOS should have had since release 1.0.

It took just under seven minutes to RESTORE some 1.3 megabytes of files from four floppies, plus one more minute to create a Master Index, but not counting the time actually taken to swap diskettes. That's not bad at all! Anyone who's too busy to do that on a regular basis deserves whatever catastrophe may befall him.

CHKMEDIA—as in "check media"—is either pretty slick or pretty sloppy. Going by my experience, it runs quickly and non-destructively. It never revealed anything wrong, and I never caught it in any error.

PARK.—Winchester heads "fly" through the air over the recording medium when it's spinning, at 3600 rpm, and they "land" when it stops. This utility lets you position the heads outside the normal data area before powering down, so they come to rest where they can't do any damage.

FORMAT is the replacement for the IBM utility that (no fault of its own) tripped me up, as noted above. In addition to what's provided with DOS 1.1, it adds two more options: "/G," which allows you to proceed directly without time-consuming prompts and confirmations, and "/V," for full verification (recommended for hard-disk volumes, time-consuming on floppies, but essential for freedom from errors).

DISKCOPY replaces IBM's volume-to-volume copy utility. It works fine. Just don't expect to copy a 2.3-megabyte hard-disk volume onto a 160-kilobyte single-sided floppy or vice versa. The media have to match.

sys copies the (modified) operating system onto any volume, hard-disk or floppy, where room's been left for it. It's essentially pointless for hard-disk volumes beyond A: but handy for making new hard-disk-boot floppies.

Documentation. If you take the time to read the documentation—and it's easier to read than many examples, including some from IBM—you can't go too wrong if you've been hanging around PC documentation for a while. The absolute neophyte will need a little help—but doesn't that go without saying?

The section on hardware installation includes enough illustrations for you to get it right even if you're a confirmed illiterate. The software installation procedures and the sections on using the Davong utilities are explained step by step, and include illustrations of the screen displays all along the line. If you take your time and follow the instructions faithfully, you should have no difficulty in getting your hard-disk subsystem up and running.

In short, the documentation is sound, and even superior by current standards.

DOS 2.0 and IBM's Big Nudge. This past spring, IBM shot a double-whammy at folks like Davong: it released DOS version 2.0, and it unveiled its own hard disk for the PC, a 10M-byte one.

[Editor's note: Since this review was written, Davong has started supplying its Multi-OS operating system with its hard-disk drives. Multi-OS is compatible with IBM's DOS 2.0 and offers a number of features not present in the operating system originally shipped with the Davong drives. Among those features are: three levels of password protection, easier access to different disk volumes, support of multiple drives, cache memory (the use of RAM to speed up disk operations by eliminat-

ing many of them), and automatic detection and circumvention of bad disk sectors. Multi-OS also allows multiple operating systems—DOS, Pascal, and CP/M—and languages to reside on the same disk. The Multi-OS requires a 128K system.]

IBM's own Winchester may well lock away that segment of the market that wants nothing to do with products without the horizontal-lines logo—but that market segment would probably not have looked anywhere else, anyway. For the person who's willing, though, to lift up his head and look around him, the Davong system offers more flexibility at a lower price.

If, for instance, you already own an IBM PC and want to upgrade it to have a 10-megabyte hard disk, the IBM upgrade will cost you almost \$3500 (of course, for that price you also get more expansion slots than you had previously). A comparable Davong upgrade is priced at \$2095, and you get all the added features of Multi-OS. Additionally, Davong has an 18-megabyte streaming tape backup available.

Trying out Davong's hard-disk subsystem for the IBM PC has been a flirtation with strong magic. I love the elbow-room, although I would hate to become dependent upon it. The speed advantage is a sometime thing—until you try to imagine floppies handling the same load of programs and data.

The Davong subsystem does what it's supposed to, and does it reliably for a price that is not out of sight. It provides an amplification of PC power that many users should not be without.

Circle No. 93 on Free Information Card

SPECIFICATIONS DAVONG 5-Mb HARD DISK SYSTEM

Range: 5 to 128 megabytes, formatted
Upgrade unit capacities: 5, 10, 15, 21, 32 megabytes
Access time (ms): 3 (min)
110 (avg)
200 (max)
Latency time (ms): 8.3 (avg)
Rotational speed: 3600 rpm
Peak transfer rate: 625K/second
Backup option: floppy disk or 18-megabyte tape cartridge
Operating systems: IBM DOS, Pascal, CP/M, Concurrent CP/M
Programmable disk cache: to 512 megabytes
Flexible volume mapping: supported by Multi-OS
Local networking: supported by Multi-OS
Password protection: supported by Multi-OS (3 levels)
Price: 5 megabytes (int.), \$1845
5 megabytes (ext.), \$1995
10 megabytes (int.), \$2095
10 megabytes (ext.), \$2395
32 megabytes (int.), \$3695
32 megabytes (ext.), \$3995

JVC Telstar 19" Monitor/ Receiver

JAPAN Victor Corp. (JVC) has entered the U.S. high-performance, cable-ready video monitor/TV receiver consumer marketplace with three new models. For our evaluation purposes, we selected its top-of-the-line "Telstar" Model C-2073US 19"-diagonal system with infrared remote control.

Although this JVC Telstar monitor/receiver provides convenient video (including RGB) and audio inputs, it is not modular in design. Therefore, it is more likely to be compared with RCA's VGM 2023S 25", 127-channel system, or its 19" equivalent, than with the other "separate" systems we recently tested. Like the RCA and a majority of other high-performance systems we have seen, the JVC Telstar uses a SAW filter in the i-f section. A comb filter separates the luminance and color signals while providing excellent resolution and video bandwidth.

Suggested retail price for the JVC Telstar C-2073US monitor/receiver, including remote controller, is \$750.

General Description. The Telstar C-2073US is built around an in-line, quick-start 19" color picture tube. Its channel indicator consists of LED (light-emitting diode) numeric displays. Below the channel displays are VIDEO and CATV legends that light up to indicate which program source has been selected and a STAND BY legend that lights up when power is on but no program source has been selected.

Grouped in a vertical column below the legends are the system's four primary controls, all touch-bar operated. They consist of a VIDEO/TV program source selector, up/down CHANNEL scanner, and up/down VOLUME control and an on/off POWER switch. The CHANNEL and VOLUME touch bars are two-function affairs. Touching the left side of the CHANNEL bar initiates downward scanning through the channels,

while touching the right side initiates upward scanning. Similarly, touching the left side of the VOLUME bar decreases sound level, while touching the right side increases it.

Located above the channel displays are an "electronic eye" and the pickup for the remote-control receiver. The electronic-eye circuit can be switched in and out. When switched in, the "eye" glows green and its circuit automatically adjusts brightness, contrast, and color for best picture under changing ambient light conditions.

A set of standard COLOR, TINT, BRIGHT(ness), CONTRAST, fine DETAIL, and V(ertical) HOLD rotary controls and the MAIN POWER switch are located behind a door to the right of the primary-control panel. Also behind this door is a number of special-function switches. One switch permits selection of either cable or standard broadcast TV channels. (A handy conversion table is fixed

Although the Telstar system uses a factory-preset all-electronic, micro-processor-controlled, phase-locked-loop (PLL) tuner, UP and DOWN FINE tuning controls are provided for trimming the receiver's tuning to obtain clearest picture and sound reception from nonbroadcast r-f signals from VCRs, electronic games, etc. An unusual secondary control located behind the door is a slide switch that can be used to select either FAST or SLOW channel scanning when the door is open. In the FAST position, weak channels may be skipped, since the afc circuit does not have sufficient time to lock onto them. Finally, there is an AFC (automatic frequency control) switch behind the door that is disabled whenever the door is swung open.

The infrared (IR) remote-control system used in the Telstar monitor/receiver is almost identical to those used in the RCA, NEC, Sony, and Sears TV

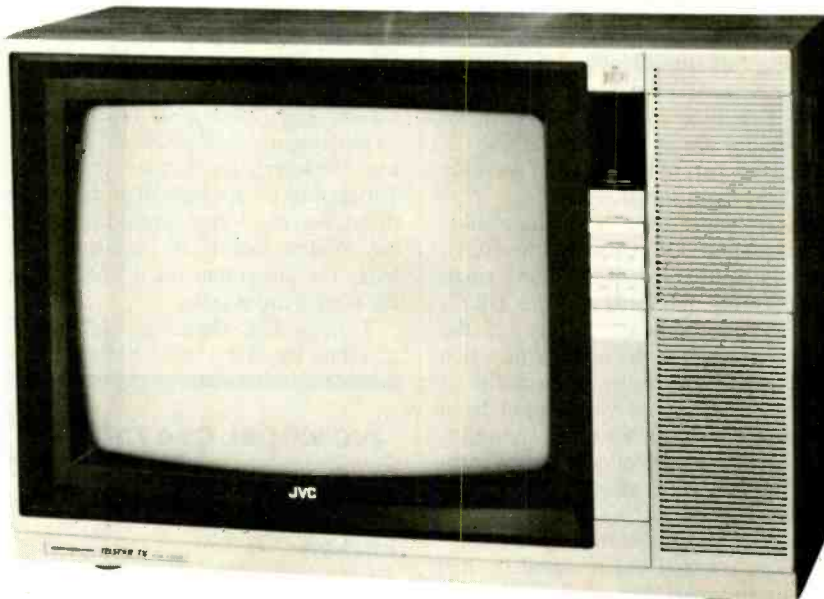

The Model C-2073US comes with an infrared remote control.

on the inside surface of the door for quick reference.) There is also a DISC switch for selecting either automatic discrimination between 50- and 60-frame (foreign or domestic) or 60-frame-only reproduction from VHD video disc players. (The 60-frame-only position is recommended when weak stations are being received.) When the DISC switch is set to AUTO, correction is automatically made for any vertical stretch that may occur when 50-Hz European video discs are played back through the Telstar receiver. Another switch, labeled EE, permits the electronic-eye circuit to be switched in and out.

receivers we have recently evaluated. The MAIN POWER switch must be set to ON for the remote power switch to operate and for the system to operate. Ten numeric pushbutton switches on the remote hand controller permit direct channel access as well as up/down channel scanning. In addition to the up/down VOLUME push-bar control, there is a separate MUTE pushbutton that can be used to temporarily completely turn off the Telstar's audio.

The Telstar C-2073US's electronic circuitry is typical of that used in the other high-performance TV receivers we have reviewed in recent issues. It is

contained on four major printed-circuit board assemblies, and uses 18 ICs and 66 transistors. The power and deflection assembly employs a switched power supply to provide a source of tightly regulated 110 volts dc to the flyback transformer and other circuits. All CRT voltages, including for the filament, are derived from the flyback supply. Only the tuner board assembly has its own transformer-driven 60-Hz regulated power supply, which provides a source of 12 volts dc for the microprocessor-controlled remote-control decoder, frequency synthesizer, and PLL sections. These circuits are almost identical to those used in TV receivers we have reviewed in recent months.

Only five ICs are used on the main signal processor pc-board assembly: i-f, agc, and afc IC, color-signal processing IC, sync separator and sound i-f detector IC. A special seven-pin IC provides automatic black-level control.

The audio amplifier, which drives a 4" x 6" oval loudspeaker, is contained on a separate subassembly. It is claimed to offer better-than-average sound quality, the result of careful component selection and use of a special "ripple filter" that is part of the sound i-f detector IC on the main signal assembly.

As in almost all modern color video monitors and TV receivers, the RGB-output amplifiers are located on a small pc assembly mounted on the CRT's socket. One unusual feature of the Telstar receiver is the manner in which the composite-video signal from the r-f detector output and video input from the VIDEO jack are selected. The selection process is controlled by seven transistors arranged as amplifiers and buffers and two transistors that cut off the video from the jack or from the i-f detector. The selected video signal is then sent to the comb filter section.

The most unusual feature of the Telstar Model C-2073US is not visible from the outside. It is the use of special JVC "chip" resistors and capacitors. These components do not have the usual pigtailed and are not mounted in holes in the board. They are glass-coated, approximately 3/8" x 3/16" x 1/8" blocks with metallized ends that solder directly onto the printed circuit pads. During assembly they are glued onto the board. For removal, they have to be twisted free while the ends are unsoldered. To replace such a chip component, JVC advises preheating it with a blower, such as a hairdryer, preparing little solder balls at the pads, and then soldering the component into place with a 30-watt soldering iron while you are holding the

glass-covered body with a tweezer.

These chip components are not color coded, but the value is printed on the body in a simple code. The number 123 on a resistor, for example, means that the resistance is 12 times 1000 (three zeros) or 12,000 ohms. Capacitors are coded in the same way, with a letter added to indicate tolerance or temperature coefficient. The 123 on a capacitor means a 12,000-pF or 0.012-μF capacitor. Resistors are all 1/4-watt and can be simply replaced with equivalent, standard carbon-composition types. Capacitors are all rated for 50 V. Aside from the use of these chip components, the Telstar monitor/receiver is relatively accessible for servicing, with excellent diagrams, board layouts and instructions supplied in the JVC service manual.

Laboratory Measurements. While the Telstar's critical tuner parameters measured a few dBm lower than those we obtained for the NEC component color system we reviewed in June 1983, they still represent excellent performance. The 134-channel tuner exhibited outstanding sensitivity and noise-figure characteristics that assure that the Telstar will do just as well as its competition, even in deep-fringe reception areas. Video bandwidth measured 4.0 MHz via tuner input and 4.1 MHz from the VIDEO input jack.

Though JVC claims a resolution of 350 lines for direct and 330 lines for r-f

input, we verified between only 320 to 340 lines on our test pattern setup. However, this is not really a true measurement, since it depends on the viewer's judgement of how far down the wedge pattern one can still distinguish individual lines. In any event, the Telstar's resolution was excellent.

The combined resolution, dc restoration, and overall stability of the picture could also be verified by oscilloscope photos of the color-bar test-pattern signal. Deflection linearity and convergence were perfect over the entire screen. There was no evidence of pin-cushioning, and the grey scale appeared 100%.

One of our important tests is overall picture comparison and evaluation in a studio test setup, where we can compare an actual color picture with its reproduction via a studio camera. Our usual panel of experienced studio technicians gave the Telstar an excellent rating, comparing it with previously viewed RCA, Sony, NEC, and Sears screen pictures. Color fidelity was as good as with any of these comparison receivers. Furthermore, we found no apparent difference between the Telstar's excellent pictures and those of the RCA and Sony receivers we previously rated as tops.

User Comment. The Telstar Model C-2073US offers top-notch performance in terms of reception, detail, and color fidelity. Like the RCA VGM 2023S, it combines the functions of a compact

JVC MODEL C2073US 19" TELSTAR MONITOR/RECEIVER LABORATORY MEASUREMENTS

Parameter	Measurement
Sensitivity, vhf (Ch. 3):	-56 dBm
Sensitivity, uhf (Ch. 20):	-54 dBm
Noise figure, vhf (Ch. 3):	10 dB
Noise figure, uhf (Ch. 20):	14 dB
Video bandwidth to CRT (-6 dB):	4.0 MHz
(Monitor only):	4.1 MHz
Oscillator stability (Ch. 3):	0.05 MHz
(105 to 130 V ac, 2 hr) (Ch. 20):	0.05 MHz
Fine tuning range:	0.6 MHz
Agc dynamic range:	66 dB
Dc restoration:	100%
Horizontal linearity:	100% left; 100% right
Vertical linearity:	100% top; 100% bottom
Convergence:	100% at worst
Pin-cushion effect:	None
Voltage regulation, B+:	95%
(105 to 130 V ac)	
High-voltage regulation:	95%
(105 to 130 V ac)	
Size:	18 1/2"H x 19 5/8"D x 27 1/2"W
Weight:	59 lb
Power Rating:	85 W

CREATIVE COMPUTING

WIN AN ATARI® SWEEPSTAKE

Save up to 33% on Creative Computing, too!

The Creative Computing Sweepstakes is open to all our readers. No purchase is necessary—and you'll receive a fantastic Atari home computer system worth over \$1600 if you're the lucky winner!

How the Sweepstakes works

Just mail the attached card or the coupon below after filling in your name and address. Be sure to indicate whether you're also subscribing to *Creative Computing* at the special rates shown—you can save as much as 33%.

Then, if you win, you'll get a superb Atari personal computer system: the Atari 800 with 16K RAM and 10K ROM... an 810 Disk Drive... a 16K RAM Memory Module for extra memory... a pair of Joystick Controllers for game interaction. Use the Atari to handle small business and professional applications as well as sophisticated home processing functions—and, of course, for entertainment. Analyze your investments, learn languages, do



business accounting, play video games. Programmable in Basic or Assembly, the 800 can use all Atari peripherals and can control up to four disk drives and a 60 lpm printer. In all, the 800 and its accessories form a package worth a full \$1620 at retail!

You're sure to win with *Creative Computing*!

Whether you win our Sweepstakes or not, the hours you spend with a computer are certain to be winners when you subscribe to *Creative Computing*. It's the Number One magazine of computer applications and software—filled with in-depth evaluations of computers, peripherals and software, plus applications and software that you can run directly on your computer.

Why not enjoy a year or more of *Creative Computing* at our low introductory prices? You'll save up to 33% if you subscribe at the same time you enter our Sweepstakes!

Atari is a registered trademark of Atari, Inc.



OFFICIAL RULES

No Purchase Necessary

- On an official entry form or a 3" x 5" piece of paper, hand-print your name, address and zip code. Enter as often as you wish, but mail each entry separately to Creative Computing Sweepstakes, P.O. Box 5215, Boulder, Colorado 80322. Entries must be received no later than December 31, 1983, and the drawing will be held by January 28, 1984. All entries become the property of Creative Computing, which reserves the right to reprint the name and address of the winner.
- The winner will be selected in a random drawing from among all entries received, under the supervision of the publishers of Creative Computing, whose decision will be final. Only one prize will be awarded in this Sweepstakes. Winner will be notified by mail and may be required to execute affidavit of eligibility and release. Odds of winning will depend on the number of entries received. Creative Computing will arrange delivery of prize. Taxes are the responsibility of the winner. Any manufacturer's claims and warranties will apply, but Creative Computing makes no claims or warranties with regard to any prizes. Prize is not transferable. No substitutions for prizes.
- Sweepstakes open to all residents of the U.S., its territories and possessions, except employees (and their families) of Creative Computing, its affiliates, and its advertising and promotion agencies. Void wherever prohibited or restricted by law.
- For the winner's name, send a stamped, self-addressed envelope to Creative Computing Sweepstakes, Circulation Department, One Park Avenue, New York, N.Y. 10016.

OFFICIAL ENTRY FORM

Mail to: Creative Computing Sweepstakes
P.O. Box 5215, Boulder, Colorado 80322

YES! Enter my name in the Creative Computing Sweepstakes and start my subscription to *Creative Computing* for the term checked:

- One year (12 issues) only \$19.97—20% off!
- Two years only \$36.97—26% off!
- Three years only \$49.97—33% off!

Savings based on full one-year subscription price of \$24.97.

NO I don't wish to subscribe now, but tell me if I've won the Creative Computing Sweepstakes.

CHECK ONE:

- Payment enclosed.
- Bill me later.

8H526

Mr./Mrs./Ms. _____ (please print full name)

Address _____ Apt. _____

City _____ State _____ Zip _____

Offer valid only in the U.S., its territories and possessions. Please allow 30 to 60 days for delivery of first issue if you subscribe.

GAMES! GAMES! GAMES!

**BASIC
COMPUTER
GAMES**

**MORE
BASIC
COMPUTER
GAMES**

Action books from Creative Computing

Basic Computer Games, edited by David Ahl, is a great collection of 101 fascinating game programs, all written in easy-to-use Microsoft® BASIC. Play Craps, Combat, Lunar LEM Rocket, Boxing, Bowling—and 96 others. With introduction, notes on Microsoft BASIC, and conversion table for other BASICs.

More Basic Computer Games, edited by David Ahl and Steve North, is a challenging sequel with 84 exciting new games. Complete with sample runs, program listings and illustrations. All games run in Microsoft BASIC (conversion table included).

More *Basic Computer Games* also available in TRS-80® edition. Each volume is 8 1/4" x 11", softcover, illustrated.

Only \$7.95 each!

Registered Trademarks Microsoft, Microsoft Consumer Products, Inc., TRS-80, Radio Shack Division of Tandy Corp.

For faster service,
**PHONE TOLL FREE:
800-631-8112**

(In NJ only: 201-540-0445)

Also available at your
local bookstore or computer store.

Creative Computing Press

Dept. NF5C 39 East Hanover Avenue
Morris Plains, NJ 07950

Send me _____ **Basic Computer Games** at \$7.95* plus \$1.50 postage and handling each. #6C

Send me _____ **More Basic Computer Games** at \$7.95* plus \$1.50 postage and handling each. #6C2

Send me _____ **More Basic Computer Games, TRS-80 Edition** at \$7.95* plus \$1.50 postage and handling each. #6C4

PAYMENT ENCLOSED \$

*Residents of CA, NJ and NY State add applicable sales tax. Outside USA add \$3.00 per order.

CHARGE MY: (Charge and phone orders \$10 minimum)

American Express MasterCard Visa

Card No. _____ Exp. Date _____

Signature _____

Mr./Mrs./Ms. _____
(please print full name)

Address _____ Apt. _____

City/State/Zip _____

Send me a FREE Creative Computing Catalog.

...JVC TELSTAR

color TV receiver with a video monitor. But unlike the RCA system, the Telstar's capability as a monitor is more limited, since it has only a single VIDEO and single AUDIO input. This means that you can connect either a VCR or a video-disc player or a computer, but only one video/audio input at a time. There is no provision for stereo sound, and there is no video output and no provision for audio outputs for remote speakers. In this respect, the Telstar is less flexible if you want to use it as the central building block for a full video system.

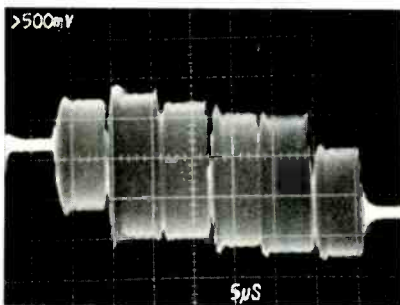
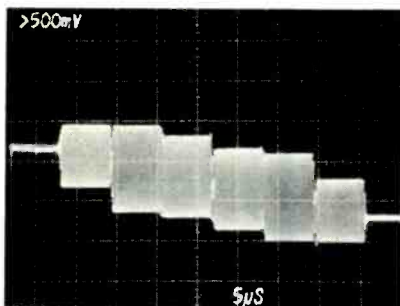

Color-bar input at tuner (top) and output at comb filter input.

Inclusion of a single loudspeaker, without at least some audio outputs for external amplifier systems, appears likely to be a limitation if and when stereo sound is telecast.

We compared the Telstar against recently reviewed competition in technical terms. Now let us see how it stacks up in terms of dollar value. The Sears 19" color monitor, together with a 105-channel tuner, carries a suggested retail price of \$1000. RCA's 25" color TV receiver with 127-channel tuning capability and video monitor combination lists at \$1080, while NEC's 25" 133-channel system lists for \$1400. And a 19" Sony 105-channel system lists for \$1370. The 134-channel JVC Telstar C-2073US, at a suggested retail price of only \$750, therefore, represents excellent dollar value, even in light of its flexibility limitations. —Walter Buchsbaum

Circle No. 92 on Free Information Card

CABLE TV

CONVERTERS

Largest Selection
of Equipment Available
\$ Buy Warehouse Direct & Save \$



36 channel
converter
\$45.95

36 channel
wired remote
converter
only
\$88.95



Send \$2 for complete catalog
of converters and equipment

Quantity Discounts • Visa • Master Charge
Add 5% shipping — Mich. residents add 4% sales tax

C&D Electronics, Inc.
P.O. Box 21, Jenison, MI 49428
(616) 669-2440

PROFIT MAKER

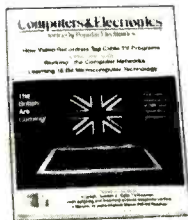

Computers & Electronics not only sells itself at a nice profit, it creates awareness of the hardware and software in your store. It's like having another salesperson on your staff—one who *pays you*. One who goes home with customers and continues to influence buying decisions long after you're closed for the day. If you're interested in a low-ticket item with top-of-the-line sales power, let's talk now.

CALL COLLECT: (212) 725-7679

Or write: Ziff-Davis Publishing Company
Retail Sales
One Park Avenue
New York, NY 10016



Minimum order, 10 copies.
We pay all shipping costs to your store.



Visible-Light Laser Diodes More About Ultrasonics A New Non-Volatile RAM

By Forrest M. Mims, III

EVER since the laser diode was invented (almost simultaneously at three US research laboratories) in 1962, scientists have dreamed of developing one that emits visible light continuously at room temperature. Have they finally succeeded? Read the latest developments in this month's 21st birthday tribute to the laser diode.

Next, we'll examine a wheelchair guided by Polaroid's ultrasonic ranging system. Then we'll look at a clever new approach to power-off data retention in CMOS static RAM that's creating a major stir in the semiconductor memory industry.

But right now let's take care of those readers who have requested copies of previous installments of this column or its predecessors. You can find back issues of this magazine at many public libraries. In addition, installments of "Experimenter's Corner" and "Project of the Month" that appeared from 1975 through 1978 have been published in *103 Projects for Experimenters* (Tab Books, Inc., 1981). Columns that appeared from 1979 through 1981 have been compiled in *The Forrest Mims Circuit Scrapbook* (McGraw-Hill, 1983).

Visible-Light Laser Diodes

How would you like to have a compact laser no bigger than a pocket pen-

light? Moreover, what if this midget laser could emit a bright red beam just as narrow, intense and powerful as that emitted by a much bulkier helium-neon (HeNe) laser? And would you be impressed if this laser included a built-in modulator circuit for transmission of both analog and digital signals from a battery-powered circuit?

Though you cannot yet purchase a laser with these remarkable properties, I'm happy to report the technology for this amazing new laser has already arrived in the form of a new generation of *visible-light-emitting laser diodes*. We'll discuss this new technology shortly. But first let's briefly review the background of this new development so you can better appreciate its significance.

Visible Light Vs. Near Infrared. Figure 1 shows the light sensitivity of the typical human eye. The graph is called the *photopic luminosity curve*. It shows that visible light ends and near infrared begins at or near a wavelength of about 720 nanometers (nm). However, the curve is asymptotic at both extremes since the actual point at which the eye no longer responds is determined by the intensity of the radiation.

For example, I know a laser technician who several years ago accidentally looked into the beam of a powerful neodymium doped YAG laser and reported seeing a bright orange glow. A quick glance at the photopic luminosity curve shows that this is impossible since the YAG laser emits at a wavelength of 1060 nm, well beyond the range of human vision. Perhaps the technician, who was fortunate his eyes were not permanently injured by this experience, ac-

tually observed some of the visible light used to "pump" the YAG laser crystal. Or perhaps he saw the 1060 nm.

In any event, I've often clearly observed the "invisible" 880 nm radiation emitted by the new aluminum gallium arsenide (AlGaAs) light-emitting diodes (LEDs). Of course, in the interest of accuracy, I should note that these LEDs emit a spectrum of wavelengths *centered* at 880 nm. In other words, some of the radiation is closer to the visible wavelengths than the 880 nm figure suggests.

I've related these two examples to illustrate the controversy that surrounds the definition of where visible light ends and near-infrared radiation begins. Until recently the reports of researchers who claimed to have developed "visible-light" laser diodes were generally viewed with considerable skepticism. With these thoughts in mind, let's look at the evolution of the visible-light laser diode.

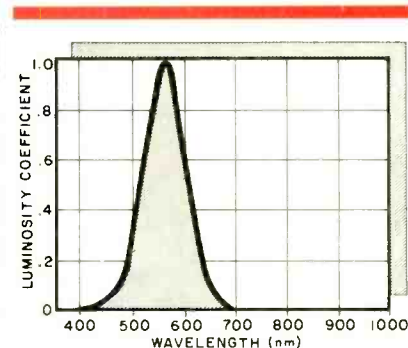

Fig. 1. The photopic luminosity curve of the typical human eye.

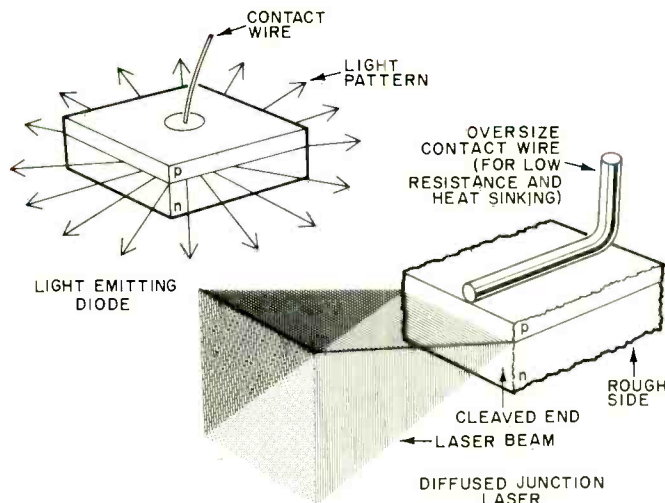

Fig. 2. Physical structure of a simple LED and junction laser.

Visible-Light-Emitting Laser Diodes. The first laser diodes were made in 1962 from gallium arsenide (GaAs), a semiconductor alloy still used to make many such lasers. Figure 2 compares the simplest possible light-emitting diode chip with an early GaAs laser diode. The laser is a p-n diode alike in nearly all respects to the LED. Unlike ordinary LEDs, however, the laser version has a very smooth, flat junction, and two opposing ends of the chips have been cleaved to form perfectly flat, parallel reflective facets that function as end mirrors. The mirrors provide the optical feedback necessary to establish and sustain laser operation. Radiation is emitted from the chip at the junction region of both facets.

Today's sophisticated laser diodes have structures much more complex than the simple p-n junction version shown in Fig. 2. Nearly all are made by forming multiple layers of semiconductor alloys into a sandwich-like configuration. This confines to the junction region radiation that would otherwise be absorbed in the crystal or escape out the sides of the chip. I described several of these structures in an earlier column you may want to review ("Solid State Developments," POPULAR ELECTRONICS, December 1980).

At room temperature, GaAs lasers emit invisible near-infrared radiation at a wavelength centered at about 904 nm. The wavelength range of these lasers is much narrower than similar diodes operated as non-laser infrared emitting diodes.

However, even the very first laser diodes emitted red light because they could only be operated when cooled to the temperature of liquid nitrogen (-196°C). Light is shifted downward in wavelength from near-infrared to visible red because the emission wavelength of *any* light-emitting diode, laser or otherwise, decreases with the temperature of the diode's junction. A liquid nitrogen cooled GaAs laser, for example, emits a wavelength of about 845 nm. At this temperature, the laser operates continuously.

As a development engineer for the Air Force, I once designed and worked with a cryogenically cooled laser diode. I will remember the brilliant, cherry red beam the laser emitted. Of course, operating a laser diode, or any other device for that matter, at the temperature of liquid nitrogen is a major hassle. That's why scientists have long sought to develop a laser diode that emits visible light *and* does so continuously at room temperature.

Several kinds of room temperature laser diodes that emit radiation at the far end of the visible red portion of the spectrum were developed in the United States during the 1960's and early 1970's. One was made from gallium arsenide phosphide (GaAsP), an alloy that emits at about 860 nm. A second was made from aluminum gallium arsenide (AlGaAs), an alloy that then emitted wavelengths as low as 805 nm.

These early visible-light lasers could not be operated continuously at room temperature. Instead, they were driven by brief (200 ns) current pulses.

I've used both kinds of lasers with various drive circuits. Although they produce a visible red light, the intensity is very low. The light from the GaAsP lasers I've used could only be seen when the room lights were dimmed. The emission from the AlGaAs lasers was slightly brighter. When viewed straight on, the chip emitted a bright but tiny sparkle of red. For practical purposes, neither kind of laser can be considered useful as a visible-light emitter.

As early as 1970, RCA, a leader in laser diode research and development, had produced lasers that emitted at 690 nm in a pulse mode, but they were unreliable due to the high current density required to attain laser operation. During the late 1970's, however, RCA scientists produced laser diodes of AlGaAs that operated continuously at room temperature and emitted at wavelengths as low as 740 nm.

Recently the race to develop practical, visible-light laser diodes has intensified. The main incentives are laser-scanned audiodiscs and video discs and laser printers. In both cases laser diodes

could be better utilized as compact, low-power consuming radiation sources if only their emission wavelengths could be reduced. This would permit the laser beam to be focused to a smaller spot than that available from a conventional near-infrared emitting laser diode.

The small spot size of focused light from visible laser diodes would mean that audiodiscs and videodiscs could carry as much information as competing discs designed for use with the HeNe laser. And the laser non-impact printer could achieve better resolution. Furthermore, the laser printer would require less power since the same energy could now be focused into a smaller space.

While virtually all important advances in laser diode technology over the past twenty years took place in the United States, several Japanese companies have recently made major breakthroughs in the development of visible-light laser diodes. Until a few years ago, the very best visible laser diodes made both in this country and Japan emitted in the visible red above about 700 nm. But recently, scientists at Japan's Sharp Corp. announced the first laser diode to emit continuously at wavelengths below 700 nm. Various versions of their new AlGaAs laser deliver from 5 to 10 mW (about the same power as a small penlight) at 683 nm.

Shortly after Sharp announced its new laser, an even bigger surprise came from Omron Tateisi Electronics, another Japanese company. Omron announced the development of indium gallium arsenide phosphide (InGaAsP) laser diodes that emit at about 621 nm at room temperature! This wavelength is

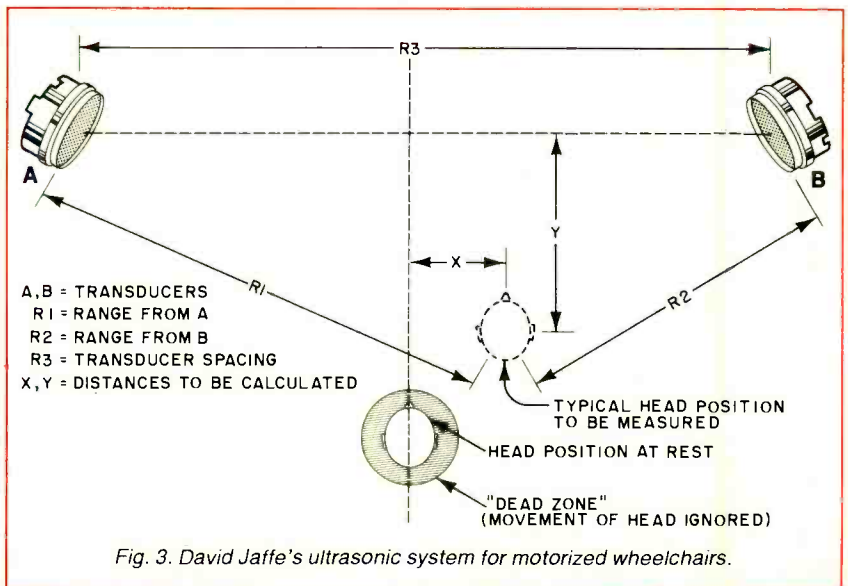

Fig. 3. David Jaffe's ultrasonic system for motorized wheelchairs.

COMMODORE 64

(more power than Apple II at half the price)

COMPUTER AND SOFTWARE SALE

VIC-20

(a real computer at the price of a toy)

\$139.00*

- 170K DISK DRIVE \$179.00*
- TRACTION FRICTION PRINTER \$119.00*

(* with software savings applied)

WE
HAVE
THE
BEST
SERVICE

WE
HAVE
THE
LOWEST
PRICES

\$77.00*

- 40-80 COLUMN BOARD \$99.00*
- VOICE SYNTHESIZER \$69.00*

(* with Cassette and Gortek purchase)

COMMODORE 64 COMPUTER \$139.00

You pay only \$239.00 when you order the powerful 84K COMMODORE 64 COMPUTER! LESS the value of the SPECIAL SOFTWARE COUPON we pack with your computer that allows you to SAVE OVER \$100 off software sale prices!! With only \$100 of savings applied, your net computer cost is \$139.00!! LESS a \$49.50 BONUS PACK of 30 programs on tape or disk we give you absolutely FREE!!!

170K DISK DRIVE \$179.00

You pay only \$279.00 when you order the 170K Disk Drive! LESS the value of the SPECIAL SOFTWARE COUPON we pack with your disk drive that allows you to SAVE OVER \$100 off software sale prices!! With only \$100 of savings applied, your net disk drive cost is \$179.00. LESS a \$49.50 BONUS PACK of 30 disk programs we give you absolutely FREE!!!

TRACTION FRICTION PRINTER \$119.00

You pay only \$219.00 when you order the Comstar T/F deluxe line printer that prints 8 1/2 x 11 full size, single sheet, roll or fan fold paper, labels etc. 40, 66, 80, 132 columns. Impact dot matrix, bi-directional, 80 CPS. LESS the value of the SPECIAL SOFTWARE COUPON we pack with your printer that allows you to SAVE OVER \$100 off software sale prices!! With only \$100 of savings applied your net printer cost is only \$119.00.

80 COLUMN BOARD \$149.00

You pay only \$149.00 for this 80 Column Board when it is purchased with a COMMODORE 64 Computer or a Disk Drive or a Printer or a Monitor. If purchased alone the sale price is \$169.00. Included with this board is word processor pack, electronic spread sheet and mail merge data base on two tapes. List \$249.00. (Disk add \$10.00).

EXECUTIVE WORD PROCESSING PACKAGE

SCRIPT 64 EXECUTIVE WORD PROCESSOR is the finest available for the COMMODORE 64 Computer! THE ULTIMATE for PROFESSIONAL wordprocessing application. Featuring simple operation, powerful text editing with a customized word dictionary, complete cursor and insert/delete key controls, line and paragraph insertion, automatic deletion, centering, margin settings and output to all printers. Included is a powerful MAIL MERGE When used with THE COMPLETE DATA BASE PACKAGE. List \$99.00. Sale \$79.00. Coupon Price \$52.00. (Disk only).

SPECIAL SOFTWARE COUPON

We pack a SPECIAL SOFTWARE COUPON with every COMMODORE 64 COMPUTER-DISK DRIVE-PRINTER-MONITOR we sell! This coupon allows you to SAVE OVER \$100 OFF SALE PRICES! \$200-\$300 savings are possible!! (example)

PROFESSIONAL SOFTWARE COMMODORE 64

Name	List	Coupon
Executive Word Processor	\$99.00	\$52.00
Complete Data Base	\$89.00	\$46.00
Electronic Spreadsheet	\$89.00	\$46.00
Accounting Pack	\$69.00	\$32.00
Total 5.2 Word Processor—Plus		
Tape	\$69.00	\$37.00
Disk	\$79.95	\$42.00
Total Text 2.6 Word Processor—		
Tape	\$44.95	\$26.00
Disk	\$49.95	\$26.00
Total Label 2.6	\$24.95	\$12.00
Disk	\$29.95	\$15.00
Quick Brown Fox Word Processor	\$69.00	\$40.00
Programmers Reference Guide	\$20.05	\$12.50
Programmers Helper	\$69.00	\$40.00
Basic Tutor	\$29.95	\$15.00
Typing Tutor	\$29.95	\$15.00
Sprite Designer	\$16.95	\$10.00
Medicinemen	\$19.95	\$12.00
Weather War II	\$19.95	\$12.00
Music-Maker	\$24.95	\$13.00
EDU-Pack	\$24.95	\$13.00
3D Maze Craze	\$24.95	\$13.00
Professional Joy Stick	\$24.95	\$12.00
Light Pen	\$39.95	\$20.00
Deluxe Dust Cover	\$ 8.95	\$ 4.60

(and many other items)

Write or call for

Sample SPECIAL SOFTWARE COUPON!

PROFESSIONAL BUSINESS SOFTWARE EXECUTIVE QUALITY BY TIME WORKS!

The Cadillac of business programs for Commodore 64 Computers

Item	List	*SALE
Inventory Management	\$89.00	\$69.00
Accounts Receivable	\$89.00	\$69.00
Accounts Payable	\$89.00	\$69.00
Payroll Management	\$89.00	\$69.00
Cash Flow Management	\$89.00	\$69.00
Sales Analysis	\$89.00	\$69.00
General Ledger	\$89.00	\$69.00
(* COUPON PRICE \$59.00)		

VIC-20 COMPUTER \$77.00

You get the Commodore VIC-20 Computer for only \$77.00 when you buy at sale prices: The Commodore Data Cassette for only \$69.00 and the Gortek Introduction to Basic program for only \$19.95. TOTAL LIST PRICE \$302.95. SPECIAL PACKAGE SALE PRICE \$165.25.

40-80 COLUMN BOARD \$89.00

A fantastic price breakthrough for VIC-20 owners on this most wanted accessory!! "Now you can get 40 or 80 Columns on your T.V. or Monitor Screen." Plus we add a word processor with mail merge, electronic spread sheet, time manager and terminal emulator!! These PLUS programs require 8K or 16K RAM memory. (Disk add \$10.00).

VOICE SYNTHESIZER \$59.00

Votrax Based. Make your VIC-20 COMPUTER TALK! Has features equivalent to other models costing over \$370.00. You can program an unlimited number of words and sentences and even adjust volume and pitch. You can make adventure games that talk! A must for enhancing your programming creativity and pleasure.

60K MEMORY EXPANDER \$59.00

Sixslot — Switch selectable — Reset button — Ribbon cable. A must to get the most out of your VIC-20 Computer. Includes FREE \$29.95 adventure game.

8K RAM CARTRIDGE \$39.95

Increases programming power 2 1/2 times. Expands total memory to 33K (33,000 bytes). Memory block switches are on outside of cover! Includes FREE \$16.95 game.

16K RAM CARTRIDGE \$69.00

Increases programming power 4 times. Expands total memory to 41K (41,000 bytes). Memory block switches are an outside cover! Includes FREE \$29.95 adventure game!!

12" GREEN SCREEN MONITOR \$109.00

Excellent quality GREEN PHOSPHOROUS VIDEO MONITOR with antiglare, 1920 characters (80 characters x 24 rows). Save your TV! a must for 80 column word processors. PLUS \$9.95 for VIC 20 or Commodore 64 Cable.

12" AMBER SCREEN MONITOR \$149.00

Premium quality AMBER VIDEO MONITOR With antiglare, (80 characters x 24 rows), exceptionally clear screen, faster scanning, 1000 lines. PLUS \$9.95 for VIC 20 or Commodore 64 Cable.

- LOWEST PRICES • 15 DAY FREE TRIAL • 90 DAY FREE REPLACEMENT WARRANTY
- BEST SERVICE IN U.S.A. • ONE DAY EXPRESS MAIL • OVER 500 PROGRAMS • FREE CATALOGS

Add \$10.00 for shipping, handling and insurance. Illinois residents please add 6% tax. Add \$20.00 for CANADA, PUERTO RICO, HAWAII orders. WE DO NOT EXPORT TO OTHER COUNTRIES.

Enclose Cashiers Check, Money Order or Personal Check. Allow 14 days for delivery, 2 to 7 days for phone orders, 1 day express mail! Canada orders must be in U.S. dollars. VISA — MASTER CARD ACCEPTED

PROTECTO ENTERPRISES

(WE LOVE OUR CUSTOMERS)

BOX 550, BARRINGTON, ILLINOIS 60010
Phone 312/382-5244 to order

Circle No. 40 on Free Information Card

www.americanradiohistory.com

AMAZING DEVICES

LASERS

RUBY LASER RAY GUN — Intense visible red beam, burns and welds the hardest metals. HAZARDOUS device. Kits available.
RUB3 PLANS includes part sources \$15.00

CARBON DIOXIDE BURNING AND CUTTING LASER — produces a continuous beam of energy. HAZARDOUS device — Kits available. LC5 PLANS includes part sources \$15.00

VISIBLE LASER LIGHT GUN — produces intense red beam for special effects and other various optical applications. Hand-held enclosure houses batteries.
LGU3 PLANS \$10.00 LGU3K KIT/PLANS (minus tube) \$99.50

IR PULSED LASER RIFLE — produces 15-30 watt pulses at 9000A at 200-2000 per second.
LRG3 PLANS \$10.00 LRG3K KIT/PLANS (minus diode) \$119.50

BEGINNER POCKET LASER — visible red simulated device produces an excellent monochromatic source of light.
LHC2 PLANS \$5.00 LHC2K KIT/PLANS \$24.50

HIGH ENERGY VARIABLE AND PROGRAMMABLE PAIN FIELD GENERATORS. REQUIRE NO CONTACT — Recently developed device produces directional fields of moderate to high SPL capable of producing intense pain and discomfort. HAZARDOUS IF NOT USED WITH DISCRETION. SOLD FOR ANIMAL CONTROL — MAY BE USED IN CERTAIN INSTANCES TO DISCOURAGE UNWANTED ENCOUNTERS.
PPF1 PROG/VAR PLANS \$15.00 PPF1K KIT/PLANS \$175.00
PSP3 VAR HAND-HELD PLANS \$7.00 PSP3K KIT/PLANS \$44.50

PHASOR BURNING WAND — capable of burning flesh. generates 3500 volts of continuous DC power.
PSW3 PLANS \$8.00 PSW3K KIT/PLANS \$59.50

PARALYZING SHOCKING WAND — produces 100,000 watt pulses of stunning power.
PG1W PLANS \$10.00 PG1WK KIT/PLANS \$79.50

Above electrical devices are hand-held and may be used for PERSONAL OFFENSE.

SMURFS

SNOOPER PHONE — allows user to call his premises and listen in without the phone ever ringing.
SNP2 PLANS \$7.00 SNP2K KIT/PLANS \$49.50

LONG RANGE WIRELESS MIKE — miniature device clearly transmits over 1 mile.
FBT9 PLANS \$7.00 FBT9K KIT/PLANS \$34.50

WIRELESS TELEPHONE TRANSMITTER — long range all automatic, undetectable.
VWPM5 PLANS \$7.00 VWPM5K KIT/PLANS \$34.50

TALK AND TELL — clearly and automatically records both sides of a telephone conversation when phone is being used.
TAT2K KIT/PLANS \$14.50 TAT20 READY TO USE \$24.50

Our order phone is available 24 HOURS, 7 DAYS A WEEK. Write for FREE catalog of our many products.
We accept Master Charge or Visa. Please allow 10% for shipping. On orders OVER \$50.00 WE PAY freight.

SENO TO: SCIENTIFIC SYSTEMS
DEPT. Q1, P.O. BOX 716 AMHERST, NH 03031
OR CALL FOR ORDERING ONLY 1-603-673-4730



MAGIC "INPUT/OUTPUT" MUG

Let the world know when you're on a coffee break. When hot liquid is poured in, one message disappears and another takes its place on the computer screen. Fascinating to watch. Big 10 oz. size. Fine quality white English porcelain. 10 day money-back guarantee if not completely satisfied. **\$8.95**

Call Toll-Free Mon.-Fri. 9am-6 pm
1-800-B-E-S-W-E-E-T
exc. Fla. or mail coupon.

sweet gum inc. CE103

15490 NW 7th Ave., N. Miami, FL 33169
Please send me the Magic "Input/Output" Mug.
Quant. ___ @ \$8.95 Add \$2 each for shipping & hand.
Fla. residents add 5% sales tax. Total \$_____
Encl. is Check MO Charge my MasterCard
Visa Credit Card # _____
Exp. Date _____

Just send me your free COMPUTERMANIA Catalog for now. *

Signature _____
Name _____
Address _____
City _____
State _____ Zip _____

Circle No. 16 on Free Information Card

ELECTRONICS SCIENTIST

lower than that emitted by the HeNe laser.

Will laser diodes that emit visible light replace HeNe lasers? In some applications they might. While laser diodes produce a much more broadly diverging beam than helium neon lasers, a single convex lens can focus the light from a laser diode into a beam as narrow as that from a HeNe laser. Of even more significance, a laser diode can be operated from a compact battery-powered supply, and its light output can be pulse or intensity modulated.

The laser diode's biggest drawback (yes, there's a catch) is its temperature sensitivity. The current supplied to the laser must exceed a certain threshold point before the laser will begin to function as a laser and not merely as an LED. The threshold point, however, decreases with temperature. To avoid destroying the diode by pumping too much current through it, the laser chip must be cooled to a constant temperature (perhaps by a thermoelectric module). Or it must be powered by a temperature regulated supply. Alternatively, the supply can be regulated by a photodiode circuit that monitors the radiation from one end of the laser. This set-up automatically compensates for temperature changes since the radiation from a laser diode biased by a constant current increases in power as temperature decreases. This guarantees that the laser will not be operated above the limit where excessive optical radiation causes damage to the chip's facets.

Its temperature sensitivity notwithstanding, the era of the visible-light-emitting laser diode has finally arrived. Hopefully, the demand created by the videodisc and laser non-impact printer industries will warrant mass production of these important new lasers. When that occurs, prices will fall. You can then expect to see various kinds of pen-light-size laser diode assemblies, complete with battery-powered, regulated supplies and, perhaps, self-contained modulator circuits.

More About Ultrasonics

In the June 1983 installment of this column, I described in some detail Polaroid's ultrasonic ranging system. One of the applications I briefly mentioned was an automatic wheelchair guidance system for quadriplegics. The system helps these people perform tasks such as guiding a motor driven wheelchair through narrow passages like doorways and halls.

After reading this column, David L. Jaffe, the wheelchair's developer, sent along additional details about this fascinating device. Mr. Jaffe, who is with the Veterans Administration Medical Center in Palo Alto, CA, designed the prototype chair as a student project at Stanford University.

Stanford has a well-deserved reputation for encouraging sophisticated design projects. Mr. Jaffe's project, which was sponsored by the Veterans Administration, was carried out at the Smart Product Design Laboratory of Stanford's Mechanical Engineering Department.

Mr. Jaffe's use of Polaroid's range-finders is more sophisticated than implied in the literature I received from Polaroid. According to his letter and a diagram I've reproduced as Fig. 3, "Two sensors were aimed at the user's head. Then, by computer-aided triangulation, the user's head position in rectangular or cylindrical coordinates was determined."

"In operation," Jaffe writes, "the user would tilt his/her head in the direction that he/she wished the chair to travel. The magnitude of tilt controlled the speed. The user's head became a proportional 'joystick'."

The chair was also equipped with forward-facing ultrasonic sensors to detect potential obstacles. The chair was automatically stopped when an obstacle was detected within a preprogrammed distance.

The chair had still other ultrasonic sensors. Jaffe writes, "Side facing sensors allowed the vehicle to travel automatically at a fixed distance from a wall on either side of the chair. The cruise-control mode enabled the vehicle to navigate in a straight line at a constant speed. The net result was a vehicle that could be used by individuals who did not have use of their hands. The Polaroid sensor system provided a man/machine interface that did not require physical contact."

Recently Jaffe has developed a much improved model of his prototype wheelchair. The new one uses a single-board STD computer and is programmed entirely in Fortran. Also, the head detection sensors have been remounted behind the user's head to simplify the process of entering and leaving the wheelchair. Already one version of the new chair has been delivered to a user in France.

Jaffe's work with the Polaroid ultrasonic sensors has stimulated several other clever ideas. I hope he'll pass the details along as he pursues them. If he does, I'll certainly report on them in this

column. In the meantime, if you wish additional information about the automated wheelchair, write David L. Jaffe at the VA Medical Center (3801 Miranda Avenue, Palo Alto, CA 94304).

A New Non-Volatile RAM

The traditional non-volatile RAM is a memory chip that retains data when disconnected from an external power supply. In recent years, the concept of non-volatility has also come to mean ultra-low-power CMOS RAMs that receive standby power from a small battery.

To the best of my knowledge, one of the first consumer products to incorporate a "non-volatile" battery-powered CMOS RAM was Hewlett-Packard's HP-25 programmable calculator. The "continuous memory" provided by this calculator was a major breakthrough for its time.

Today, of course, many consumer products incorporate various kinds of true non-volatile RAMs and, especially, battery-powered low-power CMOS RAMs. Two main approaches are used: conventional CMOS RAMs continuously powered by an on-board rechargeable battery or the main supply battery; and electrically erasable PROMs (EEPROMs). Of these, the battery-powered back-up methods are by far the most popular. Besides being easier to implement and use, they're also cheaper.

In principle, battery back-up systems for CMOS RAMs are very simple. In practice, however, they can be tricky to design. Those that employ a rechargeable nickel cadmium cell, for instance, require various charging components

and, perhaps, a nonstandard supply voltage and additional support circuitry. Those that receive continuous standby power from a system's main battery require a means to preserve the RAM's contents while the battery is being changed.

A capacitor can provide a few minutes or so of standby power during the time it takes to change the batteries. But the memory's contents will be lost if the batteries run down before they're changed.

Recently, Mostek Corporation announced a new solution to the non-volatility problem that meets many of the objections to previous approaches. Mostek's idea is to include a pair of miniature, long-lived lithium power cells in a package mounted atop a standard 24-pin dual in-line package. Mostek calls the piggyback battery package a lithium "Top Hat." The DIP itself contains a CMOS static RAM to which has been added on-chip analog circuits that monitor the power supplied to the chip and switch to one of the two on-board lithium cells when the external power fails or is switched off.

This new development represents a major advance in solid-state memory technology, and it's already generated lots of excitement—and concern—in the semiconductor memory industry. In a recent telephone conversation, Michael Bolan, a product line manager at Mostek, told me his company has been flooded with inquires since the first version of the new non-volatile memory product was announced. According to Bolan, the new product, which is shown partially disassembled in Fig. 4, "is a completely pre-engineered solution to a nasty problem."

Bolan said two major developments made the new memory product a reality. One is the ultra-low standby power

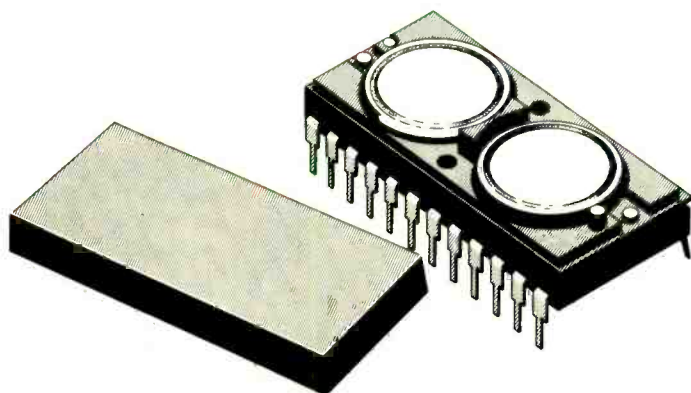
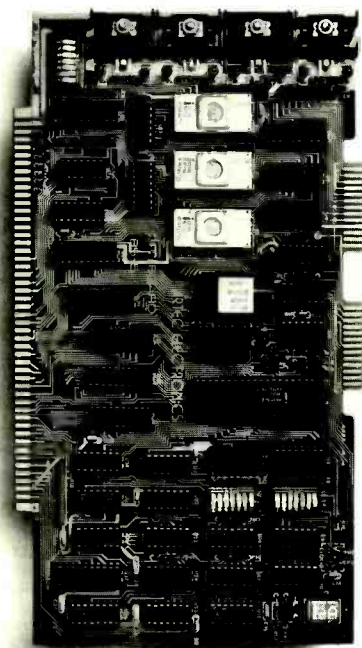

Fig. 4. How lithium cells are installed in Mostek's RAM.

Hire a fast thinker.



5 MHz CPU Card

- Intel 8085A-2 microprocessor
- Hardware floating point
- Performs calculations six times faster than other CPUs
- On-board monitor in PROM
- 1K RAM scratch pad
- Keyboard or RS232C terminal
- Variable clock frequency

PRICE—\$450

(California residents add 6% sales tax)

Call or write Artec for details.

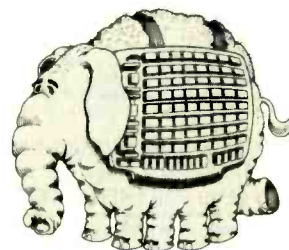

ARTEC ELECTRONICS, INC.

605 Old County Rd., San Carlos, CA 94070

Telephone (415) 592-2740

Circle No. 55 on Free Information Card

PREVENT HI-TECH HEADACHES

Our Isolators eliminate equipment interaction.



clean up interference, curb damaging power line spikes and lightning bursts.

ISO-1 Isolator

3 isolated sockets; quality spike suppression; basic protection. . . \$76.95

ISO-3 Super-Isolator

3 dual isolated sockets; suppressor; commercial protection. 115.95

ISO-17 Magnum Isolator

4 quad isolated sockets; suppressor; laboratory grade protection. . . 200.95

ESP Electronic Specialists, Inc.

171 S. Main St., Box 389, Natick, MA 01780

Toll Free Order Desk 1-800-225-4876
MasterCard, VISA, American Express

Circle No. 51 on Free Information Card



For Home or Business
WHAT...WHEN...HOW...

BE A COMPUTER PROGRAMMER

Train at home in spare time! No previous experience needed! Now you can learn it all! Computer programming...computer applications...computer games...everything you ever wanted to know about computer operations! Write your own computer programs or use hundreds of programs already available...budgeting, real estate, bookkeeping, expenses, investments, interest, taxes, shopping lists, vacation planning, addresses, phone numbers, routing...even foreign languages and graphics.

You'll know what really happens when you have a computer problem with a bank, store, loan company, oil company, utility or anyone else. You'll be able to talk their language, understand why and how things happen...to be able to take the offensive when you're the victim of a computer error. Experts explain everything in easy-to-understand language with step-by-step directions.

- TIMEX COMPUTER INCLUDED WITH YOUR TRAINING • Plugs into any TV
- SEND FOR FREE FACTS!

ICS COMPUTER TRAINING, Dept. PD093
SINCE 1981 Scranton, Pennsylvania 18515

Please rush me free facts and color brochure that tells how I can learn computer applications, programming and operation at home in spare time. No cost. No obligation.

Name _____ Age _____
Address _____
City/State/Zip _____

...ELECTRONICS SCIENTIST

consumption of the static CMOS RAM, only about 5 nanoamperes. The other is an analog voltage sensing circuit that consumes essentially no current.

Mostek calls its new memory the Zeropower™ RAM. The first version is the MK48Z02, a 2K-by-8-bit static RAM that appears to external devices like any other 2K-by-8-bit static RAM. Later the company plans to introduce 8K-by-8-bit and 32K-by-8-bit versions.

How it Works. Figure 5 is a block diagram of the new chip. In operation, it functions like any ordinary static CMOS RAM when powered by an external supply of 5V. When the supply falls below 4.5V, however, all the inputs to the chip are disabled by the analog voltage monitoring circuit. This protects the data in the chip.

When the supply voltage falls below 3V, the analog circuitry switches the lithium cell having the highest output voltage to the power-supply bus. It then automatically disconnects the bus from the external supply.

When external power to the chip again exceeds about 3V, the analog circuitry again connects the external supply to the internal power bus. It then disconnects the lithium cells that supplied standby power.

The analog circuitry of the MK48Z02 even monitors the two lithium power cells. If the voltage of either falls below about 2V, the chip will not execute a data write cycle. This warns the user that the lithium cells may soon reach the end of their useful life.

Battery Life Projections. By now you're probably wondering just how long the "useful" life happens to be for the lithium cells in the MK48Z02. Michael Bolan reports that the ultra-low power consumption of the new chip means the lithium cells have a projected life expectancy equal to their shelf life. Bolan forecasts a battery life of ten years! The MK48Z02 sells for \$22 in quantities of 1000. For additional information, write Mostek Corp (1215 W. Crosby Road, Carrollton, TX 75006).

Adding an Output Interface to a Clock Module

The wide variety of inexpensive liquid-crystal-display watches and clocks now available is truly remarkable. Equally good news for the electronics experimenter is that watches and clocks

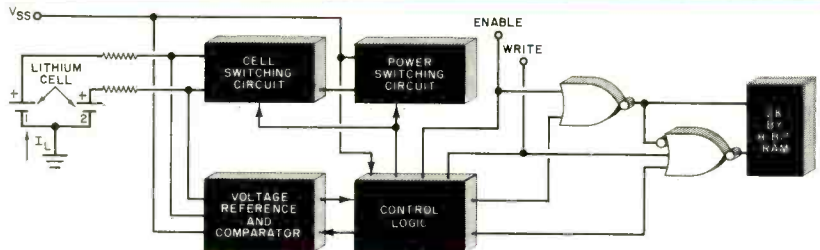

Fig. 5. Block diagram (above) of Mostek's lithium-cell RAM.

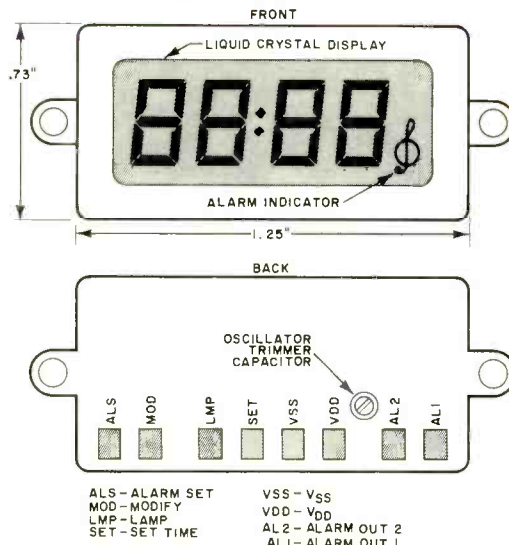
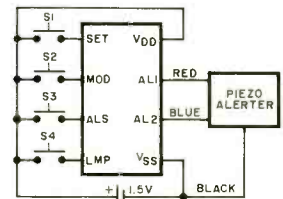

Fig. 6. At left are front and back views of PCIM-161A clock module.

Fig. 7. Circuit below shows how to add an alerter to the module output.



with a built-in alarm function can be easily modified to control external devices such as radios and lights. All that's necessary is to connect a suitable interface circuit to the clock's alarm outputs.

In this column we'll add an output interface to an LCD clock module designed to be installed in a user-supplied enclosure. Similar interfacing methods may work with preassembled digital alarm clocks and watches.

The Clock Module. The module that I've interfaced, the model PCIM-161A, is one of a family of miniature LCD clock modules made by PCI Displays (1145 Sonora Court, Sunnyvale, CA 94086). This module was once sold by Radio Shack for \$19.95. Though no longer a catalog item, it is still available in some stores. It can also be purchased from PCI representatives for \$20 (or \$15 in quantities of 10 to 99). If the price seems too high, you might prefer to attempt adding an output interface to a standard, premanufactured digital alarm clock or watch. Keep in mind, however, that the circuit to be described has been tried only with the PCIM-161A. It may not work with other clocks.

Figure 6 shows both front and back views of the PCIM-161A module. The crystal-controlled module has an accuracy of ± 2.5 minutes per year. It should be powered by a 1.3-to-1.6-V supply. At 1.5V it typically consumes 6 mA.

Figure 8 shows how the module can be connected to a piezo alerter (muRata PKM11-6A0, Radio Shack 273-064 or similar). When the alarm is activated, the alerter emits a tone interrupted at 1-Hz rate with a 25% duty cycle.

Setting the calendar, actual time, and alarm time of this clock module requires a procedure similar to that of any non-keyboard digital clock.

An SCR Output Interface. Figure 8 shows a straightforward output interface circuit for the PCIM-161A. In operation, the alarm signal applied to the base of *Q1* is amplified and applied through *D1* to the gate of *SCR1*. This turns on the SCR and, in turn, pulls in the relay. The SCR stays on after the alarm signal ends unless the reset switch (*S5*) is momentarily opened. Diode *D2* absorbs any back emf that is generated by the relay coil when the circuit is reset.

Applications. The interfaced clock module is ideal for turning lights and appliances on or off at any desired time. For best results, install the module on the front panel of a small, plastic enclosure. Install pushbuttons *S1* through *S5* on the front panel below the clock module. Install the interface circuit and holders for a 1.5- and 9-V battery inside the enclosure. Include a suitable jack for connecting devices to be controlled by the relay contacts.

Before mounting the clock's control switches (*S1* through

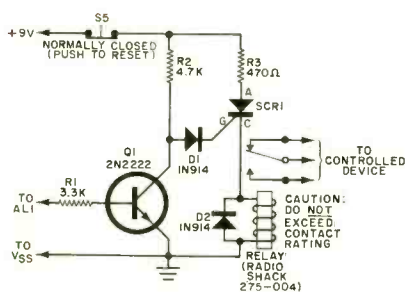

Fig. 8. Output interface for clock module.



Active Electronics

**NUMBER ONE IN
QUALITY
SERVICE
AVAILABILITY**

**THE WORLD'S MOST
COMPLETE PROFESSIONAL
AND HOME ELECTRONICS
ENTHUSIAST INVENTORY**

- Semiconductors + Memories
- Microprocessors + Support Circuits
- Microcomputer Systems + Peripherals
- Passive Electronic Components
- Hand Tools, Wire Wrapping, Soldering Equipment + Hardware

**NOW AVAILABLE — FREE
1983 80-page catalog**

A complete listing of products and specifications

Call, write or circle the inquiry card for your free copy today.

P.O. Box 8000, Westboro, Mass. 01581
CALL TOLL FREE: 1-800-343-0874

Mass customers call (617) 366-0500

Circle No. 56 on Free Information Card

FREE SOCKETS!

Send **\$1.00** postage and handling

for DIP Socket Deal!

8, 14, 16, 24 and 40 pin DIP Sockets

plus we will send you FREE our 56 page catalog with \$1.00 OFF Coupon on any purchase.

How can you lose?

SINTEC COMPANY
28 8th Avenue
Box 410
Frenchtown, NJ 08825

When Ordering
Call Toll Free:
1-800-526-5960
In NJ call (201) 996-4093

Fill in below or ask for Socket Deal

I want the Socket Deal Enclosed is my \$1.00 cash.

Name _____

Address _____

City _____ State _____ Zip _____

SAVE ON ELECTRONICS



HP-41CV
\$207.99

HP-32E Scientific	129.99	82169A HP-IB Interface	349.99
HP-34C Programmable	54.99	82905B/248 80 col Pntr	649.99
HP-37E Financial	29.99	7470A/003 IL Plotter	1299.00
HP-10C Scientific	57.99	82180A Extnd Functns	59.99
HP-11C Programmable	74.99	82181A Extnd Memory	59.99
HP-12C Financial	99.99	82182A Time Module	59.99
HP-15C Programmable	99.99	82183A Extnd I/O	59.99
HP-16C Hexadecimal	99.99	82184A Plotter ROM	59.99
HP-41C Alpha Prog	149.99	HP-41 Appl Pacs - from	26.99
HP-75C Computer	739.99	HP-41 Sol Books	11.99
HP-97 Oesk Progrmbie	599.99	82700A 8K Mem for 75	149.99
82104A Card Reader	149.99	HP-75 VisiCalc	169.99
82143A Printer	289.99	HP-75 Math Pac	129.99
82153A Wand	99.99	HP-75 Text Formatter	84.99
82160A IL Module	94.99	HP-75 Sol Books - from	32.99
82161A Cassette Drive	347.99	Non-HP Items	
82162A HP-IL Printer	347.99	HP-41 System Case	79.99
82163A Video Interface	169.99	Port-X-Tender to 10 pts	139.99
82164A RS-232 Intrfc	249.99	HP-41 Synthetic Prog	16.99
82168A Acoustic Modem	429.99	80 col Video Interface	269.99

Texas Instrument



TI-99/4A Computer \$149.99
Less TI Rebate 50.00
Your net cost 99.99

PHP 1200 Peripheral Expansion Box	\$199.99
PHP 1500 Speech Synthesizer	84.99
PHP 1600 Acoustic Telephone Modem	169.99
PHP 2700 Program Recorder with cable	59.99
PHP 1100 Wired Remote Controllers	28.99
PHM 3026 Extended BASIC	79.99
PHM 3055 Editor/Assembler	42.99
PHM 3058 Mini-Memory	79.99

Call for TI-99/4A Software

Buy any 3 of these 7 and get a free Peripheral Exp. Box

PHP 1220 RS-232 Card	\$139.99
PHP 1240 Disk Controller Card	219.99
PHP 1250 Exp Box Disk Drive	329.99
PHP 1260 Memory Expans Card	249.99
PHP 1270 P-code Card	219.99
PHM 3111 TI Writer	84.99
PHM 3113 Microsoft Multiplan	84.99

CC-40 Handheld Computer	\$199.99
HX-1000 Printer - 4 color Plotter	159.99
HX-2000 Wafertape Drive	109.99
HX-3000/P RS-232 and Parallel interface	104.99
TI-55-II Scientific/Statistical Calculator	39.99
LCD Programmer Hexadecimal Converter	59.99

Sharp

PC-1250 Micro Pocket BASIC Computer	\$89.99
CE-125 Printer/Microcassette for PC-1250	149.99
PC-1500 Advanced 4K Handheld Computer	179.99
CE-150 Cassette Interface/4-color Printer-Plotter	179.99
CE-151 4K Memory Expansion for PC-1500	49.99
CE-155 8K Memory Expansion for PC-1500	79.99
CE-159 8K Battery Memory for PC-1500	99.99
CE-161 16K Battery Memory for PC-1500	159.99
PC-1500 Software ROMs	59.99

Casio

FX-700P Handheld BASIC Computer	69.99
FA-3 Cassette Interface for FX-700P	34.99
FP-12 Printer for FX-700P	59.99
FX-450 Solar Scientific Hexadecimal	32.99
FX-98 Solar Credit Card Scientific	24.99
HR-7 Handheld Printing Calculator	29.99
MT-45 Keyboard with Chords, Bass, Rhythms	159.99
MT-65 Home Entertainment Keyboard	249.99
MT-70 Advanced Electronic memory Organ	299.99
TS-100 Thermometer Calculator Watch	39.99
TC-500 Touch-sensor Calculator Watch	34.99
CFX-20 Scientific Calculator Watch	34.99
DW-5000 G-Shock 200m Watersport Watch	49.99
AQ-30W Watersport Digital/Analog Watch	29.99
AA-85 "Blue Thunder" Watch	34.99

Smith-Corona

Ultrasonic All Electronic Portable	399.99
Intrepid "Ball" Element-style	289.99

Use cashier's check, postal money order, VISA, or M/C. Psnl checks take five weeks to clear. Add shipping. ¹⁰ of your order is 36 minimum. East of Missp Rev air 11.50 CA res add 6% Subject to availability. USA d/cies.

ORDER 800-421-5188 Outside
TOLL FREE Information line (213) 633-3262 CA 4K HI

tam's Tam's Inc, Dept CE-9
INCORPORATED 14932 Garfield Ave.
Paramount, CA 90723
(213) 633-3262

Circle No. 42 on Free Information Card

ELECTRONICS SCIENTIST

S4), test the clock for proper operation. It may be necessary to use double-pole switches that hold the inputs low when they're not switched high.

WARNING: You *must* follow safe wiring procedures if you use this circuit to control devices powered by the household line. Insulate all exposed connections. Do not exceed the contact ratings of the relay. The clock and interface should not be used for any application in which a circuit malfunction might cause injury to persons or property.

Xenon Flash Circuit Correction

Mike Marks of Milwaukee, WI, a self-described and sharp-eyed "oscillator freak," detected an error in the May 1983 installment of "Experimenter's Corner." The subject of that column was "Experimenting with Electronic Flash Circuits," and Fig. 3 (p. 92) showed a single-flash xenon strobe circuit. The oscillator portion of the high-voltage power supply was incorrectly drawn. A correct version of the circuit is shown in Fig. 9.

Incidentally, many other oscillator circuits can be used in this circuit. For example, I've used unijunction transistor oscillators and 555 timers operated in the astable mode.

New Devices

A Programmed IC Socket. "Have you ever found a second source IC device that's functionally correct but has a pinout that doesn't match your circuit board layout?" So begins an advertise-

ment by Apronics, a division of AP Products, Inc. (9450 Pineneedle Dr., P.O. Box 603, Mentor, OH, Oh44060).

The Apronics solution to this common problem is a new IC socket called the Programmed Socket. It permits identical ICs having different pinout patterns to be used in the same circuit. The appropriate Apronics Programmed Socket is installed in the original socket on the circuit board. The new IC is then plugged into the Apronics socket.

Computer hobbyists will be among the first to line up for this new IC socket because memory chips that are functionally identical may have different pin diagrams.

The first Apronics socket is a 28-pin version having double-sided, selective gold contacts. For more information about this socket, you can write Apronics or call the company toll free at 800-792-0137 (outside Ohio only).

A New 5-Volt EEROM. The 5213 is a 16K electrically erasable read-only memory (EEROM) made by Seeq Technology, Inc. (1849 Fortune Dr., San Jose, CA 95131). Unlike earlier EEROM's the 5213 can be operated from a single 5-V only supply. It should therefore find application in many new designs.

Seeq Technology has published a 14-page application note for the 5213 that's must reading for anyone thinking about designing a memory system using conventional ROM's, PROM's, or ultraviolet-erasable PROM's. Entitled "System Applications Using the 5213 E²ROM," the note details electrical characteristics of the new chip. Included are complete details on the operation of the chip during write and erase cycles. For a free copy of this very complete application note, write Seeq Technology's sales department at the address given above. ◊

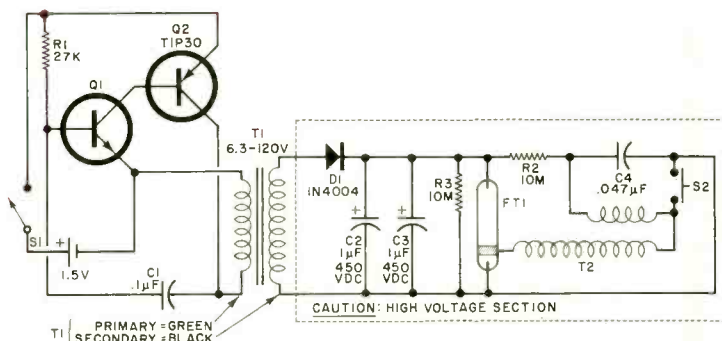

Fig. 9. Single-flash xenon strobe circuit.

MAKE RADIO SHACK YOUR PARTS PLACE™

Wide Selection! Low Prices! "Hometown" Shopping!

Versatile New ICs

Low As **159**

TCM5089 Telephone Tone-Dialing Generator. Accurate dual-tone output with low THD. Micro-processor addressable—ideal for use in an auto-dial modem. Line or 9 VDC. 16-pin DIP with data. 276-1301 3.99

ICL7660 Voltage Converter IC. Input: +5 VDC. Output: -5 VDC, up to 10 mA. Ideal for memory circuits. 8-pin DIP with data. 276-2335 3.79

MC3423 Overvoltage Sensor IC. Protects sensitive electronic circuitry by triggering an external LED or crowbar SCR in the event of line transients or loss of regulation. Usable from 4.5 to 40 VDC. 8-pin DIP with data. 276-1717 1.59

21-Range LCD Multimeter

\$20 Off!

Reg. 59.95

39.95

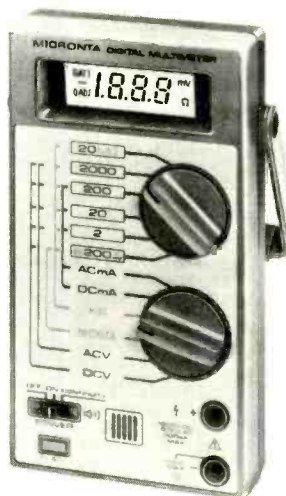

Audible Continuity & Range-Change Indicator

Reduced 33%! Time-saving continuity function "beeps" at less than 300 ohms circuit resistance. "Diode check" allows testing of diodes and transistors. Measures AC and DC voltage, AC and DC current, and resistance up to 20 megohms. Overload protected. 6³/₈ x 3¹/₂ x 1³/₈". With manual, spare fuse, test leads. Requires two "AA" batteries. 22-191 **Sale 39.95**

Melody Synthesizer

NEW!
5.99

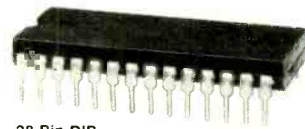

28-Pin DIP

AY-3-1350 Melody Synthesizer. 28 built-in tunes! NMOS device is ideal for doorbells and musical funboxes. Pre-programmed with Toraador, William Tell, Yankee Doodle, Blue Danube, Star Wars, America, Beethoven's 5th, other pop and classical favorites. Or add a PROM and create your own. Auto switch-off at end of tune. With data. 276-1782 **5.99**

10 x 10cm Solar Cell

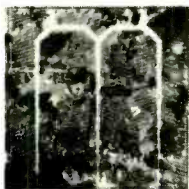

Harness "Free" Power That's Available Every Sunny Day

Save \$8.07

Reg. 17.95 **9.88**

Cut 45%. Build a panel for charging batteries or powering projects. This quality cell, approximately 4" square, produces 0.42 VDC at 2 amps in full sun. Wire several in series for more voltage. 276-128 **Sale 9.88**

Universal Breadboard

NEW!
19.95



This 2¹/₄ x 6¹/₂" builder's board is mounted on a 7 x 4" "stay-put" steel base with rubber feet. Accepts DIPs, discrete components and up to 22-gauge wire. Total of 640 plug-in tie points. 3 binding posts for power hookup, etc. 276-169 **19.95**

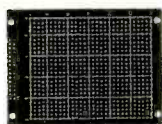

Universal PC Board
NEW! 1.95

Accepts ICs up to 40 pins. Total of 750 indexed holes with solder rings, two busses, one grounding strip. Mounting holes at corners. 3³/₈ x 2⁷/₈". 276-168 1.95

Sealant Tape



NEW!
2.49

Waterproof, non-corrosive, stays flexible. Ideal for outdoor antenna connections. 5 ft. x 1/2". 278-1645 2.49

Coax Stripper

NEW!
9.95



Adjustable blades for perfect stripping of RG-6, RG58, RG8M, RG62 and other cables from 3/16 to 5/16" dia. 278-240 9.95

PC Board Spacers

NEW!
69¢

Pkg. of 8



Nylon type, mount PC boards 3/8" from chassis or enclosure. Snap into place. 270-1391 **Set, 69¢**



Lighted Switch

NEW! 4.95

120VAC SPDT Push-On/ Push-Off. Contacts: 3A at 120 VAC. Lamp requires 12 volts, AC or DC. Mounts in 1/2" diameter hole. 275-676 4.95

Power Cable



18-Gauge 3.29

Two-conductor, color-coded cable is ideal for many uses. 25 feet. 278-1250 3.29

Cable Clips

NEW!
1.99



Pkg. of 10

Keeps cables up to 3/8" dia. in place. Adhere to smooth, non-porous surfaces, indoors or out. 278-1640 **Pkg. of 10/1.99**

Resistor Networks

NEW! 89¢



IC Pin Spacing

Five separate 1/4-watt resistors in one package. Ideal for LED current limiting and digital circuits.

Ohms	Cat. No.	Each
470	271-095	89
1000	271-096	89
10k	271-097	89

Transient Protector



1.49

V8ZA1. This MOV (metal oxide varistor) protects circuits operating at 5 VDC and below. Absorbs potentially damaging voltage transients. 276-569 1.49

Keep Up With New Developments

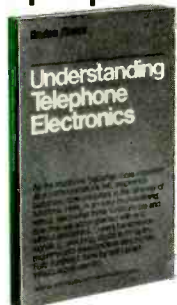

3.49

From Texas Instruments Learning Center

2.95

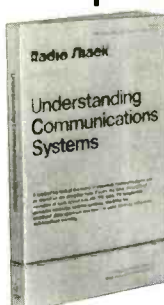

Understanding Telephone Electronics. Learn how your phone works and read about the impact electronics is making on telephone systems. Illustrated. 256 pages. 62-1388 3.49

Understanding Communications Systems. Covers the basics of electronic communications—telephone, television, facsimile, data links and more. Illustrated. 256 pages. 62-2018 2.95

"Jumbo" Neon Lamp

NEW! 1.99



Each

Pilot lights that can't be overlooked! Require 3/8" diameter mounting hole.

Color	Cat. No.	Each
Red	272-710	1.99
Green	272-711	1.99

Miniature 4PDT Relay



Cut 26%
Reg. 4.69 **3.49**

Switches up to four circuits! Contacts: 3A at 125 VAC. 120VAC coil. PC or socket mounting. 1³/₈ x 1¹/₈ x 1³/₁₆". 275-212 **Sale 3.49**

Ferrite Beads

NEW!
89¢

Pkg. of 10



For EMI/RFI Reduction

Install over insulated wires or component leads to reduce RFI and stabilize circuits. Diameter of hole: 0.7mm. BF40 material. 273-098 **Pkg. of 10/89¢**

Radio Shack®

A DIVISION OF TANDY CORPORATION • OVER 8600 LOCATIONS WORLDWIDE

Prices apply at participating Radio Shack stores and dealers

4164

64K DYNAMIC
200 NS

\$595

TMM2016

2KX8 STATIC
200 NS

\$415

STATIC RAMS

2101	256 x 4 (450ns)	1.95
5101	256 x 4 (450ns) (cmos)	3.95
2102-1	1024 x 1 (450ns)	.89
2102L-4	1024 x 1 (450ns) (LP)	.99
2102L-2	1024 x 1 (250ns) (LP)	1.49
2111	256 x 4 (450ns)	2.49
2112	256 x 4 (450ns)	2.99
2114	1024 x 4 (450ns)	8/9.95
2114-25	1024 x 4 (250ns)	8/10.95
2114L-4	1024 x 4 (450ns) (LP)	8/12.95
2114L-3	1024 x 4 (300ns) (LP)	8/13.45
2114L-2	1024 x 4 (200ns) (LP)	8/13.95
2147	4096 x 1 (55ns)	4.95
TMS4044-4	4096 x 1 (450ns)	3.49
TMS4044-3	4096 x 1 (300ns)	3.99
TMS4044-2	4096 x 1 (200ns)	4.49
MK4118	1024 x 8 (250ns)	9.95
TMM2016-200	2048 x 8 (200ns)	4.15
TMM2016-150	2048 x 8 (150ns)	4.95
TMM2016-100	2048 x 8 (100ns)	6.15
HM6116-4	2048 x 8 (200ns) (cmos)	4.75
HM6116-3	2048 x 8 (150ns) (cmos)	4.95
HM6116-2	2048 x 8 (120ns) (cmos)	8.95
HM6116LP-4	2048 x 8 (200ns) (cmos)(LP)	5.95
HM6116LP-3	2048 x 8 (150ns) (cmos)(LP)	6.95
HM6116LP-2	2048 x 8 (120ns) (cmos)(LP)	10.95
Z-6132	4096 x 8 (300ns) (Qstat)	34.95

LP = Low Power Qstat = Quasi-Static

DYNAMIC RAMS

TMS4027	4096 x 1 (250ns)	1.99
UPD411	4096 x 1 (300ns)	3.00
MM5280	4096 x 1 (300ns)	3.00
MK4108	8192 x 1 (200ns)	1.95
MM5298	8192 x 1 (250ns)	1.85
4116-300	16384 x 1 (300ns)	8/11.75
4116-250	16384 x 1 (250ns)	8/11.95
4116-200	16384 x 1 (200ns)	8/12.95
4116-150	16384 x 1 (150ns)	8/14.95
4116-120	16384 x 1 (120ns)	8/29.95
2118	16384 x 1 (150ns) (5v)	4.95
4164-200	65536 x 1 (200ns) (5v)	5.95
4164-150	65536 x 1 (150ns) (5v)	6.95

5V = single 5 volt supply

EPROMS

1702	256 x 8 (1us)	4.50
2708	1024 x 8 (450ns)	3.95
2758	1024 x 8 (450ns) (5v)	5.95
2716	2048 x 8 (450ns) (5v)	3.95
2716-1	2048 x 8 (350ns) (5v)	5.95
TMS2516	2048 x 8 (450ns) (5v)	5.50
TMS2716	2048 x 8 (450ns)	7.95
TMS2532	4096 x 8 (450ns) (5v)	5.95
2732	4096 x 8 (450ns) (5v)	4.95
2732-250	4096 x 8 (250ns) (5v)	8.95
2732-200	4096 x 8 (200ns) (5v)	11.95
2764	8192 x 8 (450ns) (5v)	9.95
2764-250	8192 x 8 (250ns) (5v)	14.95
2764-200	8192 x 8 (200ns) (5v)	24.95
TMS2564	8192 x 8 (450ns) (5v)	17.95
MC68764	8192 x 8 (450ns) (5v)(24 pin)	39.95
27128	16384x8 Call	Call

5v = Single 5 Volt Supply

EPROM ERASERS

	Timer	Capacity Chip	Intensity (uW/Cm ²)	
PE-14		6	5,200	83.00
PE-14T	X	6	5,200	119.00
PE-24T	X	9	6,700	175.00
PL-265T	X	20	6,700	255.00
PR-125T	X	16	15,000	349.00
PR-320	X	32	15,000	595.00

Z-80

2.5 Mhz	
Z80-CPU	3.95
Z80-CTC	4.49
Z80-DART	10.95
Z80-DMA	14.95
Z80-PIO	4.49
Z80-SIO/0	16.95
Z80-SIO/1	16.95
Z80-SIO/2	16.95
Z80-SIO/9	16.95

4.0 Mhz

Z80A-CPU	4.95
Z80A-CTC	4.95
Z80A-DART	11.95
Z80A-DMA	16.95
Z80A-PIO	4.95
Z80A-SIO/0	16.95
Z80A-SIO/1	16.95
Z80A-SIO/2	16.95
Z80A-SIO/9	16.95

6.0 Mhz

Z80B-CPU	11.95
Z80B-CTC	13.95
Z80B-PIO	13.95
Z80B-DART	19.95

ZILOG

Z6132	34.95
Z8671	39.95

CRYSTALS

32.768 khz	1.95
1.0 mhz	4.95
1.8432	4.95
2.0	3.95
2.097152	3.95
2.4576	3.95
3.2768	3.95
3.579535	3.95
4.0	3.95
5.0	3.95
5.0688	3.95
5.185	3.95
5.7143	3.95
6.0	3.95
6.144	3.95
6.5536	3.95
8.0	3.95
10.0	3.95
10.738635	3.95
14.31818	3.95
15.0	3.95
16.0	3.95
17.430	3.95
18.0	3.95
18.432	3.95
20.0	3.95
22.1184	3.95
32.0	3.95

CRT CONTROLLERS

6845	14.95
68B45	19.95
HD46505SP	15.95
6847	11.95
MC1372	6.95
68047	24.95
8275	29.95
7220	99.95
CRT5027	39.95
CRT5037	49.95
TMS9918A	39.95
DP8350	49.95

KEYBOARD CHIPS

AYS-2376	11.95
AYS-3600	11.95
AYS-3600 PRO	11.95

8000

8035	5.95
8039	6.95
INS-8060	17.95
INS-8073	24.95
8080	3.95
8085	5.95
8085A-2	11.95
8086	29.95
8087	CALL
8088	39.95
8089	89.95
8155	6.95
8155-2	7.95
8156	6.95
8185	29.95
8185-2	39.95
8741	39.95
8748	24.95
8755	24.95

8200

8202	24.95
8203	39.95
8205	3.50
8205	1.80
8212	3.85
8216	1.75
8224	2.25
8226	1.80
8228	3.49
8237	19.95
8237-5	21.95
8238	4.49
8243	4.45
8250	10.95
8251	4.49
8253	6.95
8253-5	7.95
8255	4.49
8255-5	5.25
8257	7.95
8257-5	8.95
8259	6.90
8259-5	7.50
8271	39.95
8272	39.95
8275	29.95
8279	8.95
8279-5	10.00
8282	6.50
8283	6.50
8284	5.50
8286	6.50
8287	6.50
8288	25.00
8289	49.95

DISC CONTROLLERS

1771	16.95
1791	24.95
1793	26.95
1795	49.95
1797	49.95
2791	54.95
2793	54.95
2795	59.95
2797	59.95
6843	34.95
8272	39.95
UPD765	39.95
MB8876	29.95
MB8877	34.95
1691	17.95
2143	18.95

CONNECTORS

RS232 MALE	2.50
RS232 FEMALE	3.25
RS232 HOOD	1.25
S-100 ST	3.95

6800

68000	59.95
6800	3.95
6802	7.95
6808	13.90
6809E	19.95
6809	11.95
6810	2.95
6820	4.35
6821	3.25
6828	14.95
6840	12.95
6843	34.95
6844	25.95
6845	14.95
6847	11.95
6850	3.25
6852	5.75
6860	9.95
6862	11.95
6875	6.95
6880	2.25
6883	22.95
68047	24.95
68488	19.95

6800 = 1MHZ

68B00	10.95
68B02	22.25
68B09E	29.95
68B09	29.95
68B10	6.95
68B21	6.95
68B45	19.95
68B50	5.95

6800 = 2MHZ

6502	4.95
6504	6.95
6505	8.95
6507	9.95
6520	4.35
6522	7.95
6532	9.95
6545	22.50
6551	11.85

6500 1 MHZ

6502A	6.95
6522A	9.95
6532A	11.95
6545A	27.95
6551A	11.95

6500 2 MHZ

6502B	14.95
-------	-------

6500 3 MHZ

6502B	14.95
-------	-------

UARTS

AY3-1014	6.95
AY5-1013	3.95
AY3-1015	6.95
PT1472	9.95
TR1602	3.95
2350	9.95
2651	8.95
TM56011	5.95
IM6402	7.95
IM6403	8.95
INS8250	10.95

GENERATORS BIT-RATE

MC14411	11.95
BR1941	11.95
4702	12.95
COM5016	16.95
COM8116	10.95
MMS307	10.95

FUNCTION

MC4024	3.95
LM566	1.49
XR2206	3.75
8038	3.95

74LS00

74LS00	.24	74LS173	.69
74LS01	.25	74LS174	.55
74LS02	.25	74LS175	.55
74LS03	.25	74LS181	2.15
74LS04	.24	74LS189	8.95
74LS05	.25	74LS190	.89
74LS08	.28	74LS191	.89
74LS09	.29	74LS192	.79
74LS10	.25	74LS193	.79
74LS11	.35	74LS194	.69
74LS12	.35	74LS195	.69
74LS13	.45	74LS196	.79
74LS14	.59	74LS197	.79
74LS15	.35	74LS221	.89
74LS20	.25	74LS240	.95
74LS21	.29	74LS241	.99
74LS22	.25	74LS242	.99
74LS26	.29	74LS243	.99
74LS27	.29	74LS244	1.29
74LS28	.35	74LS245	1.49
74LS30	.25	74LS247	.75
74LS32	.29	74LS248	.99
74LS33	.55	74LS249	.99
74LS37	.35	74LS251	.59
74LS38	.35	74LS253	.59
74LS40	.25	74LS257	.59
74LS42	.49	74LS258	.59
74LS47	.75	74LS259	2.75
74LS48	.75	74LS260	.59
74LS49	.75	74LS266	.55
74LS51	.25	74LS273	1.49
74LS54	.29	74LS275	3.35
74LS55	.29	74LS279	.49
74LS63	1.25	74LS280	1.98
74LS73	.39	74LS283	.69
74LS74	.35	74LS290	.89
74LS75	.39	74LS293	.89
74LS76	.39	74LS295	.99
74LS78	.49	74LS298	.89
74LS83	.60	74LS299	1.75
74LS85	.69	74LS323	3.50
74LS86	.39	74LS324	1.75
74LS90	.55	74LS352	1.29
74LS91	.89	74LS353	1.29
74LS92	.55	74LS363	1.35
74LS93	.55	74LS364	1.95
74LS95	.75	74LS365	.49
74LS96	.89		

Do Kay Computer Products, Inc.

VISIT OUR RETAIL STORE

2100 DE LA CRUZ BLVD.

SANTA CLARA, CA 95050

16K APPLE II RAM CARD

BARE BOARD 14.00

ASSEMBLED 42.50

*Apple is a trademark of Apple Computer, Inc.

INTERFACE

8T26	1.65
8T28	1.95
8T95	.95
8T96	.95
8T97	.95
8T98	.95
DM8131	2.90
DP8304	2.25
DS8835	1.89
DS8836	.99

EPROMS

1702	1ns	2.95
2708	450ns	2.98
2758	450ns	5.89
2716	450ns	3.90
2716-1	350ns	5.90
TMS2516	450ns	5.49
TMS2716	450ns	7.89
2532	450ns	5.35
2732	450ns	4.90
2764	450ns	CALL
MC68764	450ns	34.95

DYNAMIC RAMS

TMS 4027	250ns	.79
UPD 411	300ns	2.89
MM 5280	300ns	2.89
MK4108	200ns	1.74
MM 5298	250ns	1.74
4027	250ns	2.00
4116	200ns	CALL
4116	150ns	CALL
4164	200ns	CALL
4164	150ns	CALL

STATIC RAMS

2101	450ns	1.80
5101	450ns	3.89
2102-1	450ns	.78
2102L-2	250nsLP	1.44
2111	450ns	2.48
2112	450ns	2.58
2114	450ns	1.74
2114L-4	450nsLP	1.84
2114L-3	300nsLP	1.84
2114L-2	200nsLP	1.94
2147	55ns	4.89
TMS4044-4	450ns	3.15
TMS4044-3	300ns	3.45
TMS4044-2	200ns	3.89
MK4118	250ns	9.69
TMM2016	200ns	4.15
TMM2016	150ns	4.89
HM6116-4	200ns	5.90
HM6116-3	150ns	6.90
HM6116-2	120ns	8.95
Z6132	300ns	32.95

LP = LOW POWER

RESISTORS

1/4 WATT 5% CARBON FILM
ALL STANDARD VALUES
FROM 1 OHM TO 10 MGE OHM

50 PCS. SAME VALUE	.0200
100 PCS. SAME VALUE	.0150
1000 PCS. SAME VALUE	.0125

6500 1 MHz

6502	5.25
6504	6.85
6505	7.60
6507	9.85
6520	3.95
6522	4.95
6532	5.95
6545	16.95
6551	10.95

2 MHz

6502A	8.95
6522A	9.95
6532A	11.90
6545A	27.90
6551A	11.90

3 MHz

6502B	11.90
-------	-------

APPLE ROM SET

69.95

AUTOSTART ROM

34.95

74LS00	.23	74LS123	.77	74LS253	.57
74LS01	.23	74LS124	2.88	74LS257	.57
74LS02	.23	74LS125	.47	74LS258	.57
74LS03	.23	74LS126	.47	74LS259	2.73
74LS04	.23	74LS132	.57	74LS260	.57
74LS05	.23	74LS136	.37	74LS266	.53
74LS08	.23	74LS137	.97	74LS273	1.47
74LS10	.23	74LS138	.53	74LS275	3.33
74LS11	.25	74LS139	.53	74LS279	.47
74LS12	.25	74LS145	1.18	74LS280	1.96
74LS13	.39	74LS147	2.47	74LS283	.67
74LS14	.39	74LS148	1.33	74LS290	.87
74LS15	.29	74LS151	.53	74LS293	.87
74LS20	.23	74LS153	.53	74LS295	.97
74LS21	.23	74LS154	1.88	74LS298	.87
74LS22	.23	74LS155	.67	74LS324	1.73
74LS26	.29	74LS156	.67	74LS352	1.27
74LS27	.23	74LS157	.63	74LS353	1.27
74LS28	.29	74LS158	.57	74LS363	1.33
74LS30	.23	74LS160	.67	74LS364	1.93
74LS32	.25	74LS161	.63	74LS365	.47
74LS33	.49	74LS162	.67	74LS366	.47
74LS37	.29	74LS163	.63	74LS367	.43
74LS38	.29	74LS164	.67	74LS368	.43
74LS40	.23	74LS165	.93	74LS374	1.37
74LS42	.43	74LS166	1.93	74LS374	1.37
74LS47	.49	74LS168	1.73	74LS377	1.17
74LS48	.74	74LS169	1.73	74LS378	1.17
74LS49	.74	74LS170	1.47	74LS379	1.33
74LS51	.23	74LS173	.67	74LS385	1.88
74LS54	.23	74LS174	.53	74LS386	.43
74LS55	.28	74LS175	.53	74LS390	1.17
74LS63	1.23	74LS181	2.13	74LS393	1.17
74LS73	.37	74LS189	8.93	74LS395	1.17
74LS74	.33	74LS190	.87	74LS399	1.47
74LS75	.37	74LS191	.87	74LS424	2.93
74LS76	.37	74LS192	.77	74LS447	.35
74LS78	.47	74LS193	.77	74LS490	1.93
74LS83	.58	74LS194	.67	74LS668	1.67
74LS85	.67	74LS195	.67	74LS669	1.87
74LS86	.37	74LS196	.77	74LS670	1.47
74LS90	.53	74LS197	.77	74LS674	9.63
74LS91	.87	74LS221	.87	74LS682	3.18
74LS92	.53	74LS240	.93	74LS683	3.18
74LS93	.53	74LS251	.59	74LS684	3.18
74LS95	.73	74LS242	.97	74LS685	3.18
74LS96	.87	74LS243	.97	74LS688	2.38
74LS107	.37	74LS244	1.27	74LS689	3.18
74LS109	.37	74LS245	1.47		
74LS112	.37	74LS247	.73	81LS95	1.47
74LS113	.37	74LS248	.97	81LS96	1.47
74LS114	.37	74LS249	.97	81LS97	1.47
74LS122	.43	74LS251	.57	81LS98	1.47

UARTS

AY3-1014	5.85
AY5-1013	3.90
AY5-1015	6.90
TR1602	3.90
IM6402	7.85
IM6403	8.85
INS8250	10.49

LEDS

Jumbo Red	10/1.00
Jumbo Green	6/1.00
Jumbo Yellow	6/1.00

DIP SWITCHES

4 Position	.85
5 Position	.90
6 Position	.90
7 Position	.90
8 Position	.95

EXAR

XR2206	3.75
XR2207	3.75
XR2208	3.90
XR2211	5.25
XR2240	3.25

RCA

CA 3010	.95
CA 3013	1.99
CA 3023	2.75
CA 3035	2.49
CA 3039	1.25
CA 3046	1.25
CA 3053	1.45
CA 3059	2.90
CA 3060	2.90
CA 3065	1.75
CA 3080	1.10
CA 3081	1.65
CA 3082	1.65
CA 3083	1.65
CA 3086	.80
CA 3089	2.10
CA 3130	1.25
CA 3140	1.15
CA 3146	1.75
CA 3160	1.15
CA 3401	.59
CA 3600	3.45

-VIEWMAX 80-

A Full Function
80-Column
card for Apple II

\$149⁹⁵

APPLE JOYSTICKS 29.95

APPLE SUPER COOLING FANS

49.95

WITH SURG PROTECH
69.95

APPLE PADDLES 9.95

APPLE UPGRADE TRS-80
4116 - 200_{ns}
CALL

Do Kay Computer Products, Inc.

2100 De La Cruz Blvd.
Santa Clara, CA 95050
(800) 538-8800

Calif. Residents
(800) 848-8008

Local Phone
(408) 988-0697

STORE HOURS:

MON-FRI 8:30 A.M. - 5:30 P.M.
SAT 10:00 A.M. - 3:00 P.M.



VISA



TERMS: For shipping include \$2.00 for UPS Ground. \$3.00 for UPS Blue Label Air. \$10.00 minimum order. Bay Area residents add 6 1/2% Sales Tax. California residents add 6% Sales Tax. We reserve the right to limit quantities and substitute manufacturer. Prices subject to change without notice. Send SASE for complete list.

APPLE II USERS DISK DRIVE!

- Includes metal cabinet
- Color matches Apple
- 35 tracks/single side
- Includes cable
- Use with Apple II controller

225.95

CONTROLLER CARD 79.95

EPROM ERASERS

HOLDS 15 EPROMS
ERASES IN 20 MINUTES

59.95

2.5 MHz	
Z80-CPU	3.35
Z80-PIO	3.35
Z80-CTC	3.35
Z80-DMA	12.49
Z80-DART	14.38
Z80-SIO/0	16.95
Z80-SIO/1	16.95
Z80-SIO/2	16.95
Z80-SIO/3	16.95

4.0 MHz	
Z80-CPU	4.90
Z80-PIO	4.90
Z80-CTC	4.90

Z 80

SERIES

Z80A-DMA	21.95
Z80A-DART	15.95
Z80A-SIO/0	20.95
Z80A-SIO/1	20.95
Z80A-SIO/2	20.95
Z80A-SIO/3	18.95

6.0 MHz	
Z80B-CPU	14.95
Z80B-PIO	12.95
Z80B-CTC	12.95

ZILOG	
Z6132	32.95
Z8671	38.95

WIREWAP CARDS

FR-4 Epoxy Glass Laminate With Gold-Plated Contact Fingers

S-100 BUSS

P100-1	Bare—No Foil Pads	15.90
P100-2	Horizontal BUSS	22.90
P100-3	Vertical BUSS	22.90
P100-4	Single Foil Pads per Hole	23.90

GENERAL PURPOSE

22/44 PIN (.156" SPACING)		
P441-3	Vertical BUSS, 4.5" x 6"	13.90
P442-3	Vertical BUSS, 4.5" x 9"	14.90
36/72 PIN (.1" SPACING)		
P721-3	Vertical BUSS, 4.5" x 6"	13.90
P722-3	Vertical BUSS, 4.5" x 9"	14.90

APPLE

P500-1	Bare—No Foil Pads	15.90
P500-3	Horizontal BUSS	22.90
P500-4	Single Foil Pads per Hole	23.90

5 1/4" DISKETTES

ATHANA OR NASHUA

SSSD 18.95

SSDD 22.95

DSDD 27.95

BULK

SSDD SOFT

\$1.65 EA

LINEAR			
LM301	.32	LM741	.29
LM308	.75	LM747	.75
LM309K	1.25	LM748	.49
LM311	.64	LM1310	2.45
M317T	1.65	MC1330	1.69
LM317K	1.70	MC1350	1.25
LM318	1.49	MC1358	1.69
LM323K	3.75	LM1414	1.49
LM324	.59	LM1458	.55
LM337K	3.90	LM1488	.65
LM339	.79	LM1489	.65
LM377	2.25	LM1800	2.45
LM380	1.25	LM1889	2.45
LM386	1.00	LM3900	.59
LM555	.65	LM3914	3.70
LM556	.95	LM3915	3.70
LM567	1.45	LM3916	3.70
LM723	.99	75451	.35
LM733	.95	75452	.35
		75453	.35

ORDER TOLL FREE

(800) 538-8800
(800) 848-8008

(CALIFORNIA RESIDENTS)

APPLE*
COMPATIBLE
POWER
SUPPLY
\$84.95

Disc Controllers

1771	15.95
1791	27.95
1793	29.95
1795	49.95
1797	49.95
6843	32.95
8272	39.00
UPD765	34.95
1691	17.95

6800

1 MHz	
6800	4.75
6802	7.89
6808	8.45
6809	11.95
6809E	17.95
6810	2.89
6820	3.50
6821	2.95
6828	13.95
6840	7.95
6843	32.95
6844	24.95
6845	13.95
6847	11.95
6850	3.20
6852	3.50
6860	9.89
6862	11.90
6875	6.89
6880	1.80
6883	22.95

2 MHz

68B00	9.95
68B02	21.95
68B09	28.95
68B09E	28.95
6810	7.89
6810	11.95
68B45	33.95
68B50	11.95

3 MHz

68000	57.95
-------	-------

IC Sockets

IC SOCKETS

	ST	W/W
8 PIN	.10	.49
14 PIN	.12	.50
16 PIN	.15	.57
18 PIN	.20	.85
20 PIN	.25	.99
22 PIN	.25	1.30
24 PIN	.25	1.40
28 PIN	.35	1.50
40 PIN	.40	1.80

ST = Soldertail
W/W = Wirewrap

5 1/4" FLOPPY DISKS

FLIP FILE
CAPACITY 75 EA

19.95



9000 SERIES

9316	.95
9334	2.39
9368	3.69
9401	8.95
9601	.69
9602	1.39
96502	1.79

CLOCK CIRCUITS

MM5314	4.90
MM5369	3.90
MM5375	4.90
MM58167	8.90
MM58174	10.95
MSM5832	6.90

CRYSTALS

	1.90	6.144	2.69
32.768 KHz	4.50	6.5536	2.69
1.00 Hz	4.50	8.0	2.69
1.8432	4.50	8.0	2.69
2.0	3.90	10.0	2.69
2.097152	3.90	12.0	2.69
2.4576	2.69	14.31818	2.69
3.2768	2.69	15.0	2.69
3.579545	2.69	16.0	2.69
4.0	2.69	17.430	2.69
5.0	2.69	18.0	2.69
5.0688	2.69	18.432	2.69
5.185	2.69	20.0	2.69
5.7143	2.69	22.1184	2.69
6.0	2.69		2.69

8000

8035	4.95	8251	4.39
8039	5.95	8253	6.89
8080A	3.89	8253-5	7.89
8085A	5.89	8255	4.39
8086	24.95	8255-5	5.19
8088	34.95	8257	7.89
8155	7.75	8259	6.85
8156	8.75	8272	39.00
8185	29.00	8275	29.00
8202	27.95	8279	8.89
8205	27.95	8279-5	9.89
8212	1.79	8282	6.49
8214	3.75	8283	6.49
8216	1.69	8284	5.49
8224	2.19	8286	6.49
8226	1.79	8287	6.49
8228	3.34	8288	24.95
8237	19.00	8289	39.00
8238	4.39	8741	34.95
8243	4.39	8748	14.95
8250	10.49	8755	29.95

VOLTAGE REGULATORS

7805T	.75	7908T	.85
7808T	.75	7912T	.85
7812T	.75	7915T	.85
7815T	.75	7924T	.95
7824T	.85		
7805K	1.29	7905K	1.39
7812K	1.29	7912K	1.39
7815K	1.29	7915K	1.39
7824K	1.29	7924K	1.39
7905T	.85		

T = TO-220
K = TO-3

CONNECTORS

RS232	Male	3.00
RS232	Female	3.50
RS232	Female Right Angle	4.95
RS232	Hood	1.20
	30 pin Edge	2.49
	44 pin Edge	2.49
	50 pin Edge	2.69
	86 pin Edge	3.90
	100 pin ST	3.90
	100 pin W/W	4.90

DoKau

Computer Products, Inc.

2100 De La Cruz Blvd.
Santa Clara, CA 95050
(800) 538-8800

Calif. Residents
(800) 848-8008

Local Phone
(408) 988-0697

STORE HOURS:

MON-FRI 8:30 A.M.-5:30 P.M.
SAT 10:00 A.M.-3:00 P.M.



TERMS: For shipping include \$2.00 for UPS Ground. \$3.00 for UPS Blue Label Air. \$10.00 minimum order. Bay Area residents add 6 1/2% Sales Tax. California residents add 6% Sales Tax. We reserve the right to limit quantities and substitute manufacturer. Prices subject to change without notice. Send SASE for complete list.

Discover the hidden power of your TS1000 and ZX-81

**The 50 ready-to-run
programs in this book
will show you how!**

If you suspect you're not getting all you can from your Timex Sinclair 1000, here's a new book that will make sure you do.

In The Timex Sinclair 1000 Idea-Book, David H. Ahl puts 25 years of experience to work—to help you put your computer to work.

Each of the 50 complete, pre-tested programs is designed to illustrate a specific problem-solving technique. By working these programs on your own computer, you'll understand more fully its hidden strengths. Plus, you'll learn how to overcome its inherent weaknesses.

Armed with this knowledge, you're ready to put your Timex to work performing a multitude of practical, everyday tasks. Ten informative chapters show you how to solve problems using:

- Repetitive trial
- Convergence
- Recursion
- Compounding
- Probability
- Geometry
- Science
- Simulation
- Drill
- Practice

Order your copy of The Timex Sinclair 1000 IdeaBook today—and start taking full advantage of your TS 1000 and ZX-81.

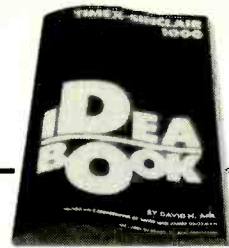

MAIL TODAY TO:
CREATIVE COMPUTING PRESS

Dept. ND6H, 39 East Hanover Avenue
Morris Plains, NJ 07950

Please send me _____ copies of The Timex Sinclair 1000 IdeaBook for only \$8.95 each, plus \$2.00 shipping & handling per book. 3P

Total Amount \$ _____

Payment Enclosed. (CA, NJ and NY State residents please add applicable sales tax.)

Charge my. (Charge and phone orders: \$10 minimum)
 American Express MasterCard Visa

Card # _____ Exp. Date _____

Signature _____

NAME _____
(please print)

ADDRESS _____

CITY _____

STATE _____ ZIP _____

*Outside U.S. add \$3 for shipping and handling.

Check here to receive a FREE catalog of computing books, magazines and guides.

For faster service, PHONE TOLL FREE:

800-631-8112

(In NJ only 201-540-0445)

Also available in your local bookstore and computer store.

TOLL FREE ORDERS • 1-800-826-5432
(IN CALIFORNIA: 1-800-258-6666)

AK, HI OR INFORMATION • (213) 380-8000

5 KEY ASSEMBLY

 \$1.00 EACH
CONTAINS 5 SINGLE-POLE NORMALLY OPEN SWITCHES MEASURES 3 3/4" LONG

6 KEY ASSEMBLY

 \$1.25 EACH
CONTAINS 6 SINGLE-POLE NORMALLY OPEN SWITCHES MEASURES 4 1/4" LONG

120V INDICATOR

 75¢ EACH
NEON INDICATOR, RATED 120 V 1/3 W. MOUNTS IN 5/16" HOLE - RED LENS.
10 FOR \$7.00
100 FOR \$65.00

MULTI-SWITCHES

5 STATION INTERLOCKING 3-2PDT AND 2-6PDT SWITCHES ON FULLY INTERLOCKING ASSEMBLY 3 1/4" BETWEEN MOUNTING CENTERS. \$2.50 EACH

5 STATION NON-INTERLOCKING

SAME AS ABOVE, EXCEPT EACH SWITCH OPERATES INDEPENDENTLY. \$2.50 EACH

13 VDC RELAY

 CONTACT: S.P.N.C. 10 AMP @ 120 VAC ENERGIZE COIL TO OPEN CONTACT. COIL: 13 VDC 650 OHMS SPECIAL PRICE \$1.00 EACH

FREE! SEND FOR **NEW LARGER 48 PAGE CATALOG**

MINIATURE TOGGLE SWITCHES

ALL ARE RATED 5 AMPS @ 125 VAC

S.P.D.T. (on-on)

P.C. STYLE, NON-THREADED BUSHING. 75¢ EACH
10 FOR \$7.00



S.P.D.T. (on-on)

SOLDER LUG TERMINALS. \$1.00 EACH
10 FOR \$9.00
100 FOR \$80.00



S.P.D.T. (on-off-on)

SOLDER LUG TERMINALS. \$1.00 EACH
10 FOR \$9.00
100 FOR \$80.00



S.P.D.T. (on-off-on)

NON-THREADED BUSHING. P.C. STYLE. 75¢ EACH
10 FOR \$7.00



S.P.D.T. (on-on)

P.C. LUGS, THREADED BUSHING. \$1.00 EACH
10 FOR \$9.00
100 FOR \$80.00



D.P.D.T. (on-on)

SOLDER LUG TERMINALS. \$2.00 EACH
10 FOR \$19.00
100 FOR \$180.00



ALL ELECTRONICS CORP.
905 S. VERMONT • P.O. BOX 20406 • LOS ANGELES, CA 90006

- QUANTITIES LIMITED
- MINIMUM ORDER \$10.00
- USA \$2.50 SHIPPING
- NO C.O.D.
- FOREIGN ORDERS INCLUDE SUFFICIENT SHIPPING
- CALIF. RES. ADD 6.2%

Circle No. 3 on Free Information Card

NOW!

GET IBM-PC Capacity at a Fraction of IBM's Price!

New NETRONICS 16 Bit EXPLORER 88-PC Kit

Starts at Just **\$399.95** - Accepts All IBM Peripherals.

It's true! Now you can enjoy the power of the Intel 8088—the same microprocessor which powers the IBM-PC—and run any program compiled for the IBM-PC...starting at only \$399.95!

Take this easy, low cost way to learn 16-bit technology! Two-board system features:

1. 8088 mother board with 5-slot expansion bus; accepts any hardware designed for IBM-PC; and
2. 64K memory board, expandable to 256K; with IBM compatible RS232 communications port.

Any disk-operating system which works on the IBM will work directly on the EXPLORER 88-PC, and all programs compiled for the IBM will run on it.

The system monitor ROM included in the Starter system features a user-friendly operating system that allows easy program generation and debugging. The commands include display/modify memory...display/modify registers...input/output data to I/O ports...block moves...single-step trace mode...go/run with optional breakpoint and register reports...cassette load/save with file labels...plus a complete system test program that tests and reports condition of ROM, RAM, cassette interface, timer, DMA controller, interrupt controller, and the communications port. These test programs not only allow easy debugging of software but they serve as hardware and software learning tools.

The EXPLORER 88-PC STARTER KIT includes a mother board, memory/I/O board, all components needed, sockets for IC's used, one 62-pin bus connector and complete assembly/test instructions. All you need is a soldering iron, solder, a power supply, and a standard RS232 terminal (Netronics has 2 low-cost ones to choose from).
Explorer 88-PC Starter Kit...\$399.95

- + 10.00 p&i
- (wired & tested, add \$100.00)
- Extra 62-pin connectors at \$4.25 ea. + 1.00 p&i.

Use your own terminal with the EXPLORER 88-PC or, if you plan to expand it to be fully IBM compatible, we offer our IBM compatible keyboard and an IBM compatible color graphics board (only available wired and tested).

- IBM compatible keyboard...\$299.95 + 10.00 p&i.
- IBM compatible color board...\$299.95 + 10.00 p&i.
- Additional ROM required...\$35.00.

Set your own pace! Invest and learn, at the rate YOU want! Add to your EXPLORER 88-PC:

- Deluxe heavy-duty steel cabinet that houses either two 5 1/4" floppies or a 5 1/4" hard disk with one floppy. This cabinet features a brush-finish front panel and a wood-grained sleeve.
- EXPLORER 88-PC Cabinet...\$199.95 + 18.00 p&i.

A heavy-duty open frame power supply with fan that can be used in your own cabinet or installed into the Netronics cabinet is available as follows:

- 10 amp power supply for system + 2 floppies...\$149.95 + 8.00 p&i.
- As above + extra power for 1 hard disk...\$169.95 + 8.00 p&i.
- IBM compatible disk controller board. Controls four 5 1/4" floppy drives (w/2 drive cable). Available wired and tested only...\$250.00 + 8.00 p&i.
- Monitors and BIOS source listings: available on either disk or hard copy at \$35.00. Please specify format and system required.
- INTEL 8086/8088 user manual...\$15.00 + 1.50 p&i.
- THE 8086 BOOK by RECTOR & ALEX...\$16.00 + 1.50 p&i.

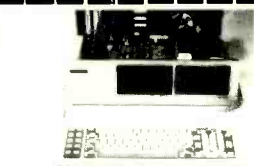

Special IBM compatible system: with keyboard, color graphics board, floppy disk controller, 64K RAM, cabinet, standard power supply and a single 5 1/4" floppy drive...\$1899.95 + 25.00 p&i.

IBM compatible hard disks, built-in modern board, eeprom burner, print buffer system plus more will be available shortly.

Over 100 EXCLUSIVE Products and Kits—including the 'Speak Easy' universal voice synthesizer, a Diagnostic card with built-in logic probe for the IBM-PC, terminals, monitors, the ELF and EXPLORER 85 computers, and much more, are described in our upcoming catalog. It's yours FREE if you check here

For Canadian orders please double the amount of p&i shown. IBM-PC is a registered trademark of IBM Corporation.



"p&i" stands for "postage and insurance".

CALL TOLL FREE 1-800-243-7428 for Charge Card Orders.

In Conn., call 203-354-9375. Conn. res. add sales tax.

TO ORDER BY MAIL, CHECK BOXES FOR PRODUCTS DESIRED AND MAIL ENTIRE AD TO:

NETRONICS R & D LTD.
333 Litchfield Rd., New Milford, CT 06776

- Amount enclosed
- OR Charge my
- VISA
- MASTERCARD

Acct. No. _____ Exp. Date _____

Signature _____

PRINT NAME _____

Address _____ City _____ State _____ Zip _____

TIMEX/SINCLAIR PRODUCT DIRECTORY

	Cassette signal conditioner	Connectors, cables	Hardware power supply	Hardware repeat keys	Hardware, sound generator/synthesizer	Hardware, video	Hardware, misc.	Interface, analog floppy disk	Interface, parallel/printer	Interface, serial	Joystick	Keyboard	Keyboard overlay	Memory, RAM	Memory, ROM	Memory, non-volatile	Modem	Monitors	Printers	Software, business	Software, educational	Software, entertainment	Software, graphics	Software, personal/home utility	Supplies, cassette	Supplies, misc.	Books
1 A+ Associates 175 Fifth Ave., Suite 3119 New York, NY 10010						•							•						•	•	•	•	•	•	•	•	•
2 Aardvark-80 2352 S. Commerce Walled Lake, MI 48088																					•						
3 Aerco Box 18093 Austin, Texas 78760		•				•		•	•										•					•			
4 Brainchild Computer Works P.O. Box 506 Pewaukee, WI 53072																					•	•					
5 Byte Bak c/o Minchey Enterprises, Rt. 3, Bx. 147 Brodie Rd., Leesville, SC 29070						•			•		•		•			•			•	•							
6 Cinagro Software 155 Seventh St. Rochester, NY 14609														•										•			
7 Compusoft Publishing 535 Broadway El Cajon, CA 92021																										•	
8 Computer Continuum 301 16th Ave. San Francisco, CA 94118		•				•	•												•			•	•		•		
9 Cottage-Technology 5720 W. Little York, Suite 178 Houston, TX 77091			•			•													•								
10 Data Asstette 52 S. Third St. Oxford, PA 19363	•		•			•		•	•		•	•	•	•					•	•	•			•			
11 Datacon P.O. Box 41 Flossmoor, IL 60422																			•	•	•	•	•				
12 Down East Computers Box 3096 Greenville, NC 27834	•						•								•												
13 Eagle Sales/Mindware P.O. Box 784 Cambridge, MA 02238																			•	•	•	•		•			
14 E. Arthur Brown Co. 1702 Oak Knoll Dr. Alexandria, MN 56308				•						•			•					•	•		•				•		
15 E.Z. Key Suite 75, 7111 Southern Artery Quincy, MA 02169										•	•														•		
16 Filesixty P.O. Box 1469, Murray Hill Station New York, NY 10156												•															
17 Heath Computer Services 950 E. 52 South Greentown, IN 46936																			•	•			•		•		
18 Hunter 1630 Forest Hills Dr. Okemos, MI 48864																•											
19 Intercomputer Box 90, Pu dental Center Boston, MA 02199		•				•																		•	•		
20 Jameco 1355 Shoreway Rd. Bellmont, CA 94002												•	•	•					•	•	•	•					
21 Leading Edge 225 Turnpike Street Canton, MA 02021																		•	•								
22 Melbourne House 333 E. 46th St. New York, NY 10017																			•	•	•	•	•			•	
23 Memotech 7550 W. Yale Ave., Suite 200 Denver, CO 80227		•						•	•		•		•						•	•		•		•			
24 Peak P.O. Box 8005, Suite 231 Boulder, CO 80306-8005																			•		•			•			

	Cassette signal conditioner	Connectors, cables	Hardware power supply	Hardware repeat keys	Hardware sound generator/synthesizer	Hardware, video	Hardware, misc.	Interface, analog	Interface, floppy disk	Interface, parallel/printer	Interface, serial	Joystick	Keyboard	Keyboard overlay	Memory, RAM	Memory, ROM	Memory, non-volatile	Modem	Monitors	Printers	Software, business, educational	Software, entertainment	Software, graphics	Software, personal/home utility	Supplies, cassette	Supplies, misc.	Books
5	Pleasantrees 7760 N. Hopdown Tucson, AZ 85741																										
6	Quicksilva, Inc. 426 West Nakoma San Antonio, TX 78216																										
7	Ramex International P.O. Box 50 Utica, MI 48087																										
8	Robotec, Inc. P.O. Box 55 Rossford, Ohio 43460																										
9	Simplex Software 55 Sutter St., Suite 623 San Francisco, CA 94104																										
0	Sinclair Place P.O. Box 2288 Redmond, WA 98052																										
1	Sinware Box 323 Dixon, NM 87527																										
2	Softsync, Inc. 14 E 34th St. New York, NY 10016																										
3	Solutions P.O. Box 1144 Piscataway, NJ 08854																										
4	Strategem Cybernetics 286 Corbin Place 2E Brooklyn, NY 11235																										
5	Suntronics 12621 Crenshaw Blvd. Hawthorne, CA 90250																										
6	Sync Master Route 1, Box 122 Oak Ridge, NC 27310																										
7	Timeworks P.O. Box 321 Deerfield, IL 60015																										
8	21st Century 6813 Polk St. Guttenberg, NJ 07093																										
9	York-10 Computerware 24573 Kittridge St., Dept. S-4 Canoga Park, CA 91307																										
0	Zebra Systems, Inc. 78-06 Jamaica Ave. Woodhaven, NY 11421																										

INSTRUCTIONS:

This Product Directory will help you locate manufacturers and suppliers of Timex/Sinclair products and services. If you would like further information, please fill in the coupon completely and circle the number corresponding to the company(s) you would like more information from.

Mail to:
Sync Magazine
One Park Avenue
New York, N.Y. 10016

SYNC MAGAZINE

SPD 983

One Park Avenue, New York, N.Y. 10016

Name _____
 Title _____ Occupation _____
 Company Name _____
 Address _____
 City _____ State _____ Zip _____

1. How many microcomputer(s) do you own? (Void after Nov. 30, 1983)
 A. None B. 1 C. 2 D. 3 Or More
2. Which Brands? (Check all that apply)
- | | | |
|--|--|--|
| A. <input type="checkbox"/> Apple | E. <input type="checkbox"/> Heath/Zenith | I. <input type="checkbox"/> Texas Instruments |
| B. <input type="checkbox"/> Atari | F. <input type="checkbox"/> IBM | J. <input type="checkbox"/> Timex/Sinclair |
| C. <input type="checkbox"/> Commodore/PET | G. <input type="checkbox"/> Osborne | K. <input type="checkbox"/> Other (please specify) |
| D. <input type="checkbox"/> DigitalEquipment/DEC | H. <input type="checkbox"/> Radio Shack/Tandy/TRS-80 | |

I would like more information on the following companies:

- | | | | | | | | | | | | | | | | | | | | |
|----|----|----|----|----|----|----|----|----|----|----|----|----|----|----|----|----|----|----|----|
| 1 | 2 | 3 | 4 | 5 | 6 | 7 | 8 | 9 | 10 | 11 | 12 | 13 | 14 | 15 | 16 | 17 | 18 | 19 | 20 |
| 21 | 22 | 23 | 24 | 25 | 26 | 27 | 28 | 29 | 30 | 31 | 32 | 33 | 34 | 35 | 36 | 37 | 38 | 39 | 40 |
| 41 | 42 | 43 | 44 | 45 | 46 | 47 | 48 | 49 | 50 | 51 | 52 | 53 | 54 | 55 | 56 | 57 | 58 | 59 | 60 |

Computers & Electronics Marketplace

CLASSIFIED RATES: Per Word, 15 Word Minimum. **COMMERCIAL:** \$5.00. **PERSONAL:** \$3.00, **EXPAND-AD:** \$7.50. Ads set in all bold type @ 20% premium. Ads set with background screen @ 25% premium. **DISPLAY:** 1" x 2 1/4", \$605.00. 2" x 2 1/4", \$1,165.00. 3" x 2 1/4", \$1,675.00. **GENERAL INFORMATION:** Frequency rates and prepayment discounts available. Payment must accompany order except credit card—Am. Ex., Diners, MC, VISA (include exp. date)—or accredited agency insertions. Copy subject to publisher's approval; must be typewritten or printed. First word set in caps. Advertisers using P.O. Boxes MUST supply permanent address and telephone number. Orders not acknowledged. They will appear in next available issue after receipt. Closing date: 1st of the 2nd month preceding cover date (e.g., Mar. issue closes Jan. 1). Send order & remittance to: Classified Advertising, **COMPUTERS & ELECTRONICS Magazine**, 1 Park Avenue, New York, NY 10016. Direct inquiries to Rose Lynch, (212) 725-7686.

FOR SALE

GOVERNMENT and industrial surplus receivers, transmitters, snooper scopes, electronic parts, Picture Catalog 25 cents. Meshna, Nahant, Mass. 01908.

ELECTRONIC PARTS, semiconductors, kits. FREE FLYER. Large catalog \$1.00 deposit. BIGELOW ELECTRONICS, Bluffton, Ohio 45817.

BUILD AND SAVE. TV EARTH STATION. DETECTIVE ELECTRONICS. Video Recorders, Color Cameras, advanced Telephone Projects. BROADCAST Electronics. 50 page color catalog of unusual electronic projects AIR MAILED \$3.00; with 3 hour audio cassette dramatization of our catalog \$5.00. Don Britton Enterprises, PO Drawer G, Waikiki, Hawaii 96815.

RECONDITIONED TEST EQUIPMENT \$1.00 for catalog. WALTER S TEST EQUIPMENT, 2697 Nickel, San Pablo, CA 94806, (415) 724-0587.

ELECTRONIC PARTS. Stamp for flyer, \$1.00 deposit for catalog. DAYTAPRO ELECTRONICS, 3029 N. Wilshire, Arlington Hts., IL 60004.

PRINTED CIRCUIT BOARDS, your artwork. Quick delivery. Reasonable. Atlas Circuits, Box 892, Lincolnton, NC 28092. (704) 735-3943.

SATELLITE TELEVISION... HOWARD/COLEMAN boards to build your own receiver. For more information write... ROBERT COLEMAN, Rt. 3, Box 58-APE, Travelers Rest, S.C. 29690.

SOUND SYNTHESIZER KITS—Surf \$19.95. Wind \$19.95. Wind Chimes \$24.95. Musical Accessories, many more. Catalog free. PAIA Electronics, Box J14359, Oklahoma City, OK 73114.

RF MODULATORS for SATELLITE TELEVISION, MICRO-COMPUTERS CCTV. Also monitors, cameras, kits. FREE VIDEO CATALOG. Phone (402) 987-3771. Dealers Welcomed. ATV RESEARCH, 13-P Broadway, Dakota City, NE 68731.

CABLE TV CONVERTERS & EQUIPMENT. Plans and parts. Build or buy. For more information send \$2.00: C & D ELECTRONICS INC., P.O. Box 21, Jenison, MI 49428.

FREE FLYER! IC's, resistors, capacitors, jacks, etc., plus SSM music synthesizer/audio IC's, power amp modules, analog delay IC's, computer books, and more. Also plans for analog delay/chorus unit! PGS Electronics, Route 25, Box 304 Terre Haute, IN 47802.

CABLE TV

Buy Direct & Save

SUPER SPECIALS



40 CHANNEL CONVERTER
\$29⁹⁵



35 CHANNEL REMOTE CONTROL CABLE CONVERTER
\$69⁹⁵



JERROLD 400 THE ULTIMATE CABLE TV CONVERTER



60 CHANNEL INFRARED REMOTE CONTROL
\$129⁹⁵

Send \$5 for Complete Catalog

DIRECT VIDEO SALES

P.O. BOX 1329
JEFFERSONVILLE, INDIANA 47130
CALL
1-812-282-4786

POLICE CODE UNSCRAMBLERS, lets you hear the coded messages of Police, Fire and Medical channels; plus other scanner accessories, satisfaction guaranteed. DNE Inc., Rt. 7, Box 257-A, Hot Springs, AR 71901. (501) 623-6027.

Earn Big Money - REPAIR GAMES/COMPUTERS

- Atari 2600, 2600a
- Atari 400, 800 computers

- Intellivision
- Colecovision

Each of these comprehensive EIB courses contains signature charts, schematics, technical data and complete video tape instructions! Virtually anyone familiar with basic electronics and the use of a digital meter can troubleshoot and repair the most complex digital equipment and with the use of the Signature Analysis Method most repairs can be completed in 15 minutes or less! Imagine all Atari, Intellivision and Colecovision parts available from one supplier. Send \$1.00 for parts lists and additional information, refundable with order.

ELECTRONICS WAREHOUSE CORP.

1910 Coney Island Ave., Dept. CE-10, Brooklyn, N.Y. 11230
(212) 375-2700

IF YOU ARE READY TO BUY OR SELL GAMES OR SOFTWARE, YOU NEED...

COMPUTER SHOPPER

Over 100 pages each month. Deal with individuals nationwide. Low ad rate, only 12¢ a word. Subscription: \$10/year. MC & VISA. Money back guarantee. 407 S. Washington, P.O. Box F599, Titusville, FL 32780. (305) 269-3211.

CABLE TV

CONVERTERS & EQUIPMENT

We have the largest selection of JERROLD and OAK cable converters and equipment. Such as: Jerrold SB-3, Oak N12 and Jerrold 61 channel remote control converter with FULL features DRX3-DIC-105. Plus others.

CABLE TV KITS

Cable TV Kit (Jerrold gated pulse) 39.95.

We also have a large selection of cable TV and kits including all parts, silk screen, PCB board and complete instructions.

Send for informative catalogue \$2.00

J & W ELECTRONICS, INC.

P.O. BOX 61-K
CUMBERLAND, RI. 02864

CABLE TV SECRETS, the informative publication the cable companies are trying to ban. HBO, Movie Channel, Showtime converters, etc. Send \$8.95 to: CABLE FACTS, Box 711-PE, Pataskala, Ohio 43062.

WHOLESALE: MATV/CATV/VCR equipment, Antennas, Audio, Cables, Adapters, Original and Replacement Cartridges, Stylis, Telephone Accessories, Radios, Cassette Recorders, Speakers, etc. Send letterhead for catalog, 212-897-0509, D&WP, 66-19 Booth, Rego Park, NY 11374.

FREE CATALOG. Large selection of electronic kits and parts. Chaney Electronics, Box 27038, Denver, Colorado 80227. (303) 781-5750.

FREE Catalog of special function IC's and quality components. Goldsmith Scientific, Box 318M, Commack, New York 11725.

SATELLITE TELEVISION INFORMATION \$4. Build or buy your Earth Station. Satellite Television, RD 3, Oxford, NY 13830.

ELECTRONIC KITS—Low cost Power Supplies, Amplifiers, Alarm Systems, etc. Catalog \$0.25. CBB1, Box 222, North Granby, CT 06060.

LOW, LOW COMPONENT PRICES! Ask for free flyer. Write: EEP, 11 Revere Place, Tappan, NY 10983.

SATELLITE TV BREAKTHROUGH! Build your own Low Noise Amplifier now! Send for complete instruction Manual today! Only \$10.00! XANDI, Box 25647, Dept. 22R, Tempe, AZ 85282.

PRINTED CIRCUIT BOARDS, Design and artwork Professional reasonable, fast! Printed Concepts. OEM inquiries invited. (414) 442-4548.

Worlds Most Remarkable Radar Jammer!



Causes speed radar guns and devices to read out your choice of either a percentage of your true speed when in automatic mode (example: Your speed: 76 mph, auto mode set for 75%, speed displayed - 57 mph), or the speed that you dial in when in manual mode. Transmits only in the presence of speed radar, or by manual override. Operates on both X and K bands. WARNING: The device described in this literature is not legal for use against police radar, and is not FCC approved.

For complete literature and plan package, send \$14.95 to:
Phillips Instrument Design Co. Inc.
8135 S.W. Nimbus, Building #11, Suite #114 C
Beaverton, Oregon 97005

A SINGER'S DREAM!



REMOVES VOCAL FROM MOST STEREO DISCS
The Thompson Vocal Eliminator can actually remove most or virtually all of a solo vocalist from a standard stereo record and yet leave most of the background music untouched! Not an equalizer! We can prove it works over the phone. Write or call for a 24 page brochure and demo record.
Write to: LT Sound, Dept. CE, P.O. Box 338, Stone Mountain, GA 30086. Phone (404) 493-1258

PCB 15¢ sq-in. FREE DRILLING. Quantity Discounts. International Enterprise, 6452 Hazel Circle, Simi-Valley, CA 93063.

CABLE T.V. EQUIPMENT. Channel 36r4 notch filter \$20.00. Information \$1.00. Goldcoast, P.O. Box 63/6025A, Margate, FL 30363.

MICROWAVE ANTENNA SYSTEMS

Freq. 2.1 to 2.6 GHz • 34 db Gain+
COMPLETE SYSTEMS (as pictured)
Commercial 40" Rod Style \$89.95
Parabolic 20" Dish Style \$79.95

TWO YEAR WARRANTY PARTS AND LABOR

CALL OR WRITE FOR KITS • PARTS • INDIVIDUAL COMPONENTS
We Repair All Types Down Converters & Power Supplies

Phillips-Tech Electronics

P.O. Box 34772
Phoenix, AZ 85067
(602) 265-8255





Special Quantity Pricing • Dealers Wanted

ELECTRONIC BUYER'S GUIDE: Listing companies specializing in Surplus parts, Audio, Test equipment, Computer components (I.C.'s to printers), and many hard to find parts for the experimenter. \$5.00. Electronic Data Research, P.O. Box 160811, Miami, FL 33116.

ANTENNA (antimultipath type) for UHF, VHF & FM. Patented slotted array, 26"x48", hanging vertically, inside outside use. Patented, guaranteed. Sent for only \$12 but FOB. Cash, Visa, COD ok. By SADCO, 11621 Hughes NE, Albuquerque, NM 87112. (FOB about \$4.00).

RESISTORS, 1/4W 1/2W 5% C.F. 3¢ ea., 1% Metallfilms. NO MINIMUMS. Quantity Discounts. Write: JR INDUSTRIES, 5834-A Swancreek, Toledo, OH 43614.

SATELLITE TELEVISION COMPLETE SYSTEMS. Free catalog. Call: (612) 780-4088. Write: Sunspar Sales, P.O. Box 32245 A-7, Fridley, MN 55432.

COMPUTER EQUIPMENT/PARTS

SAVE 90% Build Your own Minicomputer. Free Details. Dir-gatek, 2723 West Butler Dr., Suite 20C, Phoenix, AZ 85021.

WANT A PLEASANT SURPRISE? Call or write for quotes: Atari, Commodore, Timex, T.I., Corona (IBM work-alike), Amdek, Anadex, Apple & IBM accessories, Hayes, More, GET SURPRISED! HARDWARE SOFTWARE ANYWARE CO., 10 Coles Street, Brooklyn, NY 11231, (212) 596-3592.

APPLE BUILDERS—Send stamp for our flyer of Apple parts. IC sets, ROM sets, component packages. Shugart—Apple modification kits, Apple 9-track tape drives etc. Electrovalue, P.O. Box 376-P, Morris Plains, NJ 07950.

HARD DISK DRIVE LIQUIDATION. Major OEM is liquidating inventory of unused Shugart 8" SA 1002 5.33 megabyte hard disk drives. \$380 each. Western Digital's controller, \$350. Call: LIQUIDATORS, 803-877-9828, or send check/money order to: 105 S. Main St., Greer, SC 29651.

BUY, SELL, TRADE! New and used computer hardware/software for all major personal and small business computers. For more information and brochure send \$3.00 to N.O.L.A., P.O. Box 954, Beltsville, MD 20705.

DIRECT VIDEO is best! Complete plans and parts kit to convert VIC-20, Commodore 64 and television + I/O plans. All 3 for \$10.00. Micro-Mod Specialties, Box 1552, Evansville, WY 82636.

FREE DISCOUNT CATALOG OF SYSTEMS, PERIPHERALS AND SOFTWARE. Most major brands. Descriptions complete with options and accessories. Please indicate your specific interest and application. MICRO TREND INC., 2001 Kirby Drive, Suite #906, Houston, TX 77019. (713) 520-0107.

DISK FILE—\$9.95 holds 150 disks; includes dividers, labels, backstops for 5 1/4" and 8". Call: 800/225-0044. Weber's, Box 104CA, Adelphi, NJ 07710.

FREE! Computer supplies catalog—Low prices—Satisfaction guaranteed—DATA SYSTEMS, Box 99, Fern Park, Florida 32730. (305) 788-2145.

VIC-20 CASSETTE INTERFACE \$19.95, information \$1 refundable with order. Electronics Service Center, 5502 W. Alice, Glendale, AZ 85302.

COMPUTER SOFTWARE

VIC-20 USERS GROUP, receive newsletter, programs, discounts and more. Send SASE for information. P.O. Box 459, Dept 7, Ladson, South Carolina 29456.

TIMEX-SINCLAIR USERS: Join the group of newsletter subscribers who receive free programs every month! Software discounts, Free program, issue and catalog. Z-WEST, Box 2411, Vista, CA 92083.

TI-99/4A MOON TRIP animated graphic program on cassette. Guide module through asteroid belt. Then land on moon. Speech synthesizer and joystick capability. \$12.00 postpaid. JAG Software, P.O. Box 2225, Dept 1CE, Ocean, New Jersey 07712.

DISCOUNT SOFTWARE—Available for Apple, TRS-80, IBM/PC and TI 99/4 personal computers. Professional applications for the doctor, dentist, attorney, school administrator, teacher, contractor and general office personnel. Catalog \$1.00. Write for MONTHLY SPECIAL OFFERS! Creative Discount Software, 256 S. Robertson Blvd., Suite 2156, Beverly Hills, CA 90211.

COMPUTER PAPER—SAVES\$\$: Top quality Low single carton prices. Free shipping via UPS. Call A-1, (800) 628-8736 or (213) 804-1270.

ATARI, APPLE, IBM-PC: Extensive line educational, entertainment, business. FREE BROCHURE. New Dimension Software, 39010 Baroque, Mt. Clemens, Michigan 48044.

TI-99/4A PROGRAMMERS: Affordable Software! Catalog, only \$1. PROGRAMS SOFTWARE, 1435 Burnley Square North, Columbus, Ohio 43229.

FREE money saving bulletin on popular brand name programs and books for your small computer. Superior, Dept CE, 8030 Westchester Road, Westchester, OH 45069.

VIC-20 and C64 SOFTWARE: Special Eighty VIC-20 Programs on two cassettes, \$15.95. Postage \$1.50. Public Domain. SASE to: FANFARE SOFTWARE, 120 E. Main, El Cajon, CA 92020.

TI-99/4A OWNERS. Send for free list of new and exciting, low cost software. D.E., Box 124, Hicksville, NY 11801.

FREE Timex/VIC-20/TI99-4A/Commodore-64 programs! SASEs bring catalogs. Inexpensive! EZRAEZRA, Box 5222-C, San Diego, California 92105.

SEND NAME OF YOUR COMPUTER. We'll send you periodic data on software, books and tech sheets. SUPRIOR, Dept CE, POB M8002, Westchester, OH 45069.

TI PROGRAMS on cassette. Large selection and variety, over 700. 4 sample programs and catalog \$3.00. KS SOFTWARE, Box 27130, Cincinnati, OH 45227.

VIC-20 "ADULT" Video game "Joystick," tape, hi-resolution, state age, \$9.95. NV PE, 102 Hickory Court, Portland, IN 47371.

TI99/4A OWNERS: COMPLETE LOAN CALCULATOR. Principal, Interest, Payments, Amortization Schedule. Cassette \$8.95 + \$0.50 S/H. TECHWORKS, Box 80426, Baton Rouge, LA 70898-0426.

COLOR COMPUTER OWNERS—Free hardware and software Catalogue. Spectrum Projects, 93-15 86 Drive, Woodhaven, NY 11421. (212) 441-2807.

TI 99/4A, TS1000, ZX81 Software. Send for FREE Catalog. Midwest Software, 9922 Harwich, Crestwood, MO 63126.

POSTER® Assists Income Tax Preparation, Budgeting, Bookkeeping, Check Book Summaries, Credit Card Summaries. Simple and Accurate. BASIC program in spiral bound pamphlet. \$20 postpaid. WOODSON Products, 4025 Iyvestone Court, Matthew, NC 28105. Phone 704-542-3796.

FREE CATALOG OF DISCOUNT SOFTWARE. Specify computer. The Floppy Disk, Box 5392E, North Hollywood, CA 91616.

DON'T BUY—RENT. Game cartridges. TI99A, Atari, VIC, Commodore. \$1.00 for list and details: Rusol, Box 1668, Meriden, CT 06450.

PERFECT FOR SMALL BUSINESS—TRS-80 Model III/IV. BOOKKEEPER TIME DOME has pre-loaded files. SCRIP-SITMAILER—Letters, Envelopes — Labels, made by Scripsit. BOOKKEEPING MACHINE—printed ledgers and statements, 1400 accounts receivable. \$34.50 each. (714) 774-9383. H.A.K. Workshop, 9791 Orange, Anaheim, CA 92804.

CALENDAR PROGRAM displays any month between 1AD and 2499AD. Computes number of days between two dates. Send \$4 and SASE for program listing to: G-S Software, P.O. Box 154, Genoa, Ohio 43430. Specify VIC-20, TI-99/4A or TS1000 (16K).

COMMODORE OWNERS VIC-20 and Commodore 64 unique hardware and software free catalog from: Micro-ware Distributing, Inc., 1342B Route 23, Butler, NJ 07405. 201/838-9027.

SOFTWARE JUNKIE? Rent today's most popular computer software for pennies a day! Free brochure. The Soft Source-R Inc., P.O. Box 2931, Joliet, IL 60434.

TI-99/4A SOFTWARE: Programs for Astronomy, Mathematics, Finance, Education. Write: Eastbench Software, 1290 Cliffside Drive, Logan, UT 84321.

PAYOFF ANALYZES CREDIT CARD charge accounts, helps save \$\$\$, Cassette program for 16K TS1000, \$12.95. Ace Software, 2 E. Oak Ave., Moorestown, NJ 08057.

DON'T BUY SOFTWARE/GAMES until you test them! Rent from us for VIC Commodore TI99 Atari. Send \$3.00 for list, details & handling. Sigma Software, P.O. Box 451, Manhattan Beach, CA 90266.

VIC-20 OWNERS, use ANY tape recorder. Interface drives single or dual cassettes, with displays. Plans \$7.95. Edward's, Box 4723, Culver City 90230.

COMPUTER HARDWARE

COMPUTERS, PRINTERS, ACCESSORIES! Epson FX-80 printer, \$519.00. Gemini 10X printer, \$295.00. Okidata, p/writers, etc. Lowest prices! Free catalog! Team Computers, (203) 777-2284. 109 Church St., Suite 303, New Haven, CT 06510.

COMPUTER PUBLICATIONS

TIMEX SINCLAIR OWNERS—get monthly news, tips, programs, projects to expand 1000/1500/ZX81, \$29 per year. Back issues available. SYNTAX, RO 2 Box 457, Harvard, MA 01451. (617) 456-3661.

SAVE \$ ON COMPUTER BOOKS & SOFTWARE! For FREE DISCOUNT CATALOG write: DOWNTOWN BOOK BAZAAR, Dept. C, P.O. Box 2490, Brooklyn, NY 11202.

AMATEUR RADIO

VIDEOSCAN 1000 Slow Scan TV — HIGH RESOLUTION (amateur, phone line, monitoring, teleconferencing). CODE★STAR — DECODE Morse, RTTY, ASCII. LARGE LEDs or connect computer/printer. MORSE-A-KEYER — CW Keyboard. TRI-VOLTAGE POWER SUPPLY. Kits/Assembled. FREE brochures. MICROCRAFT CORPORATION, Box 513-PE, Thiensville, WI 53092. (414) 241-8144.

RADIO AMATEUR CALLBOOKS: Directories of Radio Amateurs around the world. Write for FREE catalog. Radio Amateur Callbook, Dept. PE, 925 Sherwood Dr., Lake Bluff, IL 60044.

TIMEX/SINCLAIR

KROK., STAR SEARCH, NOAH'S ARK, finest programs available. Machine Language action, graphics. SASE Brown Cottage, 5486 Bright Hawk, Columbia, MD 21045.

"MUST-HAVE"! Utility SOFTWARE. Cassettes-relocatable machine language. SASE for information. SIRIUS WARE, 6 Turning Mill Rd., Lexington, MA 02173.

DIRECT VIDEO is best! Complete plans and parts kit to convert ZX-81, T/S 1000 and television. Key-tone plans included. All 3 for \$10.00. Micro-Mod Specialties, Box 1552, Evansville, WY 82636.

FREE quality software for your ZX81/TS1000. SASE to 615 E. Emerson # A, MP, CA 91754.

MAX 'Z-' TECH TIMEX HI-TECH educational programs. Hardware coming soon. For samples mail \$2.00 to: CASH Progs., P.O. B. 318C, N.F.L.D., NJ 07431.

"HOW TO MARKET YOUR TIMEX/SINCLAIR SOFTWARE". Informative guide for turning your programs into profits—\$14.95, money order, VISA, M.C. (incl. card no. & exp. date). Softmark Associates, Dept. CE1, 210 Fifth Ave., New York, NY 10010.

GRAPHS AND CHARTS FOR ZX81/TS1000. Spharler Software Systems, 9 Springbrook Circle, Sacramento, CA 95831.

ZX DATA-FINDER, ZX PRO/FILE & much more professional/game/hobby machine language software. Catalog 50¢ (refundable). ROBOTEC, INC., Box 55, Rosstford, OH 43460. (419) 666-2410. VISA/MC.

AIRPLANE instrument flight simulator program. VOR DME ADF radios. Map display. Multi-leg, ILS approach. Cassette for Timex 1000. 16K computer. Send \$12.95 to Amanda Systems, P.O. Box 118, Holmdel, NJ 07733.

TS-ART Graphic program and LOGO-style educational tool. 120 brushes and backgrounds. 8 directions, line and circle drawing. Store and recall patterns. \$14.45. KSOFT, 845 Wellner Rd., Naperville, IL 60540.

C.B. EQUIPMENT

CB MODIFICATIONS, conversions, books, plans, kits, repairs. Catalog \$2. CBCI, Box 31500PE, Phoenix, AZ 85046. (602) 996-8700.

CABLE TV

CHANNEL 3—60db notch filter. 63.5MHz. \$32. Crosley, Dept. 607, Box 840, Champlain, NY 12919.

PLANS AND KITS

HIGH PERFORMANCE AUDIO KITS. Phono, Equalizers, Delay and more. Send for FREE catalog. PHOENIX SYSTEMS, 91 Elm Street, Manchester, Connecticut 06040. (203) 643-4484.

FREE KIT CATALOG contains test equipment. Phone (209) 772-2076. FREE SCIENTIFIC, Box 144, Valley Springs, CA 95252.

PROJECTION TV . . . Convert your TV to project 7 foot picture . . . Results comparable to \$2,500 projectors . . . Total Cost less than \$30.00 . . . PLANS & LENS \$19.95 . . . Illustrated information FREE. Macrocoma-cb, Washington Crossing, Pennsylvania 18977. Creditcard orders 24 Hours. (215) 736-3979.

ROBOTICS—BOOKS—build your own robot. Write now for FREE catalog! Kohn Co./CE4, Box 16265, Alexandria, VA 22302.

FREE information on how you can build your own computer for less than \$30. Atlas Engineering, Box 943, Department 13, Skokie, IL 60076.

VIC-20, CONVERT 8K EXPANSION TO 16K, free plans, program list, S.A.S.E., N.V.P.E., 102 Hickory Court, Portland, IN 47371.

INEXPENSIVE REMOTE CONTROL uses flashlight! Commercial-killer. Plans \$4.00. Catalog S.A.S.E. S. Javes, 8108 Edinburgh, Springfield, VA 22153.

MAILING LISTS

COMPUTER SHOW ATTENDEES N.Y., N.J.: 15,000 NAMES. \$30/M. P/S labels. For info, (201) 297-2526.

ALARMS

BURGLAR-FIRE ALARMS for home, business, auto. Install yourself and save. Installation manual/catalog shows how. Shows latest equipment, accessories. Lowest prices. Send \$1.00 (refundable). BURDEX SECURITY, Box 82802-CEJ, Lincoln, NE 68501.

PROTECT MICROCOMPUTERS AND ELECTRONICS! Free catalog of systems for SCHOOLS, OFFICES, HOMES. SGM Corporation, 6 West Mall, Bound Brook, NJ 08805. (201) 469-8585.

WANTED

GOLD, electronic, circuit board scrap, silver, platinum, tantalum, mercury. Ores, metals assayed. Samples evaluated. Wholesale Terminal, toll free 1-800-932-1010, (617) 326-3442 in Mass.

HIGH FIDELITY

DIAMOND NEEDLES and STEREO CARTRIDGES at DISCOUNT PRICES for SHURE, PICKERING, STANTON, EMPIRE, GRADO, AUDIO TECHNICA, ORTOFON, ADC, SONUS, MICRO-ACOUSTICS and LAST. Send S.A.S.E. free catalog. LYLE CARTRIDGES. Dept. P., Box 69, Brooklyn, NY 11218. For fast COD service Toll Free 800-221-0906. N.Y. State (212) 871-3303. 9AM-8PM except Sunday.

GOVERNMENT SURPLUS

IS IT TRUE YOU CAN BUY JEEPS FOR \$44 THROUGH THE U.S. GOVERNMENT? Get the facts today! Call (312) 742-1142 Ext. 4649.

TUBES

TUBES: "Oldies", Latest. Supplies, components, schematics. Catalog Free (stamp appreciated). Steinmetz, 7519-PE Maplewood, Hammond, Ind. 46324.

HUGE INVENTORY! Thousands of types. Wholesale prices. FREE CATALOG! ETCO Electronics, DEPT. 290, Plattsburgh, NY 12901.

COLOR PICTURE TUBES: \$55-\$75 exchange. Year warranty. ATOLL TUBES, 6425 Irving Park, Chicago, IL 60634. (312) 545-8857.

PERSONALS

MAKE FRIENDS WORLDWIDE through international correspondence, illustrated brochure free. Hermes-Verlag, Box 110660/Z, D-1000 Berlin 11, W. Germany.

CORRESPONDENCE FOR FRIENDSHIP IN PHILIPPINES, MALAYSIA. Free information. AAWS-(PE), Box 2777, Orcutt, California 93455-0777.

SCANDINAVIAN LADIES, sincere, seek correspondence for friendship. Details—Send stamp: Scannaclub, Box 4-(CE), Pittsford, NY 14534.

SUNBELT SINGLES looking for a person of quality. Check our group. Details Box 83395, Oklahoma City, OK 73148.

UNIVERSITY DEGREES BY MAIL! Bachelors, Masters, Ph.Ds. Free revealing details. Counseling, Box 317-EP10, Tustin, California 92680.

INSTRUCTION

LEARN WHILE ASLEEP! HYPNOTIZE! Astonishing details, strange catalog free! Autosuggestion, Box 24-ZD, Olympia, Washington 98507.

MEDICAL ELECTRONICS TECHNOLOGY, home study. Troubleshoot medical instruments. WTI, P.O. Box 3124, Fresno, CA 93650-3124.

UNIVERSITY DEGREES BY SPECIAL EVALUATION of existing credits and Job Experience. Fast, inexpensive. Call (614) 863-1791. Or write: EVALUATION, Box 13151-A10, Columbus, Ohio 43213.

REPAIR ELECTRONIC ORGANS—Revised home study course covers all current makes and models. Free booklet. Niles Bryant School, P.O. Box 20153, Sacramento, CA 95820.

F.C.C. COMMERCIAL RADIOTELEPHONE LICENSE. Home Study. Fast, Inexpensive! Free details. COMMAND, D-100 Box 2223, San Francisco 94126.

UNIVERSITY DEGREES BY MAIL! Bachelors, Masters, Ph.D.s . . . Free revealing details. Counseling, Box 317-PE10, Tustin, California 92680.

BE F.C.C. LICENSED! Get your General Radiotelephone License with our new shortcuts and easy to follow material. Sample Exams, Includes RADAR ENDORSEMENT. \$19.95 ppd. SPI-RO DISTRIBUTORS, P.O. Box 1538-C, Hendersonville, NC 28793.

BUSINESS OPPORTUNITIES

FREE CATALOGS. Repair air conditioning, refrigeration. Tools, supplies, full instructions. Doolin, 2016 Canton, Dallas, Texas 75201.

MECHANICALLY INCLINED individuals desiring ownership of Small Electronics Manufacturing Business—with-out investment. Write: BUSINESSES, 92-K10 Brighton 11th, Brooklyn, New York 11235

MAILORDER OPPORTUNITY! Start profitable home business without experience or capital. Information free. Mail Order Associates Inc., Dept 53, Montvale, NJ 07645.

ERASE DEBTS with little-known law—create wealth!! Details FREE—Wealth Kit, No. EE10, Billings, NY 12510.

ONE MAN CRT FACTORY. T.V.'s, Business machines, Monitors, Scopes, VDT's. \$3.00 rebuilding nets \$100-\$500 each tube. Higher profits overseas. New/used. FACTORY, 1909 Louise, Crystal Lake, IL 60014. (815) 459-0666.

BORROW \$300-\$30,000 INTEREST FREE! Keep indefinitely! Free Details. Write: American, 1601 Main, Plainfield, Indiana 46168.

BORROW \$30,000 without interest! All eligible. Repay anytime. Free details! Infohouse—508CE, 533 Sutter, San Francisco, CA 94102.

BUMPER STICKER PRINTING DEVICE. Cheap, Simple, Portable. Free details, Bumper, POB 22791 (PE), Tampa, FL 33622.

MAKING MONEY WITH PERSONAL COMPUTERS! 3 cassette package \$19.95, with book \$25.00. Computer Resources, 1659 Mills Street, Chula Vista, CA 92010.

PICTURE TUBE REBUILDING EQUIPMENT—new and used. ATOLL TELEVISION, 6425 Irving Park, Chicago, Illinois 60634. (312) 545-6667.

MULTI-LEVEL HARDWARE/SOFTWARE SALES FROM YOUR HOME. Send \$3 for details & application. Alpha Byte, 2434 Madison Ave., Baltimore, MD 21217.

"PROFESSIONAL" GIANT SCREEN PROJECTION TV . . . "Don't be fooled by cheap imitations!" . . . "Build and sell the best with lenses and screens utilized by Sony, Zenith, Pioneer, and Magnavox!" . . . Simple Construction! . . . Unlimited profits! . . . Illustrated dealers information and complete parts catalog \$2.00 . . . Money back guarantee! . . . POLI-VISION, 187-C Cypress St., Throop, PA 18512.

MAKE ADDITIONAL INCOME and have tax write-offs. FREE info. Contact Dept. H, P.O.B. 222, Harbor City, CA 90710.

PROJECTION TV . . . MAKE \$\$\$'s assembling Projectors . . . Easy . . . Results comparable to \$2,500 projectors . . . Your total cost less than \$20.00 . . . PLANS, LENS & Dealers information \$17.50 . . . Illustrated information FREE . . . Macrocomacbx, Washington Crossing, Pennsylvania 18977. Credit-card orders 24 Hours, (215) 736-2880.

FOR INVENTORS

INVENTORS! IDEAS HAVE VALUE!

Ever think of an idea, forget it and see it later on the market? Many people don't forget, act quickly and are rewarded by American Industry. Write down your idea! We offer free disclosure registration and initial consultation regarding your idea's potential value. Call or write without delay for your free information package.

AMERICAN INVENTORS CORPORATION
82 Broad St., Dept. CE
Westfield, MA 01086
413-568-3753

A fee Based Marketing Company
Offices Coast to Coast

INVENTIONS, IDEAS, NEW PRODUCTS WANTED! Industry presentation/national exposition. Call free 1-800-528-6050—Arizona, 1-800-352-0458. X831.

EMPLOYMENT OPPORTUNITIES

ELECTRONICS/AVIONICS EMPLOYMENT OPPORTUNITIES. Report on jobs now open. Details FREE. Aviation Employment Information Service, Box 240E, Northport, New York 11768.

JOBS OVERSEAS - Big money fast. \$20,000 to \$50,000 plus per year. Call 1-216-453-3000, ext. 4609.

GOVERNMENT JOBS—Thousands of vacancies must be filled immediately. \$17,634 to \$50,112. Call 716-842-6000, Ext 3906.

GETTING JOBS in films, TV: \$10. Video editing overview: \$25. WPC, Box 2020, Burbank, CA 91507.

"COMPUTERS: How To Break into The Field." New book gets you ONLINE to career! \$7.95: Computer Access Consultants, P.O. Box 224-A, Ridley Park, PA 19078.

BOOKS & MAGAZINES

PUBLISHERS' OVERSTOCKS. BARGAIN BOOKS 2,000 titles, all subjects! Free catalog: Hamilton's, 98-85 Clapboard, Danbury, CT 06810.

SATELLITE, MICROWAVE, VIDEO, Audio Components and Equipment. Send \$1 for 1983 catalog. DSCo, Department B, 3110 Evelyn Street, Roseville, MN 55113.

CRASH course in Microcomputers, bestseller, only \$19.95. Order from Per Aspera Press, P.O. Box 265, St. Joseph, MI 49085.

SATELLITE TV VIEWERS
Get the most complete weekly listings
Send \$1 for sample copy.

Satellite TV Week

P O Box 308, Fortuna, California 95540
800-358-9997 (U.S.) • 800-536-8787 (Calif.)
707-725-2476 (all others)

RECORDS/TAPES

RECORDS—TAPES! Discounts to 73%. All labels; no purchase obligations; newsletter; discount dividend certificates. 100% guarantees. Free details. Discount Music Club, 650 Main St., PO Box 2000, Dept. 5-1083, New Rochelle, NY 10801.

REAL ESTATE

NEW...FREE CATALOG! Top real estate values coast to coast! Please specify types, property and location desired. UNITED FARM AGENCY, 612-EP West 47th, Kansas City, MO 64112.

RUBBER STAMPS

RUBBER STAMPS, BUSINESS CARDS. Free catalog 1-800-851-4945, Jackson's, E-100, Brownsville Rd., Mt. Vernon, Ill. 62864.

RETAIL ROSTER

ALASKA

JUNEAU ELECTRONICS—1000 Harbor Way, 99801, (907) 586-2260. Apple, Osborne Hardware/Software/Peripherals. Full service and support.

CALIFORNIA

P.C. COMPUTERS, 10166 San Pablo Ave., El Cerrito 94530. (415) 527-6044. Commodore 64, VIC-20, Pet Specialists. In-House Maintenance.

CONNECTICUT

C&E DISTRIBUTING—Edgewood drive, Jewett City 06351, (203) 427-0657. Retail outlet and wholesaling for dealers.

NEW HAMPSHIRE

COMPUTER MART of NEW HAMPSHIRE, 170 Main Street, Nashua 03060. 603-883-2386. THE APPLE SPECIALISTS. Full line Hardware/Software. Training/Service.

OHIO

COLUMBUS—HEATHKIT ELECTRONIC CENTER, 2500 Morse Rd., (614) 475-7200. Heath/Zenith Computers, Software, Peripherals, Robotics, Training.

PENNSYLVANIA

MARKETLINE SYSTEMS INC., 975 Jaymor, Southampton 18966. 215-355-5400. Microcomputers, terminals, printers, supplies, monitors, modems, diskettes, etc.

WASHINGTON

LYNNWOOD-MEDIA MAN—18500 33rd W., Suite B-2 (98036) (In the Alderwood Plaza), 206/775-8544. Software and supplies for Apple, Atari, IBM, Commodore.

WISCONSIN

MILWAUKEE—HEATHKIT ELECTRONIC CENTER, 5215 W. Fond du Lac, (414) 873-8250. Heath/Zenith Computers, Software, peripherals, robotics.

PICTURE your Expand-Ad® in all BOLD type! Call (212) 725-3927 for more information.

FREE CATALOG!

Send for your FREE *Creative Computing* Catalog of books, buyer's guides, and more! Write to:
Creative Computing Catalog
Dep NALX39 East Hanover Ave.
Morris Plains, NJ 07950

Computer Mart

RATE: Ads are 2" by 3". 1 insertion: \$625.00. 6 insertions: \$600.00 ea. 12 insertions: \$575.00 ea. Closing date: 1st of the 2nd mo. preceding cover date. Send order and remittance to Computer Mart, Computers & Electronics, 1 Park Ave., N.Y., N.Y. 10016. Direct inquiries to (212) 725-4216.

KEYBOARD for ATARI 400™

Replace standard membrane keyboard with an easily installed and color matched pushbutton keyboard. Complete with instructions \$119.95

SECRETS of SATELLITE TV®

New manual explores the purchase and installation of satellite TV receivers \$-7.95

TV IF & RF MODULE

Includes TUNERS, IF AMP, vidac and sound detectors \$85.00

Catalog includes information on VIDEO products, experimenters KITS, and interesting manuals \$2.00
VISA and MasterCard accepted by phone (415) 439-7470. Include 5% shipping. Calif. residents add tax.

Abex
P.O. BOX 26601-C2
SAN FRANCISCO, CA 94126

CIRCLE NO. 13 ON FREE INFORMATION CARD

EPROM PROGRAMMER \$146

EPROM ERASER \$39.95

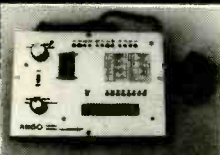

ERASER

- contains same features as competitors' but cost less than one half their price
- erases up to 9 chips
- 6 mW/cm² on chips
- chip drawer prevents UV exposure to users
- long life LV tube

PROGRAMMER

- PROGRAMS & COPIES: 2516, 2532, 2716, 2732, 2732A.
- 4K INTERNAL RAM BUFFER STORAGE CAPACITY.
- NO PERSONALITY MODULE REQUIRED.
- POWER CAN BE REMOVED FROM ZIF SOCKET WHEN LOADING EPROMs.
- BINARY ADDRESS AND DATA DISPLAY.
- INDEPENDENT UNIT - VERIFIES, PROGRAMS, INPUTS DATA FROM BINARY KEYBOARD, LOADS DATA FROM EPROM TO RAM, AND CHANGES ANY BIT OF DATA.
- FULL 90-DAY GUARANTEE ON ALL PRODUCTS FOR ANY DEFECTS IN MATERIALS AND WORKMANSHIP.

ANGO ELECTRONICS CORP. 212-685-6336
P.O. BOX 112
HARRISON, NJ 07029 TLX: 421531 ARTISTI

MAIL ORDERS: PLEASE ADD \$3.00 HANDLING CHARGE
NEW JERSEY RESIDENTS: PLEASE ADD 6% SALES TAX

CIRCLE NO. 38 ON FREE INFORMATION CARD

16K RAM PACKS ONLY VIC 20 \$42.95 U.S. ZX81

32K RAM PACKS \$60.00 U.S.
Please state your machine name on your order. 6 month warranty. Add \$2.95 p+h.

EXPANDABLE RAM PACKS - VIC ONLY

16K Ram Pack \$69.95 U.S. + P&H
32K Ram Pack \$89.95 U.S. + 3.50 P&H
The following can be built into your Ram Pack now or later we will install

IC Chips Toolkit \$19.95 U.S. - 50c P&H
IC Chips Machine Code Monitor \$19.95 U.S. + 50c P&H

PLUS available soon Intel 8088 Co-processor + 40 Colonn Rom. Installs in your expandable Ram Pack only

3 Slot Mother Board + 8K Ram \$77.95 U.S. + \$2.95 P&H. comes with battery connector. mode switchable to Vic + 3K Vic + 8K Vic + 16K. isolation switch. for super expander cartridge 6 month warranty. runs any commercial software at the flick of a switch

Send cheque or money order to

CHADWELL'S SOFTWARE

Dept. CM. 230. 4144A 97 Street
Edmonton, Alberta, Canada T6E 5Y6

U.S. ORDERS WELCOME
DEALER INQUIRIES WELCOME

CIRCLE NO. 49 ON FREE INFORMATION CARD

SPEECH SYNTHESIS

NEW! SAVE \$\$ ONLY \$59 KIT
TRS 80 ZX81 TIMEX VIC20 APPLE II

- UNLIMITED VOCABULARY \$89
- AMPLIFIER + SPEAKER BUILT
- INPUT FOR EAR - MUSIC INTE

SMART EARS!

SPEECH RECOGNITION \$69
INPUT FOR ABOVE LISTED COMPUTERS & OTHERS CALL (SOME NEED I/O)

MUSIC SYNTHESIS

STEREO 16 LINE CONTROL PORT
PLAY 3 PART MUSIC, EFFECT DRUMS ECT.
1/0 PORT TO CONTROL ROOM \$49 KIT
HOME SECURITY EARS ECT BUILT \$59

AUDIO VISION 1279 N. NORMANDIE LOS ANGELES, CA 90027
SPEECH CHIP SX-01 \$36
ADD \$3 SHIPPING @AFTER 48 HRS
(213) 6605217

CIRCLE NO. 33 ON FREE INFORMATION CARD

Wasting Money! We Have the World's Most Cost Effective Development System.



Send for Free Brochure

- Includes HexKit 1.0, a powerful 100% machine code editor/debugger utility program that makes coding for 8-bit Micros a snap.
- Program from Commodore VIC-20 Keyboard into built-in 4K ROM emulator.
- Jumper to target ROM socket
- Test programs in circuit
- Built-in EPROM programmer and power supply

PROMQUEEN CARTRIDGE: \$199, U.S.; \$269, CAN.



Distributed in U.S. by **Arbutus Total Soft, Inc.**, 4202 Meridian, Suite 214, Bellingham, WA 98226. Phone 800-426-1253.

in Washington 206-733-0404
Distributed in Canada by IBC/
DISTRIBUTION CANADA,
4047 Cambie St.

Vancouver, BC V5Z 2X9.
Phone 604-879-7812 Visa/MC accepted

Promqueen 64 \$299.
8K board/w 1 Eprom \$29.95
16K board/w 1 Eprom \$39.95
C-64 board/w 1 Eprom \$39.95

CIRCLE NO. 43 ON FREE INFORMATION CARD

\$241.20 WEEKLY

working one or two hours a day while using your personal computer. **GUARANTEED.** Simple program process. No special skills or experience beyond Basic computer knowledge. Free details/application.

Computer Technology Group/Systems

Suite 172
11417 West Avenue
San Antonio, Tx 78213

CIRCLE NO. 53 ON FREE INFORMATION CARD

TRS-80 DISCOUNT COMPUTERS

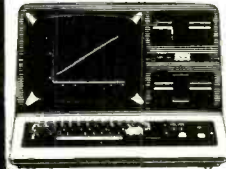

CALL US LAST for the LOWEST price!

918-825-4844

it will be worth the call!

AMERICAN BUSINESS COMPUTERS

118 S. MILL ST. PRYOR, OK. 74361

CIRCLE NO. 37 ON FREE INFORMATION CARD

PRINTER STAND or DESK

- * Size: 27h x 24d x 27" w.
- * Black Painted Steel
- * Sh. Wt. 75 Lbs.
- * Shipped Freight Collect
- * Use Order No. 2A70585

\$39.95



FAN CONTROL

Controls Speed Of AC MOTORS!

ONLY \$388 3 for \$10.00

Muffin Fans, Caravel Fans, Blowers, ETC... Good for 115/220 VAC up to 6 amps stall current. Control rated at 1.6 amps. Size: 1 1/4 x 2 x 1" Shaft mounting. Use Order No. 3BS0269.

BNF Enterprises

119r FOSTER St.
Peabody MA 01960 (617) 531-5774
40 Page Catalog

Customer Pays All Shipping Charges.

CIRCLE NO. 45 ON FREE INFORMATION CARD

TIMEX-SINCLAIR ZX81 1000



Directory

* Where to find: Disk Drives, RAM Extensions, Printers, Modems, Keyboards, Game & Serious Software, Books, Periodicals, Programming Aids, and other Exciting Accessories!

* Articles on: Special applications like Control Circuitry, Enhanced Graphics, Voice Generation, Music Synthesis, Video Inversion, Light Pens, Joysticks, etc.

* Complete Descriptions: We'll tell you what it is, what it does, how much it costs, and where to buy it.

* Jam-packed w/photographs: We knew you'd want to see what these products look like. So, we got pictures and put them in!

Only \$5.95 ... Postpaid!

Send First Class in the U.S.A.
To Order: Send check, money order, or VISA/MC number and expiration date. MN residents add 6% sales tax. Dealer Inquiries Welcome.

E. Arthur Brown Company
Dept. TC-10 1702 Oak Knoll Drive
Alexandria, MN 56308 Ph: 612/762-8847

CIRCLE NO. 64 ON FREE INFORMATION CARD

COMPUSETTE

- Precision 5 Screw Cassette
- Premium Quality Tape
- Labeled Both Sides
- Individually Boxed
- Freight Paid On All Orders
- Guaranteed Against Defects

	COMPUSETTE (5 MIN. PER SIDE)	COMPUSETTE + (10 MIN. PER SIDE)
25	\$20.00 (80')	\$22.50 (90')
100	\$70.00 (70')	\$80.00 (80')
500	\$330.00 (66')	\$365.00 (73')

OUT OF STATE (800)527-1227
TEXAS (214)349-0081 C.O.D.



EACH CASSETTE INCLUDES A NORELO CONTAINER
TEXAS RESIDENTS ADD 5% SALES TAX

BUY NOW SAVE 10%

IF CHECK OR MONEY ORDER ACCOMPANIES ORDER (GOOD ONLY IN THE CONTINENTAL UNITED STATES)

P.O. BOX 38651 DALLAS, TX 75238

CIRCLE NO. 72 ON FREE INFORMATION CARD

TOROIDAL POWER TRANSFORMERS

Small size • Low noise • Easy mounting



Ideal for audio amps, CRT monitors and computers where low hum is required.

Includes mounting washer with center hole for screw.

Examples of 117V-60Hz transformers in stock:

Size-Weight ODxH	Secondaries* Volts/Current	Unit price 1	in qty 2-4
40VA-1.1 lbs 2.8"x1.3"	2x8.5V/2.3A	\$29.00	\$24.40
	2x12V/1.67A		
	2x15V/1.33A 2x24V/.83A		
100VA-2.2 lbs 3.7"x1.4"	2x8.5V/5.8A	\$33.00	\$28.60
	2x12V/4.1A		
	2x15V/3.3A 2x18V/2.7A		
340VA-3.3 lbs 4.5"x2.3"	220V/1.55A	\$53.60	\$46.50
	2x24V/7.1A		
	2x30V/5.7A		

*May be used separately, in parallel, or in series.
Call to order or write for listing of off-the-shelf toroidal transformers 20VA-600VA
Terms: C.O.D., VISA, MASTERCARD or Money Order
Shipping: Add \$1.00/lbs for UPS (+\$1.50 for C.O.D.)

(301) 459-8898 TOROID CORPORATION OF MARYLAND
4720-Q Boston Way, Lenham, MD 20706

CIRCLE NO. 90 ON FREE INFORMATION CARD

★MICROCOMPUTER★ BUSINESS SOFTWARE

MEDICAL MGMT...
DENTAL MGMT...
INSURANCE AGENT
LEGAL BILLING....
PROPERTY MGMT..
AND MUCH MORE !

UNIVAIR INTERNATIONAL

9024 St. Charles Rock Road
ST. LOUIS, MISSOURI U.S.A. 63114

(314) 426-1099

CIRCLE NO. 91 ON FREE INFORMATION CARD

CONVERT YOUR TV TO A HIGH QUALITY MONITOR

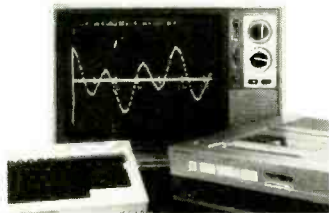

USE WITH COMPUTERS, VCR's & CAMERAS

Kit permits Dual Mode operation on B&W or Color sets
• Hi-resolution • Up to 80 characters per line • Wide bandwidth • Direct Video • Safe-Easy installation

34⁹⁵
ACVM

DVM-1 Hot Chassis kit with Audio available
Send for complete Audio/Video equipment catalog



Box 411, Los Angeles, CA 90028
(213) 466-5333

CIRCLE NO. 92 ON FREE INFORMATION CARD

YORK 10™ CASSETTES



- LOWER PRICES
- LONGER LENGTHS

DATA TRAC C-06, C-12, C-24

From the leading supplier of Computer Grade Cassettes, new, longer length C-12's (6 minutes per side) provide the extra few feet needed for some 16K programs.

- Premium 5-screw shell with leader
- BASF tape
- Error Free • Money back Guarantee

ITEM	1 DOZ	2 DOZ	SHIPPING/HANDLING \$3.50
C-06	7.00	13.00	NOTE: Outside 48 Cont. States shipping \$3.50 PLUS \$1 per caddy per dozen cassettes per dozen boards per 10 discs In Cont. U.S. shipments are by UPS unless Parcel Post requested California residents add Sales Tax
C-12	7.50	14.00	
C-24	9.00	17.00	
Hard Box	2.50	4.00	

FOR IMMEDIATE SHIPMENT USE YOUR VISA OR MASTERCARD Call: 213/700-0330

YORK 10™ Computerware
9525 Vassar Ave. #P1 Chatsworth, CA 91311

CIRCLE NO. 93 ON FREE INFORMATION CARD

ATTENTION APPLE LOVERS 100% APPLE COMPATIBLE

DISK DRIVE	\$199.
DUAL DISK CONTROLLER	\$ 49.
Z-80 BOARD	\$ 85.
80 COLUMN BOARD	\$159.

MONITORS

ZENITH ZVM 121 12" Green Screen	\$ 89.
AMDEK COLOR I+ 13" Color	\$289.

FREE BROCHURE

**!!CALL US FOR
LOWEST PRICES ON
OTHER ACCESSORIES!!**

XICOM COMPUTER PRODUCTS
414 B. West Fifth Sreet
Naperville, Illinois 60566
(312) 961-1616

MC, Visa

CIRCLE NO. 94 ON FREE INFORMATION CARD

ATARI 2600* GAME DEVELOPERS

VIDEO GAME DEVELOPMENT BOARD

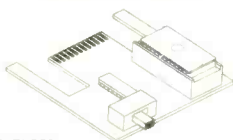

FEATURES

- CONVENIENT ZIF SOCKET BY AMP
- SWITCH SELECTABLE FOR 2716/2732
- FULLY ASSEMBLED AND TESTED
- HIGH QUALITY FIBERGLASS PC BOARD
- GOLD EDGE CONNECTOR
- RF NOISE SHIELD (PROM NOT INCLUDED)

SEND CHECK DR. M.D. FOR \$16.96 PLUS \$1.50 FOR POSTAGE AND HANDLING TO

VIDEO DEVELOPMENT CORP.
BOX 539
GLENCOE, MD. 21152
301-428-0605

MD. RESIDENTS ADD 5% SALES TAX
DEALER INQUIRIES INVITED
ALLOW 4 WEEKS FOR DELIVERY

*ATARI AND 2600 ARE TRADEMARKS OF ATARI INC.

CIRCLE NO. 95 ON FREE INFORMATION CARD

Full Size Keyboard Conversion

10 3/4 x 7 1/4 x 2 1/8

For
Your
ZX81/
TS1000

SUN KD-81

\$59.95



Easy To Install

No Soldering — No Modifications

41 Keys with Full Size Space Bar — Allows Touch Typing
Same Key Layouts as Sinclair • Two Color Keytops
Keyboard Case Holds Both Keyboard and Computer
Commands and Graphics Spelled Out on Keytops
Rear Cutout for Any RAM or Expansion Modules

16K Piggyback RAM Module P.N. MX 16 \$49.95

SUNTRONICS CO., INC.

In Calif. Call 213-644-1149

Outside Calif. Call 1-800-421-5775

Or send Check or M.O. to

P.O. Box 1957 Hawthorne CA 90250

California residents add 6 1/2% sales tax



Add \$4.00 ship/handling. VISA/Mastercard include expiration date

FREE CATALOG!

Just let us know and we'll mail you a FREE *Creative Computing* Catalog—16 pages filled with books, buyer's guides, magazines, and more!

To get your FREE catalog, write to: *Creative Computing* Catalog, Dept NA3N 39 East Hanover Ave., Morris Plains, NJ 07950.

VIC-20

NEW

VIC-20 INTERFACING BLUE BOOK
 Did you know that your VIC can be used to control a 99c toy motor so effectively that it runs like a precision machine? Or that you can build an accurate digital thermometer using the VIC and four parts costing less than \$5? These and other interfacing projects selected for usefulness, ease of construction and low cost are detailed in the VIC-20 Interfacing Blue Book, a veritable gold mine of practical information on how to build a variety of interfaces for your computer.
 Projects include: Connecting VIC to your stereo; Pickproof digital lock; Capacitance meter; Liquid level sensor; Telephone dialer; Voice output; 8K/16K RAM/ROM expansion; 128K RAM expansion; 8-bit precision D/A; 8-bit converter; MX-80 interface and more.
 Written by a college professor in a friendly and informative style, the Blue Book gives you every operation, schematics, program listings, parts list, construction hints and sources of materials for each one of the 30 projects.
 If you want to get the most out of your VIC this book is a must. Cost is \$14.95 (less than 50¢ per project!). Price includes postage.

microsignal Dept 9
 P.O. BOX 22
 MILLWOOD NY 10548

VIC-20

CIRCLE NO. 96 ON FREE INFORMATION CARD

Home Control System for the VIC 20

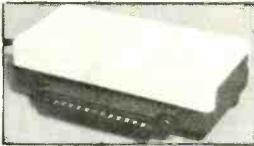

- * Control up to 256 lights & appliances
- * ON, OFF, ALLON, ALLOFF Commands
- * 9 levels of Brightness
- * Manual & Time Control Software
- * Uses BSR remote switches
- * Plugs into User Port

only **\$59⁹⁵**

MasterCard or VISA Accepted
 Call 215 861-0850 to Order
GENESIS COMPUTER CORP.
 1444 Linden Street
 Bethlehem, PA 18018

VIController

CIRCLE NO. 97 ON FREE INFORMATION CARD

TS1000 ZX81



3-Color Keyboard Symbols with Conversion Instructions

- Plastic TS1000-ZX81 keyboard symbols in Black, Red and Blue. Opaque background. Will fit all standard-size keys. Adhesive backing for easy application.
- Simple illustrated instructions will show you how to convert a cheap (about \$20) surplus keyboard to a full-size TS1000/ZX81 console. "...as easy as stringing wire on a fence."
- Do's and Don'ts for selecting a surplus keyboard.
- Bonus for the "pro" - Schematic Diagram of Computer.

MULE Electronics \$99⁵

Dept. 310
 444 Lincoln Blvd.
 Venice, California 90291

*Add \$1.50 F&H. California residents add 6.5% tax. Money-back guarantee, of course.

CIRCLE NO. 98 ON FREE INFORMATION CARD



Memorium
 COMPUTER SERVICE
 VILLAGE DATA CENTER
 P.O. BOX 603
 JOSHUA TREE, CA 92252

Choose from Our Menu
 Monday-Friday
 8:00 AM — 5:00 PM

Our sales staff is happy to take your order.

- #1. Medical
- #2. Dental
- #3. CA9 Programs
- #4. Construction Accounting
- #5. School Administration
- #6. Word Processing
- #7. General Accounting

The above items are now being served for console users of the Apple and IBM PC Computers.

To make reservations, or to inquire about our weekly SPECIALS.



Call
(619) 365-6668



CIRCLE NO. 99 ON FREE INFORMATION CARD

VIC-20 SOFTWARE

Did you know that you can transfer just about any software on expansion ROM cartridges for the VIC-20 onto cassette tape or disc for your own use?

Well, with our board, which plugs into the VIC-20 expansion port and 8k or 16k of expansion RAM, you can copy games (Sargon Chess™) programming aids (VICMON™), music, word processors, and just about anything else on expansion cartridges, for about the price of one cartridge!

only **\$34.95** (postage paid in cont. us)
 Calif. Res. add sales tax

nimrod computer
 3823 OCEAN VIEW BLVD.
 MONTROSE, CA 91020, SUITE 433

CIRCLE NO. 100 ON FREE INFORMATION CARD



RADIO SHACK TRS-80's™

We offer Special Discounts, Free Shipping and a Toll Free Order Number

1-800-531-7466 TOLL FREE

Pan American Electronics

Dept. P.E. - 1117 Conway Avenue
 Mission, Texas 78572
 (512) 581-2766 Telex 767339

CIRCLE NO. 101 ON FREE INFORMATION CARD

THE PEOPLE'S COMPUTER SUPPLY



YOUR TIMES SINCLAIR ZX80-81 IS A FOOLER. IT LOOKS LIKE A TOY. BUT DON'T LET LOOKS FOOL YOU! TRY SOME OF OUR AD ONS & SEE WHAT YOU CAN REALLY DO WITH THE FOOLER.

- HERE ARE JUST A FEW OF OUR HARDWARE ITEMS:
- | MEMOTECH PRODUCTS | |
|-------------------------------------|---------------------|
| 1 64K MEMOPAK | \$144 ⁹⁵ |
| 2 32K MEMOPAK | \$95 ⁹⁵ |
| 3 16K MEMOPAK | \$49 ⁹⁵ |
| 4 HIGH RESOLUTION GRAPHICS | \$95 ⁹⁵ |
| 5 FULL SIZE DIRECT CONNECT KEYBOARD | \$99 ⁹⁵ |
- No soldering plugs into edge connector
6. MAKE IT TALK TO YOU WILLIAM STUART SYSTEMS SPEECH SYNTHESIS \$99⁹⁵

DISK CONTROL CARD \$179.95

WE ALSO SELL MONITORS & PRINTERS FOR THE TIMES SINCLAIR ZX80-81
 VISA, MASTER CARD & AMEX Foreign Orders Please Add \$5.50
 & MONEY ORDERS U.S. Orders Please Add \$3.00
 PERSONAL CHECK Printer & Monitor Orders add \$7.50
 ALLOW 2 WEEKS

THE PEOPLE'S COMPUTER SUPPLY
 P.O. Box 664, Sidney, Nebraska 69162
 Order Phone: Tel. 308-254-3208

AERCO Factory Authorized Disk Drive Systems Distributor

CIRCLE NO. 102 ON FREE INFORMATION CARD

TIMEX SINCLAIR ZX81
\$99⁹⁵
64K RAM PACK
 No Ram Pack Wobble
GENEX
 INTERNATIONAL
48945 VAN DYKE, UTICA MI 48087
 Check or Money Order add \$5.00 s/h
 Michigan residents add 4% tax



EXTENSIVE CATALOG AVAILABLE

CIRCLE NO. 103 ON FREE INFORMATION CARD

R.I.S.T. Inc. ANNOUNCES SPEECH SYNTHESIZER

ORDER NOW **SALE** ORDER NOW

\$59⁹⁵

Phrase Finder Program \$5. VALUE FREE
 Speech Synthesis Manual \$10. VALUE FREE

Apple II, II+

TRS80 Models I, III
 Commodore 64, VIC 20
 ZX80/81 and TS1000
 Regularly \$89.95

Now Only \$59.95 - \$4.00 sh/hd.

Complete or Starter Kits Available

*** 10 Day Money-Back Guarantee ***
 Send check or M.O. COD add \$1.50 to: R.I.S.T. Inc.,
 Dept G 1083, P.O. Box 499 Ft. Hamilton Station,
 Brooklyn, NY 11209 212-259-4934.
 N.Y.S. RESIDENTS ADD 8 1/4% TAX.

CIRCLE NO. 104 ON FREE INFORMATION CARD

POWER LINE PROBLEMS?



SPIKE-SPIKERS™... The Solution!

Minimize equipment damaging spikes and conducted RF noise to or from sensitive equipment. Transient surge protection plus low pass RFI hash filtering. All units 120V 15A.



MINI II \$44.95

Wall Mount
3-stage filter
2 sockets

QUAD II \$59.95

Wall mount. Dual 3-stage filter
4 sockets & light

DELUXE \$79.95

Dual 5-stage filtered
ckts. 8 switch sockets
main switch, fuse, light



Kelglo Electronics Co., Inc.

65 84 Ruch Rd., Dept. C.E.
Bethlehem, PA 18017

Order Factory Direct

215-837-0700

Out of State

800-523-9685

DEALERS INVITED

PA Res. Add 6% • COD add \$3.00 + Shipping

CIRCLE NO. 105 ON FREE INFORMATION CARD

TIMEX-SINGLAIR



With well over 135 new and exotic peripherals and software items, you're sure to find what you need for business, personal, or fun TS1000-ZX81 computing. Includes: Computers, Memories to 1 megabyte, Mass Storage, Keyboards, Small & Full Size Printers, Telecomputing, Books and Technical Brochures, and other Accessories too numerous to mention here. Our software line is heavy with Business, Personal, Technical, and Educational titles! If you like games, we have nothing but the best. This catalog carries in-depth and educational descriptions as well as photographs and illustrations. Write for your free copy today!

E. Arthur Brown Company

Dept. 1702 Oak Knoll Drive
Alexandria, MN 56308 Ph. 612/762-8847

CIRCLE NO. 106 ON FREE INFORMATION CARD



LEO ELECTRONICS, INC.
8921 S. Sepulveda • 208
Los Angeles, CA 90045
(213) 641-3101 (800) 421-2418
TLX: 664-688 Interline LSA

LOOK!!

LOW PRICES

RAMS

4116 (200ns) 1.10
4116 (150ns) 1.25
4164 (200ns) 4.65
4164 (150ns) 4.85
2114 (200ns) 1.50
6116P-3 4.25

EPROMS

2708 2.50
2716 3.20
2716-1 5.00
TMS 2716 4.75
2732 3.95
2532 4.50
2764 8.00

MICROPROCESSORS

Z-80A 4.50
8080A 2.75
8085A 6.00

REGULATORS

ALL .75
TO-220

TERMS: Check, Visa, Mastercard. Call for C.O.D.
U.S. Funds only. California residents add 6% sales tax.
SHIPPING: Add \$2.00 for Ground and \$5.00 for Air.
ALL MAJOR MANUFACTURERS
ALL PARTS 100% GUARANTEED
Prices subject to change without notice

CIRCLE NO. 107 ON FREE INFORMATION CARD

Put 64K CP/M 2.2 in your TRS-80 Model III.

Our plug-in Shuffleboard III comes with 16K and gives you the full power of 64K CP/M 2.2, the industry standard operating system.



Tap into over 2,000 off-the-shelf business programs such as dBASE II, SuperCalc, WordStar, etc. READ/WRITE and RUN software from Osborne, Xerox, Superbrain, Kaypro II, HP 125 and TeleVideo. You can even READ/WRITE IBM PC software for CP/M 86.

Simple to install. Shuffleboard III plugs into two existing sockets inside your Model III. No permanent modifications, no cut traces, no soldering. You'll be up and running in minutes. For only \$299. Includes MBASIC Interpreter, a software manual and a first class user's manual. Coming soon: an 80 x 24 Video Board and a Floppy Disk Controller.

See the Shuffleboard at your local computer store or order directly from us. Credit card orders shipped directly from stock. Sorry, no COD's. Free 12 page brochure. Call (415) 483-1008

Memory Marchant

14866 Doolittle Drive

\$299.

San Leandro, CA 94577

CIRCLE NO. 108 ON FREE INFORMATION CARD

Get more out of your Apple with the MICRO on the Apple Series

Vols. 1, 2, & 3 \$24.95
+ \$2.00 shipping each volume

Each book includes more than 30 programs —

all on DISKETTE

Machine Language Aids
I/O Enhancements
Runtime Utilities
Graphics & Games
Hardware & Reference
Information

To order toll free:

1-800-345-8112

In PA 1-800-662-2444

MICRO INK, Dept. CE

P.O. Box 6502

Amherst, NH 03301

603-889-4330

CIRCLE NO. 109 ON FREE INFORMATION CARD

COMPUTERS

TELEMARKETING
Works For You

1-800-841-0860

Call For Your
Discount Prices

Write For Free Price List

commodore • EPSON

IBM SMITH-CORONA

FRANKLIN • OKIDATA

EAGLE • TRS-80

MICRO MANAGEMENT SYSTEMS

TELEMARKET DEPT. 12

2803 Thomasville Rd. E. • Coiro, Ga.

912-377-7120

CIRCLE NO. 110 ON FREE INFORMATION CARD

PROMPT DELIVERY! AND TRY TO BEAT THESE IC PRICES:

DYNAMIC RAM

64K	200 ns	\$5.25
64K	150 ns	5.45
64K	120 ns	6.00
16K	200 ns	1.49

EPROM

2764	250 ns	\$6.35
2732	450 ns	3.89
2716	450 ns	3.19
2532	450 ns	4.60

STATIC RAM

6264P-15	150 ns	\$38.00
6116P-3	150 ns	5.00
2114	200 ns	1.55

Z80A FAMILY

CPU, CTC, or PIO	\$3.39
DART	7.99
DMA or SIO0	12.50

MasterCard/VISA or UPS CASH COD

Factory New, Prime Parts

MICROPROCESSORS UNLIMITED

24,000 South Peoria Ave.

BEGGS, OK 74421

(918) 267-4961

Prices: 7/15/83

Prices subject to change. Call for volume prices. Subject to available quantities. Shipping & insurance extra. Cash discount prices shown. Please expect higher prices on some parts due to world wide shortages.

CIRCLE NO. 111 ON FREE INFORMATION CARD

MICROSETTE

5/4-inch DISKETTES

- Single or double sided, all double density (SSDD, DSDD).
- Soft sector, reinforced hub.

CASSETTES

- Error-free computer grade.

ITEM	10 PACK	50 PACK
SSDD	\$25.00	\$100.00
DSDD	35.00	150.00
C-10	7.50	32.50
C-20	9.00	39.00
C-60	11.00	50.00
C-90	15.00	70.00

UPS SHIPPING INCLUDED
In Continental USA
CA Customers add taxes

MICROSETTE CO.
475 Ellis St., Mtn. View,
CA 94043 (415) 968-1604

CIRCLE NO. 112 ON FREE INFORMATION CARD

SALES POWER

Computers & Electronics not only sells itself at a nice profit, it helps sell the hardware and software in your store too. Because it goes home with customers and continues to influence buying decisions long after you're closed for the day. Let's talk now.

CALL COLLECT:
(212) 725-7679

Or write:

Ziff-Davis Publishing
One Park Avenue
New York, NY 10016



Minimum order: 10 copies. We pay all shipping costs.

MODULES FOR
TIMEX-Sinclair
 NEW MD-2 DIRECT CONNECT
MODEM \$119.95 Kit
 \$149.95 W&T

with New SMART Menu Driven,
 SOFTWARE Included FREE

- Send & Receive Programs by Phone
- Copy Information Into Memory, Print It, Review It, Save It On Tape, Send Text From Memory
- Use Timex 2040 Printer or Any RS-232 Printer.
- RS-232 Printer Port Provided.
- No Extra Memory Required, But With 64K Memory You Can Store Up To 60 Full Screens

RS-232 Printer Interface \$59.95 Kit \$69.95 Ass.
 BB-1 Control Module, 8 Relays 8 TTL Inputs \$69.95

UM-64 64K Memory
 Battery Backup, Prom/Rom Socket, Reset Sw. Plus Exclusive Feature. Copy the Timex Rom into the 0-8K Area of Ram, flip a Sw & operate out of RAM. MODIFY it to suit your needs. Add new commands.
 \$119.95 Kit \$129.95 Assembled

Gorilla/Banana Printer Discounted to only \$239.95
 See "Leading Edge" Ad in this magazine

BYTE-BACK CO. Rt. 3 Box 147 Brodie Rd.
 Leesville, S.C. 29070 Ck. COD VISA M/C AM EXP
 Ph. 803-532-5812 Add \$4.95 shipping to all orders
 10 day money back guarantee plus 90-day warranty

CIRCLE NO. 122 ON FREE INFORMATION CARD

HAVING LOADING PROBLEMS ?



GET A Z-DUBBER

Because of the great variation in cassette recorders used with the ZX80/81/TS1000 (some in very poor shape) you may be having a hard time loading cassette programs. The (Z-Dubber) connects between the cassette recorder and the computer, and its circuitry produces a much better signal for the computer to read. The (Z-Dubber) also allows you to connect two cassette recorders together to make perfect backup copies. The Z-Dubber can be yours for \$31.95 post-paid. Add \$2.50 for shipping outside the US, Canada or Mexico.

CHARGE OR COD ORDERS CALL
1-800-227-3800
 ASK FOR OPERATOR 225

BYTESIZE PO BOX 12309 DEPT CJ
 MICRO TECHNOLOGY SEATTLE, WA 98111
 (206) 236-BYTE

CALL OR WRITE FOR DEALER INFORMATION

CIRCLE NO. 123 ON FREE INFORMATION CARD

UNIPROM



THE VERSATILE EPROM HANDLER

- Reads programs 2704, 2708, 2758, 2508, 2518, 2716 (supply) 2532, 2732, INTEL'S 2722A and the 8755A (INTEL/NEC).
- Reads/erases/programs Hitachi 48016 EEPROM'S
- No personally modules required
- All signals are 5-100 compatible (can adapt to most other buses)
- Port mapping occupies NO memory space.
- Bus clock rates exceeding 6mhz.
- All software is 8080/8085/Z80 compatible.
- Software "user" friendly.
- All software is fully CP/M & CDSOS compatible.

Board (A&T) with extensive documentation \$199.00
 Disk software (8" or NORTHSTAR 5.25") \$38.00
 EPROM-based software with source listing \$55.00
 Expansion console, 24 pin \$50.00

Featured in July, August '82 Microsystems

CER-TEK
 6020 Doniphan (915) 581-8897 El Paso, TX 79932
 ELECTRONICS MANUFACTURING SINCE 1975

CIRCLE NO. 124 ON FREE INFORMATION CARD

Radio Shack and TDP-100



COLOR COMPUTER
 ★ GAMES ★
 ★ HOME & WORK ★
 ★ PROGRAMMER AIDS ★

Dealer Inquiries Invited

COMPUTERWARE®
 Box 668 •
 6809 Specialists Encinitas, CA 92024
 (619) 436-3512
 Computerware is a trademark of Computerware

CIRCLE NO. 125 ON FREE INFORMATION CARD

VIC

VIC 20	\$249	\$100.00
VIC 64	\$595	\$397.00
DATASETTE		\$69
VIC PRINTER		\$380
GORF		\$36
SNAK MAN		\$18
SERPENTINE		\$36

AND MUCH MORE!

- Discounts on Large Orders
- MasterCard and VISA 1-a Accepted

FREE CATALOG

Name _____
 Address _____
 Zip _____

Cougar Computer Systems
 1319 Bailey Ave. Add 3%
 Buffalo, NY 14206 for
 (716) 895-0672 Shipping

CIRCLE NO. 125 ON FREE INFORMATION CARD

3M Scotch DISKETTES



Free Calculator
 from 3M
 with
 5 box
 order!

Toll Free 800-323-1872 If it's worth remembering, it's worth 3M diskettes.
 IN IL (312) 963-9136

STOCK UP ON HIGH QUALITY 3M DISKETTES AT UNBELIEVABLE LOW PRICES DURING THIS SPECIAL OFFER!

Description	List Price	Your Cost 10-40	Your Cost 50+
5 1/4" Single Side, Double Density	\$ 4.20	\$ 2.30	\$2.20
5 1/4" Double Side, Double Density	6.00	3.25	3.10
5 1/4" Single Side, Quad 96TPI	5.80	3.20	3.05
5 1/4" Double Side, Quad 96TPI	7.80	4.35	4.20
8" Single Side, Single Density	4.45	2.40	2.30
8" Single Side, Double Density	5.55	2.95	2.80
8" Double Side, Double Density	7.10	3.90	3.75
5 1/4" and 8" Head Cleaning Kit	33.30	19.75	—

Authorized Distributor
 Information Processing Products **3M** MasterCard VISA

MasterCard, Visa, C.O.D. or NET 30 days with Approved Credit
 All diskettes will ship the same day via UPS. UPS charges will be added to your invoice. Diskettes are packaged in a 2 piece re-usable storage box. All products are 100% guaranteed error free.
 Call for a free copy of our full line Catalog!

CIRCLE NO. 126 ON FREE INFORMATION CARD

BUSINESS SOFTWARE PACKAGE
\$59
 Reg. \$159

Features:

- Accounting Ledger
- Inventory Control
- Letter Writer
- Mail-Out

For TI-99 VIC-20 ATARI COM-64

Toll Free 1-800-221-7171
 In Ga. 1-404-925-4686

BIZWARE, INC. 5014 Hwy. 29/Lilburn, Ga. 30247

CIRCLE NO. 127 ON FREE INFORMATION CARD

SAVE 90%

YES you can save up to 90% on a computer system for home or office.

68000 microsystem (8MHz) with 128KB & three RS-232C ports, \$252.00

8086 microcomputer with 128KB & three RS-232C ports, \$204.00

Floppy Interface as little as \$60.00

Also Z80A-8080A systems, CRT's Monitor Roms & parts

FREE CATALOG

DIGATEK CORPORATION
 Suite 7
 2723 West Butler Drive
 Phoenix, Az. 85021

ROLL-YOUR-OWN TECHNOLOGY AND SAVE A BUNDLE

CIRCLE NO. 128 ON FREE INFORMATION CARD

COMPUTER MART
FORMAT
2" X 3"

PICTURE YOUR AD HERE!

NEXT CLOSING DATE:
SEPT 23

**SINGLE-CHIP
MICROCOMPUTER**

BOARD & KITS

- * 8048/8049/8050/8748
- * 8035/8039/8040/8749
- * 8031/8051/8751
- * 65110/6500/11/12/13
- * 65110/65410

Boards from \$24.95
Kits from \$55.95

TECH STAR LABORATORY
Suite 504C
1701 N Greenville Ave
Richardson, TX 75081

CIRCLE NO. 129 ON FREE INFORMATION CARD



**Music
Teacher
in a Box?**

To get ahead in music, you need to know music theory. PAIA's Chord Computer helps you understand both music and keyboards better by cramming the equivalent of pages and pages of music theory into a compact, calculator-style package.

The Chord Computer is easy to use. Simply select a chord letter, and the Chord Computer's LCD 31-key piano keyboard display will show which notes to play for the selected chord. Press another button to choose sharp, flat, major, minor, augmented, diminished, 6th, 7th or 9th chords — including inversions. The Chord Computer can also display complete scales for all keys, or even transpose them at the touch of a button.

Serious about music? The Chord Computer could be the best investment you'll ever make. **only \$59.95** (+\$2.50 postage/handling) **Order yours today**

CHARGE TO VISA OR MC TOLL-FREE
1-800-654-8657 9AM to 5PM CST MON-FRI

Ask for your free PAIA catalog.
Direct mail orders and inquiries to: Dept. 10-P

PAIA Electronics, Inc.

1020 W. Wishshire - Oklahoma City, OK 73116 (405) 843-9626

CIRCLE NO. 130 ON FREE INFORMATION CARD

**TRS-80
COMPUTER
DISCOUNTS**

- Factory Direct
- Best Prices Anywhere
- No Out-of-State Taxes
- 100% Radio Shack Warranty
- Free Price List
- Authorized TRS-80

**SCOTT TASSO
ASSOCIATES**

175 North Delsea Drive
Vineland, N.J. 08360

800-257-0426

NJ 609-691-7100

CIRCLE NO. 131 ON FREE INFORMATION CARD

A/D 8 channels + D/A 8 channels

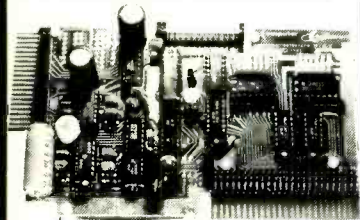

**APPLY YOUR MICRO TO ANALOG
SIGNAL PROCESSING & CONTROL**

Connects to μ processor buss of most 280 & 6502 computers including Timex, TRS-80, Apple, CBM 64. Our pin rearrangement feature eases interfacing.

FAST: 200,000 samples per sec with 280A.

EASY TO PROGRAM: One PEEK chooses the channel, starts conversion & gets data. Routines provided.

SOFTWARE AVAILABLE: FFT in 280, 256 points in one second, storage scope for Timex.

LOW COST: Assembled & tested \$195. Cable \$15. Please call or write for free catalog.

Computer Continuum

301 Sixteenth Avenue
San Francisco, CA 94118 (415) 752-6294

CIRCLE NO. 132 ON FREE INFORMATION CARD

**KCS
ELECTRONICS
CORPORATION**

SEMICONDUCTOR PARTS & PRODUCTS

**FACTORY PRIME
DEVICES INCLUDE:**

- Capacitors — all types & styles • Chokes & Coils • Connectors
- Digital & Linear IC's
- Hardware & Accessories
- Digital & Linear IC's
- IC Sockets • Memory Resistors — fixed & variable • Transformers
- Transistors & More

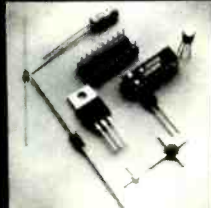

MANUFACTURERS SUCH AS: Motorola, National, NEC, J.W. Miller, Texas Instruments and more!

WE STOCK & SUPPLY DEVICES FOR: OEM's, Distributors, Hobbyists, Magazine Projects, Engineers, Schools, Technicians & You!

Send for **FREE Catalog** or Call:

(602) 274-2885 P.O. Box 33205
Phoenix, AZ 85067

CIRCLE NO. 133 ON FREE INFORMATION CARD

**GLoucester
COMPUTER**

PD/EL all features of Promqueen less mimic mode. Software enhanced to include EPROM QC utilities, RS-232 communication, printouts. 28 pin ZIF socket.

Reads, edits runs and programs all 5 volt 2500 and 2700 series EPROMs plus variety of EEPROMs all without personality modules. Commodore C-64 host computer. Inquire about the mimic mode capability in our VIC Promqueen.

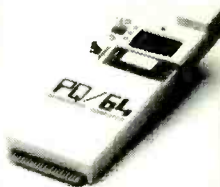

\$299.00

ROM Packs Industrial quality circuit cards are socketed, solder masked, fully bypassed, and include a ground plane for low noise operation. Includes 1 EPROM, 8K & 16K models for VIC-20 and C-64. Specify 2732 or 2764 EPROM type. Molded plastic case. **\$39.00**

GLoucester COMPUTER
1 Blackburn Center, Gloucester, MA 01930 617-283-7719

CIRCLE NO. 134 ON FREE INFORMATION CARD

**ATTENTION!
Superstars of the Future**

As a firm representing such fine artists as: Harry Blackstone, Jimmy Walker, Rupert Holmes, Richie Havens, Sherman Hemsley, Beatlemania, Blood, Sweat & Tears and many others, we have realized that the **INCREDIBLY TALENTED ARTISTS** of the software industry desire and need expert representation.

Whether you have already received acclaim or are a budding new artist, please call or write so that we may discuss your potential further.

Contact: Valerie Koob Ass't. to the President
Software Superstars Management
Div. of Spottlite Entertainment Enterprises, Ltd.
221 West 57th Street, New York, N.Y. 10019
(212) 586-6750 TELEX 640552 SPOTLITE NYK



CIRCLE NO. 135 ON FREE INFORMATION CARD

\$1,250.00

**FRANKLIN
SYSTEM**

- | | |
|------------------------------|----------|
| SYSCOM II (Apple Compatible) | \$ 550. |
| APPLE IIe SYSTEM | \$1,675. |
| FRANKLIN 1200 | \$1,599. |

***APPLE TYPE DRIVE \$ 180.**

- | | |
|------------|--------|
| 128 K Card | \$ 250 |
| GEMINI 10 | \$ 300 |

FREE BROCHURE

**!!WE WILL BEAT
ANY PRICE!!**

SOFTSELL SYSTEMS

P. O. Box 18928

Philadelphia, Pa. 19119

Visa, MasterCard preferred or C.O.D

Apple is a trademark of Apple Computer

CIRCLE NO. 136 ON FREE INFORMATION CARD

Tele Video® Users!

TEACH YOUR TELEVIDEO® WORDSTAR®!

TV2000 PRICES SLASHED!! NOW \$179!!
(was \$220)

FEATURES

- 92 WordStar® commands
- The Power of a dedicated word processor
- No loss of TeleVideo® attributes
- Soft switch activated
- Cuts WordStar® learning time to an hour

INCLUDES

- microprocessor
- 46 Keycaps with WordStar® legends
- 45 Page WordStar® manual

WordTechSystem

953 Mountain View Dr., Suite 114
Lafayette, California 94549
(415) 254-7747



TRADEMARKS WORDSTAR MICROPRO
INTERNATIONAL
TELEVIDEO TELEVIDEO SYSTEMS, INC.

CIRCLE NO. 137 ON FREE INFORMATION CARD

TRS-80+ MOD I, III, COCO, T199/4a
TIMEX 1000, OSBORNE, others

GOLD PLUG - 80

Eliminate disk reboots and data loss due to oxidized contacts at the card edge connectors.
GOLD PLUG 80 solders to the board edge connector. Use your existing cables. (if gold plated)

GOLD PLUG 80 Mod I (6)	\$54.95
Keyboard/EI (mod I)	18.95
Individual connectors	9.95
COCO Disk Module (2)	18.95
Ground tab extensions	1.00
Disk Drives (all R.S.)	9.95
Gold Disk Cable 2 Drive	29.95
Four Drive Cable	39.95
GOLD PLUG 80 Mod III (6)	54.95
Internal 2 Drive Cable	29.95
Mod III Expansion port	10.95
USA shipping \$1.45	Can/Mex \$4.
Foreign \$7.	TEXAS 5% TAX

MasterCard
E.A.P. CO.
P.O. BOX 14
KELLER, TEXAS 76248
(817) 498-4242
+ trademark Tandy Corp

VISA
MC/VISA

CIRCLE NO. 138 ON FREE INFORMATION CARD

64K for VIC 20™ SELECT-A-RAM™



SELECT-A-RAM

STANDARD FEATURES

- 8K BLOCKS SELECTABLE FROM THE KEYBOARD OR BY SOFTWARE COMMAND
- TWO EXPANSION SLOTS
- WRITE PROTECTION
- RESET SWITCH
- EXPANDABLE TO 128K WITH ADDITION OF 64K EXPANSION MODULES
- COMPATIBLE WITH ROM CARTRIDGES
- ONE YEAR WARRANTY ON PARTS AND LABOR
- 15 DAY MONEY BACK GUARANTEE

SELECT-A-RAM \$118
64K EXPANSION MODULE \$165
TRADE INS ACCEPTED
3K-55 / 5K-510 / 16K-520

VIC 20 IS A TRADEMARK OF COMMODORE ELECTRONICS LIMITED
ATARI 400 AND 800 ARE TRADEMARKS OF ATARI INC.

512-441-3202 PO BOX 43006 Austin, Tx. 78745-0001



CIRCLE NO. 139 ON FREE INFORMATION CARD

Vohrax® SC-01A SPEECH SYNTHESIZER

\$50 Each
(\$40 in hundreds)

Order in Ones or Thousands

The SC-01A Speech Synthesizer is a completely self-contained solid state device. This single chip phonetically synthesizes continuous speech of unlimited vocabulary.

Computer interfaces and text-to-speech algorithms also available for product development.

Micromint is the largest U.S. distributor of the SC-01A. Call us for a price quote.

Call 1-800-645-3479, in N.Y. 1-516-374-6793

MICROMINT INC.
561 Willow Avenue
Cedarhurst, NY 11516



Add \$2.00 for shipping & handling.

CIRCLE NO. 140 ON FREE INFORMATION CARD

Shelf Conscious?

Now you can organize your copies of

Computers & Electronics

Now your magazines can be a handsome addition to your decor, well organized, and easy to find, thanks to these durable library-quality cases or binders. They're made of luxury-look leatherette over high-quality binders board. And both styles are custom-designed for this or any magazine you save, with size, color, and imprint selected by the publisher. FREE transfer foil included for marking dates and volumes.



Magazine binders

hold your issues on individual snap-in rods, combining them into one volume.
\$7.95 each; 3 for \$22.50; 6 for \$42.95.
Mixed titles OK for quantity prices.



Open-back cases

store your issues for individual reference. \$6.95 each; 3 for \$19.75; 6 for \$37.50. Mixed titles OK for quantity prices.



CHARGE ORDERS ONLY—
for your convenience PHONE 24 HRS.
TOLL-FREE 800-526-0790.
In NJ only 201-540-0445.

USE THIS COUPON

Computers & Electronics

P.O. Box 5120, Philadelphia, PA 19141

Please send: Cases Binders
TITLE _____ QUANT. _____

Computers & Electronics: _____
(Other): _____

ENCLOSED IS \$ _____ * Add \$1.00 per order for post. & handling. Outside USA add \$2.50 per unit ordered. Send U.S. funds only.

CHARGE (Min. \$10): VISA
 American Express Master Charge

Card # _____

Exp. Date _____

Signature _____

Print Name _____

Address _____

City/State/Zip _____

*PA residents add 6% sales tax.

Computers & Electronics

ADVERTISERS INDEX

RS no.	ADVERTISER	PAGE no.
50	Active Electronics	105
15	Air National Guard	59
3	All Electronics Corp.	113
35	Apple Computer	32-33
55	Artec	103
	C & D Electronics	98
	Classified Advertising	118-128
	Cleveland Institute of Electronics, Inc	46-49
29	Commodore Computer	3
19	Communications Electronics	5
60	CompuServe	Cover 3
11	Computer Mail Order	78
14	Digi-Key Corp.	114-115
44	Dokay Computer Products	110-111
51	Electronic Specialists	104
46	Global Specialties	6
	Grantham College of Engineering	23
24,28	Heath Co.	36-39, 54-55
65	Hewlett-Packard	15
41	IBM Corp.	17
	ICS	104
21	Jameco Electronics	112
22	JDR Microdevices	108-109
20	Leading Edge	Cover 4
	Lerna-Tronics, Inc.	84
48	3M Company	63
30	Maxell	Cover 2
	McGraw-Hill	69
31	McIntosh Laboratory, Inc.	84
	Memotech	21
	Memtek Products	7
	National Technical Schools	26-29
	Netronics, R & D Ltd.	113
17,53	New Horizons	1,91
75	Novation, Inc.	19
	NRI Schools	8-11,87
40	Protecto Enterprises	101
	Radio Shack	41,107
	Scientific Systems	102
36	Sintec Co.	105
16	Sweet Gum Inc.	102
39	Tab Books	93
42	Tam's Inc.	106
82	Tektronix	67
74	Yield House, Inc.	53



LAST NIGHT, 39 MUSICIANS HAD A COMPU SERVE CONFERENCE, SO DID 31 M.D.S, 49 SPORTS FANS AND 640 APPLE POLISHERS, AND NO ONE HAD TO LEAVE HOME.

The Electronic Forum, Cheaper than Long Distance and Much More Rewarding.

Every night on the CompuServe Information Service, professional and social groups discuss a wide range of subjects. From what's new in medical technology to what's nouvelle in continental cuisine.

And every day more computer owners who share a common interest are discovering this exciting new way to exchange ideas and even transfer hard copy data.

And besides electronic forums, they leave messages for each other on our national bulletin board, "talk" informally on our CB simulator, and communicate via CompuServe's electronic mail.

But best of all, in most cases, CompuServe subscribers get all of these state of the art communications options, plus a world of on-line information and entertainment for the cost of a local phone call plus connect time.

To become part of this flexible communications network, all you

need is a computer, a modem and CompuServe. CompuServe connects with almost any personal computer, terminal, or communicating word processor.

To receive an illustrated guide to CompuServe and learn how you can subscribe, contact or call

CompuServe

Consumer Information Service, P.O. Box 20212
5000 Arlington Centre Blvd., Columbus, OH 43220

800-848-8199

In Ohio call 614-457-0802

Circle No. 60 on Free Information Card

An H&R Block Company



BUY A BANANA.™ SAVE A BUNCH.

Meet the Banana,™ the very tough, versatile, portable, and reliable dot-matrix printer from Gorilla.™

At \$249.95 retail it's an ideal and inexpensive companion for personal computers like Apple® (or Apple "look alikes" such as Franklin® or Albert®), TI®, Commodore®, TRS-80®, Kaypro®, Timex®, Osborne®, etc.

After that, it's merely comparable to other printers that can cost up to three times as much: 10" carriages (to handle standard 9½" paper), 80 columns, graphics capability, 10 characters per inch (expandable to 5 cpi) draft-quality print (for perfectly acceptable form letters, data processing,

business reports, etc.) tractor feed (for precise alignment and quick loading), parallel or serial interface (take your pick), self-inking ribbon cassette (for long life and easy installation), 10 portable pounds in weight, and compatibility with so many of the most popular personal computers on the market.

Plus its printhead features a unique single-hammer design that eliminates a lot of moving parts, to eliminate a lot of annoying repairs.

That's the Banana: silly name, serious service. It's everything the expensive dot-matrix printers are . . .

Except expensive.



Leading Edge Products, Inc., 225 Turnpike Street, Canton, Massachusetts 02021
Toll-free: 1-800-343-6833; In Massachusetts (617) 828-8150. Telex 951-624.

MODEL NO. 20 ON THE INFORMATION CARD