

Popular Electronics®

WORLD'S LARGEST-SELLING ELECTRONICS MAGAZINE

JANUARY 1980/\$1.25

Rebirth of Bass-Reflex Speakers
TRS-80 Computer "Real Time" Timer
Low-Cost "Micro Meter" for DC Volts

A Personal Radiation Monitor

● Solid-State Detector ● Portable ● Chirp Alarm



14024 14278
Popular Electronics



**Tested
In This
Issue**

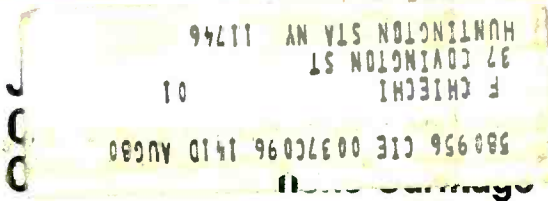



We're looking for the most original use of an Apple since Adam.

What in the name of Adam do people do with Apple Computers?

You tell us.

In a thousand words or less.

If your story is original and intriguing enough, you could win a one-week all-expense paid trip for two to Hawaii. Which is the closest we could come to paradise.

Win fabulous prizes for creative writing.

To enter, drop by your nearest Apple dealer and pick up an entry blank. Fill it out. Then write an article, in 1000 words or less, describing the unusual or interesting use you've found for your Apple.

A jury of independent judges will cast the deciding vote for the grand prize: a week for two, airfare included, in Hawaii.

The judges will also choose 16 additional winners, two each from eight categories:

graphics/music, entertainment, home, business, education, scientific, professional, and industrial. And each winner will choose from a long list of longed-after Apple peripherals—from Apple Disk II's to Graphics Tablets to printers. Or you can take a \$250 credit towards the purchase of any Apple product.

The contest ends March 31, 1980. All winners will be notified by May 15.

Entry forms are available at your participating Apple dealer. Call 800-538-9696, (800-662-9238 in California), for the one nearest you.

Mail the entry blank, your article and any photos to: Apple Computer, "What in the name of Adam" contest, 10260 Bandle Drive, Cupertino, CA 95014.

And may the juiciest application win.



Sports Radar^{T.M.}



Here's how an exciting new micro-electronic breakthrough will make your children heros and improve your tennis game.

Just point the gun and read the results.

When Roger started pitching for his little league team, he was just another player. And his arm was no better than anybody elses.

Two months later a small miracle took place. Roger was the best pitcher on the team and had a fast ball that was the most powerful in his league—and all thanks to his father.

Roger's success came from a radar gun—the same type device used by police to catch speeding motorists.

SCRAMBLED EGGS

The minute Roger's father was able to clock his son's pitching speed, Roger was subconsciously given a daily challenge of pitching harder and faster to beat his previous speed. The more he practiced, the better he got.

Roger's father paid \$2,000 for the radar gun. But in his upper class neighborhood, it wasn't too unusual for a father to spend that kind of money to help his son.

SPEEDING CITATION

A large manufacturer of radar-type security devices saw what Roger's father had done and felt that there was a definite need to produce a low cost radar unit designed exclusively for the sports market.

The company, Solfan Systems, developed the Sports Radar gun—a major breakthrough in projectile speed detection as well as electronic radar circuitry.

Using the doppler effect of radar and phased-lock-loop circuits, Solfan has developed the Sports Radar gun that compares to even the most sophisticated of police radar units that cost \$2,000.

OVERLAND EXPRESS

The Sports Radar gun is held in your hand and pointed toward the pitcher. You turn it on, press the ready button, and point the gun. The gun will ignore the moving arm of the pitcher but will lock in on the moving ball. The radar unit would then follow the ball for approximately ten milliseconds and the built in computer measures and computes the speed and flashes the reading on the display. The gun registers the speed to the exact mileage within one-half miles per hour.

The gun can be mounted on a tripod so that the person taking the measurements can also catch the ball.

In tennis, the speed of the serve can be measured by aiming the gun at the person serving. You can also use the unit by yourself by setting the unit on a tripod and measuring the speed from behind.

WORKING AND PLAYING

Aside from its extreme accuracy and advanced electronics, the unit is priced to meet the budget of every sports-minded athlete or parent. It's only \$149.95 complete.

You can measure the speed of baseballs, soccer balls, tennis balls, golf balls, hockey pucks, downhill skiers, radio controlled model airplanes or anything that moves—even automobiles.



The speed is flashed on the large LED display and is shown in miles per hour.

The unit accepts two commercially available 6-volt lantern batteries which you can purchase locally or from JS&A for only \$2 each. The batteries will last for weeks with normal use.

SUCCESS AND GOOD THINGS

The unit comes in a sports blue color and weighs 38.4 ounces, exclusive of batteries. It's rugged, well built and designed to endure the typical use and abuse it would normally receive.

We urge you to test this exciting new product during our 30-day free trial. Order the Sports Radar gun. When you receive it, measure your child's pitching speed. Test it on your own tennis serve. See how knowing your speed will actually improve it as you try to out perform your previous record fast pitch or serve. Then decide if the Sports Radar gun doesn't make a very exciting addition to your sports equipment.

ONE FOR THE MONEY

If you are not convinced that the Sports Radar gun is something that you'll use constantly to help improve your game, return it for a prompt and courteous refund, including your \$3.50 postage and handling. You can't lose—and chances are your son will at least have the most popular new product in the neighborhood.

To order one for your test, simply send your check for \$149.95 plus \$3.50 for postage and handling to JS&A Group, Inc., at the address shown below. (Illinois residents please add 5% sales tax.) Credit card buyers may call our toll-free number below. If you wish to buy a set of two six-volt batteries, simply add \$4.00 to your order.

We'll then send your unit, the batteries (if you order them from us), a 90-day limited warranty and complete easy-to-understand instructions.

Radar electronics for the sports enthusiast is now a reality. Watch your game improve by ordering your Sports Radar gun at no obligation, today.

JS&A PRODUCTS THAT THINK®
Dept. PE One JS&A Plaza
Northbrook, Ill. 60062 (312) 564-7000
Call TOLL-FREE 800 323-6400
In Illinois Call (312) 564-7000
© JS&A Group, Inc., 1979

The World's biggest SALE of Bearcat® scanners!

Communications Electronics™, the world's largest distributor of radio scanners, celebrates the Electra introduction of four new Bearcat brand monitors with the world's largest scanner sale. From now, until January 31, 1980, you can save hundreds of dollars during the world's largest scanner sale!

Even the new Bearcat models 300, 220 and Eight Track scanners are on sale. If you've previously purchased a Bearcat scanner, then you already know you're getting all the real, live excitement that a television program or newspaper can't provide. If you don't have at least one Bearcat scanner, the time to buy is now!

Since CE distributes more scanners worldwide than anyone else, we can give you rock bottom prices. Our warehouse facilities are equipped to process over 1,000 Bearcat scanner orders per week and our order lines are always staffed 24 hours. We also export Bearcat scanners to more than 300 countries and military installations. Almost all items are in stock for immediate shipment, so save now and get a Bearcat scanner during the world's largest scanner sale!

NEW! Bearcat® 300

Available February - March, 1980
List price \$499.95/CE price \$329.00

7-Band, 50 Channel • Service Search • No-crystal scanner • AM Aircraft and Public Service bands. • Priority Channel • AC/DC Bands: 32-50, 118-136 AM, 144-174, 421-512 MHz. The new Bearcat 300 is the most advanced automatic scanning radio that has ever been offered to the public. Since the Bearcat 300 has over 2,100 active frequencies in memory, you can touch one button and search any of many preprogrammed services such as police, fire, marine and government. Of course, you still can program your own frequencies and monitor up to 50 channels at once. Since the Bearcat 300 uses a bright green fluorescent digital display, it's ideal for mobile applications. The Bearcat 300 now has these added features: Service Search, Display Intensity Control, Hold Search and Resume Search keys, Separate Band keys to permit lock-in/lock-out of any band for more efficient service search. Reserve your Bearcat 300 now for February-March, 1980 delivery.

Bearcat® 250

List price \$399.95/CE price \$259.00

50 Channels • Crystalline • Searches Stores • Recalls • Self-Destruct • Priority channel • 50 Channel • 6-Band. Frequency range 32-50, 146-174, 420-512 MHz. The Bearcat 250 performs any scanning function you could possibly want. With push button ease you can program up to 50 channels for automatic monitoring. Push another button and search for new frequencies. There are no crystals to limit what you want to hear. A special search feature of the Bearcat 250 actually stores 64 frequencies, and recalls them, one at a time, at your convenience. Automatic "count" remembers how often frequencies are activated by transmission—so you know where the action is. Decimal display shows the channel, frequency and other programmed features. The priority feature samples your programmed frequency every two seconds. Plus, a digital clock shows the time at the touch of a button. The Bearcat 250. Scanning like you've never seen or heard before.



NEW! 50-Channel Bearcat 300

NEW! Aircraft Bearcat 220

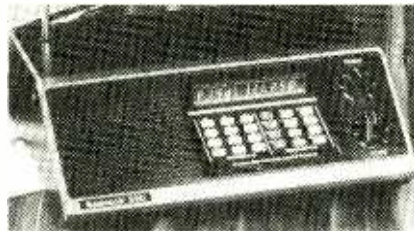

Aircraft Bearcat® 220

List price \$399.95/CE price \$259.00

Aircraft and public service monitor. Frequency range 32-50, 118-136 AM, 144-174, 420-512 MHz. The Bearcat 220 is one scanner which can monitor all public service bands plus the exciting AM aircraft band channels. Up to twenty frequencies may be scanned at the same time.

Not only does this new scanner feature normal search operation, where frequency limits are set and the scanner searches between your programmed parameters, it also searches marine or aircraft frequencies by pressing a single button. These frequencies are already stored in memory so no reprogramming is required. The Bearcat 220 also features a Priority channel, Dual scanning speeds, Patented track tuning and Direct channel access and AC/DC operation.

NEW! Bearcat® 211

List price \$339.95/CE price \$229.00

Frequency range: 32-50, 146-174, 420-512 MHz. The Bearcat 211. It's an evolutionary explosion of features and function. 18-channel monitoring. With no-crystal six-band coverage. Dual scan speeds. Color-coded keyboard. Even a digital clock. All at a modest price. More scanning excitement than you bargained for.

Bearcat® 210

List price \$299.95/CE price \$199.00

10 Channels • 5 Bands • Crystalline Frequency range: 30-50, 146-174, 420-512 MHz. Use the simple keyboard to select the 10 channels to be scanned. Automatic search finds new frequencies. The 210 features patented selectable scan delay, push button lockout, single antenna, patented track tuning, AC/DC operation. With no crystals to buy. Ever!

NEW! Bearcat® 8 Track

List price \$99.95/CE price \$79.00

4 Channels • 2 Bands • Plays off any AC or DC Powered 8 Track Tape Player. Frequency range: 36-44, 152-162 MHz. The Bearcat 8 Track Scanner. It converts any 8 track tape player into a live-action scanning radio.

This incredibly compact 4-channel/2-band crystal scanner plugs into the tape player where an 8 track cartridge normally goes. Police, fire, emergency calls—as-it-happens scanning excitement—from an existing home entertainment center, in-car/in-boat system or portable 8 track tape player. The Bearcat 8 Track Scanner plugs live-action into any 8 track player. Anywhere. Crystal certificates # A-135cc are \$4.00 each.

Bearcat® Four-Six

List price \$169.95/CE price \$109.00

The first 4 Band, 6 Channel, Hand-Held Scanner. Frequency range: 33-47, 152-164, 450-512 MHz. The Bearcat Four-Six offers "hip pocket" access to police, fire, weather and special interest public service broadcasts. Lightweight. Extremely compact. The Bearcat Four-Six—with its popular "rubber ducky" antenna and belt clip—provides "go anywhere/hands-off" scanning.

NEW! Aircraft and UHF

Bearcat® ThinScan™

List price \$149.95/CE price \$99.00

World's smallest scanner! The Bearcat ThinScan™. High-performance scanning has never been this portable. There are now three models available. The BC 2-4 L/H receives 33-44 and 152-164 MHz. The BC 2-4 H/U receives 152-164 and 450-508 MHz. The new high-performance Aircraft ThinScan model BC 2-4 AC receives 118-136 and 450-470 MHz. Go ahead, size it up. The Bearcat ThinScan™ measures 2 3/4" across. Just 1" deep. And 5 1/2" high. Four crystal-controlled channels are scanned every 1/2 second providing immediate access to police, fire, weather and other special-interest broadcasts.



NEW! Bearcat 8 Track scanner

CIRCLE NO. 1 ON FREE INFORMATION CARD

INCREASED PERFORMANCE ANTENNAS

If you want the utmost in performance from your Bearcat scanner, it's essential that you use an external antenna. We have six base and mobile antennas specifically designed for receiving all bands. Order #A60 is a magnet mount mobile antenna. Order #A61 is a gutter clip mobile antenna. Order #A62 is a trunk-clip mobile antenna. Order #A63 is a 3/4 inch hole mount. Order #A64 is a 3/8 inch snap-in mount, and #A70 is an all band base station antenna. All antennas are \$25.00 and \$3.00 for UPS shipping in the continental United States.

OTHER BEARCAT ACCESSORIES

SP50 AC Adapter \$12.00
SP51 Battery Charger \$12.00
SP55 Carrying Case for Four-Six \$15.00
SP57 Carrying Case for ThinScan \$15.00
SM210 Service manual for Bearcat 210 \$15.00
SM220 Service manual for Bearcat 220 \$15.00
SM250 Service manual for Bearcat 250 \$15.00
B-31.2 V AA Ni-Cad's for Four-Six (Pack of 4) \$15.00
B-41.2 V AAA Ni-Cad's for ThinScan (Pack of 4) \$15.00
B-5R Replacement memory battery for Bearcat 210 \$5.00
A-135cc Crystal certificate \$4.00
Add \$3.00 shipping for all accessories ordered at the same time.

TEST A BEARCAT SCANNER FREE

Test any Bearcat brand scanner purchased from Communications Electronics™ for 31 days before you decide to keep it. If for any reason you are not completely satisfied, return it in new condition with all parts in 31 days, for a courteous and prompt refund (less shipping and handling charges).

MADE BY ELECTRA

Since all Bearcat scanners are products of Electra Company, a Division of Masco Corporation of Indiana, you can be assured of the finest monitor radios available in the world. With your Bearcat scanner, you will receive a complete set of simple operating instructions and a one-year limited warranty from Electra. If service is ever required for any Bearcat scanner just send your receiver to an Electra national service center.

BUY WITH CONFIDENCE

All Bearcat scanners are extraordinary scanning instruments. They provide virtually any scanning function that the most professional monitor could require. To get the fastest delivery from CE of any Bearcat scanner, send or phone your order directly to our Scanner Distribution Center. Be sure to calculate your price using the CE prices in this ad. Michigan residents please add 4% sales tax. Written purchase orders are accepted from approved government agencies and most well rated firms at a 10% surcharge for net 30 billing. All sales are subject to availability. All sales on accessories are final. Prices and specifications are subject to change without notice. Out of stock items will be placed on backorder automatically unless CE is instructed differently. International orders are invited with a \$10.00 surcharge for special handling in addition to shipping charges. All shipments are F.O.B. Ann Arbor, Michigan. No COD's please. Cashier's checks will be processed immediately and receive an order priority number. Personal checks require three weeks bank clearance.

Mail orders to: Communications Electronics, Box 1002, Ann Arbor, Michigan 48106 U.S.A. Add \$5.00 per scanner for U.P.S. ground shipping, \$9.00 for faster U.P.S. air shipping or \$30.00 for overnight delivery to most major U.S. cities via Federal Express or Airborne Air Freight. If you have a Master Charge or Visa card, you may call anytime and place a credit card order. Order toll free 800-521-4414. If you are outside the U.S. or in Michigan, dial 313-994-4444. You may also order via TWX 810-223-2400. Dealer inquiries invited. All order lines at Communications Electronics™ are staffed 24 hours.

Since this multi-million dollar scanner sale is the world's largest, please order today at no obligation to assure a prompt order confirmation and delivery.

When you follow the leader to real excitement, your journey ends at Communications Electronics. Autoprogramming™, Scanner Distribution Center™ and CE logos are trademarks of Communications Electronics.™ *Bearcat is a federally registered trademark of Electra Company, a Division of Masco Corporation of Indiana. Copyright © 1979 Communications Electronics™



COMMUNICATIONS ELECTRONICS™

854 Phoenix □ Box 1002 □ Ann Arbor, Michigan 48106 U.S.A.
Call TOLL-FREE (800) 521-4414 or outside U.S.A. (313) 994-4444

**We're first
with the best.™**

POPULAR ELECTRONICS



About the cover:

The personal radiation monitor featured this month can be used to check relative levels from many types of radioactive sources.

Cover Art by George Kelvin

JOSEPH E. MESICS Publisher
ARTHUR P. SALSBERG Editorial Director
LESLIE SOLOMON Technical Director
JOHN J. McVEIGH Technical Editor
JOHN R. RIGGS Managing Editor
HAROLD A. RODGERS Senior Editor
ALEXANDER W. BURAWA Features Editor
EDWARD I. BUXBAUM Art Director
ANDRE DUZANT Technical Illustrator
CARMEN VELAZQUEZ Production Editor
BETTY LOUISE KNOWLES Editorial Assistant
Contributing Editors Hal Chamberlin, Lou Garner, Glenn Hauser Julian Hirsch, Forrest Mims
JEFF NEWMAN Assistant to the Editor
LINDA BLUM Advertising Service Manager
MARIE MAESTRI Executive Assistant
EDGAR W. HOPPER Publishing Director

Feature Articles

A SECOND LIFE FOR VENTED SPEAKERS / David B. Weems _____	48
<i>Modern designs here revived interest in reflex speaker systems.</i>	
THE LM339, A GREAT COMPARATOR / Clement S. Pepper _____	67
<i>Four useful applications for a low-cost comparator.</i>	
LISSAJOUS PATTERN QUIZ / Robert P. Balin _____	76

Construction Articles

BUILD A PERSONAL RADIATION MONITOR / John Steidley, Martin Nakashian and Gerald Entine _____	39
<i>Detects local radiation levels with new CdTe detector.</i>	
A SIMPLE "REAL TIME" TRS-80 TIMER / Howard Berenbon _____	58
<i>Use for timing electric appliances, chess games and other applications.</i>	
MEASURE WEAK DIRECT CURRENTS WITH THE SENSITIVE MICRO METER / I. Queen _____	59
<i>Employs digital techniques to answer your questions.</i>	
BUILD A METAL LOCATOR / Robert Krieger _____	70
<i>Low-cost unit for searching out metal objects.</i>	

Columns

STEREO SCENE / Harold A. Rodgers _____	20
<i>Short Subjects.</i>	
EXPERIMENTER'S CORNER / Forrest M. Mims _____	77
<i>Solid-State Oscilloscope Wrap-Up.</i>	
HOBBY SCENE / John J. McVeigh _____	81
DX LISTENING / Glenn Hauser _____	84
<i>A World of News.</i>	
COMPUTER BITS / Hal Chamberlin _____	86
<i>Microcomputer Power Supplies.</i>	
SOFTWARE SOURCES / Leslie Solomon _____	90
TIPS AND TECHNIQUES _____	91
PROJECT OF THE MONTH / Forrest M. Mims _____	93
<i>Digital Stopwatch.</i>	

Julian Hirsch Audio Reports

JVC MODEL KD-A8 CASSETTE DECK _____	24
OSAWA MODEL MP20 PHONO CARTRIDGE _____	30
CELESTION DITTON MODEL 662 SPEAKER SYSTEM _____	31

Electronic Product Test Report

PHILIPS MODEL PM3232 OSCILLOSCOPE _____	82
--	----

Departments

EDITORIAL / Art Salsberg _____	4
<i>Electronic Safety.</i>	
LETTERS _____	6
OUT OF TUNE _____	6
NEW PRODUCTS _____	8
NEW LITERATURE _____	14
OPERATION ASSIST _____	98
ADVERTISERS INDEX _____	107
PERSONAL ELECTRONICS NEWS _____	112

POPULAR ELECTRONICS (ISSN 0032-4485): Published monthly by Ziff-Davis Publishing Company, at One Park Avenue, New York, NY 10016. Philip B. Korsant, President; Selwyn Taubman, Treasurer; Bertram A. Abrams, Secretary. One year subscription, U.S. and Possessions, \$13.00; Canada, \$16.00; all other countries, \$18.00; cash orders only, payable in U.S. currency. COPYRIGHT © 1979 BY ZIFF-DAVIS PUBLISHING COMPANY. ALL RIGHTS RESERVED.

ZIFF-DAVIS PUBLISHING COMPANY
Editorial and Executive Offices
One Park Avenue, New York, New York 10016
212-725-3500
Joseph E. Mesics (725-3568)
John J. Corton (725-3578)
Bonnie B. Kaiser, Eastern Adv. Mgr. (725-3580)

Midwestern Office
Ted Welch

Suite 1400, 180 N. Michigan Ave.,
Chicago, IL 60601 (312-346-2600)

Western Office
3460 Wilshire Blvd., Los Angeles, CA 90054
213-387-2100

Western Representative: Norm Schindler
7050 Owensmouth Ave., #209
Canoga Park, CA 91303 (213-999-1414)

Japan: James Yagi, Oji Palace Aoyama;
6-25, Minami Aoyama, 6 Chome, Minato-Ku,
Tokyo, 407-1930/6821, 582-2851

ZIFF-DAVIS PUBLISHING COMPANY

Philip B. Korsant, President
Furman Hebb, Executive Vice President
Philip T. Heffernan, Sr. Vice President
Edward D. Muhlfield, Sr. Vice President
Philip Sine, Sr. Vice President
Lawrence Sporn, Vice President, Circulation and Marketing
Richard Friese, Sr. Vice President
Baird Davis, Vice President, Production
George Morrissey, Vice President
Sydney H. Rogers, Vice President
Sidney Holtz, Vice President
Albert S. Traina, Vice President
Paul H. Chook, Vice President
Edgar W. Hopper, Vice President
Robert N. Bavier, Jr., Vice President
Selwyn Taubman, Treasurer
Bertram A. Abrams, Secretary

W. Bradford Briggs, Vice Chairman

ZIFF CORPORATION

William Ziff, Chairman
I. Martin Pompadur, President
Hershel B. Sarbin, Executive Vice President

POPULAR ELECTRONICS, January 1980, Volume 17, Number 1. Published monthly at One Park Avenue, New York, NY 10016. One year subscription rate for U.S. and Possessions, \$13.00; Canada, \$16.00; all other countries, \$18.00 (cash orders only, payable in U.S. currency). Application to mail at controlled circulation postage rates is pending at Salem, Illinois 62881. Authorized as second class mail by the Post Office Department, Ottawa, Canada, and for payment of postage in cash.

POPULAR ELECTRONICS including ELECTRONICS WORLD. Trade Mark Registered. Indexed in the Reader's Guide to Periodical Literature.

COPYRIGHT © 1979 BY ZIFF-DAVIS PUBLISHING COMPANY. ALL RIGHTS RESERVED.

Ziff-Davis also publishes Boating, Car and Driver, Cycle, Flying, Popular Photography, Skiing, Stereo Review, Electronic Experimenter's Handbook, Tape Recording & Buying Guide, Stereo Directory & Buying Guide, and Communications Handbook

Editorial correspondence: POPULAR ELECTRONICS, 1 Park Ave. New York NY 10016. Editorial contributions must be accompanied by return postage and will be handled with reasonable care; however, publisher assumes no responsibility for return or safety of manuscripts, art work, or models.

Forms 3579 and all subscription correspondence: POPULAR ELECTRONICS, Circulation Dept., P.O. Box 2774, Boulder CO 80302. Please allow at least eight weeks for change of address. Include your old address, enclosing, if possible, an address label from a recent issue.

Permissions. Material in this publication may not be reproduced in any form without permission. Requests for permission should be directed to Jerry Schneider, Rights and Permissions, Ziff-Davis Publishing Co., One Park Ave., New York, NY 10016

The publisher has no knowledge of any proprietary rights which will be violated by the making or using of any items disclosed in this issue.



Editorial

ELECTRONIC SAFETY

Fatalities due to electric shock are rather rare. Nonetheless, one should not lightly dismiss the hazards of working with and around electronic equipment. It makes sense to minimize any risk, you'll agree, regardless of how small it is. Accordingly, here's a partial list of personal safety rules that I've practiced in recent years.

- (1) Hire someone to erect your ham, CB or TV roof antenna. Seems that every few months someone doing it himself hits an electric power line . . . and poof!
- (2) If you're working on electronic equipment, be sure the ac plug is pulled out of the wall socket; don't ever depend on an on-off switch to do the job.
- (3) Beware of transformerless sets; they might have a "hot" chassis. (Use an isolation transformer to play safe.)
- (4) Don't use a wet finger to check signal paths.
- (5) Replace frayed ac line cords or extension cords as soon as you notice them.
- (6) If your electric drill cannot be grounded, be sure to use one that has double insulation.
- (7) Check your communication gear for proper lightning protection.
- (8) Discharge electrolytic capacitors before starting work on equipment.

There are other, even more remote, hazards that are somewhat related to electronics. These include laser light, microwave energy, and ionizing radiation (medical/dental X rays, nuclear radiation, etc.).

The biological effects of the last can be insidious, of course, since there is no proven bottom threshold for genetic damage. Not to worry, though, say all the journals I've read. Irradiation from natural and man-made sources are said to be well within "acceptable" limits. Typical whole body annual doses are reported to be 0.102 rem for natural radiation, 0.072 rem for medical radiation, and 0.0026 from TV and other consumer electronic products, for a total of about 0.176 rem. The long-term maximum yearly "safe" dose is said to be 0.500 rem, so there appears to be plenty of leeway.

Nonetheless, some people worry about radiation exposure, especially when a nuclear accident occurs. Under normal circumstances, radiation from nuclear reactors, fallout, etc., accounts for less than 0.005 rem/year, which is a tiny addition to anyone's radiation burden. To place this in its proper perspective, terrestrial radiation in Denver, Colorado is about 0.058 rem higher than in Florida. So one can substantially reduce a dose rate simply by moving to a coastal plain area. Should anyone be terribly concerned about nuclear power plant leakage, radioactive waste deposits, or what-have-you, the radiation monitor described in this issue may give you some reassurance.

Art Salsberg



Step up to your next computer.



STEP UP TO A C4P FROM OHIO SCIENTIFIC

You know about computers. In fact, you probably own one now. One that you might be thinking of expanding. We have a better idea. Take a giant step into the personal computing future with an amazing, new C4P from Ohio Scientific.

SPEED SEPARATES THE COMPUTERS FROM THE TOYS

The C4P MF has execution speed that is twice as fast as Apple II or Commodore PET and over THREE times as fast as TRS-80. They are many times faster than the recently introduced flock of video game type computers. And, as if that weren't fast enough, the C4P nearly doubles its speed when equipped with the GT option.

Just look at the back panel of the C4P MF.



All the I/O you'll ever need!

SCUND

- 1—programmable tone generator 200 — 20KHz
- 1—8 bit companding digital to analog converter for music and voice output.

HUMAN INPUT EXPANSION

- 2—8 axis joystick interfaces
- 2—10 key pad interfaces

HOME INTERFACE

- 1—AC-12 AC remote control interface

DISPLAY

- 32 x 64 with upper and lower case 2048 Characters.
- 256 x 512 effective Graphic Points
- 16 Colors

SOFTWARE

Ohio Scientific offers a comprehensive library of both systems and applications software for the C4P.

The C4P is an outstanding premium computer — years ahead of the market. We know because there's nothing quite like it for the price, anywhere. And probably won't be for a very long time.

C4P \$698

8K BASIC-in-ROM 8K of static RAM and audio cassette interface. Can be directly expanded to 32K static RAM and two mini-floppy disks.

C4P MF \$1695

All the features of the C4P plus real time clock, home security system interface, modem interface, printer interface, 16 parallel lines and an accessory BUS. The C4P MF starts with 24K RAM and a single mini-floppy and can be directly expanded to 48K and two mini-floppies. Over 45 diskettes now available including games, personal, business, educational and home control applications programs as well as a real time operating system, word processor and a data base management system.

Computers come with keyboards and floppies where specified. Other equipment shown is optional.

For literature and the name of your local dealer, CALL 1-800-321-6850 TOLL FREE.

OHIO SCIENTIFIC

1333 SOUTH CHILLICOTHE ROAD
AURORA, OH 44202 • (216) 562-3101

CIRCLE NO. 48 ON FREE INFORMATION CARD



Letters

COMMENTS ON PRINTER ARTICLE

Your otherwise excellent "How to Buy a Computer Printer" article (November 1979) unfortunately misrepresented the dot-matrix

printhead. The vast majority of impact print-heads are only one column wide and print the character one column at a time, with four or five columns per character. I don't think anyone making a microcomputer printer wastes the hardware to have the 35 solenoids that would be required for the device you picture. —Mike Firth, Dallas, TX.

Sorry if the illustration was misleading. It was meant only to demonstrate how various pins can be fired to generate a character in print. You are correct that most printers form each character a column at a time. —Ed.

We read with disappointment your remarks on electrosensitive printers in "How to Buy a Computer Printer." Electrosensitive paper for our Comprint 912 is not "very fragile" and

does not require handling with "utmost care to prevent wrinkling and soiling." And electrosensitive paper is not "impossible to photocopy." Finally, this paper costs about half that of plain paper and reusable ribbons. —Harlan E. Dybdahl, Computer Printers Intl., Inc., Mountain View, CA.

The drawbacks noted about electrosensitive printers, after noting their important advantages, are largely true. Your company's printer is, in part, an exception to the rule, since it uses a paper that is, indeed, not fragile and does produce good photocopies. —Ed.

ADDRESS CORRECTION

For our "Tunable FM Antenna Amp" described on page 12, September 1979, note that our correct address is Andover House, 247 N. Main St., Andover, MA 01810. —Roland M. von Sacken.

MASSAGING THE PROGRAMS

The "Simple TRS-80 Programs Solve Electronics Calculations" article (August 1979) contains a few errors. Level 1, for example, cannot differentiate between two letters as being equal unless the letters are assigned numerical values. These appear in Table 1 on lines 60, 62, 65, and 67 and in Table 2 on lines 370, 380, and 390. Corrections are as follows:

TABLE 1

10 R=1:C=2:V=3:P=4
30 P."SELECT DESIRED FUNCTION"
50 ON A G. 70, 110, 145, 180
(delete lines 60, 62, 65, and 67)

TABLE 2

1 Q=1:F=2:B=3

When running a 4K machine, one usually conserves as much memory as possible. For this reason, for example, lines 100 through 150 in Table 2 could be put on one line. —David Street, Pottstown, PA

In the Ohm's Law program, line 40 asks for a numerical input (A), but the computer tells the user to enter letter R, C, V, or P. When a letter is entered at a request for numerical information, the input variable is assigned to the value currently associated with that letter. Since R, C, V, and P are not referenced earlier in the program, A is set to approximately 1.90432E-6. The statement "IF A=R G. 70" asks if A is numerically equal to R, not if A contains the letter R. Changes should be as follows:

40 IN. "RESISTANCE=R, CURRENT=C,
";A\$
60 IF A\$="R" G. 70
62 IF A\$="C" G. 110
65 IF A\$="V" G. 145
67 IF A\$="P" G. 180

A\$ is read as A-string, where a string variable may contain a letter or a string thereof. This error is made again on lines 360 through 390. —William C. Crowder, Winnetka, IL.

Out of Tune

In "Vehicle Low-Fuel Indicator" (August 1979), in Fig. 3, component placement guide, change the labelling of Q2 to SCR1 and Q3 to Q2.

ACE 200-K with 728 solderless plug-in tie points, two 5-way binding posts. Capacity, up to eight 16-pin DIPs.

\$18.95

ACE 201-K (shown here) with 1032 solderless plug-in tie points, two 5-way binding posts. Capacity, up to twelve 14-pin DIPs.

\$24.95

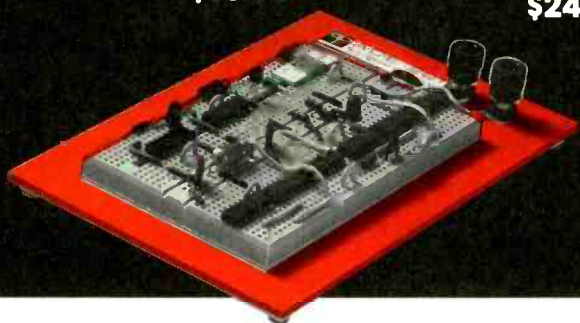

A P All-Circuit Evaluator kits give you the best...for less.

Assemble your A P "ACE" yourself (easy with our instructions) and you save money.

Then you save time—time after time—because there's no faster or easier way to prototype.

You figure out your circuit, plug it in for testing. You decide to improve your layout, and you make your moves as quickly as you think them up. It's super-fast breadboarding—with the electronic integrity you expect from A P Products. Our solderless plug-in tie points are a special noncorroding alloy. Use them over and over again. They continue to grip hard, make excellent contact.

Where to buy? Phone (toll-free) 800-321-9668 for the name of your local A P Distributor. And ask for our complete A P catalog, The Faster and Easier Book.



"Faster and Easier is what we're all about."



A P PRODUCTS INCORPORATED
1359 W. Jackson St.
Painesville, Ohio 44077
Tel. 216/354-2101
TWX: 810-425-2250

1057-192 p.—All About Telephones (\$7.95)

An Extraordinary Offer to introduce you to the benefits of Membership in

ELECTRONICS BOOK CLUB

take any **6** (up to 9 books) of these 24 unique electronics selections (values to \$111.55) for only **\$1.99** for **ALL SIX**

with a Trial Membership in the Book Club that guarantees to save you 25% to 75% on a wide selection of electronics books



Facts About Club Membership

- The 6 introductory book selections of your choice carry publisher's retail prices of up to \$111.55. They are yours for only \$1.99 for all 6 (plus postage/handling) with your Trial Membership.
- You will receive the Club News, describing the current Selections, Alternates, and other books, every 4 weeks (13x a year).
- If you want the Selection, do nothing, it will be sent to you automatically. If you do not wish to receive the Selection, or if you want to order one of the many Alternates offered, you simply give instructions on the reply form (and in the envelope) provided, and return it to us by the date specified. This date allows you at least 10 days in which to return the form. If, because of late mail delivery, you do not have 10 days to make a decision and so receive an unwanted Selection, you may return it at Club expense.
- To complete your Trial Membership, you need buy only four additional monthly Selections or Alternates during the next 12 months. You may cancel your Membership any time after you purchase these four books.
- All books—including the Introductory Offer—are fully returnable after 10 days if you're not completely satisfied.
- All books are offered at low Member prices, plus a small postage and handling charge.
- Continuing Bonus: If you continue after this Trial Membership, you will earn a Dividend Certificate for every book you purchase. Three Certificates plus payment of the nominal sum of \$1.99 will entitle you to a valuable Book Dividend of your choice which you may choose from a list provided Members.

May we send you your choice of 6 of these practical time-and-money-saving book selections as part of an unusual offer of a Trial Membership in Electronics Book Club?

Here are quality hardbound volumes, each specially designed to help you increase your know-how, earning power, and enjoyment of electronics. Whatever your interest in electronics, you'll find Electronics Book Club offers practical, quality books that you can put to immediate use and benefit.

This extraordinary offer is intended to prove to you through your own experience, that these very real advantages can be yours...that it is possible to keep up with the literature published in your areas of interest, and to save substantially while so doing. As part of your Trial Membership, you need purchase as few as four books during the coming 12 months. You would probably buy at least this many anyway, without the substantial savings offered through Club Membership.

To start your Membership on these attractive terms, simply fill out and mail the coupon today. You will receive the 6 selections (up to 9 books) of your choice for 10-day inspection. YOU NEED SEND NO MONEY. If you're not delighted, return the books within 10 days and your Trial Membership will be cancelled without cost or obligation.

ELECTRONICS BOOK CLUB, Blue Ridge Summit, Pa. 17214
CIRCLE NO. 23 ON FREE INFORMATION CARD

ELECTRONICS BOOK CLUB

Blue Ridge Summit, Pa. 17214

Please open my Trial Membership in ELECTRONICS BOOK CLUB and send me the 6 selections circled below. I understand the cost of the books I have selected is only \$1.99 for all 6, plus a small shipping charge. If not delighted, I may return the books within 10 days and owe nothing, and have my Trial Membership cancelled. I agree to purchase at least four additional books during the next 12 months, after which I may cancel my membership at any time.

604/882 637/628 678 714 730
861/905 952 1053 1085 1097 1101
1119 1123 1120 1128 1138 1152
1168 1169 1174 1176 1201 1241 6277

Name _____ Phone _____
Address _____
City _____
State _____ Zip _____

(Valid for new Members only. Foreign and Canada add 15%.) PE-180



New Products

Additional information on new products covered in this section is available from the manufacturers. Either circle the item's code number on the Free Information Card or write to the manufacturer at the address given.

Budget FM Tuner

NAD's Model 4020 is an FM tuner whose no-frills design uses a conventional dial-type station readout and eschews meters in favor of tuning and signal strength in-



dicators using LEDs. According to the unit's specs, an input of 38 dBf is sufficient to give 50-dB quieting in stereo. High-level (65 dBf) S/N is 70 dB, with channel separation of at least 32 dB, 30-15,000 Hz. Stereo THD is rated at 0.4% at 100% modulation; alternate channel selectivity is said to be 62 dB. \$175.

CIRCLE NO. 89 ON FREE INFORMATION CARD

Microtek Bidirectional Printer

Microtek's MT-80 series bidirectional impact printer features 80- and 120-column printing at a rate of 125 characters per second. It has the full 96 upper- and lower-case ASCII character set in three software-selectable fonts (5, 10, and 15 char-

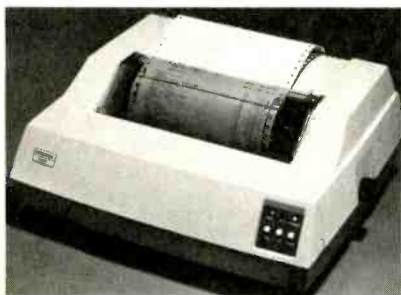

acters/inch) on original plus three copies. The 10-cpi font uses a 7 × 9 dot matrix. Microprocessor controlled, the printer contains a 240-character buffer and can accommodate up to 4K of optional data buffers in 1K increments. A comprehensive self-diagnostic program is automatically run on power up. Features pin-feed paper

handling; accepts fan-fold forms from 4.5" to 9.5" wide; up to 10 tabs; skip-over perforation capability. Size is 7.3" × 17.7" × 14.8" (185 × 450 × 375 mm). \$835 serial RS-232 version.

CIRCLE NO. 91 ON FREE INFORMATION CARD

Edmund "Heat Sleuth"

Edmund Scientific's "Heat Sleuth" is a compact electronic device that helps track down costly heated-air leaks quickly and easily. Its heat wand traces small currents of air from shrunken caulking, inef-



fective weatherstripping, cracks in siding, etc. It can also be used to check the effectiveness of refrigerator door seals, air-conditioning losses, and excessive heat accumulation around furnaces and water heaters. The solid-state Sleuth features a meter that indicates temperature variations as low as 0.2° over a 35° to 95° F range, but is most effective when used on cold and/or windy days. Operates on a standard 9-volt battery. \$39.95.

CIRCLE NO. 92 ON FREE INFORMATION CARD

Hitachi 5-inch Dual-Trace Scope

Hitachi's Model V-152 5" oscilloscope provides a dc-to-15-MHz (-3-dB) bandwidth and dual-trace operation. Among its features are a built-in sync separator for video, X-Y operation, Z-axis input for intensity modulation, a trace rotator, ×10 sweep-time magnifier, and 5" (127-mm) CRT with 8 × 10 divisions. Display modes include CH1, CH2, DUAL, ADD, and DIFF. Specifications: 5 mV to 5 V/div. ±5% sensitivity dc to 15 MHz; 0.2 μs to 0.2 s/div. ±5% sweep time in 19 steps; 100 ns/div. maximum sweep rate; 24 ns rise time; more than 4 div. at 15 MHz nondistorted maximum amplitude; 1-megohm shunted by 30 pF input impedance; dc to 500 kHz, 5 mV to 5 V/div. X-Y operation with 3° phase difference from dc to 10 kHz.

CIRCLE NO. 93 ON FREE INFORMATION CARD

CB Glass-Mounted Antenna

Astro-Fantom from Avanti is a new half-wave omnidirectional CB mobile antenna that measures only 22" (560 mm) tall and can be mounted on glass without tools in a matter of minutes. No ground plane is required nor are there any holes to drill. An

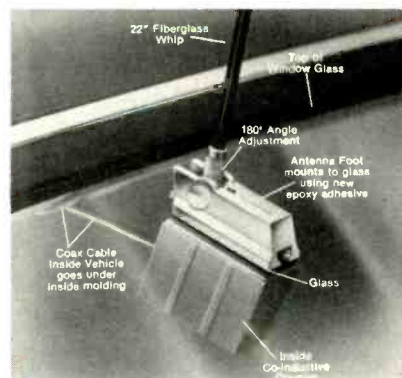

on-glass design developed by Avanti makes mounting of the antenna base on the outside of a vehicle window and the coaxial cable on the inside simple and convenient. A conductive coupler establishes a tuned circuit to transmit and receive signals directly through the glass. The antenna can be quickly removed for storage, car washing, and theft protection.

CIRCLE NO. 94 ON FREE INFORMATION CARD

Hypercardioid Microphone

Beyer Dynamic's new M-69 hypercardioid dynamic microphone is designed for live performance and recording applications. Its frequency response, rated at 50 to 16,000 Hz, is said to be almost ruler flat



above 150 Hz, with a smooth rolloff that eliminates rumble without excessive loss of low bass. In addition, its sharp directionality suppresses feedback and audience noise. With a rated output of -51 dBm and 200-ohm impedance, the M-69 is said to minimize noise problems of preamp input stages and tolerate well the long cable runs often necessary in live recording. The mic is supplied with a standard Cannon-type 3-pin connector. \$150.

CIRCLE NO. 95 ON FREE INFORMATION CARD

Electronic Ruler Computer

Chafitz, Inc., has announced that it will be the exclusive distributor of an advanced

NEW PRODUCTS

The Protectors

The two products shown below are the latest in Space-Age Electronic Home Security. Do you know which one is right for you?

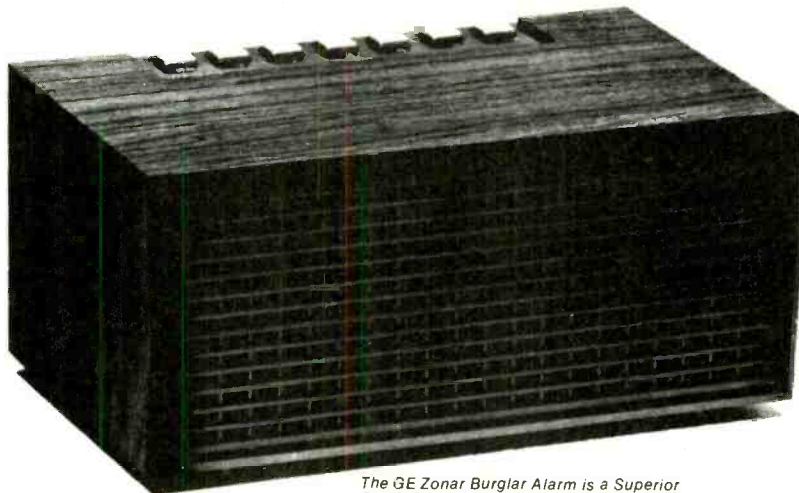

The GE Zonar Burglar Alarm is a Superior Fail-Safe unit that has an invisible ultrasonic beam to detect intruders.



The Micro FM Wireless Mike has a range of over 300 ft. and transmits through any standard FM Radio.

The two new products shown in this ad are the latest in space-age electronics. The Zonar Burglar Alarm compares with similar burglar alarms selling for \$200 or more. The Micro FM Wireless Mike, the worlds smallest wireless microphone, represents new technology in the field of FM Radio-Electronics.

We bought both of these products from the manufacturers and tested them under every possible condition. The following are the results of our experiments with both the Zonar Burglar Alarm and the Micro FM Wireless Mike. Please read on. The results may surprise you!

THE GE ZONAR BURGLAR ALARM

The new GE Zonar Burglar Alarm sounds a loud (85db) alarm — so loud that it can cause pain — and scare away intruders that cross the invisible ultrasonic beam.

The Zonar Burglar Alarm requires no installation and it is portable, so you can place it anywhere in your home. Operating the Zonar is as easy as turning on your television. To arm the unit, you simply press the On Instant or On Delay button. You now have 35 seconds to leave your home. When you return, you enter and you have 10 seconds to press in your secret code numbers. This will disarm your unit. The personalized code numbers for alarm shut-off means that only you or your family knows the code to disarm the alarm.

The Zonar Burglar Alarm looks like a handsome piece of furniture and its small unobtrusive design helps to make it less noticeable. It measures only 7" X 4" X 3" and weighs less than two pounds. To help protect your home or office, it comes with warning decals for windows or doors that state, "WARNING Protected by Electronic Surveillance Equipment", to help deter potential burglars.

The GE Zonar Burglar Alarm is battery operated, so even if a burglar cuts off your power, the unit will still be operational to alert you and your neighbors.

The GE Zonar Burglar Alarm comes with

complete instructions and a One-Year limited warranty backed by General Electric. Should your unit ever malfunction, you may drop it off at any authorized General Electric Dealer or you may use GE's convenient service-by-mail center.

To order your unit for a 30-day test, simply send your check for \$69.95 plus \$2.50 postage and handling to Chandler's, One Chandler Plaza, Chantilly, Virginia 22021 (Virginia residents please add 4% sales tax.) Credit Card Buyers may call our 24-hour Toll-Free number below.

THE MICRO FM WIRELESS MIKE

The micro FM Wireless Mike is a miniature microphone that picks up your voice and transmits it through any standard FM radio.

The new Micro FM Wireless Mike measures only 1½" X ½" and weighs less than one ounce. We found that the superior electronic components put into the microphone surpass anything else on the market. It has a transmitting range of over 300 feet (the length of a football field) and its exceptional fidelity gives you clear reception with practically no interference. Unlike citizen band radios, which operate in the 27 to 29 Megahertz range, the Micro FM Wireless Mike uses the 88 to 108 Megahertz range, giving you the freedom to operate from your car radio, portable radio or home stereo.

BUT WAIT. THERE'S MUCH MORE. The Micro FM Wireless Mike is capable of more than just being a remote mike. It can be used as an intercom in both your home and office. For example, if you are in the garage and your wife or children are in the upstairs bedroom, you can turn on the mike and use it just like an intercom. Secondly, it is small and can be clipped to your jacket while in meetings or during a speech in your conference room or office. The Micro FM Wireless Mike is FCC approved for use in homes, apartments, offices or factories.

Finally, it's inexpensive — only \$29.95 complete with 27" flexible antenna, carrying case, operating instructions and a fresh 1.3 volt

mercury battery (which can be replaced at any hearing aid or radio-electronics store).

Your Micro Mike comes with a 90 day limited warranty backed by two substantial companies. Should a malfunction ever occur, there's a complete service-by-mail center as close as your postman.

The Micro FM Wireless Mike can be ordered by calling our 24-hour toll-free number below or by sending your check for \$29.95 for one or \$58.00 for two. Please add \$1.25 each for postage and handling and Virginia residents add 4% sales tax.

OUR OPINION

We are convinced that both of these new products are superior in value and quality.

The Micro FM Wireless Mike and the GE Zonar Burglar Alarm are backed by two substantial American companies. MLI Industries and General Electric both have years of experience in manufacturing and design leadership. Chandler's is one of America's innovative companies specializing in bringing the American public new and unique products — additional assurance that your prudent investment is well secured.

With any Chandler's product, you may return it within 30 days for a full, courteous and prompt refund with positively no questions asked and we even refund our postage and handling charge. There's no risk when you can own the best. Order one or both of our remarkable new products, at no obligation today.

Chandler's

Innovative Products

Dept. PE One Chandler Plaza, Box 137
Chantilly, Virginia 22021 (703) 631-2024

CALL TOLL-FREE... 800-638-1287
In Maryland Call... 800-492-1275

ASK FOR OPERATOR #109F

Chandler's, Inc., 1979



Advance Dual Time Alarm Chronograph

With new 9.5 mm thin styling, 24 hour alarm, full 24 hour precision stopwatch, and much, much more.

Featuring:

- Famous Quartz Accuracy to ± 5 sec/mo
- Built-in Electronic Calendar
- Dual Time Zones
- Day of the Week Indicator
- Continuously Shown Liquid Crystal Display
- AM PM Indicator
- Easily Adjusted "Snap" Bracelet
- Night Light For Evening Viewing

Thinnest Dual Time Alarm Chronograph Available For Under \$100

\$39.95

Quartz quality, new ultra-thin design and fantastic features are the best words to describe this exciting new chronograph. The thin design of case and bracelet is a perfect match for the multitude of uses that make this world timer the best watch value on the market today anywhere.

See what you get for only \$39.95

- **24 Hour Alarm**—Pleasant but effective alarm can be preset for any minute of the day or night. Constantly read indicator lets you know when the alarm is set
- **Snooze Feature**—At the push of a button you can snooze for 5 more minutes before the alarm resounds
- **Dual Time**—Set this world timer for your home time and the time of any other city in the world at the touch of a button. An easily read indicator lets you know which time you're viewing. Shows hour, minute, and running seconds in both time zones.



24 hours, 59 min., 59.9 sec

- **Full 24 Hour Chronograph**—With $\frac{1}{10}$ sec. precision, add time and lap time. Add time lets you time everything from a telephone call to a trip—up to 24 full hours. Lap time lets you time each component within an event



Continuously Shows:

- Hours, minutes, seconds
- Day of the week indicator
- AM PM indicator
- Alarm indicator



- **Month And Date** at the push of a button

Tuesday, December 25

- **COMPARE THINNESS**—Thinnest Dual Time Alarm Chronograph available for this low price

Seiko	\$250	10.5mm
Citizen	\$255	11.0mm
Texas Instruments	\$125	12.0mm
Advance Dual Time	\$ 39.95	9.5mm

- **Handsome Styling**—Crated, quality stainless steel back and bracelet. Optional goldtone model now available with 3 micron quality gold plating at \$44.95

- **Unconditionally Guaranteed**—For one full year against defective parts and workmanship. 15 day return option if not completely satisfied. Return for prompt refund

Easy To Order. Just call our toll free number below or fill in the convenient order form. Comes in attractive gift box. Order yours today!

MEDIA MARKETING, INC.

10155-9 Plano Road, Dallas, TX 75238

Yes! Please send me _____ Dual Time Alarm Chronograph(s) with unconditional guarantee at \$39.95, plus \$2.50 postage, insurance and handling. Texas residents add 5% sales tax.

Silvertone Goldtone \$44.95

Name _____

Address _____

City _____

State _____ Zip _____

Check or money order enclosed

For even faster service, charge to:

Master Charge/Visa Expires _____

Account # _____

Signature _____

ORDER TOLL FREE 1-800-527-7066

In Texas Call 1-214-349-3120

PE-1 ©MMI 1979

NEW PRODUCTS *continued*

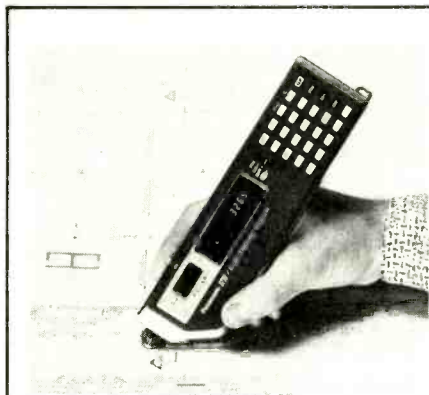

Ruler/Computer developed by Panasonic Co. The "Ruler That Thinks" employs a small displacement measuring wheel to directly measure lengths, distances, areas, volumes, etc., in linear, square, or cubic units in any scale from any document. A multifunction calculator is integrated into the ruler to permit measured data to be used automatically in computations. Intermediate measurements can be stored in the calculator's memory. The computer displays values directly in millimeters, centimeters, or meters and converts to either inches or feet simply by pressing a function key. Additional features include addressable memory; metric and area conversion; percent, add-on, and discount computation; square-root and pi keys; floating decimal arithmetic; mixed calculations; etc. \$99.95.

CIRCLE NO. 96 ON FREE INFORMATION CARD

AR Vertical Speaker System

The Model AR92 occupies the economy end of Acoustic Research's line of vertical speaker systems. The three-way, floor-standing system features a specially designed 10" (254-mm) acoustic-suspension woofer, 1 1/2" (38-mm) liquid-cooled dome



midrange semihorn driver, and 3/4" (19-mm) liquid-cooled dome tweeter. Crossovers are at 700 Hz and 7.5 kHz, and system response is down 3 dB at 44 Hz. Three-position switches provide level control for the midrange driver and tweeter. System impedance is nominally 4 ohms (3.2 ohms minimum), and sensitivity is 87 dB SPL (on-axis at 1 meter) when driven by 1 watt of power. Dimensions are 31 3/8" X 14" X 11 7/16" D (797 X 356 X 291 mm). \$300.

CIRCLE NO. 97 ON FREE INFORMATION CARD

Heath Microprocessor Trainer Accessory

Now you can upgrade Heathkit's Model ET-3400 microprocessor trainer to full personal-computer status with the ETA-3400 accessory. Providing 1K of additional



RAM (up to 4K optionally), the accessory features a new monitor in ROM, tiny-BASIC interpreter in ROM, an audio cassette interface, and a serial interface for a video terminal. Connects to the trainer with a 40-conductor ribbon cable (supplied). \$150 kit; \$47 for optional 3K RAM chip set.

CIRCLE NO. 90 ON FREE INFORMATION CARD

Head-Maintenance Kit

Designed to fit easily into a standard compact cassette box, which in turn will fit into any cassette storage cabinet, the TDK HC-05 head-maintenance kit contains a



selection of items necessary for proper care of tape heads. Included are a non-toxic head-cleaning fluid, a mirror, a brush, felt probes, and a probe applicator. \$5.99.

CIRCLE NO. 98 ON FREE INFORMATION CARD

Microcomputer Intrusion Alarm

The MassaSonic Ultrasonic Intrusion Alarm uses a microcomputer system said to distinguish real targets from moving air and thus eliminate false alarms. The unit plugs into any normal ac outlet and is rat-

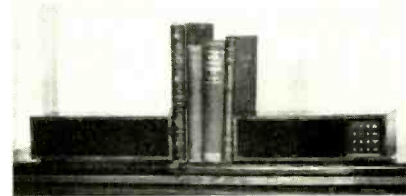

Start Computing For Just \$129.95 With An
8085-Based Professional Computer Kit—

Explorer/85

100% compatible with all 8080A and
8085 software & development tools!

No matter what your future computing plans may be, Level "A"—at \$129.95—is your starting point.

Starting at just \$129.95 for a Level "A" operating system, you can now build the exact computer you want. Explorer/85 can be your beginner's system, OEM controller, or IBM-formatted 8" disk small business system...yet you're never forced to spend a penny for a component or feature you don't want and you can expand in small, affordable steps!

Now, for just \$129.95, you can own the first level of a fully expandable computer with professional capabilities—a computer which features the advanced Intel 8085 cpu, thereby giving you immediate access to all software and development tools that exist for both the 8085 and its 8080A predecessor (they are 100% software compatible)—a computer which features onboard S-100 bus expansion—plus instant conversion to mass storage disk memory with either 5-1/4" diskettes or standard IBM-formatted 8" disks.

For just \$129.95 (plus the cost of a power supply, keyboard/terminal and RF modulator, if you don't have them already), Explorer/85 lets you begin computing on a significant level...applying the principles discussed in leading computer magazines...developing "state of the art" computer solutions for both the industrial and leisure environment.

Level "A" Specifications

Explorer/85's Level "A" system features the advanced Intel 8085 cpu, an 8355 ROM with 2k deluxe monitor/operating system, and an 8155 ROM-1/O—all on a single motherboard with room for RAM/ROM/PROM/EPROM and S-100 expansion, plus generous prototyping space.

(Level "A" makes a perfect OEM controller for industrial applications and is available in a special Hex Version which can be programmed using the Netronics Hex Keypad/Display.)

PC Board: glass epoxy, plated through holes with solder mask
• I/O: provisions for 25-pin (DB25) connector for terminal serial I/O, which can also support a paper tape reader...provision for 24-pin DIP socket for hex keypad/display...cassette tape recorder input...cassette tape recorder output...speaker output...LED output indicator on SOD (serial output) line...printer interface (less drivers)...total of four 8-bit bus one 6-bit I/O ports • Crystal Frequency: 6.144 MHz • Control Switches: reset and user (RST 7.5) interrupt...additional provisions for RST 5.5, 6.5 and TRAP interrupts onboard • Counter/Timer: programmable, 14-bit binary • System RAM: 256 bytes located at F800, ideal for smaller systems and for use as an isolated stack area in expanded systems...RAM expandable to 64k via S-100 bus or 4K on motherboard.

System Monitor (Terminal Version): 2k bytes of deluxe system monitor ROM located at F800 leaving 0000 free for user RAM/ROM. Features include tape load with labeling...tape dump with labeling...examine/change contents of memory...insert data...warm start...examine and change all registers...single step with register display at each break point, a debugging/training feature...go to execution address...move blocks of memory from one location to another...fill blocks of memory with a constant...display blocks of memory...automatic baud rate selection...variable display line length control (1-255 characters/line)...channelized I/O monitor routine with 8-bit parallel output for high speed printer...serial console in and console out channel so that monitor can communicate with I/O ports.

System Monitor (Hex Version): Tape load with labeling...tape dump with labeling...examine/change contents of memory...insert data...warm start...examine and change all

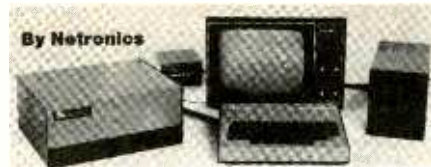

registers...single step with register display at each break point...go to execution address. Level "A" in the Hex Version makes a perfect controller for industrial applications and can be programmed using the Netronics Hex Keypad/Display.



Hex Keypad/Display.

Level "B" Specifications

Level "B" provides the S-100 signals plus buffers/drivers to support up to six S-100 bus boards and includes: address decoding for onboard 4k RAM expansion select-able in 4k blocks...address decoding for onboard 8k EPROM expansion select-able in 8k blocks...address and data bus drivers for onboard expansion...wait state generator (jumper select-able), to allow the use of slower memories...two separate 5 volt regulators.

Level "C" Specifications

Level "C" expands Explorer's motherboard with a card cage, allowing you to plug up to six S-100 cards directly into the motherboard. Both cage and cards are neatly contained inside Explorer's deluxe steel cabinet.

Level "C" includes a sheet metal superstructure, a 5-card gold plated S-100 extension PC board which plugs into the motherboard. Just add required number of S-100 connectors

Level "D" Specifications

Level "D" provides 4k or RAM, power supply regulation, filtering decoupling components and sockets to expand your Explorer/85 memory to 4k (plus the original 256 bytes located in the 8155A). The static RAM can be located anywhere from 0000 to 0FFF in 4k blocks.

Level "E" Specifications

Level "E" adds sockets for 8k of EPROM to use the popular Intel 2716 or the TI 2516. It includes all sockets, power supply regulator, heat sink, filtering and decoupling components. Sockets may also be used for soon to be available RAM IC's (allowing for up to 12k of onboard RAM).

Order A Coordinated Explorer/85 Applications Pak!

Experimenter's Pak (SAVE \$12.50)—Buy Level "A" and Hex Keypad/Display for \$199.90 and get FREE Intel 8085 user's manual plus FREE postage & handling!

Student Pak (SAVE \$24.45)—Buy Level "A," ASCII Keyboard/Computer Terminal, and Power Supply for \$319.85 and get FREE RF Modulator plus FREE Intel 8085 user's manual plus FREE postage & handling!

Engineering Pak (SAVE \$41.00)—Buy Levels "A," "B," "C," "D," and "E" with Power Supply, ASCII Keyboard/Computer Terminal, and six S-100 Bus Connectors for \$514.75 and get 10 FREE computer grade cassette tapes plus FREE 8085 user's manual plus FREE postage & handling!

Business Pak (SAVE \$89.95)—Buy Explorer/85 Levels "A," "B," and "C" (with cabinet), Power Supply, ASCII Keyboard/Computer Terminal (with cabinet), 16k RAM, 12" Video Monitor, North Star 5-1/4" Disk Drive (includes North Star BASIC) with power supply and cabinet, all for just \$1599.40 and get 10 FREE 5-1/4" minidiskettes (\$49.95 value) plus FREE 8085 user's manual plus FREE postage & handling!

Continental U.S.A. Credit Card Buyers Outside Connecticut

CALL TOLL FREE 800-243-7428

To Order From Connecticut Or For Technical Assistance, Etc. Call (203) 354-9375

Netronics R&D Ltd., Dept. PE-1
333 Litchfield Road, New Milford, 06776

Please send the items checked below—

- Explorer/85 Level "A" Kit (ASCII Version), \$129.95 plus \$3 p&h.
- Explorer/85 Level "A" Kit (Hex Version), \$129.95 plus \$3 p&h.
- 8k Microsoft BASIC on cassette tape, \$64.95 postpaid.
- 8k Microsoft BASIC in ROM Kit (requires Levels "B," "D," and "E"), \$99.95 plus \$2 p&h.
- Level "B" (S-100) Kit, \$49.95 plus \$2 p&h.
- Level "C" (S-100 6-card expander) Kit, \$39.95 plus \$2 p&h.
- Level "D" (4k RAM) Kit, \$69.95 plus \$2 p&h.
- Level "E" (EPROM/ROM) Kit, \$5.95 plus \$06 p&h.
- Deluxe Steel Cabinet for Explorer/85, \$49.95 plus \$3 p&h.
- ASCII Keyboard/Computer Terminal Kit (features a full 128 character set, upper & lower case, full cursor control, 75 ohm video output convertible to baudot output, selectable baud rate, RS232-C or 20 ma, 1/O, 32 or 64 character by 16 line formats, and can be used with either a CRT monitor or a TV set (if you have an RF modulator), \$149.95 plus \$2.50 p&h.
- Hex Keypad/Display Kit, \$69.95 plus \$2 p&h.
- Deluxe Steel Cabinet for ASCII Keyboard/Terminal, \$19.95 plus \$2.50 p&h.
- Power Supply Kit (± 8V @ 5 amps) in deluxe steel cabinet, \$39.95 plus \$2 p&h.
- Gold Plated S-100 Bus Connectors, \$4.85 each, postpaid.
- RF Modulator Kit (allows you to use your TV set as a monitor), \$8.95 postpaid.
- 16k RAM Kit (S-100 Board expands to 64k), \$199.95 plus \$2 p&h.
- 32k RAM Kit, \$329.95 plus \$2 p&h.
- 48k RAM Kit, \$459.95 plus \$2 p&h.
- 64k RAM Kit, \$589.95 plus \$2 p&h.
- 16k RAM Expansion Kit (to expand any of the above up to 64k), \$139.95 plus \$2 p&h each.
- Intel 8085 cpu User's Manual, \$7.50 postpaid.
- Special Computer Grade Cassette Tapes, \$1.90 each or 3 for \$5, postpaid.
- 12" Video Monitor (10 MHz bandwidth), \$139.95 plus \$5 p&h.
- North Star Double Density Floppy Disk Kit (One Drive) for Explorer/85 (includes 3 drive S-100 controller, DOS, and extended BASIC with personalized disk operating system—just plug it in and you're up and running!), \$699.95 plus \$5 p&h.
- Power Supply Kit for North Star Disk Drive, \$39.95 plus \$2 p&h.
- Deluxe Case for North Star Disk Drive, \$39.95 plus \$2 p&h.
- Experimenter's Pak (see above), \$199.90 postpaid.
- Student Pak (see above), \$319.85 postpaid.
- Engineering Pak (see above), \$514.75 postpaid.
- Business Pak (see above), \$1599.40 postpaid.

sonalized disk operating system—just plug it in and you're up and running!)

Total Enclosed \$
(Conn. res. add sales tax) By—
 Personal Check M.O./Cashier's Check Visa Master Charge
(Bank # _____)

Acct # _____
Signature _____ Exp. Date _____
Print Name _____
Address _____
City _____
State _____ Zip _____
 Send Me Information

By Netronics

ASCII/BAUDOT,
STAND ALONE



Computer Terminal COMPLETE FOR ONLY \$149.95

The Netronics ASCII/BAUDOT Computer Terminal Kit is a microprocessor-controlled, stand alone keyboard/terminal requiring no computer memory or software. It allows the use of either a 64 or 32 character by 16 line professional display format with selectable baud rate, RS232-C or 20 ma. output, full cursor control and 75 ohm composite video output.

The keyboard follows the standard typewriter configuration and generates the entire 128 character ASCII upper/lower case set with 96 printable characters. Features include onboard regulators, selectable parity, shift lock key, alpha lock jumper, a drive capability of one TTY load, and the ability to mate directly with almost any computer, including the new Explorer/85 and ELF products by Netronics.

The Computer Terminal requires no I/O mapping and includes 1k of memory, character generator, 2 key rollover, processor controlled cursor control, parallel ASCII/BAUDOT to serial conversion and serial to video processing—fully crystal controlled for superb accuracy. PC boards are the highest quality glass epoxy for the ultimate in reliability and long life.

VIDEO DISPLAY SPECIFICATIONS

The heart of the Netronics Computer Terminal is the microprocessor-controlled Netronics Video Display Board (VID) which allows the terminal to utilize either a parallel ASCII or BAUDOT signal source. The VID converts the parallel data to serial data which is then formatted to either RS232-C or 20 ma. current loop output, which can be connected to the serial I/O on your computer or other interface, i.e., Modem.

When connected to a computer, the computer must echo the character received. This data is received by the VID which processes the information, converting to data to video suitable to be displayed on a TV set (using an RF modulator) or on a video monitor. The VID generates the cursor, horizontal and vertical sync pulses and performs the housekeeping relative to which character and where it is to be displayed on the screen.

Video Output: 1.5 P/P into 75 ohm (EIA RS-170) • **Baud Rate:** 110 and 300 ASCII • **Outputs:** RS232-C or 20 ma. current loop • **ASCII Character Set:** 128 printable characters—



BAUDOT Character Set: A B C D E F G H I J K L M N O P Q R S T U V W X Y Z . ? : * 3 \$ # ! . . 9 0 1 4 5 7 : 2 / 6 8 •
Cursor Modes: Home, Backspace, Horizontal Tab, Line Feed, Vertical Tab, Carriage Return. Two special cursor sequences are provided for absolute and relative X-Y cursor addressing •
Cursor Control: Erase, End of Line, Erase of Screen, Form Feed, Delete •
Monitor Operation: 50 or 60Hz (jumper selectable).

Continental U.S.A. Credit Card Buyers Outside Connecticut

CALL TOLL FREE 800-243-7428

To Order From Connecticut Or For Technical Assistance, Etc. Call (203) 354-9375

Netronics R&D Ltd., Dept. PE-1

333 Litchfield Road, New Milford, CT 06776

Please send the items checked below—

- Netronics Stand Alone ASCII Keyboard/Computer Terminal Kit, \$149.95 plus \$3.00 postage & handling.
 - Deluxe Steel Cabinet for Netronics Keyboard/Terminal In Blue/Black Finish, \$19.95 plus \$2.50 postage and handling.
 - Video Display Board Kit alone (less keyboard), \$89.95 plus \$3 postage & handling.
 - 12" Video Monitor (10 MHz bandwidth) fully assembled and tested, \$139.95 plus \$5 postage and handling.
 - RF Modulator Kit (to use your TV set for a monitor), \$8.95 postpaid.
 - 5 amp Power Supply Kit In Deluxe Steel Cabinet (± 8VDC @ 5 amps, plus 6-8 VAC), \$39.95 plus \$2 postage & handling.
- Total Enclosed (Conn. res. add sales tax) \$
By—
 Personal Check Cashiers Check/Money Order
 Visa Master Charge (Bank # _____)
- Acct # _____
Signature _____ Exp. Date _____
Print Name _____
Address _____
City _____
State _____ Zip _____
 Send Me More Information

CIRCLE NO. 38 ON FREE INFORMATION CARD

In recent years over 500,000 music lovers chose a Realistic[®] receiver over Kenwood[®], Pioneer[®] and Technics[®] ...



Why?

We make it easy for you. Radio Shack is a retailer as well as a manufacturer. When the store is also the factory, you're apt to get less fiction and more fact. Also, Radio Shack has more company-owned and operated service stations than almost anyone we know of in the audio business (54 to be specific).

We've stood the test of time. Could it be we sell so much Realistic because we've been around since 1921 — long before those other brands were even a twinkle in daddy's eye? Although hi-fi is typically a younger person's product, maybe the kids prefer to bet their hard-earned bucks on the outfit with the grayest hair.

We have the edge on technology. Then there's this to consider: The same company that puts Realistic out front also builds and markets the world's most popular personal computer, the TRS-80.[™] It seems to us that a company smart enough to design

equipment as innovative and complex as a computer is a logical one to choose to build your stereo receiver!

We're close to you. Need another good reason to buy Realistic? Let's take availability. Instead of tens or hundreds of places to find it, we offer over 7,300 — wherever you go in the USA or Canada — and a surprising number of overseas locations as well. Being more available doesn't necessarily make us more lovable. But it goes a long way towards assuring you of being able to get in touch with us when you need advice on adding a tape deck or replacing a lost instruction manual.

We've challenged the rest and won your trust. Incidentally, we're not picking on Kenwood, Pioneer and Technics. The same half-million-plus folks who chose Realistic also probably had a crack at buying Sansui,[®] Marantz[®] and Fisher.[®] The important thing is ... they didn't!

Radio Shack[®]

A DIVISION OF TANDY CORPORATION
FORT WORTH, TEXAS 76102

The Nationwide Supermarket of Sound[®]

ed at 120° of coverage in any room up to 1,000 sq. ft. Control is via a touch key-board through which one of more than 1700 three-digit codes can be entered to disarm the unit. When tripped, the system sounds a siren rated at 105 dB SPL at 1 ft for four minutes and rearms automatically. An optional battery/siren unit provides up to 48 hours of continuous emergency power. \$270. Address: Massa Products Corp., 280 Lincoln St., Hingham, MA 02043.

Motorola All-Electronic Car Radio

Motorola's in-dash Model 830SX AM/FM-stereo radio with cassette player has electronic station scan and search, 5-station memory for each band, Dolby noise



reduction, a mute switch, and a CrO₂ tape switch. Station frequencies and time are displayed with numeric LEDs. The radio produces up to 20 watts rms power at 1%

THD (DIA method). The muting switch operates on both AM and FM, and the Dolby system can be used on both FM and tape. Other controls include front-to-rear fader, left-right balance, bass and treble, and a loudness contour switch. The cassette deck features automatic tape reversing, locking fast forward and rewind, tape-direction indicator, and automatic eject when radio or ignition is turned off. Specifications: 65-dB FM selectivity at 400 kHz; 62-dB S/N at 100 microvolts; 0.105% max wow and flutter; 40-dB separation. \$450.

CIRCLE NO. 99 ON FREE INFORMATION CARD

Stereohedron Pickup

Newly added to the line of Pickering cartridges using the Stereohedron stylus geometry is the XSV-4000, designed for tracking ability equal to the demands of direct-to-disc and digitally mastered records. Equipped, like other Pickering cartridges, with a brush said to provide low-frequency damping and also remove dust from the record grooves, the new model operates with an effective stylus force of 1 gram ± 0.25 gram. Output is rated at 0.7 mV/cm/s ± 2 dB, with frequency

response reported to extend from 10 to 36,000 Hz. Designed to work into a load of 47 kilohms in parallel with 275 pF, the pickup has a rated separation of 35dB at 1 kHz. Styli for monophonic LPs and 78-rpm discs are available at extra cost. \$160.

CIRCLE NO. 100 ON FREE INFORMATION CARD

Transtronics Continuity Checker

The "Electronic Workmate" is a new lead-less continuity checker from Transtronics. It needs no hookup leads because the cir-



cuit is completed through the hands and body of the user. It can be used to troubleshoot circuits and components, trace wiring, and simplify cable and harness assembly. \$15.95. Transtronics Co., 13101 N.E. Hwy. 99, Vancouver, WA 98665.

This chip changed your life.

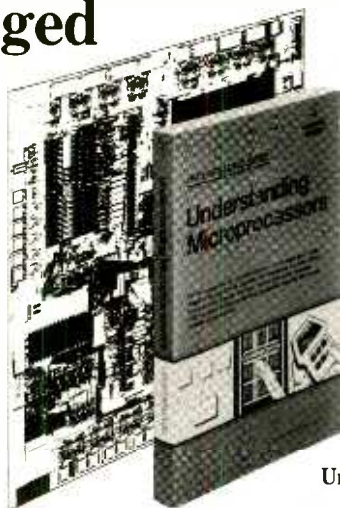

This book tells you how. And why.

Understanding Microprocessors.
From the Texas Instruments
Learning Center. 288 pages. \$4.95.

Learn quickly and easily about the explosive impact microprocessors have had on electronics technology.

How the "miracle chip" works to make those things you use everyday — calculators, appliances, microwave ovens, stereos, tv, automobiles — even toys and games — do the remarkable things they do.

Understanding Microprocessors is the latest addition to the Texas Instruments Understanding Series™.

All TI Understanding Series books are ideal for those who want to learn about today's technology — without having to devote years to the study.

Written in bright, clear, down-to-earth language, and fully illustrated, you'll find these books to be invaluable tools for your personal entry into the microelectronics revolution. See coupon for all details.



- LCW8161 **Basic Electricity and DC Circuits** \$19.95
1026 pages. Building blocks for a thorough working knowledge of DC circuits.
- LCB3361 **Understanding Solid-State Electronics** \$3.95
270 pages — New 3rd edition. Individualized approach for learning microelectronic basics.
- LCB3311 **Understanding Digital Electronics** \$3.95
265 pages. The springboard for a look into the fascinating world of today's electronic logic devices, circuits and systems.
- LCB4023 **Understanding Microprocessors** \$4.95
288 pages. For the newcomer to microprocessors. What they are, what they do and how they work.
- LCB3321 **Understanding Calculator Math** \$3.95
224 pages. Unlocks the real power of your handheld calculator — loaded with practical applications.

Add sales tax, except AK, DE, MT, NH, OR.

Mail check or money order to Texas Instruments, P.O. Box 3640, M/S 84, Dallas, Texas 75285.

Orders in Continental U.S. shipped prepaid. Foreign orders: Prepaid in U.S. dollars only. Include shipping costs.

Prices subject to change without notice. PEL180

Name _____

Address _____

City _____ State _____ Zip _____

TEXAS INSTRUMENTS
INCORPORATED



New Literature

VIDEO EQUIPMENT REFERENCE BOOK

In addition to information on major video equipment brands (Sony, JVC, Panasonic, etc.), a new 64-page catalog from Adwar has listings and rates of video equipment rentals, film-to-tape transfer and duplication, and modifications for video cameras, recorders, and monitors. Several new modifications applicable to the up-grading of home videocassette equipment are given. Address: Adwar Video Corp., 100 Fifth Ave., New York, NY 10011.

PC BOARD GRAPHICS BULLETIN

A new electronic circuit packaging, repair, and prototyping system called Quik-Circuit™ from Bishop Graphics is described in Technical Bulletin No. QC-102. The Quik-Circuit system is for use in building printed circuit boards and prototypes quickly and making on-the-spot pc board repairs. It uses pressure-sensitive copper component mounting configurations, donut pads, tape and copper sheets and is particularly intended for low-voltage applica-

tions such as TTL, ECL, and CMOS. Address: Bishop Graphics, Inc., 5388 Sterling Center Dr., Box 5007, Westlake Village, CA 91359.

RELAY SPECIALTIES CATALOG

The most recent segment of a planned four-volume master source book of relays, timers, and other control components, is a 144-page catalog illustrating and describing relays of approximately 20 U.S. manufacturers, stocked by Relay Specialties. Manufacturers include Potter-Brumfield, Struthers-Dunn, C.P. Clare, and others. Address: Relay Specialties, Inc., 13-00 Plaza Rd., Fair Lawn, NJ 07410.

OSBORNE MICROCOMPUTER BOOKS

A brochure from Osborne & Assoc. lists new additions to its catalog of books on microcomputers, as well as software material and consulting and design services available. Also included is information on upcoming publications such as handbooks for 8086 and PET users. Programs in BASIC for the PET computer are available on cassette. Address: Osborne/McGraw-Hill Inc., 630 Bancroft Way, Berkeley, CA 94710.

KEYBOARD CATALOG AND APPLICATION GUIDE

A 36-page catalog (No. KB79-1) describes the Cherry line of both hard-contact (gold crosspoint) and solid-state (capacitive) keyboards as well as switches, and keycaps. A five-page introductory

section gives step-by-step procedures for solving keyboard problems with any type of board. Particular details are given on the new solid-state keyboards. Address: Cherry Electrical Products Corp., 3600 Sunset Ave., Waukegan, IL 60085.

CONCEALED MOBILE ANTENNA BROCHURE

Antenna Specialists' new six-page brochure (SD-726) features its ASP-1000 "no-profile" totally concealed uhf antenna. It also contains information and specs on the complete line of high- and low-band vhf and uhf professional disguise antennas, including universal and replacement models. Address: The Antenna Specialists Co., 12435 Euclid Ave., Cleveland, OH 44106.

SEMICONDUCTOR CROSS-REFERENCE

The new Workman Semiconductor Catalog and Cross Reference (X79) contains over 150,000 WEP references to numbers of similar units from other sources. Specifications and outlines are given. Address: Workman Electronic Products, Inc., Box 3828, Sarasota, FL 33578.

DIP HANDLING SYSTEMS

A new 20-page catalog covers DIP insertion, extraction and handling systems and special tools—all for use with MOS ICs. Special items include a Mini Drill series, a plated-through hole inspection prism, "Heat-a-Dip" stations, etc. Address: Micro Electronic Systems Inc., 159 Main St., Danbury, CT 06810.

Don't settle for less. Get the best from Vector!

SLIT WRAP™

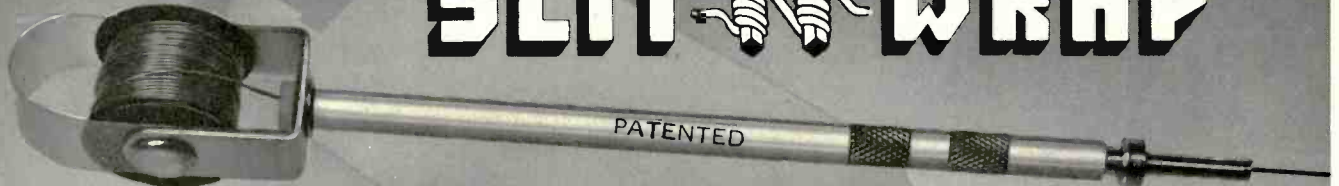

Check the facts:

✓ Vector tools slit insulation over full wrapped length of post—*competitive tool wedges wire against post corner, a less reliable way.*

✓ Daisy-chain wiring  reduces number of wraps needed.

✓ Vector tool passes MIL-STD-1130A, wrap spec. par. 5.6. *No such claims made for competitor tool.*

✓ Rugged 28 AWG Tefzel silver plated wire or compact polyurethane wire.

✓ Fast wrapping! 3 X faster than conventional manual wrap tools. Wraps on .1" spaced pins.

✓ **MOTORIZED** and **MANUAL TOOLS** by Vector—*manual only by competitor.*

Cross section cut on diagonal at bottom unwrap wire at top.



 P184-4T with NiCad batteries, recharger, \$105.

 P184-4T1 110 volt AC model, \$105.

 P184 manual model, \$30.

YOU CAN DEPEND ON VECTOR TOOLS—the result of thousands of hours of intensive development

Vector Electronic Company
INCORPORATED

12460 Gladstone Av., Sylmar, CA 91342; phone 213-365-9661, twx 910-496-1539

690679

CIRCLE NO. 55 ON FREE INFORMATION CARD

POPULAR ELECTRONICS

BEST BUY

TOP QUALITY AND POWER COMBINE
TO GIVE YOU THE FIRST AIR FRESHENING/
IONIZING SYSTEM THAT EVEN SAVES YOU MONEY



SYSTEM FIVE

The Air Energizer shown above is the least expensive negative ion generator on the market, selling for only \$74.95. That's \$5 cheaper than our nearest competitor. It is also the best. If you are comparing units you need to know the facts. With the UTP Air Energizer you even get *more* for your \$5 *less*. We can charge less and give you a higher quality unit because we are a common ownership company. And we are in business to serve you and your environmental needs. Our major competitor is a mail order house that promotes dozens of products every year, but the UTP Ion Research Center is a branch of an educational publishing company. For the past several years we have researched and developed one special electronic product: negative ion generators. This specialization enables us to be the industry's frontrunners. And the System Five Air Energizer is our latest breakthrough in Air Ionization.

WHAT DO IONS DO FOR YOU?

Frankly, as marketing director I was pretty skeptical of our Ion Research team's work until one day two years ago when I was walking to work. The season's first thunderstorm had just ended. The air was sparkling clean and almost magically alive. I took a deep breath. The new energy in the fresh air made my head tingle. But as I walked into the office building where I work I immediately felt a drop in energy. The air was dull and lifeless—"stuffy feeling".

Was I experiencing what our Ion Researchers had been telling me all along for the last four years? I decided to test it. I put a UTP Air Energizer on my desk. Skepticism gave way to enthusiasm. I felt great. I still have that unit on my desk.

WHAT MADE THE DIFFERENCE

Have you ever wondered what makes this kind of difference in the air? It isn't just our attitude when we're out in Nature versus being in a crowded city. It isn't that it's a weekend and not a workday.

The difference lies in the electrical balance of the air or the quantity of "ions" present.

WHAT ARE IONS?

Ions are electrically charged atoms in the air with either a positive or negative charge. The sun and cosmic rays as well as lightning and fast-moving water (like waterfalls, surf) generate trillions of negative ions every day. The more negatively ionized the air, the fresher and more alive it is. Air pollution, artificially controlled climates (with air conditioning and heating) and electronic equipment all produce excess positive ions, depriving the air of these small negative air ions and creating dead "stuffy" air.

WHAT'S THE SOLUTION?

Our rapid-growth technology, which sometimes takes its toll on the quality of our air, has also come up with the solution. Following Nature's model of the thunderstorm which uses a high electrical charge to purify, revitalize and stimulate the air, the UTP Air Energizer has been developed imitating this process. Both the thunderstorm and the Air Energizer fill the air with negative ions, restoring the natural electrical balance to the polluted, energy-depleted air. But the Air Energizer can be used indoors in the home, office, work-shop, laboratory, etc., keeping a fresh supply of ionized oxygen flowing from its emitters night and day. This new breakthrough in fresh air control is not a cover-up which masks or deodorizes, but the unit actually removes the dust, smoke, bacteria and pollen particles from the air by attaching ions to them and causing them to sink to the earth where they can be vacuumed up rather than inhaled. At the same time ions electrically stimulate the energy-stripped air.

MORE FOR LESS

Why do we say you get more for less money? A typical marketing technique is to take your weakness and assert that it is one of your strengths. This is exactly what our competitor has done. Their ads proclaim the wonders of "miracle fuzz", the bronze fuzz ball emitter on their unit. But using bronze fuzz and calling it a new invention is really old hat. It was first introduced in England many years ago. In fact we ourselves brought out a bronze fuzz unit called System Three over a year ago because it's cheaper than needles. But we are discontinuing it because we want to maintain our reputation for the highest quality, and stainless steel emitter needles are so much better. A single, large fuzz ball emitter is difficult, if not impossible, to clean. It quickly gets so dirty that its efficiency is reduced. We are the only manufacturer we know of that uses *self-cleaning* stainless steel emitter needles.

YOUR CHOICE OF TWO TOP-QUALITY UNITS!

There's only one unit that's better than System Five. That's our own System Four. It sells for \$159. It has an even higher ion output. Plus! Our special **Dial-An-Ion** allows you to adjust the ion output anywhere from low to high. Not everyone knows that the need for ions varies. A large smoky room will require higher output than a small room. And some people want fewer ions while sleeping than while working. The new System Four is our answer to this need for output flexibility. And we're the first and only ones to offer this special feature at this price. If System Four is better why did we bring out System Five?

CIRCLE NO. 64 ON FREE INFORMATION CARD

Not everybody is willing to pay \$159 for an air ionizing unit, no matter how good it is. Just like not everyone drives Rolls Royces. Most drive less expensive cars.

System Four is for the person who wants the absolute best quality and doesn't mind paying a little extra to get it. If you want highest ion output, flexibility, and a beautiful oak paneled case, buy System Four.

If you want something at half the price of System Four, but still better than any other units costing up to \$250, buy System Five.

HOW TO GET ONE

To place your order now just send a check for **\$74.95** plus \$3 shipping for System Five. Or send **\$159** plus \$4 shipping for System Four. Tell us your full street address as we cannot ship to Post Office boxes.

Our unit is dependable and trouble-free, but if by rare chance any problems occur our service-by-mail center sends off your unit within 24 hours of receipt or sends a replacement so you are not without fresh air and can enjoy your dust-free environment. And each Air Energizer is backed by a full one year limited warranty.

HOW TO GET ONE FAST!!!

Credit card holders can call our toll-free number below. Order a unit now and if you are not satisfied with its effects within 10 days simply return it for a full cash refund. Order your Air Energizer today.

UTP

Read "The Golden Egg"

University of the Trees Press
ION RESEARCH CENTER
BOX 644 PE, BOULDER CREEK, CA 95006
Call Toll-Free . . . 800-538-0750
In California call (408) 338-6663
Send check or use your Master Charge,
Visa or American Express card.

WE HAVE ION DETECTORS!

Now you can prove to yourself which unit has the highest output. These high quality, low cost detectors enable you to do scientific tests and comparisons. Our **Econometer** contains a neon light that blinks in the presence of negative ions. The more ions, the faster it blinks. The **Ionometer** gives you a sensitive meter to compare readings between units. The **Ionoscope** gives you three sensitivity ranges for advanced and accurate detection.

ECONOMETER . . . (pen size) . . . \$7.50
IONOMETER . . . (3"x2"x1½") . . . \$49.95
IONOSCOPE . . . (5½"x3"x1¼") . . . \$99.95
Add \$2.00 per detector for shipping.

New from NRI! **25" color TV that tunes** DIAGONAL **by computer, programs** **an entire evening's** **entertainment.**

Just part of NRI's training in servicing TV, stereo systems, video tape and disc players, car and portable radios.



Only NRI home training prepares you so thoroughly for the next great leap forward in TV and audio... digital systems. Already, top-of-the-line TV's feature digital tuning, computer programming is appearing, and new digital audio recording equipment is about to go on the market.

NRI is the only home study school to give you the actual "hands-on" training you need to handle servicing problems on tomorrow's electronic equipment. Because only NRI includes this designed-for-learning, 25" diagonal color TV with electronic tuning, built-in digital clock, and computer programmer as part of your training. With this advanced feature, you can pre-program an entire evening's entertainment... even key lock it in to control children's viewing.

As you assemble it, you learn how digital tuning systems work, how to adjust and service them. You work with the same advanced features used in the new programmable TV's and video tape recorders. It's exclusive NRI training that keeps you up with the leading edge of technology.

**Exclusive
Designed-for-learning
Concept**

The color TV you build as part of NRI's Master Course looks, operates, and performs like the very finest commercial sets. But behind that pretty picture is a unique designed-for-learning chassis...



the only such unit in the world. Rather than retrofit lessons to a hobby kit or an already-built commercial set, NRI instructor/engineers have designed this television so each step of construction is a learning experience.

As you build it, you perform meaningful experiments. You see what makes each circuit work, what it does, how it interacts with other circuits. You even introduce defects, troubleshoot and correct them as you would in actual practice. And you end up with a magnificent, big-picture TV with advanced features. One you can sell or use in your home.

**Also Build Stereo,
Test Instruments**

That's just a start. You demonstrate basic principles and circuits on the unique NRI Discovery Lab®, then apply them as you assemble a fine AM/FM stereo receiver, complete with speakers. You also get practical experience as you build your own test instruments, including a 5" triggered sweep oscilloscope, CMOS digital frequency counter, color bar generator, and transistorized volt-ohm meter. Use them for learning, use them later for professional servicing of TV, audio, and video equipment.

**Complete, Effective Training
Includes Video Systems**

Using NRI's exclusive methods, you learn far more than TV servicing. You'll be prepared to work with stereo systems, car radios, record and tape players, transistor radios, short-wave receivers, PA systems, musical instrument amplifiers, electronic TV games, even video tape recorders and tape or disc

video players. Your training covers just about every kind of electronic entertainment equipment available now or in the near future.

And because NRI has unmatched experience gained in over 60 years and a million students worth of training, your course is designed for ease of learning and practical utility. You need no previous experience of any kind. Starting with the basics, exclusive "bite-size" lessons cover subjects thoroughly, clearly, and concisely. "Hands-on" experiments reinforce theory for better comprehension and retention. And your personal NRI instructor is always available for consultation, ready with explanations, answers, and advice.

**Send for Free
Detailed Catalog...
No Salesman Will Call**

Get all the facts on this exciting course and its potential for you by mailing the postage-paid card today. Our free 100-page catalog includes color photos of all kits and equipment, complete lesson plans, convenient time payment plans, and information on other electronics courses. You'll also find out about NRI's new Computer Technology Course that includes your personal

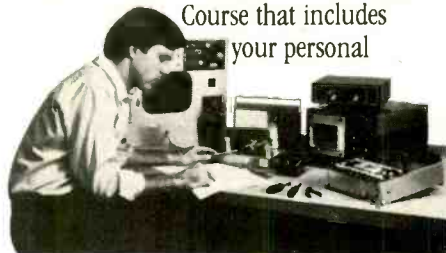

microcomputer. Or Complete Communications with 2-meter transceiver that gets you ready for opportunities in broadcasting, 2-way radio, microwave, and other growing fields. If card has been removed, write to:



NRI Schools
McGraw-Hill Continuing
Education Center
3939 Wisconsin Ave.
Washington, D.C. 20016





Stereo Scene

By Harold A. Rodgers
Senior Editor

SHORT SUBJECTS

ON A RECENT trip to Japan as the guest of Lux Audio, I was able to prevail upon my hosts to supply me with a listening room in which I could use some of their equipment at length. All of the demonstrations we had heard up to that point (a group of sales representatives and several other journalists were also on the trip) were of the 10-to-15-minute variety. Unfortunately, it is hard to get more than a fleeting impression of a piece of audio gear in that short a time. It struck me, therefore, that a prolonged listening session might stimulate the intellect (I would get to know the equipment better) and the esthetic sense (I could hear a piece of music all the way through).

Feedback: Friend or Foe? I should preface my account of what happened by admit-

ting that up to now I have been very skeptical about claims of substantial differences of amplifiers. Detailed accounts of double-blind tests in which experienced listeners had been unable to distinguish power amplifiers of highly divergent design by sound as long as they were operated within their limits had impressed me profoundly. Accordingly, I had come to the conclusion that most of the subtle sonic differences were due to transient overloads. The experience on this occasion, however, suggests that other factors may well be involved.

The main character in the scenario is the Luxman MQ-68 power amplifier, a *vacuum-tube* design. The most unusual feature of this amp is that its feedback loop is switchable to give 16 dB of feedback or no feedback at all. In the open-loop mode, the unit delivers 20 watts per channel to an 8-ohm load with 0.3% THD. Closing the loop raises the output power to 25 watts per channel and lowers THD to 0.05%. What we were listening for was any apparent difference between the two modes.

Obviously, there was a difference—otherwise this tale would be pointless—but it was hardly what I had expected. With feedback connected, the bass was clearer and "tighter," an effect that can be explained on the basis of the lower output impedance (higher damping factor) characteristic of that mode of operation. But, at the same time, the treble seemed to become compressed and some sense of ambience seemed to disappear. It is not obvious why this occurred.

Transient intermodulation does not seem to be the answer, for the amplifier is very clean in the open-loop mode. Furthermore,

feedback level is modest, and slew limiting is not usually a problem with vacuum-tube audio amps. One possible answer is that, while the higher damping factor exercises tighter control over the woofer, it simultaneously overdamps the tweeter. That is to say, it may be preferable to let the tweeter radiate whatever energy is stored as acoustic power, even if it is slightly late, rather than to damp it out. This idea is not as far-fetched as it may sound at first, nor is it even new. It seems to have been thinking along these lines that prompted ESS to use current feedback (which, unlike the voltage feedback usually applied, lowers damping factor) in the amplifier for its Transar. The idea is that since the speaker is designed to have no significant resonances in its operating pass-band, damping is unnecessary and would only be a hindrance.

This view is not necessarily endorsed by Lux personnel, and they, in fact, have suggested further experimentation to see if a less conjectural explanation can be found. Any findings will, in due course, be reported in this column. In the meantime, Lux engineers are carefully studying feedback to be certain when and how its application really does "make a good amplifier better."

Additional Notes on Ambience. Since the October installment of this column, which dealt with ambience and its recovery from recordings, some errors have been brought to my attention along with some expansion of ideas presented at that time. First, my apologies to Erik Rørbeek Madsen of Bang & Olufsen, whose name was mangled.

Bob Berkovitz of Teledyne Acoustic Research, who was working with David Hafler at the time the ambience circuit was devised, points out that in the original version the level control was from common neutral of secondary speakers to common ground of the amplifiers. Thus, if the control is set for its maximum resistance a maximum of out-of-phase information emanates from the secondary speakers. At its minimum setting, the two sets of speakers are effectively in parallel, giving double stereo. In intermediate positions, the control feeds any desired mix of in-phase and out-of-phase components to the secondary speakers.

Since the impedance of the control should be approximately the same as impedance of the speakers, another variation is possible:

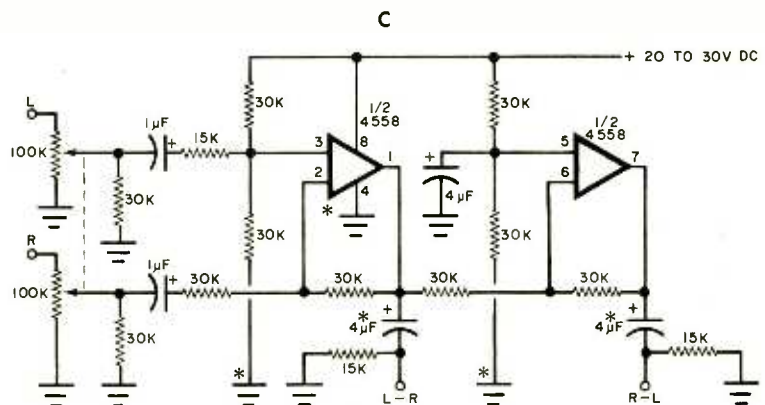
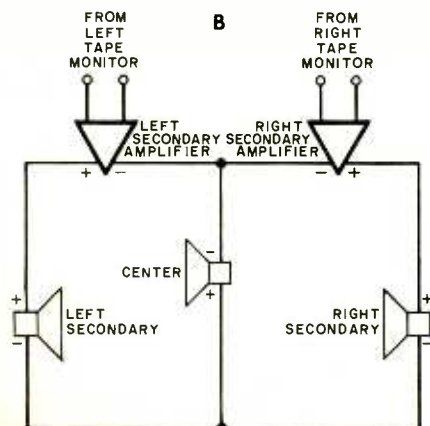
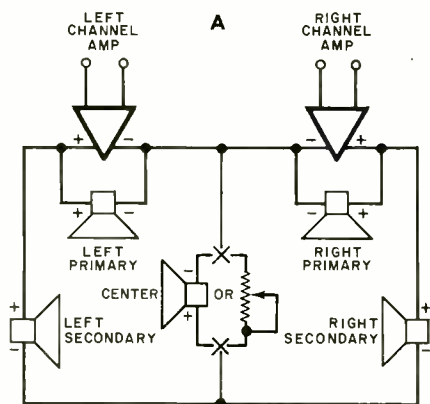







Fig. 1. Variations on speaker arrangements given in October 1979.

Fig. 2. A practical version of the circuit shown at C in the October 1979 issue.



fact: a Genuine Shure upgrade stylus is unquestionably the biggest bargain in hi-fi

We strongly urge you to check your stylus for wear at least once a year to protect your records and maintain the highest standards of listening pleasure. Regardless of when (or where) you purchased your Shure cartridge, there is a Genuine Shure replacement stylus available which will bring your cartridge right back to its original specifications. Even better, *you may actually be able to improve its performance significantly over the original with a Genuine Shure upgrade stylus...* at surprisingly low cost! For example:

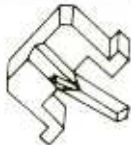
IF YOU OWN:	UPGRADE WITH:	THIS IS THE RESULT:
 <p>V15 Type III SERIES</p>  <p>M95 SERIES</p>	<p>VN35HE Hyperelliptical stylus</p>  <p>N95HE* Hyperelliptical stylus</p> 	<p>A dramatic reduction of harmonic and intermodulation distortion (formerly available only to owners of the incomparable V15 Type IV) is now possible with the V15 Type III and the M95 Series of cartridges simply by replacing the stylus. The Hyperelliptical stylus configuration contacts the record groove in a "footprint" that is longer and narrower than the popular Biradial tip design, making it pre-eminent for reproduction of the stereo-cut groove.</p>
 <p>M70 SERIES</p>	<p>N72EJ Biradial (Elliptical) stylus</p>  <p>N72B Spherical stylus</p>	<p>Improved trackability, especially at high frequencies, due to a new, redesigned low-mass N72 stylus assembly.</p>
<p>ANY M91, M92, M93</p>	<p>N91ED* stylus</p>	<p>Much improved trackability due to the lower effective tip mass of the nude Biradial (Elliptical) stylus tip. Less tracing distortion compared with a Spherical stylus tip.</p>
<p>ANY M71, M73, M75</p>	<p>N75 TYPE 2* Series styli</p>	<p>Improved trackability at higher frequencies due to a stylus assembly with a lower effective tip mass.</p>
<p>ANY M44 Series</p>	<p>N55E* stylus</p>	<p>Lower tracking force with a Biradial (Elliptical) stylus, lower distortion, lower effective tip mass.</p>
<p>M3D, M7D</p>	<p>N21D* stylus</p>	<p>Improved performance at lower tracking forces.</p>

* Before purchasing any replacement stylus be certain your turntable is compatible with the tracking force of the stylus you select.

**Always insist on a Genuine Shure replacement stylus.
Look for the name "Shure" on the stylus grip.**

Genuine Shure upgrade styli by



Shure Brothers Inc., 222 Hartrey Ave., Evanston, IL 60204

In Canada: A. C. Simmonds & Sons Limited

Outside the U.S. or Canada, write to Shure Brothers Inc., Attn: Dept. J6 for information on your local Shure distributor.

Manufacturers of high fidelity components, microphones, sound systems and related circuitry.

CIRCLE NO. 52 ON FREE INFORMATION CARD

New Super SCORPION™

**When you're
deadly serious about
CB antenna performance.**

No other 60" full-range mobile CB antenna offers all these quality and reliability features!

Full 60" radiator. Much greater radiating surface than conventional base loaded mobile antennas—over 33% increase in "mileage gain."

"Static Ball" tip for dissipation of wind static charge. Protects garage doors from nicking and grooving.

17-7PH stainless steel TAPERED whip. Less pattern distortion due to lower wind drag at highway speeds. No tuning required, VSWR less than 1 to 1.5.

Stainless steel shock spring absorbs blows from branches, garage doors.

Heavy duty coil. Precision-wound of 12 gauge, enamel-coated copper wire for high efficiency and reserve power capability.

Antenna Specialists' LEVERLOK™ quick release. Firm, positive electrical and mechanical connection, instant disconnect, with the twist of a lever.

Tough, high-impact LEXAN® base in clean, contemporary design for maximum protection of loading coil. Mounts easily on roof or trunk lip.

LEXAN is a registered trademark of General Electric Co.

Full 17' of professional grade coaxial cable RG-58U with maximum braid coverage for best shielding, lowest signal loss. In-line miniature connector simplifies installation.

Five year limited warranty—our assurance of utmost quality of design, construction and reliability.

the antenna specialists co. 

a member of The Allen Group Inc.
12435 Euclid Ave., Cleveland, Ohio 44106

Export: 2200 Shames Drive, Westbury, L.I., New York 11590
Canada: A. C. Simmonds & Sons, Ltd.

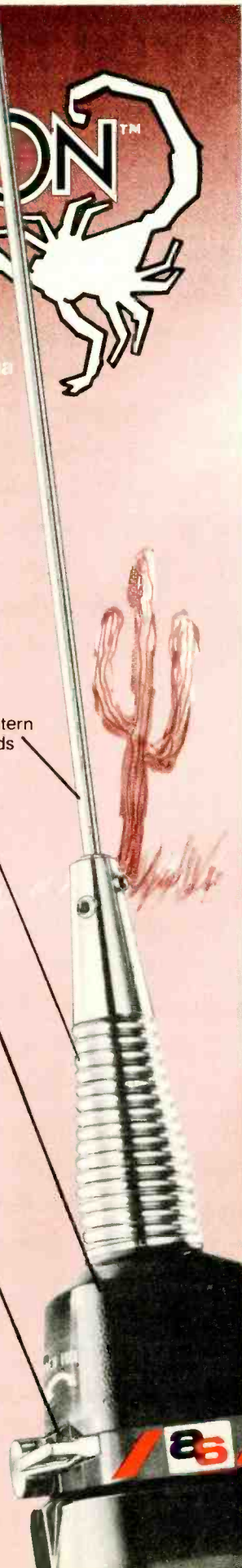

substitute an additional loudspeaker for the control. This speaker would carry an L R signal and should be located halfway between the primary pair to solidify the center image. Circuits A and B, originally given in October, are both candidates for this treatment as shown in Fig. 1.

Concerning circuit C, C.F. Kerry Gaulder, chief engineer of Source Engineering, points out that scaling of the resistors so that signals from left and right channels have equal gain is not entirely a straightforward matter. He has designed a practical version of the circuit that he kindly consented to have published here (Fig. 2).

The 100k potentiometer at the input gives a broad enough range of control to allow the circuit to be connected either to a spare low-level output (a tape monitor, for example) or to the power amp's loudspeaker terminals. Power should be applied to the ambience circuit before the rest of the system is turned on, otherwise a strong "thump" will be delivered to the loudspeakers. This problem can be cured by using a balanced, bipolar power supply. The ground connections marked with asterisks should be returned to the negative bus in that case, and the output coupling capacitors, also marked with asterisks, can be omitted if desired. The IC can be a type 4558 op amp or equivalent, and the 100-kilohm dual ganged input pot should have a linear taper. The load presented to the pot by the rest of the circuit and the 30-kilohm shunt resistors give an approximate audio taper.

Audiophile Recordings.

MOUSSORGSKY: PICTURES AT AN EXHIBITION, NIGHT ON BALD MOUNTAIN. The Cleveland Orchestra, Lorin Maazel conducting. Telarc Digital 10042. It seems like a pretty safe bet that most of the people who listen to *Pictures at an Exhibition* do so in recorded performances rather than in concert halls, which means that, while they may think they know what Ravel's brilliant orchestration sounds like, they don't at all. Compression and limiting, the principal culprits in watering down sonics have been banished from this disc, producing a sound that is certainly a revelation (though still not quite as good as "live"). The vast dynamic range, especially from the deep percussion (a Telarc trademark?) pushes the disc to its extremes. Surface noise is never a problem, but is just barely audible in soft passages. *Night on Bald Mountain* was revised considerably by Rimsky-Korsakov (who was also no slouch as an orchestrator). It is not quite the tour de force that *Pictures* is, but this recording really captures it well.

CARLO CURLEY GOES DIGITAL: THE ALLEN DIGITAL COMPUTER ORGAN IN THE GREAT HALL, ALEXANDRA PALACE, LONDON. Chalfont SDG 303. Here is true poetic justice—a digital recording of a digital electronic organ. The recording has excellent dynamic range (enough to incinerate your speakers with steady loud tones, if you're not careful) and an amazing clarity. This is not your everyday electronic organ—it has 164 stops, 5,500 watts of amplifier power and 380 speakers—and it ought to show "purists" who insist on pipes a thing or two. Curley has put the vast technology to good use, choosing satisfying registrations and interpretations for works from Baroque through Late Romantic. ◇

Our recording tape is considered by most audiophiles to be the world's finest tape

Our tape window is welded in to keep dust out.

Our pressure pad is locked into a special four-sided retainer to maintain perfect tape-to-head contact.

Our slip sheet is made of a substance that's so slippery, even glue can't stick to it.

Our leader not only keeps you from making recording errors, it also keeps your tape heads clean.

Our special guide rollers make sure our tape stays perfectly aligned with your tape heads.

Our cassette is held together by steel screws to assure precise alignment and even distribution of pressure on all sides of the cassette.

Our standard cassette shell is finished to higher tolerances than industry standards.

Our tape is anchored to our hub by a special clamping pin that makes slippage impossible.

There's more to the world's best tape than the world's best tape.

Our reputation for making the world's best tape is due in part to making the world's best cassettes.

In fact, we put more thought

and more work into our cassettes than most manufacturers put into their tape.

We do all this, because at Maxell

we believe in a simple philosophy.

To get great sound out of a cassette takes a lot more than just putting great tape into it.

maxell

Maxell Corporation of America, 60 Oxford Drive, Moonachie, N.J. 07074

CIRCLE NO. 33 ON FREE INFORMATION CARD

www.americanradiohistory.com

Julian Hirsch Audio Reports

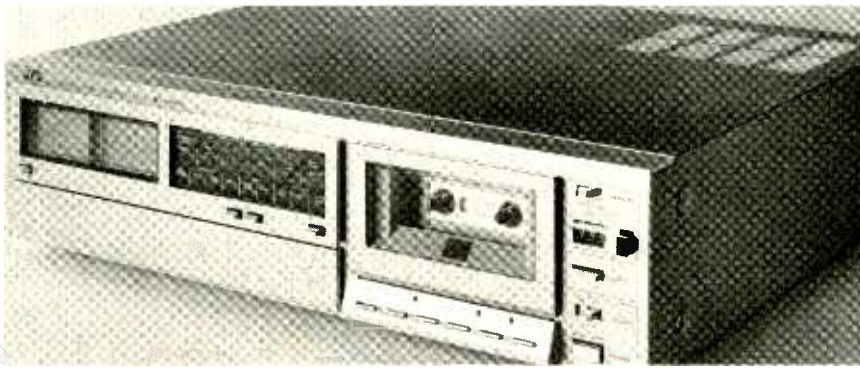

JVC Model KD-A8 cassette deck has computerized tape optimization



Of all the features in the Model KD-A8 cassette deck, the automatic computerized tape optimization system that

JVC calls "B.E.S.T." (Bias, Equalization, Sensitivity-of-Tape tuning) is the most striking. With it, the deck is fully compatible with all modern tape formulations, including metal-particle.

This front-loading deck has two motors, two heads, and a logic-operated solenoid transport control system. It also has JVC's ANRS noise-reduction system plus a Super ANRS system that gives additional high-frequency dynamic range. Operating flexibility, head design, and mechanical and electronic sophistication make the KD-A8 one of the most advanced cassette decks presently on the market.

Relatively compact, the KD-A8 measures only 17 $\frac{1}{4}$ "W \times 15 $\frac{1}{2}$ "D \times 4 $\frac{1}{4}$ "H (450 \times 390 \times 124 mm) and weighs 24.2 lb (11 kg). Suggested retail price is \$850.

General Description. Most of the KD-A8's controls are located behind a door on the lower part of the front panel. Pressing a button swings the door down to reveal a pair of microphone jacks, a headphone jack, two small recording-level controls, and a single output-level control.

On this subpanel are also three lever switches. TAPE SELECT has positions for CrO₂, NORM, FeCr, and METAL that set approximate bias and recording equalization for each basic tape type. Selection between chrome and ferric (NORM) is made automatically by the notch on the back of chrome (or other 70- μ s, high-bias) cassettes.

The ANRS switch has OFF, ON, and SUPER positions. (ANRS is almost identical in effect to the Dolby-B system, although its circuits are quite different. The two are sufficiently alike so that Dolby tapes can be played satisfactorily on an ANRS deck, and vice-versa.) SUPER compresses the high frequencies of a recorded signal and, during playback, applies a complementary expansion. The result is a slightly greater dynamic range at the higher audio frequencies. Tapes made with Super ANRS, are fully compatible neither with ANRS nor Dolby.

Labelled s&L (Search & Lock), the third switch is used to set recording gains automatically when the maximum level from the source can be determined in advance, as when dubbing. In its MANUAL position, the switch allows recording gain to be set by the two input-level controls in the usual manner. If the highest level to be recorded is presented while the switch is held in its spring-loaded SET position, the circuits follow the program and "hold" the maximum level encountered. They then electronically adjust recording gain for a +3-dB indication from this signal when the switch is

deck is fully compatible with all tape formulations including metal-particle

released and allowed to return to its s&L position. This gain setting is maintained until the deck is shut off or until the circuit is cleared by setting the switch to MANUAL.

Below the back-lighted cassette compartment are the touch switches that control the transport mechanism through solenoids. Although their functions are similar to those of most other cassette-deck controls, they are interlocked in an unusual way. For example, to set up recording levels, REC and PAUSE must be pressed simultaneously, after which the PLAY button must be touched. The PAUSE control can be released only by pressing PLAY or STOP. It is not necessary to stop the tape to switch between fast forward, rewind, and play. A "flying-start" recording can be made while playing a tape by holding down PLAY and pressing REC.

The MEMORY system can be set to have the deck go into either STOP or PLAY when the rewinding tape registers 000 on the tape counter, and a TIMER STANDBY feature allows unattended power switch-on and operation by an external timer in either playback or record.

The display system consists of paired meters calibrated from -20 to +5 dB and an array of 20 red and green LEDs. Below the LEDs are two small buttons labelled COMPUTER CAL START and PRESET and a third labelled REC MUTE. The LEDs give visual indication of operating status at all times, a necessity in view of the deck's many modes of operation. Four LEDs indicate the basic tape type selected, two indicate whether ANRS or SUPER ANRS has been switched on, and one with the legend NON REC lights when recording is inhibited by the absence of a safety tab on the cassette. An s&L LED informs the user when the Search & Lock recording-gain system is operating in place of the regular input-level controls. Finally, a REC MUTE LED comes on when the button below it is held in to mute the recording input signal without stopping tape motion. Used with the PAUSE button, REC MUTE permits editing of a tape as it is being made and eliminates stop/start transients that sometimes accompany operation of a PAUSE control.

The key feature of the KD-A8 is its microprocessor-controlled B.E.S.T. tape-optimization system. With a tape loaded and the TAPE SELECT switch set for its formulation, a touch of the COMPUTER CAL START button sets the system into operation.

First, the transport advances slightly to make sure that coated tape contacts the heads. Then a 1000-Hz reference tone, followed by a 6300-Hz tone, are recorded on both channels. During the recording of the 6300-Hz tone, bias is automatically adjusted over a considerable range in 32 discrete steps. The recording stops, the tape is rapidly rewound, and the section just recorded is played back. The bias level that yields a 6300-Hz playback level equal to the level of the 1000-Hz reference signal is stored in computer memory and is used during the balance of the recording with that tape.

(Continued on page 26)

Sabtronics NEW Hand-held Digital Multimeters . . .

The only thing that beats their performance is their price.

Accurate performance you can rely on, time after time. That's what you expect from a quality DMM. But don't expect to pay as much for it any more. Because now Sabtronics brings you top quality DMMs with more features and better accuracy than other comparable units on the market today. And they cost surprisingly less!

We cut the price. Not the quality.

What you get is a precision crafted unit that features single-chip LS² logic, laser trimmed resistor network and a stable band-gap reference element for better long term accuracy. Basic DCV accuracy is 0.1%. The Model 2035A gives you 32 measurement ranges over 6 functions and the Model 2037A an additional two temperature ranges.

First in features. First in price.

Both models feature touch-and-hold capability with the optional probe — its so convenient, you'll wonder why the expensive models haven't got it yet! And two-terminal input for all measurement functions — this eliminates lead switching and makes your job easier. The Model 2037A even has a built-in temperature measuring circuit with a -50°C to +150°C range (-58°F to +302°F) and is supplied complete with the sensor

probe. Of course, auto zero, auto polarity and overload protection are standard. And you get 200 hour operation from a single 9V transistor battery. A low battery indicator warns you of the last 20% of battery life. The large, crisp LCD readouts allow easy viewing even in bright sunlight.

Assembling either kit is simple with our easy-to-follow, step-by-step instructions. And the built-in calibration references allow you to calibrate the unit any time, any place.

We've even eliminated difficult inter-connect wires. All parts mount on the PC board. The only wires you solder are the two battery-snap leads.

Biggest value in small DMMs

To sell hand-held DMMs with all these features at such low prices, we had to sacrifice profits. But we never sacrificed quality or performance. We are so sure that the Model 2035A and 2037A are the best values available that we offer a money-back guarantee. Examine either unit in your own home for 10 days, and if you are not convinced that it is the best value for your money, return it in its original condition for a prompt

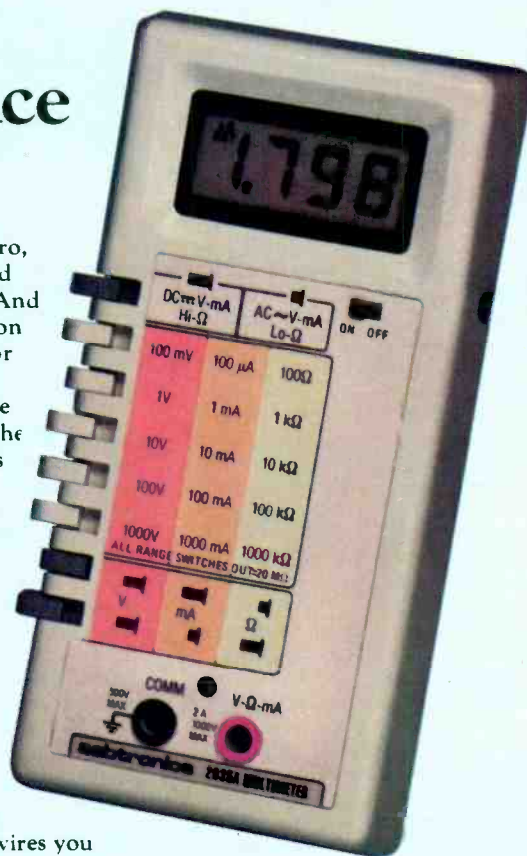

and courteous refund of the purchase price (less shipping and handling). Order yours today! Use the convenient order form or call us with your Master Charge or Visa number.

Making Performance Affordable

sabtronics INTERNATIONAL INC.

13426 Floyd Circle M/S 24 • Dallas Texas 75243
Telephone 214/783-0994

BRIEF SPECIFICATIONS:

DC VOLTS: 100 μ V - 1000V, 5 ranges
AC VOLTS: 100 μ V - 1000V, 5 ranges
DC CURRENT: 0.1 μ A - 2A, 5 ranges
AC CURRENT: 0.1 μ A - 2A, 5 ranges
Hi-OHMS: 0.1 Ω - 20M Ω , 6 ranges
Lo-OHMS: 0.1 Ω - 20M Ω , 6 ranges
TEMPERATURE: -50°C - +150°C
(-58°F - +302°F), 2 ranges
(Model 2037A only).

WEIGHT: 11 oz. (excl. battery)
OVERLOAD PROTECTION: 1000V DC or AC peak all voltage ranges; 250V DC or AC peak all Ohms ranges; 2A/250V fuse all current ranges.

Mail to: Sabtronics International, Inc., 13426 Floyd Circle, M/S 24, Dallas, Tx 75243.

Please send me . . .

_____ Model 2035A Hand-held Multimeter kit(s) @ \$74.95 each	\$ _____
_____ Model 2035A Hand-held Multimeter assembled @ \$99.95 each	\$ _____
_____ Model 2037A Hand-held Multimeter kit(s) @ \$89.95 each	\$ _____
_____ Model 2037A Hand-held Multimeter assembled @ \$119.95 each	\$ _____
_____ #THP-20 Touch-and-hold Probe(s) @ \$19.95	\$ _____
_____ Shipping and Handling @ \$5.00 per instrument*	\$ _____
For delivery in Texas, add 5% Sales Tax	\$ _____
I enclose <input type="checkbox"/> check <input type="checkbox"/> money order <input type="checkbox"/> Master Charge <input type="checkbox"/> Visa	TOTAL . . . \$ _____
(Allow 2-3 weeks clearance time for personal checks). 10% deposit for C.O.D.	
Charge my credit card # _____	Expiry Date _____

Name _____
Street _____ Apt. _____
City _____ State _____ Zip _____

*Continental U.S. only. AK, HI & PR: \$6.00. Canada: \$7.50. Foreign: \$19.00 Airmail.

Next, a 10,000-Hz signal is recorded while the recording equalization is varied in eight steps for first one and then the other channel. Following this, a 1000-Hz signal is recorded on both channels in 16 steps of increasing amplitude. The deck plays back these signals and determines the equalization that gives a 10,000-Hz playback level equal to that of the 1000-Hz reference tone in each channel. This value is stored for subsequent use.

Since overall sensitivity might have been changed slightly by the above operations, the 1000-Hz playback sequence is used to set overall record/playback gain to the level required by the ANRS circuits. The tape then rewinds to the beginning and stops, ready for use.

The complete process takes less than 25 seconds. Shutoff of the deck causes loss of the stored information. One can use the fixed settings for each basic type of tape by pressing the PRESET button. As each portion of the B.E.S.T. cycle is completed, a green LED comes on to show that BIAS, EQ, and SENS have been set. At the end of the cycle, the READY LED comes on. (If the PRESET button is used, the PRESET LED comes on.)

If for any reason, such as an incorrect setting of the TAPE SELECT switch, the computer cannot find appropriate settings, it repeats the test cycle. If the problem persists, the PRESET LED comes on and an ERROR LED blinks. (This latter LED can be extinguished only by pressing the PRESET button.) When the computer's work is done, the sequentially flashing LED display becomes a peak program-level indicator that responds to the stronger of the two channel signals. In this mode, the LEDs come on at levels of -10, -5, 0, +5, and +10 dB.

Laboratory Measurements. We tested the deck with the tapes recommended by JVC: Maxell UD-XLI for NORM, TDK SA for CrO₂, Sony Duad for FeCr, and Scotch Metafine for METAL. JVC says that similar tapes should give essentially identical results after use of the B.E.S.T. system. We verified this by spot testing, but did not perform full tests with any other brands of tape.

The playback frequency response was measured with TDK and TEAC standard tapes for the 120- and 70-microsecond equalization characteristics. Both tapes yielded no more than ±1-dB response variation over their full range (40 to 10,000 Hz for TEAC, 40 to 12,500 Hz for TDK).

Record/playback frequency response at a -20-dB level with all four recommended tapes differed only slightly, and then mostly at frequencies above 10 kHz. Although there were almost no signs of the usual head-contour ripples in the bass range, the low-frequency response rolled off slightly below 100 Hz and more rapidly below 45 Hz. There were measurable differences in high-frequency response between the PRESET and B.E.S.T. adjustments, but these too were above 10 kHz.

Larger differences between the tapes were apparent in the record/playback response at a 0-dB level. With UD-XLI, the response was nearly flat up to about 7 kHz and dropped at higher frequencies to in-

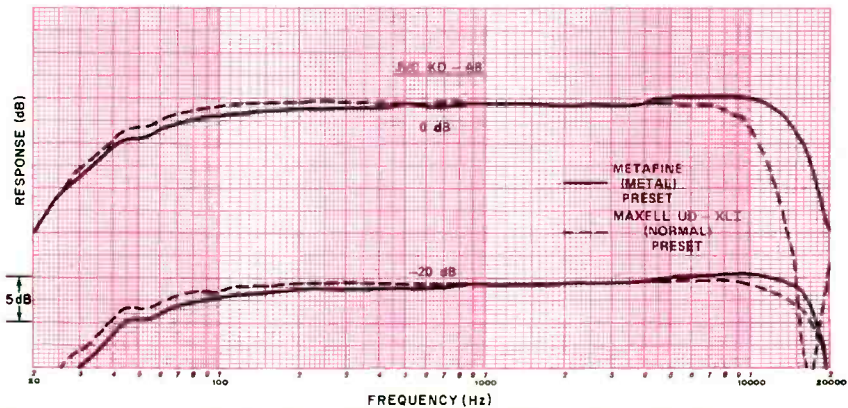

Frequency responses for two types of tape with preset bias and equalization.

tersect the -20-dB curve at 15 kHz or 16 kHz, depending on whether the PRESET or B.E.S.T. was used. TDK SA had a more extended high-frequency response than UD-XLI, and with B.E.S.T., the 0-dB curve remained above the -20-dB curve all the way to 20 kHz. Sony Duad tape had even better resistance to saturation, especially with B.E.S.T., which kept the two curves 10 dB apart to 20 kHz.

Metafine tape had virtually the same response shape at 0 and -20 dB, with the full 20-dB difference still present at 10 kHz and 15 to 16 dB separating the curves even at 20 kHz. This is a level of performance akin to what we would expect from a good-quality home open-reel deck at 7½ ips and never from a cassette deck (least of all from a two-head deck).

Tracking error of the recording and playback ANRS circuits amounted to less than 1 dB at any frequency up to 15 kHz at recording levels of -20 to -40 dB. It typically was less than 0.5 dB. Performance this good is rarely seen in conventional Dolbyized cassette decks as it requires exact matching of recording and playback signal levels for the specific tape used. This facility is not always available on today's cassette decks, but JVC's B.E.S.T. system accurately performs this matching function every time COMPUTER CAL is pressed.

A LINE input of 70 mV or a microphone input of 0.16 mV was needed for a 0-dB recording level. The microphone pream-

plifier overloaded at 115 mV, an unusually high figure for a cassette deck. Playback output from a 0-dB signal was between 260 and 287 mV, depending on the tape used. Unweighted S/N ratio, referred to the level that gave 3% playback distortion (a +7- to +8-dB signal, depending slightly on the tape used) was 48 to 50 dB. With A weighting, S/N ranged from 56.5 dB (UD-XLI) to 60 dB (Metafine). ANRS improved the S/N, with CCIR/ARM weighting, to 66.2 dB with Metafine tape. Noise increased by about 10 dB though the microphone input at maximum gain but was much less at more reasonable gain settings. Playback third-harmonic distortion at a 0-dB recording level was 0.5% with UD-XLI and SA, 1% with FeCr, and 0.7% with Metafine.

One major problem with metal tapes has been erasure, which requires a very powerful magnetic field and usually a special erase-head design. JVC has solved that problem, as we measured a 75-dB erasure at 1 kHz from a 0-dB recording with Metafine and better than 80 dB with other tapes. (The residual signal was below the noise level and could not be detected even with a narrow-band spectrum analysis.) Crosstalk between channels was 55 dB down with a TDK AC-352 test tape at 1 kHz. Tape speed was 0.3% fast but did not vary over the length of a C60 cassette. Flutter was the lowest we have ever measured from a cassette recorder; with TDK AC-342 tape, it was 0.028% wrms and

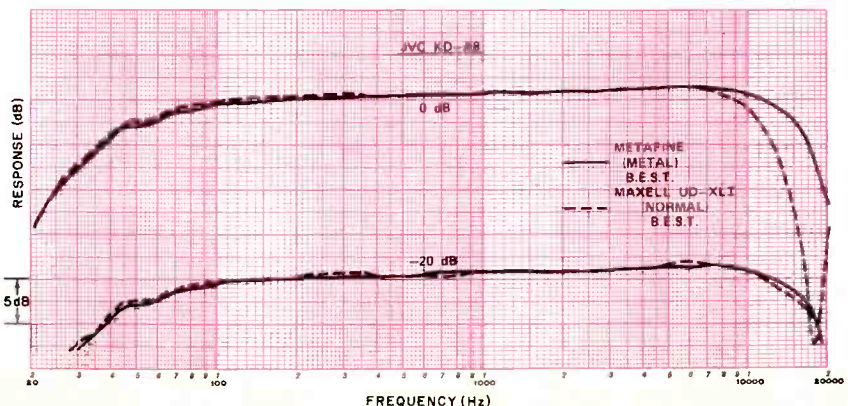

Frequency responses using the B.E.S.T. optimization system.

Sabtronics gives you DMM and Frequency Counter kits with more features, better performance and incredibly lower prices

Model 2010A Bench/Portable DMM:

\$69.95 kit

Features: 3½ digit LED display • 31 measurement ranges • 6-Functions • 0.1% Basic DCV accuracy • Touch-and-hold capability • Hi-Lo Ohms • 40 Hz to 40 kHz frequency response • Auto Zero, Auto Polarity • Overload protected • Overrange indication • Single chip LSI logic • Laser-trimmer resistor network and ultra-stable band-gap reference for better long term accuracy • Built-in NiCd battery charging circuit.

Brief Specifications: DC Volts 100µV to 1000V in 5 ranges; AC Volts 100µV to 1000V in 5 ranges; DC Current 0.1µA to 10A in 6 ranges; AC Current 0.1µA to 10A in 6 ranges; Resistance 0.1Ω to 20MΩ in 6 ranges; Diode Test Current 0.1µA to 1mA in 3 ranges; Input impedance, 10MΩ on AC and DC volts; Power requirement, 4.5 to 6.5 VDC (4 "C" cells) or optional AC adapter/charger.



\$69.95



Model 2015A Bench/Portable DMM:

\$89.95 kit

Same features and specifications as Model 2010A except with large, 0.5" LCD 3½ digit display.

Optional Accessories:

- #AC-115, AC adapter/charger \$7.95
- #THP-20, Touch and Hold Probe \$19.95
- #NB-120 NiCd Battery Set \$17.00

\$89.95

Model 8610A Frequency Counter:

\$89.95 kit

Features: 8-digit LED display • 10 Hz to 600 MHz guaranteed frequency range (5 Hz to 750 MHz typical) • 3 Gate times • 10 MHz TCXO Time base • Auto decimal point • Overflow indicator • Leading zero blanking • Resolution to 0.1 Hz • Built-in charging circuit for NiCd batteries.

Brief Specifications: Frequency Range, switch selectable, 10 MHz, 100MHz, 600 MHz • Sensitivity, ± 10mV RMS to 100 MHz, ± 50mV RMS, 100 MHz to 450 MHz; 90mV RMS 450 MHz to 600 MHz • Impedance, 1 MΩ, 10 MHz and 100 MHz ranges; 50Ω, 600 MHz range • Gate time (switch selectable) 0.1 sec, 1 sec, 10 sec • Temperature stability, 0.1 ppm/°C • Ageing rate < ± 5 ppm/yr • Accuracy, 1 ppm or 0.0001% • Input protection, 150V RMS to 10 kHz (declining with frequency) • Power Requirement, 4.5 to 6.5V DC @ 300mA (4 "C" cells) or optional AC adapter/charger (7.5 to 9V DC @ 300mA).

Also available Model 8110A, same as 8610A except maximum frequency is 100MHz and without battery charging circuit: \$59.95 kit

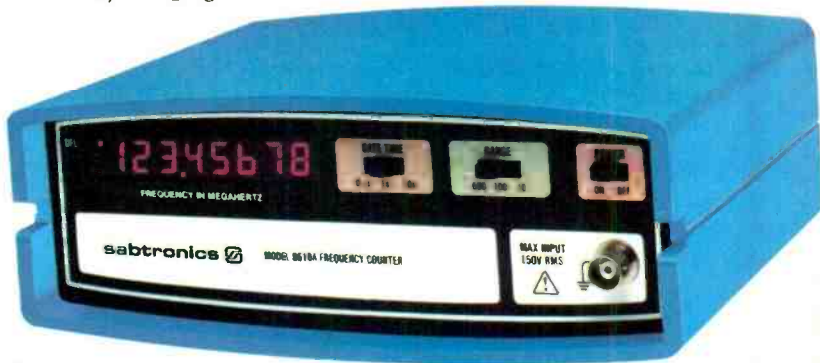

\$89.95

Ordering Information

USA - Add \$5.00 per kit for shipping & handling. Personal checks have to clear before goods are shipped (allow 2-3 weeks). For faster delivery send cashiers check or money order. 10% deposit for C.O.D. orders.

CANADA - Add \$6.00 per kit for shipping & handling. No C.O.D. Payment in U.S. funds.

OVERSEAS - Add \$21.00 per kit for airmail delivery. Payment by bank draft in U.S. funds.

Making Performance Affordable

sabtronics INTERNATIONAL INC.

13426 Floyd Circle M/S24 Dallas, Texas 75243
Telephone 214/783-0994

Discover today's high-resolution 3½-digit DMM

B&K-PRECISION's LCD Model 2815



Model 2815 \$150

- 0.01 ohm, 100nA, 100 μ V resolution
- 0.1% DC accuracy
- Shielded and protected to stay accurate in rf fields
- Fully overload protected on all ranges
- Auto-zero and auto-polarity
- Alternating high-/low-power ohms ranges for solid-state circuitry measurements

Compare the resolution offered by the new B&K-PRECISION Model 2815 with any other DMM in its price class. Its high resolution stands alone. The 2815 also delivers 0.1% DC and 0.3% AC accuracy. For added convenience, a tilt stand is built-in.

Available for immediate delivery at your local B&K-PRECISION distributor

BK PRECISION
DYNASCAN CORPORATION

6460 West Cortland Street
Chicago, Illinois 60635 • 312/889-9087

In Canada: Atlas Electronics, Ontario
Int'l. Sys. Empire Exp. 270 Newtown Rd., Plainville, L.I., NY 11803

CIRCLE NO. 10 ON FREE INFORMATION CARD

(Continued from page 26)

$\pm 0.04\%$ CCIR (weighted peak). Combined record/playback flutter was only slightly greater at 0.033% and 0.055%. In the fast speeds, the transport wound through a C60 cassette in 70 seconds.

Meter ballistics were slightly slower than for a true VU meter, reading about 90% of the steady state value on 0.3-second tone bursts repeated once per second. The peak LEDs, of course, responded instantly to this signal, with a decay time of about a second. A 200-nW/m Dolby-level test tape gave a reading of

TIMER STANDBY mode, is that timing must be set to allow an extra minute or so of operation before the desired program appears, since the deck goes through the B.E.S.T. cycle whenever power is first applied.

Our only criticism concerns the exposed COMPUTER CAL buttons. Although the manual warns against touching START while the tape is in motion, as it will then be erased, it is too easy to make this mistake. We feel it would have been preferable had these buttons been located behind the hinged door.

Performance Specifications

Specification	Rating	Measured
R/P frequency response		
-20-dB level	Metafine: 25-17,000 Hz ± 3 dB TDK SA: 25-17,000 Hz ± 3 dB Maxell UD-XL I: 25-16,000 Hz ± 3 dB	44-17,500 Hz ± 3 dB 40-18,500 Hz ± 3 dB 34-17,500 Hz ± 3 dB
0-dB level	Metafine: 25-12,500 Hz ± 3 dB TDK SA: 25-8,000 Hz ± 3 dB	38-16,000 Hz ± 3 dB 40-12,000 Hz ± 3 dB
With B.E.S.T., -20 dB for all tape types	40-12,500 Hz ± 1 dB	100-13,000 Hz ± 1 dB (MET) 100-13,800 Hz ± 1 dB (SA) 75-12,000 Hz ± 1 dB (XL-I) 75-11,500 Hz ± 1 dB (FeCr) 60 dB
S/N Ratio ANRS OFF	60 dB (A-wtd, 1 kHz, 3% THD, Metafine tape)	
ANRS ON	Improved by 5 dB at 1 kHz by 10 dB above 5 kHz	Improved 9.5 dB wide-band (CCIR/ARM wtd)
Channel separation	35 dB at 1 kHz	55 dB at 1 kHz
Flutter	0.035% wrms 0.12% DIN	0.028% wrms 0.04% DIN/CCIR
Harmonic distortion (1 kHz, metal tape)	0.4% 3rd harmonic at 0 dB	0.7%
FF/rewind time (C60)	85 seconds	70 seconds
Input sensitivity	MIC 0.2 mV LINE 78 mV	0.16 mV 70 mV
Outputs	LINE 0-300 mV PHONES 0.5 mW max, 8-1,000 ohms	Max. 260 to 287 mV Not measured

+3.5 dB on the recorder's meters; +1 dB corresponded to the 160-nW/m used on some test tapes; and +5 dB corresponded to the 250 mW/m used on more recent tapes. The headphone level was sufficient to drive even 200-ohm phones to uncomfortable listening levels.

User Comment. The B.E.S.T. system made all tapes essentially equal in low-level frequency response. Other differences, such as headroom, distortion, noise, and dropouts, remained measurable and sometimes audible.

Fortunately, considering the sophistication of the product, the owner's manual is very specific in warning of possible incorrect operation. For instance, if the TIMER STANDBY switch is left on in RECORD, the next time power is applied, the deck will go into record and erase anything on the tape. Hence, one must take care to set the TIMER switch to OFF before shutting off the deck or return recorded cassettes to proper storage. Another peculiarity, related to the

Overall sound quality of the deck was easily as good as we have ever heard from a cassette recorder. Our severe test of reproducing FM interstation hiss was easily passed. With UD-XL I tape, there was a barely audible difference between reference signal and tape playback—not in the high frequencies, but in the low-frequency quality. Using the other tapes, the deck rendered the noise signal very accurately, which is unusual, especially because the recording level was -5 dB on the meters. The unit's exceptional headroom of 7 to 8 dB above indicated 0 dB paid off here.

Although our signal sources were limited to disc records, we can attest that the KD-A8's performance, especially with Metafine tape rivals that of some fine open-reel decks. Yet, considering its exceptional versatility and compatibility with virtually any quality tape, its price is certainly reasonable. If you're a dedicated tape nut, it will probably seem attractive.

CIRCLE NO. 101 ON FREE INFORMATION CARD

ORIGINAL MASTER RECORDING

A BRAND NEW EXPERIENCE

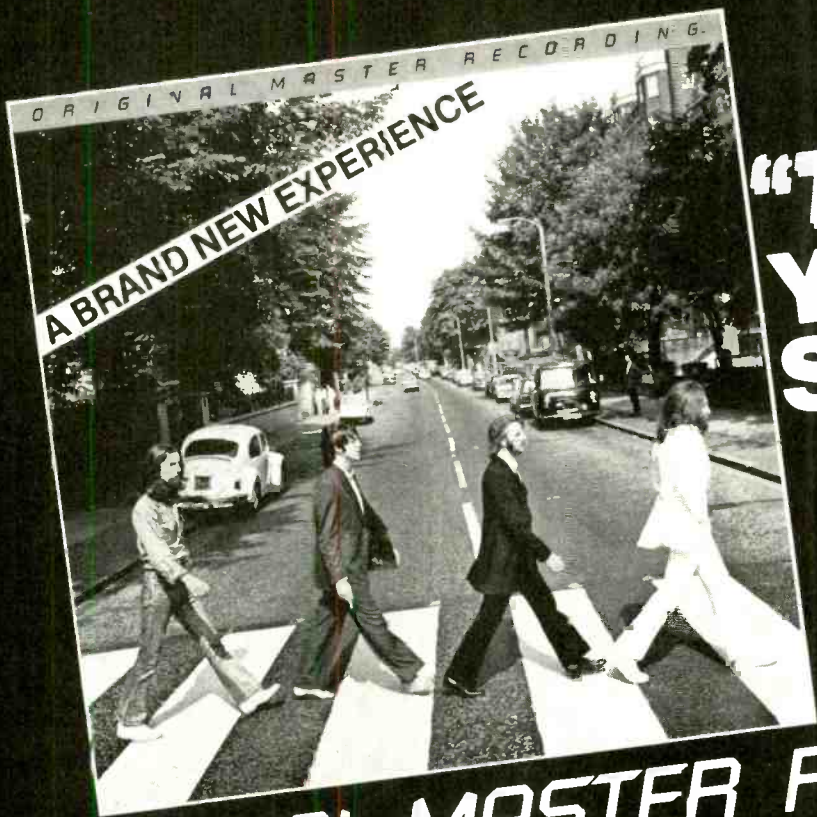

“TURN ON”
YOUR
STEREO

ORIGINAL MASTER RECORDINGS™ The State Of The Art.

The key high fidelity component guaranteed to improve your stereo system. **Super High Fidelity** is achieved by total quality control, using **only Original Stereo Master Tapes!** Our exclusive **Half-Speed Mastering** technique insures natural musical clarity and impact; our high definition **Super Vinyl** disc is custom pressed overseas. Each pressing is protected by a **Static Free Inner Sleeve** and placed in a **Special Heavy Duty Protective Package.** The result is your favorite music by your favorite artists on the highest quality, **Limited Edition** pressings. Your stereo system will **come alive** with the sounds of the original performance!

Available from select audio stores!

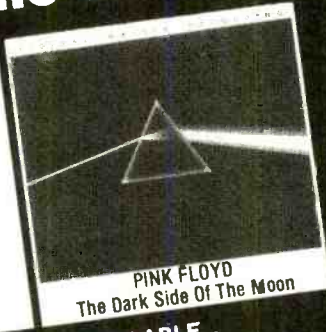

- ALSO AVAILABLE...
- JOE SAMPLE
 - AL STEWART
 - THE MYSTIC MOODS ORCHESTRA
 - JOHN KLEMMER
 - STEELY DAN
 - THE CRUSADERS
 - L.A. PHILHARMONIC ORCHESTRA
 - GEORGE BENSON
 - LITTLE FEAT
 - GRATEFUL DEAD
 - EMMYLOU HARRIS
 - GORDON LIGHTFOOT



P.O. BOX 919 • CHATSWORTH, CA 91311
(213) 993-4945
CIRCLE NO. 36 ON FREE INFORMATION CARD

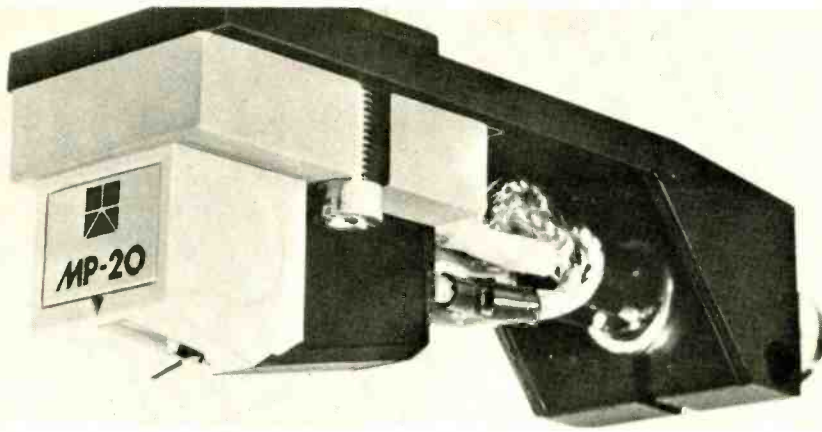

Osawa Model MP20 induced-magnet stereo phono cartridge



THE NEW Osawa MP20 phono cartridge heads the line of cartridges imported from Japan by Osawa & Co.

(USA), Inc. Like the previous Osawa cartridges, the MP20 employs the induced magnet principle, but several refinements in details provide it with exceptional performance qualities.

Price of the MP20 is \$175. The cartridge is also available installed in a magnesium-aluminum universal headshell as the Model MP20H for \$200.

General Description. The fixed magnet is made of samarium-cobalt, enabling the mass and size of the magnet system to be reduced without sacrifice of magnetic strength. The armature, moved by the stylus cantilever, is of the permalloy magnetic material used in other Osawa cartridges. The cartridge body is molded of a fiberglass-reinforced plastic for high rigidity and freedom from internal resonances. Its mounting surface is exceptionally thick and contacts the headshell of the tonearm over an extended area to ensure close alignment with the shell surface. The contact pins are gold-plated to prevent corrosion and provide a low-resistance electrical connection. The stylus assembly is easily replaceable by the user.

The moving system of the Osawa MP20 is responsible for much of its outstanding performance. The stylus cantilever is made of boron, an extremely hard, rigid material, and is supported by a butyl-rubber damping system that maintains the compliance constant over a wide range of temperature and humidity conditions. The diamond stylus shape is elliptical with radii of 0.4×0.7 mils and is nude-mounted to the cantilever.

The MP20 is meant to be terminated in 47,000 ohms shunted by a 100-picofarad capacitance, and has a nominal output of 4 millivolts at a 5-cm/s velocity, with channels balanced within 1.5 dB. The frequency response (no test record or tolerance is specified) is given as 20 to 23,000 Hz. The range of tracking forces is 1.5 to 2.0 grams, with 1.8 grams being the optimum force. The cartridge is slightly heavier than some, weighing 7.8 grams.

Laboratory Measurements. We installed the cartridge in the moderately massive tonearm of an integrated record player and operated it at the recommended 1.8-gram force. The ability of the cartridge to track very high velocities was demonstrated by the excellent sine-wave output it produced from the 30-cm/s 1000-Hz tones on the Fairchild 101 test record. The 300-Hz tones of the German Hi Fi Institute record were playable at their maximum 100-micron level without audible distortion, and at the 90-micron level when we used the 1.5-gram minimum rated force. Very high-level 32-Hz tones on one of our records were tracked easily even when the force was a mere 0.6 gram!

Cartridge output was 4 mV when playing

the 3.54-cm/s standard-level bands of the CBS STR100 test record with the levels of the two channels matched within 0.2 dB. The 1000-Hz square wave of the CBS STR112 test record showed about 4 cycles of damped ringing at about 20,000 Hz. Our measured vertical stylus angle with the CBS STR160 record was 23° .

Measurements with several types of test records showed a very flat frequency response up to about 15,000 Hz, with a rising output between 15,000 Hz and the 20,000-Hz upper limit of most of the records. The output was typically 4 to 6 dB higher at 20,000 Hz than at 1000 Hz. To verify the high-frequency stylus resonance, we used the JVC TRS-1005 record, which sweeps from 1 to 50 kHz. The peak, approximately 2.5 dB in amplitude, was at about 25,000 Hz, after which the output fell off rapidly.

To a greater extent than frequency response, the measured channel separation of a cartridge is a function of the test record used. Results obtained from a number of test records yielded 25 to 30 dB of separation in midrange. There was a wider variation in the separation at 20,000 Hz, ranging from 10 to 25 dB, depending on the test record used. With the TRS-1005 record, we found that channel separation maintained a strong 20 dB or more at frequencies well above the 25,000-Hz stylus resonance.

Tracking distortion of the cartridge was measured with the Shure TTR102 and TTR103 test records. Behavior of the MP20 was rather unusual with both rec-

smooth, flat
response with
no coloration
of any kind

ords. IM distortion with the TTR102 record and the 10.8-kHz tone-burst distortion on the TTR103 record varied only slightly over the wide range of recorded velocities on these test records. Measured values fell between 1.7% and 3% at velocities from 7 to 30 cm/s. Although we have measured lower distortion from a number of cartridges at low velocities, we have rarely seen such low distortion, particularly IM, at the highest velocities.

The tracking ability of the MP20 was emphatically confirmed when we played the Shure ERA III and ERA IV "Audio Ob-

Performance Specifications

Specification	Rating	Measured
Output voltage (1 kHz, 3.54 cm/s)	2.8 mV	4 mV
Channel balance (1 kHz)	1.5 dB	0.2 dB
Frequency response	20-23,000 Hz	Confirmed
Channel separation (1 kHz)	25 dB	30 dB (STR100)
Weight	7.8 grams	Not measured
Tracking-force range	1.5-2.0 grams (optimum 1.8 grams)	Confirmed
Recommended load	47,000 ohms; 100 pF	Confirmed

stacle Course" records. The highest levels of every selection on both records were played with no sense of strain at the rated 1.8-gram force of the cartridge. This has been matched by at most one or two cartridges that we have tested in the past.

User Comment. With respect to its relatively high output, close channel-level matching, outstanding channel separation, and low distortion, the MP20 is one of the most refined and compromise-free cartridges on the market. It will track anything we know of that has been recorded commercially on discs. It sounds every bit as good as it measures—better, in fact, since we could not hear any effects of high-frequency resonance. Of course, there is little or no program material on records above 15,000 Hz, and most speakers have a reduced output at those frequencies. In addition, although load capacitance does not seem to be critical, the total presented by our turntable cables and preamp input considerably exceeds

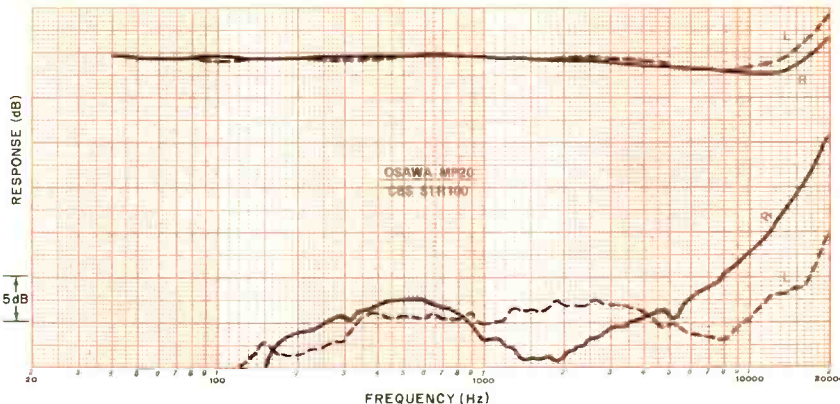

Frequency response and crosstalk for left and right channels.

100 pF. At any rate, we heard only a smooth, flat response with no coloration of any kind, and with the sense of ease that denotes solid tracking and low distortion.

It looks and sounds to us as though Osa-
wa has added a worthy leader to its car-
tridge product line.

CIRCLE NO. 102 ON FREE INFORMATION CARD

Celestion Ditton 662 three-way speaker system with passive radiator



THE Ditton 662 is the top of Celestion's line of loud-speaker systems. Employing a three-way design, it has

dome-type midrange and treble drivers and a 12" (305-mm) woofer working in conjunction with a 12" passive radiator. Celestion calls the latter an "Auxiliary Bass Radiator," or ABR. Rated response of this floor-standing model is 38 to 20,000 Hz \pm 3 dB into a 2-pi-steradian space (a hemisphere) in front of the unit.

Impedance is a nominal 8 ohms, and the Ditton is rated to handle 20 to 160 watts of continuous power. It is also rated to deliver a 90-dB SPL when driven by 2.9 watts of pink noise.

The system enclosure measures 41%¹/₂" H \times 15%³/₄" W \times 11%¹/₄" D (1057 \times 400 \times 298 mm) and weighs about 75 lb (34 kg). The enclosure is available in oiled American walnut or elm finish. Two snap-on grilles cover the entire front surface of the cabinet. Price is \$749.50.

mirror-image pairs
provide good
stereo spread

General Description. More than half the 90-liter volume of the cabinet is devoted to the bass radiators. The two heavy 12" cones appear to be superficially identical, but the lower ABR lacks a voice coil and magnet structure and has an 18-Hz resonant frequency. Combined with the driven radiator, the ABR gives the bass system a Q of 0.49 and a -3-dB point of 38 Hz.

Crossover to a 2" (50.8-mm) dome radiator occurs at 700 Hz. The crossover network includes compensating components to equalize the impedance variations of the midrange driver and provide a proper resistive termination for a third-order Butterworth bandpass filter. A similar approach is used in the treble crossover, which drives a ¾" (19.1-mm) dome tweeter at frequencies from 4500 Hz to the upper limit of the speaker system. The tweeter is protected by a 500-mA fast-acting fuse. No external midrange and tweeter level controls are provided.

Both upper-range drivers are offset from the center line of the cabinet. Accordingly, to ensure good stereo imaging, the systems are made in mirror-image pairs.

Laboratory Measurements. We set up two Ditton 662s in the front of our listening room in the normal stereo configuration, locating them about 6" (152 mm) from the wall. The response curve in the reverberant field of the room revealed a smooth, slightly rising high end, with only a slight difference in high-frequency response between the two speaker systems when measured on-axis of one and about 30° off-axis of the other. This condition indicates good high-frequency dispersion.

Bass response was measured separately for the driven and passive (ABR) cones, using close mike spacing. We then combined the two curves to form the bass curve of the system. Acoustic crossover between the two cones occurred at about

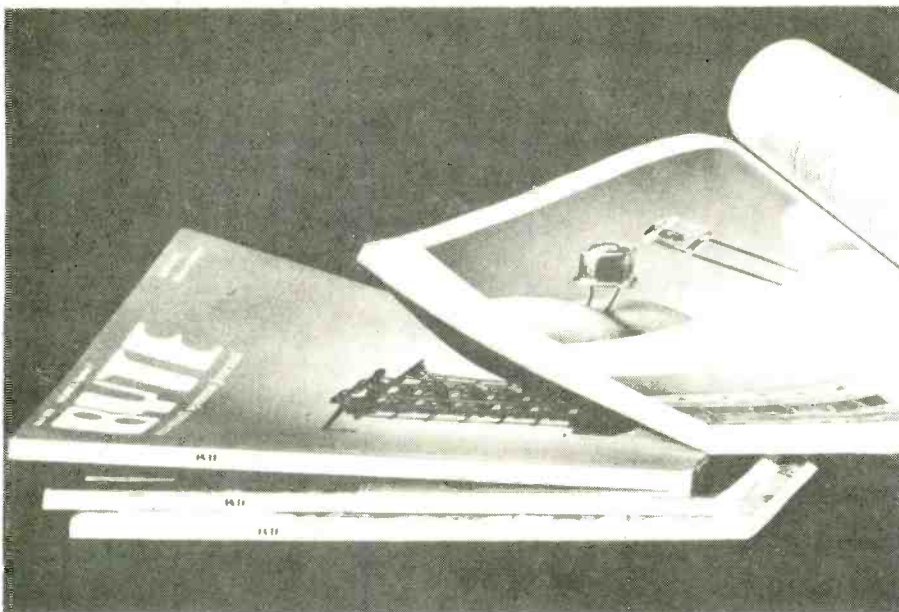

Get the inside story...

on software, hardware, simulations, computer games, robotics, computers and calculators, languages and compilers, custom systems design and scores of applications.

Read **BYTE**®

BYTE, the leading magazine in the personal computer field, will keep you aware of fast-paced changes in the ever growing world of microprocessors. You'll find **BYTE** tutorials invaluable, reports on home computer applications instructive, and the reviews of computer products stimulating.

Tutorial information in **BYTE** is of interest to both the beginner and experienced computer user. **BYTE**'s editorial content explores the fun of using and applying computers for personal satisfaction in activities from electronic music to electronic mail,

from games to pragmatic personal business. In **BYTE** is found authoritative yet easily read coverage of principles of computer hardware and software design, approaches to novel applications, and essentials of proven interest to personal computer enthusiasts.

Each month serious computer users read **BYTE**. They're rewarded with timely articles by professionals, computer scientists and competent amateurs. Isn't it time you got the inside story? Subscribe now to **BYTE**, the Small Systems Journal.

Fill in and mail the coupon today. Read your first copy of **BYTE**. If it is everything you expected, honor our invoice. If it isn't, just write "Cancel" on the invoice and mail it back. You won't be billed and the first issue is yours at no charge.

Allow 6 to 8 weeks for processing. If you have any questions, dial toll free 800-258-5485. This is the number of the **BYTE** Subscription Department.

© **BYTE** Publications, Inc. 1978

BYTE Subscription Dept. P.O. Box 590 Martinsville, NJ 08836

Please enter my subscription for

One year \$15 (12 issues) Two years \$27 Three years \$39

Check enclosed entitles me to 13 issues for price of 12 (North America only)

Bill Visa Bill Master Charge Bill me (North America only)

Card Number _____ Expiration Date _____

Signature _____ Name (please print) _____

Address _____

City _____ State/Province/Country _____ Code _____

Foreign Rates (To expedite service, please remit in U.S. Funds)

Canada or Mexico One year \$17.50 Two years \$32 Three years \$46.50

Europe, one year (air delivered) \$25

All other countries, one year (surface delivered) \$25. Air delivery available on request.

7339

CIRCLE NO. 12 ON FREE INFORMATION CARD

55 Hz. Splicing the bass curve to the mid-range and high-frequency curve, we obtained an overall frequency-response variation of ± 3.5 dB from 27 to 20,000 Hz, which slightly bettered Celestion's rating. Needless to say, this is excellent performance from any speaker system. The shape of the curve suggested either a slight rise at the low- and high-frequency ends of the spectrum or a broadly depressed midrange. Our curve revealed a strong resemblance to the anechoic response curves published by Celestion in that the rises and dips occurred at the same frequencies, although they tended to be slightly greater in our measurements.

Bass distortion of the woofer system was exceptionally low. At a 1-watt input, distortion was less than 1% down to 40 Hz and rose slowly to 2.5% at 30 Hz and 7% at 25 Hz. (These figures were derived by

sounded right with every kind of music and delivered prodigious low-bass output

combining readings made at the driven and passive cones.) Increasing the drive to 10 watts made surprisingly little difference in distortion at most frequencies: measurements were 3.6% at 30 Hz and 10% at 25 Hz.

System impedance was about 8 ohms in local minima at 100 and between 1000 and 2000 Hz and dropped to about 7 ohms at 20,000 Hz. Maximum values were 22 ohms at 5000 Hz, 38 ohms at 50 Hz, and more than 50 ohms at 20 Hz. When driven by 2.83 volts of random noise in the octave centered at 1000 Hz, the system delivered an 89-dB SPL 1 meter from the grille. This is slightly greater sensitivity than rated, although the measurements were made under somewhat different conditions. The tone-burst response was good at all frequencies tested though not exceptional.

User Comment. We were impressed with the smoothness and balance of the Ditton 662's sound. There was no harshness or other unnatural coloration to remind us that we were listening to a speaker system. In every part of the audio range, this speaker system easily held its own in A-B comparison with other fine speaker systems. It sounded "right" with every type of music we played and delivered prodigious low-bass output without distortion when called upon to do so. The sound was never heavy or boomy, even on male voices. Stereo imaging was good.

This is one speaker system we would be happy to live with on a long-term basis. Its excellent musical properties are sufficient to overcome our reluctance to make room for a pair of large, heavy boxes.

CIRCLE NO. 103 ON FREE INFORMATION CARD

Six professional scopes offer build-it-yourself savings

Save up to 46% when you build it yourself.

Only in the Heathkit Catalog will you find this selection of six professional oscilloscopes, each with its own special features and low price. Compare Heathkit prices with similar assembled scopes and see how much you can save when you build it yourself.

Heathkit Model	Trace	Bandwidth MHz	Vertical Sensitivity*	Delay Lines	Regulated high voltage	Mu-metal shielding	Low kit price
10-4235	dual	DC-35	2mV/cm to 10V/cm	yes	yes	full	\$869.95
10-4510	dual	DC-15	1mV/cm to 5V/cm	yes	yes	full	\$649.95
10-4550	dual	DC-10	10mV/cm to 20V/cm	no	yes	full	\$399.95
10-4555	single	DC-10	10mV/cm to 20V/cm	no	yes	full	\$349.95
10-4205	dual	DC-5	10mV/cm	no	no	partial	\$279.95
10-4105	single	DC-5	10mV/cm	no	no	partial	\$199.95

*Under full bandwidth

Heathkit manuals make kitbuilding easy



Easy-to-follow Heathkit assembly manuals take you step by step from unpacking to final plug-in. Anyone can do it. And when you build it yourself, you can service it yourself. Your manual becomes a handy service guide.

Replacement parts are readily available from the Heath factory or from Heathkit Electronic Centers. And experienced service techs are just a phone call away to help you during building or servicing.

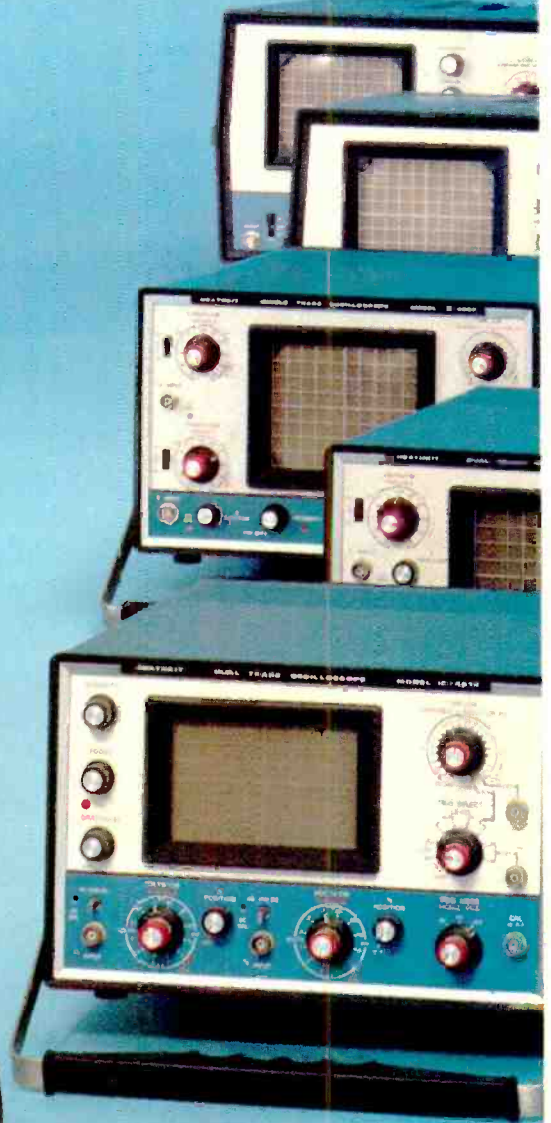

FREE Catalog



Complete details on Heathkit Oscilloscopes and nearly 400 other Heath electronic kits for your home, work or pleasure are in the new Heathkit Catalog. Send for yours today or pick one up at your Heathkit Electronic Center.

Heathkit®

Heathkit Products are also sold and serviced at Heathkit Electronic Centers (units of Veritechnology Electronics Corporation) in major cities throughout the U.S. See your white pages.

GX-375

Heath Company, Dept. 010-616, Benton Harbor, MI 49022

You gotta shop around.

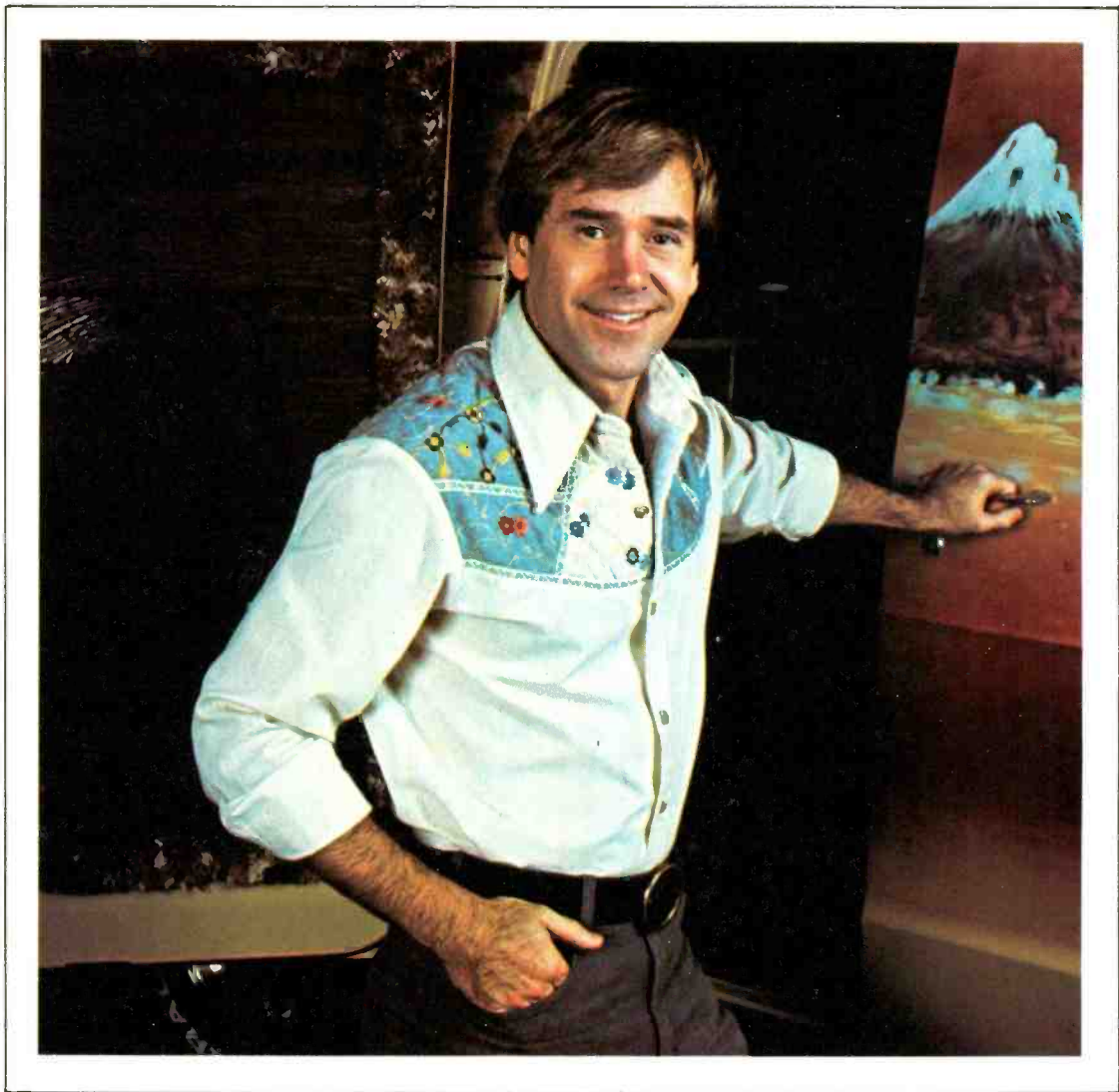

**When you do, you'll probably pick CIE.
You can't afford to settle for
less when it comes to something like
electronics training that could
affect your whole life.**

When you shop around for tires, you look for a bargain. After all, if it's the same brand, better price — why not save money?

Education's different. There's no such thing as "same brand." No two schools are alike. And, once you've made your choice, the training you get stays with you for the rest of your life.

So, shop around for your training. Not for the bargain. For the best. Thorough, professional training to help give you pride and confidence.

* * *

If you talked to some of our graduates, chances are you'd find a lot of them shopped around for their training. They pretty much knew what was available. And they picked CIE as number one.

Why you should shop around yourself.

We hope you'll shop around. Because, frankly, CIE isn't for everyone.

There are other options for the hobbyist. If you're the ambitious type — with serious career goals in electronics — take a close look at what we've planned for you at CIE.

What you should look for first.

Part of what makes electronics so interesting is it's based on scientific discoveries — on ideas! So the first thing to look for is a program that starts with ideas and builds on them!

That's what happens with CIE's Auto-Programmed® Lessons. Each lesson takes one or two principles and helps you master them — before you start using them!

How practical is the training?

This is the next big important question. After all, your career will be built on what you can do — and on how well you do it.

Here are ways some of CIE's troubleshooting programs help you get your "hands-on" training...

With CIE's Experimental Electronics Laboratory...



you learn and review the basics — perform dozens of experiments. Plus, you use a 3-in-1 precision Multimeter to learn testing, checking, analyzing!



When you build your own 5 MHz Triggered-Sweep, Solid-State Oscilloscope you take your first real professional step. You use it as a doctor uses an X-ray machine — to "read" waveform patterns... lock them in... study, understand and interpret them!

When you get your Zenith 19-inch Diagonal Solid-State Color TV you

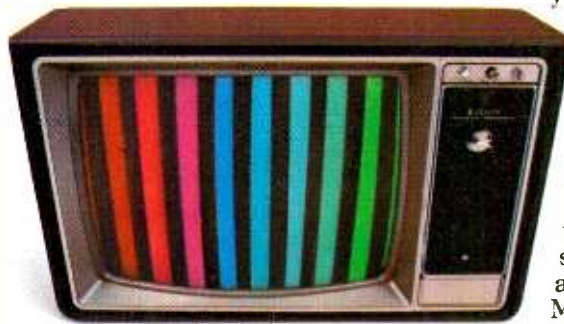

Pattern simulated.

apply your new skills to some real on-the-job-type troubleshooting! You learn to trace signal flow... locate malfunctions... restore perfect operating standards — just as with any sophisticated electronics equipment!



When you work with a completely Solid-State Color Bar Generator — actually a TV signal transmitter — you study up to ten different patterns on your TV screen... explore digital logic circuits... observe the action of a crystal-controlled oscillator!

Of course, CIE offers a more advanced training program, too. But the main point is

simply this:

All this training takes effort. But you'll enjoy it. And it's a real plus for a troubleshooting career!

Do you prepare for your FCC License?

Avoid regrets later. Check this out before you enroll in any program.

For some troubleshooting jobs, you must have your FCC License. For others, employers often consider it a mark in your favor. Either way, it's government-certified proof of specific knowledge and skills!

More than half of CIE's courses prepare you for the government-administered FCC License exam. In continuing surveys, nearly 4 out of 5 CIE graduates who take the exam get their Licenses!

Shop around... but send for CIE's free school catalog first!

Mail the card. If it's gone, cut out and mail the coupon. If you prefer to write, mention the name and date of this magazine. We'll send you a copy of CIE's FREE school catalog — plus a complete package of independent home study information! For your convenience, we'll try to have a representative contact you to answer your questions. Mail the card or coupon — or write: CIE, 1776 East 17th St., Cleveland, OH 44114.

CIE Cleveland Institute of Electronics, Inc.

1776 East 17th Street, Cleveland, Ohio 44114
Accredited Member National Home Study Council

YES... I'm shopping around for the **right** kind of career training in electronics troubleshooting — and CIE sounds well worth looking into. Please send me my FREE CIE school catalog — including details about troubleshooting courses — plus my FREE package of home study information! PE06

Print Name _____

Address _____ Apt. _____

City _____

State _____ Zip _____

Age _____ Phone _____ (area code)

Check box for G.I. Bill information:
 Veteran Active Duty

Mail today!

From PERCOM

One-Drive System:

\$399. (40-track) & \$675. (77-track)

Two-Drive System:

\$795. (40-track drives) & \$1350. (77-track drives)

Three-Drive System:

\$1195. (40-track drives) & \$2025. (77-track drives)

Requires Expansion Interface, Level II BASIC & 16K RAM.

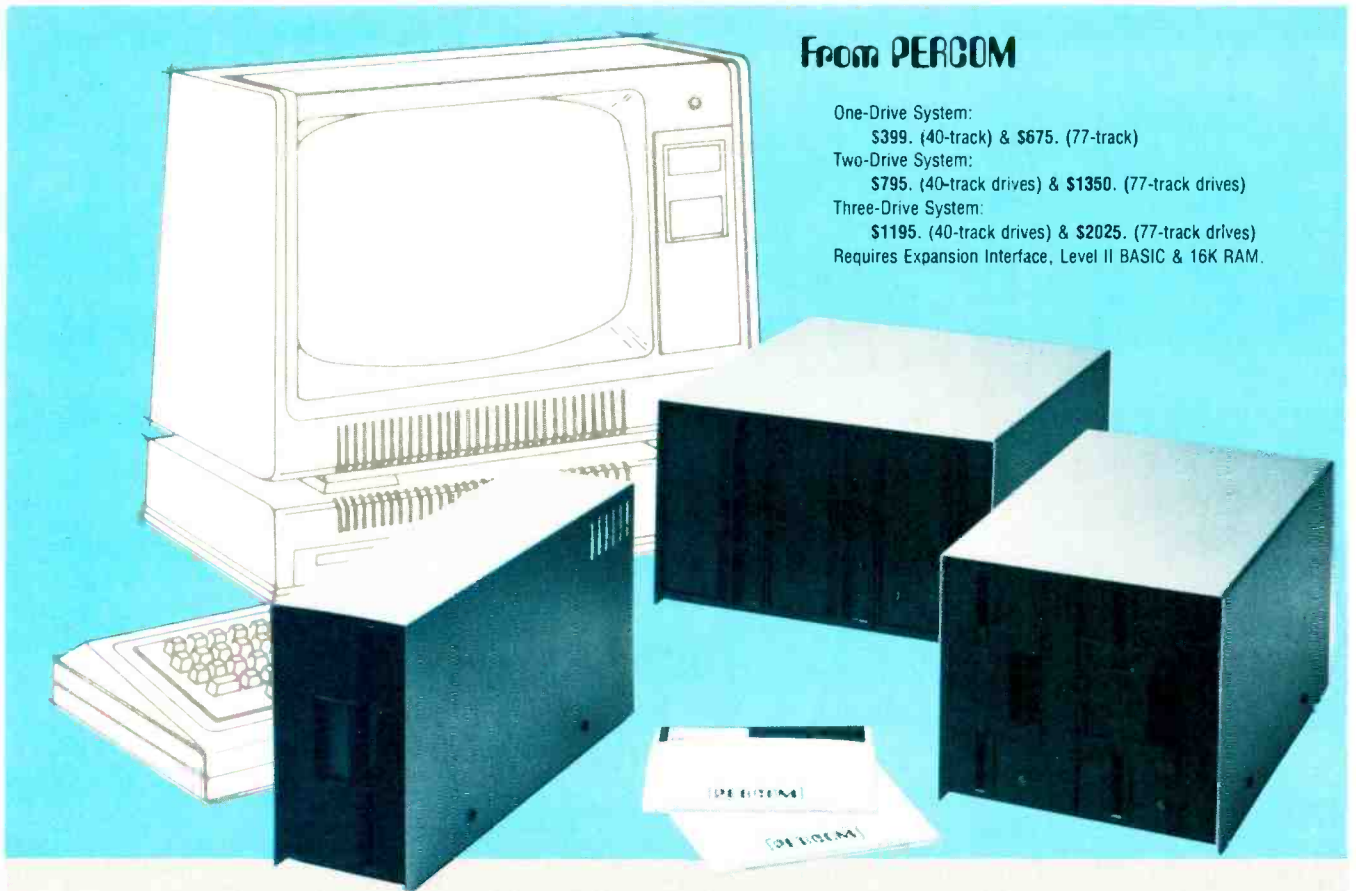

Low Cost Add-On Storage for Your TRS-80*. In the Size You Want.

When you're ready for add-on disk storage, we're ready for you.
Ready with six mini-disk storage systems — 102K bytes to 591K bytes of
additional *on-line* storage for your TRS-80*.

- Choose either 40-track TFD-100™ drives or 77-track TFD-200™ drives.
- One-, two- and three-drive systems immediately available.
- Systems include Percom PATCH PAK #1™, on disk, at no extra charge. PATCH PAK #1™ de-glitches and upgrades TRSDOS* for 40- and 77-track operation.
- TFD-100™ drives accommodate "flippy disks." Store 205K bytes per mini-disk.
- Low prices. A single-drive TFD-100™ costs just \$399. Price includes PATCH PAK #1™ disk.
- Enclosures are finished in system-compatible "Tandy-silver" enamel.

Whether you need a single, 40-track TFD-100™ add-on or a three-drive add-on with 77-track TFD-200™s, you get more data storage for less money from Percom.

Our TFD-100™ drive, for example, lets you store 102.4K bytes of data on one side of a disk — compared to 80K bytes on a TRS-80* mini-disk drive — and 102.4K bytes on the other side, too. Something you can't do with a TRS-80* drive. That's almost 205K bytes per mini-disk.

And the TFD-200™ drives provide 197K bytes of on-line storage per drive

— 197K, 394K and 591K bytes for one-, two and three-drive systems.

PATCH PAK #1™, our upgrade program for your TRSDOS*, not only extends TRSDOS* to accommodate 40- and 77-track drives, it enhances TRSDOS* in other ways as well. PATCH PAK #1™ is supplied with each drive system at no additional charge.

The reason you get more for less from Percom is simple. Peripherals are not a sideline at Percom. Selling disk systems and other peripherals is our main business — the reason you get more engineering, more reliability and more back up support for less money.

In the Product Development Queue . . . a *printer interface* for using your TRS-80* with any serial printer, and . . . the *Electric Crayon*™ to map your computer memory onto your color TV screen — for games, animated shows, business displays, graphs, etc. Coming PDQ!

™ TFD-100, TFD-200, PATCH PAK and Electric Crayon are trademarks of PERCOM DATA COMPANY.
*TRS-80 and TRSDOS are trademarks of Tandy Corporation and Radio Shack which have no relationship to PERCOM DATA COMPANY.

PERCOM

PERCOM DATA COMPANY, INC.
211 N. KIRBY • GARLAND, TX. • 75042

To order add-on mini-disk storage for your TRS-80*, or request additional literature, call Percom's toll-free number: 1-800-527-1592. For detailed Technical information call (214) 272-3421.

Orders may be paid by check or money order, or charged to Visa or Master Charge credit accounts. Texas residents must add 5% sales tax.

Percom 'peripherals for personal computing'

THOUGH its function as a personal warning monitor is not as important as that of a fire alarm or a gas detector, a radiation monitor can give peace of mind to people who are apprehensive about the hazards of possible radiation leakage and radioactive devices. This concern is obviously heightened whenever the news media report a nuclear incident of one kind or another.

The RED-ONE battery-powered radiation monitor project described here detects local radiation levels from man-made and natural sources. It indicates relative radiation, which is perfectly satisfactory for alerting one to excess radiation levels.

Two versions of the monitor are described. The simpler one produces an audible "chirp" for each detected gamma ray. The other teams up a three-decade counter with the basic circuit to count and display gamma-ray events over a controlled period of time, sounding a chirp for each event.

The RED-ONE is a sophisticated unit that offers many advantages over earlier radiation detectors. Replacing fragile, cumbersome, and less-sensitive Geiger-Muller tubes, this monitor is built around a solid-state cadmium-telluride (CdTe) detector. About the size of a transistor, the device offers high sensitivity, low bias-voltage requirements, extremely low power consumption, and solid-state reliability. Moreover, cost is competitive with tube-detector types.

Radiation and Its Detection. Gamma rays can occur naturally (from substances such as uranium) or can be man-made (as in a nuclear power plant). Radioactive gases, such as those released during the Three Mile Island nuclear power plant incident, and medical diagnostic and therapeutic isotopes are typical man-made gamma-ray sources.

Each radioisotope produces gamma rays of specific energies which are measured in electron volts (eV), the energy acquired by an electron accelerated by a potential difference of one volt. Gamma rays have high energies mea-

BUILD A

Personal Radiation Monitor

Uses latest cadmium-telluride detector to provide audible or visual indication of radiation level

BY JOHN STEIDLEY
MARTIN NAKASHIAN and
GERALD ENTINE



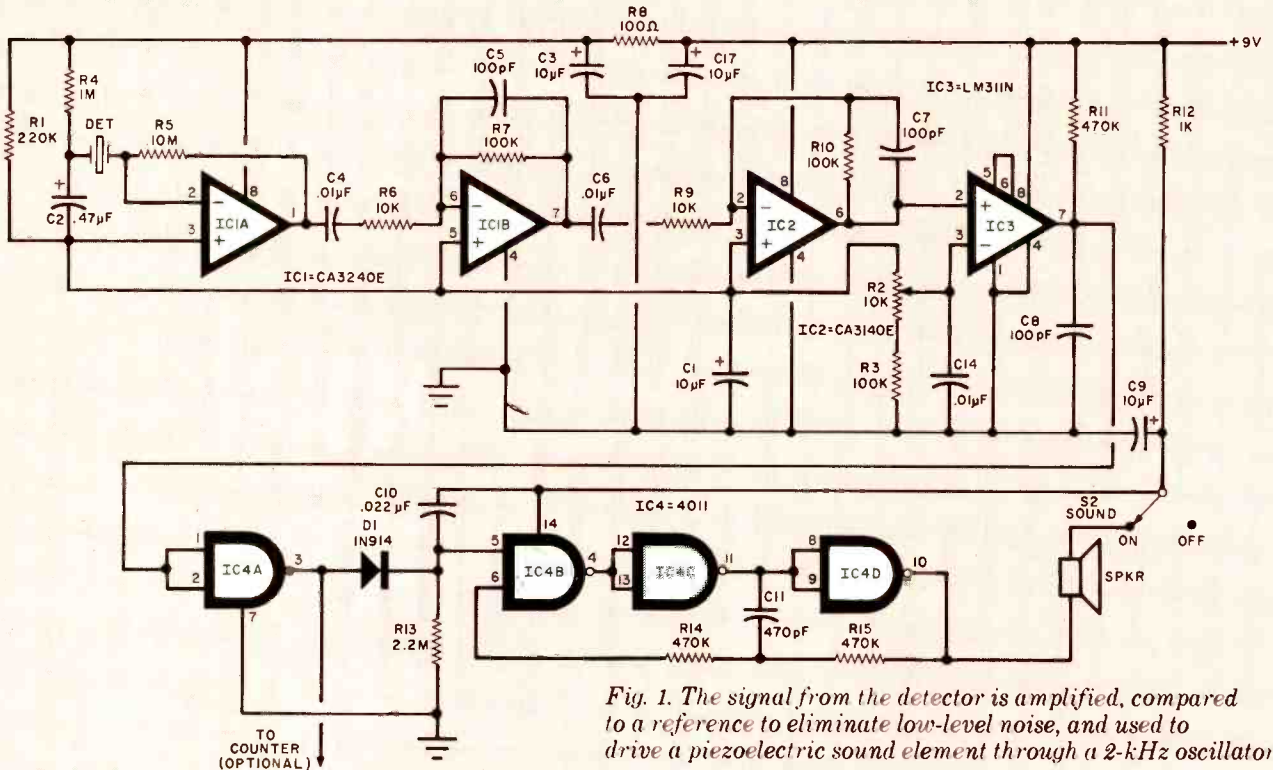

Fig. 1. The signal from the detector is amplified, compared to a reference to eliminate low-level noise, and used to drive a piezoelectric sound element through a 2-kHz oscillator.

PARTS LIST—FIG. 1

- C1, C3, C17—10- μ F, 16-V tantalum
- C2—0.47- μ F, 35-V tantalum
- C4, C6, C14—0.01- μ F disc ceramic
- C5, C7, C8—100-pF disc ceramic
- C10—0.022- μ F disc ceramic
- C11—470-pF disc ceramic
- D1—1N914 diode
- DET—CdTe radiation detector (see text and Note below)
- IC1—CA3240E dual FET op amp (RCA)

- IC2—CA3140E op amp (RCA)
 - IC3—LM311N comparator (National)
 - IC4—4011 quad NAND gate
- The following are 1/4-watt, 10% resistors unless otherwise specified:
- R1—220,000 ohms
 - R2—10,000-ohm pc potentiometer
 - R3, R7, R10—100,000 ohms
 - R4—1 megohm
 - R5—10 megohms
 - R6, R9—10,000 ohms
 - R8—100 ohms

- R11, R14, R15—470,000 ohms
 - R12—1000 ohms
 - R13—2.2 megohms
 - SPKR—Piezoelectric sound element (Kyocera KBS 27DB-3A or similar)
 - S2—Spst switch
 - Misc.—Suitable enclosure, 9-volt battery including holder and power on/off switch, 0.005" brass foil for shield, machine hardware, etc.
- Note—For availability of kit and parts, see Parts List for Fig. 2.

sured in thousands of electron volts (keV), the typical range being from 100 to 1000 keV. Lower-energy rays are absorbed by even a fraction of an inch of lead, while high-energy rays can pass through many inches of lead.

When gamma rays are absorbed by a CdTe detector such as that used in RED-ONE, an electrical-charge burst is produced and amplified to detect the event. Higher-energy rays produce greater charge bursts.

The gamma-ray sensor in RED-ONE is designed to allow detection of reasonable gamma-ray levels and to permit many interesting experiments to be made. For example, bricks in many New England fireplaces have detectable (though very-low-level) amounts of radioactivity. By observing indications with either version of the monitor, an estimate of activity level can be made.

About the Circuit. The basic detector/beeper circuit is shown in Fig. 1. The output of radiation detector DET goes to the input of the FET operational amplifier, which provides impedance matching and initial amplification. Additional amplification is provided by IC1B and IC2. Feedback capacitors C5 and C7 shape the pulse and improve S/N.

The output from IC2 at pin 6 is about 40 μ s wide and has a height that is proportional to the amount of charge deposited on the detector. Signal level here is about 1 mV/keV of collected charge. Unfortunately, thermally generated charge carriers and leakage current in the detector also produce about 30 mV of noise impulses. Adjustment of R2, however, ensures that comparator IC3 discriminates against and prevents this low-level noise from triggering the comparator. Signal pulses that override

the noise cause the comparator's output and, hence, NAND gate IC4A's input to go low. Resistor R13 keeps pin 5 of IC4B low to turn off the 2000-Hz (approximately) oscillator made up of IC4B, IC4C, IC4D, R14, R15, and C11.

When a detected event causes IC4A to go low, IC4A's output goes high. This high signal is passed through now forward-biased diode D1 to raise the pin-5 output of IC4B, which causes the oscillator to sound via the piezoelectric transducer, SPKR. The approximately 20-ms C10R13 time constant maintains the high state of pin 5 of IC4B. When IC4A reverts to low, D1 prevents rapid discharge of C10 and maintains the time constant. The oscillator thus generates a 20-ms chirp for each detected gamma-ray event.

If you wish to count and display the number of events as they are generated

Radiation Monitor *continued*

When *S5* is set to MANUAL, the pin-1 output from *IC9A* continuously increments the counter/display for each incoming count from *IC4A*. When 999 counts are exceeded, pin 14 of *IC10* goes low and, via NAND gate *IC5B*, clocks flip-flop *IC9B*. The output of *IC9B* at pin 13 is NANDed with a 2-Hz signal from *IC7* to flash OVER (*LED1*) two times a second.

This flashing continues until START switch *S4* is pressed to reset *IC9B*.

Internal timing is based on 100-Hz 555 timer oscillator *IC6*. Frequency is determined by *C13*, *R13*, *R30*, and adjustable *R29*. The oscillator drives divide-by-100 *IC7*, whose output at pin 14 is 1 Hz. Counter *IC8*, switch *S5*, NAND gate *IC5A*, and flip-flop *IC9A* generate

1-, 10-, 40-, and 100-second timing periods. START switch *S4* initiates timing by resetting the two counters and flip-flop.

Power for the Fig. 1 circuit can be a conventional 9-volt battery or dc power supply. When the Fig. 2 circuit is added, four AA cells in series can be used to power the LED display. POWER switch *S1* controls both power sources.

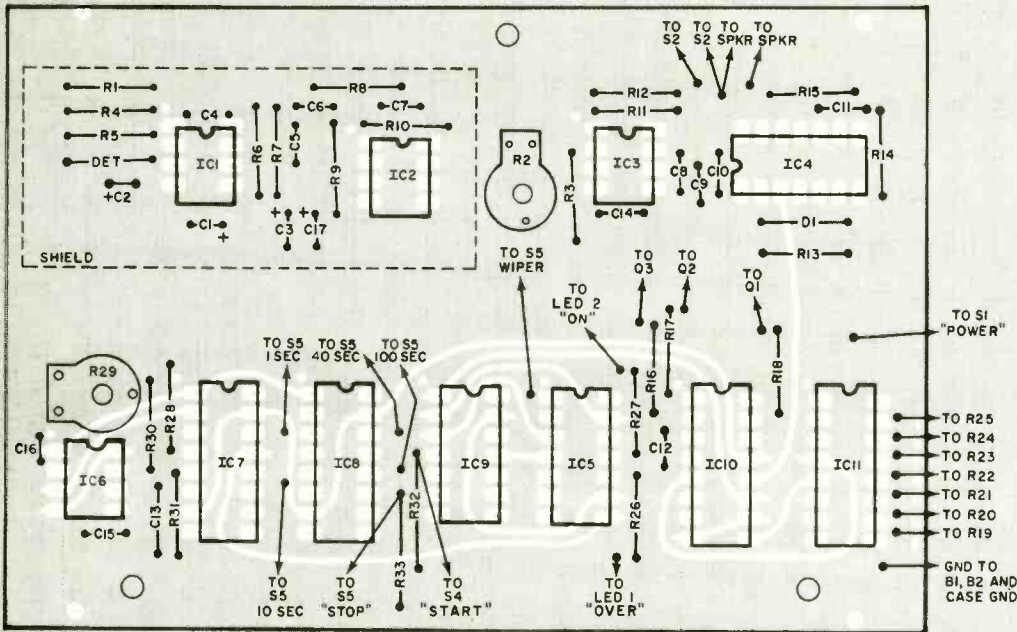
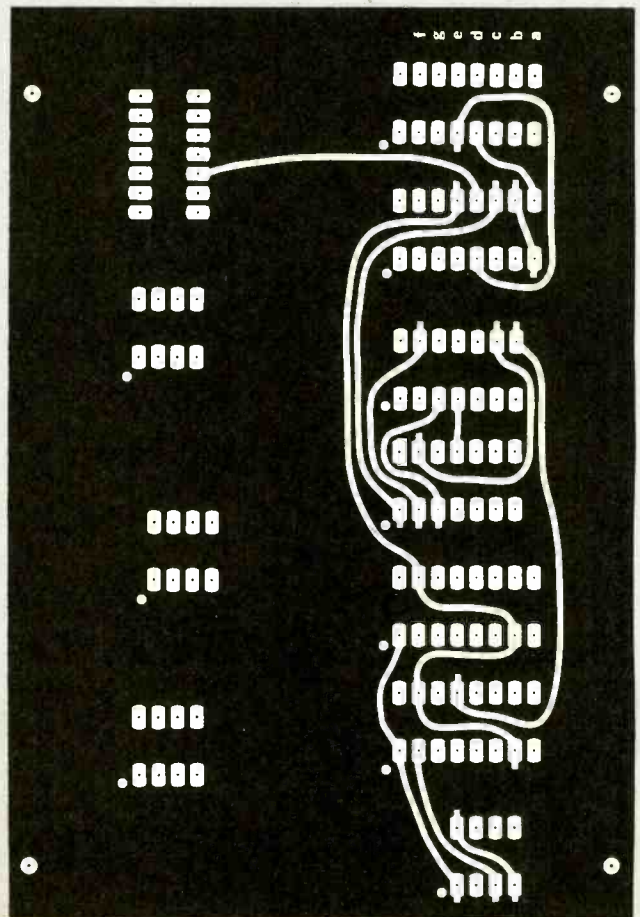
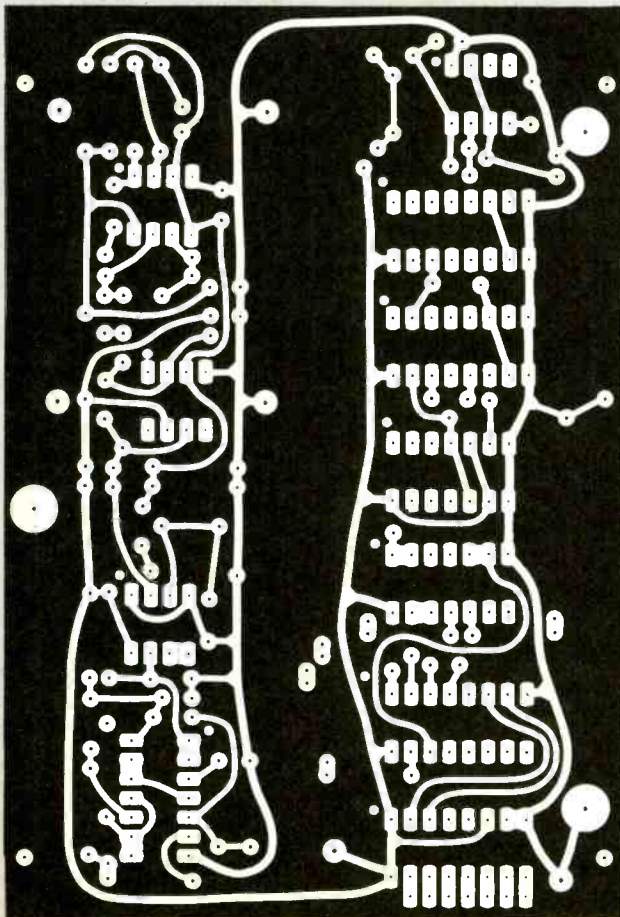

Fig. 3. Actual-size etching and drilling guides for the two-sided pc board are shown below. Component mounting on the top is at left. Note that the upper portion of the board (containing the audible circuit shown in Fig. 1) can be detached if only that circuit is to be used.



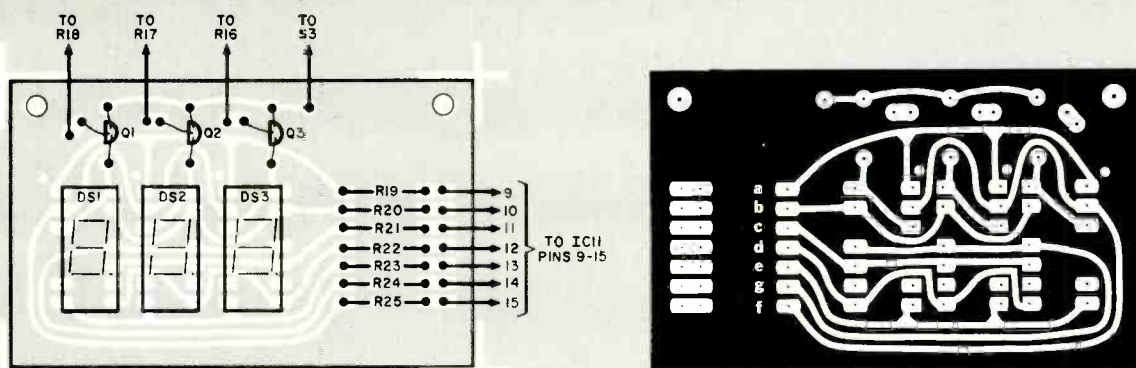

Fig. 4. Actual-size etching and drilling guide and component layout for the display board.

Construction. Since there are relatively high-impedance, low-level analog signals present in the *IC1* and *IC2* stages of RED-ONE, good circuit-board construction techniques *must* be exercised. The use of a printed circuit board and Molex Soldercons is strongly recommended.

Actual-size etching and drilling guides for the double-sided board and its component-placement diagram are shown in Fig. 3. At some component locations, pads appear only on the bottom side of the board. At these points, holes should be drilled from the bottom and components mounted from the top. If you elect to build only the beeper version of the Red One, you can separate and disregard the upper half of the guide. The only interconnecting trace between the two guide sections is from *IC4* to *IC10*.

The etching-and-drilling guide and component-placement diagram for the optional display board are shown in Fig. 4. This is a single-sided board.

In addition to normal precautions used when soldering solid-state devices, special care must be taken with the detector. Use a low-wattage, fine-tipped soldering pencil and fine solder and provide a heat sink for the leads with longnose pliers. Use only enough heat and solder to give reliable, solid connections.

Begin assembly by installing and soldering into place the resistors, capacitors, and Soldercons (if used) on the main pc board. Some points that require soldering on both sides of the board are indicated by short tabs on the pc pads. In addition, any pad on the component side of the board from which a foil runs requires soldering to the component lead. This suggests the use of Molex Soldercons as opposed to IC sockets. Provisions for using miniature clips at

critical test points and where interboard connections occur are indicated in the Fig. 3 component-placement diagram.

Tape a $\frac{1}{8}$ " (3.2-mm) thick piece of foam rubber around the detector to cushion it from mechanical shock. (Because of its piezoelectric design, any mechanical shock to it will cause the detector to generate a false output.) Use copper foil or 0.005" (0.13-mm)

thick brass to fabricate an electrical interference shield to prevent external influence on the low-level analog signals generated in the detector. Shape it as an open-faced box measuring $2\frac{1}{2}$ " \times 1" \times $\frac{1}{2}$ " (63.5 \times 24.5 \times 12.7 mm). Then solder the box to four miniature clips spaced on the board as indicated in Fig. 3. (This box also holds the foam-rubber-wrapped detector gently against

(Continued on page 46)

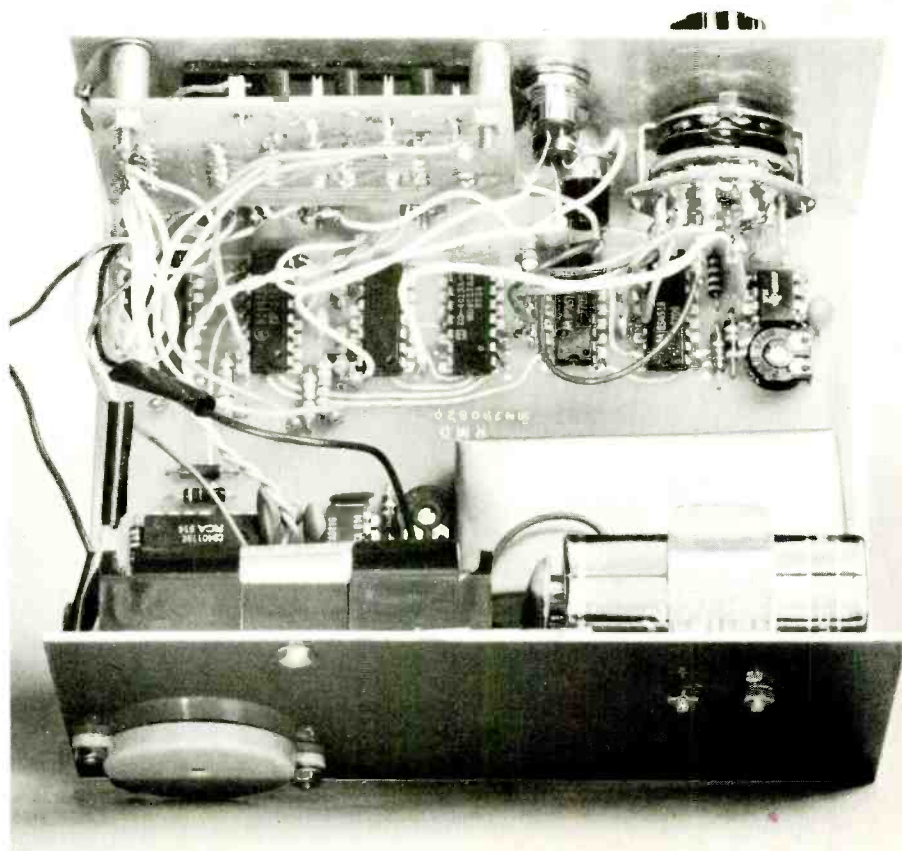
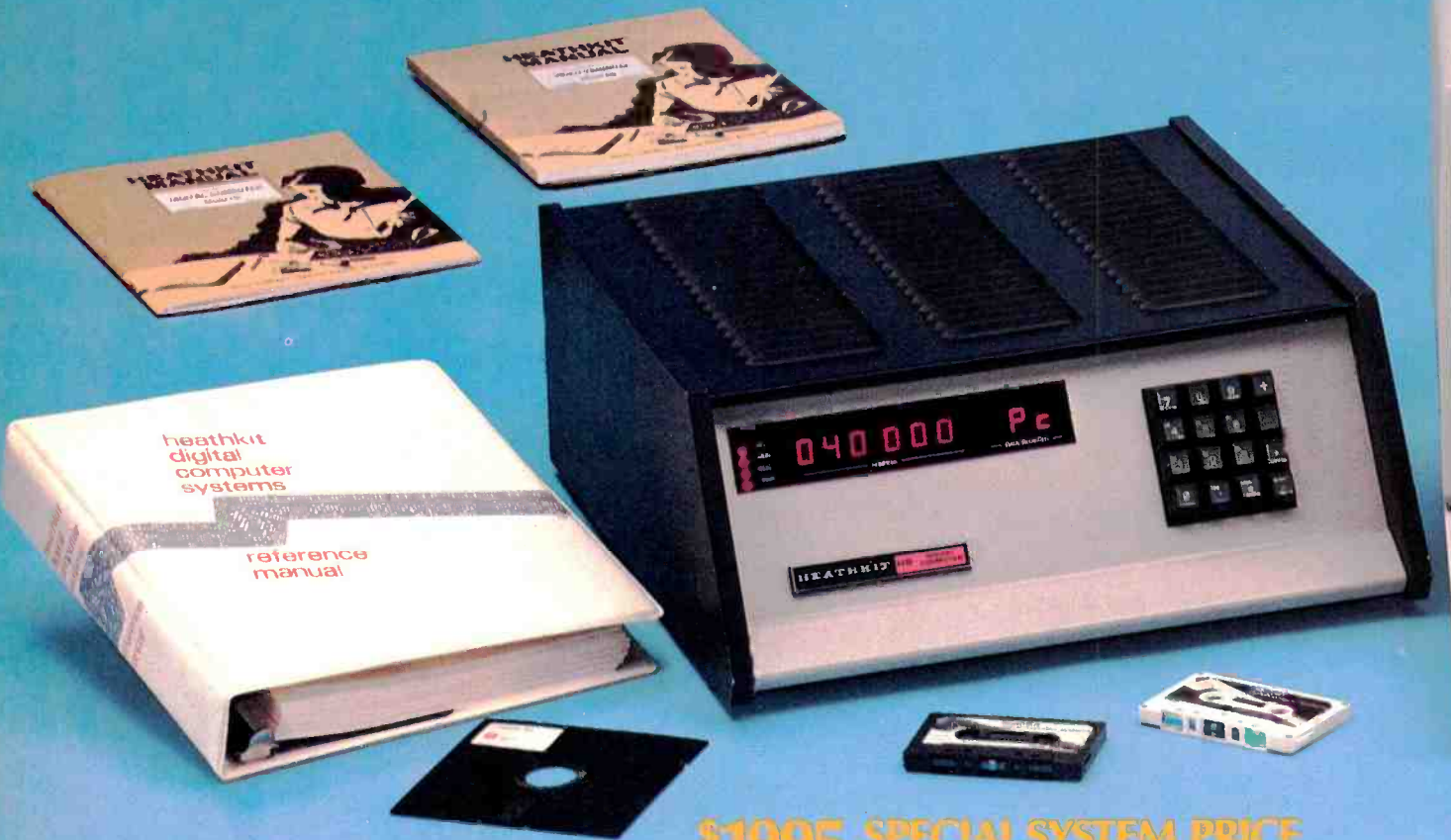

Photo of the author's prototype shows the main pc board mounted on chassis bottom with sound element on back and display on front.

One of the best values computers is now



\$1995 SPECIAL SYSTEM PRICE

includes H8 Computer with 16K memory, four-port serial I/O and operating software, plus H17 Floppy Disk System (shown here with optional second drive) and H19 CRT Terminal — all in kit form.

Heathkit H8 Computer

- 8080A CPU has more software written for it than any other CPU
- 7 plug-in board positions for flexibility in configuring your system
- Up to 65K memory capacity
- Front panel keyboard for direct access to registers and memory

\$289 kit purchased separately. Was \$379. **You save \$90.**
\$349.00 assembled

Heathkit H17 Floppy Disk System

- Instant access to programs and data
- 100K bytes storage area
- 250 mS typical random access time

- Includes interface controller board
\$495.00 kit purchased separately
\$550.00 assembled

Heathkit H19 Smart Video Terminal

- Z80 microprocessor-controlled
 - 25 x 80, upper and lower case
 - Direct cursor addressing
 - 8-user-function keys
- \$675.00 kit purchased separately
\$995 assembled

5% discount on software, memory and interfacing

Special 5% discount applies to all software, memory and interface

boards when purchased with the H8 system.

Seven plug-in board positions on the H8 let you configure any combination of memory and I/O's that suits you. Heathkit memory boards come in 16K, 8K and 4K increments. Interface boards are available for parallel, serial and cassette I/O's.

Wide selection of software

No computer system is better than the software that supports it. The wide selection of H8 software includes operating systems software and MICROSOFT™ BASIC.

HUG has over 400 programs

An extensive library of programs is available to owners of Heathkit Com-

in high-performance \$90 better.



puters through the Heath User's Group (HUG). The experience of this computerite group can help you get the most from your computer.

Plus Heathkit service

You get the most thorough documentation ever written when you buy your Heathkit Computer. So it's easy to get your system assembled and operating quickly.

And you get one of the most reliable service organizations after you buy. More than 55 service locations throughout the U.S., plus a factory service phone give you fast access to experts when you need them.

It's all at your Heathkit Electronic Center

Computers, peripherals, software and accessories — in kit or assembled form — you'll find them all at your Heathkit Electronic Center. You'll even find educational support like

the special self-instruction programs that teach you BASIC and Assembly language programming.

Check the white pages in the city nearest you for the location of your Heathkit Electronic Center*:

Alexandria, VA
Anaheim, CA
Atlanta, GA
Baltimore, MD
Boston, MA
Buffalo, NY
Chicago, IL
Cincinnati, OH
Cleveland, OH
Columbus, OH
Dallas, TX
Denver, CO
Detroit, MI
El Cerrito, CA
Fair Lawn, NJ
Frazer, PA
Hartford, CT
Houston, TX
Indianapolis, IN
Jericho, NY
Kansas City, KS
Los Angeles, CA
Louisville, KY
Miami, FL
Milwaukee, WI
Minneapolis, MN

New Orleans, LA
Norfolk, VA
Ocean, NJ
Oklahoma City, OK
Omaha, NB
Philadelphia, PA
Phoenix, AZ
Pittsburgh, PA
Pomona, CA
Providence, RI
Redwood, CA
Rochester, NY
Rockville, MD
Sacramento, CA
Salt Lake City, UT
San Antonio, TX
San Diego, CA
San Jose, CA
Seattle, WA
St. Louis, MO
St. Paul, MN
Tampa, FL
Toledo, OH
White Plains, NY
Woodland Hills, CA

FREE CATALOG

Write for a **FREE** Heathkit Catalog containing the complete line of Heathkit Computers, plus nearly 400 other electronic kits for your home, work or pleasure.

Heath Company, Dept. 010-614,
Benton Harbor, Mich. 49022



Heathkit

*Units of Veritechnology Electronics Corporation. Prices stated here are mail order and may be slightly higher at retail locations. CP-179 Prices subject to change without notice.

www.americanradiohistory.com

plug in and go soldering

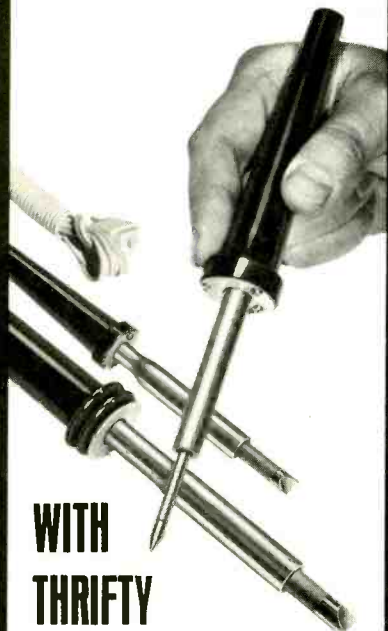

WITH
THRIFTY
MARKSMAN IRONS

BY **Weller**[®]

Pre-tinned tips for instant action. Five different ratings for technicians and hobbyists. Heat- and impact-resistant handles grip comfortably. Premium, stainless steel barrel for strength, corrosion resistance, and more even temperatures. Cone shape, screw-driver, chisel tips; Soldering Kit, Hot Knife Kit for wire stripping and plastic cutting. Full-view card pack lets you see and read about these UL-listed, factory-pre-tested irons before you buy.

See your local distributor or write....



The Cooper Group
Electronics Division

WELLER[®] • WISS[®] • XCELITE[®]
P.O. BOX 728, APEX, NORTH CAROLINA 27502, 919/362-7511
CIRCLE NO. 18 ON FREE INFORMATION CARD

Radiation Monitor *continued*

the main pc board.) Rubber cement a 4" X 2½" X ⅜" (102 X 63 X 9.5 mm) piece of foam-rubber carpet pad to the bottom of the main pc board. Assemble the display board, if used.

All components should be mounted inside a prepared metal case that measures 5"W X 3¼"D X 2¼"H (127 X 92.3 X 70 mm) if you build the counter/display version of the project (smaller if you elect to build only the beeper version). Install the *SPKR* chirper on the outside surface of the box's rear wall, the battery holder on the inside surface. Rubber cement the main pc board assembly to the floor of the box, making sure it will not interfere with the controls or battery holder and does not contact the case. (The foam rubber between main pc board assembly and case ensures maximum mechanical protection and vibration insulation.)

Mount the display board with ⅝" (9.5-mm) long spacers and machine hardware, using a ground lug on one post. Install the switches, LEDs, and connecting wires, referring back to Fig. 1 and the component-placement guides. Don't forget the ground wire to the chassis (case), and use twisted-pair leads for *S2* and *SPKR*. Label the front panel with a dry-transfer lettering kit and cement a red filter over the display window.

Calibration and Use. Prior to applying power to the RED-ONE, recheck all wiring and component orientations. Then turn on the power and, with a voltmeter connected from pin 3 of *IC3* to ground, adjust *R2* for minimum voltage. This lowers the noise threshold so that triggering will occur even on electrical noise. Output pin 7 of *IC3* will now fire rapidly or be continuously at ground potential. This will cause a steady tone or continuous chirping.

Using the voltmeter, or an oscilloscope set to the dc mode, slowly adjust *R2* to raise the *IC3* pin-3 reference voltage toward maximum. Chirp rate will gradually decrease, eventually ceasing altogether. Continue to adjust *R2* only slightly past this point. This eliminates false triggering on electrical noise. Gamma rays that deposit less than the minimum energy required to overcome this threshold will also be rejected. The equivalent energy of a typical low-level gamma photon is 30 keV.

Calibrate the timing chain by adjusting *R29* and observing total on time of *LED2* with *S5* in one time position. With a little patience, you can adjust *R29* to obtain accuracy within a fraction of a

second. Gross adjustment can be made in the 10- and fine adjustment in the 100-second periods. Accuracy is determined by the stability of *IC6* and its associated resistors and capacitors.

RED-ONE can be used to estimate exposure to radiation from natural and man-made isotopes and to measure changes in exposure. Units of radiation exposure include the roentgen, which is approximately equal to the absorption of 0.01 joule of gamma radiation by 1 kg of matter, and the rem (roentgen-equivalent-man), which measures the equivalent biological damage to man by any form of radiation. Average radiation exposure in the U.S. is about 0.2 rem/yr from natural sources. RED-ONE's sensitivity is between 20 and 40 counts/min/millirem/hr. Hence, natural background radiation produces about 1 count/min.

Natural background radiation levels can vary by as much as a factor of two, depending on where you live, the materials from which your house is built, and your altitude above sea level (the last due to cosmic rays). In addition, variables in detector construction and electronic components influence noise level and, therefore, overall detection sensitivity. Actual count-rate measurements are not as important as are changes in count rate due to the presence of radioactive material or environment changes.

It is important to note that random emissions of radioactivity will cause the monitored rate to apparently change from reading to reading. To estimate this statistical deviation, assume that any given count is accurate to within plus and minus the square root of the number of counts. Therefore, a display of 100 should be interpreted as 100 ± 10 counts, a display of 120 counts as 120 ± 11, etc. This means that the numerical difference between any two measurements is significant only if it is greater than the sum of the two square roots. For example, if your readings are 100 and 120, the numerical difference is 20 and square-root sum is 21 (10 + 11); because 20 is less than 21, there is no reason for concern. However, if your figures are 100 and 169, the difference is 69 and square-root sum is 23 (10 + 13), which gives you reason for concern because 69 is much greater than 23.

Once you have established a normal background level for your RED-ONE, you can compare readings at various locations and investigate possible radioactive sources. So now you can satisfy your curiosity about radiation levels in your locale. ♦

BUY ONE of these great professional books and GET ONE FREE

(values up to \$60.00)
when you join the
**COMPUTER
PROFESSIONALS'
BOOK CLUB**



Choose any one of these books at the special club discount, and select any other as your gift Free of Charge when you enroll:

AUTOMATIC DATA PROCESSING HANDBOOK
Edited by The Diebold Group, Inc.
168/075 Pub. Pr., \$38.95 Club Pr., \$25.75

PROGRAMMING LANGUAGES By A. B. Tucker, Jr.
654/158 Pub. Pr., \$22.00 Club Pr., \$16.50

MINICOMPUTER SYSTEMS, 2nd Ed. By R. H. Eckhouse
787/026 Pub. Pr., \$21.95 Club Pr., \$16.50

**MICROCOMPUTERS/MICROPROCESSORS:
Hardware, Software & Applications** By J. L. Hilburn & P. N. Julich
771/499 Pub. Pr., \$22.50 Club Pr., \$16.50

MICROPROCESSOR APPLICATIONS MANUAL
By Motorola, Inc.
435/278 Pub. Pr., \$38.00 Club Pr., \$26.50

THE 8080A BUGBOOK: MICROCOMPUTER INTERFACING AND PROGRAMMING By P. R. Rony, D. G. Larsen & J. A. Titus
783/845 Pub. Pr., \$9.95 Club Pr., \$8.45

MICROCOMPUTER-BASED DESIGN By J. Peatman
491/380 Pub. Pr., \$26.50 Club Pr., \$18.95

DATA BASE DESIGN By G. Wiederhold
701/30X Pub. Pr., \$24.50 Club Pr., \$18.25

PRINCIPLES OF INTERACTIVE COMPUTER GRAPHICS, 2nd Ed. By W. M. Newman & R. F. Sproull
463/387 Pub. Pr., \$24.95 Club Pr., \$19.95

PROGRAMMING FOR MINICOMPUTERS By J. C. Cluley
785/49X Pub. Pr., \$17.50 Club Pr., \$13.50

REAL-TIME PROGRAMMING WITH MICROCOMPUTERS By R. C. Turner
786/372 Pub. Pr., \$16.95 Club Pr., \$13.95

MEMORY DESIGN: Microcomputers and Mainframes By Electronics Magazine
191/549 Pub. Pr., \$18.50 Club Pr., \$15.50

HOW TO DESIGN AND BUILD YOUR OWN CUSTOM TV GAMES By D. L. Heiserman
786/585 Pub. Pr., \$14.95 Club Pr., \$11.95

HANDBOOK OF OPERATIONAL AMPLIFIER CIRCUIT DESIGN By D. F. Stout, edited by M. Kaufman
617/97X Pub. Pr., \$29.95 Club Pr., \$17.50

ANALOG SYSTEMS FOR MICROPROCESSORS AND MINICOMPUTERS By P. H. Garrett
786/496 Pub. Pr., \$18.95 Club Pr., \$14.95

ENCYCLOPEDIA OF COMPUTER SCIENCE
Edited by A. Ralston & C. L. Meek
769/01X Pub. Pr., \$60.00 Club Pr., \$39.95

MICROPROCESSOR AND MICROCOMPUTER SYSTEMS By G. V. Rao
783/659 Pub. Pr., \$24.50 Club Pr., \$19.50

THE Z-80 MICROCOMPUTER HANDBOOK By W. Barden, Jr.
784/914 Pub. Pr., \$8.95 Club Pr., \$7.60

Why YOU should join now!

- **BEST BOOKS IN YOUR FIELD**—Books are selected from a wide range of publishers by expert editors and consultants to give you continuing access to the latest books in your field.
- **BIG SAVINGS**—Build your library and save money too! We guarantee savings of at least 15% off publishers' list prices on every book. Usually 20%, 25% or even higher!
- **BONUS BOOKS**—You will immediately begin to participate in our Bonus Book Plan that allows you savings between 70-80% off the publisher's price of many books.
- **CONVENIENCE**—14 times a year you receive the Club Bulletin FREE, fully describing the Main Selection and alternate selections, together with a dated reply card. If you want the Main Selection, you simply do nothing—it will be shipped automatically. If you want an alternate selection—or no book at all—you simply indicate it on the regular reply card and return it by the date specified. You will have at least 10 days to decide. If, because of late mail delivery of the Bulletin you should receive a book you do not want, just return it at the Club's expense.

As a Club member, you agree only to the purchase of four books (including your first selection) over a two-year period.

Computer Professionals' Book Club

P.O. Box 582, Hightstown, New Jersey 08520

Please enroll me as a member and send me the two books indicated, billing me for my first selection only at the discounted member's price, plus local tax, postage and handling. If not satisfied, I may return the books within 10 days and my membership will be cancelled. I agree to purchase a minimum of 3 additional books during the next 2 years as outlined under the club plan described in this ad. Membership in the club is continuous but cancellable by me any time after the four book purchase requirement has been fulfilled.

Write Code # of
FREE selection here

Write Code # of
FIRST selection here

Orders from outside the U.S. must be prepaid with international money orders in U.S. dollars.

Charge my VISA MASTER CHARGE* Exp. Date _____

Credit Card # _____ *MC Bank # _____

Signature _____

Name _____

Address _____

City, State, Zip _____

Corporate Affiliation _____

This order subject to acceptance by McGraw-Hill. All prices subject to change without notice. Offer good only to new members. A postage and handling charge is added to all shipments.

P39429



A SECOND LIFE FOR VENTED SPEAKERS

BY DAVID B. WEEMS

How modern design approaches have revived interest in reflex speaker systems.

A DECADE ago the bass-reflex speaker was an endangered species. During the last few years, however, it has made a spectacular comeback, and is now a respected competitor of acoustic suspension systems.

The arrival of acoustic suspension speakers in the 1950s was an important milestone in loudspeaker development. Reversing the traditional practice of putting a stiffly suspended speaker in a large cabinet to achieve good low-bass response, the acoustic- or air-suspension system used a driver with an ultracompliant suspension mounted in a small enclosure. The timing was fortuitous. Stereo, just around the corner, would put a premium on space-saving speakers. When demonstrations proved that the little acoustic-suspension speakers could outperform many larger systems, the era of the compact speaker system began.

Though the closed box beat the reflex competition on several counts, there was a single overriding reason why many manufacturers converted their production to sealed systems: the reflex was just too complex and unpredictable. Leading engineers argued about how to tune the system and how big to make the box. G.A. Briggs, the late English authority, once compared reflex enclosures to heads of lettuce, saying that

one rule, "the bigger the better," applied to both. Later he added the qualifier, "within reason." "Like lettuce," he said, "loudspeaker enclosures can get so big they go to seed."

In the 1950s, "within reason" was about the only guide available. Hobbyists built enclosures to dimensions obtained from charts that scaled box volumes according to advertised speaker diameter and ignored all other parameters. Thoughtful experimenters, suspicious of such reliance on cone size alone, wished for a more precise guide. So it wasn't surprising that the audio world greeted the acoustic-suspension speaker with enthusiasm—and almost abandoned the reflex.

The surrender to the closed box was not quite total, though. James F. Novak, now Vice President of Engineering at Jensen Laboratories, made an analysis of enclosures for high-compliance speakers in 1959 that reiterated some of the virtues of the reflex. He claimed that high-compliance drivers in properly designed vented boxes reduced distortion and extended bandwidth. Novak described an ideal reflex system consisting of a driver with relatively high magnetic damping in a box that had an air compliance lower than that of the driver's equivalent suspension compliance. He specified the relatively low Q (amplitude

of the peak at resonance) of 0.3 to 0.4 for the driver. Novak's speaker/box compliance ratio was 1.44. (The compliance of an air volume for a given driver varies directly with the volume of the air and inversely with the square of the driver's effective piston area.)

Novak's work introduced a new principle to vented speaker design, the optimum volume concept. His compliance ratio brought precision to the drivers in the specified range of Q. With drivers outside that range, particularly those with higher Qs, the results remained unpredictable.

A. N. Thiele, an Australian electrical engineer, saw Novak's paper and noticed that Novak's mechanical equivalent circuit for the reflex had the same general form as an electrical high-pass filter. Applying filter theory to reflex design, Thiele found that he could predict characteristics such as cut-off frequency, optimum enclosure tuning, and the shape of the response curve near cut-off. In 1962 he published a definitive paper in an Australian journal that laid the foundation for a new approach to vented loudspeakers. He included data for 28 different designs, or alignments. Although his work was largely ignored in the United States, after about 10 years it was "discovered." Thiele's analysis was expanded by Richard Small, an Ameri-

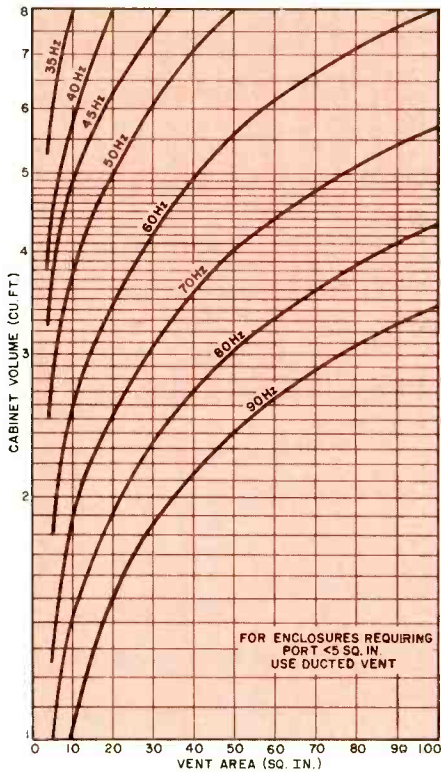

Fig. 1. Design chart to be employed for enclosures with simple vent.

can engineer who subsequently emigrated to Australia; it was then put to practical use by Ray Newman, Senior Systems Engineer at Electro-Voice; D. B. Keele, Jr., now Senior Transducer Engineer at JBL; Pat Snyder of Speak-erlab, and others.

Woofers and Resonators. To fully appreciate Thiele's contribution, you must compare the present state of the art to that of just a few years ago. Vented speaker systems have been in use for about 50 years, but that half-century has been filled with widespread misconceptions and even superstitions about how such speakers work. During that time there was no mystery about the performance of Helmholtz resonators themselves.

Helmholtz, studying the resonance behavior of air volumes in the mid-19th century, showed that any enclosed air volume that is vented will have a single natural frequency of resonance determined by the volume of the enclosed air and the area of the vent. Specifically, it is the mass of air in the port coupled to the compliance of the air in the enclosure that produces the resonance. As the vent is made smaller, the air directly in the vent reaches a higher velocity and forces air in front and back of the open-

ing to move with it. The increased moving mass lowers the frequency of resonance. To tune a small volume of air to a very low frequency, a simple vent must be small in area. Alternatively, a duct can be coupled to the vent to trap an even larger mass of vibrating air, reducing the frequency of resonance still further or allowing a larger vent for a given resonant frequency. Dimensions of vents and ducts (made from cardboard tubing obtainable from stationery or business supply stores) for tuning various enclosure volumes are given in Figs. 1 and 2 (the latter developed by Novak).

When a driver is installed in a ported box, the cone action alternately compresses and expands the enclosed air. Near the tuned frequency of the enclosure, the air "piston" in the port moves in phase with the driver cone, damping the movement of the cone rather heavily and making it appear to stand still at resonance. This damping, which offers some relief from the prodigious cone excursions that occur at low frequencies, is what attracted experimenters to vented designs in the first place. But too often their speakers exhibited a low-frequency hump that gave the reflex the derisive nickname "boom box."

In 1969, while researching an article for POPULAR ELECTRONICS, I asked engineers at several major companies for advice to hobbyists on how to design and tune a vented speaker. One group suggested that the box be tuned to the frequency of the driver's free air resonance, a traditional practice. A few advocated putting the box resonance above the driver resonance because such tuning produced a flatter impedance curve in the usable band. (Instead of the familiar double-humped curve, with the humps approximately equal in amplitude, this produced a large hump at a very low frequency and a minor hump at the upper resonance.) Still others contended that the box should be tuned below the driver's free air resonance so that the port could control distortion at the lowest frequencies.

Thiele's answer to the tuning question, interestingly, gives a clue as to why engineers from different companies offered such sharply conflicting advice in 1969. It's all a matter of driver Q. If Q lies in the range specified by Novak, the box should be tuned to the driver resonant frequency; higher Q demands a tuning below resonance and lower Q a tuning above. To see the details of how this works we'll have to look at Thiele's align-

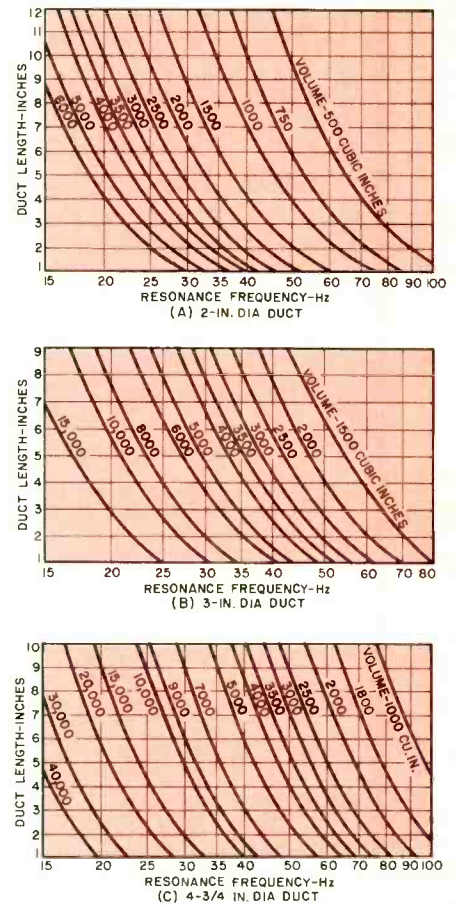

Fig. 2. Design charts for cardboard tube-ducted enclosures. Tubing diameters are inside measurements; duct length is measured from cabinet front.

ment chart. This, as rewritten by Keele, appears in Table I. Definitions are given in Table II.

Let's examine the data for alignment #5, a fourth order Butterworth (maximally flat) alignment. A good starting point is the value for Q_T , 0.383. This is the total Q of the speaker in the system, including internal amplifier resistance and resistance added by the speaker cable. For amplifiers with high damping factors, and with adequate speaker cables, Q_T can be considered to equal that of the driver alone. So for alignment #5 a speaker with a Q of about 0.38 would be ideal. Notice that this fits within the range specified by Novak.

Next we look for V_B , box volume. The table specifies the ratio of box volume to speaker compliance volume (V_{AS}) as 0.7072. A designer would either obtain the value of V_{AS} from the manufacturer of the driver or he would measure it himself. Then he would multiply V_{AS} by 0.7072 to get the theoretically correct box volume. In the real world no reflex enclosure is perfect so this volume must

be enlarged. When Small applied Thiele's original data to typical vented enclosures, he found that he had to add about 30 percent to the theoretically correct volume to get the low-frequency performance predicted by the data.

In Thiele's original paper, the box volume ratio was not included in the table; instead a speaker/box compliance ratio was stated. A speaker/box compliance ratio would give the same value as a V_{AS}/V_B ratio, the inverse of the ratio shown in Table I. For alignment #5 that would be $1/0.7072$ or 1.414. If that figure looks familiar it is almost exactly the ratio specified by Novak as optimum. Moving to other aspects of box design, the f_3/f_s ratio is 1.000. That shows that the system's bass response will be 3 dB down at the frequency of the driver's free-air resonance. The f_B/f_s ratio is also 1.000, so the box should be tuned to the free air resonance of the driver.

Now look at alignments #1-#4, for speakers with higher magnetic damping (lower Q). In #4, for example, a driver with a Q just slightly lower than that of #5 has a V_B/V_{AS} ratio that is less than half that of #5. Thus if you had two drivers that were identical except for Q, the one with the Q of 0.303 could be put into a box less than half the volume of that required by the driver with the Q of 0.383. But the other data for #4 show that the speaker with the lower Q will have its low-frequency cut-off moved up to $1.43 f_s$ when the box is properly tuned to $1.23 f_s$.

On the other hand, speakers with higher Q's fit into the alignments beyond #5 and demand larger boxes, larger at least in the acoustical sense—in relation to the driver's equivalent air compliance. These boxes should be tuned to frequencies below the driver's resonant frequency. The reason for this kind of tuning is shown in Fig. 3. High-Q speakers have smaller magnets which give less control on the moving system at resonance. Coupled with a resonator these speakers may be subject to peaking before cut-off, but if they are matched to a box tuned too low, the combination of a box that rolls off the bass response and a driver that peaks can produce a flat response down to cut-off. Some of the Chebychev alignments extend the low-frequency cut-off to well below the driver resonance, but at the expense of some ripple in the passband. And if the Q is higher than about 0.7, distortion is greater.

Many engineers consider alignment #5 a good choice. Although this align-

Alignment details			Box design				Aux. circuit	
No.	Type	Ripple (dB)	f_3/f_s	f_B/f_s	V_B/V_{AS}	Q_T	Peak Lift (dB)	f_{PK}/f_s
1	QB ₃	—	2.68	2.000	0.0954	0.180	—	—
2	QB ₃	—	2.28	1.730	0.1337	0.209	—	—
3	QB ₃	—	1.77	1.420	0.2242	0.259	—	—
4	QB ₃	—	1.45	1.230	0.3390	0.303	—	—
5	B ₄	—	1.000	1.000	0.7072	0.383	—	—
6	C ₄	—	0.867	0.927	0.9479	0.415	—	—
7	C ₄	0.13	0.729	0.829	1.372	0.466	—	—
8	C ₄	0.25	0.641	0.757	1.790	0.518	—	—
9	C ₄	0.55	0.600	0.716	2.062	0.557	—	—
9.5	C ₄	1.52	0.520	0.638	2.60	0.625	—	—
—	—	—	—	—	—	—	—	—
15	B ₆	—	1.000	1.000	0.366	0.299	+6.0	1.07

Reprinted with permission from the Journal of the Audio Engineering Society.

ment will normally require a driver with a Q of approximately 0.38, it can be used with drivers of lower Q—with a sacrifice in system efficiency—if a resistance is put in series with the driver. The added resistance raises the Q_T to 0.383, and the design is executed as if the driver had been designed with a Q of 0.383.

To summarize the Thiele alignment data and make some comparisons, a driver with a very low Q can have an optimum box volume that is small compared to the driver's equivalent air volume compliance. This doesn't necessarily mean small boxes because low-Q speakers typically have a high compliance. Table III shows this correlation clearly. A system composed of a low-Q speaker in an optimum box volume should be tuned to a frequency above that of the driver's free-air resonance and it will cut off above that frequency. While this may seem to limit the low-frequency range of these speakers, note that speakers with low Qs also usually have low resonant frequencies. A high-Q speaker needs a box volume that

is large compared to its equivalent compliance air volume, but this box will be tuned below the speaker's free-air resonance. Again, high-Q speakers typically have lower compliance and higher resonance frequencies, so the box volume that is acoustically large for them may seem rather moderate to the beholder. These relationships may explain why engineers who worked with different kinds of drivers in the 1950s and 1960s offered such divergent advice on box design and tuning. Each school of thought was working on a single aspect of a larger problem. Thiele put it all together and developed a general theory of vented loudspeaker systems.

The Thiele data can be used in various ways. One obvious application is to design a box to match an existing driver. But it can just as easily show how to design a driver to fit a certain box size. The designer can compute an ideal cone mass, magnet size, voice-coil resistance, and other specifications for a driver that will work well in such a box. Or, knowing the specifications of this

(Continued on page 56)

Symbol	Definition
B	Butterworth—alignments with flat response down to cutoff.
C	Chebychev—alignments with some degree of ripple in response.
QB	Quasi-Butterworth alignments.
f_s	Frequency of driver's free-air resonance.
Q_{TS} or Q	Q of driver at f_s .
Q_T	Total Q of the driver in the system at f_s . With modern amplifiers of low internal resistance, and a high damping factor, Q_T will be approximately the same as Q_{TS} unless speaker cable is excessively long or of inadequate gauge.
V_{AS}	Equivalent air compliance of driver. The volume of air that offers a compliance to the driver that is equal to the compliance of the driver's suspension.
V_B	Volume of air in box.
f_3	Cutoff frequency, response down 3 dB from mid-band level.
f_B	Frequency of box resonance, determined by internal volume of air and vent characteristics.
f_{PK}	Frequency of peak lift produced by auxiliary equalizer.

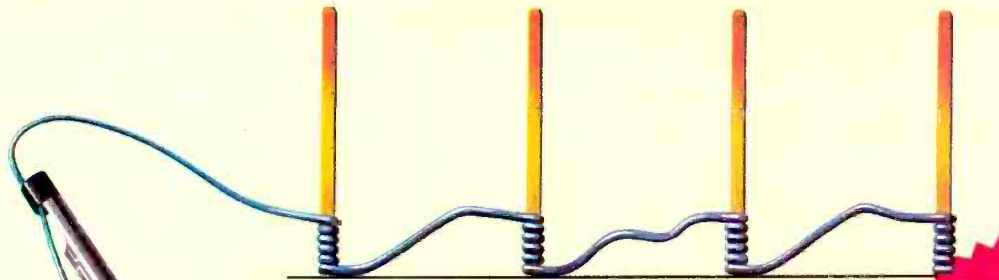

WHY CUT? WHY STRIP? WHY SLIT?
WHY NOT...

NEW

JUST WRAP™ WIRE WRAPPING TOOL

- AWG 30 Wire
- .025" Square Posts
- Daisy Chain or Point To Point
- No Stripping or Slitting Required
- ...JUST WRAP™...
- Built In Cut Off
- Easy Loading of Wire
- Available Wire Colors: Blue, White, Red & Yellow

U.S.A., FOREIGN PATENTS PENDING

traditional Wire-Wrapping

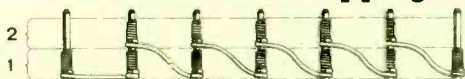

JUST WRAP Wire-Wrapping



JUST WRAP TOOL WITH ONE 50 FT. ROLL OF WIRE		
COLOR	PART NO	U.S. LIST PRICE
BLUE	JW-1-B	\$ 14.95
WHITE	JW-1-W	14.95
YELLOW	JW-1-Y	14.95
RED	JW-1-R	14.95
REPLACEMENT ROLL OF WIRE 50 FT.		
BLUE	R-JW-B	\$ 2.98
WHITE	R-JW-W	2.98
YELLOW	R-JW-Y	2.98
RED	R-JW-R	2.98
JUST WRAP-UNWRAPPING TOOL		
	JUW-1	\$ 3.49



OK MACHINE & TOOL CORPORATION 3455 CONNER ST.,
BRONX, N.Y. 10475 (212) 994-6600/TELEX 125091

*MINIMUM BILLING \$ 25.00/ADD SHIPPING CHARGE \$ 2.00/NEW YORK CITY/STATE RESIDENTS ADD APPLICABLE TAX.

CIRCLE NO. 41 ON FREE INFORMATION CARD

Train with NTS for the MicroComputers, digital the first name

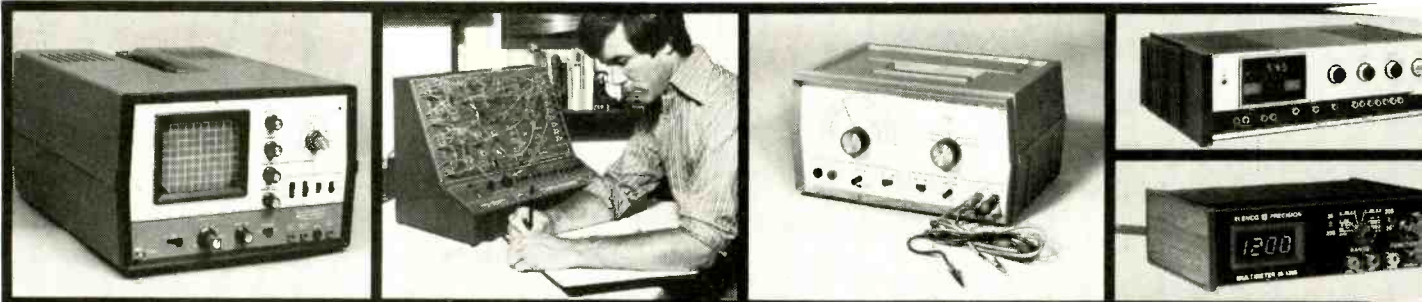

MicroComputers

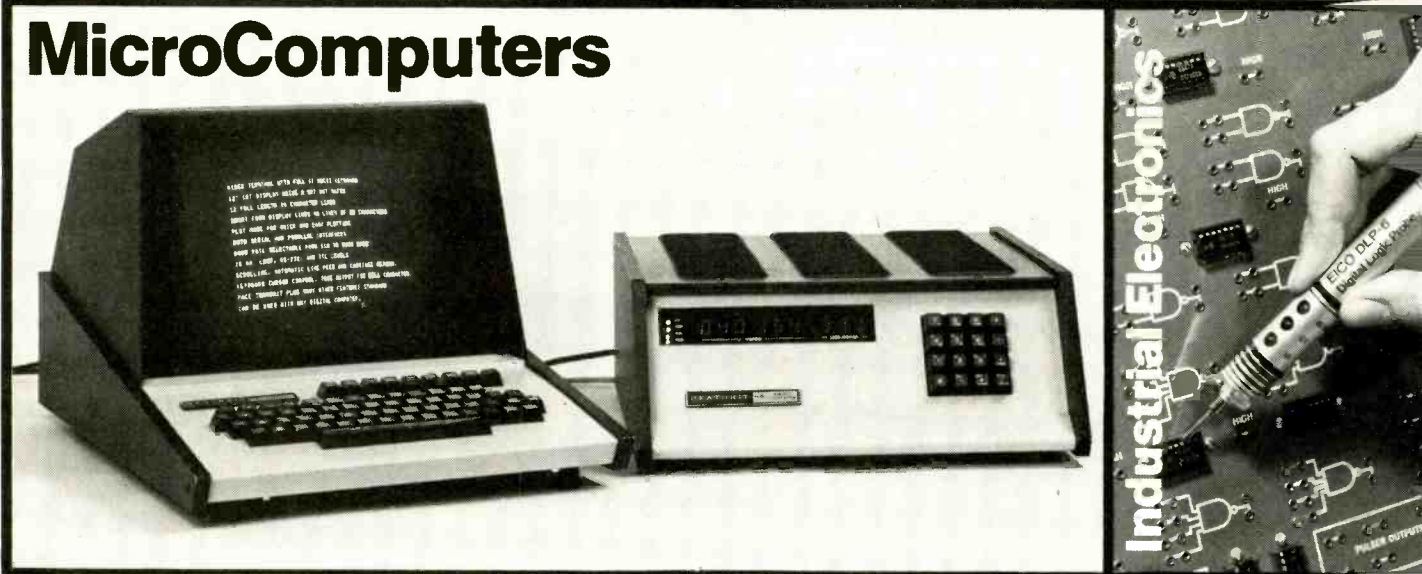

The world of electronics is daily becoming more challenging. Technology is growing more specialized, and the importance of digital systems increases every day. Test instruments, home entertainment units and industrial control systems are all going digital. And now, NTS training programs include a wider choice of solid-state and digital equipment than ever before offered in any home study course: Advanced NTS/Heath digital color TV (25" diagonal with optional programming capability), NTS/Heath microcomputer, digital test equipment, digital stereo receiver (70 watts per channel), NTS compu-trainer, plus much more state-of-the-art equipment to make your training exciting and relevant.

The equipment you receive with NTS training programs is selected to provide you with a solid

background in electronic systems. Kits and lessons are designed to work together to demonstrate electronic principles and applications. The kit-building not only shows you how electronic hardware functions, but how various circuit designs accomplish different purposes. Your lessons guide you through any number of experiments associated with many projects. This is the Project-Method, and it works. Step-by-step, you learn how and why digital electronics has become a part of our world, and the even bigger role it is sure to play in the future.

Whether you are looking for training in Consumer, Commercial, or Industrial electronics, NTS offers fourteen courses, some basic, many advanced, in several areas of electronics. An all-new full-color NTS catalog shows you what each course covers,

electronics of the future.

systems and more...from
in home study.

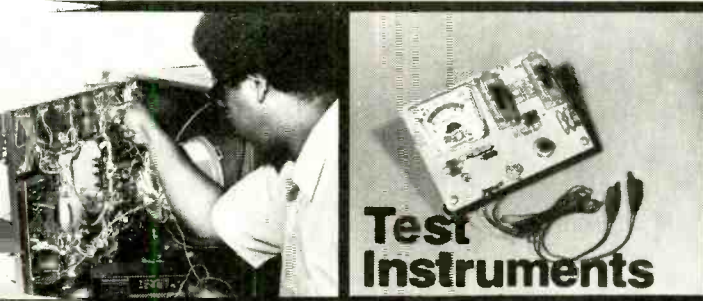

Test Instruments

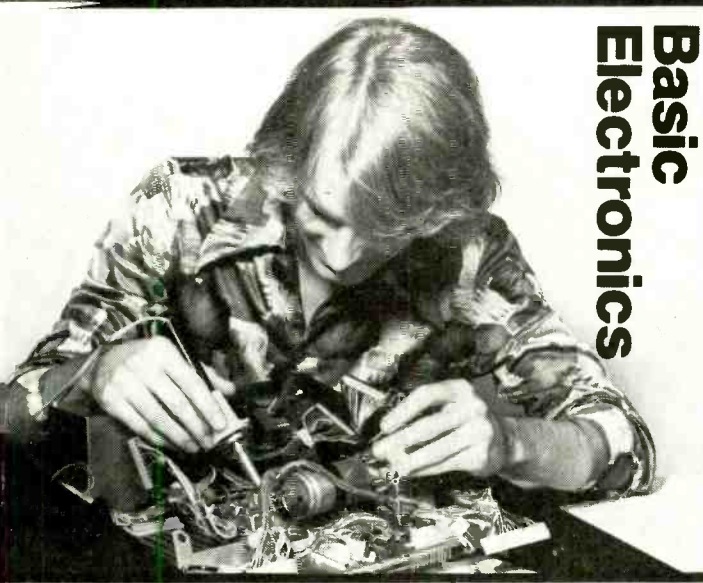

Basic Electronics



Digital Color TV

Simulated TV Reception

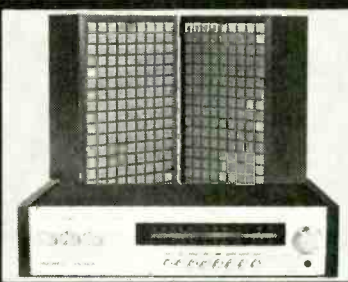

and every piece of equipment included.
Send for it today, and see for yourself what's really happening in electronics training technology at NTS. Find out how much has changed, and what new directions the field is taking. You'll probably want to be a part of it.
It's free. Just mail the card or coupon. Today.

**NO OBLIGATION. NO SALESMAN WILL CALL.
APPROVED FOR VETERAN TRAINING.**

NATIONAL TECHNICAL SCHOOLS

TECHNICAL-TRADE TRAINING SINCE 1905
Resident and Home-Study Schools
4000 South Figueroa St., Los Angeles, Calif. 90037

NATIONAL TECHNICAL SCHOOLS Dept. 205-010
4000 South Figueroa Street, Los Angeles, California 90037

Please send FREE Color Catalog and Sample Lesson.

- Color TV Servicing
- B & W TV and Radio Servicing
- FCC License Course
- Electronic Communications
- Electronics Technology
- Audio Electronics Servicing
- Digital Electronics
- MicroComputers/MicroProcessors

Name _____

Address _____

Apartment Number _____ Age _____

City _____

State _____ Zip _____

- Check if interested in G.I. Bill information.
- Check if interested ONLY in classroom training in Los Angeles.

VENTED SPEAKERS *Continued*

driver, he can calculate the performance of the driver in various boxes. Although the Thiele alignments show optimum values, systems based on them may have box volumes other than those indicated by the table. Proper use of the data can let the designer predict system performance by computer, instead of by guesswork and trial and error.

As mentioned earlier, Thiele's original publication provided 28 different alignments. Table I shows 11: Thiele's first 9, an additional one labeled "9.5" by Keele, and an example of an electronically assisted design in #15. The table shown here was revised by Keele to make it more useful for designing a box to fit a driver rather than designing a driver to match a specific box volume.

Here is a concrete example of how to use the Thiele data. Let's assume a woofer with the following specifications: $f_s = 40$ Hz, $Q = 0.41$, $V_{AS} = 5$ ft³. The box should be tuned to $0.927 f_s$, or 37 Hz. This system will have a cutoff frequency of $0.867 f_s$, or about 35 Hz. If the value for the driver's Q had fallen between the values indicated in the table for adjacent alignments, the designer would interpolate to get correct box volume, resonance, and cutoff frequency.

Equalized Alignments. The first 9 alignments, and Keele's 9.5 alignment, consist of simple speaker/box combinations driven by a typical power amplifier. Thiele's complete listing shows systems with significant bumps or dips in the response curves that must be corrected by auxiliary electronic equalization. Some of these alignments are of little more than academic interest. For example, one group requires a great amount of bass boost at frequencies below the box resonance. Such systems would show excessive cone motion, a potential problem for all unfiltered vented speakers but one that extra boost below resonance would surely aggravate. Unloading occurs because below resonance the air in

the vent moves as if in series with the cone, and out of phase with it. Now hardly at all restrained, the cone can be driven into distortion or even damaged by low-frequency noise or pulses. Many amplifiers and receivers have low-frequency filters, effective at infrasonic frequencies, but many listeners mistakenly fail to use them because they don't want to impair their system's frequency response. With vented speakers a correctly designed filter will give the effect of more bass, not less, because the bass is firm and undistorted.

Cone surging can also be eliminated by choosing Thiele's 15th alignment. It

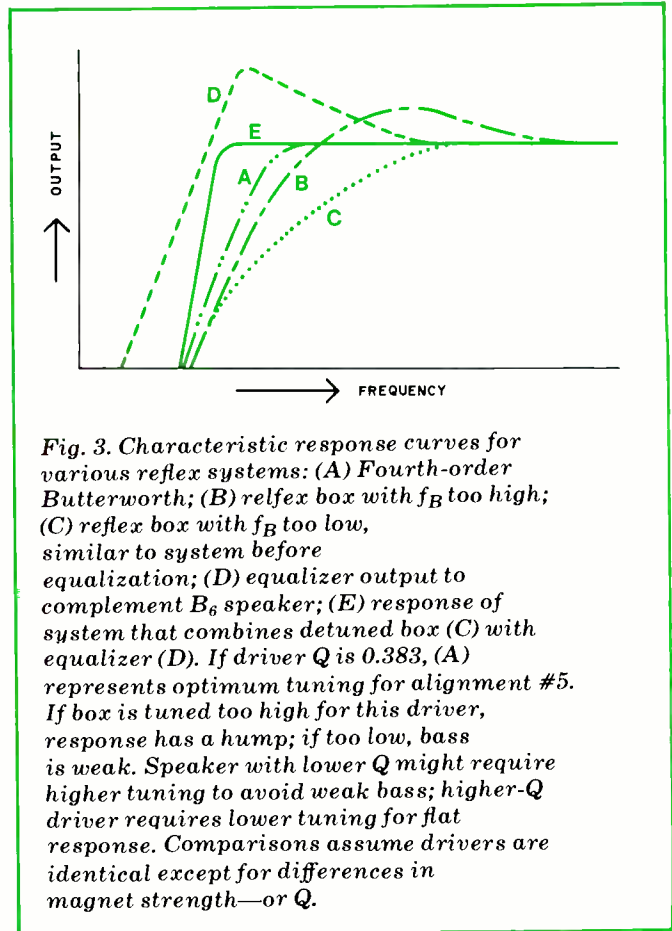

Fig. 3. Characteristic response curves for various reflex systems: (A) Fourth-order Butterworth; (B) reflex box with f_B too high; (C) reflex box with f_B too low, similar to system before equalization; (D) equalizer output to complement B_6 speaker; (E) response of system that combines detuned box (C) with equalizer (D). If driver Q is 0.383, (A) represents optimum tuning for alignment #5. If box is tuned too high for this driver, response has a hump; if too low, bass is weak. Speaker with lower Q might require higher tuning to avoid weak bass; higher- Q driver requires lower tuning for flat response. Comparisons assume drivers are identical except for differences in magnet strength—or Q .

offers a double dividend: a bass boost gives extended bandwidth in a small box and a cutoff of infrasonic noise. Alignments #15 and #4 use drivers of about the same Q and boxes close to the same size. But check the two systems for bass range. The assisted system gives response down to the free-air resonance of the driver instead of cutting off at $1.45f_s$ as does #4. A driver with a free-air resonance of 35 Hz would cut off at about 51 Hz in alignment #4; alignment #15 with electronic assist extends its response to 35 Hz.

Keele has greatly expanded Thiele's data to include a wider range of drivers. His method is roughly this: design a system according to one of the first 9 alignments, then lower f_B by a half octave to produce a drooping low-frequency response. By adding a second-order high-pass filter with a Q of 2 and a 6-dB boost at $1.07f_b$, we can flatten the response and reduce the cutoff point to f_s .

Keele suggests that any driver with a resonance and a Q so placed that the ratio f_s/Q falls between 80 and 160 Hz is suitable for this alignment. The alignment works with relatively high-resonance, high- Q drivers as well as with

TABLE III—THIELE/SMALL PARAMETERS FOR SEVERAL TYPICAL DRIVERS

Brand	Model	Advertised diameter (in.)	f_s (Hz)	Q_{TS}	V_{AS} (cu ft)	V_{AS} (liters)
Electro-Voice	SP12C	12	45	0.67	5.9	165
	SP15C	15	40	0.45	9.9	280
JBL (Prof. Series)	2145	12	30	0.51	5.5	155
	2135 (Ext. range)	15	40	0.25	10.5	300
	2231 (Low Freq. driver)	15	16	0.21	26.0	735
Speakerlab	1204A	12	16.1	0.176	17.9	500
	W1508S	15	18.8	0.239	31.9	900

low-resonance, low-Q drivers. An appropriate driver in this sixth-order Butterworth alignment (all vented systems are at least fourth-order) should give a cut-off at 25 to 50 Hz. To use Keele's method, the designer chooses a box volume that is approximately equal to $4.1 Q^2 V_{AS}$, then tunes that box to $0.3 f_s/Q$. These same relationships hold in the data shown in Table I. Where the table shows only a single Q value, the Keele technique can be applied to any driver with a suitable ratio of resonance to Q.

Considering the advantages of the B_6 alignment, it would be helpful if manufacturers would include tunable, 6-dB boost circuits in their amplifiers. An owner of a typical fourth-order Butterworth system could convert to sixth-order assisted operation by adding a longer tuning duct to the enclosure and switching in the boost that gives the proper response. For the present, if you want to experiment with equalized alignments you will have to build your own equalizer. Pat Snyder of Speakerlab has designed an equalizer to be inserted into the tape-monitor circuit of almost any amplifier or receiver. As originally designed, his circuit offers a variable degree of boost—from 0 dB up to about 10 dB. You can adjust the frequency of the boost by choosing two matched capacitors for each channel.

Vents and "Vent Substitutes." A small box can be tuned to a low frequency by a small simple vent, but a port can be too small for good performance. A small vent radiates just as much power as a larger one but causes air to move through it at higher velocity. If the velocity is great enough it will cause whistling and hissing and possibly even distortion. A box with a small vent can be tuned to the same frequency by enlarging the vent and adding a duct behind it.

In some small enclosures where a very low box resonance is necessary, the duct can occupy so much volume that the enclosure must be enlarged to accommodate the duct. Such systems can be tuned to the proper frequency by use of a "drone cone," or passive radiator. This "vent substitute" is a suspended cone, essentially a speaker without a motor. The drone can be tuned by adjusting its mass; the greater the mass, the lower its frequency of resonance. Because a vent substitute is solid and far denser than a gas, such as the air in a duct, the passive radiator requires hardly any more space than the panel area it occupies. Early systems of this

type usually had drones equal in diameter to that of the woofer, but current practice makes the drone's effective cone area about twice that of the woofer. An enlarged passive radiator piston can more easily provide the volume velocity necessary to effectively load the woofer.

Driver Parameters. Some people have objected that normal production variations in drivers preclude such precise calculations in box design. This has been answered in studies by Keele and Snyder. One driver parameter that is difficult for manufacturers to control precisely is compliance. In fact, in some kinds of suspension systems, the compliance changes with temperature or humidity. Fortunately, compliance variations are usually cancelled by compensating changes in other parameters. For example, if the compliance of a driver is reduced, the frequency of resonance will be raised, but the Q is also raised to a similar degree. Thus, the ratio of resonance to Q, a really important factor, is hardly affected. If the mass of the moving system is constant and the magnetic field around the voice coil unimpaired, the speaker will perform according to design specifications.

Finally we come to another aspect of the bass-reflex problem that has often plagued hobbyists, the information dam. Several years ago I wrote to a company and asked for specifications on its woofers. The reply suggested that I rely on the reputation of the brand rather than upon specifications. In the past there was an excuse for such reticence, the unreliability of acoustical measurements made under differing conditions. In fact most measurements were useful only to experienced engineers who could interpret them correctly. But most of the required measurements for Thiele data can be made by tests that are fairly simple and easily reproducible. There is no longer any reason for the attitude shown in the letter mentioned above. Several companies now offer complete Thiele data for their speakers. Table III shows some representative drivers with a summary of the Thiele data for each.

While the closed-box loudspeaker—which Small has shown to be analogous to a second-order filter network—still offers the ultimate in design simplicity, its overwhelming advantage has been reduced by the Thiele approach to vented-system design. It looks as if the bass reflex, having fallen into virtual oblivion, has been reborn, Phoenix-like, from its own ashes. ◇

WHAT'S NEW IN HOME ELECTRONICS?



Find out in the latest Heathkit Catalog. It's filled with exciting kits in every price range, all easy to assemble, all at build-it-yourself savings.

Discover the fun you and your family can have building your own home computer, stereo system, color TV. Discover the pride of saying, "I built it myself." It's easier than you think.

Send today for your FREE Heathkit Catalog.



Heathkit®

If coupon is missing, write Heath Co., Dept. 010-613, Benton Harbor, MI 49022

Send For FREE Catalog Today!

Send to: Heath Co. Dept. 010-613, Benton Harbor, MI 49022

Send my free Heathkit Catalog now. I am not currently receiving your catalog.

Name _____

Address _____

City _____ State _____

CL-724B _____ Zip _____

CIRCLE NO. 5 ON FREE INFORMATION CARD

Simple hardware addition plus BASIC Level-1 program creates a multipurpose timer to operate electric appliances, for timing chess games, and other useful control applications

A SIMPLE "REAL TIME"

TRS-80 TIMER

A relatively simple BASIC program and an even simpler hardware addition to a TRS-80 Level I 4K digital computer, forms a programmable timer that can be set for a time period of one second to almost any desired interval. The BASIC program uses two "for-next" loops to calculate the desired delay. INPUT #A at line 590 activates the cassette relay which, in turn, operates the control circuit shown in the figure.

When the program is run, the user is prompted when it is necessary to enter a delay time, etc. For example, assume a three-minute timing interval. When the display indicates "ENTER DELAY TIME MODE," type "2" (for selecting minutes) on the keyboard, the computer will then prompt, "DELAY IN MINUTES," which is answered by typing in "3". The machine will then display "PRESS ENTER TO START THE TIMER." Once this is done, the timer is in operation. After three minutes, the TRS-80 will activate an external alarm. To de-activate the alarm, depress the TRS-80 "RESET" pushbutton (located behind the rear expansion door).

Construction. The circuit shown can be assembled on a small piece of perforated board, just large enough to hold the components.

Insert the subminiature phone plug of the TRS-80 cassette interface connector into jack J1. Relay K1 can be used to activate a heavy-duty relay operated by the ac power line for higher-current applications. ◇

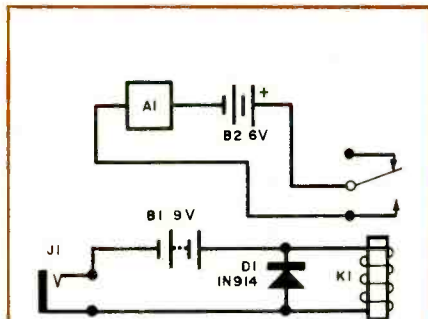

Control circuit is activated by cassette relay at line 590.

PARTS LIST

- A1—6-V alarm (Sonalert or similar)
- B1—9-V battery with holder
- B2—6-V battery with holder
- D1—1N914 or similar
- J1—Subminiature jack
- K1—Miniature relay, 500-ohm coil, 6-V dc (Radio Shack 275-004 or similar)
- Misc.—Perforated board, mounting hardware, cable, etc.

PROGRAM

```

10 CLS
20 PRINT "TRS-80 REAL TIME TIMER"
30 PRINT
40 PRINT "A PROGRAMMABLE TIMER"
50 PRINT
60 PRINT "ENTER DELAY TIME MODE"
70 INPUT "(1) FOR SECONDS (2) FOR
   MINUTES (3) FOR HOURS";B
80 IF B=1 GOTO 500
90 IF B=2 GOTO 600
100 IF B=3 GOTO 700
110 GOTO 60
500 PRINT
510 G=1
520 INPUT "DELAY IN SECONDS";S
530 INPUT "PRESS ENTER TO START
   THE TIMER";A$
540 FOR J= 1 TO S
550 FOR K= 1 TO 470 * G
560 NEXT K
570 NEXT J
580 PRINT "DELAY COMPLETED, CIR-
   CUIT ACTIVATED"
590 INPUT #A
600 PRINT
610 G=60
620 INPUT "DELAY IN MINUTES";S
630 GOTO 530
700 PRINT
710 G=60
720 INPUT "DELAY IN HOURS";S
730 INPUT "PRESS ENTER TO START
   THE TIMER";A$
740 FOR J= 1 TO S
750 FOR K= 1 TO 60
760 FOR L= 1 TO 470 * G
770 NEXT L
780 NEXT K
790 NEXT J
800 GOTO 580
810 END
    
```

Measure Weak Direct Currents with the Sensitive Micro Meter

BY I. QUEEN

Low-cost op-amp system can measure solar-cell output and currents in other low-level circuits.

IF YOU PLAN to measure the output of a solar cell under low-light conditions, to work with micropower ICs, or otherwise experiment with weak-current circuits, you'll need a sensitive current meter. The Sensitive μ Meter presented here will allow you to measure direct currents as small as a fraction of a microampere. Moreover, it is not subject to the disadvantages associated with standard panel microammeters—high cost, fragile movements, and relatively high internal resistance.

The project employs an operational amplifier to increase the sensitivity and effectively decrease the input impedance of a moderately priced, readily available 0-to-50 microammeter. It has three switch-selected scales; 0 to 0.5 μ A; 0 to 5 μ A; and 0 to 50 μ A. The circuit can be powered by a supply furnishing as little as ± 2 or ± 4 V, and can be constructed for about \$15.

Circuit Operation. A simple circuit for current-measuring applications is shown in Fig. 1. When an input current I is applied to the inverting input of the op amp, an inverted output signal is generated by the op amp. If the gain of the operational amplifier is very high, we can consider that the entire input current flows through feedback resistor R . An output voltmeter M , which is calibrated in terms of I , measures the product IR . The voltage drop across the operational amplifier is practically zero (the output voltage divided by the op amp's open-loop gain).

The schematic of the Sensitive μ Meter is shown in Fig. 2. Switch $S2$ selects the range and determines the feedback resistance of the stage. When the switch is in its center (off) position, the feedback resistance is $R3$, one megohm. An input current of 0.5 μ A will cause the output of the op amp to be 0.5 volt above ground when only $R3$ is in the feedback loop.

This output voltage will cause full-scale deflection of 0-to-50-microammeter $M1$ if the effective resistance between the output terminal of the operational amplifier and the negative terminal of the meter is 10,000 ohms. The internal resistance of the meter specified in the parts list is 1620 ohms, so the balance of the required resistance is supplied by $R4$. This trimmer potentiometer is adjusted for full-scale deflection of the meter movement when the op amp output is at $+0.5$ volt.

The project is most sensitive when $S2$ is in its center (off) position and the feedback resistance is one megohm. In this operating mode, full-scale deflection of the meter corresponds to an input current of 0.5 μ A. Higher-current ranges are obtained by shunting $R3$ with other resistors to lower the overall feedback resistance. This is accomplished by placing $S2$ in one of its two other positions. When the range switch is placed in its 5 μ A position, the parallel combination of $R1$ and $R3$ causes the meter to deflect to full scale if the input current is five microamperes. Similarly, placing $S2$ in its 50 μ A position shunts $R3$ with $R2$ and causes full-scale deflection of

the meter movement when an input current of fifty microamperes exists.

Two shorting switches are included in the circuit. Switch $S1$ shorts the input of the project. It is used in conjunction with potentiometer $R5$ to zero the meter movement. The other switch ($S3$) is used to short the terminals of $M1$ when the meter is not being used. This minimizes mechanical shocks to the meter movement when the project is being transported. Diodes $D1$ and $D2$ protect the project from excessive input voltages. Jack $J2$ provides access to $M1$ so that the meter can be used in isolation from the rest of the project.

You might wonder why the circuit provides for a 0-to-50-microampere scale when meter movement, $M1$, covers this range on its own. The following exercise performed by the author will illustrate the need for such a scale. A solar cell was connected across input jack $J1$ and illuminated so that the Sensitive μ Meter indicated a current of 50 μ A. The cell was then connected to $J2$ and its output current measured using $M1$ alone. It indicated a current of 1 μ A.

The reason for this discrepancy between the two readings is that $M1$ presents a higher resistance to the solar cell when it is used independently than the project as a whole does. It is desirable to keep the internal impedance of a current-measuring instrument as low as possible. Thus, it is better to employ the project as a whole (as opposed to $M1$ or a similar meter alone) in the measurement of currents up to 50 μ A.

There is another significant advantage to the use of the Sensitive μ Meter as opposed to a microammeter alone. Due to the clipping action of protective diodes $D1$ and $D2$, the maximum output voltage of the op amp on any of the three ranges is

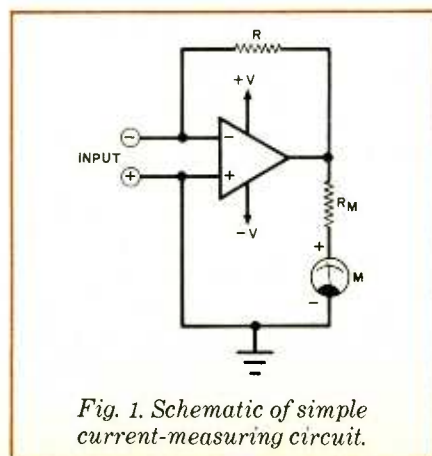

Fig. 1. Schematic of simple current-measuring circuit.

PARTS LIST

- C1—0.1- μ F disc ceramic
 D1, D2—1N914 diode
 IC1—LM308N operational amplifier
 J1—Open-circuit miniature phone jack
 J2—Closed-circuit subminiature phone jack
 J3—Phono jack (must be insulated from project enclosure)
 M1—0-to-50- μ A meter movement (Radio Shack No. 22-051 or equivalent)
 The following are $\frac{1}{4}$ -watt, 5%-tolerance carbon-composition fixed resistors, unless otherwise specified:
 R1—110,000 ohms (can be a series connection of 100,000 ohms and 10,000 ohms)
 R2—10,000 ohms
 R3—1 megohm
 R4—10,000-ohm, linear-taper trimmer potentiometer
 R5—50,000-ohm linear-taper potentiometer
 R6—2700 ohms
 R7—10 megohms
 S1, S3—Spst toggle switch
 S2—Spdt toggle switch with center-off position
 Misc.—Suitable enclosure, perforated or printed circuit board, IC socket, circuit board spacers, machine hardware, control knob, hookup wire, solder, etc.

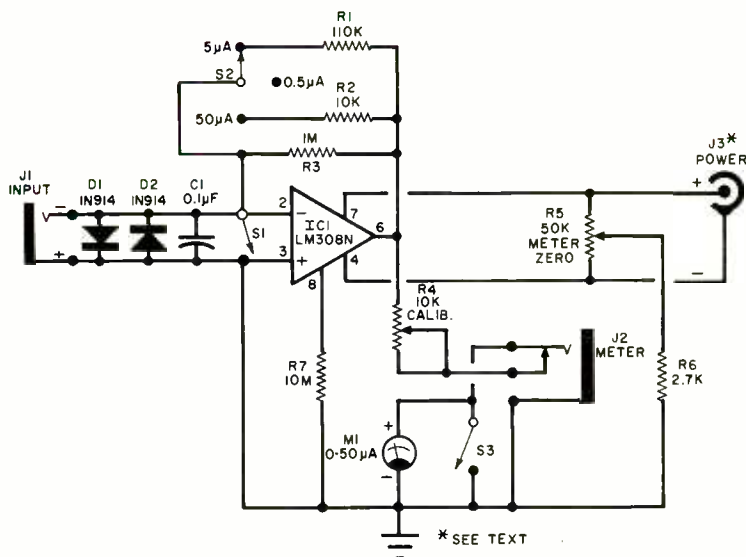

Fig. 2. The gain of the operational amplifier and, hence, the range of the meter are determined by the amount of resistance in the feedback circuit.

approximately 0.7 volt. This corresponds to less than a 50% overload of meter movement *M1*, one that is highly unlikely to cause any permanent damage to the movement. An unprotected microammeter, on the other hand, can easily be "zapped" by the inadvertent application of high current overloads, a fact to which more than one electronics experimenter can ruefully attest.

Power for the circuit is furnished by an external supply via phono jack *J3*. Note that the shell of this power jack must be insulated from chassis ground. The operational amplifier specified for use as *IC1* is an LM308, a precision op amp that can be used with supply voltages ranging from ± 2 to ± 20 volts. Accordingly, a supply capable of furnishing bipolar voltages within these extremes (or a single-ended one rated at 4 to 40 V) should be employed to power the Sensitive μ Meter. Potentiometer *R5* is connected across the supply to allow zeroing of the meter movement under no-input conditions (*S1* closed) for any suitable supply voltage.

Construction. The project is relatively simple, so the use of a perforated board and point-to-point wiring is an acceptable assembly technique. Alternatively, the project can be constructed using wrapped-wire or printed circuit connections. The author

housed his prototype in a 4" \times 2" \times 1½" (10.2 \times 5.1 \times 3.8 cm) aluminum utility box. A Radio Shack No. 22-051 0-to-50-microammeter was used for *M1*. This meter fits the enclosure with only a slight amount of overlap at the edges. Of course, a larger enclosure can be employed if it is preferred over the one selected by the author.

An LM307 operational amplifier can be used for *IC1* in place of an LM308 if pin 3 is connected to project ground through the parallel combination of a 30,000-ohm resistor and a 0.1- μ F disc ceramic capacitor. This op amp will provide performance comparable to that of the LM308 if the circuit is modified as just described. Other operational amplifiers can also be used if variations in pinouts and possible compensation requirements are taken into account.

Calibration and Use. Connect a suitable power supply to *J3*, observing polarities. Then close *S1*, place *S2* in its 0.5 μ A position, and open *S3*. Set the wiper of *R4* halfway between the two extremes of its travel and adjust potentiometer *R5* for a zero reading on meter movement *M1*. Then open *S1* and place *S2* in its 50 μ A position. Connect a suitable source of weak dc current to the input jack of the project using a length of shielded cable terminated with a miniature phone plug. A 1.5-volt battery and a series-connected 1-megohm

potentiometer can be used as a source of low-level dc.

Depending on the capabilities and sensitivity of the test equipment available to you, monitor either the current at *J1* or the voltage at the output of the operational amplifier. Adjust the amplitude of the input current so that it equals 50 μ A. Alternatively, monitor the output voltage of the op amp and adjust the amplitude of the input current until the voltmeter reads +0.500 volt. Then adjust trimmer potentiometer *R4* to obtain a full-scale (50 μ A) reading on *M1*.

The Sensitive μ Meter is now calibrated and ready for use. In view of its high sensitivity, it is a remarkably stable instrument. At the start of each measuring session, the meter should be zeroed by adjusting potentiometer *R5*. It should not be necessary to continually touch up this adjustment if a battery or regulated line-powered supply is used in conjunction with the project.

Thanks to the protective action of *D1* and *D2*, the meter movement is relatively immune from damage caused by current overloads. Overloads should still be avoided, however, especially severe ones that could damage the protective diodes. Finally, remember that it is good practice to keep shorting-switch *S3* closed when the project is not being used. This will damp the meter movement and minimize the effects of physical shock upon it. \diamond

ELECTRONIC MAGIC BOX

MOST OF the tools employed by fortune tellers in the practice of their craft—tarot cards, crystal balls, tea leaves, rune stones, etc.—were developed centuries ago. Now there's the Magic Black Box, a swami of the electronics world that employs digital techniques to divine and display answers to questions posed to it.

The Magic Black Box is a fun project that's relatively easy to build. It employs an EPROM, CMOS and low-power Schottky logic ICs, a 555 timer, and two eight-digit, seven-segment calculator-type LED displays. Current demand is low enough to make the use of a battery power source practicable. Total project cost is approximately \$30.

About the Circuit. The Magic Black Box is shown schematically in Fig. 1. Astable multivibrator *IC1* functions as a master clock, generating a train of pulses with a 98% duty cycle which is applied to various address counters and a display blanker. Counter *IC2* receives clock pulses directly from the

clock and generates a four-bit nibble that is applied to the four lower-order address input pins of read-only memory *IC4*. The nibble is also applied to the address inputs of 1-of-16 demultiplexer *IC6*, which selects and grounds the appropriate common-cathode lines of the display.

Clock pulses generated by *IC1* are also applied to NOR gate *IC7C*, which gates them and allows them to pass in inverted form to 12-bit counter *IC3*. This CMOS counter prescales the train of clock pulses by a factor of four and supplies a six-bit message-select word to the six higher-order address inputs of ROM *IC4*. An initial word is generated by *IC3* when power is first applied to the circuit. At that time, RC network *R3C2* produces a momentary logic-0 which is inverted by *IC7D* and applied to the reset input of the counter.

Read-only memory *IC4* accepts the ten-bit word generated by counters *IC2* and *IC3* and generates at its output a corresponding eight-bit word. The output lines of the ROM are buffered by

driver *IC5*, which can source enough current to cause the LED display to glow. This display is composed of *DIS1* and *DIS2*, two eight-digit, seven-segment surplus calculator readouts.

Clock pulses from *IC1* are also inverted by NOR gate *IC7B*. The inverted pulses are applied to the OUTPUT ENABLE inputs of tri-state driver *IC5*, causing the outputs of this chip to enter their high-impedance "off" state for seven microseconds after each negative transition at pin 3 of *IC1*. This allows the data that appears at the output of the ROM to stabilize, and precludes any possibility of display ghosting, an ailment common to many early digital clocks that used LSI circuits.

When CONJURE switch *S1* is depressed, a logic 0 is applied to pin 8 of *IC7C* and pin 3 of *IC7A*. Clock pulses are then inverted and gated to counter *IC3*. The logic 0 generated by *S1* is inverted by *IC7A*, and the resulting logic 1 is applied to the ENABLE inputs (pins 18 and 19) of demultiplexer *IC6*. This blanks the display during the interval

*Parlor game
displays random,
digitally generated
answers to
your questions*

BY MICHAEL J. FRIESE

*No possibility
Not on Sunday
I bet against it
The stars say so
Barely possible
Definitely yes*



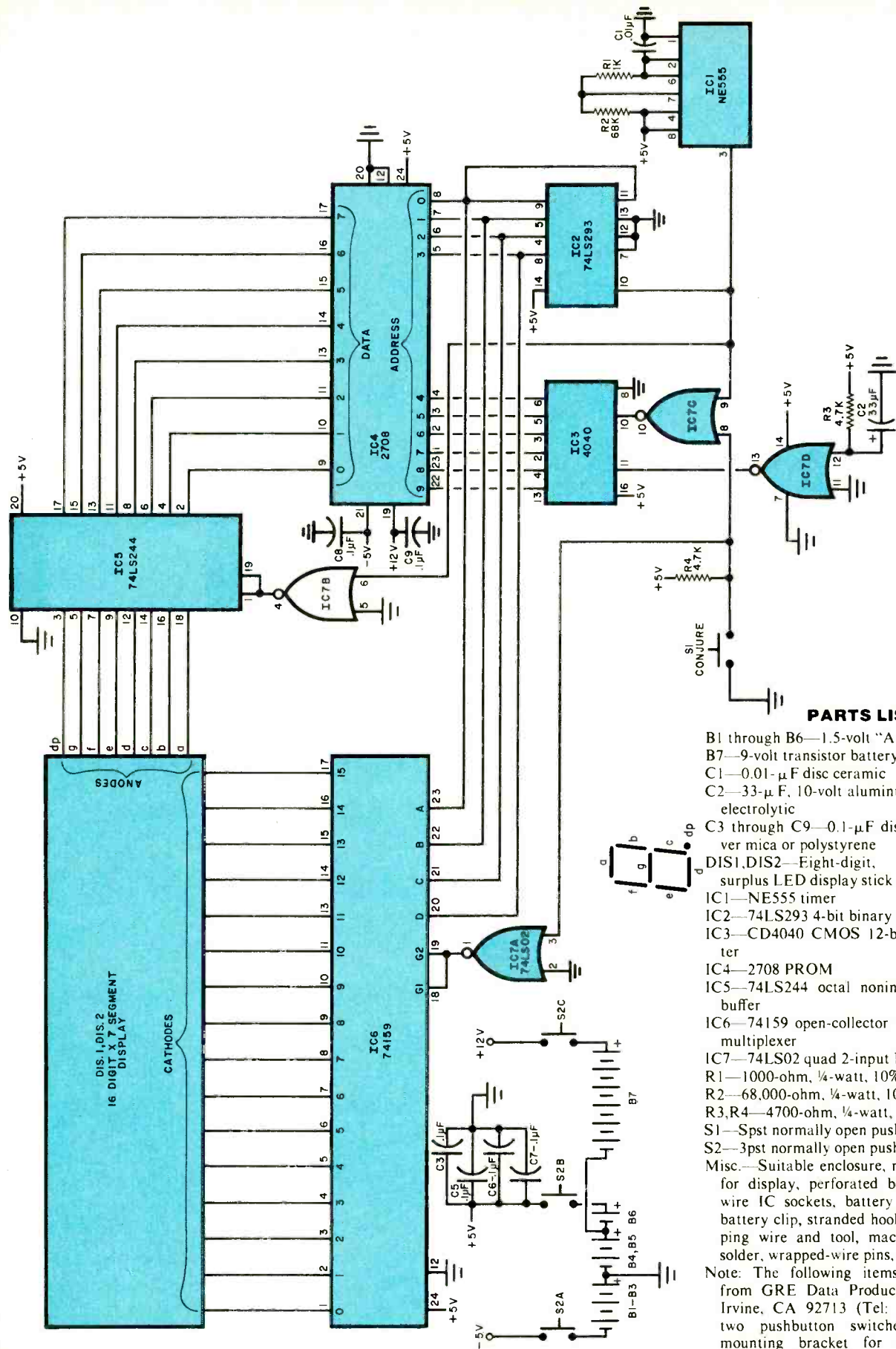

Fig. 1. Schematic diagram of the Magic Box. Answers are stored in the preprogrammed PROM IC4 and supplied to the display when called for.

PARTS LIST

- B1 through B6—1.5-volt "AA" cell
 - B7—9-volt transistor battery
 - C1—0.01- μ F disc ceramic
 - C2—33- μ F, 10-volt aluminum or tantalum electrolytic
 - C3 through C9—0.1- μ F disc ceramic, silver mica or polystyrene
 - DIS1, DIS2—Eight-digit, seven-segment surplus LED display stick
 - IC1—NE555 timer
 - IC2—74LS293 4-bit binary counter
 - IC3—CD4040 CMOS 12-bit binary counter
 - IC4—2708 PROM
 - IC5—74LS244 octal noninverting tristate buffer
 - IC6—74159 open-collector 4-to-16-line demultiplexer
 - IC7—74LS02 quad 2-input NOR gate
 - R1—1000-ohm, 1/4-watt, 10% resistor
 - R2—68,000-ohm, 1/4-watt, 10% resistor
 - R3, R4—4700-ohm, 1/4-watt, 10% resistor
 - S1—Spst normally open pushbutton switch
 - S2—3pst normally open pushbutton switch
 - Misc.—Suitable enclosure, red acrylic filter for display, perforated board, wrapped-wire IC sockets, battery holders, 9-volt battery clip, stranded hookup wire, wrapping wire and tool, machine hardware, solder, wrapped-wire pins, etc.
- Note: The following items are available from GRE Data Products, Box 17296, Irvine, CA 92713 (Tel: 714-751-7341): two pushbutton switches secured to mounting bracket for \$2.50; preprogrammed 2708 PROM for \$15.00. Prices include postage and handling for U.S. orders. Add \$1.00 for orders to be shipped to Canada, \$4.00 for orders to be shipped elsewhere. California residents, add 6% state sales tax.

that the Magic Black Box is conjuring up an answer to the question.

The project requires three supply voltages referenced to ground. Three AA cells (B1, B2, B3) generate -5 volts (actually -4.5 volts) for the V_{BB} line of ROM IC4. Three additional AA cells (B4, B5, B6) provide +5 volts (actually +4.5 volts) for the positive supply terminals of the logic ICs and the 555 timer. The ROM requires an additional positive voltage, +12 volts. This is derived from the series connection of two AA cells (B4 and B5, which are also used to generate +4.5 volts for the logic ICs) and B7, a nine-volt transistor battery. The various supply lines are bypassed by capacitors C3 through C9 to enhance circuit stability. Power is applied to the Magic Black Box by depressing three-pole pushbutton switch S2.

Programming Details. The 64 messages that the author composed for display by his Magic Black Box appear in Table I. A specially programmed PROM is needed to generate these responses. If you are an experienced hobbyist with

access to a 2708 PROM programmer, you can burn in the device yourself. Use either the hexadecimal listing that appears in Table II or the octal listing shown in Table III. If you don't want to program a PROM on your own, you can purchase a preprogrammed one from the source given in the Parts List.

The PROM can be programmed for the reproduction of messages other than those listed in Table I. Because the project employs seven-segment readouts, some letters cannot be displayed. Nevertheless, careful word selection will make it possible to convey most messages unambiguously. The display's character set appears in Table IV. Note that some alphanumeric characters have alternate seven-segment representations. These can be employed for variety or as upper-case characters.

Experimentation is facilitated by the Magic Black Box PROM Generator program listed in Table V. This compact BASIC program eliminates much of the drudgery that would otherwise be associated with the formulation of new

messages. It takes care of such housekeeping details as ASCII-to-seven-segment character translation, upper-to-lower-case character translation, message centering and editing.

To use the program, initialize your version of BASIC, allocating 1K of uncommitted memory for future use. This block of RAM will be used to store the 64 encoded messages that can be

WHEN YOU HAVE 1702s WHO NEEDS 2708s?

There are PROMs that can be used in the Magic Black Box other than 2708s. If you built the low-cost EPROM programmer that appeared in the February and March 1978 issues of POPULAR ELECTRONICS, you will probably prefer to use 1702s. Although they are low-density PROMs, they are inexpensive, readily available, and require only two power-supply voltages.

The circuit shown in this box replaces one 2708 with four 1702s and

one 74LS138 1-of-8 decoder/demultiplexer. Modifications to the Magic Black Box are minimal. Add one 16-pin and three 24-pin IC sockets to the perforated circuit board. Wire all 1702 address lines in parallel, and do the same for all 1702 data lines. The 1702s require +5-, -9-volt and ground connections, so the +12- and -5-volt supplies can be eliminated and a -9-volt supply installed instead. Make sure that the power supply wiring to each IC socket has been performed correctly before installing the 1702s.

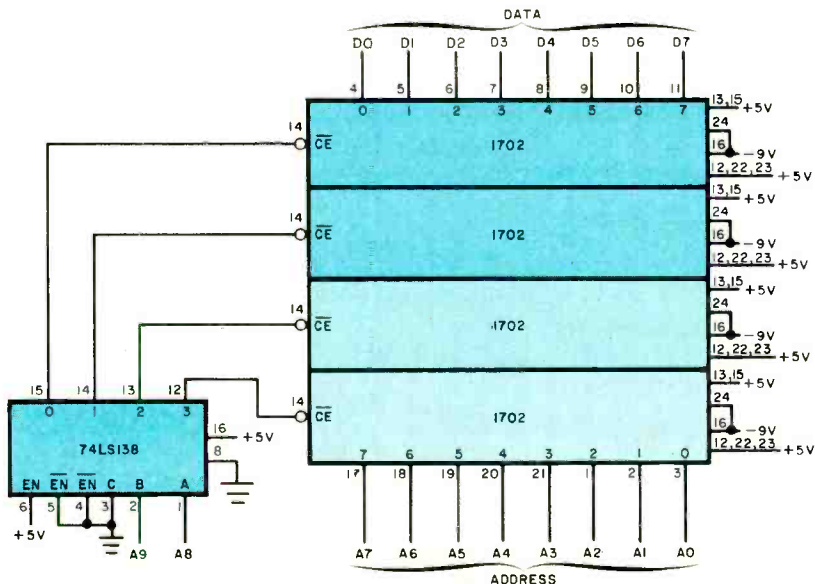

**TABLE I—
MAGIC BLACK BOX
MESSAGE REPERTOIRE**

PHRASE 1	: your QUESTION? :
PHRASE 2	: I CAN't SAY :
PHRASE 3	: I SHAlL not SAY :
PHRASE 4	: I CAN't tell :
PHRASE 5	: REPEAT QUESTION :
PHRASE 6	: I CAN not tell :
PHRASE 7	: I CAN not SAY :
PHRASE 8	: It IS UNCLEAR :
PHRASE 9	: try AGAIN :
PHRASE 10	: SURELY YOU JEst :
PHRASE 11	: I CAN't tell YOU :
PHRASE 12	: LETS SEE :
PHRASE 13	: YES :
PHRASE 14	: YES YES YES YES :
PHRASE 15	: IS DECIDEdly SO :
PHRASE 16	: probably SO :
PHRASE 17	: probably YES :
PHRASE 18	: DEFINITELY SO :
PHRASE 19	: DEFINITELY YES :
PHRASE 20	: AssERtedly SO :
PHRASE 21	: A POSSIBIlity :
PHRASE 22	: I CAN SEE that :
PHRASE 23	: Good CHANCE :
PHRASE 24	: Great CHANCE :
PHRASE 25	: It IS probable :
PHRASE 26	: AssERtedly YES :
PHRASE 27	: It IS POSSIBLE :
PHRASE 28	: the stars SAY SO :
PHRASE 29	: I HOPE SO :
PHRASE 30	: Of COURSE :
PHRASE 31	: It IS POSSIBLE :
PHRASE 32	: no doubt :
PHRASE 33	: POSSIBly SO :
PHRASE 34	: DEFINITE CHANCE :
PHRASE 35	: uh-huh :
PHRASE 36	: fAIR CHANCE :
PHRASE 37	: sounds Good :
PHRASE 38	: I'll bet on it :
PHRASE 39	: No :
PHRASE 40	: No No No No No :
PHRASE 41	: DECIDEdly not :
PHRASE 42	: probably no :
PHRASE 43	: probably not :
PHRASE 44	: DEFINITELY no :
PHRASE 45	: DEFINITELY not :
PHRASE 46	: I doubt it :
PHRASE 47	: NO CHANCE :
PHRASE 48	: I dont SEE that :
PHRASE 49	: barely probable :
PHRASE 50	: not a CHANCE :
PHRASE 51	: little CHANCE :
PHRASE 52	: unfortunately no :
PHRASE 53	: the stars SAY no :
PHRASE 54	: AbsOLUTELY not :
PHRASE 55	: Of COURSE not :
PHRASE 56	: tINY CHANCE :
PHRASE 57	: fAIR CHANCE :
PHRASE 58	: POSSIBly not :
PHRASE 59	: NOPE :
PHRASE 60	: Not on SUNDAY :
PHRASE 61	: No POSSIBIlity :
PHRASE 62	: SLIGHT CHANCE :
PHRASE 63	: I bet AGAINst it :
PHRASE 64	: PUSH the button :

burned into the PROM. Now load the program and run it. Your computer will inquire as to the address of the first of the memory slots that have been set aside for the storage of encoded messages. Reply in decimal notation, e.g., 16384 decimal is equivalent to 4000 hex-encoded binary. The computer will then reply, "PHRASE 1?", signalling that it is ready to receive the first of the messages to be burned into the PROM.

Type in the first message and hit RETURN. Then enter the next one and again

depress the RETURN key. Repeat this procedure for each of the remaining messages, for a maximum of 64 responses. To go back and edit any particular phrase, type its identifying number and hit RETURN. The necessary correction can then be made. To list all the remaining phrases from the current identifying number through the sixty-fourth, type LIST and hit RETURN. When you have entered all 64 messages and have edited them to your satisfaction, you can transfer the data stored in the

1K block of RAM into the PROM. Don't forget to save the data you obtain in tape or disk form.

Construction. The circuit of the Magic Black Box is not very complicated, so any appropriate assembly technique can be employed. The author assembled his prototype using wrapped-wire connections, and mounted all components except for the batteries and their holders on a piece of perforated board measuring 5" x 3" (12.7 cm x 7.6 cm). He installed all components except C3 through C8, DIS1, and DIS2 in Wire-Wrap sockets. A photograph of the prototype circuit board with key components called out appears in Fig. 2.

Easily one of the best bargains in optoelectronics on today's market, surplus seven-segment LED calculator display sticks are employed as the project's readouts. The largest units commonly available have eight or nine digits and are priced at less than \$2 each. Two such displays are required for the Magic Black Box's 16-digit readout. Ideally, the two will be able to be butted together to form one continuous 16-digit display. Most display sticks are not designed to do this, however, so a little custom craftsmanship is in order.

Carefully grind down one end of each display stick. If your displays are like most, you will destroy some of the printed circuit foil traces along the edge of the stick when you do this. Carefully rewire the affected connections using No. 30 or thinner wire. Test each display stick to verify that it performs the same as it did before the modification. Then solder wrapping-wire pins to the 16 foil pads along the bottom of each display

TABLE II—HEXADECIMAL ROM LISTING

4000	00	6E	5C	1C	50	00	67	3E	79	6D	70	06	3F	37	53	00
4010	00	00	00	06	00	39	77	37	70	00	6D	77	EE	00	00	00
4020	06	00	6D	76	77	38	38	00	54	5C	70	00	6D	77	EE	00
4030	00	00	06	00	39	77	37	70	00	70	7B	38	E8	00	00	00
4040	50	79	73	79	77	70	00	67	3E	79	6D	70	06	3F	E7	00
4050	00	06	00	39	77	37	00	54	5C	70	00	70	7B	38	E8	00
4060	00	06	00	39	77	37	00	54	5C	70	00	6D	77	EE	00	00
4070	00	06	70	00	06	6D	00	3E	37	39	38	79	77	00	00	00
4080	00	00	00	70	50	6E	00	77	3D	77	06	E7	00	00	00	00
4090	6D	3E	50	79	38	6E	00	6E	3F	3E	00	1E	79	6D	F0	00
40A0	06	00	39	77	37	70	00	70	7B	38	38	00	6E	3F	EE	00
40E0	00	00	38	79	70	6D	00	6D	79	79	80	80	80	00	00	00
40C0	00	00	00	00	00	00	00	6E	79	ED	00	00	00	00	00	00
40D0	6E	79	6D	00	6E	79	6D	00	6E	79	6D	00	6E	79	ED	00
40E0	06	6D	00	5E	79	39	06	5E	79	5E	38	6E	00	6D	BF	00
40F0	00	00	73	50	5C	7C	5F	7C	38	6E	00	6D	BF	00	00	00
4100	00	00	73	50	5C	7C	5F	7C	38	6E	00	6E	79	ED	00	00
4110	00	5E	79	71	06	37	06	70	79	38	6E	00	6D	BF	00	00
4120	00	5E	79	71	06	37	06	70	79	38	6E	00	6E	79	ED	00
4130	00	77	6D	6D	79	50	70	79	5E	38	6E	00	6D	BF	00	00
4140	00	77	00	73	3F	6D	6D	06	7C	06	38	06	70	EE	F0	00
4150	00	06	00	39	77	37	00	6D	79	79	00	70	74	5F	F0	00
4160	00	00	3D	5C	5C	5E	00	39	76	77	37	39	F9	00	00	00
4170	00	00	3D	50	78	5F	70	00	39	76	77	37	39	F9	00	00
4180	00	06	70	00	06	6D	00	73	50	5C	7C	5F	7C	38	FE	00
4190	00	77	6D	6D	78	50	70	7B	5E	38	6E	00	6E	79	ED	00
41A0	00	06	70	00	06	6D	00	73	3F	6D	6D	06	7C	38	F9	00
41B0	70	74	7B	00	6D	70	5F	50	6D	00	6D	77	6E	00	6D	BF
41C0	00	00	00	06	00	76	3F	73	79	00	6D	BF	00	00	00	00
41D0	00	00	00	3F	71	00	39	3F	3E	50	6D	F9	00	00	00	00
41E0	00	06	70	00	06	6D	00	73	3F	6D	6D	06	7C	38	F9	00
41F0	00	00	00	00	54	5C	00	5E	5C	1C	7C	F0	00	00	00	00
4200	00	00	73	3F	6D	6D	06	7C	38	6E	00	6D	BF	00	00	00
4210	5E	79	71	06	37	06	70	79	00	39	76	77	37	39	F9	00
4220	00	00	00	00	00	1C	74	40	74	1C	F4	00	00	00	00	00
4230	00	00	71	77	06	50	00	39	76	77	37	39	F9	00	00	00
4240	00	00	6D	5C	1C	54	5E	6D	00	3D	5C	5C	DE	00	00	00
4250	00	06	02	38	38	00	7C	70	00	5C	54	00	04	F0	00	00
4260	00	00	00	00	00	00	37	DC	00	00	00	00	00	00	00	00
4270	00	37	5C	00	37	5C	00	37	5C	00	37	5C	00	37	DC	00
4280	00	5E	79	39	06	5E	79	5E	38	6E	00	54	5C	F0	00	00
4290	00	00	73	50	5C	7C	5F	7C	38	6E	00	54	DC	00	00	00
42A0	00	00	73	50	5C	7C	5F	7C	38	6E	00	54	5C	F0	00	00
42B0	00	5E	79	71	06	37	06	70	79	38	6E	00	54	DC	00	00
42C0	00	5E	79	71	06	37	06	70	79	38	6E	00	54	5C	F0	00
42D0	00	00	00	06	00	5E	5C	1C	7C	70	00	04	F0	00	00	00
42E0	00	00	00	37	3F	00	39	76	77	37	39	F9	00	00	00	00
42F0	06	00	5E	5C	54	70	00	6D	79	79	00	70	74	5F	F0	00
4300	7C	5F	50	78	38	6E	00	73	50	5C	7C	5F	7C	38	FE	00
4310	00	00	54	5C	70	00	5F	00	39	76	77	37	39	F9	00	00
4320	00	38	04	70	70	38	79	00	39	76	77	37	39	F9	00	00
4330	1C	54	71	5C	50	70	1C	54	5F	70	7B	38	6E	00	54	DC
4340	70	74	7B	00	6D	70	5F	50	6D	00	6D	77	6E	00	54	DC
4350	00	77	7C	6D	3F	38	3E	70	7B	38	6E	00	54	5C	F0	00
4360	00	3F	71	00	39	3F	3E	50	6D	79	00	54	5C	F0	00	00
4370	00	00	70	06	37	6E	00	39	76	77	37	39	F9	00	00	00
4380	00	00	00	71	77	70	00	39	76	77	37	39	F9	00	00	00
4390	00	00	73	3F	6D	6D	06	7C	38	6E	00	54	5C	F0	00	00
43A0	00	00	00	00	00	00	37	3F	73	F9	00	00	00	00	00	00
43B0	00	37	5C	70	00	5C	54	00	6D	3E	37	5E	77	EE	00	00
43C0	00	37	5C	00	73	3F	6D	6D	06	7C	06	38	06	70	EE	00
43D0	00	6D	38	06	37	76	70	00	39	76	77	37	39	F9	00	00
43E0	06	00	7C	7B	70	00	77	3D	77	06	37	6D	70	00	04	F0
43F0	73	3E	6D	76	00	70	74	7B	00	7C	1C	70	70	5C	D4	00

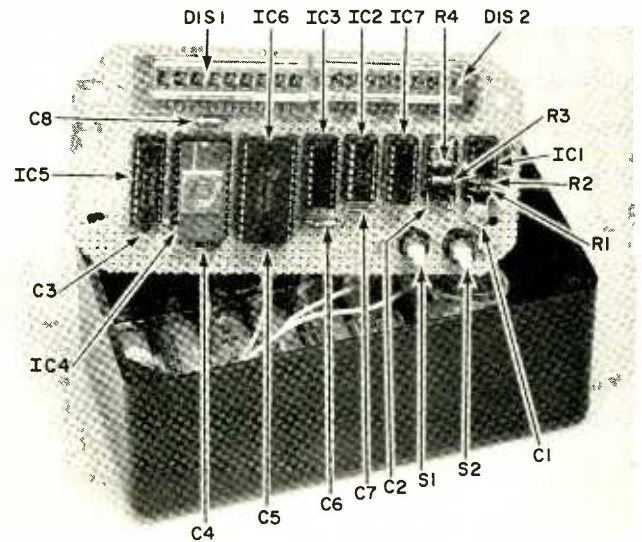

Fig. 2. Photo shows interior of author's prototype.

stick. Mount the display sticks side by side on the perforated board; and, using eight wrapping wires, interconnect the corresponding segment and decimal-point pins of each stick.

Drill holes at the lower right portion of the perforated board and mount push-button switches *S1* and *S2*. Mount eight wrapped-wire IC sockets as was done on the prototype's circuit board (Fig. 2). From left to right, the sockets are of the following sizes: 20 pins; 24 pins; 24 pins; 16 pins; 14 pins; 14 pins; 14 pins; and 14 pins. The socket at the extreme right will accommodate *IC1*, *R1*, *R2* and *C1*. The next socket can hold *R3*, *R4*, and *C2*.

Select a suitable enclosure for the Magic Black Box. The author chose a Bakelite box measuring 6" x 3 1/8" x 2 1/4" (15.2 x 7.9 x 5.7 cm) with a 1/8-inch (3.2-mm) thick red acrylic cover. Drill the necessary holes for battery holders for *B1* through *B7* and install the holders. If you don't want to drill the enclosure, secure the battery holders to it with double-sided adhesive tape. Now wire all power connections, referring to the schematic for the power terminals associated with each IC. Use 4-inch (10.2-cm) lengths of stranded hookup wire to interconnect the battery holder terminals and power switch *S2*.

Connect *S2* to the perforated board's power busses and install bypass capacitors *C3* through *C8*. Install the remaining resistors and capacitors in the extreme right and next-rightmost IC sockets using Fig. 2 as a guide. Take care to orient polarized capacitor *C2* correctly. Then make wrapped-wire connections to complete the balance of the circuit shown in Fig. 1.

Install *B1* through *B7* in their holders and close power switch *S2*. Using a voltmeter, check the polarities of the +5-, +12- and ±5-volt supply lines. If they are correct, open *S2* and install *IC1*, *IC2*, *IC3*, *IC5*, *IC6* and *IC7*. Observe standard MOS handling procedures when installing *IC3*. Once again close power switch *S2*. All segments of each digit should glow, forming 8s, and all decimal points should glow as well. If only one digit glows, chances are that the 555 timer being used as *IC1* cannot tolerate the combination of low supply voltage and high duty cycle. Replace this IC with other 555s until you find one that oscillates properly.

Keep *S2* depressed and close CONTACT switch *S1*. The display should blank out. Open *S1* but keep *S2* closed. Double-check the voltages at pins 12, 19, 21 and 24 of the socket that will

accommodate *IC4*. If the readings are correct, open *S2* and install PROM *IC4* in its socket. Observe MOS handling procedures when mounting the PROM in its socket. Now depress *S2* again. The display should read, "Your question?". Keep *S2* depressed and momentarily close *S1*. The readout should briefly blank out and then display a randomly selected message.

Once you are satisfied that the project is functioning properly, install it in

the enclosure you have selected. As mentioned earlier, the author housed his prototype in a small Bakelite box (hence the project's name) with a red acrylic top plate. This red cover serves to enhance display legibility. The perforated circuit board was bolted to it using 6-32 machine hardware and suitable spacers. Finally, the acrylic top plate was secured to the enclosure using four 4-40 machine screws, resulting in a compact, sturdy package.

(Continued on page 66)

TABLE III—OCTAL ROM LISTING

0 000	000	156	134	034	120	000	147	076	171	155	160	006	077	067	123	000
0 020	000	000	000	006	000	071	167	067	160	000	155	167	356	000	000	000
0 040	006	000	155	166	167	070	070	000	124	134	160	000	155	167	356	000
0 060	000	000	006	000	071	167	067	160	000	160	173	070	270	000	000	000
0 100	120	171	163	171	167	160	000	147	076	171	155	160	006	077	267	000
0 120	000	006	000	071	167	067	000	124	134	160	000	160	173	070	270	000
0 140	000	006	000	071	167	067	000	124	134	160	000	155	167	356	000	000
0 160	000	006	160	000	006	155	000	076	067	071	070	171	167	320	000	000
0 200	000	000	000	160	120	156	000	167	075	167	006	267	000	000	000	000
0 220	155	076	120	171	070	156	000	156	077	076	000	036	171	155	360	000
0 240	006	000	071	167	067	160	000	160	173	070	070	000	156	077	276	000
0 260	000	000	070	171	160	155	000	155	171	171	200	200	200	000	000	000
0 300	000	000	000	000	000	000	000	156	171	355	000	000	000	000	000	000
0 320	156	171	155	000	156	171	155	000	156	171	155	000	156	171	355	000
0 340	006	155	000	136	171	071	006	136	171	136	070	156	000	155	277	000
0 360	000	000	163	120	134	174	137	174	070	156	000	155	277	000	000	000
1 000	000	000	163	120	134	174	137	174	070	156	000	156	171	355	000	000
1 020	000	136	171	161	006	067	000	160	171	070	156	000	155	277	000	000
1 040	000	136	171	161	006	067	000	160	171	070	156	000	156	171	355	000
1 060	000	167	155	155	171	120	160	171	136	070	156	000	155	277	000	000
1 100	000	167	000	163	077	155	155	006	174	006	070	006	160	356	000	000
1 120	000	006	000	071	167	067	000	155	171	171	000	160	164	137	360	000
1 140	000	000	075	134	134	136	000	071	166	167	067	071	371	000	000	000
1 160	000	000	075	120	173	137	160	000	071	166	167	067	071	371	000	000
1 200	000	006	160	000	006	155	000	163	120	134	174	137	174	070	373	000
1 220	000	167	155	155	173	120	160	173	136	070	156	000	156	171	355	000
1 240	000	006	160	000	006	155	000	163	077	155	155	006	174	070	371	000
1 260	160	164	173	000	155	160	137	120	155	000	155	167	156	000	155	277
1 300	000	000	000	006	000	166	077	163	171	000	155	277	000	000	000	000
1 320	000	000	000	077	161	000	071	077	076	120	155	371	000	000	000	000
1 340	000	006	160	000	006	155	000	163	077	155	155	006	174	070	371	000
1 360	000	000	000	000	124	134	000	136	134	034	174	360	000	000	000	000
2 000	000	000	163	077	155	155	006	174	070	156	000	155	277	000	000	000
2 020	136	171	161	006	067	006	160	171	000	071	166	167	067	071	371	000
2 040	000	000	000	000	000	034	164	100	164	034	364	000	000	000	000	000
2 060	000	000	161	167	006	120	000	071	166	167	067	071	371	000	000	000
2 100	000	000	155	134	034	124	136	155	000	075	134	134	336	000	000	000
2 120	000	006	002	070	070	000	174	173	160	000	134	124	000	004	360	000
2 140	000	000	000	000	000	000	000	067	334	000	000	000	000	000	000	000
2 160	000	067	134	000	067	134	000	067	134	000	067	134	000	067	334	000
2 200	000	136	171	071	006	136	171	136	070	156	000	124	134	360	000	000
2 220	000	000	163	120	134	174	137	174	070	156	000	124	134	360	000	000
2 240	000	000	163	120	134	174	137	174	070	156	000	124	134	360	000	000
2 260	000	136	171	161	006	067	006	160	171	070	156	000	124	134	360	000
2 300	000	136	171	161	006	067	006	160	171	070	156	000	124	134	360	000
2 320	000	000	000	006	000	136	134	034	174	160	000	004	360	000	000	000
2 340	000	000	000	067	077	000	071	166	167	067	071	371	000	000	000	000
2 360	006	000	136	134	124	160	000	155	171	171	000	160	164	137	360	000
3 000	174	137	120	173	070	156	000	163	120	134	174	137	174	070	373	000
3 020	000	000	124	134	160	000	137	000	071	166	167	067	071	371	000	000
3 040	000	070	004	160	160	070	171	000	071	166	167	067	071	371	000	000
3 060	034	124	161	134	120	160	034	124	137	160	173	070	156	000	124	334
3 100	160	164	173	000	155	160	137	120	155	000	155	167	156	000	124	334
3 120	000	167	174	155	077	070	076	160	173	070	156	000	124	134	360	000
3 140	000	077	161	000	071	077	076	120	155	171	000	124	134	360	000	000
3 160	000	000	160	006	067	156	000	071	166	167	067	071	371	000	000	000
3 200	000	000	000	161	167	160	000	071	166	167	067	071	371	000	000	000
3 220	000	000	163	077	155	155	006	174	070	156	000	124	134	360	000	000
3 240	000	000	000	000	000	067	077	163	371	000	000	000	000	000	000	000
3 260	000	067	134	160	000	134	124	000	155	076	067	136	167	356	000	000
3 300	000	067	134	000	163	077	155	155	006	174	006	070	006	160	356	000
3 320	000	155	070	006	075	166	160	000	071	166	167	067	071	371	000	000
3 340	006	000	174	173	160	000	167	075	167	006	067	155	160	000	004	360
3 360	163	076	155	166	000	160	164	173	000	174	034	160	160	134	324	000

OK

The LM 339

A Great Comparator

Four independent comparator circuits on one chip can be used in a variety of analog and digital applications

BY CLEMENT S. PEPPER

THE KEY WORD to describe the 339 quad comparator is *versatility*. This device can interface a slow-moving analog signal to almost any logic family, will drive a LED, detect high- and/or low-voltage limits and can be used as a monostable oscillator.

What makes the 339 so versatile? Consider its power requirements as an example. The chip will work from a single dc source between 2 and 32 volts, or a split power supply from ± 1 to ± 18 volts. Current drain is a meager 0.8 mA, independent of supply voltage.

The common-mode range includes ground, even when operated from a single supply. With a typical input bias current of 25-nanoamperes, a 3-nanoampere offset and a 3-mV input offset voltage, the input can "look" at almost any source impedance without loading.

The 339 output stage is an npn transistor having an uncommitted collector so that an external pullup resistor can be used with a supply voltage different than that used by the remainder of the device. You can even hard-wire the outputs in an OR configuration. The transistor output stage will sink up to 20 mA, but you may have to live with a high saturation voltage (with 4 mA it is 250 mV). The output is compatible with TTL (fan-out of 2), DTL, ECL, MOS and CMOS.

The 339 chip contains four identical

comparators, and is available from many parts suppliers at prices as low as \$1 each.

Device Operation. The pinout for the 339 is shown in Fig. 1A. The numbers across each row indicate the noninverting and inverting inputs with the associated outputs for each of the four comparators in the chip.

A basic comparator is shown in Fig. 1B. Here, the input signal V_{IN} is compared with a fixed reference V_{REF} . Whenever the input signal exceeds the reference level by just a couple of millivolts, the output (V_O) goes high. This action is illustrated by the associated waveforms.

Unfortunately, such a basic circuit can oscillate during the transition period, and although this might present a problem with slow analog signals, it would cause no trouble for the fast transition times associated with digital signals. This can be averted by using a small amount of positive feedback as shown in Fig. 1C. The feedback not only speeds up the transition, but adds a little hysteresis. Feedback resistor R_F is typically a high value, 10 megohms for example.

While hysteresis can eliminate the transient oscillation, it can also be put to work in a useful manner such as "cleaning up" input waveforms, acting like a

Schmitt trigger. However, most Schmitt triggers lack adjustability, and further along in this article, we will illustrate a 339 Schmitt trigger that does not have this problem.

Analog-to-Digital Interface. The input for a frequency counter is a good example of an analog-to-digital interface (not to be confused with an A/D converter as used in computers).

The input of a frequency counter must be capable of accepting a wide variety of signals, slow or fast, and provide a signal compatible with the digital counter circuits that follow. Also, since the input levels can span a broad range of levels, sensitivity adjustments are required. Then there must be a "threshold" established either to reject noise, or possibly to match a digital source. Such a circuit is shown in Fig. 2A.

Sine-wave performance (10 kHz) is shown in Fig. 2B with a 3-volt rms input and Fig. 2C with 1-volt rms input. This circuit has been used with excellent results to 1 MHz.

CMOS to TTL Translation. The circuit shown in Fig. 2A is also useful for translating various logic families. For this application, two series-connected 1N914 diodes may be substituted for the 2000-ohm potentiometer. This estab-

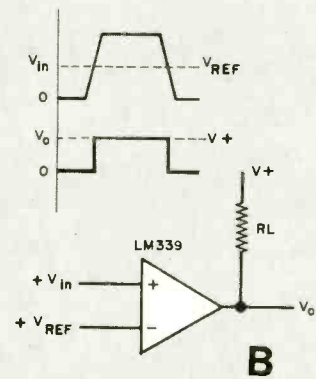
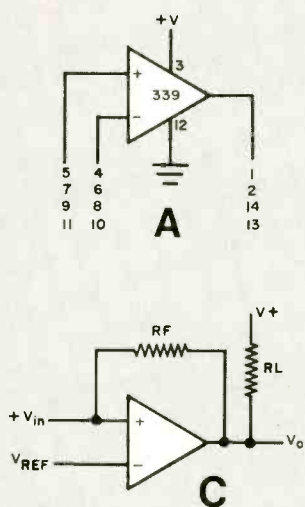

Fig. 1. Pinout of the LM339 (A). Comparator with basic waveforms (B). Comparator with feedback resistor for faster switching action (C).

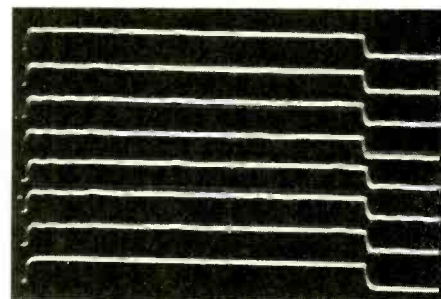

Fig. 3. Outputs of two separate 339 packages (four at top, four at bottom) show excellent matching.

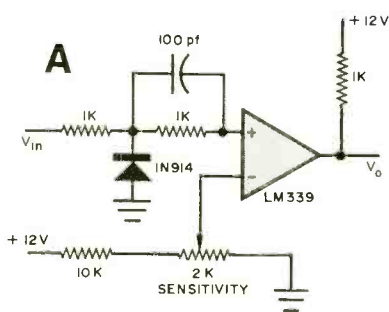
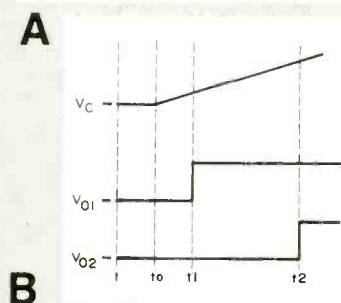
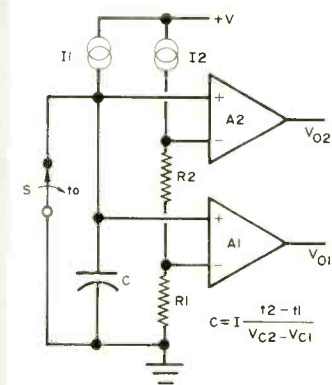
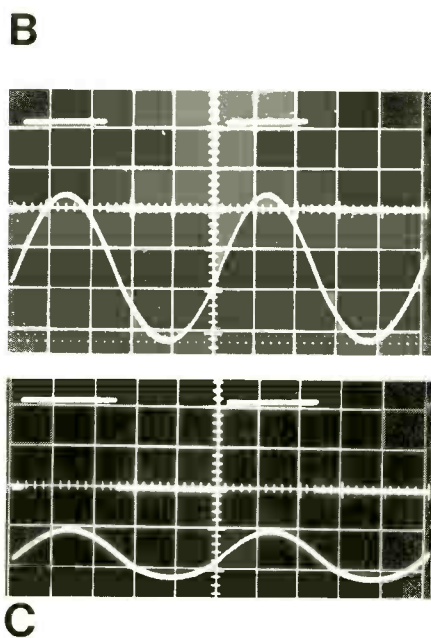

Fig. 2. Counter input circuit (A). Output with 10-kHz, 3-volt input (B) and 10-kHz, 1-volt (C). Outputs are upper traces, with 5 V/div. Sine waves are at 2 V/div.



lishes a 1.4-volt reference compatible with both TTL and CMOS operating from a 5-volt supply. The 1000-ohm pullup resistor connected at the output has to be connected to the TTL 5-volt supply.

During the design of an 8-input oscilloscope circuit, the author connected eight such circuits, with all eight inputs connected to a source having a pulse 8-microseconds wide. The upper four traces of Fig. 3 came from one 339 package, while the lower four traces came from another 339 package. Actual time variations are about 200 nanoseconds. This illustrates the quality of diffusion techniques these days.

High and Low Limit Detection.

Two comparators working together sense the low and high limits in the simplified capacitance measuring scheme shown in Fig. 4A. The unknown capacitor (C) is charged from a constant-current source (I1). This results in a linear charging ramp whose slope is proportional to the capacitance (Fig. 4B). The limit voltages are 0.10 and 1.10 volts, so that the measurement becomes that of the time required to charge the capacitor to this higher voltage.

In the complete circuit (Fig. 4C), the addition of an exclusive-OR gate yields a pulse whose width is scaled to the val-

ue of the capacitor. Scope traces of a typical measurement are shown in Fig. 4D. The capacitance can be determined from the width of the pulse.

Earlier in this article, hysteresis was mentioned as one way to get high and low limit detection, such as used in a Schmitt trigger. The circuit shown in Fig. 5A uses a single comparator which does not have the precision of the dual comparator approach but is useful with looser tolerance circuits.

Although the circuit appears tricky, it is easy to understand. First, you have to know the desired upper and lower switching voltages. Then, select a zener

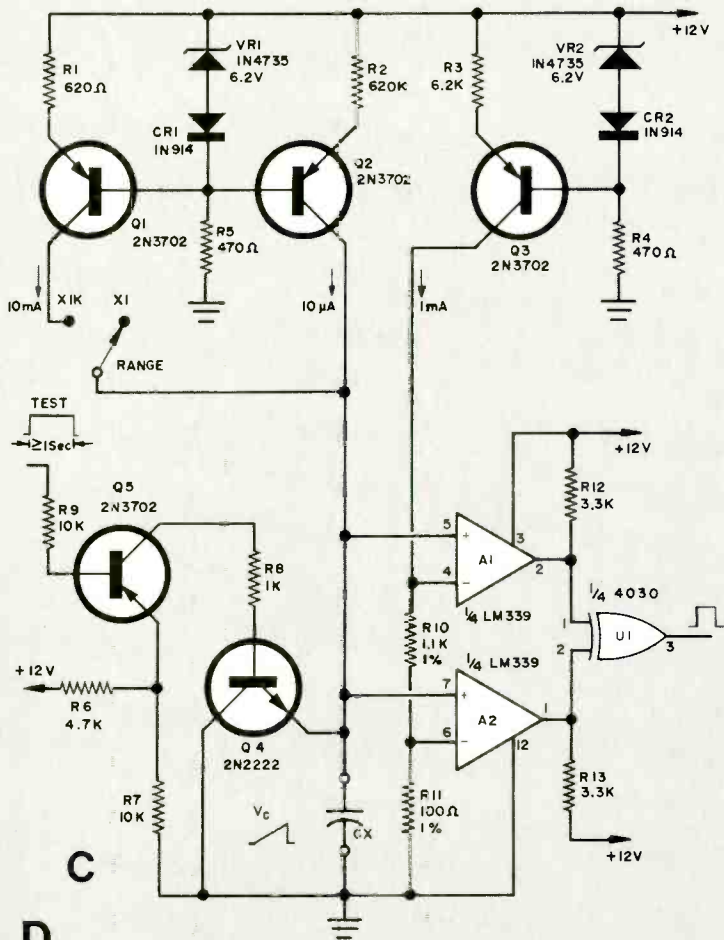
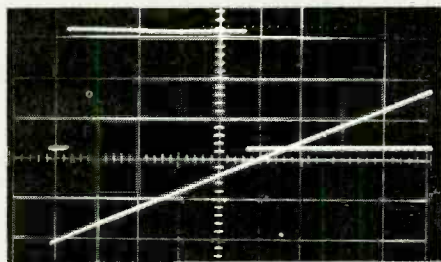

Fig. 4. Basic capacitance measuring circuit (A) and timing diagrams (B). Complete circuit (C) and output for 4.7 μ F (D).



diode that falls midway between these voltages. Part of the problem comes when trying to get a zener diode of the correct value since zeners come in specific voltages. Therefore, pick the closest value. Select R1 for 5 to 10 mA of zener current.

When the 339 output is low, some of the current through R1 flows through R2 and R3 into the output. We can safely assume that none flows into the noninverting (+) input. Pin 5 of the 339 will now be lower than the zener.

With the 339 output high, current flows through R4, R3 and R2 into the zener diode.

Although we will not go into a detailed circuit analysis, the "trick" here is to select the resistor values. In the circuit shown in Fig. 5A, the switching points are 7.7 and 4.0 volts. Build the circuit and vary the resistor values to get a feel for circuit operation. A typical waveform is shown in Fig. 5B.

Monostable. The circuit for a 339 monostable is shown in Fig. 6A, with an output waveform shown in Fig. 6B.

The inverting (-) input of the comparator is biased about 1.25 volts positive by the 6.8-megohm and 1-megohm voltage divider.

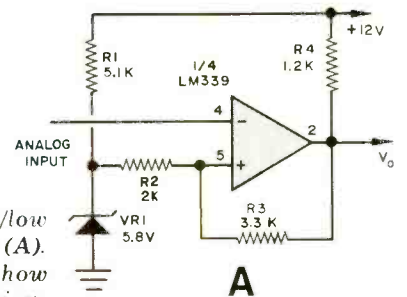

Fig. 5. High/low limit detector (A). Waveforms (B) show switching action.

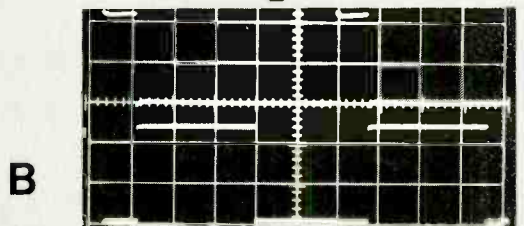
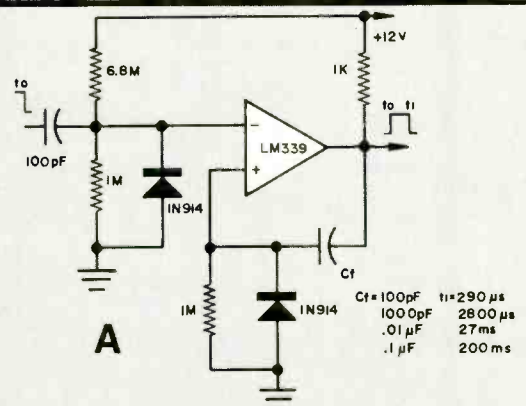
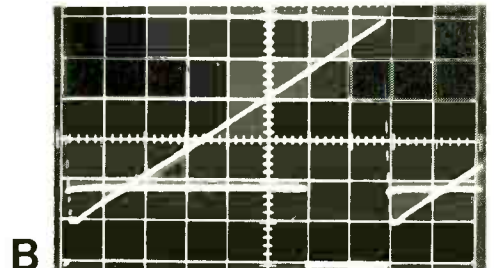

Fig. 6. Monostable circuit (A). In (B) 1710-Hz input is at top, output below (5 V/div).

Triggering occurs on a negative-going input which forces the inverting input below ground. The 1N914 diode limits this to one diode drop. The resulting positive-going output is fed back to the noninverting (+) input, and the timing is determined by the discharge time of the feedback capacitor C_F and the 1-megohm resistor. This time is proportional to the capacitance value for the ranges shown in Fig. 6A.

Although this circuit may require some "tweaking" to achieve specific monostable action, it is useful to know about if you have an unused comparator in your design and require a monostable. ◇

BUILD A Metal Locator

BY ROBERT KRIEGER

WHETHER it is put to work in searching for buried treasure, locating sunken pipes, or combing the Australian outback for fragments of a fallen space station, a metal locator can be a useful instrument. The locator described here uses a highly sensitive superheterodyne circuit. It is a true "from-scratch" project in which you even fabricate the search-head pickup-coil assembly. Assuming all parts and materials are bought new for this project, total cost should run about \$20.

Circuit Operation. The metal locator, shown in block-diagram form in Fig. 1, functions on the beat-frequency (heterodyning) principle. Here, two high-frequency r-f signals are combined, or "beat" together, in the FET mixer to produce a difference frequency. (Actually, the mixer output contains the original frequencies along with their sum and difference, but it is the difference frequency that interests us because it is the only one that lies in the audio range.)

The original signals are produced by a pair of FET oscillators operating at 650 kHz. The frequency was chosen on the basis of tests showing that, up to 350 kHz, sensitivity and depth of penetration are fairly low and constant for moderately small objects. At 400 kHz, there is a sharp increase in performance that persists up to 1.3 MHz, where the copper-

Low-cost,
high-sensitivity unit
for searching out
metal objects



DSI STOPS BRANDS A thru Z with more counter for less money FACTORY WIRED 500 MHz • 1 PPM TCXO • 8 DIGITS



- Two BNC Inputs
- 1 Meg and 50 Ohm Input
- Factory Wired and Tested
- Made in USA
- 50 Hz to 512 MHz

Compare These Features and You Will Buy DSI

- 8 Digits Not 6 or 7 Digits
- 1 PPM TCXO Not 1.5 PPM - 10 PPM
- Resolution 1 Hz @ 50 MHz Not 10 Hz
- Resolution 10 Hz @ 450 MHz Not 100 Hz

FREQUENCY COUNTER STRAIGHT TALK

There are only three functional requirements for a frequency counter: 1. Good accuracy over temperature 2. Resolution 3. Sensitivity

Good accuracy over temperature. Crystal oscillators drift with temperature changes. This change is specified in parts per million (PPM). The 5500 TCXO (temperature compensated crystal oscillator) holds an accuracy of 1 PPM from 17° to 40°C. This corresponds to ± 450 Hz at 450 MHz. Counters with 2 PPM accuracy would read to ± 900 Hz at 450 MHz. Counters with 10 PPM accuracy would read to ± 4500 Hz and so on.

Resolution. What is the value of the least significant digit displayed? A counter with 10 Hz resolution would display 146.52000 MHz as 146.52000 i.e. with the last digit left off. A counter with 100 Hz resolution would display 146.5200. The 5500 with 8 Digits is capable of resolving 1 Hz from 50 Hz to 50 MHz, and 10 Hz from 50 MHz to 500 MHz. Counters with only 7 digits usually can only resolve 10 Hz to 50 MHz and 100 Hz to 500 MHz. The above effects, accuracy and resolution are cumulative. Example: a seven-digit counter with 1.5 PPM accuracy reading 450 MHz would only be accurate to ± 675 Hz (± .00 Hz last digit error) or ± 775 Hz. The 5500 with eight full digits and 1 PPM accuracy would be accurate to ± 450 Hz ± 10 Hz (last digit error) or ± 460 Hz maximum. Not bad for \$99.95. You really need that eighth digit to achieve real accuracy.

Sensitivity. The 5500 requires only 10-15 mv of signal to stabilize and achieve an accurate reading. A one watt hand-held can be read with accuracy at a distance of 15-20 ft. from the counter using the T600 antenna. Counters with 150 mv sensitivity will only stabilize at distances of less than a foot.

The outstanding sensitivity of the 5500, the result of its unique engineering design, and built-in preamp assures stable, accurate readings every time you key up your transmitter.

If you are tired of receiving a plastic bag of sometimes surplus, sometimes defective material only to spend all night trying to solder both sides of the PC Board because the manufacturer chose to use low cost PC Boards without plated-thru holes; if you chose a kit because you only budgeted a hundred dollars for a frequency counter, then the DSI 5500 Counter is the answer. It is 100% factory assembled and tested. DSI strives to purchase the highest quality, prime materials imposing the most rigorous quality requirements possible. Every PC Board that DSI manufactures is plated-thru solder re-flowed, and 100% factory assembled, tested and burn-in in the USA, assuring years of trouble-free service. DSI has worked hard to achieve our worldwide reputation for the best price to quality feature ratio in the industry. DSI's 5500 now makes it possible to buy a 100% factory assembled accurate 8-digit frequency counter for under \$ 100.00. Buy quality — Buy performance — Buy cost effectiveness — Buy DSI.

FOR INFORMATION — DEALER LOCATION — ORDERS — OEM
CALL 800-854-2049 CALIFORNIA RESIDENTS CALL 800-542-6253

Model	Price	Frequency Range	Accuracy Over Temperature	SENSITIVITY			Number of Reads	Power Requirements	Size		
				100 Hz - 25 MHz	50 - 250 MHz	250 - 450 MHz			H	W	D
5500	\$99.95	50 Hz - 512 MHz	TCXO 1 PPM 17° - 40°C	10 - 15 MV	10 - 15 MV	15 - 50 MV	6	*115 VAC or 8.2 - 14.5 VDC	1 1/2"	5"	5 1/2"

*With AC-9 Adaptor.

5500 wired factory burn-in with limited warranty. Prices as shown or specifications subject to change without notice.
TERMS: MC - VISA - AE - Check - M.O. - C.C.D. In U.S. Funds. Please add 10% to a maximum of \$10.00 for shipping, handling and insurance. Orders outside of USA & Canada, please add \$20.00 additional to cover air shipment. California residents add 6% Sales Tax.



DSI INSTRUMENTS, INC.
9550 Chesapeake Drive
San Diego, California 92123
(714) 535-8402
CIRCLE NO. 21 ON FREE INFORMATION CARD

- 5500 Wired \$99.95
- 5500/W 558A 119.95
- Includes Rechargeable NiCad Battery Pack and AC Adapter
- T600 BNC Antenna 7.95
- AC-9 AC Adapter 7.95

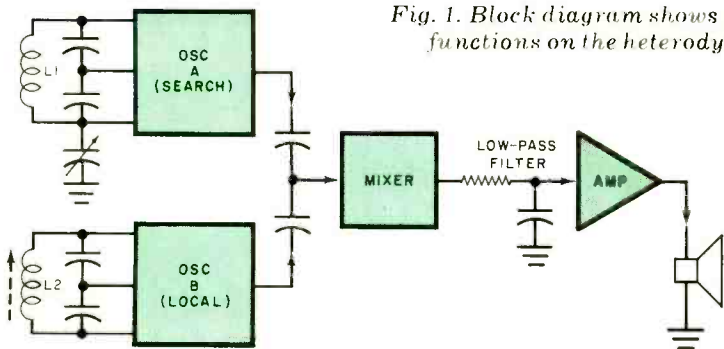

Fig. 1. Block diagram shows how the locator functions on the heterodyning principle.

braided Faraday shield (more about the shield later) loses its effectiveness. A frequency of 650 kHz gives excellent sensitivity and offers convenience in final adjustment. As designed, the metal locator can detect a nickel in free air at a distance of 6" (152 mm) or buried at a depth of 3" (76 mm) or more.

Assume that oscillators A and B in Fig. 1 are set to 650.454 and 650.400 kHz, respectively. Combining these in the FET mixer, we obtain signals at 650.454 kHz, 650.400 kHz, 1300.854

kHz and 54 Hz in the output. Since all we wish to pass on to the amplifier is the audible 54-Hz signal, the low-pass filter removes all higher frequencies. After amplification, the 54-Hz signal is heard from the loudspeaker.

When $L1$, the inductor that forms the search head, is brought near a metallic object (on the surface or buried), its inductance changes slightly. The deeper the object is buried, the less the change. With $L1$ acting as one of the frequency-

the variation in $L1$ causes a frequency shift, say, to 650.440 kHz. Now, the difference between 650.440 kHz and the 650.400-kHz frequency of fixed oscillator B is 40 Hz. This means that the audible tone has shifted from 54 to 40 Hz to indicate the proximity to $L1$ of a metallic object.

The metal locator contains two stable Colpitts oscillators ($Q1$ and $Q2$ circuits in Fig. 2) that are both tuned to operate in the 650-kHz range. The oscillators are essentially identical, except that one employs search-head coil $L1$ as the inductive element and the other has small tunable inductor $L2$.

For operation, $C1$ is set at its midpoint and then $L2$ is adjusted so that both oscillators are at zero beat (same frequency). Varying $C1$ will then tune oscillator $Q1$ out of zero beat and cause an audio tone to be heard. Note that source resistor $R4$ in the $Q2$ circuit is greater in value than $R3$ in the $Q1$ circuit. Since the $Q1$ circuit produces a low level of oscillation, it is necessary to damp the $Q2$ oscillator

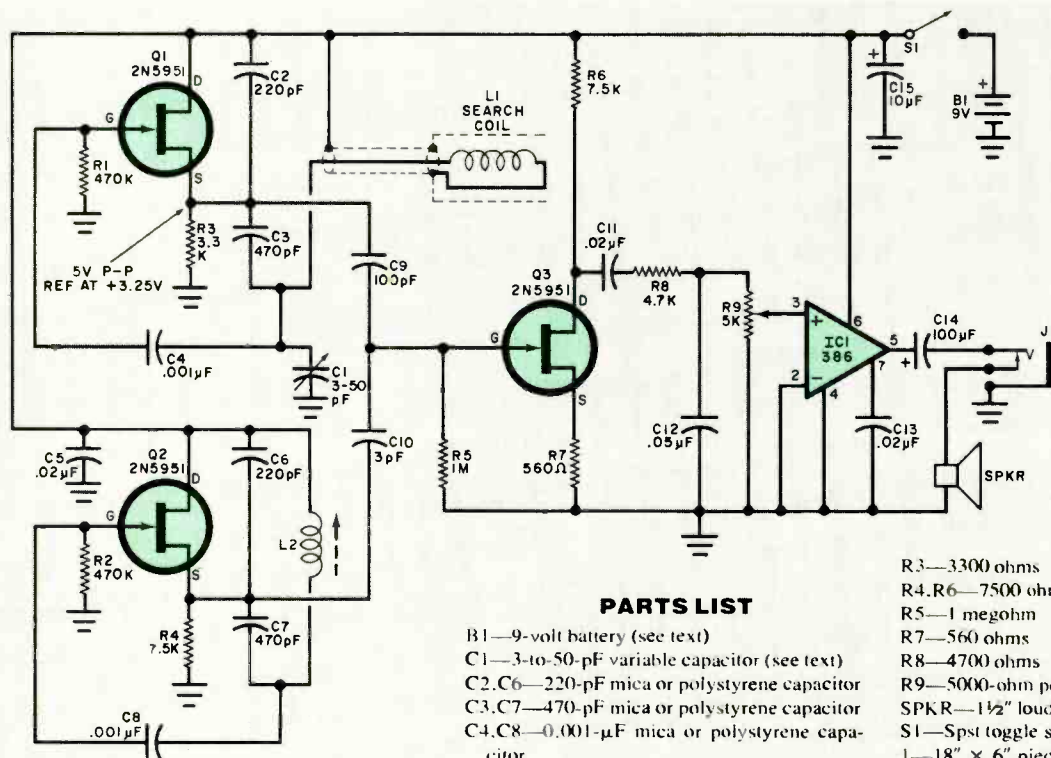

Fig. 2. Two stable Colpitts oscillators ($Q1$ and $Q2$) are tuned to operate in the 650-kHz range. They are essentially identical except for the two inductors.

PARTS LIST

- B1—9-volt battery (see text)
 - C1—3-to-50-pF variable capacitor (see text)
 - C2, C6—220-pF mica or polystyrene capacitor
 - C3, C7—470-pF mica or polystyrene capacitor
 - C4, C8—0.001- μ F mica or polystyrene capacitor
 - C5, C11, C13—0.02- μ F capacitor
 - C9—100-pF mica or polystyrene capacitor
 - C10—3-pF capacitor
 - C12—0.05- μ F capacitor
 - C14—100- μ F, 16-volt electrolytic
 - C15—10- μ F, 16-volt electrolytic
 - IC1—LM386 1/2-watt audio amplifier IC
 - J1—Miniature transfer-type phone jack
 - L1—Search coil (see text)
 - L2—AM loopstick antenna with tunable slug
 - Q1, Q2, Q3—2N5951 n-channel FET
- The following are 1/4-watt, 10% tolerance resistors unless otherwise noted:
- R1, R2—470,000 ohms
 - R3—3300 ohms
 - R4, R6—7500 ohms
 - R5—1 megohm
 - R7—560 ohms
 - R8—4700 ohms
 - R9—5000-ohm potentiometer

- SPKR—1 1/2" loudspeaker
- S1—Spst toggle switch
- 1—18" \times 6" piece of 1/4" plywood for search-head coil form
- 1—36" length of 3/4" diameter aluminum tubing
- 1—5' length of RG-58U coaxial cable
- 1—2' length of RG-8U coaxial cable
- Misc.—Perforated board (or printed-circuit board—see text); socket for IC1; 9-volt battery clip; Bud No. CU234 or similar aluminum case; 40' No. 28 enamel- or Mylar-coated magnet wire; control knobs (2); white glue; epoxy cement; plastic tape; 1/2" foam insulation tape; plastic cement; two small brass screws; machine hardware; spacers; hookup wire; solder; etc.

to match the $Q1$ oscillator. This is the reason for the greater value for $R4$.

The key to operation of a Colpitts oscillator is the pair of capacitors that form a voltage divider across the inductor ($C2$ and $C3$ for $Q1$ and $C6$ and $C7$ for $Q2$). The capacitors and inductor in each circuit determine the frequency of operation for that circuit. In the $Q1$ and $Q2$ circuits, the FET's source is at signal ground. Therefore, because of the split capacitor action, the signal at the bottom of the inductor is 180° out-of-phase with that at the drain. Since the transistor inverts the signal by 180° and the split tank circuit inverts another 180° , an in-phase signal is fed back to the gate and sustains oscillations.

Increasing the value of $C3$ or $C7$ decreases the amount of feedback to the gate. If the value of this capacitor is made too large, there will not be enough feedback to sustain oscillation. Lowering its value to, say, 300 pF increases feedback and virtually guarantees oscillation, but the sine wave will not be as "clean" as it would be with a 560-pF capacitor value. The ratio of $C2$ to $C3$ or $C6$ to $C7$ should be about 1:3 for best overall operation. Although $Q1$ and $Q2$ appear to be arranged in a unity-gain source-follower configuration, $R3$ and $R4$ are actually working off the drains, since the sources are at feedback ground.

Mixer $Q3$ heterodynes the r-f signals and provides some degree of preamplification for amplifier $IC1$. Resistor $R8$ and capacitor $C12$ make up the low-pass filter that prevents r-f from entering $IC1$.

Construction. There is nothing particularly difficult in assembling the metal detector. The only conceivable problem area might be in fabricating the search-head assembly, which requires relatively simple woodworking. Several hours are required for allowing the glue to set in the search-head assembly. Therefore, it is best to start construction by fabricating this assembly and, while the glue is setting, assemble the electronics package.

Cut two $5\frac{3}{4}$ " (146-mm) and one 5" (127-mm) disks from a sheet of $\frac{1}{4}$ " (6.4-mm) thick plywood. Lightly sand the cut edges to remove all splinters. Locate and mark the center of each disk and drill a $\frac{1}{16}$ " (1.6-mm) hole through each. Liberally coat both sides of the smaller disk with white glue and temporarily assemble the three disks with the smaller in the middle, using a nail to align the holes. Press lightly and then disassem-

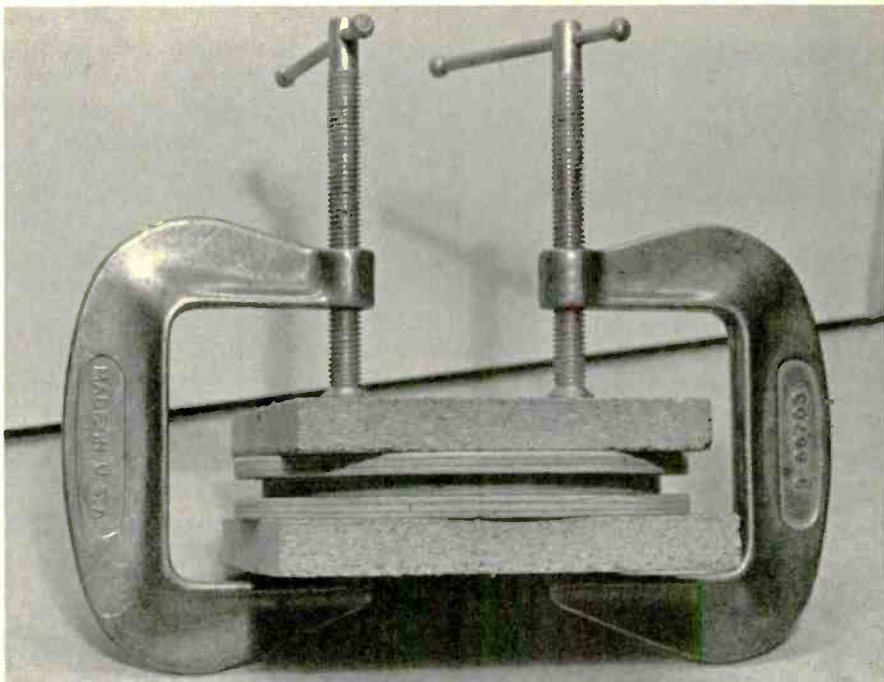

Fig. 3. Glue three plywood discs together with the smaller one in the middle. Use clamps or weights to ensure proper bonding.

Fig. 4. When glue has had time to set thoroughly, draw a D-shaped form on the assembly as shown.

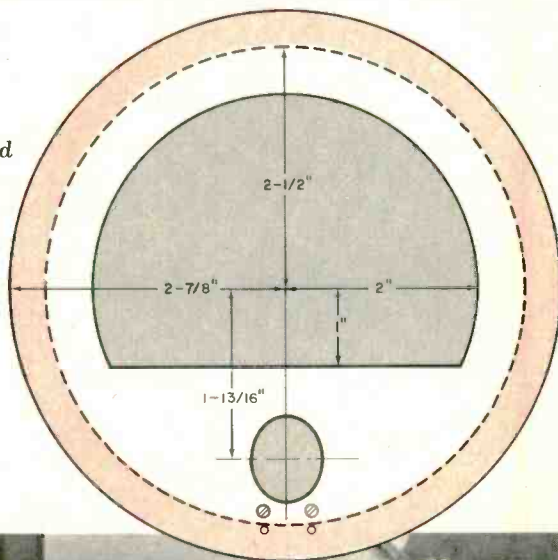

Fig. 5. Use a coping or sabre saw to cut out the form drawn on disc in Fig. 4.

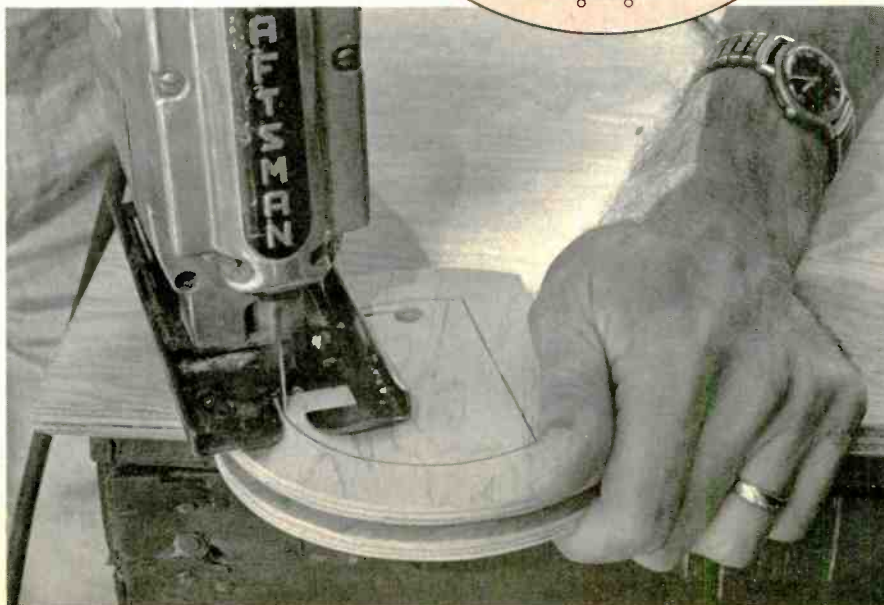



Fig. 6. Drill shaft hole with wood bit, tilting it away from D cutout by about 18 degrees.

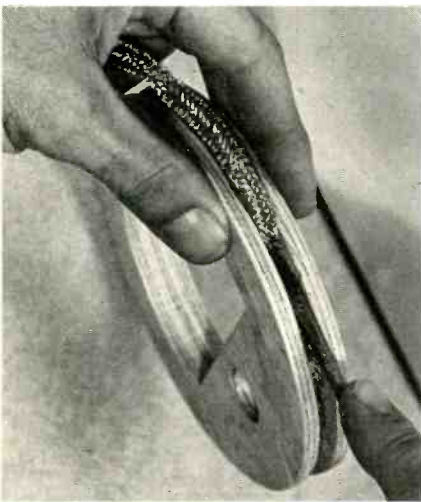

Fig. 7. The 20-turn coil is shielded with the braid from RG-8U coaxial cable.

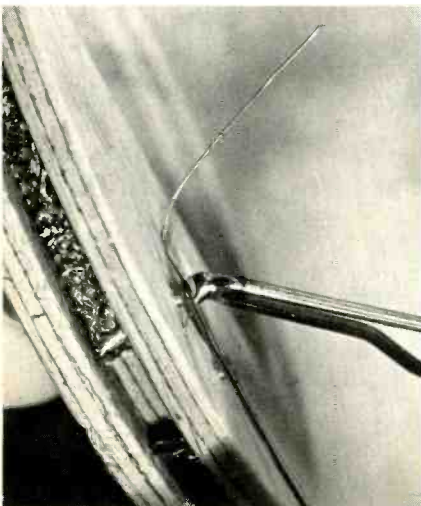

Fig. 8. Bring free end of braid up through plywood sandwich and solder to an adjacent screw.

ble. Allow the glue to air dry until the surfaces are just tacky. Then reassemble with the nail to assure proper alignment and clamp or weight the "sandwich" until the glue sets (Fig. 3). Alternatively, you can use epoxy cement as the binder, aligning the disks with the nail and clamping or weighting immediately upon application. Set the assembly aside for at least 6 hours to allow the glue or cement to set solidly.

Meanwhile, referring back to Fig. 2, assemble the electronics package on a piece of perforated board, using either point-to-point or Wire Wrap techniques. If you are particularly ambitious, you can design and fabricate your own printed circuit board for the project. In any event, use a socket for IC1 and, if possible, sockets for Q1 and Q2.

Do not wire L1 or C2 into the circuit just yet or mount the circuit board assembly into the case until directed to do so. Note that C1 specified in the Parts List is a standard 365-pF capacitor. To reduce it to 50 pF, carefully remove all but one of its rotor plates, taking care to avoid bending the remaining plate.

Once the glue or cement has thoroughly set in the search-head assembly, remove the clamps or weights. Pry out and discard the nail. Then, referring to Fig. 4, draw a D-shaped form on the assembly as shown. Use a sabre or coping saw to cut out this form (Fig. 5). Lightly sand the cut edges to remove all splinters and rough spots. Referring back to Fig. 4, locate the centers of the shaft and wire-exit holes. Drill the latter with a 1/16" bit. Use a 3/4" (19.1-mm) wood bit to drill the shaft hole, tilting it away from the D cutout by about 18° (Fig. 6). The angle is not critical, but it should be between 15° and 20° from perpendicular to permit convenient handling of the metal detector.

The 20-turn coil to be wound in the groove formed in the search-head sandwich must be shielded to reduce ground capacitance effects. The shield is a length of copper braid removed from RG-8U coaxial cable. Carefully slit the outer plastic jacket from about a 24" (61-cm) length of coax. Then slide the inner conductor out of the braid. With your fingers, flatten the braid and press one turn into the groove. Use a Phillips screwdriver to force the braid in place as shown in Fig. 7. Be sure to leave a gap of 3/8" (9.5 mm) between the braid ends.

Drive two small brass screws into the top of the plywood sandwich near the shaft hole. Solder a length of hookup wire to one end of the braid. Pass the

Photo of the completed metal locator with handle on front, controls on top, bottom and sides. Speaker is just under the handle.



free end up through one of the 1/16" holes, and solder to the head of the adjacent screw. (Fig. 8). Cover the braid with a single layer of plastic tape, as shown in Fig. 9.

Use No. 28 enamel- or Mylar-coated magnet wire to wind the search coil. Scrape away about 1/2" (12.7 mm) of the insulation and pass the wire up through the same hole as the wire to the shield is routed to the brass screw. Solder to the same screw. Then wind 20 turns of the magnet wire into the groove. Pass the free end up through the other 1/16" hole and solder to the screw adjacent to the hole. Coat the windings completely with plastic cement to prevent them from shifting and affecting frequency stability.

When the cement sets, cover the winding with a single layer of plastic tape. Lay in another turn of the wire braid, again leaving a 3/8" gap between the ends and connecting one end, via a length of hookup wire, to the screw to which the inner braid and one end of the search coil is connected. Note, when

you are finished with this part of construction there should be three wires soldered to one screw and only one to the other. For thermal protection, cover the outer braid with a single layer of 1/4" wide polyfoam weather stripping.

Several inches up on the aluminum shaft, drill a 1/4" hole through which to pass the coaxial cable that interconnects electronics package with search coil. On the other end of the shaft, measure down 1/2" and 1 1/2" and drill 1/8" holes directly in line with the 1/4" hole. Place the search-head assembly on a flat, level surface, top side up. Run a liberal bead of epoxy cement inside the shaft hole and around the head end of the shaft. Slide the shaft into the hole, orienting it so that the 1/4" hole faces toward the screws in the search-head assembly. Prop the assembly up and let stand undisturbed until the epoxy cement sets.

When the cement sets, pass a 36" (914-mm) length of RG-58U coax through the 1/4" hole and route through the shaft. Prepare the end of the coax and connect and solder it to the heads of the screws to which the search coil and shield are connected. The shield goes to the screw head to which the coil's two shield and one coil wires are connected, while the inner conductor goes to the other screw, as shown in Fig. 10.

Now, referring to Fig. 11, machine the cabinet for mounting L2, SPKR, S1, J1, C1, R9, B1's bracket, the handle and shaft, and the circuit-board assembly. Carefully deburr all holes. Then mount the handle, shaft, and battery bracket, in that order, with appropriate machine hardware. (Note that the shaft fits through a 3/4" hole at one end of the box and is held in place with two sets of 6-32

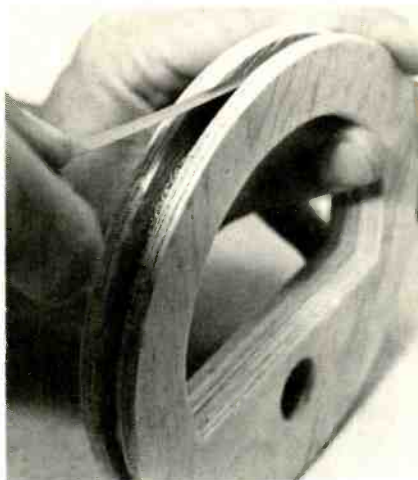

Fig. 9. Cover the coax shield braid with a single layer of plastic electrical tape.



Fig. 10. Coax is routed to search coil through the shaft with ends soldered to the proper screws.

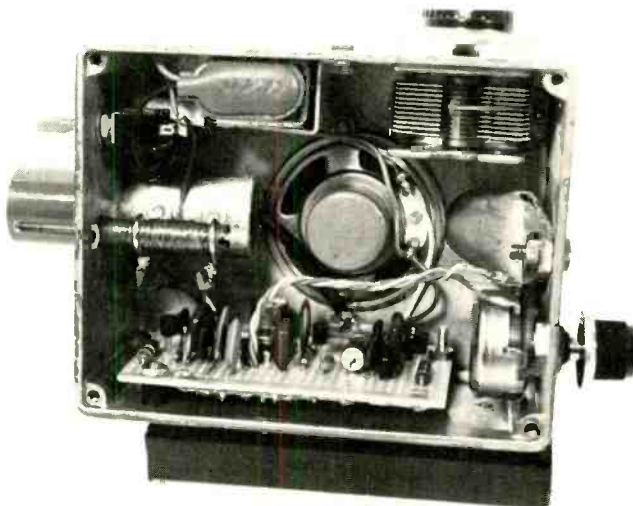

Fig. 11. Photo showing inside of author's prototype. The shaft fits through hole at left. Handle and speaker are shown on the back of enclosure here.

× 1 1/4" machine screws, nuts, and lock-washers through one wall of the box.)

Next, mount the speaker, C1, J1, S1, R9, and L1 in their respective locations. Mount these components in the order given and connect and solder lengths of hookup wires to their lugs. Referring back to Fig. 2, connect and solder the free ends of the wires to the appropriate points in the circuit. Then mount the circuit board assembly inside the box, using spacers and 6-32 hardware. Snap the connector onto the battery terminals and slip the battery into its bracket.

Operation and Use. The critical factor in a metal detector is in the adjustment of both its oscillators to function on the same frequency. If possible, each oscillator should be tested separately with a frequency counter. If a counter is not available, use a standard AM broadcast-band radio tuned near the low end of the band (about 650 on the dial) and defeat first one and then the other oscillator by temporarily opening the source circuit while tuning. Tune the search (Q1) oscillator first and then the local (Q2) oscillator to the same frequency, adjusting L2 to bring the latter to the same frequency. When the oscillator and the radio are tuned to the same frequency, you will hear a "dead-air space," a band of silence resulting from the presence of an unmodulated carrier.

To use the metal detector, give it a couple of minutes to stabilize after first applying power. Adjust C1 for zerobeat and then back off so that you hear a low-frequency tone from the speaker or earphone. Pass the search head over a metal object, and the tone should shift upward or downward in frequency, depending on the side to which you tuned off zerobeat.

One final note: Maintain a low volume level from the speaker to prolong battery life. You can use an 8.4-volt mercury battery for B1 to provide superior service, since this type of battery maintains a relatively constant voltage over a longer period than can ordinary carbon-zinc batteries.

In Conclusion. As you use the metal detector described here, you will soon come to realize how well it works for locating buried metallic objects. Always bear in mind, however, that the smaller the object or the deeper it is buried, the more difficult it will be to locate. When working in noisy environments, such as at a beach with a pounding surf, use an earphone for best results. ◇

LISSAJOUS PATTERN QUIZ

BY ROBERT P. BALIN

An unknown frequency can be determined by applying it to a scope's vertical terminals, while a signal of known frequency is applied to the horizontal. The resulting display, a Lissajous pattern, can then be analyzed to find the unknown. The ratio between the frequencies is equal to the ratio of the number of cycles (including halves) produced in each direction. For example, if there were 3.5 horizontal cycles and two vertical, the ratio would be 3.5:2 or 7:4. Then, if the horizontal frequency were 1000 Hz, the unknown would be 7/4 times 1000 or 1750 Hz. See if you can determine the unknown frequencies for the Lissajous patterns shown here. Answers are below.

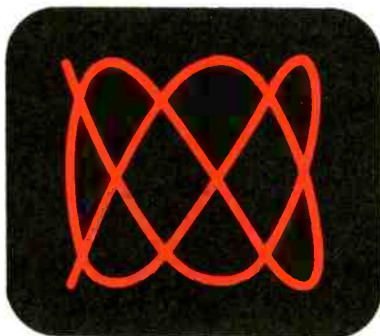

1. V = 2800 Hz. H = _____

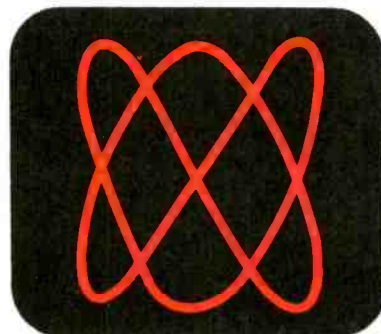

2. H = 500 Hz. V = _____

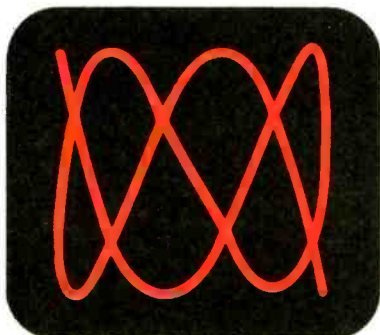

3. V = 1400 Hz. H = _____

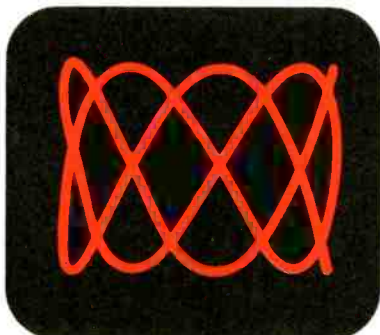

4. H = 240 Hz. V = _____

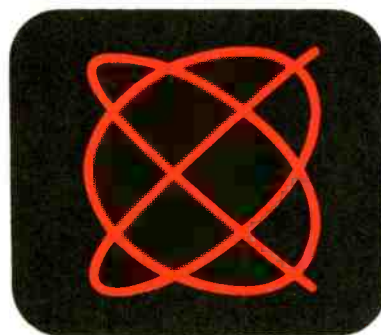

5. V = 1000 Hz. H = _____

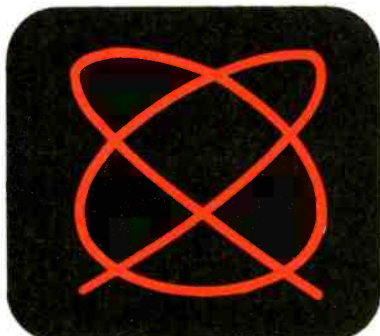

6. H = 60 Hz. V = _____

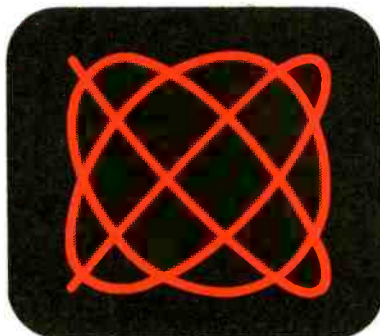

7. V = 4200 Hz. H = _____

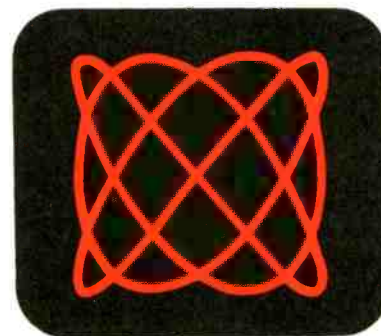

8. H = 120 Hz. V = _____

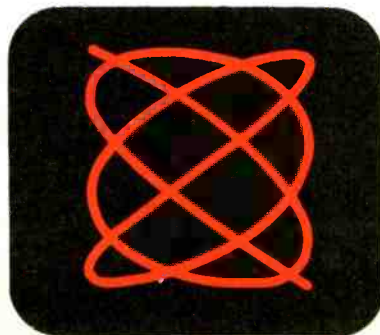

9. V = 3500 Hz. H = _____

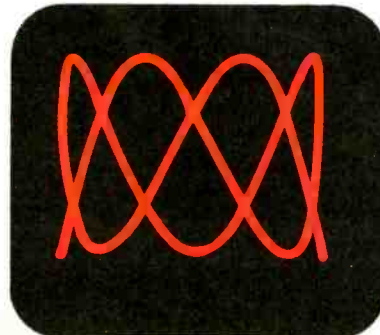

10. H = 900 Hz. V = _____

- ANSWERS:
 1. 7:4, 1600 Hz
 2. 3:2, 750 Hz
 3. 7:3, 600 Hz
 4. 9:4, 540 Hz
 5. 5:7, 4900 Hz
 6. 4:5, 48 Hz
 7. 7:6, 3600 Hz
 8. 4:3, 160 Hz
 9. 5:7, 4900 Hz
 10. 8:3, 2400 Hz
 5. 5:6, 1200 Hz

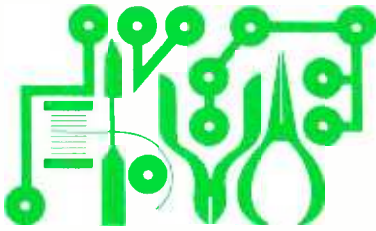

Experimenter's Corner

By Forrest M. Mims

SOLID-STATE OSCILLOSCOPE WRAP-UP

ONE OF the most popular topics that has been covered in this column is the solid-state oscilloscope. Many readers have requested additional information on this subject. Others have designed and built scopes of their own. This month, we'll review the recent history of solid-state scopes and describe several reader-designed versions. First, let's review a few basics.

How They Work. Figure 1 is a block dia-

array of optical elements such as LEDs or liquid crystals. Only one vertical column in the display is enabled at any instant, and the instantaneous amplitude of the applied waveform determines which element within that column is activated. If the horizontal sweep is synchronized with the frequency of the input signals, the outline of the applied waveform will be displayed as a pattern of dots. Synchronization can be achieved either by manually adjusting the timebase or by

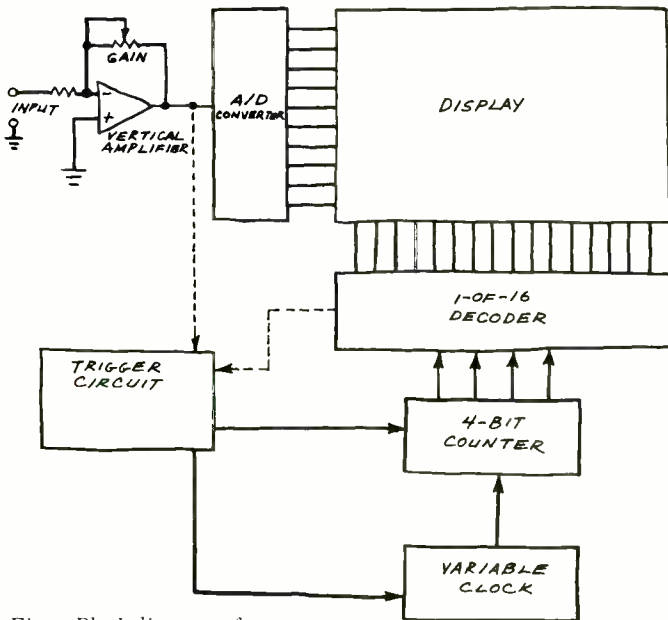

Fig. 1. Block diagram of typical solid-state scope.

gram of a basic solid-state scope. The horizontal sweep circuit is very straightforward and can be made up of standard TTL or CMOS ICs. An advantage of the CMOS logic family is its low power consumption and the flexibility of one of its members, the 4017, a chip that combines a counter and 1-of-10 decoder in a single package. The clock can be a simple 2-gate oscillator or an IC timer.

Most of the design variations in solid-state scopes occur in the vertical section's analog-to-digital converter. Early scopes required complicated voltage divider/comparator/decoder networks. Now, however, all of these functions are available in chips such as National Semiconductor's LM3914.

The operation of most solid-state scopes is straightforward. The display consists of an

means of an automatic trigger circuit that starts the sweep when the amplitude of the input signal exceeds a preselected value.

Early Solid-State Scopes. The development of visible LEDs in the early 1960's made possible compact graphic displays that could serve as the screens of solid-state scopes if teamed up with suitable driving and scanning circuitry. Back then, however, LEDs cost \$10 each and the necessary drive circuits would have been very complex. Accordingly, most work in the area of LED displays was limited to military projects.

I began experimenting with solid-state scope designs when LED prices began to tumble in the early 1970's. For those readers who have requested additional information, here's a condensed history of the solid-state scopes that have appeared in POPULAR ELECTRONICS and *Electronics* magazines:

In February 1974, I assembled a crude scope with a display made from eight LEDs. Figure 2 is a simplified schematic of this scope. The vertical drive circuit was far too complex for convenient expansion, so I experimented with series-connected LEDs having slightly different turn-on voltages. A rising voltage applied to a string of such LEDs causes them to light up in sequence. In spite of its simplicity, this method proved impractical because the LEDs had to be selected for various turn-on voltages.

Another simple way to create a bar-graph display is to connect LEDs across each of the resistors in a voltage divider, as shown in Fig. 3. As the voltage applied across the divider is increased, the voltage drop across each resistor increases proportionally. If the resistance of each resistor in the chain is larger than the one above it, then the LEDs will light up in bar-graph fashion as the voltage applied across the entire divider net-

Fig. 2. Simplified schematic of an original scope with display made from eight LEDs.

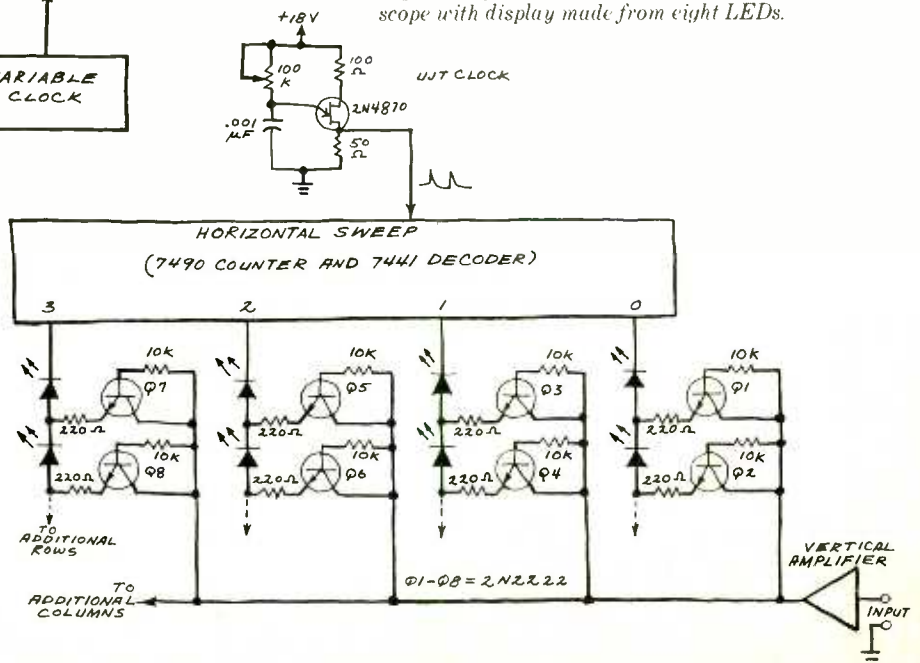

work increases. For example, using the resistance values shown in Fig. 3, I constructed a circuit in which the LEDs began to glow

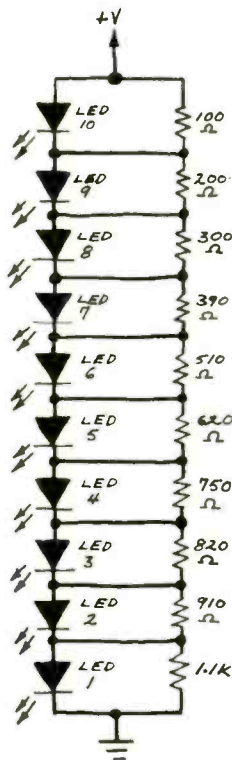

Fig. 3. Voltage-divider LED bargraph display.

when the applied voltage was increased to the values shown below.

Led	Voltage
1	8.1
2	9.0
3	10.0
4	10.7
5	11.7
6	12.7
7	14.0
8	15.0
9	16.0
10	17.5

This vertical-axis circuit is very simple, but it has some major drawbacks. The input voltage must attain a relatively high value before the first LED begins to glow. Also, only bar-graph (not moving-dot) operation is possible. Nevertheless, I've

used this method to make a miniature solid-state scope with a 10 × 10 LED screen. Figure 4 shows the circuit in simplified form. Excluding its power supply, this scope fits with room to spare in a pocket-calculator-size enclosure. Vertical sensitivity is adjustable from 0.01-volt per LED to 1.0 volt per LED, and horizontal sweep is adjustable from 20 microseconds per LED to 1.0 second per LED. Total power consumption of the display with all LEDs on is 308 milliwatts. The drive electronics consume another 54 mW. For more information about this scope, refer to "LEDs Replace CRT in Solid-State Scope" (*Electronics*, June 26, 1975, p. 110) and my book *LED Projects* (Howard W. Sams & Co., 1976, pp. 92-95).

A few years ago, Vernon Boyd de-

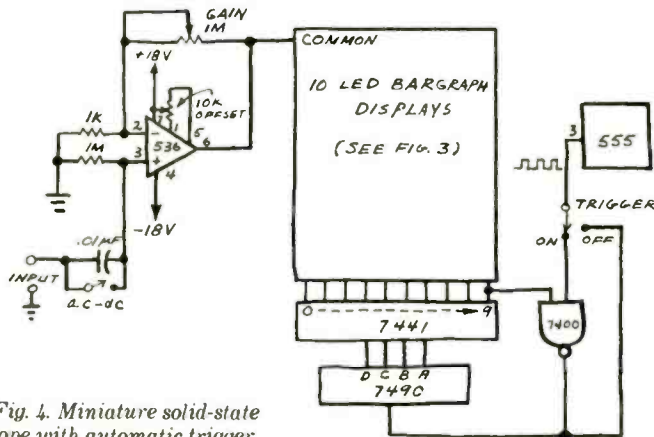

Fig. 4. Miniature solid-state scope with automatic trigger.

Audio-Technica LIFESAVER™ for the life of your records!

SPRAY AND BUFF EACH RECORD JUST ONCE AND ENJOY...

- No static for 50 plays or more
- No increase in surface noise or distortion even after 100 plays
- More efficient record cleaning with any system, wet or dry
- Protection against environmental attack, loss of vinyl plasticizers
- Improved sound from all records, any age, any speed
- Elimination of many "skips" or "repeats" with worn or damaged records

You can't buy better protection for your records than LIFESAVER with DiscProtect™ formula. Its unique combination of ionic and non-ionic chemistry creates a microscopic layer of protection, molecularly bonded to last for years.

The ideal antistat and record lubricant, LIFESAVER preserves and improves every record you own. It's everything you would expect from the leader in advanced-technology phono cartridges and state-of-the-art recordings. Available at all Audio-Technica dealers today.



audio-technica
INNOVATION □ PRECISION □ INTEGRITY

scribed an improved solid-state scope in *Electronics* (November 24, 1977, pp. 128-130). His circuit employed a string of comparators and a decoder/driver network to generate a moving-dot readout. Almost one year later, the October 1978 installment of this column briefly described an improved scope with a 10 × 16 LED screen. Construction and operating details followed in the April 1979 "Project of the Month."

The August 1979 "Project of the Month" was a "matchbox" LED oscilloscope. The key to the simplicity and tiny size of this scope was the use of the new LM3914 dot/bar display driver. Additional information about this scope, which can easily be expanded to provide a larger, more useful display, can be found in a brief article I wrote for *Electronics* (May 24, 1979, p. 169).

The most recent article in *POPULAR ELECTRONICS* related to solid-state scope technology was the hand-held LED spectrum analyzer featured on the cover of the September 1979 issue. This circuit's vertical driver is an LM3915, the logarithmic version of the LM3914.

Taken together, these articles will give you a good background in solid-state scope operation. If you don't have back issues of the various magazines that have been mentioned, consult a public or technical library.

Readers' Solid-State Scopes. Several readers have designed and built various solid-state scopes. For example, Bill Cikas, a self-taught electronics enthusiast

Fig. 5. Vertical section of scope designed by reader Bill Cikas.

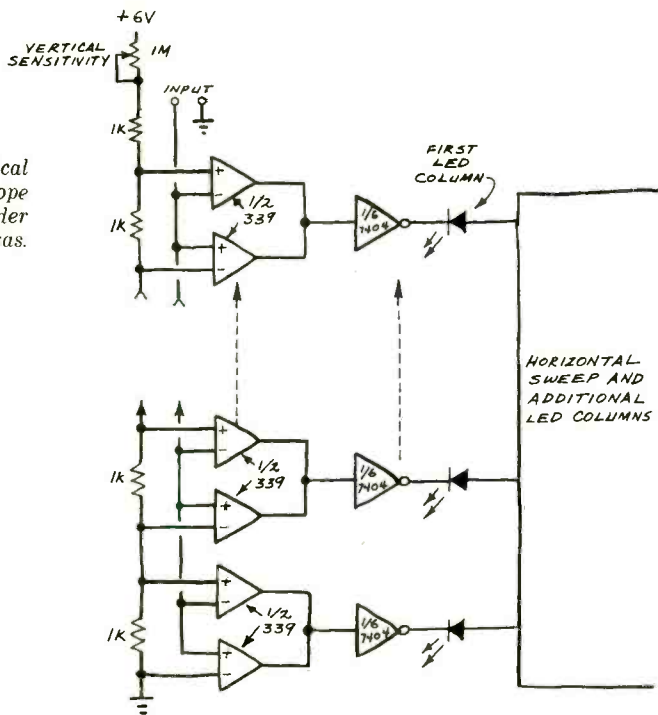
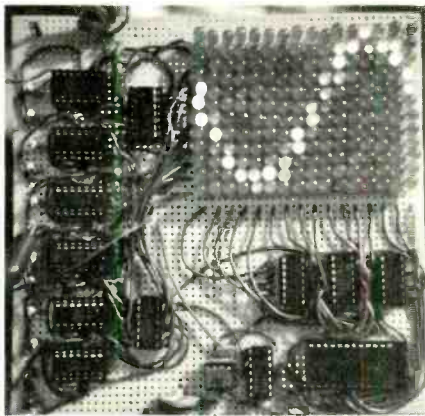

Fig. 6. Photo below is of solid-state scope whose circuit is shown in Fig. 5.



living in Rockford, Illinois, has designed a scope with a 12 x 16 element LED display that fits on a 6" x 6" (15.3 x 15.3 cm) perforated board. A portion of the scope's vertical section is shown in Fig. 5, and a photo of the scope displaying a well defined sine wave appears in Fig. 6.

Steven Bolotin, a Chicago high school student, modified the scope described in the April 1979 installment of this column to permit both the negative and positive

halves of a waveform to be displayed. The modification, which is shown in Fig. 7, is inserted between the vertical amplifier and analog-to-digital converter and causes the incoming wave to ride on an adjustable dc level.

Joe Sharp of Orange, Virginia, has worked on the resolution problem caused by the limited number of display elements in the screen of a solid-state scope. He has determined that at least thirty display columns are required for every ten display rows to minimize smearing of the trace. Joe's scope employs three cascaded LM3914s, thirty 10-element LED bar arrays, and provides automatic trigger, ac/dc operation and various other features.

Gregory Kovacs, a student at Eric Hamber Secondary School in Vancouver, British Columbia, has provided details of a sophisticated solid-state scope project he has undertaken. For his half-term electronics project, Greg designed and assembled a scope that can display the waveforms of signals with frequencies of several hundred kilohertz.

A noteworthy feature of Greg's scope is the use of a Siemens UAA170 IC dot generator. Like the more recently introduced

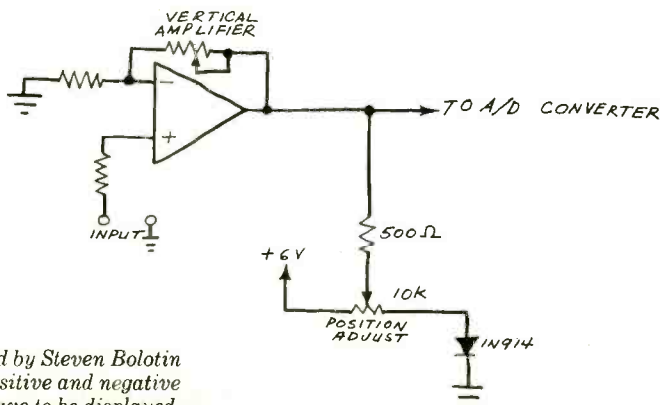

Fig. 7. Circuit designed by Steven Bolotin that permits positive and negative halves of a wave to be displayed.



LET ORDINARY ANTENNAS CRAWL INTO THEIR HOLES. **SHAKESPEARE GOES MAGNETIC!**

No more drill holes! No more bolts! Shakespeare has come up with a series of magnetic antennas that hug your car... rooftop or trunk... like a long lost friend.

The Cling's the Thing! Shakespeare's new and improved magnetic mounts incorporate design features that assure you of positive holding power and permanent alignment. They cling at all car speeds, and resist all but the most severe impact from overhanging foliage.

You can have the confidence in Shakespeare's magnetic mounts that you have in Shakespeare fiberglass antennas, the best sellers in CB.

Shakespeare

ELECTRONICS AND FIBERGLASS DIVISION
Antenna Group, P.O. Box 246, Columbia, S.C. 29202

INFLATION 10% FIGHTER

CASH REBATE

Enclose this coupon with the "Proof of Purchase" seal you will find inside the antenna package of your new Shakespeare magnetic antenna. Shakespeare will mail you a check for 10% of the manufacturer's suggested retail price. Allow 4 weeks for handling.

Sure, I'll fight inflation! Send me a 10% rebate check:

NAME _____

ADDRESS _____

CITY _____

STATE _____ ZIP _____

DEALER _____

ADDRESS _____

Offer good through January 31, 1980, void where prohibited by law.

LM3914, the UAA170 eliminates the complicated voltage divider/comparator/decoder network that would otherwise be required for the scope's vertical section. In a paper describing his project, Gary observes that a scope using a single UAA170 vertical display driver would be limited to a maximum input frequency of only 50 Hz or so. Therefore, he assembled ten separate vertical display boards, each with its own UAA170 and column of 16 LEDs, and scanned each board with a conventional counter/decoder circuit.

Each display board contains an op-amp sample-and-hold circuit controlled by a Siliconix DG181 analog switch. A horizontal sweep sequentially strobes each display board's sample-and-hold circuit and the sampled voltage level is held until the next strobe pulse arrives. The result is the capability of displaying input waveforms having frequencies of up to 1 MHz.

An important consequence of Greg's decision to use individual sample-and-hold circuits is that his circuit can function as an analog *storage scope*. It can sample and display on its screen for several minutes any waveform before degradation caused by leakage in the sample-and-hold capacitors occurs. Figure 8 is a photo that shows the high-quality trace the circuit provides.

Looking Ahead. Solid-state scopes have a very bright future. Thanks to the LM3914

and similar moving-dot display drivers, experimenters and hobbyists can easily design their own scopes. By cascading vertical and horizontal driver ICs, oscilloscopes with displays containing hundreds of LEDs are possible. Although building such a scope would be tedious (the display board in one of my scopes has more than 650 solder connections), cost is no longer the limiting factor it was before LEDs could be purchased in volume for less than 10¢ each.

Homebrew scopes will become even simpler when manufacturers produce LED dot/bar displays with integral solid-state decoder/drivers. A complete scope could then be assembled in building-block fashion simply by connecting display columns to a standard horizontal sweep circuit. Individual, discrete LEDs are fine for low-resolution scopes, but are for a few reasons unattractive if high resolution is desired. Several alternative display technologies are available, the least costly being liquid crystals. Unfortunately, liquid-crystal displays are too slow for conventional multiplexing techniques.

Recently, however, Ian A. Shanks of the Royal Signals and Radar Establishment in Malvern, England, solved the liquid-crystal addressing problem with a design that continuously applies signals to all elements of the display. Shanks has assembled a prototype storage oscilloscope with a 100 × 100 element display measur-

ing 2.5" × 2.5" (6.45 cm × 6.45 cm). The waveform is displayed as a black line on a light background. It can be projected onto a screen by removing the display's reflective back and using it like a transparency in a slide projector. Shanks is building a new scope with a 128 × 256 element display and believes that a 1,000 × 1,000 element display can be made.

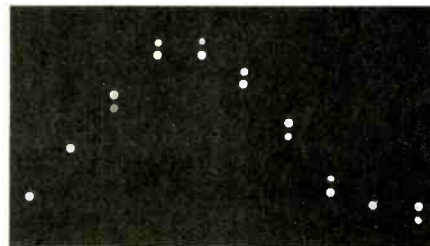

Fig. 8. Photo of waveform displayed on scope designed by Gregory Kovacs.

In Conclusion. The oscilloscope is the most important and useful piece of test equipment available. Hopefully, these solid-state scope developments will lead to pocket-size, high-resolution, full-feature scopes affordable by most experimenters and hobbyists. In the meantime, those described here show how you can make contributions to this new technology. ♦

8-digit precision. To go.

Here's a battery-operated counter with a battery of features: CSC's MAX-100 digital frequency counter. Direct readings from under 20 Hz to past 100 MHz (past 500 MHz with optional prescaler). Big display. Turn-on-and-read operation. Battery-rechargeable-AC options. Plus all the other features and specs you'd expect in a \$250 frequency counter—all for \$101* less! For more information, CALL TOLL-FREE 1-800-243-6077 (during business hours, Eastern Time, except in Connecticut).



Smarter tools for testing and design.



70 Fulton Terr., New Haven, CT 06509 (203) 624-3103
*\$149 Suggested U.S. resale. Available at selected local distributors. Prices, specifications subject to change without notice.
© Copyright 1979 Continental Specialties Corporation

For more information on advertised products, equipment tested, etc., circle appropriate number on postpaid Free Information Card.

★ **FREE!** ★



NEW CATALOG OF HARD-TO-FIND PRECISION TOOLS

Jensen's new catalog is jam-packed with more than 2000 quality items. Your single source for hard-to-find precision tools used by electronic technicians, scientists, engineers, instrument mechanics, schools, laboratories and government agencies. This popular catalog also contains Jensen's world-famous line of more than 40 tool kits. Send for your free copy today!

JENSEN TOOLS & ALLOYS
1230 SOUTH PRIEST DRIVE · TEMPE, AZ 85281

CIRCLE NO. 62 ON FREE INFORMATION CARD

Hobby Scene



By John McVeigh, Technical Editor

FM AND AFC

Q. *The FM radio in my car does not stay tuned to a station. Rather, it tends to lose that signal and even tune in another station. Is there a circuit you can provide that will remedy this problem?*—*T.I. Rueth, Jefferson, WI.*

A. From what you say, it seems that the culprit is your receiver's afc (automatic frequency control) circuit. Afc is incorporated into FM radios to keep the radio tuned to one station and cancel thermally induced drift. However, afc circuits have their limitations. Perhaps the most troublesome is the tendency to be captured by a signal on an adjacent channel that is stronger than the desired signal.

Some receivers that have afc also include a switch which allows the user to defeat the afc function. This switch is a great aid when an attempt is made to tune

in a relatively weak station. If the switch is left in the "afc on" position, the afc function will pull the receiver over to the stronger, adjacent-channel signal. Placing the switch in its "afc off" position disables the afc and greatly eases tuning in and holding the desired signal.

in a relatively weak station. If the switch is left in the "afc on" position, the afc function will pull the receiver over to the stronger, adjacent-channel signal. Placing the switch in its "afc off" position disables the afc and greatly eases tuning in and holding the desired signal.

If your receiver has such a switch, try placing it in the "afc off" position. This should prevent the receiver from being distracted by strong, off-channel signals. If your receiver lacks such a switch, you can either modify it so that the afc is switchable or employ some means such as a tuneable trap to attenuate the unwanted signal.

Perhaps the principal advantage to the use of an external trap is that it requires no modification of the receiver. However, it is difficult to construct a trap with a high enough Q to adequately attenuate an undesired signal 400 kHz or so away without also attenuating the desired signal. A more realistic way to attenuate the undesired signal is with a directional antenna, but that is not practical in a mobile application such as yours.

Assuming that you have no trepidations about modifying your receiver, adding an afc-defeat switch is perhaps the most ef-

fective way to enhance weak-signal reception. A simplified block diagram of an FM receiver is shown here. Note that a portion of the demodulated signal present at the output of the discriminator is applied to a low-pass filter.

This filter converts the discriminator output into an afc control voltage in the following manner. If the local (variable frequency) oscillator is not operating on the correct frequency, the output of the discriminator will contain both the desired modulation signal and a dc component. The filter output, however, contains only the dc component. The magnitude and polarity of the dc level depend upon the error in the frequency generated by the local (variable frequency) oscillator.

The filtered dc level is applied to a voltage-controlled reactance, usually a voltage-variable capacitance (a Varactor diode). The reactance changes its value,

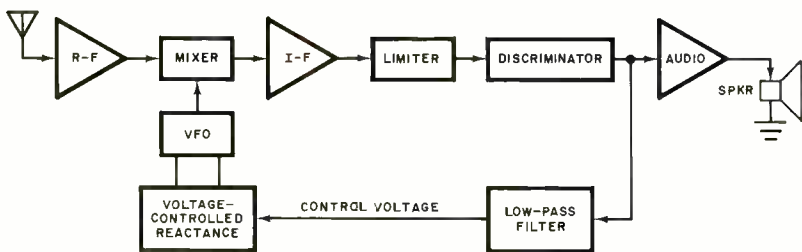

shifting the output of the vfo toward its optimum frequency. If the vfo starts to drift, the control loop brings it back into line.

It can thus be seen that the loop must be opened if the afc is to be defeated. Perhaps the best way to do this is to insert an spst switch between the tap at the discriminator output and the low-pass filter or between the filter output and the voltage-controlled reactance. Many commercial designs employ resistive coupling between the filter and reactance and defeat the afc function by shunting the control voltage to ground.

PROTECTIVE DIODES

Q. *Why do many relays that are keyed by transistors have reverse-biased diodes connected across them?*—*Dennis Barnes, Medford, OR.*

A. A typical relay-driver circuit is shown in the figure. The function of diode *D* is to protect driver transistor *Q* from damage caused by inductive voltage spikes. Relay coil *K* has inductance as well as inherent resistance. Mathematically, the voltage across a coil is equal to its inductance multiplied by the rate at which the current flowing through it changes with respect to time ($V_L = L di/dt$).

When base drive is first applied to *Q*, current begins to flow through the coil. The voltage transient induced across the coil is positive because the time rate of change of the current through the coil is positive.

Assume now that protective diode *D* has not yet been added to the circuit and that base drive is being removed from the transistor. The collector side of the coil becomes positive with respect to the supply side. This second transient increases the voltage drop from collector to emitter as the transistor is coming out of saturation and is going into cut-off. Depending on the electrical parameters

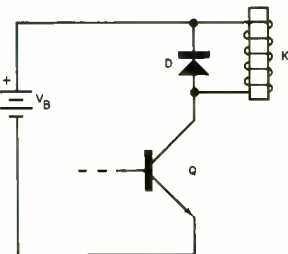

of the relay coil and the circuit to which it is connected, this voltage spike can be quite large—several hundred volts is not uncommon. This overvoltage can spell the doom of a low-voltage switching transistor.

Connecting diode *D* as shown in the figure prevents this spike from harming *Q*. As the transistor cuts off, the voltage spike forward-biases the diode, clamping the collector-to-emitter voltage drop to one diode drop above the supply voltage. The only disadvantage to diode protection is that the time required for the relay to drop out is extended slightly. This happens because current flows through the diode and the coil during the voltage transient. However, the increase in hold-in time is small enough to be of no consequence in most applications.

TTL FREQUENCY DOUBLER

Q. *Do you have a circuit for a frequency doubler employing TTL digital ICs?*—*Steve Hillage, Portland, OR.*

A. The circuit shown here will double the frequency of a square wave applied to its

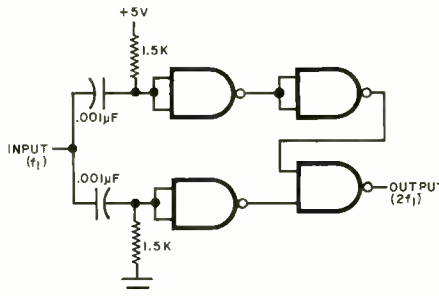

input. It can be assembled using a TTL quad NAND gate such as a 7400. The values of the resistors and capacitors comprising the input differentiators are not especially critical, so reasonable substitutions can be made. Note that this circuit is *not* intended for use with sine waves and other analog waveforms.

Have a problem or question in circuitry, components, parts availability, etc? Send it to the Hobby Scene Editor, POPULAR ELECTRONICS, One Park Ave., New York, N.Y. 10016. Though all letters can't be answered individually, those with wide interest will be published.



Product Test Reports

Philips Model PM3232 Dual-Beam Oscilloscope



MOST dual-trace oscilloscopes employ a single set of deflection plates and an electronic switch to "write" the two waveforms on the CRT screen. This approach has some shortcomings (see box), most of which can be eliminated by using a dual-beam system and separate deflection plates for each channel. The dual-beam approach is the one taken by Philips Test and Measuring Instruments in its Model PM-3232 oscilloscope.

The 10-MHz PM3232 oscilloscope has a single electron gun from which two beams are obtained with the aid of two totally separate sets of deflection plates and vertical amplifiers. In effect, then, this scope consists of two independent single-beam instruments, the two sharing a common CRT, sweep circuit, and power supply.

Measuring 20"D × 13"W × 7¼"H (50.3 × 32.6 × 18.5 cm), the scope weighs a mere 9.5 kg (21 lb). Price is \$1195.

General Description. Each of the scope's vertical amplifiers is rated to respond from dc to 10 MHz in the dc mode (2 Hz to 10 MHz in the ac mode). The specified rise time is 35 ns, while deflection sensitivity is from 2 mV/cm to 10 volts/cm in 12 selectable ranges. Maximum permissible input potential is

±400 volts dc plus peak. Long-term drift is rated at 0.25 cm/hour. Input impedance is 1 megohm shunted by 20 pF.

The scope is designed so that its two vertical amplifiers can also be used in the X-Y mode. Phase shift between channels is specified at less than 5° at 100 kHz.

The triggered-sweep system has a range of from 0.5 second/cm to 0.2 μs/cm in 20 switchable steps. Triggering can be from either input channel or from an external source. The input level for the external trigger is specified to be less than 1 volt peak-to-peak at 10 MHz at an input impedance of 100 kilohms shunted by 5 pF. The trigger mode is either automatic or normal or from TV-frame or line pulses. (They are sync stripped internally).

Intensity modulation is also provided. This ac coupled input has a 47 kilohms input impedance and requires a drive signal level in excess of 20 volts. The intensity-modulation frequency range is from 20 to 1000 Hz.

Provided is a built-in calibrator that delivers a 600-mV peak-to-peak signal with an accuracy of 1%. The frequency of this signal is approximately 2000 Hz.

The scope's CRT has a 4"L × 3¼"H (102 × 82.6 mm) display area. It features a 10-kV

accelerator potential to insure a bright display at fast writing speeds. A metal-backed phosphor is used inside the CRT to prevent burning of the phosphor and to produce a very bright on-screen display.

Housed in a utility-grey metal cabinet, the scope comes with a separate carrying handle and fold-away front tilt stand. A protective cover fits over the entire front of the scope during storage and transport. Compartments inside the molded-plastic cover are provided for storage of the test cables. A locking mechanism built into the cover engages with a slot in the control panel to keep the cover securely in place.

Testing the Scope. For our tests, we connected the 10-MHz PM3232 in parallel with a 15-MHz laboratory-grade scope to permit us to observe very fast pulse waveforms simultaneously on both. The 15-MHz scope served as a standard against which the PM3232 was judged. Using this setup, we encountered a few surprises.

During our tests, the two traces on the PM3232's CRT did not waver from the highest down to the lowest sweep speeds. No matter what signals we applied to the two inputs, both traces always lined up properly, with no discernible time displacement between signals. We determined that this scope maintained rock-steady triggering even with pulses of only a few nanoseconds duration and low duty cycle. We also discovered that the PM3232 could trigger from either edge of the very-fast pulses of the test signal. The PM3232 held trigger long after our 15-MHz laboratory scope gave out. The excellent trace visibility, even at very high writing speeds (when the X5 magnifier was switched in), attests to the design of the new CRT and power supply used in the PM3232.

In comparison observations, we noted that both scopes displayed the waveforms clearly. However, the PM3232's display had none of the ringing that was clearly in evidence on the 15-MHz scope's waveforms when we used test signals with very fast rise and fall times. This illustrates why a well-designed 10-MHz scope that has a Gaussian response and no peaking coils (like the PM3232) is more useful for pulse observations than a wider-bandwidth scope whose top end drops sharply.

In an actual frequency-response test, we discovered that the PM3232 considerably exceeded its specified range in both the ac and dc modes. In fact, we had steady, reliable triggering out to beyond 30 MHz. We did not try to determine at just what point the scope failed to yield a usable trace waveform, but it was obvious that it was beyond the 30-MHz point.

Input sensitivity and calibration accuracy were also considerably well within specifications. The two vertical amplifiers performed identically, with no discernible phase shift up to 500 kHz. Triggering was positive and held rock-steady in both the internal and external modes of operation.

User Comment. The Philips Model PM3232 oscilloscope was a pleasure to use. Its con-

Dual-Beam VS Dual-Trace Oscilloscope

The simultaneous display of two waveforms on an oscilloscope screen is usually performed by what is termed a "dual-trace" system. (Fig. 1) Here, two similar but independent vertical amplifiers are used to influence the trace generated by a single-gun electrostatic cathode ray tube (CRT). An electronic switch built into the scope is used to select one of the two inputs. At that instant, the scope appears to have only one vertical amplifier. (Only one amplifier is activated at any given instant; the other is held in cutoff.)

The trace of the signal on the electronic-switch-selected channel appears on-screen and can be located anywhere on the CRT by operating that channel's vertical position con-

and appear as a series of narrow square waves that can be visually disturbing.

Dual-trace oscilloscope manufacturers avoid this problem by including a second ("alternate") switching mode. In this mode, one input channel is switched in at the beginning of a sweep and remains on-screen for the duration of that sweep. On the next sweep, the second channel is switched on and the first is cut off. At relatively high sweep speeds, the two appear to be on-screen simultaneously.

There are, of course, problems in the alternate mode, just as there are in the chop mode. When low repetition rate signals are viewed, the cut-off channel's trace may disappear from the screen momentarily. The result is a display

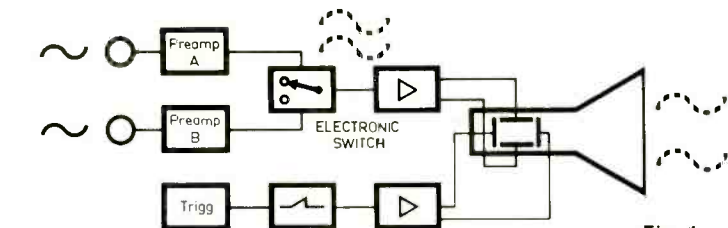

Fig. 1

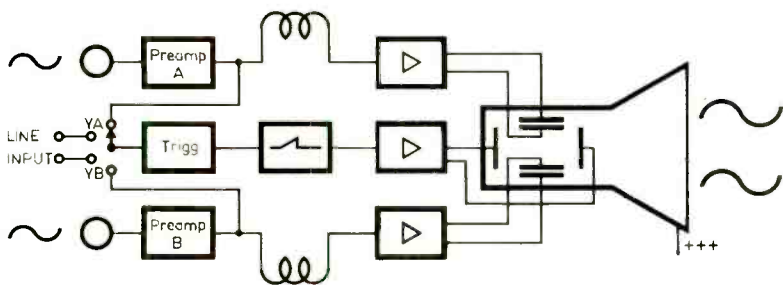

Fig. 2

trol. Amplitude of the trace depends on where that channel's vertical sensitivity is set.

On the next clock pulse, the electronic switch cuts off the first vertical amplifier and turns on the second identical channel. The input waveform for this channel is then displayed and positioned on the CRT screen in accordance with the setting of its controls.

If the electronic switch operates at a high enough frequency (called "chopping") and there is a correlation between input and switching frequencies, the two images appear on-screen simultaneously and are independently controllable. If there is a correlation between the input and switching frequencies, however, the viewed images can be broken up

that appears to be a single trace that jumps up and down at a low rate on the CRT screen. A companion problem is that the sweep is usually triggered at different times by two related but different frequency signals. Hence, determining time relationships between two signals becomes difficult. This is particularly annoying when a stream of time-related digital signals is being observed.

Philips has overcome the problems inherent in the alternate and chop modes in the Model PM3232 oscilloscope by using a two-beam trace-writing system (Fig. 2). This technique permits two traces to be controlled and displayed simultaneously and eliminates the need for the electronic switch.

control panel is well laid out and easy to read and interpret. Signal, trigger, and mode selection are accomplished via a bank of smooth-operating pushbutton switches. A separate pair of pushbutton switches permits either channel A or channel B (or both) beam selection.

In operation, the PM3232 performed in a manner we normally expect from costlier laboratory-grade oscilloscopes. The controls operated smoothly and positively. Trace waveforms on the CRT were bright and easy to see, even at writing speeds well beyond

the scope's 10-MHz high end. Electrical performance was flawless.

The asking price of the PM3232 is not inexpensive. However, when one considers this instrument's performance, which is on a par with many laboratory oscilloscopes costing several times more, the price is insignificant. If you can afford to spend \$1000 for an oscilloscope, you can't afford not to consider an extra \$200 for the assurance the PM3232 provides in delivering every bit of the performance you pay for.

CIRCLE NO. 105 ON FREE INFORMATION CARD



THE ONE-STOP
MUSIC SHOP
AT WHOLESALE PRICES

THIS MONTH'S
SUPER SPECIALS!

CAR STEREO

SANYO CASSETTE IN-DASH WITH RADIO		PIONEER CASSETTE IN-DASH WITH RADIO	
FT-1498	\$259.90	KP-4000	\$129.90
FT-2400	224.90	KP-3500	144.90
FT-489	139.90	KP-5005	144.90
FT-648	154.90	KP-8000	154.90
FT-1490-2	164.90	KP-8005	154.90
FT-1495	169.90	KP-8500	179.90
FT-842	94.90	KE-2000	184.90
FT-842	104.90	KE-2002	209.90
FT-1400	5.95	KE-3000	234.90
FT-1405	114.90	KE-5000	274.90
		KPX-9000	299.90
		KPX-9500	209.90

JENSEN

CASSETTE UNDERDASH		CASSETTE UNDERDASH	
J1001 (6x9 Separates)	594.50	KP-272	\$69.90
J1065 (6x9 Trax II 50 Watts)	62.50	KP-292	84.90
J1033 (6x9 Trax II 100 Watts)	78.50	KP-373	84.90
J1101 (4x10 Trax II 45 Watts)	62.50	KP-575	99.90
J1130 (4x10 Trax II 50 Watts)	78.50	KP-666	89.90
J1174 (5x4 Trax II 50 Watts)	62.50	KP-775	114.90
J1124 (5x4 Trax II 75 Watts)	78.50	KP-885	109.90
J1069 (6x9 Coax 45 Watts)	39.50	KPX-600	129.90
J1037 (6x9 Coax II 90 Watts)	58.50	KP-707G	164.90
J1077 (5x4 Coax 45 Watts)	39.50	AD-312 (2 Watts)	\$39.90
J1041 (5x4 Coax II 75 Watts)	48.50	AD-320 (20 Watts)	47.90
		AD-360 (70 Watts)	139.90
		AD-50 (5 Band Eq.)	109.90
		AD-50 (5 Band Eq. I)	159.90
		GM-12 (12 Watts)	31.90
		GM-40 (20 Watts)	52.90
		GM-120 (20 Watts)	129.90
		CD-7 (7 Band Eq.)	129.90

We carry the full line of car equipment by such names as Sanyo, Craig, Marantz, Pioneer, Jensen & Audiovox. Write for free catalog.

CAR SPEAKERS	
TS-M2 Tweeter	28.90/Pr
TS-T3 Tweeter	39.90/Pr
TS-168 Three Way	84.90/Pr
TS-694 6x9 Coax	59.90/Pr
TS-695 6x9 3 Way	69.90/Pr
TS-90 2 Way Surface	69.90/Pr
TX-X9 2 Way Surface	134.90/Pr

BLANK TAPES

CASSETTE TAPES		REEL-TO-REEL TAPES	
Ampex Grand Master II C-90	3.11	Scotch 212 1800 FT	4.35
Ampex Grand Master I C-90	2.79	Scotch 207 1800 FT	5.19
BASF Pro I C-90	2.99	TDK L-1800 1800 FT	5.22
BASF Pro II C-90	2.99		
Fujix for II C-90	2.99		
Scotch Lo Noise C-90 3 Pk	4.99/3		
Scotch Master III C-90	3.29		
Sony LNX C-90	1.64	TDK L-500 (2 Hour)	12.95
Sony HFX C-90	2.35	Sony L-500 (2 Hour)	12.95
Sony Ferrichrome C-90	3.25	Fuj L-500 (2 Hour)	12.95
TDK D C-90	1.19	Scotch L-500 (2 Hour)	12.95
TDK D C-120	1.68	Sony L-750 (3 Hour)	17.50
TDK D C-180	2.10		
TDK AD C-60	2.99		
TDK AD C-90	1.68	Maxell T-120 (4 Hour)	17.95
TDK AD C-120	2.45	TDK L-120 (4 Hour)	16.50
TDK SA C-60	3.48	JVC T-120 (4 Hour)	16.50
TDK SA C-90	2.15	Fuj T-120 (4 Hour)	16.85
	2.28	Scotch VV-250 (4 Hour)	16.50

MINIMUM ORDER 12 TAPES - 100% GUARANTEED
Call or write for super low prices on Maxell tapes

CARTRIDGES

audio-technica		SHURE	
AT-20SS	124.90	V15 Type IV	84.90
AT-15SS	84.50	V15 Type III	62.50
AT-14SA	47.50	M95HE	34.90
AT-12SA	32.50	M95HE	34.90
AT-10	12.90	M95ED	29.90
		M70E	20.50
88TS	69.50	M44E	14.90
68HEE S	51.90	M70E	9.90
68HEE	39.90		
680EE	24.90		
50GE	12.90		

EMPIRE

audio-technica		PICKERING	
2000Z	54.50	K5W/5000	89.90
2000T	29.50	K5W/3000	45.90
2000E/III	18.50	K5W/500	34.90
EDR 9	114.50	K5W/625	24.50
		K5W/400	21.50
		PAC	9.90

ACCESSORIES

DISCWASHER		HEADPHONES	
Complete System	10.95	Koss Pro 4AA	39.90
Disk	34.95	Koss Pro 4AA	46.50
Discorganizer	9.95	Koss HV/LC	34.50
16 oz D3 Refill	10.95	Koss HV/A	31.50
Zerostat Anti-static Gun	14.95	Seinnenser HD414	42.50
SC-1 Stylus Cleaner	4.95	Seinnenser HD424	64.50
Discflog	15.95	Seinnenser HD420	49.50
Fuzzbuster II Radar Detector	82.90	Seinnenser HD430	72.50
Beam Box FM & Antenna	34.50		
Beam Box FM-10 Antenna	64.50		

RECORDS

Pop, Rock, Jazz, R & B	
All 7.98 List	\$4.99
All 8.98 List	\$5.49
All 9.98 List	\$5.99

50¢ additional fee cassette or 8-track, please specify.
Minimum order: \$25.00

WE STOCK THE COMPLETE SCHWANN CATALOG.

HOW TO ORDER: For immediate shipment, send money order or certified check. Two weeks delay on personal checks. Please add \$3.50 per order for shipping & handling (\$5.50 for orders outside continental U.S.) N.Y.S. residents add tax. Payment must be in U.S. dollars only. No C.O.D.'s. All merchandise 100% guaranteed, brand new & factory fresh.



33 PARK ROW, DEPT. PE, NEW YORK, N.Y. 10038
TO ORDER: CALL MON-SAT 9AM-6PM EASTERN TIME
TOLL FREE (800) 221-8180
ALL OTHER MATTERS: CALL (212) 732-8600

CALL OR WRITE FOR FREE 120 PAGE CATALOG

CIRCLE NO. 32 ON FREE INFORMATION CARD

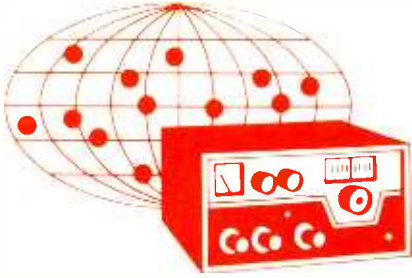

DX Listening

By Glenn Hauser

A WORLD OF NEWS

IF YOU rely on domestic radio and TV networks, newspapers and magazines, for news about the world, you are getting only one side of the story. No matter how diligently those who process the news for you may strive to be objective, their points of view inevitably reflect an American bias. Most people aren't even aware they have the alternative of hearing news direct from many countries around the world on shortwave.

On our domestic media, everything has to pass the test of "Is it news in America"? That's why there's so little coverage of Latin America and Africa—except for crises. The truth is, our world is so interdependent that we ignore events elsewhere at our own peril.

Equally as important as getting news from other countries, about other countries, is getting news from other countries about the USA. You may ask, what value can this have? We have a highly developed and extensive free press. The answer is that for once and at last, you will be getting a fresh perspective on events in the USA.

From some stations you will hear lies and distortions; others simply place a different emphasis on the importance of different stories. There really is no one correct order of priority in the day's news, though by comparing ABC, CBS and NBC evening television newscasts, all of which originate within a few blocks of each other, you might conclude that there is.

For a modest investment in a shortwave radio, you will suddenly have access to a world of news, without the intervention of American reproducers. About 60 countries can be picked up with news in English. The latest times and frequencies appear four times a year in POPULAR ELECTRONICS, with updates almost every month. While we don't give the exact times for newscasts, virtually every transmission listed contains at least one newscast—in most cases on the hour or at the beginning of the broadcast.

British Newscasts. Far in front of all others in the objectivity and breadth of its world news coverage is the *BBC*. The World Service carries news on the hour, but not every hour, to allow some flexibility in scheduling other programmes. There are many other news-related shows, such as "The World Today", "Outlook", "24 Hours" and "Radio Newsreel" carried five or seven days a week at fixed times.

Evidence of the myopia among American domestic broadcasters is the fact that only a handful out of thousands of stations rebroadcast *BBC* 'network' news on a regular basis. It's safe to say that the idea has not even occurred to most of them, though certainly the idea that they should join an American network has been considered and accepted.

Of course, *BBC* broadcasts are noncommercial, and its newscasts may not be 'sponsored'. Stations relaying it would be obliged to go nine minutes without a local commercial. So you see the standard *BBC* newscast has about three times as much news in it as the commercial 'five-minute' newscast.

On the other hand, shortwave listeners can hear news and feature programs from all domestic commercial networks, on one station—*AFRTS*. The commercials are removed, but replaced with public service announcements. Still, it is enlightening to hear how much news-in-depth programming is available from the networks but seldom heard at a waking hour from affiliates.

Several other shortwave stations are outstanding in their regional news coverage. For Europe, *Swiss Radio International's* weekday broadcasts of "Dateline" are excellent, as are *Radio Nederland's* "Newline."

For Africa, the *BBC* is again the leader, as it serves as a surrogate 'domestic' station for the continent of Africa, with special programming in English from Britain, but for and about Africa. This is something it does not attempt to do for any other region. Other stations with distinct African services, but within the range of the *BBC*, are *Radio France Internationale*, *Voice of America* and *Voice of Germany*.

Other Areas. *Radio Japan* is the leader in Asian News, with 10-minute Asian newscasts concluding each of its hours to North America, at 0035 and 0220 GMT. *Radio Australia* emphasizes the Pacific and Asian angle, and is more easily heard than *Radio Japan*.

South America does not have any such representative on shortwave. The only countries with international services in English are Argentina, Brazil, Chile and Ecuador. Argentina does not have a commitment to news, the station is hard to pick up, and the country is in a state of chaos. Brazil offers the best potential, if liberalization continues and if its station decides to get off its soft-features-and-music kick. Chile's only interest

is in pushing its anti-communist line. The Ecuadorian station isn't Ecuadorian at all, but American, with the same wire services heard on domestic stations.

Israel is the only country in the Middle East with an effective North American service in English. Its news coverage receives both praise and criticism, which is a sign they're on the right track.

Eastern Europe is a dark area where 'news' has to meet the requirement of portraying the state in a favorable light. Mostly, it's just boring; but if you seek out such programs as "From the Foot of the Column" on Fridays from *Radio Budapest*, or "News About the Soviet Union" nightly on *Radio Moscow*, you will begin to get a glimpse of what we would call news—as opposed to the political rhetoric rampant on the stations' regular "newscasts."

You never know where a major news story is going to develop next. With the help of the schedules in POPULAR ELECTRONICS, you can get all kinds of points of view on it—in many cases direct from where it's happening.

A New Decade. What will the 1980s bring in the shortwave radio field? The prospect of more and better shortwave receivers seems assured. Digital readout will be the rule rather than the exception. Receivers will be more compact without the drawbacks of reduced selectivity and image rejection.

More and more third-world countries will get into international broadcasting. The Voice of Nigeria is expected to be testing new 500-kW transmitters now, enabling it to begin services to North America and other previously untargeted areas within a few months.

Gabon, a small African nation, began speaking in a big voice last September with tests of "Africa Number One", thanks to French financial assistance. The station was expected to become a relay for *Radio France Internationale*, which already devotes the lion's share of its efforts to dawn-to-dusk broadcasts in French to Africa on as many as a dozen frequencies at once direct from France—neglecting its friends in North America, for instance.

Venda, one of the South African 'homelands' of questionable independence, announced plans to begin an international broadcasting service audible throughout the world, as soon as funds become available. Thus, "Radio Thohoyandou" may one day become a household word.

Denmark has kept a token shortwave service on the air since foreign languages were dropped in favor of Danish only via an ailing and now puny 50-kilowatt transmitter. It has announced it would activate a 500-kW shortwave transmitter at a new site, Mors, in northern Denmark—but not before 1983 or 1984. It remains to be seen whether legal restrictions on broadcasting in English will be lifted once it is in service. The staff of *Radio Denmark* has always wanted to maintain broadcasts in English.

Slow-scan television may be tried by shortwave broadcasters. *Radio Australia* has inquired whether monitors would like to see a picture now and then in addition to listening; and a *Radio Japan* listener expressed the desire for SSTV accompanying a report on bathing-suit fashions!

Updating Listings. The following changes and additions should be made in the "English Broadcasts" listings that appeared in the December issue.

GMT/UTC	Station	Frequencies
0900-0930	NSB, Tokyo	6115
1000-1500	R. Moscow (via Cuba)	9600, ex-1300
1100-	TWR-Bonaire	15255, not 15225
1130-1400	CBC North. Serv.	6065, not 6195
1200-1230	Kol Israel	25640, 17605, 17560, not 25625, 15600
1200-1230	R. Tashkent	11785, not 5975
1200-1255	R. Peking	9820, ex-15520
1220-1250	R. Ulan Bator	9574, not 9553 (varies)
1230-1551	WYFR	21525, 17785 (Sun only)
1300-1500	R. Australia	17795, not 11705, and 9770
1515-1530	V. of Greece	17710, 15125, not 17830
1530-2200	R. Moscow (via Havana)	11860, ex-11840; ex-1330
1600-1630	R. Norway	not 15345
1600-1745	BBC	17885, not 17880
1705-1755	R. France, Int.	21675, 21620, 17860, 17850, 17795, 17720, not 21705 and 21595
1700-1800	NCJB, Ecuador	17790, ex-17825
1700-1800	WYFR	17845, 21615
1709-1745	BBC	17830, 15260 (Sat & Sun only)
1745-1830	BBC	21710
1840-1900	WYFR	21615, 17845, 15440, 15130
1815-1845	Swiss R. International	17760, ex-17730
1900-2000	HCJB, Ecuador	17890, 15295, ex-17895, 15225
1900-2000	WYFR	21615, 15130
2000-2030	AWR, Andorra	6215
2000-2030	R. Algiers	add 11810
2000-2030	Kol Israel	9815, 7412.5, not 17645, 15415, 15130, 11805
2000-2100	WYFR	Not 21710
2000-2245	BBC	11920
2010-2140	R. Havana Cuba	11920
2100-2145	R. Nacional, Venezuela	15400 (time and frequency vary; irregular), not 2200- not 15420
2115-2430	BBC	11805, 9605
2100-2350	WYFR	17890, 15295, ex-17895, 15225
2130-2200	HCJB, Ecuador	11735, ex-15305
2200-2215	R. Japan (via Portugal)	
2200-2300	CBC Radio	Mon-Fri only; 9760, not 9575
2230-2300	Kol Israel	15300, possibly additional broadcasts later in evening.
2245-2300	UN Radio	11830, not 11920
2300-2330	R. Vilnius	7215, 7150
2300-0200	R. Moscow	15455, 15180, 11780, 9765, 9685, 9610, 9530, 9490, 7165, not 15425, 7205, 7195, 7130, 7115, 7105, 6125, 5940
2335-2355	SODRE, Uruguay	11885, 9515
0000-0500	R. Moscow (Via Havana)	6115
0030-0100	R. Kiev	15240, not 15180, 6020, 5980
0000-0200	VOA	17730, 9640, ex-9650
0030-0230	BBC	not 15070
0030-0500	HCJB, Ecuador	11910, ex-11915
0145-0215	Swiss R. Int.	15305, not 9660
0200-0255	R. Peking	15600, not 17855
0230-0445	BBC	not 11910
0230-0600	HCJB, Ecuador	add 15115
0300-0315	Austrian Radio	delete
0300-0330	R. Kiev	11690, 9735, 9505, 7400, 7150, not 9580, 7320, 7260, 7175, 5970
0300-0330	R. Portugal	11925, ex-11935
0300-0350	V. of Free China	15270
0330-0400	R. Finland	9645, ex-9675
0400-0430	R. Norway	6185, not 11850, 5965
0500-0530	R. Portugal	11925, ex-11935

7400 TTL	7400 TTL CON'T	T.I./M.M.I.	74LS241	74LS240 IN	74LS244
7400 .18	74107 .35	74LS240	74LS243	74LS373	74LS374
7408 .21	74141 .85	74LS243	74LS374	74LS373	74LS374
7410 .18	74155 .80	74LS243	74LS374	74LS373	74LS374
7412 .34	74157 .80	74LS243	74LS374	74LS373	74LS374
7413 .65	74161 .85	74LS243	74LS374	74LS373	74LS374
7416 .32	74165 .85	74LS243	74LS374	74LS373	74LS374
7420 .20	74175 .90	74LS243	74LS374	74LS373	74LS374
7425 .30	74181 1.35	74LS243	74LS374	74LS373	74LS374
7427 .32	74195 .95	74LS243	74LS374	74LS373	74LS374
7437 .28	74279 .75	74LS243	74LS374	74LS373	74LS374
7438 .28	74367 .75	74LS243	74LS374	74LS373	74LS374
7440 .18	74393 1.95	74LS243	74LS374	74LS373	74LS374
7451 .18	MISC TTL	74LS243	74LS374	74LS373	74LS374
7454 .18	74LS00 .40	74LS243	74LS374	74LS373	74LS374
7454 .18	74LS03 .35	74LS243	74LS374	74LS373	74LS374
7474 .35	74LS09 .55	74LS243	74LS374	74LS373	74LS374
7475 .55	74LS20 .40	74LS243	74LS374	74LS373	74LS374
7485 .85	74LS26 .50	74LS243	74LS374	74LS373	74LS374
7490 .40	74LS27 .45	74LS243	74LS374	74LS373	74LS374
7492 .50	74LS74 .95	74LS243	74LS374	74LS373	74LS374
7493 .50	74LS122 .55	74LS243	74LS374	74LS373	74LS374
7495 .70	74LS157 1.50	74LS243	74LS374	74LS373	74LS374

2114L	1024 X 4 Static	\$475
450 ns		

2708	450ns AMD. SGS	\$8.50
1024 X 8 EPRM		

LOGIC PROBE KIT	SOROC TERMINAL
CSC \$1795	IQ 120 \$759.00

MISC TTL CON'T		
74LS165	1.65	LM556 .85
74LS197	.75	LM711N/H .38
74S03	.65	LM720N 2.75
74S05	.65	LM723N .55
74S51	.60	LM725H 3.25
74S182	.99	LM733N .95
LINEAR		LM741N/H .35
LM102H	3.00	LM747N .80
LM108H	4.50	LM3900 .75
LM300H	1.25	TRANSISTORS
LM301N	.35	2N2222A 5/1.00
LM311N	.79	2N2907A 5/1.00
LM320T5	1.25	2N3055 .85
LM320M5	1.25	2N3904 6/1.00
LM320T12	1.25	2N3906 6/1.00
LM320T15	1.25	2N4401 6/1.00
LM322N	1.75	2N4403 6/1.00
LM323K	5.50	1N4003 15/1.00
LM320K5	5.00	1N4005 12/1.00
LM340T5	1.25	1N4007 10/1.00
LM340T12	1.25	1N4148 20/1.00
LM340T15	1.25	1N5237B 10/1.00

CONCORD COMPUTER COMPONENTS
 1973 SO. STATE COLLEGE - ANAHEIM, CA. 92806
 Visa- Master Charge Minimum Order-10.00
 Check or M.O. (714) 937-0641 Add 1.00 for Frt.
 No COD Cal. Res. add 6%

Put us on the shelf with your other classics.

MK II

DIMENSION LAB SERIES

We wrote the book on miniature speakers, from Design to Production! Our five models speak for themselves in total performance, styling, and features that are found in no other speakers... such as, Solid Walnut Cabinetry, full 12 db cross-over network, a specially designed cone with our exclusive rubber surround, and a deep throw speaker basket. These are just a few of the reasons why our Bass is unequalled in the Industry. "Dimension Minis" are Proven best by listening test."

Come in for a demonstration and judge for yourself.

See and Hear the New Dimension in Sound at Your Local Stereo Dealer.

DIMENSION
 819 S. Kraemer • Placentia, CA 92670
 (714) 630-5440

Representative and Dealer Inquiries Welcome

20th Anniversary

STATEMENT OF OWNERSHIP, MANAGEMENT AND CIRCULATION (Required by 39 U.S.C. 3685).

1. Title of Publication: Popular Electronics. A. Publication No. 00324485. 2. Date of filing: October 1, 1979. 3. Frequency of issue: Monthly. A. No. of issues published annually: 12. B. Annual subscription price: \$13.00. 4. Location of known office of publication: One Park Avenue, New York, New York 10016. 5. Location of the Headquarters or General Business offices of the publishers: One Park Avenue, New York, New York 10016. 6. Names and complete addresses of publisher, editor, and managing editor: Publisher, Joseph E. Mesics, One Park Avenue, New York, New York 10016; Editor, Arthur P. Salsberg, One Park Avenue, New York, New York 10016; Managing Editor, John R. Riggs, One Park Avenue, New York, New York 10016. 7. Owner: Ziff-Davis Publishing Company, One Park Avenue, New York, New York 10016; Ziff Corporation, One Park Avenue, New York, New York 10016. 8. Known bondholders, mortgagees, and other security holders owning or holding 1 percent or more of total amount of bonds, mortgages or other securities: None.

10. Extent and nature of circulation	Average no. copies each issue during preceding 12 months	Actual no. copies of single issue published nearest to filing date
A. Total No. Copies Printed (Net Press Run)	505,078	483,931
B. Paid Circulation		
1. Sales through Dealers and Carriers, Street Vendors and Counter Sales	81,906	85,000
2. Mail Subscriptions	325,616	303,900
C. Total Paid Circulation (Sum of 10B1 and 10B2)	407,522	388,900
D. Free Distribution by Mail, Carrier or Other Means Samples, Complimentary, and Other Free Copies	11,032	10,207
E. Total Distribution (Sum of C and D)	418,554	399,107
F. Copies not distributed		
1. Office Use, Left Over, Unaccounted, Spoiled After Printing	3,142	4,732
2. Returns from News Agents	83,382	80,092
G. Total (Sum of E, F1 and 2 — should equal net press run shown in A)	505,078	483,931

11. I certify that the statements made by me above are correct and complete.

WILLIAM L. PHILLIPS,
Assistant Treasurer

12. For Completion by Publishers Mailing at the Regular Rates: (Section 132.121, Postal Service Manual)

39 U.S.C. 3626 provides in pertinent part: "No person who would have been entitled to mail matter under former section 4359 of this title shall mail such matter at the rates provided under this subsection unless he files annually with the Postal Service a written request for permission to mail matter at such rates."

In accordance with the provisions of this statute, I hereby request permission to mail the publication named in item 1 at the phased postage rates presently authorized by 39 U.S.C. 3626.

WILLIAM L. PHILLIPS,
Assistant Treasurer



Computer Bits

By Hal Chamberlin

MICROCOMPUTER POWER SUPPLIES

NEXT TO the cabinet enclosure, the dc power supply is probably the most mundane component of a microcomputer system. As a result, it is often overlooked by the prospective purchaser of such a system.

One should know that the power supply has a great deal of influence over the reliability and expandability of the system, as well as size and weight. While a well-designed and constructed power-supply system is usually ignored by the user, a marginal power supply constantly calls attention to itself through unexplained system crashes, overheating or outright failures.

Changing Power Requirements. Before discussing the various power supply philosophies and technologies, we will examine the actual power requirements of today's systems.

Early personal computers such as the Altair-8800 and other S-100 bus machines required three or four different power supply voltages (+12, +5, -5, and -12 volts after regulation) at fairly high current levels. These requirements were a result of the microprocessor and memory IC's used by these machines. In particular, the early 1K static semiconductor memory IC's required as much as 1.5 amperes of +5 volts for each 4K. With full memory (64K) installed, up to 24 amperes of current was needed for the memory. The CPU and other peripherals could easily swell this figure beyond 30 amperes! With that kind of current consumption, power distribution and cooling became major design considerations.

Modern microcomputer circuitry requires far less power than the earlier units. The biggest improvement is in memories, where a full 64K of modern dynamic RAM actually consumes less than 1 ampere and fits entirely on a single printed-circuit board.

The introduction of low-power Schottky TTL logic reduced the consumption of other parts of the system to about a quarter of their former levels. In addition, some systems now require only one voltage level (+5 volts) to operate the microprocessor, memory, and miscellaneous logic. Consequently, power supply design and cooling is much less of a problem for them.

Central vs Local Regulation. All power-supply voltages used by microcomputer circuitry must be carefully regulated for safe and reliable operation, of course. Two distinctly different approaches to doing this have evolved over the history of microcomputers. The first and most obvious method used one high-current central regulator for each voltage in the system. This was the method used exclusively in the past.

However, some problems arose with power distribution. When dealing with low voltages, such as 5 volts, at high-current levels, even short lengths of heavy wire or a slightly oxidized electrical contact could develop a substantial voltage drop. For example, at 30 amperes a resistance of 0.0016 ohms will create a drop of about 50 millivolts, a 1-percent loss at 5 volts. Keep in mind that TTL logic can only tolerate a 5% loss before malfunctioning!

Another problem with central regulation is that the heavy power supply wiring from board to board also transmits digital noise generated on one board to all other boards in the system. Elaborate systems of chokes and bypass capacitors on each board were needed to prevent such noise coupling.

Many microcomputer systems today, notably S-100 systems, use local regulation on each board. The main power supply in such systems provides rectified and filtered (but unregulated) voltages that are about 50% higher than

An urgent appeal to the 76,000,000 Americans whose emergency calls for help on the highway were answered by REACT.

In less than the time it will take you to read this appeal, REACT teams all over the U.S. and Canada will have answered about 80 such calls for help with their CB radios—one emergency every 7½ seconds, 24 hours a day, seven days a week, an average of more than 4.4 million emergencies per year!

What is REACT?

Most of the 25 million Americans who own CB radios, and a great many who don't, have heard of REACT and know something about the tremendous free emergency services these volunteers perform, for the American public. Very few know the extent to which REACT has been instrumental in saving lives, helping their neighbors save valuable time in a thousand ways, and saving America's precious fuel. Here's what you should know about REACT.

REACT is a tax exempt non-profit organization whose only mission is to bring help immediately when there is trouble through the use of CB radios.

REACT International's Board of Directors is a distinguished group of American citizens, also serving on a volunteer basis, each with special background and experience in areas that contribute to the strength and stature of REACT—a former head of the Federal Communications Commission... an executive of the American National Red Cross... a staff member of the International Association of Chiefs of Police. Over one-third of the directors have personal experience in the actual operation and training of a REACT team.

REACT is recognized by law enforcement, public service and other governmental organizations at all levels. It maintains a formal cooperative working agreement with the American National Red Cross, providing local disaster communications for Red Cross Chapters. REACT works closely with the U.S. Department of Transportation and state police in highway safety and communications affairs. As Col. Sam Smith, retired head of Missouri's Highway Patrol puts it:



"The contribution to highway safety and service to the public made by these REACT volunteers is incredible—at no cost to the taxpayer. There is no way government could provide such outstanding service at any price. The public owes REACT a tremendous debt of gratitude."

REACT is a volunteer association. Its 50,000 members are organized into more than 2,000 highly disciplined, autonomous REACT teams throughout the country coordinated, supported and represented by their International Headquarters in Chicago, Illinois. REACT members donate their time, energy and even their personal finances to organized monitoring of CB radio channel 9. This is the channel officially designated by the Federal Communications Commission to be used for emergencies and assistance to travelers only. When a call is heard by a REACT monitor, he immediately telephones the proper authorities to rush necessary assistance.

For 17 years now, REACT volunteers—ordinary folks just like you and me with CB radios and a powerful desire to help their neighbors—have been helping motorists in trouble on the highway. Now they need your help. I ask every responsible citizen to read this appeal carefully and then give your support to this great American Institution.

Shirley Joe Higgins
National Safety Sheriff

REACT volunteers are from all walks of life, every race and religion, every trade or profession—truckers, doctors, firemen, housewives, businessmen, students.



REACT volunteers are thoroughly trained. They know the best, most efficient communications procedures—just like a police radio dispatcher. They keep complete monitor records, lists of authorities and service organizations. They know who to call and when.

How do you benefit?

Last year alone, REACT volunteers were instrumental in bringing help faster to the victims of more than a million automobile accidents alone—seventeen minutes faster than accidents not reported by CB, according to research conducted in Detroit, Michigan, by Wayne State University. Over three million motorists received valuable highway or city directions that cut literally millions of miles—and thousands of gallons of fuel—from their driving.



... but REACT serves its communities in many other important ways.

If your community has ever suffered the agonies of tornadoes, floods, or other natural disasters it's almost a certainty that your REACT teams played a vital role, providing local emergency communications when power and phone lines were down... assisting the Red Cross in disaster relief by delivering emergency food and medical supplies... transporting the injured... helping police with crowd control. In a hundred other ways REACT teams serve the public in community projects such as March of Dimes drives, communications for parades,

scout activities and county fairs. All in the spirit of public service that is so uniquely American.

How is REACT financed?

Funds to operate and administer REACT International have come to us in the solid, traditional American way—100% from private contributions and the dues from the members themselves.

Through the years, about 30% of REACT International's operating budget has been provided by contributions and grants from a variety of public spirited corporations, and the balance by REACT members themselves through annual dues of \$5.00 per member.

These funds are used entirely to provide vital training programs; identification materials; a quarterly newspaper that communicates ideas and experiences to improve REACT team operations; inter-team communications; a Junior REACT program to train future REACTers in both citizenship and emergency procedures; and liaison with public safety and other government organizations.



Each individual, autonomous REACT team may also charge local dues and accept tax deductible contributions from local businessmen, to pay the cost of local meetings, training sessions and miscellaneous team expenses. But in its entire seventeen year history, no REACT team has ever charged the public for its services.

Why a financial crisis now?

For the first time in its history, REACT is appealing directly to the American public—the true beneficiaries of REACT volunteer emergency services—for financial support. We do so reluctantly, realizing that skyrocketing costs are hitting every citizen where it hurts. But inflation is not REACT's most serious problem. Through the years, REACT has relied heavily on the generous contributions of manufacturers, particularly those in the communications industry to help us provide the tools necessary for effective volunteer emergency communications. However, even our modest goals for industry support for 1979 have not been realized.



Our combined income for 1979 is below our minimum operating forecast by nearly 20%. Some vital services already have been curtailed. International Headquarters staff and facilities have been cut to the bone. But it's not enough.

Without your direct tax deductible support... unless the public now comes to the aid of REACT... the effectiveness of the program will be further and seriously jeopardized.

We cannot, and will not, ask our REACT members for additional dues or assessments. They should not be forced to pay additionally for the privilege of serving the public! In fact... we have pledged to our membership that any public funds generated by this appeal in excess of our immediate budgeting needs and the financial safety of REACT International will be returned to the membership in the form of reduced dues for 1980.

How much is needed? How much should you give?

REACT needs are truly modest for such a large organization. We are not out to impress anyone—except with the quality and value of our volunteer emergency services.

So whatever you send will be a godsend. \$5.00... \$10.00... more if you can.

All contributions will be acknowledged and are fully tax deductible. If you send us \$5.00, we will send you, as a token of our appreciation, a "Help" flag for display on your vehicle if you are stalled on the highway... plus a list of all REACT team locations so you can call directly for help on CB channel 9. If you send us \$10.00 or more, we'll also send you a beautiful 1979 Road Atlas which includes both CB information and a useful national mileage chart.

Please do not send cash. A check or money order is safer and it provides you proof of contribution for income tax deduction purposes.

Emergency Fund
REACT International, Inc.
75 E. Wacker Drive, Chicago, IL 60601

Dear REACTers: It's my turn to help! Here's my tax deductible contribution to keep REACT strong, and continue its voluntary emergency communications service to the public.

Amount \$ _____ check
money order enclosed.

Name _____

Address _____

City _____ State _____ Zip _____

CIRCLE NO. 50 ON FREE INFORMATION CARD

CORDLESS



CONVENIENCE

THE REMOTE CONTROL STARTER FOR YOUR CAR IS ONE OF OUR PRODUCTS THAT WILL HELP YOU ACHIEVE THIS

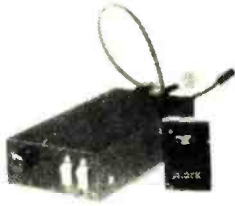

THE REMOTE CONTROL STARTER IS THE ULTIMATE IN MOTORING CONVENIENCE. THE TRANSMITTER IS SLIGHTLY LARGER THAN A CREDIT CARD CALCULATOR. NO MORE WAITING FOR A COLD CAR TO WARM UP OR A BOILING CAR IN SUMMER TO COOL OFF BEFORE YOU CAN GET IN. JUST START IT FROM YOUR HOME OR OFFICE AND SIT INTO A COMFORTABLE ENVIRONMENT WHEN YOU ARE READY TO DRIVE AWAY.

THE ON BOARD COMPUTER INSTALLED IN YOUR CAR MAKES THIS ALL POSSIBLE. IT ALSO PROVIDES THE SAFETY FEATURE OF PREVENTING FALSE START UP FROM STRAY SIGNALS BY USING AN INTERNAL CODING SYSTEM, SO THERE IS NO CHANCE OF FALSE STARTING BY NOISE SIGNALS OR EVEN OTHER TRANSMITTERS OF THE COMPUTER START. UNLESS THE "KEY" CODE EXACTLY COINCIDES.

WHEN THE REMOTE START BUTTON IS ACTIVATED THE MICROCOMPUTER COMPARES THE SIGNAL WITH THE REGISTERED CODE AND STARTS THE ENGINE. BY DETECTING THE AMBIENT TEMPERATURE INSIDE THE CAR, THE COMPUTER AUTOMATICALLY ADJUSTS TO SET THE APPROPRIATE IDLE TIME, RANGING FROM 6:12 MINUTES. ANOTHER UNIQUE FEATURE OF THE COMPUTER START IS IF THE ENGINE FAILS TO START, ABOUT 4 SECONDS LATER, THE STARTER RUNS AGAIN FOR ABOUT 1.5 SECONDS. THE PROGRAM REPEATS ITSELF UNTIL THE ENGINE STARTS OR A TOTAL OF 8 TIMES. BETWEEN THE FOURTH AND FIFTH TIME THE AUTOMATIC ACCELERATOR - PEDALLING DEVICE GIVES IT GAS.

THE REMOTE CONTROL STARTER COMES WITH A 1 YEAR GUARANTEE AND A FURTHER ASSURANCE FROM TEKNION THAT YOU MUST BE SATISFIED OR YOUR MONEY REFUNDED. TO ORDER YOUR STARTER SEND, CHECK, OR MONEY ORDER OR CHARGE CARD NO. [BANKAMERICA (VISA), MASTER CHARGE] FOR \$295 (CANADA \$395) TO THE ADDRESS BELOW OR CREDIT CARD BUYERS CAN USE OUR TOLL FREE NUMBER TO PLACE THEIR ORDER. ACT NOW AND START ENJOYING THE BENEFITS OF YOUR STARTER SOON.

N.Y. AND ONT. RESIDENTS PLEASE ADD SALES TAX.

ORDER TOLL FREE
24 HOURS 7 DAYS/ WEEK
1-800-528-6050 EXT. 309
IN ARIZONA
1-602-955-9710 EXT. 309
CANADA
1-800-268-4830 EXT. 309
IN TORONTO CALL 787-2811

TEKNION

1333 - 54th ST. DEPT. PE.
BROOKLYN, N.Y. 11219

CANADA
3018 BATHURST ST. DEPT. PE.
TORONTO, ONT M6B3B6

DEALER INQUIRIES INVITED

the final regulated voltages required by the boards. For example, 8 volts is usually supplied for the 5-volt line and 16 volts for the 12-volt line.

Each board contains an IC regulator for each different voltage required by that board. Although the cost of 30 amperes worth of 1-ampere regulators may be more than a single 30-ampere central regulator, the small regulators can be purchased one at a time, along with the expansion boards.

Local voltage regulation overcomes many of the problems associated with centrally regulated power distribution. Voltage drops in the main power distribution are of little consequence as long as it is not so great as to exceed regulation capability of the local regulators. Ground wiring, though, must remain heavy because voltage drops along ground leads either add to or subtract from the *logic* signal voltages. This might lead to the possibility of a zero being interpreted as a one or vice-versa. Local regulators also prevent noise coupling both forward and backward through them, thus reducing the need for noise-filtering components. Again, this does not help ground noise, which must still be controlled through the use of heavy ground wiring and multiple ground connections to the boards.

Local regulation is not without its problems, however. The most severe of these is that the local regulators dissipate a lot of heat, in many cases as much as the board logic itself. This causes a considerably greater buildup of heat around sensitive logic components than would occur in an equivalent centrally regulated system. Here, all of the regulator heat is in the power supply area. As a result, locally regulated boards should not draw much more than 1 ampere from the unregulated supply unless a fan is present in the system to remove the 10 or more watts of heat that this represents. The 1-ampere restriction, however, is much less of a problem now than it was in the past.

Another problem with local regulation that concerns some people is fail-safe operation. All local and most central regulators are *series* elements which control the output voltage by acting as a variable series resistance. If the regulator element should fail as a short circuit, the twice-as-high unregulated voltage directly enters the logic circuitry, perhaps causing severe damage. A large centrally regulated power supply can absorb the cost of elaborate crowbar overvoltage protection circuitry, but

the cost of adding such circuitry to each board in a locally regulated system would be prohibitive. Although integrated-circuit regulators have only modest overvoltage protection circuitry built-in (usually a zener diode across the output), other internal protection makes short-circuit failures very rare.

Perhaps the most insidious problem with local regulators is over-reliance on their regulation capabilities. For proper operation, most IC regulators require an unregulated input at least 2 volts higher than the regulated output voltage. With any less input, the device simply stops regulating and passes ripple and noise directly to the logic circuitry. The problem is insidious because, although a voltmeter may indicate sufficient unregulated voltage (such as +7.5 volts into a 5-volt regulator), the superimposed ripple voltage may momentarily drop below the critical 7-volt level. Use a dc-coupled oscilloscope to check this problem.

Power Conversion Systems. Ignoring the exact method of regulation, most of the bulk and cost of a microcomputer power supply is in the power conversion system, which takes 117-volt ac power and produces rectified and filtered low-voltage dc for the regulators. Three methods of power conversion are used.

The first, which is probably the most common, is the classic iron-core transformer and bridge or center-tapped rectifier system, with a bulk capacitor filter. While conceptually simple and inexpensive, this method has many pitfalls for the inexperienced designer. The most serious of these is the extremely poor voltage regulation which must be overcome by the regulator. It is not unusual for the low-load/high-line output voltage to be double that of the full-load/low-line output voltage. If the regulator is to function under the latter condition, normal conditions will mean a very high unregulated input voltage and, consequently, a lot of heat dissipation in the regulators. Marginally designed power supplies of this type will drop out of regulation during momentary low-line conditions, and possibly cause malfunction of the microcomputer.

The second, although more expensive, approach is to use a *constant voltage transformer* (CVT). This type of transformer has *two* winding "windows" in the core, with the primary in one window and the secondary in the other. A large ac capacitor is connected across one of the secondaries that resonates

the winding with the 60-Hz input and thus provides a good deal of regulation. Such transformers are also called *ferroresonant* because of the resonating capacitor. When combined with a conventional rectifier and filter, such a transformer can hold unregulated voltage variations to less than 10%, which reduces regulator dissipation and increases immunity to line-voltage variation. Also, since the transformer puts out an approximately square waveform, a smaller-valued filter capacitor can be used to partially counteract the higher cost and bulk of the CVT. Some of the better S-100 mainframes use CVTs.

There is yet a third power-conversion method that is finding increased acceptance as costs decline. This is the direct off-the-line switching power supply. Such a unit first rectifies and filters line voltage directly without a transformer to provide about 150 volts dc. This high voltage then operates a power oscillator in the 15-to-30-kHz range. The resulting high-voltage, high-frequency ac is stepped down to lower output voltages with a lightweight ferrite-core transformer. The lower-voltage, frequency ac is then rectified and filtered again to provide the final output voltages. Usually the oscillator is constructed so that feedback from one of the output voltages, typically +5 volts, controls its frequency or waveform. It therefore provides sufficient regulation for direct operation of logic. The primary advantages of switching power supplies are small size and light weight for their output capability and a high regulation efficiency, lower heat dissipation, and inherent central regulation.

Safety Approval. Safety testing of a microcomputer's power supply can be a long and expensive process for its manufacturer. When 117 volts is present in the cabinet of a computer, the whole unit must be subjected to a number of stringent tests, some of which are destructive. One solution to this problem is to provide the step-down transformer as a separate unit, much like a calculator battery eliminator, and only have low voltages in the microcomputer. If this is done, only the transformer must be tested, which is a much simpler process. Although limited to smaller machines with low-power consumption, modern low-power ICs make viable.

In sum, one should be aware of the importance of power supplies in microcomputers and add this consideration when making buying judgments.



Featuring

RCA 1802 COSMAC CPU

Own a powerful home computer system, starting for just \$99.95—a price that gets you up and running the very first night with your own TV for a video display. \$99.95 ELF II includes RCA 1802 8-bit microprocessor addressable to 64k bytes with DMA, interrupt, 16 registers. ALU, 256 byte RAM, full hex keyboard, two digit hex output display, stable crystal clock for timing purposes, RCA 1861 video IC to display your programs on any video monitor or TV screen and 5 slot plug in expansion bus (less connectors) to expand ELF II into a giant!

ELF II Explodes Into A Giant!

Master ELF II's \$99.95 capabilities, then expand with GIANT BOARD KLUGE BOARD 4k RAM BOARDS TINY BASIC ASCII KEYBOARD LIGHT PEN ELF BUG MONITOR COLOR GRAPHICS & MUSIC SYSTEM TEXT EDITOR ASSEMBLER DISASSEMBLER VIDEO DISPLAY BOARD and, another great reason for getting your ELF now—

BREAKTHROUGH!

Netronics proudly announced the release of the first 1802 FULL BASIC, written by L. Sandlin, with a hardware floating point RPN math package (requires 8k RAM plus ASCII and video display boards), \$79.95 plus \$2 p&h. Also available for RCA VIP and other 1802 systems Board includes area for a ROM version.

Master This Computer In A Flash!

Regardless of how minimal your computer background is now, you can learn to program an ELF II in almost no time at all. Our *Short Course On Microprocessor & Computer Programming*—written in non technical language—guides you through each of the RCA COSMAC 1802's capabilities, so you'll understand everything ELF II can do and how to get ELF II to do it! Don't worry if you've been stumped by computer books before. The *Short Course* represents a major advance in literary clarity in the computer field. You don't have to be a computer engineer in order to understand it. Keved to ELF II, it's loaded with "hands on" illustrations. When you're finished with the *Short Course*, neither ELF II nor the RCA 1802 will hold any mysteries for you.

In fact, not only will you now be able to use a personal computer creatively, you'll also be able to read magazines such as BYTE INTERFACE AGE POPULAR ELECTRONICS and PERSONAL COMPUTING and fully understand the articles. And, you'll understand how to expand ELF II to give you the exact capabilities you need!

If you work with large computers, ELF II and the *Short Course* will help you understand what they're doing.

Get Started For Just \$99.95, Complete!

\$99.95 ELF II includes all the hardware and software you need to start writing and running programs at home, displaying video graphics on your TV screen and designing circuits using a microprocessor—the very first night—even if you've never used a computer before.

ELF II connects directly to the video input of your TV set, without any additional hardware. Or, with an \$8.95 RF modulator (see coupon below), you can connect ELF II to your TV's antenna terminals instead.

ELF II has been designed to play all the video games you want, including a fascinating new target/missile gun game that was developed specifically for ELF II. But games are only the icing on the cake. The real value of ELF II is that it gives you a chance to write machine language programs—and machine language is the fundamental language of all computers. Of course, machine language is only a starting point. You can also program ELF II with assembly language and tiny BASIC. But ELF II's machine language capability gives you a chance to develop a working knowledge of computers that you can't get from running only

Write and run programs—the very first night—even if you've never used a computer before!

You're up and running with video graphics for just \$99.95 — then use low cost add-ons to create your own personal system that rivals home computers sold for 5-times ELF II's low price! pre-recorded tape cassettes.

ELF II Gives You The Power To Make Things Happen!

Expanded, ELF II can give you more power to make things happen in the real world than heavily advertised home computers that sell for a lot more money. Thanks to an ongoing commitment to develop the RCA 1802 for home computer use, the ELF II products—being introduced by Netronics—keep you right on the outer fringe of today's small computer technology. It's a perfect computer for engineering, business, industrial, scientific and personal applications.

Plug in the GIANT BOARD to record and play back programs, edit and debug programs, communicate with remote devices and make things happen in the outside world. Add Kluge (prototyping) Board and you can use ELF II to solve special problems such as operating a complex alarm system or controlling a printing press. Add 4k RAM Boards to write longer programs, store more information and solve more sophisticated problems.

ELF II adds on already include the ELF II Light Pen and the amazing ELF BUG Monitor—two extremely recent breakthroughs that have not yet been duplicated by any other manufacturer.

The ELF BUG Monitor lets you debug programs with lightning speed because the key to debugging is to know what's inside the registers of the microprocessor. And, with the ELF BUG Monitor, instead of single stepping through your programs, you can now display the entire contents of the registers on your TV screen. You find out immediately what's going on and can make any necessary changes.

The incredible ELF II Light Pen lets you write or draw anything you want on a TV screen with just a wave of the "magic wand." Netronics has also introduced the ELF II Color Graphics & Music System—more breakthroughs that ELF II owners were the first to enjoy!

ELF II Tiny BASIC

Ultimately, ELF II understands only machine language—the fundamental coding required by all computers. But, to simplify your relationship with ELF II, we've introduced an ELF II Tiny BASIC that makes communicating with ELF II a breeze.

Now Available! Text Editor, Assembler, Disassembler And A New Video Display Board!

The Text Editor gives you word processing ability and the ability to edit programs or text while it is displayed on your video monitor. Lines and characters may be quickly inserted, deleted or changed. Add a printer and ELF II can type letters for you—error free—plus print names and addresses from your mailing lists!

ELF II's Assembler translates assembly language programs into hexadecimal machine code for ELF II use. The Assembler features mnemonic abbreviations rather than numerics so that the instructions on your programs are easier to read—this is a big help in catching errors.

ELF II's Disassembler takes machine code programs and produces assembly language source listings. This helps you understand the programs you are working with—and improve them when required.

The new ELF II Video Display Board lets you generate a sharp, professional 32 or 64 character by 16 line upper and lower case display on your TV screen or video monitor—dramatically improving your unexpanded \$99.95 ELF II. When you get into longer programs, the Video Display Board is a real blessing!

Now Available!

- A-D/D-A Board Kit includes 1 channel (expandable to 4) D-A, A-D converters, \$39.95 plus \$2 postage & handling.
- PILOT Language—A new text-oriented language that allows you to write educational programs on ELF II with speed and ease! Write programs for games...unscrambling sentences...spelling drills... "fill in the missing word" tests, etc.! PILOT is a must for any ELF II owner with children. PILOT Language on cassette tape, only \$19.95 postpaid!
- Game Package on cassette tape (requires 4k RAM), \$9.95 plus \$2 postage & handling.

Clip Here and Attach to Your Order Below!

Netronics R&D Ltd., Dept PL-1
333 Litchfield Road, New Milford, CT 06776

PHONE ORDERS ACCEPTED!
Call (203) 354-9375

Yes! I want my own computer! Please rush me—



RCA COSMAC ELF II kit at \$99.95 plus \$3 postage and handling (requires 6.3 to 8 volt AC power supply)

Deluxe Metal Cabinet with Plexiglas dust cover for ELF II \$29.95 plus \$2 postage

I am also enclosing payment (including postage & handling) for the letters checked below!

Tom Pittman's Short Course On Microprocessor & Computer Programming teaches you just about everything there is to know about ELF II or any RCA 1802 computer. Written in non technical language it's a learning breakthrough for engineers and laymen

- ALSO AVAILABLE FOR ELF II**
- GIANT BOARD™ kit with cassette I/O, RS-232 C, 11X-11, 8-bit P/I/O decoders for 14 separate I/O instructions, and a system monitor editor. \$39.95 plus \$2 p&h.
 - Kluge (Prototyping) Board accepts up to 36 IC's \$17.00 plus \$1 p&h.
 - 4k Static RAM kit. Addressable to any 4k page in RAM. \$89.95 plus \$3 p&h.
 - Color Display Board with expansion bus (one required for each plug in board). \$5.70 ea. postpaid.
 - Expansion Power Supply (required when adding 4k RAM). \$34.95 plus \$2 p&h.
 - Professional ASCII Keyboard kit with 128 ASCII upper/lower case set, 96 printable characters, on-board regulator, parity, lock, selection and choice of 4 hand shaking signals, to mate with almost any computer. \$64.95 plus \$2 p&h.
 - Deluxe metal cabinet for ASCII Keyboard. \$19.95 plus \$2 postage.
 - Video Display Board kit lets you generate a sharp professional 32 or 64 character by 16 line upper and lower case display on your TV screen or video monitor—dramatically improving your unexpanded \$99.95 ELF II plus \$2 p&h.
 - ELF II Tiny BASIC on cassette tape. Commands include SAVE, LOAD, ±, ×, ÷, !
 - 26 variables A-Z, LET, IF, THEN, INPUT, PRINT, GO TO, GO SUB, RETURN, END, REM, CLEAR, LIST, RUN, PLOT, PEEK, POKE. Comes fully documented and includes alphanumeric generator required to display alphanumeric characters directly on your TV screen without additional hardware. Also plays tick tack toe plus a drawing game that uses ELF II's hex keyboard as a 40x32 4k memory required. \$14.95 postpaid.
 - Tom Pittman's Short Course on Tiny Basic for ELF II \$5 postpaid.
 - ELF-BUG™ Deluxe System Monitor on cassette tape. Allows displaying the contents of all registers on your TV at any point in your program. Also displays 24 bytes of memory with full addresses, banking cursor and auto scrolling. A must for the serious programmer! \$14.95 postpaid.
 - Text Editor on cassette tape gives you the ability to insert, delete or edit lines and words from your programs while they are displayed on your video monitor. Add printer and you can use ELF II to type error free letters, plus insert names and addresses from your mailing list. \$19.95 postpaid.
 - Assembler on cassette tape translates assembly language programs into hexadecimal machine code for ELF II use. Mnemonic abbreviations for instructions (rather than numerics) make programs easier to read and help prevent errors. \$19.95 postpaid.
 - Disassembler on cassette tape takes machine code

Total Enclosed \$ _____
(Don't forget add tax)

CHARGE IT! Exp. Date _____
 Visa Master Charge Bank # _____

Account # _____

Print Name _____
Address _____
City _____
State _____ Zip _____

DEALER INQUIRIES INVITED

FREE SWTP

CATALOG

Audio—Computers
Instruments
Kits & Assembled

COMPUTER
PRODUCTS
CATALOGUE



Southwest Technical Products Corporation
219 W. RHAPSODY
SAN ANTONIO, TEXAS 78216

CIRCLE NO. 53 ON FREE INFORMATION CARD

SEE YOUR DEALER TODAY

DEMAND THE ORIGINAL

'Firestik'[®]

"THE FUEL-SEEKER"

**DON'T TAKE NO FOR AN ANSWER!!
THE #1 WIRE-WOUND AND MOST
COPIED ANTENNA IN THE WORLD!**

Rugged, Shatterproof Fiberglass . . .

CB Antennas and accessories for marine, RV,
truck, auto, van and motorcycles, etc.

Five Colors
Spun Gold, Silver-Gray, Black, Red and White.

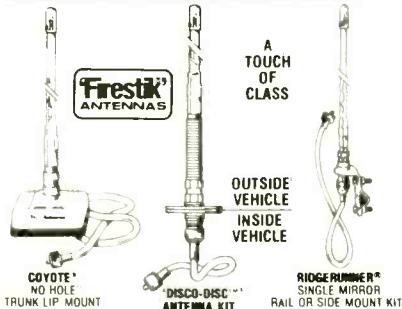

SEND FOR FREE CATALOG

'Firestik'[®] Antenna Company
2614 East Adams/Phoenix, AZ 85034

Name _____
Street _____
City _____
State _____

Zip _____
Our 17th Year Serving
the CB & Communications Market

5-YEAR REPLACEMENT WARRANTY

CIRCLE NO. 46 ON FREE INFORMATION CARD

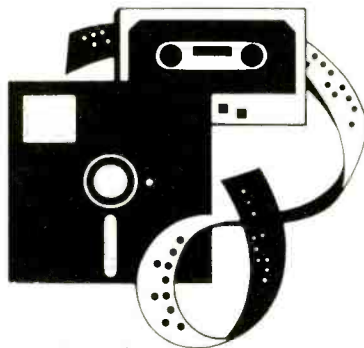

Software Sources

By Leslie Solomon
Technical Director

Apple Things. Amongst this firm's software for the Apple II is Typesetter (\$22.95) a high-resolution graphics character system with scaling colors, upper and lower case, PET-style graphics, and an extra character set; Data Handler (\$49.95) a file handling and manipulating system with disk-oriented data base management; Text Editor/Word Processor (\$99.95) a character-oriented editor and operating system; Linfit (\$6.95) a linear regression forecasting analysis and plotting package; Hires Tic-Tac-Toe (\$4.95) four dimensional "tic-tac-toe" using high-resolution graphics; and a series of program packs. Hires programs, and a line of business programs. Andromeda Computer Systems, P.O. Box 19144, Greensboro, NC 27410 (Tel: 919-852-1482).

Computer Mail. PCNET is now making available software for the PET (other computers will be forthcoming) to provide mail support for personal computer users with the conventional telephone system. It is hoped that a combination of the PAN software (\$12 on cassette) and a modem will provide this service. Contact People's Computer Company, 1263 El Camino Real, Box E, Menlo Park, CA 94025 (Tel: 415-323-3111).

6809 Operating System. PSYMON (Percom System Monitor) is a 1K operating system for Percom's SS-50 bus compatible 6809 control computer and other 6809 systems. It includes 8 monitor-type commands and 15 callable utilities. Firmware is available in five ROM versions: Percom SBC/9 (\$39.95), Percom 6809, Creative Micro Systems EXORcisor, Percom-adapted SWTP MP-2A, and SWTP MP-09 6809 system. The latter four are \$69.95 each. A user manual that includes a listing is \$9.95. Percom Data Company, 211 N. Kirby, Garland, TX 75042 (Tel: 1-800-527-1592).

Apple Text Editor. APPLE-WRITER is a powerful text editor for Apple II that includes merging, full text control such as insertion and deletion, text rearrangement, auto search and replacement, text justification, upper and lower case. With a 48K machine, 12 full pages of text can be stored. The package consists of two diskettes (working and backup) with one diskette including a full

interactive tutorial that the user can call on-screen for quick learning or review. Available from Apple dealers at \$75.

PET/CBM Programs. Three new PET/CBM software packages: "Checkbook" assists in balancing a checkbook, selects and displays checks by person, purpose or date, and sums checks by category or person. "Accounts" allows creation of data base for names, addresses, invoice and purchase order numbers, and amounts of purchase. It locates specific companies, determines amounts owned and displays past-due accounts. "Calendar" keeps track of appointments, schedules social engagements and is an all-purpose datebook. Each program: \$9.90 for cassette, \$12.95 diskette. Specify computer. TIS, Box 921, Los Alamos, NM 87544.

Apple Word Processing. SUPER-TEXT is a multi-paging system that allows viewing two pages simultaneously. You can keep notes on one screen while you edit the other. It is a character-oriented editor with complete cursor control, has built-in floating-point math and auto tab, you can add or insert a character, word or line; features auto LFCR to eliminate word breaking at end of line, right and left justification, scrolling, move to block marker, copy, delete or save on disk. It also has print controls, single or double line spacing, variable page length and width, and automatic page numbering. Underscoring, line centering and auto link and printing of multiple text files are also included. \$99.95. Muse Co., 7112 Darlington Drive, Baltimore, MD 21234 (Tel: 301-661-8531).

**Put Professional Knowledge and a
COLLEGE DEGREE
in your Electronics Career through**

HOME STUDY



**Earn Your
DEGREE**

No commuting to class. Study at your own pace, while continuing your present job. The Grantham home-study program leads first to the A.S.E.T. and then to the B.S.E.T. degree. Our free bulletin gives full details. Write for *Bulletin ET-80*.

Grantham College of Engineering
2500 So. LaCienega Blvd.
Los Angeles, California 90034

GRANTHAM'S FCC LICENSE STUDY GUIDE
—377 pages. 16 FCC-type practice tests, 1465 questions with answers and discussions—covering third, second, and first class radiotelephone license exams. Preparation for each separate class of license is presented in a separate section of the book. \$15.75 postpaid. Order from:

GSE Publications
P. O. Box 35499, Los Angeles, Calif. 90035

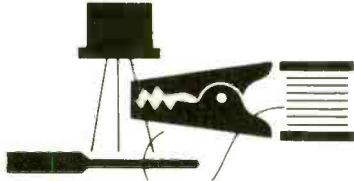

Tips & Techniques

AMBIENT LIGHT COMPENSATION

A problem common to most photosensor circuits is their inability to cope with wide variations in the intensity of ambient light. The circuit shown here provides ambient light compensation and makes an ideal

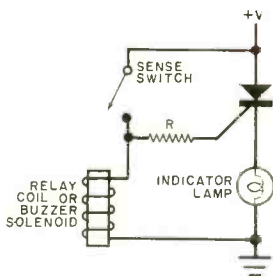

front end for optical signal and position sensing systems. Field effect transistor $Q1$ behaves like a variable resistor which

automatically adjusts its resistance to hold phototransistor $Q2$'s collector at a constant dc level. The FET will not try to compensate for, correct or cancel the ac (optical) signal as long as the gate rises and falls with the source. The time constant $R1C1$ should be chosen to be several times greater than the period of the lowest frequency optical signal to be received. The FET can adjust the phototransistor's response over the many decades of light levels from near darkness to bright sunlight. The 2N5484 FET, whose gate-to-source voltage is nominally 1.5 to 2.5 volts, is suited for this application and the FPT120B is a very responsive and sensitive phototransistor. —P.D. Wesley, Marion, IN.

PROBE CHOPSTICKS

When testing components or measuring circuit parameters with a VOM or other instrument employing test probes, try holding the probes as if they were chopsticks. With a little practice, you'll be able to maintain excellent control over the probes and still have one hand free to hold the object under test, adjust knobs, etc. —Will Hobbs, Portland, OR.

KEEPING IC'S COOL

Integrated circuits are notoriously heat sensitive. Unless a minimum of heat is used, soldering an IC in place can result in

CONSUMERS CO. TAPES — DISCOUNTS — STEREO

Minimum Order 10 Tapes.

TDK

SAC-90	2.99	DC-45	1.07
SAC-60	2.22	DC-60	1.12
ADC-45	1.59	DC-90	1.52
ADC-60	1.75	DC-120	2.10
ADC-90	2.50	DC-180	2.95
ADC-120	3.69	Metal-60	8.95

VHS — VIDEO

VT-120	4 hr	19.25	VT-60	2 hr	13.50
VT-90	3 hr	16.25	VT-30	1 hr	11.50

MEMOREX

High Bias C-90	3.79	MRX3 C-60	1.95
High Bias C-60	2.79	MRX3 C-90	2.79
MRX3 C-30	1.65	MRX3 C-120	3.89
MRX3 C-45	1.79	Hd. Clnr	1.49

SPECIALS

C-120 (3pk)	3 for 7.49	60-8tk (2pk)	2 for 3.29
90-8tk (2pk)	2 for 3.99	7x1800 Reel	2.99

— AMPEX —

Grndmtr II C-90	3.00
Grndmtr II C-60	2.45
Grndmtr I C-90	2.75
Grndmtr I C-60	2.20
350 Series C-60	59
370 Series C-120	99

BASF

Studio C-90	2.49
Pro III/III C-90	2.95
Pro III/III C-60	2.28
Perf. C-90	1.99
Perf. C-60	1.39
Perf. C-45	1.15

KOSS HEADPHONES

PRO4-AA	37.90	K6-ALC	24.75
PRO4-AAA	46.50	K6-A	17.95
HV-1LC	35.50		

SOUNDGUARD

Preserv'n Kits	5.59	Preserv'n Refill	3.29
Rec. Clnr Kit	5.59	Rec. Clnr Refill	3.29
Rec. Work Pad	5.59	Tot. Care System	10.99

FREE OFFER!

FREE: REVOLVING CASSETTE RACK
Holds 20 Tapes. With Orders Over \$50



Send M.O. or Cer. Check for 2 day delivery. Pers'n'l checks, 2 wk delay. Add \$2.75 for shipg. & hdg. per 10 tapes. NYS res add s/s tax. Nc. C.O.D.'s. Free Catalog!

CONSUMERS CO.

P.O. Box 590 Dept. PE-18
Mt. Vernon, N.Y. 10551
Phone: (914) 664-2909

CIRCLE NO. 63 ON FREE INFORMATION CARD

BATTERY-WRAP

WIRE WRAPPING TOOL

MODEL BW-2630

- POSITIVE INDEXING
- ANTI-OVERWRAPPING
- BITS AVAILABLE FOR AWG 26, 28 & 30
- BATTERY OPERATED
- LIGHT WEIGHT

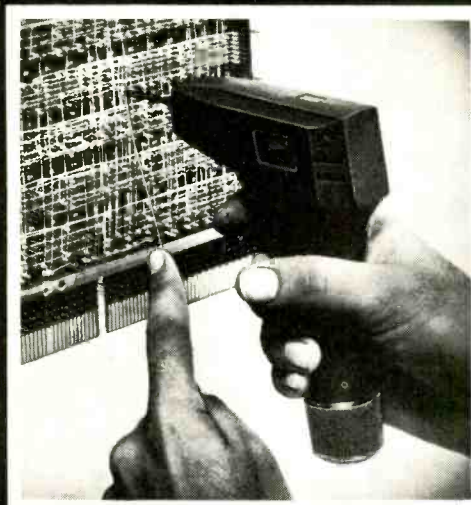

\$19⁸⁵*

BATTERIES AND BIT NOT INCLUDED

U.S.A.
FOREIGN
PATENTS
PENDING



BW-2630	BATTERY-WRAP TOOL	\$19.85
BT-30	BIT FOR AWG 30	\$ 3.95
BT-2628	BIT FOR AWG 26 & 28	\$ 7.95
RB-20	TWO NI-CAD BATTERIES	\$10.75

OK MACHINE & TOOL CORPORATION
3455 CONNER STREET, BRONX, N.Y. 10475, U.S.A.

PHONE (212) 994-6600 • TELEX: 125091

*MINIMUM BILLING \$25.00 / ADD SHIPPING CHARGE \$2.00 / NEW YORK CITY / STATE RESIDENTS ADD APPLICABLE TAX.

CIRCLE NO. 42 ON FREE INFORMATION CARD

www.americanradiohistory.com

It's a musical instrument!

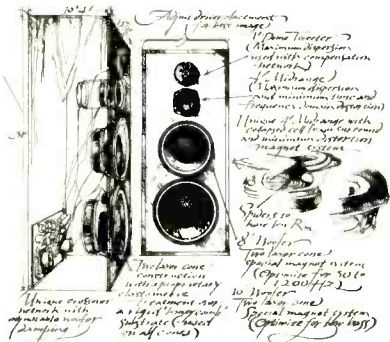

The handcrafted Speakerlab Thirties featuring the patented Nestorovic Woofer System™ are unlike any speakers you've ever heard. Find out about Speakerlab's innovative speakers, kits, and raw speakers. You can save up to 50% when you build them yourself.

Read about all the details in our free catalog. Send for yours today!

170

name _____

address _____

city _____ state _____

zip _____



TIPS continued

its destruction. However, there is a simple way to prevent overheating. Simply spray the IC with an aerosol coolant before soldering its pins. Take care in doing this—lowering an IC's temperature too much can cause cold solder joints. This technique can also be used when unsoldering and removing IC packages. —Robert Appel, Newark, NJ.

A SIMPLE SECURITY SYSTEM

The simple and inexpensive circuit shown here can be employed as a security alarm. If the normally open sense switch is closed, the buzzer or relay will be activated and the SCR will turn on. After the sense switch has reopened (or the burglar has cut the wires running to it), the buzzer will be silenced but the lamp will remain

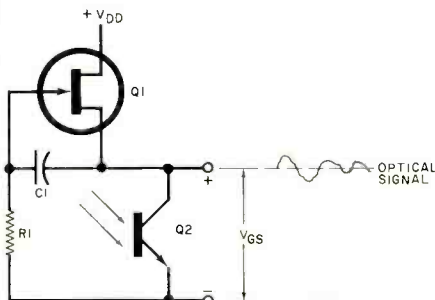

glowing. This lamp can be used to activate a central alarm or simply to indicate which entry point was being used if more than one entrance is equipped with a sense switch. Just about any components can be used, with the SCR chosen to handle the current through the lamp and resistor *R* chosen to limit gate current to an acceptable value. —Kenneth B. Blois, APO San Francisco

ETCHING BRASS

Metal name or call letter plates really dress up a radio shack. You can readily make them using the process of electro-etching, even if you have no etching experience. The brass is connected to the positive terminal of a six-volt storage battery or line-operated dc power supply. A strip of copper flashing is attached to the negative terminal. Both are hung in a glass or plastic container filled with a copper sulphate (blue vitriol) solution. The brass plate becomes etched at any point where the solution contacts it. Any portion of the metal protected by a substance resistive to the etchant will remain intact. Wax is a suitable etch resistor.

Prepare a brass blank for etching by dipping it in hot paraffin. Then, using any pointed tool, scribe the lettering you want to etch. To make the solution, stir one quart of copper sulphate crystals into a quart of water until dissolved. The solution will take on a clear blue color. Then place the metal strips in the etchant and connect them to the power supply terminals. Incidentally, the process can be employed in reverse if raised lettering is desired. Blue vitriol crystals are readily available. They are commonly used to discourage the growth of roots in sewers and drain pipes. —Harry J. Miller, Sarasota, FL.

SAVE!

MONEY • TIME • FREIGHT

- ♪ QUALITY STEREO EQUIPMENT AT LOWEST PRICES.
- ♪ YOUR REQUEST FOR QUOTATION RETURNED SAME DAY.
- ♪ FACTORY SEALED CARTONS—GUARANTEED AND INSURED.
- ♪ SAVE ON NAME BRANDS LIKE:

PIONEER	SANSUI
KENWOOD	DYNACO
SHURE	SONY
MARANTZ	KOSS

AND MORE THAN 50 OTHERS
BUY THE MODERN WAY
BY MAIL—FROM



BANK CARDS ACCEPTED

12 East Delaware
Chicago, Illinois 60611
312-664-0020

CIRCLE NO. 29 ON FREE INFORMATION CARD

GET YOURS FREE

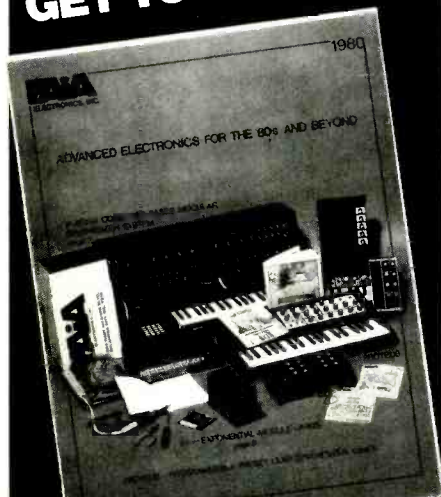

PMA'S 1980 CATALOG
NEW IDEAS IN MUSICAL
ELECTRONICS

**PLEASE RUSH MY
FREE 1980 CATALOG**

name _____

address _____

city _____ state _____ zip _____

PMA ELECTRONICS, Dept. 1- P 1020 W. Wilshire, Oklahoma City, OK 73116

CIRCLE NO. 45 ON FREE INFORMATION CARD



10% OFF

Radio Shack TRS-80
and accessories (full warranty)

All printers below interface to TRS-80

CENTRONICS

- 779-1, no tractor, list \$1245 \$ 949
- 779-2 with tractor, List \$1350 1049
- 702-2 with tractor VFU, List \$2480 1995
- 703-2 with tractor VFU, List \$2975 2395
- 730-1 parallel interface, List \$995 895

T.I. 810 for TRS 80, List \$1940 \$1735

NEC Spinwriter for TRS-80, letter-quality, 55 cps \$2475

TRS-80 DISK DRIVES

AS LOW AS \$369

f.o.b. Syracuse, New York. Prices subject to change and offers subject to withdrawal without notice. WRITE FOR FREE CATALOG

MiniMicroMart

1618 James St., Syracuse NY 13203
(315) 422-4467 TWX 710-541-0431

CIRCLE NO. 35 ON FREE INFORMATION CARD

PROJECT OF THE MONTH

Digital Stopwatch

BY FORREST M. MIMS

HERE'S a two-digit counter with a crystal-controlled timebase that you can either use as a stopwatch or modify for other timing applications. The timebase (see Fig. 1) uses an MM5369 crystal-controlled oscillator/divider. This chip generates a stable 60-Hz reference when connected to a standard 3.58-MHz color TV oscillator crystal. A miniature trimmer capacitor (C_2 , 1.5 to 20 pF or similar) permits you to tune the oscillator to precisely the right frequency. For best results, connect an accurate frequency counter to pin 7 and adjust C_2 until the counter indicates a frequency of 3.579545 MHz.

If you don't have a miniature trimmer capacitor, substitute a 5-pf capacitor for C_2 . Then twist two lengths (approximately 2" or 5.1 cm long) of wrapping wire together and solder one end of each wire to each lead of C_2 , leaving the other end of each wire unconnected. The two leads form a "gimmick" capacitor in parallel with C_2 . Now you can trim the oscillator by snipping off short sections at the free ends of the twisted wires until the desired frequency is obtained.

The 60-Hz output of the MM5369 is divided down to 10 Hz by a 4017 CMOS counter and is further divided to 1 Hz by a second 4017. These two output signals are the project's timebase.

Figure 2 is the schematic of the counter portion of the Digital Stopwatch. Depending on the position of S_3 , either 1-Hz or 10-Hz square waves are applied to the input of the 4518 CMOS dual BCD up-counter. To prepare the project for the timing of an event, place S_2 in its STOP position and toggle S_1 from CLEAR to READY. Then place S_2 in its START position at the beginning of the interval to be timed. When the event is over, place S_2 in its STOP position. The elapsed time will be frozen and displayed on the LED readout.

This circuit can be modified to take advantage of the latch built into the 4511 CMOS decoder/driver ICs. When a logic one is applied to pin 5 of these chips, the data present at their BCD inputs are stored. This permits the continuing display of the result of one timing sequence while the dual counter is timing a later event.

The basic two-digit counter shown in Fig. 2 will increment from 0.0 to 9.9 seconds in 0.1-second steps when the 10-Hz timebase is selected, and from 0 to 99 seconds in 1-second steps when the 1-Hz pulse train is routed to the counter. To in-

crease the maximum timing intervals, you can add more counter/divider/display stages. For more resolution (e.g., time measurements to the nearest one hun-

dreth of a second), design a circuit that will multiply the frequency of the 10-Hz pulse train by a factor of ten. Then use the 100-Hz output as the timebase. ◊

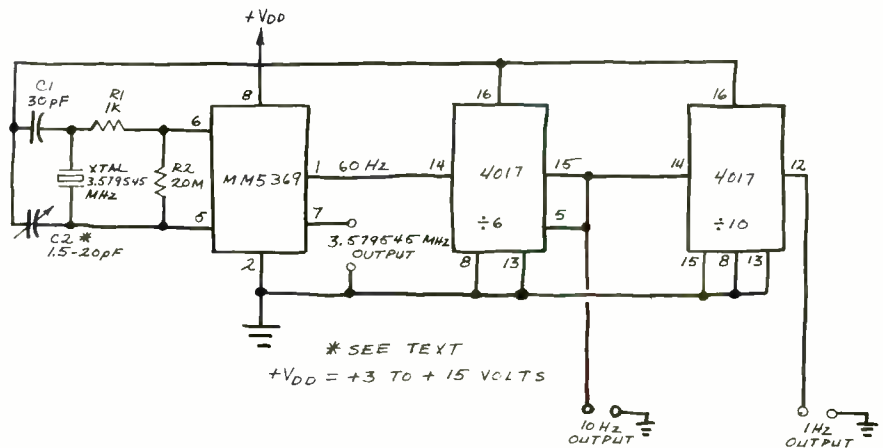

Fig. 1. Schematic of a precision crystal-controlled timebase.

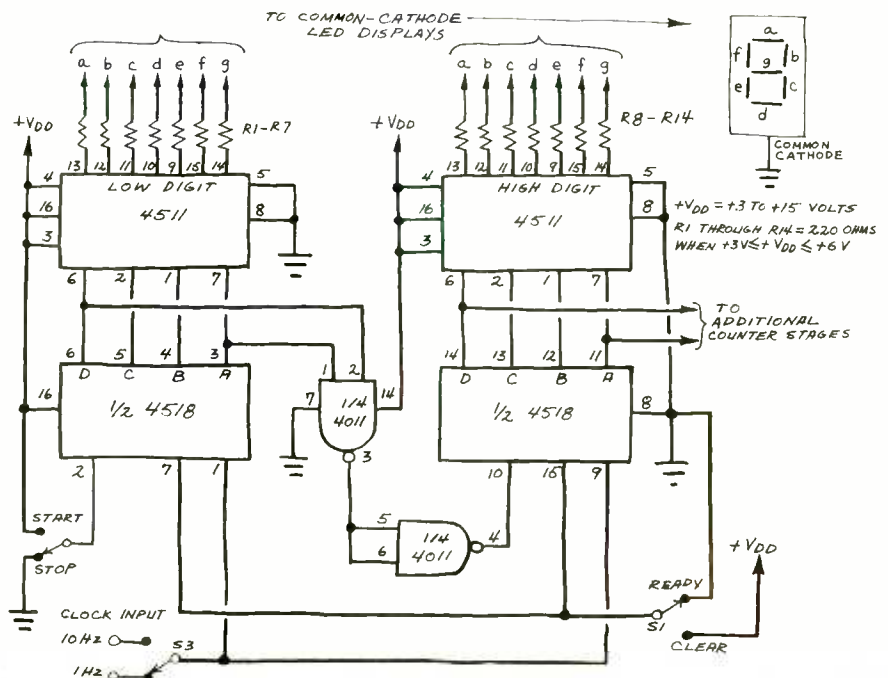

Fig. 2. Circuit for a two-digit digital counter/stopwatch.

NEW PRODUCTS!

Super Color S-100 Video Kit \$99.95
Expandable to 256 x 192 high resolution color graphics. 6847 with all display modes computer controlled. Memory mapped. 1K RAM expandable to 6K. S-100 bus 1802, 8080, 8085, Z80 etc.

Gremlin Color Video Kit \$59.95
32 x 16 alpha/numerics and graphics; up to 8 colors with 6847 chip, 1K RAM at E000. Plugs into Super Elf 44 pin bus. Not expandable to high resolution Graphics.

Quest Super Basic

Quest, the leader in inexpensive 1802 systems announces another first. Quest is the first company worldwide to ship a full size Basic for 1802 systems. A complete function Super Basic by Ron Cenko including floating point capability with scientific notation (number range $\pm 1.7E38$), 32 bit integer ± 2 billion; Multi dim arrays; String arrays; String manipulation; Cassette I/O. Save and load. Basic, Data and machine language programs; and over 75 Statements, Functions and Operators.

Easily adaptable on most 1802 systems. Requires 12K RAM minimum for Basic and user

Elf II Adapter Kit \$24.50

Plugs into Elf II providing Super Elf 44 and 50 pin bus plus S-100 bus expansion (With Super Expansion). High and low address displays. State and mode LED's optional \$18.00.

1802/16K Dynamic RAM Kit \$149.00
1802/S-100 expandable to 32K. Hidden refresh w/clocks up to 4 MHz w/no wait states Addl. 16K RAM \$79.00.

programs. Cassette version in stock now. ROM versions coming soon with exchange privilege allowing some credit for cassette version.

Super Basic on Cassette \$40.00

Tom Pittman's 1802 Tiny Basic Source listing now available. Find out how Tom Pittman wrote Tiny Basic and how to get the most out of it. Never offered before. \$19.00

S-100 4-Slot Expansion \$ 9.95

Super Monitor VI.1 Source Listing \$15.00

Coming Soon: Assembler, Editor, Disassembler, DA/AD, Super Sound/Music, EPROM programmer.

Same day shipment. First line parts only
Factory tested. Guaranteed money back
Quality IC's and other components at factory prices.

INTEGRATED CIRCUITS

7400TL	LM323K-5	5.95	CD4021	1.25
7400N	LM323K-12	1.50	CD4022	1.10
7400N	LM323K-15	1.50	CD4023	2.80
7404N	LM3201-5	1.60	CD4024	2.50
7409N	LM3207-8	1.60	CD4025	2.80
7410N	LM3207-12	1.50	CD4026	2.00
7414N	LM3201-15	1.60	CD4027	66
7420N	LM324N	1.75	CD4028	85
7422N	LM324N	1.50	CD4029	1.85
7424N	LM324N	1.50	CD4030	1.00
7426N	LM324N	1.50	CD4031	1.00
7428N	LM324N	1.50	CD4032	1.00
7429N	LM324N	1.50	CD4033	1.00
7430N	LM324N	1.50	CD4034	1.00
7432N	LM324N	1.50	CD4035	1.00
7434N	LM324N	1.50	CD4036	1.00
7436N	LM324N	1.50	CD4037	1.00
7438N	LM324N	1.50	CD4038	1.00
7440N	LM324N	1.50	CD4039	1.00
7442N	LM324N	1.50	CD4040	1.00
7444N	LM324N	1.50	CD4041	1.00
7446N	LM324N	1.50	CD4042	1.00
7448N	LM324N	1.50	CD4043	1.00
7450N	LM324N	1.50	CD4044	1.00
7452N	LM324N	1.50	CD4045	1.00
7454N	LM324N	1.50	CD4046	1.00
7456N	LM324N	1.50	CD4047	1.00
7458N	LM324N	1.50	CD4048	1.00
7460N	LM324N	1.50	CD4049	1.00
7462N	LM324N	1.50	CD4050	1.00
7464N	LM324N	1.50	CD4051	1.00
7466N	LM324N	1.50	CD4052	1.00
7468N	LM324N	1.50	CD4053	1.00
7470N	LM324N	1.50	CD4054	1.00
7472N	LM324N	1.50	CD4055	1.00
7474N	LM324N	1.50	CD4056	1.00
7476N	LM324N	1.50	CD4057	1.00
7478N	LM324N	1.50	CD4058	1.00
7480N	LM324N	1.50	CD4059	1.00
7482N	LM324N	1.50	CD4060	1.00
7484N	LM324N	1.50	CD4061	1.00
7486N	LM324N	1.50	CD4062	1.00
7488N	LM324N	1.50	CD4063	1.00
7490N	LM324N	1.50	CD4064	1.00
7492N	LM324N	1.50	CD4065	1.00
7494N	LM324N	1.50	CD4066	1.00
7496N	LM324N	1.50	CD4067	1.00
7498N	LM324N	1.50	CD4068	1.00
7500N	LM324N	1.50	CD4069	1.00
7502N	LM324N	1.50	CD4070	1.00
7504N	LM324N	1.50	CD4071	1.00
7506N	LM324N	1.50	CD4072	1.00
7508N	LM324N	1.50	CD4073	1.00
7510N	LM324N	1.50	CD4074	1.00
7512N	LM324N	1.50	CD4075	1.00
7514N	LM324N	1.50	CD4076	1.00
7516N	LM324N	1.50	CD4077	1.00
7518N	LM324N	1.50	CD4078	1.00
7520N	LM324N	1.50	CD4079	1.00
7522N	LM324N	1.50	CD4080	1.00
7524N	LM324N	1.50	CD4081	1.00
7526N	LM324N	1.50	CD4082	1.00
7528N	LM324N	1.50	CD4083	1.00
7530N	LM324N	1.50	CD4084	1.00
7532N	LM324N	1.50	CD4085	1.00
7534N	LM324N	1.50	CD4086	1.00
7536N	LM324N	1.50	CD4087	1.00
7538N	LM324N	1.50	CD4088	1.00
7540N	LM324N	1.50	CD4089	1.00
7542N	LM324N	1.50	CD4090	1.00
7544N	LM324N	1.50	CD4091	1.00
7546N	LM324N	1.50	CD4092	1.00
7548N	LM324N	1.50	CD4093	1.00
7550N	LM324N	1.50	CD4094	1.00
7552N	LM324N	1.50	CD4095	1.00
7554N	LM324N	1.50	CD4096	1.00
7556N	LM324N	1.50	CD4097	1.00
7558N	LM324N	1.50	CD4098	1.00
7560N	LM324N	1.50	CD4099	1.00
7562N	LM324N	1.50	CD4100	1.00
7564N	LM324N	1.50	CD4101	1.00
7566N	LM324N	1.50	CD4102	1.00
7568N	LM324N	1.50	CD4103	1.00
7570N	LM324N	1.50	CD4104	1.00
7572N	LM324N	1.50	CD4105	1.00
7574N	LM324N	1.50	CD4106	1.00
7576N	LM324N	1.50	CD4107	1.00
7578N	LM324N	1.50	CD4108	1.00
7580N	LM324N	1.50	CD4109	1.00
7582N	LM324N	1.50	CD4110	1.00
7584N	LM324N	1.50	CD4111	1.00
7586N	LM324N	1.50	CD4112	1.00
7588N	LM324N	1.50	CD4113	1.00
7590N	LM324N	1.50	CD4114	1.00
7592N	LM324N	1.50	CD4115	1.00
7594N	LM324N	1.50	CD4116	1.00
7596N	LM324N	1.50	CD4117	1.00
7598N	LM324N	1.50	CD4118	1.00
7600N	LM324N	1.50	CD4119	1.00
7602N	LM324N	1.50	CD4120	1.00
7604N	LM324N	1.50	CD4121	1.00
7606N	LM324N	1.50	CD4122	1.00
7608N	LM324N	1.50	CD4123	1.00
7610N	LM324N	1.50	CD4124	1.00
7612N	LM324N	1.50	CD4125	1.00
7614N	LM324N	1.50	CD4126	1.00
7616N	LM324N	1.50	CD4127	1.00
7618N	LM324N	1.50	CD4128	1.00
7620N	LM324N	1.50	CD4129	1.00
7622N	LM324N	1.50	CD4130	1.00
7624N	LM324N	1.50	CD4131	1.00
7626N	LM324N	1.50	CD4132	1.00
7628N	LM324N	1.50	CD4133	1.00
7630N	LM324N	1.50	CD4134	1.00
7632N	LM324N	1.50	CD4135	1.00
7634N	LM324N	1.50	CD4136	1.00
7636N	LM324N	1.50	CD4137	1.00
7638N	LM324N	1.50	CD4138	1.00
7640N	LM324N	1.50	CD4139	1.00
7642N	LM324N	1.50	CD4140	1.00
7644N	LM324N	1.50	CD4141	1.00
7646N	LM324N	1.50	CD4142	1.00
7648N	LM324N	1.50	CD4143	1.00
7650N	LM324N	1.50	CD4144	1.00
7652N	LM324N	1.50	CD4145	1.00
7654N	LM324N	1.50	CD4146	1.00
7656N	LM324N	1.50	CD4147	1.00
7658N	LM324N	1.50	CD4148	1.00
7660N	LM324N	1.50	CD4149	1.00
7662N	LM324N	1.50	CD4150	1.00
7664N	LM324N	1.50	CD4151	1.00
7666N	LM324N	1.50	CD4152	1.00
7668N	LM324N	1.50	CD4153	1.00
7670N	LM324N	1.50	CD4154	1.00
7672N	LM324N	1.50	CD4155	1.00
7674N	LM324N	1.50	CD4156	1.00
7676N	LM324N	1.50	CD4157	1.00
7678N	LM324N	1.50	CD4158	1.00
7680N	LM324N	1.50	CD4159	1.00
7682N	LM324N	1.50	CD4160	1.00
7684N	LM324N	1.50	CD4161	1.00
7686N	LM324N	1.50	CD4162	1.00
7688N	LM324N	1.50	CD4163	1.00
7690N	LM324N	1.50	CD4164	1.00
7692N	LM324N	1.50	CD4165	1.00
7694N	LM324N	1.50	CD4166	1.00
7696N	LM324N	1.50	CD4167	1.00
7698N	LM324N	1.50	CD4168	1.00
7700N	LM324N	1.50	CD4169	1.00
7702N	LM324N	1.50	CD4170	1.00
7704N	LM324N	1.50	CD4171	1.00
7706N	LM324N	1.50	CD4172	1.00
7708N	LM324N	1.50	CD4173	1.00
7710N	LM324N	1.50	CD4174	1.00
7712N	LM324N	1.50	CD4175	1.00
7714N	LM324N	1.50	CD4176	1.00
7716N	LM324N	1.50	CD4177	1.00
7718N	LM324N	1.50	CD4178	1.00
7720N	LM324N	1.50	CD4179	1.00
7722N	LM324N	1.50	CD4180	1.00
7724N	LM324N	1.50	CD4181	1.00
7726N	LM324N	1.50	CD4182	1.00
7728N	LM324N	1.50	CD4183	1.00
7730N	LM324N	1.50	CD4184	1.00
7732N	LM324N	1.50	CD4185	1.00
7734N	LM324N	1.50	CD4186	1.00
7736N	LM324N	1.50	CD4187	1.00
7738N	LM324N	1.50	CD4188	1.00
7740N	LM324N	1.50	CD4189	1.00
7742N	LM324N	1.50	CD4190	1.00
7744N	LM324N	1.50	CD4191	1.00
7746N	LM324N	1.50	CD4192	1.00
7748N	LM324N	1.50	CD4193	1.00
7750N	LM324N	1.50	CD4194	1.00
7752N	LM324N	1.50	CD4195	1.00
7754N	LM324N	1.50	CD4196	1.00
7756N	LM324N	1.50	CD4197	1.00
7758N	LM324N	1.50	CD4198	1.00
7760N	LM324N	1.50	CD4199	1.00
7762N	LM324N	1.50	CD4200	1.00
7764N	LM324N	1.50	CD4201	1.00
7766N	LM324N	1.50	CD4202	1.00
7768N	LM324N	1.50	CD4203	1.00
7770N	LM324N	1.50	CD4204	1.00
7772N	LM324N	1.50	CD4205	1.00
7774N	LM324N	1.50	CD4206	1.00
7776N	LM324N	1.50	CD4207	1.00
7778N	LM324N	1.50	CD4208	1.00
7780N	LM324N	1.50	CD4209	1.00
7782N	LM324N	1.50	CD4210	1.00
7784N	LM324N	1.50	CD4211	1.00
7786N	LM324N	1.50	CD4212	1.00
7788N	LM324N	1.50	CD4213	1.00
7790N	LM324N	1.50	CD4214	1.00
7792N	LM324N	1.50	CD4215	1.00
7794N	LM324N	1.50	CD4216	1.00
7796N	LM324N	1.50	CD4217	1.00
7798N	LM324N	1.50	CD4218	1.00
7800N	LM324N	1.50	CD4219	1.00
7802N	LM324N	1.50	CD4220	1.00
7804N	LM324N	1.50	CD4221	1.00
7806N	LM324N	1.50	CD4222	1.00
7808N	LM324N	1.50	CD4223	1.00
7810N	LM324N	1.50	CD4224	1.00
7812N	LM324N	1.50	CD4225	1.00
7814N	LM324N	1.50	CD4226	1.00
7816N	LM324N	1.50	CD4227	1.00
7818N	LM324N	1.50	CD4228	

SOUND EFFECTS GENERATOR BASIC KIT
Now CHANEY ELECTRONICS MAKES IT POSSIBLE TO BUILD YOUR OWN SOUND EFFECTS GENERATOR WITHOUT SPENDING A FORTUNE. WE SUPPLY YOU WITH THE 1176477 SOUND CHIP PLUS AN ETCHED AND DRILLED GLASS EPOXY PC BOARD WITH SCHEMATIC AND LAYOUT INSTRUCTIONS. THIS BOARD MAKES IT EASY TO BUILD A GENERATOR CAPABLE OF PHASER SOUNDS, LOCOMOTIVE, SIRENS, AIRPLANES, CLOCKS, ETC. DOES NOT REQUIRE DIP SWITCHES OR OTHER EXPENSIVE UNUSUAL COMPONENTS. YOU SUPPLY ONLY A FEW STANDARD RESISTORS, CAPACITORS, SWITCHES, POTS, SPEAKER, 2N2222 TRANSISTOR AND 9V BATTERY.

BASIC KIT CONTAINING:
1176477, PC BOARD AND INSTRUCTIONS ONLY. C23883 \$5.95

2N2222 TRANSISTOR FOR ABOVE C23884 .39 EACH
IF YOU HAVE ALREADY PURCHASED THE 1176477 CHIP YOU MAY BUY THE PC BOARD AND INSTRUCTIONS ONLY. C23885 \$4.00

LATCH SLAVE TRIGGER KIT
WE SUPPLY ALL THE COMPONENTS PLUS SCHEMATIC TO MAKE A SENSITIVE SLAVE TRIGGER WHICH WILL FIRE YOUR SLAVE STROBE WHEN YOU TRIGGER YOUR MASTER STROBE. C23886 \$1.50

6VDC Xenon Flasher Kit
Batteries operated design with variable duty cycle light at approx. 100 Hz. 1/2 sec. operating rate. Compatible with all parts & PC board. (See catalog) C23887 \$8.00

120 VAC Xenon Strobe Kit
Complete variable rate strobe light. Can be used in series. Board in card and instructions. C23911 \$7.50

LED Panel Mounting Kit
12 sets for \$1.00 C23707

RO170 Rectifier
Peak: 1000V @ 250mA. 5 for \$1.00 C23704 100 for \$15.00

Tube Specials
7A4, 6X4, 6X5, 6X6, 6X8, 6X9, 6X4, 6X5, 6X6, 6X8, 6X9. 2 for \$1.00

LED Flasher Kit
Simple to build kit using popular 500 series LEDs. Includes 1/2 sec. duty cycle. Includes the PC board. (9V battery is not included) C23261 \$2.49

Digital Counting Module
Made for an electronic counter. Includes 1/2 sec. duty cycle. Includes the PC board. (9V battery is not included) C23262 \$2.00

Wheel of Fortune
Includes game device and LED's. Includes 1/2 sec. duty cycle. Includes the PC board. (9V battery is not included) C23263 \$8.99

S.A.-1 Readout
Prints 1000 counts. Includes 1/2 sec. duty cycle. Includes the PC board. (9V battery is not included) C23264 \$2.00

Jumbo Red LED
Optimized for use in readout. Includes 1/2 sec. duty cycle. Includes the PC board. (9V battery is not included) C23265 \$1.00

Color Crystal
Miniature color crystal. Includes 1/2 sec. duty cycle. Includes the PC board. (9V battery is not included) C23266 \$1.00

GE Sub-C Nicon
Miniature color crystal. Includes 1/2 sec. duty cycle. Includes the PC board. (9V battery is not included) C23267 \$2.00

AA Nicads & Charger
2 for \$1.00 C23268 \$6.95

CHANEY electronics inc.
P.O. BOX 27038, DENVER, CO. 80227 (303) 781-5750
Send for our free giant catalog of unique items!!

CIRCLE NO. 13 ON FREE INFORMATION CARD

NEW! THE SOLAR ENERGY WATCH
A remarkable achievement in micro circuit computerization
Introducing one of the world's most accurate sun-powered timepieces — 6 function, back-lighted LCD digital quartz — in your choice of 24 hour ALARM or stop watch CHRONOGRAPH.
Not \$199.50 Not \$149.50 Not \$99.00
ONLY \$29.50

Now solar power comes of age with a "State-of-The-Art" engineering design breakthrough that obsolesces all other watches.
Here is handsome, high performance timekeeping at its space age finest — the result of electronically programmed integrated circuitry and micro computer technology.
AND — if you've read all the other national advertisements for solar watches — at a price we defy anyone else to match!
Check these features: Charged by silicon solar cells that gather and store energy (for months at a time) from sunlight, daylight, even a lightbulb. Rarely needs batteries; resetting • Accurate to within

1 minute a year • Clearly visible day or night • Displays hours, minutes, seconds • month, date, day • Striking contemporary design • Superb craftsmanship • Choice of 24 hour alarm or chronograph • Climatically sealed in ruggedly elegant stainless steel • Full 2 year warranty.
AND GUARANTEED TO OUTPERFORM ANY OTHER WATCH OR IT COSTS YOU NOTHING!

SOLAR CHRON 111 PRESIDENTIAL BLVD. BALA-CYNWYD, PA 19004
Jambit Corp. Division

Yes please send me _____ SOLAR ALARM _____ SOLAR CHRONOGRAPH
@ \$39.50 each, plus \$2.50 insured shipping and handling. Pa. Residents please add 6%
Check or money order enclosed for \$ _____
Charge to my _____ VISA _____ MASTER CHARGE _____ Expiration Date _____

ACCOUNT # _____
SIGNATURE _____
NAME _____
ADDRESS _____
CITY _____ STATE _____ ZIP _____

CREDIT CARD BUYERS USE OUR TOLL FREE NUMBER 800-257-7850
Ask for Operator No. 55
In New Jersey, call 1-800-322-8650

Solar Chron Industries
(division of Jambit Corp.)
111 Presidential Blvd. Bala-Cynwyd, PA 19004
Call our toll free number for quickest service or send your check, m.o. or credit card information to us. Be sure to specify ALARM or CHRONOGRAPH (STOP WATCH). We accept VISA, Master Charge. Add \$2.50 for insured shipping and handling. Pa. residents please add 6% sales tax. © SOLAR CHRON INDUSTRIES 1979

CIRCLE NO. 61 ON FREE INFORMATION CARD

The world of electronics gee-wizardry

Test Equipment • Burglar/Fire Alarms • Hobbyist & Automotive Electronics

EICO CATALOG
The Newest and Best Values in Electronic and Factory Assembled Tools

-YOURS FREE.

32-pages of test instruments — from the latest digital multimeters to the famous EICO scopes. Security systems. Automotive and hobbyist products. Kits and assembled. EICO quality. EICO value. For FREE catalog, check reader service card or send 50¢ for first class mail.

EICO 108 New South Road Hicksville, N.Y. 11801

CIRCLE NO. 22 ON FREE INFORMATION CARD

MICROWORLD™
BRINGING INFORMATION TECHNOLOGY TO YOUR DOORSTEP

✓ Quality Microcomputer Products
✓ Good Delivery
✓ Prices You Can Afford

\$1349 Double density HORIZON I KIT (reg. \$1599)

Heath Data Systems Printer ... \$ 895
IP-125 Printer by Integral Data ... \$ 749
TI-810 Impact Printer ... \$1695
Soroc IQ 120 Video Terminal ... \$ 795
Hazeltine 1500 Video Terminal ... \$ 995
Mime Terminal ... \$ 742
Novation CAT Modem ... \$ 199
Hitachi 9" Monitor ... \$ 184

place your order TOLL FREE
1-800-528-1418

MICROWORLD™
1425 W. 12th Place Tempe, AZ 85281 602-894-1193

CIRCLE NO. 34 ON FREE INFORMATION CARD

FREE IC or FET's WITH \$5 & \$10 ORDERS! DATA SHEETS WITH MANY ITEMS.

DIODES & RECTIFIERS	TRANSISTORS	TRANSISTORS	TRANSISTORS	LINEAR IC's
1N456 10	2N2196 20 24	2N4121 3/51	2N5639 2/51	LM3400 5 1/20
1N456 10 6/51	2N718 24	2N4212 3/51	2N5640 2/51	LM3401 5 1/20
1N456 10 6/51	2N720 48	2N4241 5/51	CP643 5/51	LM3402 6 1/20
1N456 10 6/51	2N722 48	2N4248 5/51	CP650 5/51	LM3403 12 1/20
1N456 10 6/51	2N723 48	2N4251 5/51	CP651 5/51	LM3404 15 1/20
1N456 10 6/51	2N724 48	2N4252 5/51	E100 4/51	LM3404 24 1/20
1N456 10 6/51	2N725 48	2N4253 5/51	E101 3/51	LM3406 5E
1N456 10 6/51	2N726 48	2N4254 5/51	SE102 3/51	LM3407 2.50
1N456 10 6/51	2N727 48	2N4255 5/51	E115 3/51	LM3408 2E
1N456 10 6/51	2N728 48	2N4256 5/51	MPF102 2/51	NE555V 2/51
1N456 10 6/51	2N729 48	2N4257 5/51	MPF104 3/51	NE556A 50 9E
1N456 10 6/51	2N730 48	2N4258 5/51	MPF112 4/51	LM7400CH 2E
1N456 10 6/51	2N731 48	2N4259 5/51	S080 MP5515 2/51	LM7400CN 2E
1N456 10 6/51	2N732 48	2N4260 5/51	SE1001 4/51	LM7234 2/51
1N456 10 6/51	2N733 48	2N4261 5/51	SE1002 4/51	LM7236 3/51
1N456 10 6/51	2N734 48	2N4262 5/51	SE1003 4/51	LM739N 1/0E
1N456 10 6/51	2N735 48	2N4263 5/51	SE1004 4/51	LM741C 3/51
1N456 10 6/51	2N736 48	2N4264 5/51	SE1005 4/51	LM741CN 4/51
1N456 10 6/51	2N737 48	2N4265 5/51	SE1006 4/51	LM741CN 3/51
1N456 10 6/51	2N738 48	2N4266 5/51	SE1007 4/51	LM741CN 3/51
1N456 10 6/51	2N739 48	2N4267 5/51	SE1008 4/51	LM741CN 3/51
1N456 10 6/51	2N740 48	2N4268 5/51	SE1009 4/51	LM741CN 3/51
1N456 10 6/51	2N741 48	2N4269 5/51	SE1010 4/51	LM741CN 3/51
1N456 10 6/51	2N742 48	2N4270 5/51	SE1011 4/51	LM741CN 3/51
1N456 10 6/51	2N743 48	2N4271 5/51	SE1012 4/51	LM741CN 3/51
1N456 10 6/51	2N744 48	2N4272 5/51	SE1013 4/51	LM741CN 3/51
1N456 10 6/51	2N745 48	2N4273 5/51	SE1014 4/51	LM741CN 3/51
1N456 10 6/51	2N746 48	2N4274 5/51	SE1015 4/51	LM741CN 3/51
1N456 10 6/51	2N747 48	2N4275 5/51	SE1016 4/51	LM741CN 3/51
1N456 10 6/51	2N748 48	2N4276 5/51	SE1017 4/51	LM741CN 3/51
1N456 10 6/51	2N749 48	2N4277 5/51	SE1018 4/51	LM741CN 3/51
1N456 10 6/51	2N750 48	2N4278 5/51	SE1019 4/51	LM741CN 3/51
1N456 10 6/51	2N751 48	2N4279 5/51	SE1020 4/51	LM741CN 3/51
1N456 10 6/51	2N752 48	2N4280 5/51	SE1021 4/51	LM741CN 3/51
1N456 10 6/51	2N753 48	2N4281 5/51	SE1022 4/51	LM741CN 3/51
1N456 10 6/51	2N754 48	2N4282 5/51	SE1023 4/51	LM741CN 3/51
1N456 10 6/51	2N755 48	2N4283 5/51	SE1024 4/51	LM741CN 3/51
1N456 10 6/51	2N756 48	2N4284 5/51	SE1025 4/51	LM741CN 3/51
1N456 10 6/51	2N757 48	2N4285 5/51	SE1026 4/51	LM741CN 3/51
1N456 10 6/51	2N758 48	2N4286 5/51	SE1027 4/51	LM741CN 3/51
1N456 10 6/51	2N759 48	2N4287 5/51	SE1028 4/51	LM741CN 3/51
1N456 10 6/51	2N760 48	2N4288 5/51	SE1029 4/51	LM741CN 3/51
1N456 10 6/51	2N761 48	2N4289 5/51	SE1030 4/51	LM741CN 3/51
1N456 10 6/51	2N762 48	2N4290 5/51	SE1031 4/51	LM741CN 3/51
1N456 10 6/51	2N763 48	2N4291 5/51	SE1032 4/51	LM741CN 3/51
1N456 10 6/51	2N764 48	2N4292 5/51	SE1033 4/51	LM741CN 3/51
1N456 10 6/51	2N765 48	2N4293 5/51	SE1034 4/51	LM741CN 3/51
1N456 10 6/51	2N766 48	2N4294 5/51	SE1035 4/51	LM741CN 3/51
1N456 10 6/51	2N767 48	2N4295 5/51	SE1036 4/51	LM741CN 3/51
1N456 10 6/51	2N768 48	2N4296 5/51	SE1037 4/51	LM741CN 3/51
1N456 10 6/51	2N769 48	2N4297 5/51	SE1038 4/51	LM741CN 3/51
1N456 10 6/51	2N770 48	2N4298 5/51	SE1039 4/51	LM741CN 3/51
1N456 10 6/51	2N771 48	2N4299 5/51	SE1040 4/51	LM741CN 3/51
1N456 10 6/51	2N772 48	2N4300 5/51	SE1041 4/51	LM741CN 3/51
1N456 10 6/51	2N773 48	2N4301 5/51	SE1042 4/51	LM741CN 3/51
1N456 10 6/51	2N774 48	2N4302 5/51	SE1043 4/51	LM741CN 3/51
1N456 10 6/51	2N775 48	2N4303 5/51	SE1044 4/51	LM741CN 3/51
1N456 10 6/51	2N776 48	2N4304 5/51	SE1045 4/51	LM741CN 3/51
1N456 10 6/51	2N777 48	2N4305 5/51	SE1046 4/51	LM741CN 3/51
1N456 10 6/51	2N778 48	2N4306 5/51	SE1047 4/51	LM741CN 3/51
1N456 10 6/51	2N779 48	2N4307 5/51	SE1048 4/51	LM741CN 3/51
1N456 10 6/51	2N780 48	2N4308 5/51	SE1049 4/51	LM741CN 3/51
1N456 10 6/51	2N781 48	2N4309 5/51	SE1050 4/51	LM741CN 3/51
1N456 10 6/51	2N782 48	2N4310 5/51	SE1051 4/51	LM741CN 3/51
1N456 10 6/51	2N783 48	2N4311 5/51	SE1052 4/51	LM741CN 3/51
1N456 10 6/51	2N784 48	2N4312 5/51	SE1053 4/51	LM741CN 3/51
1N456 10 6/51	2N785 48	2N4313 5/51	SE1054 4/51	LM741CN 3/51
1N456 10 6/51	2N786 48	2N4314 5/51	SE1055 4/51	LM741CN 3/51
1N456 10 6/51	2N787 48	2N4315 5/51	SE1056 4/51	LM741CN 3/51
1N456 10 6/51	2N788 48	2N4316 5/51	SE1057 4/51	LM741CN 3/51
1N456 10 6/51	2N789 48	2N4317 5/51	SE1058 4/51	LM741CN 3/51
1N456 10 6/51	2N790 48	2N4318 5/51	SE1059 4/51	LM741CN 3/51
1N456 10 6/51	2N791 48	2N4319 5/51	SE1060 4/51	LM741CN 3/51
1N456 10 6/51	2N792 48	2N4320 5/51	SE1061 4/51	LM741CN 3/51
1N456 10 6/51	2N793 48	2N4321 5/51	SE1062 4/51	LM741CN 3/51
1N456 10 6/51	2N794 48	2N4322 5/51	SE1063 4/51	LM741CN 3/51
1N456 10 6/51	2N795 48	2N4323 5/51	SE1064 4/51	LM741CN 3/51
1N456 10 6/51	2N796 48	2N4324 5/51	SE1065 4/51	LM741CN 3/51
1N456 10 6/51	2N797 48	2N4325 5/51	SE1066 4/51	LM741CN 3/51
1N456 10 6/51	2N798 48	2N4326 5/51	SE1067 4/51	LM741CN 3/51
1N456 10 6/51	2N799 48	2N4327 5/51	SE1068 4/51	LM741CN 3/51
1N456 10 6/51	2N800 48	2N4328 5/51	SE1069 4/51	LM741CN 3/51
1N456 10 6/51	2N801 48	2N4329 5/51	SE1070 4/51	LM741CN 3/51
1N456 10 6/51	2N802 48	2N4330 5/51	SE1071 4/51	LM741CN 3/51
1N456 10 6/51	2N803 48	2N4331 5/51	SE1072 4/51	LM741CN 3/51
1N456 10 6/51	2N804 48	2N4332 5/51	SE1073 4/51	LM741CN 3/51
1N456 10 6/51	2N805 48	2N4333 5/51	SE1074 4/51	LM741CN 3/51
1N456 10 6/51	2N806 48	2N4334 5/51	SE1075 4/51	LM741CN 3/51
1N456 10 6/51	2N807 48	2N4335 5/51	SE1076 4/51	LM741CN 3/51
1N456 10 6/51	2N808 48	2N4336 5/51	SE1077 4/51	LM741CN 3/51
1N456 10 6/51	2N809 48	2N4337 5/51	SE1078 4/51	LM741CN 3/51
1N456 10 6/51	2N810 48	2N4338 5/51	SE1079 4/51	LM741CN 3/51
1N456 10 6/51	2N811 48	2N4339 5/51	SE1080 4/51	LM741CN 3/51
1N456 10 6/51	2N812 48	2N4340 5/51	SE1081 4/51	LM741CN 3/51
1N456 10 6/51	2N813 48	2N4341 5/51	SE1082 4/51	LM741CN 3/51
1N456 10 6/51	2N814 48	2N4342 5/51	SE1083 4/51	LM741CN 3/51
1N456 10 6/51	2N815 48	2N4343 5/51	SE1084 4/51	LM741CN 3/51
1N456 10 6/51	2N816 48	2N4344 5/51	SE1085 4/51	LM741CN 3/51
1N456 10 6/51	2N817 48	2N4345 5/51	SE1086 4/51	LM741CN 3/51
1N456 10 6/51	2N818 48	2N4346 5/51	SE1087 4/51	LM741CN 3/51
1N456 10 6/51	2N819 48	2N4347 5/51	SE1088 4/51	LM741CN 3/51
1N456 10 6/51	2N820 48	2N4348 5/51	SE1089 4/51	LM741CN 3/51
1N456 10 6/51	2N821 48	2N4349 5/51	SE1090 4/51	LM741CN 3/51
1N456 10 6/51	2N822 48	2N4350 5/51	SE1091 4/51	LM741CN 3/51
1N456 10 6/51	2N823 48	2N4351 5/51	SE1092 4/51	LM741CN 3/51
1N456 10 6/51	2N824 48	2N4352 5/51	SE1093 4/51	LM741CN 3/51
1N456 10 6/51	2N825 48	2N4353 5/51	SE1094 4/51	LM741CN 3/51
1N456 10 6/51	2N826 48	2N4354 5/51	SE1095 4/51	LM

GIANT 1¢ SALE



A PENNY MORE GETS YOU TWO



40-TWO WATT RESISTORS, carbo-films, carbons, some 5%ers, (#456)	1.29	80 for 1.30
50-TERMINAL STRIPS, ass'd solder and screw types, 2 lugs & up, (#334)	1.29	100 for 1.30
1-WATCH CUTS, LED, who knows how good, micro-digital bonanza, (#5115)	1.29	2 for 1.30
10-1000V 1A RECTIFIERS, 1N4007, epoxy case, axial leads, (#5926)	1.29	20 for 1.30
6-25 WATT PLASTIC POWER, 2N6100 series, TO-220, 200bvcbo, 3A, (#1786)	1.29	12 for 1.30
4-CALCULATOR AC JACKS, 3 terminals, takes mini plug, (#2316)	1.29	8 for 1.30
65-PRE-FORMED WATERS, popular values, for PC appl., (#2444)	1.29	130 for 1.30
200-PC BOARD PARTS: boards loaded w/100% parts, hobby bonanza, (#5946)	1.29	400 for 1.30
40-LOW NOISE RESISTORS, 1/8 & 1/2 W, oxide & magnetic film, (#220)	1.29	80 for 1.30
40PC-SEMI-CON SURPRISE, ass't. zeners, diodes, etc. untested, (#2226)	1.29	80 for 1.30
20-TRANSISTOR ELECTROLYTICS, ass't. voltages from 5-100 mid, (#453)	1.29	40 for 1.30
1-LASCR OPTO COUPLER, type H11C3, mini dip, (#5700)	1.29	2 for 1.30
10-UPRIGHT ELECTROS, 100% ass'd values and voltages, (#5900)	1.29	20 for 1.30
2-GE 3W AUDIO AMP, type PA-263 IC chip, mono, (#1522)	1.29	4 for 1.30
1-MERCURY TILT SWITCH, N.C. rated 24VDC @ .05A, w/leads, (#5686)	1.29	2 for 1.30
50-CAP SPECIAL, ass't. values in mylar, mica, ceramic, disc, etc. (#3775)	1.29	100 for 1.30
40-FEEDBACK CAPACITORS, used for hams, UHF circuitry, (#5688)	1.29	80 for 1.30
40-PLASTIC TRANSISTORS, ass'd untested and hobby, (#2604A)	1.29	80 for 1.30
6-12V INDICATORS, w/leads, test lamp manufacturers excess, (#5893)	1.29	12 for 1.30
4-12 VOLT LAMPS, w/leads, popular voltage, 100% of uses, (#5942)	1.29	8 for 1.30
1-12 VDC SOLENOID, similar to Guardian 16-P, w/plunger, 1/4" stroke, (#6013)	1.29	2 for 1.30
1-TV/AUDIO SHIELDED CABLE, 2 cond. 15 ft. w/RCA phone plugs, (#5812)	1.29	2 for 1.30
10-POWER TAB TRANSISTORS, NPN, plastic, TO-220, (#5629)	1.29	20 for 1.30
6-PRECISION TRIM POTs, ass'd singles and multi-turns, untested, (#3389)	1.29	12 for 1.30
20-1N4148, 4 NANO, SWITCHING DIODE, axial leads, 10mA, 100%, (#3000)	1.29	40 for 1.30
2-5.1V 5UD ZENERS, 10W, DO-35, 5%, untested, (#5287)	1.29	4 for 1.30
4-PUSHBUTTON ALARM SWITCH, 125 VAC 1A SPST, NC, (#5289)	1.29	8 for 1.30
6-CABLE & PLUG SET, 2 cond. 3.5mm mini plug w/6 polarized cable, (#5737)	1.29	12 for 1.30
50-MOLEX PINS, for connectors w/5mm holes, 11/16", crimp-on, (#5836)	1.29	100 for 1.30
5-"SUPER" 2N2222, NPN, ICBO:60V, hfe:100 1W @ 2A, TO-92, 100%, (#5952)	1.29	10 for 1.30
10-RESISTOR NETWORKS, assorted values in dips and singles, (#5699)	1.29	20 for 1.30
4-VARIABLE DIODES, var. tuner capacitance, 20-50 pf, (#5887)	1.29	8 for 1.30
50-PRECISION RESISTORS, 1/4, 1 & 2 watts, 1%, assorted types, (#363)	1.29	100 for 1.30
60-CERAMIC CAPS, ass't. values, NPO's, etc. (#5901)	1.29	100 for 1.30
30-MOLEX CONNECTORS, nylon, ass'd styles, colors, & of cond. (#5835)	1.29	60 for 1.30
10-IF-FM OP AMPS, by RCA, FM-UHF circuitry, TO-5, 10 leads, (#5951)	1.29	20 for 1.30
4-ROCKER SWITCHES, DPDT, solder electric terminals, (#3302)	1.29	8 for 1.30
1-RELAY, BABCOCK 6VDC, SPST, plastic case (#5807)	1.29	2 for 1.30
1-25 AMP BRIDGE RECTIFIER, 50 volts, 100% (#5948)	1.29	2 for 1.30
50-1N4000 RECTIFIERS, 100V, DO-35, 5%, untested, (#2594)	1.29	100 for 1.30
30PC-HEAT SHRINK, Thermo-fit, useful ass't. of sizes, shrink 50% (#5248)	1.29	60 for 1.30
10-SLIDE SWITCHES, SPST, SPDT, etc. all shapes and sizes, (#5927)	1.29	20 for 1.30
25-DTL's, 100% prime, ass'd flip flops, etc. marked, (#3709)	1.29	50 for 1.30
10-MAN-3's, 7 segment, w/bubble magnifier, 100% material, (#3842)	1.29	20 for 1.30
4-PL-259 COAX PLUG, mates to 50-239, Amphenol, (#5221)	1.29	8 for 1.30
1-LITE SENSITIVE UNIJUNCTION TRANSISTOR, programmable, (#5719)	1.29	2 for 1.30
100-PRE-FORMED 1/2 WATERS, popular values, some 5 & 10 %ers, (#1060)	1.29	200 for 1.30
4-PHOTODIODES, DAVID ELECTRONICS TRANSISTORS, (#3276)	1.29	8 for 1.30
40-POWER RESISTORS, assorted types, includes 2 to 10 watters, (#228)	1.29	80 for 1.30
15-NE-2 LAMPS, neon red, for 110VAC, less resistor, (#1435)	1.29	30 for 1.30
30-"CRIMP-ON" TERMINALS, rings and spades, for # 12-20 wire, (#3955)	1.29	60 for 1.30
50-ONE-WATT RESISTORS, popular assort, some 5%ers, 100% of uses, (#3844)	1.29	100 for 1.30
30-FT. WIRE-WRAP WIRE, 30 gauge, insulated, continuous length, (#3803)	1.29	60 for 1.30
6-SPDT MICRO SLIDE SWITCH, only 3/77" cube, for PC mount, (#3429)	1.29	12 for 1.30
10-PR-RCA PLUGS & JACKS, for audio, speakers, etc. (#402)	1.29	20 for 1.30
5-2N3055 HOBBY TRANSISTORS, TO-3, (#3771)	1.29	10 for 1.30
6-SINGLE PIN MICRO GREEN LEDS, 3V, 10 mils, "pin heads", 100%, (#6126)	1.29	12 for 1.30
6-JUMBO RED LEDS, 1.5-3 V @ 10 mA, 100% material, 100% of uses, (#2135)	1.29	12 for 1.30
6-MAGNETIC DISCS, shatter-resistant Plastalloy, 13/16" dia, (#6099)	1.29	12 for 1.30
5-PHOTO CELLS, Vactec 900, disc type, R: 2K ohm (dark) w/leads, (#6135)	1.29	10 for 1.30
1-12VDC SPDT RELAY, 180 ohm coil, 25 mA, 1x1x1 1/2" sealed (#5937)	1.29	2 for 1.30
10-VOLUME CONTROLS, ass't. values, audio, and switch too! (#592)	1.29	20 for 1.30
60-PREFORMED DISC CAPS, handy assortment of values, marked, (#1811)	1.29	120 for 1.30
10-AXIAL ELECTROS, ass't. values and capacitance, (#5910)	1.29	20 for 1.30
2-DOUBLE-SIDED PC BOARDS, 3"x12", high quality G-10 glass, (#5694)	1.29	4 for 1.30
60-TUBULAR CAPACITORS, ass'd 100mfd to 1mf to 600 WVDC, (#35A219)	1.29	120 for 1.30
6-MICRO MINI REED SWITCHES, 1" long, for alarms, relays, etc., (#1258)	1.29	12 for 1.30
10-TANTALUM ELECTROS, ass'd mini, axial, hermetically sealed, (#5848)	1.29	20 for 1.30
50-DISC TYPE CAPS, incl: NPO, hi-Q, mylar, ceramics, ass'd values, (#437)	1.29	100 for 1.30
60-COILS & CHOKES, ass'd RF, OSC, IF, parasitic types, (#35A297)	1.29	120 for 1.30
6-SWITCHCRAFT PHONO JACKS, hi-Q, chassis mount, teflon base, (#5119)	1.29	12 for 1.30
30-SUBMINI IF TRANSFORMERS, slug tuned, shielded, (#3549)	1.29	60 for 1.30
40-ADJUSTABLE WHITE CORES, center cut for best adjust, (#5701)	1.29	80 for 1.30
10-PC TRIMPOTS, screwdriver adjust, assorted values, (#3346)	1.29	20 for 1.30
25-4" CABLE TIES, plastic, like Ty-wrap style, (#5217)	1.29	50 for 1.30
5-CRYSTALS, may include: CB, ham various shapes and sizes, (#5716)	1.29	10 for 1.30
3-MICRO SWITCHES, SPST, NO contact, plunger style, solder tabs, (#5785)	1.29	6 for 1.30
65-MOLEX SOCKETS, "on-a-strip", for 8-40 pin ICs (#1609)	1.29	130 for 1.30
6-PAIRS 9V BATTERY CLIPS, w/red & black color-coded leads, (#2852)	1.29	12 for 1.30
6-1M340T VOLTAGE REGULATORS, 5 to 24 volts, TO-220, (#5897)	1.29	12 for 1.30
40-POLY-ETHYLENE CAPACITORS, ass'd values and voltages, (#1052)	1.29	80 for 1.30
15-THERMISTORS, resistor that change with the temperature, (#2048)	1.29	20 for 1.30
65-1/4 WATT RESISTORS, ass'd values, metal film, marked, (#5797)	1.29	130 for 1.30
10-MODULAR SWITCHES, Centralab "push-on" type, up to 4PDT, (#3150)	1.29	20 for 1.30
5-"MOTORS MOTORS", small, high speed, ass'd sizes, 3-6VDC, (#2551)	1.29	10 for 1.30
50-MICAS ass't. sizes-n-shapes, incl. "silvers" too! (#373)	1.29	100 for 1.30
10-TRANSISTOR SOCKETS, for npn and pnp types, (#5944)	1.29	20 for 1.30
4-HOBBY VOLTAGE REGULATORS, LM-309, 320, 340's, TO-3, (#3330A)	1.29	8 for 1.30
12-PANEL SWITCHES, assorted slides, rotary, modulars, etc. (#295)	1.29	24 for 1.30
60-RESISTOR SPECIAL, 1/4 to 1 watt, carbons, carbo-films, etc. (#35896)	1.29	120 for 1.30
65-HALF WATT RESISTORS, ass'd, carbons, carbo-films, various values, (#454)	1.29	130 for 1.30
10-MV-54 MICRO-MINI LEDS, flat top style, diffused red lens, (#1789)	1.29	20 for 1.30
15-HUMBucker CONTROLS, assorted values, manufacturers dump, (#3807)	1.29	30 for 1.30
1-POWER TAB TRIAC, 100% prime, 400 V 10 A TO-220, (#6216)	1.29	2 for 1.30

Operation Assist

If you need information on outdated or rare equipment—a schematic, parts list, etc.—another reader might be able to assist. Simply send a postcard to Operation Assist! POPULAR ELECTRONICS, 1 Park Ave. New York, NY 10016. For those who can help readers, please respond directly to them. They'll appreciate it. (Only those items regarding equipment not available from normal sources are published.)

Music & Sound Inc., model DMS6-FM A, AM, FM intercom. Need schematic or description of 6+ drop resistor. Paul Wojcik, 207 N. 18th St., Barrington, IL 60010.

Fisher model 203 and 180 AM/FM receiver. Jackson model 648-S tube transistor tester. Need manual, schematic and recent charts. Avery Comarow, 524-B Springvale Rd., Great Falls, VA 22066.

Hallcrafters model S-38A receiver. Need schematic and service manual. Robert P. Meagley, 5909 Jefferson Blvd., Frederick, MD 21701.

Pearce-Simpson model 550 AM marine transceiver. Need schematics, operation manual, and crystal information. Charles C. Boehnke, Box 223, Los Gatos, CA 95030.

Raytheon model 402-2M10 P N 348086 data terminal. Need operation manual, and schematics. J. Nowinsky, 3167B Congress Hill AFB, UT 84056.

Tektronix type 531 oscilloscope. Need service and operations manual. Henry Schanding, W3RRF, 1250 Saunders Dr., Elizabeth City, NC 27909.

Wurlitzer model 518 amplifier. Need schematic. Russell Campbell, Box 141, Thessalon, Ontario, Can.

Acoustiflex model 200 stereo AM/FM receiver. Need schematic. Wayne Hill, 7704 E. Michigan Ave., Jackson, MI 49201.

Bell & Howell model 2423 stereo tape recorder. Service manual and schematic needed. Daniel Kluth, 805 N. Chatsworth, St. Paul, MN 55104.

Sylvania type 216 signal generator. Schematic and operating instructions needed. D.C. James, 15037 E. LaDonna Hacienda Hts., CA 91745.

Hickok model 6000A tube tester. Need schematics, operating manual and tube chart. Elan model 2 ignition scope. Need schematic and operating instructions. Guy Edwards, 104 Hancock, San Francisco, CA 94114.

Zenith model 5M-191 radio. Need schematic and parts list. Raymond Friend, 236 W. Pearl St., Butler, PA.

Precision Manufacturing Co., model 78 VTVM. Need schematic and operating manual. Steve Lind, Box 1171, Athens, OH 45701.

Hallcrafters radio model SX62 and Stromberg Carlson Co., Ltd., model 5788 triggered time base oscilloscope. Need any information available. John Greeland, Box 138, Helli-grews, Nfld. AOA 2T0.

Jackson model 634 dynamic tube tester. Need chart listings, schematic and instruction manual. Donald Godward, 415 W. Dickerson, Bozeman, MT 59715.

Knight model KG 790 AM/FM stereo tuner and Zenith model 6-G-60 IM AM radio. Need maintenance, service instructions and schematics. C. T. Huth, 146 Schonhardt St., Tiffin, OH 44883.

Silvertone model 1434, chassis # 185 10501 and model 1484, chassis 185 11040 musical amplifiers. Need schematics, operating manuals and any other information. Carl J. McCormick, 6723 Old Mooringsport Rd., Shreveport, LA 71107.

Magnavox model MX 1620 4 channel receiver. Need schematic and parts list. Michael J. Murphy, 3245 Braeburn Circle, Ann Arbor, MI 48104.

Tektronix model 909 scientific desk calculator and model 926 cartridge programmer. Need schematics and operator's manual. Kurt Inman, 350 Nelson Rd., Scotts Valley, CA 95066.

Solar model CF capacitor analyzer. Need schematic and instruction manual. E. J. Homa, 2936 5th St., Muskegon Hts., MI 49444.

Varo model R-748 TRC-47 receiver. Need schematic and service manual. S. Korb, 807 N. 8th St., Burlington, IA 52601.

RCA model 151 cathode ray oscilloscope. Need schematic and operating manual. R. E. Fields, R2, Box 5, Rush, CO 80833.

Superior Instruments Co., model 777 VTVM. Need instruction manual, schematic, calibration and service information. Jacob Landy, 11 Gardenia Lane, Hicksville, NY 11801.

Motorola model FMRU16V(A) FM receiver. Need schematics, parts list, technical service manuals and operation manuals. Charles J. Rainey, 9590 N. Range Line Rd., River Hills, WI 53217.

Century model CT-1 in-circuit condenser tester and Lafayette LSG-10 signal generator. Need owners manual and schematics. Jack Wise, 1229 Rapids Road, New Braunfels, TX 78130.

RCA Victor model T62 radio. Need schematic, service manual or any information available. David Weisenthal, 29 Northview Ave., Montclair, NJ 07043.

"TIE-PIN" CONDENSER MIKE 2 for \$3.99

3/8" dia. x 1/2" Metal enclosed, unit omnidirectional. Frequency response 20-20,000 Hz. Less tie pin or lapel clip. 600 ohm impedance. Price: \$5.99. Cat. No. 5730

ULTRASONIC TRANSDUCER 2 for \$3.99

92CUS375

HY-GAIN ONE ARM BANDIT MIKES

Only \$14.99 2 FOR \$15

Take one hand command of your mobile or base rig with Hy-Gain's One Arm Bandit Mike. ON/OFF VOLUME, SQUELCH, CHANNEL SELECTOR, SPEAKER, and DIGITAL DISPLAY are all conveniently located where your fingers are. Comes with 6 ft. multi-conductor, color coded, coiled cable, (separate) for easy integration into any type of rig. Size: 4 1/2" x 2 1/2" x 1 1/2". Wt. 9 oz. No. 92CUS886

SEND FOR FREE CATALOG

POLY PAKS®

P.O. BOX 942-E1
SO. LYNNFIELD, MA 01940

HOW TO ORDER
We honor MASTERCARD, VISA, check, and COD. (25% down). Order by phone or mail. Minimum order \$8. Please state Cat. No. & description, name & month of magazine. Canadian: add \$5. Foreign: add \$15. US funds. Excess will be returned. TERMS: add postage. RATED: Net-30. Phone: (617) 245-3828

DIGI-KEY CORPORATION

Quality Electronic Components

800-847-6344

MINN. AK., HI. RESIDENTS

218-681-6674



DON'T FORGET OUR DISCOUNTS WHEN COMPARING PRICES

I.C.'S • RESISTORS • TRANSISTORS • CAPACITORS • DIODES • I.C. SOCKETS & PINS • SWITCHES • CLOCK MODULES • OPTOELECTRONICS • BREADBOARDING & TESTING DEVICES • DRAFTING SUPPLIES • DATA BOOKS • HEAT SINKS • WIRE • TOOLS ... AND MORE ... WRITE FOR FREE CATALOG ...

TIME-TEMPERATURE PROGRAMMABLE MODULE USER PROGRAMMABLE FOR:

- 12 or 24 Hour Drives
- 70 and 90 °C, as well as virtually any number of temperature ranges
- Format of flashing clock on front
- 50 LED's for frequency or alarm

MA1021 by Motorola



- 12 or 24 Hour Drives
- 70 and 90 °C, as well as virtually any number of temperature ranges
- Format of flashing clock on front
- 50 LED's for frequency or alarm

MA1021 by Motorola

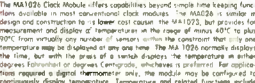

- 12 or 24 Hour Drives
- 70 and 90 °C, as well as virtually any number of temperature ranges
- Format of flashing clock on front
- 50 LED's for frequency or alarm

MA1021 by Motorola

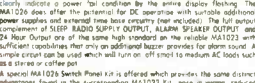

- 12 or 24 Hour Drives
- 70 and 90 °C, as well as virtually any number of temperature ranges
- Format of flashing clock on front
- 50 LED's for frequency or alarm

MA1021 by Motorola



- 12 or 24 Hour Drives
- 70 and 90 °C, as well as virtually any number of temperature ranges
- Format of flashing clock on front
- 50 LED's for frequency or alarm

MA1021 by Motorola

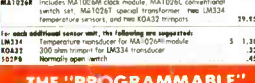

- 12 or 24 Hour Drives
- 70 and 90 °C, as well as virtually any number of temperature ranges
- Format of flashing clock on front
- 50 LED's for frequency or alarm

MA1021 by Motorola



- 12 or 24 Hour Drives
- 70 and 90 °C, as well as virtually any number of temperature ranges
- Format of flashing clock on front
- 50 LED's for frequency or alarm

MA1021 by Motorola

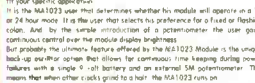

- 12 or 24 Hour Drives
- 70 and 90 °C, as well as virtually any number of temperature ranges
- Format of flashing clock on front
- 50 LED's for frequency or alarm

MA1021 by Motorola

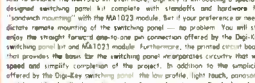

- 12 or 24 Hour Drives
- 70 and 90 °C, as well as virtually any number of temperature ranges
- Format of flashing clock on front
- 50 LED's for frequency or alarm

MA1021 by Motorola



- 12 or 24 Hour Drives
- 70 and 90 °C, as well as virtually any number of temperature ranges
- Format of flashing clock on front
- 50 LED's for frequency or alarm

MA1021 by Motorola



- 12 or 24 Hour Drives
- 70 and 90 °C, as well as virtually any number of temperature ranges
- Format of flashing clock on front
- 50 LED's for frequency or alarm

MA1021 by Motorola

TEXAS INSTRUMENTS I.C. SOCKETS

SOLDER TAIL DIP SOCKETS



- Saw profile
- Face grid design for maximum retention force
- Redundant contact points
- YOUR CHOICE - TIN OR GOLD*
- * Minimum of 150 microinches gold (not solder)
- EXCELLENT SURFACE QUALITY

TIN INLAY SOLDER TAIL Series C-15 MIL 200 Microinches Tin

Part No.	Description	1	10	100
8508	8-pin solder tail	10	88	60
8514	14-pin solder tail	15	130	100
8520	20-pin solder tail	22	270	200
8518	18-pin solder tail	22	180	140
8522	22-pin solder tail	27	240	200
8524	24-pin solder tail	27	240	200
8528	28-pin solder tail	33	310	280
8530	30-pin solder tail	33	310	280
8536	48-pin solder tail	48	480	400

GOLD INLAY SOLDER TAIL Series C-15 MIL 250 Microinches Gold

Part No.	Description	1	10	100
8458	8-pin solder tail	10	88	60
8464	14-pin solder tail	15	130	100
8470	20-pin solder tail	22	270	200
8468	18-pin solder tail	22	180	140
8474	22-pin solder tail	27	240	200
8476	24-pin solder tail	27	240	200
8480	28-pin solder tail	33	310	280
8482	30-pin solder tail	33	310	280
8488	48-pin solder tail	48	480	400

WIRE WRAP DIP SOCKET



- Standard profile
- Universal mounting and packaging capabilities
- Wire-wrap compatible - .015" thru .021" rectangular
- on round dual in-line leads
- Wire-wrap compatible - .015" providing a true position of .010" on leads for efficient automatic wire-wrap
- YOUR CHOICE - TIN OR GOLD*
- * Minimum of 150 microinches gold (not solder)
- EXCELLENT SURFACE QUALITY

TIN PLATED WIRE WRAP Series C-15 MIL 250 Microinches Tin

Part No.	Description	1	10	100
8108	8-pin wire wrap	10	88	60
8114	14-pin wire wrap	15	130	100
8120	20-pin wire wrap	22	270	200
8118	18-pin wire wrap	22	180	140
8124	22-pin wire wrap	27	240	200
8126	24-pin wire wrap	27	240	200
8130	28-pin wire wrap	33	310	280
8132	30-pin wire wrap	33	310	280
8138	48-pin wire wrap	48	480	400

GOLD INLAY WIRE WRAP Series C-15 MIL 250 Microinches Gold

Part No.	Description	1	10	100
8108	8-pin wire wrap	10	88	60
8114	14-pin wire wrap	15	130	100
8120	20-pin wire wrap	22	270	200
8118	18-pin wire wrap	22	180	140
8124	22-pin wire wrap	27	240	200
8126	24-pin wire wrap	27	240	200
8130	28-pin wire wrap	33	310	280
8132	30-pin wire wrap	33	310	280
8138	48-pin wire wrap	48	480	400

MOLEX I.C. SOCKET PINS

Part No.	Description	1	10	100
851C	8.00" M	10	88	60
852C	8.00" M	15	130	100
853C	8.00" M	22	270	200
854C	8.00" M	22	180	140
855C	8.00" M	27	240	200
856C	8.00" M	27	240	200
857C	8.00" M	33	310	280
858C	8.00" M	33	310	280
859C	8.00" M	48	480	400

TEXAS INSTRUMENTS GOLD EDGEBOARD CONNECTORS

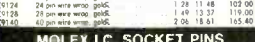

- 50 (Wt. Wire) to 75 (Gold) Mil microinch gold inlay
- Pre-welded, double-ended contact design
- Copper-Nickel CA 715 alloy
- Bifurcated contact points
- Pre-welded, double-ended contact design
- Contacts are user removable

NOTE: Dimensions below are for pins to center measurement followed by the distance separating the two pins.

MA SERIES - 100" EDGEBOARD CONNECTORS

Part No.	Description	1	10	100
MA100	100-pin	10	88	60
MA101	101-pin	15	130	100
MA102	102-pin	22	270	200
MA103	103-pin	22	180	140
MA104	104-pin	27	240	200
MA105	105-pin	27	240	200
MA106	106-pin	33	310	280
MA107	107-pin	33	310	280
MA108	108-pin	48	480	400

MA SERIES - 125" EDGEBOARD CONNECTORS

Part No.	Description	1	10	100
MA125	125-pin	10	88	60
MA126	126-pin	15	130	100
MA127	127-pin	22	270	200
MA128	128-pin	22	180	140
MA129	129-pin	27	240	200
MA130	130-pin	27	240	200
MA131	131-pin	33	310	280
MA132	132-pin	33	310	280
MA133	133-pin	48	480	400

MA SERIES - 150" EDGEBOARD CONNECTORS

Part No.	Description	1	10	100
MA150	150-pin	10	88	60
MA151	151-pin	15	130	100
MA152	152-pin	22	270	200
MA153	153-pin	22	180	140
MA154	154-pin	27	240	200
MA155	155-pin	27	240	200
MA156	156-pin	33	310	280
MA157	157-pin	33	310	280
MA158	158-pin	48	480	400

MA SERIES - 200" EDGEBOARD CONNECTORS

Part No.	Description	1	10	100
MA200	200-pin	10	88	60
MA201	201-pin	15	130	100
MA202	202-pin	22	270	200
MA203	203-pin	22	180	140
MA204	204-pin	27	240	200
MA205	205-pin	27	240	200
MA206	206-pin	33	310	280
MA207	207-pin	33	310	280
MA208	208-pin	48	480	400

MA SERIES - 250" EDGEBOARD CONNECTORS

Part No.	Description	1	10	100
MA250	250-pin	10	88	60
MA251	251-pin	15	130	100
MA252	252-pin	22	270	200
MA253	253-pin	22	180	140
MA254	254-pin	27	240	200
MA255	255-pin	27	240	200
MA256	256-pin	33	310	280
MA257	257-pin	33	310	280
MA258	258-pin	48	480	400

MA SERIES - 300" EDGEBOARD CONNECTORS

Part No.	Description	1	10	100
MA300	300-pin	10	88	60
MA301	301-pin	15	130	100
MA302	302-pin	22	270	200
MA303	303-pin	22	180	140
MA304	304-pin	27	240	200
MA305	305-pin	27	240	200
MA306	306-pin	33	310	280
MA307	307-pin	33	310	280
MA308	308-pin	48	480	400

MA SERIES - 400" EDGEBOARD CONNECTORS

Part No.	Description	1	10	100
MA400	400-pin	10	88	60
MA401	401-pin	15	130	100
MA402	402-pin	22	270	200
MA403	403-pin	22	180	140
MA404	404-pin	27	240	200
MA405	405-pin	27	240	200
MA406	406-pin	33	310	280
MA407	407-pin	33	310	280
MA408	408-pin	48	480	400

MA SERIES - 500" EDGEBOARD CONNECTORS

Part No.	Description	1	10	100
MA500	500-pin	10	88	60
MA501	501-pin	15	130	100
MA502	502-pin	22	270	200
MA503	503-pin	22	180	140
MA504	504-pin	27	240	200
MA505	505-pin	27	240	200
MA506	506-pin	33	310	280
MA507	507-pin	33	310	280
MA508	508-pin	48	480	400

MA SERIES - 600" EDGEBOARD CONNECTORS

Part No.	Description	1	10	100
MA600	600-pin	10	88	60
MA601	601-pin	15	130	100
MA602	602-pin	22	270	200
MA603	603-pin	22	180	140
MA604	604-pin	27	240	200
MA605	605-pin	27	240	200
MA606	606-pin	33	310	280
MA607	607-pin	33	310	280
MA608	608-pin	48	480	400

MA SERIES - 800" EDGEBOARD CONNECTORS

SD SYSTEMS Industry Compatible μ P Boards and Kits

SD ExpandoRAM

The EXPANDORAM is available in versions from 16K up to 64K, so for a minimum investment you can have your own memory system that will grow with your needs. This is a dynamic memory with the invisible on-board refresh, and IT WORKS!

Interfaces with Altair, IMSAI, SOL 8, Cromemco, SBC 100 and others. Bank Selectable. Phantom Power. 8VDC, +16VDC, 5 Watt - Lowest Cost Per Bit - Uses Popular 4116 RAM's - PC Board is double sided masked and has silk-screen parts layout - Extensive documentation clearly written - Complete kit includes all sockets for 64K. Designed to work with 280, 8080, 8085 CPU's - No wait states required - 16K boundaries and protection via Dip switches - Memory access time: 375ns. Cycle time: 500ns

Versafloppy I Flexible Disk Drive Controller

Handles up to four drives simultaneously: Minis, full-size, one or two sided, single density IBM 3740 compatible. Operates with SDDS or CP/M memory system. Use with 280, 8080, and 8085 CPU's. Utilizes FO1771B-1 Controller device. Control and diagnostic software available in PROM. Interrupt operation optional.

VDB-8024 Video Display Board

\$100 bus compatible - Full 80 characters displayed by 80 resolution 10 matrix. Composite or TTL video output - Keyboard power on interface - Forward and reverse scrolling - Blinking, underlining, field reverse, field protect and combinations. Full cursor control. 96 upper and lower case characters. 32 special character set. 128 additional user programmable characters. Optional On-board 280 Microprocessor - 2K bytes independent on-board RAM memory - Glitch-free display.

Z-80 Starter System

The Z80 Starter Kit by SD Systems uses the powerful Z80 microprocessor as the heart of the complete micro-system on a single board. Learn a step-by-step introduction to microcomputers with a keyboard and display, audio cassette interface, PROM programmer, wire-wrap expansion area, 4 channel Counter Timer and on board RAM and PROM. Complete Operation and Instruction Manual included. Z80G Monitor in ROM.

Intersil LED or LCD 3 1/2" DIGIT PANEL METER KITS

Build a working DPM in 1/2 HOUR WITH THESE COMPLETE EVALUATION KITS. Test these new parts for yourself with our easy to use prototype kits complete with A/D converter and LCD display (10 or 1000 in LED) for the 7091. Kits include all materials including PC board for the functioning panel. ICL7106EY (LCD) \$29.95 ICL7107 (LED) \$24.95

HYBRID AUDIO POWER AMPLIFIERS

P/N	Matching Transformer
SI-1010G(10W) \$ 6.95	TR10 \$ 7.90
SI-1020G(20W) \$13.95	TR20 \$10.90
A-SI-8(Socket for above)	95
SI-1030G(30W) \$19.00	TR30 \$12.90
SI-1050G(50W) \$27.80	TR50 \$17.90
A-SI-10(Socket for above)	95

* Note: One Transformer can power two audio amplifiers.

INTERISIL EVALUATION KITS

Power Amplifiers	IC48510FV/KIT	\$32.25	8-Digit Encoder	ICW7206E/VKIT	\$ 9.95
	IC48520FV/KIT	34.45	8-Digit Decoder	ICW7207E/VKIT	\$ 9.60
	IC48530FV/KIT	32.00	8-Digit Counter	ICW7208E/VKIT	9.90
8-Digit Stopwatch	IC48705E/VKIT	22.05	8-Digit Display Kit	68015AMP/R	49.90
6-Digit Stopwatch	ICW7215E/VKIT	19.25	16-Bit Shift Register	89S05AMP/R	32.50

POWER SUPPLIES FROM ADTECH POWER

Model	Vdc	Amps	Model	Vdc	Amps
APS 5-3	5	3.0	APS 5-6	5	6.0
APS 12-1.6	12	1.6	APS 12-4	12	4.0
APS 15-1.5	15	1.5	APS 15-3	15	3.0
APS 24-1	24	1.0	APS 24-2.2	24	2.2

SYM-1 NEW LOW KIM-1 MICROCOMPUTER

Model 8020A \$169 Model 8022A \$19.95

Includes: Fully Assembled & Tested \$179.00

Including: Documentation

KTM-2 CRT/TV Kbd Term \$349

FLUKE FUNCTION GENERATOR KIT

XR2206KB

OPERATES ON EITHER SINGLE OR 16V SPLIT SUPPLY

INCLUDES ALL PARTS TO BE MOUNTED ON PC BOARD

POWER SUPPLY NOT INCLUDED

Model 8020A \$169 Model 8022A \$19.95

NEW 30 MEGAHERTZ PORTABLE, DUAL TRACE MINI SCOPE

MS-15	MS-215	MS-230	Options
15 MEGAHERTZ	Dual Trace	Dual Trace	4x4xx
MS-215	Single Trace	Single Trace	4x4xx
MS-230	Dual Trace	Dual Trace	4x4xx
MS-15/215	3.5 lbs (2" Hx4" Wx5" D)	1.0 lb (1" Hx1" Wx1" D)	1.0 lb (1" Hx1" Wx1" D)
MS-15/215	3 lbs (2" Hx4" Wx5" D)	1.0 lb (1" Hx1" Wx1" D)	1.0 lb (1" Hx1" Wx1" D)
MS-230	3.5 lbs (2" Hx4" Wx5" D)	1.0 lb (1" Hx1" Wx1" D)	1.0 lb (1" Hx1" Wx1" D)
MS-230	3.5 lbs (2" Hx4" Wx5" D)	1.0 lb (1" Hx1" Wx1" D)	1.0 lb (1" Hx1" Wx1" D)

PET 2001 PERSONAL COMPUTER

Quite portable, very affordable and unbelievably versatile, the PET computer may very well be a lifetime investment....

PET 2001-8	Computer Standard PET with integral cassette and numeric keyboard. 8K bytes of memory. \$795.00
PET 2001-16N	Computer 16K bytes, large keyboard w/separate numeric pad and graphics. \$995.00
CBM 2001-16B	Computer As above but has standard typewriter. No graphics keys. \$995.00
PET 2001-32N	Computer identical to 2001-16N with 32K bytes of memory. \$1295.00
CBM 2001-32B	Computer identical to 2001-16B with 32K bytes of memory. \$1295.00
CBM 2002	Printer 80 column dot matrix printer with plain paper or forms handling tractor feed. Full graphics. \$995.00
CBM 2003	Printer 80 column dot matrix printer. Plain paper printer with full graphics feed. \$849.00
CBM 2040	Dual Floppy Dual drive intelligent mini floppy system. 241K net user storage capacity. \$1295.00
C2N	External Cassette Cassette player/recorder to use with PET 2001/8/16/32. \$95.00
PET to IEEE	Cable Use this cable to connect your floppy or printer to any CBM Computer. \$49.95
IEEE to IEEE	Cable Use this cable when connecting more than one peripheral to any CBM Computer. \$49.95
User Manual	160 pages covering all facets of user operation, programming and I/O for PET computers. \$9.95

5% CARBON FILM RESISTORS

ACE All-Circuit Evaluators

WITH POWER

POWERACE 103 POWERACE 101 POWERACE 102

923101 \$124.95 923101 \$79.95 923102 \$124.95

Triple-output power. The general purpose. The complete digital supply for prototyping model for prototyping prototyping lab with both linear and digital all types of circuits. FREE logic probe built in!

ANCRONIA

H.O. Box 2208P, Culver City, CA 90230. California residents add 6% sales tax. Minimum Order: \$10.00. Add \$1.00 to cover postage and handling. Master Charge and Visa welcomed. Please include your charge card number. Interbank number and expiration date. PHONE ORDERS (213) 641-4064

TUCSON	CULVER CITY	SANTA ANA	PORTLAND
4518 E. Broadway Tucson, AZ 85711 (602) 881-2368	11080 Jefferson Blvd Culver City, CA 90230 (213) 399-3595	13001 E. Linden Ave Santa Ana, CA 92705 (714) 447-8424	1125 N. E. 82nd Ave Portland, OR 97220 (503) 256-6541
CANADA & MEXICO	SUNNYVALE	ATLANTA	HOUSTON
5656 Fraser St. #100 Sunnyvale, CA 94088 (604) 324-0727	10541 E. Camino Real Sunnyvale, CA 94087 (408) 243-4121	3330 Piedmont Rd. N.E. Atlanta, GA 30305 (404) 261-7100	2649 Richmond Houston, TX 77068 (713) 578-2498

AB RCR Resistor Center STACKPOLE

THIS MONTH I.C.C. INTRODUCES QUALITY ALLEN-BRADLEY AND STACKPOLE, TYPE RCR, MILITARY GRADE RESISTORS, WITH ESTABLISHED RELIABILITY OF ONLY 0.01% TO 0.001% FAILURES PER THOUSAND HOURS OF OPERATION AT 50% RATED WATTAGE! THESE HOT MOLDED CARBON COMPOSITION RESISTORS OFFER UNIFORM DIMENSIONS DUE TO EXCLUSIVE MOLDING PROCESS AND ARE RECOGNIZED AS THE MOST RELIABLE OF ALL ELECTRONIC COMPONENTS.

Price Per Each 10%, 1/4 or 1/2 Watt Resistor \$0.06 Price Per Each 5%, 1/4 or 1/2 Watt Resistor \$0.09

PLEASE NOTE: RESISTORS ARE SOLD IN MULTIPLES OF 5 PER VALUE ONLY.

Resis- tance (Ohm)	CATALOG NUMBER			Resis- tance (Ohm)	CATALOG NUMBER			Resis- tance (Ohm)	CATALOG NUMBER			Resis- tance (Ohm)	CATALOG NUMBER			
	1/4 WATT	1/2 WATT	1/2 WATT		1/4 WATT	1/2 WATT	1/2 WATT		1/4 WATT	1/2 WATT	1/2 WATT		1/4 WATT	1/2 WATT	1/2 WATT	1/4 WATT
2.0	12-27007	13-27007	14-27007	560	12-56207	13-56207	14-56207	156200	12-156207	13-156207	14-156207	156200	12-156207	13-156207	14-156207	156200
2.7	13-27007	14-27007	15-27007	620	13-62207	14-62207	15-62207	156220	13-156220	14-156220	15-156220	156220	13-156220	14-156220	15-156220	156220
3.3	14-27007	15-27007	16-27007	680	14-68207	15-68207	16-68207	156820	14-156820	15-156820	16-156820	156820	14-156820	15-156820	16-156820	156820
3.9	15-27007	16-27007	17-27007	750	15-75207	16-75207	17-75207	157520	15-157520	16-157520	17-157520	157520	15-157520	16-157520	17-157520	157520
4.3	16-27007	17-27007	18-27007	820	16-82207	17-82207	18-82207	158220	16-158220	17-158220	18-158220	158220	16-158220	17-158220	18-158220	158220
4.7	17-27007	18-27007	19-27007	910	17-91207	18-91207	19-91207	159120	17-159120	18-159120	19-159120	159120	17-159120	18-159120	19-159120	159120
5.1	18-27007	19-27007	20-27007	1000	18-100207	19-100207	20-100207	160000	18-160000	19-160000	20-160000	160000	18-160000	19-160000	20-160000	160000
5.6	19-27007	20-27007	21-27007	1100	19-110207	20-110207	21-110207	161000	19-161000	20-161000	21-161000	161000	19-161000	20-161000	21-161000	161000
6.2	20-27007	21-27007	22-27007	1200	20-120207	21-120207	22-120207	162000	20-162000	21-162000	22-162000	162000	20-162000	21-162000	22-162000	162000
6.8	21-27007	22-27007	23-27007	1300	21-130207	22-130207	23-130207	163000	21-163000	22-163000	23-163000	163000	21-163000	22-163000	23-163000	163000
7.5	22-27007	23-27007	24-27007	1400	22-140207	23-140207	24-140207	164000	22-164000	23-164000	24-164000	164000	22-164000	23-164000	24-164000	164000
8.2	23-27007	24-27007	25-27007	1500	23-150207	24-150207	25-150207	165000	23-165000	24-165000	25-165000	165000	23-165000	24-165000	25-165000	165000
8.8	24-27007	25-27007	26-27007	1600	24-160207	25-160207	26-160207	166000	24-166000	25-166000	26-166000	166000	24-166000	25-166000	26-166000	166000
9.1	25-27007	26-27007	27-27007	1700	25-170207	26-170207	27-170207	167000	25-167000	26-167000	27-167000	167000	25-167000	26-167000	27-167000	167000
9.5	26-27007	27-27007	28-27007	1800	26-180207	27-180207	28-180207	168000	26-168000	27-168000	28-168000	168000	26-168000	27-168000	28-168000	168000
10	27-27007	28-27007	29-27007	1900	27-190207	28-190207	29-190207	169000	27-169000	28-169000	29-169000	169000	27-169000	28-169000	29-169000	169000
11	28-27007	29-27007	30-27007	2000	28-200207	29-200207	30-200207	170000	28-170000	29-170000	30-170000	170000	28-170000	29-170000	30-170000	170000
12	29-27007	30-27007	31-27007	2200	29-220207	30-220207	31-220207	172000	29-172000	30-172000	31-172000	172000	29-172000	30-172000	31-172000	172000
13	30-27007	31-27007	32-27007	2400	30-240207	31-240207	32-240207	174000	30-174000	31-174000	32-174000	174000	30-174000	31-174000	32-174000	174000
15	31-27007	32-27007	33-27007	2600	31-260207	32-260207	33-260207	176000	31-176000	32-176000	33-176000	176000	31-176000	32-176000	33-176000	176000
16	32-27007	33-27007	34-27007	2800	32-280207	33-280207	34-280207	178000	32-178000	33-178000	34-178000	178000	32-178000	33-178000	34-178000	178000
18	33-27007	34-27007	35-27007	3000	33-300207	34-300207	35-300207	180000	33-180000	34-180000	35-180000	180000	33-180000	34-180000	35-180000	180000
20	34-27007	35-27007	36-27007	3300	34-330207	35-330207	36-330207	183000	34-183000	35-183000	36-183000	183000	34-183000	35-183000	36-183000	183000
22	35-27007	36-27007	37-27007	3600	35-360207	36-360207	37-360207	186000	35-186000	36-186000	37-186000	186000	35-186000	36-186000	37-186000	186000
24	36-27007	37-27007	38-27007	3900	36-390207	37-390207	38-390207	189000	36-189000	37-189000	38-189000	189000	36-189000	37-189000	38-189000	189000
27	37-27007	38-27007	39-27007	4200	37-420207	38-420207	39-420207	192000	37-192000	38-192000	39-192000	192000	37-192000	38-192000	39-192000	192000
30	38-27007	39-27007	40-27007	4500	38-450207	39-450207	40-450207	195000	38-195000	39-195000	40-195000	195000	38-195000	39-195000	40-195000	195000
33	39-27007	40-27007	41-27007	4800	39-480207	40-480207	41-480207	198000	39-198000	40-198000	41-198000	198000	39-198000	40-198000	41-198000	198000
36	40-27007	41-27007	42-27007	5100	40-510207	41-510207	42-510207	201000	40-201000	41-201000	42-201000	201000	40-201000	41-2		

Radio Shack — Your No. 1 Parts Place™

Low Prices and New Items Every Day!

Low-Power Schottky ICs

Low As **49¢**

- 100% Prime
- Guaranteed Specs

Improved 5-volt logic devices use Schottky diode technology for minimum propagation delay and high speed at minimum power.



Type	Cat. No.	ONLY
74LS00	276-1900	.49
74LS02	276-1902	.59
74LS04	276-1904	.59
74LS08	276-1908	.49
74LS10	276-1910	.59
74LS13	276-1911	.99
74LS20	276-1912	.59
74LS27	276-1913	.69
74LS30	276-1914	.59
74LS32	276-1915	.69
74LS47	276-1916	1.29
74LS51	276-1917	.59
74LS73	276-1918	.69
74LS74	276-1919	.69
74LS75	276-1920	.99
74LS76	276-1921	.79
74LS85	276-1922	1.29
74LS90	276-1923	.99
74LS92	276-1924	.99
74LS93	276-1925	.99
74LS123	276-1926	1.19
74LS132	276-1927	.99
74LS151	276-1929	.99
74LS157	276-1930	1.19
74LS161	276-1931	1.49
74LS164	276-1932	1.49
74LS175	276-1934	1.19
74LS192	276-1935	1.49
74LS193	276-1936	1.49
74LS194	276-1937	1.49
74LS196	276-1938	1.59
74LS367	276-1835	1.19
74LS368	276-1836	1.19
74LS373	276-1843	2.39
74LS374	276-1944	2.39

4000-Series CMOS ICs

Type	Cat. No.	EACH
4001	276-2401	.69
4011	276-2411	.69
4012	276-2412	.79
4013	276-2413	.99
4017	276-2417	1.69
4020	276-2420	1.69
4021	276-2421	1.69
4023	276-2423	.69
4027	276-2427	.99
4028	276-2428	1.29
4046	276-2446	1.89
4511	276-2447	1.69
4049	276-2449	.79
4050	276-2450	.79
4051	276-2451	1.49
4066	276-2466	1.39
4070	276-2470	.79
4518	276-2490	1.49
4543	276-2491	1.99

All Prime from Major Semiconductor Manufacturers. Specs and Pin Out Diagram Included with Each Device.

MC14553 3-Digit BCD Counter IC **2.99**

CMOS chip replaces over 8 separate ICs in a digital display circuit. Input pulse shaping. Master reset pin. 16-pin DIP. 276-2498 2.99

RAM Memory ICs **2.49**

Low As
2102 1024 x 1 Array. Low-cost static memory chip. 16-pin DIP. Buy 8 and save! 276-2501 2.49 Ea. or 8/14.95
2114L 1024 x 4 Array. NMOS static RAM. 18-pin DIP. 276-2504 10.99

NEW! Rectangular LED Lamps **99¢**



High-brightness. Can be stacked vertically or horizontally. Max. forward current: 30 mA. Typical forward voltage: 2.5.
276-070. Red. 2.99¢
276-071. Green. 2/99¢
276-072. Yellow. 2/99¢

NEW! Pair of LED Digits **1.98**

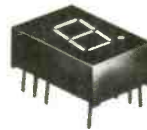

These 10mm 7-segment, red displays are ideal low-cost readouts for any projects. For multiplexed or direct drive. Max. forward current: 45mA/segment.
Common Anode. 276-1643 2/1.98
Common Cathode. 276-1644 2/1.98

NEW! Oscillator/Divider IC **2.69**



CMOS IC with 17 binary divider stages produces a highly stable 60 Hz square wave. Uses a TV 3.58 MHz crystal reference. Very low power operation over wide 3-15VDC range. 8-pin DIP.
276-1769 2.69
3.58 MHz Crystal 2.99

LED Bar/Dot Display Driver **3.49**

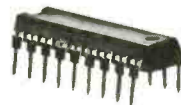

LM3914N. Features 10 adjustable analog steps, bar or dot display mode. Current-regulated LED outputs. 8 to 25VDC supply. 16-pin DIP. 276-1707 3.49
LM3915N. As above but with 3 dB log steps. 276-1708 3.49

NEW! Silicon Solar Cells **5.99**



Convert light to electrical power. All deliver 0.45V at rated current. Use several in series/parallel for higher voltages or current.
276-122. 1/2 3" cell. Rated 500 mA ... 5.99
276-123. Full 3" cell. Rated 1 amp ... 8.99

Hall-Effect Sensors **1.98**



Open-Collector Output
Detects magnetic fields electronically. 750 gauss "on" threshold. Constant amplitude independent of frequency. Similar to type ULN 3006. Ideal for tachs, position sensing, pulse counting. 5 to 16V supply. TO-92 case. With data. 276-1646 Pkg. of 3/1.98

Unique LEDs



A Tri-Color. Displays red, green, yellow. Uniform light output of 0.6 mcd. Forward voltage: 2.2VDC. Max. current: 25mA. T1-94 case style. 276-035 1.39
B Red Flasher. Operates directly from 5VDC power source. Pulse rate: 3 Hz. Max current: 20 mA at 5VDC. 276-036 1.29

10 Assorted Mini Reed Switches **1.98**



Hermetically sealed. Gold-plated contacts close when magnetic field is present. Includes mini and micro types. 276-1610 Pkg. of 10/1.98

Permanent Magnet Motors **99¢**



Up to 10,000 RPM at no load. Long leads for easy hook-up. Motor is 1 1/2 x 1/8". Shaft, 3/16 x 1/4". 273-206 2/99¢

12/24-Hr. LCD Clock Module **19.95**



Actual Size

24-Hour Alarm Shows Time/Day/Date

Complete clock module — just add switches and battery! 0.25" LCD display has built-in backlight, alarm set, PM and snooze indicators. Operates up to a year on single 1.5V battery. Accuracy: ± 13 seconds per month. 277-1005 19.95

Top Octave Synthesizer IC **6.99**

NEW!
6.99



S50240. PMOS oscillator/frequency divider chip generates 13 equal-tempered notes from C₈ to C₆ to form the heart of any electronic keyboard instrument. CMOS compatible square wave outputs have 50% duty cycle for driving additional dividers or voice filters. Operates from single supply from 11 to 16 volts. 16-pin DIP. 276-1780 6.99

MC14553 3-Digit BCD Counter IC **2.99**

CMOS chip replaces over 8 separate ICs in a digital display circuit. Input pulse shaping. Master reset pin. 16-pin DIP. 276-2498 2.99

RAM Memory ICs **2.49**

Low As
2102 1024 x 1 Array. Low-cost static memory chip. 16-pin DIP. Buy 8 and save! 276-2501 2.49 Ea. or 8/14.95
2114L 1024 x 4 Array. NMOS static RAM. 18-pin DIP. 276-2504 10.99

4" Cooling Fan **12.95**

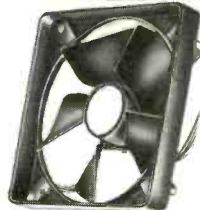

12.95
Super Quiet Operation

Ideal for cooling power supplies, microcomputers, hi-fi and Ham gear. Delivers up to 70 CFM. Diecast venturi. U.L. recognized motor. For 120VAC, 60 Hz. 273-241 12.95

Dual Analog Delay IC **10.95**

10.95



Continuously Variable—Many Audio Applications

SAD1024A. "Bucket Brigade" device has 2 separate 512-stage shift registers which can be used independently or in combination. Provides continuously variable electronic delay for complex audio signals to create reverb, echo, phase shift, chorus and vibrato effects. Reliable NMOS design operates from single supply. With applications circuits and data. 16-pin DIP. 276-1761 10.95

WHY WAIT FOR MAIL ORDER DELIVERY?
IN STOCK NOW AT OUR STORE NEAR YOU!

Radio Shack®

A DIVISION OF TANDY CORPORATION • FORT WORTH, TEXAS 76102
OVER 7000 LOCATIONS IN 40 COUNTRIES

Prices may vary at individual stores and dealers

7400 TTL

SN7400N	18	SN7400	29
SN7401N	18	SN7401	35
SN7402N	18	SN7402	49
SN7403N	18	SN7403	50
SN7404N	18	SN7404	50
SN7405N	20	SN7405	50
SN7406N	29	SN7406	59
SN7407N	20	SN7407	59
SN7408N	20	SN7408	59
SN7409N	18	SN7409	35
SN7410N	18	SN7410	175
SN7411N	20	SN7411	45
SN7412N	20	SN7412	49
SN7413N	40	SN7413	43
SN7414N	70	SN7414	79
SN7415N	25	SN7415	85
SN7417N	25	SN7417	85
SN7420N	25	SN7420	85
SN7421N	30	SN7421	80
SN7422N	39	SN7422	80
SN7423N	29	SN7423	85
SN7425N	29	SN7425	85
SN7426N	29	SN7426	85
SN7427N	25	SN7427	85
SN7428N	39	SN7428	85
SN7430N	25	SN7430	85
SN7432N	25	SN7432	85
SN7433N	25	SN7433	85
SN7437N	25	SN7437	85
SN7438N	25	SN7438	85
SN7439N	25	SN7439	85
SN7440N	20	SN7440	79
SN7441N	89	SN7441	89
SN7442N	49	SN7442	295
SN7443N	75	SN7443	295
SN7444N	75	SN7444	295
SN7445N	75	SN7445	295
SN7446N	89	SN7446	129
SN7447N	79	SN7447	129
SN7448N	79	SN7448	129
SN7449N	79	SN7449	129
SN7450N	20	SN7450	59
SN7451N	20	SN7451	59
SN7452N	20	SN7452	59
SN7453N	20	SN7453	59
SN7454N	25	SN7454	59
SN7455N	20	SN7455	59
SN7456N	20	SN7456	59

Cromemco Incorporated

TU-ART Digital Interface



Cromemco's TU-ART digital interface is a convenient interface for CRT terminals, line printers, modems, and other devices. Has 2 serial I/O ports, 2 B-bit parallel I/O ports, and 10 independent programmable interval timers. Baud rates are software-selectable from 110-76,800 baud. Has vectored prioritized interrupts so it is able to support the powerful vectored interrupt structure of a Z80 microprocessor. 10 interval timers with real-time capability.

Serial I/O Ports:
 All of ports 2
 Max. rate: RS-232C 20mA current loop
 Low baud range: 110-9600 baud
 High baud range: 850-76,800 baud
 Software selectable

Interval Timers:
 All of timers 10
 Timer range: D 16 32 msec (software selected)
 Timer resolution: 64 microseconds
 Max. interval: 100 msec

General Information:
 UART Type: 6501
 Power requirements: 18V @ 1.0A, 15V @ 400mA
 Operating environment: 0-55°C

Special Features:
 Max. rate: 12.400 msec @ 65,536
 Prioritization of TU-ART ports internally prioritized
 Provision for multiple TU-ARTs, daisy-chaining

TRT-W (Assembled) \$295.00

TELEPHONE/KEYBOARD CHIPS

AY-5-100	Push Button Telephone Dialer	\$14.95
AY-5-200	Rotary Dialer	4.95
AY-5-500	CMOS Clock Generator	4.95
AY-5-236	Keyboard Encoder (88 keys)	14.95
ICM207	Keyboard Encoder (88 keys)	7.95
74C52	Keyboard Encoder (16 keys)	7.95
74C53	Keyboard Encoder (20 keys)	6.25

ICM CHIPS

ICM7045	CMOS Precision Timer	24.95
ICM7205	CMOS LED Stopwatch/Timer	19.95
ICM7208	Oscillator Counter	7.50
ICM7209	Seven Decade Counter	19.95
ICM7209	Clock Generator	6.95

NMOS READ ONLY MEMORIES

MCM6571	128 X 9 X 7 ASCII Shifted with Greek	13.50
MCM6574	128 X 9 X 7 Math Symbol & Pictures	13.50
MCM6575	128 X 9 X 7 Alpha Control Char Gen	13.50

DISCRETE LEDS

200' dia.	5/51	125' dia.	5/51
KC556R red	4/51	KC209R red	4/51
KC556G green	4/51	KC209G green	4/51
KC556Y yellow	4/51	KC209Y yellow	4/51
KC556C clear	4/51		

TIME-X T1001 LIQUID CRYSTAL DISPLAY CLASS II FIELD EFFECT



4 DIGIT 5¹/₂ CHARACTERS
THREE ENUNCIATORS
2.00" X 1.20" PACKAGE
INCLUDES CONNECTOR

T1001-Transmissive \$7.95
T1001A-Reflective 8.25

DISPLAY LEDS

TYPE	POLARITY	HT	PRICE	TYPE	POLARITY	HT	PRICE		
MAN 2	Common Anode-red	270	2.95	MAN 6730	Common Anode-red-D	560	99		
MAN 3	5 x 7 Dot Matrix-red	300	4.95	MAN 6740	Common Cathode-red-D	560	99		
MAN 4	Common Cathode-red	125	25	MAN 6750	Common Cathode-red	560	99		
MAN 4	Common Cathode-green	187	195	MAN 6760	Common Anode-red	560	99		
MAN 7G	Common Anode-green	300	1.25	MAN 6780	Common Cathode-red	560	99		
MAN 7Y	Common Anode-yellow	300	99	MAN 6790	Common Anode-red	560	99		
MAN 7Z	Common Anode-red	300	75	DL704	Common Cathode-red	300	99		
MAN 74	Common Cathode-red	300	1.25	DL707	Common Anode-red	300	99		
MAN 82	Common Anode-yellow	300	49	DL726	Common Cathode-red	500	149		
MAN 84	Common Cathode-yellow	300	49	DL741	Common Anode-red	600	125		
MAN 3520	Common Anode-orange	300	49	DL745	Common Anode-red	1	630	149	
MAN 3630	Common Anode-orange	1	300	99	DL747	Common Anode-red	600	149	
MAN 3640	Common Cathode-orange	300	99	DL749	Common Cathode-red	1	630	149	
MAN 4610	Common Anode-orange	300	99	DL750	Common Cathode-red	600	149		
MAN 4540	Common Cathode-orange	400	99	FD338	Common Cathode-red	110	350		
MAN 4710	Common Anode-red	400	99	FD370	Common Cathode	250	69		
MAN 4730	Common Anode-red	1	400	99	FD358	Common Cathode	1	357	99
MAN 4740	Common Cathode-red	400	99	FD359	Common Cathode	357	75		
MAN 4810	Common Anode-yellow	400	99	FD365	Common Cathode(FND500)	500	99		
MAN 4840	Common Cathode-yellow	400	99	FD367	Common Anode (FND510)	500	99		
MAN 5610	Common Anode-orange-D	560	99	5082-7730	Common Anode	300	99		
MAN 5630	Common Anode-orange	1	560	99	HDSF-3400	Common Anode-red	800	150	
MAN 5640	Common Cathode-orange-D	560	99	HDSF-3403	Common Cathode red	800	150		
MAN 5650	Common Cathode-orange	1	560	99	5082-7300	4 x 7 Sgl. Digit-7-Seg	110	350	
MAN 5660	Common Anode-orange	560	99	5082-7302	4 x 7 Sgl. Digit-LHDP	600	195		
MAN 6680	Common Cathode-orange	560	99	5082-7304	Overrange character (L,1)	600	150		
MAN 6710	Common Anode-red-D	560	99	5082-7340	4 x 7 Sgl. Digit-Hexadecimal	600	250		

MISCELLANEOUS

TL074CN	Quad Low Noise Bi-Fet Op Amp	2.49
TL149CN	Switching Regulator	4.49
TL495CP	Single Switching Regulator	1.75
ICM207	Divide by 1 Prescaler	10.95
9590	Hi-Speed Divisor by 10 Prescaler	11.95
4N33	Photo-Darlington Opto-Isolator	3.95
MK50240	Top Octave Freq. Generator	17.50
D50026CH	5MHz 2-phase MOS clock driver	3.75
277	777 red num. display with logic chip	14.95
M55320	TV Camera Sync. Generator	9.95
M55330	4 1/2 Digit DPM Logic Block (Special)	3.95
LD110/111	3 1/2 Digit A/D Converter Set	25.00/set
MC14433P	3 1/2 Digit A/D Converter	13.95

LITRONIX ISO-LIT 1

Photo Transistor Opto-Isolator
(Same as MCT 2 or 4N25)

49¢ each

SN 76477 SOUND GENERATOR

Generates Complex Sounds
Low Power Programmable

\$3.95 each

C/MOS

CD4000	23	CD4070	55
CD4001	23	CD4071	23
CD4002	23	CD4072	49
CD4006	1.19	CD4076	1.19
CD4007	49	CD4087	23
CD4009	49	CD4088	99
CD4010	49	CD4093	99
CD4011	23	CD4094	1.25
CD4012	25	CD4098	2.49
CD4013	1.09	MC1408	1.09
CD4014	1.19	MC1409	14.95
CD4016	49	MC1411	14.95
CD4017	1.19	MC1414	14.95
CD4018	49	MC1419	14.95
CD4019	49	MC1433	14.95
CD4020	1.19	MC1436	1.19
CD4021	1.19	MC1437	1.19
CD4022	1.19	MC1438	1.19
CD4023	1.19	MC1439	1.19
CD4024	1.19	MC1440	1.19
CD4025	1.19	MC1441	1.19
CD4026	1.19	MC1442	1.19
CD4027	1.19	MC1443	1.19
CD4028	1.19	MC1444	1.19
CD4029	1.19	MC1445	1.19
CD4030	1.19	MC1446	1.19
CD4031	1.19	MC1447	1.19
CD4032	1.19	MC1448	1.19
CD4033	1.19	MC1449	1.19
CD4034	1.19	MC1450	1.19
CD4035	1.19	MC1451	1.19
CD4036	1.19	MC1452	1.19
CD4037	1.19	MC1453	1.19
CD4038	1.19	MC1454	1.19
CD4039	1.19	MC1455	1.19
CD4040	1.19	MC1456	1.19
CD4041	1.19	MC1457	1.19
CD4042	1.19	MC1458	1.19
CD4043	1.19	MC1459	1.19
CD4044	1.19	MC1460	1.19
CD4045	1.19	MC1461	1.19
CD4046	1.19	MC1462	1.19
CD4047	1.19	MC1463	1.19
CD4048	1.19	MC1464	1.19
CD4049	1.19	MC1465	1.19
CD4050	1.19	MC1466	1.19
CD4051	1.19	MC1467	1.19
CD4052	1.19	MC1468	1.19
CD4053	1.19	MC1469	1.19
CD4054	1.19	MC1470	1.19
CD4055	1.19	MC1471	1.19
CD4056	1.19	MC1472	1.19
CD4057	1.19	MC1473	1.19
CD4058	1.19	MC1474	1.19
CD4059	1.19	MC1475	1.19
CD4060	1.19	MC1476	1.19
CD4061	1.19	MC1477	1.19
CD4062	1.19	MC1478	1.19
CD4063	1.19	MC1479	1.19
CD4064	1.19	MC1480	1.19
CD4065	1.19	MC1481	1.19
CD4066	1.19	MC1482	1.19
CD4067	1.19	MC1483	1.19
CD4068	1.19	MC1484	1.19
CD4069	1.19	MC1485	1.19
CD4070	1.19	MC1486	1.19
CD4071	1.19	MC1487	1.19
CD4072	1.19	MC1488	1.19
CD4073	1.19	MC1489	1.19
CD4074	1.19	MC1490	1.19
CD4075	1.19	MC1491	1.19
CD4076	1.19	MC1492	1.19
CD4077	1.19	MC1493	1.19
CD4078	1.19	MC1494	1.19
CD4079	1.19	MC1495	1.19
CD4080	1.19	MC1496	1.19
CD4081	1.19	MC1497	1.19
CD4082	1.19	MC1498	1.19
CD4083	1.19	MC1499	1.19
CD4084	1.19	MC1500	1.19
CD4085	1.19	MC1501	1.19
CD4086	1.19	MC1502	1.19
CD4087	1.19	MC1503	1.19
CD4088	1.19	MC1504	1.19
CD4089	1.19	MC1505	1.19
CD4090	1.19	MC1506	1.19
CD4091	1.19	MC1507	1.19
CD4092	1.19	MC1508	1.19
CD4093	1.19	MC1509	1.19
CD4094	1.19	MC1510	1.19
CD4095	1.19	MC1511	1.19
CD4096	1.19	MC1512	1.19
CD4097	1.19	MC1513	1.19
CD4098	1.19	MC1514	1.19
CD4099	1.19	MC1515	1.19
CD4100	1.19	MC1516	1.19
CD4101	1.19	MC1517	1.19
CD4102	1.19	MC1518	1.19
CD4103	1.19	MC1519	1.19
CD4104	1.19	MC1520	1.19
CD4105	1.19	MC1521	1.19
CD4106	1.19	MC1522	1.19
CD4107	1.19	MC1523	1.19
CD4108	1.19	MC1524	1.19
CD4109	1.19	MC1525	1.19
CD4110	1.19	MC1526	1.19
CD4111	1.19	MC1527	1.19
CD4112	1.19	MC1528	1.19
CD4113	1.19	MC1529	1.19
CD4114	1.19	MC1530	1.19
CD4115	1.19	MC1531	1.19
CD4116	1.19	MC1532	1.19
CD4117	1.19	MC1533	1.19
CD4118	1.19	MC1534	1.19
CD4119	1.19	MC1535	1.19
CD4120	1.19	MC1536	1.19
CD4121	1.19	MC1537	1.19
CD4122	1.19	MC1538	1.19
CD4123	1.19	MC1539	1.19
CD4124	1.19	MC1540	1.19
CD4125	1.19	MC1541	1.19
CD4126	1.19	MC1542	1.19
CD4127	1.19	MC1543	1.19
CD4128	1.19	MC1544	1.19
CD4129	1.19	MC1545	1.19
CD4130	1.19	MC1546	1.19
CD4131	1.19	MC1547	1.19
CD4132	1.19	MC1548	1.19
CD4133	1.19	MC1549	1.19
CD4134	1.19	MC1550	1.19
CD4135	1.19	MC1551	1.19
CD4136	1.19	MC1552	1.19
CD4137	1.19	MC1553	1.19
CD4138	1.19	MC1554	1.19
CD4139	1.19	MC1555	1.19
CD4140	1.19	MC1556	1.19
CD4141	1.19	MC1557	1.19
CD4142	1.19	MC1558	1.19
CD4143			

CASH TIGHT? We're Priced Right.

☆ SOCKET SPECIAL: ☆ CLOCK AND CASE: ☆

18 pin, tin soldertail low profile types from a major manufacturer. 20/\$1.95 (less than a dime apiece... when do you think you'll see them at that price again?). Limited quantity!

MA1003 plus matching case for \$19.95. Requires 12V DC and two time-set switches for operations; built-in timebase for mobile, van, car applications. While they last.

16K MEMORY EXPANSION CHIP SET: \$87.20!

Expands memory in TRS-80* Model I and Model II, Apple, Exidy Sorcerer, Heath H89, and newer PET machines. Low power, high speed (250 ns) parts with DIP shunts for TRS-80* conversion. Coming soon: A high-density, Model II compatible RAM board with bank select!

*TRS-80 is a trademark of the Tandy Corporation

WE'VE GOT COST-EFFECTIVE MEMORY BOARDS FOR A NUMBER OF SYSTEMS . . .

These fully static, 5 MHz, low power boards are the perfect complement to any system. Available at computer stores world-wide under the CompuPro™ name. Choose from unkit (sockets, bypass caps presoldered in place), assembled, or qualified under our high-reliability Certified System Component (CSC) program. 1 year limited warranty. See our catalog for full information on these and other peripherals.

Name	Buss & Notes	Unkit	Asm	CSC
8K Econoram IIA	S-100	\$149	\$179	\$239
32K Econoram IX-32	Dig Grp	\$559	\$639	n/a
32K Econoram X	S-100	\$529	\$649	\$789
32K Econoram XI	SBC/BLC	n/a	n/a	\$1050
16K Econoram XIII-16	S-100 (1)	\$329	\$419	\$519
24K Econoram XIII-24	S-100 (1)	\$429	\$539	\$649
32K Econoram XIII-32	S-100 (1)	\$559	\$699	\$849
16K Econoram XIV	S-100 (2)	\$299	\$359	\$459
32K Econoram XV-32	H8 (3)	\$599	\$729	n/a

- (1) Bank select board addressable on 4K boundaries. Compatible with Cromemco, Alpha Micro, and others.
- (2) Extended addressing (24 address lines). Single block addressable on 4K boundaries.
- (3) Bank select option for implementing memory systems greater than 64K.

Econoram is a trademark of Godbout Electronics.

TERMS: Allow 5% for shipping excess refunded. Cal res add tax. VISA®/Mastercharge® call our 24 hr order desk at (415) 582-0636. COD OK with street address for UPS. Prices good through cover month of magazine.

GODBOUT

GODBOUT ELECTRONICS
Bldg. 725, Oakland Airport, CA 94614

HAPPY
NEW
YEAR!!

SEND FOR OUR FREE CATALOG — IT'S PRICELESS!

CIRCLE NO. 25 ON FREE INFORMATION CARD

Save on Calculators

Model	Your Cost
HP 41C Scient	\$244.95
Card Reader/41C	159.95
Printer/41C	289.95
HP 34C Scient	174.95
HP 38C Bus	174.95
HP 38E Bus	99.95
HP 33C Scient	99.95
HP 33E Scient	74.95
HP 37E Bus prog	62.95
HP 32E Adv Scient	58.95
HP 31E Scient	42.95
HP 87 Scient Prog	299.95
HP 97 Scient Print	594.95
HP 29C Scient Cfm	139.95
HP 92 Bus Print	399.95

**hp HEWLETT
PACKARD**



"C" stands for continuous memory. We carry an enormous stock of HP accessories. All units come complete. One year guarantee by HP.

TEXAS INSTRUMENTS

Model	Price	Model	Price	Model	Price
Ti-59	209.95	Ti 5040	94.95	Ti Computer 99/4	Call us
PT100C	146.95	Ti 5100	43.95	Ti Translator	259.95
PC100A for 59 56 52	TI 5200	Call us	Ti Thermostat	109.95	
Ti-58C	179.95	Ti 5225	Call us		
Ti 47	49.95	Ti 5230	Call us		
Ti 55	35.95	Ti 5015	62.95		
Ti 50	35.95	Ti 5025	79.95		
Ti 25	28.95	MBA	58.95		
Ti 35	23.95	Data Card	23.95		



Huge inventory of TI accessories on hand at all times, guarantee by TI

SPECIALS

320 Seko watches to choose from	Chronograph Digital SS	119.95
"Diana" digital analog SS	Alarm Chronograph SS	159.95
Carrier type "Tank" Mens/Ladies	Solar Alarm Chronograph SS	189.95
gold/leone	Memory Bank Calculator SS	159.95
Musical Alarm Chronograph SS	Alarm Digital Quartz SS	179.95
Wildtim Alarm Perp/Calndr SS	Multi Alarm Goldtone	199.95
Calculator Watch, Alarm SS	Dual Time Zone Digital	99.95
Large selection Seikos Also TI, Juvenia, Uf Casio & Gruen	Divers 500 FT Quartz #60581	223.95
Sony TVs all models	Craig Translator	Call us
Sony Betamax SL5400 4 1/2 hrs	Dictating Machines	Call us
RCA Selecta VDT6000 6 hrs	all kinds	Call us

Casio Sharp Canon Boris Chess Games Victor Sanyo Pearlcoiler Polaroid Panasonic Amana Linton Apf Atari Neovision and others. Prices are f.o.b. J.A. Add \$4.95 for shipping hand-held cases in USA. CA residents add 6% sales tax. We will beat any advertised price if the condition has the goods on hand. Goods subject to availability. See our 120 page catalog. Call Monday thru Saturday 7AM to 6PM. Outside-CA toll free 800-421-8045. In CA Call below at 415-582-0636.

OLYMPIC SALES COMPANY, INC.
216 South Oxford Avenue • P.O. Box 74545 • Los Angeles, CA 90004
(213) 301-3911 or (213) 301-1202 • Telex 67-3477

CIRCLE NO. 44 ON FREE INFORMATION CARD

BEAT HIGH GAS PRICES!



CALL FREE
800-257-7955



ELECTRIFY YOUR BIKE!

PEDALPOWER exciting new bike drive tames tough hills. Be independent. Shop when you want. Fits all Bikes, Adult Trikes. Installs in minutes. Thousands sold. Recharges overnight. Travels 100 miles for a dime. **MONEY BACK GUARANTEE.**

Call toll free: 800-257-7955*

Or send today for

**FREE ILLUSTRATED
PEDALPOWER BOOKLET**
Plus free information on complete line of Electric Cars, Electric Bikes and Trikes.

General Engines Co.

5611 Mantua Blvd.
Sewell, N.J. 08080

*In N.J., Alaska, or HI. Call Collect. (609) 468-0270

DEALER INQUIRIES INVITED

CIRCLE NO. 24 ON FREE INFORMATION CARD

BULLET PO BOX 401244P GARLAND TEXAS ELECTRONICS 75040

SE 01 Sound Effects Kit \$16.95

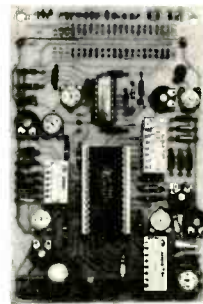

The SE-01 is a complete kit that contains all the parts to build a programmable sound effects generator. Designed around the new Texas Instruments SN78477 Sound Chip, the board provides banks of MINI DIP switches and pots to program the various combinations of the SLF Oscillator, VCO, Noise, One Shot, and Envelope Controls. A Quad Op Amp IC is used to implement an Adjustable Pulse Generator, Level Comparator and Multiplex Oscillator for even more versatility. The 3" x 5" PC Board features a prototype area to allow for user added circuitry. Easily programmed to duplicate Explosions, Phaser Guns, Steam Trains, or almost an infinite number of other sounds. The unit has a multiple of applications. The low price includes all parts, assembly manual, programming charts, and detailed 76477 chip specifications. It runs on a 9V battery (not included). On board 100mW amp will drive a small speaker directly, or the unit can be connected to your stereo with incredible results! (Speaker not included).

• 76477 CHIP IS INCLUDED. EXTRA CHIPS \$2.95 EACH
• \$16.95 LESS SPEAKER & BATTERY

From T.I.: TL490 BAR/DOT DRIVER IC. Drives 10 LED's with adjustable analog steps. Units are cascadable up to 10 (100 steps). Drives LED's directly. Great for voltage, current, or audio displays. Similar in features to LM3914 with specs and circuit notes.

2.95

NEW!



XAN SUPER DIGITS

.6" JUMBO LED
7 SEGMENT

RED
99¢



6640 COMMON ANODE
6920 COMMON CATHODE

NOW A SUPER READOUT AT A SUPER BUY! These are factory fresh prime LED readouts, not seconds or rejects as sold by others. Compare our price and send for yours today, but hurry, the supply is limited! SPECIFY: COMMON ANODE OR COMMON CATHODE

NEW ITEMS

LM3046	(CA3046) Transistor Array	.75
LM3909	Led Flasher	.50
CA3086	RCA Transistor Array	.80
MC1438R	Power Op Amp/Driver	.50
1N4148	Prime Full Lead	100/2.50
LM3302	Quad Comparator	.89
2SC1849	High Freq NPN TO-92	6/1.00

POTENTIOMETER ASSORTMENT

A mix of new, panel mount 3/8" bushing pots in various values. Some dual, some with switches. 10/2.00

1/2W RESISTOR ASSORTMENT

A good mix of 5% and 10% values in both full lead and PC lead devices. All new, first quality. (Asst.) 200 pieces/2.00

SLIDE SWITCH ASSORTMENT

An outstanding bargain. Includes miniature and standard sizes and multi-position units. All new first quality, name brand switches. Try one pack and you'll reorder more. SPECIAL — 12 for \$1.20 (Assortment)

PARTS

301 OP AMP 8 LEAD CAN	3/1.00
723 VOLT REG 10 LEAD CAN	.50
*13741 FET INPUT 741 MINI DIP	3/1.10
30 000 @ 1% VOLT COMPUTER GRADE	2.10
7N4400 NPN GEN PURPOSE	8/1.00
2N4402 PNP COMPLIMENT	8/1.00
2N6028 P.U.T. W/SPECS	.50
LM380 2W AUDIO IC W/SPECS	1.00
LM377 DUAL LM380 W/SPECS	2.50
*7815 VOLT REG 1A 15V	.69
*725 LOW NOISE OP AMP	.99
EL 1 OPTO ISOLATOR MINI DIP	.80
*MEM 831 DUAL GATE MOSFET. DIODE PROTECTED. SIMILAR TO 40673	.40
MV1824 VARICAP DIODE 10 PFD	49
1N4003 1A 200V DIODE	15/1.00
11P30 TAB PNP POWER	3/1.00
*MC1551 FM IF. DISC IC	.50

*INDICATES ITEM IS "HOUSE NUMBER"

LED'S

JUMBO GREEN	4/89
JUMBO RED	5/89
MEDIUM RED (7/8")	.15
MEDIUM GRN OR YELLOW	.16

7 WATT AUDIO AMP KIT

SMALL SINGLE HYBRID IC AND COMPONENTS FIT ON A 2" x 3" PC BOARD (INCLUDED). RUNS ON 12 VDC. GREAT FOR ANY PROJECT THAT NEEDS AN INEXPENSIVE AMP. LESS THAN 3% THD @ 5 WATTS. COMPATIBLE WITH SE-01 SOUND KIT. **\$5.95**

DIGIT AUTO/VAN CLOCK

• LARGE W/ CHARACTERS (LED)
• QUARTZ XTAL TIMEBASE
• ALARM & SNOOZE OPTIONS
• NOISE FILTERING
• EASY TO ASSEMBLE
• 4" x 3" x 1 1/2"
• DRILLED & PLATED PC BOARDS
NEW!
COMPLETE KIT 12 VDC

ULTRASONIC RELAY KIT

INVISIBLE BEAM WORKS LIKE A PHOTO ELECTRIC EYE. USE UP TO 25 FT APART. COMPLETE KIT. ALL PARTS & PC BOARDS. **\$21.50**

• NO C.O.D.'S
• SEND CHECK M.O. OR CHARGE CARD NO.
• PHONE ORDERS ACCEPTED ON VISA AND MASTERCARD ONLY. (214) 278-3553
• ADD 5% FOR SHIPPING
• TX RES. ADD 5% STATE SALES TAX
• FOREIGN ORDERS ADD 10% (EXCEPT CANADA) (20% AIRMAIL) U.S. FUNDS ONLY

CIRCLE NO. 11 ON FREE INFORMATION CARD

Active Electronic Sales Corp.

Zilog

Z8001	\$195.00	16 Bit CPU with segmented address space to 8 Megabytes
Z8002	\$150.00	16 Bit CPU with non segmented address space to 64K bytes
Z8000DB	\$1500.00	A complete single board Z8000 microcomputer system. Contains the Z8002 microprocessor, 16K words of dynamic RAM, 2K word monitor PROM, dual serial interfaces, four counter/timers and 32 programmable parallel I/O lines

All Products Stocked in Depth Largest Zilog Inventory

Z80-CPU	2.5 MHz	\$ 9.95	Z80-DMA	2.5 MHz	\$26.85
Z80A-CPU	4.0 MHz	11.95	Z80A-DMA	4.0 MHz	33.60
Z80-PIO	2.5 MHz	7.20	Z80-SIO/O	2.5 MHz	36.00
Z80A-PIO	4.0 MHz	8.40	Z80A-SIO/O	4.0 MHz	39.50
Z80-CTC	2.5 MHz	7.20	Z80-SIO/1	2.5 MHz	36.00
Z80A-CTC	4.0 MHz	8.40	Z80A-SIO/1	4.0 MHz	39.50
			Z80-SIO/2	2.5 MHz	36.00
			Z80A-SIO/2	4.0 MHz	39.50

MICROPROCESSOR CHIP SETS

Part No.	Price	Part No.	Price	Part No.	Price
8080A	\$5.95	6800	\$6.95	65C2	\$9.95
8085	12.95	6802	11.95	65C4	9.95
				65C5	9.95
8212	3.45	6810	3.95		
8214	3.95	6820	3.95	65C0	6.95
8216	3.25	6821	3.95	6522	9.95
8224	2.95	6850	4.25	65C2	13.95
8226	2.25	6852	3.95	65E1	13.95
8228	3.98				
8238	4.75				
8251	5.75	1802LE	9.95	1854LE	6.95
8253	14.95	1824LE	3.50	1856LE	1.95
8255	5.75	1852LE	1.50	1858LE	1.95
8257	10.95	1853LE	1.45	1859LE	1.50
8259	14.95				

METAL POWER TRANSISTORS

Homotaxial — Best Quality

2N3054	.65	60V	NPN	TO-66
2N3055	.69	70V	NPN	TO-3
2N3442	1.50	160V	NPN	TO-3
2N3771	1.95	50V	NPN	TO-3
2N3772	1.95	100V	NPN	TO-3
2N3773	2.50	160V	NPN	TO-3

Universal SCR

C106D	.34	400V	5.0 AMP	TO-220
-------	-----	------	---------	--------

EPROM'S

C2708	1K x 8	450 ns	\$ 9.95
TMS2716	16K (2K x 8)	450 ns	\$24.95
	(3 power supplies) T.I. Version		
C2716/TMS2516	16K (2K x 8)	450 ns	\$29.95
	(Single 5V supply — Intel version)		

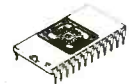

MOS MEMORIES

Part No.	MOS Static RAM's	Price
2101	1K (256 x 4) 350ns 22 PIN	\$1.95
2102LFPC	1K (1K x 1) Low Power 350ns 16 PIN	1.19
2102LHPC	1K (1K x 1) Low Power High Performance 250ns 16 PIN	1.29
2102-1PC	1K (1K x 1) 450ns 16 PIN	0.94
2102-2PC	1K (1K x 1) 650ns 16 PIN	0.89
P2111-25	1K (256 x 4) 250ns 18 PIN	2.25
P2112-35	1K (256 x 4) 350ns 18 PIN	2.25

Part No.	MOS Dynamic RAM's	Price
416-5	16K (16K x 1) 300ns 16 PIN	9.95
TMS4060-30	3K (4K x 1) 300ns 22 PIN	2.95
TMS4060-20	4K (4K x 1) 200ns 22 PIN	3.95

Part No.	UART's	Price
AY5-1013A	0 to 40K BAUD 40 PIN	4.50
AY3-1015	0 to 30K BAUD 40 PIN Single 5V supply	5.50

Part No.	1K CMOS RAM	Price
5101	1K (256 x 4) 450ns 22 PIN Low Power	3.95

Part No.	4K CMOS RAM	Price
P4315-45L	4K (4K x 1) 450ns 18 PIN	14.95

Part No.	SHIFT REGISTERS	Price
3341PC	FIFO 700 KHz	4.95
3341APC	FIFO 1 MHz	5.50
3342PC	64 Bit Shift Register	4.95
3347PC	80 Bit Shift Register	4.95

Part No.	ECL RAM	Price
10410ADC/HM2106	256 x 1 Bit Fully Decoded 15ns 16 PIN	Special 1.95

LINEAR I.C.'s

LM324N	59	LM741CN-8	29
LM339N	59	LM747CN-14	59
LM348N-14	99	LM748CN-8	39
LM555N-8	29	TBA810DAS	1.29
LM556N-14	59	LM1458N-6	49
LM723CN-13	49	LM3403N-14	39
LM725CN-8	1.25	LM3900N	59
LM739CN-14	29	LM4136N-14	39

Special of the Month

4K STATIC RAM

2114L Low Power \$4.95

4K (1024 x 4) 300ns



1980 IC MASTER

JUST RELEASED over 2700 PAGES

Complete integrated circuit data selector. Master guide to the latest I.C.'s including microprocessors and consumer circuits. 45,000 device types listed. 5,000 new device types added. Complete new section on MPU boards & Systems.

Free Quarterly Updates **\$69.95**



SOUND & MUSIC GENERATOR I.C.

Creates almost any type of sound, from music to gunshots and explosions. High level op amp output. 28 pin DIP. Operates from one 9V battery. With data.

"Lowest Price Offered Anywhere"

SN76477N (600' centers) **\$2.43**

SN76477NF (400' centers) **\$2.29**

New small package



MICROCOMPUTER BOARDS

NFC MICROCOMPUTERS	Rockwell International
1K80A \$299.00	AIM65 \$375.00

Based on the 8080A the board has both 1K FA's, and 1K electrically erasable PROM expandable to 4K x 8 and 8K x 8 on board. Complete with keypad with 25 real keys and 8 bright, 500 digit for display.

As a learning aid AIM65 gives you an assembled, tested and warranted R6502 based microcomputer system with a full sized keyboard, an alphanumeric 20 character display and uniquely, an alphanumeric 20 column thermal printer. An on board Advanced Interface Monitor program provides extensive control and program development functions. 1K RAM.

TEXAS INSTRUMENTS Low Profile Sockets

Lowest prices anywhere for the highest quality, an unbeatable combination. Over one million pieces in stock.

Contacts	Price	Contacts	Price
8 PIN	.08	22 PIN	.22
14 PIN	.12	24 PIN	.24
16 PIN	.14	28 PIN	.28
18 PIN	.18	40 PIN	.40
20 PIN	.20		



Synertek[®] SYM-1 \$239.00

Fully assembled, tested, documented and expandable. Powerful 6502 8-bit microprocessor, 6-digit hex LED display. KIM-1 hardware compatibility. Single plus 5V power requirements.

Texas Instruments TM990/185 \$333.00

A complete learning aid that in conjunction with the Tutorial Text offers hands on experience with microprocessors, I/O, memory and assembly language programming. Offers advanced features such as 45 key alphanumeric keyboard, a powerful instruction set, multiply and divide, vectored interrupts, single bit I/O manipulation parallel I/O and addressing modes.

L.E.D. LAMPS

LED209	T-1 3 mm Red	.09
LED211	T-1 3 mm Green	.14
LED212	T-1 3 mm Yellow	.14
LED220	T-1 1/2 5 mm Red	.11
LED222	T-1 1/2 5 mm Green	.19
LED224	T-1 1/2 5 mm Yellow	.16

DISPLAYS

FND357	375	Common Cathode	1.09
FND367	360	Common Cathode (high brightness)	1.29
FND500	500	Common Cathode	1.09
FND507	500	Common Anode	1.09
FND560	500	Common Anode (high brightness)	1.29
FND567	500	Common Cathode (high brightness)	1.29
DL704	300	Common Cathode	1.29
DL707	300	Common Anode	1.29
DL747	630	Common Anode	2.29

ISOLATORS

ILD74	Dual Opto Isolator	1500V	1.29
ILO74	Quad Opto Isolator	1500V	3.95
MCT6	Dual Opto Isolator	1500V	1.29
TIL111	Opto Coupler	1500V	.69
4N26	Opto Isolator	2500V	.59
4N28	Opto Isolator	500V	.59
4N29	Opto Isolator	2500V	.69
4N32	Opto Isolator	2500V	.69

Active Electronic Sales Corp.

P.O. BOX 1035 FRAMINGHAM, MASSACHUSETTS 01701

Over-the-counter sales, 12 Mercer Rd., Natick, Mass 01760 Behind Zayres on Rte. 9 Telephone Orders & Enquiries (617) 879-0077

MINIMUM ORDER \$10.00 • ADD \$2.00 TO COVER POSTAGE & HANDLING

Foreign customers please remit payment on an international bank draft or international postal money order in American dollars.

IN CANADA: 5651 FERRIER ST. MONTREAL, QUEBEC H4P 2K5 Tel.: (514) 731-7441

4800 DUFFERIN ST. DOWNSVIEW, ONTARIO M3H 5S9 Tel.: (416) 661-1115

BAXTER CENTRE 1050 BAXTER ROAD OTTAWA, ONTARIO K2C 3P2 Tel.: (613) 820-9471

3070 KINGSWAY VANCOUVER, B.C. V5R 5J7 Tel.: (604) 438-3321



HICKOK 3 1/2 Digit Mini-Multimeter
MODEL LX 303 \$69.50

Sinclair PDM35 digital MultiMeter
Reg. \$69.95 \$49.95

BK PRECISION 3 1/2-Digit Portable DMM
• Over head Protected • Battery or AC operation • 3" high LED Display • Auto Zeroing • Model 2800 comes complete with test leads, operating manual and spare fuse

NLS 15 MHz Mini Oscilloscope
Model MS 15
Reg. \$318.00 \$269.95

Logic Probe
Model LP 1
• Compact, circuit powered • Detects pulses as short as 50 nsec • Multi-family compatibility DTL/TTL/HTL/CMOS

30MHz Dual Trace with Delay Line
Reg. \$1100.00 \$892.50

Function Generator
Model 7001
Sine, square, triangle and separate TTL Square wave output

GOULD 15 MHz Dual Trace
• Triggers in excess of 25 MHz

Weller Controlled Output Soldering Station
Reg. \$77.50 \$49.95

Weller 'Xcelite'

Service Master Attache Style Tool Kit Tool Cases
Model 99SM \$47.50
Model TC 100/ST \$279.95
Model 99P \$49.95

Roll Kit
Reg. \$37.95 \$19.95

Miniature High Fidelity Stereo Speaker System.
Reg. \$139.00 \$69.50

Magnifier LAMP
Model MG 10A \$49.50

Chess Challenger
Model BCC \$74.95

700 Series Precision ground and polished magnification lens. Uses 22W T-9 Circline fluorescent.

RC Circuit Box/RCA-VIZ
• 36 resistors (15 ohms to 10 megohms) • 18 capacitors (100 pF to 0.22 uF) • Model WC 412A Reg. \$49.95 \$42

30MHz Portable Frequency Counter
Reg. \$130.00 \$65.00

SENCORE TV-VTR-MATV and Video Analyzer
Model VA48 \$945.75 Reg. \$1095.00

ES CONTINENTAL SPECIALTIES 100 MHz 8-Digit Counter \$127.50
• 20 Hz-100 MHz Range • 6" LED Display • Fully Automatic Reg. \$150.00 • Includes 100 IPC clip-lead input cable manual

ES Digital Capacitance Meter
Model 820 \$249.95

BSR SYSTEM X-10 Remote Control for Lights & Appliances
4 Piece Starter Kit Reg. \$87.95 \$79.50

Bearcat Scanner
Model 250 \$299.95

Touch K100 Scanner
Reg. \$269 \$199.95

Logic Monitor
Model LM-1 \$59.95 complete

WHL NEW ISO-TIP "Quick Charge"
Model 7800 \$29.95

BSR 500MHz Prescaler
Model 1500 \$249.95

CODE-A-PHONE Telephone Answering Devices
Model 1400 \$199.95

BSR Changer Accessories
Model BSR-129 \$29.95

Microflame Deluxe Gas Torch Kit
Model 4400 Reg. \$39.95 \$29.95

In-Dash AM/FM 8 Track Stereo
C 777 \$52.50

AM/FM Cassette Stereo
CAS 888 \$57.50

Stereo Power Booster POW-40
40 WATTS STEREO 20 WATTS PER CHANNEL BASS BOOST \$24.95

FREE 1979 Catalog

"We Will Beat Any Advertised Price"

FORDHAM
855R Conklin St. Farmingdale, N.Y. 11735

We bought 350,000 LED's. And you get the savings.
Reds, greens, yellows, orange, small, medium, large. Bags of 25 - mixed \$2.75. That's only 11¢ each. Compare this bargain up to twice our price.

FACTORY PRIME
SBI - Polar LED 59¢ ea. or 10 for \$5

LAB-BENCH VARIABLE POWER SUPPLY KIT
5 to 20 VDC at 1 AMP. Short circuit protected by current limit. Uses IC regulator and 10 AMP Power Darlingtons. Very good regulation and low ripple. Kit includes PC Board, all parts, large heatsink and shielded transformer. 50 MV TYP Regulation \$15.99 KIT

LED BAR GRAPH AND ANALOG METER DRIVER
New from National Semi. #LM3914. Drives 10 LED directly for making bar graphs, audio power meters, analog meters, LED oscilloscopes, etc. Units can be stacked for more LED's. A super versatile and truly remarkable IC. Just out!

SPECIAL PRICE: \$3.99 INCLUDES 12 Page Spec. Sheet

CLOCK MODULE OPTIONS
MA1008 A and D MA1013
Switches and pot for all options
Includes:
5 push buttons
1 toggle
1 10K pot \$2.50
Alarm Parts (including high impedance transducer) Much more efficient than a speaker \$1.50
Transducer only (unbelievably loud!) \$1.10

16K DYNAMIC RAM CHIP WORKS IN TRS-80 OR APPLE II
16K X 1 Bits 16 Pin Package Same as Mostek 4116-4 250 NS access 410 NS cycle time. Our best price yet for this state of the art; RAM 32K and 64K RAM boards using this chip are readily available. These are new fully guaranteed devices by a major mfg.

VERY LIMITED STOCK!
"MAGAZINE SPECIAL" - 8/\$79.50

SONY 23 WATT AUDIO AMP MODULE
#STK-054. 23 WATTS SUPER CLEAN AUDIO. 20 HZ to 100 KHZ ± 2 DB. HYBRID. SILICON. SELF-CONTAINED MODULE. ONLY 1 1/4 x 2 1/2 IN. WITH DATA.
COMPARE AT UP TO TWICE OUR PRICE! \$6.99 each

60 Hz CRYSTAL TIME BASE \$4.95 (Complete Kit)
Uses MMS369 CMOS divider IC with high accuracy 3.579545 MHZ Crystal. Use with all MOS Clock Chips or Modules. Draws only 1.5 MA. All parts, data and PC Board included 100 Hz. same as above, except \$5.95.

FAIRCHILD PNP "SUPER TRANSISTOR"
2N4402 TO-92 Plastic Silicon PNP Driver. High Current. VCEO-40 HFE-50 to 150 at 150 MA FT-150 MHZ. A super "BEEFED-UP" Version of the 2N3906.
8 FOR \$1.19

MICRO MINI TOGGLE SWITCHES 6 for \$5 with hardware.
Sound Activated Switch not a kit. Already assembled Clap your hands and turn on lights, music boxes, coffee pots, etc. Full spec. sheet with each unit.
69¢ ea. 10 for \$5.50

JUMBO IC ASSORTMENT
All new not rejects. BIG computer mfg. Surplus. Some standard marked, many house numbered. TTL, DTL, LINEAR. All prime. 1st line.
50 for \$1.59 500 for \$12.95

NATIONAL SEMICONDUCTOR "COLOSSUS JR." JUMBO CLOCK MODULE MA1013 BRAND NEW!

\$8.50 (3 FOR \$15) (IAC XFMR \$1.95)

ASSEMBLED! NOT A KIT! **PERFECT FOR USE WITH A TIMEBASE.**

- Bright 4 digit 0.7" LED Display
- Complete-Add only Transformer and Switches
- 24 Hour Alarm Signal Output
- 12 Hour Real Time Format
- 50 or 60 Hz Operation
- Power Failure Indication
- LED Brightness Control
- Sleep and Snooze Timers
- Alarm "on" and PM Indicators
- Direct Drive - No RFI
- Direct Replacement for MA1012
- Comes with Full Data

TOSHIBA POWER AUDIO AMP
5.8 WATTS RMS Typical Output. 50 to 30,000 HZ ± 3 DB. For CB's, tape decks, PA's, etc. Works off of a single supply voltage from 10.5 to 18 VDC. 10 Pin plastic DIP with special built in heat sink tab. Perfect for use on 12VDC. \$399 each With Data.

Digital Research: Parts
(OF TEXAS)
P.O. BOX 401247 • GARLAND, TEXAS 75040 • (214) 271-2461

TERMS: Add 50¢ postage, we pay balance. Orders under \$15 add 75¢ handling. No C.O.D. We accept Visa, MasterCard and American Express cards Tex. Res. add 5% Tax. Foreign orders (except Canada) add 20% P&H. 90 Day Money Back Guarantee on all items.
Write for our free catalog full of many useful bargains.

Electronics Classified

REGULAR CLASSIFIED: COMMERCIAL RATE: For firms or individuals offering commercial products or services, \$2.75 per word. Minimum order \$41.25. **EXPAND-AD® CLASSIFIED RATE:** \$4.10 per word. Minimum order \$61.50. Frequency discount: 5% for 6 months; 10% for 12 months paid in advance. **PERSONAL RATE:** For individuals with a personal item to buy or sell, \$1.60 per word. No minimum! **DISPLAY CLASSIFIED:** 1" by 1 column (2-1/4" wide), \$330. 2" by 1 column, \$660.00. 3" by 1 column, \$990.00. Advertiser to supply firm positives. For frequency rates, please inquire. Send order and remittance to Classified Advertising, **POPULAR ELECTRONICS**, One Park Avenue, New York, N.Y. 10016. For inquiries, contact Linda Lemberg at (212) 725-7686.

FOR SALE

FREE! Bargain Catalog — I.C.'s, LED's, readouts, fiber optics, calculators parts & kits, semiconductors, parts, Poly Paks, Box 942PE, Lynnfield, Mass. 01940.

GOVERNMENT and industrial surplus receivers, transmitters, snooper scopes, electronic parts. Picture Catalog 25 cents. Meshna, Nahant, Mass. 01908.

LOWEST Prices Electronic Parts. Confidential Catalog Free. KNAPP, 4750 96th St N., St. Petersburg, FL 33708.

ELECTRONIC PARTS, semiconductors, kits. FREE FLYER. Large catalog \$1.00 deposit. **BIGELOW ELECTRONICS**, Bluffton, Ohio 45817.

RADIO — T.V. Tubes — 36 cents each. Send for free catalog. Cornell, 4213 University, San Diego, Calif. 92105.

AMATEUR SCIENTISTS. Electronics Experimenters. Science Fair Students... Construction plans — Complete, including drawings, schematics, parts list with prices and sources... Robot Man — Psychedelic shows — Lasers — Emotion/Lie Detector — Touch Tone Dial — Quadrasonic Adapter — Transistorized Ignition — Burglar Alarm — Sound Meter... over 60 items. Send \$1.00 (no stamps) for complete catalog. Technical Writers Group, Box 5994, University Station, Raleigh, N.C. 27650.

SOUND SYNTHESIZER KITS — Surf \$16.95, Wind \$16.95, Wind Chimes \$22.95, Musical Accessories, many more. Catalog free. PAIA Electronics, Box J14359, Oklahoma City, OK 73114.

TELETYPE EQUIPMENT: Copy Military, Press, Weather, Amateur, Commercial Transmissions. Catalog \$1.00. **WEATHER MAP RECORDERS:** Copy Satellite Photographs, National-Local Weather Maps. Learn How! \$1.00. Atlantic Sales, 3730 Nautilus Ave., Brooklyn, NY 11224. Phone: (212) 372-0349.

WHOLESALE C.B.'s. Scanners, Antennas, Catalog 25 cents. Crystals: Special cut, \$4.95, Monitor \$3.95. Send make, model, frequency. G. Enterprises, Box 461P, Clearfield, UT 84015.

BUILD AND SAVE TELEPHONES, TELEVISION, DETECTIVE, BROADCAST Electronics. We sell construction plans with an Engineering Service. Speakerphones, Answering Machines, Carphones, Phonevision, Dialers, Color TV Converters, VTR, Games, \$25 TV Camera, Electron Microscope, Special Effects Generator, Time Base Corrector, Chroma Key, Engineering Courses in Telephone, Integrated Circuits, Detective Electronics. **PLUS MUCH MORE.** NEW Super Hobby Catalog PLUS year's subscription to Electronic News Letter, \$1.00. Don Britton Enterprises, 6200 Wilshire Blvd., Los Angeles, Calif. 90048.

UNSCRAMBLERS FOR any scanner. Several models available. Free literature. Capri Electronics, 8753T Windom, St. Louis, MO 63114.

UNSCRAMBLER KIT. Tunes all scramble frequencies. may be built in most scanners, 2-3/4 x 2-1/4 X 1 1/2. \$19.95. Factory built Code-Breaker \$29.95. Free Catalog: **KRYSTAL KITS**, Box 445, Bentonville, Ark. 72712. (501) 273-5340.

SpeakerGuts.



The absolute latest in advanced speaker technology. **Wave Aperture™ Drivers.** The Patented **Nestovic Woofer System.** raw speaker components selected for their excellence. Horns, crossovers, subwoofers, woofers, midranges, horn and dome tweeters. Over 30 in all. Build your own speaker system and we'll provide top quality speakers and design information. Send for FREE 48 page color catalog from the largest, most experienced speaker kit manufacturer in the world. **DON'T DELAY. Write today!**

Speakerlab®
Dept. 168, 735 N. Northlake Way
Seattle, Washington 98103

NAME BRAND Test Equipment. Up to 50% discount. Free catalog. Saiten Electronics, Box 82, Skokie, Illinois 60077.

UNSCRAMBLE CODED MESSAGES from Police, Fire and Medical Channels. Same day service. Satisfaction guaranteed. **Don Nobles Electronics, Inc.,** Rt. 7, Box 610, Hot Springs, Arkansas 71901. (501) 623-6027.

POLICE FIRE SCANNERS, crystals, antennas, CBs, Radar Detectors. HPR, Box 19224, Denver, CO 80219.

CB RADIOS, VHF-UHF Scanners, Crystal, Antennas, Radar Detectors. Wholesale. Southland, Box 3591, Baytown, TX 77520.

PRINTED CIRCUIT supplies, chemicals, tools, artwork, plating solutions. Major credit cards. Catalog \$2.00, refundable. **CIRCOLEX,** Box 198, Marcy, NY 13403.

RECONDITIONED TEST EQUIPMENT \$1.00 for catalog. **WALTER'S TEST EQUIPMENT,** 2697 Nickel, San Pablo, CA 94806. (415) 758-1050.

NEGATIVE ION GENERATORS AND ACCESSORIES. (Kits). Fascinating details — \$1.00. **Golden Enterprises,** Box 1282-PE, Glendale, Arizona 85311.

Telephone Listening Device

Record telephone conversations in your office or home. Connects between any cassette or tape recorder and your telephone or telephone LINE. Starts automatically when phone is answered. Records both sides of phone conversation. Stops recorder when phone is hung up. This device is not an answering service.



Each
\$18.95
Qty. Disc Avail.

Super Powerful Wireless Mic

10 times more powerful than other mics. Transmits up to 1/4 mile to any FM radio. Easy to assemble kit. 15V battery (not incl.).

Call (305) 725-1000 or send \$18.95 + \$1.00 shipping per item to **USI Corp., P.O. Box PE-2052, Melbourne, FL 32901.** **COD's accept.** For catalog of transmitters, voice scramblers and other specialty items, enclose \$2.00 to USI Corp.

AUDIO NOISE REDUCTION KIT — 318 SILENCER for tapes, records, FM. Free brochure. **LOGICAL SYSTEMS,** 3314 'H' St., Vancouver, Washington 98663.

BARGAINS GALORE! Monthly swap sheet for radio collectors, hams, experimenters, etc. Send long SASE for sample. **Electronics Trader,** Box 2377, Argus, CA 93562.

FREE SAMPLE of optical fiber if you send for our catalog of fiber optic and electronic supplies. **FIBERTRONICS,** Box 322, Primos, PA 19018.

TREMENDOUS BUYS In New And Gov't Surplus Equipment

Dial Telephone "SUPER BUY"

• Save us the labor costs of cleaning and polishing and save \$555 on standard dial telephones. Work on any commercial system. Complete. (no parts missing) in good working order. Your choice of desk or wall models. These are take-outs from commercial service (not toys). Instructions furnished.



Wall Model #735-MPE \$7.95
Desk Model #735-PE

FREE CATALOG Shows BIG SAVINGS On

• ELECTRONICS • ELECTRICAL • ALARM SYSTEMS • TELEPHONES • PUMPS
• BINOCULARS • GEAR MOTORS • WINCHES • SURVIVING INSTRUMENTS
• GENERATORS • COMPRESSORS • HYDRAULICS • POWER TOOLS • WELDERS
• POWER PLANTS • CHEMICAL SPRAYING • TARPAPLANS • MANY OTHERS

Surplus Center Box 82209-PE Lincoln, Ne. 68501

NEW ELECTRONIC PARTS. Continuously stocked. Stamp brings catalog. **Daytop Electronics,** 3029 N. Wilshire Ln. Arlington Hts., IL 60004.

SATELLITE TV FOR THE HOME

Our receiver lets you get over 75 channels of television directly from the satellites!: HBO, Showtime, super stations, sports and movies from around the world. **Works Anywhere.**

FCC licensing no longer required.

—3 WAYS TO GO—

- **Buy complete**—our 24-channel tunable receiver, LNA and feed, only \$1,600.
- **Assemble**—our kit, all parts included, 2-day project.
- **Construct**—from our new step-by-step plans—**SAVE!**

Complete details covered in our Home Earth Station manual. Send \$7.95 today (refundable against any purchase), or call our 24-hr. C.O.D. Hotline: (305) 869-4283.

SPACECOAST RESEARCH
P.O. Box 442, Dept. S, Altamonte Springs, FL 32701



ELECTRONICS COMPLETED KITS. No wiring. FM mic. VU meter. Touch control switch programmable music block. Wheel fortune game, etc. Save up to 50%. Write for free catalog today. Postcard will do. **Supertronics Inc.,** 39 Bowery, Box 88, New York, NY 10002.

SATELLITE TELEVISION — MOVIES, SPORTS, etc. Build or buy earth station. Send \$3.00 for information. **Satellite T.V.,** Box 140, Oxford, NY 13830.

B&K Test Equipment 18% discount. Free catalog. Free Shipping. **Spacetrone-AD,** 948 Prospect, Eimhurst, IL 60126.

MEASURE CAPACITORS DIGITALLY to ± 1% with your counter using our Capacitance-to-Period Converter. \$16.95. Free Brochure. **Hall Engineering,** Dept. PE, PO Box 506, Martinsville, NJ 08836.

HOW TO BUILD CROSSOVERS. Design and construction book. \$5.00. Book of tables showing component values for 2590 discreet impedance-frequency points. 6 dB/oct 58.00. 12 dB/oct \$8.00. Mesalab. 3942 Mesa Ave., Sarasota, FL 33583.

NEW CATALOG of low cost electronic parts. Send for FREE copy. **ALL ELECTRONICS CORP.,** Dept. F, 905 S. Vermont Ave., Los Angeles, CA 90006.

FIX CB RADIOS for yourself, friends or profit. Complete manual now \$10.95 from **A.P. SYSTEMS, P.O. Box 488 PE, Milford, PA 18337.** (717) 686-5900.

New Morse-A-Word Code Reader



IDEAL FOR BEGINNERS, SOUL'S AND AMATEURS. CONNECTS TO YOUR RECEIVER SPEAKER. FULL EIGHT CHARACTER READOUT ORDER MAWE \$249.95. KIT \$169.95. SEND CHECK OR MONEY ORDER. USE YOUR VISA OR MASTER CHARGE. ADD \$3.50 FOR SHIPPING.

Microcraft Corporation Tel: 414-241-8144
P.O. Box 513 PE, Thiensville, Wisconsin 53092

GIANT-SCREEN TV. Projection system kit includes lens, plans, instructions. \$16.00. Guaranteed. **ADP Enterprises,** Box AW-2, Brisbane, CA 94005.

LOW, LOW Component Prices! Ask for free flyer. Write: **E.E.P.** 11 Revere Place, Tappan, NY 10983.

SIMPLE 31C DIGITAL AUTO DOCUMENTATION for temp., oil, and voltmeter gauges, P.P. USA - Canada. \$3.25. Boards and components now available. **Digital World, P.O. Box 5508, Augusta, GA 30906.**

RF POWER TRANSISTORS — MRF 455A — \$17.95. MRF 454A — \$24.95. 2N 5591 — \$8.90. 2N 6084 — \$14.50. more. TV, audio, radio, VTR transistors, IC's, diodes. SG 613 — \$5.90. STK 013 — \$8.40. AN 239 — \$4.90. more. Send for free catalog. B & D Enterprises, P.O. Box 32, Mt. Jewett, PA 16740. (814) 837-6820. 24 hours.

STUDIO II CONVERSION TO MICROCOMPUTER — Plans \$5.00. Kits available. Aresco, Box 1142, Columbia, MD 21044.

BUY DIRECT! TV semiconductors, parts, chemicals at distributor's cost. Free catalog. MIDWEST SEMICONDUCTOR, Dept. P, 4411 W. North Ave., Milwaukee, WI 53208.

BUILD THE ARTISAN ELECTRONIC ORGAN... The 20th century successor to the classic pipe organ. Kits feature modular construction, with logic controlled stops and RAM Pre-Set Memory System. Be an arti-san. Write for our free brochure. AOK Manufacturing, Inc., Box 445, Kenmore, WA 98028.



LOUD AND CLEAR.
Read all about the K—the amazing speaker that has the power to reproduce even the lowest bass notes—loud and clear. Features the brilliant cornerhorn design with speakerlab innovations like Magnar™ damped horn drivers. One of the only kits available for this unique loudspeaker. Read about K's and all the other great Speakerlab speakers and parts in our free catalog.

Speakerlab
To get yours, write
SPEAKERLAB Dept. 159
735 N. Northlake Way
Seattle WA
98103

SCANNER CRYSTALS \$2.85. PLL conversion crystals \$4.00. 50c P&H. Diversified Marketing, 2010 So. 139th Cir., Omaha, NE 68144.

OSI CHALLENGER 1P — Superboard II, 90 page step-by-step programming manual, \$5.95 + \$1.00 P&H. TIS, Box 921, Los Alamos, NM 87544.

DISCOUNT C.B. SCANNERS, ACCESSORIES. Free Catalog Crystals: CB, Ham, Scanner. All freqs. Same day service. XTALS, Box 42-E, Prospect Hts., IL 60056.

TRS-80 USERS: We have hardware and software. Write for current list. HARTMANN-LANG, Box 693, Chatham, NJ 07923.

SENSITIVE CONVERTER 1600 — 2400 megahertz \$99.95. Details for stamp. GW Electronics, POB 688, Greenwood, Indiana 46142.

NEW FALL 1979 TEST EQUIPMENT CATALOG AVAILABLE 108 pages of quality used equipment. Write for free copy. Tucker Electronics Co., Box 401060, Garland, TX 75040.

PRINTED CIRCUIT BOARDS, your artwork. Quick delivery. Reasonable. Atlas Circuits, Box 974, Waynesville, NC 28786.

POLICE SCANNERS — WHOLESALE PRICES. Over 25 models. Bearcat 300 — \$349.95. Regency M 100 — \$229.95. Bearcat 220 & 250 — \$259.95. Same day shipping. VISA MC. (415) 573-1624. Free catalog. Write: Scanners Unlimited, 1326 El Camino Real, Belmont, CA 94002.

MEMORY BOARD with 72 INTEL 2107B in sockets. \$70 or \$1 each. George Murphy, RD1, Fort Plain, NY 13339.

FREE CA3140 OpAmp with every order. All top quality merchandise. Send for bargain catalog. KEY ELECTRONICS, Box 3506P, Schenectady, NY 12303.

100 ELECTRONIC PARTS with 9 drawer parts organizer only \$5.00 plus \$1.50 shipping. Parts are 100% usable. Includes prime semiconductors. Cunningham, POB 123, Leetonia, Ohio 44431.

16K DYNAMIC RAMS Upd 416 tested pullouts guaranteed. Set of 8, \$45 \$6 ea. Jim Terry, P.O. Box 61411, Sunnyvale CA 94008. (408) 733-7299.

NAME BRAND TEST EQUIPMENT at discount prices. 72 page catalogue free. Write: Dept. PE, North American Electronics, 1468 West 25th Street, Cleveland, OH 44113.

PLANS AND KITS

PRINTED CIRCUIT Boards from sketch or artwork. Kit projects. Free details. DANOCINTHS Inc., Box 261, Westland, MI 48185.

ELECTRONICS KITS: For information, send self addressed stamped envelope. GI Kits, Box 2329, Garland, TX 75041.

HI FI STEREO AMPLIFIER. Build your own, at half market price! Info \$1.00. Otech, P.O. Box 1245, Des Plaines, IL 60018.

DOLBY DECODER now assembled for \$100. Also Kit encode/decode. Reviews. PEJ INTEGREX, Box 747, Havertown PA 19083.

AMAZING ELECTRONIC PRODUCTS

LASERS SUPER POWERED, RIFLE, PISTOL, POCKET - SEE IN DARK - PYRO. TECHNICAL DE-BUGGING, UNSCRAMBLERS, GIANT TESLA, STUNWAND, TV DISRUPTER, ENERGY PRODUCING, SCIENTIFIC DETECTION, ELECTRICITY, CHEMICAL, ULTRASONIC, CB, AERO, AUTO AND MECH DEVICES. HUNDREDS MORE - ALL NEW PLUS INFO UNLTO PARTS SERVICE

INFORMATION unlimited

CATALOG \$1 Dept. E8, Box 716, Amherst, NH 03021

FREE KIT Catalog contains Test and Experimenter's Equipment. Dage Scientific Instruments, Box 1054P, Livermore, CA 94550.



**TIGER 500
SIMPLI-KIT**

FOR THE DO-IT-YOURSELFER

NOW! a high quality CD ELECTRONIC IGNITION SYSTEM in kit form.

Contains all components and solder to build complete Solid-State Electronic CD Ignition System for your car. Assembly requires less than 3 hours.

- Increases MPG 15%
- Increases horsepower 15%
- Plugs and Points last 50,000 miles
- Eliminates 4 or 5 tune-ups
- Instant starting, any weather
- Dual system switch

Fits only 12 volt neg. ground...
Only \$26.95 postpaid

Tri-Star Corporation
P.O. Box 1727, Grand Junction, Colorado 81501

NR-2 ADAPTIVE NOISE FILTER KIT as featured in Radio Electronics August, September issues. Reduces audio noise 12db! Works with all program sources; tape or FM broadcast. Even works with Dolby systems. \$69.95. Free information. Dealer inquiries invited. Mastercharge/VISA. Advanced Audio Systems, Dept. NR-2, P.O. Box 24, Los Altos, CA 94022. (408) 377-7148.

NEW — PLANS TO BUILD UNSCRAMBLER. Totally integrated circuit design based on available IC's. Includes instructions, drawings, schematics, and parts list, \$3.95. Unscrambler, P.O. Box 7577, Huntington, West Virginia 25777.

PROJECTION TV... Convert your TV to project 7 Foot picture. Results equal to \$2,500 projector. Total cost less than \$200. PLANS & LENS \$16.00. Illustrated info. FREE: Macrocom, Washington Crossing, PA 18977.

BUILD 200 WATT CHANNEL AUDIO POWER AMPLIFIER for \$125. Send self-addressed, stamped envelope for details: BHL, P.O. Box 2804, C.S., Pullman, WA 99163.

FANTASTIC AUTOMOBILE PROJECT. My plans. Your time. Cheap parts. Automatic self-contained system starts car and operates accessories, i.e. heater, air conditioner, etc. Complete assembly/hook-up instructions \$5.00 and SASE. Jack Curran, 59 Adlai Circle, S.I., NY 10312.

IMPROVE YOUR COST/PERFORMANCE RATIO, 200% PUT YOUR MONEY WHERE IT REALLY COUNTS, IN QUALITY COMPONENTS AND A HIGH PERFORMANCE DESIGN. BUY A PHOENIX SYSTEM KIT.

FOR SALE:

PARAMETRIC EQUALIZER KIT	P-94-S	\$ 99.00
ANALOG DELAY LINE KIT (MONO)	P-1220-M	\$ 50.00
(175 KHZ @ 40 MS.) (STEREO)	P-1220-S	\$ 75.00
TAPE NOISE REDUCTION KIT	P-518-S	\$ 59.00
BI-FET PREAMP KIT	P-1130-PA	\$ 90.00
BI-FET PA/DISCO MIXER KIT	P-1130-DM	\$130.00

SEND FOR SPECS/CATALOG
PHOENIX SYSTEMS/378 SPANNAHILL ROAD/MONROE, CONN. 06468

30 DAY MONEY BACK GUARANTEE ON ALL PHOENIX PRODUCTS

BUILD 200 WATT CHANNEL AUDIO POWER AMPLIFIER for \$125. Send self-addressed, stamped envelope for details: BHL, P.O. Box 2804, C.S., Pullman, WA 99163.

PERSONALS

MAKE FRIENDS WORLDWIDE through international correspondence, illustrated brochure free. Hermes-Verlag, Box 110660 Z, D-1000 Berlin 11, W. Germany.

MAILORDER SUCCESS! Interested? Free exposé. TWP-V, Box 6226, Toledo, Ohio 43614.

SAVE MONEY, become non-smoker. You can quit, thousands have. Send \$4.50 check, cash, money order. AMLU, Box 336, Monroe, Utah 84754.

LOFTINESS MUSIC? Connoisseur's recommendations—\$2. Box 5600. Jax, FL 32207.

PENFRIENDS — ENGLAND — USA, through correspondence. Send age, interests. Free reply. Harmony, Box IPE, Brooklyn, New York 11223.

INSTRUCTION

UNIVERSITY DEGREES BY MAIL! Bachelors, Masters, Ph.D's. Free revealing details. Counseling, Box 317-PE01, Tustin, California 92680.

LEARN WHILE ASLEEP! HYPNOTIZE! Astonishing details, strange catalog free! Autosuggestion, Box 24-ZD, Olympia, Washington 98507.

INTENSIVE 5 week course for Broadcast Engineers. FCC First Class license. Student rooms at the school. Radio Engineering Inc., 61 N. Pineapple Ave., Sarasota, FL 33577/2402 Tidewater Trail, Fredericksburg, VA 22401. (703) 373-1441.

RADIO BROADCASTING: Become DJ, engineer. Start your own station — investment/experience unnecessary! Receive free equipment, records. Free details. Broadcasting, Box 130-A1, Paradise, CA 95969.

LEARN ELECTRONIC ORGAN SERVICING at home. Completely revised course covers latest models including digital, LSI's, synthesizers, etc. NILES BRYANT SCHOOL, PO Box 20153, Sacramento, CA 95820.

FIX CB RADIOS for yourself, friends or profit. Complete manual now \$10.95 from A.P. SYSTEMS, Box 488P, Milford, PA 18337, (717) 686-5900.

PASS FCC EXAMS

The Original FCC Tests-Answers exam manual that prepares you at home for FCC First and Second class Radiotelephone licenses. Newly revised multiple-choice exams cover all areas tested on the actual FCC exam. Plus "Self-Study Ability Test." Proven! \$9.95 postpaid. Moneyback Guarantee.

COMMAND PRODUCTIONS P.O. Box 26348 P
Radio Engineering Division San Francisco, CA 94126

BEGINNERS! Learn to Design and Trouble Shoot Electronics Circuits. New Book Tells How. Send \$7.95 to Chapel Company, Dept. PE-1, 3724 Colonial Ave., Erie, PA 16506.

FOR INVENTORS

PATENT AND DEVELOP Your invention. Registered Patent Agent and Licensed Professional Engineer. Send for FREE PATENT INFORMATION every inventor should have. Richard L. Miller, P.E., 3612 Woolworth Building, New York, NY 10007. (212) 267-5252.

INVENTIONS WANTED

FREE CONSULTATION • NO IDEA TOO SMALL
Disclosure protection. Cash or royalties from manufacturers seeking new ideas. For free information on how to protect your ideas. Call or Write

American Inventors Corp.

59 Interstate Dr Dept PE
West Springfield, MA 01089 (413) 737-5376
A Fee Based Service Company

TUBES

RADIO & T.V. Tubes — 36 cents each. Send for free Catalog. Cornell, 4213 University, San Diego, Calif. 92105.

TUBES: "Oldies", Latest Supplies, components, schematics. Catalog Free (stamp appreciated). Steinmetz, 7519-PE Maplewood, Hammond, Ind. 46324.

TUBES-RECEIVING, Industrial and Semiconductors Factory Boxed. Free price sheet including TV, Radio and audio parts list. Transletronic, Inc., 1365 39th St., Brooklyn, New York 11218. Telephone: (212) 633-2800. Toll free: 800-221-5802.

RADIO AND TV TUBES 1938 to 1978 \$1.00 ea. PRELLER TV, Augusta, AR 72006. (501) 347-2281.

GOVERNMENT SURPLUS

MANUALS for Govt Surplus radios, test sets, scopes. List 50 cents (coin). Books, 7218 Roanne Drive, Washington, D.C. 20021.

SURPLUS JEEPS — \$19.30!! — CARS — \$13.50!! — 650.000 ITEMS!! — GOVERNMENT SURPLUS!! — Most COMPREHENSIVE DIRECTORY AVAILABLE tells how, where to buy!! — YOUR AREA — \$2. — MONEYBACK GUARANTEE!! — "Government Information Services", Department GE-1, Box 99249, San Francisco, California 94109

GOVERNMENT SURPLUS. Buy your Area. How, where. Send \$2.00. SURPLUS HEADQUARTERS BUILDING. Box 30177-PE. Washington, D.C. 20014.

"GOVERNMENT SURPLUS DIRECTORY" Buy 500,000 items (including Jeeps) . . . low as 2c on dollar! Most complete information available — \$2.00. Surplus Disposal. Box 19107-HA. Washington, DC 20036.

SURPLUS Government Property. Booklet tells how, where. Moneyback Guarantee. \$1.00. ADP Enterprises. Box AW-7. Brisbane, CA 94005.

JEeps . . . \$33.30! . . . 525,000 Items! Buy In Your Area! How! Where! — "Moneyback GUARANTEED 1980 Government SURPLUS Directory" — Including: "Buy G-Lands." — "G-Oil G-Gas LOTTERIES." Guides — \$2.00. GSURPLUS. Box 2009-N. Syracuse, NY 13220.

HIGH FIDELITY

DIAMOND NEEDLES and Stereo Cartridges at Discount prices for Shure, Pickering, Stanton, Empire, Grado, Audio Technica, Osawa, Satin and ADC. Send for free catalog. LYLE CARTRIDGES, Dept. P, Box 69, Kensington Station, Brooklyn, New York 11218. Toll Free 800-221-0906 9AM -8PM except Sunday.

ALTERNATE ENERGY



AUTO ALTERNATOR TECHNOLOGY HANDBOOK

- NOW YOU CAN Buy Alternators Locally for \$10 or Less! Obtain 220V or 440V or Run 400cyc Surplus Equip. Use Auto Regs or Build Simple Adjustable IC Electronic Reg for 0-120V 100A power plants. Also Detailed Data & Steps for Rewinding and Core Modifications easily using simple tools! **Legacy** Plus many Efficiency Increase Hookups. Schematics etc. to Fully utilize Engine, Water and Wind Energy Systems. It's NO Secret! Just \$5.00 PPD. 1st Cl. **Don't Miss It!**

ESSco's Pubs. Ref P E
BOX 2004, MT. Vernon, N.Y. 10550

WANTED

GOLD, Silver, Platinum, Mercury, Tantalum wanted. Highest prices paid by refinery. Ores assayed. Free circular. Mercury Terminal, Norwood, MA 02062.

TELEPHONES & PARTS

TELEPHONES UNLIMITED, EQUIPMENT SUPPLIES. ALL TYPES, REGULAR, KEYED, MODULAR. FREE CATALOG. Call now toll free. (800) 824-7888. In California (800) 852-7777. Alaska-Hawaii (800) 824-7919. Ask for operator 738.

ALARMS



Burglar-Fire Protection

Protect Your Life, Home, Business, Auto, etc.

- Our catalog shows how. Install your own alarm systems and devices and save \$\$\$\$.
- We offer FREE write-in engineering service.

FREE CATALOG Lowest Prices on Reliable, High-Quality Alarm Systems and Devices

Burdex Security Co., Box 82802-PE Lincoln, Ne. 68501

QUALITY INTRUSION ALARMS. Ultrasonic — Wireless — Perimeter. Simple Installation. Catalog \$1. EAC. Box 7881B. Colorado Springs, CO 80933.

BUSINESS OPPORTUNITIES

I MADE \$40,000.00 Year by Mailorder! Helped others make money! Details 25c. Torrey, Box 318-NN, Ypsilanti, Michigan 48197

FREE CATALOGS. Repair air conditioning, refrigeration, Tools, supplies, full instructions. Doolin, 2016 Canton, Dallas, Texas 75201.

NEW LUXURY CAR WITHOUT COST! Free Report. Co-dex-ZZ. Box 6073, Toledo, Ohio 43614. (419) 865-5657.

BE YOUR OWN BOSS! Stuffing envelopes! Unlimited income! Details \$1.00. to: AA1 Brazell, 7332 Grand Oaks, Citrus Heights, CA 95610.

MECHANICALLY INCLINED INDIVIDUALS

Assemble electronic devices in your home. Knowledge or experience not necessary. Get started in spare time. Above average profits. \$300-\$600/Wk possible. Sales handled by others. Write for free details.

ELECTRONIC DEVELOPMENT LAB

Box 1560PE, Pinellas Park, FL 33585

MECHANICALLY INCLINED individuals desiring ownership of Small Electronics Manufacturing Business — without investment. Write: BUSINESSSES, 92-K2 Brighton 11th, Brooklyn, New York 11235.

MILLIONS in Mail!!! Free Secrets. Transworld-17, Box 6226. Toledo, OH 43614.

ERASE DEBTS with little-known law — create wealth!! Details FREE — Blueprints, No. EE1. Box 100, LaGrangeville, NY 12540.

BORROW \$25,000 "OVERNIGHT." Any purpose. Keep indefinitely! Free Report! Success Research, Box 29263-GA, Indianapolis, Indiana 46229.

BIG MONEY! Interested? Free disclosure. Febre-V, Box 6073, Toledo, Ohio 43614. (419) 865-5657.

EARN \$750/1000 STUFFING ENVELOPES WEEKLY! Rush stamped, return envelope, +25c: ASHCO. Box 4394-PE1, Corpus Christi, TX 78408.

EARN \$1,000 MONTHLY, sparetime, homework. "GUARANTEED." "Free Details." Write: UNICORN, ZD1, 326 Bonfoy, Colorado Springs, CO 80909.

MAKE MONEY AT HOME building electronic circuits. Over 45 different projects including burglar alarms, telephone hold button, color organs, digital clocks, etc. You buy parts wholesale. Send \$1.00 for catalog or send \$9.95 for complete book of schematics and layouts of all our projects. PPG, 14725 Oxnard, Van Nuys, CA 91411.

FREE Inflation-Beater Book 2042 Unique, Proven Enterprises. "Fabulous "Little Knowns." Work home! Haylings-S. Carlsbad, CA 92008.

SPARE TIME FORTUNE in Vinyl Repair. Huge demand creates exceptional profits. We supply everything. Details free. VIP, 2012 Montrose, Chicago, IL 61618.

EARN \$1000 STUFFING 1000 ENVELOPES! Money back guaranteed. Details \$1.00. D. Fraser, 208 S. 4th, DeSoto, MO 63020.

EMPLOYMENT OPPORTUNITIES

ELECTRONICS/AVIONICS EMPLOYMENT OPPORTUNITIES. Report on jobs now open. Details FREE. Aviation Employment Information Service, Box 240E, Northport, New York 11768.

ELECTRONIC FIELD SERVICE — Nationwide positions. Employer pays fees (312) 398-5535. Field Service Search, PO Box 544, Arlington Hts., IL 60004.

ELECTRONIC TECHNICIANS, ENGINEERS, PROGRAMMERS. California employment opportunities. Booklet includes: Names, Addresses, Phone Nos., Salaries and Relocation Information. Over 15,000 openings. Send \$12.50 to: Data Search, P.O. Box 3791, San Jose, CA 95156.

THINKING About RELOCATING? CHECK THE JOB MARKET Before You Move. TEXAS Has The LOWEST UNEMPLOYMENT RATE in the NATION. Send \$2.00 for Classified Section of Sunday Newspaper. Specify DALLAS, HOUSTON, FORT WORTH, SAN ANTONIO, AAXTON. Dept. 401, Drawer 28439, Dallas, TX 75228.

INSTANT CASH COMMISSIONS Full or part time. Free sales kit features America's largest line low priced Business, Printing, Advertising Specialties, Signs, Calendars and other necessities used daily by business people. Profitable repeat order. No experience. No investment. No collections or deliveries. Write today. National Press, Dept. 007, North Chicago, IL 60064.

HYPNOTISM

FREE Hypnotism. Self-Hypnosis. Sleep Learning Catalog! Drawer H400 Ruidoso, New Mexico 88345.

DO-IT-YOURSELF

AUDIO/ANALOG/SYNTHESIS. Plans, parts, kits, etc. for the most exciting sound projects ever. Get on our mailing list. send 25c to: CFR Associates Inc., Newton, N.H. 03858.

POSITION OPEN

\$27,500 FIRST YEAR. Unlimited future for Hard-working energetic salesperson, with strong interest in selling. Save gas. work 25 miles from home. 1-800-247-2446. Mr. Brooks.

REAL ESTATE

BIG . . . FREE . . . SPRING CATALOG! Over 2,700 top values coast to coast!! UNITED FARM AGENCY, 612-EP, West 47th, Kansas City, MO 64112.

RUBBER STAMPS

RUBBER STAMPS, BUSINESS CARDS. Many new products. Catalog, Jackson's, E-100, Brownsville Rd., Mt. Vernon, Ill. 62864.

MAGNETS

MAGNETS. All types. Specials-20 disc or 10 bar, or 2 stick or 8 assorted magnets. \$1.00. Magnets, Box 192-H, Randallstown, Maryland 21133.

BOOKS AND MAGAZINES

FREE book prophet Elijah coming before Christ. Wonderful bible evidence. MEGIDDO Mission, Dept. 64, 481 Thurston Rd., Rochester, N.Y. 14619.

ELECTRONIC MUSIC and home recording in Polyphony magazine. Advanced applications, interviews, projects, computer music. Sample \$1.50. Subscription (6 issues), \$8.00 US/\$10.00 foreign. POLYPHONY, Box P20305, Okla. City, OK 73156.

CB TECH'S — Get ready for the new band! Tune in with SSB Engineering Practice Manuals. Latest info on conversions and mods. Both vol. 1 and vol. 2 in stock. Write for free fact sheet, or send \$14.95 per vol. to: SSB Publications, Box 960, Hyannis, MA 02601.

MOTION PICTURE/VIDEO FILMS

YOUR DOLLARS GO FURTHER before & after Xmas with Sportlite Films! Compare prices: Columbia Pic. travel subjects, "Wonders of Africa" & "Wonderful Israel", ea. 200' Std 8 B&W, \$2.45 per reel. Closeout. '72 Munich Olympic films, Std 8 B&W 200'. Aquatics — Spitz: Track & Field — Ryun: Competitive sports — Spinks Bros.: USA vs USSR basketball, \$2.75 ea. set of 3. \$7.25 PPD. Tommy Armour "Play Better Golf" Grip & Stance, S-8 200' B&W \$3.95; Std 8 \$2. "RFK — Story of his Life" & "Cowboy" w/ J. Lemmon and G. Ford, 200' S-8 B&W \$6.95 ea del (list \$10.95). W.C. Fields "Much Ado About Golf" 16 mm B&W/Sd classic 400'. \$25. del. Ali-Williams: Johnson/Ketchel 16 mm B&W Sd (10 min), Ali's 1st fight on film, \$32.95 + \$1. ship. Ali vs Spinks I, 4 reels full length S-8 Col/Sd only \$150. for 64 min. '70 Indy 500 vivid color action 200' Al Unser, Std 8, \$10.95; S-8 \$16.95. Mickey Wright shows how to hit long ball & cut slice. 50' Std 8 B&W \$3. ea. Space Special, Apollo XV "Ride of Rover" S-8 200' B&W \$4.95. Ill. Res. add 5% tax. 51-pg Enter. catalog Video Tapes \$1.25; New 45-pg Columbia sports cat., \$1.25; 64-pg Universal cat. \$1.25 (\$2. foreign). Marketing Films, flyers 50c. Columbia, Universal, Sportlite, Ring Classics order forms. 40c ea. SPORT-LITE FILMS, Elect-1, Box 24-500, Speedway, IN 46224.

CATALOGS

FREE! World's Leading Novelty Catalog. 1800 Jokes, Tricks, Science, Sports, Hobbies. Johnson-Smith, C-24, Mt. Clemens, MI 48043.

MISCELLANEOUS

MPG INCREASED! Bypass Pollution Devices easily. REVERSIBLY!! Free details — Posco GEE1, Box 300, LaGrangeville, NY 12540.

NEW CAR FREE YEARLY! Workable secret method — free information: Supercar, Box 28101-N, St. Louis, MO 63119.

GASOLINE MILEAGE INCREASED DRAMATICALLY!! Details FREE!! Toll-free recording, 1-800-446-8289 anytime. Techneering, Box 12191 E. Norfolk, VA 23502.

FREE PROMOTIONAL ALBUMS, concert tickets, stereos, etc. Information: Barry Publications, 477 82nd Street, Brooklyn, NY 11209.

PROTECT YOUR AUTOMOBILE FROM THEFT! Free information. Fleming Sales, 3304 Tanterra Circle, Dept. PE1, Brookeville, MD 20729.

Linda says - Check it out!

Leader L80-507A 20 MHz
Reg. 580.00/499.00

Hickok 15 MHz Triggered
Reg. 565.00/399.00

Hickok 15 MHz Dual Trace
Reg. 795.00/599.00

Hickok 30 MHz Dual Trace
Reg. 1,149.00/869.00

NLS Mini Scope 15 MHz
Reg. 318.00/239.95

NLS Mini Scope 15 MHz Dual Trace
Reg. 435.00/359.95

NLS Mini Scope 30 MHz Dual Trace
Reg. 539.00/425.00

Leader L80508
20 MHz Dual Trace
Reg. 770.00/599.00

Hickok Model LX303
Meter 66.95

CSC Logic Monitor
Model LM-1 49.95

Hickok Function Generator
Reg. 225.00/159.95

Beckman LCD Meter
Model 300. 99.95
Model 310. 129.95

Platt Tool Case
Reg. 89.95/59.95

Weller Xcelite Service Master
Model 99SM 39.95
Roll Kit Model 99PR 15.95

CSC Logic Probe LP-1 39.95

Weller Elect. Soldering
Station EC2000
Reg. 125.00/99.95
EC1000
Reg. 99.95/75.95

B&K Scope 1432P
15 MHz Dual Trace
Reg. 840.00/599.00

Hickok Model 440
Semiconductor Curve Tracer
Reg. 235.00/179.95

Leader L80520
30 MHz Dual Trace
Reg. 1,050.00/799.00

CSC PS-500 Prescaler 49.95
CSC 100 MHz Counter 99.95
CSC Max 50 Counter 59.95
CSC Max 550 Counter 99.95

Frequency counters, oscilloscopes, signal generators, multimeters, tools, and probes are among hundreds of products available. Large inventory of Tektronix, Hewlett-Packard, General Radio, Fluke, and Boonton available with replacement parts as well. Master Charge — Visa Cards accepted. Come in, call or write for free brochures 9AM - 9PM Monday through Friday. Export inquiries invited.

CTG

Communications
Technology
Group, Incorporated

448 Merrick Road, Oceanside, N. Y. 11572 U.S.A. (516) 536-5724
Communications for Worldwide Use Telex 640-488/TWX 510-225-5736

CIRCLE NO. 15 ON FREE INFORMATION CARD

THE MICROCOMPUTER MART

COMPUTER RETAIL-STORES

MICROCOMPUTER MART RATE: 1" x 1 Column (1-5.8") \$125. 1-1.2" x 1 Column (1-5.8") \$187.50. 2" x 1 Column (1-5.8") \$250.00. For frequency rates, please inquire (212) 275-3485. Send order and remittance to MicroComputerMart, POPULAR ELECTRONICS, One Park Avenue, New York, NY 10016.

NEW JERSEY

COMPUTER MART OF NEW JERSEY

501 Route 27
Iselin, N.J. 08830
(201) 283-0600



The
Microcomputer
People®

CALIFORNIA

OHIO SCIENTIFIC

We carry the full line of Ohio Scientific Microcomputers.
Data Products Maintenance
128 N. Garfield Ave.
Monterey Park, CA 91754
(213) 573-5991 (714) 994-4180

FREE SOFTWARE CATALOG FOR APPLE II OWNERS

Sales • Service • Leasing
of
Apple • Atari • DEC
plus
All Accessories & supplies.
Open Tuesday-Sunday
RAINBOW COMPUTING INC.
9719 Reseda Blvd.
Northridge, CA 91324
(213) 349-5560

OHIO

BAND-ORCH, INC.

Complete Ohio
Scientific Line
337 East State Street
Alliance, Ohio 44601
(216) 821-2600
VISA Master Charge

PENNSYLVANIA

SOFTWARE FOR THE TRS-80 ARTCO ELECTRONICS

302 Wyoming Avenue
Kingston, PA 18704
(717) 287-1014

MICHIGAN



COMPLETE ATARI LINE
Reserve your Atari Computer NOW
A.C.C.I. (313) 549-2870
AMERICAN COMPUTER
CENTER INC.
4132 N. Woodward
Royal Oak, MI 48073

GEORGIA

GRAHAM BUSINESS COMPUTER

Featuring Full Line Ohio Scientific
5725 Buford Highway
Suite 216
Atlanta, GA 30340
(404) 457-8540

Radio Shack DEALER

COMPUTER CENTER MICRO MANAGEMENT SYSTEMS



Up to 15% Discount
on TRS-80's

We have the highly reliable
Lobo Disk Drive in stock!

Mini-Wall—Downtown Shopping Center
Cairo, Georgia 31728
(912) 337-7120

FLORIDA

COMPUTER CENTER OF THE PALM BEACHES



Specializing in Apple Business and Engineering
Systems. Pascal Systems in stock. Custom
S-100 Systems. Authorized service for
Apple, Micropolis, Shugart. We service all
other systems.
2833 Exchange Court
West Palm Beach, FL 33409
(305) 689-3233

Personal Electronics News

VIDEO DISK INTERCHANGEABILITY may soon be achieved as a result of a five-year patent-exchange agreement between N. V. Philips and Sony Corp. The agreement allows the two companies to use each other's patent rights on a wide range of products, including optical audio and video disks. Philips and Sony have both been conducting independent research and development on video systems.

WORLD'S FIRST COMPUTERIZED GUITAR is what Castle Toy Co. calls its \$45 "Superstar Guitar" with built-in microprocessor. A child or adult can pick up the guitar for the first time and instantly play 12 different prerecorded popular tunes, it is claimed. Users can also compose and record their own tunes and play them back at will.



A PERSONAL STRAP-ON STEREO SYSTEM designed to provide hands-free operation has been made available by Aspen Recreational Products, Ltd. for skiers, bikers, hikers, and other sporting types. The "Audiopac" consists of a Pioneer KP373 stereo cassette player housed in a heavily padded chestpack case that has ample room for cassette storage and matching headphones whose earcups can be removed for easy mounting in a motorcycle helmet. The player has locking fast forward and reverse, a loudness button, and automatic play after rewind. It can deliver 10 hours of play from built-in rechargeable batteries. For AM-FM stereo radio listening, the 15-oz. "Bone Fone" from JS&A (312-564-7000), which wraps around your neck like a scarf and doesn't require headphones, is used for the same applications.

ELECTRONIC GAME PURCHASES will increase 22% per annum through 1983, according to a forecast made in a "Home and Coin-Operated Electronic Games" study by Frost & Sullivan, Inc., New York City. The \$518-million market in 1978 is expected to jump to \$802 million this year and increase to \$1.4 billion within five years. The submarkets to generate the greatest growth will include programmable-games cartridges (539%), programmable-games consoles (178%), and nonvideo electronic games (150%).

D.C. RADAR-DETECTOR LAW is unconstitutional, according to a landmark ruling by a District Superior Court. It was ruled that the law violated the First, Fourth, Fifth, Ninth, and Tenth Amendments to the Constitution and went far beyond even prior restraint in anticipation of wrongdoing. The decision sets the stage for a pending appeal in Michigan, where a 1929 police radio law has been stretched by state police to include radar detectors. Last April, a Michigan Appeals Court ruled radar detectors exempt from the police radio law. The case has recently been reopened by the court and a concurrent action is pending in federal court. Virginia, the only other state ever to have a radar detector law, had the enforcement provision of its statute struck down in 1978 as unconstitutional.

SATELLITE-TO-HOME BROADCASTS have begun in Canada in an experimental program, conducted by Canada's Department of Communications. Designed to test the feasibility of direct-home broadcasting to remote and rural areas via small, low-cost earth stations, the project involves some 12 hours of daily programming over Telsat, Canada's Anik B domsat (domestic satellite). Selected families in Ontario, British Columbia, and perhaps the Yukon and Northwestern Territories will participate in the program with earth stations on loan to them.

A NAVIGATION COMPUTER with an accuracy of one-tenth nautical mile was announced by William A. Davis (Castro Valley, CA). To use it, one simply enters two altitudes, the two declinations of class-A stars, and two G.H.A.s of the stars. Then in about 40 seconds, the computer calculates longitude and latitude of the two possible positions or fixes—even if the navigator has no idea where he is! The computer also calculates distances between any two points on earth and gives the true bearing between them.

A COMPUTERIZED MUSIC TYPESETTING SYSTEM developed by Dataland of Denmark solves the problem of converting a composer's handwritten manuscript into printable form. Called the "scannote" system, it is reported to produce a music masterprint automatically and at considerably less cost than other existing methods. The system employs a special piano keyboard to play in, note by note, the voices in a score, which are then computer-processed and "played back" in a digital plotter to produce finished copy for offset printing.

COBRA'S PUNCH-THROUGH SOUND COMES TO CAR STEREO.



The same technology that brought a quality of sound to CB never before thought possible, now brings a quality of sound to car stereo never before heard.

Introducing Cobra's Punch-Through Sound.

AM/FM Stereo sound. 8-track or cassette sound. Big, booming sound that gives you great highs and low-down

lows. Because whichever

Cobra receiver you choose, you get a full 25 watts of

power plus an

FM sensitivity of 1.9 micro-

volts. And when you

match your

Cobra receiver to any one of Cobra's

2-way or 3-way speakers you get a sound that really sings. Add a Cobra graphic equalizer/amplifier and boost your power output to 60 watts. And get a sound you can feel.

See your Cobra radio dealer today. And when you buy a Cobra you also get a one year warranty and the assurance that there's a national network of factory service centers to help you with installation, service and advice.

Because whether it's CB or Autosound, if it comes from Cobra you know it's going to sound great.



Cobra®

Music Loud and Clear.

Cobra Communications Products
DYNASCAN CORPORATION

5460 W Cortland St., Chicago, Illinois 60635

Write for color brochure.



CIRCLE NO. 56 ON FREE INFORMATION CARD

THE K40 SPEECH PROCESSOR

The **K40**
Speech Processor.
So unique it's patented.
So good its guaranteed
to out-perform any
microphone on any radio.

CLIPS ANYWHERE WITHOUT A CLIP!

Molded four-pole internal magnet clamps instantly to any steel surface. Steering column, metal dash, roof top, or the side of your CB radio. No groping for your mounting clip.

PROCESSES SPEECH WITH A COMPUTER CIRCUIT!

It's its own computer—it automatically monitors your speech and adjusts it in micro-second increments pumping so much db gain into your speech that you get 400% more power than a standard mike.

SOUND SENSITIVE 2 INCHES OR 2 FEET!

A microphone so sensitive it will select your voice and process your speech no matter how close or far you are from the microphone.

TWO MICS WITH ONE SWITCH!

Switch up for a high-pitched transmission for cutting congested city traffic. Switch down for a mellow base in open, uncluttered rural areas.

NOISE CANCELLING

Pull the Processor directly to your mouth and speak directly into the mic. The Processor adjusts to your voice—and blanks out *all* the cab noise while you're speaking. Automatically.

FRESH CHARGE WITH NO BATTERIES!

Patented electronic storage system recharges while you listen to the radio. It provides a fresh electrical charge every time you squeeze the trigger. You never replace batteries.

Double Guarantee

GUARANTEE I:

The K40 Speech Processor is guaranteed to outperform any microphone it replaces or return it for a complete and full refund within 7 days from the K40 Dealer that installed and tuned it.

GUARANTEE II:

Unconditionally guaranteed for 12 months. Guaranteed against cracking, chipping, or rusting. Guaranteed against mechanical failure. Guaranteed against electrical failure. No exclusions. No gimmicks. For a full 12 months.

\$42.50*

American Antenna Elgin, IL 60120

*suggested retail.

CIRCLE NO. 6 ON FREE INFORMATION CARD

SOLD AND SERVICED EXCLUSIVELY BY 3,500 REGISTERED K40 DEALERS THROUGHOUT THE U.S. AND CANADA

www.americanradiohistory.com