

Popular Electronics®

WORLD'S LARGEST-SELLING ELECTRONICS MAGAZINE

MARCH 1979/\$1.25

Special Focus on Hi-Fi Speakers

- SPEAKER DESIGN INNOVATIONS • HOW TO UNDERSTAND TEST REPORTS
- THE IMPORTANCE OF POWER-HANDLING CAPACITY

Build the "Morse-A-Word"

AUTOMATICALLY CONVERTS CODE TO WORDS AND NUMBERS

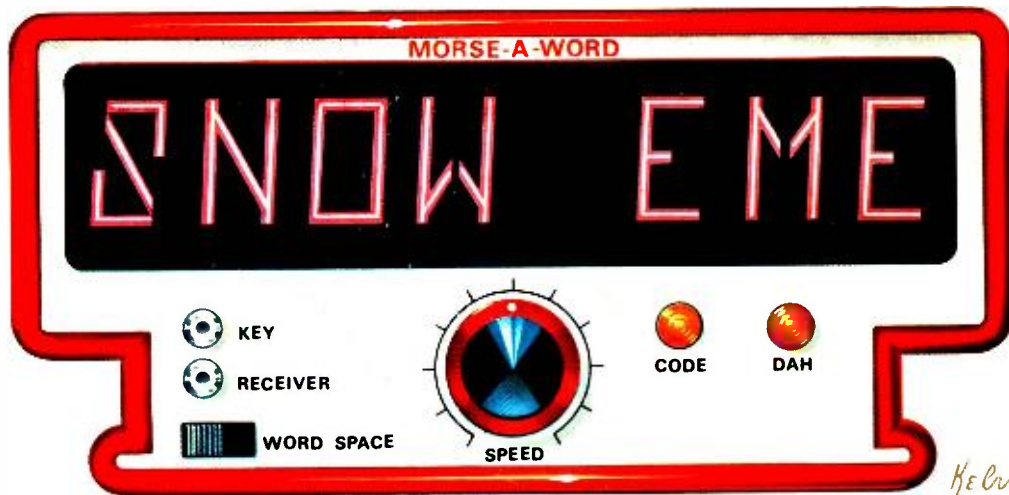
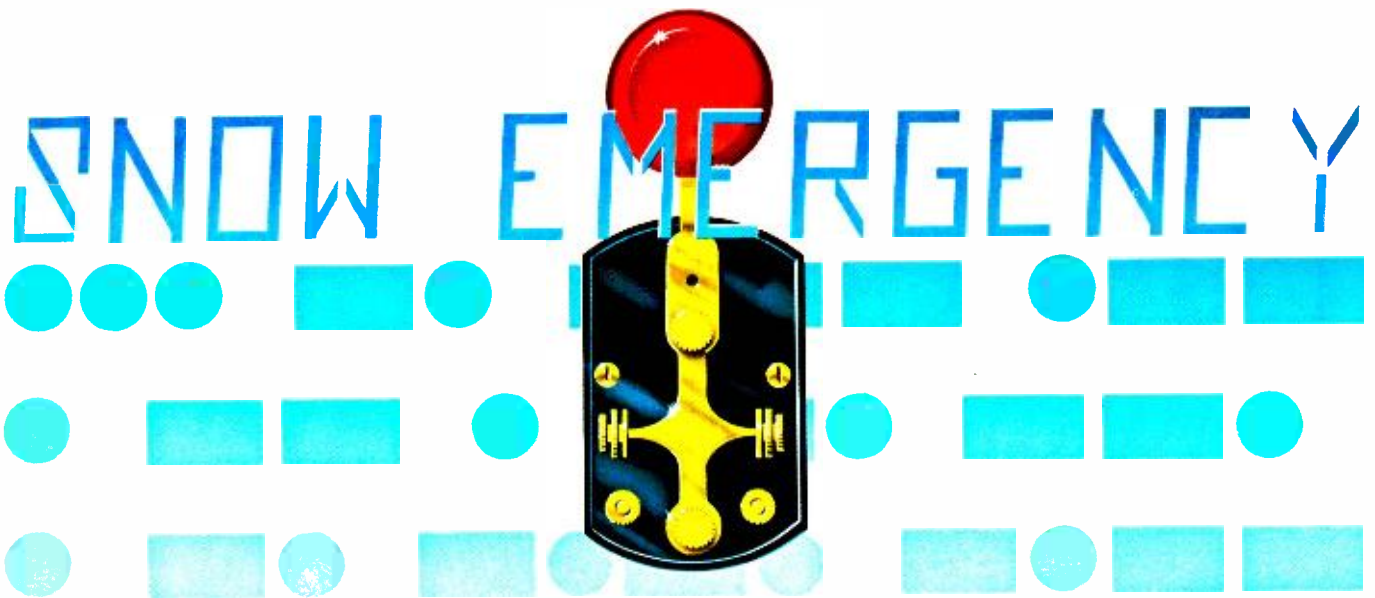

Tested
In This
Issue

Scott 480A Integrator
Philips AF877 Single
Ohio Scientific Super

680896 KRK B6122R99 6410 DEC79

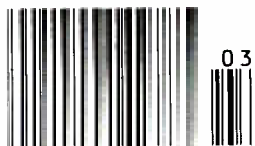

Popular Electronics



Introducing Electroscan. A quiet CB radio!

We finally built a CB so complete, there's only one popular feature it doesn't have.

Radio Hash. You know, the irritating noise you hear every time your squelch is wide open.

Because Motorola's exclusive VariCom® noise elimination system combines RF and IF gain to selectively reduce noise on the channels. It trims away radio hash for cleaner operation, especially when the squelch is wide open and you're listening really hard.

The Electroscan's microprocessor also has the convenient programmable memory which allows you to set, in the sequence you desire, any 10 channels you enjoy listening to everyday.

The Electroscan also offers a scanner

which lets you search quickly for either an available, open channel to continue your conversation... or the nearest occupied channel to locate other CB'ers.

Besides these features, Electroscan also offers the Extender® noise blanker and fully variable noise limiter. Plus variable control/dynamic gain microphone that adjusts mic gain over a 20 db range to make your voice sound better.

So stop in today at a Motorola® Dealer and take a look at the Electroscan, the first CB that virtually eliminates radio hash.



MOTOROLA
CB

To find the dealer nearest you, write: Market Relations Manager, Motorola, Inc., Automotive Products Division, 1299 East Algonquin Road, Schaumburg, Illinois 60196.
® Motorola, VariCom, and Extender are registered trademarks of Motorola Inc.

CIRCLE NO. 61 ON FREE INFORMATION CARD

JS&A's new program will save consumers millions.



Micro TV Breakthrough

Remember the \$400 Sinclair Micro TV? Here's the story on the greatest TV value ever.

That Sinclair TV shown above is small—the smallest TV in the world.

And when it was first introduced last year, it made history. So did its high price—\$395.

Our company never sold the unit for two reasons: 1) It was being promoted as a pocket TV and we felt it would not fit in most pockets and 2) We felt \$395 was too high a price for the unit regardless of its quality, size and features.

But we were wrong. Thousands of them were sold and it was selected as one of the most exciting new products of the year.

WE BOUGHT ONE

A few months ago we purchased a Sinclair TV and discovered another feature we didn't like. The unit included a 220-volt converter for European operation. This meant that every American who bought the set had to pay extra for the converter even though very few Americans would be taking their TV to Europe.

So we came up with an idea. We went to England and purchased thousands of sets directly from the factory without the converter. We were also able to save money by eliminating the normal mark ups by importers, wholesalers and distributors.

We can now offer you the unit for only \$249.95 and if you want the 220-volt converter, your cost is only \$19.95 extra.

LESS THAN WHOLESALE

JS&A would be offering the exact same Sinclair TV at a price less than Sinclair's actual wholesale price in the United States and we would still make enough profit to pay for the cost of this advertisement.

There is one feature we liked very much about the set. Its rechargeable batteries are built into the unit. Larger portable TV's offer \$60 optional rechargeable battery packs that must be purchased separately. Ours is built in and included in the price.

The Sinclair TV comes complete with an American AC adapter and charger, ear phones, carrying case, rechargeable batteries and a built-in antenna for both VHF and UHF. It

also comes with a cigarette lighter power converter, so you can watch all your favorite TV channels from your boat, plane, motor home or car without even using your batteries.

PHOTOGRAPHIC QUALITY

We were well aware of Sinclair's advanced electronics and quality features. But what we found particularly exciting was its picture tube. Even though the 2" (measured diagonally) tube is small, the TV's resolution resembles that of a clear sharp photograph. You can even read small telephone numbers when they're flashed on the screen.



The Sinclair unit is offered in this advertisement with the same accessories available in the \$395 system with the exception of the 220-volt power converter.

The Sinclair is also convenient. You can take it on trips and entertain your children while you fly or drive. You can keep it on your desk at work and monitor the latest news or stock market reports. And you can view the soap operas as you work around the house. We even took ours to the ball game to watch those instant replays.

BIG POCKETS

But don't expect to carry it in your pocket—it won't fit unless you have big pockets. The unit measures 1 7/8" x 4" x 6 1/4" and weighs just 28 ounces which includes the built-in batteries.

The TV is serviced in the United States by Sinclair's service-by-mail facility. If service is ever required during its one-year limited warranty, just slip it in its handy mailer and send it to them for repair. Your solid-state unit should operate for years without a problem, but if it ever needs repair, it's good to know that service is an important part of our program.

For \$249.95, the Sinclair Micro TV is worth your test. Order one from JS&A. Take it with you on a trip, bring it to your office, or carry it with you around the house. See how clear and sharp the picture is and how closely it resembles a black and white photograph. Then decide if you want to keep it. If not, no problem. Simply return your TV within 30 days for a prompt and courteous refund. We just want you to prove to yourself, the miracle of space-age electronics before you decide.

AMERICA'S LARGEST

Sinclair Radionics is one of England's largest electronics manufacturers and JS&A is America's largest single source of space-age products—further assurance that your modest investment is well protected even though the unit is offered at such a bargain price.

To order your Sinclair Micro TV, simply send your check for **\$249.95** plus \$3.00 postage and handling (Illinois residents, please add 5% sales tax) to the address shown below or credit card buyers may call our toll-free number below. But please act quickly.

The Sinclair TV is an outstanding product that was priced too high. If you felt like we did and you waited, your timing is perfect. Order a Sinclair Micro TV at no obligation, today.

JS&A PRODUCTS
THAT THINK®

Dept. PE One JS&A Plaza
Northbrook, Ill. 60062 (312) 564-7000
Call TOLL-FREE **800 323-6400**
In Illinois Call **(312) 564-7000**

©JS&A Group, Inc., 1979

We've cut your final cost on Bearcat® scanners up to \$150!

Communications Electronics™ celebrates the introduction of three new Bearcat scanners with special cash rebates of up to \$20.00 on all Bearcat brand monitors. During February and March, 1979, when you purchase your Bearcat scanner from any Communications Electronics™ Scanner Distribution Center, you will get a special rebate coupon and a proof of purchase invoice that entitles you to a portion of the biggest scanner rebate in our history. In addition, prices have been drastically cut during our special sale to make your final price the lowest ever. Check out the super features of Bearcat scanners and select the models that are right for you at work, home or in your car.

Bearcat® 250

List price \$399.95/CE price \$269.00/\$20 Rebate
Your final cost is a low \$249.00

50 Channels • Crystallines • Searches • Stores Recalls • Self-Destruct • Priority channel

The Bearcat 250 performs any scanning function you could possibly want. With push button ease you program 50 channels (five banks of ten channels each). Push another button and search for new frequencies. There are no crystals to limit what you want to hear. A special search feature of the Bearcat 250 actually stores 64 frequencies, and recalls them, one at a time, at your convenience. Automatic "count" remembers how often frequencies are activated by transmission—so you know where the action is. Decimal display shows the channel, frequency and other programmed features. The priority feature samples your programmed frequency every two seconds. Plus, a digital clock shows the time at the touch of a button. This is the only monitor radio that has received the Communications Electronics quality control approval rating #1. Our highest quality grade for technologically sophisticated equipment. The Bearcat 250. Scanning like you've never seen or heard before. In stock for immediate shipment!

New Bearcat® 220

Available April - May, 1979. Order before March 31, 1979 to qualify for \$20.00 CE direct rebate.

List price \$379.95/CE price \$299.00/\$20 Rebate†
Your final cost is a low \$279.00

Aircraft and public service monitor

We have received thousands of requests to have a scanner capable of monitoring the aircraft frequencies. The Bearcat 220 is one scanner which can monitor all public service bands plus the exciting aircraft band channels. In fact, the Bearcat 220 covers seven bands. Low and High VHF. UHF. UHF-Government. UHF-T. 2-meter and 3/4 meter amateur and Aircraft. Up to twenty frequencies may be scanned at once. Or frequencies can be arranged into two banks of ten frequencies each, allowing the listener to choose the bank of most interest.

Not only does this new scanner feature normal search operation, where frequency limits are set and the scanner searches between your programmed parameters, it also searches all marine or aircraft frequencies by pressing a single button. These frequencies are already stored in memory so no reprogramming is required. The frequency Reception Range is 32-50, 118-136, 144-174 and 420-512 MHz. The Bearcat 220 also features a Priority channel, Dual scanning speeds. Patented track tuning and Direct channel access.

New Bearcat® 211

Available March, 1979

List price \$329.95/CE price \$239.00/\$20 Rebate
Your final cost is a low \$219.00

The Bearcat 211. It's an evolutionary explosion of features and function. More channels than the Bearcat 210. Added scan control. Plus, a full complement of state-of-the-art innovations that increase scanning capabilities—and quicken the excitement.

18-channel monitoring. With no-crystal six-band coverage. Dual scan speeds. Color-coded keyboard. Even a digital clock. All at a modest price. Take a look. Here's more scanning excitement than you bargained for.

Frequency reception range: 32-50, 146-174, 420-512 MHz. Sensitivity: 0.4 microvolts. All accessories included!



NEW! 18-channel Bearcat® 211



NEW! Aircraft monitor Bearcat® 220

Now Bearcat® 210

List price \$299.95/CE price \$219.00/\$20 Rebate
Your final cost is a low \$199.00

10 Channels • 5 Bands • Crystallines

Improved reliability and performance
Use the simple keyboard to select the 10 channels to be scanned. Band coverage includes Low, High, UHF, UHF-T, 2 and 3/4 meter Ham—and other government law enforcement UHF frequencies. Automatic search finds new frequencies. Decimal display shows the channel and frequency being monitored. The 210 features patented selectable scan delay, push button lockout, single antenna, patented track tuning, AC/DC operation. With no crystals to buy. Ever!

Bearcat® 12

List price \$179.95/CE price \$126.00/\$15 Rebate
Your final cost is a low \$111.00

The finest crystal scanner ever offered.

More features, more channels, more action. The Bearcat 12 monitors 10 channels over five bands (Low and High VHF, UHF, UHF-T, and 2-meter Ham). Scan delay lets you listen to both sides of a two-way, same-frequency conversation. Variable scan rate puts you in control of the scan speed. Other features include automatic squelch, individual lockout, and more. The Bearcat 12 has more of what you're scanning for.

Bearcat® 8

List price \$159.95/CE price \$112.00/\$10 Rebate
Your final cost is a low \$102.00

8 Channels • 5 Bands • Handsome wood case

Bearcat® 6

List price \$119.95/CE price \$84.00/\$5 Rebate
Your final cost is a low \$79.00

6 Channels of Exciting Low or High VHF action.

Bearcat® 3 (One band)

List price \$119.95/CE price \$84.00/\$7.50 Rebate
Your final cost is a low \$76.50

The "selectable" scanning radio.

Bearcat® Four-Six

List price \$169.95/CE price \$119.00/\$10 Rebate
Your final cost is a low \$109.00

The first 4 Band, 6 Channel, Hand-Held Scanner. The Bearcat Four-Six offers "hip pocket" access to police, fire, weather and special interest public service broadcasts. It receives Low, High, UHF, and UHF-T bands. Lightweight. Extremely compact. The Bearcat Four-Six—with its popular "rubber ducky" antenna and belt clip—provides "go anywhere/hands-off" scanning. When it comes to scanning "to go," Bearcat has it.

Bearcat® Hand-Held

List price \$129.95/CE price \$91.00/\$5 Rebate
Your final cost is a low \$86.00

NEW Ultra Small

Bearcat® ThinScan™

Available March - April, 1979 Order before 3/31/79, to qualify for \$10.00 CE direct rebate.

List price \$149.95/CE price \$119.00/\$10 Rebate†
Your final cost is a low \$109.00

World's smallest scanner!
The Bearcat ThinScan™ High-performance scanning has never been this portable. It goes anywhere. ThinScan™ slips easily into a shirt pocket. Hands-off convenience—within easy reach. Slim, trim. But with the professional capabilities you expect from a Bearcat.

Go ahead, size it up. Bearcat's ThinScan™ measures 2 3/4" across. Just 1" deep. And 5 1/2" high. Ideal for law enforcement agents to covertly receive transmissions from "body mikes". Four crystal-controlled channels are scanned every 1/2 second providing immediate access to police, fire, weather and other special-interest broadcasts on High and Low VHF bands. With light-emitting diodes indicating the channels being monitored. And individual lock-out switches for by-passing any channel not of current interest. Frequency reception range: 33-44, 152-164 MHz. Weight: 10 ounces. Sensitivity: 1 Microvolt. Selectivity: -45dB @ 25 KHz

The Bearcat ThinScan™ The professional portable. The small high-performance scanner anywhere. Size it up. It won't let you down.

Bearcat® Alert™ Warning Radio

List price \$79.95/CE price \$64.00/\$5 Rebate†
Your final cost is a low \$59.00

Early warning for the 1979 tornado season!

† Rebates on these units are offered directly from Communications Electronics™

TEST A BEARCAT SCANNER FREE

Test any Bearcat brand scanner from Communications Electronics™ for 31 days before you decide to keep it. If you do, you'll own the most sophisticated and technologically advanced scanner available. If for any reason you are not completely satisfied, return it in new condition with all accessories in 31 days, for a courteous and prompt refund (less shipping charges and rebate credits).

NATIONAL SERVICE

With your Bearcat scanner, we will send all accessories, a complete set of simple operating instructions and a one-year limited warranty. If service is ever required on any Bearcat scanner purchased from Communications Electronics™, just send your receiver to one of our approved national service centers. When you purchase your scanner from CE, you're buying from the world's leader in no-crystal high technology scanners. We've sold more synthesized scanners than any other company.

MADE BY ELECTRA QUALITY CHECKED BY CE

Since all Bearcat scanners sold by Communications Electronics™ are products of Electra Company, a Division of Masco Corporation of Indiana, you can be assured of the finest monitor radios available in the world. In addition, our Quality Control Department further audits the quality of every Bearcat model sold by us to insure the high reliability inherent in Bearcat scanners.

THE SMALL PRINT

All sales are subject to availability. Prices and specifications are subject to change without notice. This special rebate offer on all Bearcat brand scanners is good only when purchased from Communications Electronics™, Scanner Distribution Center™ between February 1 and March 31, 1979. Communications Electronics™ Proof or Purchase Invoice and special rebate coupon (enclosed with your order) must be postmarked by April 15, 1979. Rebates on Bearcat scanner models 220, ThinScan™ and Alert™ Warning Radio will be processed exclusively by Communications Electronics™. Offer good in U.S.A. International shipments are welcome without rebate offer. Void where taxed or prohibited by law. Offer limited to one rebate per scanner. If returned for credit during our 31 day free trial, rebate and shipping costs will be deducted from refund. Resellers, companies, clubs and organizations (profit and non-profit) are not eligible for rebates. Allow 4-6 weeks after rebate request for check.

BUY WITH CONFIDENCE

All Bearcat scanners are extraordinary scanning instruments. They provide virtually any scanning function that the most professional monitor could require. To get the fastest delivery of any Bearcat scanner, send or phone your order directly to our Scanner Distribution Center™. Be sure to calculate your price using the CE prices in this ad. Your rebate will be returned separately from your order. Michigan residents please add 4% sales tax. Crystal certificates are available for \$5.00 each. These certificates allow you to order crystals directly from the manufacturer. Base or mobile antennas specifically designed for all Bearcat scanners are \$25.00 each postpaid. Mail orders to: Communications Electronics™, Box 1002, Ann Arbor, Michigan 48106 U.S.A. Add \$5.00 per scanner for U.P.S. U.S. ground shipping or \$9.00 for even faster U.P.S. air shipping. If you have a MasterCard or Visa card you may call and order toll free 800-521-4414 to place a credit card order. If you are outside the U.S. or in Michigan, dial 313-994-4444. Dealer inquiries invited. All order lines at Communications Electronics™ are staffed 24 hours.

Since this rebate offer is the biggest in our history, you must place your order today at no obligation to assure prompt delivery.

Autoprogramming, Scanner Distribution Center™ and CE logos are trademarks of Communications Electronics™.

Copyright © 1979 Communications Electronics™



854 Phoenix □ Box 1002 □ Ann Arbor, Michigan 48106 U.S.A.
Call TOLL-FREE (800) 521-4414 or outside U.S.A. (313) 994-4444

We're first with the best.™

Coming Next Month

- BUILD A TRUE RMS VOLTMETER
- DESIGN OF TRANSMISSION-LINE TRANSFORMERS
- "MORSE-A-WORD" PART 2: CONSTRUCTION
- AUDIO REPORTS:
Kenwood KT-917 FM Tuner
Realistic SCT-30 Cassette Deck

Cover Art by George Kelvin

POPULAR ELECTRONICS, March 1979, Volume 15, Number 3. Published monthly at One Park Avenue, New York, NY 10016. One year subscription rate for U.S. and Possessions, \$13.00; Canada, \$15.00; all other countries, \$18.00 (cash orders only, payable in U.S. currency). Second Class postage paid at New York, NY and at additional mailing offices. Authorized as second class mail by the Post Office Department, Ottawa, Canada, and for payment of postage in cash.

POPULAR ELECTRONICS including ELECTRONICS WORLD, Trade Mark registered. Indexed in the Reader's Guide to Periodical Literature.

COPYRIGHT © 1979 BY ZIFF-DAVIS PUBLISHING COMPANY. ALL RIGHTS RESERVED. Ziff-Davis also publishes Boating, Car and Driver, Cycle, Flying, Popular Photography, Skiing, Stereo Review, Electronic Experimenter's Handbook, Tape Recording & Mixing Guide, Stereo Directory & Buying Guide, and Communications Handbook.

Material in this publication may not be reproduced in any form without permission. Requests for permission should be directed to Jerry Schneider, Rights and Permissions, Ziff-Davis Publishing Co., One Park Ave., New York, NY 10016.

Editorial correspondence: POPULAR ELECTRONICS, 1 Park Ave., New York, NY 10016. Editorial contributions must be accompanied by return postage and will be handled with reasonable care, however, publisher assumes no responsibility for return or safety of manuscripts, art work, or models.

Forms 3579 and all subscription correspondence: POPULAR ELECTRONICS, Circulation Dept., P.O. Box 2774, Boulder, CO 80302. Please allow at least eight weeks for change of address. Include your old address, enclosing, if possible, an address label from a recent issue.

The publisher has no knowledge of any proprietary rights which will be violated by the making or using of any items disclosed in this issue.



Feature Articles

- 72 **WHAT IS THE VOLTAGE?!** / Thomas R. Fox
A quiz on voltage regulating characteristics of common components.

Construction Articles

- 35 **THE MORSE-A-WORD, PART ONE: THEORY AND SYSTEM OPERATION!** / George Steber
LED readout displays words and numbers when Morse code is received.
- 67 **BUILD A LOW-COST TRANSISTOR TESTER!** / Cyril C. Miller
Tests small-signal or high-power transistors and diodes.
- 69 **AN AUTOMATIC GARAGE-DOOR CLOSER!** / William Vancura
Triggers electronic system to close door after selected time period.
- 74 **BUILD THE "SUPER MARKER"!** / Paul Lutus
Allows precise tuning of shortwave receivers.

Special Focus on Speakers

- 41 **INNOVATIONS IN SPEAKER DESIGN!** / George Tlamsa
A look at the continuing evolution of speaker technology.
- 55 **INTERPRETING SPEAKER TEST RESULTS!** / Julian Hirsch
Understanding test methods and published results makes reports more meaningful.
- 59 **THE IMPORTANCE OF POWER-HANDLING CAPACITY!** / Tim Holl
Recognizing speaker power limit subtleties can prevent damage or increased distortion.

Columns

- 20 **STEREO SCENE!** / Ralph Hodges
Music and Noise.
- 78 **HOBBY SCENE Q & A!** / John McVeigh
- 80 **EXPERIMENTER'S CORNER!** / Forrest M. Mims
Eavesdropping on Light.
- 85 **DX LISTENING!** / Glenn Hauser
Intercontinental TV-DX
- 89 **COMPUTER BITS!** / Hal Chamberlin
Random Number Generators.
- 94 **PROJECT OF THE MONTH!** / Forrest M. Mims
A High-Resolution LED Display.

Julian Hirsch Audio Reports

- 22 **PHILIPS MODEL AF877 SEMIAUTOMATIC RECORD PLAYER**
- 24 **H. H. SCOTT MODEL 480A INTEGRATED AMPLIFIER**

Electronic Product Test Report

- 76 **OHIO SCIENTIFIC SUPERBOARD II COMPUTER**

Departments

- 4 **EDITORIAL!** / Art Salsberg
The Electronic Activist.
- 6 **LETTERS**
- 6 **OUT OF TUNE**
*"Experimenter's Corner" (December 1978);
"Build a Disco Preamp/Mixer" (September 1978).*
- 8 **NEW PRODUCTS**
- 93 **SOFTWARE SOURCES**
- 106 **ELECTRONICS LIBRARY**
- 111 **OPERATION ASSIST**
- 115 **ADVERTISERS INDEX**
- 116 **PERSONAL ELECTRONICS NEWS**

JOSEPH E. MESICS
Publisher

ARTHUR P. SALSBERG
Editorial Director

LESLIE SOLOMON
Technical Director

JOHN J. McVEIGH
Technical Editor

JOHN R. RIGGS
Managing Editor

ALEXANDER W. BURAWA
Features Editor

EDWARD I. BUXBAUM
Art Director

ANDRE DUZANT
Technical Illustrator

CARMEN VELAZQUEZ
Production Editor

RUTH POLSKY
Editorial Assistant

Contributing Editors
**Hal Chamberlin, Lou Garner, Glenn Hauser
Julian Hirsch, Ralph Hodges, Forrest Mims**

JEFF NEWMAN
Assistant to the Editor

LINDA BLUM
Advertising Service Manager

KATHERINE REINHARDSEN
Executive Assistant

EDGAR W. HOPPER
Publishing Director

ZIFF-DAVIS PUBLISHING COMPANY

Philip B. Korsant, President
Furman Hebb, Executive Vice President
Phillip T. Heffernan, Sr. Vice President
Edward D. Muhlfield, Sr. Vice President
Philip Sine, Sr. Vice President, Secretary
Lawrence Sporn, Sr. Vice President, Circulation and Marketing
Baird Davis, Vice President, Production
George Morrissey, Vice President
Sydney H. Rogers, Vice President
Sidney Holz, Vice President
Albert S. Traina, Vice President
Paul H. Chook, Vice President
Edgar W. Hopper, Vice President
Robert N. Bavier, Jr. Vice President
Selwyn Taubman, Treasurer

W. Bradford Briggs, Vice Chairman

ZIFF CORPORATION

William Ziff, Chairman
I. Martin Pompadur, President
Hershel B. Sarbin, Executive Vice President

ZIFF-DAVIS PUBLISHING COMPANY

Editorial and Executive Offices
One Park Avenue, New York, New York 10016
212-725-3500

Joseph E. Mesics (725-3568)
John J. Corton (725-3578)
Bonnie B. Kaiser (725-3580)

Midwestern Office

Suite 1400, 180 N. Michigan Ave.
Chicago, IL 60601 (312-346-2600)
Midwest Representative: Buzz Vincent
Western Office
9025 Wilshire Boulevard, Beverly Hills, CA 90211
213-273-8050, BRADshaw 2-1161
Western Advertising Manager: Bud Dean

Western Representative: Norm Schindler
Suite 205, 20121 Ventura Blvd
Woodland Hills, CA 91364 (213-999-1414)

Japan: James Yagi, Oji Palace Aoyama,
6-25, Minami Aoyama 6 Chome, Minato-Ku,
Tokyo, 407-1930/6821, 582-2851



Editorial

THE ELECTRONICS ACTIVIST

That's you! A person with a consuming interest in the science of electronics, based on a new comprehensive study of POPULAR ELECTRONICS subscribers.

It means that you're not simply a reader who is content to sit back and casually watch the electronics world go by. You're in the forefront of the consumer electronics revolution that has taken place in recent years, combining a desire to know about and to experience electronic developments. As a consequence, you've put your mind, time and money where your interests lie.

If you're a typical PE subscriber, you're a 32-year-old male who attended college (some 16% of you have done postgraduate study). Moreover, six out of ten subscribers are employed in electronics or a related field. And the same six-out-of-ten ratio holds true for work in a managerial or professional capacity.

You're involved in virtually every aspect of consumer electronics at one time or another, our study reveals, crossing over from audio and tape recording to microcomputers to experimentation to communications as you see fit. Ninety percent of you have participated in electronics experimentation and/or kit building at some time in your electronics lives, while 86% have been involved with audio and/or tape recording, 75% in communications, and 41% in microcomputers.

An aggressive interest in electronics doesn't come cheap, we know. Subscriber involvement in electronics activities (excluding color TV, VCR, and projection TV) is backed up by their ownership of equipment typically valued at \$2,950. Interestingly, three out of four subscribers purchased some type of electronic gear in the past 12 months, spending on the average \$670. Forty-eight percent spent a whopping \$473 on audio equipment alone. (The average amount spent by 11% last year for microcomputers, incidentally, was \$909.) Extrapolate this figure for our full paid circulation (415,000) and we're talking about some 40-million dollars spent on computers and peripherals.

What's past is prologue to the coming year, of course. Here, our study indicates that 49.1% plan to purchase audio equipment, 26.8% microcomputer equipment, 25% communications equipment, and 43.3% test equipment. And this doesn't include educational courses and books, tools, record albums, raw tape, et al!

So clearly, your commitment to electronics is very much evident. We intend to continue to whet your appetites for this exciting field by introducing some mind-boggling electronics information that we have in the works, one of which is in the video area. Watch for it.

Here it is at last... **THE FIRST FLOPPY DISK BASED COMPUTER FOR UNDER \$1000**



The C1P MF
\$995

- Complete mini-floppy computer system
- 10K ROM and 12K RAM
- Instant program and data retrieval

The Challenger 1P Mini-disk system features Ohio Scientific's ultra-fast BASIC-in-ROM, full graphics display capability and a large library of instant loading personal applications software on mini-floppies including programs for entertainment, education, personal finance, small business and now *home control!*



The C1P MF configuration is very powerful. However, to meet your growth needs it can be directly expanded to 32K static RAM and a second floppy by simply plugging these options in. It also supports a printer, modem, real time clock and AC remote interface as well as the OS-65D V3.0 development oriented operating system.

Or Start with the C1P
CASSETTE BASED Computer for just \$349.

The cassette based Challenger 1P offers the same great features of the mini-disk system including a large software library except it has 4K RAM and conservative program retrieval time. Once familiar with personal computers, you'll be anxious to expand your system to the more powerful C1P MF.

You can move up to mini-disk performance at any time by adding more memory and the disk drive. Contact your local Ohio Scientific dealer or the factory today.

*Both systems require a video monitor, modified TV or RF converter and home television for operation. Ohio Scientific offers the AC-3 combination 12" black and white TV/monitor for use with either system at \$115.00 retail.

All prices, suggested retail.

OHIO SCIENTIFIC

1333 S. CHILLICOTHE RD., AURORA, OHIO 44202 (216) 562-3101

CIRCLE NO. 37 ON FREE INFORMATION CARD



Letters

Elf μ C KIT SUPPLIERS

I would like to build your "Elf Microcomputer" (August 1976) for use in a science-fair project. I am interested, therefore, in obtaining the basic Elf in kit form and would appreciate it if you could give the names and addresses of a few companies from which it can be obtained. —Gregory Valvo, Pittsburgh, PA.

Two major Elf kit suppliers are: Netronics R&D Ltd. (333 Litchfield Rd., New Milford, CT 06776; tel. 203-354-9375) and Quest Electronics (P.O. Box 4430C, Santa Clara, CA 95054; tel. 408-988-1640).

MISSING DX COLUMN

Where is your DX Listening column in the January 1979 issue? I flipped through the pages of POPULAR ELECTRONICS to page 85, where it was supposed to be according to the

Table of Contents, and all I found was an ad. —Mike Stadler, Clifton Springs, NY.

Sorry, but a last-minute press change forced us to omit the column in our January issue and place it in the February issue instead. The Table of Contents was already on press, so we had no time to change it. We regret any inconvenience this may have caused.

AUTO CHARGE ANALYZER

The device presented in "Trouble Shooting for Automotive Electronic Systems" (January 1979) resembles a portion of our patented (No. 4,086,531) Charging System Analyzer. Mr. Caristi's circuit is not a complete charging system analyzer. In effect, it is a programmed LED voltmeter. Your readers should be informed that an accurate analysis of the system requires more data than just voltage.

We suggest that you remind your readers that circuits published in POPULAR ELECTRONICS are for their personal use only. Any commercial (for sale) application should be thoroughly checked for possible patent infringement. —Larry Graham, Marketing Manager, Compunetics, Inc., Troy, MI.

AID FOR HANDICAPPED

Being blind and physically handicapped as well, I find it difficult to pursue my interest in electronics as a hobby. I would appreciate hearing from any of your readers who might have information on aids (tapes, records,

etc.) pertaining to electronics for those with my handicaps. A pen pal would also be welcome. Thanks. —Richard Jastro, 10618 Arleta Ave., Michigan Hills, CA 91345.

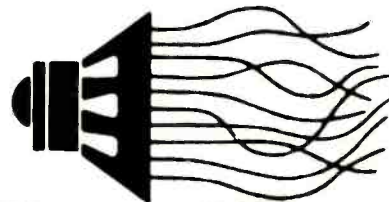

Out of Tune

In "Build a Disco Preamp/Mixer" (September 1978), pin 11 of IC6, Fig. 6, should be connected to -15 V, not $+15$ V as shown. The foil pattern is correct.

In "Experimenter's Corner" (December 1978), pin 4 of the 74193 programmable counter in Fig. 7 should not be grounded, but either left uncommitted or tied to $+5$ volts. Pin 14 of the counter should be grounded. In the "Project of the Month," the bus at the bottom of the schematic connected to pin 8 of the 74193, etc., is a ground bus. In the same diagram, resistors R5 through R12 should be 1000 ohms each. The sixth line of the paragraph beginning with, "Test the circuit by loading . . ." should say, ". . . switch S1A from LOAD to READY . . ."

MIMIC

IDEAL FOR THE
BEGINNER, HOBBYIST,
STUDENT, AND
ENGINEER

The \$50 Microcomputer

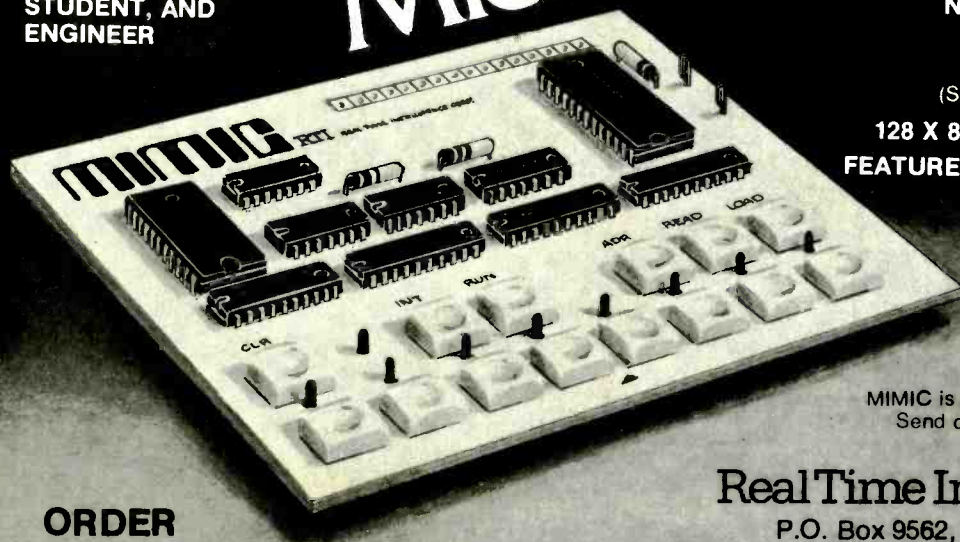

COMPLETELY SELF-CONTAINED
NEEDS ONLY A 6V BATTERY
FOR FULL OPERATION

FULLY DOCUMENTED
(SAMPLE PROGRAMS INCLUDED)

128 X 8 ONBOARD RAM SUPPLIED

FEATURES 57 INSTRUCTIONS, PLUS:
STOP AND WRITE TO DISPLAY
MANUAL, ELECTRICAL &
SOFTWARE INTERRUPTS

BUS ACCESSIBLE FOR
PERIPHERAL DEVICES

MIMIC is available in unassembled KIT form.
Send check or money order for \$50.00 to:

Real Time Intelligence Corp.
P.O. Box 9562, Rochester, New York 14604

ORDER
NOW!

Mass. residents please add 5% Sales Tax. New York residents please add 7% Sales Tax.
Allow 4 - 6 weeks for delivery

CIRCLE NO. 46 ON FREE INFORMATION CARD

POPULAR ELECTRONICS

A lot of signal. For a little cost.



When it comes to signal sources, high precision and versatility don't have to mean high price. Proof? Our new function and pulse generators!

MODEL 2001 SWEEPABLE FUNCTION GENERATOR.

A wide-range 1 Hz-100 KHz source for stable, low-distortion sine waves; fast rise/fall-time square waves; high-linearity triangle waves . . . as well as a TTL square-wave output.

The 2001's voltage-controlled oscillator lets you remotely shift the generator's frequency by applying a DC voltage, or using an AC voltage to sweep its output over a 100:1 range. A pushbutton-selectable DC offset, allows you to shift output waveform centers above or below baseline at will. With its five overlapping ranges, high- and low-level outputs, Model 2001 is a remarkable value for professionals and hobbyists at \$124.95.*

MODEL 4001 ADVANCED PULSE GENERATOR.

If we tried to list all the 4001's advantages, we'd run out of space before running out of features . . . so

here are the highlights: Model 4001 is a precision digital pulse generator with fast rise and fall times covering 0.5 Hz—5 MHz in 5 overlapping ranges. Pulse width and spacing are independently variable, 100 nsec—1 sec.

Whatever type of testing you have in mind, the 4001 has a mode to match. Continuous. One-shot. Trigger. Gate. Even a compliment mode to instantly invert the generator's main outputs. And there's much more, including external triggering; square-wave, fixed TTL and variable outputs . . . to name but a few. The more digital work you do, the more you need our 4001. At \$149.95*, it's very easy to afford.

WHY SETTLE FOR LESS?

Get the signal generators you've been looking for. At the price you've been waiting for. **NEED MORE INFORMATION? CALL 203-624-3103** to order, or for the name of your local distributor. Prices slightly higher outside USA.

© 1978, Continental Specialties Corporation. Prices, specifications subject to change without notice.

*Manufacturer's suggested list.

Corporate Headquarters:
Continental Specialties Corporation
70 Fulton Terr., Box 1942, New Haven, CT 06509
351 California St., San Francisco, CA 94104
(415) 421-8872, TWX 910-372-7992

CONTINENTAL SPECIALTIES CORPORATION



CIRCLE NO. 12 ON FREE INFORMATION CARD

Europe, Africa, Mid-East: **CSC UK LTD.**
Shire Hill Industrial Estate, Units 1 and 2
Saffron Walden, Essex CB 11 3AQ
Telephone Number: SAFFRON WALDEN 21682
TLX 817477



New Products

Additional information on new products covered in this section is available from the manufacturers. Either circle the item's code number on the Free Information Card or write to the manufacturer at the address given.

Sparkomatic In-Dash AM/FM Stereo Receiver/Cassette Player

The Sparkomatic in-dash Model SR 3400 is a high-power AM/FM stereo receiver with built-in cassette player and digital



clock. It is rated to deliver 40 watts at 1% (rms) THD. Controls include: separate variable bass and treble controls; separate balance and fader controls; local/distance selector; elapsed-time and reset controls; loudness, muting, and high filter switches; and AM/FM selector. Other features include a four-digit frequency and time numeric display; LED stereo indicator; and locking fast-forward and rewind buttons. FM sensitivity is rated at 1 μ V in mono and 2 μ V in stereo, both for 30 dB S/N, while AM sensitivity is 10 μ V for 20 dB S/N. Stereo separation at 1000 Hz is rated at 35 dB, i-f rejection at 75 dB, and image rejection at 55 dB. Cassette wow and flutter is rated at 0.3% and S/N at 40 dB.

CIRCLE NO. 91 ON FREE INFORMATION CARD

Capacitance Measuring Attachment

The Digital Capacitance Converter can be used with any calibrated oscilloscope or most counter/timers to determine capacitance values. When used with a counter/timer, it allows capacitance to be read directly in pF or μ F, depending on the setting



of the Converter's range switch. The upper range, limited by the leakage of the capacitor under test, can extend well beyond 10,000 μ F, for low-leakage components. The unit measures only the capacitor's discharge time, which also takes the capacitor's leakage into consideration. Each of the two ranges has a separate calibration control; there is also a "zero" control to cancel any stray capacitances. Accuracy is rated by the manufacturer at better than 1% with a high-quality counter/timer. The DCC is powered by a 9-volt transistor battery, and operates accurately down to as low as 5 volts. Made by International Instrumentation Inc. \$40.

CIRCLE NO. 92 ON FREE INFORMATION CARD

Series 20 Integrated Amplifier

The A-27 amplifier from Series 20 switches automatically between Class A operation at power levels of 3 watts or less and the more efficient Class B mode for up to 120 watts continuous power (measured into 8 ohms, from 5-30,000 Hz, with 0.015% THD or less; 4-ohm power, 180 watts at 0.03%



THD). Other unusual features include a phono equalizer section with FET input stages, front-panel cartridge load resistance and capacitance selectors, main and sub controls for both bass and treble, and adjustable subsonic filter (6 or 12 dB/octave below 15 Hz), and moving-coil as well as moving-magnet cartridge inputs. \$1250.

CIRCLE NO. 93 ON FREE INFORMATION CARD

Atari Personal Computer System

Atari, developers of the video game, PONG, recently introduced a personal computer—the Atari-800™. It's designed to be connected directly to a color or B&W TV receiver. It features expandable memory (shipped with 8K of RAM and expandable to 48K) and is supported by optional pe-

ripheral components (printer and floppy-disk system) and comprehensive software. Built into the basic console are both a cassette recorder and an Atari BASIC cartridge. The console contains a full alphanumeric keyboard; composite video output and built-in r-f modulator with TV Channel 2 or 3 selector; four controller ports; internal speaker; two cartridge slots for program insertion; four internal cartridge slots for user-replaceable memory cartridges; custom-designed video graphics display chip; and serial I/O port. The cassette system includes: automatic motor controller; 2-channel operation; 3-digit tape counter; audio track that plays through TV receiver; 600 bps operation; automatic volume and tone control; 400K data storage per C120 cassette.

CIRCLE NO. 94 ON FREE INFORMATION CARD

Gould Dual-Trace Oscilloscope

The new portable Model OS253 12-MHz oscilloscope from Gould Inc. features dual-

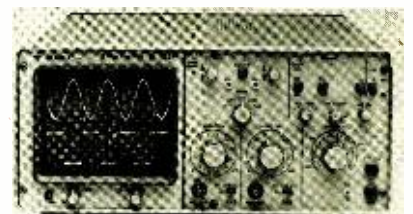

trace and X-Y display capability. Other features include: 2 mV/cm vertical sensitivity with ac, dc, and ground coupling; channel sum and difference operation with channel-2 inversion; bright-line operation; dc-coupled Z-modulation input; calibrator output; and front-panel trace-rotate control. Horizontal sweep rates are continuously variable over 18 ranges from 500 ns/cm to 0.3 s/cm, with a maximum effect sweep rate of 100 ns/cm at 5 \times expansion. Triggering is ac coupled from an internal or external source, with positive or negative slope and level selected by a variable control. Featuring an 8 \times 10 cm CRT, the scope measures 18"D \times 12"W \times 5 $\frac{1}{2}$ "H (46 \times 30.5 \times 14 cm) and weighs about 13 $\frac{1}{4}$ lb (6 kg). \$695.

CIRCLE NO. 95 ON FREE INFORMATION CARD

Audio Pro Computer-Controlled Receiver

The Audio Pro TA-150 FM/AM receiver has no internal moving parts. Its one control knob is read opto-electronically, with no mechanical connections to the receiver's interior. Selector buttons determine

NOW! GET A BIG \$20 REBATE ON THESE BEST-SELLING NO-CRYSTAL BEARCAT® SCANNERS.

Now, you can get all the on-the-scene police calls, fire calls, any emergency information the second it happens—and a big \$20 factory rebate—when you buy any of these best-selling Bearcat no-crystal Scanners.

\$20 back on the Scanners America wants most. Because they're all no-crystal, fully synthesized models that operate with incredible push-button ease.

\$20 back on the

Bearcat 210. The amazing 10-channel, 5-band Scanner that brings home over 6000 frequencies as easy as using a pushbutton phone. Gives you automatic search, selective scan delay, and more.

\$20 back on the new Bearcat 211. America's mid-priced, space-age circuitry Scanner that gives you 18-channel, 6-band capability at the touch of a button. Plus direct channel access, dual scan speed, automatic squelch. Even a

built-in clock.

\$20 back on the incredible Bearcat 250. America's only 50-channel, micro-processor controlled Scanner that searches, stores, and all but thinks for you.

See your Bearcat Dealer for our \$20 rebate details—good from Feb. 1, 1979 thru March 31, 1979.

Then pick your kind of Bearcat Scanner. We'll send you back a check for \$20. Good deal.



BC 210



BC 211



BC 250

BEARCAT® SCANNERS

FOLLOW THE LEADER TO REAL EXCITEMENT.

CIRCLE NO. 18 ON FREE INFORMATION CARD

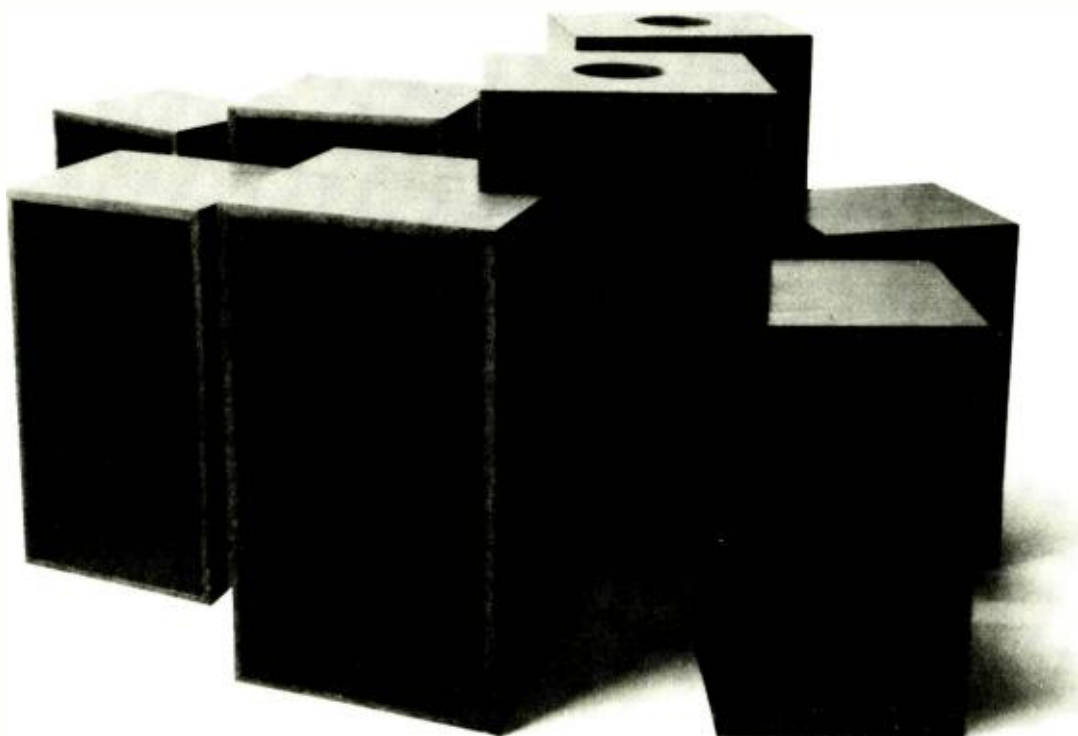

WHAT COMES OUT AS IMPRESSIVE AS WHAT

Most speaker companies try to impress you by describing the "wonderful" sound that comes out of their speakers.

At Pioneer, we think the most believable way to describe how good HPM speakers are is to tell you what went into them.

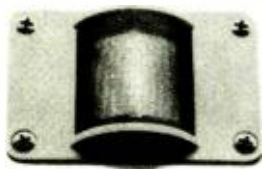

The High Polymer Molecular Supertweeter. So incredible, we named a whole line of speakers after it.

THE HPM SUPERTWEETER: SPEAKER TECHNOLOGY RISES TO NEW HIGHS.

In many speakers, you'll find that the upper end of the audio spectrum

is reproduced by an ordinary tweeter.

In HPM speakers, you'll find that the high frequencies are reproduced by a unique *supertweeter*.

It works by using a single piece of High Polymer Molecular film, (hence the name HPM) that converts electrical impulses into sound waves without a magnet, voice coil, cone, or dome.

And because the HPM supertweeter doesn't need any of these mechanical parts, it can reproduce highs with an accuracy and definition that surpasses even the finest conventional tweeter.

As an added advantage, the HPM film is curved for maximum sound dispersion. So unlike other speakers, you don't have to plant yourself in front of an HPM speaker to enjoy all the sound it can produce.

MID-RANGE THAT ISN'T MUDDLED.

For years, speaker manufacturers have labored over mid-range driver cones that are light enough to give you quick response, yet rigid enough not to distort.

Pioneer solved this problem by creating special cones that handle more power, and combine lower mass with greater rigidity. So our HPM drivers provide you with cleaner, and crisper mid-range.

Which means you'll hear music, and not distortion.



Level controls that let you adjust the sound to your listening area.



OF A SPEAKER IS ONLY GOES INTO IT.

WOOFERS THAT TOP EVERY OTHER BOTTOM.

Conventional woofers are still made with the same materials that were being used in 1945.

Every woofer in the HPM Series, however, is made with a special carbon fiber blend that's allowed us to decrease the weight of the cone, yet increase the strength needed for clarity. So you'll hear the deepest notes exactly the way the musician recorded them.

And because every HPM woofer also has an oversized magnet and a high temperature long-throw voice coil, they can handle more power without distorting.

OTHER FEATURES YOU RARELY HEAR OF

Every HPM speaker element has a cast aluminum frame, instead of the usual flimsy stamped out metal kind. So that even when you push our speakers to their limit, you only hear the music and never the frames. In fact, our competitors were so impressed, they started



You'll never hear a sound out of these die cast aluminum frames.

making what look like die cast frames, but aren't. HPM speaker cabinets are made of specially compressed board that has better acoustic properties than ordinary wood.

Their speakers have level controls that let you adjust the sound of the music to your living room.

And these features are not just found in our most expensive HPM speaker, but in every speaker in the HPM Series.

All of which begins to explain why, unlike speakers that sound great on only part of the music, HPM speakers sound great on all of it.

At this point, we suggest you take your favorite record into any Pioneer Dealer and audition a pair of HPM speakers in person.

If you think what went into them sounds impressive, wait till you hear what comes out of them.

PIONEER®
We bring it back alive.

CIRCLE NO. 54 ON FREE INFORMATION CARD

The best speaker kit isn't a kit at all!



The best speaker kit is a system designed by Electro-Voice that allows you to choose your own level of performance; from a studio monitor to a modest bookshelf system, from a wide selection of woofers, tweeters, mid-range drivers and crossovers.

Then Electro-Voice provides detailed plans on how to construct the enclosures designed specifically for the drivers you chose.

Only Electro-Voice gives you all the options. But, then, Electro-Voice is known for their superb quality speakers — not for kits.

To get your component speaker catalog and construction plans package, just send \$1.00 to Electro-Voice Component Speaker Systems, 600 Cecil St., Buchanan, MI 49107.



600 Cecil Street, Buchanan, Michigan 49107

Electro-Voice Component Speaker Systems,
600 Cecil St., Buchanan, MI 49107.

Please send me _____
E-V component speaker packages.
I have enclosed \$1.00 for each
package ordered.

Name _____

Address _____

City State Zip _____

PE-3-79

NEW PRODUCTS (Continued from page 8)



when that knob serves to control volume, balance, treble, bass or tuning. A micro-processor with memory and logic functions restores the most recently used control settings each time the receiver is switched on. An LED-string "dial" shows control settings; station frequencies are displayed digitally. Other facilities include preselector buttons for five FM and two AM stations, dual tape monitors, two phono inputs, low and high filters and switchable FM muting. Output power is 70 W continuous per channel into 8 ohms at less than 0.1% THD, from 10 to 10,000 Hz. FM sensitivity is 11 dBf (2 μ V) usable monophonic, and 35 dBf (31 μ V) stereo for 50 dB quieting sensitivity. Capture ratio is 2 dB; selectivity, 55 dB. \$995.

CIRCLE NO. 96 ON FREE INFORMATION CARD

Hustler VHF/UHF Monitor Antennas

New-Tronics has introduced four new Hustler antennas designed for the vhf/uhf public service bands of 37 to 50, 150 to 174, and 450 to 512 MHz. The Model MOS (\$9.95) is a 33-in. indoor receiver-mounted antenna. Model MOR (\$19.95) is 33 $\frac{3}{4}$ in. and has a base for mounting on a flat, horizontal surface such as a roof or deck lid. Model MOT (\$24.95) is a 34 $\frac{1}{2}$ -in. trunk-lip mount unit with no holes required. Model MOC (\$19.95) is a universal mobile-mount 34 $\frac{1}{2}$ -in. unit with an adjustable 180° swivel to keep it vertical. The latter three antennas come with appropriate lengths of RG-58 coax cable.

CIRCLE NO. 97 ON FREE INFORMATION CARD

Realistic Mini-Size "System Seven"

Radio Shack has introduced a "mini-sized" AM/FM stereo system designed especially



for apartments, dormitories, or offices. It includes the STA-7 receiver, measuring 3 $\frac{1}{2}$ "H \times 16 $\frac{1}{2}$ "W \times 11 $\frac{1}{2}$ "D (9 \times 42 \times 29 cm), and rated for 10 W/ch continuous power at 8 ohms from 20 to 20,000 Hz, 0.5% max. total harmonic distortion. With the Minimum-7 speaker systems, each of which is 7-1/16 \times 4-7/16 \times 4-5/16 (18 \times

11.5 \times 11.4 cm), equalization circuitry in the receiver is said to permit a low-end response down to 50 Hz at 90-dB levels. Equalization can be switched out for flat response with other speaker systems. The expandable system features a tuning meter, tape monitor switch, and speaker A-B selector. The complete system receiver and two speaker systems is \$219.95.

CIRCLE NO. 98 ON FREE INFORMATION CARD

Courier AM/SSB CB Transceiver

Fanon/Courier's Galaxy AM/SSB mobile CB transceiver features digital LED channel display and emergency-assistance channel 9 priority. The mobile unit is reported to offer better than 80 dB of adja-



cent-channel rejection through the use of mechanical ceramic i-f and two-pole crystal filters. An automatic gain control (agc) prevents overloading of signals stronger than 100 dB. Additional features include a noise blanker, SWR calibration, clarifier and squelch controls, microphone and r-f gain controls, PA capability, SWR calibration/S/r-f meter, and transmit and receive light.

CIRCLE NO. 99 ON FREE INFORMATION CARD

Speakerlab Speaker Kit

The "Thirty" is the first speaker system kit which is said to offer the Nestorovic woofer system. Two woofers (one 8" and one 10") share a single 1.8 cu ft enclosure and are selectively active or passive at different frequencies. An electronic network enables both woofers to work actively in up-



YOU ASKED FOR IT YOU GOT IT

DSI QUIK-KIT®

50 HZ TO 550 MHZ COUNTER KIT

95% ASSEMBLED 100% TESTED
Performance You Can Count On

FREQUENCY COUNTER APPLICATION:

- Ham Radio — Two Way Radio — CB
- Audio Amplifier & Receiver Repair
- Computer Maintenance & Construction
- A Must for TV & PLL Repair

\$99.95
MODEL 3550K

includes built-in
Pre-Amp & Prescaler



DSI OFFERS THE BEST OF TWO WORLDS . . .

An unprecedented DSI VALUE . . . in a high quality, LSI Design, 50 HZ to 550 MHZ frequency counter kit. And, because it's a DSI innovation, you know it obsoletes all competitive makes, both in price & performance.

With 95% of the assembly completed by DSI, you are only one hour away from solving all of those difficult bench problems, from adjusting 60 HZ clock-time bases to setting the frequency of a 468 MHZ Mobile Radio.

FACT: Every 3550 QUIK-KIT® PC board is factory assembled and tested before shipment. **FACT:** The problems of bad LED's, IC's, and Capacitors are a thing of the past. **FACT:** No manufacturer except DSI offers a 550MHZ frequency counter with . . . 8 digits, .5 in. LED's, TCXO, 1HZ resolution and a one year warranty on parts for under \$100.00. **FACT:** We do not know how long we can hold this low, low price. **GO WITH THE LEADER . . . BUY A DSI FREQUENCY COUNTER KIT TODAY. SAVE TIME & MONEY AND BE ASSURED IT WILL WORK THE FIRST TIME.**

DSI — GUARANTEED SPECIFICATIONS

Time Base TCXO 1PPM 65° to 85° F
Freq. Range 50HZ to 550MHZ incl. two SO239 inputs
Resolution 1HZ to 55MHZ, 10HZ to 550MHZ
Gate Time 1 sec & 1/10 sec with Auto Decimal Point
Display 8 digits, ½ inch LED with Leading Zero Blanking
Sensitivity 25MV @ 25MHZ, 150MHZ, 250MHZ;
75MV @ 450MHZ
Power Batt., 12VDC @ 300Ma, 110VAC (with AC-9)

3550K Kit \$99.95
T-101 Ant. 3.95
AC-9 AC Adp. 7.95
Shipping, Handling, Ins. 10.00

3550W Wired 149.95
T-101 (incl.) NC
AC-9 (incl.) NC
Shipping (incl.) NC



CALL TODAY TOLL FREE: (800—854-2049) Cal. Res. CALL (800—542-6253) TO ORDER OR RECEIVE MORE INFORMATION ON DSI'S FULL PRODUCT LINE OF FREQUENCY COUNTERS RANGING FROM 10HZ TO 1.3GHZ

TERMS: MC - VISA - AE - Check - M.D. - COD in U.S. Funds. Orders outside of USA & Canada, please add \$20.00 additional to cover air shipment. California residents add 6% Sales Tax.

DSI INSTRUMENTS, INC.
7924 Ronson Road, Dept. G, San Diego, CA 92111

CIRCLE NO. 15 ON FREE INFORMATION CARD
www.americanradiohistory.com



Traveling Companion

The nicest little clock radio available anywhere... that goes anywhere.

CALL 800-621-5554

Illinois Residents call 800-972-5858



Actual Size: 5½" Long x 2½" High x 2" Deep.

It's light. Small. Extremely practical. With all the features and conveniences of the clock radio by your bed—shuts itself off so you can fall asleep to your favorite music... wakes you to music or buzzer tone alarm... with snooze button and night light.

Try it on 15 day money back guarantee. Call toll-free to charge it or send just **\$39.95** plus \$3.00 for shipping to Douglas Dunhill. (Ill. add sales tax.) In rich black and anodized silver. Complete with penlight batteries and carrying case. You'll never worry about or miss a wake up call again.

Douglas Dunhill
INC. AFFORDABLE QUALITY
DD

DEPT. 73-2329
4225 FRONTAGE ROAD
OAK FOREST, ILL. 60452
© Douglas Dunhill Inc. 1978

CIRCLE NO. 62 ON FREE INFORMATION CARD

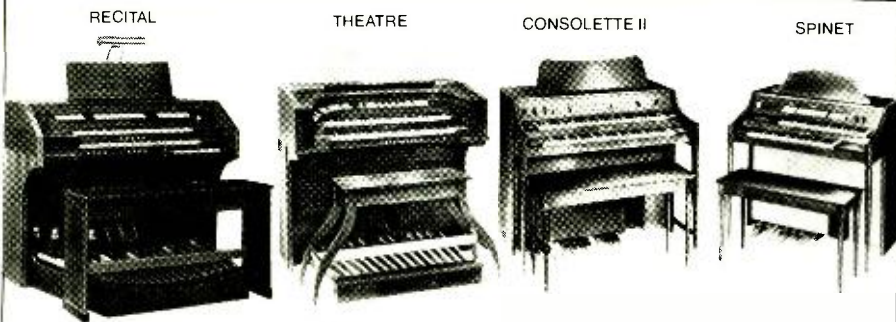

You can assemble any of these Schober Organs

—and save 50% off store prices.

This coupon will bring you the fascinating Schober color catalog which describes the organs and shows you how easy it is to assemble them from Schober's complete kits. Include \$1 if you want a 12-inch demo record.

The *Schober* Organ Corp., Dept. PE-82
43 West 61st Street, New York, N.Y. 10023

- Please send me the Schober Organ Kit Catalog.
 Enclosed is my \$1 for the 12-inch demo record.

Name _____

Address _____

City _____ State _____ Zip _____

CIRCLE NO. 47 ON FREE INFORMATION CARD

per bass frequencies, but shift some signal input away from the lower 10" woofer at lower frequencies. A three-position woofer damping switch overcomes problems with subsonic noise. A 4" midrange driver with collapsed-cell foam surround and a 1" dome tweeter complement the woofer section. Frequency response is said to be within 1 dB from 100 to 10,000 Hz, both at 0° and 30° off axis. Drivers and crossover circuit are rated at 350 W/ch max. Dimensions are 31"H x 12¾"W x 10¾" D (80 x 33 x 27 cm). \$330 with walnut cabinet, \$285 with walnut-grain vinyl.

CIRCLE NO. 100 ON FREE INFORMATION CARD

Heath Floppy-Disk Kit

Heath Company has announced availability of the Model H17 floppy-disk system in kit form. The system has a storage capacity of 102K per disk. It utilizes a fully assembled Wangco Model 82 disk drive (ex-



pandable to dual disk), an interface/disk controller board kit that plugs directly into the company's Model H8 computer mainframe, and a self-contained power supply. Seek and access times are rated at less than 250 ms. Available operating system software is designated as the Model H8-17. It includes the Heath disk operating system (HDOS) with diagnostic for unit evaluation and optimization; BUG-8 console debugger; TED-8 text editor; HASL-8 assembly language and extended Benton Harbor Basic. An extra diskette is included. \$530 for H17, \$295 for H17-1 optional second drive, \$100 for H8-17.

CIRCLE NO. 90 ON FREE INFORMATION CARD

Bib Electronic Anti-Static Device

The Groovstat 3000, from Bib Hi-Fi Accessories, is a fully electronic device (no piezoelectric cell) which uses a C-size battery to produce positive ions to clean record surfaces. All negatively charged build-up is said to be eliminated in 3 to 5 seconds. The user can hear and see that the device is working by means of an audio signal and a red neon light which are turned on when the control is operated. \$29.95. Address: Bib Hi-Fi Accessories, Inc., 3363 Garden Brook Dr., Dallas, TX 75234.

**NRI training in TV
and Audio Servicing
keeps up with the
state of the art.
Now you can learn to
service video cassette
and disc systems.**





You build color TV, hi-fi, professional instruments.

Now, in addition to learning color TV and audio systems servicing, you get state-of-the-art lessons in maintaining and repairing video cassette recorders, playbacks and the amazing new video disc players, both mechanical and laser-beam types.

Learn at Home in Your Spare Time

And you learn right at home, at your own convenience, without quitting your job or going to night school. NRI "bite-size" lessons make learning easier...NRI "hands-on" training gives you practical bench experience as you progress. You not only get theory, you actually build and test electronic circuits, a complete audio system, even a color TV.

Build Color TV, 4-Channel Audio

As part of your training in NRI's Master Course in TV and Audio Servicing, you actually assemble and keep NRI's exclusive,

designed-for-learning 25" diagonal color TV. As you build it, you introduce and correct electronic faults, study circuits to gain a better understanding of what they're for and how they interface with others.

Likewise, as part of your audio training, you construct a 4-channel stereo amplifier and tuner, complete with cabinet and speakers. You even assemble professional-grade test instruments, so you know what makes them tick, too. Then you use them in your course, keep them for actual TV and audio servicing work.

NRI Includes the Instruments You Need

You start by building a transistorized volt-ohm meter which you use for basic training in electronic theory. Then you assemble a digital CMOS frequency counter for use with lessons in analog and digital circuitry. FM principles. You also get an integrated circuit TV pattern generator, and an advanced design solid-state 5" triggered-sweep oscilloscope. Use them for learning, then use them for earning.

NRI Training Works... Choice of the Pros

More than 60 years and a million students later, NRI is still first choice in home study schools. A national survey of successful TV repairmen shows that more than half have had home study training, and among them, it's NRI 3 to 1 over any other school. (Summary of survey on request.)

That's because you can't beat the training and you can't beat the value! For hundreds of dollars less than competing schools, NRI gives you both color TV and audio...and now includes training in video cassette and disc systems. Send for our free catalog and see for yourself why NRI works for you.



Other NRI training includes Computer Technology, Complete Communications Electronics.

Free Catalog... No Salesman Will Call

Our free 100-page catalog completely describes all the equipment and every lesson. You can choose from five different TV and audio courses. Or explore the opportunities in other NRI home study courses like Computer Technology, CB and Mobile Radio, Aircraft and Marine Radio, or Complete Communications. Send the postage-paid card today and get a head start on the state of the art.

If card has been removed, write to:



NRI-Schools
McGraw Hill Continuing
Education Center
3939 Wisconsin Ave.
Washington, D.C. 20016

Learn at home at your convenience





Stereo Scene

MUSIC AND NOISE

By Ralph Hodges

IN CONTINUING the coverage of New York's annual Audio Engineering Society Convention begun last month, I am forced into a few arbitrary decisions. First of all, it is the technical papers that were delivered throughout the convention's four days that will receive virtually all my attention. Equipment was also on display, but for the most part it was studio gear that was of prime interest to working audio professionals, many of whom were presumably on hand to see it for themselves. Secondly, it's necessary to select the papers discussed; it would be impossible to comment even briefly on all of them.

So the following criteria will apply, in no particular order of precedence: (1) papers dealing with products of interest likely to be accessible to the consumer; (2) tutorial papers concerned with issues and answers bearing directly on home music reproduction; (3) papers likely to interest the electronics enthusiast; (4) papers I was able to hear delivered (all too few); and (5) papers I at least partially understood (fewer still).

Over recent years the treatment of subjects within the various branches of audio has become vastly more rigorous and specialized. For the most part, the rigor is welcome, and it will surely bring benefits in better hardware and software and more refined thought about making it better still (i.e., more appropriate to its somewhat baffling task). But the specialization is less fortunate. Not everyone has an everyday acquaintance with all areas of applied and theoretical mathematics, statistics, computer theory, instrumentation, circuit analysis, etc. It's amusing to see expressions of shocked recognition and then consternation cross the faces of auditors of some of these papers as they suddenly realize that the involved technical discourse they're struggling to follow is actually background on a completely familiar mechanism couched in terms of a completely unfamiliar conceptual model. Here, as everywhere else, we need standardization. But we do our best.

Noise. Evidently, we get a certain amount of noise in audio systems because God meant us to. But the rest of it is there because of our own ignorance and/or oversights. It can be attacked directly and successfully, however, as Apt Corporation's Tom Holman has done in his latest paper (preprint no. 1428, available from the Audio Engineering Society, 60 East 42nd Street, New York, N.Y. 10017, for \$2.00). This is a rulebook for designing against noise in the input stages for phono cartridges and tape heads, with some very authoritative commentary on noise measurement and the subjective appraisal of noise.

As Holman points out, some sorts of noise in "trickle" amounts are not necessarily unpleasant to music listeners. (A little hiss in a stereo system seems to be attractive to some people, for who-knows-just-what reason. The most sophisticated explanation I have heard is that it is random-phase between the channels, and is therefore "spacey.") Furthermore, the paper makes at least a beginning at reconciling the existing statistical data on human reaction to noise—most of it dealing with noise detection, annoyance value, and acoustic trauma—with a listening-for-pleasure situation, where the criteria may not necessarily be the same. In short, if you are interested in designing against noise (preferred choice of semiconductor devices and circuit configurations for a given application), finding out how it might be most validly measured, and learning how much we actually do know about noise and human beings, it is here, neatly researched and organized.

If you're not interested in anything about noise except its elimination, Richard Burwen presented a description of his current "Transient Noise Eliminator" that reveals the device as being somewhat more complex than many had suspected. The Burwen TNE is one of those outboard processors intended to combat ticks, pops, and scratches on phonograph records. His approach has long been recognized as somewhat more

musically acceptable than others for minor but rapidly repeating groove irregularities such as might be caused by "non-fill" of vinyl, damage from a mis-tracking phono stylus, or concentrations of dust, etc. (Some alternative devices have been found almost completely effective against deep once-around scratches, but on densely packed groove abrasions the sound becomes hashy.) In the Burwen unit, signals are in effect processed in two frequency bands, subject to the guidance of a control circuit that compares inputs from the two channels. One of the frequency bands is full-range, and its output is the normal output of the device when there is no transient-noise disturbance. The other band is limited to 300 Hz, and its output signal is substituted for the normal one when a tick or pop occurs to fill in for interruption of the full-range signal. Whether the output signals are full-range or band-limited, they are subjected to a 40- μ s analog delay to give the control circuit time to detect and act.

The control circuit consists of a differential op amp that receives the inputs of both left and right channels. The differential information is rectified after passing through a bandpass filter (15,000 to 50,000 Hz) and then split into two branches, one of which passes through a 250-Hz low-pass filter, ultimately to join the other at a comparator stage. After a suitable delay (necessary to give the audio signals time to "catch up" with the control signals), the comparator acts to switch audio outputs to the full-range or band-limited signal paths. The Transient Noise Eliminator "punches holes" in the music signal of usually no more than 1 millisecond's duration, and this is said to be responsible for its claimed lack of audible side effects. Burwen does not say that the design is perfect, but he does say that on those few occasions when it acts under the stimulation of a sharp transient in the program material (as opposed to a sharp "snap" from a defective disc surface), its only effect is to chop off the leading millisecond of the music waveform. The sound of the chop is at least as sharp as the sound of the leading edge of the waveform should have been if heard, so presumably no harm is done.

Music. Somewhat of a surprise entry at the convention was a paper by the eminent J. Robert Ashley, denouncing (albeit somewhat reluctantly and remorsefully) the current trend to in-the-round concert halls. I had not realized that

Australia's architecturally splendid Sydney Opera House incorporated a "360-degree" hall. It does, however, and Dr. Ashley brings bad news from that continent, as well as from his home city of Denver, where an acoustically similar experiment has been erected.

As you might expect, the major problem with in-the-round concert environments is a lack of early reflections from nearby sound-reflecting surfaces (because there aren't any) and an abundance of later-arriving reflections, some of them so discrete and delayed as to amount almost to echoes. Speech intelligibility is often impaired if not destroyed for many seats in the auditorium, and there is a characteristic lack of warmth to the musical sound resulting both from the lack of acoustical support for lower frequencies and the diffused, almost incoherent sounds of higher-pitched instruments such as violins. There is also difficulty with orchestra members hearing each other well enough to achieve good ensemble. (You can hear many of these effects on records—even on some made in such a distinguished acoustical environment as Boston Symphony Hall. Periodically, it has been the practice of recording engineers to bring the orchestra off the stage and out into the seating section where nearby reflecting surfaces are absent. The result is too few early reflections and too many late ones.)

Even if we don't have the opportunity or inclination to visit concert halls, we ought to be concerned about their quality, because they also serve—or should—as recording studios for their resident orchestras. If they can't hack it, recording engineers will immediately turn to close miking and an overlay of artificial acoustics created by reverb devices (often they do so anyway), and listeners to recorded music become the poorer for it. I'd like to thank Dr. Ashley for his timely if reluctant outburst.

Another surprise paper, "Evaluating the Influence of Room Acoustics on L/R Stereo Perception," was presented by the eminent Emory Cook. Harking back to some of his earlier schemes for audio-system evaluation, Mr. Cook has come up with an "auditory code" (a test signal easily qualified and quantified by the human ear alone) to grade the success of a stereo system in presenting a stable stereo image to various locations.

A tape is made of interrupted bursts of third-octave-band noise, the bursts following a dot-dash (as in Morse code) pattern on one channel and a dash-dot sequence on the other. Cook suggests

sixteen noise bands in all, with center frequencies ranging from 180 to 5,747 Hz. For each of these bands, and for each of the possible listening positions in the room, either one channel (dot-dash) or the other (dash-dot) is likely to predominate. If, of course, the balance of the system is virtually perfect for the band of frequencies and the location, a smooth, uninterrupted rush of noise will be heard if the tape is properly recorded.

Mr. Cook does not give many details on how the tape ought to be recorded (presumably, one just switches the noise generator between tape-recorder channels to create the properly interleaved pulse sequences?), but he does offer a computer program to assist in sorting out the considerable pile of data that will result if this project is carried through in the grandest possible style.

Tape Recorders. Looking at magnetic recording systems other than the digital devices discussed last month, we find that there is—or is soon to be—a semiprofessional open-reel tape machine with automatic bias and recording-equalization adjust functions that are bursting out all over on cassette decks. The relevant paper was prepared by a quartet of engineers from Matsushita Electric (Panasonic and Technics by Panasonic) in this country, and the tape machine, the Technics RS-1800, is a fabulous conglomeration of the isolated-loop transport, numerous microprocessor functions involving digital readout of real-time tape indexing, speed and speed deviation, and tension sensing for control of reel-motor torque.

The paper's translation problems from Japanese into English make me reticent about discussing it in depth, but it at least appears that the adjustment functions are carried out in much the same way as they are in the equivalent cassette decks. Bias is set for maximum output from the tape at a certain reference frequency, and then recording equalization is set for flat frequency response (within ± 0.5 dB) on playback. The whole adjustment process is programmed into memories within the machine, and it requires no work from the user other than the punching of a button to initiate the sequence. The paper (preprint no. 1387) is the lengthiest and most complete I've seen on the design of such adjustment systems, with particular emphasis on the problems caused by tape dropouts. But it does strike me as being perversely complex in its approach to a subject that is really not all

that difficult (I suspect its principal author is some years closer to a university classroom than I).

Record Players. Another Japanese quartet, this one from Sansui and headed by the also eminent Dr. S. Takahashi of QS fame, has concluded that the position of the cartridge stylus in a record player's tonearm should correspond as precisely as possible with the arm's center of percussion. I'll leave it as an exercise for tonearm zealots (of which I am certainly one) to discover exactly what the center of percussion is. But suffice it to say that it is that part along the length of a baseball bat that you should endeavor to bring into contact with the ball if you don't want your hands to experience a sharp stinging sensation.

The argument makes sense as far as it goes. It is certainly true that a stylus located at the center of percussion is least likely to be affected by agitations at the tonearm pivot area, such as are likely to be caused by acoustic feedback coupling with the motorboard. Conversely, such gyrations as the cartridge and associated parts perform as they traverse the record are least likely to play hob with the pivot assembly, should it have a little too much mechanical play or other form of instability.

Unfortunately, locating the center of percussion at the stylus tip seems to involve bringing the center of mass of the whole tonearm system well out and away from the pivot assembly—a location in which you certainly don't want it if you'd like to make a success of playing warped records. True, some tonearm designers are willing to put up with such high inertia to realize other theoretical—and even measurable—benefits. But others aren't. It will be interesting to see how Sansui's concept fares in competition with the latest low-mass arms.

Getting Smart. I am out of page space, with at least a dozen more papers worthy of comment unrepresented. Many of them will fit logically into future columns and will there appear as authoritative sources. But the ones I miss are also available as preprints from the Audio Engineering Society. (A "preprint" is a usually legibly produced version of the author's paper made available before he reads it at the convention. Many of the best papers turn into articles in the society's Journal, but some don't.) A simple request to the AES (enclose SASE) will bring a list of available preprints to you. Prices average \$2.00. \diamond

Julian Hirsch Audio Reports



Philips Model AF877 semiautomatic belt-driven record player features "direct control" drive



The new Philips Model AF877 two-speed semiautomatic record player employs a "Direct Control" (not "direct drive") drive

and speed control system. Its cast aluminum 12" (30.5-cm) platter is belt-driven by a dc servo motor. The corrective feedback voltage for the motor's servo loop comes from a tachometer generator on the platter's shaft. (As a rule, tachometer feedback in record player servo-motor systems comes from the *motor* shaft.) Belt slippage can occur under conditions of heavy loading, such as when using some record cleaning devices, and short-term belt stretching can cause wow and flutter. Hence, Philips has logically chosen to maintain a constant platter (record) speed instead of a constant motor speed with the "Direct Control" system.

The Model AF877 includes an attractive brown base with a hinged tinted plastic dust cover that remains open at any angle. With the cover

down, the player measures 16½" W × 13¾"D × 5½"H (42 × 34.8 × 14.1 cm) and weighs 12.8 lb (5.8 kg). Suggested retail price is \$249.95.

General Description. The 34-ounce (about 1-kg) platter rests on a smaller inner platter that is driven by a flexible belt. The tachometer disc, which resembles a toothed gear, is on the platter's shaft, beneath the motorboard. The disc generates a voltage in coils surrounding it in proportion to the rotation speed of the turntable. This voltage is converted to dc, which is compared to a stable dc reference. The amplified difference is the drive signal for the turntable motor.

The motor controls are electronic touch contacts, similar to those used on other recent Philips turntables. Two are for selecting either the 33 ⅓- or 45-rpm speed (which simultaneously turns on the motor) and one stops the motor. The fourth is a REJECT control, that raises the tonearm and returns it to its rest before shutting off the motor. This action also occurs

automatically at the end of a record, but the initial start-up and cueing of the tonearm must be done manually. All the motor controls are grouped near the right front of the motorboard.

Behind the ON contacts are two small knobs for adjusting each speed over a limited range of nominally ±3%. The speed is continuously monitored on an array of nine red LEDs that come on sequentially with each 1% increment on either side of the nominal speed. (The center LED glows when the turntable speed is exactly at the selected speed.) The display is much more visible and easily interpreted than the usual stroboscope markings.

The tonearm consists of a low-mass straight aluminum tube that is mounted in low-friction pivots and balanced by an adjustable threaded counterweight. The die-cast aluminum head shell supports the cartridge at an offset angle to provide a low tracking error. The shell mates with the tonearm through a four-pin plug and socket with a locking ring. (This shell is not interchangeable with the four-pin plug-in shell widely used on Japanese tonearms and some European models.) A plastic installation jig simplifies setting the stylus overhang for minimum tracking error.

motor controls are electronic touch contacts

The Model AF877 has a unique feature, which has been used on some earlier Philips record players. It is a tonearm support post that contains the tracking force gauge. When the tonearm is placed on the rest, its downward force is measured, corrected for any difference that might exist when it is in the plane of the record, and displayed in a window on the motorboard near the speed-indicator section. The force scale is calibrated over a 0.5-to-3-gram range at 0.25-gram intervals. The indicator is a green horizontal line whose length is

proportional to the force. Near to the tonearm's base are the antiskating dial, with separate scales for spherical and elliptical styli, and the cueing lever. The latter gently raises and lowers the tonearm through a viscous damped mechanism.

To reduce the susceptibility of the record player to vibration and acoustic feedback, the platter and tonearm are mounted rigidly to a subchassis that is suspended on three leaf springs from the motorboard and mounting base. The motor itself is also isolated from the base on springs, thus decoupling it in two stages from the record-playing components to minimize transmitted vibration.

Laboratory Measurements. To evaluate the Philips Model AF877 record player, we installed a Sonus Red Label cartridge in its tonearm. The installation was simplified by the open design of the head shell and the easy-to-use jig that verified the correct overhang adjustment. The unique Philips force-indicating system eliminated the necessity to first balance the tonearm and then set in the desired force. We simply turned the counterweight until the force dial indicated the desired value when the tonearm was on its rest post.

A comparison with an accurate balance gauge revealed that the force calibration was accurate to better than

0.1 gram over its full range. The tracking error was also about as low as can be achieved with a pivoted arm of this length or measured visually with a protractor. It was less than 0.4°/in. of radius for radii between 2½" and 6" (6.4 and 15.2 cm). The capacitance to ground in each signal output, including that of the integral cables, was a very low 70 pF.

The success of Philips' efforts to reduce tonearm mass was confirmed by our measurements. Including the cartridge, which weighs 5.5 grams, the effective mass at the stylus location was only 16.5 grams. The net effective tonearm mass of 11 grams was one of the lowest we have measured. (Most record-player tonearms have a mass of about 20 grams.) The low mass produced a 10-Hz resonance with the rather high compliance of the Sonus stylus, which is an ideal frequency for avoiding warp tracking problems without loss of low bass response. The amplitude of the resonance was also very low at a mere 3 to 4 db.

The turntable flutter was not quite as low as rated, although this is very subject to differences in test records and interpretation of meter readings. The weighted peak DIN flutter was 0.09%, and the weighted rms JIS flutter was 0.07%. On the spectrum analyzer, we could see that the flutter frequency components were concentrated in the vicinity of 15 Hz. The rumble was a good -34 dB in an unweighted (NAB) measurement and was principally at frequencies around 8 Hz. When we measured it with ARL weighting, which attenuates the measurement response below 500 Hz at a 6-dB/octave rate, we obtained the very impressive figure of -66 dB. This ranks with one or two of the finest turntables we have previously measured and is at least 6 dB lower than a typical good direct-drive turntable.

The antiskating dial is completely off the tonearm. Hence, it can be adjusted while playing a record for equal distortion in both channels with the aid of a special high-velocity test record. We found that the antiskating dial agreed closely with the tracking force setting and was within 0.25 grams. Most tonearms require that the antiskating be set about 1 gram greater than the tracking force for best compensation. The cueing device worked smoothly, and the tonearm did not drift outward significantly during its

Product Focus

The Philips "Direct Control" system of speed control is the most logical method of stabilizing a turntable. Many turntable ills arise from a discrepancy between the rotations of the motor and the platter. This is one of the strong features of direct-drive turntables, since the motor and platter are effectively one unit and the servo feedback that stabilizes the motor does the same for the platter.

One of the problems one faces when applying feedback around a compliant member such as a flexible belt is that there is a considerable phase shift in torque transmission through the belt. If the platter slows down momentarily, a corrective signal is sent to the motor to speed it up, which it does. However, there can be an appreciable time lag, or at least a phase shift, between the time the motor responds and the time that response reaches the heavy platter. An even longer time lapse is required for the platter to respond because of its mass. If the process is applied carelessly, the result is likely to be a system with a low-frequency oscillation (hunting) that would be unacceptable in a record player. Perhaps it was problems such as this that discouraged other manufacturers from using this system.

Judging from the performance of the Model AF877, Philips has built the correct phase shifts and loop gains into its servo because we found no sign of instability. In a system such as this, one cannot expect the feedback to reduce flutter frequency components by very much, and we saw no evidence that that had been achieved (flutter was certainly low enough, but not unusually so). The feedback action, given the available torque and platter mass, would seem to have been concentrated on maintaining the correct speed under a variety of static

load conditions. In this, it seems to have been very successful.

Another feature, not exclusive to Philips but nevertheless an example of Philips' logical approach to product design, is the straight tonearm. Most tonearms have an "s" shape, in which the cartridge shell emerges from the end of the tonearm at the correct angle to the line joining the stylus to the pivot to minimize tracking error. Having the cartridge axis tangent to the tonearm's tube is an undeniable manufacturing convenience, but it is the only advantage we can see to using an angled or S-shaped arm tube. Nevertheless, many tonearm manufacturers attempt to assign other virtues to this shape when it has none.

The shortest distance between two points is a straight line, and the shorter the length of a piece of tubing, the lower will be its mass. This is completely self-evident, and is the rationale for using a straight tubular tonearm if one wishes to reduce mass to a minimum. (The desirability of this will be evident to anyone who has warped records to play.) Unfortunately, the straight-tube tonearm requires that the cartridge be mounted at an angle. Also, to eliminate or reduce torsional resonance problems, it is desirable that the stylus be on the tonearm's axis. This calls for a head shell that supports the body of the cartridge at an angle to the tonearm, with its stylus in line with the arm, as Philips has done.

This system works very well, as our tests have shown. Although it is not compatible with the almost universally used plug-in headshell found on many other players, it is plain that Philips was less interested in compatibility than in making the best possible tonearm for its record players. What Philips has done adds to the total suitability of the Model AF877.

Performance Specifications

Specification	Rating	Measured
Wow & flutter	0.05% DIN	0.09% DIN
	0.03% wrms	0.07% wrms (JIS)
Rumble	-50 dB DIN A	-34 dB NAB
	-70 dB DIN B	-66 dB ARLL
Pitch control range	±3%	Confirmed
Arm tracking error (max)	0.9 min/cm (0.38°/in.)	0.4°/in
Bearing friction	Less than 15 mg	Not measured
Resonant frequency	10 Hz (with Philips test cartridge)	10 Hz (with Sonus Red Label cartridge)
Effective moving mass	16.5 g	11 g

descent; it repeated at most a second or two of the program. The automatic shutoff at the end of a record or when the REJECT contact was touched required about 12 seconds to cycle through.

The LED speed display gave a very clear indication of turntable speed. We noted that the center LED remained on over a small range of speeds, amounting to about ±0.3%. However, when care was taken to set the vernier speed control in the center of that range, the actual speed was

turntable speed displayed on array of nine red LEDs

usually within 0.1% of the correct value. The maximum range of the vernier was approximately the rated ±3%.

Because of the spring suspension of the platter and tonearm system from the mounting base, we expected

the Model AF877 to be relatively insensitive to vibration conducted through its base. This proved to be the case, although it was not as thoroughly isolated as some turntables we have tested that used very heavy bases on soft isolators. Nevertheless, the Model AF877 was above average for belt-driven record players in its isolation and was far better than most direct-drive players. The suspension is soft enough so that the entire turntable can be rocked or jarred quite vigorously while playing a record without causing the pickup to lose contact with the groove, even though there was usually a transient "wow."

User Comment. We were very favorably impressed with the total performance of the Philips Model AF877 record player. It was exceptional in most of its measured characteristics with the rare quality of having everything work just as one would expect. In most record players we have used, there is at least something that re-

quires "fudging" in order to achieve the desired results. For example, many tonearms, when balanced in the horizontal plane, do not give fully accurate force readings and must be checked against an external gauge. Most antiskating systems provide much less than the optimum correc-

rumble measured 6 dB lower than typical direct-drive model

tion when set to agree with the tracking force setting. Many tonearms do not have accurate, unambiguous means to position the stylus for correct overhang. These and other annoyances were completely lacking in the Model AF877. This is an "all-together" record player that works as it should and whose performance in many respects is far beyond what one usually finds at its price.

The Direct Control drive maintains the correct record speed even under rather heavy loads. Bearing down on the record with a cleaning brush or cloth may slow down the rotation momentarily, but it recovers in a second or so, suggesting a healthy reserve of torque in the drive system. One of the most worthwhile benefits of the low-mass tonearm was its ability to track severely warped discs. In fact, the Model AF877 was able to play all of our severely warped records with no more drastic results than an occasional momentary "wow" or thump at the crest of the warp.

We have tried to be as critical as possible, hoping to find something that was omitted from the Model AF877 or that did not perform up to expectations. If this record player has any flaws or "bugs," we failed to uncover them. This is notable by any standards.

CIRCLE NO. 101 ON FREE INFORMATION CARD

H.H. Scott's Model 480A is a moderate-priced, high-performance, 85-W/ch integrated amplifier



The Model 480A is the most powerful integrated stereo amplifier in the new line of audio components from H.H. Scott. It is rated to deliver 85 watts/channel into 8-ohm loads from 20 to 20,000 Hz with no more than 0.03% THD. It is also an exceptionally flexible and full-

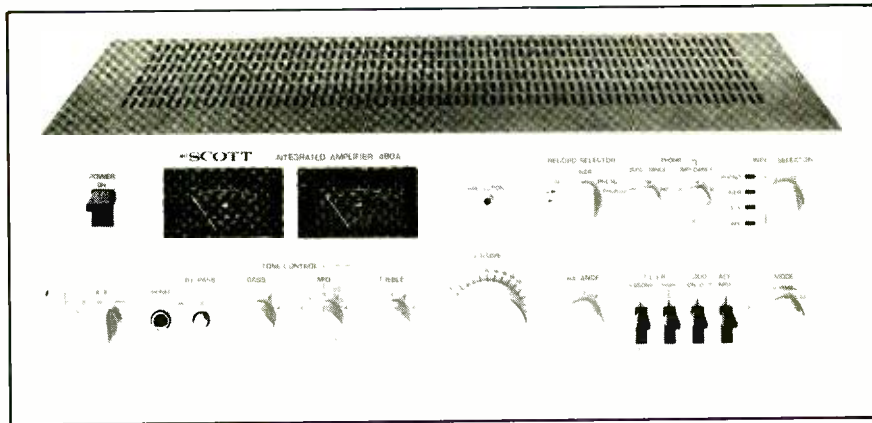

two phono preamps permit simultaneous recording and listening to different record players

featured amplifier whose design reflects the latest hi-fi trends.

The amplifier's styling appears to be more in line with that of most integrated amplifiers currently available on the U.S. audio market, a departure from the somewhat "European" look of Scott components in recent years. The satin-aluminum-finish front panel shows off the brighter metal knobs to good advantage, and color signal indicators are used with restraint and good taste.

The amplifier measures 17"W × 14¼"D × 5¼"H (43 × 33 × 13.2 cm) and weighs 29 lb (13 kg). Its suggested retail price is \$400.

General Description. The electrical performance specifications of the Scott Model 480A, as discussed later, are clearly those of a top-quality audio amplifier. Physically, the amplifier has some special features, many of which are not unique individually but which are unusual in combination. For example, there are separate program-selector controls for listening and tape recording, with sources for two magnetic phono cartridges, two tape decks, and two high-level inputs. The

input-selector knob's panel legends are supplemented by red lights that indicate which source is being heard. The two positions for the tape decks on the record selector are labelled to indicate their use for dubbing from either deck to the other.

At least one other manufacturer (Yamaha) uses a somewhat similar system of independent listening and recording source selection, but Scott has gone even further by providing separate preamplifier sections for its two phono inputs. This gives a listener the option of taping from one record while listening to another, the latter played on a different turntable, of course. Advantage has also been taken of the dual preamplifier design to give each input slightly different control features. PHONO 1 has separately adjustable input capacitance and resistance with controls on the front panel. Resistances of 30,000, 50,000, and 100,000 ohms are available, as are capacitances of 100, 250, and 400 picofarads. PHONO 2 has fixed input loads of nominally 50,000 ohms and 250 picofarads, but it has a two-position sensitivity switch (on the rear of the amplifier) that gives it nominal input sensitivities of 2.5 or 5 millivolts for rated output.

The Model 480A's triple tone controls (BASS, MID, and TREBLE) are detented in 11 positions. A BY-PASS pushbutton switch is provided for routing the program around all tone control circuits simultaneously for flat response. The VOLUME control is stepped, its attenuation in decibels calibrated at intervals that increase by 1 dB near the upper end of its range to 4 dB near the bottom of the range. The BALANCE control has a detented center position too. A switch controls the MODE (NORMAL and REV STEREO

and R and L channel and summed L + R MONO). The SPEAKER selector switch permits one to activate either, both, or neither of two pairs of speaker outputs. A separate position on the SPEAKER switch activates a PHONES jack on the front panel.

The five remaining controls are lever switches. They include POWER, SUBSONIC, and HIGH filter switches. Both filters have the desirable 12 dB/octave slopes in their cut-off regions. Another switch is for controlling LOUDNESS compensation. The last switch is for inserting a signal-processing accessory—such as a noise reducer, expander, time-delay unit, equalizer, etc.—into (and removing it from) the program path through jacks on the rear of the amplifier.

The Model 480A is protected against overloads, short-circuited outputs, and internal failures by a relay that instantly disconnects the outputs from the loads if any dc component appears at the outputs. The relay and protective circuits also provide a turn-

separate bass, mid, and treble tone controls

on time delay of several seconds to prevent transients from reaching the speaker systems. A red PROTECTION indicator comes on when the relay is tripped.

The two output level meters are calibrated in watts and dBW (decibels referred to 1 watt). They have a fairly fast attack and a slower decay time so that they tend to follow program level contours. They are calibrated to indicate only the order of magnitude of the output power into 8-ohm loads, over a range of from 0.001 to 100 watts, in decade steps.

On the rear apron of the amplifier is a DIN socket that duplicates the functions of the TAPE 2 inputs and outputs. Insulated spring clips are used for the speaker outputs. Two accessory ac outlets are provided, one of which is switched. An output-power slide-switch selector that can be accessed with a screwdriver through a hole in the rear apron, can reduce the 85-watt maximum output of the amplifier to 55 watts. The ac line cord is separate, and plugs into a three-pin socket on the rear apron.

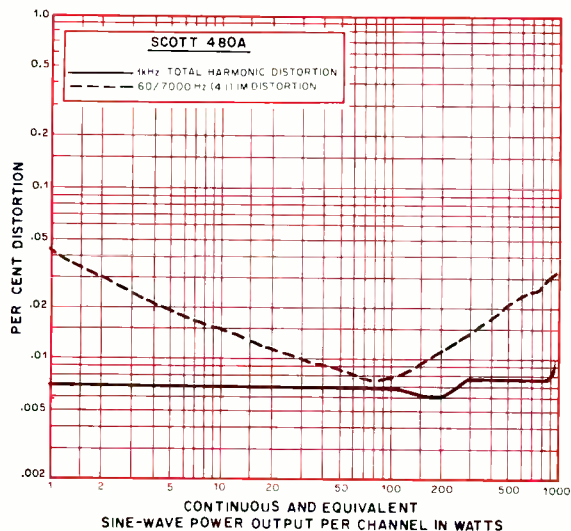

THD and IM distortion at 8 ohms.

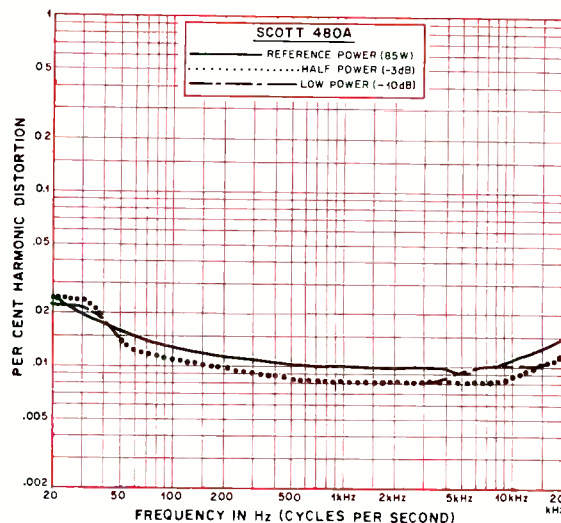

Percent harmonic distortion at three power levels.

Laboratory Measurements. The one-hour FTC preconditioning period with both channels of the amplifier driven at one-third rated power at 1000 Hz into 8-ohm loads left the Model 480A only mildly warm to the touch. The 1000-Hz power output at the clipping point was 105 watts/channel, for an IHF clipping headroom rating of 0.92 dB. IHF dynamic headroom rating was 1.91 dB, since the amplifier could deliver 132 watts in a 20-ms burst before clipping occurred. (The continuous clipping outputs into 4 and 16 ohms were 136 and 69 watts, respectively.)

Distortion at 1000 Hz was very low and virtually constant with power. (It was also notable for being purely second harmonic, and we never were able to detect any higher order distortion components down to our minimum resolution level of about 0.003%.) For all outputs between 0.1 and 90 watts, the distortion was between 0.007% and 0.008% and reached 0.014% at 100 watts. Intermodulation (IM) distortion was only slightly greater, measuring between 0.008% and 0.015% at most usable power levels between 1 and 30 watts. It rose to 0.043% at 0.1 watt (and even higher in the milliwatt range), and more slowly at higher power outputs to a low 0.035% at 100 watts.

At 85 watts/channel, distortion was about 0.01% over most of the audible

1000-Hz power output clipped at 105 W/ch

Product Focus

The Scott Model 480A has several interesting circuit features, including the placement of the SUBSONIC and HIGH audio filters in the power-amplifier feedback loop to minimize the amount of circuit complexity without loss of performance. The phono preamplifiers employ a three-stage configuration, with two transistors providing voltage gain and the third operating as an emitter follower to provide current gain for the feedback network. A direct result of this is the elimination of slew-induced distortion at high frequencies. This can be inferred to some extent from our measurement of the phono-overload limit, which was as great at 20,000 Hz as anywhere else in the audio range.

The power amplifiers use a current mirror loaded differential pair for the input, coupled to a class-A voltage amplifier with a constant collector load. Following the voltage amplifier are fully complementary Darlington-connected driver and output transistors. The input differential transistors are in a single package to match their thermal drifts and minimize dc offset. (The amplifier is direct coupled to the speakers and within its own feedback loop.)

We have no detailed information on the power limiter circuit that converts the 85-watt amplifier to a 55-watt amplifier with a simple switch operation. Such features have been used from time to time on other amplifiers, but in this case it is not easy to appreciate its benefits. The power reduction (about 1.9 dB) is hardly enough to make the difference between safe and unsafe operation of one's speaker systems. In fact, it is difficult to conceive of a speaker system good enough for use with this amplifier that would not be able to safely accommodate its full power.

frequency range. It reached 0.014% at 20,000 Hz. Below 100 Hz, the readings followed the increasing distortion in our signal generator, which was about 0.025% at 20 Hz—well within the amplifier's ratings, and really mostly in the input signal itself. At lower power levels, distortion was slightly lower. Output power meters were calibrated with reasonable accuracy at 1 and 10 watts output.

To drive the amplifier to a 1-watt reference output, 15 mV was required at the high-level input. The A-weighted S/N, referred to 1 watt, was 78.2 dB. Phono sensitivity was 0.21 mV on PHONO 1 and PHONO 2 (H₁), with a 77.4 dB S/N and a clipping input of 350 mV at 1000 Hz. The LO sensitivity setting for PHONO 2 yielded a 0.47-mV sensitivity, with a huge 690-mV overload capacity. We also checked the phono overload limits at 20 and 20,000 Hz. After correcting for the RIAA equalization response, we determined that the phono preamplifier dynamic range was uniform throughout the entire audio band.

The IHF slew factor, measured through the high-level inputs, was in excess of 25. This means that when we drove the amplifier to rated output at 1000 Hz and maintained the same drive level, the 500-kHz upper limit of our signal source was reached without visible waveform distortion on the output signal ($500/25 = 20$ slew factor according to IHF-A-202, 1978). The low-level gain of the amplifier decreased with increases in frequency, at a rate that prevented any possibility of slew-induced distortion from audio-band signals.

(Continued on page 31)

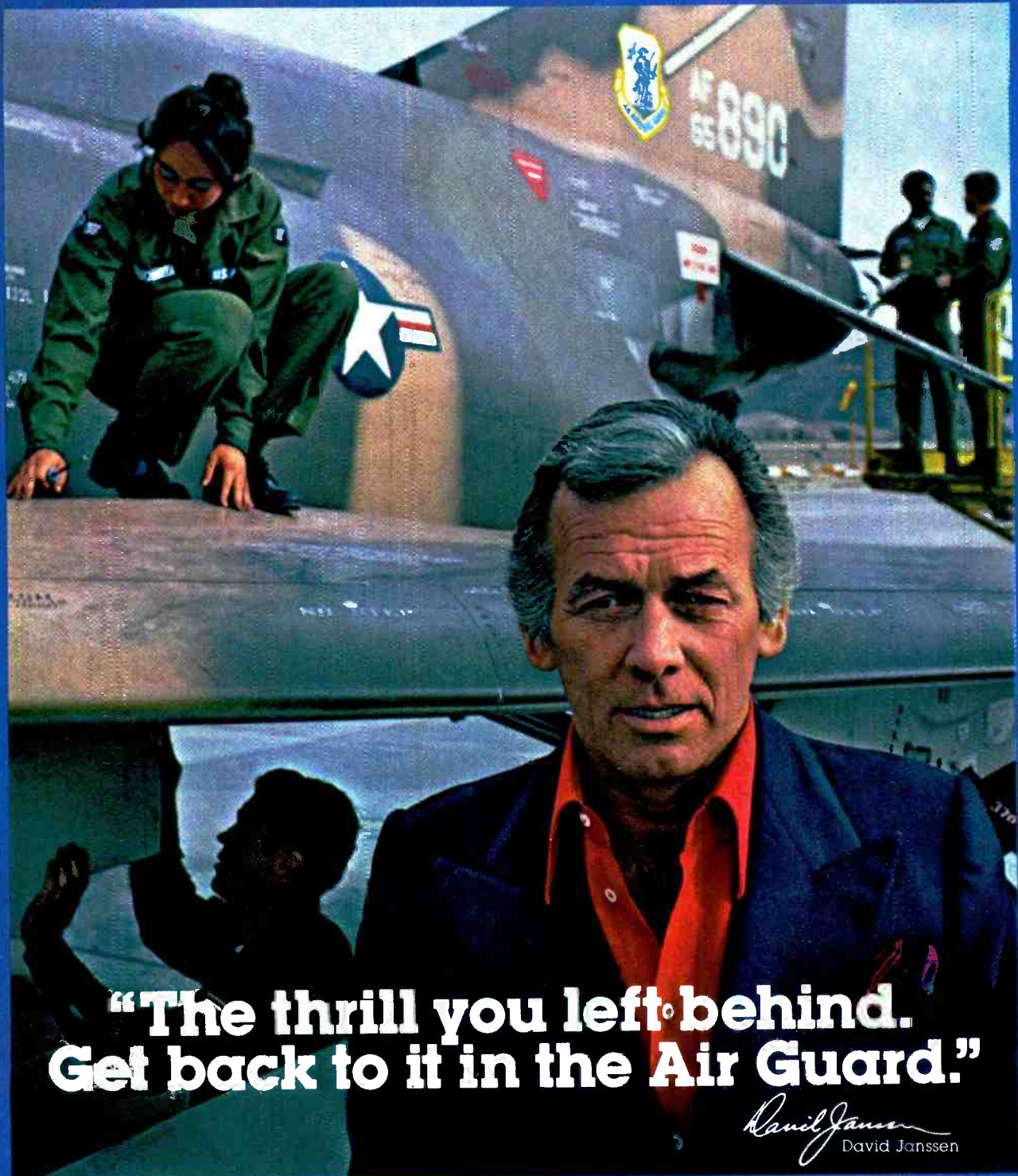

**“The thrill you left behind.
Get back to it in the Air Guard.”**

David Janssen
David Janssen

The roar of a jet engine. A blip on a radar screen in a darkened room. The crackle of voices over a communications center radio. The satisfaction of an important job well done.

The excitement you left behind you can find again, in the Air National Guard.

And you'll find a lot more, too. Good pay. Insurance and retirement. Advanced skills training.

If there's room in your life for a little of that old excitement, there's room for you in the Air Guard.

See your local Air National Guard recruiter. Or call us, toll-free 800-638-0936 (except in Alaska, Hawaii and Puerto Rico). In Maryland, call 301-981-3610.

**We Guard
America's Skies.**

CIRCLE NO. 32 ON FREE INFORMATION CARD



The Guard belongs.

These new **Persuader™ Antennas** low profile, extra long whip deliver performance equal to, or better than anything else on the road!

There's a hand-wound, hand-tuned
coil in the cup...



a major advance in
antenna technology
from the Antenna Pros
field tested and
field proven by
thousands of CBers

Only \$34.98 suggested retail. Compare
with K-40 at \$38.50 or any other antenna. You'll see
there's no comparison.

5 year guarantee

Materials and workmanship of PERSUADER ANTENNAS
(Models 13505 & 17605) are guaranteed for a full five years
if this antenna is installed by the dealer and a full three years
if this antenna is installed by the consumer.

Any part that fails within the guarantee period will be replaced absolutely free
provided the registration card has been completely filled out and returned to
Antenna Incorporated.



A word from the Old Pro:

When you buy this antenna,
my reputation... built over 38 years in
the antenna business... will be riding on
your roof. I'm confident that the
Persuader Antennas will persuade you...
you've chosen the Best.

M.R. Friedberg, President
Antenna Incorporated

In stock at your dealer now...

or call the Antenna Hotline... 1-800-447-4700.
(Illinois: 800-332-4400; Sorry, no Hotline service in Alaska or Hawaii).



Charge to Visa or Master Charge... and we'll
have your nearest dealer ship your Persuader
Antenna promptly, in the mount and color of your choice. Hotline
orders add \$1.50 for shipping and handling. Applicable local
taxes extra. Allow 2 to 4 weeks for delivery.

The family of fine antennas from the fine antenna family.



26301 Richmond Road, Cleveland, Ohio 44146 (216) 464-7075

In Canada: Cardon Import Canada Ltd., P.O. Box 937 Hamilton, Ontario L8N 3P9
Antenna Incorporated, International Division, P.O. Box 1002 Rockville Centre, New York 11571
CIRCLE NO. 6 ON FREE INFORMATION CARD

Completely pre-assembled and pre-tuned

Just take it out of
the package, and
install it on the
car. No tuning
necessary...
check it out with
a watt meter and
see for yourself!

Super-good looking
low silhouette
design.
Your choice of
cup colors
design-coordinated
to late-model cars.

SIERRA
BRONZE



DIAMOND-FIRE
BLACK



ATLANTIS
BLUE



FIRETHORN
RED



SNOWCAP
WHITE



CLASSIC
SILVER
AS
SHOWN

AND
CRYSTAL
CLEAR

60" Stainless steel
tapered whip...
and NO spring

There's a
Coil-in-the-cup

Magnet
Mount

These features will persuade you... The Persuader™ Antenna is Your Best Antenna Choice

60" Stainless Steel Tapered Whip...and No Spring

The super-long whip increases the aperture of the antenna. This increases

- the signal capture area on reception
 - the transmit signal and radiation intensity at the horizon
 - bandwidth to well over a 40-channel capability
- The .125" diameter whip is tapered, so shock is distributed evenly. There's no spring to stretch, break, or bend the whip away from the straightest possible upright position.

Exclusive coil-in-cup design

Loading of most low-profile antennas is by a simple printed circuit board that can't be tuned and will eventually burn out. These new Persuader antennas are completely pre-assembled and pre-tuned and feature an actual hand-wound, hand-tuned copper wire loading coil tested with 500 watts, rated at 100 watts continuous. It's even more efficient than our base-loaded coils because it's wound to a larger diameter, with fewer turns.

This unique design also involves fewer mechanical and electrical connectors—fewer resistive contacts between loading coil and cable terminations—less chance for dust, moisture or road gunk to contaminate the contacts.

This concept has been field tested by thousands of CBers in our Model 13503 (shorter whip, plain white cup). Your good buddies will tell you everything we say about it is true.

Available with Trunk-Lip or Magnet Mount

for performance:

- SWR of 1.5:1 or less across all 40 AM and SSB channels.
- Shunt-fed loading coil is DC grounded for quiet performance; bleeds off static from rain, snow, air particles. Performance is virtually identical to body mount antennas.
- Center-roof placement of magnet mount provides your most uniformly omni-directional signal. (Can also mount on trunk lid).
- Unique Antenna Incorporated design provides capacitive coupling. Aluminum plate puts the ground potential right at the mounting surface.

for convenience: Magnet and trunk lip, the two easiest installations! Place the antenna where you want it, plug the cable into the transceiver. No holes to drill. Readily removed for anti-theft protection. Magnet mount supplied with 12' RG-58/U coaxial cable with PL-259 type connector; trunk lip mount with 17' of cable.

for magnet mount adherence: Heavy-duty 2½" magnet in plastic cup with soft rubber gasket. Holds at top highway speeds of 55 mph. (Trunk lip mount recommended for vinyl roof cars.) Since it won't walk, it won't detune! "Oil-can" effect of cup; resting on gasket, provides a larger magnet plane than if the magnet itself were touching the surface—yet there's less weight on the car, less scratch potential.

All magnet mount benefits are standard... not an extra-cost accessory!

(Continued from page 26)

Tone controls were flexible enough for almost any purpose. The bass turnover frequency was variable, while the treble-response curves were hinged at about 2000 Hz. The maximum midrange adjustment of about ±6 dB provides useful tone-control action, without the possibility of producing bizarre effects. The response of the SUBSONIC filter was down 3 dB at 20 Hz, 12 dB at 10 Hz, and 27 dB at 5 Hz. The response of the HIGH filter was down 3 dB at 7000 Hz. Both filters had the rated 12 dB/octave slopes.

Loudness compensation was relatively mild. It boosted both the lows and the highs but had no effect until the VOLUME control was well into the lower half of its range. The RIAA phono equalization response was within ±0.5 dB from 20 to 20,000 Hz. When

measured through the inductance of a typical phono cartridge, the phono response rose slightly at high frequencies, to a maximum of +2 dB at 10,000 Hz, before returning to normal at 20,000 Hz. The input resistance of the PHONO 1 circuit measured 32,000, 47,000, and 72,000 ohms, with a capacitance of 130, 300, and 500 pF. The input impedance of the PHONO 2 circuit was 47,000 ohms shunted by 280 picofarads.

User Comment. Impressive as its measured performance was, the Scott Model 480A amplifier impressed us as being somewhat more than the sum of its parts. This is difficult to appreciate from a mere listing of the manufacturer's specifications and our test results. We found no weaknesses in the amplifier or any respects in which it fell

Performance Specifications

Specification	Rating	Measured
Continuous power into 8 ohms, 20–20,000 Hz	85 Watts at 0.03% THD	Confirmed
IM distortion at rated power	0.03%	Confirmed
Frequency response (±0.5 dB)	20–20,000 Hz	Confirmed
Power bandwidth at –3 dB	10–40,000 Hz	Not checked
Damping factor (1 kHz, 8 ohms)	At least 100	Not checked
Input sensitivity (rated out)		(for 1 watt out, IHF-A-202, 1978)
Phono	2.5 mV	0.21 mV
High level	150 mV	15 mV
Maximum input voltage		
Phono	180 mV	360 mV
High level	10 V	at least 10 V
Signal-to-noise ratio (shorted input, A-wtd)		(A-wtd, IHF-A-202, 1978)
Phono	90 dB re. 10 mV	77.4 dB re. 1 watt
High level	95 dB	78.2 dB
Tone control range		
BASS (100 Hz)	±10 dB	+9/–10 dB
MID (1 kHz)	±6 dB	Confirmed
TREBLE (10 kHz)	±10 dB	+8.5/–10 dB
Filter attenuations (12 dB/oct)		
HIGH (8 kHz)	–3 dB	7 kHz/–3 dB
SUBSONIC (18 Hz)	–3 dB	20 Hz/–3 dB
RIAA tolerance (20–20,000 Hz)	±0.5 dB	+0/–0.5 dB

fact:
**February and March are
 be-kind-to-your-records/
 check-your-stylus months...**



**FREE! Stylus inspection and
 cleaning wherever you see this sign:**

A cartridge is forever—your stylus isn't! Even though you can't see stylus wear, it affects the performance of your entire hi-fi system. A worn stylus could even ruin your records! We urge you to have your stylus professionally inspected *no less than once a year.*

During February and March, audio dealers displaying this sign will have trained personnel and the equipment necessary to examine your stylus for wear or damage. They'll professionally clean your stylus and tell you if it's time to replace it.

FREE!
stylus cleaning brush

A practical and safe way to clean your stylus! Synthetic bristles with the right amount of stiffness to remove dust and lint buildup efficiently without damaging the stylus tip. Free when you have your stylus inspected at a participating Shure dealer.



Bring your cartridge back to original specs

The performance of your cartridge depends largely on the stylus assembly and only a genuine Shure replacement stylus can restore your cartridge to its original performance! Give your record collection the protection it deserves, insist on the words "This Stereo Dynetic® stylus is precision manufactured by Shure Brothers Inc." on the box, and the name SHURE on the replacement stylus you buy. Don't settle for substitutes—your record collection is too valuable!



SPECIAL NOTE:

Genuine Shure replacement styli are available for virtually all Shure stereo magnetic cartridges—whatever their age. If your dealer doesn't have yours, write to us.

Replacement styli by...



Shure Brothers Inc. • 222 Hartrey Ave. • Evanston, IL 60204
 In Canada: A.C. Simmonds & Sons Limited
 Manufacturers of high fidelity components,
 microphones, sound systems and related circuitry.

CIRCLE NO. 48 ON FREE INFORMATION CARD

below an "excellent" rating. There were no minor "bugs," such as switching transients, uneven control operation, ambiguous control labelling or operating instructions, or other annoyances that manage to appear in most products we test, no matter how good their overall performance.

Although we are usually less than enthusiastic about loudness controls (at least, those that do not include a separate overall gain adjustment), we even found the loudness compensation of this amplifier to be pleasing and listenable. This may have been due in part to an accidental combination of speaker efficiency and incoming signal levels, but we suspect it is also connected with Scott's use of a very mild boost at low frequencies instead of the exaggeration of so many loudness compensating circuits.

**one of the best
 performers in its
 price/power class**

Needless to say, in listening to the Model 480A, we never heard anything but what was present in the program. Many of the sonic properties attributed to audio components are really related to the system as a whole. With the Scott Model 480A, in combination with the Philips Model AF877 record player and a Sonus cartridge, as an example, we could operate the system at maximum gain without a trace of audible hiss or hum more than a few inches from the speaker systems. Perhaps this was merely a fortuitous combination of components, but we found it to be completely in harmony with our impressions of the Scott amplifier from other tests and use. This is the sort of behavior one hopes to experience in a very expensive, highest quality music system, but encountering it in a moderate-priced system is worthy of special mention.

If none of the unusual features of the Scott Model 480A is of special importance to you, just think of this amplifier as one of the best performers in its price and power range, and by all means include it in your buying considerations. To us, the Model 480A bodes well for the successful reemergence of H.H. Scott as a factor in the American audio market.

CIRCLE NO. 102 ON FREE INFORMATION CARD

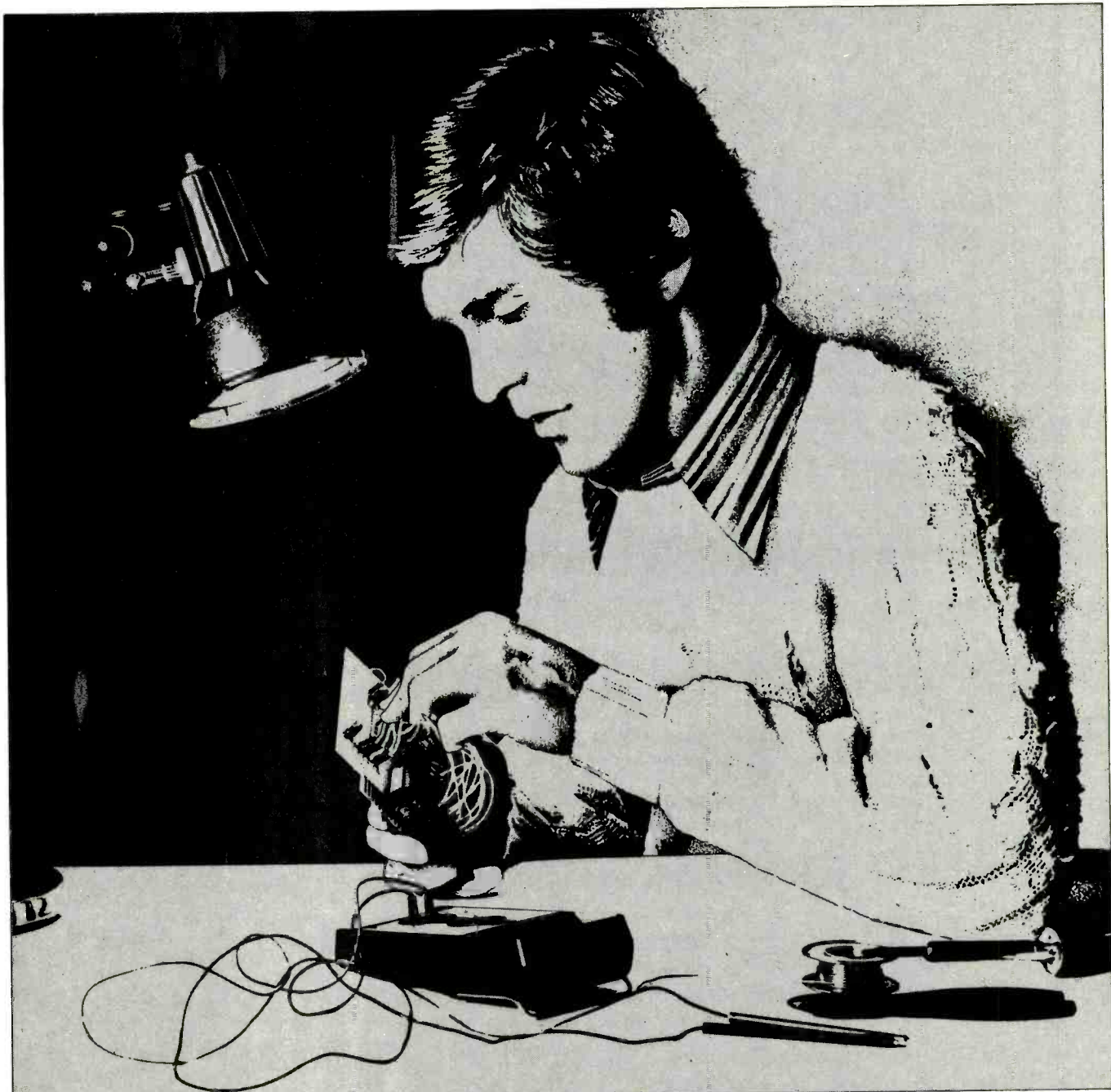

YOU'RE READING POPULAR ELECTRONICS.

That already says a lot about you. That you're fascinated by the diversity of electronics. Everything from microcomputers to audio, from construction projects to ham radio. Who knows what area of electronics will catch your interest next? That's why you read P.E. To keep in touch with all that's new and best in the many worlds of consumer electronics.

Popular Electronics

World's largest-selling electronics magazine

ALL NEW AND ADVANCED DMM

by Sabtronics
for only \$89.50

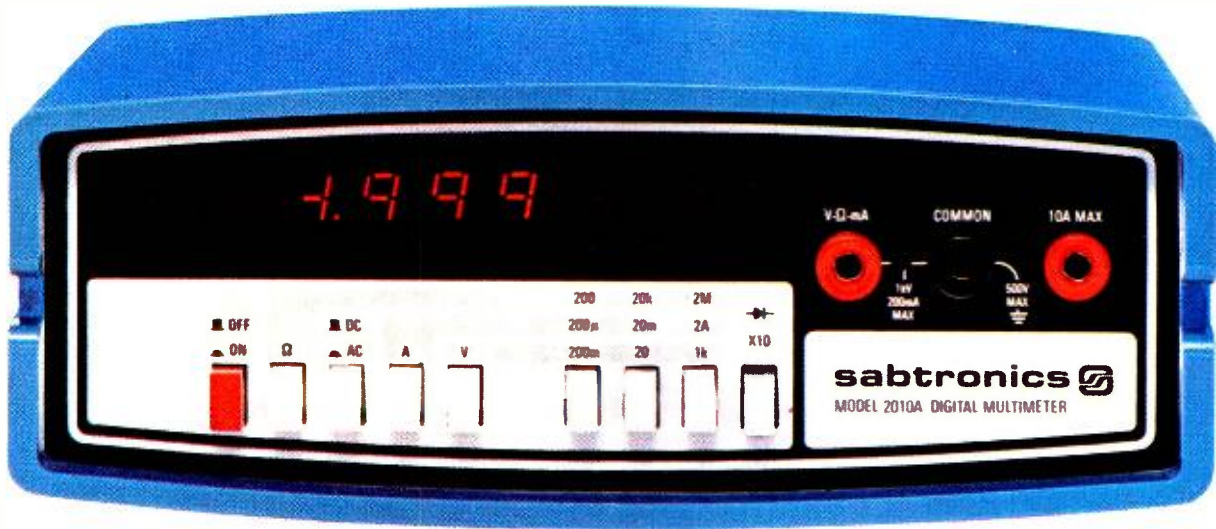

Designed and made in U.S.A.

The new and advanced Sabtronics Model 2010A is absolutely amazing . . . it gives you more performance, features and accuracy at a price no other Digital Multimeter can approach. It is versatile and rugged, for bench and portable use, with laboratory standard accuracy.

Greater Long-Term Accuracy

State-of-the-Art design features include a laser-trimmed decade resistor network and an ultra-stable band-gap reference element to insure long-term accuracy. Basic DCV and Ohms accuracy is 0.1% ±1 Digit, guaranteed for one year. With 31 ranges and 6 functions you can measure AC and DC volts from 100 μV to 1000V; AC and DC current from 0.1 μA to 10 A; resistance from 0.1 Ω to 20 MΩ.

Unique X10 Multiplier Switch

This exclusive feature of the Model 2010A gives you a convenient means of selecting the next higher decade range. The Hi-Lo Power Ohms capability gives you three High-ohm ranges that supply enough voltage to turn on a silicon junction for diode or transistor testing. Measure in-circuit component resistance with three Low-ohm ranges.

Touch and Hold Capability

The optional touch and hold probe allows you to make measurements in hard-to-reach places without taking your eyes off the probe tip. A button on the probe retains the display reading after the probe tip is removed from the test point.

Other Important Features

This quality instrument includes an ACV Frequency Response of 40 Hz to 40 kHz, automatic polarity, automatic zero, automatic decimal point, overrange indication, and overload protection on all functions and ranges. The bright LED display gives readings to ±1999 and is easy to read in dim light or bright light.

Reliability and Performance at Low Cost

The Model 2010A is factory tested, calibrated and is supplied complete with test leads, probes and detailed operating manual. A full compliment of optional accessories is available to increase the versatility of your 2010A DMM. Because you buy factory direct, you get this high-quality, full performance instrument at an incredibly low price of only \$89.50.

Brief Specifications

- DC Volts:** 100μV to 1000V in 5 ranges
- AC Volts:** 100μV to 1000V in 5 ranges
- DC Current:** 0.1μA to 10 A in 6 ranges
- AC Current:** 0.1μA to 10 A in 6 ranges
- Resistance:** 0.1Ω to 20 MΩ in 6 ranges
- Diode Test Current:** 0.1μA, 10μA, 1mA
- ACV Frequency Response:** 40Hz to 40kHz
- Input Impedance:** 10 MΩ on ACV and DCV
- Overload Protection:** 1200 VDC or RMS on all voltage ranges except 250 VDC or RMS on 100mV and 1 V AC ranges. Fuse protected on ohms and mA ranges.
- Power Requirement:** 4.5 to 6.5 VDC (4 "C" cells) optional NiCd batteries or AC adapter/charger
- Display:** 0.36" (9.2mm) Digits reading to ±1999
- Size:** 8"W x 6.5"D x 3"H (203 x 165 x 76 mm)
- Weight:** 1.5 lbs. (0.68kg) excl. battery

(Batteries not included)

Orders Yours Today

Call us with your Mastercharge or Visa order or use the convenient order form to take advantage of this special introductory offer.

Making Performance Affordable

sabtronics 

13426 Floyd Circle M/S 24 • Dallas, Texas 75243
Telephone 214/783-0994

To: Sabtronics International, Inc., 13426 Floyd Circle M/S 24, Dallas, TX 75243

PLEASE SEND ME THE FOLLOWING:

Model 2010A Digital Multimeter(s)	@\$89.50	\$
AC Adapter/Charger(s)	@\$ 7.50	\$
Nickel-Cadmium Battery sets	@\$17.00	\$
Touch-and Hold Probes	@\$18.00	\$
For delivery in Texas, add Sales Tax		\$
Shipping, Handling and Insurance per unit \$4.00*		\$
<input type="checkbox"/> Check enclosed <input type="checkbox"/> Money Order, or bill my <input type="checkbox"/> Master Charge <input type="checkbox"/> Visa	TOTAL	\$ _____

Account No. _____ Expiry Date _____

Name _____

Street _____

City _____ State _____ Zip _____

*Continental U.S. only. AK, HI & PR, \$5.00. Canada \$6.50. Foreign: \$19.00 Airmail.

PE-3

BY GEORGE STEBER

NOW YOU can literally sit back and read messages sent in International Morse even if you don't know the code. The "Morse-A-Word" project presented here automatically converts incoming dits and dahs from a communications receiver or telegraph key into alphanumeric symbols for display on a multicharacter LED readout. The display operates in moving-character fashion to make it easy to read the messages.

With this project, SWLs can listen in on commercial and amateur code traffic. And for beginning as well as veteran radio amateurs, the Morse-A-Word makes an excellent operating and code-training aid. Cost of a complete kit including a prepunched and lettered chassis and two two-character displays is \$150. One or two additional displays can be added at moderate cost.

This project is similar to the Morse-A-Letter featured in the January 1977 issue of POPULAR ELECTRONICS. Its display capability has been expanded, however. At the builder's option, the Morse-A-Word can display two, four, six or eight characters simultaneously. All

The MORSE- A-WORD

PART ONE: Theory and System Operation

LED readout displays words and numbers when Morse code is received



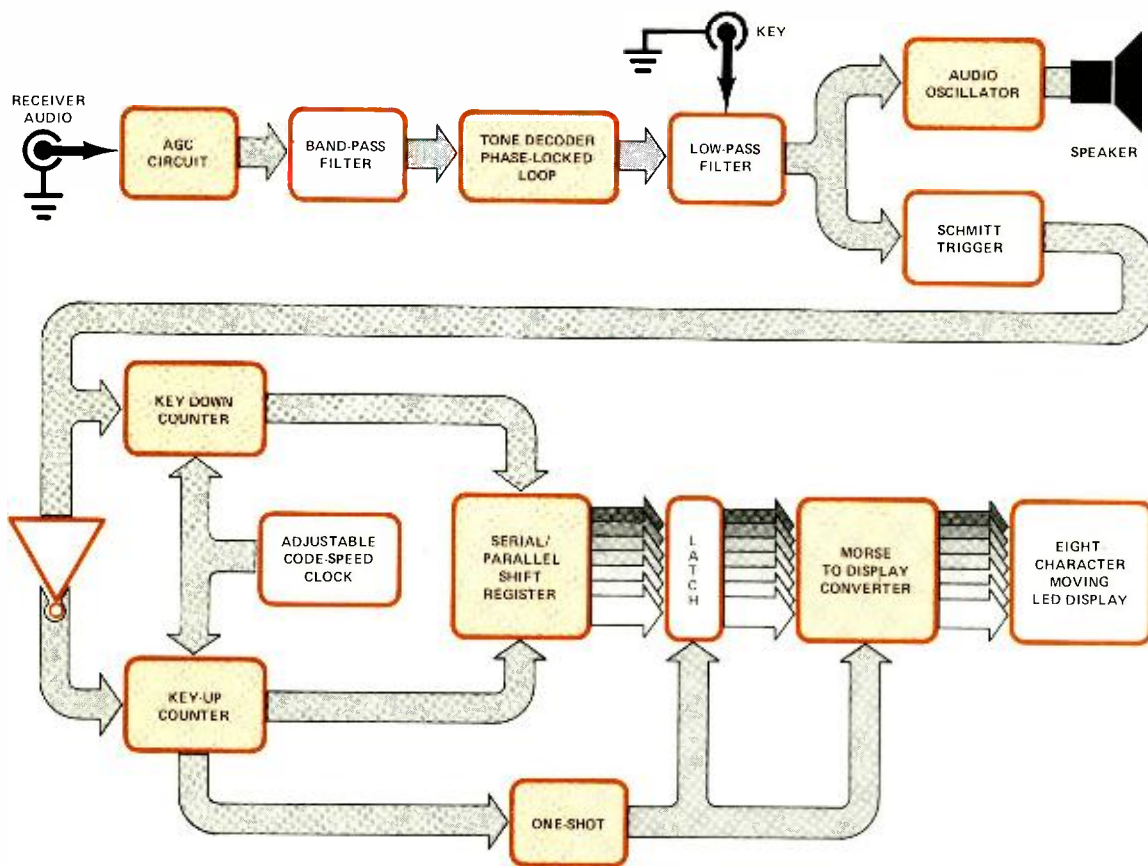

Fig. 1. Block diagram of the Morse-A-Word system shows how the incoming signal in code is processed for alphanumeric display.

characters—letters, numerals, punctuation marks and, if desired, word spaces—are displayed and shifted from right to left as new ones stream in.

Double-sided pc boards hold the LED display and main decoder circuits. A single-sided board accommodates the power supply.

It should be mentioned at the outset that the reliable conversion of Morse code radio signals into alphanumeric characters is not easy. Signal fading, atmospheric and man-made noise, and human errors present major difficulties. Consequently, no device can perfectly decode all received signals all of the time. The highly sophisticated Morse-A-Word circuit has been designed to provide a very high degree of accuracy, however, and will do a very creditable decoding job in far-from-ideal situations.

System Analysis. A block diagram of the Morse-A-Word is shown in Fig. 1. The complete schematic of the main decoding circuit is in Fig. 2, and the display circuit is shown in Fig. 3.

PARTS LIST: MAIN DECODING CIRCUIT

C1,C2,C5,C10,C12,C15,C17,C18 through C21,C23—0.1- or 0.05- μ F disc ceramic
 C3, C7—22- μ F, 10-volt tantalum
 C4—0.05- μ F disc ceramic
 C6,C9,C11—0.01- μ F Mylar
 C8—1- μ F, 10-volt tantalum
 C13—0.22- μ F Mylar
 C14—6.8- μ F, 10-volt tantalum
 C16—0.47- μ F, 10-volt tantalum
 C22—27-pF disc ceramic
 D1,D2,D3—1N270 germanium diode
 IC1, IC2—7495 4-bit shift register
 IC3,IC6,IC15,IC17—74161 4-bit counter
 IC4,IC8—741 operational amplifier (8-pin mini-DIP)
 IC5—74174 hex D flip-flop
 IC7—7414 hex inverting Schmitt trigger
 IC9,IC10—7489 64-bit RAM
 IC11—74121 monostable multivibrator
 IC12—555 timer
 IC13—567 PLL tone decoder
 IC14—1702A PROM
 IC16—7402 quad 2 input NOR gate
 IC18—7483 4-bit binary adder
 IC19—7485 4-bit magnitude comparator
 J1,J2—Phono jack
 LED1, LED2—Red light-emitting diode

Q1—2N3823 n-channel JFET
 The following are 1/4-watt, 10% tolerance fixed resistors.
 R1,R4,R27—220 ohms
 R2—10,000 ohms
 R3,R13,R15—470 ohms
 R5—15,000 ohms
 R6,R17,R21 through R26—1000 ohms
 R7—150,000 ohms
 R8—330 ohms
 R10—680 ohms
 R11,R19—6800 ohms
 R12—270,000 ohms
 R16—47,000 ohms
 R18—12,000 ohms
 R9,R14—500-ohm pc trimpot
 R20—5000-ohm pc trimpot
 R28—500-ohm linear-taper potentiometer with ganged spst power switch
 S1—Spst slide or toggle switch
 SPKR—8-ohm dynamic loudspeaker
 Misc.—Printed circuit board, IC sockets or Molex Soldercons, suitable enclosure, LED holders, pc standoff insulators, control knob, machine hardware, hookup wire, solder, etc.
 Note—For parts and kit ordering information, refer to the Parts Availability list.

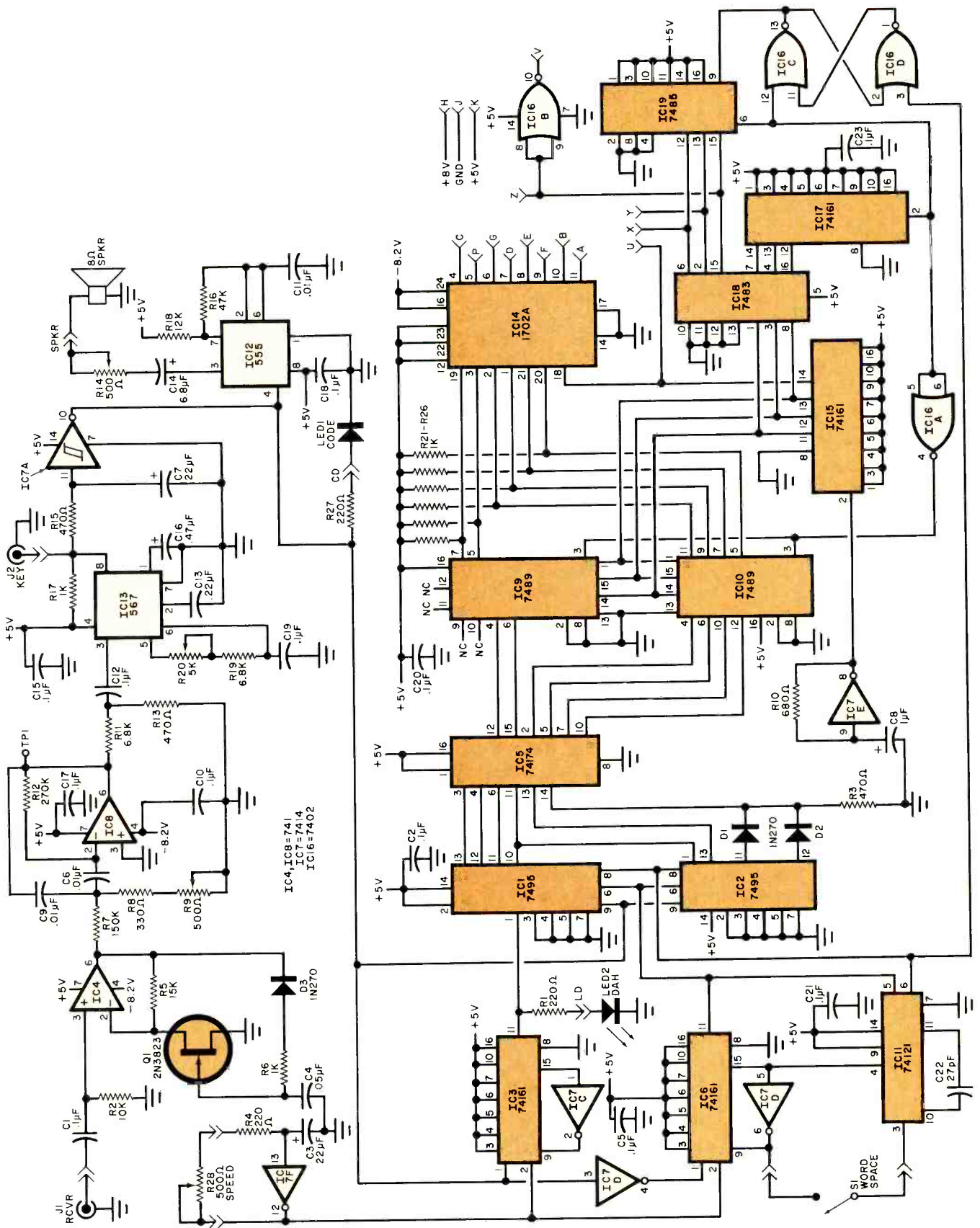

Fig. 2. Schematic diagram of the main decoder circuit. If the audio output of a radio receiver is used, it is applied to J1. An input from a telegraph key is applied to J2. Parts list is on facing page.

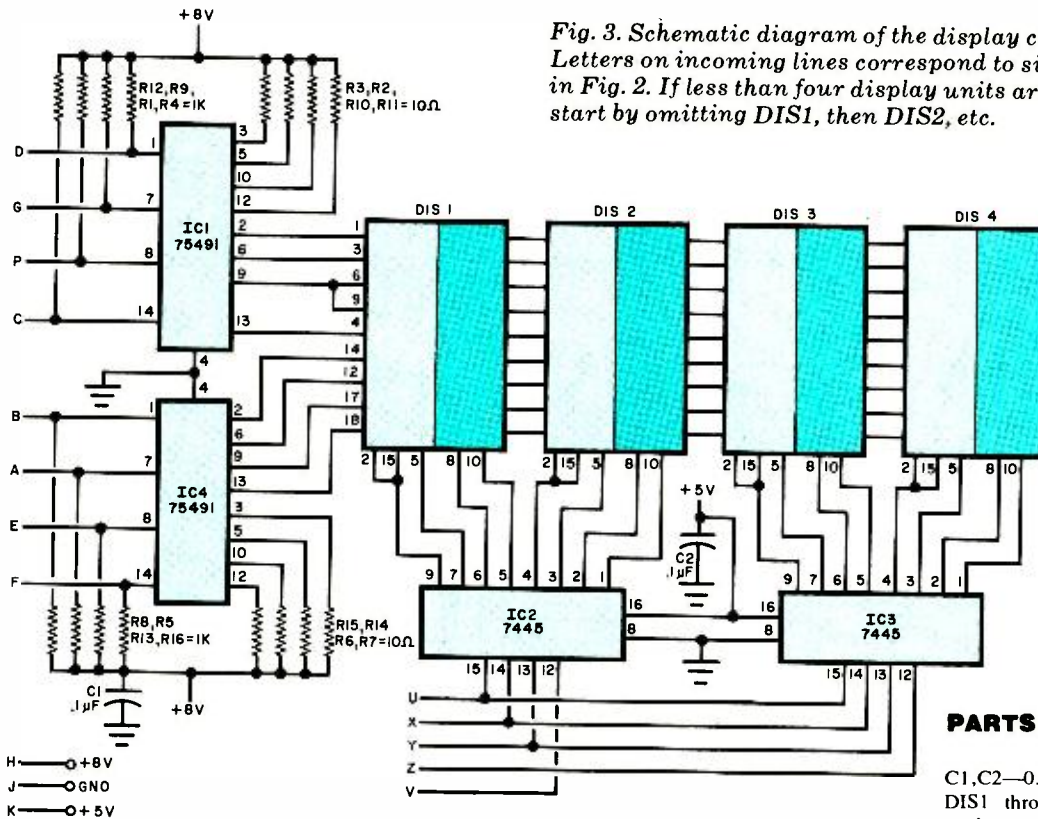

Fig. 3. Schematic diagram of the display circuit. Letters on incoming lines correspond to similar points in Fig. 2. If less than four display units are used, start by omitting DIS1, then DIS2, etc.

PARTS LIST: DISPLAY CIRCUIT

- C1, C2—0.1- or 0.05- μ F disc ceramic
- DIS1 through DIS4—IEE 1785R dual alphanumeric LED display
- IC1, IC4—75491 MOS-to-LED display driver
- IC2, IC3—7445 or 74145 BCD-to-decimal decoder/driver
- The following are 1/4-watt, 10% tolerance fixed resistors.
- R1, R4, R5, R8, R9, R12, R13, R16—1000 ohms
- R2, R3, R6, R7, R10, R11, R14, R15—10 ohms
- Misc.—Printed circuit board, Molex Soldercons for displays, Soldercons or IC sockets for driver ICs, red bezel for displays, solid hookup wire, solder, etc.
- Note—For parts and kit ordering information, refer to the Parts Availability list.

Referring to Fig. 1, the audio output of a radio receiver is applied to an agc stage which limits the amplitude excursions of the input signal. The output of the agc stage drives an active bandpass filter whose response is centered at 1200 Hz. A tone decoder with a phase-locked loop, whose response is also peaked at 1200 Hz, receives signals from a bandpass filter and demodulates them. This decoder generates a low voltage when the transmitter's telegraph key is down and a high voltage under

key-up conditions. A low-pass filter smooths the output of the tone decoder and can accept a telegraph key input for code practice use.

Further signal processing is performed by a Schmitt trigger which "squares up" and inverts the signals applied to it. At the output of the Schmitt trigger, a logic 1 corresponds to a key-down condition, and a logic zero to a key-up condition. Signal processing is now complete, and clean, TTL-compatible Morse signals are available to the di-

PARTS LIST: POWER SUPPLY

- C1, C2—2200- μ F, 16-volt upright electrolytic
- C3—1000- μ F, 10-volt upright electrolytic
- C4—1000- μ F, 16-volt upright electrolytic
- D1—1N5232 5.6-volt zener
- D2—1N756 8.2-volt zener
- F1—1/2-ampere fast-blow fuse
- Q1—2N6121 npn tab (TO-220) transistor
- R1—68-ohm, 1/2-watt, 10% resistor
- R2—47-ohm, 1/2-watt, 10% resistor
- RECT1—1-ampere, 50-PIV modular bridge rectifier
- S1—Spst power switch (part of main circuit R28)
- T1—12.6-volt, 2-ampere center-tapped transformer (Stancor P8130 or equivalent)
- Misc.—Printed circuit board, pc-mount heat sink for Q1, silicone thermal compound, fuseholder, pc standoff insulators, line cord and strain relief, hookup wire, machine hardware, solder, etc.
- Note—For parts and kit ordering information, refer to the Parts Availability list.

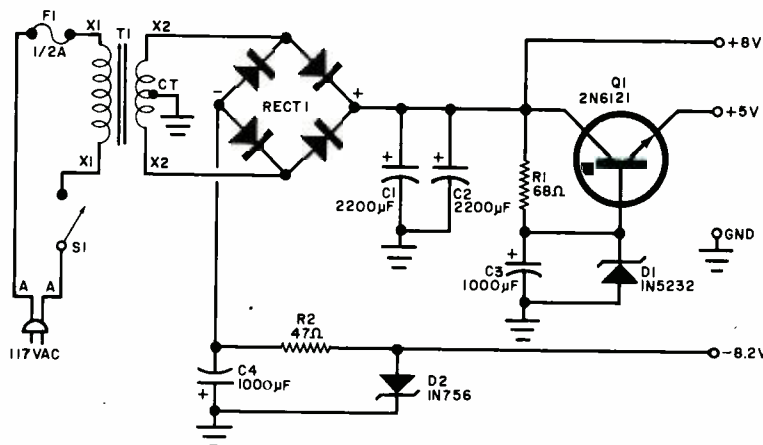

Fig. 4. Schematic diagram of power supply circuit. The main decoder requires 750 mA at 5 volts and 20 mA at -8.2 volts. Display is best with 8-volt supply.

gital decoding circuits.

The digitized Morse is first applied to two counters. One counter, but not both, will be enabled to count, depending on whether the key is up or down. These circuits count at a rate dependent on the frequency of an adjustable code-speed clock. The clock frequency should be adjusted to match the speed of the incoming code, but this adjustment can be off by as much as $\pm 50\%$ and still result in solid copy.

Whenever the key-up counter detects an element space, a condition that occurs when it counts less than eight clock pulses, it serially transfers a logic 0 or 1 to the next stage, an eight-bit serial/parallel shift register. The latter is always initialized with the binary word 00000001 so that the beginning of each Morse character will be uniquely decodable. Whether a logic 1 or 0 is transferred to the shift register in subsequent steps is determined by the condition of the key-down counter, which distinguishes between dits and dahs. If the key-down counter counts more than seven clock pulses, the code element is a dah and a logic 1 is transferred to the shift register. Otherwise, it is a dit and a logic 0 is transferred to the shift register. The detection scheme is similar to that employed in the Morse-A-Letter, and has been found to be very reliable.

This procedure continues until the key-up counter detects a space longer than an element space (longer than seven clock periods), whereupon the circuit determines that a complete character has been sent. The unique binary code present in the shift register can now be transferred to a latch for decoding and display. However, if the key-up counter continues to count more than 15 clock pulses, this is interpreted as a space between words and a blank character is inserted in the latch after the last character is received. Because many CW stations do not send word spaces, the circuit contains a switch to defeat the word-space feature.

A 16-element RAM (in which only 8 elements are used) stores the Morse characters obtained from the latch. The RAM is synchronized to the eight-character display by an address counter and a ROM which decodes the Morse characters for display. A standard multiplexed circuit is employed for display of stored characters, which appear on IEE 1785R two-character LED displays. The

PARTS AVAILABILITY

The following are available from Microcraft Corp., Box 513, Theinsville, WI 53092:

- No. MAWK-1. Complete kit of parts, including prepunched and lettered cabinet and two dual-character IEE 1785R LED displays, \$149.95. (One or two additional dual-character displays can be ordered at the builder's option.)
- No. EPK-1. Essential parts kit including two (main and display) pc boards, preprogrammed ROM, all ICs, sockets, resistors and capacitors, one dual-character IEE 1785R LED display, but not including power supply, hookup wire, solder, loudspeaker, enclosure, control knob, jacks and miscellaneous hardware, \$99.50.
- No. PCBK-1. Set of three (main, display and power supply) pc boards, \$24.00.
- No. MB-1. Etched and drilled, double-sided,

glass epoxy main pc board with plated-through holes, \$12.50.

- No. DB-1. Etched and drilled, double-sided, glass epoxy display pc board with plated-through holes, \$7.00.
 - No. PSB-1. Etched and drilled, glass epoxy power supply pc board, \$5.50.
 - No. PSK-1. Power supply kit, including pc board and all components, \$22.00.
 - No. Rom-1. Preprogrammed 1702A ROM, \$10.00.
 - No. DSP-1. One dual-character IEE 1785R LED display, \$9.00.
 - No. CAB-1. Prepunched and lettered enclosure, \$17.00.
 - No. CT-1. Alignment and code practice cassette tape, \$6.00.
- Prices include shipping and handling within the continental USA. Wisconsin residents, add 4% sales tax.

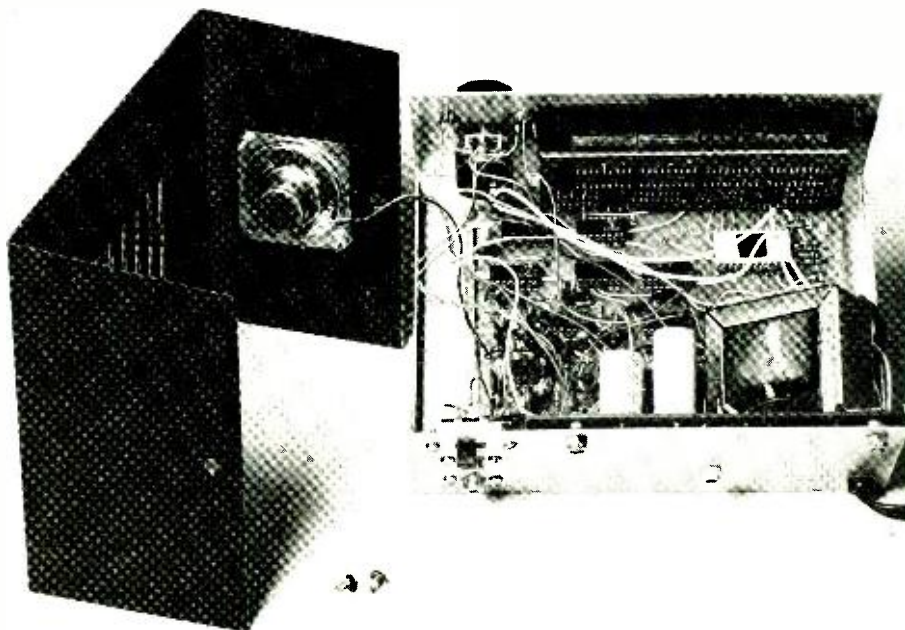

Photo shows internal assembly of the author's prototype. Display board is on front panel, power supply on back.

circuit has been designed to provide a moving-character type of display which introduces new characters at the right-most position and moves each of the existing characters to the left, one position at a time, as characters are received. It takes just a few minutes to accustom yourself to reading this type of presentation. Once you get the hang of it, reading code is a breeze.

The Morse-A-Word's main decoder

circuit power requirements are 750 mA at +5 volts and 20 mA at -8.2 volts. The display circuit also calls for 8 volts at approximately 100 mA. Voltages as low as 5 V can be used to power the display, but it will not be as bright. A suggested power supply is shown in Fig. 4.

In Part Two of this article, next month, we will describe how to assemble, align, and use the project. Programming instructions for IC14 will be included. ◇

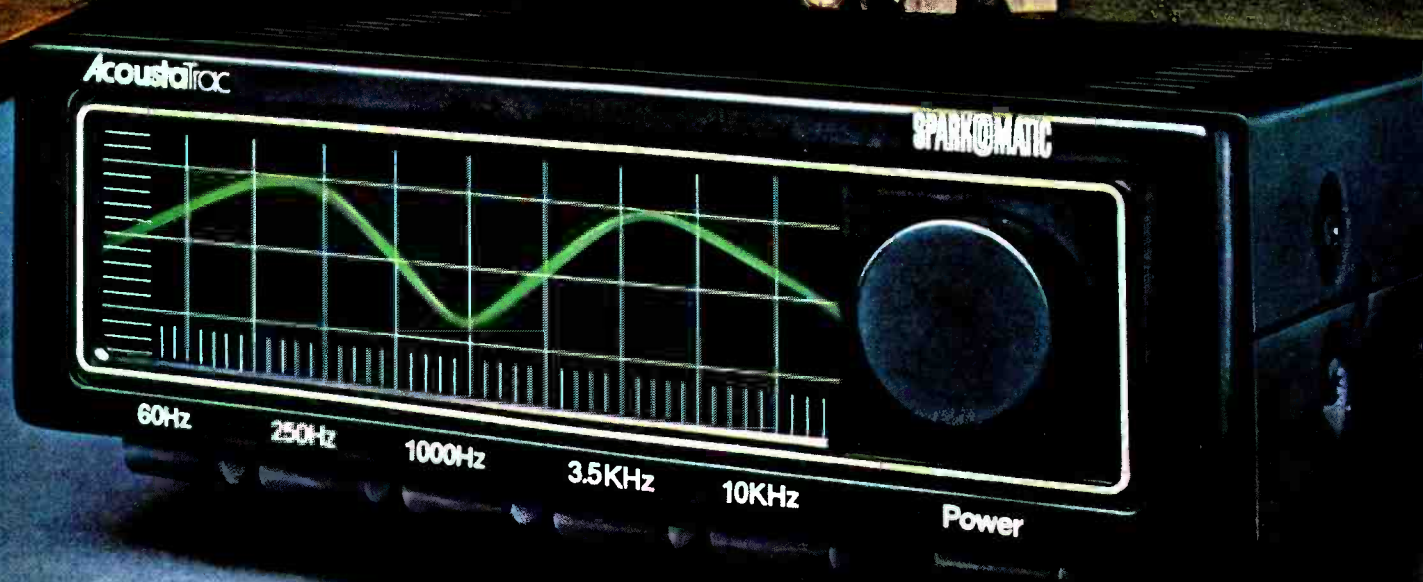

THE SPARKOMATIC SOUND.

NOW THE TRAVELIN' MAN CAN SEE GREAT CAR HIGH FIDELITY TAKE SHAPE BEFORE HIS EYES.

For years you've been judging car high fidelity solely with your ears. Now, thanks to Sparkomatic AcoustaTrac™, you can also judge car sound with your eyes!

The AcoustaTrac is a graphic equalizer which features a visual response curve on an illuminated screen.

So while you're adjusting the sound of your car's stereo radio or tape deck to your personal listening tastes, you can actually see the amplifier response you've shaped. And with Sparkomatic's AcoustaTrac you can keep track of the shape your high fidelity is in.

Of course, as a power booster the AcoustaTrac is unparalleled at boosting audio output power while giving you total control to "mix" the bass, midrange and highs.

It features slide controls that allow you wide adjustability of five different frequency bands. Plus 40 watt RMS stereo power, front-to-rear fader control, and a power indicator light. Compact size (2" h x 6-3/16" w x 6-1/2" d). Fits comfortably under-dash.

So if you want a graphic equalizer that lets you graphically see the beautiful sound you'll be hearing, get the Sparkomatic AcoustaTrac.

Patent Pending

SPARKOMATIC
For the Travelin' Man™

For our free complete Car Sound Catalog write: "For The Travelin' Man", Dept. PH, Sparkomatic Corporation, Milford, PA 18337.

CIRCLE NO. 51 ON FREE INFORMATION CARD

Special FOCUS on Speakers

1. Innovations in Speaker Design

2. Interpreting Speaker Test Results

3. The Importance of Power-handling Capacity

Innovations in Speaker Design

BY GEORGE TLAMSA

IN THEIR never-ending quest to produce the *perfect* loudspeaker, engineers are continuously developing new materials, enclosures, transducers, circuits and systems. The result? Literally hundreds of loudspeaker systems in a great variety of shapes and sizes, employing dramatically different operating principles, all vie for consumer acceptance. This often bewildering array of loudspeaker designs can easily create confusion and make a meaningful buying decision difficult at best.

In this article, we will examine the basic types of loudspeaker components and systems, placing special emphasis on the latest advances in loudspeaker technology. First, we'll look at the various transducers (drivers), and then loudspeaker enclosures. Finally, we will see how loud-

speaker engineers are putting all the components together to produce contemporary speaker *systems*, taking both the effects of the listening room and psychoacoustics into account.

The Drivers.

As its name implies, the function of a driver (or more properly an electroacoustic transducer) is to impart motion to the air surrounding it. This motion will in the ideal case correspond exactly to the time-varying nature of the electrical signal applied to it. Our ears, in turn, will perceive the motion as sound.

There are many ways to convert a time-varying electrical signal into sound waves, as witnessed by the

great variety of drivers found in today's speaker systems. Let's examine the principle types of drivers presently in use, and see how each measures up to the ideal transducer.

The Dynamic Speaker. The oldest of all the driver types employed today is the dynamic speaker. Its design goes back to the mid-Twenties when Chester Rice and E.W. Kellogg produced the first functional prototype. Although the dynamic driver has over the years been improved in a number of ways, the principle is the same.

The typical dynamic speaker employs a conical diaphragm driven by a magnetic motor. Motion is imparted to the diaphragm via the interaction of a time-varying magnetic field generated by an electromagnet and a static field set up by a permanent magnet. In the

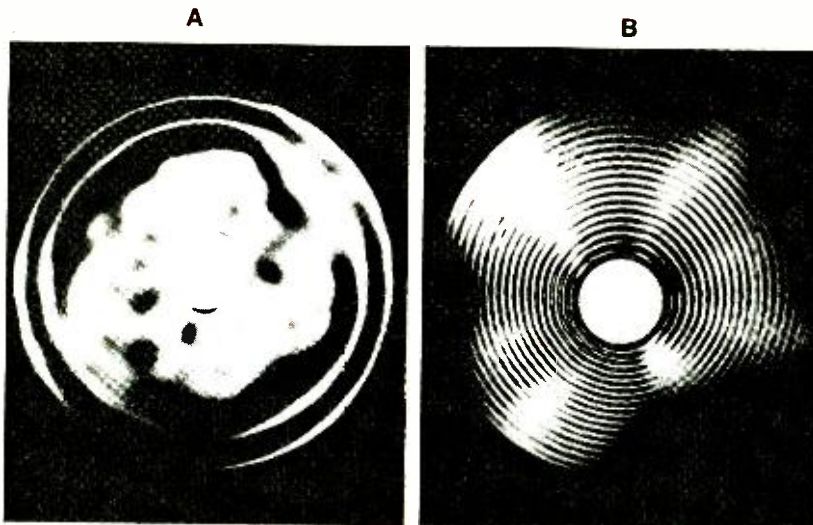

Fig. 1. Holographic analysis shows cone breakup in dynamic driver. In 8-inch woofer driven by 2000-Hz signal (A), standing waves appear at edge. At 9000 Hz (B), they occupy entire cone surface.

early days of dynamic speakers, sufficiently strong permanent magnets were not available, so the static field was supplied by an electromagnet called a *field coil*.

The time-varying field is set up by a *voice coil*, an electromagnet driven by the output of the power amplifier. The magnetic field set up by the voice coil varies in step both in amplitude and polarity with the audio-frequency current supplied by the amplifier. Alternate repulsion and attraction between the two magnets cause the cone (diaphragm), which is attached to the

voice coil and a supporting structure, to compress or rarefy the nearby air, depending on its motion relative to the air mass.

When the cone is moving forward, it compresses the air in front of it and rarefies the air behind it. Similarly, when the cone is moving backward it compresses the air behind and rarefies the air in front. It can thus be seen that the driver is a dipole radiator, simultaneously generating two out-of-phase acoustic signals. At low frequencies, these two signals will meet while still in an out-of-phase condition

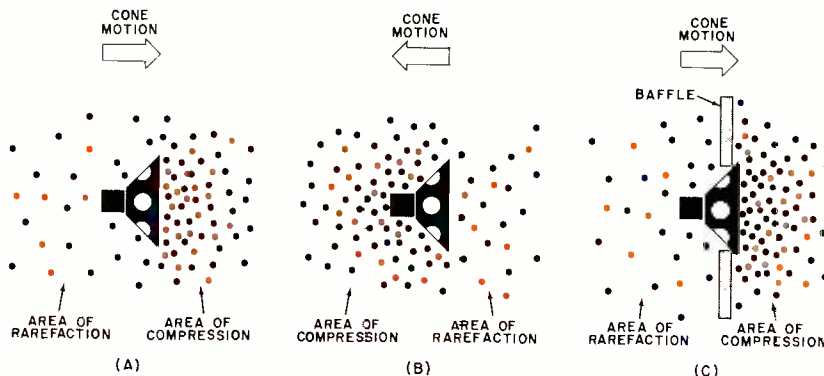

Fig. 2. Cone compresses and rarefies air as shown at (A) and (B). Baffle (C) separates two air masses to prevent cancellation.

and cancel each other out. To prevent this destructive interference, either the "front wave" or the "back wave" will have to be phase-shifted before it meets up with its counterpart. Alternatively, one component of the speaker output must be attenuated or otherwise prevented from reaching the other. Whichever of these design alternatives is chosen is usually performed by the loudspeaker *enclosure*. More on this later.

Ideally, the dynamic driver behaves like a rigid piston over its entire operating (frequency) range. A practical driver, however, cannot provide this ideal over the entire audible spectrum. Its useful bandwidth will always be limited to those frequencies where it can approximate a *point source*. That is, to those frequencies whose wavelengths are large compared to the diaphragm's physical dimensions.

Above these frequencies, the driver begins to "beam" (become directional) due to diffraction effects. The cone of the driver ceases to act as a rigid piston and undergoes a series of flexing motions that are structural resonances. This can be seen in Figs. 1A and 1B.

These images were generated in the Netherlands at the Philips Research Labs by holographically observing the motion of an 8-inch (20.3-cm) woofer cone. At low frequencies, the cone vibrates as a rigid surface. Above a certain frequency, standing waves begin to appear on the cone. For example, Fig. 1A reveals loops and nodes just starting to appear at the periphery of the cone when the woofer is driven by a 2000-Hz sine wave. When the frequency of the drive signal is increased to 9000 Hz, severe cone breakup occurs. Its entire surface is covered with loops and nodes (Fig. 1B), and only a little sound is radiated.

Not only do these effects make the driver directional as the operating frequency is increased, but they also cause fluctuations in its frequency response. If the dimensions of the driver are kept small to enhance its mid-range and high-frequency response, it will not be able to move enough air to provide the substantial acoustic output at low frequencies required for high-fidelity reproduction.

It is obvious that no conventional dynamic driver can single-handedly cover the full range of audible frequencies. This has led to the develop-

The ideal cone material would be lightweight (for efficiency and good transient response) and very stiff (for extended frequency response). Recently, some woofers have been made using carbon-fiber pulp as the cone material. During the Sixties, the BBC experimented with sandwich-construction cones utilizing special plastics. Aluminum has also been

used directly through the ribbon, which acts as both a voice coil and a diaphragm.

One problem that the designer of any dynamic driver must confront is the dissipation of heat produced in the voice coil, which generally has a very low impedance (4 to 8 ohms). If the coil draws too much current, the heat generated in its windings can melt the insulation on the wire (and perhaps the wire itself) resulting in a burn-out of the driver. Even if this doesn't happen, excessive heat will deform the coil and weaken the binder that holds it to the coil form. A discussion of these problems is included in another article in this section.

An interesting variation on the standard dynamic driver is the Watkins dual-impedance woofer used by Infinity Systems in its top-of-the-line speakers. This otherwise conventional woofer has two voice coils, one with a standard impedance and a secondary coil with a low impedance. The two are electrically coupled together by series and parallel LC networks. Ordinarily, the tuned circuit applies the amplifier output to the standard voice coil. However, at frequencies near the fundamental resonance of the speaker system, where the impedance presented to the amplifier reaches its maximum value, the tuned circuit routes signals to the secondary, low-impedance voice coil. This provides the amplifier with a virtually constant load impedance throughout the bass region.

The Electrostatic Driver. As its name implies, this type of driver generates a motive force for its diaphragm by the interaction of electric rather than magnetic fields. In a typical electrostatic design, a large diaphragm of lightweight material is placed between two perforated (acoustically transparent) electrodes. The diaphragm is electrically polarized relative to the electrodes, which maintain a large electrostatic field. The audio signal is applied to the two electrodes in push-pull fashion. Under these conditions, the diaphragm will vibrate in step with the audio drive signal and produce sound.

In an electrostatic driver, the driving force is uniform over the entire diaphragm surface. (Compare that to the dynamic driver, in which the diaphragm is driven over a small portion of its overall surface.) The result is that the electrostatic doesn't suffer as

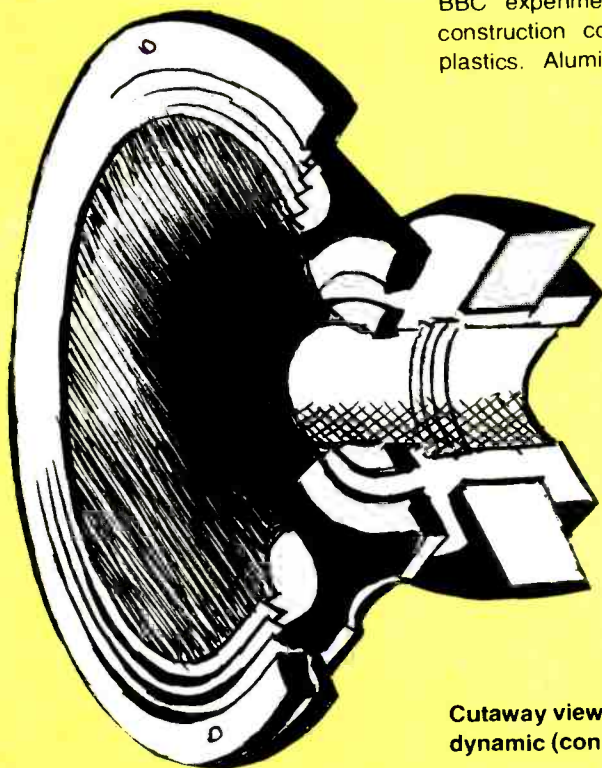

Cutaway view of dynamic (cone) driver.

ment of specialized dynamic speakers, each designed to handle a given portion of the audio spectrum. A typical speaker system employing all dynamic drivers will contain a woofer, a midrange driver, and a tweeter. Some systems employ four or even more drivers, with a *supertweeter* handling the extreme highs and/or a *subwoofer* reproducing the deepest bass notes. From the standpoint of system engineering, however, it is often desirable to employ drivers with useful frequency ranges as large as possible.

In the case of a woofer, useful frequency range can be increased by making the cone more rigid. One early approach to increasing the diaphragm's rigidity was to change its shape from that of a simple (true) cone into a "cone" with rounded sides. Today's really large woofers like Electro-Voice's 30-inch (76.2-cm) unit are constructed in this manner.

Most of the engineering effort dedicated to improving the dynamic woofer has been channeled into the development of new materials for the cone to replace the paper traditionally used.

used in the fabrication of woofer cones. Finally, some manufacturers have tried doping paper cones with special coatings for added stiffness. The Bextrene woofer is a representative product of this type of experimentation, and is commonly employed in British speaker systems.

Tweeters can be made using paper cones, but today the dome tweeter is an increasingly popular alternative. The dome has the advantage of permitting the use of a large voice coil (for power handling), but must be made of very lightweight material if it is to be an efficient radiator. Among the materials used to fabricate tweeter domes are Mylar-type plastics, polystyrenes, treated fabrics, and, notably, beryllium alloys. Beryllium is one of the hardest metals known and is extremely lightweight. It is thus ideal for dome diaphragms. Dynamic tweeters, by the way, needn't have the familiar voice-coil construction, as evidenced by the ribbon tweeter. This driver utilizes a thin corrugated metal "ribbon" placed in a static magnetic field. Audio-frequency current is passed di-

“If you’re going to learn electronics, you might as well learn it right!”

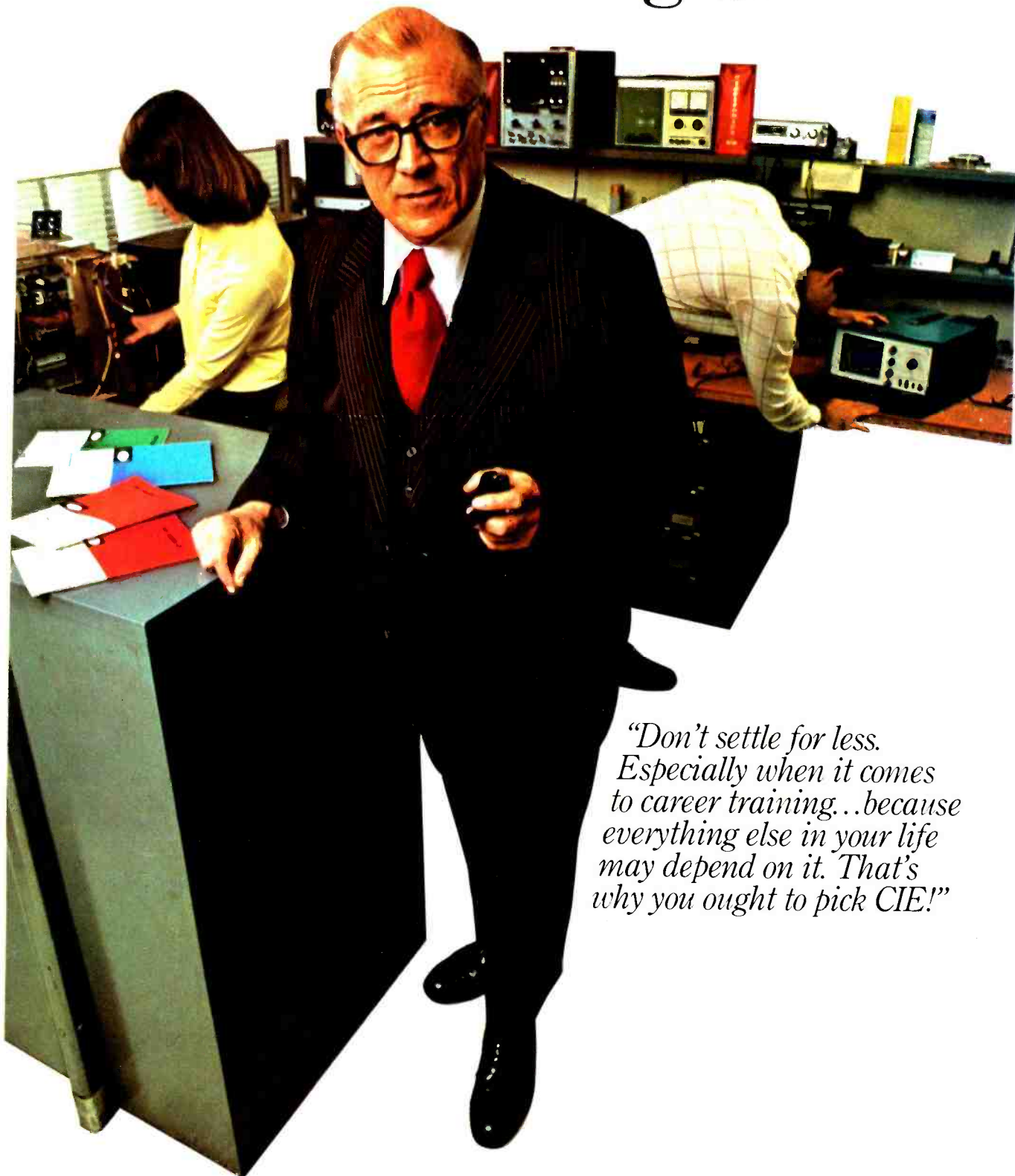

“Don’t settle for less. Especially when it comes to career training...because everything else in your life may depend on it. That’s why you ought to pick CIE!”

You've probably seen advertisements from other electronics schools. Maybe you think they're all the same. They're not!

CIE is the largest independent home study school in the world that specializes exclusively in electronics.

...

Meet the Electronics Specialists.

When you pick an electronics school, you're getting ready to invest some time and money. And your whole future depends on the education you get in return.

That's why it makes so much sense to go with number one... with the specialists... with CIE!

There's no such thing as bargain education.

If you talked with some of our graduates, chances are you'd find a lot of them shopped around for their training. Not for the lowest priced but for the best. They pretty much knew what was available when they picked CIE as number one.

We don't promise you the moon. We do promise you a proven way to build valuable career skills. The CIE faculty and staff are dedicated to that. When you graduate, your diploma shows employers you know what you're about. Today, it's pretty hard to put a price on that.

Because we're specialists, we have to stay ahead.

At CIE, we've got a position of leadership to maintain. Here are some of the ways we hang onto it...

Our step-by-step learning includes "hands-on" training.

At CIE, we believe theory is important. And our famous Auto-Programmed® Lessons teach you the principles in logical steps.

But professionals need more than theory. That's why some of our courses train you to use tools of the trade like a 5 MHz triggered-sweep, solid-state oscilloscope you build yourself—and use to practice troubleshooting. Or a beauty of a 19-inch diagonal Zenith solid-state color TV you use to perform actual service operations.

Our specialists offer you personal attention.

Sometimes, you may even have a question about a specific lesson. Fine. Write it down and mail it in. Our experts will answer you promptly in writing. You may even get the specialized knowledge of all the CIE specialists. And the answer you get becomes a part of your permanent reference file. You may find this even better than having a classroom teacher.

Pick the pace that's right for you.

CIE understands people need to learn at their own pace. There's no pressure to keep up... no slow learners hold you back. If you're a beginner, you start with the basics. If you already know some electronics, you move ahead to your own level.

Enjoy the promptness of CIE's "same day" grading cycle.

When we receive your lesson before noon Monday through Saturday, we grade it and mail it back—the same day. You find out quickly how well you're doing!

CIE can prepare you for your FCC License.

For some electronics jobs, you must have your FCC License. For others, employers often consider it a mark in your favor. Either way, it's government-certified proof of your specific knowledge and skills!

More than half of CIE's courses prepare you to pass the government-administered exam. In continuing surveys, nearly 4 out of 5 CIE graduates who take the exam get their Licenses!

For professionals only.

CIE training is not for the hobbyist. It's for people who are willing to roll up their sleeves and go to work... to build a career. The work can be hard, sure. But the benefits are worth it.

Send for more details and a FREE school catalog.

Mail the card today. If it's gone, cut out and mail the coupon. You'll get a FREE school catalog plus complete information on independent home study. For your convenience, we'll try to have a CIE representative contact you to answer any questions you may have.

Mail the card or the coupon or write CIE (mentioning name and date of this magazine) at: 1776 East 17th Street, Cleveland, Ohio 44114.



Patterns shown on TV and oscilloscope screens are simulated.

CIE Cleveland Institute of Electronics, Inc.
1776 East 17th Street, Cleveland, Ohio 44114

Accredited Member National Home Study Council

YES... I want the best of everything! Send me my FREE CIE school catalog—including details about troubleshooting courses—plus my FREE package of home study information. PE 85

Print Name _____

Address _____ Apt. _____

City _____

State _____ Zip _____

Age _____ Phone (area code) _____

Check box for G.I. Bill information: Veteran Active Duty

MAIL TODAY!

Special Focus on Speakers

drastically from "breakup" (the excitation of resonant modes on the diaphragm) as the dynamic driver. Transient response is excellent due to the diaphragm's low mass. The electrostatic driver is basically hung on a frame. It doesn't have a box enclosure, so a great deal of "coloration" (or frequency-response fluctuations caused by the enclosure) is avoided.

Of course, the electrostatic driver is not completely free from problems. Bass cancellation caused by destructive interference between the front and back waves does occur. Also, the diaphragm does become directional at high frequencies, where breakup modes occur. It is difficult to get a large acoustic output from an electrostatic. The diaphragm cannot make large excursions, and placing it in an electric field strong enough to produce high sound levels will result in dielectric breakdown of the air and arcing, which almost always causes permanent damage to the speaker. Without

special design features, the acoustic output of an electrostatic driver is limited. Nonetheless, these designs, when executed properly, are remarkably good speakers. Some of the most highly regarded "purist" speakers are electrostatics. The famous Quad electrostatic speaker is a good example.

A solution to the limited-output problem of electrostatics has been developed by Dayton Wright Associates, Ltd. The driver is sealed in an airtight plastic bag. Actually, this is standard practice, because the electrodes and diaphragm must be kept free of contamination. The trick is that the bag is filled with SF₆ (sulphur hexafluoride)

rather than air. This gas is a better dielectric than air in that it can support a much larger electric field before it breaks down and arcing takes place. Hence, in the Dayton Wright electrostatic driver, the voltage on the electrodes can be stepped up very high, making the speaker capable of generating increased acoustic levels.

One last word about electrostatic drivers—the impedance they present to the power amplifier is high, and is largely made up of capacitive reactance. This is in strong contrast to the low impedance of the typical dynamic driver, which has a large resistive component. Very few amplifiers are able to drive an electrostatic driver directly. (Most of those that can are made by the speaker manufacturer and are sold with the drivers as integrated systems.) A step-up transformer can be used between an amplifier and the driver, but the amplifier will still be subjected to reactive loading. Some power amplifiers can tolerate this, but others cannot.

The Walsh Driver. Both the dynamic and electrostatic drivers can be considered "conventional" transducers in that they have been with us for many years. A relatively recent trend among loudspeaker engineers, however, has been to dispense with conventional drivers entirely and develop new types of transducers. One product typifying this approach is the Walsh driver, which is used by Ohm Acoustics in its Model F loudspeaker system.

This driver is a tall, upright cone constructed of three successive bands of material—titanium on top, then aluminum, and finally paper at the bottom of the cone. It is driven at the top by a specially-designed voice coil, and the bottom of the cone is held in place by a surround. This unique driver is a full-range, omnidirectional, and coherent radiator. There is no phase cancellation of waves leaving different parts of the diaphragm as the sound is radiated as a uniform wavefront. The Walsh driver's only major drawback is its relative inefficiency.

The Planar Magnetic. This is an electrodynamic driver that outwardly looks like an electrostatic speaker. As we have already mentioned, the electrostatic driver utilizes a large planar diaphragm of low mass to achieve excellent transient response, and the

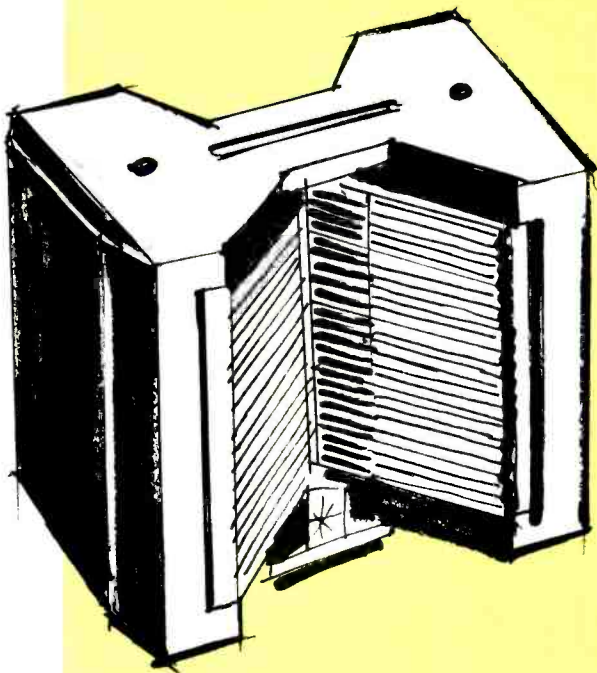

Heil air motion transformer (above) and ATD woofer (right).

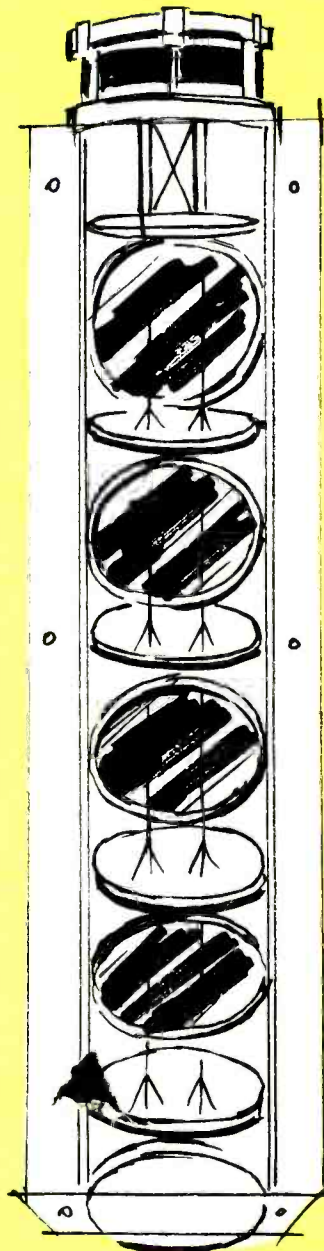

planar magnetic is its electromagnetic analog. This driver has a lightweight planar diaphragm with a pattern of conducting material bonded to its surface. The diaphragm is placed between two perforated magnets, thus forming a voice-coil/magnet "motor." Audio current passes through the diaphragm's conductor, generating a magnetic field that interacts with the static magnetic field to produce the force which generates the sound waves. The driver has the good transient response and other advantages of electrostatics. It is hung on a frame support, so there is no box to introduce coloration, but bass cancellation is a problem. In a full-range planar magnetic system, two or more drivers are often used because individual drivers do become directional at wavelengths small compared to their dimensions. This driver was pioneered by Magnepan, and that company's speaker systems use only pla-

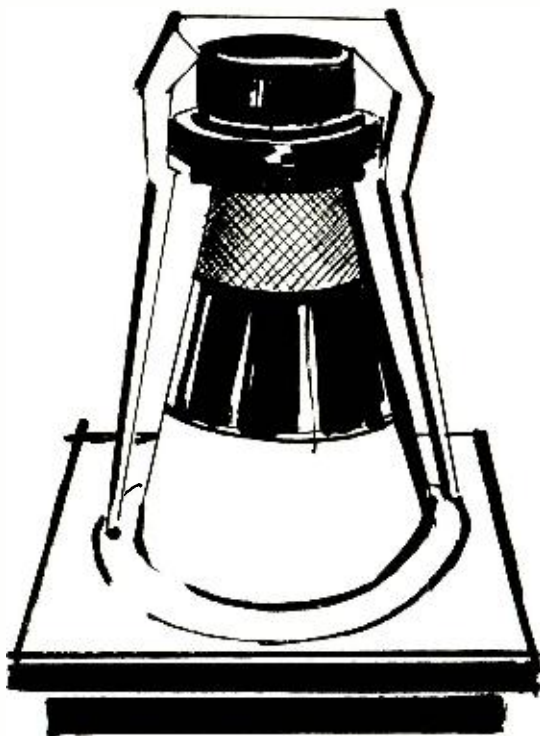

Walsh driver used in the Ohm F speaker system

nar magnetic drivers. The driver's main disadvantage is inefficiency. The planar magnetic driver need not be a full-range transducer. For example, Infinity Systems makes a planar magnetic tweeter (they call it the EMIT tweeter) which it includes in most of its speaker systems.

Heil Drivers. A distant relative of the planar magnetic driver is the Heil Air Motion Transformer or AMT, a midrange and high-frequency driver found in speakers manufactured by ESS. Its diaphragm utilizes a lightweight Mylar material with an imprinted conductor pattern, but there the similarity with the planar magnetic just about ends. In the Heil driver, the diaphragm is folded up like an accordion and is placed in a uniform magnetic field. Application of audio-frequency current generates a magnetic field, which causes the many folds to squeeze air out from between them, producing sound. The AMT is a high-efficiency device capable of uniform response from the midrange to very high frequencies.

The high efficiency of the Heil AMT tweeter prompted experimentation with a low-frequency driver of the same design. This turned out to be problematic—the Heil driver has a cavity resonance above its nominal operating range. In the case of the tweeter, the resonance falls in the ultrasonic region, but a Heil woofer would resonate in the midrange. Undaunted, Dr. Oskar Heil designed another equally unusual driver, the ATD woofer. This unit has five small (4-inch or 10.2-cm) lightweight horizontal diaphragms mounted one above the other, all connected by a set of four lightweight carbon-fiber rods. The rods are driven by a conventional voice-coil assembly, and they in turn excite the diaphragms. The diaphragms are mounted in acoustic reflectors that isolate the "top wave" radiation from the "bottom wave." The entire columnar driver is mounted on a large, flat baffle intended to isolate front and back radiation as much as possible, but bass cancellation is a problem with this design.

Piezoelectric Drivers. An alternative driver for the high frequencies is offered by the piezoelectric driver. Pioneer uses a novel tweeter, dubbed the HPM, which is made of a piezoelectric polymer it developed. This is a

plastic-like material that, unlike a crystal, can be made into thin sheets and fashioned into a variety of shapes. The HPM driver utilizes the film in a cylindrical configuration, and is loaded with an acoustic "lens" to control dispersion. Transient and high-frequency response of the driver is very good because the moving mass of the diaphragm is negligible. The driver operates by the structural expansion and contraction of the film. It is, however, inappropriate for low-frequency applications as it is incapable of large air displacements.

The "Massless" Driver. The plasma driver, found in the Hill Type-1 speaker system by Plasmatronics, is a realization of the loudspeaker engineer's dream—a transducer with essentially no mass. Sound radiation is achieved by the expansion and contraction of ionized air through which an audio current is passed. In the plasma driver, an air/helium mixture in a small cavity is subject to a high-voltage discharge which completely ionizes it (strips valence electrons from the molecules to produce positive and negative ions). The gas then becomes an electrically conductive plasma. Passage of audio-frequency current through the plasma causes local temperature and pressure fluctuations, the pressure fluctuations being sound waves. Because the plasma driver has no diaphragm and effectively no mass, it has excellent high-frequency and transient response. The idea is not new, but the Plasmatronics driver is said to eliminate many of the drawbacks of older designs, such as noisy operation and carbonizing of the electrodes. In the Hill Type-1 system, the plasma driver handles frequencies from 700 Hz up. It's major disadvantage is high operating cost. Bottles of pressurized helium are built into the loudspeaker systems and must be replaced an average of two or three times annually, for an operating cost of about 30¢ per hour.

The Enclosures.

The area of perhaps the most controversy among loudspeaker engineers and audiophiles has been the design of the enclosure. Predictably, there has been a proliferation of enclosure types, each characterized by certain advantages and disadvan-

tages. What follows is a discussion of the role of the enclosure in sound reproduction and an examination of those types found in today's systems.

The Infinite Baffle. The simplest speaker enclosure, the infinite baffle, neatly illustrates the role the enclosure plays. We have already mentioned that such transducers as dynamic and electrostatic drivers radiate two out-of-phase components. The process is shown in Fig. 2. When the cone of the dynamic driver moves forward, the air in front is pressurized and the air behind is rarefied (A). The reverse occurs when the diaphragm is moving backward (B). A substantial pressure gradient is therefore set up by the motion of the loudspeaker's diaphragm.

When driven by a low-frequency signal, the diaphragm moves relatively slowly and radiates long acoustic wavelengths. In an attempt to equalize pressures, the compressed air rushes to the other side of the cone. This results in the mutual cancellation of the two out-of-phase sound waves, and little acoustic energy is radiated. At higher frequencies, however, the diaphragm is moving much more quickly and wavelengths are short. The pressurized air does not have time to reach the rarefied region and destructive interference does not occur. Cancellation, therefore, is a problem encountered principally in the bass region.

To prevent bass cancellation, the driver can be mounted on an infinite baffle (Fig. 2C), in theory an infinitely large flat surface. Such a baffle will prevent any destructive interference by totally shielding the rarefied region. Obviously, no baffle can be infinitely large, and practical "infinite" baffles have finite dimensions.

The baffle must be large if satisfactory bass reproduction is to be achieved. This is the drawback of the infinite baffle principal. Good design practice dictates that, with the driver mounted at the center of the baffle,

the dimension of any one side should not be less than one wavelength at the lowest frequency to be reproduced. For a cutoff frequency of 40 Hz, the baffle size on each side of center should therefore be 14 feet (4.3 m). Few listening rooms can accommodate such a structure!

Sealed Enclosures. To attempt to provide the infinite baffle's prevention of bass cancellation in a design of more manageable dimensions, sealed enclosures are used. If the driver is mounted in a sealed box, the back wave has no place to go and stays inside the cabinet. The enclosure must be filled with sound-absorbing material to damp the rear radiation of the diaphragm. Otherwise, standing waves will form at any frequency where one dimension of the box equals an integral multiple of one-half wavelength of the radiated sound wave. As a result, not only would the system's frequency response suffer, but also the mechanical resonances of the box itself would be excited by the sound pressures created by the standing waves.

The sealed box has its problems. It is inherently inefficient because all of the rear radiation is damped out and converted into heat. Sealed enclosures housing standard woofers must be large if significant bass output is to be obtained, because the acoustic impedance seen by the rear of the driver will increase as the box volume decreases. Furthermore, if the air in the box is too stiff for the driver, the fundamental resonant frequency of the system will be too high for good bass performance. This design, however, enjoys the significant advantage of having a relatively gradual roll-off in low-frequency response below the fundamental resonance (about 12 dB per octave). This means, among other things, that the system won't ring excessively at resonance.

One special type of sealed box is the *acoustic suspension* enclosure. In this design, a woofer with a very compliant suspension is placed in a small sealed box. The small volume of air in the box has a high acoustic reactance that compensates for the high mechanical compliance of the driver. The box is completely sealed, with the back radiation of the woofer absorbed by damping material. This scheme enables a suitable driver mounted in an enclosure of small dimensions to re-

produce very low frequencies. The acoustic suspension enclosure was introduced to audiophiles in the 1950's by Edgar Villichur of Acoustic Research, and was largely responsible for the bookshelf speaker coming into its own. The design is found in many contemporary speaker systems and can be viewed as a sealed-box enclosure with a special matching of the woofer compliance to the volume of the box.

An interesting variation on the acoustic suspension theme has been developed by Cerwin-Vega which the company calls Thermo-Vapor Suspension. It involves the use of an acoustic suspension enclosure filled with a gas that for a given volume is more compressible (compliant) than air. The Cerwin-Vega design results in high-level deep bass from a small enclosure with relatively high efficiency. (Most acoustic suspension designs are notoriously inefficient.)

The Bass Reflex. To make use of the rear radiation that goes to waste in a sealed box, the bass reflex was introduced. An enclosure of this type is not completely sealed. Rather, it has an opening (a "port" or "vent") of carefully selected proportions that acts as a sound radiator at very low frequencies to reinforce the frontwave output of the driver. The port is "tuned" (its area and length predetermined) to radiate in phase with the active driver. The bass reflex enclosure is really a Helmholtz resonator—of the same sort as a wine jug or an ocarina—because when excited by sound waves of the right wavelength it resonates and produces sound from the port.

If a ported system is designed properly, bass output is augmented and the overall efficiency of the system compared to that of a sealed enclosure is increased. The box volume can be made quite small and still generate significant bass output. The enclosure's disadvantages are an unevenness in bass output and a notable tendency to ring near the frequency of resonance. (Vented-box systems roll off at 18 dB per octave below the system resonance.) Still, the design is fundamentally successful, and this is verified by the fact that a vast number of speaker systems on the market today employ it.

The Acoustic Labyrinth. This is another distinct enclosure type, al-

though its most common incarnation, the *transmission line* (see Fig. 3), is rudimentarily similar to the bass reflex design. The basic concept behind the acoustic labyrinth is to provide a long acoustic path behind the woofer for attenuation and phase shifting of different components of the woofer's rear radiation. One way to achieve this result is to set up a complex series of internal baffles within the enclosure, these being filled with sound-absorbing material. This is often impractical as the cabinet must be quite large.

The transmission line is basically a long duct, one end of which is coupled to the rear of the woofer. The other end terminates in a port. The duct accomplishes two things. First, it provides a long path for attenuation of the rear radiation of the woofer at certain frequencies. Secondly, it results in reinforcement of the woofer's front-wave output near the system's fundamental resonance. The duct is filled with sound-absorbing material, and the frequency-dependent characteristic of the attenuation is such that very long wavelengths are relatively unaffected, but the shorter wavelengths (which comprise most of the woofer's output) are strongly suppressed. The unattenuated sound, which is very low in frequency, reaches the port in phase with the front wave of the woofer and augments it. The interesting twist to this design is that the sound-absorbing material in the duct not only attenuates acoustic energy, but also maintains a slower speed of sound propagation than that in air. This means that for a given frequency, the wavelength of a sound wave will be shorter in the duct than it would be in air. The duct can therefore be made to reinforce very low audio frequencies without being enormously long—transmission lines of 8 feet in length can provide useful response down to around 30 Hz.

The actual transmission line need not be a straight tube. To the contrary, it is almost always a folded duct. Reflections from the folds in the duct are minimized by using densely-packed absorbing material at these spots.

The ideal absorbing material is not the fiberglass insulation universally used in other enclosures but long-fiber wool. Transmission line speakers with awesome bass output can be made surprisingly small—perhaps the best example of this being the Obelisk produced by Shahinian Acoustics. The speaker system, which measures only $26\frac{3}{4} \times 14 \times 12$ inches ($67.9 \times 35.6 \times 30.5$ cm), can really hold its own on pipe organ music. What you gain in clean bass from a transmission line you pay for in terms of efficiency. These systems are generally less efficient than bass reflex designs.

The Passive Radiator. A more direct spin-off of the bass reflex enclosure is one that replaces the port with a passive diaphragm—the passive radiator. Although the acoustic impedance seen at the diaphragm "vent" is different from that in a ported system,

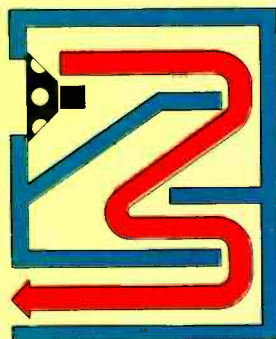

Fig. 3. The acoustic labyrinth loudspeaker enclosure.

the passive radiator works according to the same basic principles. The box resonates at a frequency near the fundamental resonance of the active driver, at which point the passive radiator augments the output of the driver.

It is worth mentioning that ported designs in general have reached a high level of sophistication in recent years due to the application of a unified theory of vented-box speakers developed by A. N. Thiele. Thiele's theory has enabled designers to optimize bass reflex designs in a relatively straightforward manner. The result has been an increasing number of ported systems without many of the uneven response problems of the older bass reflex systems.

Horns. No discussion of speaker enclosures would be complete without

some mention of horns. A number of speaker systems available today use horns on some of the individual drivers, almost always the midrange and high-frequency units. A horn is basically an acoustic transformer that couples the air at the surface of the driver's diaphragm with the air in the listening room. The "throat" of the horn is small and fits over the diaphragm. Its "mouth" is much larger and conducts the radiated sound waves into the room.

The horn permits driver displacement to be small without sacrificing acoustic output. This means lower distortion and higher power-handling, as well as increased efficiency. The dimensions and shape of a horn must be carefully determined for the device to function without acting as a resonant tube. In addition, the interface between the driver and horn must be set up to avoid phase cancellation due to diffraction. For this reason, "phasing plugs" are used to couple the driver with the horn.

You'll find horns used mainly as midrange and high-frequency drivers in most hi-fi systems because they are of manageable size. Predictably, the effective horn length required for bass frequencies is very large. (You can sometimes see bass speaker bins with straight horns at rock concerts. They are very long, as much as 6 to 8 feet or 1.8 to 2.4 meters.) One solution to the size problem is the "folded" horn in which the horn is folded back on itself to decrease the overall size of the cabinet. The famous Klipschorn speaker uses this principle, as shown in Fig. 4. However, the horns are difficult and expensive to construct.

Most horn designs seen today are not new. Folded horns, multicell horns, and sectoral horns have all been around for a while. One interesting design used by JBL, among others, involves the use of an acoustic lens at the horn mouth. These lenses look somewhat like the louvers on a ventilation duct. Their purpose is to alter the directional characteristics of the horn—an important task, because many horns tend to beam severely in parts of their frequency ranges, resulting in a shrill sound. Other developments in horns include improved structural designs for making the horn rigid and lightweight (and less expensive), and the use of novel phasing plugs such as the "Tangerine" developed by Altec.

The System.

If a speaker design is to be successful, it must be engineered as a *system*, with each component designed to work harmoniously with all the others. Accordingly, there have been design innovations that involve the overall system rather than one particular component such as the driver, crossover network or enclosure. Some of these innovations flow from considering the listening room as part of the audio system. Others are due to increased attention to phase response, low-bass response, etc. Let's look at how this systems approach is affecting loudspeaker design.

The Room/Speaker Interface.

From the loudspeaker engineer's point of view, the least controllable element in any audio system is the room/speaker interface and a number of speaker designers have directed their attention to trying to cope with it. An excellent example of this heightened sensitivity to room effects is the well-known Bose 901 series of loudspeakers, whose design is based on what Bose calls Direct/Reflected Sound. The 901 system employs eight rear-firing drivers and one front-firing driver. Its rear baffle is angled to direct the two sets of four drivers each to different room areas, and the front baffle has a mild curvature. This system, when used in a reasonably reverberant room, will reflect large amounts of sound off the walls, creating a reflected sound field that works with the direct sound of the front driver to produce a feeling of spaciousness and a "concert hall" effect. Another interesting feature of the design is the fact that its drivers are all 4-inch cone radiators. Low-frequency reproduction is achieved by constructive interference of the many drivers, whose individual outputs combine in phase at

low frequencies to give the desired bass output. These drivers are somewhat limited in high-frequency response, so an equalizer is provided with the system to adjust the characteristic of the drive signal accordingly.

Allison Acoustics also designs its speakers with the listening room in mind. The Allison Model 1, for example, has a prism-shaped columnar enclosure with side-firing, acoustic-suspension woofers placed to minimize frequency-response aberrations due to room reflections. Allison's Model 4 is a true bookshelf system designed to use the shelf to its advantage. The woofer is placed at the top of the cabinet and effectively radiates into the shelf. Again, standing-wave formation is minimized with this scheme. The top-of-line AR speaker, the AR-9, also employs side-firing woofers.

It should be mentioned that *all* speakers are to some extent sensitive to room placement. As a rule, those designed to take the listening room directly into account are, not surprisingly, more sensitive to room placement than others. To get smooth frequency response and optimum directional characteristics, speaker placement must be experimented with until the "right" location for a room is found.

A number of speakers on the market today permit you to alter their directional characteristics to suit a particular room. One representative system is Infinity's massive Quantum Reference Standard, which has both forward- and rear-firing tweeters mounted on a cabinet with "flaps" that swivel in the horizontal plane. Moving the flaps enables you to change the dispersion characteristics of the speaker. The Leak Model 3090 speaker system has its mid-range and high-frequency drivers in a separate enclosure from the woofer. The two enclosures are connected by a swiveling mount. This enables the listener to change the firing position of the woofer relative to the higher-frequency drivers. For example, the woofer can be aimed at a nearby wall, and the midrange and tweeter pointed directly at the listener.

"Linear Phase" Speakers. The philosophy of the new linear phase speaker is this: if phase effects are important in program listening, the hi-fi system should have flat phase-vs.-frequency response as well as flat amplitude-vs.-frequency response. For a

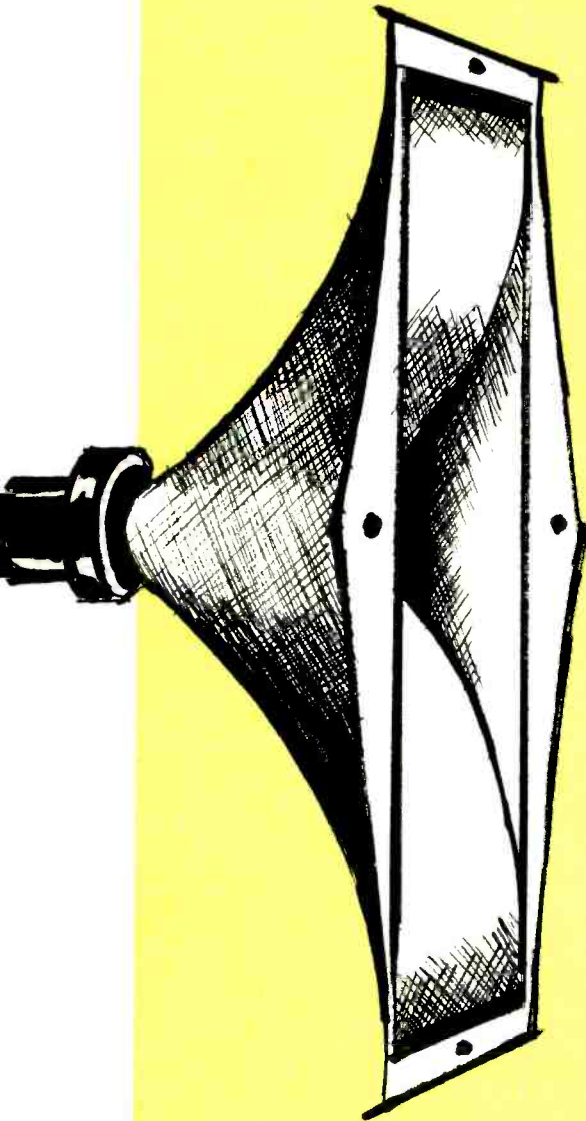

Typical horn loudspeaker.

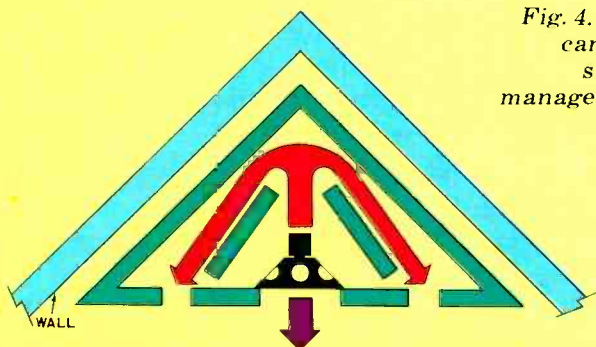

Fig. 4. Large bass horn can be folded into a structure of more manageable dimensions. Walls of room act as extensions of the horn.

speaker to have flat phase response, it should introduce no phase shift that can be detected at the listener's position. Now, the typical multi-way speaker system does introduce phase shift, because of the effects of its crossover circuits, and because of the fact that the different drivers, mounted on a flat baffle, have effective centers of radiation that are spatially displaced, resulting in a path-length difference between each driver and the listener's ears. In fact, the phase shift introduced in the crossover is the more serious of the two because there is a large discontinuity in the phase response of the network at the crossover frequency. The sharper the crossover's filters (say, having rolloffs of 12 or 18 dB/octave as opposed to 6 dB/octave), the greater the discontinuity. On the other hand, the path length difference resulting from the mounting of the drivers creates a time delay on the order of 1 millisecond, which translates to about 6 degrees of phase shift at 1000 Hz.

Bang and Olufsen was a major force in the early work on phase-compensated speakers. The most interesting work in this area has involved the design of crossover networks that eliminate phase anomalies. The ideal crossover for flat phase response uses active circuits (that is, multi-amping is necessary) and a "filler" driver that is active over a narrow band of frequencies centered at the crossover frequency. The filler driver is not intended to radiate significant acoustic power over a wide bandwidth. Rather, it's there only to smooth out the rift in the phase-response curve without serious disruption of the amplitude response.

In Bang and Olufsen's phase-compensated speakers, the filler-driver/crossover combination is employed and the drivers are mounted on an angled baffle. The angle of the baffle is set so that, at the hypothetical listening position, there is no path-length difference between the two drivers. Even though B&O systems use filler drivers, they don't require multi-amping because the filler drivers are

carefully designed to work with passive crossover networks (they are more efficient than the main drivers, for one thing).

A number of other manufacturers, such as Technics and B&W, have produced systems intended to have flat phase response. All of these systems utilize offset mounting of the drivers, with the tweeter generally set several inches in back of the woofer to eliminate path-length differences. Often, for example, the main cabinet houses the woofer and the midrange and tweeter are mounted on small baffles set back on top of the woofer enclosure. It's worth noting that the Walsh driver mentioned earlier (it's employed in the Ohm F system) is, besides its other qualities, a true linear-phase speaker.

It must be said that there is no agreement as to whether a speaker with flat phase response is necessary. In fact, a growing body of evidence indicates that, when music or speech program material is heard in a reverberant environment, phase effects are of little importance to the listener. It is only with specialized test signals and very specialized listening environments that phase effects other than basic phase cancellation (destructive interference) can be heard. After all, the typical listening room, introducing sound reflections as it does, totally randomizes the phase information in the acoustic signal by the time it reaches the listener's ears. It has been said that "it can't hurt" to have a linear-phase speaker, which is true, ideally. But a number of designs currently on the market introduce amplitude response aberrations due to diffraction effects caused by the offset mounting of the drivers. These response anomalies are audible. This is worthy of consideration, because a number of manufacturers go to great pains to make their baffles smooth and free of structural discontinuities simply to minimize diffraction of high-frequency sound (consider the latest designs by Avid, for example).

Electrostatic Systems. As mentioned earlier, a solution to the limited-output problem of electrostatics is exemplified by the formidable Dayton Wright electrostatic speaker. The electrodes and diaphragm are immersed in an atmosphere of SF₆, which can support very high polarizing and driving voltages without breaking

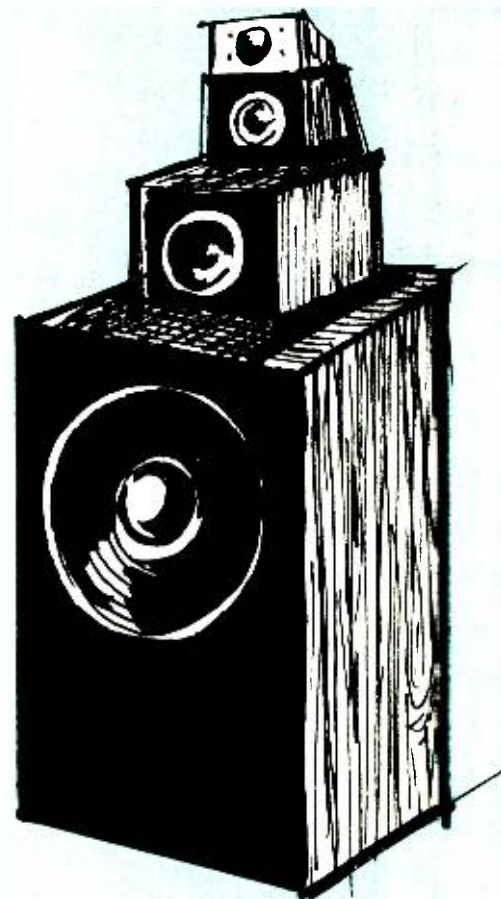

"Linear phase" speaker system.

down and arcing. Hence, the Dayton Wright system is capable of generating more acoustic output than standard electrostatics. The system is provided with a special power amplifier that is capable of driving the almost totally reactive load of the speakers (which would be a horror for many conventional amplifiers). The Dayton Wright is a two-way system. Frequencies above 10,000 Hz are handled by a piezoelectric tweeter.

Another novel (and equally massive) electrostatic system is the Beveridge 2SW. This speaker employs a single 6-foot electrostatic panel, but the driver is loaded with a unique acoustic lens that gives the system wide dispersion in the horizontal plane. Ordinarily, a single electrostatic panel would become highly directional at high frequencies, especially if it were large enough to provide significant bass output. In the Beveridge speaker, the effective size of the radiator is quite small, because the mouth of the lens is a narrow slit rather than a large, wide panel. The Beveridge system is provided with a specially-designed vacuum tube power amplifier as well as two subwoofers to

Special Focus on Speakers

augment the electrostatic driver's bass output in the lowest octave.

The Beveridge 2SW represents an interesting means of obtaining controlled high-frequency output from an electrostatic speaker. Other designers take different approaches, such as multi-way systems with two or more electrostatic drivers of different panel sizes. Some manufacturers, such as RTR, utilize electrostatic tweeters composed of several small panels

placed at angles to one another so they radiate into a wide solid angle.

Equalized Systems. Some designers utilize electronic equalizers to compensate for frequency response deficiencies of the speaker system, as is done in the Bose 901 series mentioned earlier. These equalizers are generally placed between the preamp and power amp, and have either fixed equalization or a minimum of user controls so their performance isn't hindered by user adjustments. Another example of equalized systems is Electro-Voice's Interface line of speakers, some of which include equalizers that smooth out bass response and control high-frequency roll-off.

Powered Speakers. Speaker designers who want absolute control over the electronic circuits to be interfaced with their systems use powered speakers. These speakers contain power amplifiers that are built right into the speaker cabinet. Systems of this kind are almost always multi-amped. That is, the system will contain a separate amplifier for each driver, as well as an electronic crossover at the input, so you drive the "speaker" with the output of a preamp. There are some obvious advantages to this scheme. For one thing, it is probably the most cost-effective way to drive a speaker system. Multi-amping enables you to match each transducer with its appropriate drive level, and therefore gives you a maximally efficient system. Additionally, there are none of the power losses that occur in higher-order passive networks, so you can provide each driver directly with only the power it needs and no more. (This isn't really critical in hi-fi systems, but if you're setting up a stage system for the Grateful Dead or designing a monitor system for a big studio, it is.) Other advantages of multi-amping are potentially lower distortion and smoother frequency response. Regarding the latter, the active crossover can be designed to introduce no phase shift of one band relative to another. Accordingly, near the crossover point, where more than one driver is radiating the same signal, destructive interference won't occur. In any event, if multi-amping is important in a particular application, the powered loudspeaker is an efficient way to do it. Another feature, exemplified by the Powered Advent speaker system,

is compactness. The bulky power amps are built right into the cabinet.

The ultimate powered speaker system is one that utilizes *motional feedback* to correct for driver nonlinearities such as in the Philips RH-545. This is a three-way tri-amplified system with a small transducer mounted on the woofer cone. The transducer generates a signal proportional to the woofer output, which is fed back and subtracted from the input signal (just like the negative feedback used in every audio amplifier). The signal that drives the speaker is thus "compensated" for the woofer's nonlinearities. Feedback systems of this sort are primarily useful for reducing distortion in a speaker's bass output. They aren't generally used for the higher-frequency drivers for practical reasons.

Subwoofers. A relatively recent trend in the design of loudspeaker systems involves the use of large dynamic drivers for reproduction of the deepest bass and separate "satellite" speakers for the upper bass, mid-range, and treble frequencies. Because audio frequencies below 70 Hz or so are nondirectional to the human ear (it can't locate their source), a system can be set up to operate with a single subwoofer covering the range of, say, 20 through 70 Hz, and a pair of satellite speakers for the higher frequencies. (Alternatively, a separate woofer can be used for each channel and its operating range increased accordingly.) As evidence of this trend you need only note the increasing number of "mini" speakers on the market, made by manufacturers like ADS, Visonik, Braun, etc. If the satellites are not intended to reproduce any low bass (anything significantly below 100 Hz) they can be made very small. The ADS Model 200 II, for example, measures only $6\frac{3}{4} \times 4\frac{1}{4} \times 4\frac{5}{8}$ inches ($17.1 \times 11.7 \times 10.8$ cm) and has a rated frequency response of 85 to 20,000 Hz ± 3 dB. (Response goes down to 55 Hz ± 6 dB.) The advantage of using a single subwoofer in a low-profile cabinet and two small, lightweight satellites is clear from the standpoint of aesthetics and placement in the average room. If desired, the woofer can be hidden in an out-of-the-way place because its output does not affect stereo imaging. The compact satellites are easy to find room for.

Acoustique 3A International has

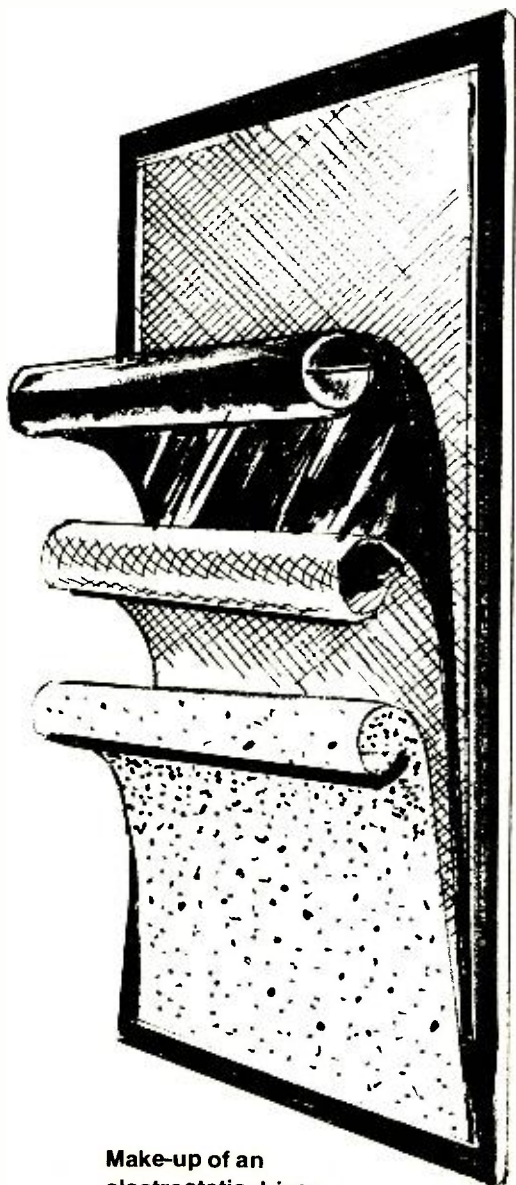

Make-up of an electrostatic driver.

Special Focus on Speakers

taken the idea of the hidden subwoofer to its extreme with its Triphonic system. Here the woofer is a self-powered, motion-feedback system concealed in a coffee table. The higher frequencies are handled by two small (17 × 10 × 7 inches) satellite speakers. A single stereo amplifier is re-

quired to drive the system because the woofer is self-powered.

One disadvantage of the subwoofer/satellite approach in terms of cost is the fact that these systems generally have to be bi-amplified. An electronic crossover and separate amp for the woofer is needed. If the woofer is reproducing frequencies down to 20 Hz, and is of the acoustic suspension type (as is not uncommon), you'll need plenty of power for it, too!

In Conclusion.

Although there aren't all that many generic types of speakers and enclosures, the number of variations on the basic designs that have been tried at one time or another is huge. Each design attempts to solve the problem(s) its creator sees as most pernicious (whether they are real or imagined). However, one thing is certain—as time has passed, the fundamental designs have been improved and refined to the point that well-executed examples of each design type will *all* be good-sounding speakers. ◇

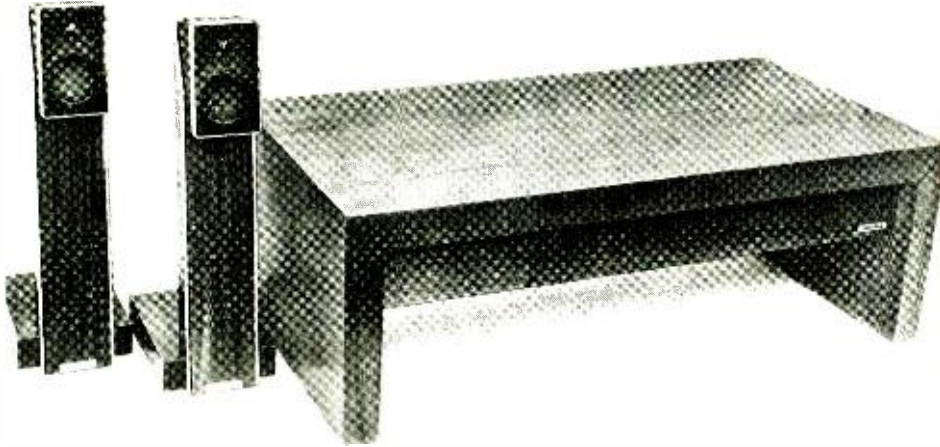

Mesa's subwoofer housed in an enclosure disguised as a coffee table is meant to be used with a pair of small satellite speakers (left).

FEW IF ANY difficulties are encountered in testing electronic audio components such as amplifiers and tuners in a hi-fi system. The reason for this is that we are dealing with generally well-understood effects (power, sensitivity, distortion, noise, etc.), and the measuring procedure is defined by standards issued by the Institute of High Fidelity (IHF) and other organizations. Hence, we can reasonably well define the performance of such products under test. Not so for speaker systems, which have yet to come under a testing standard (although an IHF technical committee has been activated to generate such a standard).

Unlike electronic components, the electromechanical loudspeaker is far from a simple device with a uniquely defined output that can be directly related to an input signal. Until a testing standard is formulated, those of us who test speaker systems must establish our own laboratory procedures based on what we consider to be important characteristics. This is the rub, because as things now stand, there is no agreement as to just which characteristic of a speaker system's output is related to its sound and which, therefore, should be measured.

Interpreting Speaker Test Results

BY JULIAN HIRSCH

Hirsch-Houck Laboratories

The Problems. Although the input to a speaker system is electrical and can be specified quite well (assuming one considers it as a voltage only because the complex input makes it very difficult to measure the true input power), its output is *acoustic* energy. This energy is commonly expressed as a sound pressure level, or SPL, in decibels relative to 0.0002 dynes/cm². The SPL measurement per se is not

difficult to make with a suitable calibrated microphone. However, there remains the question of the testing environment and the physical relationship between the speaker system and microphone during the test.

The acoustical SPL output of a speaker system is a function of the direction and distance between the microphone and speaker system and the driving frequency. If the frequency

response is measured in an anechoic chamber—the most commonly used test environment, with the microphone on the central axis of the system—one may obtain a reasonably “flat” response curve. Bear in mind, though, that “flat” for a speaker system is not the same as “flat” when applied to the response of an amplifier or even of a phono cartridge. Every driver in a speaker system is subject to countless unwanted response variations from its cone and voice-coil suspensions, the cone itself, the supporting basket, the cabinet edges, and many other factors. As a result, what is obtained in an actual test is a very rough, irregular response curve. This response curve is usually so irregular that its useful content is obscured. Hence, it is common practice to use filtering and pen damping in the graphic level recorder to smooth out the rough edges, so to speak, leaving a more general—and often more informative—contour of the speaker system’s response.

No matter how the measurement is made, we cannot avoid the fact that the response will be different for every different microphone position relative to the speaker system. An on-axis response is essentially worthless as an indicator of how the speaker system will sound or even of its intrinsic merit. If the response is measured at a number of different microphone locations while sampling the sound field over a wide angle in front of, or even through a full sphere surrounding, the speaker system, it is possible to process the data with a computer to obtain a plot of the total power response as a function of frequency. This is a measure-

ment of the total acoustic energy the speaker system radiates in *all* directions, into the hemisphere or spherical volume that loads the system.

There is good reason to think that the power response of a speaker system is more closely related to the way it sounds in a real listening room than in any anechoic measurement along a single axis or several axes. This is not to imply that such a measurement—indeed, *any* possible measurements—will ever be able to define or describe the performance of a speaker system with the accuracy that such measurements can describe the nature of amplifier or tuner performance. There are many orders of magnitude of difference between the subtleties detectable by the human ear and processed by the brain and anything that can be picked up by a microphone and processed by a computer. Nevertheless, in a home environment a speaker system *does* radiate sound in all directions although not necessarily uniformly. Most of this output, after reflection and some absorption, eventually reaches the listener’s ears. For this and other reasons, we have long felt that such a measurement (power response rather than any single-axis pressure response) is the most meaningful way to measure the general, octave-by-octave, frequency response of a speaker system.

Our Procedure. Fortunately, a computer or a large number of microphones are not really needed for a power-response measurement. Another and often simpler technique is to use a reverberant chamber for a test environment. This is an odd-shaped room with no parallel surfaces, its walls, floor, and ceiling made of hard, nonabsorbing material. All the sound emitted by a speaker system in such a room, after many reflections, will produce a uniform, homogenized sound field at any point in the room. Like an anechoic chamber, a reverberant

room can be used only for middle- and high-frequency measurements. A reasonable-sized anechoic room may be useful only down to 100 Hz or so, and the cut-off for a reverberant room can go up to 500 Hz.

At Hirsch-Houck Laboratories, we have neither an anechoic nor a reverberant chamber. We have found that a normally furnished listening room behaves much like a reverberant chamber. Beyond a distance of 10 ft (3 m) or so from the speaker system, the sound field is semireverberant. That is, the measured SPL changes little as the microphone is moved about. The room’s response is not “flat” with frequency, of course, due to the normal absorption by the boundary surfaces and furnishings. These surfaces cause the high-frequency response to roll off in any measurement. However, we have been able to compensate for this rolloff with gratifying success. To do this, we measure the response of two calibrated speaker systems in a normal stereo listening setup at the front of the room, spaced about 10 feet apart. We place the microphone on-axis with and about 12 ft (3.7 m) from the left speaker system. At this point, the microphone is angled about 40° off-axis from the right speaker system. Then we run response curves for both speaker systems separately but on the same chart paper, using a “warble tone” swept oscillator and heavy pen damping in the recorder to obtain the smoothest possible curve. The two curves, from 100 to 20,000 Hz, usually have “ripples” from standing wave effects in the room. We find, however, that these standing waves tend to cancel out between the speaker systems. This yields a relatively smooth line average for a reasonable curve. (Fig. 1).

Knowing the actual reverberant-room response of our speaker systems from data supplied by the manufacturer and knowing that our microphone is flat within ± 1 dB up to 20,000 Hz, we can draw a correction curve. When this curve is added to the response curve of any other speaker system measured in the same room, we obtain a response curve roughly equivalent to the speaker system’s total power response. Although acousticians will probably flinch at the approximate nature of this measurement and the various assumptions that have been made in its performance, we find that we usually come

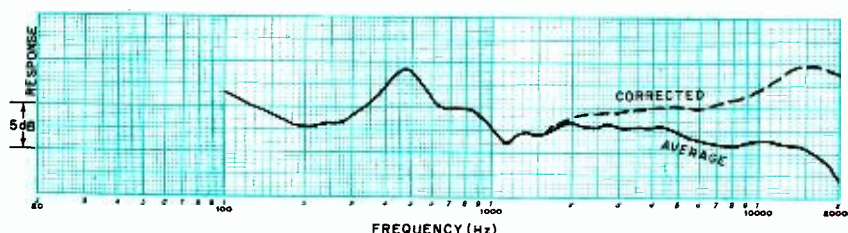

Fig. 1. Average response curve is for left and right speakers and corrected curve takes room characteristics into account.

within 2 or 3 dB of a true reverberant response measurement when we have access to that data from a speaker manufacturer. This is accurate enough for our purposes.

Although the curve obtained extends down to 100 Hz, it is not valid below about 300 Hz because of the unavoidable resonance effects of our room. At lower frequencies, we place the microphone as close as possible to the woofer's cone and run a curve from 20 to 1000 Hz (Fig. 2). (No warble tone is needed since close-microphone measurement is not affected by the room and gives essentially a true anechoic response.) This measurement is not valid much above 300 Hz, where the dimensions of the woofer cone become comparable to the wavelength of sound, but we carry it up to 1000 Hz for the same reason that our quasireverberant measurement is carried down to 100 Hz.

Having obtained two sets of curves, we splice them together to form a single composite frequency response (Fig. 3). By extending each curve beyond its most accurate range, we find it easier to overlap them for the best splice. On occasion, there is little overlap range and we must make an educated guess about the splice point. In many cases, the two curves have considerable overlap and there is no doubt about the accuracy of the composite frequency-response curve.

One might fairly ask how we can call this composite curve a "frequency response" plot of a speaker system. Our reasoning is that the midrange and high-frequency portion of the curve is a fair representation of the speaker system's total power output over that range and consequently represents how much energy it will radiate into almost any room. Regardless of the room's characteristics, a peak or a drop in output at the high frequencies will almost always be heard as a brightness or dullness of the sound, and irregularities in the midrange generally correlate with difficult-to-define colorations one often hears from a speaker system. While this portion of the curve is fairly appli-

cable to any listening room, the bass response is drastically affected by the room size and placement of the speaker systems. In most cases, it would be quite impossible to produce any curve that really reflects how the speaker system will perform in any arbitrary room.

Given the above, we content ourselves with showing the low-frequency (anechoic) response obtained with close microphone spacing. This is a "worst-case" condition; the actual bass performance will always be better in any real room, where the boundaries will reinforce the low-frequency output of the system. The curve we give is useful for comparing speaker systems. The magnitude and width of the low-frequency output rise at resonance also give a good indication of the Q of the woofer.

In spite of its unorthodox derivation, the composite response curve relates well to how the speaker system sounds in our test room and how it is likely to sound in most "real" listening rooms. It is worth noting that the two separate response curves at high frequencies reveal very clearly how good the dispersion of a tweeter is in the upper registers. An omnidirectional speaker system, or a system with very

good dispersion, will reveal little or no difference between the two curves, one on-axis and the other 40° off-axis, at any frequency, but most speaker systems will reveal at least several decibels difference at frequencies beyond 10,000 Hz.

Other Tests. We also measure the harmonic distortion of the woofer between 100 Hz and its lower frequency limit (Fig. 2). We use the same close microphone technique here employed for the bass response measurement, but the microphone's output goes to a spectrum analyzer instead of a chart recorder. The output levels of second and third harmonics (higher order components are almost never significant) are combined to obtain a THD reading at each 10-Hz frequency increment. The woofer is driven with a constant 2.83 volts and then at a constant 8.94 volts, which correspond to power levels of 1 watt and 10 watts into an 8-ohm load. We do not measure distortion at higher frequencies because the irregularity of the system's response makes the test impossibly complicated unless very specialized automatic plotting equipment is used.

A bass distortion measurement tells

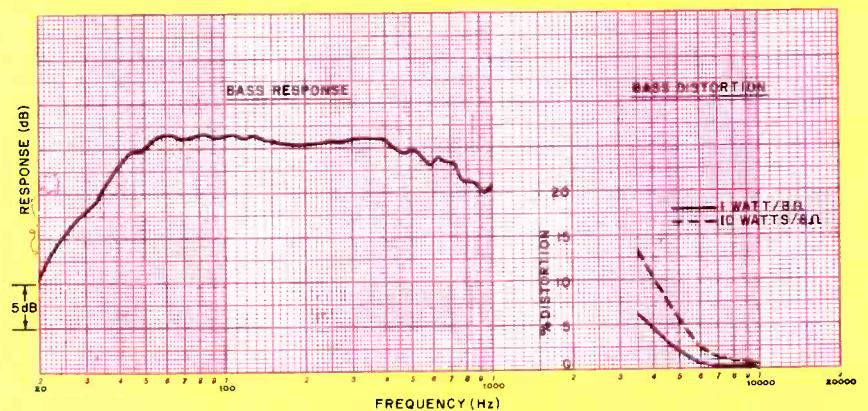

Fig. 2. At left is a typical bass response from 20 to 1000 Hz. At right are typical distortion curves below 100 Hz at two power levels.

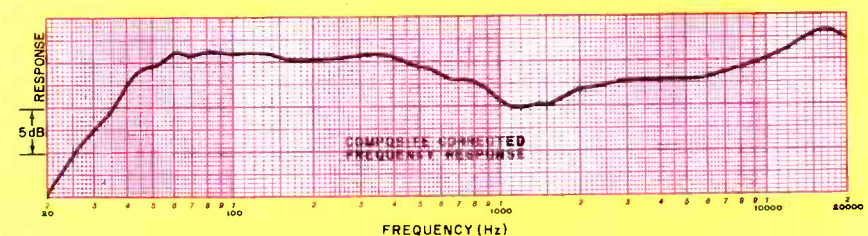

Fig. 3. A composite corrected frequency response. It is formed by splicing the curves from 100 to 20,000 and from 20 to 1000 Hz.

us how low the speaker system will go before the woofer ceases to be coupled to the air load of the room. At this frequency, distortion begins to rise rapidly. For a typical bookshelf speaker system, the distortion may measure in the vicinity of 1 percent or so down to about 60 Hz, rising somewhat at 50 Hz and very abruptly at lower frequencies. Regardless of its measured frequency response (measured at a low drive level), such a system will not produce usable, undistorted bass at frequencies much below 50 Hz because its cone is no longer coupled to the room, causing excessive distortion.

One thing everyone should know about his speaker system is how much drive is required to produce a given SPL output. (This is related to how much amplifier power capability is needed.) This information is given in our *sensitivity* measurement. (This is not *efficiency*, although the two are related, since we do not know how much electrical power we are actually delivering to the speaker system, or how much acoustic power it is producing.) We drive the speaker system with 2.83 volts of band-limited pink noise (an octave wide and centered at 1000 Hz) and measure the SPL at 1 meter in front of the grille. We prefer this signal to full-bandwidth pink noise because it measures the sensitivity in the important midrange, where most of the subjective volume is produced.

Impedance is measured by driving

the speaker system's voice coil directly from the swept oscillator of our frequency response plotter, with the graphic level recorder in parallel with the output of our oscillator and the speaker system. The 600-ohm output of the oscillator looks like a constant-current source to the speaker system. Hence, the voltage across the speaker system and recorder is directly proportional to the impedance as the frequency sweeps from 20 to 20,000 Hz. Since the amplitude scale of the recorder chart is logarithmic, we calibrate it before each measurement by substituting a precision resistance decade box for the speaker system and calibrating over a range of 1 to 100 ohms (Fig. 4).

Although we still examine the toneburst responses of a speaker system as part of our test sequence, these do not lend themselves to objective interpretation unless the speaker system is unusually good or bad. We usually drive the speaker with 4-cycle bursts while varying the frequency and observing the behavior of the acoustic output in the operating range of each driver. It is generally necessary to locate the microphone fairly close to the speaker system (within a foot or so) and on the axis of the driver being studied to avoid interference from the other drivers and room reflections. This is one of the tests that really should be made in an anechoic chamber, since it is almost impossible to eliminate room effects from delayed reflections off the walls unless the microphone is so close to the speaker that it may affect the actual output. (One cannot assess total system performance under this condition.)

Interpreting Results. From the

general shape of the composite response curve, one can determine by inference whether the system will sound bright or heavy, have midrange coloration, or perhaps be one of the few really smooth and uncolored reproducers available. A very flat curve usually means that the speaker system is very good, but moderate irregularities do not necessarily mean that the system is a poor performer. Our comments on the sound of a speaker in the "User Comment" section of our reports should help in interpreting the curves.

Very low bass distortion usually means that a speaker system will sound clean in the low bass range and that it can probably be equalized for a flatter, more extended bass output with a suitable graphic equalizer, without risking excessive distortion or damage. Higher bass distortion, such as 2% or 3% in the 50-to-100-Hz range does not necessarily sound bad since the ear is very tolerant of low-order harmonic distortion, especially at low frequencies. If the speaker system is capable of delivering a healthy output in the low-bass range, a moderate amount of distortion will probably never be noticed.

The impedance curve is important to anyone who plans to parallel two pairs of speaker systems on a single amplifier. We give in our reports the lowest impedance observed.

The sensitivity rating is a rough guide to how much amplifier power will be needed to drive the speaker system to a given SPL. Most acoustic-suspension systems produce an 85-dB SPL at 1 meter for a nominal 1-watt input (the range is typically 82 to 88 dB). Ported or vented systems may range from 88 to 92 dB, while a few will reach 94 or 95 dB. These figures do not tell how loud a speaker system will play; they tell you how much power is required to play at a given level. Their usefulness is mainly to permit you to compare competing systems. For example, a speaker system rated at 92 dB will require only one-tenth as much amplifier power as one with an 82-dB sensitivity rating, for the same listening level.

Finally, we should mention that our test figures will rarely, if ever, agree with any supplied by a speaker system manufacturer. This is because totally different test methods were used, which is not a reflection on either the manufacturer or on our test results. ♦

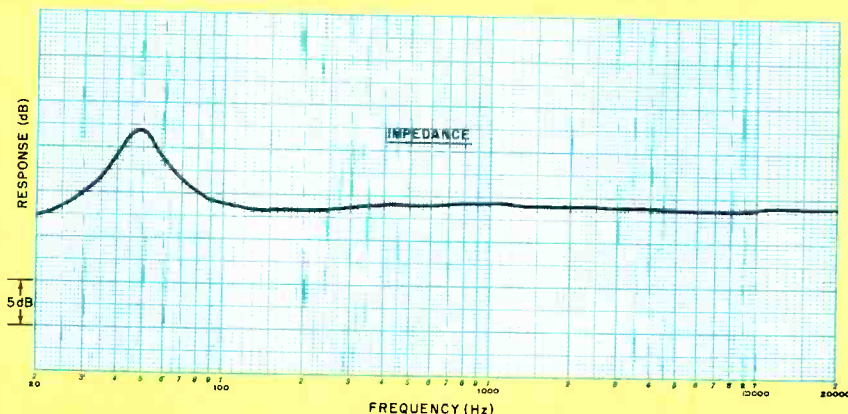

Fig. 4. A typical impedance curve obtained by driving the speaker system from the swept oscillator of frequency response plotter.

The Importance of Power-handling Capacity

BY TIM HOLL
Teledyne Acoustic Research

THE AMOUNT of power a speaker can handle without incurring damage is little understood by most audio enthusiasts. For example, why can a loudspeaker with a high power rating be damaged in a particular situation when one with a lower rating is undamaged? Why do some speaker systems that are provided with fuses still suffer overload damage without the fuse being blown? To answer these and other questions, we must first recognize the power limitations of a loudspeaker system in two failure areas—thermal and mechanical.

Thermal Failure. To understand why thermal failure occurs, we first determine what a loudspeaker does with the input power it receives. We are familiar with audio amplifiers that deliver 50, 100, 200, or even as much as 700 watts per channel. However, few of us know how many watts—that is, actual acoustic watts—a loudspeaker delivers. An indication can be obtained, however, by considering the output of a large pipe organ. It will typically deliver 12 to 14 acoustic watts in a spacious environment. A conventional saxophone, on the other hand, delivers about 0.3 watts, a piano 0.4 watts, a bass singer 0.03 watts and speech at a normal level about 0.000024 watts.

Obviously, we are now looking at much smaller power levels than those considered by the average hi-fi enthusiast because he is thinking of electrical input to a speaker, not its acoustic output. The enormity of the difference is seen if we consider the 12 to 14 watts delivered by a large

pipe organ. In the average house, this amount of acoustic power would literally shake the house.

Thus, we can see that, for even extremely loud listening levels in the home, we are only considering acoustic power outputs of no more than a few watts. To supply this power, however, it is often necessary to have an amplifier with a large power output because of speaker inefficiencies. This brings up the subject of just how efficient high-efficiency speakers are when compared to low-efficiency units—how inefficient even the high-efficiency systems are is not generally appreciated. Acoustic-suspension speakers can have efficiencies as low as 0.2%, ported systems about 1% and horns up to approximately 15% to 20%. For most current speakers, for every 100 W of electrical power deliv-

ered to a speaker, only about 0.2 to 1 watt of acoustical power is delivered as actual sound! The rest of the power (over 99 watts, in this case) goes almost entirely into heating the voice coils on the speaker drive units. (A very small amount of power is used to overcome mechanical resistances in the drive units while another small amount heats the leads from amplifier to speaker).

Let us now look at what happens when we apply this power to a speaker's input. Figure 1 shows typical heating and cooling of a conventional midrange unit with a 1"-diameter voice coil for a constant sine-wave input. A steady state is rapidly reached around 105°C (221°F) above ambient (about 20°C or 68°F). Usually, thermal breakdown occurs when adhesives used in the construction melt or fail. This is

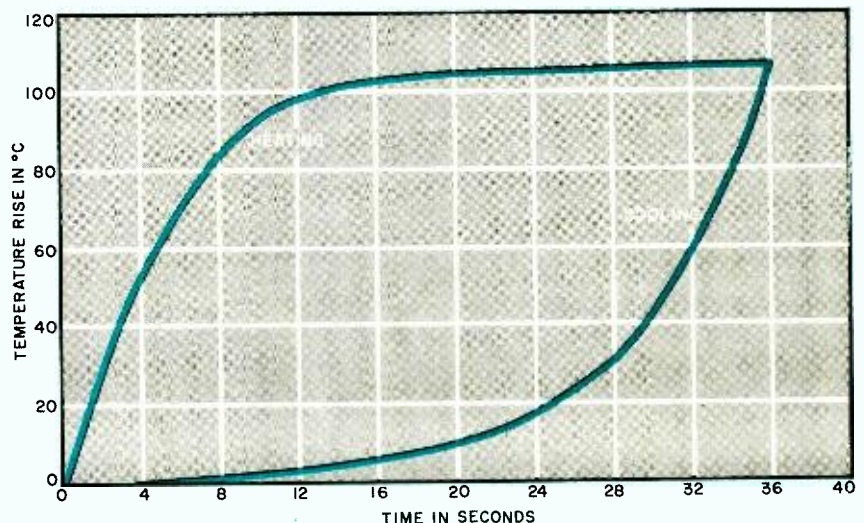

Fig. 1. Heating rate of a midrange coil when a nominal 10 watts of 1-kHz sine wave is applied, and the cooling rate when the signal is removed.

“... a loudspeaker cannot [always] be played as loud after several hours of use as it can when first turned on.”

usually at temperatures of about 170°C (338°F) to 180°C (356°F). Consequently, it would appear to be safe to use 10 watts continuously applied to our hypothetical unit. Unfortunately, it is not!

To understand why, let's first examine what happens when the temperature rise apparently levels out. At this point, all the power that's producing heat is not merely raising the temperature. It is travelling across the air gap in which the coil sits to the other metal parts and magnet (Fig. 2) causing them to heat up. Since the metal parts have a larger mass than the voice coil,

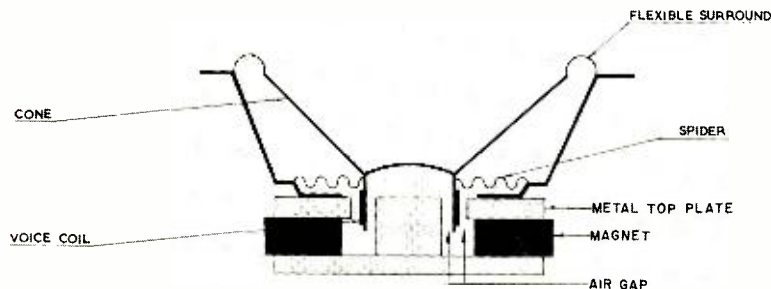

Fig. 2. Cross section of a typical loudspeaker drive unit with voice coil sitting in air gap.

however, the former is slower in reaching its maximum heat level. As shown in Fig. 3, it takes about two hours for the temperature to stabilize to a point where all the heat received by the structure is, in turn, transmitted to the air around the unit. During this time, the metal rises to about 68°C (154°F) above ambient. But, more significantly, the voice coil rises with it to about 155°C (311°F) above ambient—close to the failure level of adhesives.

What does all this mean to the loudspeaker user and loudspeaker designer? We need to look even further into the subject to see how the designer can optimize the situation, but we already see one danger point for the user. A loudspeaker voice coil will rapidly heat and cool with variations in level applied with a typical music sig-

nal, as indicated by Fig. 1. However, this rapid variation in temperature will have upper levels determined by how long the system has been playing, as seen in Fig. 3. Consequently, a loudspeaker cannot be played as loud after several hours of use as it can when first turned on. This may explain why simple fusing so often fails to protect a system. A low-current fuse which would provide adequate protection for all signals after any period of playing is simply not practical, as it would mean limiting the system to unrealistically low levels for most normal listening conditions.

What can the designer do? One obvious answer is to transfer more heat away from the unit, possibly with heat-

still transfer the 9.9 watts? To answer this takes a complex study of heat transfer mechanisms. The results of one such study are described below.

In this study it was found that in the type of unit used as an example, about 3% of the heat was transferred from the coil to the metalwork by radiation, none was transferred by convection, and 97% was conducted through the air in the gap. This explains the high temperature differential between coil and metalwork, as air is a fairly poor conductor of heat (the air in our homes is heated by convection, a mechanism that does not occur in the voice coil gap). Attempts to improve radiation by having blackened coil formers and blackened metalwork had little effect, giving an increase in power handling of only 12%. To make inroads, we need improvements of several hundred percent, as each doubling in power handling means that we can safely play the system 3 dB louder (12% is an improvement of 0.5 dB in output).

The obvious answers to improvement in power handling lie in two areas—increasing the maximum temperature the unit can withstand and improving heat conduction away from the voice coil. Higher maximum temperatures require the use of adhesives that will withstand higher temperatures without softening or breaking down. As stated earlier, these adhesives normally have an upper limit of about 189°C. Adhesives that can withstand higher temperatures are now becoming available and are being used on a few drive units. Generally speaking however, most voice coils still have the sort of temperature limit we have been dealing with.

We are thus limited to the upper temperature limit of about 180°C (356°F). Is it possible to handle more power before reaching this limit? One obvious way is to increase the surface area of the voice coil. High-power speakers for electric guitar amplification, for example, often achieve their power-handling ability by using tweeters with large voice coils—sometimes 4 or 5 inches in diameter. Unfortunately, large voice coils cause two se-

sink fins on the metalwork. Unfortunately, this will work only if he can efficiently transfer the heat from voice coil to metalwork. This is where we have the major temperature differential in the order of 90°C (194°F). If we could reduce this differential to, say, 20°C (68°F), then for the same input power of 10 watts, we would only get a long-term voice coil rise of about 90°C (194°F) instead of 155°C (311°F). This would occur because, under steady-state conditions, about 9.9 watts is generated as heat in the voice coil, crosses the air gap to the metalwork, and is then transmitted by the metalwork to the surrounding air. The temperature difference necessary between coil and metalwork for this 9.9 watts is about 90°C. How can it be reduced to, say, 20°C (68°F) and

rious degradations in tweeter or mid-range performance. First, for accurate reproduction of transients and high frequencies, a tweeter voice coil has to be lightweight, so it can't be very large. Secondly, a large voice coil automatically means a large acoustic radiating surface which, in turn, means a tweeter that will become seriously directional even at relatively low frequencies.

Another way to handle more power for a given sound pressure level before reaching this limit is to use a much more efficient tweeter and pad it down in the crossover network to the level of the rest of the system. Thus, much less power is applied to the tweeter (the attenuator network used should, of course, be able to handle the rest of the power). Such a tweeter of midrange element would have to be horn loaded for sufficient increase in efficiency. This approach is quite valid, but does produce systems with treble directionality problems since the radiating area of a horn is that of its mouth. This is really only fully satisfactory when used in systems specifically designed to make use of these directionality effects (a very complex subject in its own right). It also explains why power-handling failures

are less likely to occur in fully horn-loaded systems; they don't handle more power, they just play significantly louder. Hence, the amplifier level does not get turned up as much and the loudspeakers do not get as much power fed to them.

Magnetic Fluids. Recently, another method of improving the ability to handle power before failure temperatures are reached has become available to the loudspeaker designer. This method significantly improves the transfer of heat from the voice coil and across the voice coil air gaps by replacing the air in the gaps with a special oil that has an excellent thermal conductivity.

The oil is the base of a remarkable new material called *magnetic fluid*, a molecular suspension of ferrite particles in an oil carrier. This fluid is attracted by magnetic fields and thus is firmly held in the air gap of a loudspeaker, as shown in Fig. 4. Now, for the first time, a new generation of high-power-handling tweeters and midrange units of the small size necessary if a design with good dispersion characteristics is desired can be built. Such units are now incorporated in an increasing number of American manufacturers' models and will, it is believed, soon be seen in systems from both Europe and the Far East.

Using a combination of high-temperature adhesives and magnetic fluid, loudspeakers having much better power handling capabilities than before can be designed. Why, then, is it

still possible to damage loudspeakers thermally? This is where we look at the last part of the story, the signal applied to the speaker.

Loudspeaker Signals. In most systems the woofers are large and have large voice coils and lots of metalwork; tweeters have small coils and a much smaller mass of metal; and midrange units lie somewhere in between. Obviously, a tweeter cannot handle power as well as can a woofer. It is fortunate for the designer, therefore, that loudspeakers are designed to play music and not constant-amplitude sine-wave signals. This means that he can take advantage of music spectra, such as those given in Fig. 5, in the design of individual drive units for a system. It also means, unfortunately, that it is relatively easy to misuse the system, often without realizing it.

Misuse of a system, in a thermal damage context, means changing the spectrum of the signal applied so that too much power is applied to the most vulnerable units, the tweeters. The spectra shown in Fig. 5 are for a variety of rock-music records, which generally present the worst thermal problem for two reasons. Firstly, and most obviously, rock music is simply played louder. Secondly, its spectrum generally puts more power into the system at higher frequencies, reaching a broad maximum around 800 Hz. In contrast, classical music reaches a maximum power level somewhere around 500 Hz. Consequently, classi-

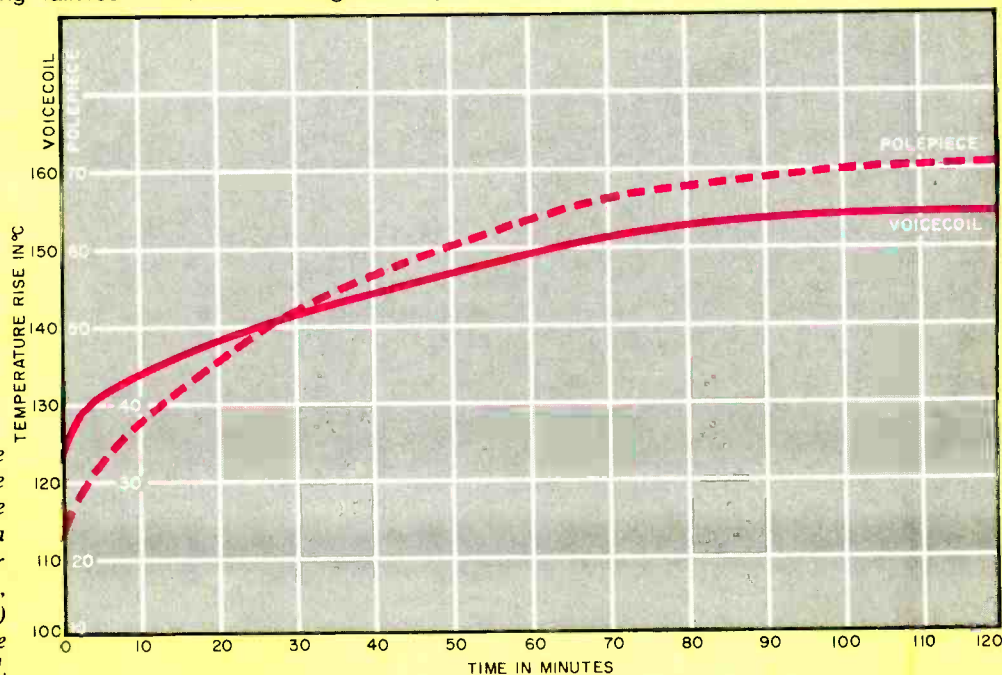

Fig. 3. Temperature rise of the voice coil and pole piece of a mid-range speaker with a 1-kHz, 10-watt (nominal) sine-wave signal applied.

24 ISSUES APARTMENT LIFE YOU PAY ONLY \$7.97 Reg. Rate: 24 iss. \$14.97	7 ISSUES FLY FISHERMAN YOU PAY ONLY \$9.97 Reg. Rate: 7 iss. \$11.97	18 ISSUES Popular Science YOU PAY ONLY \$7.46 Reg. Rate: 18 iss. \$14.91	26 ISSUES Sports Illustrated PAY ONLY \$12.77 Reg. Rate: 26 iss. \$32.50
12 ISSUES Better Homes and Gardens YOU PAY ONLY \$8.00 Newsstand Rate: 12 iss. \$11.40	18 ISSUES FORTUNE PAY ONLY \$16.75 Reg. Rate: 18 iss. \$36.00	12 ISSUES PHOTOGRAPHY YOU PAY ONLY \$6.99 Reg. Rate: 12 iss. \$13.98	12 ISSUES Stereo Review YOU PAY ONLY \$4.99 Reg. Rate: 12 iss. \$9.98
12 ISSUES Boating YOU PAY ONLY \$9.97 Reg. Rate: 12 iss. \$15.00	12 ISSUES GOLF YOU PAY ONLY \$4.97 Reg. Rate: 12 iss. \$9.94	12 ISSUES psychology today YOU PAY ONLY \$6.97 Reg. Rate: 12 iss. \$12.00	25 ISSUES TIME PAY ONLY \$14.97 Reg. Rate: 25 iss. \$31.25
51 ISSUES Business Week PAY ONLY \$28.50 Reg. Rate: 51 iss. \$63.75	12 ISSUES HOUSE BEAUTIFUL YOU PAY ONLY \$6.97 Reg. Rate: 12 iss. \$10.00	18 ISSUES REDBOOK YOU PAY ONLY \$11.93 Newsstand Rate: 18 iss. \$22.50	32 ISSUES TV GUIDE YOU PAY ONLY \$9.53 Lowest Available Sub Rate
12 ISSUES CAR DRIVER YOU PAY ONLY \$5.99 Reg. Rate: 12 iss. \$11.98	12 ISSUES Ms. YOU PAY ONLY \$5.97 Reg. Rate: 12 iss. \$10.00	26 ISSUES Rolling Stone YOU PAY ONLY \$12.00 Reg. Rate: 26 iss. \$18.00	52 ISSUES TV GUIDE YOU PAY ONLY \$15.50 Lowest Available Sub Rate
12 ISSUES Cycle YOU PAY ONLY \$5.99 Reg. Rate: 12 iss. \$11.98	18 ISSUES Mechanix ILLUSTRATED YOU PAY ONLY \$5.96 Reg. Rate: 18 iss. \$11.90	9 ISSUES RUNNER YOU PAY ONLY \$8.97 Reg. Rate: 9 iss. \$13.50	15 ISSUES us YOU PAY ONLY \$8.97 Lowest Available Sub Rate
16 ISSUES ESQUIRE YOU PAY ONLY \$10.00 Newsstand Rate: 16 iss. \$20.00	23 ISSUES Newsweek YOU PAY ONLY \$13.25 Reg. Rate: 23 iss. \$28.75	7 ISSUES SKIING YOU PAY ONLY \$5.99 Reg. Rate: 7 iss. \$8.98	29 ISSUES U.S. NEWS & WORLD REPORT YOU PAY ONLY \$9.97 Reg. Rate: 29 iss. \$12.25
18 ISSUES Field & Stream YOU PAY ONLY \$5.97 Reg. Rate: 18 iss. \$11.93	12 ISSUES Popular Electronics YOU PAY ONLY \$8.97 Reg. Rate: 12 iss. \$13.00	12 ISSUES SPORTS AFIELD YOU PAY ONLY \$7.50 Reg. Rate: 12 iss. \$15.00	12 ISSUES Woman YOU PAY ONLY \$7.50 Newsstand Rate: 12 iss. \$15.00



Magazines At Discount You SAVE up to 50%

Here's your chance for a real bargain bonanza on your favorite magazines. You may select as many as five of these titles at the special introductory rates shown—up to 50% off! To order, mail card or call—Toll-Free 800-247-2160

In Iowa, call toll-free 1-800-362-2860.

Magazines At Discount.

A division of Ziff-Davis Publishing Co., P.O. Box 601, Broomall, Pennsylvania 19008.



“... many speakers have been damaged by amplifiers that are apparently lower-powered than the rating of the speakers.”

cal music does not generally impose such a high power level into the tweeters and midrange units of a system.

In a typical piece of rock music on one system, it was found that, when 35 watts was applied to the system the tweeter received only 1 watt. If we assume that this system was rated at 100 watts on a music signal, then a “safe” test signal of 20 watts could easily destroy the tweeter since it could handle only about 1/35 of 100 watts. This is the first point—*Never* apply sine-wave test signals of more than one or two watts to a loudspeaker system, and never maintain such test signals on a tweeter for more than a few minutes!

Another way of changing the energy content of a music signal is to drive an amplifier into clipping, which immediately produces a disproportionately high average power by reducing the peak-to-average ratio. This is why it is frequently found that loudspeakers have been damaged by amplifiers that are apparently lower-powered than the rating of the loudspeaker. In this context, if high sound levels are frequently desired, and the amplifier power rating is within the limits of the loudspeakers being used, it is a good idea to place a mark on the volume control to represent the maximum “safe” setting. This position is easy to find if an oscilloscope is available (or can be borrowed) because it is the volume level just before clipping sets in on the loudest record in one’s record or tape collection. If an oscilloscope is not available, the setting is more uncertain and should thus be a position of the volume control above which distortion audibly appears on loud piano music.

Other areas of such damage can be an amplifier’s high-frequency instability above the audio range; careless interconnection of components such as tape-deck monitor circuits; and fast wind on certain tape recorders where the tape is near the playback head, producing an unwanted high-frequency signal. The latter problem is easily prevented by *always* remembering to turn the volume to zero when fast

winding. If one wishes to listen while in fast wind to find some section of the tape, the treble control should be turned down to minimum and the volume kept as low as possible.

Finally, one last area of thermal damage to loudspeakers should be explored: continuous, high-level, discotheque music. This type of music should not be played for many continuous hours owing to the severe reduction in thermal overload capacity it causes. Only loudspeakers specifically designed for this type of application are relatively safe to use under these trying circumstances.

Fusing. Fusing is of very limited value in protecting systems against thermal overload. The best type of fuse is one having its own thermal link. To some extent, this allows for both instantaneous high-current overload and a longer-term lower-level current overload. One such series of fuses is the “Fusetron” FNM series, the best value of which should be found by consultation with the loudspeaker manufacturer, if possible.

The problems with fusing a system are multifold. The fuse cannot match the long-term thermal constants of the loudspeaker drive units and, what is more, it can be chosen only for maximum input levels. These occur in the lower midrange where loudspeakers are built to handle the power. However, the vulnerable tweeters remain largely unprotected, so all the other precautions discussed still have to be observed. It is possible to fuse the tweeter individually, of course, to provide much better protection. This, however, will change the frequency response of the system somewhat, as will now be shown.

Let us assume that a typical three-way system is rated as being safe on music program material with amplifiers rated at up to 100 watts rms per channel. This means that the tweeter itself is probably safe with about 3 or 4 watts rms applied. If the system is rated for 8 ohms, the tweeter probably falls to about 6 ohms; for a maximum input of 4 watts, this means a maximum safe current of 0.8 ampere. Such a fuse would have a resistance

of about 0.5 ohm, attenuating the tweeter by about 1 dB. This attenuation is worthwhile if useful fusing protection is deemed necessary.

Finally, a word on a somewhat expensive type of thermal protection which could be (but is not yet, to my knowledge) incorporated at the design stage, especially in powered loudspeakers. The idea of any thermal protection is to prevent the voice-coil from rising above a certain temperature (which can be determined in the design stages). This is best achieved by actually detecting that temperature by continuously monitoring the dc resistance of the voice coil, since this resistance is directly related to temperature. Several less costly systems have been suggested that monitor directly the temperature of a series resistor. The simplest circuit uses a thermal circuit breaker bonded to the resistor. The problem here is that it is impossible to match the highly complex heat-transfer mechanism in the loudspeaker and thus impossible to match the temperature-rise characteristic of the voice coil.

Mechanical Overload. Generally speaking, mechanical overload can be in one of two forms: irreversible damage and cumulative damage. The second form is in the hands of the designer, while the first lies mainly in the hands of the user.

To elaborate, irreversible overload damage can occur when large overload signals cause the woofer cone-coil assembly to “bottom” and the coil and/or cone to buckle. This can be caused by a drastic overload at low frequencies, such as when an organ record is played at an excessively high level. The only real protection against this type of overload damage is plain common sense. Don’t attempt to drive a given loudspeaker beyond its capabilities—a point that is usually easy to detect due to the rapid onset of a high level of audible distortion. It should not be forgotten here, too, that the various units in a system can be driven beyond their capabilities by other, usually brief, signals. For example, dropping a pick-up arm onto a record or causing a stylus to jump by

Special FOCUS on Speakers

jolting the turntable can cause extreme movements in bass units and damage to the voice-coil, especially with very high-powered amplifiers. For similar reasons, if large switching transients occur when controls are changed, care should be taken to turn down the volume before these controls are operated.

The other type of mechanical overload damage is cumulative. It can be produced by work-hardening and eventual fracture of the wires going from the terminal strip to the voice coil on a loudspeaker drive unit. The only answer here lies in the design of the drive unit so that the wires used in this application can withstand continuous flexure. One such type of wire is called tinsel. It's made in multi-stranded form, with the tension being taken by a number of cotton or nylon cores. The only instance in which such precautions do not really apply is in the case of tweeters which operate above about 5000 Hz. Movements here are so small that such work-hardening does not generally occur.

We have covered various areas in which overload can occur and have implied that no single comprehensive protection method exists apart from common-sense precautions. To apply this common sense, however, we need to know what power our loudspeakers can actually handle.

Unfortunately, the foregoing is not simple. Examining loudspeaker specifications will show such power handling terms as: (1) 100 watts rms, (2) 100 watts program material, (3) 100

watts, (4) 100 watts continuous power, and (5) may be safely used with amplifier rated at up to 100 watts rms on normal speech and music program material.

Many other terms may also be found, but only number (5) above or some similar phrasing is of any real value to the consumer. Number (1) may be true at some frequencies but, apart from some specialized speakers, would result in frying the tweeter. Number (2) is not valid either, unless more information is given. For example, does it mean program material not clipping on an amplifier of 100 watts or does it mean an average program material level of 100 watts? The latter would allow full use of an amplifier of about 1000 watts since a typical modern recording has an average-to-maximum power ratio of about 10:1. Number (3) obviously requires more information, and (4) has the same shortcomings as number (1).

The only way out of all this confusion in specifications (if the system is going to be played at high levels) is to get some definitive statement about

the maximum safe amplifier power for a loudspeaker system before purchase. Finally, if high sound-pressure levels *are* required, don't forget that a high-powered speaker does not necessarily play louder than a lower-powered system. Loudness is determined not only by how much power can be put into a speaker before damage ensues, but also by how efficient that speaker system is. For this reason it is possible to double power-handling capability by using two loudspeaker systems per channel. However, twice the power handling means only a 3-dB increase in sound level at maximum safe power, a very expensive way to achieve this 3 dB. Moreover, it should not be forgotten that two loudspeakers in parallel (especially if those systems have impedances of 4 ohms) may provide a dangerously low equivalent impedance for the amplifier being used, whereas putting those same speakers in series may adversely affect woofer damping and produce "boomy" bass. These problems are compounded by much more complex ones of placement, interference patterns, and so on, and become worse if *different* speakers are paired up to improve power handling. The obvious answer is to buy the correct system for the purpose in the first place.

Conclusion. If high sound pressure levels are desired from a home hi-fi system, one should adhere to precautions outlined in this article. In general terms, the average user of high-quality speaker systems will never experience overload damage unless some other part of his system fails and "takes the loudspeaker with it." ◇

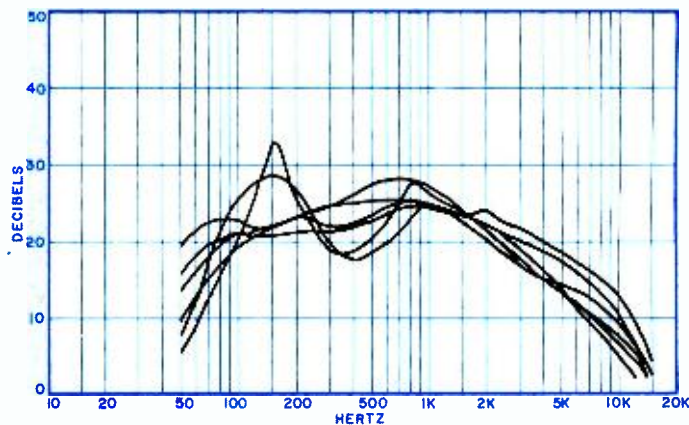

Fig. 5. One-third octave analysis of six rock recordings based on rms levels held for at least five seconds.

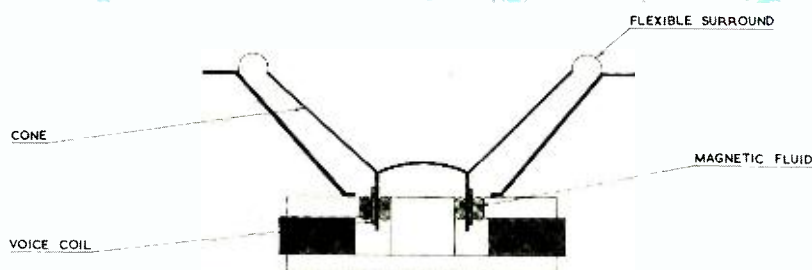

Fig. 4. Cross section of a loudspeaker drive with magnetic fluid to conduct heat across the voice-coil air gap.

Build a Low-Cost Transistor Tester

BY CYRIL C. MILLER

*Tests small-signal, high-power, or phototransistors,
SCR's, FET's and conventional diodes.*

THE SIMPLE, low-cost transistor tester described here can check small- and large-signal as well as medium- and high-power npn and pnp transistors, n-channel FET's, conventional and light-activated SCR's, phototransistors, and diodes. The tester is easy to build and use.

In operation, all you do is insert the device to be tested into a socket, press a TEST button, and observe a meter. A three-conductor cable is used for testing devices that are too large for the tester's sockets. There is no power switch because the circuit consumes very little power, which also means that a device under test cannot be damaged by test conditions.

The circuit for the transistor tester is shown in the schematic diagram.

Construction. The tester can be assembled in a 5" × 2.5" × 1.5" (12.7 × 6.4 × 3.8 cm) plastic case with an aluminum cover. Neither parts location nor wiring is critical.

The meter movement, four sockets, and three switches can be mounted on the cover. Wire sockets SO1 and SO2 to accommodate the two different basings commonly used for small transistors and wire SO3 to accommodate a three-conductor cable to test devices that do not fit the sockets. Socket SO4 is used for high-power transistors. Point-to-point wiring, using terminal strips, can be used to assemble the project.

A satisfactory substitute for the meter movement specified in the Parts List is Radio Shack's No. 22-051, a 50- μ A movement with the same characteris-

tics. However, this meter is slightly larger and may require a larger case for the project. A 100- μ A meter movement can be used if the value of R3 is changed to 10,000 ohms. Alternatively, a 1-mA movement can be used if the value of R3 is changed to 1000 ohms and the value of R5 is changed to 220 ohms. (Bear in mind that some loss in sensitivity may occur with these changes.)

Use insulated material between SO4 and the metal cover of the case. (The metal cases of power transistors are the collector terminals.) Also, use low-profile fillister-head screws for mounting the socket so that, when a power transistor is plugged into SO4, its base and emitter pins will fit the socket and its case will make the collector's electrical connection. Before mounting SO4, be sure the base and emitter pin openings in the cover plate are large enough to prevent the transistor's pins from shorting to the metal plate.

Any type of lettering can be used to label the switches and sockets. The single AA cell that supplies power for the circuit should be mounted in a battery holder affixed to the bottom of the plastic case.

External test leads can be fabricated from lengths (about 7") of color-coded stranded hookup wire. Solder a miniature insulated alligator clip to one end of each wire and a plug that mates with SO3 to the other ends of the wires. (In the prototype, a conventional transistor socket was used for the plug. The socket pins were removed and the ends of the three test leads were tinned with solder to serve as pins. The stiff wires were inserted into the socket from the top until

they protruded to conventional transistor pin length. A short length of heat-shrinkable tubing was then used to secure the three leads to the socket.)

Calibration. Install the AA cell, but do not secure the cover to the case until R4 has been adjusted. Insert the test cable into SO3 and connect a 1000-ohm resistor between the collector and emitter clips of the test cable. With S1 set to LOW (S2 can be in either position), the meter's pointer should swing to approximately half-scale. With S1 in the HI position, very little deflection should occur. Return S1 to its LOW position and remove the resistor.

Short together the emitter and collector alligator clips while adjusting potentiometer R4 until the meter's pointer swings to full scale. Setting S1 to HI should keep the pointer at full scale.

Switch S2 can be checked for proper operation by inserting an npn or pnp transistor known to be good into the proper socket, noting which leads are for the base, collector, and emitter. With S2 set to the appropriate position, press S3 (TEST); you should observe a significant increase in meter pointer deflection. If the pointer does not swing up-scale, S2 is probably reversed; in which case, either relabel the switch or rotate the switch by 180°.

This completes calibration. Fasten the cover in place.

Operation. Semiconductors can be checked as detailed in the Table. If you are uncertain whether a transistor under test is npn or pnp, set S2 to its alternate

TESTING PROCEDURES

Device to be tested	Socket	S1	S2	Initial meter indication	Test indication	Remarks
Small-signal pnp transistor	1	LOW	PNP	Low	Increase	Socket 1 for EBC, 2 for BCE
Small-signal npn transistor	1	LOW	NPN	Low	Increase	Socket 1 for EBC, 2 for BCE
Medium-power transistor	1	LOW	As required	Low	Increase	
High-power transistor	4	HI	As required	Low	Increase	
N-channel FET	1	LOW	PNP	Low	Increase	
SCR	1	LOW	As required	Low	High	SCR will lock on. S1 or S2 to opposite position to unlock.
Light-activated SCR	2	LOW	As required	Low	Not required	Expose to strong light to test.
Photo transistor	1	LOW	As required	Low	Not required	Expose to moderate light to test.
Diodes*	Test leads	LOW				

*Use external test cables. Observe meter indication. Flip S2 to opposite side. Note second meter indication. One indication should be high, the other low.

positions and press TEST in both cases. The position of S2 in which an up-scale meter pointer deflection is obtained identifies the transistor type.

Note that the initial meter indication in the Table is always low. If it is high, set S2 to its alternate position. If a high indication persists, the device under test is defective. If a low indication is obtained, press TEST and note the up-scale deflection of the meter's pointer. Since the me-

ter is not calibrated in absolute values, it will be necessary to test several devices of known characteristics to gain familiarity with meter indications.

In addition to checking semiconductors, the tester can be used to determine the condition of electrolytic capacitors ranging in value from several microfarads to several thousands of microfarads. To do this, connect the capacitor to the collector and emitter alligator

clips of the test cable and observe the meter. If the capacitor is shorted, the meter's pointer will swing fully up-scale and remain there. With a good capacitor, the pointer will initially swing far up-scale and then slowly return to a low value at a rate proportional to the capacitor's value.

To test SCR's, connect them to the correct socket or test leads and note the meter's indication. When the TEST switch is pressed, the meter's pointer should swing to full-scale. This high indication should remain until either S1 or S2 is switched to its alternate position. When testing a light-activated SCR, a low indication should be obtained when the SCR is in the dark, and a full-scale indication should be obtained when the LASCR is exposed to bright light. The TEST switch is not required here. The same approach is used for testing phototransistors. (The tester can also be used as a crude lightmeter when testing phototransistors.)

To test a diode, connect it between the collector and emitter alligator clips on the test cable. There is no need to observe polarity. Note the meter indication; the pointer will swing up-scale when the diode is forward biased and down-scale when it is reverse biased. Set S2 to the alternate position; the meter's pointer should swing in the opposite direction. The ratio between the two indications is determined by the diode's resistance ratio.

In Conclusion. The simple transistor tester described here can help you to quickly test bipolar transistors and separate them according to type. As a bonus, you can test n-channel FET's, SCR's, diodes, and even the condition of electrolytic capacitors can be checked. ◇

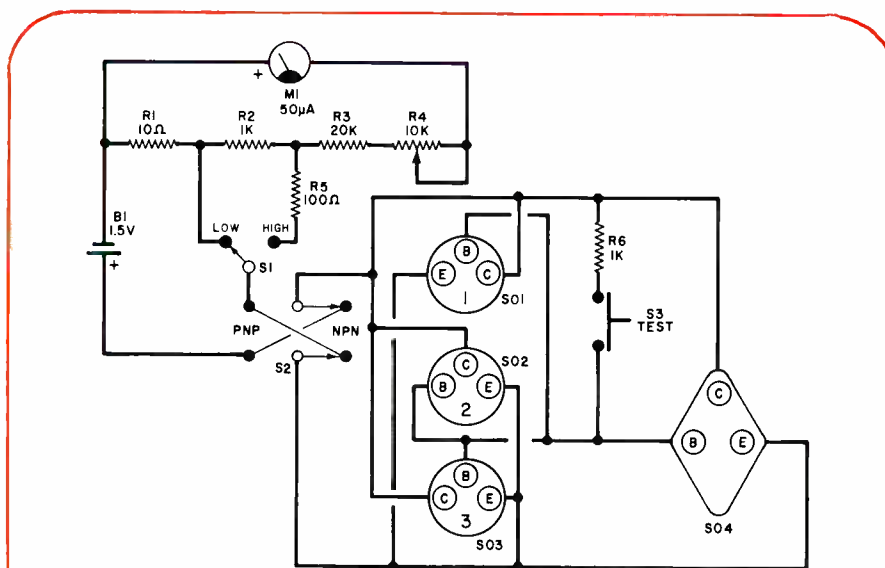

Test circuit is simple to build and use with Table above as guide.

PARTS LIST

- B1—1 5-volt AA cell
- M1—50- μ A meter movement (see text)
- R1—10-ohm, 1/2-watt resistor
- R2, R6—1000-ohm, 1/2-watt resistor
- R3—20,000-ohm, 1/2-watt resistor
- R4—10,000-ohm linear-taper potentiometer
- R5—100-ohm, 1/2-watt resistor
- S1—Spdt switch
- S2—Dpdt switch

- S3—Miniature normally open pushbutton switch
- S01, S02, S03, S04—Transistor socket (see text)
- Misc.—Plastic case with aluminum cover (see text); penlight-cell holder; power-transistor mounting kit; insulated miniature alligator clips (3); terminal strips; 1000-ohm resistor (for calibration); machine hardware; color-coded stranded hookup wire; solder; etc.

Simple circuit triggers electronic system to close garage door after selected time period.

AN AUTOMATIC GARAGE-DOOR CLOSER

THE STANDARD electrically powered radio-controlled garage-door opener has a drawback. It can be falsely triggered by a CB or amateur radio transmitter or other actuating signal, or the user can forget to send a signal command to close the door. In either case, an open garage door could invite thieves to remove valuable equipment—bicycles, lawn mowers, etc. The "Auto Closer" described here overcomes this problem. It automatically commands the system to close the door after a preselected time interval, providing improved security and convenience. The automatic function can be disabled by the user, too, in the event that it is desirable to keep the garage door open.

About the Circuit. The Auto Closer is shown schematically in Fig. 1. Switch *S1* is the door-position sense switch; it remains open as long as the garage door is closed. The open switch prevents the Auto Closer circuit from drawing current from the power supply and keeps it isolated from the rest of the door opener circuit. When the sense switch closes as the door opens, 24 volts ac from the main opener power supply is applied to the Auto Closer. Diode *D5* rectifies the ac into pulsating dc which is filtered by *C1* and *R3*. Zener diode *D1* provides +15 volts regulated for *IC1*, a CMOS 4020 14-stage binary counter.

When power is first applied to the Auto Closer, *R1* and *C2* momentarily keep pin 11 of *IC1* high, ensuring that the counter is reset as the timing cycle begins. A 60-Hz signal from the opener power supply is coupled by *R2* to the counter's clock input. This clocking signal is peak limited by diodes *D2* and *D3*, thereby protecting the counter IC from

excessive input levels. The outputs of the twelfth, thirteenth and fourteenth counter stages are available at pins 1, 2, and 3, respectively. When the counter is clocked by a 60-Hz signal, the periods of the square waves at these three outputs are 68 seconds (pin 1), 136 seconds (pin 2) and 272 seconds (pin 3). Each output is high for one-half of its square-wave period.

The time interval that the Auto Closer will hold the door open before automatically closing it is selected by connecting *R4* to one of the output pins of *IC1*. If, for example, *R4* is connected to pin 1, no base current will flow into *Q1* for 34 seconds and the garage door will remain open. At the end of that time, pin 1 will go high and source base current for *Q1* through *R4*. When *Q1* begins to conduct, the coil of reed relay *K1* becomes energized.

This causes the contacts of *K1* to place diode *D4* across the 24-volt ac line. The negative half-cycle of the ac control input is shorted out by the diode. This not only triggers the control circuit to close the door, but also allows the Auto Closer circuit to remain active until the door closes far enough to reopen sense switch *S1*. Capacitor *C3* is connected across the coil of *K1* to keep the relay from chattering and to protect *Q1* from inductive transients. When *S1* reopens, *R5* discharges the Auto Closer capacitors and effectively resets the circuit after a few seconds to ready it for another cycle. Output switch *S2* allows you to keep the garage door open for extended periods of time by effectively deactivating the Auto Closer.

Two other time periods are available. If *R4* is connected to pin 2, the garage door will be closed after 68 seconds

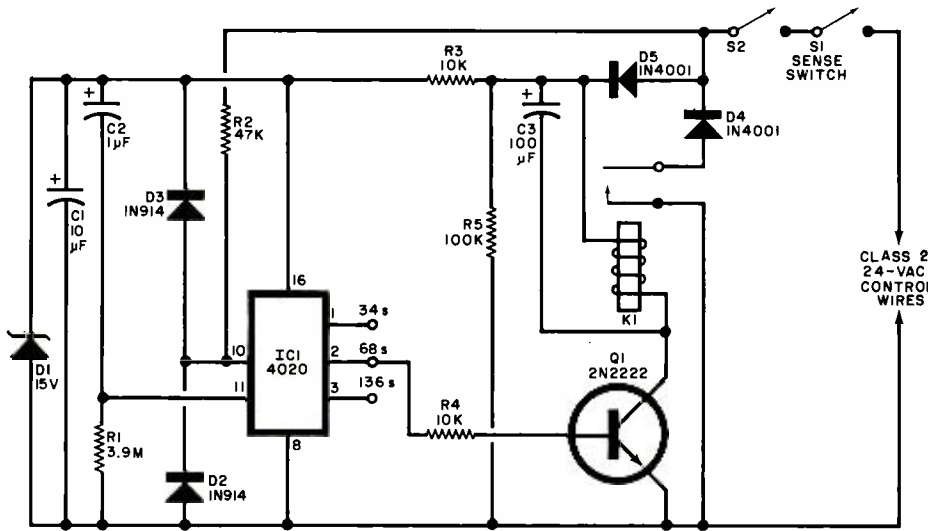

Fig. 1. Schematic of circuit. CMOS counter IC1 develops the delay interval from the 60-Hz line frequency.

PARTS LIST

- C1—10- μ F, 25-volt electrolytic
 - C2—1- μ F, 25-volt electrolytic
 - C3—15- μ F, 25-volt electrolytic
 - D1—15-volt, 400-mW zener diode
 - D2, D3—1N914 switching diode
 - D4, D5—1N4001 rectifier
 - IC1—CD4020 or MC14020 14-stage CMOS ripple counter
 - K1—12-volt reed relay (Arrow-M DA-1A or equivalent)
 - Q1—2N2222 npn silicon switching transistor
- The following are 1/4-watt, 10% tolerance carbon-composition fixed resistors:
- R1—3.9 megohms
 - R2—47,000 ohms
 - R3, R4—10,000 ohms
 - R5—100,000 ohms

- S1—SPST spring-loaded, normally open lever switch or other suitable door sense switch (see text)
 - S2—SPST toggle switch
- Misc.—Printed circuit or perforated board, IC socket or Molex Soldercons, suitable enclosure, hookup wire, solder, machine hardware, etc.
- Note.—The following are available from William Vancura, 4115 35th Avenue, Moline, Illinois 61265: kit of parts, less enclosure and switches \$15 plus \$1 postage and handling; 12-V reed relay, \$5 plus \$1 P&H; etched and drilled pc board, \$4 with SASE.

have elapsed. Connecting the resistor to pin 3 results in a 136-second delay. The latter interval is enough time for one person to move two cars out of the garage and into the driveway. A delay of 68 seconds is enough time to open the trunk, place a package in it, close the trunk, enter the car, buckle up, start the car once or twice and coax the car into the driveway. A 34-second delay is ideal for an efficient individual who moves quickly but is a cautious driver. Any time delay less than 34 seconds increases the possibility of hitting the door.

The Door Opener. A typical garage door opener employs a "Class 2" wiring system. Basically, this means that the control system comprises a low-voltage supply (usually 24 volts ac derived from a step-down transformer), a control relay which applies power to the motor, and one or more activating switches. The low-voltage power supply cannot cause any serious accidental shocks and permits the use of relatively inexpensive bell wire in connections to the activating switches and relay. A typical system schematic is shown in Fig. 2.

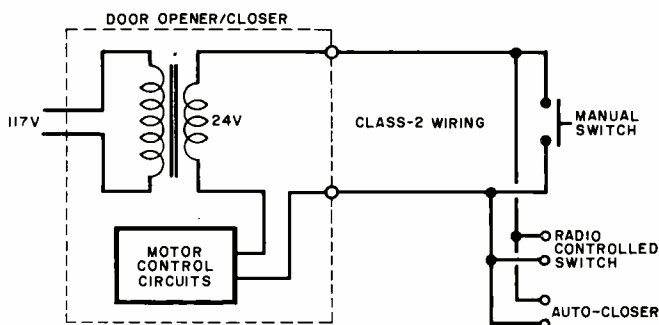

Fig. 2. Class 2 wiring of a typical garage door opener.

Several activating switches can be and usually are wired in parallel across the opener's control input terminals. The system schematic shows a manual pushbutton switch, a radio-controlled switch, and the Auto Closer so connected. Normally, the control circuit is designed to be able to supply power to several low-power switching devices via the Class 2 control wiring itself. This is how both the Auto Closer and radio-controlled switch's receiver are powered.

Construction. Wire-Wrap, point-to-point or printed-circuit techniques can be employed in the construction of the Auto Closer. Parts placement and lead dress are not critical. Although the printed circuit board (see Fig. 3) has been designed to accommodate a reed relay, a perf-board version of the project could use a standard low-power relay such as the Radio Shack No. 275-003.

In any event, use an IC socket or Molex Soldercons with the CMOS counter. Do not insert the IC into its socket at this time. Select the delay period suitable for your application and connect the lead of R4 to the corresponding pin of the IC socket. Be sure to observe polarities and pin basing of semiconductors and electrolytic capacitors.

The Auto Closer should be housed in a metallic or plastic enclosure approximately 4" x 2 1/4" x 2 1/4" (10.2 x 5.7 x 5.7 cm). An on/off switch (S2) should be mounted on the enclosure if a remote power switch is not used. The mounting of the sense switch depends on how the door-open condition is to be sensed. One possibility is to install the switch in the Auto Closer enclosure and attach a lever arm to it. The arm can be extended to the door to sense the door-up position. Alternatively, you can replace the travel-limit switch of the motor control circuit with one that has an extra set of contacts. The normally open contacts can be used as sense switch S1.

If your garage door opener applies low voltage dc across the control lines instead of 24 volts ac, the Auto Closer circuit should be modified as follows. Replace Q1, C3, D4 and K1 with a 1-ampere SCR. The anode of the SCR should be connected to the anode of D5 and the pole of S2. The cathode should be connected to pin 8 of IC1, the bottom leg of R5, etc. The gate should be connected to R4, whose value and that of R3 should be changed to 1000 ohms. Instead of connecting one end of R2 to the D5S2 node, apply 60-Hz CMOS-compatible square waves between it and pin

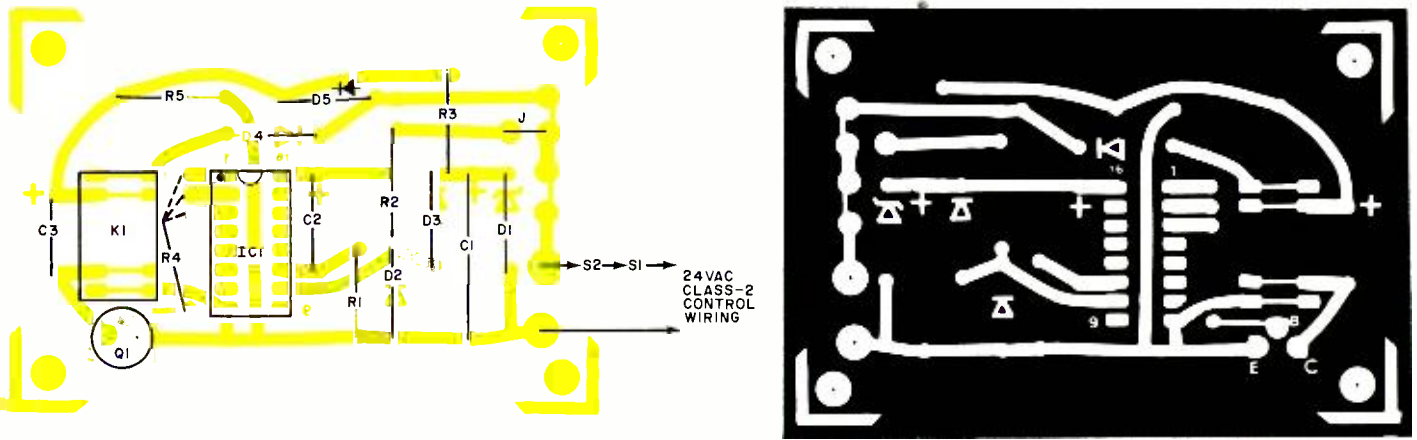

Fig. 3. Etching and drilling and parts placement guides for a suitable pc board.

8 of IC1. Zener diode D1 can be eliminated if the dc control voltage is greater than (or equal to) 12 volts and less than 15 volts.

Checkout. After the Auto Closer has been assembled, but before the CMOS counter has been installed in its socket, temporarily connect one end of a convenient length (about 4 to 6 feet or 1.2 to 1.8 m) of hookup wire to pin 8 of the IC socket. Connect one end of a similar length of hookup wire to the anode of D5. Next, attach the two free ends to the Class 2 control wiring of the garage door opener and measure the ac voltage between the anode of D5 and pin 8 of the IC socket. You should obtain a reading of about 24 volts. Measure the dc voltage between pins 16 and 8 of the IC socket. It should be about +15 volts. Finally, measure the voltage between pins 10 and 8. The meter should read about +15 volts in the dc mode and slightly more in the ac mode. If you have an oscilloscope, look at the signal waveform. You should see a sine wave clipped at 0 and 15 volts.

Momentarily clip a jumper between

pins 16 of the IC socket and that to which R4 is connected. The relay coil should become energized and the door opener activated. Removing and replacing the jumper should cause the door opener mechanism to reverse its direction. If the relay chatters while the jumper is connected, the door will jerk back and forth and the Auto Closer will not reliably close the door. This problem can be caused by a defective C3 or one with insufficient capacitance.

When the Auto Closer is working reliably, it is time to install IC1 in its socket. The normal precautions should be taken when handling this CMOS device. Disconnect the Auto Closer from the Class 2 wiring and place the circuit board on a 10" x 10" (25.4 x 25.4 cm) sheet of aluminum foil. Also, place the IC (still in its protective foam carrier) and both hands on the foil, which should be grounded. Keeping the heels of both hands on the foil, remove the IC from its protective carrier and insert it into the socket, paying close attention to pin locations. Then permanently install the circuit board in the project enclosure. Reconnect the Auto Closer to the Class 2 control wiring.

If all is well, the door (after having been opened) will begin to close only after the selected delay has elapsed. When the door begins to close, momentarily disconnect the Class 2 control wires from the Auto Closer so that the relay drops out. Each time the Auto Closer is disconnected, the counter will reset itself. Complete the wiring of the sense and power switches and verify the operation of both.

Installation. The Auto Closer is now ready for permanent installation. If a remote sense switch is used, the Auto Closer can be mounted in any convenient location. Just be sure that the control and sense switch wires are positioned so that they do not interfere with the proper operation of the door opener mechanism.

Two methods of mounting an Auto Closer equipped with a built-in lever sense switch are shown in Figs. 4A and 4B. The latter installation is less sensitive to minor variations in the stopping position of a door riding on tracks beside the sense switch lever. A slight bend at the tip of the lever arm prevents the door from snagging and damaging itself. The mounting method shown in Fig. 4B allows the project enclosure to be mounted easily on the door track using a 4" (10.2-cm) hose clamp. The ceiling mount (Fig. 4A) will work equally well with either a single-piece trackless door or a multi-section tracked door.

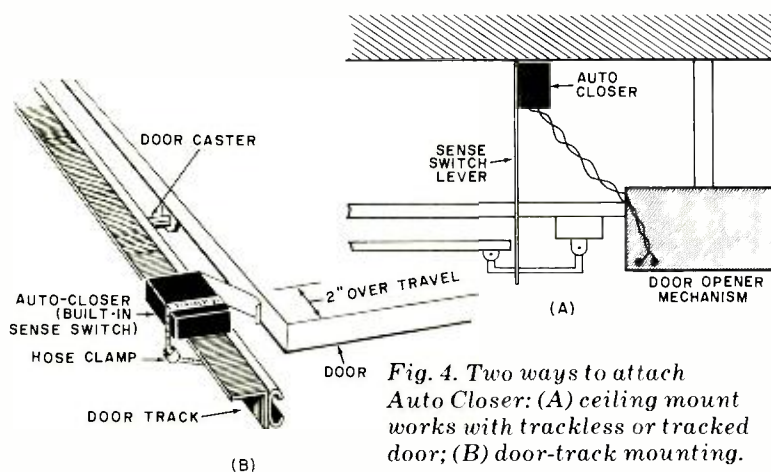

Fig. 4. Two ways to attach Auto Closer: (A) ceiling mount works with trackless or tracked door; (B) door-track mounting.

In Conclusion. You will surely find the Auto Closer to be a great convenience and an effective security device. Keep in mind, however, that you can very easily lock yourself out of the house should you forget your keys, the opener's pocket transmitter, or to disable the Auto Closer! ◇

What is the voltage?

BY THOMAS R. FOX

A stimulating educational quiz on the voltage regulating characteristics of common electronic components.

AS NEARLY every electronics hobbyist knows, the zener diode is an extremely useful component. Nearly all regulated power supplies, including those using IC voltage regulators, are built around one or more zener diodes. (Most IC regulators have internal zener diodes.) The voltage-versus-current curve for an ideal 6.7-volt zener diode is shown in Fig. 1. The rather unusual appearance of this graph is due to the fact that a zener diode is usually reverse biased. By convention, both the voltage across and the current through the diode are negative.

This graph tells us that the ideal zener acts like a voltage source with zero ohms of internal impedance whenever the voltage applied across it equals or exceeds its zener voltage, which for this diode is 6.7 volts. The diode does not allow the voltage applied across it by an

external source to exceed its zener voltage. Real-life zeners do exhibit a very slight increase in voltage as more current flows through them. This is the result of a small amount of internal "bulk" resistance.

Although zener diodes are probably the best known components endowed

with this voltage regulating ability, many others exhibit this same characteristic. Most other components, however, are only fair-to-poor voltage regulators and are infrequently used in this application. For physical reasons, diodes cannot be manufactured with zener voltages less than two volts. Accordingly, to obtain low regulated voltages, other components must be used even though they are far from ideal regulators.

The following quiz tests your knowledge of the voltage regulating characteristics of some common electronic com-

ponents. A few rare species have been thrown in to make the quiz a bit more stimulating. The basic test circuit is shown in Fig. 2.

To simplify matters, several assumptions will be made. . . .

- The battery symbolizes a 100-volt regulated power supply.
- The resistance of power resistor R varies from one circuit to the next so that the magnitude of the current flowing through a component is "typical" for the particular device. Also, the resistance of R is great enough so that the maximum ratings of the component are not exceeded.
- The voltmeter has an input impedance of 1000 megohms and can be neglected in most cases.
- Unless otherwise noted, all components are at room temperature (68-77 °F, 20-25 °C).

TABLE OF VOLTAGES

100 V	97.85 V
2 V	0.2 V
14 V	6.7 V
0 V	0.7 V
0.13 V	50 V
24.6 V	0.35 V
12 V	3.3 V
1.0 V	1.4 V

60 V

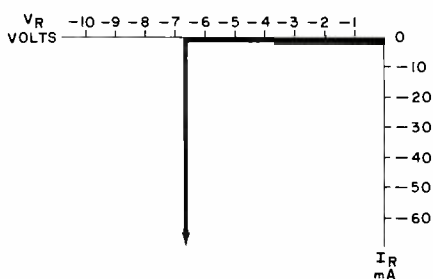

Fig. 1. V-I curve of an ideal 6.7-volt zener diode.

ponents. A few rare species have been thrown in to make the quiz a bit more stimulating. The basic test circuit is shown in Fig. 2.

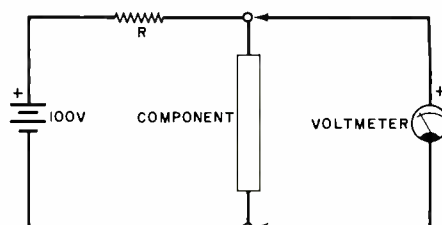
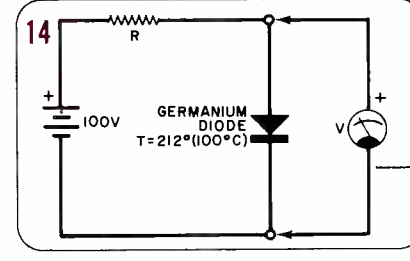
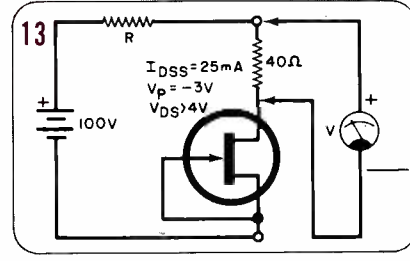
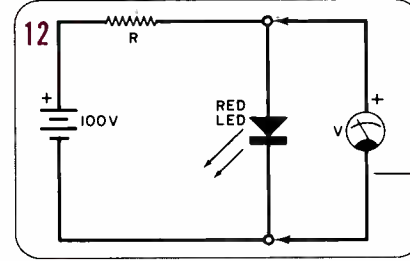
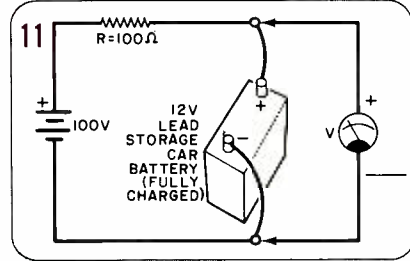
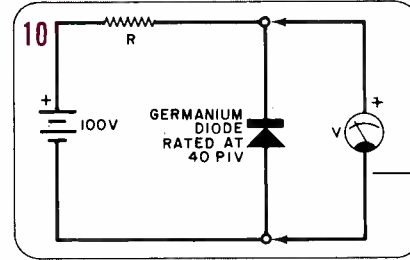
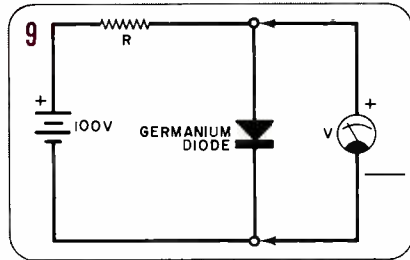
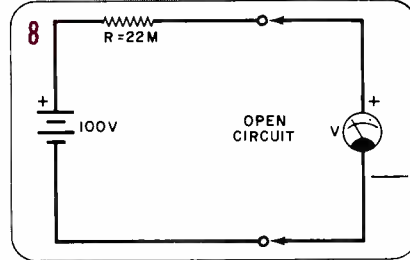
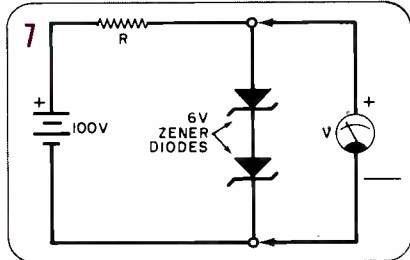
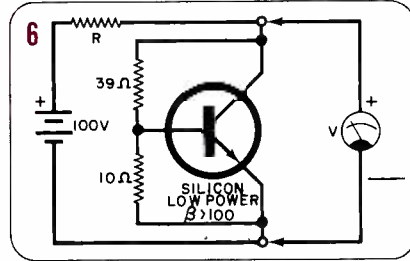
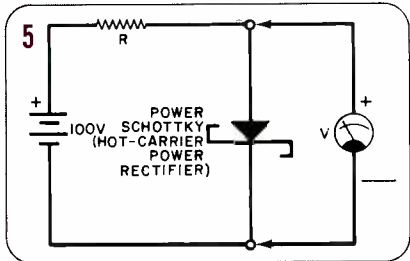
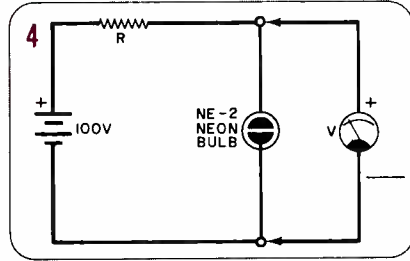
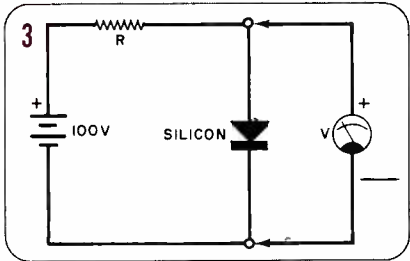
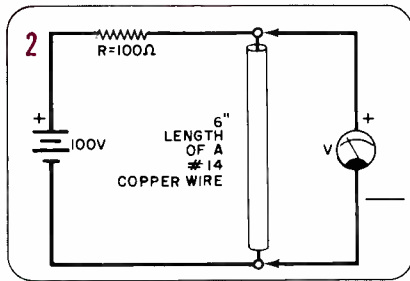
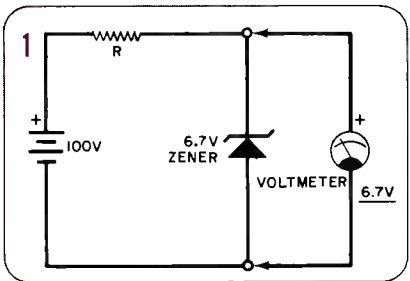

Fig. 2. Basic quiz circuit.



ANSWERS TO ZENER VOLTAGE QUIZ

Circuit 14	0.2 V
Circuit 13	1.0 V
Circuit 12	2 V
Circuit 11	14 V
Circuit 10	50 V
Circuit 9	0.35 V
Circuit 8	97.85 V
Circuit 7	1.4 V
Circuit 6	3.3 V
Circuit 5	0.13 V
Circuit 4	60 V
Circuit 3	0.7 V
Circuit 2	0 V

- All diodes are conducting relatively low forward currents (approximately 1 mA) unless specified otherwise. The LED in Circuit 12 is operated at "normal" current levels to achieve "normal" brightness.

- The specific voltages listed in the Table are approximate.

To take the quiz, examine each of the 14 circuits and estimate the voltage indicated by the voltmeter. Next, refer to the 17 voltages listed in the Table and select the value closest to the voltage you think the voltmeter will indicate. Finally, write this voltage on the line next to the voltmeter. As an extra challenge, three of the voltages in the Table will not correspond to any of the circuits.

Example: Refer to Circuit 1. Assuming that the resistance of R is chosen so that approximately one-half of the maximum recommended current flows through the zener diode, it is obvious that the voltmeter will read 6.7 volts (the diode's zener voltage). Remember—the maximum current rating of the device and the exact resistance of R is not important; that the value of R is chosen so that the device exhibits its typical operating characteristics is important. The voltage in the table that is closest to 6.7 volts is 6.7 volts. Thus, we have written 6.7 volts on the line next to the meter. What the author has chosen as the best answers are given after the circuits. ◇

BUILD THE "SUPER MARKER"

Inexpensive marker generator with selectable 100-, 50-, 20-, or 10-kHz output allows precise tuning of shortwave receivers.

A STABLE source of marker frequencies is one accessory that belongs in every shortwave listener's shack. Many receivers contain built-in 100-kHz calibrators, but for exact tuning, smaller marker increments are required. The Shortwave Super Marker described in this article is an inexpensive, easily built frequency standard that will provide precise markers at selectable increments of 100, 50, 20, or 10 kHz. Built around a quartz crystal, two npn transistors, and a CMOS divider IC, the project can be assembled in two hours or less. Total parts cost is about \$15.

About the Circuit. Transistor Q1, the quartz XTAL and their associated components comprise a stable 100-kHz oscillator. Trimmer capacitor C1 allows the

user to zero-beat the oscillator against a frequency source of known accuracy such as radio station WWV or WWVH. The 100-kHz output of the oscillator is applied to pin 14 of IC1, the clock input of a CD4017 CMOS decade counter/divider with ten decimal outputs.

Depending on the position of S1, the RESET terminal of IC1 is either grounded or connected to one of three decoded decimal outputs. When the RESET terminal (pin 15) is grounded, IC1 functions as a ÷10 counter and a 10-kHz pulse train appears at pin 2. If pin 15 is connected to pin 1, the counter resets itself every 5 clock pulses and a 20-kHz pulse train is developed. Connecting pin 15 to pin 4 causes the counter to reset after every second clock pulse. The counter then acts as a ÷2 stage and produces a

50-kHz output. When pin 15 is connected to pin 2, the counter resets itself on the negative edge of each clock pulse, acting like a ÷1 stage and producing a 100-kHz pulse train at pin 2.

Transistor Q2 and its associated components comprise an amplifier which is driven by the programmable counter's output pulses. This stage amplifies the harmonics of the fundamental pulse train frequency so that they are of usable strength up to 30 MHz. Accordingly, if S1 is placed in the 100-kHz position, the user will hear marker signals every 100 kHz as he tunes across the dial of his general-coverage receiver. Successively higher-order harmonics will be increasingly weaker, but usable markers will be found to at least 30 MHz, the upper limit of most receivers.

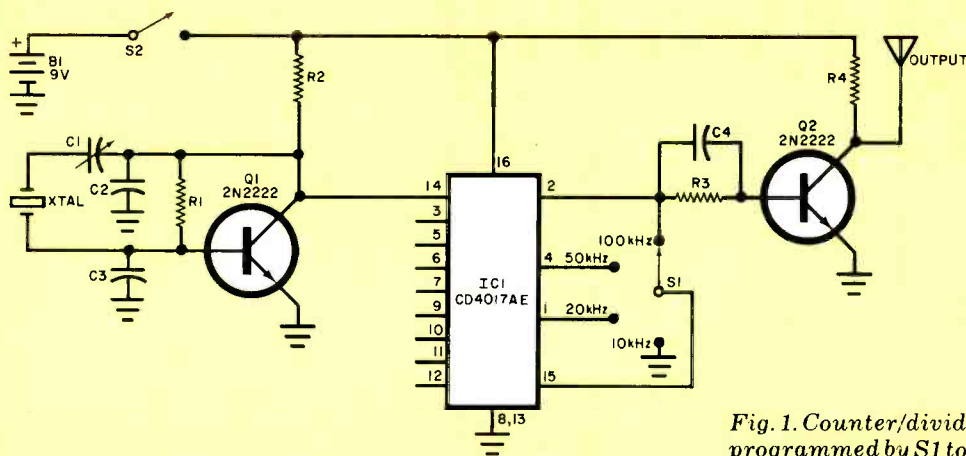

Fig. 1. Counter/divider IC1 can be programmed by S1 to provide marker frequencies at selected intervals.

PARTS LIST

B1—9-volt transistor battery
 C1—7-to-45-pF trimmer
 C2,C3—0.001- μ F disc ceramic
 C4—50-pF disc ceramic
 IC1—CD4017AE CMOS decade counter/divider with decoded decimal outputs
 Q1,Q2—2N2222 npn silicon transistor

The following are 1/4-watt, 10% tolerance fixed carbon-composition resistors:
 R1—150,000 ohms
 R2,R3—8200 ohms
 R4—5600 ohms
 S1—1-pole, 4-position nonshorting rotary switch

S2—Spst toggle switch
 XTAL—100-kHz quartz crystal
 Misc.—Molex Soldercons or IC socket, printed circuit or perforated board, suitable enclosure, battery holder and clip, hookup wire, machine hardware, circuit board standoffs, solder, etc.

Construction. Parts placement is not critical, so printed circuit or point-to-point perforated board techniques can be employed. The use of an IC socket or Molex Soldercons is recommended for mounting the CMOS device. Carefully observe the standard precautions when handling the CMOS device and pay attention to the pin basing of both the IC and transistors. Any four-position rotary switch can be used for *S1*. If you already have a switch with more than four positions, you can use it in the circuit if the extra positions are grounded.

The output antenna shown in the schematic is simply a length of hookup wire that can either be wrapped around the antenna lead-in (if a single wire feed is used) or physically placed close to the r-f input stage. No direct connection between the Super Marker and receiver is required. The project can be housed in any small enclosure or even mounted inside the receiver if space is available. For simplicity, a 9-volt battery is used as the power source. However, a small well-filtered, line-operated supply can be used instead. A third alternative is to tap the receiver's dc supply or, if the project is to be used with an older tube-type receiver, the ac filament voltage can be rectified, filtered and zener regulated.

Calibration. Tune your receiver to WWV or WWVH at 2.5, 5, 10 or 15 MHz. With the Super Marker's antenna coupled to the input of the receiver and switch *S1* in the 100-kHz position, close power switch *S2*. You should hear both the NBS transmission and an audio tone whose pitch will vary as trimmer capacitor *C1* is adjusted. If you don't hear the audio tone, increase the coupling between the Super Marker's antenna and the receiver input.

Carefully adjust *C1* so that the audio tone decreases in pitch and becomes a "flutter" on the NBS transmission. Ideally, *C1* should be set for a zero beat. That is, the marker and r-f carrier are at exactly the same frequency and no beat note is created. Adjust the trimmer capacitor during the portions of the WWV or WWVH transmission when only second ticks and no continuous audio tone superimposed on the ticks are heard. Otherwise, you may zero beat the marker to the modulating tone instead of the r-f carrier.

A nonmetallic screwdriver, alignment, or neutralization tool should be used when making these adjustments. Even so, you might find that the presence of the tool and/or your hand will affect the

oscillator's frequency. Withdraw the tool and your hand between adjustments to ensure that a true zero beat has been obtained.

It's a good idea to drill a hole in the project enclosure so that *C1* can be adjusted after the enclosure has been "buttoned up." This will minimize the detuning effects of hand, tool and even enclosure capacitance. Also, this hole will enable you to periodically touch up the adjustment of *C1* without having to remove the top of the enclosure.

Use. Turn on the receiver's bfo and tune up the band until another marker is encountered. (Don't confuse a broadcaster's carrier with a marker. Open and close power switch *S2*. The marker tone should appear and disappear as power is applied to and removed from the circuit.) Note the frequency indicated on the dial and tune back to WWV or WWVH. Next, place *S1* in the 50-kHz position and tune up the band until you encounter a marker. The dial frequency should be midway between that of WWV or WWVH and the previously noted marker frequency. With *S1* in the 20-kHz position, you should detect five markers—one at the NBS station's frequency, one at the previously noted marker frequency, and three spaced evenly between the two. In the 10-kHz mode, the Super Marker should generate ten evenly spaced markers across this 100-kHz band segment.

The Super Marker will allow you to tune your receiver very precisely even if its tuning mechanism and dial are less than optimum. Let's assume that a weak DX station you've been chasing is listed as transmitting on 15.370 MHz. Tune your receiver to WWV or WWVH and turn on the Super Marker. Place *S1* in the 100-kHz position, turn on the receiver's bfo and tune up three markers to 15.300 MHz. Place *S1* in the 50-kHz position and tune up one marker to 15.350 MHz. Next, place *S1* in the 10-kHz position and tune up two markers and open *S2*. Your receiver is now tuned to exactly 15.370 MHz. If propagation conditions are favorable, you'll hear the station with no need for further tuning.

If the desired station is transmitting at, say, 15.380 MHz, the procedure is less complicated. After tuning to 15.300 MHz, place *S1* in the 20-kHz position and tune up four markers to exactly 15.380 MHz. You can develop your own tuning procedures after you have logged some time practicing with the Super Marker. ◇

FREE SWTH

CATALOG

**Audio—Computers
Instruments
Kits & Assembled**

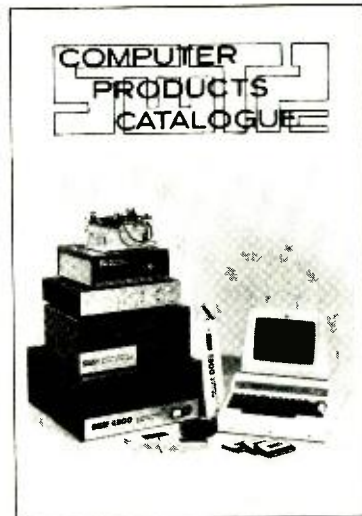

Southwest Technical Products Corporation
219 W. RHAPSODY
SAN ANTONIO, TEXAS 78216

CIRCLE NO. 50 ON FREE INFORMATION CARD

ISO-TIP

**cordless
soldering
iron for
heavy-use
applications.**



**Complete
recharge in an
hour;**

**partial recharge
for use in a
few minutes.**

Up to 125 electronic joints or more per charge. Low voltage, battery powered, ground free isolated tip design. Ask your electronics dealer.

16 snap-in tips
to fit any job
plus a PC Drill.

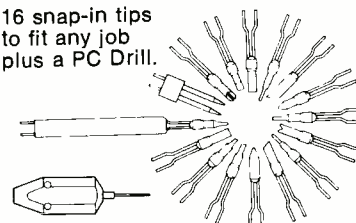

WAHL CLIPPER CORPORATION
Originators of Practical Cordless Soldering
Sterling, Illinois 61081 • (815) 625-6525
"Manufacturing Excellence Since 1919"
CIRCLE NO. 56 ON FREE INFORMATION CARD

McIntosh

"A Technological Masterpiece ..."



McIntosh C 32

"More Than a Preamplifier"

McIntosh has received peerless acclaim from prominent product testing laboratories and outstanding international recognition! You can learn why the "more than a preamplifier" C 32 has been selected for these unique honors.

Send us your name and address and we'll send you the complete product reviews and data on all McIntosh products, copies of the international awards, and a North American FM directory. You will understand why McIntosh product research and development always has the appearance and technological look to the future.

Keep up to date.
Send now - - -

McIntosh Laboratory Inc.
Box 96 East Side Station
Binghamton, NY 13904

Name _____

Address _____

City _____ State _____ Zip _____

If you are in a hurry for your catalog please send the coupon to McIntosh. For non-rush service send the Reader Service Card to the magazine.

CIRCLE NO. 58 ON FREE INFORMATION CARD

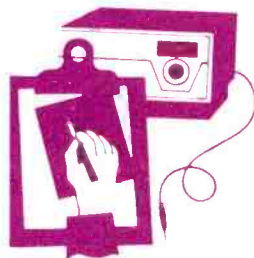

Product Test Reports

Ohio Scientific Superboard II Computer



Photo by John Kane

Single-board unit has 4K of RAM, and on-board BASIC in ROM

BACK IN 1975, we built our first microcomputer and had to pay almost \$350 for the microprocessor chip alone. Adding 4K of memory, an I/O port, and some means of entering the BASIC brought the price up to almost \$1000. Things have changed a lot in four years. Microprocessor chips are selling for a fifteenth of the price (often even less) than they did at the outset. Just about everything else having to do with personal computers has also dropped considerably in price. Still, one usually expects to pay more than \$500 for a minimum "appliance" personal computer. It comes as a pleasant surprise, then, that Ohio Scientific's (1333 Chillicothe Rd., Aurora, OH 44202; Tel: 216-562-3101) Superboard II is priced at a very modest figure of \$279.

The Superboard II is a single-board wired and tested computer that comes with 4K of RAM (expandable on-board to 8K), a 53-key upper- and lower-case keyboard, a Kansas City tape interface, a machine-language monitor in ROM, and 8K Microsoft BASIC in ROM.

The Superboard II is a "basic" computer. It comes without case and power supply. A complete version is the Chal-

lenger IP, which comes wired and tested with a power supply and case for \$349.

General Description. Built around a 6502 microprocessor chip, the Superboard II also contains 1K of dedicated memory for video besides having 4K of user memory. In addition to its upper- and lower-case alphanumeric characters, it can produce user-defined symbols as well as a set of gaming symbols to produce a screen of up to 256 x 256 points. The alphanumeric display is 25 characters per line and 25 lines (convertible to 30 x 30) on an overscanned TV receiver or video monitor. All you need to get the system up and running are a 5-volt power supply capable of delivering 3 amperes of current, a video monitor (or TV receiver plus r-f modulator), and a cassette player.

The single large printed-circuit board on which the computer is assembled is clean and uncluttered. The clock oscillator is crystal-controlled, and all ICs are in sockets. There are also on board three 16-pin IC sockets for future hardware experiments and a 40-pin IC socket that serves as a bus expander.

The alphanumeric keyboard occupies

POPULAR ELECTRONICS

the forward section of the computer board. Autorepeat is featured in all character keys, including the space bar. One touch of a key puts the selected character on the screen of the monitor. Holding the key down puts a string of the same character on screen for as long as the key is held down. (There is a slight pause between the first and all subsequent characters.)

Available hardware options include an expander board that can support 24K of RAM, a dual mini-floppy interface, a port adapter for a printer or modem, and a 48-line expansion interface. In the software area, an assembler/editor, an extended machine-language monitor, and a complete software library are planned.

When the system is first turned on, it comes up in the monitor mode. If you ask for BASIC, the system responds instantly with the BASIC resident in ROM. The BASIC itself is from Microsoft and is a conventional 8K type. It has the usual complement of commands, statements, expressions, functions, string-handling capabilities, and includes tape SAVE and LOAD commands. The monitor has the usual basic commands and includes tape-cassette commands.

User Report. The video display in our test Superboard II was set for 25 characters on 25 lines. The spacing between the lines was minimal but readable.

We cranked in several BASIC programs that we have used with our 8080 microprocessor based computer. With slight changes in some BASIC commands (we used a different BASIC from that provided), the programs ran properly.

In graphics applications, a particular symbol is "called" to the screen by POKEing the character's code to the address of the video location where it is to be displayed. There are extra character codes to accommodate the additional nonstandard graphic symbols.

The Superboard II uses a 1K single format graphics system and plots can be made at almost any angle. Access to the graphics can be made through either BASIC or machine-language routines. A complete manual that accompanies the computer details operation, BASIC, and graphics.

We used the Superboard II for several weeks and quickly became accustomed to its operation. Although we're used to having 64 to 80 characters per line, we became reasonably comfortable with the 25-character/line format of this computer. (Evidently, Ohio Scientific designed the Superboard II with the idea that it would be used primarily with a home TV receiver. Since 32 characters/line would be the practical limit in such a setup, a 25-character by 25-line or 30-character by 30-line format is not unreasonable.) Another minor objection we have is that the system is not readily expandable.

Lest we color this report with our own exclusive opinions of this computer, we decided to take it and its accessories to a computer club meeting and see what other computer enthusiasts thought of it. Almost without exception, the Superboard II met with approval, considering its attributes, its low price, and inclusion of video output, tape interface, keyboard, and BASIC in ROM.

We can heartily recommend the Superboard II computer system for the beginner who wants to get into microcomputers with a minimum of cost. Moreover, this is a "real" computer with full expandability. And it is a ready-to-go system for almost the same price one would have to pay for a stripped-down single-board system to which one must add a keyboard, video output, BASIC, and cassette-tape interface. Also, the Microsoft BASIC is a real plus. ◊

CIRCLE NO. 104 ON FREE INFORMATION CARD

MARCH 1979

VECTOR PACKAGING MATERIALS SAVE TIME & MONEY

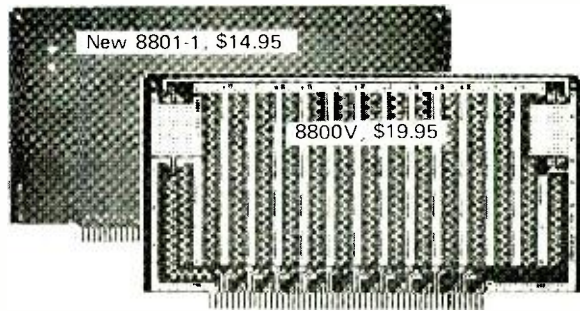

S100 CARDS—100 PLUG CONTACTS—Convenient universal tinned pads and bus lines. For interface, memory expansion, breadboarding. Mount almost anything anywhere on card.

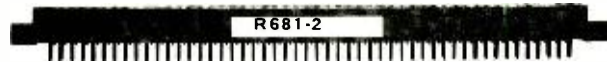

S100 CONNECTORS for WIRE WRAPPING or SOLDERING

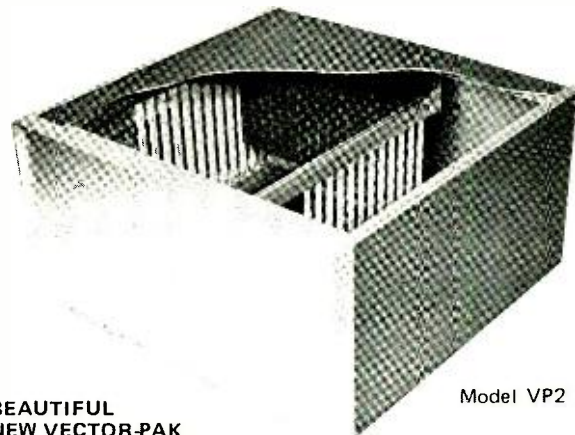

Model VP2

BEAUTIFUL NEW VECTOR-PAK

CASES for micro-computer circuitry, assembled. Constructed of aluminum, finished in vinyl. Slide out covers for easy access. Includes card guides, heavy chassis plate, perforated bottom cover for cooler operation. Card guides perpendicular to front panel, Model VP1, \$163.00. Card guides parallel to front panel, Model VP2, \$159.00.

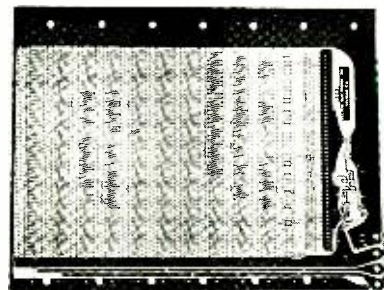

Model 8803

S100 MOTHERBOARD, \$29.50. 11 positions ready for connectors. Glass epoxy, etched circuitry for passive or active termination, 12 tantalum capacitors and instructions.

PLUS revolutionary Slit-N-Wrap wiring tools, Micro-Vector-board[®] printed circuit kits, I.C. sockets, extenders.

Prices subject to change without notice.
Send for new catalog.



VECTOR ELECTRONIC COMPANY, Inc.

12460 Gladstone Avenue, Sylmar, CA 91342

phone (213) 365-9661, twx 910-496-1539

Our toll-free number which can be used by customers outside of California is 800-423-5659 540777

CIRCLE NO. 55 ON FREE INFORMATION CARD

Hobby Scene



By John McVeigh, Technical Editor

WHITE NOISE FILTER

Q. My wide-band power amplifier recently blew almost every solid-state device in it. For no apparent reason, it simply self-destructed. The manufacturer says that the interstation hiss from an FM tuner is really bad for this amp. Can you furnish a circuit that will filter it out? My tuner is a high-quality tube type. —Martin J. Anderson, Mushegon, MI.

A. The circuit shown in Figure A (choose resistance values to match the output impedance of your tuner and input impedance of your amplifier) is an effective filter for interstation hiss, which is an approximation of white noise. This type of noise is a complex waveform with a Gaussian amplitude characteristic. It is formed by contributions from all

frequencies over a broad but specified bandwidth and has a flat spectral power density. Thus, it contains equal energy per unit of frequency (Hertz).

White noise is analogous to white light in that it contains all sounds perceptible to the human ear. White light includes all wavelengths of visible light (colors) perceptible to the human eye. White noise is a useful diagnostic signal when analyzing the frequency response of audio components and transducers.

Another signal related to white noise is pink noise. This signal contains equal energy per octave. Because there are more octaves in the bass region than in the treble, pink noise has more low-frequency content than white noise and sounds "warmer." Plots of amplitude versus frequency for white (dashed line) and pink noise (solid line) are shown in

Fig. B. Note that pink noise displays a -3 -dB/octave characteristic.

Many spectrum analyzers designed for audio applications (such as the Real Time Analyzer project in POPULAR ELECTRONICS for September and October 1977) are "constant percentage bandwidth" types. That is, the bandwidth of each bandpass filter in this type of analyzer is an unchanging percentage of its center frequency. If white noise is applied to the analyzer, a rising 3-dB/octave characteristic will be displayed. If a pink noise filter with a -3 -dB/octave response is inserted between the noise source and analyzer, a flat response will be seen. (Refer to "Build a Pink Noise Generator for Audio Testing" in POPULAR ELECTRONICS July 1977.)

Now that we've discussed the nature of white noise, it should be apparent that the filter I have facetiously included as Fig. A is simply an open circuit between input and output that will prevent the passage of any audio-frequency signal. There is nothing sinister about white noise. It is simply a wideband audio signal and I am puzzled that the manufacturer of your amplifier made the statement that he did. White noise is no more harmful to audio electronics than, say, a

END PAPER POLLUTION!

In Office, Home, Lab, Workshop

**HANDY, HUSKY, HEAVYDUTY
SHELF FILES**

KEEP MAGAZINES, CATALOGS,
MANUALS, JOURNALS, PLANS
**NEAT and FULLY
ORGANIZED!**

Eliminate the mess of loose magazines, newspapers, catalogs, etc. in office, lab, workshop. Find what you want when you want it by using these handy shelf or desk files. Ends personal paper pollution problems once and for all! Adhesive ID labels included. Letter size: 9" X 11 1/2" X 3 3/4". Use credit card to order. Mail coupon below. Satisfaction guaranteed.



Professional Aids Co., Suite 000
1 S. Wacker Dr., Chicago, Ill. 60606

Check for Free Catalog

Please rush postpaid Fiberboard Desk and Shelf Files as checked below

How Many	Qty	Size	Price	Total Price
	8	Letter Size	\$12.95	
	25	Letter Size	28.97	

I enclose \$ full payment. Ship p.p.d.

Bill Company We are rated.

Charge it to Visa Mastercharge TOTAL _____

Acct No _____ Exp Date _____

Name _____

Address _____

City/State/Zip _____

Illinois Residents add 5% Sales Tax. please Other sizes from digest to newspaper available

78

CIRCLE NO. 44 ON FREE INFORMATION CARD

NOW...

Add-on Mini-Disc for the TRS-80*



Dual and triple drives also available.

only

\$399⁰⁰

from

PERCOM

PERCOM DATA COMPANY, INC.
Dept. PE • 318 BARNES • GARLAND, TEXAS 75042
Phone: (214) 272-3421
To Order Call 1-800-527-1592

*RADIO SHACK and TRS-80 are trademarks of Tandy Corporation which has no relationship to PERCOM DATA COMPANY INC.

CIRCLE NO. 42 ON FREE INFORMATION CARD

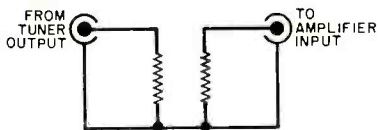

Fig. A. Circuit for filter.

destruction of almost every semiconductor in it—suggests an apocalyptic event. A mammoth transient on the power line is one possibility. A varistor transient suppressor such as one of General

problem from another direction and obtained excellent results. Here's the procedure I followed.

The power company supplies you with electricity via a step-down transformer, whose secondary is at 220 volts center-tapped. The center tap is grounded with 110 volts between it and either end of the secondary. The two 110-volt lines are 180° out of phase. To solve the RFI problem, you must connect the radio to the opposite 110-volt line. Either move the radio to a power socket connected to the other line or have a licensed electrician rewire the junction box so that the radio's socket is no longer on the same side of the center tap. —Thomas Rider, Rainelle, WV.

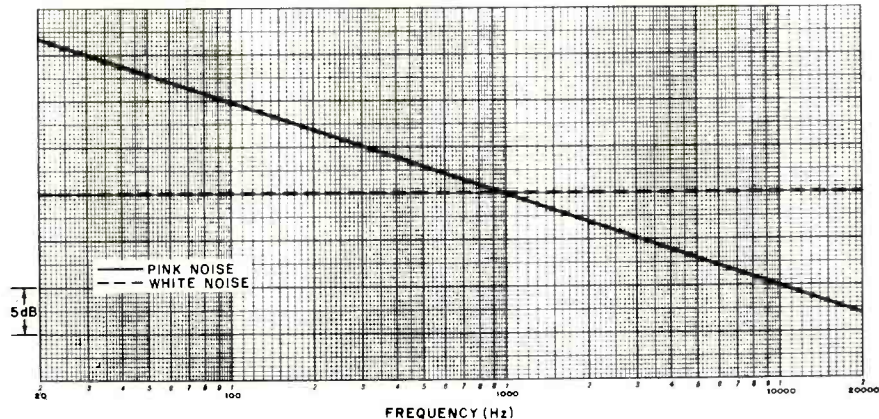

Fig. B. Frequency characteristics of white and pink noise.

musical passage that contains evenly balanced bass, midrange and treble content. If you crank the system gain up, the average power output and dissipation of the amplifier might be higher than that normally encountered during musical listening sessions.

What happened to your amplifier—the Electric's MOV devices will protect line-powered equipment from the destructive effects of such transients.

MORE ON LIGHT DIMMER RFI

Q. After reading your Q&A about Light Dimmer RFI, I approached the

A. Thanks for your suggestion. However, your solution may work only in cases of conducted RFI, not radiated interference. If the r-f is reaching the radio via its antenna input, moving the radio to the other side of the center tap will not necessarily decrease the coupling between the radiating conductors and the antenna. In such a situation, as well as in one in which a neighbor's appliance is suffering from radiated RFI, a filter near the r-f generating thyristor is needed.

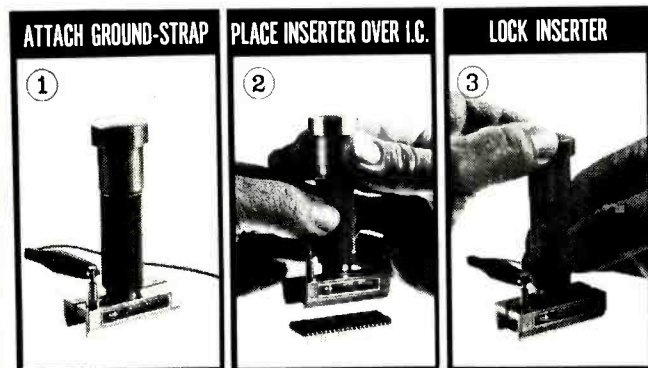

IC INSERTION TOOL 36-40 PIN CMOS-SAFE

Unique new insertion tool. Also aligns bent-out pins. A twist of the handle compresses the pins to proper .600 inch spacing and locks the IC into the tool. Then simply place the tool on the socket and depress the plunger for instant and accurate insertion. Features heavy chrome plating throughout for reliable static dissipation. Includes terminal lug for attachment of ground strap.

\$795
EACH

MINIMUM BILLING \$25.00 ADD SHIPPING CHARGE \$1.00
NEW YORK STATE RESIDENTS ADD APPLICABLE TAX



OK MACHINE & TOOL CORPORATION
3455 CONNER ST., BRONX, N.Y. 10475 U.S.A.
TELEX 125091

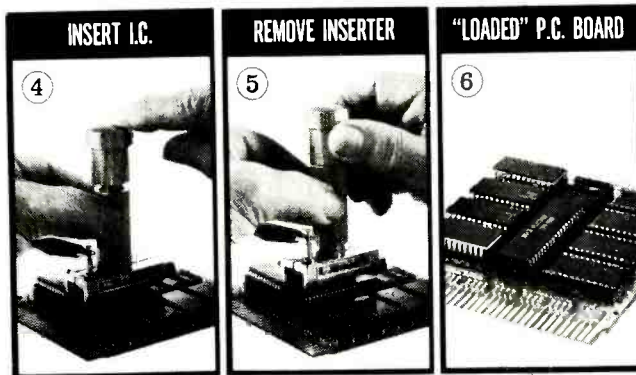

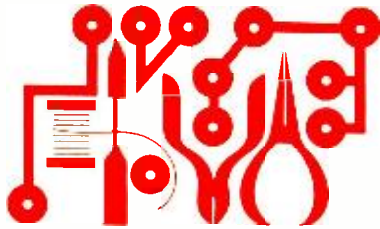

Experimenter's Corner

By Forrest M. Mims

EAVESDROPPING ON LIGHT

WE ARE literally surrounded by modulated sources of light, both natural and artificial. Seeking them out can be an enlightening and entertaining experience. This month we're going to do just that.

We ordinarily discuss circuits that are *not* available as preassembled commercial products. This column, however, marks a departure from our general practice in that it calls for the use of a commercially available, battery-powered audio amplifier. Of course, you can use a home-brew audio amplifier that you have on hand, or you can build one using an audio IC or a few transistors. You can then begin tracking down modulated light sources within minutes of reading this column, assuming you already have a few common components.

Suitable Detectors and Amplifiers. Silicon solar cells, photodiodes, phototransistors and other photovoltaic devices can all be employed as sensors in the detection of modulated light sources. Whatever sensor is employed can usually be directly connected to the input of the audio amplifier. In some cases, however, a transformer or other impedance-matching device or circuit will be required.

Although the high-fidelity amplifier found in any home audio system can be used with excellent results, a portable amplifier is best suited for this application because it can be readily used outdoors and in automobiles. Shown in Fig. 1 is a Realistic Micro-Sonic battery-powered amplifier I have used with suitable sensors to detect many different modulated light sources over the past several years.

Notice the miniature plug inserted into the amplifier's microphone jack. This plug contains a small silicon photodiode whose two leads are soldered directly to the plug's terminals. The opening in the plastic cap intended for the connecting cable was enlarged slightly with a ream-

er so that as much light as possible could strike the photodiode.

You might be able to save a little money by using one of the transistorized amplifier modules sold by some electronic parts suppliers. Mount the amplifier in a plastic case along with a battery, volume-control potentiometer and speaker. Incidentally, defective portable tape recorders are a good source of amplifier modules.

Many different kinds of light detectors can be connected to the audio amplifier. For very low light levels, I've found that a large-area silicon solar cell works best. However, this type of cell is easily broken so you will need to attach the cell you select to a rigid substrate of plastic, metal or wood. A few drops of cement will secure it in place. You can give additional protection to the cell as well as provide a directional detection capability by installing it at one end of a (10 to 30 cm) plastic, aluminum or cardboard tube. A lens is not necessary if the surface area of the cell is about the same as that of the tube's aperture. Use a long tube and paint its inside surface flat black for best results.

Most inexpensive, large-area silicon

solar cells available on the surplus market are *not* supplied with connection leads. It is very important to use care when soldering connection leads to these cells because improper soldering procedures will cause the fragile electrodes to peel away from the cell.

The thin upper electrode is more difficult to solder than the large electrode that covers the entire bottom of the cell. For best results, heat a portion of the upper electrode near a corner of the cell if it is rectangular or near the perimeter if it is circular. Apply heat for only a few seconds with a low-power iron and then apply a small amount of solder. Next remove $\frac{1}{4}$ " (3.2 mm) of insulation from one end of a length of Wire-Wrap wire and place the exposed conductor along the electrode adjacent to the solder. Reheat the solder for a moment. It will suddenly flow over and around the wire to provide a perfect solder connection. Use this same procedure to solder a wire to the cell's bottom electrode.

You will have to provide a means for protecting the wire leads after the cell is mounted on a card or in a tube. I prefer to attach a shielded phono cable to the tube or card and then solder the cell's leads to the cable. This prevents the leads attached to the cell from being broken by a sudden jerk. The shielded cable reduces unwanted noise from nearby ac power lines and other sources.

For special-purpose detectors, try light-emitting diodes instead of solar cells. The peak response of a LED is confined to a much narrower group of wavelengths than that of a solar cell, and roughly corresponds to the wavelength emitted by the diode when forward biased. For example, a high-efficiency, GaAs:Si near-infrared emitter

Fig. 1. Portable battery powered amplifier suitable for monitoring modulated light. Plug inserted into microphone jack incorporates a miniature silicon photodiode.



YOURS FREE

Everything that's New and Exciting
in Electronics...All in the
NEW, Hot-Off-The Press

HEATHKIT® CATALOG

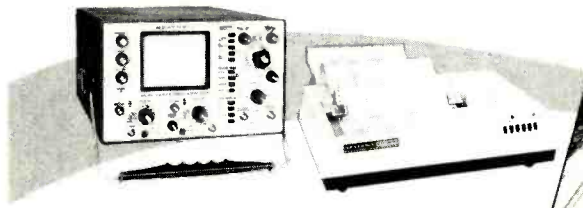

Read about nearly 400 exciting do-it-yourself kits including Amateur Radio Equipment, Personal Computers, Home Improvement Products, Stereo Hi-Fi, Programmable Color TV, Automotive, Aircraft and Marine Accessories, Test Instruments, R/C Modeling, Self-Learning Programs and lots more! Something for everyone, and everything is easy to build and fun to use — it's the Heathkit way!



Send for your
FREE Catalog Today!

Heathkit products are displayed, sold and serviced at Heathkit Electronic Centers coast to coast. (Units of Schlumberger Products Corporation). See the white pages of your phone book. If coupon is missing, write Heath Company, Dept. 010-510, Benton Harbor, Michigan 49022



HEATH		FREE!
Schlumberger		
Heath Company, Dept. 010-510 Benton Harbor, Michigan 49022		
Please send me my FREE Heathkit Catalog. I am not currently receiving your catalog.		
Name _____		
Address _____		
City _____		State _____
CL-676		Zip _____

CIRCLE NO. 5 ON FREE INFORMATION CARD

plug in and go soldering

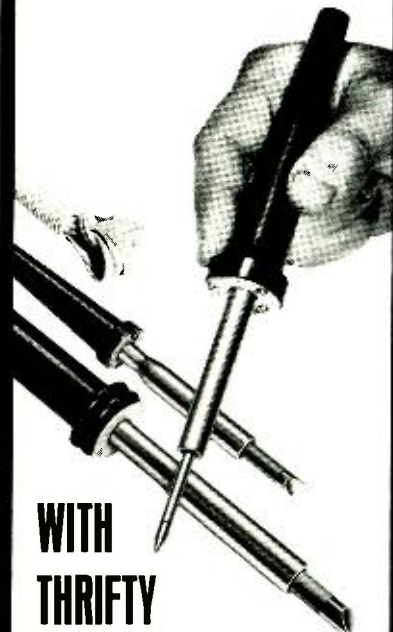

WITH
THRIFTY
MARKSMAN IRONS

BY **Weller**[®]

Pre-tinned tips for instant action. Five different ratings for technicians and hobbyists. Heat- and impact-resistant handles grip comfortably. Premium, stainless steel barrel for strength, corrosion resistance, and more even temperatures. Cone shape, screw-driver, chisel tips; Soldering Kit, Hot Knife Kit for wire stripping and plastic cutting. Full-view card pack lets you see and read about these UL-listed, factory-pre-tested irons before you buy.

See your local distributor or write...



The Cooper Group
Electronics Division

WELLER[®] • WISS[®] • XCELITE[®]

PO BOX 728, APEX, NORTH CAROLINA 27502, 919/362-7511

CIRCLE NO. 13 ON FREE INFORMATION CARD

has a peak spectral response at about 940 nanometers.

Visible LEDs work as detectors also, but they are not as efficient as near-infrared LEDs. Figure 2 shows a GaAs



Fig. 2. Infrared emitting diode connected to miniature phone plug.

infrared emitter soldered to a miniature plug that can be inserted directly into a modular amplifier's input jack.

Whatever detector you select, tune in as many different light sources as possible. Many LED clock, watch and calculator displays are multiplexed at relatively low-frequencies and will usually produce a buzz or hum. Fluorescent lamps and neon lights produce a very strong 120-Hz buzz. Several years ago, a long-range light-beam communications experiment I was conducting was interrupted by a persistent buzz originating from a large neon advertising sign more than two miles away! Flickering candles, matches, lighters, campfires and fire-

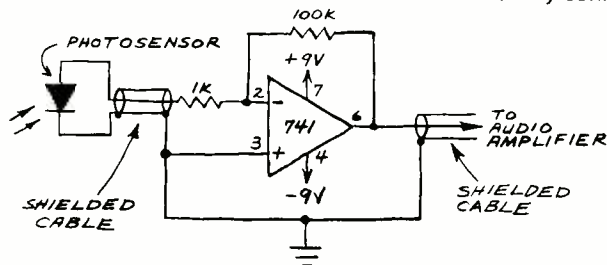

Fig. 3. Simple op-amp preamplifier for monitoring modulated light sources.

places produce a variety of interesting sounds.

Electrical storms are particularly fascinating to monitor, especially at night. Lightning flashes produce the same crackling and popping sounds as those heard over a radio during a storm. The light detector, however, finds line-of-sight discharges which makes it possible to identify areas of peak activity.

Although the photodetector's sensitivity is reduced in daylight due to the unwanted dc bias which is produced, lightning can still be detected. Often, in fact, you'll detect with a solar cell lightning that you cannot see with your eyes.

Steady light originating from the sun and dc-powered lamps normally produces only a hiss. Movement, however, adds a new dimension to steady light sources. You will discover its effect the first time you "hear" light from the sun interrupted by a picket fence or overhead branches. You will even be able to

pick up the hum of a flying insect by capturing the sunlight reflected from its oscillating wings. Similarly, you will detect the wing beats of a hummingbird when you position your detector so as to form a straight line with the sun and a bird hovering at a feeder.

To liven up the otherwise uninspiring hiss produced by a flashlight, tap its reflector with a pencil. This will cause a pleasant chime-like sound as the filament vibrates in and out of the reflector's focal point.

Calvin R. Graf, an acquaintance who shares my interest in monitoring modulated light sources, has described some of these and many other observations in a recently published book entitled *Listen to Radio Energy, Light and Sound* (Howard W. Sams & Co., Inc., 1978). Calvin's book reports on many of his personal observations and suggests experiments that can be conducted easily.

Op Amp Preamplifier. The circuit shown in Fig. 3 will serve as a crude but effective preamplifier for a battery-powered portable amplifier. The preamplifier can be assembled on a small perforated board. Insert the leads from a pair of 9-volt battery connector clips through a 1/4"

hole drilled in the board and tie a knot in the leads to keep them from pulling loose. Then solder them to the appropriate circuit nodes. (Red is positive and black is negative.) Connect the preamp to the amplifier with shielded cable.

The voltage gain of the preamp is the quotient of R_2 divided by R_1 . With the values shown on Figure 3, its gain is 1000. This should be more than adequate for most sensors. Too high an input signal will overdrive the audio amplifier, so keep the volume control set to a low level when using the preamp.

A word of caution is in order for those who want to eavesdrop on light in noisy areas. An earphone will prove very helpful when the ambient sound level is high, but be sure the volume is turned to a low level until you have focused in on a light source you wish to monitor. Unexpected flashes of light can produce very loud sounds!

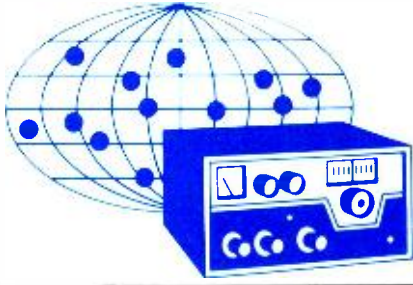

DX Listening

By Glenn Hauser

INTERCONTINENTAL TV - DX

THE ULTIMATE in terrestrial DX is tuning in overseas television broadcasts. Though it's now possible to see foreign TV programs by eavesdropping on satellites, there's nothing to beat the thrill of picking up an overseas TV transmission *direct*, without the help of a satellite relay.

Since TV frequencies go no lower than 40 MHz, it takes very good propagation conditions to push the maximum useable frequency past the 40-MHz mark. This is the same F₂-layer skip which makes worldwide contact routine, on the lower, shortwave bands.

The only time F₂ passes 40 MHz with any regularity is during solar cycle peaks. We are entering the upswing of Cycle 21 right now. Such DX will be possible for the next two years or so. By the time the next sunspot peak occurs, around 1991, the lowest of these TV channels will have been phased out in favor of uhf. So now is *the* time to get in on worldwide TV DX.

This correlates closely with conditions on the 10 and 6 meter ham bands. If a certain area is being heard on 10, this can serve as a pilot to conditions on higher frequencies. If DX is coming in on 6 meters, it's likely that TV DX will be there too from the same area, on the same or lower frequencies. However, propagation tends to be best just below the fluctuating maximum useable frequency (MUF).

Though a few dedicated TV DXers have imported receivers which will demodulate foreign video, it is not necessary to go this far. We can more easily tune for the audio channels of TV signals on radio receivers. However, if you can obtain a British or European multi-standard TV set, by all means do so.

The two prime frequencies to monitor are 41.25 MHz (French ch. 2) and 41.50 MHz (British ch. 1). Only Britain, France, and Belgium use AM, rather than FM for TV sound. Britain and France also pro-

vide the advantage (for DX listeners) of audio on lower frequencies than video—meaning we'll hear the audio first, as the MUF ascends.

Several powerful transmitters operate on each of these channels, some slightly offset. It would certainly pay to include these two frequencies on your scanner. In North America, the MUF from Europe peaks in the mid-to-late morning hours. If this is an inconvenient time to listen, you can simply use a timer and make an audio tape, which you can scan later at

TABLE I—TV FREQUENCIES, 40–62 MHz

MHz	Channel	Audio/Video	Where Used
41.25	F2	AM	France (many), Monaco
41.48	B1-	AM	Northern Ireland
41.50	B1	AM	U. K. (many)
41.52	B1+	AM	Wick, U.K.
41.547	B1++	AM	Cornwall, U.K.
44.993	B1-	V	Northern Ireland
45.00	B1	V	U. K. (many)
45.007	B1+	V	Wick, U.K.
45.047	B1++	V	Cornwall, U.K.
45.25	NZ1	V	New Zealand (several)
46.25	Au0	V	Australia (several)
48.23	B2-	AM	U. K.
48.25	B2	AM	U. K. (many)
48.25	E2	V	Europe, Africa, Mideast (many)
48.26	E2+	V	Europe
48.27	B2++	AM	U. K.
49.75	E2A, R1	V	Austria, E. Europe, USSR, China (many)
50.75	NZ1	FM	New Zealand (several)
51.743	B2-	V	U. K.
51.75	B2	V	U. K. (many)
51.75	Au0	FM	Australia (several)
51.757	B2+	V	U. K.
52.40	F2	V	France (many), Monaco
53.25	B3	AM	U. K. (many)
53.75	E2	FM	Europe, Africa, Mideast (many)
53.75	ItA	V	Italy (many)
53.76	E2+	FM	Europe
53.77	E2++	AM	Belgium
54.40	F4	AM	France
55.24	A2-	V	N. & S. America (many)
55.25	A2	V	N. & S. America (many); see text
55.25	E3	V	Europe, Africa, Asia (many)
56.25	R1	FM	China, USSR, Eastern Europe
56.75	B3	V	U. K.
57.25	Au1	V	Australia (several)
57.75	—	V	China
58.23	B4--	AM	U. K.
58.25	B4	AM	U. K. (many)
59.25	R2	V	USSR, Eastern Europe
59.25	ItA	FM	Italy (many)
59.74	A2-	FM	N. & S. America (many)
59.75	A2	FM	N. & S. America (many); see text
59.76	A2+	FM	N. & S. America (many)
60.75	E3	FM	Europe (many)
61.743	B4-	AM	U. K.
61.75	B4	AM	U. K. (many)

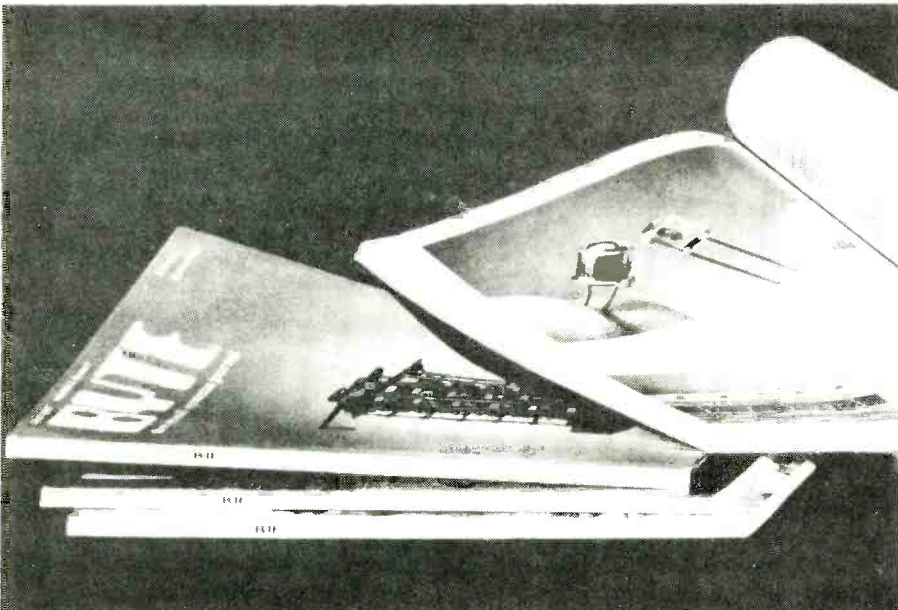

Get the inside story...

on software, hardware, simulations, computer games, robotics, computers and calculators, languages and compilers, custom systems design and scores **Read BYTE.**

BYTE, the leading magazine in the personal computer field, will keep you aware of fast-paced changes in the ever growing world of microprocessors. You'll find **BYTE** tutorials invaluable, reports on home computer applications instructive, and the reviews of computer products stimulating.

Tutorial information in **BYTE** is of interest to both the beginner and experienced computer user. **BYTE's** editorial content explores the fun of using and applying computers for personal satisfaction in activities from electronic music to electronic mail,

from games to pragmatic personal business. In **BYTE** is found authoritative yet easily read coverage of principles of computer hardware and software design, approaches to novel applications, and essentials of proven interest to personal computer enthusiasts.

Each month serious computer users read **BYTE**. They're rewarded with timely articles by professionals, computer scientists and competent amateurs. Isn't it time you got the inside story? Subscribe now to **BYTE**, the Small Systems Journal.

Fill in and mail the coupon today. Read your first copy of **BYTE**. If it is everything you expected, honor our invoice. If it isn't, just write "Cancel" on the invoice and mail it back. You won't be billed and the first issue is yours at no charge.

Allow 6 to 8 weeks for processing. If you have any questions, dial toll free 800-258-5485. This is the number of the **BYTE** Subscription Department.

© **BYTE** Publications, Inc. 1978

BYTE Subscription Dept. P.O. Box 590 Martinsville, NJ 08836
Please enter my subscription for

One year \$15 (12 issues) Two years \$27 Three years \$39

Check enclosed entitles me to 13 issues for price of 12 (North America only)
 Bill Visa Bill Master Charge Bill me (North America only)

Card Number _____ Expiration Date _____

Signature _____ Name (please print) _____

Address _____

City _____ State/Province/Country _____ Code _____

Foreign Rates (To expedite service, please remit in U.S. Funds)

Canada or Mexico One year \$17.50 Two years \$32 Three years \$46.50

Europe, one year (air delivered) \$25

All other countries, one year (surface delivered) \$25. Air delivery available on request.

7339

CIRCLE NO. 10 ON FREE INFORMATION CARD

your convenience at higher speed, for signs of programmed audio.

This is exactly what I did last Halloween, and I was rewarded with two solid hours of tape (1600-1800 GMT) of both British and French TV audio. This was done with nothing but a short random-wire antenna and a cheap 6-band portable including the 30-50 MHz range. It was carefully pre-tuned to the correct frequency. Such receivers are sufficiently broad-band to pick up two signals 250 KHz apart. For clearest AM audio when listening to an FM-mode receiver, tune about 100 kHz to either side of the carrier frequency.

This was the first time I had heard European TV in North America. I had received the same two channels in 1970 while in Thailand, and sent taped reports both to London and Paris, though I was certain of what I had received. The BBC refused to verify, and French TV refused to answer. So this time I'm content to listen and tape.

Table I shows all the TV video and audio frequencies used in the world in the 40-62-MHz range. F₂ is not likely to go much higher than listed; but, if the sunspot count hits a record high, this could happen. Of course, without a TV tuner of the proper standards, the video will be unintelligible, but just hearing the buzz should be a valuable tip-off that the DX is 'in', and corresponding audio channels should be checked.

You'll note that some of these fall within the 6-meter (50-54-MHz) ham band. A good sensitive 6-meter setup can be a valuable asset in TV DX listening. These 'intruders' would be better DX than any ham stations you will hear.

If Europe is pounding in on the 41 MHz channels, keep checking higher and higher European frequencies. The MUF from Down Under peaks in our late afternoons or early evenings. This is the time to check 45.25 and 46.25 MHz for video; and 50.75 and 51.75 MHz for audio from New Zealand and Australia. At

**TABLE II—SWBC
HARMONIC BANDS**

MHz range	Harmonic	Fundamental Band
28.400-29.200	4	7 MHz
28.500-29.325	3	9 MHz
28.750-31.000	5	6 MHz
30.200-30.900	2	15 MHz
35.100-35.925	3	11 MHz
35.400-35.800	2	17 MHz
38.000-39.100	4	9 MHz
42.900-43.500	2	21 MHz
45.300-46.350	3	15 MHz
51.200-52.200	2	25 MHz

TABLE III—RECENTLY HEARD HARMONICS

MHz	Harmon-ic	Funda-mental	Station, Location	Typical Time GMT
29.020	4	7.255	BBC, U.K.	1425
30.140	2	15.070	BBC, U.K.	1330, 1430
30.210	2	15.105	BBC, Ascension	1300
30.260	2	15.130	R. Moscow	1330
30.290	2	15.145	R. Jornal do Comercio, Recife, Brazil	1345
30.300	2	15.150	Deutsche Welle, Antigua	1330
30.328	5	6.0656	R. Super, Colombia	1325
30.360	2	15.180	BBC, U.K. (Arabic)	1345, 1415
30.390	2	15.195	VOA, Ascension (Spanish)	1330
30.440	2	15.220	R. Exterior, Spain	1300
30.474	5	6.0948	La Voz del Centro, Colombia	1330, 1630, 2145
30.520	2	15.26	RCI, Sackville, N.B.	1800
30.520	2	15.26	BBC, Ascension	2100
30.630	2	15.315	RCI, Portugal	1430
30.670	2	15.335	R. Exterior, Spain	1400, 1600
30.790	2	15.395	BBC, U.K.	1400
30.800	2	15.400	BBC, Ascension	1710

the same time, watch out for video buzz on 49.75 MHz, which will signal reception from China or the Soviet Far East.

Single-hop skip distances at these frequencies are on the order of 5000 km, so if you have a clear shot on American ch. 2, it's possible to get stations from one coast to the other via F₂. This is not to be confused with the much more common sporadic E, which skips at 1/3 to 1/2 of this distance. Also, there are stations all over Latin America using U.S. standards on ch. 2, as well as other pockets here and there—such as South Korea, Philippines, Samoa, Saudi Arabia.

On the same video frequency as American ch. 2 is European-system ch. 3. If you are lucky enough to have DX coming in on ch. E3, you can receive the video on an American set tuned to ch. 2, simply by adjusting the vertical hold (and perhaps the horizontal). But since audio is 5.5 MHz above, rather than 4.5 MHz, an unmodified U.S. set won't pull in audio at the same time, even if the MUF is reaching that high.

Caution—domestic U.S. TV sets radiate varying amounts of video signal around 45 MHz and audio around 41 MHz. The exact frequencies depend on the set's i-f and the fine tuning setting. Don't jump to the conclusion you've got overseas TV coming in, when it may be a neighbor's TV set, or even your own.

Harmonic DX. Another kind of DX to enjoy during sunspot peaks is harmonic DX in the 30-MHz range and above. Shortwave broadcast stations radiate small amounts of signal on exact 2nd, 3rd, 4th and even higher multiples of

their fundamental frequencies. When conditions are favorable, these are heard with surprising strength over great distances. The most likely frequency ranges for this are in Table II.

Note that some of these overlap, and that an out-of-band fundamental, or higher order harmonic, could put a signal just about anywhere else in the low range. If you can tune the range continuously, it's easy to spot these AM signals bearing programming-type talk and music, in contrast to all the intermittent FM 2-way signals assigned to the 30–50-MHz band or the SSB and CW of the 50-MHz ham band.

Some shortwave receivers which supposedly tune up to 30 MHz, can be pushed to 31 MHz, covering at least one prime 'harmonic band'. Such is the case with the FRG-7. If you use a cheap 30–50-MHz receiver, you will find lots of extraneous signals to confuse you—images of local FM and TV stations; interference over the whole band from shortwave utility stations near 10.7 MHz, riding in on the usual 10.7-MHz i-f of these receivers; and receiver-generated images from 21.4 (2 x 10.7) MHz below. This can be especially confusing around 43 MHz, where both images and true transmitted harmonics from 21-MHz band stations fall.

Table III shows a few of the harmonics the author has recently monitored in the 30-MHz area. Some frequencies may change, of course, as international broadcasters change their fundamental frequencies.

DXers specializing in the tropical (6 MHz and below) shortwave bands are

B&K-PRECISION'S

new digital probe offers more than logic



Model DP-50

- Reveals pulse presence to 50MHz
- Priced at only \$50
- Multi-family, compatible with TTL, DTL, RTL, CMOS, MOS, and HiNIL
- Clearly displays in-circuit logic activity
- Memory mode to "freeze" pulse display
- Pulse mode to "stretch" short pulses
- 2 megohm input impedance
- Typically detects pulses to 10 nanoseconds
- Overload and reverse polarity protected

The new B&K-PRECISION DP-50 50MHz digital probe simplifies the troubleshooting and analysis of all digital circuits by clearly displaying in-circuit logic activity and pulse presence.

This compact instrument includes every important logic probe feature and more. Three bright LED indicators display pulse presence and high- and low-logic states. Unlike ordinary logic probes, the DP-50 digital probe will continue to indicate pulse presence to 50MHz.

Available for immediate delivery at your local distributor.

BK PRECISION
DYNASCAN CORPORATION

6460 West Cortland Street
Chicago, Illinois 60635 • 312/889-9087
In Canada: Atlas Electronics, Ontario

CIRCLE NO. 9 ON FREE INFORMATION CARD

Get the Most Out of Your Computer with Creative Computing

Software and Applications. Pragmatic, well documented programs with complete listings on data base systems, word processing, communications, simulations, investment analysis, games, music synthesis, computer art, business functions, building control and more.

System Evaluations. In-depth, probing evaluations of personal and small business systems every issue. Non-sensory reviews of software from independents as well as the majors

Regular Features. Operating Systems Q and A Columns on the TRS-80, Apple and PET. Book reviews Programming techniques Short programs Computer games. New products. Even a dose of fiction and foolishness

We guarantee that Creative Computing will help you get more out of your personal, school, or business computer or we'll give you your money back!

- 3 years \$40 (Save \$32 over retail price)
- 2 years \$28 (Save \$20 over retail price)
- 1 year \$15 (Save \$9 over retail price)

Foreign: Surface add \$9/yr. Air add \$24/yr.

To order, send payment or bankcard (Visa or Master Charge) number and expiration date with your name and address to Creative Computing, Attn: Claire P.O. Box 789-M, Morristown, N.J. 07960

Save time! Phone bankcard orders toll-free to:

800-631-8112

(In NJ call 201-540-0445)

creative computing

P.O. Box 789-M Morristown, NJ 07960

CIRCLE NO. 14 ON FREE INFORMATION CARD

Put Professional Knowledge and a COLLEGE DEGREE in your Electronics Career through HOME STUDY

Earn Your DEGREE

by correspondence, while continuing your present job. No commuting to class. Study at your own pace. Learn from complete and explicit lesson materials, with additional assistance from our home-study instructors. Advance as fast as you wish, but take all the time you need to master each topic. Profit from, and enjoy, the advantages of directed but self-paced home study.

The Grantham electronics degree program begins with basics, leads first to the A.S.E.T. degree, and then to the B.S.E.T. degree. Our free bulletin gives complete details of the program itself, the degrees awarded, the requirements for each degree, and how to enroll. Write for *Bulletin E-80*.

Grantham College of Engineering
(2500 South La Cienega Blvd.)
P. O. Box 35499
Los Angeles, CA. 90035

Worldwide Career Training thru Home Study

CIRCLE NO. 23 ON FREE INFORMATION CARD

complaining about generally poor reception. This is largely due to increased lower-frequency absorption as the higher frequencies work better and better. It would be wise to be flexible enough to take advantage of the solar cycle, and DX each frequency range when it is best. Now is the time to concentrate on 20-60 MHz.

Tropical Bands Threatened.

There's some apprehension that even when tropical reception improves toward the next solar cycle trough, DX listening may have been ruined on the 60-meter band. There have been proposals to allow high-powered international broadcasting on this band.

This would be very advantageous for the international listening audience when the MUF falls below 6 MHz, as it often does between Europe and North America during the winter in solar trough years. However, it would severely hinder reception of many third-world stations which presently occupy this band almost exclusively.

A letter-writing campaign seems to have had some success in opposing this move, coupled with the Third World's realization that they can bring to bear a powerful voting bloc at the World Administrative Radio Conference, set to begin this September in Geneva. The WARC will reallocate the entire electromagnetic spectrum, to conform with present-day needs and those anticipated until the end of the century. ♦

Build The World's Most Powerful 8-Bit Computer Featuring The Famous Intel 8085! Explorer/85™

Starting for just \$129.95 you can now build yourself a sophisticated, state-of-the-art computer that can be expanded to a level suitable for industrial, business and commercial use. You learn as you go... in small, easy-to-understand, inexpensive levels!

- **Features Intel 8085 cpu/100% compatible with 8080A software!**
- **Onboard S-100 bus (up to 6 slots)!**
- **Onboard RAM and ROM expansion!**
- **Built-in deluxe 2K Monitor/Operating ROM!**
- **Cassette/RS 232 or 20 mA J4-1/2 8-bit parallel I/O and timer all on beginner's Level "A" system!**

EXPLORER/85 gives you "big computer" features immediately, without turning you into an appliance operator. doomed to run pre developed software for life. Simply connect EXPLORER to a terminal, video monitor or tv set and 8 volt power supply and start running programs, the very first night! Level "A" teaches you machine language and computer fundamentals. It lets you run exercise programs including programs to examine the cpu registers, examine memory, fill memory, move memory and make up games. You can load and play back these programs on an ordinary tape cassette—and display your efforts on any tv screen, video monitor or printer. (\$8.95 RF modulator required for tv use.) The simplified architecture of the Intel 8085 makes EXPLORER far easier to understand than computers using the older, more complex but less powerful 8080A. Then when you're ready, EXPLORER can be expanded—by you—to rival the power of any 8-bit computer on earth. Or you can customize it to perform a dedicated task, thanks to onboard prototyping, RAM and ROM expansion capabilities.

LEVEL "A" SPECIFICATIONS

EXPLORER's Level "A" system features an advanced Intel 8085 cpu, which is 50% faster than its 8080A predecessor, yet 100% compatible with 8080A software which, you'll discover, exists by the ton. "Big computer" features include an 8355 ROM with 2K deluxe monitor/operating system which has two programmable 8-bit bi-directional parallel I/O ports, built-in cassette interface with tape control circuitry to allow labeling cassette files, and commands which include: display contents of memory...run at user location (go to)...insert data...move contents of memory...examine registers individually or all...fill command (to fill the contents of memory with any variable), automatic baud rate selection, programmable characters per line display output format, and more! An 8155 RAM—I/O chip contains 256 bytes of RAM, two programmable 8-bit bi-directional and one programmable 6-bit bi-directional I/O ports plus programmable 14-bit binary counter/timer, user interrupt and reset switches. Onboard expansion provisions exist for up to six S-100 boards, 4K of RAM and 8K of ROM, PROM or EPROM.

As featured in POPULAR ELECTRONICS

EXPLORER/85 shown with Video Monitor and Keyboard/Video Terminal

CHOICE OF HEX KEYPAD OR TERMINAL INPUT

If you plan to customize EXPLORER for dedicated use, we recommend that you order the hex keypad input. But if you are planning to go whole hog and blow EXPLORER up into a full size, state-of-the-art system with 8K or extended basic (coming soon), up to 64K of memory, floppy disks, telephone interface, printers, and all sorts of S-100 plug-ins—you'll be better off with the Keyboard/Video Terminal input. The \$149.95 EXPLORER Keyboard/Video Terminal includes full ASCII decoding with 128 ASCII upper/lower case set, 96 printable characters, onboard regulators and selectable display formats—32x16 for tv set or 64x16 for video monitor (not included).

EXPAND EXPLORER, LEVEL-BY-LEVEL

Level "B", at \$49.95, adds S-100 signals plus onboard RAM/ROM decoding. Includes all parts necessary to generate the signals for S-100 bus accessories. Just add two S-100 bus connectors and you have a complete S-100 compatible computer with a world of add-ons at your fingertips. Choose from hundreds of products to satisfy your individual needs. Level "B" kit also includes the address decoders for onboard RAM and ROM expansion, which are addressable anywhere in the 65K field.

Level "C" expansion, at \$39.95, expands the S-100 bus to allow a total of six S-100 cards to be plugged into EXPLORER's motherboard and contained in EXPLORER's steel cabinet. Includes all hardware, mounting brackets, board guides, etc. Just add the number of S-100 bus connectors you need.

Level "D" expansion, at \$69.95, gives you 4K of onboard static RAM utilizing 2114 IC's. Your board will also accept four 2716 EPROM's, which can be purchased separately. You now have an advanced mainframe that can be customized with the peripherals of your choice to fit any (or all) specific requirements. Each level of EXPLORER is separately regulated for the ultimate in stability. Factory service is available from Nelronics. Order your EXPLORER today!

ORDER FROM THIS COUPON TODAY!

Nelronics R&D Ltd., Dept PE 3, 333 Litchfield Road, New Milford, CT 06676

<input type="checkbox"/> Level "A" EXPLORER/85 kit (specify <input type="checkbox"/> terminal or <input type="checkbox"/> hex keypad input) \$129.95 plus \$3 p&h	<input type="checkbox"/> Deluxe Steel Cabinet for EXPLORER/85 \$39.95 plus \$3 p&h
<input type="checkbox"/> Power Supply kit, 5 amp, ±8 volt, \$34.95 plus \$2 p&h	<input type="checkbox"/> Deluxe Steel Cabinet for Keyboard/Video Terminal, \$19.95 plus \$2.50 p&h
<input type="checkbox"/> Intel 8085 User's Manual, \$7.50 p&h	<input type="checkbox"/> RF Modulator kit \$8.95 p&h
<input type="checkbox"/> ASCII Keyboard/Video Terminal kit, \$149.95 plus \$3 p&h	<input type="checkbox"/> Total Enclosed (Conn. res. add tax) \$
<input type="checkbox"/> Hex Keypad kit for hex version, \$69.95 plus \$2 p&h.	<input type="checkbox"/> VISA <input type="checkbox"/> Master Charge Exp Date
<input type="checkbox"/> Level "B" S-100/Onboard RAM/ROM Decoder kit (less S-100 connectors), \$49.95 plus \$2 p&h	Account #
<input type="checkbox"/> Level "C" S-100 5-Card Expander kit (less connectors), \$39.95 plus \$2 p&h	PHONE ORDERS CALL (203) 354-9375
<input type="checkbox"/> S-100 Bus Connectors (gold), \$4.85 each	Name _____
<input type="checkbox"/> Level "D" 4K Onboard RAM kit, \$69.95 plus \$2 p&h	Print _____
	Address _____
	City _____
	State _____ Zip _____

DEALER INQUIRIES INVITED

CIRCLE NO. 34 ON FREE INFORMATION CARD





Computer Bits

By Hal Chamberlin

RANDOM NUMBER GENERATORS

RANDOM number generator subroutines are taken for granted by nearly all computer users. Every version of the BASIC programming language, even the simplest "tiny BASIC", has a random number function. Probably the heaviest usage of random numbers is in games where chance is an element. Other applications of random numbers include real-world simulations, program testing, and the generation of white noise in music programs.

While BASIC users have a seemingly infinite reservoir of random numbers at their disposal simply by using the RND function, machine-language users also have applications for random numbers. Serious mathematical simulations where BASIC is too slow or 6-digit accuracy is not enough, are written in machine language and may need a high-speed source of random numbers. Music synthesis is usually done in machine language and requires random numbers for noise generation and subtle variations in the sound for naturalness. Also, games on small computers such as the KIM-1 or any of the TV or arcade systems must be programmed in machine language, and they need random numbers as well. Thus we will be looking at random number generator programs in general and two in particular that are effective yet simple enough to program in machine language.

Properties. Although there is a variety of methods for generating random numbers, several traits are shared by all of

them. The most distinctive is that the subroutine does not really *generate* random numbers, it merely *transforms* an input number into an output number. When generating a string of numbers, the previous output is simply fed back into the generator which then proceeds to generate a new output. The generator subroutine itself is a fixed mathematical function that does the input-to-output transformation. Although the output is related to the input in an obscure way, it seems to be completely unrelated to it in the end application.

The initial input used when the generator is started is called the *seed* and can usually be any number except zero. One consequence of the input-to-output transformation is that if the same seed is used on different occasions, the sequence of (pseudo) random numbers generated will be exactly the same. While this may not seem to be satisfactory random behavior, it does have advantages. For example, in debugging a program that utilizes random numbers, it is useful to be able to recreate known bugs and verify the effectiveness of corrections. On the other hand, when using a game program you want to be sure that the seed is different every time it is run. Forming a seed from the date and time supplied by the user is one possibility. Another is scanning through *all* of memory and forming the sum of what is found which is quite effective when semiconductor RAM is utilized for the memory function.

The generator transformation function

TABLE I—A AND B VALUES FOR LINEAR CONGRUENTIAL METHOD

Wordlength	Sequence length	A	B
8	256	77	55
12	4096	1485	865
16	65536	13709	13849
24	16777216	732573	3545443
32	4294967296	196314165	907633515

name _____

address _____

city _____

state _____

zip _____

MAIL THIS COUPON AND WE'LL SEND YOU THE BEST SPEAKER CATALOG YOU EVER READ!

No kidding. Speakerlab's catalog took longer to write than some of our competitors have been in business. In fact, we created an industry by "building great kits so you can afford great speakers." Our catalog is an invaluable



manual of speaker function and design. And, it will introduce you to the finest speaker kits made anywhere...with the strongest money-back guarantee. Find out for yourself...FREE. FREE. that is. Mail the coupon now.



The world of electronics gee-wizardry

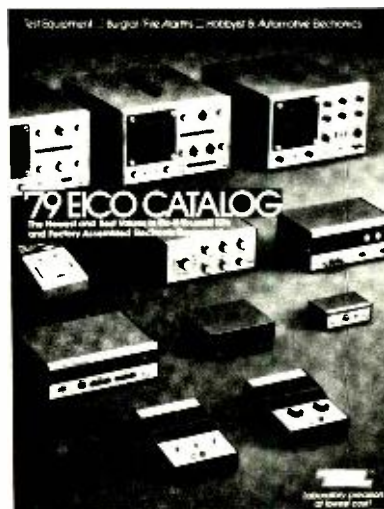

-YOURS FREE.

32-pages of test instruments — from the latest digital multimeters to the famous EICO scopes. Security systems. Automotive and hobbyist products. Kits and assembled. EICO quality. EICO value. For FREE catalog, check reader service card or send 75¢ for first class mail.



SAVE!

MONEY • TIME • FREIGHT

QUALITY STEREO EQUIPMENT AT LOWEST PRICES.

YOUR REQUEST FOR QUOTATION RETURNED SAME DAY.

FACTORY SEALED CARTONS—GUARANTEED AND INSURED.

SAVE ON NAME BRANDS LIKE:

PIONEER	SANSUI
KENWOOD	DYNACO
SHURE	SONY
MARANTZ	KOSS

AND MORE THAN 50 OTHERS
BUY THE MODERN WAY
BY MAIL—FROM

illinois audio

12 East Delaware
Chicago, Illinois 60611
312-664-0020

CIRCLE NO. 24 ON FREE INFORMATION CARD

SEE YOUR DEALER TODAY

PAL ANTENNAS

CB — AMATEUR — MARINE
FIBERGLASS ANTENNAS

DON'T TAKE NO FOR AN ANSWER



Our 16th Year Serving
the CB and
Communications Market



FRANK "BAGGY" SACKS
PRESIDENT

DEALER & DISTRIBUTOR
INQUIRIES INVITED



LOOK FOR THIS LOGO

SEND FOR FREE CATALOG

2614 E. ADAMS • PHOENIX, ARIZONA 85034

NAME _____
STREET _____
CITY _____
STATE _____ ZIP _____

CIRCLE NO. 41 ON FREE INFORMATION CARD

almost always uses integer arithmetic and the function is carefully chosen according to the word size of the computer. Since the output numbers are also integers with a finite number of bits, it is obvious that, at some point in the sequence, the seed will pop up again. From this point forward the sequence repeats itself.

An efficient random number generator will generate all or nearly all of the 2^n different numbers that can be represented by an n-bit word before repeating. Thus in a 16-bit computer, about 65,000 random numbers can be generated with single precision arithmetic before repeating.

The numbers produced by the generator are constrained to be within a certain range. The RND function in BASIC for example usually generates fractional numbers in the range of 0 to, but not including, +1.0. The machine language routines to be described generate unsigned integer numbers between 0 and $2^n - 1$. In either case, the range of the numbers is easily changed by multiplying and adding constants to them.

The random numbers themselves are uniformly distributed. This is a statistical term that means that all of the possible numbers in the allowable range are equally likely to occur. Some applications require normally distributed numbers where those near the middle of the range are more likely than those toward either extreme. This kind of distribution is most useful in simulating natural quantities such as the weight of a randomly chosen ripe apple. A true normal distribution can be closely approximated by adding up 12 uniform random numbers (range assumed to be between 0 and 1.0), and subtracting 6.0 from the sum. The mean (most likely value) of the normal distribution will then be zero and the standard deviation (a measure of how concentrated the numbers are around the mean) will be 1.0.

Methods. One of the most popular random number algorithms is called the linear congruential method. The transformation equation is: (new number) = $[A \times (\text{old number}) + B] \text{ MOD } M$ where A and B are carefully chosen constants. Unsigned integer arithmetic is assumed when performing the multiplication by A and addition of B. The MOD function means to divide by M and keep just the remainder. If M-1 is the largest possible unsigned integer for the computer's wordlength, then the MOD function is automatically performed by ignoring

THE ONE-STOP MUSIC SHOP AT WHOLESALE PRICES

J&R

BLANK TAPES		REEL-TO-REEL	
<p>Amperex Grand Master 1 C-90 \$14.99 Amperex Grand Master 1 C-90 \$12.79 BASF Professional 11 or 111 C-90 \$2.99 Maxell UD C-90 \$2.99 Maxell UDXL 1 or 11 C-90 \$3.47 Maxell UDXL 1 or 11 C-90 \$3.47 Scotch low noise C-90 \$4.99 (for 3) Scotch Master 11 or 111 C-90 \$3.24 Scotch Master 11 or 111 C-90 \$3.24 Sanyo Ferrichrome C-90 \$3.98 TDK D C-90 \$1.80 TDK D C-90 \$1.80 TDK D C-120 \$2.10 TDK D C-180 \$2.10 TDK AD C-90 \$1.14 TDK AD C-90 \$2.32 TDK SA C-90 \$2.22 TDK SA C-90 \$3.18</p>		<p>Maxell UD 36-90 1800 ft. \$6.99 Maxell UDXL 36 908 1800 ft. \$6.75 Maxell UD 36 180 3600 ft. \$16.30 Scotch 212 1800 ft. \$4.36 Scotch 232 1800 ft. \$4.36 TDK L-1800 1800 ft. \$6.22</p>	
CASSETTE TAPES		VIDEO TAPES	
<p>BETA FORMAT Sony L-750 (3 Hour) \$14.95 Sony L-500 (2 Hour) \$13.95 Scotch L-500 (2 Hour) \$13.95 Zaveth L-500 (2 Hour) \$13.95 Amperex L-500 (2 Hour) \$12.95</p>		<p>BETA FORMAT JVC F-120 (4 Hour) \$18.75 TDK F-120 (4 Hour) \$19.50 Fuji T-120 (4 Hour) \$17.95 RCA VK-300 (4 Hour) \$18.50 RCA VK-125 (2 Hour) \$14.95 Panasonic NVT-120 (4 Hour) \$18.95 Panasonic NVT-60 (2 Hour) \$14.95</p>	
Minimum Order 12 Tapes — 100% Guaranteed			
CARTRIDGES			
audio-technica		SHURE	
<p>AT-20 SLA \$119.00 AT-15 SLA \$85.00 AT-14 SLA \$49.00 AT-12 SLA \$34.00 AT-10 \$12.00</p>		<p>V15 TYPE IV \$89.90 V15 TYPE III \$64.95 M5EED \$29.75 M5EED \$21.00 M4E \$13.00 M3E \$9.00</p>	
STANTON		PICKERING	
<p>M5S \$72.00 M5EIE S \$55.00 M5EIE \$40.00 M5EIE \$26.00 S50E \$12.00</p>		<p>XV/3000 \$49.95 XV15/200E \$39.95 XV15/50E \$32.50 XV15/625E \$25.77 XV15/400E \$22.45</p>	
EMPIRE			
<p>2000Z \$59.90 2000T \$31.50 2000EII \$19.50 4000I \$29.90</p>		<p>XV/3000 \$49.95 XV15/200E \$39.95 XV15/50E \$32.50 XV15/625E \$25.77 XV15/400E \$22.45</p>	
HEADPHONES			
SENNHEISER		KOSS	
<p>HD-44 \$23.88 HD-400 \$26.98 HD-414 \$44.98 HD-424 \$60.28</p>		<p>PRO 4 AAA \$39.90 PRO 4 AAA \$40.00 HV7/LLC \$29.97 HV7/LLC \$35.97 K5A \$19.97</p>	
<p>HOW TO ORDER: For shipment within 48 hours, send money order or certified check. Two weeks delay on personal check. Please add \$3.50 per order for shipping & handling, \$6.80 for orders outside U.S.I., N.Y.S. residents add tax. No C.O.D.'s. All merchandise 100% guaranteed, brand new & factory fresh.</p>			
<p>33 PARK ROW, DEPT. PE, NEW YORK, N.Y. 10038 CALL TOLL FREE (800) 221-8180 CALL OR WRITE FOR FREE CATALOG</p>			
CIRCLE NO. 28 ON FREE INFORMATION CARD			

SOLDER CREAM

the new, quick, easier way to solder

You can now apply solder with just the squeeze of a tube. The solder is in a paste form, premixed with just the right ratio of flux. Its tacky consistency "holds" components temporarily prior to heating. Available in 3 alloys to meet most applications.



Electronic/Electrical: A 60/40 alloy with non-corrosive rosin flux for all types of wiring.
Plumbing & Sheet Metal: For most metal joining applications except aluminum.
Stainless Steel & Silver Jewelry: A tin/silver alloy with special flux; contains no lead. Blends in so well, you can hardly tell where it's been used.

ORDER NOW only **\$7.50** for all **3**

PLUS Bonus Pak of Emergency Solder
A flat tape-like solder that melts with a match. Ideal for most on-the-spot emergency repairs.

MULTICORE SOLDERS
DEPT. A, WESTBURY, N.Y. 11590

Send me all 3 solder cream alloys at the special price of \$7.50 and include my bonus Emergency Solder

NAME _____
ADDRESS _____

CITY/STATE ZIP _____
Price includes shipping and handling. Send Check or Money Order. N.Y. State residents add approx. sales tax.

ERSIN **SOLDERS**

CIRCLE NO. 57 ON FREE INFORMATION CARD

overflow when the other operations are performed; no actual division is necessary! Thus if the wordlength is 16 bits (one can combine several bytes to make any wordlength desired), multiplication by A can be performed with an integer multiply subroutine (see "Computer Bits" for Sept. 1978). Only the lower half of the product, which will almost surely overflow 16 bits, is added to B and the lower 16 bits of the sum, which may also overflow, is stored as the new random output.

Choosing A and B is tricky but the proper choice will insure that all 2^n (where n is the wordlength) possible numbers will be generated once before the sequence repeats. By using a wordlength of 32 bits, over 4 billion numbers can be generated before repeating. This is over a month running time at 1,000 numbers per second! If A and B meet the following requirements then not only will the sequence length be the maximum, but it will almost certainly be random enough for all but the most sophisticated applications.

1. A MOD 8 must be equal to 5.
2. A should be larger than \sqrt{M} but smaller than $M - \sqrt{M}$.
3. A, when expressed in binary, should have a "random looking" bit pattern.
4. C should be an odd number.
5. C/M should be approximately equal to .21132.

Suitable values of A and B for some common wordlengths are in Table I. One drawback of this type of generator, besides requiring a multiplication to perform, is that the least significant few bits of the numbers are not very random. Thus if random bits are necessary, the most significant bits should be used.

Another type of random number generator that is extremely efficient in machine language is based on simulating a feedback shift register in software. The only arithmetic operations needed are shifts and exclusive-ORs; no multiplication is required. Like the previous method, it is tied to the computer's wordlength but with multiple precision operations, any wordlength can be used. The procedure to generate a new number from an old one is as follows:

1. Shift the number left one bit position bringing in a zero on the right end and putting the overflow bit into the carry flag.
2. If the carry flag is off, the process is complete.
3. If the carry flag is on, flip selected bits in the shifted number. This may be

INCLUDES VIDEO INTERFACE



ELF II by Netronics
As Featured in POPULAR ELECTRONICS

Now available! Text Editor, Assembler, Disassembler and a new Video Display Board!

The TEXT EDITOR gives you word processing ability and the ability to edit assembly language programs while they are displayed on your video monitor. Lines and characters may be quickly inserted, deleted or changed. Add a printer and ELF II can type letters for you—error free—plus insert names and addresses from your mailing list!

ELF II'S ASSEMBLER translates assembly language programs into hexadecimal machine code for ELF II use. The Assembler features mnemonic abbreviations rather than numerics so that the instructions on your programs are easier to read—this is a big help in catching errors!

ELF II'S DISASSEMBLER takes machine code programs and produces assembly language source listings. This helps you understand the programs you are working with and improve them when required.

The new ELF II Video Display Board lets you generate a sharp, professional 32 or 64 character by 16 line upper and lower case display on your tv screen or video monitor—dramatically improving your unexpanded \$99.95 ELF II. When you get into longer programs, the Video Display Board is a real blessing!

Get Your Hands On A Computer That Grows As Fast As Your Own Understanding!

Stop reading about computers and get your hands on one! With ELF II and our new Short Course On Microprocessor & Computer Programming, by Tom Pittman, you can master computers in no time at all! ELF II can execute all 91 RCA 1802 commands. The Short Course quickly teaches you how to use each of these capabilities.

ELF II'S \$99.95 price includes video output—so you can display alphanumerics and graphics on your tv screen or video monitor. You can also enjoy video games including a fascinating new target/missile gun game that was developed specifically for ELF II.

But games are only the icing on the cake. ELF II is a small but powerful computer. It gives you a highly effective learning tool for only \$99.95—then expands as your understanding of computers grows.

If you want power to solve real world problems, ELF II has a lot more to offer than "famous name" computers selling for many times ELF II's low price. ELF II adds on are among the most sophisticated on the market today—at any price! No wonder IEEE chapters plus hundreds of universities and major corporations now use ELF II to introduce students and employees to microprocessor computing.

Start working with the incredibly versatile and foolproof ELF II and you'll understand why!

More Powerful Than Your College Degree!

A knowledge of computers may soon be more important to your earning power than a college degree. It doesn't matter whether you're a scientist, engineer, businessman or professional. Understand computers and you can command MONEY!

Master This Computer In A Flash!

Regardless of how minimal your computer background is now, you can learn to program an ELF II in almost no time at all. Our Short Course On Microprocessor & Computer Programming was written in non-technical language and it leads you through each of the RCA COSMAC 1802's capabilities, so you'll understand everything ELF II can do—and how to get ELF II to do it! Don't worry if you've been stumped by computer books before. The Short Course represents a major advance in literary clarity in the computer field. You don't have to be a computer engineer in order to understand it!

Keyed to ELF II it's loaded with "hands on" illustrations. When you're finished with the Short Course neither ELF II nor the RCA 1802 chip will hold any mysteries for you!

In fact, not only will you be able to use a personal computer creatively, you'll also be able to read magazines such as BYTE, INTERFACE, AGE, POPULAR

Now Available • Text Editor, Assembler & Disassembler!

Featuring the 1802 ELF II RCA COSMAC microprocessor/mini- COMPUTER ONLY \$99.95

ELECTRONICS and PERSONAL COMPUTING and understand the articles

If you work with larger computers, ELF II and our Short Course will help you to understand what makes them tick.

Get Started For Just \$99.95. Complete!

ELF II was developed as a trainer for engineers, hobbyists, technicians and students. Yet it offers advanced features not yet available elsewhere at any price.

With ELF II, you learn to use machine language, the fundamental language of all computers. Higher level languages such as FORTRAN and BASIC must be translated into machine language before a computer can understand them. With ELF II, you build a solid foundation in computers so you'll really know what you're doing.

For \$99.95 your ELF II also includes video output and you can connect it directly to the video input of your tv set without additional hardware. Or with an \$8.95 RF Modulator, you can connect ELF II to your tv's antenna terminals instead.

ELF II'S 5 card expansion bus (connectors not included) lets you expand ELF II as your needs grow. If you're an engineer or hobbyist you can also use ELF II as a counter, alarm, lock, thermostat, timer, telephone dialer or for countless other applications.

ELF II Expands Into A Giant!

Once you've mastered computer fundamentals, ELF II can give you more power to make things happen in the real world than famous name computers that would cost you a lot more money! Thanks to the ongoing RCA 1802 research and development by Netronics, ELF II can now be expanded with some of the most technically advanced small computer add-ons on the market.

Plug in the GIANT BOARD™ to record and play back programs, edit and debug programs, communicate with remote devices and make things happen in the outside world. Add Kluge Board and you can use ELF II to solve special problems such as operating a more complex alarm system or controlling a printing press. Add 4k RAM Boards to write longer programs, store more information and solve more sophisticated problems.

Expanded, ELF II is perfect for engineering, business, industrial, scientific and personal applications. No other small computer is backed by such an advanced research and development program!

ELF II adds on already include the ELF II Light Pen and the amazing ELF BUG™ Monitor—two extremely recent breakthroughs that have not yet been duplicated by any other manufacturer.

The ELF BUG™ Monitor lets you debug programs with lightning speed because the key to debugging is to know what's inside the registers of the microprocessor. And with the ELF BUG™ Monitor instead of single stepping through your program you can now display the entire contents of the registers on your tv screen. You find out immediately what's going on and can make any necessary changes.

The incredible ELF II Light Peg lets you write or draw anything you want on a tv screen with just a wave of the "magic wand." Netronics has also introduced the ELF II Color Graphics & Music System—more breakthroughs that ELF II owners were the first to enjoy!

ELF II Tiny BASIC

Like all computers, ELF II understands only machine language—the language computers use to talk to each other. But, to make life easier for you, we've developed an ELF II Tiny BASIC that lets you talk with ELF II in simple words that can be typed out on a keyboard such as PRINT, RUN and LOAD.

Ask Not What Your Computer Can Do... But WHAT CAN IT DO FOR YOU?

Don't be trapped into buying an expensive dinosaur, simply because you can afford it. ELF II is more advanced and more fun to use than big name computers that cost a lot more money. With ELF II you learn to write and run your own programs. You're not just a keypunch operator. No matter what your particular interests are, ELF II is the latest way to get into computers. Order from the coupon below!

Netronics R&D Ltd., Dept PE-3
333 Litchfield Road, New Milford, CT 06776

Yes! I want my own computer! Please rush me—



(Supply)

Power Supply (required): \$4.95 postpaid

RCA 1802 User's Manual: \$5 postpaid

Tom Pittman's Short Course On Microprocessor & Computer Programming teaches you just about everything there is to know about ELF II or any RCA 1802 computer. Written in non-technical

language it's a learning breakthrough for engineers and laymen alike. \$5 postpaid.

Deluxe Metal Cabinet with Plexiglas dust cover for ELF II: \$79.95 plus \$2.50 p&h.

I am also enclosing payment (including postage & handling) for the items checked below!

I want my ELF II wired and tested with power supply, RCA 1802 User's Manual and Short Course—all for just \$149.95 plus \$3 p&h.

ALSO AVAILABLE FOR ELF II:

GIANT BOARD™ kit with cassette I/O, RS 232 C, 16 I/O, 8 bit P I/O decoders for 14 separate I/O instructions and a system monitor/editor. \$39.95 plus \$2 p&h.

Kluge (Prototype) Board accepts up to 36 IC's. \$17.00 plus \$1 p&h.

4k Static RAM kit. Addressable to any 4k page to 64k. \$89.95 plus \$3 p&h.

Gold plated 86-pin connectors (one required for each thing in display). \$5.70 ea. postpaid.

Expansion Power Supply (required when adding 4k RAM). \$34.95 plus \$2 p&h.

Professional ASCII Keyboard kit with 128 ASCII upper/lower case set, 96 printable characters, onboard regulator, parity logic selection and choice of 4 hand shaking signals to mate with almost any computer. \$64.95 plus \$2 p&h.

Deluxe metal cabinet for ASCII Keyboard. \$19.95 plus \$2.50 p&h.

Video Display Board kit lets you generate a sharp professional 32 or 64 character by 16 line upper and lower case display on your tv screen or video monitor—dramatically improving your unexpanded \$99.95 ELF II kit's inside ASCII Keyboard cabinet. \$89.95 plus \$2 p&h.

ELF II Tiny BASIC on cassette tape. Commands include SAVE, LOAD, etc. \$3.

26 variables Z LET IF/THEN INPUT PRINT GO TO GO SUB RETURN END REM CLEAR LIST RUN, PLOT PEEK POKE. Comes fully documented and includes alphanumeric generator required to display alphanumeric characters directly on your tv screen with optional additional hardware. Also plays lock-tack type letters stick 4k memory required. \$14.95 postpaid.

Tom Pittman's Short Course on Tiny Basic for ELF II. \$5 postpaid.

ELF-BUG™ Deluxe System Monitor on cassette tape. Allows displaying the contents of all registers on your tv at any point in your program. Also displays 24 bytes of memory with full addresses, blinking cursor and auto scrolling. A must for the serious programmer! \$14.95 postpaid.

Text Editor on cassette tape gives you the ability to insert, delete or edit lines and words from your programs while they are displayed on your video monitor. (Add printer and you can use ELF II to type error-free letters & plus insert names and addresses from your mailing list.) \$19.95 postpaid.

Assembler on cassette tape translates assembly language programs into hexadecimal machine code for ELF II use. Mnemonic abbreviations for instructions rather than numerics make programs easier to read and help prevent errors. \$19.95 postpaid.

Disassembler on cassette tape takes machine code

PHONE ORDERS ACCEPTED!
Call (203) 354-9375

Total Enclosed \$

(Conn. res. add tax)

CHARGE IT! Exp. Date

Visa Master Charge

(Bank # _____)

Account # _____

programs and produces assembly language source listings to help you understand and improve your programs. \$19.95 on cassette tape.

SAVE \$9.90—Text Editor, Assembler & Disassembler purchased together, only \$49.95! (Require Video Display Board plus 4k memory.)

ELF II Light Pen, assembled & tested. \$7.95 plus \$1 p&h.

ELF II Color Graphics & Music System Board kit. \$49.95 plus \$2 p&h.

ELF II connects directly to the video input of your tv set without additional hardware. To connect ELF II to your antenna terminals instead, order RF Modulator. \$8.95 postpaid.

Coming Soon: A I) A Converter, Controller Board and more.

Print Name _____

Address _____

City _____

State _____ Zip _____

DEALER INQUIRIES INVITED

CIRCLE NO. 33 ON FREE INFORMATION CARD



A P Terminal and Distribution Strips are ideal building blocks for your breadboarding.

Now you can put together as simple or as elaborate a breadboard as you want—and be sure of top quality all the way—and pay only for what you need. Using A P Terminal and Distribution Strips as modules is the world's most economical way to assemble full-performance solderless breadboards.

You know how our strips work. Your electronic components plug right into the spring clip terminals behind

each hole. You complete your circuits with ordinary solid wire jumpers—you don't need special patch cords. Terminals clip tight, make superb contact time after time. (They're noncorrosive copper alloy 770.)

These versatile building blocks come in a wide variety of shapes and sizes, and we include hardware and mounting templates with each strip. You get all the flexibility in the world.

Where? At your nearby A P Products dealer. Need the address? Phone (toll-free) 800-321-9668. And ask for the complete A P catalog, *The Faster and Easier Book*.



A P PRODUCTS INCORPORATED

Box 110A • 72 Corwin Drive
Painesville, Ohio 44077
Tel. 216/354-2101
TWX: 810-425-2250

Faster and Easier is what we're all about.

accomplished by exclusive-ORing a mask word with the shifted number. The process is now complete.

Thus the key to this generator is to find a suitable mask. It is highly desirable to use a mask that gives a maximum length sequence which in this case is $2^n - 1$ since zero transforms into itself. If such a mask is not used, some seeds may produce very short sequences, even for long words. The best way to find a suitable mask is to write a simple program that actually counts the number of iterations necessary before an initial seed of 0001 is returned. Suitable masks for several popular word-lengths are given in Table II.

The numbers produced by this generator are not as good as with the first generator but the individual bits produced are highly random. The results are more than adequate however for games and white noise generation and one could hardly ask for a simpler procedure. The

TABLE II—MASK WORDS FOR FEEDBACK SHIFT REGISTER METHOD

Wordlength	Sequence length	Mask
8	255	1D
12	4095	1D9
16	65535	1D87
24	16777215	1D872B
32	4294967295	1D872B41

performance as a number generator may be improved by iterating it several times (such as $N+3$ where N is the wordlength) to get each number.

Testing. In any critical application it is necessary to test a homebrew random number generator before using it extensively. Even the RND function in BASIC is much better in some versions than others. While proper testing is a complex mathematical subject, one thing is definite: visually looking at a printout of a few numbers in the sequence is not a very reliable test. In fact, the "eyeball test" would probably flunk even the best generators because people tend to see patterns in small collections of things and any such patterns are not "supposed" to happen in a random sequence. One reasonably good visual test however is to generate a string of random bits and then fill the screen of a bit-mapped graphic display interface with them. Any visible regularity that covers a significant portion of the screen is probably a clue to a poor random number generator. ◇



Software Sources

8080/6800 File Management.

"Now what was the name of that good French restaurant in Chicago?" If you filed it once, DATA FILE can find it. The program responds to any information you can recall about the contents of a file by displaying the rest of the file. It can, for example, remind you who belongs to all those long-distance numbers on your phone bill. The program is available for 6800 or 8080 systems, and runs in 1K, using remaining RAM for storage. Features include facilities for editing and updating files, automatic top-of-memory check ensuring no data is accidentally lost, and continuous display of memory addresses for saving all data on tape or disk. 6800 versions are available as a listing only, or with either K.C. cassette or SWTP disk, all starting at 0110 Hex. 8080 versions are available as listing only, with Tarbell or National Multiplex CC-7 or CC-8 cassette (specify) or Intel-format paper tape, or on North Star disk; starting address may be 0000, 2000 or 2A00 hex. Listings are \$10, listing with cassette or tape \$15, and listings with disk, \$16. Practical Programming Co., Box 2069, North Brunswick, NJ 08902.

1802 Programming Aids. The *1802 Programmer's Notebook* includes information on software relocation and register-assignment techniques, timing constants, clock calibration, and short programs for time-of-day clock, hex frequency counter, hex random number, and hex addition and multiplication. \$1.00 plus self-addressed, stamped envelope, from David R. Wright, 128 Campus Ave., Ames, IA 50010.

PILOT for TRS-80. PILOT is a language designed for computer-assisted education, and is said to be so simple that even 6-year-olds have taught themselves to program in it. In this TRS-80 form, it includes PILOT program statements and commands (including CLOAD, CSAVE and line-printer commands) plus TRS-80 screen-clear and graphics commands. TRS-80 PILOT requires Level-II, 4K or 16K. \$50. Jeff Lasman, PRACTICAL APPLICATIONS, P.O. Box 4139, Foster City, CA 94404.

TRS-80 Word Processor. The Electric Pencil word-processor program is now available for the Radio Shack TRS-80, as well as an optional serial-printer output interface with

lower-case and control-key modification instructions. Written in machine code, not BASIC, for faster running, it will load into either Level-I or Level-II TRS-80s with 16K. It will operate upper-case only in unmodified machines, or upper/lower-case with the modification kit. Printers used can be either the Radio Shack printer and expansion box, or any RS-232 printer running 110-9600 baud, with the optional interface. Other features include 2-key rollover and repeat, line and character insert/delete, forward/reverse scrolling, string search with optional replace, block moves, page titling and numbering, and print formatting. The TRS-80 Electric Pencil is

\$100; the TRS-232 printer output interface with instructions only for lower-case modification (parts will be available later) is \$40. Small System Software, Box 483, Newbury Park, CA 91320.

8080 Simulator for KIM-1. 8080 programs can be run on a 6502-based KIM-1 with this program. It executes the entire 8080 instruction set and maintains 8080 registers for convenient examination or modification. It runs in less than 1K of memory, and can be relocated in ROM and adapted to other 6502 systems. \$19.50. Dann McCreary, 4758 Mansfield St. #2P, San Diego, CA 92116.

THE MICROCOMPUTER MART

Advertisement

CALIFORNIA

Omega Microcomputers
Quality Personal — Business Systems
Apple II — Alpha Micro
3535 Torrance Blvd.
Suite 10
Torrance, Ca 90503
(213) 370-9456

Rainbow Computing
Complete Apple II Line
10723 White Oak Avenue
Granado Hills, CA 91344
(213) 360-2171

COLORADO

Amptec, Inc.
Send For Our Catalog—10% Off
5975 North Broadway
Denver, CO 80216
(303) 571-8033

Byte Shop
Complete Apple II Line
3464 South Acoma Street
Englewood, CO 80110
(303) 761-6232

MARYLAND

Computers Unlimited, Inc.
Tomorrow's Technology Today
907 York Road
Towson, MD 21204
(301) 321-1553

MICHIGAN

The Computer Mart
We Will Not Be Undersold
1800 West 14 Mile Road
Royal Oak, MI 48073
(313) 576-0900

United Microsystems Corporation
The Professional Computer Store
2601 South State Street
Ann Arbor, MI 48104
(313) 688-6806

NEW JERSEY

Computer Mart of New Jersey
The Microcomputer People (tm)
501 Route 27
Iselin, NJ 08830
(201) 283-0600

NEW YORK

Byte Shop of Long Island
The Affordable Computer Store
2721 Hempstead Turnpike
2 Blocks East Of Wantagh Parkway
Levittown, New York 11756
(516) 731-8116

Byte Shop of New York
The Affordable Computer Store
130 East 40th Street
New York, NY 10016
(212) 889-4204

Computer Mart of New York
First In The East
118 Madison Avenue
(30th Street Entrance)
New York, NY 10016
(212) 686-7923

OHIO

Ohio Microcomputer Specialists
Imsai Personal and Business Systems
1265 Grandview Avenue
Columbus, OH 43212
(614) 488-1849

OKLAHOMA

Microlithics, Inc.
Medical Systems-Differential Diagnosis
2918 MacArthur Boulevard
Oklahoma City, OK 73127
(405) 947-5646

PENNSYLVANIA

Personal Computer Corporation
OEM Specialists
Frazer Mall
Lancaster Avenue and Route 352
Frazer, PA 19355
(215) 647-8463

SOUTH CAROLINA

Byte Shop #32
The Affordable Computer Store
1920 Blossom Street
Columbia, SC 29205
(803) 771-7824

CANADA

TJB Microsystems, LTD
Your Commodore Pet Headquarters
10991-124th Street
Edmonton, Alberta, Canada
T5M 0H9
(403) 455-5298

Dealers: For information about how to have your store listed in THE MICROCOMPUTER MART, please contact: POPULAR ELECTRONICS, One Park Ave., New York, N.Y. 10016 • (212) 725-3568.

NORTH STAR



HORIZON 1, DOUBLE DENSITY, kit,
list \$1599 01-3501-1 \$1349
Factory assem, list \$1899 01-4501-1 \$1599

HORIZON 2, Double Density, Kit
List \$1999 01-3502-1 \$1699
Factory assem, list \$2349 01-4502-1 \$1939

COMPLETE MINIFLOPPY DISK, Kit
Double density \$699 (order 01-7735-1) \$589
Factory assembled, double density
List \$799 (01-7745-1) \$689

TRS-80 OWNERS:
Write for catalog on specials
SAVE 10% to 20%!

SORCERER COMPUTER SYSTEM

8K RAM, List \$895 (37-5008 0) \$787
16K RAM, List \$1150 (37-5016 0) 1012
32K RAM, List \$1395 (37-5032 0) 1232

SHIPPING Add \$12 per system for Sorcerer
and floppy disk systems, add \$5

Write for free catalog

MiniMicroMart, Inc.
1618 James St., Syracuse NY 13203
(315) 422-4467

CIRCLE NO. 31 ON FREE INFORMATION CARD

PROJECT OF THE MONTH

BY FORREST M. MIMS

A HIGH-RESOLUTION LED DISPLAY

A thin, high-resolution, two-dimensional display with X-Y addressability would have many applications in such fields as television, oscilloscopes, electronic games, micro-computer displays and alphanumeric and graphic data displays for pocket calculators and data loggers.

Experimental flat-screen displays have been made based on gaseous discharge, electrofluorescence, light-emitting diodes and liquid crystal technologies. The liquid crystal method appears to offer the greatest economy and certainly the thinnest configuration, but this display medium cannot yet change states fast enough for television applications.

The technology needed to build large-area LED displays has been available for a decade, but the high cost of the LEDs themselves and the addressing circuits they require has thus far restricted their use to military and laboratory applications. Now that low-cost visible LEDs are available, you can assemble a 16 x 10, 160-element LED display for less than \$20—assuming you can procure the LEDs for less than 10¢ each.

Figure A is the circuit diagram of the array. The ten 330-ohm resistors limit current to the LEDs, providing about 10 mA to each LED if a 5-volt power supply is used.

The exact construction method employed in the assembly of the display depends on the lead arrangement of the LEDs. Figure B is a photograph of the 160-element display assembled on a perforated board with 0.1-inch hole centers and a copper solder pad at most holes (Radio Shack 276-1551 or similar).

I used yellow LEDs, but you can use red or green LEDs if you prefer. I also painted the LED side of the board black before installing the LEDs to enhance the display's contrast. The current-limiting resistors can be seen near the lower left of the display.

Although the electrical circuit of the array is very simple, its construction requires a good deal of patience. First, all the LEDs must be soldered to the board. That alone requires 320 separate solder connections. Then all the anodes in each horizontal row and all the cathodes in each vertical col-

TAPE DISCOUNTS

Minimum order 10 tapes



CASSETTES

UDXL I or II C-60	2.99
UDXL I or II C-90	3.99
UDC-60	2.49
UDC-90	2.99
LNC-46	1.29
LNC-60	1.49
LNC-90	2.39
LNC-120	3.29

8-TRACK

LN 46 8tk	1.99
LN 60 8tk	2.29
LN 90 8tk	2.59
UD 46 8tk	2.39
UD 90 8tk	2.99

OPEN REEL

UD35-90 1800 x 7	5.79
UD-35-180 3600 x 10 1/2	15.99
LN50-60 1200 x 7	4.59
LN35-90 1800 x 7	4.99

MEMOREX

CASSETTES

C-60	2.19
C-90 3 pk.	3 for 5.49
C-120	4.50

8-TRACK

60 MIN 8tk	2.99
90 " 8tk 2pk.	2 for 4.99

SPECIAL

Soundguard Record Preservation Kit	5.59 ea
Soundguard Record Preservation Refill	3.59 ea

Lifetime Product Guarantee! Order Now!
Orders shipped within 1-3 days. Please add \$2.00
for shpg. & hdlg. per 10 tapes N.Y.S. residents
add sales tax. NO COD'S. FREE CATALOG

CONSUMERS CO

P.O. Box 550 Dept. P03

Mt Vernon NY 10551 Phone 1914/664-2909

CIRCLE NO. 11 ON FREE INFORMATION CARD



John Simonton's time-proven design provides two envelope generators VCA, VCO & VCF in a low cost, easy to use package.

Use alone with its built-in ribbon controller or modify to use with guitar, electronic piano, polytonic keyboards, etc.

The perfect introduction to electronic music and best of all, the Gnome is only \$59.95 in easy to assemble kit form. Is it any wonder why we've sold thousands?

- () Send GNOME MICRO-SYNTHESIZER Kit (\$59.95 plus \$2.00 postage)
- () GNOME MICRO-SYNTHESIZER (Fully Assembled) \$100.00 plus \$2 postage
- () Send FREE CATALOG

name: _____
address: _____
city: _____ state: _____ zip: _____

BAC, VISA MC card no. _____
DEPT. 3-P
1020 W. WILSHIRE, OKLAHOMA CITY, OK 73116

CIRCLE NO. 40 ON FREE INFORMATION CARD

BY POPULAR DEMAND!

MS-215 Dual Trace Miniscope

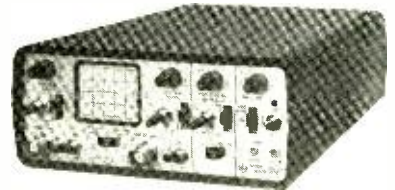

With Rechargeable Batteries & Charger Unit. \$435

- 15-megahertz bandwidth.
- External & internal trigger.
- Auto or line sync modes.
- Power usage — < 15 W.
- Battery or line operation.
- 2.9" H x 6.4" W x 8.0" D.



Non-Linear Systems, Inc.

Originator of the digital voltmeter.

Box N, Del Mar, California 92014

Telephone (714) 755-1134 TWX 910-322-1132

CIRCLE NO. 36 ON FREE INFORMATION CARD

umn must be connected together with bus wires. This requires 320 additional solder connections.

The resistors and output connections to the board's copper fingers require another 72 solder connections, resulting in a total of 712 solder connections! Don't be discouraged though. I was able to complete the board shown in Figure B in less than four hours—and that included plenty of short breaks to relieve eye strain.

PROJECT OF THE MONTH

(Continued)

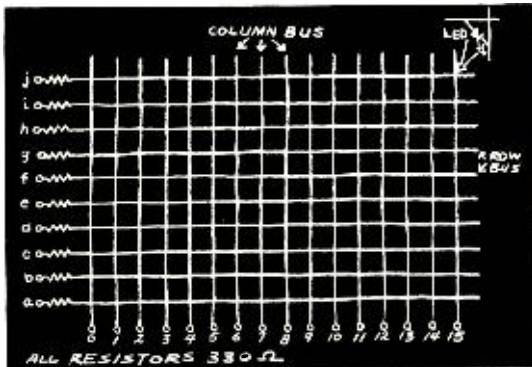

Fig. A. 10 x 16 160-element LED display.

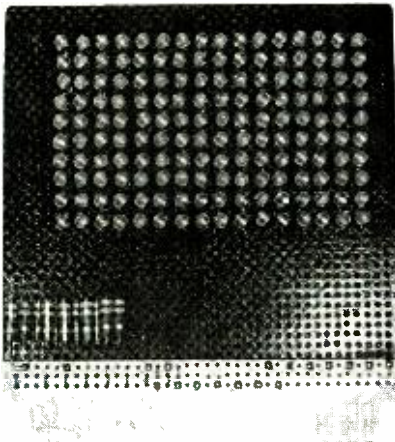

Fig. B. Prototype 160-element flat-screen LED array.

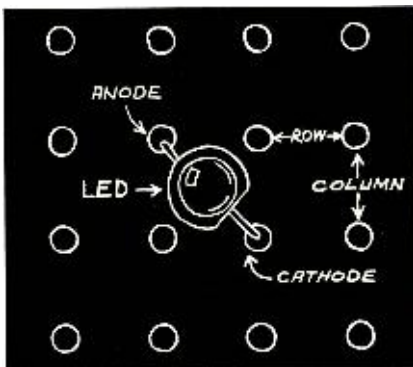

Fig. C. Orientation of individual LED in array.

The following tips will simplify the assembly of the display board:

- Select LEDs with leads parallel to their viewing axis and make sure the leads fit the holes in the board you select.
- Test each LED before it is soldered in place. You can make a temporary test jig from a 6-volt battery, 330-ohm resistor and some clip leads.
- Install one column of ten LEDs at a time. Make sure the diodes are oriented as shown in Figure C. The cathode lead is usually indicated by a notch or flat area in the epoxy encapsulant.
- Bend the leads of each LED outward slightly on the back side of the board. Turn the board over and place it on two supports so the LEDs hang from their leads.
- Use a low-wattage iron and small-diameter solder to solder one lead of each LED to its copper foil pad. Turn the board over and make sure the LEDs are aligned

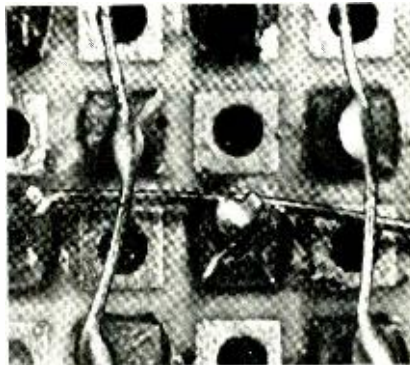

Fig. D. Row and column buses are soldered to LED leads on back of board.

properly. Then solder the remaining leads.

Follow these steps to solder all sixteen columns. Be sure to keep the LEDs perfectly aligned for best results. If you have trouble keeping the columns straight, tape a pencil to the board adjacent to each column while the diodes are being soldered.

Use tinned, small-diameter (e.g. No. 26) wire or stripped Wire-Wrap wire for the column and row buses. Solder the row buses first. The easiest way is to lay a wire along the anode leads in one row so the wire touches each solder pad. Then use a very small amount of solder to tack the wire to each pad. The column buses must be soldered above the row buses since the bus wires are uninsulated. Figure D is a small portion of the completed board.

The display board is completed by soldering lengths of Wire-Wrap wire from points a through f and 0 through 15 in Fig. A to the copper fingers on the board. Try to select an orderly pin-connection arrangement to simplify the interface to a driving circuit. The connection pattern can be considered a bus, and the bus connections for the prototype board that I built are listed according to the pin designations of a 44-terminal edge connector socket (the pin designations are marked on the socket):

LED Array Connection	S-44 Socket
0	7
1	8
2	9
3	10
4	11
5	12
6	13
7	14
8	15
9	16
10	17
11	18
12	19
13	20
14	21
15	22
a	A
b	B
c	C
d	D
e	E
f	F
g	H
h	J
i	K
j	L

This bus leaves plenty of spare lines that can be used by an array driving circuit. In the next Project of the Month, I will describe a driving circuit that uses the array as the screen of a solid-state experimental oscilloscope. ◇



Same day shipment. First line parts only. Factory tested. Guaranteed money back. Quality IC's and other components at factory prices.

INTEGRATED CIRCUITS

7400 TTL	LM340T-18	1.00	CD3451-1	35	8212	2.90
7400N	LM340T-18	1.00	CD3451-2	35	8212	2.90
7400N	LM343H	4.50	CD4516	1.00	8216	2.90
7400N	LM3470	1.15	CD4518	1.00	8225	2.90
7400N	LM3477	4.50	CD4520	1.00	8228	2.90
7400N	LM3479	5.00	CD4522	1.00	8351	8.50
7400N	LM3480	1.00	CD4528	1.00	8253	10.00
7400N	LM3481	1.00	CD4533	5.75	8257	10.00
7400N	LM3482	1.00	CD4566	2.25	8257	19.50
7400N	LM3483	1.00	CD4583	4.50	8258	19.50
7400N	LM3484	2.00	CD4585	1.00	8259	19.50
7400N	LM3485	2.00	CD4587	1.00	8260	19.50
7400N	LM3486	2.00	CD4589	1.00	8261	19.50
7400N	LM3487	2.00	CD4590	1.00	8262	19.50
7400N	LM3488	2.00	CD4591	1.00	8263	19.50
7400N	LM3489	2.00	CD4592	1.00	8264	19.50
7400N	LM3490	2.00	CD4593	1.00	8265	19.50
7400N	LM3491	2.00	CD4594	1.00	8266	19.50
7400N	LM3492	2.00	CD4595	1.00	8267	19.50
7400N	LM3493	2.00	CD4596	1.00	8268	19.50
7400N	LM3494	2.00	CD4597	1.00	8269	19.50
7400N	LM3495	2.00	CD4598	1.00	8270	19.50
7400N	LM3496	2.00	CD4599	1.00	8271	19.50
7400N	LM3497	2.00	CD4600	1.00	8272	19.50
7400N	LM3498	2.00	CD4601	1.00	8273	19.50
7400N	LM3499	2.00	CD4602	1.00	8274	19.50
7400N	LM3400	2.00	CD4603	1.00	8275	19.50
7400N	LM3401	2.00	CD4604	1.00	8276	19.50
7400N	LM3402	2.00	CD4605	1.00	8277	19.50
7400N	LM3403	2.00	CD4606	1.00	8278	19.50
7400N	LM3404	2.00	CD4607	1.00	8279	19.50
7400N	LM3405	2.00	CD4608	1.00	8280	19.50
7400N	LM3406	2.00	CD4609	1.00	8281	19.50
7400N	LM3407	2.00	CD4610	1.00	8282	19.50
7400N	LM3408	2.00	CD4611	1.00	8283	19.50
7400N	LM3409	2.00	CD4612	1.00	8284	19.50
7400N	LM3410	2.00	CD4613	1.00	8285	19.50
7400N	LM3411	2.00	CD4614	1.00	8286	19.50
7400N	LM3412	2.00	CD4615	1.00	8287	19.50
7400N	LM3413	2.00	CD4616	1.00	8288	19.50
7400N	LM3414	2.00	CD4617	1.00	8289	19.50
7400N	LM3415	2.00	CD4618	1.00	8290	19.50
7400N	LM3416	2.00	CD4619	1.00	8291	19.50
7400N	LM3417	2.00	CD4620	1.00	8292	19.50
7400N	LM3418	2.00	CD4621	1.00	8293	19.50
7400N	LM3419	2.00	CD4622	1.00	8294	19.50
7400N	LM3420	2.00	CD4623	1.00	8295	19.50
7400N	LM3421	2.00	CD4624	1.00	8296	19.50
7400N	LM3422	2.00	CD4625	1.00	8297	19.50
7400N	LM3423	2.00	CD4626	1.00	8298	19.50
7400N	LM3424	2.00	CD4627	1.00	8299	19.50
7400N	LM3425	2.00	CD4628	1.00	8300	19.50
7400N	LM3426	2.00	CD4629	1.00	8301	19.50
7400N	LM3427	2.00	CD4630	1.00	8302	19.50
7400N	LM3428	2.00	CD4631	1.00	8303	19.50
7400N	LM3429	2.00	CD4632	1.00	8304	19.50
7400N	LM3430	2.00	CD4633	1.00	8305	19.50
7400N	LM3431	2.00	CD4634	1.00	8306	19.50
7400N	LM3432	2.00	CD4635	1.00	8307	19.50
7400N	LM3433	2.00	CD4636	1.00	8308	19.50
7400N	LM3434	2.00	CD4637	1.00	8309	19.50
7400N	LM3435	2.00	CD4638	1.00	8310	19.50
7400N	LM3436	2.00	CD4639	1.00	8311	19.50
7400N	LM3437	2.00	CD4640	1.00	8312	19.50
7400N	LM3438	2.00	CD4641	1.00	8313	19.50
7400N	LM3439	2.00	CD4642	1.00	8314	19.50
7400N	LM3440	2.00	CD4643	1.00	8315	19.50
7400N	LM3441	2.00	CD4644	1.00	8316	19.50
7400N	LM3442	2.00	CD4645	1.00	8317	19.50
7400N	LM3443	2.00	CD4646	1.00	8318	19.50
7400N	LM3444	2.00	CD4647	1.00	8319	19.50
7400N	LM3445	2.00	CD4648	1.00	8320	19.50
7400N	LM3446	2.00	CD4649	1.00	8321	19.50
7400N	LM3447	2.00	CD4650	1.00	8322	19.50
7400N	LM3448	2.00	CD4651	1.00	8323	19.50
7400N	LM3449	2.00	CD4652	1.00	8324	19.50
7400N	LM3450	2.00	CD4653	1.00	8325	19.50
7400N	LM3451	2.00	CD4654	1.00	8326	19.50
7400N	LM3452	2.00	CD4655	1.00	8327	19.50
7400N	LM3453	2.00	CD4656	1.00	8328	19.50
7400N	LM3454	2.00	CD4657	1.00	8329	19.50
7400N	LM3455	2.00	CD4658	1.00	8330	19.50
7400N	LM3456	2.00	CD4659	1.00	8331	19.50
7400N	LM3457	2.00	CD4660	1.00	8332	19.50
7400N	LM3458	2.00	CD4661	1.00	8333	19.50
7400N	LM3459	2.00	CD4662	1.00	8334	19.50
7400N	LM3460	2.00	CD4663	1.00	8335	19.50
7400N	LM3461	2.00	CD4664	1.00	8336	19.50
7400N	LM3462	2.00	CD4665	1.00	8337	19.50
7400N	LM3463	2.00	CD4666	1.00	8338	19.50
7400N	LM3464	2.00	CD4667	1.00	8339	19.50
7400N	LM3465	2.00	CD4668	1.00	8340	19.50
7400N	LM3466	2.00	CD4669	1.00	8341	19.50
7400N	LM3467	2.00	CD4670	1.00	8342	19.50
7400N	LM3468	2.00	CD4671	1.00	8343	19.50
7400N	LM3469	2.00	CD4672	1.00	8344	19.50
7400N	LM3470	2.00	CD4673	1.00	8345	19.50
7400N	LM3471	2.00	CD4674	1.00	8346	19.50
7400N	LM3472	2.00	CD4675	1.00	8347	19.50
7400N	LM3473	2.00	CD4676	1.00	8348	19.50
7400N	LM3474	2.00	CD4677	1.00	8349	19.50
7400N	LM3475	2.00	CD4678	1.00	8350	19.50
7400N	LM3476	2.00	CD4679	1.00	8351	19.50
7400N	LM3477	2.00	CD4680	1.00	8352	19.50
7400N	LM3478	2.00	CD4681	1.00	8353	19.50
7400N	LM3479	2.00	CD4682	1.00	8354	19.50
7400N	LM3480	2.00	CD4683	1.00	8355	19.50
7400N	LM3481	2.00	CD4684	1.00	8356	19.50
7400N	LM3482	2.00	CD4685	1.00	8357	19.50
7400N	LM3483	2.00	CD4686	1.00	8358	19.50
7400N	LM3484	2.00	CD4687	1.00	8359	19.50
7400N	LM3485	2.00	CD4688	1.00	8360	19.50
7400N	LM3486	2.00	CD4689	1.00	8361	19.50
7400N	LM3487	2.00	CD4690	1.00	8362	19.50
7400N	LM3488	2.00	CD4691	1.00	8363	19.50
7400N	LM3489	2.00	CD4692	1.00	8364	19.50
7400N	LM3490	2.00	CD4693	1.00	8365	19.50
7400N	LM3491	2.00	CD4694	1.00	8366	19.50
7400N	LM3492	2.00	CD4695	1.00	8367	19.50
7400N	LM3493	2.00	CD4696	1.00	8368	19.50
7400N	LM3494	2.00	CD4697	1.00	8369	19.50
7400N	LM3495	2.00	CD4698	1.00	8370	19.50
7400N	LM3496	2.00	CD4699	1.00	8371	19.50
7400N	LM3497	2.00	CD4700	1.00	8372	19.50

8212	2.90
8216	2.90
8225	2.90
8228	2.90
8351	8.50
8253	10.00
8257	10.00
8258	19.50
8259	19.50
8260	19.50
8261	19.50
8262	19.50
8263	19.50
8264	19.50
8265	19.50
8266	19.50
8267	19.50
8268	19.50
8269	19.50
8270	19.50
8271	19.50
8272	19.50
8273	19.50
8274	19.50
8275	19.50
8276	19.50
8277	19.50
8278	19.50
8279	19.50
8280	19.50
8281	19.50
8282	19.50
8283	19.50
8284	19.50
8285	19.50
8286	19.50
8287	19.50
8288	19.50
8289	19.50
8290	19.50
8291	19.50
8292	19.50
8293	19.50
8294	19.50
8295	19.50
8296	19.50
8297	19.50
8298	19.50
8299	19.50
8300	19.50
8301	19.50
8302	19.50
8303	19.50
8304	19.50
8305	19.50
8306	19.50
8307	19.50
8308	19.50
8309	19.50
8310	19.50
8311	19.50
8312	19.50
8313	19.50
8314	19.50
8315	19.50
8316	19.50
8317	19.50
8318	19.50
8319	19.50
8320	19.50

IT'S NEW! IT'S EXCITING! POLY PAKS GIANT "INFLATION FIGHTING" SALE!



SALE

A PENNY MORE GETS YOU TWO*

*Buy any item on this page and choose 2nd item for only one penny!

- 3 MICROPROCESSOR/SUPPORT CHIPS, asst. MM 5780-90 series, 24-28 pin (#5639) 1.29 6 for 1.30
- 5 CLOCK/CALCULATOR CHIPS, asst. MM5378, 75-5377 etc. (#5638) 1.29 50 for 1.30
- 25 DTL FAIRCHILD IC's, gates and flip flops, Dip. 100 (#3709) 1.29 10 for 1.30
- 1-24 VOLT 50 MILLI TRANSFORMER, 115 V input, open frame, 1" x 1" x 3/4" (#5631) 1.29 2 for 1.30
- 10-2N3704 TRANSISTORS, silicon, TO-18 case, hfe-300, 100% (#5625) 1.29 20 for 1.30
- 10-2N3705 TRANSISTORS, silicon, TO-18 case, hfe-150, 100% (#5626) 1.29 20 for 1.30
- 10D3321 TRANSISTORS, low power, silicon, hfe-60, TO-18 (#5627) 1.29 20 for 1.30
- 1 ALLEN BRADLEY POT. 10K, 2-1 4 wire, type J, 2" x 1/2" shaft (#1748) 1.29 2 for 1.30
- 50 ASST. RED LEADS, 20x or better, various styles and types (#5624) 1.29 100 for 1.30
- 10 G.E. POWER TAB TRANSISTORS, D4040, NPN, Hfe-200 (#5629) 1.29 20 for 1.30
- 60 PRECISION RESISTORS, 1/4 watt, 1%, marked, long leads (#5453) 1.29 20 for 1.30
- 1-12VDC SMIL REED RELAY, spst, N.O., 2200 ohms, 7/8" x 5/16" (#5515) 1.29 2 for 1.30
- 50 TEMP. COEFFICIENT VOLTAGE REF. DIODES, asst. u-test, +/-50% (#5647) 1.29 100 for 1.30
- 12 LM-380 IC's, 2 watts, dip, 50% yield, U-test (#1975) 1.29 24 for 1.30
- 100 RED LEAD DISC CAPS, assorted values, 50% material (#4888) 1.29 200 for 1.30
- 50 SHOCKLEY DIODES, most popular switching diode, hobby & untested (#1072A) 1.29 100 for 1.30
- 6 OPTO-COUPLER, 1500V isolation, hobby material, U-test (#2629A) 1.29 12 for 1.30
- 4 CHERRY MICRO SWITCH, 125 VAC, 150 mA, H-type E-13, screw terminals (#5525) 1.29 8 for 1.30
- 5 SPST PUSHBUTTON MOMENTARIES (rt. angle, etc. mt., on on) (#5635) 1.29 10 for 1.30
- 25 TTL's, with 7400's, u-test, dips (#2415A) 1.29 50 for 1.30
- 100-CAPACITOR SPECIAL, discs, mylar, lytixa, core (#2738) 2.49 200 for 2.50
- 10-VOLTAGE REGULATORS, hobby LM320, 340, TO-3 (#3330) 2.49 20 for 2.50
- 30-PANEL SWITCHES, slides, rotaries, mod. etc. (#3268) 2.49 40 for 2.50
- 200-RESISTOR SPECIAL, 1/4 to 1W, carbon, metal (#3084) 2.49 400 for 2.50
- 200-HALF WATTERS, resistors, carbon, metal (#3046) 2.49 400 for 2.50
- 100-NATIONAL IC BOMBAZERS, linears, 7400s ROMS (#2860) 2.49 200 for 2.50
- 15-1M3407 TUBES, 810V, 810V, TO-220 (#2426) 2.49 50 for 2.50
- 100-POLYSTYRENE CAPS, asst. values, voltage, hi-Q (#2729) 2.49 200 for 2.50
- 50-THERMISTORS, resistors that change with temp (#4089) 2.49 100 for 2.50
- 20-INDUCTORS, untested, 2, 4, & amp, full wave (#4021) 2.49 40 for 2.50
- 15-MIXED BLENDED, resistors, various, mod. etc. (#3618) 2.49 30 for 2.50
- 150-QUARTER WATTERS, resistors, metal film, marked (#3413) 2.49 300 for 2.50
- 100-PLASTIC TRANSISTORS, untested, TO-18 (#2904) 2.49 200 for 2.50
- 200-PREFORMED RESISTORS, 1/4, 1/2, 1W, marked, asst. (#2608) 2.49 400 for 2.50
- 150-PRECISION RESISTORS, 1/4, 1W, 1%, marked, asst. (#2426) 2.49 300 for 2.50
- 60-DIPPED MYLARS, shiny finish, asst. values (#2587) 2.49 120 for 2.50
- 30-VOLUME CONTROLS, audio, linear, asst. values (#2421) 2.49 60 for 2.50
- 300-SILICON SIGNAL DIODES, micro, glass, covers look 50% yield (#2628) 2.49 600 for 2.50
- 15-CLOCK/CALCULATOR CHIPS, asst. values, marked, etc. (#5638) 2.49 30 for 2.50
- 10-PUSH SWITCHES, push-to-break, opt. alarm (#5289) 2.49 24 for 2.50
- 12-MICROPROCESSORS, and support IC's, (#5639) 2.49 24 for 2.50
- 150-GLASS ZENERS, 400 MW, untested, better than 50% yield (#2740) 2.49 300 for 2.50
- 75-CARBON FILM RESISTORS, 1/4, 1/2, 1W, 1%, marked, asst. (#3534) 2.49 150 for 2.50
- 250-UNMARKED CAPACITORS, polystyrene, molded, pop values (#3805) 2.49 300 for 2.50
- 100-1M4148/914 SWITCHING DIODES, 50% yield, untested (#2418) 2.49 500 for 2.50
- 30-PC TRIM POTENTIOMETERS, thumbwheel, screwdriver asst. (#3345) 2.49 60 for 2.50
- 15-SLIDE VOLUME CONTROLS, audio, asst. values, dual, singles (#3057) 2.49 30 for 2.50
- 75-4" CABLE TIES, plastic, 1/8" x 1/2" (#3250) 2.49 150 for 2.50
- 10-CRYSTALS, may include CB, Ham & more (#3250) 2.49 20 for 2.50
- 100-TERMINAL STRIPS, from 2 pins up (#3138) 2.49 200 for 2.50
- 30-HE-ZEMER LAMPS, all 100% good (#2613) 2.49 60 for 2.50
- 40-FR. SHIELDED CABLE, 1 cond., milco, open (#3877) 2.49 80 ft. for 2.50
- 3-SOUND TRIGGERS, sound triggers, ac w/amp (#3425) 2.49 20 for 2.50
- 10-CB CRYSTALS, for phase lock loop, HAM, MC/18 (#5050) 2.49 20 for 2.50
- 50-4 LAYER SHOCKLEY DIODES, Asst. pop. voltages (#1072) 2.49 100 for 2.50
- 75-8N7400 TTL IC's, untested 50% yield, pop types (#3248) 2.49 200 for 2.50
- 30-LM380 AUDIO IC's, 2 watts on a dip 50% yield (#5284) 2.49 60 for 2.50
- 75-LINEARS, 100% yield, 50% yield, amp-dips, mids-dips (#2416) 2.49 150 for 2.50
- 100-TTL & LINEAR MIXED, with 7400's, 80% yield (#2411) 2.49 200 for 2.50
- 150-PREFORMED DISC CAPACITORS, mark-a-value, asst. (#2605) 2.49 300 for 2.50
- 10-CALCULATOR KEYBOARDS, 20 keys up and (#3524) 2.49 20 for 2.50
- 2000 FACTORY REJECT DIODES, zenars, rect, signal, untested (#5369) 2.49 4000 for 2.50
- 40-AXIAL ELECTRO CAPS, 1/2, 1W, 1%, marked, asst. (#3277) 2.49 80 for 2.50
- 40-UPRIGHT ELECTRO CAPS, asst. values & capacitance, (#3226) 2.49 80 for 2.50
- 150 RED DISC SPECIAL, Erie, mostly marked, pop values (#5341) 2.49 300 for 2.50
- "WATCH OUTS", LED, who knows how good (#527) 2.49 2 for 2.50
- 10 1000V 1 AMP RECTIFIERS, IN4007, 2384 2.49 20 for 2.50
- 150 MOLEX IC connectors, for 14, 16, 18, 40 sockets (#3324) 2.49 300 for 2.50
- 25 POWER TAB TRANSISTORS, TO-202, 30 watts (#425) 2.49 50 for 2.50
- 10 PUSH MICRO TOGGLE SWITCHES, asst. (#5635) 2.49 20 for 2.50
- 10 MICRO TOGGLE SWITCHES, panel, at, (#5636) 2.49 20 for 2.50
- 50 2 AMP METAL CASE AXIAL RECTS. up to 1KV, 4000G 2.49 100 for 2.50
- 100 MINI BLOCK CAPACITORS, Erie, Red sq disc style, (#3528) 2.49 200 for 2.50
- 20 PLESSEY 0.1MF 100 VDC 1" SQUARE CAPS 5581 2.49 40 for 2.50
- 10 TV-FM 300 OHM THIN LEAD SPLICERS (#5534) 2.49 2 for 2.50
- 2.9 NI-NI BATTERY CHARGER 110vac, 408R 2.49 2 for 2.50
- 4 MIKE HOLDERS, for CB's and other mobile rigs (#5634) 2.49 8 for 2.50
- 10 PLESSEY CAPS, 1MF 100V 1" sq. CERAMICS (unmarked) (#5633) 2.49 20 for 2.50
- 100 PLESSEY CAPS, mixed values marked and unmarked (#5613) 2.49 200 for 2.50

LEDS:

- YOUR CHOICE 5 for \$1.00
1c SALE 10 for \$1.01
- | Order by Cat. No. | Color | 1c SALE |
|-------------------|----------------------|---------|
| 1788 | MICRO TOPHAT RED | |
| 1795 | JUMBO TOPHAT RED | |
| 1802 | MICRO SINGLE PIN RED | |
| 1848 | MICRO YELLOW | |
| 2135 | JUMBO RED | |
| 2136 | JUMBO TAPER RED | |
| 2137 | MICRO RED | |
| 2190 | JUMBO RED CLEAR | |

WE'RE OVERLOADED WITH BRAND NEW IC'S

Sale	2 for	Order by type number	Sale	2 for
SN7401	-.18	SN7476	-.29	
SN7403	-.18	SN7477	-.29	
SN7406	-.18	SN7478	-.29	
SN7410	-.18	SN7479	-.29	
SN7420	-.18	SN7480	-.29	
SN7426	-.29	SN7486	-.36	
SN7437	-.29	SN7496	-.36	
SN7440	-.29	SN7460	-.65	\$.11
SN7450	-.29	SN7468	-.65	\$.11
SN7455	-.29	SN74168	-.89	.90
SN7464	-.29	SN74182	-.89	.90
		SN74195	-.79	.80
		SN74195	-.69	.70

LYTIC KLINIC ELECTRO'S

- Order by Cat. No. 1c SALE
- | V | 1c SALE | |
|------|---------|--------------------------|
| 10 | 15 | 10 for \$1.20 for \$1.01 |
| 10 | 25 | 8 for \$1.16 for \$1.01 |
| 10 | 50 | 8 for \$1.12 for \$1.01 |
| 10 | 15 | 8 for \$1.12 for \$1.01 |
| 10 | 15 | 8 for \$1.16 for \$1.01 |
| 50 | 15 | 6 for \$1.12 for \$1.01 |
| 50 | 25 | 4 for \$1.08 for \$1.01 |
| 100 | 15 | 3 for \$1.04 for \$1.01 |
| 100 | 25 | 2 for \$1.04 for \$1.01 |
| 1000 | 3 | 2 for \$1.4 for \$1.01 |
| 1000 | 16 | 1 for \$1.2 for \$1.01 |
- All PC type except for twisted Axial

RIBBON CABLE AT THIN PRICES

Cond	Sale	2 for	* Ultra flat! #28 AWG
10	10 ft	\$1.98	2 for \$1.99
14	8 ft	1.98	16 ft 1.99
20	5 ft	1.98	10 ft 1.99
25	4 ft	1.98	8 ft 1.99
30	4 ft	1.98	8 ft 1.99
35	4 ft	1.98	8 ft 1.99
36	3 ft	1.98	6 ft 1.99
40	2 ft	1.98	4 ft 1.99
45	2 ft	1.98	4 ft 1.99
60	1 ft	1.98	2 ft 1.99

Order by Cat. No. 3939 and conductors. color coded.

HOW TO ORDER

When ordering, always use catalog number, type no., the name of the magazine you are ordering from and the month

FREE! FREE! Buy \$20.00 Worth Choose Any Two \$1.29 Items Free

1N4000 Epoxy Rectifiers

Cat. No.	Type	Volts	Sale	1c SALE!
2377	1N4001	50	10 for \$.75	20 for \$.76
2378	1N4002	100	10 for .85	20 for .86
2379	1N4003	200	10 for .95	20 for .96
2380	1N4004	400	10 for 1.19	20 for 1.20
2381	1N4005	600	10 for 1.39	20 for 1.40
2382	1N4006	800	10 for 1.49	20 for 1.50
2383	1N4007	1000	10 for 1.59	20 for 1.60

POLY PAKS®

P.O. BOX 942-E3
80, LYNNFIELD, MA
01940
Terms: Add Postage Rated: Net 30
Phone: (617) 245-3828
Retail: 16-18 Del Carmine St.
MINIMUM ORDER: \$8 Wakfield, MA

Radio Shack: No. 1 Parts Place

Low Prices and New Items Everyday!

Top-quality devices, fully functional, carefully inspected. Guaranteed to meet all specifications, both electrically and mechanically. All are made by well-known American manufacturers, and all have to pass manufacturer's quality control procedures. These are not rejects, not fallouts, not seconds. In fact, there are none better on the market! Always count on Radio Shack for the finest quality electronic parts!

TTL and CMOS Logic ICs

Full-Spec Devices
Direct from
Motorola and
National Semiconductor



Type	Cat. No.	ONLY
7400	276-1801	35c
7402	276-1811	39c
7404	276-1802	35c
7406	276-1821	49c
7410	276-1807	39c
7413	276-1815	79c
7420	276-1809	39c
7427	276-1823	49c
7432	276-1824	49c
7441	276-1804	99c
7447	276-1805	99c
7448	276-1816	99c
7451	276-1825	39c
7473	276-1803	49c
7474	276-1818	49c
7475	276-1806	79c
7476	276-1813	59c
7485	276-1826	1.19
7486	276-1827	49c
7490	276-1808	79c
7492	276-1819	69c
74123	276-1817	99c
74145	276-1828	1.19
74150	276-1829	1.39
74154	276-1834	1.29
74192	276-1831	1.19
74193	276-1820	1.19
74194	276-1832	1.19
74196	276-1833	1.29
4001	276-2401	49c
4011	276-2411	49c
4012	276-2412	69c
4013	276-2413	89c
4017	276-2417	1.49
4020	276-2420	1.49
4021	276-2421	1.49
4023	276-2423	69c
4027	276-2427	89c
4028	276-2428	1.29
4046	276-2446	1.69
4049	276-2419	69c
4050	276-2450	69c
4051	276-2451	1.49
4066	276-2466	99c
4070	276-2470	69c
4511	276-2417	1.69
4518	276-2490	1.49
4543	276-2491	1.89

SN-76477 Sound/Music Synthesizer IC



2.99 Featured in Oct. Popular Electronics

Creates almost any type of sound — music to 'gunshots'! Built-in audio amp includes 2 VCO's. LF osc., noise gen., filter, 2 mixers, envelope modulator, logic circuit. 28-pin DIP. With data applications circuits. 276-1765 2.99

Analog Audio Delay IC MN 3002

10.95



For Phase-Shifter, Reverb & Delay Circuits

'Bucket Brigade' device uses 512 shift registers to provide a continuously variable electronic delay for complex audio signals. Includes data sheet and applications circuits. 276-1760 10.95

Heat Sinks

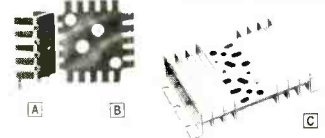

A TO-220. For PC board-mounted power semiconductors in TO-220 cases. Anodized aluminum. 276-1363 79c
B TO-3 Sink. For PC or chassis mtg. 276-1364 1.39
C Universal. Mounts 2 devices; accepts 9 case styles. 276-1361 2.69

Top-Quality IC and PCB Accessories

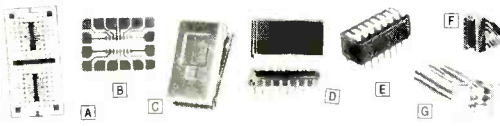

A PC Board. Mounts two 14 or 16-pin ICs or sockets for bread boarding. Copper clad 2 1/2 x 5 1/2". 276-151 2.99
B PC Board. Mounts single 14 or 16-pin IC or socket. 276-024 Pkg. of 2/99c
C 16-Pin IC Test Clip. 276-1951 3.99
D 16-Pin DIP Header. With snap-on cover. 276-1980 1.29
E 8-Rocker 16-Pin DIP Switch. 276-1301 1.99
F Vertical 16-pin Socket. For LED displays. 276-1986 1.49
G 16-Pin DIP Jumper Cable. 18" long. 276-1976 3.99

Project Boxes

Aluminum Cover



The popular, low-cost way to house your electronic experiments

3 1/2 x 2 1/2 x 1 1/2" 270-230 1.19
 4 x 2 1/2 x 2 1/4" 270-231 1.29
 5 1/2 x 2 1/2 x 1 1/2" 270-233 1.49
 6 1/2 x 3 1/2 x 2" 270-627 1.79
 7 1/2 x 4 1/2 x 2 1/2" 270-232 2.49

Miniature Hobby Motors



High-torque permanent magnet type. 1/16" dia shaft.
A 12VDC, 350mA. 2x13/16" 273-210 69c
B 6-VDC, 500mA. 1 5/8 x 3/4" 273-209 Pkg. of 2/99c

8080A Microprocessor and Support Chips

New — 100% Prime



All With Full Data and Specs

8080A Microprocessor. 2 μs cycle time. 276-2510. 12.95
 8208 Bus Driver. 8-bit bidirectional. 276-2508. 5.95
 8154 128x8-Bit RAM I/O. 40-pin DIP. 276-2511. 9.95
 8212 I/O Port. Data latch and buffer. 276-2512. 4.95
 8224 Clock and Generator Driver. 276-2524. 3.95
 8228 System Controller and Bus Driver. 276-2528. 6.95
 8251 Programmable Communication Interface. 276-2551. 9.95
 8255 Programmable Peripheral Interface. 276-2555. 9.95

RAM Memory ICs

Under 450 nS Access Time
 2102 1024 x 1 Array. Low-cost static memory chip. 16-pin DIP. Buy 8 and save!
 276-2501 2.49 Ea. or 8/14.95
 2114L 1024 x 4 Array. NMOS static RAM. 18-pin DIP
 276-2504 12.95

PC Potentiometers

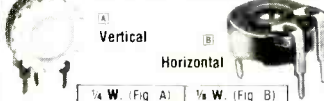

Ohms	1/4 W (Fig A)		1/2 W (Fig B)	
	Cat No.	Ea.	Cat No.	Ea.
500k	271-226	49c	271-333	39c
1k	271-227	49c	271-334	39c
5k	271-217	49c	271-335	39c
10k	271-218	49c	271-336	39c
25k	—	—	271-336	39c
50k	271-219	49c	—	—
100k	271-220	49c	271-338	39c
500k	271-221	49c	—	—
1Meg	271-229	49c	—	—

4cm x 2cm Solar Cells 2 1/4" Dia.



A 4cm x 2cm. Silicon-type cell converts light to electrical power, delivering up to 100 mA at 0.5V. Use several in series-parallel for higher voltage or current. 276-120 2.99
B 2 1/4" Round. Highly efficient silicon cell delivers up to 400 mA at 0.5V. Ideal for solar power projects, battery charging. 276-121 5.99

Molded Connectors



Molded nylon body. Each circuit rated 8A @ 250V Standard D93 pin diameter.
A 4-Pin Male. 274-224 99c
 6-Pin Male. 274-226 1.19
 9-Pin Male. 274-229 1.39
 12-Pin Male. 274-232 1.49
B 4-Pin Female. 274-234 99c
 6-Pin Female. 274-236 1.19
 9-Pin Female. 274-239 1.39
 12-Pin Female. 274-242 1.49
 2-Pin Male & Female. (Not Shown.) Pair 89c
 274-222

IC Breadboard Sockets

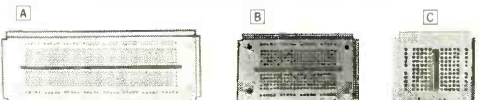

Modular boards snap together and feature standard 0.3" center. Accept 22 through 30-gauge solid hookup wire.
A 550 connections in 2 bus strips of 40 tie points each with 47 rows of 5 connected tie points. 2 1/2 x 6". 276-174 9.95
B 270 connections in 2 bus strips of 40 tie points each with 23 rows of 5 connected tie points. 2 1/2 x 3 3/4". 276-175 5.95
C Mini-Socket. 22 rows of 5 tie points each, plus 2 bus strips with 10 connections each. 2 1/2 x 1 1/2". 276-176. Reg. \$3.95 Sale 2.99

Digital Project Accessories



A Bezel with Lens. Special high contrast filter for LED displays. 3 1/2 x 1 1/2" lens opening. 270-301. Reg. \$3.95 Sale 3.49
B Deluxe Display Case. Sleek molded case with red lens — mount up to four 0.6" or eight 0.3" LED digits. With bracket. 1 1/2 x 3 7/8 x 4 7/16". 270-285. Reg. \$3.95 Sale 2.99
C MA 1003 Clock Case. For automotive clock modules. Accepts 3 pushbutton switches (not included). With bracket, blue lens. 3 1/2 x 2 1/2 x 2". 270-303 5.95

Computer Data Manuals and Semiconductor Handbook

A Intel 8080/8085 Programming Manual. Handy reference for programming with Intel's assembly language. 62-1377 3.95
B Intel Memory Design Handbook. Explains use of Intel's memory components and support circuits in systems. 62-1378 3.95
C Intel Data Catalog. 928 pages of specifications on most of Intel's standard microcomputer-related products. 62-1379 4.95
D Semiconductor Reference and Application Handbook. Complete specs and applications for popular IC transistors, diodes. 276-4002 Reg. \$1.95 Sale 99c

MC14553 3-Digit BCD Counter IC

2.99



CMOS chip replaces over 8 separate IC's in a digital display circuit. Input pulse shaping, master reset pin. 16-pin DIP. 276-2498 2.99

WHY WAIT FOR MAIL ORDER DELIVERY?
 IN STOCK NOW AT OUR STORE NEAR YOU!

Prices may vary at individual stores and dealers

Radio Shack

A DIVISION OF TANDY CORPORATION • FORT WORTH, TEXAS 76102
 OVER 7000 LOCATIONS IN NINE COUNTRIES

Transistor Checker

— Completely Assembled —
— Battery Operated —



The ASI Transistor Checker is capable of checking a wide range of transistor types, either "in circuit" or out of circuit. To operate, simply plug the transistor to be checked into the front panel socket, or connect it with the alligator clip test leads provided. The unit safely and automatically identifies low, medium and high power PNP and NPN transistors. Size: 3 1/4" x 6 1/4" x 2". "C" cell battery not included.

Trans-Check \$29.95 ea.

Custom Cables & Jumpers



DB 25 Series Cables

Part No.	Cable Length	Connectors	Price
DB25P-4-P	4 Ft	2-DP25P	\$15.95 ea
DB25P-4-S	4 Ft	1-DP25P-1-25S	\$16.95 ea
DB25S-4-S	4 ft	2-DP25S	\$17.95 ea

Dip Jumpers

DJ14-1	1 ft	1-14 Pin	\$1.59 ea
DJ16-1	1 ft	1-16 Pin	1.79 ea
DJ24-1	1 ft	1-24 Pin	2.79 ea
DJ14-1-14	1 ft	2-14 Pin	2.79 ea
DJ16-1-16	1 ft	2-16 Pin	3.19 ea
DJ24-1-24	1 ft	2-24 Pin	4.95 ea

For Custom Cables & Jumpers: See JAMECO 1979 Catalog for Pricing

CONNECTORS

25 Pin-D Subminiature

DB25P (as pictured)	PLUG (Meets RS232)	\$2.95
DB25S	SOCKET (Meets RS232)	\$3.50
DB51226-1	Cable Cover for DB25P or DB25S	\$1.75

PRINTED CIRCUIT EDGE-CARD

156 Spacing 1-in Double Row-Out — Bilateral Contacts — Fits 054 to 070 P.C. Cards		
15/30	PINS (Solder Eyelet)	\$1.95
18/36	PINS (Solder Eyelet)	\$2.49
22/44	PINS (Solder Eyelet)	\$2.95
50/100 (100 Spacing)	PINS (Wire Wrap)	\$6.95
50/100 (125 Spacing)	PINS (Wire Wrap)	R681-1 \$6.95

Solar Cells 2x2cm

- 0.4 volts
 - 100mA
 - 4J1 MW
- Can be added in series for higher voltage or parallel for higher current.
- #SC 2x2 \$1.95 ea. or 3/\$5.00

Magnetically Activated Switch

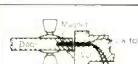

The 9250 0002 is a single pole normally closed switch. When the magnet is engaged, the circuit is open. This switch is only suitable for use in non-magnetic doors and windows.

#9250-0002 2/\$1.00

AC Wall Transformer



Ideal for use with clocks, power supplies or any other type of AC application.

Part No.	Input	Output	Price
AC 250	117V/60Hz	12 VAC 250mA	\$3.95
AC 500	117V/60Hz	12 VAC 500mA	\$4.95

Regulated Power Supply



- Uses LM 309K
- Heat sink provided
- P.C. board construction
- Provides a solid 1 amp @ 5V
- Includes components, hardware and instructions
- Sizes 3-1/2" x 5" x 2" high

JE200 \$14.95

INSTRUMENT/CLOCK CASE



This case is an injection molded unit that is ideal for uses such as DVM, COUNTER, or CLOCK cases. It has dimensions of 4 1/2" in length by 4" in width by 1-9/16" in height. It comes complete with a red bezel.

PART NO: IN-CC \$3.49 each

MICROPROCESSOR COMPONENTS

8080A/8800A SUPPORT DEVICES		MICROPROCESSOR MANUALS	
8080A CPU	\$ 9.95	M-280 User Manual	\$7.40
8212 8-Bit Input/Output	3.25	M-CDP1802 User Manual	7.50
8213 Priority Interrupt Control	5.95	M-2950 User Manual	5.00
8216 Bi-Directional Bus Driver	3.49		
8224 Clock Generator Driver	3.95		
8256 Bus Driver	3.49		
8228 System Controller: Bus Driver	5.95		
8238 System Controller	5.95		
8251 Prog Comm 1/0 (USART)	7.95	2513(2140) Character Generator (upper case)	59.95
8253 Prog Interval Timer	14.95	2513(3021) Character Generator (lower case)	9.95
8255 Prog Periph 1/0 (PPI)	9.95	2516 Character Generator	10.95
8257 Prog DMA Control	19.95	MM5230N 2048 Bit Read Only Memory	1.95
8259 Prog Interrupt Control	19.95		
8080/8800 SUPPORT DEVICES		RAM'S	
MC6800 MPU	\$14.95	1101 Static	\$1.49
MC6800CP MPU with Clock and Ram	24.95	1103 1024X1 Dynamic	.99
MC6810AI 128K Static Ram	5.95	2101(8101) 256X4 Dynamic	3.95
MC6821 Periph Inter Adapt (MC6820)	7.49	2102 1024X1 Static	1.75
MC6828 Priority Interrupt Controller	12.95	2111(1111) 256X4 Static	3.95
MC6830B 1024K Bit ROM (MC6830-B)	14.95	2112 256X4 Static MOS	4.95
MC6850 Asynchronous Comm Adapter	7.95	2114 1024X4 Static 50ns low power	10.95
MC6860 Synchronous Serial Data Adapt	9.95	2114-3 1024X4 Static 300ns	10.95
MC6860 6400 8000s Digital MIOEM	14.95	2114-3 1024X4 Static 300ns low power	11.95
MC6860 2400 8000s MIOEM	14.95	5101 256X4 Static	7.95
MC6880A Quad 3-State Bus Trans (MC6876)	2.25	5280 2107 4096X1 Dynamic	9.95
		7489 16X4 Static	1.75
		74S200 256X1 Static Tristate	4.95
		74S201 256X1 Static	2.95
MICROPROCESSOR CHIPS - MISCELLANEOUS		74S244 16K Dynamic 16 pin	4.95
2801(7801) CPU	\$19.95	UMK4027	
280A(780-1) CPU	24.95	UPD414 4K Dynamic 16 pin	14.95
CDP1802 CPU	19.95	IMK4116	
8650 MPU	19.95	ISL	
8035 8-Bit MPU w/clock RAM 1/0 lines	19.95	ISL	
PR085 CPU	19.95	IMS4045 1024X4 Static	14.95
TMS9900UL 16 Bit MPU w/hardware multiply & shift	49.95	2117 16 384X1 Dynamic	9.95
		MM5262 2Kx1 Dynamic	4.00
		ROM'S	
		1702A 20x8 FAMOS	\$5.95
		MS2516 16K* EPROM (Intel 2716)	49.95
		(2716) *Requires single -5V power supply	
		MS2532 4Kx8 EPROM	89.95
		2708 8K* EPROM	10.95
		2716 16K* EPROM	29.95
		27216 **Requires 3 voltages: -5V, -5V, -12V	
		5203 20x8 FAMOS	14.95
		6301(17611) 1024 Tristate Bipolar	3.99
		6330(17602) 256 Open C Bipolar	2.95
		MS2532 32X8 Open Collector	3.95
		825115 4096 Bipolar	19.95
		825123 32X8 Tristate	3.95
		74186 512 TTL Open Collector	9.95
		74189 256 TTL Open Collector	3.95
		74S287 1024 Static	2.95
		UART'S	
A-Y-5-1013 30K BAUD	5.95	74S287 1024 Static	2.95

NEW!! IN STOCK... POWERACE

ALL-CIRCUIT EVALUATORS WITH POWER

- 1680 solderless, plug-in tie points - will hold up to 18 14-pin DIP's
- Breadboard elements accept all DIP sizes including RTL, DTL, TTL and CMOS devices. 10-5's and discrete with leads up to .032 dia
- All connections to bond switches, indicators, power supplies and meters are made via solderless, plug-in tie-point blocks on control panels.
- Interconnect with any solid 20 to 30 AWG wire.
- Breadboard elements are mounted on ground plane. Ideal for high frequency and high-speed low-noise circuits.
- Short-circuit-protect fused power supplies.
- Operate on 110 to 130 VAC at 60 Hz.
- Space age compact styling and high-grade components permit convenient, organized and quick prototyping.
- All models are 7.5" wide, 11.5" deep and 4.0" high (real) 9.75" high (front) and weigh approx. 2.5 lbs.

BK PRECISION 3 1/2-Digit Portable DMM

- Inexpensive Protection
- 3 1/2 High LED Display
- Range of AC operation
- Acc. 2% over
- 100 Hz 0.1 ohm resolution
- Overrange warning
- 10 meg ohm impedance
- DC Accuracy 0.1% typical

Ranges: DC Voltage 0-1000V
AC Voltage 0-1000V
Freq Response 50-500 Hz
DC AC Current 0-100mA
Resistance 0.1 to meg ohm
Size 6 1/2 x 4 1/2 x 2 1/2

Model 2800 \$99.95

Accessories:
AC Adapter BC-28 \$9.00
Batteries BP-26 20.00
Carrying Case LC-28 7.50

100 MHz 8-Digit Counter

CORPORATE ELECTRONICS CORPORATION

- 20 Hz-100 MHz Range
- 8 LED Display
- Crystal-controlled timebase
- Fully Automatic
- Portable - completely self-contained
- Size 1.75" x 7.38" x 5.63"

Four power sources: 1. battery, 110 or 220V with charger, 12V with auto lighter adapter and external 7-10V power supply.

MAX-100 \$134.95

ACCESSORIES FOR MAX 100

Mobile Charger/Eliminator use power from car battery Model 100 - CLA \$3.95

Charger/Eliminator use 110 V AC Model 100 - CAI \$9.95

NEW Mini-Max 6 Digit 50MHz Frequency Counter

- Guaranteed frequency range of 100 Hz to 50 MHz
 - Full 6 digit display with anti-gate trigger
 - Fully automatic range, polarity, slope, trigger, input level switching not required
 - Lead-zero blanking - All zeros to the left of the first non-zero digit are blanked. Kilo Hertz and Mega Hertz decimal points automatically light up when the unit is turned on.
 - Built in input overvoltage protection
 - Use 9V Battery or 110/220V power
 - Complete with mini antenna
 - Lightweight - Only 8oz
- MINI-MAX \$89.95

Accessories For Mini-Max

Part No.	Description	Price
MM-AA	Antenna	\$ 3.95
MM-CS	Carrying Case	3.95
MM-IPC	Input cable with clip leads	3.95
MM-AC2	110V adapter	9.95
MM-AG3	220V adapter	9.95

\$5.00 Minimum Order - U.S. Funds Only
California Residents - Add 6% Sales Tax
Spec Sheets - 25¢
1979 Catalog Available - Send 41¢ stamp

Jameco ELECTRONICS

a division of JAMES ELECTRONICS of California

MAIL ORDER ELECTRONICS - WORLDWIDE
1021 HOWARD AVENUE, SAN CARLOS, CA 94070
ADVERTISED PRICES GOOD THRU MARCH

PHONE ORDERS WELCOME (415) 592-8097

The Incredible "Pennywhistle 103"



\$139.95 Kit Only

The Pennywhistle 103 is capable of recording data to and from audio tape without critical speed requirements for the recorder and it is able to communicate directly with another modern and terminal for telephone, teletype and communications. In addition it is free of critical adjustments and is built with non-precision ready available parts.

Data Transmission Method: Frequency Shift Keying (full-duplex, half-duplex, selectable)
300 Baud
Maximum Data Rate: 300 Baud
Data Format: Asynchronous Serial (return to mark level required between each character)
Receive Channel Frequencies: 2025 Hz for space, 2225 Hz for mark
Transmit Channel Frequencies: 1070 space, 1270 mark. High 025 space, 2225 mark. Switch selectable. Low (normal)
Receive Sensitivity: 45 dbm accurately coupled
Transmit Level: 15 dbm nominal. Adjustable from 6 dbm to 20 dbm
Receive Frequency Tolerance: Frequency reference automatically adjusts to allow for operation between 1800 Hz and 2400 Hz
Digital Data Interface: RS-232C or 20-MA current loop (receiver is optoisolated and non-polar)
Power Requirements: 120 VAC single phase 10 Watts
Physical: All components included on a single 5" by 9" printed circuit board. All components included: Frequency Counter and/or Oscilloscope to align.

TRS-80 16K Conversion Kit

Expand your 4K TRS-80 System to 16K. Kit comes complete with:
• 8 each UPD416 (16K Dynamic Rams)
• Documentation for conversion

TRS-16K \$115.00

Special Offer - Order both your TRS-16K and the Sup'R MOD II Interface kit together (retail value \$144.95) for only \$139.95

COMPUTER CASSETTES



6 EACH 15 MINUTE HIGH QUALITY C-15 CASSETTES
• PLASTIC CASE INCLUDED
• 12 CASSETTE CAPACITY
• ADDITIONAL CASSETTES AVAILABLE #C-15-S2 \$50 ea

CAS-6 \$14.95

(Case and 6 Cassettes)

SUP 'R' MOD II

UHF Channel 33 TV Interface Unit Kit
Wide Band B/W or Color System
• Converts TV to Video Display for home computers. CCTV camera, Apple II, works with Cromeco Dazzler, SOL-20, IRS-80, Challenger, etc.
• MOD II is pretuned to Channel 33 (UHF).
• Includes coaxial cable and antenna transformer.

MOD II \$29.95 Kit

RS-232 CONTROL CENTER

Plug in your modem, computer, program programmer, terminal, printer, etc. and selectively control data flow.

• Same Contour as Pennywhistle 103
• Total, self-contained
• Includes 2 master ports and 3 slave ports

PART NO. RS-232CC \$89.95 kit only

Ideal for use with the TRS 80 and others
• Plug/Jack interface to any computer system requiring remote control of cassette functions

CASSETTE CONTROLLER

The CC100 controls cassette motor functions, monitors tape location with its internal speaker and requires no power. Eliminates the plugging and unplugging of cables during computer loading operation from cassette.

63-Key Unencoded Keyboard



This is a 63-key, terminal keyboard newly manufactured by a large computer manufacturer. It is unencoded with SPST keys, unattached to any kind of PC board. A very solid molded plastic 13 x 4" base suits most application. IN STOCK \$29.95/each

Hexadecimal Unencoded Keypad

19-key pad includes 1-10 keys ABCDEF and 2 optional keys and a shift key \$10.95/each

7400 TTL Table listing various integrated circuits like SN7400N, SN7401N, SN7402N, SN7403N, SN7404N, SN7405N, SN7406N, SN7407N, SN7408N, SN7409N, SN7410N, SN7411N, SN7412N, SN7413N, SN7414N, SN7415N, SN7416N, SN7417N, SN7418N, SN7419N, SN7420N, SN7421N, SN7422N, SN7423N, SN7424N, SN7425N, SN7426N, SN7427N, SN7428N, SN7429N, SN7430N, SN7431N, SN7432N, SN7433N, SN7434N, SN7435N, SN7436N, SN7437N, SN7438N, SN7439N, SN7440N, SN7441N, SN7442N, SN7443N, SN7444N, SN7445N, SN7446N, SN7447N, SN7448N, SN7449N, SN7450N, SN7451N, SN7452N, SN7453N, SN7454N, SN7455N, SN7460N

Jameco Electronics Kits Digital Stopwatch Kit JE900 \$39.95. Includes: Use Intel 7205 Chip, Plated thru double-sided P.C. Board, LED display (red), Times to 99 min 59.59 sec with auto reset, auto display controlled, Three stopwatches in one, Single event split (cumulative) and Taylor (sequential) timing, Uses 3 penlite batteries, Size 4.5 x 2.15 x .90. JE900 \$39.95

JE200 5v lamp power supply \$14.95, JE730 4-digit clock kit 14.95, JE2206B Function Generator \$19.95, JE747 Jumbo 6-digit clock kit 29.95

DISCRETE LEDS Table listing various LEDs like 200, 125, 185, 170, 190 dia. with color and price. Includes TMEX T1001 LIQUID CRYSTAL DISPLAY \$7.95

DIAPY LEDS Table listing various LED types like MAN 1, MAN 2, MAN 3, MAN 7C, MAN 7Y, MAN 7G, MAN 7E, MAN 82, MAN 84, MAN 3620, MAN 3630, MAN 3640, MAN 4610, MAN 4620, MAN 4640, MAN 4650, MAN 4720, MAN 4730, MAN 4740, MAN 4750, MAN 4810, MAN 4820, MAN 4830, MAN 4840, MAN 4850, MAN 6640, MAN 6650, MAN 6660, MAN 6670, MAN 6680, MAN 6690, MAN 6710

RCA LINEAR, CALCULATOR CHIPS/DRIVERS, CLOCK CHIPS, MOTOROLA. Lists various ICs like CA30131, CA30132, CA30133, CA30134, CA30135, CA30136, CA30137, CA30138, CA30139, CA30140, CA30141, CA30142, CA30143, CA30144, CA30145, CA30146, CA30147, CA30148, CA30149, CA30150, CA30151, CA30152, CA30153, CA30154, CA30155, CA30156, CA30157, CA30158, CA30159, CA30160, CA30161, CA30162, CA30163, CA30164, CA30165, CA30166, CA30167, CA30168, CA30169, CA30170, CA30171, CA30172, CA30173, CA30174, CA30175, CA30176, CA30177, CA30178, CA30179, CA30180, CA30181, CA30182, CA30183, CA30184, CA30185, CA30186, CA30187, CA30188, CA30189, CA30190, CA30191, CA30192, CA30193, CA30194, CA30195, CA30196, CA30197, CA30198, CA30199, CA30200

IC SOLENTAL - LOW PROFILE (TIN) SOCKETS, SOLENTAL STANDARD (TIN), SOLENTAL STANDARD (GOLD), WIRE WRAP SOCKETS (GOLD) LEVEL #3. Lists various socket types and prices.

1/4 WATT RESISTOR ASSORTMENTS - 5% CAPACITOR 50 VOLT CERAMIC DISC CAPACITORS. Lists resistor and capacitor assortments with prices.

Jameco Electronics PHONE ORDERS WELCOME (415) 592-8097. MAIL ORDER ELECTRONICS - WORLDWIDE. 1021 HOWARD AVENUE, SAN CARLOS, CA 94070. ADVERTISED PRICES GOOD THRU MARCH. CIRCLE NO. 29 ON FREE INFORMATION CARD

TELEPHONE/KEYBOARD CHIPS, ICM CHIPS, NMOS READ ONLY MEMORIES, MISCELLANEOUS, LITRONIX ISO-LIT 1, SOUND GENERATOR, TV GAME CHIP AND CRYSTAL, EXAR, DIODES, SCR AND FW BRIDGE RECTIFIERS, TRANSISTORS. Lists various components and their prices.

C/MOS Table listing various CMOS and MOSFET ICs like CD4006, CD4007, CD4008, CD4009, CD4010, CD4011, CD4012, CD4013, CD4014, CD4015, CD4016, CD4017, CD4018, CD4019, CD4020, CD4021, CD4022, CD4023, CD4024, CD4025, CD4026, CD4027

74C00 Table listing various CMOS inverters like 74C00, 74C01, 74C02, 74C03, 74C04, 74C05, 74C06, 74C07, 74C08, 74C09, 74C10, 74C11, 74C12, 74C13, 74C14, 74C15, 74C16, 74C17, 74C18, 74C19, 74C20, 74C21, 74C22, 74C23, 74C24, 74C25, 74C26, 74C27, 74C28, 74C29, 74C30, 74C31, 74C32, 74C33, 74C34, 74C35, 74C36, 74C37, 74C38, 74C39, 74C40, 74C41, 74C42, 74C43, 74C44, 74C45, 74C46, 74C47, 74C48, 74C49, 74C50, 74C51, 74C52, 74C53, 74C54, 74C55, 74C56, 74C57, 74C58, 74C59, 74C60, 74C61, 74C62, 74C63, 74C64, 74C65, 74C66, 74C67, 74C68, 74C69, 74C70, 74C71, 74C72, 74C73, 74C74, 74C75, 74C76, 74C77, 74C78, 74C79, 74C80, 74C81, 74C82, 74C83, 74C84, 74C85, 74C86, 74C87, 74C88, 74C89, 74C90, 74C91, 74C92, 74C93, 74C94, 74C95, 74C96, 74C97, 74C98, 74C99, 74C100

74LS00 Table listing various CMOS inverters like 74LS00, 74LS01, 74LS02, 74LS03, 74LS04, 74LS05, 74LS06, 74LS07, 74LS08, 74LS09, 74LS10, 74LS11, 74LS12, 74LS13, 74LS14, 74LS15, 74LS16, 74LS17, 74LS18, 74LS19, 74LS20, 74LS21, 74LS22, 74LS23, 74LS24, 74LS25, 74LS26, 74LS27, 74LS28, 74LS29, 74LS30, 74LS31, 74LS32, 74LS33, 74LS34, 74LS35, 74LS36, 74LS37, 74LS38, 74LS39, 74LS40, 74LS41, 74LS42, 74LS43, 74LS44, 74LS45, 74LS46, 74LS47, 74LS48, 74LS49, 74LS50, 74LS51, 74LS52, 74LS53, 74LS54, 74LS55, 74LS56, 74LS57, 74LS58, 74LS59, 74LS60, 74LS61, 74LS62, 74LS63, 74LS64, 74LS65, 74LS66, 74LS67, 74LS68, 74LS69, 74LS70, 74LS71, 74LS72, 74LS73, 74LS74, 74LS75, 74LS76, 74LS77, 74LS78, 74LS79, 74LS80, 74LS81, 74LS82, 74LS83, 74LS84, 74LS85, 74LS86, 74LS87, 74LS88, 74LS89, 74LS90, 74LS91, 74LS92, 74LS93, 74LS94, 74LS95, 74LS96, 74LS97, 74LS98, 74LS99, 74LS100

Active Electronic Sales Corp.

LINEAR I.C.'S

LM324N	.49	Quad Op Amp
LM339N	.49	Quad Comparator
LM555N-8	.29	Timer
LM556N-14	.59	Dual Timer
LM723CN	.34	Voltage Regulator
LM723CH	.39	Voltage Regulator
LM741CH	.37	Op Amp
LM741CN 8	.24	Op Amp
LM1458N-8	.39	Dual Op Amp

VOLTAGE REGULATORS

PART NO.	UNIT PRICE	DESCRIPTION
LM323K	\$5.50 \$4.95	3 Amp 5 Volt Regulator
78H05KC	\$5.75	5 Amp 5 Volt Positive Regulator TO3
7800UC Series TO-220/LM340T	79	Positive Voltage Regulators (Plastic) 1 Amp 5, 6, 8, 12, 15, 18, 24 Volts
78MOOHC Series TO-5/LM340H	\$1.50	Positive Voltage Regulator 1/2 Amp 5, 6, 8, 12, 15, 18, 24 Volts
7800KC Series TO-3/LM340K	\$1.60	Positive Voltage Regulator 1 Amp 5, 6, 8, 12, 15, 18, 24 Volts
78LOOAWC Series TO-92	29	Positive Voltage Regulator 100 MA 2, 6, 5, 6, 2, 8, 2, 12, 15 Volts
7900UC Series TO-220/LM320T	\$1.10	Negative Voltage Regulator 1 Amp 5, 6, 8, 12, 15, 18, 24 Volts
79MOOHC Series TO-5/LM320H	\$1.50	Negative Voltage Regulator 1/2 Amp 5, 6, 8, 12, 15, 20, 24 Volts
7900KC Series TO-3/LM320K	\$1.95	Negative Voltage Regulator 1 Amp 5, 6, 8, 12, 15, 18, 24 Volts
78MGT2C	\$1.25	Dual In Line Adjustable 4 Terminal Positive Voltage Regulator
78GUI TO-220	\$1.45	1 Amp Adjustable Positive Voltage Regulator
78S4OPC	\$2.50	Switching Regulator

Features.....

BRAND NEW!

JUST RELEASED
1979 IC MASTER

2500 pages

Complete integrated circuit data selector Master guide to the latest I.C.'s including microprocessors and consumer circuits.

Free Quarterly Updates **\$39.95**



CMOS I.C.'S

CD4000BE	17	CD4042BE	59	CD4515BE	\$1.95
CD4001BE	17	CD4043BE	57	CD4516BE	69
CD4002BE	17	CD4044BE	55	CD4518BE	73
CD4006BE	87	CD4046BE	99	CD4519BE	67
CD4007BE	17	CD4049BE	33	CD4520BE	49
CD4008BE	75	CD4050BE	33	CD4522BE	99
CD4009BE	39	CD4051BE	54	CD4526BE	99
CD4010BE	39	CD4052BE	54	CD4527BE	\$1.09
CD4011BE	17	CD4053BE	54	CD4528BE	69
CD4012BE	17	CD4060BE	99	CD4531BE	71
CD4013BE	32	CD4066BF	44	CD4539BE	99
CD4014BE	73	CD4068BE	21	CD4542BE	\$1.19
CD4015BE	69	CD4069BE	21	CD4543BE	\$1.39
CD4016BE	35	CD4070BE	29	CD4555BE	65
CD4017BE	62	CD4071BE	21	CD4566BE	65
CD4018BE	69	CD4072BE	21	CD4567BE	\$2.25
CD4019BE	39	CD4073BE	21	CD4582BE	73
CD4020BE	69	CD4075BE	21	CD4584BE	60
CD4021BE	69	CD4076BE	79	CD4585BE	90
CD4022BE	69	CD4077BE	25	40014PC	59
CD4023BE	17	CD4078BE	21	40085PC	\$1.09
CD4024BE	49	CD4081BE	21	40097PC	60
CD4025BE	17	CD4082BE	21	40098PC	60
CD4026BE	\$1.39	CD4085BE	69	40160PC	89
CD4027BE	39	CD4086BE	69	40161PC	89
CD4028BE	57	CD4089BE	40	40162PC	89
CD4029BE	74	CD4104BE	\$2.25	40163PC	99
CD4030BE	35	CD4502BE	85	40174PC	89
CD4033BE	\$1.45	CD4508BE	\$2.25	40175PC	89
CD4034BE	\$2.25	CD4510BE	88	40192PC	\$1.19
CD4035BE	64	CD4511BE	99	40193PC	\$1.19
CD4040BE	74	CD4512BE	59	40194PC	\$1.10
CD4041BE	74	CD4514BE	\$1.95	40195PC	\$1.10

Texas Instruments Low Profile Sockets



Finest Quality Socket available in the world. Nobody can match Texas Instruments quality — a unique combination of I.C. technology and multi-metal expertise.

Over one million pieces in stock.

Contacts	Price	Contacts	Price
8 PIN	.08	22 PIN	.22
14 PIN	.12	24 PIN	.24
16 PIN	.14	28 PIN	.28
18 PIN	.18	40 PIN	.40
20 PIN	.20		

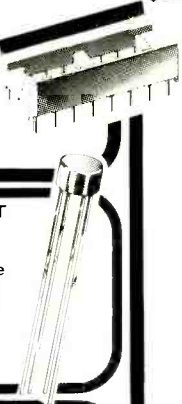

MICROPROCESSOR CHIPS CPU's

Part No.	Price
8080A	5.95 5.50
6800	8.95 7.95

INTERFACE SUPPORT CIRCUITS

Part No.	Price	Part No.	Price
8212	1.98	8255	5.95
8214	4.95 3.95	8257	9.95
8216	1.98	8259	14.95
8224	2.75		
8226	1.98	6810	3.95 3.50
8228	4.75	6820	4.95 3.95
8238	4.75	6821	4.95 3.95
8251	5.95 4.95	6850	5.95 4.95
8253	14.95	6852	5.95 4.95

MOS Static RAM's

Part No.	Price
2102LFPC	\$1.19
1K 350NS (Low Power)	
2102-1PC	\$9.99
1K 450NS	
2114	\$7.50
4K (1K x 4) 300NS	
2114	\$6.50
4K (1K x 4) 450NS	

MOS Dynamic RAM's

Part No.	Price
4K 4027	\$2.95
4K (4K x 1) 300NS 16 PIN	
416-3	\$9.95
200NS	
416-5	\$7.95
300NS	

UART's

Part No.	Price
AY5-1013A	\$4.95
AY3-1015	\$5.95
1K CMOS RAM	
Part No.	Price
5101	\$4.95
450NS (Low Power)	
5101	\$3.95
800NS	

GENERAL INSTRUMENT

1 Amp Rectifiers (Epoxy)		1.5 Amp Single Phase Silicon Bridge Rectifiers	
Part No.	Price	Part No.	Price
1N4001	50V .029	W06M	600V .34
1N4002	100V .039	W08M	800V .39
1N4002	200V .045		
1N4004	400V .049		
1N4005	600V .055		
1N4006	800V .065		
1N4007	1000V .07		



SWITCHING DIODES

Part No.	Price
1N914 (100V 4NS)	.027
1N4148 (100V 4NS)	.027

L.E.D. LAMPS

LED209	T-1 3mm Red	.09
LED211	T-1 3mm Green	.14
LED212	T-1 3mm Yellow	.13
LED220	T-1 3/4 5mm Red	.11
LED222	T-1 3/4 5mm Green	.15
LED224	T-1 3/4 5mm Yellow	.14

MAJOR MANUFACTURER



Part No.	Price	Part No.	Price
Z80-CTC	\$10.90	Z80-DMA	40.00 \$32.20
Z80A-CTC	\$13.10		
Z80-CPU	14.95 \$13.60	Z80-SIO/0	59.00 \$45.00
Z80A-CPU	24.95 \$16.20	Z80A-SIO/0	65.00 \$50.00
Z80-PIO	7.95 \$10.90	Z80-SIO/1	59.00 \$45.00
Z80A-PIO	11.95 \$13.10	Z80A-SIO/1	65.00 \$50.00

P.O. BOX 1035 FRAMINGHAM, MASSACHUSETTS 01701

Over-the-counter sales,
12 Mercer Rd., Natick, Mass 01760
Behind Zayres on Rte. 9
Telephone Orders & Enquiries (617) 879-0077

MINIMUM ORDER \$10.00 • ADD \$2.00 TO COVER POSTAGE & HANDLING

Foreign customers please remit payment on an international bank draft or international postal money order in American dollars.

IN CANADA 3 LOCATIONS

5851 FERRIER ST.
MONTREAL, QUEBEC
H4P 2K5
Tel: (514) 735-6425

4800 DUFFERIN ST.
DOWNSVIEW, ONTARIO
M3H 5S9
Tel: (416) 861-1115

BAXTER CENTRE
1050 BAXTER ROAD
OTTAWA, ONTARIO
K2C 3P2
Tel: (613) 820-8471



CIRCLE NO. 2 ON FREE INFORMATION CARD

www.americanradiohistory.com

Active Electronic Sales Corp.



Electronics Library

A PROGRAMMED COURSE IN BASIC PULSE CIRCUITS

Organized in a programmed instruction format, this text relates the basics of pulse circuits in an easy-to-follow manner. Pulse parameters and waveform principles are first examined, followed by a comprehensive examination of RC circuit applications and characteristics. Effect of RC time constant on waveforms, RC high- and low-pass filters, pulse and pulse-train response of RC circuits, and use of applicable charts and equations are among the topics covered. Properties of RLC circuits are also presented. The reader is then familiarized with a number of semiconductor devices, including unijunction transistors, SCR's, and zener diodes, along with their applications in transistor clipper circuits, diode clippers, and sweep generators. Astable, monostable, and bistable multivibrators too are studied, and the book's final chapters cover pulse transformers and blocking oscillators. The programmed instruction format of this book makes it ideal for those wishing to independently study or familiarize themselves with pulse circuits and their application to computers and radio-communications.

Published by Gregg Division, McGraw-Hill Book Company, 1221 Ave. of the Americas, New York, NY 10020. 293 p. \$9.95 soft.

THE RADIO AMATEUR'S HANDBOOK, 1978; 55th Edition

by the ARRL Headquarters Staff

The latest edition of the standard reference work contains new and revised theory sections to reflect a shift in FCC examination procedures, which now emphasize "why" as opposed to "how to" rote memory answers. Also included are an interesting line of construction projects. A completely new chapter on radio design techniques and methods has been added. Coverage of antennas and semiconductors has been revised and expanded. New material on satellites and TVI has been incorporated. Among the projects appearing for the first time are a link-coupled antenna tuner, a steerable phased antenna array for use on 40 meters, and a 200-MHz power amplifier of advanced design. New charts, data sections, and profuse illustrations highlight the book.

Published by the American Radio Relay League, 225 Main Street, Newington, CT 06111. 711 pages, including index. \$13.50, hard cover in U.S., \$14.50 in Canada, and \$15.50 elsewhere. \$8.50, soft cover in U.S., \$9.50 in Canada, and \$10.50 elsewhere.

PHYSICS OF STEREO/QUAD SOUND

by Joseph G. Traylor

Here are explanations in simple terms of how various components of a high-fidelity system work and why they are used. The author first discusses the fundamentals of sound and the basic physical laws governing it. Concepts such as wave properties, force, power, and the decibel are covered. The theory of operation and application of recording transducers is the next lesson, with most of the information being relevant to microphones, though there is a section on guitar pickups too. Chapter 3 explains amplification, with notes on vacuum tubes and semiconductors, distortion, and heat. Other topics studied are impedance, capacitive and inductive reactance, the storage and retrieval of audio signals, the role of loudspeakers in playback, and a review of basic radio theory including amplitude and frequency modulation and noise in radio systems. The last chapter of the book is devoted to quadraphonic sound and media. Reference sections and appendices within the book introduce mechanics, tell what to look for when purchasing a high-fidelity system, suggest further reading, and define a number of hi-fi and scientific terms. Numerous diagrams, charts, and graphs.

Published by The Iowa State University Press, Ames IA 50010. 190 pages. \$9.50, soft cover.

A STEP BY STEP INTRODUCTION TO 8080 MICROPROCESSOR SYSTEMS

by David L. Cohen and James L. Melsa

This introductory work on microprocessors assumes no knowledge of the subject and is a good source of information if you're just getting into the field. It is also an aid to understanding data sheets and instruction manuals of microprocessor and computer manufacturers. The early portion of the book describes 8080 structure and the concepts of bits, bytes, machine instructions, and registers. Material on software follows: stored programs, memory, system monitors, terminal I/O, editors, assemblers, stacks, and subroutines are introduced. System hardware is not ignored, and in the latter part of the book appears information covering microcomputer hardware, interface devices, interrupts and real-time clocks, and peripherals. There is a bit of information about microprocessors other than the 8080, and this is contained in a short comparison of the 6800, Z80, 8085, F8, and a few others. The last chapter acquaints the reader with cross assemblers, time sharing, and high-level languages. Useful listings of 8080 machine instructions and the ASCII code appear in the appendices.

Published by Dilithium Press, Box 92, Forest Grove, OR 97116. 169 pages. \$7.95, soft cover.

BEGINNING COMPUTER SCIENCE

by James L. Poirot and David N. Groves

The lightning-like evolution of the computer

industry has educators scrambling to keep up with new developments. This text, reflecting the activity in this field, is intended to be used in an introductory course covering computer organization, applications, programming, and arithmetic/logic functions. A broad overview of the computing field covers, history, basic logic and Boolean algebra, calculators, and microcomputers. The text is well illustrated, and sources for hardware, magazines, suggested reading, and a selected reference to periodical articles provide the means for the reader to expand his knowledge and keep abreast of this fast-moving field.

Published by Sterling Swift Publishing Co., Box 188, Manchaca, TX 78652. 290 pages. \$9.95, soft cover.

HANDBOOK FOR ELECTRONIC CIRCUIT DESIGN

by Campbell Loudoun

Electronic circuit design is reviewed with application of theory and consideration of parameters and specifications of components and devices. The author expounds the advantages of design that takes into consideration device life expectancy and aging, quality control, worst-case circuit performance analysis, etc. Such considerations preclude system failure during later stages of design. Many schematics and graphs are presented to reinforce the reader's understanding of material covered in the text. Topics covered include design principles, wave filters, audio amplifiers, r-f circuits, and digital logic troubleshooting. Reference information given in the book's appendices explain color codes, series and parallel resonant circuit characteristics, graphic solution for inductive and capacitive reactances in parallel, deMorgan's theorems, I^2L information, standard potentiometer tapers, and preferred resistance values. All aspects of successful design are covered including computer-aided design, testing, and approval.

Published by Reston Publishing Co., Inc., Reston, VA 22090. 276 pages. \$17.95, hard cover.

TOWERS' INTERNATIONAL FET SELECTOR

by T.D. Towers

This is both a reference and a cross-reference listing of FETs from the U.S., Japan and Europe. Data is listed in tabular form, by type number, and gives all information needed to select an FET for a specific application. In addition to dimensional and operating parameters, the tables list general areas of application, such as audio amplifiers or TV uhf mixers. European and American substitutes are listed, where available. The tables are preceded by an introduction to the FET, and appendices include package outline and pin-out diagrams, manufacturers' house codes, and manufacturers' addresses.

Published by TAB Books, Blue Ridge Summit, PA. 17214. 137 pages. \$4.95 soft cover, \$7.95 hard cover.

MA1003 CLOCK AND CASE: \$19.95!

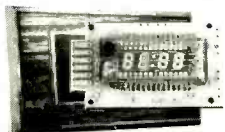

Easy to build — just add 12V DC and 3 time setting switches. Ideal for mobile use. Blue-green fluorescent readouts. Case available separately for \$5.95; clock module for \$16.50.



TRS-80 CONVERSION KIT \$109 (3/\$320)

Upgrades 4K version to 16K, or populates Memory Expansion Module. Easy instructions. 250 ns low-power chips. 1 year warranty, dip shunts. Also works with Apple and Exidy Sorcerer machines



12V 8A POWER SUPPLY \$44.50



12A @ 50% duty cycle, foldback current limiting, over-voltage protection, many more features. Does not include case

ABOUT YOUR SUBSCRIPTION

Your subscription to POPULAR ELECTRONICS is maintained on one of the world's most modern, efficient computer systems, and if you're like 99% of our subscribers, you'll never have any reason to complain about your subscription service.

We have found that when complaints do arise, the majority of them occur because people have written their names or addresses differently at different times. For example, if your subscription were listed under "William Jones, Cedar Lane, Middletown, Arizona," and you were to renew it as "Bill Jones, Cedar Lane, Middletown, Arizona," our computer would think that two separate subscriptions were involved, and it would start sending you two copies of POPULAR ELECTRONICS each month. Other examples of combinations of names that would confuse the computer would include: John Henry Smith and Henry Smith; and Mrs. Joseph Jones and Mary Jones. Minor differences in addresses can also lead to difficulties. For example, to the computer, 100 Second St. is not the same as 10th 2nd St.

So, please, when you write us about your subscription, be sure to enclose the mailing label from the cover of the magazine—or else copy your name and address exactly as they appear on the mailing label. This will greatly reduce any chance of error, and we will be able to service your request much more quickly.

FULLY STATIC COMPUTER MEMORY!

Most Econoram™ are available as unkits (sockets, bypass caps pre-soldered in place), assembled and tested, or qualified under the Certified Systems Component (CSC) high-reliability program.

We've been providing top quality memory (without charging top dollar) for over 4 years — see your computer store or our flyer for more info.



Name	Bus	Speed	Unkit	Assm	CSC
8K ECONORAM II™	S-100	2 MHz	\$139	\$159	N/A
16K ECONORAM IV™	S-100	4 MHz	\$295	\$329	\$429
12K ECONORAM VII™	H8	2 MHz	\$200	\$270	N/A
24K ECONORAM VII™	S-100	4 MHz	\$445	\$485	\$605
32K ECONORAM IX™	DigGrp	4 MHz	\$649	N/A	N/A
32K ECONORAM X™	S-100	4 MHz	\$599	\$649	\$789
32K ECONORAM XI™	S-100	4 MHz	N/A	N/A	\$1050

COMPLEX SOUND GENERATOR CHIP (76477) FROM TEXAS INSTRUMENTS. WE'VE GOT THEM FOR \$2.75... AND THEY'RE AMAZING!

TERMS: Cal res add tax. VISA/Mastercharge — call 24 hr order desk (415) 562-0636. Allow 5% shipping (more for power supply), excess refunded. COD OK with street address for UPS. Prices good through cover month of magazine. Orders under \$15 add \$1 handling.

FREE CATALOGUE: Remember how we used to offer a free flyer? Well, now we have so much stuff it's a catalogue... still free, though. Send your name and address.



BILL GODBOUT ELECTRONICS
-BOX 2355 OAKLAND AIRPORT, CA 94614

CIRCLE NO. 22 ON FREE INFORMATION CARD



Sanken HYBRID AUDIO POWER AMPLIFIERS
10 Watt - 20 Watt - 30 Watt - 50 Watt

- Multi-purpose linear amplifiers for commercial and industrial applications.
- Less than 0.5% harmonic distortion at full power level.
- 1/2 dB response from 20 to 100,000 Hz.
- Single or split (dual) power supply.
- Rugged, compact and lightweight packages.
- Built-in current limiting for SI-1050G and efficient heat radiating construction.

TYPICAL CONNECTIONS

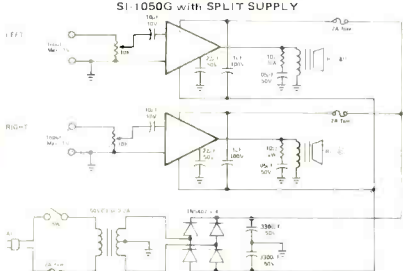

P/N	Power	Price	Matching Transformer	P/N	Price
SI-1010G	10W	\$ 6.95	TR10	\$ 7.90	
SI-1020G	20W	\$13.95	TR20	\$10.90	
A-SI-8	(Socket for above)			95	
SI-1030G	30W	\$19.00	TR30	\$12.90	
SI-1050G	50W	\$27.80	TR50	\$17.90	
A-SI-10	(Socket for above)			95	

* Note: One Transformer can power two Sanken audio amplifier modules.

Data Sheet with application Notes - \$.50

SUPER KIM . . . \$395.00
Economic expansion into more RAM, user EPROM and pro type area on one modern, compact fully assembled and integrated board. Total compatibility with KIM-1 software. On board 5V, 3A regulator and TTY, RS232 and Audio Tape Interfaces.

FLUKE Model 8020A
\$169

MICROPOWER Timing Circuit XR-1555CP
Interall's Universal Counter System
EVALUATION KIT ICM7226EV \$ 59.95

SYM-1
The Complete MICRO-Computer System
\$269.00

Intersil LED or LCD 3 1/2 DIGIT PANEL METER KITS
BUILD A WORKING DPM IN 1/2 HOUR WITH THESE COMPLETE EVALUATION KITS
Test these new parts for yourself with Intersil's low cost prototyping kits complete with A/D Converter and LCD display (for the 7106) or LED display (for the 7107). Kits provide all materials including PCB board, a functioning panel meter.

XR-2206KB FUNCTION GENERATOR KIT
Includes all components, PC board and instructions. \$19.95

15 Megahertz PORTABLE MINI-SCOPES
DUAL TRACE MS-215 \$43500
SINGLE TRACE MS-15 \$31800
with RECHARGEABLE BATTERIES & CHARGER
PORTABLE (2.7" H x 6.4" W x 7.5" D)
AVAILABLE OPTIONS — usable on both the MS-215 and the MS-15
41-140 Leather Carrying Case \$45.00 — 41-141 10 to 1 Probe \$24.50

Ballantine Model 1010A Dual Channel/X-Y Scope
A professional oscilloscope to fit your basic needs.
\$695

KIM-1 MICROCOMPUTER
Fully Assembled & Tested
\$17900 including Documentation

1802 SERIES
LD: Ceramic 55 to 125 C
LE: Epoxy -40 to + 85 C
1802LD \$19.95 1802LE \$11.20
1824LD 14.00 1824LE 8.05
1824LD 7.75 1824LE 3.55
1852LD 8.25 1852LE 1.90
1853LD 5.65 1853LE 1.45
1854LD 11.70 1854LE 8.50
1856LD 4.50 1856LE 1.10
1857LD 5.50 1857LE 1.10
1858LD 5.65 1858LE 1.45
1859LD 5.65 1859LE 1.45

GRI-ASCII KEYBOARD KIT
753K Keyboard \$59.95
756K Keyboard \$64.95
701 Enclosure (753 only) \$14.95
702 Enclosure (both) \$29.95

PET 2001 PERSONAL COMPUTER
Quite portable, very affordable and unbelievably versatile, the PET computer may very well be a lifetime investment.
Model Description Price
2001 Computer w/8K \$795.00
2020 PET Printer \$695.00
C2N External Cassette \$ 99.95

HICKOK LX 303 DIGITAL MULTIMETER
Compact. Accurate. Dependable. With easy-to-read 1/2" liquid crystal display for convenient use in any kind of light. Weighs only 8 ounces. Operates up to 200 hrs on a single 9 volt battery. Nineteen ranges including 200mV to 1000V DC, 100 to 10 Megohms, 100 and 1000 VAC ranges, 10uA and 10mA ranges. Excellent overload protection, color coordinated case and color coded panel.
\$74.95

ANCRONA HAS THE SOURCERER™ COMPUTER \$895.00
STANDARD FEATURES: Z80-4K ROM-8K RAM-Dual Cassette I/O-30 Lines of 64 Characters-64 Defined Characters and 64 User Defined Characters-512 x 240 Graphic Resolution-Edge Card Connection to S100 Bus-Serial and Parallel I/O
OPTIONS: Expandable to 32K RAM-8 Slot S100 Bus-Printer-Disk Storage-Telephone-Voice-Home Controller

5% CARBON FILM RESISTORS
1/4W \$1.69
1/2W \$1.79
All values from 10Ω to 10 MΩ — Only in multiples of 100 pcs per value

The Instructor 50
Desktop Computer from SIGNETICS Complete, Ready-To-Use Microprocessor Learning Package Includes everything you need to write, run and debug machine language programs. Housed in one compact package.
\$350.00

ANCRONA Send Check or Money Order to:
P.O. Box 2208P, Culver City, CA 90230. Arizona residents add 6% sales tax. Minimum Order: \$10.00. Add \$1.00 to cover postage and handling. Master Charge and Visa welcomed. Please include your charge card number. Interbank number and expiration date. PHONE ORDERS (213) 641-4064

ARIZONA 4518 E. Broadway Tucson, AZ 85711 (602) 881-2348	CALIFORNIA 11800 Jefferson Blvd Culver City, CA 90230 (213) 390-3595	CALIFORNIA 1305 E. Colton Ave Santa Ana, CA 92705 (714) 547-8424	OREGON 1125 N.E. 82nd Ave Portland, OR 97220 (503) 254-5541
CANADA, B.C. 5630 Fraser St. Vancouver, B.C. V5W 2V4 (604) 324-0707	CALIFORNIA 1054 E. El Camino Real Sunnyvale, CA 94087 (408) 243-4121	GEORGIA 3330 Piedmont Rd. N.E. Atlanta, GA 30305 (404) 261-7100	TEXAS 2649 Richmond Houston, TX 77098 (713) 528-3489

CIRCLE NO. 4 ON FREE INFORMATION CARD

Original Japanese Replacement Parts for TV, Stereo and CB

25-UP 10-24 1-9	25-UP 10-24 1-9	25-UP 10-24 1-9	25-UP 10-24 1-9	25-UP 10-24 1-9	25-UP 10-24 1-9
2SA102 29 34 39 2SA473 45 55 60 2SA484 1.85 2.05 2.35 2SA495 25 30 35 2SA497 90 1.15 1.25 2SA509 30 35 40 2SA562 25 30 35 2SA564A 29 34 39 2SA634 35 40 45 2SA636 80 85 90 2SA643 30 35 40 2SA673 30 40 45 2SA678 40 50 55 2SA683 40 50 55 2SA684 40 50 55 2SA685 40 50 55 2SA689A 50 60 65 2SA706 85 95 105 2SA720 30 35 40 2SA733 25 27 30 2SA747 4.15 4.35 4.85 2SB22 45 50 55 2SB54 30 35 40 2SB77 30 40 45 2SB176 36 40 45 2SB188 20 27 30 2SB187 20 27 30 2SB324 25 36 40 2SB387 1.10 1.20 1.35 2SB405 25 30 35 2SB407 70 85 95 2SB483 1.00 1.05 1.15 2SB474 70 80 90 2SB507 70 80 90 2SB511 70 75 85 2SB557 2.05 2.45 2.75 2SC183 40 50 55 2SC184 40 50 55 2SC372 20 27 30 2SC373 20 27 30 2SC406 70 75 85 2SC382 30 40 45 2SC387A 30 40 45 2SC394 25 30 35 2SC458 20 27 30	2SC460 45 50 55 2SC481 1.25 1.35 1.45 2SC482 1.25 1.35 1.45 2SC485 1.25 1.35 1.45 2SC495 45 55 60 2SC509 30 40 45 2SC511 2.90 3.10 3.25 2SC535 30 35 40 2SC620 45 50 55 2SC632A 35 40 45 2SC634A 40 45 50 2SC639A 3.20 3.50 3.90 2SC710 20 27 30 2SC711 20 27 30 2SC712 20 27 30 2SC717 35 40 45 2SC730 2.95 3.15 3.35 2SC732 2.00 2.10 2.20 2SC733 20 25 30 2SC734 20 25 30 2SC735 20 25 30 2SC756 1.45 1.75 1.95 2SC756A 2.00 2.10 2.20 2SC778 2.80 3.10 3.30 2SC781 1.95 2.15 2.45 2SC784 30 36 40 2SC789 76 85 95 2SC793 1.95 2.15 2.45 2SC799 1.95 2.15 2.45 2SC828 20 27 30 2SC829 20 27 30 2SC839 30 35 40 2SC867A 4.00 4.25 4.50 2SC900 20 27 30 2SC930 20 27 30 2SC945 20 27 30 2SC1000BL 35 40 45 2SC1013 45 60 65 2SC1014 50 60 65 2SC1018 70 75 85 2SC1030 1.80 2.05 2.35 2SC1056 4.50 4.70 4.90 2SC1060 65 75 85 2SC1061 70 80 90 2SC1096 45 50 55	2SC1114 3.40 3.60 3.80 2SC1116A 3.20 3.45 3.80 2SC1124 80 85 95 2SC1127 80 85 95 2SC1128 80 85 95 2SC1162 70 75 85 2SC1166 26 36 40 2SC1178 3.10 3.50 3.85 2SC1173 50 65 70 2SC1177 10.90 12.40 13.80 2SC1209 25 35 40 2SC1226 50 60 70 2SC1229A 50 60 70 2SC1231 1.70 1.90 2.15 2SC1239 2.10 2.65 2.85 2SC1306 1.25 1.65 1.85 2SC1307 2.15 2.65 2.85 2SC1318 30 40 45 2SC1364 30 40 45 2SC1383 30 40 45 2SC1384 30 40 45 2SC1424 2.75 2.85 2.95 2SC1448A 1.00 1.10 1.20 2SC1475 86 88 95 2SC1509 85 80 85 2SC1567A 80 85 75 2SC1675 25 30 35 2SC1678 1.25 1.40 1.55 2SC1887 40 45 50 2SC1727 1.20 1.25 1.30 2SC1728 70 75 85 2SC1760 85 100 110 2SC1775 30 35 40 2SC1816 1.45 1.70 1.95 2SC1908 26 35 40 2SC1909 2.00 2.55 2.75 2SC1945 4.40 4.90 5.50 2SC1957 80 70 80 2SC1969 3.50 3.80 4.30 2SC1973 60 65 70 2SC1974 1.25 1.65 1.85 2SC1975 1.25 1.65 1.95 2SC2009 75 80 85 2SC2021 55 60 65 2SC2028 50 60 65 2SC2029 1.45 1.75 1.95	2SC2072 3.55 3.75 3.85 2SC2076 45 60 65 2SC2091 85 1.05 1.15 2SC2092 1.75 1.95 2.20 2SC2098 3.00 3.20 3.45 2SD72 50 60 65 2SD77 1.30 1.40 1.55 2SD92 1.40 1.55 1.75 2SD180 1.55 1.75 1.95 2SD187 30 40 45 2SD218 2.95 3.20 3.45 2SD234 60 70 80 2SD235 60 70 80 2SD261 30 35 40 2SD287 2.50 2.65 2.85 2SD291 2.05 2.45 2.75 2SD313 80 85 70 2SD315 80 70 80 2SD325 80 85 75 2SD330 89 79 89 2SD356 70 75 80 2SD358 70 80 90 2SD359 75 85 95 2SD427 1.75 1.95 2.20 2SD525 70 75 85 2SD526 60 70 80 2SK19 45 50 55 2SK23 80 95 105 2SK30 40 45 50 2SK33 60 65 75 2SK34 50 55 60 2SK41 50 55 60 2SK56 60 65 75 3SK22Y 1.60 1.70 1.80 3SK36 1.20 1.35 1.50 3SK37 1.70 2.00 2.30 3SK40 1.25 1.40 1.55 3SK41 1.25 1.40 1.55 3SK42 1.25 1.40 1.55 3SK48 3.30 3.40 3.70 3SK49 1.25 1.40 1.55 3SK77 2.00 2.15 2.25 AN15 1.55 1.65 1.85 AN228 4.10 4.30 4.50 AN239 4.10 4.30 4.80	AN247P 2.40 2.60 2.90 AN274 1.50 1.70 1.95 AN313 4.20 4.40 4.60 AN315 1.75 1.95 2.20 BA511A 1.70 1.95 2.15 BA521 1.85 2.05 2.35 HA1151 1.45 1.70 1.85 HA1156 1.60 1.75 1.95 HA1306W 1.90 2.10 2.40 HA1322 2.40 2.60 2.90 HA1339 2.45 2.65 2.95 HA1339A 2.45 2.65 2.95 LA1222 2.10 2.30 2.50 LA3101 3.45 3.60 3.75 LA4031P 1.75 1.95 2.20 LA4032P 1.75 1.95 2.20 LA4220 2.25 2.40 2.55 LA4400 1.65 2.05 2.35 LD3141 1.70 1.80 1.90 M5116P 1.45 1.60 1.85 M51613L 1.95 2.15 2.45 MN3001 13.20 14.85 16.50 MN3002 9.25 10.40 11.55 MN3003 5.64 6.34 7.04 PLLO1A 4.00 4.15 4.55 PLLO2A 4.95 5.20 5.80 PLLO3A 7.50 7.90 8.70 SC264A 7.00 7.40 7.80 SG609 4.10 4.30 4.50 SG613 5.05 5.45 5.85 SM5104 7.90 8.40 9.00 STK011 3.55 3.95 4.35 STK013 8.90 10.00 11.10 STK015 4.10 4.30 4.80 STK050 23.10 25.98 28.86 STK415 7.10 7.80 8.10 STK435 4.45 4.95 5.55 STK439 8.00 9.00 10.00 TA7045M 1.95 2.15 2.45 TA7056P 1.95 2.15 2.45 TA7060P 85 1.05 1.15 TA7061P 85 1.05 1.15 TA7062P 1.05 1.20 1.35 TA7063P 1.25 1.35 1.50 TA7074P 1.70 3.85 4.00	TA7089P 1.95 2.15 2.45 TA7092A 4.40 4.80 5.40 TA7120P 1.45 1.65 1.85 TA7139P 1.55 1.75 1.95 TA7153P 5.70 5.90 6.10 TA7203P 2.45 2.60 2.85 TA7204P 1.95 2.10 2.45 TA7208P 1.55 1.75 1.95 TA7214P 3.90 4.20 4.50 TA7310P 1.25 1.40 1.55 TA7607P 5.80 6.00 6.20 TA7609P 4.40 4.60 4.80 TB8A105H 1.85 2.05 2.35 TC5080P 4.80 5.00 5.80 TC5081P 2.90 3.10 3.30 TC5082P 3.30 3.45 3.80 UHC001 4.90 5.10 5.80 UHC002 4.90 5.10 5.60 UHC003 4.90 5.10 5.60 UHC004 4.90 5.10 5.60 UHC005 4.90 5.10 5.60 UHC006 4.90 5.10 5.60 UPC20C 2.00 2.40 2.70 UPC141C 2.30 2.40 2.50 UPC167A 3.25 3.45 3.65 UPC554C 1.60 1.70 1.80 UPC555H 1.60 1.70 1.80 UPC572C 3.70 4.10 3.69 UPC574C 9.0 1.08 1.20 UPC575C 1.25 1.40 1.55 UPC576 1.85 2.05 2.35 UPC592H2 75 85 95 UPC1001H21 85 2.05 2.35 UPC1008C 4.85 5.15 5.75 UPC1020H 1.85 2.05 2.35 UPC1025 1.85 2.05 2.35 UPC1028 1.40 1.62 1.80 UPC1031H 2.52 2.74 2.98 UPC1032H 1.70 1.85 2.10 UPC1152H 2.90 3.10 3.30 UPC1156L 1.85 2.05 2.35 UPC277C 5.70 5.80 6.10 UPD857C 7.90 8.30 8.40 UPD858C 7.00 7.10 7.20 UPD861C 8.70 8.90 9.10

PRICES MAY CHANGE WITHOUT NOTICE COD ORDERS WELCOMED

Minimum order \$10.00 - N.J. Residents add 5% Sales Tax.
We pay postage for prepaid orders of \$50.00 or more.
Under \$50.00, add \$1.00, Canada \$1.50.
Quantity Discount Prices - Ask for our complete price list -
Manufacturer inquiries welcome - All parts guaranteed.

IMMEDIATE DELIVERY WITHIN 48 HOURS
ON ALL TRANSISTORS IN STOCK

TOLL FREE TELEPHONE

Nationwide 800/631-1250 Local 201/748-5089

HOURS: Mon. - Fri. 8 to 5:30 Sat. 8 to 1



NEW-TONE ELECTRONICS INTERNATIONAL
P. O. Box 1738, Bloomfield, N. J. 07003
New Jersey Phone: 201/748-6171

CIRCLE NO. 35 ON FREE INFORMATION CARD

CODE-A-PHONE
Telephone Answering Devices
Wireremote Command
Model 1400 \$199.95
Model 1500 \$249.95

SENCORE
TV-VTR-MATV
and Video Analyzer
Model VA48 \$875.00
Reg \$975.00

ESC CONTINENTAL SPECIALTIES
100 MHz 8-Digit Counter \$119.00
PS500 500MHZ Prescaler \$52.95
Digital Capacitance Meter Model 820 \$110.50
Transistorized LCR Bridge Model LCR 740 Reg \$319.40 \$271.95
BSR Changer Accessories \$24.95

BK PRECISION 3 1/2-Digit Portable DMM Model 2800 \$85
Model 2810 \$110.50
15 MHz Mini Oscilloscope Model MS 15 Reg \$318.00 \$269.95
Service Master Attache Style Tool Kit Model 99SM \$42.95
Tool Cases Model TC 100 ST Reg \$78.95 \$269.95
Roll Kit Model 99PR \$15.95
SUPER SPECIAL Model L80 508 Reg \$715.00 \$654.50
Magnifier LAMP Model MG 10A \$49.50
700 Series POCKET CRICKET TRANSISTOR/FET TESTER Reg \$125.00 \$99.95
Auto Stereo 40 Watt Power Booster POW-40 Reg \$39.95 \$24.95
VOM Multimeters 20K ohm/v \$19.95
1K ohm/v \$9.95

WAHL NEW ISO-TIP "Quick Charge" \$27.95
Logic Monitor Model LM 1 \$52.95
Attach Tool Case with 2 Removable Pallets Model 600T Reg \$89.00 \$65.00
In-Dash AM/FM 8 Track Stereo C-777 \$52.50
AM/FM Cassette Stereo CAS 808 \$57.50
Substitution Box \$51
Controlled Output Soldering Station \$45.00
FREE 1979 Catalog

WELLER Xcelite
6" x 9" 3-Way Speaker \$14.95
15MHz 3" Dual Portable Trace Scope Model 1432P Reg \$780.00 \$663.
Weller Controlled Output Soldering Station \$45.00
Call TOLL FREE (800) 645-9518

HICKOK Function Generator Model 270 \$169.15
Hickok Function Generator Model 270 \$169.15
Hickok Function Generator Model 270 \$169.15

CIRCLE NO. 20 ON FREE INFORMATION CARD

www.americanradiohistory.com



855R Columbia St. Farmingdale, N.Y. 11735

Operation Assist

If you need information on outdated or rare equipment—a schematic, parts list, etc.—another reader might be able to assist. Simply send a postcard to Operation Assist POPULAR ELECTRONICS, 1 Park Ave., New York, NY 10016. For those who can help readers, please respond directly to them. They'll appreciate it. (Only those items regarding equipment not available from normal sources are published.)

S.C.A. Service Company model SCA-1 decoder. Need assembly instructions, parts layout and adjustment. R. Harding, 80 Elizabeth Village, Carrollton, GA 30117.

Wells Gardner, Navy Radio Receiver. 54 to 30 MHz, model RAO-3, Type CWQ-46187-A. Need manufacturing alignment instructions or technical manual. Donald A. Weiler, 4641 Kawanee Ave., Metairie, LA 70002.

Sanyo model 34401, chassis 564 51035, reel-to-reel recorder. Need owner's and/or service manual. W. Erwin, Box 422, Polk City, FL 33868.

Dyn-Sonic AM/FM Stereo, 8 Track model DS-3055. Need schematic, parts layout and parts list. William G. Wentz, Jr., 106 Fannin, Goodlettsville, TN 37072.

Jackson tube tester model 648. Need tube charts since 1964. Carlton Wilson, Box 535, Altavista, VA 24517.

Presto Recording Corporation type CDR Console tape recorder. Need operation manual. Fairchild SM-2. Need replacement stylus. Thomas F. Blue, Jr., Box 1765, Louisville, KY 40201.

Daytonia Red Baron and **Quintron** solid-state metal detectors needed. W.G. Esick, 2607 E. 13th, Wichita, KS 67214.

Saab/Bendix model 9FBSA AM-FM auto radio. Need schematic or **Sams** auto radio series 110. Peter Moranski, 35 Riverse Rd., Fishkill, NY 12524.

Electro nuclear DX navigator Loran C model 102A. Schemat-

ic or manual needed. Dave Piersen, Box 66, Maynard, MA 01751.

Eldico model SSB 100 Mil. Need instruction manual. W.E. Whitlock, 1214 Vilsmeier Rd., Lansdale, PA 19446.

Lake Manufacturing Company Voycall amplifier type S100GLA, serial # 125851. Need tube layout and schematic. Allan W. Young, 157 Bragg Ave., Grass Valley, CA 95945.

Hammarlund model HZ-129-X communications receiver. Need bandspread drive assembly, consisting of knob, shaft, bushing, flywheel and rim drive. Gerald Koske, 10204 Thayer Rd., Wonder Lake, IL 60097.

U.S. Signal Corps DY-94/GRC-10, R-125/GRC-10, T-235/GRC-10, F-237/GRC and systempatch panel. Need schematics and manuals. Gary B. Rogers, 1115 Briarcliff Rd., Perry, GA 31069.

Bell 900 stereo receiver. Need schematic and parts list. R. Swaljug, 3059 N. Oleander Ave., Chicago, IL 60635.

Mediator A71-C. Need potentiometric voltmeter manual. **Rese Engineering** 1051. Need pulse generator manual. R. Sandell, 26 G.H. Baker Dr., Urbana, IL 61801.

Sentinel Radio model 293-W. Need glass tuning dial. **Emerson Radio** serial number EC-5983264. Need cabinet and handle. Stanley Liszewski, 182 Fairview Ave., Paramus, NJ 07652.

Philco model 42-1015 radio, 4 Band MX, 2X SW, FM-12 tube. Need service data. **Loewe** Super 32 radio made in Germany in early 1930's. Need service data and tube type 2HMD. R.G. Paton, 56 Glengarry Rd., Auckland 7, New Zealand.

Globe Electronics Globe Star CB. Need schematic. W.L. Fisher, Lawrence Rd., RFD 1, Mohegan Lake, NY 10547.

Sansui model 5000 AM/FM tuner amplifier unit. Need instruction manual. Terry Miller, 1375 Toedtl Dr., Boulder, CO 80303.

Hallcrafters model S118. Need schematic. Harry H. Munyan, 238 Cavin St., Clayton, NJ 08312.

Hallcrafters SX-140K amateur band receiver. Need opera-

tion and alignment manual. Doug Kowalski, 7319 Donna Dr., Middleton, WI 53562.

Hickok 640 AF oscilloscope. Need power transformer. Kenneth Grant, 409 Danube, Borger, TX 79007.

Philco model 42-1015 FM, MW, 2XSW receiver and **Atwater Kent** model P717X 3-band receiver. Need service manuals. R. G. Paton, 56 Glengarry Rd., Glen Eden, Auckland 7, New Zealand.

Superior Instruments Co., model TD-55. Need schematic, circuit diagram, tube charts and operation manual for tube tester. Larry Cook, 362 East South St., Richland Center, WI 53581.

Sherwood model S8900 FM stereo receiver. Schematic. Charles Butler, AOE N.A.S. Whiting Field, Milton, FL 32570.

Morrow Radio Phones model 5W1 transceiver. Schematic. Vincent Peery, Box 579, Johnson, KS 67858.

Grundig model TK-46 tape recorder. Schematic. Raymond Clayman, 1644 Fairfield Ave., Kingsport, TN 37664.

National Radio Co., 190 receiver. Will buy discarded receiver for parts. Ralph J. Monson, Rt. 1 Box 736, Lancaster, VA 22503.

R.C.A. model R.C. 22 receiving tube series. Need information on how to purchase. B. J. Maxwell, 139 Oswald St., Breaux Bridge, LA.

Pilot model 900 stereo tuner amplifier. Need schematic, instruction manual and alignment data. J. Radlick, 36651 Tulane, Sterling Heights, MI 48077.

McMurdo Silver Company, Vomag model 900 test meter. Operating instructions. M. Stanfa, 519 N. 16th St., Murphysboro, IL 62966.

Radiac AN/PDR-49A and DT-191A/PDR-49 set and detector. Need instruction manual and schematics. David Moody, 4305 So. 8 St., Terre Haute, IN 47802.

Capehart model 8TPR-103 or 8TPR-23R, serial #40101107 stereo record player. Need schematic and parts list. William C. Pollard, 1403-A Williams Dr., Georgetown, TX 78626.

FAIRCHILD RED LED LAMPS

#FLV5057 Medium Size Clear Case RED EMITTING. These are not retested off-spec units as sold by some of our competition. These are factory prime first quality new units.



10 FOR \$1.19
50 FOR \$4.95

"WE BOUGHT 250,000 PCS."

"THE COLOSSUS"

FAIRCHILD SUPER JUMBO LED READOUT

A full .80 inch character. The biggest readout we have ever sold! Super efficient. Compare at up to \$2.95 each from others!

YOUR CHOICE \$1.49 EA
FND 847 Common Anode
FND 850 Common Cathode (6 for \$6.95)

NATIONAL SEMICONDUCTOR JUMBO CLOCK MODULE

MA1008A
BRAND NEW!



\$6.95

2 FOR \$13

(AC XFMR \$1.95)

- FEATURES
- FOUR JUMBO 3/8 INCH LED DISPLAYS
 - 12 HR REAL TIME FORMAT
 - 24 HR ALARM SIGNAL OUTPUT
 - 50 OR 60 HZ OPERATION
 - LED BRIGHTNESS CONTROL
 - POWER FAILURE INDICATOR
 - SLEEP & SNOOZE TIMERS
 - DIRECT LED DRIVE (LOW RFI)
 - COMES WITH FULL DATA

ASSEMBLED! NOT A KIT.

ZULU VERSION!
We have a limited number of the 24 HR Real time version of this module in stock.
#MA1008D — \$9.95

PERFECT FOR USE WITH A TIMEBASE

COMPARE AT UP TO TWICE OUR PRICE!

MANUFACTURER'S CLOSEOUT!

16K DYNAMIC RAM CHIP

WORKS IN TRS-80 OR APPLE II

16K X 1 Bits 16 Pin Package Same as Mostek 4116-4 250 NS access 410 NS cycle time. Our best price yet for this state of the art RAM. 32K and 64K RAM boards using this chip are readily available. These are new, fully guaranteed devices by a major mfg.

\$14.95 each

8 FOR \$89.95

VERY LIMITED STOCK!

EXPERIMENTER'S CRYSTAL



.262, 144 KHZ. This frequency is 2 to the 18th power. Easily divided down to any power of 2, and even to 1HZ. New by CTS-Knight. A \$5 value!

\$1.25 each
4.00 MHZ — \$1.75

SALE!

1N4148 DIODES

High speed switching diodes. Silicon. Same as 1N914. Brand New. Full Leads. Prime!

100 FOR \$2 1000 FOR \$17.50

FAIRCHILD PNP "SUPER TRANSISTOR"

2N4402 TO-92 Plastic Silicon PNP Driver High Current VCEO-40 HFE-50 IO-150 at 150 MA FT-150 MHZ A super BEEFED-UP Version of the 2N3906

8 FOR \$1

JUMBO IC ASSORTMENT

All new, not rejects. BIG computer mfg. Surplus. Some standard marked, many house numbered. TTL, DTL, LINEAR. All prime, 1st line.

50 for \$1.59 500 for \$12.95

MOTOROLA POWER TRIAC

TO-220 CASE
15 AMP 400 PIV
SPECIAL 89¢ each
5 FOR \$3.95

COMPLEMENTARY POWER TRANSISTORS

SILICON NPN and PNP, TO-220 CASE. VCEO - 40V PD - 30 WATTS FOR AUDIO POWER AMPS, ETC.
YOUR CHOICE
TIP29 - NPN
TIP30 - PNP

3 FOR \$1

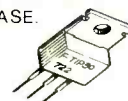

FET SALE!

2N4304 Brand New N Channel Junction FET BVGDO-30V IDSS-15 MA Typ 1500 uMhos TO-18 Plastic Case. Mfg. by Teledyne.

6 FOR \$1

60 Hz CRYSTAL TIME BASE

\$4.95 (Complete Kit)
Uses MM5369 CMOS divider IC with high accuracy 3.579545 MHz Crystal. Use with all MOS Clock Chips or Modules. Draws only 1.5 MA. All parts, data and PC Board included.

GE COMPUTER CAPACITOR #2

10,000 MFD 16 WVDC Super small: 3/8"x1/8" in. Computer Grade! 20 VDC Surge

\$1.59 ea. 3 for \$3.95

HY GAIN OP-AMP AND RELAY CONTROL BOARD

We do not know what these boards were used in, but they do contain a wealth of quality components. Board has 2-12VDC 200 OHM SPDT Mini Relays. 1-CD4001 CMOS. 4-LM358 High Performance OP AMPS (same as 1/2 LM324). 1-MOTOROLA MC3340 Mini Dip. 1-Audio Output Transformer. 1-TIP30 30 WATT PNP Power Transistor, plus 70 more assorted components. All parts easily removed. LIMITED STOCK: \$2.49 each

Digital Research Corporation

(OF TEXAS)

P.O. BOX 401247A GARLAND, TEXAS 75040 • (214) 271-2461

TERMS: Add 30¢ postage, we pay balance. Orders under \$15 add 75¢ handling. No C.O.D. We accept Visa, MasterCard, and American Express cards. Tex. Res. add 5% Tax. Foreign orders (except Canada) add 20% P & H. 90 Day Money Back Guarantee on all items.

Electronics Classified

REGULAR CLASSIFIED: COMMERCIAL RATE: For firms or individuals offering commercial products or services, \$2.50 per word. Minimum order \$37.50. **EXPAND-AD* CLASSIFIED RATE:** \$3.75 per word. Minimum order \$56.25. Frequency discount: 5% for 6 months; 10% for 12 months paid in advance. **PERSONAL RATE:** For individuals with a personal item to buy or sell, \$1.50 per word. No minimum! **DISPLAY CLASSIFIED:** 1" by 1 column (2-1/4" wide), \$300. 2" by 1 column, \$600.00. 3" by 1 column, \$900.00. Advertiser to supply film positives. For frequency rates, please inquire. **GENERAL INFORMATION:** Ad copy must be typewritten or clearly printed. Payment must accompany copy except when ads are to be billed on credit cards — American Express, Diners Club, Master Charge, VISA (supply expiration date) — or when ads are placed by accredited advertising agencies. First word in all ads set in caps. All copy subject to publisher's approval. All advertisers using Post Office Boxes in their addresses **MUST** supply publisher with permanent address and telephone number before ad can be run. Advertisements will not be published which advertise or promote the use of devices for the surreptitious interception of communications. Ads are not acknowledged. They will appear in first issue to go to press after closing date. Closing Date: 1st of the 2nd month preceding cover date (for example, March issue closes January 1st). Send order and remittance to Classified Advertising, **POPULAR ELECTRONICS**, One Park Avenue, New York, N.Y. 10016. For inquiries, contact Linda Lemberg at (212) 725-3924.

FOR SALE

FREE! Bargain Catalog—I.C.'s, LED's, readouts, fiber optics, calculators parts & kits, semiconductor parts. Poly Paks, Box 942PE, Lynnfield, Mass. 01940.

GOVERNMENT and industrial surplus receivers, transmitters, snooper scopes, electronic parts, Picture Catalog 25 cents. Meshna, Nahant, Mass. 01908.

LOWEST Prices Electronic Parts. Confidential Catalog Free. KNAPP, 4750 96th St N., St. Petersburg, FL 33708.

ELECTRONIC PARTS, semiconductors, kits. **FREE FLYER.** Large catalog \$1.00 deposit. **BIGELOW ELECTRONICS**, Bluffton, Ohio 45817.

RADIO—T.V. Tubes—36 cents each. Send for free catalog. Cornell, 4213 University, San Diego, Calif. 92105.

AMATEUR SCIENTISTS, Electronics Experimenters. Science Fair Students... Construction plans — Complete, including drawings, schematics, parts list with prices and sources... Robot Man — Psychedelic shows — Lasers — Emotion Lie Detector — Touch Tone Dial — Quadraphonic Adapter — Transistorized Ignition — Burglar Alarm — Sound Meter... over 60 items. Send 50 cents coin (no stamps) for complete catalog. Technical Writers Group, Box 5994, University Station, Raleigh, N.C. 27650.

SOUND SYNTHESIZER KITS—Surf \$14.95, Wind \$14.95, Wind Chimes \$19.95, Musical Accessories, many more Catalog free. PAIA Electronics, Box J14359, Oklahoma City, OK 73114.

HEAR POLICE / FIRE Dispatchers! Catalog shows exclusive directories of "confidential" channels, scanners. Send postage stamp. Communications, Box 56-PE, Commack, N.Y. 11725.

UNSCRAMBLERS: Fits any scanner or monitor, easily adjusts to all scrambled frequencies. Only 4" square \$29.95, fully guaranteed. Dealer inquiries welcomed. PDQ Electronics, Box 841, North Little Rock, Arkansas 72115.

TELETYPE EQUIPMENT for sale for beginners and experienced computer enthusiast. Teletype machines, parts, supplies. Catalogue \$1.00 to: ATLANTIC SALES, 3730 Nautilus Ave., Brooklyn, NY 11224. Tel: (212) 372-0349.

WHOLESALE C.B., Scanners, Antennas, Catalog 25 cents. Crystals: Special cut, \$4.95, Monitor \$3.95. Send make, model, frequency. G. Enterprises, Box 461P, Clearfield, UT 84015.

BUILD AND SAVE TELEPHONES. TELEVISION, DETECTIVE, BROADCAST Electronics. We sell construction plans with an Engineering Service. Speakerphones, Answering Machines, Carphones, Phonovision, Dialers, Color TV Converters, VTR, Games, \$25 TV Camera, Electron Microscope, Special Effects Generator, Time Base Corrector, Chroma Key, Engineering Courses in Telephone, Integrated Circuits, Detective Electronics. **PLUS MUCH MORE.** NEW Super Hobby Catalog PLUS year's subscription to Electronic News Letter, \$1.00. Don Britton Enterprises, 6200 Wilshire Blvd., Los Angeles, Calif. 90048.

NAME BRAND Test Equipment. Up to 50% discount. Free catalog. Salen Electronics, Box 82, Skokie, Illinois 60076.

SURPLUS COMPONENTS. Communication and test equipment. Illustrated catalog 25 cents. E. French, P.O. Box 249, Aurora, Illinois 60505.

WEATHER MAP RECORDERS: Copy Satellite Photographs, National-Local Weather Maps. Learn How! \$1.00. Atlantic Sales, 3730 Nautilus Ave., Brooklyn, N.Y. 11224. Tel: (212) 372-0349.

NAME BRAND TEST EQUIPMENT at discount prices. 72 page catalogue free. Write: Dept. PE, North American Electronics, 1468 West 25th Street, Cleveland, OH 44113.

UNSCRAMBLERS FOR any scanner. Several models available. Free literature. Capri Electronics, 8753T Windom, St. Louis, MO 63114.

RADIO SHACK Authorized Sales Center Special 10% savings on catalog prices including TRS-80. Free delivery on orders over \$50.00. 1117 Conway, Mission, TX 78572.

UNSCRAMBLER KIT. Tunes all scramble frequencies. may be built-in most scanners. 2-3/4 x 2-1/4 X 1.2. \$19.95. Factory built Code-Breaker. \$29.95. Free Catalog: KRYSTAL KITS, Box 445, Bentonville, Ark. 72712. (501) 273-5340.

CB RADIOS, VHF-UHF Scanners, Crystal, Antennas, Radar Detectors. Wholesale. Southland, Box 3591, Baytown, TX 77520.

BARGAINS GALORE! Buy-sell-trade classifieds in "Electronics Trader" only 10¢ word! Send \$2.00 for next four issues. Electronics Trader, Darwin, CA 93522.

TRANSISTORS FOR C-B Repair, IC's and diodes TV audio repairs 2SC756A — \$2.40, 2SC1306 — \$2.95, 2SC1307 — \$3.85, PLOZAG — \$7.50, AN239 — \$5.50, STK439 — \$8.95. Many more. FREE Catalog and transistor. B&D Enterprises, Box 32, Mt. Jewett, PA 16740.

CIRCUIT BOARDS from production-ready artwork. Free details. **QUANTITY discounts. CM CIRCUITS, 22 Maple Ave., Lackawanna, NY 14218.**

UNSCRAMBLE CODED MESSAGES from Police, Fire and Medical Channels. Same day service. Satisfaction guaranteed. Don Nobles Electronics, Inc., Rt. 7, Box 265B, Hot Springs, Arkansas 71901. (501) 623-6027.

MONTHLY PICTURE FLYER. Quality Surplus Electronic parts. Low Prices. Star-Tronics, Box 683, McMinnville, OR 97128.

PRINTED CIRCUIT supplies, chemicals, tools, artwork, plating solutions. Major credit cards. Catalog \$1.00, refundable. CIRCOLEX, Box 198, Marcy, NY 13403.

RECONDITIONED TEST EQUIPMENT \$1.00 for catalog. WALTER'S TEST EQUIPMENT, 2697 Nickel, San Pablo, CA 94806, (415) 758-1050.

PDP-8 MINICOMPUTER with 8K memory in excellent condition. 3 extra 4K memory panels (condition: 2 good, 1 unknown). 1 Spare core stack (excellent condition). 2 model 33ASR teletypes (fair condition). Supplies, manuals, programs, prints, power supplies, cables & hundreds of spare boards. David A. Bader, 15 Longwood Circle, Bath, PA 18014.

20 WATT OP AMP!!! Genuine integrated circuit op amp delivers 20 watts into 4 ohms, 10 watts into 8 ohms. Internal current limiting and thermal shutdown. Package uses 11 inline pins, and has flat metal surface for mounting to heat sink. \$9.00 each, ppd. Data and applications sheet included. **GEOFFREY SOUND LABS**, Dept. OA, 24 N. Wabash, Room #823, Chicago, IL 60602.

HAVE YOU GOTTEN ONE of Don Lancaster's INCREDIBLE SECRET MONEY MACHINES yet? \$6.95 postpaid. Synergetics, PE-7 Box 1112, Parker, AZ 85344. VISA accepted.

SANKEN 50 WATT Power Amp Chip: \$19.95; transformer 60 Hz 117v. PRI. 50 v sec (rms) 2.5 amps. cont. (rms): \$4.00; speaker 10 ounce ceramic tweeter, 4 1/2" cone, 250 HMS: \$3.00 new and \$2.00 slightly used; capacitors, 200v., .022 mf: \$8.00 per 100; .33 mf: \$15.00 per 100; .39 mf: \$15.00 per 100; 1.0 mf: \$30.00 per 100, 200 mf 6.3v: \$10.00 per 100; .0062 10% 600v disk ceramic temperature stable: \$5.00 per 100. All prepaid. Prairie Sounds, Box 982, Champaign, IL 61820.

PRINTED CIRCUIT BOARDS from your camera ready artwork, positive, negative, or magazine art. Reasonable. Free details. Richard Allran, Box 974, Waynesville, NC 28786.

ELECTRONIC PARTS. Tubes, Semiconductors, Phonograph Needles, **FREE CATALOG.** Rey Enterprises, Box 1539, Hialeah, FL 33011.

CHEMICALS. Lab Supplies. Lowest prices, fastest service anywhere. Listing 25¢ Westech Corp., Box 593, Logan, Utah 84321.

NEW ELECTRONIC PARTS. Continuously stocked. Stamp brings catalog. Daytapro Electronics, 3029 Wilshire Ln., Arlington Hts., IL 60004.

FREE

THE GREAT ELECTRONIC THINGS & IDEAS BOOK!

HUNDREDS OF UNUSUAL PARTS, GAOGETS & IDEA ITEMS. UNAVAILABLE IN STORES OR CATALOGS ANYWHERE! Bargain prices on everything! New items in every issue! Rush postcard for your copy!

ETCO ELECTRONICS Dept. 035, North Country Shopping Ctr., Plattsburgh N.Y. 12901

B&K Test Equipment. Free catalog. Free Shipping. Dinosaur discounts. Spaceltron-AR, 948 Prospect, Elmhurst, IL 60126.

SURPLUS ELECTRONICS

ATTENTION HOBBYISTS — SEND FOR YOUR FREE CATALOG

Great buys in tape drives, keyboards, power supplies, and transformers. We also have heat sinks, steel cabinets, I/O terminals video displays, printers, and equipment cases. And of course components, fans, wire, and cable. Write now to

130 Northeastern Blvd.
Worldwide Electronics Nashua, N.H. 03060

BUILD THE ARTISAN ELECTRONIC ORGAN... The 20th century successor to the classic pipe organ. Kits feature modular construction, with logic controlled stops and RAM Pre-Set Memory System. Be an ar-ti-san. Write for our free brochure. AOK Manufacturing, Inc., Box 445, Kenmore, WA 98028.

WRITE US AND WE'LL SEND YOU THE BEST CATALOG YOU EVER READ!

No kidding. Speakerlab's catalog took longer to write than some of our competitors have been in business. In fact, we created an industry by "building great kits so you can afford great speakers." Our catalog is an invaluable manual of speaker function and design. And, it will introduce you to the finest speaker kits made anywhere...with the strongest money-back guarantee. Find out for yourself...FREE, FREE, that is. Write now. Right now.



Speakerlab®

Dept. C-PE, 735 N. Northlake Way
Seattle, WA 98103

THE BEST CB ANTENNA

SEND FOR FREE **PAL** FULL LINE CATALOG AND DECAL



Antenna Corp.

2614 EAST ADAMS · PHOENIX ARIZONA 85034

POLICE/FIRE SCANNERS, crystals, antennas, CBs. Radar Detectors. HPR, Box 19224, Denver, CO 80219.

LOW. LOW Component Prices! Ask for free flyer. Write: EEP, 11 Revere Place, Tappan, NY 10983.

NEGATIVE ION GENERATORS AND ACCESSORIES (Assembled Kits). Fascinating Details—\$1.00 Golden Enterprises, Box 1282-PE, Glendale, Arizona 85311.

CARBON FILM RESISTORS 1/4W, 1/2W - 1.7 cents each. Free sample / specifications. Other components. COMPONENTS CENTER, Box 295, W. Islip, New York 11795.

Super Powerful Wireless Mic
10 times more powerful than other mics
Transmits up to 1/2 mile to any FM radio
Easy to assemble kit. 15V battery (not incl.)
Call (305) 725-1000 or send **\$18.95 + \$1.00**
shipping to USI Corp., P.O. Box PE-2052,
Melbourne, FL 32901. COD's except. For
catalog of transmitters, voice scramblers
and other specialty items, enclose \$2.00 to USI Corp.

\$18.95
Dist. Disc Avail.



TEKTRONIX 575 CURVE TRACER, \$495; Tektronix RM561A Scopes, \$200 ea; General Radio 650A Bridge \$100. Other items available. Serious inquiry please. Ball, 2135 Feather Rd., Vinton, VA 24179.

RENT, LEASE, SELL TVS! Guaranteed complete system \$15.00. Perry's Rental Systems, Box 1407, Santa Maria, CA 93456.

PLANS AND KITS

AMAZING ELECTRONIC PRODUCTS

LASERS SUPER POWERED, RIFLE, PISTOL, POCKET - SEE IN OAK - PYRO TECHNICAL DE-BUGGING, UNCRAMBLERS, GIANT TESLA, STUNWAND, TV DISRUPTER, ENERGY PRODUCING, SCIENTIFIC DETECTION, ELECTRICITY CHEMICAL, ULTRASONIC, CS, AUTO AUDIO AND MECH DEVICES, HUNDREDS MORE - ALL NEW PLUS INFO UNLTD PARTS SERVICE

INFORMATION unlimited
CATALOG \$1 Dept. E8, Box 716, Amherst, NH 03031

FREE KIT Catalog contains Test and Experimenter's Equipment. Dage Scientific Instruments, Box 1054P, Livermore, CA 94550.

TIGER 500 SIMPLI-KIT

FOR THE DO-IT-YOURSELFER
NOW! a high quality CD ELECTRONIC IGNITION SYSTEM in kit form.
Contains all components and solder to build complete Solid-State Electronic CD Ignition System for your car. Assembly requires less than 3 hours

- Increases MPG 15%
- Increases horsepower 15%
- Plugs and Points last 50,000 miles
- Eliminates 4 or 5 tune-ups
- Instant starting, any weather
- Dual system switch

Fits only 12 volt neg. ground...
Only **\$26.95** postpaid

Tri-Star Corporation
P.O. Box 1727 Grand Junction, Colorado 81501

BUILD YOUR OWN SYMPHONY OF SOUND!



It's fun and easy—takes just minutes a day! Complete kits for organs, pianos, strings, rhythms, amplifiers, synthesizers. Also factory assembled. 104-page catalog \$2.00

WERSI

Wersi Electronics, Inc.
Dept. ZD, 1720 Hempstead Road
Lancaster, PA 17601

CB/HAM HIGH GAIN ANTENNAS. Modulation boosting VOX-COMPRESSOR. Portable 300MHz COUNTER with memory! Plans \$3.00 ea. \$7.50 all. Many others, catalog with order, PANAXIS, Box 130-A3, Paradise, CA 95969.

TV-OSCILLOSCOPE CONVERTER externally adapts TV into audio frequency oscilloscope. Info. \$1.00. Plans \$5.00, with P.C. \$12.00. Evolutionics, Box 855-E, San Rafael, CA 94902.

PROJECTION TV . . . Convert your TV to project 7 Foot picture. Results equal to \$2,500 projector. Total cost less than \$20.00. PLANS & LENS \$16.00. Illustrated info. FREE: Macromcc, Washington Crossing, PA 18977.

FREQUENCY COUNTERS 50 MHZ \$59.95, 500 MHZ \$79.95. Flashing LED's \$1.00. Digital clocks \$12.95. Lec-Tronix, Box 42, Madison Heights, Michigan 48071.

PRINTED CIRCUIT Boards from sketch or artwork. Kit projects. Free details. DANOCI Inc., Box 261, Westland, MI 48185.

DIGITAL TACHOMETER for automobiles. Works with standard and electrical ignition systems. Plans \$2.00. David Marecek, 1904 Paige Place N.E., Albuquerque, N. Mex. 87112.

FM STEREO TRANSMITTER — Broadcast in STEREO to any FM receiver. Plans —\$3.50. Kits — \$19.50. Assembled — \$24.50. Advanced Technical Products, Box 2292, Iowa City, Iowa 52240.

DOLBY ADD-ON ENCODES/DECODES RECORDINGS. FM. Quality components, complete kit. Calibration tapes. Comprehensive test report. PEM INTEGREX, Box 747, Havertown, PA. 19083.

PHOENIX SYSTEMS Quality Audio Kits

*880 Audio Delay Line Tube 78 P-1220N \$50 P-1220B \$75

*Tape Noise Reduction No. 77 P-515 \$59

*BiFet Preamp/DiCk Mixer Sept 78P-1130PA\$90 P-1130DM\$130

MAIL: CATERWALKER • 370 SPRINGHILL ROAD • ROCKFORD, ILL. 61106 (708) 261-4104

TELEPHONES & PARTS

OMAK PHONE CENTER. All types of telephones — keyed, modular and decorator. Catalog \$1.00 (refundable). Master Charge & VISA accepted. Box 38, Beardstown, IL 62618. (217) 323-3963.

TELEPHONES UNLIMITED, Equipment Supplies. All types, Regular, Keyed, Modular. Catalog 50 cents. Box 1147E, San Diego, California 92112.

ALARMS

QUALITY BURGLAR-FIRE ALARM EQUIPMENT at discount prices. Free Catalog! Steffens, Box 624K, Cranford, N.J. 07016.

Burglar - Fire - Smoke Alarm Catalog

- Billions of dollars lost annually due to lack of protective warning alarms.

FREE CATALOG Shows you how to protect your home, business and person. Wholesale prices. Do-it-yourself. Free engineering service.

Burdex Security Co.

Box 82802 PE-039 Lincoln, Ne. 68501

PROFESSIONAL ALARM SYSTEMS and supplies at wholesale prices. FREE CATALOG. CAPCO, Box 5980-CPE3, Incline Village, Nevada 89450.

MUSICAL INSTRUMENTS

UP TO 60% DISCOUNT. Name brand instruments catalog. Freeport Music, 114 G, Mahan St., W. Babylon, N.Y. 11704.

HIGH FIDELITY

DIAMOND NEEDLES and Stereo Cartridges at Discount prices for Shure, Pickering, Stanton, Empire, Grado and ADC. Send for free catalog. LYLE CARTRIDGES, Dept. P, Box 69, Kensington Station, Brooklyn, New York 11218. For Fast Service call Toll Free 800-221-0906.

HEAR YOUR TV in simulated stereo. Movie theatre sound realism. Free details. Triangle Electronics, Box 377X, Merrick, N.Y. 11566.

WANTED

GOLD, Silver, Platinum, Mercury, Tantalum wanted. Highest prices paid by refinery. Ores assayed. Free circular. Mercury Terminal, Norwood, MA 02062.

WANTED! CB DEALERS AND DISTRIBUTORS

PAL Antenna Corp.

2614 EAST ADAMS • PHOENIX ARIZONA 85034

TUBES

RADIO & T.V. Tubes—36 cents each. Send for free Catalog. Cornell, 4213 University, San Diego, Calif. 92105.

TUBES: "Oldies". Latest. Supplies, components, schematics. Catalog Free (stamp appreciated). Steinmetz, 7519-PE Maplewood, Hammond, Ind. 46324.

TUBES-RECEIVING, Industrial and Semiconductors Factory Boxed. Free price sheet including TV, Radio and audio parts list. Transletronic, Inc., 1365 39th St., Brooklyn, New York 11218. Telephone: (212) 633-2800. Toll free: 800-221-5802.

RADIO AND TV TUBES 1938 to 1978 \$1.00 ea. PRELLER TV, Augusta, AR 72006. (501) 347-2281

TUBES 29¢ up, no minimum order necessary. Also have obsolesces. Free list. Conelco, Box 632, Trona, CA 93562.

GOVERNMENT SURPLUS

MANUALS for Govt Surplus radios, test sets, scopes. List 50 cents (coin). Books, 7218 Roanne Drive, Washington, D.C. 20021.

JEEPS—\$59.30! — CARS—\$33.50! — 200,000 ITEMS! — GOVERNMENT SURPLUS — Most COMPREHENSIVE DIRECTORY AVAILABLE tells how, where to buy — YOUR AREA — \$2.00 — MONEYBACK GUARANTEE — Government Information Services, Department GE-55, Box 99249, San Francisco, California 94109 (433 California).

GOVERNMENT SURPLUS. Buy in your Area. How, where. Send \$2.00. Surplus, 30177-PE Headquarters Building, Washington, D.C. 20014.

"GOVERNMENT SURPLUS DIRECTORY." Buy 250,000 items (including Jeeps) . . . low as 2¢ on dollar! Most complete information available — \$2.00. Surplus Disposal, Box 19107-HC, Washington, DC 20036.

PERSONALS

MAKE FRIENDS WORLDWIDE through international correspondence, illustrated brochure free. Hermes-Verlag, Box 110660 Z, D-1000 Berlin 11, Germany.

INSTRUCTION

SCORE high on F.C.C. Exams . . . Over 300 questions and answers. Covers 3rd, 2nd, 1st and even Radar. Third and Second Test, \$14.50; First Class Test, \$15.00. All tests, \$26.50. R.E.I., Inc., Box 806, Sarasota, Fla. 33577.

UNIVERSITY DEGREES BY MAIL! Bachelors, Masters, Ph.D's. Free revealing details. Counseling, Box 317-PE03, Tustin, California 92680.

LEARN WHILE ASLEEP! HYPNOTIZE! Astonishing details, strange catalog free! Autosuggestion, Box 24-ZD, Olympia, Washington 98507.

1979 "TESTS - ANSWERS" for FCC First Class License. Plus - "Self Study Ability Test." Proven! \$9.95 Unconditional Moneyback Guarantee. Command Productions, Box 26348-P, San Francisco, CA 94126.

MATHEMATICS. ELECTRONICS. Advanced mathematics. Engineering mathematics. Digital Technology. Free catalog. IHSI, Box 1189, Panama City, FL 32401.

INTENSIVE 5 week course for Broadcast Engineers. FCC First Class license. Student rooms at the school. Radio Engineering Inc., 61 N. Pineapple Ave., Sarasota, FL 33577 and 2402 Tidewater Trail, Fredericksburg, VA 22401.

BROADCAST STATION: Start your own. Home, school, church, business operation. Get free equipment, records. Details free. "Broadcasting", Box 130-A3, Paradise, CA 95969.

PASS FCC EXAMINATIONS — 1st - 2nd - 3rd - Radar. Proven method by Victor Veley, noted author-teacher. Part I, Workbook consisting of hundreds of problems with complete solutions. Part II, Question and Answer Manual has hundreds of practice questions. Complete course — Both Manuals, \$14.95 postpaid. Oeffinger Publishing, Box 1240, Garden Grove, Calif. 92642.

MAGNETS

MAGNETS. All types. Specials-20 disc, or 10 bar, or 2 stick or 8 assorted magnets. \$1.00. Magnets, Box 192-H, Randallstown, Maryland 21133.

FOR INVENTORS

PATENT AND DEVELOP Your invention. Registered Patent Agent and Licensed Professional Engineer. Send for FREE PATENT INFORMATION every inventor should have. Richard L. Miller, P.E., 3612 Woolworth Building, New York, NY 10007. (212) 267-5252.

HAVE YOU AN INVENTION? We evaluate, develop, improve and market meritorious inventions and ideas. For free brochure write, call: Inventors Guild, P.O. Box 411, Fort Washington, PA 19034. (215) 233-5252.

PRINTING

QUALITY—PRINTING. Good prices, prompt service. Free catalog. Deep South, Dept. E-3, Clinton, Mississippi 39056.

BUSINESS OPPORTUNITIES

I MADE \$40,000.00 Year by Mailorder! Helped others make money! Torrey, Box 318-NN, Ypsilanti, Michigan 48197.

FREE CATALOGS. Repair air conditioning, refrigeration. Tools, supplies, full instructions. Dookin, 2016 Canton, Dallas, Texas 75201.

NEW LUXURY Car Without Cost. Free Details! Codex-ZZ, Box 6073, Toledo, Ohio 43614.

GET RICH!!! Secret law erases debts. Free report exposes millionaire \$\$ secrets. Blueprints, No. EE3, 453 W. 256, NYC 10471.

MECHANICALLY INCLINED individuals desiring ownership of Small Electronics Manufacturing Business — without investment. Write: BUSINESSES, 92-K2 Brighton 11th, Brooklyn, New York 11235.

MILLIONS in Mail!!! Free Secrets. Transworld-17, Box 6226, Toledo, OH 43614.

MECHANICALLY INCLINED INDIVIDUALS — WANTED —

Assemble electronic devices in your home. Get started in spare time. Experience, Knowledge or Investment Not Necessary. Expect big profits: \$300 - \$600 Wk. Possible. Write for free literature telling how.

ELECTRONIC DEVELOPMENT LAB
BOX 1560PE, Pinellas Park, FL 33565

EARN \$1,000 MONTHLY sparetime, homework. "Guaranteed." Free details, Write: UNICORN, ZD3, 1140 Chelton, Colorado Springs, CO 80910.

VINYL'S WHERE THE MONEY IS! Professionally repair, re-finish, recolor furniture, luggage, car tops. Quick, easy. Two small \$20 jobs a day earn you \$1,000 a month. Homes, cars, offices, restaurants, unlimited customers. Start earning after a few days practice. Sensational details Free. VIP, 2012 Montrose, Chicago 60618.

BORROW \$25,000 "OVERNIGHT." Any purpose. Keep indefinitely! Free Report! Success Research, Box 29263 GC, Indianapolis, Indiana 46229.

\$1200.00 MONTHLY Correcting Pupils' Lessons!!! Start immediately. Free Report. Send self-addressed stamped envelope. Home, Box 98201-SJX, San Diego, CA 92109.

ADVERTISING BUSINESS — You own it! \$400 first week or money back. Write: Action Ad Clock, Room AC-376-IC, 1512 Jarvis, Chicago, IL 60626.

START YOUR business without cash or credit. Free details. Limited time offer. Box 16428, San Diego, CA 92116.

EMPLOYMENT OPPORTUNITIES

ELECTRONICS AVIONICS EMPLOYMENT OPPORTUNITIES. Report on jobs now open. Details FREE. Aviation Employment Information Service, Box 240E, Northport, New York 11768.

INSTANT CASH COMMISSIONS Full or part time. Free sales kit features America's largest line low priced Business, Printing, Advertising Specialties, Signs, Calendars and other necessities used daily by business people. Profitable repeat order. No experience. No investment. No collections or deliveries. Write today, National Press, Dept. 908, North Chicago, IL 60064.

RADIO-TV JOBS . . . Stations hiring nationwide! Free details: "Job Leads", 1680-PG Vine, Hollywood, CA 90028.

MAJOR NY publisher has IMMEDIATE opening for freelance acquiring editor ELECTRONIC handbooks, troubleshooting manuals, texts. Qualified candidate should have successful publishing record, good leads to other tech writers, heavy publication copy editing experience. Resume: Box 203, POPULAR ELECTRONICS, Classified, 1 Park Ave., N.Y., N.Y. 10016.

REAL ESTATE

BIG . . . FREE . . . SPRING CATALOG! Over 2,600 top values coast to coast!! UNITED FARM AGENCY, 612-EP, West 47th, Kansas City, MO 64112.

RUBBER STAMPS

RUBBER STAMPS, BUSINESS CARDS. Many new products. Catalog. Jackson's, E-100, Brownsville Rd., Mt. Vernon, Ill. 62864.

BOOKS AND MAGAZINES

POPULAR ELECTRONICS INDEXES For 1977 now available. Prepared in cooperation with the Editors of "P.E.," this index contains hundreds of references to product tests, construction projects, circuit tips and theory and is an essential companion to your magazine collection. 1977 Edition, \$1.50 per copy. All editions from 1972 onward still available at the same price. Add \$.25 per order for postage and handling. \$.50 per copy, foreign orders. INDEX, 6195 Deer Path, Manassas, Va. 22110.

FREE book prophet Elijah coming before Christ. Wonderful bible evidence. MEGIDDO Mission, Dept. 64, 481 Thurston Rd., Rochester, N.Y. 14619.

DO-IT-YOURSELF

MODULAR TELEPHONES now available. Sets and components, compatible with Western Electric concept. Catalog 50 cents. Box 1147W, San Diego, California 92112.

AUDIO ANALOG SYNTHESIS. Plans, parts, kits, etc. for the most exciting sound projects ever. Get on our mailing list, send 25¢ to: CFR Associates Inc., Newton, N.H. 03858.

COMPLETE LINE Security Systems for home, Business. Send self addressed, stamped envelope. Darbar, Box 1147E, San Diego, CA 92112.

MOTION PICTURE FILMS

IN MARCH, IT'S SPORTLITE FOR MAIL ORDER FILM VALUES! Order new Columbia Pictures S8 400' color sound features: Charles Bronson "Breakout," Peter Falk "Machine Gun McCain," More From Emmanuelle; Sean Connery "The Anderson Tapes," Walter Matthau "Fail Safe," and Brian's Song — Football — extra long. \$47.95 ea + \$1.00 for shipping. Columbia Pictures price \$54.95 ea (you save \$5.00 on every film you buy). Tear out this ad & mail order today! Auto sports film specials: 1977 Indy "500", A.J. Foyt's "Glorious Fourth" S8 color \$17.95 ea + 90¢ shipping. Al Unser's 1st. 70 Indy "500" 200' S8, \$15.95 ea + 90¢ shipping. Penny Pinchers: Darlington "500" 40's Action. 200' St 8 color, \$8.95 ea (sells for \$3. less than Columbia or Universal S8 B W). Call action line: (312) 236-8955. Universal 64-pg catalog \$1.10 (foreign \$2.20). Columbia, Sportlite, Universal, Ring Classics order forms 40¢ ea with flyers. SPORTLITE FILMS, Elect-3 79, Box 24-500, Speedway, IN 46224.

HYPNOTISM

FREE Hypnotism. Self-Hypnosis. Sleep Learning Catalog! Drawer H400, Ruidoso, New Mexico 88345.

MISCELLANEOUS

MPG INCREASED! Bypass Pollution Devices easily, REVERSIBLY!! Free details — Posco GEE3, 453 W. 256, NYC 10471.

CORVAIR PARTS — 4500 different parts stocked. Giant Catalog \$3.00. Clark's Corvaire Parts Inc., Shelburne Falls, MA 01370.

CLASSIFIED ADVERTISING ORDER FORM

1	2	3
4	5	6
7	8	9
10	11	12
13	14	15
16	17	18
19	20	21
22	23	24
25	26	27
28	29	30
31	32	33
34	35	36

Please refer to heading on first page of this section for complete data concerning terms, frequency dis counts, closing dates, etc. WORD COUNT 15 WORD MINIMUM. Include name and address. Name of city (Des Moines) or of state (New York) counts as one word each. Zip Code not counted. Count each abbreviation, initial, single figure or group of figures or letters as a word. Symbols such as 35mm, C.O., P.O., AC, etc., count as one word. Hyphenated words count as two words. Telephone numbers count as one word.

Words _____

\$2.50 Commercial Rate
\$3.75 Expand-Ad Rate
\$1.50 Personal Rate

- Insertions _____
 Enclosed is \$ _____
 CHARGE. You will be billed monthly.
 American Express Master Charge
 Visa Diners Club



Account # _____

Expiration Date _____ Master Charge Interbank # (4 digits above name) _____

SIGNATURE _____

PRINT NAME _____

ADDRESS _____

CITY _____ STATE _____ ZIP _____

PE 3/79

Popular Electronics

ADVERTISERS INDEX

READER SERVICE NO.	ADVERTISER	PAGE NO.
2	Active Electronics Sales Corp.	104
4	Ancrona Corp.	108
6	Antenna, Inc.	30, 31
7	AP Products, Inc.	92
8	B & F Enterprises	109
9	B & K Precision, Dynascan Corp.	87
10	Byte, Inc.	86
	Chaney Electronics	107
	Cleveland Institute of Electronics Inc.	44, 45, 46, 47
1	Communications Electronics	2
11	Consumers Company	94
12	Continental Specialties Corp.	7
13	Cooper Group, The	84
14	Creative Computing Magazine	88
16	Digi-Key Corporation	105
	Digital Research Corporation	111
62	Douglas Dunhill	14
15	DSI Instruments, Inc.	13
	Edmund Scientific Co.	107
17	EICO	89
18	Electra Company	9
	Electro-Voice, Inc.	12
20	Fordham Radio Supply	110
21	General Engines Company	107
22	Godbout Electronics, Bill	108
23	Grantham College of Engineering	88
5	Heath Company	81, 82, 83
24	Illinois Audio	90
25	Integrated Circuits	96
26	IE Integrated Electronics	109
27	International Components Corporation	109
28	J & R Music World	90
29	Jameco Electronics	102, 103
	JS & A National Sales Group	1
58	McIntosh Laboratory, Inc.	76
	Micro Computer Mart	93
31	Mini Micro Mart	94
61	Motorola	Cover 2
57	Multicore	90
32	National Guard	27, 28, 29
33	Netronics	91
34	Netronics	88
35	New-Tone Electronics	110
36	Non-Linear Systems	94
	NRI Schools	16, 17, 18, 19
37	Ohio Scientific Instrument	5
38	OK Machine & Tool Corporation	79
39	Olson Electronics	115
40	PAIA Electronics, Inc.	94
41	PAL "Firestick" Antenna Corporation	90
42	Percom Data Company, Inc.	78
43	Poly Paks	98
44	Professional Aids	78
45	Quest Electronics	97
	Radio Shack	101
46	Real Time Intelligence	6
	Sabtronics International, Inc.	34
47	Schober Organ Corporation, The	14
59	Scientific Audio Electronics	Cover 3
48	Shure Brothers, Inc.	32
49	Solid State Sales	107
50	Southwest Technical Products Corporation	75
51	Sparkomatic	40
	Speakerlab, Inc.	89
52	Tab Books	15
53	Technics by Panasonic	Cover 4
54	U.S. Pioneer Electronics	10, 11
55	Vector Electronics	77
56	Wahl Clipper Corporation	75

PLANNING TO MOVE?

Let us know 8 weeks in advance so that you won't miss a single issue of **POPULAR ELECTRONICS**. Attach old label where indicated and print new address in space provided. Also include your mailing label whenever you write concerning your subscription. It helps us serve you promptly.

Write to: P.O. Box 2774, Boulder, CO 80322 giving the following information:

Change address only Extend my subscription

ENTER NEW SUBSCRIPTION

1 year \$13.00 Payment enclosed (1 extra BONUS issue)
 Allow 30-60 days for delivery. Bill me later

AFFIX OLD LABEL

If you have no label handy, print OLD address here.

Name _____ please print

Address _____

City _____

State _____ Zip _____

NEW ADDRESS HERE 0384

Name _____ please print

Address _____ Apt. _____

City _____

State _____ Zip _____

Additional postage on foreign orders add \$3 a year for Canada, \$5 a year for all other countries outside the U.S. and its possessions. Cash only on foreign orders, payable in U.S. currency

8-TRACK 40-MINUTE BLANK **CASSETTE 60 MINUTE BLANK**

SALE 49¢ **SALE Pkg. of 3 79¢**

TA-907 TA-879

•Erased Not Used • 1 lb

Reg. 99¢

LESS THAN 27¢ EA. Reg. 1.49

CB HAND MIKE

SALE 299 Reg. 5.49

CB-735

•Built-In Volume Control
 •5000 Ohms Impedance
 •5' Coiled Cord W/6-Pin DIN Plug
 •Shpg. wt 2 lbs.

SALE SWR METER 799

FIELD STRENGTH INDICATOR

CB-067 Reg. 11.88

•For Accurate Tuning of CB Antenna •Styles Vary
 •Range 2 to 30MHz •52 Ohms Impedance •Wt 1 lb

AC BATTERY ADAPTER

329 Reg. 5.89

BA-159

•For Radios, Recorders, Calculators and More!
 •6.75 9V @ 300mA
 •Includes Plug for Mini. Micro Co-Ax Jacks
 •Styles Vary

CB SLIDEMOUNT

SALE 159 Reg. 1.99

AU-149

•For Under-Dash Mounting of CB's, Radios, etc.
 •Shpg. wt. 2 lbs.

LAPEL MICROPHONE

SALE 99¢ Reg. 1.98

MM-174

•Hi-Impedance Crystal
 •3.5mm Mini Plug
 •Shpg. wt. 1/4 lb.

Olson 1000 OHMS PER VOLT TESTER

SALE 799 Reg. 12.50

TE-184 LIMIT 1

•Pocket Size Goes Anywhere
 •Wt. 3 lbs.

CB NOISE FILTER 100 AMP

SALE 59¢ Reg. 1.28

CB-454

•For Alternator/Generator
 •Filters Out Unwanted Noise in Any 2-Way Radio •1 lb.

Olson electronics

Dept. IN 260 S. Forge St. Akron, Ohio 44327

NAME _____

ADDRESS _____

CITY _____

STATE _____ ZIP _____

Qty.	Stk #	Description	Price Ea	Total

For 24 Hour PHONE Service Call (216)535-1800

Tax _____
 Postage _____
 Total _____

Please send me a free subscription to Olson Value Packed Catalog. (Within the Continental USA Only)

FREE!

Video-disc viewing through home TV receivers has become a reality with MCA DiscoVision from Magnavox. Backing up the introduction of the DiscoVision player, Magnavox has available a wide range of video discs. Included in the catalog of listings and descriptions are such current feature motion pictures as "Jaws," "Sgt. Pepper's Lonely Hearts Club Band," "American Graffiti," and "Animal House" and such oldies as "Frankenstein," "Dracula," and the Marx Brothers' "Animal Crackers." Currently available selections, numbering more than 200 and including educational films, retail for \$5.95 to \$15.95.

CBS Toys has given Compucolor Corp. the first license to produce and market a low-cost color graphics version of the popular game "Othello" for the Compucolor II computer. Combining elements of luck, skill, patience, and logic, Othello can be played by one person with Compucolor II; or two people can play the game with Compucolor II acting as a referee to record scoring and disallow illegal moves. It is also possible to pick up some playing tips by watching the Compucolor II play itself.

Portable calculators do more than calculate nowadays. For example, Casio's new line includes one with

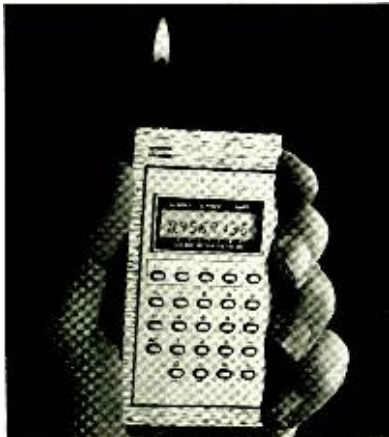

a cigarette lighter, another that hangs from a chain as a fashion pendant. Sharp's '79 entries include a model with an AM radio, and one with a world clock for international travelers.

Award certificates for SSTV activity is being offered by *Amateur Television Magazine*. Certificates range from Basic award through several levels of difficulty to a Master Scanner award. The beginning-level certificate requires the operator to have five confirmed SSTV contacts on each of any five ham bands. Bands used for all levels can be any combination of the contestant's choosing. Additional awards are available for working increasing numbers of stations on increasing numbers of bands.

A young people's satellite network that provides nonviolent TV programming on a daily basis has been announced by Warner Cable Corp. The all-day Nickelodeon (TM) programming will be available to U.S. cable-TV operators for distribution to subscribers able to receive programs beamed by satellite to earth receiving stations. More than 5-million subscribers can currently receive such programs, and the number is expected to double as more earth receiving stations are built.

Solar energy moves forward with operation of the nation's largest high-temperature solar energy system for heating and cooling at Honeywell's General Offices in Minneapolis. It is the first solar system of its kind to provide all of a major building's heating and cooling needs on sunny days and was designed, funded, and built by Honeywell for its new eight-story office building. Tracking the sun and focusing its energy on liquid-filled pipes are 252 trough-like collectors. The liquid, which gets as hot as 350° F, is pumped into an isolation heat exchanger that allows different fluids, pressures, and flow rates to be used in the two-loop system necessitated by Minnesota's extreme cold temperatures. Excess heat is stored underground in two 18,000-gallon tanks until needed at night or when the sky is overcast.

In 1978, Zenith Radio Corporation is celebrating its 60th anniversary as a manufacturer of home entertainment products. Zenith began in 1918 when two partners formed the Chicago Radio Laboratory, which was located near the old Edgewater Beach Hotel. The company manufactured equipment for the amateur radio market under the tradename Z-Nith, derived from 9ZN, the call letters of the amateur radio station operated by the partners.

RCA's 50-millionth TV receiver was produced last December. The 19" ColorTrak shown at left in the photo is contrasted with the company's



first receiver, a 10" monochrome model built in 1946. RCA estimates that the industry sold a record 10-million color-TV receivers during 1978.

A Junior REACT Program has been launched for young CBers. The Junior Program creates a new membership category at the International level and encourages teams not already doing so to consider accepting young people as Junior members. Eligibility for the Junior Program is open to youngsters between 12 and 18 years old. Junior members receive their own identification card and a Junior Division REACT decal.

An electronic message transmission system is being tested by the Postal Service. It could be in operation in as little as three years. Using this system, computers send messages by bouncing them off a satellite to the specified receiving points on earth. The message is then put into an envelope for delivery in the next day's mail. Assuming the volume of messages sent is sufficient to support the system, each message could be sent for as little as 10¢ or 11¢, according to Postmaster General William F. Bolger.

The "Maker Of The Microphone Award," given annually in honor of Emile Berliner, inventor of the microphone and disc record, has been awarded to the late Dr. Peter C. Goldmark, developer of the fine-groove LP disc record and other audio and video innovations. Dr. Goldmark was the fifteenth to receive the award, which will be presented only 25 times to commemorate the fact that Emile Berliner was only 25 years old when he invented the microphone. Dr. Goldmark's sons accepted the award for their father, who died in an auto accident last year, from Oliver Berliner, grandson of Emile Berliner.

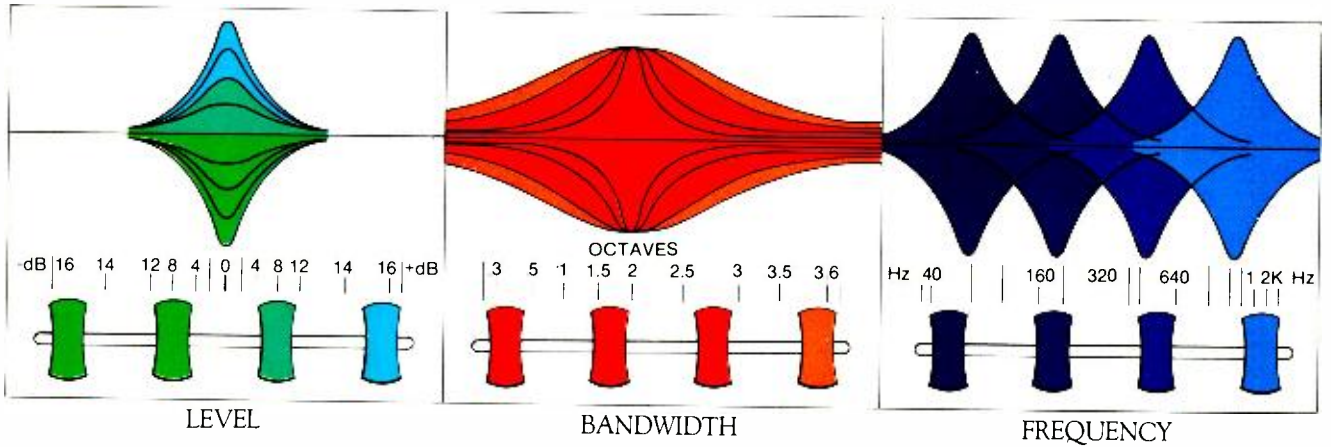

With the graphic equalizer, you have a limited number of chances to correct an infinite number of potential problems in a recording or listening environment. You're dealing with fixed bandwidths and fixed frequencies. You can only increase or decrease the level. When boosting or cutting frequencies,

you have to settle for the nearest one or two octaves. It's a compromise. With the parametric, you're provided an infinite number of solutions. Bandwidth, frequency and level are each determined by you. Any musical problem can be isolated and corrected. And that's what all the excitement's about.

The graphic reason to buy our parametric.

At SAE, the battle has always been for complete musical control. Control that would allow you to correct for any inadequacy in any recording or listening environment.

Now the battle is over. You won.

SAE introduces the 180 Parametric Equalizer.

Actually, if you work for a recording studio, "introducing" would hardly be appropriate. You'd be working with parametrics already. Very simply, it's a matter of flexibility and precision. And very simply, with the SAE 180, the flexibility and precision of your sound control are absolutely limitless.

We should let the parametric speak for itself.

Problem: The lead singer is overpowered by the back-up group.

Solution: Set Level control to +10dB. Sweep Frequency control until the voice is brought

forward. Adjust Bandwidth control to encompass the full voice range. Tailor Level control to exact voice presence desired.

How much does a machine like this cost? How can I afford a component that can acoustically correct a system? How can I buy an electronic box that can fix a listening room and a recording at the same time?

The SAE 180 costs \$250.* That's how.

What we have is a small miracle that is also an attainable reality. Imagine: Complete, precise, musical control for the price of a common graphic.

Remember that word: Parametric. Remember that number: 180. And remember that name: SAE.

*Nationally advertised value, actual retail prices are established by SAE Dealers.



I want control. Send information.

Name _____

Address _____

City _____ State _____ Zip _____

SEND TO: SAE, P.O. Box 60271, Terminal Annex,
Los Angeles, California 90060

SAE

Scientific Audio Electronics, Inc.
CIRCLE NO. 59 ON FREE INFORMATION CARD

While our competitors were listening to Technics Linear Phase speakers, we introduced phase two.

When Technics introduced Linear Phase speakers two years ago, we took the audio world by surprise. And why not. After all, Technics Linear Phase speakers were the first speakers to actually show waveform fidelity. Not simply with tone bursts and sine waves, but by actually comparing the waveforms of live musical instruments

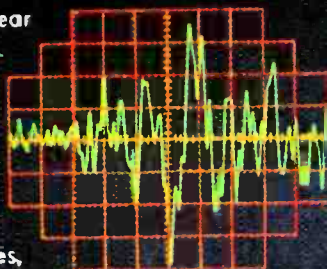

Piano Waveform.

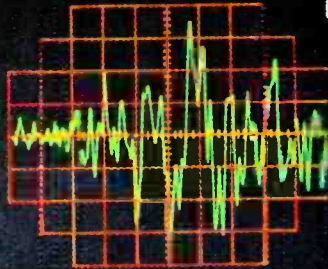

Piano Waveform reproduced by SB-7070.

to the output waveforms of our Linear Phase speakers.

Now with the 3-way SB-6060 and 4-way SB-7070 (shown below), Technics takes you to phase two. Because compared to our first Linear Phase speakers both give you wider frequency extension, flatter frequency response and even more phase linearity, which means even better waveform fidelity.

How did we make such good speakers even better? We started with BASS (Basic Acoustic Simulation System), an IBM 370-based interactive computer system. With it, Technics engineers can do what they only dreamed of doing in the past: Calculate the acoustic pressure and distortion characteristics of transducers without physically building and measuring countless prototypes.

Next we took these computer-derived drivers and combined them with Technics' unique phase-controlling crossover network. And of course we staggered the drivers to align their acoustic centers precisely.

It's easy to see the result of all this technology. Just compare the waveforms. On the left is a waveform of a live piano. On the right, the piano as reproduced by the SB-7070. That's waveform fidelity.

Listen to the 4-way SB-7070. What you'll hear is its smooth transition between low, midrange and high frequencies. Then notice the bass response. It's deep and tight. With much more punch, better definition and even less IM distortion than its predecessor. That's because when the upper bass

frequencies are handled by a separate driver, the woofer does a much better job at handling the lower bass frequencies.

You'll also hear vocals that are smooth and natural.

That's because the SB-7070's high-midrange driver was designed with "free edge" construction to avoid coloration of

the critical upper-midrange frequencies.

And by adding a new, smaller tweeter with improved dispersion characteristics, the SB-7070's high-end frequency response was extended to 32 kHz.

Technics 3-way SB-6060 and 4-way SB-7070. For music that sounds like it was originally played. Live.



All cabinet is simulated wood.

Technics
Professional Series

CIRCLE NO. 53 ON FREE INFO FORM ON CARD