

HEAR PILOT-TO-TOWER TALK WHILE IN FLIGHT

14278

Popular Electronics

WORLD'S LARGEST-SELLING ELECTRONICS MAGAZINE

MAY 1977/\$1.25

FOR HI-FI BUFFS

- HOW TO MATCH STEREO COMPONENTS BY \$\$\$
- HIRSCH-HOUCK LABS EXAMINES:
SENNHEISER'S WIRELESS STEREO HEADPHONES
TEAC'S PORTABLE STEREO CASSETTE DECK

FOR COMMUNICATION HOBBYISTS

- MORSE CODE ALPHANUMERIC READOUT ON TV
- TESTING KENWOOD'S DIGITAL HAM TRANSCEIVER

HANDS-ON REPORT FOR EXPERIMENTERS

- THE NEW "NO CAMERA" PC BOARD KITS

VOICE COMMUNICATIONS WITH COMPUTERS!

...speech recognition device substitutes for keyboard

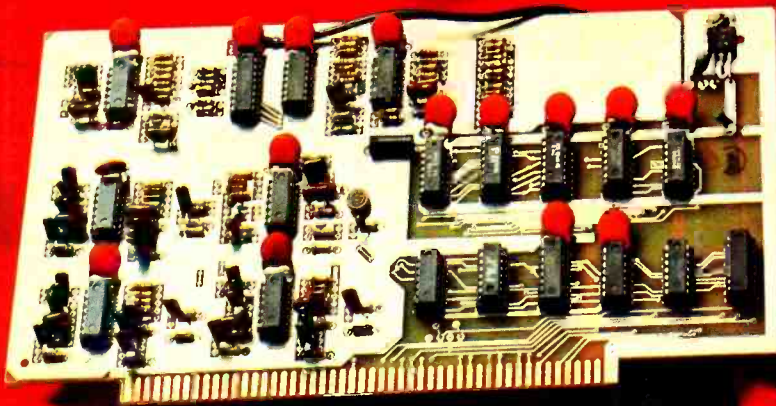

PE
TESTED

MAJOR
PROJECT
BREAKTHROUGH

05

600896 KRK B6122R99 5410 DEC78

14024 14278

Popular Electronics

The 40-channel Cobra 29XLR. From the sleek brushed chrome face to the matte black housing, it's a beauty. But its beauty is more than skin deep. Because inside, this CB has the guts to pack a powerful punch.

The illuminated 3-in-1 meter tells you exactly how much power you're pushing out. And pulling in. It also measures the system's efficiency with an SWR check. In short, this Cobra's meter lets you keep an eye on your ears.

The Digital Channel Selector shows you the channel you're on in large LED numerals that can be read clearly in any light. There's also switchable noise blanking to reject short-pulse noise other systems can't block. The built-in power of DynaMike Plus. Automatic noise limiting

and Delta Tuning for clearer reception.

And the added protection of Cobra's nationwide network of Authorized Service Centers with factory-trained technicians to help you with installation, service and advice.

The Cobra 29XLR. It has 40 channels. And it has what it takes to improve communications by punching through loud and clear on every one of them. That's the beauty of it.



Punches through loud and clear.

Cobra Communications Products
DYNASCAN CORPORATION

6460 W. Cortland St., Chicago, Illinois 60635

Write for color brochure

EXPORTERS: Empire • Plainview, N.Y. • CANADA: Atlas Electronics • Toronto

CIRCLE NO. 15 ON FREE INFORMATION CARD

PUNCH AND BEAUTY





Whether you're a
seasoned practitioner
or a striving beginner...

Here are the
fundamentals.

Software Design
for Microprocessors.
378 pages
only \$12.95.*

Basic Electricity and DC
Circuits. 1,016 pages
only \$19.95.*

Both of these new books get down to basics – present clear, readable discussions. Loaded with examples, references, graphs, tables. Also, data sheets, bibliography and appendices. You're *encouraged* to learn – and apply your knowledge to practical situations.

Software Design for Microprocessors. Helps you understand the hardware/software relationship of microprocessors. A convenient, stand-alone text, suitable for both first-time users of microprocessors and the technically advanced.

Beginning chapters deal with basic terms, basic machine architecture, instructions and addressing. Successive chapters treat the process of generating software, defining required support and documentation, and designing a simple machine to program a problem. Sample problems at the conclusion allow you to apply your new knowledge.

Basic Electricity and DC Circuits.

A self-teaching course designed to enable you to predict and control the behavior of most basic and complex DC circuits. Each lesson begins with a listing of objectives – what new skills and knowledge you should have upon successful completion. The text within each chapter is arranged so that you progress at your own pace, with answers to commonly asked questions presented at key points.

Examples show you how to use the principles of basic DC electricity as

they are taught. You'll analyze basic DC circuit schematics and find yourself experimenting with your own designs. Plus, a quiz included at the end of each lesson allows you to gauge your progress.

If you're a hobbyist, student, or simply interested in broadening your knowledge of electronics, these books are *must* additions to your library. Use the coupon below to order your copies today.



PE-2

Texas Instruments Learning Center.

Mail checks and money orders to: P. O. Box 3640, M/S 84, Dallas, Texas 75285. Postage paid. Add state and local taxes where applicable.

Mail company purchase orders to: P. O. Box 5012, M/S 84, Dallas, Texas 75222. Postage and taxes will be added to your invoice.

Please send me _____ copies of (LCB 1891) Software Design for Microprocessors at \$12.95* per copy. _____ copies of Basic Electricity and DC Circuits at \$19.95* per copy.

I enclose check money order for \$ _____

Name _____

Address _____

City _____ State _____ Zip _____

†All states except AK, DE, HI, MT, NH, OR.

*Suggested retail price; subject to change without notice.
© 1976 Texas Instruments Incorporated

TEXAS INSTRUMENTS
INCORPORATED

THE CATS TO CATCH.

“Roar Power” puts these new 40-channel CB's from Pearce-Simpson out in front. The Lion 40™ and Tiger 40™. Built with all the power and prestige you'll ever need in the CB jungle. As well as some advanced Pearce-Simpson features that command real attention. Like HetroLock™, for zeroing in on the right frequency. Receiv-O-Slide™ tuning for the best reception and superior adjustment of signals (even from “off-freq.” sets). And the Lion's bold new LED digital read-out.

Both sets are backed by Pearce-Simpson's over quarter-century of experience in personal two-way communications. And both are available right now. So stop by your Pearce-Simpson dealer today. He'll be glad to help you make the big cats roar.

For further information, write Pearce-Simpson, 4701 N.W. 77th Ave., Miami, FL 33166. In Canada, Scotcomm Radio, Inc., 4643 Levesque Blvd., Chomesday, Laval, Quebec.



PEARCE-SIMPSON
DIVISION OF GLADDING CORPORATION
THE CB RADIO • MARINE RADIO • ANTENNA PEOPLE.

CIRCLE NO. 47 ON FREE INFORMATION CARD

POPULAR ELECTRONICS

Popular Electronics®

WORLD'S LARGEST-SELLING ELECTRONICS MAGAZINE

FEATURE ARTICLES

NEW "NO-CAMERA" PRINTED CIRCUIT BOARD METHODS	A. A. Mangieri	55
<i>How to make etching and drilling guides directly from printed matter.</i>		
HOW TO MATCH HI-FI COMPONENTS		66
<i>Price tags serve as a good guide to apportioning your money.</i>		
MAY-AUGUST ENGLISH-LANGUAGE SW BROADCASTS	Richard E. Wood	101

CONSTRUCTION ARTICLES

INTRODUCING SPEECHLAB—THE FIRST HOBBYIST VOCAL INTERFACE FOR A COMPUTER		
<i>Now your computer can respond to vocal commands.</i>		
BUILD A LEGAL IN-FLIGHT AIRLINE RECEIVER	Cass R. Lewart	61
<i>Hear pilot-to-control conversations with low-cost Varactor-diode crystal set.</i>		
MORSE CODE AUTOMATIC READOUT ON A TV SCREEN	George R. Steber	64
<i>Interface the Morse-A-Letter to a "TV Typewriter."</i>		

COLUMNS

STEREO SCENE	Ralph Hodges	18
<i>The Decontamination Squad.</i>		
SOLID STATE	Lou Garner	76
<i>VMOS—MOSFET's With Muscle.</i>		
EXPERIMENTER'S CORNER	Forrest M. Mims	86
<i>Using LED's as Light Detectors.</i>		
HOBBY SCENE	John J. McVeigh	88
COMPUTER BITS	Hal Chamberlin	96
<i>Debugging Aids.</i>		
CB SCENE	Ray Newhall	98
<i>Uncle Charlie Is Snowed-In.</i>		
DX LISTENING	Glenn Hauser	100

JULIAN HIRSCH AUDIO REPORTS

HOW HEADPHONES ARE TESTED	26
SENNHEISER MODEL HDI 434 INFRARED HEADPHONES	32
TEAC MODEL PC-10 CASSETTE RECORDER	36

ELECTRONIC PRODUCT TEST REPORTS

KENWOOD MODEL TS-820 TRANSCEIVER	90
MURA MODEL PRX-100 "PRM" CB MICROPHONE	93
B&K PRECISION MODEL 1471B OSCILLOSCOPE	94

DEPARTMENTS

EDITORIAL	Art Salsberg	4
<i>The CB Crossover Point.</i>		
LETTERS		6
NEW PRODUCTS		12
NEW LITERATURE		17
NEWS HIGHLIGHTS		40

POPULAR ELECTRONICS, May 1977, Volume 11, Number 5, Published monthly at One Park Avenue, New York, NY 10016. One year subscription rate for U.S., \$9.98; U.S. Possessions and Canada, \$12.98; all other countries, \$14.98 (cash orders only, payable in U.S. currency). Second Class postage paid at New York, NY and at additional mailing offices. Authorized as second class mail by the Post Office Department, Ottawa, Canada, and for payment of postage in cash.

POPULAR ELECTRONICS including ELECTRONICS WORLD, Trade Mark Registered. Indexed in the Reader's Guide to Periodical Literature.

COPYRIGHT © 1977 BY ZIFF-DAVIS PUBLISHING COMPANY. ALL RIGHTS RESERVED.

Ziff-Davis also publishes Boating, Car and Driver, Cycle, Flying, Modern Bride, Popular Photography, Skiing and Stereo Review.

Material in this publication may not be reproduced in any form without permission. Requests for permission should be directed to Jerry Schneider, Rights and Permissions, Ziff-Davis Publishing Co., One Park Ave., New York, NY 10016.

Editorial correspondence: POPULAR ELECTRONICS, 1 Park Ave., New York, NY 10016. Editorial contributions must be accompanied by return postage and will be handled with reasonable care; however, publisher assumes no responsibility for return or safety of manuscripts, art work, or models.

Forms 3579 and all subscription correspondence: POPULAR ELECTRONICS, Circulation Dept., P.O. Box 2774, Boulder, CO 80302. Please allow at least eight weeks for change of address. Include your old address, enclosing, if possible, an address label from a recent issue.

EDGAR W. HOPPER
Publisher

ARTHUR P. SALSBERG
Editorial Director

LESLIE SOLOMON
Technical Editor

JOHN R. RIGGS
Managing Editor

IVAN BERGER
Senior Editor

ALEXANDER W. BURAWA
Features Editor

EDWARD I. BUXBAUM
Art Director

JOHN McVEIGH
Associate Editor

ANDRE DUZANT
Technical Illustrator

PATRICIA GIRRIER-BROWN
Production Editor

Contributing Editors
HAL CHAMBERLIN, LOU GARNER
GLENN HAUSER, JULIAN HIRSCH
RALPH HODGES, FORREST MIMS
RAY NEWHALL, WILFRED SCHERER

JOSEPH E. HALLORAN
Advertising Director

JOHN J. CORTON
Advertising Sales

LINDA BLUM
Advertising Service Manager

PEGI McENEANEY
Executive Assistant

STANLEY NEUFELD
Associate Publisher

ZIFF-DAVIS PUBLISHING COMPANY
Popular Electronics
Editorial and Executive Offices
One Park Avenue New York, New York 10016
212-725-3500

Hershel B. Sarbin, President
Furman Hebb, Executive Vice President
John R. Emery, Sr. Vice President, Finance and Treasurer
Phillip T. Heffernan, Sr. Vice President
Edward D. Muhlfeld, Sr. Vice President, Sports Division
Philip Sine, Sr. Vice President
Frank Pomerantz, Vice President, Creative Services
Arthur W. Butzow, Vice President, Production
Lawrence Sporn, Vice President, Circulation
George Morrissey, Vice President
Sydney H. Rogers, Vice President
Sidney Holtz, Vice President
Albert S. Traina, Vice President
Philip Korsant, Vice President
Paul H. Chook, Vice President
Edgar W. Hopper, Vice President
Charles B. Seton, Secretary

William Ziff, Chairman
W. Bradford Briggs, Vice Chairman

Midwestern Office
The Patis Group, 4761 West Touhy Ave.,
Lincolnwood, Illinois 60644, 312 679-1100
Thomas Hockney, Michael Neri, Gerald E. Wolfe
Western Office
9025 Wilshire Boulevard, Beverly Hills, CA 90211
213 273-8050; BRadshaw 2-1161
Western Advertising Manager: Bud Dean

Japan: James Yagi
Oji Palace Aoyama, 6-25, Minami Aoyama
6 Chome, Minato-Ku, Tokyo 407-1930/6821,
582-2851



The publisher has no knowledge of any proprietary rights which will be violated by the making or using of any items disclosed in this issue.



Editorial

THE CB CROSSOVER POINT

I felt the pulse of the CB industry this past February at the second annual Personal Communications 2-Way Radio Show, where some 380 manufacturers exhibited their newest CB transceivers, antennas and accessories. It was strong, though beating a little slower than in the recent past. Clearly, the crossover sales point from 23-channel CB transceivers to 40-channel units had not yet been reached in February, although indications are that it will have happened by the time you read this.

A transition period is, of course, a natural state of events, especially when the old and the new are running side by side, with the former sold at spectacular discounts. What we were watching at the PC-77 trade show was "tomorrow," while "today" was having its last hurrah in the marketplace. Making my way through the exhibit hall, I became aware of a few 40-channel misconceptions shared by some dealers and distributors—and perhaps passed on to their customers. Two of them were: 40-channel CB transceivers only produce two watts of r-f output power and they exhibit inferior modulation. Both are fallacious, of course!

Now, really, there is simply no reason why, given good design, expanding a band of frequencies a paltry 150 kHz should influence r-f power output or modulation capability. Sure, a warmed-over 23-channel design that exhibited poor automatic modulation limiting to begin with won't be able to hack it, though passing FCC type-acceptance tests. (These are actually being performed now. The "good old days" of passing tests by submitting paper results to the FCC are over, thankfully). However, we've tested enough new 40-channel rigs to verify that they can provide as much r-f carrier output power and modulation throughout the new, expanded band as the 23's. Moreover, the new rigs are decidedly less prone to overmodulate owing to improved modulation limiters. This means fewer cases of voice distortion and, more important, less splatter to interfere with adjacent channel communication.

Interestingly, the foregoing points were emphasized by a major CB radio manufacturer at a Show press meeting. Furthermore, a spokesman analyzed the signal strength required at the receiver for a standard 10-dB signal-to-noise ratio in a typical urban environment to illuminate another advantage for 40-channel rigs. Assuming a typical receiver sensitivity of 0.5 microvolts for 10-dB (S + N)/N, about 14.5 microvolts of *additional* signal strength is required for the current 23 channels to make the standard due to interference from on-channel users; 15 microvolts more at the receiver is needed to combat adjacent-channel interference, for a total of 30 microvolts. In contrast, the upper new channels require only a total of 1.5 microvolts to receive an intelligible communication, the manufacturer estimated.

As a consequence of the above, the communication range with the upper new channels is estimated to be four times that of the lower 23 channels (30 microvolts/1.5 microvolts = 20 times = 26 dB). Typical area coverage on the new channels (actually, 80% of the upper new ones, since some are still within splatter distance of the original 23) would, therefore, be enlarged about 16 times.

For CB'ers trying to get through during rush-hour traffic, the upper 17's on a 40-channel AM rig might be considered to simulate the effectiveness of single sideband on one of the less popular lower 23 channels. So, though 23-channel transceivers are tremendous bargains (and hard to resist), right now, 40 channels is the way to go to fully appreciate the utility of the citizens band.

**One Call.
Your Mallory distributor's
got them all.**

Take the search and wait out of your electronic parts finding.

Go straight to your Mallory distributor, by phone or in person.

Get to know the convenience and economy of simplified single-source buying. To

deliver exactly what you want in parts, quality, and quantity. Immediately from stock on hand, or in most cases within 24 hours from the factory.

Your Mallory distributor goes all out for his Number 1 VIP . . . you. Get in touch with him soon. Mallory Distributor Products Company, a division of P. R. Mallory & Co. Inc., Box 1284, Indianapolis, Indiana 46206. (317) 856-3731.

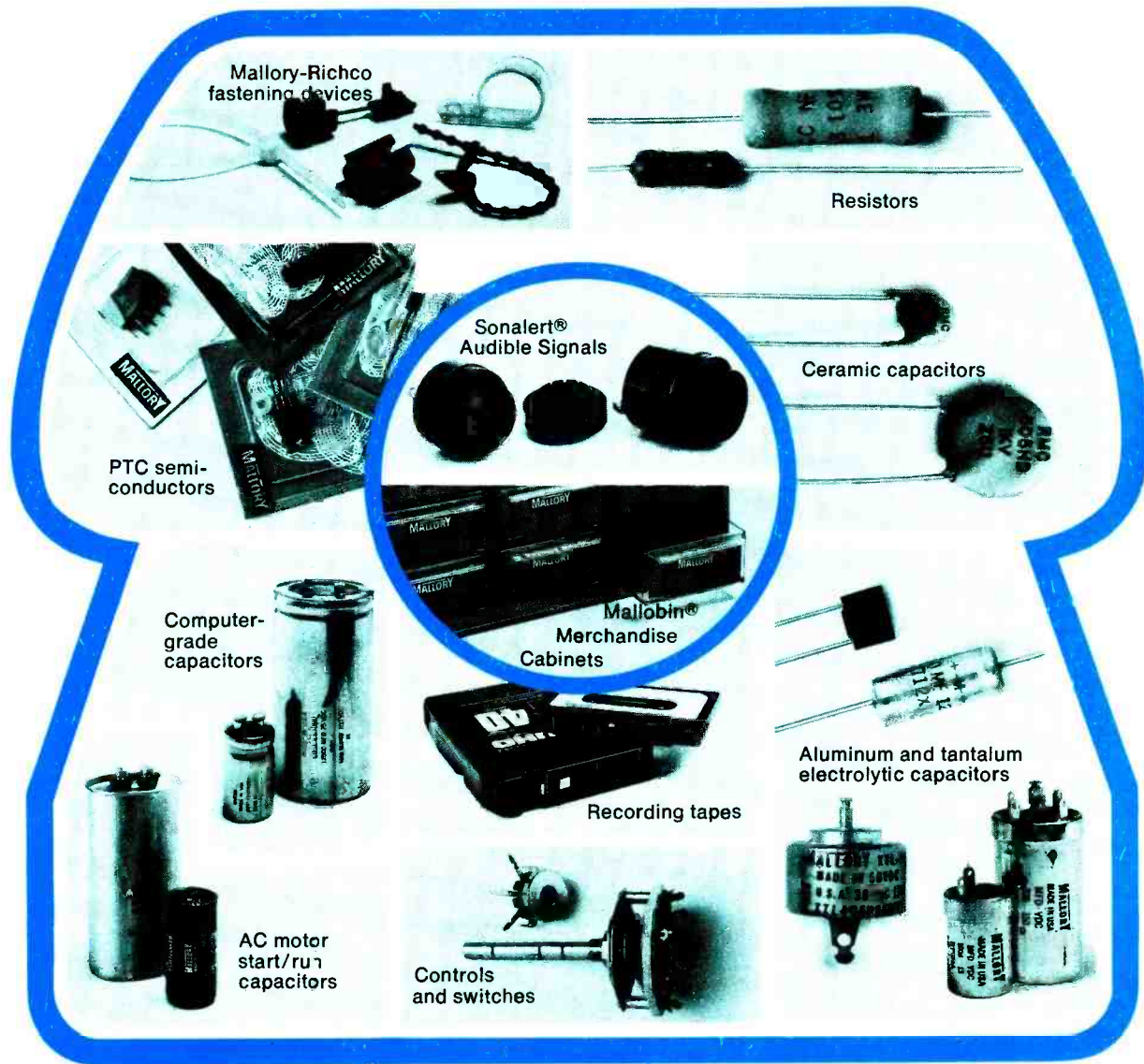

MALLORY

Capacitors • Controls • Fastening Devices • Resistors • Security Products • Semiconductors • Solderless Terminals • Switches



Letters

ABOUT PC ARTWORK

I recently tried, for the first time, GC Electronics' new Lift-It direct-art pc kit and have a few questions I hope you will answer. First, if I

attempted to use the Lift-It master to directly expose positive-resist-treated pc blanks, would it work? I fear that the black ink will not have the density required to block out light. Secondly, if the Lift-It artwork would work, what are chances for POPULAR ELECTRONICS to print the pc etching and drilling guides as negative artwork so that one-timers like me could use commonly available negative resist without having to reverse the exposure mask? —Warren D. White, Berkeley, CA.

We have used the Lift-It artwork directly to expose presensitized pc blanks with a high degree of success. During our experience, we have not had one instance where the ink was not dense enough to exclude light. (For detailed information about the Lift-It kit and

another direct-art kit from Datak, see the feature article in this issue.)

As for printing our pc etching and drilling guides as negative artwork, we have anticipated you. As you can see, beginning in this issue, our pc artwork is now printed in the negative format. We have taken this step because a recent survey revealed that almost all spray-on photoresist available to the hobbyist is the negative variety (although GC Electronics does sell a positive photo-resist). By printing our pc artwork in negative format, readers can save at least one step in the board fabrication process.

CONSTANT VERSUS VARIABLE

I believe that the explanation of dual-slope analog-to-digital conversion on page 37 of the "Multimeters For Electronics" story (February 1977) is incorrect. The T_1 to T_2 time period is a constant—a specific number of oscillator pulses—not a variable as stated in the text. —David E. Purdy, Philadelphia, PA

You're correct. It's the T_2 to T_3 time that's the variable.

SIMPLE TO SIMPLER

The SCR trigger circuit for possible use in protecting CB and other electronic equipment in automobiles shown in the January 1977 CB Scene can be further simplified when applied to CB transceivers. This is particularly true in the case where the rig has a three-prong plug for the 12-volt line and one of the prongs is not used. In my circuit (see below),

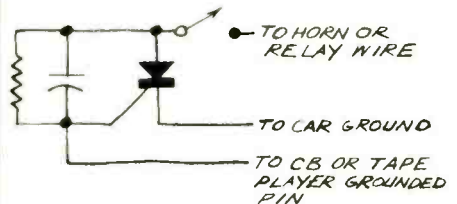

note the elimination of the relay. Wire #3 goes to the unused prong of the plug, while the unused contact in the mating female connector goes to ground. Removal of the power cable or physical removal of the CB rig or tape recorder from the vehicle will trigger the vehicle's horn. From actual experience, I can attest that the circuit has paid for itself in value of equipment protected. —Robert B. McKinley, Jr., Tinton Falls, NJ.

AMPLIFIER DIAGRAMS SWITCHED

In my article "Classes of Audio Amplifiers" (March 1977), the diagrams for Figs. 5 and 6 have been interchanged. The captions are correct. —Len Feldman.

SILENCER PC BOARDS AVAILABLE

Although no source was given for pc boards in my article "Build a Silencer" (March 1977, p 57), they are available from me at the following address: Ronald Miles, Rte. 1, Box 190, Rustburg, VA 24588. Price is \$4.60 per board. Virginia residents, add 4% sales tax.

About damping, bi-amping and the Crown DC-300A

Because of inertia, speaker transducers over-react to amplifier signals. This can be minimized by speaker design, but it can't be eliminated entirely. In the process, the transducers feed spurious signals back into the signal processing units.

A good amplifier is designed to control excessive transducer excursions by reducing — and absorbing — the unwanted signals generated by such excursions. It's part of a process audio engineers call damping. The Crown DC-300A power amplifier, in addition to its other well-known specifications, has a damping factor of 700, which means it should easily control speaker excursions. (A rating of 400 is considered good.)

But in a standard hi-fi stereo system, the DC-300A can't do all the damping it was designed for. The sound is a little muddier than it should be.

Why? Because the speaker crossovers — with their own impedance — get in the way. The amp is not directly

hooked up to the transducers.

Solution? Move the crossovers back between amp and pre-amp. Add another DC-300A and bi-amp the speakers.

The DC-300A now damps excessive transducer excursions efficiently. Which can mean crisper, cleaner sound.

Each transducer now has 155 watts of power available to drive it, and is limited only by its own characteristics. Which can mean more sound pressure.

There can also be less distortion, since harmonics of low-frequency distortion cannot feed to high-frequency transducers through the crossover.

Are you interested in how to use all the power and performance of a Crown DC-300A amplifier? Write. We'll send you information about the Crown VFX-2A, a two-channel variable-frequency crossover that makes bi-amping easy. Plus reprints of some articles that may help you decide if bi-amping is for you.

Crown VFX-2A

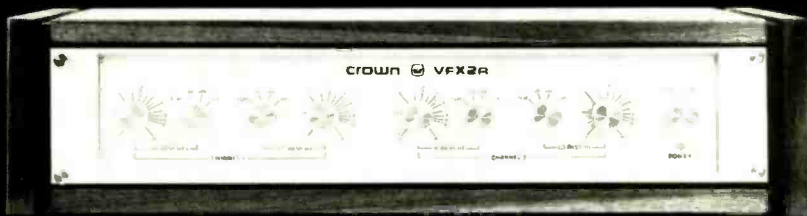

CROWN

Box 1000, Elkhart IN 46514

101-416 p.—Electronic Circuit Design Handbook-4th Edition (\$17.95)

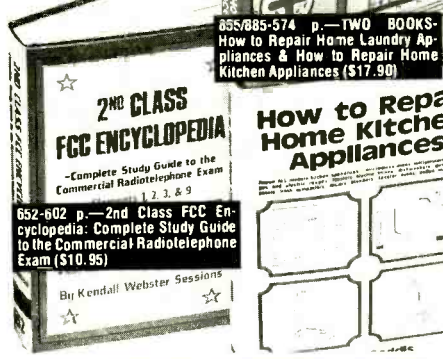
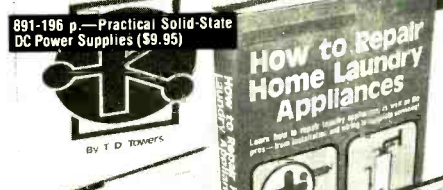
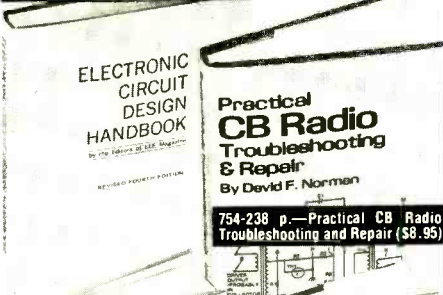

An Extraordinary Offer to introduce you to the benefits of Membership in
ELECTRONICS BOOK CLUB
 take any **3** of these unique electronics books (value to \$627.00) for only **99¢** each
 with a Trial Membership in the Book Club that guarantees to save you 25% to 75% on a wide selection of electronics books

May we send you your choice of these 3 practical, time-and-money-saving books as part of an unusual offer of a Trial Membership in Electronics Book Club?

Here are quality hardbound volumes, each especially designed to help you increase your know-how, earning power, and enjoyment of electronics. Whatever your interest in electronics, you'll find Electronics Book Club offers practical, quality books that you can put to immediate use and benefit.

This extraordinary offer is intended to prove to you, through your own experience, that these very real advantages can be yours... that it is possible to keep up with the literature published in your areas of interest, and to save substantially while so doing. As part of your Trial Membership, you need purchase as few as four books during the coming 12 months. You would probably buy at least this many anyway... without the substantial savings offered through Club Membership.

To start your Membership on these attractive terms, simply fill out and mail the coupon today. You will receive the 3 books of your choice for 10-day inspection. YOU NEED SEND NO MONEY! If you are not delighted, return the books within 10 days and your Trial Membership will be cancelled without cost or obligation.



Facts About Club Membership

- The 3 introductory books of your choice carry publishers' retail prices of up to \$62.70. They are yours for only 99¢ each (plus postage handling) with your Trial Membership.
- You will receive the Club News, describing the current Selection, Alternates and other offerings, every 4 weeks (13 times a year).
- If you want the Selection, do nothing; it will be sent to you automatically. If you do not wish to receive the Selection, or if you want to order one of the many Alternates offered, you simply give instructions on the reply form (and in the envelope) provided, and return it to us by the date specified. This date allows you at least 10 days in which to return the form. If, because of late mail delivery, you do not have 10 days to make a decision and so receive an unwanted Selection, you may return it at Club expense.
- Personal service for your account—no computers used!
- To complete your Trial Membership, you need buy only four additional monthly selections or alternates during the next 12 months. You may cancel your Membership any time after you purchase these four books.
- All books—including the introductory Offer—are fully returnable after 10 days if you're not completely satisfied.
- All books are offered at low Member prices, plus a small postage and handling charge.
- **Continuing Bonus:** If you continue after this Trial Membership, you will earn a Dividend Certificate for every book you purchase. Three Certificates, plus payment of the nominal sum of \$1.99, will entitle you to a valuable Book Dividend of your choice which you may choose from a list provided Members.

ELECTRONICS BOOK CLUB
 P.O. Box 10
 Blue Ridge Summit, Pa. 17214

Please open my Trial Membership in **ELECTRONICS BOOK CLUB** and send me the 3 books circled below. I understand the cost of the books I have selected is only 99¢ each, plus a small shipping charge. If not delighted, I may return the books within 10 days and owe nothing, and have my Trial Membership cancelled. I agree to purchase at least four additional books during the next 12 months, after which I may cancel my membership at any time.

101	132/627/672	563/536	628/637
652	714	743	748/749
754	785	800	836
841	855/885	891	970

Name _____ Phone _____
 Address _____
 City _____
 State _____ Zip _____

(This offer valid for new Members only. Foreign and Canada add 10%) PE-57

Where do the pros get their training?



Almost half of the successful TV servicemen have home study training and with them, it's NRI 2 to 1. It's a fact! Among men actually making their living repairing TV and audio equipment, more have taken training from NRI than any other home study school. More than twice as many!

A national survey*, performed by an independent research organization, showed that the pros named NRI most often as a recommended school and as the first choice by far among those who had taken home study courses from any school. Why? Perhaps NRI's 62-year record with over a million students . . . the solid training and value built into every NRI course . . . and the designed-for-learning equipment originated by NRI provide the answer. But send for your free NRI catalog and decide for yourself.



25" Diagonal Color TV... And 4-channel Quadraphonic Stereo.

As a part of NRI's Master Course in color TV/Audio servicing, you build a 25" diagonal solid state color TV with console cabinet. As you build it, you perform stage-by-stage experiments designed to give you actual bench experience. And you get a Quadraphonic system with 4 speakers. NRI's

instru-
ments are
a cut
above the
average,
including
a transistor-
ized volt ohm-
meter, triggered

sweep 5" oscilloscope, CMOS digital frequency counter and digital integrated circuit color TV pattern generator. They're top professional quality, designed to give you years of reliable service. You can pay hundreds of dollars more for a similar course and not get a nickel's worth extra in training and equipment.

Widest Choice of Courses and Careers.

NRI doesn't stop with just one course in TV/Audio servicing. You can pick from five different courses (including an advanced color course for practicing technicians) so you can fit your training to your needs and your budget. Or, you can go into Computer Technology, learning on a real, digital computer you build yourself. Communications with your own 400 channel digitally-synthesized VHF transceiver. Aircraft or Marine Electronics. CB, Mobile Radio, and more.

Free Catalog... No Salesman Will Call.

Send the postage-paid card for our free color catalog showing details on all NRI electronics courses. Lesson plans, equipment, and career opportunities are fully described. Check card for information on G.I. benefits. No obligation, no salesman will call. Mail today and see for yourself why the pros select NRI two to one!

If card is missing, write,

*Summary of survey results upon request.



Two Famous Educators... NRI and McGraw-Hill.

NRI is a part of McGraw-Hill, world's largest publishers of educational material. Together, they give you the kind of training that's geared for success . . . practical know-how aimed at giving you a real shot at a better job or a business of your own. You learn at home at your convenience, with "bite-size" lessons that ease learning and speed comprehension. Kits designed to give you practical bench experience also become first-class professional instruments you'll use in your work.



NRI SCHOOLS

McGraw-Hill Continuing Education Center
3939 Wisconsin Avenue,
Washington, D.C. 20016



New Products

Additional information on new products covered in this section is available from the manufacturers. Either circle the item's code number on the Reader Service Card inside the back cover or write to the manufacturer at the address given.

PRESIDENT 40-CHANNEL CB TRANSCEIVER

The "Zachary T" 40-channel CB AM base-station transceiver from President Electronics features a new automatic speech compression circuit and a PLL in the frequency synthesizing system. The compressor is designed to provide consistent high-level modulation, while the PLL circuit is said to provide



better on-frequency response than is possible with a conventional synthesizer. Selectivity is rated at -65 dB. Controls include volume, r-f and mike gain, anl (with manual override) and PA/CB switches. Also on the front panel is an S/r-f meter. Back-panel jacks provide for both ac and dc power input, antenna connection, and hookup of PA and external speakers. The earphone and mike jacks are up front. The transceiver also features a LED numeric channel display. \$249.95.

CIRCLE NO. 92 ON FREE INFORMATION CARD

SANSUI HIGH-POWER STEREO RECEIVER

Sansui's high-power Model 9090DB AM/stereo FM receiver is rated at 125 watts / channel (8 ohms) minimum rms at no more than 0.1% THD. The power amplifier is direct-coupled throughout, with fully complementary parallel push-pull OCL circuitry. Twin power meters provide convenient output power monitoring. Built in is a Dolby noise reduction system that can be used for both encoding and decoding for full flexibility. The tuner section features a PLL IC multiplex demodulator



12

that provides improved stereo separation on FM. FM sensitivity is rated at 9.8 dBf (1.7 μ V) and capture ratio and alternate-channel selectivity are rated at 1.5 and 85 dB, respectively. A front-panel microphone jack, with its own level control, permits mixing any selected source with the microphone signal for use in PA systems. \$750.

CIRCLE NO. 93 ON FREE INFORMATION CARD

CIBCO CB PERFORMANCE MONITOR

A constant CB performance indicator that features light-emitting diodes for easy monitoring of SWR and transmitter output power is available from CiBco Division of Southwest Factories, Inc. The Model CPI II in-line monitor employs a green LED that indicates trans-



mission output of 3.5 watts or more. A red LED comes on when reflected power exceeds a 1.8:1 SWR. (The red LED doubles as a speech modulation indicator.) Indications are produced automatically by pressing the microphone switch. In case of trouble, the red LED flashes an immediate warning. Hence, shorting or theft of the antenna is immediately evident, preventing damage to the output transistors in a CB transmitter. The monitor comes with a PL259 connector for easy installation between transceiver and antenna. \$19.95. Address: CiBco Div., Southwest Factories, Inc., 3801 Willow Springs, Oklahoma City, OK 73112.

MICRO-ACOUSTICS PHONO CARTRIDGE

The Model 282-e stereo phono cartridge from Micro-Acoustics has a unique design that is said to enable it to track warped records 25% better than competitive cartridges. It is also said to be immune to the effects of cable ca-



pacitance and not to be tonearm sensitive. The cartridge is fitted with a 0.002 x 0.007 mil elliptical diamond stylus. Frequency response is rated at 5 to 20,000 Hz \pm 2 dB, tracking force range at 0.75 to 1.5 grams, separation at nominally 25 dB at 1000 Hz (15 dB at 10,000 Hz), and output voltage at 3.5 mV/channel at 5 cm/s peak recorded velocity. Load requirements are not critical and can

be anywhere in the range from 10,000 to 100,000 ohms. Similarly, cable capacity is not critical at 100 to 1500 pF.

CIRCLE NO. 94 ON FREE INFORMATION CARD

AMI MICROCOMPUTER KIT

American Microsystems, Inc., is offering its S6800 μ P in kit form for computer hobbyists. The top-of-the-line Model EVK 200 kit contains all necessary components for complete construction, including a preprogrammed ROM for system monitor and general software utilities. Only a power supply and suitable I/O devices are required for operation. Level-control circuitry, baud-rate generation (50 to 9600 baud), and adjustability are built into the basic board. The CPU is the AMI S6800 eight-bit chip, with an instruction execution of 2 μ s and memory access time of 575 ns. The system provides four available interrupt vectors and three types of DMA. A 1-MHz clock provides a 100- μ s and 1-ms timer. Also on-board are the I/O interfaces and an EPROM programmer (EPROM device included). \$495. (Also available fully assembled as Model EVK 300 for \$765.)

CIRCLE NO. 95 ON FREE INFORMATION CARD

AVR LOGIC PROBE

The Catch-A-Pulse logic probe from AVR is compatible with RTL, DTL, TTL, CMOS, MOS, and with microprocessors using 3.5-V to 15-V power supplies. Thresholds are automatically programmed for multi-logic-family operation. The memory circuit for single or



multi-pulse detection resets automatically. LED's indicate high and low levels, open-circuit logic, and pulses. Designed for carrying in a shirt pocket, the probe has a protective cap for the top, and a removable coiled cord. \$24.95.

CIRCLE NO. 96 ON FREE INFORMATION CARD

KOSS ELECTROSTATIC STEREO PHONES

The Model ESP/10 electrostatic stereo headphones made by Koss plug into an electrostatic energizer unit that can be operated on as little as 25 watts of continuous power per channel. The energizer, which accommodates two sets of headphones, has semi-



POPULAR ELECTRONICS

Old Fashion **VALUE**

in the **U.S.A.** Tradition

Our 6800 computer system represents the best value available today, with no sacrifice in performance.

I would like to explain why this is true. The most basic reason is that the 6800 is a simpler, more elegant machine. The 6800 architecture is memory oriented rather than bus oriented as are the older 8008, 8080 and Z-80 type processors. This is an important difference. It results in a computer that is far easier to program on the more basic machine language and assembly language levels. It also results in a far simpler bus structure. The 6800 uses the SS-50 bus which has only half the connections needed in the old S-100 (IMSAI/MITS) bus system. If you don't think this makes a difference, take a look at the mother boards used in both systems—compare them. The SS-50 system has wide, low impedance 0.1 lines with good heavy, easily replaced Molex connectors. The S-100 bus, on the other hand, has a very fine hair-like lines that must be small enough to pass between pins on a 100 contact edge connector. I'll give you one guess which is the most reliable and noise free. As for cost—well any of

you who have purchased extra connectors for your S-100 machines know what kind of money this can run into. The 6800 is supplied with all mother board connectors. No extras, or options like memory, or connectors for the mother board are needed in our 6800 system.

The 6800 is not beautiful, but "Oh Boy" is it functional. That plain black box is strong and it has an anodized finish. This is the hardest, toughest finish you can put on aluminum. Most others use paint, or other less expensive finishes. The 6800 does not have a pretty front panel with lights and multicolor switches. This is because the lights and switches are not only expensive, and unnecessary, but also a great big pain to use. We don't crank up the 6800; we use an electric starter—a monitor ROM called Mikbug. He automatically does all the loading for you without any time wasting switch flopping. So in the 6800 system you don't buy something expensive (the console) that you will probably want to stop using as soon as you can get your hands on a PROM board and a good monitor.

That's another thing. Mikbug[®] is a standard Motorola part. It is used in many systems and supported by the Motorola software library in addition to our own extensive collection of programs. It is not an orphan like many monitor systems that are unique to the manufacturer using them and which can only run software provided by that manufacturer. Check the program articles in Byte, Interface and Kilobaud. You will find that almost all 6800 programs are written for systems using a Mikbug[®] monitor. Guess how useful these are if you have some off-brand monitor in your computer.

The 6800 will never win any beauty prizes. It is like the Model "T" and the DC-3 not pretty, but beautiful in function. It is simple, easy to use and maintain and does its job in the most reliable and economical way possible. What more could you want?

Mikbug[®] is a registered trademark of Motorola Inc.

SWTPC 6800

Computer System

with serial interface and 4,096 words of memory \$395.00



Enclosed is \$395 for my SwTPC Computer Kit Send Data

or BAC _____ # _____

or MC _____ Ex Date _____

NAME _____

ADDRESS _____

CITY _____ STATE _____ ZIP _____

Southwest Technical Products Corp., Box 32040, San Antonio, Texas 78284

VALUE & PERFORMANCE

EICO's 30 Years Experience
Assures More Electronics Value
For Your Money!

TEST INSTRUMENTS



NEW!

EICO 388 COLOR BAR GENERATOR

Pocket-size, battery operated with LED Indicator. MOS LSI IC provides 9 digitally controlled, stable patterns. Crystal controlled chroma and timing oscillators. Simply connects to TV's VHF antenna terminals.

Wired \$89.95

EICO 390 FUNCTION/SWEEP GENERATOR

Outstanding features include: Sine, Square, Triangle Waveforms; 2 Hz to 200 KHz frequency range; Linear and Log Sweep; Calibrated attenuator. VCO for External Frequency Control; BNC Front Panel Output.

Wired \$169.95

EICOCRAFT® IC KITS

**EC-5000
SCA
ADAPTOR KIT
ONLY \$12.95**



Convert your FM radio or receiver to pick up the official FCC-licensed background music service (SCA). IC decoder/adaptor permits hearing uninterrupted, commercial-free music broadcast by many FM stations. (For personal, non-commercial use only)

IC PROJECT KITS NOW AVAILABLE

EC-5100 ESP Tester \$10.95
EC-5200 "Decision Maker" \$9.95
EC-5400 Stereo Power Amplifier \$10.95
EC-5500 Stereo Pre-Amp \$9.95
EC-5600 Electronic Lock \$11.95
EC-5700 Universal Power Amp \$8.95

BURGLAR/FIRE ALARMS

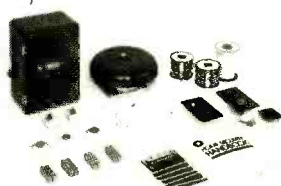

SS-500 BURGLAR/FIRE ALARM SYSTEM

Professional Security System designed for easy do-it-yourself installation. Features EICO FC-100 Control Center with AC/DC automatic transfer to battery operation. Complete system includes Installation Handbook. Add additional sensors, bells, to suit your own needs. **\$159.95**

SD-75 BATTERY OPERATED FIRE/SMOKE ALARM

Ionization-type detector gives earliest possible fire warning. Mounts directly to ceiling with 2 screws. "Beeps" when battery needs replacement. U.L. listed **\$39.95**

CB ACCESSORIES



NEW!

EICO 700 CB FREQUENCY COUNTER

Compact in-line mobile frequency counter for the serious CB'er/Hobbyist. Operates automatically on transmit. 10 Hz to 30 MHz. **\$99.95**

EICO LR-3 "LONG RANGER" INLINE PREAMP

Bring in those distant/weak signals. Boosts receiver sensitivity up to 20 db. Automatic transmit/receive switching. **\$29.95**

EICO CM-2 "CHANNEL MONITOR" AUTO-SWITCH

Automatically silences car radio when CB call is received/transmitted. **\$29.95**

HOBBY/AUTOMOTIVE



NEW!

BW-300 ALPHA BRAINWAVE MONITOR

Lowest cost, battery operated, professional Biofeedback System. IC Circuit design features an active filter and 5-microvolt sensitivity. Complete with stethoscopic earphone, electrode headband and instructions.

Kit \$34.95 Wired \$59.95

885 "TUNEMASTER" ENGINE ANALYZER

Automatic all-in-one test bench for all 6 or 12 volt ignitions—conventional or transistorized. Giant 6" meter with 6 color coded scales. Complete with tune-up and trouble-shooting manual.

Wired \$59.95

FREE EICO CATALOG

The more you know about electronics, the more you'll appreciate EICO. Every EICO product is designed to provide you with the most pleasure and quality performance for your money. The fact that more than 3 million EICO products are in use attests to their quality and performance.

"BUILD-IT-YOURSELF" and save up to 50% with our famous electronic kits.

For the latest EICO Catalog and name of nearest EICO Distributor, check reader service card or send 50¢ for fast first class mail service.

EICO-283 Malta Street, Brooklyn, N.Y. 11207

Leadership in creative electronics since 1945.



peak-indicating level meters and features an automatic overload device that protects against excessive audio input levels. The LED indicator glows when the protection circuit is activated and shuts off the energizer. Once the protection circuit is activated, it keeps the energizer shut off for 3 to 4 seconds after the excessive level drops to a safe value. **\$300.**

CIRCLE NO. 97 ON FREE INFORMATION CARD

MAYCOM CB MOBILE ANTENNAS IN COLOR

Riotous Red, Lily White, Big Blue, Sand Tan, Cat Black, Down Brown, Grimly Gray, Machine Green, and Yellin' Yellow are the colors of a new line of CB "Colorwhip" mobile antennas from MayCom. The antennas and mounts can be purchased in matching or mixed colors to complement or coordinate with the vehicles on which they are installed. The patented fiberglass whips come in 4' and 6' (1.2 and 1.8 m) lengths with top-loaded, helically wound radiators, plastic sheaths, and chrome-plated brass ferrules. Prices are \$10.25 and \$11.25, respectively. No-drilling Model GW-7 trunk mounts are also available in color for \$13.45.

CIRCLE NO. 98 ON FREE INFORMATION CARD

HEATH HIGH-BAND SCANNING RECEIVER

The Model GR-1131 high-band scanner from the Heath Company monitors any combination of eight channels in the "emergency-services" public-safety band between 146 and 174 MHz, including those from the U.S.

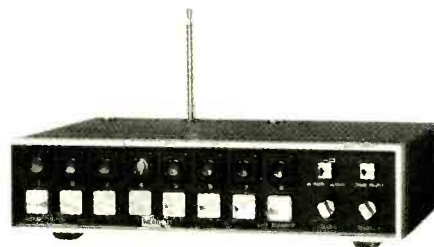

Weather Service. The receiver scans each channel, stopping at any that is active, and resumes scanning after the transmission. A priority channel feature checks the channel in which the user is most interested every four seconds and automatically switches to it if there is activity there. Features include channel lockout buttons, lighted channel indicators, automatic/manual channel selection, and a four-pole crystal filter for good selectivity. For crowded areas, an optional eight-pole filter is available. Also featured are a built-in telescoping antenna and provision for an external antenna. Ac or 12-volt dc operation. **\$89.95.**

CIRCLE NO. 90 ON FREE INFORMATION CARD

AMP HAND WIRE STRIPPER

AMP Special Industries Hand Wire Stripper employs front-feed stripping action to make short wires easy to strip. A built-in sensor

POPULAR ELECTRONICS

THE TERMINAL YOU ASKED FOR

CT-64

- * 16 LINES – 64 or 32 CHARACTERS PER LINE
- * SCROLLING ON EITHER OF TWO PAGES OF DISPLAY
- * 128 CHARACTER ASCII SET – UPPER AND lower CASE LETTERS
- * PRINTS CONTROL CHARACTERS IF DESIRED
- * FULL 32 CHARACTER CONTROL DECODING
- * FULL 8 BIT MEMORY
- * 110/220 Volt 50-60 Hz POWER SUPPLY
- * COMPLETELY INDEPENDENT DESIGN—Usable with any 8 bit ASCII computer or with modem for time share applications.
- * MOLDED PLASTIC COVER – MATCHING MONITOR AVAILABLE

Now you can buy it. The terminal that has all the features that people have been asking us to include. The CT-64 has all the functions that you could want in a terminal and they may be operated by either switches, or through a software program.

All cursor movements, home-up and erase, erase to end of line, erase to end of frame, read on, read off, cursor on, cursor off, screen reversal, scroll, no scroll, solid cursor, blinking cursor, page selection and a beeper to warn you of end of page; all are provided for your use in the CT-64.

You may also switch from upper case only teletype style operation to upper-lower case typewriter style operation. You can reverse the field on individual words to highlight them, or you can reverse the whole screen.

CT-64 is complete with keyboard, power supply serial interface and case. A matching 9 inch monitor with coordinated covers is also available to make a complete system.

CT-64 Terminal Kit **\$325.00**

MM-1 Monitor (assembled) **\$175.00**



219 W. Rhapsody

San Antonio, Texas 78216

You are right, it's just what I have been asking for.

- Enclose is \$325.00 for the CT-64
- Send the MM-1 monitor too. Send Data
- or BAC _____ # _____
- or MC _____ Ex Date _____

NAME _____

ADDRESS _____

CITY _____

STATE _____

ZIP _____

Southwest Technical Products Corp.
219 W. Rhapsody, San Antonio, Texas 78216



measures the wire and adjusts the tool for optimum stripping action with minimum hand pressure. The tool is molded of lightweight plastic. Wire and cable up to #12 AWG solid or stranded can be cut and stripped by the tool. Paired wires can be stripped simultaneously. \$33. Address: AMP Special Industries, Valley Forge, PA 19482.

KEYBOARD VIDEO INTERFACE

The Merlin keyboard video interface, from MiniTerm Associates, provides ASCII characters (20 lines of 40 characters), high-resolution graphics, and optional monitor and editor functions. The two boards include a DMA controller that permits displaying any part of the computer memory. Also, since the display's starting address is software-controlled, the memory segment displayed can be changed with every screen refresh. Dense graphics will display 2k words of memory as 160H by 100V dots; sparse graphics displays

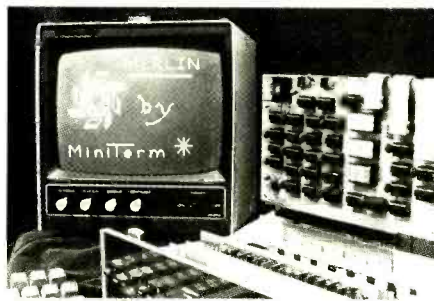

1k as 80H by 100V. Versions of Merlin for Altair, Imsai, Southwest 6800 and Digital Group computers are available at \$249.00 kit plus \$34.95 for an optional on-board 2k ROM for the monitor and editor functions.

CIRCLE NO. 99 ON FREE INFORMATION CARD

POLYTRON OP AMP DESIGNER TESTER

Designed to help both the beginner and experienced user to experiment with and test circuits containing one or two op amps, the "Dual Op Amp Designer Tester" from Polytron Devices doesn't require any soldering. Components other than op amps can be plugged in. Features include solderless tie points, two 10k potentiometers, four pairs of binding posts, four IC sockets. Model 202 with ± 15 -V, 100-mA dc regulated power supply is \$55; Model 201, using 9-V batteries, is \$33. Address: Polytron Devices, Inc., Box 398, Paterson, NJ 07524.

PIONEER AM/STEREO FM TUNER

Pioneer's Model TX-9500II AM/stereo FM tuner has an automatic pilot-signal canceller that minimizes 19-kHz leakage into the audio

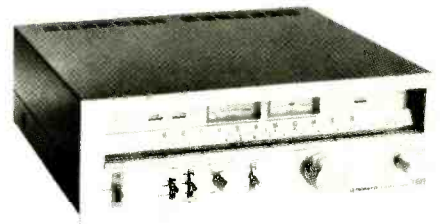

section. Featuring both narrow- and wide-band operation, it also has a SAW (surface acoustic wave) filter that minimizes adjacent-channel interference. A switch permits using the amplifier/speaker system, minus oscilloscope, to detect multipath reflections as the FM antenna is adjusted. The alternate position of this switch generates a 440-Hz signal every 1.6 seconds (equivalent to 50% FM modulation) for checking the level on a tape deck before recording off the air. Specifications include: 8.8 dBf (1.5- μ V) sensitivity in mono; 13.2 dBf (2.5 μ V) in mono and 36.1 dBf (35 μ V) in stereo 50-dB quieting sensitivity; 77 to 82 dB S/N at 65 dBf; 20 to 15,000 Hz $+0.2/-0.5$ dB stereo frequency response; and 0.05% to 0.07% distortion in mono at 1000 Hz. \$400.

CIRCLE NO. 100 ON FREE INFORMATION CARD

Aircommand 40-channel CB..



From the people who bring you Marantz—the world's finest stereo systems—comes the Aircommand CB-640—the finest in 40-channel CB. With Aircommand you get over 25 years experience in outstanding 2-way communications products.

Full 6 Watts of audio power. Provides plenty of punch so your speaker cuts through freeway noise.

Dual-conversion super-heterodyne receiver with dual-cascaded ceramic filters. Together, both features provide the most complete rejection of unwanted signals, assuring you unsurpassed selectivity and sensitivity.

4 big Watts of RF power. Aircommand delivers the maximum power legally allowable to let you belt out the big sound.

100% modulation capability. Even when you talk softly into the mike, your message cuts through loud and clear, thanks to one of the most advanced mike preamp and compressor designs in CB today. With Aircommand, you don't have to spend an extra \$30 to \$40 on a "power mike." You can't buy better modulation than Aircommand.

Specially tailored frequency response.

LED 40-channel selection display. Easy-to-read, night or day.

8-LED (light emitting diode) meter display. Provides an easy-to-read display of SWR (standing wave ratio), modulation, and incoming or outgoing signal strength—instantly, accurately.

Special emergency Channel 9 scan with exclusive Aircommand "beep" alert. No matter what channel you're on, a special Aircommand CB-640 circuit continuously and silently monitors Emergency Channel 9. When someone starts transmitting on Channel 9, a unique "beep" alerts you, so you can tune yourself in and give assistance.

Public address capability. The versatile Aircommand CB-640 public address package lets you (1.) Talk into the CB mike and out an exterior public address speaker. (2.) Attach a tape recorder to the auxiliary jack on the



New Literature

VOLTAGE-SURGE SUPPRESSOR CROSS-REFERENCE

A new cross-reference application note, AN504A, for voltage-surge suppressors to protect power semiconductors is available. Over 175 General Electric parts numbers are listed, along with the International Rectifier replacements that are exact mechanical duplicates, including the same power-handling capability. Address: Semiconductor Division, International Rectifier, 233 Kansas St., El Segundo, Calif. 90245.

SEMICONDUCTOR TEST INSTRUMENTS

A 6-page brochure from B&K Precision describes the company's complete line of discrete semiconductor test instruments. Products featured include the Model 530 semiconductor tester with unity-gain frequency measurement up to 1500 MHz. Technical specifications provide data on in-circuit and out-of-

circuit tests, applied test currents, indicator, calibration and limiting in-circuit shunt values. Applications for each model are also discussed. Address: B&K Precision, 6460 W. Cortland Ave., Chicago, IL 60635.

GUIDE TO SOLDERING ALUMINUM

A 6-page brochure from Multicore Solders provides information on soldering aluminum. Performance information including a table on the solderability of various wrought and cast aluminum alloys is presented with application and technical data, joint recommendations and soldering techniques. Technical specifications and performance of the company's Alu-Sol 45D are also discussed. Address: Multicore Solders, Westbury, NY 11590.

CB ANTENNA CATALOG

A new catalog SP-4 from Antenna Incorporated describes its line of Citizens Band antennas and accessories. Specifications are provided for each base and mobile antenna with similar styles listed together for easy reference. Replacement parts and accessories are also included. The catalog, Form SP-4, is available from Antenna Incorporated distributors.

VOLTAGE DROP MEASUREMENTS

"Forward Voltage Drop Measurements" is the title of Tech Tips 4-6 from Westinghouse. The 3-page article, written to assist in making accurate measurements on power diodes

and thyristors that can be used as a quality control check or matching criteria for operating devices in parallel, utilizes a simplified diagram of a test circuit and explains ways to avoid inaccurate measurements caused by pulse widths, duty cycles, peak currents, mounting and measurement techniques. Address: Semiconductor Division, Westinghouse Electric Corp., Youngwood, PA 15697.

EXACT REPLACEMENT GUIDES

Thordarson Meissner, Inc. offers two new cross-reference replacement guides for CB radios and TV sets. "TV Replacement Parts Guide" Form TVPG 9 and "CB Replacement Parts Guide" Form CBRG 2 include 127 new exact electronic replacement products recently made available by the company. Guides are available from Thordarson distributors.

WIRE-WRAPPING AND TOOL CATALOG

Catalog 36G is the new 58-page catalog from O.K. Machine and Tool Corp. which describes its line of Wire-Wrapping tools and machines. Additions to the line, including circuit boards, closures and instrument cases, are described; an illustrated section explains the technology of Wire-Wrapping. Address: O.K. Machine and Tool Corp., 3455 Conner St., Bronx, NY 10475.

...You never heard it so good!!!

CB-640 rear panel, and boom your tape out through the same external speaker. (3.) Mix your voice from the CB microphone with the program material on the tape recorder. Both voice and tape sound at the same time through the external speaker. (4.) Beam your received signal through the external speaker.

Built-in standing wave ratio circuitry. Measures the efficiency of the antenna system for optimum performance.

Other outstanding features include: Delta fine tuning control, digital synthesizer with phase-locked loop,

automatic noise limiting switch, noise blanking switch, squelch control, RF gain control.

Also available: Aircommand CB-140; Aircommand CB-340. All 3 units bring you state-of-art design, flawless craftsmanship and day-in, day-out reliability. Try them out now at your Superscope Aircommand dealer.

TM **Aircommand** by **SUPERSCOPE.**

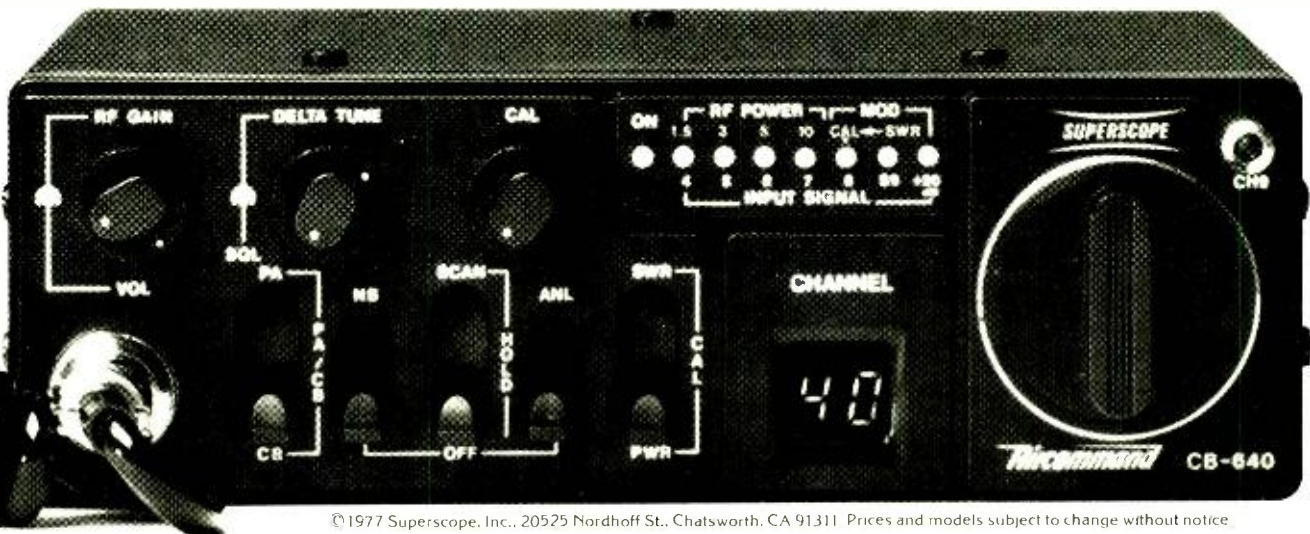

© 1977 Superscope, Inc., 20525 Nordhoff St., Chatsworth, CA 91311. Prices and models subject to change without notice.



Stereo Scene

By Ralph Hodges

THE DECONTAMINATION SQUAD

FOR THE PAST few months (whenever I've remembered to), I've been asking people how they care for their phonograph records. Their replies have been highly individualistic. On the one hand we have the manic camp, systemized to the point where they feel vaguely uncomfortable listening to a record that has not been put through an elaborate cleaning ritual, whether they can hear any noise or not. (I number myself among this group.) At the other extreme are those joyous devil-may-cares who may blow on a disc several times (quite ineffectually, no doubt) as they carry it to the turntable, but otherwise hardly give the matter a thought.

In my circle, almost everyone who takes records seriously owns some sort of cleaning appliance for them. Velvet- or plush-covered pads and specially designed brushes are common (choice of pad or brush seems to depend on intui-

tive "feel" for the cleaning process), as are Dust Bugs and similar devices. These may or may not be used religiously. I have seen some Dust Bugs so begrimed that their use would probably be a hazard rather than a help to the condition of any decent record, so the benign-neglect approach is not always inappropriate.

Ask the Experts. Why, after all these years, is record hygiene still a matter of guesswork rather than science? The question would be a fascinating one if its answer weren't so obvious. Ask the phono-cartridge manufacturers, whose interest in properly maintained records is readily apparent: "You know, we've always been meaning to look into that. We use the Whatchamacallit, or at least there's one at every testing station, and it seems to do okay. But then again, in the absence of a suitable control sam-

ple . . ." Ask the record companies: "All our records are clean and defect-free when they leave the plant, and with reasonable care . . ." In other words, no one—or at least no one who doesn't intend to manufacture a record-cleaning device of his own—has the time to undertake the research necessary. And no wonder, because when you think about it, such a research project turns out to be fairly formidable.

A few hardy types, including some of my eminent colleagues in the press, have made yeomanly attempts to settle the issue in the laboratory. Their tests have generally taken two forms. The first is to play the dirty record, count (somehow) the number and severity of the ticks and pops presumably caused by dirt, then clean the record with the device under test, and play it again to note the improvement, if any. The trouble here is that the very process of playing a record alters its noise content. According to theory, certain dust particles will become embedded in the vinylite material by the stylus pressure—embedded too firmly for removal by any practical cleaning device. Hence the cleaning device under test faces the handicap of working with a record that has already been damaged by being played when dirty. But then, if you go on to play the record several more times, the severity of the "tick" caused by the embedded particle may abate considerably, as repeated passages of the stylus smooth the blight on the groove wall. Play the record with a different stylus and the "tick" may disappear altogether, because the stylus rides lower or higher in the groove.

Testing approach number two involves the visual inspection of the dirty and cleaned record with a high-magnification device such as a scanning electron microscope. Here the problem is that on one hand, you can't be sure that what you do see will cause noise. (Certain particles will be nudged aside or missed by the stylus.) On the other hand, what you can't see may cause noise. (An invisible residue of the cleaning agent may gum the stylus and/or raise the base noise level.) Also, there is the considerable drawback of the time involved in examining the whole record—or even a significant portion of it—with high magnification. And time is critical, because with each passing moment the record acquires a little bit of *new* dust.

Common to both tests are such quandaries as how do you manage to use the cleaning device consistently (most of

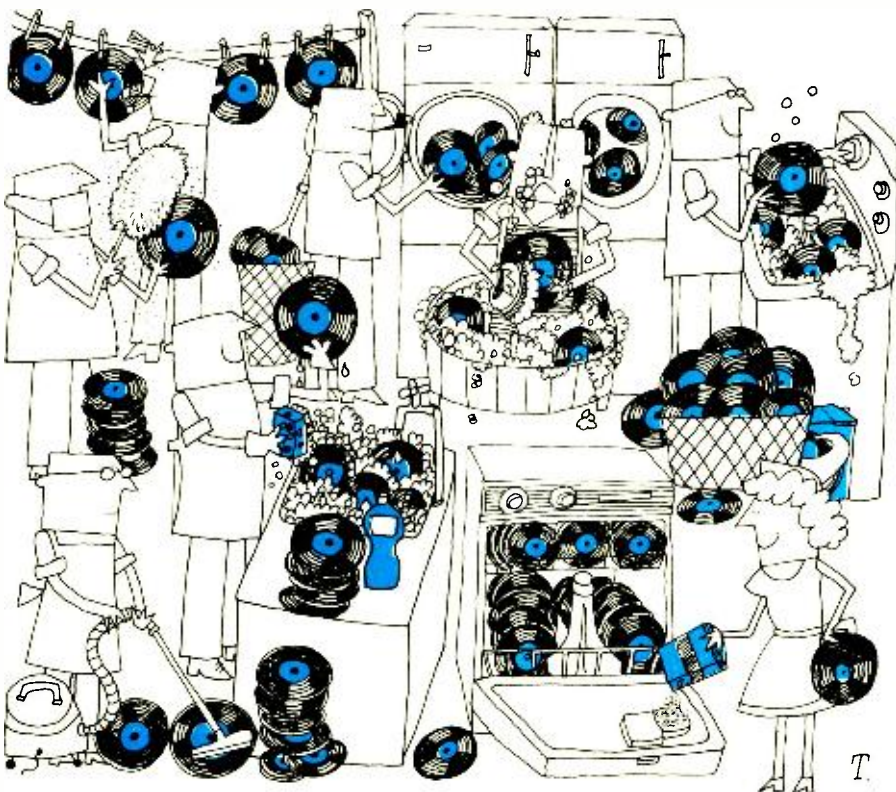

MAGAZINES AT DISCOUNT!

You SAVE up to 50%

Here's your chance for a real bargain bonanza on your favorite magazines. Select as many as five of these titles at the low introductory rates shown below—up to 50% off. Use attached card to order or write to: MAGAZINES AT DISCOUNT, A Division of Ziff-Davis Publishing Co., P.O. Box 2703, Boulder, Colorado 80322.



- APARTMENT LIFE (21)** You pay only \$7.97
Reg. Rate: 24 Issues for \$14.97
- BOATING (01)** You pay only \$6.00
Reg. Rate: 12 Issues for \$10.00
- CAR & DRIVER (02)** You pay only \$3.99
Reg. Rate: 12 Issues for \$7.98
- CYCLE (03)** You pay only \$3.99
Reg. Rate: 12 Issues for \$7.98
- FLYING (04)** You pay only \$7.99
Reg. Rate: 12 Issues for \$12.00
- HANDY ANDY (57)** You pay only \$5.88
Reg. Rate: 10 Issues for \$7.95
- PLAYBOY (34)** You pay only \$12.00
Newsstand Rate: 12 Issues for \$19.00
- POPULAR ELECTRONICS (06)** You pay only \$6.99
Reg. Rate: 12 Issues for \$9.98
- POPULAR PHOTOGRAPHY (07)** You pay only \$4.99
Reg. Rate: 12 Issues for \$9.98
- POPULAR SCIENCE (35)** You pay only \$4.50
Newsstand Rate: 12 Issues for \$9.00
- PSYCHOLOGY TODAY (08)** You pay only \$7.00
Reg. Rate: 12 Issues for \$12.00
- SPORTS ILLUSTRATED (38)**
You pay only \$9.75 for 25 Issues
Newsstand Rate: 25 Issues for \$25.00
Basic annual rate: 52 Issues for \$20.00
- STEREO REVIEW (11)** You pay only \$3.99
Reg. Rate: 12 Issues for \$7.98
- TENNIS (39)** You pay only \$4.75
Reg. Rate: 12 Issues for \$9.50
- TIME (40)** You pay only \$12.50
Newsstand Rate: 25 Issues for \$25.00
- TV GUIDE (41)** You pay only \$8.35
Lowest Available Sub. Rate for 32 Issues

them are hand operated), and how do you establish an adequate control sample of the record. It has been shown repeatedly that "identical" pressings of the same record are far from identical to the stylus and the record-playing environment. According to one theory, the vinylite material of a record takes on a molecular "set" when it is molded, so that the entire disc—or certain random sections of it—acquires a permanent static charge. If the charge distribution varies from pressing to pressing (as it logically should), you have no hope of getting identical pressings.

The Mechanism of Dirty Discs.

The laboratory is revealing but not always authoritative about the record-cleaning question. The reported experiences of long-time record users are valuable but difficult to verify. At this point we need a working hypothesis of how records get dirty so that we can consider what *ought* to be done to get them clean again. Surprisingly, there is no universal consensus on the "mechanism" of dirty discs, but here is the theory to which I generally subscribe.

First, there are airborne particles. These settle on the record as they settle on everything, and remain there unless disturbed. Perhaps they are attracted and held in place by some "net" static charge molded into the record. Then there is grosser debris, from the jacket liner or the turntable mat. This is highly visible and hence disturbing, but most of it is too big to penetrate the record grooves and thus is probably harmless. However, its persistent presence suggests that smaller, invisible bits lie within the grooves themselves.

Next comes the record-playing process, which nicely parallels the workings of a Van de Graaff generator. The intimate contact of stylus and groove (much more intimate with the superior tracing and tracking of today's cartridges) builds up some surface voltages on the disc that are probably quite impressive. These are local charges, but they apparently cooperate with any net charges present in various ways. With your record cleaner you can drag a dust particle some inches away from its location on the record surface, only to have it break free and skip back to its precise point of origin.

When the record becomes surface-charged it acts on dust, certain colloids, and anything else available just as an electrophorus acts on a pith ball. The charges give rise to three noise-producing mechanisms. First, they hold dust

in place where they can be played by the stylus and pounded into the vinyl. No casual puff of breath or swipe of record cleaner will effectively dislodge them. Second, they create noises—sometimes quite alarming ones—in themselves, by freely discharging through the phono cartridge. Cartridges and arms differ in their susceptibility to this, but in a dark room you can often see sparks generated as a record is played, accompanied by loud "bam" sounds through the speakers. In milder cases the static discharges are virtually indistinguishable from noise created by dust contamination.

Third, the colloids attracted by the charges often build up to form a tar-like coating on the grooves that interferes with tracing and ultimately gums up phono styli. The irreplaceable Percy Wilson studied the atmosphere's content of such substances and their effects on discs. Ponder his results for a few minutes and you'll begin to sense the onset of black-lung disease.

On to the Bizarre. More recently, Bruce Maier of Discwasher has documented the effects of fingerprints (always to be avoided) on records, and also raised the subject of certain fungi that subsist on vinylite and that are actually encouraged by the use of some record-cleaning solutions. I was not at all impressed by Dr. Maier's ideas until, several years ago, I visited Singapore, one of the brisker hi-fi markets of today and, being a mere ninety miles from the equator, a miasma of heat and humidity. There, in the home of a prominent audiophile, I saw my first—heaven help us!—*green* record. According to my host, the algae-like growth forms within a few days. He takes his records to the washroom and uses soap and water to combat it. (I noted few other green records in Singapore, so perhaps he was doing something Dr. Maier wouldn't have approved of.)

Getting wet. Many record listeners (Singaporeans excepted) endorse a high-humidity environment as being ideal for the static problem. They place open jars of water beneath their turntables' closed dust covers, or spend a fortune on a large and quiet humidifier. I advise against this. My first reason (another will be discussed later on) is obvious: rust! Back when I could manage long vacations, I summered in a little cottage not twenty-five feet from a quiet seaside harbor. Hardly two years had passed before my tonearm (a cring-

ingly expensive model) began to show characteristic brown stain creeping out of its pivot housing. Most of the arm was aluminum, stainless steel, and/or chrome plated. Unfortunately, the pivot bearings weren't (and few are, for excellent reasons).

Some record-cleaning devices deliberately apply a moisture slick on the record surface and let the stylus plow through that. If there's anything wrong with these appliances (aside from the above) it's hard to detect. In the opinion of some, the stylus cantilever acts as a wick to draw fluid up toward the cartridge. I've never heard anyone complain about this, however. Perhaps what's most suspicious is that the "wet cleaners" tend to remove *all* noise, including that which is molded into the record as groove imperfections. This effect has been ascribed to surface tension, viscosity, and the fact that sound wavelengths are different in water than in air. Or perhaps it's simply a function of the fluid's lubrication. No one seems to know for sure, but a significant number of audiophiles—particularly those with overbright systems—seem to swear by wet playing.

The Author's Approach. I suspected you were interested in my own record-cleaning techniques, and I thought you'd never ask. With the record rotating on the turntable, I begin with an anti-static device such as the Discwasher "Zerostat" pistol, which produces clouds of positive and negative ions when the trigger is squeezed or released. This treatment is simply to release the debris particles being held by static charges, which then can be scooped up by a velvet or plush cleaning pad. (Some claim that such a pad won't scoop unless its bristles are slanted, but my experience suggests that a curvature in the contour of the cleaner accomplishes the same thing as a slanted pile). A little moisture will help the dust particles adhere to the bristles, and I am indebted to a reader for pointing out that open-mouthed breathing on a record will lightly fog it with condensed pure water vapor. So I breathe on the record as I brush.

As the record plays I use a device similar to a Dust Bug, but with a difference. Some years ago, at the height of a very humid summer (remember the objections raised to humidity earlier), I came up against an unaccountable, steady "tththth" sound on a record I knew was intrinsically good and well cared for. What?! Could it be static, encouraged by the high humidity to dis-

MIDLAND POWER

IT'S WHAT YOU GET WHEN YOU RUN WITH NUMBER 1.

For 1977, Midland gives you the power to communicate. To reach out beyond your personal horizon.

In an entire new generation of Midland 40-channel CB radios, spearheaded by the remarkable Midland 838.

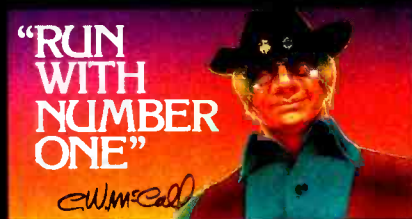

CIRCLE NO. 37 ON FREE INFORMATION CARD

The 838 features switchable automatic noise limiter, noise blanker and audio filter. Plus an automatic channel advance and volume control right on the mike, and a big, bright L.E.D. digital channel indicator.

But the 838 is only one of Midland's '77 CB line, which includes eighteen very comfortably priced base-station, mobile and portable 40-channel models.

All backed by Midland's 15 years of CB experience, Midland's warranty and

convenient service centers, coast to coast.

No wonder we sold over 2 million Midland CB's last year, making us the world's number 1 CB brand.

Midland Power. It's what you want from a CB. It's what you get when you run with number 1.

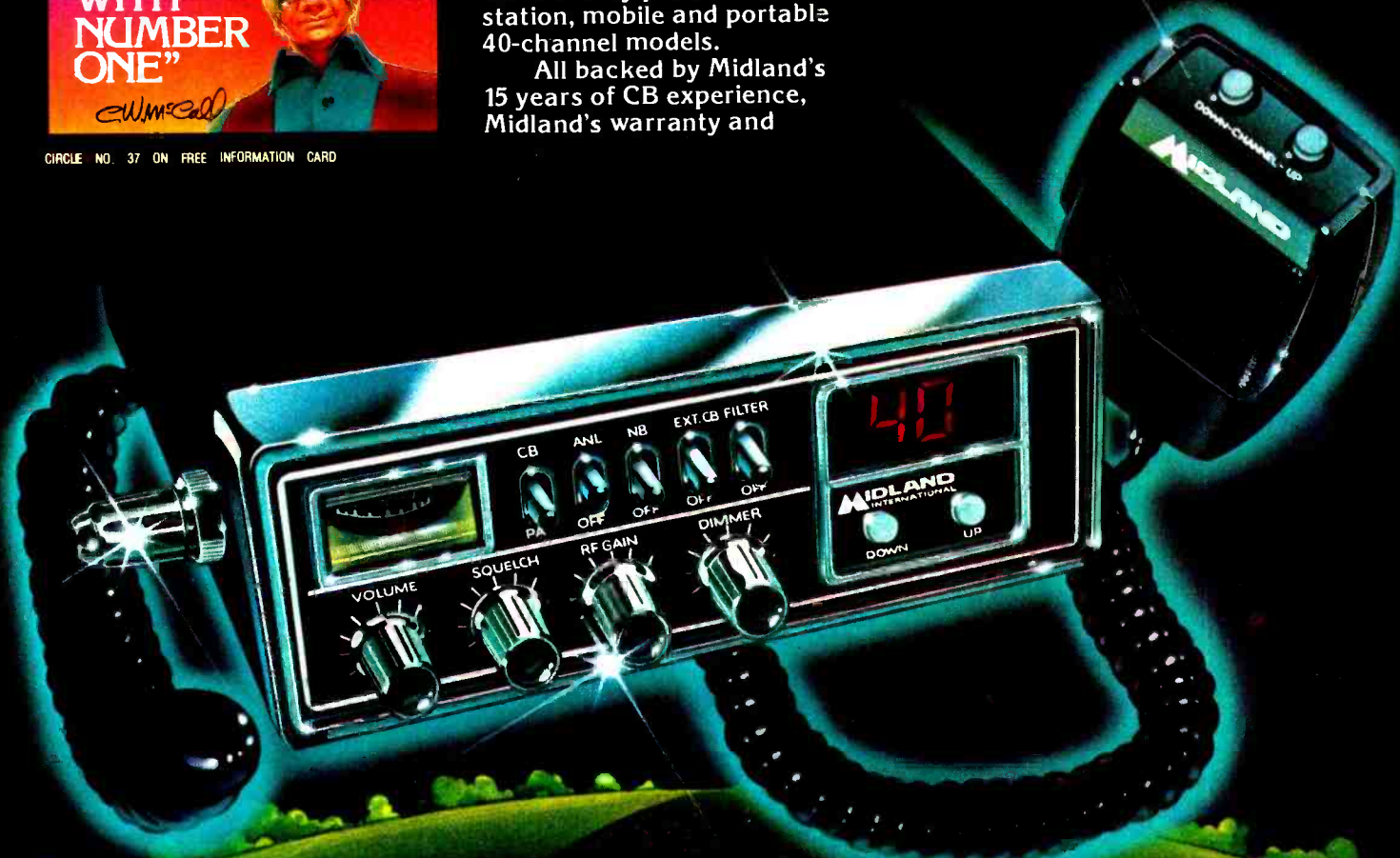

MIDLAND CB

A member of the Beneficial Corporation Family.

Shop for these exciting new products from Midland International: Medallion Car-Sound Products • Goodwin Sporting Goods • Benchmark Tools • Midland Televisions • Young World Toys

www.americanradiohistory.com

THE STORM ALARM.

IT WARNS YOU ABOUT STORMS THE WAY A SMOKE ALARM WARNS YOU ABOUT FIRES.



It sounds an alarm. A built-in alarm that's set off any time — night or day — when severe weather threatens. The alarm is triggered by a signal from your local National Weather Service transmitter. After it sounds, a report on the danger and survival instructions come on.

When conditions are normal, the Storm Alarm picks up the weather station's continuous, up-to-the-minute forecasts.

Unlike ordinary weather radios, which the user must monitor, the Storm Alarm continually monitors itself. The alarm sounds full blast whether or not you have the volume turned up and are listening. You're warned even when sleeping. Crystal-controlled and switch-selectable.

Superior reception from as far out as 40-50 miles. Works on AC. Built-in back-up battery feature. 25" telescoping antenna. 2 1/4" speaker. Unit only 3" x 5" x 1 1/4".

With all these features, it's no wonder a leading electronics magazine called the Storm Alarm a "sensitive weather receiver and, for a relatively low price, an excellent disaster alarm."

Get the Storm Alarm. It's a foul and fair weather friend.

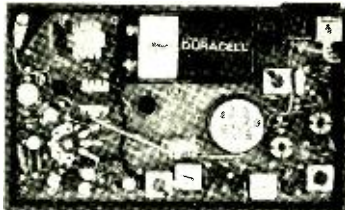

STORM ALARM FROM WEATHER ALERT

637 So. Dearborn, Chicago, IL 60605

Please send _____ (qty) Storm Alarm units at \$37.50 each (includes shipping and handling). Enclosed is \$_____

Check enclosed BankAmericard
 Master Charge American Express

(Master Charge Bank No. _____)

Card No. _____

Expiration Date _____

Name _____

Address _____

City _____

State _____ Zip _____

Signature _____

PE 5



© 1978 by WeatherAlert™, Chicago, Ill. 60605

Illinois residents add 5% sales tax. Alaska, Hawaii, Puerto Rico residents add \$2.50 per unit for special shipping and handling. Not available in Canada.

charge through the cartridge in a rather relaxed fashion? Within ten minutes I had acquired one of the record-tracking/cleaning devices that has conductive bristles intended to be grounded at the tonearm or preamp input. To my fascination, I found that the annoying sound disappeared within a few moments of my lowering the bristles to the record surface, and reappeared a few moments after I had raised them. Needless to say, I held onto this contraption, and it has been doing a fine job ever since. This is my idea of how to clean records; I welcome comments.

As long as this article has been, it has left out some pertinent points: the how and whys of stylus cleaning; the efficacy of the new friction-reducing record sprays; the "dust-bug" brushes that come attached to cartridges; the reason some records seem to be more static-prone than others; and the ways in which cartridge/tonearm choice and alignment can effect the annoyance factor of record noise (they can, apparently). I don't have firm responses to any of these (implied) questions, but I do have opinions, which will be forthcoming later on. In the meantime, let me give you several warnings:

(1) Don't rashly buy a record cleaner meant to be used while the record is playing if your turntable has limited torque, as many belt-drive units do. Dust-Bug-type devices are usually okay, but the ones that span an entire LP radius or which are driven off the turntable itself may make it impossible for your record player to get up to speed.

(2) Don't use the turntable's dust cover as a record cleaner. Laboratory tests have shown pretty conclusively that many dust covers provide an excellent path for acoustic feedback. Keep the cover removed or at least raised when you play a record. It is meant only to keep the turntable clean when it is *not* in use, and I don't know of any responsible turntable manufacturer who claims that it is otherwise.

(3) Experiment with anything meant to be applied to a record cautiously. All solvents and even distilled water are suspect with many, although they are beloved by some. When you feel you must evaluate a record-treating substance, dose one half (180 degrees) of a good record with the stuff and leave the other half untreated. At 33 1/3 rpm you should be able to detect the transition from the one side to the other (at 45 rpm things may happen too fast). And be prepared to buy a new record just in case your experiment doesn't work. ◇

afs® / Kriket® CB speaker Sound and Safe!



kamel™

Hump-mount speaker

Speakers are our only business.

They have to be better!

Designed with security and superior sound in mind, the AFS / KRIKET KAMEL KC-3085 hump-mount external speaker rests snugly on the transmission hump while driving. CB dials are readily visible.

CB transceiver mounts on speaker base forming single unit. No installation problems. For maximum security, unplug antenna and power leads, lift unit and place in trunk. No screws to uncrew. No hassle. No annoying rattles while driving. Scid!

"WORKING WALL" enclosure of cross-laminated fiberboard deadens static and channel noise, eliminates voice distortion.

AFS makes having an expensive CB rig in your car or truck safe and worthwhile. Isn't it about time somebody did?

Kriket Cares

Available at CB dealers everywhere



ACOUSTIC FIBER SOUND SYSTEMS, INC.
7999 KNUE ROAD, SUITE 116 INDIANAPOLIS, INDIANA 46250 (317) 842-0620

Canadian Distributor Muntz Canada Ltd. 1149 Pioneer Road Burlington Ontario, Canada (416) 639-5373

All AFS®/KRIKET® speakers are manufactured in the U.S.A. using American materials and craftsmanship.

Copyright 1976 Acoustic Fiber Sound Systems, Inc.
www.americanradiohistory.com



Audio Reports

HOW HEADPHONES ARE TESTED

MANY PEOPLE are aware, at least in general terms, of some of the effects that room reflections and resonances have on the perceived frequency response of a loudspeaker. For example, the bass response varies widely as one moves about the room, usually being strongest at an opposite wall or corner or close to the woofer, and weakest in the center of the room. High frequencies, on the other hand, are progressively absorbed by room furnishings as one moves away from the speaker. High-frequency level can also change greatly at different angles between the listener and the speaker.

There are ways to circumvent these problems, and even put them to good use, when measuring loudspeaker performance. Most designers, though, choose to test a speaker in an anechoic chamber (a room whose interior surfaces absorb essentially all sound impinging on them, and reflect little or nothing to a microphone placed in the chamber). In this way, the characteristics of the speaker can be determined, free from interaction with its surroundings.

In the case of headphones, the audible results are closely related to the dimensions of the wearer's ear cavity, and the manner in which the earpieces fit the pinna or external ear. These are analogous to the relationship of the room to the loudspeaker. Although anechoic measurements might be possible with headphones, they would be of little practical value since the ear affects the frequency response through the entire audio range.

It is possible to measure headphone response directly on a human head by means of probe microphones inserted into the ear cavity. This is valuable for psychoacoustic and physiological studies, but clearly is of no use to someone wishing to evaluate a headphone. It would be convenient to have a "standard ear," on which any phone could be checked. Even if such an ear were not identical to any specific human ear, it would provide a test bed on which to make comparative headphone measurements.

There are standard artificial ears—several different types, in fact. Some have been shaped to correspond roughly to the external human ear, but others merely present a flat surface to the headphone's ear cushion, with a cavity drilled in the center to expose the end of a calibrated capacitor microphone that simulates the eardrum. This is the basic configuration of the ANSI standard headphone coupler, which we use in slightly modified form for our headphone tests.

The original purpose of the standard coupler was to measure headphone response in the speech frequency range (300 to 5000 Hz). It was recognized that resonances in the coupler cavity would produce severe response changes at higher frequencies. The standard coupler has a 6-cc cavity, simulating the volume of a typical ear. The shape of this cavity is subject to slight modification to suit the particular type of headphone being tested.

Experiments made by Koss Electronics indicated that a good correlation between measured frequency response and the subjective headphone response would be achieved with a slight modification of the shape of the coupler cavity (keeping its volume at the standard 6 cc). The Koss coupler, which we use for our tests, conforms to the 1949 ANSI standard, except for the details of the cavity shape. It is a flat plate coupler into which our test microphone fits snugly. When the headphones are mounted on the coupler stand, the normal tension of the headband provides sealing around the ear cushion of the measured earpiece, equivalent to what would exist with normal wearing.

Although the Koss coupler makes it possible to measure headphone frequency response through the full audible range, it has a few intrinsic high-frequency resonances that make measurements less reliable above 10,000 Hz. Our coupler has been calibrated by Koss, with the aid of a calibrated set of its ESP-9 electrostatic phones. This enables us to check the performance of the test set-up and also provides an absolute calibration of sound pressure level (SPL), since the output of the ESP-9 phones is known at a particular frequency and drive level.

To measure the frequency response of a headphone, it is placed on the coupler and driven from an amplifier whose input is derived from our General Radio frequency-response plotter. The microphone output goes directly to the graphic level recorder input, and the chart reads out directly in dB on the SPL scale (referred to 0.0002 dyne/cm²). The voltage across the phone is set to a value recommended by the manufacturer (usually in the range of 1 to 3 volts) and a swept response measurement is made using a fast chart speed (25 inches per minute) and moderate pen damping (pen speed, 3 inches per second) to smooth out small variations caused by the coupler.

Distortion is measured at 1000 Hz as a function of applied voltage. The microphone output goes direct-



Some guys rely on their 2-way radios more than others.

Fighting a fire takes tough men. And tough equipment. Equipment like the Motorola® 2-way radios carried by so many fire fighters.

Today you can own a 2-way radio with many of the engineering principles that go into Motorola professional radios.

You can own a Motorola CB.

Features like gain control, audio compression, and noise limiting are built in, fully automatic.

So a Motorola CB is exceptionally simple to operate. Yet offers outstanding talk/listen performance.

A top-fire 3½-inch professional-quality speaker produces an audio fidelity that must be heard to be fully appreciated.

A power mic that doesn't require batteries, that doesn't cost extra, is standard equipment.

When you've made 2-way radios as long as Motorola, the result is a radio with a difference you can hear.

Whether you're fighting a fire. Or fighting the traffic home.



Motorola CB

From the voice of experience in 2-way radio.

To find the dealer nearest you, write: Customer Relations Manager, Motorola Inc., Automotive Products Division, 333 Northwest Ave., Northlake, Illinois 60164. Motorola is a registered trademark of Motorola Inc.

CIRCLE NO. 38 ON FREE INFORMATION CARD

www.americanradiohistory.com



You gotta shop around.

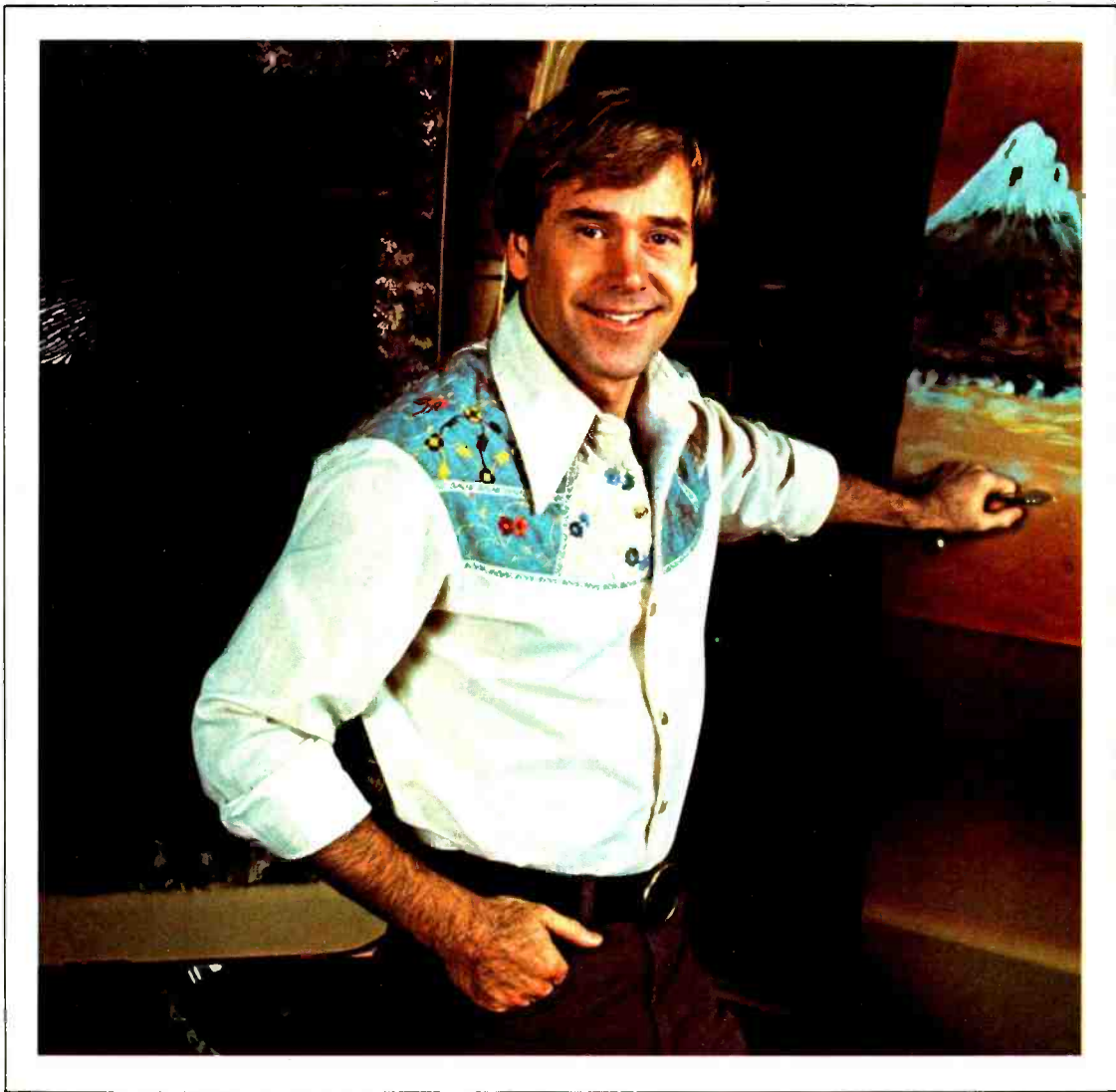

**When you do, you'll probably pick CIE.
You can't afford to settle for
less when it comes to something like
electronics training that could
affect your whole life.**

When you shop around for tires, you look for a bargain. After all, if it's the same brand, better price – why not save money?

Education's different. There's no such thing as "same brand." No two schools are alike. And, once you've made your choice, the training you get stays with you for the rest of your life.

So, shop around for your training. Not for the bargain. For the best. Thorough, professional training to help give you pride and confidence.

* * *

If you talked to some of our graduates, chances are you'd find a lot of them shopped around for their training. They pretty much knew what was available. And they picked CIE as number one.

Why you should shop around yourself.

We hope you'll shop around. Because, frankly, CIE isn't for everyone.

There are other options for the hobbyist. If you're the ambitious type – with serious career goals in electronics – take a close look at what we've planned for you at CIE.

What you should look for first.

Part of what makes electronics so interesting is it's based on scientific discoveries – on ideas! So the first thing to look for is a program that starts with ideas and builds on them!

That's what happens with CIE's Auto-Programmed® Lessons. Each lesson takes one or two principles and helps you master them – before you start using them!

How practical is the training?

This is the next big important question. After all, your career will be built on what you can do – and on how well you do it.

Here are ways some of CIE's troubleshooting programs help you get your "hands-on" training...

With CIE's Experimental Electronics Laboratory...

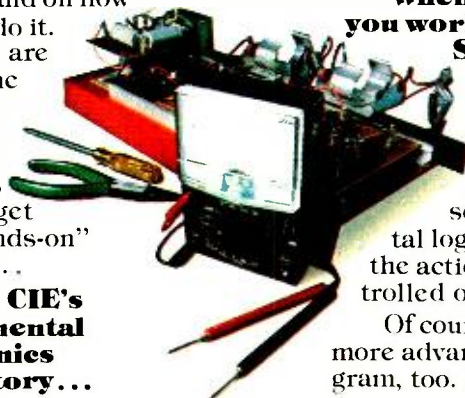

you learn and review the basics – perform dozens of experiments. Plus, you use a 3-in-1 precision Multimeter to learn testing, checking, analyzing!



When you build your own 5 MHz Triggered-Sweep, Solid-State Oscilloscope you take your first real professional step. You use it as a doctor uses an X-ray machine – to "read" waveform patterns... lock them in... study, understand and interpret them!

When you get your Zenith 19-inch Diagonal Solid-State Color TV you

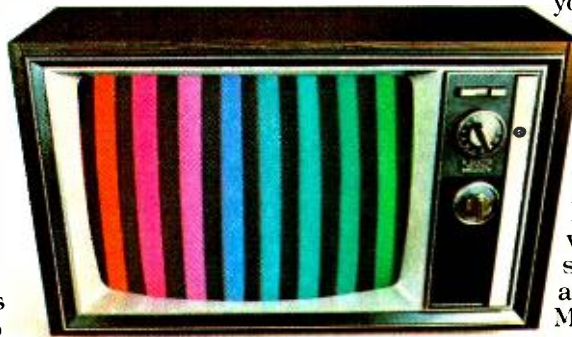

Pattern simulated.

apply your new skills to some real on-the-job-type troubleshooting! You learn to trace signal flow... locate malfunctions... restore perfect operating standards – just as with any sophisticated electronics equipment!



When you work with a completely Solid-State Color Bar Generator – actually a TV signal transmitter – you study up to ten different patterns on your TV screen... explore digital logic circuits... observe the action of a crystal-controlled oscillator!

Of course, CIE offers a more advanced training program, too. But the main point is

simply this:

All this training takes effort. But you'll enjoy it. And it's a real plus for a troubleshooting career!

Do you prepare for your FCC License?

Avoid regrets later. Check this out before you enroll in any program.

For some troubleshooting jobs, you must have your FCC License. For others, employers often consider it a mark in your favor. Either way, it's government-certified proof of specific knowledge and skills!

More than half of CIE's courses prepare you for the government-administered FCC License exam. In continuing surveys, nearly 4 out of 5 CIE graduates who take the exam get their Licenses!

Shop around... but send for CIE's free school catalog first!

Mail the card. If it's gone, cut out and mail the coupon. If you prefer to write, mention the name and date of this magazine. We'll send you a copy of CIE's FREE school catalog – plus a complete package of independent home study information! For your convenience, we'll try to have a representative contact you to answer your questions. Mail the card or coupon – or write: CIE, 1776 East 17th St., Cleveland, OH 44114.

CIE Cleveland Institute of Electronics, Inc.
1776 East 17th Street, Cleveland, Ohio 44114
 Accredited Member National Home Study Council

YES... I'm shopping around for the **right** kind of career training in electronics troubleshooting – and CIE sounds well worth looking into. Please send me my FREE CIE school catalog – including details about troubleshooting courses – plus my FREE package of home study information! PE-34

Print Name _____

Address _____ Apt. _____

City _____

State _____ Zip _____

Age _____ Phone _____ (area code)

Check box for G.I. Bill information:
 Veteran Active Duty

Mail today!

ly to a Hewlett-Packard 3580A spectrum analyzer, on which all significant harmonic amplitudes can be measured. Impedance is measured by driving the phones through a fairly high resistance and plotting the voltage across them on the chart recorder. The resistance axis of the recorder chart is calibrated against a precision standard decade resistor, substituted for the headphones.

Interpreting the frequency-response curve of a headphone measured in this way is not as easy as we would like it to be. Sometimes the response is relatively flat over most of the audio range, and this is always associated with a phone which has a smooth, natural sound. Sometimes there will be one or more huge peaks (as great as 30 dB in amplitude) in the upper midrange. Such a phone always sounds harsh and unnaturally colored. The difficulty is in the intermediate cases, which comprise the majority of

phones. Their response curves often have rather sizable peaks or holes in the range of a few kilohertz. These cannot easily be separated into true headphone response and the coupler response. Many of these phones sound excellent, virtually indistinguishable from some which test much better, while others that are seemingly not too different sound mediocre.

Thus, as with speakers, the only way to buy a headphone is to listen for yourself. With headphones, you have the advantage that the listening room is not a part of the equation, so the phones will sound the same in your home as at the dealer's showroom. Since the physical "fit" of a headphone can be as important as its sound, a personal selection is highly desirable. Test reports can be a guide to those phones that are worthy of your consideration, but response curves should never take priority over the judgment of your own ears.



SENNHEISER MODEL HDI 434 INFRARED HEADPHONES

Cordless headphones provide unfettered personal listening.



8"W × 3.15"D × 0.7"H (20.3 × 8 × 1.8 cm), and the headphones weigh 13.5 oz (420 g) including battery. Prices: \$209 for the Model HDI 434 phones and \$184 for the SI 434 infrared transmitter.

General Description. The earcups of the headphones house magnetic open-air drivers. The earcups are designed to provide little or no isolation from external sounds. The semirigid headband has a padded adjustable inner band that rests on the user's head.

On the rear of the right earcup are a pair of slide-type controls for separately adjusting the volume levels in the two earcups. A slide-type switch allows selection of normal stereo listening, channel-A mono through both earcups, or channel-B mono through both earcups. A separate switch controls power to the headphones from its own 9-volt battery. The left earcup has no controls; it houses the battery that powers the phones. A clear plastic on the front edge of the right earcup protects an infrared sensor that picks up the invisible beam radiated by the transmitter.

Across the front panel of the transmitter is a row of 12 light-emitting diodes (LED's) that generate the invisible infrared carrier beam. A separate LED, located at the far left of the panel, is used as the power-on indicator for the line-powered transmitter. The pushbutton power switch is located at the far right of the front panel.



With these innovative, cordless, stereo headphones, the listener can be free at last from the tether that attached him to the headphone jack. In the past, most attempts at designing cordless hi-fi headphones failed to meet the high quality sound needs of the home listener. The various cordless approaches tried were plagued by poor sound quality, high noise levels, and inability to handle stereo program material. The new Model HDI 434 infrared stereo

phones from Sennheiser have solved most of the technical problems.

The Model HDI 434 is actually a headphone "system" that consists of rather large (but lightweight) phones and a separate infrared transmitting unit. No physical connection is needed between the phones and transmitter, nor are there antennas or other appendages on the phones themselves. The only link between the phones and the transmitter is an invisible infrared beam. The transmitter plugs into the headphone jack of any amplifier, tuner, or tape deck.

The infrared transmitter measures

You may have noticed that few turntable manufacturers call your attention to the critical role of the tonearm in record playback. Dual is an exception.

Whatever the shape, materials, or mechanics of a tonearm, the goal is always the same: to maintain the cartridge in the correct geometric relationship to the groove, and to permit the stylus to follow the contours of the groove

Why we want you to know more about tonearms. And why others may not.

walls freely and accurately. Whenever the stylus cannot follow the groove undulations, it will gouge its own way. And as we have

frequently reminded you, there is no way to repair a damaged record. Every tonearm designer should consider

geometry, mass, balance, resonance, bearing friction, and the accuracy and stability of settings for stylus force and anti-skating. However despite the simple fact that the shortest distance between two points is a straight line, some designers are more concerned with appearance. Hence the curved tonearm, whose deviations between pivot and stylus simply add mass, reduce rigidity and increase the likelihood of resonance.

Dual engineers have always designed for optimum performance. The essential differences in approach and results are indicated below. You might keep all this in mind when you are considering your next turntable. Chances are you'll want it to be a Dual.

Dual

United Audio Products, 120 So. Columbus Ave., Mt. Vernon, N.Y. 10552
Exclusive U.S. Distribution Agency for Dual

The curved tonearm may appear longer than the Dual tonearm, but both actually have the identical effective length and horizontal tracking angle.

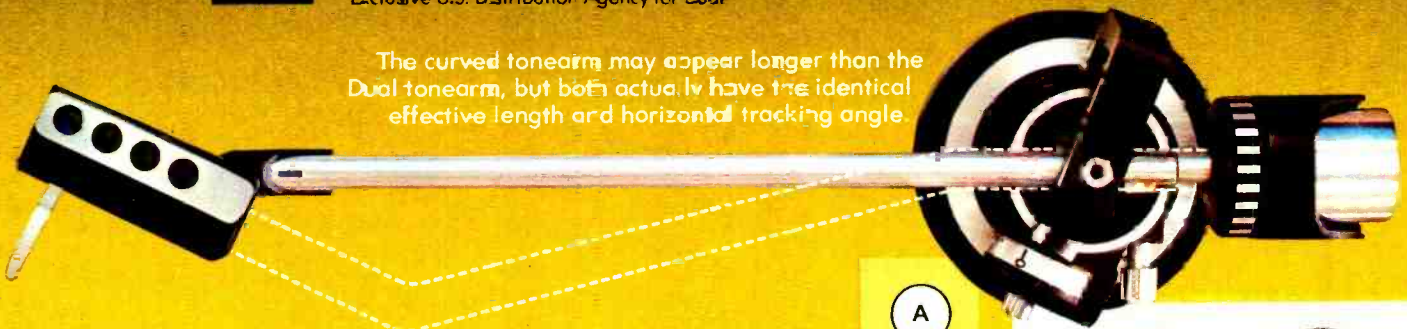

Actual size of Dual tube (A) and typical curved tonearm (B). For the same effective length, straight Dual tonearm has lower mass and resonance, yet greater rigidity.

Dual 1249. Single-play/multi-play. Belt-drive. Fully automatic start and stop, plus continuous repeat. Mode Selector parallels tonearm to record in single-play; 5% pitch control; illuminated strobe; cue-control viscous-damped in both directions; multi-calibrated anti-skating. Less than \$280.

Dual 510. Similar except semi-automatic. Lead-in groove sensor. Tonearm lifts automatically at end of play and motor shuts off. Less than \$200.

Dual 302. Semi-automatic. Less sensor, strobe and pitch-control. Less than \$160.



Gimbal-mounted Dual tonearms pivot horizontally and vertically on identical sets of pivot points and high-precision low-friction bearings. Bearing friction: vertical, $\lt; 0.007 \text{ gram}$; horizontal, $\lt; 0.015 \text{ gram}$.

Stylus force, applied by long coiled spring around vertical pivot, remains perpendicular to record even if turntable is not level.

Specifications (DIN B): Rumble, >66dB; Wow and flutter, $\pm 0.05\%$

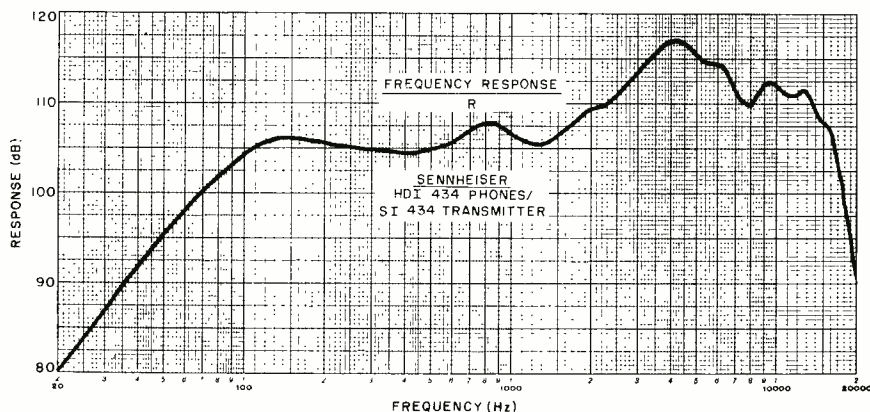

Overall frequency response of headphones and transmitter.

In operation, the transmitter is placed in a location where its beam will cover the preferred area of the listening room. Then, with the headphone worn in the usual manner, the stereo program is heard just as with conventional headphones. The big difference here is that the listening volume is set by the slide controls on the right earcup.

It is important to have a sufficient, but not excessive, modulation level driving the transmitter. This is accomplished by turning up the volume control of the audio component that drives the transmitter until the glowing LED on the latter suddenly begins to flash, and then backing off slightly until the flashing just ceases. Thereafter all volume level adjustments are made by operating the controls on the phones.

The stereo program is carried over the infrared beam on two subcarrier frequencies—95 kHz for the left channel and 250 kHz for the right channel. The specifications call for a 30-kHz deviation at 1-volt input to the transmitter and 50-kHz deviation at the 1.5-volt maximum allowable input. The headphones contain two FM discriminators that are tuned to the subcarrier frequencies and are capable of demodulating signals with deviations as great as 50 kHz.

The specifications for the phones call for a frequency response of 20 to 20,000 Hz (no tolerance given) with less than 1% THD at 1000 Hz (at an unspecified level) and a maximum output capability of 108 dB SPL. The S/N ratio is rated at approximately 60 dB, and estimated operating life of the standard 9-volt battery is 100 hours.

Laboratory Measurements. We tested the acoustic performance of the phones on a modified ANSI headphone coupler in the usual manner. The transmitter was placed a few feet from the

headset and driven directly from our General Radio response plotter. Having determined that a 1-volt drive level to the transmitter resulted in spurious "birdies" at frequencies beyond 12,000 Hz, we reduced the drive to 0.5 volt for the response measurement.

The midrange response was very flat, varying only ± 1.5 dB from 100 to 1700 Hz. The output rose at higher frequencies and was at or above the midrange level all the way up to our measurement limit of about 16,000 Hz. The low-frequency output, as is usually the case with open-air headphones, dropped off at a 12 dB/octave rate below 100 Hz. The midrange SPL was about 105 dB, or 111 dB at the recommended maximum operating level of 1 volt.

The overload indicator glowed at a 1.15-volt input with frequencies of 1000 Hz or lower. Overload occurred at smaller signal voltages at high frequencies, reducing to 0.43 volt at 10,000 Hz and 0.32 volt at 15,000 Hz. The distortion of the acoustic output of the headphone was less than 1% for drive levels up to about 1 volt at 1000 Hz. With the phone's volume controls set to maximum, the distortion increased abruptly above about 1.2 volts. This was apparently due in part to overdriving the headphone amplifiers, since reducing the setting of the volume controls by 10 dB resulted in a more gradual increase in distortion, to 2% at 1.8 volts and 3.4% at 3 volts. Distortion is not a problem when using the phones, since it became appreciable only when the SPL exceeded a very loud 110 dB.

The S/N was measured relative to the output at 1000 Hz with a drive level of 1.15 volts. Without weighting, the S/N was 40 dB, and with CCIR weighting it was 54 dB. The stereo channel separation reduced with increasing frequency, from 40 dB at 100 Hz to 21 dB at 3000

Hz. It remained in the 18-to-21-dB range from 3000 to 15,000 Hz. The electrical impedance of the transmitter input was 100,000 ohms up to about 1000 Hz. It decreased to between 13,000 and 25,000 ohms in the 10,000-to-20,000-Hz range.

User Comment. Considered only as stereo headphones, we would rate these on a par with other Sennheiser phones we have tested. They are excellent, producing a clean, wide-range, transparent sound that could not be distinguished from conventional phones.

The listening volume was most satisfactory, and we heard no background hiss or other noise that was not in the program material. In other words, the

Editor's Note: The listening experience with these infrared phones may differ according to the environment and the placement of the transmitter. For example, using the same new Sennheiser phones in a large (25 ft \times 19 ft \times 8 ft) wood-paneled listening room in the editor's home, a person standing in front of the transmitter or the headphone wearer did *not* change the sound quality received by the phones when the infrared transmitter was positioned near the corner of the room (a position also tried during Hirsch-Houck tests). Furthermore, in this position, headphone reception was not at all marred by noise when turning a head or even one's back so that the phone receiver's single sensor was facing away from the transmitter. Nor was there any change in sound when a cigarette lighter was flicked, a pipe lighted, or pipe smoke blown by the headphone user. Moreover, the signal-to-noise ratio did not even exhibit an apparent change when the user walked into a hallway off the listening room so that he was *behind* the transmitter. Turning one's head in this area, however, did cause a high level of noise to occur, as did standing under a strong spotlight.

It should be mentioned, as a footnote, that this listening room has angled ceilings emanating from four-foot-high paneled walls and rising to a flat plasterboard ceiling surface. In contrast, Hirsch-Houck's ceiling is constructed with acoustic panels. These differences evidently account for the contrary results in infrared reception. It's obvious that, in the editor's home, the environment enhanced reflections of the infrared beams. As a consequence, the performance of these infrared stereo phones was superb with no reservations whatsoever.

Shakespeare's Double Trucker Antenna.TM Professional. Co-phased. And no strong two ways without it.

Ask a trucker about the best antenna team for your CB operations. He knows the Citizens Band. And he knows the performance of Shakespeare's Double Trucker Antenna. Because the men who ride for a living can't settle for anything small-time in their signal power.

Those two solid fiberglass whips stand firmly upright for maximum range and clarity. Perfectly co-phased through Shakespeare's exclusive Diplexer phasing harness. Pre-tested and pre-tuned for the 40 channel band. Delivering the kind of performance true Knights of the Road depend on.

Shakespeare

**The best antenna going.
And coming.**

Shakespeare's Double Trucker Antenna, Style 464-1/ Installs quickly and easily on any horizontal bar up to 3/4". Comes complete with corrosion proof mirror mount, cable and all connectors. Under \$35.

S/N of the infrared system was at least as good as that of the FM and commercial phonograph records we used for program sources.

The transmitter evidently radiates a fan-shaped pattern into the room, which does not reflect from room boundaries to any significant extent (unlike ultrasonic remote-control devices, whose output can be "bounced" off a wall to reach around a corner). This means that the phones must be in a direct line of sight with the transmitter, although distance does not seem to be a problem. (We covered 30 feet or more without difficulty.) However, if someone walks between the listener and the transmitter, the sig-

nal drops markedly or disappears altogether, delivering a burst of noise like that of an unmuted FM tuner when the signal drops out. Interestingly, a crackling sound occurred when the listener flicked a flint-type lighter, followed by noise when the lighter's flame appeared.

If one turns away from the transmitter, or even to the side so that the left ear is closest to the transmitter, however, a loss of signal is likely to occur. We found this in some ways to be restrictive, although one quickly adjusts to the minor limitation. This occurs because the receiver sensor is on the front of the right earpiece. The answer, it would seem, would be to either place a sensor on

each earpiece or mount a single one at the top of the rigid headband to prevent shadowing of the receiver as the wearer moves or turns.

Aside from the above, we were highly impressed with the concept used by these phones, as well as its execution. The system does a remarkably fine job without excessive weight or bulk. True, they are among the most expensive headphones you can buy, but they also do things that no other phones can. One simply has to experience the wonderful feeling of not being tied down to a headphone's umbilical cord to appreciate it. And, the sound is truly superb.

CIRCLE NO 101 ON FREE INFORMATION CARD

TEAC MODEL PC-10 CASSETTE RECORDER

Portable stereo recorder has performance characteristics of home component types.



The Model PC-10 portable cassette recorder is part of Teac's new "Esoteric" line. It is one of the new breed of true high-fidelity portable stereo recorders with all the features and performance quality expected of deluxe home cassette decks. It comes with a separate ac power supply for line operation and can be operated in the field from six D cells that fit within its case.

The recorder measures 11½" W × 9½" D × 3½" H (29.2 × 24.1 × 8.9 cm) and weighs 11 lb (5 kg). Nationally advertised value is approximately \$500.

General Description. The recorder features a direct-drive dc capstan motor that is servo-controlled through a phase-locked loop (PLL). This eliminates belts and flywheels; it starts up and brings the transport to final operating speed rapidly. (There is a separate dc motor for the tape hubs.) The PLL motor drive makes the recorder's operating speed relatively

independent of supply voltage and temperature, the latter specified over a range of 32° to 140° F (0° to 60° C).

The cassette well is on what would be the top of the recorder when it is placed on a shelf or table. When the recorder is carried over a shoulder via its built-on strap, the cassette well is on the side for convenient loading and unloading. A small lever opens the cassette cover, while a firmer push on the lever ejects the cassette. Located near the cassette well is a pushbutton-resettable index counter.

The control panel is dominated by two large VU meters, whose scales are labelled with the standard Dolby level mark at the +3 indexes. Between the meters is a PEAK LEVEL LED that flashes when momentary peaks reach +6 dB. The meters and PEAK LEVEL indicator function in playback as well as in the record mode.

The transport mechanism is controlled by two slide-type levers. The upper lever has STOP and PLAY positions, and next to it is the REC button that must

be pressed before going to PLAY if a recording is to be made. The second lever has three positions. The left position is for rewind, center position for off, and right position for fast forward tape motion. Neither lever can be moved unless the other lever is in its stop (center) position. A PAUSE button is located just below the REC button. A red indicator comes on for the record mode.

The REC level controls for the left and right channels are concentrically ganged together. The lowest quarter of their adjustment range is marked in white as a warning that input signal levels are excessive if the controls must be set so low. Otherwise, the rest of the scales are in red for the right channel and green for the left channel. A small button below the level controls can be pressed to momentarily illuminate the VU meters or pressed and twisted to lock on the illumination. A similar button connects the right-channel meter to give an indication of battery condition.

Separate BIAS and EQ (equalization) switches are provided for setting the operating conditions to suit most tape formulations. The bias levels roughly correspond to those used with low-noise ferric-oxide and CrO₂ (or the chrome equivalent) tapes. The EQ characteristics conform to the standard 120- and 70-μs curves for these tapes. (The instruction booklet that comes with the recorder lists a number of suitable tapes and recommended switch settings.) The DOLBY NR switch turns on and off the Dolby B noise-reduction system, and the LIMITER switch turns on and off a peak limiter that takes effect at levels over +3 dB.

The positions on the MIC ATT switch are labelled 0, 15, and 30 (dB). With this switch properly set, it is possible to record very high sound levels without

There's more to Realistic[®] 40-channel CB than just 17 added channels...



there's 17 years of know-how!

With so many new and unproven brands on the CB bandwagon, the reasons for buying Realistic are clearer than ever. Seventeen years' experience and sales of a million sets annually have shown us what it takes to be a leader:

Intelligent, reliable engineering. Easy-to-find sales and service — to the tune of 4800 Radio Shacks in the USA alone. And low prices that are possible only because Radio Shack is a do-it-yourself company, from factory to warehouse to sales counter.

Take a look at our new high-performance mobile transceiver, the TRC-467. Advanced phase-lock loop circuitry generates all 40 channels with an electronic precision far beyond the limits of the multi-crystal sets.

Three ceramic IF filters improve the selectivity for a whopping 80 dB of adjacent-channel rejection. An automatic noise limiter cuts pulse interference, and it's switchable for maximum clarity on stronger signals.

Illuminated signal strength/RF output meter and channel selector, LED modulation indicator — conveniences that make your CB easier and more fun to use. With dynamic plug-in microphone, adjustable mobile bracket, and power cables for any vehicle with 12 VDC positive or negative ground.

Come in today and see the TRC-467. Designed, manufactured and sold only by "the" CB experts — Radio Shack. Just 119.95*.



These two credit cards honored at most Radio Shacks
*Prices may vary at individual store and dealers

SOLD ONLY WHERE YOU SEE THIS SIGN:

Radio Shack[®]

A TANDY COMPANY • FORT WORTH, TEXAS 76107
OVER 5000 LOCATIONS IN NINE COUNTRIES

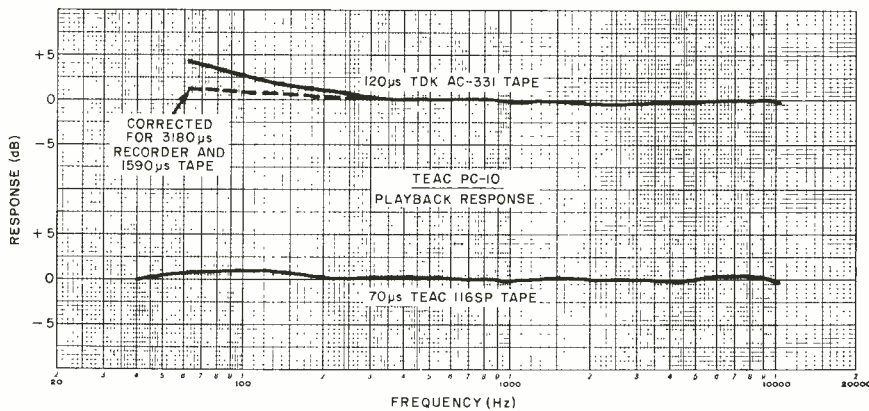

Playback frequency response tests using two different types of tape.

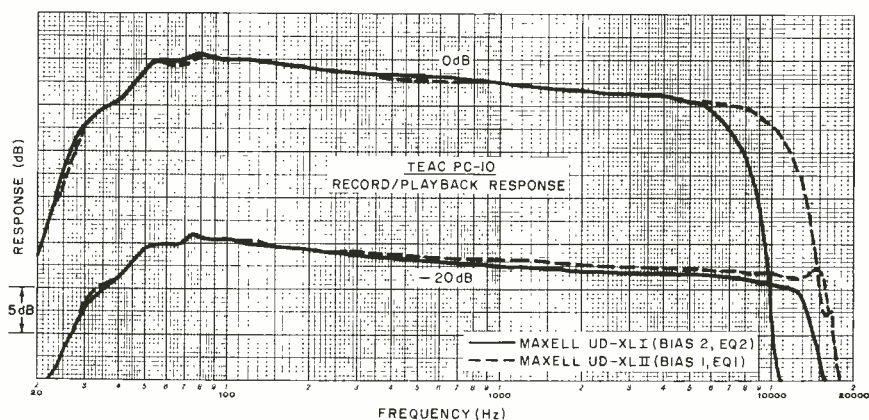

Overall record/playback frequency responses at 0 dB and -20 dB.

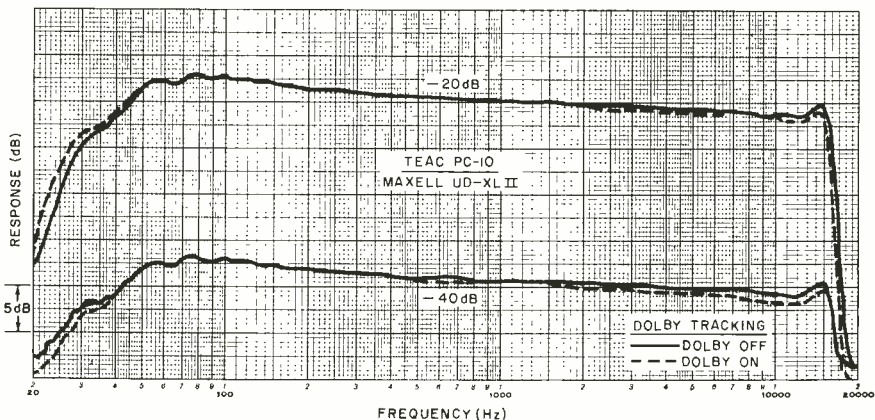

Response curves showing Dolby tracking error at two levels.

overloading the microphone preamplifier stages.

Set into the right side of the recorder is a well that contains the various input and output connectors, a slide switch for selecting either the microphone or line inputs, playback output jacks, a headphone jack, and a small volume control for the built-in speaker. There is also a jack for connecting the external ac power supply to the recorder.

The published performance specifications of the recorder are similar to those for a better-quality line-operated cassette deck. The recorder can be oper-

ated continuously for approximately two hours with six fresh D cells installed.

Laboratory Measurement. We used TDK AC-331 tape with 120 μ s equalization and Teac 116SP tape with 70 μ s equalization during our playback frequency response tests. In both cases, the response was flat within ± 0.5 dB from 150 to 10,000 Hz, with a maximum departure from flatness of only 1 dB at the lower frequencies (which extended, respectively, to 63 and 40 Hz with the two tapes).

Several types of tapes were used to

measure the overall record/playback frequency response. The curves obtained with Maxell's ferric-oxide UD-XL I and cobalt-treated ferric-oxide UD-XL II (designed to be used with "chrome" bias and equalization) tapes were typical of the recorder's performance with other high-quality tapes. The frequency response was a nearly straight line that sloped downward with increasing frequency. The total variation was ± 3 dB from 35 to 12,500 Hz using UD-XL I tape and from 35 to 15,500 Hz with UD-XL II tape. The principal difference between the two tapes was not in their frequency responses but in their high-frequency saturation characteristics. When the measurement was made at 0 dB instead of the usual -20 dB, the UD-XL II tape delivered a much better high-frequency response.

The tracking error of the Dolby circuits between the recording and playback conditions (they are supposed to be exactly balanced at all levels and frequencies) was excellent. At levels of -20 and -40 dB, there was no more than 1 dB of change in response at any frequency when using the Dolby system.

A line input of 62 mV or a microphone input of 0.22 mV was needed for a 0-dB recording level. The latter increased to 1.6 and 8 mV when the MIC ATT switch was set to its 15- and 30-dB positions, respectively. The microphone overload levels were 82, 550, and 1550 mV in the three positions of the MIC ATT switch. The playback output from a 0-dB recording level varied somewhat with the tape used. The premium ferric-oxide tapes—Maxell UD-XL II and TDK SA—gave about a 0.7-to-0.8-volt output, which roughly corresponds to the rated 0.775-volt output. However, the UD-XL I tape yielded a higher output at 0.93 volt.

The playback distortion from a 0-dB recording at 1000 Hz was 0.63% with UD-XL I and 0.8% with UD-XL II tapes. The 3% THD level was reached with respective recording levels of +6.5 and +5 dB. The PEAK indicator flashed at +5 dB. The recording limiter had no effect at 0-dB or lower levels, but it made a worthwhile reduction in playback distortion when the recording levels were well off-scale on the meters. For example, at +7 dB, with UD-XL II tape, the distortion reduced from 5.3% to 2.1% with the limiter switched in. At +10 dB, the distortion was a still-tolerable 3.5%, but at 20 dB it reached an unacceptable 10%. It is clear that the presence of the limiter is not a justification for entirely ignoring recording levels.

We were pleased to note that the VU

meters were correctly named, at least with respect to their performance. Their ballistics matched the specifications for professional VU meters, with a 0.3-second, 1000-Hz tone burst occurring once per second to give exactly the same meter indication as a continuous tone of the same level.

With UD-XL I tape, the S/N referred to the 3% THD level was 56.5 dB unweighted, 60.5 dB with IEC A weighting, and 56.5 dB with CCIR/ARM weighting (the type preferred by Dolby Laboratories). With the Dolby system switched in, these figures improved to 61, 68, and 66.5 dB. With UD-XL II tape, the S/N was not quite as good, yielding readings of 55 dB unweighted, 59 dB IEC A weighted, and 56 dB CCIR weighted. The Dolby system improved these figures to 56.5, 65.5, and 66 dB. The noise level through the microphone inputs was 14.5 dB greater at full gain but much less with normal settings of the recording gain. Playing a 200-nanoweber/meter standard Dolby level tape provided meter readings within 0.5 dB of the Dolby calibration marks on the meters.

The measured wow was the 0.01% residual of our test equipment and tapes. Unweighted rms and flutter measured 0.145% in both the playback and combined record/playback tests. These figures cannot be compared to Teac's own rating, which was based on a weighted measurement. The transport operated smoothly and reliably and moved a C60 cassette from end to end in about 84 seconds. The crosstalk between stereo channels was -45 dB at 1000 Hz, measured with a TDK AC-352 test tape. All these tests were made using an ac power supply.

User Comment. The overall performance of this recorder is squarely in the class of the better component-type cassette decks used in home hi-fi systems. In fact, with respect to distortion and noise levels, almost perfect playback equalization, and virtually ideal Dolby tracking, this recorder was superior to all but a handful of the component cassette decks we have tested.

Used in a fixed home hi-fi system, the recorder's sound quality and handling convenience left little to be desired. Our only criticism of its operation concerns the eject lever. With the recorder slung over a shoulder, it is very easy to brush against the lever and inadvertently open the cassette door. Otherwise, this fine little recorder offers the best of portable and fixed operation, albeit at a price.

CIRCLE NO. 102 ON FREE INFORMATION CARD

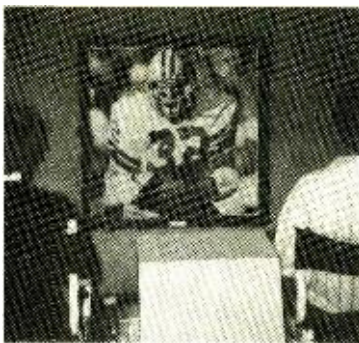

FITS WITH ANY DECOR - YOU CAN CHOOSE ANY TYPE WOOD OR FORMICA THAT MATCHES YOUR FURNITURE FACTS

1. The special LIFESCREEN® lens and front surface mirror, supplied by Extron are the same type used by major big screen television manufacturers (Sony, Muntz, etc.). THESE PROFESSIONAL COMPONENTS SHOULD NOT BE CONFUSED WITH THE CHEAP PLASTIC MAGNIFYING IMITATIONS NOW FLOODING THE MARKET BECAUSE OF THE POPULARITY OF BIG SCREEN TELEVISION.
2. Kodak Ektalite screen (recommended because it is 16 TIMES BRIGHTER than a flat matte surface and 6 TIMES BRIGHTER than most flat beaded movie screens) is the same used by major big screen television manufacturers. The Ektalite screen is made of a special treated sheeting laminated to a spherically curved "shell" frame. The Ektalite screen dramatically outperforms all other types of screens by reflecting all its incident light back to the viewer instead of absorbing it. Its parabolic shape rejects extraneous light, thereby concentrating a highly efficient and directionally selective television image that is exceptionally sharp and colorful.
3. Can be used with or without remote control television because the control panel is faced toward you like any conventional television.
4. This system will reproduce whatever signals it receives. We therefore do not recommend it in poor reception areas. The distortion would be enlarged.

Extron LIFESCREEN® Projection System
8831 Sunset Blvd
W. Hollywood, Calif 90069

BUILD THE LIFESCREEN® BIG SCREEN COLOR TELEVISION

THE CREATION OF BIG SCREEN TELEVISION OFFERS
A NEW DIMENSION IN TELEVISION VIEWING

- Sporting Events Are An Experience As Exciting As Being There!
- Movies Are Seen The Way They Were Meant To Be Seen!
- Ping And Other Video Games Are More Exciting Than Ever!
- Can Be Used With Video Tape Playback Equipment!



NO ELECTRONIC SKILLS REQUIRED

The LIFESCREEN® TV was designed for the 'Do-It-Yourself' enthusiast who wishes to have the enjoyment and excitement of a professional Big Screen TV but refuses to pay the \$1500 to \$4000 and higher prices that most major manufacturers charge for it is luxury

HOW TO ORDER COMPONENTS

The LIFESCREEN® Lens and Front Surface mirror can be ordered from Extron.
The Kodak Ektalite Screen can be purchased from a local Kodak retailer for about \$100.

The Sharp 13" Model 13A21 Color TV can be purchased from a local Sharp retailer for about \$300.

Extron can supply you with the screen or the television for the prices quoted above.

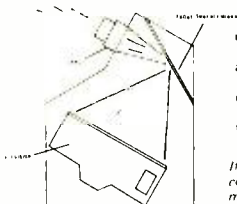

HOW THE LIFESCREEN® PROJECTION SYSTEM WORKS

If you now own a portable color TV that has a bright, color pure picture, IT MAY BE ACCEPTABLE with minor alterations. DETAILS WITH PLANS

START BY ORDERING YOUR PLANS TODAY!

Don't be discouraged because this is a kit! This system when built according to instructions is every bit as good as the projection TV's on the market today

Please Rush Me one complete set of LIFESCREEN® Plans @ \$9.00

Please also send me the items checked below

LIFESCREEN® Lens @ \$150.00

LIFESCREEN® Front Surface Mirror @ \$20.00

All prices F. O. B. Factory

Name _____

Address _____

City _____

State _____ Zip _____

Extron LIFESCREEN® Projection System 8831 Sunset Blvd.
W. Hollywood, Calif 90069
Calif. residents add 6% Sales Tax

TOTAL \$ _____

Enclosed

Charge to my credit card

Card Name _____

Card Number _____

Expiration Date _____

CIRCLE NO 25 ON FREE INFORMATION CARD

BYTE

The Small Systems Journal

Isn't it time you had your own personal computer?

Read BYTE, the leading national publication covering the fantastic new field of personal computer applications. Today, large scale integration has made it possible for the individual to enjoy the unique benefits of a general purpose computing system. Now, an entire micro industry markets microcomputer related items, products that range from computer system kits to peripherals, software and literature on the subject. But where should you go for all the details about your personal involvement in computer technology?

Read BYTE, the Small Systems Journal devoted exclusively to microcomputer systems. Every issue a monthly compendium of lively articles by professionals, computer scientists, and serious amateurs.

Fill in subscription coupon today, or phone your request directly — call 603/924-7217 and ask for subscription department. Read your first copy of BYTE, if it's everything you expected, honor our invoice. If it isn't, write 'CANCEL' across invoice and mail it back. You won't be billed and the first issue is yours

Allow 4 to 6 weeks for processing.

BYTE 70 Main St., Peterborough, N.H. 03458 07A5

Please enter my subscription to BYTE ...

\$12 One Year \$22 Two Years \$30 Three Years

Bill me Check Enclosed

Bill BankAmericard Bill Master Charge

Credit Card Number

Credit Card Expiration Date

Name (Please Print) _____

Address _____

City _____ State _____ Zip _____

CIRCLE NO 12 ON FREE INFORMATION CARD

NEWS HIGHLIGHTS

Auto Cigar Lighter Transmitter

It looks like the car's cigar lighter, since it's in the lighter slot. But the "Merc," developed by Mallard Manufacturing, Sterling, IL, is a one-ounce transmitter that, when pushed in just like a cigarette lighter, sends a coded signal that opens a garage door. The Merc (Mallard Electronic Radio Control) is said to work with any door opener on the market, and can be easily unplugged and moved to another car. Since it stays in the lighter slot, it isn't easily misplaced or, since it looks like the lighter, stolen. The Merc transmitter and companion receiver will sell for about \$65 together.

Hearing-aid TV Captions

The Federal Communications Commission has given approval to an electronic system for producing captions on TV programs for hearing-impaired viewers whose TV receivers are equipped with the proper decoding accessory. While this gives the nod to manufacturers who wish to make the accessories, it does not require stations to supply the captions. PBS (Public Broadcasting Service) has been experimenting with the system for two years, but opposition has come from the commercial networks who want more time for testing. According to estimates presented to the FCC, the equipment to produce the captions will cost each station \$30,000 to \$50,000 and encoding the programs is expected to add another \$1000 to \$3400/hr to production costs.

"Citizens Band" Movie

"Citizens Band," a feature movie about the phenomenon of CB radio and its effect on the lives of some of the people who use it, is being filmed on locations in Marysville and Yuba City in northern California. The Fields Company production for Paramount Pictures release is to be a contemporary comedy-drama about the personal adventures of an interrelated group of characters in Everytown, U.S.A. The movie depicts various uses of CB radio, including heroic rescue operations in highway and air emergencies. All the principal performers who use CB radios in the picture were given CB equipment and operating instructions long before the start of production so that they would become accomplished CB'ers and play their roles authentically.

The "Leap Second" Year

To keep official time in step with the spinning earth, a leap second was inserted into the world's time at the end of 1976. By recommendation of the International Time Bureau in Paris, France, the leap second began on December 31, 1976, at precisely 23:59:60 Universal Coordinated Time. It ended at 00:00:00 on January 1, 1977, making the "leap second" part of 1976, not 1977. This additional second was inserted by all standard time organizations around the world, including WWV, WWVB, and WWVH in the U.S. The 1976 leap second

was the sixth since the practice began in 1972, and is required because, in comparison with atomic clocks, the earth is slowing down enough so that the extra second is needed to keep the clocks synchronized to the spin of the earth to within one second.

WWV/WWVH Cutback

On February 1, 1977, the National Bureau of Standards discontinued broadcasts on the less-used frequencies of its two time and frequency radio stations. The affected frequencies are 20 and 25 MHz at WWV (Fort Collins, Colorado) and 20 MHz at WWVH (Kauai, Hawaii). Both stations will continue to broadcast on 2.5, 5, 10, and 15 MHz with no change in radiated power. Radio station WWVB will continue broadcasting on 60 kHz with no changes. Broadcast equipment previously used on the discontinued frequencies will be converted to serve as back-up systems for the remaining frequencies, and will be automatically turned on if the primary transmitters or antennas fail. The NBS also announced that this partial discontinuance of service will be reviewed periodically as changes occur in radio propagation conditions, sun-spot activity, etc. If conditions warrant, a resumption of service on the higher frequencies will be considered.

Video Equipment Bright Spot

Frost & Sullivan, a market research organization, has detected many long-term bright spots in consumer electronics, including video tape systems, video discs, video games, and video projection systems. Despite stiff competition from the Japanese and Taiwan manufacturers for the TV receiver market, Frost & Sullivan concludes that the U.S. can dominate the field of video entertainment systems because of its early start and sophisticated circuitry. The video game market, which checked in at \$26 million in 1976, is expected to climb to more than \$130 million by 1985. There are now more than 70 companies in the field. Video tape systems will be dominated by the Japanese, with a market peaking in 1980 before giving way to video disc systems . . . if the industry agrees to standardization of software and hardware, says Frost & Sullivan.

Marine Guidelines for CB Monitors

The Coast Guard has established guidelines to assist volunteer CB-monitoring groups in relaying boating distress information. The guidelines are required to make sure a message gets through the various relay stations unchanged. The boatman can't reach the Coast Guard directly on CB because the Coast Guard doesn't monitor CB channels, a task left to REACT teams and other CB groups. The Coast Guard needs the following information: name and description of the boat, position, nature of the assistance required, number of persons aboard, radio frequencies available, name of the owner or operator and his home port and telephone number, and the name and phone number of the original contact for confirmation and callbacks.

handic®



Now you can buy Europe's No.1 CB in the U.S.A.

The country that created superior steel, jet fighters, automobiles and cameras has also created the world's finest CB equipment.

handic, from Sweden, is the best selling, most popular CB in all Europe.

It is a true system. Base stations, mobiles, hand-helds and accessories interface with one another as a system should.

handic CBs have not only met but exceeded all FCC specifications at their time of introduction. Including the extraordinarily handsome new 40 channel line.

Ruggedly made for tough Swedish geography and extreme weather conditions, yet stunningly designed, handic has drawn rave reviews from CB publications in the U.S.



handic USA, Inc., 14560 N.W. 60th Ave., Miami Lakes, FL 33014

- A handic 240 - in-dash 40 ch/5w Mobile CB/AM/FM Radio MPX (LED) - \$259.95
- B handic 230 - under-dash 40 ch/5w Mobile CB (LED) - \$199.95
- C handic 21 - 2 ch/1w Hand-held CB - \$59.95
- D handic 32 - 3 ch/2w Hand-held CB - \$69.95
- E handic 43C - 4 ch/3w Hand-held CB - \$89.95
- F handic 65C - 6 ch/5w Hand-held CB - \$109.95
- G UCB - Universal Cassette, Recharge/Power Holder for Hand-helds - \$19.95
- H handic S-12 - Selective Call for Base & Mobile - \$79.95
- I handic 305 - 3 ch/5w Mobile CB - \$79.95
- J handic 4005 - 40 ch/5w Base CB w/Sub-receive (LED) - \$279.95
- K handic 3605 - 40 ch/5w Base (LED) - \$249.95
- L handic 007 - 8ch/hi-lo band Scanner w/FM Radio - \$239.95
- M handic 006-H-L - 8ch/hi-lo band or UHF Scanner - \$149.95
- N handic 004-U - 4ch/hi-lo band or UHF Pocket Scanner - \$139.95
- O BK-305 - Power-pak for handic 305, 605, 006 - \$34.95
- P handic 80 - Base Power Mike - \$49.95

Please send the free handic color catalog and name of my nearest dealer.

Name _____

Address _____

City _____

State _____

Zip _____

handic
USA Inc.



Telephone (305) 558-1522 Telex: 519139
Kennedy Building - 14560 N.W. 60th Ave.
Miami Lakes, Florida 33014 USA

Meet The Digital Group



Clockwise from top: CPU, Video Monitor, Impact Printer, Keyboard, Cassette Storage System with Four Drives

If you are seriously considering the purchase of a microcomputer system for personal or business use... or just beginning to feel the first twinges of interest in a fascinating hobby... the Digital Group is a company you should get acquainted with.

For many months now, we've been feverishly (and rather quietly) at work on our unique, high-quality product—a microcomputer system designed from the inside out to be the most comprehensive, easy-to-use and adaptable system you'll find anywhere. And our reputation has been getting around *fast*. In fact, you may have already heard a little something about us from a friend. We've found our own best salesmen are our many satisfied customers.

There's a good reason. Simply, the Digital Group has a lot to offer: state-of-the-art designs, a totally complete systems philosophy, unexcelled quality, reasonable software, affordable prices and the promise that our products will not become rapidly obsolete, even in this fast-moving, high-technology field.

The Advantages

Here are a few specific advantages of our product line:

- We offer interchangeable CPUs from different manufacturers (including the new "super chip" — the Z-80 from Zilog) which are interchangeable at the CPU card level. That way, your system won't become instantly obsolete with each new design breakthrough. The major portion of your investment in memory and I/O is protected.
- Digital Group systems are complete and fully featured, so there's no need to purchase bits and pieces from different manufacturers. We have everything you need, but almost any other equipment can be easily supported, too, thanks to the universal nature of our systems.
- Our systems are specifically designed to be easy to use. With our combination of TV, keyboard, and cassette recorder, you have a system that is quick, quiet, and inexpensive. To get going merely power on, load cassette and go!

- Design shortcuts have been avoided — all CPUs run at full maximum rated speed.
- All system components are available with our beautiful new custom cabinets. And every new product will maintain the same unmistakable Digital Group image.

The Features

Digital Group Systems — CPUs currently being delivered: Z-80 by Zilog, 8080A/9080A, 6800, 6500 by MOS Technology.

All are completely interchangeable at the CPU card level. Standard features with all systems:

- Video-based operating system
- Video/Cassette Interface Card
 - 512 character upper & lower case video interface (1024 optional)
 - 100 character/second digitally synthesized audio cassette interface
- CPU Card
 - 2K RAM, Direct Memory Access (DMA)
 - Vectored Interrupts (up to 128)
 - 256 byte 1702A bootstrap loader
 - All buffering, CPU dependencies, and housekeeping circuitry
- Input/Output Card
 - Four 8-bit parallel input ports
 - Four 8-bit parallel output ports
- Motherboard

Prices for standard systems including the above features start at \$475 for Z-80, \$425 for 8080 or 6800, \$375 for 6500.

More

Many options, peripherals, expansion capabilities and accessories are already available. They include rapid computer-controlled cassette drives for mass storage, printers, color graphics interfaces, memory, I/O, monitors, prom boards, multiple power supplies, prototyping cards and others. Software packages include BASICs, Assemblers, Disassemblers, Text Editors, games, ham radio applications, software training cassettes, system packages and more (even biorhythm).

Sounds neat — now what?

Now that you know a little about who we are and what we're doing, we need to know more about you. In order for us to get more information to you, please take a few seconds and fill in our mailing list coupon. We think you'll be pleased with what you get back.

the digital group

P.O. Box 6528
Denver, Colorado 80206
(303) 777-7133

OK, I'd like to get to know you guys better. Send me the whole package!

Name _____

Address _____

City/State/Zip _____

BY HORÁCE ENEA
AND JOHN REYKJALIN



**BREAKTHROUGH
PROJECT**

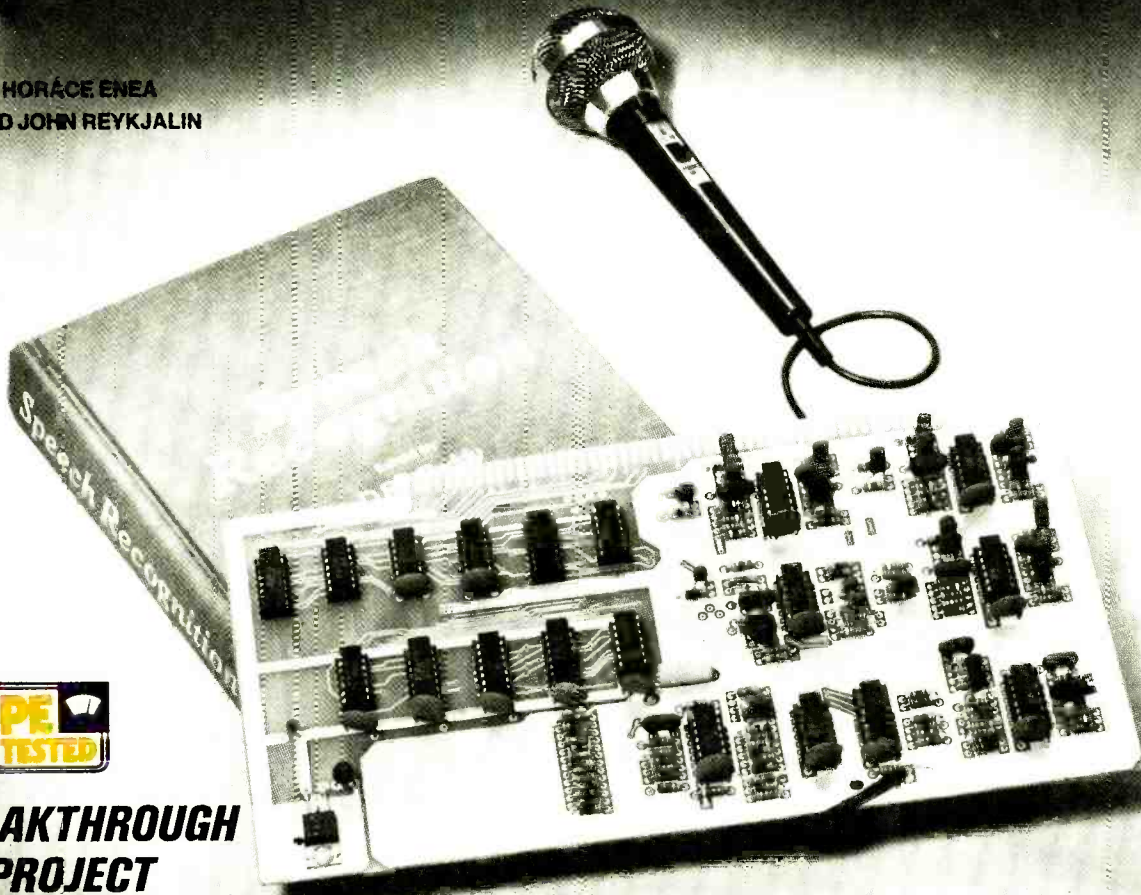

INTRODUCING **SPEECHLAB**

THE FIRST HOBBYIST VOCAL INTERFACE FOR A COMPUTER!

*Now your computer can respond to vocal commands
by the simple addition of a \$250 single-board unit.*

IMAGINE being able to *talk* to your computer and have it respond by way of a hard-copy device or by activating some external appliance! Computer hobbyists can now enjoy this facility by building "Speechlab," a new, low-cost (under \$250) computer peripheral. To use it, all one does is plug the single Speechlab pc board into an Altair-bus connector (used by many microcomputer manufacturers), enter a special program, and the computer does the rest.

It's a state-of-the-art approach at a moderate cost.

One section of the program allows the user to "train" the computer to accept a vocal input (via a microphone), analyze the spoken word, and create a digitized version that is stored in memory. The second part of the program allows the user to speak to the Speechlab and have the computer generate the output selected for that particular sound.

The vocabulary size of Speechlab is a

function of the speech recognition algorithm used and the amount of memory available. For the program used in this article, it is 64 bytes per spoken word.

The unique characteristics of Speechlab open many formerly closed doors. Since Speechlab will operate with any audio input (not necessarily a recognized language), a person who's vocally handicapped can operate almost any number of appliances (TV receiver, stereo system, solenoid-operated door,

Fig. 1. The mic input is amplified, filtered and applied to S1 along with raw audio, zero-crossing detection, and three reference voltages. Output of S1 is computer selected by switch S2 for digitizing.

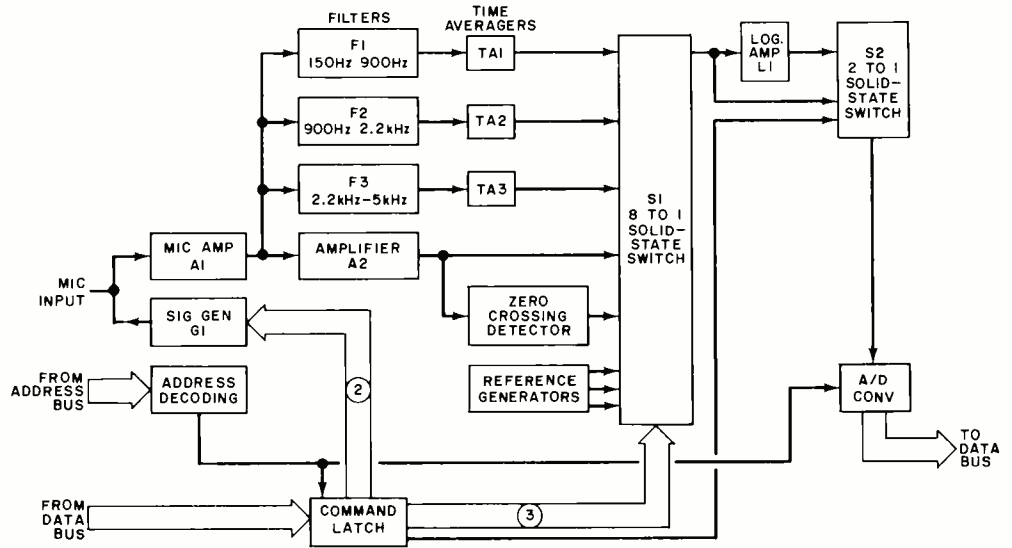

etc.) using a repeatable sound such as a grunt. One can use Speechlab, too, as a vocal processor to add spoken commands to many computer games (such as the "Star Trek" game), or enter the world of artificial intelligence and advanced programming.

Circuit Operation. The basic block diagram of Speechlab is shown in Fig. 1. The audio input is amplified by A1 and applied to three 80-db/decade rolloff band-pass filters F1, F2, and F3. These filters encompass the ranges of 150 to 900 Hz, 900 Hz to 2.2 kHz, and 2.2 kHz to 5 kHz, respectively. These ranges correspond to the frequency ranges of the first three resonances of the average human vocal tract.

Each filter is passed to a time averager (TA1, TA2, and TA3) to generate a voltage proportional to the level of the speech waveform within each band.

The amplified audio signal from A1 is further amplified by A2 to generate an unfiltered waveform that can swing ± 2 volts about a rest level of 2 volts. This signal is also applied to a zero-crossing detector that generates a voltage proportional to the number of times the speech waveform crosses the 2-volt rest level in a given period of time, thus generating a measure of the dominant frequency in the speech signal.

These five voltages—TA1, TA2, TA3, A2, and ZCD—are fed to solid-state switch S1 along with three reference voltages used for calibration and self test. A computer output command selects one of these five voltages to be passed through S1.

The selected output from S1 is passed to a second solid-state switch (S2), and to a logarithmic amplifier (L1) that emphasizes the low-level signal be-

fore being passed to S2. Switch S2 can select either the direct output from S1, or the output from L1, and pass this selected signal to a 6-bit A/D converter where the voltage is converted to a digital value. The output of the A/D converter is fed to the computer data bus.

All operations of the Speechlab are controlled through a single I/O port (address AF_{hex}). As shown in Fig. 2, six bits are used: bit-5 disables the 8-to-1 multiplexer (S1), and is used when switching between bands; bit-4 controls signal generator G1 which is used either to drive the microphone so that it acts like a miniature loudspeaker for prompting during voice input, or to drive the filters and zero-crossing detector during calibration and test; bit-3 selects either linear or logarithmic scaling of the voltage applied to the A/D converter; while bit-2, bit-1, and bit-0 select one of the eight signals from S1 for A/D conversion.

The input data word contains the 6-bit A/D output in bits 0 through 5, bit-6 is unused and is always 0, while bit-7 is the A/D converter status with a 1 corresponding to busy, and 0 corresponding to finished.

Speechlab is physically configured to occupy one slot in the Altair bus, and the complete schematic is shown in Fig. 3 through Fig. 7.

Construction. The two foil patterns (Speechlab uses one double-sided pc board) are shown half-size in Fig. 8. (Blow up to full size on film only.) Component layout is shown in Fig. 9.

All the components are mounted on one side of the board, with all the soldering done on the noncomponent side. Sockets are recommended for all IC's since most of them are MOS-types that

may be damaged by improper handling.

Integrated circuits IC1, IC4, IC7, IC8, IC9, IC15, and IC16 should be selected so they are capable of delivering a 4-volt output when using a 5-volt supply. Dual flip-flop IC14 can be from any manufacturer but Fairchild, as their truth table is somewhat different from the conventional table.

Start construction by installing the voltage regulator (IC6), all the discrete components, and the IC sockets—do not install the IC's at this time. Check the board for correct parts installation, and to make sure that there are no solder bridges between adjacent foil traces. Mount the board in an Altair bus connector, and check for the presence of 5 volts at the output of the voltage regulator and at the appropriate socket pins. Remove the board from the computer.

Install IC2 through IC5, IC10 through IC14, and IC17 through IC22. Install the board back in the Altair bus connector, and turn on the computer. Load the test

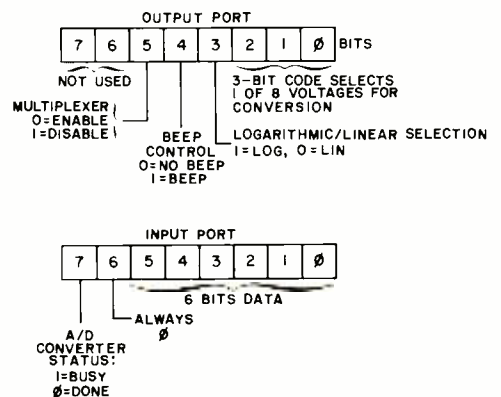

Fig. 2. Input and output port bit configuration.

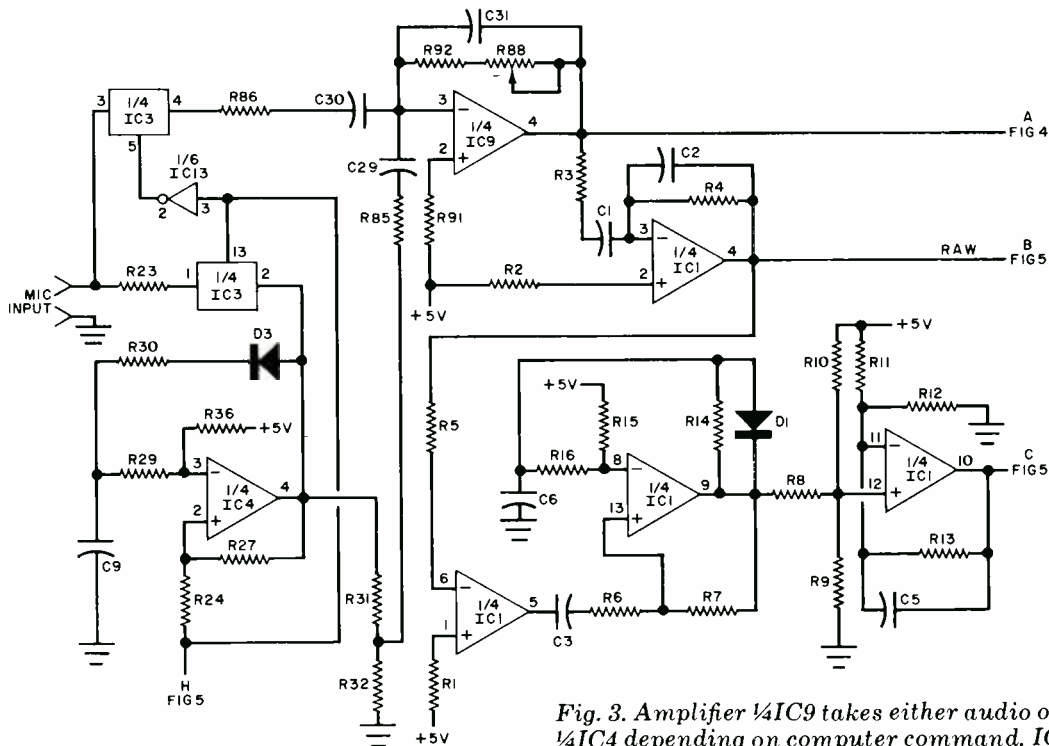

Fig. 3. Amplifier $\frac{1}{4}$ IC9 takes either audio or tone from $\frac{1}{4}$ IC4 depending on computer command. IC1 circuits are used as raw audio amplifier and zero-crossing detector.

PARTS LIST

Unless otherwise noted, the following capacitors are 10% Mylar types, and all picofarad sizes are CM05 types.

- C1, C16, C21, C43, C47, C49, C52, C57—0.0047 μ F
- C2, C31—100 pF
- C3, C17, C20—270 pF
- C4, C7, C8, C10, C12, C19, C27, C32, C33, C34, C35, C36, C37, C44, C55, C61, C62—0.1 μ F, 25-V disc
- C5, C14, C18, C24, C54, C60—0.01 μ F
- C6, C42, C45, C53, C56—240 pF
- C9, C40, C48—0.022 μ F
- C11, C29—47 pF
- C13—15 μ F, 25 V tantalum
- C15, C22, C51, C59—0.0015 μ F
- C23—0.0022 μ F
- C25, C26, C28, C38—1 μ F
- C30, C39, C46—0.047 μ F
- C41—0.1 μ F
- C50, C58—0.001 μ F
- D1, D3 through D6—1N4148 or 1N914 diode
- D2—1N746 diode
- IC1, IC4, IC7, IC8, IC9, IC15, IC16—LM3900 quad amp
- IC2—4051 8-to-1 analog multiplex
- IC3—4016 quad analog switch
- IC5—LM311 comparator
- IC6—78M05 5-volt regulator
- IC10—4024 7-stage binary counter
- IC11, IC18—74C174 D flip-flop
- IC12—4050 hex buffer
- IC13, IC22—4049 hex buffer inverter
- IC14—4013 (see text) dual-D flip-flop
- IC17—74LS30 8-input NAND gate
- IC19—8097 three-state hex buffer
- IC20—8093 three-state quad buffer
- IC21—4001 NOR gate
- MIC—Mura DX-121 dynamic microphone (part of stereo set Mura DX-242)

L1—22- μ H choke

Unless otherwise noted, the following resistors are $\frac{1}{4}$ -W, 5%

- R1—619,000 ohms, 1%
- R2—1 megohm, 1%
- R3—6810 ohms, 1%
- R4—332,000 ohms, 1%
- R5—200,000 ohms, 1%
- R6, R20, R21—30,000 ohms
- R7, R100—3 megohms
- R8, R9, R10, R12, R14, R16, R104—1 megohm
- R11—910,000 ohms
- R13—2.7 megohms
- R15, R48—10 megohms
- R17, R18—20,000 ohms
- R19, R22, R106—10,000 ohms
- R23—1000 ohms
- R24, R27—1.2 megohms
- R25, R34, R39—470,000 ohms
- R26, R38—750,000 ohms
- R28, R31—100,000 ohms
- R29—110,000 ohms
- R30—39,000 ohms
- R32—47,000 ohms
- R33, R41—68,100 ohms, 1%
- R35, R96, R102—75,000 ohms
- R36—3.9 megohms
- R37, R46—357,000 ohms, 1%
- R40, R50, R52, R54, R56, R58, R60, R61—10,000 ohms, 1%
- R42—12,100 ohms, 1%
- R43, R49—4750 ohms, 1%
- R44—4320 ohms, 1%
- R45, R47—681,000 ohms, 1%
- R51, R53, R55, R57, R59—4990 ohms, 1%
- R62—274,000 ohms, 1%
- R63—7500 ohms
- R64, R66, R72, R75—160,000 ohms
- R65, R71—12,000 ohms

R67, R70—300,000 ohms

- R68—931,000 ohms, 1%
 - R69—2 megohms
 - R73—620,000 ohms
 - R74, R76, R90, R92—62,000 ohms
 - R77—15,000 ohms
 - R78, R83, R84—147,000 ohms, 1%
 - R79, R80, R87—51,100 ohms, 1%
 - R81, R82, R89—174,000 ohms, 1%
 - R85—330,000 ohms
 - R86—680 ohms
 - R88—100,000-ohm pc trimmer potentiometer
 - R91—270,000 ohms
 - R93—249,000 ohms, 1%
 - R94—4300 ohms
 - R95, R97, R103, R105—360,000 ohms
 - R98, R101—820,000 ohms
 - R99—845,000 ohms, 1%
 - R107—158,000 ohms, 1%
 - R108—4700 ohms
 - R109, R111, R117, R119—82,000 ohms
 - R110, R116—5100 ohms
 - R112, R115—180,000 ohms
 - R113—549,000 ohms, 1%
 - R114—1.6 megohms
 - R118—510,000 ohms
 - R120—6800 ohms
 - R121—2000 ohms
- Misc.—Sockets (one 8-pin, thirteen 14-pin, seven 16-pin), regulator mounting hardware, tie-wrap etc.
- Note 1: The following is available from Heuristics Inc., 900 N. San Antonio Rd. (Suite C-1), Los Altos CA 94022 (Tele: 415-948-2542): complete kit of all parts including pc board, sockets, microphone, hardware manual, and 200-page lab manual, SpeechBasic, and assembly language programs at \$249. (California residents please add 6½% sales tax.)

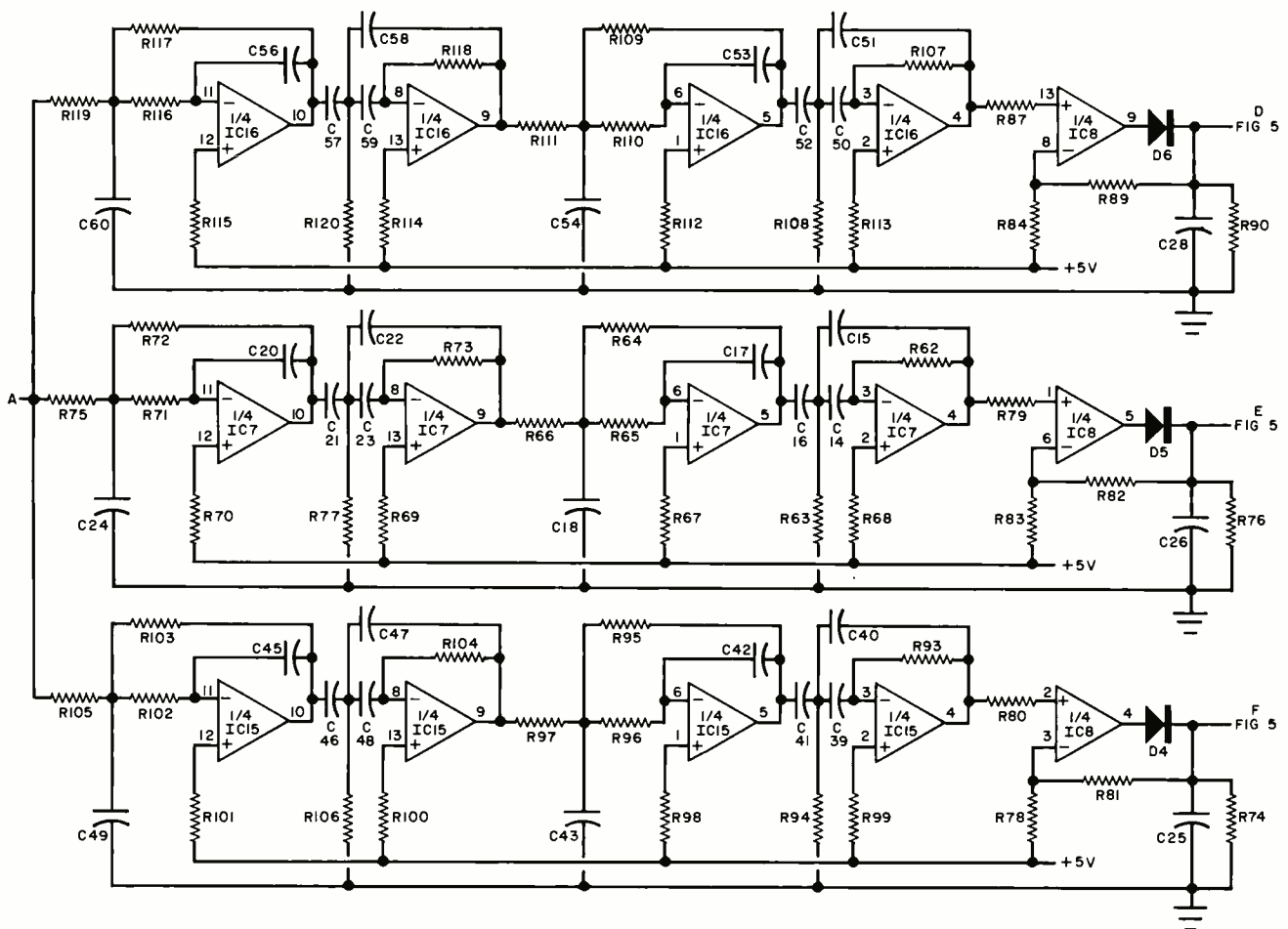

Fig. 4. Three bandpass filters and their associated time averagers. They encompass three ranges corresponding to frequency ranges of the first three resonances of an average human vocal tract.

program of Table I at 100 (hex). **NOTE:** all program data in this article is in hex.

You must jump to your monitor routine at address 0164-0165. Load address 195 with 05 and run the program. This will input the fixed reference voltage levels to the A/D converter and check the signal paths from switch S1 to the computer data bus.

After running this program, examine locations 200 through 20F, 300 through 30F, and 400 through 40F. Location 200 through 20F should contain 12 ± 4 , 300 through 30F should contain 24 ± 4 , and 400 through 40F should contain 36 ± 4 .

Insert the remaining IC's in their sockets, load location 195 with 10, and run the test program (Table I). This test uses the signal generator (G1) to create an input for the filters, amplifiers, and zero-crossing detector, and thereby checks the remaining signal paths on the board and calibrates the microphone preamplifier. After running the program, examine locations 200 to 20F to see if it contains 16 to 18. If not, adjust potentiometer R88 and rerun the program until these outputs occur.

Calibration and Test Program.

The test program (Table I) is a general-purpose calibration, test, and diagnostic program for the Speechlab. It loads at location 100 and requires memory from 100 to 600 for program and data areas. Locations 163-165 should be loaded

with a jump to your monitor address so that the program will return control to your monitor after execution. If you do not have a monitor, place a halt at this location.

The program collects four 256-byte buffers of data from four of the eight pos-

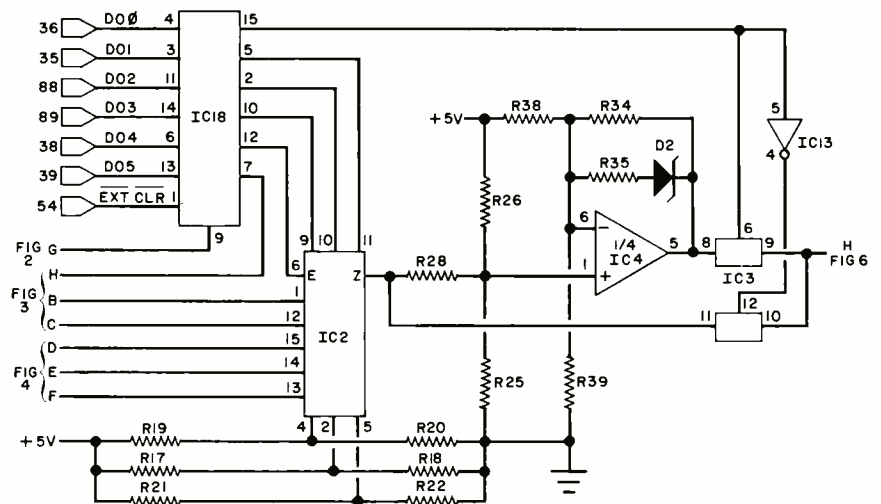

Fig. 5. Command latch (IC18) can activate tone generator and switch S1 (IC2). Op amp (1/4 IC4) is logarithmic amplifier.

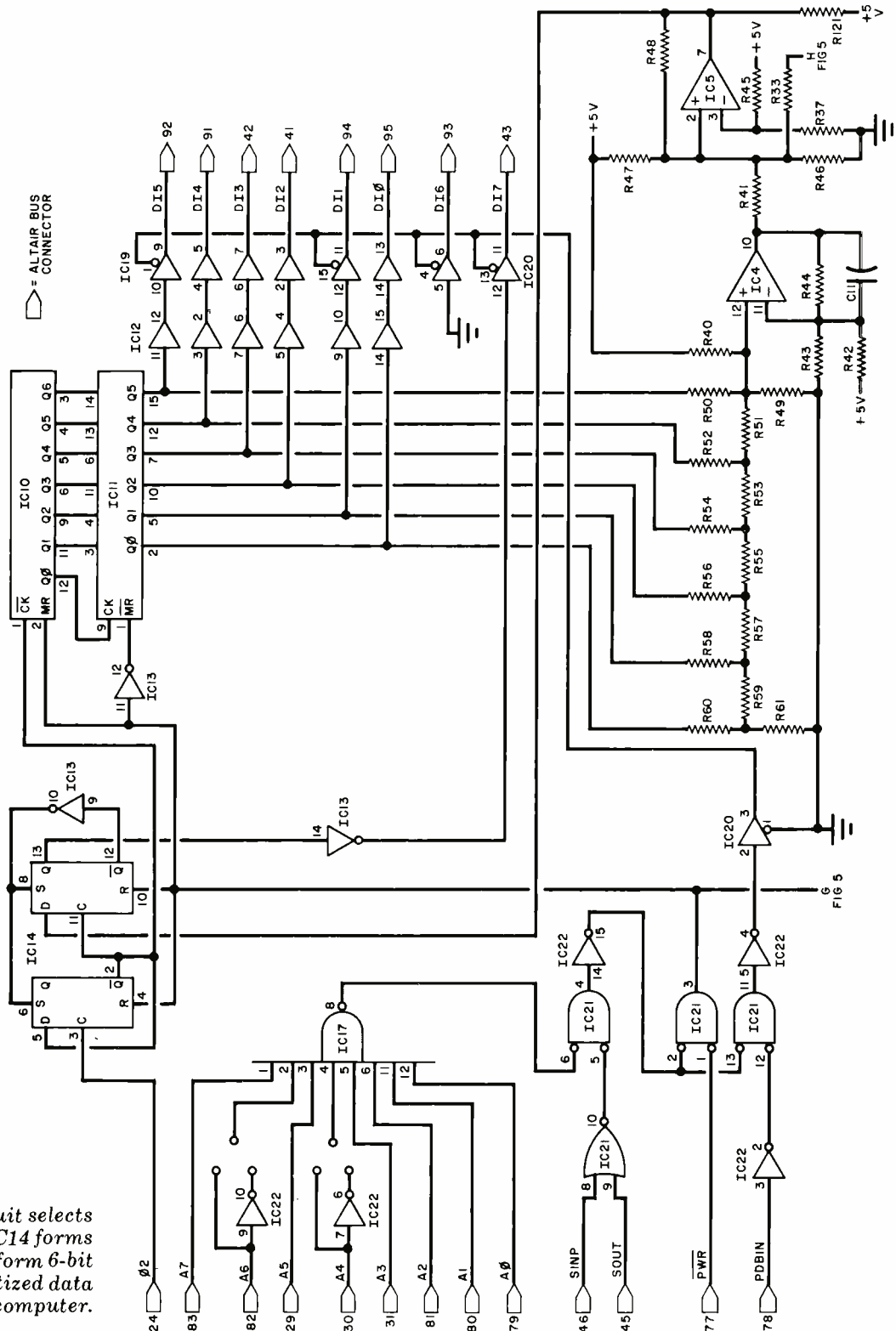

Fig. 6. IC17 circuit selects board address and IC14 forms S2. IC10 and IC11 form 6-bit A/D converter. Digitized data is then passed to computer.

sible inputs to the A/D converter. The first of the four bands is specified by the Test Command word, which also specifies beeper on/off and linear or logarithmic scaling. The next three bands are 1, 2, and 3 greater than specified by the Test Command word. Each band is sampled every five milliseconds until 256 samples have been collected from

each of the four bands. Data from the first band is stored in 200 to 2FF, the second band from 300 to 3FF, the third from 400 to 4FF, and the fourth from 500 to 5FF.

For example, if the Test Command word is set to 00, after the test program is run, the four data areas will contain numbers representing the outputs of

band-0 (low frequency), band-1 (mid frequency), band-2 (high frequency), and band-3 (zero-crossing detector). Anything that was spoken into the microphone while the program was running, is filtered, converted into a binary number, and stored in the data areas.

If the Test Command word is set to 05, the first three data areas will contain

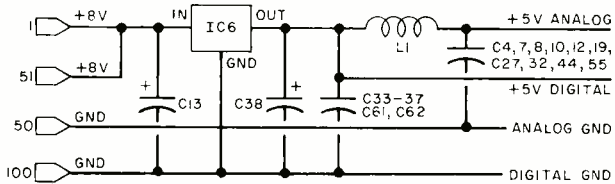

Fig. 7. Power supply circuit is conventional. Note bypass capacitors that are actually mounted between IC power supply pins and ground.

constant numbers corresponding to the three reference voltage levels to the A/D converter on band 5, 6, and 7. This is useful for checking the A/D converter operation and isolating problem areas to one side or the other of the 8-to-1 analog switch S1.

If the Test Command word is set to 10, signal generator G1 is enabled which begins to "beep" the microphone and connects the signal-generator output into the microphone preamplifier A1. The four data areas contain data from bands 0, 1, 2, and 3 as when the Test Command word was 00, but the input signal comes from the signal generator rather than from the microphone. This allows calibration of the microphone preamplifier and isolates problems in one of the filter-averager chains.

Adding bit-3 to the command word will cause logarithmic rather than linear data scaling and will isolate problems to the log amplifier or either of the two analog switches comprising S2, the 2-to-1 analog switch.

Various combinations of bits in the Test Command word will allow quick calibration and fault isolation, and also provide a quick way to look at raw data from any input through the microphone.

Software. A simple technique for speech recognition of the digits zero through nine with a recognition rate of 90% or better, is shown in the flowchart of Fig. 10. An 8080 program for this algorithm is shown in Table II. The program starts at memory location 0100 and requires less than 4K bytes of storage including table space.

There are two modes of operation—training and performance. During training, speech examples of the digits are read into the microphone and the parameters of the speech input are extracted and placed in the tables. In the performance mode, an unknown utterance is presented and recognized.

To use the program, enter it into the computer starting at location 0100, and then run the program. The Teletype will respond with "T" (train) or "P" (perform). Type a "T" and the Teletype will respond with "NUMBER?" which can be between 0 and F. Type the digit you desire, and the microphone will emit a "beep" indicating that the speech window is open. When this beep occurs, vocalize the same digit you just typed in. The microphone will beep again to indicate that the speech window is now closed. The machine will then type T or

TABLE I

0100		ORG 100H
0100 =		START EQU 100H
0100 210002		LXI H, START+100H
0103 228D01		SHLD TEMP1
0106 210003		LXI H, START+200H
0109 228F01		SHLD TEMP2
010C 210004		LXI H, START+300H
010F 229101		SHLD TEMP3
0112 210005		LXI H, START+400H
0115 229301		SHLD TEMP4
0118 3A9501	GO	LDA COMAND
011B CD6601		CALL INPUT
011E 2A8D01		LHLD TEMP1
0121 77		MOV M/A
0122 2C		INR L
0123 228D01		SHLD TEMP1
0126 3A9501		LDA COMAND
0129 C601		ADI 1
012B CD6601		CALL INPUT
012E 2A8F01		LHLD TEMP2
0131 77		MOV M/A
0132 2C		INR L
0133 228F01		SHLD TEMP2
0136 3A9501		LDA COMAND
0139 C402		ADI 2
013B CD6601		CALL INPUT
013E 2A9101		LHLD TEMP3
0141 77		MOV M/A
0142 2C		INR L
0143 229101		SHLD TEMP3
0146 3A9501		LDA COMAND
0149 C403		ADI 3
014B CD6601		CALL INPUT
014E 2A9301		LHLD TEMP4
0151 77		MOV M/A
0152 2C		INR L
0153 229301		SHLD TEMP4
0156 CA5F01		JZ STOP
0159 CD7701		CALL DELAY
015C C31801		JMP GO
015F 3E00	STOP	HUI A/D
0161 D3AF		OUT OAH
0163 C3XXX		JMP SYSTEM
0166 F620	INPUT	ORI 20H
0168 D3AF		OUT OAFH
016A E6DF		ANI ODFF
016C D3AF		OUT OAFH
016E DBAF	LOOP	IN OAFH
0170 17		RAL
0171 DA6E01		JC LOOP
0174 DBAF		IN OAFH
0176 C9		RET
0177 C5	DELAY	PUSH B
0178 3E05		MVI A,5
017A FE00	DELO	CPI 0
017C CABB01		JZ REYDEL
017F 0669	DEL1	MVI B,69H
0181 00		HOP
0182 00		HOP
0183 05		DCR B
0184 C2B101		JNZ DEL1
0187 3D		DCR A
0188 C37A01		JMP DELO
018B C1	REYDEL	POP B
018C C9		RET
C000 =		SYSTEM EQU OC000H
018D		TEMP1 DS 2
018F		TEMP2 DS 2
0191		TEMP3 DS 2
0193		TEMP4 DS 2
0195 YY		COMAND EQU *
0100 21 00 02 22 BD 01 21 00 03 22 8F 01 21 00 04 22		
0110 91 01 21 00 05 22 93 01 3A 95 01 CD 66 01 2A BD		
0120 01 77 2C 22 8D 01 3A 95 01 C6 01 CD 66 01 2A BF		
0130 01 77 2C 22 8F 01 3A 95 01 C6 02 CD 66 01 2A 91		
0140 01 77 2C 22 91 01 3A 95 01 C6 03 CD 66 01 2A 93		
0150 01 77 2C 22 93 01 CA 5F 01 CD 77 01 C3 18 01 3E		
0160 00 D3 AF C3 53 00 F6 20 D3 AF E6 DF D3 AF DB AF		
0170 17 DA 6E 01 DB AF C9 C5 3E 05 FE 00 CA BB 01 06		
0180 69 00 00 05 C2 81 01 3D C3 7A 01 C1 C9 9B F7 F0		
0190 FE 57 DC 49 E2 A6		

"HANDS ON" EXPERIENCE WITH A TALKING COMPUTER

BY LESLIE SOLOMON, Technical Editor

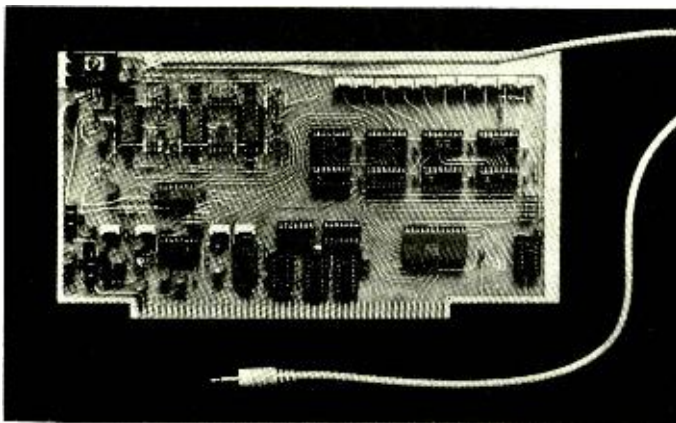

While testing the Speechlab, we borrowed an AI Cybernetic Systems (Box 4691, University Park, NM 88003) Model-1000 Speech Synthesizer (\$325, assembled) to see if our microcomputer could "talk" as well as "hear." The Model 1000 is designed to fit into one slot of an Altair bus and delivers its output via an audio cable that can be plugged into any audio amplifier system. The output level is 0.6 volt p-p; impedance is 1000 ohms; and frequency range is 150 to 4500 Hz.

This synthesizer is phoneme-oriented. Accordingly, you can program it to say anything, as opposed to speech synthesizers that have only several words fixed in ROM. Essentially, the Model 1000 is a hardwired analog of the human vocal tract and various portions of the circuit emulate the vocal cords, the lungs, and the variable-frequency resonant acoustic cavity of the mouth, tongue, lips and teeth.

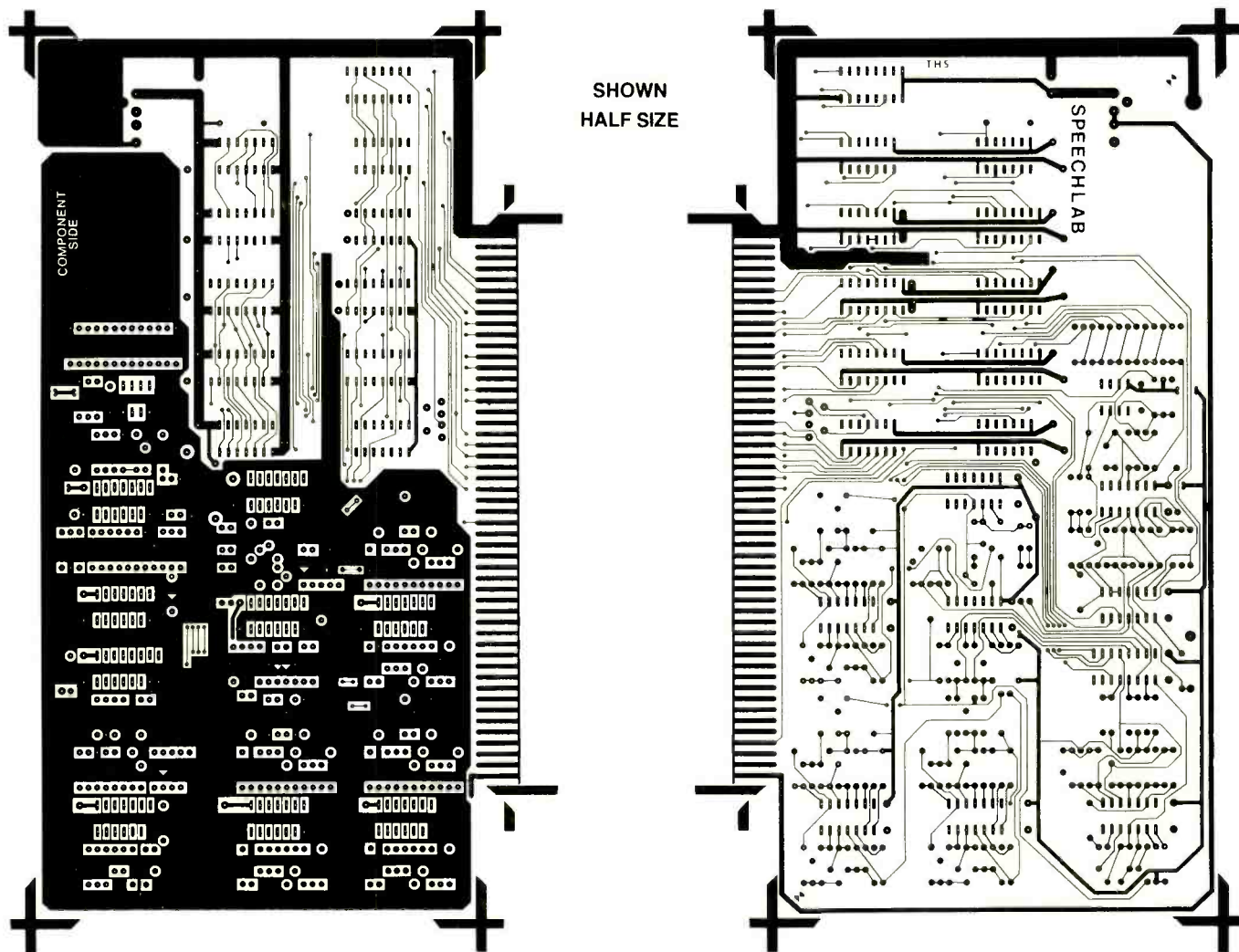

Fig. 8. Etching and drilling guides for pc board are shown half size. Guide at left is the component side. Component layout is in Fig. 9.

P again. You answer with a T, and the process is continued as long as you want. Do not exceed 16 entries with this sample program.

Once you have some vocalized digits in memory, run the program again. This time, when the Teletype asks T or P, answer with a P (for perform). Now, as you

speak the digits into the microphone, the Teletype will respond by typing that digit. When used in a quiet room, with the same vocalization, this algorithm can be

All the information necessary to perform the synthesis functions are located within a ROM that is accessed by the program. Words and sentences are formed by supplying a string of ASCII characters as would be done when outputting to any port, except that these strings also use some non-alphanumeric characters (i.e., the "+" is used to form "th" as in "thaw" or "earth"). Each ASCII character represents a particular phonetic sound or phoneme. If desired, you can create a program that produces simultaneous printout and "voiceout" of the same string.

The device requires very little software to implement: less than 50 bytes of assembly language or a handful of BASIC statements. The manual accompanying the synthesizer covers speech generation in detail, how it is created, and what is involved. It also illustrates how to "mechanize" speech, with several examples shown.

After working with the synthesizer for a couple of weeks, we

found that we have a lot to learn about how humans create speech. After many hours of studying, experimenting, and re-doing programs, we made the Model-1000 utter some recognizable sentences. It is not easy, our experience showed, even when one uses the wealth of instructions provided.

Working with a phoneme-oriented speech synthesizer is a little like learning to use a microprocessor. All the logic is there, but programming it properly is another story. Like working with a processor for the first time, one must crawl frustratingly before walking. Slowly, however, the ideas start to percolate. Our computer still talks with a rather heavy "robotic" accent, but we have hopes that someday it will "humanize."

To paraphrase Sam Johnson: "Sir, a computer talking is like a dog walking on its hind legs. It is not done well; but you are surprised to find it done at all." We have a long road ahead to the "HAL-9000," but the first step has been taken.

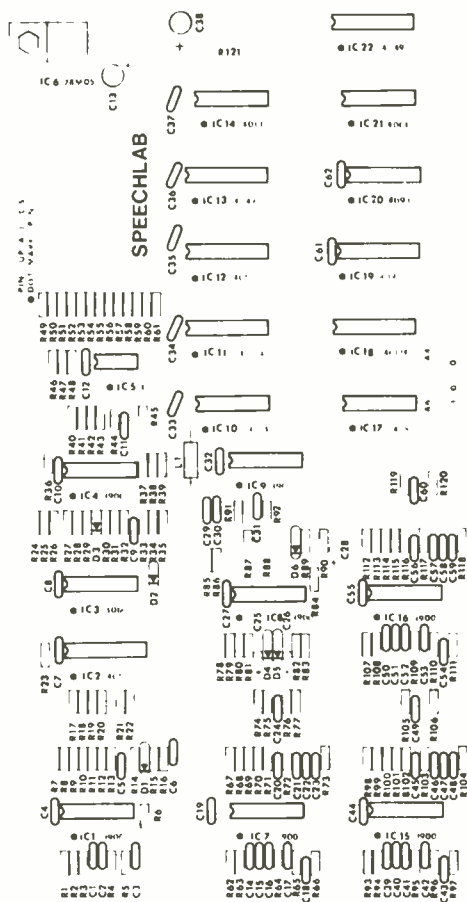

Fig. 9. Component layout for the Speechlab. See etching and drilling guide on previous page.

expected to have a recognition rate greater than 90%.

The program works as follows: the sampling subroutine is entered to obtain a sample of the amplitude every 10 milliseconds in each of the three frequency bands and to estimate the number of zero crossings during each time period. One hundred and fifty samples are collected, allowing up to 1.5 seconds of speech (between microphone "beeps"). A preset threshold is used to find the beginning and end of the word. The duration of the word can now be computed by a simple subtraction. Typically, this duration will be about 400-milliseconds for the digits. The duration time is divided by 16 to select 16 evenly spaced parameters from the three bands and zero-crossing information.

The 64 bytes obtained (16 parameters from each of the four bands) are compared with similar parameters which were collected during the training mode. A summation (running total) of the difference between the 64 parameters of the sample and the parameters of the training "templates" is computed. The totals represent a measure of the difference between the sample and each of the previously stored templates. The tem-

TABLE II

0100	31	20	10	CD	5B	R3	21	35	AP	CD	3A	03	CD	8F	03	FF
0110	54	72	1A	01	CD	33	01	C3	00	01	FE	50	C2	2B	01	CD
0120	58	03	CD	79	01	CD	01	03	C3	00	P1	3E	3F	CD	7E	03
0130	C3	00	01	F5	C5	D5	F5	CD	5B	03	21	3D	08	CD	3A	03
0140	CD	DA	03	32	6E	04	3C	47	3A	6D	04	B8	DA	2B	01	CD
0150	5D	03	CD	A3	02	CD	99	01	D0	07	04	3A	6E	04	4F	16
0160	48	CD	F7	02	11	13	07	CD	A3	03	68	69	0E	40	11	CD
0170	06	CD	0C	01	E1	D1	C1	F1	C9	C5	D5	E5	CD	A3	02	CD
0180	99	01	CD	07	04	CD	3D	02	F1	D1	C1	C9	F5	FP	7E	23
0190	E0	77	23	0D	C2	0D	01	F1	C9	0F	00	21	6F	04	CD	F9
01A0	03	FF	06	D2	R2	01	79	FF	96	C2	9F	P1	21	44	PR	C3
01B0	9D	02	79	1D	32	08	07	47	CD	F4	03	FE	06	DA	CC	01
01C0	79	FE	96	C2	B8	P1	21	4E	0B	C3	9D	02	79	3D	3D	12
01D0	09	07	00	3C	12	C7	0A	FF	0A	DA	A6	01	0E	01	CD	F9
01E0	03	FF	06	D2	ED	01	79	FE	0A	C2	DE	01	C9	3A	C7	06
01F0	01	4F	3A	0A	07	01	4F	C3	08	01	21	FF	FF	22	13	00
0200	3E	00	32	6E	04	3A	6D	04	3D	4F	06	00	C5	79	07	4F
0210	21	15	0B	09	46	23	4E	21	13	00	56	23	5E	CD	B7	01
0220	DA	2B	02	C1	0D	FA	39	02	C3	0C	02	21	13	00	70	21
0230	71	C1	79	32	6E	04	C3	24	02	3A	6E	04	C9	CD	64	02
0240	06	00	48	16	40	1E	00	5F	21	13	07	CD	D5	03	CD	75
0250	02	1C	78	FE	3F	C2	48	02	04	3A	6D	04	B8	C2	42	02
0260	CD	FA	01	C9	3A	6D	04	07	4F	3F	00	21	15	0B	77	21
0270	0D	C2	6F	01	79	F5	C5	F5	21	C6	B6	16	00	19	94	
0280	F2	05	02	2F	1C	57	78	07	21	15	00	4F	06	00	09	21
0290	7A	86	77	D2	98	02	29	34	F1	C1	D1	E1	C9	CD	3A	03
02A0	C3	00	01	3E	FA	CD	E3	02	CD	40	03	3E	64	CD	E3	02
02B0	21	6F	04	1F	96	16	00	7A	FE	04	CA	C6	P2	CD	D3	02
02C0	77	23	14	C3	B7	D2	3E	0A	CD	F3	02	1D	C2	B5	02	CD
02D0	4B	03	C9	F6	20	D3	AF	E6	DF	D3	AF	DB	AF	17	DA	DP
02E0	02	1F	C9	C5	FF	00	CA	F5	02	06	69	00	00	P5	C2	EP
02F0	02	3D	C3	E4	02	C1	C9	F5	D5	06	0E	1E	09	79	1F	4F
0300	1D	CA	0E	03	74	D2	39	01	02	1E	47	C1	FE	P2	D1	F1
0310	C9	F5	D5	1F	09	78	47	79	17	4F	1D	CA	2F	P3	78	17
0320	D2	27	01	92	C1	16	04	92	D2	16	01	02	C1	16	03	17
0330	5F	3E	FF	A9	4F	7B	1F	D1	F1	C9	7E	FF	00	CA	47	01
0340	CD	70	03	23	C3	1A	03	CD	5B	03	C9	F5	3E	10	D1	AF
0350	3E	64	CD	F3	02	3E	00	D1	AF	F1	C9	F5	3E	10	CD	70
0360	03	3E	0A	CD	70	03	3E	00	CD	70	03	3E	00	P3	F1	C9
0370	F5	DB	08	07	D2	71	03	F1	E3	01	C4	00	00	00	00	00
0380	00	F6	0F	C6	30	FF	3A	DA	70	03	C6	07	C3	70	03	DB
0390	00	66	40	CA	01	00	01	E6	7E	1	70	01	00	00	00	00
03A0	00	00	00	00	00	00	00	00	00	00	00	00	00	00	00	00
03B0	F1	C9	32	0A	07	78	0A	CA	BE	03	3A	0A	27	C9	70	00
03C0	3A	2A	07	79	F5	C5	10	F7	02	C4	08	AF	D2	D1	01	00
03D0	24	D1	C1	F1	C9	CD	C4	01	7E	7	CD	0F	01	E6	7E	FF
03E0	3D	20	01	FF	1A	DA	F6	03	FE	41	DA	2B	C1	FF	47	
03F0	3F	DA	20	01	F6	07	D6	30	C9	AF	C5	06	03	86	21	05
0400	C2	FD	03	C1	23	0E	09	21	08	26	22	00	07	3A	C7	06
0410	4F	16	05	7D	F7	02	16	17	1D	11	F1	16	00	69	2	11
0420	07	21	00	00	12	0F	07	1E	13	05	2A	0F	07	44	4D	16
0430	0A	CD	11	03	06	00	3A	06	07	5F	16	00	0D	A1	03	16
0440	04	D7	02	21	6F	04	09	54	5D	2A	00	07	0E	P4	CD	
0450	0C	01	22	00	07	2A	0F	27	44	4D	2A	11	07	54	5D	CD
0460	A3	01	60	69	22	0F	07	D1	1D	C2	29	04	C9	10	CD	FF
0030	DA	0C	FF	02	54	20	4F	52	28	50	3F	00	4F	55	4D	
0040	42	45	52	0F	4E	4F	53	50	45	45	43	00	4F	55	4D	
0050	54	20	4F	46	20	57	49	4F	44	4F	57	00	00	32	5C	00

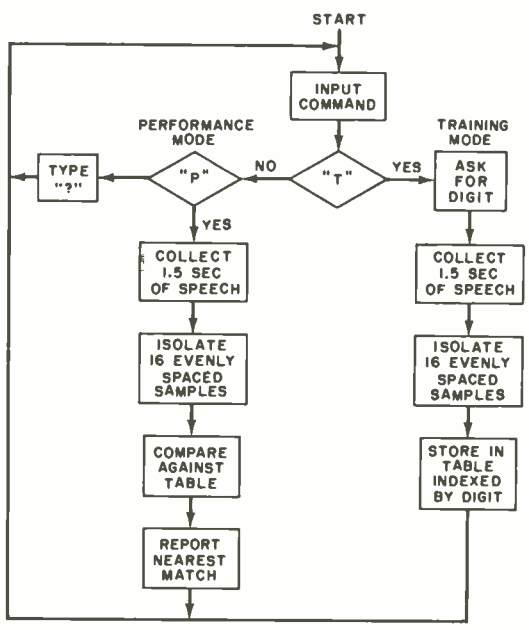
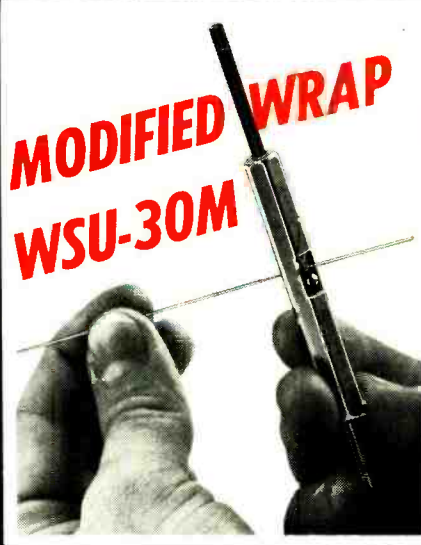

Fig. 10. Flow chart of a simple program that is used to "T" (train) and "P" (perform) a vocal operation. The program is shown in Table II.

plate with the smallest difference from the sample is then selected as the answer (output).

The above algorithm, while relatively simple, illustrates many of the basic concepts of speech recognition. A manual supplied with the Speechlab kit contains descriptions of other approaches to speech recognition, along with sample programs to demonstrate the techniques of speech recognition. ◇

HOBBY-WRAP WIRE-WRAPPING, STRIPPING, UNWRAPPING TOOL FOR AWG 30 (.025 SQUARE POST)



STRIP



WRAP



UNWRAP

REGULAR WRAP

PART No. WSU-30

TYPES OF WRAP

■ A "Regular" bit wraps the bare wire around the terminal. A "Modified" bit wraps a portion of insulation around the terminal in addition to the bare wire. This greatly increases the ability to withstand vibration.

MODIFIED WRAP

PART No. WSU-30M

HOBBY-WRAP WIRE-WRAPPING, STRIPPING, UNWRAPPING TOOL FOR AWG 30 (.025 SQUARE POST)

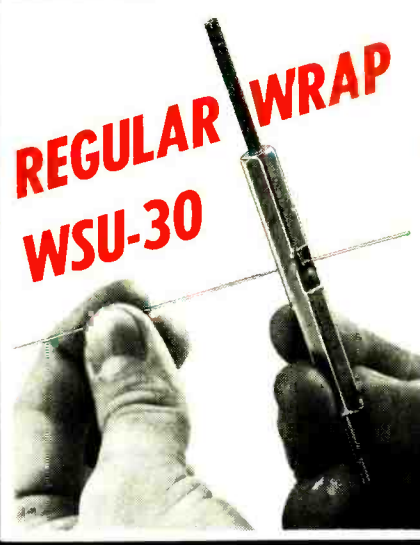

STRIP



WRAP

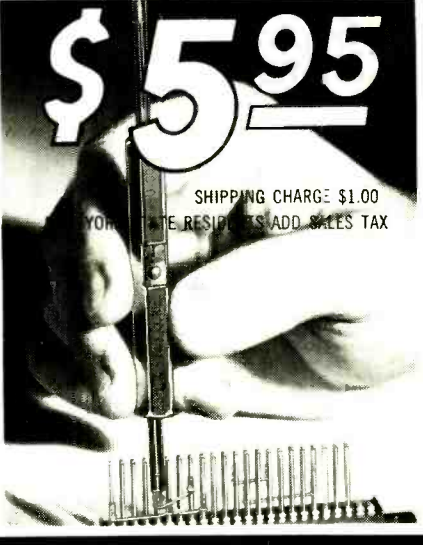

UNWRAP

OK MACHINE & TOOL CORPORATION

3455 CORNER STREET, BPOX, NEW YORK, N.Y. 10475 U.S.A. • PHONE: (312) 894-6600
TELEX: 25091 TELEX: 232395

MOST \$600 RECEIVERS SOUND AS GOOD AS THIS ONE.



UNFORTUNATELY FOR THEM, THIS ONE SELLS FOR UNDER \$300.*

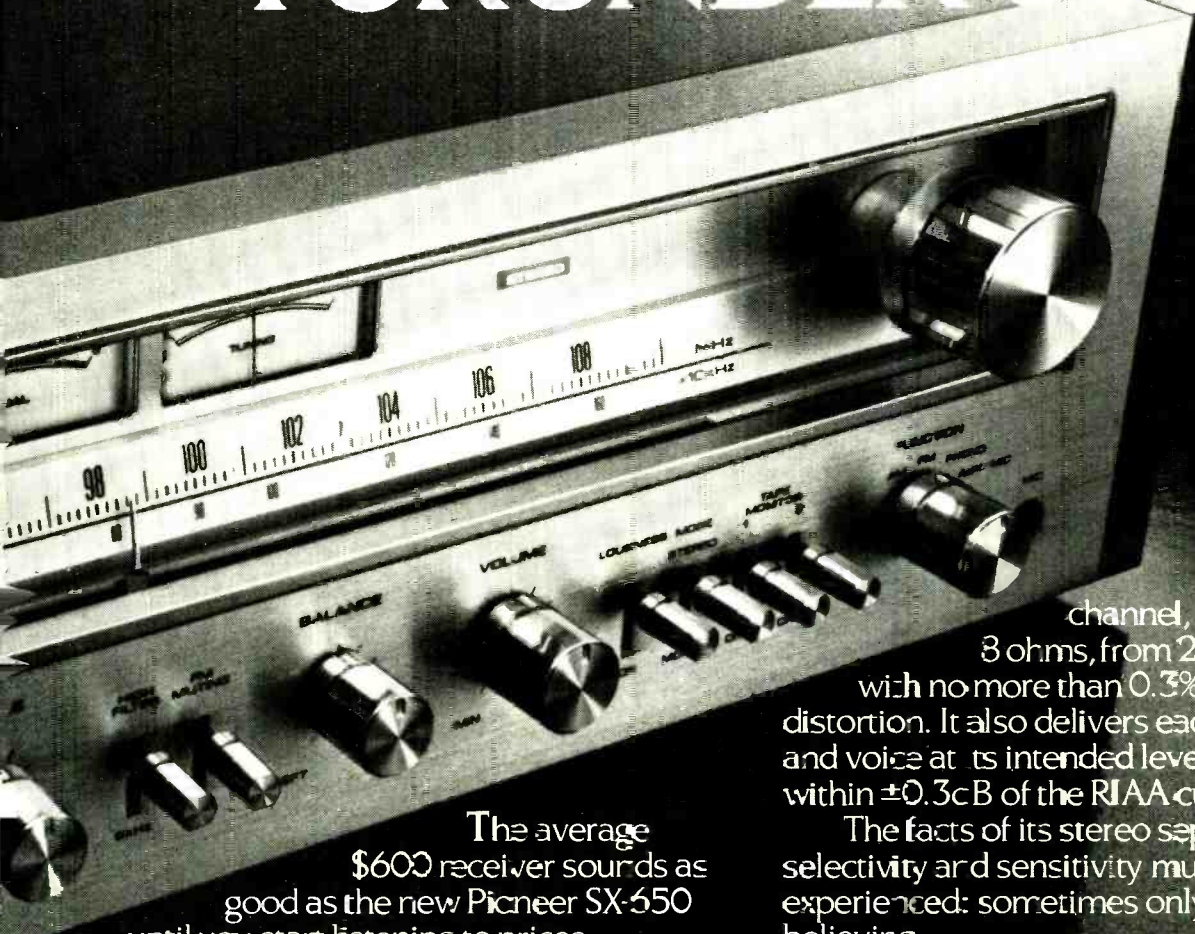

The average \$600 receiver sounds as good as the new Pioneer SX-650 until you start listening to prices.

If \$600 is your kind of price, an SX-650 should qualify as your kind of receiver. Not only will it give you the kind of features and sound quality you'd expect for that kind of money; it'll also leave you with roughly half your receiver budget unexpectedly unspent.

But suppose your idea of a receiver price is somewhere under \$300*. The SX-650 will sound better to you than anything you thought you could afford. Because it has more power, a wider frequency range, less distortion, and far greater versatility than most other receivers in that category.

It's a fact that the SX-650 provides a continuous power output of 35 watts per

channel, min. RMS into 8 ohms, from 20 to 20,000 Hz, with no more than 0.3% total harmonic distortion. It also delivers each instrument and voice at its intended level, balanced within ± 0.3 dB of the RIAA curve.

The facts of its stereo separation, selectivity and sensitivity must really be experienced: sometimes only hearing is believing.

You'll also be impressed by what you don't hear from the SX-650. You won't hear the thousand miscellaneous acoustic devils that live in the limbo between FM stations on lesser receivers.

On your next visit to a high fidelity dealer, listen to a Pioneer SX-650 with any reasonably accurate speakers.

You'll find either its price or its performance amazing. Depending on which you hear first.

PIONEER®

U.S. Pioneer Electronics Corp., 75 Oxford Drive, Moonachie, New Jersey 07074.
*The value shown in this ad is for informational purposes only. Actual resale prices will be set by the individual Pioneer dealer at his option.

CIRCLE NO. 65 ON FREE INFORMATION CARD

POWER.

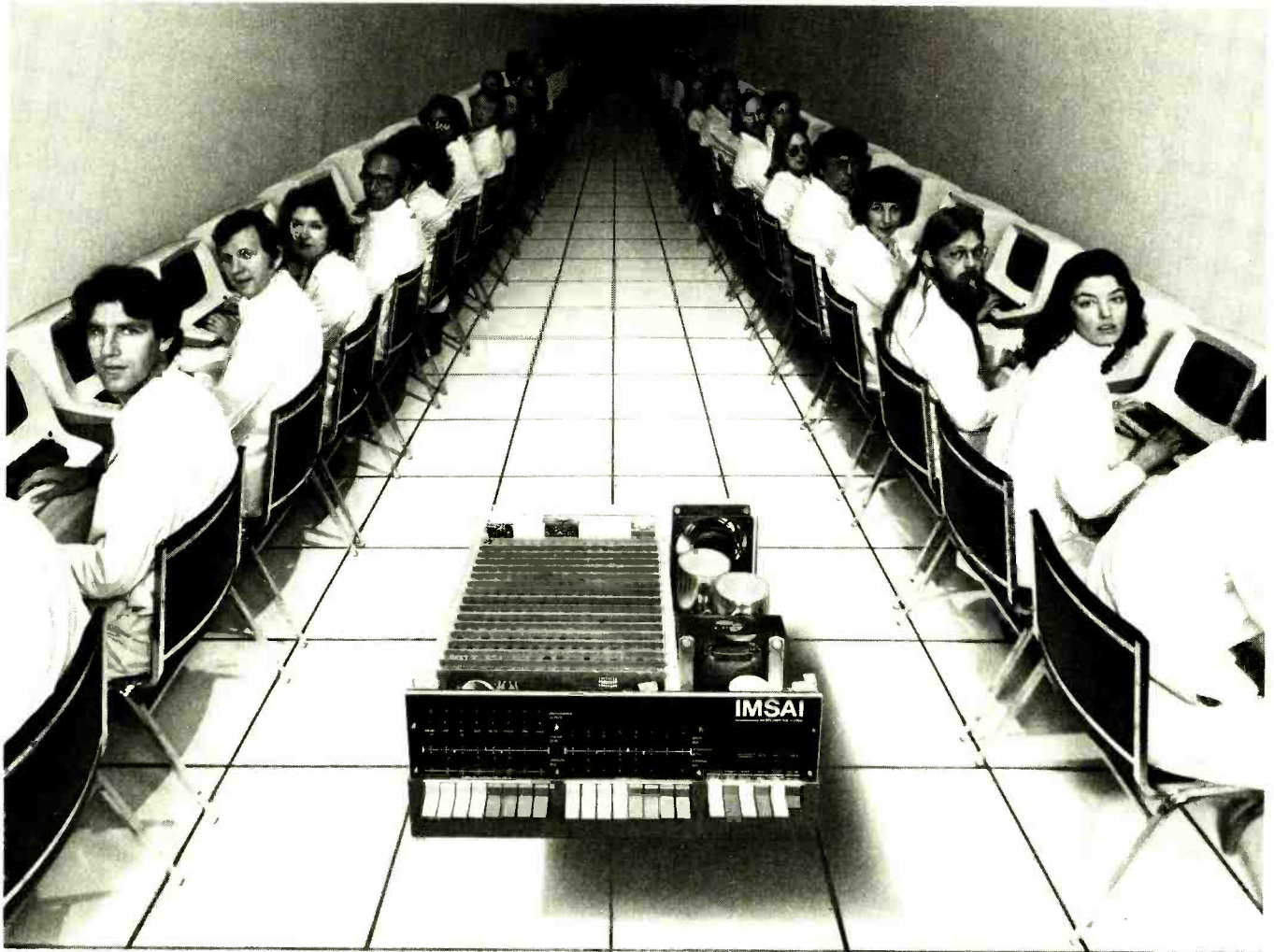

IMSAI Introduces the Megabyte Micro.™

The Megabyte Memory

Until today, the largest memory you could fit and address in a single microcomputer CPU was 65K.

Now, IMSAI presents an incredible memory system for micros 16 times more powerful than yesterday's best.

Imagine, a full megabyte of power from sixteen 65K RAM boards.

And, to control all this, the IMSAI Intelligent Memory Manager (IMM), the super control board.

You can write protect blocks throughout the full megabyte. Or, map in 16K blocks.

Plus, preset 16 mapping configurations with protect for high speed transfer or rapid change.

All interrupts are fully vectored, and there's an interrupt if an attempt is made to write into protected memory.

There's even a real "time of day" clock.

65K, 32K and 16K RAM Boards

Until today, the most memory you could plug into a single slot was 16K.

Now, IMSAI presents memory boards in astonishing multiples of sixteen: 65K, 32K and 16K low power, dynamic RAM Boards. They can be used in any S-100 bus computer individually or in combination to form conventional systems up to 65K bytes.

Every board is fast. With "hidden refresh" and *no* "wait state."

The Complete Megabyte Microcomputer System

The IMSAI Megabyte Micro™ is only part of the story. The full system can include dual floppy disks, terminals, plotters, printers and tape cassettes.

IMSAI also offers the finest high level and peripheral software available. Paper tape and Tape Cassette I/O and super Disk Operating Systems. Plus, BASIC and Disk BASIC with more high level languages coming.

Until today, the microcomputer's potential was just something you talked about.

Now, you can put it to work. Powerfully.

CIRCLE NO. 30 ON FREE INFORMATION CARD

GENTLEMEN:

I'm power hungry!

- Send 65K RAM Board Kit \$2599 Assembled \$3899
 Send 32K RAM Board Kit \$749 Assembled \$1099
 Send 16K RAM Board Kit \$449 Assembled \$679
 Send IMM ROM Control Kit \$299 Assembled \$399
 Send IMM FROM Control Kit \$499 Assembled \$699
 Send full catalog \$1.00

Check/MO enclosed. Amt. \$
Charge my: BAC M/C

Exp. Date: _____

Sig. _____

Send name of my nearest IMSAI dealer

Name _____

Company _____ Title _____

Address _____

City _____

State/Zip _____

IMSAI®

IMSAI Manufacturing Corporation
14860 Wicks Blvd.
San Leandro, CA 94577
(415) 483-2093 TWX 910-366-7287

NEW NO-CAMERA PRINTED CIRCUIT BOARD METHODS

*How to use GC Calectro and Datak kits
for making pc boards directly from printed matter.*

BY A. A. MANGIERI

YOU CAN now copy pc etching and drilling guides directly from the printed page without using a camera or laying out an artwork master. Two pc kits that can accomplish this dream feat for the electronics hobbyist are now on the market. One of these kits is called "Lift-It" from GC Electronics; the other is Datak's No. ER-4 kit.

The two direct-copy pc kits use different approaches to achieve essentially the same end. The Lift-It technique actually lifts the printed pattern from the page with a paint-on transparent film that has an affinity for the printing ink. The ER-4 technique uses a no-camera photographic process to duplicate or reverse a printed image or a positive or negative transparency, depending on how the copy film is exposed. Either copy method will greatly speed up the artwork portion of a construction project in which a pc board is used.

Kit Lineups. The Calectro No. J4-828

Lift-It kit from GC contains seven chemicals in bottles and cans, three trays, and pc contact film. The chemical lineup includes the paint-on Lift-It film solution around which the kit is built, board-stripping solution, contact film developer, board developer, paint-on resist lacquer, aerosol resist sensitizer, and premixed ferric-chloride etching solution. Two of the trays supplied are aluminum and are meant for the developing processes, while the third tray is plastic and is for etching only.

The only additional items needed for making printed circuit boards with the Lift-It kit are a yellow "safe" light, any of several light sources for exposing the contact film and board, and copper-clad board blanks. All chemicals in the kit come premixed and ready to use.

Datak's No. ER-4 kit uses a unique direct-photocopy process, called Pos-Neg. The kit contains four chemicals, a printing frame with yellow filter, artwork aids (layout film, drafting tape, and di-

rect-etch dry-transfer pc patterns), photocopy film, and two copper-clad pc blanks. The two types of film developer, film fixer, and ferric-chloride etchant are supplied in powder form (to be mixed when needed), while the board developer and photoresist come ready to use.

The only additional materials needed with the ER-4 kit are a photoflood lamp, three glass or plastic trays, and bottles for the home-mix chemicals.

With both kits, you receive complete, detailed instructions on how to use them. In both cases, materials are supplied for making both positive and negative exposure masks for use with pre-sensitized pc blanks (single-sheet original artwork can measure up to 5" by 5").

Note: The two methods are described separately on the following two pages. Methods of transferring from artwork to pc board are given on the final page of this article.

THE "LIFT-IT" METHOD

If you are new to pc techniques and have little or no experience in working with photographic techniques, the GC Lift-It kit may prove to be more convenient to use. There are no photo methods used in making the first film artwork.

Since using the Lift-It method destroys the original published etching and drilling guide, it pays to photocopy both sides of the magazine page on which the artwork appears so that none of the published material is lost. Cut the page from the magazine, trim the artwork to leave about 1/4" (6.35 mm) excess on all sides, and tape the artwork flat on a sheet of waxed paper. Paint the Lift-It emulsion over the entire surface of the artwork and allow to dry for 15 minutes. Repeat painting on the Lift-It emulsion and allowing it to dry until six thin, even coatings have been built up. After applying the final coating, allow the emulsion to dry for at least two hours.

When final drying is complete, soak the artwork in warm, soapy water for an hour or more. Remove the artwork from the soaking bath and carefully remove the softened paper from the Lift-It film by rubbing with the tip of your finger. Be careful to avoid tearing, stretching, or deforming the film. If particles of paper

prove to be stubborn, return the artwork to the soaking bath for 15 minutes to a half hour. Finally, when all particles of paper have been removed from the film, allow the latter to completely air dry, after which you can apply a coat of the Lift-It emulsion to the ink side of the film. Make this coat as thin as possible.

You can greatly reduce the time to make the first artwork if, after applying the Lift-It emulsion, you dry it under a heat lamp or in a just-warm oven. Arrange the heating to dry the film in 3 to 5 minutes. (The wet emulsion is milky; as it dries, it becomes clear.) Using heat to speed up the drying, you can put the artwork in the soaking bath after 30 to 45 minutes of final drying. To reduce soaking time, tape the artwork, paper side up, to a clean glass plate and place both in the bath. After 10 minutes or so of soaking, cautiously rub the surface of the paper to break up any glaze. Repeatedly rub the paper gently until it begins to roll off in small bits at first and then in larger pieces. If the paper stubbornly adheres to the film, do *not* rub harder; allow additional soaking time and then proceed.

The prepared artwork can be used as is to expose presensitized pc blanks treated with positive photoresist, such as GC's No. 22-232 spray-on positive

resist (use only GC No. 22-225 resist developer when using this positive photoresist—not the No. J4-630 board developer supplied in the Lift-It kit).

Positive to Negative. Assuming you are using negative photoresist and have a Lift-It positive, the next step is to make a negative of the Lift-It artwork. To do this, you use the contact film supplied in the kit. The procedure is simple. Working under safe-light conditions, you cut the film to size, place it glossy side up in a contact frame (such as GC's No. 22-280 frame), place over the film the Lift-It positive with ink side down, close the frame, and expose it under cool-white fluorescent light. If you do not have a contact frame, two clean sheets of glass will do. Excellent results are obtained with a pair of 20-watt cool-white fluorescent lamps at a distance of 4" (10.2 cm). Exposure time will first have to be established by exposing segments of a thin strip of the film for 1/2, 1, 2, and 4 minutes.

Once you have established the correct exposure time and have exposed the film through the Lift-It positive, switch to safe-light conditions, remove the film from the contact frame, and place it, dull side up, on a clean sheet of glass. Flow onto the film a liberal quanti-

THE "POS-NEG" METHOD

The Pos-Neg method used in the Datak ER-4 kit depends on accurate timing during the exposure of the sensitized film supplied in the kit. Using the Pos-Neg copy mode, you can directly copy the pc etching and drilling guide from the printed page. This results in a film positive that can be used directly to expose positive-resist-sensitized pc blanks.

To use the direct-copy Pos-Neg method, you begin by loading the contact frame (included in the kit) with the printed etching and drilling guide with the artwork facing up, followed by a narrow test strip of the sensitized film with its brown side up, and with the yellow filter on top. The whole is firmly sandwiched together between the contact frame and its top glass.

Next, you expose the test strip in blocks for 30 to 100 seconds at 10-second intervals. After developing and fixing the exposed film strip, you may find only one block satisfactory for your

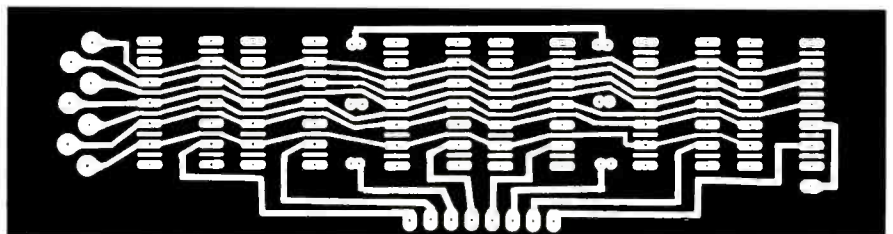
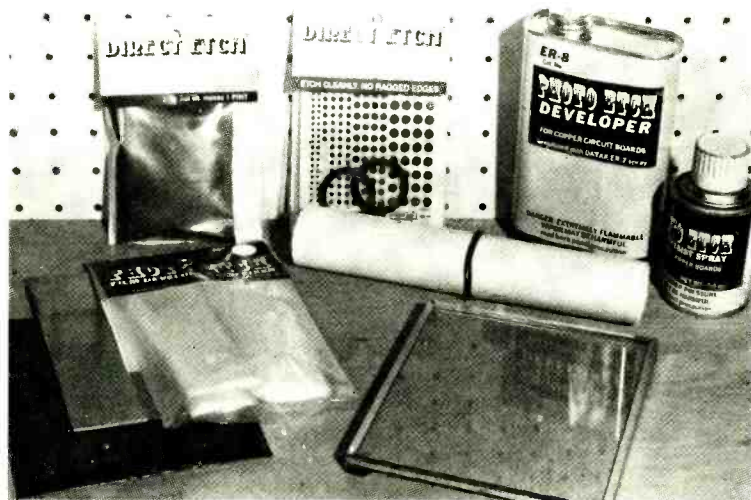

Typical ER-4 mask.



Mask made using the "Lift-It" process.

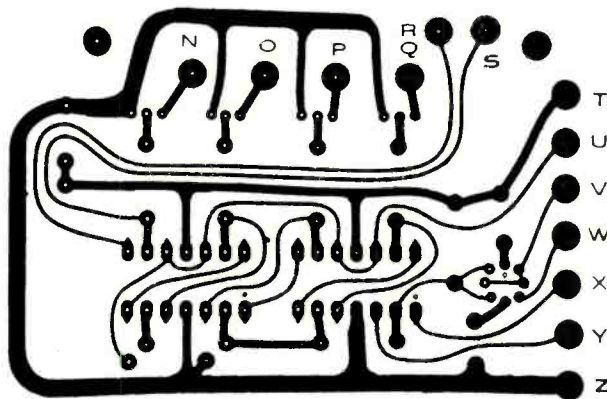

needs. The "good" block will have almost opaque blacks surrounded by a slight brownish haze in the "clear" areas. It is usually necessary at this point to run off another test strip, this time in 3-second steps that span the exposure time of the "good" test block, to determine the exact required exposure time within 3 seconds.

Since the Pos-Neg technique involves both direct and indirect lighting effects, it is quite critical. An accurate enlarger timer to control the on-time of the photo-flood light will prove helpful. If you do not have an enlarger timer, you can use a clock with a sweep second hand and manually control the lamp.

At all times, the presensitized film must be in intimate contact with the printed etching and drilling guide. Additionally, there can be no "print-through" in the artwork. If printing on the reverse side of the page from the etching and drilling guide is visible, back the artwork with matte black paper.

The simplest of the photo copying

procedures with the ER-4 kit is the duplication of a positive from positive or negative film transparency. Here, again, you must determine the proper exposure time. You load the contact frame with the grey side of the sensitized film up, transparency, and yellow filter on top, and expose in blocks for 20 to 90 seconds in 10-second intervals. After developing and fixing the exposed film, the correct exposure time will be that represented by the block with opaque black areas surrounded by water-clear areas.

Positive to Negative. Two separate exposures of the sensitized film are required to make a positive from a film negative or vice-versa. First, you must determine a "clearing" time. To do this, you load the contact frame with the film test strip with its grey side up and place the yellow filter on top. Then, you expose the strip in blocks for 20 to 90 seconds in 10-second intervals. After this, you develop the film in fresh developer at 68° F (20° C) for 2 minutes, place it in

ty of contact-film developer. Soak a wad of cotton with the developer and rub gently, in a circular motion, over the entire dull surface of the exposed film. After a minute or two, the areas of the film that were not exposed to the exposing light will begin to dissolve and come away from the film. Continue rubbing until all soft areas of emulsion have been removed. Be as gentle as possible with your rubbing because the emulsion left behind at this point will be soft. When all unwanted emulsion has been removed, rinse the film under gently running warm water and allow to dry completely.

What you should now have is a high-contrast film negative with opaque orange areas surrounding water-clear conductor areas. The details should be as sharp as they are in the Lift-It positive. Carefully examine the film negative for discontinuities and other flaws. You can repair discontinuities by cutting away the appropriate portions of the film with a razor blade or sharp X-acto knife. Pits and other flaws in the emulsion can be repaired with the paint-on resist lacquer in the kit.

Although exposure time is not critical, gross underexposure will result in complete removal of the emulsion. Conversely, gross overexposure might preclude any development at all.

the fixer for 5 minutes, wash it under gently running water, and allow it to dry. The test strip should go from fully opaque black to fully water clear, with one or two intermediate shades. If the first fully clear block was exposed for 60 seconds, the clearing time is 70 seconds, for example. Record the clearing time for future reference.

Now, to reverse your film transparency, you first expose the entire test strip through the yellow filter for the recorded clearing time. Then, remove the yellow filter and substitute it with the film transparency and expose again in blocks for 3 to 21 seconds at 3-second intervals. After developing, fixing, and washing the test strip, select the block that has opaque blacks with water-clear whites. You now know the exposure times for both clearing and copying.

The ER-4 Pos-Neg system sounds more complicated than it really is. Once you gain some experience with it, it will be no more difficult to use than were other "photo" methods used in the past.

FROM ARTWORK TO BOARD

With very little practice, you can easily photosensitize copper-clad pc blanks. The blanks must be flat and free of ragged edges. The best way to deal with a ragged edge is to use a fine steel file to remove copper burrs and fine emery cloth to smooth the edges. Next, thoroughly scour the copper with a steel-wool soap pad until it has a burnished finish and sheds water. Rinse thoroughly and allow to air dry, either at ambient room temperature or in a just-warm oven. Do *not* wipe the blank dry with a towel. The blank is now ready to be sensitized with photoresist.

Go to safe lighting conditions and place the pc blank with its copper side up on a couple of thicknesses of newspaper, thoroughly shake the can of spray resist, and spray a thin, even coating of the resist over the entire copper surface. Dry the resist for an hour at room temperature or for 15 minutes in a just-warm oven. Then inspect your work under safe lighting. If the coating of resist lacquer appears to be too thin, apply a second thin, even coat and again allow to dry. Before taking on a big job, develop a "feel" for the spray technique, using a piece of scrap pc blank.

Finishing Steps. Under safe light, place the sensitized pc blank in the contact printing frame and place the exposure mask on top. Make absolutely certain that the proper side of the mask is in contact with the blank. You can now expose the blank with any of four light sources, detailed in the instructions supplied with the kits. A fluorescent lamp with two 20-watt cool-white tubes at a distance of 4" from the top of the contact frame is suitable. You will have to determine the proper exposure time by trial and error with sensitized scrap pc blank.

Once the blank has been exposed, go to safe lighting and immerse it in the appropriate pc board developing solution and agitate. Remove the blank from the solution promptly when the circuit pattern appears, usually in about a minute or less. At this point, the resist is no longer sensitive to light, and you can switch back to normal lighting. Flush the developed blank under gently running water and allow to air dry at room temperature for an hour or in a just-warm oven for about 20 minutes. At no time before the board is dry should you touch the resist pattern. The pattern will still be soft and easily damaged.

After drying is complete, carefully inspect the pattern for faults and use

paint-on resist lacquer or dry-transfer patterns to touch up any breaks. Then etch the blank in pc etching solution. You can speed up the etching time by preheating the etching solution by setting the bottle of solution in hot water until it becomes too hot to handle. Do *not* pour the etchant into a pot and heat it directly on a stove. Pour the etchant into a glass or plastic tray large enough to accommodate the pc blank. Place the blank, copper side down, in the hot etchant and agitate the bath by gently rocking it back and forth. Periodically check the progress of the etching after 20 minutes. When all unwanted areas of copper have been etched away, remove the pc board from the etchant and thoroughly rinse it under running water. Then remove the resist on the copper with pc board stripping solution.

The final step in making a professional-quality pc board at home is to trim the board to size and drill all component-lead and mounting holes. From initial artwork to ready-to-go etched and drilled board, the job should take between five and eight hours, depending on the size and complexity of the board. The boards you make with either of the two kits described here will be indistinguishable from boards made by a professional. ◇



WIRE WRAPPING TOOL

For AWG 30, .025" (0,63mm) sq. post, "MODIFIED" wrap, positive indexing, anti-overwrapping device



OK MACHINE & TOOL CORPORATION

3455 Conner St. Bronx, N Y 10475 / (212) 994-6600 / Telex 125091

NEW

HOBBY-WRAP
Model BW-630



Battery
wire
wrapping
tool

ONLY **\$34⁹⁵** (batteries not included)
COMPLETE WITH BIT
AND SLEEVE

If You're Still Playing Games It's Because You Haven't Seen Our Software Library

This Library is the most comprehensive work of its kind to date. There are other software books on the market but they are dedicated to computer games. The intention of this work is to allow the average individual the capability to easily perform useful and productive tasks with a computer. All of the programs contained within this Library have been thoroughly tested and executed on several systems. Included with each program is a description of the program, a list of potential users, instructions for execution and possible limitations that may arise when running it on various systems. Listed in the limitation section is the amount of memory that is required to store and execute the program.

Each program's source code is listed in full detail. These source code listings are not reduced in size but are shown full size for increased readability. Almost every program is self instructing and prompts the user with all required running data. Immediately following the source code listing for most of the programs is a sample executed run of the program.

This Library is destined to become one of the reference bibles for the small computer field, due to its versatility and uniqueness and the ease of operation of the programs it contains. These volumes are deductible as a business expense when purchased by a company. Send your remittance for prompt delivery, while supplies last. Volume discounts are available to qualified dealers.

The entire Library is 1000 pages long, chock full of program source code, instructions, conversions, memory requirements, examples and much more. ALL are written in compatible BASIC executable in 4K MITS, SPHERE, IMS, SWTPC, PDP, etc. BASIC compilers available for 8080 & 6800 under \$10 elsewhere.

This LIBRARY is a complete do it yourself kit. Knowledge of programming not required. EASY to read and USE. Written in compatible BASIC immediately executable in ANY computer with at least 4K, NO other peripherals needed.

VOLUME ONE	Pert Tree Rate Return 1 Return 2 Schedule 1	Pony Roulette Sky Diver Tank Teach Me
Part 1		
BOOKKEEPING	Part 2	PICTURES
Bond	GAMES	A. Newman
Building	Animals Four	J.F.K.
Compound	Astronaut	Linus
Cyclic	Bagel	Ms. Santa
Decision 1	Bio Cycle	Nixon
Decision 2	Cannons	Noel Noel
Depreciation	Checkers	Nude
Efficient	Craps	Peace
Flow	Dogfight	Policeman
Installment	Golf	Santa's Sleigh
Interest	Judy	Snoopy
Investments	Line Up	Virgin
Mortgage		
Optimize		
Order		

VOLUME TWO	Rand 2 Solve Sphere Trian Stars Track Triangle Variable Vector	Differences Dual Plot Exp-Distri Least Squares Paired Plot Plotpts Polynomial Fit Regression Stat 1 Stat 2 T-Distribution Unpaired Variance 1 Variance 2 XY
Part 3		
MATH & ENGINEERING	Part 4	APPENDIX A
Beam	PLOTTING & STAT	BASIC
Conv.	Binomial	STATEMENT DEF
Filter	Chi-Sq.	
Fit	Coeff	
Integration 1	Confidence 1	
Integration 2	Confidence 2	
Intensity	Correlations	
Lola	Curve	
Macro		
Max. Min.		
Navaid		
Optical		
Planet		
PSD		
Rand 1		

VOLUME THREE
Part 5
ADVANCED BUSINESS
Billing
Inventory
Payroll
Risk
Schedule 2
Shipping
Stocks
Switch

VOLUME FOUR
Bingo
Bonds
Bull
Enterprise
Football
Funds 1
Funds 2
Go-Moku
Jack
Life
Loans
Mazes
Poker
Popul
Profits
Qubic
Rates
Retire
Savings
SBA
Tic-Tac-Toe

VOLUME I & II – \$24.95 each
VOLUME III – \$39.95 each
VOLUME IV – \$9.95 each

Add \$1.50 per volume for postage and handling.

SCIENTIFIC RESEARCH

1712-P FARMINGTON COURT
CROFTON MD 21114

Phone Orders call (800) 638-9194

Information and Maryland Residents Call (301)-721-1148



NEW 3½ Digit Multimeter from B&K-PRECISION



BK PRECISION MODEL 283—\$170

**...you'll want it for its features
...but it's the price that will sell you!**

- High intensity LED display is easily read from at least 6 feet in the brightest room.
- Measures AC and DC voltage, AC and DC current and resistance.
- 0.5% DC accuracy.
- 100% overrange (1000 scale reads to 1999).
- Automatic polarity.
- Automatic decimal point.
- Flashing overrange indication on display.
- Four voltage ranges to 1000V
- Four current ranges to 1000mA.
- Six resistance ranges to 10 meg.
- In-circuit resistance measurements at voltage levels below conduction threshold of semiconductors.
- Overload protection on all ranges.

Complete new circuitry makes the Model 283 the most dependable and versatile 3½ digit multimeter you can buy. The extra-bright display allows you to use it where other units would cause reading problems. The selectable "low ohms" function permits accurate measurement of semiconductor shunted resistors.

An optional, internal battery pack (BP-83, \$50.00) provides 8 hours of continuous use on one overnight charging and charges when the Model 283 is in use on 115/230VAC.

Thoughtful, convenience features like a side carrying handle, tilt stand and detachable line cord add to its usefulness.

Your B&K-PRECISION distributor has them in stock and will be glad to demonstrate its features to you. Call him, or write for additional information.

BK PRECISION
DYNASCAN
CORPORATION

6460 West Cortland Avenue
Chicago, Illinois 60635 • 312/889-9087
In Canada: Atlas Electronics, Ontario



Build a Legal In-Flight AIRLINE RECEIVER

*Hear pilot-to-control conversations while in-flight
with low-cost Varactor-tuned crystal set.*

BY CASS R. LEWART

UNTIL NOW, "armchair pilots" wishing to listen to airplane-to-tower communications have had to confine their activities to ground-based monitoring. But the project described here—essentially a vhf crystal set with a small audio amplifier—will allow reception of such conversations when the user is on board an airliner. It will do so *without creating any hazard* to the plane's navigation system. The receiver is easily built, using readily available, inexpensive parts.

About the Circuit. Unlike superheterodyne receivers, whose local oscil-

lators generate signals which can interfere with reception in the 108-to-118-MHz radio-navigation band, this project can be used with complete safety. The heart of the project is a 4-transistor audio amplifier with a built-in speaker, shown schematically in Fig. 1. Power switch *S1* is ganged with *R1*, the volume control. The amplifier draws current from a single 9-volt transistor battery, *B1*.

A few modifications transform this amplifier module into an airline receiver, shown schematically in Fig. 2. The receiver comprises a tuned r-f circuit (*L1*, *C1* and *D1*), a demodulator (*D2*) and the modular audio amplifier. The tuned cir-

cuit is unusual in one respect—it uses a voltage variable capacitor or Varactor as the variable capacitance. This diode, when reverse biased over a range of 0 to 9 volts, behaves like a variable capacitor of 5 to 15 pF. Because *C1* is in series with *D1*, the effect of the fixed capacitor is negligible. The combination of *L1*, a small hand-wound coil, and *D1* resonate to provide coverage from 118 through 135 MHz. (Construction details for *L1* are given on the next page.)

A short piece of insulated, stranded hookup wire serves as an antenna. The wire is terminated with a pin or banana plug (*P1*), and is connected to the rest of

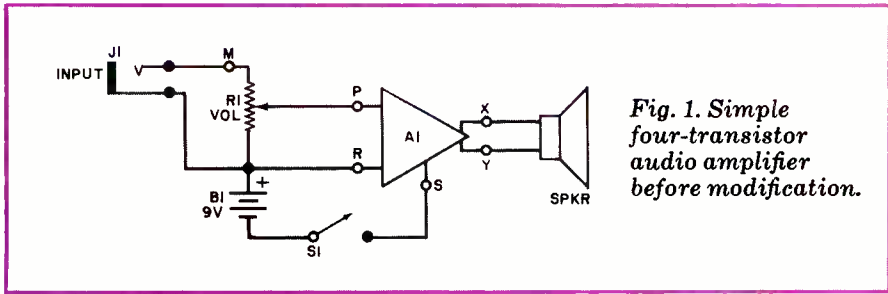

Fig. 1. Simple four-transistor audio amplifier before modification.

the circuit via *J2*, a pin or banana jack. Signals are thus applied to the tuned circuit, which is resonated by means of *R1*. This potentiometer, which served as the volume control in the unmodified amplifier, functions as a voltage divider to apply variable reverse bias across *D1*.

After the vhf signal has been boosted by the parallel LC circuit, it is demodulated by germanium diode *D2* and applied to the audio amplifier. The output of the amplifier drives a dynamic earphone plugged into jack *J1* (the former input to the amplifier).

Construction of the receiver is greatly simplified by modifying a ready-built audio module and adding a few additional components. In the author's prototype, a Radio Shack 277-1008 amplifier was used. However, other units can be used equally well. The additional components fit in place of the module's speaker.

Start by removing the three small Phillips screws which secure the amplifier pc board to the plastic enclosure. Then remove jack *J1* and unsolder the leads running to it. Raise the pc board and unsolder the leads connected to the speaker. Remove the speaker by softening the glue holding it to the plastic enclosure. Use acetone or nail-polish remover and pry the speaker away with a sharp knife. Then attach what were the speaker leads (points X and Y) to *J1*. Polarity is not important.

Refer to Fig. 3A and 3B for the following steps. Open the pc foil running from the volume control (*R1*) to the amplifier input (point P) and to the input jack (point M) by scraping it off with a sharp blade. Connect the terminal previously running to point M to one side of switch *S1* (point S), which is ganged with *R1*. Solder a wire to the wiper of *R1* and connect the other end to one side of *C1* and the anode of *D1*. Then solder a wire to the pc foil that formerly ran to the wiper of *R1* (on the other side of the break in the foil), and attach the other end of the wire to the anode of *D2*.

Next, drill a hole about 1-9/16" (3.97 cm) from the top of the enclosure on the left side (as viewed from the rear) to accommodate *J2*, the antenna input jack. Mount the jack and secure the pc board to the enclosure with the three small Phillips screws. To form *L1*, wind five turns of No. 24 enamelled copper wire on a 3/8-inch (9.53-mm) form, spaced about 10 turns per inch. Scrape the insulation off the ends of *L1* and position the coil in the speaker cutout of the pc board. Connect *D1*, *D2*, *L1*, and *C1* as indicated in the schematic, using *J2*

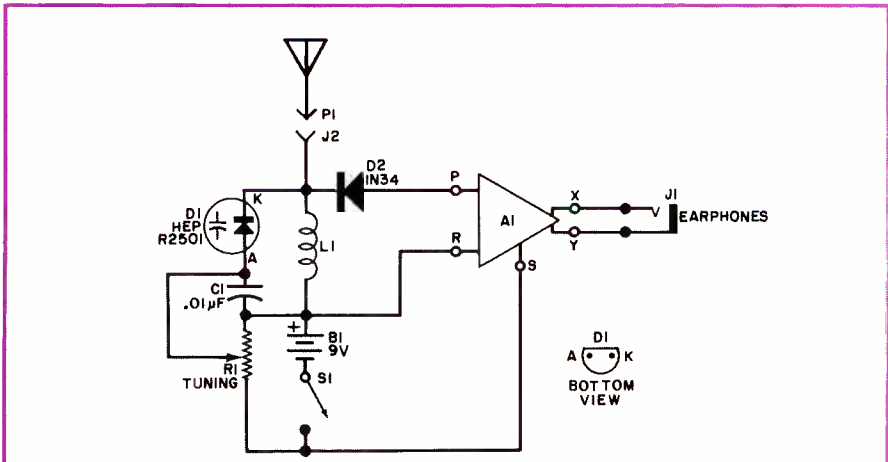

Fig. 2. Schematic of the amplifier with minor additional circuits needed to make airline receiver.

PARTS LIST

- A1—Modular Amplifier (Radio Shack 277-1008 or equivalent)
- B1—9-volt transistor battery
- C1—0.01-μF, 50-V disc ceramic capacitor
- D1—5-15-pF voltage-variable capacitance diode (Motorola HEP R2501—do not substitute)
- D2—1N34 germanium diode
- J1—Miniature phone jack (part of A1)
- J2—Pin or banana jack
- L1—Five turns of No. 24 enamelled copper wire on a 3/8-inch form, approx. 10 turns per inch
- P1—Pin or banana plug
- R1—Volume/tuning control (part of A1)
- S1—Spst switch (ganged with R1, part of A1)
- Misc.— Dynamic earphone (8 ohms), hook-up wire, solder, etc.

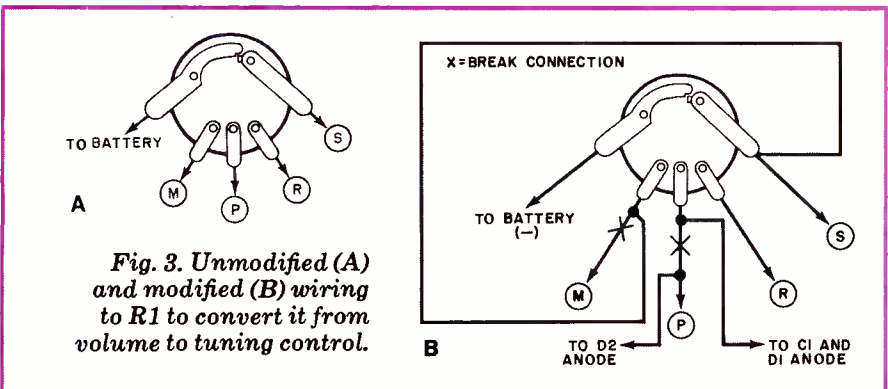

Fig. 3. Unmodified (A) and modified (B) wiring to R1 to convert it from volume to tuning control.

for mechanical support. Be sure to observe correct polarity for the diodes or you will damage them. Solder all remaining connections.

Alignment. The best way to align the receiver is to couple it to a signal generator producing an output at 125 MHz with internal 400-Hz modulation. Connect a small dynamic earphone to *J1* and set the tuning control (*R1*, the former volume control). Compress or expand the winding of *L1* for maximum audio output. If you can't get access to a signal generator with the required output, just go to your local airport. Connect a short (one foot or so) wire terminated with a suitable plug to *J2*, and listen to transmissions from the airport tower. Adjust *L1* for best reception with *R1* at center position.

Operation. The airline receiver is very simple to use. When you are taking a flight, try to get a seat near the window. Attach the antenna wire to the window with a small piece of masking tape, and plug the earphone into *J1*. This will allow you to monitor the pilot's conversations without causing a commotion.

You will not usually know the exact frequencies used by a particular airplane. Airport towers generally transmit and receive below 120 MHz. Other communications can be found anywhere between 120 and 135 MHz. Between take-off and the time when a plane reaches cruising altitude, its pilot will use several frequencies in succession, communicating with the tower, departure control, and possibly to the particular airline controller. Similarly, the pilot will use several frequencies during the descent.

Each conversation will be brief, lasting only a few seconds. Accordingly, an important characteristic of this receiver is its broad selectivity as compared to that of a superheterodyne receiver. The user can therefore leave the tuning control at its center position. The pilot's transmission will still be heard—even if the tuned circuit is not resonant exactly at the operating frequency. The receiver can be quickly retuned for optimum reception if desired. Another possibility is to continuously tune the receiver back and forth, scanning the band until you can hear the pilot's voice.

When using the receiver, you may try to explain to the stewardess what you are doing in case other passengers think you are using a radio that might foul up airline communications. Your radio is similar to a tape recorder which would be permitted on board. ◇

LEADER LAS-5500
AUDIO SYSTEMS ANALYZER
7 Instruments-In-One!

An extraordinary range of applications for every audio designer, engineer and technician who wants professional results

<p>OSCILLOSCOPE</p> <ul style="list-style-type: none"> • DC to 10MHz • bandwidth, AC • 2Hz-10MHz (-3dB) • 20mV/Div. vert. sens. 	<p>ATTENUATOR</p> <ul style="list-style-type: none"> • 600Ω input/output impedance • 0-101dB attenuation range, ±2% accuracy 	<p>DRIFT METER</p> <ul style="list-style-type: none"> • 3KHz ±0.1% test freq. source • 0.3Vrms signal output 	<p>WOW/FLUTTER METER</p> <ul style="list-style-type: none"> • 3KHz ±10% and 3-15KHz ±10% range
<p>AUDIO FREQUENCY OSCILLATOR</p> <ul style="list-style-type: none"> • Frequency, 10Hz-1MHz, 5 ranges • <0.5% distortion, 500Hz-20KHz and better 	<p>AC MILLIVOLT METER</p> <ul style="list-style-type: none"> • Reads as low as 30μV ranging to 100V, 12 steps. • ±3% full scale accuracy • 5Hz-100KHz freq. resp. 	<p>DUMMY LOAD</p> <ul style="list-style-type: none"> • To 100W rated power • 8Ω (L,R) impedance 	<p>At \$1995, the LAS-5500 saves up to 50% it's a smart investment!</p>

LEADER Instruments Corp.

151 Dupont Street, Plainview, N.Y. 11803 (516) 822-9300
West Coast: 7713 Denmore Ave., Van Nuys, Calif. 91406 (213) 989-2760 In Canada: Omnitronics Ltd., Montreal, Quebec

CIRCLE NO 34 ON FREE INFORMATION CARD

FREE McIntosh CATALOG and FM DIRECTORY

Get all the newest and latest information on the new McIntosh Solid State equipment in the McIntosh catalog. In addition you will receive an FM station directory that covers all of North America.



MX 113

FM/FM STEREO - AM TUNER AND PREAMPLIFIER

SEND TODAY!

McIntosh Laboratory, Inc.
East Side Station P.O. Box 96
Binghamton, N.Y. 13904
Dept. PE

NAME _____

ADDRESS _____

CITY _____ STATE _____ ZIP _____

If you are in a hurry for your catalog please send the coupon to McIntosh.
For non rush service send the *Reader Service Card* to the magazine.

CIRCLE NO 35 ON FREE INFORMATION CARD

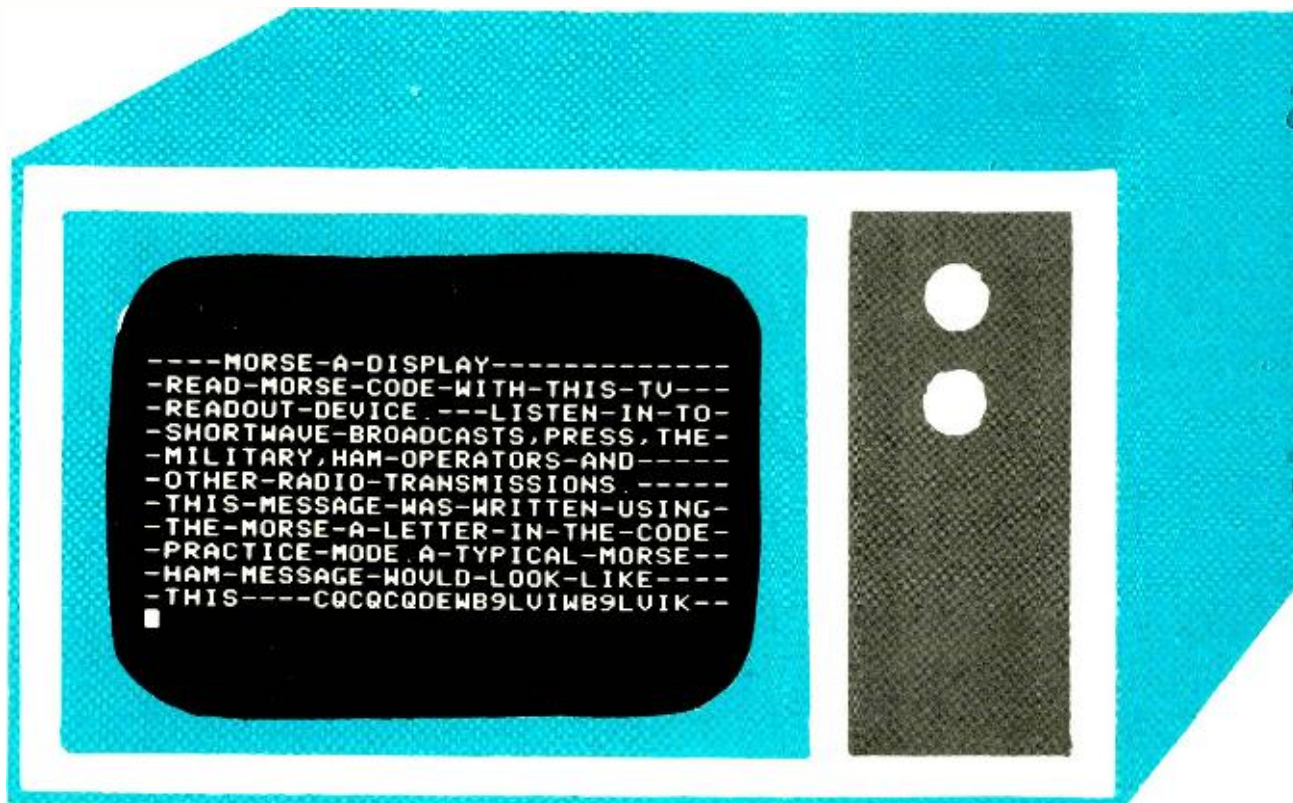

MORSE CODE AUTOMATIC READOUT ON A TV SCREEN

How to interface the Morse-a-Letter to a "TV Typewriter."

BY GEORGE R. STEBER, WBSLVI

ALTHOUGH the Morse-A-Letter (January 1977) deciphers Morse code signals very effectively, its usefulness is somewhat limited by its single-character LED readout. At higher code speeds, the characters are displayed briefly, straining the operator's ability to copy down the entire text. However, it's easy to interface the Morse-A-Letter to a "TV typewriter." This combination, called "Morse-A-Display," will allow message display in page format—a boon to CW operators and SWL's interested in copying Morse.

Designed with this application in mind, the Morse-A-Letter contains all electronics necessary for converting dits and dahs to TTL-compatible ASCII-6 code. The required interface is simple and straightforward. All features of the original project are retained.

ASCII. Before examining the interface, let's review some basics of ASCII code. This will help us understand how the Morse-A-Letter/TV typewriter team op-

erates. ASCII is a standard 8-bit information code used with most computers and data terminals. It may be used in the parallel (all bits present simultaneously on separate lines) or serial (one bit at a time on a single line) mode. Most systems do not use the eighth bit of the code and it is, therefore, assumed to be a logic one at all times. Some systems, however, use the eighth bit for parity or error testing. The remaining seven bits provide a total of 128 possible charac-

ters. Of these, one group of 32 is reserved for the upper case alphabet and a few punctuation marks. Another group of 32 is used for numbers, spacing and additional punctuation symbols. Rarely used punctuation marks and a lower case alphabet are assigned a third group of 32. Finally, the last 32 combinations are assigned as machine or control commands. This group does not actually get printed but is provided to handle hardware operations such as line feed (LF) or carriage return (CR). If only upper case alphanumeric are needed, only the first two groups of 32 codes are required, and only six of the eight bits of the code are used. This diminutive ASCII code is called ASCII-6 and is essentially the code produced by the Morse-A-Letter. No control codes are produced by the Morse-A-Letter, however, so most "housekeeping" operations (line feed, carriage return, etc.) must be performed by the TV terminal. This does not present a real problem, since most TV terminals are programmed to handle

INTERCONNECTIONS	
Morse-A-Letter Connector	TV Terminal Connector
A13	Bit 7*
A21	Bit 6
A20	Bit 5
A19	Bit 4
A18	Bit 3
A17	Bit 2
A16	Bit 1
A14	Strobe
A1, A9	Ground

* Optional, see text

these operations automatically in the absence of specific commands.

Interfacing. Almost any TV terminal capable of receiving TTL-level, 7-bit parallel ASCII code can be used with the Morse-A-Letter. Most terminals will work well with the ASCII-6 code without any changes or additions. However, some terminals require the presence of the seventh bit (B7—not to be confused with edge connector location B7) to produce a question mark (?), due to the method used to check control characters. If the seventh bit is required by your terminal, don't despair! It can easily be obtained because B7 is merely the complement of B6 for the 41 valid ASCII characters produced by the Morse-A-Letter. This modification requires a small amount of additional wiring on the Morse-A-Letter circuit board. Fortunately, no additional parts are needed since an unused inverter (actually one half of IC5, a 7413 dual NAND Schmitt Trigger) is already "on the board."

To generate bit 7, connect a wire from B6 of the ASCII output (edge connector location A21) to pin 13 of IC5. Also, connect a wire from pin 8 of IC5 to edge connector location A13. This becomes B7 of the ASCII code. Keep in mind that

many TV terminals will function adequately with just the ASCII-6 code, so this addition may be optional.

The TV terminal will normally require a "data ready" signal to tell it when an ASCII character is applied to its input connector. This signal is also sometimes referred to as a "keypressed strobe" or "new character" pulse. It is usually a positive going pulse that appears whenever the ASCII character is ready to be entered. The Morse-A-Letter provides this new character pulse in the form of a positive going pulse at edge connector location A14, which is generated every time a new Morse character is received.

A word of caution is in order. If your terminal does not utilize TTL levels at the ASCII input connector and/or requires a negative-going strobe pulse, an additional interface is needed.

As an example of an interface, the Table lists the wiring requirements for interfacing the Morse-A-Letter to the Southwest Technical Products CT-1024 Terminal, which has a TTL-compatible input and a positive strobe line. All that's required is connecting a suitable cable from the appropriate points on the Morse-A-Letter connector to the TV terminal connector. Note that no power supplies or additional electronics are

necessary. Most other TV terminals will interface in a similar manner.

Operation. There are no adjustments required for the Morse-A-Display other than the normal code speed adjustment. It will function in either the code practice or the reception mode. Once a signal is properly tuned in, the television display will read out the incoming characters directly on the television screen. Illegal Morse characters will be displayed as "@"." Noisy signals may generate strings of "E"s or "T"s on the screen, but this is normal. Do not expect to view perfectly edited copy since word spaces are rarely sent in Morse code and the Morse-A-Display is not designed to decode them. This is not a serious handicap, however, and with a little practice you will be able to read complete messages from the screen. To copy high-speed Morse, it might be desirable to reduce the Morse-A-Letter's C9 from 6.8 microfarads to 2.0 microfarads in the original circuit. This reduces noise immunity slightly, but enables copy at code speeds up to 50 WPM or more.

Remember it is illegal to pass information garnered from ship-to-shore, military, or press transmissions to third parties. ♦

SCORE 2 WAYS WITH MARK TEN B AND...

You can add real zip to engine performance and eliminate the need for 3 out of 4 tune-ups with a Mark Ten B Capacitive Discharge Electronic Ignition. Over a million happy, satisfied users testify to the fact that the Mark Ten B really does:

- Eliminate 3 out of 4 tune-ups.
- Improve gasoline mileage—up to 20%.
- Give dramatic increases in acceleration and general performance.
- Extend spark plug life 3 to 10 times.
- Give instant all weather starts.

Put spark under the hood and score with *real* performance!

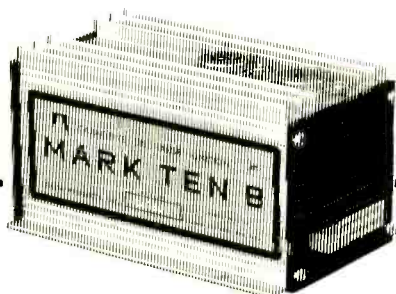

DELTA'S MOUNTAIN MAN SADDLE BAG CAN AND ACCESSORY CARRIER*

The only carrier with truly innovative engineering, Delta's Mountain Man Carrier installs *without drilling a single hole*. A completely unique concept, it forms the basic unit of the first modular system ever devised to carry a variety of accessories. Look at these great features:

- Versatility: use alone with one or two jerry cans, or use with other Mountain Man accessories. (Sorry, cans not included.)

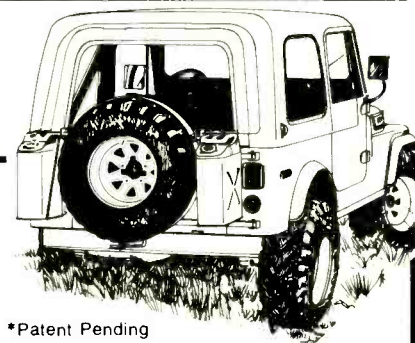

*Patent Pending

- Fits all externally mounted 14", 15" and 16.5" tires.
- Easy installation; all you need is a wrench.
- Made of rugged 11 gauge steel for strength and durability.

Winner of PV4 Magazine's 1976 Product Of The Year Award, it will score on your 4WD, van, pickup, or mini, and it's a steal at only \$39.95 F.O.B.

DELTA PRODUCTS, INC.

One Delta Way, Dept. PE, Grand Junction, Colorado 81501 (303) 242-9000

Please send _____ Saddle Bag Carrier(s) @ \$39.95 F.O.B.
 Check enclosed Charge my Master Charge
 BankAmericard

Credit Card #

Interbank No. Exp Date

(Master Charge only) Mo Year

- I have enclosed \$2.00 for my complete Mountain Man catalog (to be applied toward my first purchase).
- Please rush free brochure on Mark Ten CDI Systems.

Name _____
 Address _____
 City _____ State _____
 Phone _____ Zip _____

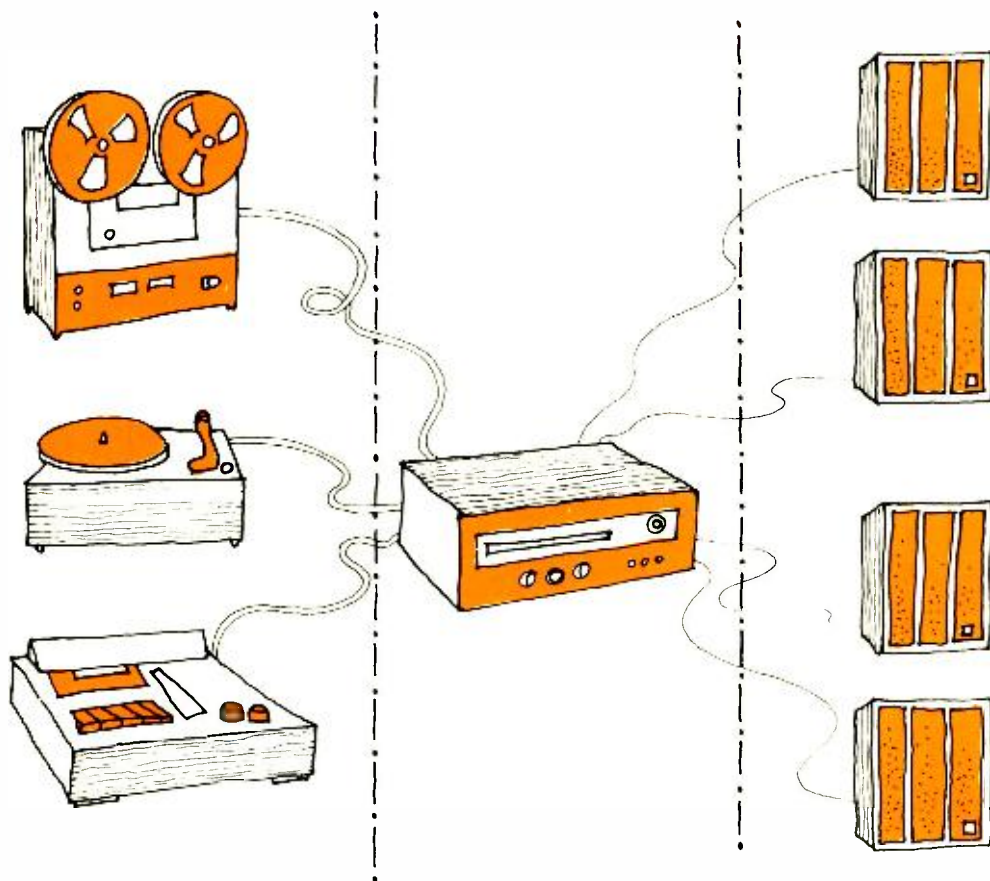

HOW TO MATCH HI-FI COMPONENTS

Price tags serve as a good guide to apportioning dollars for each component.

MATCHING hi-fi components of a stereo or four-channel system means that each component must operate compatibly with each other.

For example, your loudspeakers should be efficient enough to deliver satisfactory sound levels—especially in the low bass region—when driven by the amplifier or receiver of your choice. Yet, they should have sufficient power-handling capacity to avoid damage if driven by too much power.

In another sense, compatibility also means that one component should not have substantially better performance

than another component in the system. It would be foolish, for example, to have a \$300 single-play turntable, \$800 receiver, and two speaker systems at \$500 each and then add a \$19.95 phono cartridge. The latter's electrical/mechanical performance would be well below that of the other components in the system. As a result, one would not get the full performance capability inherent in the better components. Remember that the final reproduced audio will sound only as good as the weakest component link in the system.

One can often ignore electrical and

mechanical considerations at the onset of rounding up his choices, however, by viewing compatibility in terms of each component's price tag. Thanks to competition among manufacturers, the quality of each type of component varies almost directly in relation to its price (although exceptions can always be found to virtually any generalization).

Most newcomers to component hi-fi (and some experienced audiophiles, too) have little or no idea of how to apportion their dollars to the various components they plan to buy.

Many audio dealers try to simplify this

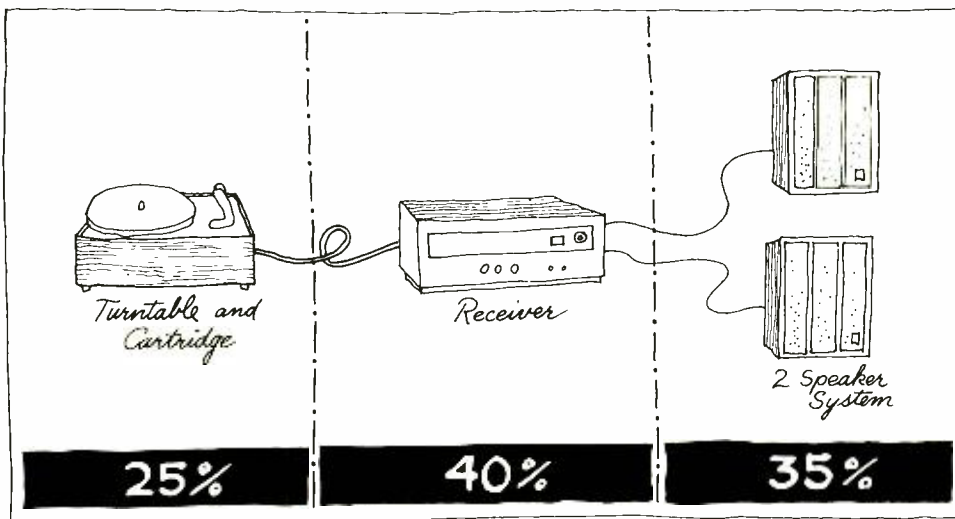

Fig. 1. Apportioning dollars to a stereo receiver/turntable/speaker system.

problem by "assembling" pre-selected components into a complete system. Such systems usually bear a single price tag and offer significant savings over the prices of the individual components added together. There are both advantages and disadvantages in choosing such a dealer-selected system. Certainly, if the dealer is knowledgeable and reputable, you are at least

assured that the components which have been put together in this way will work compatibly with each other—and the savings in making a single purchase from one source are often worthwhile. On the other hand, you may have different ideas about which components you think sound better with which other components. Consequently, your dream system may not be represented by any

of the pre-selected groupings offered by the dealer.

In addition, it is common practice for some dealers (but not all) to have loud-speaker systems "custom designed" by local manufacturers who are essentially cabinet makers rather than speaker system designers. Since such speakers are rarely advertised nationally, almost any "suggested retail price" can be assigned

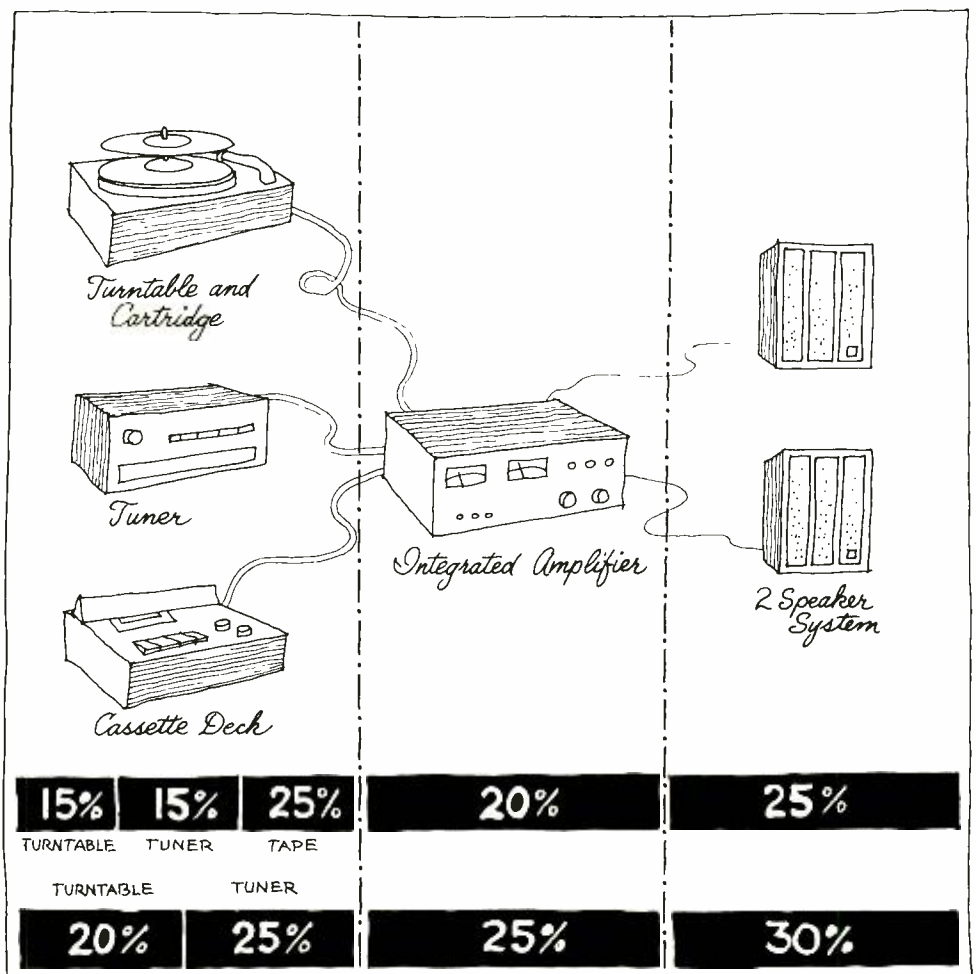

Fig. 2. Percentage of dollars to be spent on components for a system including tuner and cassette deck.

to them. In such instances, the "savings" shown in the final system price tag may actually be the result of reducing these speaker prices to more realistic levels. (This practice is not universal, of course.) What we are suggesting is that each component in such systems be analyzed and evaluated for its own mer-

fast rules; these are simply rough guidelines. In the system shown, any tape equipment would be considered extra and is not included in the initial percentage breakdown.

Suppose you decided to include a cassette deck as part of your initial hi-fi investment, and that you prefer to have

quality. In Fig. 3 we have represented a typical quadraphonic system centered around a 4-channel receiver. Again, percentages are shown below for each element of the system. If we assume that you are prepared to spend \$3000 for such a system (note that it includes both an open-reel tape deck and a stereo

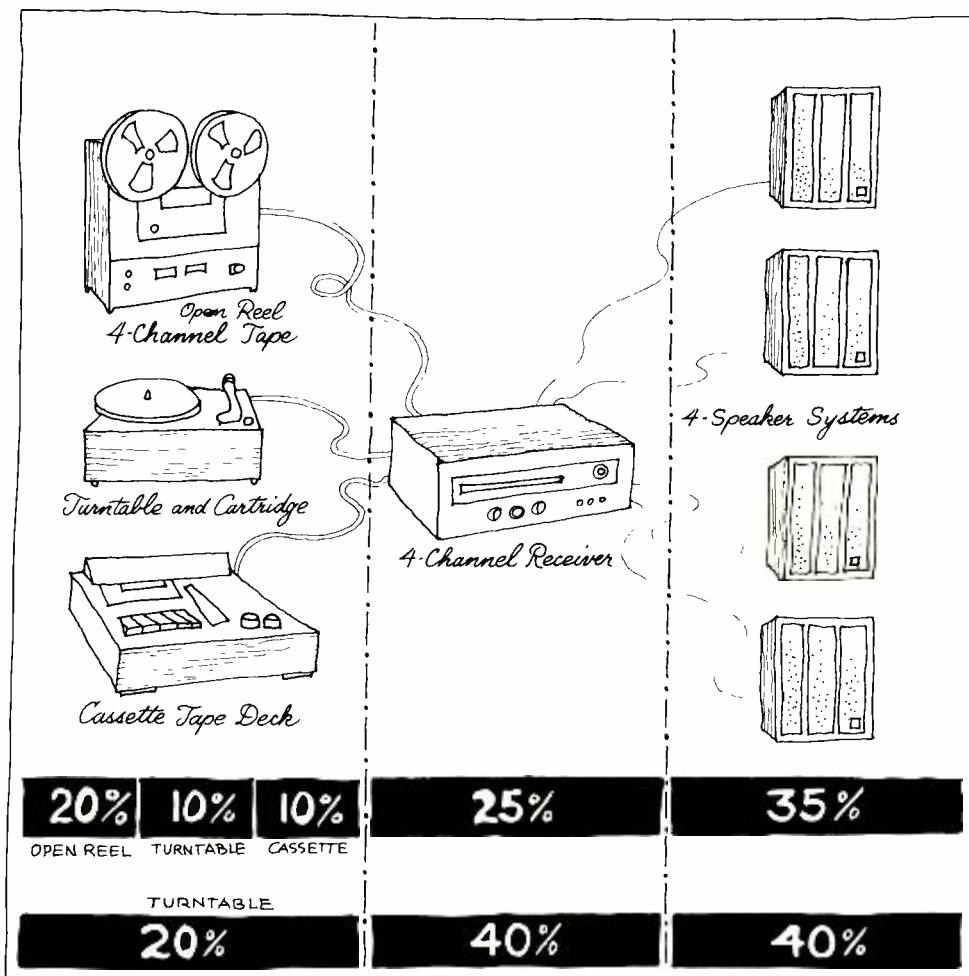

Fig. 3. How dollars should be apportioned for a four-channel system with open-reel and cassette decks.

its and performance—for that is the essence of shopping for components for your own high-fidelity system.

Apportioning Hi-Fi Dollars. By far the greatest number of high fidelity stereo component systems consist of an all-in-one receiver, a turntable system (either single-play or multiple-play) and a pair of loudspeaker systems. This basic layout is shown in Fig. 1. Below it is a typical cost breakdown in percentages of available dollars. As an example, if you have \$500 to spend on such a basic system, you might consider a turntable (including the phono cartridge, which is usually purchased separately) selling for approximately \$125, a \$200 receiver and two speakers for about \$87.50 each. There are, of course, no hard-and-

a separate tuner and an integrated amplifier (preamplifier-amplifier combination) instead of a receiver. Your system might then look something like that shown in Fig. 2, with the percentages spent for each component given below. Since such a system is necessarily more expensive than the simpler, 4-piece arrangement, let's start with a budget of \$1000. You might spend \$150 for a turntable and cartridge, \$150 or so for a separate FM/AM tuner, \$250 for a cassette deck with Dolby, \$200 for an integrated amplifier and perhaps \$125 for each of your two speaker systems. If the tape deck is eliminated for the moment, percentages could be reassigned as shown in the lower percentage table.

Quadraphonic systems necessarily cost more than stereo systems of equal

cassette unit) your dollars might be apportioned as follows: \$600 for the open-reel deck, \$300 for the cassette deck and a similar amount for the turntable/cartridge combination (you will need a cartridge designed to play CD-4 records this time), \$750 for the 4-channel receiver and \$262.50 for each of the four speakers in the system. If you were to omit the tape decks and had only \$2000 to spend, the lower percentage table in Fig. 3 suggests that you might spend \$800 on the 4-channel receiver, \$200 for each of the four speakers needed, and up to \$400 for the turntable/cartridge combination.

Specs To Expect. Although specifications are certainly not the only criterion involved in making an intelligent



Print Your Heart Out.

With help from the Digital Group, naturally.

Now, that small computer system you own or have been considering for personal or business use suddenly becomes a lot more usable—with the addition of a full-size *impact* printer from the Digital Group. A printer designed for small computers that need big output (like yours).

With the Digital Group printer, you can print your heart out...and it won't cost an arm and a leg. The Digital Group printer is available for less than \$500. That's right—\$500.

Just look at these specifications:

- Fast—120 characters per second
- 96 characters per line
- 12 characters per inch horizontal
- 6 lines per inch
- Makes up to 4 copies simultaneously
- Character set and pitch variable under software control—double width characters, etc.
- 5 x 7 character matrix
- Ribbon has built-in re-inkers for a life of 10,000,000 characters
- Paper can be either a standard 8½-inch roll, fanfold or cut page
- Interfaces to 8-bit parallel ports

There are lots of capabilities and outstanding features of the Digital Group printer...and (as always) the best news is our price. Kit prices start as low as \$495 for the printer and interface card. It simply can't be beat.

Find out all the facts about the Digital Group printer now. Just fill in the coupon below or give us a call for the details. We think you'll find a place for our printer in your system...and in your heart.

the digital group

P.O. Box 6528
Denver, Colorado 80206
(303) 777-7133

Quick. I want to print my heart out.
Send me all the details on your full-size impact printer.

Name _____

Address _____

City/State/Zip _____

Please print.

Be the “New Professional” in electronics

**CREI trains you at home
for one of the most important
career levels in electronics—
plus offers you special
arrangements for engineering
degrees**

Most people think there are only two levels of careers in electronics: the technician level and that of the degree engineer.

There is, however, a third and very important level. It is that of the engineering technician or *practical* engineer. The growing importance of this career level has created what might well be called the “New Professional” in electronics.

If you look at the various levels of employment in electronics, you will understand why this “New Professional” is so important.

The average technician is a person who has had vocational training in electronics. He understands the basic principles of electronics so he can troubleshoot, repair and maintain equipment. He usually works under close supervision in performing his duties.

The engineer has college training in electronics. He usually supervises technician personnel and is responsible for planning and developing of electronic equipment and systems. Frequently, however, engineers are more heavily trained in the scientific principles of electronics and less in their practical application.

The engineering technician, by contrast, is a specialist in the practical application of electronics. His training usually consists of a two-year college program in electronic engineering technology. In many organizations, the engineering technician handles several of the responsibilities of the degree engineer. He often has the title of engineer.

CREI programs are designed to give you at home the same level and depth of training you receive in a two-year college program in electronic engineering technology. CREI programs are, in fact, more extensive than you will find in many colleges. And CREI gives you the opportunity to specialize in your choice of the major fields of electronics.

Unique Design Lab

CREI gives you both theory and practical experience in circuit design with its Electronic Design Laboratory Program. The professional equipment included in this program allows you to construct, test out and correct the circuits you design until you have an effective circuit.

This Lab Program helps you understand advanced electronics. It also gives you practical experience in many other important areas of electronics, as in pro-

Career Training at Home

totop construction, breadboarding, test and measurement procedures, circuit operation and behavior, characteristics of electronic components and how to apply integrated circuits.

Only CREI offers the unique Lab Program. It is a complete college Lab and, we believe better than you will find in most colleges. The "Lab" is one of the factors that makes CREI training interesting and effective. And the professional equipment in this program becomes yours to keep and use throughout your professional career after you complete the training.

Engineering Degree

CREI offers you special arrangements for earning credit for engineering degrees at certain colleges and universities as part of your home study training program. An important advantage in these arrangements is that you can continue your full time job while "going to college" with CREI. This also means you can apply your CREI training in your work and get practical experience to qualify for career advancement.

Wide Program Choice

CREI gives you a choice of specialization in 14 areas of electronics. You can select exactly the area of electronics best for your career field. You can specialize in such areas as computer electronics, communications engineering, microwave, CATV, television (broadcast) engineering and many other areas of modern electronics.

Free Book

In the brief space here, there isn't room to give you all of the facts about CREI college-level, home study programs in electronics. So we invite you to send for our free catalog (if you are qualified to take a CREI program). The catalog has over 80, fully illustrated pages describing your opportunities in advanced electronics and the details of CREI home study programs.

Qualifications

You may be eligible to take a CREI college-level program in electronics if you are a high school graduate (or the true equivalent) and have previous training or experience in electronics. Program arrangements are available depending upon whether you have extensive or minimum experience in electronics.

Send for this **FREE** Book describing your opportunities and CREI college-level programs in electronics



Mail card or write describing qualifications to

CREI **CAPITOL
RADIO
ENGINEERING
INSTITUTE**

**McGraw-Hill Continuing Education Center
3939 Wisconsin Avenue Northwest
Washington, D.C. 20016**

Accredited Member National Home Study Council

GI Bill

CREI programs are approved for training of veterans and servicemen under the G.I. Bill.



**EVERY CB'er
NEEDS A
GOOD
BUDDY.**

**NOW
HE'S
HERE!**

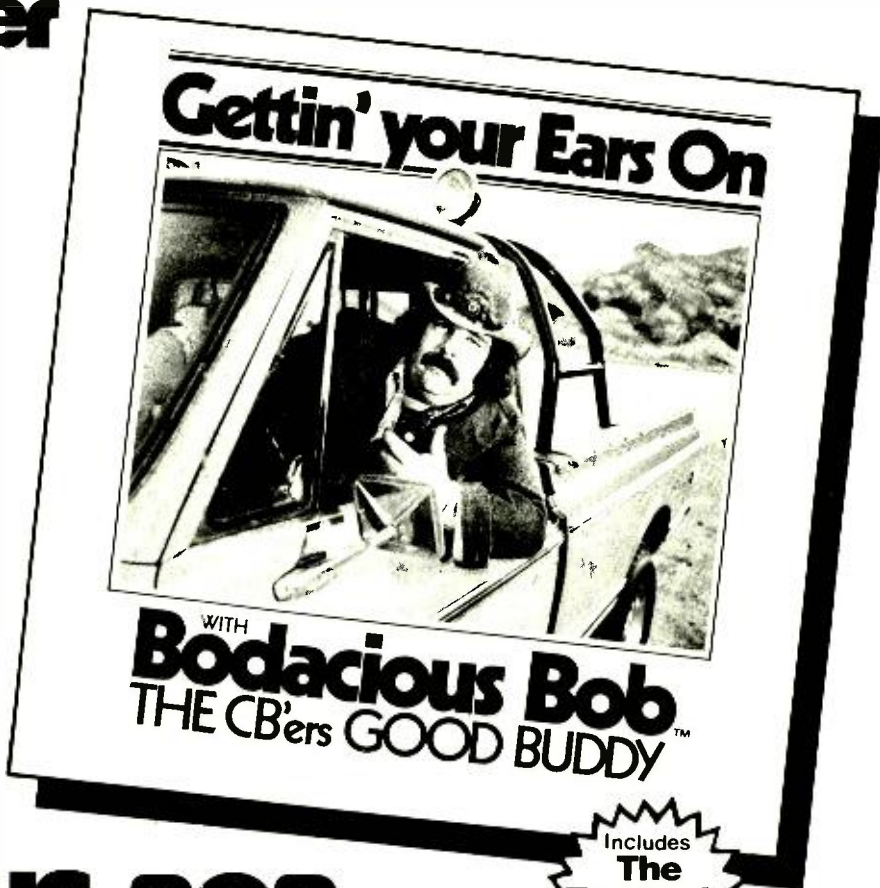

Includes
**The
Trucker's
Prayer**

BODACIOUS BOB

and his first album of CB songs & stories.

GET A COPY ON BODACIOUS.

He has somethin' to say to all
CB'ers — old or new.

- The history and future of CB
- The hottest new CB slang from around the country
- City CB'n
- Country CB'n
- How to get the max out of your rig
- CB courtesy, safety, theft prevention and fun
- Shakin' the "CB Jeebies"
- The sunspot "crisis"
- The Trucker's Prayer
- Gettin' into The Squelch Squad

**PLUS - 2 ORIGINAL
CB HIT SONGS!**

- "On the Road"
(the story of a once-lonely trucker)
- "Get a Copy"
(with impersonations of famous people talkin' on their CB's)

Plus other original music, from country to rock.
And lots more! Order yours today!

Available on LP, 8-track, or cassette.

©1977 Audio Products, Inc.
20969 Ventura Blvd., Woodland Hills, Calif. 91364

©1977 Audio Products, Inc. All Rights Reserved

10-4 Bodacious. You're talkin' on my channel. Send me:

- _____ LP(s) @ \$6.95
- _____ 8-track tape(s) @ \$7.95
- _____ cassette tape(s) @ \$7.95

Total of order: _____

(Check or money order please) (Calif. residents add 6% sales tax.)

Charge to my: _____

BankAmericard # _____

or Master Charge # _____

Exp. Date _____

Signature _____

Name _____

Address _____

City _____

State _____ Zip _____

Mail orders to: BODACIOUS BOB
Box 1020 • Woodland Hills, Ca. 91364

PE

TABLE I PRICE CATEGORIES

	Low Price	Medium Price	High Price
Tuners			
Integrated	up to \$150	\$150-350	Over \$350
Amplifiers	up to \$200	\$200-400	Over \$400
Receivers	up to \$250	\$250-500	Over \$500
Turntables			
(Less Cartridge)	up to \$125	\$125-250	Over \$250
Cassette Decks	up to \$200	\$200-400	Over \$400
Open-Reel Tape Decks	up to \$400	\$400-800	Over \$800

choice of a hi-fi component, they certainly have a bearing on the type of performance you can expect from each component. The specifications which apply to loudspeakers (and, for that matter, headphones) are not easily related to the kind of sound you can expect to hear. Aside from making certain that the speakers you select are efficient enough to provide adequate sound levels when matched with the electronics of your

choice, and also rugged enough to handle maximum input power available, choosing loudspeakers is a wholly subjective exercise. The specifications of other components, such as tuners, amplifiers (or receivers, which combine both tuner and amplifier sections), turntable system, and even tape decks are related to their prices. Table I categorizes low-, medium-, and high-priced electronic components, tape decks, and

turntable systems in terms of actual 1977 dollars.

With these price ranges in mind, refer to Table II for a general idea of the major specifications you can expect to find for components in each of the price categories. Only the major specifications have been listed, and they are by no means the only ones that should be considered. Remember, too, that you are likely to find that some specifications are better than others for a given product in a given price category. Your evaluation process should take these differences into account, along with your own particular needs. For example, what appears to be a superb tuner in its price class may otherwise have less-than-superb selectivity. If you live in an area where there are only a few FM stations on the dial, this may be of little significance to you, whereas greater sensitivity or 50 dB quieting may be more important. Conversely, if you live close-in to strong signals and are surrounded by a great many nearby stations, selectivity could be more important than sensitivity. ◇

TABLE II TYPICAL SPECIFICATIONS OF SOME COMPONENTS

	LOW PRICE	MEDIUM PRICE	HIGH PRICE
TUNER (OR TUNER SECTION OF RECEIVER)			
IHF Sensitivity μ V (dBf) (mono)	3.0 (14.7) or lower	2.0 (11.2) or lower	1.8 (10.3) or lower
50 dB quieting sensitivity μ V (dBf), mono/stereo	10(25.2)/50(39.1)	5(19.2)/40(37.2)	3(14.7)/30(34.7)
S/N (dB); mono: stereo	60/50	68/60	70/65
Selectivity (dB)	50 or more	60 or more	80 or more
Capture Ratio (dB)	3.0 or less	2.0 or less	1.3 or less
THD (%) (1 kHz, mono/stereo)	1.0/1.5 or less	0.5/0.8 or less	0.2/0.3 or less
Stereo Separation (dB, 1kHz)	30 or more	35 or more	40 or more
AM Suppression	40 or more	50 or more	60 or more
AMPLIFIER (OR RECEIVER AMP SECTION)			
Power Out/Channel (Continuous watts)	10-30	30-100	over 100
Rated THD (at full output) (%)	1.0 or less	0.5 or less	0.2 or less
Rated IM Distortion (%)	1.0 or less	0.5 or less	0.2 or less
Damping factor	10 or more	30 or more	50 or more
Phono Hum (dB below 10 mV input)	60 or more	65 or more	70 or more
Aux Hum (below rated output)	70 or more	75 or more	80 or more
TURNTABLE SYSTEMS			
Wow-and Flutter (% Wrms)	0.15 or less	0.10 or less	0.05 or less
Rumble (dB, per DIN B)	55 or more	60 or more	70 or more
CASSETTE DECKS			
Frequency Response (Hz \pm 3dB)	50-12,000	30-15,000	20-18,000
Wow-andFlutter (% Wrms)	0.2 or less	0.12 or less	0.1 or less
S/N (dB, less Dolby)	45 or more	48 or more	50 or more
OPEN-REEL DECKS			
Highest Speed (ips)	7½	7½	15
Freq. Response at highest speed (Hz \pm 3 dB)	40-15,000	30-20,000	20-21,000
S/N	50 or more	55 or more	60 or more
Wow and Flutter	0.15 or less	0.1 or less	0.07 or less

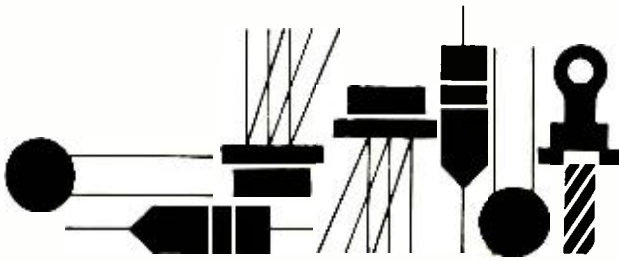

Solid State

By Lou Garner

VMOS—MOSFETS WITH MUSCLE

GENERALLY, MOSFET's have been characterized as low-voltage, low-power, very high-impedance devices suitable for preamps, mixers, i-f amplifiers, detectors and other low-level applications. Where moderate power levels were needed, one used bipolar devices or dual-technology IC's such as the *BiMOS* op amp discussed in last month's column. About mid-1976, however, *Siliconix, Inc.* (2201 Laurelwood Road, Santa Clara, CA 95054), introduced the first member of a new family of medium-to-high-power MOSFET's. Manufactured using a unique internal structure, the new devices featured output currents measured in amperes rather than milliamps and power ratings specified in watts rather than milliwatts while retaining the advantages of more familiar designs—extremely high input impedances and high forward transconductances. Unfortunately, the new MOSFET's were relatively expensive and in short supply when first introduced, limiting their potential applications at the consumer level. In less than a year, however, production has expanded, new types have been announced, prices have dropped to within the reach of experimenters and hobbyists, and the devices are being stocked by a number of industrial electronics distributors.

The basic differences in construction between conventional MOSFET's and the high-power Siliconix devices are illustrated in the simplified cross-sectional views given in Fig. 1. In a conventional device, Fig. 1A, a p-type semiconductor substrate serves as the basic body for the transistor. During the manufacturing process, n+ type source and drain areas are diffused into the p-type body. An insulating silicon dioxide layer is grown and aluminum electrodes for the source, drain and insulated gate terminals are deposited on the unit. In operation, the control channel is induced by the gate's electric field along the top surface of the substrate between the n+ regions, with current flow horizontally from source to drain. In the Siliconix design, Fig. 1B, an n+ semiconductor serves as the substrate and, eventually, as the drain electrode. An n-epi layer is diffused above the substrate, with a p- "body" region and an n+ source subsequently diffused into this layer. The epi region effectively increases the device's drain-source breakdown voltage. In the next processing step, a V-shaped groove is etched through the source and "body" regions into the epi layer. An insulating silicon dioxide film is grown and the aluminum source and insulated gate electrodes are deposited on the device. In operation, the control channel is induced on both surfaces of the "body" region facing the V-shaped gate, with current flow vertically from the source through the control channel and epi layer to the substrate/drain. Since the current flow is vertically through the semiconductor rather than horizontally across a surface, the transistor is called a "Vertical MOS" or VMOS device. The improved power handling capability of VMOS designs as compared to conventional MOSFET construction is due to several factors, including its higher drain-source breakdown voltage and greater current density, the latter a result of the effectively larger control region established by the two channels created on either side of the V-shaped gate.

Currently, all members of the VMOS family are n-channel enhancement-mode field effect transistors. A total of six devices are in production, divided into two series of three transistors each, but a third high-current (10 A) series is under development and should be available in the near future. All six devices feature high input impedances, zener diode protected gates to withstand static discharges, and short switching times (typically, 4 ns), permitting their use in r-f and vhf as well as audio and dc circuits. All are resistant to thermal runaway as well as secondary breakdown and are suitable for operation at temperatures from -55° to +150°C. Featuring output characteristics similar to those of a pentode vacuum tube, all types have typical transconductances of better than 250 millimhos.

Intended for medium-power applications and assembled in standard TO-3 packages, types VMP1, VMP11 and VMP12

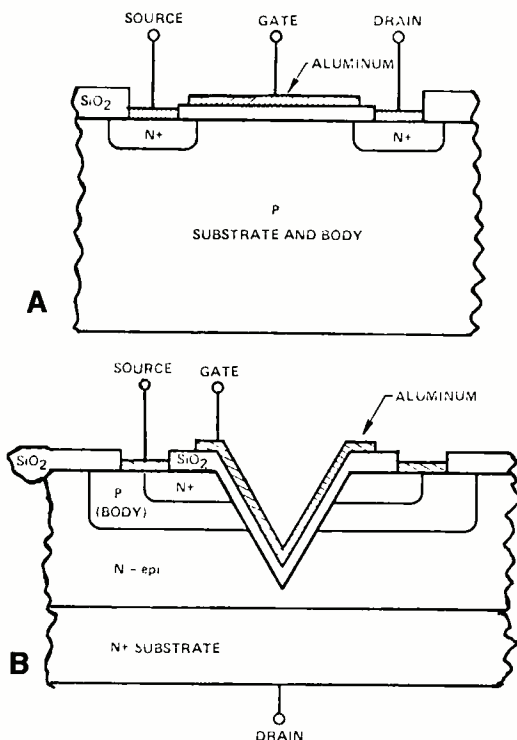

Fig. 1. Conventional MOS (A) and VMOS (B) cross-sections.

have maximum drain current ratings of 2.0 A and can dissipate up to 25.0 W at case temperatures not exceeding 25°C, with a thermal derating factor of 5°C/W. Lower power types VMP2, VMP21 and VMP22 are assembled in TO-39 cases and have maximum drain current ratings of 1.5 A together with maximum power dissipation ratings of 4.0 W at case temperatures of 25°C and a thermal derating factor of 30°C/W. At ambient temperatures of 25°C, the lower power units have a maximum free air dissipation rating of 1.0 W. Types VMP11 and VMP21 have maximum drain-source and drain-gate voltage ratings of 35.0 volts, types VMP1 and VMP2 of 60.0 V, and, finally, types VMP12 and VMP22 of 90 V.

As long as maximum ratings and correct dc polarities are observed, VMOS transistors can be used in virtually all circuits for which standard MOSFET's and bipolar types are specified. Compared to conventional MOSFET's, the VMOS units offer the advantages of higher voltage and power capabilities coupled with greater resistance to damage from static discharges. Compared to bipolar types, the VMOS transistors offer much higher input impedances, faster operation, and

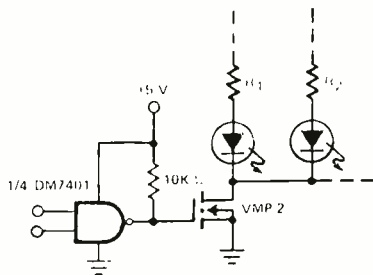

Fig. 2. VMOS application as a LED driver.

freedom from thermal runaway and secondary breakdown. Suggested VMOS transistor circuit applications are illustrated in Figs. 2 through 6. These were abstracted from the data sheets for the devices as well as from Siliconix Application Note AN76-3, a 12-page publication entitled *VMOS—A Breakthrough in Power MOSFET Technology*.

With its high input impedance, the VMOS transistor can interface directly with all types of logic circuits, including CMOS as well as TTL, serving as a power driver for such devices as magnetic cores, incandescent lamps, relays, solenoids and LED's. A typical multiple LED driver circuit is given in Fig. 2. Here, a 7401 TTL NAND gate serves as a signal source for the VMOS transistor which, in turn, drives a number of LED's. Suitable series current limiting resistors (*R1*, *R2*, etc.) are provided for each LED.

The dc incandescent lamp dimmer circuits given in Fig. 3 illustrate techniques for using the VMOS transistor as a control device. In the simpler and less efficient of the circuits, Fig. 3A, the transistor serves as a series element, with its drain-source resistance controlled by an adjustable gate bias. In operation, considerable power is dissipated in the transistor as the light is dimmed for the device behaves as a simple resistance.

The more efficient circuit, Fig. 3B, uses the VMOS transistor as a variable duty cycle switch which is either fully "on" or fully "off," thereby dissipating relatively little power. In operation, a pair of 34011 NAND gates serves as a pulse oscillator, with the feedback needed to start and sustain oscillation provided by a 0.001-μF capacitor. The oscillator's pulse symmetry is controlled by the ratio of the 100-k fixed resistor and 250-k potentiometer, with light-dimming achieved by changing the relative width of the on and off periods. If desired, the oscillator can be strobed by the application of a suitable bias to the first NAND gate, as shown, or the two inputs may be tied together for continuous operation.

SYSTEM 5000

The New Programmable Clock Kit from Digital Concepts. \$29.95



SYSTEM 5000 is the programmable clock kit that makes kit building a new experience. The system has been designed to meet a variety of particular requirements and tastes, and programming techniques are used to create a truly individualized timepiece. Numerous functions and features are provided for maximum flexibility and adaptability, and any or all can be used to construct many different types of time keeping and timing devices.

SYSTEM 5000 is not a simple LED time of day clock, but a full feature digital timing system. Programming is accomplished by connecting the appropriate jumpers and switches to produce the desired system configuration. Complete assembly and programming manuals are included.

SYSTEM 5000 has a fluorescent readout panel with four 0.5" numerals that brighten and dim automatically according to the ambient light. This unique digital display provides optimum readability at all times from almost any viewing angle.

SYSTEM 5000 can be built as a desk clock, alarm clock, calendar, clock or all of these in one full feature timepiece. The Duplicate Time Register can monitor elapsed time or another Time Zone such as GMT. A ten minute 10' remainder capability is included for Radio Station use. A quartz time base is available for high precision stability and uninterrupted operation if the AC line should fail.

SYSTEM 5000 is an automatically control AC or DC accessories up

to 700 Watts by adding the optional relay. Plug in your radio or stereo to construct a full fun from slark radio that puts you to sleep with gentle music and wakes you to music, a tone or both. The system will also control TV's, small appliances or other accessories. SYSTEM 5000 can be used to construct timers for a variety of applications. It is ideal for automatic process times and controllers in laboratories, workshops, and engineering facilities. SYSTEM 5000 includes all components, speaker, two time setting switches, and comprehensive instruction and programming manuals. Case & switches for programmable additional functions are not included but available as options. \$29.95

FEATURES AND SPECIFICATIONS

Timekeeping Functions	Display	General
<ul style="list-style-type: none"> Time of Day Register Duplicate Time Register True 24 Hour Alarm Duplicate 24 Hour Alarm 10 Minute Snooze on Alarms True Four Year Calendar One Hour Down Counter 	<ul style="list-style-type: none"> Bright 4 Digit Fluorescent Panel Automatic Brightness Circuit 17 or 24 Hour Display Format PM and Power Failure Indication 1 Hz Activity Indicator Power On Clear Direct Drive Eliminates all RF! 	<ul style="list-style-type: none"> Forward or Reverse Time Setting Reset and Count Inhibit Controls Seconds Display Single 9 Volt Battery Backup 700 Watt Relay Optional 50 or 60 Hz 117Vac. 3 Watts 1.5 H x 4 W x 4 D

RELAY OPTION - \$4.00

Includes 700 watt relay and all interface components. Will control AC or DC accessories such as appliances, stereos, etc.

QUARTZ TIME BASE OPTION - \$6.95

Generates precise 60 Hz buffered output with exceptional stability, reliability, and accuracy. Direct interface to System 5000 and most other clocks. Includes Quartz Crystal, IC Divider, trimmer, compact G-10 board, all necessary components, instructions, and installation directions.

SWITCH OPTION - \$3.75

Contains 4 black SPST pushbuttons, 2 black DPDT pushbuttons and 2 black SPST slide switches. Programs all major features.

CASE OPTION - \$11.00

This deluxe hand finished solid walnut (3 8" cabinet forms an ideal housing for the completed system. Includes rear panel and standard blue facelate, extra facelates (blue or green) are \$1.00 ea. Cabinet dimensions: 5 1/2" x 5 1/2" x 3 1/2".

ORDER THIS EXCITING KIT TODAY AND PUT ELECTRONIC TIMEKEEPING TO WORK FOR YOU!



Send your check or money order today for fast delivery. Add 5% to total order to cover shipping and insurance. N.J. residents must also add 5% sales tax.



digital concepts

Digital Concepts Corporation • 745 Route 46
Saddle Brook, New Jersey 07862 • (201) 845-7101

The fabulous Phi-Deck[®] family of 5 cassette transports under \$100 in quantities of 10



- Featuring:
- Die-cast frames
 - Remote controllable
 - Precise, fast head engage/disengage
 - Quick braking
 - Search FF/rewind 120 ips
 - Speed ranges from .4 to 20 ips

Electronic packages and mag heads for most applications

For application in:

- Micro processing
- Data recording/logging/storage
- Programming
- Instrumentation
- Industrial Control
- RS232 Data storage
- Security/automatic warning systems
- Test applications
- Audio visual/education
- Telephone interconnect
- Hi-Fi
- Point of sale



Title I A Division of the Economy Co.

4605 N. Stiles P.O. Box 25308

Oklahoma City, Oklahoma 73125 (405) 521-9000

- I am interested in application no. _____
- Have Representative call Send application notes

Name _____ Title _____

Company Name _____

Address _____

City _____ State _____ Zip _____

Phone Number _____

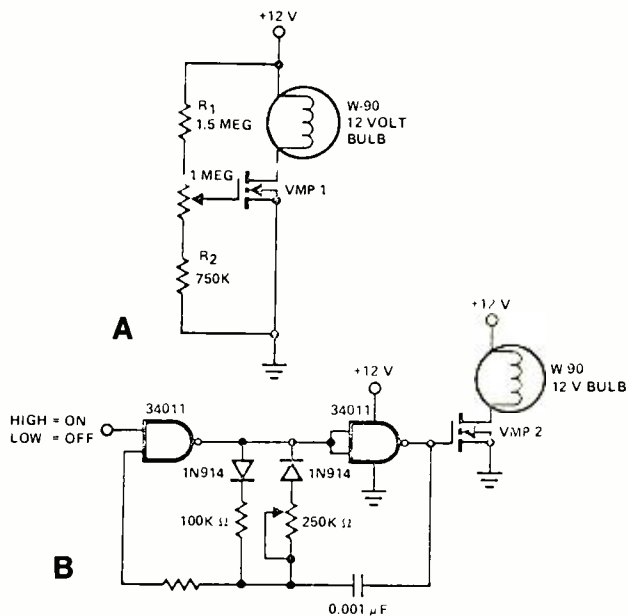

Fig. 3. VMOS light dimmer circuits: (A) Continuous (analog) control; (B) Pulse-width switched type.

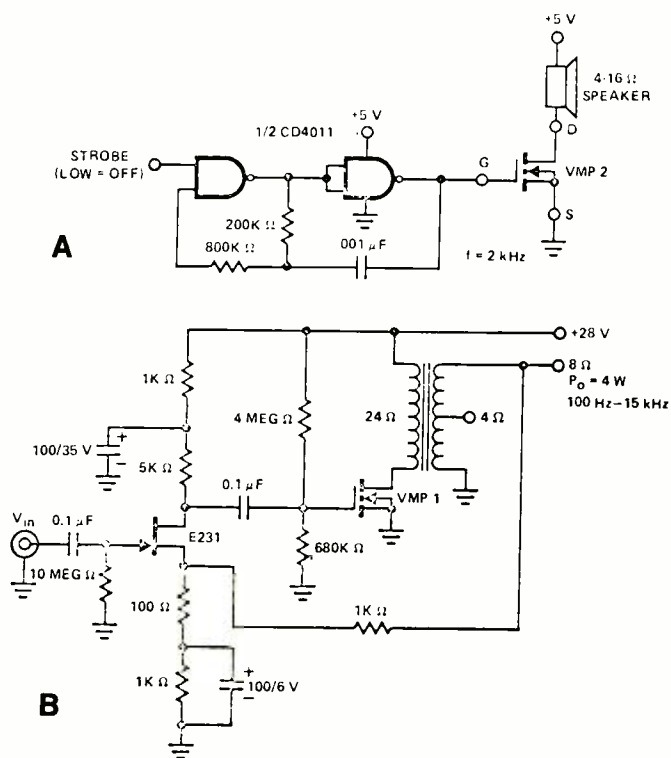

Fig. 4. VMOS audio circuits: (A) Alarm; (B) Class A amplifier.

Two of many possible audio circuit applications for VMOS transistors are illustrated in Fig. 4. The first, Fig. 4A, is a simple sound source which may be used in intrusion and fire alarms or similar projects. The design features a NAND gate oscillator similar to the one used in the second lamp dimmer circuit, with the VMOS transistor serving as a power driver for a PM loudspeaker.

The second, Fig. 4B, employs a single VMOS transistor as a Class A linear power amplifier in conjunction with a JFET preamp stage. Suitable for use in radio receivers, TV sets,

record players, intercoms, and low-power PA installations, the circuit can deliver 4 watts to a suitably matched loudspeaker load and has a reasonably flat frequency response from 100 Hz to 15 kHz. Overall distortion is kept to within 2% (at 3 W output) by 10 dB of inverse feedback provided by a 1-k resistor between the output and the preamp's source electrode. A 28-volt dc supply is required.

With their fast switching characteristics, VMOS transistors are suitable for many high-frequency projects. A typical linear vhf amplifier circuit is illustrated in Fig. 5. Designed for operation in the 144-to-146-MHz band, the design may be used in both transmitter and receiver applications. As a transmitter power amplifier, the stage has a minimum power gain of 12 dB and can deliver 5 W PEP at 146 MHz. If used as a receiver r-f preamp, the design can furnish 11 dB gain with a low noise factor of only 2.4 dB. All resistors are half-watt types and the coils are hand-wound, with T1 consisting of 8 turns of #24

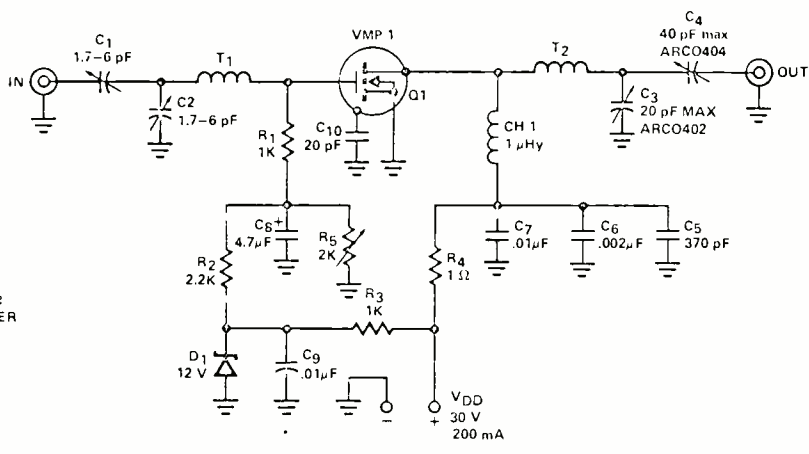

Fig. 5. Vhf linear amplifier using a VMOS transistor.

AWG, 1/8-in. diam., close-wound, and T2 of 5 turns of #24 AWG, 1/8-in. diam., close-wound. In common with most vhf designs, careful layout and proper lead dress during assembly are essential for optimum circuit performance.

A further example of the VMOS transistor's versatility is found in the high-power audio amplifier circuit shown in Fig. 6. Of potential interest to audiophiles and more advanced experimenters, the design is suitable for use in high-quality stereo or quadraphonic systems. Capable of delivering 40 watts to an 8-ohm load, the amplifier has an essentially flat closed-loop frequency response (exclusive of the r-f input filter) from 1 Hz to 1 MHz and a slew rate of better than 100 V/μs. Its total harmonic distortion at 1 kHz, full rated output, is less than 0.05%. Featuring a Class AB quasi-complementary push-pull output stage using three paralleled VMOS transistors in each arm, the circuit is described in detail in Siliconix Design Aid DA76-1, *The MOSPOWER™ FET Audio Amplifier*. In addition to the schematic diagram and a suggested dc power supply circuit, the 4-page publication includes pc board and chassis layouts, response curves, signal waveforms, construction and adjustment hints, and a detailed parts list.

Reader's Circuit. Both early and contemporary design concepts are combined in the interesting AM broadcast band receiver circuit illustrated in Fig. 7. Submitted by William J. Wolf (3543 Dubarry Rd., Indianapolis, IN 46226), the circuit features a *reflex* front-end, an IC op amp audio amplifier and a Darlington power output stage. Old timers probably will re-

SHOP YOUR NEARBY RADIO SHACK FOR QUALITY PARTS AT LOW PRICES!

Top quality devices, fully functional and carefully inspected. Guaranteed to meet all specifications, both electrically and mechanically. All are made by well known American manufacturers, and all have to

pass manufacturer's quality control procedures. These are not rejects, not fallouts, not seconds. In fact, there are none better on the market! Count on Radio Shack for the finest quality parts.



TTL Digital ICs

First Quality Devices Made by National Semiconductor and Motorola

Type	Cat No	Reg	SALE
7400	276-1801	\$ 49	29c
7402	276-1811	\$ 49	29c
7404	276-1802	\$ 59	29c
7406	276-1821	\$ 69	39c
7408	276-1822	\$ 49	29c
7410	276-1807	\$ 49	29c
7413	276-1815	\$1 19	69c
7420	276-1809	\$ 49	29c
7427	276-1823	\$ 69	39c
7432	276-1824	\$ 69	39c
7441	276-1804	\$1 59	89c
7447	276-1805	\$1 99	89c
7448	276-1816	\$1 99	89c
7451	276-1825	\$ 49	29c
7473	276-1803	\$ 79	39c
7474	276-1818	\$ 79	39c
7475	276-1806	\$1 19	69c
7476	276-1813	\$ 79	49c
7485	276-1826	\$1 59	89c
7486	276-1827	\$ 69	49c
7490	276-1808	\$1 19	69c
7492	276-1819	\$1 19	69c
74123	276-1817	\$1 69	89c
74145	276-1828	\$1 49	1 19
74150	276-1829	\$1 79	1 39
74154	276-1834	\$1 79	1 19
74192	276-1831	\$1 69	99c
74193	276-1820	\$1 69	99c
74194	276-1832	\$1 69	1 19
74196	276-1833	\$1 69	1 19

74C and 4000 Series CMOS ICs

Type	Cat No	Reg	SALE
74C00	276-2301	\$ 69	39c
74C02	276-2302	\$ 69	39c
74C04	276-2303	\$ 69	39c
74C08	276-2305	\$ 69	39c
74C74	276-2310	\$1 29	59c
74C76	276-2312	\$1 69	69c
74C90	276-2315	\$2 29	99c
74C192	276-2321	\$2 49	1 29
74C193	276-2322	\$2 49	1 29
4001	276-2401	\$ 69	39c
4011	276-2411	\$ 69	39c
4013	276-2413	\$1 29	89c
4017	276-2417	\$2 49	1 49
4020	276-2420	\$2 49	1 49
4027	276-2427	\$1 29	89c
4049	276-2449	\$ 99	69c
4050	276-2450	\$ 99	69c
4511	276-2447	\$2 69	1 69
4518	276-2490	\$2 49	1 49

Linear ICs

First Quality Devices by National Semiconductor and Motorola



Type	Cat No	Reg	SALE
301AH	276-017	\$ 69	29c
324N	276-1711	\$1 99	1 49
339N	276-1712	\$1 99	1 49
386CN	276-1731	\$1 99	99c
555CN	276-1723	\$1 49	89c
556CN	276-1728	\$2 99	1 29
565CN	276-1724	\$2 99	1 29
567CN	276-1725	\$2 99	1 39
723CN	276-1740	\$ 99	59c
723H	276-009	\$ 99	59c
741CN	276-007	\$ 69	35c
741H	276-010	\$ 69	35c
3900N	276-1713	\$1 99	59c
3909N	276-1705	\$1 29	99c
3911N	276-1706	\$2 19	1 99
4250CN	276-1732	\$1 99	1 19
4558CN	276-038	\$ 99	69c
13741H	276-1733	\$2 59	1 49
75491	276-1701	\$1 49	69c
75492	276-1702	\$1 49	69c

8080A Microcomputer Chip

Direct Plug-In Replacement for Intel 8080A

1795

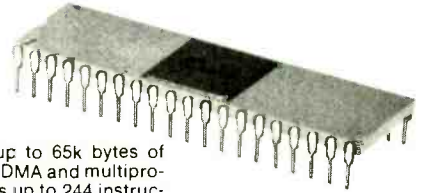

A CPU with a 16-bit address bus capable of addressing up to 65k bytes of memory and up to 256 I/O ports. "TRI-State" data bus gives it DMA and multiprocessing capability, and all buses are TTL compatible. Handles up to 244 instructions of variable length, with 6 general purpose registers plus an accumulator. 40-pin DIP. 100% Prime. 276-2510 17.95

LEDs/Optoelectronics



Item	Cat No	Reg	SALE
L Red LED	276-041	2/99c	2/69c
L Cir LED	276-017	2/99c	2/69c
M Red LED	276-026	2/99c	2/69c
M Cir LED	276-040	2/99c	2/69c
S Red LED	276-042	2/99c	2/69c
Infrared Det	276-140	\$1 19	
Infrared Em	276-141	\$1 19	
Solar Cell	276-115	\$1 49	
PhotoCell	276-116	\$ 99	
FPT 100	276-130	\$ 79	

Digital Displays

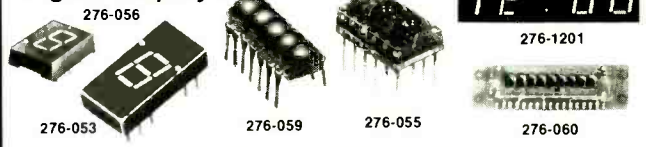

Digits	Size	Drive	Cat. No	Reg	SALE
1	0 3	Anod	276-053	\$2 99	1 99
1	0 3	Cath	276-062	\$2 99	1 99
1	0 3	Anod	276-1210	4/58 97	4/6 95
1	0 3	Cath	276-1211	4/58 97	4/6 95
1	0 6	Anod	276-056	\$3 99	2 99
1	0 6	Cath	276-066	\$3 99	2 99

Project Accessories

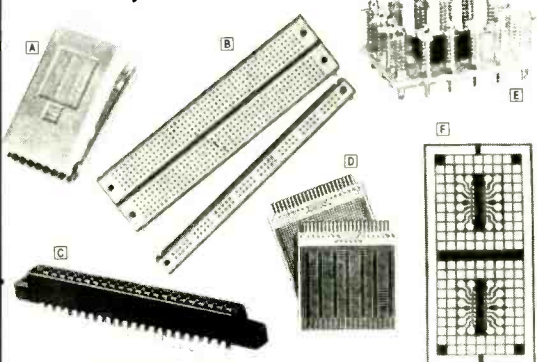

- IC Troubleshooting Test Clip. Test up to 16 pins with probes or clips. 276-1951 4 99
- Experimenter Socket. 2x47 rows of 5 connected tie points. 276-172 9 95
- Bus Strip. 2x40 connected tie points. Clips to socket above. 276-173 1 99
- 22-Pin Edge-Card Board Connector. 14 terminals. 276-1551 2 99
- Standard Edge-Card Board. 22-pin. 1295 mounting holes. 276-152 2 99
- 2-Voltage Source Edge-Card Board. 1368 mounting holes. 276-154 2 99
- 3-Voltage Source Edge-Card Board. 1368 mounting holes. 276-153 2 99
- Solderless IC Experimenter Kit. For 8, 14 or 16-pin IC's. 277-101 2 99
- Experimenter's PC Board. Mount 2 IC's. 8, 14 or 16-pin. 276-151 2 49
- Plastic Face Plates 2x6x4. 99c
- Brown Tint. 270-298 99c
- Red Tint. 270-299 99c
- Photographic PC Board Processing Kit. Complete negative process. 8 pieces. 276-1560. Reg. \$12 95 Sale 9 95

Selected Diodes

Type	Cat. No	Reg	SALE
1N4001	276-1101	2/S. 39	2/29c
1N4003	276-1102	2/S. 59	2/39c
1N4004	276-1103	2/S. 69	2/49c
1N4005	276-1104	2/S. 79	2/59c
1N4735	276-561	2/S. 89	2/69c
1N4739	276-562	2/S. 89	2/69c
1N4742	276-563	2/S. 89	2/69c
1N4744	276-564	2/S. 89	2/69c
1N5401	276-1141	2/S. 69	2/59c
1N5402	276-1142	2/S. 89	2/69c
1N5403	276-1143	2/S. 99	2/79c
1N5404	276-1144	2/S. 19	2/89c
1N914/4148	276-1122	10/99c	

SCRs and Triacs

Device	Rating	Cat. No.	Reg.	SALE
SCR	50V, 6A	276-1089	\$ 99	69c
SCR	100V, 6A	276-1090	\$1 29	79c
SCR	200V, 6A	276-1067	\$1 39	89c
SCR	400V, 6A	276-1020	\$1 49	99c
Triac	50V, 6A	276-1003	\$ 99	69c
Triac	100V, 6A	276-1002	\$1 29	79c
Triac	200V, 6A	276-1001	\$1 39	89c
Triac	400V, 6A	276-1000	\$1 49	99c

Reference Books

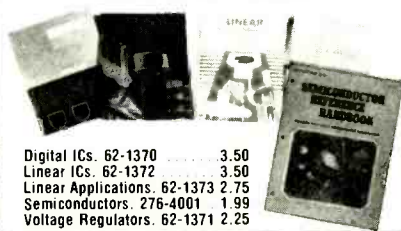

- Digital ICs. 62-1370 3.50
- Linear ICs. 62-1372 3.50
- Linear Applications. 62-1373 2.75
- Semiconductors. 276-4001 1.99
- Voltage Regulators. 62-1371 2.25

ASCII Encoded Computer Keyboard

Reg. 67.99 **49.95** Pkg.

Style May Vary from Photo



Operates on the scan principle utilizing TTL logic. With repeat key, negative/positive going data valid strobe, latch outputs, shift and shift-lock capability. True/false ASCII outputs, 6 extra control keys. With all necessary parts, including TTL components. Does not include test jigs, optional features or case and hardware. See store sales persons for parts list. 277-117. Complete Pkg. Sale 49.95

Low-Profile DIP Sockets



8-Pin.	276-1995	Reg. 2 for \$ 69	Sale 2/59c
14-Pin.	276-1999	Reg. 2 for \$1 19	Sale 2/99c
16-Pin.	276-1998	Reg. 2 for \$1 19	Sale 2/99c
28-Pin.	276-1997	Reg. \$1 19 Each	Sale 99c
40-Pin.	276-1996	Reg. \$1 39 Each	Sale 1 19

WHY WAIT FOR MAIL DELIVERY? IN STOCK NOW AT OUR STORE NEAR YOU!

OVER 5000 LOCATIONS IN NINE COUNTRIES

Radio Shack

A TANDY COMPANY • FORT WORTH, TEXAS 76107

Heathkit®

SPRING 1977

Heathkit products are known world-wide for quality, performance and VALUE. And no matter what your interest — there's a kit that's just right for you. Every Heathkit product comes with a thorough step-by-step assembly manual that leaves nothing to chance, and all our kits are backed by our famous "We won't let you fail" pledge. See all the exciting electronic products YOU CAN BUILD YOURSELF right here in this catalog.

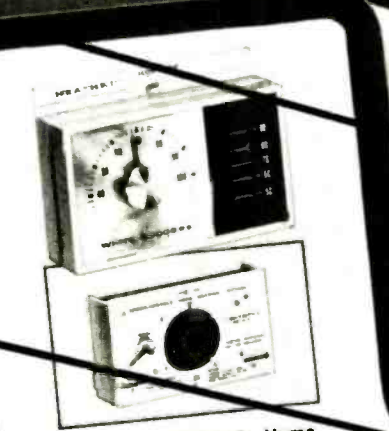

HEATH
MAIL ORDER CATALOG

"Heath" and "Heathkit" are registered trademarks of Heath Company.

© 1977 Heath Company
See Index on page 3

Heath Company, Dept. 1C-29
Benton Harbor, Michigan 49022
POPULAR ELECTRONICS

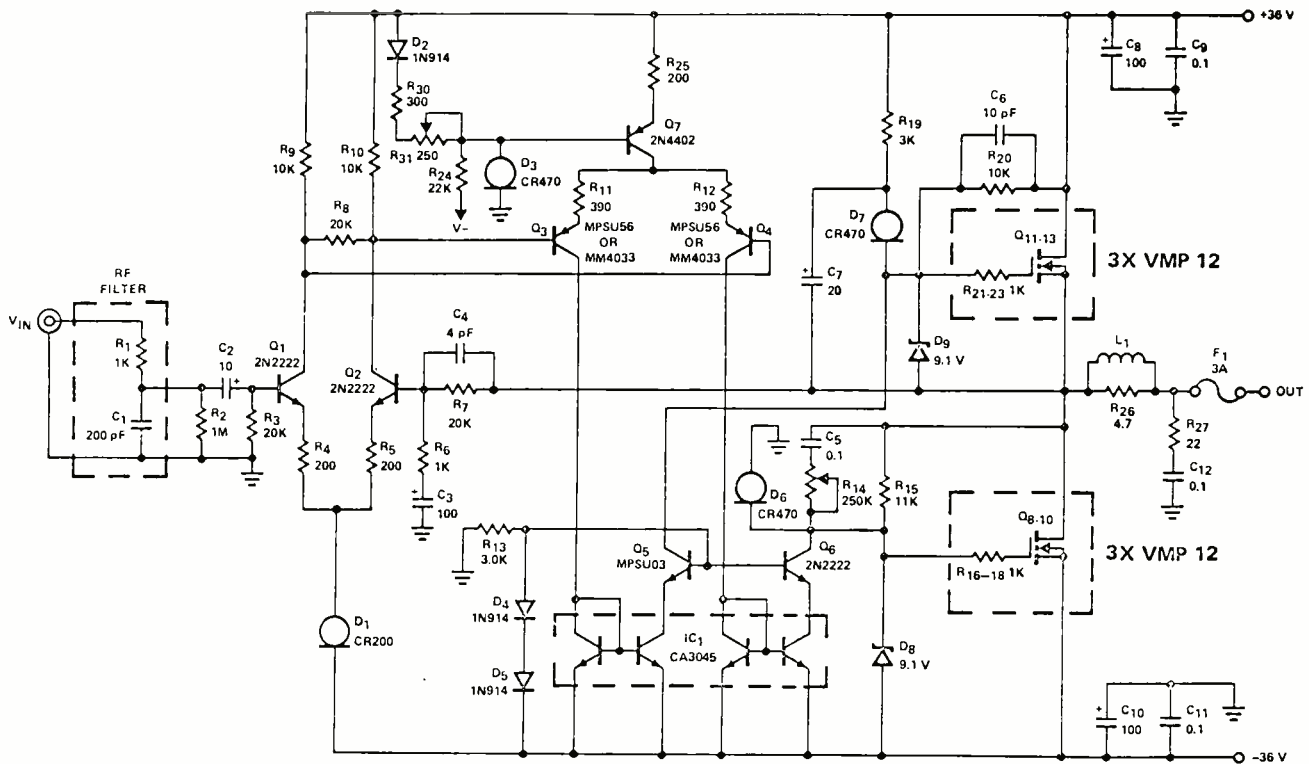

Fig. 6. 40-watt audio amplifier featuring a VMOS transistor output stage.

member the reflex circuit concept with a touch of nostalgia. Popular in the early to middle 50's, when good quality r-f transistors cost as much as fifty dollars each (pre-inflation dollars, at that!), the reflex circuit permits a single device to amplify two different signals—r-f and audio—*simultaneously*.

In operation, r-f signals picked up and selected by tuned circuit L1-C1 are applied to Q1, serving, initially, as an r-f amplifier. An amplified signal is developed across r-f collector load L2 and coupled through C3 to a detector network consisting of D1, R2, D2 and r-f bypass C2. The resulting demodulated (audio) signal *also is applied* to Q1, now serving as an audio amplifier and developing an amplified signal across the audio collector load, T1's primary winding. The RFC (L2) acts virtually as a short as far as audio signals are concerned. The audio signal is next coupled through gain control R3 and dc blocking capacitor C4 to op amp IC1, which serves to drive the final power output stage, Darlington connected pair Q2-Q3. A PM loudspeaker, shunted by R9, serves as the output load. Inverse feedback is provided across the power output and driver stages through R8 to minimize distortion and optimize over-

all performance. Reflex amplifier (Q1) base bias is furnished through R1, the op amp's offset biases through R5 and R6 with, finally, the Darlington receiving its base bias directly from IC1 through current limiting resistor R7, bypassed by C6. Circuit operating power is supplied by B1, controlled by S1.

Except for the hand-wound loop antenna coil, L1, William has specified standard, readily available components in his design. Transistor Q1 is a general purpose pnp device similar to Radio Shack's type RS-101, IC1 is one section of an inexpensive type LM3900 quad op amp, Q2 and Q3 are hobby-grade type 2N3055 npn power transistors, and D1 and D2 are general-purpose diodes similar to types 1N34 or 1N60. A 2.5-mH RFC is used for L2, while T2 is a small 10-k to 2-k inter-stage audio transformer similar to Radio Shack's No. 273-1378. Tuning capacitor C1 is a standard 365-pF unit and all other capacitors are low-voltage disc ceramics except for C4, which is a 15-volt electrolytic. The fixed resistors are all one-quarter or one-half watt types. Any standard PM loudspeaker with an 8- or 16-ohm voice coil may be used as the output device. The power switch, S1, is a spst toggle, slide or

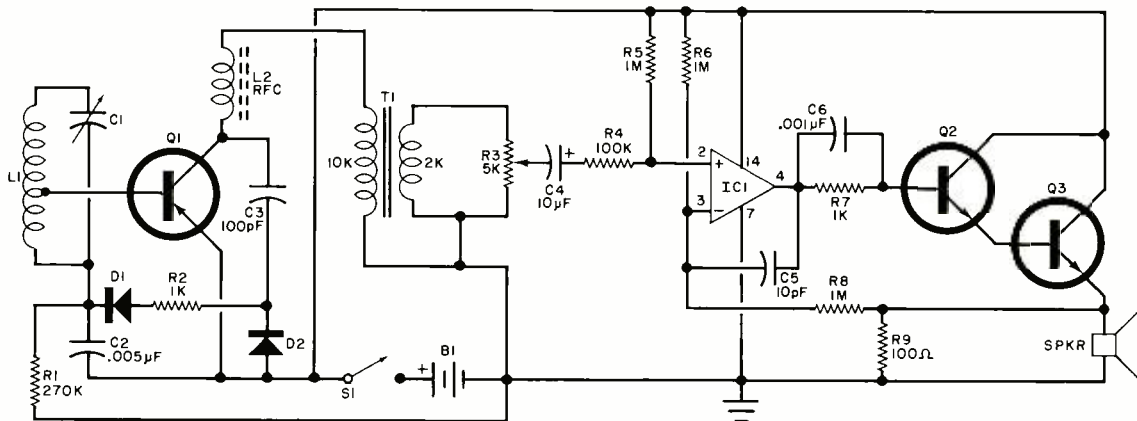

Fig. 7. Broadcast band receiver has reflex front end and IC op amp audio amplifier.

rotary type, with the power pack, B1, made up of six series-connected size "C" or "D" flashlight cells. William describes L1 as a loop antenna consisting of 16 turns of #22 solid copper insulated hook-up wire tapped at 12 turns and close-wound on a wooden frame measuring 10 in. high by 13 in. long by 3 in. wide.

Although neither layout nor lead dress should be critical when duplicating the circuit, good wiring practice should be followed, with signal carrying leads kept short and direct, heat sinks provided for the power transistors (Q2 and Q3), and all dc polarities observed. The reader suggests that the entire circuit, including the loudspeaker and power pack, can be assembled conveniently within the wooden frame supporting the loop antenna. Depending on Q1's individual characteristics, some experimentation with R1's value may be required for optimum performance. Some hobbyists also may wish to experiment with the number of turns on the loop antenna coil or with C1's value to obtain coverage of other radio bands. If desired, a multiple tapped coil and suitable selector switch can be provided for multi-band operation.

Device/Product News. Suitable for use in instruments, audio systems, controls, and similar analog applications, a new low-cost dual operational amplifier with a unity gain bandwidth over 2.5 MHz has been introduced by *Motorola Semiconductor Products, Inc.* (P.O. Box 20912, Phoenix, AZ 85036). Designated types MC4558/MC4558C, the new devices are offered in round metal cases as well as in ceramic and plastic 8-pin MiniDIP's. Internally compensated, the new op amps feature a typical large-signal voltage gain of 200 V/mV at 25°C and a CMRR of 90 dB. The two amplifiers within each package are closely matched with respect to both gain and phase, and both are protected against load short circuits.

If your requirements are for a quad rather than dual unit, you should be interested in the RC/RM4156 announced recently by *Raytheon Semiconductor* (350 Ellis St., Mountain View, CA 94040). Supplied in plastic or ceramic 14-pin DIP's, the op amps are short-circuit protected and feature a minimum unity gain bandwidth of 2.8 MHz.

The *Fairchild Camera and Instrument Corp.* (LSI Group, 464 Ellis St., Mountain View, CA 94042) is now offering a new dynamic bipolar 4096-bit random access memory (RAM) designed for operation on a single 5-V dc supply. Two versions of the new RAM are in production. Both are organized as 4096 × 1 bits and have a power consumption of 350 mW active, 70 mW standby, and 500 mW in page mode. The standard 93481 has a maximum access time of 120 ns with a 280-ns cycle time, and a page mode access and cycle time of 75 ns. The faster version, type 93481A, has a maximum access time of 100 ns with a 240-ns cycle time, and a page mode access and cycle time of 65 ns. Manufactured using Fairchild's Isoplanar Integrated Injection Logic process, the new RAM's are TTL compatible and are supplied in standard 16-pin ceramic DIP's.

National Semiconductor Corp. (2900 Semiconductor Drive, Santa Clara, CA 95051) has developed a new single-chip IC containing a pair of monolithic npn transistors matched to within 50 μV of each other. Identified as type LM194, the matched pair has a noise figure so low that it is virtually immeasurable and features a minimum current gain of 500, a current-gain match of better than 2%, a CMRR of better than 120 dB, and a low drift of less than 0.1 μV/°C. With a maximum collector-emitter voltage rating of 40 V and a maximum power dissipation of 500 mW, the LM194 is supplied in a 6-lead TO-5 style metal case. ◇

**MIND-ABSORBING PROJECTS FOR
ELECTRONIC EXPERIMENTERS
AND HOBBYISTS**



**1977
ELECTRONIC
EXPERIMENTER'S HANDBOOK**

**Helps you get it together
with a score of
build-it-yourself projects.**

This latest edition includes a host of exciting construction projects for audio buffs—Audio-Controlled Detailed Power Shut Off; 9-Channel Stereo Equalizer . . . For fun and games—FLIP, a CMOS Logic Game; Sound Effects with the 555 IC Timer . . . for experimenter's—ESP Testing Machine; How to Make Double-Sided PC Boards; IC Digital Logic Memory Probe . . . for computer/calculator enthusiasts—An Under-\$30 Scientific Calculator; Microcomputer Primer; Bits-to-Dots Computer Video. There's a host of other projects including The Executive Digital Temper Countdowner • Versatile Nickel-Cadmium Battery Charger • Shirt-Pocket Metronome • Hall Effect Magnetometer • Low-Cost Metal Locator • 3-Way Photo Flash Tripper • The 99-cent Wonder IC • High-Value Electrolytic Capacitor Meter • Guitar Sound Intensifier • IC Photo Tachometer • R-F Transistor Tester • And more! PLUS: Microcomputer product buying guide and a basic digital logic course. All with complete construction plans, parts lists and printed-circuit board patterns. Many projects are unique designs not available elsewhere. Only \$1.85!

Ziff-Davis Publishing Co.
Consumer Service Division
595 Broadway, New York, N.Y. 10012

PE-577

Please send the 1977 ELECTRONIC EXPERIMENTER'S HANDBOOK 1'm enclosing \$1.85 (\$1.50 plus 35c for postage and handling). Outside U.S.A. \$3.00, postpaid.

Residents of Calif., Col., Fla., Ill., Mich., Mo., N.Y. State, D.C. and Tex. add applicable sales tax (postage and handling charges non-taxable).

print name _____

address _____

city _____ state _____ zip _____

COMING UP IN THE JUNE

Popular Electronics®

SPECIAL FOCUS ON TEST INSTRUMENTS

**DIGITAL IC TESTER PROJECT
BUYER'S GUIDE TO SCOPES
40-MHz DIGITAL FREQUENCY COUNTER
MILLIAMMETERS ON A BUDGET**

**POWER AND MODULATION CAPABILITY
OF 40-CHANNEL CB TRANSCEIVERS**

**HOW TO PROGRAM CALCULATORS
FOR FUN AND GAMES**

**BUILD A STATE-OF-THE-ART
BATTERY CHARGE MONITOR**

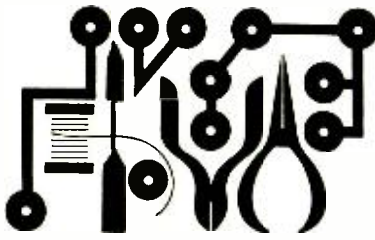

Experimenter's Corner

By Forrest M. Mims

USING LED'S AS LIGHT DETECTORS

LIGHT emitting diodes have many applications including status indication, digital readout, signal isolation, and light-beam communication. But did you know LED's can also be used as light detectors?

You can easily demonstrate the photo-

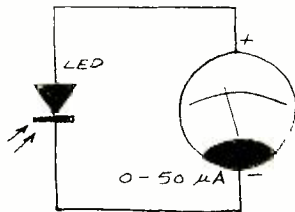

Fig. 1. Simple LED detector demonstration circuit.

sensitivity of a LED by using the simple circuit in Fig. 1. An infrared emitting LED such as the Texas Instruments TIL32 is connected directly to the terminals of a 0-50 microampere meter. This forms a *photovoltaic* circuit, and when the LED is placed near a desk lamp or other bright light source, the meter will indicate a photocurrent of at least 10 or 15 microamperes.

Though gallium-arsenide infrared emitting diodes make the best light detectors, visible emitters made from gallium arsenide phosphide, gallium phosphide, and other materials also work. For best results, use LED's with clear encapsulants. Remember that just as LED's emit a narrow spectrum of light,

they are sensitive to relatively narrow wavelength bands. Thus a green emitting diode will detect green light better than a red emitter; and infrared emitters will detect infrared far better than visible emitters.

LED's operated as detectors have several very practical applications. For example, an optoisolator can be made by mounting two infrared emitting diodes at either end of a short length of heat shrinkable tubing. The resulting op-

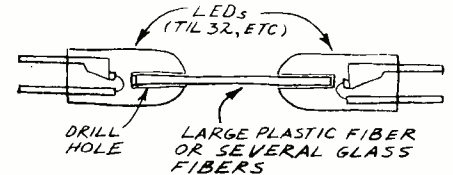

Fig. 2. LED-LED optoisolator using optical fiber coupling.

toisolator can then be used in either direction since the LED's can both emit and detect infrared.

You can also couple two epoxy-encapsulated LED's with a short length of plastic or glass optical fiber. Just bore a small hole in the top of each LED, using care to avoid striking the chip or its

Treat yourself to a new direct reading DVM today.



DVM35
POCKET PORTABLE
ANALOG REPLACEMENT
3-digit, 1% DCV
Battery or AC
Only \$134



DVM36
LAB ACCURATE
POCKET PORTABLE
3½ digit, .5% DCV
Battery or AC
Only \$158



DVM32
BENCH & FIELD MASTER
3½ digit, .5% DCV
Battery or AC
Only \$198



DVM38
"PRIME" STANDARD AT
YOUR FINGERTIPS
3½ digit, .1% DCV
Auto-Ranging
Only \$348

A COMPLETE LINE OF DVMs TO FILL YOUR EVERY NEED OR WANT.

You can be sure more times in more circuits, under more adverse conditions, with greater versatility, accuracy, and meter protection than any other digital multimeters on the market today; and for less money, too. 10 Day Free Trial: Try any of these famous DVMs for 10 days. If the DVMs in use don't prove exactly what we say, return them to your Sencore FLPD Distributor.

SENCORE

Want more information? We would like to tell you all about the Sencore DVMs by sending you a 24-page Sencore News, a six-page brochure, and the name of your nearest Sencore Distributor today... simply write or circle reader's service number.

3200 Sencore Drive, Sioux Falls, SD 57107

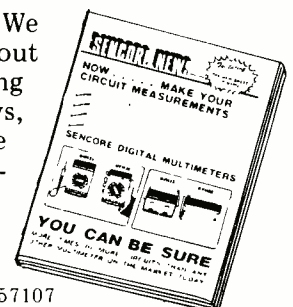

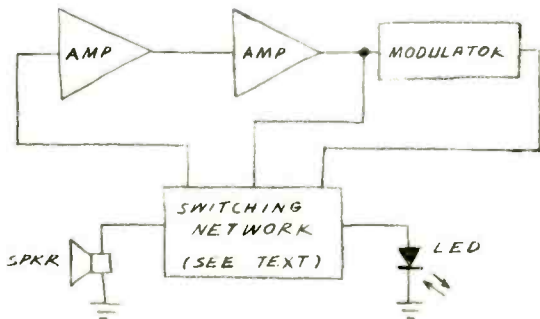

Fig. 3. Block diagram for single LED transceiver.

upper electrode wire. Then insert some clear epoxy, the fiber, and secure the fiber in place until the epoxy has cured. Figure 2 shows how two LED's are coupled together using this method.

Another possible application for a LED in the detector mode is to monitor the light intensity arriving from the sun or artificial sources at the face of a seven-segment LED display. An unused decimal-point LED could be used as the light detector for a circuit which could automatically control the brightness of the display.

The most intriguing application for

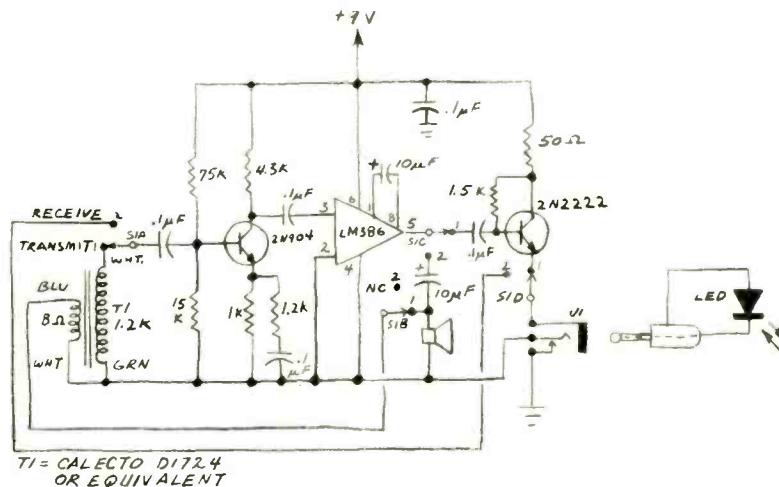

Fig. 4. Schematic diagram of a practical LED-LED transceiver.

LED's operated as detectors lies in the field of light-beam communications. One problem with light-beam communicators designed to operate through the atmosphere is optical alignment. (The most perplexing problem, of course, is the atmosphere itself.) Conventional light-beam communicators with separate LED transmitters and photodetector receivers must use two lens systems or complicated optics which allows both to use the same lens or lenses.

LED-LED communicators, however, need only one lens per transceiver. Then when the transmitter of one unit is aligned with the receiver of a second unit, the transmitter of the second unit is automatically aligned with the receiver of the first.

A Practical LED-LED Transceiver. The block diagram for a basic amplitude-modulated light beam transceiver using a single infrared LED as both a

You've seen the rest... now try the best.

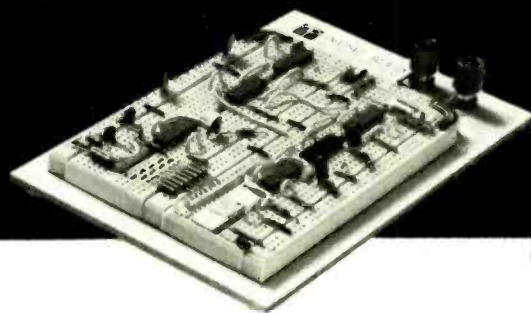
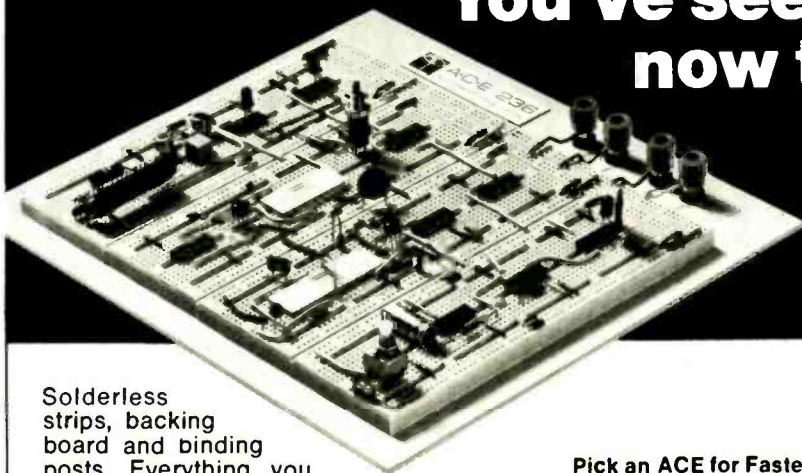

Solderless strips, backing board and binding posts. Everything you need to build and test your own circuit. Used to be you'd get a circuit idea, lay out a pc board, print it, solder everything together, trouble-shoot, change your layout, try a new board, and spend absolutely too much time breadboarding. Now A P ACE All Circuit Evaluators let you breadboard in a fraction of the time. Make your changes immediately. Keep full leads on your components. Avoid the heat damage possible with repeated soldering and de-soldering. A P made the first modern solderless breadboard, and we still make them best.

Pick an ACE for Faster and Easier solderless circuit building and testing.

Send for our complete A P catalog, The Faster and Easier Book.

Part No.	ACE Model No.	Tie Points	DIP Capacity	No. Buses	No. Posts	Board Size (inches)	Price Each
923333	200-K (kit)	728	8 (16's)	2	2	4-9/16x5-9/16	\$18.95
923332	208 (assem.)	872	8 (16's)	8	2	4-9/16x5-9/16	28.95
923334	201-K (kit)	1032	12 (14's)	2	2	4-9/16x7	24.95
923331	212 (assem.)	1224	12 (14's)	8	2	4-9/16x7	34.95
923326	218 (assem.)	1760	18 (14's)	10	2	6-1/2x7-1/8	46.95
923325	227 (assem.)	2712	27 (14's)	28	4	8x9-1/4	59.95
923324	236 (assem.)	3648	36 (14's)	36	4	10-1/4x9-1/4	79.95

Order from your A P distributor today. Our distributor list is growing daily. For the name of the distributor nearest you call Toll-Free 800-321-9668.

A P PRODUCTS INCORPORATED

Box 110 Painesville, OH 44077
(216) 354-2101 TWX: 810-425-2250



source and a detector is illustrated in Fig. 3. The circuit consists of a preamplifier, amplifier, LED driver and a switching network to switch the LED from the input of the preamplifier (receive mode) to the output of the driver (transmit mode). Several years ago I described a LED-LED communicator patterned upon this basic design in POPULAR ELECTRONICS ("Communicate Over Light Beams with the First Single-LED Transceiver," March 1974, p. 66). While this transceiver worked quite well, it used a relatively large audio amplifier module.

Figure 4 is the circuit diagram for a more up-to-date LED-LED transceiver made with an LM386 audio amplifier IC. Thanks to the LM386, the new circuit is much smaller and somewhat simpler than the original version. Also, the new circuit incorporates a simplified one-transistor modulator, a single 8-ohm speaker which doubles as a microphone, and a 9-volt battery.

I have assembled a working version of the circuit in Fig. 4 and installed it in a miniature bakelite cabinet measuring 3-1/4" x 2-1/8" x 1-1/8" (8.26 x 5.4 x 2.86 cm). There isn't enough room here to include all the construction details, but here are a few assembly tips: Use a perforated board measuring 2" x 1-15/16" (5.08 x 4.92 cm) to leave room for the 9-volt battery. Remove the upper two corners of the board to make room for the cabinet's cover screws. A 2" speaker fits perfectly in the space between battery and the upper end of the cabinet. All the components except the LED can be installed in a circle on the circuit board around the base of the speaker. The 4pdt switch fits between the upper two cover screw receptacles. Because of the limited space, the switch handle will have to emerge from the side of the cabinet opposite the front of the speaker.

Use a miniature phone jack to connect the LED to the circuit. Besides providing an automatic on-off switch, this will allow you to experiment with various kinds of LED's. It will also let you place the LED some distance from the circuit and simplify experimentation with different lenses.

I've used the transceiver in Fig. 4 for communications through the atmosphere and a fiber optic cable. Results with a 10-meter (32.8') length of glass fiber with an attenuation of a few hundred dB per kilometer were excellent. This cable should soon be available from some of the firms which specialize in experimenters' electronics components. Until then, you can try high-loss plastic fibers or stick to the atmosphere. ◇

Hobby Scene



By John McVeigh

SUPPRESSING BLOWER HASH

Q. *I built the CB converter described in the October issue and have installed it in a 1976 Plymouth Fury. However, the blower fan motor (for air conditioning, heating, and defrosting) creates so much static that it is impossible to operate it and the converter simultaneously. I do not have this problem when I use the AM/FM radio "straight through." Can you suggest a filter that will suppress this interference?—W. B. Grandjean, Baton Rouge, LA.*

A. I recommend the installation of 0.25- μ F coaxial capacitors across the terminals of each blower motor. The capacitor will act as a short circuit to the r-f hash generated by the sparking at the motor brushes, but will not affect the system from a dc point of view. The capacitors can be obtained from most auto supply houses, and can also be used to silence noisy gauges and sender units. Be sure that the case of the converter and the shield of the antenna lead-in are well grounded.

FM STATION LISTINGS

Q. *I would like to obtain a listing of FM radio stations. Do you know where I could get one?—Mrs. Don Ginest, Lakin, KS.*

A. As I recall, a very comprehensive list of FM broadcasters is offered by the Worldwide TV-FM DX Assoc., Box 163, Deerfield, IL 60015. Also, there's a listing in *North American Radio-TV Station Guide*, by Vane A. Jones, published by Howard W. Sams & Co.

NIXIE INTERFACE

Q. *How can I trigger 170-volt Nixie tubes with the 12-to-14-volt "digit enable" pulse from a 5313 clock chip?—LeRoy Lee, Altus, OK.*

A. I think the most inexpensive way to do this is to have the digit enable pulses turn on high-voltage npn switching transistors. These in turn would apply the

high voltage to the individual tubes. A suitable transistor is the Motorola HEP S0027. It has a collector-to-emitter breakdown voltage rating of 300 volts, maximum collector current of 500 mA, and a typical cut-off frequency of 50 MHz. However, if you go this route, be sure to include current limiting resistors at the base and collector of each transistor. Of course, some chips provide BCD outputs which can be decoded by suitable IC decoder/drivers. For example, the 7441 is specifically designed for use with Nixies.

TTL VS. CMOS

Q. *The circuit for the "Westminster Chime" clock (November 1976) uses CMOS IC's. Is it possible to use TTL IC's in place of them, or a mixture of the two?—Murray Voakes, Essex, Ontario.*

A. Although similar CMOS and TTL gates and sequential logic circuits perform the same functions—a CMOS 2-input NAND gate is logically equivalent to a TTL 2-input NAND—there are differences in input and output impedances, drive capabilities, operating voltages, etc. The great advantage of TTL over CMOS is operating speed. However, CMOS has it all over TTL in the areas of power consumption at slow speeds and noise immunity when higher operating voltages are used. In this application, switching speeds are low enough to allow CMOS to run significantly cooler than TTL. This means that a smaller power supply can be used. In fact, CMOS is becoming so popular that several manufacturers are offering MOS devices that have the same pinouts as the 7400 TTL series. This allows one to convert from TTL to CMOS with a minimum of pc board modifications. So I really don't see going TTL or hybrid in this circuit. Surplus CMOS is inexpensive, an all-CMOS design requires no level interfacing, and power supply demands are greatly reduced. As a final note, many CMOS devices are now zener diode "clamped" and won't self-destruct when you touch them!

Logic Probe 1 is a compact, enormously versatile design, test and troubleshooting tool for all types of digital applications. By simply connecting the clip leads to the circuit's power supply, setting a switch to the proper logic family and touching the probe tip to the node under test, you get an instant picture of circuit conditions.

LP-1's unique circuitry—which combines the functions of level detector, pulse detector, pulse stretcher and memory—makes one-shot, low-rep-rate, narrow pulses—nearly impossible to see, even with a fast scope—easily detectable and visible. HI LED indicates logic "1", LO LED, logic "0", and all pulse transitions—positive and negative as narrow as 50 nanoseconds—are stretched to 1/3 second and displayed on the PULSE LED.

By setting the PULSE/MEMORY switch to MEMORY, single-shot events as well as low-rep-rate events can be stored indefinitely.

While high-frequency (5-10MHz) signals cause the "pulse" LED to blink at a 3Hz rate, there is an additional indication with unsymmetrical pulses: with duty cycles of less than 30%, the LO LED will light, while duty cycles over 70% will light the HI LED.

In all modes, high input impedance (100K) virtually eliminates loading problems, and impedance is constant for all states. LP-1 also features over-voltage and reverse-polarity protection. Housed in a rugged, high-impact plastic case with strain-relieved power cables, it's built to provide reliable day-in, day-out service for years to come.

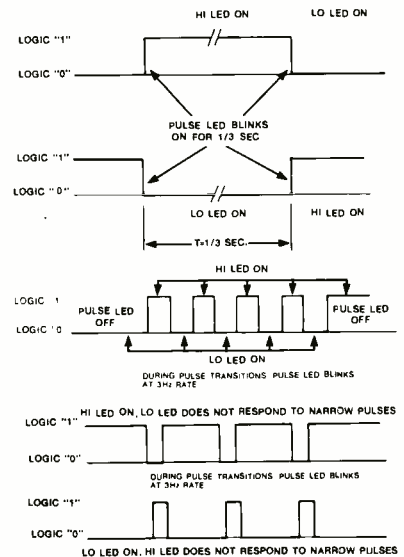

CSC'S MULTI-FAMILY LOGIC PROBE 1. AT \$44.95, IT DIGS UP A LOT OF INFORMATION WITHOUT BURYING YOUR BUDGET.

HI/LO LED's—Display level (HI-logic "1", LO-logic "0") of signal activity at node under test

PULSE LED—Lets you know what's going on—and off. Indicates positive and negative pulse and level transitions. LP-1 stretches pulses as narrow as 50 nanoseconds to full 1/3 sec. (3Hz pulse rate)

PULSE/MEMORY Switch—PULSE position detects and stretches pulses as narrow as 50 nanoseconds to 1/3 sec. Switch to MEMORY and it stores single shot and low-rep-rate events indefinitely; HI/LO LED's remain active

Logic Family Switch—TTL/DTL or CMOS matches Logic "1" and "0" levels, for greater versatility. High Input Impedance—100K virtually eliminates circuit loading problems and is constant in both "0" and "1" states. CMOS position also compatible with HTL, HiNIL and MOS logic

Non-corrosive nickel-plated probe tip and clip leads—For reliable contacts and maximum life

Rugged high impact plastic case—Built to take it in the lab or in the field

Protected—Features built-in reverse polarity and over-voltage protection; strain-relieved power cable

\$44.95 Price tag—Costs so little it can be your personal property

CONTINENTAL SPECIALTIES CORPORATION



EASY DOES IT

44 Kendall St, Box 1942, New Haven, CT 06509
 TWX: 710-465-1227
 West Coast office: Box 7809, San Francisco, CA 94119
 TWX: 910-372-7992; Canada: Len Finkler Ltd.,
 Ontario; Mexico: Elpro, S.A., Mexico City, 5-23-30-04

See your CSC dealer or call 203-624-3103 (East Coast) or 415-421-8872 (West Coast) 9 AM to 5 PM local time. Major credit cards accepted. Add \$2.50 for shipping and handling in the U.S. and Canada on direct orders of \$50.00 or less; \$3.00 for orders over \$50.00. On all foreign orders add 15% to cover shipping and handling.

CIRCLE NO. 13 ON FREE INFORMATION CARD



Product Test Reports

KENWOOD MODEL TS-820 TRANSCEIVER

All-band hf transceiver has operating versatility and built-in speech processor.



ALTHOUGH Kenwood's new Model TS-820 160 - through - 10 - Meter SSB/CW amateur transceiver physically resembles its popular Model TS-520, the two are very different in terms of circuit design and built-in features. Also, the TS-820 can accommodate an optional digital frequency readout, whereas the TS-520 cannot. Other new features (discussed later) clearly make the new transceiver Kenwood's "top of the line."

The transceiver is housed in a rugged, gray-finished cabinet that measures 13-3/16" D x 13 1/8" W x 6" H (33.5 x 33.3 x 15.3 cm). A versatile (110- or 220-V, 50- or 60-Hz) ac power supply is built-in, as well as a small loudspeaker. A handle on the right side of the cabinet provides a means for carrying the 35.2-lb (16-kg) transceiver. The basic TS-820 transceiver is priced at \$830. The optional *DG-1* digital frequency readout, which mounts inside the TS-820's cabinet and can be added at any time, is \$170. Other options include the *CS-820-20* 500-Hz CW crystal filter (\$45), the *DS-1A* dc/dc converter for mobile use (\$59), and the *VFO-820* external vfo (\$139).

General Description. The transceiver circuitry is solid state, except for a 12BY7A driver and two S-2001A (a pin-for-pin 6146B equivalent) final amplifier tubes. The usual complement of transmitter and receiver tuning controls is provided. The multi-function, switch-controlled meter indicates final amplifier

plate current or voltage, relative r-f output, alc circuit operation, compression level from the built-in r-f speech processor, and S units.

When the **MODE** switch is set to **TUN** or **FSK**, power input to the finals is automatically reduced so that the tubes' rated plate dissipation is not exceeded. The r-f speech processor is activated by pulling out the **COMP LEVEL/PROC** control. The amount of the compression (indicated on the meter) is adjusted by rotating this control.

The transmitter pi network and transceiver preselector controls are grouped together. The **PLATE** tuning control uses a vernier for easy adjustment. The **LOAD** control is concentric with a **FIX CH** switch that selects any one of four crystal-controlled channels in the **FIX** mode (crystals optional).

The center-detented **IF SHIFT** control is concentrically paired with the receiver incremental tuning (**RIT**) control, the latter activated by a pushbutton. The **CW CAR** level and **SSB MIC** gain controls are also paired, as are the **RF GAIN** and **AF GAIN** controls. An **RF ATT** push-button switch inserts a 20-dB attenuator at the receiver's antenna input to combat overload and desensitization by strong local signals.

The **BAND** switch has positions for all amateur bands between 1.8 and 29.7 MHz, as well as **JJY/WWV** (reception only) on the 15-to-15.5-MHz band. The 10-Meter band is covered in four 500-kHz segments. (There is also a position on the **BAND** switch labelled **AUX**, which

apparently can be used for operations outside the regular ham bands, although the manual does not mention it.)

The **FUNCTION** switch is normally left in the **VFO** position to allow the internal vfo to control the transceiver frequency. When set to **FIX**, both frequencies are controlled by internal crystal oscillators, with up to four frequencies selectable by the **FIX CH** switch. The **VFO:R** position uses the internal vfo to control the receiver's frequency, while the **FIX:R** position puts the receiver under crystal control and the transmitter under vfo control. When either the transmitter or the receiver is on vfo control, the **FIX** and **RMT** positions are used with the **AUX** crystal-controlled channels of the remote vfo to zerobeat the vfo to channel frequency.

A separate **HEATER** switch is provided to shut off the tube heaters when the transceiver is used for reception only. All **VOX** controls are mounted on the front panel for ready access. Because the **VOX** circuit controls the changeover relay on **CW** (semi-break-in) as well as **SSB**, it is most convenient to have the **DELAY** control up front for easy adjustment as conditions warrant.

The large tuning knob operates two circular dial scales, one calibrated at 1-kHz intervals (numbered every 10 kHz), and the other calibrated at 50-kHz intervals and numbered from 0 to 500 every 100 kHz. The dial index can be moved to calibrate the scale against the 25-kHz marker oscillator or **WWV**. The dial setup uses Kenwood's "mono-scale" kilohertz dial system which fits the full 500-kHz tuning range on a single small dial with 1-kHz calibration intervals. The scale is rotated 10 turns for edge-to-edge coverage of each band segment.

When the optional digital frequency display is installed, as it was on our test model, the fluorescent readout appears in a window above the mechanical dial scales. Above the numeric display are four **LED**'s that indicate when the **ATT** (attenuator) is on and when **FIX**, **VFO**, and **RIT** functions are active.

A button labelled **DH** (display hold) permits the numeric display to be "frozen" to store a frequency for quick retuning. When the display is frozen, you can tune about using the mechanical dial. To return to the original frequency, you simply note the counter display, release the **DH** button, and tune until that number again appears in the display.

The single-conversion receiver has an 8830-kHz i-f. A phase-locked-loop (**PLL**) circuit gives the benefits of both single and multiple conversion with few of the disadvantages of either. The local oscil-

lator consists of 11 separate band-switch-selected voltage-controlled oscillators or vco's (one for each band). These oscillators employ varactor diodes. The output of the vco is heterodyned with a crystal oscillator to produce a frequency between 3.33 and 3.83 MHz. The heterodyne oscillator also consists of 11 separate oscillators. The 3.33-to-3.83-MHz signal is then heterodyned with the output of a crystal-controlled carrier oscillator operating near 8830 kHz to generate an output between 5.0 and 5.5 MHz.

Tuning is by a conventional 5.0-to-5.5-MHz, highly stable and linear Clapp vfo. The vfo's output is compared with a down-converted vco signal by a phase comparator whose output trims the output frequency of the vco. Thus, the vco is phase locked to the 5.0-to-5.5-MHz tunable oscillator to effectively transfer the linearity and stability of the latter to the 10.5-to-39-MHz local oscillator. A phase-lock sensor disables the vco if PLL action fails, preventing off-frequency operation.

There are two separate carrier oscillators. One, controlled by two switchable crystals, operates on SSB transceive and on CW receive. The other functions in the transmit FSK and CW modes, when the receive and transmit frequencies are slightly separated.

A very useful feature is the IF SHIFT, which allows the i-f passband to be moved approximately ± 1.7 kHz without affecting the pitch of the received signal. The IF SHIFT electronically varies the frequency of the carrier oscillator in the PLL system. This causes the vco to move exactly as much as the carrier frequency, resulting in no net change in the relationship between the signal and oscillator frequencies. Because the filter is fixed, the signal is moved through the filter passband.

The built-in r-f speech processor provides up to 50 dB of compression. Here's how it works. The audio input signal is applied to a balanced modulator operating at 455 kHz and is then passed through a filter to remove one sideband. The remaining sideband is compressed—not limited—by an agc amplifier. It is further filtered to remove distortion products beyond the desired modulation passband, down-converted to audio, and finally applied to the main balanced modulator of the transmitter.

Some 10 dB of r-f negative feedback is used in the driver and output stages to reduce odd-order IM products by 6 to 10 dB. This makes the signal unusually clean and free from splatter that could

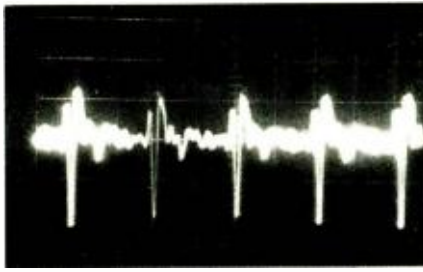

10-W avg. output with sustained "Ahhh" driving transmitter.

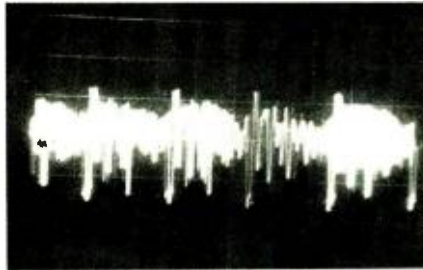

Average power increased to 40 W with 20 dB of compression.

interfere with QSO's on nearby frequencies. Alc is also used to prevent driving the output tubes into nonlinearity.

The transceiver has a built-in SSB receiver that is always tuned to the transmitter frequency so the operator can monitor his transmitted signal. R-f is sampled just before the driver stage, heterodyned down to audio by a product detector, and injected into the receiver's audio amplifier when the MONITOR switch is on. This is a good way to determine the effects of the r-f processor and to determine how much background noise is increased when compression is introduced.

The optional digital frequency display module counts the frequency to the nearest 10 Hz, then rounds off and displays the operating frequency to the nearest 100 Hz. Accuracy of the display is guaranteed to be 1 ppm/month.

Transmitter Tests. On 80 Meters, a two-tone test resulted in 200 W PEP input to the final amplifiers. PEP output into a 50-ohm dummy load was 115 to 120 W. Key-down CW input power measured 165 W, and CW output 100 to 110 W. On SSB, carrier suppression varied from 53 dB (LSB) to 58 dB (USB). The unwanted sideband was 60 dB down when a 1000-Hz modulating signal was applied. Distortion products measured as follows: third order -32 to -34 dB referenced to the two tones, -38 to -40 dB referenced to PEP; fifth order -56 dB referenced to the two tones, -62 dB

referenced to PEP. An audio input of 1 mV at 1000 Hz was sufficient to fully modulate the transmitter on the 7-MHz band.

The r-f speech processor produced some interesting results. A sustained "Ahhh" driving the transmitter to full PEP yielded an average power output of 10 W when no compression was applied. With 20 dB of compression (as indicated on the transceiver's meter), the average power output increased to 40 W. Peak power remained at the same level with or without compression. This translates to a 6-dB increase in "talk power," equivalent to an increase of one "ideal" S unit at the receiving end. This increase is nearly equivalent to switching in a 1000- or 1200-W PEP linear.

Of course, the processor (like all processors) introduced some a-f distortion and degraded the unwanted sideband suppression. At a modulating frequency of 1000 Hz, and at 10 dB of compression, the second harmonic of the modulating frequency was 30 dB down—equivalent to 3.2% of distortion. Unwanted sideband suppression measured 50 dB. At 750 Hz, the second harmonic measured -28 dB (4% distortion) when 10 dB of compression was introduced. The third harmonic (2250 Hz) was 20 dB down (10% distortion), and unwanted sideband suppression measured 30 dB. When a 500-Hz tone was used to modulate the transceiver, the unwanted sideband suppression improved to -35 dB. Finally, when a 400-Hz modulating tone was applied, the second harmonic measured -40 dB (1% distortion) at 10 dB of compression. The third harmonic was 10 dB down (32% distortion), and the unwanted sideband suppression measured 25 dB.

Alc action was very good. Flat-topping simply did not appear, even at maximum alc. Audio response measured (at the 6-dB points) 325-2800 Hz (USB) and 240-2700 Hz (LSB). When the speech processor was used, the response was slightly altered. Maximum VOX release time was approximately one second. When the release was shortened to allow semi-break-in CW keying, no shortened first dot or dash occurred. That is the exception, rather than the rule, among today's amateur rigs!

To check the transceiver's frequency stability (rated at better than 100 Hz/hour after a one-hour warmup and less than 1000 Hz of drift in the first hour after a one-minute warmup), the transceiver was attached to a dummy load and placed in the TUNE mode at 7 MHz, yielding an r-f power output of about 15

RESULTS OF RECEIVER TESTS

Frequency (MHz)	Sensitivity (μV) for 10 dB (S+N)/N		Image Rejection (dB)	I-f Signal Rejection (dB)	Band-to-Band Gain* (dB)
	SSB	CW			
1.8	0.1	0.05	96	100	0
3.5	0.1	0.063	92	90	-3
7	0.08	0.05	86	96	0
14	0.1	0.056	70	92	-3.5
21	0.1	0.063	66	96	-3
28	0.1	0.063	68	96	-1

(+1 dB on
29.5-MHz
segment)

*Overall gain—not affecting sensitivity—determined by comparing audio output on each band, referenced to 1.8 and 7 MHz, produced by a given input signal. Variations in band-to-band gain occur below the agc threshold and have no effect above it.

W. The frequency of this output signal was measured by coupling a frequency counter to the dummy load. After a brief stabilization period (much less than the allowable hour), the drift averaged about 96 Hz/hour for the next few hours. The final transmitter test we performed was the measurement of r-f harmonics at the antenna output jack. They were consistently 40 dB below the fundamental.

Receiver Tests. Results of our measurements of sensitivity, image rejection, i-f signal rejection, and difference in band-to-band gain appear in the Table. Note that sensitivity measurements at these very low signal levels are usually accurate to within ± 3 dB. However, even within this margin, the TS-820's receiver tested extremely "hot." A 50- μV signal (nominal) was required for an S9 meter reading; a 1- μV signal produced an S2.5 reading. Inserting the r-f attenuator in the input line (by means of the front panel pushbutton) dropped signal levels 20 dB. The receiver incremental tuning varied the receive frequency ± 3000 Hz. Unwanted sideband rejection measured 60 dB at 1000 Hz and 50 dB at 500 Hz.

No crossover birdies were found when signals below 10,000 μV were applied to the input. Internal spurious signals measured 0.2 μV (equivalent) at 21.200 MHz and less than 0.1 μV (equivalent) at 2 and 21 MHz. Two 320- μV signals (-57 dBm, or 70 dB above the SSB sensitivity) spaced 25 kHz apart created third-order IM (intermodulation) products equivalent to the rated sensitivity (0.1 μV for 10 dB (S+N)/N). An undesired 32,000- μV (-17 dBm) signal 110 dB above a 0.1- μV desired signal desensitized the receiver by depressing the desired signal 1 dB. The receiver section was very

resistant to blocking (overload). No loss of output level or increase in distortion was detected when input signals of up to 100,000 μV (-7 dBm) were applied.

When the r-f input signal varied from 0.1 to 1 μV (a 20-dB change), the audio output rose 18 dB. When the input signal was raised from 1 μV to 10 μV , the agc came into play and the audio output rose only 1 dB. A 100-dB change in r-f (from 1 to 100,000 μV) caused the audio output to increase only 2 dB. Release time from an S9 signal level to full recovery was approximately 0.75 second when the agc switch was in the FAST position and 4.5 seconds in the SLOW mode.

Nominal overall response—which included the i-f passband and audio responses—measured as follows: 400 to 2150 Hz at -6 dB, 200 to 3525 Hz at -60 dB (USB); 275 to 1850 Hz at -6 dB, 75 to 3300 Hz at -60 dB (LSB); 700 to 1250 Hz at -6 dB, 335 to 1685 Hz at -60 dB (CW). These measurements were made below the agc threshold. The differences between USB and LSB are easily explained by the fact that the frequency of the carrier oscillator feeding the balanced modulator is deliberately shifted for proper generation of USB and LSB signals. It is the change of the relationship between the skirts of the fixed crystal filter and this carrier oscillator that causes different overall responses in the USB and LSB modes. However, in both modes the unwanted sideband suppression was 60 dB at 1000 Hz and 50 dB at 500 Hz.

The transceiver produced 1.5 W of audio output into 8 ohms. A 1000-Hz sine wave was used for this test, and at the start of clipping total harmonic distortion was less than 2%.

In our final receiver test, we applied a pulse train composed of 0.0005- μs -wide pulses at a 60-Hz rate. This pulse train

(at 100 dB above 1 $\mu\text{V}/\text{MHz}$ bandwidth) completely obliterated a 3- μV input signal. A 10- μV signal was depressed by at least 10 dB due to agc capture by the noise pulses. However, when the TS-820's noise blanker was activated, normal agc action was restored and undisturbed copy of even 0.1- μV signals became possible! But the blanker had no effect on low-level pulses (less than 50 dB above 1 $\mu\text{V}/\text{MHz}$ bandwidth).

On The Air. With few exceptions, we confined our on-the-air testing to the 7-MHz band. Operation was equally divided between SSB and CW. During the weeks we operated this transceiver, we never felt the need to use our linear.

It seemed as natural to scan the bands with the digital numeric frequency display as it was to observe the position of a dial scale against an index line. Let us assure anyone who is not ready to make the added investment in the digital display that the mechanical dial is accurate to within about 100 Hz of the digital display.

We were pleased to note that the transceiver can be tuned with its own meter, and modulated within the maximum limits defined by its alc meter scale without compromising performance. The front-panel VOX controls proved to be rock stable. On CW, the delay could be set so that the transmitter would drop out between characters below 20 wpm and between words at higher speeds. This is not really QSK (full break-in keying), but it's pretty close! Both the keying and modulation received numerous unsolicited compliments from stations contacted. Only rarely useful on SSB, the IF SHIFT proved to be valuable on CW. It let us move QRM off the skirts of the 500-Hz filter to the point of inaudibility, without changing the pitch of the desired signal.

During our tests, an idling truck blanketed us with ignition noise at S9. Switching in the noise blanker effectively eliminated—not just reduced—the interference! This was a most impressive demonstration, which left us regretting that the blanker could not dispose of types of noise other than impulse noise.

In actual QSO's, we verified that the r-f speech processor gave a one to two S-unit improvement in signal strength. However, the processor does cause some signal distortion. Thus, the processor should be used (and is intended for use) only under conditions that warrant it. Under strong-signal conditions, all speech processors impair intelligibility to some degree. On the other

hand, when the going gets tough, a good processor like the one in this transceiver can make the difference between contact and no contact.

No sound at all could be heard from the transceiver's cooling fan. The "silent" fan's cooling effectiveness was undeniable, however. After almost two hours of either SSB or CW operation, the cabinet was cool to the touch everywhere except directly above the final tubes, where it was faintly warm.

The TS-820 is certainly a full-feature all-band ham transceiver. The only gripe we do have concerns the top-facing speaker, which managed to lose much

of its meager output in our acoustically treated ceiling. For fixed-station operation, the owner would do well to connect an external speaker to the rear-panel output jack.

In sum, the TS-820's versatility and fine performance and the obvious top craftsmanship that has been spent on its design will fill any ham with pride of ownership. If we had to pick the most attractive feature among so many admirable ones, it would be the "digital hold." With this "memory" function, we'll never again fail to return exactly to a QSO frequency after a brief listen off-channel.

CIRCLE NO 103 ON FREE INFORMATION CARD

MURA MODEL PRX-100 "PRM" CB MICROPHONE

Peak-redistribution modulation effectively increases signal power.



THE MURA PRM microphone contains a conditioning system that redistributes the asymmetrical sharp-peak portions of speech to make the signal more symmetrical. At the same time, it also holds down the peaks to allow the lower-energy components of the signal to be effectively higher in energy than would be possible with a "straight" microphone. This peak-redistribution modulation (PRM) is accomplished electronically by delaying the large sharp-peak components of the signal for minute amounts of time in relation to the lower-energy signals before passing them on to the transmitter's modulator. The result can be an effective *average* modulated signal without adverse distortion.

One of the new PRM microphones for CB use is the push-to-talk Model PRX-100. It has a gain control for setting up the optimum output level for any particular CB transmitter according to the operator's voice amplitude. (The microphone cannot be used with certain CB transceivers on the market. These are

detailed by manufacturer and model on the card on which the microphone is packaged.) Operating impedance is 0 to 2500 ohms. Power for the microphone system is obtained from an internal 9-volt battery. Price is \$39.95.

Test Results. We checked the Model PRX-100 with the aid of a dual-trace oscilloscope to observe simultaneously the output of the transducer cartridge and the conditioned output signal from the PRM circuit. Asymmetry at the cartridge was demonstrated with the maximum sharp-peak excursions in the positive direction. The conditioned output still produced some asymmetry, but in the opposite direction and to a lesser degree. However, the peak ratios, compared to the in-between lower-energy components, were reduced sufficiently to permit an overall higher average output level which potentially increased the average power of the modulated signal.

We also made comparisons with other microphones and with different voices. We noted that less improvement was obtained when compared to the output of the poorer-quality microphones than was the case with better units. (Lower-quality, less-expensive microphones usually exhibit their best symmetry, with lower positive/negative-peak ratios.) It should be noted that the advantages gained by using a PRM microphone apply mostly to limited-level amplifying or modulating systems in which operation is below the overload or clipping level. Systems that employ clippers or some form of automatic modulation control (amc) generally tend toward symmetry and higher average signal levels.

The "Click and Pop" machine

only by

SAE



Ever since the invention of the recorded disc annoying "clicks" and "pops" caused by scratches, static and imperfections have consistently disturbed the listening pleasure of music lovers.

Now, SAE introduces the unique model 5000, an Impulse Noise Reduction System which eliminates those unwanted sounds with no adverse effect on the quality of the recorded material.

This breakthrough in electronic circuitry is so demonstrably effective that the SAE 5000 is destined to become an essential part of any sound system.

The SAE 5000 is compact and sleek, built to SAE's exacting standards, and ready to enhance the performance of any system, from the standard receiver/turntable combination, to the most sophisticated audiophile components.

SAE is proud to add the 5000 to their broad line of *Components for the Connoisseur*.

SAE

Scientific Audio Electronics, Inc.
P.O. Box 60271, Terminal Annex
Los Angeles, Cal. 90060

Please send more information on the 5000.

Name _____

Address _____

City _____

State _____ Zip _____

PE 577

CIRCLE NO 53 ON FREE INFORMATION CARD

Empire's Blueprint For Better Listening

No matter what system you own, a new Empire phono cartridge is certain to improve its performance.

The advantages of Empire are threefold.

One, your records will last longer. Unlike other magnetic cartridges, Empire's moving iron design allows our diamond stylus to float free of its magnets and coils. This imposes much less weight on the record surface and insures longer record life.

Two, you get better separation. The small, hollow iron armature we use allows for a tighter fit in its positioning among the poles. So, even the most minute movement is accurately reproduced to give you the space and depth of the original recording.

Three, Empire uses 4 poles, 4 coils, and 3 magnets (more than any other cartridge) for better balance and hum rejection.

The end result is great listening. Audition one for yourself or write for our free brochure, "How To Get The Most Out Of Your Records." After you compare our performance specifications we think you'll agree that, for the money, you can't do better than Empire.



EMPIRE

Already your system sounds better.

Empire Scientific Corp.
Garden City, New York 11530

The polarity and characteristics of the existing microphone, as well as the frequency response or phase shifts in the modulating system, play an important role as to whether or not any significant improvement can be obtained with the use of a PRM microphone with a given degree of maximum modulation.

We noted that the low-frequency response of the microphone was somewhat less than usual. This resulted in a slightly crisper signal for better intelligence under adverse conditions.

User Comment. In many situations, with the gain control of the microphone set at maximum, the output level can be high enough to severely overload the modulator. This can produce heavy clipping or overmodulation, the latter beyond the signal-handling capabilities

of an amc system. Although the use of the microphone can make a signal sound somewhat louder, it may possibly do so at the price of high distortion and excessive adjacent-channel splatter. Therefore, caution should be taken in setting the microphone's gain. This is best done while observing the modulated r-f waveform on an oscilloscope and setting the level control so that the signal does not cause excessive or distorted modulation.

Whether or not a change to this type of microphone will be of benefit in any particular case can be determined by listening to the CB signal under maximum-modulation conditions. (The Model PRX-100 is rated to deliver up to a 4-dB increase in average modulated power, which we confirmed.)

CIRCLE NO 104 ON FREE INFORMATION CARD

B&K PRECISION MODEL 1471B OSCILLOSCOPE

Has dual-trace and trigger functions desirable in testing modern circuits.



A GOOD general-purpose oscilloscope for servicing and electronics experimenting should have a linear triggered sweep with a broad selection of sweep rates and triggering sources. It should also have two independent traces to permit observation of both the input and output signals of a circuit under test. Moreover, its vertical amplifiers should have sufficient bandwidth and sensitivity to enable the user to work with high-frequency signals with very low and very high amplitudes. The vertical amplifiers should be dc coupled to permit the scope to double as a voltmeter, and both amplifiers should have identical characteristics to permit the instrument to be used for a vector display. Finally, if the scope is to be used in TV servicing, it should have provisions for frame and line sweeps to serve as a vectorscope for chroma alignment.

All of these characteristics can be found in B&K Precision's Model 1471B dual-trace oscilloscope.

The scope measures 16"D × 9.6"W ×

7.7"H (40.4 × 24.5 × 19.6 cm) and weighs 18 lb (8.2 kg). Price is \$495.

General Details. Each of the vertical amplifiers in this dual-trace solid-state oscilloscope has a bandwidth that goes from dc to at least 10 MHz, risetime of 35 ns, 3% or less overshoot and ringing with a 100-kHz square-wave input, and 1 megohm paralleled by 22 pF input resistance. The deflection factor of the vertical amplifiers is from 0.01 volt/cm to 20 volts/cm in 11 calibrated ranges, fully variable between range settings.

Either amplifier (trace) can be selected separately, or the scope can be operated in the dual-trace (simultaneous display of both channels) mode. In the dual-trace mode, the traces are chopped at a 200-kHz rate at all sweep rates up to 1 ms/cm, while alternate-trace operation is automatically switched in for all faster sweep rates. Channel separation in the dual-trace mode is better than 60 dB at 1000 Hz.

The sweep circuit shared by both

channels can be automatically triggered without an input signal to the scope. The sweep range is from 1 μ s/cm to 0.5 s/cm, with full variability between ranges. In addition, the sweep can be magnified 5 \times , yielding a maximum sweep speed of 0.2 s/cm. There is less than 3% (typical) horizontal linearity distortion.

The switch-selectable sweep triggering can be either internal or external and from the channel in use. (Channel A is selected in the dual-trace mode.) At almost all levels, either the positive or the negative slope of the input signal can be selected to initiate the triggering. Alternatively, the triggering can be automatic. The sweep can be triggered from 20 Hz to better than 10 MHz in the internal mode (1-cm deflection on the CRT's graticule) or dc to 10 MHz from an external trigger signal. A built-in sync separator is provided to permit observation with high stability of any portion of a complex TV waveform.

The horizontal amplifier can be accessed through the channel-B connector on the front panel of the scope and is selected by one position on the sweep speed control when the instrument is in the vectorscope mode. The horizontal amplifier then has a deflection factor of from 0.01 volt/cm to 20 volts/cm, which is the same as that of the vertical amplifier, and a frequency response from dc to 1 MHz.

Intensity modulation on the Z axis is available via a TTL-compatible connector on the rear panel of the scope. A logic low increases trace brightness, while a logic high decreases the brightness. The input resistance to the Z axis is 10,000 ohms.

The scope features a 5" (12.7-cm) flat-screen CRT. Over the face of the CRT is an 8 \times 10 cm blue-colored engraved graticule. The bezel that holds the graticule in place can be removed easily to allow insertion of the vector overlay needed for color TV alignment. A 1-volt p-p square-wave source permits checking and calibration of the vertical amplifiers without having to use external sources.

User Comment. The Model 1471B oscilloscope is an excellent general-purpose instrument. Calibration was originally performed with a very accurate external voltage source. After operating the scope for six hours a day over a period of two weeks, we again calibrated the scope and found it to be still "on the head."

During our in-service tests, we deter-

mined that the scope's sync holds up under even very-low-level and relatively high-frequency signals. The trace was steady, and we experienced no trace break-up in the chop mode. The light blue color of the graticule was very easy on the eyes and permitted relatively long term waveform observation without causing optical fatigue.

All controls on the scope are clearly identified, the knobs are shaped and sized for comfortable user "feel," and the controls have positive, smooth action. The combination tilt stand/carrying

handle features a solid locking mechanism in both the carry and tilt positions.

During our tests, we used a pair of optional No. PR-31 combination 10:1 direct probes (\$25) that proved to be excellent for general-purpose work. They feature miniature spring-loaded clip-tips that enable use in circuits where terminals are very tightly spaced.

If you need fast risetime, extended bandwidth, critical circuit timing, and accurate and stable waveform viewing, the Model 1471B is an excellent choice.

CIRCLE NO 105 ON FREE INFORMATION CARD

An exciting, new magazine!

Personal Computing

If you don't have your own computer by now, chances are there's one in your immediate future. Personal computers are now being sold at about the price of home stereo systems. Experts project that 1,000,000 personal systems will be up and running by 1980.

PERSONAL COMPUTING will serve as your guide into this exciting new technology. We'll provide you with all the up-to-date information on new computer products, computer clubs, computer stores, and important personal computing events. In addition, each issue contains easy-to-follow, nontechnical articles on computer programming and computer jargon. These articles illustrate how you can use personal computers at home, school, and work.

Get your FREE issue now

Fill out the subscription form below, and we'll send you a complimentary copy. If you don't agree that *Personal Computing* is everything we say it is, simply write "Cancel" on the invoice and return it to us. If you do want to subscribe, simply pay the bill. In any case, the first issue is on us!

A one year subscription to *PERSONAL COMPUTING* is just \$8.00

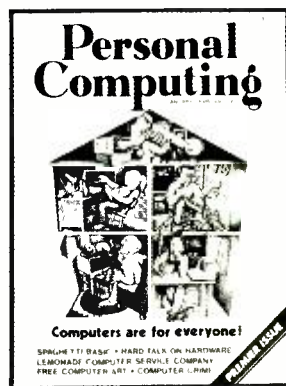

Please enter my subscription to *Personal Computing*. I understand that the first issue is free.

Bill me Enclosed is my check for \$ _____
 BankAmericard Master Charge Am Express
 Credit Card # _____

Credit Card Expiration Date _____

Name (print) _____

Address _____

City _____

State _____ Zip _____

Note: *PERSONAL COMPUTING* is a bi-monthly publication (6 issues per year). Rates: \$8/year in the United States. Mexico and Canada: \$10 surface mail and \$12 airmail. All others: \$26 airmail.

PERSONAL COMPUTING/167 Corey Road, Brookline, MA 02146, USA

CIRCLE NO 48 ON FREE INFORMATION CARD



Computer Bits

By Hal Chamberlin

DEBUGGING AIDS

WHAT DO you use your computer's front panel for? Loading programs into memory, monitoring their execution, altering their execution with the sense switches, single-stepping the program to find errors ("bugs"), changing memory locations, and troubleshooting hardware are some examples. Last month, the role of monitor programs such as Motorola's Mikbug in performing routine computer operation tasks was described here. It should have been apparent that the use of a monitor for such functions is far more convenient than using a traditional front panel. But what about non-routine, troubleshooting tasks such as tracing the execution of a new, untried program or locating a hardware malfunction on a new board? Many hobbyists feel that a control panel is indispensable in such situations. Let us examine how monitor software can be used to perform even these "debugging" functions more effectively than a front panel.

Breakpoints. Assume that you have just finished writing a relatively complex program of 200 instructions in machine

language and are ready to test it. First you load it into memory, hopefully using a monitor and keyboard. After loading by hand, you save the program on tape just in case it wipes itself out in memory as errant programs often do. Then using the monitor's "G" command you execute the program. Chances are it does not execute properly. In fact, it's probably not even close. At this point debugging begins, which can take considerable time without good debugging tools.

If you have an Altair, Imsai or other front-panel oriented computer you will probably single-step your way through the program in an effort to find out where it goes awry. This means simply that the computer is placed in a single-step operating mode where every operation of the "single-step" switch causes exactly one machine cycle to be executed. Generally, as each cycle is executed, you can see in the console lights the memory or input/output address referenced by the cycle and the data transferred. Additional status lights identify the type of cycle out of about a half-dozen possibilities. However there are many things that the

panel lights fail to show. For example, when executing an "add register B to register A" instruction in single-step mode, you will only see the memory address of the instruction and the operation code, 200 in octal. You will not see the contents of register A, register B, or the result of the addition. Even the condition flags such as overflow are hidden from view. Obviously the panel is of limited value if you think the root of a particular bug lies in incorrect register contents or if there is an uncertainty as to what a specific instruction does. If this information is critical (as it often is), you must temporarily modify your program to store the necessary data into memory and then halt so that it may be examined.

Another often encountered difficulty is that single-stepping through a loop a dozen times to catch an error that occurs on the thirteenth iteration can take a long time. If the problem occurs on the 387th iteration it would not even be practical to single-step. Again the program must be temporarily modified to make it halt close to the error condition. Such temporary patches are called "breakpoints."

Many monitors have commands or functions that make inserting and keeping track of breakpoints much easier. A command like "3:213B" might insert a breakpoint at location 213 in page 3 (octal notation). What would actually happen is that the monitor would first look at the indicated address and save whatever was there. Next it would store a CALL instruction in the same location which would transfer control to a "breakpoint subroutine" in the monitor. This monitor

*

TEST OF DOUBLE PRECISION SUBTRACT

001:000 006 123	MVI B,123Q	SET BC TO 123:156 = 21358 DECIMAL
001:002 016 156	MVI C,156Q	
001:004 026 356	MVI D,356Q	SET DE TO 356:312 = -4405 DECIMAL
001:006 036 312	MVI E,312Q	
001:010 315 000 003	CALL DSUB	DO THE SUBTRACTION
001:013 311	RET	RETURN TO THE MONITOR

*

DOUBLE PRECISION SUBTRACT REGISTERS B AND C FROM D AND E WITH RESULT PLACED IN D AND E

*

003:000 173	DSUB	MOV A,E	SUBTRACT LOWER BYTES
003:001 221		SUB C	
003:002 137		MOV E,A	MOVE RESULT INTO E
003:003 172		MOV A,D	SUBTRACT UPPER BYTES
003:004 230		SBB B	
003:005 127		MOV D,A	MOVE RESULT INTO D
003:006 311		RET	RETURN

Fig. 1. Program to be traced.

```

002:232 123 3:0,3:6T      (Command to trace between 003:000 and 003:006
002:232 123 1:0G        (Command to start execution at 001:000

003:000 173  A=312 B=123 C=156 D=356 E=312 H=113 L=002 SP=017:374 FLG=
003:001 221  A=130
003:002 137  E=130
003:003 172  A=356
003:004 230  A=203 FLG=SA
003:005 127  D=203

002:232 123 (next command)

```

Fig. 2. Monitor printout with trace.
Underlined portion typed by user.

routine prints the contents of all registers and the condition flags.

Now that the breakpoint is set up, the program would be entered with the normal "G" command. When it got to the "CALL BREAKPOINT" instruction that was inserted, the registers and flags would be printed. After the printout, the monitor would be waiting for another command. When the breakpoint is no longer needed, an "E" command might erase the breakpoint and restore the instruction it saved.

A more sophisticated monitor could allow multiple breakpoints. It would automatically keep track of the instruction displaced by each breakpoint and identify the breakpoint when the registers were printed. A really good breakpoint routine might even execute the saved instruction after printing and then automatically return to the program being debugged. In this case, a breakpoint could not be placed on top of a JUMP or CALL instruction.

A breakpoint routine can also take care of the "error on the 387th loop" problem mentioned earlier. Each time the breakpoint routine is entered, a software counter is decremented. If the counter is not zero, the user program is re-entered without printing the registers. Only when the counter finally does become zero do the registers get printed—thus saving a lot of time and paper. There would, of course, be a command to set the initial value of the counter.

Some microprocessors make the task of implementing a breakpoint facility in a monitor much easier. In the 8080 a normal CALL instruction is three bytes long. When placed in a breakpoint location, the three bytes that were there have to be saved. These three bytes might represent as many as three separate instructions making the "print registers and continue" function very difficult to implement. The 6800 or 6502, on the other hand, has a one-byte BREAK instruction that seems to be custom designed for just this function.

Software Single-Step. Although breakpoint capability in a monitor greatly simplifies the debugging of machine language programs, it is not real single-stepping. A different class of monitor routines called "trace routines" allows the software equivalent of single-stepping. It is interesting to note that some microprocessors are "dynamic" and cannot be stopped to allow the usual hardware single-step function. With these, a trace routine is the only way to get a single-step operation.

Tracing is really equivalent to putting a breakpoint at every instruction in a program. Then when the program is executed, a printout of the location, instruction, and all registers would be given for each instruction executed. This would be exactly equivalent to manual single-stepping with the bonus of a written record of every aspect of the program execution. In a machine with a lot of registers, time and paper may be saved by only printing the registers that have *changed* since the last printout. A useful trace feature in a monitor would allow the setting of *trace limits* so that only the program section of interest would be traced. A fancy trace feature might even allow multiple sets of trace limits with possibly a counter to delay the printing until a specified number of traced instructions has been executed.

How are trace routines actually implemented? One simple method is to use the interrupt feature of the microprocessor itself. With this method, a simple circuit added to the computer is activated to issue an interrupt whenever an instruction is executed. This interrupt would prohibit further interrupts and cause execution of the monitor trace print subroutine. The print routine would not re-enable interrupts until just before it returns to the interrupted program, the one being traced. This prevents the trace print routine from being traced itself. The trace limit feature is implemented by having the trace print routine check if the instruction about to be print-

ed is within the trace limits. If it is not, printing is suppressed and a return to the program is executed. An example is shown in Figs. 1 and 2.

Another method involves *interpreting* the instructions of the traced program rather than executing them. An interpreter is a program that acts just like the microprocessor itself. It literally looks at the operation codes, addresses, and other components of the instruction and, through software, accomplishes the same result as the real microprocessor would have. The purpose of this is that the interpreter program may also store or print detailed information about the instructions it "executes", something the real microprocessor, of course, would not do. This technique requires much more complex software than breakpoints or trace using interrupts does but it has an important advantage. Since the interpreter routine *simulates* the machine, it can also simulate hardware features that the real machine may not have, such as memory protect. While debugging, the simulator would trap any instruction that attempts to jump outside of the protected area as well as any instruction that tries to write into protected memory.

Unfortunately the standard, readily available monitors in read-only memory generally do not have these debugging functions. If anything, a simple breakpoint facility is all that is offered. Specialized monitors, designed primarily for debugging rather than routine operations, on the other hand can probably do everything that has been discussed as well as other handy functions. These monitors are often found in the microprocessor manufacturer's development systems, such as Intel's MDS or Motorola's Exorciser (meaning to "exorcise" bugs) and are quite expensive. However the functions described are not difficult to implement and are certainly worth the effort needed to write them. Club meetings provide opportunities to exchange such software with fellow hobbyists. ◇

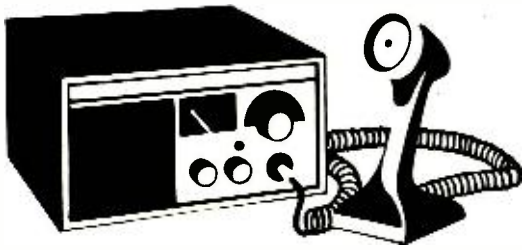

CB Scene

By Ray Newhall, KW16010

UNCLE CHARLIE IS SNOWED-IN

THEY tell us that even the ladies' room at Gettysburg is stacked high with mailbags. The FCC offices there process all Class D (now the "Citizens Band Radio Service") license applications and, between January 1st and 26th, had received more than 832,000 new CB license applications. However, reports are that their computer facility has been working so effectively that expected delays in processing those applications which were properly filed are only two to four weeks. To the FCC's delight, no more than 20% of applications received have included fees, which have to be returned since there is no longer a license charge.

Best estimates are that the FCC will issue more than 990,000 CB licenses in January. That represents an increase of more than 50% above the next greatest month (March 1976). The FCC believes that more than 8,000,000 new CB'ers will go on the air during 1977 and that the total number of licenses issued will exceed 16 million by the end of the year.

Total sales do not appear to account for the flood of license applications received. It appears that many would-be CB'ers are taking advantage of the fee amnesty and are being joined by many others who have been operating without a license. Also, different members of the same family are applying for their own licenses. FCC people tell me that, in many cases, a half dozen or so applications are arriving in the same envelope.

Why Were the Fees Dropped? As most of you know, the FCC handed CB'ers a nice Christmas present by suspending all fees, effective January 1st 1977. That sudden move was not entirely in the spirit of Christmas, however. It was prompted by a court decision ordering the FCC to suspend *all* fees until fee schedules are restructured, based upon the actual costs for issuance of licenses. In fact, they were ordered to refund all fees collected since January 1975, but don't hold your breath in anticipation; the

FCC's records on CB licensees do not go back that far in many cases. It is likely that fees will be reestablished again within a few months, and Congress might even pass legislation which permits the Commission to charge fees to help support the enforcement effort.

Some New Developments. When the fourth general meeting of PURAC was adjourned on January 27, it marked the halfway point in the advisory group's two-year Congressional charter. Earlier that morning the meeting was opened with an address by Al Gross, the first licensed CB'er (19W-0001). He recounted all the early efforts to get CB rolling, dating back to World War II. He showed us a pocket-sized walkie-talkie which had been used by the OSS during the war. It was this tiny radio transceiver that convinced the FCC and others that there was a viable future in personal radio communications.

Based on discussions at the meeting, quick FCC action is likely on a proposal by the public safety task group that the four callsign digits, "0911", be set aside for the exclusive use of state-level public service agencies as an emergency-aid callsign. These special calls, a "K" followed by the State's two-letter abbreviation and the four digits "0911," would be issued to any State applying for licensing under the National Emergency Radio Aid (NEAR) program. For example, in Connecticut the NEAR callsign to summon emergency road assistance on channel 9 would be KCT-0911.

The advisory committee was told that the FCC's Office of Plans and Policy would soon release a radio spectrum inventory report which would study areas of the spectrum for future expansion of Personal Radio Services, including:

- A new FM band somewhere between 218 and 225 MHz.

- Future allocation of a portion of the reserved spectrum near 900 MHz.

A new band of FM frequencies at about 220 MHz ("Class E") was first pro-

posed nearly ten years ago; it now appears that it will be considered anew, but prospects are dim for its adoption. In contrast, the possibility of using 900 MHz for distant CB expansion is viewed more optimistically by the FCC. In any event, the FCC pronounced that the recently expanded 27-MHz band "... won't be eliminated ... is here to stay."

Meanwhile, how many CB'ers have considered moving up to the old Class A band around 465 MHz (now redesignated the General Mobile Radio Service)? Here you can use up to 50 watts of power and antenna heights up to 200 feet. Repeaters and automatic phone patches are permitted. It offers nearly all the features now enjoyed by the hams on the 2-Meter band. However, the equipment is several times the cost of present CB equipment.

From the "Future Needs" Task Group, Cary Hershey, a sociologist at Columbia University, made an interesting observation. In response to a question from the floor regarding the damaging effect of Smokey reports by mobile CB units, he said:

"We have considered the 'Smokey Syndrome' in depth and weighed its negative effects against other factors relating to personal use radio. We have concluded that the sociological advantages to the American public in talking and listening, in direct communication with one another as opposed to all listening only to the media, far outweigh the opportunities offered a minority of criminals using CB to evade the law."

He continued by pointing out that the more inventive law-enforcement agencies have found that the so-called Smokey Syndrome can actually assist their enforcement efforts.

In the area of "Rules Compliance," the committees noted that rules infractions have dropped significantly. They rate the most serious violations as those involving the continued use of "linears" to exceed r-f power output limits and deliberate interference with communications. Though FCC members rate the non-use of callsigns high on their list of violations, the non-FCC members of PURAC tend to down-grade the seriousness of this violation and are examining alternate means of transmitter identification. The primary argument against the Automatic Transmitter Identification Signal (ATIS) involves the management of a data base of information on 30-million or more transmitters. This writer, who is also a data-processing consultant, believes that the FCC will eventually have

ORGANIZATION OF THE PERSONAL RADIO SERVICES, Part 95

Old Class Designation	New Designation	Part 95 Sub-part
Class A	General Mobile Radio Service	A
Class C	Radio Control (R/C) Service	C
Class D	Citizens Band (CB) Radio Service	D
—	All Technical Specifications	E

to bite the bullet and spend the money to do the job properly. It is an expensive operation.

The FCC is determined to make it very risky to operate overpowered rigs. The reason it is so up-tight about external power amplifiers (linears) is because laboratories operating in both the government and private sectors have now determined that more than 60% of all CB-caused TVI results directly from the use of these illegal devices. This is particularly true with the "cheapie" import varieties that are being sold illegally in the United States. They cause all sorts of havoc on frequencies outside of the CB band, and are illegal to manufacture, sell, or even to own in this country. In spite of this, someone managed to slip a packet of sales material onto the FCC reception table at the PURAC meeting! TVI complaints, mostly CB-related, have increased more than ten-fold over the past two or three years.

It has now also been determined through extensive field tests that modern TV receivers are less susceptible than was originally thought to fundamental signals. Most TVI occurs under conditions of severe front-end overloading of the receiver, whether caused by an antenna preamplifier or by an extremely powerful CB signal. In a recent field test by the FCC's Field Operations Bureau, where 32 randomly selected CB-related TVI complaints were examined in depth, 63% were the direct result of external power amplifiers used to boost the CB signal well above the legal limit.

Rules Simplification. I have just completed a review of the reorganized version of Part 95, as reported earlier in this column, and I find it a great improvement over the older versions. These should be readily available through the GPO by the time this column is published. The three classes of personal-use radio services have been renamed under the overall designation of "Personal Radio Services" as shown in the Table listing. The 27 MHz CB service (Class D) has been designated the "Citi-

zens Band (CB) Radio Service." All of Part 95 required to be read and understood by a CB operator is contained in *Sub-part D*. This sub-part will be available as a separate publication.

The PURAC efforts to simplify Part 95 are still not complete. Work is already underway to simplify the language as well as the structure. It is expected that this work will be completed and available to the public by late summer 1977.

Legal Problems For CB'ers. As more and more CB'ers go on the air, their legal problems appear to be growing by leaps and bounds. Throughout the country, individual communities are attempting to outlaw CB by the use of local zoning or nuisance ordinances. In Connecticut, for example, there is a statute which was enacted long before CB was authorized making it illegal to operate a radiotelephone in a moving vehicle. Taxis, amateur radio operators, business radio users and commercial radiotelephone are exempted from the law, which appears to leave only CB'ers who can and have been arrested by the State Police. However, there are State Representatives who have pledged to work for the repeal of this law during the current legislative session.

But the number of legal actions which have reached the courts, involving either CB'ers or hams, has increased ten-fold within the past ten years, and a consid-

erable amount of legal precedent is being accumulated. The *Personal Communications Foundation* is a new non-profit legal organization which was formed recently for the purpose of collecting and redistributing all the legal data available on such cases. Its services are free except for the actual cost of reproducing and mailing materials to those attorneys who request it in defense of a personal radio user. If you should have a legal problem, your lawyer may contact them in Lancaster, CA 93534 (805-942-0144). ◇



ISO-TIP®
QUICK CHARGE
Cordless
Soldering Iron
completely
recharges in
3½-4 hours.
Low voltage,
battery powered,
ground free
isolated tip
design.

16 snap-in tips
to fit any job
plus a PC
Drill.

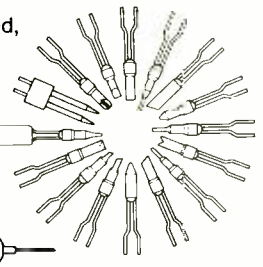

WAHL CLIPPER CORPORATION
ORIGINATORS OF PRACTICAL CORDLESS SOLDERING
• Sterling, Illinois 61081 • (815) 625-6525
"Manufacturing Excellence Since 1919"
CIRCLE NO 66 ON FREE INFORMATION CARD

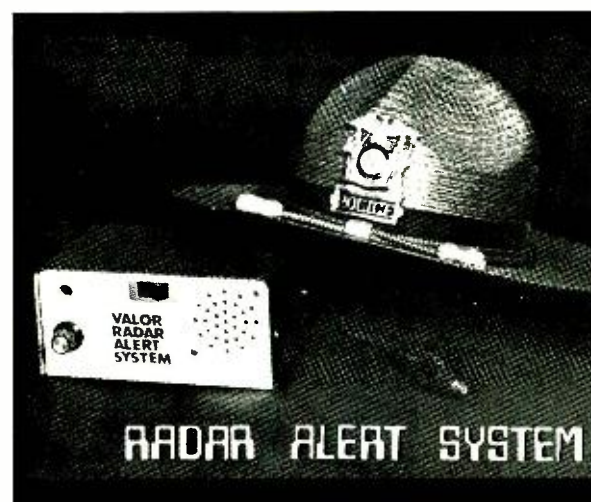

RAS, our "seeing eye dog," gives drivers ample time to slow down before "the man" records his speed.

This system, the most advanced detector on the market, is designed to minimize false signals.

Simply plug into lighter or wire direct. Select audio/visual or visual only with a flip of a switch.

**ENJOY TRAVEL MORE
AND WORRY LESS!**

Retail \$109.95

**SPECIAL AT
\$89.95**

ELECTRONICS UNLIMITED
P.O. BOX 73
LEBANON, TN. 37087
(615) 449-1901

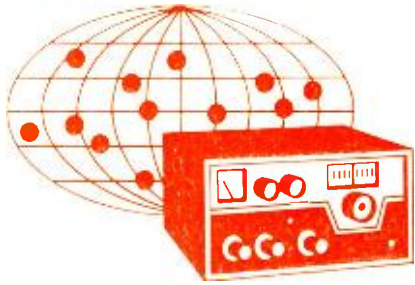

DX Listening

By Glenn Hauser

Secret Shortwave Stations. If you scan the non-broadcast bands with a good, sensitive receiver for evidence of broadcast programming, you should discover, as we did last fall, a number of tropical-band harmonics in the 18–25 MHz range. Some of them are listed below. As the sunspot count picks up, so should harmonic reception, even up to 31 MHz. Whether you hear the stations listed depends on skip conditions, but there is likely to be less interference on weekends. F₂ propagation peaks around noon, but sporadic E (short skip) can extend into the evening.

In regular out-of-broadcast-band tuning, you'll also find broadcast programs transmitted on SSB. Most feed the remote retransmission sites. Guyana Broadcasting Service is seldom armchair copy on 3.290 or 5.950 MHz, but when they activate 16.454 MHz, listening is easy. Radio Monte Carlo feeds Arabic programs of pop music to its MW relay on Cyprus, via 15.575 or 17.555 MHz frequently heard during the morning in North America. Chilean stations such as Radio Colo-Colo and Radio Cooperativa can be heard on 12.250, 6.6845 or 4.885 MHz at irregular hours.

MHz	Harmonic	Fundamental (MHz)	Station
24.3298	4	6.08245	R. Nacional, Peru
24.024	4	6.006	R. Reloj, Costa Rica
24.020	4	6.005	BBC, Ascension
23.850	2	11.925	Rdif. Portuguesa
23.630	2	11.815	BBC, Ascension
23.610	2	11.805	WYFR, Massachusetts
23.540	2	11.770	BBC, Ascension
19.860	4	4.965	R. Santa Fe, Colombia
19.480	2	9.740	Rdif. Portuguesa
19.328	4	4.832	R. Reloj, Costa Rica
19.210	2	9.605	Deutsche Welle, Antigua
19.100	2	9.550	R. Habana Cuba
19.050	2	9.525	R. Habana Cuba
18.5688	3	6.1896	La Voz de los Centauros, Colombia
18.3456	3	6.1152	La Voz del Llano, Colombia
18.315	3	6.105	La Pantera, Mexico
18.2262	3	6.0754	La Voz del Junco, Honduras
14.835	3	4.945	R. Colosal, Colombia
12.320	2	6.160	Em. Nueva Granada, Colombia

The World Station. Matching its image as the "number one" SW service in English, the BBC also publishes the best program guide, "London Calling." New subscribers to the illustrated free monthly had been turned down due to rising costs. But in April BBC began accepting subscriptions from anyone paying the new charge of \$10 per year (630 Fifth Ave., New York, NY 10020). Alternatively, you can consult our fortnightly column, *Short Waves*, in the Roundup section of the Sunday Denver Post.

A few late-April features we can tell you about here: *Theatre of the Air*, Sa-

turdays at 1830 GMT, Sundays at 0030 and 1130, presents Anouilh's "Antigone," Apr. 23/24. *Radio Theatre*, Sun. 1900, Thurs. 1345, Fri. 0030 has James Fairfax plays, "No Holds Barred," Apr. 17/21/22, and "Let's Play Politics," Apr. 24/28/29. Documentaries, Sun. 1709, Tues. 0030, Thurs. 1130 are "The Right Sort of Food," Apr. 17/19/21, and "The Changing Role of the Ambassador," Apr. 24/26/28. And Wed. 1430, Thurs. 0030, Fri. 2030, "One Hundred Years of Recorded Sound," Apr. 20/21/22, and "Shakespeare on Record," Apr. 27/28/29.

DX Programs. Radio Nederland is broadcasting a "Communications System Course" covering radio, TV, radar, navigation and radio astronomy, written by Jim Vastenoud. Besides broadcasting each lesson two weeks in a row, printed lessons and illustrations are available free. You can still enroll in this course, which began April 7 on the Thursday "DX Juke Box" programs, and continues through the summer. R. Nederland is also celebrating 50 years of SWBC with a special QSL card, and yours truly is celebrating his 10th anniversary as a DX correspondent on the April 21 program. You can also hear our DX report in Spanish, the second Friday of each month on "Espacio DX-ista."

DX listeners are invited to participate in or monitor a ham net discussing all phases of DX'ing and SWL'ing, Wednesdays at 2130 GMT on 7.275 ±0.005 MHz (perhaps an hour earlier by GMT during daylight time). NCS is Charles, WB9NWF. Medium-wave DX'ers exchange tips Monday mornings at 0700 (0600 GMT, starting in May) on 3.900 MHz; listen for Skip, K0SBV, or Ross, W9BG.

The hams also operate a well-organized "intruder watch" designed to expunge non-ham stations from their bands, and qualified SWL's are invited to help. Contact the ARRL Intruder Watch, E. H. Conklin, K6KA, 402 Oliveta Pl., Box 1, La Cañada, CA 91011.

Mark Your Calendar. The International Committee of the Red Cross broadcasts only 4 hours a day, 3 days a week, 6 weeks a year, making its QSL more of a prize than others from Switzerland. Here's the schedule, via SBC on 7.210 MHz, for the rest of 1977: May 23/25/27; July 25/27/29; Sept. 26/28/30; Nov. 21/23/25, at 0600-0700, 1130-1230, 1700-1800, 2200-2300 GMT. The last, and possibly the first, have a chance of being heard in North America this time of year. Mondays are in English; Wednesdays, French/German; and Fridays, Spanish/Arabic.

If you make a point of listening to certain stations on important dates, you may hear extended or special programming. For a starter, try 5.047 MHz on April 27, Togo's National Day. Deutsche Welle is 24 years old on May 3. Liberation Day in Czechoslovakia is May 9, and R. Prague itself marks 54 years on May 18. Cameroun stations on 4.9725 and 5.010 MHz may observe National Day on May 20. Guyana Independence Day is May 26, a good time to check

16.454 MHz. May 31 is Republic Day in South Africa. Tunisia's National Day is June 1, and June 2 is Italy's Day of the Republic. Haiti's 4VEH celebrates 27 years on the air June 2—check 9.770 and 11.834 MHz. FEBC, Philippines is

29 on June 4, while Philippine Independence Day is June 12. Republic Day in Iceland, June 17, just might bring some special transmission on 12.175 MHz. (Dates were compiled by Cees van der Zalm for the Benelux DX Club.) ◇

MAY-AUGUST ENGLISH-LANGUAGE SW B'CASTS by Richard E. Wood

TO EASTERN NORTH AMERICA

TIME-EDT	TIME-GMT	STATION	QUAL*	FREQUENCIES, MHz
6:28 a.m.-8:00 p.m.	1028-2400	**Montreal, Canada (Northern Service)	G	9.625, 11.72 (includes French, etc.)
7:00-7:25 a.m.	1100-1125	Tirana, Albania	F	9.50, 11.865
7:00-9:00 a.m.	1100-1330	Melbourne, Australia	G	9.58
7:00-9:30 a.m.	1100-1330	London, England	G	5.99 (via Sackville), 6.195 (via Antiqua), 11.79 (via Antiqua, tentative by midsummer) 15.07
7:00-10:00 a.m.	1100-1400	**VOA, Washington, USA	G	5.955, 9.73
7:05-8:25 a.m.	1105-1225	Trans-World Radio, Bonaire, N.A.	G	11.815
7:45-8:05 a.m.	1145-1205	**Montreal, Canada	G	9.56, 11.72
8:00-8:30 a.m.	1200-1230	Jerusalem, Israel	G	11.655, 15.10, 15.485, 17.685
8:00-8:55 a.m.	1200-1255	Peking, China	F	11.685
8:10-8:30 a.m.	1210-1230	**Santiago, Chile	F	9.566, 11.81, 15.15
8:15-8:30 a.m.	1215-1230	Athens, Greece	F	15.345, 17.83
		HCB, Quito, Ecuador	G	11.745
8:30-9:00 a.m.	1230-1300	Stockholm, Sweden	G	15.305
8:30-10:00 a.m.	1230-1400	Trans-World Radio, Bonaire, N.A.	G	15.255 (Sat., Sun.)
8:30-11:30 a.m.	1230-1630	HCB, Quito, Ecuador	G	11.745, 15.115
9:15-9:45 a.m.	1315-1345	Berne, Switzerland	G	15.14
9:30-10:00 a.m.	1330-1400	Helsinki, Finland	G	15.11
9:30-11:00 a.m.	1330-1500	**London, England	G	15.07
10:00-10:15 a.m.	1400-1415	**Montreal, Canada	G	15.325, 17.74
10:00-10:30 a.m.	1400-1430	Oslo, Norway	G	15.175 (Sun.)
		Stockholm, Sweden	G	15.305
10:30-11:00 a.m.	1430-1500	Helsinki, Finland	G	15.11
11:00 a.m.-12 noon	1500-1600	London, England	G	17.84 (via Ascension), 9.58 (via Sackville Sat., Sun.)
11:15-11:30 a.m.	1515-1530	Athens, Greece	P	11.73, 15.345, 17.83
12 noon-12:15 p.m.	1600-1615	London, England	G	9.58 (via Sackville)
			G	17.84 (via Ascension)
12:00 noon-12:30 p.m.	1600-1630	Oslo, Norway	G	15.175 (Sun.)
12:04-12:56 p.m.	1604-1656	**Paris, France	G	15.20, 15.30, 15.425, 17.72, 17.80, 17.82, 21.62
12:15-2:30 p.m.	1615-1830	London, England	G	9.58 (via Sackville), 15.07
1:00-4:00 p.m.	1700-2000	**Kuwait, Kuwait	F	9.555, 9.58, 11.845
2:00-2:30 p.m.	1800-1830	**Montreal, Canada	G	11.855, 15.325, 17.82
		**Kampala, Uganda	F	15.325 (Tues., Thur., Sat., Sun.)
2:30-3:00 p.m.	1830-1900	**Montreal, Canada	G	11.855, 15.325, 17.82
2:50-4:00 p.m.	1850-2000	**Abidjan, Ivory Coast	G	11.92 (Sun.)
3:00-3:30 p.m.	1900-1930	**Montreal, Canada	G	11.855, 15.325, 17.82
3:00-4:00 p.m.	1900-2000	**Algiers, Algeria	F	11.91, 15.42 (variable)
3:00-6:00 p.m.	1900-2200	**Jeddah, Saudi Arabia	F	11.855
3:30-4:00 p.m.	1930-2000	**Montreal, Canada	G	11.855, 15.42, 17.82
4:00-4:30 p.m.	2000-2030	**Montreal, Canada	G	15.29, 15.325, 17.82
		**Tehran, Iran	F	9.022, (11.77 alternate)
		Jerusalem, Israel	G	9.009, 9.425, 9.815, 11.655, 15.10
4:00-5:00 p.m.	2000-2100	Accra, Ghana	F	11.85 (irregular)
4:00-5:20 p.m.	2000-2120	**Hilversum, Holland	G	11.73 (via Talata)
4:50-5:50 p.m.	2050-2150	**Havana, Cuba	G	11.865, 17.75
5:00-5:30 p.m.	2100-2130	**Brazzaville, Congo	G	15.19
5:00-5:50 p.m.	2100-2150	**Johannesburg, S. Africa	F	5.98, 9.585
5:00-6:00 p.m.	2100-2200	**Brasilia, Brazil	G	15.24 (11.78, 15.245 alternate)
5:15-6:45 p.m.	2115-2245	London, England	G	9.58, 11.75
5:30-6:50 p.m.	2130-2250	Hilversum, Holland	G	9.715, 11.73 (exc. Sun.)
6:00-6:15 p.m.	2200-2215	**Belgrade, Yugoslavia	F	6.10, 7.24, 9.62
6:00-6:30 p.m.	2200-2230	**Montreal, Canada	G	11.855, 15.325
		Oslo, Norway	F	15.175 (Sun.)
		**Caracas, Venezuela	F	15.40 (varies, Mon.-Fri.)
6:00-7:15 p.m.	2200-2315	**Cairo, Egypt	G	9.805
6:00-8:30 p.m.	2200-0030	Ankara, Turkey	G	9.515, 11.88
6:30-7:00 p.m.	2230-2300	Jerusalem, Israel	G	9.435, 9.815, 11.655, 15.10, 15.485
		Moscow, U.S.S.R.	G	7.105, 7.15, 7.355, 7.40, 9.655, 9.685, 11.735, 11.75, 11.87, 12.05
6:30-7:20 p.m.	2230-2320	Johannesburg, S. Africa	F	5.98, 9.585, 11.90
6:45-7:00 p.m.	2245-2300	London, England	G	5.975, 7.325, 9.58, 11.75

CATCH-A-PULSE II[®] LOGIC PROBE

10 Nsec SPEED AT 3.5 to 15V LEVELS
ONLY \$39.95



Compatible with RTL, DTL, TTL, CMOS, MOS, and Microprocessors using a 3.5 to 15V power supply. Thresholds automatically programmed. Automatic resetting memory. No adjustment required. Visual indication of logic levels, using LEDs to show high, low, bad level or open circuit logic and pulses. Highly sophisticated, shirt-pocket, portable (protective tip cap and removable coil cord). Eliminates need for heavy test equipment. A definite savings in time and money for engineer and technician.

- 10 Nsec pulse response
- Open circuit detection
- Multi-family
- Replaceable tip & cord
- High input impedance
- Pulse stretching

Send \$39.95 (Calif. residents add 6% sales tax) to:

Pat. Pend. Dealer inquiries welcome
AR ELECTRONICS
Box 26205 San Diego, CA 92126 [714] 566 1570

CIRCLE NO 2 ON FREE INFORMATION CARD

*** SAVE GAS! SAVE ON TUNE-UPS!**
MODERNIZE and Bring Your Car "UP-TO-DATE" with the MOST EFFICIENT Ignition ever Invented!



ALLISON XR-700
* The "XR-700" is a COMPLETELY NEW Ignition System that replaces the inefficient Breaker-Points and Condenser with a highly RELIABLE, Invisible "Infra-red" Light-Beam which CONTROLS the Latest design Solid-State POWER MODULE. This new "Patented" Invention produces the HIGHEST ENERGY, Longest Duration Spark of ANY Ignition System manufactured TODAY!

- * CUSTOMERS REPORT: "THE XR-700 MORE THAN PAYS FOR ITSELF...and KEEPS ON SAVING MONEY with..."
- ★ INCREASED "GAS-MILEAGE" up to 30%!
 - ★ ELIMINATING COSTLY "TUNE-UPS"!
 - ★ IMPROVED ENGINE PERFORMANCE!
 - ★ QUICKER STARTING IN ANY WEATHER!
 - ★ FASTER ACCELERATION...SMOOTHER RUNNING!
 - ★ PLUGS LAST UP TO 4-TIMES and LONGER!

* THE XR 700 has NO moving parts to wear out...never needs adjustment! Engineered to OUTLAST Your Car...So RELIABLE...So PERFECTED...that we give you a LIFETIME WARRANTY...FREE Repair or Replacement* for as long as you OWN the Unit...even if you change Cars, we will supply the necessary Parts FREE.

* FITS ALL ENGINES...Domestic or Foreign...4, 6 or 8-Cylinder
* EASY INSTALLATION...Completely Factory ASSEMBLED!

Thousands sold at \$59.95
*** NOW...ONLY.. \$39.95** (Calif. Res. add Tax)
THAT'S EVERYTHING...INCLUDING POSTAGE & INSURANCE

* SAVE! ORDER FACTORY DIRECT!
Send Check or M/O, State Car Make, Year and No. of Cylinders
* MASTERCHARGE or BANKAMERICARD Cardholders
Order by TOLL FREE PHONE (800) 423-6525 Ext. 3

CALL or WRITE for FREE BROCHURE
* America's Oldest and Largest Manufacturer of Opto-Electronic Ignition Systems. ©



ALLISON AUTOMOTIVE CO.
1267 - PO, East EDNA PL., COVINA, CAL. 91722

CIRCLE NO 7 ON FREE INFORMATION CARD

FREE catalog

of over
2000
small tools,
measuring
instruments,
and supplies



- ELT
- COL
- DRILLS
- FILM LOADERS
- PS. . . PAGES. . GRAVERS
- GRINDERS . HAMMERS
- INCLINOMETERS JACKS
- KNIVES. . LATHES . LEATHER-
ETTES. . LOUPES . MINIATURE
- TOOLS... METRIC TOOLS... MULTI-
TESTERS. . NEGATIVE FILES
- NIPPERS. . OILERS... PIN VISES
- PLIERS. . PROBES. . RIFFLERS . .
- SCISSORS. . SNARES. . SOLDER
ING SUPPLIES. . TEST INSTRU-
MENTS. . TWEEZERS. . VIEWERS
- . . VISES. . WRENCHES
- ADH. . ABRASIVES . .
- G. . BOOKS
- LIMATORS
- EPOXIES.
- CALIPERS



National Camera
2000 West Union Ave. Dept. JA
Englewood, Colo., U.S.A. 80110

CIRCLE NO 39 ON FREE INFORMATION CARD

SAVE!

MONEY • TIME • FREIGHT

QUALITY STEREO EQUIPMENT
AT LOWEST PRICES.

YOUR REQUEST FOR QUOTA-
TION RETURNED SAME DAY.

FACTORY SEALED CARTONS—
GUARANTEED AND INSURED.

SAVE ON NAME BRANDS LIKE:
A.D.C. KLH
A.R. SHURE
DYNACO KOSS
SONY FISHER

PIONEER
AND MORE THAN 50 OTHERS
BUY THE MODERN WAY
BY MAIL—FROM



Department 217S
12 East Delaware
Chicago, Illinois 60611
312-664-0020

CIRCLE NO 31 ON FREE INFORMATION CARD

6:50-7:10 p.m.	2250-2310	**Santiago, Chile	F	9.56, 11.81, 15.15
7:00-7:30 p.m.	2300-2330	Stockholm, Sweden	G	6.12, 9.695, 11.705
		Moscow, U.S.S.R.	G	7.105, 7.15, 7.355, 7.40, 9.685, 11.735, 11.75, 11.87, 12.05,
		Vilnius, U.S.S.R.	G	9.655, 9.72, 9.745, 11.77
			G	11.90 (Sat., Sun.)
7:00-7:50 p.m.	2300-2350	**Buenos Aires, Argentina	G	11.71 (Mon.-Fri.)
7:30-8:00 p.m.	2330-2400	Helsinki, Finland	P	11.755
		**Radio Clarin, S. Domingo, Dom. Rep.	G	11.70 (irregular)
		London, England	G	5.975, 6.12 (via Antigua, tent. by midsummer) 7.325, 9.58
7:30-8:30 p.m.	2330-0030	Moscow, U.S.S.R.	G	7.105, 7.355, 7.40, 9.655, 9.685, 9.72, 9.745, 11.735, 11.75, 11.77, 11.87, 11.90, 12.05
7:45-8:45 p.m.	2345-0045	Tokyo, Japan	F	15.27, 15.30
8:00-8:25 p.m.	0000-0025	Tirana, Albania	G	7.065, 9.75 (varies)
8:00-8:30 p.m.	0000-0030	Oslo, Norway	F	9.645, 11.86 (Sun.)
8:00-8:55 p.m.	0000-0055	Sofia, Bulgaria	G	9.70 (alternate 9.705)
		Peking, China	F	11.675, 11.945, 15.06
8:00-9:00 p.m.	0000-0100	**VOA, Washington, USA	G	6.19, 9.67, 11.83, 11.895
8:00-10:45 p.m.	0000-0245	**Luxemburg	F	6.09
8:00 p.m.-1:06 a.m.	0000-0506	**Montreal, Canada (Northern Service)	F	6.085, 9.625
8:15-8:30 p.m.	0015-0030	Brussels, Belgium	G	9.725
8:30-8:55 p.m.	0030-0055	Prague, Czechoslovakia	F	6.055, 9.74
8:30-9:00 p.m.	0030-0100	Stockholm, Sweden	F	11.955
		Kiev, U.S.S.R.	G	9.60, 9.61, 11.69, 11.735, 12.05
8:30-9:30 p.m.	0030-0130	Moscow, U.S.S.R.	G	7.15, 9.53, 9.655, 9.685
		**Trans-World Radio, Bonaire, N.A.	G	11.925
8:30-11:30 p.m.	0030-0330	London, England	G	5.975, 6.12 (via Antigua, tent. by midsummer) 7.325, 9.51, (via Greenville), 9.58 (via Ascension)
8:40-11:00 p.m.	0040-0300	HCJB, Quito, Ecuador	G	9.56, 11.915
9:00-9:15 p.m.	0100-0115	Vatican, City	G	5.995, 9.605, 11.70
9:00-9:20 p.m.	0100-0120	Rome, Italy	G	9.575, 11.91
9:00-9:30 p.m.	0100-0130	Vilnius, U.S.S.R.	G	7.15, 7.215, 9.61, 11.69, (Sat., Sun.)
		Montreal, Canada	G	9.535
9:00-9:45 p.m.	0100-0145	Berlin, Ger. Dem. Rep.	P	9.73
9:00-9:55 p.m.	0100-0155	Peking, China	G	7.12, 9.78 (via Tirana), 9.94, 11.945, 15.06
		Prague, Czechoslovakia	G	5.93, 7.345, 9.54, 9.63, 9.74, 11.99
9:00-11:00 p.m.	0100-0300	Melbourne, Australia	G	15.32, 17.795
9:00-11:30 p.m.	0100-0330	Havana, Cuba	G	11.725, 11.93
9:00 p.m.-12 mdt.	0100-0400	Madrid, Spain	G	6.08, (alternate 6.065) 11.88 (exp. Sun)
9:10-9:30 p.m.	0110-0130	**Santiago, Chile	F	9.566, 11.81, 15.15
9:30-9:50 p.m.	0130-0150	Cologne, Ger. Fed. Rep.	G	6.01, 6.04 (via Antigua), 6.075, 9.565, 9.605
9:30-9:55 p.m.	0130-0155	Tirana, Albania	G	6.20, 7.30
		Vienna, Austria	P	6.155, 9.77
9:30-10:25 p.m.	0130-0225	Bucharest, Rumania	F	5.99, 9.57, 9.68, 11.775, 11.94
9:30-10:30 p.m.	0130-0230	Moscow, U.S.S.R.	G	7.15, 7.215, 9.53, 9.685, 9.70 (via Sofia)
9:45-10:15 p.m.	0145-0215	Berne, Switzerland	G	5.965, 6.135, 9.725, 11.715
10:00-10:30 p.m.	0200-0230	Budapest, Hungary	G	6.00, 7.215, 9.585, 9.833, 11.91 (Exc. Sun.)
		Oslo, Norway	F	9.645, 11.86, 15.175 (Sun.)
		Montreal, Canada	G	6.085, 9.535
		Warsaw, Poland	P	6.095, 6.135, 7.27, 9.675, 11.815, 11.84, 15.12
10:00-10:55 p.m.	0200-0255	Peking, China	F	9.94, 12.01, 12.055
10:00-11:20 p.m.	0200-0320	Hilversum, Holland	G	6.165 (via Bonaire)
10:00-11:30 p.m.	0200-0330	Cairo, Egypt	G	9.475
10:10-10:30 p.m.	0210-0230	**Santiago, Chile	F	9.566, 11.81, 15.15
10:15-10:30 p.m.	0215-0230	Athens, Greece	F	9.75, 9.76, 11.73
10:30-10:55 p.m.	0230-0255	Tirana, Albania	G	6.20, 7.30
10:30-11:00 p.m.	0230-0300	Stockholm, Sweden	F	9.695, 11.705
		Moscow, U.S.S.R.	G	7.39, 9.50, 9.53, 9.61, 9.685, 9.70 (via Sofia)
10:30-11:15 p.m.	0230-0315	Berlin, Ger. Dem. Rep.	P	9.73
11:00-11:30 p.m.	0300-0330	Budapest, Hungary	F	6.00, 7.215, 9.585, 9.833, 11.91 (Tues. Fri.)
		Kiev, U.S.S.R.	G	7.39, 9.61
		Lisbon, Portugal	F	6.025, 11.935
		Moscow, U.S.S.R.	G	9.50, 9.685, 9.70 (via Sofia)
11:00-11:35 p.m.	0300-0335	Warsaw, Poland	P	6.095, 6.135, 7.27, 9.675, 11.815, 11.84, 15.12
11:00-11:55 p.m.	0300-0355	Peking, China	G	7.12, 9.78 (via Tirana)
11:00 p.m.-12 mdt.	0300-0400	Buenos Aires, Argentina	G	9.69 (Mon.-Fri.)
		Prague, Czechoslovakia	G	5.93, 7.345, 9.54, 9.63, 9.74, 11.99
11:00-12:25 a.m.	0300-0425	**Johannesburg, S. Africa	F	5.98, 7.27
11:00 p.m.-1:00 a.m.	0300-0500	HCJB, Quito, Ecuador	G	6.095, 9.56, 11.915
11:10-11:30 p.m.	0310-0330	**Santiago, Chile	F	9.566, 11.81, 15.15

11:30-11:55 p.m.	0330-0355	Tirana, Albania Vienna, Austria	G P	6.20, 7.30 6.155, 9.77
11:30 p.m.-12 mdt.	0330-0400	Moscow, U.S.S.R.	G	7.39, 9.50, 9.61, 9.685, 9.70 (via Sofia)
11:30 p.m.-12:30 a.m.	0330-0430	London, England	G	5.975, 6.12 (via Antigua, tent. midsummer)
11:30 p.m.-12:50 a.m.	0330-0450	Havana, Cuba	G	11.725, 11.76, 11.93
12:00 mdt.-12:15 a.m.	0400-0415	Budapest, Hungary	G	6.00, 7.215, 9.585, 9.833, 11.91 (Tues., Fri.)
12:00 mdt.-12:25 a.m.	0400-0425	Bucharest, Rumania	F	5.99, 6.155, 6.19, 9.57, 9.68, 11.775, 11.94
12:00 mdt.-12:30 a.m.	0400-0430	Oslo, Norway	F	9.645, 11.86 (Sun.)
12:30-1:00 a.m.	0430-0500	London, England	G	6.175 (via Antigua)
12:50 p.m.-2:00 a.m.	0450-0600	Havana, Cuba	G	11.725, 11.93
1:00-1:15 a.m.	0500-0515	Jerusalem, Israel	G	7.412, 9.815, 11.655
1:00-1:30 a.m.	0500-0530	Lisbon, Portugal	G	6.025, 11.935
1:00-3:00 a.m.	0500-0700	HCJB, Quito, Ecuador	G	6.095, 9.56
1:00-3:30 a.m.	0500-0730	London, England	G	6.175, (via Antigua) 9.51 (via Antigua, tent. by midsummer)

TO WESTERN NORTH AMERICA

TIME-PDT	TIME-GMT	STATION	QUAL*	FREQUENCIES, MHZ
4:00-4:15 a.m.	1100-1115	Tokyo, Japan	P	5.99
4:00-5:25 a.m.	1100-1225	Trans-World Radio, Bonaire, N.A.	G	11.815
4:00-6:30 a.m.	1100-1330	London, England	G	5.99 (via Sackville), 6.196 (via Antigua), 11.75 (via Tebrau), 11.79 (via Antigua tent. midsummer)
4:00-7:00 a.m.	1100-1400	**VDA, Washington, USA **4VEH, Cap-Haitien, Haiti	G G	5.955, 9.73 9.77, 11.835
5:00-5:15 a.m.	1200-1215	Tokyo, Japan	P	5.99
5:00-5:30 a.m.	1200-1230	**Tashkent, U.S.S.R.	G	9.60, 11.925
5:10-5:30 a.m.	1210-1230	**Santiago, Chile	F	6.195, 9.566, 11.81, 15.15
5:15-5:30 a.m.	1215-1230	HCJB, Quito, Ecuador	G	11.745
5:30-7:00 a.m.	1230-1400	Trans-World Radio Bonaire, N.A.	G	15.255 (Sat., Sun.)
5:30-9:30 a.m.	1230-1630	HCJB, Quito, Ecuador	G	11.745, 15.115
6:00-6:15 a.m.	1300-1315	Tokyo, Japan	P	5.99
6:30-6:50 a.m.	1330-1350	**Santiago, Chile	F	6.195, 9.566, 11.81, 15.15
6:30-8:00 a.m.	1330-1500	**Delhi, India	F	11.81
7:00-7:30 a.m.	1400-1430	Tokyo, Japan **Tashkent, U.S.S.R.	G G	9.505 9.60, 11.925
7:00-8:20 a.m.	1400-1520	**Hilversum, Holland	G	11.73 (via Talata)
7:00-9:55 a.m.	1400-1655	Manila, Philippines (VOP)	F	9.58 (Closes 1555 Sun.)
8:00-8:15 a.m.	1500-1515	Tokyo, Japan	G	9.505
8:00-9:00 a.m.	1500-1600	London, England	G	17.84 (via Ascension) also 9.58 (via Sackville Sat., Sun.)
9:00-9:15 a.m.	1600-1615	Tokyo, Japan London, England	G G	9.505 9.58, 15.365 (via Sackville), 17.84 (via Ascension)
9:04-9:56 a.m.	1604-1656	**Paris, France	G	15.20, 15.30, 15.425, 17.72, 17.80, 17.82, 21.62
9:15-10:09 a.m.	1615-1809	London, England	G	9.58, 15.365 (via Sackville)
9:42-9:51 a.m.	1642-1651	Hilversum, Holland	G	15.19, 17.775 (Mon.-Fri.)
10:00-10:15 a.m.	1700-1715	Tokyo, Japan	G	9.505
10:00 a.m.-1:00 p.m.	1700-2000	**Kuwait, Kuwait	F	9.555, 9.58, 11.845
10:09-11:00 a.m.	1709-1800	London, England	G	9.58, (via Sackville)
11:00-11:09 a.m.	1800-1809	London, England	G	9.58 (via Sackville), 11.815 (via Ascension)
11:00-11:15 a.m.	1800-1815	Tokyo, Japan	G	15.105
11:00-11:30	1800-1830	**Kampala, Uganda Oslo, Norway	F F	15.325, (Tues., Thur., Sat., Sun.) 11.895 (Sun.)
11:45 a.m.-1:00 p.m.	1845-2000	**Abidjan, Ivory Coast	G	11.92 (Sun.)
12 noon-12:15 p.m.	1900-1910	**Papeete, Tahiti	F	11.825, 15.17 (exc. Sun.)
12:00-12:15 p.m.	1900-1915	Tokyo, Japan	G	15.105
1:00-1:15 p.m.	2000-2015	Tokyo, Japan	G	15.105
1:00-2:20 p.m.	2000-2120	Hilversum, Holland	G	11.73 (via Talata)
1:30-1:50 p.m.	2030-2050	**Santiago, Chile	F	9.566, 11.81, 15.15
1:30-2:00 p.m.	2030-2100	**Kampala, Uganda	F	9.73 (Sat., Mon. Wed., Fri.)
2:00-2:15 p.m.	2100-2115	Tokyo, Japan	G	15.105
2:00-2:30 p.m.	2100-2130	**Brazzaville, Congo	G	15.19
2:00-3:00 p.m.	2100-2200	**Brazilia, Brazil	G	15.24 (alternates 11.78, 15.245)
2:30-3:30 p.m.	2130-2230	**Taipei, Taiwan	F	15.225
3:00-3:15 p.m.	2200-2215	Tokyo, Japan	G	15.105
3:00-3:30 p.m.	2200-2230	**Caracas, Venezuela	F	15.40 (varies; Mon.-Fri.)
3:00-5:00 p.m.	2200-2400	**VDA, Washington, USA Montreal, Canada	F F	17.82, 17.895, 21.61 5.96 (Mon.-Fri.)
3:30-4:00 p.m.	2230-2300	Jerusalem, Israel	G	9.435, 9.815, 11.655, 15.10, 15.485
3:30-4:20 p.m.	2230-2320	Johannesburg, S. Africa	F	5.98, 9.585, 11.90
3:30-5:30 p.m.	2230-0030	Moscow, U.S.S.R.	G	9.635, 9.78, 12.05, 15.14, 15.18, 15.455, 17.72
3:50-4:10 p.m.	2250-2310	**Santiago, Chile	F	9.566, 11.81, 15.15
4:00-4:30 p.m.	2300-2330	Tokyo, Japan	G	15.105
4:00-5:00 p.m.	2300-2400	**Pyongyang, Dem. Rep. Korea	F	11.535, 15.63 (variable)

Put Professional Knowledge and a COLLEGE DEGREE in your Electronics Career through HOME STUDY

Earn Your DEGREE

by correspondence, while continuing your present job. No commuting to class. Study at your own pace. Learn from complete and explicit lesson materials, with additional assistance from our home-study instructors. Advance as fast as you wish, but take all the time you need to master each topic. Profit from, and enjoy, the advantages of directed but self-paced home study.

The Grantham electronics degree program begins with basics, leads first to the A.S.E.T. degree, and then to the B.S.E.E. degree. Our free bulletin gives complete details of the program itself, the degrees awarded, the requirements for each degree, and how to enroll. Write for *Bulletin E-77*.

Grantham College of Engineering

2000 Stoner Avenue

P. O. Box 25992

Los Angeles, CA 90025

Worldwide Career Training thru Home Study

CIRCLE NO 27 ON FREE INFORMATION CARD

COMPUTER MUSIC?



OUR EQUALLY TEMPERED D A CONVERTER MAKES IT EASY!

- 5+ octaves of control voltage from 6 bits of data
- hand-shaking logic
- use with any processor.
- drives even the simplest linear oscillators & filters.

8780 D A CONVERTER KIT \$34.95
(plus \$1.00 postage for mail orders)

8782 ENCODED KEYBOARD \$109.95 . . wt. 20 lbs.

COMPLETE SYNTHESIZER PACKAGES AS LOW AS \$239

MODULES: VCO's, VCF's, NOISE SOURCES, & MORE
• keyboards shipped freight collect

DETAILS IN OUR FREE CATALOG

PAIA
ELECTRONICS

DEPT 5-P
1020 W. WILSHIRE BLVD.
OKLAHOMA CITY, OK 73116

CIRCLE NO 45 ON FREE INFORMATION CARD

HEAR-IT-YOURSELF KIT



This is a Speakerlab 7, a 4-element acoustic suspension speaker kit you can assemble yourself in an hour with simple tools.

It saves you up to 50% over comparable ready made systems. Read about the S7 and other systems and raw speakers we sell in a new 40 page catalog. It's a fact-packed manual with chapters on acoustic theory, enclosures, choosing drivers and design principles.

And it's free. Just write us and ask for the most complete catalog/manual ever written on speaker building.

Speakerlab
Dept. PE10 5500 35th NE Seattle WA 98105

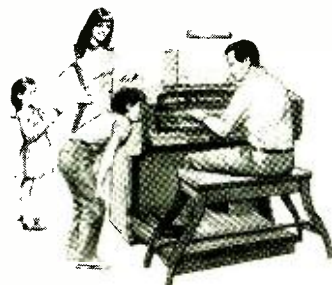

Our whole family helped assemble this wonderful Schober Organ... and now we all play it!

Talk about real family fun! We all worked together, for a few hours almost every day. Almost too soon, our Schober Organ was finished. Our keen-eyed daughter sorted resistors. Mom soldered transistor sockets, although she'd never soldered anything before. And it did our hearts good to see the care with which our son—he's only 12—installed the transistors. Me? I was the quality control inspector—they let me do the final wiring.

Our completed Schober Organ compares favorably with a "ready-made" one costing twice as much! (The five models range from \$650 to \$2850.)

Just send the coupon for the fascinating Schober color catalog (or enclose \$1 for a 12-inch LP record that lets you hear as well as see Schober quality).

The *Schober* Organ Corp., Dept. PE-71
43 West 61st Street, New York, N.Y. 10023

- Please send me Schober Organ Catalog.
 Enclosed please find \$1.00 for 12-inch L.P. record of Schober Organ music.

NAME _____
ADDRESS _____
CITY _____ STATE _____ ZIP _____

4:00-4:30 p.m.	2300-2330	London, England	G	6.175, 9.51 (via Sackville), 9.58 (via Ascension)
4:30-5:00 p.m.	2330-2400	**Radio Clarin, S. Domingo, Dom. Rep.	G	11.70 (irregular Mon.-Fri.)
4:30-5:30 p.m.	2330-0030	London, England	G	6.12 (via Antigua tent. by midsummer) 6.175, 9.51 (via Sackville)
5:00-5:15 p.m.	0000-0015	Tokyo, Japan	G	15.105
5:00-6:00 p.m.	0000-0100	**VOA, Washington, USA	G	11.83, 11.895, 15.40
5:30-6:00 p.m.	0030-0100	Moscow, U.S.S.R.	G	9.635, 9.78, 12.05, 15.14, 15.18, 15.455, 17.72
5:30-6:30 p.m.	0030-0130	**Trans-World Radio, Bonaire, N.A.	G	11.925
5:30-8:30 p.m.	0030-0330	London, England	G	6.12 (via Antigua, tent. by midsummer) 6.175 (via Sackville), 9.51 (via Greenville), 9.58 (via Ascension)
5:40-8:00 p.m.	0040-0300	HCJB, Quito, Ecuador	G	9.56, 11.915
6:00-6:15 p.m.	0100-0115	Tokyo, Japan	G	15.105
6:00-6:30 p.m.	0100-0130	Moscow, U.S.S.R.	G	9.635, 9.78, 12.05, 15.14, 15.18, 15.455
6:00-7:00 p.m.	0100-0200	Taipei, Taiwan	F	15.425, 17.89
6:00-8:00 p.m.	0100-0300	Melbourne, Australia	G	15.32, 17.795
6:00-9:00 p.m.	0100-0400	Madrid, Spain	F	6.08, (alternate 6.065), 11.88
6:10-6:30 p.m.	0110-0130	**Santiago, Chile	F	6.195, 9.566, 11.81, 15.15
7:00-7:30 p.m.	0200-0230	Moscow, U.S.S.R.	G	9.635, 9.78, 11.86, 12.05, 15.14
7:30-8:00 p.m.	0230-0300	Stockholm, Sweden	F	9.695, 11.705
8:00-8:15 p.m.	0300-0315	Moscow, U.S.S.R.	G	9.635, 9.78, 11.86, 15.14
8:00-8:30 p.m.	0300-0330	Tokyo, Japan	G	15.105
8:00-8:30 p.m.	0300-0330	Kiev, U.S.S.R.	G	9.58, 9.635, 9.78, 11.86
8:00-8:55 p.m.	0300-0355	Seoul, Rep. Korea	F	11.86
8:00-9:20 p.m.	0300-0420	Moscow, U.S.S.R.	G	9.655, 12.05
8:00-10:00 p.m.	0300-0500	Peking, China	G	7.12, 9.78 (via Tirana), 11.445, 12.055, 15.06, 15.385, 17.735, 17.855
8:10-8:30 p.m.	0310-0330	**Johannesburg, S. Africa	F	5.98, 7.27
8:20-9:25 p.m.	0320-0425	HCJB, Quito, Ecuador	G	6.095, 9.56, 11.915
8:22-8:28 p.m.	0322-0328	**Santiago, Chile	F	6.195, 9.56, 11.81, 15.15
8:30-9:00 p.m.	0330-0400	**TIFC, San Jose, Costa Rica	F	6.035, 9.645, (opens 0300 Sat., Sun.)
8:30-9:15 p.m.	0330-0415	Erevan, U.S.S.R.	G	9.54, 9.735, 11.69, 15.14 (Sat./Tue./Wed./Fri.)
8:30-9:30 p.m.	0330-0430	Moscow, U.S.S.R.	G	9.54, 9.58, 9.635, 9.735, 9.78, 11.69, 15.14, 11.87, 12.00, 12.05, 15.10, 15.21
8:30-9:15 p.m.	0330-0415	Berlin, Ger. Dem. Rep.	F	11.89, 12.00
8:30-9:30 p.m.	0330-0430	London, England	G	6.12 (via Antigua tent. midsummer) 6.175 (via Sackville)
9:00-9:15 p.m.	0400-0415	Tokyo, Japan	G	15.105
9:00-9:30 p.m.	0400-0430	Oslo, Norway	F	6.18, 9.55, 9.645
9:00 p.m.-12:30 a.m.	0400-0730	Budapest, Hungary	F	6.00, 7.215, 9.585, 9.833, 11.91 (Tue., Fri.)
9:30-10:00 p.m.	0430-0500	Montreal, Canada	G	9.655, 11.765
9:30-12:30 a.m.	0430-0730	Moscow, U.S.S.R.	G	9.54, 9.58, 9.635, 9.71, 9.78, 11.69, 11.87, 12.00, 12.05, 15.10, 15.21
10:00-10:15 p.m.	0500-0515	Berne, Switzerland	G	9.725, 11.715
10:00-10:30 p.m.	0500-0530	Sofia, Bulgaria	F	9.70 (alternate 9.705)
10:00-11:20 p.m.	0500-0620	London, England	G	6.175 (via Antigua)
10:00-12 mdt.	0500-0700	Jerusalem, Israel	F	7.412, 9.815, 11.655
10:00 p.m.-12:30 a.m.	0500-0730	Tokyo, Japan	G	15.105
10:30-10:50 p.m.	0530-0550	Lisbon, Portugal	F	6.025, 11.935 (varies)
11:00-11:15 p.m.	0600-0615	Hilversum, Holland	G	6.165, 9.715, (via Bonaire)
11:00-11:30 p.m.	0600-0630	HCJB, Quito, Ecuador	G	6.095, 9.56
11:00 p.m.-12 mdt.	0600-0700	London, England	G	6.175 (via Antigua)
11:25 p.m.-1:25 a.m.	0625-0825	Cologne, Ger. Fed. Rep.	G	9.51 (via Antigua tent. by midsummer) 5.96 (via Antigua) 6.10 (via Malta), 6.185, 9.545 9.505
11:30 p.m.-12:50 a.m.	0630-0750	Tokyo, Japan	G	9.505
12:00-12:15 a.m.	0700-0715	Oslo, Norway	P	6.18, 9.645 (Sun.)
1:00-1:15 a.m.	0800-0815	Seoul, Korea	F	9.73
1:00-2:20 a.m.	0800-0920	Buenos Aires, Argentina	F	9.69 (Mon.-Fri.)
1:00-3:00 a.m.	0800-1000	**Kuala Lumpur, Malaysia	G	15.275
1:00-7:00 a.m.	0800-1400	**Hilversum, Holland	G	9.63 (via Bonaire)
2:00-2:15 a.m.	0900-0915	Tokyo, Japan	G	9.505
2:30-2:50 a.m.	0930-0950	Tokyo, Japan	G	9.505
3:00-3:30 a.m.	1000-1030	**Hilversum, Holland	G	9.715 (via Bonaire)
3:50-4:10 a.m.	1050-1110	Manila, Philippines (FEBC)	F	11.92
		**Port Moresby, Papua-New Guinea	F	4.89
		Tokyo, Japan	G	9.505
		**Santiago, Chile	G	6.195, 9.566, 11.81, 15.15
		Tokyo, Japan	G	5.99
		**Santiago, Chile	G	6.195, 9.566, 11.81, 15.15

* Reception quality, East Coast (West Coast) location: G-good, F fair, P poor

** Not intended for North America, but receivable satisfactorily

Dates refer to local date in target area.

ELECTRONICS MARKET PLACE

REGULAR CLASSIFIED: COMMERCIAL RATE: For firms or individuals offering commercial products or services. \$2.25 per word. Minimum order \$33.75.
EXPAND-AD CLASSIFIED RATE: \$3.35 per word. Minimum order \$50.25. Frequency discount: 5% for 6 months; 10% for 12 months paid in advance. **READER RATE:** For individuals with a personal item to buy or sell. \$1.35 per word. No minimum! **DISPLAY CLASSIFIED:** 1" by 1 column (2-1/4" wide), \$260.00. 2" by 1 column, \$520.00. 3" by 1 column, \$780.00. Advertiser to supply film positives. For frequency rates, please inquire.
GENERAL INFORMATION: Payment must accompany copy except when ads are placed by accredited advertising agencies. First word in all ads set in caps. All copy subject to publisher's approval. All advertisers using Post Office Boxes in their addresses **MUST** supply publisher with permanent address and telephone number before ad can be run. Advertisements will not be published which advertise or promote the use of devices for the surreptitious interception of communications. Ads are not acknowledged. They will appear in first issue to go to press after closing date. Closing Date: 1st of the 2nd month preceding cover date (for example, March issue closes January 1st. Send order and remittance to **POPULAR ELECTRONICS**, One Park Avenue, New York, New York 10016. Attention: Hal Cymes

FOR SALE

FREE! Bargain Catalog—I.C.'s, LED's, readouts, fiber optics, calculators parts & kits, semiconductors, parts Poly Paks, Box 942PE, Lynnfield, Mass. 01940.

GOVERNMENT and industrial surplus receivers, transmitters, snooper scopes, electronic parts. Picture Catalog 25 cents. Meshna, Nahant, Mass. 01908

LOWEST Prices Electronic Parts Confidential Catalog Free. KNAPP, 3174 8th Ave S.W., Largo, Fla 33540.

ELECTRONIC PARTS, semiconductors, kits FREE FLYER. Large catalog \$1.00 deposit. BIGELOW ELECTRONICS, Bluffton, Ohio 45817.

RADIO—T.V. Tubes—36 cents each. Send for free catalog. Cornell, 4213 University, San Diego, Calif. 92105

AMATEUR SCIENTISTS, Electronics Experimenters, Science Fair Students—Construction plans—Complete, including drawings, schematics, parts list with prices and sources. Robot Man—Psychedelic shows—Lasers—Emotion/Lie Detector—Touch Tone Dial—Quadraphonic Adapter—Transistorized Ignition—Burglar Alarm—Sound Meter...over 60 items Send 50 cents coin (no stamps) for complete catalog. Technical Writers Group, Box 5994, University Station, Raleigh, N.C. 27607

METERS—Surplus, new, used, panel or portable. Send for list. Hanchett, Box 5577, Riverside, CA 92507

MECHANICAL, ELECTRONIC devices catalog 10 cents. Greatest Values—Lowest Prices. Fertik's, 5249 "D", Philadelphia, Pa. 19120.

SOUND SYNTHESIZER KITS—Surf \$12.95, Wind \$12.95, Wind Chimes \$17.95, Electronic Songbird \$6.95, Musical Accessories, many more. Catalog free. PAIA Electronics, Box J14359, Oklahoma City, OK 73114

BUGGED??? New locator finds them fast. Write: Clifton, 11500-L N.W., 7th Avenue, Miami, Florida 33168

YOU WILL SAVE BIG MONEY! Surplus, Clearouts, Bankruptcy, Inventory, Deals Catalog \$1 (redeemable). ETCOA Electronics, Box 741, Montreal, H3C 2V2 US Inquiries.

HEAR POLICE/FIRE Dispatchers! Catalog shows exclusive directories of "confidential" channels, scanners. Send postage stamp. Communications, Box 56-PE, Commack, N.Y. 11725.

UNSCRAMBLERS Fits any scanner or monitor, easily adjusts to all scrambled frequencies. Only 4" square \$29.95, fully guaranteed. Dealer inquiries welcomed. PQO Electronics, Box 841, North Little Rock, Arkansas 72115.

RECONDITIONED Test Equipment \$0.50 for catalog. Walter's Test Equipment, 2697 Nickel, San Pablo, CA 94806.

POLICE, Fire monitors, scanners, crystals, CB Transceivers, New Crystal-less scanners. Discount priced. Box 19224, Denver, CO 80219.

TELETYPE EQUIPMENT for sale for beginners and experienced computer enthusiasts. Teletype machines, parts, supplies Catalogue \$1.00 to ATLANTIC SALES, 3730 Nautilus Ave., Brooklyn, NY 11224. Tel: (212) 372-0349.

JAPANESE TRANSISTORS, all transistors original factory made. Free catalog. West Pacific Electronics, P.O. Box 3879, Torrance, CA 90510.

ELECTRONIC ignition: Capacitor-Discharge, pointless. Auburn Sparkplugs, Wheel Stabilizers, Information 20 cents. Anderson Engineering, Epsom, N.H. 03234.

WHOLESALE C.B., Scanners, Antennas, Catalog 25 cents. Crystals. Special cut. \$4.95, Monitor \$3.95. Send make, model, frequency. G. Enterprises, Box 461P, Clearfield, UT 84015.

COMPUTER HOBBYISTS—classified advertising newsletter. \$3.75/year. Free Sample. ON_LINE, 24695 Santa Cruz Hwy., Los Gatos, CA 95030.

SURPLUS COMPONENTS. Communication and test equipment. Illustrated catalog 25 cents. E. French, P.O. Box 249, Aurora, Illinois 60505.



ORGAN KITS KEYBOARDS

THE ULTIMATE IN DESIGN AND SOUND

Demo Record & Brochure \$1.00

Wurlitzer reproductions

DEVTRONIX ORGAN PRODUCTS, Dept. C
5872 Amapola Dr. • San Jose, CA 95129

SURPLUS 'SMART' TERMINALS, components, serious music synthesizer kits, plans, parts, and more. Send SASE for FREE INFO Package. CFR Associates, POBF, Newton, N.H. 03858.

CB RADIOS, monitors, crystals, CD ignitions. Southland, Box 3591-B, Baytown, Texas 77520

CB CRYSTALS over 20,000 standard and specials in stock from 6.0 MHz to 45.0 MHz. Call or write for information package. Dealer inquiries invited. Roberts Electronics Sales, 73563 29 Palms Highway, 29 Palms, California 92277. (714) 367-6235.

SURPRISES GALORE! Projects, ham radio, music synthesizers, etc. IC's, pots, hardware, crystals, keyboards, resistors, etc. Send 13 cents stamp for catalogue. UTEP, Box 26231B, Salt Lake City, Utah 84125

BUILD YOUR OWN SPEAKERS AND SAVE UP TO 50%.

Send for our free, fact packed 40 page catalog manual and learn how to assemble your own multi element stereo speakers from scratch or from kits. Don't settle for inferior speakers on design, construction, + parts, enclosures, mirrors, woofers, tweeters and horns. Write us today.

SPEAKERLAB
Dept. PE A, 5500 35th N.E.
Seattle, Washington 98105

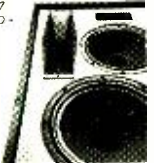

BUILD AND SAVE TELEPHONES, TELEVISION, DETECTIVE, BROADCAST Electronics We sell construction plans with an Engineering Service, Speakerphones, Answering Machines, Carphones, Phonevision, Dialers, Color TV Converters, VTR, Games, \$25 TV Camera, Electron Microscope, Special Effects Generator, Time Base Corrector, Chroma Key Engineering Courses in Telephone, Integrated Circuits, Detective Electronics PLUS MUCH MORE NEW Super Hobby Catalog PLUS year's subscription to Electronic News Letter, \$1.00 Don Britton Enterprises, 6200 Wilshire Blvd., Los Angeles, Calif. 90048.

NAME BRAND Digital/Analog Test Equipment. Discount prices. Free catalog. Salen Electronics, Box 82, Skokie, Illinois 60076

TELEPHONES UNLIMITED. Equipment, Supplies, All types, Regular, Keyed, Modular. Catalog 50 cents. Box 1147E, San Diego, California 92112.

CB RADIOS—Police Scanners, Wholesale only! Send letterhead for lowest prices anywhere. Four Wheeler, 10PE New Scotland, Albany, N.Y. 12208.



Patent Pending

THERE IS NO OTHER TELESCOPE LIKE IT! THE NEW EDMUND 4 1/4", f/4 NEWTONIAN WIDE FIELD REFLECTOR TELESCOPE

Clear, bright, spectacular wide angle views of stars, moon, comets... easy to use... portable!

IN SECONDS YOU'RE SCANNING THE ASTOUNDING UNIVERSE, able to see and study the breath-taking cosmos as perhaps you never have before. awesome vastness, unbelievable orderliness, stark silent beauty. All the fascinating heavenly mysteries are yours to enter and explore. This new reflector telescope makes it easy for everyone to span a thousand light-years to space-age enjoyment of the heavens and outdoors. No complicated set up! Just insert the eyepiece, focus, and its big 3 1/2" field of view gives you more stars in a single view than any other type of telescope. Bright, crisp, finely resolved images to capture your interest and imagination. It's probably the easiest to use telescope ever... over your shoulder, in your lap, on a tripod. Or just rotate the spherical base on its own mount for use on a table, car hood. Take it anywhere (only 17", 10 lb.). Top quality optical system. 4 1/4", f/4 parabolic primary mirror (1/8 wave, 17 F.L.), prealigned 1/8 wave diagonal on a coated optical window seals optics from moisture and dust. 28mm Kellner eyepiece (gives 15X, higher without other eyepiece or Barlow) Fast focusing (25 to infinity) Bright Scharfianian red (doesn't impair night vision) adj. carrying strap. A first scope must be an ideal second scope!

There is no other telescope like it. NO. 2001AV \$149.95 Ppd.

COMPLETE AND MAIL COUPON NOW

EDMUND SCIENTIFIC CO., 300 Edscorp Bldg., Barrington, N. J. 08007

Send me _____ unique Edmund Telescope(s)
#2001AV @ \$149.95 ea \$ _____

Service & Handling Charge \$ 1.00
Enclosed is Check / M.O. For TOTAL of \$ _____

Charge my American Exp. Signature _____
BankAmericard / Master Chg. (Please Print)

Interbank No. _____ Name _____
Card No. _____ (Please Print)

Expiration Date _____ Address _____

City _____

State _____ Zip _____

30-DAY MONEY-BACK GUARANTEE. You must be satisfied or return any purchase in 30 days for full refund.

HELPING TO DEVELOP AMERICA'S TECHNOLOGY FOR OVER 30 YEARS.

GIANT FREE 164 PG. CATALOG

4500 UNUSUAL BARGAINS FOR HOBBYISTS, SCHOOLS, INDUSTRY

EDMUND SCIENTIFIC CO.
300 Edscorp Bldg.
Barrington, N.J. 08007
America's Greatest
Science • Optics • Hobby Center
(609) 547-3488

POLY PAK'S IS THE "BARREL KIT KING" OF THE WORLD!

Poly Pak's EXCLUSIVE BARREL KITS[®] ARE LIKE FINDING MONEY!!!

Each kit carries a money-back guarantee!
Test 'em yourself 'n save! Includes 100% material, too!



KIT #237
LED DISPLAY
MOLEX PINS
200 for \$1.98
Fine 1/2" long, 1/10" spacing
For displays, keyboards,
Wt. 4 ozs. SE3594

BARREL KIT #210 A / GLOWIN' PANELS
3 for \$1.98
4" x 1" panels that glow blue-green with 110VAC.
Use for note sites, indicators, etc. Cat. No. SE3550

BARREL KIT #198 TRANSISTORS DARLINGTONS
50 for \$1.98
Motorola dumps 1,000,000 TO-220 in barrels. NPNs & PNP's. Cat. No. SE3533

BARREL KIT #184 1/4-WATT METAL FILM
150 for \$1.98
100% metal film resistors. Long leads. Cat. No. SE3413

BARREL KIT #159 MODULAR SWITCHES
25 for \$1.98
Centralab switches. TV-makers, mess. Dpdt, spdt, etc. Brand new. Cat. No. SE3150

BARREL KIT #135 MICRO MINI LAMPS
20 for \$1.98
Imaginal Micro size (1/4" x 1/4") with wire leads. 3 to 5 VDC. 40 mAs. SE3259

BARREL KIT #112 MICRO MINI LEADS
40 for \$1.98
All the tiny leads, axial, upright of Monsanto, Litronix, variety of colors. Yield 50% or better. SE3139

BARREL KIT #92 3 AMP EPOXY RECTIFIERS
100 for \$1.98
Cosmetic rejects, electrically fine business. You check 'em, it's not for us. Assat. voltages. SE3204

BARREL KIT #76 1-WATT ZENERS
100 for \$1.98
Factory same as 400-mw's. Never-to-see-again under 6, 8, 10, 12, 15V. Offer glass. Double plug. Cat. No. SE2741 Untested.

BARREL KIT #56 POWERS! POWERS!
100 for \$1.98
Large distributor cleaned house. Barrels of power resistors 3 to 7 watts. Cat. No. SE2724

BARREL KIT #31 METALLIC RESISTORS
100 for \$1.98
Made mostly by Gurney, the finest resistor made. Mostly 1/2 watters, 1 to 5% to 1% & a barrel's values. Cat. No. SE2609

BARREL KIT #228 MULTI-DIGIT READOUTS
10 for \$1.98
Barrels of 3's, 6's, & 9-digit readouts, some with driver chips. Wt. 4 ozs. Untested. No. SE3628

BARREL KIT #205 MINI BLOCK CAPACITORS
50 for \$1.98
Unbelievable! Worth \$50. High precision submini caps for all applications. Wt. 3 ozs. Cat. No. SE3528

BARREL KIT #194 10-AMP INLINE BRIDGE RECTIFIERS
20 for \$1.98
Assat voltage. We can't test 'em. No. SE3475

BARREL KIT #182 JUMBO RED LEADS
15 for \$1.98
100% material, user cancellation from factory. 100% of projects, red leads. Cat. No. SE3369

BARREL KIT #158 MAGNIFIED MAN-3'S
20 for \$1.98
MAN-3's. 7-seg readout, with built-in magnifier. Factory discontinued line. 100% material. Cat. No. SE3325 100%

BARREL KIT #134 CALCULATOR CHIPS
15 for \$1.98
National type. Cat. No. MM5736, etc. Untested. Cat. No. SE3258

BARREL KIT #109 TERMINAL STRIPS
100 for \$1.98
Wide asst. of terminal strip connectors, from 1 contact up. Strip manufacturers barrel dump is your gain. Wt. 1 lb. Cat. No. SE3136

BARREL #91 SILVER MICAS
100 for \$1.98
Axial, red case, variety of physical sizes & values. Cat. No. SE3018

BARREL KIT #73 TRANSISTOR ELECTROS
50 for \$1.98
We don't want to separate wide asst voltages & values up to 300 mV. Cat. No. SE2747

BARREL KIT #54 8 DIGIT READOUTS
10 for \$1.98
Bargain of a lifetime! All we got was 1 barrel — one "blond digit" types. Multiplexed. Cat. No. SE2722

BARREL KIT #30 PREFORMED RESISTORS
200 for \$1.98
We got barrels of 1/2 watt, 100, 1/4, 100 1/2 watters. No. SE2608 100% good

BARREL KIT #225 SOUND TRIGGERS
150 for \$1.98
"Hand clasp" sensitive crystal mike amplifiers, triggers. SCR. Cat. No. SE3625

BARREL KIT #203 CALCULATOR KEYBOARDS
10 for \$1.98
It's true! 20-key, 4 function keyboards at ridiculous give-away. Wt. 12 ozs. Cat. No. SE3524

BARREL KIT #192 NYLON GEARS
40 for \$1.98
Wide variety of sizes 1" to 3" gears for the mechanical gear train hobbyist. Wt. 10 ozs. No. SE3427

BARREL KIT #181 MICRO GEARERS
100 for \$1.98
1-Watt, tiny, 100% material. No shorts, no opens. DO-7 & micro epoxy units. Cat. No. SE3536

BARREL KIT #154 CLOCK CHIPS
20 for \$1.98
We gathered an assortment of clock chips, alarm, clock, dir, beepers, who knows, all mixed. Cat. No. SE3308

BARREL KIT #131 TANTALUM ELECTROS
30 for \$1.98
Mixed, marked prime, top grade asst. values, voltages. Cat. No. SE3255

BARREL KIT #108 TO-5 PLASTIC TRANSISTORS
40 for \$1.98
Includes PNP, NPN, 2N-3638, 2N3641, 2N5000 series, etc. Untested.

BARREL KIT #88 LITRONIX LED READOUTS
10 for \$1.98
100% good. Single digit, plus, etc. — all to 100. Not from factory, all mixed. Have fun! No. SE2861

BARREL KIT #71 CAPACITOR SPECIAL
100 pcs. \$1.98
micas, molydes, micaflats, ceramics, discs, etc. Nifty 100% good. Cat. No. SE2738

BARREL KIT #40 PNP HIGH-POWER TRANSISTORS
20 for \$1.98
Popular germanium TO-3 case SE2614 100% good

BARREL KIT #27 PREFORMED DISCS
150 for \$1.98
Hi-Fi mfr's shelf inventory but it dumped 'em in barrels. Preformed for PC use. Mixed values too! SE2605

BARREL KIT #17 LINEAR & 7400 DIPS
100 for \$1.98
Marked and unmarked, internal numbers, if raw factory stock. Cat. No. SE2431

BARREL KIT #8 SUBMINIATURE IF TRANSFORMERS
75 for \$1.98
Amazing, includes 45KHz, case antenna, who knows? Cat. No. SE2422 100% good

BARREL KIT #2 LINEAR OR AMPS. DIPS
75 for \$1.98
Un. tested. Marked 14 and/or with 16 pin dips, may include gate registers, flip flops, counters. SE2415 Untest.

BARREL KIT #221 IC SOCKETS
8 for \$1.98
Mfr untested Four 14-pin, four 18-pin. Solder tail, 10-profile. No. SE3621

MIXED READOUTS
15 for \$1.98
Barrels of untested 177, 367, 609, 603, MAN-3's. Wt. a buy! No. SE3619

100 for \$1.98
PLUGS, SOCKETS
Distributor unloads! Includes AC, DC, RF, audio, 4-9 pin, all kinds, Wt. 1 lb. Cat. No. SE3527

BARREL KIT #191 CARBOFILM RESISTORS
800* for \$1.98
1/2 pound, approx. 1/4" x 1/2" wafer. Assat values. Unmarked. Cat. No. SE3445

BARREL KIT #149 ROCKER SWITCHES
12 for \$1.98
No. SE3302

BARREL KIT #128 MINI DIP IC'S
100 for \$1.98
Large mfr dumped 100's of lbs into barrels. Includes 7418, LM-340-8, 703, 667, 655, 658—but who knows? Wt. 1 lb. SE3245

BARREL KIT #104 SLIDE VOLUME CONTROLS
10 for \$1.98
Cat. No. SE1057

BARREL KIT #87 NATIONAL IC BONANZA
100 for \$1.98
Types: 9011, 100 series, PFLs, ROMs, reg. int. clock & vol. chips, loads, etc. Cat. No. SE2860 Untested.

BARREL KIT #68 2 WATTERS
100 for \$1.98
Suppliers throw 'em in the barrel. It's a 1/2 gold mine. All marked. Cat. No. SE2735

BARREL KIT #39 2N3055 HOBBY TRANSISTORS
15 for \$1.98
Failouts of the famous 2N4055 SE2617 100%

KIT #26 PLASTIC TRANSISTORS
100 for \$1.98
Type TO-92 (TO-18), all manufacturers, variety of 2N's. Cat. No. SE2604

BARREL KIT #15 MOSFET TRANSISTORS
60 for \$1.98
All 4 leaders, TO-18 case includes "LIP" transistors too! Cat. No. SE2429

BARREL KIT #7 VOLUME CONTROL
30 for \$1.98
Singles, duals, variety of values, styles, big mms, small ones. Cat. No. SE2421

BARREL KIT #1 SN7400 DIP IC'S
75 for \$1.98
Marked 14 and/or with 16 pin dips, may include gate registers, flip flops, counters. SE2415 Untest.

BARREL KIT #217 25 for LAMPS!
\$1.98
Distributor unloads barrels of assat bulbs, mostly voltages to 24V. Screw & bayonet. 4 ozs. No. SE3611

BARREL KIT #201 6V INDICATORS
15 for \$1.98
Test lamp manufacturer dumps inventory! Worth 60¢ ea. Like strain-o-wheat. Cat. No. SE3526

BARREL KIT #188 400 Parts
\$1.98
Includes resistors, caps, transformers, rectifiers, diodes, etc. for p.c. work. Performed, dumped into barrels by factory. 100% good. Cat. No. SE3401

BARREL KIT #181 MINI TRIM POTS
30 for \$1.98
Assat values 100 to 1 meg. What a buy. Single turn. 3/4 Wt. 6 oz. SE3345

BARREL KIT #144 RCA PHONO PLUGS
40 for \$1.98
1,000,000 RCA phono plugs for this one. You hi-fiers know what they are. 100% material. SE3293

BARREL KIT #126 UPRIGHT ELECTROS
40 for \$1.98
1mf to 300mf in mixture of voltages. 100% marked in good. SE3226

BARREL KIT #99 PHOTO ELECTRIC CELLS
10 for \$1.98
Assat GE types, CDS types, color-coded resistors in barrel. But value is there. 4 oz. SE3046 Untested

BARREL KIT #83 HOBBY LEADS
40 for \$1.98
74's, 72's, singles, resistors, etc. 33 to 0.6. Not from factory, all mixed. Have fun! SE2855

BARREL KIT #65 MIXED READOUTS
10 for \$1.98
Factory returns — such numbers as MAN-4's, MAN-3's, etc. — all in barrel. No time to separate. Cat. No. SE2733 Untested.

BARREL KIT #37 1 AMP "BULLET" RECTIFIERS
100 for \$1.98
Famous style, assat, voltages, silicon, assat includes all types of voltages to 1KV. Cat. No. SE2615

BARREL KIT #25 METAL CAN TRANSISTORS
100 for \$1.98
Includes TO-5, TO-1, TO-18, etc., assorted 2N numbers, unmarked, etc. Cat. No. SE2603 Untested.

BARREL KIT #14 PRECISION RESISTORS
200 for \$1.98
Marked and unmarked 1/4, 1/2, 2 watts. No. SE2428

BARREL KIT #4 "4000" RECTIFIERS
100 for \$1.98
1N4000 series. May include 25, 50, 100, 200, 400, 600, 800 and 1000 volts. SE2417

BARREL KIT #211 LO-PROFILE TO-5
50 for \$1.98
NPN power transistors, mostly good. Fivev 40V, 1c 2A, life 30-100. Up to 2nd MIZI Like RCA 2N189 Wt. 12 oz. No. SE3551

BARREL KIT #200 9 DIGIT READOUT MODULES
5 for \$1.98
with calculator driver chips beneath epoxy. Cat. No. SE3525

BARREL KIT #186 KEYBOARD CHIPS
10 for \$1.98
Truthfully we can't test 'em. MM5740's. Keyboard encoder chips. No. SE3414

BARREL KIT #160 V. REGULATORS
10 for \$1.98
LM309C, TO-3 V.R.'s barreled. Buy by the pound, Cat. No. SE3330

BARREL KIT #138 PANEL SWITCHES
30 for \$1.98
Did you hear of OAK? An other equit maker barreled all types of rotary, electronic, slides, etc. SE3268

BARREL KIT #115 MOLEX 100% GOOD SOCKETS
200 for \$1.98
Calculator maker dump! We got a zillion of 'em.

BARREL KIT #93 HALF WATTERS
200 for \$1.98
Resistor factory tried to fool us by mixing 100% color-coded resistors in barrel. But value is there. 4 oz. SE3046 Untested

BARREL KIT #81 GERMANIUM RESISTORS
200 for \$1.98
P.C. upright type, color coded, 1/2 watt. Assat values. Come to us in a barrel. Cat. No. SE2746 100% good

BARREL KIT #58 SLIDE SWITCHES
30 for \$1.98
All shapes, sizes, spst, opt. momentary, etc. Tremendous ship pak for 100's of switching projects. Cat. No. SE2726 100% good

BARREL KIT #35 NEON LAMPS
30 for \$1.98
Famous SE-2's. All prime, but factory made millions and barreled 'em. Your advantage. Cat. No. SE2613

BARREL KIT #19 DIPPED MYLARS
60 for \$1.98
Finest capacitors made, shiny finish. Imagine factory dipping 'em in barrels. Cat. No. SE2597 100% good

BARREL KIT #10 ROMS-REGISTERS
75 for \$1.98
Un. tested. 2's to 40 pin devices, marked, internal factory numbers. Cat. No. SE2424

BARREL KIT #3 SWITCHING DIODES
100 for \$1.98
Imagine famous switching diodes at these prices! Cat. No. SE2418 Untested.

Buy 10 BARREL KITS AND CHOOSE THE 11th KIT Free

NEW FACTORY ARRANGEMENTS! Why mix 'em? They decided to "throw bags into types, then throw bags into barrels". WE DON'T TEST! You test 'em yourself. Buy types of your choice at barrel prices!
BARREL PRICES!

LINEARS
Order by Cat. No. SE3171 and Type No.

LM300M 30 for \$1.98	LM1810N 30 for 1.98
LM307V 40 for 1.98	LM1902N 30 for 1.98
LM309V 30 for 1.98	LM211N 80 for 1.98
LM319V 30 for 1.98	LM2901N 30 for 1.98
LM339N 30 for 1.98	LM2901N 30 for 1.98
LM351V 30 for 1.98	LM7528M 20 for 1.98
LM703N 80 for 1.98	LM75451V 40 for 1.98
LM1303N 30 for 1.98	
LM1304N 30 for 1.98	
LM1310N 30 for 1.98	

Case code: V=Mini dip; H=TO-6; N=DIP.

U-TEST EM-N-CHOOSE EM IC'S

Terms: Add postage. Rated: net 30.
Phone: Wakefield, Mass. (617) 245-3829
Retail: 16-18 Del Carmine St., Wakefield.
POLY PAKS
P.O. BOX 9426 LYNNFIELD, MA. 01940
C.O.D.'s MAY BE PHONED

CRYSTALS

THESE FREQUENCIES ONLY

Part #	Frequency	Case Style	Price
CY14	1 000 MHz	HC33 U	\$5.95
CY2A	2 000 MHz	HC33 U	\$5.95
CY3A	4 000 MHz	HC18 U	\$4.95
CY7A	5 000 MHz	HC18 U	\$4.95
CY12A	10 000 MHz	HC18 U	\$4.95
CY14A	14 318.18 MHz	HC18UJ	\$4.95
CY19A	18 000 MHz	HC18 U	\$4.95
CY22A	20 000 MHz	HC18 U	\$4.95
CY30B	32 000 MHz	HC18 U	\$4.95

XR-2206KB Kit \$27.95 XR-2206KA Kit \$17.95

WAVEFORM GENERATORS		TIMERS	
XR 205	\$8.40	XR 555CP	1.55
XR 2206CP	4.49	XR 556CP	1.85
XR 2207CP	3.85	XR 556P	2.25
STEREO DECODERS		PHASE LOCKED LOOPS	
XR 1310CP	\$3.20	XR 1486	3.85
XR 1310EP	3.20	XR 1488	5.80
XR 1800P	3.20	XR 1489	1.80
XR 2587	2.99	XR 2808	5.20

CONNECTORS

PRINTED CIRCUIT EDGE-CARD

156 Spacing-Tin-Double Read-Out

Bifurcated Contacts — Fits 054 to 070 P.C. Cards

15/30	PINS (Solder Eyelet)	\$1.95
18/36	PINS (Solder Eyelet)	\$2.49
22/44	PINS (Solder Eyelet)	\$2.95
50/100	100 Spacing PINS (Solder Eyelet)	\$6.95

25 PIN-D SUBMINIATURE

DB25P	PLUG	\$3.25
DB25S	SOCKET	\$4.95

3 1/2 DIGIT DVM KIT



This 0-2VDC .05 per cent digital voltmeter features the Motorola 3 1/2 digit DVM chip set. It has a 4" LED display and operates from a single -5V power supply. The unit is provided complete with an injection molded black plastic case complete with Bezel. An optional power supply is available which fits into the same case as the 0-2V DVM allowing 117 VAC operation.

A. 0-2V DVM with Case \$49.95
B. 5V Power Supply \$14.95

VECTOR WIRING PENCIL

Vector Wiring Pencil P173 consists of a hand held featherweight soldering pencil which is used to guide and wrap around wire. It has a self-contained replaceable bobbin (also comprised leads or terminals) inserted on the pen-like "P" Pattern Vector board. Connections between the encoder wire and component leads, both terminals are made by soldering. Complete with 250 FT of lead wire. \$9.50

REPLACEMENT WIRE — BOBBINS FOR WIRING PENCIL

W36-3-A-Pkg 3	250 ft 36 AWG GREEN	\$2.40
W36-3-B-Pkg 3	250 ft 36 AWG RED	\$2.40
W36-3-C-Pkg 3	250 ft 36 AWG CLEAR	\$2.40
W36-3-D-Pkg 3	250 ft 36 AWG BLUE	\$2.40

1/16 VECTOR BOARD

Part No	L	W	Price	2-Up
PHENOLIC 61P-14 062 x x P	4.50	6.50	1.72	1.54
169P-14 029 x x P	4.50	1.00	1.69	1.52
61P-14 062	4.50	6.50	2.01	1.86
EPoxy 61P-14 062	4.50	8.50	2.56	2.31
169P-14 062	4.50	1.00	5.04	4.5
EPoxy GLASS 169P-14 062	8.50	1.00	9.23	8.26
169P-14 062C1	4.50	1.00	6.80	6.12

HEAT SINKS

205-CB	Beryllium Copper Heat Sink with Black Finish for TO 5	\$ 25
291-36H	Aluminum Heat Sink for TO 220 Transistors & Regulators	\$ 25
680-75A	Black Anodized Aluminum	\$1.60

HEXADECADEM 19-KEY PAD



\$10.95 each

63 KEY KEYBOARD



\$19.95

HD0616 16 LINE TO FOUR BIT PARALLEL KEYBOARD ENCODER \$7.95

JOYSTICK



*5K Pots \$6.95
*100K Pots \$7.95

MICROPROCESSOR COMPONENTS

8080A	CPU	\$19.95	8228	System Controller - Bus Driver	\$10.95
8212	8 Bit Input/Output	4.95	MC6800L	8 Bit MPU	35.00
8214	Priority Interrupt Control	15.95	MC6820L	Periph Interface Adapter	15.00
8216	Bi-Directional Bus Driver	6.95	MC6810A P1	128 x 8 Static RAM	6.00
8224	Clock Generator/Driver	10.95	MC6830L7	1024 x 8 Bit ROM	18.00
CDP1802	- with user manual	39.95	780	CPU	49.95

CPU S		RAM S			
8080	Super 8080	24.95	1101	256 x 4 Static	\$ 1.49
8080A	Super 8080	19.95	2101	256 x 4 Static	1.75
SR S		DYNAMIC			
2504	1024 Dynamic	5.95	2107	512 x 1 Dynamic	1.99
2516	Hex. 32 Bit	7.00	2111	256 x 4 Static	6.95
2519	Hex. 40 Bit	4.00	2117	256 x 4 Static	1.14
2524	512 Dynamic	2.49	810	256 x 4 Static	6.95
2525	1024 Dynamic	4.00	8115	256 x 4 Static	2.25
2527	Dual 356 Bit	1.95	8200	256 x 4 Static	3.95
2529	Dual 512 Bit	3.20	8321	256 x 4 Static	2.95
2532	Dual 80 Bit	1.95	8322	256 x 4 Static	2.95
2533	1024 Static	4.00	8323	256 x 4 Static	2.95
3341	16 x 4 Rnc	3.95	8324	256 x 4 Static	2.95
UART S		PRIMS			
AV-9101	30K Baud	55.95	1101A	2048 Parole	11.95
ROM S		EPRM			
2513	Char. Mem	5.95	8201	1024 1T Static Bipolar	3.49
2516	Char. Mem	10.95	8301-1	256 Open Collector Bipolar	2.85
15387	1024 Bit Programmable	1.95	8331-1	256 1T-Static Bipolar	2.95

SPECIAL REQUESTED ITEMS

MC3061P	3.90	CD4508	6.75	82S115	25.00	3341	6.95
MC4016P (74416)	7.50	CD4515	6.50	5841	9.95	9368	3.95
MC14583	3.50	CD4520	2.70	M550240	17.50	MC1408L7	9.95
MC14562	14.50	MC45571	17.50	11590	19.95	LD110 LD111	25.00
CD4059	9.95	MC45573	17.50	DS0026CH	3.75	AV-5-9100	17.50
CD4070	.95	MC45575	17.50	TIL308	10.50	95190	13.95

ELECTRONIC 'PENDULUM' CLOCK

- Unique Electronic 'Swing' Pendulum
- Real Furniture Quality
- Handcrafted Unfinished Wood Case
- Large 7 Hours and Minutes LED Display
- Alarm Feature
- 12 or 24 Hour Mode
- Time Set Push Buttons
- Use Module For Easy Assembly
- Special programed ROM in pendulum for animated effect!

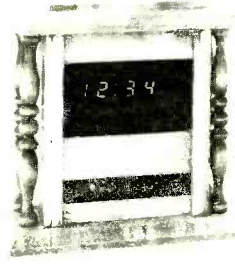

Dimensions - 10 1/4" x 10 1/2" x 3 3/4"
KIT — UNFINISHED* \$59.95
*One Unfinished
ASSEMBLED — STAINED* \$69.95
*Case Assembled

BUGBOOK

Continuing Education Series

- BUGBOOK I & II - Basic concepts of TTL Logic — over 90 experiments \$17.00/set
- BUGBOOK IIa - Introduces UART — recommended for RTTY enthusiast \$5.00/book
- BUGBOOK III - Explores 8080 chip — introduces Mark 80 Microcomputer \$15.00/book

555 TIMER APPLICATIONS SOURCEBOOK WITH EXPERIMENTS — over 100 design techniques \$6.95/book
CMOS-M-DESIGNERS PRIMER AND HANDBOOK a complete CMOS instruction manual \$6.00

introductory Offer — all 6 books (worth \$49.95) SPECIAL - \$42.95

CONTINENTAL SPECIALTIES

PROTO BOARD 6 \$15.95 (6" long X 4" wide)	Other CS Proto Boards	PRD TO CLIPS
PB100 - 4.5" x 6" \$ 19.95	PB101 - 5.8" x 4.5" 29.95	14 PIN \$4.50
PB102 - 7" x 4.5" 39.95	PB103 - 9" x 6" 59.95	16 PIN 4.75
PB104 - 9.5" x 8" 79.95	PB203 - 9.75 x 6 1/2 x 2 1/4 75.00	24 PIN 8.50
PB204 - 9.75 x 6 1/2 x 2 1/4 120.00 (includes power supply)	Logic Monitor \$84.95 for DTL, TTL, TTL or CMOS Devices	DESIGN MATES
		DM1 - Circuit Designer 54.95
		DM2 - Function Generator 69.95
		DM3 - RC Bridge 59.95

QT PROTO STRIPS

QT type	#holes	price
QT 59B	590	12.50
QT 59B	bus strip	2.50
QT 475	470	10.00
QT 47B	bus strip	2.25
QT 355	350	8.50
QT 355	bus strip	2.00
QT 185	180	4.25
QT 125	120	3.75
QT 85	80	3.25
QT 75	70	3.00

Experimentor 300 \$ 9.95
Experimentor 600 \$10.95

\$5.00 Minimum Order — U.S. Funds Only
Spec Sheets - 25¢ — Send 35¢ Stamp for 1977A Catalog
California Residents — Add 6% Sales Tax
Dealer Discount Available — Request Pricing

James ELECTRONICS
1021-A HOWARD AVE., SAN CARLOS, CA. 94070
PHONE ORDERS WELCOME — (415) 592-8097
All Adverised Prices Good Thru May

PARATRONICS

LOGIC ANALYZER KIT

(as shown in Feb. Popular Electronics)
Troubleshoot any type of digital system including Microcomputers
includes IC power supply PC Board, case and manual
LA100 KIT \$189.00



DIGITAL AUTO INSTRUMENT

SEVEN DIFFERENT INSTRUMENTS!
MEETS OR EXCEEDS ORIGINAL AUTOMOTIVE SPECS!
Please specify which one of the seven models you want when ordering — these do not all come in one unit
Each model must be bought separately.

1 TACHOMETER 0 to 9900 RPM	4 SPEEDOMETER* 0 to 99 MPH
2 WATER TEMP 100-250°F	5 OIL PRESSURE 0 to 80 PSI
3 FUEL LEVEL Percentage Low Fuel Indicator	6 OIL TEMP 200-350°F
	7 BATTERY MONITOR 1 Volts From 11-15 VDC



BRIGHT YELLOW ORANGE 3 LED DISPLAY

Kit includes case, bracket and all components — complete.
Nothing else to buy. 12 Volt NEG GND.
DIMENSIONS 3 1/4 x 4 x 2
KIT: \$49.95
*Add \$10.00 for required speed transducer. ASSEMBLED: \$59.95

DIGITAL STOPWATCH

- Bright 6 Digit LED Display
- 1 PPM to 99 minutes 59.99 seconds
- Crystal Controlled Time Base
- Three Stopwatches in One
- Times Single Event — Split & Taylor
- Size 4.5" x 2.15" x .90" (not included)
- Uses 3 Penrite Cells

Kit — \$39.95
Assembled — \$49.95
Heavy Duty Carry Case \$5.95



Stop Watch Chip Only (7205) \$19.95

Timeband

20 General 1" Face with Lenses and Reflector Corporation

DIGITAL ALARM CLOCK \$16.95

- 24-Hour Alarm
- DOZE Button
- 100% Solid State
- Large Red Led Display (.8" high)
- AM/PM Indicator
- Seconds Display at touch of button
- SPECIFY BLACK OR IVORY



QUARTZ DIGITAL AUTO CLOCK OR ELAPSED TIMER!

Elapsed Timer: Hrs, Mins and Secs
12 or 24 Hr Capacity
Simple Reset - Start Pushbutton Control

Complete kit includes mounting bracket, case and all components. Nothing else to buy. Includes MMS1314 chip, large 4 LED's, accuracy better than 1 min. per month, internal battery backup, 12 volt non polar operation.
DIMENSIONS 4 1/4 x 4 x 2
12 or 24 HOUR MODE
Kit: \$29.95
Assembled: \$39.95



CASE ONLY (includes hardware, mounting bracket and bezel) \$6.50

JE700 CLOCK

The JE700 is a low cost digital clock but is a very high quality unit. The unit features a simulated analog case with dimensions of 6" x 2 1/2" x 1 1/2". It utilizes a MAN72 high brightness readout and the MMS1314 clock chip.
12 or 24 Hour
115 VAC
\$17.95

DIGITAL CLOCK KIT — 3 1/2 INCH DIGITS

4 DIGIT KIT \$49.95
4 DIGIT ASSEMBLED \$59.95
6 DIGIT KIT \$69.95
6 DIGIT ASSEMBLED \$79.95

This clock features big 3 1/2" high digits for viewing in offices, auditoriums, etc. Each digit is formed by 31 bright 0.2" LED's. The clock operates from 117 VAC, has either 12 or 24 hr operation. The 6 digit version is 2 7/8" x 3 1/2" x 1 1/2" and the 4 digit is 1 8" x 3 1/2" x 1 1/2". Kits come complete with all components, case and transformer.
Specify 12 or 24 Hour When Ordering

JE803 PROBE

The Logic Probe is a unit which is for the most part indispensable in trouble shooting logic functions. TTL, DTL, CMOS. It detects the power it needs to operate directly off the circuit under test, drawing a scant 10 mA max. It uses a MAN72 readout to indicate any of the following states: 0, 1, LOW, 1.5, 0.5, 2. The Probe can detect high frequency pulses to 45 MHz. It can be used at MOS levels or circuit damage will result.

\$9.95 Per Kit
printed circuit board



T²L 5V 1A Supply
This is a standard TTL power supply using the well known LM309 regulator. It provides a solid 1 AMP at current of 5 volts. We try to make things easy for you by providing everything you need in one package, including the hardware for only \$9.95 Per Kit

7400N TTL

SN7400N	16	SN7455A	25	SN74154N	100
SN7401N	16	SN7455B	22	SN74155N	99
SN7402N	21	SN7470N	45	SN74156N	99
SN7403N	16	SN7472N	39	SN74157N	99
SN7404N	18	SN7473N	50	SN74160N	125
SN7405N	24	SN7474N	32	SN74161N	99
SN7406N	20	SN7475N	50	SN74162N	99
SN7407N	29	SN7476N	37	SN74163N	99
SN7408N	25	SN7477N	50	SN74164N	110
SN7409N	18	SN7478N	50	SN74165N	110
SN7410N	18	SN7479N	50	SN74166N	125
SN7411N	20	SN7480N	78	SN74167N	50
SN7412N	33	SN7481N	99	SN74170N	210
SN7413N	45	SN7482N	39	SN74172N	895
SN7414N	70	SN7483N	350	SN74177N	90
SN7415N	35	SN7484N	249	SN74174N	125
SN7416N	35	SN7485N	79	SN74175N	99
SN7417N	35	SN7486N	79	SN74176N	90
SN7418N	35	SN7487N	49	SN74179N	99
SN7419N	33	SN7488N	49	SN74180N	99
SN7420N	49	SN7489N	49	SN74181N	249
SN7421N	39	SN7490N	79	SN74182N	95
SN7422N	39	SN7491N	75	SN74183N	195
SN7423N	37	SN7492N	400	SN74184N	200
SN7424N	42	SN7493N	160	SN74185N	200
SN7425N	27	SN7494N	100	SN74186N	1500
SN7426N	27	SN7495N	60	SN74187N	600
SN7427N	27	SN7496N	60	SN74188N	395
SN7428N	27	SN7497N	60	SN74189N	195
SN7429N	27	SN7498N	60	SN74191N	125
SN7430N	26	SN7499N	60	SN74192N	80
SN7431N	26	SN7500N	60	SN74193N	80
SN7432N	26	SN7501N	60	SN74194N	275
SN7433N	26	SN7502N	60	SN74195N	125
SN7434N	26	SN7503N	60	SN74197N	75
SN7435N	26	SN7504N	60	SN74198N	175
SN7436N	26	SN7505N	60	SN74199N	175
SN7437N	26	SN7506N	60	SN74200N	559
SN7438N	26	SN7507N	60	SN74201N	559
SN7439N	26	SN7508N	60	SN74202N	559
SN7440N	26	SN7509N	60	SN74203N	600
SN7441N	26	SN7510N	60	SN74204N	600
SN7442N	26	SN7511N	60	SN74205N	600
SN7443N	26	SN7512N	60	SN74206N	600
SN7444N	26	SN7513N	60	SN74207N	600
SN7445N	26	SN7514N	60	SN74208N	600
SN7446N	26	SN7515N	60	SN74209N	600
SN7447N	26	SN7516N	60	SN74210N	600
SN7448N	26	SN7517N	60	SN74211N	600
SN7449N	26	SN7518N	60	SN74212N	600
SN7450N	26	SN7519N	60	SN74213N	600
SN7451N	26	SN7520N	60	SN74214N	600
SN7452N	26	SN7521N	60	SN74215N	600
SN7453N	26	SN7522N	60	SN74216N	600
SN7454N	26	SN7523N	60	SN74217N	600
SN7455N	26	SN7524N	60	SN74218N	600
SN7456N	26	SN7525N	60	SN74219N	600
SN7457N	26	SN7526N	60	SN74220N	600
SN7458N	26	SN7527N	60	SN74221N	600
SN7459N	26	SN7528N	60	SN74222N	600
SN7460N	26	SN7529N	60	SN74223N	600
SN7461N	26	SN7530N	60	SN74224N	600
SN7462N	26	SN7531N	60	SN74225N	600
SN7463N	26	SN7532N	60	SN74226N	600
SN7464N	26	SN7533N	60	SN74227N	600
SN7465N	26	SN7534N	60	SN74228N	600
SN7466N	26	SN7535N	60	SN74229N	600
SN7467N	26	SN7536N	60	SN74230N	600
SN7468N	26	SN7537N	60	SN74231N	600
SN7469N	26	SN7538N	60	SN74232N	600
SN7470N	26	SN7539N	60	SN74233N	600
SN7471N	26	SN7540N	60	SN74234N	600
SN7472N	26	SN7541N	60	SN74235N	600
SN7473N	26	SN7542N	60	SN74236N	600
SN7474N	26	SN7543N	60	SN74237N	600
SN7475N	26	SN7544N	60	SN74238N	600
SN7476N	26	SN7545N	60	SN74239N	600
SN7477N	26	SN7546N	60	SN74240N	600
SN7478N	26	SN7547N	60	SN74241N	600
SN7479N	26	SN7548N	60	SN74242N	600
SN7480N	26	SN7549N	60	SN74243N	600
SN7481N	26	SN7550N	60	SN74244N	600
SN7482N	26	SN7551N	60	SN74245N	600
SN7483N	26	SN7552N	60	SN74246N	600
SN7484N	26	SN7553N	60	SN74247N	600
SN7485N	26	SN7554N	60	SN74248N	600
SN7486N	26	SN7555N	60	SN74249N	600
SN7487N	26	SN7556N	60	SN74250N	600
SN7488N	26	SN7557N	60	SN74251N	600
SN7489N	26	SN7558N	60	SN74252N	600
SN7490N	26	SN7559N	60	SN74253N	600
SN7491N	26	SN7560N	60	SN74254N	600
SN7492N	26	SN7561N	60	SN74255N	600
SN7493N	26	SN7562N	60	SN74256N	600
SN7494N	26	SN7563N	60	SN74257N	600
SN7495N	26	SN7564N	60	SN74258N	600
SN7496N	26	SN7565N	60	SN74259N	600
SN7497N	26	SN7566N	60	SN74260N	600
SN7498N	26	SN7567N	60	SN74261N	600
SN7499N	26	SN7568N	60	SN74262N	600
SN7500N	26	SN7569N	60	SN74263N	600
SN7501N	26	SN7570N	60	SN74264N	600
SN7502N	26	SN7571N	60	SN74265N	600
SN7503N	26	SN7572N	60	SN74266N	600
SN7504N	26	SN7573N	60	SN74267N	600
SN7505N	26	SN7574N	60	SN74268N	600
SN7506N	26	SN7575N	60	SN74269N	600
SN7507N	26	SN7576N	60	SN74270N	600
SN7508N	26	SN7577N	60	SN74271N	600
SN7509N	26	SN7578N	60	SN74272N	600
SN7510N	26	SN7579N	60	SN74273N	600
SN7511N	26	SN7580N	60	SN74274N	600
SN7512N	26	SN7581N	60	SN74275N	600
SN7513N	26	SN7582N	60	SN74276N	600
SN7514N	26	SN7583N	60	SN74277N	600
SN7515N	26	SN7584N	60	SN74278N	600
SN7516N	26	SN7585N	60	SN74279N	600
SN7517N	26	SN7586N	60	SN74280N	600
SN7518N	26	SN7587N	60	SN74281N	600
SN7519N	26	SN7588N	60	SN74282N	600
SN7520N	26	SN7589N	60	SN74283N	600
SN7521N	26	SN7590N	60	SN74284N	600
SN7522N	26	SN7591N	60	SN74285N	600
SN7523N	26	SN7592N	60	SN74286N	600
SN7524N	26	SN7593N	60	SN74287N	600
SN7525N	26	SN7594N	60	SN74288N	600
SN7526N	26	SN7595N	60	SN74289N	600
SN7527N	26	SN7596N	60	SN74290N	600
SN7528N	26	SN7597N	60	SN74291N	600
SN7529N	26	SN7598N	60	SN74292N	600
SN7530N	26	SN7599N	60	SN74293N	600
SN7531N	26	SN7600N	60	SN74294N	600
SN7532N	26	SN7601N	60	SN74295N	600
SN7533N	26	SN7602N	60	SN74296N	600
SN7534N	26	SN7603N	60	SN74297N	600
SN7535N	26	SN7604N	60	SN74298N	600
SN7536N	26	SN7605N	60	SN74299N	600
SN7537N	26	SN7606N	60	SN74300N	600
SN7538N	26	SN7607N	60	SN74301N	600
SN7539N	26	SN7608N	60	SN74302N	600
SN7540N	26	SN7609N	60	SN74303N	600
SN7541N	26	SN7610N	60	SN74304N	600
SN7542N	26	SN7611N	60	SN74305N	600
SN7543N	26	SN7612N	60	SN74306N	600
SN7544N	26	SN7613N	60	SN74307N	600
SN7545N	26	SN7614N	60	SN74308N	600
SN7546N	26	SN7615N	60	SN74309N	600
SN7547N	26	SN7616N	60	SN74310N	600
SN7548N	26	SN7617N	60	SN74311N	600
SN7549N	26	SN7618N	60	SN74312N	600
SN7550N	26	SN7619N	60	SN74313N	600
SN7551N	26	SN7620N	60	SN74314N	600
SN7552N	26	SN7621N	60	SN74315N	600
SN7553N	26	SN7622N	60	SN74316N	600
SN7554N	26	SN7623N	60	SN74317N	600
SN7555N	26	SN7624N	60	SN74318N	600
SN7556N	26	SN7625N	60	SN74319N	600
SN7557N	26	SN7626N	60	SN74320N	600
SN7558N	26	SN7627N	60	SN74321N	600
SN7559N	26	SN7628N	60	SN74322N	600
SN7560N	26	SN7629N	60	SN74323N	600
SN7561N	26	SN7630N	60	SN74324N	600
SN7562N	26	SN7631N	60	SN74325N	600
SN7563N	26	SN7632N	60	SN74326N	600
SN7564N	26	SN7633N	60	SN74327N	600
SN7565N	26	SN7634N	60	SN74328N	600
SN7566N	26	SN7635N	60	SN74329N	600
SN7567N	26	SN7636N	60	SN74330N	600
SN7568N	26	SN7637N	60	SN74331N	600
SN7569N	26	SN7638N	60	SN74332N	600
SN7570N	26	SN7639N	60	SN74333N	600
SN7571N	26	SN7640N	60	SN74334N	600
SN7572N	26	SN7641N	60	SN74335N	600
SN7573N	26	SN7642N	60	SN74336N	600
SN7574N	26	SN7643N	60	SN74337N	600
SN7575N	26	SN7644N	60	SN74338N	600
SN7576N	26	SN7645N	60	SN74339N	600
SN7577N	26	SN7646N	60	SN74340N	600
SN7578N	26	SN7647N	60	SN74341N	600
SN7579N	26	SN7648N	60	SN74342N	600
SN7580N	26	SN7649N	60	SN74343N	600
SN7581N	26	SN7650N	60	SN74344N	600
SN7582N	26	SN7651N	60	SN74345N	600
SN7583N	26	SN7652N	60	SN74346N	600
SN7584N	26	SN7653N	60	SN74347N	600
SN7585N	26	SN7654N	60	SN74348N	600
SN7586N	26	SN7655N	60	SN74349N	600
SN7587N	26	SN7656N	60	SN74350N	600
SN7588N	26	SN7657N	60	SN74351N	600
SN7589N	26	SN7658N	60	SN74352N	600
SN7590N	26	SN7659N	60	SN74353N	600
SN7591N	26	SN7660N	60	SN74354N	600
SN7592N	26	SN7661N	60	SN74355N	600
SN7593N	26	SN7662N	60	SN74356N	600
SN7594N	26	SN7663N	60	SN74357N	600
SN7595N	26	SN7664N	60	SN74358N	600
SN7596N	26	SN7665N	60	SN74359N	600
SN7597N	26	SN7666N	60	SN74360N	600
SN7598N	26	SN7667N	60	SN74361N	600
SN7599N	26	SN7668N	60	SN74362N	600
SN7600N	26	SN7669N	60	SN74363N	600
SN7601N	26	SN7670N	60	SN74364N	600
SN7602N	26	SN			

TUBES

RADIO & TV Tubes—36 cents each. Send for free Catalog. Cornell, 4213 University, San Diego, Calif. 92105

TUBES receiving, factory boxed, low prices, free price list. Translertonic, Inc., 1365 39th Street, Brooklyn, N.Y. 11218A. Telephone 212-633-2800.

TUBES "Oldies". Latest Supplies, components, schematics. Catalog Free (stamp appreciated). Steinmetz 7519-PE Maplewood, Hammond, Ind. 46324.

RECEIVING TUBES National Brands. Up to 80% discount. National Audio, 2500 Channing Road, Cleveland, Ohio 44118.

TAPE AND RECORDERS

RENT 4-Track open reel tapes—free brochure Stereo-Parti, P.O. Box 7, Fulton, CA 95401.

WE WILL BEAT any price sheet in America. Featuring TDK, MAXELL, and others. Tape World International, 220 Spring St., Butler, PA 16001.

BASF TAPE: We carry only BASF so our prices are the lowest! All tapes new and GUARANTEED. Enclose this ad with any order and we'll pay shipping (USA only). INTERGALACTIC ENTERPRISES, 1043 Kirts, Troy, Michigan 48084.

BLANK TAPE BONANZA TDK 10 SA-C90 \$30.85, 10 SA-C60 \$21.85, MAXELL 12 UDC-90 \$35.31, 10 UD35-90 \$49.99, 12 UDXL-C90 (I or II) \$41.43. All prices include shipping (PA add 6% sales tax). Give us a try! Tape World International, 220 Spring St., Butler, PA 16001.

DO-IT-YOURSELF

MODULAR TELEPHONES now available. Sets and components, compatible with Western Electric concept. Catalog 50 cents. Box 1147W, San Diego, California 92112.

NEGATIVE ion generator. Construction plans \$7.50. Complete kit \$165.00. Golden Enterprises, Box 1282PE, Glendale, Arizona 85311.

ABOUT YOUR SUBSCRIPTION

Your subscription to POPULAR ELECTRONICS is maintained on one of the world's most modern, efficient computer systems, and if you're like 99% of our subscribers, you'll never have any reason to complain about your subscription service.

We have found that when complaints do arise, the majority of them occur because people have written their names or addresses differently at different times. For example, if your subscription were listed under "William Jones, Cedar Lane, Middletown, Arizona," and you were to renew it as "Bill Jones, Cedar Lane, Middletown, Arizona," our computer would think that two separate subscriptions were involved, and it would start sending you two copies of POPULAR ELECTRONICS each month. Other examples of combinations of names that would confuse the computer would include: John Henry Smith and Henry Smith; and Mrs. Joseph Jones and Mary Jones. Minor differences in addresses can also lead to difficulties. For example, to the computer, 100 Second St. is not the same as 100 2nd St.

So, please, when you write us about your subscription, be sure to enclose the mailing label from the cover of the magazine—or else copy your name and address exactly as they appear on the mailing label. This will greatly reduce any chance of error, and we will be able to service your request much more quickly.

Popular Electronics

Hundreds of references to subjects, products, and technical tips that you know are in the magazine but can never find when you want them — all arranged for fast, easy reference.

Prepared in cooperation with the magazine editors, each of these handy indexes covers a full year of 12 issues and is an indispensable companion to your magazine collection.

1976 Edition

\$1.50 each plus 25 cents per copy for postage and handling (50 cents for foreign orders).

Back index editions also still available from 1972 onwards. When ordering, mention magazine title and specify volume years desired. Please be sure to include correct postage — avoid having your order returned.

POPULAR ELECTRONICS INDEX
Box 2228, Falls Church, Va., 22042

INDEXES

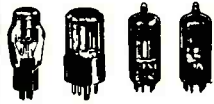

70% OFF LIST!

1AD2	1.67	6AR5	.92
1B3	1.67	6AU4	2.07
1BC2	1.59	6AU5	2.54
1K3	1.67	6AU6	1.34
1S2A	1.04	6AU8	2.25
1U4	1.67	6AV6	1.16
1V2	1.02	6AW8	1.88
1X2B	1.64	6AX4	1.59
2AH2	1.67	6AY3	1.59
2AV2	1.32	6AZ8	3.37
2D21	1.95	6BA6	1.41
2GK5	1.65	6BA11	2.06
2HA5	1.43	6BC5	1.41
3AT2	1.65	6BE6	1.55
3BS2	1.79	6BH6	1.59
3CN3	1.74	6BH11	2.13
3CU3	2.06	6BJ6	1.74
3CY3	1.85	6BK4	3.14
3D13	1.79	6BK7	2.18
3GK5	1.62	6BL8	1.16
3HA5	1.61	6BM8	1.56
3HQ5	2.39	6BN6	2.07
3JC6	2.16	6BN8	1.73
3V4	2.30	6BN11	3.09
4AU6	1.67	6BQ5	1.65
4B26	1.49	6BQ7A	2.19
4CB6	1.16	6BR8A	2.24
4DT6	1.64	6BV11	2.48
4E7	1.52	6BX6	1.56
4E17	1.52	6BZ6	1.32
4H58	1.58	6C4	1.65
4JC6	2.15	6C5	3.28
4JD6	1.98	6CA4	1.70
4KE8	2.60	6CA7	2.34
4LJ8	1.91	6CB6	1.40
5A05	1.61	6CD6	2.98
5AR4	2.15	6CG3	1.65
5CG8	1.71	6CG7	1.28
5EW6	1.71	6CG8	1.82
5GH8	1.98	6CJ3	1.58
5G17	1.25	6CL3	1.70
5GS7	1.43	6CL6	2.18
5GZ7	1.76	6CL8	2.04
5HZ6	1.26	6CM6	1.77
5JK6	1.77	6CM7	1.80
5JL6	2.10	6CS6	1.76
5KE8	2.60	6CU5	1.73
5LJ8	1.85	6CW4	4.17
5U4GB	1.31	6CW5	1.43
5Y3GT	1.38	6D6	2.39
5Y4GT	2.10	6DA6	2.10
6A8	4.70	6DJ8	2.50
6AB4	1.61	6DK6	1.55
6AC7	3.87	6DL4	2.39
6AC10	1.82	6DQ6	2.25
6AD10	3.86	6DT6	1.40
6AF4	2.31	6DW4	1.58
6AF9	2.39	6DX8	1.17
6AG7	4.53	6E5	3.90
6AH6	2.40	6EA8	1.65
6AJ8	2.10	6EB8	2.52
6AL3	1.28	6EH7	1.61
6AL5	1.37	6EJ7	1.50
6AM8	2.31	6EM7	2.37
6AN8	1.91	6EU7	1.70
6AQ5	1.43	6EW6	1.50
6AQ8	1.49	6EW7	2.51

EDLIE BARGAIN BONANZA OF HIGHEST QUALITY TUBES

BUY BRAND NEW MANUFACTURER'S BOXED TUBES (Raytheon, Dumont, IEC Mullard, etc.) AT 70% OFF LIST! HERE IS A BIGGER & BETTER LIST THAN WE EVER OFFERED BEFORE... AND REMEMBER... 70% OFF LIST!

ALL TUBES BRAND NEW MANU. BOXED 70% OFF

MINIMUM ORDER \$10.00

MONEY BACK GUARANTEE

Terms: Minimum order \$10.00. Include postage. Either full payment with order or 30% deposit, balance C.O.D. F.O.B. Levittown, N.Y.

6FGT	4.09	6J7	4.35	6L7	4.50
6FG6	1.43	6J10	2.66	6LB6	3.38
6FG7	2.40	6JB6	2.54	6LE8	2.39
6FM7	1.94	6JC6A	1.88	6LFB	3.36
6FO7	1.28	6JD6	1.94	6LF8	2.46
6GE5	1.64	6JE6GA	3.51	6LH6	3.23
6GF7	2.24	6JF6	2.90	6LJ8	1.85
6GH8	1.32	6JH6	1.50	6LM8	2.00
6GJ7	1.25	6JH8	2.64	6LN8	1.14
6GK5	1.95	6JM6A	2.28	6LR6	3.23
6GK6	1.47	6JN6	2.13	6LT8	1.71
6GM6	1.76	6JS6C	3.12	6LUR	2.01
6GM8	3.30	6JT6	2.54	6LX8	1.11
6GS7	1.52	6JT8	2.01	6M11	3.30
6GU7	1.76	6JU6	2.99	6MB8	1.95
6GW8	1.47	6JU8	1.86	6MD8	2.46
6GX6	1.46	6JV8	1.89	6MG8	1.41
6GX7	1.92	6JW8	1.41	6SA7	3.74
6H6	3.33	6K6GT	1.71	6SG7	3.95
6HA5	1.61	6K7GT	2.40	6SJTGT	2.33
6HB7	1.62	6K8	3.60	6SK7GT	2.40
6HE5	2.01	6KA8	2.04	6SL7GT	2.40
6HF5	3.96	6KD6	3.54	6SN7GT	1.59
6HF8	2.28	6KE8	2.66	6SQ7GT	2.42
6HQ5	2.13	6KM6	3.54	6T8A	2.01
6HS5	3.09	6KT8	2.28	6T10	2.36
6HS6	2.66	6KV6	2.81	6U8A	1.64
6HS8	2.00	6KZ8	1.71	6U10	1.70
6HV5	3.72	6L6GB	2.57	6V6	4.01
6HZ6	1.34	6L6	4.50	6V6GT	1.92
6J5GT	1.77			6X4	1.52

WRITE FOR FREE VALUE PACKED CATALOG

EDLIE ELECTRONICS, INC. 2700-NP HEMPSTEAD TPKE., LEVITTOWN, N. Y. 11756

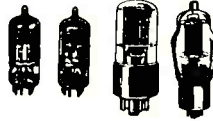

70% OFF LIST!

6XS6T	1.55	13GF7	2.19
6X8	1.92	13Z10	2.69
6X9	1.88	14BL11	3.27
7F8	9.00	14BR11	2.60
7KY6	2.16	15BD11A	2.36
7Y7	3.60	15CW5	1.43
8A8	1.13	15KY8	3.05
8AC9	2.43	16A8	1.71
8AR11	3.12	16LUR	3.12
8BA11	2.36	17AY3	1.59
8BM11	3.39	17BE3	1.59
8BQ11	2.49	17BF11	2.51
8BU11	2.42	17BR3	1.38
8CB11	3.24	17BS3	1.59
8CG7	1.28	17CT3	1.43
8CW5	1.43	17CU5	1.32
8JU8	1.43	17DW4	1.58
8JV8	1.95	17JM6	2.55
8LT8	1.68	17JN6	2.27
9AQ8	2.31	17JQ6	2.25
9GH8	1.76	17JZ8	1.74
9JW8	1.32	17KV6	3.05
9KX6	2.16	19CG3	1.65
10CW5	1.43	19T8	2.61
10DX8	1.17	20AQ3	1.31
10GF7	2.18	21GY5	2.10
10GK6	1.91	21HB5	2.01
10GN8	2.01	21JS6	4.31
10JT8	2.16	21JZ6	2.24
10JY8	1.56	21LR8	2.09
10KR8	2.15	21LU8	2.04
11AF9	2.39	22JF6	2.79
11AR11	2.60	22JRE	2.99
11BM8	2.09	22KM6	3.23
11BT11	3.17	23Z9	2.15
11FY7	1.67	24JF6	3.36
11KY8	2.31	25CG3	1.46
11LQ8	2.27	29KQ6	3.53
11MS8	1.71	30AE3	1.41
12AB5	1.49	31JS6	3.03
12AT6	1.19	31LQ6	3.20
12AT7	1.43	31LZ6	3.54
12AU6	1.52	33GY7A	2.74
12AU7	1.29	34CE3	1.68
12AV6	1.08	35C5	1.37
12AX7	1.32	35W4	.93
12AZ7	1.83	35Z5GT	1.49
12B4	1.86	36KD6	3.53
12BA6	1.22	38HE7	3.08
12BE6	1.28	38HK7	3.00
12BF11	2.49	40K66GA	3.42
12BH7	1.67	42EC4A	1.77
12BY7	1.50	42KN6	2.88
12CL3	1.52	45B5	2.70
12CU5	1.85	50A1	3.30
12DQ6	2.21	50B5	1.28
12DW4	2.19	50C5	1.29
12DW7	1.61	50EH5	1.55
12FX5	1.41	50LGT	2.06
12GN7	2.34	80	2.50
12HL7	2.04	6267	2.10
12JB6A	2.90	6973	2.03
12MD8	2.00	7025A	1.32
12SL7	2.43	7189A	1.82
12SN7	1.85	7199	2.16
12SQ7	3.72	7247	1.71
12X4	.99	7591	3.15

S.D. SALES CO.

P. O. BOX 28810 - D
DALLAS, TEXAS 75228

JUMBO LED CAR CLOCK



\$16.95
KIT

Alarm Option - \$1.50
AC XFMR - \$1.50

THE HOTTEST SELLING KIT WE EVER PRODUCED!

You requested it! Our first D.C. operated clock kit. Professionally engineered from scratch. Not a makeshift kluge as sold by others. Features:

- A. Bowmar Jumbo -.5 inch LED array.
- B. MOSTEK - 50250 - Super Clock Chip.
- C. On board precision crystal time base.
- D. 12 or 24 Hr. Real Time Format.
- E. Perfect for cars, boats, vans, etc.
- F. P.C. Board and all parts (less case) included.

**50,000 SATISFIED CLOCK
KIT CUSTOMERS CANNOT
BE WRONG!**

THIS MONTH'S SPECIALS

AMD - 8080A \$14.95
Z-80 CPU 49.95
82S129 1K PROM 2.50

60 HZ CRYSTAL TIME BASE S.D. SALES EXCLUSIVE!

KIT FEATURES:

- A. 60HZ output with accuracy comparable to a digital watch.
- B. Directly interfaces with all MOS Clock Chips.
- C. Super low power consumption (1.5 ma typ.)
- D. Uses latest MOS 17 stage divider IC.
- E. Eliminates forever the problem of AC line glitches.
- F. Perfect for cars, boats, campers, or even for portable clocks at ham filed days. **2/\$10.00**
- G. Small size; can be used in existing enclosures. Kit includes Crystal, Divider IC, PC Board, Plus all necessary parts and specs. **At last count - over 20,000 sold!**

\$5.95

1702A 2K EPROM

We tell it like it is. We could have said these were factory new, but here is the straight scoop. We bought a load of new computer gear that contained a quantity of 1702 A's in sockets. We carefully removed the parts, verified their quality, and are offering them on one heck of a deal. First come, first served. Satisfaction guaranteed! U.V. Eraseable. **\$6.95 ea. 4/\$25**

UP YOUR COMPUTER!

21L02-1 1K LOW POWER 500 NS STATIC RAM Time is of the essence! And so is power. Not only are our RAM's faster than a speeding bullet but they are now very low power. We are pleased to offer prime new 21L02-1 low power and super fast RAM's. Allow us to STRETCH your power supply farther and at the same time keep the wait light off. **8 for \$12.95**

S.D. SALES EXCLUSIVE

\$12.95 MOS 6 DIGIT UP-DOWN COUNTER \$12.95

40 PIN DIP. Everything you ever wanted in a counter chip. Features: Direct LED segment drive, single power supply (12 VDC TYPE.), six decades up/down, pre-loadable counter, separate pre-loadable compare register with compare output, BCD and seven segment outputs, internal scan oscillator, CMOS compatible, leading zero blanking, 1MHz. count input frequency. Very limited quantity! WITH DATA SHEET

7400-19c	7411-29c	7451-19c	7490-65c	74153-75c
74LS00-49c	7413-50c	7453-19c	74LS90-95c	74154-1.00
7402-19c	7416-69c	7473-39c	7492-75c	74157-75c
74LS02-49c	7420-19c	7474-35c	7493-69c	74161-95c
7404-19c	7430-19c	74LS74-59c	7495-75c	74164-1.10
74L04-29c	7432-34c	7475-69c	7496-89c	74165-1.10
74S04-44c	7437-39c	7476-35c	74121-38c	74174-95c
74LS04-49c	7438-39c	7480-49c	74123-65c	74181-2.50
7406-29c	7440-19c	7483-95c	74132-1.70	74191-1.25
7408-19c	7447-85c	7485-95c	74S138-1.95	74192-1.25
7410-19c	7448-85c	7486-45c	74141-75c	74193-1.00
				74195-69c

TTL INTEGRATED CIRCUITS

P.C. LEAD DIODES

1N4148/1N914 100/\$2.00
1N4002-1A, 100 PIV 40/\$1.

HEAVY DUTY Full Wave Bridge

25 AMP 50 PIV \$1.25

DISC CAP ASSORTMENT

PC leads. At least 10 different values. Includes .001, .01, .05, plus other standard value. **60/\$1.00**

1000 MFD Filter Caps

Rated 35 WVDC Upright style with PC leads. Most popular value for hobbyists. Compare at up to \$1.19 ea. from franchise type electronic parts stores. S.D. Special 4/\$1.



Slide Switch Assortment

Our best seller. Includes miniature and standard sizes; single and multi-position units. All new, first name brand. Try one package and you'll reorder more! Special 12/\$1.00



RESISTOR ASSORTMENT

1/4W 5% & 10% PC leads. A good mix of values. **200/\$2.**



TRANSISTOR SPECIALS

EN2222 NPN 8 for \$1.00
EN2907 PNP 8 for \$1.00
2N3904 NPN 8 for \$1.00
2N4400 NPN 10 for \$1.00
2N4402 PNP 8 for \$1.00

LED's WITH CLIPS

Jumbo Red, RL-2 by Litronix. With plastic mtg. clips which are very scarce. **4 for \$1.00**

C&K MINI TOGGLE SWITCH

No. 7101. S.P.D.T. Panel mount or P.C. mount. **79c 3 for \$2.**



SIX DIGIT LED ALARM CLOCK KIT

We made a fantastic kit even better. Redesigned to take advantage of the latest advances in I.C. Clock technology. Features: Litronix Dual 1/2 inch displays, Mostek 50250 super clock chip, Single I.C. segment driver, SCR ditit drivers. Greatly simplified construction. More reliable and easier to build. Kit includes all necessary parts (except case). P.C.B. or XFMR optional. **ALL NEW DESIGN!** P.C. Board - 3.00 AC XFMR - \$1.50 KIT \$9.95

Motorola SCR

2N4443. 8 AMP 400 PIV. P.C. Leads 3/\$1.

FAIRCHILD - TBA 641

4W. Audio power Amp. Just out! In special heat sink DIP. One super audio IC. **\$1.50 with data**

FND-359 - Led Readout

.4 IN. Common Cathode. High efficiency. Has FND-70 PIN OUT. **59c**

OUR CATALOG

is chocked full of rare parts bargains, deals, RAM or CPU kits, plus much more. Yours **FREE!**

PRICES SHOWN SUBJECT TO CHANGE WITHOUT NOTICE.



\$15.95

COMPUTER POWER SUPPLY

A very fortunate purchase. One of the best industrial quality REGULATED supplies we have seen. High performance, small size. Input is 120 VAC 60 HZ. Has the following regulated outputs: -5VDC@800MA; -15VDC @ 1.25 AMP; -25VDC @ 180 MA. Sold at a fraction of original cost. Do yourself a favor and order NOW. We expect a quick sellout.

NEXT MONTH:

S.D. will have music for your ears. Watch our ads.

For your Imsai or Altair 8080 Computer:

Z-80 CPU Kit - \$149. 4K Low Power Ram Kit - \$89.95

Call your BankAmericard or Master Charge order in on our continental United States toll free Watts:

1-800-527-3460

Texas Residents Call Collect:

214/271-0022

Special Thanks to: Dennis, Fred, Abe, Bill, Sam, Hal, Tom, Alex, John, Ely, and Larry

S.D. SALES CO.
P. O. BOX 28810
Dallas, Texas 75228

ORDERS OVER \$15.00 - CHOOSE \$1.00 FREE MERCHANDISE

INSTRUCTION

LEARN ELECTRONIC ORGAN SERVICING at home all makes including transistor. Experimental kit—trouble-shooting. Accredited NHSC. Free Booklet NILES BRYANT SCHOOL 3631 Stockton, Dept. A, Sacramento, Calif. 95820

SELF-STUDY CB RADIO REPAIR COURSE THERE'S MONEY TO BE MADE REPAIRING CB RADIOS. This easy-to-learn course can prepare you for a career in electronics enabling you to earn as much as \$16.00 an hour in your spare time. For more information write CB RADIO REPAIR COURSE Dept. PE057 531 N. Ann Arbor, Oklahoma City, Okla. 73127

LEARN WHILE ASLEEP! HYPNOTIZE! Astonishing details, strange catalog free! Autosuggestion, Box 24-ZD, Olympia, Washington 98507

UNIVERSITY DEGREES BY MAIL, Bachelors, Masters, Ph.D's ... Free revealing details. Counseling, Box 317-PE5, Tustin, California 92680.

INTENSIVE 5 week course for Broadcast Engineers FCC First Class license. Student rooms at the school Radio Engineering Inc. 61 N. Pineapple Ave., Sarasota, FL 33577 and 2402 Tidewater Trail, Fredericksburg, VA 22401

PRACTICAL Electronic Training FCC license. Free home study catalog Genn Tech, 5540 Hollywood Blvd., Los Angeles, CA 90028. Or, Ra-Tel Electronics, P.O. Box 167, "P" Toronto, Ont., Canada U.S. Inquiries

LEARN BASIC Digital Troubleshooting by correspondence Course includes text and demonstration modules. Educational Technologies, Box 224, Reynoldsburg, Ohio 43068

CB ERS—Be a "Ham" We'll teach you! Life Membership \$4.00. American Radio Council, Box 1171-K, Garland, Texas 75040.

HIGHLY EFFECTIVE Degree Program in Electronics Engineering Advance rapidly! Our 31st Year Free literature. Cook's Institute, Box 20345, Jackson, Miss. 39209.

BURGLAR/FIRE EXPERTS NEEDED for cars, homes, industry. Learn high profit systems installation at home spare time. Simple, quick, complete. Free information by mail. No salesman. Security Systems Management School (home-study), Dept. 7373-057, Little Falls, N.J. 07424

GET YOUR COMMERCIAL FCC License. New exams by author of successful published workbooks of FCC Practice Tests 500 Questions Second Class, \$11.95; 200 First Class, \$7.95; 100 Radar, \$4.95; postpaid. Save, all three \$19.95. Complete mathematical solutions. Free counselling service Victor Veley, P.O. Box 14, La Verne, Calif. 91750

GRANTHAM'S FCC LICENSE STUDY GUIDE — 377 pages, 1465 questions with answers discussions — covering third, second, first radiotelephone examinations \$13.45 postpaid. GSE, P.O. Box 25992, Los Angeles, California 90025.

F.C.C. EXAM MANUAL

PASS FCC EXAMS! Memorize, study — "Test Answers" for FCC 1st and 2nd class Radio Tele. phone licenses. Newly revised, multiple-choice questions and diagrams cover all areas tested in FCC exams plus "Self Study Ability Test." \$9.95 postpaid. Moneyback Guarantee

COMMAND PRODUCTIONS P.O. BOX 26348-P RADIO ENGINEERING DIVISION SAN FRANCISCO, CALIF. 94126

BROADCAST STATION? Operate your own FM, Cable, Carrier-Current from home, school, church or as money making business. Free details "Broadcasting", Box 5516-AE, Walnut Creek, CA 94596

GO FIRST CLASS! Complete FCC examination questions — diagrams — answers plus "topical study" guide, \$8.95 EGW Publications, Box 5516-AE, Walnut Creek, CA 94596

SCORE high on F.C.C. Exams... Over 300 questions and answers. Covers 3rd, 2nd, 1st and even Radar. Third and Second Test, \$14.50. First Class Test, \$15.00. All tests, \$26.50. R.E.I., Inc. Box 806, Sarasota, Fla. 33577

PERSONALS

MAKE FRIENDS WORLDWIDE through international correspondence. Illustrated brochure free. Hermes-Verlag, Box 110660-Z, D-1000 Berlin 11, Germany

WARTS Vergo Cream is painless, safe, easy, gentle. Buy Vergo at better pharmacies.

INVENTIONS WANTED

INVENTORS Manufacturers Need New Products. Free "Recommended Procedure," by a creative fee-based invention service company. Washington Inventors Service, 422-T Washington Building, Washington, D.C. 20005

INVENTORS

RECOGNITION... FINANCIAL REWARD... OR CREDIT FOR "INVENTING IT FIRST" MAY BE YOURS!

If you have an idea for a new product, or a way to make an old product better, contact us, "the idea people" We'll develop your idea, introduce it to industry, negotiate for cash sale or royalty licensing. Write now without cost or obligation for free information. Fees are charged only for contracted services. So send for your FREE "Inventor's Kit." It has important Marketing Information, a special "Invention Record Form" and a Directory of 1001 Corporations Seeking New Products.

RAYMOND LEE ORGANIZATION
230 Park Avenue North New York, NY 10017

At no cost or obligation, please rush my FREE "Inventor's Kit No. A-112"

Name _____
Address _____
City _____ State _____ Zip _____
Phone No. _____ Area Code _____

MAGNETS

MAGNETS. All types. Specials-20 disc, or 10 bar, or 2 stick or 8 assorted magnets \$1.00. Magnets, Box 192-H Randallstown, Maryland 21133

WANTED

GOLD, Silver, Platinum, Mercury wanted. Highest prices paid by refinery. Ores assayed. Free circular. Mercury Terminal, Norwood, MA 02062.

AUTO BURGLAR ALARM KIT
KIT #ALR-1 \$9.95
#ALR-1WT WIRED & TESTED \$19.95

MOBILE LED CLOCK
12 OR 24-HOUR OPERATION MODEL #2001
12 VOLT AC OR DC POWERED
SIX LARGE 4" DIGITS
KIT #2001 COMPLETE KIT (LESS 9V BATTERY) 29.95 EA 3 OR MORE \$27.95 EA
ASSEMBLED UNITS WIRED & TESTED ORDER #2001 WT (LESS 9V BATTERY) \$39.95 3 OR MORE \$37.95 EA
115 VAC Power Pack #AG-7 \$2.00 EA

21L02 MEMORY OR FAULT-INDICATOR
PRIME .450 NS LOW POWER
1-24 \$1.95
25-99 1.75
100-199 1.90
200-499 1.45
Over 500 1.40

OP AMPS
3/81.00
301 TO-5
709 DIP
709 TO 5
741 DIP
741 M-DIP
741 TO 5
747 TO 5

DIODES
IN 4002 1A 100 PIV 12/\$1.00
IN 4005 1A, 600 PIV 11/\$1.00
IN 4007 1A, 1000 PIV 10/\$1.00
RECTIFIER 2.5A, 1000 PIV 4/\$1.00
IN 914 SIL SIGNAL 20/\$1.00
IN 4148 SIL SIGNAL 20/\$1.00
DYAC 28V 4/\$1.00

PC TRIM POTS
MM5312 \$ 4.95 25K 6/\$1.00
MM5314 3.95 47K 6/\$1.00
MM5375 AB 3.95 SPECTROL
CT-7001 7.95 10K 10/TURN
CT-7002 13.95 95c
MM5369 2.50 4/\$3.00

JUMBO DIGIT CLOCK KIT \$9.95 ea.
A complete Kit (less Cabinet) featuring six 5" digits, MM5314 IC, 12/24 Hr. time, 50/60 HZ., Plug-Transformer, Line Cord, Switches, and all Parts. (Ideal Fit in Cabinet II) Kit # 5314.5 WITH PC Boards \$19.95 ea. 2/\$38.

JUMBO DIGIT CONVERSION KIT
Convert small digit LED clock to large 5" displays. Kit includes 6 - 5" LED's, Multiplex PC Board & easy hook up info.
Kit # JD-1CC For common Cathode
Kit # JD-1CA for common Anode

DISCRETE LED'S
JUMBO RED
10 FOR \$1.00
100 FOR \$9.50

DIGITAL CLOCK IC'S
MM5312 \$ 4.95
MM5314 3.95
MM5375 AB 3.95
CT-7001 7.95
CT-7002 13.95
MM5369 2.50

60 HZ. XTAL TIME BASE
Will enable Digital Clock Kits or Clock-Calendar Kits to operate from 12V DC
1"x2" PC Board
Power Req: 5-15V (2.5 MA. TYP.)
Easy 3 wire hookup
Accuracy: ± 2PPM
#TB-1 (Adjustable)
Complete Kit \$4.95 ea
Wir & Cal \$9.95

VARIABLE REGULATED 1 AMP POWER SUPPLY KIT
• VARIABLE FROM 4 to 14V
• SHORT CIRCUIT PROOF
• 723 IC REGULATOR
• 2N3055 PASS TRANSISTOR
• CURRENT LIMITING AT 1 AMP
KIT IS COMPLETE INCLUDING DRILLED & SOLDER PLATED FIBERGLASS PC BOARD AND ALL PARTS (Less TRANSFORMER) KIT #PS-01 \$8.95
TRANSFORMER 24V CT will provide 300MA at 12V and 1 Amp at 5V with #PS-01 \$3.50

RED OR GREY PLEXIGLAS
3"x6"x1/8"
FOR DIGITAL BEZELS
95¢ ea. 4/\$3

25 AMP BRIDGE
\$1.95 ea.
3/\$5.00
100 PIV

NYLON WIRE TIES
8" TIE WRAP 100/\$1.95
4" TIE WRAP 100/\$1.75

IC SOCKETS
PINS 1 24 25 100
8 \$ 20 \$ 22 \$ 20
14 25 22 20
16 28 25 23
18 31 28 26
24 50 45 40
28 60 55 50
40 75 70 65

MOLEX PINS
Form inexpensive sockets
100 for \$1.25
Reel of 1000 - \$8.50

NEW LSI TECHNOLOGY FREQUENCY COUNTER KIT
8 LARGE 4" RED LED DIGITS
• ONLY 8 IC'S! • XTAL TIME BASE
A truly "State of the Art" counter using quality components throughout.
KIT INCLUDES: DETAILED INSTRUCTIONS, XTAL, TOP QUALITY FIBERGLASS DOUBLE SIDED PC BOARD, IC'S WITH SOCKETS AND ALL PARTS LESS POWER SUPPLY AND CABINET.
50 MHZ COUNTER KIT #FC-50 \$69.95
5 VOLT REGULATED 1 AMP POWER SUPPLY KIT #PS-02 \$9.95
350 MHZ PRESCALER KIT #PSL-350 23.95
650 MHZ PRESCALER KIT #PSL-650 \$29.95
CABINET (& MTG HARDWARE) #CAB III \$19.95
[CABINET WILL HOUSE #FC-50, #PS-02, AND A PRESCALER]
DELIVERIES TO START IN MAY, 1977

60 HZ. XTAL TIME BASE
Will enable Digital Clock Kits or Clock-Calendar Kits to operate from 12V DC
1"x2" PC Board
Power Req: 5-15V (2.5 MA. TYP.)
Easy 3 wire hookup
Accuracy: ± 2PPM
#TB-1 (Adjustable)
Complete Kit \$4.95 ea
Wir & Cal \$9.95

SET OF 6 FND-359 WITH MULTIPLEX PC BOARD 6.95
Fairchild Super Digit FND-359
4" Char. Hl. 7-segment LED RED Com. Cath. Direct pin replacement for popular FND-70.
95¢ ea. 10/\$8.50
100/\$79.00

ORDER BY PHONE OR MAIL Orders Under \$15 Add \$1.00 Handling
COD ORDERS WELCOME Fla. Res. Please Add 4% Sales Tax.

DIGI-KEY CORPORATION

Quality Electronic Components

DON'T FORGET OUR DISCOUNTS WHEN COMPARING PRICES

PRICE BREAKTHROUGH ON 741S'

741500	28	741500	28	741590	57	7415157	75	7415148	79
741500	28	741502	33	741592	57	7415158	75	7415149	79
741502	28	741537	33	741593	57	7415160	1.02	7415152	84
741503	28	741538	33	7415107	39	7415161	1.02	7415152	75
741504	29	741540	28	7415108	39	7415162	1.02	7415152	75
741505	29	741542	28	7415112	39	7415163	1.02	7415152	75
741508	29	741547	29	7415113	39	7415164	1.02	74152-3	79
741509	29	741548	29	7415114	39	7415168	1.14	74152-0	65
741510	28	741551	28	7415125	49	7415169	1.14	74152-0	65
741511	28	741554	28	7415126	49	7415170	1.14	74152-0	65
741512	28	741555	28	7415132	81	7415173	1.34	74153-6	67
741513	47	741573	39	7415136	39	7415174	1.36	74153-7	67
741514	1.02	741574	39	7415138	39	7415175	1.36	74153-8	67
741515	28	741575	52	7415139	39	7415190	1.18	74153-6	67
741520	28	741576	39	7415151	75	7415191	1.18	74156-0	234
741521	28	741578	39	7415153	75	7415196	1.36	71159-7	77
741522	28	741583	79	7415154	75	7415197	1.36	71159-7	77
741523	33	741586	39	7415155	75	7415247	29	71159-7	77
741527	33			7415156	75			71159-7	77

INTEGRATED CIRCUITS — TTL, CMOS, LINEAR & MOS

7400	21	7476	32	74181	2.15	4012	23	4520	1.14
7401	21	7480	70	74182	2.19	4013	40	4527	1.68
7402	21	7482	70	74184	2.19	4014	96	4528	.88
7403	21	7483	70	74185	2.19	4015	96	4585	1.23
7404	21	7485	89	74186	3.50	4016	40	2102-1	1.99
7405	21	7486	28	74189	3.50	4017	105	8080A	24.95
7406	25	7489	2.19	74190	1.23	4018	105	CA3046	.75
7407	25	7490	44	74191	1.23	4019	23	LM7111N	1.25
7408	21	7491	70	74192	88	4020	84	LM4007	1.80
7409	21	7492	44	74193	88	4021	1.14	LM324A	1.28
7410	21	7493	44	74194	88	4022	1.14	LM340-5	1.25
7411	21	7495	70	74195	88	4023	23	LM340-6	1.25
7412	21	7496	70	74197	88	4024	1.14	LM340-7	1.25
7413	25	7497	70	74197	88	4025	23	LM340-11	1.25
7414	89	74100	1.28	74198	1.49	4026	1.68	LM340-13	1.25
7415	25	74107	30	74199	1.49	4027	40	LM340-118	1.25
7416	25	74109	33	74201	1.09	4028	89	LM3401	1.25
7420	21	74121	35	74209	55	4029	1.14	LM3909N	.88
7421	25	74122	44	74365	.67	4030	23	LM3909N	.69
7423	35	74123	63	74366	.67	4033	1.51	MC1456	1.00
7425	35	74125	40	74367	.67	4034	3.50	MC1459V	1.15
7426	25	74126	40	74368	.67	4035	1.14	MC3302P	1.15
7427	33	74132	70	8093	.40	4040	1.14	NE536T	3.24
7428	28	74141	88	8094	.40	4041	.79	NE540L	2.04
7430	21	74145	70	8095	.67	4042	79	NE555V	.48
7432	25	74147	1.63	8096	.67	4043	70	NE556A	.88
7433	30	74148	1.30	8097	.67	4044	70	NE560B	3.83
7437	25	74150	1.16	8098	.67	4046	1.86	NE560B	3.83
7438	25	74151	70	75150	1.16	4049	40	NE560B	3.83
7440	21	74153	65	75450	.88	4050	40	NE565A	1.25
7442	53	74154	1.03	75451	.61	4051	1.26	NE566V	1.28
7443	63	74155	70	75452	.61	4052	1.26	NE567V	1.36
7445	70	74156	70	75453	.61	4053	1.26	UA709CV	.44
7446	70	74157	70	75454	.61	4060	1.58	UA710CA	.44
7447	70	74160	88	75491	.81	4066	79	UA711CA	.53
7448	70	74161	88	75492	.84	4071	23	UA723CA	.60
7450	21	74162	88	75493	1.09	4072	23	UA733CA	.75
7451	21	74163	88	75494	1.19	4073	23	UA741CV	.44
7453	21	74164	96	82525	2.19	4075	23	UA747CA	.70
7454	21	74174	98	4000	.23	4081	23	UA748CV	.48
7459	21	74166	1.26	4001	.23	4082	23	UA7805CU	1.25
7460	21	74170	2.64	4002	.23	4502	79	UA7806-2U	1.25
7470	30	74173	1.42	4006	1.23	4510	1.14	UA7808CU	1.25
7472	30	74174	98	4007	.23	4511	1.05	UA7812CU	1.25
7473	30	74175	93	4008	.79	4514	2.80	UA7815CU	1.25
7474	30	74176	79	4009	.44	4515	2.80	UA7818CU	1.25
7475	49	74177	79	4010	.44	4516	1.23	UA7824CU	1.25
		74180	70	4011	.23	4518	1.14		

NEW

HOBBY WRAP
Model BW-630



Battery wire wrapping tool

\$34.95
ONLY (no tax)
COMPLETE WITH BIT AND SLEEVE

WIRE WRAPPING WIRE IN BULK
Red or Black 30 ga. Kynar

100	\$2.00	500	\$8.50	1000	\$15.00
-----	--------	-----	--------	------	---------

SILICON DIODES

1N4001	64.10	5.50/C	\$49/M
1N4002	66.10	5.50/C	\$51/M
1N4003	68.10	5.50/C	\$52/M
1N4004	70.10	5.50/C	\$54/M
1N4005	82.10	7.05/C	\$63/M
1N4006	90.10	7.75/C	\$69/M
1N4007	99.10	8.60/C	\$77/M
1N4148	40.10	3.50/C	\$29/M

Double Digit Discounts Save You Even More!

1/2 WATT ZENER DIODES

NS2228 3.0v	15 \$11/C	NS2268 7.5v	15 \$11/C
NS2228 3.6v	15 \$11/C	NS2278 8.2v	15 \$11/C
NS2288 3.9v	15 \$11/C	NS2388 8.7v	15 \$11/C
NS2298 4.3v	15 \$11/C	NS2398 9.1v	15 \$11/C
NS2308 4.7v	15 \$11/C	NS2408 10v	15 \$11/C
NS2318 5.1v	15 \$11/C	NS2418 11v	15 \$11/C
NS2328 5.6v	15 \$11/C	NS2428 12v	15 \$11/C
NS2338 6.0v	15 \$11/C	NS2438 13v	15 \$11/C
NS2348 6.2v	15 \$11/C	NS2448 14v	15 \$11/C
NS2358 6.8v	15 \$11/C	NS2458 15v	15 \$11/C

BUY A-P PRODUCTS & BISHOP GRAPHICS FROM DIGI-KEY

SIGNETICS ANALOG MANUAL... \$5.95

PLESSEY SAMPLER

An Assortment of Metallized Polyester Capacitors
300 Caps 18 Values **\$26.00**

LED LAMPS

NSLS053 T-1 1/2"	.18	\$15/C
NSLS056 T-1 1/2"	.18	\$15/C

LED DUAL DIGITS

PRICED PER PAIR OF 2 DIGITS

MSN373 0.3" CC	\$2.20/Pair
MSN374 0.3" CA	\$2.20/Pair
MSN384 0.5" CC	\$2.60/Pair
MSN384 0.5" CA	\$2.60/Pair
MSN783 0.7" CC	\$3.00/Pair
MSN784 0.7" CA	\$3.00/Pair

ALL LEADS BROUGHT OUT FOR EASE OF APPLICATION

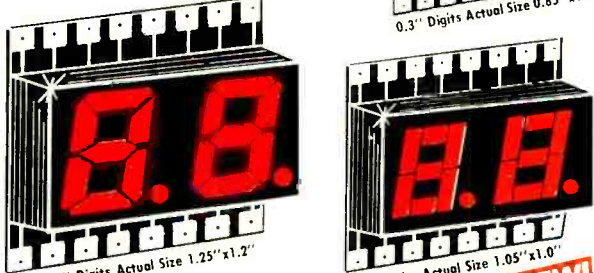

0.3" Digits Actual Size 0.85" x 0.85"
0.7" Digits Actual Size 1.25" x 1.25"
0.5" Digits Actual Size 1.05" x 1.05"

MA 1003 CAR CLOCK

NEW — FOR CAR OR BOAT!

12 Hour Only
12 Volt DC
Crystal Time Base
Bright Green Digits
Assembled and Tested



The MA1003 bright green fluorescent display offers a brilliance that cannot be achieved by LED displays, a feature that sold Detroit!

0.3" Digits Actual Size 1.75" x 3.05" **MA1003 \$24.95**

Includes 2 Push Button Switches

MA1002 0.5" High Digits



Actual Size: 1.375" x 3.05"

MA1002A	12 Hour AM-PM	\$10.50
MA1002C	24 Hour	\$10.50
SPECIAL TRANSFORMER & SWITCHES		\$3.45

ABOUT OUR CLOCKS

The MA1002 and MA1010 series clock modules by National Semiconductor for fully assembled and tested clocks using a 4 digit LED display and an MOS integrated circuit on the same board. Simply connect switches and our special transformer and you have a fully functioning clock.

The MA1003 clock module is a fully assembled and tested 12 hour clock using a high brilliance green fluorescent display and crystal time base making it perfect for car, boat or other portable use. It operates directly from 12 volts DC so no transformer is needed. Our price includes three push button switches for setting the time.

MA1002A	5' LED 12 Hour AM-PM Clock Module	\$10.50
MA1002A SET	Module with Transformer & Switches	\$13.95
MA1002C	5' LED 24 Hour Clock Module	\$10.50
MA1002C SET	Module with Transformer & Switches	\$13.95
MA1003	12 Volt Car Clock with Switches	\$24.95
MA1010A	84' LED 12 Hour AM-PM Clock Module	\$13.00
MA1010A SET	Module with Transformer & Switches	\$16.45
MA1010C	84' LED 24 Hour Clock Module	\$13.00
MA1010C SET	Module with Transformer & Switches	\$16.45

RADIAL ELECTROLYTICS

47.50V .08	65.10	22.50V .12	1.00/10	330.25V .23	1.86/10
1.30V .08	65.10	100.10V .10	.77/10	470.16V .32	1.81/10
2.250V .08	65.10	100.16V .11	.85/10	470.25V .29	2.35/10
3.350V .08	65.10	100.25V .13	1.10/10	1000.10V .24	1.96/10
4.750V .08	65.10	100.50V .21	1.71/10	1000.16V .29	2.35/10
10.16V .08	65.10	220.10V .13	1.08/10	1000.25V .42	3.33/10
10.25V .08	65.10	220.16V .15	1.16/10	2200.10V .42	3.33/10
10.50V .10	75.10	220.25V .21	1.71/10	2200.16V .54	4.30/10
22.16V .08	67.10	330.10V .15	1.16/10	2200.25V .58	4.67/10
22.25V .09	70.10	330.16V .21	1.66/10	3300.16V .89	7.14/10
		330.16V .21	1.66/10		

AXIAL ELECTROLYTICS

47.50V .11	90.10	33.25V .14	1.15/10	330.16V .29	2.35/10
1.30V .11	90.10	33.50V .19	1.52/10	330.25V .32	2.34/10
3.350V .12	95.10	47.16V .14	1.31/10	470.16V .32	2.35/10
3.350V .12	100.10	47.25V .17	1.30/10	470.25V .37	3.00/10
4.750V .11	90.10	47.50V .21	1.17/10	1000.10V .33	2.65/10
4.750V .12	95.10	100.10V .14	1.13/10	1000.16V .39	3.13/10
10.25V .12	100.10	100.16V .17	1.30/10	1000.25V .56	4.50/10
10.25V .12	100.10	100.25V .20	1.55/10	2200.10V .50	3.96/10
10.50V .14	115.10	100.50V .29	2.30/10	2200.16V .62	4.95/10
22.16V .12	100.10	220.10V .18	1.47/10	2200.25V .79	6.36/10
22.25V .13	105.10	220.16V .20	1.55/10	3300.16V .95	7.63/10
22.50V .17	132.10	220.25V .29	2.35/10	4700.16V .09	8.70/10
33.16V .12	100.10	330.10V .14	1.16/10	10000.10V 1.15	9.19/10
		330.10V .14	1.16/10		

MA1010 0.84" High Digits



Actual size: 1.75" x 3.75"

MA1010A	12 Hour AM-PM	\$13.00
MA1010C	24 Hour	\$13.00
SPECIAL TRANSFORMER & SWITCHES		\$3.45

SEND FOR OUR FREE CATALOG
WE STOCK A WIDE VARIETY OF PARTS NOT IN THIS AD PLUS MANY SPECIALLY PRICED BARGAINS!

DATA BOOKS

TTL IC's 595 p	\$4.00
Linear IC's 957 p	\$5.00
CMOS 74C 256 p	\$3.00
Memory IC's 592 p	\$3.00
Interface IC's 464 p	\$4.00
Volt Regs 128 p	\$3.00
Linear Appl 1 432 p	\$4.00
Linear Appl 2 246 p	\$3.00
Audio 196 p	\$3.00
MOS LSI IC's 713 p	\$4.00
CMOS 4000 278 p	\$3.25
Analog Manual 637 p	\$5.95

SLIDE SWITCHES

SPST .15	1.20/10	10.00/C
SPDT .19	1.70/10	13.00/C
DPDT .23	2.00/10	19.00/C

STRANDED HOOK UP WIRE

20 ga PVC	2.50/100'	10.00/500'
-----------	-----------	------------

EMPLOYMENT OPPORTUNITIES

ELECTRONICS/AVIONICS EMPLOYMENT OPPORTUNITIES. Report on jobs now open. Details FREE. Aviation Employment Information Service, Box 240E, Northport, New York 11768.

OVERSEAS JOBS — NOW HIRING! High Pay! All Occupations. Transportation. Computerized Reports — \$2.00. TRANSWORLD, International Airport, Box 90802-N, Los Angeles, Calif 90009.

HYPNOTISM

SLEEP learning Hypnotic method 92% effective Details free ASR Foundation, Box 23429EG, Fort Lauderdale, Florida 33307

FREE Hypnotism Self-Hypnosis, Sleep Learning Catalog! Drawer H400, Ruidoso, New Mexico 88345.

AMAZING self-hypnosis record releases fantastic mental power. Instant results! Free trial. Write: Forum (AA5), 333 North Michigan, Chicago 60601

TREASURE FINDERS

TREASURE may lie beneath your feet! Discover gold, silver, coins, rings, artifacts and more with world-famous, deeper-detecting White's metal detectors. From \$59.95. Dealers world-wide. Free literature! White's Electronics, Dept. PD7-C, 1011 Pleasant Valley Rd., Sweet Home, OR 97386.

REAL ESTATE

BIG, NEW, FREE, SUMMER 1977 CATALOG! Over 2,600 top values coast to coast! UNITED FARM AGENCY, 612-EP, West 47th, Kansas City, MO 64112.

RUBBER STAMPS

RUBBER STAMPS, BUSINESS CARDS. Many new products Catalog Jackson's, Dept. K, Brownsville Rd., Mt. Vernon, Ill 62864.

Olson ELECTRONIC PARTS AND ACCESSORIES



AU-580 AUTO RADIO Pushbutton AM 1099 VOICE ACTIVATED SWITCH

99c Activates devices such as lights, tape recorders etc. Comes with 5' leads 3 x 1" Operates on 4.5 VDC Shpg wt 1/2 lb

Reg. 1.98 XM-556

	Reg.	Sale
60 Min. Cassette, Pkg. of 3, TA-879 . . .	1.49	.87
2V. RED L.E.D., Pkg. of 5, PL-233	1.99	.59
40 Min. 8-Track Tape, TA-90769	.39
Elect. Cap. Kit, 50 Asst., CD-407	5.00	1.70
Black Light Bulb, XM-291	1.00	.49
CB Converter for Car, CB-417	14.99	9.99
Resistors 1/2-1 watt, Pkg. 100, RR-077 .	1.79	.79
Volume Controls, 12 Asstd. VC-274 . . .	1.00	.49
Empire 999 Mag. Phono Cart. PC-188 . .	9.99	6.99
3-6V DC Hobby Motors, 5 Asstd. MO-333	2.00	.59
Solder Terminal Strips, 40 Asstd. XM-501	1.30	.50
Double Face Foam Tape 3/4" x 52", TA-903	1.00	.80
1/4 RPM Timing Motor, 117 VAC, MO-277 .	.49	.30
8 RPM Revers. Motor 117 VAC, MO-393 .	2.50	.99
Ceramic Disc Cap., 100 Asstd. CC-210 .	1.29	.80
Knob Kit, 25 Pcs. Asstd., KN-030	1.00	.69
8-Track Tape Deck Chassis, RA-383 . . .	17.00	12.99
7 Seg. L.E.D. Display Com. K., XM-414 .	2.00	1.00
Stepping Relay, 6-12 VDC, 10 Pos., SW-843	5.00	3.00
2S8474 TO '66 Output Trans., TR-147 . .	3.79	1.19
Fairchild 703 Type IC, TR-29399	.39
IC Grab Bag, 10 Asstd. Types, TR-422 . .	1.19	.50
Calculator IC Chip, Nortec 4202, TR-424 .	6.00	2.99
SCR Grab Bag, 25 Asstd. Types, TR-446 .	2.69	.90
Cadium Photo Cells, Pkg. of 2, TR-512 . .	.90	.49
12 Digit Calculator IC, XM-330	6.00	1.49
20 Key Calculator Keyboard, XM-339 . . .	6.00	1.29

Send to: Olson Electronics, Dept. IX 260 S. Forge St., Akron, Ohio 44327. Allow for Postage, C.O.D. 20% Deposit. Ohio Residents Add 4% Sales Tax.

FREE Ask for our Catalog when you Order

CIRCLE NO. 43 ON FREE INFORMATION CARD

INTERNATIONAL ELECTRONICS UNLIMITED

10% OFF WITH \$25 ORDER
15% OFF WITH \$100 ORDER
 THESE DISCOUNTS APPLY TO TOTAL OF ORDER — SPECIALS INCLUDED

TTL					
7400	.13	7451	.17	74151	.89
7401	.16	7453	.17	74154	1.20
7402	.15	7454	.17	74155	.97
7403	.15	7460	.17	74156	.97
7404	.16	7464	.35	74157	.99
7405	.19	7465	.35	74158	1.79
7406	.20	7470	.30	74160	1.23
7407	.28	7472	.30	74161	.97
7408	.18	7473	.35	74162	1.39
7409	.19	7474	.28	74163	1.09
7410	.16	7475	.30	74164	.99
7411	.25	7476	.30	74165	.99
7413	.43	7481	.68	74166	1.25
7414	.65	7481	.88	74170	2.10
7416	.35	7486	.40	74171	1.49
7417	.35	7489	2.25	74174	1.23
7420	.16	7490	.43	74175	.97
7422	.30	7491	.75	74176	.89
7423	.29	7492	.48	74177	.84
7425	.27	7493	.48	74180	.90
7426	.26	7494	.78	74181	2.45
7427	.29	7495	.79	74182	.79
7430	.20	7496	.79	74184	2.00
7432	.23	7496	.98	74185	2.90
7437	.25	74105	.44	74187	5.75
7438	.25	74107	.37	74190	1.15
7440	.15	74121	.38	74193	1.25
7441	.89	74122	.38	74194	.95
7442	.59	74123	.65	74191	.85
7443	.73	74125	.54	74194	1.25
7444	.73	74126	.58	74195	.74
7445	.73	74132	.89	74196	1.23
7446	.81	74141	1.04	74197	.75
7447	.79	74145	1.04	74198	1.73
7448	.79	74150	.97	74199	1.69
7450	.17	74151	.79	74200	5.45



CALC. KIT ONLY \$9.95
ADAPTER -60Hz \$3.95

CALCULATOR KIT LITRONIX 1602 MEMORY

- FULL ACCUMULATING MEMORY — STORES AND RECALLS SUBTOTALS
- % KEY — PERFORMS ALL PERCENT FUNCTIONS INCLUDING ADD-ONS, DISCOUNTS, MARKUPS AND TITLES
- 8 KEY — ALWAYS DOLLAR AND CENTS ENTRIES WITHOUT PRESSING DECIMAL POINT KEY
- SQUARE ROOT — PERFORMS SQUARE ROOT BY PRESSING — AND — SEQUENTIALLY
- ARITHMETIC LOGIC — LETS SOLVE OTHER PROBLEMS IN ADDING MACHINE MODE
- FLOATING DECIMAL SYSTEM — AUTOMATIC DECIMAL POINT POSITIONING FOR FULL 8-DIGIT ACCURACY
- OVERFLOW SAVE — IN CASE OF OVERFLOW IN DISPLAY, THIS CLEAR THE CONDITION AND ALLOWS CALCULATOR TO CONTINUE USING THE OVERFLOWED RESULT DIVIDED BY 10
- AUTOMATIC TIMEOUT TO SAVE BATTERIES

7489 \$1.79
 64 bit ROM TTL 16 pin

8008 \$19.95
8080A \$19.95

MM5369 Divider mDIP \$2.35
 Crystal 3.58 MHZ color TV \$1.50

1702A \$6.95
 2048 bit static PROM elect. prog. UV ears. 24 pin

CALCULATOR DISPLAY \$99 c
 9 MAN 3 B ON PC BOARD

2102 \$1.49
 1024 bit static RAM 16 pin

KEYBOARD \$99 c
 20 KEYS 2 SLIDE SW

LINEAR CIRCUITS

300	\$ 71	371	2.42	723	.62
401	.29	176	.68	733	.89
402	.53	380	1.90	739	1.07
304	.80	180-B	1.25	741	.32
405	.71	381	1.75	747	.71
307	.26	382	1.75	748	.35
308	.89	511	2.93	1458	.62
109K	1.15	440	4.95	1800	2.48
310	1.07	550	.79	3900	.49
311	.95	555	.45	7524	.71
119	1.13	556A	1.19	7525	.90
1201	1.39	581	3.39	8038	4.25
120K	1.19	562	3.39	8864	2.25
422	1.70	565	1.18	75150	1.75
324	1.52	566	1.95	75451	.35
119	1.58	567	1.95	75452	.35
140A	1.69	709	.26	75453	.35
140T	1.49	710	.35	75491	.71
372	2.93	711	.26	75492	.80

CALCULATOR CHIPS

- C15002 12 digit, 4 function fixed decimal battery operation — 40 pin 1.95
- C15005 12 digit, 4 function plus memory, fixed decimal — 20 pin 2.49
- MM5725 8 digit, 4 function, floating decimal 18 pin 1.98
- MM5736 8 digit, 4 function, 9V battery operation — 18 pin 2.95
- MM5738 8 digit, 5 function plus memory and constant floating decimal, 9V battery operation — 24 pin 3.95
- MM5739 9 digit, 4 function, 9V battery operation — 22 pin 3.95

733 \$0.59
DIFFERENTIAL VIDEO AMPLIFIER.

DVM CHIP 4 1/2 DIGIT — \$6.95
 MM5330 P channel device provides all logic for 4 1/2 digit volt meter. 16 pin DIP with data.

IC BREADBOARD \$1.80 ea.
 Accommodates 5 16 pin IC's with additional interconnection holes. 1/16" phenolic with silver plated copper circuits. 2 5/16" x 6 9/16"

CMOS

4000A	.26	4018A	1.19	4064A	.89
4001A	.25	4020A	1.72	4068A	.44
4002A	.25	4021A	1.18	4069A	.44
4006A	1.35	4022A	.94	4071A	.26
4007A	.26	4023A	.25	4072A	.35
4008A	1.52	4024A	.89	4073A	.39
4009A	.57	4025A	.25	4075A	.39
4010A	.54	4027A	.59	4078A	.39
4011A	.29	4028A	.98	4082A	.35
4012A	.25	4030A	.44	4518A	1.56
4014A	.45	4035A	1.27	4528A	1.56
4014A	1.27	4040A	1.19	4585A	2.10
4015A	1.27	4042A	1.47		
4016A	.48	4049A	.59		
4017A	1.01	4050A	.59		

IC SOCKETS Solder Tail - low profile

8 pin	.17	24 pin	.42
14 pin	.20	28 pin	.59
16 pin	.22	40 pin	.69
18 pin	.29		

FREE CATALOG AVAILABLE ON REQUEST

Satisfaction guaranteed. Shipment will be made postage prepaid within 3 days from receipt of order. Payment may be made with personal check, charge card (include number and exp. date), or money order. Phone Orders — Bo/A and M/C card or C.O.D.

Add \$1.00 to cover shipping and handling if order is less than \$10.00. California residents add sales tax. Include shipping expense for orders shipped out of U.S. and Canada approx. 10% of order.

INTERNATIONAL ELECTRONICS UNLIMITED
 VILLAGE SQUARE, P.O. BOX 449
 CARMEL VALLEY, CA 93924 USA
 PHONE (408) 659-3171

TV GAME CHIP \$24.95
 AY-3-8500-1 Six games with scoring and sound

Mark I Clock Kit \$13.95
 A six digit clock kit with one double sided P.C. board accommodates MM5114 clock chip and 6 FND159 .325" displays. 12-24 hour, 50-60 Hz. Contains all necessary components, 3 switches and complete assembly instructions with schematic. Connections for remote displays.

OPTO ISOLATORS

MC D2	Opto isolator diode	1.09
MC T2	Opto isolator transistor	.70

SPECIAL DEVICES

372	AF-IF Strip Detector DIP	2.93
546	AM Radio Receiver Subsystem DIP	.75
1310	FM Stereo Demodulator DIP	2.90
1496	Balanced Modulator-Demodulator	.99
1800	Stereo Multiplexer DIP	2.48
ULN2208	FM Gain Block 34db (typ) mDIP	1.18
ULN2209	FM Gain Block 48db (typ) mDIP	1.35
2513	Character Generator 64x85 DIP-24	10.20
3046	Transistor Array DIP-14	.73

2518 \$2.95
HEX 32-bit STATIC SHIFT REGISTER

LED DISPLAYS

MAN 1	\$1.95	DL33B	.45
MAN 2	3.95	DL33-	.35
MAN 5	2.25		
MAN 7	1.49	DISCRETE LED'S	
MAN 8	2.25	ME 4	.29
MAN 66	2.25	MV10B	.25
MAN 72	1.25	MV50	.12
MAN 3620	1.50	NSL100	.12
FND 359	.95		
FND 500	1.89	MV5020	
FND 507	.95	RED	.15
DL10A	2.19	CLEAR	.15

7400 TTL				
7400	21	7442	1.08	74121 55
7401	21	7448	1.15	74122 49
7402	21	7450	2.6	74123 105
7404	21	7451	27	74125 60
7405	24	7453	27	74126 81
7406	45	7454	41	74132 300
7407	45	7460	22	74141 115
7408	25	7472	39	74150 110
7409	25	7473	45	74151 125
7410	20	7474	45	74153 135
7411	30	7475	80	74154 125
7413	85	7482	1.75	74155 121
7416	43	7483	1.15	74157 130
7417	43	7485	1.12	74161 145
7420	21	7486	45	74164 165
7422	1.50	7489	2.49	74165 170
7425	43	7490	69	74166 170
7427	37	7491	70	74171 195
7428	33	7492	82	74175 195
7430	26	7493	82	74180 105
7432	31	7494	91	74181 355
7437	47	7495	91	74191 150
7438	40	7496	91	74195 100
7440	21	74100	1.25	74197 100
7441	1.10	74107	49	74298 130

5400 SERIES				
5400	100	5475	1.50	
5404	1.25	5486	1.90	
5410	1.00	5493	2.00	
5426	1.25	54100	1.80	
5473	1.50	54LS04	1.00	

C MOS				
4001AE	29	4022AE	1.20	
4002AE	29	4023AE	29	
4007AE	29	4024AE	1.50	
4009AE	58	4025AE	35	
4010AE	58	4026AE	1.49	
4011AE	29	4028AE	1.60	
4012AE	29	4029AE	2.90	
4013AE	52	4030AE	65	
4015AE	1.25	4037AE	4.50	
4018AE	65	4040AE	2.40	
4019AE	1.10	4044AE	1.50	
4019AE	65	4047AE	2.75	
4020AE	1.75	4049AE	75	
4021AE	1.50	4050AE	75	

MOTOROLA CIRCUITS				
MC725P	1.50	MC1804P	98	
MC740L	1.55	MC1806P	98	
MC790P	1.50	MC1810P	98	
MC832P	1.48	MC2053L	43	
MC1004L	2.25	MC3004L	1.42	
MC1008L	1.25	MC3006P	1.44	
MC1010L	1.25	MC3007P	1.32	
MC1015L	1.25	MC3021L	2.15	
MC1036L	1.25	MC3021P	2.15	
MC1037L	1.25	MC3060L	2.65	
MC1352P	3.05	MC3062L	3.00	
MC1406CP	1.95	MC4024P	2.20	
MC1468L	2.90	MC14501CP	3.18	
MC1469R	2.50	MC14502CP	1.18	
MC1510G	8.00	MC14507CP	8.2	
MC1514L	4.50	MC14510CP	2.40	
MC1550G	1.50	MC14511CP	2.76	
MC1558L	4.37	MC14512CP	1.92	
MC1595L	6.25	MC14519CG	9.4	
MC1596G	3.31	MC14528CP	1.74	
MC1723CG	1.25	MC4004A	4.80	

JAPANESE CIRCUITS							
AN136	2.90	HA1312	4.05	STK056	11.35	TA7201P	6.40
AN203	3.75	HA1322	5.20	STK415	11.50	TA7203P	7.00
AN208	4.75	HA1339	5.20	TA7045M	3.50	TA7204P	6.50
AN210	3.10	LA1201	4.25	TA7054P	3.05	TA7205P	6.50
AN211	3.30	LA1364	4.70	TA7055P	5.50	TA78005M	2.50
AN214	4.90	LA1366	6.00	TA7060P	1.85	TA78005P	1.95
AN217	3.30	LA1367	5.90	TA7061P	2.25	TA78012M	2.50
AN229	6.35	LA3301	4.85	TA7139P	.40	TA78012P	1.95
AN234	3.55	LA4030	4.85	TA7063P	2.25	TA78015M	2.50
AN239	6.50	LA4031P	3.50	TA7074P	4.90	TA78015P	1.95
AN241	3.20	LA4051P	4.65	TA7075P	4.90	TC9100P	12.00
AN245	6.50	TB48105	3.50	TA7076P	4.55	UPC16C	2.50
AN274	3.95	LD3080	4.00	TA7089P	2.90	UPC20C	5.00
AN277B	3.40	LD3120	3.10	TA7102	5.15	UPC41C	3.95
AN288	4.80	LD3141	2.40	TA7106P	3.25	UPC48C	3.95
AN328	4.05	M5112	4.40	TA7120P	2.20	UPC554C	3.90
AN343	3.90	M5115PR	5.80	TA7120P-C	2.20	UPC563H2	8.00
BA511	3.50	M5155	2.85	TA7122AP	2.30	UPC566H	2.25
BA521	3.95	SG613	5.40	TA7124P	1.85	UPC575C	4.10
HA1158	6.30	STK011	10.50	TA7146P	4.10	UPC1001H2	5.15
HA1159	6.60	STK015	6.50	TA7150P	4.55	UPC1020H	5.50
HA1202	3.10	STK025	12.50	TA7153P	6.90	UPC1025	5.50
HA1306W	5.20	STK032	14.20	TA7200P	6.25		

74L SERIES TTL					
74L00	33	74LS04	45	74LS113	98
74L10	33	74LS10	39	74LS138	1.89
74L30	33	74LS20	39	74LS154	2.50
74L42	1.50	74LS51	39	74LS386	5.50
74L86	69	74LS74	65	74LS153	2.25
74LS00	39	74LS112	65	74S387	1.95

74H00 TTL					
74H00	33	74H11	33	74H53	39
74H01	33	74H20	33	74H55	39
74H04	33	74H21	33	74H73	59
74H05	35	74H30	33	74H74	59
74H10	33	74H40	33	74H76	60

MISC CIRCUITS					
BC184L	60	LM309K	1.95	SN15844N	55
CA3001	75	LM351AN	70	SN15946	55
CA3005	80	LM741CP	40	SN158097N	60
CA3006	1.10	LM1458M	65	SN72560P	4.50
CA3018	1.60	MFC9020	1.15	SN727410N	85
CA3018A	1.60	MR995A	1.05	SN72741C	45
CA3026	2.15	MSC9967P1	50	SN72748P	49
CA3035	2.45	N5558	55	UA703C	95
CA3039	3.95	N8598B	5.00	UA709C	40
CA3058	1.90	NE555V	45	USF7733393	2.40
CK707P	45	PA771131	45	998879R	6.50
C5134J	1.15	PL94551	45	996079	12.50
C5135J	1.20	RC14370B	35	998979	9.00
C5136	1.25	SC9962P	70	936-50	1.10
IC3(GE)	1.50	SC9966P	1.25	9313DC	1.20
LM301AN	35	SN15830N	50	93L28DC	2.75

POSITIVE VOLTAGE REGULATORS				
LM340K-5	1.95			
LM340K-6	1.95			
LM340K-8	1.95			
LM340K-12	1.95			
LM340K-15	1.95			
LM340K-18	1.95			
LM340K-24	1.95			
LM340T0-5	1.75			
LM340T0-6	1.75			
LM340T0-8	1.75			
LM340T0-12	1.75			
LM340T0-15	1.75			
LM340T0-18	1.75			
LM340T0-24	1.75			

NEGATIVE REGULATORS AVAILABLE				
LM340K-5	1.95			
LM340K-6	1.95			
LM340K-8	1.95			
LM340K-12	1.95			
LM340K-15	1.95			
LM340K-18	1.95			
LM340K-24	1.95			
LM340T0-5	1.75			
LM340T0-6	1.75			
LM340T0-8	1.75			
LM340T0-12	1.75			
LM340T0-15	1.75			
LM340T0-18	1.75			
LM340T0-24	1.75			

IC'S ON THE MOVE					
BBD BUCKET BRIGADE DEVICE					
MM3001	1.95	MN3002	11.70	MM3003	9.45
HALL IC DN834	1.25	DN837	1.50		
DN835	1.35	DN838(NEW)			
SN76001	1.75	SN76002	1.95		
PLLO2A	MIDLAND PHASE LOCK LOOP			12.00	

MICROPROCESSOR CHIPS					
1404A	3.25	2102	2.50	MM5013	3.25
C1702A	19.95	C2708	95.00	8008	19.95
2101	6.95	C4702A	19.95	8080A	29.95
MK4200 P-11	4096x1 Bit Dynamic Ram			9.95	
C5101-3	1024 Bit (256x4) Static C-Mos Ram			4.50	
MC14514	4 Bit Latch 4 to 16 Line Decoder			4.25	

CALL OR WRITE FOR FURTHER INFORMATION, SPEC'S AVAILABLE

ELECTROLYTIC CAPACITORS				
2 2MF50	AXIAL LEADS	15		
3 3MF10	AXIAL LEADS	15		
10MF25	AXIAL LEADS	15		
10MF50	AXIAL LEADS	15		
10MF150	AXIAL LEADS	20		
25MF35	AXIAL LEADS	15		
30MF25	AXIAL LEADS	15		
47MF25	RADIAL LEADS	15		
47MF50	RADIAL LEADS	20		
100MF16	RADIAL LEADS	15		
100MF25	RADIAL LEADS	20		
500MF50	AXIAL LEADS	60		
1000MF35	AXIAL LEADS	65		

CARBON RESISTORS				
Minimum 5 Pcs Per Value				
QUANTITY PRICING				
5-25	30-95	100-495		
±.5%	06	05	04	
±.25%	08	07	06	
STANDARD RESISTANCE VALUES				
OHMS				
270	820	4.7K	27K	
300	910	5.1K	33K	
330	1.0K	6.8K	47K	
470	1.5K	7.5K	100K	
510	2.2K	8.2K	330K	
560	2.7K	10K	1.0M	
680	3.3K	15K		
750	3.9K	22K		

HOBBY SPECIALS				
YOU TEST 'EM SAVE BIG MONEY				
Power Pac	100 Asst (includes Case T03, T066, T0220, T0202)		\$2.99	
Transistor/ Diode Pac	100 Asst (includes Case T05, T039, T018, D07 0041)		\$1.99	
I C Pac	100 Asst (includes 14 & 16 Pin)		\$3.50	
Resistor Pac	50 Asst (Assorted values)		\$1.50	
Mos Fet Pac	10 Asst (many top #s Case T021)		\$0.99	
SCR Pac	100 Asst (5mV to 10V Series) Case to 92, VR 10-100V I400MA IGT 200MA		\$4.00	

ZENER DIODES				
1/2 & 1 Watt 10% 30 each UP TO 33V. GREATER THAN 33V CALL FOR PRICING				

PACE/PATHCOM PART #'S				
130079	4.00	IP20-0123	2.75	
1300821	65	IP20-013	2.50	
13-0122	1.75	IP20-014	3.00	
83-0005	2.00	IP20-0142	3.00	
83-0007	2.50	IP20-0139	4.30	
83-0008	2.00	IP20-0154	6.00	
83-0015	3.00	IP20-0155	2.50	
IP20-0005	3.00	IP20-016	4.00	
IP20-0010	4.00	IP20-017	2.75	
IP20-0034	85	IP20-0176	2.85	
IP20-0037	85	IP20-0191	7.25	
IP20-0045	2.00			
IP20-0073	2.75			
IP20-0093	2.50			

JAPANESE TRANSISTORS + CB. AUDIO. INDUSTRIAL									
2SA52	60	2SC206	1.00	2SC774	1.75	2SC1173	95	2SD77	1.00
2SA316	75	2SC240	1.10	2SC775	2.75	2SC1175	65	2SD81	3.25
2SA473	75	2SC281	65	2SC776	3.00	2SC1209	95	2SD88	1.50
2SA449	1.95	2SC282	3.00	2SC777	4.00	2SC1213	75	2SD118	3.25
2SA490	80	2SC320	75	2SC778	4.00	2SC1226A	1.25	2SD130	1.25
2SA490	70	2SC350	75	2SC781	3.00	2SC1237	4.50	2SD141	2.25

SON OF A CHEAP CLOCK STILL \$14.50

500 KHz, 2 lead crystal.....\$4.95
 8PST OIPSWITCH.....\$1.95
 \$100 bus edge connector (specify solder tail or wirewrap).....\$5.00
 Lop profile solder tail sockets:
 8 pin.....10/\$1.85
 14 pin.....10/\$3.70
 16 pin.....10/\$3.85

NEW! SPDT SWITCH

PARTS

NEW, PC MOUNT TYPE (BUSHING NOT THREADED). INCLUDES MOUNTING FRAME FOR EXTRA SUPPORT LTD QTY!

GODBOUT READOUT SPECIAL!

actual size

BILL GODBOUT ELECTRONICS
 BOX 2355, OAKLAND AIRPORT, CA 94614
 TERMS: Add 50c orders under \$10; add postage when indicated. Cal res add tax. BankAmericard* and Mastercharge* call (415) 562-0636, 24 hours.

12 Volts, 8 Amps

95c **POWER! CB, HAM, BENCH--\$39.95** **or 95c each**

Now you can connect CB and ham transceivers...auto tape players...portable TVs...anything requiring a solid, stable DC voltage...to your AC house current...also makes a superb lab or bench supply. Crowbar overvoltage protection, short protection, .05V regulation, current limiting, adjustable output 11-14V, RF bypassing, and EASY ASSEMBLY---heat sinks, power transistors, etc. mount on board. PLEASE INCLUDE POSTAGE.

036 CIRCLE NO. 26 ON FREE INFORMATION CARD

For faster service

USE ZIP CODE

on all mail

PLANS AND KITS

AMAZING ELECTRONIC PRODUCTS

LASERS SUPER POWERED, RIFLE, PISTOL, POCKET SEE IN DARK PYRO TECHNICAL DE BUGGING UNCRAMBLERS GIANT TESLA STUNWAND TV DISRUPTER ENERGY PRODUCING SCIENTIFIC DETECTION ELECTRIFYING CHEMICAL ULTRASONIC CB AERO AUTO AND MECH DEVICES, HUNDREDS MORE ALL NEW PLUS INFO UNLTD PARTS SERVICE

INFORMATION unlimited

CATALOG \$1 Box 626 Lord Jeffrey P2 • Amherst, N.H. 03031

FREE KIT Catalog contains Test and Experimenters' Equipment. Dage Scientific Instruments, Box 1054P, Livermore, CA 94550.

TIGER SST SIMPLI-KIT

FOR THE DO-IT-YOURSELFER

NOW! a high quality CD Electronic Ignition System in kit form.

Contains all components and solder to build complete Solid-State Electronic CD Ignition System for your car. Assembly requires less than 3 hours.

- Increases MPG 15%
- Increases horsepower 15%
- Plugs and Points last 50,000 miles
- Eliminates 4 of 5 tune-ups
- Instant starting, any weather
- Dual system switch

Fits only 12 volt neg ground Only \$21.95 postpaid

Tri Star Corporation
 P.O. Box 1727 Grand Junction, Colorado 81501

MORSE A-LETTER KIT Decodes/displays Morse code See January Popular Electronics. Complete parts kit except chassis cabinet \$109.95 Etched drilled PC board \$17.95 SELECT CIRCUITS 1411 Lonsdale Road Columbus, Ohio 43227

TAPE-SLIDE synchronizer tap-dissolve multiprojector programmer plans \$5.50 Free catalog Millers 1896 Maywood S Euclid OH 44121

DIGITAL Circuits Timers Clocks combination lock meters, testers New and advanced Stamp for catalog GeeBee, Box 1661 Downey, Calif 90240

WERSI KITS

Organs, Pianos, Strings Rhythms, PA Systems

104-page catalog \$2

WERSI electronics, Inc.
 Dept. A2, Box 5318, Lancaster, PA 17601

POCKET COLOR BAR GENERATOR kit 16 patterns \$49.95 Plans \$4.95 Workshop Box 493PA Bethpage New York 11714

FIVE OCTAVE Touch Sensitive Electronic PIANO Kit Components \$245 airmail U.S.A. Canada Claf Products, 31 Mountfield Road Brimhall Chesham England

THE KING OF KITS Artisan Organ Kits feature all new modular construction with logic controlled stops and RAM Preset Memory System. Write for brochure to AOK Manufacturing Inc. P.O. Box 445 Kenmore WA 98028

AMPLIFIER KITS 35 watts output 0.5 THD \$15 to Benchmark, 2149 Star St Berkeley CA 94705

TESLA COIL 40 SPARKS Plans \$7.50 Information 75 cents Huntington Electronics, Box 2009-P Huntington, Conn 06484

250MHZ PRESCALER for 25 Mhz counters Protected 50 ohm input \$19.95 Free literature, MLG Enterprises P.O. Box 788, Laconia, N.H. 03246

CATALOGS

FREE! Consumer Service Division Catalog. Includes a wide variety of products associated with the special interests of readers of Ziff-Davis magazines — PSYCHOLOGY TODAY, POPULAR PHOTOGRAPHY, STEREO REVIEW, POPULAR ELECTRONICS, BOATING, FLYING, CAR & DRIVER, CYCLE, SKING. Send for YOUR free catalog today. Consumer Service Div.: 595 Broadway, Dept. CL, N.Y., NY 10012.

BULLET ELECTRONICS
 (214)823-3240 PO BOX 19442 P DALLAS TX 75219

ULTRASONIC SENDER-RECEIVER KIT

A special buy on a high quality ultrasonic transducer allows us to offer this kit at a super price — but hurry, quantities are limited! You can build intrusion alarms, motion detectors, remote controls, echo ranging or liquid level measurement equipment. We supply the basic transmitter and receiver electronics including a drilled and plated PC board. The units work at 23KHz with a range of 20 ft. and can be positioned opposite each other or side by side and bounced off a solid surface. The output will sink up to 300ma to drive a relay, alarm circuit, etc

ORDER US-01 \$19.95

AUTOMATIC TIME-OUT CIRCUIT for ultrasonic or mechanical switch alarms. Provides a five second entry delay. Sounds alarm for one minute, then re arms itself. Requires 6-15VDC. \$3.95

MK-03 AIRCRAFT CLOCK/TIMER KIT

24 hour real time and up to 24 hrs. elapsed time are available independently on the same set of 6 .4" LED readouts. Clock has presettable alarm. Timer has reset, hold and count functions. Size 4 1/2" L X 2 1/2" H X 1 3/8" W. Allows mounting in standard instrument case. Because of the many options and mounting variations the kit is sold less case & switches. The unit has noise and over voltage protection. For 9 to 14VDC. \$26.95 QUALITY PC BOARD & COMPONENTS.

MINI GRANDFATHER CLOCK KIT

Would you give over one hundred dollars for a completely ELECTRONIC GRANDFATHER CLOCK KIT?? Well, what if it had large 1" LED readouts... and LED SWINGING PENDULUM & TICK-TOCK SOUND & a super SYNTHESIZED OSCILLATOR with frequency volume and sustain adjust and it CHIMED THE HOURS (like 3 times for 3 o'clock)? What if we gave you all the components, xfmr, spkr, & a set of quality plated boards; and told you it was 6.5" X 4.5" ? Still not good enough??? Then how about for \$39.95? Now that's a DEAL.

BUILD A COMPLETE CDI IGNITION KIT AT A FRACTION OF THE COST OF OTHER UNITS. A special buy allows us to sell the complete kit at this low price! Up to 40,000 volts from your present ignition without changing the coil. Simple connections.

INCLUDES: Special toroid transformer
 Drilled and Plated board
 Complete instructions
 All resistors and caps
 All semiconductors

\$9.95

(Does not include heatsink or case.) For 12V negative ground

TERMS: NO COD'S * Send check or M.O. * Add 5% postage Tx. res. add 5% tax * Foreign add 10% (20% airmail) * Orders under \$10. add 60¢ handling * Repair service available * Accepting phone orders on Master Chg & BAC.

CIRCLE NO. 11 ON FREE INFORMATION CARD

CB... and everything else you want to know in the... 1977 COMMUNICATIONS HANDBOOK

Here's everything you want to know—need to know —about Citizens Band Radio, Amateur Radio, Short wave Listening, Police Fire Monitoring, Marine Radio. Features, specifications, latest prices and photos of equipment on the market are at your fingertips in the Handbook's directory buying sections. **CITIZENS BAND**—The new modified FCC rules, how to get started (no test, no fee), how it's used, buying tips, the 40-channel transceivers. **PUBLIC SERVICE BAND**—Monitor radios for listening in on police, fire, mobile telephone, airline conversations and weather reports. **AMATEUR RADIO**—How to get started, license privileges and study tips, slow-scan TV, satellite communications, new Novice rules. **MARINE RADIO/TELEPHONE**—Rules and regulations for pleasurecraft, two way radio equipment types. **SHORT-WAVE 1977**—Latest happenings in the SW field, international stations to listen to, SW clubs, utility broadcast listening without knowing Morse Code. **IN ALL A ONE-STOP BUYING GUIDE FOR ALL CONSUMER COMMUNICATION RADIOS AND TRANSCEIVERS!** Only \$1.95!

COMMUNICATIONS HANDBOOK, PE-577
 Consumer Service Division,
 595 Broadway, New York, N.Y. 10012.

Please send the 1977 Communications Handbook. I'm enclosing \$2.50 (\$1.95 plus 55c for postage and handling). Outside U.S.A. \$3.00, postpaid.

Residents of CA, CO, FL, IL, MI, MO, NY STATE, DC and TX add applicable sales tax. Postage and handling charges non taxable.

Print name _____
 Address _____
 City _____
 State _____ Zip _____

Radio Hut

Money back guarantee. NO COD'S. Texas residents add 5% sales tax. Add 5% of order for postage and handling. Orders under \$15.00 add 75 cents. Foreign orders add 10% for postage.

For your convenience, call your BankAmericard or Master Charge orders in on our Toll Free Watts Line: 1-800-527-2304. Texas residents call collect: 1-214-271-8423.



P. O. Box 64783P
Dallas, Texas 75206



Memorex computer boards
with IC's, diodes, transistor, etc.
5 Boards containing
100 - 200 IC's
ONLY \$4.25

BRIDGE RECTIFIERS

1 Amp	50V	.85
6 Amp	50V	1.10
10 Amp	50V	1.25
25 Amp	50V	1.39

READOUTS

FND70	.4" C.C.	.59
FND800	.8" C.C.	1.69
TI 6 digit array	C.C.	3/1.00
MAN 8	.3" CA Yellow	.89
LT767	.7" C.C. 4 digit stick	3.25

POSITIVE VOLTAGE REGULATORS

LM340-5	LM340-15
LM340-6	LM340-18
LM340-8	LM340-24
LM340-12	

To-220 case. Your Choice
.75 Each

NEGATIVE REGULATORS

7905	7915
7912	

To-220 case. Your Choice
.75 Each

FINNED HEATSINK for above regulators

2-3/4" High 2-1/2" Wide
1" Depth **ONLY .39 Each**

HEATSINK with pass transistor to increase regulator to 5 amps.
ONLY .99 Each

BATTERY CLIPS

Standard 9V battery clip with 4 1/2" tinned leads. **25/\$1.00**

LINEARS

LM309K	.95
LM380 (8 Pin)	.75
LM380 (14 Pin)	1.00
LM3900	.30
LM710	.25
LM711	.25
LM723	.40
LM748	.25
NE555	.35
NE556	.95
NE555	.95
NE566	.95
NE567	1.10
1458	.75
RCA 3043	.49
75491	.25
75492	.25

60Hz Crystal Time Base Kit - Kit enables a MOS clock circuit to operate from a DC power source. Ideal for car, camper, van, boat, etc.

60Hz output with an accuracy of .005% (typ.) Low power consumption 2.5 ma (typ.). Small size will fit most any enclosure. Single MOS IC oscillator/divider chip 5-15 volts DC operation.

ONLY \$4.95
2 for \$9.00

RESISTORS

Over 50,000,000 in stock

330 ohm	1/8W	20K	ohm	1/4W
470 ohm	1/4W	22K	ohm	1/4W
680 ohm	1/2W	27K	ohm	1/4W
1K ohm	1/4W	33K	ohm	1/4W
1.2K ohm	1/4W	39K	ohm	1/4W
2.2K ohm	1/4W	43K	ohm	1/4W
3.3K ohm	1/4W	47K	ohm	1/4W
4.7K ohm	1/4W	82K	ohm	1/4W
6.8K ohm	1/4W	100K	ohm	1/4W
10K ohm	1/4W	150K	ohm	1/4W
		220K	ohm	1/4W

All resistors are PC lead, but are not pull offs. 100 min. order for each value. No Mix. **100/.99 Cents**

RADIO HUT GUARANTEE

If you are not satisfied with any of our products **NO MATTER WHAT THE REASON** we offer you a full money back guarantee if the product or products are returned within **14 days** after you receive them.

PLASMA DISPLAY KIT

Kit Includes: 12 digit display .4" Character Power supply for display above Complete specs for hookup.

Line cord Not Included. **ONLY \$3.95**



TRANSISTORS - DIODES

*MJE1103	3/1.00
MJ3001	1.30
2N2222	6/1.00
2N2369	6/1.00
2N2905	4/1.00
*2N2907	15/1.00
2N3906	6/1.00
2N4400	6/1.00
2N4443 SCR	3/1.00
RCA 200 V 115 W NPN	.95
1N4004	15/1.00
1N4007	10/1.00
1N4148 (1N914)	20/1.00
3N201 VHF Pre amp	.80
D40C1 Power Darl	5/1.00

*House numbered and P.C. Lead

WATERGATE SPECIAL

Telephone Relay automatically starts and stops tape recorder. No batteries required. Kit complete with drilled P.C. Board.
Parts and Case ONLY \$9.95

TI CALCULATOR CHIPS

TMS103 w/specs.	.99
TMS107 w/specs.	.99

HARDWARE

New, includes 2-56, 4-40, 6-32 and 8-32 screws and nuts. A very usable selection.
1/2 pound \$1.50
1 pound \$2.60

PROJECT CASES

SMALL \$1.50	MEDIUM \$2.00	LARGE \$2.75
D - 2-1/2"	D - 2"	D - 2-1/2"
W - 4-3/4"	W - 4-7/8"	W - 7"
H - 1-7/8"	H - 3-1/2"	H - 4"

All cases have a sloped front, white with black wrinkle finish.

LOW POWER SHOTTY

74LS00	.25	74LS74	.49
74LS02	.25	74LS90	.85
74LS04	.30	74LS132	.90
74LS08	.25	74LS138	.89
74LS10	.25	74LS139	.89
74LS11	.32	74LS155	.90
74LS20	.31	74LS157	1.00
74LS21	.33	74LS162	1.39
74LS22	.33	74LS163	1.39
74LS27	.30	74LS175	1.09
74LS30	.31	74LS193	1.09
74LS32	.33	74LS258	1.09
74LS37	.40	74LS367	.70
74LS38	.35	74LS368	.70

ORDER BY PHONE. Charge your order to BankAmericard or Master Charge.
Use our Toll Free Watts
1-800-527-2304

UNSCRAMBLER KIT

for all Scanners

- Tunes easily
- Full instructions included
- Easy to install
- 3 1/2" x 3 1/2" x 1 1/2"

ONLY \$14.95

CLOCK KIT

- Kit includes • LT701 clock module
- Power Supply
 - Punched case
 - 12 or 24 hour operation

Complete except for line cord

LT701E	12 hour clock
LT701G	24 hour clock

ONLY \$14.95

CMOS SALE

CD4000	.16	CD4040	1.00
CD4001	.16	CD4041	.69
CD4002	.16	CD4042	.59
CD4007	.16	CD4043	.60
CD4009	.45	CD4044	.59
CD4010	.45	CD4047	.59
CD4011	.16	CD4049	.35
CD4012	.16	CD4050	.35
CD4013	.29	CD4051	.90
CD4014	.75	CD4053	.90
CD4015	.75	CD4056	1.00
CD4016	.29	CD4058	.90
CD4017	.80	CD4060	1.00
CD4018	.80	CD4066	.69
CD4019	.39	CD4069	.30
CD4021	.90	CD4071	.16
CD4022	.90	CD4076	.99
CD4024	.70	CD4077	.39
CD4025	.19	CD4102	.68
CD4027	.39	CD4116	.39
CD4028	.75	CD4507	.40
CD4029	.99	CD4512	.50
CD4030	.16	CD4516	.85
CD4034	2.30	CD4518	.85
CD4035	.99	CD4520	.85

LM-4
• 0.03% Accuracy • 13 ranges: 4 vdc, 4 vac & 5 ohms • Automatic zeroing & polarity with 0.03% accuracy • Overload indication • Battery powered with batteries & charger unit included • Test leads included • 1.9"H x 2.7"W x 4.0"D \$227.00

NON-LINEAR SYSTEMS, INC.



LM-3
The Voltmeter • 0.5% Accuracy • 100% over-range • 19 ranges: 4 vdc, 4 vac, 5 ohms and, with the 3 current shunts which are included, 3 dc amps and 3 ac amps. • Automatic zeroing and polarity with 0.5% accuracy • Overload indication • Battery powered with batteries & charger unit included • Test leads included • 1.9"H x 2.7"W x 4.0"D \$147.00

LM-3.5
The Voltmeter • 0.5% Accuracy • 100% over-range • 19 ranges: 4 vdc, 4 vac, 5 ohms and, with the 3 current shunts which are included, 3 dc amps and 3 ac amps. • Automatic zeroing and polarity with 0.5% accuracy • Overload indication • Battery powered with batteries & charger unit included • Test leads included • 1.9"H x 2.7"W x 4.0"D \$147.00

FM-7
• Rugged, portable & battery powered with batteries & charger unit included • High sensitivity: 30 mV -50 Hz to 30 MHz (100 mV -10 Hz to 50 Hz & 30 MHz to 60 MHz) • Input overload protection • 1.9"H x 2.7"W x 4.0"D \$195.00

SC-5
• Extends the range of the NLS FM-7 Frequency Meter — and almost any 50 MHz frequency meter — to upper VHF and UHF frequency bands • 30-mV sensitivity • Accurate to 1 ppm

• Rugged, portable & battery powered with batteries & charger unit included • 1.9"H x 2.7"W x 4.0"D • Interface cable & input cable included \$127.00

LM-40
• 0.1% Accuracy • 13 ranges: 4 vdc, 4 vac & 5 ohms • Automatic zeroing and polarity with 0.1% accuracy • Overload indication • Battery powered with batteries & charger unit included • Test leads included • 1.9"H x 2.7"W x 4.0"D \$190.00

39-439 Leather Case (used w/models LM-Series, FM-7, SC-5) \$16.00

SGS-ATES — Audio Power Amplifier IC's

TBA800	5 watt	\$1.95
TBA810S	7 watt	2.10
TBA810AS	7 watt	2.10
TBA820	2 watt	1.35
TBA830S	4.2 watt	1.95
TCA940	10 watt	3.30
TDA2002	8 watt	4.20
TD2010	12W Hi-Fi	5.25
TD2020	20W Hi-Fi	6.00

Our Ancrona Information Book 101 contains 92 pages of data & application notes on using SGS-ATES Audio Amps. Get your copy now. Only \$4.95

ACE 236



3,648 Solderless Plug-In Tie Points
CAPACITY: Up to 36 14-Pin DIP's
• 4 5-way binding posts • 10-1/4" x 9-1/4" • Fully assembled — 512 separate 5-tie point terminals, 32 vertical distribution buses (each with 5 connected 5-tie-point terminals) plus 4 horizontal buses (each with 18 connected 4-tie-point terminals). \$79.95

555C FROM FAIRCHILD
MINI-DIP PKG 3 for \$1.00

FLUKE MODEL 8030A DIGITAL MULTIMETER
3-1/2 digit, six-function multimeter. Measurement functions include ac volts (true rms), dc volts, ac current (true rms), dc current, resistance, and diode test. Each function, except the diode test, is supplemented by 5 selectable ranges for a total of 26 ranges (one range for diode test). \$250.00

FLUKE MODEL 80T-150C
Temperature Probe Converts a dc voltmeter into a thermometer with a range of -55°C to +150°C. \$125.00

AMD 2900 SERIES BIPOLAR MICROPROCESSOR CIRCUITS

AM2901DC	\$42.00	\$31.50
AM2902PC	3.82	3.18
AM2905PC	10.10	8.10
AM2906PC	11.20	8.95
AM2907PC	8.10	7.00
AM2909PC	8.95	7.15
AM2911PC	5.95	4.75
AM2913PC	4.10	3.15
AM2914DC	60.00	45.00
AM2918PC	5.40	4.32
AM2919PC	4.50	3.81
AM29704PC	15.75	12.60
AM29705PC	15.75	12.60
AM29720PC	5.00	4.20
AM29721PC	5.00	4.20
AM29750DC	4.50	3.60
AM29751DC	4.50	3.60
AM29760DC	6.80	5.50
AM29761DC	6.80	5.50
AM29803DC	7.65	5.95
AM29811DC	4.85	3.90

INTERSIL 8038 PRECISION WAVEFORM GENERATOR & VCO
P/N 8038CCPD \$3.90

CLIPLITE 10 for \$1.50
New LED Mounting System



- CLIPLITE mounts from the front of the Panel in a .250 hole on 3/8" centers. Panel thickness from 1/16" to 1/8".
- CLIPLITE equalizes and increases the brightness of commonly used wide beam LEDs.
- CLIPLITE is to be used with 2000' dia. LEDs.
- Specify colors—red, green, amber, or yellow when ordering.

8080A/9080A 8-BIT MICROPROCESSOR COMPONENTS

C8080A	\$19.50
AM9080ADC	21.00
P8212	4.00
P8216	3.40
AM8224PC	5.90
P8226	3.50
AM8228PC	8.20
AM8238PC	8.20
C8251	14.30
C8255	13.50

AUDIO POWER AMPLIFIERS
5.5 WATT AN315
Designed for mobile radios, tape players, etc. Easy to use, High Gain — 53 dB (Closed Circuit) \$3.90 ea

JAPANESE TRANSISTORS

2SC1973	1.30	2SC828	.75
2SC1974	3.00	2SC829	.75
2SC1975	3.00	2SC126A	.75
2SC2034	3.40	2SC1359	.90

MICROPROCESSOR KITS

AMD AM2900K1 — Evaluation & Learning Kit	\$289.00
SIGNETICS 2650K T9000 — Microprocessor Kit	99.00
FAIRCHILD F8 Microprocessor Kit	185.00
INTERSIL IM6100 Microprocessor Tutorial System Includes following modules: 6950 Intercept Jr, 6951 Jr RAM, 6952 Jr Programmable ROM-P/ROM & 6953 Jr Serial I/O	583.00
INTERSIL 6957 Audio Visual Module for IM6100	125.00

PLESSEY SL1600 APPLICATIONS MANUAL
Contains 114 pages circuit data, system design and technical data for SL1600 Series Radio Communications Integrated Circuits. \$1.95

SAM'S BOOKS

TTL Cookbook/No. 21035/336 pgs	\$8.95	First Class Radio Telephone License Handbook, 4th Ed./21144/416 pgs	\$7.50
IC OP-AMP Cookbook/20969/592 pgs	\$12.95	Semiconductor Replacement Guide/21092/256 pgs	\$3.95
Second Class Radiotelephone License Handbook, 5th Ed./21111/448 pgs	\$7.50	Building & Installing Electronic Intrusion Alarms 20929/136 pgs	\$4.50
Transistor Substitution Handbook, 16th Ed. 21333/384 pgs	\$4.95	Understanding IC Operational Amplifiers 20855/128 pgs	\$3.95
Reference Data for Radio Engineers, 6th Ed. 21218/1344 pgs	\$30.00	How To Use IC Logic Elements, 2nd Ed. 21081/160 pgs	\$4.50
Basic Electricity/Electronics Series, Vol. 1 Basic Principles and Applications/20167/320 pgs	\$5.50	Understanding CMOS Integrated Circuits 21129/144 pgs	\$4.95
Transistor Specifications Manual, 8th Ed. 21335/224 pgs	\$6.95	TV Typewriter Cookbook/21313/256 pgs	\$9.95

CARBON FILM RESISTORS (5%)
Only in Multiples of 100 pcs per value (ohms)

10	100	1.0K	10K	100K	1.0M
11	110	1.1K	11K	110K	1.1M
12	120	1.2K	12K	120K	1.2M
13	130	1.3K	13K	130K	1.3M
15	150	1.5K	15K	150K	1.5M
16	160	1.6K	16K	160K	1.6M
18	180	1.8K	18K	180K	1.8M
20	200	2.0K	20K	200K	2.0M
22	220	2.2K	22K	220K	2.2M
24	240	2.4K	24K	240K	2.4M
27	270	2.7K	27K	270K	2.7M
30	300	3.0K	30K	300K	3.0M
33	330	3.3K	33K	330K	3.3M
36	360	3.6K	36K	360K	3.6M
39	390	3.9K	39K	390K	3.9M
43	430	4.3K	43K	430K	4.3M
47	470	4.7K	47K	470K	4.7M
51	510	5.1K	51K	510K	5.1M
56	560	5.6K	56K	560K	5.6M
62	620	6.2K	62K	620K	6.2M
68	680	6.8K	68K	680K	6.8M
75	750	7.5K	75K	750K	7.5M
82	820	8.2K	82K	820K	8.2M
91	910	9.1K	91K	910K	9.1M

1" (26mm) GaAsP LED NUMERIC DISPLAY
EP1000 (Common Anode)

1 Piece	-\$4.90
3 Pieces	-\$13.00
5 Pieces	-\$19.00

PLESSEY POLYESTER (CAPACITOR) MINI BOX

MF	V	MF	V	MF	V
001	1000	10	100	039	250
0012	1000	14	100	047	250
0015	1000	14	100	056	250
0018	1000	14	100	068	250
0022	1000	14	100	082	250
0027	1000	14	100	100	250
0033	1000	14	12	100	18
0039	630	14	15	100	20
0047	630	14	18	100	21
0056	630	14	22	100	23
0063	630	14	27	100	26
0082	630	14	33	100	30
01	630	14	39	100	33
012	630	14	47	100	36
015	630	14	56	100	39
018	400	15	68	100	47
022	400	15	82	100	54
027	400	15	100	100	60
033	250	15	1	100	60

SANKEN HYBRID AUDIO POWER AMPLIFIERS

SI-1010G (110W output) ...	\$ 6.90
SI-1020G (120W output) ...	\$13.95
SI-1050G (50W output) ...	\$26.80

Data Sheet with Application Notes — \$0.50

AM1702A-6 ORIGINAL AMD
1.5 MSEC GUARANTEED
1 PIECE — \$ 5.90
8 PIECES — \$38.00

MATSUO DIPPED TANTALUM CAPACITORS

MF	V	S	MF	V	\$
1	35	33	6	16	40
15	35	33	6	35	45
22	35	33	10	16	42
33	35	33	10	25	45
47	35	33	10	35	90
68	35	33	15	20	45
1	35	33	15	35	132
1	35	40	22	16	45
2	20	33	33	20	132
2	25	40	47	20	153
3	35	45	68	16	162
4	35	45	100	16	162

PLESSEY SAMPLER
300 METALIZED CAPACITORS
18 DIFFERENT STD. VALUES \$26.00

FAIRCHILD TECHNOLOGY KITS
Complete Specifications on Back of Each Kit

DIGITS

FTK0001	0.5" High Common Cathode Digit	\$ 1.00
FTK0002	0.5" High Common Anode Digit	1.00
FTK0003	0.35" High Common Cathode Digit	0.75
FTK0004	0.8" High Common Cathode Digit	2.00
FTK0005	0.8" High Common Anode Digit	2.00

0.8" HIGH DISPLAY ARRAYS

FTK0010	12 Hour, 3 1/2 Digit Clock Display	7.00
FTK0011	24 Hour, 4 Digit Clock Display	8.00

LED LAMPS

FTK0020	10 Red LED Lamps	1.00
FTK0021	5 Mixed Colored LED Lamps	1.00
FTK0022	10 LED Mounting Clips	1.00
FTK0023	5 Three Piece LED Mounting Adapters	1.00

PHOTO TRANSISTORS

FTK0030	5 Flat Lens Photo Transistors	1.00
FTK0031	5 Round Lens Photo Transistors	1.00
FTK0032	3 Flat Lens Photo Darlington's	1.00
FTK0033	3 Round Lens Photo Darlington's	1.00

PHOTOARRAYS

FTK0040	9-Element Tape Reader Array	16.00
FTK0041	12-Element Card Reader Array	24.00
FTK0042	Reflective Opto Coupler	4.00

COUPLERS

FTK0050	3 General Purpose Dpto Couplers	1.00
FTK0051	Darlington Opto Coupler	1.00

MOS CLOCK CIRCUITS

FTK0400	Digital Clock/Calendar Circuit (FCM7001)	7.00
FTK0401	Digital Clock/Calendar with BCD Outputs (FCM7002)	7.00
FTK0402	Direct Drive Digital Clock Circuit with AC Output (FCM3817A)	5.00
FTK0403	Direct Drive Digital Clock Circuit with DC Output (FCM3817D)	5.00
FTK0405	Direct Drive Digital Clock/Calendar Circuit (FCM7015)	6.00

KITS

FTK0J06	Automobile Clock Kit	40.00
FTK0J01	6-Digit Wall Clock/Calendar	55.00

CONTINENTAL SPECIALTIES

PROTO BOARDS & EXPERIMENTERS
Build & test circuits as fast as you think

PB-6	\$15.95	PB103	\$59.95
PB100	19.95	PB104	79.95
PB101	29.95	EX300	9.95
PB102	39.95	EX600	10.95

RESISTOR KITS
5% CARBON FILM RESISTORS

1/4 WATT KIT
42 Different Values (68 to 4.7 MΩ)
20 Each Value

1/2 WATT KIT
42 Different Values (68Ω to 4.7 MΩ)
20 Each Value

1/4W — \$24.90 PER KIT
1/2W — \$25.90 PER KIT

COMPLETE WITH STORAGE BIN

DIP SOCKETS
LOW PROFILE, SOLDER, TIN

Pin	1-24	25-49	50 up
8 Pin	16	15	14
14 Pin	19	18	17
16 Pin	21	20	19
18 Pin	28	27	26
20 Pin	34	33	32
22 Pin	36	35	34
24 Pin	37	36	35
28 Pin	44	43	42
36 Pin	59	58	57
40 Pin	62	61	60

STANDARD, SOLDER, GOLD

8 Pin	30	27	24
14 Pin	38	35	32
16 Pin	42	41	40
18 Pin	52	47	43
22 Pin	70	65	60
24 Pin	79	63	57
28 Pin	110	100	90
36 Pin	175	140	126
40 Pin	175	159	145

WIREWRAP GOLD (Level No. 3)

10 Pin	45	4	37
14 Pin	38	38	37
16 Pin	42	42	41
18 Pin	75	68	62
24 Pin	105	95	85
28 Pin	140	125	110
36 Pin	159	145	130
40 Pin	175	155	140

CORDLESS HOBBY-WRAP TOOL—BW-630

- Battery Operated (Size C)
- Weighs ONLY 11 Ounces
- Wraps 30 AWG Wire onto Standard DIP Sockets (0.025 inch)
- Complete with built-in cut and sleeve

\$34.95 (batteries not included)

WIRE-WRAP KIT — WK-2-W
WRAP • STRIP • UNWRAP

- Tool for 30 AWG Wire
- Roll of 50 ft. White 30 AWG Wire
- 50 pcs, each 1", 2", 3" & 4" lengths — pre-stripped white wire

\$11.95

LOGIC MONITOR 1
Simultaneously displays static and dynamic logic states of DTL, TTL, HTL or CMOS DIP ICs. Pocket size. \$74.95

LOGIC MONITOR 2
Displays static and dynamic states of digital ICs such as C MOS, HTL, TTL, DTL & RTL. Selectable threshold control. \$124.95

LOGIC PROBE LP-1
Compact, circuit-powered multifunction logic probe. Multi-family compatibility. DTL/TTL/HTL/CMOS. Traces logic levels and pulses through digital circuitry. \$44.95.

WIRE WRAP TOOL WSU-30
WRAP • STRIP • UNWRAP — \$5.95

WIRE WRAP WIRE — 30 AWG
25 ft. min. \$1.25 50 ft. \$1.95 100 ft. \$2.95
1000 ft. \$15.00 SPECIFY COLOR: White, Yellow, Red, Green Blue or Black

BREADBOARD JUMPER WIRE KIT
Each kit contains 350 wires cut to 14 different lengths from 0.1" to 5.0". Each wire is stripped and leads are bent 90° for easy insertion. Wire length is classified by color coding. All wire is solid tinned 24 gauge with PVC insulation. The wires come packed in a convenient plastic box BK-1 \$9.95

SOCKETS & BUS STRIPS
Plug in, wire, test, modify or expand without patch cords or solder. Snap together to form breadboard needed.

PN/Description	Term's	Price
QT59S Socket	118	\$12.50
QT59B Bus	20	2.50
QT47S Socket	94	10.00
QT47B Bus	16	2.25
QT35B Socket	70	8.50
QT35B Bus	12	2.00
QT18S Socket	36	4.75
QT12S Socket	24	3.75
QT8S Socket	16	3.25
QT7S Socket	14	3.00

PROTO-CLIP
For power-on/hands off signal tracing. Bring IC leads up from PC board surface for fast troubleshooting.

PC14	14-pin	\$ 4.50
PC16	16-pin	4.75
PC24	24-pin	8.50

BOOKS AND MAGAZINES

FREE book prophet Elijah coming before Christ. Wonderful bible evidence Megiddo Mission. Dept 64, 481 Thurston Rd., Rochester, N.Y. 14619

BACK ISSUE MAGAZINES 1890 to 1976 Free list Send stamped envelope to Everybody's Bookshelf, Dept PE 317 West 6th, Los Angeles CA 90014

BUSINESS OPPORTUNITIES

I MADE \$40,000 00 Year by Mailorder! Helped others make money! Free Proof. Torrey, Box 318-NN, Ypsilanti, Michigan 48197

FREE CATALOGS. Repair air conditioning, refrigeration Tools, supplies, full instructions Doolin, 2016 Canton, Dallas, Texas 75201

MAILORDER MILLIONAIRE helps beginners make \$500 weekly Free report reveals secret plan! Executive (1K5), 333 North Michigan, Chicago 60601

GET RICH with Secret Law that smashes debts and brings you \$500 to \$5 Million cash Free report! Credit 4K5, 333 North Michigan, Chicago 60601

HIGHLY PROFITABLE ONE-MAN ELECTRONIC FACTORY

Investment unnecessary, knowledge not required, sales handled by professionals. Postcard brings facts about this unusual opportunity. Write today! Barta-DR, Box 248, Walnut Creek, CA 94597.

FREE SECRET BOOK "2042 UNIQUE. Proven Enterprises" Fabulous "Little Knowns" Work home! Haylings-B, Carlsbad, Calif 92008

HOW TO MAKE \$2,000 WEEKLY at home using other people's money. Guaranteed Free Details. Richlieu, Box 25357, Dept F5, Houston 77005

MAKE BIG MONEY in spare time selling Tubes, Antennas, Speakers, Test Equipment, Lite Bulbs, Hi-Fi, etc. No investment. Free information Allied Sales, Pimento, IN 47866 (812) 495-6555.

LIFETIME OPPORTUNITY for mechanically/electronically inclined individuals. Operate Successful Manufacturing Business. Mark, 92-K Brighton 11th, Brooklyn, New York 11235

NEW LUXURY Car Without Cost. Free Details! Codex-ZZ, Box 6073, Toledo, Ohio 43614.

STUFF ENVELOPES \$250 + Thousand, supplies. Enclose stamped, addressed envelope. Enterprises, Route One, Box 263-E5, Pauls Valley, OK 73075.

MISCELLANEOUS

WINEMAKERS: Free illustrated catalog yeasts, equipment. Semplex, Box 12276P, Minneapolis, Minn. 55412.

POPULAR ELECTRONICS INDEXES For 1976 now available. Prepared in cooperation with the Editors of "P.E." this index contains hundreds of references to product tests, construction projects, circuit tips and theory and is an essential companion to your magazine collection. 1976 Edition, \$1.50 per copy. All editions from 1972 onward still available at the same price. Add \$.25 per order for postage and handling. \$.50 per copy, foreign orders. INDEX, Box 2228, Falls Church, Va 22042

TTL 7400N

SN7400N	.13	SN74125N	.40
SN7401N	.14	SN74126N	.40
SN7402N	.14	SN74128N	.59
SN7403N	.14	SN74132N	.69
SN7404N	.17	SN74136N	.59
SN7405N	.17	SN74141N	.68
SN7406N	.25	SN74142N	3.70
SN7407N	.25	SN74143N	3.98
SN7408N	.17	SN74144N	3.98
SN7409N	.17	SN74145N	.69
SN7410N	.14	SN74147N	1.58
SN7411N	.20	SN74148N	1.19
SN7412N	.21	SN74150N	.95
SN7413N	.39	SN74151N	.61
SN7414N	.64	SN74153N	.61
SN7416N	.24	SN74154N	.95
SN7417N	.29	SN74155N	.70
SN7420N	.14	SN74156N	.64
SN7421N	.20	SN74157N	.59
SN7422N	.20	SN74159N	2.50
SN7423N	.25	SN74160N	.85
SN7425N	.25	SN74161N	.85
SN7426N	.22	SN74162N	.85
SN7427N	.25	SN74163N	.85
SN7428N	.28	SN74164N	.97
SN7430N	.14	SN74165N	1.09
SN7432N	.23	SN74166N	1.09
SN7433N	.30	SN74167N	2.75
SN7437N	.21	SN74170N	1.69
SN7438N	.21	SN74172N	8.75
SN7440N	.14	SN74173N	1.24
SN7442N	.37	SN74174N	.94
SN7443N	.68	SN74175N	.84
SN7444N	.85	SN74176N	.77
SN7445N	.65	SN74177N	.76
SN7446AN	.70	SN74178N	1.19
SN7447AN	.67	SN74179N	1.49
SN7448N	.69	SN74180N	.67
SN7450N	.14	SN74181N	1.94
SN7451N	.14	SN74182N	.59
SN7453N	.14	SN74184N	1.74
SN7454N	.14	SN74185AN	1.74
SN7460N	.14	SN74186N	6.95
SN7470N	.26	SN74188N	2.98
SN7472N	.25	SN74190N	1.04
SN7473N	.29	SN74191N	1.04
SN7474N	.29	SN74192N	.84
SN7475N	.46	SN74193N	.84
SN7476N	.30	SN74194N	.89
SN7480N	.35	SN74195N	.59
SN7481AN	.95	SN74196N	.87
SN7482N	.55	SN74197N	.73
SN7483AN	.65	SN74198N	1.64
SN7484AN	1.50	SN74199N	1.64
SN7485N	.84	SN74221N	1.14
SN7486N	.30	SN74246N	1.95
SN7489N	1.85	SN74247N	1.70
SN7490AN	.43	SN74248N	1.75
SN7491AN	.59	SN74249N	1.75
SN7492AN	.44	SN74251N	1.05
SN7493AN	.44	SN74265N	.85
SN7494N	.69	SN74278N	1.99
SN7495AN	.67	SN74279N	.57
SN7496N	.65	SN74283N	1.39
SN7497N	2.50	SN74284N	4.50
SN74100N	.97	SN74285N	4.50
SN74104N	.42	SN74290N	.85
SN74105N	.42	SN74293N	.83
SN74107N	.28	SN74298N	1.64
SN74109N	.47	SN74351N	1.92
SN74110N	.52	SN74365N	.65
SN74111N	.69	SN74366N	.65
SN74116N	1.50	SN74367N	.65
SN74120N	1.40	SN74368N	.65
SN74121N	.34	SN74390N	1.40
SN74122N	.38	SN74393N	1.40
SN74123N	.48	SN74490N	1.90

TTL LOW POWER SCHOTTKY

SN74LS00N	.23	SN74LS138N	1.25
SN74LS01N	.23	SN74LS139N	1.35
SN74LS02N	.23	SN74LS145N	1.19
SN74LS03N	.23	SN74LS151N	.99
SN74LS04N	.28	SN74LS153N	.99
SN74LS05N	.28	SN74LS155N	1.45
SN74LS06N	.23	SN74LS156N	1.45
SN74LS09N	.23	SN74LS157N	1.99
SN74LS10N	.23	SN74LS158N	1.50
SN74LS11N	.23	SN74LS160N	1.50
SN74LS12N	.25	SN74LS161N	1.50
SN74LS13N	.65	SN74LS162N	1.50
SN74LS14N	1.35	SN74LS163N	1.50
SN74LS15N	.23	SN74LS164N	1.60
SN74LS20N	.23	SN74LS168N	2.25
SN74LS21N	.23	SN74LS169N	2.25
SN74LS22N	.23	SN74LS170N	2.70
SN74LS26N	.37	SN74LS174N	1.25
SN74LS27N	.27	SN74LS175N	1.25
SN74LS28N	.30	SN74LS181N	3.30
SN74LS30N	.23	SN74LS190N	1.80
SN74LS32N	.33	SN74LS191N	1.80
SN74LS33N	.85	SN74LS192N	1.80
SN74LS37N	.37	SN74LS193N	1.80
SN74LS38N	.37	SN74LS194AN	1.30
SN74LS40N	.27	SN74LS195AN	1.30
SN74LS42N	.89	SN74LS196N	1.40
SN74LS47N	1.10	SN74LS197N	1.40
SN74LS48N	1.10	SN74LS221N	1.30
SN74LS49N	1.10	SN74LS240N	2.50
SN74LS51N	.23	SN74LS241N	2.40
SN74LS54N	.23	SN74LS242N	2.40
SN74LS55N	.23	SN74LS243N	2.40
SN74LS56N	1.75	SN74LS244N	2.50
SN74LS73N	.45	SN74LS247N	1.30
SN74LS74N	.45	SN74LS248N	1.30
SN74LS75N	.45	SN74LS249N	1.30
SN74LS76N	.45	SN74LS251N	1.50
SN74LS78N	.45	SN74LS253N	1.50
SN74LS83AN	1.39	SN74LS257N	1.40
SN74LS85N	1.60	SN74LS258N	1.40
SN74LS86N	.48	SN74LS261N	2.95
SN74LS90N	.89	SN74LS266N	.55
SN74LS91N	1.15	SN74LS279N	.75
SN74LS92N	.85	SN74LS283N	1.35
SN74LS93BN	.85	SN74LS290N	1.30
SN74LS95AN	1.50	SN74LS293N	1.30
SN74LS96N	1.65	SN74LS295AN	1.75
SN74LS107N	.45	SN74LS298AN	1.75
SN74LS109N	.50	SN74LS324AN	2.25
SN74LS112N	.45	SN74LS332AN	1.45
SN74LS113N	.45	SN74LS353AN	1.70
SN74LS114N	.45	SN74LS365AN	.69
SN74LS122N	.89	SN74LS366AN	.69
SN74LS123N	.99	SN74LS367AN	.69
SN74LS124N	1.95	SN74LS368AN	.69
SN74LS125N	.75	SN74LS375AN	.75
SN74LS126N	.75	SN74LS386AN	.59
SN74LS132N	1.19	SN74LS395AN	1.95
SN74LS136N	.50	SN74LS670AN	2.75

CMOS

CD4000BE	.09	CD4035BE	.99	CD4507BE	.52
CD4001BE	.18	CD4040BE	.99	CD4510BE	1.05
CD4002BE	.13	CD4041BE	.67	CD4511BE	1.25
CD4006BE	.99	CD4042BE	.63	CD4512BE	1.15
CD4007BE	.17	CD4043BE	.45	CD4514BE	2.50
CD4008BE	.80	CD4044BE	.45	CD4515BE	2.50
CD4009BE	.37	CD4046BE	2.45	CD4516BE	1.40
CD4010BE	.37	CD4047BE	2.45	CD4518BE	.90
CD4011BE	.18	CD4048BE	.37	CD4519BE	.79
CD4012BE	.17	CD4050BE	.37	CD4520BE	.79
CD4013BE	.37	CD4051BE	1.15	CD4522BE	1.98
CD4014BE	.89	CD4052BE	1.15	CD4526BE	1.50
CD4015BE	.89	CD4053BE	1.19	CD4527BE	1.50
CD4016BE	.37	CD4055BE	1.29	CD4528BE	1.50
CD4017BE	.94	CD4060BE	1.40	CD4531BE	1.25
CD4018BE	.99	CD4066BE	.59	CD4539BE	1.20
CD4019BE	.42	CD4068BE	.24	CD4555BE	.75
CD4020BE	1.04	CD4069BE	.24	CD4556BE	.75
CD4021BE	.99	CD4070BE	.24	CD4585BE	1.80
CD4022BE	.89	CD4071BE	.24	74C85/40085PC	1.20
CD4023BE	.18	CD4072BE	.29	74C160/40160PC	1.50
CD4024BE	.67	CD4073BE	.29	74C161/40161PC	1.50
CD4025BE	.17	CD4075BE	.29	74C162/40162PC	1.50
CD4026BE	1.39	CD4076BE	1.05	74C163/40163PC	1.50
CD4027BE	.39	CD4078BE	.24	74C174/40174PC	1.40
CD4028BE	.75	CD4081BE	.24	74C175/40175PC	1.40
CD4029BE	.79	CD4082BE	.29	74C192/40192PC	1.50
CD4030BE	.37	CD4085BE	.75	74C193/40193PC	1.50
CD4033BE	1.60	CD4086BE	.75	74C195/40195PC	1.40
CD4034BE	2.95	CD4502BE	1.15		

MOS AND BI-POLAR MEMORIES

P/N	Description	Price
C1702A	(1 Microsecond) 256 x 8 EPROM	8.95
C1702A	(1.5 Microsecond) 256 x 8 EPROM	5.95
C2708	1K x 8 EPROM (450 NS)	49.00
8080A	8 Bit MOS CPU (2 microseconds)	14.95
2102-1P	1K Static Ram 1024 x 1 (450 NS)	2.50
3342PC	Quad 64 Bit Static Shift Register	4.50
3347PC	Quad 80 Bit Static Shift Register	4.50
3341APC	4 x 64 MOS FIFO 1 MHz Shift Register	4.50
TMS0117NC	Decimal Arithmetic Processor	10.00
LCM1001	Microprocessor Learning Module	149.95
TMS4024NC	64 x 9 FIFO	8.95
TMS4050NL	4K Dynamic RAM Plastic 300NS (18 Pin)	6.95
TMS4060NL	4K Dynamic RAM Plastic 300NS (22 Pin)	6.95
A5-1013P	8 Bit UART	6.95
SEMI 4804A	4K STATIC RAM 1024 x 4 (450 NS) single 5V supply	14.95
93415PC	1K RAM 40 NS Open Collector	11.00
93425PC	1K RAM 40 NS Tri-State	11.00
AM2901DC	4 Bit Bi-Polar Microprocessor slice	31.50
AM2902PC	Carry Look Ahead Circuit	3.18
AM29055PC	Quad 2 Input Bus Transceiver	8.10
AM2907PC	Quad Bus Transceiver with Tri-State Receiver and Parity	7.00
AM2909PC	4 Bit Cascadable Microprogram Sequencer	7.15
AM2918PC	Quad Deregister with Standard and Tri-State Outputs	4.32
F8 Kit	8 Bit Microprocessor Evaluation Kit with Software	185.00

TEXAS INSTRUMENTS DATA BOOKS

LCB1011	Understanding Solid State Electronics	2.95
LCB1891	Software Design for Microprocessors	12.95
LCC4041	Power Data Book	3.95
LCC4112	TTL Data Book	4.95
LCC4131	Transistor and Diode Data Book	4.95
LCC4151	Linear and Interface I.C. Data Book	3.95
LCC4200	Semiconductor Memories Data Book	2.95
LCC4230	Optoelectronics Data Book	2.95
LCC4241	Linear Control Circuits Data Book	2.95

FAIRCHILD DATA BOOKS

Power Data Book	3.00
Bi-Polar Memory Data Book	2.50
Linear Integrated Circuit Data Book	2.95
Low Power Schottky and Macrologic TTL	1.75
Interface Data Book	1.00
Raytheon Linear Integrated Circuit Data Book	1.50
State Scientific CMOS 'B' Series Data Book	2.50
Unirode Semiconductor Data Book	4.95

"ONLY MAJOR MANUFACTURERS SUPPLIED"

This is a partial listing. Our complete catalogue lists many more device types & series which are available. "Our quality cannot be surpassed".
 "How can you beat the combination — the finest quality, current production, latest date code devices from the major manufacturers as Texas Instruments & Fairchild Semiconductor — At the lowest prices — Surely an unbeatable combination. Get the most value for your Dollar".
 Active Electronic provides the three essentials in Semiconductor Distribution — 1. QUALITY
 2. INVENTORY
 3. PRICE
 We now offer the lowest mis pricing for major manufacturers devices only, with the largest variety of devices available from stock, from one source.
 We offer Rolls Royce quality at Volkswagen pricing.

Active Electronic Sales Corp.

P.O. BOX 1035 FRAMINGHAM, MASSACHUSETTS 01701
 Telephone Orders & Enquiries (617) 879-0077 New Catalogue available on request
 NOW IN CANADA 5647 Ferrier st. 44 Faeken Dr-Unit 25 MINIMUM ORDER \$10.00 + ADD \$1.00 TO COVER
 2 Locations Montreal, Quebec Rexdale, Ontario POSTAGE & HANDLING * Canadian customers add 30%
 Tel. (514) 735-6429 Tel. (416) 677-4287 for duty and handling. All federal and provincial taxes extra.

We offer the largest variety of current production Texas Instruments and Fairchild Semiconductor only 74LS devices from stock. Even though the competition for current production major manufactured 74LS devices is limited, we are dedicated to provide the best prices possible. As our costs decrease, we pass the savings on to you, our customer.

Popular Electronics

MAY 1977
ADVERTISERS INDEX

READER SERVICE NO. ADVERTISER PAGE NO.

1	A P Products, Inc.	87
2	AVR Electronics	101
	Acoustic Fiber Sound Systems, Inc.	25
3	Active Electronic Sales Corp.	122
6	Advanced Microcomputer Products	106
7	Allison Automotive Company	101
8	Anrona Corp.	121
	Audio Products, Inc.	74
10	B&K Product of Dynascan	60
11	Bullet Electronics	118
12	Byte Publications	39
	CREI Capital Radio Engineering Institute	70, 71, 72, 73
	Cleveland Institute of Electronics, Inc.	28, 29, 30, 31
15	Cobra, Product of Dynascan	SECOND COVER
13	Continental Specialties Corporation	89
14	Crown	6
16	Delta Products, Inc.	65
17	Digi-Key Corporation	115
	Digital Concepts	77
18	Digital Group, The	42
67	Digital Group, The	69
19	EICO	14
20	Edie Electronics	112
21	Edmund Scientific Co.	105, 124
22	Electronic Book Club	7
64	Electronics Unlimited	99
23	Eltron	120
24	Empire Scientific	94
25	Extron LIFESCREEN Projection System	39
26	Godbout Elecs., Bill	118
27	Grantham College of Engineering	103
28	Handic U.S.A. Inc.	41
5	Health Company	80, 81, 82, 83
	IMSAI Manufacturing Corporation	54
31	Illinois Audio	102
32	International Electronics Unlimited	116
33	James Electronics	110, 111
34	Leader Instrument Corp.	63
35	McIntosh Laboratory Inc.	63
36	Mallory & Co., Inc., P.R.	23
37	Midland International	23
38	Mototrola	27
	NRI Schools	8, 9, 10, 11
39	National Camera	102
40	New-Tone Electronics	117
41	OK Machine & Tool Corporation	51
42	OK Machine & Tool Corporation	58
43	Olson Electronics	116
44	Optoelectronics	114
45	PAIA Electronics	103
46	Pace CB	FOURTH COVER
47	Pearce-Simpson, Inc.	2
48	Personal Computing Magazine	95
49	Pickering & Co.	THIRD COVER
69	Poly Paks	109
50	Quest Electronics	123
51	Radio Hut	119
	Radio Shack	37
52	Radio Shack	79
53	S A E	93
54	S D Sales Co.	113
55	Schober Organ Corp. The	104
56	Scientific Research	59
57	Secore	86
58	Shakespeare Company	35
59	Solid State Sales	120
60	Southwest Technical Products Corporation	13
61	Southwest Technical Products Corporation	15
	Speakerlab, Inc.	104
62	Superscope, Inc.	16, 17
	Texas Instruments Incorporated	1
29	Triple I	77
65	U.S. Pioneer Electronics	52, 53
4	United Audio Products, Inc.	33
66	Wahl Clipper Corporation	99
68	Weatheralert, Inc.	24

CLASSIFIED ADVERTISING 105, 106, 112, 114, 116, 118, 120, 122

PLANNING TO MOVE?

Let us know 8 weeks in advance so that you won't miss a single issue of POPULAR ELECTRONICS.

Attach old label where indicated and print new address in space provided. Also include your mailing label whenever you write concerning your subscription. It helps us serve you promptly.

Write to: P.O. Box 2772, Boulder, CO 80323, giving the following information:

Change address only Extend my subscription

ENTER NEW SUBSCRIPTION

1 year \$9.98 Payment enclosed (1 extra BONUS issue)

Allow 30-60 days for delivery. Bill me later

AFFIX OLD LABEL

If you have no label handy, print OLD address here.

Name _____ please print

Address _____

City _____

State _____ Zip _____

NEW ADDRESS HERE 0206

Name _____ please print

Address _____

City _____

State _____ Zip _____

Additional postage per year for Canada add \$3 For countries outside U.S. and Canada add \$5—cash in U.S. currency only

P.O. Box 4430C Santa Clara, CA 95054
(408) 988-1640

Same day shipment. First line parts only. Factory tested. Guaranteed money back. Quality IC's and other components at factory prices.

INTEGRATED CIRCUITS

7400TTL	17	74LS00N TTL	28	LM339N	95	NE555V	13	CD4026	3 85
7400N	17	74LS02N	28	LM311N	90	NE564A	100	CD4027	35
7402N	17	74LS03N	24	LM318	90	NE567V	125	CD4028	170
7404N	19	74LS05N	34	LM318	135	NE570	90	CD4030	42
7405N	22	74LS10N	28	LM323K-5	6 95	79L05	90	CD4032	2 00
7406N	22	74LS10N	28	LM323K-5	6 95	79L05	90	CD4043	1 30
7407N	23	74LS13N	87	LM324K-12	1 35	75L08	1 75	CD4044	2 00
7408N	17	74LS14N	14	LM324K-15	1 35	75L08	1 75	CD4046	2 00
7411N	28	74LS20N	28	LM324K-15	1 35	75L08	1 75	CD4049	2 00
7412N	17	74LS23N	34	LM324K-15	1 35	75L08	1 75	CD4050	5 50
7413N	63	74LS26N	41	LM324K-15	1 35	75L08	1 75	CD4051	2 00
7414N	20	74LS28N	28	LM324K-15	1 35	75L08	1 75	CD4060	2 10
7415N	139	74LS30N	39	LM324K-15	1 35	75L08	1 75	CD4066	8 50
7416N	39	74LS32N	46	LM324K-15	1 35	75L08	1 75	CD4069	4 00
7438N	25	74LS75N	65	LM340A-8	1 60	IN4001	0 6	CD4070	4 00
7440N	78	74LS80N	110	LM340K-12	1 60	IN4002	0 6	CD4071	4 00
7441N	85	74LS85N	189	LM340K-12	1 60	IN4003	0 6	CD4072	4 00
7442N	104	74LS121N	52	LM340K-12	1 60	IN4004	0 6	CD4073	4 00
7443N	60	74LS123N	52	LM340K-12	1 60	IN4005	0 6	CD4076	1 75
7444N	36	74LS131N	59	LM340K-12	1 60	IN4005	0 6	CD4078	4 00
7445N	17	74LS132N	115	LM340K-12	1 60	IN4005	0 6	CD4079	4 00
7446N	32	74LS151N	150	LM340K-12	1 60	IN4005	0 6	CD4082	4 50
7447N	49	74LS153N	150	LM340K-12	1 60	IN4005	0 6	CD4082	4 50
7448N	0	74LS157N	140	LM340K-12	1 60	IN4005	0 6	CD4082	4 50
7449N	99	74LS190N	205	LM340K-12	1 60	IN4005	0 6	CD4082	4 50
7450N	45	74LS221N	195	LM340K-12	1 60	IN4005	0 6	CD4082	4 50
7451N	49	74LS258N	220	LM340K-12	1 60	IN4005	0 6	CD4082	4 50
7452N	75	74LS260N	220	LM340K-12	1 60	IN4005	0 6	CD4082	4 50
7453N	89	74LS279N	280	LM340K-12	1 60	IN4005	0 6	CD4082	4 50
7454N	39	74LS30N	30	LM340K-12	1 60	IN4005	0 6	CD4082	4 50
7455N	39	74LS30N	30	LM340K-12	1 60	IN4005	0 6	CD4082	4 50
7456N	39	74LS30N	30	LM340K-12	1 60	IN4005	0 6	CD4082	4 50
7457N	39	74LS30N	30	LM340K-12	1 60	IN4005	0 6	CD4082	4 50
7458N	39	74LS30N	30	LM340K-12	1 60	IN4005	0 6	CD4082	4 50
7459N	39	74LS30N	30	LM340K-12	1 60	IN4005	0 6	CD4082	4 50
7460N	39	74LS30N	30	LM340K-12	1 60	IN4005	0 6	CD4082	4 50
7461N	39	74LS30N	30	LM340K-12	1 60	IN4005	0 6	CD4082	4 50
7462N	39	74LS30N	30	LM340K-12	1 60	IN4005	0 6	CD4082	4 50
7463N	39	74LS30N	30	LM340K-12	1 60	IN4005	0 6	CD4082	4 50
7464N	39	74LS30N	30	LM340K-12	1 60	IN4005	0 6	CD4082	4 50
7465N	39	74LS30N	30	LM340K-12	1 60	IN4005	0 6	CD4082	4 50
7466N	39	74LS30N	30	LM340K-12	1 60	IN4005	0 6	CD4082	4 50
7467N	39	74LS30N	30	LM340K-12	1 60	IN4005	0 6	CD4082	4 50
7468N	39	74LS30N	30	LM340K-12	1 60	IN4005	0 6	CD4082	4 50
7469N	39	74LS30N	30	LM340K-12	1 60	IN4005	0 6	CD4082	4 50
7470N	39	74LS30N	30	LM340K-12	1 60	IN4005	0 6	CD4082	4 50
7471N	39	74LS30N	30	LM340K-12	1 60	IN4005	0 6	CD4082	4 50
7472N	39	74LS30N	30	LM340K-12	1 60	IN4005	0 6	CD4082	4 50
7473N	39	74LS30N	30	LM340K-12	1 60	IN4005	0 6	CD4082	4 50
7474N	39	74LS30N	30	LM340K-12	1 60	IN4005	0 6	CD4082	4 50
7475N	39	74LS30N	30	LM340K-12	1 60	IN4005	0 6	CD4082	4 50
7476N	39	74LS30N	30	LM340K-12	1 60	IN4005	0 6	CD4082	4 50
7477N	39	74LS30N	30	LM340K-12	1 60	IN4005	0 6	CD4082	4 50
7478N	39	74LS30N	30	LM340K-12	1 60	IN4005	0 6	CD4082	4 50
7479N	39	74LS30N	30	LM340K-12	1 60	IN4005	0 6	CD4082	4 50
7480N	39	74LS30N	30	LM340K-12	1 60	IN4005	0 6	CD4082	4 50
7481N	39	74LS30N	30	LM340K-12	1 60	IN4005	0 6	CD4082	4 50
7482N	39	74LS30N	30	LM340K-12	1 60	IN4005	0 6	CD4082	4 50
7483N	39	74LS30N	30	LM340K-12	1 60	IN4005	0 6	CD4082	4 50
7484N	39	74LS30N	30	LM340K-12	1 60	IN4005	0 6	CD4082	4 50
7485N	39	74LS30N	30	LM340K-12	1 60	IN4005	0 6	CD4082	4 50
7486N	39	74LS30N	30	LM340K-12	1 60	IN4005	0 6	CD4082	4 50
7487N	39	74LS30N	30	LM340K-12	1 60	IN4005	0 6	CD4082	4 50
7488N	39	74LS30N	30	LM340K-12	1 60	IN4005	0 6	CD4082	4 50
7489N	39	74LS30N	30	LM340K-12	1 60	IN4005	0 6	CD4082	4 50
7490N	39	74LS30N	30	LM340K-12	1 60	IN4005	0 6	CD4082	4 50
7491N	39	74LS30N	30	LM340K-12	1 60	IN4005	0 6	CD4082	4 50
7492N	39	74LS30N	30	LM340K-12	1 60	IN4005	0 6	CD4082	4 50
7493N	39	74LS30N	30	LM340K-12	1 60	IN4005	0 6	CD4082	4 50
7494N	39	74LS30N	30	LM340K-12	1 60	IN4005	0 6	CD4082	4 50
7495N	39	74LS30N	30	LM340K-12	1 60	IN4005	0 6	CD4082	4 50
7496N	39	74LS30N	30	LM340K-12	1 60	IN4005	0 6	CD4082	4 50
7497N	39	74LS30N	30	LM340K-12	1 60	IN4005	0 6	CD4082	4 50
7498N	39	74LS30N	30	LM340K-12	1 60	IN4005	0 6	CD4082	4 50
7499N	39	74LS30N	30	LM340K-12	1 60	IN4005	0 6	CD4082	4 50
7500N	39	74LS30N	30	LM340K-12	1 60	IN4005	0 6	CD4082	4 50

QUEST ELECTRONICS

IC SOCKETS	75	CRYSTALS	4 50	6 5536 MHz	4 30
Solder Tin Low Profile	75	1 MHz	4 50	1 8420 MHz	4 50
PW 1UP PW 1UP	75	2 MHz	4 50	2 09152 MHz	7 75
8 15 24 36	4 50	4 MHz	4 50	2 27678 MHz	7 50
16 20 28 38 58	4 50	8 MHz	4 50	3 90 3 2766 MHz	7 50
18 27 40 61	4 50	16 MHz	4 50	5 0688 MHz	4 50
22 35	4 50	32 MHz	4 50	5 184 MHz	4 50
27 40	4 50	64 MHz	4 50	5 7144 MHz	4 50
32 45	4 50	128 MHz	4 50	5 795 MHz	1 50
37 50	4 50	256 MHz	4 50	18 432 MHz	4 50
42 55	4 50	512 MHz	4 50	22 1164 MHz	4 50
47 60	4 50	1024 MHz	4 50		
52 65	4 50	2048 MHz	4 50		
57 70	4 50	4096 MHz	4 50		
62 75	4 50	8192 MHz	4 50		
67 80	4 50	16384 MHz	4 50		
72 85	4 50	32768 MHz	4 50		
77 90	4 50	65536 MHz	4 50		
82 95	4 50	131072 MHz	4 50		
87 100	4 50	262144 MHz	4 50		
92 105	4 50	524288 MHz	4 50		
97 110	4 50	1048576 MHz	4 50		
102 115	4 50	20			

**AMAZING & HARD-TO-FIND
SCIENCE BUYS!
ALTERNATE ENERGY
SPACE AGE • HOBBIES**

3000 MI. POWER FOR AM RADIOS



Remarkably clearer reception of ball games far off, your old hometown, up to 3000 mi. away "subject to local cond." deluxe ultrasensitive indoor directional AM Antenna for hi-fi, tuner inputs.

No. 72,263AV ... (3 1/2 x 9 1/2 x 11") \$117.50 Ppd.

SAVE 50%! 8 x 20 MONOCULAR



Top quality Spy Scope, a \$30 value, now \$14.95! Special purchase saves you 50%. 100% coated optics; 393 ft. field of view. Only 2 oz.—stores in pocket, purse, glove box.

No. 1568AV .. \$14.95 Ppd.

SAVE 50%-DELUXE AM/FM WALL RADIO



Surplus Philco-Ford radio chassis (14 1/4 x 13 1/2 x 3 1/2") mounts anywhere. 11 transist., AM/FM hi-sens. tuner, AFC, 2 3/4" dia. speaker. Orig. cost \$30 ea. in 3,000 quant. Retail over \$40.

No. 72,275AV (NEW! READY TO PLAY!) \$19.95 Ppd.
SAVE \$6 MORE! BUY 3 OR MORE @ \$17.95 Ppd.

NASA-CHOSEN FOR APOLLO/SOYUZ



The Astronauts used this super 20X60 binocular (modified) to view Earth! Big 60 mm objective lenses; 173-ft. field of view at 1000 yds. Relative brightness, 9.0. Fully coated optics, more!

No. 1556AV (9 1/4 x 8 1/2"; 47.5 oz) \$99.95 Ppd.

SOLAR ENERGY CUBE



Demonstration of sunlight converting to kinetic energy! Clear plastic cube in sun with its 3 silicon solar cells powers motor to whirl the propeller. Actually produces 1.5v DC, 825 ma.

No. 42,287AV (4x4x4") \$23.95 Ppd.

LOW COST PORT. INFRA-RED EYE



Self-cont. scope (90° nite vision) has 6032 IR converter tube. f/3.5 telephoto lens, adjust. triplet eyepiece. 1.6X Not avail. to Cal. res. except spec. auth'd.

No. 1683AV (6.12v DC) \$299.95 Ppd.
No. 1685AV (SUPER 2.5X BINOC. 1) \$329.95 Ppd.

PRO ELECTRONIC SOUND CATCHER



Parabolic mike w/ 18 3/4" transparent reflecting shield & 2 I.C.'s in amplifier magnifies signals 100X over omni-directional mikes. Catch sounds never before heard; highest signal to noise ratio poss. 5 1/2 lb.

No. 1649AV (REQ. 2.9V BATT.) \$299.00 Ppd.

15% EFFICIENT SOLAR CELL!



Largest, most powerful ever for terrestrial use, to build solar panels where max. power per unit area is req. Output up to 12w per sq. ft. Produces .8A @ .45v; .38w output. 2" x 2" sq. 20Z.

No. 42,514AV \$39.95 Ppd.

MEASURE WIND SPEED ANYWHERE



Hold handy (16 oz.) low cost Anemometer into the wind, quickly read wind speed on its big dial—from 5 to 70mph. Acc. to ±3% of full scale (2.1 mph), no batts., adjustments, recalibration req.!(7 1/2" HIGH)

No. 42,428AV. \$19.95 Ppd.

QUALITY DETECTOR UNDER \$40



Our fully transistorized BFO unit can locate a quarter at 18". Powerful 6 trans.-oscillator-amplifier circuit. Comp. to others priced 50% more! Aluminum, just 2 lb.

No. 80,222AV \$39.95 Ppd.



SUPER POWER FOR ANY AM RADIO

New Antenna Assist Turns A Tiny Transistor Into A Tiger!

This amazing antenna assist has pulled in stations up to 1000 miles away! Just set it beside your radio (no wires, clips, grounding) and fine-tune Select-A-Tenna's dial to the same frequency—"gangbusters"! Terrific for sportsmen, vacationers, shut-ins, radio & electronics buffs, Service men & women—anyone who wants to "get" home to a favorite station. Great for clearing weak signals in radio depressed areas, off-coast islands, stations in crowded frequencies, hard-to-tune stations way up on the dial. Solid state—no tubes to replace. Uses no electricity or batteries—works almost forever! Tough, break-resistant plastic case blends with any decor.

STOCK NO. 72,095N JUST \$19.95 Ppd.

ULTRA SELECT-A-TENNA (TUNES OVER 1000 MILES AWAY)

Currently in use on Alaska's north slope where radio reception is very difficult. Has jack input & jack to which you attach 50 ft. of antenna wire (not included).

STOCK NO. 72,147AV ONLY \$24.95 Ppd.



The Edmund BIOSONE II

turns brainwaves into an audible or visual signal. \$149.95

KNOW YOUR ALPHA FROM YOUR THETA!

For greater relaxation, concentration... monitor your alpha/theta brainwaves.

Features Normally Found Only In Units Selling For More Than \$200.00—And 3 Feedback Modes.

The portable, professional quality Edmund Biosone II boasts 3 feedback modes—LED FM tone, threshold tone; a test mode to check overall system of operation. Easy to use, this beautiful 4-pound, simulated walnut unit (9 1/2 x 5 3/8 x 4 1/4") can be operated at home, in office or clinic. It gives you outputs to allow further monitoring of logic signal, raw EEG, filter output, meter, and FM. Total brainwave monitoring capability, incl. filter select feedback, with wide range calibration sensitivity control (5-100 microvolts). Completely safe, the Edmund Biosone II is similar to an electroencephalograph (EEG), enabling you to identify the electrochemical activity that exists at all times in the human brain. In addition to letting you know when you're most relaxed, Biosone II is a great conversation piece. Included at its low price are a set of electrodes, an earphone jack for private use. Uses latest advances in linear circuitry, runs on two 9v transistor batteries (not included).

STOCK NO. 1668AV Just \$149.95 ppd.
LOW COST STARTERS' UNIT, No. 71,809AV \$59.95 ppd.

"SEE" MUSIC IN PULSATING COLOR

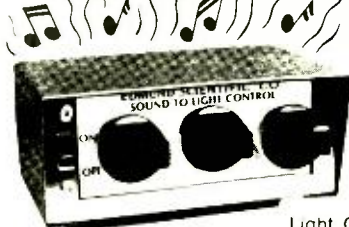

The Edmund 3-Channel Color Organ \$18.50

COMPLETELY ASSEMBLED! LESS THAN HALF THE PRICE OF OTHER MODELS!

Create your own audio "light show", add a new dimension to your music listening pleasure with the bargain-priced Edmund 3-Channel Sound To Light Control. Lets you modulate 3 independent strings of colored lamps with the intensity of your music. They flash and vary in brightness related to the music's rhythm, pitch and volume—a pulsating light performance to music! You get volume and frequency sensitivity to a peak rating of 300 watts per channel. Just plug in your favorite colored flood or spotlight, and turn on! Great price, too. This high quality, fully assembled unit in metal housing, with 3 individually controlled circuits, is priced at less than half that of others. Complete instructions are included with this terrific value.

ASSEMBLED \$18.50 Ppd.
No. 42,309AV

UNASSEMBLED, IN KIT FORM \$15.95 Ppd.
No. 42,336AV ONLY

GIANT FREE 164 PG. CATALOG



4,000 UNUSUAL BARGAINS FOR HOBBYISTS, SCHOOLS, INDUSTRY

COMPLETE AND MAIL COUPON NOW

EDMUND SCIENTIFIC CO. 300 Edscorp Bldg., Barrington, N. J. 08007
Send me the following:
Stock No. Quantity Price Ea.

SEND FREE 164 PG. CATALOG "AV"
Charge my American Exp
BankAmericard Master Chg

Interbank No. _____
Card No. _____

Expiration Date _____
30-DAY MONEY-BACK GUARANTEE. You must be satisfied or return any purchase in 30 days for full refund.

Stock No.	Quantity	Price Ea.

Add handling charge \$ _____ 1.00
Enclosed is check, M.O. in amount of \$ _____

Signature _____
Address _____
City, State, Zip _____

Two sources of perfection in stereo sound.

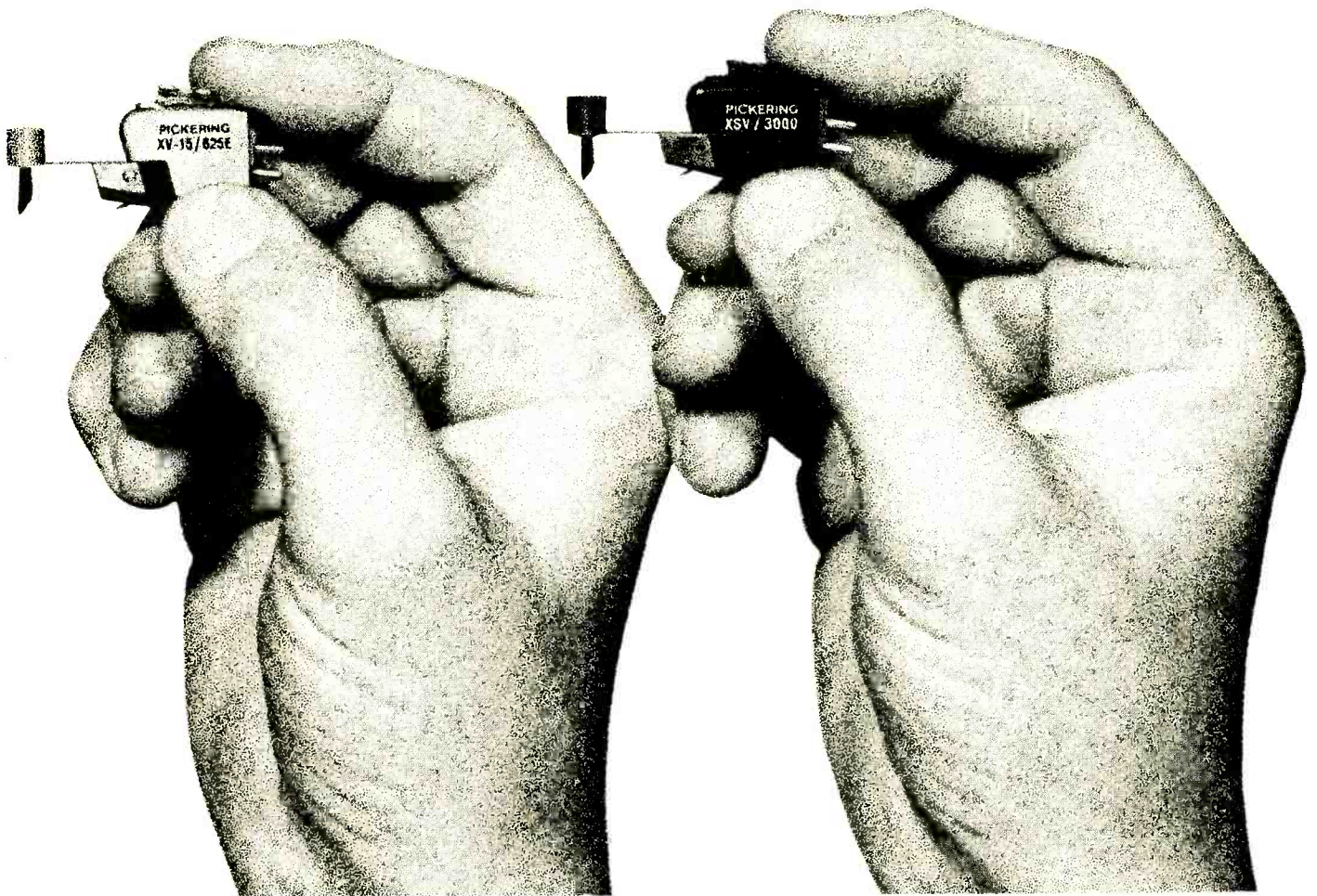

Match one to your equipment

“The right Pickering Cartridge for your equipment is the best Cartridge money can buy.”

We've been saying that for years; and tens of thousands of consumers have profited by applying this principle in assembling their playback systems.

If you have a fine manual turntable, the XSV/3000 is a perfect choice.

If you have a high quality automatic turntable, then installing an XV-15/625E in its tone arm is a perfect choice.

The summary advice of **Stereo's** Lab Test, in an unusual dual product review, we think brilliantly states our position: “The XV-15/625E offers performance per dollar; the XSV/3000, the higher absolute performance level.” That makes both of these cartridges **best buys!**



FREE!

Pickering's new XSV/3000 is a remarkable development. It possesses our trademarked Stereo-hedron Stylus Tip, designed to assure the least record wear and the longest stylus life achievable in these times with a stereo cartridge. Its frequency response is extraordinarily smooth and flat; its channel separation is exceptional; its transient response affords superb definition. It represents a whole new concept of excellence in stereo cartridges.

Read the whole evaluation report. Send for your free copy of the **Stereo** “Lab Test” reprint; write to Pickering & Co., Inc., 101 Sunnyside Blvd., Plainview, N.Y. 11803. Department PE-5

 **PICKERING**

“for those who can hear the difference”

PICKERING & CO., INC., COPYRIGHT 1977

CIRCLE NO. 49 ON FREE INFORMATION CARD



That bad language on your CB may not be bad language.

It may be bad CB.

Every CBer knows who the enemy is.
Static.

And while nobody yet has come up with a way to
kill it, Pace has hurt it. A lot.

Because every Pace CB has a minimum
of six noise suppressors built into it.
Some as many as nine!

So, while there's still no
such thing as noise-free
CB, a Pace comes as close
to it as you're going to get.



PACE 40 CHANNEL MODEL #8015

Pace. We're very bluenosed about bad language.
So we're doing everything
we can to clean up the
CB airwaves.

pace CB

PACE CB/PACE TWO-WAY RADIO PRODUCTS
BY PATHCOM INC., HARBOR CITY, CA 90710

**When you've got a Pace
40-channel CB,
you've got the world by the ears.**

For your convenience there are seven Pace regional warranty centers, plus more than 300 independent Pace service repair centers around the nation.

CIRCLE NO. 46 ON FREE INFORMATION CARD

www.americanradiohistory.com