

DIGITAL MULTIMETERS FOR HOBBYISTS

14278

Popular Electronics®

WORLD'S LARGEST-SELLING ELECTRONICS MAGAZINE FEBRUARY 1977/\$1.25

NEW, PRACTICAL OP AMP CIRCUITS

includes a differential
PC board tester

HOW TO ADD DIGITAL FREQUENCY READOUT TO SHORTWAVE RECEIVERS

TEST REPORTS:

Pioneer CT-F8282 Stereo Cassette Deck
Acoustic Research AR-16 Speaker System

BUILD A LOW-COST LOGIC ANALYZER

Data-domain instrument for troubleshooting
microcomputers and other digital equipment

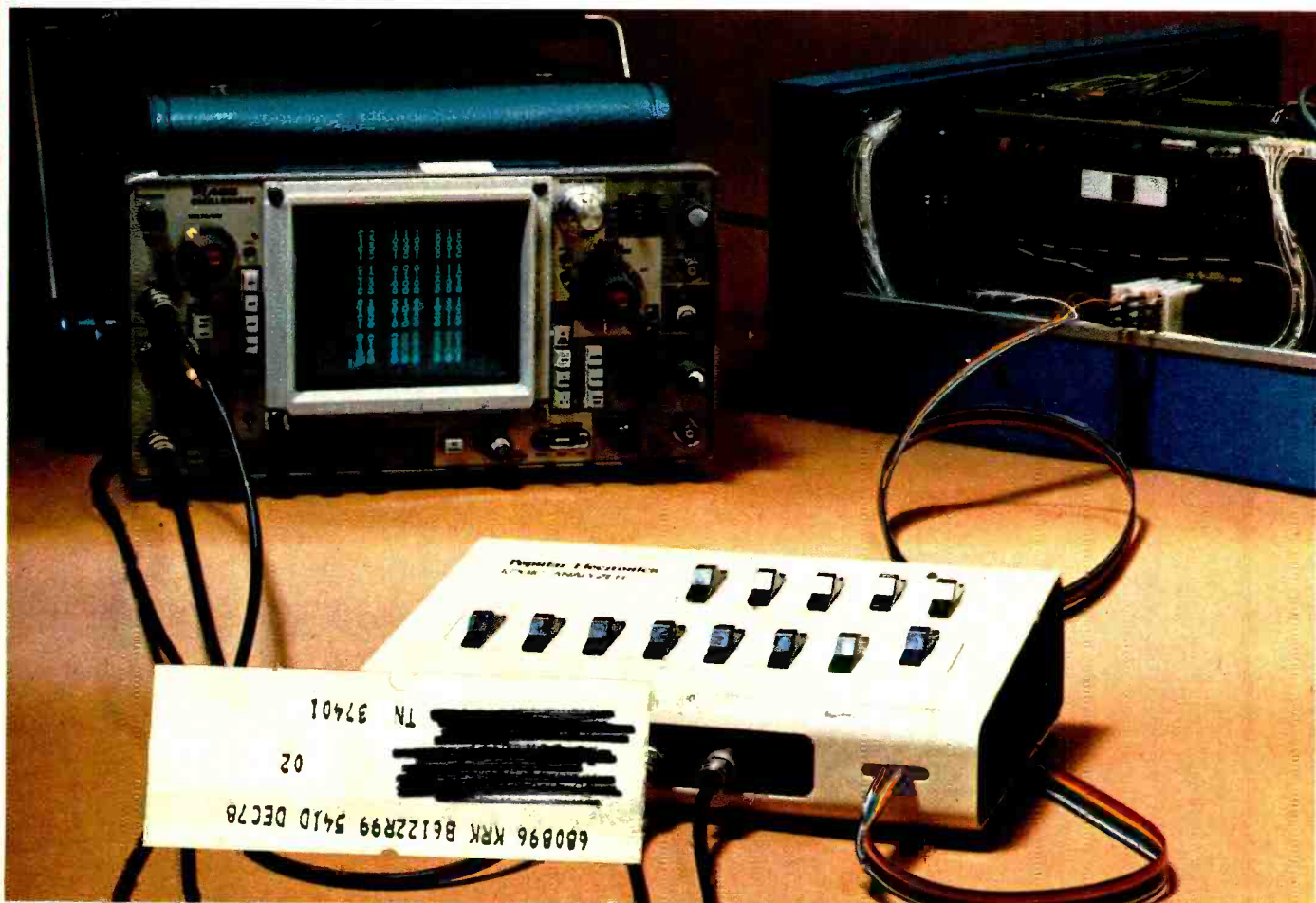

Retailers: Notice of display-allowance plan is within last three pages.

www.americanradiohistory.com



THE COBRA 32XLR. A TECHNOLOGICAL PUNCHTHROUGH.

Cobra has a reputation for punching through loud and clear. The new Cobra 32XLR, of course, continues the reputation. And creates another — for innovative design, superb engineering and technical superiority.

Start with the illuminated 4-in-1 meter. It tells you exactly how much power you're pushing out and pulling in. As well as monitoring your modulation in precise percentages. And measuring your punch with an SWR check. In short, the 32 XLR lets you keep an eye on your ears.

ScanAlert, Cobra's unique scanning system, continually monitors Channel 9 when you're on another channel. If an emergency comes up, the ScanAlert light goes on. And the incoming message automatically locks the receiver on the active channel.



The 32XLR's Digital Channel Selector is the very latest. With large LED numerals — for a read-out that registers clearly and quickly. Plus switchable "pulse block" noise blanking that rejects short-pulse noise not normally blocked by other systems. Which makes it the most effective in the business. Finally, add automatic noise limiting, Dynamike Plus (with built-in power mike) and Delta Tuning.

The new Cobra 32XLR. It has virtually everything. And it has everything to do just one thing. Punch through loud and clear.



Punches through loud and clear.

Cobra Communications Products
DYNASCAN CORPORATION
6460 W. Cortland St., Chicago, Illinois 60635

Remote Control Racer



A new fun
leisuretime activity
made possible by
the new electronics.

Computer logic has added a new fun way to control remote control products.

The Remote Control Racer is a competition scale model race car controlled by a transmitter using computer logic.

Think of it. Remotely drive a model race car from as far as sixty feet—turning left and right, going forward and reverse. It's great fun for hobbyists, children and the whole family.

DIGITALLY PROPORTIONAL CONTROL

The steering is controlled as you control the steering wheel on your remote control unit. Turn the wheel slightly to the right and the car wheels turn slightly to the right. Turn your control fully to the left and the car wheels turn fully to the left.

There is no transmission required to go from forward to reverse as the high quality servo motor simply reverses polarity to change gears. Press the forward lever on your remote unit and you go forward. Press the reverse lever and you go in reverse. It's just that quick.

BUILT TO THE FINEST DETAIL

The camber caster-action front wheels parallel a full-sized car's suspension system and they actually tilt on the turns. An independent floating rear axle maintains positive traction even on rough terrain.

The Remote Racer replaces the gasoline powered remote control race cars that have

The Remote Control Racer is a well built, well engineered electronic instrument with a 90 day limited warranty. JS&A further guarantees your satisfaction—if you are not absolutely satisfied with the value, quality or fun you are having, fine—return your racer within ten days for a full refund. You can't lose.

To order, credit card buyers simply call our toll-free number below and specify the color and quantity you want. Or send a check for \$52.45 (\$49.95 for each Racer plus \$2.50 for postage, insurance and handling to the address shown below. (Ill. residents add 5% sales tax).

By return mail, you'll receive a Remote Control Racer, the remote control unit, batteries, a 90 day limited warranty and simple operating instructions. Your unit should never require service but if it should, JS&A's service-by-mail facility is as close as your mail box. JS&A is America's largest single source of space-age products and a substantial company—further assurance that your modest investment is well protected.

Find out the thrill and fun of racing model race cars remotely. Order one or two Remote Control Racers today.



*The remote control unit (left) controls the race car's electronics (center).
The four "C" cell batteries fit in the underside of the Racer.*

SOPHISTICATED ELECTRONICS

The sophisticated electronics in the Remote Control Racer consists of 40 transistors. When you operate the control unit, the transmitter generates computer digital logic in a train of digital pulses which then are amplified and transmitted to the racer. The racer then has a sensitive receiver which receives the pulses and in turn translates them into data that eventually translates into power for the car.



The sleek lines of the Remote Control Racer follows the designs of some of the more popular race cars. The car measures 3½"x5"x12".

sold for well over \$100 a unit. Remote gas powered models give off odors and are often temperamental. The Remote Racer is quiet so it can be run indoors and it is not dangerous so even children can safely play with it.

START A RACE CLUB

You can run as many as six different cars in a race as each car will be on a separate remote control frequency. There are four different colors available, red, white, blue, and yellow and each racer comes equipped with its matching remote control unit.

Start a local competition race club, entertain guests with your new adult toy, or give it to your children as one of their most prized possessions. There are many fun ways to use your Remote Racer.

There are two separate circuits used for forward and for reverse. Each circuit utilizes two "C" cell batteries available anywhere. If you only go forward, the two forward batteries will last approximately two hours.

CIRCLE NO 67 ON FREE INFORMATION CARD

\$49⁹⁵

NATIONAL
INTRODUCTORY
PRICE

JS&A NATIONAL
SALES
GROUP

DEPT. PE JS&A Plaza
Northbrook, Illinois 60062
CALL TOLL-FREE .. 800 241-8444
In Georgia call ... 800 282-1333

© JS&A Group, Inc., 1976

SAVE UP TO 50% ON PARTS.

Hobbyist or professional, there are probably a lot of circuits you build just for the fun of it. And a lot you'd *like* to build, but never get around to.

One reason is the cost of parts. Parts you buy for one project, but can't re-use... because you haven't time to take them carefully apart. Or because of heat and mechanical damage that occur when you do.

Now, there's an easier way that can save you big money on parts *and hours on every project*, as well: *Proto-Board® Solderless Breadboards*

Now, assembling, testing and modifying circuits is as easy as pushing in — or pulling out — a lead. IC's, LED's, transistors, resistors, capacitors... virtually every kind of component... connect and interconnect instantly via long-life, nickel-silver contacts. No special patch

MODEL	NO. OF TIE-POINTS	14-PIN DIP CAPACITY	SUGG LIST	OTHER FEATURES
PB-6	630	6	\$15.95	Kit — 10-minute assembly
PB-100	760	10	19.95	Kit — with larger capacity
PB-101	940	10	29.95	8 distribution buses — higher capacity
PB-102	1240	12	39.95	Large capacity moderate price
PB-103	2250	24	59.95	Even larger capacity only 2.7¢ per tie-point
PB-104	3060	32	79.95	Largest capacity lowest price per tie-point
PB-203	2250	24	75.00	Built-in 1% regulated 5V 1A low ripple power supply
PB-203A	2250	24	120.00	As above plus separate +5V and -15V internally adjustable regulated outputs

*Manufacturer's suggested list
Prices and specifications subject to change without notice

ords or jumpers needed — just lengths of ordinary #22-30 AWG solid hookup wire

Circuits go together as quickly as you can think them up. And parts are re-usable, so as your "junk box" builds, you build more and more projects for less and less money.

Before you invest in your next project, invest in a CSC breadboard. See your dealer or order by phone: 203-624-3103 (East Coast) or 415-421-8872 (West Coast) — major charge cards accepted. You've got nothing to lose... and a lot to gain.

CONTINENTAL SPECIALTIES CORPORATION

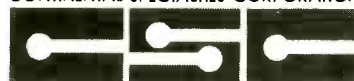

44 Kendall Street
Box 1942 New Haven, CT 06509
203-624-3103 TWX 710-465-1227
West Coast office: Box 7809 San Francisco, CA
94119 • 415-421-8872 TWX 910-372-7992

© 1976 Continental Specialties Corporation

CIRCLE NO. 18 ON FREE INFORMATION CARD



Popular Electronics®

WORLD'S LARGEST SELLING ELECTRONICS MAGAZINE

FEATURE ARTICLES

MULTIMETERS FOR ELECTRONICS Clayton L. Hallmark	31
<i>Part 2—Digital multimeters.</i>	
NEW, PRACTICAL OP AMP CIRCUITS Sol D. Prensky	47
<i>Including a differential pc board tester.</i>	
CURRENT "FOLDBACK" PROTECTS POWER SUPPLY & LOAD Jerome May	59
<i>How a 723 IC can be used for load and supply regulation.</i>	
NOAA WEATHER RADIO OPERATING LOCATIONS	92

CONSTRUCTION ARTICLES

LOW-COST DIGITAL LOGIC ANALYZER G. Muething, I. Spector & C. Wong	40
<i>Data-domain instrument for troubleshooting digital equipment.</i>	
DIGITAL FREQUENCY READOUT FOR SHORTWAVE RECEIVERS David L. Mattis	49
<i>Programmable counter provides accurate display of receiver frequency.</i>	
CONFERENCE TALK TIMER Walter W. Schopp	62
<i>Compact, versatile project has selectable time intervals.</i>	
QUIZ-GAME ELECTRONICS Michael S. Robbins	64
<i>Player-response circuit imitates quiz shows.</i>	

COLUMNS

STEREO SCENE Ralph Hodges	17
<i>Halloween at the Waldorf.</i>	
SOLID STATE Lou Garner	66
<i>Timers and Counters.</i>	
EXPERIMENTER'S CORNER Forrest M. Mims	75
<i>Flip-flops and Decade Counters.</i>	
HOBBY SCENE Q&A John J. McVeigh	77
CB SCENE Ray Newhall	85
<i>PURAC—A Voice For CB'ers.</i>	
AMATEUR RADIO Herbert S. Brier	87
<i>Speech Processors.</i>	
COMPUTER BITS Stephen B. Gray	89
<i>Computer Stores.</i>	

JULIAN HIRSCH AUDIO REPORTS

TAPE RECORDER HEADROOM EXPLAINED	23
PIONEER MODEL CT-F8282 CASSETTE DECK	24
ACOUSTIC RESEARCH MODEL AR-16 SPEAKER SYSTEM	26

ELECTRONIC PRODUCT TEST REPORTS

HEATHKIT MODEL IM-2202 DIGITAL MULTIMETER	78
SHARP MODEL CB-800A AM MOBILE CB TRANSCEIVER	79

DEPARTMENTS

EDITORIAL Art Salsberg	4
<i>Hanging Fire.</i>	
LETTERS	6
NEW PRODUCTS	12
NEW LITERATURE	16
OPERATION ASSIST	94
ELECTRONICS LIBRARY	96

POPULAR ELECTRONICS, February 1977, Volume 11, Number 2, Published monthly at One Park Avenue, New York, NY 10016. One year subscription rate for U.S. \$9.98; U.S. Possessions and Canada, \$12.98, all other countries, \$14.98 (cash orders only, payable in U.S. currency). Second Class postage paid at New York, NY and at additional mailing offices. Authorized as second class mail by the Post Office Department, Ottawa, Canada, and for payment of postage in cash.

POPULAR ELECTRONICS including ELECTRONICS WORLD, Trade Mark Registered. Indexed in the Reader's Guide to Periodical Literature.

COPYRIGHT 1977 BY ZIFF-DAVIS PUBLISHING COMPANY. ALL RIGHTS RESERVED.

Ziff-Davis also publishes Boating, Car and Driver, Cycle, Flying, Modern Bride, Popular Photography, Skiing and Stereo Review.

Material in this publication may not be reproduced in any form without permission. Requests for permission should be directed to Jerry Schneider, Rights and Permissions, Ziff-Davis Publishing Co., One Park Ave., New York, NY 10016.

Editorial correspondence: POPULAR ELECTRONICS, 1 Park Ave., New York, NY 10016. Editorial contributions must be accompanied by return postage and will be handled with reasonable care, however, publisher assumes no responsibility for return or safety of manuscripts, art work, or models.

Forms 3579 and all subscription correspondence: POPULAR ELECTRONICS, Circulation Dept., P.O. Box 2774, Boulder, CO 80302. Please allow at least eight weeks for change of address. Include your old address, enclosing if possible, an address label from a recent issue.

EDGAR W. HOPPER
Publisher

ARTHUR P. SALSBERG
Editorial Director

LESLIE SOLOMON
Technical Editor

JOHN R. RIGGS
Managing Editor

STEPHEN B. GRAY
Senior Editor

ALEXANDER W. BURAWA
Feature Editor

EDWARD I. BUXBAUM
Art Director

JOHN McVEIGH
Associate Editor

ANDRE DUZANT
Technical Illustrator

PATRICIA GIRRIER-BROWN
Production Editor

Contributing Editors
HAL CHAMBERLIN, LOU GARNER
GLENN HAUSER, JULIAN HIRSCH
RALPH HODGES, ART MARGOLIS
FORREST MIMS, RAY NEWHALL
SOL PRENSKY, WILFRED SCHERER

JOSEPH E. HALLORAN
Advertising Director

JOHN J. CORTON
Advertising Sales

LINDA BLUM
Advertising Service Manager

PEGI McENEANEY
Executive Assistant

STANLEY NEUFELD
Associate Publisher

ZIFF-DAVIS PUBLISHING COMPANY
Popular Electronics
Editorial and Executive Offices
One Park Avenue New York, New York 10016
212-725-3500

Hershel B. Sarbin, President
Furman Hebb, Executive Vice President
John R. Emery, Senior Vice President, Finance and
Treasurer

Phillip T. Heffernan, Senior Vice President, Marketing
Edward D. Muhlfeld, Senior Vice President, Sports Division
Philip Sine, Senior Vice President

Frank Pomerantz, Vice President, Creative Services
Arthur W. Butzow, Vice President, Production
Lawrence Sporn, Vice President, Circulation

George Morrissey, Vice President
Sydney H. Rogers, Vice President
Sidney Holtz, Vice President
Al Traina, Vice President

Philip Korsant, Vice President
Paul H. Chook, Vice President, Market Planning
Charles B. Seton, Secretary

Edgar W. Hopper, Vice President, Electronics Div
William Ziff, Chairman
W. Bradford Briggs, Vice Chairman

Midwestern Office
The Pattis Group, 4761 West Touhy Ave.,
Lincolnwood, Illinois 60644, 312 679-1100
GERALD E. WOLFE, THOMAS HOCKNEY
Western Office
9025 Wilshire Boulevard, Beverly Hills, CA 90211
213 273-8050, BRadshaw 2-1161
Western Advertising Manager, BUD DEAN

Japan: James Yagi
Oji Palace Aoyama 6-25, Minami Aoyama
6 Chome Minato-Ku, Tokyo 407-1930/6821,
582-2851



The publisher has no knowledge of any proprietary rights which will be violated by the making or using of any items disclosed in this issue.



Editorial

HANGING FIRE

The October 1976 issue of the *IEEE Spectrum* (an electrical engineering society publication) had an interesting editorial focus entitled: "What Went Wrong?" In addition to covering such failures as the Northeast electrical blackout of '65 and a multi-million-dollar radar project that flopped, promising developments that got sidetracked or delayed were discussed. These included electronic video recording (EVR), ovonic devices, thermoelectricity, the video telephone, emitter-coupled logic, AM stereo, and two-way cable TV.

None of the above is "dead," but they have not exhibited the growth that the excitement of their debuts hopefully promised. Offhand, I can add easily to the list of slow-start concepts that float around. Some, like a virus, come to life many years later; others are not widely adopted for one reason or another.

For example, I edited a cover-story article on microwave ovens in 1959, which indicated that sales were expected to skyrocket. *What went wrong?* A scathing attack was presented by *Consumer Reports* on the appliance's safety (causing tightened standards) that turned off consumers for more than a decade.

Attending a press meeting in the early Sixties, I was treated to a new concept in hi-fi—a servo-feedback system, called "Integrand, that was supposed to counter distortion emanating from speakers." *What went wrong?* I have no idea, but it simply never got off the ground, though the more recent Philips "Motional Feedback" system uses the same general concept.

I recall, too, going to a final task force meeting on the type of stereo FM that should be recommended to the FCC. The majority of attendees chose the Crosby System, which did not degrade the signal-to-noise ratio of the second channel. *What went wrong?* The GE/Zenith proposals were adopted because it was felt by the FCC that many FM broadcasters would not be able to survive without an SCA channel to supplement income, which GE/Zenith retained (together with higher noise) and Crosby did not.

Then there was Educating, using four channels multiplexed on FM, with receivers built by Sylvania Electric; Norelco's 45-rpm automobile record player (which I owned prior to auto tape's introduction); Ampex's floppy magnetic audio disc; wireless microphones; 35-mm audio magnetic tape introduced by Everest Records; a flame loudspeaker whereby flames modulated the air stream (Stanford Research Institute); the magnetic amplifier, which the Bureau of Ships, U.S. Navy, called "... the rising star of electronics in 1960"; and so on.

There are new, promising electronic stars on the horizon today. I wonder how they will fare when faced by the perspective of a few decades? These include the video disc (introduced in 1966) which is supposed to reach the marketplace sometime this year. (I viewed a third V-D system last week, Telefunken's TED. Color was great, but 10-minute play time for a flexible disc that will sell for \$4 to \$10 on a machine that is expected to cost at least \$500 appears to be out of the running for the public when contrasted with RCA's and Philips' longer playing time systems.) There is also a Class D audio amplifier that has been touted now for three years. And then there are Bubble Memories, which by their great density capability could take over the computer memory world if the price is driven down.

I won't count out any of the concepts, products, devices or systems that never live up to their promise, however. Not when I think of Michael Faraday's observation of semiconductor properties in 1833 and wireless detectors that were used in 1906. Just a little research laboratory twist, and a combined transfer and varistor device emerged in 1948. It is called a transistor.

you don't listen to the Realistic Mach One...

you experience it!

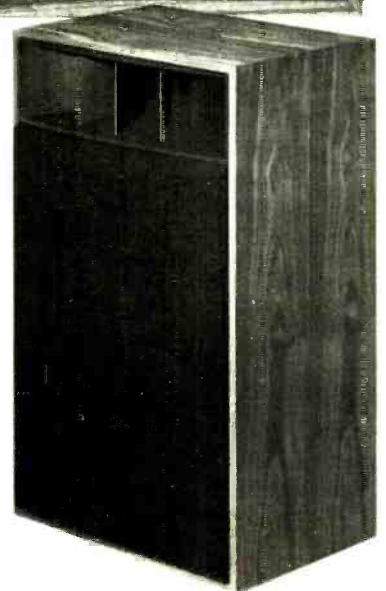

Realistic® and Radio Shack lower the cost of thrilling theatre-like sound. 22 years of design know-how and sales of a million speakers annually have shown us how. Powerful 15" woofer. Multi-cell midrange horn. High-compliance tweeter horn. Removable grille for easily balancing midrange and treble response. And genuine walnut veneer cabinetry. It's a real experience to hear the Mach One at live-performance listening levels. Bring in your favorite LP and we'll give you a thundering demonstration that will change your notions about who's really pioneering in hi-fi. Buy the amazing Mach One and we'll also give you a 5-year limited warranty. Ask for 40-4024 at your nearby Radio Shack store or participating dealer. **199^{50*}**

SOLD ONLY WHERE YOU SEE THIS SIGN:

Radio Shack®

A TANDY COMPANY • FORT WORTH, TEXAS 76107
5000 LOCATIONS IN NINE COUNTRIES



Use your credit card
at most stores

*Price may vary at individual stores and dealers

FEBRUARY 1977

CIRCLE NO. 53 ON FREE INFORMATION CARD

5

Empire's Blueprint For Better Listening

No matter what system you own, a new Empire phono cartridge is certain to improve its performance.

The advantages of Empire are threefold.

One, your records will last longer. Unlike other magnetic cartridges, Empire's moving iron design allows our diamond stylus to float free of its magnets and coils. This imposes much less weight on the record surface and insures longer record life.

Two, you get better separation. The small, hollow iron armature we use allows for a tighter fit in its positioning among the poles. So, even the most minute movement is accurately reproduced to give you the space and depth of the original recording.

Three, Empire uses 4 poles, 4 coils, and 3 magnets (more than any other cartridge) for better balance and hum rejection.

The end result is great listening. Audition one for yourself or write for our free brochure, "How To Get The Most Out Of Your Records." After you compare our performance specifications we think you'll agree that, for the money, you can't do better than Empire.



EMPIRE

Already your system sounds better.

Empire Scientific Corp.
Garden City, New York 11530



Letters

HIGH-LEVEL FEEDBACK & TIM

The various articles in the "Special Focus on Audio" section in the September 1976 issue of POPULAR ELECTRONICS all propose operational amplifiers with input-to-output gains of one, meaning that very large amounts of feedback are employed. Dr. Matti Ojala of Finland has shown that transient intermodulation distortion (TIM) becomes significant when feedback exceeds about 20 dB and is severe for larger feedback factors. Personal experience with high-gain op amps in a preamp circuit was that amplitude-versus-frequency response was controlled within 0.25 dB, but it "just didn't sound right." When I became aware of "Ojala distortion," it was pretty obvious that this was the fault.—*Paul W. Klipsch, Klipsch & Associates, Inc., Hope, AR.*

SWITCH TO NEW SWITCH

In "Build the Roadmate CB Converter" (October 1976), a dpst switch is specified in the Parts List. This should be a dpdt switch.—*Andrew Ciffer, Somerset, NJ*

IDENTIFYING THE COMPUTER

In "How To Select a Hobbyist Microcomputer" (December 1976), the lead photo has no caption identifying the equipment shown. Could you please tell me what this equipment is?—*Claude Jolly, Granite City, IL*

The CRT terminal shown on page 51 is the Model D301 made by Informer, Inc., 8332 Osage Ave., Los Angeles, CA 90045. It sells for \$1890.

A BETTER CAPACITANCE METER

I suggest the following changes for the "Low-Cost Capacitance Meter" featured in the October 1976 issue of POPULAR ELECTRONICS. First, to prevent the voltage rating from being exceeded with 3-, 6-, or 9-volt capacitors under test, two 1N914 diodes can be connected in series across *BP1* and *BP2*, with the anode of the pair going to *BP1* and the cathode to *BP2*. This will limit the terminal potential to 1.5 volts maximum. Second, by installing a 47-ohm, 1/2-watt resistor between the rotor of *S2A* and ground, the switch contacts will last longer and the charge on the capacitor under test will discharge less rapidly. Third, by removing the connection between the OFF position of *S1A* and the anode of *D1*,

no excessive current will flow through *Q1* as *C3* and *C4* discharge. Fourth, a mini DIP, such as the MC1558 or any dual 741 or amp, can be used to replace the two IC's if desired.—*Marvin J. Moss, Atlanta, GA.*

PE SPARKS EXPERIMENTING

I feel I owe POPULAR ELECTRONICS a letter of thanks and commendation. I hadn't dabbled in electronics since the dawn of the solid-state era until January of this year. Since then, PE has been very helpful in updating my knowledge of semiconductor theory and application and refreshing my memory on general electronics. I was planning to build a chess clock by coupling together two digital clock kits until I noticed two articles in PE that made me opt for a better design. As a result of the sequence generator described in the February 1976 Experimenter's Corner and "How Multiplexed LED Displays Simplify Circuits" in the March 1976 issue, I was able to design my improved chess clock. Many thanks for accelerating my project to reality and elevating it to an interesting experience.—*James H. Williams, Knoxville, TN.*

HAM/CB'ER FOR SHARING BAND

I would like to compliment you on your Editorial, "Majority Rules—The Bitter Pill" (November 1976). As both a Ham (W6TNS/7) and an avid CB'er, I can vouch for the wisdom of your words. I am inexorably convinced that there must be a "common meeting ground" where hams and CB'ers can intermingle and learn from each other. CB'ers are extremely susceptible to peer pressure, and I do not buy the argument that this "unwashed multitude" will ruin whatever they touch.

The pressure on the amateur 220-MHz band by 15- to 30-million people is going to mount in the next few years in direct proportion to the skip interference on the Citizens Band. It seems to me that the amateur fraternity would be well-advised to invite the CB'ers to share this relatively unused band, rather than lose it as they did 11 meters.—*Donald L. Stoner, Mercer Island, WA*

QUESTION OF SAFETY

There is a serious error in "Propagation Forecasts For Radio Communications" (November 1976) on page 36, column 2. A Wratten No. 4 is not a neutral-density filter, per Kodak publication No. B-3 titled "Kodak Filters For Scientific and Technical Uses." The No. 4 is a light yellow filter. Neutral densities are Wratten No. 96, available in densities from 80% light transmission to 0.01% (neutral density 0.1 to 4.0). These are supplied in gelatin only. Should you wish to obtain these in glass, they can be supplied by Tiffen Mfg. Co., 71 Jane St., Roslyn, N.Y.—*John H. Rose II, Warren, MI*

Thanks. We endorse your recommendation. The author, however, confirms that he has been using the No. 4.

WHY SETTLE FOR LESS— THAN A 6800 SYSTEM

MEMORY—

All static memory with selected 2102 IC's allows processor to run at its maximum speed at all times. No refresh system is needed and no time is lost in memory refresh cycles. Each board holds 4,096 words of this proven reliable and trouble-free memory. Cost—only \$125.00 for each full 4K memory.

INTERFACE—

Serial control interface connects to any RS-232, or 20 Ma. TTY control terminal. Connectors provided for expansion of up to eight interfaces. Unique programmable interface circuits allow you to match the interface to almost any possible combination of polarity and control signal arrangements. Baud rate selection can be made on each individual interface. All this at a sensible cost of only \$35.00 for either serial, or parallel type

PROCESSOR—

"Motorola" M6800 processor with Mikbug® ROM operating system. Automatic reset and loading, plus full compatibility with Motorola evaluation set software. Crystal controlled oscillator provides the clock signal for the processor and is divided down by the MC14411 to provide the various Baud rate outputs for the interface circuits. Full buffering on all data and address busses insures "glitch" free operation with full expansion of memory and interfaces.

POWER SUPPLY—

Heavy duty 10.0 Amp power supply capable of powering a fully expanded system of memory and interface boards. Note 25 Amp rectifier bridge and 91,000 mfd computer grade filter capacitor.

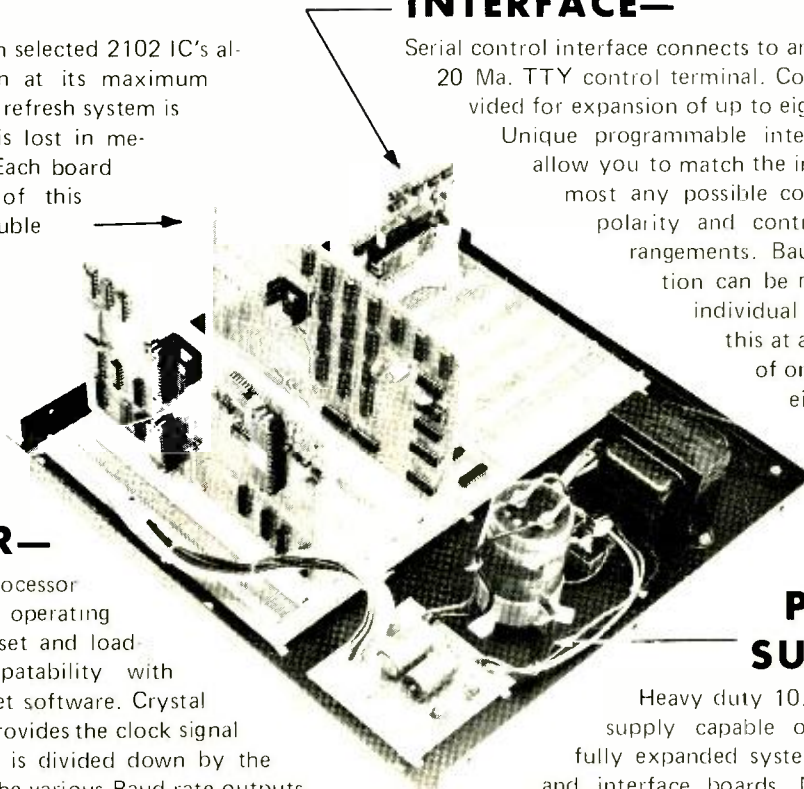

DOCUMENTATION—

Probably the most extensive and complete set of data available for any microprocessor system is supplied with our 6800 computer. This includes the Motorola programming manual, our own very complete assembly instructions, plus a notebook full of information that we have compiled on the system hardware and programming. This includes diagnostic programs, sample programs and even a Tic Tac Toe listing.

Mikbug® is a registered trademark of Motorola Inc.

SWTPC 6800
Computer System

with serial interface and 4,096 words of memory. \$395.00



Enclosed is \$395 for my SwTPC Computer Kit Send Data

or BAC _____ # _____

or MC _____ Ex Date _____

NAME _____

ADDRESS _____

CITY _____ STATE _____ ZIP _____

Southwest Technical Products Corp., Box 32040, San Antonio, Texas 78284

Only NRI

25" designed-

DIAGONAL

Color TV



Quadraphonic



Two home training schools give you a hobby-kit Color TV to assemble. Two others give you a commercial set right off the shelf. Neither was designed to teach you how to repair Color TV's. Only NRI invested the time and money to design equipment with learning in mind!

No other home training school gives you both a solid state Color TV and SQ™ Quadraphonic Receiver complete with four speakers . . . all in one course. In fact, to even match this kind of thorough training at another school, you'd have to take an extra

course costing hundreds of dollars more. And only NRI courses in Color TV/Audio servicing let you learn on equipment designed specifically for training.

It's the only way you can (1) get the feel of typical commercial circuitry, (2) learn bench techniques while building complete units from the "ground" up, (3) perform over 35 "in-set" experiments during construction, and (4) end up with a 25" diagonal solid state Color TV with cabinet and a 4-channel Audio Center.

NRI passes the savings on to you

NRI engineering eliminates the cost of buying from an outside source. We pay no salesman's commission. Students are enrolled by mail only. The savings are passed on to you in the form of low tuition fees, extras like the TV's console cabinet and the Quadraphonic System; professional test instruments like a 5" triggered sweep oscilloscope, CMOS digital frequency counter, and integrated circuit Color TV pattern generator. You can pay hundreds of dollars more for similar courses and not

™ Trademark of CBS, Inc.

gives you this for-learning ...plus complete Audio Center.

get a nickel's worth more in training and equipment.

More know-how per dollar

It all boils down to the quality of training you get for your money. In our 62-year history, more than a million students have come to NRI and we're fully approved for career training under the G.I. Bill. We know the right way to make home training pay dividends for you.

Some of those "right" things are bite-size lessons to ease understanding and speed learning . . . personal consultation, and prompt grading of all tests . . . a full-time staff of engineer/instructors to help if you need it . . . the right kind of kits and experiments to give you hands-on training . . . and fully professional programs oriented to full or part-time career needs.

Also CB, Computer, & Other Courses

NRI offers not one, but five TV/Audio servicing courses so you can tailor your training to your budget. Or you can study other opportunity fields like Digital Computer Electronics, Citizens Band Radio, Communications, Aircraft or



Marine Electronics, Mobile Radio and more. Send for your free catalog and see for yourself that no one gives you more training and equipment for your dollar. There's no obligation and no salesman will call.

If card is missing, write to:

NRI
McGraw-Hill
NRI SCHOOLS
McGraw-Hill Continuing
Education Center
3939 Wisconsin Avenue
Washington, D.C. 20016



New Products

Additional information on new products covered in this section is available from the manufacturers. Either circle the item's code number on the Reader Service Card inside the back cover or write to the manufacturer at the address given.

MAGITRAN CB THEFT ALARM

From Magitran, the CB 10-33 Touch-Activated Alarm is a self-contained mobile equipment protection system. An ear-piercing 100-dB signal is emitted the instant a CB unit is



touched. Small enough to be concealed under the dash, the unit operates on a 9-volt transistor battery that will continuously sound the alarm for over three hours, according to the manufacturer. \$29.95.

CIRCLE NO 92 ON FREE INFORMATION CARD

HEATHKIT "COMPUTER" COLOR TV

Heathkit's Model GR-2001 color TV receiver kit features a 25" (63.5-cm) black-matrix ultra-rectangular picture tube, PLL horizontal and vertical-hold circuits and high-quality sound. With optional accessories, the receiver has complete programming capability through a computer-like system that can be set up for up to 32 channel changes during any two 12- or 24-hour viewing periods. Programming is via a calculator-type keyboard. Once accomplished, the programmer takes over operation of the receiver, changing channels automatically at the appropriate times. Other optional items include an on-screen digital clock and an automatic antenna rotor control. The latter automatically rotates the antenna to the pre-selected directions for best reception on each channel with each change of channels. Basic receiver kit price is \$279.95; accessory items and cabinet are extra.

CIRCLE NO 90 ON FREE INFORMATION CARD

BOSE SPEAKER SYSTEM

The Bose Model 901 Series III speaker system retains the basic concepts used in the original Model 901 while providing better efficiency, low-bass capability, and adaptability



to a wider range of listening environments. It employs the 901's direct/reflected sound concept, multiple full-range drivers, active equalization, and uniform power radiation. New driver design and an Acoustic Matrix™ enclosure provide better efficiency. The one-piece plastic enclosure has partially isolated chambers, one for each driver. Each chamber joins one of three Reactive Air Columns to provide a controlled interaction between the different drivers. The enclosure does not affect system frequency or transient response. It is designed to reduce cone motion to increase accuracy and the dynamic range of the bass response. \$749 for two speaker systems and equalizer unit.

CIRCLE NO 93 ON FREE INFORMATION CARD

PRIDE FREQUENCY COUNTER & CLOCK

The Pride TF-1000 is a combined frequency counter and selectable 12- or 24-hour digital clock for CB and amateur radio use. The six-digit unit switches automatically from clock to frequency counter when the transmitter is activated. The clock continues to count, and the time is again displayed when transmission is completed. The TF-1000 operates from 1 to 40 MHz and can be used with CB and amateur transceivers with outputs from 3 to 200 watts. Measures 9 3/4"D x 8 1/2"W x 3"H (21.6 x 7.6 x 24.8 cm). \$179.95.

CIRCLE NO 94 ON FREE INFORMATION CARD

IMSAI PRINTER

The Imsai Printer is a new 44-column dot-matrix printer designed for use with the Imsai 8080 and many other computers. The printer interfaces to an 8-bit parallel port. It is said to be simple to program and install. It is self-contained, with case, cable, power supply,

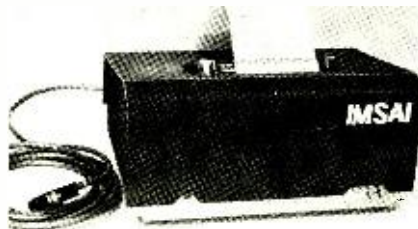

timing, control and character generation included. The font is the standard 64-character ASCII subset; double-size characters are software selectable. An automatic line-wraparound feature prints lines with more than 44 characters on two lines. Multiple copies can be printed using carbon or NCR paper. \$399 kit, \$549 assembled.

CIRCLE NO 95 ON FREE INFORMATION CARD

JENSEN THREE-WAY CAR SPEAKER

Jensen's flush-mount Triaxial is said to be the only car stereo speaker on the market with a woofer, tweeter and midrange driver in one unit. The woofer is 6" x 9", the 3" midrange is direct-radiating, 2" tweeter is solid state. Rated at 35 watts, the speakers are compatible with 4- and 8-ohm radio or tape units. The kit includes two speakers with 20-oz magnets, grilles, mounting hardware, and connecting cables, at \$114.95.

CIRCLE NO 91 ON FREE INFORMATION CARD

GE 40-CHANNEL CB TRANSCEIVER

General Electric's Model 3-5812 40-channel mobile CB transceiver features a warning light that alerts the user that the antenna system needs adjustment. Other features include internal burnt-out protection for up to five minutes of transmission time, switchable noise blanker, ANL, delta tuning, PA,



scquelch, and modulation indicator. Power output is rated at the 4-watt legal maximum; adjacent channel selectivity is 50 dB at ±10 kHz; and receiver sensitivity at 0.5 μV. Measures 8"D x 6 1/2"W x 2 1/4"H (20.3 x 16.5 x 5.7 cm). \$174.95.

CIRCLE NO 96 ON FREE INFORMATION CARD

CROWN STEREO EQUALIZER

The Crown Model EQ-2 is an 11-band/channel stereo equalizer that provides full equalization from 20 Hz to 20 kHz. Each band features a ±15dB boost or cut capability. The filters are half-octave, constant-bandwidth design, set nominally on octave centers. Each filter has an associated control that allows a

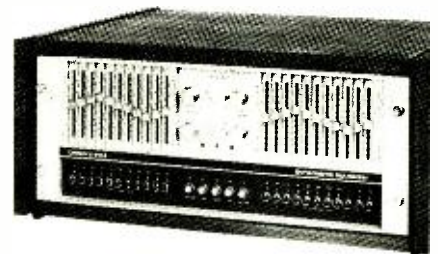

±0.5-octave adjustment of the center frequency. The two channels can be cascaded to produce a full-range, half-octave equalizer. Shelving-type tone controls permit adjusting bass or treble frequency response before detailed equalization. LED clipping-level indicators monitor four critical internal points to signal overloading. Automatic 5-to-7-second muting at turn-on prevents the passing of system turn-on transients to the speakers. Frequency response is 10 Hz to 100 kHz

POPULAR ELECTRONICS

What you don't hear is as impressive as what you do.

Up to now the most you could expect from a medium-priced cassette deck was rather medium performance. But now there's the RS-630US. The medium-priced cassette deck with high-priced performance.

We started by going to work on the sounds you don't want to hear with any cassette deck. When we finished, we ended up with virtually inaudible wow and flutter (0.09% WRMS). Negligible distortion. Transistorized switching that reduces signal loss. And a S/N ratio where there's practically no room for noise (-63dB with Dolby* and CrO₂ tape).

That's what you won't hear. What you will hear is a frequency response of 30Hz to 16kHz (CrO₂ tape). That means cymbals, brass and strings will sound crisp, smooth and natural. The reasons: A super alloy tape head formed under intense heat and pressure. As well as high-grade premium transistors.

You can also forget tape hiss. Because we use a two-stage direct-coupled equalizer as well as Dolby.* So that soft musical passages will remain quiet.

The RS-630US also has highly accurate peak-check meters that let you set the recording levels without the fear of overload distortion. So you get highly accurate recordings. With excellent dynamic range.

There are also dual output level controls. A CrO₂ tape selector switch. A lockable pause control. And Auto-Stop at the end of the tape in both record and playback modes.

So if you've been looking for a cassette deck with outstanding performance, audition the RS-630US. It only sounds expensive.

*Dolby is a trademark of Dolby Laboratories, Inc. Cabinetry is simulated wood.

Technics

by Panasonic

CIRCLE NO. 61 ON FREE INFORMATION CARD



VALUE & PERFORMANCE

EICO's 30 Years Experience
Assures More Electronics Value
For Your Money!

TEST INSTRUMENTS



NEW!

EICO 388 COLOR BAR GENERATOR
Pocket-size, battery operated with LED indicator. MOS LSI IC provides 9 digitally controlled, stable patterns. Crystal controlled chroma and timing oscillators. Simply connects to TV's VHF antenna terminals.
Wired \$89.95

EICO 390 FUNCTION/SWEEP GENERATOR
Outstanding features include: Sine, Square, Triangle Waveforms; 2 Hz to 200 KHz frequency range; Linear and Log Sweep; Calibrated attenuator, VCO for External Frequency Control; BNC Front Panel Output.
Wired \$169.95

EICOCRAFT® IC KITS

**EC-5000
SCA
ADAPTOR KIT
ONLY \$12.95**



Convert your FM radio or receiver to pick up the official FCC-licensed background music service (SCA). IC decoder/adaptor permits hearing uninterrupted, commercial-free music broadcast by many FM stations (For personal, non-commercial use only).

IC PROJECT KITS NOW AVAILABLE

EC-5100 ESP Tester \$10.95
EC-5200 "Decision Maker" \$9.95
EC-5400 Stereo Power Amplifier \$10.95
EC-5500 Stereo Pre-Amp \$9.95
EC-5600 Electronic Lock \$11.95
EC-5700 Universal Power Amp \$8.95

BURGLAR/FIRE ALARMS



SS-500 BURGLAR/FIRE ALARM SYSTEM
Professional Security System designed for easy do-it-yourself installation. Features EICO FC-100 Control Center with AC/DC automatic transfer to battery operation. Complete system includes Installation Handbook. Add additional sensors, bells, to suit your own needs. **\$159.95**

SD-75 BATTERY OPERATED FIRE/SMOKE ALARM
Ionization-type detector gives earliest possible fire warning. Mounts directly to ceiling with 2 screws. "Beeps" when battery needs replacement. U.L. listed. **\$39.95**

CB ACCESSORIES



NEW!

EICO 700 CB FREQUENCY COUNTER
Compact in-line mobile frequency counter for the serious CB'er/Hobbyist. Operates automatically on transmit. 10 Hz to 30 MHz. **\$99.95**

EICO LR-3 "LONG RANGER" INLINE PREAMP
Bring in those distant/weak signals. Boosts receiver sensitivity up to 20 db. Automatic transmit/receive switching. **\$29.95**

EICO CM-2 "CHANNEL MONITOR" AUTO-SWITCH
Automatically silences car radio when CB call is received/transmitted. **\$29.95**

HOBBY/AUTOMOTIVE

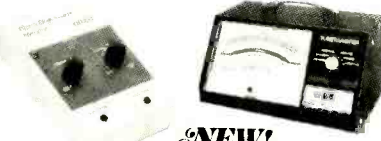

NEW!

BW-300 ALPHA BRAINWAVE MONITOR
Lowest cost, battery operated, professional Biofeedback System. IC Circuit design features an active filter and 5-microvolt sensitivity. Complete with stethoscopic earphone, electrode headband and instructions.
Kit \$34.95 Wired \$59.95

885 "TUNEMASTER" ENGINE ANALYZER
Automatic all-in-one test bench for all 6 or 12 volt ignitions—conventional or transistorized. Giant 6" meter with 6 color coded scales. Complete with tune-up and trouble-shooting manual.
Wired \$59.95

FREE EICO CATALOG

The more you know about electronics, the more you'll appreciate EICO. Every EICO product is designed to provide you with the most pleasure and quality performance for your money. The fact that more than 3 million EICO products are in use attests to their quality and performance.

"BUILD-IT-YOURSELF" and save up to 50% with our famous electronic kits.

For the latest EICO Catalog and name of nearest EICO Distributor, check reader service card or send 50¢ for fast first class mail service.

EICO-283 Malta Street, Brooklyn, N.Y. 11207

Leadership in creative electronics since 1945.



±0.3 dB; 20 Hz to 20 kHz ±0.1 dB. Measures 19"W x 14½"D x 7½"H (48.3 x 36.8 x 19 cm). \$899.

CIRCLE NO. 97 ON FREE INFORMATION CARD

RAIDER ROOF-TOP CB ANTENNA

Designed for permanent installation, the Model 700 roof-top antenna from Raider is for pickup trucks, station wagons, campers, recreational vehicles and standard passenger cars. The snap-in mount provides support for the antenna, which is said to be largely unaffected by high wind velocities. The only tools required for installation are an electric drill with a 3/8" bit, adjustable wrench, and a pair of wire cutters. The 700 comes with a stainless-steel whip, chrome-plated shock spring, or snap-in mount, and 17 feet of coaxial cable with a standard PL-259 plug at one end. **\$19.95.**

CIRCLE NO. 98 ON FREE INFORMATION CARD

SCOTT STEREO RECEIVER

Scott's new medium-price Model R336 AM/stereo FM receiver, features clutched bass and treble controls. Rated at 42 watts per

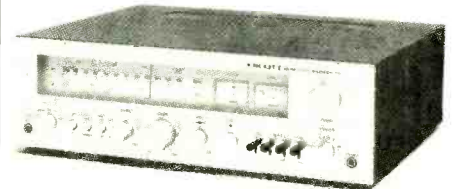

channel with less than 0.3% THD, the receiver has less than 0.15% IM distortion. The receiver features two independent tape monitors, signal-strength and center tuning meters, and a three-position FM deemphasis switch. **\$400.**

CIRCLE NO. 99 ON FREE INFORMATION CARD

EDSYN DESOLDERING TOOL

The "Silverstat Soldapult" from Edsyn is a manual desoldering tool said to protect sensitive FET and MOSFET devices from failure due to static electricity, while isolating the operator from a direct short. The tool is a handheld spring-loaded vacuum device with fully enclosed loading shaft, high/low vacuum adjustment, and fast bayonet-type disassembly. A conductive plastic tip and barrel housing is said to allow any built-up static charge to drain off harmlessly through the hand to ground.

CIRCLE NO. 100 ON FREE INFORMATION CARD

ONEIDA COLOR PICTURE TUBE RESTORER

From Oneida, the Nu-Color restorer is said to restore all needed colors to old color picture tubes. The restorer plugs into most 70° and 90° picture tubes and has separate slide-potentiometer adjustments for the three colors. The original color strength is restored through "boosted and individual biasing networks that increase emission and maintain constant color levels." Two models (70A and 90A) accommodate most 12" (30.5-cm) through 25" (63.5-cm) color picture tubes. **\$24.95 each.** Address: Oneida Electronic Mfg., Inc., Meadville, PA 16335.

NEWS HIGHLIGHTS

Semiconductor Industry Booms

Sales of consumer electronics products reached approximately \$10 billion in 1975. According to a report by the Business Communications Company, \$2.5 billion of these sales came from a new group of products that include CB radios, scanners, hand-held calculators, wide-screen TV and telephone answering devices. Tied to the rapidly changing lifestyle of the typical consumer, this new group is expected to become a \$7.7 billion market by 1980, reaching \$13.5 billion by 1985.

Solar-Powered Calculator

Royal Solar I, a solar-powered hand-held electronic calculator, has been introduced by Litton Industries. The pocket-size unit operates without conventional batteries, recharging itself continuously when exposed to artificial light or sunlight. It uses 46 miniature solar cells on its surface. The display is a liquid crystal device with 8-digit capacity, signs for memory usage, minus sign and capacity overflow. It is expected to retail for \$99.95.

Direct-to-Disc LP's

"Direct-to-disc" phono albums are being made available by Audio Technica. Unlike conventional LP's, direct-to-disc records bypass the tape recording stage of production. Studio performances are mixed and recorded directly onto a master disc, eliminating the problems of tape noise, distortion and limited dynamic range. The albums, available under the "Umbrella" label, will retail at \$12.95.

1 × 2 Callsigns

The FCC has announced an amendment to its Rules to permit the issuance of specific 1 × 2 callsigns (callsigns with one letter, one digit and two letters) in the Amateur Band, with suffixes beginning with the letter "X" or prefixed by the letter "N." These will be available to eligible Amateur Extra Class applicants.

E.I.A. Activities

The EIA has spoken out against proposed legislation by Congress to form a new Federal agency to act as consumer advocate in all types of consumer action. The Consumer Electronics Group of the EIA questioned the need for this proposed agency as costly and unnecessary with the potential for creating problems for both business and the consumer. The threat of a presidential veto caused sponsors to drop the measure for the present. However, revised legislation is expected to be introduced in the future.

The American National Metric Council recently formed to study metrication and start a "think metric" program in the United States has named the EIA as secretariate to its Electronic Equipment and Components Sector Committee.

3-D Television

Three-dimensional television is no longer a science fiction writer's fantasy. A method of wide-screen 3-D video projection, developed by Bruce D. Stephens, a television producer and consultant, enables stereoscopic presentations of live or prerecorded television programming with the image size and width of a wide-screen motion picture. As is required of all stereoscopic methods, the left and right eye orientations of the same scene must be segregated and assigned to the appropriate eye of each observer. In this technique, the two differing orientations are projected through a polarizer and re-directed toward the screen so they are superimposed. "Polalite" viewing spectacles allow each eye to see only the viewpoint intended for it, resulting in full depth perception. Motion picture 3-D presentations used this principle in the past.

Kirlian Photography Debunker

Kirlian photography—recording on film the aura emanating from a human body—is said to be due to an electrical phenomenon related to the amount of moisture in the skin, according to researchers in *Science*. Some had purported that the brightness of an aura, as depicted in a Kirlian photograph, reflected one's mental and physical health. Researchers have found that the amount of water in the skin determines the size and brightness of the aura recorded on film. The dryer the skin, the brighter the aura. The moisture is said to be transferred to the film, changing the electrical discharge pattern that is triggered by the metal plate under the film.

Holiday Inns' CB Network

Holiday Inns has announced plans to provide a nationwide citizens band network to assist motorists who need road information or help due to mechanical breakdown. The program is currently being tested among 15 Holiday Inns in the Boston area. Also being studied is an arrangement set up by the Maryland State Troopers in cooperation with that state's department of tourism, where a separate channel has been reserved for dispensing road information. This eliminates most of the interference and interruptions that occur on the regular channels.

Hams to Sail

Licensed hams will be able to operate a high-power amateur station on board the *Santa Mercedes*, during a 56-day cruise offered by Prudential Lines. Departing from San Francisco April 26 (from Los Angeles April 28) the ship will cruise to Mexico, the Caribbean and completely around South America. Instruction in code classes and license upgrading will be available along with a variety of social activities. For additional information write: Prudential Lines, One California Street, San Francisco, CA 94111.

The phono cartridge that doesn't compromise any modern record.

AT15Sa



Choosing an AT15Sa can add more listening pleasure per dollar than almost anything else in your hi-fi system. First, because it is one of our UNIVERSAL phono cartridges. Ideally suited for every record of today: mono, stereo, matrix or discrete 4-channel. And look at what you get.

Uniform response from 5 to 45,000 Hz. Proof of audible performance is on an individually-run curve, packed with every cartridge.

Stereo separation is outstanding. Not only at 1 kHz (where everyone is pretty good) but also at 10 kHz and above (where others fail). It's a result of our exclusive Dual Magnet* design that uses an individual low-mass magnet for each side of the record groove. Logical, simple and very effective.



Now, add up the benefits of a genuine Shibata stylus. It's truly the stylus of the future, and a major improvement over any elliptical stylus. The AT15Sa can track the highest recorded frequencies with ease, works in

*TM. U.S. Patent Nos. 3,720,796 and 3,761,647.

any good tone arm or player at reasonable settings (1-2 grams), yet sharply reduces record wear. Even compared to ellipticals tracking at a fraction of a gram. Your records will last longer, sound better.



Stress analysis photos show concentrated high pressure with elliptical stylus (left), reduced pressure, less groove distortion with Shibata stylus (right).

The AT15Sa even helps improve the sound of old, worn records. Because the Shibata stylus uses parts of the groove wall probably untouched by other elliptical or spherical styli. And the AT15Sa Shibata stylus is mounted on a thin-wall tapered tube, using a nude square-shank mounting. The result is less mass and greater precision than with common round-shank styli. It all adds up to lower distortion and smoother response. Differences you can hear on every record you play.

Don't choose a cartridge by name or price alone. Listen. With all kinds of records. Then choose. The AT15Sa UNIVERSAL Audio-Technica cartridge. Anything less is a compromise.

audio-technica

INNOVATION □ PRECISION □ INTEGRITY



AUDIO-TECHNICA U.S., INC., Dept. 27P, 33 Shiawassee Ave., Fairlawn, Ohio 44313



New Literature

ELECTRONIC PROJECT CATALOG

Graymark Enterprises offers a catalog listing over 50 electronic projects and 1000 electronic components. Among the items listed are a strobe light, color organ, metal detector and amplifier. Address: Graymark Enterprises, Box 17359, Irvine, CA 92713.

DIGITAL INSTRUMENT CATALOG

An 8-page catalog entitled "Digitals" covers a wide variety of digital instruments ranging from programmers, digital clocks, a digital clock/thermometer and timers, to digital frequency counters. Each instrument is illustrated and complete specs are provided. Address: ESE, 5051 Centinela Ave., Inglewood, CA 90302.

BUYER'S GUIDE TO MULTIMETERS

A new brochure from Amprobe Instrument, "Buying One of the More Popular VOM's," describes features and applications of comparable VOM's from three major manufacturers. The brochure includes specification information on resistances, ac and dc current, temperature, sensitivity, fuse protection, ranges, dimensions and standard accessories. Address: Amprobe Instrument Div. of SOS Consolidated, Inc. 630 Merrick Rd., Lynbrook, NY 11563.

EDMUND CATALOG

Edmund Scientific's new 164-page catalog, #771, contains over 4500 items for experimenters, students and hobbyists. Among the many items described are an ultraminiature AM radio that measures only 1 11/16" x 1 3/16" x 11/16"; solar collector panels for house and water heating; and Biosone II, an alpha/theta monitor that identifies electrochemical activity in the human body. Address: Edmund Scientific Co., 380 Edscorp Bldg., Barrington, NJ 08007.

DATA COMMUNICATIONS BULLETIN

A new, 5-page bulletin from Tele-Dynamics describes its line of data communications equipment, including modems, acoustic couplers, frequency division multiplex subsets and test equipment. Each product is illustrated and specifications and applications information are provided. Also included is a section on available accessories. Address: Tele-Dynamics Division of AMBAC Industries, Fort Washington, PA 19034.



Stereo Scene

By Ralph Hodges

HALLOWEEN AT THE WALDORF

NEW YORK'S annual Audio Engineering Society convention (held at the Waldorf Astoria) generally falls on and around October 31. Since the business of this distinguished gathering is to exchange tricks and (one hopes) treats, the date is highly appropriate.

I had hoped in this single column to cover most of the highlights of the 1976 convention. As things have turned out, I've barely found room to deal with three papers out of dozens that were presented. All three do relate to a common subject, however—one that is perhaps especially seasonal because it involves a trick and also a bit of a masquerade.

The Ultimate Illusion. Many feel that the ultimate audio illusion—and the final objective of high fidelity—is to be able to turn (acoustically) a small room into a large one, a large room into an open-air environment, and an open-air environment back into a small room. As usual, several papers dealing with aspects of this subject were presented. Ignoring the quadraphony papers for the moment (or at least until I understand them), the rest dealt with how the illusion of acoustic space (i.e., large and small rooms, or no room at all) can be *simulated* with the ever-growing resources for signal processing we now have available. "Faking it" in this way bothers some purists, including myself. But it is probably true that if we *can* learn to fake it successfully, we will learn in the process how to design and place microphones so as to properly capture the real thing.

First of all, what makes rooms acoustical entities, identifiable as large or small, dead or bright, when we hear music played in them? Sound reflections reaching us from the room's surfaces, of course. But then, what differences in reflections account for the different sounds of rooms? Depending on the room, reflections differ in their arrival times (how long they take to reach us after the sound coming directly from the musical

instrument is heard), spectral shape (alterations in the reflections' frequency balance), and density (number of reflections heard per unit of time).

To paraphrase Daniel Queen's latest paper (which he did not officially present, but which was available if you cornered him in the corridor and asked for it), arrival times of reflections fall into three categories (see Fig. 1): arrivals within 1 millisecond, those within 65 milliseconds, and those within 1, 2, or even 4 seconds. The 1-millisecond arrivals, if strong enough, are bad: they interfere with our localization of the original sound source (confuse the stereo image, if you will). Arrivals within from 1 to 65 milliseconds are generally good; they "fuse" with the direct sound, making it seem louder (however, they also profoundly affect the perceived spectral shape of the sound, which may not always be good). Arrivals after 65 milliseconds can be good or bad; they are perceived as room reverberation detached from the original sound, and they may be heard as a rich afterglow or a ragged string of echoes. As Queen points out, they tend to diminish intelligibility, but they are vital to our appreciation of certain types of music.

Fortunately, arrivals within 1 millisecond are rarely troublesome, because the reflecting surface has to be

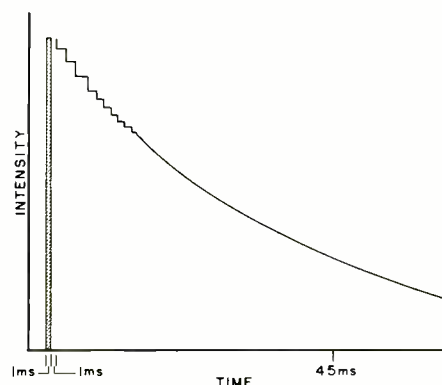

Fig. 1. A 1-ms sonic impulse and its reverberation train.

very close to either the sound source or the listener for them to occur (although the cabinets of some speaker systems provide such surfaces, as do the cases and lids of grand pianos, which can make them exasperatingly difficult to record). Arrivals within 65 milliseconds dominate in small rooms, which is why music sounds so loud in them. But after 65 milliseconds the absorptive materials in the small room have soaked up almost all this reflected sound energy.

In a large room such as a concert hall, a sound may easily have travelled for 65 milliseconds (roughly corresponding to 65 feet) before it undergoes even its *first* reflection from a wall or ceiling. Since it is these "bounces" from walls and ceilings that account for much of the absorption of sound (and in a small room many bounces will take place within 65 milliseconds, a concert hall doesn't even begin to assert its absorptive influence until many milliseconds have passed. That is why large auditoriums tend to have such prominent reverberation, and why architects strive so mightily to make that reverberation sound "nice." (This is not to say that concert halls provide the listener *no* reflective arrivals within 65 milliseconds; a good hall provides many, and they are very important.)

Turning the Trick. Well, that seems simple (although lengthy) enough. All we need do to turn our pitiful listening rooms into splendid opera houses is to provide reflected sounds persisting longer than 65 milliseconds. And we can provide that (since our rooms cannot) with delayed sounds coming either from distantly spaced microphones (four-channel recordings of the "ambient" type, in other words), or with artificially created delays (tape delays, bucket-brigade or even digital delays, reverberation systems using metal plates, springs, or tiled bathrooms, long cardboard tubes with a speaker at one end and a microphone at the other, almost *ad infinitum*). Hence our resources are vast. Unfortunately, the results achieved with them have been generally disappointing.

Many people have by now heard four-channel stereo or some other technique that attempts to alter acoustical space. Few, I suspect, have ever heard the walls of the listening room seem to disappear, as they should. We admire the ingenuity of the hardware, the onward march of separation figures, and the exquisite construction of the theoretical foundation. We even hear improvement

Be the “New Professional” in electronics

**CREI trains you at home
for one of the most important
career levels in electronics —
plus offers you special
arrangements for engineering
degrees**

Most people think there are only two levels of careers in electronics: the technician level and that of the degree engineer.

There is, however, a third and very important level. It is that of the engineering technician or *practical* engineer. The growing importance of this career level has created what might well be called the “New Professional” in electronics.

If you look at the various levels of employment in electronics, you will understand why this “New Professional” is so important.

The average technician is a person who has had vocational training in electronics. He understands the basic principles of electronics so he can troubleshoot, repair and maintain equipment. He usually works under close supervision in performing his duties.

The engineer has college training in electronics. He usually supervises technician personnel and is responsible for planning and developing of electronic equipment and systems. Frequently, however, engineers are more heavily trained in the scientific principles of electronics and less in their practical application.

The engineering technician, by contrast, is a specialist in the practical application of electronics. His training usually consists of a two-year college program in electronic engineering technology. In many organizations, the engineering technician handles several of the responsibilities of the degree engineer. He often has the title of engineer.

CREI programs are designed to give you at home the same level and depth of training you receive in a two-year college program in electronic engineering technology. CREI programs are, in fact, more extensive than you will find in many colleges. And CREI gives you the opportunity to specialize in your choice of the major fields of electronics.

Unique Design Lab

CREI gives you both theory and practical experience in circuit design with its Electronic Design Laboratory Program. The professional equipment included in this program allows you to construct, test out and correct the circuits you design until you have an effective circuit.

This Lab Program helps you understand advanced electronics. It also gives you practical experience in many other important areas of electronics, as in pro-

Career Training at Home

totop construction, breadboarding, test and measurement procedures, circuit operation and behavior, characteristics of electronic components and how to apply integrated circuits.

Only CREI offers the unique Lab Program. It is a complete college Lab and, we believe better than you will find in most colleges. The "Lab" is one of the factors that makes CREI training interesting and effective. And the professional equipment in this program becomes yours to keep and use throughout your professional career after you complete the training.

Engineering Degree

CREI offers you special arrangements for earning credit for engineering degrees at certain colleges and universities as part of your home study training program. An important advantage in these arrangements is that you can continue your full time job while "going to college" with CREI. This also means you can apply your CREI training in your work and get practical experience to qualify for career advancement.

Wide Program Choice

CREI gives you a choice of specialization in 14 areas of electronics. You can select exactly the area of electronics best for your career field. You can specialize in such areas as computer electronics, communications engineering, microwave, CATV, television (broadcast) engineering and many other areas of modern electronics.

Free Book

In the brief space here, there isn't room to give you all of the facts about CREI college-level, home study programs in electronics. So we invite you to send for our free catalog (if you are qualified to take a CREI program). The catalog has over 80, fully illustrated pages describing your opportunities in advanced electronics and the details of CREI home study programs.

Qualifications

You may be eligible to take a CREI college-level program in electronics if you are a high school graduate (or the true equivalent) and have previous training or experience in electronics. Program arrangements are available depending upon whether you have extensive or minimum experience in electronics.

**Send for this FREE Book
describing your opportunities
and CREI college-level
programs in electronics**

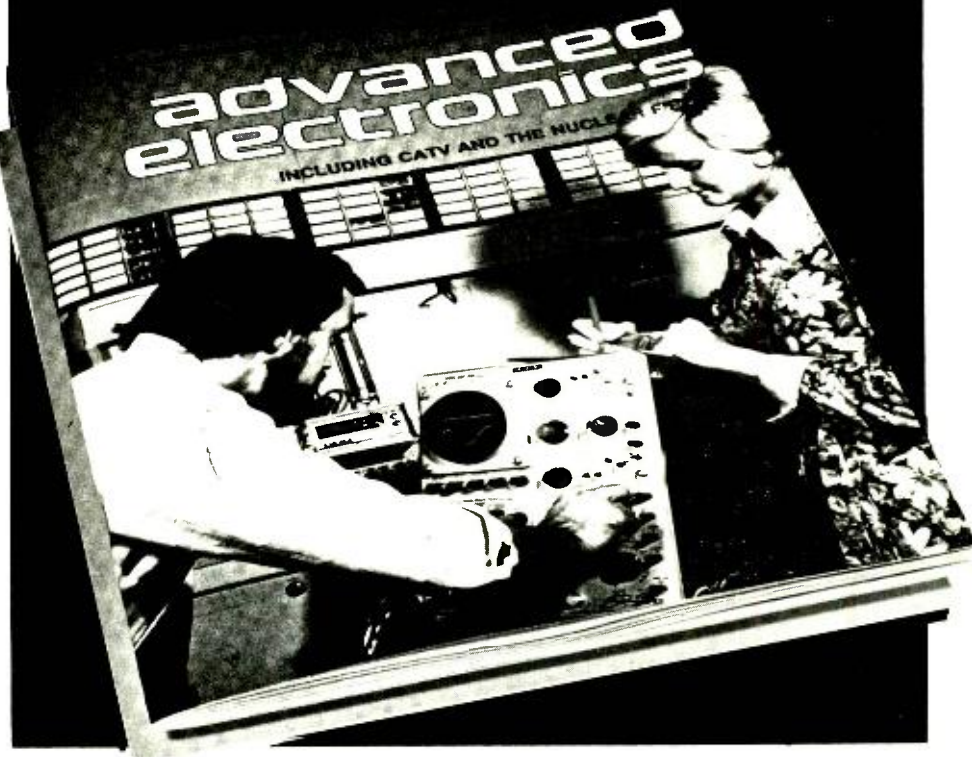

Mail card or write describing qualifications to

CREI **CAPITOL
RADIO
ENGINEERING
INSTITUTE**

**McGraw-Hill Continuing Education Center
3939 Wisconsin Avenue Northwest
Washington, D.C. 20016**

Accredited Member National Home Study Council

GI Bill

*CREI programs
are approved
for training of
veterans and
servicemen under
the G.I. Bill.*



of sorts in each new generation of equipment. But we rarely, if ever, cross the threshold into a shift of perceived reality. The trick just doesn't get turned.

Heroic Measures. The shortcomings of these techniques have been acknowledged reluctantly (if at all) by the audio industry. But behind the scenes researchers have been occupied with them all the same. The main approach, if I may crudely generalize, has been a complicated and taxing game of "find the flaw"—explain why a system that seemingly should work doesn't.

It's good to see the opposite tack being taken at last; that is, the tack of creating something that does work, no matter what, and finding out why, rather than starting with something that doesn't work (too well, anyway) and attempting to discover why not. Two papers presented at the convention appear to adopt this pragmatic approach, taking as their starting points techniques of simulation—that is, their only intent is to deceive the listener with a *seemingly* realistic experience; for the present they are largely content to forget about absolute realism and its pursuit.

Audio/Pulse manufactures a digital reverberation "simulator" that is intended merely to process ordinary stereo programs, with its output ideally appearing at one or more pairs of "rear" speakers, the key pair of which is located to either side and perhaps above and just behind the listener. In a paper prepared by Audio/Pulse's Peter Mitchell and Richard DeFreitas, five "essential characteristics" of concert-hall ambience are laid down, which become five conditions to be met by a successful reverb simulator. In condensed form:

(1) A satisfactory simulator probably doesn't have to provide a duration of reverberation (reverberation time) equivalent to that of a typical concert hall. Instead, it should be able to feed off whatever reverberation has been captured in the recording to prolong the reverberation time.

(2) The spectral shape of the reverberant energy will inevitably be altered by the hall in which the music is played. The playback system should copy this spectral change, but it is not the function of the reverberation simulator itself to supply this equalization; nor should it.

(3) The simulator should be capable of closely approximating the arrival-time density of concert-hall reverberation. This density tends to be high.

(4) So far as is possible, the simulator should provide arrival times that are ran-



Fig. 2. The Acoustic Research Digital Time Delay System, showing six of the sixteen speaker channels and a side view of electronics.

domly spaced. Regularly spaced arrivals cause effects such as "flutter echo."

(5) In a concert hall, the reverberant field can't be localized and is diffuse. The simulator's artificial field should have the same characteristics.

As a recipe for a successful reverb simulator (and the Audio/Pulse device has been shown to be capable of successful spatial illusions in several demonstrations), the above five points are gratifyingly straightforward. If we examine current four-channel systems in their light, several points stand out right away. For one thing, the usual rear-channel content of an ambient four-channel recording is merely a more distant miking of what the front channels reproduce. It is localizable in most cases, although localization is diminished somewhat by distance, and fixed microphone spacing and the nature of certain microphone arrays may prevent it from being sufficiently random in arrival times. Does this point the way to any new procedures for quadraphonic recording? Your guess is as good as mine.

AR's Acoustic Arena. Recent work at Acoustic Research has led to an especially interesting research tool for ambience experiments: a sixteen-channel concert-hall simulator (Fig. 2). This may recall Bolt Beranek & Newman's concert-hall simulator, which I described in this column almost two years ago. However, while BB&N's system derives signals from tape delays and reverb chambers, the AR configuration employs simple digital delays determined by a study of computerized models of real acoustical spaces.

To judge from a paper (by Paul Milner) distributed by AR at the AES convention, the AR experiments are beginning to bear fruit in determining the *minimum* and perhaps even *optimum* re-

quirements for creating a spatial illusion. Milner used a six-channel system for his listening tests, with various combinations of simple fixed delays being fed to the four "rear" loudspeakers. By inference, the result was a satisfactory spatial effect. Then Milner progressively narrowed the frequency band over which the delays occurred, to learn at what point the spatial illusion would start to deteriorate. In other words, all four "ambience" speakers always reproduced a full-range signal, but the frequency band over which these signals underwent delays was increasingly narrowed. Outside of the delay band, the signal was not delayed.

Without going further into Milner's procedures, we can tackle the results (gleaned from the statistically analyzed impressions of a small listening panel) right away. They were that, below about 200 Hz, delaying the signal did little or nothing to enhance the spatial illusion. Likewise, eliminating delays above 6 kHz harmed nothing and in some cases improved conditions for certain listening positions in the room where long-delayed sharp transients would otherwise confuse localization.

For a digital delay system, such limiting of the delay bandwidth would bring very attractive reductions in the cost of each channel. And the apparent unimportance of processing frequencies below 200 Hz opens the door to a common bass system instead of full-range speakers for each channel.

These findings have been anticipated by others in the past, but never so well documented under real music-listening conditions. Put the AR results together with those of Audio/Pulse and you may see the emergent beginnings of a truly effective spatial-illusion system—perhaps even a genuine four-channel system—somewhere around the corner. ◇



Audio Reports

TAPE RECORDER HEADROOM EXPLAINED

ALTHOUGH the term “headroom” is frequently used in connection with tape recorders, it is not specifically defined by any single measurement standard. Nevertheless, it is one of the most important characteristics of a tape deck (actually more important in most cases than frequency response) and its significance must be appreciated if one is to realize the machine’s potential.

Every tape recorder has some form of recording level indicator, usually a pair of meters that show the level in each channel and occasionally these are supplemented by a single fast-responding LED indicator that flashes on high-level peaks that are too brief in duration to register on the meters. The relationship between these two levels—the meter reading and the instantaneous peak—is closely connected with the concept of headroom and is the reason for its importance.

The level meter usually indicates the signal voltage present at some part of the recording amplifier. Depending on the characteristics of the recording head and the tape for which the machine is adjusted, the calibrated 0-dB meter level corresponds to some specific flux density recorded on the tape. Each manufacturer is free to choose his own “zero level,” although there are several standard levels used in professional machines and some home recorders.

Flux levels are expressed in nanowebers per meter (nW/m) of tape width. The actual number of flux lines is of little importance to the user. Doubling the width of the recorded track on the tape doubles the number of flux lines passing the playback head gap during a given linear tape movement, which in turn doubles the output voltage from the head. This is the reason for the superior signal-to-noise (S/N) ratio of wider tape formats (e.g., half-track versus quarter-track, or any of the 1/4" tape formats versus cassette tape).

A given tape formulation can be magnetized only up to a certain point before its magnetic coating begins to saturate. Beyond this point, a further increase in recording level does not produce a proportional increase in tape magnetization (and, correspondingly, in playback output). This affects the playback signal in two ways. First, the dynamics of the program are compressed, since a program peak that drives the tape into saturation does not produce more output during playback than a lower level portion of the pro-

gram. Secondly, the distortion of the playback signal increases.

Although the magnetic storage ability of a tape is a function of frequency, we can simplify this discussion by assuming that the tape response is uniform across the audio band. Because of the recording head characteristics, however, it is usually necessary to preemphasize or boost the higher frequencies during recording to obtain a flat playback frequency response. Thus, the maximum tolerable level before which saturation occurs will decrease as the frequency increases. Since this effect becomes more severe at lower tape speeds, a cassette recorder is inherently inferior to an open-reel recorder in its ability to record high levels without saturation, especially at high frequencies.

Now let us return to that recording level meter, whose 0-dB mark supposedly indicates the maximum permissible recording level. It does, but that level is not the same for all machines. Ordinary meters respond relatively slowly to brief transients and may not give any indication on a peak that far exceeds the tape saturation level. Music and voice program material may have instantaneous peaks from 10 to 20 dB greater than their average levels as indicated by a typical level meter. For most amateur recording purposes, the lower figure is probably more realistic, especially if the program has already been recorded or broadcast, in which case its peaks have already been limited.

Suppose that a recorder’s meters have been calibrated to indicate 0 dB when the signal is 5 dB lower than the low-frequency saturation level, which is usually considered to be the level that produces 3% distortion in the playback output. If the average level indicated by the meter is about -5 dB, one can reasonably expect to make a recording without serious peak compression, assuming a 10-dB peak/average ratio. In fact, one can often operate even closer to the 0-dB mark on such a machine (which is typical of many cassette recorders) without serious loss of quality. The headroom of this hypothetical recorder, at low and middle frequencies, is 5 dB. It is the difference between the indicated maximum recording level and the point where tape saturation occurs.

But what about the high frequencies, which are boosted during recording? Obviously, they will saturate with a lower input level than the low and middle

frequencies. Because of this, tape recorder frequency response is measured at a reduced input level, usually -10 to -15 dB for open-reel machines and -20 dB for cassette recorders. A cassette recorder that gives a flat record/playback frequency response at -20 dB will have a marked loss of high frequencies in playback if the recording is made at 0 dB. Our test reports show both curves, giving some idea of the loss of high-frequency headroom, which is largely a function of the design of the recording head as well as of the tape characteristics.

Although each recorder manufacturer selects his own 0-dB level, many use the so-called "Dolby level" of 200 nW/m for cassette recorders. If all recorders used this level as a 0-dB reference, it would be easy to compare their midrange headroom. However, in the design of a recorder, there are trade-offs between frequency response, distortion, and S/N ratio, with each manufacturer selecting his own criteria. If the 0-dB level is set higher than 200 nW/m, the apparent S/N compared to a 0-dB level is increased. This is only "apparent" because the true S/N rating should be referred to the level giving 3% playback distortion instead of to the recorder's 0-dB reference. Since such a recorder will distort with only a slight overload, the user will speedily learn to keep his average recording level around -10 dB, which points up the fallacy of trying to "extend" dynamic range in this way.

The opposite effect occurs when the 0-dB point is set at a lower flux level, as in the Pioneer Model CT-F8282 reviewed this month. Pioneer has made 0 dB correspond to 160 nW/M, which is about 3 dB below the Dolby level. In effect, this gives an extra 3 dB of

apparent headroom over the recorder's zero level before the reference distortion level is reached. When the total frequency-response characteristics of the machine are studied, it can be seen that Pioneer has not attempted to extend the high-frequency response beyond the 13,000-to-15,000-Hz range. Instead, the recording equalization and bias have been matched to the head characteristics to give a rather good high-frequency headroom characteristic so that a strong response is maintained to 10,000 Hz or beyond, even at 0 dB. This makes the published specifications less impressive than they might have been, but it results in cleaner, less compressed recordings. There is little or no audible loss from the attenuation of frequencies beyond 13,000 Hz or so, and the quality improvement from the headroom increase is much more likely to be heard and appreciated by the user.

To interpret our test data on cassette recorders (the same thing applies, to a much smaller degree, to open-reel machines), look at the S/N ratio referred to the 3% distortion level and the meter reading corresponding to that level. This will reveal, in a rough way, how high the average recording levels can be set to realize the full dynamic range of the machine. Then, look at the 0-dB and -20 -dB frequency-response curves to see how much distance there is between them, and if and where they intersect. Most machines have an intersection of these curves between 12,000 and 18,000 Hz but some have curves that never intersect. The greater the gap between the two curves, and the higher their intersection frequency, the better the headroom.



PIONEER MODEL CT-F8282 CASSETTE DECK

Front-load deck features operating simplicity and solenoid controls.



Pioneer's Model CT-F8282 front-loading cassette deck has a two-

motor, solenoid-operated tape transport, with a servo-controlled dc-motor capstan drive. A separate high-torque dc motor operates the tape hubs in fast-forward and rewind. The transport controls are short levers that extend horizontally from the front panel below the cassette well.

They operate with a very light touch, since they merely energize the solenoids that perform the actual mechanical and electrical switching operations. The levers can be operated in any sequence, without going through STOP, obviating the risk of damaging the tape. A separate PAUSE switch is located to the right of the control levers. The deck can be set up in advance for unattended recording or playback, and will go into operation when power is applied by an ex-

ternal timer switch. It shuts down mechanically and disengages the heads when the tape ends.

The styling of the cassette deck matches other Pioneer components. The control panel and controls are satin-finished aluminum, and the wooden case is finished in walnut-grain vinyl. The deck measures $17\frac{3}{4}$ "W \times $13\frac{1}{2}$ "D \times $7\frac{5}{8}$ "H (45 \times 34.3 \times 19.4 cm) and weighs 27 lb (12.3 kg). \$400.

General Description. The cassette is installed vertically through a large opening in the front panel and can be covered by a swing-down clear-plastic window. Unlike other cassette decks, this one does not have an EJECT lever. Instead, with the tape stopped (even in the PAUSE mode) the cassette is simply pulled off the drive hubs and removed by hand. This is just about the simplest and easiest withdrawal system we have seen. It leaves the cassette completely visible while it is in the machine. The re-

cord/playback and erase heads feature ferrite construction.

To the right of the cassette well, the upper portion of the control panel contains two large illuminated level meters that are calibrated from -20 to +3 dB, the latter indicated as the Dolby level for calibration purposes. During playback, the meters show the level actually present at the LINE outputs and are controlled by the OUTPUT level controls. Between the meters, a red LED indicator comes on when the deck is in the RECORD mode and another flashes when program peaks reach +5 dB to warn of potential distortion from over-recording.

Below the meters are a three-digit index counter and four pushbutton switches. One switch activates the MEMORY REWIND feature, stopping the tape in REWIND when the index counter returns to a previously set 000 reading. Another turns on and off the DOLBY system, and an indicator light above the button. The remaining switches are labelled BIAS and EQ, with STD settings for high-performance ferric-oxide tapes and CrO₂ settings for chromium-dioxide tapes or the cobalt-treated equivalent tapes, such as TDK SA and MAXELL UD-XL II. When both buttons are depressed, a CrO₂ indicator above them lights. For recording on ferrichrome tapes, the STD bias and CrO₂ EQ settings are used; CrO₂ EQ should be used for their playback. A chart in the instruction manual suggests switch settings for most popular tapes.

Below the pushbutton switches are concentric INPUT level controls for the two channels and another concentric pair of OUTPUT playback level controls. At the right side of the panel are two 1/4" (6.35-mm) MIC and PHONES jacks. At the lower left of the panel is the pushbutton POWER switch.

On the rear panel of the deck are the input and output phono jacks, a DIN socket, and a switch that connects the recording inputs to either the phono jacks or the DIN socket. The DIN switch also inserts a 10-dB attenuator in the recording inputs and can be used when high-level output microphones are plugged into the front panel jacks (replacing the LINE inputs with the MIC signals) to prevent overloading the input stages. There is also a single unswitched ac outlet on the rear panel.

Laboratory Measurements. Although the instruction manual suggests control settings for many tape types, there was no indication of which specific tapes had been used at the factory for

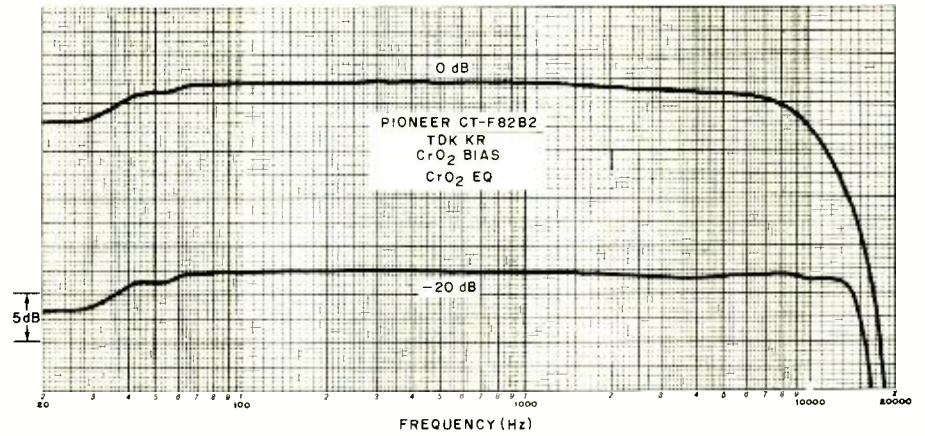

Response with TDK KR tape using CrO₂ bias and equalization.

bias adjustments. Therefore, we measured the record/playback frequency response with a number of high quality tapes, including TDK Audua, SA, and KR (CrO₂), Maxell UD-XL I and UD-XL II, Scotch Master, and two ferrichrome tapes, Scotch Classic and Sony FeCr.

The response varied little among the several ferric-oxide tapes, but TDK Audua seemed to yield a bit better high-frequency response and was chosen for further tests with the STD bias and EQ settings.

The TDK SA and Maxell UD-XL II tapes gave identical responses, but TDK KR gave the flattest overall response and was used with the CrO₂ bias and Eq. The Sony FeCr gave good results with the recommended FeCr settings, but Scotch Classic exhibited the loss of high frequencies, which we have observed in machines that have been biased for the Sony tape. Playback frequency response was measured using the new TDK AC-331 test tape for STD (120 μs) equalization, and with a Teac tape for CrO₂ (70 μs) equalization.

The playback equalization was accurate with both switch settings, varying less than ±1 dB over the 63-

to-10,000-Hz range of the TDK tape and between +1.5 and -3 dB over the 40- to-10,000-Hz range of the Teac tape. Most of the variation in both cases took place below 100 Hz. The record/playback response with TDK "Audua" tape was flat within 0.5-dB overall from 60 to 8000 Hz, dropping off to -3 dB at 35 and 12,000 Hz. Overall, the variation was ±3 dB from 20 to 13,500 Hz. TDK KR tape gave an almost ruler-flat response of ±1 dB from 37 to 13,500 Hz and ±3 dB from 20 to 15,000 Hz. The other tapes were generally similar to the TDK Audua in their response, with the output sloping off gently above 10,000 Hz and more rapidly above 13,000 Hz.

For a recording level of 0 dB, an input of 57 mV was required at the LINE inputs and 0.14 mV at the MIC inputs. The MIC circuit overloaded at a fairly safe 105 mV, which could have been increased to more than 300 mV with the DIN switch. The maximum output level from a 0-dB recording was between 0.6 and 0.75 volt, depending on the tape used. With the OUTPUT control set for a 0-dB meter deflection, the output was 0.5 volt. The PEAK indicator flashed at exactly +5 dB, with an abrupt switching characteristic

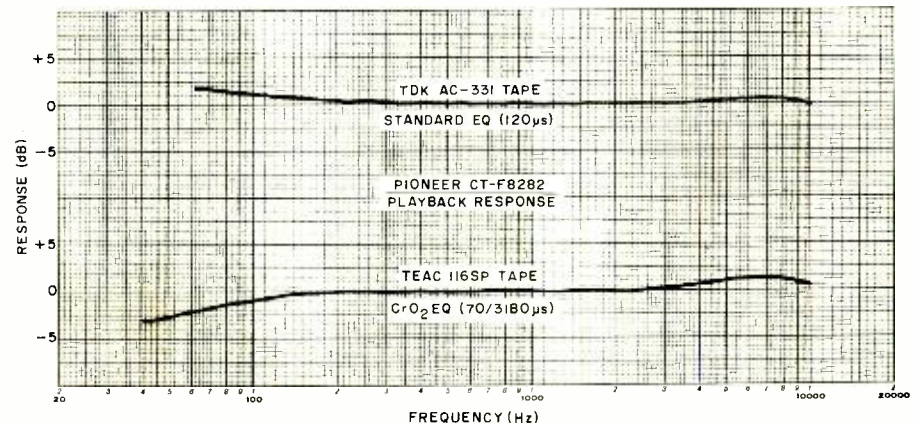

Playback response with two tapes at different equalization settings.

that eliminated the ambiguity sometimes associated with LED-type peak indicators. The meter ballistics were slightly underdamped, giving a 2-dB overshoot with 0.3-second tone bursts. The crosstalk from track 2 to track 1 at 1000 Hz, measured with a TDK AC-352 test tape, was -40 dB.

At a 0-dB recording level (3 dB below the Dolby standard level of 200 nW/m), the harmonic distortion on playback was a very low 0.5% with TDK KR, about 0.9% with TDK Audua, and 1% with TDK SA tapes. The distortion increased gradually up to +5 dB, where it was respectively 0.9%, 2%, and 0.9%. To achieve a 3% playback distortion level, we had to record at +7 dB with Audua, +8 dB with KR, and +8.5 dB with SA tapes. These levels are far off scale on the meters giving the assurance that, so long as the PEAK indicator does not flash more than occasionally, the distortion should be negligible.

The S/N ratio was checked with the three tapes with and without Dolby and unweighted and with IEC "A" and CCIR weighting. The unweighted S/N, referred to the 3% distortion level, was 48 dB with Audua and 54 to 55 dB with the KR and SA tapes. Using "A" weighting and the Dolby system, the S/N was 61.5 dB with Audua and 63 to 64 dB with the other tapes. Using Dolby's preferred CCIR weighting, these figures were improved by 0.5 to 1.5 dB. Through the mic inputs, at maximum gain, the A-weighted noise level increased by 10 dB, but at normal settings of the gain control the increase was much less. On our test unit, the Dolby circuit "tracking" error at a

-20-dB level caused a dip of about 5 dB in the response in the 3000-to-6000-Hz range. At other recording levels, this effect was much less.

The wow was 0.02%, which is approximately the residual of the test tape and flutter (unweighted rms) was 0.1%. In a combined record/playback measurement, the results were identical.

In the fast-forward and rewind modes, a C-60 cassette was moved from end to end in 59 seconds.

User Comment. The "human engineering" that went into the design of the deck makes it very easy to use, especially since there is almost literally nothing one can do to operate it improperly, other than selecting the incorrect bias or equalization. Tape loading and removal procedures are ideal for eye-level operation and nearly as good at waist level. We appreciated not having the cassette pop out noisily as it does on some tape decks, and its insertion and removal are as simple as reaching into the roomy compartment and grasping the sides of the cassette. In addition, the transparent cover allows the exact playing status of the cassette to be seen at a glance, including how much tape remains to be played.

Even though most solenoid-operated tape transports use pushbuttons of one type or another to energize the solenoids, the lever system on this deck is equally convenient to use, with the advantage that the levers remain mechanically depressed after they are pushed. Hence, the operating status of the machine can be seen without re-

course to signal indicators. The very light finger pressure required to operate the levers is an immediate "giveaway" to their electromechanical operation. Another nicety, which we have not seen on many recorders, is the access hole in the cassette head cover for azimuth alignment.

Although, technically speaking, the published record/playback frequency response ratings of the deck were met in our tests, it is clear that the response beyond 13,000 Hz has been slightly sacrificed in favor of low distortion and improved high-frequency "headroom." From the user's point of view, this is the proper compromise to make (and some compromise is always necessary in designing a cassette recorder) since frequencies beyond 13,000 Hz are rarely present in the program material. Their absence will rarely be noticed, whereas distortion, noise, and high-frequency tape saturation will. This deck has above-average performance in each of these respects.

The meters read line output levels in playback, rather than showing the playback level ahead of the OUTPUT control as in most recorders. Also, the usual Dolby level of 200 nW/m as a 0-dB reference is not employed. Pioneer uses -3 dB, or 160 nW/m. These criticisms, to be sure, are minor and do not in any way detract from the fact that the Pioneer CT-F8282 is a fine-sounding, easy-to-use, and handsomely styled tape deck. In the popular-price range (for top-quality two-head machines), the deck compares favorably with any competitive decks in sound and performance.

CIRCLE NO 102 ON FREE INFORMATION CARD

ACOUSTIC RESEARCH MODEL AR-16 SPEAKER SYSTEM

Small, 2-way system delivers true bass, smooth middles and highs.

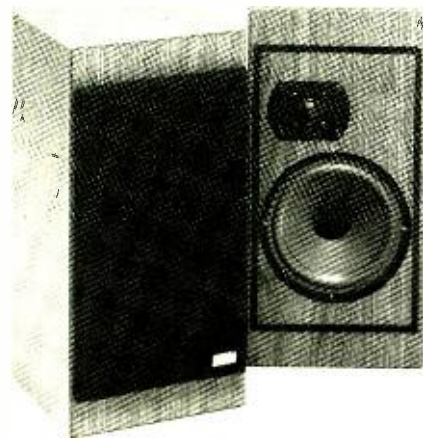

The Acoustic Research people recently have designed some new speaker systems that supplement, but do not at present supersede the older, well-known AR systems. The smallest and least expensive of the new generation of AR speaker systems is the Model AR-16. This true bookshelf-size two-way system has an 8" (20.3-cm) acoustic-suspension woofer that crosses over at 1300 Hz to a 1" (2.54-cm) dome tweeter. A three-position toggle switch on the rear of the enclosure provides a modest increase or decrease in high-frequency output, relative to the normal or "flat" condition.

The compact speaker system measures 19 $\frac{1}{8}$ " \times 9 $\frac{1}{2}$ " \times 8 $\frac{1}{2}$ " D (50.5 \times 25 \times 21.6 cm) and weighs 21 lb (9.5 kg). Value is \$115 with walnut-grain veneer, \$99.95 with walnut-grain vinyl.

General Description. The AR-16's nominal system impedance is 8 ohms, and efficiency is similar to that of many small acoustic suspension systems. AR rates the speaker system to deliver an 85-dB sound pressure level (SPL) at a distance of 1 meter with 1 watt of drive power. Although it can be used satisfactorily with a 25-watt/channel amplifier, the speaker system is designed to withstand the output of a 100-watt/channel amplifier, driven to clipping 10% of the time with ordinary music program material. According to AR, the free-air resonance of the woofer is 25 Hz, and system resonance is at 55 Hz.

CB servicing is PROFITABLE with the B&K-PRECISION 40-channel CB Test Bench



MODEL 1040
\$250

The B&K-PRECISION CB service-master is designed for rapid programmed testing and trouble shooting of any CB transceiver—even 40-channel models!

When used with a scope and signal generator, you can:

- Measure signal-to-noise ratio of CB receiver
- Measure audio output power
- Measure audio distortion percentage
- Measure receiver sensitivity
- Check AGC
- Measure effectiveness of CB noise limiter or blanker (when used with an impulse noise generator)
- Measure squelch threshold
- Measure adjacent channel rejection on any channel
- Measure transmitter AM power output—even mobile!
- Measure SSB power output with TRUE peak-reading RF Wattmeter
- Check AM modulation
- Check SSB modulation with a two-tone test—the only accurate way!
- Measure antenna SWR—even mobile!
- Check the transceiver in the car to determine if the problem is in the antenna system or the transceiver

You can save \$500—\$1,500 in equipment costs because the CB Servicemaster eliminates many of the test instruments you would otherwise need for CB servicing. These instruments, or their functions, are built into the unit:

- Audio wattmeter • Audio generator • Distortion meter • RF wattmeter/dummy load • DB meter • SWR bridge

These instruments—which you should have, if you don't own them already, are all you need to get the maximum use from your CB Servicemaster. And the B&K-PRECISION CB Servicemaster is compatible with most oscilloscopes, frequency counters, signal generators and power supplies on the market today.



MODEL 1403A—3", 5 MHz
Recurrent Sweep Oscilloscope

Checks CB modulation and provides viewing of 27MHz CB envelope when used with the Model 1040. Small, compact and inexpensive, it frees other scopes for more effective use. \$209



MODEL 1640—Regulated Power Supply

Designed especially for CB and other mobile equipment, the 1640 eliminates changes in supply voltage due to load variations. A stable power supply is essential to precise testing of the transceivers. Less than 0.8% variation from zero to full load, 3 amps continuous, 5 amps surge. Adjustable to any output from 11 to 15 VDC. Suppressed zero scale for greater accuracy. Overload protected. \$100

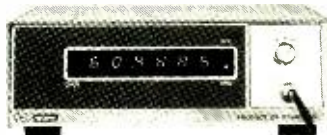

MODEL 1801—
Digital Frequency Counter

To quickly determine the exact frequency of a CB channel, the 1801 automatically displays it for you in large, easy-to-read digits. You can tune oscillators precisely, conduct audio frequency analysis tests. Six digit display is updated five times per second. Accuracy guaranteed to 40MHz; 60MHz typical. \$240

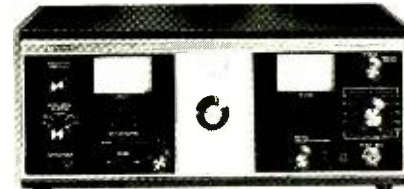

MODEL 2040—40-Channel CB Signal Generator

Covers all 40 channels, AM and SSB with built-in capability. Ultra-stable crystal-controlled, phase-locked-loop frequency generation. Has 5 ppm accuracy. Output attenuator and vernier provide calibrated outputs from 100,000 μ V to 0.1 μ V for receiver sensitivity measurements. Includes EIA standard noise test signal generator to check receiver noise suppression. Internal 400, 1000 and 2500 Hz modulating frequencies—can also be externally modulated. Internal protection against 5W RF input. \$475

B&K PRECISION DYNASCAN CORPORATION
Makers of Cobra CB Equipment

6460 W. Cortland Avenue, Chicago, Illinois 60635 • 312/889-9087
In Canada: Atlas Electronics, Ontario

For additional information, contact your B&K-PRECISION distributor for our comprehensive brochure describing the operation of the Model 1040 CB Servicemaster and the CB Service Center—or write us for your free copy.

CIRCLE NO 14 ON FREE INFORMATION CARD

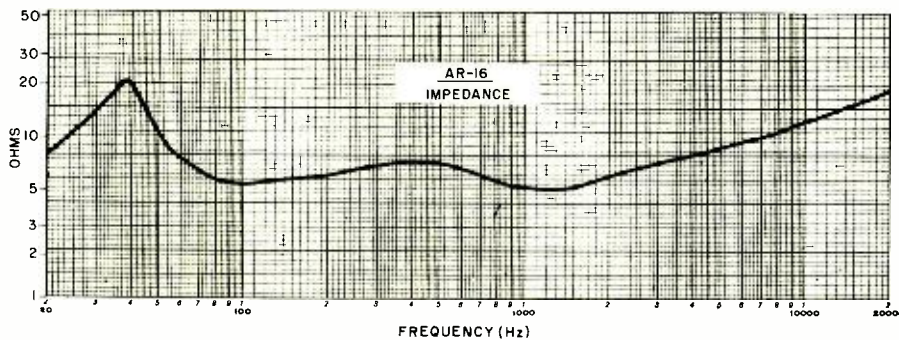

Impedance curve shows peak slightly below rated system resonance.

To minimize diffraction effects, which can occur when the speaker drivers are recessed behind the mounting board and which can produce an irregular polar response, the drivers are mounted flush with the front surface of the speaker board. The front is finished to match the rest of the cabinet, and the drivers are covered by a removable acoustically transparent foam plastic grille.

Laboratory Measurements. The frequency response of the speaker system was measured in the reverberant field of our test room at a distance of 12' to 15' (3.7 to 4.8 m) from the speakers over a frequency spectrum ranging from 100 Hz upward. The woofer response, up to several hundred hertz, was measured with a closely spaced microphone to simulate anechoic conditions and eliminate the influence of the room on the measurement. Splicing the two curves, and correcting for the known response of the microphone and room, we obtained an unusually "flat" frequency response of ± 1.5 dB from 100 to 15,000 Hz. There was a 3.5-dB rise at the bass resonance of about 60 Hz. The overall response variation was an impressive ± 2.5 dB from 30 to 15,000 Hz.

Our measurements were made with the tweeter switch set to NORMAL. A boost or cut of 3 to 5 dB at frequencies above 1500 Hz was measured with the

switch set to its other positions. Driving the speaker with the equivalent of 1 watt into an 8-ohm load (2.8 volts), the total harmonic distortion (THD) below 100 Hz was less than 2% down to 45 Hz and increased smoothly to 10% at 33 Hz and 20% at 26 Hz. When we increased the drive level to 10 watts, the distortion characteristic had a similar shape, but the actual distortion levels were considerably higher. The measured distortion at 10 watts was between 3% and 7% from 100 to 45 Hz and increased to 20% at 36 Hz.

The system impedance was about 6 ohms at its minimum points of 100 and 1300 Hz, but it was typically 6 to 8 ohms over much of the audio range. It rose to a peak of 20 ohms at 38 Hz (well below the rated system resonance of 55 Hz) and climbed smoothly beyond 2000 Hz to 20 ohms at 20,000 Hz. The impedance was not significantly affected by the setting of the tweeter level switch.

In our "efficiency" measurement (actually a sensitivity measurement), when the speaker system was driven at a nominal 1-watt level by an octave of random noise centered at 1000 Hz, the SPL was 91 dB at a distance of 1 meter from the front surface. This is slightly higher than we have measured from some other larger acoustic-suspension systems, even when allowance is made for the 1.25-dB apparent increase in efficiency

due to the actual impedance's being 6 ohms instead of 8 ohms at the test frequency.

Noting that there was no sign of the crossover frequency in the response curve, we carefully examined the tone burst response in the crossover region as well as at lower and higher frequencies. We could find no trace of the anomaly that sometimes occurs in the tone-burst response at the crossover point. The tone bursts were reproduced very well at all frequencies.

User Comment. In the simulated live-versus-recorded listening test, the Model AR-16 was a very accurate reproducer, though not quite "perfect" on any of the music selections we used in this test. The departures from facsimile reproduction of the live sound were difficult to define in terms of frequency response. In general, they took the form of a slight "coolness" or "dryness" in the lower midrange. It is in this frequency range that the speaker system was notably free of the artificial emphasis that is all too common with other systems.

The sound from the Model AR-16 belies its compact dimensions. It is not surprising, though nonetheless gratifying, to find a small, inexpensive speaker system that can deliver a smooth, well-dispersed middle- and high-frequency response, but we have come to expect a certain thinness of low bass from such systems. This was not our experience with the Model AR-16; it can deliver a room-filling, true bass when required.

This is not a speaker system that can be played loud enough to rattle the walls, unless you are willing to accept appreciable distortion levels. The 10-watt distortion curve clearly illustrates that, although the woofer does not "fall apart" when driven hard, it is not at its best under these conditions. AR suggests that a pair of Model AR-16's, driven with 25 watts/channel of amplifier power will produce a 103-dB SPL in a typical 3000 cu ft (85 cu m) living room. We did not attempt to verify this because we were satisfied that the speaker system is more than equal to the task of supplying larger-than-life, clean sound in a typical home environment, with no obvious coloration.

The Model AR-16, in our opinion, is a worthy addition to the AR product line. Comparing it to its predecessors should convince anyone that there has been substantial progress in speaker system performance, much of which is embodied in this diminutive system.

CIRCLE NO 103 ON FREE INFORMATION CARD

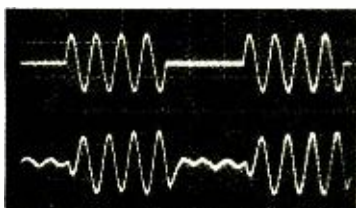

Tone-burst responses at 100 Hz (left), 1300 Hz (below left), and 10,000 Hz (below).

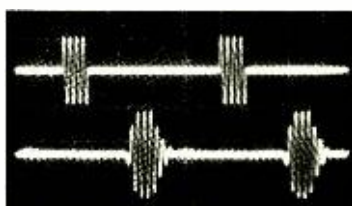
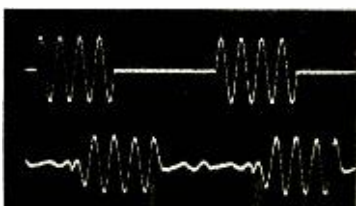

afs® / Kriket® CB speaker Sound and Safe!



kamel™

Hump-mount speaker

Speakers are our only business.

They have to be better!

Designed with security and superior sound in mind, the AFS / KRIKET KAMEL KC-3085 hump-mount external speaker rests snugly on the transmission hump while driving. CB dials are readily visible.

CB transceiver mounts on speaker base forming single unit. No installation problems. For maximum security, unplug antenna and power leads, lift unit and place in trunk. No screws to unscrew. No hassle. No annoying rattles while driving. Solid!

"WORKING WALL" enclosure of cross-lam-nated fiberboard deadens static and channel noise, eliminates voice distortion.

AFS makes having an expensive CB rig in your car or truck safe and worthwhile. Isn't it about time somebody did?

Kriket Cares™

Available at CB dealers everywhere



ACOUSTIC FIBER SOUND SYSTEMS, INC.
7999 KNUE ROAD, SUITE 116 - INDIANAPOLIS, INDIANA 46250 (317) 842-0620

Canadian Distributor Muntz Canada Ltd. 1149 Pioneer Road Burlington Ontario, Canada (416) 639-5373

All AFS®/KRIKET® speakers are manufactured in the U.S.A. using American materials and craftsmanship.

Copyright 1976 Acoustic Fiber Sound Systems, Inc.

www.americanradiohistory.com

Experience the excitement of owning the finest *personal* computer – IMSAI 8080

Waiting for you -- all the incredible performance and power of the IMSAI 8080. And at a price you would normally pay for a home music system: \$699 in kit; \$931 assembled.

WORLD OF USES

The IMSAI 8080 is a superbly engineered, quality computer. It is versatile, expandable and powerful, putting literally hundreds of

applications and uses at your fingertips. Imagine sitting at your desk and enjoying interaction with your IMSAI 8080! Press the on switch and you're ready for game playing, research, education, business applications, or for laboratory instrument control. It has all the power you need, and more, to make your application ideas come alive.

GROWS WITH YOU

The IMSAI 8080 is designed for many years of pleasure. With its open-chassis engineering you can expand your system by adding peripherals and interfaces. The 22-slots and 28 amp power supply mean that you can plug-in today's, plus tomorrow's modules.

Right now you can add a module for displaying color graphics and characters on TV; a ready-to-use keyboard; small and large printers, and a single interface that lets you attach multiple devices including a cassette tape recorder. Expect the latest, exciting equipment from IMSAI. We are committed to leadership in this, expanding technology.

EASY TO PROGRAM

With our BASIC language you can operate the IMSAI 8080 quickly and easily. Technically knowledgeable? Use our assembly language to develop sophisticated and unique software.

**If you're thinking personal computer,
treat yourself to the very best –
IMSAI 8080**

Send for free four-color brochure
or \$1 for catalog. Call or write for
name of nearest dealer.

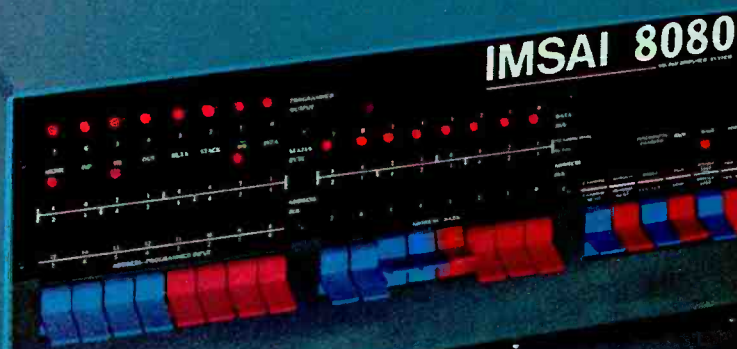

IMSAI

IMSAI Manufacturing Corporation
14860 Wicks Blvd.
San Leandro, CA 94577
(415) 483-2093
TWX 910-366 7287

European Distributor
Harper Industry Products, Ltd.
6079 Sprendlingen 2
West Germany

Prices: USA Domestic

CIRCLE NO. 35 ON FREE INFORMATION CARD



MULTIMETERS FOR ELECTRONICS

BY CLAYTON L. HALLMARK

PART 2: *Digital Multimeters*

LAST MONTH, we discussed the traditional VOM and analog, or meter-type, electronic multimeters. Here, the focus is on the newest type of electronic multimeter—the digital multimeter, or DMM.

DMM's offer most of the advantages of analog-type instruments, plus a few that are unique. The use of numeric displays in place of meter movements, for example, makes reading measurements easier and eliminates interpretation errors common with multi-scale analog meters. They also make possible a more

accurate instrument, since a measurement with more digits is obtained than is possible with an analog instrument.

Technical Details. The accuracy of a DMM is stated in percentage of reading, rather than in percentage of full-scale. This means a more uniform accuracy throughout a given range. To illustrate, a DMM with a 2% accuracy on the 100-volt dc range would be accurate to within 2 volts at 100 volts and 0.4 volt at 20 volts. Therefore, at 20 volts, the DMM would be five times as accurate as

the analog meter. (In practice, this disparity might be even greater, considering that many DMM's are more accurate than the 2% figure in our example.)

In addition to the stated accuracy, the DMM may be off by ± 1 count in the least-significant (farthest right) digit. This means that, if 1000 volts is displayed by an instrument with a 0.1%, ± 1 digit accuracy, the actual potential being measured can be anywhere between 998 and 1002 volts, based on a deviation of 1 volt for the 0.1% error and 1 volt for the one-digit error.

Ac accuracy. Ac voltage accuracy is usually somewhat worse than the dc accuracy and is usually limited to a specified bandwidth. Outside the specified frequency range, the accuracy drops off rapidly. Also, ac accuracy is usually specified for a sine-wave input; any other type of waveform will degrade the accuracy. In addition, distorted sine waves produce serious accuracy errors.

Resistance power. Sounding like a contradiction in terms, resistance power simply means how much current/voltage will be applied to the device under test by the DMM when using the instrument in the resistance-measuring mode. On low ohmic ranges, the excessive current or voltage can be sufficient to damage sensitive semiconductors.

Protection. You will pay good money for a DMM, so you will want to use it as long as possible. Always keep in mind that someday you might use the resistance-measuring function to try to measure line voltage. Unless your meter is protected on all ranges and functions, it will likely be damaged beyond repair. And if you accidentally set it up on the wrong range or function, it may cost almost as much to repair as to replace it, if it is damaged.

Ruggedness. If you are going to use your DMM in the field, make sure it has an "impact-resistant" case and, if possi-

ble, a case that will protect the knob and switch controls and display from damage if the instrument is dropped onto a hard surface on its face.

Digits. A common way of classifying DMM's is by the number of digits in its display. This can often be confusing because an instrument that displays a maximum count of 1999 has 3½ digits, not 4 as a first glance might lead you to believe. The initial digit is actually a half digit that is either blanked or displayed as a 1 and only a 1. The half digit is sometimes called the "overrange" digit, since it permits measurements to be made somewhat beyond the selected range.

If a 3-digit instrument with overranging is used to measure a potential that changes from 99.9 to 100.2 volts, the second potential could be read to the nearest 0.1 volt without having to change ranges. Without overranging capability, the meter would have to be



B&K Precision Model 280 (shown also on preceding page).

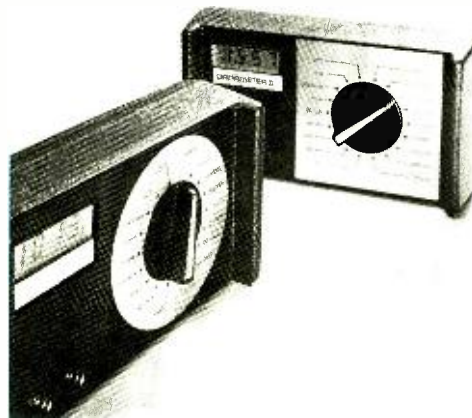

Danameter 2000A and Danameter II 2000A

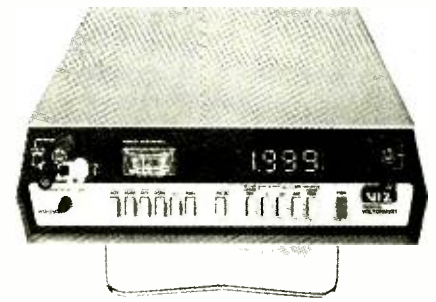

Viz WD-750A VoltOhmyst

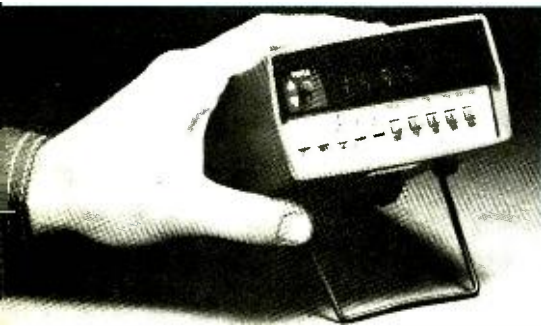

John Fluke Model 8030A



Simpson Model 380

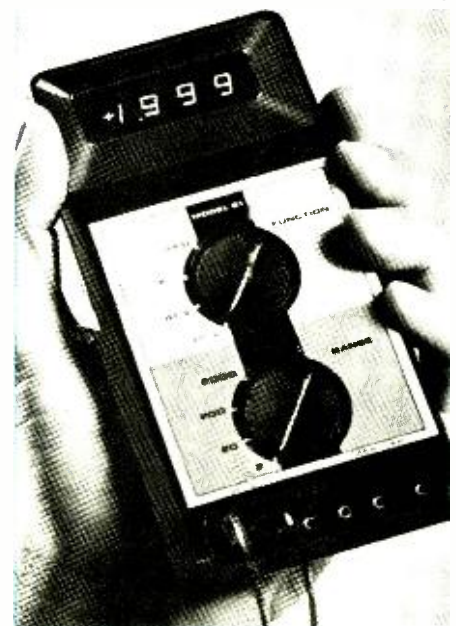

Data Tech Model 21

Shakespeare's White Knight. The best antenna going. And coming.

Shakespeare comes on strong for the new 40 channel era. With high performance CB antennas that turn on the power on all 23 or 40 channel CB transceivers.

Shakespeare's new White Knight Antenna combines the rugged, mechanical strength of gleaming white fiberglass with precision engineered electronic components. Components like the high quality loading coil permanently fused in a solid polycarbonate thermoplastic base. Totally impervious to the environment. And pre-tuned to an SWR of 1.9 to 1 or less over the 40 channel band (1.3 to 1 or less at the center). To assure maximum range and peak performance everytime you key the mike. That's what sets the White Knight antenna apart from all the others.

Ride full tilt into the 40 channel era with the new White Knight CB Antenna. And take the Shakespeare performance route home.

The White Knight Antenna.
Style 430/available in a variety
of pre-assembled mounting
styles. Complete with cables
and connectors. Under \$25.



Shakespeare

Coming on strong for the Knights of the Road.

Shakespeare Company/Antenna Group, P.O. Box 246, Columbia, S.C. 29202
In Canada: Len Finkle Ltd., Ontario.

switched to the 1000-volt range, where it would correctly indicate 100 volts to the nearest 1 volt instead of the nearest 0.1 volt.

Overranging. This is sometimes specified as a percentage by which this feature extends the range capability of the instrument. Hence, if a 4½-digit DMM has a maximum display capability of 19999, it is said to have 100% overranging because 19999 is about 100% greater than 9999. And if a 4½-digit DMM has a maximum display count of 11999, it is said to have 20% overranging because the maximum without overranging would be 9999.

Resolution. A related DMM specification is resolution, which is one part in the maximum reading. The resolution of a 4-digit instrument with 20% overranging is one part in 11,999.

Sensitivity. This is sometimes confused with resolution and is the lowest displayable increment of voltage that is

represented by the least-significant digit in the display when the meter is set to its lowest range. A 4-digit meter with a 100-mV lowest range and the capability of displaying 100.00 mV has a sensitivity of 10 microvolts.

DMM's For Servicing. There are many digital multimeters from which the service technician and hobbyist can choose. (A list of manufacturers of such instruments is given in the table. The manufacturers can supply technical literature and prices for the digital instruments they make.) Most instruments for servicing and hobby use are in the low- and moderate-price ranges. They offer a wide variety of ranges, functions, and features that can be matched to just about any test and measurement job you might have.

Controls. The front-panel controls and jacks on most DMM's are similar to and serve the same purposes as in the

VOM. This means that the typical DMM is operated in a manner similar to that of a VOM. The RANGE and FUNCTION switches in DMM's are generally separate controls. The "hot" input jack is usually labelled $v \Omega$ for ac and dc voltage and resistance and MA for ac and dc current, both referenced to a COM jack. Some DMM's also have a ZERO control that is used to set the display to all zeros when the two test probes are shorted to each other.

Overrange indication. The "overrange" indication is displayed whenever the input to the instrument is greater in magnitude than the setting of the RANGE switch allows. In some instruments, the indicator for this condition is an OVER (or OVERRANGE) lamp, while in others the overload is indicated by a 1 in the half-digit position with the other digits blanked or by some other distinctive display feature.

Polarity display. Almost all modern

(continued on page 38)



Data Precision Model 175



Hewlett-Packard Model 3476A

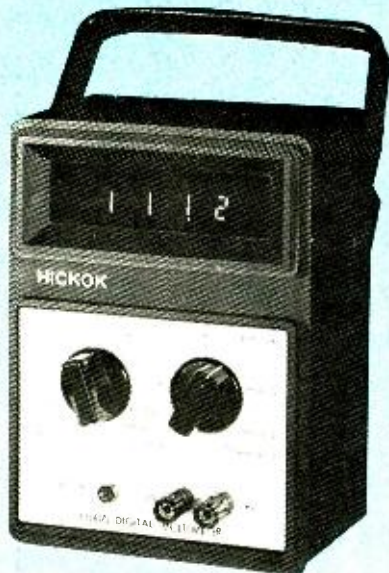

Hickok Model 3300A



Heathkit Model IM-102



Sencore Model DVM35



Non-Linear Systems Model LM-3.5

The ultimate base

For people who want the finest in CB radio, there is the Tram D201 base station. Each base station is hand assembled with care, patience and infinite skill to produce a radio with superb performance and a host of outstanding features.

The Tram D201 base station is rigidly inspected and subjected to the industry's most thorough and demanding testing procedures. The result is a distinctive precision instrument created by craftsmen for people who appreciate owning the very best.

Find out more about the ultimate base and the complete line of Tram mobile CB radios. Send for a free brochure or see your local CB dealer.

The mark of CB quality since 1960

TRAM TRAM/DIAMOND CORPORATION
Lower Bay Road, P.O. Box 187, Winnisquam, NH 03289
(603) 524-0622.



CIRCLE NO. 37 ON FREE INFORMATION CARD

www.americanradiohistory.com

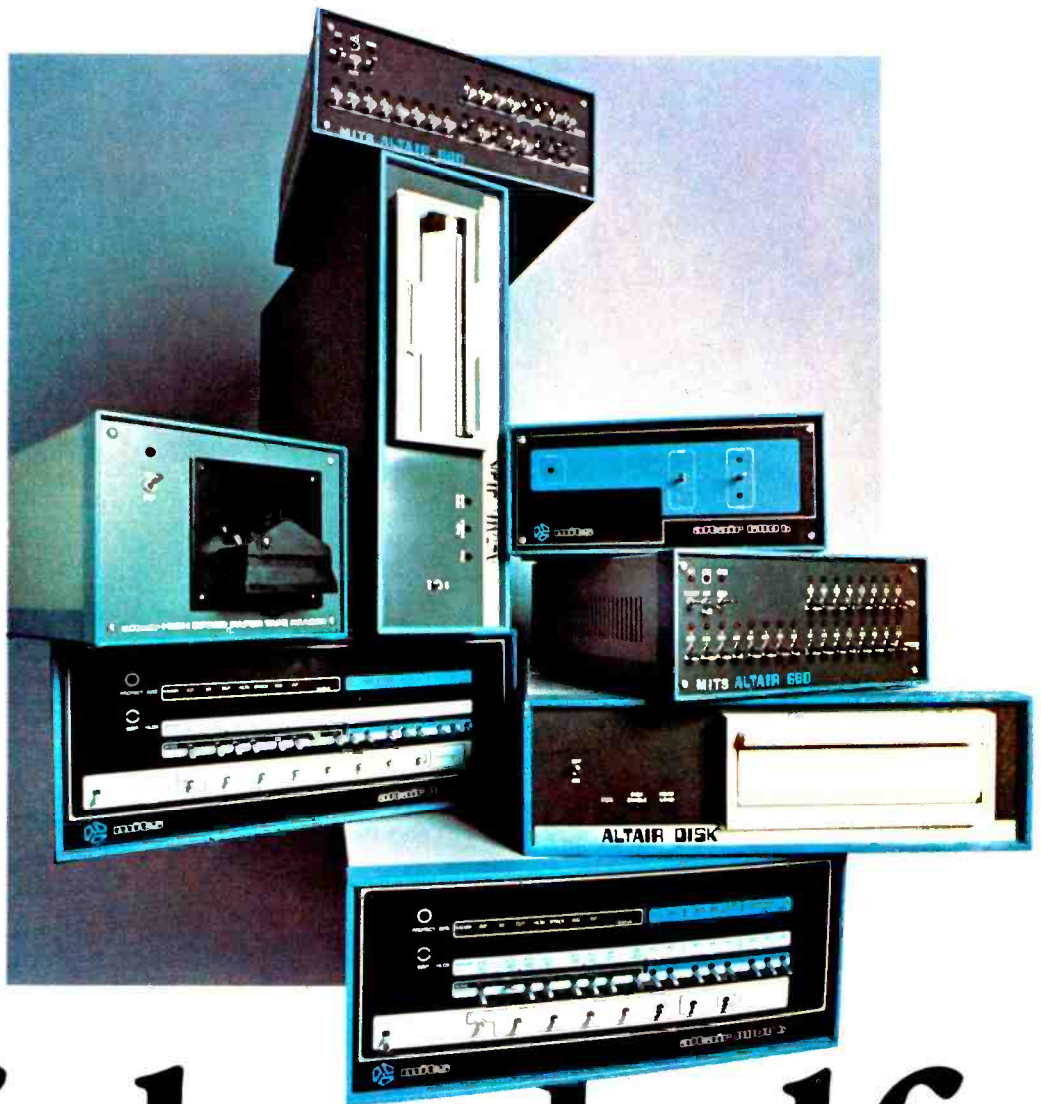

Now you can buy an Altair™ 8800b or an Altair 680b computer right off the shelf. Altair plug-in boards, peripherals, software and manuals are also available. Check the list below for the MITS dealer in your area.

off the shelf.

ALTAIR COMPUTER CENTER
8105 SW Nimbus Ave
BEAVERTON, OR 97005

COMPUTER KITS (S.F. area)
1044 University Ave
BERKELEY, CA 94710
(415)-845-5300

THE COMPUTER STORE
(Arrowhead Computer Co.)
820 Broadway
SANTA MONICA, CA 90401
(213)-451-0713

GATEWAY ELECTRONICS, INC.
OF COLORADO
2839 W. 44th Ave
DENVER, CO 80211
(303)-458-5444

COMPUTER SHACK
3120 San Mateo N.E.
ALBUQUERQUE, NM 87110
(505)-883-8282, 883-8283

ALTAIR COMPUTER CENTER
4941 East 29th St
TUCSON, AZ 85711
(602)-748-7363

ALTAIR COMPUTER CENTER
2801 Cornhusker Hwy
LINCOLN, NB 68504
(402)-466-1853, 466-6759

COMPUTER PRODUCTS UNLIMITED
2412 Broadway
LITTLE ROCK, AR 72206
(501)-371-0449

ALTAIR COMPUTER CENTER
110 The Annex
5345 East Forty First St
TULSA, OK 74135
(918)-664-4564

ALTAIR COMPUTER CENTER
5750 Bintliff Drive
HOUSTON, TX 77036
(713)-780-8981

COMPUTERS-TO-GO
4503 West Broad St
RICHMOND, VA 23230
(804)-335-5773

MICROSYSTEMS (Washington, D.C.)
6605A Backlick Rd
SPRINGFIELD, VA 22150
(703)-569-1110

THE COMPUTER STORE
Suite 5
Municipal Parking Building
CHARLESTON, W. VA. 25301
(304)-345-1360

THE COMPUTER ROOM
3938 Beau D'Rue Drive
EAGAN, MN 55122
(612)-452-2567

THE COMPUTER STORE
OF ANN ARBOR
310 East Washington Street
ANN ARBOR, MI 48104
(313)-995-7616

THE COMPUTER STORE, INC.
(Hartford area)
63 South Main Street
WINDSOR LOCKS, CT 06099
(203)-627-0188

CHICAGO COMPUTER STORE
517 Talcott Rd
PARK RIDGE, IL 60068
(312)-823-2388

GATEWAY ELECTRONICS, INC.
8123-25 Page Blvd
ST. LOUIS, MO 63130
(314)-427-6116

BYTE TRONICS
Suite 103
1600 Hayes St.
NASHVILLE, TN 37203
(615)-329-1979

THE COMPUTER STORE, INC.
120 Cambridge St
BURLINGTON, MA 01803
(617)-272-8770

ALTAIR COMPUTER CENTER
269 Osborne Road
ALBANY, NY 12211
(518)-458-6140

THE COMPUTER STORE
OF NEW YORK
55 West 39th St
NEW YORK, NY 10018
(212)-221-1404

THE COMPUTER SYSTEMCENTER
3330 Piedmont Road
ATLANTA, GA 30305
(404)-231-1691

MARSH DATA SYSTEMS
5405 B Southern Comfort Blvd
TAMPA, FL 33614
(813)-886-9890



CIRCLE NO. 43 ON FREE INFORMATION CARD

GOING FROM ANALOG TO DIGITAL

Digital circuits cannot by themselves measure such analog parameters as voltage, current, and resistance. It is necessary, therefore, for the digital circuits in a DMM to be preceded by analog-to-digital (A/D) converters that present analog information in a form that digital circuits can use. Essentially, the A/D converter feeds a set number of pulses to the digital counting circuits, the number of pulses depending on the magnitude of the parameter being measured. The greater the magnitude of the analog parameter (or the longer a gate is held open), the greater the number of pulses delivered to the counting circuits. There are basically two types of converters used in DMM's today. One is the single-slope converter shown in diagram A, the other is a dual-slope converter, shown in diagram B.

The single-slope converter, used in many low-cost DMM's, contains a capacitor that is linearly charged from a constant-current source. The potential across the capacitor is applied to the inverting (-) input of a voltage comparator, a form of operational amplifier. The unknown voltage to be measured is applied to the noninverting (+) input of the comparator. In a voltage comparator, when the potential at the + input is greater than that at the - input, the output from the comparator is high.

As the potential across the capacitor, and hence across the - input of the comparator, reaches a level that just slightly exceeds, by a few millivolts, the potential at the + input, the comparator switches to a low-output state.

The output of the comparator is fed to a three-input gate, along with the pulses from a stable oscillator of known frequency and a control signal that can be either high or low. When both the comparator and control signals are high, the oscillator pulses can pass through the gate and on to the counter circuit. If either the comparator output or the control signal are low, the gate will be disabled, preventing the oscillator pulses from passing through to the counter.

In operation, the control signal causes the counter to reset to zero and, via elec-

tronic switching, turns off the gate and discharges the capacitor. Hence, the oscillator signal cannot pass through the constant-current source. As the unknown voltage at the input is greater than the potential across the capacitor, the output of the comparator is high and allows the oscillator signal to pass on to the counter. As soon as the capacitor potential exceeds the unknown voltage, the comparator switches state and disables the gate, preventing any more oscillator pulses to be passed on to the counter. Another signal then causes the display to indicate the state of the counter. After a predetermined interval, the special control signal resets the gate, discharges the capacitor, and prepares for the start of a new cycle.

Note that the accuracy of the single-slope converter depends on the stability of the oscillator, voltage comparator, and constant-current source and the quality of the capacitor. Noise on the input signal can produce faulty indications in this system.

Better digital multimeters use dual-slope conversion (circuit B). This system also uses a capacitor that is charged by a constant-current source, but charging is performed by an integrator circuit, using an op amp. In this manner, the capacitor can be linearly charged and then linearly discharged to provide the voltage/time conversion required. This eliminates long-term drift due to component instability, temperature variations, and noise on the input signal and provides for better accuracy, the last between 0.5% and 0.01%.

In circuit B, let us assume that the system has been reset so that the integrating capacitor has been discharged and the counter/display is at zero. The control signal connects the comparator input to the unknown input voltage, which is negative in this case. Due to the arrangement of the circuit, at time T_0 , the output at the integra-

tor will be slightly negative and the output of the comparator, whose + input is referenced to ground, will be low. Under these conditions, the gate will not allow the oscillator signal to pass through, since its other input is low.

The unknown potential at the input applied to the - input of the integrator causes the op amp to charge the capacitor. As this voltage passes through zero (time T_1), it turns on the comparator which, in turn, allows the oscillator pulses to pass through the gate to the counting circuits. The capacitor continues to charge and the counter continues to count until it reaches, in this case, the 10-volt count. At this time, the counter generates an "overrange" signal. The overrange signal occurs at time T_2 and electronically switches the integrator input from the unknown input voltage to an internal fixed dc reference voltage of positive polarity. Note that the time from T_1 to T_2 completely fills the counters once. This time is not fixed because the charging rate is determined by the level of the unknown voltage. A high voltage reduces the T_1 -to- T_2 period, while a low voltage increases it.

At time T_2 , the reference voltage starts the integrator in the opposite direction and linearly discharges the capacitor. The reference voltage is held stable by internal circuitry. The linear discharge continues, as does the count (gate held open by the high level of the comparator's output), until the decreasing ramp passes through zero (time T_3), forcing the comparator to change output state and shut down the gate to stop the counter.

When the gate shuts down, the counters display a count that is directly proportional to the ratio of the unknown voltage to the reference voltage. If a high-quality integrator capacitor and a stable reference voltage are used in the circuit, the accuracy of the system can be quite good.

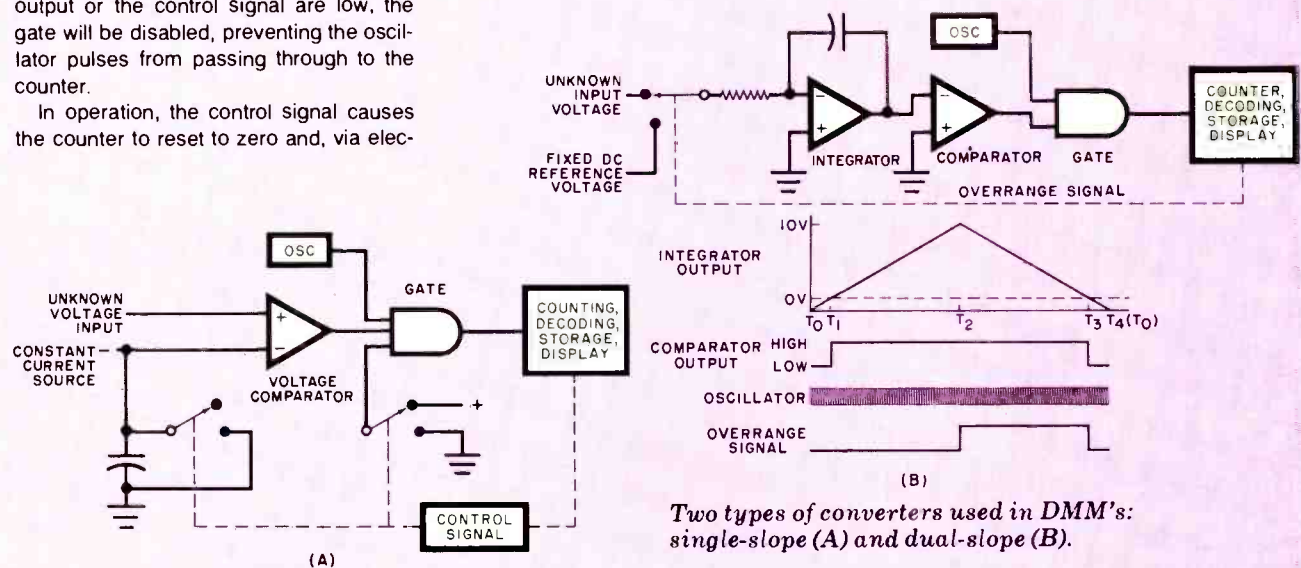

Two types of converters used in DMM's: single-slope (A) and dual-slope (B).

COMPARISON OF METER SPECIFICATIONS

	DVM	VTVM	FETVOM	VOM
Accuracy (%)	(S*) 0.1-2 (L*) 0.4-0.004	3-5 1-3	3-4 1-2	1-5
Frequency Limit	(S) 20Hz-20 kHz (L) To 100 MHz	To 4 MHz, 250 MHz with probe To 700 MHz	To 3 MHz, 250 MHz with probe To 1 MHz, 500 MHz with probe	To 100 kHz
Ac impedance	(S) 10 megohms (L) 1-10 megohms	10 megohms 10 megohms	1-10 megohms 10 megohms	0/5 kilohms per volt 20 kilohms per volt Avg.
Waveform response	(S) Avg. (L) Avg., rms	Peak, p-p Avg., rms	Peak, p-p Avg.	Avg.
Voltage readings (min. and max.)	(S) 10 μ V- 1000 V (L) 1 μ V- 1000 V	0.2 mV- 1500 V 20 μ V- 1000 V	0.1 mV- 1500 V 200 μ V- 1000 V	5 mV- 6000 V
Resistance readings	(S) 1 ohm- 10 megohms (L) 0.0001 ohm- 10 megohms	0.2 ohm- 1000 megohms 0.2 ohm- 5000 megohms	0.2 ohm- 1000 megohms 0.2 ohm- 500 megohms	0.2 ohm- 100 megohms

*S = Service type. L = Laboratory type.

DMM's feature automatic polarity indication in the display, activated by internal circuitry according to the polarity of the dc voltage or current being measured. (In some instruments, + is implied, while other instruments display both + and -.) With the autopolarity feature built into a DMM, there is no need to transpose test probes or to flip a polarity-reversing switch, which further simplifies instrument operation. And positioning of the decimal point in the display is also automatic whenever the RANGE switch is operated.

Probes. Some DMM's come with probes that have switchable isolation resistors in them to prevent capacitive loading when making dc voltage and r-f circuit measurements. High-voltage and r-f probes are also available to extend a meter's basic voltage and frequency ranges.

Since most DMM's are average-sensing and rms-calibrated, any input other than a pure sine wave on the ac function can cause an error in the reading obtained. At low signal levels, the ± 1 -count ambiguity can lead to serious measurement errors. If a 3-digit DMM is set to the 0.1-volt range and the indicated display is 0.010, for example, the one-count ambiguity would mean that the true potential could be 0.009 or 0.011 volt, an error of 10%.

Choosing a DMM. You must determine which type of DMM best suits your needs. If you plan on using your DMM

as a bench-only instrument, a line-powered DMM will probably be your first choice. On the other hand, if you intend to use your DMM almost exclusively in the field, battery power is a must. An instrument that must be used for both field and bench testing should be capable of being operated on battery power in the field and line power on the bench.

The number of digits in the display will influence the type or model instrument you choose. In most cases, every added digit boosts the cost of the DMM. So, if you are working with 20% resistors and capacitors and most schematic diagrams indicate tolerances to only two decimal places, a 2½-digit DMM is all you really need. Of course, if you are working with high-level technology, do not look for an instrument with less than 3½ digits in the display.

The type of display you choose may also be important. The three most popular types used in DMM's today are the red LED, orange gas-discharge, and LCD (liquid crystal display) displays. Except for the gas-discharge type, which can be either seven-segment or individual 0-through-9 format, the displays are arranged in seven segments. For most indoor work, the LED display is convenient. You can work with an instrument with a LED display even where ambient light levels are quite low, since the display itself lights up. For outside work, where the ambient light is very bright, a LED display is likely to wash out and become unreadable unless a light hood is used. Here, the LCD offers a high degree of legibility, since contrast increases with increasing light levels. The disadvantage of the LCD is that it is very difficult to read when the light level is relatively low. The gas-discharge display bridges the gap between the LED and LCD displays.

Although most DMM's that would be used by the experimenter/hobbyist have a 10-megohm input resistance, you may find instruments with different input impedances specified. Keep in mind that the input resistance will be in parallel with the device or circuit being measured and that even a 10-megohm input resistance across a 10,000-ohm load represents a loading error of 0.1% that must be added to the instrument's accuracy specifications. If you are thinking of using a DMM with a 1000-megohm or greater input resistance to avoid loading effects, remember that changing temperature will introduce errors in the measurement. Also keep in mind that there is quite a difference between input resistance and input impedance. Input

DMM MANUFACTURERS

- Ballantine Laboratories, Inc.**
Box 97, Boonton, NJ 17005
- B&K Precision**
6460 W. Cortland, Chicago, IL 60635
- Dana Laboratories, Inc.**
2401 Campus Dr., Irvine, CA 92713
- Data Precision Corp.**
Audubon Rd., Wakefield, MA 01880
- Data Technology Corp.**
2700 S. Fairview Rd., Santa Ana, CA 92704
- DeForest Electronics**
40 Fairfield Pl., W. Caldwell, NJ 07006
- Dynascan Corp., B&K**
1801 W. Belle Plaine Ave., Chicago, IL 60613
- John Fluke Mfg. Co.**
Box 43210, Mountlake Terrace, WA 98043
- Heath Co.**
Benton Harbor, MI 49022
- Hewlett-Packard**
1501 Page Mill Rd., Palo Alto, CA 94304
- Hickok Electrical Inst. Co.**
10514 Dupont St., Cleveland, OH 44108
- Leader Instrument Corp.**
151 Dupont St., Plainview, NY 11803
- Non-Linear Systems Inc.**
Box N, Del Mar, CA 92014
- Sencore Inc.**
3200 Sencore Dr., Sioux Falls, SD 57107
- Simpson Elect. Co., Div. of AGM**
853 Dundee Ave., Elgin, IL 60120
- Systron-Donner Corp., Instrument Div.**
10 Systron Dr., Concord, CA 94518
- Tektronix Inc.**
Box 500, Beaverton, OR 97077
- Viz Test Instrument Group**
335 E. Price St., Philadelphia, PA 19144

resistance is specified for dc measurements, while input impedance is for ac measurements. Too, besides input resistance, there is also input resistance due to capacitance of the test-probe cable with which to contend.

Depending on the type of work you will be doing, even a basic DMM may not be what you need. If you do a lot of alignment, where tuned circuits must be "tweaked" for maximum or minimum response at some particular frequency, you will need a "trend" indicator incorporated into your DMM. This device is usually an analog-type meter movement. The numeric display will indicate the value of the parameter being measured, while the meter movement will indicate the trend taking place.

There are some mechanical considerations, too. For a portable field instrument, look for a handle that can also double as a tilt stand to elevate the front of the instrument at a convenient viewing angle. Such handles are usually standard equipment on modern DMM's. Another thing to look for is nonskid rubber "feet" on the bottom of the instrument's case. The feet will not only prevent the DMM from being accidentally brushed off your workbench onto a hard floor, it will also make using the DMM easier by keeping it in place when you press a switch with only one hand.

The matter of instrument size is usually a personal taste. Obviously, if you plan to use the DMM primarily for field service, the smaller the better. You may also want a very compact instrument on your workbench, which is fine if the instrument packs all the ranges, functions, and features you need. But bear in mind that larger instruments often offer functions and conveniences not available in a compact DMM.

Actually, which digital multimeter you buy depends on the applications for which it is intended and how much money you have to spend. You would not, for example, pay the premium price demanded for a 0.01% laboratory-grade DMM when a 0.1% accuracy is all you will ever need.

The best advice is to tailor the instrument to the type of work you will be doing. Once you fulfill your needs for functions, ranges, features, and size, look into such things as accessories, auto-ranging, etc., if your budget will allow them. The new DMM's on the market (and those still to come) are offering features and functions that either did not exist before or commanded very high prices in the past. The newer instruments offer more for less money. ◇



THE 25MHz "NOW" SCOPE with 5sec-1μsec DELAYED SWEEP DUAL TRACE/DUAL CHANNEL

- Built-in delay circuitry, continuously variable, from 1μsec to 5sec... plus 5mV/Div sensitivity.
- Selectable synchronization — automatic, normal, single trace and reset modes with H-F rejection.
- X10 magnification; ±3% overall accuracy, both chan's.
- Displays leading edge of pulse or pulse train for quick functional determination.
- 20,000:1 delay jitter — X-Y phase difference below 3° @ 100KHz.
- External Sweep Sensitivity: (X-Y) 5mV/Div to 2V/Div, 10 steps. \$1395 with accessories

LEADER
Instruments Corp.

151 Dupont Street, Plainview, N.Y. 11803 (516) 822-9300

West Coast: 7733 Densmore Ave., Van Nuys, Calif. 91406 (213) 989-2760 In Canada: Omnitronics Ltd., Montreal, Quebec

CIRCLE NO 42 ON FREE INFORMATION CARD

You've seen the rest...now try the best.

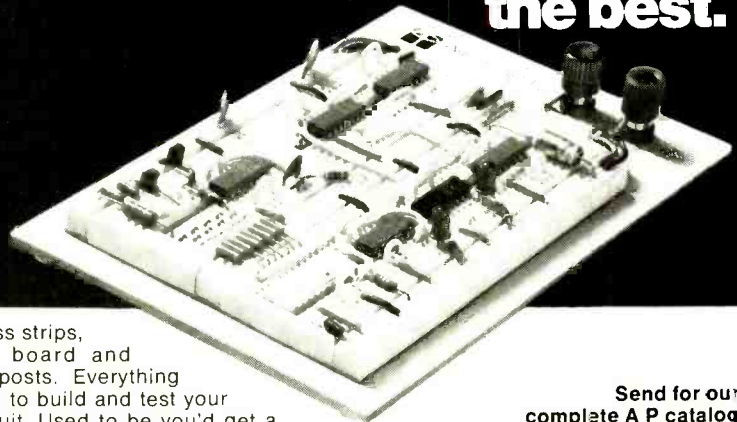

Solderless strips, backing board and binding posts. Everything you need to build and test your own circuit. Used to be you'd get a circuit idea, lay out a pc board, print it, solder everything together, troubleshoot, change your layout, try a new board, and spend absolutely too much time breadboarding. Now A P ACE All Circuit Evaluators let you breadboard in a fraction of the time. Make your changes immediately. Keep full leads on your components. Avoid the heat damage possible with repeated soldering and desoldering. A P made the first modern solderless breadboard, and we still make them best.

Send for our
complete A P catalog
The Faster and Easier Book.

Pick an ACE for Faster and Easier solderless circuit building and testing.

Part No.	ACE Model No.	Tie Points	OIP Capacity	No. Buses.	No. Posts	Board Size (inches)	Price Each
923333	200-K (kit)	728	8 (16's)	2	2	4-9/16x5-9/16	\$18.95
923332	208 (assem.)	872	8 (16's)	8	2	4-9/16x5-9/16	28.95
923334	201-K (kit)	1032	12 (14's)	2	2	4-9/16x7	24.95
923331	212 (assem.)	1224	12 (14's)	8	2	4-9/16x7	34.95
923326	218 (assem.)	1760	18 (14's)	10	2	6-1/2x7-1/8	46.95
923325	227 (assem.)	2712	27 (14's)	28	4	8x9-1/4	59.95
923324	236 (assem.)	3648	36 (14's)	36	4	10-1/4x9-1/4	79.95



**AP PRODUCTS
INCORPORATED**
Box 110 - H Painesville, OH 44077
(216) 354-2101 TWX: 810-425-2250

Order from your A P distributor today.
Our distributor list is growing daily.
For the name of the distributor nearest
you call Toll-Free 800-321-9663.

Digital circuitry has spawned a variety of troubleshooting aids, including logic probes, pulse generators, IC clip-type testers, logic comparators, and multiple-trace oscilloscopes. All are most useful—up to a point. That point is reached when the digital equipment contains a microprocessor, as in computers, scanning monitors, video games, microwave ovens, etc.

In such cases, how does one examine a number of operating interdependent circuit lines for debugging purposes? Industry knows how—with a “logic analyzer,” an instrument with a bottom price of about \$2500. Now, however, you can build your own logic analyzer for less than \$190.

The Logic Analyzer presented here features eight input lines and an ability to examine sequential data before or after a reference event, displaying a truth table consisting of 1's and 0's on any oscilloscope CRT. This is called a data-domain logic analyzer. (There are, of course, other types of analyzers, one of which displays a timing diagram on a scope's CRT.)

Why a Logic Analyzer? Because digital logic operates at two different voltage levels (0's and 1's), the first special-digital test instrument was the simple digital probe. The digital probe uses some type of indicator, usually a LED, to indicate the presence or absence of a signal at any selected single point in a circuit. Since digital circuits usually consist of a number of IC's that all operate from a common timing clock, even if a single digital probe gives a proper indication at a given test point, there is no way of determining if the observed pulse is correctly timed.

The shortcomings of the digital probe led to the development of the IC “clip” tester in which 14 or 16 LED's could indicate the logic states at each of the IC pins. Note that the status of the logic is of interest only at a specified instant in time related to the clock. This brings up another problem—clock speed. With most clock rates, single 14/16-pin LED indicator probes may display only a blur (except at the ground and power pins of the IC), with the blur rate, or light intensity, a function of the clock speed. Hence, unless you are able to drastically slow down the clock rate, you still will not be able to discover anything but the presence or absence of signals, whether or not they are correctly timed.

Using a logic analyzer with an oscilloscope, you can display a “truth table” of the digital circuit being tested under ac-

PE TESTED *BREAKTHROUGH PROJECT*

Low-Cost Digital Logic Analyzer

Data-domain instrument for troubleshooting any type of digital system including microcomputers.

BY G. MUETHING, I. SPECTOR, AND C. WONG

tual operating conditions. Simply by selecting a “trigger word” consisting of a particular set of 1's and 0's, the analyzer will freeze the 15 8-bit digital words that precede the selected trigger word and display the data so that it can be analyzed at your leisure. A switch also allows the observation of the 15 digital words that follow the trigger word if the problem is thought to lie in that direction. By changing the trigger word, which is brightness accented in the display, as you step through the truth table, it becomes possible to examine the digital logic from start to finish. In essence, then, the Logic Analyzer is a form of electronic “time machine” that can freeze digital events before or after any selected point in time.

Because a computer consists of a number of interlocking digital circuits, each carefully timed from a common clock signal, the misplacement of one bit among thousands can cause a great deal of trouble. Programs that can be properly written will not run because of an erroneous bit being generated within the system.

Why not use a conventional oscilloscope? True, you can see a small group of bits at any given time. But if the system under test is running at the usual clock rates, the picture displayed will

keep changing and be blurred. The scope can display a signal only after it has been triggered. If you happen to trigger on the problem itself, you have further complications. Because computers, peripherals, ROM's, and other digital devices may not repeat the same state over and over again, a scope without storage capability cannot display a “snapshot” of a one-time logic event for subsequent analysis. In some cases, the scope is a necessity, as only a scope can display the detailed waveform information that can give the user an insight by an intuitive process where a waveform “just doesn't look right”. A good scope can also show up fast transient “glitches” that, although they disturb circuit operation, may not show up on an analyzer. However, if you rely strictly on a scope for analysis, solving many system problems would be virtually impossible.

The low-cost Logic Analyzer in this article will add a form of storage to any oscilloscope, perform the sixteen 8-bit data word freeze as previously described, and provide the electronics experimenter with a state-of-the-art digital test instrument that rivals those costing several hundred dollars more. In use, you simply connect the three analyzer outputs to the horizontal, vertical, and

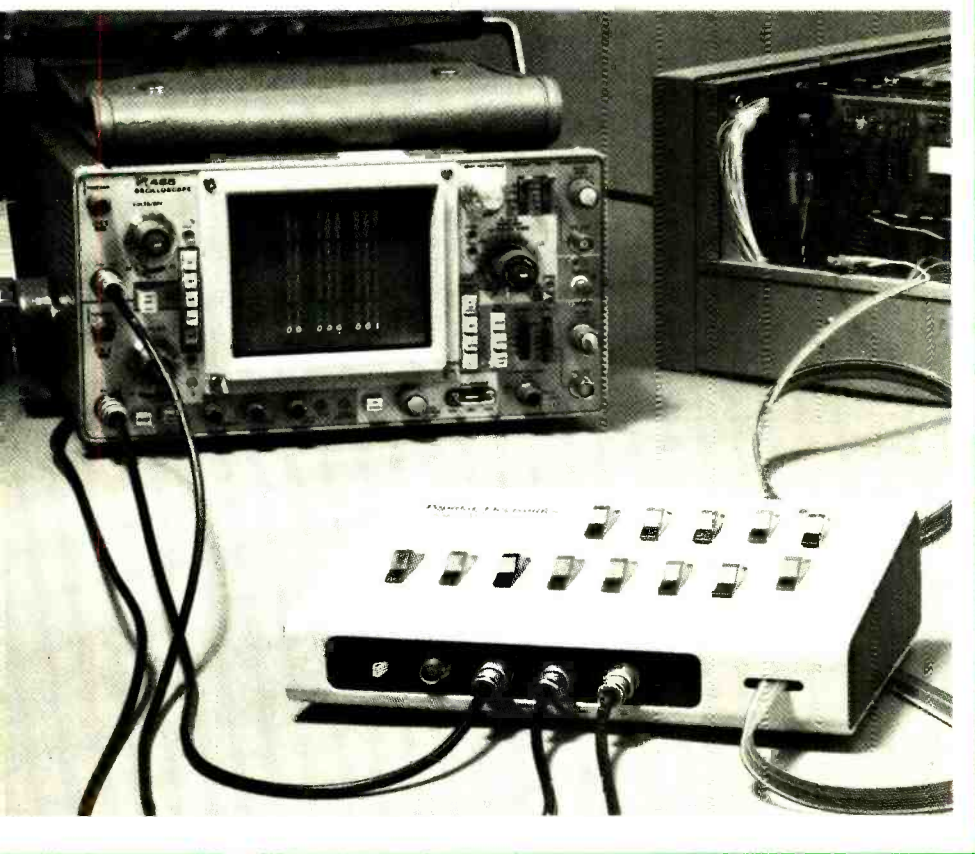

blanking inputs of a scope and connect the eight data-input and the clock and ground probes to the circuit being analyzed. When the trigger word keyed in via control-panel switches appears, the Analyzer will automatically trigger, collect, store, and display 16 sequential 8-bit words in either octal or hex format, as shown in Fig. 1. The analyzer will accept data rates as high as 8-million bytes/second.

Another front-panel control allows the user to select either "positive time" in which the selected trigger word appears intensified on the top of the CRT screen with the next 15 sequential data words below it, or "negative time" in which the 15 data words leading up to the trigger word appear first with the brightened trigger word at the bottom of the screen.

One other control provides the choice of a "snapshot" that catches and displays an individual 16-word table for as long as you like or a "moving picture" display in which the data for each table is collected and automatically displayed so you can dynamically observe the operation of the circuit. The specifications for the logic analyzer are shown in the box.

Circuit Operation. Operation of the analyzer can best be understood by ref-

erring to the block diagram of Fig. 2. (The complete schematic diagram is shown in sections in Figs. 3 through 7.) The inputs to the system are the 8-bit signals (BIT 0 through BIT 7), the system clock, and the common or ground bus of the digital circuit under test. The data and clock inputs are buffered by IC1 and IC2. The eight data signals are latched by IC4 and IC5 before loading into data memory IC6 and IC7. This 16-word data memory is the "heart" of the analyzer. It stores sequential data words from the digital system under test.

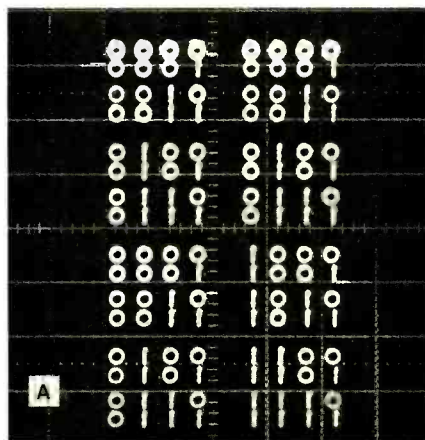

The buffered clock signal is fed to half of IC2 that can be set to operate on either the negative or positive edge, depending on the setting of S10. This signal is applied to the display control logic made up of IC11 through IC15. The other input to the display logic is from comparator IC3. This circuit uses S1 through S8 to set up the desired trigger word, with the switches set to either 1, 0, or X as required. (The X is a "don't care" state.) When the comparator receives the input data word that matches its switches, a signal is passed to the display control logic. When S11 is set to the POS TIME position, for example, data collection begins when the comparator detects the trigger word. After 16 clock pulses, data collection stops so that the memory contains the trigger word followed by the next 15 data words. In the NEG TIME position of S11, the memory stores data continuously until the trigger word occurs. When this happens, data collection is halted, leaving the memory with the 15 data words leading up to the trigger, plus the trigger word itself.

During the data collection period, the display control logic sends a signal to the blanking logic system made up of IC22 through IC24, Q1, and Q2 to inhibit the display. At the end of this period, the blanking signal is removed and a bit-by-bit scan of the memory contents is initiated. Scanning is accomplished by data multiplexer IC16, which is controlled by three of the eight output bits of horizontal control ROM IC19. Thus, even though the data memory provides a full 8-bit wide data word to the input of the multiplexer, only one bit at a time is sent to the 1-0 character generator made up of half of IC20, and Q3.

The character generator uses this information and the CRT beam positioning signals from the IC20 horizontal D/A (di-

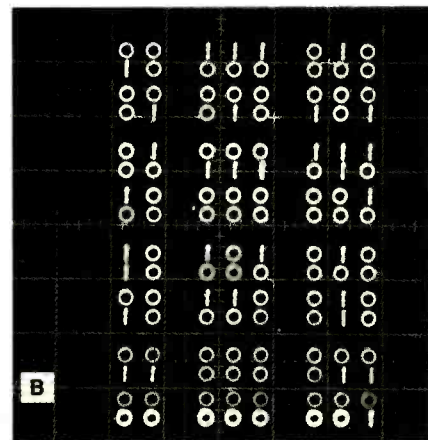

Fig. 1. Trigger word is intensified at top of hex display (A) with the 15 following data words. In octal display (B), trigger word is at bottom with the 15 data words leading up to it.

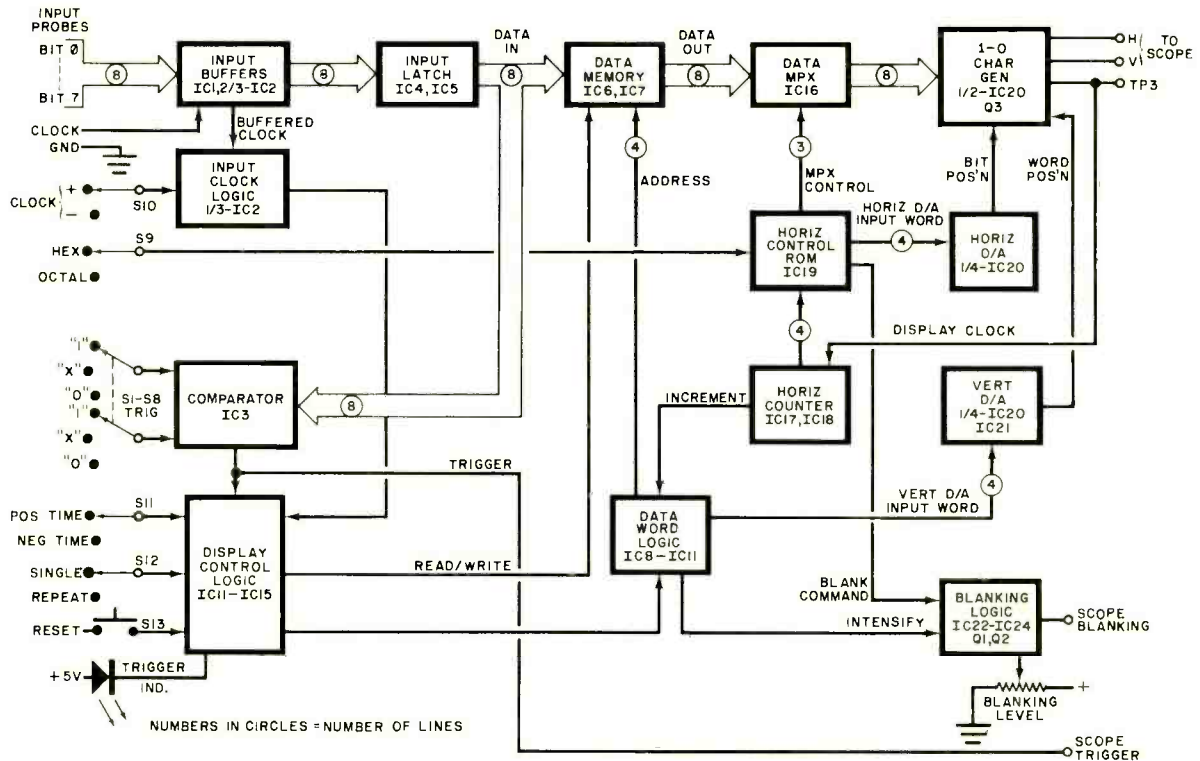

Fig. 2. Block diagram of analyzer shows basic signal routing.

PARTS LIST

C1—2200- μ F, 16-volt electrolytic capacitor
 C2—220- μ F, 50-volt electrolytic capacitor
 C3—10- μ F, 50-volt electrolytic capacitor
 C4, C5—150-pF, 10% disc capacitor
 C6—15-pF, 10% disc capacitor
 C7, C8, C9, C10—0.1- μ F, 20% disc capacitor
 C11—300-pF, 10% disc capacitor
 C12—180-pF, 10% disc capacitor
 C13—0.01- μ F, 20% disc capacitor
 D1, D2, D3—1N4002 or similar rectifier diode
 IC1, IC2—74LS14 Schmitt-trigger input hex inverter (Fairchild 15-V input only)
 IC3—74S15 open-collector output triple three-input AND gate
 IC4, IC5, IC9—74LS175 quad latch
 IC6, IC7—7489 RAM (16 \times 4)
 IC8—74LS161 four-bit synchronous counter
 IC10—74LS83 four-bit adder
 IC11, IC12, IC22—7400 quad two-input NAND gate
 IC13, IC14, IC18—74LS73 dual JK flip-flop (do not substitute)
 IC15—7473 dual JK flip-flop (do not substitute)
 IC16—74LS151 8-to-1 multiplexer
 IC17—74LS90 decade counter
 IC19—8223 256-bit open-collector output PROM, or similar
 IC20—LM3900 quad current amplifier
 IC21—7407 open-collector output hex buffer
 IC23—74LS21 dual four-input AND gate
 IC24—7406 open-collector output hex inverter
 IC25—LM309K 5-volt regulator
 J1 through J4—UG-625 BNC connector

LED1—Light-emitting diode (any color)
 Q1, Q3—2N3904 silicon transistor
 Q2—2N3905 silicon transistor
 The following resistors $\frac{1}{4}$ watt, 5%:
 R1 through R27—4700 ohms
 R28—3300 ohms
 R29—470 ohms
 R30—1000 ohms
 R31, R32, R33—8200 ohms
 R34, R35, R36—2700 ohms
 R37—1800 ohms
 R38—2000 ohms
 R39, R40—33,000 ohms
 R41, R42—56,000 ohms
 R43, R44, R45—22,000 ohms
 R46, R47—24,000 ohms
 R48, R49—130,000 ohms
 R51, R52—180 ohms
 R53—47,000 ohms
 R54, R55—11,000 ohms
 The following resistors $\frac{1}{4}$ -watt, 2% tolerance:
 R56—4700 ohms
 R57—2400 ohms
 R58—5100 ohms
 R59—2700 ohms
 R50—5000-ohm trimmer potentiometer (Spectrol 43P502 or similar)
 S1 through S8—double-pole 3-position pc-mounted switch
 S9 through S12—dpdt pc-mounted switch
 S13—momentary-action dpst pc-mounted switch
 S14—spst switch (panel mount)
 T1—dual-winding power transformer with 16-volt CT and 22-volt winding

Misc.—Line cord, strain relief, mounting hardware, 3 feet of Spectra-Strip multicolored flat ribbon cable (26 gauge), 16-pin DIP socket, 16-pin flat ribbon DIP plug, heat sink for voltage regulator, hookup wire, solder, suitable case and mounting brackets, probe tip connectors, etc.

Note: The following items are available from Paratronics, Inc., Dept. 100, Los Gatos, CA 95030: Complete kit of parts, No. LA-100KIT, with tested IC's, power supply, pc board, case, and manual for \$189.00. For separate parts: drilled double-sided printed circuit board, No. LA-100 PC, \$29.95; programmed horizontal control ROM, No. LA-100ROM, \$15.95; power supply, No. LA-100PS, \$39.95; complete set of switches, connectors, hardware and data probes, No. LA-100HW, \$39.95; Case, No. LA-100CASE, \$39.95. Comprehensive applications and assembly manual, LA-100MAN \$4.95. Please add 5% to above items for shipping and handling within U.S., 10% outside the U.S. California residents, add 6% sales tax.

Free copies of etching and drilling guides for the pc board, components-placement diagram, and horizontal control PROM programming information are available on request by sending a self-addressed stamped 9" \times 12" envelope with 26 ϕ postage to: POPULAR ELECTRONICS, Dept. LA, One Park Ave., New York, NY 10016.

gital/analog) and the IC20-IC21 vertical D/A circuits to write a 1 or 0 at the proper location on the CRT screen.

The horizontal D/A circuit receives its 4-bit data word from the horizontal con-

trol ROM, which receives its address data from the horizontal counter made up of IC17 and IC18. It is the incrementing of the horizontal counter that causes the beam to move from right to left

across the face of the CRT as the data word is written.

When the last bit is displayed, horizontal counter IC17-IC18 "rolls over" to 0 and sends the increment signal to the

data word logic IC8 through IC11. This causes the address of the data memory to advance to the next word location and simultaneously sends a command to the vertical D/A converter that causes the CRT beam to move down one row in preparation for display of the next word. This process continues until all sixteen of the words of interest have been written on the CRT screen.

If S12 is set to the SINGLE mode, the display control logic prevents the data memory from collecting new input data so that the same information is written on the CRT screen. The writing speed is fast enough so that a flicker-free "snapshot" of the memory contents is dis-

played. This snapshot will remain on the screen until the RESET switch S13 is operated, at which time the TRIGGER LED comes on and the analyzer is armed to "capture" another 16-word data set. When S12 is in the REPEAT mode, the display control logic provides an automatic reset signal after the display of each 16-word truth table.

Blanking between bits is provided by the remaining bit of the horizontal control ROM. This ROM performs three separate functions: control of the data multiplexer, control of the horizontal D/A converter, and blanking control. This use of a ROM as a controller is called "microprogramming," an efficient design

technique used in a number of high-level computers. An "intensify" command from the data-word logic permits the trigger word to appear brighter than the other data words on the CRT screen.

The trigger pulse generated by comparator IC3 occurs each time the trigger word appears. The resultant output pulse can be connected to the sync input of an oscilloscope anytime it is necessary to "look" at a specific signal in the circuit under test. This important feature is useful for troubleshooting equipment for glitches, timing, or intermittent problems that occur only during particular logic states.

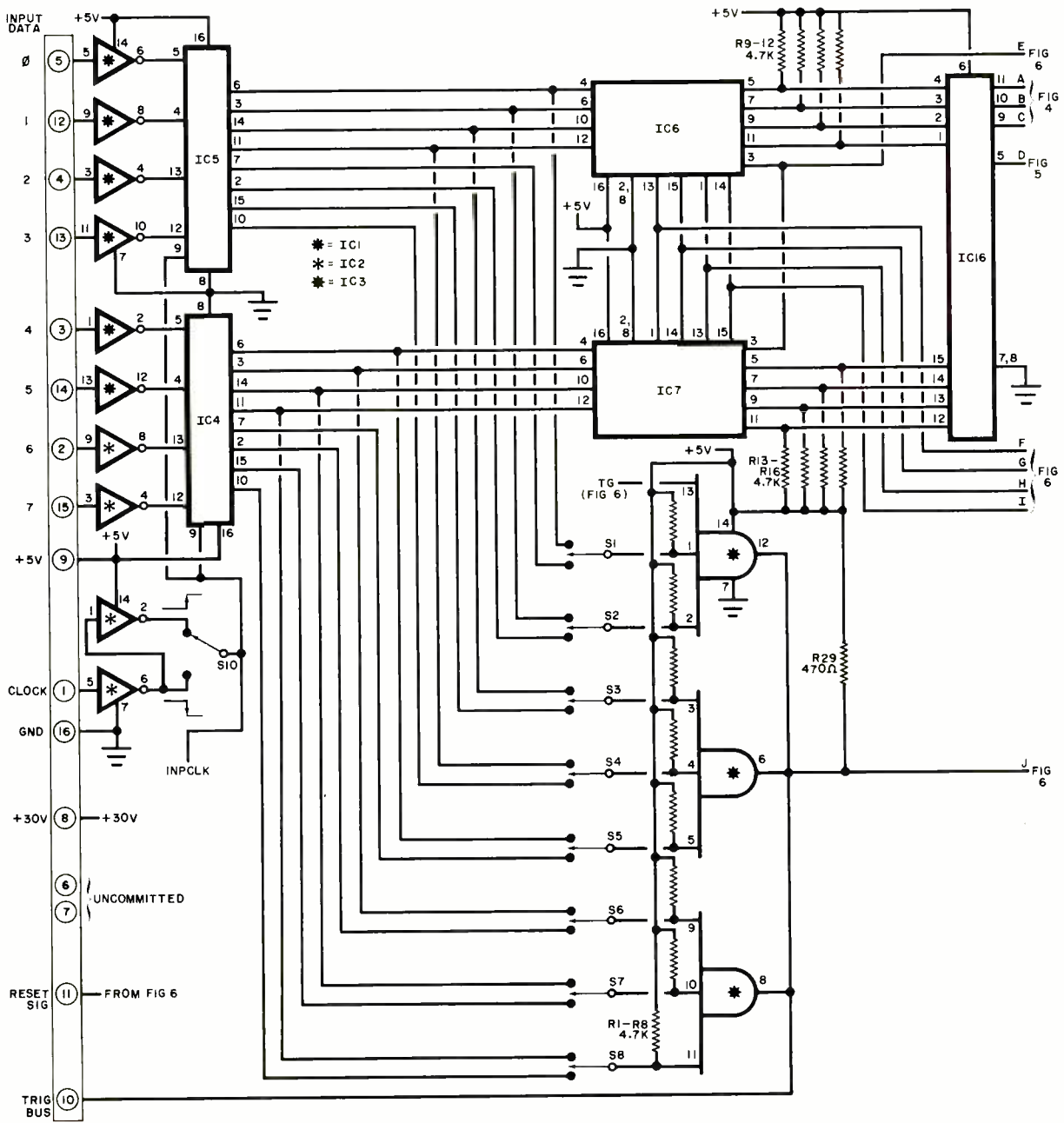

Fig. 3. Input buffers, trigger detector, memory, and data multiplexer.

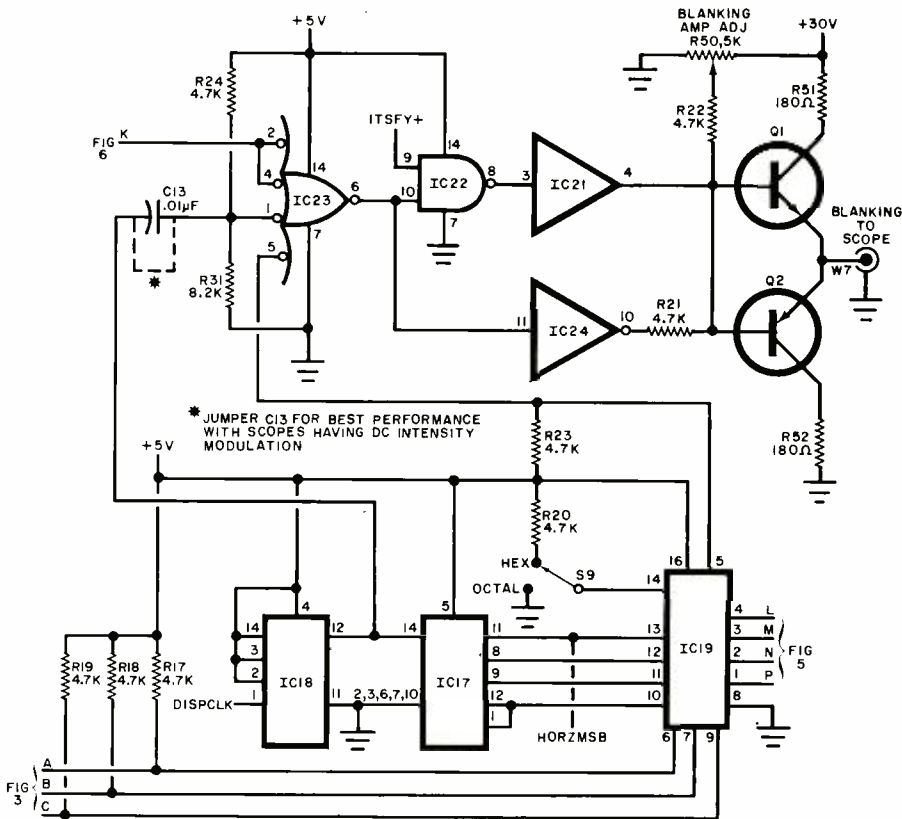

Fig. 4. Vertical control and blanking.

Construction. Because of the complexity of the circuit, and the critical placement of certain components, such as the 1-0 character generator, a high-quality, two-sided pc board with plated-through holes is highly recommended for this project. (See Note in Parts List for source from which etching and drilling guide, component layout diagram, and programming information for the horizontal control ROM can be obtained).

Both sides of the pc board contain components. Start assembly by installing the optional sockets for all the IC's on the side of the board labelled IC SIDE. Then mount all resistors, capacitors, and diodes, making sure that polarity-sensitive devices are correctly oriented.

Mount voltage regulator IC25 in place, using silicone grease, or a thermally conductive gasket between its case and the board. A suitable heat sink should be used if the board is to be mounted inside a case. The case provided with the kit comes with a heat sink. Install the IC's, transistors, and blanking control R50. The IC side of the board should look like the assembled board shown in Fig. 8 when you are finished.

Turn the board over to the SWITCH SIDE and mount the 13 control switches. Then, making sure that its base is high enough off the board so that it can pro-

trude through its hole on the top of the case, mount LED1. Install the 16-pin DIP socket for the flat ribbon probe cable. This completes the assembly of the board.

Mount the BNC scope connectors and on-off switch S14 on the front of the case. Then drill a hole so that the blanking amplitude potentiometer mounted on the pc board can be adjusted from outside the case. The top of the case should be punched to accept the 13 switches and the LED indicator. Make sure that all switches can be moved into all their positions. Then put a slot in the front apron to accommodate the flat ribbon cable.

Mount the transformer wherever convenient at the rear of the case. Bring the three-wire ac line cord into the case through a strain-relief.

The input probe cable is made up of a 3' (about 1-m) length of 10-conductor, flat-ribbon cable. The last conductor in the cable is coded black for ground. Connect the ribbon cable to the 16-pin DIP plug with the black cable (ground) mating with pin 16. The other conduc-

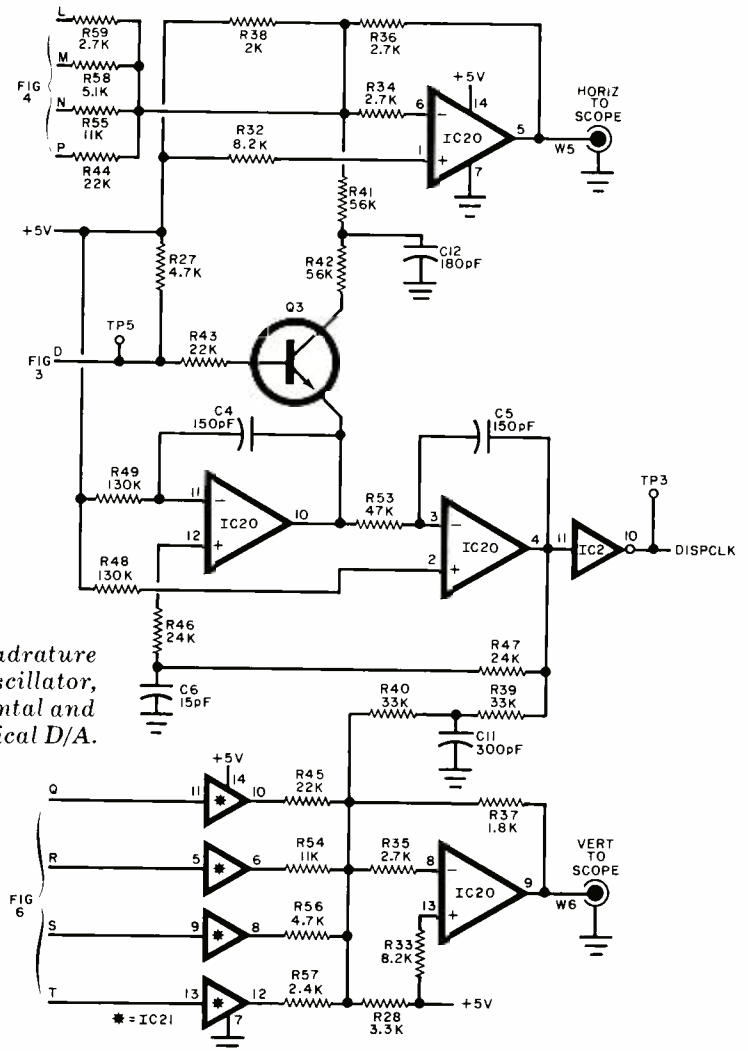

Fig. 5. Quadrature oscillator, horizontal and vertical D/A.

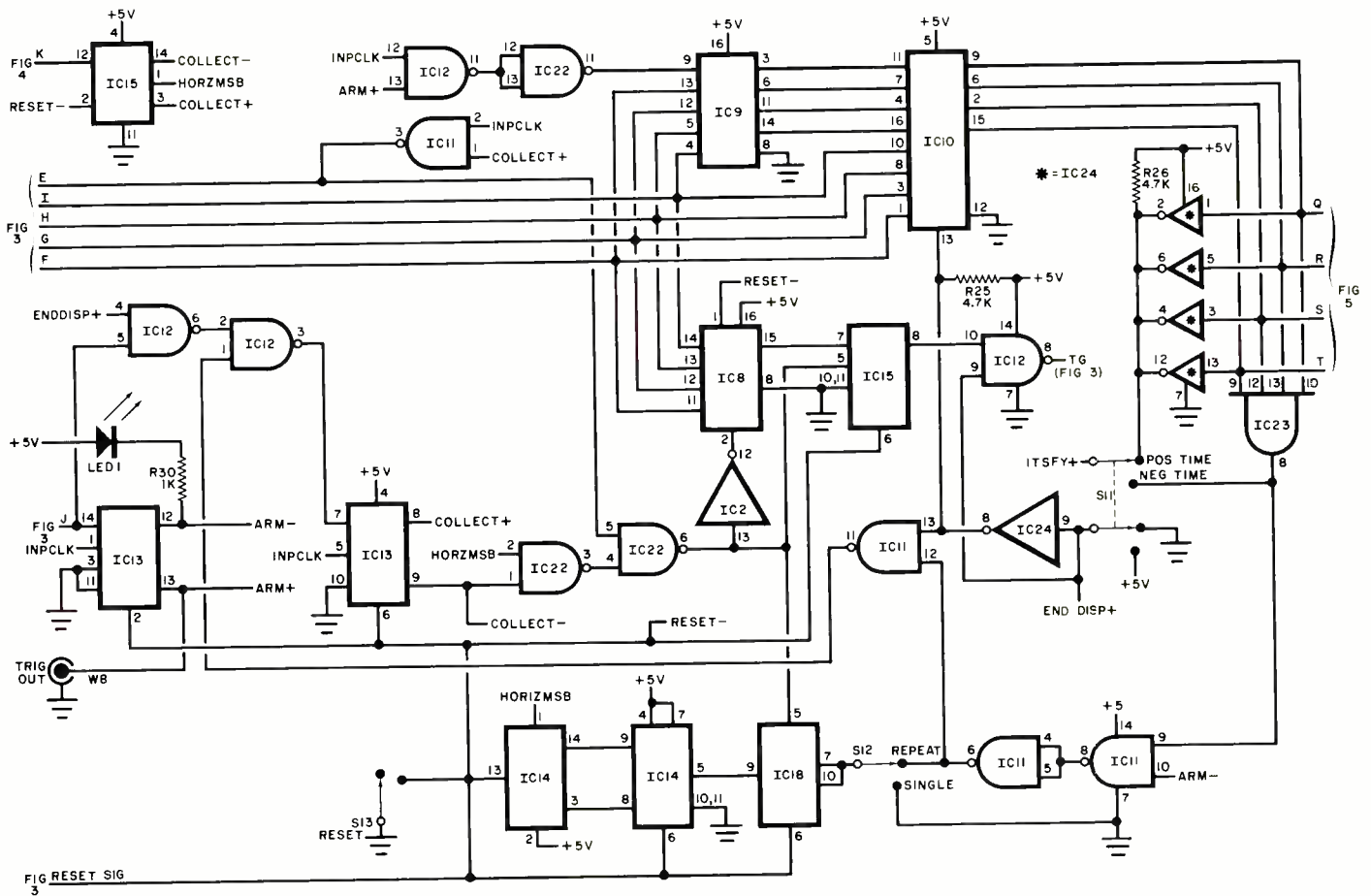

Fig. 6. Horizontal logic and mode control logic.

tors can go to the plug pins in a color-coding scheme.

At the free end of the ribbon cable, separate the 10 leads at least 4" (10.2 cm) and attach universal pin connectors. This type of connector will mate with conventional IC clips and wrapped-wire pins. If desired, ball clips or EZ hooks can be substituted. Plug the probe assembly connector into its socket on the pc board and pass the cable out of the case through its slot on the front apron and assemble the case.

Checkout. Plug the line cord into an ac outlet and turn on the power. Verify the output of the 5-volt power supply at TP1 using a voltmeter. With an oscilloscope, check for the presence of an approximately 20-kHz clock at TP3.

Activate the blanking output at W7 by placing the eight trigger switches to the "X" (center) position, selecting the SINGLE mode, depressing the RESET pushbutton to activate the front-panel LED, and flipping the clock polarity switch (S10) one or more times. This last step generates switch contact bounce that simulates an incoming clock pulse train. When the LED goes off, the blanking

signal will appear at board pad W7.

Using the oscilloscope, measure the peak amplitude of the blanking pulse. This pulse can be adjusted up to approximately 30 volts by adjusting R50. **Do not** exceed the manufacturer-specified blanking requirements for your scope.

Set the scope vertical attenuator to approximately 0.5-volt/cm and check the D/A signals at W5 (horiz) and W6 (vert). The waveforms should appear as "descending staircase" waveforms, with the W5 signal much higher in frequency.

Using the scope in the XY mode, connect the horizontal, vertical, and blanking outputs of the analyzer to the appropriate scope connectors. To assure a clean display, it is suggested that you

use coaxial cables for the interconnections between the analyzer and scope.

Place the scope horizontal and vertical amplifiers to approximately 0.5-volt/cm. With the analyzer input probes unconnected, and the trigger switches still set to the "X" (center) position, depress the RESET pushbutton to illuminate the LED. When the clock polarity switch (S10) is flipped, a truth table should appear on the CRT. Adjust the scope controls until the display is centered on screen and fills most of it.

Adjust the focus and intensity controls to obtain a clear well-defined display.

One interesting feature of the Logic Analyzer is that it can be used to observe and learn its internal operation.

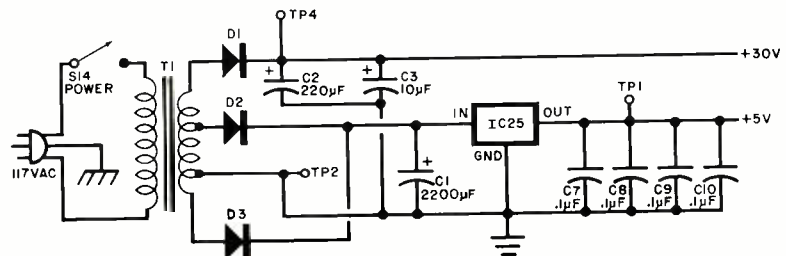

Fig. 7. Power supply is 5 volts, regulated.

For example, to see how the 4-bit address of the data memory sequentially changes during data collection, connect the first four data probes (BIT 0 through BIT 3) to pins 14, 13, 12, and 11 respectively, of IC8. The remaining four probes should remain unconnected. Connect the input clock probe to IC2 pin 10 (or TP3) and set the analyzer controls to HEX, REPEAT, NEG TIME, and the clock-polarity switch to the falling edge position. Set the first four trigger switches (S1 through S4) to 1111 and the last four to X. The selected trigger word should appear intensified at the bottom of the table, with the 15 prior binary address words listed in sequence above it.

LOGIC ANALYZER SPECIFICATIONS

Trigger Word: 0 to 8 bits wide; selected by eight 3-position switches; choose 0, 1, or X (don't care).

Display Format: Sixteen sequential 8-bit words arranged in an octal or hexadecimal truth table.

Positive Time Display: Trigger word intensified at top of truth table with next 15 data words listed below.

Negative Time Display: Trigger word intensified at bottom of truth table with prior 15 data words listed above.

Single Mode: Continuous display of one 16-word truth-table until RESET button is activated.

Repeat Mode: Display of sequential 16-word truth tables.

Maximum Input Data Rate: 8 million bytes/second.

Input Clock: Provides timing reference for input data; selectable positive or negative clock edge.

Trigger Indicator: LED on front panel indicates when trigger word has occurred.

Trigger Output: Auxiliary scope sync pulse; generated when trigger word occurs.

Input Probes: Constructed of color-coded flat-ribbon cable terminated in universal pin connectors.

Input Load: Inputs are buffered for minimal loading and have hysteresis for noise rejection.

Power Supply: +5 volts at 700 mA, +30 volts at 25 mA.

Logic Family Compatibility: TTL, DTL, RTL, MOS, CMOS, to 15-volt logic swing.

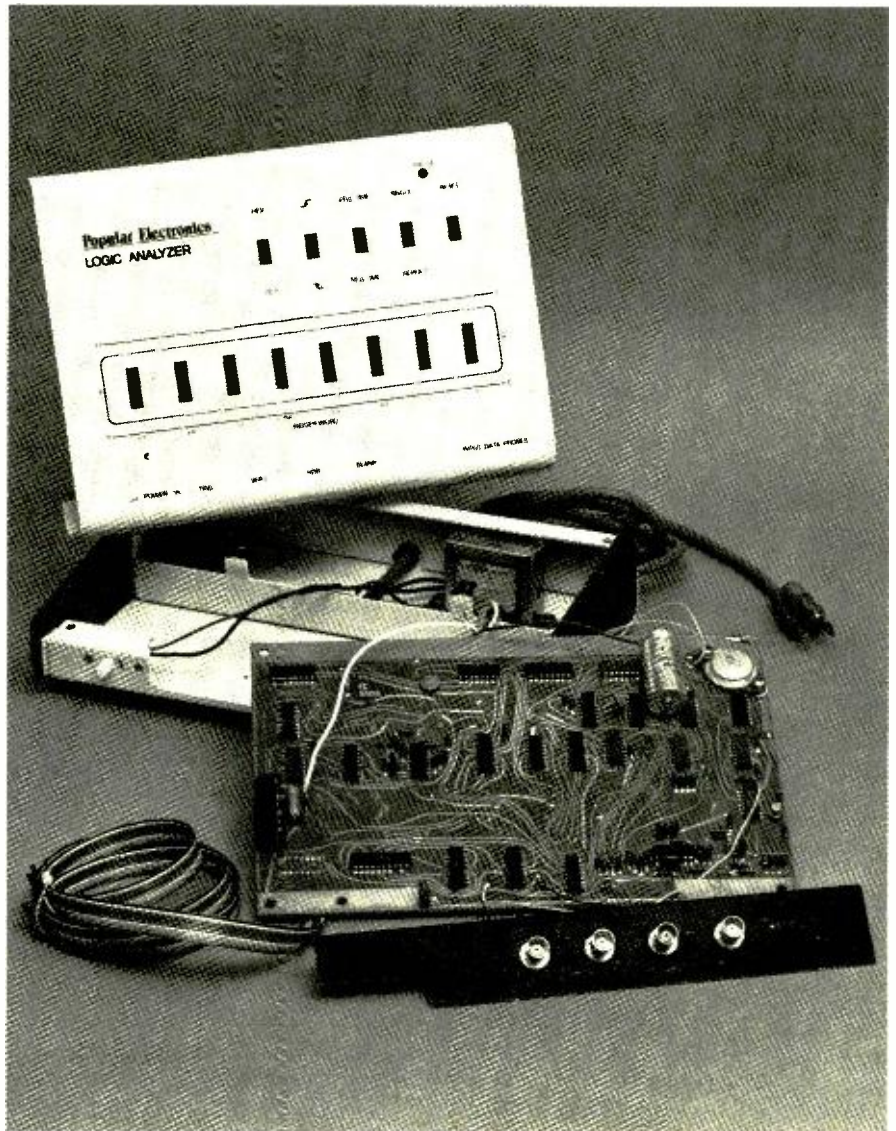

Fig. 8. Completed board and connector panel ready for assembly.

Continue to familiarize yourself with the operation of the analyzer by triggering from different address locations and changing the settings of the display control switches. The probes can be moved to other portions of the circuit, such as the horizontal counter, display-control logic, and the data-word logic.

You can couple the first four probes to the counter (7490 or similar) in any digital counter circuit to examine the operation of that circuit. In fact, the right side of the hex portion of the display in Fig. 1 shows the output of a "good" 4-bit counter while the left side shows the output of a counter whose MSB (most significant bit) is stuck at 0. Using this technique, you can follow the signals through almost any digital circuit and be able to "snapshot" any block of pulses so that they can be examined for faulty pulses.

The analyzer shows its flexibility when

used to check a computer or program. The octal portion of Fig. 1 shows the steps of a typical 8080 ADD and STORE program leading up to a branch instruction. The trigger word 00 000 001 is the branch address and is intensified at the bottom of the display.

In Closing. The Logic Analyzer we have described can be used for all types of testing and troubleshooting of digital circuits and systems. However, its true flexibility is revealed when the instrument is used for testing and troubleshooting digital-computer and other time-dependent circuits and systems. What makes our Logic Analyzer particularly attractive is its relatively low price. Used as an accessory to an existing oscilloscope and built from scratch, it costs only a fraction of commercially made logic analyzers on the market. ◇

NEW, PRACTICAL OP AMP CIRCUITS

BY SOL D. PRENSKY

including a differential pc board tester

AS WE WILL learn from the two very useful circuit applications described here, the operational amplifier (or op amp) can be used in strikingly different ways.

In-Circuit Current Testing. Since an op amp is basically a differential amplifier, it can be used in a unique metering circuit to determine the presence of current flow in a conductor—and approximately the amount of cur-

rent—whether or not the conductor is a copper wire or a pc foil trace. This can be done without breaking the conductor.

Such a metering device can come in handy if you have a crowded pc board and you suspect one of the active elements (transistor, diode, or IC) is not working. Instead of risking pc board damage due to the heat required to remove the suspect semiconductor, or having to cut a trace to insert a meter, all you have to do is press a couple of

sharp probe tips to the copper trace at (for example) the supply bus, and see if that particular element is drawing current, and if the magnitude of the current is within specifications.

The circuit for the current tester is shown in Fig. 1 in two forms—depending on whether you want to use a low-level (1-volt) dc voltmeter or a current meter as the readout.

Operation is based on the fact that at room temperatures, all conductors have

Fig. 1. Op amp in (A) measures slight voltage differential between two probes, amplifies it, and drives dc voltmeter. Addition of another op amp in (B) permits driving ammeter.

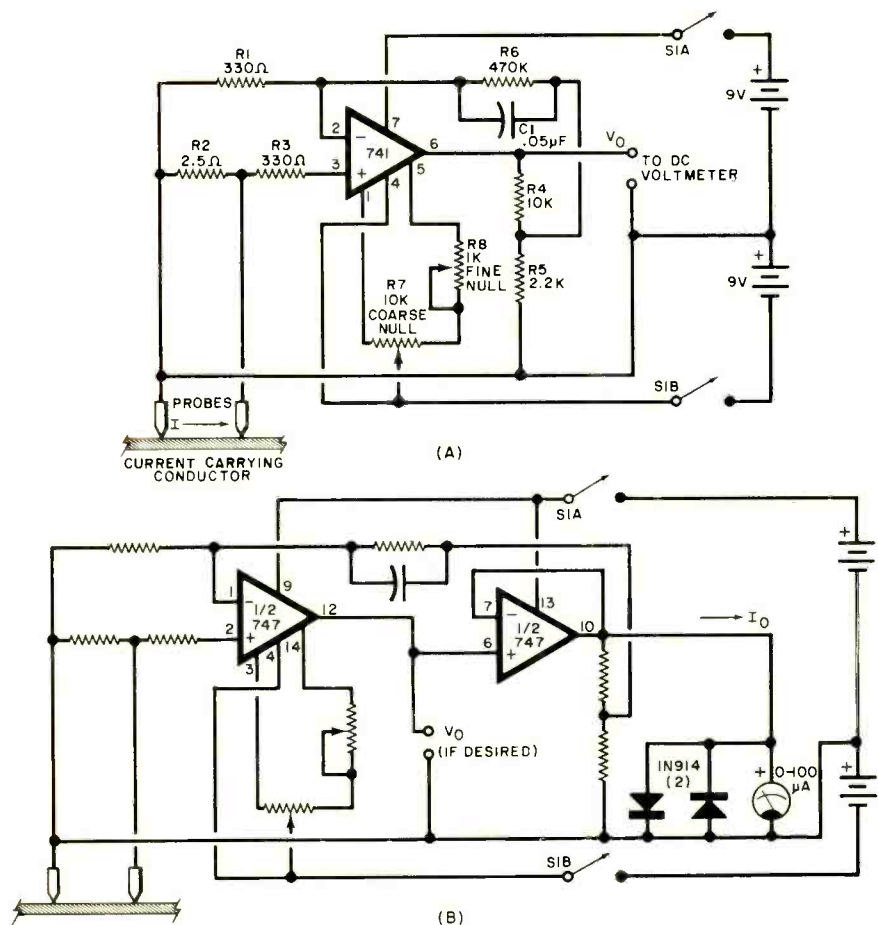

PUT THE "IGNITION OF THE FUTURE" ON YOUR CAR TODAY!

MODERNIZE and Bring Your Car "UP-TO-DATE" with the MOST EFFICIENT Ignition ever invented!

End "Tune-Up" Problems FOREVER caused by Points and Condenser



ALLISON XR-700

with the Exclusive...Solid-State Voltage Regulator.

The ONLY Ignition System that has COMPLETELY overcome the Problems that have baffled the Auto Industry for Years!

SO RELIABLE (99.9+%)... SO PERFECTED... that it will soon be STANDARD on most Future new Cars!

ALLISON Rated #1 by Official Testing Laboratory as the BEST "Fuel Saving" Ignition System of ALL the Different Ignition Systems Tested!

* The "XR-700" is a COMPLETELY NEW Ignition System employing the Most Advanced Technology, that replaces the inefficient Points and Condenser with an infrared Light Beam to Trigger the Latest type of Solid-State Power Components Once installed... "XR-700" has NO moving Parts to wear out or adjust. It works without Friction or wear. Not affected by Dirt, Oil, Moisture, Vibration or extreme Engine Temperatures! **RUGGED and RELIABLE!**

* The "XR-700" is engineered to OUTLAST YOUR CAR!

* The "XR-700" produces the MAXIMUM "High Energy" Long Duration Spark... from your present car's Ignition Coil This permits the Positive Firing of Spark Plugs, even under the most Adverse conditions. Also, Eliminates "Engine Misfire," resulting in more COMPLETE COMBUSTION! Thus you get IMPROVED Fuel Mileage, a HIGHER Performance Level... keeps Plugs FROM FOUING and gives LONGER Plug Life!

Customers Report:

★ "IT MORE THAN PAYS FOR ITSELF!"

- ★ INCREASES Gas Mileage up to 30%!
- ★ SAVES Money on Costly "Tune-Ups"!
- ★ Gives Continuous PEAK Performance!
- ★ QUICKER Starting in Any Weather!
- ★ Smoother Running... Faster Acceleration!
- ★ Plugs Last Up to 4-Times LONGER!"

* Reliability PROVEN in Millions of Customer Miles to be so exceptionally GOOD... that every "XR-700" has a LIFETIME WARRANTY! FREE Repair or Replacement for as long as you OWN the Unit!... and even if you CHANGE Cars, Allison will supply you the necessary PARTS to fit ANY Point-Type Distributor... FREE! (Include \$2 for Postage & Handling.)

* FITS ALL CARS. Domestic & Foreign. 4, 6 or 8-Cylinder.

★ DO-IT-YOURSELF... EASY INSTALLATION!

The New "XR-700" is Completely Factory Assembled. Thoroughly TESTED! New Precision "Drop-in" Mounting Bracket, with color-coded, "Snap-Together" wire connections. No Distributor. Removal necessary. Protection against incorrect Hook up!

Thousands sold at \$59.95 • ONLY **\$39.95** COMPLETE (Cal. Res. add Tax) NOW! Allison's Production Technology offers you the same Premium Quality XR-700 at this SPECIAL LOW PRICE... THAT'S EVERYTHING... INCLUDING POSTAGE & INSURANCE

★ ORDER WITH CONFIDENCE... install the "XR-700", and prove to your own SATISFACTION that it is as advertised, or return it within 30 days for a FULL Refund of the Purchase Price

★ SAVE! ORDER FACTORY DIRECT. Send Check or M.O., State Car Make, Year, No. Cylinders

* MASTER CHARGE or BANKAMERICARD Card Holders. ORDER by TOLL-FREE PHONE (800) 423-6525, Ext. 2 or Send us (1) Your Number, (2) Interbank No., (3) Exp. Date.

SEND FOR FREE BROCHURE and Comparison Sheet.

"CB" USERS: The "XR-700" completely ELIMINATES the Major Cause of Primary (Ignition Noise) Interference

* If you have already installed a "Capacitive Discharge" Ignition * Convert your "C.D." Unit to BREAKERLESS! INCREASE ITS EFFICIENCY with "XR-CD"... only \$29.95

* America's Oldest and Largest Manufacturer of Opto-Electronic Ignition Systems. ©



ALLISON AUTOMOTIVE CO.

1267 - PO, East EDNA PL., COVINA, CAL. 91722

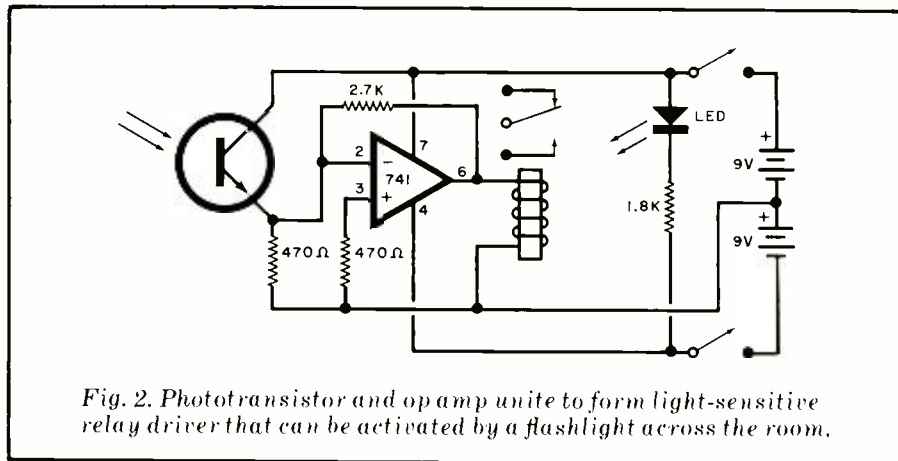

Fig. 2. Phototransistor and op amp unite to form light-sensitive relay driver that can be activated by a flashlight across the room.

some resistance (albeit small) and, when current flows through the conductor, there is a slight voltage drop between any two points along the conductor. Typically, such voltage drops are in the microvolt range; but with a voltage amplifier having a gain of 1000 or more, the minute voltage can be brought up to a reasonably measurable value.

The basic circuit shown in Fig. 1A uses an 8-pin mini DIP 741 with a dc voltmeter. This circuit takes advantage of the high common-mode rejection ratio (CMRR) of the op amp to reject any noise pickup voltages that are common to both input terminals. To keep the value of feedback resistor R_6 to a reasonable value, the output of the op amp (pin 6) drives the combination of R_4 and R_5 with the feedback taken from the junction of these two resistors. This voltage divider action in the feedback voltage multiplies the conventional gain $(1 + R_6/R_1)$ by the voltage divider ratio $(R_4 + R_5)/R_5$ to produce a theoretical voltage gain of approximately 1400 times 5.5 or 7700.

Since any residual offset voltage generated within the op amp is also multiplied by this factor, two offset (coarse and fine) potentiometers (R_7 and R_8) are provided to trim the offset close to zero with the input probes shorted.

Figure 1B uses a 747 dual op amp package to drive a 100- μ A meter that is used as the readout. Two diodes are used to protect the meter from accidental overloads. Operation of the circuit is otherwise the same as that of Fig. 1A.

In experiments with these circuits, probing a current-carrying conductor produced "ball-park" figures of 12 mV/inch or 12 μ A/inch, for each milliampere of current flow. In general, it would be too much to expect either precision or close calibration results from such a general-purpose circuit as opposed to a specialized (and expensive) instrumen-

tation amplifier. Nevertheless, the circuits of Fig. 1 do indicate current flow in a conductor and can be reasonably calibrated. For improved stability, a premium op amp such as Precision Monolithics OP2, National LF156, etc., may be used. Where currents greater than approximately 1.5-mA are concerned, the sensitivity of the circuit can be reduced by lowering the value of feedback resistor R_6 .

Photo Switch. The circuit shown in Fig. 2 illustrates how an op amp, in conjunction with a phototransistor and relay, can be used to activate a relay with a conventional flashlight used as the remote "transmitter." With the relay connected across the speaker coil leads, this circuit makes an excellent "commercial killer." The op amp's pinout is for an 8-pin mini DIP.

The phototransistor is connected to the op amp to produce an inverter amplifier gain of about 50. For most "across the room" distances, using a typical flashlight, the output of the op amp will be sufficient to energize a sensitive relay. (A Sprague 401-A050-A05 requires about 6 mA at 3 volts, for example.) If any other type of relay is to be used, keep in mind that the op amp can deliver only about 10 mA at best, so if higher currents are required, a transistor relay driver must be used.

Although almost any type of sensitive phototransistor can be used, the prototype involved half of an opto-isolator (LED and phototransistor in one package) that had been sawed in half. In these units, the phototransistor sensitive area is protected from ambient light by a built-in IR filter so that the quiescent current before flashlight illumination is practically negligible. The LED power-on indicator requires about 10 milliamperes for operation and may be eliminated if it is not required. ◇

ALTHOUGH "beginner's" shortwave receivers provide an inexpensive entry to a fascinating hobby, they do have limitations. A major one is poor dial calibration, which makes monitoring and QSL procedures difficult.

Fortunately, external circuitry can compensate for this limitation. The digital frequency display project presented here will allow the user to determine a transmitter's frequency to the nearest kilohertz on a bright, stable LED display. It accepts an input signal from the receiver's local oscillator, converts the signal to a TTL-compatible form which is then counted. Programmable counters are pre-loaded to compensate for the receiver i-f, thus allowing direct readout of the received frequency. The project will work with most single- and multiple-conversion receivers from the longwave broadcast band through 10 meters (30 MHz). Total project cost is about \$110.

About the Circuit. The schematic diagram of the digital frequency readout is shown in Fig. 1. An input signal from the receiver's local oscillator is coupled through *C1* and *R1* and applied to the gate of *Q1*, an n-channel FET. Diodes *D1* and *D2* clip signals exceeding + or -0.7 volt, protecting the FET from excessive signal voltages. The output of *Q1*, developed across *R3*, drives emitter follower *Q2*, an npn bipolar transistor. This combination results in a two-stage amplifier presenting a high input impedance to minimize local oscillator loading and a low-impedance output at TTL lev-

DIGITAL FREQUENCY READOUT FOR SHORTWAVE RECEIVERS

Programmable counters provide direct display of received frequency to 30 MHz.

els. Ferrite beads *L1* and *L2*, together with disc capacitor *C3*, are used for r-f decoupling on the +5-volt line.

A two-stage Schmitt trigger composed of NAND gates *IC1A* and *IC1B* converts the amplified local oscillator signal into a square wave, which is then gated by *IC1C*. The gating interval (10 milliseconds) is provided by a crystal controlled time base and divide chain. A 4-MHz square wave generated by *IC19* is first divided by 4 by the flip-flops in *IC2*. The 1-MHz output of the second flip-flop is further divided by two dual decade counters (*IC3* and *IC4*) to yield a 100-Hz reference signal. The second decade counter in *IC4* is wired as a bi-quinary counter to provide a symmetrical square-wave output signal. This counter also supplies three control signals to *IC5*, which generates the latch and preset control pulses at the end of each counting (gate) interval which govern the counting and display *IC's*.

For a 10-ms counting interval, a 50-Hz gating signal is required. It is obtained by dividing the symmetrical 100-Hz output of *IC4* by two. This is performed by *IC6*, a JK flip-flop. The 50-Hz square



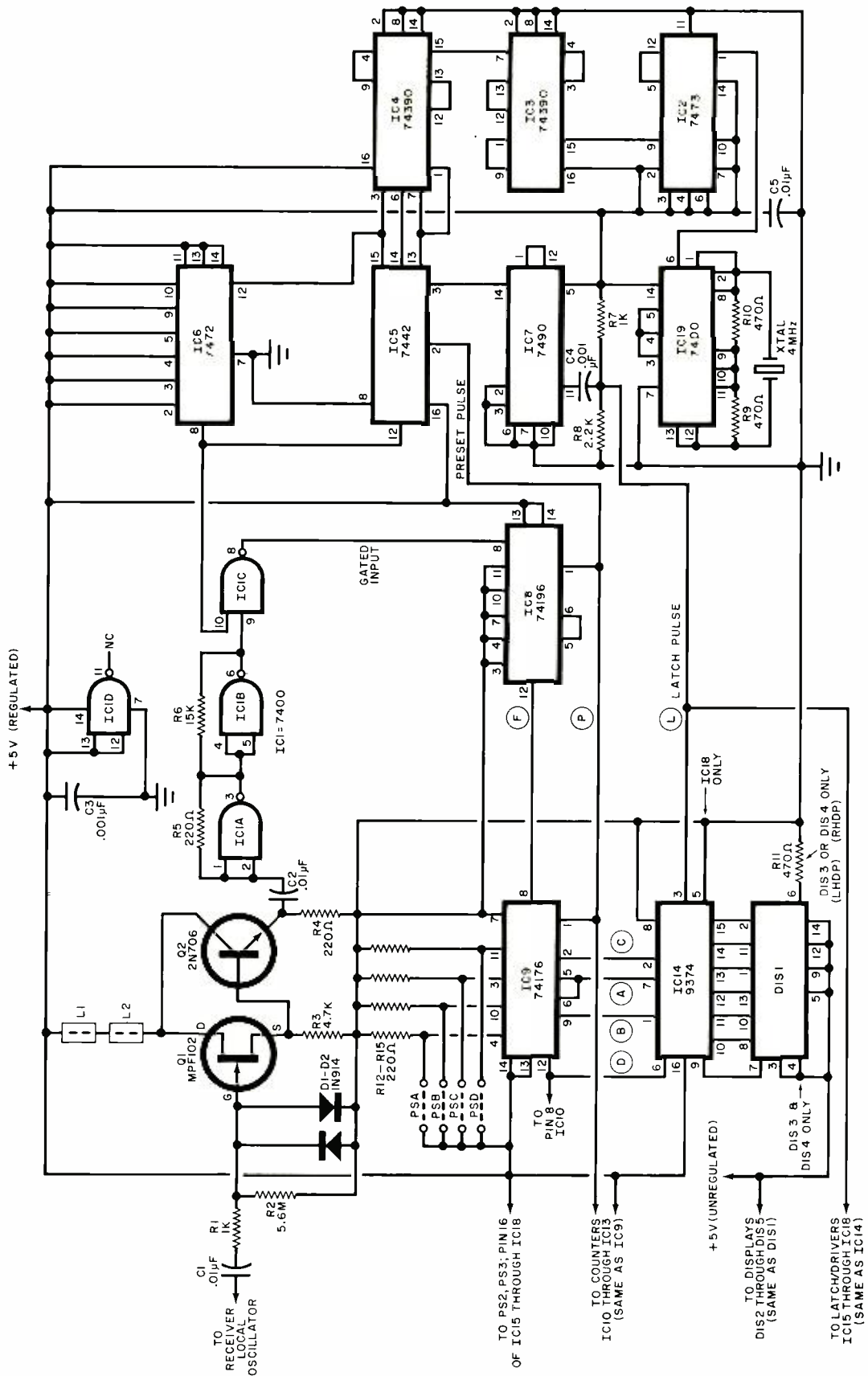

Fig. 1. Schematic diagram. For simplicity, only one decade of display is shown.

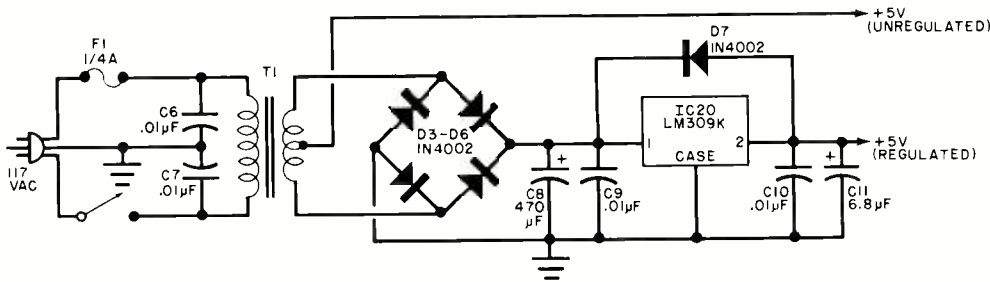

Fig. 2. Schematic diagram of the power supply.

wave is applied to both IC5 and to one input of NAND gate IC1C. When the gate signal is high (for 10 ms), IC1C passes an inverted version of the squared local oscillator signal to counters IC8 through IC13. During the 10-ms "low" period, IC5 produces the latch and preset control pulses.

Even though the counters resolve the local oscillator frequency to the nearest 0.1 kHz during the 10-ms gate interval, the received frequency is displayed only to the nearest kilohertz. The use of the undisplayed 0.1-kHz counter (IC8) eliminates the bothersome "bobble" in the least significant digit in other frequency readouts, thus providing a steady frequency display. A 1-kHz bobble occurs only when the counter is at the borderline between two frequencies—for example, 6.1649 and 6.1650 MHz.

Counter IC8 is specified as a 74196 programmable counter IC, but IC9 through IC13 are specified as 74176 IC's. The 74196 is used to insure reliable performance to 30 MHz. However, a hand-picked 74176 which can function up to 30 MHz can be used in place of the costlier 74196. The preset feature of these IC's permits the display of the re-

ceived signal's frequency, even though the counters are working with the local oscillator frequency, which is actually higher or lower by the intermediate frequency of the receiver. Counters IC9 through IC13 can be pre-loaded with any value determined by programming jumpers or switches at points PSA through PSD. The counters are loaded with this number at the reception of the preset pulse prior to the initiation of each counting interval.

At the end of every tenth counting cycle, a latch pulse appears at the output (pin 11) of IC7. It is then differentiated by C4, R8, and R7 and applied to latch/decoders IC14 through IC18. When this happens, the binary information accumulated in the programmable counters is transferred, stored, and decoded for display on seven-segment LED readouts DIS1 through DIS5. The latch pulse is generated by IC5. Although preset pulses are produced after each counting interval, only one in every ten counts is transferred to the 9374 latch/decoders (IC14 through IC18). This is so because IC7 divides the input signal from IC5 to produce a latch pulse with a frequency of 10 Hz.

As a result, the display flickers noticeably when the frequency is changing. Also, blurring and readout of spurious eight's—common problems with seven-segment displays—do not occur during a shift in frequency. Rather, the 10-Hz latch rate permits the display to track each frequency change with legible readout values.

The project's power supply (Fig. 2) is

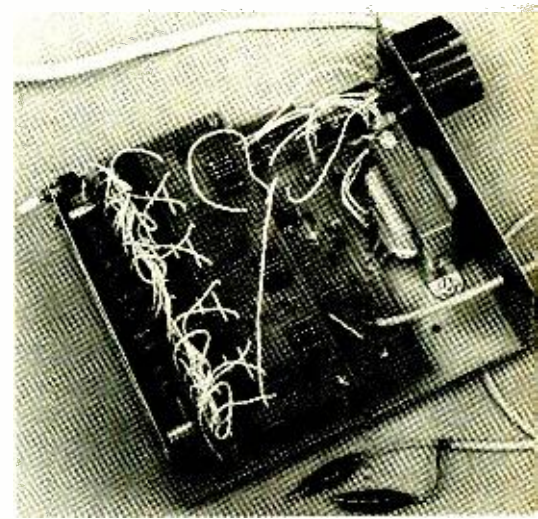

Fig. 3. Photo of prototype.

PARTS LIST

C1,C6,C7,C9—0.01-µF, 1000-volt disc ceramic capacitor
 C2,C5,C10—0.01-µF, disc ceramic capacitor
 C3,C4—0.001-µF disc ceramic capacitor
 C8—470-µF, 25-volt electrolytic capacitor
 C11—6.8-µF, 25-volt tantalum capacitor
 D1,D2—1N914 switching diode
 D3 through D7—1N4002 rectifier
 DIS1 through DIS5—MAN-1 or MAN-64 common anode seven-segment LED display
 F1—¼-ampere, 250-volt, 3-AG slow-blow fuse.
 IC1,IC19—7400 quad 2-input NAND gate
 IC2—7473 dual JK master-slave flip-flop
 IC3,IC4—74390 dual 4-bit decade counter (Texas Instruments)
 IC5—7442 BCD-to-decimal decoder
 IC6—7472 JK master-slave flip-flop
 IC7—7490 decade counter
 IC8—74196 45-MHz presettable decade counter (see text)
 IC9 through IC13—74176 25-MHz presettable decade counter

IC14 through IC18—F9374PC latch/7-segment decoder/driver (Fairchild)
 IC20—LM309K 5-volt regulator
 L1,L2—Ferrite bead (½" × ⅛" or 3.2 × 3.2 mm)
 Q1—MPF102 n-channel JFET
 Q2—2N706 npn transistor
 The following resistors are ¼-watt, 5% tolerance:
 R1,R7—1000 ohms
 R2—5.6 megohms
 R3—4700 ohms
 R4,R5,R12 through R29—220 ohms
 R6—15,000 ohms
 R8—2200 ohms
 R9 through R11—470 ohms
 S1—SPST miniature toggle switch
 PS1 through PS3—DIP switches (see text)
 T1—12.6-volt, 1.2-ampere center-tapped transformer
 XTAL—4-MHz, 0.0025% tolerance crystal
 Misc.—Suitable enclosure (7¼" × 6¼" ×

2¾" or 18.4 × 15.9 × 7 cm suggested); red Plexiglas bezel (5¼" × 1" or 13.3 × 2.5 cm); transistor sockets; IC sockets or Molex Soldercons; heat sink compound; TO-3 heat sink (1¼" or 3.2-cm fins); metal spacers; machine hardware; line cord; coaxial cable; rubber grommets; hookup wire; solder; fuseholder, etc.

Note: The following are available from Mattis Electronics, Box 162, Morton Grove, IL 60053. Set of three etched, drilled and plated pc boards (No. SW-1), \$18.95; 4-MHz precision crystal (No. SW-2), \$9.95; Five F9374PC latch/decoder/driver IC's (No. SW-3), \$15.95; Kit of parts including three pc boards, crystal, IC's, discrete semiconductors and pc board components (No. SW-4), \$74.95; Complete kit of parts including enclosure and power-supply components (No. SW-5), \$109.95. All prices include shipping charges within the USA. Illinois residents add 5% sales tax.

**CIE has
a terrific idea
for a few people
who know what
they want.**



If you want success in electronics . . . if you want the skills people are glad to pay for . . . find out about CIE training. It's a terrific idea that can get you on your way to success in electronics troubleshooting.

Let's face it, learning valuable new skills isn't something you just breeze through. Especially in a modern technological field like electronics troubleshooting. You've got to really *want* success if you're going to build your skills properly.

But, oh boy, the rewards when you do! In today's world, the ones who really *know* electronics troubleshooting find that people . . . even industries . . . look for their help.

What about you? How much do you want the thrill of success . . . of being in demand? Enough to roll up your sleeves and work for it?

Why it pays to build troubleshooting skills.

Suppose the automated production controls on an assembly line break down. Imagine how much money the manufacturer can lose when help doesn't come *fast!* And it takes a skilled electronics troubleshooter to move in . . . locate the problem . . . solve it . . . and get the lines moving again.

Or take a TV station. Breakdowns are costly in broadcasting where time is money. Viewers won't sit forever waiting for sound or the picture to come back. Before they change channels, the station needs to get back on the air again — with the help of a skilled troubleshooter.

No question about it. Building new skills in electronics troubleshooting is an investment in your future. It's well worth the effort.

Why you should get CIE to help you do it.

Troubleshooting starts with *ideas* . . . principles. CIE's Auto-Programmed® Lessons help you get the idea — at your own most comfortable pace. Step by step at home, you explore each principle — each theory — until you understand it thoroughly and completely. Then you start to use it.

How CIE helps you turn ideas into reality.

If you're a beginner, you start with CIE's Experimental Electronics Laboratory. You actually perform over 200 experiments to help you grasp the basics. Plus you use a 3-in-1 Precision Multimeter to get your first taste of the testing, checking, analyzing steps you take in troubleshooting!

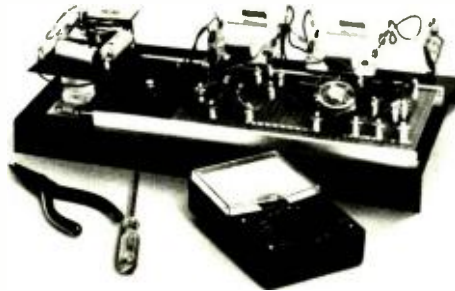

How 3 practical steps help you build troubleshooting skills.

You'll take your first practical step in professional troubleshooting when you build your own 5MHz triggered-sweep, solid-state oscilloscope.

As a trained troubleshooter, you'll use your oscilloscope the way a doctor uses his X-ray machine. As a student, you learn how to "read" waveform patterns on a big, 8cm. x 10cm. screen . . . how to "lock them in" for closer study . . . how to understand and interpret what they tell you.

Your second practical, skill-building step begins when you get your Zenith 19-inch diagonal, solid-state color TV — featuring nine removable modules! Now's your chance to apply the new skills you learned with your oscilloscope!

With CIE's guidance, you perform actual service operations — the kind you'd handle on the job as a trained troubleshooter! Using the TV, you learn to trace signal flow . . . detect and locate malfunctions . . . restore perfect operating standards . . . just as you would with any sophisticated electronics equipment.



Finally, step three rounds out your experience as you work with a completely solid-state color bar generator — actually a TV signal transmitter that produces ten different display patterns on your TV screen!

You study a gated color bar rainbow . . . crosshatch lines . . . dot patterns.

You explore digital logic circuits . . . observe the action of a crystal-controlled oscillator!

This practical, "hands on" training takes concentration and effort. But it's enjoyable and rewarding. And it's a great way to prepare for a troubleshooting career!

Why it's important to get your FCC License.

For some troubleshooting jobs, you *must* have your FCC License. For others, employers often consider it a mark in your favor. It's government-certified proof of specific knowledge and skills!

Almost 4 out of 5 CIE graduates who take the exam get their Licenses. More than half of CIE's courses can prepare you for it . . . and the broadest range of career opportunities!

Free catalog!

Mail the card. If it's gone, cut out and mail the coupon. If you prefer to write, mention the name of this magazine. We'll send you a copy of CIE's FREE school catalog — plus a complete package of independent home study information! For your convenience, we'll try to have a representative call to help you with course selection. Mail the card or coupon . . . or write: CIE, 1776 East 17th Street, Cleveland, Ohio 44114.

CIE Cleveland Institute of Electronics, Inc.

1776 East 17th Street, Cleveland, Ohio 44114
Accredited Member National Home Study Council

YES . . . I want to succeed in electronics. Send me my FREE CIE school catalog — including details about troubleshooting courses — plus my FREE package of home study information!

NAME (please print) _____

ADDRESS _____ APT. _____

CITY _____

STATE _____ ZIP _____

AGE _____ PHONE (area code) _____

Check box for G. I. Bill information:

Veteran Active Duty

PE-28

Mail today!

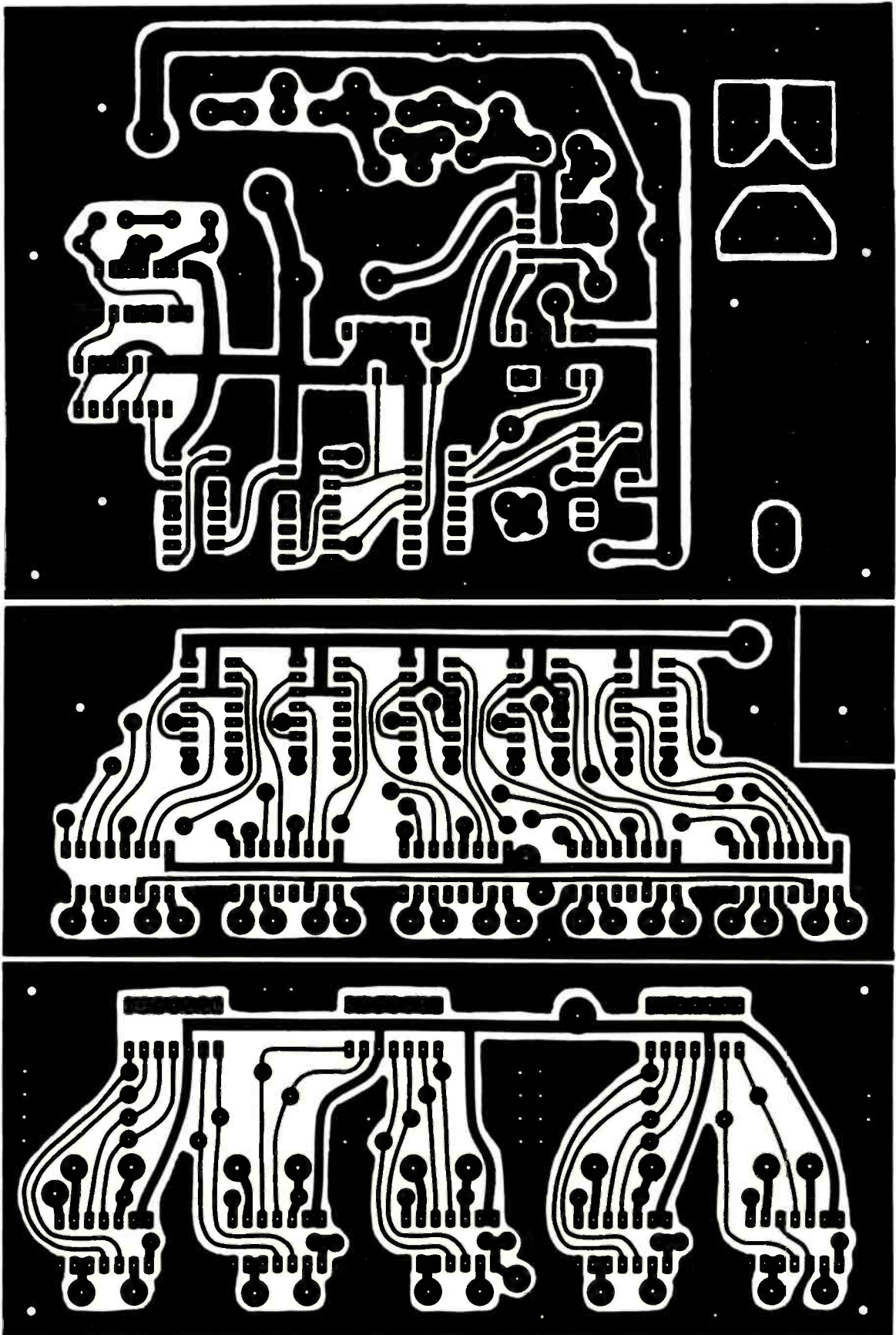

Fig. 4. Etching and drilling guides for main (top), display (center), and counter (bottom) pc boards.

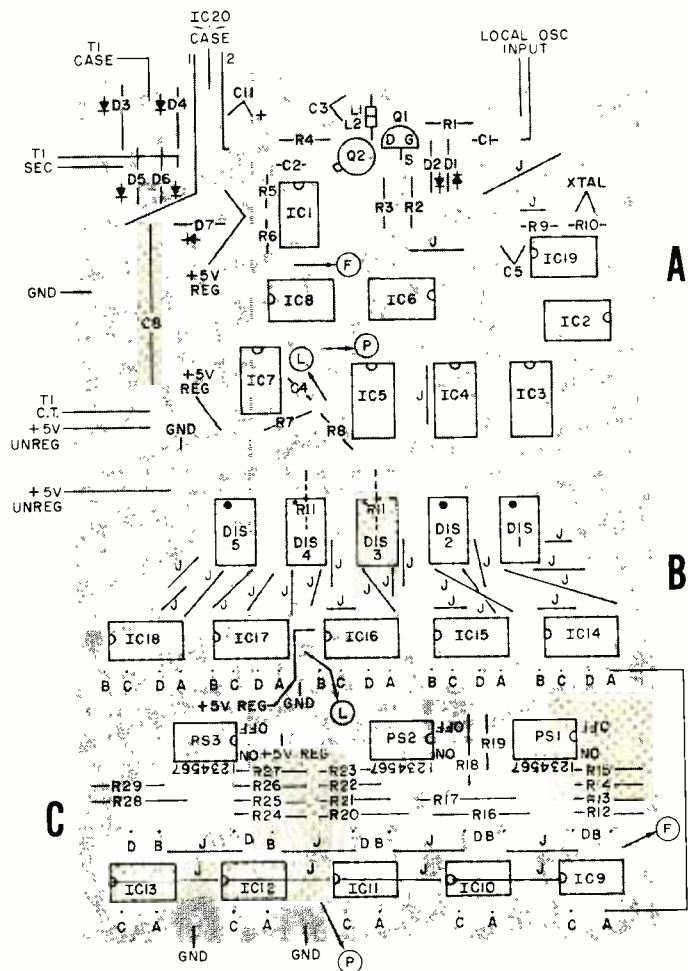

Fig. 5. Parts placement guides for main (top), display (center), and counter (bottom) pc boards.

a combination full-wave and bridge rectifier using a single 12.6-volt, center-tapped transformer. Two dc outputs are provided. The bridge rectifier (D3 through D6) delivers pulsating dc to C8 which acts as a filter. The filtered dc (+16 volts) is then applied to IC20, an LM309K voltage regulator, which is protected against transients by D7, C9 and C10. A well-regulated +5-volt dc output is thus provided for the TTL IC's and the input circuit.

Another +5-volt dc source is derived from the center tap of T1, D3 and D4. The three components form a full-wave rectifier, but its output is unfiltered and unregulated. This output is used to power the seven-segment readouts (DIS1 through DIS5). The unfiltered, pulsating dc has a ripple frequency of 120 Hz, which is great enough to prevent display flicker and results in a display brightness comparable to that obtained with a steady dc source. Removing the display current demand from the regulated supply substantially reduces the amount of heat generated in the power transformer

and voltage regulator IC, but causes no adverse effects. Display segment current limiting is performed internally by the 9374 IC's which also contain internal latch memories. No external current limiting resistors or bistable latch IC's are required, as is often the case with other decoder/driver chips.

Construction. The project should be assembled using printed circuit boards and IC sockets or Molex Soldercons. Transistor sockets (standard and TO-3) are also recommended for Q1, Q2, and IC20. The author used three pc boards in his prototype (Fig. 3). The boards can be interconnected with short lengths of No. 20 stranded hookup wire. Suitable etching and drilling guides are shown in Figs. 4 and 5 (A, B, and C) for the Main, Display, and Counter boards, respectively. Use the minimum amount of heat necessary for good solder connections. Be sure to observe polarities and pin basings of discrete semiconductors, IC's, and electrolytic capacitors.

Figure 3 shows how the boards and

power supply components were mounted in the project enclosure. The Counter and Main pc boards were secured to the bottom of the cabinet using 3/4-inch (1.9 cm) threaded metal spacers, while the Display board was mounted behind a bezel on the front of the case using 1/2-inch (1.3-cm) threaded metal spacers. Voltage regulator IC20 must be properly heat sunk and mounted on the exterior of the enclosure's rear panel. Use heat sink compound to insure proper heat transfer, and be sure to connect a length of hookup wire between the regulator socket's center ground bus and the Main pc board's ground. Also, make sure that IC20's mounting screws are in firm contact with the IC's case and the TO-3 socket's ground bus. The author also recommends grounding the power transformer's case.

Because TTL IC's are high-current switching devices, the steep edges of their output waveforms contain large amounts of r-f energy. Unless certain precautions are taken, this r-f will produce high noise levels at the receiver output. First, a metal case must be used—but it must also be perforated or vented to allow heat to dissipate. Second, both the project's and receiver's enclosures must be tied to a good earth ground. Third, both sides of the ac power line must be bypassed with 0.01- μ F disc ceramic capacitors (C6 and C7).

Checkout and Use. A typical receiver's local oscillator is shown schematically in Fig. 6. Whether the receiver uses a FET, tube, or transistor oscillator, the point where the local oscillator signal must be tapped off is the same—at the capacitor coupling the output of the oscillator to the mixer. The author suggests that the signal be sampled on the local oscillator side of the coupling capacitor. For the following three popular SW receivers, the appropriate points are: Realistic DX-160, junction of C12 and R32 (drain of Q8); Lafayette HA-600A, junction of C6 and R21; Heathkit GR-78, junction of C308, R203, and R204. (Note: if you are using a tube-type receiver, beware of high voltage!) The connection should be made with small-diameter coaxial cable such as RG-58-U. You might find it desirable to mount an RCA phono jack on the back of receiver and bring the coax from the local oscillator output to this point. Then you can interconnect the display and receiver with a short coaxial jumper terminated with an RCA phono plug. Alternatively, you can terminate one end of the jumper with small alligator clips, as

TABLE A
CONVERTING DECIMAL NUMBERS TO BCD

Number	BCD				
	8	4	2	1	
0	0	0	0	0	0
1	0	0	0	1	0
2	0	0	1	0	0
3	0	0	1	1	0
4	0	1	0	0	0
5	0	1	0	1	0
6	0	1	1	0	0
7	0	1	1	1	0
8	1	0	0	0	0
9	1	0	0	1	0

TABLE B
COUNTER BOARD PROGRAMMING ASSIGNMENTS

Programming section	PS3		PS2		PS1
Programming input number	7654321		7654321		7654321
BCD designation	81-8241		8241-82		41-8241
Actual programming*	1111001		0011100		1010010
Counter controlled	IC13	IC12	IC11	IC10	IC9
Frequency displayed (receiver off)	9	9	.5	4	4 MHz

*0=no jumper or open switch (OFF),
1=jumper or closed switch (ON).

WWVH at 5 MHz. Tune the receiver to the station's carrier as accurately as possible. You can best do this by turning on the bfo—if your receiver has one—and zero beating the carrier. If no bfo is available, tune in the carrier for maximum signal strength. Now turn the project on. The readout will display a frequency somewhat above or below that of WWV's carrier. Subtract the number display from 105.000 to obtain the number needed for counter programming. For example, if the display reads 5.456 MHz, subtract 5.456 from 105.000. You will obtain a remainder of 99.544, which is then programmed into the counters in BCD form as illustrated in TABLES A and B.

The display should now read 5.000 MHz. Programming can be verified by tuning in an AM broadcast station of known frequency for maximum signal strength. Observe the displayed frequency. If it is off by 1 kHz or so, adjust the programming of IC9 so that the correct frequency is displayed. The project is now properly programmed for receivers with a fixed i-f for all bands and no further adjustments are needed. When the receiver is turned off but the project left on, the readout will display the number you have programmed into the counters.

Some multiple conversion receivers, such as the Heath GR-78, will require different programming for different bands. Thumbwheel switches with BCD outputs can be mounted on the front panel and used in place of jumpers or DIP switches. This will greatly speed programming.

The project is *not* suitable for use with those multiple conversion receivers having second (lower) i-f's with variable frequency (local) oscillators operating below the first i-f. In such a case, the tunable oscillator's output frequency is highest when the receiver is tuned to the lowest frequency within a given band. Conversely, the oscillator's output frequency is lowest when the receiver is tuned to the highest frequency within the band. However, receivers using this type of i-f generally have dial mechanisms with wide bandsread and frequency readout to the nearest one or five kilohertz. Therefore, they do not need the kind of improvement this project can provide.

For inexpensive SW receivers, however, this project is an enormous asset. Not only will it greatly enhance the user's enjoyment of shortwave listening, it will also make station tuning and logging a "breeze." ♦

was done with the prototype (Fig. 3). The clip would then be attached to the proper tie point within the receiver.

The counters will be programmed with DIP switches (seven spst switches mounted in a DIP) or with wire jumpers on the counter board. If you are using DIP switches, make sure that all switches are in the OFF position. If wire jumpers are to be used, do not install any of them yet.

Turn the power switch (S1) on. The display should read 0.000 with the second zero to the left of the decimal point blanked off. Insert No. 22 solid jumpers across the IC sockets at the number 5 positions of PS1 and PS3 and at the number 3 position of PS2 (see compo-

nent placement guide). Or, if DIP switches are used, close the switches at these positions. Then momentarily insert a jumper across the other IC socket positions and verify that the corresponding counter responds according to Table B. For DIP switches, this is accomplished by turning the remaining switches on and off. As voltage is applied to each programming input, the BCD value of that input will be displayed on the corresponding LED readout.

After completing the checkout procedure turn the power off and connect the hot and ground sides of the coaxial jumper to receiver's local oscillator output and chassis, respectively. Turn on the receiver and tune it to WWV or

Fig. 6. Typical local oscillator circuit

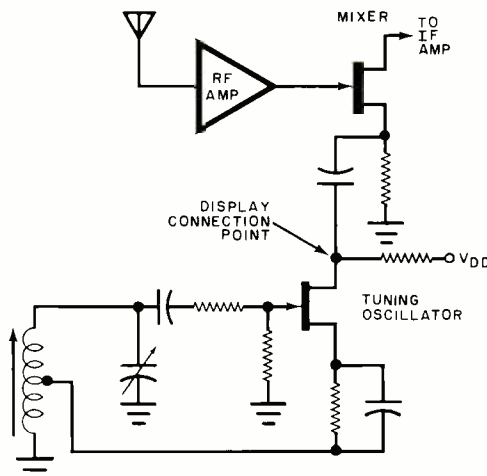

WHILE MOST modern power supplies are designed to protect themselves against overloads and short circuits, the protection often doesn't go far enough. In many modern projects—particularly those involving computers—the load on the power supply can cost a great deal more than the supply itself. A practical power supply for modern projects, then, should protect both itself and the load. With an inexpensive 723 precision voltage regulator IC and a handful of components, you can build such a "full-protection" power supply.

Unlike most other regulator IC's, the 723 can be programmed to automatically drop the output current to a small fraction of maximum under overload and short-circuit conditions. This "foldback" current is similar to conventional current limiting up to the maximum current rating of the supply. But while a conventional current limiter will keep right on pumping maximum current into the load, the foldback circuit will go to maximum and then signal the series-pass transistor in the 723 to drop the output current to a mere fraction of its capability.

The actions of both conventional and foldback limiting are graphically illustrated in Fig. 1. Note the downward slope of the short-circuit current, I_{SC} , for the foldback characteristic as opposed to the zero slope of the line for conventional current limiting.

The functional diagram of the 723 is shown in Fig. 2. Pin designations on the diagram are for the dual in-line (DIP) configuration of this IC. Below the diagram are the pin designations for the round (TO-100) configuration of this IC. Some of the IC's more important maximum specifications are: 40 V from +V and V_C to -V; 150 mA maximum current for internal series-pass transistor; 900 mW DIP (800 mW round) maximum power dissipation; 0.001- μ F frequency-compensation capacitor; 0.03% regulation at load; input-output voltage differential, 30 V minimum. On the TO-100, pin 5 is connected to the case.

Regulation Differences. A basic current limiter using a 723 is shown in Fig. 3. This circuit can be programmed to operate in either a low- (2-to-7-) or high- (7-to-35-) volt range by proper selection of voltage-divider resistors $R1$ and $R2$. (Note: To avoid confusion during calculations, two $R1$ - $R2$ divider networks are shown. The resistor values calculated will be the same in both divider networks.)

If only the high-voltage range is de-

Current "Foldback" Protects Power Supply & Load

BY JEROME MAY

*How a 723 IC
can be used for
both load and
supply regulation.*

sired, switch $S1$ goes to HI, and V_{REF} goes to the noninverting, or +, input of the error amplifier in the 723 through a 5000-ohm resistor ($R4$). The output current of the IC is sensed by $R3$ and fed to the $Q2$ current sense amplifier in the 723. When the potential across $R3$ exceeds about 0.7 volt, $Q2$ diverts any increase in base current from the error amplifier to $Q1$ inside the IC. This limits the available current from the 723 to the IC's rated maximum. Unfortunately, if the load resistance goes to zero, this maximum current will still be pumped into the load.

Now, consider the foldback modification shown in Fig. 4. (This circuit is identical to the Fig. 3 circuit except that $R5$ and $R6$ have been added as shown.) The ratio of $R5/R6$ shifts the operating point of $Q2$ inside the 723 so that, when the voltage drop across $R3$ biases on $Q2$, any increase in the drop across $R3$ (beyond the point at which the transistor first starts to conduct) diverts increasing current away from the base of the 723's $Q1$ transistor. Thus, the output current "folds back" after the maximum programmed current is obtained. Note, however, that because a finite voltage drop is required to keep the 723's $Q2$ transistor conducting, the output current can never go to zero; it simply folds back to a small fraction of the maximum current the IC can deliver.

Calculations. To program a 723 for the current-foldback regulator, first determine values for $R1$ and $R2$ to fix the output voltage. To determine the foldback current ("knee" in Fig. 1), $R3$ is calculated after selecting convenient values for $R5/R6$.

If the output is to be less than 7 volts, the $R1A$ - $R2A$ divider network goes directly to the 723's V_{REF} input with $S1$ in the LO position as shown in Fig. 3. The basic formula from which to work is $V_O = V_{REF} R2A/(R1A + R2A)$, from which we obtain $R1A = R2A(V_{REF} - V_O)/V_O$ and $R2A = V_O R1A / (V_{REF} - V_O)$. Assume that the desired $V_O = 5$ volts and that $V_{REF} = 6.2$ volts. Select an arbitrary value of several thousand ohms—say, 10,000 ohms — for $R2A$. Therefore, $R1A = 10,000(6.2 - 5)/5 = 2400$ ohms. Hence, for a 5-volt output, the values of $R1A$ and $R2A$ should be 2400 and 10,000 ohms, respectively.

Should you desire an output of greater than 7 volts, $S1$ should be set to HI, which bypasses $R1A$ and $R2A$ by switching in $R4$ and placing the $R1B$ - $R2B$ divider in the circuit. The basic for-

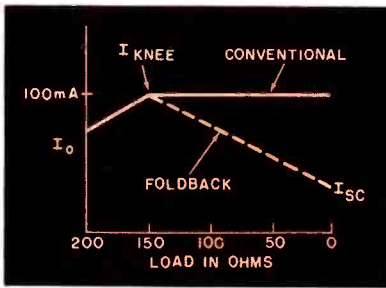

Fig. 1. Dashed line shows downward slope of short-circuit current for the foldback characteristic.

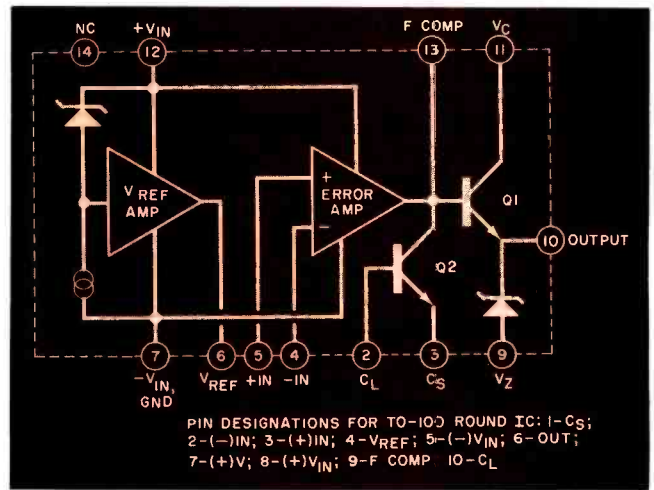

Fig. 2. Functional diagram of the DIP 723. Pin designations for TC-100 are also given.

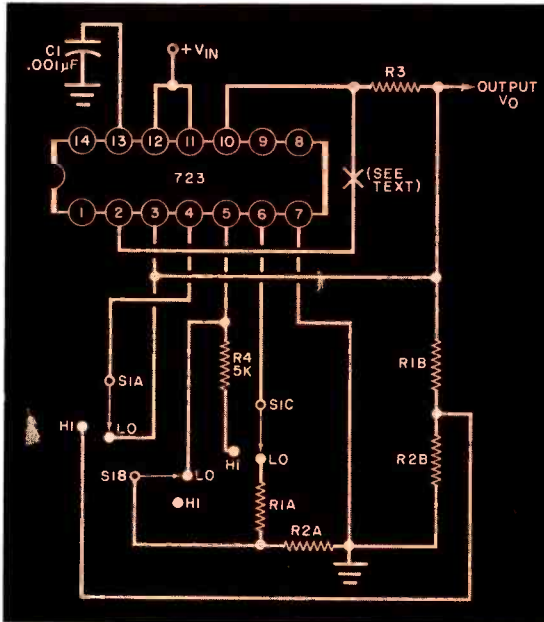

Fig. 3. Basic current limiter can operate in either a low (2 to 7 volts) or high (7 to 35) range by proper selection of resistors R1 and R2. See Fig. 4 for added circuit at point "X".

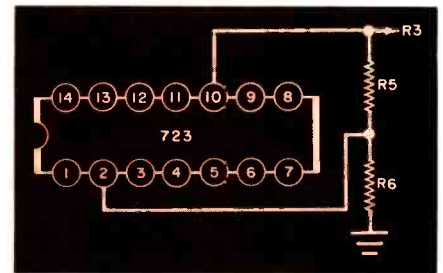

Fig. 4. Voltage divider at "X" in Fig. 3 shifts operating point.

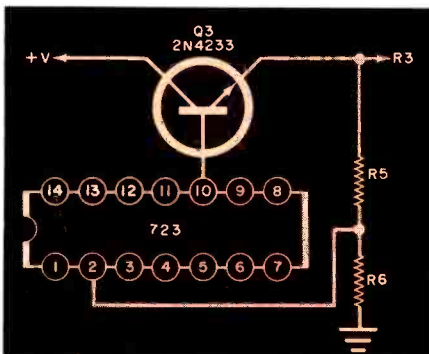

Fig. 5. Use of an npn series-pass transistor to increase capacity.

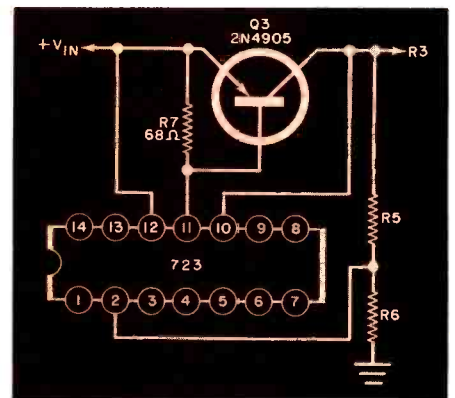

Fig. 6. If a pnp transistor is used as series-pass element, add a bias resistor.

mula here is $V_O = V_{REF} (R1B + R2B) / R2B$. Therefore, $R1B = R2B(V_O - V_{REF}) / V_{REF}$ and $R2B = V_{REF} R1B / (V_O - V_{REF})$. This time, let us assume that the output is to be 15 volts and that V_{REF} remains the same at 6.2 volts. Again arbitrarily selecting a value of 10,000 ohms for $R2B$, $R1B = 10,000 (15 - 6.2) / 6.2 = 14,193$ ohms.

Now, select the maximum current the supply is to deliver to the load. For example, assume that at $V_O = 15$ volts, you want an I_{MAX} of 100 mA. Now, select values for $R5$ and $R6$ (Fig. 4 shows how these components connect into the basic circuit). Assume that $R5$ and $R6$ have values of 1000 and 10,000 ohms, respectively. (Note: The smaller the ratio

of $R5/R6$, the lower will be the resistance for $R3$ to provide the required limiting. Bear in mind that the short-circuit current will be reduced for larger values of $R3$.)

From the equation $I_{MAX} = [V_O R5 + 0.7(R5 + R6)] / R3R6$, we obtain $R3 = [V_O R5 + 0.7(R5 + R6)] / I_{MAX} R6$. Therefore, $R3 = [15(1000) + 0.7(1000 + 10,000)] / (0.1 \times 10,000) = 22.7$ ohms. Since the formula for short-circuit current is $I_{SC} = 0.7(R5 + R6) / R3R6$, $I_{SC} = 0.7(1000 + 10,000) / (22.7 \times 10,000) = 35$ mA. This is about a third of the actual current the 723 supply is designed to deliver. The short-circuit current can be reduced, but then new values of the ratio $R5/R6$ will have to be se-

lected to determine the 100-mA foldback point.

A current of 35 mA at 15 volts is a hefty half-watt to dissipate on an IC chip. Therefore, a better approach to the design of the supply would be to use an external series-pass transistor with adequate heat-sink protection. The circuit utilizing an npn series-pass transistor (Q3) is shown in Fig. 5. If all you have available is a pnp transistor, you can use it, along with an additional bias resistor (R7), as shown in Fig. 6. In either case, if the circuit is to be used to power a particular project, be sure the transistor's voltage, current, and power dissipation figures are capable of accommodating the load at full power. ♦

EARN \$1000 OR MORE PER ORDER IN YOUR SPARE TIME SELLING OUR SIDING HOME-KITS.

Our HOME-KIT is a complete covering of aluminum, steel, or vinyl siding for a home. They're available in 14 sizes and 22 colors. They're easy to apply and easy to sell because our dealer prices (your cost) allow you to buy at about 1/3rd of the national average installed price.

Each new dealer must install a HOME-KIT on his own home in order to gain application experience and have something to show to his prospective customers.

Fill in the coupon on this page and send it to us. We'll promptly mail you your FREE FRANCHISE (if still available in your county) and FREE DEALERSHIP. You'll also receive FREE SAMPLES of our product and our 48 page CONFIDENTIAL DEALER'S MANUAL AND WHOLESALE PRICE LIST. The manual is extremely valuable. It explains how to apply siding, discusses each type of siding material available, and tells you how to sell it.

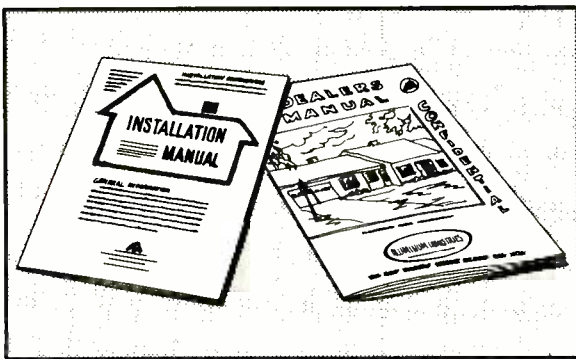
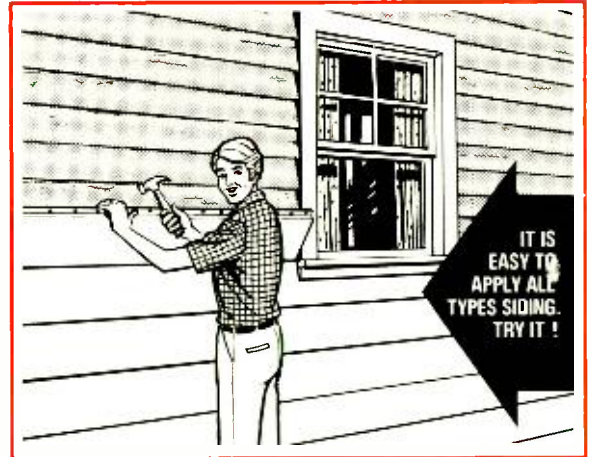

Your first HOME-KIT includes a complete set of professional siding applicator's tools and detailed, yet easy to follow, step-by-step, illustrated instructions... all free of additional charges. Plus, a FREE 50 lesson course on everything you'll ever have to know about selling and applying siding.

Once you decide to become an Aluminum Industries dealer, all of our merchandising, advertising and sales experience (over 30 years of it) becomes available to you... FREE!

SELL YOUR CUSTOMERS ON MONTHLY PAYMENTS.

HOME-KITS can be sold on monthly payments. No down payment is required. Details are in your free CONFIDENTIAL DEALERS MANUAL AND WHOLESALE PRICE LIST.

PLEASE... do not delay. We can only award a limited number of active franchises in any county. As soon as we receive your inquiry, we'll reserve your franchise for you until you decide whether or not to become a dealer. But act now, before your county is closed.

NOTICE

If, after applying a HOME-KIT to your home you decide that you would rather not become an Aluminum Industries dealer, you are under no obligation to do so. But we think that once you see how easy a HOME-KIT is to apply and how beautiful and maintenance free it makes your home, you will find it is quite easy and very profitable to sell HOME-KITS to your friends and neighbors.

APPLICATION FOR DEALERSHIP [PE-27]

WITHOUT OBLIGATION, please mail me all of the materials mentioned above including my FREE 48-page CONFIDENTIAL DEALER'S MANUAL AND WHOLESALE PRICE LIST, FRANCHISE & DEALERSHIP, AND SAMPLES. I own a home which needs to be re-sided and I understand that I must purchase a HOME-KIT for my home before I can sell them to the public. **NOTE** No salesman will knock on your door, we distribute exclusively by mail

My name is: _____ (please print)

I would like to be considered for a: Part-time dealership Full-time dealership

Address of property I own which needs re-siding: STREET _____

CITY _____ STATE _____ ZIP _____

This property is in _____ county.

My mailing address is: STREET _____

CITY _____ STATE _____ ZIP _____

My present occupation is: _____

My phone number is: _____

SIGNATURE _____ DATE _____



Dept. PE-27
300 Phillips Rd.
North Little Rock, AR 72117



Conference TALK TIMER

BY WALTER W. SCHOPP

*Compact, versatile project
has selectable time intervals.*

IT IS a well-known fact that public speakers frequently run over their allotted time. This "Talk Timer" is an ideal device for keeping speakers within their time limits and getting a conference moving on schedule. Its use need not be confined to conferences, however. It can be used in any timing application in the kitchen, in the radio shack, near the telephone, etc.

When the unit is turned on and the RESET button is pressed, a green light glows for the TALK period (adjustable from 5 to 60 minutes). At the end of that time, a yellow light comes on, and the SUMMARIZE period (adjustable from 5 to 15 minutes) begins. When the total time is up, a red light comes on.

The project can be built easily at a total parts cost of about \$30.

About the Circuit. The Talk Timer has a fairly low parts count due to the fact that two Exar XR-2400 IC's are used. Each chip contains a 555 timer and eight flip-flops (divide-by-two counters) in a 16-pin DIP. Each open-collector flip-flop output is accessible at a specific pin, and any number of them can be connected together. The result is a summed output signal with a period from RC to 255RC, where RC is the time con-

stant of the timing resistor and capacitor.

The schematic diagram of the Talk Timer is shown in Fig. 1. Duration of the "talk" period is controlled by IC1, and that of the "summarize" period by IC2. A 15-second time constant is used in each timer, determined by R7, R8, and C2 for IC1 and R14, R15, and C8 for IC2. Because this time constant is fairly short, reasonably sized capacitors can be used. Also, adjustment of R8 and R15 is much easier for this interval than for one considerably longer. (The overall accuracy of each timer depends on that of its reference time constant.) For the "talk" period, the 4RC through 128RC outputs of IC1 are selectively summed to give an output signal with a duration of 5 to 60 minutes in 5-minute increments. For the "summarize" period, the 4RC through 32RC outputs of IC2 are combined to give an output signal of 5, 10, or 15 minutes.

When power is initially turned on, both timers are reset. All three lamps (I1-I3) glow, and the unit is ready for operation. When RESET switch S1 is depressed, one pole momentarily disconnects SCR1 and SCR2 from the unregulated +7.5-volt supply (point A). This turns off the SCR's and lamps I2 (SUMMARIZE) and I3 (STOP). Lamp I1 (TALK) will glow

again when S1 is released. The other pole of S1 applies a pulse from capacitor C3 to the reset terminal of IC2 (pin 10) and to the reset and trigger (pin 16) terminals of IC1. Thus, IC1 starts timing and its output goes low.

At the end of the selected "talk" period, the output of IC1 goes high and causes SCR1 and I2 to conduct. Simultaneously, a pulse is applied to the trigger input of IC2. This IC then times out the SUMMARIZE period. At the end of that interval, IC2's output goes high and turns on SCR2. This activates I3 and the Sonalert (if used). The Talk Timer can then be reset for the next speaker by depressing S1. Also, the unit can be reset at any time during the TALK and SUMMARIZE intervals by pressing RESET.

A suitable power supply providing regulated and unregulated outputs is shown schematically in Fig. 2. For stability, the two timing chips are connected to the 6.8-volt regulated output (point B). The rest of the circuit (the SCR's and indicator lamps) is connected to the unregulated output.

Construction. Assembly techniques and parts placement are not critical. Printed circuit or perforated board can be used, with hard wire or wrapped wire

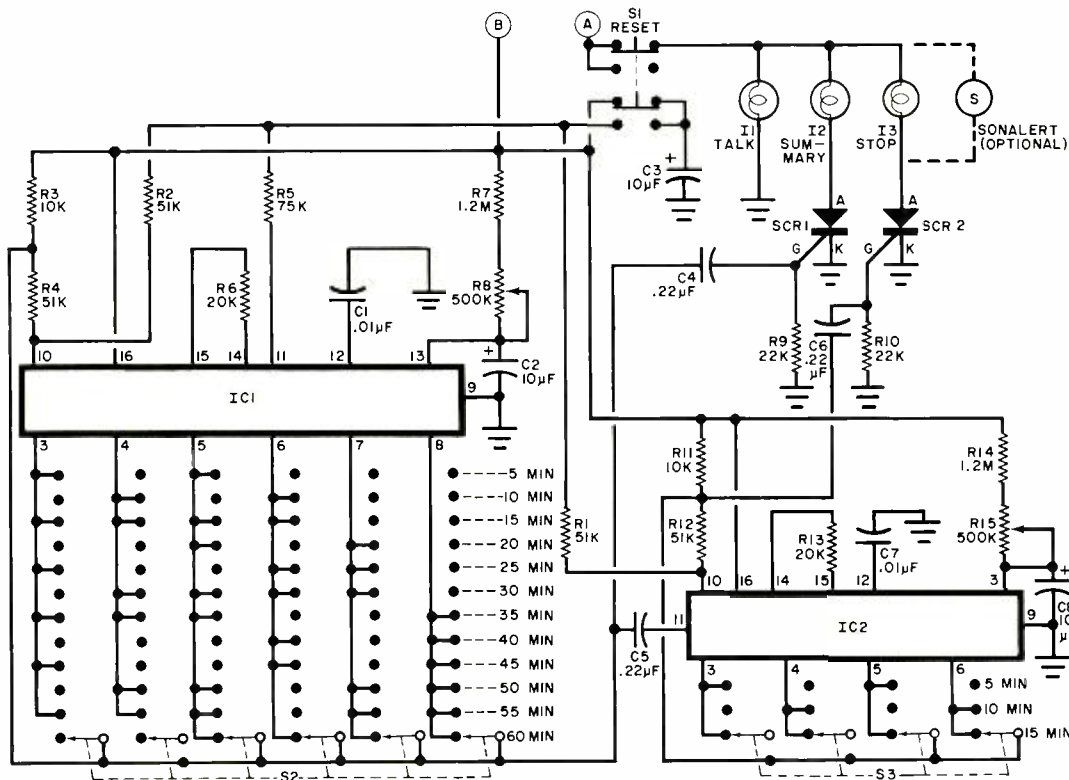

PARTS LIST

C1, C7—0.01- μ F disc ceramic capacitor
 C2, C3, C8—10- μ F, 25-volt tantalum capacitor
 C4 through C6—0.22- μ F Mylar capacitor
 I1 through I3—No. 44 or 47 pilot light
 IC1, IC2—XR-2240CP programmable timer (Exar)
 The following fixed resistors are 1/4-watt, 10% tolerance components.

R1, R2, R4, R12—51,000 ohms
 R3, R11—10,000 ohms
 R5—75,000 ohms
 R6, R13—20,000 ohms
 R7, R14—1.2 megohms
 R9, R10—22,000 ohms
 R8, R15—500,000-ohm trimmer potentiometer
 S1—Dpdt momentary pushbutton switch
 S2—6-pole, 12-position nonshorting rotary switch (Centralab 2025 or equivalent)

S3—4-pole, 3-position nonshorting rotary switch (Centralab 2011 or equivalent)

SCR1, SCR2—1-ampere, 100-volt silicon controlled rectifier (Radio Shack 276-1059 or equivalent)

Misc.—Lensed lamp holders, printed circuit or perforated board, IC sockets or Molex Soldercons, suitable enclosure, switch knobs, Sonalert (optional), hookup wire, solder, etc.

Fig. 1. Two timer-counter IC's reduce parts count for the project.

connections. The use of sockets or Molex Soldercons is recommended for the IC's. Care should be taken when wiring S2 and S3. The many contacts on these rotary switches make it easy to wire them incorrectly, and make it difficult to find the error after assembly. Lampholders with colored lenses should be used with I1 (green), I2 (yellow), and I3 (red).

Adjustment. The only adjustments

that need to be made are the settings of R8 and R15. Using a dc-coupled oscilloscope or high-threshold logic probe, observe the signals at pin 1 of each IC. During the "talk" period, the waveform at pin 1 of IC1 should change state every 15 seconds when R8 is properly adjusted. During the "summarize" period, pin 1 of IC2 will change state every 15 seconds when R15 is set correctly. Try to adjust these RC time constants as

precisely as possible, because the overall accuracy of the Talk Timer depends entirely on them.

No matter what your application may be, the Talk Timer is set up and operated in this manner—connect the project to the ac line, close power switch S4, select the desired talk and summary times with rotary switches S2 and S3, respectively, and activate and reset the system using RESET switch S1. \diamond

PARTS LIST

C9—2500- μ F, 15-volt electrolytic capacitor
 C10—0.001- μ F disc ceramic capacitor
 D1 through D4—1N4001 rectifier diode
 D5—6.8-volt, 1-watt zener diode (1N3016B or equivalent)
 R16—33-ohm, 1/2-watt resistor
 S4—Spst toggle switch
 T1—117V/6.3-volt, 1.2-ampere transformer
 Misc.—Line cord, terminal strips, hookup wire, solder, machine hardware, etc.

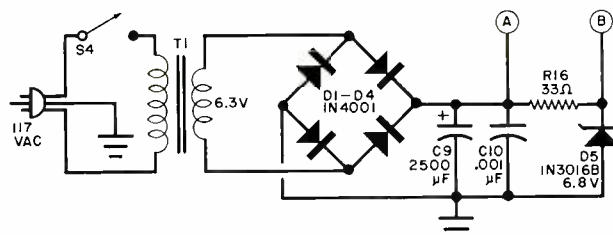

Fig. 2. Schematic of suitable power supply.

QUIZ-GAME ELECTRONICS

BY MICHAEL S. ROBBINS



Here's a player-response circuit that will enable you to imitate quiz shows at home or with larger audiences.

POPULAR TV quiz shows use electrical or electronic apparatus to determine which contestant makes the first response, thereby getting first crack at a

question. Here's a simple circuit that will enable high school and college groups to emulate the quiz shows. It can be used for fun at home, too.

The circuit shown will energize a lamp to identify which player pushes his button first, sound an audible alarm, and lock out the buttons of the other players.

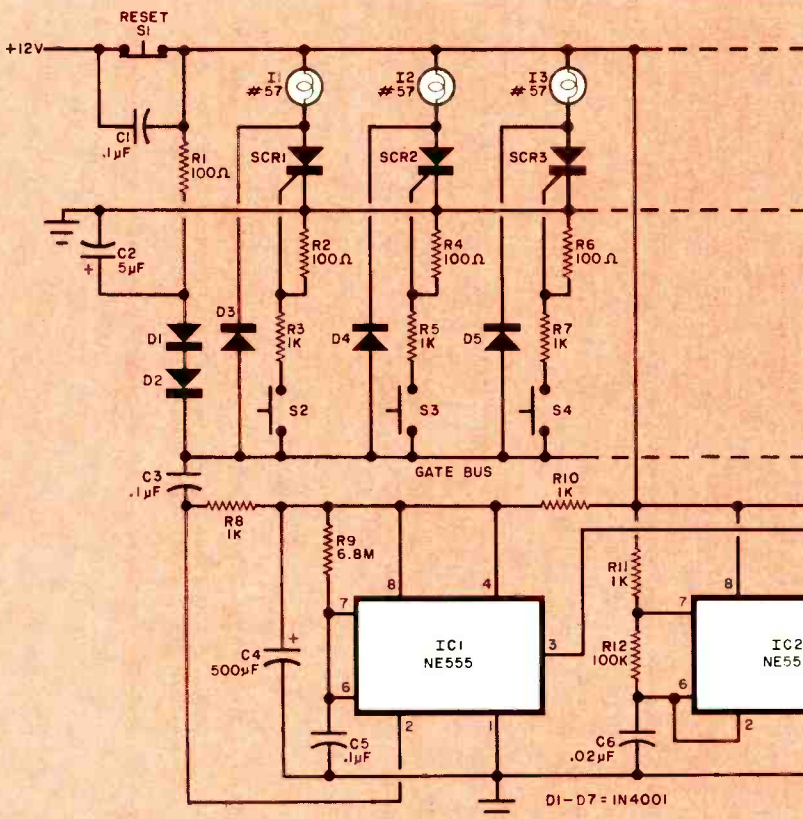

PARTS LIST

- C1, C3, C5—0.1- μ F, 50-volt disc ceramic capacitor
- C2—5- μ F, 25-volt electrolytic capacitor
- C4—500- μ F, 25-volt electrolytic capacitor
- C6—0.02- μ F, 50-volt disc ceramic capacitor
- C7—10- μ F, 25-volt electrolytic capacitor
- D1 to D7—1N4001 diode
- I1 to I3—No. 57 pilot lamp
- IC1, IC2—555 IC timer
- R1, R2, R4, R6—100-ohm resistor
- R3, R5, R7, R8, R10, R11—1000-ohm resistor
- R9—6.8-megohm resistor
- R12—100,000-ohm resistor
- S1—Spst normally closed, momentary pushbutton switch
- S2 to S4—Spst normally open, momentary pushbutton switch
- SCR1 to SCR4—HEP R1221 or equivalent
- Misc.—Utility boxes, pc or perforated board, lamp sockets, wire, solder, hardware, etc.

Schematic diagram for the game circuit. By adding SCR networks, the circuit can be expanded to include any number of players.

The solid-state design is inexpensive to build and can be expanded to include any number of players and a combination of alarms could be used.

Circuit Operation. The heart of the system is an inexpensive SCR. When a contestant presses his button, the gate of his particular SCR (one for each player) is connected to the positive gate bus. The SCR turns on and the indicator is lit. Since the voltage across the SCR is nearly zero during conduction, the normally positive gate bus will be pulled down to almost 0 volts through the diode which ties the bus to the SCR's anode. When this happens, the bus will not be able to supply enough gate current to turn any other SCR on. Thus the other players' buttons are locked out until the referee resets the circuit.

This dip in voltage on the bus activates IC1, a 555 unit operating as a one-shot. A one-second pulse from IC1's output activates IC2, a 555 in the astable mode, producing a tone in the speaker for the same length of time. Since the output of IC2 is a square wave, an appreciable inductive "kick" can appear across the speaker coil. Two clipping diodes are connected across the output of IC2 to protect the transis-

tors inside the 555 from excessive voltage spikes.

Once a pulse of current flows into an SCR, it will conduct indefinitely (the player need not keep his button continuously depressed) until the anode current falls below the holding current, I_H . When this happens, the SCR turns off. In this circuit, the indicator lamp will continue to glow and all other pushbuttons will be locked out until the referee pushes the RESET button, S1.

The duration and pitch of the tone may be adjusted by changing the values of the timing components associated with IC1 and IC2. For example, changing R9 from 6.8 megohms to 1 megohm will shorten the duration to about 0.2 seconds, while substituting a 10-megohm resistor will extend the interval to about two seconds. Replacing the 100,000-ohm R12 with a 500,000-ohm resistor will raise the frequency of the tone from 350 Hz to about 1000 Hz. Since tastes vary, you might install potentiometers in place of these two fixed resistances, and adjust them to produce the desired pitch/duration combination.

Any small 8-ohm speaker will be sufficient for this application. Power can be obtained from any source capable of producing 500 mA at 9 to 12 volts dc. A

lantern battery or a small full-wave power supply will work fine.

Construction. The system can be constructed in several different configurations. One of the most versatile arrangements is to mount each contestant's pushbutton, indicator lamp, and SCR network in a small utility box, which is placed before him. All of the boxes are connected together by a three-conductor cable. The tone generator, RESET button, and power supply can then be installed in a utility box mounted at the referee's position.

An alternative arrangement is to mount all of the circuitry behind a panel on which the indicator lamps are installed. Twisted-pair or zip cord can be used to connect the circuitry to pushbuttons at the contestants' and referee's positions. Other configurations might be suggested by your own particular situation.

Parts placement is not critical, so the circuitry can be assembled on a printed circuit board or a piece of perforated board, mounted in any small, convenient utility box.

All you need now to use the system are contestants, brain teasers and prizes to be won! ◇

Get More from Your Car with a Mark 10 System.

The best-selling CDI system of its kind in the world—now at discount prices!

Would you like more power? Better mileage? And could you stand to eliminate 3 out of 4 of those expensive tune-ups? Well, that's what the MARK 10 capacitive discharge electronic ignition system is all about. Very simply, it boosts the spark to your engine—promoting better combustion, and minimizing combustion contaminants. Spark plug life is extended, all-weather starts are insured, and you can feel an increase in acceleration and overall engine performance—*no matter what kind of car you drive.* Learn more about a MARK 10 CDI system for your car (and take advantage of year-end discount prices), when you write today for a catalog and price list.



DELTA PRODUCTS, INC.
P.O. Box 1147, Dept. PE
Grand Junction, CO 81501
(303) 242-9000

I want to know more about Mark Ten CDI's. Send me complete no-nonsense information on how they can improve the performance of my car.

Name _____

Address _____

City _____ State _____ Zip _____

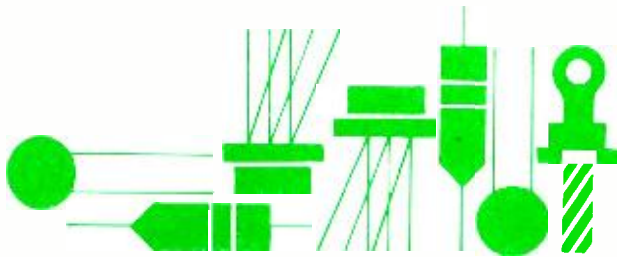

Solid State

TIMERS AND COUNTERS

By Lou Garner

A NUMBER of semiconductor manufacturers offer special devices designed specifically for use in timing and counting systems quite aside from watch and clock IC's. A typical family may include from two to four or more devices. The 8240, 8250, and 8260, for example, are a family of monolithic programmable timer circuits manufactured by *Intersil, Inc.* (10900 N. Tantau Ave., Cupertino, CA 95014) which can be used in a variety of interesting and exciting projects. Supplied in 16-pin DIP's, TTL compatible, and capable of operation on dc sources of 4 to 18 volts, these devices are suitable for use in process control, appliance and darkroom programmable timers; inventory checking, loading, filling and summing counters; music synthesis, harmonic synchronization and other frequency generation applications; analog-to-digital and digital-to-analog converters; sample and hold circuits; and pattern and waveform generators.

Terminal (pin) connections for the 8240, 8250 and 8260 family are identified in Fig. 1. Each device comprises an accurate low-drift oscillator, a counter section of cascaded master-slave flip-flops and suitable logic and control circuitry. The integral time-base oscillator can be set with an external R-C network or, if preferred, disabled, with the time base supplied by an external clock. The counter outputs are open-collector transistors which can be programmed easily at the external pins using wire connections or standard thumbwheel switches. With additional logic circuitry, timing can be programmed by a computer or microprocessor, thus permitting the devices to be used in complex automated control systems.

The 8260 is designed specifically to time accurate delays in seconds, minutes and hours. It has a maximum count of 59 and a carry-out gate, permitting several units to be cascaded for operation as a clock synchronized by the 60-Hz ac power line. With a maximum count of 99, the 8250 is optimized for decimal counting and delay, and can be programmed by standard binary coded decimal (BCD) thumbwheel switches. Each device has a counting capability of two decades, permitting selection of time delays from 1 RC to 99 RC (RC representing the external timing network), while a carry-out gate allows an expansion to as many decades as is needed. Finally, the 8240 employs conventional binary counting, using eight flip-flops to divide down the base frequency and providing 8 suboctaves of the fundamental simultaneously when operated in the astable mode. When used in the monostable mode, the output collectors can be wired for AND logic to give any combination of pulse widths needed from 1 RC to 255 RC. All three devices offer a typical accuracy of $\pm 5\%$ and a low drift of only ± 100 ppm/ $^{\circ}$ C (typical).

Typical practical applications for the 8240/50/60 family are illustrated schematically in Figs. 2 through 5. These are but a sampling of the circuits featured in the 16-page technical bulletin for the devices as well as Intersil's 23-page *Timer/Counter Applications Brochure*. All of the designs employ standard components and, with neither layout nor lead dress overly cri-

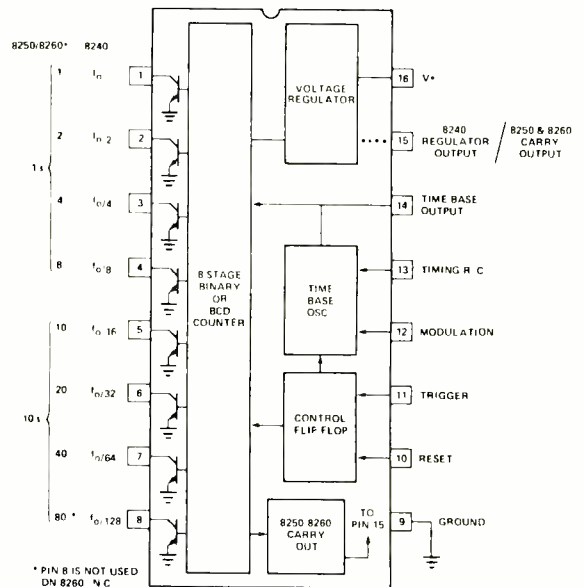

Fig. 1. Pin connections for 8240/50/60.

tical, may be duplicated quite easily in the home laboratory or workshop using conventional construction techniques, provided good wiring practice is observed. Intersil devices are stocked primarily by franchised industrial distributors such as *Arrow, Kierulff, Schweber, Weatherford, and Semiconductor Specialists*.

An unusual, but valuable, application for a timer/counter is shown in Fig. 2—synthesis of a signal bearing a fractional harmonic relationship to an accurate reference frequency. Here, a 100-Hz output signal is developed which is synchronized with and stabilized by a 60-Hz signal derived from the ac power line. In operation, this is achieved by a combination of frequency multiplication and division. The timer/counter's inter-

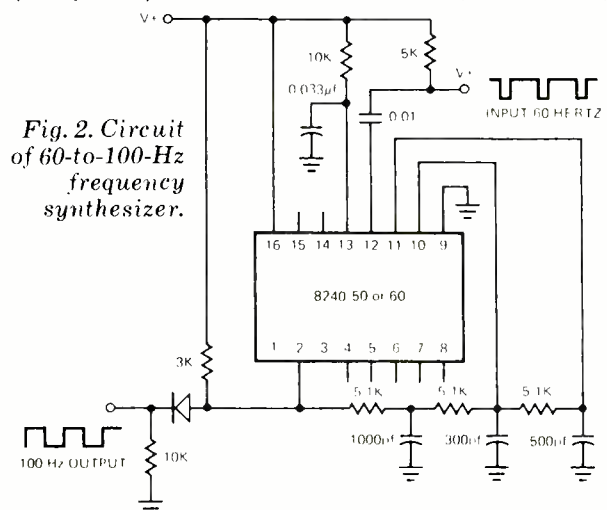

Fig. 2. Circuit of 60-to-100-Hz frequency synthesizer.

nal time base oscillator is set to a multiple of the reference frequency by means of the R-C timing network connected to pin 13 and is synchronized with it as in any harmonic generator. This signal is then divided by the counter chain. In the circuit shown, the 60-Hz reference frequency is multiplied by 5 and divided by 3 to develop the 100-Hz output signal. Frequency synthesizers may be used in a variety of projects—such as special-purpose test generators, clocks for control and process logic systems, tone sources for electronic musical instruments or remote control applications, or references for timing instrumentation.

With a few simple modifications and the addition of a voltage comparator and a flip-flop, a staircase generator may be adapted for use as an analog-to-digital converter, as shown in Fig. 3. If an 8240 is used, the digital output is an 8-bit binary signal, while a type 8250 (with a corresponding change in resistor array ratios) provides a 2-digit BCD output. In operation, an input strobe pulse first resets then triggers the 8240/50 and, at the same time, sets the flip-flop which enables the counter. The staircase signal developed by the 741 op amp counts down until it reaches the analog input voltage level, at which time the type 111 comparator changes state, resetting the flip-flop and stopping the count. The digital word at the timer/counter's eight outputs is the complementary binary (or BCD) equivalent of the analog input. The maximum conversion time is approximately 2.6 ms.

Using three cascaded 8250's and featuring an optional readout display, the programmable event counter circuit given in Fig. 4 can be used in numerous applications. Typically, it can serve to count and limit the number of moves in a game, for loading or package filling to preset quantities, for inventory control, and, with suitable sensors, even for limiting the number of individuals entering (or leaving) a restricted area, such

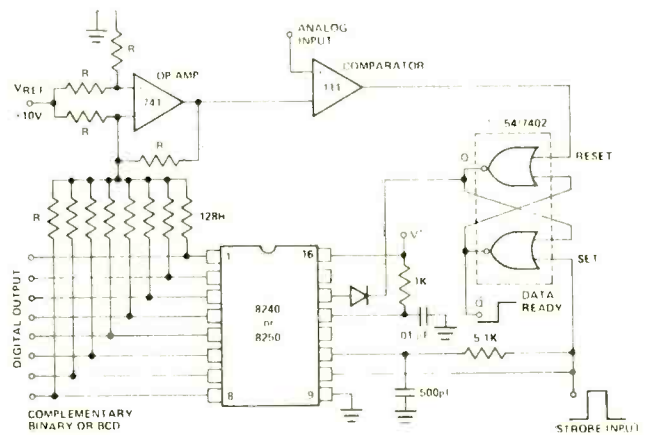

Fig. 3. Analog-to-digital converter circuit.

as an auditorium, dance hall, or production plant. Extremely versatile, its applications are limited only by the imagination and skill of the designer and by the peripheral circuits or devices (such as alarms, solenoids, relays, valves, or motors) with which it is used. In operation, the six decade counter is preset (programmed) to the maximum desired count by means of six BCD thumbwheel switches. Action is initiated when the START COUNT pushbutton switch is closed, enabling both the programmed and the readout display counters, the latter a type 7208. Thereafter, the circuit begins counting the desired items or events, receiving its information in the form of negative-going pulses from its input line. The signal count pulses may be derived from microswitches, photoelectric sources, temperature transducers, pressure switches or other devices, depending on the specific application. The output is developed as a 0-to-5-volt step function; at the start of count-

NEW

FROM



THE

HOBBY~WRAP

COMPLETE WITH BIT AND SLEEVE

ONLY **\$34⁹⁵**



Now you, the hobbyist, can do wire-wrapping professionally with our easy to use Hobby-Wrap gun.

Model BW-630

025 sq. post, AWG 30 wire (batteries not included)

OK MACHINE & TOOL CORPORATION
3455 Conner St., Bronx, N.Y. 10475 / (212) 994-6600 / Telex 125091

YOU CAN BE SURE

MORE TIMES IN MORE CIRCUITS WITH SENCORE DIGITAL MULTIMETERS

SENCORE

A NEW BREED OF DVM'S BACKED BY 25 YEARS OF ALL AMERICAN CRAFTSMANSHIP, WITH SIX EXCLUSIVE FEATURES, SO YOU CAN BE MORE SURE, MORE OFTEN AND ALL WITH HI & LO POWER OHMS FOR MEASURING ACCURATELY IN SOLID STATE CIRCUITS.



DVM35 \$134
3 digit LED display, 1% DCV accuracy, battery or AC operated



F ONE THIRD LESS CIRCUIT LOADING to make you sure that you are affecting the circuit being tested as little as possible for more accurate measurements. Sencore digitals are 15 megohm, others are 10 megohm.



E 2000 DCV range to make you sure that you can measure TV boost volts, scope voltages, medical equipment, etc. Other digitals stop at 1000 volts. High voltage probe extends measuring capabilities to 50 KV.



E PROTECTED INSIDE AND OUT so you can be sure that your meter is working and not in the repair shop. Drop it from 10 feet, apply 1000 volts overload and even apply volts on ohms accidentally and Sencore digitals keep right on working.

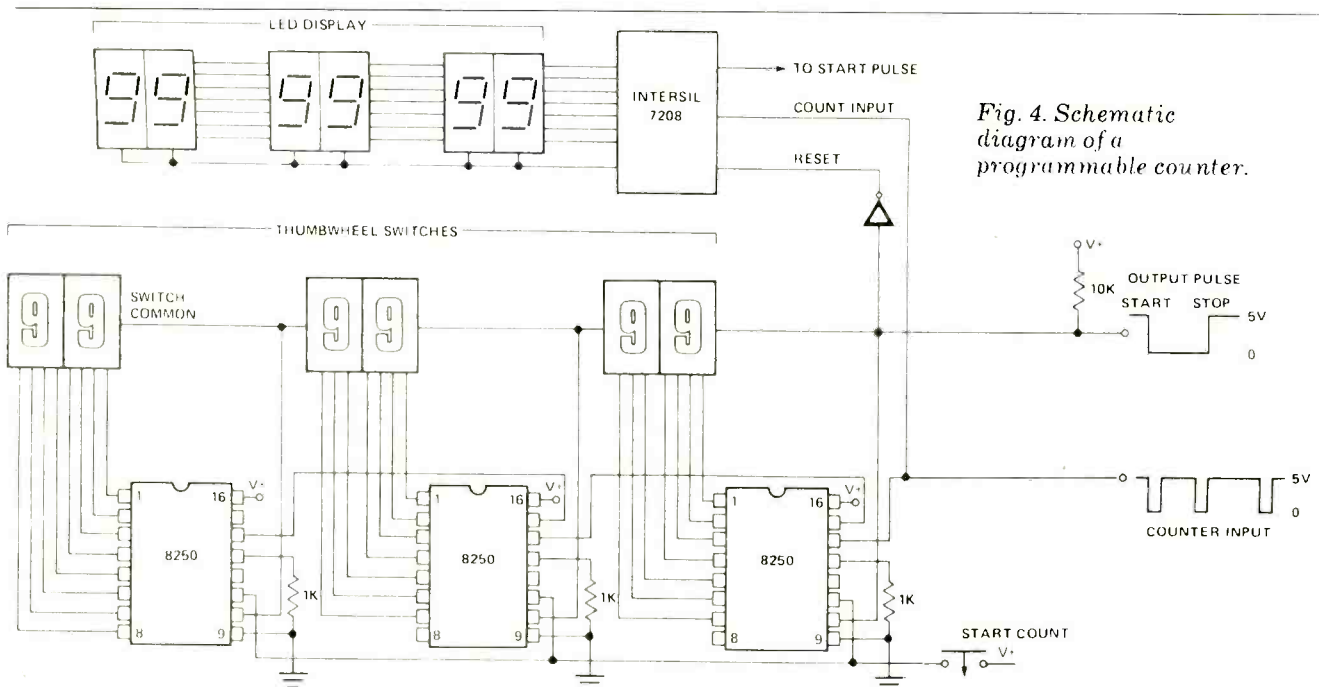

Fig. 4. Schematic diagram of a programmable counter.

ing, the output level drops from 5 volts (positive) to 0, remaining at this level until the count is complete. The accumulating count is shown on the six-digit LED display until the count pre-set by the thumbwheel switches is reached, at which time the output level changes state (returns to a five-volt value), resetting the system. The change in output voltage level can be applied to additional control circuitry to close (or open) a relay, actuate a motor or solenoid, set off an alarm, or initiate whatever action is required by the individual installation.

Reader's Circuit. One of our many friends north of the border, Doug Wood (9 Peter Ave., Guelph, Ontario, Can., N1E 1T5), has been experimenting with light-controlled relays and feels that one of his designs may be of interest to other readers. Suitable for use in a variety of remote switching applications, his circuit, shown in Fig. 5, features a pair of light-activated SCR's and two sensitive-reed relays. Doug writes that he has used it as a TV "commercial killer" and for switching a radio receiver, operating the circuit by means of a flash-



DVM36 \$158
3½ digit LED display,
.5% DCV accuracy,
battery or AC operated



DVM32 \$198
3½ digit LED display,
.5% DCV accuracy,
battery or AC operated
with automatic battery saver



DVM38 \$348
3½ digit LED display,
.1% DCV accuracy,
AC operated, auto-ranging,
auto-zero, king size pushbuttons



4 BATTERY SAVING FEATURES WHEN INSTRUMENT IS NOT IN USE so you can be sure that your meter will be ready the next time you need it. Push the button on the probe on the DVM35 and DVM36 and only then do you start drawing current from your battery. An automatic patented circuit does the same job for you automatically when you apply voltage to the DVM32. The DVM38 is AC operated.



5 100% MADE RIGHT LIFETIME GUARANTEE so you can be sure your meter was made right. If at any time you discover that a Sencore DVM was not made right, Sencore will make it right, parts and labor free of charge, for the lifetime of the product.

Plus other "make sure" features such as — direct reading with no parallax error — no effect from magnetic fields such as motors & RF fields — lab accuracy with high resolution — auto-polarity auto-zeroing and auto-ranging on the DVM38 . . . and you can see why you can be sure more times, in more circuits, than with any other multimeter on the market today — and for less money than old fashioned analog meters.

TEN DAY FREE TRIAL

6 10 DAY FREE TRIAL to be sure that Sencore digitals are all that we say they are. Simply march into your Sencore distributor and ask for a free trial or pay cash with a promise of a 10 day money back guarantee, if not 100% satisfied. Or, write Sencore, and we will see that our distributor contacts you.

SENCORE 3200 SENCORE DRIVE
SIOUX FALLS, S.D. 57107

CIRCLE NO 55 ON FREE INFORMATION CARD

Fig. 5. Circuit for a remote light-operated switch.

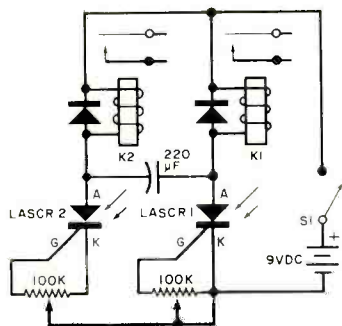

light or camera flash unit. Generally, the more powerful the light source used as a trigger, the greater the control range.

Doug has interconnected two conventional LASCR control circuits with a 220-µF commutation capacitor to form what is essentially a light-activated flip-flop. In operation, the two circuits are activated alternately to provide the required switching action. Consider, for example, that LASCR2 is conducting, energizing K2 and permitting the commutation capacitor to charge through K1 so that LASCR1's anode is at the dc source voltage. If light is now applied to LASCR1, this device will switch to a conducting state, discharging the commutation capacitor and momentarily removing LASCR2's anode voltage, causing this device to switch to an "open" or nonconducting state. When this happens, K2 is de-energized, K1 is energized, and the commutation capacitor is charged in the reverse direction. The circuit will then continue to operate in this state until light is applied to LASCR2, at which time the action reverses, with K2 energized and K1 de-energized. The small diodes across the relay coils serve to damp switching transients and suppress voltage spikes, while the variable resis-

tors in the LASCR gate-cathode circuits act as sensitivity controls.

With neither parts placement nor the wiring arrangement especially critical, the circuit may be duplicated using any preferred construction technique. Doug does suggest, however, that the LASCR's be mounted inside fiberboard, plastic or metal tubes (preferably with flat black interiors) to insure a directional response characteristic and avoid false triggering by extraneous light. The LASCR's are inexpensive low-voltage types (typically, *Radio Shack* No. 276-1096), and the diodes are general-purpose silicon rectifiers, such as type 1N4001. Standard 100k potentiometers are used as the sensitivity controls. The commutation capacitor should be a nonpolarized type; if this type is not available, one can be made up by connecting two 400- to 500-µF, 10-to-15-volt dc electrolytics in series back-to-back. Although Doug used reed relays for K1 and K2 in his model (typically, *Radio Shack* No. 275-230), conventional relays may be used if preferred (such as CALECTRO type D1-966). The ON-OFF switch, S1, is a spst toggle, slide or rotary type. Operating power is supplied by a 9-volt battery or line-operated dc power supply.

After the circuit assembly is completed and double-checked for possible errors, the unit's operation can be tested by using a sharply focused flashlight to trigger first one, then the other, LASCR, listening for the relay "clicks" signifying contact opening and closure. Next, the relay (K1 and K2) contacts are connected to switch the external load, taking care to observe the relay contacts' maximum ratings. If heavy power loads are to be switched, it may be necessary to add additional "booster" relays. Finally, the control unit is mounted in its desired operating position and the sensitivity controls are adjusted for optimum performance. The ideal settings are those which insure

HEATHKIT®

Practical projects for the "inside" season! Special sales and offers too!

WINTER, 1977

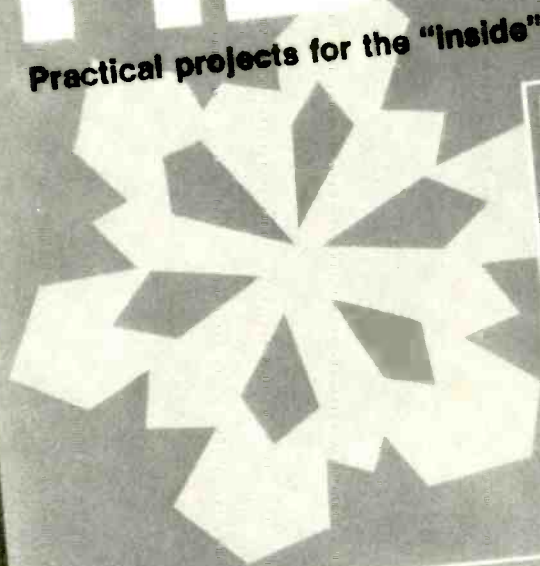

Digital Clocks and Weather Monitors —
See pages 2, 3, 9



NEW — High-Performance
3-Way Speaker System
See page 33

NEW — Universal
Color TV Game
See pages 3, 65

Amateur Radio Equipment —
See pages 64-76



NEW — "Touch Control"
Light Switch
See pages 77, 98

NEW — Two-Way
Freezer Alarm
See pages 77, 96

Stereo and 4-Channel Components — See pages 25-41



Automotive Accessories —
See pages 15-23



Color and B&W TV's — See pages 85-91



Self-study
Electronics
Courses —
See pages
79, 92-94



Test Instruments —
See pages 42-47, 52-63



MAIL ORDER CAT.

"Heath" and "Heathkit" are registered trademarks of Heath Company.

© 1976 Heath Company
See index on page 3

FREE!

Some of the most exciting electronic kits ever to come along are described in this NEW Heathkit Catalog.

NEW! HW-2036 Synthesized 2-meter Amateur Radio Transceiver.

Our finest 2-meter unit ever, with all the operating convenience and versatility you need for reliable 2-meter communications. Features complete offset capability and a built-in continuous tone encoder to access repeaters, plus new performance specifications that set an industry standard.

NEW! AR-1515 Stereo FM-AM Receiver.

Outstanding specifications and performance make the AR-1515 receiver the "heart" of any truly sophisticated stereo system. 70 watts, minimum RMS, per channel into 8 ohms with less than 0.08% total harmonic distortion from 20-20,000 Hz. Plus digital frequency readout and advanced styling others will be sure to copy.

NEW! GR-2001 Computerized Color TV.

The most convenient color TV system ever — you "program" it to change channels when you want. You can sequence an entire evening's viewing, then just sit back and relax. You can also "program" children's viewing so they watch only what you want them to watch. You can even have the GR-2001 automatically rotate your outdoor antenna for the best reception from each station. A truly sensational color TV breakthrough!

PLUS nearly 400 other superb, easy-to-build, money-saving products. You'll find a complete line of digital electronic clocks and weather instruments that give you important information "by the numbers" and with

electronic accuracy. Items for your car, home or office including an exciting combination clock/indoor-outdoor temperature monitor with a special temperature alarm.

Our self-study courses are now in use by the thousands! A really effective and low-cost way to teach yourself about electronics for fun, for knowledge, or for profit. We also have a wide selection of popular books covering almost everything in electronics.

There are many more exciting products to read about too! Home convenience items like a practical freezer alarm, a touch-control light switch, intercoms and a unique doorbell that lets you program a tune of your choice. Automotive instruments and accessories that help you keep your car running right for top performance and economy. Marine equipment that will make you a better boater and fisherman. Model aircraft Radio Control gear to give you championship performance. Security systems to protect your home and family. And of course, our world-famous Amateur Radio equipment and test and service instruments.

These are among the nearly 400 quality, fun-to-build kits described in this new Heathkit catalog. Kits for every interest. All with the world-famous Heathkit assembly manual — a step-by-step instruction guide that makes kitbuilding easy and leaves nothing to chance. And all backed by our "We won't let you fail" promise. Find out about the satisfaction, savings and FUN of kitbuilding.

Send for your FREE copy today!

HEATH Schlumberger	Heath Company Benton Harbor, Michigan 49022
<input type="checkbox"/> Please send me my FREE Heathkit Catalog. <input type="checkbox"/> I am not on your mailing list.	Send a FREE Catalog to my friend. Dept. 10-263
Name _____	Name _____
Address _____	Address _____
City _____ State _____	City _____ State _____
Zip _____	Zip _____

CL-624

CIRCLE NO. 5 ON FREE INFORMATION CARD

Sinclair DM2 Multimeter

COMPREHENSIVE, ACCURATE, PORTABLE and REALLY RUGGED



State-of-the-art circuit design, incorporating high-quality components, has resulted in a professional, 3-1/2 digit instrument of outstanding performance and reliability at a realistic price.

A custom-designed MOS LSI digital processing IC controls the auto-polarity dual-slope-integration A to D converter. The circuit built around this IC uses a MOSFET op-amp input buffer with 0.1% metal-film resistors. The result is excellent accuracy and stability with a very high basic input impedance. The instrument reads to ± 1999 and has a basic accuracy on the 1 VDC range of $0.3\% \pm 1$ digit. Four 8 mm LED displays provide excellent legibility and angle of view. Front panel switch provides battery or line operation. 10 day money-back guarantee. 1 year manufacturer's warranty

Credit Card and Company P.O.'s call (516) 829-5858

PLEASE SEND ME:

- DM2 Multimeter (includes AC adapter) **\$99.50**
- Carrying Case **\$19.95**
- Power Pack **\$3.90**

Add \$3.50 shipping and handling.

Check or money order enclosed

for \$ _____

Charge my:

BankAmericard Master Charge

No: _____

M.C. Bank No. _____

Exp. Date: _____

New York residents add City and/or State Taxes.

technology trends

P.O. BOX 732
MANHASSET, NY 11030

Signature _____

Name _____

Company _____

Address _____

City _____

State _____ Zip _____

PE-277

CIRCLE NO 62 ON FREE INFORMATION CARD

positive actuation by the controlling light source but avoid false triggering by variations in ambient light levels.

Device and Product News. Motorola has introduced a bipolar LSI circuit that should be of interest to advanced experimenters working with microprocessor systems. The new device, called a Priority Interrupt Controller (PIC), allows priority control on the interrupt inputs to a microprocessor and has been dually designated the MC8507/MC-6828 to indicate that its performance has been optimized for the M6800 microprocessor system. However, it also may be used in non-M6800 applications. Basically, the PIC eliminates the software interrupt polling routing in systems containing eight or multiples of eight I/O devices, such as the Peripheral Interface Adapter (PIA), Asynchronous Communications Interface Adapter (ACIA), Synchronous Serial Data Adapter (SSDA), and so on. Functionally, the PIC can change the interrupt vector, reserved in memory for hardware interrupts, into one-of-eight alternate vectors assigned to the I/O service routines. The PIC modifies the low-order bytes of the reserved interrupt address. The MC8507/MC6828 is offered in both ceramic and plastic 24-pin DIP's.

On the other hand, if you're working with conventional logic circuits used in critical areas, you may want to investigate two new IC's announced recently by *Teledyne Semiconductor* (Mountain View, CA 94040). Designed for applications in high (electrical) noise areas, the HiNIL 306 and 307 both contain two 2-input NOR gates and two 3-input NOR gates. The 306 features active pullup outputs and 10-mA output drive currents, which permits it to drive lines up to 10 feet without loss of noise immunity. The 307 has open collectors so the outputs can be collector OR'd. Both devices operate on 10 to 16 V dc. Typical applications include CMOS input interface, industrial controls, medical instrumentation, and marine electronics. The HiNIL 306 and 307 are available in standard 16-pin DIP's in both plastic and ceramic versions.

National Semiconductor Corporation (2900 Semiconductor Drive, Santa Clara, CA 95051), has combined classical circuit techniques with an ion-implanted p-channel MOS process to create a new low-cost 8-bit analog-to-digital converter. Designated type MM5357, the new A/D converter contains a chain of 256 identical resistors connected in series, 255 analog switches, a high-impedance input comparator, output latches, and control logic on a single monolithic chip. In operation, conversion is performed using the successive approximation technique, whereby an unknown analog voltage is compared to the voltages at the resistor tie points by means of analog switches. A 10-volt reference applied across the resistor chain sets 256 precision voltages against which the unknown input voltage is compared by the analog switches under control of the on-chip logic. Requiring +5 and -12 V dc sources and dissipating approximately 170 mW, the MM5357 is supplied in an 18-pin Epoxy-B DIP.

National Semiconductor also has developed a new series of monolithic frequency-to-voltage converters with a combination high-gain op-amp-and-comparator. Identified as the LM2907 and LM2917 tachometer speed switches, they are specifically designed to operate relays, lamps, and other components when the input frequency reaches or exceeds a selected rate, and are especially suited for speedometers, tachometers and automotive lock and clutch controls where over-or-under speed sensing is required. The devices use a combination op-amp-and-comparator with a floating transistor as output, and can furnish either a supply-referenced load of 50 mA or a swing-to-ground for zero frequency. ◇

1702A MANUAL EPROM PROGRAMMER

Features hex keypad, two digit hex address and two digit hex data display. Controls include load, clear, go! (step), key/copy, data in/ data out, and counter up/ down. Profile card includes high voltage pulse regulator, timing, 8 bit address and 8 bit data drivers/receivers. Two 6 1/2" x 9" stacked cards with spacers. Allows programming in 20 minutes - copying in 5 minutes. Requires +5, -9, and +80 volts.

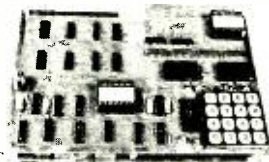

ASSEMBLED \$299.95
KIT \$189.95

NOW

The best of two worlds... use our 1702 EPROM programmer as a manual data/address entry programmer... or connect it to your processor.

IMSAI/ALTAIR computer interface (requires 3 output ports, +1 input port) and software \$49.95

Briefcase unit with power supplies and interface connectors (assembled and tested only) \$599.95

ANNOUNCING

Our NEW 16K Byte Pseudo-Static, IMSAI/ALTAIR compatible RAM. Single card slot. Uses less power than equivalent low power RAM. All memory chips socketed. Uses all prime, factory fresh ICs. High quality, two-sided, through-hole-plated circuit board. Crystal controlled, totally invisible refresh system requires NO software management. Just plug it in and use like STATIC memory.

Complete kit \$349.95
Assembled, tested, and burned in \$549.95

ASSOCIATED ELECTRONICS

12444 Lambert Circle • Garden Grove, CA 92641
(714) 539-0735

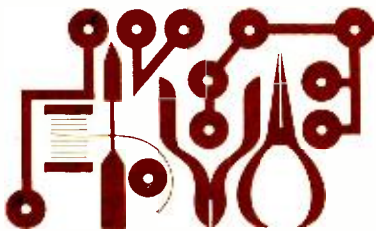

Experimenter's Corner

By Forrest M. Mims

FLIP-FLOPS AND DECADE COUNTERS—PART 1

Counting circuits perform many important roles in digital electronics. They are used to measure frequency, compute time, divide pulse streams by a fixed constant, generate signal sequences, and perform many other useful operations.

The common flip-flop is a fundamental counter circuit. The best way to understand a flip-flop is to build an ultra-simple flip-flop from a pair of inverters. But first, let's establish a couple of important definitions.

In digital electronics an electrical signal is either *high* or *low*. These two states are used to represent the binary bits 1 and 0. In positive logic, 1 is high and 0 is low. Negative logic means 1 is low and 0 is high. Since digital logic IC's commonly operate from a single-ended power supply, a high state represents a voltage near the supply voltage. A low state represents a voltage near 0 volt or ground.

With these basic definitions in mind, we can easily design a simple flip-flop from two of the six inverters in a 7404 hex inverter. As you may already know, the signal at the input of an inverter is changed from high to low (or from low to high) at the output. All we have to do to make a simple flip-flop is connect the in-

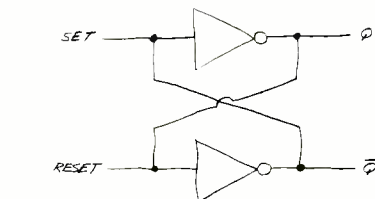

Fig. 1. The basic flip-flop.

verters in crisscross fashion as shown in Fig. 1. When the output of the upper inverter is high, the output of the lower inverter is low. Similarly, when the output of the upper inverter is low, the output of the lower inverter is high. We therefore have a circuit which can occupy one of two stable states. That, of course, is the simplest definition of the flip-flop.

Figure 2 shows a practical version of this ultra-simple flip-flop with an LED state indicator at both outputs. The resistor limits current through the LED's to a safe 10 milliamperes or so. You can assemble the circuit on a molded plastic solderless breadboard (a *must* for experimenters and design engineers alike) in a few minutes. If you don't have a 5-volt supply, use a fresh 6-volt battery and drop the voltage to about 5 volts with a 1N914 diode connected so that it is forward biased between the battery's positive terminal and the circuit.

When power is applied to the circuit,

one of the LED's will glow. Momentarily grounding the SET input will cause only the Q output LED to glow. If the RESET input is momentarily grounded, only the Q LED will glow. Note that the LED continues to glow after the input signal is removed. This memory or latching action is the key to the operation of many kinds of complex logic circuits.

The ultra-simple flip-flop in Fig. 2 is not practical for counting applications. However, it's possible to make a binary counter by using gates instead of inverters, and by adding a couple of gates which allow the circuit to flip or flop only on command from an external clock pulse.

The 7473 Dual J-K Flip-Flop. We can actually assemble a clocked flip-flop from the four gates in a 7400 quad NAND Gate, but a far more convenient approach is to use a ready-made version such as the 7473 dual J-K flip-flop. This flip-flop will toggle back and forth between its two output states when connected to a 555 clock circuit as shown in Fig. 3.

The circuit in Fig. 3 makes a nice dual LED flasher—but it also demonstrates the important flip-flop applications of counting and dividing. You can see this by assembling the circuit on a solderless breadboard (which I urge you to do), and disconnecting the cathode of the LED at the \bar{Q} output (pin 13 of the 7473) and connecting it to the clock output of the 555 (pin 3). Now, if you slow down the clock frequency to a few Hertz by adjusting the 100K pot, you will see that the LED flashes at exactly half the rate of the LED connected to the clock. In other words, the flip-flop is functioning as a divide-by-two counter.

All kinds of possibilities open up if we connect the unused Q output of the flip-flop to the clock input of the second flip-flop in the 7473. Figure 4 shows how to wire things together on your solderless breadboard. Obviously the second flip-

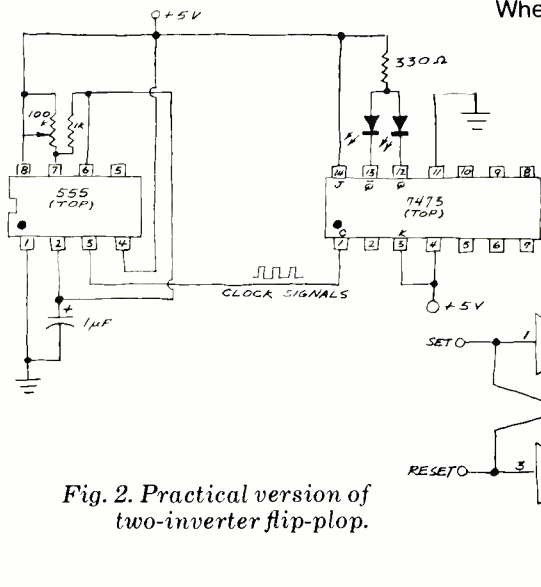

Fig. 2. Practical version of two-inverter flip-flop.

Fig. 3. 7473 flip-flop with 555 clock circuit.

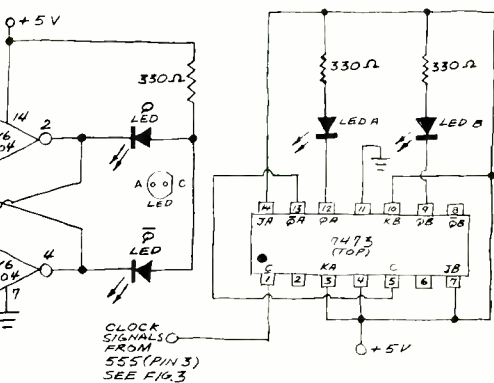

Fig. 4. Two-bit counter made from 7473 dual flip-flop.

flop in this new circuit will receive only half as many clock pulses as the first flip-flop. Therefore its Q LED will flash at only one-fourth the rate of the clock frequency. So now we have a divide-by-four counter. And this gives us a two-bit binary output circuit.

To see how the circuit operates as a two-bit counter, remove the *CLOCK* LED and arrange the two flip-flop LED's so the one which is connected to the second flip-flop (the slow one) is to the left of the other one. By slowing down the clock you'll see this flash sequence (off = 0; on = 1):

LED B LED A
 0 0
 0 1
 1 0
 1 1
 0 1
 0 1
 (etc.)

This binary sequence, of course, corresponds to the decimal count 0 . . . 1 . . . 2 . . . 3 . . . 0 . . . etc. The circuit is called a two-bit counter since it recycles when the count exceeds two bits.

A really useful counter can be made by cascading four flip-flops to give four-bit capability. This would permit a deci-

mal count of from 0 to 15. By means of external connections which automatical-

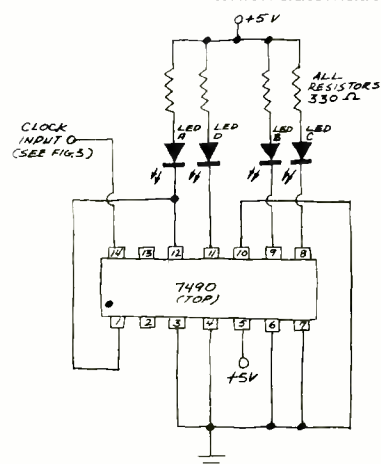

Fig. 5. 7490 four-bit counter.

ly reset the counter when a desired count has been reached, a range of count intervals could then be achieved.

Several quad flip-flop (four-bit) counter chips are available so there is no need to use separate gate or flip-flop packages. Since a 0 to 9 count has more applications than a full 0 to 15 count (at least for us decimal-oriented human beings!) let's take a look at the 7490 Decade Counter.

7490 Decade Counter. As its name implies, the 7490 Decade Counter is primarily intended for 0 to 9 counting. To provide a range of applications, one of its internal flip-flops is not connected to the others. This gives two separate counters in one package: a divide-by-two and a divide-by-five. Connecting the A output (pin 12) to the *CLOCK* input of the divide-by-two flip-flop (pin 14) forms a chain of four flip-flops which counts from 0000 to 1001 (0 to 9) before recycling.

Figure 5 shows how to connect the 7490 to the 555 clock of Fig. 3. When the circuit is running, you will obtain the following count sequence:

D	C	B	A	
0	0	0	0	(0)
0	0	0	1	(1)
0	0	1	0	(2)
0	0	1	1	(3)
0	1	0	0	(4)
0	1	0	1	(5)
0	1	1	0	(6)
0	1	1	1	(7)
1	0	0	0	(8)
1	0	0	1	(9)
0	0	0	0	(0)
0	0	0	1	(1)

(etc.)

In simplest terms, the four flip-flops in the 7490 count from 0 to 9 and then recycle. ◇

Checklist of Books for the Libraries of Technicians, Hobbyists & Students

- RADIO NEW BOOKS JUST PUBLISHED**
- Master Transistor IC Substitution Handbook. 504 p. \$7.95
 - Servicing Medical & Bioelectronic Equipment. 336 p. \$8.95
 - Model Railroad Electronics. 294 p. \$24.00
 - Linear IC Applications Handbook. 280 p. \$6.95
 - Broadcast Engng. Maint. Hdbk. 532 p. 235 il. \$19.95
 - Complete Hdbk of Locks Locksmithing. 328 p. 348 il. \$6.95
 - Practical Solid-State DC Power Supplies. 196 p. 151 il. \$6.95
 - Optoelectronics Guidebk.—with tested projects. 196 p. \$5.95
 - Transistor Ignition Systems. 252 p. 162 il. \$5.95
 - TV Lighting Handbook. 228 p. 261 il. \$12.95
 - How to Repair Home Kitchen Appliances. 294 p. 205 il. \$5.95
 - Fun With Electronics. 140 p. 88 il. \$3.95
 - Talk-Back TV: Two-Way Cable Television. 238 p. 64 il. \$5.95
 - Understanding Use Modern Signal Generators. 294 p. \$6.95
 - 106 Easy Electronic Proj. Beyond Transistors. 224 p. \$5.95
 - Using Modern Electr. Serv. Test Eqp't. 252 p. 177 il. \$5.95
 - Mathematics Unraveled—Commonsense Approach. \$6.95
 - Master Tube Substitution Handbook. 322 p. 548 il. \$4.95
 - Modern Guide to Digital Logic. 294 p. 222 il. \$6.95
 - VHF UHF Fire, Police, Ham Scanners Man. 250 p. 114 il. \$6.95
 - OP AMP Circuit Design & Applications. 280 p. 239 il. \$6.95
 - Master Hdbk of Digital Logic Appl. 392 p. 287 il. \$7.95
 - CET License Handbook 2nd ed. 448 p. 381 il. \$8.95
 - The Electronic Musical Instr. Manual. 210 p. 385 il. \$6.95
 - Microprocessor Microprogramming Hdbk. 294 p. 176 il. \$6.95
 - Sourcebook of Electronic Organ Circuits. 168 p. 101 il. \$4.95
 - Build Your Own Working Robot. 238 p. 83 il. \$5.95
 - Cbr's Handybook of Simple Hobby Projs. 168 p. 114 il. \$3.95
 - Fire & Theft Security Systems 2nd ed. 192 p. 114 il. \$5.95
 - How to Rpr. Home Laundry Appliances. 280 p. 137 il. \$5.95
 - Piloting Navigation & Pocket Calculator. 392 p. 233 il. \$8.95
- DO-IT-YOURSELF, AUTOMOTIVE & APPLIANCES**
- How to Make Your Own Built-In Furniture. 336 p. 758 il. \$5.95
 - Homeowner's Handy "Do-It" Manual. 280 p. 84 il. \$7.95
 - Building Model Ships From Scratch. 378 p. 83 il. \$7.95
 - Homeowner's Guide to Saving Energy. 196 p. 84 il. \$5.95
 - Customizing Your Van. 192 p. 150 il. \$3.95
 - The Woodworker's Bible. 434 p. 1151 il. \$5.95
 - Dog Owner's Medical Manual. 252 p. 237 il. \$5.95
 - How to Train a Watchdog. 224 p. 45 il. \$5.95
 - Motorcycle Repair Handbook. 392 p. 260 il. \$6.95
 - Step-By-Step Guide: Carburetor Tuneup/Overhaul. 224 p. \$4.95
 - Complete Hdbk of Model Railroad. 350 p. 238 il. \$6.95
 - Homeowner's Guide to Solar Heating Cooling. 196 p. \$4.95
 - Do-It-Yourselfer's Guide: Home Plan Constr. 238 p. \$4.95
 - Step-By-Step Guide to Brake Servicing. 238 p. 248 il. \$4.95
 - Step-By-Step Guide: Chrysler Eng. Maint. Rpr. 256 p. \$5.95
 - Subcontract Your House: Bldg. Remodel. 196 p. 63 il. \$4.95
 - Auto Electronics Simplified. 256 p. 202 il. \$5.95
 - The Complete Auto Electric Handbook. 210 p. 139 il. \$5.95
 - Concrete & Masonry. 392 p. 213 il. \$5.95
 - Practical Home Constr. Carpenter Hdbk. 448 p. 180 il. \$5.95
 - How to Repair Diesel Engines. 308 p. 237 il. \$5.95
 - Central Heating Air Cond. Repair Guide. 320 p. 285 il. \$6.95
 - Small Appliance Repair Guide—Vol. 2. 210 p. 119 il. \$4.95
 - Elect. Wiring/Lighting For Home Office. 204 p. 155 il. \$4.95
 - How to Repair Small Gasoline Engines. 2nd Ed. 392 p. \$6.95
 - How to Repair Home Auto Air Cond. 208 p. over 100 il. \$4.95
- ELECTRONICS TECHNOLOGY COMPUTERS CALCULATORS**
- Modern Electronics Math. 686 p. 424 il. \$8.95
 - Master Hdbk of 1001 Prac. Electr. Circ. 602 p. 1250 il. \$9.95
 - Impedance. 196 p. 90 il. \$5.95
 - Intro to Medical Electronics-2nd ed. 320 p. 126 il. \$7.95
 - Computer Programming Handbook. 518 p. 114 il. \$8.95
 - Computer Technician's Handbook. 480 p. over 400 il. \$8.95
 - Microelectronics. 266 p. 228 il. \$5.95
 - Basic Digital Electronics. 214 p. 117 il. \$4.95
 - Switching Regulators Power Supplies. 252 p. 128 il. \$6.95
 - Adv. Appl. for Pocket Calculators. 304 p. 275 il. \$5.95
 - Tower's Intern. Transistor Selector. 140 p. 17 + 10. \$4.95
 - Electr. Convns. Symbolic Formulas. 224 p. 252 il. \$4.95
 - Effective T shooting with EVM Scopes. 238 p. 185 il. \$5.95
 - Getting the Most Out of Electronic Calculators. 204 p. 281 il. \$4.95
 - Aviation Electronics Handbook. 406 p. 227 il. \$8.95
 - How to Test Almost Everything Electr. 160 p. 144 il. \$3.95
 - Digital Logic Electronics Handbook. 308 p. 226 il. \$6.95
 - Modern Applications of Linear IC's. 276 p. 301 il. \$9.95
 - 10-Minute Test Tech. For PC Svcs. 216 p. 114 il. \$4.95
 - Electr. Unraveled—New Commonsense Approach. 228 p. \$5.95
 - How to Shoot/Repair Electr. Test Eqp't. 252 p. 143 il. \$6.95
 - Understanding Using the Oscilloscope. 272 p. 170 il. \$5.95
 - Industrial Electr.—Principles & Practice. 416 p. 380 il. \$8.95
 - Dictionary of Electronics. 420 p. 487 il. \$4.95
- RADIO & TV SERVICING**
- Color TV Trouble Factbk—Probs Sols 3rd ed. 434 p. \$5.95
 - Solid-State Color TV Photo Symp. Guide. 224 p. 169 il. \$5.95
 - Beginner's Guide to TV Repair. 176 p. 50 il. \$4.95
 - Shooting With the Dual-Trace Scope. 224 p. 252 il. \$5.95
 - TV Troubleshooter's Hdbk—3rd ed. 448 p. over 300 il. \$4.95
 - Color TV Case Histories Illustrated. 238 p. 219 il. \$5.95
 - TV Schematics: Read Between the Lines. 252 p. 188 il. \$5.95
 - Logical Color TV Troubleshooting. 240 p. 151 il. \$5.95

- TV Bench Servicing Techniques. 228 p. 177 il. \$4.95
 - Modern Radio Repair Techniques. 260 p. 36 il. \$4.95
 - How to Interpret TV Waveforms. 256 p. 250 il. \$4.95
 - All-In-One TV Alignment Handbook. 304 p. 145 il. \$5.95
 - TV Tuner Schematic/Servicing Manual. 224 p. 287 il. \$6.95
 - How to Use Color TV Test Instruments. 256 p. 230 il. \$5.95
 - Home-Call TV Repair Guide. 144 p. 20 il. \$3.95
 - Pinpoint TV Troubles in 10 Minutes. 327 p. 394 il. \$5.95
- CB, COMMUNICATIONS & HAM RADIO**
- CB Schematic Svcing. Manuals each 200 p. \$5.95. Vol 1 Krik Browning, Hy-gain, Penney's. Vol 2 Teaberry, Unimetrics, Pearce-Simpson, Siltronix. Vol 3 E.F. Johnson, SBE-Linear, Sonar, Royce. Vol 4 Pace Fanon Courier. \$7.95
 - Complete Shortwave Listener's Hdbk. 288 p. 101 il. \$6.95
 - CB Radio Operator's Guide—2nd ed. 256 p. 139 il. \$5.95
 - How to Hear/Speak CB in a Short-Short. 172 p. 85 il. \$3.50
 - Pictorial Guide to CB Radio Install/Rpr. 256 p. 304 il. \$5.95
 - Practical CB Radio T shooting & Repair. 238 p. 108 il. \$5.95
 - Complete FM 2-Way Radio Hdbk. 294 p. 111 il. \$6.95
 - Amat. FM Conversion/Constr. Projs. 256 p. 187 il. \$3.95
 - Bdcast Ann'r: 3rd Class FCC Study Guide. 168 p. 19 il. \$3.95
 - How To Be A Ham—Incl. Latest FCC Rules. 192 p. 25 il. \$3.95
 - Commercial FCC License Handbook. 444 p. 150 il. \$5.95
 - The 2-Meter FM Repeater Circuits Hdbk. 312 p. 194 il. \$6.95
 - RTTY Handbook. 320 p. 230 il. \$6.95
 - Citizens Band Radio Service Manual. 228 p. 84 il. \$5.95
 - AMATEUR RADIO STUDY GUIDES: Novice \$5.95 General \$7.95 Advanced \$5.95 Extra \$5.95 Incentive \$4.95
- HOBBY ELECTRONICS**
- How to Read Electronic Circuit Diagrams. 192 p. 140 il. \$4.95
 - 21 Simple Trans. Radios You Can Build. 140 p. 122 il. \$3.95
 - Basic Electricity/Beginning Electronics. 252 p. 191 il. \$5.95
 - Radio Control for Models. 350 p. 417 il. \$6.95
 - MOSFET Circuits Guidebook. 196 p. 104 il. \$4.95
 - Prac. Circuit Design for the Experimenter. 196 p. 119 il. \$4.95
 - 111 Digital & Linear IC Projects. 210 p. 275 il. \$5.95
 - Radio Astronomy for the Amateur. 252 p. 96 il. \$5.95
 - Build-It Book of Mini Test Meas. Instr. 238 p. 151 il. \$4.95
 - RF & Digital Test Eqp't. You Can Build. 252 p. 217 il. \$5.95
 - Miniature Projects For Electr. Hobbyists. 168 p. 77 il. \$3.95
 - Practical Triac SCR Projs. For The Exp. 192 p. 147 il. \$4.95
 - Integrated Circuits Guidebook. 196 p. 119 il. \$5.95
 - Solid-State Circuits Guidebook. 252 p. 227 il. \$5.95
 - Electronics For Shutterbugs. 204 p. 109 il. \$5.95
 - Prac. Test Instruments You Can Build. 204 p. 157 il. \$4.95
 - How to Build Solid-State Audio Circuits. 320 p. 190 il. \$5.95
 - Radio-Electronics Hobby Projects. 192 p. 214 il. \$4.95
 - Handbook of IC Circuit Projects. 224 p. 136 il. \$4.95
 - Solid-State Projs. for the Experimenter. 224 p. 228 il. \$4.95
 - Electronic Experimenter's Guidebook. 182 p. 86 il. \$4.95
 - 125 One-Transistor Projects. 192 p. 125 il. \$4.95
 - 64 Hobby Projects for Home & Car. 192 p. 159 il. \$4.95
- AUDIO, HI-FI & ELECTRONIC MUSIC**
- Electronic Music Circuit Guidebook. 224 p. 180 il. \$6.95
 - Q & A About Tape Recording. 264 p. 102 il. \$5.95
 - Handbook of Multichannel Recording. 322 p. 196 il. \$7.95
 - Auto Stereo Service & Installation. 252 p. 245 il. \$5.95
 - Svc. Cassette & Cartridge Tape Players. 294 p. 196 il. \$6.95
 - Experimenting With Electronic Music. 180 p. 103 il. \$4.95
 - Cassette Tape Recorders: How Work Care Repair. 204 p. \$4.95
 - Acoustic Techniques for Home & Studio. 224 p. 168 il. \$5.95
 - Pictorial Guide to Tape Recorder Rprs. 256 p. 320 il. \$4.95
 - How to Repair Musical Instrument Amps. 288 p. 50 il. \$5.95
 - Jap. Radio, Record, Tape Player Svcg. Manual. 228 p. \$6.95
 - Servicing Electronic Organs. 196 p. 158 il. \$7.95
 - Tape Recording for Fun & Profit. 224 p. over 200 il. \$5.95
- ALL-NAME COLOR & B&W TV SCHEMATIC/SERVICING MANUALS**
- Each vol has complete service data, parts lists, full-size schematics, and all other info needed. Each 8 1/2 x 11, 196 pgs. Each only \$5.95 unless marked. CDLDR TV: Adm. Vol. 1. Vol. 2. \$6.95. GE Vol. 1. Vol. 2. Vol. 3. Jap. Vol. 1. Vol. 2. \$4.95. Vol. 3. \$4.95. Airline. Vol. 4. Vol. 5. Magnavox Vol. 1. \$4.95. Vol. 2. \$4.95. Vol. 3. \$4.95. Mot. Vol. 1. \$4.95. Vol. 2. \$4.95. RCA Vol. 1. Vol. 2. Vol. 3. Vol. 4. Vol. 5. Sears. Serv. Modular Recr. Vol. 1. \$6.95. Vol. 2. \$4.95. Syl. Vol. 1. Vol. 2. Toshiba. Zenith Vol. 1. Vol. 2. Vol. 3. Vol. 4. B&W TV: Adm \$7.95. GE \$7.95. Jap. \$6.95. Mag. \$4.95. Mot. \$4.95. Philco \$4.95. RCA \$7.95. Syl. \$4.95. Zenith \$7.95.
- NO RISK COUPON-MAIL ENTIRE AD**
- TAB BOOKS, Blue Ridge Summit Pa 17214
 Please send me books checked above
- I enclose \$_____ send postpaid
 Please invoice on 10-day FREE trial
- Name _____ Phone _____
 Company _____
 Address _____
 City _____ State _____ Zip _____
- SAVE POSTAGE by remitting with order. Foreign add 10%. Pa. residents add 6%. PE 27



cover the 17 new channels. In fact, the FCC has specifically prohibited the use of external add-on circuits to expand channel coverage. However, there is one twist. Some manufacturers of PLL-synthesis transceivers are offering to "re-manufacture" rigs to cover the full 40 channels. The use of phase-locked loops in frequency generation makes this rather simple. The principal modification involves adding more combinations to the $\pm N$ part of the synthesizer. The FCC has not objected to this program. Your transceiver uses crystal synthesis, and therefore cannot be so modified. Note, however, that it is permissible to use receiving converters with any receiver. Such a converter could be teamed up with your car radio for full-band coverage. A representative circuit appeared in the October 1976 issue of POPULAR ELECTRONICS.

By John McVeigh

Have a problem or question on circuitry, components, parts availability, etc? Send it to the Hobby Scene Editor, POPULAR ELECTRONICS, One Park Ave., New York, NY 10016. Though all letters can't be answered individually, those with wide interest will be published.

LOW-POWER AUDIO AMP

Q. Can you show me a schematic for an audio amp to boost signals from my crystal set?—Rick Laird, Omaha, NE

A. The LM380 audio amplifier is well suited for this application. It has a high input impedance, requires a single-ended power supply, and will deliver up

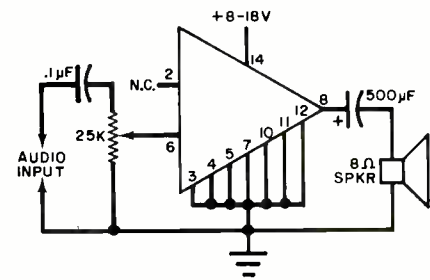

to 2.5 watts or more of output power to an 8-ohm speaker. Note that seven pins of the IC are tied together and grounded. They should be connected to a heat sink (such as a large copper "land" on a pc board) at least six square inches (38.7 cm²).

40-CHANNEL CB MODIFICATION

Q. I own a Royce Model 1-602A 23-channel mobile transceiver and would like to have it modified to cover the expanded Citizens Band. Can I do this?—Don J. Chillstrom, Wickenburg, AZ.

A. As a general rule, 23-channel transceivers will not be able to be adapted to

CRYSTAL CHECKER

Q. Do you have a simple circuit for checking crystals in the 2- to 6-MHz range?—William J. Bills, Maitland, FL.

A. This tester can be used with crystals over the 0.1-to-10-MHz range. The lamp

(a GE 1869, 10-volt, 14-mA type or equivalent) will light when the crystal is not in the circuit or is bad and when the switch is closed. When a good crystal is installed, the circuit oscillates and current through the lamp drops below 10 mA. The lamp will then dim or go out.

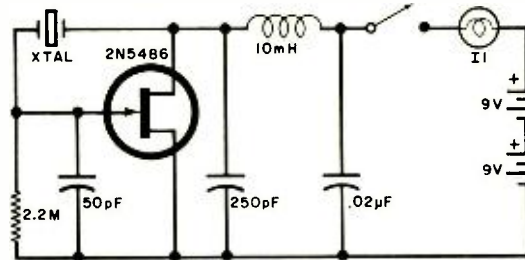

TONE-ACTIVATED RELAY

Q. I have built a digital clock using a Mostek MK50252N chip which incorporates a "beeper" alarm. Is there a circuit I can add which will convert the beeps into a steady dc level, which will in turn cause a transistor to conduct and energize a relay? I would like to use the alarm function to turn appliances on.—Paul D'Ermielie, Staten Island, NY.

A. One way of performing this function is to use a tone decoder IC like the 567. This chip has been featured in the Experimenter's Corner and has an output stage that can sink up to 100 mA. All you

would have to do is select the proper values of resistance and capacitance for response at the output frequency of the alarm. Here's another solution. In the circuit shown, the diode produces pulsating dc which is smoothed out by the RC combination with a time constant of about one second. (Values can be changed for a different time constant). When the capacitor charges up sufficiently, it will source base current for the switching transistor, which will turn on and energize the relay. When the beeper stops, the transistor will cut off. Any general-purpose switching transistor can be used. Be sure that the relay coil is compatible with the transistor, and that its contacts can handle the current demand of the appliances.

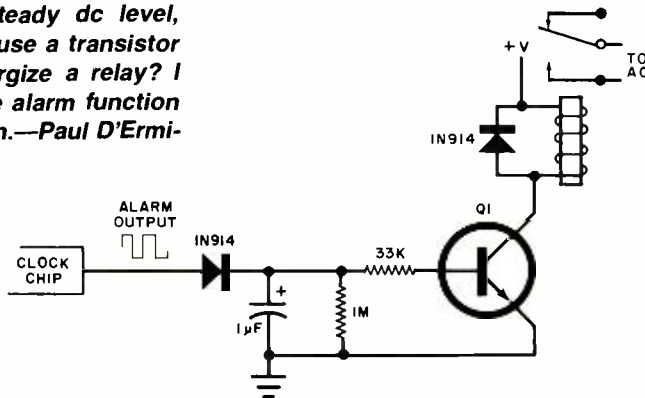



Product Test Reports

HEATHKIT MODEL IM-2202 DIGITAL MULTIMETER KIT

3½ digits with gas-discharge display for field and bench testing.



THE COST of owning a high-accuracy digital multimeter has dropped considerably over the past couple of years. Today, you can buy for less than \$250 a DMM with features and accuracy that rival laboratory-grade instruments of only a few years ago. One instrument that reflects this trend is the Model IM-2202 DMM from Heathkit. Its low price brings to the user a 3½-digit display, 0.5% to 0.2%, ±1-digit accuracy on dc, and the capability of measuring ac and dc voltage and current and resistance over wide ranges. In addition, the DMM has built-in ac and rechargeable nickel-cadmium cell dc power supplies that make it equally suitable for bench and field servicing.

The Model IM-2202 DMM measures 8¼"W × 8"D × 3"H (21 × 20.3 × 7.6 cm) with its handle folded to the rear and weighs 7 lb (3.2 kg). Available only in kit form, it sells for \$199.95.

Technical Details. The DMM's white control panel labelled in black is clean and functional. Arranged in a column along the left side of the panel are three banana jacks labelled from top to bottom MA, c (common), and v/Ω for the testable inputs. To the right of the jacks is the display window, below which is a bank of four pushbutton switches that are labelled AC, DC/Ω, v/Ω, and MA. The right third of the panel is occupied

by a large range/function switch that also has positions for power OFF and BATT (battery check, specified on the panel at 4.6 volts minimum). Accessible through a small hole in the upper right corner of the panel is the screwdriver-adjustable ZERO control.

There are five dc-voltage ranges that go to 100 mV and 1, 10, 100, and 1000 volts full-scale. The input resistance is 50 megohms on the 100-mV range, 500 megohms on the 1000-volt range, and 10 megohms on the remaining ranges. The accuracy of the instrument is specified at 0.5%, ±1 digit using the built-in references and 0.2%, ±1 digit using laboratory standards. The DMM can safely handle an overload of 300 volts on the 100-mV and 1-volt ranges and 1000 volts on the three highest ranges.

The ac voltage ranges are the same as for the dc-voltage function, except that on the 1000-volt range the maximum specified input is 750 volts. Input impedance is 10 megohms, paralleled by 120 pF on the two lowest ranges and 60 pF on the upper ranges. The overload capability is 250 volts on the 100-mV and 1-volt ranges and 750 volts on all other ranges. The accuracy of the instrument is 1.0%, ±1 digit over a frequency range of from 40 to 1000 Hz (except 40 to 10,000 Hz on the 100-mV and 1-volt ranges) using the built-in references. Using laboratory references, the

accuracy is 0.5%, ±1 digit from 40 to 1000 Hz, except to 2000 Hz on the 750-volt range.

Current in both the ac and the dc function can be measured to 100 μA and 1, 10, 100, and 1000 mA full-scale. The voltage drop in dc is 100 mV on the 100-μA and 1-mA ranges, 150 mV on the 10- and 100-mA ranges, and 300 mV on the highest range. On ac, the drop is 100 mV on the three lowest ranges, 150 mV on the 100-mA range, and 300 mV on the 1000-mA range. Accuracy on dc is 0.5% (except 1% on the 1000-mA range), ±1 digit with the built-in references and 0.2% (except 0.5% on the 1000-mA range) with laboratory standards. Ac accuracy is 1.0% (1.5% on the 1000-mA range), ±1 digit from 40 to 10,000 Hz on the built-in references and 0.5% (1.0% on the 1000-mA range), ±1 digit from 40 to 10,000 Hz. The input is coupled through a 3-ampere fuse to shunt diodes for overload protection with inputs exceeding about 1.2 volts.

There are also five resistance ranges that go to 100, 1000, 10,000, 100,000 ohms and 1 megohm full-scale. Test current is 1.0 mA on the first two ranges, 0.1 mA on the 10,000-ohm range, 1.0 μA on the 100,000-ohm range, and 10 μA on the highest range. The open-circuit potential at the test probes is 12 volts. Accuracy is 2%, ±1 digit using the built-in references. Positive input protection to 400 volts is provided by a blocking diode, while negative input protection is provided by a 0.03-ampere fuse and a shunt diode.

The DMM has a maximum display count of 1999, and its overrange capability is 100% on all but the 1000-volt dc and 750-volt ac ranges. Normal-mode rejection is stated as 35 dB or better, while common-mode rejection is 80 dB or better. The instrument can be operated 1500 volts above power line ground during line operation. The stated operating temperature is from 10° C to 40° C.

The instrument can be operated on either 110 to 130 or 220 to 260 volts 50 or 60 Hz line power, depending on an internal setting. It consumes 5 watts of power during battery charging.

The displays used are large ½" (12.7-mm) seven-segment orange gas-discharge types. Both + and - are displayed when taking dc measurements, depending on the polarity at the input to the DMM. An over range condition is indicated in the display by a flashing 1 in the half-digit location. The meter also features dual-slope A/D (analog-to-digital) conversion, automatic blanking of leading zeros, rechargeable nickel-cad-

mium cells that come standard, a carrying handle that doubles as a convenient tilt stand, and nonskid rubber feet.

About the Kit. Although this is a relatively complex digital multimeter, the kit is fairly easy to assemble owing to the well-written and well-illustrated assembly manual that comes with it. But for a handful of components, all parts mount on three printed circuit boards, including the function selecting pushbutton switches and the rotary range/function switch.

High-quality components and materials are used throughout the instrument. The printed circuit boards are epoxy-fiberglass, two of the three are double-sided with plated-through holes, and all three are silk-screened to show component values and orientation. Except for three resistors, all resistors are 5% tolerance or better. All hardware lines up exactly so that bolting together is a breeze.

There is very little in the way of tedious point-to-point wiring with this kit. The DMM uses a factory-prepared cable harness and switches that mount directly on the input circuit board. This reduces considerably the time required to assemble the kit and virtually eliminates the wiring errors that often crop up when

using point-to-point wiring in a complex kit.

During assembly, we ran into one minor snag. We could not obtain the proper display indication on the highest resistance range during calibration. However, when we changed one component (supplied by Heath), everything worked out fine. All told, it took us approximately 17 hours to assemble and calibrate the DMM.

User Comment. We calibrated the DMM using both its built-in references and laboratory references. Using the built-in references, the instrument's accuracy on all ranges and functions equalled or bettered the published specifications. When we used laboratory references, the accuracy we obtained was well within the published specifications. Needless to say, this DMM provides greater accuracy than needed for less than laboratory-grade testing.

There are several things about this DMM that appealed to us. First off, it is very easy to operate. The range/function switch is large and easy to handle and its position labelling is clear and unambiguous. Pushbutton function selection is convenient. And the large gas-discharge displays are easy to read from

any angle, up close, and at a distance. Even the test cable plugs have built-in convenience. When they are plugged into the front panel, the plugs still allow another instrument, such as an oscilloscope, to be plugged into them.

Though the Model IM-2202 is not as compact as some take-along battery-powered field-service DMM's, its larger size and weight offer the advantage of higher accuracy than usual. The intermediate size of the instrument also assures that it will not get lost on a crowded workbench or accidentally brushed off the bench onto a hard floor.

In both test-bench and field-service environments, the DMM acquitted itself admirably. After having used it for several months under all kinds of servicing conditions, we checked out its calibration. There was no significant change, and in most cases no detectable change.

The Model IM-2202 is a good-looking instrument that should fill the needs of most professionals and amateurs. It is also very reasonably priced for a highly accurate instrument that can be operated on both ac and dc power and comes standard with nickel-cadmium cells and recharging circuitry.

CIRCLE NO. 104 ON FREE INFORMATION CARD

SHARP MODEL CB-800A CB MOBILE AM TRANSCEIVER

23-channel digital LED-display rig with excellent overload characteristics.

WITH new 40-channel CB rigs moving into the market place, this probably represents the last 23-channel mobile CB unit we will test. Nonetheless, 23-channel CB transceivers represent good value for the money; in some cases, unbelievable bargains. And the manufacturer of the CB transceiver examined here advises that this 23-channel unit will remain in its product line for a while.

The Model CB-800A AM CB transceiver from Sharp uses digital frequency synthesis and features a LED numeric display to indicate the channel in use. As a special feature, when the transceiver is set to Channel 9, the display flashes to tell the user that this emergency channel is in use. The transceiver has an unusually low price of only \$149.95 to provide these latest technical features.

The usual lineup of controls and features are offered by the transceiver. These include: volume and variable

squench controls, S/r-f meter, switchable automatic noise limiter, Delta tune, PA operation, external-speaker jack, detachable dynamic microphone, full legal power output, TVI traps, 10.8-to-15.6-volt dc, negative- or positive-ground power requirements, voltage regulation, line filtering, and reverse-polarity protection.

The mobile transceiver measures 7 $\frac{7}{8}$ "D \times 5 $\frac{3}{4}$ "W \times 2 $\frac{1}{4}$ "H (20 \times 14.6 \times 5.7 cm).

General Description. The double-conversion receiver has i-f's located at 11.275 MHz and 455 kHz. A diode-protected r-f stage and two mixer stages are arranged in common-emitter configurations. A ceramic filter in the emitter circuit of the second mixer, plus two cascaded ceramic filters at the output of the mixer provide the 455-kHz selectivity. The i-f section, detector, second-conversion oscillator, and an agc amplifier for

the i-f strip are incorporated into a single IC chip. Two outboard transistors provide another amplified agc loop for the r-f and first mixer stages and the squench section. A series-gate anl following the detector drives an audio amplifier stage. The audio stage, in turn, drives an IC that contains the remainder of the audio section, including the output amplifier.

The digital frequency synthesis system employs a phase-locked loop (PLL). A single IC includes a 10.240-MHz crystal oscillator and a network that divides by 1024 to furnish the 10-kHz standard reference signal. A FET voltage-controlled oscillator (vco) that operates in the 38.240-to-38.530-MHz range provides the heterodyning signal to produce the 11.275-MHz i-f at the first mixer. The comparison reference from the vco is obtained by mixing the output from the vco with the 36-960-MHz crystal-controlled signal to produce difference frequencies in the range of 1.280 to 1.570

The better the training the better you'll

Send for
FREE
illustrated
career
guide

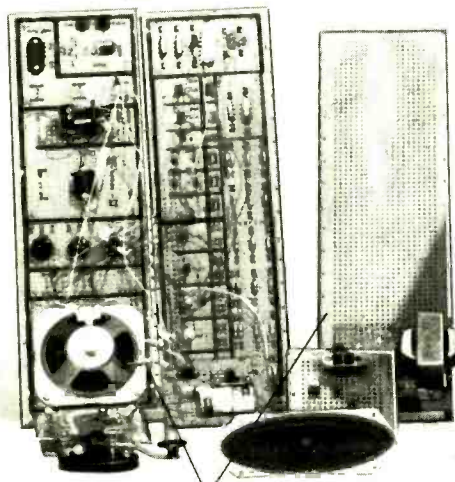
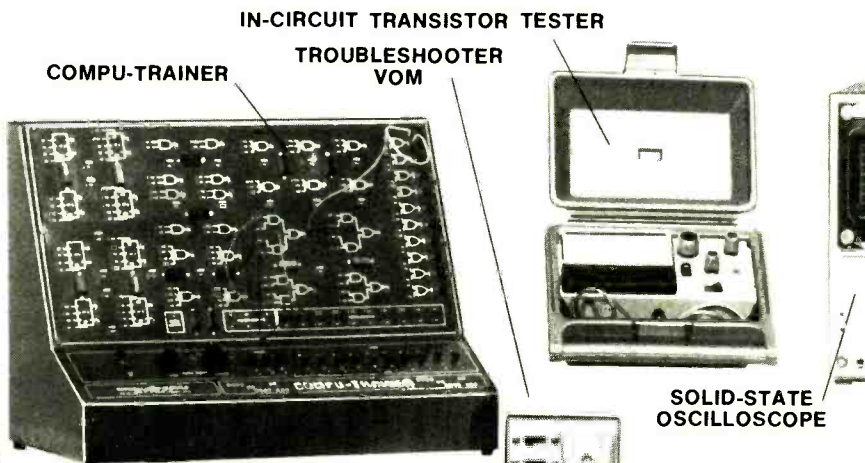
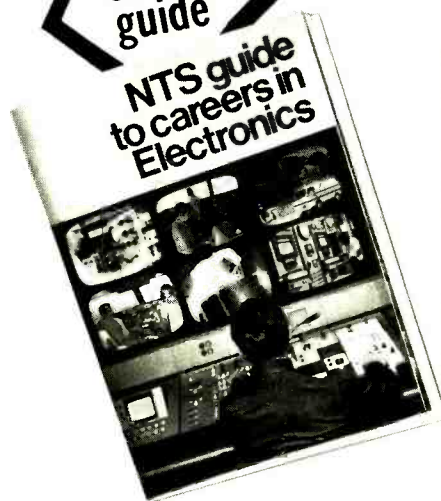

ELECTRO-LAB



(Simulated TV Reception)

As an NTS student you'll acquire the know-how that comes with first-hand training on NTS professional equipment. **Equipment you'll build and keep.** Our courses include equipment like the **NTS/Heath GR-2001 computerized color TV (25" diagonal)** with varactor diode tuning and digital read-out channel selection. (optional programming capability and digital clock avail.).

Also pictured above are other units — 5" solid state oscilloscope, vector monitor scope, solid-state stereo AM-FM receiver with twin speakers, digital multimeter, and more. It's the kind of better equipment that gets you better equipped for the electronics industry.

This electronic gear is not only designed for training; it's field-type — like you'll meet on the job, or when you're making service calls. And with NTS easy-to-read, profusely illustrated lessons you learn the theory behind these tools of the trade.

Choose from 12 NTS courses covering a wide range of fields in electronics, each complete with equipment, lessons, and manuals to make your training more practical and interesting.

Compare our training; compare our lower tuition. We employ no salesmen, pay no commissions. You receive all home-study information by mail only. All Kits, lessons, and experiments are described in full color. Most liberal refund policy and cancella-

and the equipment be equipped.

COMPARE OUR
KITS AND LESSONS.
COMPARE OUR
TUITION.

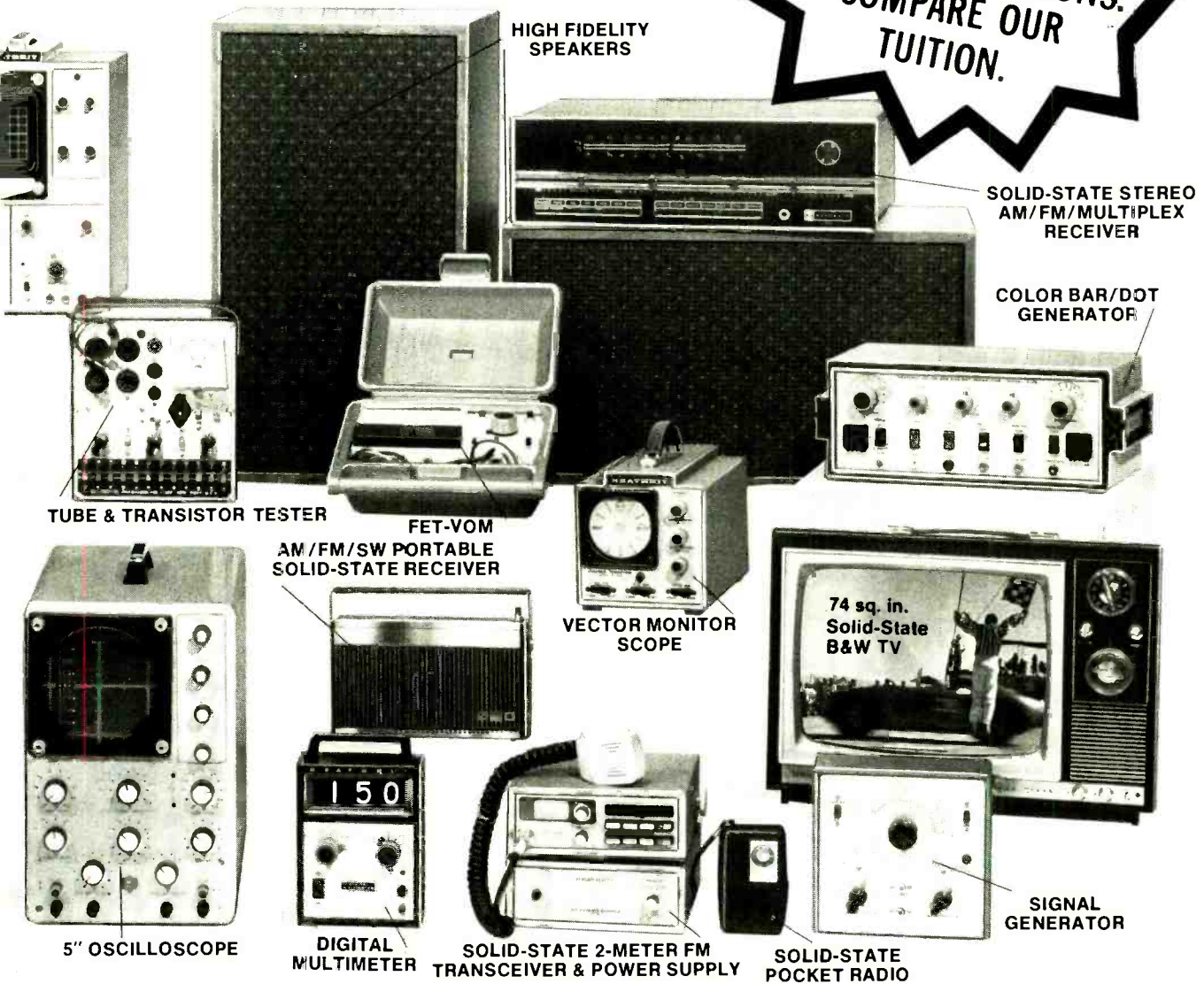

tion privileges spelled out. Make your own comparisons, your own decision. Mail card today, or clip coupon if card is missing.

NO OBLIGATION. NO SALESMAN WILL CALL

APPROVED FOR VETERAN TRAINING

Get facts on new 2-year extension

NATIONAL TECHNICAL SCHOOLS

TECHNICAL-TRADE TRAINING SINCE 1905
Resident and Home-Study Schools
4000 So. Figueroa St., Los Angeles, Calif. 90037

NATIONAL TECHNICAL SCHOOLS Dep: 205-027

4000 South Figueroa St., Los Angeles, Calif. 90037

Please send FREE Color Catalog and Sample Lesson.
NO OBLIGATION. NO SALESMAN WILL CALL.

- | | |
|---|--|
| <input type="checkbox"/> Color TV Servicing | <input type="checkbox"/> Electronics Technology |
| <input type="checkbox"/> B & W TV and Radio Servicing | <input type="checkbox"/> Computer Electronics |
| <input type="checkbox"/> Electronic Communications | <input type="checkbox"/> Basic Electronics |
| <input type="checkbox"/> FCC License Course | <input type="checkbox"/> Audio Electronics Servicing |

NAME _____ AGE _____

ADDRESS _____ APT # _____

CITY _____ STATE _____

Please fill in Zip Code for fast service _____

- Check if interested in G.I. Bill information.
 Check if interested ONLY in classroom training in Los Angeles.

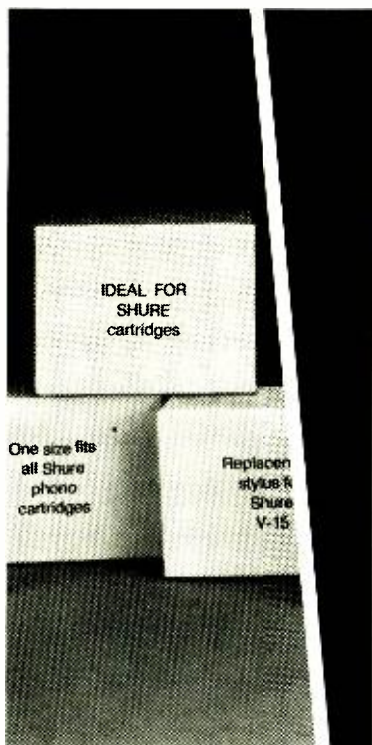

Needle in the hi-fi haystack

Even we were astounded at how difficult it is to find an adequate other-brand replacement stylus for a Shure cartridge. We recently purchased 241 random styli that were not manufactured by Shure, but were being sold as replacements for our cartridges. Only ONE of these 241 styli could pass the same basic production line performance tests that ALL genuine Shure styli must pass. But don't simply accept what we say here. Send for the documented test results we've compiled for you in data booklet # AL548. Insist on a genuine Shure stylus so that your cartridge will retain its original performance capability—and at the same time protect your records.

Shure Brothers Inc.
222 Hartrey Ave., Evanston, IL 60204
In Canada A.C. Simmonds & Sons Limited

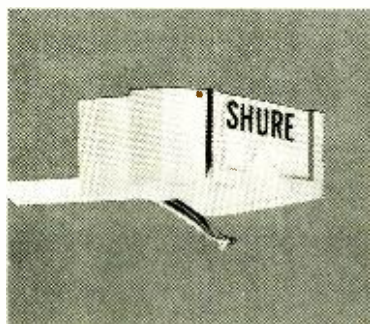

Manufacturers of high fidelity components, microphones, sound systems and related circuitry.

MHz. The difference frequencies are reduced to the 10-kHz vco comparison signal through an IC that can be programmed to divide by a number between 128 and 157. The two reference signals are applied to an IC phase comparator that properly tunes the vco and PLL according to the desired channel selected by the channel-selector switch. The second-conversion crystal oscillator operates at a frequency of 11.730 MHz.

The outputs of the vco and an 11.275-MHz crystal oscillator are combined in a mixer in the transmitter. Spurious responses are minimized by bandpass filter circuits. The rest of the transmitter consists of a buffer amplifier and driver and power amplifiers. The output of the power amplifier goes through a dual-Pi filter for matching to 50-ohm loads. TVI traps tuned to 54 and 51 MHz minimize second- and third-harmonic radiation. As is usually the case, speech amplification and collector-modulation of the driver and power amplifier stages in the transmitter are obtained from the receiver's audio-amplifier section. Automatic modulation control (amc) is included here. Antenna and other circuit transfers are accomplished with a relay.

The channel LED display is activated through the selector switch and a diode-switching array. Flashing of the display on Channel 9 is controlled by a multi-vibrator.

Measurements. The sensitivity of the receiver measured 0.5 μV (rated 0.7 μV) for 10 dB (S + N)/N with 1000 Hz at 30% modulation. The overall audio response at 6 dB down was nominally 500 to 2625 Hz. The maximum available sine-wave power output was 2 watts at 2.5% THD with a 1000-Hz tone and an 8-ohm load. On PA, the output measured 2.5 watts.

Primary image rejection for signals near 49.6 MHz was greater than 80 dB, while secondary-image rejection for signals 910 kHz lower than the CB signal was 64 dB. I-f signal rejection was 60 to 64 dB, depending on the channel in use. Additional unwanted signals were 56 dB down for frequencies approximately 200 kHz below the CB signal. Other unwanted signals were a minimum of 60 dB down. Adjacent-channel rejection at 1 dB desensitization was 55 dB on both sides of each channel.

The agc held the audio output change to within 7 dB with an 80-dB input-signal change at 1 to 10,000 μV . The meter indicated S9 with a nominal 3.5- μV signal. The squelch threshold range for normal output was 0.3 to 10,000 μV .

Operating the transceiver at 13.8 volts dc, the transmitter's output measured 3.75 watts, depending on the channel in use. During modulation, amc compression began near 85% modulation and held to 15 dB compression beyond this point with close to 100% modulation at 4.5% THD. Adjacent-channel splatter was down 50 dB with a 1000-Hz test tone. With voice operation, the splatter held to at least 55 dB down. The overall 6-dB down response was nominally 275 to 4500 Hz. The transmitter's frequency tolerance was within 5 Hz of +105 Hz on any channel.

User Comment. The transceiver is neatly styled, with a black case and panel and satinized silver-colored trim. The chrome-finished control knobs add a nice accent. Small lever switches handle the anl and Delta-tune functions. (Delta tune shifts the receiver's frequency a fixed amount of about ± 1000 Hz). The VOLUME and SQUELCH controls are rotary potentiometers, the positions of which can be readily observed and felt.

The LED display and S/r-f meter are located behind an oblong window. However, the meter is very small and can be difficult to read under some conditions. When the transceiver is switched to PA operation, the letters "PA" appear in the LED display. (Under very high ambient-light conditions, all the segments of the LED's sometimes reflect light, which can obscure the channel numerals.)

The anl system was highly effective on very short and rapid noise spikes, although its performance was not as good on slow repetitive and broader pulses. Nevertheless, the overall performance in a noisy vehicle was good. Due to an elaborate line-filter setup, we were not bothered with vehicle noises induced in the 12-volt supply line. The noise suppression was superior to that used in other mobile transceivers.

We were particularly impressed by the overload characteristics of the receiver, which by measurement did not exhibit distortion with signal inputs of 100,000 μV . Furthermore, no distortion or blocking effects were audibly noted from a CB transmitter located 30' (9.1 m) removed from the transceiver's antenna.

Another plus for this transceiver is that its receiver audio response falls off fairly rapidly below 1000 Hz. This results in a somewhat high-pitched sound that lacks boominess. It gives the advantage of better-than-usual intelligibility from a bottom-facing speaker in mobile installations.

CIRCLE NO 105 ON FREE INFORMATION CARD

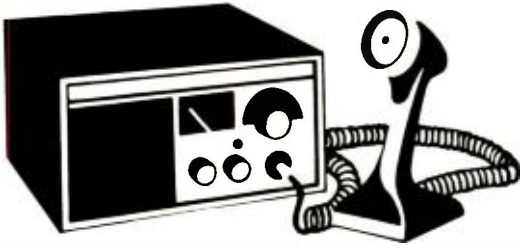

CB Scene

By Ray Newhall, KWI6010

PURAC—A VOICE FOR CB'ERS

THE THIRD quarterly general meeting of the Personal Use Radio Advisory Committee (PURAC) to the FCC was held in Norfolk, Virginia, on October 28. The FCC hosted the gathering in a theater near their Field Operations branch offices. More than 100 representatives of CB industry, clubs, and leading publications; law enforcement agencies; the broadcasting industry; insurance companies; hams, and individual CB'ers were there to discuss their common problems, to hear the FCC's problems and to advise the FCC on the future course of personal-use radio communications.

In the past, FCC communications with radio users have always consisted of their "legal eagles" talking with other "legal eagles," and they understood each other. Now with such extensive use of CB by the general public, the FCC has found that it cannot effectively communicate with the public so it sent out a call for help from the CB industry and the CB'ers themselves. Public response at the first three meetings was better than the FCC had hoped. PURAC has become the vehicle by which any interested CB'er can work actively on a task group of his choice to help make CB a more viable, useful means of personal communications. He can talk with the FCC "wheels" face-to-face and be heard.

PURAC, chaired by John Johnson of the FCC, is organized into ten "task areas," each headed by a "Task Coordinator". An FCC representative has also been assigned to work actively in each of the task areas. The task/study areas are as follows:

1. *Operator Training Programs*: Recommend syllabus, methods and training programs for CB operators. Task Coordinator: Dave Gamer
2. *Technical Standards*: Recommend material for, and organization of, the Technical Regulations sub-part of Part 95. Task Coordinator: Lee Bergren
3. *Part 95 Readability*: Recommend reorganization and rewrite of Part 95 to improve readability. Coordinator: Randy Knowles

4. *Disseminating Information*: Recommend systems for distributing information on CB topics to the CB public in the fastest, most economical, most accurate manner. Coordinator: Bill Bradford

5. *User Rule Compliance*: Recommend approaches and methods for improving user rule compliance. Coordinator: Stuart Lipoff

6. *Electromagnetic Compatibility*: Recommend susceptibility requirements and interference limits necessary to achieve electromagnetic compatibility between CB units and other electronic devices. Coordinator: John Sodolski

7. *Public Safety Uses of Personal Radio*: Recommend improvements in Part 95 to enhance the contributions of CB to public safety. Coordinator: Nathan Maryn

8. *Equipment Theft*: Recommend methods for reducing the number of CB sets stolen from users. Coordinator: Manny Hoffman

9. *Local Interference Problems*: Recommend remedial solutions for on-going complaints of interference created by CB transceivers. Coordinator: Stu Meyer

10. *Personal Use Radio Communication Needs*: Advise on current and future two-way radio communication needs of the general public, and recommend segments of the radio spectrum to meet those needs. Coordinator: Ted Andros

Each task/study group is staffed by volunteers who have offered their time to contribute to one or more sub-committee tasks. POPULAR ELECTRONICS has pledged to work actively on many Task Groups. This columnist will be pleased to assist any reader who wants to take part in PURAC activities by putting him in touch with the appropriate Task Coordinator. We will also pass-on well-considered, constructive suggestions from our readers. The next general meeting of PURAC will be held in Washington, D.C., on January 27, 1977.

PURAC Progress Report. It is far too early to expect major results from PURAC, since the first two general meetings were concerned primarily with organization, ground rules, and the subjects to which PURAC should address itself. Also, major shifts in attitude and performance in a bureaucracy such as the FCC are slow in coming, and rules-

making procedures take even longer. None-the-less, some changes have already taken place as a result of PURAC:

- Engraved serial numbers will be required on all CB rigs manufactured since January 1, 1977. This does not itself solve the theft problem, but it is a step in the right direction.

- This writer had the opportunity to preview a TV tape on CB and its problems produced by a group of TV stations as a means of educating the public about CB and its relation to the TVI problem.

- By the time you read this, there will be a newly reorganized edition of Part 95 available. It separates the technical requirements from operating regulations, so that all information a CB'er needs to know is in one spot. (The new issue does not yet reflect all rules changes.) Although this first revision is still in "legalese," Task Group 3 is currently rewriting it in English for a future edition. These new editions do *not* obsolete the editions in circulation in January, 1977, because they do not represent substantial changes in content.

The FCC has now issued more than 12 million CB licenses, and there are more than 18 million CB transmitters in use, according to FCC estimates. The FCC recently conducted test samplings in a number of areas across the nation and determined that fewer than 10% of the CB'ers are now operating without licenses, but that still represents well over a million operators who would rather risk a \$10,000 fine than pay 80¢ per year for the right to operate legally.

Following the 40-channel announcement in July, license applications fell-off about 8% to 10% for each of the next three months, and were down to a level of about 300,000 per month by October. FCC expects them to increase again shortly after the beginning of 1977.

Incidentally, the average turn-around time for issuing licenses during the period from July through September was under 17 days, and the FCC now believes it can continue to issue them in that time frame even though the demand may increase. There was one instance late last spring when a whole block of licenses were erroneously sent to the wrong Zip Codes and were lost by the Postal Service. It was necessary for them to be reissued and remailed.

Nearly 10% of all applications for Class D licenses must be returned to the applicants. The FCC urges CB'ers to read Form 505 carefully. Each month, 20,000 applications are returned because the wrong fee was enclosed. (The license fee of \$4.00 for a Class D license

HAM CB SWL

they come through **LOUD AND CLEAR** in the all-new **1977 COMMUNICATIONS HANDBOOK**

Here is everything you want to know — need to know about Citizens' Band, Amateur Radio, Shortwave Listening.



DON'T TURN A DIAL. In fact don't even buy a dial or anything else until you've checked out the 1977 Communications Handbook. Whatever your radio specialty — whether you're an old hand or just getting started — this vital "how-to" guide will help you get greater value, greater enjoyment out of every minute you spend with your equipment.

The all-new 1977 COMMUNICATIONS HANDBOOK is scheduled to go on sale nationally March 1977

YOU CAN RESERVE YOUR COPY NOW AT THE SPECIAL PRE-PUBLICATION PRICE OF ONLY \$1.50 POSTPAID.

Regular newsstand price is \$1.95; mail order \$2.50.

So to make sure you come through "Loud and Clear" in 1977...

RESERVE YOUR COPY NOW AND SAVE WITH THIS SPECIAL PRE-PUBLICATION OFFER AVAILABLE TO READERS OF POPULAR ELECTRONICS MAGAZINE ONLY.

PRE-PUBLICATION RESERVATION FORM

Communications Handbook PE-277
Consumer Service Division
595 Broadway, New York, N.Y. 10012

Enclosed is \$1.50. Please reserve my copy of the 1977 Communications Handbook to be mailed to me when published. (Residents of Cal., Col., Fla., Ill., Mich., Mo., N.Y. State, D.C. and Tex. add applicable sales tax.) OUTSIDE U.S.A. \$2.

Print Name _____
Address _____
City _____
State _____ Zip _____

has been in effect since March 1976, and the license is valid for a five-year period.) Each month, 10,000 license applications are returned because the applicant is too young. An applicant *must* be 18 years of age to be granted a Class D CB license, though the restriction that the applicant must be a U.S. citizen has been removed.

Much of the business of the third general meeting of PURAC concerned the growing problems of CB-related electromagnetic interference. In addition to the obvious increase in noise, skip, and adjacent channel interference on CB itself, of more concern is the staggering increase in CB-caused TVI (television interference) and interference with solid-state audio equipment.

The leading causes of TVI are:

1. Harmonic radiation from CB units.
2. Use of illegal linears.
3. TV and audio equipment deficiencies.
4. Attempted "fringe" reception by the TV viewer.

We are not too concerned with the last two causes listed because CB is not at fault (more about this later). However, we *must* be concerned with the first two because they represent about one third of all TVI problems and they are the fault of CB users and equipment. The new rules make it the *legal* responsibility of the CB'er to correct this type of interference wherever a complaint has been filed.

Harmonic radiations occur at multiples of the operating or fundamental frequency. For CB, these would occur at 54 MHz (TV Channel 2), 81 MHz (TV Channel 5), 108 MHz, etc. The new regulations have attempted to reduce harmonic radiations generated by rigs built after January 1, 1977 by requiring that harmonics be suppressed at least 60 dB down from the power output of the fundamental frequency (the old specification required about 49 dB suppression). Thus new transceivers will be limited to 4 microwatts of harmonic output. The TV manufacturers wanted CB harmonics suppressed by 100 dB, but FCC set these comments aside with the warning that CB manufacturers had better prepare now for stiffer limitations in the future.

How can the CB'er tell whether TVI is caused by his rig or the TV receiver? It is very simple once the CB'er understands harmonic radiation. If the TV exhibits TVI only on channel 2 or channel 5 when the transmitter is keyed, it is probably the fault of the CB rig. If TVI shows up on other channels as well, the fault is prob-

ably that the TV receiver cannot filter out strong signals at 27 MHz.

However, there is seldom a single cause of TVI. The FCC warns that, in most cases of bad interference, there are usually at least two system malfunctions before TVI becomes a problem. If the cause can be traced to the CB rig, then the CB'er *must* either correct it or cease operations. If the TV receiver is at fault, most TV manufacturers will supply corrective information and free parts, if necessary. Even though the fault is in the TV, it is in the interest of the CB'er to work with his neighbor to help him solve the problem.

Actually, harmonic radiation problems do not always originate in the CB transmitter, but they may also be introduced by any device which is inserted into the antenna lead line, such as an SWR meter or a coaxial switch. A linear amplifier in the line, even when *turned-off*, may increase the harmonic radiation by 9 dB or more. The increase in harmonic radiation when the linear is turned on may be much more than that.

On the point of linears, the FCC has determined that nearly all TV receivers within 500 feet of an operating linear will experience serious TVI, and nearly half the TV sets within a quarter mile will be affected. These figures are for linears which operate properly. Those which are not properly matched can cause even greater problems, but they are easily detected by FCC monitoring equipment. The FCC is aware that some stations are operating linears. Accordingly, the FCC has pledged to get them off the air, and if the illegal operators do not get rid of them voluntarily, it is prepared to seize their equipment and take the outlaws to court.

Consumer Electronics Legislation. At the present time, the FCC does not have any control power to set electromagnetic immunity standards for TV or other electronic communication or home entertainment devices which are not intended to transmit r-f emissions.

The Communications Reform Act of 1976, the so-called "Bell Bill" because it was largely written by telephone company lawyers and strengthened the monopolistic position of the communications utility companies, ran out of time when Congress adjourned. But it is bound to be revived by the 95th Congress. Extensive hearings are planned by both House and Senate committees. We believe that any such reform review should consider *all* our country's communications problems. ◇



Amateur Radio

By Herbert S. Brier

SPEECH PROCESSORS

YOU HAVE probably noticed that speech processors are being used more and more by radio amateurs. This recent trend prompted me to procure a logarithmic speech processor and see exactly what such a device can do to an SSB signal. My last involvement with speech processors was in the good-old AM days, when a good processor made a moderate improvement in the readability of weak voice signals. When the signals were subject to selective fading, processed signals often sounded louder but were actually *less* readable than when the processor was turned off. Consequently, our expectations for the new processor were not of the highest. However, after using it on the air for many months, we are convinced that the new generation of speech processors actually does what the designers claim—improve SSB signal readability up to six dB when conditions are worst. On the other hand, when signals are loud and clear, the majority of operators—especially locals—prefer the sound of unprocessed signals.

Historically, from the beginning of telephone and radiotelephone communications, engineers have worked to improve the efficiency of voice circuits. In ordinary conversation, the human voice can occupy a nominal bandwidth of 56 to 5700 Hz and a dynamic range up to 85 dB. Because the bandwidth of any signal is directly related to the highest frequency transmitted, extensive tests were conducted to determine the highest voice frequencies that had to be transmitted to preserve the readability of the reproduced speech. This was found to be nominally 3000 Hz. It was also found that frequencies below 500 Hz or so could be attenuated without reducing readability appreciably, although eliminating too many of them made the speech sound tinny.

As a result of such studies, international and domestic telecommunications regulations specify a 3000-Hz bandwidth for voice circuits. Many users prefer to transmit frequencies between 400 and 2500 Hz; others prefer 400 to 2800

Hz. Tailoring the modulating frequencies transmitted by a SSB transmitter is simple. Select the desired filter bandwidth—2100 Hz, for example. Then displace the (suppressed) carrier frequency by an amount equal to say, the lowest modulating frequency above the high-frequency knee of the filter selectivity curve (for lower sideband transmissions). Shift the carrier frequency by the same amount *below* the low-frequency knee for upper sideband transmissions.

Amplitude Variations. It has been found that voice frequencies logarithmically centered around 100 Hz contain most of the speech energy and vary widely in amplitude but contribute little to the readability of the speech. In contrast, the frequencies between 300 and 3000 Hz do not contain much energy and do not vary much in amplitude but contain most of the spoken intelligence. Viewing the output signal of a voice-modulated SSB transmitter on an oscilloscope reveals that the lower voice components produce the highest modulation peaks, with the high-frequency peaks about 12 dB lower. Early speech processors increased the transmitter's speech amplifier gain to bring the amplitude of the higher frequency components up to the desired level. Those processors also chopped off the amplitude of all voice peaks to the threshold voltage of a stage. Feeding the clipped signals through a low-pass filter with a cutoff frequency of 3000 Hz kept the high-frequency harmonics generated by the clipper from modulating the transmitter. Unfortunately, the low-order harmonics of the clipped low frequencies still remained in the voice passband, making the processed speech sound "different" but barely more readable than unprocessed speech.

Logarithmic Speech Processors.

The wide availability of versatile IC amplifiers has given new life to transmitter speech processors. In the logarithmic speech processor described in *QST* for August 1974, the microphone signal is

first amplified 20 to 30 dB more than it would otherwise be. It is then passed through a high-pass filter with a low-frequency cutoff of approximately 50 Hz to remove most of the low-frequency, variable amplitude component. The signal is next fed to a logarithmic amplifier and clipper. The signal from the clipper—now a more-or-less constant-amplitude, 300-to-3000-Hz signal—goes through a low-pass filter with a 2950-Hz cut-off frequency to remove the high-frequency distortion products from the signal before it is applied to the microphone connector of the transmitter.

Another more-elaborate logarithmic speech processor (described in *QST* for March 1976) full-wave rectifies the audio signal before feeding it to the logarithmic amplifier and clipper. The output signal drives an exponential amplifier whose output modulates the transmitter. This processor also uses an input high-pass filter and an output low-pass filter.

Operating a Speech Processor.

The first step in getting good results from a speech processor is to adjust the transmitter and its microphone gain control so that the transmitter r-f output peaks are not being clipped before the speech processor is placed in the line. Tune up the transmitter into a dummy load and turn the microphone gain control so that the maximum output peaks displayed on an oscilloscope just start to decrease in height. Next, turn on the processor with the microphone connected to the processor input and its output connected to the transmitter microphone jack. With the processor input and output controls full on, talk into the microphone while backing down the output control until the maximum pattern height on the oscilloscope is the same as after the mike gain adjustment. The processor input gain control is adjusted to match propagation conditions. In general, the better conditions are, the less processing should be used. When signals are strong and interference is weak, some operators turn off their processors entirely.

One of the most annoying characteristics of some speech processors is the loud roar that replaces the operator's voice when he stops talking. This roar is usually most evident when transmissions are controlled with a push-to-talk switch (PTT) rather than by VOX. We discovered by experiment that VOX operation with a short delay to cut off the roar generated by a noisy blower eliminated the criticism of the signal elicited by PTT operation. ◇

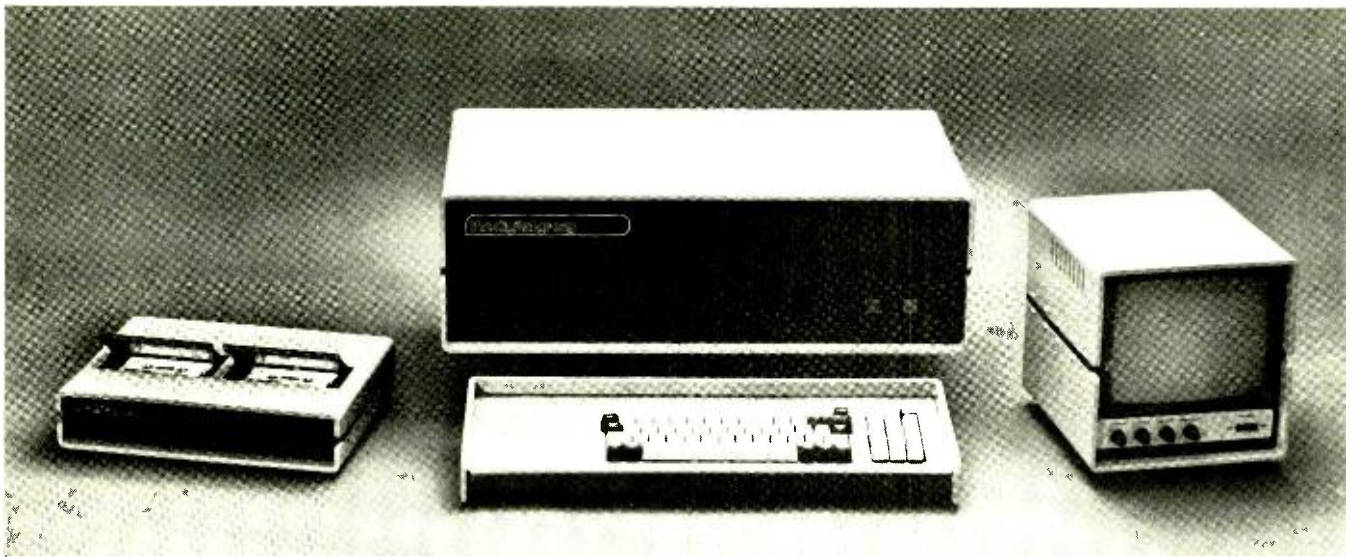

Cabinets clockwise from top CPU, Dual-cassette drive, Keyboard, 9" Monitor

Meet The Digital Group

If you are seriously considering the purchase of a microcomputer system for personal or business use... or just beginning to feel the first twinges of interest in a fascinating hobby... the Digital Group is a company you should get acquainted with.

For many months now, we've been feverishly (and rather quietly) at work on our unique, high-quality product—a microcomputer system designed from the inside out to be the most comprehensive, easy-to-use and adaptable system you'll find anywhere. And our reputation has been getting around *fast*. In fact, you may have already heard a little something about us from a friend. We've found our own best salesmen are our many satisfied customers.

There's a good reason. Simply, the Digital Group has a lot to offer: state-of-the-art designs, a totally complete systems philosophy, unexcelled quality, reasonable software, affordable prices and the promise that our products will not become rapidly obsolete, even in this fast-moving, high-technology field.

The Advantages

Here are a few specific advantages of our product line:

- We offer interchangeable CPUs from different manufacturers (including the new "super chip" — the Z-80 from Zilog) which are interchangeable at the CPU card level. That way, your system won't become instantly obsolete with each new design breakthrough. The major portion of your investment in memory and I/O is protected.
- Digital Group systems are complete and fully featured, so there's no need to purchase bits and pieces from different manufacturers. We have everything you need, but almost any other equipment can be easily supported, too, thanks to the universal nature of our systems.
- Our systems are specifically designed to be easy to use. With our combination of TV, keyboard, and cassette recorder, you have a system that is quick, quiet, and inexpensive. To get going merely power on, load cassette and go!
- Design shortcuts have been avoided—all CPUs run at full maximum rated speed.
- All system components are available with our beautiful new custom cabinets. And every new product will maintain the same unmistakable Digital Group image.

The Features

Digital Group Systems—CPUs currently being delivered: Z-80 by Zilog 8080A/9080A 6800 6500 by MOS Technology

All are completely interchangeable at the CPU card level. Standard features with all systems:

- Video-based operating system

- Video/Cassette Interface Card
512 character upper & lower case video interface
100 character/second audio cassette interface
- CPU Card
2K RAM, Direct Memory Access (DMA)
Vectored Interrupts (up to 128)
256 byte I702A bootstrap loader
All buffering, CPU dependencies, and housekeeping circuitry
- Input/Output Card
Four 8-bit parallel input ports
Four 8-bit parallel output ports
- Motherboard

Prices for standard systems including the above features start at \$475 for Z-80, \$425 for 8080 or 6800, \$375 for 6500.

More

Many options, peripherals, expansion capabilities and accessories are already available. They include rapid computer-controlled cassette drives for mass storage, memory, I/O, monitors, prom boards, multiple power supplies, prototyping cards and others. Software packages include BASICs, Assemblers, Disassemblers, Text Editors, games, ham radio applications, software training cassettes, system packages and more (even biorhythm).

Sounds neat — now what?

Now that you know a little about who we are and what we're doing, we need to know more about you. In order for us to get more information to you, please take a few seconds and fill in our mailing list coupon. We think you'll be pleased with what you get back.

the digital group

P.O. Box 6528
Denver, Colorado 80206
(303) 777-7133

OK, I'd like to get to know you guys better
Send me the whole package!

Name _____

Address _____

City/State/Zip _____



Computer Bits

By Stephen B. Gray

COMPUTER STORES

THE FIRST hobby-computer store opened in Los Angeles in July 1975. Now, a year and a half later, there are well over 100 of them across the country. Why such a rapid rise? As one store owner observed, a computer store "provides the place, the people and the knowledge to help out the hobbyist." It provides the hobbyist with a place to look over different computers, to ask questions, and often the chance to try out a computer, hands-on. In this way, he can look before he leaps.

A Typical Store. At one time there were two basic types of stores. Both sold a variety of peripherals, but one sold only MITS Altair computers, while the other sold several other makes. The former type of store can concentrate on a single line of computers, and develop an expertise in the sales, operation and service of a minimum number of mainframe machines. Now, however, as different models pour into the marketplace, some stores that previously sold only the 8800b and 680b computers also carry others. A substantial number, though, still prefer to concentrate on the two Altair models, offering a host of peripherals to go with them.

If you walk into a typical computer store today, you'll find at least one operating computer connected to a Teletype or to a keyboard terminal and a TV monitor or receiver, or to a complete CRT terminal. Sometimes a peripheral or two are also on-line, such as a cassette-storage device, or a graphics terminal or printer. Other computers are on counters or in display cases, along with memory boards, Teletype paper and tape, extender boards, power supplies, TV monitors, interface boards, printers, terminals, breadboards, keyboards, etc. Not every store will have all these, but many do.

Test equipment is also on the shelves, including logic probes, logic monitors, perhaps a pulse generator, and maybe even a frequency counter. Some tools

may also be on display, such as for wire-wrapping, soldering and desoldering. There are computer stores that also carry basic tools such as pliers, screwdrivers, soldering irons, etc.

A good supply of parts is essential, since half of the hobby computers built from kits don't work when first turned on. Not all of that is caused by solder bridges and miswiring. So, to repair the damage, the hobbyist may need IC's, LED's, and IC sockets, which most stores carry, along with breadboarding hardware, hookup wire, etc.

Books and Software. Many stores devote a large amount of space to books. As one store manager put it, "We carry books about everything on computers and data processing except the social issues." That store has books on hardware design, digital techniques, flowcharting, even on multiple regression and telecommunications. They have programming texts on assembler,

BASIC, APL, FORTRAN, ALGOL, and several other languages. They also carry software books, offering assembly-language programs (such as the Scelbi series on the 8080 and 8008) and BASIC programs (including "101 BASIC Computer Games"). In addition to programs being offered as listings in these books, the store also has many programs on PROM memory chips, on paper tape, and on cassette.

Magazine racks are used by many stores to display up to half a dozen different hobby magazines. And there's always a bulletin board, with notices of meetings, "For Sale" ads for computer hardware, listings of computer courses, etc.

You may also find T-shirts, lettered with slogans such as "Does Not Compute," "Real Time Operator," or "Baud Rated."

Chains. Most of the stores are independently owned. There are several chains, one with over a dozen stores, mainly in California, another with half a dozen in the Northeast. Late last year, an industrial electronics distributor announced plans to establish computer display counters in their twelve U.S. branches, with "working models of five microprocessor kits, three non-assembled kits, plus four additional microprocessor chips not in kit form. Two complete developmental systems will be available. In addition, books, power supplies, tape readers, and accessories in kit form will be carried."

COMING UP IN THE MARCH

Popular Electronics[®]

SPECIAL FOCUS ON CB, including:

- The New 40-Channel CB Radios & FCC Rules and Regulations
- Crystal/Synthesized/PLL Frequency-Generation Methods
- Sunspots and Their Predicted Effect on Communications

**BUILD A DIGITAL
BICYCLE SPEEDOMETER
PROGRAMMING IDEAS FOR
THE COSMAC "ELF"
AUDIO AMPLIFIER OUTPUT STAGES**

how often could you use an Xcelite® "99"?

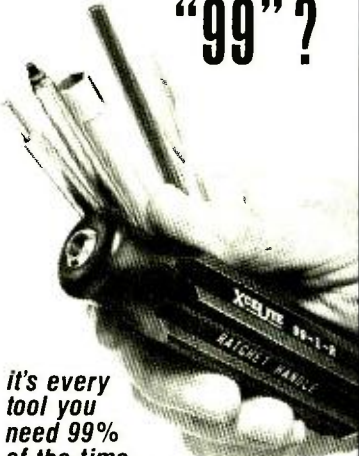

*it's every
tool you
need 99%
of the time...
an Xcelite original!*

it's a screwdriver



...for slotted, Phillips, Frearson, Bristol, clutch head, Scrulox® screws; in inch and metric size Allen hex and Allen hex ballpoint socket types; and Pozidriv® style.

it's a nutdriver

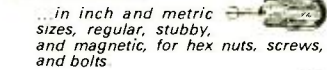

...in inch and metric sizes, regular, stubby, and magnetic, for hex nuts, screws, and bolts

it's a reamer



it's extendable

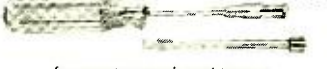

...for greater reach and torque.

5 DIFFERENT HANDLE STYLES

...regular and Tee, with and without reversible ratchet; junior, and stubby; all with Xcelite's unique spring device for quick blade insertion and removal. All shockproof, breakproof (UL).

85 INTERCHANGEABLE BLADES

...all the popular types and sizes. All precision-made, genuine Xcelite quality. Fit all five handles.

IN SETS, KITS, OR PIECEMEAL

...roll-up service kits, compact, stand-up, plastic-cased sets; or individually as needed.

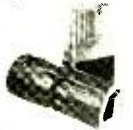

in stock at leading
electronic distributors...nationwide

Weller-Xcelite Electronics Division



The Cooper Group

P. O. BOX 728,
APEX, NORTH CAROLINA 27502

CIRCLE NO. 64 ON FREE INFORMATION CARD

The company's president says, "The industrial distributor has never really catered to the hobbyist, but always allowed cash sales because many engineers and buyers from industry bought small quantities for their personal use. With the advent of the microprocessor, a whole new market of "Computerists" has developed. These people are engineers, programmers, and technicians from industry who are learning, designing, and programming microprocessor systems at home. They want a place to browse, read, have hands-on practice, and see what they are buying."

Repair Facilities. Some computer stores offer repair services. One store in New York fixes an item free if you bought it there and if it's still within the warranty period. After that, the charge is \$10 to \$12 an hour. The alternative is to send your computer or pc board or peripheral to the manufacturer, and if the warranty has expired, you pay \$15 to \$22 an hour, plus shipping. The most common problems with computers built

board, or a memory board, or the rest of the computer, you can narrow it down by taking the two or three boards into a computer store that has a machine like yours in operation. They'll plug in your boards, one at a time, after first checking for shorts that might cause trouble, and you'll soon have a better idea of where the problem is. There's no charge for this informal checkout, unless you want the store to go further in localizing the problem. However, since there are usually several hobbyists in a computer store at almost any time of the day, especially during the lunch hour and after work, you might get some very useful advice from someone who had the same problem.

Idea Exchange. Because computer stores are often meeting places for computer "freaks," they are good places to go to listen in, if you're a beginner, and to join in the conversation, once you've learned the ropes. You can learn what others think of this or that computer or pc board or program, you can often find



The Computer Mart (New York) typifies hobbyist stores around country.

from kits are solder bridges and miswiring. If the kit has otherwise been put together correctly, and if the store has a good digital electronics technician, you might save time and money by having your computer, or board, or whatever, repaired right there. One store manager expects his repair business to increase as more and more people with little or no electronics knowledge or ability try to build a computer, so he's expanding his service department.

If you can't get your computer to work, and don't know if it's the fault of the CPU

out from the store manager what new products are about to become available, and you can often watch one of the store assistants checking out a new piece of equipment. You can also often watch other hobbyists using the store's computer to check out some new program or peripheral, and thus help you decide if it's something you want to get into.

In short, there's no better place than a good computer store to see what's available, to find out what's going to be on the market, to chat with others afflicted with computeritis, and to get help. ◇

Unique full-function 8-digit wrist calculator... available only as a kit.

A wrist calculator is the ultimate in common-sense portable calculating power. Even a pocket calculator goes where your pocket goes—take your jacket off, and you're lost!

But a wrist-calculator is only worth having if it offers a genuinely comprehensive range of functions, with a full-size 8-digit display.

This one does. What's more, because it is a kit, supplied direct from the manufacturer, it costs only a very reasonable \$19.95. And for that, you get not only a high-calibre calculator, but the fascination of building it yourself.

How to make 10 keys do the work of 27

The Sinclair Instrument wrist calculator offers the full range of arithmetic functions. It uses normal algebraic logic ('enter it as you write it'). But in addition, it offers a % key; plus the convenience functions \sqrt{x} , $1/x$, x^2 ; plus a full 5-function memory.

All this, from just 10 keys! The secret? An ingenious, simple three-position switch. It works like this.



1. The switch in its normal, central position. With the switch centered, numbers—which make up the vast majority of key-strokes—are tapped in the normal way.

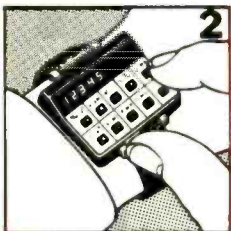

2. Hold the switch to the left to use the functions to the left above the keys...

3. and hold it to the right to use the functions to the right above the keys.

The display uses 8 full-size red LED digits, and the calculator runs on readily-available hearing-aid batteries to give weeks of normal use.

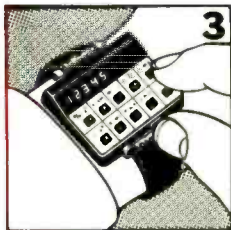

Assembling the Sinclair Instrument wrist calculator

The wrist calculator kit comes to you complete and ready for assembly. All you need is a reasonable degree of skill with a fine-point soldering iron. It takes about three hours to assemble. If anything goes wrong, Sinclair Instrument will replace any damaged components free: we want you to enjoy assembling the kit, and to end up with a valuable and useful calculator.

Actual Size

Contents

Case and display window.
Strap.
Printed circuit board.
Switches.
Special direct-drive chip (no interface chip needed).
Display.
Batteries.

Everything is packaged in a neat plastic box, and accompanied by full instructions.

The only thing you need is a fine-point soldering iron.

All components are fully guaranteed, and any which are damaged during assembly will be replaced free.

The wrist-calculator kit is available only direct from Sinclair Instrument. Take advantage of this 10 day money-back offer.

Send the coupon today.

**KIT
ONLY
\$19.95**

**Sinclair Instruments Inc.
6 Commercial Street
Hicksville, N.Y. 11801**

To: Sinclair Instruments Inc.
6 Commercial Street
Hicksville, NY 11801

PE-2

Please send me

_____ Sinclair wrist calculator kit(s) at \$19.95\$ _____

_____ Sales tax (NY residents) _____

_____ Shipping & handling (\$2.50 per unit) _____

Enclosed is check/MO (payable to
Sinclair Instruments Inc.)

TOTAL \$ _____

Name _____

Address _____

City _____

State _____

Zip _____

I understand that you will refund the purchase price of the kit in full if I return it in saleable condition within 10 days of receipt.

Put Professional Knowledge and a
COLLEGE DEGREE
 in your Electronics Career through
HOME STUDY

Earn Your DEGREE

by correspondence, while continuing your present job. No commuting to class. Study at your own pace. Learn from complete and explicit lesson materials, with additional assistance from our home study instructors. Advance as fast as you wish, but take all the time you need to master each topic. Profit from, and enjoy, the advantages of independent study.

The Grantham electronics degree program begins with basics, leads first to the A.S.E.T. degree, and then continues through the B.S.E.E. degree level. Our free bulletin gives complete details of the program itself, the degrees awarded, the requirements for each degree, and how to enroll. Write or phone (no collect calls please) and ask for BULLETIN E-77

Grantham School of Engineering
 2000 Stoner Ave., Los Angeles, CA 90025

• Telephone (213) 477-1901 •

Worldwide Career Training thru Home Study
 CIRCLE NO. 34 ON FREE INFORMATION CARD

**The POLY 88
 Microcomputer
 System
 is here!**



POLY 88 is a complete, solid and trustworthy personal computer. No technological background is required to enjoy this versatile machine.

The POLY 88 is the invaluable tool for the home and office. With it, children can play or even develop their own mathematical and scientific games. Simple or Complex equations and projections can be programmed, stored and altered in the BASIC programming language. The POLY 88 starts at \$595 in kit form.

If you are in need of a quality tool, the POLY 88 is it.

PolyMorphic Systems

737 S. Kellogg, Goleta, CA 93017
 (805) 967-2351

CIRCLE NO. 51 ON FREE INFORMATION CARD

NOAA WEATHER RADIO OPERATING LOCATIONS

The National Oceanic and Atmospheric Administration (NOAA) National Weather Service is the sole government-operated radio system for communicating attack or weather disaster warnings directly to the public—as well as regular weather reports. A vhf high-band receiver or scanning monitor is required to pick up these broadcasts.

Transmitter Site	Call Letters	Frequency (MHz)	Illinois	
			Chicago	KWO-39 162.55
Alabama			Indiana	
*Birmingham	KIH-54	162.55	Evansville	KIG-76 162.55
*Cheha	KIH-58	162.475	Indianapolis	KEC-74 162.55
*Dozier	KIH-59	162.55		
*Florence	KIH-57	162.475	Iowa	
Huntsville	KIH-20	162.40	Des Moines	KEC-75 162.55
*Louisville	KIH-56	162.475	Kansas	
Mobile	KEC-61	162.55	Wichita	KEC-59 162.55
*Montgomery	KIH-55	162.40	Kentucky	
*Tuscaloosa	KIH-60	162.40	Ashland	KIH-39 162.55
Alaska			Bowling Green	KIH-45 162.40
Anchorage	KEC-43	162.55	Covington	KIH-42 162.55
Seward	KEC-81	162.55	Hazard	KIH-40 162.475
Arizona			Lexington	KIH-41 162.40
Phoenix	KEC-94	162.55	Louisville	KIH-43 162.475
California			Mayfield	KIH-46 162.475
Coachella	KIG-78	162.40	Somerset	KIH-44 162.55
Crescent City, Calif./	KIH-37	162.55	Louisiana	
Brookings, Ore.			Baton Rouge	KHB-46 162.40
Eureka	KEC-82	162.40	Lake Charles	KHB-42 162.55
Los Angeles	KWO-37	162.55	Morgan City	KIH-23 162.475
Monterey	KEC-49	162.40	New Orleans	KHB-43 162.55
Point Arena	KIH-30	162.40	Maine	
Sacramento	KEC-57	162.40	Ellsworth	KEC-93 162.40
San Diego	KEC-62	162.40	Portland	KDO-95 162.55
San Francisco	KHB-49	162.55	Maryland	
San Luis Obispo	KIH-31	162.55	Baltimore	KEC-83 162.40
Santa Barbara	KIH-34	162.40	Salisbury	KEC-92 162.40
Colorado			Massachusetts	
Denver	KEC-76	162.55	Boston	KHB-35 162.40
Connecticut			Hyannis	KEC-73 162.55
New London	KHB-47	162.40	Michigan	
Florida			Alpena	KIG-83 162.55
Daytona Beach	KIH-26	162.40	Clio	KIH-29 162.40
Jacksonville	KHB-39	162.55	Detroit	KEC-63 162.55
Key West	KIH-25	162.40	Grand Rapids	KIG-63 162.55
Miami	KHB-34	162.55	Marquette	KIG-66 162.55
Panama City	KGG-67	162.55	Sault Sainte Marie	KIG-74 162.55
Pensacola	KEC-86	162.40	Traverse City	KIH-22 162.55
Tallahassee	KIH-24	162.40	Minnesota	
Tampa	KHB-32	162.55	Duluth	KIG-64 162.55
West Palm Beach	KEC-50	162.40	Minneapolis	KEC-65 162.55
Georgia			Mississippi	
Atlanta	KEC-80	162.55	*Ackerman	KIH-51 162.475
Savannah	KEC-85	162.40	*Booneville	KIH-53 162.55
Hawaii			*Bude	KIH-48 162.55
Hilo	KBA-99	162.55	Gulfport	KIH-21 162.40
Honolulu	KBA-99	162.55	*Iverness	KIH-50 162.55
Kokee	KBA-99	162.40	Jackson	KIH-38 162.40
Mt. Haleakala	KBA-99	162.40	*McHenry	KIH-47 162.475

*Oxford	KIH-52	162.40
*Rose Hill	KIH-49	162.55
*Beaufort	WXJ-23	162.475
*Columbia	WXJ-20	162.40
*Florence	WXJ-22	162.55
*Greenville	WXJ-21	162.55

Missouri		
Kansas City	KID-77	162.55
St. Joseph	KEC-77	162.40
St. Louis	KDO-89	162.55

Nebraska		
*Omaha	KIH-61	162.40

New Jersey		
Atlantic City	KHB-38	162.40

New Mexico		
Albuquerque	KIG-84	162.40

New York		
Buffalo	KEB-98	162.55
New York City	KWO-35	162.55
Rochester	KHA-53	162.40

North Carolina		
Cape Hatteras	KIG-77	162.55
New Bern	KEC-84	162.40
Wilmington	KHB-31	162.55

Ohio		
Akron	KDO-94	162.40
Cleveland	KHB-59	162.55
Columbus	KIG-86	162.55
Sandusky	KHB-97	162.40

Oklahoma		
Tulsa	KIH-27	162.55

Oregon		
Astoria	KEC-91	162.40
Coos Bay	KIH-32	162.40
Eugene	KEC-42	162.40
Newport	KIH-33	162.55
Portland	KIG-98	162.55

Pennsylvania		
Erie	KEC-58	162.40
Philadelphia	KIH-28	162.475
Pittsburgh	KIH-35	162.55

South Carolina		
Charleston	KHB-29	162.55
Myrtle Beach	KEC-95	162.40

Tennessee		
Nashville	KIG-79	162.55

Texas		
Brownsville	KHB-33	162.55
Corpus Christi	KHB-41	162.55
Dallas	KEC-56	162.40
Fort Worth	KEC-55	162.55
Galveston	KHB-40	162.55
Houston	KGG-68	162.40
Pharr	KHB-33	162.40

Utah		
Salt Lake City	KEC-78	162.55

Vermont		
Burlington	KIG-60	162.40

Virginia		
Manassas	KHB-36	162.55
Norfolk	KHB-37	162.55

Washington		
Neah Bay	KIH-36	162.55
Seattle	KHB-60	162.55
Yakima	KIG-75	162.55

Wisconsin		
Green Bay	KIG-65	162.55
Milwaukee	KEC-60	162.40

*Stations expected to be in operation by end of 1977.

FREE McIntosh CATALOG and FM DIRECTORY

Get all the newest and latest information on the new McIntosh Solid State equipment in the McIntosh catalog. In addition you will receive an FM station directory that covers all of North America.



MX 113

FM/FM STEREO - AM TUNER AND PREAMPLIFIER

SEND TODAY!

McIntosh Laboratory, Inc.
 East Side Station P.O. Box 96
 Binghamton, N.Y. 13904
 Dept. PE

NAME _____
 ADDRESS _____
 CITY _____ STATE _____ ZIP _____

If you are in a hurry for your catalog please send the coupon to McIntosh.
 For non rush service send the Reader Service Card to the magazine.

CIRCLE NO 44 ON FREE INFORMATION CARD

★ **FREE!** ★

NEW CATALOG OF HARD-TO-FIND PRECISION TOOLS

Jensen's new 128-page catalog is jam-packed with more than 2800 quality items. Your single source for hard-to-find precision tools used by electronic technicians, scientists, engineers, instrument mechanics, schools, laboratories and government agencies. This wanted catalog also contains Jensen's world-famous line of more than 40 tool kits. Plus 10 pages of useful "Tool Tips" to aid in tool selection. Send for your free copy today!

JENSEN TOOLS and ALLOYS
 4117 N. 44th Street, Phoenix, Arizona 85018

CIRCLE NO. 40 ON FREE INFORMATION CARD

DIXIE SAVE ON Brand Name Audio Components BY MAIL

Write Today for Our FREE Audio Catalog

DIXIE is one of the oldest and largest audio component mail order houses in the country. Our prices on brand name components are actually LOWER than "Discounters". See our new catalog or call us for a price quote. Everything shipped factory-sealed with full manufacturer's warranty.

DIXIE HI-FIDELITY PE-2
 2040 Thalbro Street, Richmond, Va. 23230
 804-257-4241

Please rush me your FREE Audio Catalog and complete information. I understand there is no obligation.

Name _____
 Address _____
 City _____
 State _____ Zip _____

CB

where the
ACTION'S
at

Millions of 2-way CB radios are in use—millions of new ones are being sold annually to new CBers and for replacing old units—what a market for repair service. It's the biggest thing in electronics since color TV. There's only one thing wrong with CB growth—the lack of technicians capable of servicing CB radios. That's why many TV shops are expanding into CB and why new CB shops are opening up all over the country. Going CB servicing rates run from \$12 to \$24 per hour.

To get into CB radio servicing, full-time or part-time, you need test equipment, an FCC operator license and to learn how. To learn how, you can buy the **CB RADIO REPAIR COURSE** for cash, on a monthly payment plan, or charge the cost to your BankAmericard or Master Charge account.

To make it easy to study, this 70-lesson course employs the **PROGRAMMED** teaching technique and sticks to the target—CB radio. Study at your own pace as you receive the self-examining lessons. We can't guarantee that you will become a CB expert since that depends on you.

To get the facts about this course, write a letter or card or mail the coupon below today. No salesman will call.

CB RADIO REPAIR COURSE, INC.

Dept. PE-27

531 N. Ann Arbor
Oklahoma City, OK 73127

Please send information about your Course to:

Name _____
Address _____
City _____ State _____ Zip _____

CIRCLE NO 16 ON FREE INFORMATION CARD

INTRODUCING



The NEW PHLANGER KIT

Phil Spector's original "Big Hurt" sound is EXACTLY duplicated using PAIA's new constant time delay PHLANGER. This unit features a 1024 stage Charge Coupled Device analog shift register that exactly duplicates the effect of 2 tape recorders running out of synchronization.

Multiple user controls allow effects ranging from chorusing, voice doubling and reverb to full "Jet Plane" effects. Optional foot pedals provide hands free control of internal oscillator sweep speed or manual spectrum sweeping.

#1500.....PHLANGER Kit.....\$59.95
(plus shipping for 4 lbs.)

PAIA - FREE CATALOG -
ELECTRONICS DEPT. 2-P
1020 W. WILSHIRE BLVD.
OKLAHOMA CITY, OK 73116

CIRCLE NO 48 ON FREE INFORMATION CARD

Operation Assist

If you need information on outdated or rare equipment—a schematic, parts list etc.—another reader might be able to assist. Simply send a postcard to Operation Assist POPULAR ELECTRONICS 1 Park Ave. New York, NY 10016. For those who can help readers please respond directly to them. They'll appreciate it! (Only those items regarding equipment not available from normal sources are published.)

Blaupunkt Verona type 20103 hi-fi radio. Any service material, especially dial cord restringing info. Lewyn F. Cutten, Jr., 102 W. Idaho St., Ellensburg, WA 98926.

Halicrafters S-20-R shortwave receiver. Any information or owner's manual or photocopy. Bradley Richelson, 8 Randolph St., Plymouth, NH 03264.

RCA military receiver Model RAL-6, type CRV-46156. Serial 172. Rect. Power Unit # CRV-20131. Circa December 29, 1941. Covers 0.3 to 23 MHz. Schematic diagrams or any other info. George Tobin, New Gloucester, ME 04260.

Superior Instruments Co. Model TV-11 Tube Tester. Model 76 CR bridge and signal tracer, Model 77 VTVM. Instruction manuals and schematics. John Schreyer, W2KQV, 610 Bay 25 St., Far Rockaway, NY 11691

Philco-Tropic Model 39-750. Schematic and/or service manual and parts source. Irving Leiboff, 667 E. 34 St., Brooklyn, NY 11203.

Hammarlund Model SP-600J receiver. Alignment information. W. Harwood, Box 563, Hudson Hope, BC, Canada V1C 1V0.

Paco Model C-20 Resis-Capacity Ratio Bridge. Instruction manual and schematic. Jose Varas, 515 4th St., Union City, NJ 07087

Realistic Model 105 Tube Tester. Schematic and/or operations manual. Dr. Ali Allmaker, Woodcock Rd., Williamstown, MA 01267.

Jetronic Model AN-USM-81 oscilloscope. Need schematic and instruction manual. Ben Goble, Rockmont College, 8801 W. Alameda Ave., Lakewood, CO 80226.

Radson Model RT-70A radio telephone. Operation manual and wiring diagram. John K. Jakvis, DR 520, Schertz, TX 78154

Panoramic Model LP-1 sonic analyzer. Need schematic, manual or source of information. Gregory A. Marks, 1737 Sanford, Ann Arbor, MI 48103.

De Vry 5" oscilloscope and transistor voltmeter. Construction manual or schematics needed. Paul Etchason, 406 W. Monroe, Kokomo, IN 46901.

Arkay FL-10 amplifier. Need service or operating manual and schematic. Edwin L. Dews, 703 Tammy, San Antonio, TX 78216

Friden Model 132 electronic calculator. Schematic and/or service manual. Steven Eubanks, 8833 Westlawn Blvd., Olmsted Falls, OH 44138.

Kaar Model TR 327 Citizens Band radio. Schematic and alignment data. M. W. Murphy, Rt. 2 Box 554, Hayden Lake, ID 83835

RCA Model 816K superheterodyne receiver. Need any available information. Jim Burrell, Rte. 2, Sallis, MS 39160.

Bendix RT-221AE-28 aircraft transceiver. Need service manual or schematic. George Kapsokavadis, 23 Kolotroni St., Kerkyra, Greece.

Knightkit VTVM. Need schematic and calibration instructions. Don Bradley, P. O. Box 1213, Uallejo, CA 94590.

Friden Model 5023 computer. Operating and service manuals. John G. Peters, 1905 Victory Blvd., Unit 11, Glendale, CA 91201

Ultronic Systems Videomaster 7700 computer terminal. Need service manual, modem requirements and any available data. Charles E. Gerhardt, 2134 Springhill, Dallas, TX 75228

Halicrafter Model S-40B receiver. Schematic or any available information. Ron J. Jones, 4871 Kingridge Dr., San Jose, CA 95124.

Alexander Model ALX CR900 battery-ac tape recorder. Need schematic and service manual. Mr. Bailey, 426 Slocum Ave., Neptune, NJ 07753

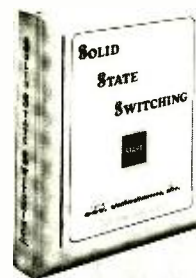

World's First Solid State Potentiometer

- No Moving Parts
- Nothing to Wear Out
- 100% Environment Proof

Available early 1977 along with revolutionary new non-capacitive Solid State Switch. So simple to adopt to your specific application... enables any engineer or amateur to design and fabricate space age instrument controls, rheostats, terminal keyboards, etc.

To reserve your kit now and for more information, call us or mail coupon today!

I'm interested! Please send me your FREE BROCHURE about the Kit.

Name _____

Company _____

Address _____

City _____

State _____ Zip _____

DDF Semiconductors, Inc.

1191 Chess Drive • Foster City, CA 94404
(415) 574-2541

CIRCLE NO. 41 ON FREE INFORMATION CARD

CONFUSED BY ELECTRONIC IGNITION CLAIMS ?

The PROOF is in PERFORMANCE!

Amazing MEGASPARK, the advanced-design Opto-Electronic Breakerless Ignition System, FITS ANY CAR! Replaces points and condenser — gives longer spark plug life. Increases performance, mileage and driving satisfaction while cutting fuel and maintenance costs dramatically. Learn the facts and don't settle for less than the best. Models from \$29.50 to \$64.50

The only unit that gives you all these features:

- LIFETIME WARRANTY
- DIFFERENTIAL AMPLIFIER CIRCUITRY
- FULL INTERNAL VOLTAGE REGULATION
- AUTOMATIC OVERCURRENT PROTECTION

Rush name and address for FREE information package including catalog and discount offer. Or call toll-free 24-hours 800-648-4711 Ext. 22

MEGASPARK™

by Ignition Systems Inc.

2547 8th Street
Berkeley, CA 94710
(415) 845-3584

CIRCLE NO. 36 ON FREE INFORMATION CARD
POPULAR ELECTRONICS

WHY THE BOX?



Perfect listening.

All Stax Earspeakers™ connect through an adaptor box to your power amp, integrated amp or receiver, just like speakers. The box permits a vastly superior electrostatic principle to be used in Stax personal listening instruments.

Results? Incredible transients. Response curves that match the human ear perfectly. And no “flaking” of preamp circuitry that occurs with those non-box “headphones” that plug into the front panel.

Why the box? Because you can tell the difference.

STAX: The inventor of the electrostatic earspeaker.

Distributed in the U.S. by:

 **American Audioport**
Columbia, MO 65201

FREE

IC or FET's WITH \$5 & \$10 ORDERS. DATA SHEETS WITH MANY ITEMS.

DIODES	TRANSISTORS	TRANSISTORS	TRANSISTORS	LINEAR IC'S					
ZENERS & RECTIFIERS	2N706	\$0.24	2N4091	3/51	2N5638	2/51	LM3040	5	\$1.75
1N456 to 1N459	2N718	24	2N4092	5/51	2N5640	2/51	LM3041	5	1.75
1N460 to 1N463	2N720	48	2N4121	3/51	CP663	54.00	LM3042	6	1.75
1N464 to 1N467	2N722	3/51	2N4122	3/51	CP657	55.00	LM3043	12	1.75
1N468 to 1N471	2N724	\$0.28	2N4124	5/51	CP651	54.00	LM3045	15	1.75
1N472 to 1N475	2N726	2N4248	5/51	E101	3/51	LM3047	24	1.75	
1N476 to 1N479	2N728	2N4249	5/51	E101	3/51	LM3048	24	1.75	
1N480 to 1N483	2N730	2N4250	5/51	E102	3/51	LM3049	24	1.75	
1N484 to 1N487	2N732	2N4274	5/51	E175	3/51	LM3050	29	2.50	
1N488 to 1N491	2N734	2N4302	\$0.28	MPF102	2/51	NE555V*	2/51		
1N492 to 1N495	2N736	2N4322	5/51	2N3003	2/51	NE556A	\$0.90		
1N496 to 1N499	2N738	2N4328	5/51	2N3005	2/51	LM741CH	29		
1N500 to 1N503	2N740	2N4330	2/51	MP55515	3/51	LM790CN	29		
1N504 to 1N507	2N742	2N4331	5/51	SE1001	4/51	LM723H	2/51		
1N508 to 1N511	2N744	2N4395	\$0.24	SE1002	4/51	LM723M*	3/51		
1N512 to 1N515	2N746	2N4418	5/51	SE1003	4/51	LM723N	2/50		
1N516 to 1N519	2N748	2N4474	\$0.80	SE2002	4/51	LM741CH	3/51		
1N520 to 1N523	2N750	2N4551	\$1.50	SE5001 to 3/51	LM741CN*	4/51			
1N524 to 1N527	2N752	2N4585	5/51	SE5002	3/51	LM741CN4	34		
1N528 to 1N531	2N754	2N4686E	2/51	SE5020	3/51	LM741CN	35		
1N532 to 1N535	2N756	2N4881	\$2.50	TI975	3/51	74BCJ DIP	35		
1N536 to 1N539	2N758	2N4882	5/51	DIGITAL IC'S		74CJ DIP	1.00		
1N540 to 1N543	2N760	2N4883	6/51	MM5738N	\$2.95	84CJCP PDIP	80		
1N544 to 1N547	2N762	2N4885	5/51	MM5739N	\$2.95	84CJCP	1.00		
1N548 to 1N551	2N764	2N4908	4/51	SN7410N	\$1.00	LM1458M*	3/51		
1N552 to 1N555	2N766	2N4909	5/51	SN74101N	\$1.00	LM1211N	\$1.40		
1N556 to 1N559	2N768	2N4912	5/51	SN74102N	.16	2XZ595CP	1.55		
1N560 to 1N563	2N770	2N4915	6/51	SN74103N	.16	2700E	1.95		
1N564 to 1N567	2N772	2N4918	5/51	SN74104N	.16	CA3026A	1.75		
1N568 to 1N571	2N774	2N4919	5/51	SN74105N	.16	CA3046	1.45		
1N572 to 1N575	2N776	2N4920	5/51	SN74106N	.16	LM3078N	1.84		
1N576 to 1N579	2N778	2N4921	5/51	SN74107N	.16	CA3085	.55		
1N580 to 1N583	2N780	2N4922	5/51	SN74108N	.16	LM3090N	.55		
1N584 to 1N587	2N782	2N4923	5/51	SN74109N	.16	RC4194D	1.50		
1N588 to 1N591	2N784	2N4924	5/51	SN74110N	.16	LM3091N	2.50		
1N592 to 1N595	2N786	2N4925	5/51	SN74111N	.16	LM3092N	2.00		
1N596 to 1N599	2N788	2N4926	5/51	SN74112N	.16	CA4558N	.55		
1N600 to 1N603	2N790	2N4927	5/51	SN74113N	.16	NE555V	.95		
1N604 to 1N607	2N792	2N4928	5/51	SN74114N	.16	NE556V	.50		
1N608 to 1N611	2N794	2N4929	5/51	SN74115N	.16	LM74105	1.25		
1N612 to 1N615	2N796	2N4930	5/51	SN74116N	.16	LM74106	1.25		
1N616 to 1N619	2N798	2N4931	5/51	SN74117N	.16	DM75492	.89		
1N620 to 1N623	2N800	2N4932	5/51	SN74118N	.16				
1N624 to 1N627	2N802	2N4933	5/51	SN74119N	.16				
1N628 to 1N631	2N804	2N4934	5/51	SN74120N	.16				
1N632 to 1N635	2N806	2N4935	5/51	SN74121N	.16				
1N636 to 1N639	2N808	2N4936	5/51	SN74122N	.16				
1N640 to 1N643	2N810	2N4937	5/51	SN74123N	.16				
1N644 to 1N647	2N812	2N4938	5/51	SN74124N	.16				
1N648 to 1N651	2N814	2N4939	5/51	SN74125N	.16				
1N652 to 1N655	2N816	2N4940	5/51	SN74126N	.16				
1N656 to 1N659	2N818	2N4941	5/51	SN74127N	.16				
1N660 to 1N663	2N820	2N4942	5/51	SN74128N	.16				
1N664 to 1N667	2N822	2N4943	5/51	SN74129N	.16				
1N668 to 1N671	2N824	2N4944	5/51	SN74130N	.16				
1N672 to 1N675	2N826	2N4945	5/51	SN74131N	.16				
1N676 to 1N679	2N828	2N4946	5/51	SN74132N	.16				
1N680 to 1N683	2N830	2N4947	5/51	SN74133N	.16				
1N684 to 1N687	2N832	2N4948	5/51	SN74134N	.16				
1N688 to 1N691	2N834	2N4949	5/51	SN74135N	.16				
1N692 to 1N695	2N836	2N4950	5/51	SN74136N	.16				
1N696 to 1N699	2N838	2N4951	5/51	SN74137N	.16				
1N700 to 1N703	2N840	2N4952	5/51	SN74138N	.16				
1N704 to 1N707	2N842	2N4953	5/51	SN74139N	.16				
1N708 to 1N711	2N844	2N4954	5/51	SN74140N	.16				
1N712 to 1N715	2N846	2N4955	5/51	SN74141N	.16				
1N716 to 1N719	2N848	2N4956	5/51	SN74142N	.16				
1N720 to 1N723	2N850	2N4957	5/51	SN74143N	.16				
1N724 to 1N727	2N852	2N4958	5/51	SN74144N	.16				
1N728 to 1N731	2N854	2N4959	5/51	SN74145N	.16				
1N732 to 1N735	2N856	2N4960	5/51	SN74146N	.16				
1N736 to 1N739	2N858	2N4961	5/51	SN74147N	.16				
1N740 to 1N743	2N860	2N4962	5/51	SN74148N	.16				
1N744 to 1N747	2N862	2N4963	5/51	SN74149N	.16				
1N748 to 1N751	2N864	2N4964	5/51	SN74150N	.16				
1N752 to 1N755	2N866	2N4965	5/51	SN74151N	.16				
1N756 to 1N759	2N868	2N4966	5/51	SN74152N	.16				
1N760 to 1N763	2N870	2N4967	5/51	SN74153N	.16				
1N764 to 1N767	2N872	2N4968	5/51	SN74154N	.16				
1N768 to 1N771	2N874	2N4969	5/51	SN74155N	.16				
1N772 to 1N775	2N876	2N4970	5/51	SN74156N	.16				
1N776 to 1N779	2N878	2N4971	5/51	SN74157N	.16				
1N780 to 1N783	2N880	2N4972	5/51	SN74158N	.16				
1N784 to 1N787	2N882	2N4973	5/51	SN74159N	.16				
1N788 to 1N791	2N884	2N4974	5/51	SN74160N	.16				
1N792 to 1N795	2N886	2N4975	5/51	SN74161N	.16				
1N796 to 1N799	2N888	2N4976	5/51	SN74162N	.16				
1N800 to 1N803	2N890	2N4977	5/51	SN74163N	.16				
1N804 to 1N807	2N892	2N4978	5/51	SN74164N	.16				
1N808 to 1N811	2N894	2N4979	5/51	SN74165N	.16				
1N812 to 1N815	2N896	2N4980	5/51	SN74166N	.16				
1N816 to 1N819	2N898	2N4981	5/51	SN74167N	.16				
1N820 to 1N823	2N900	2N4982	5/51	SN74168N	.16				
1N824 to 1N827	2N902	2N4983	5/51	SN74169N	.16				
1N828 to 1N831	2N904	2N4984	5/51	SN74170N	.16				
1N832 to 1N835	2N906	2N4985	5/51	SN74171N	.16				
1N836 to 1N839	2N908	2N4986	5/51	SN74172N	.16				
1N840 to 1N843	2N910	2N4987	5/51	SN74173N	.16				
1N844 to 1N847	2N912	2N4988	5/51	SN74174N	.16				
1N848 to 1N851	2N914	2N4989	5/51	SN74175N	.16				
1N852 to 1N855	2N916	2N4990	5/51	SN74176N	.16				
1N856 to 1N859	2N918	2N4991	5/51	SN74177N	.16				
1N860 to 1N863	2N920	2N4992	5/51	SN74178N	.16				
1N864 to 1N867	2N922	2N4993	5/51	SN74179N	.16				
1N868 to 1N871	2N924	2N4994	5/51	SN74180N	.16				
1N872 to 1N875	2N926	2N4995	5/51	SN74181N	.16				
1N876 to 1N879	2N928	2N4996	5/51	SN74182N	.16				
1N880 to 1N883	2N930	2N4997	5/51	SN74183N	.16				
1N884 to 1N887	2N932	2N4998	5/51	SN74184N	.16				
1N888 to 1N891	2N934	2N4999	5/51	SN74185N	.16				
1N892 to 1N895	2N936	2N5000	5/51	SN74186N	.16				
1N896 to 1N899	2N938	2N5001	5/51	SN74187N	.16				
1N900 to 1N903	2N940	2N5002	5/51	SN74188N	.16				
1N904 to 1N907	2N942	2N5003	5/51	SN74189N	.16				
1N908 to 1N911	2N944	2N5004	5/51	SN74190N	.16				
1N912 to 1N915	2N946	2N5005	5/51	SN74191N	.16				
1N916 to 1N919	2N948	2N5006	5/51	SN74192N	.16				
1N920 to 1N923	2N950	2N5007	5/51	SN74193N	.16				
1N924 to 1N927	2N952	2N5008	5/51	SN74194N	.16				
1N928 to 1N931	2N954	2N5009	5/51	SN74195N	.16				
1N932 to 1N935	2N956	2N5010	5/51	SN74196N	.16				
1N936 to 1N939	2N958	2N5011	5/51	SN74197N	.16				
1N940 to 1N943	2N960	2N5012	5/51	SN74198N	.16				
1N944 to 1N947	2N962	2N5013	5/51	SN74199N	.16				
1N948 to 1N951	2N964	2N5014							

Poly Pak's EXCLUSIVE \$1.98



100'S OF BARRELS PURCHASED!
For the first time anywhere, Poly Pak merchandisers introduce a new way in buying the economical way. Raw stock from the "barrel". Remember the "good ole days"? They're back again. The same way merchandisers

throughout the United States buy from various factories... their overruns in barrels. Poly Pak has done the same. Therefore you are getting the same type of material as the RE-TESTERS DO!
TEST 'EM YOURSELF 'N SAVE!

Every kit carries a money back guarantee!

INCLUDES "100%" MATERIAL TOO!!!!

Buy 10 BARREL KITS AND CHOOSE THE 11TH Free

OP AMP SPECIALS

LM301N	5 for \$1.19	LM381N	3 for 4.00
LM301V	4 for 1.19	LM555H	3 for 1.19
LM308V	4 for 1.19	LM565N	3 for 1.19
LM309H	2 for 1.19	LM703N	3 for 2.50
LM322N	3 for 3.00	LM709H	5 for 1.19
LM324N	3 for 3.00	LM710N	2 for 1.19
LM339N	3 for 1.19	LM723N	2 for 1.19
LM370N	3 for 2.50	LM737N	4 for 1.19
LM377N	3 for 4.00	LM747H	2 for 1.19
LM380V	2 for 1.19	LM748V	5 for 1.19
		LM1800N	3 for 2.50
		LM300N	3 for 1.19
		LM4250H	3 for 2.50

Code H = TO5 case, V = Mini Dip, N = DIP.

BARREL KIT #201
6V INDICATORS
15 for \$1.98
Thump lamp manufacturer thumps inventors! Worth the ooz. Like grain-o-wheat. Cat. No. 2E 3526

BARREL KIT #200
9 DIGIT READOUT MODULES
5 for \$1.98
with calculator & logic chips beneath epoxy. Cat. No. 2E 3515

BARREL KIT #195
CARBO-FILM RESISTORS
75 for \$1.98
Hard to find, but we got millions. Lo & Hi values. 1/2 and 1/4 watt, 5%, 10% tol. All marked. 100% good. Cat. No. 2E 3534

BARREL KIT #188
400 Parts
\$1.98
Includes resistors, caps, transformers, rectifiers, diodes, etc. for p.c. work. Preformed, dumped into barrels by factories. 100% good. Cat. No. 2E 3401

BARREL KIT #186
KEYBOARD CHIPS
10 for \$1.98
Truthfully we can't test em, MM5740's keyboard encoder chips. How good they are we don't know. Cat. No. 2E 3414

BARREL KIT #205
MINI BLOCK CAPACITORS
100 for \$1.98
Unbelievable! Worth \$60. High precision submini caps for all applications. Cat. No. 2E 3528

BARREL KIT #203
CALCULATOR KEYBOARDS
10 for \$1.98
It's true! 20-key, 4 function keyboards at ridiculous give-away. Wt. 12 ozs. Cat. No. 2E 3524

BARREL KIT #163
MINI TRIM POTS
30 for \$1.98
Asst. values 100 to 1 meg. What a buy. Single turn. 1/4 W. Wt. 6 oz. Cat. No. 2E 3345

BARREL KIT #161
POP! PLASTIC TRANSISTORS
25 for \$1.98
2N3904's with some 2N3906's of 100% material. TU-92. Preformed. Cat. No. 2E 3343

BARREL KIT #160
V. REGULATORS
15 for \$1.98
LM309KC TO-3 V.R.'s barrel. Hot by the pound. Wt. 2E 3330

BARREL KIT #159
MODULAR SWITCHES
25 for \$1.98
Centralab switches. T-u-makers excess. Dpdt. Gpdt. etc Brand new. Cat. No. 2E 3310

BARREL KIT #158
MAGNIFIED MAN-3'S
12 for \$1.98
MAN-3's 7-sek readout, with built-on magnifier. Factory discontinued line. 100% material. Cat. No. 2E 3325

BARREL KIT #184
1/2-WATT METAL FILM
150 for \$1.98
100% metal film resistors. Long leads. 2E 3413

BARREL KIT #182
JUMBO RED LEDS
15 for \$1.98
100% material, user cancellation from factory dumps. 3V 10 mts. For 100's of projects, red lens. Cat. No. 2E 3369

BARREL KIT #145
MINI TRANSFORMER
15 for \$1.98
Miniature transformer back again. Asst. outputs, interesting and audio. Only 1/2 oz. Wt. 2 lbs. Cat. No. 2E 3294

BARREL KIT #144
RCA PHONO PLUGS
40 for \$1.98
1,000,000 RCA phono plugs for this one. You hi-fi-ers know what they are. 100% material. 2E 3293

BARREL KIT #143
75-PC TRANSISTORS
\$1.98
100% material. TU-92, factory discontinued lines, pnp's mixed with npn's. 2N4100-1-2-3-4. 2E 3290

BARREL KIT #138
PANEL SWITCHES
30 for \$1.98
Did you hear of OAK? Another top maker barrelled all types of rotary switches, slides, etc. 2E 3268

BARREL KIT #134
CALCULATOR CHIPS
15 for \$1.98
National type. Can be MM5736, 3A, etc. Untested. Cat. No. 2E 3258

BARREL KIT #157
MOLEX CONNECTORS
75 for \$1.98
Nylon, white cable connectors, ass't. factory over-run. NO PICKLE! Mixed in barrels. Cat. No. 2E 3324

BARREL KIT #154
CLOCK CHIPS
20 for \$1.98
We gathered an assortment of clock chip, alarm, calendar, beepers, who knows, all mixed. Cat. No. 2E 3308

BARREL KIT #128
MINI DIP IC'S
75 for \$1.98
Large mfg dumped 100's of lbs into barrels. Includes 7414, LM-390-8, 704, 567, 555, 556, but who knows? Wt. 1 lb. Cat. No. 2E 3245

BARREL KIT #127
AXIAL ELECTROS
40 for \$1.98
Asst. capacities and voltages. Cat. No. 2E 3227

BARREL KIT #126
UPRIGHT ELECTROS
40 for \$1.98
4ml to 300ml in miniature of voltages. 10% marked in good. 2E 3226

BARREL KIT #119
PRECISION RESISTORS
100 for \$1.98
PREFORMED! Designed for printed circuit work. 1/4, 1/2, 1 W. Marked values, 1 and 2% values. 2 ozs. 2E 3205

BARREL KIT #118
MINI SCRS
50 for \$1.98
UNHEALVABLE! TO-92 plastic SCIS in barrels... rite from factory. Includes all voltages up thru 200 prv. 2E 3135

BARREL KIT #133
C-MOS IC'S
60 for \$1.98
Deliberately thrown in barrels, so we can't test 'em! The famous CD4000 series. How good? Who knows? Cat. No. 2E 3257

BARREL KIT #131
TANTALUM ELECTROS
30 for \$1.98
Mixed, marked prime, top grade asst. values, voltages. Cat. No. 2E 3255

BARREL KIT #109
TERMINAL STRIPS
100 for \$1.98
Wide asst. of terminal strip connectors, from a contact up. Strip manufacturers barrel dump is your gain. Wt. 1 lb. Cat. No. 2E 3136

BARREL KIT #104
SIDE VOLUME CONTROLS
10 for \$1.98
Cat. No. 2E 1057

BARREL KIT #101
RESISTOR SPECIAL
200 for \$1.98
Includes: 1/4, 1/2, 1, 2-watt, carbon. 100% good. 2E 3054

BARREL KIT #99
PHOTO ELECTRIC CELLS
10 for \$1.98
Asst. GE types, CDS types. Mixed by factory. Big job for us to separate. 100% good. Cat. No. 2E 3052

BARREL KIT #93
HALF WATTERS
200 for \$1.98
Resistor factory tried to fool by mixing 1/2 to 1/4 color-coded resistors in barrel. But value is there. 1/2 oz. 2E 3046

BARREL KIT #115
MOLEX SOCKETS
200 for \$1.98
100% good. TO-92 plastic SCIS in barrels... rite from factory. Includes all voltages up thru 200 prv. 2E 3135

BARREL KIT #112
MICRO MINI LEDS
40 for \$1.98
All the tiny leds, axial, upright of Monsanto, Litronix, variety of colors. Yield 60% or better. 2E 3138

BARREL KIT #86
LITRONICS LED READOUTS
10 for \$1.98
177's, 722's, singles, triplex, etc. 10 to 100. Bot from factory. All mixed. Have fun! Cat. No. 2E 2861

BARREL KIT #87
NATIONAL IC BONANZA
100 for \$1.98
Types: 5000, 4100 Series, DTLs, ROMs, registers, clock & pulse chips, linear, etc. Cat. No. 2E 2860

BARREL KIT #86
HOBBY LEDS
40 for \$1.98
747's, 727's, singles, triplex, etc. 33 to 0.6. Bot from factory. All mixed. Have fun! Cat. No. 2E 2859

BARREL KIT #83
VOLT REG
15 for \$1.98
Factory rejected them but length of leads. May include 5, 6, 8, 12, 15, 18, 24 volts. Power fun! Cat. No. 2E 2635

BARREL KIT #81
SUBMINI RESISTORS
200 for \$1.98
PC, upright type, color coded. 1/2 watt. Asst. values. Come to us in a barrel. Power fun! Cat. No. 2E 2746

BARREL KIT #76
1-WATT ZENERS
100 for \$1.98
Factory same as 400-mw's. Never-to-see-again offer. 6, 8, 10, 12, 15V, under glass. Double plug. All good. Cat. No. 2E 2741

BARREL KIT #75
400MW ZENERS
100 for \$1.98
Factory out of biz. Amazing offer: 6, 8, 10, 12, 15V. You test. Hierarchically nested glass cap. Double plug. Cat. No. 2E 2740

BARREL KIT #73
TRANSISTOR ELECTROS
50 for \$1.98
We don't wish to separate wide asst voltages & values up to 300 mf. Cat. No. 2E 2747

BARREL KIT #71
CAPACITOR SPECIAL
100 pcs. \$1.98
mica's, molds, plastics, electrolytic, etc. Nifty! 100% good. Cat. No. 2E 2738

BARREL KIT #68
2 WATTERS
100 for \$1.98
100% good. Suppliers, throw 'em in the barrel. It's a hi' gold mine. All marked. Cat. No. 2E 2735

BARREL KIT #65
MIXED READOUTS
10 for \$1.98
Factory returns - see numbers as MAN-4's, MAN-7's, MAN-8's, 11 barrels & no time to separate. Cat. No. 2E 2733

BARREL KIT #62
MIXED IC'S
100 for \$1.98
All shapes: 7400 Series 8000, 9000, ROMS, RTL's, DTL's, linear of all kinds. Cat. No. 2E 2730

BARREL KIT #61
POLYSTYRENE CAPS
100 for \$1.98
Finest caps made. As a gamble we bought 10 barrels from factory, mixed values. All good. Cat. No. 2E 2729

BARREL KIT #58
SLIDE SWITCHES
30 for \$1.98
All shapes, sizes, spot, momentary, etc. Try them, discuss slide for 100's of switching projects. Cat. No. 2E 2726

BARREL KIT #56
POWERS! POWERS!
\$1.98 100 for \$1.98
Large distributor cleaned house. Barrel of new resistors 3 to 7 watts. Cat. No. 2E 2724

BARREL KIT #54
DIGIT READOUTS
10 for \$1.98
Barrel of a lifetime! All right, got was 1 barrel... the "blister dig" type. Multi-plexed. Cat. No. 2E 2722

BARREL KIT #48
741 MINI DIP "BONANZA"
50 for \$1.98
Barrels in a barrel's market. How many can we get tested. Cat. No. 2E 2626

BARREL KIT #46
6.25 WATT AMPLIFIERS
25 for \$1.98
Hobby type, factory fall-outs. 2E 2624

BARREL KIT #40
PNP HIGH-POWER TRANSISTORS
20 for \$1.98
Popular germanium TO-18 case 2E 2618 100% good

BARREL KIT #39
2N3055 HOBBY TRANSISTORS
15 for \$1.98
Fallouts of the famous 2N3055. 2E 2617 100%

BARREL KIT #37
1 AMP "BULLET" RECTIFIERS
100 for \$1.98
Famous style, axial voltages, silicon, axial includes all types of voltages to JKV. Cat. No. 2E 2615

BARREL KIT #35
NEON LAMPS
30 for \$1.98
Famous NE-2's. All prime, but factory made millions and barrelled 'em. Your advantage. Cat. No. 2E 2613

BARREL KIT #31
METAL FILM RESISTORS
100 for \$1.98
Made mostly by Corning, the finest resistor made. Mostly 1/2 watt, 1% to 5% tol. & 1/2 barrel. Cat. No. 2E 2609

BARREL KIT #27
PREFORMED DISCS
100 for \$1.98
Hi-P mfr's shelf inventory but he dumped 'em in barrels. Preformed, for PC use. Mixed values too! 2E 2605

BARREL KIT #27
PREFORMED DISCS
100 for \$1.98
Hi-P mfr's shelf inventory but he dumped 'em in barrels. Preformed, for PC use. Mixed values too! 2E 2605

BARREL KIT #26
PLASTIC TRANSISTORS
100 for \$1.98
Type TO-92 (TO-18), all manufacturers, variety of 2N's. Cat. No. 2E 2604

BARREL KIT #25
METAL CAN TRANSISTORS
100 for \$1.98
Includes TO-5, TO-18, TO-18, etc. assorted 2N numbers, unmarked etc. Cat. No. 2E 2603

BARREL KIT #20
LONG LEAD DISCS
100 for \$1.98
"auction sale". Prime, marked only. Long leads. Cat. No. 2E 2598 100% good

Poly Paks C-R-A-C-K-S

Wow! INCREDIBLE PRICES

BUY ANY 10 TAKE 15% BUY 100 TAKE 25%

SN7400N	50.16	SN7442N	53	SN7494N	78	SN74160N	88
SN7401N	16	SN7445N	69	SN7495N	78	SN74161N	79
SN7402N	16	SN7446N	79	SN7496N	78	SN74162N	88
SN7403N	16	SN7448N	76	SN74100N	98	SN74165N	99
SN7404N	16	SN7449N	76	SN74106N	65	SN74173N	1.39
SN7405N	18	SN7450N	16	SN74107N	33	SN74175N	89
SN7406N	20	SN7451N	16	SN74112N	65	SN74176N	79
SN7407N	25	SN7452N	16	SN74114N	65	SN74177N	79
SN7408N	16	SN7453N	16	SN74121N	38	SN74181N	88
SN7409N	18	SN7454N	16	SN74123N	59	SN74184N	1.75
SN7410N	16	SN7455N	16	SN74125N	59	SN74185N	1.75
SN7411N	25	SN7456N	16	SN74126N	59	SN74190N	1.15
SN7412N	25	SN7457N	16	SN74127N	1.00	SN74191N	1.05
SN7413N	16	SN7458N	16	SN74132N	1.00	SN74192N	87
SN7414N	16	SN7459N	16	SN74133N	88	SN74193N	83
SN7415N	16	SN7460N	16	SN74134N	88	SN74194N	73
SN7416N	16	SN7461N	16	SN74135N	79	SN74195N	73
SN7417N	32	SN7462N	16	SN74136N	79	SN74196N	88
SN7418N	16	SN7463N	16	SN74137N	79	SN74197N	1.49
SN7419N	16	SN7464N	16	SN74138N	79	SN74198N	1.49
SN7420N	32	SN7465N	16	SN74139N	79	SN74199N	1.49
SN7421N	29	SN7466N	16	SN74140N	79	SN74200N	1.49
SN7422N	29	SN7467N	16	SN74141N	79	SN74201N	1.49
SN7423N	29	SN7468N	16	SN74142N	79	SN74202N	1.49
SN7424N	29	SN7469N	16	SN74143N	79	SN74203N	1.49
SN7425N	27	SN7470N	16	SN74144N	79	SN74204N	1.49
SN7426N	27	SN7471N	16	SN74145N	79	SN74205N	1.49
SN7427N	27	SN7472N	16	SN74146N	79	SN74206N	1.49
SN7428N	27	SN7473N	16	SN74147N	79	SN74207N	1.49
SN7429N	27	SN7474N	16	SN74148N	79	SN74208N	1.49
SN7430N	27	SN7475N	16	SN74149N	79	SN74209N	1.49
SN7431N	27	SN7476N	16	SN74150N	79	SN74210N	1.49
SN7432N	27	SN7477N	16	SN74151N	79	SN74211N	1.49
SN7433N	27	SN7478N	16	SN74152N	79	SN74212N	1.49
SN7434N	27	SN7479N	16	SN74153N	79	SN74213N	1.49
SN7435N	27	SN7480N	16	SN74154N	79	SN74214N	1.49
SN7436N	27	SN7481N	16	SN74155N	79	SN74215N	1.49
SN7437N	26	SN7482N	16	SN74156N	79	SN74216N	1.49
SN7438N	26	SN7483N	16	SN74157N	79	SN74217N	1.49
SN7439N	26	SN7484N	16	SN74158N	79	SN74218N	1.49
SN7440N	16	SN7485N	16	SN74159N	79	SN74219N	1.49
SN7441N	84	SN7486N	16	SN74160N	88	SN74220N	1.49

Cat. No. 2E 1981

7400 TTL			
7400	21	7442	1.08
7401	21	7448	1.15
7402	21	7450	2.6
7404	21	7451	27
7405	24	7453	27
7406	45	7454	41
7407	45	7460	22
7408	25	7472	39
7409	25	7473	45
7410	20	7474	45
7411	30	7475	80
7413	85	7482	1.75
7416	43	7483	1.15
7417	43	7485	1.12
7420	21	7486	45
7422	150	7489	2.49
7425	43	7490	69
7427	37	7491	1.20
7428	33	7492	82
7430	26	7493	82
7432	31	7494	91
7437	47	7495	91
7438	40	7496	91
7440	21	74100	1.25
7441	1.10	74107	49

5400 SERIES			
5400	1.00	5475	1.50
5404	1.25	5486	1.90
5410	1.00	5493	2.00
5426	1.25	54100	1.80
5473	1.50	54LS04	1.00

C MJS			
4001AE	.29	4022AE	1.20
4002AE	.29	4023AE	.29
4007AE	.29	4024AE	1.50
4009AE	.58	4025AE	.35
4010AE	.58	4026AE	1.49
4011AE	.29	4028AE	1.60
4012AE	.29	4029AE	2.90
4013AE	.52	4030AE	.65
4015AE	1.25	4037AE	4.50
4016AE	.65	4040AE	2.40
4018AE	1.10	4044AE	1.50
4019AE	.65	4047AE	2.75
4020AE	1.75	4049AE	.75
4021AE	1.50	4050AE	.75

MOTOROLA CIRCUITS			
MC725P	1.50	MC1741CG	.98
MC740L	1.55	MC1804P	.98
MC790P	1.50	MC1806P	.98
MC832P	.48	MC1810P	.98
MC1004L	1.25	MC2053L	.45
MC1008L	1.25	MC3006L	1.32
MC1010L	1.25	MC3007P	1.32
MC1011L	1.25	MC3021P	2.15
MC1036L	1.50	MC3021P	2.15
MC1037L	1.50	MC3060L	2.65
MC1352P	.05	MC3062L	3.00
MC1406CP	.35	MC4024P	2.20
MC1468L	2.90	MC14501CP	.31
MC1469P	2.50	MC14502CP	1.18
MC1510G	8.00	MC14507CP	.82
MC1514L	4.50	MC14510CP	2.40
MC1550G	1.50	MC14511CP	2.76
MC1558L	4.37	MC14512CP	1.92
MC1595L	6.25	MC14513G	.94
MC1596G	3.31	MC14528CP	1.74
MC1723CG	1.25	MC4044P	4.80

JAPANESE CIRCUITS			
AN136	2.90	HA1312	4.05
AN203	3.75	HA1322	5.20
AN208	4.75	HA1339	5.20
AN210	3.10	LA1201	4.25
AN211	3.30	LA1364	4.70
AN214	4.90	LA1366	6.00
AN217	3.30	LA1367	5.90
AN229	6.35	LA3301	4.85
AN234	5.75	LA4030	4.85
AN239	6.50	LA4031P	3.50
AN241	3.20	LA4051P	4.65
AN245	6.50	LD3001	3.35
AN274	3.95	LD3080	4.00
AN277B	3.40	LD3120	3.10
AN288	4.80	LD3141	2.40
AN328	4.05	M5112	5.40
AN343	3.90	M515PR	4.80
BA511	3.50	M5155	2.85
BA521	3.95	SG613	5.40
HA1158	6.30	STK011	10.50
HA1159	6.60	STK015	6.50
HA1202	3.10	STK025	12.50
HA1306W	5.20	STK032	14.20
STK056	11.35	TA7201P	6.40
STK415	11.50	TA7203P	7.00
TA7045M	1.50	TA7204P	6.50
TA7054P	3.05	TA7205P	6.50
TA7055P	5.50	TA78005M	2.50
TA7060P	1.85	TA78005P	1.95
TA7061P	2.25	TA78012M	2.50
TA7062P	2.25	TA78012P	1.95
TA7063P	2.25	TA78015M	2.50
TA7074P	4.90	TA78015P	1.95
TA7075P	4.65	TC9100P	12.00
TA7076P	4.55	UPC16C	2.50
TA7092P	6.50	UPC20C	5.00
TA7102	5.15	UPC41C	3.95
TA7106P	3.25	UPC48C	3.95
TA7120P	2.20	UPC554C	3.90
TA7120P-C	2.20	UPC563H2	8.00
TA7122AP	2.30	UPC566H	2.25
UPC575C	4.10	UPC575C	4.10
UPC1001H2	5.15	UPC1001H2	5.15
UPC1020H	4.55	UPC1020H	4.55
UPC1025	6.90	UPC1025	5.50
TA7200P	6.25	TA7200P	6.25

74L SERIES TTL			
74L00	33	74LS04	45
74L10	33	74LS10	39
74L30	33	74LS20	39
74L42	1.50	74LS51	39
74L86	69	74LS74	65
74LS00	39	74LS112	65

MISC CIRCUITS			
BC184L	.60	LM309K	1.95
CA3001	.75	LM351AN	70
CA3005	.80	LM741CP	.40
CA3006	1.10	LM1458M	.65
CA3018	1.60	MFC9020	1.15
CA3026	2.15	MRR95A	1.05
CA3035	2.45	MSC9967P1	50
CA3039	1.35	N5558	.55
CA3056	1.90	N8598B	5.00
CA7077P	.45	PA71131	45
CS134J	1.15	PL994551	45
CS135J	1.20	RC14370B	35
CS136	1.25	SC9962P	70
IC3(GE)	1.50	SC9966P	1.25
LM301AN	.35	SN15830N	.50

POSITIVE VOLTAGE REGULATORS			
LM340K-5	1.95	LM340K-6	1.95
LM340K-8	1.95	LM340K-12	1.95
LM340K-15	1.95	LM340K-18	1.95
LM340K-24	1.95	LM340K-24	1.95
LM340T0-5	1.75	LM340T0-8	1.75
LM340T0-12	1.75	LM340T0-12	1.75
LM340T0-15	1.75	LM340T0-18	1.75
LM340T0-24	1.75		

IC'S ON THE MOVE			
BBD-BUCKET BRIGADE DEVICE			
MM3003	9.45		
HALL IC DN834	1.25	DN837	1.50
DN835	1.35	DN838(NEW)	
SN76001	1.75	SN76002	1.95
PLL02A MIDLAND PHASE LOCK LOOP			12.00

74H00 TTL			
74H00	33	74H11	33
74H01	33	74H20	33
74H04	33	74H21	33
74H05	35	74H30	33
74H10	33	74H40	33

CARBON RESISTORS			
250	270	820	4.7K
300	910	5.1K	33K
470	1.0K	6.8K	47K
510	1.5K	7.5K	100K
560	2.2K	8.2K	330K
680	3.3K	15K	
750	3.9K	22K	

HOBBY SPECIALS			
YOU TEST 'EM SAVE BIG MONEY			
Power Pac	100 Asst. (includes Case T03, T066 T0220, T0202)	\$2.99	
Transistor/ Diode Pac	100 Asst. (includes Case T05, T039, T018, D07, 0041)	\$1.99	
I.C. Pac	100 Asst. (includes 14 & 16 Pin)	\$3.50	
Resistor Pac	50 Asst. (Assorted values)	\$1.50	
Mos Fet Pac	10 Asst. (similar top #'s Case T072)	\$0.99	
SCR Pac	100 Asst. (many top C103 Series) Case to 92, VR-10-100V, I 400MA, IGT:200MA	\$4.00	

MICROPROCESSOR CHIPS			
1404A	3.25	2102	2.50
C1702A	19.95	C2708	95.00
2101	6.95	CA702A	19.95
MK4200 P-11	4096x1 Bit Dynamic Ram		9.95
C5101-3	1024 Bit (256x4) Static C-Mos Ram		4.50
MC14514	4 Bit Latch 4 to 16 Line Decoder		4.25

ELECTROLYTIC CAPACITORS

2.2MF50	AXIAL LEADS	15
3.3MF10	AXIAL LEADS	15
3.3MF10	NO POLARITY	15
10MF25	AXIAL LEADS	15
10MF50	AXIAL LEADS	15
10MF150	AXIAL LEADS	20
25MF95	AXIAL LEADS	15
30MF25	AXIAL LEADS	15
47MF25	RADIAL LEADS	15
47MF50	RADIAL LEADS	20
100MF16	RADIAL LEADS	15
100MF25	RADIAL LEADS	20
500MF50	AXIAL LEADS	60
1000MF35	AXIAL LEADS	65

CARBON RESISTORS

QUANTITY PRICING			
5-25	30-95	100-495	
1/4w5%	.06	05	04
1/2w5%	.08	07	06

ZENER DIODES

1/2 & 1 Watt 10% .30 each UP TO 33V.			
GREATER THAN 33V CALL FOR PRICING			

PAGE/PATHCOM PART #S

130079	4.00	IP20-0123	2.75
1300821	.65	IP20-0131	2.50
13-0122	1.75	IP20-0141	3.00
83-0005	2.00	IP20-0142	3.00
83-0007	2.50	IP20-0139	4.30
83-0008	2.00	IP20-0154	6.00
83-0015	3.00	IP20-0155	2.50
IP20-0005	3.00	IP20-0161	4.00
IP20-0016	4.00	IP20-0177	2.75
IP20-0034	.85	IP20-0176	8.25
IP20-0037	.85	IP20-0191	.72
IP20-0045	2.00		
IP20-0073	2.75		
IP20-0093	2.50		

JAPANESE TRANSISTORS * CB. AUDIO. INDUSTRIAL

2SA52	60	2SC206	1.00	2SC774	1.75	2SC1173	.95	2SD77	1.00
2SA316	.75	2SC2400	1.10	2SC775	2.75	2SC1175	.65	2SD81	3.25
2SA473	.75	2SC291	.65	2SC776	3.00	2SC1209	.55	2SD88	1.50
2SA483	1.95	2SC292	3.00	2SC777	4.00	2SC1213	.75	2SD118	3.25
2SA489	80	2SC320	.75	2SC778	4.00	2SC1226A	1.25	2SD130	1.25
2SA490	.70	2SC352	.75	2SC781	3.00	2SC1237	4.50	2SD141	2.25
2SA505	.70	2SC353	.75	2SC783	1.00	2SC1239	4.00	2SD151	2.25
2SA564	.50	2SC371	.70	2SC784	.70	2SC1243	1.50	2SD170	2.00
2SA628	65	2SC372	.70	2SC785	1.00	2SC1293	.85	2SD180	2.75
2SA643	.85	2SC394	.70	2SC789	1.00	2SC1306	4.75	2SD201	1.95
2SA647	2.75	2SC458	.70	2SC793	2.50	2SC1307	5.75	2SD218	4.75
2SA673	.85	2SC460	.70	2SC796	3.15	2SC1308	4.75	2SD235	1.50
2SA679	3.75	2SC478	.80	2SC797	2.50	2SC1317	.60	2SD300	2.00
2SA682	.85	2SC481	1.85	2SC798	3.20	2SC1318	.70	2SD313	1.10
2SA699	1.30	2SC482	1.75	2SC799	4.15	2SC1325	4.95	2SD315	.75
2SA699A	1.45	2SC491	2.50	2SC802	3.75	2SC1327	.70	2SD316	2.50
2SA705	.55	2SC495	1.10	2SC803	4.00	2SC1338	1.75	2SD317	1.25
2SA815	.85	2SC497	1.60	2SC815	.75	2SC1346	.80	2SD318	.95
2SA816	.85	2SC502	1.50	2SC828	.75	2SC1347	.80	2SD325	1.25
		2SC515	.80	2SC829	.75	2SC1364	1.50	2SD341	.95
2SB22	.65	2SC517	4.25	2SC830	1.60	2SC1377	5.50	2SD350	3.25
2SB54	.70	2SC535	.75	2SC838	.70	2SC1383	.75	2SD352	.80
2SB56	.70	2SC536	.65	2SC839	.85	2SC1384	.85	2SD380	5.70
2SB77	.70	2SC537	.70	2SC922	.55	2SC1409	1.25	2SD389	.75
2SB128	2.25	2SC563	2.50	2SC929	.70	2SC1410	1.25	2SD390	.75
2SB152	4.50	2SC607							

GODBOUNT

BILL GODBOUNT ELECTRONICS
BOX 2355, OAKLAND AIRPORT CA 94614
TERMS add 50¢ to orders under \$10. No COB. Cal
res add tax. MasterCard/BankAmericard call
(415) 562-0636, 24 hours. SEND FOR OUR FLYER

SEND
FOR
OUR
FREE
FLYER

LIMITED QUANTITY SPECIALS

ALL ITEMS BELOW WHILE THEY LAST AND ARE SUBJECT TO PRIOR SALE.

LED MOUNTING GIZMO --- press fits into 1/8" panel or glue to thinner metal. Fits standard size LED (no minis or jumbos)...10/51



SUBMINI PC MOUNT SLIDE SWITCH
Center off SPDT. Only 5/8" by 2" with pins on 1/8" centers. A VERY GOOD BUY.....10/52

THE REAL THING FROM MONSANTO
MAN-10A seven segment readout with bar, not dot, LEDs. Limit 8 to a customer. Digit is .27" high.....95¢ each

The following are house or military numbered ICs, and include pinout/datasheet

988 ONE-SHOT similar to 74121.....4/51.00

SN14058 DUAL 4 INPUT AND GATE with open collector or totem pole output.....7/51.00

C4347 TRIPLE 3 INPUT NOR GATE house-numbered SP370A.....6/51.00

7472 FLIP FLOP house numbered.....5/51.00

INTEL 3101-4 BIPOLAR 4 X 16 RAM super fast. Same pinout as 74S189. TTL, single +5VDC supply.....\$1.50 each

75325.....3/52.00

SILICON SIGNAL/SWITCHING DIODES.....35/52.00

WE NOW DISTRIBUTE KNOWLEDGE

We are happy to carry the Adam Osborne & Associates series of books on microcomputers, as lucid and complete a treatment of the subject as we've seen to date. All books postpaid in the USA, set of all three books available for only \$25.00.

VOL 1 "An Introduction to Microcomputers" Order book #2001. Gives the basics of uP based systems.....\$7.50

VOL 2 This recent addition gives up-to-date information on microprocessors --- equivalent to hundreds of pages of data sheets. Order book #3001.....\$12.50

VOL 3 "8080 Programming for Logic Design" #4001 \$7.50

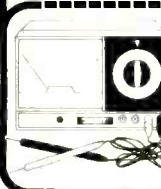

Multi Meter \$14.99

An outstanding buy...6 DC Volt ranges, 3 DC current, 5 AC Volts, 2 ohms, and 48 scale too. 50 uA movement; plus "off" position damps meter for safe transportation. Includes 34 inch test leads but less 1 AA battery. Small---a compact 5 3/4" x 3 3/4" x 1 5/8". Please add \$1 postage and handling.

CIRCLE NO. 32 ON FREE INFORMATION CARD

For faster service USE ZIP CODE on all mail

P.O. Box 4430C Santa Clara, CA 95054 (408) 988-1640

Same day shipment. First line parts only. Factory tested. Guaranteed money back. Quality IC's and other components at factory prices.

INTEGRATED CIRCUITS

7400TTL	SN74ALS14N	59	LM741CH	35	CD4026	25	74C906	1/50
SN7400N	SN74ALS15N	75	LM741N	25	CD4027	55	74C926	10/50
SN7402N	SN74ALS20N	110	LM7339N	82	CD4029	170	74C926T	12/00
SN7404N	SN74ALS28N	150	LM7339N	82	CD4040	45	74C926T	12/00
SN7410N	SN74ALS28N	150	LM7339N	82	CD4043	35	8096	7/5
SN7414N	SN74ALS107N	52	LM7339N	82	CD4043	35	8096	7/5
SN7420N	SN74ALS138N	202	ME40L	3.90	CD4050	55	8110	4/50
SN7430N	SN74ALS258N	202	ME40L	3.90	CD4050	55	8120	4/50
SN7444N	LINEAR	1.90	NE555V	43	CD4058	65	8120	4/50
SN7447N	CA3082	2.90	NE555V	43	CD4058	65	8120	4/50
SN7450N	CA3089	2.75	NE555A	1.00	CD4059	40	8124	3/50
SN7473N	LM303AN	35	NE555A	1.00	CD4071	40	8124	3/50
SN7474N	LM303AN	35	NE555V	1.85	CD4072	40	8126	2/75
SN7475N	LM307N	35	NE557V	1.25	CD4073	40	8197	2/45
SN7480N	LM309N	89	SN75451CN	38	CD4075	40	8198	2/45
SN7490N	LM309N	89	SN75452CN	38	CD4075	40	8198	2/45
SN7492N	LM311H	90	SN75491CN	50	CD4078	40	8198	2/45
SN7493N	LM311H	90	SN75492CN	50	CD4081	40	2101	1/45
SN7495N	LM318	1/35	SN75494CN	89	CD4082	45	2101	1/45
SN7400N	LM320K 5.5	1/35	SN75494CN	89	CD4082	45	2101	1/45
SN74107N	LM320K 5.5	1/35	AD7010	18.00	CD4082	45	2101	1/45
SN74121N	LM320K 5.5	1/35	AD7010	18.00	CD4082	45	2101	1/45
SN74145N	LM320K 15	1/35	AD7010	18.00	CD4082	45	2101	1/45
SN74150N	LM320K 15	1/35	AD7010	18.00	CD4082	45	2101	1/45
SN74151N	LM320K 15	1/35	AD7010	18.00	CD4082	45	2101	1/45
SN74152N	LM320K 15	1/35	AD7010	18.00	CD4082	45	2101	1/45
SN74153N	LM320K 15	1/35	AD7010	18.00	CD4082	45	2101	1/45
SN74154N	LM320K 15	1/35	AD7010	18.00	CD4082	45	2101	1/45
SN74155N	LM320K 15	1/35	AD7010	18.00	CD4082	45	2101	1/45
SN74156N	LM320K 15	1/35	AD7010	18.00	CD4082	45	2101	1/45
SN74157N	LM320K 15	1/35	AD7010	18.00	CD4082	45	2101	1/45
SN74158N	LM320K 15	1/35	AD7010	18.00	CD4082	45	2101	1/45
SN74159N	LM320K 15	1/35	AD7010	18.00	CD4082	45	2101	1/45
SN74258N	LM320K 15	1/35	AD7010	18.00	CD4082	45	2101	1/45
SN74259N	LM320K 15	1/35	AD7010	18.00	CD4082	45	2101	1/45
SN74260N	LM320K 15	1/35	AD7010	18.00	CD4082	45	2101	1/45
SN74261N	LM320K 15	1/35	AD7010	18.00	CD4082	45	2101	1/45
SN74262N	LM320K 15	1/35	AD7010	18.00	CD4082	45	2101	1/45
SN74263N	LM320K 15	1/35	AD7010	18.00	CD4082	45	2101	1/45
SN74264N	LM320K 15	1/35	AD7010	18.00	CD4082	45	2101	1/45
SN74265N	LM320K 15	1/35	AD7010	18.00	CD4082	45	2101	1/45
SN74266N	LM320K 15	1/35	AD7010	18.00	CD4082	45	2101	1/45
SN74267N	LM320K 15	1/35	AD7010	18.00	CD4082	45	2101	1/45
SN74268N	LM320K 15	1/35	AD7010	18.00	CD4082	45	2101	1/45
SN74269N	LM320K 15	1/35	AD7010	18.00	CD4082	45	2101	1/45
SN74270N	LM320K 15	1/35	AD7010	18.00	CD4082	45	2101	1/45
SN74271N	LM320K 15	1/35	AD7010	18.00	CD4082	45	2101	1/45
SN74272N	LM320K 15	1/35	AD7010	18.00	CD4082	45	2101	1/45
SN74273N	LM320K 15	1/35	AD7010	18.00	CD4082	45	2101	1/45
SN74274N	LM320K 15	1/35	AD7010	18.00	CD4082	45	2101	1/45
SN74275N	LM320K 15	1/35	AD7010	18.00	CD4082	45	2101	1/45
SN74276N	LM320K 15	1/35	AD7010	18.00	CD4082	45	2101	1/45
SN74277N	LM320K 15	1/35	AD7010	18.00	CD4082	45	2101	1/45
SN74278N	LM320K 15	1/35	AD7010	18.00	CD4082	45	2101	1/45
SN74279N	LM320K 15	1/35	AD7010	18.00	CD4082	45	2101	1/45
SN74280N	LM320K 15	1/35	AD7010	18.00	CD4082	45	2101	1/45
SN74281N	LM320K 15	1/35	AD7010	18.00	CD4082	45	2101	1/45
SN74282N	LM320K 15	1/35	AD7010	18.00	CD4082	45	2101	1/45
SN74283N	LM320K 15	1/35	AD7010	18.00	CD4082	45	2101	1/45
SN74284N	LM320K 15	1/35	AD7010	18.00	CD4082	45	2101	1/45
SN74285N	LM320K 15	1/35	AD7010	18.00	CD4082	45	2101	1/45
SN74286N	LM320K 15	1/35	AD7010	18.00	CD4082	45	2101	1/45
SN74287N	LM320K 15	1/35	AD7010	18.00	CD4082	45	2101	1/45
SN74288N	LM320K 15	1/35	AD7010	18.00	CD4082	45	2101	1/45
SN74289N	LM320K 15	1/35	AD7010	18.00	CD4082	45	2101	1/45
SN74290N	LM320K 15	1/35	AD7010	18.00	CD4082	45	2101	1/45
SN74291N	LM320K 15	1/35	AD7010	18.00	CD4082	45	2101	1/45
SN74292N	LM320K 15	1/35	AD7010	18.00	CD4082	45	2101	1/45
SN74293N	LM320K 15	1/35	AD7010	18.00	CD4082	45	2101	1/45
SN74294N	LM320K 15	1/35	AD7010	18.00	CD4082	45	2101	1/45
SN74295N	LM320K 15	1/35	AD7010	18.00	CD4082	45	2101	1/45
SN74296N	LM320K 15	1/35	AD7010	18.00	CD4082	45	2101	1/45
SN74297N	LM320K 15	1/35	AD7010	18.00	CD4082	45	2101	1/45
SN74298N	LM320K 15	1/35	AD7010	18.00	CD4082	45	2101	1/45
SN74299N	LM320K 15	1/35	AD7010	18.00	CD4082	45	2101	1/45
SN74300N	LM320K 15	1/35	AD7010	18.00	CD4082	45	2101	1/45
SN74301N	LM320K 15	1/35	AD7010	18.00	CD4082	45	2101	1/45
SN74302N	LM320K 15	1/35	AD7010	18.00	CD4082	45	2101	1/45
SN74303N	LM320K 15	1/35	AD7010	18.00	CD4082	45	2101	1/45
SN74304N	LM320K 15	1/35	AD7010	18.00	CD4082	45	2101	1/45
SN74305N	LM320K 15	1/35	AD7010	18.00	CD4082	45	2101	1/45
SN74306N	LM320K 15	1/35	AD7010	18.00	CD4082	45	2101	1/45
SN74307N	LM320K 15	1/35	AD7010	18.00	CD4082	45	2101	1/45
SN74308N	LM320K 15	1/35	AD7010	18.00	CD4082	45	2101	1/45
SN74309N	LM320K 15	1/35	AD7010	18.00	CD4082	45	2101	1/45
SN74310N	LM320K 15	1/35	AD7010	18.00	CD4082	45	2101	1/45
SN74311N	LM320K 15	1/35	AD7010	18.00	CD4082	45	2101	1/45
SN74312N	LM320K 15	1/35	AD7010	18.00	CD4082	45	2101	1/45
SN74313N	LM320K 15	1/35	AD7010	18.00	CD4082	45	2101	1/45
SN74314N	LM320K 15	1/35	AD7010	18.00	CD4082	45	2101	1/45
SN74315N	LM320K 15	1/35	AD7010	18.00	CD4082	45	2101	1/45
SN74316N	LM320K 15	1/35	AD7010	18.00	CD4082	45	2101	1/45
SN74317N	LM320K 15	1/35	AD7010	18.00	CD4082	45	2101	1/45
SN74318N	LM320K 15	1/35	AD7010	18.00	CD4082	45	2101	1/45
SN74319N	LM320K 15	1/35	AD7010	18.00	CD4082	45	2101	1/45
SN74320N	LM320K 15	1/35	AD7010	18.00	CD4082	45	2101	1/45
SN74321N	LM320K 15	1/35	AD7010	18.00	CD4082	45	2101	1/45
SN74322N	LM320K 15	1/35	AD7010	18.00	CD4082	45	2101	1/45
SN74323N	LM320K 15	1/35	AD7010	18.00	CD4082	45	2101	1/45
SN74324N	LM320K 15	1/35	AD7010	18.00	CD4082	45	2101	1/45
SN74325N	LM320K 15	1/						

DIGI-KEY CORPORATION
Quality Electronic Components
Double-Digit Discounts
Save You Even More

2102-1	8080A	LM3909
\$1.99	\$24.95	69¢

NATIONAL SEMICONDUCTOR CLOCK MODULES

MA1010A 12 Hour (AM-PM) Version . . . \$13.00
MA1010C 24 Hour Version . . . \$13.00



0.84" High LED Digits

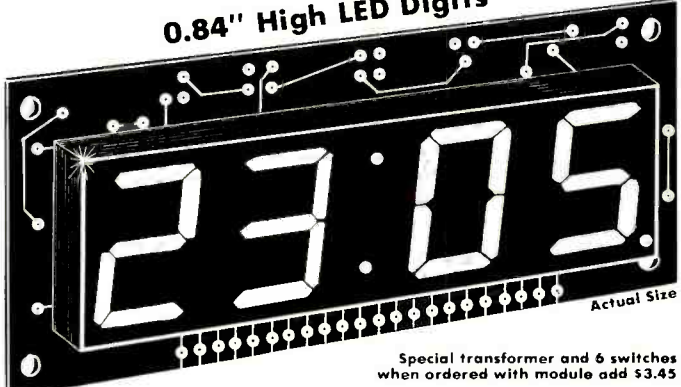

Special transformer and 6 switches, when ordered with module add \$3.45

MA1002A 12 Hour (AM-PM) Version . . . \$10.50
MA1002C 24 Hour Version . . . \$10.50

0.5" High LED Digits



Special transformer and 6 switches, when ordered with module add \$3.45.



MA1002 & MA1010 Electronic Clock Modules

The MA1002 & MA1010 Series Electronic Clock Modules are assembled and pretested modules which combine a monolithic MDS-LSI integrated clock circuit, 4-digit LED display, power supply and other associated discrete components on a single printed circuit board to form a complete electronic clock movement. The user need only a transformer and switches to construct a digital clock for application in clock radios, alarm or instrument panel clocks. Time-keeping may be from 50 or 60 Hz inputs and 12 or 24 hour display formats may be chosen. Direct LED drive eliminates RF interference. Time setting is made easy through use of "Fast" and "Slow" scanning controls.

The MA1002A and MA1010A have a 12 hour display with an AM and PM indicator. The MA1002C and MA1010C have a 24 hour display.

Features include alarm "on" and "PM" indicators, "sleep" and "snore" timers and variable brightness control capability. The modules are extremely compact, the MA1002 measuring 1.375" by 3.05", the MA1010 measuring 1.75" by 3.75". This small size is achieved by bonding the I.C. to the back of the circuit board.

It is highly recommended that the transformer be obtained with the clock module as it is a special dual secondary type not otherwise readily available.

Hobby-Wrap-30 \$5.95
Strips, Wraps and Unwraps 30 ga. wire on standard wire wrapping pins

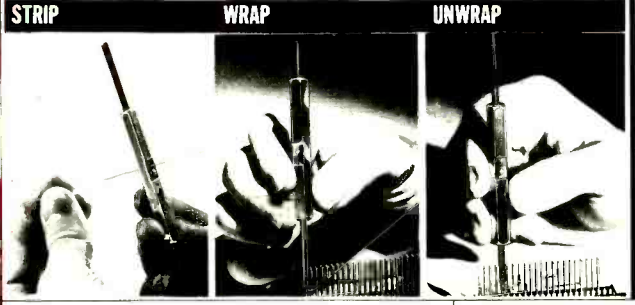

Double Digit Discounts Save You Even More!

ACE201-K \$24.95
1,032 SOLDERLESS PLUG-IN TI POINTS
CAPACITY: 1 P TO 12 14-PIN DIP'S
TWO 5-way binding posts
Size: 4 9/16" by 7 1/2"
Kit form

WIRE WRAPPING WIRE
Red or Black Kynar insulated pre-cut and stripped 30 ga. wire of insulation is removed from each end

Insulation Length	No. in Pkg.	Price per Pkg.
1.0"	100	\$2.50
2.0"	100	\$2.65
2.5"	100	\$2.65
3.0"	100	\$2.75
3.5"	100	\$2.75
4.0"	100	\$2.80
4.5"	100	\$2.90
5.0"	100	\$3.00
6.0"	50	\$1.60
7.0"	50	\$1.70
8.0"	50	\$1.80
9.0"	50	\$1.90
10.0"	50	\$2.00
15.0"	50	\$2.50

SLIDE SWITCHES
Single Pole Single Throw
.15 1.20/10 10.00/C

Double Pole Double Throw
23 2.00/10 19.00/C

BATTERY HOLDERS
1-AA .26¢
2-AA .42¢
1-C .35¢
2-C .42¢
1-D .35¢
2-D .42¢

BISHOP GRAPHICS Printed Circuit Drafting Aids are now available from Digi-Key

RADIAL ELECTROLYTICS

47.50V .08	6510	22.50V .12	100/10	330/25V .23	1.86/10
1.50V .08	6510	100/6.3V .09	75/10	470/10R .21	1.71/10
2.2/50V .08	6510	100/10V .10	77/10	470/16V .23	1.81/10
3.3/50V .08	6510	100/16V .11	85/10	470/25V .29	2.35/10
4.7/35V .08	6510	100/25V .13	100/10	1000/16V .24	1.96/10
4.7/50V .08	68/10	100/50V .21	1.71/10	1000/16V .29	2.35/10
10/16V .08	6510	220/10V .13	0.8/10	1000/25V .42	3.33/10
10/25V .08	6510	220/16V .15	1.16/10	2200/10V .42	3.33/10
10/50V .08	75/10	220/25V .21	1.71/10	2200/16V .54	4.30/10
22/16V .08	67/10	220/50V .29	2.35/10	2200/25V .58	4.67/10
22/25V .09	70/10	330/10V .15	1.16/10	3300/16V .69	7.14/10
		330/16V .21	1.66/10		

INTEGRATED CIRCUITS - TTL, CMOS, LINEAR & MOS

7400 21	7476 32	74181 2.15	4012 23	4520 1.14
7401 21	7480 70	74182 79	4013 40	4527 1.68
7402 21	7482 70	74184 2.19	4014 96	4528 .88
7403 21	7483 70	74185 2.19	4015 96	4585 1.23
7404 21	7485 89	74188 3.50	4016 40	2102-1 1.99
7405 21	7486 78	74189 3.50	4017 05	8080A 24.95
7406 25	7489 2.19	74190 1.23	4018 05	CA3046 .75
7407 25	7490 44	74191 1.23	4019 23	LM211N 1.25
7408 21	7491 70	74192 88	4020 14	LM309K 1.80
7409 21	7492 44	74193 88	4021 14	LM324A 1.26
7410 21	7493 44	74194 88	4022 96	LM340T-5 1.25
7411 21	7494 70	74195 88	4023 23	LM340T-6 1.25
7412 21	7495 70	74196 88	4024 84	LM340T-8 1.25
7413 25	7496 70	74197 88	4025 23	LM340T-12 1.25
7414 89	74100 1.28	74198 1.49	4026 68	LM340T-15 1.25
7416 25	74107 30	74199 1.49	4027 40	LM340T-18 1.25
7417 25	74109 33	74201 89	4028 89	LM340T-24 1.25
7420 21	74121 35	74279 55	4029 14	LM3900N .80
7421 25	74122 44	74365 67	4030 23	LM3909N .69
7422 35	74123 61	74366 67	4033 51	MC1456V 1.00
7423 35	74125 61	74367 67	4034 30	MC1458V .53
7425 35	74125 61	74368 67	4035 14	MC3302P 1.15
7426 25	74126 40	8093 40	4040 14	NE56T 3.24
7427 33	74132 70	8094 40	4041 79	NE540 2.04
7428 28	74141 88	8095 67	4042 79	NE555V .48
7430 21	74145 70	8096 67	4043 70	NE566A .88
7432 25	74147 1.63	8097 67	4044 70	NE560B 3.83
7433 30	74148 1.30	8098 67	4045 86	NE567V 1.36
7437 25	74150 1.16	75150 1.16	4046 70	NE568 3.83
7438 25	74151 70	75450 1.16	4049 40	NE569B 3.83
7440 21	74153 65	75450 88	4050 40	NE565A 1.25
7442 53	74154 1.03	75451 61	4051 26	NE566V 1.28
7443 43	74155 70	75452 61	4052 26	NE567V 1.36
7445 70	74156 70	75453 61	4053 26	UA709CV .44
7446 70	74157 70	75454 61	4056 58	UA710CA .44
7447 70	74160 88	75491 81	4066 79	UA711CA .53
7448 70	74161 88	75492 81	4071 23	UA712CA .63
7450 21	74162 88	75493 1.09	4072 23	UA713CA .75
7451 21	74163 88	75494 1.19	4073 23	UA714CV .44
7453 21	74164 96	82225 2.19	4075 23	UA747CA .70
7454 21	74165 1.15	4000 23	4081 23	UA749CV .49
7459 21	74166 1.26	4001 23	4082 23	UA7805CU 1.25
7460 21	74170 2.64	4002 23	4502 79	UA7806CU 1.25
7470 30	74173 1.42	4006 1.23	4510 114	UA7808CU 1.25
7472 30	74174 98	4007 23	4511 12	UA7812CU 1.25
7473 30	74175 98	4008 79	4514 280	UA7813CU 1.25
7474 30	74176 79	4009 44	4515 280	UA7818CU 1.25
7475 49	74177 79	4010 44	4516 23	UA7824CU 1.25
	74180 70	4011 23	4518 14	

WIRE WRAPPING WIRE IN BULK
Red or Black 30 ga. Kynar

100' \$2.00	500' \$8.50	1000' \$15.00
-------------	-------------	---------------

ENTIRE ROCKWELL CALCULATOR LINE ON DISCOUNT IN OUR LATEST CATALOG

MOLEX PINS
Make your own IC sockets on a PC board

85/C	8.20/M	38.20/5M	275.00/50M
------	--------	----------	------------

SILICON DIODES

1N4001	64/10	5.50/C	\$49/M
1N4002	66/10	5.60/C	\$51/M
1N4003	68/10	5.80/C	\$52/M
1N4004	70/10	5.95/C	\$54/M
1N4005	82/10	7.05/C	\$63/M
1N4006	90/10	7.75/C	\$69/M
1N4007	99/10	8.60/C	\$77/M
1N4148	40/10	3.50/C	\$29/M

Double Digit Discounts Save You Even More!

RESISTOR ASSORTMENTS

5 ea all 10% 1/4 w. val. 10 thru 5.6 meg (350 pcs)	\$12.00
5 ea all 10% 1/4 w. val. 22 thru 22 meg (425 pcs)	\$11.00

1/2 WATT ZENER DIODES

1N5226B 3.3v 15 111/C	1N5236B 7.5v 15 111/C
1N5227B 3.6v 15 111/C	1N5237B 8.2v 15 111/C
1N5228B 3.9v 15 111/C	1N5238B 9.1v 15 111/C
1N5229B 4.3v 15 111/C	1N5239B 10 15 111/C
1N5230B 4.7v 15 111/C	1N5240B 10v 15 111/C
1N5231B 5.1v 15 111/C	1N5241B 11v 15 111/C
1N5232B 5.6v 15 111/C	1N5242B 12v 15 111/C
1N5233B 6.0v 15 111/C	1N5243B 13v 15 111/C
1N5234B 6.2v 15 111/C	1N5244B 14v 15 111/C
1N5235B 6.8v 15 111/C	1N5245B 15v 15 111/C

PERF BOARD
0.1" spacing between holes

4 1/2" x 6"	\$1.71
4 1/2" x 7"	\$4.25

TERMINALS
for above perf board

1 \$1.50/C

LED LAMPS

NLS5053 1.1 1/4" 18 \$15/C
NLS5056 1.1 1/4" 18 \$15/C

LED DISPLAYS

FND357 CC 375' \$1.75
FND500 CA 500' \$1.75
FND 507 CA 500' \$1.75
FND800 CC 800' \$3.50
FND807 CA 800' \$3.50

DATA BOOKS



DATA BOOKS

TTL IC's 595 p.	\$4.00
Linear IC's 957 p.	\$5.00
CMOS IC's 256 p.	\$3.00
Transistors 288 p.	\$3.00
Memory IC's 592 p.	\$3.00
Interface IC's 464 p.	\$4.00
Volt. Regs. 128 p.	\$3.00
Linear Appl. 1 432 p.	\$4.00
Linear Appl. 2 246 p.	\$3.00
Audio 196 p.	\$3.00

AXIAL ELECTROLYTICS

47/10V .11	90/10	33/25V .14	115/10	330/16V .29	2.35/10
1/30V .11	90/10	33/50V .19	152/10	330/25V .52	2.54/10
3/35V .12	95/10	47/16V .14	115/10	470/16V .32	2.55/10
3.3/50V .12	100/10	47/25V .17	130/10	470/25V .37	3.00/10
4.7/25V .11	90/10	47/50V .21	117/10	1000/10V .33	2.65/10
4.7/35V .12	95/10	100/10V .14	113/10	1000/16V .39	3.15/10
4.7/50V .12	100/10	100/16V .11	130/10	1000/25V .54	4.50/10
10/25V .12	100/10	100/25V .20	155/10	2200/10V .50	3.96/10
10/50V .14	115/10	100/50V .29	230/10	2200/16V .62	4.95/10
22/16V .12	100/10	220/10V .18	142/10	2200/25V .79	6.26/10
22/25V .13	105/10	220/16V .20	155/10	3300/16V .95	8.70/10
22/50V .17	132/10	220/25V .29	235/10	4700/16V 0.9	8.30/10
33/16V .12	100/10	220/50V .40	323/10	10000/10V 1.15	9.19/10
		330/10V .14	116/10		

WIRE-WRAPPING TOOL \$5.95
Wraps, Unwraps & Strips 30 ga. Wire

1/4 & 1/2 WATT 5% CARBON FILM RESISTORS
Se each in multiples of 5 per value
\$170/100 & \$12.00/1000 of same value
1 ohm thru 1.0 megohm

HARDWARE

2-56 1/4 Screw	99/C	7-20/M
2-56 1/2 Screw	99/C	7-65/M
4-40 1/4 Screw	55/C	3-65/M
4-40 1/2 Screw	60/C	4-05/M
6-32 1/4 Screw	65/C	4-46/M
6-32 1/2 Screw	75/C	4-85/M
8-32 3/8 Screw	90/C	5-85/M
8-32 5/8 Screw	99/C	7-00/M
2-56 Hex Nut	55/C	3-66/M
6-32 Hex Nut	60/C	4-06/M
8-32 Hex Nut	65/C	4-15/M
No. 2 Lockwasher	85/C	5-75/M
No. 4 Lockwasher	45/C	3-00/M
No. 6 Lockwasher	45/C	3-00/M
No. 8 Lockwasher	45/C	3-00/M

DOUBLE-DIGIT DISCOUNT SCHEDULE

Merchandise	Discount	Merchandise	Discount
\$ 0.00-\$24.99	NET	\$100.00-\$999.99	Less 15%
\$25.00-\$99.99	NET	\$1000.00-\$9999.99	Less 20%

STANDARD SHIPPING/HANDLING CHARGE
If your merchandise total after discount is between
\$ 0.00-\$1.99 add \$2.00 \$ 50.00-\$99.99 add \$0.25
\$100.00-\$249.99 add \$0.75 \$1000.00 & up No Charge
\$250.00-\$499.99 add \$1.50

Includes shipping and insurance to USA & Canada

COD ORDERS ACCEPTED FOR SAME DAY SHIPMENT - CALL 218-681-6674

"Only Quality Components Sold!"
DON'T FORGET TO APPLY DISCOUNT SCHEDULE

DIGI-KEY CORPORATION
Box 677, Thief River Falls, MN 56701 218-681-6674

AMAZING & HARD-TO-FIND SCIENCE BUYS! ALTERNATE ENERGY • SPACE AGE • HOBBIES

NEW WIDE FIELD TELESCOPE

Enjoy clearest, brightest, most spectacular wide angle views of stars, moon, comets with our unique, easy-to-use portable 4 1/4", f/4 Newtonian reflector. Only 17", 10 lb.! Take it anywhere. No. 2001AV \$149.95 Ppd. There is no other telescope like it.



SAVE 50%! 8 x 20 MONOCULAR

Top quality Spy Scope, a \$30 value, now \$14.95! Special purchase saves you 50%. 100% coated optics; 393 ft. field of view. Only 2 oz.—stores in pocket, purse, glove box. No. 1568AV...\$14.95 Ppd.



NASA-CHOSEN FOR APOLLO/SOYUZ

The Astronauts used this super 20X60 binocular (modified) to view Earth! Big 60 mm objective lenses; 173-ft. field of view at 1000 yds. Relative brightness, 9.0 Fully coated optics, more! (9 1/4 x 8 1/4"; 47.5 oz) No. 1556AV.....\$99.95 Ppd.



GIANT MAGNET, LITTLE PRICE!

Tie a line to our over-150 lb.-lift ceramic magnet and haul up treasure from the sea. 4 ceramic magnets, in series, between steel plates A 1-lb. "giant"! (1 x 1 1/4 x 4 3/4") No. 42,318AV, \$11.95 Ppd.



BUILD A WORKING STEAM ENGINE

Exact 6x8 1/4" hi replica of Single Acting Engine can power erector set assemblies, runs on tap water; you control speed, make whistle blow. Adult supervision. 35 parts. No. 72,202AV, \$27.50 Ppd.



SUPER POWER FOR ANY AM RADIO

Antenna assist has pulled in stations 1000 miles off! No wires, clips, grounding. Solid state—no elec. batts., tubes. No. 72,095AV \$19.95 Ppd. ULTRA SELECT-A-TENNA No. 72,147AV.....\$24.95



GIANT FREE 164 PG. CATALOG



4500 UNUSUAL BARGAINS FOR HOBBYISTS, SCHOOLS, INDUSTRY

EDMUND SCIENTIFIC CO.
300 Edscorp Bldg.
Barrington N.J. 08007
America's Greatest
Science • Optics • Hobby Center
16091 547-3488

COMPLETE AND MAIL COUPON NOW

EDMUND SCIENTIFIC CO. 300 Edscorp Bldg., Barrington, N. J. 08007



SEND FREE

164 PG. CATALOG AV

Charge my American Exp
 BankAmericard Master Chg

Interbank No _____

Card No _____

Expiration Date _____

30-DAY MONEY-BACK GUARANTEE. You must be satisfied or return any purchase in 30 days for full refund

Send me the following:

Stock No. _____ Quantity _____ Price Ea. _____

Stock No.	Quantity	Price Ea.

Enclosed is _____ check, _____ M.O. in amount of \$ _____

Add handling charge \$ _____ 1.00

Signature _____

Address _____

City, State, Zip _____

HELPING TO DEVELOP AMERICA'S TECHNOLOGY FOR OVER 30 YEARS.
CIRCLE NO. 24 ON FREE INFORMATION CARD

PLANS AND KITS

AMAZING ELECTRONIC PRODUCTS

LASERS SUPER POWERED RIFLE, PISTOL, POCKET, SEE IN DARK, PYRO, TECHNICAL DE-BUGGING, UNCRAMBLERS, GIANT TESLA, STUNWAND, TV DISRUPTER, ENERGY PRODUCING, SCIENTIFIC DETECTION, ELECTRIFYING CHEMICAL, ULTRASONIC, CB, AERO, AUTO AND MECH DEVICES, HUNDREDS MORE... ALL NEW PLUS INFO UNLTD PARTS SERVICE

INFORMATION Unlimited

CATALOG \$1 Box 626 Lord Jeffery Pl. • Amherst, N. H. 03091

FREE KIT Catalog contains Test and Experimenter's Equipment, Dage Scientific Instruments, Box 1054P, Livermore, CA 94550.

TIGER SST SIMPLI-KIT

FOR THE DO-IT-YOURSELFER

NOW! a high quality CD Electronic Ignition System in kit form.

Contains all components and solder to build complete Solid-State Electronic CD Ignition System for your car. Assembly requires less than 3 hours.

- Increases MPG 15%
- Eliminates 4 of 5 tune-ups
- Increases horsepower 15%
- Instant starting, any weather
- Plugs and Points last 50,000 miles
- Dual system switch

Fits only 12 volt neg. ground. . . Only \$21.95 postpaid

Tri-Star Corporation

P.O. Box 1727 Grand Junction, Colorado 81501

FIVE OCTAVE Touch Sensitive Electronic PIANO KIT. Components \$229 airmail U.S.A., Canada. Clet Products, 31, Mountfield Road, Bramhall, Cheshire, England SK7 1LY.

TAPE-SLIDE Synchronizer, lap-dissolve, multiprojector, audiovisual plans, \$8.50. Sampler, \$1.00. Millers, 1896 Maywood, S. Euclid, OH 44121.

TESLA COIL—40" SPARKS! Plans \$7.50, Information 75 cents. Huntington Electronics, Box 2009-P, Huntington, Conn. 06484.

HIGH FIDELITY

DIAMOND NEEDLES and Stereo Cartridges at Discount prices for Shure, Pickering, Stanton, Empire, Grado and ADC. Send for free catalog: LYLE CARTRIDGES, Dept. P, Box 69, Kensington Station, Brooklyn, New York 11218.

SAVE 50% build your own speaker system write: McGee Radio Electronics, 1901 McGee Street, Kansas City, Missouri 64108.

BURGLAR ALARMS

DIALING UNIT automatically calls police. \$29.95. Free security equipment catalog. S&S Systems, 5619-C St. John, Kansas City, MO 64123. (816) 483-4612.

ELECTRONIC Smoke Detectors, home and auto burglar alarms. Catalogue \$1.00 refundable. EMS, 5709 Tomahawk Trail, Durham, NC 27704.

TUBES

RADIO & T.V. Tubes—36 cents each. Send for free Catalog. Cornell, 4213 University, San Diego, Calif. 92105.

TUBES receiving, factory boxed, low prices, free price list. Translertonic, Inc., 1365 39th Street, Brooklyn, N.Y. 11218A, Telephone: 212-633-2800.

TUBES: "Oldies", Latest. Supplies, components, schematics. Catalog Free (stamp appreciated). Steinmetz, 7519-PE Maplewood, Hammond, Ind. 46324.

PERSONALS

MAKE FRIENDS WORLDWIDE through international correspondence. Illustrated brochure free. Hermes-Verlag, Box 110660/Z, D-1000 Berlin 11, Germany.

WARTS. Vergo® Cream is painless, safe, easy, gentle. Buy Vergo® at better pharmacies.

TREASURE FINDERS

TREASURE may lie beneath your feet! Discover gold, silver, coins, rings, artifacts and more with world-famous, deeper-detecting White's metal detectors. From \$79.50. Dealers world-wide. Free literature! White's Electronics, Dept. PD7-C, 1011 Pleasant Valley Rd., Sweet Home, OR 97386.

WANTED

GOLD, Silver, Platinum, Mercury wanted. Highest prices paid by refinery. Ores assayed. Free circular. Mercury Terminal, Norwood, MA 02062.

WANTED information to build holograms. 19 Chippewa, Royal Oak, Mich. 48073.

CLASSIFIED ADVERTISING ORDER FORM

Please refer to heading on first page of this section for complete data concerning terms, frequency discounts, closing dates, etc.

1	2	3	4	5
6	7	8	9	10
11	12	13	14	15
16	17	18	19	20
21	22	23	24	25
26	27	28	29	30
31	32	33	34	35

WORD COUNT: 15 WORD MINIMUM. Include name and address. Name of city (Des Moines) or of state (New York) counts as one word each. Zip Code numbers not counted. (Publisher reserves right to omit Zip Code if space does not permit.) Count each abbreviation, initial, single figure or group of figures or letters as a word. Symbols such as 35mm, COD, PO, AC, etc., count as one word. Hyphenated words count as two words. Telephone numbers count as one word.

_____ Words **\$2.25 (Commercial Rate)** **\$1.35 (Reader Rate)**

Payment of \$ _____ enclosed for _____ insertion(s).

CHARGE: American Express BankAmericard Master Charge Diners Club

for _____ insertion(s). You will be billed monthly.

Account # _____ Expiration Date _____

Master Charge Interbank # (4 digits above name) _____

SIGNATURE MUST BE PROVIDED BELOW

PRINT NAME _____

ADDRESS _____

CITY _____ STATE _____ ZIP _____

SIGNATURE _____ PE-277

6 Digit LED Clock Kit - 12/24 hr.

\$9.95 QTY. 12
ea. OR MORE

\$10.95 QTY.
ea. 6-11

\$11.95 QTY.
ea. 1-5

- KIT INCLUDES**
- INSTRUCTIONS
 - QUALITY COMPONENTS
 - 50 or 60 Hz OPERATION
 - 12 or 24 HR OPERATION

6-LED Readouts (FND-359 Red, com. cathode)
1-MIM5314 Clock Chip (24 pin)
13-Transistors
3-Switches
6-Capacitors
5-Diodes
9-Resistors
24-Molex pins for IC socket

LARGE .4" DIGITS!
ORDER KIT #850-4
AN INCREDIBLE VALUE!

"Kit #850-4 will furnish a complete set of clock components as listed. The only additional items required are a 7-12 VAC transformer, a circuit board and a cabinet, if desired."

Printed Circuit Board for kit # 850-4 (etched & drilled fiberglass) \$2.95
Mini Brite Red LED's (for color in clock display) pkg. of 5 1.00
Molded Plug Transformer 115/10 VAC (with cord) 2.50
NOTE: Entire Clock may be assembled on one PC Board or Board may be cut to remote display.
Kit #850-4 will fit Plexiglas Cabinet II

6 Digit-LED Clock-Calendar-Alarm Kit

This is a complete, top of the line, Kit for the person that wants the best. Some of the many features and options are: 12/24 time, 28-30-31 day calendar, alternates time (8 sec) and date (2 sec) or can display time only and date on demand, 24 hr alarm - 10 minute snooze, alarm set indicator, 50/60 HZ. line operation or use with Xtal time base (#TB-1), built in OSC for battery back-up / AC failure, Aux. timer, CHOICE OF DIGITS.

- Kit #7001B 6 - .4" Digits **\$39.95**
- Kit #7001C 4 - .6" Digits & 2-." [Seconds] **\$42.95**
- Kit #7001X 6 - .6" Digits **\$45.95**

Kits are complete (less cabinet) including PC boards, power supply, IC socket, 9 switches, 16 transistors and all parts required for above features and options [All #7001 Kits Will Fit Cabinet I]

PRINTED CIRCUIT BOARDS for CT-7001 Kits sold separately with assembly info. PC Boards are drilled Fiberglass, solder plated and screened with component layout. Specify for #7001B or #7001C (Set of 2) \$7.95

JUMBO DIGIT CLOCK KIT

A complete Kit (less Cabinet) featuring: six .5" digits, MM5314 IC, 12/24 Hr. time, 50/60 HZ., Plug Transformer, Line Cord, Switches, and all Parts.
[Ideal Fit in Cabinet II] **\$19.95 ea. 2/*38.**
Kit #5314-5

JUMBO DIGIT CONVERSION KIT

Convert small digit LED clock to large 5" displays. Kit includes 6-.5" LED's, Multiplex PC Board & easy hook-up info.
Kit #JD-1CC For common Cathode **\$9.95 ea. 2/*19.**
Kit #JD-1CA For common Anode

SEE THE WORKS Clock Kit
Clear Plexiglas Stand

- 6 Big .4" digits
 - 12 or 24 hr. time
 - 3 set switches (back)
 - Plug transformer
 - All parts included
- Plexiglas is pre-cut & drilled.
Size: 6" H x 4" W x 1 1/2" D

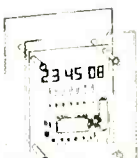

A SUPER LOOPING
CLOCK
Kit #850-4

Fairchild Super Digit FND-359

4" Char. HT.
7 segment LED
RED Com. Cath.
Direct pin
replacement for popular FND-70

95¢ ea., 10/\$8.50
100/\$79.00

SET OF 6 FND-359
WITH MULTIPLEX
PC BOARD \$6.95

25 AMP BRIDGE
\$1.95 ea.
3/\$5.00
100 PIV

TELEPHONE FORMAT
KEYBOARD
BY Chomerics

2-1/4"x3"
5/32"
thick

\$4.95
6/*28.

7-SEG LED COMMON CATHODE

COLOR	HT.	DEC.	PT.	PREA
FND-359 RED	4"	RHDP		\$.95
FND-503 RED	5"	RHDP		\$1.35
DL-750 RED	6"	LHDP		\$1.95
XAN-654 GREEN	6"	NDP		\$1.95
XAN-664 RED	6"	NDP		\$1.95

COMMON ANODE

DL-747 RED	6"	LHDP		\$1.95
MAN-72 RED	3"	LHDP		\$1.25
XAN-81 YELLOW	3"	RHDP		\$1.75
XAN-351 GREEN	3"	RHDP		\$1.50
XAN-361 RED	3"	RHDP		\$1.50
XAN-362 RED	3"	LHDP		\$1.50
XAN-662 RED	6"	NDP		\$1.95
XAN-692 RED	6"	NDP		\$1.95

Form Inexpensive Sockets 100 for \$1.25 Reel of 1000 - \$8.50

MOLEX PINS

SCHOTTKY DTL

TTL	930	\$.09
74S00	35	832
74S01	40	937
74S04	55	7447
74S05	60	7448
74S09	56	7541
74S10	40	7542
74S20	50	7542
74S22	45	7542
74S40	45	
74S50	45	
74S51	55	
74S60	85	
74S64	56	

LED DRIVERS

LM309H TO-5 \$ 9.95
LM309K TO-3 1.25

VOLTAGE REGULATORS

LM340T 181AB 1.75
LM340T 24 TAB 1.75
723 DIP .75
723 TO-5 .75

DIGITAL CLOCK IC's

MM5312	\$ 4.95
MM5314	3.95
MM5375 AB	3.95
CT 7001	7.95
CT 7002	13.95
50380	3.95
MM5369	2.50

XTAL

3.579545 MHZ. \$ 1.95

60 HZ. XTAL TIME BASE KIT

Will enable Digital Clock or Clock Cal. Kits to operate from 12VDC. Uses MM5369 and 3.58MHZ XTAL. Req. 5-15VDC/2.5 MA. 1"x2" PC Board. Easy 3 wire hookup Accuracy: ± 2 PPM

#TB-1 [adjustable]
Complete kit \$4.95 ea
Wired & Cal. \$9.95 ea

MOBILE LED CLOCK

12 OR 24-HOUR OPERATION
12 VOLT AC or DC POWERED FOR FIXED OR MOBILE OPERATION.
SIX LARGE .4" DIGITS!

KIT OR ASSEMBLED

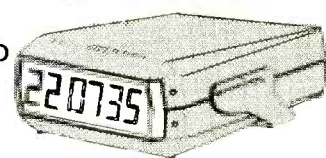

MODEL 2001

ACCURATE TIME WITH ADJUSTABLE XTAL TIME BASE

Approx. Size:
1 3/4" H x 4" W x 4 1/2" D

BATTERY BACK UP FOR POWER FAILURE OR TRANSPORTING FROM HOUSE TO CAR ETC

- 6 JUMBO .4" RED LED'S BEHIND RED FILTER LENS WITH CHROME RIM
- SET TIME FROM FRONT VIA HIDDEN SWITCHES • 12/24 Hr. TIME FORMAT
- STYLISH CHARCOAL GRAY CASE OF MOLDED HIGH TEMP. PLASTIC
- BRIDGE POWER INPUT CIRCUITRY - TWO WIRE NO POLARITY HOOK-UP
- OPTIONAL CONNECTION TO BLANK DISPLAY (Use When Key Off in Car. Etc.)
- TOP QUALITY PC BOARDS & COMPONENTS EXCELLENT INSTRUCTIONS
- MOUNTING BRACKET INCLUDED

Kit #2001 COMPLETE KIT (Less 9V Battery) **29.95 EA** 3 OR MORE **\$27.95 EA**
115 VAC Power Pack #AC 1 **\$2.50 EA**
ASSEMBLED UNITS WIRED & TESTED ORDER #2001 WT (LESS 9V BATTERY) **\$39.95 EA** 3 OR MORE **\$37.95 EA** Assembled Units May Be Mixed With Kits for Qty. Price

CPU \$19.95 ea.

NS8080AD
Micro Processor Chip
Prime National LSI
40 Pin socket
\$.50 with each 8080A!

450 ns MEMORY

Fairchild 1K Ram
low, low, low power.
2102L1PC \$1.95 ea.
25-99 \$1.75 ea.
100-199 \$1.60 ea.
200 or more \$1.45 ea.

JUMBO RED LED's 12/\$1.00 50/\$3.95

PRESCALE	EXAR	OP AMPS
11C90DC \$15.95 95H90 9.95	XF2556 \$ 1.75 XR2567 \$ 1.95	3/1000 301 TO-5 709 DIP 709 TO 5 741 DIP 741 M DIP 741 TO-5 747 DIP 748 DIP
DIODES	TRANSISTORS	DISCRETE
IN 4002 1A, 100 PIV 12/\$1.00 IN 4005 1A, 600 PIV 11/\$1.00 IN 4007 1A, 1000 PIV 10/\$1.00 RECTIFIER 2.5A, 1000 PIV 4/\$1.00 IN 914 SIL SIGNAL 20/\$1.00 IN 4148 (1N914 Equiv) 20/\$1.00 DYAC 2BV 4/\$1.00	2N2722 TO 18 5/\$1.00 2N2754 TO 5 2/\$1.00 2N2712 TO 98 5/\$1.00 2N3415 TO 92 5/\$1.00 2N3704 TO 92 5/\$1.00 2N4400 TO 92 5/\$1.00 2N4125 TO 92 5/\$1.00 2N4249 TO 92 5/\$1.00 2N4437 TO 92 5/\$1.00 2N6307 PUT 2/\$1.00 2N5457 N J Fet 2/\$1.00	JUMBO RED LED's 12/\$1.00 50/\$3.95 100/\$7.50
PLUG TRANSFORMERS	LINEAR	PC TRIM
12VAC at 150 MA \$2.50 12VAC at 500 MA 3.50 7 VAC at 1.75VA 2.50	555 TIMER 2/\$1.00 556 DUAL TIMER .95 565 PLL .95 566 FUNCTION GEN. 1.75 567 TONE DECODER 1.75	POTS 25K 6/\$1.00 4.7K 6/\$1.00
IC SOCKETS	COMPUTER	SPECTROL
PINS 8 \$ 1.24 25 \$ 2.20 14 \$ 2.25 22 \$ 2.20 16 \$ 2.28 25 \$ 2.23 18 \$ 3.11 28 \$ 2.26 24 \$ 5.00 45 \$ 4.40 28 \$ 6.00 55 \$ 5.00 40 \$ 7.50 70 \$ 6.65	8080A 1K Ram 10.95 1701 E Prom 8.05 5203 E Prom 8.05 2102L1PC 1K Ram 1.95	10K 10TURN 95c 4/\$3.00
	MOLEX PINS	MISC. PRIME IC's
	REEL OF 1000 \$ 8.50 STRIP OF 100 1.25	FAIRCHILD 9316 (741611) \$ 9.95 75234 DUAL CORE SENSE AMP 1.50 MM 502H TO 5 SHIFT REG 95

PLEXIGLAS CABINETS

Black, White or Clear Cover

Great for Clocks or any LED Digital project. Clear-Red Chassis serves as Bezel to increase contrast of digital displays.



CABINET I
3" H, 6 1/4" W,
5 1/2" D

CABINET II
2 1/2" H, 5" W, 4" D

ANY SIZE / COLOR **\$6.50 ea. 2/*12.**

3" x 6" x 1 1/8" RED OR GREY PLEXIGLAS FOR DIGITAL BEZELS **95¢ ea. 4/*3**

Visit Our Store at 823 S. 21st. Avenue, Hollywood, FL.

OPTOELECTRONICS, inc.

BOX 219 • HOLLYWOOD, FLA. 33022 • (305) 921-2056



ORDER BY PHONE OR MAIL
COD ORDERS WELCOME
(\$1.00 CHG.)
Orders Under \$15 Add \$1.00 Handling
Fla. Res. Please Add 4% Sales Tax.

WE PAY ALL SHIPPING IN CONTINENTAL USA - OTHERS ADD 5% (10% FOR AIRMAIL)

INSTRUCTION

LEARN ELECTRONIC ORGAN SERVICING at home all makes including transistor. Experimental kit—trouble-shooting. Accredited NHSC, Free Booklet NILES BRYANT SCHOOL, 3631 Stockton, Dept. A, Sacramento, Calif. 95820.

EARN ELECTRONICS DEGREE by correspondence. Free information bulletin. Grantham, 2000 Stoner Avenue, Los Angeles, California 90025.

LEARN BASIC Digital Troubleshooting by correspondence. Course includes text and demonstration modules. Educational Technologies, Box 224, Reynoldsburg, Ohio 43068.

FCC EXAMINATIONS. Complete First, Second, Third Questions-Answers. Proven "topical" study method included. \$8.00. "Guaranteed Exams", Box 5516-AB, Walnut Creek, CA 94596.

BREAK INTO TV/RADIO Broadcasting. Disc Recording career. Expert reveals secret avoiding disappointment, wasted time/money. Free information. Box 921, Beverly Hills, Calif. 90213.

F.C.C. EXAM MANUAL

PASS FCC EXAMS! Memorize, study — "Test Answers" for FCC 1st and 2nd class Radio-Telephone licenses. Newly revised multiple-choice questions and diagrams cover all areas tested in FCC exams plus "Self-Study Ability Test" \$9.95 postpaid. Moneyback Guarantee.

COMMAND PRODUCTIONS P.O. BOX 26348-P
RADIO ENGINEERING DIVISION SAN FRANCISCO, CALIF. 94126

SCORE high on F.C.C. Exams. Over 300 questions and answers. Covers 3rd, 2nd, 1st and even Radar. Third and Second Test, \$14.50; First Class Test, \$15.00. All tests, \$26.50. R.E.I., Inc., Box 806, Sarasota, Fla. 33577.

UNIVERSITY DEGREES BY MAIL! Bachelors, Masters, Ph.D's. Free revealing details. Counseling, Box 317-PE02, Tustin, California 92680.

SELF-STUDY CB RADIO REPAIR COURSE. THERE'S MONEY TO BE MADE REPAIRING CB RADIOS. This easy-to-learn course can prepare you for a career in electronics enabling you to earn as much as \$16.00 an hour in your spare time. For more information write: CB RADIO REPAIR COURSE, Dept. PE027, 531 N. Ann Arbor, Oklahoma City, Okla. 73127.

LEARN WHILE ASLEEP! HYPNOTIZE! Astonishing details, strange catalog free! Autosuggestion, Box 24-2D, Olympia, Washington 98507.

GRANTHAM'S FCC LICENSE STUDY GUIDE — 377 pages, 1465 questions with answers/discussions — covering third, second, first radiotelephone examinations. \$10.70 postpaid. GSE, 2000 Stoner, Los Angeles, California 90025.

INTENSIVE 5 week course for Broadcast Engineers. FCC First Class license. Student rooms at the school. Radio Engineering Inc., 61 N. Pineapple Ave., Sarasota, FL 33577 and 2402 Tidewater Trail, Fredericksburg, VA 22401.

FREE Educational Electronics Catalog. Home study courses. Write to: Edukits Workshop, Department 721D, Hewlett, N.Y. 11557.

PRACTICAL Electronic training. FCC license. Free home study catalog. Genn Tech., 5540 Hollywood Blvd., Los Angeles, CA 90028. Or, Ra-Tel Electronics, P.O. Box 167, "P" Toronto, Ont., Canada. U.S. inquiries.

BROADCAST STATION—FM or CABLE. Start your own, become a DJ, get free tapes-records! Free details, "Broadcasting," Box 5516-AB, Walnut Creek, CA 94596.

DRAFTING—Blueprint Reading. Mechanical, Electronic, Architectural home courses \$25.00. Send \$2.00 first lesson. Prior Inc., 23-09 169th Street, Whitestone, New York City 11357.

10% OFF WITH \$25 ORDER
15% OFF WITH \$100 ORDER

THESE DISCOUNTS APPLY TO TOTAL OF ORDER — SPECIALS INCLUDED

TTL				
7400	.13	7451	.17	74153 .89
7401	.16	7451	.17	74154 1.20
7402	.15	7454	.17	74155 .97
7403	.15	7456	.17	74156 .97
7404	.16	7464	.35	74157 .99
7405	.19	7465	.35	74158 1.29
7406	.20	7470	.30	74160 1.23
7407	.28	7472	.30	74161 .97
7408	.18	7473	.35	74162 1.39
7409	.19	7474	.28	74163 1.09
7410	.16	7475	.49	74164 .99
7411	.25	7476	.30	74165 .99
7413	.43	7481	.68	74166 1.25
7414	.65	7485	.88	74170 2.10
7416	.35	7486	.40	74171 1.49
7417	.35	7489	2.25	74174 1.23
7420	.16	7490	.43	74175 .97
7422	.30	7491	.75	74176 .89
7423	.29	7492	.48	74177 .84
7425	.27	7493	.48	74180 .90
7426	.26	7494	.78	74181 2.45
7427	.29	7495	.79	74182 .79
7430	.20	7496	.99	74184 1.90
7432	.23	74100	.98	74185 2.20
7437	.25	74105	.44	74187 5.75
7438	.25	74107	.37	74190 1.15
7440	.15	74121	.38	74191 1.25
7441	.89	74122	.38	74192 .95
7442	.59	74123	.65	74193 .85
7443	.73	74125	.54	74194 1.25
7444	.73	74126	.58	74195 .74
7445	.73	74132	.89	74196 1.25
7446	.81	74141	1.04	74197 .73
7447	.79	74145	1.04	74198 1.73
7448	.79	74150	.97	74199 1.69
7450	.17	74151	.79	74200 5.45

LINEAR CIRCUITS				
300	Pos. V Reg (super 723) TO-5	\$ 7.71		
301	Hi Perf Op Amp mDIP TO-5	.29		
302	Volt Follower TO-5	.53		
304	Neg V Reg TO-5	.80		
305	Pos V Reg TO-5	.71		
307	Op AMP (super 741) mDIP TO-5	.26		
308	Micro Pwr Op Amp mDIP TO-5	.84		
309K	5V 1A regulator TO-1	1.35		
310	V Follower Op Amp mDIP	1.07		
311	Hi perf V Comp mDIP TO-5	.95		
319	Hi Speed Dual Comp DIP	1.13		
1201	Neg Reg 5, 12, 10 TO-20	1.39		
120K	Neg Reg 1.5, 12 TO-20	1.78		
322	Psychrom Timer DIP	1.70		
324	Quad Op Amp DIP	1.52		
329	Quad Comparator DIP	1.58		
340K	Pos V reg (5V, 6V, 8V, 12V, 15V, 18V, 24V) TO-3	1.69		
340T	Pos V reg (5V, 6V, 8V, 12V, 15V, 18V, 24V) TO-20	1.49		
372	AF-IF Strip detector DIP	2.93		
373	AM/FM/SSB Strip DIP	2.42		
376	Pos V Reg mDIP	1.30		
380	2w Audio Amp DIP	1.68		
380-8	Jw Audio Amp mDIP	1.55		
381	Lo Noise Dual preamp DIP	1.75		
382	Lo Noise Dual preamp DIP	1.75		
383	High New rate Op Amp	2.95		
340	Power driver TO-5	2.95		
550	Pres V Reg DIP	.79		
555	Timer mDIP	.45		
556A	Dual 555 Timer DIP	1.19		
560	Phase Locked Loop DIP	3.39		
562	Phase Locked Loop DIP	3.39		
565	Phase Locked Loop DIP TO-5	1.98		
566	Function Gen mDIP TO-5	1.15		
567	Tone Decoder mDIP	1.95		
709	Operational AMP TO-5 or DIP	.26		
710	Hi Speed Volt Comp DIP	.35		
711	Dual Difference Compar DIP	.26		
723	V Reg DIP	1.82		
732	Diff. video AMPL TO-5	.89		
739	Dual Hi Perf Op Amp DIP	1.07		
741	Comp Op Amp mDIP TO-5	.71		
747	741 Dual Op Amp DIP or TO-5	.32		
748	Freq Adj 741 mDIP	.35		
1458	Dual Comp Op Amp mDIP	.62		
1800	Stereo multiplexer DIP	2.48		
1900	Quad Amplifier DIP	3.89		
7524	Comp Mem Sense AMPL DIP	.71		
7525	Comp Mem Sense AMPL DIP	.98		
8038	Voltage control osc. DIP	4.25		

1702A UV ERASABLE PROM
— 2048 bit static PROM 256x8
elect programmable & erasable TTL/DTL comp.

\$6.95

2102 RAM	
1024 bit fully decoded static RAM	
DIP TTL compatible — 16 pin DIP	\$ 1.49
ALARM CLOCK CHIP	
MM5375AA 4-6 digit, 12 hour, mHz snooze-alarm, brightness control capability, alarm tone output 24 pin DIP	\$3.95
5738 CALCULATOR CHIP	
8 digit multiplexed — inc function — chain operation 2 key memos — floating decimal — independent constant memories with led with only digit driver — V _{CC} built-in 24 pin	2.95
7001 CLOCK CHIP	
4-6 digit, 12-24 hr. alarm, timer and date circuits — with data	\$5.95
DVM CHIP 4 1/2 DIGIT	
MM5310 — P channel device provides all logic for 4 1/2 digit volt meter, 16 pin DIP with data	\$6.95

TANTALUM CAPACITOR KIT \$19.95

1st quality capacitors in a durable styrene utility box — with color code charts.

Each: 1 ufd 35V 10 ufd 10V 1 ufd 35V 2.2 ufd 35V 67 ufd 16V 4.7 ufd 16V 10 ufd 25V 15 ufd 20V 22 ufd 16V 33 ufd 16V 47 ufd 16V 47 ufd 16V

SPECIAL DEVICES	
372 AF-IF Strip Detector DIP	2.93
546 AM Radio Receiver Subsystem DIP	.75
1310 FM Stereo Demodulator DIP	2.90
1496 Balanced Modulator-Demodulator	.99
1800 Stereo multiplexer DIP	2.48
LLN2208 FM Gain Block 34db (typ) mDIP	1.18
LLN2209 FM Gain Block 48db (typ) mDIP	1.35
JS13 Character Generator 64x8x5 DIP-24	10.20
3046 Transistor Array DIP-14	.73

CLOCK CHIPS	
MM5311 6 digit multiplexed BCD, 7 seg, 12-24 Hr, 50-60 Hz — 28 pin	4.45
MM5312 4 digit multiplexed BCD, 7 seg, 1pps, 12-24 Hr, 50-60 Hz — 24 pin	3.95
MM5314 6 digit multiplexed 12-24 Hr, 50-60 Hz 24 pin	4.45
MM5316 4 digit, 12-24 Hr, 50-60 Hz, alarm 40 pin	4.95

SHIFT REGISTERS	
MM5011 1024 bit accum. dvn	1.75
MM5016 500 x12 bit dvn	1.59
MS-4025 Quad 25 bit	.99
2504 1024 bit multiplexed dvn	3.95

IC SOCKETS	
Solder Tail - low profile	
8 pin	\$.17 24 pin .42
14 pin	.20 28 pin .59
16 pin	.22 40 pin .69
18 pin	.29
WIRE WRAP - gold plate	
14 pin	.49

MULTIPLE DISPLAYS	
MSN11 1 digit 12" red LED	1.79
HP5082 5 digit 11 red LED	3.49
2405	
HP5082 4 digit 11 red LED	3.25
7414	
SP-425 09 9 digit 25 gas disch	1.29

FREE CATALOG AVAILABLE ON REQUEST

Satisfaction guaranteed. Shipment will be made postage prepaid within 3 days from receipt of order. Payment may be made with personal check, charge card (include number and exp. date), or money order. Phone Orders — BolA and M/C card or C.O.D.

Add \$1.00 to cover shipping and handling if order is less than \$10.00. California residents add sales tax. Include shipping expense for orders shipped out of U.S. and Canada approx. 10% of order.

INTERNATIONAL ELECTRONICS UNLIMITED
P.O. BOX 3036-R MONTEREY, CA. 93940 USA
PHONE (408) 659-3171

FEBRUARY SPECIALS

LINEAR	
301 Hi perf op amp	mDIP .25
311 Hi perf V Comp	DIP .71
365 Timer	mDIP .24
365 Phase Locked Loop	DIP .98
723 V Reg	DIP .56
739 Dual Hi Perf Op Amp	DIP .89
741 Comp Op Amp	mDIP .26
1458 Dual Comp Op Amp	mDIP .54
8864 9 DIG Led Cath Drvr	DH 1.95
75150 Dual Line Driver	mDIP 1.52
75454 1351 Dual Periph. Driver	mDIP .29
75491 Quad Seg Driver for LED	DIP .62
TTL	7474 .22 74164 .85
	7432 \$.19 7490 .39 74165 .85
	7437 .20 74121 .29 74193 .73
	7438 .18 74123 .49 9602 .59
CENTRAL PROCESSING UNIT	
8008	\$19.95
8080	\$19.95

Mark I Clock Kit

A six digit clock kit with a double sided P.C. board accommodates MM5114 clock chip and 6 BND159 .375" displays, 12-24 hour, 50-60 Hz. Contains all necessary components, 3 switches, and complete assembly instructions with schematics. Connections in remote display.

Mark I	\$13.95
Transformers	
117VAC — 12V 300 ma PC Mount	\$3.95
117 VAC — 12V 300 ma wall mount	\$4.95

AUTO CLOCK KIT

6 digits .375" red led's
Operates from 12V DC or AC
Crystal control for high accuracy
Supplied with case

2 mounting bracket
Contains internal 9V battery for operation of timing circuit (without display) when removed temporarily from power. Uses 5314 clock circuit. Supplied with all necessary components and assembly instructions.

\$33.95
COMPLETELY ASSEMBLED \$44.95

DISPLAYS		DISCRETE LED'S	
MAN1	3.95	ME4	\$.29
MAN2	3.95	ME40	.12
MAN3	1.95	NSI100	.12
MAN4	2.25	NSI101	.12
MAN5	2.25	NSI102	.15
MAN6	2.49		
MAN7	1.49	MY3020	
MAN8	2.25	RED	.15
DL10A	2.19	GREEN	.15
FND500	1.89	AMBER	.15
MS711	1.19	CLEAR	.15

OPTO ISOLATORS
MC02 Opto isolator diode 1.09
MC12 Opto isolator transistor .70

Data included with order on request.
Add \$.30 ea. if item is priced below \$1.00.

INVENTIONS WANTED

INVENTORS Manufacturers Need New Products. Free "Recommended Procedure," by a creative fee-based invention service company. Washington Inventors Service, 422-T Washington Building, Washington, D. C. 20005

INVENTORS

RECOGNITION...FINANCIAL REWARD...OR CREDIT FOR "INVENTING IT FIRST" MAY BE YOURS!

If you have an idea for a new product, or a way to make an old product better, contact us, "the idea people" We'll develop your idea, introduce it to industry, negotiate for cash sale or royalty licensing. Write now without cost or obligation for free information. Fees are charged only for contracted services. So send for your FREE "Inventor's Kit." It has important Marketing Information, a special "Invention Record Form" and a Directory of 500 Corporations Seeking New Products.

RAYMOND LEE ORGANIZATION
230 Park Avenue North, New York, NY 10017

At no cost or obligation, please rush my FREE "Inventor's Kit No. A-112".

Name _____ Please Print
Address _____
City _____ State _____ Zip _____

TAPE AND RECORDERS

RENT 4-Track open reel tapes—free brochure. Stereo-Parti, P.O. Box 7, Fulton, CA 95401.

RECORDS—TAPES! Discounts to 73%, all labels; no purchase obligations; newsletter; discount dividend certificates; 100% guarantees. Free details Discount Music Club, 650 Main St., Dept 5-0277, New Rochelle, New York, N.Y. 10801.

EDISON CYLINDER phonograph recordings on cassette. SASE list. Talen, 10605 Double Spur, Austin, TX 78759.

GOVERNMENT SURPLUS

MANUALS for Govt Surplus radios, test sets, scopes. List 50 cents (coin). Books, 7218 Roanne Drive, Washington, D.C. 20021.

GOVERNMENT SURPLUS. How and where to Buy in your area, send \$2.00. Surplus, 30177-PE Headquarters Building, Washington, D.C. 20014.

RECORDS

RECORD RATERS WANTED! Anyone qualifies. We ship you nationally released LP's to rate. We pay postage and handling. You pay nothing for LP's. All you pay is small membership fee. Applicants accepted "first come basis." Write: E.A.R.S., Inc., Dept PE, Box 10245, 5521 W. Center Street, Milwaukee, Wisconsin 53210.

S.D. SALES CO.

P.O. BOX 28810 - D
DALLAS, TEXAS 75228

Z-80 CPU CARD KIT FOR IMSAI/ALTAIR

\$149.^{KIT}

From the same people who brought you the \$89.95 4K RAM kit. We were not the first to introduce an IMSAI/ALTAIR compatible Z-80 card, but we do feel that ours has the best design and quality at the lowest price.

The advanced features of the Z-80 such as an expanded set of 158 instructions, 8080A software compatibility, and operation from a single 5VDC supply, are all well known. What makes our card different is the extra care we took in the hardware design. The CPU card will always stop on an M1 state. We also generate TRUE SYNC on card, to insure that the rest of your system functions properly. Dynamic memory refresh and NMI are brought out for your use. Believe it or not, not all of our competitors have gone to the extra trouble of doing this.

As always, this kit includes all parts, all sockets, and complete instructions for ease of assembly. Because of our past experience with our 4K kit we suggest that you order early. All orders will be shipped on a strict first come basis. Dealers inquiries welcome on this item.

Kit shipped with 2 MHZ crystals for existing 500NS memory. Easily modified for faster RAM chips when the prices come down.
Z-80 Manual - \$7.50 Separately.

Kit includes Zilog Manual and all parts.

JUMBO LED CAR CLOCK

\$16.95 KIT

You requested it! Our first DC operated clock kit. Professionally engineered from scratch to be a DC operated clock. Not a makeshift kluge as sold by others. Features: Bowmar 4 digit .5 inch LED array, Mostek 50252 super clock chip, on board precision time base, 12 or 24 hour real time format, perfect for cars, boats, vans, etc. Kit contains PC Board and all other parts needed (except case). 50,000 satisfied clock kit customers cannot be wrong!

FOR ALARM OPTION ADD \$1.50
FOR XFMR FOR AC OPERATION ADD \$1.50

60 HZ CRYSTAL TIME BASE FOR DIGITAL CLOCKS S.D. SALES EXCLUSIVE!

KIT FEATURES:

- A. 60HZ output with accuracy comparable to a digital watch.
- B. Directly interfaces with all MOS Clock Chips.
- C. Super low power consumption. (1.5 ma typ.) **\$5.95 or 2/\$10.**
- D. Uses latest MOS 17 stage divider IC.
- E. Eliminates forever the problem of AC line glitches.
- F. Perfect for cars, boats, campers, or even for portable clocks at ham field days.
- G. Small Size, can be used in existing enclosures.

KIT INCLUDES CRYSTAL, DIVIDER IC, PC BOARD PLUS ALL OTHER NECESSARY PARTS & SPECS

50HZ CRYSTAL TIME BASE KIT - \$6.95

All the features of our 60HZ kit but has 50HZ output. For use with clock chips like the 50252 that require 50HZ to give 24 hour time format.

THIS MONTH'S SPECIALS!

- 300.00 KHZ CRYSTAL - \$1.50
- 8080A - CPU CHIP by AMD - \$19.95
- 82S129 - 256 x 4 PROM - \$2.50
- N.S. 8865 OCTAL DARLINGTON DRIVERS 3 for \$1.00
- Z-80 - CPU by ZILOG - \$69.95
- MM5204 - 4K EPROM - \$7.95

Prices in effect this month ONLY!

4K LOW POWER RAM BOARD KIT THE WHOLE WORKS - \$89.95

Imsai and Altair 8080 plug in compatible. Uses low power static 21L02-1 500ns. RAM's, which are included. Fully buffered, drastically reduced power consumption, on board regulated, all sockets and parts included. Premium quality plated thru PC Board.

7400-19c	7411-29c	7451-19c	7490-65c	74153-75c
74LS00-49c	7413-50c	7453-19c	74LS90-95c	74154-1.00
7402-19c	7416-69c	7473-39c	7492-75c	74157-75c
74LS02-49c	7420-19c	7474-35c	7493-69c	74161-95c
7404-19c	7430-19c	74LS74-59c	7495-75c	74164-1.10
74L04-29c	7432-34c	7475-69c	7496-89c	74165-1.10
74S04-44c	7437-39c	7476-35c	74121-38c	74174-95c
74LS04-49c	7438-39c	7480-49c	74123-65c	74181-2.50
7406-29c	7440-19c	7483-95c	74132-1.70	74191-1.25
7408-19c	7447-85c	7485-95c	74S138-1.95	74192-1.25
7410-19c	7448-85c	7486-45c	74141-75c	74193-1.00
TTL INTEGRATED CIRCUITS				

STICK IT!
in your clock
in your DVM, etc.!

\$3.95

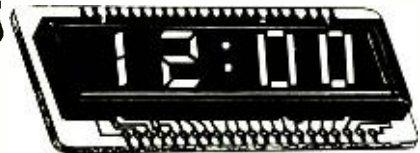

4 JUMBO .50" DIGITS ON ONE STICK! (with colons and AM/PM Indicator)

Huge Special Purchase Not Factory Seconds As sold by others!

BUY 3 for \$10.

BOWMAR 4 DIGIT LED READOUT ARRAY

The Bowmar Opto-Stick. The best readout bargain we have ever offered. Has four common cathode jumbo digits with all segments and cathodes brought out. Increased versatility since any of the digits may be used independently to fit your applications. Perfect for any clock chip, especially direct drive units like 50380 or 7010. Also use in freq. counters, DVM's, etc. For 12 or 24 hour format.

UP YOUR COMPUTER!

21L02-1 1K LOW POWER 500 NS STATIC RAM TIME IS OF THE ESSENCE!

And so is power. Not only are our RAM's faster than a speeding bullet but they are now very low power. We are pleased to offer prime new 21L02-1 low power and super fast RAM's. Allows you to STRETCH your power supply farther and at the same time keep the wait light off. **8 for \$12.95**

\$12.95

S.D. SALES EXCLUSIVE! MOS 6 DIGIT UP-DOWN COUNTER

\$12.95

40 PIN DIP. Everything you ever wanted in a counter chip. Features: Direct LED segment drive, single power supply (12 VDC TYP.), six decades up/down, pre-loadable counter, separate pre-loadable compare register with compare output, BCD AND seven segment outputs, internal scan oscillator, CMOS compatible, leading zero blanking, 1MHZ. count input frequency. Very limited qty. **WITH DATA SHEET**

WESTERN DIGITAL UART

No. TR1602B. 40 pin DIP This is a very powerful and popular part.

NEW-\$6.95 with data LIMITED QUANTITY

RESISTOR ASSORTMENT

1/4 W 5% and 10% PC leads. A good mix of values. **200/\$2.**

FAIRCHILD BIG LED READOUTS

A big .50 inch easy to read character. Now available in either common anode or common cathode. Take your pick. Super low current drain, only 5MA per segment typical.

FND 510 Common Anode
FND 503 Common Cathode
PRICE SLASHED! 59c each

TERMS:

Money Back Guarantee. No COD. Texas Residents add 5% tax. Add 5% of order for postage and handling. Orders under \$10. add 75c. Foreign orders: **US Funds ONLY!**

SLIDE SWITCH ASSORTMENT



Our best seller. Includes miniature and standard sizes, single and multi-position units. All new, first quality, name brand. Try one package and you'll reorder more. **SPECIAL 12/\$1.**

MOTOROLA POWER DARLINGTON Back in Stock!

Like MJ3001. NPN 80V. 10A. HFE 6000 TYP. TO-3 case. We include a free 723C volt reg. with schematic for power supply. **SPECIAL-\$1.99**

CALL YOUR BANK AMERICARD OR MASTER CHARGE ORDER IN ON OUR CONTINENTAL UNITED STATES TOLL FREE WATTS:

1-800-527-3460

Texas Residents Call Collect

214/271-0022

S.D. SALES CO.
P.O. BOX 28810 · D
Dallas, Texas 75228

For orders over \$15.00 Choose \$1.00 FREE mdse.

EDI

ULTRASONIC TRANSDUCER

Transmits or receives 40K Hz ultrasonic waves. Used in building remote controls for radios, TVs, appliances, remote switching, signaling and ultrasonic intrusion protecting devices and alarms.

M-1 **2.49**

DYNAMIC TRANSISTOR CHECKER

Tests transistors in circuit or out of circuit. The Dynamic Transistor Checker lets you match transistors in working circuits to improve the operation. It will test Go and No Go at currents from 5ma to 50ma and will show current gain, electrical open and short circuits. Tests low, medium and high power transistors both PNP and NPN types. Complete with transistor socket test clips and leads. Uses VM2 or C1 1/4 battery. Size of case 6 1/2" x 3 1/2" x 2"

F-144 **9.99**

DC POWER SUPPLY

This DC power supply will deliver four ranges of DC voltages 4.5V, 8V, 9V and 12V. It will supply a fully filtered output of one of these voltages at 150 milliamperes capacity. Can be used for any DC power supply within the voltage range and capacity, such as operating a small battery radio, operating a small calculator, or powering miscellaneous laboratory experiments. Uses standard 117V 60C AC power. Output binding posts accept BNC or banana plugs. With 4 1/2' cord and plug. Size of case 5" x 2 1/2" x 1 1/2" x 1 1/2".

15.88 Value
F-145 **5.99**

TRANSISTORIZED SIGNAL TRACER

EDI Special!!

This transistorized signal tracer can be used by technicians and service men to audibly trace signals of RF and IF and audio circuits from the antenna to the speaker stage by stage. An ideal tool for servicing audio equipment, amplifiers, tuners, receivers, turntables, etc. Has 2" speaker and test leads. Uses N555 9V transistor battery. Size of case 5" x 2 1/2" x 1 1/2" x 1 1/2". Leads and instructions included.

Was 17.88
F-171 **9.99**

ELECTRONIC DUAL TRACE OSCILLOSCOPE

CONVERSION INSTRUMENT

Convert Your Old Oscilloscope To Dual Trace With Simpson Model 318-SR

Now you don't have to trade in your old oscilloscope. You now can easily convert it to an up-to-date dual trace scope with the Simpson model 318-SR conversion instrument. For just a fraction of Simpson's original suggested selling price of \$189.95. Specifications: Switching Rates Approximately 150, 500, 15000Hz. Signal Frequency Response $\pm 10\%$. 0-100K Hz. Maximum Signal Output 25-Volt Peak To Peak. Input Impedance 100K Ohm. Maximum Input At Max. Gain 5-Volt Peak to Peak. Dimensions 11 1/2" H x 7 1/2" W x 7 1/2" D.

LIMITED QUANTITY

F-486 EDI Value Price **29.99**

VOICE ACTIVATED SOLID STATE SWITCH

Lights on when activated and opens when circuit is momentarily disconnected. Features sensitivity adjustment.

S-45 **1.49** 3/4.00

PANASONIC MODEL 450C-II

CD-4 SEMICONDUCTOR TYPE STEREO CARTRIDGE

Special Diamond Stylus Tip • Stylus Pressure Range 1.5 to 2.5 gr. Special!! **\$59.88** Value

CB-11 **19.99**

24-KEY DESK CALCULATOR KEYBOARD

High torque type contacts • Connects on circuit board • Fringe leads, vep, and 4 slide switches • 7 1/2" B.S. x 3 1/4" H. B.S. x 1 1/2" H. B.S. • 1 1/4" Lower board • Shipping wt. 1 lb.

1.99

E-206 3/5.50

SPERRY-RAND UNIVAC KEYPUNCH KEYBOARD ASSEMBLY

A fantastic assembly, filled with quality component parts. The ideal training keyboard • a super bargain on a complete assembly. Size 13" x 8 1/2" x 4 1/2". Shipping Wt. 10-Lbs.

N-45 **18.88**

PKG/10 1 1/2-VOLT HOBBY MOTORS

High Torque Type • Small In Size

Ideal For Hobbyists, Experiments, Etc.

X-11 **.99**

PRECISION 1-RPM TIMING MOTOR

Timing Motor For Clocks, Displays, Etc.

Shipping Wt. 1/4-LB.

G-400 **.39** 3/1.00

4-RANGE DIGITAL READOUT INTERVAL TIMER KIT

4 time functions: 1.59 Sec., 1.99 Sec., 1.99 Min., 1.99 Min. • 1/2" High Nixie Tube Readouts • For darkroom use in both processing & enlarging processes • As a timer for sport & contest events (stop watch) • Provides timed 120V AC outlet and S.P. NO contact to trigger buzzer alarm or visual signals • Full Wiring Instructions included • No Cabinet Or Case Available For Timer.

100.00 VALUE • Accurate to 1/10 of 1% • LED for Visual Timing SPECIAL **19.99**

Send for free catalog - satisfaction guaranteed

Min. Order \$3.00 - Allow For Postage

Ill. Residents Add 5% Sales Tax

Prices good thru February 28, 1977 or while stocks last.

Notice: Some items may be of limited quantities and subject to prior sale.

ELECTRONIC DISTRIBUTORS, INC.

DEPT. PE 1-4900 ELSTON

CHICAGO, ILL. 60630

Tel: 312/283-4800

CLUBS

HEY! Got Old Radio Programs, trade-em. Join International Club. \$2. Winslow, Box 281, Roosevelt, N.Y. 11575.

REAL ESTATE

BIG, FREE, SPRING 1977 CATALOG! Over 2,600 top values coast to coast! UNITED FARM AGENCY, 612-EP, West 47th, Kansas City, MO 64112

EMPLOYMENT OPPORTUNITIES

OVERSEAS JOBS — NOW HIRING! High Pay! All Occupations. Transportation. Computerized Reports — \$2.00. TRANSWORLD, International Airport, 3623-N, Los Angeles, Calif. 90009.

AUSTRALIA — NEW ZEALAND, WANT YOU!!! 50,000 Jobs! Transportation! Latest information. \$2.00. AUSTCO, Box 3623-N, Long Beach, Calif. 90803.

ELECTRONICS/AVIONICS EMPLOYMENT OPPORTUNITIES. Report on jobs now open. Details FREE. Aviation Employment Information Service, Box 240E, Northport, New York 11768.

RUBBER STAMPS

RUBBER STAMPS, BUSINESS CARDS Many new products. Catalog Jackson's, Dept. K, Brownsville Rd., Mt. Vernon, Ill. 62864.

DO-IT-YOURSELF

MODULAR TELEPHONES now available. Sets and components, compatible with Western Electric concept. Catalog 50 cents. Box 1147W, San Diego, California 92112.

WANT HELP? Where/what to buy, design, build, get working. All areas including audio; CB; Remote-Control; recording; security; telephone; TV; etc. For an informative answer fast, send letter with full particulars and \$8.00 to: E.R. Gunny, Consultant, 7612 Alverstone Avenue, Los Angeles, Calif. 90045.

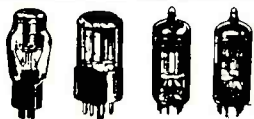

70% OFF LIST!

1AD2	1.59	6AU8	2.15
1B3GT	1.58	6AV6	1.11
1K3	1.58	6AW8A	1.79
1S2A	2.27	6AX4GTB	1.52
1U4	1.58	6AY3B	1.52
1V2	.96	6AZ8	2.30
1X2B	1.56	6BA6	1.34
2AH2	1.59	6BA11	1.95
2AV2	1.26	6BE6	1.47
2D21	1.95	6BH11	1.77
2GK5	1.58	6BJ6	1.65
3A3C	1.61	6BK4C6	2.98
3A5	2.50	6BK7B	2.07
3AT2B	1.56	6BL8	1.10
3BS2	1.70	6BM8	1.10
3CU3A	1.95	6BN6	1.97
3CY3	1.76	6BN8	1.56
3DJ3	1.70	6BN11	2.46
3GK5	1.55	6BQ5	1.56
3HA5	1.53	6BQ7A	2.09
3H05	2.27	6BR8A	2.12
3JC6A	2.06	6BX6	1.49
3V4	1.83	6BZ6	1.26
4AU6	1.58	6C4	1.58
4BL8	.92	6CA4	1.60
4BZ6	1.41	6CA7	2.04
4CB6	1.10	6CB6A	1.32
4DT6	1.56	6CG3	1.58
4EH7	1.46	6CD6GA	2.83
4EJ7	1.46	6CG7	1.22
4HS8	1.50	6CG8A	1.73
4JC6A	2.04	6CJ3	1.50
4JD6	1.88	6CL3	1.61
4KE8	2.48	6CL6	2.07
4L8	1.80	6CL8	1.95
5A04	4.50	6CM7	1.71
5EW6	1.63	6CU5	1.65
5GH8A	1.88	6CW4	3.30
5GJ7	1.11	6CW5	1.02
5GS7	1.17	6DJ8	2.25
5GX7	1.68	6DL4	2.39
5HZ6	1.20	6D06	2.15
5JK6	1.47	6DT6A	1.32
5JL6	1.47	6DW4	1.50
5KE8	2.48	6DX8	1.01
5L8	1.76	6EA8	1.58
5U4GB	1.23	6EB8	2.40
5Y3GT	1.32	6EH7	1.53
5Y4GT	1.14	6EJ7	1.43
6A8	4.69	6EM7	2.25
6AB4	1.53	6EJ7	1.61
6AC7	2.36	6EW6	1.43
6AC10	1.73	6EJ7	2.38
6AD10	3.68	6FGGT	3.49
6AF4	2.21	6FG6	1.29
6AF9	2.13	6FG7	2.18
6AH6	2.94	6FM7	1.85
6AJ8	1.74	6G5	2.16
6AL3	.92	6GF7A	2.12
6AL5	1.31	6GH8A	1.26
6AN8A	1.82	6GJ7	1.11
6AO5	1.35	6GK5	1.86
6AO8	.98	6GK6	1.41
6AR5	.81	6GM6	1.68
6AS8	2.48	6GM8	3.30
6AU4GT	1.97	6GS7	1.37
6AUSGT	2.41	6GU7	1.68
6AU6A	1.31	6GW8	.98

EDLIE BARGAIN BONANZA OF HIGHEST QUALITY TUBES

BUY BRAND NEW MANUFACTURER'S BOXED TUBES (Raytheon, Dumont, IEC Mullard, etc.) AT 70% OFF LIST!

HERE IS A BIGGER & BETTER LIST THAN WE EVER OFFERED BEFORE... AND REMEMBER... 70% OFF LIST!

ALL TUBES BRAND NEW MANU. BOXED 70% OFF

MINIMUM ORDER \$7.50

MONEY BACK GUARANTEE

Terms: Minimum order \$7.50. Include postage. Either full payment with order or 20% deposit, balance C.O.D.

6GX6	1.38	6JH8	2.51
6H6	2.71	6JM6A	2.16
6HA5	1.53	6JN6	2.03
6HB7	1.55	6JN6	3.54
6HE5	1.91	6JS6C	2.95
6HF5	3.78	6JT6	2.40
6HF8	2.16	6JT8	1.91
6H05	2.03	6JU6	2.84
6HS5	2.94	6JW8	1.77
6HS6	1.46	6JV8	1.80
6H58	1.91	6JW8	1.35
6HV5	3.54	6K6GT	1.64
6HZ6	1.28	6K7GT	2.24
6J5	1.89	6K8	4.69
6J7	2.31	6KA8	1.95
6J10	2.45	6KD6	3.38
6JB6	2.42	6KE8	2.45
6JG6A	1.79	6KM6	3.38
6JG6	1.85	6KT8	2.18
6JG6C	3.35	6KV6A	2.67
6JG6A	2.67	6KZ8	1.64
6JH6	1.43	6L6	4.86

WRITE FOR FREE VALUE PACKED CATALOG

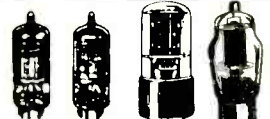

70% OFF LIST!

6L7	2.84	12BH7A	1.58
6LB6	3.23	12BY7	1.43
6LE8	2.27	12DQ6B	2.10
6LF6	3.20	12FX5	1.34
6LF8	2.34	12GN7	2.22
6LJ8	1.76	12HL7	1.95
6LM8	1.95	12JB6A	2.55
6LN8	1.05	12MD8	1.77
6LT8	1.64	12SL7	2.31
6LJ8	1.92	13GF7A	2.09
6LX8	1.05	13Z10	2.55
6M11	2.76	14BL11	3.11
6M88	1.52	15BD11A	2.25
6MD8	2.34	15CW5	.87
6SA7	2.04	15KY8A	2.91
6SG7	2.30	16A8	1.23
6SJ7	2.19	16L8A	2.97
6SK7	2.03	17AY3A	1.52
6SL7GT	2.30	17B3	1.32
6SN7GT	1.52	17BF11	2.39
6S07	2.01	17BR3	1.23
6T8A	1.92	17B53	1.52
6T10	2.25	17CK3	1.31
6U8A	1.56	17C05	1.26
6U10	1.62	17DW4	1.41
6V6	3.57	17JN6	2.16
6X4	1.46	17J06	1.85
6X5GT	1.47	17JZ8	1.43
6Y9	1.82	19CG3	1.58
7F8	6.00	20AQ3	1.17
7V7	3.00	21GY5	2.01
8A8	.93	21HB5	1.92
8AC9	1.88	21J56	4.30
8AR11	2.46	21JZ6	2.10
8B10	1.80	21LR8	1.89
8BA11	2.25	21LJ8	1.86
8BM11	2.30	22JF6	2.66
8BQ11	1.98	22J86	2.73
8BU11	2.30	22KM6	3.08
8CG7	1.12	23Z9	1.91
8JV8	1.86	24JF6C	3.20
8L8	1.61	25CG3	1.38
9A08	2.31	29K06	3.53
9G8H	1.67	30AE3	1.17
9JW8	1.26	31JS6C	2.89
10CW5	1.02	31L06	3.05
10DX8	.98	31JZ6	3.38
10GK6	1.82	33GY7A	2.42
10GN8	1.92	35C5	1.31
10J18	2.06	35W4	.89
10JY8	1.50	35Z5GT	1.41
10K8	2.04	36K06	3.36
11AF9	2.13	38H7	2.92
11AR11	2.46	38H7	2.86
11BM8	1.86	40K6GA	3.26
11FV7	1.52	42EC4A	1.59
11KX8	2.20	42KN6	2.75
11MS8	1.53	50B5	1.21
12AB5	1.41	50C5	1.23
12AT6	1.13	50E5H	1.47
12A7	1.37	50GY7A	3.60
12AU7A	1.23	50L6GT	1.95
12AV6	1.02	80	1.88
12AX7A	1.13	6267	2.10
12AZ7A	1.74	6973	1.85
12BA4	1.77	7025A	1.13
12BA6	1.16	7189A	1.73
12BE6	1.22	7199	2.06

EDLIE ELECTRONICS, INC.

2700-KP HEMPSTEAD TPKE., LEVITTOWN, N. Y. 11756

SOCKETS

LOW PROFILE, SOLDER, TIN

8 Pin	0.16	0.15	0.14	18 Pin	0.28	0.27	0.26	28 Pin	0.44	0.43	0.42
14 Pin	0.19	0.18	0.17	22 Pin	0.36	0.35	0.34	36 Pin	0.59	0.58	0.57
16 Pin	0.21	0.20	0.19	24 Pin	0.37	0.36	0.35	40 Pin	0.62	0.61	0.60

STANDARD, SOLDER, TIN				STANDARD, SOLDER, GOLD				WIREWRAP GOLD (Level No.3)			
14 Pin	1.24	25.49	50.100	8 Pin	1.24	25.49	50.100	10 Pin	1.24	25.49	50.100
16 Pin	0.27	0.25	0.24	14 Pin	0.30	0.27	0.24	14 Pin	0.39	0.38	0.37
18 Pin	0.35	0.32	0.30	16 Pin	0.38	0.35	0.32	16 Pin	0.43	0.42	0.41
24 Pin	0.49	0.45	0.42	18 Pin	0.52	0.47	0.43	18 Pin	0.75	0.68	0.62
28 Pin	0.99	0.90	0.81	24 Pin	0.70	0.63	0.57	24 Pin	1.05	0.95	0.85
36 Pin	1.39	1.26	1.15	28 Pin	1.10	1.00	0.90	28 Pin	1.40	1.25	1.10
40 Pin	1.59	1.45	1.30	36 Pin	1.75	1.40	1.26	36 Pin	1.59	1.45	1.30
				40 Pin	1.75	1.55	1.45	40 Pin	1.75	1.55	1.40

SOLID-STATE

Digital Auto Clock

Build-It-Yourself Kit

FROM



TECHNOLOGY KIT
automobile clock

FAIRCHILD

COMPLETE KIT
— ONLY \$40.00

Our Quality Is Best!

NEW 7400 SERIES CMOS

74C00N	38	74C74N	90	74C157N	340	74C195N	180
74C02N	40	74C75N	100	74C160N	210	74C221N	210
74C04N	60	74C83N	275	74C161N	210	74C901N	100
74C08N	40	74C85N	275	74C162N	210	74C902N	100
74C10N	50	74C86N	100	74C163N	210	74C903N	100
74C14N	220	74C87N	1400	74C164N	180	74C904N	100
74C20N	50	74C89N	270	74C165N	180	74C906N	100
74C30N	50	74C93N	270	74C173N	180	74C907N	100
74C32N	50	74C95N	180	74C174N	170	74C914N	270
74C42N	210	74C107N	90	74C175N	170	80C95	100
74C43N	330	74C151N	300	74C192N	210	80C97	100
74C73N	120	74C154N	570	74C193N	210		

SAMS BOOKS

TTL COOKBOOK No.21035	\$8.95
IC OP-AMP COOKBOOK No.20969	\$12.95
SECOND CLASS RADIOTELEPHONE LICENSE HANDBOOK, 5TH Ed. No.21111	\$7.50
TRANSISTOR SUBSTITUTION HANDBOOK, 15th Ed. No.21169	\$4.50
REFERENCE DATA FOR RADIO ENGINEERS, 6th Ed. No.21218	\$30.00
BASIC ELECTRICITY/ELECTRONICS SERIES, Vol.1: BASIC PRINCIPALS AND APPLICATIONS No.20167	\$5.50
TV TYPEWRITER COOKBOOK No.21313	\$9.95

TRANSISTOR SPECIFICATIONS MANUAL, 7th Ed. No.21208

\$5.95

FIRST-CLASS RADIOTELEPHONE LICENSE HANDBOOK, 4th Ed. No.21144

\$7.50

SEMICONDUCTOR REPLACEMENT GUIDE No.21092

\$3.95

BUILDING & INSTALLING ELECTRONIC INTRUSION ALARMS No.20929

\$4.50

UNDERSTANDING IC OPERATIONAL AMPLIFIERS No.20855

\$3.95

HOW TO USE IC LOGIC ELEMENTS, 2nd Ed. No.21081

\$4.50

UNDERSTANDING CMOS INTEGRATED CIRCUITS No.21129

\$4.95

OK WIRE-WRAP TOOL & WIRE

WSU 30	Wire wrap tool	\$5.95
R-30S 0050	50ft. roll, blue wire	30AWG \$1.98
R-30Y 0050	50ft. roll, yellow wire	30AWG \$1.98
R-30W 0050	50ft. roll, white wire	30AWG \$1.98
R-30R 0050	50ft. roll, red wire	30AWG \$1.98

CONTINENTAL SPECIALTIES

Proto boards & experimenters

Build & test circuits as fast as you think!

PB-6	\$15.95	PB103	\$59.95
PB100	19.95	PB104	79.95
PB101	29.95	EX300	9.95
PB102	39.95	EX600	10.95

CARBON FILM RESISTORS (5%)

Only in Multiples of 100 pcs per value (ohms)

*W ... \$1.69 per 100
*W ... \$1.79 per 100

10 100	1.0K	10K	100K	1.0M
11 110	1.1K	11K	110K	1.1M
12 120	1.2K	12K	120K	1.2M
13 130	1.3K	13K	130K	1.3M
15 150	1.5K	15K	150K	1.5M
16 160	1.6K	16K	160K	1.6M
18 180	1.8K	18K	180K	1.8M
20 200	2.0K	20K	200K	2.0M
22 220	2.2K	22K	220K	2.2M
24 240	2.4K	24K	240K	2.4M
27 270	2.7K	27K	270K	2.7M
30 300	3.0K	30K	300K	3.0M
33 330	3.3K	33K	330K	3.3M
36 360	3.6K	36K	360K	3.6M
39 390	3.9K	39K	390K	3.9M
43 430	4.3K	43K	430K	4.3M
47 470	4.7K	47K	470K	4.7M
51 510	5.1K	51K	510K	5.1M
56 560	5.6K	56K	560K	5.6M
62 620	6.2K	62K	620K	6.2M
68 680	6.8K	68K	680K	6.8M
75 750	7.5K	75K	750K	7.5M
82 820	8.2K	82K	820K	8.2M
91 910	9.1K	91K	910K	9.1M

PROTO BOARDS

With built-in regulated short-proof power supplies

PB203	5V, 1 amp regulated power supply	\$7.50
PB203A	5V, 1 amp and ±15V, 5 amp regulated power supply	120.00

LOGIC MONITOR 1

Simultaneously displays static and dynamic logic states of digital ICs such as R, DTL, TTL, HTL or CMOS. Traces logic levels and pulses through digital circuitry. DIP ICs. Pocket size. \$74.95

LOGIC MONITOR 2

Displays static and dynamic logic states of digital ICs such as R, CMOS, HTL, TTL, DTL & CRTL. Selectable threshold control. \$124.95

RESISTOR ASSORTMENTS

Each assortment contains 5 pcs each of 10 different values. Values included are shown in (Ohms)

*W5% (50 pcs total) ... \$1.75 / *W5% (50 pcs total) ... \$1.85

Ass't. 1: 10, 22, 33, 47, 100, 150, 220, 270, 330, 390 ohm

Ass't. 2: 470, 560, 680, 820 ohm, 1K, 1.2K, 1.5K, 1.8K, 2.2K, 2.7K

Ass't. 4: 3.3K, 3.9K, 4.7K, 5.6K, 6.8K, 8.2K, 10K, 12K, 15K, 18K

Ass't. 5: 22K, 27K, 33K, 39K, 47K, 56K, 68K, 82K, 100K, 120K

Ass't. 6: 150K, 180K, 220K, 270K, 330K, 390K, 470K, 560K, 680K, 820K

Ass't. 7: 1M, 1.2M, 1.5M, 1.8M, 2.2M, 2.7M, 3.3M, 3.9M, 4.7M, 5.6M, 6.8M, 8.2M, 10M, 12M, 15M, 18M

(%W Assortment No. 7 doesn't include 5.6M)

Ass't. 8R: (All seven Ass't. 7 above) plus 5.6M

*W5% 350 pcs total: \$10.95 *W5% 350 pcs total: \$11.55

SOCKETS & BUS STRIPS

Plug-in, wire, test, modify or expand without patch cords or solder. Snap together to form breadboard needed.

PN/Description	Term's	Price
QT598 Socket	118	\$12.50
QT599 Bus	20	2.50
QT475 Socket	94	10.00
QT478 Bus	16	2.25
QT358 Socket	70	8.50
QT359 Bus	12	2.00
QT185 Socket	36	4.75
QT128 Socket	24	3.75
QT85 Socket	16	3.25
QT75 Socket	14	3.00

BREADBOARD JUMPER WIRE KIT

Each kit contains 350 wires cut to 14 different lengths from 0.1" to 5.0". Each wire is stripped and leads are bent 90° for easy insertion. Wire length is classified by color coding. All wire is solid tinned 22 gauge with PVC insulation. The wires come packed in a convenient plastic box. BK-1 \$9.95

FEBRUARY SPECIALS

SANKEN HYBRID POWER AMPLIFIER

SI-1010G \$6.90
SI-1020G \$13.95
SI-1050G \$24.95

MICROHOOK KIT

XMS Micro Hook Kit
10 for \$7.95

BUFFER REGISTERS/MULTIPLIERS LSI

N8200N	3.80	N8233B	1.50
N8201N	3.80	N8234B	1.50
N8202N	3.80	N8235B	1.50
N8203N	3.80	N8242A	2.80
N8204N	3.80	N8231B	1.50
N8230N	1.36	N8263N	10.20
N8231B	1.36	N8266B	1.75
N8232B	1.50		

MATSUO DIPPED TANTALUM CAPACITORS

MF	V	\$	MF	V	\$
1.35	33	6.8	16	40	1.50
15	35	10.0	18	42	1.50
22	35	10.0	18	42	1.50
33	35	13.0	25	45	1.50
47	35	13.0	25	45	1.50
68	35	15.0	20	45	1.50
10	35	15.0	22	45	1.50
15	35	15.0	22	45	1.50
22	35	15.0	22	45	1.50
33	35	15.0	22	45	1.50
47	35	15.0	22	45	1.50

PLESSEY POLYESTER (CAPACITOR) MINI BOX

MF	V	\$	MF	V	\$
0012	1000	14	039	250	15
0015	1000	14	047	250	15
0018	1000	14	056	250	15
0022	1000	14	068	250	17
0027	1000	14	1	100	17
0033	1000	14	12	100	18
0039	630	14	15	100	20
0047	630	14	18	100	21
0056	630	14	22	100	23
0068	630	14	27	100	26
0082	630	14	33	100	30
0100	630	14	39	100	33
0120	630	14	47	100	37
0150	400	15	56	100	44
0180	400	15	68	100	47
0220	400	15	82	100	54
0270	400	15	100	100	60
0330	250	15	1	100	60
0400	250	15	1	100	60

XR FUNCTION GENERATOR

XR-2206KA SPECIAL \$16.95
XR-2206KB SPECIAL \$26.95

Includes monolithic function generator, IC, PC board, and assembly instruction manual.

Same as XR-2206KA and includes external components for PCB board.

PLESSEY SAMPLER

300 METALLIZED CAPACITORS 18 DIFFERENT STD. VALUES \$26.00

L-15 PULSE/SWEEP FUNCTION GENERATOR KIT

FEATURES: 1 Hz to 100 KHz in 5 ranges, at constant amplitude • Sine and triangle adjustable to 20Vp-p in 600 ohms • Sine distortion is 5% typical • Voltage controlled sweep of sine and triangle waves • TTL square wave has a fully adjustable pulse and drives 600 ohms • Frequencies of lower than 1 Hz and greater than 100 kHz are obtainable • Short proof • Complete with power supply and metal case. \$55.00

ANCORNA

Minimum order \$10.00. Add \$1.00 to cover postage and handling. California Residents add 6% sales tax. Mail Order — Send check or money order to P.O. Box 2208P Culver City, CA 90230. COD, Master Charge and BankAmericard Welcomed. (Stores do not accept mail or phone orders.) Books will be shipped by 4th class rate.

• Phone Order — Call: (213) 641-4064

CALIFORNIA ANCRONA 11080 Jefferson Blvd. Culver City, CA 90230 (213) 390-3595	CALIFORNIA ANCRONA 1300 E. Edinger Ave. Santa Ana, CA 92705 (714) 547-8424	ARIZONA ANCRONA 4518 E. Broadway Tucson, AZ 85711 (602) 881-2348	OREGON ANCRONA 1125 N.E. 82nd Ave. Portland, OR 97220 (503) 254-5541	GEORGIA ANCRONA 3330 Piedmont Rd. NE Atlanta, GA 30305 (404) 261-7100	CANADA, B.C. ANCRONA 5656 Fraser St. Vancouver, BC V5W 2Z4 (423) 324-0707
--	---	---	---	--	--

World's Lowest IC Prices

SPECIAL PRICES*

MEMORIES	74152	90	HIGH SPEED	4007	16
Rams	74155	60	74H00	4008	70
2102	74157	60	74H01	4011	16
Proms	74160	75	74H04	4013	30
82523 S123 1.95	74161	75	74H10	4015	80
			74H11	4016	35
TTL	74163	75	74H40	4019	70
7400	74165	80	74H51	4020	90
7402	74173	1.25	74H52	4021	95
7403	74174	75	74H74	4023	16
7404	74175	75	74H103	50	104
7407	74177	70	74H106	50	104
7410	74180	80			
7420	74181	1.50			
7427	74182	1.50			
			LOW POWER	4027	40
			SCHOTTKY	4028	60
			74LS00	29	4030
			74LS02	29	4030
			74LS08	29	4033
			74LS10	29	4044
			74LS17	30	4044
			74LS73	45	4049
			74LS75	65	4050
			74LS151	110	4066
			74LS153	110	4068
			74LS157	110	4069
			74LS161	150	4073
			74LS163	150	4073
			74LS164	150	4075
			74LS174	110	4516
			74LS175	150	4528
			74LS193	150	4585
			74LS221	150	LINEARS
			74LS251	150	NE536T
			74LS253	150	NE555V
			74LS257	150	NE556A
			74LS258	150	1456V
			CMOS	1458V	90
			4001	16	566V
			4002	16	567V
			4006	90	540L

Order Minimum \$10.00. Add \$1.00 shipping and handling charge per order. California residents add 6% sales tax. All orders shipped First Class within 24 hours.

Order the famous Basis 6 volume Programmed Learning Course. Microcomputer Design is a Snap for \$99.50 and receive a special \$10.00 credit on any group of IC's.

Satisfaction 100% guaranteed. C.O.D. Orders Phone (day or night) 408 354-1448

ELTRON

PO BOX 2542A
Sunnyvale, CA 94087

Free monthly catalog—Just send us your name and address.

CIRCLE NO. 29 ON FREE INFORMATION CARD

COLOR TV CHASSIS AND PARTS

New 1976 mould solid state Color TV chassis and parts for use with In-Line black matrix picture tubes. They have the following features: micro-circuit technology; energy save feature; one button color tuning AFC; and super low power consumption.

We basically have two chassis: the TS951 and TS953, used to drive either 13", 15" or 19" picture tubes. Parts to be added to make a complete TV include: UHF and VHF tuners (for 19"); picture tube, tube shield; purity magnets; antenna; yoke; speaker; binding posts; cabinet; controls for 19" (on-off and four-10K pots); and 2nd stage hi-voltage boost (for 13" and 15").

We don't have a complete package, but we do have some parts available at this time. Add a few parts... a TV for 1/2 price!
13" TV Chassis (with tuners & controls) . . . 6260175 . . . \$49.50
15" TV Chassis (with tuners & controls) . . . 6260174 . . . \$49.50
19" TV Chassis (no tuners, no controls) . . . 6260172 . . . \$29.50
VHF Tuner . 6260303 . \$8.50 UHF Tuner . 6260304 . \$2.50
Antenna . 5MI00419 . \$1.50 TV Speaker . 6260177 . \$3.50
Binding Posts 4MI00442. \$1.50

INPUT/OUTPUT TERMINAL

These units were removed from a complex computer system. The terminal contains: ASC11 keyboard; CRT; drive circuits; and a complete 128 page tech. manual with operating and repair instructions, which makes it easy to modify the terminal for your applications. (Character generation unit was in a separate control device which is not supplied, but the terminal can be used in conjunction with character generator LSI chips, such as the 2513 or 2516).

The keyboard is ASC11 encoded, with a 50 key alpha-numeric (and others) block keyboard. The CRT displays up to 768 characters, depending on the desired size, approximately typewriter size up to 1/4". Great for microprocessor in/out. Sh. Wt. 35 Lb. Order # 6NB60336 - \$49.50 ea., or 2 for \$95.00, 4 for \$180.00

B&F ENTERPRISES

119 FOSTER STREET
PEABODY, MA. 01960
Phone (617) 531-5774

POSTAGE: Please add sufficient postage.

SEND FOR OUR FREE CATALOG!
Over 4,000 electronic & optical items

PHONE ORDERS WELCOME! MasterCharge, BankAmericard and American Express Accepted.



CIRCLE NO. 13 ON FREE INFORMATION CARD

2522 STATIC SHIFT REG	\$2.75
INTEL 8080 CPU	\$24.50
2518 HEX 32 BIT SR	\$6.00
2102-1 1024 BT RAM	\$1.80
5280-4K DYNAMIC RAM	\$10.50
5202A UV PROM	\$10.50
MM5203 UV PROM	\$10.50
1702A UV PROM	\$10.75
5204-4K PROM	\$18.95
MINIATURE MULTI-TURN TRIM POTS 100, 500, 2K, 10K, 100K, 200K	\$7.50 each
MINIATURE TRIM POTS Similar to Bourns 3010 style 3/16" x 5/8" x 1/4" .50, 100, 1K, 10K, 50K ohms	\$1.50 ea.
50K ohms	\$3.40
LIGHT ACTIVATED SCR's TO-18, 200V 1A	\$ 1.75

TRANSISTOR SPECIALS

2N3955 NPN Si TO-66	\$.95
2N3772 NPN Si TO-3	\$.60
2N4908 PNP Si TO-3	\$ 1.00
2N6058 NPN Si TO-3 Darlington	\$ 1.70
2N5086 PNP Si TO-92	4/5 1.00
2N4898 PNP TO-66	\$.60
2N404 PNP GE TO-5	5/5 1.00
2N3919 NPN Si TO-3 RF	\$ 1.50
MPSA 13 NPN Si TO-92	3/5 1.00
2N3767 NPN Si TO-66	\$.70
2N2222 NPN Si TO-18	5/5 1.00
2N3055 NPN Si TO-3	\$.80
2N3904 NPN Si TO-92	5/5 1.00
2N3906 PNP Si TO-92	5/5 1.00
2N5296 NPN Si TO-220	\$.50
2N6109 PNP Si TO-220	\$.55
2N3638 PNP Si TO-5	5/5 1.00
2N6517 NPN TO-92 Si	3/5 1.00

CMOS (DIODE CLAMPED)

74C02	.22	4015	95	4035	1.10
74C10	.22	4016	40	4042	.78
4001	.22	4017	1.05	4047	2.00
4002	.22	4018	1.00	4049	.40
4006	1.20	4019	.22	4050	.40
4007	.22	4022	.95	4056	.80
4009	.42	4027	.40	4071	.22
4010	.42	4028	.88	4076	.70
4011	.22	4029	1.10	4081	.22
4012	.22	4030	.22	4520	1.15
4013	.40				

LED READOUTS

FND 500-5" C.C.	\$1.75
HP 7740-3" C.C.	\$1.40
MAN-7-3" C.A.	\$1.25
NS 33-3 dig. array	\$1.35
OL 747	\$2.50

Send 25c for our catalog featuring Transistors and Rectifiers
145 Hampshire St., Cambridge, Mass.

Terms: FOB Cambridge, Mass.
Send Check or Money Order.
Include Postage. Minimum
Order \$5.00. C.O.D.'s \$20.00

PRINTED CIRCUIT BOARD

4-1/2" x 6-1/2" SINGLE SIDED EPOXY BOARD 1/16" thick, unetched
\$3.50 ea. 5/52 20
VECTOR BOARD 1" SPACING
4-5" x 6" SHEET \$1.25

7 WATT LD-65 LASER DIODE IR \$8.95.

2N 3820 P FET	\$.45
2N 5457 N FET	\$.45
TIS 43 UJT	\$.35
EP 800 TRIGGER DIODES	4/51/00
2N 6028 PROG. UJT	\$.65

VERIPAX PC BOARD

This board is a 1/16" single sided double epoxy board, 4" x 6" DRILLED and ETCHED which will hold up to 21 single 14 pin IC's or 8, 16, or LSI DIP IC's with buses for power supply connector. \$4.00

MV 5691 YELLOW-GREEN BIPOLAR LED	\$1.25
FP 100 PHOTO TRANS.	\$.50
RED, YELLOW, GREEN OR AMBER LARGE LED's	ea \$.20
14 PIN DIP SOCKETS	\$.25
16 PIN DIP SOCKETS	\$.28
MOLEX PINS	100/51/00 \$1.00
8 PIN MINI DIP SOCKETS	\$7.50
10 WATT ZENERS 3.9, 4.7, 5.6, 8.2, 12, 15, 18, 22, 100, 150 or 200V	ea \$.60
1 WATT ZENERS 4.7, 5.6, 10, 12, 15, 18 OR 22V	ea \$.25

Silicon Power Rectifiers

PRV 1A	3A	12A	50A	125A
100	06	14	30	80
200	07	20	35	1.15
400	09	25	50	1.40
600	11	30	70	1.80
800	15	35	90	2.30
1000	20	45	110	2.75

SILICON SOLAR CELLS

2 1/4" diameter
4V at 500 ma. . . \$5.00 ea., 6/\$27.50

REGULATED MODULAR POWER SUPPLIES

+15 VDC AT 100ma	\$2.95
115VAC INPUT	\$24.95
5VDC AT 1A, 115VAC INPUT	\$24.95
12 VDC AT 5 AMP	\$24.95
IN 4748 (IN914)	15/\$1.00

TANTALUM CAPACITORS

22UF 35V \$/51.00	4.7UF 35V 4/\$1.00
47UF 35V 5/\$1.00	6.8UF 35V 3/\$1.00
68UF 35V 5/\$1.00	22UF 35V \$.40
1UF 35V 5/\$1.00	33UF 35V \$.40
2.2UF 20V 5/\$1.00	300UF 6V 5/\$1.00
3.3UF 35V 4/\$1.00	150UF 15V \$.50
M7001 ALARM CLOCK CHIP	\$6.00

NATIONAL MOS DEVICES

MM1402	1.75	MM5057	2.25
MM1403	1.75	MM5058	2.75
MM1404	1.75	MM5060	2.75
MM5013	2.50	MM5061	2.50
MM5016	2.50	MM5555	4.75
MM5017	2.70	MM5556	4.75
MM5055	2.25	MM5210	1.95
MM5056	2.25	MM5260	1.75

#30 WIRE WRAP WIRE SINGLE STRAND 100 FT. \$1.40

TTL IC SERIES

7400	.15	7442	.52	74125	.40
7401	.15	7445	.70	74126	.40
7402	.15	7446	.70	74151	.70
7403	.15	7447	.70	74153	.65
7404	.20	7448	.70	74154	1.10
7405	.20	7450	.20	74155	.70
7406	.25	7472	.33	74157	.70
7407	.25	7473	.35	74161	.85
7408	.25	7474	.35	74164	.95
7409	.21	7475	.49	74165	1.05
7410	.15	7476	.35	74173	1.40
7411	.20	7480	.35	74174	.95
7412	.20	7483	.70	74175	.92
7413	.45	7485	.88	74177	.79
7414	.70	7486	.30	74180	.70
7416	.25	7489	1.85	74181	2.10
7417	.25	7490	.45	74190	1.20
7420	.20	7491	.70	74191	1.20
7425	.28	7492	.50	74192	.85
7426	.28	7493	.45	74193	.85
7427	.30	7494	.70	74194	.85
7430	.20	7495	.70	74195	.75
7432	.25	7496	.70	74196	.88
7437	.25	74107	.32	75324	1.75
7438	.25	74121	.38	75491	.65
7440	.16	74123	.65	75492	.65
7441	.85				

MINIATURE DIP SWITCHES

CTS-206-4 Four SPST switches in one minidip Package	\$1.75
CTS-206-8 Eight SPST switches in a 16 pin DIP package	\$2.85

AY 5-1013 A30K ser./bar./par./ser./un-
versal UART \$6.95

ALCO MINIATURE TOGGLE SWITCHES	
MTA 106 SPDT	\$1.20
MTA 206 DPDT	\$1.70

Full Wave Bridges

PRV	2A	6A	25A
200	.95	1.25	2.00
400	1.15	1.50	3.00
600	1.35	1.75	4.00

SANKEN AUDIO POWER AMPS

Si 1010 G10 WATTS	\$ 7.50
Si 1020 G20 WATTS	\$15.95
Si 1050 G50 WATTS	\$27.95

CCD 110 LINEAR 256 X 1 BIT SELF SCANNING CHARGE COUPLED DEVICE \$99.00

CCD 201 100 x 100 CHARGE COUPLED DEVICE \$135.00

LINEAR CIRCUITS

LM307 Op. Amp	\$.30
LM 309X 5V 1A REGULATOR	\$.95
723 - 40 + 40V V. REGULATOR	\$.50
301 748 Hi Per. Op. Amp	\$.31
320T 5, 12,	

READER

SERVICE NO.	ADVERTISER	PAGE NO.
1	A P Products, Inc.	39
2	Ace Electronics	98
4	Acoustic Fiber Sound Systems, Inc.	29
4	Adva Electronics	98
6	Advanced IC Electronics	97
7	Advanced Microcomputer Products	102
8	Allison Automotive Company	48
9	Aluminum Industries of Arkansas	61
65	American Audioport	95
10	Ancrona Corp	113
11	Aries, Inc	115
12	Associated Electronics	74
69	Audio Technica U.S., Inc	16
13	B&F Enterprises	114
14	B&K Precision, Product of Dynascan	27
17	Bullet Electronics	106
16	CB Radio Repair Course, Inc	94
	CREI Capitol Radio Engineering Institute	18, 19, 20, 21
	Cleveland Institute of Electronics, Inc	52, 53, 54, 55
15	Cobra, Division of Dynascan	SECOND COVER
18	Continental Specialties Corporation	2
19	Delta Products, Inc	65
20	Digi-Key Corporation	107
21	Digital Group, The	88
68	Discwasher, Inc	FOURTH COVER
	Dixie Hi-fidelity	93
22	EICO	14
23	Edlie Electronics, Inc	112
24	Edmund Scientific Co	108
25	Edmund Scientific Co	116
26	Edmund Scientific Co	116
28	Electronic Distributors Inc	112
29	Eitron	114
30	Empire Scientific Corp	6
32	Godbout Electronics, Bill	106
34	Grantham School of Engineering	92
5	Heath Company	70, 71, 72, 73
35	IMSAI Manufacturing Corporation	30
36	Ignition Systems Inc	94
37	Illinois Audio	96
38	International Electronics Unlimited	110
67	JS&A	1
39	James Electronics	104, 105
40	Jensen Tools and Alloys	93
41	LDF Semiconductor	94
42	Leader Instrument Corp	39
43	MITs	36
44	McIntosh Laboratory Inc	93
	NRI Schools	8, 9, 10, 11
	National Technical Schools	80, 81, 82, 83
45	New-Tone	103
46	OK Machine & Tool Corporation	67
66	Olson Electronics	96
47	Optoelectronics	109
48	PAIA	94
49	Poly Paks	101
50	Poly Paks	102
51	Polymorphic Systems	92
52	Quest Electronics	106
53	Radio Shack	5
54	S.D. Sales Co	111
55	Sencore	68, 69
56	Shakespeare Company/Antenna Group	33
57	Shure Brothers Inc	84
	Sinclair Instruments Inc	91
58	Solid State Sales	114
59	Southwest Technical Products Corp	7
60	Stanton Magnetics, Inc	THIRD COVER
	Surplus Center	97
27	Tab Books	76
61	Technics By Panasonic	13
62	Technology Trends	89
63	Tram/Diamond Corporation	35
64	Weller-Xcelitem Inc	90

CLASSIFIED ADVERTISING
97, 98, 102, 106, 110, 112, 115

HOME ENTERTAINMENT FILMS

SPEND CHRISTMAS DOLLARS ON SPORTLITE FILMS! Don't Wait / See Super Bowl X (Pittsburgh Steelers / Dallas Cowboys), 200' Color, Super or Standard 8, \$19.95 or 200' of B&W, \$8.95 — we pay the postage. 1975 Indy "500" Speedway Spectacular, 200' of Super 8 Eastman Color. \$18.95 PPD with script. 1975 World Series (Red Sox / Cincinnati Reds — 7 games to a virtual draw), same format as football, \$19.95 Color, \$8.95 B&W each PPD. Indicate size. Columbia and Castle Catalogs, 50 cents each; Sportlite order forms, 35 cents (coins or stamps, pls). SPORTLITE, Elect-2, 20 North Wacker, Chicago, IL 60606.

BUSINESS OPPORTUNITIES

I MADE \$40,000.00 Year by Mailorder! Helped others make money! Free Proof. Torrey, Box 318-NN, Ypsilanti, Michigan 48197.

HIGHLY PROFITABLE ONE-MAN ELECTRONIC FACTORY

Investment unnecessary, knowledge not required, sales handled by professionals. Postcard brings facts about this unusual opportunity. Write today! Barta-DM, Box 248, Walnut Creek, CA 94597.

HOW TO MAKE \$2,000 WEEKLY at home using other people's money. Guaranteed. Free Details. Richlieu, Box 25357, Dept. F2, Houston 77005.

\$200.00 DAY POSSIBLE. Must know electronics Preliminaries \$3.50, Box 809, Boynton Beach, Fla. 33435.

\$250 per thousand, free supplies. Rush stamped, addressed envelope. Lola Hamilton, E-12, P.O. Box 227, Princeton, ME 04668.

FREE CATALOGS. Repair air conditioning, refrigeration. Tools, supplies, full instructions. Doolin, 2016 Canton, Dallas, Texas 75201.

MAILORDER MILLIONAIRE helps beginners make \$500 weekly. Free report reveals secret plan! Executive (1K2), 333 North Michigan, Chicago 60601.

GET RICH with Secret Law that smashes debts and brings you \$500 to \$5 Million cash. Free report! Credit 4K2, 333 North Michigan, Chicago 60601.

FREE SECRET BOOK "2042 UNIQUE. Proven Enterprises" Fabulous "Little Knowns". Work home! Haylings-B, Carlsbad, Calif. 92008.

SPARE TIME CASH. Sell famous Hanover Shoes. Samples, sales kits free. No experience needed. No age limit. Big commissions Hanover Shoe, Dept. 1818, Hanover, PA 17331.

\$193.00 WEEKLY. GUARANTEED! Your home. One hour daily. Free details — Professional, Box 24543-X, Saint Louis, Missouri 63141.

BIG PROFIT in Real Estate, learn from an expert how to Successfully buy and sell residential and investment properties, plus BONUS Real Estate definitions \$2.95 LINPAUL ENTERPRISES, Box 60, Dept. PE 21, West New York, N.J. 07093.

FREE: CASH NEWSLETTER with: How To Make \$50 Anytime you need it, guaranteed. Plus: How to start \$20,000+ business (nothing to buy, ever) working five hours weekly. All only \$2: CASHCO, 2232-E Arrowhead Ave., Brooksville, FL 33512.

BOOKS AND MAGAZINES

FREE book prophet Elijah coming before Christ. Wonderful bible evidence. Megiddo Mission, Dept. 64, 481 Thurston Rd., Rochester, N.Y. 14619.

THE AUDIO AMATEUR—A quarterly publication for the serious audio constructor. Free prospectus. The Audio Amateur, Box 176Z, Peterborough, N.H. 03458.

ELECTROPLATING. Complete amateur's textbook. All metals. Electroplate metallic/nonmetallic items, \$7.00. Details free. Tropic, Box 95-P2, Palm Bay, Fla. 32905.

MUSICAL INSTRUMENTS

UP TO 60% DISCOUNT. Name brand instruments catalog. Freeport Music, 114 G. Mahan St., W. Babylon, N.Y. 11704.

MISCELLANEOUS

WINEMAKERS: Free illustrated catalog yeasts, equipment. Semplex, Box 12276P, Minneapolis, Minn. 55412.

NEW LUXURY CAR Without Cost. Free Details! Codex-ZZ, Box 6073, Toledo, Ohio 43614.

ARIES brought you the first calculator kit, and the first digital clock kit... and now brings you three of the most innovative electronic kits ever made. The System 300 Electronic Music Synthesizer kit is the most advanced in the world today, regardless of price. The AR-781 is a space-age beauty for any decor. And the wholly solid state AR-830 does the work of a \$400.00 tape memory unit.

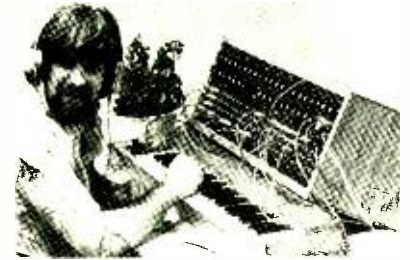

WARNING... if you're interested in a music synthesizer, don't make a move until you see our catalog first. It's more like a handbook than a catalog, with hundreds of in-depth photographs and descriptions to explain electronic music principles, and to show equipment to do the job. ARIES now offers a complete complement of modules, keyboards, and cases, matched to the most rigorous professional standards. Starter systems priced as low as \$395.00.

A clear, ruby-red cylinder shows off all six digits of this modern calendar clock. Easy-to-read numbers show the hours, minutes, and seconds, as well as the month and day every ten seconds.



Red LED 7-segment numerals are 0.33" high, in a sturdy cylinder 2-1/2" in diameter and 4-3/4" long, with finished hardwood ends. Time and calendar are controlled by 60 Hz line frequency, with a 12-month movement. Separate time and calendar adjustments. Includes all the components, PC boards, housing, and instructions. Shipping weight 2 lbs. AR-781 Clock Kit \$34.50

Add finger-touch operation to your old-fashioned dial telephone with an ARIES AR-830 Automatic Digital Telephone Dialer. This has the same layout and convenience as Ma Bell, plus other features she doesn't offer yet. For instance... AR-830 always remembers the last number you dialed, in case the line was busy and you want to try again later. Not only that, but the Dialer's memory can store as many as ten of your favorite numbers for one-touch dialing.



AR-830 uses standard dialing and muting contacts; consult local tariffs before connecting. Sh. wt. 2 lbs. AR-830 Dialer Kit \$69.50

ARIES INC.
BOX 808
Peabody, Mass., 01960
(617) 744-2400

CIRCLE NO. 11 ON FREE INFORMATION CARD

Retail Display Plan

All magazine retailers in the United States and Canada interested in earning an allowance for the display and sale of publications of the Ziff-Davis Publishing Company are invited to write for details. Sales Manager, Select Magazines, 229 Park Avenue South, New York, New York 10003.

**AMAZING & HARD-TO-FIND
SCIENCE BUYS!
ALTERNATE ENERGY
SPACE AGE • HOBBIES**

SUPER POWER FOR ANY AM RADIO

Antenna assist has pulled in stations 1000 miles off! No wires, clips, grounding. Solid state—no elec., batts., tubes
No. 72,095AVB \$19.95 Ppd.
ULTRA SELECT-A-TENNA (OVER 1000 MILES)
No. 72,147AVB\$24.95



SOLAR ENERGY CUBE

Demonstration of sunlight converting to kinetic energy! Clear plastic cube in sun with its 3 silicon solar cells powers motor to whirl the propeller. Actually produces 1.5v DC. 825 ma.



No. 42,287AVB (4x4x4)\$23.95

SAVE 50%! 8 x 20 MONOCULAR

Top quality Spy Scope, a \$30 value, now \$14.95! Special purchase saves you 50%. 100% coated optics; 393 ft. field of view. Only 2 oz.—stores in pocket, purse, glove box.
No. 1568AVB \$14.95 Ppd.



NASA-CHOSEN FOR APOLLO/SOYUZ

The Astronauts used this super 20X60 binocular (modified) to view Earth! Big 60 mm objective lenses; 173-ft. field of view at 1000 yds. Relative brightness, 9.0. Fully coated optics, more!



No. 1556AVB(9 1/4 x 8 1/2); 47.5 oz) \$99.95 Ppd.

ELECTRONIC SOUND COLLECTOR

Tune in a whisper at 20 ft., normal conversations up to 100 ft., birdcalls & high freq. sounds at almost 200 ft. Nearly twice as far over water! Check on baby, birds! 18" refl. disc, mike, etc.
No. 80,176AVB \$36.25 Ppd.



LOW COST PORT. INFRA-RED EYE

Self-cont. scope (90° nite vision) has 6032 IR converter tube, f/3.5 telephoto lens, adjust triplet eyepiece, 1.6X. Not avail. to Cal. res. except spec. auth'd.



No. 1683AVB (6,12v DC)\$299.95 Ppd.
No. 1685AVB (SUPER 2.5X BINOC.) \$329.95 Ppd.

MEASURE WIND SPEED ANYWHERE

Hold handy (16 oz.) low cost Anemometer into the wind, quickly read wind speed on its big dial—from 5 to 70mph. Acc. to ±3% of full scale (2.1 mph). no batts., adjustments, recalibration req.!



No. 42,428AVB (7 1/2" HIGH)\$19.95 Ppd.

OUR MYSTICAL MUSICAL MACHINE

... gets it on! Automatic 256-note pseudo-random tone pattern. Adjust beat, vol., pitch; finger 3 photocells to creatively vary tone of continuous "music." Output jack for patching, recorder! 1.3 lb.



No. 72,203AVB (INCL. 9v BATT.)\$59.95 Ppd.

110V FUEL MISER RECLAIMS HEAT

Save your 40% wasted heat to warm a basement, garage, rec. rm. at no extra cost! Direct it your way instead of up the chimney. Fan-forced clean hot air via easy ducting!



No. 19,194AVB (5" DIA.) Shpg. 17 lb. ...\$121.50 FOB
No. 19,195AVB (6" DIA.)

QUALITY DETECTOR UNDER \$40

Our fully transistorized BFO unit can locate a quarter at 18". Powerful 6 trans.-oscillator-amplifier circuit. Comp. to others priced 50% more! Aluminum, just 2 lb.



No. 80,222AVB \$39.95 Ppd.



**THERE IS NO OTHER TELESCOPE LIKE IT!
THE NEW EDMUND 4 1/4", f/4
NEWTONIAN WIDE FIELD
REFLECTOR TELESCOPE**

Clear, bright, spectacular wide angle views of stars, moon, comets... easy to use... portable!

IN SECONDS YOU'RE SCANNING THE ASTOUNDING UNIVERSE, able to see and study the breath-taking cosmos as perhaps you never have before... awesome vastness, unbelievable orderliness, stark silent beauty! All the fascinating heavenly mysteries are yours to enter and explore. This new reflector telescope makes it easy for everyone to span a thousand light-years to space-age enjoyment of the heavens and outdoors. No complicated set up! Just insert the eyepiece, focus, and its big 3 1/2" field of view gives you more stars in a single view than any other type of telescope. Bright, crisp, finely resolved images to capture your interest and imagination! It's probably the easiest to use telescope ever... over your shoulder, in your lap, on a tripod. Or just rotate the spherical base on its own mount for use on a table, car hood. Take it anywhere (only 17", 10 lb.). Top quality optical system: 4 1/4", f/4 parabolic primary mirror (1/4 wave, 17" F.L.); prealigned 1/4 wave diagonal on a coated optical window seals optics from moisture and dust. 28mm Kellner eyepiece (gives 15X, higher without other eyepiece or Barlow). Fast focusing (25" to infinity). Bright Scharfianian red (doesn't impair night vision), adj. carrying strap. A "first" scope... must be an ideal second scope!

There is no other telescope like it. NO. 2001AVB \$149.95 Ppd.

The Edmund BIOSONE II

turns brainwaves into an audible or visual signal. \$149.95
KNOW YOUR ALPHA FROM YOUR THETA!

For greater relaxation, concentration... monitor your alpha/theta brainwaves.

Features Normally Found Only In Units Selling For More Than \$200.00—And 3 Feedback Modes.

The portable, professional quality Edmund Biosone II boasts 3 feedback modes—LED FM tone, threshold tone; a test mode to check overall system of operation. Easy to use, this beautiful 4-pound, simulated walnut unit (9 1/2 x 5 1/2 x 4 1/4") can be operated at home, in office or clinic. It gives you outputs to allow further monitoring of logic signal, raw EEG, filter output, meter, and FM. Total brainwave monitoring capability, incl. filter select feedback, with wide range calibration sensitivity control (5-100 microvolts). Completely safe, the Edmund Biosone II is similar to an electroencephalograph (EEG), enabling you to identify the electrochemical activity that exists at all times in the human brain. In addition to letting you know when you're most relaxed, Biosone II is a great conversation piece. Included at its low price are a set of electrodes, an earphone jack for private use. Uses latest advances in linear circuitry, runs on two 9v transistor batteries (not included).

STOCK NO. 1668AVB Just \$149.95 ppd.
LOW COST STARTERS' UNIT, No. 71,809AVB \$59.95 ppd.

"SEE" MUSIC IN PULSATING COLOR

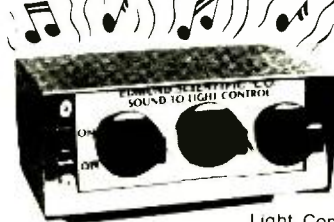

The Edmund 3-Channel Color Organ \$18.50

COMPLETELY ASSEMBLED! LESS THAN HALF THE PRICE OF OTHER MODELS!

Create your own audio "light show", add a new dimension to your music listening pleasure with the bargain-priced Edmund 3-Channel Sound To Light Control.

Lets you modulate 3 independent strings of colored lamps with the intensity of your music. They flash and vary in brightness related to the music's rhythm, pitch and volume—a pulsating light performance to music! You get volume and frequency sensitivity to a peak rating of 300 watts per channel. Just plug in your favorite colored flood or spotlight, and turn on! Great price, too. This high quality, fully assembled unit in metal housing, with 3 individually controlled circuits, is priced at less than half that of others. Complete instructions are included with this terrific value.

ASSEMBLED \$18.50 Ppd.
NO. 42,309AVB

UNASSEMBLED, IN KIT FORM \$15.95 Ppd.
No. 42,336AVB ONLY

**GIANT FREE
164 PG. CATALOG**



4500 UNUSUAL BARGAINS FOR HOBBYISTS, SCHOOLS, INDUSTRY

COMPLETE AND MAIL COUPON NOW

EDMUND SCIENTIFIC CO. 300 Edscorp Bldg., Barrington, N. J. 08007

Send me the following:

Stock No.	Quantity	Price Ea.

SEND FREE 164 PG. CATALOG "AVB"
Charge my American Exp BankAmericard Master Chg

Interbank No. _____
Card No. _____

Expiration Date _____
30-DAY MONEY-BACK GUARANTEE. You must be satisfied or return any purchase in 30 days for full refund.

Add handling charge \$ _____:1.00
Enclosed is check, M.O. in amount of \$ _____

Signature _____
Address _____
City, State, Zip _____



EDMUND SCIENTIFIC CO.

300 Edscorp Bldg., Barrington, N.J. 08007 • (609) 547-3488
America's Greatest Science • Optics • Hobby Center

According to TRUTONE RECORDS..“The Stanton calibrated 681 series is our total point of reference in our Disc Mastering Operation”

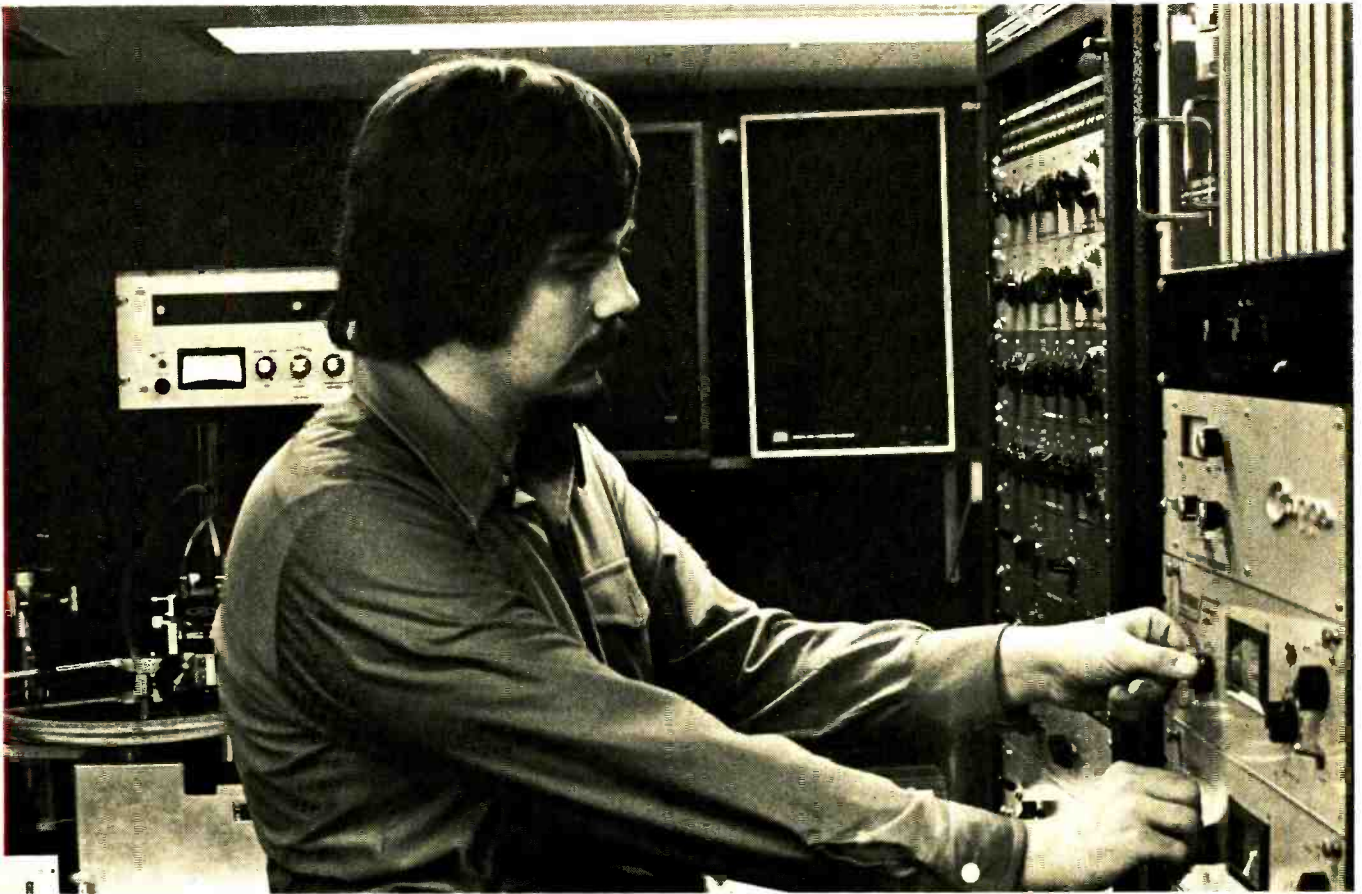

“Carl Rowatti, Chief Engineer, adjusting the Program limiters prior to cutting a master lacquer”.

Trutone can be described as a family enterprise... but what a family! Father Lou Rowatti is the President; Son Carl is Vice President and Chief Engineer; and daughter-in-law Adrienne handles the business end of the operation. They have great pride in their family, in their family's enterprise and in their products. That's why they insist on using the best — always.

Trutone Records in Northvale, New Jersey always uses the Calibrated Stanton Triple-E for A-B comparisons between tape and disc. They also use the Triple-E to check the frequency response of the cutter head (they'll record a 1,000 Hz tone and a 10 kHz tone twice a day to check the condition of the cutting stylus and the high end frequency response of the cutter head).

They make test cuts and play them back, using the Triple-E for reference, as high as 15 kHz all the way down to 30 Hz. Carl Rowatti says “We use the Stanton Calibrated 681 series as our total point of reference in our disc master-

ing operation. Everything in the studio is judged — and we think perfectly judged for quality—with this great cartridge”.

Professionals can't afford to take chances with quality. That's why they depend on Stanton in their operations.

Each Stanton 681 Triple-E is guaranteed to meet its specifications within exacting limits, and each one boasts the most meaningful warranty possible. An individually calibrated test result is packed with each unit.

Whether your usage involves recording, broadcasting, disco or home entertainment your choice should be the choice of the professionals...the Stanton 681 TRIPLE-E.

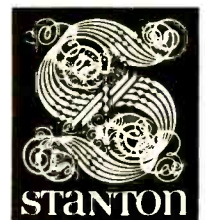

Write today for further information to:
Stanton Magnetics, Terminal Drive,
Plainview, New York 11803



Lou Rowatti inspects a master lacquer. Adrienne checks the lathe.



Carl Rowatti adjusts the pitch computer on the mastering lathe.



Carl installs the Stanton Calibrated 681 Triple-E on the playback table.



Lou Rowatti (The Prez) adjusting the high frequency limiter in his cutting room.

RESEARCH DELIVERS A Quantum Jump in Record Care

New D3 Fluid

1. Unmatched activity plus safety to vinyl additives (the critical compounds of longevity).
2. A secret non-adhering anti-static system that is measured in parts-per-billion!
3. A special chemical "release system" (pat. pend.) that allows suspended contaminants to pull away from critical micro-grooves.

The Systems Approach Of the Discwasher Brush

D3 plus the patented directional micro-fibers and absorbent backing remove—rather than line up—all dust and suspended debris.

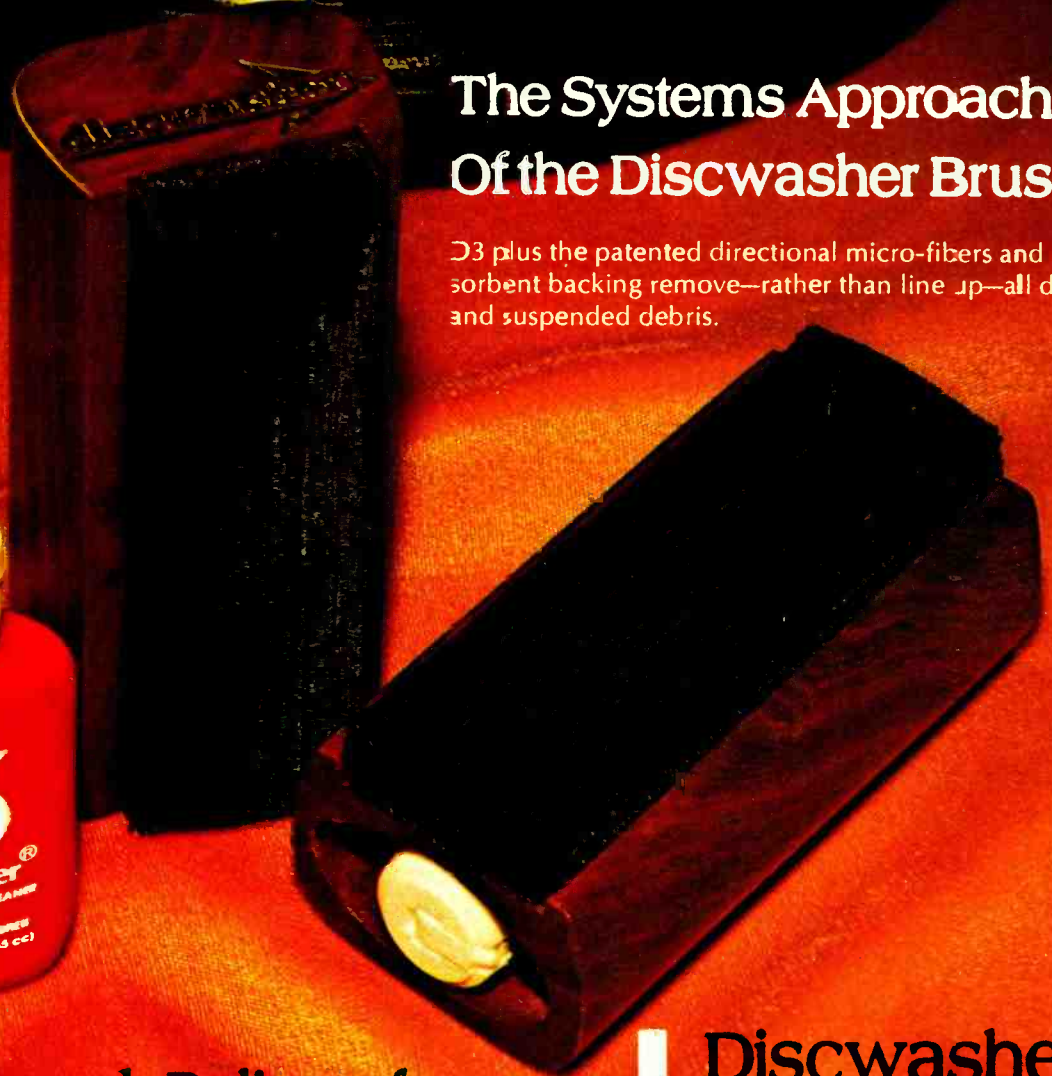

Research Delivers from



**Discwasher
Group**

1407 N. PROVIDENCE
COLUMBIA, MO 65201

CIRCLE NO. 89 ON FREE INFORMATION CARD

www.americanradiohistory.com