

FCC PROPOSES NEW CB RADIO CHANGES

Popular Electronics®

WORLD'S LARGEST-SELLING ELECTRONICS MAGAZINE SEPTEMBER 1976/\$1

**A Digital
Speedometer for
Automobiles**

**Exotic
Home Lighting
Control Project**

**Electronic Theory
With Hand
Calculators, Part III**



TEST REPORTS

**Crown Stereo Preamp
Dual 1249 Automatic
Record Player
Handicapped AM
Basic
OAE C
Tape Reader**

90684 JHN 4164M92 9440 N0776
R JOHNSON
5164 HEADBROCK LN
55425 MN 55425
52456

Special Focus on Audio

**16-PAGE BONUS ON BUYING/
USING/EXPERIMENTING/
KIT BUILDING**



**Stereo
Equalizer Kit**

**Tips on How to Choose
Speaker Systems**

Home-Brew Phono Preamps

**Stereo Enhancement with
4-Channel Tape Recordings**

**Class D and other
Audio Electronics Advances**

Experience is the best teacher. You might settle for any CB first time around. Understandably. A lot of people think they're all pretty much alike. But you'll soon discover that, like everything else, there are exceptions.

Ask the pros. America's long distance truckers. These guys talk CB day in and day out. And they demand the best. That's why truckers refer to the Cobra 29 as "The Diesel Mobile."

Listen to Cobra. You'll hear a big difference. Because the Cobra 29 gives you features which assure crystal clear reception. Like switchable noise limiting and blanking, to cut out practically all pulse and ignition interference. Add squelch control and RF gain and you've got exceptional—adjustable—receiver clarity. Even in the heaviest CB traffic. You also get Delta Tuning which makes up for the other guy, because even off-frequency transmitters are pulled in. Perfectly.

Talk to Cobra. And you know you're punching through. One glance at the

29's over-sized illuminated meter tells you just how much power you're punching out and pulling in. For voice modulation the DynaMike delivers at 100%. Same way with power: The 29 transmits at maximum power levels.

Sooner or later you'll get a Cobra. And you'll get engineering and craftsmanship second to none. Performance that will make your first CB seem obsolete. Reliability and durability that have set standards for the industry. Above all, you'll get power. The power to punch through loud and clear like nothing else. Because when it comes to CB radio, nothing punches through loud and clear like a Cobra.



Punches through loud and clear.

Cobra Communications, Products of Dynascan Corp.
1801 W. Belle Plaine, Chicago, Illinois 60613

CIRCLE NO. 14 ON FREE INFORMATION CARD

IF YOUR FIRST CB ISN'T A COBRA YOUR SECOND ONE WILL BE.



Want a rewarding career like this?

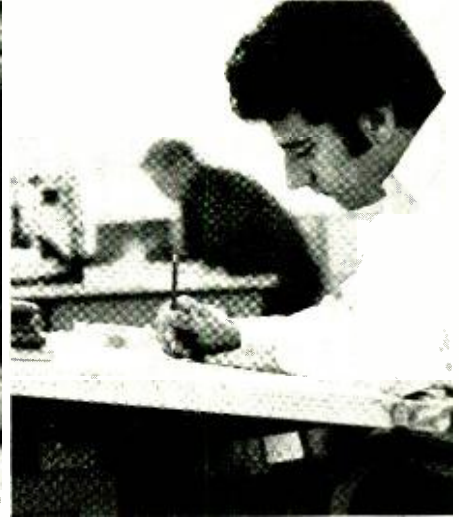

It's yours when you know Electronics Drafting!

Learn it at home the practical, step-by-step ETI way!

Imagine getting ready to move into this kind of career. ETI prepares you for the job of working closely with electronics engineers in getting electronics concepts down on paper. That's where it begins! And just think, a drafting course can be only the beginning. Ultimately, with additional study, you might be applying your specialized skills to the designs for new developments in computers. Or working with the development of new medical equipment. You might be needed for new refinements in citizens band radio . . . even watches and photographic products. You'll probably be in on developments that right now are really beyond everybody's imagination! But it's all in a future that *you* can be part of. A future where there's real enjoyment in your work and you're a respected professional. A future where the paycheck is as good as the security. An *exciting* future!

But what about learning drafting at home?

The fact is, this subject is a "natural" for home study. Electronics Technical Institute sends you all the professional tools and equipment you need—including T-squares, triangles, measuring scales, French curves, ruling pen, compass and straight edge. Then you start *learning by doing*. You move to your goal just as fast as your time and ambition permit, because you set your own pace. You don't have to waste time

or lose a single hour from your present job. And in a surprisingly short period you'll discover that you can put the T-square in place, interpret technicalities, and do the job of an accomplished draftsman!

You get personal, expert help.

You're not "all alone out there" as you do your step-by-step learning. In fact, you're "in a class of one" with an experienced, helpful instructor. He knows his job, *and he knows you*. He is chosen both for technical competence and ability as a teacher. He's licensed by the State of New Jersey. He cares about you, because your success is his success. He carefully goes over each of your assignments *personally*. He helps, suggests, corrects and encourages . . . *personally*. He gets you all set for the next step. He wants to keep you progressing as fast as possible.

Real do-the-job kits.

When you learn Drafting the ETI way, you do it the "real world" way. You learn the theory, and you work with specially developed Project Kits to carry specific assignments through to completion just as you would in a plant or office. You're prepared to tackle jobs detail by detail.

You know why that's most important? *Confidence*. After these successes, you *know* that you're a "can do" draftsman. You'll earn the Electronics Technical Institute diploma, and you can talk to any prospective employer proudly.

Get the facts FREE!

You've got everything to gain. There's no obligation. And no salesman will call. You'll simply be looking at a great future that can be *yours*. And the best time to find out is *now*. Just fill in and return the coupon, and we'll rush you the

details. They're all yours in a new, fully illustrated 44-page catalog. Don't you owe that much to yourself?



Electronics Technical Institute

Division of Technical Home Study Schools

Electronics Technical Institute, Dept. 2-473-096
Little Falls, New Jersey, 07424.

YES! I'm interested in a future in Drafting! Rush me your free career information!

Send me information on these other fields of special interest:

- | | | | |
|--|--|---|--|
| <input type="checkbox"/> TV / Audio Servicing | <input type="checkbox"/> Communications | <input type="checkbox"/> Computers | <input type="checkbox"/> Business and Engineering |
| Black and White | FCC License | Digital Electronics | Electronics Fundamentals |
| Color | Aircraft | Computer Technology | Industrial Electronics |
| Solid-State | Marine | Computer Programming | Advanced Electronics |
| CAI | Mobile Two Way | | Industrial Instrumentation |
| Closed Circuit | Microwave | | Electronics Technology |
| Video Recorders | | | Medical Electronics |
| Radio | | | |
| Hi-Fi Stereo | | | |

Check here for Veterans information.

Name _____ (please print)
Address _____
City _____ State _____ Zip _____

Logic Probe 1 is a compact, enormously versatile design, test and troubleshooting tool for all types of digital applications. By simply connecting the clip leads to the circuit's power supply, setting a switch to the proper logic family and touching the probe tip to the node under test, you get an instant picture of circuit conditions.

LP-1's unique circuitry—which combines the functions of level detector, pulse detector, pulse stretcher and memory—makes one-shot, low-rep-rate, narrow pulses—nearly impossible to see, even with a fast scope—easily detectable and visible. HI LED indicates logic "1", LO LED, logic "0", and all pulse transitions—positive and negative as narrow as 50 nanoseconds—are stretched to 1/3 second and displayed on the PULSE LED.

By setting the PULSE/MEMORY switch to MEMORY, single-shot events as well as low-rep-rate events can be stored indefinitely.

While high-frequency (5-10MHz) signals cause the "pulse" LED to blink at a 3Hz rate, there is an additional indication with unsymmetrical pulses: with duty cycles of less than 30%, the LO LED will light, while duty cycles over 70% will light the HI LED.

In all modes, high input impedance (100K) virtually eliminates loading problems, and impedance is constant for all states. LP-1 also features over-voltage and reverse-polarity protection. Housed in a rugged, high-impact plastic case with strain-relieved power cables, it's built to provide reliable day-in, day-out service for years to come.

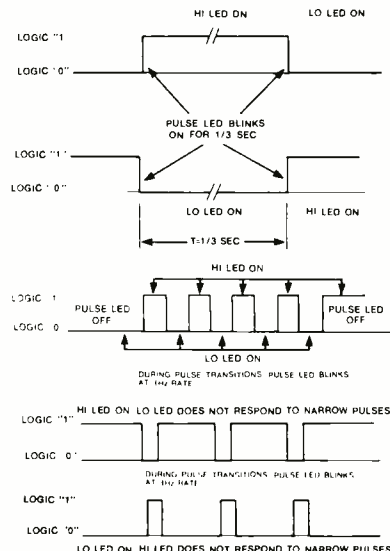

CSC'S MULTI-FAMILY LOGIC PROBE 1. AT \$44.95, IT DIGS UP A LOT OF INFORMATION WITHOUT BURYING YOUR BUDGET.

HI/LO LED's—Display level (HI-logic "1", LO-logic "0") of signal activity at node under test

PULSE LED—Lets you know what's going on—and off. Indicates positive and negative pulse and level transitions. LP-1 stretches pulses as narrow as 50 nanoseconds to full 1/3 sec. (3Hz pulse rate)

PULSE/MEMORY Switch—PULSE position detects and stretches pulses as narrow as 50 nanoseconds to 1/3 sec. Switch to MEMORY and it stores single shot and low-rep-rate events indefinitely; HI/LO LED's remain active

Logic Family Switch—TTL/DTL or CMOS matches Logic "1" and "0" levels, for greater versatility. High Input Impedance—100K virtually eliminates circuit loading problems and is constant in both "0" and "1" states. CMOS position also compatible with HTL, HiNIL and MOS logic

Non-corrosive nickel-plated probe tip and clip leads—For reliable contacts and maximum life

Rugged high impact plastic case—Built to take it in the lab or in the field

Protected—Features built-in reverse polarity and over-voltage protection; strain-relieved power cable

\$44.95 Price tag—Costs so little it can be your personal property



For more information, see your distributor or write for our catalog and distributor list.
44 Kendall St., Box 1942 New Haven, CT 06509 • 203-624-3103 TWX: 710-465-1227 West Coast office:
Box 7809, San Francisco, CA 94119 • 415-421-8872 TWX: 910-372-7992 Canada: Len Finkler Ltd., Ontario

Popular Electronics®

WORLD'S LARGEST SELLING ELECTRONICS MAGAZINE

FEATURE ARTICLES

FUSING QUIZ	Robert P. Balin	32
LEARNING ELECTRONIC THEORY WITH HAND CALCULATORS	Edward M. Noll	70
<i>Part Three: RC Coupling, Basic Amplifier Calculations, and RLC Relationships.</i>		
LED BARGRAPH READOUTS	Forrest M. Mims	74
DESIGNING OPTIMUM-Q AND SMALL INDUCTORS	R. E. Martin	101
ENGLISH-LANGUAGE SHORTWAVE BROADCASTS FOR SEPT. & OCT. 1976	Richard E. Wood	112

CONSTRUCTION ARTICLES

BUILD THE COSMAC "ELF", PART 2	Joseph Weisbecker	37
BUILD A DIGITAL SPEEDOMETER FOR YOUR CAR	Richard B. Fermoyle	42
BUILD DYNADIM II—DELUXE HOME-LIGHTING CONTROL	Russell J. Bik	48

SPECIAL FOCUS ON AUDIO

BUILD THE "DELTA-GRAPH" OCTAVE-EQUALIZER	Bryan T. Morrison	53
THE STATE OF AUDIO ELECTRONICS TODAY	Len Feldman	57
GUIDE TO "HOME-BREW" PHONO PREAMP DESIGN	Dennis A. Bohn	60
RECORDING FOR STEREO WITH 4-CHANNEL TAPE	David L. Linkletter	64
TIPS ON HOW TO CHOOSE SPEAKER SYSTEMS	Jonathan R. Sisk	66

COLUMNS

STEREO SCENE	Ralph Hodges	14
<i>Greetings from Nihon!</i>		
HOBBY SCENE	John McVeigh	30
SOLID STATE	Lou Garner	92
<i>An IC That Is Also DANDY.</i>		
CB SCENE	Ray Newhall	103
<i>FCC Proposes New CB Radio Changes.</i>		
INSIDE BASIC ELECTRONICS	Sol D. Prenskey	105
<i>Using Resistances.</i>		
DX LISTENING	Glenn Hauser	109
<i>Listening to the Relays.</i>		
COMPUTER BITS	Hal Chamberlain	116
EXPERIMENTER'S CORNER	Forrest M. Mims	121
<i>The LM380 Power Amplifier.</i>		

PRODUCT TEST REPORTS

CROWN MODEL IC-150A PREAMPLIFIER	82
DUAL MODEL 1249 AUTOMATIC RECORD PLAYER	83
HANDIC MODEL 2305 AM CB TRANSCEIVER	84
OAE MODEL OP-80A TTY PAPER TAPE READER	90
ALPHA WIRE MODEL STRP-25 WIRE STRIPPERS	91

DEPARTMENTS

EDITORIAL	Art Salsberg	4
<i>Consumer "Radiation" Protection.</i>		
LETTERS		6
OUT OF TUNE		6
<i>"Learning Electronic Theory with Hand Calculators," (July 1976)</i>		
NEW PRODUCTS		8
NEW LITERATURE		12
NEWS HIGHLIGHTS		30
TIPS & TECHNIQUES		102
OPERATION ASSIST		102
ELECTRONICS LIBRARY		120

POPULAR ELECTRONICS, September 1976, Volume 10, Number 3, Published monthly at One Park Avenue, New York, NY 10016. One year subscription rate for U.S., \$9.98; U.S. Possessions and Canada, \$11.98, all other countries, \$12.98 (cash orders only, payable in U.S. currency). Second Class postage paid at New York, NY and at additional mailing offices. Authorized as second class mail by the Post Office Department, Ottawa, Canada and for payment of postage in cash.

POPULAR ELECTRONICS including ELECTRONICS WORLD, Trade Mark Registered. Indexed in the Reader's Guide to Periodical Literature.

COPYRIGHT © 1976 BY ZIFF-DAVIS PUBLISHING COMPANY. ALL RIGHTS RESERVED.

Ziff-Davis also publishes Boating, Car and Driver, Cycle, Flying, Modern Bride, Popular Photography, Skiing and Stereo Review

Material in this publication may not be reproduced in any form without permission. Requests for permission should be directed to Jerry Schneider, Rights and Permissions, Ziff-Davis Publishing Co., One Park Ave., New York, NY 10016.

Editorial correspondence: POPULAR ELECTRONICS, 1 Park Ave., New York, NY 10016. Editorial contributions must be accompanied by return postage and will be handled with reasonable care, however, publisher assumes no responsibility for return or safety of manuscripts, art work, or models.

Forms 3579 and all subscription correspondence: POPULAR ELECTRONICS, Circulation Dept., P.O. Box 2774, Boulder, CO 80302. Please allow at least eight weeks for change of address. Include your old address, enclosing, if possible, an address label from a recent issue.

EDGAR W. HOPPER
Publisher

ARTHUR P. SALSBERG
Editorial Director

LESLIE SOLOMON
Technical Editor

JOHN R. RIGGS
Managing Editor

ALEXANDER W. BURAWA
Feature Editor

EDWARD I. BUXBAUM
Art Director

JOHN McVEIGH
Associate Editor

ANDRE DUZANT
Technical Illustrator

PATRICIA BROWN
Editorial Assistant

**LOU GARNER
GLENN HAUSER
JULIAN D. HIRSCH
RALPH HODGES
ART MARGOLIS
FORREST MIMS
HAL CHAMBERLAIN
WILFRED M. SCHERER**
Contributing Editors

JOSEPH E. HALLORAN
Advertising Director

JOHN J. CORTON
Advertising Sales

LINDA BLUM
Advertising Service Manager

PEGI McENEANEY
Executive Assistant

STANLEY NEUFELD
Associate Publisher

ZIFF-DAVIS PUBLISHING COMPANY
Popular Electronics
Editorial and Executive Offices
One Park Avenue New York, New York 10016
212-725-3500
Hershel B. Sarbin, President
Furman Hebb, Executive Vice President
John R. Emery, Senior Vice President, Finance, and
Treasurer
Philip T. Heffernan, Senior Vice President, Marketing
Edward D. Muhlfeld, Senior Vice President, Sports Division
Philip Sine, Senior Vice President
Frank Pomerantz, Vice President, Creative Services
Arthur W. Butzow, Vice President, Production
Lawrence Sporn, Vice President, Circulation
George Morrissey, Vice President
Sydney H. Rogers, Vice President
Sidney Holtz, Vice President
Al Traina, Vice President
Philip Korsant, Vice President
Paul H. Chook, Vice President, Market Planning
Charles B. Seton, Secretary
Edgar W. Hopper, Vice President, Electronics Div
William Ziff, Chairman
W. Bradford Briggs, Vice Chairman

Midwestern Office

The Patis Group, 4761 West Touhy Ave.,
Lincolnwood, Illinois 60644 312 679-1100
GERALD E. WOLFE, THOMAS HOCKNEY

Western Office

9025 Wilshire Boulevard, Beverly Hills, CA 90211
213 273-8050. BRadshaw 2-1161
Western Advertising Manager, BUD DEAN

Japan James Yagi

Oji Palace Aoyama, 6-25, Minami Aoyama
6 Chome, Minato-Ku, Tokyo 407-1930 6821,
582-2851



Member Audit Bureau
of Circulations



The publisher has no knowledge of any proprietary rights which will be violated by the making or using of any items disclosed in this issue.



Editorial

CONSUMER "RADIATION" PROTECTION

From time to time we all read about the possibility of biological damage due to "radiation" exposure. The latest "radiation" furor involved the U.S.S.R.'s microwave "spy" beams directed against our embassy personnel in Moscow. But there are some disquieting radiation considerations closer to home. For example, how much radiation exposure is safe? Will there be a damaging cumulative effect from chest X-rays, dental X-rays, color TV receivers, microwave ovens, et al? No one truly knows the answer.

Since 1968, radiological safety standards have been set by the FDA's Bureau of Radiological Health in conjunction with information from industry and interested parties. Establishment of this Federal agency was motivated by General Electric's 1968 recall of more than 100,000 color-TV receivers due to excessive radiation levels. The agency subsequently discovered that many other brands of color TV in the late '60's also had high levels of X-radiation. Today's acceptable TV X-radiation is 0.5 milliroentgens per hour at 5 cm away from the receiver per 10 square cm area.

Microwave ovens, too, exhibit radiation (not X-ray) through a small amount of leakage. The Federal limit, established in October 1971, is 1 milliwatt per cm² at 5 cm away, at the time of purchase, and 5 milliwatts maximum for the duration of oven use. The military and industry consider 10 milliwatts/cm² to be the safe limit. However, other countries—namely the U.S.S.R.—have a standard of 10 microwatts/cm² per working day, which is increased to 1 milliwatt for 15- to 20-minute exposures each day.

Obviously, there's a difference of opinion as to which level of microwave "radiation" is safe. Although, there's never been a documented case in the U.S. of harm from exposure to microwave ovens, and I'm confident that the standards are conservative, I still stay more than four feet away from an operating microwave oven (the distance at which leakage becomes unmeasurable with a standard meter).

Assuming that standards are well within safe limits, however, there are other distressing questions. Is there a danger of excessive X-ray exposure from a pre-1969 color TV receiver? How does one know when a microwave oven's door seal is unsatisfactory?

A neon bulb or household fluorescent lamp used as a wand could detect serious microwave leakage by glowing or lighting. But this method is by no means an accurate indicator. Instruments such as Simpson Electric's microwave tester, at \$195.00, are too expensive for the general public! The same is true for testers to check color-TV radiation. It was therefore interesting to receive by mail a free sample of a \$2.95 color-TV radiation detector kit that includes a film pack with processing chemicals. Developed at home (darkroom not required), it is said to reveal excessive radiation.

I haven't verified the accuracy of the foregoing (available from Dahlico, P.O. Box 19202, So. Minneapolis, MN 55419), but the concept is interesting. It makes me wonder why color-TV and microwave-oven manufacturers haven't developed a simple inexpensive device or material to enable consumers to make home radiation-danger-level tests on their products. But no placebos, please.

Art Salsberg

FROM THE COMPANY WHO'S NUMBER ONE IN CAR SPEAKERS, A GREAT LINE OF CB EQUIPMENT.

Even though you may not have heard of the Sparkomatic name, you've probably been listening to the Sparkomatic sound for the past eight years. That's how long we've been number one in car speakers. And now that we've put that kind of experience into CB, you're going to hear a lot more about us. Because we have everything in CB equipment to fit anything on wheels.

Beginning with converters. If you're just starting out in CB you'll be interested in our CB-10 converter. This easy to install unit converts any AM radio into an all channel CB receiver so you can listen to what CB is all about.

Or, if you're already well into CB, use it to monitor a particular channel while you use your transceiver for the regular action. We also have a CB-11 converter which has the added feature of a 23 channel selector knob.

We make CB transceivers to fit your price range and needs. And whether it's one of our basic mobile rigs like our CB-1123, or a multi-featured base station like the CB-5000, they're all engineered with the same Sparkomatic know-how.

And once you've got a Sparkomatic transceiver, you should back it up with one of the many antennas we make for your specific application.

Like our SA-204. It gives you three full inches of whip adjustment for optimum tuning instead of being limited to the usual 3/4 inch. Other antennas can't give you the lowest SWR (standing wave ratio) like this one can. And because

antenna so no one will know your car is CB equipped. Yet, it has everything going for it like lock-in tuning and efficient top loaded coil. And it's engineered for AM, FM and stereo, as well as CB.

Our SA-22 is perfect for mounting on station wagons, campers, vans, and cars without conventional trunks. We even have a clip-on (SA-10) or magnet mount (SA-11), which you can easily attach or remove in seconds.

And now that you're all set in CB, you should look into an external speaker. For a few bucks more you can improve greatly on intelligibility.

And nothing is better designed for this purpose than our SK-35CB with the exclusive Sparkomatic Tone Purifier™ slide control which brings in the message the way you want to hear it. And to add another dimension to the fun of owning CB, our Public Address speaker, the SK-50CB is a must.

Engineering, design, dependability, value, selection... you'll get it all with Sparkomatic CB equipment.



it's pre-wired with a plug-in connector for goof-proof installation, you know you'll get all the performance that's built into your CB radio.

Our motorized SA-301 is the retractable antenna that's completely retractable. It looks like a regular radio

Sparkomatic Corporation, Milford, Pa. 18337, CB Equipment Automotive Speakers Car Radios Competition Shifters Mechanics Creepers

SPARK@MATIC



Letters

CONVERT NATURAL TO COMMON LOGS

Common, or base-10, logarithms are often used in electronics, such as in computing decibel power figures. Unfortunately,

ly, a number of electronic calculators that provide natural log (\ln) functions fail to provide a base-10 log key. Any reader who has such a calculator can easily perform his calculations using the \ln function simply by multiplying the \ln figures by the constant 0.434. Hence, the familiar decibel formulas, expressed in natural rather than common logs, become: $G_{dB} = 4.34 \ln (P_2/P_1) = 8.68 \ln (V_2V_1)$.—Michael A. Covington, Athens, GA.

PRINTERS FOR CALCULATORS

"Here Are the New Programmable Calculators" (May 1974) was timely and informative. I note, however, that there is a need for a low-cost printer for calculators. If an

adding machine that sells for \$50 to \$60 can have a numeric printer, it should not be too difficult for a low-priced calculator to have one as well.—David W. Johnston, Washington, D.C.

Electromechanical adding machines use impact-printing mechanisms, whereas calculators use thermal printing heads. Putting an impact printer in a calculator would result in a bulky, power-hungry machine. But you're in luck because some major calculator manufacturers recently introduced small calculators with built-in thermal printing heads. Some will sell for less than \$100.

BASE ANTENNAS A HOMER

It was with much enthusiasm that I read "Special Focus on CB Radio" in the April 1976 issue. Your coverage of base station antennas was extremely well presented.—Arnal A. Cook, Bloomington, IN

MORE ON WEATHER ALERTER

The "Severe Weather Warning Alserter" (May 1976) was most interesting. I highly recommend it as an add-on to low-cost vhf weather receivers, but a few comments are in order. Perhaps the National Weather Service Office in author Lloyd's area used a 15-second alert tone at the time the article was prepared, but the new nationwide standard is now a 10-second tone. Therefore, for the Alserter to work effectively under these conditions, the value of C10 should be reduced.

During severe weather warning conditions, the warning is repeated every couple of minutes, but the alert tone is sent only once, with the initial broadcast. If a new warning is required, another warning tone is sent with its initial broadcast. Our latest directive stipulates that tests of the warning signal be conducted every day, including weekends, between 10 AM and 1 PM.

Incidentally, Congress has recently designated the NWS vhf broadcast network as a primary means of disseminating attack warnings. These would also be preceded by an alert tone.—John R. Hughes, Jr., National Weather Service, Detroit, MI.

Out of Tune

In "Learning Electronic Theory With Hand Calculators, Part One" (July 1976), the equation accompanying Fig. 4 should read:

$$R_T = \frac{1}{\frac{1}{R_1} + \left(\frac{1}{\frac{R_2 R_3}{R_2 + R_3} + R_4} \right)}$$

handic CB

TALKS BETTER...LISTENS BETTER...and it's QUIETER!



Precision matched, high performance mobile antenna FREE with purchase of the **handic 235 23 channel CB.**

handic, the one-of-a-kind Swedish designed CB now gives you a rare opportunity to own this advanced equipment at real savings. It's handic's unique engineering concepts that have generated specifications up to 250% better than FCC requirements — without frills, gimmicks or "flash-in-the-panel" lighting. The result is the cleanest CB performance around — performance that's conquered the roughest operating conditions Sweden could muster. Take advantage of the special offer. See your dealer now. You'll save money and own a handic CB with a precision matched handic antenna — a combination that's second-to-none in quality. handic... the orange color tells you it's outstanding. The performance proves it.

handic CB radios include: mobile/base transceivers, handheld portables, scanners with FM radio option, antennas, microphones, selective call, and a full line of accessories.



14560 N.W. 60th Ave., Kennedy Bldg.
Miami Lakes, Fla. 33014
(305) 558-1522
In Canada: Scotcomm Radio Inc.,
Chomedey, Laval, Quebec

handic Model MA-1
Mobile CB Antenna

SPECIAL DESIGN
for Extended Range Performance

- Optimum radiation pattern
- Top-loaded coil
- Quick thumb-screw SWR adjustment
- Fold-down construction
- Precision crafted in Scandinavia

Offer expires November 15, 1976
or on previous notification by
handic of USA, Inc.

Send For FREE Catalog!



SWEDISH-DESIGNED DEPENDABILITY

ELECTRONICS BOOK CLUB

invites you to take this
1624-page electronics library
for only

\$ **1.99**

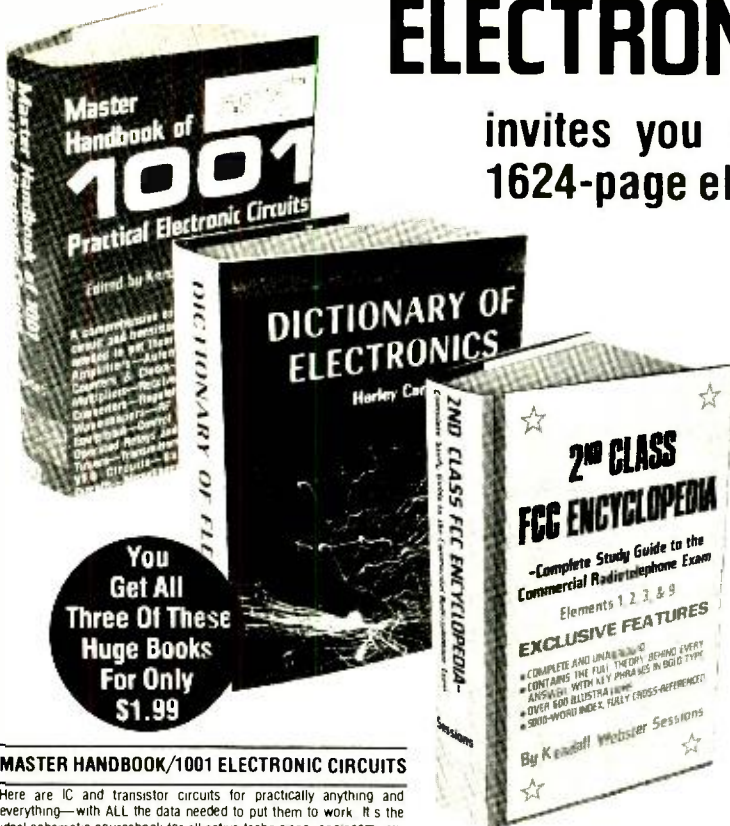

You Get All Three Of These Huge Books For Only \$1.99

- ✓ Only \$1.99 for all three!
- ✓ Regular List Price \$33.85.
- ✓ Top-Quality Hardbinding
- ✓ Features huge quick-find index
- ✓ Over 2300 illustrations
- ✓ Contains over 800,000 words
- ✓ 1624 data-packed pages

with a Trial Membership in the Book Club that Saves you 25% to 75% on a wide selection of electronics books

MASTER HANDBOOK/1001 ELECTRONIC CIRCUITS

Here are IC and transistor circuits for practically anything and everything—with ALL the data needed to put them to work. It's the ideal schematic sourcebook for all active technicians, engineers, experimenters, amateurs—for anyone who must occasionally or regularly construct or adapt electronic circuits for any purpose whatsoever. Each circuit diagram has every component carefully labeled, and every schematic is accompanied by all the info you need to construct the circuit for use in your own individual application. If there are coils to be wound, you'll find full and complete coil-winding details right there on the spot. If special parts are required, you won't have to invest a lot of time and effort before the fact, for it's all there before you in condensed captions. The circuits included are completely up-to-date, and have been designed, built, tested, reworked as necessary, and perfected. You'll find any circuit you're ever likely to need in the pages of this rich volume. Includes an ultracomplete 22-page cross-reference index so you can quickly find the circuit you need. The schematics are classified according to general application. If you're in the business of servicing/repairing commercially built electronic equipment, you're going to especially appreciate the comprehensive Appendix of IC substitutions, which includes base diagrams for most popular ICs, and gives you all the info you need to adapt the IC packages of one manufacturer to the circuit applications of another. 602 pps., over 1250 illus.

2ND CLASS FCC ENCYCLOPEDIA

Truly a one-volume electronics library all by itself—a 602-page supercourse in electronics that belongs on the bookshelf of everyone in electronics. It's as sweeping and all-encompassing as the FCC exam itself. It's a "quick-guide" to learning the answers to the 2nd and 3rd Class FCC exams (plus Element 9, for the broadcast endorsement), as well as an intensive, no-nonsense series of courses that can make you the master of any field related to radio communication. A special feature of this unique guide is the short-form, long-form answer format to hundreds of FCC-posed questions. Whenever possible the answer to a question is divided into the shortest answer needed to satisfy the FCC requirements; a longer answer then shows how any similar question may be answered, and is included for reference or for more complete understanding. Questions appear in italicized type. A boldface type section in most answers enables you to immediately extract from the detailed discussion that portion which directly answers the specific question. These "theory packets" amount to an extremely comprehensive educational approach to the FCC exam—and are just one of the many ways in which this book is one of the easiest-to-use of all radio courses. An extremely complete 5000-word index, fully cross-referenced, provides instant access to any rule, formula, circuit diagram, or technical explanation. 602 pps., over 600 illus.

DICTIONARY OF ELECTRONICS

This huge, quality dictionary is a handy reference that will serve most of your needs—extremely useful in whatever connection you have with electronics. Defines most all of the electronic terms you will run across in your everyday reading—from alpha particles through zoom lens—including those found in radio, TV, communications, radar, electronic instrumentation, broadcasting, industrial electronics, etc. The concise but clearly written definitions from all the various branches of electronics are of value to technicians, engineers, hobbyists, experimenters, and students. It provides full, complete and easily understandable explanations of thousands of specific electronics terms. A unique feature is the cross-indexing whereby key words contained in the definitions (words that are defined more fully elsewhere in the book) are printed in small capitals so the user is not left in the dark by any definition. Appendices provide you with still more data—an extensive list of units and abbreviations, graphic symbols used in schematics, component color codes, db conversion tables, data on the electromagnetic spectrum, tube base diagrams, etc. 420 pps., 487 illus.

Let us send you these three practical, time-and-money-saving books as part of an unusual offer of a Trial Membership in Electronics Book Club.

Here are quality hardbound volumes, each especially designed to help you increase your know-how, earning power, and enjoyment of electronics.

These handsome, hardbound books are indicative of the many other fine offerings made to Members' important books to read and keep volumes with your specialized interest in mind.

Whatever your interest in electronics—radio and TV servicing, audio and hi-fi industrial electronics communications, broadcasting, electronics as a hobby—you will find Electronics Book Club will help you get the job you want, keep it, improve it or make your leisure hours more enjoyable. With the Club providing you with top quality books, you may broaden your knowledge and skills to build your income and increase your enjoyment of electronics, too.

This Special Offer is just a sample of the help and generous savings the Club offers you. For here is a Club devoted exclusively to seeking out only those titles of direct interest to you. Members are annually offered over 50 authoritative books on all phases of electronics.

This extraordinary offer is intended to prove to you, through your own experience, that these very real advantages can be yours—that it is possible to keep up

with the literature published in your areas of interest—and to save substantially while so doing. As part of your Trial Membership, you need purchase as few as four books during the coming 12 months. You would probably buy at least this many anyway without the savings offered through Club Membership.

To start your Membership on these attractive terms, simply fill out and mail the coupon today. You will receive the 3-volume Electronics Library for 10-day inspection. YOU NEED SEND NO MONEY! If you are not delighted, return them within 10 days and your Trial Membership will be cancelled without cost or obligation.

ELECTRONICS BOOK CLUB, P.O. Box 10, Blue Ridge Summit, Pa. 17214

TYPICAL CLUB SELECTIONS (and List/Club prices)
 Microprocessor Microprogramming Handbook \$9.95/\$5.95—
 VHF/UHF Fire, Police, Ham Scanners Service Manual \$9.95/\$5.95—Modern Guide to Digital Logic \$9.95/\$5.95—CB Radio Schematic/Servicing Manuals—3 Volumes \$26.85 \$9.95—Color TV Trouble Factbook \$9.95/\$4.95—CBER's Handybook Of Simple Hobby Projects \$6.95/\$3.95—Modern Electronics Math \$12.95/\$8.95—Electronic Music Circuit Guidebook \$9.95/\$5.95—Build Your Own Working Robot \$8.95 \$5.95—Intro to Medical Electronics \$9.95/\$6.95—21 Simple Transistor Radios You Can Build \$6.95/\$3.95—Ham Radio Advanced Class License Study Guide \$8.95/\$4.95—Aviation Electronics Handbook \$11.95/\$7.95—Practical CB Radio Repair \$8.95/\$5.95—Radio Astronomy for the Amateur \$8.95/\$5.95

Facts About Club Membership

- The 3 introductory books carry a publisher's retail price of \$33.85. They are yours for only \$1.99 (plus postage and handling) with your Trial Membership.
- You will receive the Club News describing the current Selection, Alternates and other offerings, every 4 weeks (13 times a year).
- If you want the Selection, do nothing; it will be sent to you automatically. If you do not wish to receive the Selection, or if you want to order one of the many Alternates offered, you simply give instructions on the reply form (and in the envelope) provided, and return it to us by the date specified. This date allows you at least 10 days in which to return the form. If, because of late mail delivery, you do not have 10 days to make a decision and so receive an unwanted Selection, you may return it at Club expense.
- Personal service for your account—no computers used!
- To complete your Trial Membership, you need buy only four additional monthly selections or alternates during the next 12 months. You may cancel your Membership any time after you purchase these four books.
- All books—including the Introductory Offer—are fully returnable after 10 days if you're not completely satisfied.
- All books are offered at low Member prices plus a small postage and handling charge. Prepaid orders shipped postpaid.
- **Continuing Bonus:** If you continue after this Trial Membership, you will earn a Dividend Certificate for every book you purchase. Three Certificates, plus payment of the nominal sum of \$1.99 will entitle you to a valuable Book Dividend of your choice which you may choose from a list provided of Members.

ELECTRONICS BOOK CLUB

P.O. Box 10
Blue Ridge Summit, Pa., 17214

Please open my Trial Membership in ELECTRONICS BOOK CLUB and send my 3-volume Electronics Library, invoicing me for only \$1.99 plus shipping. If not delighted, I may return the books within 10 days and owe nothing, and have my Trial Membership cancelled. I agree to purchase at least four additional books during the next 12 months, after which I may cancel my Membership at any time.

Name _____ Phone _____

Address _____

City _____

State _____ Zip _____

(This offer valid for new Members only. Foreign and Canada add 10%) PE-96



New Products

Additional information on new products covered in this section is available from the manufacturers. Either circle the item's code number on the Reader Service Card inside the back cover or write to the manufacturer at the address given.

KENWOOD AM/STEREO FM RECEIVER

Kenwood's Model KR-5600 deluxe stereo receiver is rated at 40 watts/channel into 8 ohms with 0.5% maximum THD from 20 to 20,000 Hz. Its power amplifier section uses direct-coupled complementary-symmetry output stages and has "area of safe operation" circuit and relays that instantly cut output power should safe levels be exceeded. Op amps in the preamp section maintain a high S/N ratio. A MOSFET front end has a rated sensitivity of 1.8 μ V. Capture ratio is 1.5 dB, and alternate-channel selectivity is 80 dB. A PLL in the multiplex section provides uniform stereo separation. A 25- μ s deemphasis switch is provided for Dolby-processed FM signals. ADAPTOR OUT/IN terminals can also accommodate an outboard Dolby unit and a 4-channel conversion adaptor.

CIRCLE NO. 85 ON FREE INFORMATION CARD

ASTATIC "SILVER EAGLE" MIKE

A new version of the venerable D104 crystal desk microphone has been introduced. Called the D104 Silver Eagle, it features a push-to-talk bar in parallel with the grip-to-talk bar on the desk stand. A slide locking clamp provides "no hands" transmission. Electronic or relay switching transceivers can be used with the microphone,



which is wired with an open audio line on receive. Its coiled cable has one shielded conductor and four unshielded. All external parts, including the base, are chrome plated.

CIRCLE NO. 86 ON FREE INFORMATION CARD

"DISCO DUTY" PHONO CARTRIDGE

The Stanton 680EL has been developed for use in discotheques and radio stations. Its claimed frequency response is from 20 Hz to 18,000 Hz, with a nominal output of 1.1 mV/cm/sec \pm 2 dB. Channel separation is



said to be 30 dB, and channel balance within 2 dB. Load resistance is 47,000 ohms, and load capacitance is 275 pF. The cartridge's stylus is a 0.4 mil \times 0.7 mil elliptical diamond. Tracking force is from 2 to 5 grams, and cartridge weight is 5.5 grams. The Stanton 680EL comes with a replacement stylus. \$90.00

CIRCLE NO. 87 ON FREE INFORMATION CARD

SWTP PRINTER

Southwest Technical's Model PR-40 alphanumeric printer kit is a 5 \times 7-dot matrix impact printer which produces the 64-character upper case ASCII set with 40 characters per line. Print rate is 75 lines per minute on standard 3 $\frac{7}{8}$ -inch rolls of adding machine paper. One complete line is printed at a time from an internal 40-character line buffer memory. Printing takes place either on receipt of a carriage return command or automatically whenever the line buffer memory is filled. The unit is available in kit-form only and includes the assembled print mechanism, chassis, pc boards, components, ac power supply, assembly instruction, one ribbon and one roll of paper. \$250.00.

CIRCLE NO. 88 ON FREE INFORMATION CARD

LUXMAN SYNTHESIZED FM TUNER

The new Luxman Model 5T50 is a frequency synthesized FM tuner featuring a four-digit, seven-segment frequency readout with 200-kHz incrementation. An FM dial scale is also provided with a LED pointer that moves across the 88-108-MHz band. Tuning can also be accomplished by means of seven station presets, as well as automatic scan tuning. The preset capability uses a CMOS IC memory, which is maintained by a self-recharging battery, even when line power is turned off. A string of LED's indicates signal strength. Claimed S/N is 72 dB, capture ratio is 1.3 dB, alternate channel selectivity 80 dB, and stereo separation 48 dB at 1000 Hz, 38 dB from 30 to 10,000 Hz. Dolby noise reduction with a

400-Hz test oscillator is built-in. Claimed sensitivity is 1.7 μ V (IHF), 9.8 dBf (available power) monaural. Frequency response is 30 to 15,000 Hz, \pm 0.2, $-$ 0.5 dB. THD at 65 dBf is 0.08% at 1000 Hz (stereo). A muting switch selects one of two thresholds, or disables this feature. Output voltage is 1.5 V. Balanced (300 ohms) and unbalanced (75 ohms) antenna inputs are provided.

CIRCLE NO. 89 ON FREE INFORMATION CARD

TURNER MAGNETIC-MOUNT CB ANTENNAS

Turner has added two magnetic-mount antennas to its Signal Kicker[®] CB antennas line. The antennas use a magnet with a specification strength of 90 lb (41 kg) of direct pull. The SK900 series come with 18 ft (5.5 m) of coaxial cable. They are factory tuned for low VSWR and are designed to handle up to 500 watts of power. The stainless steel whip measures 46" (122 cm) long. The Model SK900 antenna includes a stainless steel shock spring and sells for \$28, while Model SK900 at \$25 does not have a shock spring.

CIRCLE NO. 91 ON FREE INFORMATION CARD

FISHER AM/FM STEREO RECEIVER

Fisher's Model RS1060 receiver features a PLL multiplex decoder, attenuator-type calibrated volume control, a claimed FM sensitivity of 1.7 μ V (IHF) or 9.8 dBf (available power), and a continuous power output rating of 100 W rms minimum into 8 ohms from 20 to 20,000 Hz with no more than 0.15% THD. It also has ladder-type filters in its linear phase i-f section, two tuning meters, feedback-type Baxandall tone controls, a tuned bass extender, two

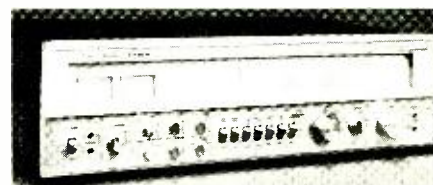

PHONO and AUX inputs and an FM DOLBY mode for use of an external Dolby noise reduction unit with the FM tuner. Two tape monitors are provided, as well as FM muting, a six-position speaker/headphone selector, switchable high and low filters, and a tone defeat switch. Phono preamp input sensitivity is 2 mV at rated output at 1000 Hz. FM capture ratio is 0.8 dBm; alternate channel selectivity, 70 dB. Measures 23 $\frac{3}{4}$ "W \times 16 $\frac{15}{16}$ "D \times 7 $\frac{3}{8}$ "H (60.3 \times 43 \times 18.7 cm), and weighs 54 lb (24.5 kg).

CIRCLE NO. 92 ON FREE INFORMATION CARD

DUMONT SINGLE-TRACE OSCILLOSCOPE

A single-trace oscilloscope with a bandwidth of dc to 5 MHz, Model 5040, is available from Dumont Oscilloscope Laboratories. It has triggered sweep,

POPULAR ELECTRONICS

The Incredible One-Hander^{T.M.}

New Realistic[®] Mobile Radio
Puts **EVERYTHING** in
One Hand. *Everything?*
Yes... **EVERYTHING!**

- Pushbutton Mike!
- Built-In Speaker!
- Illuminated Channel Selector!
- On-Off Switch!
- Volume and Squelch!

It's Patented, Too...
U.S. Pat. No. 643485

Here's What CB Magazine (May 1976)
Has to Say About Our "One-Hander"

"On the road, it performed beautifully. The 60 dB of adjacent channel rejection was a particular plus in the test area... In my opinion, this radio is one of the best innovations in mobile communications in many years. Having all of the operating controls built into the mike frees the driver from having to reach for the next channel or looking for the volume control while paying attention to traffic."



Handset shown
actual size

Invented by Radio Shack to give you one-hand control for driving safety, amazingly easy operation

A CB "first" — either-hand ONE HAND control of all functions. And the rest of the transceiver is so small you can hide it away under the dash or seat, even in the glovebox. A high-quality, super-convenient radio in every detail. With all crystals for full 23-channel coverage. Built-in blanker and ANL to chop out ignition-type noise. Ceramic filter to cut station interference. Positive or negative ground. Jack for optional extra remote speaker. FCC Type Accepted, of course. Adjustable mounting bracket, power cable for any 12VDC vehicle included. Better hurry in for yours — everybody is going to want the One-Hander!
Ask for 21-161.

149⁹⁵*



The 11 1/2 x 5 1/4 x 7" remote section is easily concealed. 3-way switch for its own built-in speaker, handset speaker external speaker.



We've put the whole works in ONE hand. Even a red LED that lights up when the set is "on" and indicates the channel number. Coiled cord extends to 5 feet, gives you freedom of movement and lets you place the handset anywhere.

FREE! NEW 1977
RADIO SHACK CATALOG

AT OUR 4200 USA
STORES AND DEALERS
STARTING SEPTEMBER 1st!

- EXCITING NEW 56TH ANNIVERSARY EDITION
- OVER 2000 EXCLUSIVE PRODUCTS
- FULL COLOR • 164 PAGES

CB • Hi-Fi • Radios • Phonos • Recorders • Tape • Antennas
Kits • Batteries • Parts • Car Stereo • PA • Intercoms • More

SOLD ONLY WHERE YOU SEE THIS SIGN:

Radio Shack[®]

A TANDY CORPORATION COMPANY
OVER 5000 LOCATIONS • 50 STATES • 9 COUNTRIES



Use your credit card
at most stores

*Retail Price May Vary at Individual Stores and Dealers.



**Antler
CB Antennas**

MAKE THE MOST OF YOUR CB POWER!

ANTLER ANTENNAS DELIVER GREATER POWER POTENTIAL

All CB radios have about the same range potential . . . yet, some CB'ers get greater range and reception. The secret's in a matched system . . . the radio and antenna system as it's installed in your particular car . . . and the best systems are topped by Antler antennas.

HERE'S WHY!

Antler antennas are more efficient . . . deliver and hold lower SWR readings. It's that simple. The more efficient your antenna . . . the better your CB can reach its full range potential.

Insist on an Antler antenna. There's a model and mount for the installation you want. You'll get better transmission to power through CB congestion by delivering all the potential of your CB. Isn't that what you want?
10 4!



Antler "POSI-GRIP" MAGNETIC MOUNT.

Grips tight at speeds in excess of 100 MPH. No installation . . . avoids targeting your car by CB thieves.

MCM Mfg. Company

6200 South Freeway
Fort Worth, Texas 76134 (817) 293-7533

CIRCLE NO. 76 ON FREE INFORMATION CARD

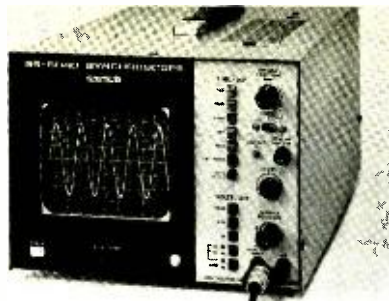

minimum vertical sensitivity of 20 mV/cm, input impedance of 1 megohm paralleled by 32 pF, a horizontal time base of 1 μ s/cm to 10 ms/cm in five calibrated steps. The horizontal amplifier accepts external sweep signals from dc to 100 kHz (-3 dB), and has an external sensitivity of 0.5 V/cm. A 5-inch CRT provides a 3.15" \times 3.94" (80 \times 100 mm) viewing area, and uses a P31 standard phosphor. A built-in calibrator provides a 1-V p-p line frequency reference signal. Measures 16.5"D \times 9"W \times 6.5"H (41.9 \times 22.8 \times 16.5 cm), and weighs 15.4 lb. (6.98 kg). \$325.

CIRCLE NO. 93 ON FREE INFORMATION CARD

TEAC HALF-TRACK TAPE DECK

Teac announces its A-3300SX-2T open-reel tape deck with a 2-channel stereo or mono format. Features three motors, three tape heads, and 7 $\frac{1}{2}$ or 15 ips. Independent left and right channel source/tape selector and VU level averaging meters are included. A manual cue lever facilitates searching and editing. Includes separate bias and equalization selectors, independent left and right channel record mode selectors, and individual input and output level controls. Accommodates 10 $\frac{1}{2}$ -inch reels. Claimed frequency response is 30 to 26,000 Hz \pm 3 dB at 15 ips; wow and flutter (NAB weighted) is 0.04% at 15 ips, and THD is less than 1% at 1 kHz, normal operating level. A headphone output jack is built-in. Measures 17 $\frac{5}{16}$ " \times 17 $\frac{5}{16}$ " \times 8 $\frac{5}{16}$ " (44 \times 44 \times 21 cm), and weighs 44 lb (20 kg).

CIRCLE NO. 94 ON FREE INFORMATION CARD

MERIX ANTI-STATIC COATING

Merix Anti-Static #79 is a non-metallic conductive coating that achieves its conductivity chemically after it is diluted with de-ionized water. It can be wiped on to an area, dries quickly, and gives conductivity to an average area of 8000 to 10,000 square feet per gallon. The coating gives readings of 20 to 100 megohms per square inch on plastics, and +100 megohms per square inch on glass surfaces. Merix Anti-Static #79 is stable, clear, neutral pH, non-flammable, and safe to use. Available in large quantities, or in sample gallons for \$58 each, or sample quarts for \$27 each. Merix Chemical Co., Div. A., Conductive Coatings, 2234 East 75th St., Chicago, IL 60649.

WEATHERALERT WEATHER RECEIVER

A new weather receiver from Weatheralert offers continuous U.S. Weather Service monitoring and sounds its internal siren when a special signal is received whenever dangerous conditions threaten. During normal operation, the receiver picks up the weather station's continuous reports. The siren trips only when the special signal is transmitted. (Volume need not be turned up to activate the siren.) The receiver is designed to operate within 40 to 50 miles (65 to 80 km) of the transmitter using its built-in telescoping antenna. An optional antenna kit extends reception range up to 80 miles (130 km). Primary ac powered, the receiver automatically switches over to batteries should a power failure occur. \$39.95. Address: Weatheralert Co., 639 S. Dearborn St., Chicago, IL 60605.

SANSUI HIGH-POWER STEREO RECEIVER

The Sansui Model 9090 stereo receiver is rated at 100 watts/channel at 0.2% maximum harmonic distortion with both channels driven into 8 ohms. The direct-coupled amplifier section features two meters with logarithmically compressed scales to cover a power output range of from 0.05 to 200 watts at 8 ohms. The receiver is equipped with zero-center tuning and signal-strength meters, the latter doubling as a multipath indicator during FM antenna alignment for eliminating multipath distortion. A phase-locked-loop IC is used in the FM (stereo) demodulator to minimize multiplex distortion and tuning noise. In addition, the receiver has a circuit to permit mixing mike signals with those from any other source. FM sensitivity is rated at 1.7 μ V, capture ratio at 1.5 dB, and selectivity at 85 dB. \$750.00.

CIRCLE NO. 96 ON FREE INFORMATION CARD

EICO MOBILE CB PREAMP

The "Long Ranger" Model LR-3 preamp boosts CB signal 20 dB on receive for increased sensitivity. Although the preamp is



inserted in the transmission line between transceiver and antenna, a carrier detection circuit isolates the preamp on transmit. Requires 12 V dc, positive or negative ground. \$29.95

CIRCLE NO. 97 ON FREE INFORMATION CARD

Learn to use a microprocessor.

This portable computer teaches you how.

Low cost, battery operated Intercept Jr. Tutorial System instructs you on today's most advanced LSI semiconductor devices, then serves double duty as an operating solid-state computer!

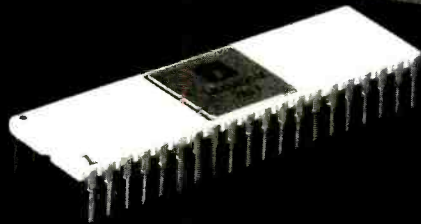
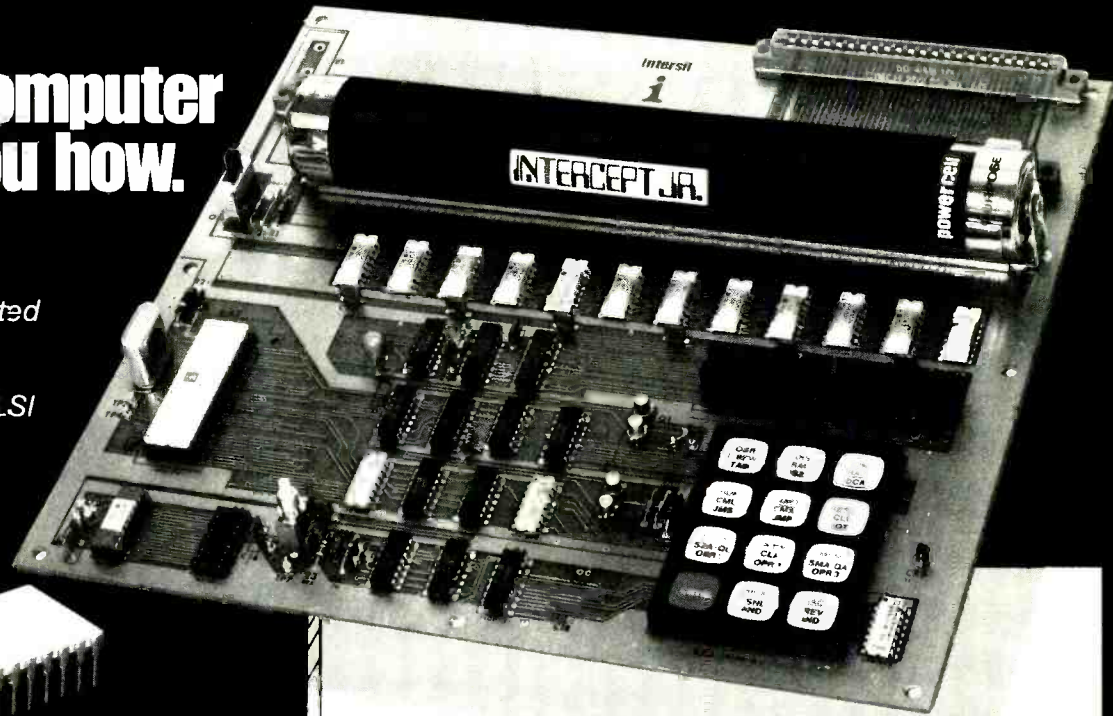

Learn microprocessors in hours.

With its detailed Owner's Handbook, Intercept Jr. teaches you basics of microprocessors, Random Access Memories (RAMs), Read Only Memories (ROMs) and input/output interfacing, all in less than 8 hours.

Contains everything you need.

Intercept Jr. is a complete all-CMOS computer on a 10- by 12-inch board. Contains batteries, entry keyboard, 8-digit LED display, RAM and ROM memory ... all controlled by an Intersil IM6100 12-bit CMOS microprocessor

An inexpensive teaching computer.

For \$281.00 you get both the handbook and the computer, plus provisions for expansion with 1024 words of additional memory, from 256 to 2048 words of added program, and input/output interfacing with terminals.



Send in coupon today.

Intersil, Inc.,
10900 North Tantau Ave., Cupertino, CA 95014.

- | | PRICE | QTY | TOTAL |
|--|----------|-------|-------|
| <input type="checkbox"/> I'm interested. Send me Intercept Jr. Tutorial System complete with Owner's Handbook. | \$281.00 | ___ S | _____ |
| <input type="checkbox"/> I need to know more. Send full technical details on Intercept Jr. | FREE | | _____ |

Plug-in Expansion Modules Also Available

- | | | | |
|---|--------|-----|-------|
| <input type="checkbox"/> RAM Module, with 1024 words of added non-volatile memory. | 145.00 | ___ | _____ |
| <input type="checkbox"/> P/ROM Module, with sockets for 256 to 2048 words of program. | 74.65 | ___ | _____ |
| <input type="checkbox"/> I/O Module, for interfacing TTY keyboard/reader and printer/punch. | 81.70 | ___ | _____ |

(California residents add 6% sales tax.) _____

PE9

TOTAL PAYMENT DUE _____

- Check enclosed.
 Money order enclosed.
 Bill me. (Please list Purchase Order no. _____)

SHIPPING ADDRESS (Please print)

name _____
 company _____
 address _____
 city _____ state _____ zip _____

CIRCLE NO. 38 ON FREE INFORMATION CARD

It's faster, easier and less expensive. That's why we call it Super-Strip.™

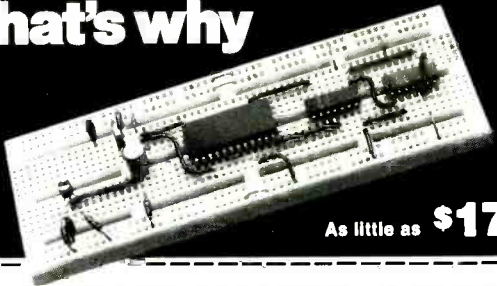

As little as **\$17**

This versatile mini breadboard features the same superior contacts, materials and construction we use in our full-scale ACE All Circuit Evaluators. Any solid hookup wire up to #20 plugs right in to connect DIPs, discretes and almost any components you have on hand. Super-Strip gives you 128 separate five-tie-point terminals in the circuit building matrix and 8 power and signal distribution lines — enough capacity to build circuits with as many as nine 14-pin DIPs. And when you're done with your hookup, just pull it apart — everything's as good as new. Super-Strips come with your choice of nickel-silver or gold-plated terminals. Plus an instant-mount backing and quick-removal screws for fast and easy stacking or racking. Heard enough? Then stop looking and start cooking with A P Products Super-Strips.

Part Number	Model Number	Terminal Type	Price Each	Quantity	Total
923252	SS-2	nickel-silver	\$17.00		
923748	SS-1	gold-plated	\$18.90		

Total for merchandise		
Sales Tax (OH and CA)		
Shipping (see table)		
TOTAL ENCLOSED		

Shipping/Handling	25.01 to 50.00	2.00
	Up to \$10.00	\$1.00
	50.01 to 100.00	2.50
	10.01 to 25.00	1.50
	100.01 to 200.00	3.00

Orders subject to acceptance at factory.
Company PO's FOB Painesville. No COD Orders

Credit Card Number

4 Numbers Above Name (MC) Good Thru _____

Signature

Print Name

Address

City State Zip

- Check or M.O. enclosed
- Charge BAC
- Charge MC
- Send catalog



DEALER INQUIRIES INVITED.

A P PRODUCTS INCORPORATED

Box 110-H Painesville, OH 44077 (216) 354-2101

CIRCLE NO. 1 ON FREE INFORMATION CARD

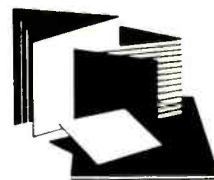

New Literature

CB ANTENNA CATALOG

Cush Craft's new 4-page catalog, C-9, includes a full line of monitor antennas; trunk-mount, jiffy mirror-mount and co-phased mirror-mount mobile antennas; omni-base antennas for permanent or temporary use; directional base-station antennas with 3, 4 and 5 element beams, including a horizontal/vertical power beam and dual beam stack kit. Antennas are illustrated and complete specifications are provided. A section on related accessories is also provided. Address: Cush Craft Corp., 621 Haywood St., Manchester, NH 03103.

TECHNICAL BOOKS CATALOG

Tab Books offers a 1976 catalog of technical and do-it-yourself books. The 44-page, fully illustrated catalog describes over 400 current and forthcoming books, plus 14 electronic book kits. Some of the subjects covered are: amateur radio license study; audio; hi-fi; basic electronics; 2-way, shortwave and CB radio; math calculators and computers; electronic music; general electronic servicing, and test equipment. A selection of TV, radio, CB and hi-fi service manuals is also included. Address: Tab Books, Blue Ridge Summit, PA.

SPEAKER CATALOG

Quam-Nichols announces its new 17-page catalog illustrating its line of loudspeakers for high fidelity, music instruments, sound systems, automotive, general purpose and industrial applications. Technical specifications are given, including dimensions, frequency response, power-handling capacity, voice-coil impedance and diameter, and magnet material. Speakers are illustrated and a section on configurations and mounting dimensions is included. Also available is a 2-page flyer describing Quam's air-suspension speakers. Address: Quam-Nichols Company, Marquette Rd. and Prairie Ave., Chicago, IL 60637.

SOLDERING AND DESOLDERING EQUIPMENT

A new, 4-page catalog, #76, from Endeco illustrates its line of soldering and desoldering equipment. Included are soldering and desoldering irons, kits, a desoldering head that converts a soldering iron into a desoldering iron, tips, desoldering bulbs, solder paks, and soldering tool stands. Cord size, wattage, voltage and tip temperature information are included. Address: Enterprise Development Corp., 5127 E. 65 St., Indianapolis, IN 46220.

let's make it dynakit

Stereo components . . . easy to make kits or assembled.

Write for free 24 page color catalog **dynaco**
dynakit

Dept. G, Box 88, Blackwood, N.J. 08012

SWTPC 6800

#1

IN PERFORMANCE

The word is getting around. There is simply no better processor available for general purpose computer work than the Motorola MC6800. This memory oriented processor is easier to program and makes possible more efficient, shorter and faster running programs than the old fashioned bus oriented processors. Have you been convinced that machine language, or assembler programs are only for the experts? Well not with a modern 6800 based computer. Anyone can learn very quickly with this simple straight-forward hexadecimal notation processor. When you add to these advantages the unique programmable interfaces and the Mikbug® ROM you truly have a "benchmark" system.

Mikbug® eliminates the tedious and time consuming job of loading the bootstrap program from the switch console each time the computer is turned "On". With Mikbug® this is automatic and you simply don't have switches and status lights. It has been said (not by us) that a switch console is essential for "hardware development," (perhaps they meant "hardware debugging"). Anyway the SwTPC 6800 system has no need for either. This is a fully developed, reliable system with no strange habits. All boards have full buffering for solid noise immune operation. One crystal type clock oscillator drives everything, processor interfaces and all; so there are no adjustments and no problems.

FOR VALUE

The SwTPC 6800 in its basic form comes complete with everything you will need to operate the computer except an I/O device. This may be either a teletype of some kind, or a video

terminal. You get a heavy duty anodized aluminum case, a 10 Amp power supply large enough to power a fully expanded system, a mother board with seven memory/processor slots and eight interface slots, a 2,048 word static memory and a serial control interface. This kit is now only \$395.00. It was introduced at \$450.00, but when processor prices went down we reduced the price of the kit accordingly.

As an owner of our 6800 computer you will get copies of our newsletter with helpful information and software listings. We have a library of software including all the common computer games and our fantastic BASIC. This is available to you for the cost of copying, you don't have to buy anything to get this material.

What more could you want? Pay a visit to our nearest dealer and see the 6800, plus our new cassette interface, graphics terminal and printer. He will be happy to demonstrate our system and to supply you with a 6800 that will fit your exact needs.

Mikbug® is a Motorola Trademark

SWTPC 6800
Computer System

with serial interface and 2,048 words
of memory \$395.00

Southwest Technical Products Corp.
219 W. Rhapsody
San Antonio, Texas 78216

The Computer Store, 820 Broadway,
Santa Monica, Calif. 90401, (213) 451-0713

Cyberdux, Microcomputer Applications,
1210 Santa Fe Dr., Encinitas, Calif. 92024
(714) 279-4189

The Micro Store, 634 South Central
Expressway, Richardson, Texas 75080
(214) 231-4088

ELS Systems, 2209 N. Taylor Rd.,
Cleveland Heights, Ohio 44112
(216) 249-7820

Microcomputer Systems Inc.,
144 S. Dale Mabry Ave., Tampa, Florida
33609, (813) 879-4301

William Electronics Supply, 1863 Wood-
bridge Ave., Edison, N.J. 08817
(201) 985-3700

Computer Mart of New York, Inc.
314 Fifth, New York, N.Y. 10001
(212) 279-1048

The Byte Shop Computer Store # 1,
1063 El Camino Real, Mountain View,
Calif. 94040, (415) 969-5464

The Byte Shop Computer Store # 2,
3400 El Camino Real, Santa Clara, Calif.
95051, (408) 249-4221

A-VID Electronics Co., 1655 E. 28th Street,
Long Beach, Calif. 90806 (213) 426-5526

Computer Warehouse Store, 584 Common-
worth Ave., Boston, Massachusetts 02215
(617) 261-1100

The Computer Workshop, Inc., 11308
Hounds Way, Rockville, Ind. 20852
(301) 468-0455

The Computer Store, Inc., 120 Cambridge
Street, Burlington, Mass. 01803
(617) 272-8770

Marsh Data Systems, 5405 B. Southern
Comfort Blvd., Tampa, Florida 33614
(813) 886-9890

Midwest Enterprises Inc., 815 Standish Ave.,
Westfield, New Jersey 07090
(212) 432-2066

The Milwaukee Computer Store, 6916 W.
North Ave., Milwaukee, WI 53213
(414) 259-9140

Control Concepts, P.O. Box 272,
Needham Heights, Mass. 02194

American Microprocessors, Equipment &
Supply Corp. at Chicagoland Airport, P.O.
Box 515, Prairie View, Illinois 60069
(312) 634-0076

The Computer Room Inc., 3938 Beau D'Rue
Dr., Eagan, Minn. 55122, (612) 452-2567

Computerware, 830 First St., Encinitas,
Calif. 92024 (714) 436-9119

Atlanta Computer Mart, 5091 B Buford
Highway, Atlanta, Ga. 30340
(404) 321-4390



Stereo Scene

By Ralph Hodges

GREETINGS FROM NIHON

ALTHOUGH you may not know it, "Nihon" is the name—or at least the likeliest phonetic rendering of the name—that the Japanese people have for their native land. There are many other things that we, and especially I, don't know about Japan, even though I've just returned from my third visit to that country in about as many years. What appears below is an amalgam of what I think I've learned on the trip and what I'm sure I don't as yet understand. The emphasis will of course be on hard information, since rumors and speculation are readily available elsewhere.

What Is Japan? For our purposes Japan is perhaps the world's leading producer of sophisticated consumer electronics. It is also one of the world's poorest markets for its own products. Outside of stores that sell them, I have never seen—much less heard—a Japanese transistor radio, except in taxicabs where they have been turned

on more for my benefit than the driver's. People do not walk around with such devices, and as nearly as I can tell from brief glimpses of resorts and scenic areas, they do not take them on trips either. Japanese-made TV receivers seem to sell well among those who can afford them, but I've never seen them used for anything other than sports events. The salesman who totted up my copious purchases in a store in the Akihabara (Tokyo's famed retail electronics district) used an abacus instead of an electronic calculator, although his store had at least three different brands of calculators on display.

If this seems to suggest that the urban Japanese consumer is backward and unappreciative of the "finer things," put the idea out of your mind. Notwithstanding a highly complex and difficult language, Japan has managed to achieve a phenomenally high percentage of literacy within its population. Consumer enthusiasm is

rampant, technological awareness is acute, and among those able to indulge themselves there is a refined appetite for the arts in all their varieties and origins.

However, the Japanese are given to setting themselves collective *and* individual goals. They wait until they can afford what they want rather than "making-do" with temporary substitutes, and they relish, I think, the anticipation as much as the actual acquisition. Having been an impoverished audiophile for too many years, I respect their attitude and admire their patience. But I think most Westerners, myself included, would consider their buying practices a strange combination of rationality and irrationality.

Hi-fi in Japan. In the U.S., the staple hi-fi product has been and is likely to remain the receiver, even though the popularity of "separates" is growing. In Japan, the receiver has never been an extraordinarily popular product, and latest reports indicate that it is dying a speedy death.

There is a rational reason for this: Japan's FM broadcasting is extremely sparse, so that a modern receiver's wide-band tuning capabilities and superb interference rejection are largely superfluous. At present, regulations allow a maximum of two broadcasting stations in any given reception area, and these tend to be widely spaced on the dial (the Japanese FM band is centered 10 MHz below that of the U.S., so that there is only a two-thirds overlap between the two; but most Japanese receivers are designed to cover the U.S. band only, and are therefore not really Japanese products at all). I am told that the people in charge are gradually being persuaded that equipment in the hands of the general populace is capable of coping with closer frequency spacings. If this view prevails, Tokyo may suddenly acquire eight or more FM stations in addition to the present two, which would make a stereo FM receiver a more practical product than it has been.

Then there is the irrational side. Receivers may be languishing in Japan, but tuners are not! The world's more widely acclaimed tuners—the classic Marantz 10B and the Sequerra, for example—bring higher prices on the Japanese market than almost anywhere else. But Japanese tuners, as good as some of them are, do not sell

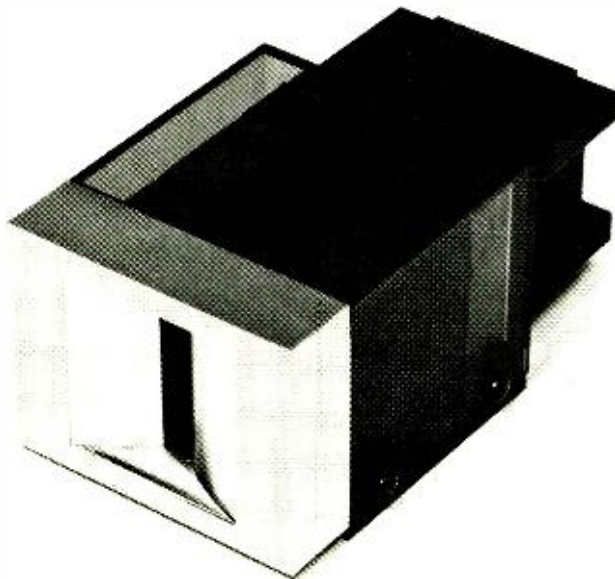
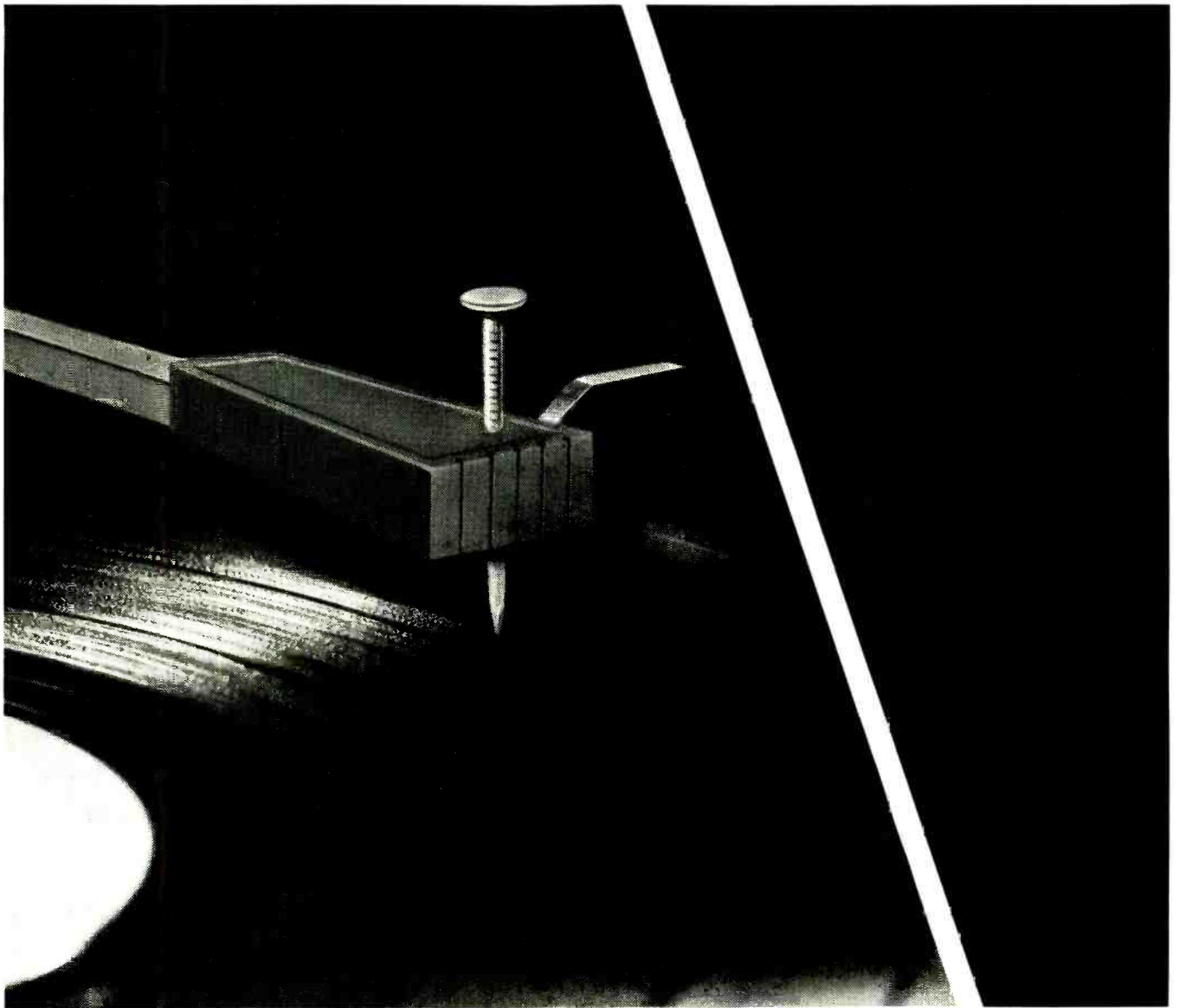
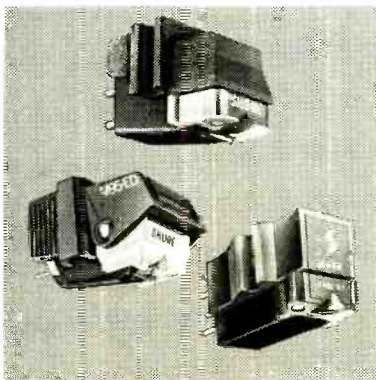

Fig. 1. The Pioneer ribbon tweeter is down only 10 dB at 100,000 Hz.



This is no way to nail down a hi-fi bargain.



Some stores think that one of their cost-cutters in assembling a "bargain" stereo system is to install a run-of-the-mill, inexpensive cartridge. After all, who's going to notice a tiny cartridge when it's surrounded by powerful speakers and a dynamite turntable? Unfortunately, some shoppers are reluctant to insist on a better cartridge when buying one of these package specials. But you are made of sterner stuff! And if you insist on a Shure cartridge, "better" doesn't have to mean more expensive. Time and time again, consumer magazines have rated Shure cartridges the best in their price category. As the source of sound for the entire system, that tiny Shure cartridge and its critical stylus determine what you'll ultimately hear. And as bargains go, that's the best tip you'll hear today—or any day!

Shure Brothers Inc.
222 Hartrey Ave., Evanston, IL 60204
In Canada: A. C. Simmonds & Sons Limited



Manufacturers of high fidelity components, microphones, sound systems and related circuitry.

CIRCLE NO. 62 ON FREE INFORMATION CARD

Learn to service Communications /CB equipment at home...with NRI'S COMPLETE COMMUNICATIONS COURSE

Learn design, installation and maintenance of commercial, amateur, or CB communications equipment.

The field of communications is bursting out all over. In Citizens Band alone, class D licenses grew from 1 to over 2.6 million in 1975, and the FCC projects about 15 million CB'ers in the U.S. by 1979. That means a lot of service and maintenance jobs . . . and NRI can train you at home to fill one of those openings. NRI's Complete Communications Course covers all types of two-way radio equipment (including CB), AM and FM



Transmission and Reception, Television Broadcasting, Microwave Systems, Radar Principles, Marine Electronics, Mobile Communications, and Aircraft Electronics. The course will also qualify you for a First Class Radio Telephone Commercial FCC License or you get your tuition back.

Learn on your own 400-channel digitally-synthesized VHF transceiver.

You will learn to service all types of communication equipment, with the one unit that is designed mechanically and electronically to train you for CB, Commercial and Amateur communications: a digitally-synthesized 400-channel VHF transceiver and AC power supply. This 2-meter unit gives you "Power-On" training. Then we help you get your FCC Amateur License with



special instruction so you can go on the air.

The complete course includes 48 lessons, 9 special reference texts, and 10 training kits. Included are: your own electronics Discovery Lab, Antenna Applications Lab, CMOS Frequency Counter, and an Optical Transmission System. You'll learn at home, progressing at your own speed, to your FCC license and into the communications field of your choice.

NEW CB SPECIALIST COURSE NOW OFFERED



NRI now offers a special course in CB Servicing. You get 37 lessons, 8 reference texts, your own CB Transceiver, AC power supply and multi-meter . . . for hands-on training. Also included are 14 coaching units to make it easy to get your commercial radio telephone FCC license—enabling you to test, install, and service communications equipment.

NRI offers you five TV/Audio Servicing Courses

NRI can train you at home to service TV equipment and audio systems. You can choose from 5 courses, starting with a 48-lesson basic course, up to a Master Color TV/Audio Course, complete with designed-for-learning 25" diagonal solid state color TV and a 4-speaker SQ™ Quadraphonic Audio System. NRI gives you both TV and Audio servicing for hundreds of dollars less than the two courses as offered by another home study school.



All courses are available with low down payment and convenient monthly payments. All courses provide professional tools and "Power-On" equipment along with NRI kits engineered for training. With the Master Course, for instance, you build your own 5" wide-band triggered sweep solid state oscilloscope, digital color TV pattern generator, CMOS digital frequency counter, and NRI electronics Discovery Lab.



*Trademark of CBS Inc.

NRI's complete computer electronics course gives you real digital training.

Digital electronics is the career area of the future . . . and the best way to learn is with NRI's Complete Computer Electronics Course. NRI's programmable digital computer goes far beyond any "logic trainer" in preparing you to become a computer or digital technician. With the IC's in its new Memory Kit, you get the only home training in machine language programming . . . experience essential to trouble shooting digital computers. And the NRI programmable computer is just one of ten kits you receive, including a TVOM and NRI's exclusive electronics lab. It's the quickest and best way to learn digital logic and computer operation.

You pay less for NRI training and you get more for your money.

NRI employs no salesmen, pays no commissions. We pass the savings on to you in reduced tuitions and extras in the way of professional equipment, testing instruments, etc. You can pay more, but you can't get better training.

More than one million students have enrolled with NRI in 62 years.

Mail the insert card and discover for yourself why NRI is the recognized leader in home training. No



salesman will call. Do it today and get started on that new career.

APPROVED UNDER GI BILL
if taken for career purposes Check box on card for details



NRI SCHOOLS
McGraw-Hill Continuing Education Center
3939 Wisconsin Avenue,
Washington, D.C. 20016



Altair, Imsai, Polymorphic, compatible products

Video Terminal Interface: Connects to standard TV monitor or modified receiver to display 16 lines of 32 or 64 characters. Characters are formed in a 7 x 9 matrix for easy readability. Character set includes 128 upper and lower case ASCII characters and 64 graphic characters for plotting on a 48 x 64 (48 x 128 with memory option) array. An 8-bit input port is provided for the keyboard. Characters are stored in the onboard memory, which may be read out of or written in to by the computer. Cursor control, text editing, and graphics software is included. \$185 (32 char.) kit. \$210 (64 char.) kit.

Poly I/O Idea Board: This will save you a lot of time in making prototype circuits. I/O port address is selectable with dip switch, and inputs and outputs are fully buffered. \$55 kit.

Analog Interface: Good for interfacing your computer to an analog world. Ten bits of resolution in and out. \$145 for one channel and \$195 for two channels (kit).

Ask about how to get a free POLY I/O Idea Board or Analog Board.

8K RAM on a single board. Connection for battery backup. \$300 kit.

Special Offer

Video Terminal Interface (32 character) and 8K RAM, \$450 kit. Expires - September 30th, 1976.

You've probably been hearing about the POLY 88 microcomputer system that uses keyboard and video. We don't have the space here to describe all the features. See it at your local computer store.

Support your local computer store.

All prices and specifications subject to change without notice. Prices are USA only. Calif. residents add 6% sales tax. All non-paid orders add 5% USA shipping, handling, and insurance. (Outside USA add 10%) BankAmericard and Master Charge accepted.

PolyMorphic Systems

737 S. Kellogg, Goleta, CA 93017
(805) 967-2351



Fig. 2. JVC's unusually large anechoic chamber.

remarkably well. I think you can put this phenomenon down to good reasons (these preferred tuners are, after all, excellent) as well as questionable ones. For example, U.S. products are considered exotic by the Japanese in ways that Japanese products are considered exotic in the U.S.

The Japanese Market. In the opinion of many people in Japan, the audio

market is more sharply and discernibly divided than in the U.S. A large part of the market buys the equivalent of consoles—usually three-piece ensembles—two speakers and a central control and program-source section. All of this is generally enclosed in free-standing furniture. Often, this will all be of Japanese manufacture.

On the next step up you'll find the beginnings of audiophilia. One



Fig. 3. The JVC sound theater has two enormous horn-loaded speaker systems.

Introducing the first pocket programmable that remembers your programs and data even when it's turned off. The new HP-25C. \$200.00*



Meet the first Scientific Programmable calculator that lets you take a breather midway through your solution *without* having to start all over again when you get back. The reason: Its memory and storage registers stay ON even when you shut it OFF†—during a phone call, a meeting or a weekend.

It's called the HP-25C. (Incidentally, the "C" stands for "Continuous Memory C-MOS" technology.) *Continuous Memory*

Here's what Continuous Memory does for you:

1. It lets you key in your favorite program—debug it—and retain it in memory for repeated use. So you gain accuracy as well as time.
2. You can add additional functions not on the keyboard (hyperbolics, octal/decimal conversions, etc.), simply by writing programs and storing them permanently in memory.
3. It enables you to gather data one place (such as at a survey jobsite) and retain your results until you get back to work with them later (just think of the time you'll save and the accuracy you'll gain because you *won't* have to re-enter information).
4. You don't lose data when you lose battery power. Here's why:

when all the decimal points display—indicating a low battery—your data and program will not be lost provided the calculator is turned OFF and the recharger is promptly connected. The HP-25C will even retain your data and program for at least 5 seconds—without *any* battery at all—while you are replacing a discharged battery with a charged one.

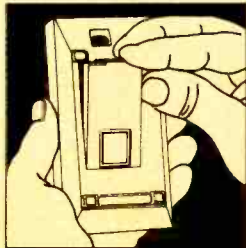

But there's more. Aside from Continuous Memory, the HP-25C is identical to our popular HP-25. Both give you a total of 72 pre-programmed functions and operations; complete keystroke programmability; branching and conditional test capability and fixed decimal, scientific and engineering (exponent in

multiples of ± 3) notations. You also get our RPN logic system with 4-register stack and 8 storage registers. And every program written for the HP-25 will work *without modification* for the HP-25C.

The HP-25C. There's never been a Scientific Programmable Calculator like it before.

Best of all, the HP-25C's got HP's name on it. And you know what that means. Design, performance and a back-up support system you just can't get anyplace else.

Why not "test touch" one for yourself? Or, if Continuous Memory is not important to your particular application, try our standard HP-25, \$145.00* For complete HP-25C specs and the name of your nearest dealer, call toll-free 800-538-7922 (in Calif. 800-662-9862).

THE HP-25C AT A GLANCE

- Program memory and storage registers stay ON at all times.
- 72 functions and operations.
- Keystroke programmability.
- Full editing capability.
- Branching and conditional test capability.
- 8 addressable memories.
- Fixed decimal and scientific notation—plus engineering notation.
- RPN logic system with 4-memory stack.
- \$200.00*



Sales and service from 172 offices in 65 countries. Dept. 254D, 19310 Pruneridge Avenue, Cupertino, CA 95014.

*Suggested retail price, excluding applicable state and local taxes—Continental U.S., Alaska & Hawaii.

†The HP-25C's C-MOS memory chips consume only 1/80,000 of the calculator's normal operating power. Thus, a fully charged battery pack can hold your programs and data for at least 1½ months with the HP-25C turned off.

**"My father built this
Schober Organ
for me!"**



You'd be proud to buy her an organ this good...but how would you feel if you'd also *built* it? It's a special kind of satisfaction. The gift of a lifetime of magnificent music, crafted with your own hands!

And you can do it! You need no prior electronic or mechanical abilities. Just the capacity to follow instructions. Every step is clearly detailed, every component is supplied. You'll find the assembly process as enjoyable as the music which follows!

And what music! For this is a truly fine instrument you will build. Far superior to most "ready-made" organs...easily comparable to others at twice the price. Kit costs range from \$650 to \$2850 for all basic components, and you can purchase it in sections to spread costs out...or have two-year time payments.

Just send the coupon for the fascinating Schober color catalog (or enclose \$1 for a record that lets you hear as well as see the quality of Schober).

The Schober Organ Corp., Dept. PE-67
43 West 61st Street, New York, N.Y. 10023

Please send me Schober Organ Catalog.
 Enclosed please find \$1.00 for 12-inch L.P. record of Schober Organ music.

NAME _____
 ADDRESS _____
 CITY _____ STATE _____ ZIP _____

CIRCLE NO. 60 ON FREE INFORMATION CARD

**LAB ACCURACY
VOLKSMETER
.02% LM-4**



With Rechargeable Batteries & Charger Unit. **\$227**

Features Include:

- Rugged - ideal for field service use. • Full four digits. • 13 ranges: 4 vdc, 4 vac & 5 ohms.
- Automatic zeroing & polarity. • Small size: 1.9" H x 2.7" W x 3.9" D. • Fully protected input.

Also a 1%, 3-digit LM-3 @ \$125 and a 0.05%, 3-1/2-digit LM-3.5 @ \$147.

See your local distributor!
 Distributor inquiries invited.



Non-Linear Systems, Inc.
 Originator of the digital voltmeter.
 Box N, Del Mar, California 92014
 Telephone (714) 755-1134 TWX 910-322-1132
 CIRCLE NO. 47 ON FREE INFORMATION CARD

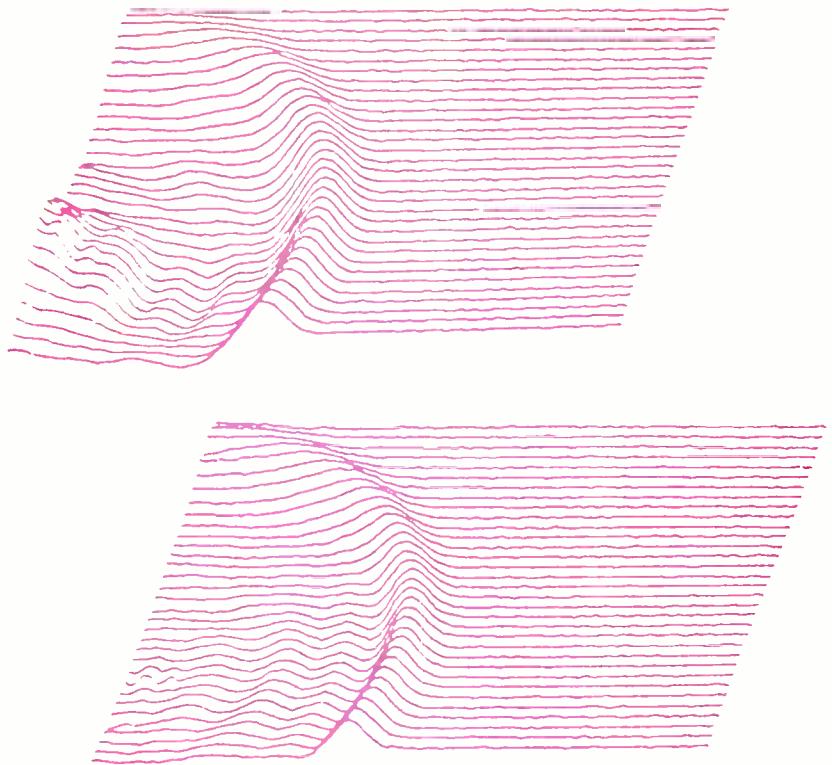

Fig. 4. Recent work at JCV includes this visual analysis of loudspeaker wavefront propagation. Here hard-dome (top) and soft-dome tweeters are compared.

Japanese enthusiast I spoke to has KLH speakers, Dynaco amplifiers, an AR turntable, and a Shure cartridge, and this is not an unusual combination. Above that level there are large loudspeaker systems—big JBL's and Bozaks, Tannoys, Klipschorns, and the most expensive Electro-Voices—together with prestige amplifiers of U.S. or European make. You'll notice a dearth of Japanese goods in this lineup, which is one of the peculiarities of the Japanese market on their own home ground.

The Potential Japanese Market.

It seems to me that what the Japanese have lacked up to now is a succession of products—or even just one product—that is universally recognized as being the *best* available. True, their tape decks are highly regarded, but in the final analysis the real Japanese enthusiast would prefer a professional Ampex, 3M, or Studer machine. Japan is the world's undisputed leader in direct-drive phono turntables, but there seems to be a lingering suspicion that the belt-drive units from western Europe and England might be better. Phono cartridges are manufactured under numerous brand names in Japan, many of which have attracted enthusiasts overseas. But the clear-

cut distinction of superiority has eluded all Japanese manufacturers, and those who have striven for it have suffered.

Paradoxically, as Japan struggles to get out of the world-wide recession precipitated by events in the West and Middle East, it may meet the recognition it has long sought, waiting just around the next bend in the road. The moving-coil phono cartridges of Denon (Nippon Columbia), originally designed to fulfill NHK requirements for FM broadcasting in Japan, are belatedly being hailed as superbly qualified contestants for the title of best phono cartridge in the world. (Denon retreated from its first entrance into the U.S. market several years ago, but it is scheduled to return in December.) Nakamichi Research has fully established itself as a manufacturer of "ultimate" cassette decks over a period of several years, so international recognition cannot be far behind. Nakamichi now has a phono cartridge, a preamplifier, and (by the time you read this) a super-power amplifier, all intended to qualify as "best" in the international sweepstakes.

Japan's Resources. Throughout its relatively brief history as a technological giant in audio, Japan has strenu-

Will other CB's catch up with Royce's Wireless?

Why wait?

Other CB makers might have a Wireless Module chassis by 1978. You can have it now!

Let's talk straight about CB today.

Right now you're probably confused. You see dozens of ads on TV and in magazines. Every CB maker claims superiority. New names are entering the field.

You ask yourself—is there a difference between different brands of CB's?

Answer: There is a big difference between Royce and *all* other CB makers! Because *only* Royce has the Wireless Module concept!

And, it is the biggest CB technological breakthrough since transistors replaced tubes.

Royce has brought computer technology to CB. With wireless modules. Automated—not hand-soldering. Precision assembly. Higher quality components. Computer tuning and testing.

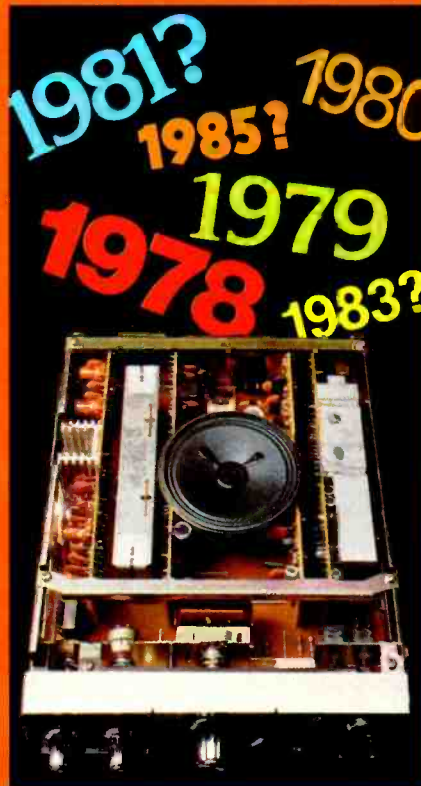

It all adds up to reliability never before dreamed possible! Long CB life! Peak power! Maximum transmitting and receiving range!

So, now you have an easy way to decide which CB to buy! And your Royce dealer can show and tell you more about the amazing new Wireless Module CB's and the entire Royce line. Stop by and see him soon! Royce Electronics Corp., 1746 Levee Road, North Kansas City, Mo. 64116.

Royce Wireless Model 1-655. 23-channel mobile CB has Amplified Automatic Gain Control circuit (AAGC) to amplify weak signals, reduce nearby overload. Phase Lock Loop (PLL) tuning adds greater reliability. Large S/RF meter. Pushbutton ANL switch minimizes noise, static. Pushbutton PA/CB switch activates powerful P.A. Pushbutton RF gain Control prevents overload from nearby stations.

Royce Wireless Model 1-658. 23-channel mobile CB Vol-U-Mike allows receiver volume adjustment from mike or front panel. Phase Lock Loop (PLL) provides reliable 23-channel operation with only 3 crystals. Large, readable S/RF meter. Pushbutton PA/CB switch activates powerful P.A. Continuous RF Gain Control prevents overload from nearby stations.

Model 1-655

Model 1-658



Royce



Royce Electronics Corporation
1746 Levee Road
North Kansas City, Mo. 64116
Call: (816) 842-7505 • Telex: 426-145

Follow the new leader!

CIRCLE NO. 57 ON FREE INFORMATION CARD

www.americanradiohistory.com

The Simple Solution to the I/O enigma.



The **3P+S** module from **Processor Technology** is the most versatile input-output card for your Sol, IMSAI, or Altair system. It has **two 8-bit parallel I/O ports, with full handshaking logic, and a serial I/O port.** All on a single card.

Check this spiffy set up. Run a keyboard and a paper tape reader into your 8080 system; then, output a TV terminal and a tape punch, all via the 3P+S. And, you can still **simultaneously** run a modem (Telephone Coupler) in and out. We could write pages about the 3P+S' talents. We did, in fact. You can get our **59-page 3P+S Owner's Manual** (with schematics and applications) for **\$4.95**. If, then, you do buy our 3P+S, we'll refund the \$4.95.

3P+S I/O Module, Kit Price

with premium grade, low-profile sockets for every IC, **\$149**

Write Us about all our Sol/IMSAI/Altair compatible plug-in modules

Processor Technology
6200-T Hollis Street
Emeryville, CA 94608

ously sought and won a commanding position in the very center of its overseas markets. But recently (at least in the U.S.) the center has been shifting somewhat, and now tends to favor high power and, to a certain extent, separate components instead of the all-in-one receiver. The Japanese are prepared to follow this and other trends wherever they may lead. Unfortunately, such a policy once again threatens to cast them in the role of follower rather than leader—an unenviable position in an industry where innovation and "breakthroughs" command so much respect.

Too little appreciation, I think, is given to the Japanese audio industry, both as an innovator and a stabilizer in new audio developments. Over the past decade, the Japanese have done some remarkable research and created some superb devices. The Denon phono cartridges are one obvious example; another is the Pioneer PT-R7 tweeter (Fig. 1), a ribbon design with a frequency response that is down barely 10 dB at 100,000 Hz and an almost impeccable transient response. This separate, raw tweeter, alas, is not part of Pioneer's overseas marketing program, and was therefore almost unknown outside of Japan until recently, when a few hardy Westerners began visiting Nihon to ferret out some of its more obscure treasures.

There are, in fact, a number of Japanese manufacturers who retain some very novel and interesting products as domestic sales items only. There are good marketing reasons for doing so. However, Japanese consumers meanwhile await confirmation of these products' excellence from abroad; when none is forthcoming, they lose interest themselves.

Highlights. I have high hopes that the image of Japan throughout the audio world will change for the better, and fairly soon. These were boosted considerably by field excursions I was able to make to the headquarters of Nakamichi Research and the research labs of JVC.

E. Nakamichi, for example, is embarking on the construction of his own personal concert hall, which he gleefully anticipates will serve both as a refined development tool for future audio products and the fulfillment of a long-standing personal dream. Nakamichi seems to relish competition, insists on iconoclasm, and does

not shrink from controversy. This is hardly the image of the Japanese manufacturer we're accustomed to.

JVC, on the other hand, probably seems rather doctrinaire to most U.S. consumers, although the company's espousal of the ANRS noise-reduction system and CD-4, both of which are JVC developments, sets it somewhat apart. How apart I hadn't realized until I visited the JVC research center.

First of all, the facilities are remarkable for an establishment of this kind. The anechoic room (Fig. 2) is one of the largest in the world, reportedly effective down to about 50 Hz. There is also a large reverberant room with a reverberation time (at mid frequencies) of almost 10 seconds. But one of the biggest showpieces is a 1,277-cubic-meter theater (Fig. 3) that can be drastically altered in acoustical characteristics via a central control console. The slats visible at the left of the photograph, highly reflective as seen, can be rotated along their long axes to expose absorbent glass-fiber backings. Finally, the wall and ceiling panels can be retracted entirely, leaving behind deep glass-wool surfaces that soak up sound like an open field on a windless day.

The mere existence of these facilities wouldn't be at all exciting unless they were being put to good use. Evidently they are. JVC is apparently engaged in deep study of sound-field propagation-researches which led to the stunning video representations of loudspeaker wavefront propagation as presented to the Audio Engineering Society in New York last October (Fig. 4). There has also been some related work on binaural recording, which is intended to be heard exclusively through headphones. On my visit I was treated to a test pressing of a binaural disc that was irresistible in its near-perfect realism. I have heard many binaural recordings and have been impressed by them all, but this was something beyond my previous experience.

In short, Japan has much to offer the worldwide audio community that we're yet to become aware of. We can, I hope, look forward to a remission of the receiver-for-any-amount-of-money-you-have-in-your-wallet syndrome and an assertion of the concept of basic, hard-working research in the interest of better sound. This is an area in which the Japanese shine. All of us would profit from basking in their glow. ♦

SBE. The single best name for single sideband.

If you take the professional approach to CB you'll end up with SBE Single Sideband—be it mobile or be it base. SIDEBANDER II and CONSOLE II are two outstanding reasons why.

SIDEBANDER II is noted for having the biggest "talk power punch" in mobile CB. It reaches those 46 SSB channels crisply and clearly with a full power of 25 watts in. And because it's synthesized, it achieves more precise frequency and better stability. Exceptional features include: noise blanker, RF and AF gain controls, clarifier, and squelch.

CONSOLE II brings frequency synthesization to home base. It's a true no-nonsense professional with performance that gets your message through and brings in signals loud and clear. Superb features include "on the air" indicator, triple-function meter, automatic load and gain controls.

Two classic examples why SBE has the answers SSB users like.



SIDEBANDER II (SBE-12CB)
SSB/AM Mobile

CONSOLE II (SBE-16CB)
SSB/AM Base



Better Communications through Creative Technology

For information write: SBE, Inc., 220 Airport Blvd. Watsonville, CA 95376

INTERNATIONAL OFFICES: E.S. Gould Marketing Co. Ltd., Quebec, Canada / Linear Systems, S.A. Geneva 1, Switzerland

More miles per pound

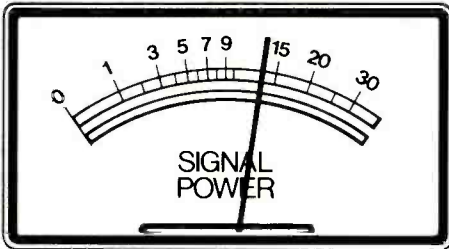

Turner mikes turn ordinary CB sets into heavyweights

Check the channels. You hear Turner mentioned a lot on CB. Most longtime CBers have a Turner mike. They often sound stronger and reach farther. It's

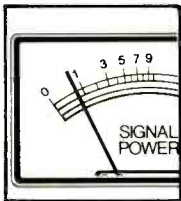

easy to understand why: Even a weak carrier signal can do the job if it has good mike input, while on the other hand a strong signal with poor modulation can be hard to copy. Demonstrate this to yourself by opening up your receiver squelch and listening to a distant station, a signal which barely swings the S-meter. Even though signal power hardly moves the needle, can you still copy through the noise? If so, that's good modulation. And you're probably listening to a Turner mike.



Many Turner models have a built-in pre-amplifier with volume control on the mike.

Mike volume control lets you adjust mike input, which allows the radio to put out a signal with all the voice modulation or "talk power" the set is designed to deliver.

A Turner mike can also add to your set's effective range by keeping input consistently high. The Turner M+3 and Road King 60 include a speech compression circuit to assure constant-level input, regardless of mouth-to-mike distances or natural rising and falling of the voice.

Or to get rid of cab rumble, traffic and



other interfering background noises that reduce effective range, consider the Road King 70, a rugged CB mike that adds noise cancelling to the other Turner features.

Ask a Turner dealer to help you get full performance out of your base or mobile CB. Or start by asking for a communications catalog from Turner, 716 Oakland Road N.E., Cedar Rapids, Iowa 52402.

TURNER
MICROPHONES
ANTENNAS

CONRAC
CORPORATION

CIRCLE NO. 79 ON FREE INFORMATION CARD

www.americanradiohistory.com

READERS' BONANZA!



Get up to 50% off

on your choice of these outstanding publications.

Take a good look at these popular magazines. Then take a look at the prices below. Bonanza! You may select as many as four of these titles at our special introductory rates—up to 50% off! Use the attached card to order or write to: Magazines at Discount, P.O. Box 2703, Boulder, Colorado 80302.

HERE'S WHAT YOU SAVE:

- BOATING - 1 YEAR. YOU PAY ONLY \$4.50**
(Regular rate: \$9.00)
- CAR & DRIVER - 1 YEAR. YOU PAY ONLY \$3.99**
(Regular rate: \$7.98)
- CYCLE - 1 YEAR. YOU PAY ONLY \$3.99**
(Regular rate: \$7.98)
- FAMILY HANDYMAN - 1 YR. (9 ISS.) YOU PAY ONLY \$6.98**
(Regular rate: \$8.55)
- FLYING - 1 YEAR. YOU PAY ONLY \$6.99**
(Regular rate: \$9.98)
- MECHANIX ILLUSTRATED - 15 ISSUES. YOU PAY ONLY \$4.97**
(Regular rate: \$7.44)
- MONEYSWORTH - 1 YEAR (26 ISSUES). YOU PAY ONLY \$3.88**
(Regular rate: \$5.00)
- PLAYBOY - 1 YEAR. YOU PAY ONLY \$12.00**
(Newsstand rate: \$19.00)
- POPULAR ELECTRONICS - 1 YEAR. YOU PAY ONLY \$6.99**
(Regular rate: \$9.98)
- POPULAR PHOTOGRAPHY - 1 YEAR. YOU PAY ONLY \$4.49**
(Regular rate: \$8.98)
- PSYCHOLOGY TODAY - 1 YEAR. YOU PAY ONLY \$7.00**
(Regular rate: \$12.00)
- SKIING - 1 YEAR (7 ISSUES). YOU PAY ONLY \$3.49**
(Regular rate: \$6.98)
- SPORTS ILLUSTRATED - 26 ISSUES. YOU PAY ONLY \$7.97**
(Newsstand rate: \$26.00)
- STEREO REVIEW - 1 YEAR. YOU PAY ONLY \$3.99**
(Regular rate: \$7.98)
- TIME - 25 ISSUES. YOU PAY ONLY \$12.50**
(Newsstand rate: \$25.00)
- TV GUIDE - 32 ISSUES. YOU PAY ONLY \$7.39**
(Lowest available rate)

SEPTEMBER 1976

If card is missing, write to: Magazines at Discount, a division of Ziff-Davis Publishing Co., P.O. Box 2703, Boulder, Colorado 80302.



By John McVeigh

"SUPERHOT" CRYSTAL SET

Q. I built a crystal set using a ferrite bar antenna, AM tuning capacitor, silicon diode, ceramic caps and crystal earphone. It works, but I can only pick up very close stations. Is there a way to increase the set's sensitivity?

—Clare Linn, New Orleans, LA

A. The crystal set isn't very sensitive because you used a silicon-diode detector. For the diode to conduct, you have to exceed the barrier potential (0.7 V)—which only a very hefty signal could do. Germanium, with a barrier potential of 0.2 V, is a better choice. The circuit shown, though, is a rather unique crystal set using a silicon diode. Tuning is accomplished by var-

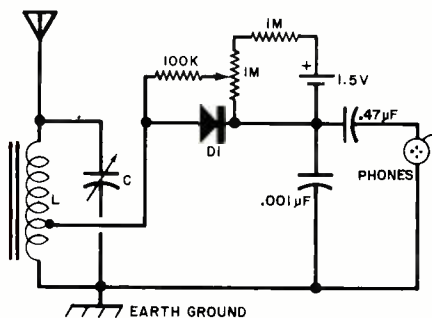

ying capacitor C. The ferrite loopstick, L, has a low-impedance tap. The 1-megohm potentiometer applies a bias voltage across the diode, ranging from 0 to 0.75 volt. Thus, the pot acts as a sensitivity control. At maximum sensitivity (0.7 V forward bias), very weak signals will be able to ride through the diode. When connected to a good antenna (a longwire or rotatable loop), this little set will deliver surprising performance. In operation, you will notice a point where advancing the sensitivity control causes the signal to drop out completely. This happens when the diode turns fully on. Back down slightly for best sensitivity. Use high-impedance crystal headphones or earphones, and an AA or C cell voltage source. The battery will last for a long, long time.

ELECTRIC MUSIC BOOKS

Q. Thanks for the recent electronic music series. Do you know of any books on the subject that I can do more research with?

—R.M., Rye, New Hampshire

A. There are many books out on electronic music and music synthesis. Here are some: *Electronic Music Circuit Guidebook* by Brice Ward (TAB), *Experimenting with Electronic Music* by Brown and Olsen (TAB), and *The New World of Electronic Music* by Walter Sear (Alfred Publishing).

HAUNTED TV RECEIVER

Q. My TV receiver is connected to a master antenna system (75-ohm cable) supplied by the apartment complex in which I live. The signal levels are more than sufficient, but the ghosts are terrible. Is there some sort of broadband network I can use to eliminate these ghosts? I'm using a 75-ohm/300-ohm transformer-balun.

—Larry Moore, FPO San Francisco

A. The ghosts are being produced by one of two circumstances. First, there might be a building nearby reflecting the signal. Since the reflection arrives later than the direct signal, a ghost appears. To cure this, the master antenna would have to be pointed so that there is a null in the direction from which the ghost is coming. Note that even if this means pointing the beam somewhat away from the direct path, the beam and distribution amplifier's gain will probably make up for the reduced signal level. Second, there might be an improper termination in one of the apartments. If the termination impedance is not 75 ohms, reflected waves can travel up and down the line, causing a series of closely spaced ghosts. The real cure for that is to correct the termination impedance.

As for a broadband ghost exorcist, the only thing that I can think of is a resistive pad (attenuator) of 75 or 300 ohms impedance, placed before or after the balun, respectively. This

would lower the overall signal level, and if the ghosts are much weaker than the desired signal, you could attenuate them into oblivion while retaining a sufficient desired signal strength.

BROADCAST STATION GUIDE

Q. Can you provide me with the title of a book that provides the call letters, frequencies, and addresses of commercial broadcasting stations?

—Harry Lee Smith, Luray, Virginia

A. Howard W. Sams & Co. (4300 W. 62 St., Indianapolis, IN 46206) publishes a useful book entitled "North American Radio-TV Station Guide," written by Vane A. Jones. It covers AM, FM and television broadcasting, and lists (among other things) frequencies, power output, call letters, and addresses under several listing formats. Canadian, United States, Mexican, and Central American stations are included.

AMATEUR CODE REQUIREMENTS

Q. I've heard a rumor that The FCC will either reduce the General Class code requirement to 5 wpm or eliminate it completely. Is this true?

—Bruce Levine, Brooklyn, NY

A. I haven't heard that specific rumor, but there are some changes being contemplated for code tests in general. First, the FCC is considering the establishment of a "Communicator Class" Amateur license. It would be a no-code ticket carrying telephony (voice) privileges in the vhf region of the spectrum. Second, the FCC has announced that it will conduct a different type of code test at a few field examination points on an experimental basis. The new test will consist of five minutes of recorded text, and a series of true-false or multiple choice questions based on the transmitted information. However, for the time being, both tests (the new and old "one-minute of solid, written copy") will be given. If the results from the two show a high degree of correlation, a new format for the receiving portion of the code test will be adopted. Although there have been many petitions asking for a reduction of the General code test from 13 to 10 wpm, the FCC has not shown much of a reaction.

Have a problem or question on circuitry, components, parts availability, etc.? Send it to the Hobby Scene Editor, POPULAR ELECTRONICS, One Park Ave., New York, NY 10016. Though all letters can't be answered individually, those with wide interest will be published.

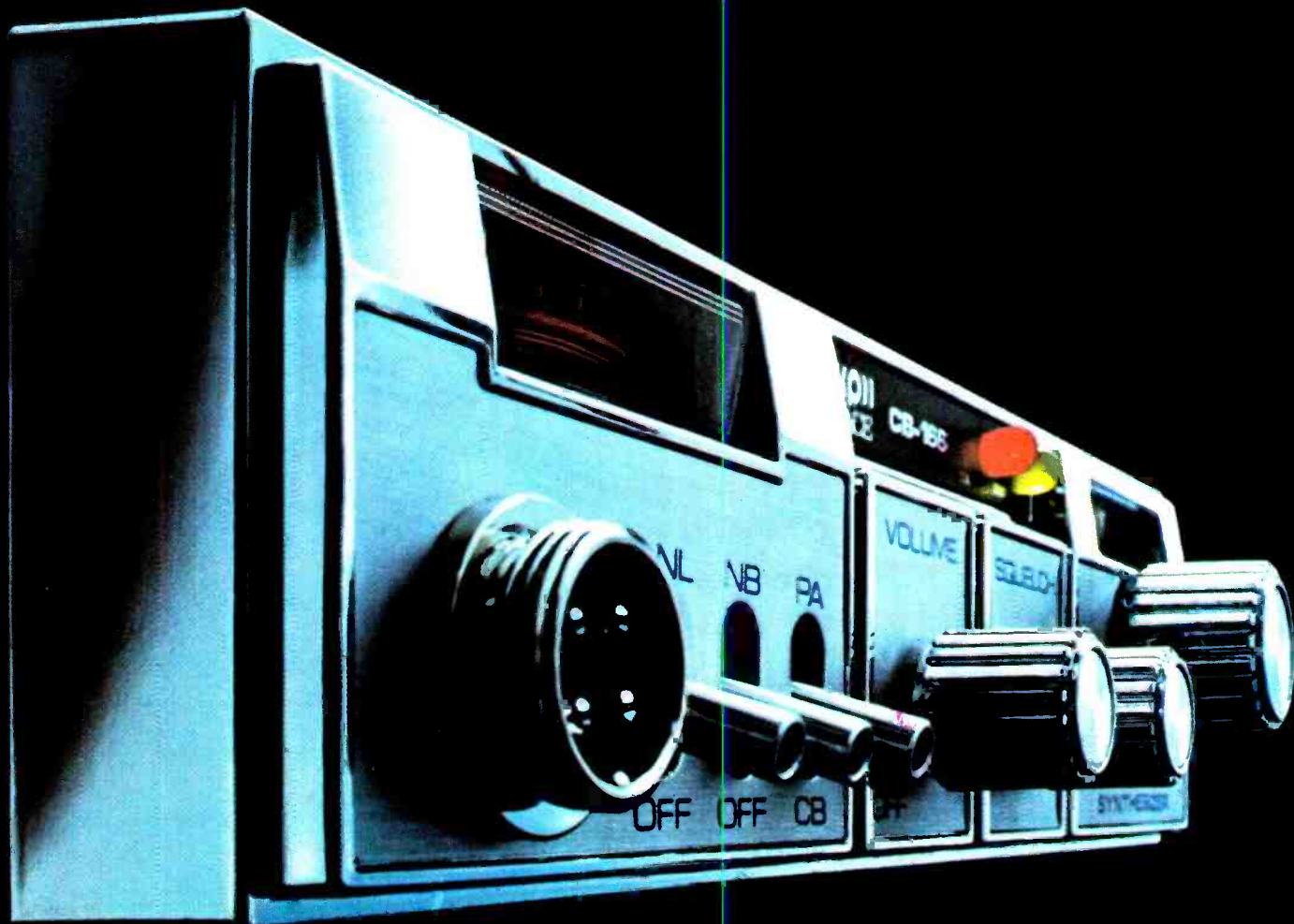

Pace. The best-selling CB in the world.

More people buy Pace than any other CB, based on estimates by Pathcom Inc. Maybe it's because:

We wanted to be #1 — and we put our money & determination on the line to make the kind of radios that would make us the leader.

The warranty we offer — just ask anybody about it.

Our quality control — which means we don't just test an occasional sample off the line, we vibrate-test almost every mobile radio we make.

Our 23 models — the largest CB line in the world with suggested prices from \$50 to \$500. Which makes it easier to choose the right radio.

Is Pace for you? We think Number One deserves #1.

Write us — Pathcom Inc. (Los Angeles), Harbor City, CA. 90710.

PACE CB

When you've got a Pace,
you've got the world by the ears.

PACE TWO-WAY RADIOS. PRODUCTS OF PATHCOM INC.

CIRCLE NO. 50 ON FREE INFORMATION CARD

FUSING QUIZ

One of the most important components in an electronic circuit is the fuse, which protects the entire system from current overload. Circuit designers, technicians, and hobbyists should be acquainted with the various types of fuses and how to use them.

To test your knowledge of fusing circuits, see how many of the following problems you can solve. For each of the circuits shown below, determine the order in which the fuses will blow as resistance R is slowly decreased to zero. Assume that the battery can deliver any required amount of current, and that each fuse has an internal resistance of one ohm, regardless of its current rating.

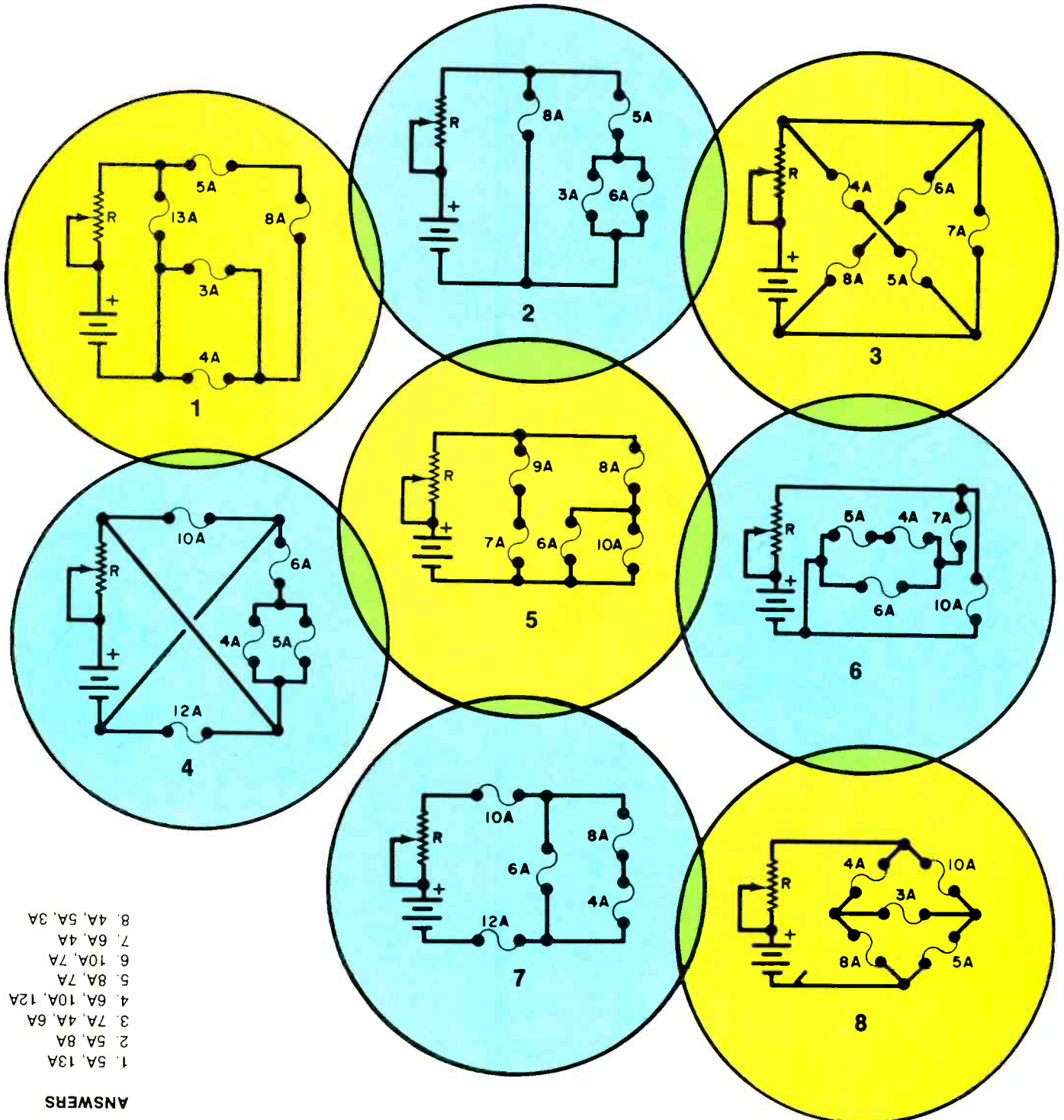

- 1. 5A, 13A
- 2. 5A, 8A
- 3. 7A, 4A, 6A
- 4. 6A, 10A, 12A
- 5. 8A, 7A
- 6. 10A, 7A
- 7. 6A, 4A
- 8. 4A, 5A, 3A

ANSWERS

If you thought a rugged, professional yet affordable computer didn't exist,

think IMSAI 8080.

Sure there are other commercial, high-quality computers that can perform like the 8080. But their prices are 5 times as high. There is a rugged, reliable, industrial computer, with high commercial-type performance. The IMSAI 8080. Fully assembled, it's \$931. Unassembled, it's \$599. And ours is available now.

In our case, you can tell a computer by its cabinet. The IMSAI 8080 is made for commercial users. And it looks it. Inside and out! The cabinet is attractive, heavy-gauge aluminum. The heavy-duty lucite front panel has an extra 8 program controlled LED's. It plugs directly into the Mother Board without a wire harness. And rugged commercial grade paddle switches that are backed up by reliable debouncing circuits. But higher aesthetics on the outside is only the beginning. The guts of the IMSAI 8080 is where its true beauty lies.

The 8080 is optionally expandable to a substantial system with 22 card slots in a single printed circuit board. And the durable card cage is made of commercial-grade anodized aluminum.

The IMSAI 8080 power

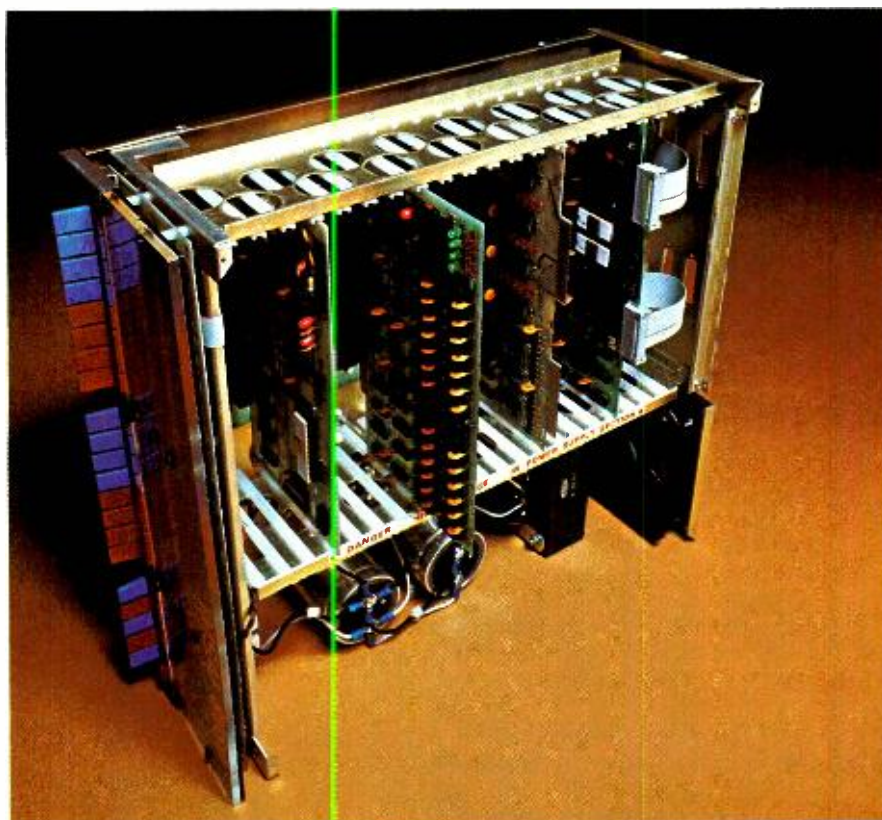

supply produces a true 28 amp current, enough to power a full system.

You can expand to a powerful system with 64K of memory, plus a floppy disk controller, with its own on-board 8080—and a DOS. A floppy disk drive, an audio tape cassette input device, a printer, plus a video terminal and a teleprinter. These peripherals will function with an 8-level priority interrupt system. IMSAI BASIC software is available in 4K, that you can get in PROM. And a new \$139 4K RAM board with software

memory protect. For the ultimate in flexibility, you can design the system for low-cost multiprocessor, shared memory capability.

Find out more about the computer you thought didn't exist. Get a complete illustrated brochure describing the IMSAI 8080, options, peripherals, software, prices and specifications. Send one dollar to cover handling.

Call us for the name of the IMSAI dealer nearest you.

Dealer inquiries invited.



IMSAI

IMS Associates, Inc.
14860 Wicks Boulevard
San Leandro, CA 94577
(415) 483-2093

PE-9

NEWS HIGHLIGHTS

CB Rip-Offs

With CB radio thefts on a meteoric rise, the new National CB Theft & Recovery Bureau is making an effort to reduce thefts and aid law-enforcement agencies in returning recovered CB rigs to their rightful owners. For a modest fee, a CB radio owner can have his name and address and the serial number of his rig entered into the Bureau's computers. "Rip-Off Strip-Off" identification decals go on his CB radio, antenna, and vehicle windshield. The decals warn potential thieves that the rig is registered and carry a reward offer to \$250 for information leading to the arrest and conviction of thieves. To help police identify owners of recovered CB rigs, the Bureau maintains a 24-hour toll-free "hot line" that is said to be available to every law-enforcement agency and insurance company in the country.

European Quadraphonic Broadcast

The first commercial quadraphonic broadcast in Europe was made over *Radio Picadilly*, Manchester, England, on last April 2. Using a Sansui QSE-5B broadcasting encoder, the station played discrete 4-channel tapes and QS 4-channel records for two days. It is estimated that 2 million homes in the UK are equipped for stereo reception, while perhaps ½ million have 4-channel capabilities.

New Amateur Regulations

Effective July 23, 1976, the Federal Communications Commission has modified Part 97, Rules and Regulations for the Amateur Radio Service. Novice Class operators will be allowed to run up to 250 watts of input power, a healthy increase over the old 75-watt limit. A Novice reaching the end of his two-year license term need no longer wait one year from the expiration date for reexamination, but can apply for a new Novice exam immediately. All licensees using Novice segments of the bands will be limited to 250 watts input power. Technicians will receive full Novice hf privileges. The Novice exam will be the only one administered by mail, unless the applicant can produce a physician's note certifying disability. Then the exam will be administered by a Commission-approved volunteer examiner. Full credit will be granted to examination elements administered in the past by mail. So, Conditionals are "grandfathered" to General Class licenses, Technicians C to Technicians. The number of distinct license classes is reduced to five by this action.

Hughes Is Alternate Source for RCA Microprocessor

Hughes Aircraft Company has signed an agreement with RCA Corp. to be a nonexclusive alternate source for the RCA CDP1802 CMOS 8-bit microprocessor and related support circuits. RCA will supply Hughes with process outlines, artwork, and tooling. The agreement also includes an option on future-generation CMOS microprocessors, including silicon-on-sapphire versions.

Engineering Technician Salaries Higher

The Engineers Joint Council, as a result of its biennial survey, says the salaries of engineering technicians increased on the average by 13.6% between 1973 and 1975. The figures were obtained from 630 employers and covered over 61,500 technicians. According to the results, the "average" engineering technician has had about fourteen and a half years of experience since leaving school, is about 34 years old, and is earning \$12,200 a year. Graduates of two-year junior college and technical institute programs start out with average salaries about \$1700 per year more than nongraduates of the same age.

Flick-of-the-Wrist Time

"Flick-it" is a new digital wristwatch introduced by Gruen. It displays the hours and minutes on its LED readout with a flick of the wrist. The seconds, month and day can be displayed by touching the Time Command Button. The mechanism which energizes the display with a flick of the wrist is set so that normal movement of the arm will not activate it. Gruen designs and makes its own watch modules.

New Audio Recording System

Elcaset is the name given to a new audio recording system introduced by Sony, Matsushita, and Teac. The Elcaset is intended to realize the convenience of the Compact Cassette and the sound quality of open-reel tape. It has a tape width of ¼" and tape speed of 3¾ ips (9.5 cm/s). The tape is pulled out of the cassette shell for transport on heads, so that the preciseness of shell construction cannot affect the running of the tape. Extra holes in the shell provide for automatic code selection of proper bias and equalizer.

Valor International CB Jamboree

In connection with the Pepsi-Cola Syracuse Gold Cup motorcycle race on Sept. 12 at the New York State Fairgrounds, Valor Enterprises will sponsor a 3-day CB jamboree at the site. It will include 250 exhibits by leading manufacturers of CB equipment, motorcycles, snowmobiles, RV's and vans.

Personal Use Radio Advisory Committee Formed

An Advisory Committee to furnish advice and recommendations on potential means of alleviating the interference and enforcement problems currently being experienced in the Citizens radio service has been created by the FCC. It is expected that the Personal Use Radio Advisory Committee will consist of approximately 15 to 25 non-Commission members, obtained from a cross-section of the Citizens Band industry (manufacturers, importers, dealers), as well as equipment users and the general public.

The small wonder



of the micro-world

Measuring just 11" wide x 11" deep x 5" high, and weighing a mere 7 pounds, the Altair™ 680b is a complete, general-purpose computer.

The secret to this revolutionary, small computer is its CPU board. This double-sided board fits along the bottom of the Altair case and plugs directly into the front panel board. It contains the new 6800 microprocessor, 1,024 bytes of RAM memory, a 256 byte PROM monitor, provisions for 768 bytes of additional PROM or ROM, and a single Interface port with a Motorola ACIA serial interface adapter which can be configured either RS-232 or TTY. A five level Baudot interface option is also available.

The Altair 680b can be programmed from front panel switches, or it can be interfaced to a video display terminal, or teletypewriter. Three additional circuit boards can be plugged inside the Altair 680b for further memory and interface expansion. The first of these boards is a 16K static RAM memory board.

Software already developed includes Altair 680 BASIC with all the features of the 8K BASIC previously developed for the Altair 8800. These include Boolean operators, the ability to read or write a byte from any I/O port or memory location, multiple statements per line, and the ability to interrupt program execution and then continue after the examination of variable values. This software takes only 6.8K bytes of memory space and a copy is included free with the purchase of the Altair 680 16K memory board.

Other software includes a resident two pass assembler. The Altair 680b is also compatible with Motorola 6800 software.

The Altair 680b is ideal for hobbyists who want a powerful computer system at an economic price. Altair 680b owners qualify

for membership in the Altair Users Group, and like other Altair owners, they receive a complimentary subscription to **Computer Notes** and complete factory support.

PRICES:

Altair 680b kit with complete, easy-to-understand assembly manual, operator's manual, and programming manual	\$466
Assembled Altair 680b	\$625
Altair 680b Turnkey model kit	395
Expander Card 680MB (required to expand 680)	\$ 24
Altair 680BSM 16K static RAM board kit with 680 BASIC	\$685
Altair 680 BASIC when purchased separately	\$200
Baudot option	\$ 42

MAIL THIS COUPON TODAY

- Enclose a check for \$_____
- BankAmericard # _____ or Master Charge # _____
- Altair 680b Kit Assembled Other (specify) _____
- enclose \$8 for postage and handling
- Please send free information package.

NAME _____

ADDRESS _____

CITY _____ STATE & ZIP _____



2450 Alamo SE/Albuquerque, NM 87106, 505-243-7821

NOTE: Altair is a trademark of MITS, Inc.

Price, specifications subject to change. Please allow up to 60 days for delivery.

HIT THE ROAD WITH THE AUTOMATIC CB. JOHNSON.

"This year, lots of folks are takin' to the road for trips and adventures of all kinds. They're getting more fun out of every mile with the automatic CE from Johnson. And y'all know it's right handy if you're in a heap of trouble, too."

That's right, Sheriff. Johnson's built-in, automatic controls make operation easier and safer, performance better. Exclusive voice tailored audio circuitry automatically drops off signals outside voice frequencies to give you great reception.



Our automatic noise limiter keeps reception clean and built-in gain control prevents blasting and fading.

Johnson's unique electronic speech compression automatically selects and compresses voice frequencies to

produce uniform, high-level modulation, maximum range. All automatically.

When you hit the road, go with Johnson CB. We back every Johnson with a full year parts and labor warranty and walk-in service at more than 850 locations. See a Johnson CB dealer and take off on *the great American adventure.*



JOHNSON

E. F. JOHNSON COMPANY, WASECA, MINN. 56093
In Canada: A. D. Simmonds & Sons, Ltd.

Joe Higgins
National Safety Sheriff

JOHNSON CB. THE GREAT AMERICAN ADVENTURE.

CIRCLE NO. 33 ON FREE INFORMATION CARD

www.americanradiohistory.com

LAST MONTH, we discussed the construction of the low-cost Elf microcomputer/trainer and gave some examples of simple programming. This month, we will describe hardware and how to make a low-cost LED replacement for the relatively expensive hex display and add a simple 8-bit I/O port. Then we'll add a 16-switch monitor that, among other things, will allow you to use a hex keyboard. We'll finish up the hardware section by showing how to use a 9-volt battery as power for a RAM circuit to hold a program for as long as six months.

When we're finished with the hardware details, it's back to the software, continuing with our programming discussion.

The Hardware. The hex displays called for in the original Elf project can be replaced with a discrete LED circuit as shown in Fig. 1. You will need a CD4508 eight-bit register, eight low-current LEDs, two 4049 hex inverters, and eight 470-ohm, 1/2-watt resistors. When the LED circuit is substituted for the hex displays, current consumption will be reduced by about 150 mA. The input comes from the data bus, which formerly went to hex displays IC4 and IC5.

When you use the LED display, you must count the LED's to arrive at the hex number displayed. The upper four LED's form the first digit, the lower four the second digit.

You can mount the LED's on the front panel. Be sure you carefully identify each. Also, when making the conversion, don't forget to modify the RUN switch circuit as shown.

You can connect an inexpensive cadmium-sulfide (CdS) cell between the EF1 line and ground. Be sure to use a photocell that has a dark resistance in excess of 200,000 ohms and a light resistance of less than 10,000 ohms. If you use any other photocell, you may have to increase the value of the resistor to pull up the EF1 line of the 1802 microprocessor. The high input impedance of the CMOS logic eliminates the need for photocell amplification. Also, several photocell inputs can be used, each connected to a different flag (EF) line.

Using a photocell input, you can program the computer to start counting when an object moves past one photocell and stop counting when the object passes a second cell. This technique allows you to determine the

speed of a moving object. It can also be used to count people, monitor motor speed, provide targets in a computer-controlled light gun or "eyes" for a computer-controlled robot, etc.

Magnetic reed switches, simple make/break switches, or similar devices can be connected to the computer via the flag-line inputs.

Several inexpensive methods of expanding the number of input and output lines can be used with this compu-

ter. One example is shown in Fig. 2. Here, a CD4058 IC is used in both the input and the output positions, while other IC's provide the necessary gating. A 69 instruction will store the values of the eight input lines in memory as a single byte.

In the output port section, a 61 instruction sets a memory byte into this port. The output port can control up to eight output lines, but you will have to add CD4050/CD4049 buffers if you wish to drive TTL loads. You can use

BUILD THE COSMAC "ELF" A LOW-COST EXPERIMENTER'S MICROCOMPUTER

PART 2

Some hardware improvements and more programming details.

BY JOSEPH WEISBECKER

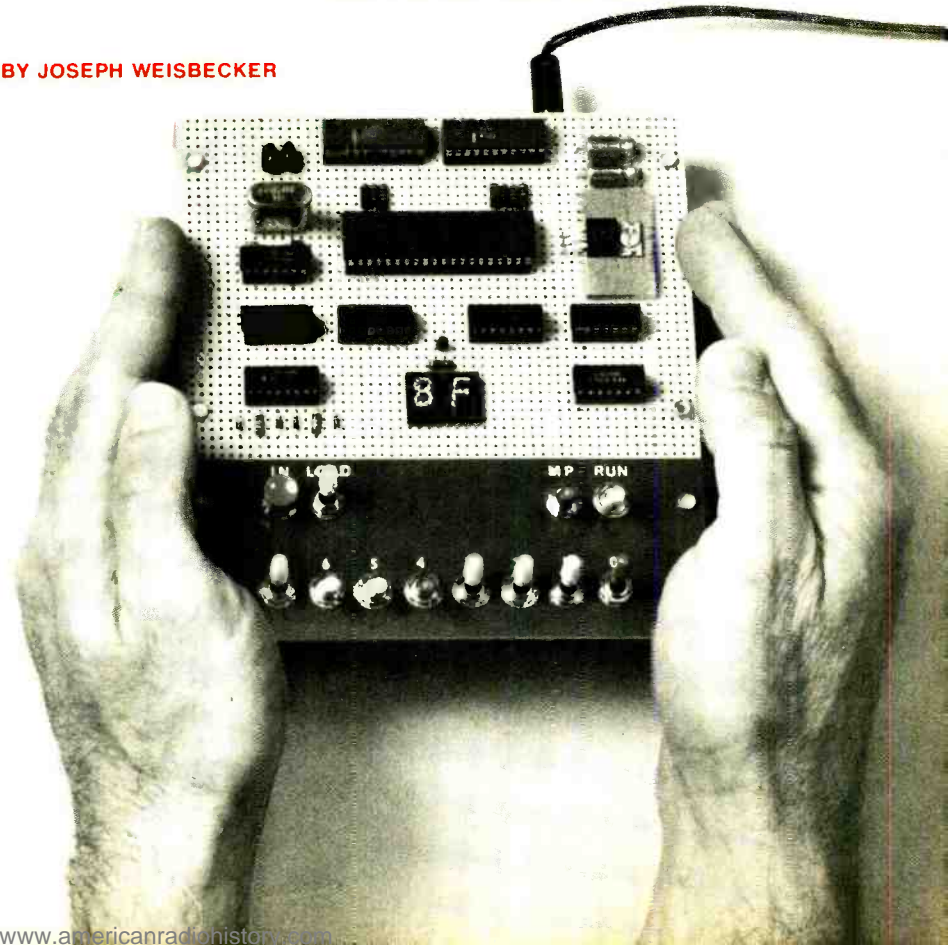

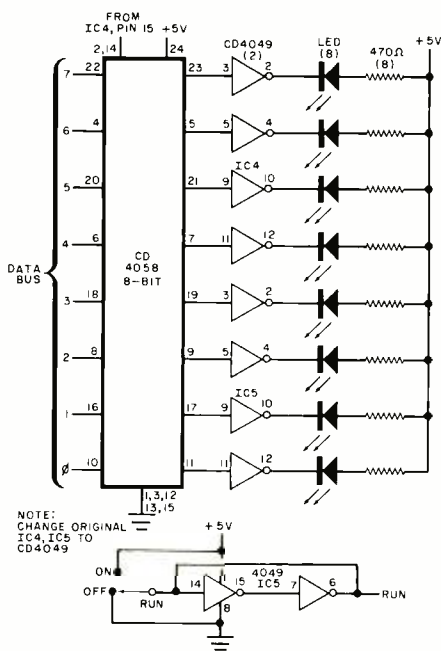

Fig. 1. Circuit for a discrete LED display.

these output lines to drive suitable transistors to control relays, lamps or LED's, or battery-powered motors, you can have the computer sequence lights, control animated displays or robots, or control a slide projector in response to tones from an audio tape. You can use the existing Q line output in the same manner for a single operation.

A simple method of controlling up to 16 output lines or monitoring the states of 16 switches is shown in Fig. 3. A 62 instruction will set the low-order digit of a memory byte into the 4-bit

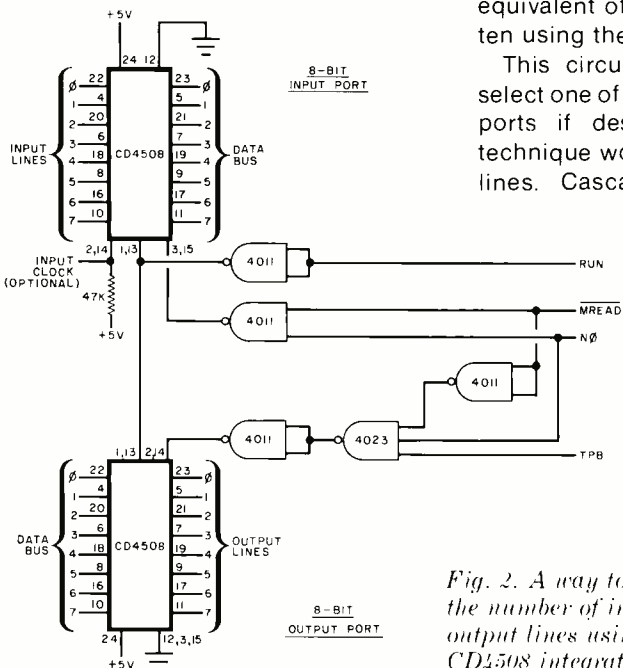

Fig. 2. A way to expand the number of input and output lines using two CD4508 integrated circuits.

CD4515 register. The output line corresponding to this digit will go low, while the other 15 remain high. To make things more interesting, the computer can determine whether the switch attached to the selected output line is closed or not by testing EF2 with a branch instruction.

The following program continuously examines all 16 switches in sequence and stops with the number of any closed switch from 0 to F in the low-order digit of R3.0:

Step	M	Bytes	Comment
1	0000	F8 FF A2 FF	R3.0 → R2.0 (memory pointer)
2	0003	13 52 E2	R3 + 1, R3.0 → M2, 2 → X
3	0006	62 22	MX → CD4515 (select switch)
4	0008	3D 03	Repeat step 2 if switch is open
5	000A	30 0A	Stop with R3.0 = closed switch number

The diodes can be omitted if only one switch at a time will be closed. This circuit and an appropriate program could permit data and instruction bytes to be loaded into memory a digit at a time from a hex keyboard instead of toggle switches. Switch debouncing could be performed with a programmed delay following each key depression. A 64-character keyboard could be used by treating it as four groups of 16 keys each, with the common side of each key group connected to a different flag line. In fact, a program to generate the Morse code equivalent of each key could be written using the Q line as the output.

This circuit can also be used to select one of 16 external devices or I/O ports if desired. Using the latter technique would permit up to 128 I/O lines. Cascading CD4515's would

permit even larger numbers of I/O lines to be handled.

A low-cost video terminal can be made using the "Scopewriter" (POPULAR ELECTRONICS, August 1974), or you can interface your computer with a cassette data interchange system.

We have only scratched the surface of I/O circuits for the Elf. The real fun (and program training) starts when you think of new things to attach to the output lines and start writing programs to activate them.

The major drawback with a RAM, or memory, system is that data stored in it is erased when the main power source is shut down. (Of course, if you could use a ROM, this wouldn't be a problem. However, ROM's must be preprogrammed with the memory data you wish to save, a costly and time-consuming approach.) Adding a cassette interface doesn't entirely eliminate the problem because a "bootstrap" is still required to be stored in memory to run the cassette.

The use of low-power COSMOS RAM IC's and a 9-volt mercury battery, as shown in Fig. 4, will allow you to save programs in memory for up to six months even with the main power to the computer turned off. The 1822 RAM's shown are pin-compatible with the 2101's specified for the original project, but some of the RAM's must be rewired as shown.

With the COSMOS RAM's installed, you can turn off power to the computer at any time. The mercury battery will supply the required standby power to the memory system so that the program will be ready to run immediately when the computer is again powered up. The newly added STANDBY switch should be turned on (+5 volts) only after power is turned on. It should be off to hold pin 17 of the RAM's at ground potential before removing power from the system.

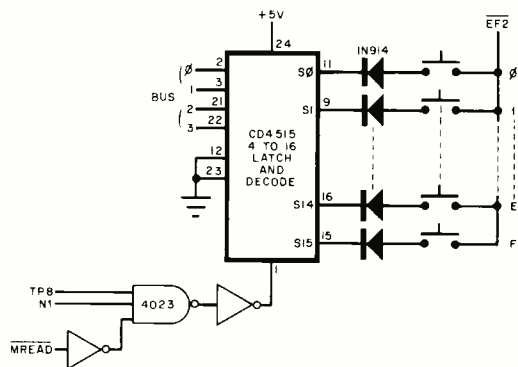

Fig. 3. A method of controlling up to 16 outputs.

Periodically check the battery's output; if it should fall too low, the memory system won't be able to hold data.

The last piece of hardware we will discuss here is the simple output driver shown schematically in Fig. 5. This is a conventional driver for almost anything that doesn't require more current than the transistor is capable of safely handling. The diode in the relay circuit removes the reverse transient spike that might otherwise damage the transistor. You can substitute a LED or even a load resistor for driving a power stage.

More Programming. The single-line output program shown below is a simple program that will flash the Q LED at a preset rate. It also provides a programmable square wave on the Q line.

Step	M	Bytes	Comment
1	0000	7A	0→Q
2	0001	F8 10 B1	10→R1.1
3	0004	21	R1-1
4	0005	91	R1.1→D
5	0006	3A 04	Repeat step 3 if D = 00
6	0008	31 00	Go to step 1 if Q = 1
7	000A	7B	1→Q
8	000B	30 01	Go to step 2

When you run this program, the square-wave frequency depends on the settings of the input switches. You can change frequency at any time. For higher frequencies, change B1 at M(0006) to A1 and 91 at M(0008) to 81. You can now select any of 256 different frequencies by altering the settings of the switches.

To modify the program to sweep the audio frequency range, use the following program:

Step	M	Bytes	Comment
1	0000	F8 FF A2	FF→R2.0
2	0003	7A	0→Q
3	0004	82 A1	R2.0→D; D→R1.0
4	0006	21 81	R1-1; R1.0→D
5	0008	3A 06	Repeat step 4 if D = 00
6	000A	31 03	Go to step 2 if Q = 1
7	000C	7B 22 82	1→Q; R2-1; R2.0→D
8	000F	32 00	Go to step 1 if D = 00
9	0011	30 04	Go to step 3

This program can be used in audio test applications. Note that R2 is used as a second counter that causes the

square-wave frequency to change after each cycle. You can hear what this sounds like by using the circuit shown in Fig. 5.

Very low frequency square waves, or long-interval timing, can be programmed by cascading counters as illustrated in the following flow chart:

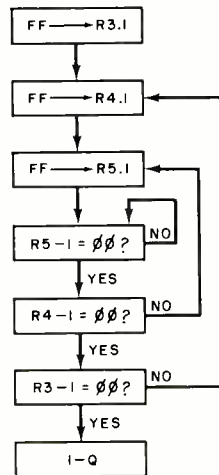

The Q line can then be used to activate a relay (as in Fig. 5), which can control house lights, motors, etc.

Suppose you wish to program a variable-pulse generator instead of square-wave generator. Use separate counts for the pulse off and on times as illustrated in the following flow chart:

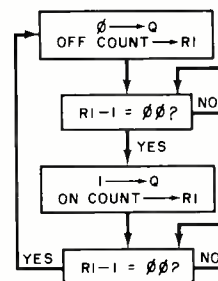

This program will flash the Q LED and put a square wave on the Q line at a rate determined by the contents of memory M (0002) from a 10 to some other number. By referring back to the Instruction Subset Table in last month's article, you should be able to interpret the above program.

Note in the program that R1 is used as a 16-bit decrementing counter (steps 3, 4, and 5). When the high-order eight bits of this counter reaches 00, the Q line goes to its opposite stage. Changing steps 2 and 4 to use the low-order byte of R1 increases the Q line's output frequency by a factor of 256.

If you use a 1-MHz crystal in the clock, the above program can generate square waves at frequencies between 0.3 and 80 Hz, depending on the byte in M(0002). By changing the B1 instruction at M(0003) to A1 and the 91 instruction at M(0005) to 81, square waves between 80 and 20,000 Hz can be generated. In this manner, your basic computer becomes a pre-settable square-wave generator.

We can rewrite the program so that the square wave's frequency becomes a function of the settings of the toggle switches as follows.

Step	M	Bytes	Comments
1	0000	F8 FF A2	FF→R2.0
2	0003	E2	2→X
3	0004	7A	0→Q
4	0005	6C B1	Switch byte→MX, D:D→R1.1
5	0007	21 91	R1-1; R1.1→D
6	0009	3A 07	Repeat step 5 if D = 00
7	000B	31 04	Go to step 3 if Q = 1
8	000D	7B 30 05	1→Q; Go to step 4

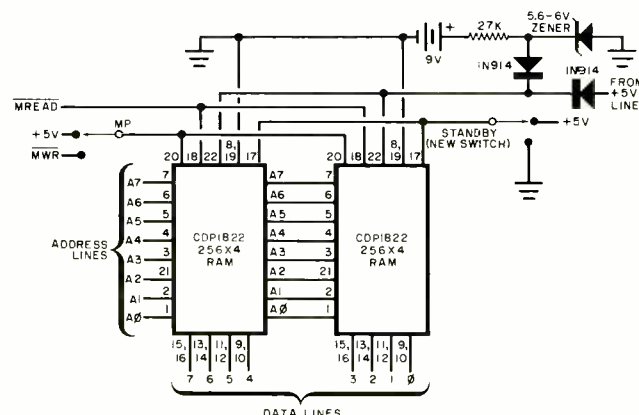

Fig. 4. Using a low-power COSMOS RAM and a 9-volt battery permits saving programs in memory.

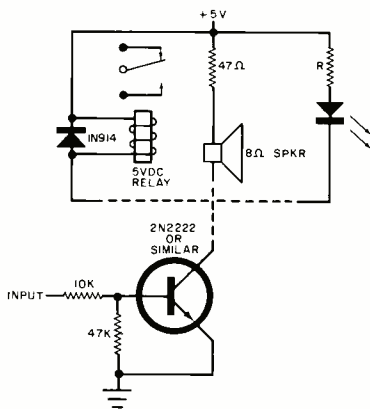

Fig. 5. Circuit to provide outputs used for testing.

In a similar manner, you can program bursts of pulses, variable-interval pulse trains, etc. You can even write a program where a list of bytes specifies a sequence of different tones to make a programmable music box.

The following two programs are "games" that demonstrate how the COSMAC instructions can be used. No added I/O circuits are required to run these programs.

Load the following sequence:

Step	M	Bytes	Comment
1	0000	E1	1→X
2	0001	F8 0F A1	0F→R1.0
3	0004	64	MX→display; X + 1
4	0005	3F 05	Wait for INPUT switch to be depressed
5	0007	6C	Switch byte → MX,D
6	0008	F8 0A F7	0A→D; D-MX→D
7	000B	51 64	D→M1; MX → display; X + 1
8	000D	30 0D 00	Stop; 00

Set both the LOAD and MP switches to off and then flip RUN to on. Have someone select any digit between 1 and 9 multiply by 10, add the original digit. Then multiply the sum by 9. Have the person who selected the digit tell you the result — but not the original digit. Set the binary code for the least-significant digit of the final answer into switches 3, 2, 1, and 0, and place the other input switches in the down position. When you depress the INPUT switch, the computer will display the unknown digit.

This program illustrates how to set a memory byte into the output display with a 6C instruction. Note the use of R1 as a memory pointer and the use of the binary subtract instruction in step 6.

The following program makes the computer "think" of a byte, which you must guess in no more than seven tries:

Step	M	Bytes	Comment
1	0000	8A AB	RA, 0→RB.0 — secret byte
2	0002	F8 AA A3	AA→R3.0 = memory pointer
3	0005	53 E3	D→M3; 3→X
4	0007	F8 07 A4	07→R4.0 = number of turns
5	000A	64 23	M3→display, 3 + 1; 3 - 1
6	000C	2A 3F 0C	RA + 1 until INPUT is depressed
7	000F	37 0F	Wait for INPUT to be released
8	0011	6C 8B	Switch byte→M3; RB.0→D
9	0013	F5 33 1A	M3-D→D; Go to step 12 if M3 ≥ RB.0
10	0016	F8 01	01→D
11	0018	30 22	Go to step 16 (show D)
12	001A	3A 20	Go to step 15 if D = 00
13	001C	53 64	D→M3; M3→display; 3 + 1
14	001E	30 1E	Stop loop
15	0020	F8 10	10→D
16	0022	53 64 23	D→M3→display; 3 + 1; 3 - 1
17	0025	24 84	R4-1, R4.0→D (turn counter)
18	0027	3A 0C	Go to step 6 if D = 00
19	0029	8B 7B	RB.0→D; 1→Q
20	002B	30 1C	Go to step 13 (show D and stop)

Place both the MP and LOAD switches in the off position after toggling the program. When you start the program by operating RUN; AA is displayed. Now, try to guess what byte the computer has selected by setting the eight INPUT switches and depressing the main INPUT switch. If 00 is displayed, you guessed correctly; if 01 is displayed, your guess is too low; if 10 is displayed, your guess is too high. You lose after seven wrong tries, at which point, the computer turns on its Q LED and the displays indicate the hidden byte. To try again, set RUN to off and then on.

The subtract instruction in step 9

HEX NUMBER SYSTEM

Decimal	Binary	Hex
0	0000	0
1	0001	1
2	0010	2
3	0011	3
4	0100	4
5	0101	5
6	0110	6
7	0111	7
8	1000	8
9	1001	9
10	1010	A
11	1011	B
12	1100	C
13	1101	D
14	1110	E
15	1111	F

sets an arithmetic overflow flag (DF) if MX is equal to or greater than D. The COSMAC instruction manual covers a detailed explanation of the use of this overflow flag in arithmetic and shift operations.

In Closing. Now that you have some familiarity with programming for the Elf, look through your back issues of POPULAR ELECTRONICS for some challenging programs to write. Try the "Logidex" game in the November 1973 issue, "Tug-of-War" game in February 1975, "Electronic Dice" in July 1975, and the "Executive Digital Temper Countdown" in December 1975. These are just a few of the many electronic games you can program instead of building. ♦

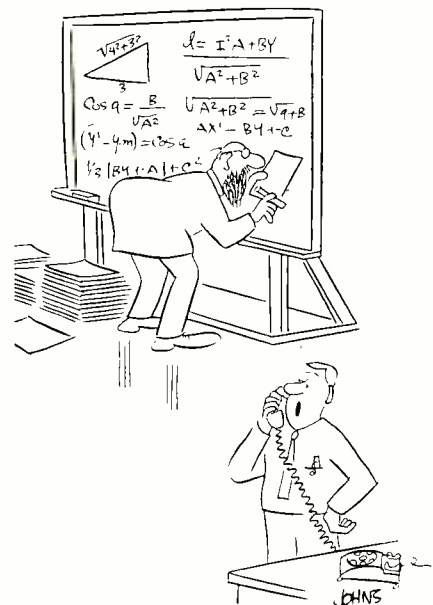

"Uh... About this loaner you sent us while our computer is being repaired..."

If you can see a difference, imagine what you'll hear.



Magnified, you can see record vinyl wearing away.



With same magnification, record vinyl shows no wear.

You're looking at the solution to one of the oldest problems in audio—how to protect records from wear, while at the same time preserving full fidelity.

It's called Sound Guard*, and it's remarkable.

Independent tests show that discs treated with Sound

Guard preservative played 100 times display the same full amplitude at all frequencies and the same absence of surface noise and harmonic distortion as "mint condition" discs played once.

A by-product of dry lubricants developed for aerospace applications, Sound Guard preservative is so smooth it reduces friction, yet so thin (less than 0.000003") it leaves even the most fragile groove modulations unaffected.

Audio Magazine has dubbed

Radio Electronics reports "At last! The long awaited record-care product has arrived. It preserves frequency response while reducing distortion and surface noise."



Surface noise after 100 plays

It's effective and safe for all discs, from precious old 78's to the newest LP's.

Sound Guard preservative, in a kit complete with non-aerosol pump sprayer and velvet buffing pad, is available in better audio stores and record departments.



Guard preservative played 100 times display the same full amplitude at all frequen-

Sound Guard preservative "the best thing for records since vinyl!" Len Feldman in

Sound Guard™ keeps your good sounds sounding good.

*Sound Guard is Ball Corporation's trademark for its record preservative. Copyright © Ball Corporation, 1976.

CIRCLE NO 64 ON FREE INFORMATION CARD

www.americanradiohistory.com

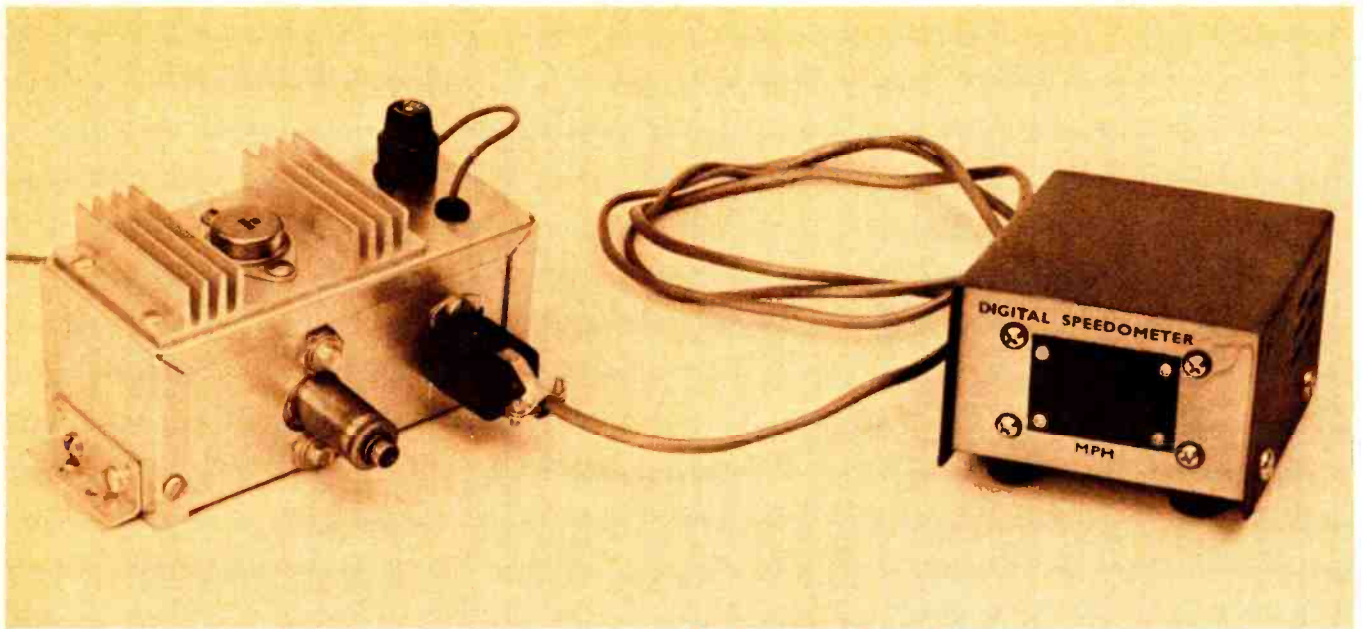

BUILD A

BY RICHARD B. FERMOYLE

DIGITAL SPEEDOMETER

FOR YOUR CAR

*Linear readout
uses 7-segment LED's.*

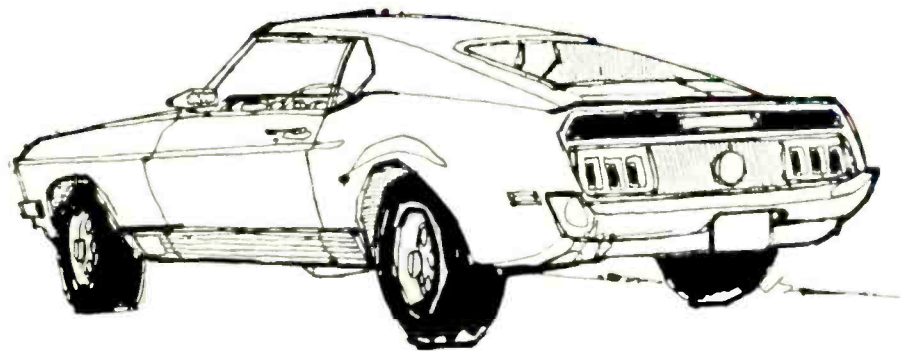

HOW accurate is your car's speedometer? Chances are it has some nonlinearities in the upper range due to increasing tension on the needle return spring. To overcome this irregularity and keep within the speed limit, you will want to build this digital speedometer. Besides, it will enable you to see what your exact

speed is at a glance. The speedometer simply converts the standard 1000 revolutions per mile of your speedometer cable to an electrical signal to drive a two-digit readout.

How It Works. The key component in the circuit (Fig. 1) is OC1, an optoelectronic device consisting of a gallium-

arsenide LED and a photosensitive silicon transistor. The two are in an enclosure but are separated by an open space. When the LED is on, and the light (which is not visible) hits the transistor, it turns on. A slotted metal disc attached to the speedometer cable is used to interrupt the light beam activating the transistor.

The voltage across the LED in OC1 is regulated by R1 and D2 and D3. The load for the phototransistor is R2 and its output is applied to IC1, which is connected as a monostable (one-shot) multivibrator. Each time the phototransistor conducts, the output (pin 6) of IC1 changes states (going from high to low) for a period determined by C4 and R10. At the end of the period (about 1 ms), the output of IC1 returns to its high state. The pulse rate is determined by the rotation of the disc interrupting the light beam in optoisolator, OC1.

The pulses from IC1 are then

counted in a conventional decade counter (with latch) consisting of IC2, IC4, IC6 and seven-segment readout DIS1. The overflow from the counter is totalled by a second decade counter consisting of IC3, IC5, IC7 and DIS2.

To prevent readout flicker, each decade counter has a latch (IC4, IC5). The outputs of the counters (IC2, IC3) are stored in the latches. When the latches are strobed, the digital value is passed to the readouts through the drivers (IC6, IC7). Thus, the readouts do not "run" as the counters cycle, but flash on with a set of digits each time the latches are strobed.

To understand the counting procedure, assume that your car is going 10 mph. Since the speedometer cable rotates 1000 rev/mile, it will be going 10,000 rev/hour or 2.77 rev/s. The metal disc used with OC1 has eight slots cut in its edge so 22 pulses per second are generated. For the readouts to display the proper information, decade counters IC2 and IC3 are allowed to count for only slightly more than 450 ms before they are reset by a positive pulse at their common zero-reset pins (2). The reset pulse is generated by IC8, which is triggered by the latch circuits in IC9.

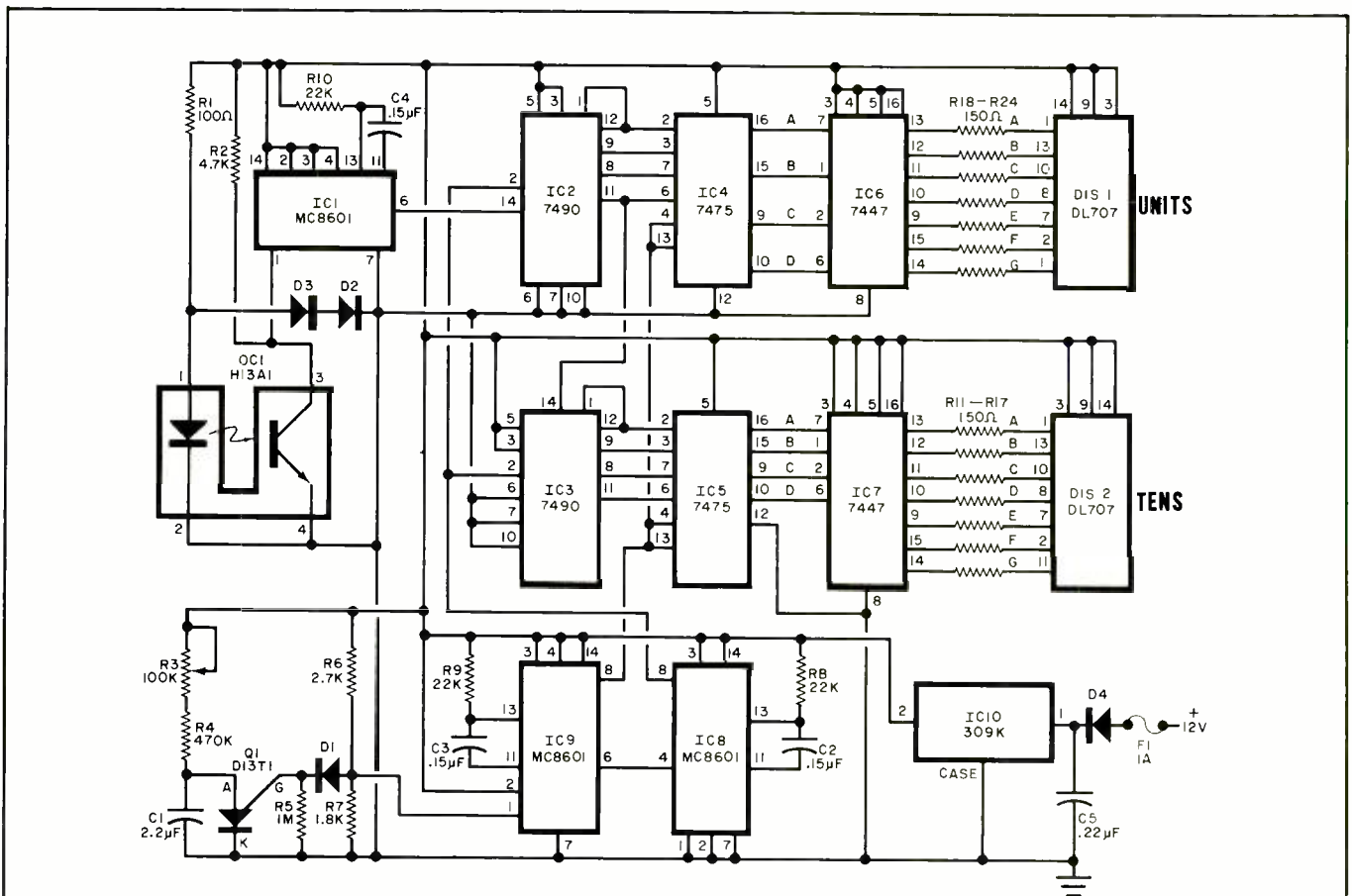

PARTS LIST

C1—2.2- μ F tantalum capacitor
 C2,C3,C4—0.15- μ F Mylar capacitor
 C5—0.22- μ F Mylar capacitor
 D1 to D4—Silicon diode (IN914 or similar)
 DIS1,DIS2—Seven-segment LED readout (Litronix DL707, MAN1, or similar)
 F1—1-A fuse and holder
 IC1,IC8,IC9—MC8601P
 IC2,IC3—7490
 IC4,IC5—7475

IC6,IC7—7447
 IC10—SD309K
 OC1—Optoelectronic coupler (GEH13A1)
 Q1—D13T1 programmable unijunction transistor
 R1—100-ohm, 1/4-W, 5% resistor
 R2—4700-ohm, 1/4-W, 5% resistor
 R3—100,000-ohm, pc-type trimmer potentiometer
 R4—470,000-ohm, 1/4-W, 5% resistor
 R5—1-megohm, 1/4-W, 5% resistor
 R6—2700-ohm, 1/4-W, 5% resistor
 R7—1800-ohm, 1/4-W, 5% resistor

R8,R9,R10—22,000-ohm, 1/4-W, 5% resistor
 R11 to R24—150-ohm, 1/4-W, 5% resistor
 Misc.—Mechanical speedometer, dual drive adapter, length of speedometer cable, suitable chassis (2), epoxy cement, heat sink and socket for IC10, plastic for readout window, metal for interrupter disc, mounting hardware, etc.
 Note—Dual drive adapter is available from S. S. White, 151 Old New Brunswick Rd., Piscataway, NJ 08854. Ask for Bulletin 7205.

Fig. 1. As the interrupter disc passes through the slot on OC1, it causes IC1 to inject a count into the decade counters. Circuit made up of Q1, IC9 and IC8 determines the timing.

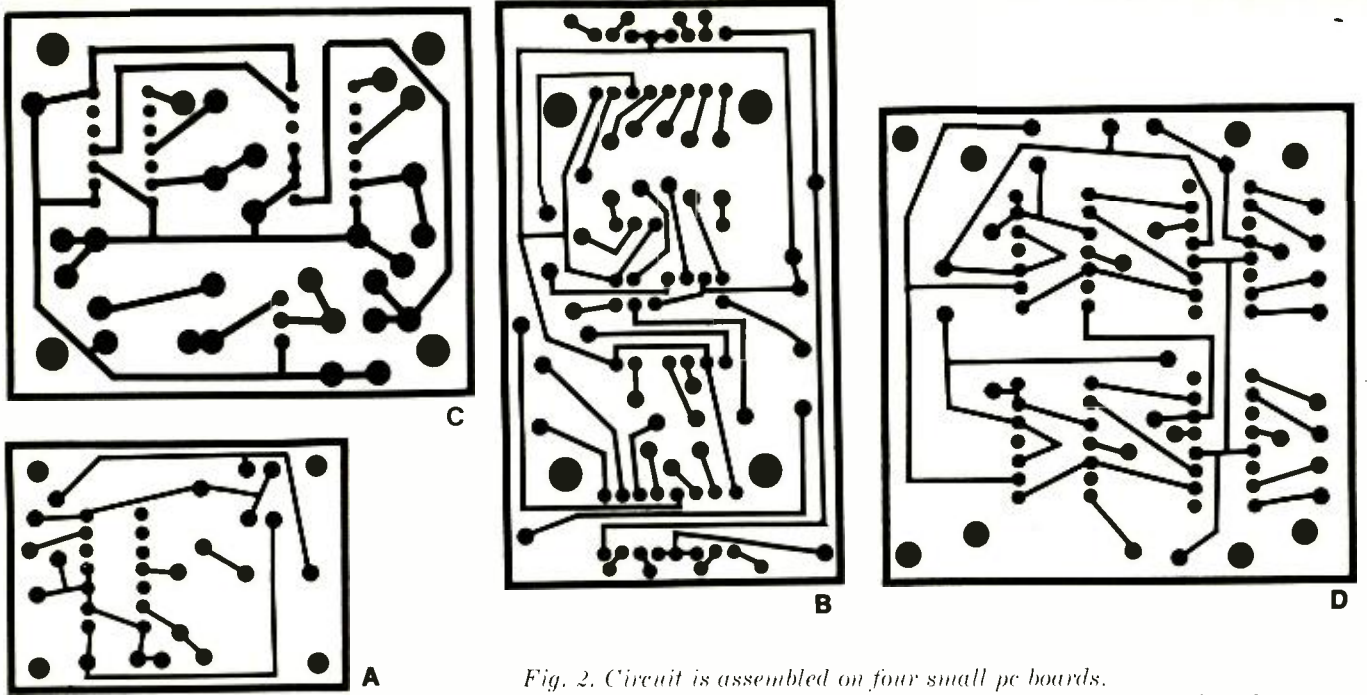
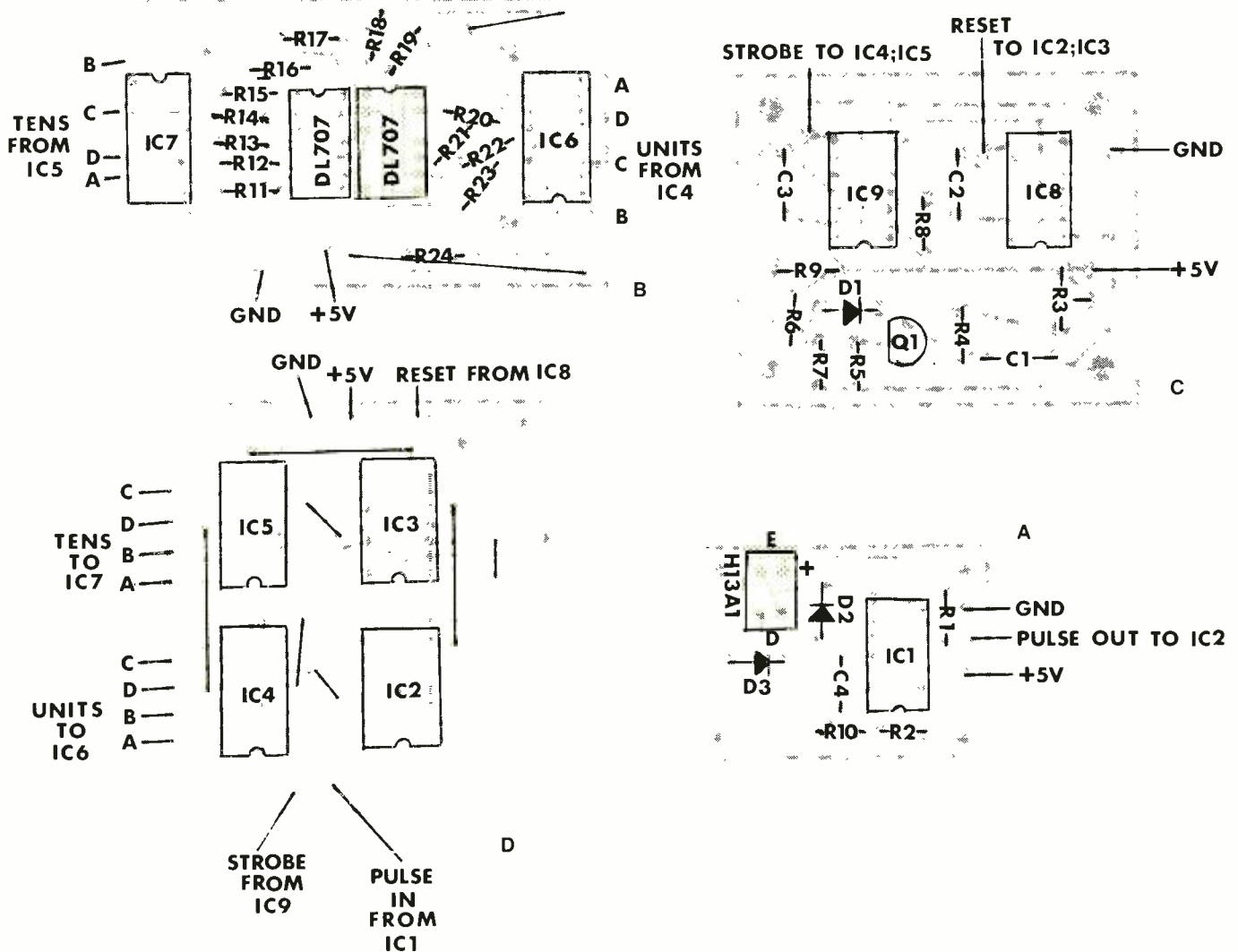

Fig. 2. Circuit is assembled on four small pc boards. Etching and drilling guides are shown above. Optoelectronic board (A) is fitted to the speedometer chassis. Display board (B) is mounted on front panel of display chassis with other two boards (C & D) inside the display chassis. Component layouts are shown below. Solid lines between solder pads are jumpers.



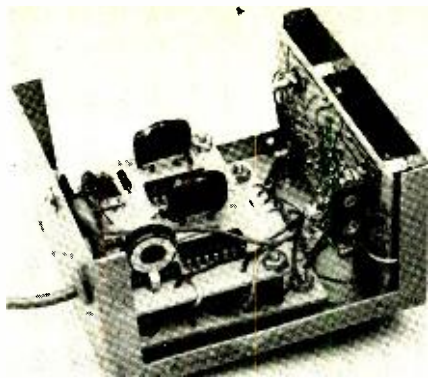

Fig. 3. This photo shows interior of the display chassis. Cable at left goes to power supply unit.

The timing for these pulses is provided by a pulse generator consisting of programmable unijunction transistor *Q1* and timing elements *R3*, *R4*, and *C1*. Each time *Q1* fires (determined by the circuit time constant), a negative-going pulse is generated at the junction of *R6* and *R7* and passed to *IC9*, which is wired as a monostable

multivibrator. The output of *IC9* is a one-millisecond pulse applied to *IC4* and *IC5*. When *IC9* times out, pin 6 returns high and triggers *IC8*, also wired as a one-shot, which generates the reset pulses for *IC2* and *IC3*.

Operating power is provided by *IC10*, a 5-volt regulator, with *D4* used as protection against accidental input voltage reversal.

Construction. The circuit is assembled on four small pc boards as shown in Fig. 2. Other than the optoelectronic board and the power supply components, two circuit boards and the display board are mounted in a small metal enclosure as shown in Fig. 3. A window for the display must be cut in the front panel with a piece of plastic cemented over the window. The two pc boards are mounted on spacers with the strobe-reset board on top (to provide access to *R3*).

Drill a small hole in the back of the enclosure for a two-conductor shielded cable. The cable carries the

+5-volt supply, pulses from *IC1*, with the shield acting as a ground.

Coupling the vehicle speedometer cable to the interrupter disc requires a mechanical fitting that will accept the male fitting presently connected to the cable. These fittings vary with the make of the car so it is necessary to get another speedometer that is a duplicate of the one you now have—either from an auto parts dealer or a junk yard. Disassemble the speedometer you obtain to remove the indicating pointer, the miles-per-hour scale, and the odometer components, as they will not be needed.

Fabricate the interrupter disc as shown in Fig. 4. Cement the disc in exactly the same place as occupied by the old indicating pointer. If your speedometer uses magnetic coupling, it must be defeated to allow the cable rotation to be coupled directly to the disc. In most cases, this can be done by applying a little epoxy between the magnet and its associated drum.

Select a two-part metal chassis to hold the modified speedometer and *IC10* on a heat sink as shown in Fig. 5. Mount the optoelectronic pc board under the interrupter disc so that the slotted edge of the disc passes through the slot in *OC1*. Then firmly secure the board in place. Wire the 5-volt supply to the cable connector and the optoelectronic pc board (using the metal chassis as common ground). Then wire the three leads from the optoelectronic board to the cable connector. Fit the two halves of the enclosure together and secure with appropriate hardware.

So that you don't lose the use of your old speedometer (you'll want to compare the two) and the odometer (which is generally required by law), obtain a dual drive adapter and an extra takeoff cable for the digital speedometer. The adapter, similar to those used in taxicabs for meter takeoff, can be found in auto parts stores, or see the Parts List.

Adjustment. The only adjustment necessary is calibration of *R3*. This is done by using an oscilloscope to get the pulses at pin 1 of *IC9* 450 milliseconds apart. If a scope is not available, it is also possible to make the adjustment by driving the car on a measured mile for one minute and setting *R3* so the meter reads 60 mph. To be sure the adjustment does not change due to vibration, secure the rotor of *R3* with a drop of epoxy. ♦

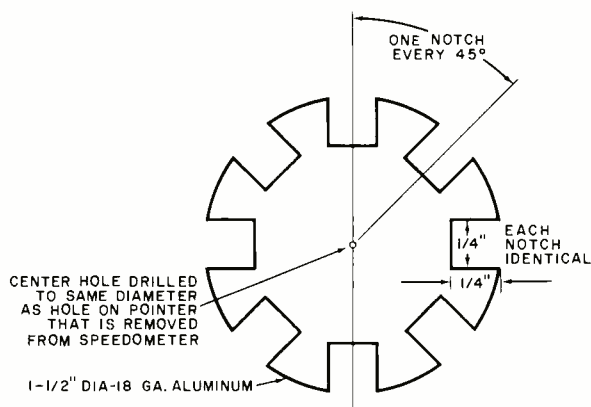

Fig. 4. Use this diagram to make interrupter disc.

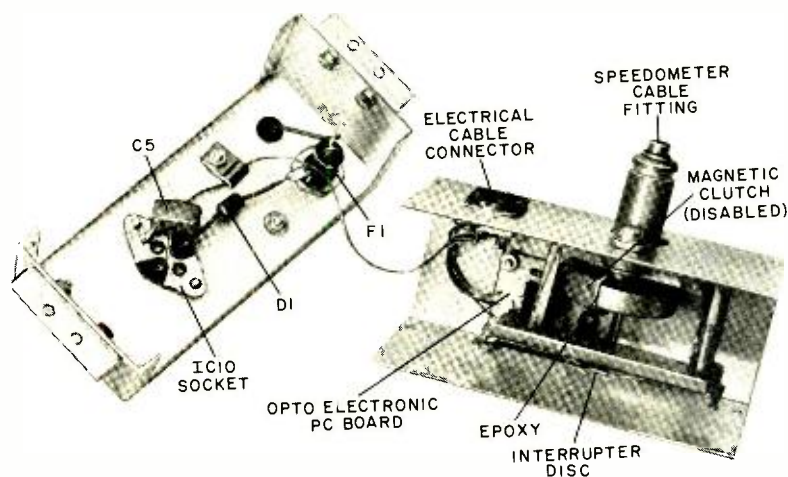

Fig. 5. Assembly of the speedometer and optoelectronic unit.

Some speakers sound fantastic on

One of today's best speakers is famous for its highs. Another has been said to deliver the best bass, and a third is loved for its mid-range performance.

**This one
sounds fantastic
on all of it.**



Each "best" speaker is terrific in its own particular area because it's engineered that way. To please people who are hung up on a particular kind of sound.

The new HPM-100 speaker system is different. It produces superlative sound across the whole spectrum.

That is not an accident.

Originally it was a challenge to our engineers: specialize in perfecting everything. Their response was to create a whole new universe of loudspeaker technology.

For the superhigh frequency range, to begin with, they gave the HPM-100 a radically new kind of super-tweeter, made with a newly developed substance called High Polymer Molecular film. This HPM film is used to convert

HPM-100
The all-around great speaker.

part of the music.

electrical energy into sound. It does so with a degree of accuracy that was previously only a theory.

That's a lot to claim, but these speakers really are that different from everything that has gone before. They work without any magnets, voice coils or domes. In fact, without any moving parts at all.

The tweeter, mid-range driver and woofer all depart just as radically from conventional speaker technology. The key innovation in all of them is a process that turns out speaker cones heavily impregnated with carbon fibers. They are rigid and tough, but still thin and light. As a result, each of them can move easily, like a well-oiled piston, to produce high and middle and low frequencies that are clearer, more natural and far more transparent than anything you'd expect to hear from a four-way speaker system.

Talk to your high-fidelity dealer about the HPM-100.

Take along a favorite recording and listen to it alternately through HPM-100's and some comparably priced speakers. Especially speakers that sound fantastic on the high frequencies, or the low ones, or the middle range.

If there's something you like about each of today's best speakers, this is the one that can give it all to you.

U.S. Pioneer Electronics Corp., 75 Oxford Drive, Moonachie, New Jersey 07074.



PIONEER

© U.S. PIONEER ELECTRONICS CORP., 1976

CIRCLE NO. 70 ON FREE INFORMATION CARD

www.americanradiohistory.com

BY RUSSELL J. BIK

THE INTRODUCTION of SCR's and triacs into light-dimmer design advanced the state of the art from the dark ages of the giant rheostat to the compact home devices of today. The Dynadim II project described in this article represents the next logical step in dimmer development. It performs all the functions of standard light dimmers and also provides automatic dimming of room lighting at adjustable rates.

As a mood setter at parties, the Dynadim II can dim lighting from full on down to any preset holding level or all the way off at dim rates ranging from a few seconds to an imperceptibly slow 40 minutes. The same slow dimming can serve as a sleep inducer by helping you to relax. It's especially handy to have around when the kids insist that the lights be left on after they are put to bed.

Shorter timing cycles can be applied to applications like providing a professional touch to the presentation of home movies and slides by bringing down the "house" lights while you attend to the projector.

How It Works. The Dynadim II circuit shown in Fig. 1 is designed to work in series with the ac power source and the load via the ac input terminals. The power to the load is regulated by triac Q3 that acts as an ac switch that closes at some point during each alternation of the input power and opens automatically each time the voltage passes through the zero point. The point in the alternation where Q3 is triggered into conduction determines how much power is supplied to the load. If triggering occurs early in the cycle, the controlled light glows at a higher average intensity than if triggering occurs later.

BUILD

DYNADIM II

**DELUXE HOME-
LIGHTING CONTROL**

Featuring an automatic dim-to-off mode from a few seconds to a slow 40 minutes, as well as conventional preset-level dimming.

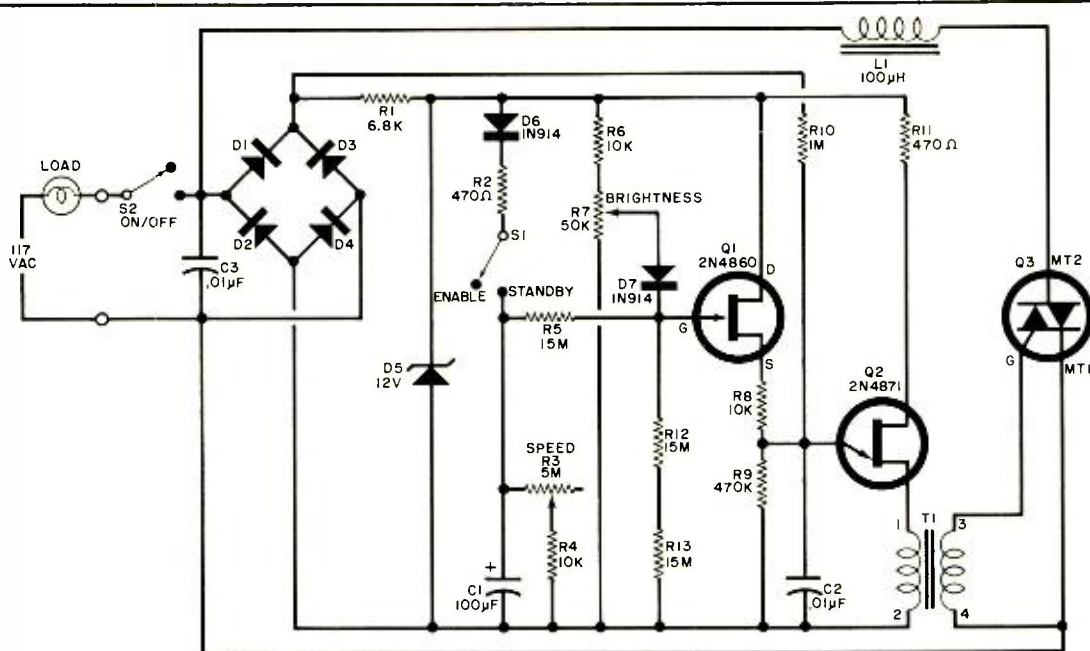

Fig. 1. Unlike a conventional light dimmer, the triac (Q3) is gated later and later in the power-line cycle as C1 discharges. Dimming time is controlled by varying discharge time to C1

PARTS LIST

C1—100-µF, 15-volt electrolytic capacitor
 C2—0.01-µF, 50-volt capacitor
 C3—0.01-µF, 200-volt capacitor
 D1 through D4—1-ampere, 200-PIV rectifier diode
 D5—12-volt zener diode (1N4742 or similar)
 D6, D7—1N914 diode
 L1—Line filter inductor approximately 100 µH at 4-amperes)
 Q1—2N4860 field-effect transistor
 Q2—2N4871 unijunction transistor
 Q3—200-volt, 6-ampere triac ECC Q2006L4
 R1—6800-ohm, ½-watt, 10% resistor
 R2, R11—470-ohm, ½-watt, 10% resistor

R3—5-megohm slide potentiometer
 R4, R6, R8—10,000-ohm, ½-watt, 10% resistor
 R5, R12, R13—15-megohm, ½-watt, 10% resistor
 R7—50,000-ohm slide potentiometer
 R9—470,000-ohm, ½-watt, 10% resistor (see text)
 R10—1-megohm, ½-watt, 10% resistor
 S1, S2—Spst slide switch
 T1—Pulse transformer with 1:1 ratio (Sprague No. 11Z12)
 Misc.—Printed circuit board; suitable chassis box with cover; insulator (goes between pc board and box); felt strips;

knobs for slide pots; bus wire; machine hardware; solder; etc.
 (The following items required only for portable table version of dimmer: 12' "remote-control" extension cord; right-angle strain relief; four rubber feet.)
 Note: The following items are available from Celltronix, 1239 Old Bayshore Hwy., San Jose, CA 95112; Etched and drilled pc board for \$5.50; complete kit of parts, including chassis box, in wall-mount version for \$24.95 and in table version for \$26.95. California residents, please add sales tax.

To send Q3 into conduction, a trigger pulse is applied to the gate of the triac by the discharge of C2 through Q2 and the primary of T1. The time constant of C2 and its resistors is rather long compared to the period of a single ac alternation. The values given in Fig. 1 were selected so that the potential across C2 just barely attains an amplitude sufficient to drive Q2 into conduction when the voltage across C1 is zero and R7 is set for minimum bias on Q1.

Closing S1 causes C1 to charge through R2 and D6, thereby increasing the bias on Q1 and allowing C2 to charge more quickly with each alternation of the ac power cycle. As a result, the Q2 oscillator circuit produces the triggering pulses for the triac earlier in the cycles, and the controlled lights brighten.

An earlier triggering can also be obtained by adjusting the R6-R7 voltage divider. The effect on the bias of Q1 is the same as raising the potential across C1, except that a static control over lighting intensity is obtained to set threshold levels.

The automatic dimming feature is obtained by opening S1 and allowing C1 to slowly discharge through R3 and R4. This causes the lighting to diminish gradually as the triggering pulses to the triac are produced later and later in each cycle.

The high resistance required to prevent the voltage from being too rapidly shunted away from C1 is provided by using a field-effect transistor as Q1 and a very high resistance in its gate circuit.

The rectified power applied to the timing circuit by the diode bridge

made up of D1 through D4 is maintained at a constant 12 volts, regardless of load, by zener diode D5. The filtering network made up of C3 and L1 reduces interference to the AM broadcast band caused by triac switching transients.

Construction. To keep the dimmer as slim and compact as possible, it is recommended that you build it on a printed circuit board. An actual-size etching and drilling guide and component placement diagram are shown in Fig. 2. Note that the entire circuit, including controls and switches, mount directly on the pc board. To avoid lead breakage from vibration, it is best to epoxy T1 to the board. It is also advisable to mount R1 about ¼" (6.4 mm) above the surface of the board to assure good heat transfer.

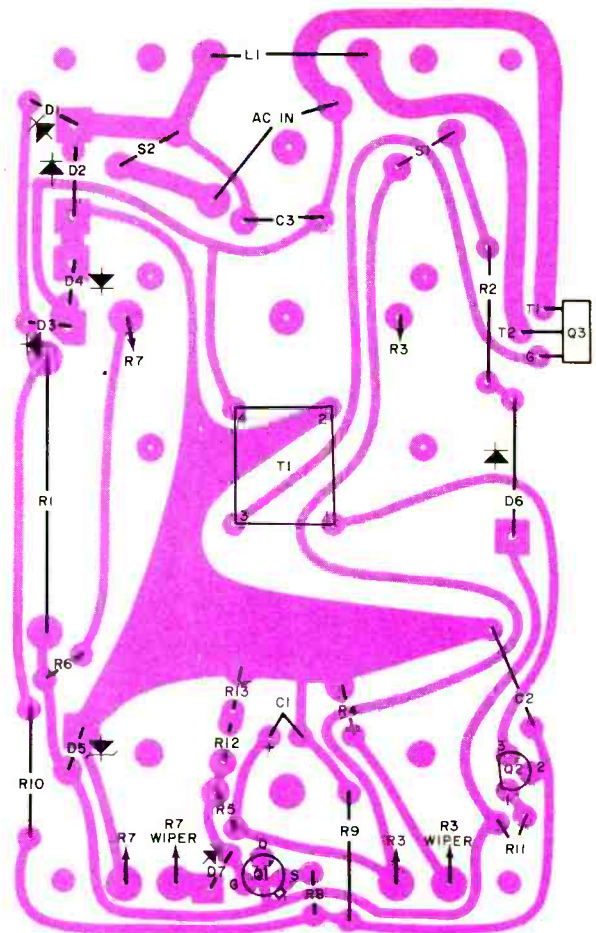
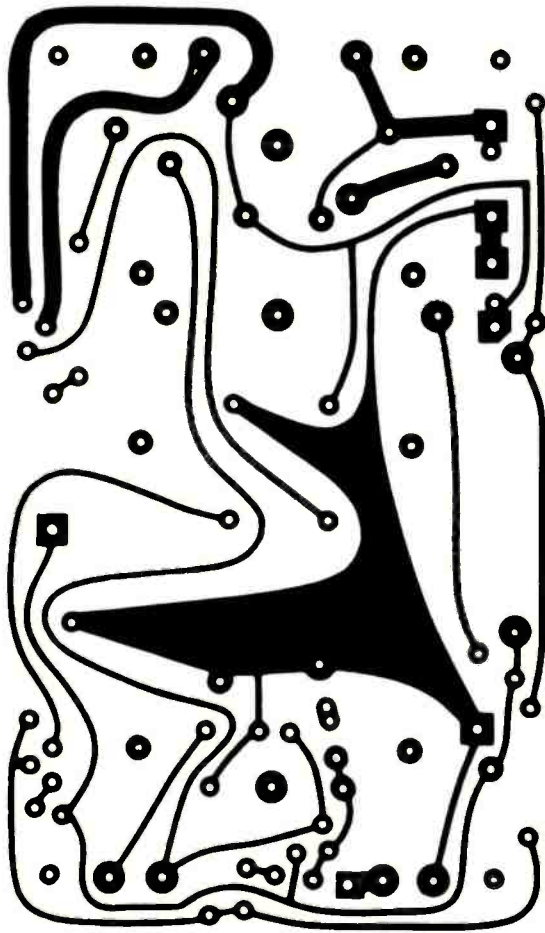

Fig. 2. Actual-size etching and drilling guide is shown above left, with component layout guide above right.

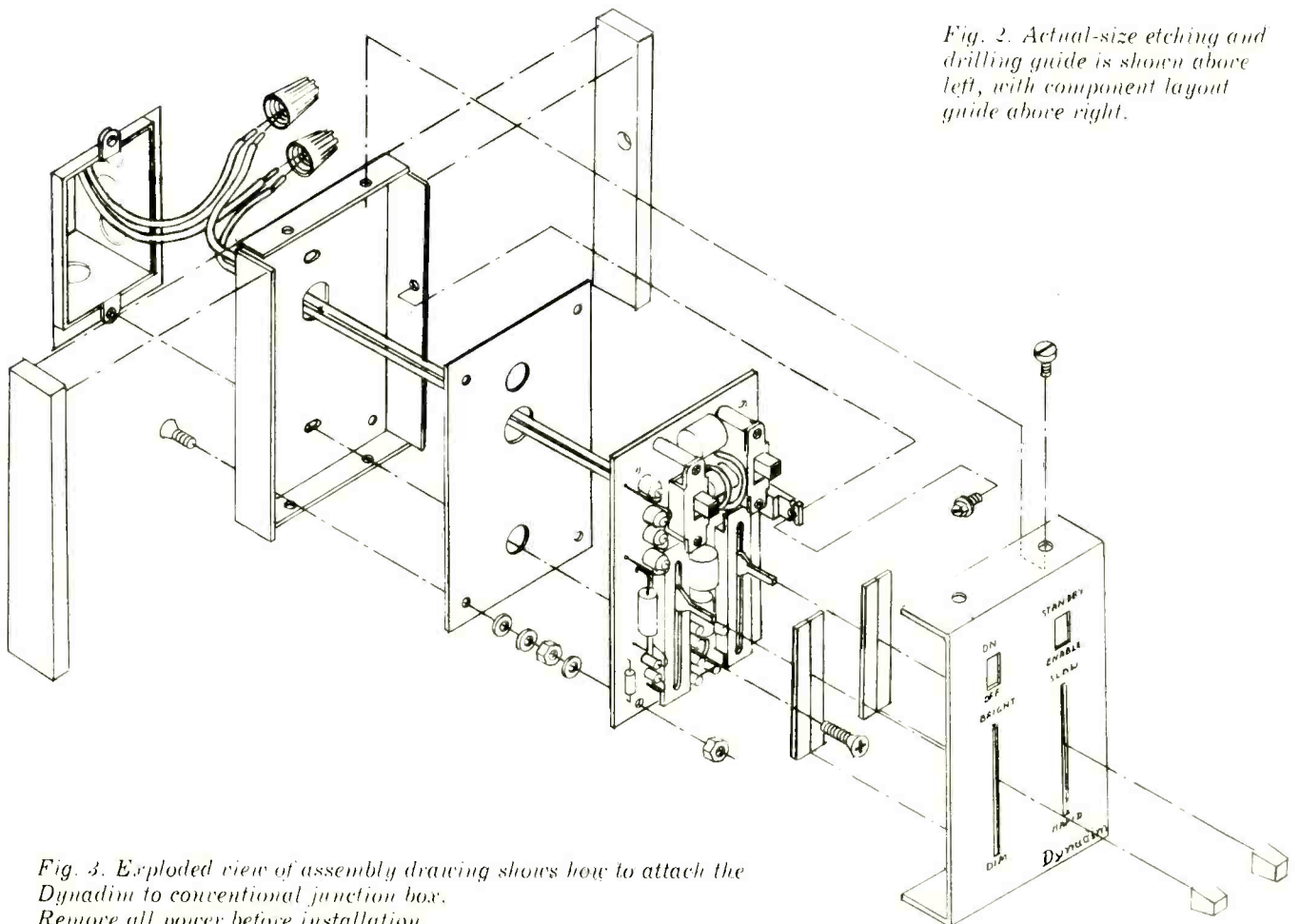

Fig. 3. Exploded view of assembly drawing shows how to attach the Dynadim to conventional junction box. Remove all power before installation.

The triac (Q3) specified in the Parts List has an electrically isolated heat-sink tab that can be bolted to the metal cover to provide good heat sinking. If you use any other type of triac, an insulating mounting kit will be required.

After wiring the board, check it over for possible solder bridges between foil traces and to ascertain that all components are properly installed and polarized. To avoid leakage problems in the high-impedance circuit around the two transistors, remove all rosin and clean the board thoroughly with alcohol.

It is important that the leakage of C1 be minimized and that Q1 be properly biased to obtain the full 40-minute time delay. The leakage through an electrolytic capacitor is inversely proportional to the number of hours it is charged. This process is cumulative over the life of the capacitor. A dramatic reduction in leakage will occur during the first few hours of operation; improvement continues into the thousands of hours. (Note: The capacitors supplied with the kit listed in the Note under the Parts List come burned in. If you buy new capacitors locally, you can burn them in once they are mounted in the project simply by leaving the dimmer turned on in the standby mode.)

The value of R9 was selected to provide optimum bias for the nominal specifications of Q1. However, differences in individual transistors may have to be compensated for by changing R9's value. Raising the resistance increases the apparent length of the timing cycle until a point is reached where the controlled light will not turn off even if C1 is discharged. The ideal value for R9 is just below the point at which this begins to occur.

You can mount the dimmer in a permanent wall mounting (at a light-switch junction box) or in a separate box for portable table use. The assembly details for the junction-box approach is shown in Fig. 3. Note that the dimmer is connected in series with the load. Make sure that all electrical power is removed from the junction box before attempting to install the dimmer.

Mount the pc board assembly inside a form-fitting enclosure, with a thin insulator between the bottom of the board and the metal rear section of the box. The metal cover should have cut-outs for the slide shafts of the potentiometers and switch toggles. Short lengths of felt fabric can be used be-

tween the inside of the front panel and the tops of the slide pots to keep out dust and other foreign material. Cement these strips in place so that they just touch each other in the two slider hole locations.

When you make the hookup to the ac line in the junction-box installation, be sure to use wire nuts for the connections.

Drill the rear wall of the dimmer's box so that it can be mounted directly on the junction box via the latter's switch mounting screws. (The original junction-box switch will no longer be needed.) In this manner, the complete dimmer can be affixed to the wall to eliminate the crowding that would exist if the entire circuit were to be "squeezed" into the junction box.

If you prefer to make your dimmer a table model, the same four screws that mount the circuit board to the box can be used to secure rubber feet to the bottom of the box in which the project is housed. In this configuration, a 12' (about 4-m) long "remote-control" extension line cord should be used to allow maximum flexibility. The lamp to be dimmed then plugs directly into the cord, which also plugs into the ac receptacle.

Using the Dimmer. For conventional control of lighting, it is recommended that the dimmer control be left in the full BRIGHT position and that the lights be controlled with the ON/OFF switch. When the dimmer is left on for long periods of time, a slight warming of the chassis will be noted. This is normal and should cause no apprehensions.

For dimming action, if you wish the lights to be full on and extinguish automatically to a very dim glow over a period of, say, 10 minutes, the procedure would be: First set the timing and dimming controls to DIM and RAPID and the STANDBY/ENABLE switch to ENABLE. The lights will extinguish quickly. Adjust the dimmer control to the position that gives the desired minimum illumination. Set the timing control to a position about four divisions above RAPID, S7 to STANDBY, and (when ready to initiate the dimming action) switch to ENABLE. The lights will begin slowly to dim to the preset level.

Although the Dynadim II itself draws very little power (about as much as an electric clock), it is advisable to turn it off when convenient. This will ensure maximum component life. ◆

IMSAI announces a unique 4K RAM board for just \$139.

Nobody has a 4K RAM board that gives you so much for your money. It's fully compatible with the Altair 8800.

Through the front panel or under software control, you can write protect or unprotect any 1K group of RAM's. Also under software control you can check the status of any 4K RAM board in 1K blocks to determine whether it's protected or not. The board has LED's that clearly show you the memory protect status of each 1K block and which block is active. And there's a circuit provided that will let you prevent the loss of data in the memory if there's a power failure. This low power board has a guaranteed 450 ns cycle time—no wait cycle required. There's nothing like the IMSAI 4K RAM board around.

Dealer inquiries invited.

IMSAI

IMSAI Associates, Inc.

	PE-9
IMS Associates, Inc. 14860 Wicks Boulevard San Leandro, CA 94577 (415) 483-2093	
Order Your IMSAI 4K RAM Board For Only \$139. Use BankAmericard, Master Charge, personal check or money order.	
<input type="checkbox"/> Send _____ 4K RAM boards today <input type="checkbox"/> Charge to my credit card <input type="checkbox"/> BAC No _____ <input type="checkbox"/> MC No _____	
Signature _____	
Name _____	
Address _____	
City, State/Zip _____	

SC-1 Stylus Cleaner: Only two reasons for existence.

- 
1. YOUR \$75
CARTRIDGE
 2. YOUR \$1,000
RECORD COLLECTION

The SC-1 stylus cleaner by Discwasher safely removes abrasive cuttings which develop on even (clean) looking styli. Only SC-1 cleaner has critical fiber density—a magnifying mirror—and a walnut case. Two reasons are enough to justify a \$6.00 expenditure. Sold by Discwasher dealers worldwide.

discwasher

A DIVISION OF DISCWASHER GROUP
COLUMBIA, MO 65201



CIRCLE NO. 20 ON FREE INFORMATION CARD

Fig. 1. Schematic of one modular equalizer channel. Two such circuits are required for stereo; four for quadrasonic systems.

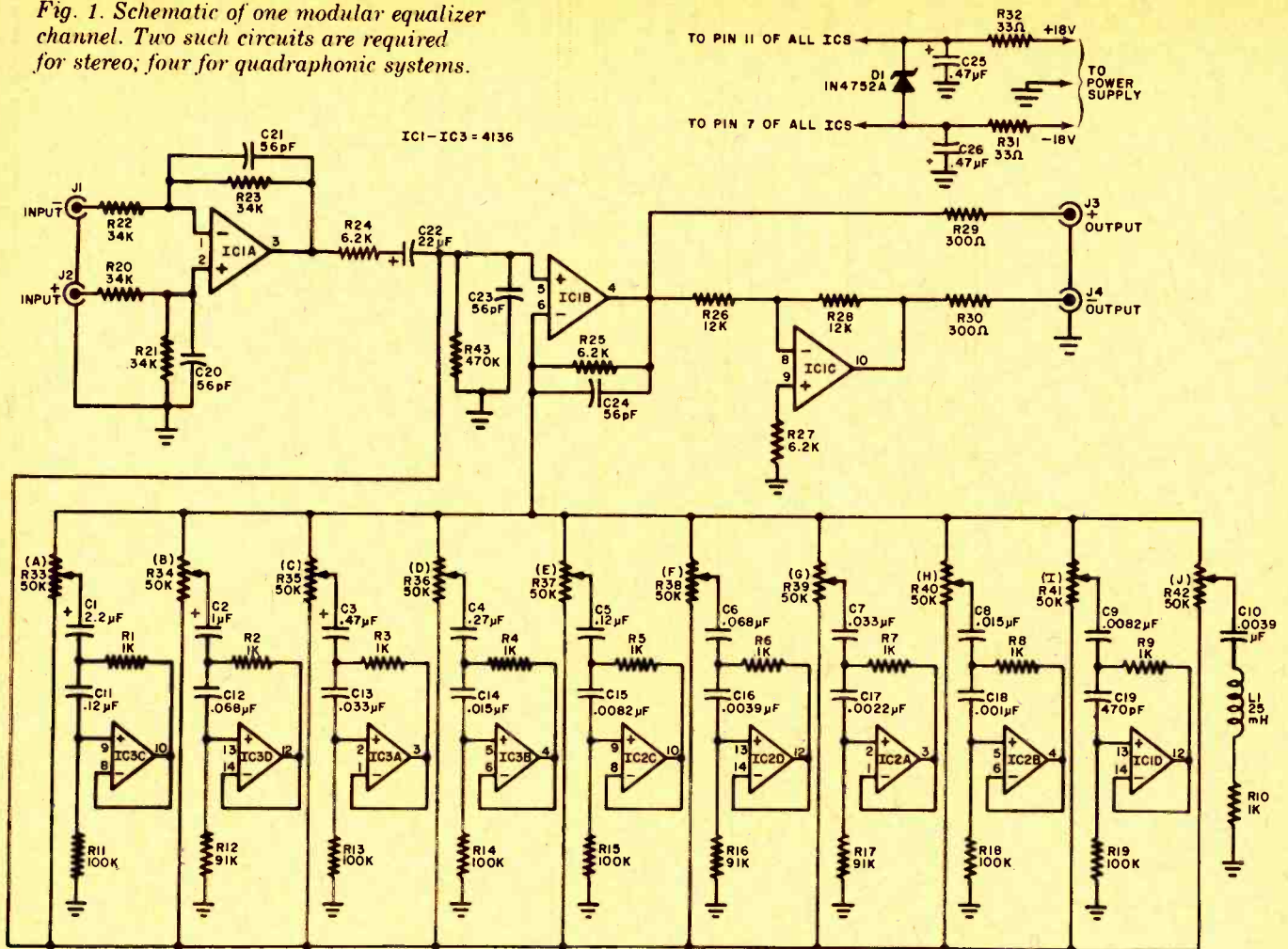

EQUALIZER MODULE PARTS LIST (per channel)

The following are 50-volt, 20% tantalum capacitors:
 C1—2.2 μ F
 C2—1 μ F
 C3, C25, C26—0.47 μ F
 The following are 50-volt, 10% Mylar capacitors:
 C4—0.27 μ F
 C5, C11—0.12 μ F
 C6, C12—0.068 μ F
 C7, C13—0.033 μ F
 C8, C14—0.015 μ F
 C9, C15—0.0082 μ F
 C10, C16—0.0039 μ F
 C17—0.0022 μ F
 C18—0.001 μ F
 The following are 50-volt, 20% disc capacitors:
 C19—470 pF
 C20, C21, C23, C24—56 pF
 C22—22- μ F, 16-volt upright aluminum electrolytic capacitor
 D1—33-volt, 1-watt zener diode (1N4752A

or equivalent)
 IC1, IC2, IC3—4136PC quad operational amplifier IC
 J1 through J4—Phono jack (optional)
 L1—25-mH toroidal inductor
 The following are 1/4- or 1/2-watt, 10% resistors
 R1 through R10—1000 ohms
 R11, R13, R14, R15, R18, R19—100,000 ohms
 R12, R16, R17—91,000 ohms
 R20 through R23—34,000 ohms
 R24, R25, R27—6200 ohms
 R26, R28—12,000 ohms
 R29, R30—300 ohms
 R31, R32—33 ohms
 R43—470,000 ohms
 R33 through R42—50,000-ohm W-taper slide-type potentiometer with silicone damping and center detent
 Misc.—Suitable enclosure; printed circuit board; eight-contact barrier block (Kulka Electric No. 670A-3100-8 or

similar); knobs for slide pots; 1/16" thick aluminum stock for rear panel, pot brace, and power supply bracket; plastic standoffs (4); shielded audio cable; hookup wire; machine hardware; solder; etc.

Note: The following items are available from Delta-Graph Electronics Co., Box 741, Pasco, WA 99301: Complete mono kit of equalizer module parts, including pc board, tested IC's, finished case, rear panel, but less power supply, No. EQ10M, for \$56.00; Stereo version of No. EQ10M, No. EQ10SP, including power supply, for \$130.00; Power supply kit for up to four equalizer modules, No. PS-4, for \$20.00; Walnut veneer cabinet that accommodates two equalizer modules and power supply, No. EQ10WC, for \$20.00; 25-mH toroidal inductor, No. EQL1, for \$1.50. Washington residents, please add 5% sales tax.

sional recording and PA applications. Resistors R20 through R23 make up a precision-balanced input stage for true differential, high common-mode rejection in balanced-line systems. When an unbalanced input is desired, as in home audio systems, the module's inverting (-) input can be grounded and the signal applied to the noninverting (+) input.

Capacitors C21, C24, C25, and C26 stabilize operation of

the op amps. Capacitors C20, C22, and C23 provide a gentle frequency-response rolloff in the range beyond the top end of the audio spectrum to limit noise and r-f interference. Resistor R43 ground references the IC1B equalizing op amp at its + input.

The output of the equalizer is fixed at 600 ohms balanced or 300 ohms single-ended by R29 and R30, which also provide short-circuit protection. Even though the 4136 op

amps have built-in overload protection, this is an added safety factor. (The op amps were also chosen for their high slew rates and superior noise ratings.) The output stage will effortlessly supply enough voltage and current to drive a dozen typical power amplifiers into clipping, even if the amplifiers are connected in parallel with each other. Furthermore, it will drive the amplifiers without an increase in THD or IM and without any loss in the bass register.

Resistors *R26*, *R27*, and *R28* and *IC1C* form an output that is shifted 180° from the + input. In single-ended applications, an output can be taken from one point while the other point is left open. Both outputs can be used in applications requiring "bridge" driven amplifiers.

Zener diode *D1* protects the op amps from overvoltages and power supply transients and permits operation from high-voltage supplies, with the addition of external current-limiting resistors. Internal current-limiting resistors *R31* and *R32* are optimized for operation with the power supply shown in Fig. 2, while providing extra power supply noise and ripple isolation.

The Fig. 2 power supply is designed to deliver ±18 volts at up to 200 mA. Since the nominal current demand of each equalizer module is 50 mA, the supply will accommodate up to four modules for quadraphonic system equalization.

Construction. The equalizer modules and power supply are best assembled on printed circuit boards, the actual-size etching and drilling guides and components-placement diagrams for which are shown in Fig. 3. Use a low-wattage soldering iron and fine solder.

Start by assembling the equalizer module. First install the resistors and capacitors, followed by the diode and toroidal coil (clip off unused leads), then the IC's, and, finally, the slide potentiometers. Be sure to orient all components properly.

The pots should be mechanically tied together to prevent them from shifting, as the sliders are operated, with an 8¾" (22.2-cm) length of ¾" × 1/16" (9.53 × 1.6-mm) aluminum. Drill 1/8" (3.16-mm) holes ¾" (19 mm) apart, starting 3/8" (9.5 mm) from one end of the strip.

Strip both ends of a 1½" (3.8-cm) length of hookup wire; solder to one end a No. 6 solder lug; and solder the other end to the "ground pot support" pad on the pc board. Place the aluminum strip over the top sections of the slide pots and align the holes in the strip with the threaded holes in the pots. Place a No. 4 washer over a 4-40 × 1/4" machine screw, and drive this screw down in the hole of the second pot. Secure the strip to the other nine pots with 4-40 × 1/4" screws.

Cut a piece of 1/16" aluminum plate to 8" × 4¾" (20.3 × 12.1 cm) and drill 3/16" (4.8-mm) holes along one of the short ends, locating and spacing them to exactly line up with the input/output and power pads on the pc board. Mount the barrier block so that its solder terminals pass through the holes and do not touch the metal plate. Then drill the holes for the spacers that will be used between the board and rear plate. Use 1/2" (12.4-mm) spacers and self-tapping 6-32 × 1/4" machine screws to fasten the spacers in place. Solder the lugs of the barrier block to the pads on the pc board.

Assemble the power supply board, carefully following the guide for it shown in Fig. 3. Be sure you properly orient the electrolytic capacitors, rectifier diodes, and transistors. Fasten down the small barrier block with No. 6 machine hardware. Note that the transformer, fuse and

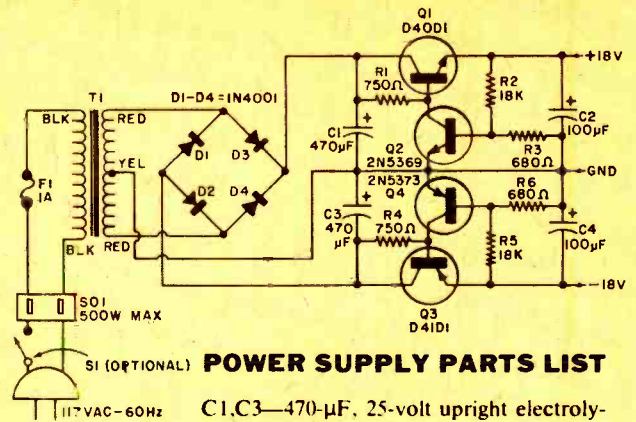

POWER SUPPLY PARTS LIST

- C1, C3—470-µF, 25-volt upright electrolytic capacitor
- C2, C4—100-µF, 25-volt upright electrolytic capacitor
- D1 through D4—1N4001 rectifier diode
- F1—1-ampere fuse
- Q1—D43C1 npn silicon transistor (General Electric)
- Q2—2N5369 npn silicon transistor
- Q3—D42C1 npn silicon transistor (General Electric)
- Q4—2N5373 pnp silicon transistor
- R1, R4—750-ohm, ½-watt resistor
- R2, R5—18,000-ohm, ½-watt resistor
- R3, R6—680-ohm, ½-watt resistor
- S1—Spst switch (optional)
- S01—Chassis-mounting ac receptacle
- T1—28-volt center-tapped, 200-mA transformer
- Misc.—Mounting panel; barrier block (Kulka Electric No. 600Y-3); machine hardware: hookup wire; solder; etc.

Fig. 2. Power supply accommodates up to four equalizer modules.

CLAIMED SPECIFICATIONS

- Frequency response:** 20 to 20,000 Hz ±0.5 dB.
- Dynamic range:** Output noise greater than 105dB below maximum output from 20 to 20,000 Hz.
- S/N ratio:** Better than 90 dB referenced to 2-volt rms rated output from 20 to 20,000 Hz.
- Band centers:** 31.25, 62.5, 125, 250, 500, 1000, 2000, 4000, 8000, 16,000 Hz nominal.
- Adjustment range:** ±15 dB maximum (30-dB total range).
- THD:** Less than 0.1% at rated output from 20 to 20,000 Hz.
- IM distortion:** Less than 0.01% at rated output 60/7000 Hz mixed 4:1; typically less than 0.003%.
- Rated output:** 2.0 volts rms into 10,000 ohms.
- Clipping output:** 10.0 volts rms into 10,000 ohms single ended, 20.0 volts rms into 10,000 ohms balanced.
- Input impedance:** 68,000 ohms single ended; externally set with terminating resistor for balanced inputs between 600 and 100,000 ohms.
- Output impedance:** 300 ohms single ended, 600 ohms balanced.
- Note:** All controls at 0 dB.

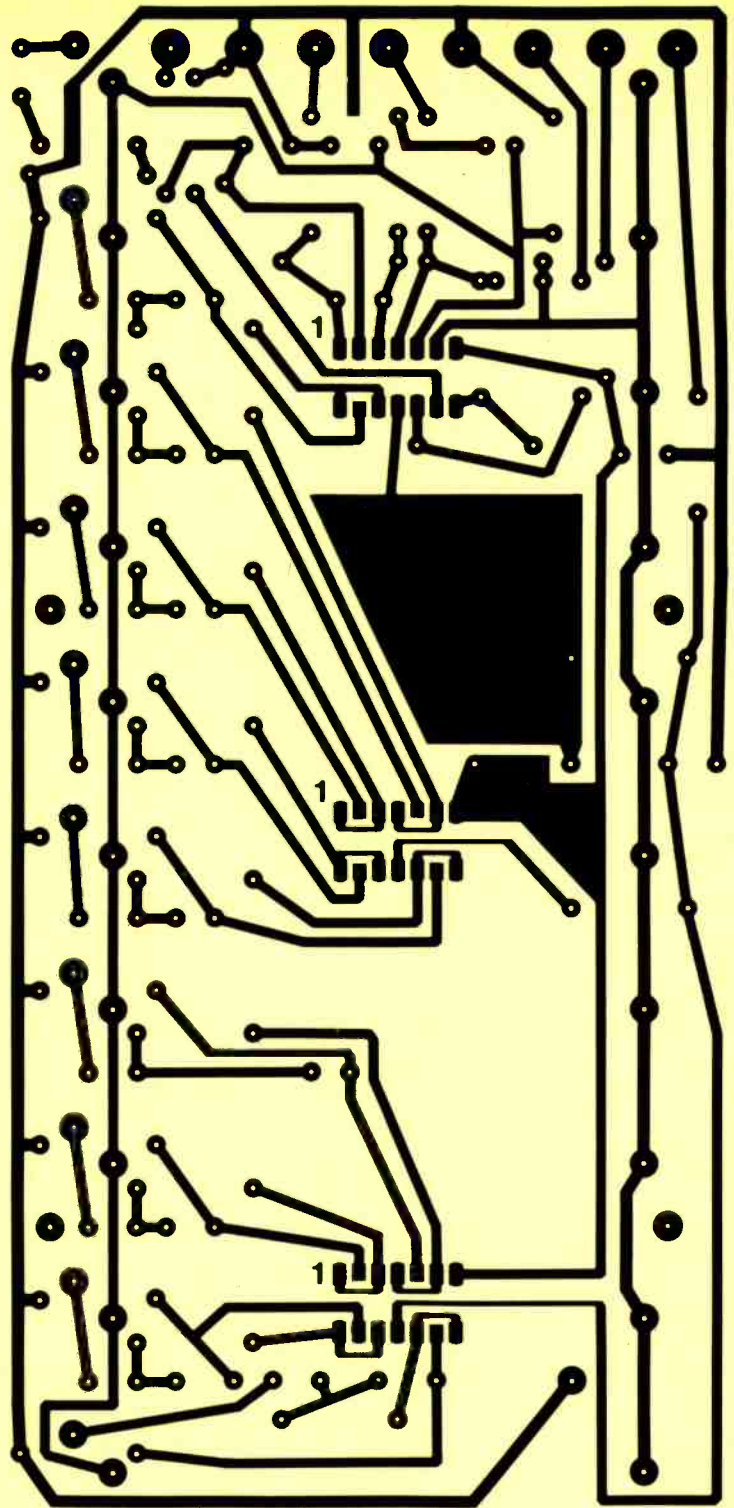
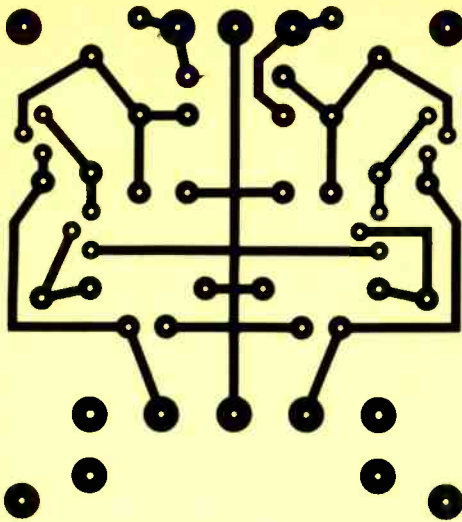
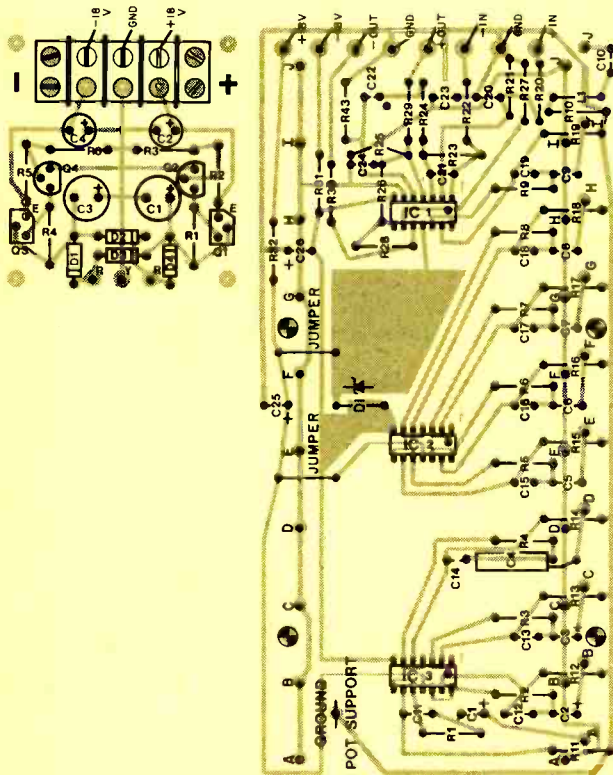

Fig. 3. Actual-size etching and drilling guides (above and right) and component placement diagrams (below) for equalizer module and power supply.



holder, and accessory ac receptacle mount off the board. Again, you will need a $1/16$ " thick aluminum backplate. Cut the plate to $6\frac{1}{2} \times 2\frac{3}{4}$ " (16.5×7 cm) and bend the plate along the short dimension $1\frac{1}{4}$ " (3.2 cm) in from the edge at a right angle. Machine the short upright section of the bracket for the line cord strain relief, accessory ac receptacle, and fuse holder. Then drill the mounting holes for the transformer and power supply board. Mount the receptacle, fuse holder, and transformer in their respective locations. Referring to Fig. 2, wire the primary circuit of T1 as shown, connecting the ends of the line cord directly across the receptacle if you are not using a power switch. If you

plan to use S1, modify the circuit as shown and plan to mount the switch on the front panel of the case in which you house the equalizer. Snap a plastic strain relief over the line cord and secure it in its hole in the bracket.

Set the power supply board near the secondary side of the transformer and connect and solder the latter's leads to the appropriate pads on the board. Then use $1/4$ " spacers to mount the board to the bracket.

With the equalizer module(s) and power supply subsection fully wired, you can set them side by side and temporarily interconnect them, following the diagram shown in Fig. 4 to check out their operation. (Note that the dia-

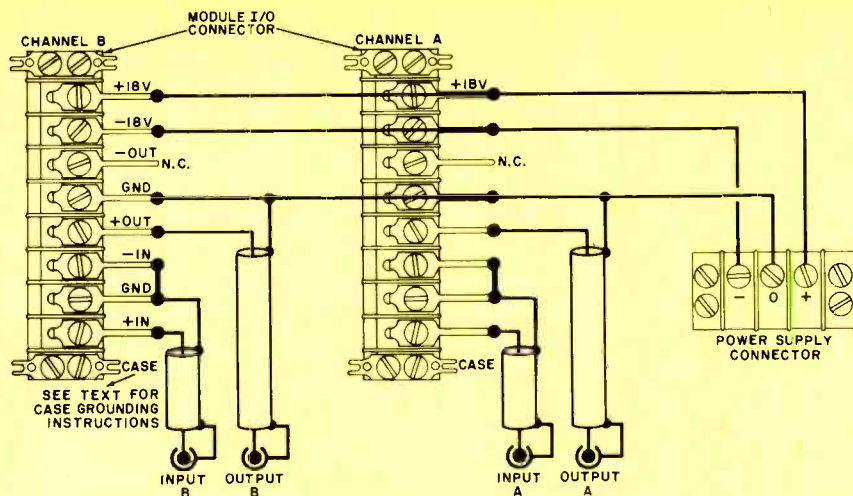

Fig. 4. Wiring scheme for home audio system is shown here with stereo setup. For mono, eliminate channel B; for 4-channel add channels C and D in same manner as shown for channel B to channel A.

gram illustrates the wiring scheme for a home stereo system. If you plan to build only a monophonic version, simply disregard everything to the left of the Channel A barrier block. Alternatively, if you are planning to build a quadraphonic equalizer, Channels C and D are added exactly in the same manner as Channel B is shown connected to Channel A.)

During tests (and in actual operation), the equalizer can be installed between the preamplifier and power amplifier in your sound system. Use shielded audio cable when making the signal-line hookups between the equalizer and your sound system. It can also be connected into the system via the tape monitor circuits, which will allow the equalizer to be switched in and out of the system with the TAPE MONITOR switch of your receiver or preamplifier.

Final Assembly. Once you are satisfied that your equalizer is operating properly, disconnect it from your sound system. Then mount the module(s) and power supply in a suitable enclosure. (Do not forget to mount the power switch, if you chose to use one, in a convenient location on the front panel of the enclosure.)

As the circuit is designed, the equalizer's audio and chassis (case) grounds are separate and brought out to terminals on the rear panel via the barrier block. If you use a nonconducting enclosure (such as a wood cabinet, plastic box, etc.), simply tie each module's case ground to its input ground. When you mount the modules in a metal enclosure and the module cases are physically grounded to the enclosure, it is wise to leave the case ground terminals floating so that the audio ground path is connected to the enclosure at only one point in the entire system. This will prevent ground loops.

In Conclusion. As you use the equalizer in your sound system, you will discover that there is a certain amount of interaction among the controls. This is a normal condition. You will also find that, to obtain the best possible equalized sound from your system, you will have to do considerable experimenting with the settings of the various slide controls. However, once you get your system properly equalized, you need never again touch the controls—unless you change speaker systems, amplifier, or cartridge, or you move your system to a different area. ♦

HERE ARE the highlights of audio electronics, circa 1976-77. A number of advances have been made, as you shall see.

Receivers. With the growing interest in the marketplace on "separates" (high-power basic amplifiers, sophisticated preamp-control units and top-notch tuners), many manufacturers who depend on receiver sales for the bulk of their component business have attempted to cover all bases this year. It is more than two years since the "100-watt-per-channel" barrier was broken by a few daring manufacturers. Now, a new power output level around 160 watts per channel seems to be the plateau for which more and more receiver makers are aiming.

New receiver designs are not concerned with increased power alone, however. Many of them offer increasingly sophisticated tone-control circuits—the type previously found only on separate preamplifiers or the more expensive integrated amplifiers. The appearance of a third tone control, which operates in the mid-frequencies (called a "presence" control in early hi-fi days) has found its way to the front panels of medium- and high-priced receivers. So

The State of Audio Electronics Today

Latest developments, including class D amplifiers.

BY LEONARD FELDMAN

have selectable turnover frequencies for bass and treble controls, which increase a receiver's versatility and permit the tailoring of the frequency response at the extremes without adversely affecting mid-band response. In deference to audio purists who frown on the use of tone controls entirely, receivers equipped with more versatile tone control systems also include switches which permit bypassing those tone controls entirely.

Historically, the more useful "add-on" electrical/electronic accessories designed for use with hi-fi components are eventually incorporated into the components. A good example is the low-cut or high-cut filter, which started out as a little "black box" accessory and is now standard on nearly every front panel of modern receivers.

This year's newest adoption of an add-on is the graphic equalizer—that *ne plus ultra* of tonal compensation devices. It divides the audio spectrum into many (5 to 24) segments for fine control of overall system frequency response. One manufacturer has incorporated a graphic equalizer with five slide controls into at least three of his popularly priced receivers, thereby eliminating the traditional rotary bass and treble control knobs.

Also borrowing from the advanced features found in "separates," some manufacturers have augmented the usual pair of tuning meters found on most receivers with a second pair whose sole function is to monitor average or instantaneous power delivered to connected loudspeakers. Power meters on receivers are anything but another "gimmick," as they permit visual adjustment of channel balance and even provide a measure of security against overdriving of speaker systems whose maximum power input capability may not be as great as the output capability of the receiver to which they are connected.

Nor are all the new receiver features externally visible. Phase-locked-loop circuitry for more stable operation of stereo multiplex systems in receivers and tuners has become almost standard in all but the very lowest priced units. The use of PLL has given rise to separation specifications of 40 dB or more. These performance figures remain true, by the way, even after years of use of the product since the PLL circuits have no adjustment coils or capacitors to drift out of alignment with time.

The use of completely independent power supplies for each of the two stereo amplification channels is another innovation in stereo receivers that may not be physically apparent from the outside of the receiver. The proponents of this technique credit it with reducing interchannel modulation effects and low-frequency IM and harmonic distortion. The twin power approach may take the form of two completely separate power transformers or may utilize separate secondary windings on a single transformer, each of which is connected to its own rectifier and filter circuits for providing power to one of the two channels. Toroidally wound power transformers are also being used increasingly in high-power receivers because of their more efficient use of space in the chassis and their superior regulation qualities.

Tuning meters have multiple functions in some new receivers. Panel switches alter the purpose of some signal-strength meters so that they display FM deviation (a handy metering technique that is particularly helpful in setting up associated recording equipment when transcribing FM or stereo FM programs on tape). More and more of these meters are also being used as multi-path indicators, which permit optimum orientation of external FM antennas for

least interference caused by delayed, reflected signals. One manufacturer has reversed the direction of meter needle deflection and repositioned meter circuitry so that it indicates best signal-to-noise ratio (FM quieting) rather than just greatest signal strength. (The two tuning points may not coincide.)

Tuners. The growing number of FM stations which crowd the dial in most major metropolitan areas have created a dilemma for many r-f circuit designers. Ideally, wide-bandwidth response in the r-f and i-f sections of a tuner (as well as in the FM detector circuits) is needed if recovered audio signals are to be as low in distortion as possible. But built-in wide-band response means lower adjacent- and alternate-channel selectivity, defeating the need to separate closely spaced stations on the dial.

A recent tabulation of FM stations lists 67 of them serving a tri-state area. Of this number, no fewer than 18 are only an FM channel width (200 kHz) apart. As many as 24 low-power stations in the area are actually assigned to the same frequency, pointing up the need for excellent capture ratio even though such "paired" stations may be in opposite geographical areas.

A very logical solution to this problem has been incorporated in some better tuners by a few manufacturers. Instead of effecting a compromise between the circuit requirements for good selectivity and low distortion they have designed products which offer selectable bandwidth. If you live in any area which is not plagued with stations that are practically "on top of each other," you can choose the wideband i-f position of the switch and enjoy low distortion figures when listening to stations that transmit good signals. Alternatively, when confronted with a portion of the dial that is overflowing with closely spaced (in frequency) stations, you simply flip a switch to the narrow position and, while distortion becomes somewhat higher, at least you are able to tune to the station of your choice without interference from adjacent- or alternate-channel signals.

Several tuner manufacturers have adopted the most accurate tuning method of all—phase-locked-loop digital circuits. Local oscillator frequencies are divided and compared (in the equivalent of a high-frequency PLL circuit) with a crystal-controlled reference frequency built into the tuner. Since tuning accuracy is then simply a function of crystal frequency accuracy, such tuners may be said to be as accurate in their frequency pin-pointing as the station transmitters themselves. In some variations, frequency is read by means of LED or other numeric readouts.

Since this "super afc" method invariably involves tuning by means of a dc voltage and varactor diodes (which replace the conventional mechanical multi-ganged tuning capacitor), the tuners lend themselves to pre-selection or pre-programming of favorite stations. Long-term "memory" of selected stations is often accomplished by including a low-voltage, long-life battery to supply power to the memory even when the tuner is turned off. Tuning meters are not required with synthesized tuners, of course, but even some of the more conventional tuners have eliminated all meters from front panels, substituting instead LED signal-strength indicators and even pairs of LED's which must glow equally to indicate correct center-of-channel tuning. This latter technique has also been applied to all-in-one receivers in budget-priced categories in the last few months.

Amplifiers and Preamps. Not to be outdone by manufacturers of all-in-one receivers, makers of separate amplifiers also have new circuit innovations to offer.

The prematurely announced Class D or switching amplifier, first exhibited nearly three years ago, is still awaited by audio fans who have been tantalized by the promise of a more efficient, cool-running, high-power, solid-state circuit that requires a minimum of heat-sinking and operates by "sampling" audio waveforms at a high-frequency (500 kHz) rate. Class B amplifiers, long the mainstay of solid-state audio electronics, are fairly efficient converters of dc energy when delivering maximum power. However, they are relatively inefficient at typical (music) listening levels. When delivering rated power, a properly designed Class D amplifier can attain efficiency figures of 80% or higher.

In a Class D amplifier, the audio input signal is used to vary the pulse width of a 500-kHz pulse train (Fig. 1). The reduced duty cycle of the amplifier section results in higher efficiency than with Class B operation. An integrating network "reads" the average width of pulses and reconstitutes the audio signal waveshape. The high-frequency "sawtooth" edges of the restored waveform are inaudible.

But Class D amplifiers are not the only ones that promise increased efficiency, reduced weight, and compact construction. Another manufacturer has developed what he calls a "Series E" circuit (also referred to as a Class G amplifier) which, while not as radical a departure as Class D, is also capable of greatly improving the efficiency of audio power amplifiers.

The Series E circuit utilizes two pairs of output transistors for each channel. The first pair, powered by a low dc supply voltage, handles low-level signal waveforms or the ascending first portion of high-level waveforms. When an audio waveform exceeds a predetermined amplitude, the second pair of output devices, powered by a much higher voltage supply, "takes over" in a smooth transition. Since

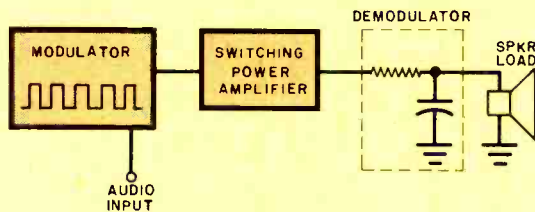

Fig. 1. With the class D switching power amplifier shown above, signal (A) at left modulates pulse (B) to give pulses of varying width (C). These are then integrated to create replica of the original signal (D).

this latter pair of devices is normally "turned off" when not needed, the result of the "pass-along" technique is greater efficiency over each pair of devices' operating range. First examples of the circuit are expected to appear in the form of a receiver.

Still another amplifier manufacturer has introduced a "current dumping" 100-W/channel power amplifier. It's actually a Class A amplifier with current dumping circuitry that's called upon when current demands are high. It uses error-correction circuits.

In addition to average-power-reading meters, some basic power amplifiers now include a series of LED indicators, each calibrated to fire at 3-dB intervals. The combination of meters plus LED indicators permits users to visually monitor the difference between "average" power delivered by their stereo amplifiers and musical transient peaks which are often 10 to 20 dB higher in amplitude. The latter might overload an amplifier for short periods without being detected by the listener.

Recognizing the wide disparity between average power levels and peak power inherent in today's wide dynamic music program sources, at least one manufacturer has produced a novel power-monitoring circuit that compares instantaneous output signal distortion with the distortion-free input signal. When that comparison discloses a significant difference in waveform between the two signals, the amplifier instantly "limits" power output so that nominally low distortion levels are maintained at all times. An indicator light accompanies the limiting action so the user can back off on the volume setting to restore full dynamic range. As for preamplifier control units and control sections of integrated amplifiers, two divergent trends seem to be evident. For the first, some manufacturers are offering more and more control and switching features on these separates. The popularity of such outboard accessories as graphic equalizers, noise-reduction devices, and dynamic range expanders has given rise to the need for more tape monitor circuits through which these devices can be connected to the audio chain. Thus, while most receivers now boast at least two monitor circuits, preamplifiers and integrated amplifiers often include three or more such circuit-interruption points. Multiple phono inputs are also popular; some of the new preamps make provision for connection of low-voltage-output moving-coil phono cartridges.

The other trend in preamplifiers seems to be away from controls, switches and knobs. A variety of control chassis is now available offering just "basic" preamplification and program selection. These most separate of separates concentrate on super-low distortion, high-input signal-handling capability and ruler-flat frequency response, leaving the control frills to less esoteric products. There are even expensive pre-preamplifiers made by a few small firms. These do nothing but provide straight voltage gain (at super-low noise levels) for moving-coil cartridges. Indeed, with the increasing number of separate equalizers available, a basic preamplifier (equipped, perhaps, with some fixed cut-off filter positions, but little else in the way of tone controls) begins to make a lot of sense to the audio perfectionist who can add such separate tone-control devices without introducing system redundancies.

As for phono preamp circuits themselves, there is increased use of high-voltage devices in the front ends of preamps, many operating from dual-polarity supplies to provide the wide, dynamic signal-handling capability now

demanded by knowing purchasers of these control units. There are some preamplifiers which claim a signal-handling capability of 500 millivolts and more. This figure is more than 46 dB greater than the nominal 2.5-mV input sensitivities which those same preamp circuits require to deliver full rated output. Add to that the signal-to-noise ratio of around 60 dB (from nominal input to residual noise and hum level) and we have preamplifier circuits with 100-dB capability—far more than the dynamic range capability of any phonograph record ever pressed.

Accessories. As the little black boxes of yesterday find their way into the complete component of today, other add-on devices take their places. Two distinct areas of audio research seem to be occupying engineers at this time. The first has to do with increased dynamic range and improved S/N. In this area we already have a host of products available, such as dynamic expanders, single-ended noise reduction devices (that do not require anything to be done to the program source when first recorded, as opposed to two-sided noise-reduction systems such as Dolby, dbx and ANRS) and dynamic noise filters. The second category of add-on device is relatively new and involves an attempt to simulate the acoustics of live concert halls in one's own listening room. Quadraphonic sound's initial

premise of accomplishing this may be challenged by purely electronic time delay systems which can be adjusted by the user to vary time delay and decay parameters. Physical placement of speakers is far less critical than with 4-channel arrays.

Two approaches to this goal are already represented by products on the marketplace. One employs a wholly analog system known as "bucket brigade" chips, operating at a delay rate determined by a digital clock. The second approach involves analog-to-digital conversion of the incoming audio signals, followed by application of the digitally encoded pulses to shift registers and, finally, re-conversion to delayed audio signals by a digital-to-analog converter. Once in digital form, the signals can be delayed by the amount desired.

We know of serious experiments in which the "space" of the living room is divided into as many as 16 sectors. Computer programs which contain information regarding a particular concert hall are fed into the system and delay times for each sector (as well as other identifying qualities of the signal "reflected" from that sector) are punched up on the 16-channel reproducing system. The system is now used for acoustic studies, but if past history is any indicator, we might find this elegant concert-hall simulator reduced in size and cost sufficiently to become next year's "add on" accessory. ♦

Guide to "Home Brew" Phono Preamp Design

Why RIAA signal processing is used, and how it affects preamp design.

BY DENNIS A. BOHN

AUDIOPHILES continue to rely on the phonograph disc as their principal program source. Because of this, they are very careful to check the phono ratings of commercial preamplifiers. In this article, we will take a look at the almost universally used RIAA equalization system, and how it affects the design of phono preamps. Also included are representative phono preamp circuits employing low-noise IC's, as well as design information for those who like to "roll their own."

Phono preamplifiers differ from other preamplifiers only in their frequency response, which is specially tailored to compensate for (equalize) the recording characteristic. If a fixed-amplitude signal is recorded on a phonograph disc while its frequency is varied from 20 to 20,000 Hz, the result will have a playback response curve similar to that in Fig. 1. This plot of phono cartridge output (amplitude) versus frequency indicates a dramatic alteration of the fixed amplitude input signal. *Playback equalization*, which is performed by the phono preamplifier, corrects this alteration and recreates the applied flat-amplitude signal. To understand why we must go through this procedure, a consideration of the recording process is necessary.

Recording and RIAA. The grooves in a stereo disc are cut by a chisel-shaped stylus, which is driven by two vibrating transducers mounted at right angles to each other (Fig. 2). The cutting stylus vibrates from side to side in step with the variations in the signal impressed on the cutter coils. This is called a "lateral cut," as opposed to the older "vertical cut" method. The resulting displacement of the groove back and forth about its center is known as *groove modulation*. The amplitude of this modulation cannot exceed a certain amount, or "cutover" will occur. That is, the

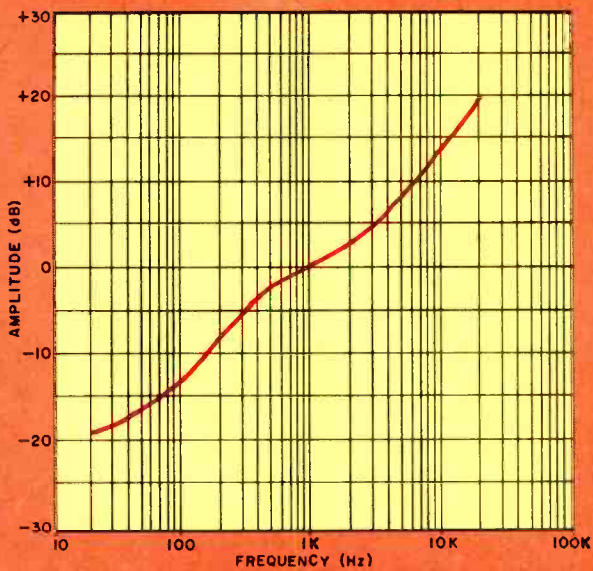

Fig. 1. RIAA recording characteristic boosts highs and attenuates bass.

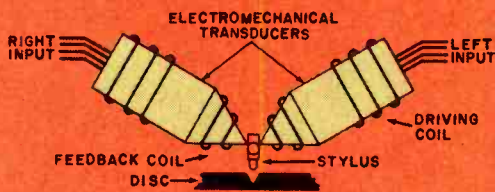

Fig. 2. A typical stereo cutting head uses negative feedback coils to counteract head resonances.

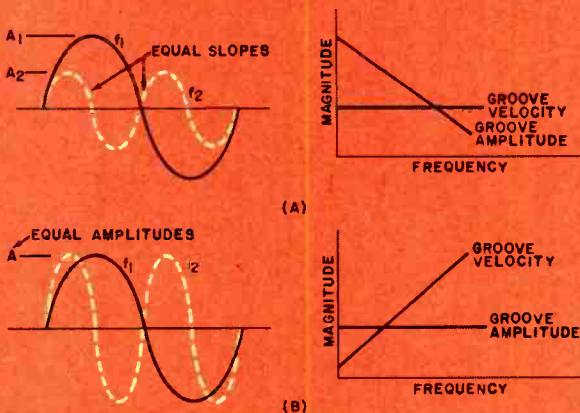

Fig. 3. In constant-velocity recording (A), groove amplitude varies with frequency. In constant-amplitude recording (B), groove velocity varies with frequency.

cutting system will break through the wall of one groove into the wall of the preceding groove. The ratio of the maximum groove amplitude possible before cutover to the minimum amplitude that will provide an acceptable S/N ratio (generally 58 dB) determines the dynamic range of a recording. This has been found to be typically 32 to 40 dB.

The signal-to noise ratio (S/N) is governed mainly by the quality of the vinyl from which a disc is made. The grainy characteristic of the vinyl surface acts as a noise generator. In the recording process, the cutting stylus is heated to smooth out the graininess, and thus minimize on-disc noise. Of course, if high-quality vinyl (with small grains) is used, the overall noise level will decrease. Interestingly, the level of noise generated by the vinyl tends to be ten times greater than that generated by the preamp. It is not uncommon for wideband (white) noise levels due to surface irregularities to rise to 10 μ V.

On the disc, an audio signal's amplitude is deposited in the form of groove modulation amplitude, and its frequency appears as the rate of change of groove modulation. This sounds simple enough, but why isn't the graph of Fig. 1 a straight horizontal line centered on 0 dB? After all, we are applying a signal of fixed amplitude.

The variation results from certain peculiarities of the recording head. Due to its physical construction, the velocity frequency response of the head (that is, how fast the cutting stylus moves in cm/sec when driven by a given input signal) exhibits a resonant peak at about 700 Hz. To counteract this undesirable effect and produce a velocity output independent of frequency, negative feedback coils are added. Therefore, the cutting head is known as a *constant velocity* device.

Figure 1 shows the pre-equalization of signals to be applied to the cutting head. The equalization curve has this particular shape for two reasons. First, low frequencies are attenuated to prevent cutover. Second, boosting the high-frequency content improves the S/N ratio. Because the driving coils of the cutting head are primarily inductive loads, their impedances are frequency dependent. If a fixed input signal causes a constant voltage to be applied across the coils, the resulting current, and thus magnetic field and rate of change of vibration, become frequency dependent. This is called *constant amplitude* recording.

Conversely, if a fixed input signal causes a fixed current to be applied to the driving coils, the resulting voltage and cutting amplitude becomes frequency dependent. This is called *constant velocity* recording. With respect to frequency, for a given input signal amplitude, the cutting head has only one degree of freedom — either vibrating *rate* (constant velocity from current drive) or vibrating *distance* (constant amplitude from voltage drive).

The terms constant velocity and constant amplitude tend to create confusion. But the key idea is that they have meaning only for a *fixed amplitude input signal*, and are used to describe the resulting behavior of the cutting head as a *function of frequency*. Changing the input level results in an *amplitude* change for constant amplitude recording, and a *velocity* change for constant velocity recording. These changes are *independent* of the input signal frequency. For example, if an input level of 10 mV results in a 0.1-mil (1 mil = 1/1000th of an inch) amplitude change for constant amplitude recording, and a velocity of 5 cm/sec for constant velocity recording, then a change of the input level to 20 mV would result in an amplitude of 0.2 mil and a velocity of 10 cm/sec — independent of frequency.

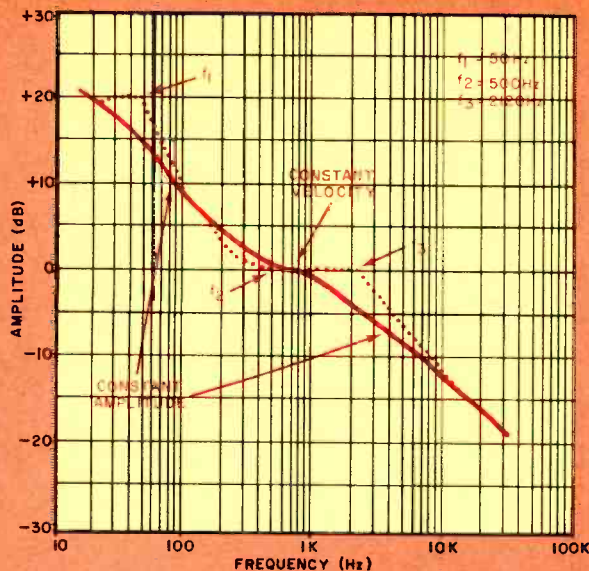

Fig. 4. RIAA playback equalization compensates for the recording characteristic that was shown in Fig. 1.

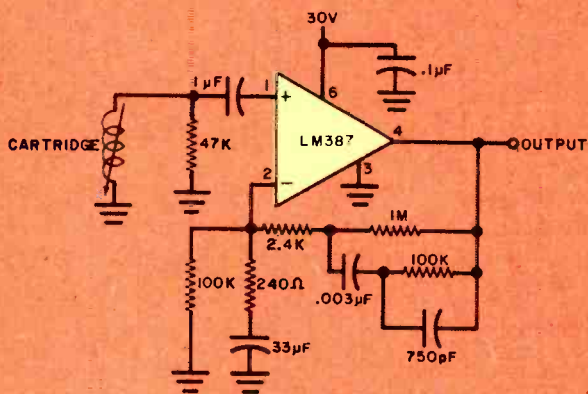

Fig. 5. Schematic of a one-channel phono preamplifier design that uses the LM387 integrated circuit.

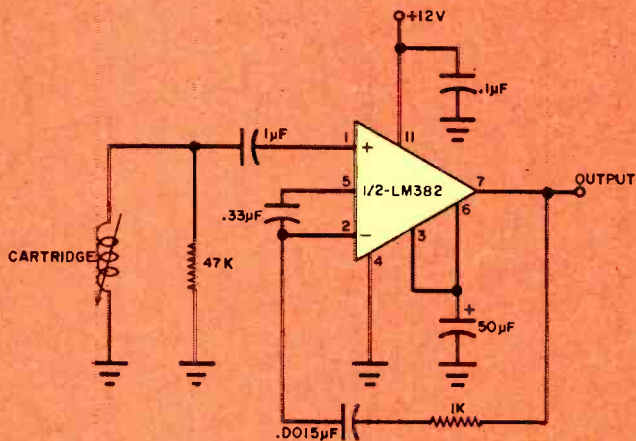

Fig. 6. This phono preamp uses the LM382 IC and has a minimum parts count.

Each of these recording methods suffers from dynamic range problems. Constant velocity recording (Fig. 3A) displays two readily observable characteristics. The amplitude varies inversely with frequency, and its slope is constant over the entire frequency range. This makes constant velocity recording ideal when magnetic pickups are used, as they are constant velocity devices. A magnetic cartridge consists of an active generator, such as a magnetic element moving in a coil (or vice versa). Its output is proportional to the speed of movement through the magnetic field, thus varying directly with groove velocity.

However, the variable-amplitude aspect of this system poses serious problems at both frequency extremes. Over the ten octaves between 20 and 20,000 Hz, the variation in groove amplitude is 1024 to 1. If 1000 Hz is taken as a reference point to establish the nominal degree of cutter amplitude modulation, then the amplitudes are so great at low frequencies that cutover will occur. At high frequencies, groove amplitude becomes so small that acceptable S/N ratios are unattainable. Indeed, displacement of the cutting stylus might not even take place.

Referring to Fig. 3B, two essentials of constant amplitude recording can be observed. In this case, groove amplitude is constant with frequency, which corrects the major disadvantage of constant velocity recording. But now groove velocity is directly proportional to frequency, and varies by a factor of 1024 to 1 over the frequencies of interest. Because magnetic pickups are constant-velocity and not constant-amplitude devices, their output levels will rise at the rate of 6 dB per octave, or double in amplitude when the frequency is doubled. To equalize such a system would require 60 dB of headroom in the preamplifier. That's not very practical!

The solution is to try and get the best of both systems by using a modified constant amplitude curve, where the midband region is allowed to operate in the constant-velocity mode. The resulting RIAA playback equalization curve is shown in Fig. 4, with the idealized version dotted and the actual realization drawn in a solid line. Three frequencies are noted as standard reference points, and are sometimes referred to as "time constants." This is a carryover from the practice of specifying corner or break frequencies by the time constants of the equivalent RC circuits that realized the response. The time constant T is measured in seconds and is the product of R in ohms and C in farads ($T = RC$). The relationship between T and corner frequency f (in hertz) is given by the equation $T = 1/(2\pi f)$, and results in time constants of 3180 μ s for f_1 , 318 μ s for f_2 , and 75 μ s for f_3 . Frequency f_2 is referred to as the *turnover* frequency because it marks the point at which the system changes from constant amplitude to constant velocity recording. Similarly, f_3 is the turnover frequency where the system reverts to constant amplitude recording.

Ceramic and Crystal Pickups. Before we consider the details of circuits providing the desired playback equalization for magnetic cartridges, a few words about ceramic and crystal transducers are in order. Unlike constant-velocity magnetic cartridges, ceramic and crystal pickups are constant-amplitude devices. Therefore they don't require equalization since their outputs are inherently flat. However, there will be some variation in output when these cartridges are used in an RIAA-equalized system. Referring to Fig. 4, we have noted that the region between f_2 and f_3 is the constant velocity portion of the curve. When a

Fig. 7. This complete preamp features phono, tuner, and tape inputs, mode switching, low noise levels, and a volume control.

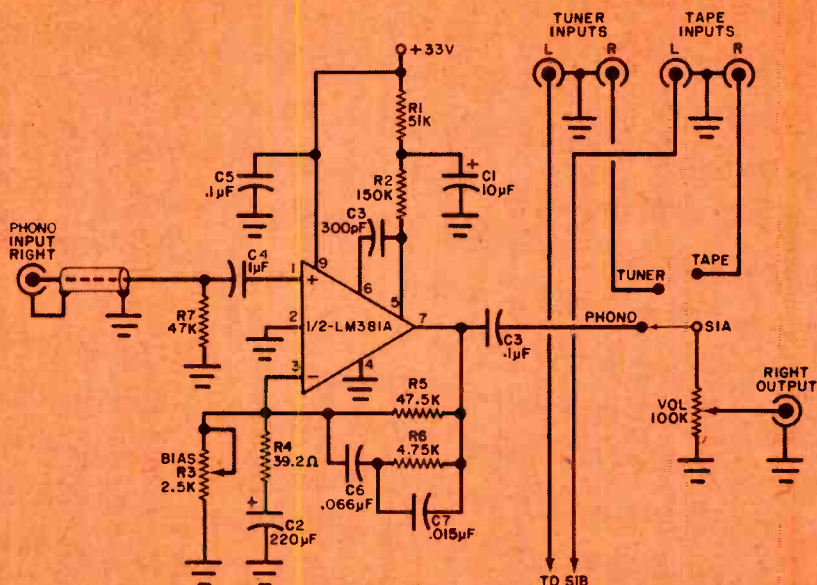

constant-amplitude transducer operates there, its output will drop 12 dB between 500 and 2120 Hz. But this is not as serious a problem as you might think. These piezoelectric transducers tend to have poor frequency response anyway, and are used only in low-fi and mid-fi systems. Interestingly, a preamp is not necessary here. Output levels are so high (100 mV to 2 V) that the cartridge can drive a power amplifier directly through passive volume and tone controls without preamplification.

Modern Designs. Unlike ceramic and crystal pickups, magnetic cartridges have very low output levels and therefore require preamplification. Typical output levels for several popular cartridges at a velocity of 5 cm/sec are as follows:

Manufacturer	Model	Output (mV) at 5 cm/sec
Empire Scientific	999	5
	888	8
Shure	V-15	3.5
	M91	5
Pickering	V-15 AT4	5

These outputs are directly proportional to velocity, so a cartridge producing 5 mV at 5 cm/sec will produce 1 mV at 1 cm/sec. It is specified as having a sensitivity of 1 mV/cm/sec. To transform cartridge sensitivity into useful preamp design information, we must know typical and maximum permissible velocities impressed on stereo records. The RIAA recording characteristic establishes a maximum recording velocity of 25 cm/sec in the 800-to-2500-Hz region. Typically, high-fidelity discs are recorded at a velocity of 3 to 5 cm/sec.

One low-noise IC circuit that will properly handle RIAA pre-emphasized program material is shown in Fig. 5. Corner frequencies f_1 , f_2 , and f_3 are set by combinations C7R4, C7R10, and C8R10, respectively. With the component values shown, it will drive a power amplifier with a 5-V rms input overload limit when it receives signal voltage from a cartridge with a 0.5-mV/cm/sec sensitivity. Since the maximum cartridge output level at 25 cm/sec is 12.5 mV, the required mid-band gain is 5V/12.5 mV or 400, and is determined by the values of R6 and R10. Resistor R2 is

inserted to stabilize the op amp, since the LM387 is not compensated for unity gain. An LM381 IC can be used in place of the LM387 by changing the appropriate pin designations.

We can make a very simple low-noise phono preamp by using the LM382 IC, which has an internal resistor matrix. The circuit is shown in Fig. 6, and has been optimized for use with a 12-to-14-volt dc supply. Its midband 0-dB reference gain is 46 dB (200) and can not easily be altered. For designs requiring gain or supply voltage changes, an LM381 or LM387 is a better choice.

An ultra-low-noise mini pre-amp based on the LM381A is shown in Fig. 7. Increased current density in the first stage of the LM381A is used to obtain optimum noise performance for magnetic cartridges. Included in this preamp are provisions for tuner and tape inputs, a mode selector switch, and ganged volume control. Tone controls are omitted but can be easily added if desired. The circuit's RIAA frequency response is within ± 0.6 dB of the standard. Its 0-dB reference gain is 41.6 dB (120), so a 1.5-V rms output signal will be generated when a nominal 12.5-mV rms input is applied. When a 33-volt supply is used, better than +25 dB of headroom (dynamic range) will be available for a typical 5-mV input signal at 1000 Hz. The input overload limit is 91 mV at midband frequencies. Signal-to-noise ratio is better than -85 dB, referenced to a 10-mV input level, and unweighted total output noise is less than 100 μ V with the input shorted. Metal-film resistors and close tolerance capacitors should be used to minimize noise and maintain adherence to the RIAA playback characteristic.

In Conclusion. RIAA equalization is a method of impressing as much information on a vinyl disc as is practicable, given the inherent limitations of the recording process and the materials used. (The actual processes involved in making a disc have not been gone into in detail here. For such a description see "Stereo Scene" POPULAR ELECTRONICS, September 1975.) Fortunately, modern IC technology has made possible the design of phono preamps which can be inexpensively reproduced by a manufacturer or experimenter, and which provide excellent performance in terms of frequency response, noise levels, and distortion. ♦

Recording For Stereo With 4-Channel Tape

Mike setups and mixing hints for making better stereo recordings.

BY DAVID L. LINKLETTER

RECORDING a live performance is a very satisfying accomplishment for an amateur tape enthusiast. It isn't as easy as it may seem, however, because setting down music in a pleasing stereo format requires the use of good recording techniques. These "tricks of the trade" have a decisive influence on the quality of the finished product. Here are some of the methods developed for live recording with a four-channel deck, followed by a mix-down to stereo to enhance sound quality.

Miking. Positioning the microphones is the first challenge. It's most important to set up microphones to avoid a "hole in the middle." (That happens when you play back in stereo and find program material left and right, but nothing in between.) Previously, recording engineers tried to overcome this by using a three-mike system. But now, with four-track machines, you can fill that hole without adding the directional blurring that results from using three microphones on two tracks. In practice, when you have four channels to work with, the best method is usually a combination of the three-microphone technique and the studio practice of miking some sound sources individually.

A typical setup for recording a band is shown in Fig. 1. Channels one and two are left and right, respectively. Drums are miked over the drummer's head and at the front of the bass drum. These two microphones are mixed onto channels one and two as "center" (individual miking of a sound source). The vocalist is recorded on channel three, and channel four is miked at a distance of 16 to 30 feet (4.9 to 9.1 m). These distances give a 15- to 30-millisecond delay, which is perhaps the ideal reverb time for maximum sonic clarity during reproduction. All microphones except the vocalist's have cardioid patterns, and all should be

high-quality transducers which can handle high sound levels with a minimum of distortion.

Figure 2 shows miking techniques employed for a choir recital. Mikes one and two are mounted high, covering the left and right portions of the choir. The piano is miked left and right, with both mikes at least one foot away from the strings. Their outputs are mixed onto channels one and two as center and right. Solo performers are recorded onto channel three, and channel four is again the distant mike.

A playback configuration with tracks one and two as left and right, respectively, track three as center, and track four as rear will result in a very good simulation of the original performance. Notice how the three-microphone technique is adhered to, with the added benefit that the vocalist(s) are separated from the instruments and clearly centered no matter where your listening position is located. The delayed sound from channel four gives a fullness not otherwise possible, and the slight delay allows details in the performance that are normally masked a chance to be heard. In recording studios, electronic or electro-mechanical delay lines are used to create the same effect.

A total of six microphones is usually the ideal number, providing left, right, center, and back signals, with two microphones remaining for individual miking of instruments. Headphones that provide good acoustic isolation are imperative for the initial mixing of multiple-track recordings during the performance. The use of a high-quality omnidirectional mike for the lead singer is recommended. This type of microphone picks up sound from surrounding instruments, filling in the "hole in the middle." Secondly, a good omnidirectional mike is generally more resistant to wind noise and breath pops than is a cardioid (unidirectional) microphone.

The vocalist's recording mike should be fastened about two inches (5.1 cm) back from the PA mike (masking tape can be used). This will lessen the variation in signal levels caused by moving the microphone. At various times, singers can be as close as zero inches to about 4 inches (10.2 cm). If the recording mike is set back, the variation will be 2 to 6 inches (5.1 to 15.3 cm), which makes compensation easier. The inverse square law is at work here, so increasing the close distance will smooth out the sound pressure levels at the mike.

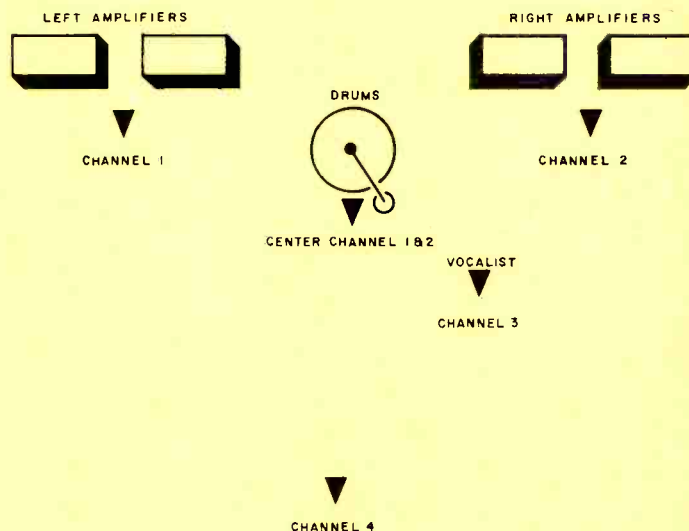

Fig. 1. Typical setup for recording a band.

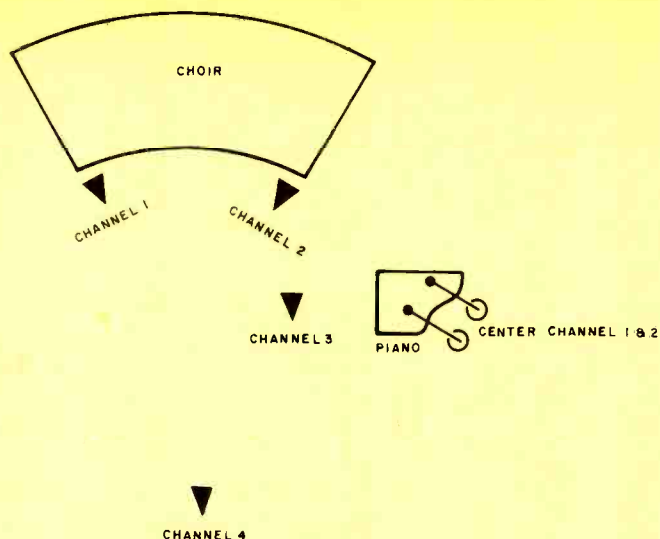

Fig. 2. Miking techniques used for recording a choir include piano at right.

Before You Hit "RECORD." Allow yourself an hour to set up before the performance begins. No matter how efficient you are, there are always ac power outlets to find, hum levels to reduce, etc. Be sure to get a level check from the band during its warmup. Record them at this time, and when all is quiet, listen to the playback. Is the balance between instruments correct? Are all the microphones getting onto the tape? The foregoing won't give you *perfect* settings because the acoustics will be somewhat different when the auditorium is filled with people. But you will get ball-park control adjustments that will require only minor changes later.

Level checks aren't always possible before choir recitals, but it's much easier to monitor the balance with headphones during the performance than is the case with a rock band. Be sure that the conductor knows you will be set up, and get approval for the location of your equipment *before* the night of the performance. (Classical musicians are sometimes "touchy" about electronics!)

Examine the recording area before the night or day of the performance if possible, and sketch a floor plan and layout of the instruments and vocalists you'll have to cover. From this information you can plan your miking setup. Clean and demagnetize the heads of your deck before you go to the performance. Bulk erase tape previously recorded, or use new tape for the recording session. This is especially important when using high-output/low-noise level tape—otherwise previous recordings on the tape might pop up in the background. Here are a few more items that are handy to have with you:

(1) A microphone snake—a consolidated set of mike extension cords to put some distance between you and the performers;

(2) Masking tape—tape all cords together to prevent interference with movement.

(3) A heavy-duty ac extension cord—Murphy's Law dictates that the nearest power outlet is at least 50 feet from where your equipment is positioned!

The Mix. When the tape is completed, odds are that friends of the performers will want copies for playback on their stereo decks. That's where the mix comes in—combining the four-track original and re-recording it into a two-channel format.

With proper care, the result can be clearer and more pleasing than a two-channel original. You can do some editing to reduce the dead time between songs, or rearrange the songs into a different sequence. The best equipment to use for the mix-down is a microphone mixer with line inputs. If you don't have one, you can make a passive mixer from six 33,000-ohm low-noise resistors, a utility box, and six line jacks (Fig. 3).

The problems that you'll face in mixing are compounded by the fact that final playback will be on someone else's equipment that might have limited frequency response, dynamic range, etc. It isn't uncommon for background instruments to simply disappear under the distortion products of the dominant instruments when a good recording is played on a low-fidelity stereo. Phil Spector and Don Kirshner have made their fortunes (in part) by producing records that sounded good when played over the finest system or the typical AM radio. Some of the basic techniques they helped develop are worth knowing, as follows.

First, volume range should be reduced. The difference between having four channels at medium-volume levels which swell to a peak is much greater than having two channels swell to a peak, and compensation for this difference must be made.

Second, mixing is best done by using two speaker systems. Choose one good pair for initial volume adjustments. The other pair should be a pair of inexpensive auto speakers. The need to keep volume levels fairly constant will become apparent when the second pair of speakers is used. Balancing the overall volume with that of the lead singer is very desirable. Reduce the band's level and boost the singer during vocals, then bring the band back up during bridges and instrumental passages. Not much change is necessary—even a 3-dB adjustment is often

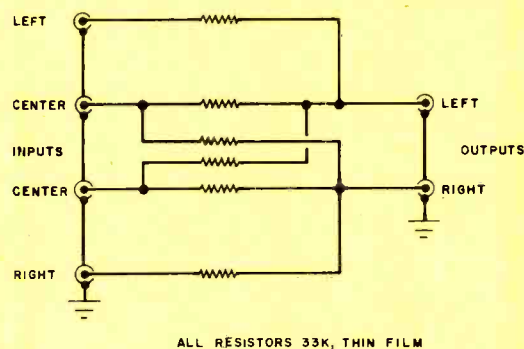

ALL RESISTORS 33K, THIN FILM

Fig. 3. Passive mixer uses six 33,000-ohm resistors, utility box and six line jacks.

adequate to keep sound within the optimum range. The fourth channel can be attenuated greatly during much of the mix and brought up only during instrumentals.

Third, use headphones that you know are balanced left to right to ensure that center information is really centered. Rely on your ears more than on the VU meters for this adjustment.

In Conclusion. Experience is really the best teacher of mixing methods. But it won't be long, if you follow these tips, before you will be able to provide mix-downs superior to two-channel originals. Of course, you will always be able to re-live the performance whenever you wish by using your four-track originals.

Tips On How to Choose Speaker Systems

What to look for where performance is concerned.

BY JOHATHAN R. SISK



YOUR CHOICE of speakers may affect the performance of your audio system more than any other component. Speaker systems should be chosen with the utmost care and forethought. However, this may be easier said than done. Most people have no real criteria for evaluating speakers and are usually persuaded to buy a particular product on the basis of enclosure type, number of drivers, size of the woofer, type of tweeter, etc. While these things do affect speaker system performance, they do not offer a concrete indication of performance. Manufacturing tolerances, design and engineering expertise, profit margin, and countless other things combine to determine the final performance and relative value of a given speaker system.

The objective in shopping for speaker systems is to find the products with the highest level of performance for a given price. The selection process may prove more confusing than enlightening on several counts. First, if you visit several dealers, you will quickly learn that there are an endless variety of claims and counter-claims. Second, unfamiliarity with specific performance criteria may limit your ability to evaluate what you hear in a dealer's showroom. Third, many dealers lack the knowledge and/or proper facilities to make valid comparisons between speaker systems. As a result, most people choose their speakers without the benefit of clinical testing or evaluation and usually settle for less than the best and may even buy an inferior product.

Buying speaker systems need not be a gamble — if you know beforehand what to look and listen for in the showroom. Just bear in mind that the function of any loudspeaker is to transform the electrical energy from an amplifier into sound waves and accurately recreate the recorded performance. Judging a speaker system's reproduction accuracy can be a very precise and scientific process if you thoroughly evaluate the following performance criteria one at a time.

Tonal Balance. Also sometimes known as octave-to-octave balance, tonal balance describes a speaker system's ability to reproduce tones from each of the 10 octaves of sound without emphasizing or diminishing the volume of any portion relative to another. A speaker system's tonal balance, more than any other factor, determines its characteristic sound.

Tonal balance is important for two reasons. First, it determines whether or not the relationship between the fundamental and harmonics (overtones) of a sound will be maintained during the reproduction. If this relationship is not maintained, the reproduced sound will differ in character from the recorded performance. Secondly, tonal balance determines to a large degree how long one can listen before experiencing listener fatigue.

To better understand the effects of a speaker system's tonal balance, one should examine the structure of a typical musical sound. Almost all sounds are a composite of a fundamental frequency and a series of harmonics at multiples of the fundamental. For example, the sound of a clarinet playing middle C is actually composed of a fundamental frequency of 262 Hz, second harmonic of 524 Hz, third harmonic of 786 Hz, fourth harmonic of 1048 Hz, and so on. These harmonics differ from the fundamental and from each other in relative amplitude.

The harmonic structure of an instrument's sound is what determines its distinctive quality or timbre. Obviously, if a speaker system has a large emphasis or de-emphasis in a portion of its range (poor tonal balance), this will change the value of all fundamentals and harmonics that fall within this range and thereby change the actual harmonic structure and the sound one hears.

Tonal balance is evaluated by carefully listening to a variety of recorded material to determine just how closely the timbre of the reproduction matches the original sound. This is accomplished in a side-by-side comparison, where each speaker system can be used as a reference point for

another, eliminating possible confusion.

Since a speaker system with excellent tonal balance will sound good with a wide variety of music, it is wise to include samples from all categories, even if your own personal tastes and interests may not be that broad. This is necessary to avoid the possibility of being misled because a particular speaker system's deficiencies in tonal balance happen to be sympathetic with a particular record. Some recordings this author has found most suitable for judging tonal balance are listed under Tonal Balance in the box.

The main criterion for judging tonal balance in a comparison test is simply to determine which system sounds most like the real thing.

For the results of an evaluation to be most meaningful, it is imperative that all comparisons be made with each speaker system playing at the same loudness. If one system is even slightly louder than another, some of the finer details of tonal balance will be obscured. Almost always, the louder system, regardless of its basic quality, will sound better at the instant of comparison. This is a serious problem because most speaker systems play at different levels of loudness for a given amount of amplifier power. To avoid this problem, many of the better dealers have special loudness-compensation switches in their demonstration facilities so that the individual level of each speaker system can be precisely matched for a valid comparison. Without such a device, the volume control of the amplifier must be adjusted with each change of speaker systems.

Frequency Range. The low and high frequency limits of a speaker system describe its frequency range. The range of human hearing is generally from about 16 to 18,000 Hz, or roughly 10 octaves of sound. A speaker system should reproduce as much of this range as possible. While most speaker systems of recent design are able to exceed the high frequency limitations of human hearing, very few even approach the 16-Hz lower limit. In fact, the vast majority of good systems do not reproduce sounds below 40 Hz without deterioration of the sound quality. Therefore, when considering how wide a range of frequencies a system will reproduce, your primary concern should be how far into the deep bass range, below 50 Hz, the system will reproduce without severe distortion. Deep bass response is important for accurate reproduction of the pipe organ, bass drum, piano, bass violin, contra bassoon, electric bass guitar, and other instruments whose fundamental tones may lie in the range below 50 Hz.

Many people are misled by speaker systems whose mid-bass range (50 to 100 Hz) has been exaggerated to conceal a deficiency in deep bass. The quantity of bass in systems like this is high, the system often sounds "boomy" and lacks the impact and depth of the original instrument it is trying to reproduce.

Before attempting to test or compare deep bass response, you should find one or more recordings with very evident low-frequency tones. A few recordings this author recommends are listed under Frequency Range in the box.

In the deep-bass test, as in all other tests, it is imperative that all comparisons be made under conditions of equal loudness and placement. Also, since many speaker systems do not reproduce very deep bass tones, the amplifier's volume control setting must be previously determined with music of predominantly middle- and high-frequency content. Using this criteria, you should readily

hear the differences in deep-bass response between speaker systems by switching from one to another when low tones are present and sustained in the music.

High-Frequency Dispersion. One of the unusual properties of sound reproduction is that, as a tone goes up in pitch (increases in frequency), the pattern of dispersion from the speaker tends to become narrower. At very high frequencies, the sound may be concentrated in a narrow path directly in front of the reproducing driver. This is undesirable because it produces inconsistencies in tonal balance throughout the listening room. Areas directly in front of the speaker system have an abundance of high frequencies, while other areas not within the dispersion pattern have a deficiency in high-frequency response.

With poor dispersion, one must listen from directly in front of the speaker system to hear properly balanced sound. This obviously limits speaker system placement. Conversely, the sound of a speaker system with good dispersion characteristics remains the same when you listen to it from almost any location in the room, and its sound should be less dependent on its physical position in the room.

Evaluating dispersion characteristics is accomplished by comparing the high-frequency balance one hears when standing directly in front (on-axis) of the speaker system to the balance one hears at various angles standing to the side (off-axis) of the system. The farther off-axis one can hear a good balance of high frequencies, the better the dispersion. With good dispersion, you should be able to hear no significant change in frequency balance when listening as much as 45° off-axis.

When performing a comparison, remember that the objective is to determine differences between on- and off-axis frequency response, not differences in tonal balance. Therefore, instead of the usual A-B test method, determine to what degree high-frequency dispersion is maintained for each speaker system on an individual basis and compare measurements. The speaker system that maintains its high-frequency output the farthest off-axis has the better dispersion.

It is recommended that all dispersion testing be done with the amplifier's controls set to mono and the balance control set so that only the right or the left channel is active. This will eliminate possible interference from the other speaker system, which could invalidate what you hear.

Dispersion-evaluation recordings should contain an abundance of high-frequency sounds (see listings under Dispersion in box). Also, many people evaluate dispersion by using the high-frequency interstation noise between FM stations.

Transient Response. A speaker system's ability to accurately reproduce sudden momentary increases in volume is termed transient response. The "explosive" sounds can be produced by most instruments, especially the percussion variety, when they are struck, strummed, or plucked. The human voice, too, produces transients when pronouncing the consonants b, p, and t.

Transients are musically important because they give impact and expression to a performance. Musicians use varying intensities of transients to create the moods they desire to convey to an audience. Cymbal crashes are just one example of this.

TEST RECORDS

The following is a list of recordings for testing various features of speaker systems. To test a given performance feature, select a recording from the category to which it refers.

Tonal Balance

Cat Stevens: *Numbers*, A&M CS5749
Joni Mitchell: *Court and Spark*, Asy. 1001
Holst: *The Planets*, London CS6734
Bach: *Three Cantatas*, Advent D1016
Frank Sinatra: *Ol' Blue Eyes Is Back*,

Reprise 2155

Quincy Jones: *Body Heat*, A&M 3617

Frequency Range

Saint-Saens: *Symphony No. 3 in C*, Columbia MS6469

Pink Floyd: *Dark Side of the Moon*, Harvest SMA11163

Richard Strauss: *Also Sprach Zarathustra*, London CS6609

Bob James: *Volume I*, CTI 6043

Dispersion

Rick Wakeman: *Journey to the Center*

of the Earth, A&M 3621

Transients

Peter Frampton: *Frampton*, A&M 4512

Thelma Houston and The Pressure Cooker: *I've Got the Music In Me*, Sheffield Lab 2

Igor Kipnis: *The English Harpsichord*, Angel SB3816

Spatial Characteristics

The Carpenters: *Horizon*, A&M 4530

Bernard Hermann: *The Mysterious Film World of Bernard Hermann*, London SPC21137

To evaluate or compare transient response, you should select recordings that feature well-recorded piano, drum, bell, acoustic guitar, banjo, cymbal, etc., sounds. Listen for the impact (attack) and sharpness of the transients. Generally, a speaker system with good transient response will make the music sound detailed and "live." (For recordings with obvious transient characteristics, see listings under Transients in box.)

Spatial Characteristics. It is difficult to define spatial characteristics and imagery because there are no clear-cut, analytical methods of measuring them. Rather, they must be evaluated by the subjective impressions of the listener.

Generally, the terms spatial characteristics and imagery refer to a speaker system's ability to recreate the ambient, or reverberant, qualities of the recorded music and to achieve the acoustic position and perspective of the various instruments and voices. For example, a speaker system with exceptional imagery can reproduce a recording of a small ensemble and provide a definite position for each performer. Yet, it can also reproduce the sound of a symphony orchestra and give the vast open feeling of a concert hall. Good spatial characteristics and imagery add the elusive quality of "realism" to a good speaker system by producing a three-dimensional perception of depth.

To evaluate spatial characteristics and imagery, it is recommended that you first listen to a recording of a single vocalist with a small backup ensemble to test for the ability of the speaker system to assign definite placement to the voice and individual instruments. An excellent recording for this purpose is the first entry under Spatial Characteristics in the box. Then listen to an orchestral recording (see second entry) to test for the recreation of the ambient atmosphere of the concert hall. It helps significantly if you close your eyes during the test and try to visualize the placement of the different sounds from the speaker.

Efficiency. Speaker system efficiency is the ratio of the amplifier input in electrical watts to the speaker system's output in dB of sound-pressure level. Phrased differently, it is how many watts are needed to achieve a certain level of loudness from a given speaker system. Systems of very high efficiency require less amplifier power to produce the same level of loudness obtained from a low-efficiency system.

Power Matching. One of the most important aspects of choosing speaker systems is to match the proper amount

of amplifier power to the speakers, according to the conditions under which they will be used. There are four basic factors to consider when power matching: the efficiency of the speaker systems, the cubic volume of the listening room, the type of furnishings in the room, and the level of loudness at which you normally listen to your music.

For every combination of speaker systems, listening room, and listener, there is a minimum level of amplifier power that will deliver the desired loudness level with good sound quality. Using less than this minimum power can cause the amplifier to be overdriven during the louder portions of the music, which causes distortion. This type of distortion is called "clipping" because the amplifier is unable to produce the full strength of the musical signal and literally clips off the top and bottom of the waveform during amplification.

Many manufacturers recommend a minimum amount of amplifier power for their speaker systems. This figure is usually valid for the listener who does not require excessive volume and where the listening room is less than 1500 cubic feet (42.5 cu m) in volume. As the size of the room increases, the power of the amplifier must be increased by the same factor; double the volume, double the power to maintain the same level of loudness.

Soft, absorbent room surfaces, such as drapes, carpets, stuffed furniture, and open doors or entry ways, increase the need for power. If you desire extreme loudness, significantly more power will be required (a barely audible increase in loudness requires double the power). It is obvious, then, that if you like to listen at high volume levels in a large "soft" room, the manufacturer's minimum power recommendation will be inadequate.

The speaker system's minimum power requirement must not be confused with the "power-handling" specification. Many people have bought the wrong amplifier for their needs by matching the speaker system's power-handling specification to the amplifier's output power specification. If a manufacturer describes his product as a "30-watt speaker system," this means that 30 watts is the maximum amount of *continuous* power the system can safely handle. If the manufacturer does not specify the minimum power for the speaker system, seek the help of a knowledgeable and trustworthy dealer.

To properly match power, begin with the manufacturer's recommendation and then make allowances for room size and furnishings and for listening level. If possible, you should audition the exact combination of hi-fi components you are considering using in your listening room before making a final decision. ♦

ATTENTION, DEALERS...

WE'RE SITTING ON THE LARGEST SELECTION OF

- ★ CB RADIOS
- ★ CB ANTENNAS
- ★ CB ACCESSORIES IN THE COUNTRY!



238 PAGES! THAT'S ONE OF THE BIGGEST CATALOGS IN AMERICA!

LITERALLY!

SEND \$5.00 FOR YOUR COPY OF OUR NEW

238 PAGE CATALOG

DEDUCTIBLE FROM YOUR FIRST ORDER!

...AND BENNIE'S ONE OF THE BIGGEST DISTRIBUTORS!



Bennies Warehouse Distribution Center

LEARNING ELECTRONIC THEORY WITH HAND CALCULATORS

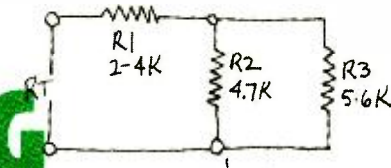

$$R_T = R_1 + \frac{1}{\frac{1}{R_1} + \frac{1}{R_2}}$$

$$= R_1 + \frac{R_1 R_2}{R_1 + R_2}$$

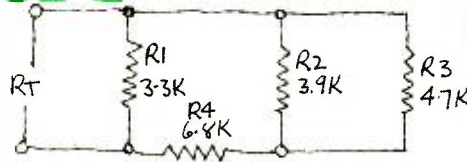

$$R_T = \frac{1}{\frac{1}{R_1} + \left(\frac{R_2 R_3}{R_2 + R_3} + R_4\right)}$$

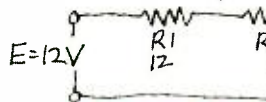

$$R = E/I$$

$$R = 12/2$$

$$R = 6$$

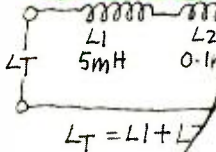

$$L_T = L_1 + L_2$$



BY EDWARD M. NOLL

PART THREE: RC Coupling, Basic Amplifier Calculations, and RLC Relationships

WITH THIS installment, we close our three-part series on using the hand-held scientific calculator in electronics. We will be focusing on RC coupling, basic amplifier calculations, and RLC relationships.

RC Coupling. When resistor-capacitor (RC) coupling is used between the stages of an amplifier, the output voltage appears across the resistor, as shown in Fig. 1. The reactance of the capacitor (X_c), a function of frequency, determines what percentage of the input voltage to the RC network appears across the output.

When the reactance of the capacitor is low in comparison to the resistance, most of the output voltage appears across the resistor. You can prove this with a few simple calculations. For example, what is the input impedance for the RC network shown in Fig. 1 when X_c is 1 ohm and R is 100 ohms.

Using the equation $Z = \sqrt{X_c^2 + R^2}$:

$$1^2 + 100^2 = \sqrt{x}$$

Display: 100.0049998

Calculate the current when V_{in} is 100 volts, using the Ohm's Law equation $I = V_{in}/Z$:

$$100 \div 100.0049998 =$$

Display: 9.999500044 -01

At this current, what is the output voltage across the resistor? Again, from Ohm's Law, we have $V_R = IR$:

$$.9999500044 \times 100 =$$

Display: 99.99500044

Note that the output voltage is almost 100% of the input voltage.

Use the equation $P = I^2 R$ to calculate the output power:

$$.999950004^2 \times 100 =$$

Display: 99.99000105

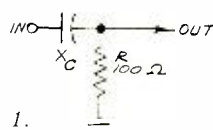

Fig. 1.

Now, repeat the same calculations when $X_c = R = 100$ ohms. You should obtain the following results:

$$Z = 141.4213562 \text{ (ohms)}$$

$$I = 7.071067813 \times 10^{-1} \text{ (amperes)}$$

$$V_{out} = 70.71067813 \text{ (volts)}$$

$$P = 50.00000002 \text{ (watts)}$$

By how much have the voltage and power declined when X_c is 100 ohms as opposed to when it was 1 ohm? For the voltage equation, use $\text{dB} = 20 \log (V_2/V_1)$:

$$20 \times (70.71067813 \div 99.99500044)$$

$$\text{) log = Display: } -3.009865686$$

For the power equation, use $\text{dB} = 10 \log (P_2/P_1)$:

$$10 \times (50.00000002 \div 99.99500044)$$

$$\text{) log = Display: } -3.01008282$$

Note that in both cases, the level is down 3 dB. What this calculation proves is that at the frequency at which $X_c = R$, the voltage across R drops 70.7%, while the power dissipated by R drops 50%. This point is

commonly referred to as the cutoff frequency, half-power point, or the 3-dB down point.

As an exercise in using the calculator, determine the parameters for the frequency at which $R = 10X_c$. The results you obtain should be as follows:

$$Z = 100.4987562 \text{ (ohms)}$$

$$I = 9.950371903 \text{ -01 (ampere)}$$

$$V_{\text{out}} = 99.50371903 \text{ (volts)}$$

How much lower is the output voltage than the input voltage? By simple subtraction, we obtain

$$100 - 99.50371903 =$$

$$\text{Display: } 0.496281 \text{ (volt)}$$

Our calculations indicate that the output voltage drops a very small amount at the frequency at which $X_c = 0.1R$. From this, we can develop an equation for C that will let us calculate the required value of capacitance: $R = 10/(2\pi fC)$, which gives us $C = 10/(2\pi fR)$. The latter equation is often used to determine the value of the interstage coupling capacitor that results in a minimum voltage loss in transferring a signal from the input to the output of the RC network. Recall that a corresponding equation can also be developed for that frequency at which the response is permitted to drop to the 70.7% level (3-dB down point): $R = X_c$, in which case, $R = 1/(2\pi fC)$ and $C = 1/(2\pi fR)$.

Several examples demonstrate the usefulness of the equations:

What is the value of C required in an RC network to set the -3-dB point at 40 Hz when R is 240,000 ohms?

$$2 \times \pi \times 40 \times 24 \text{ EE } 4 = 1/x$$

$$\text{Display: } 1.65786399 \text{ -08}$$

Hence, the value required is roughly 0.016 μF ; a 0.02- μF capacitor can be used. There would be a 7.07-volt output if the input were 10 volts at 40 Hz. Increasing the frequency to 400 Hz would result in the reactance becoming $0.1X_c$ to make the output potential 9.95 volts, or a reduction of only 0.05 volt ($10 - 9.95 = 0.05$).

In the above circuit, what value of C would be required so that an input of 10 volts at 100 Hz would produce 9.95 volts at the output? In this case, you must make certain that X_c is no greater than $0.1R$. Using the equation $C = 10/(2\pi fR)$:

$$10 \div (2 \times \pi \times 100 \times 24 \text{ EE } 4) =$$

$$\text{Display: } 6.63145596 \text{ -08}$$

Needless to say, a capacitor with a larger value would be required; this time, 0.068 μF would be appropriate.

In an RC circuit where C is 0.05 μF , what minimum R value would be re-

quired to have a -3-dB point at 120 Hz? From the formula $R = 1/(2\pi fC)$:

$$2 \times \pi \times 120 \times .05 \text{ EE } +/ - 6$$

$$= 1/x \text{ Display: } 26525.82384$$

Which means that R should be roughly 26,500 ohms. Now, what would R's value have to be at 120 Hz if it was

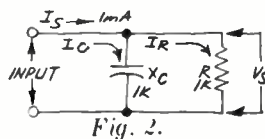

required that the output voltage be down by only a very small amount? In this case, X_c would have to be no more than $0.1R$. Hence, a ten-fold increase in the value of R, to 265,000 ohms, is indicated.

In the parallel RC network shown in Fig. 2, it is a current variation that develops a signal voltage across the network. Let us assume first that there is no capacitor. This means that a 2-mA input current will produce a 2-volt potential across R:

$$.002 \times 1000 = \text{Display: } 2$$

Assume now that both R and C are in the circuit and that X_c is 1000 ohms. What is the impedance of the network? Use the formula $Z = RX_c / \sqrt{R^2 + X_c^2}$:

$$1000 \times 1000 \div (1000^2 +$$

$$1000^2) \sqrt{x} =$$

$$\text{Display: } 707.1067813$$

The voltage across the network is calculated from the formula $V = IZ$:

$$.002 \times 707.1067813 =$$

$$\text{Display: } 1.414213563$$

To what level has the voltage declined, compared to the level obtained with no capacitor in the circuit? This voltage ratio is obtained simply by dividing V by 2:

$$1.414213563 \div 2 =$$

$$\text{Display: } 7.071067815 \text{ -01}$$

What happens to the voltage when X_c drops to 100 ohms? First, solve for Z:

$$1000 \times 100 \div (1000^2 + 100$$

$$^2) \sqrt{x} =$$

$$\text{Display: } 99.50371903$$

Note the decided drop in the impedance of the network. With this in mind, what is the output voltage?

$$.002 \times 99.50371903 =$$

$$\text{Display: } 1.990074381 \text{ -01}$$

In this case, where $X_c = 0.1R$, the output voltage has dropped to approximately 0.2 volt, or one-tenth of the potential that existed when there was no capacitor present. This demonstrates the filtering action of a parallel RC network. The approximate decline here is 90%.

What value of C is required to maintain the above level of filtering down to 100 Hz? [Use the equation $C = (1/2\pi fX_c)$]:

$$2 \times \pi \times 100 \times 100 = 1/1$$

$$\text{Display: } 1.59154943 \text{ -05}$$

A 20- μF capacitor would do a good job here.

Amplifier Calculations. Amplifiers require a number of series and parallel RC networks for decoupling, interstage coupling, and filtering. The FET amplifier stage shown in Fig. 3 employs a series RC coupling network in the gate and a parallel RC bias/filtering network in the source circuits.

The input coupling network has component values designed to complement the input impedance characteristics of the FET and low frequency response of the stage. The input impedance to the FET is high and, therefore, input resistance to the stage is determined by the value of gate resistor R_g . Source resistor R_s determines the gate-source bias, while source

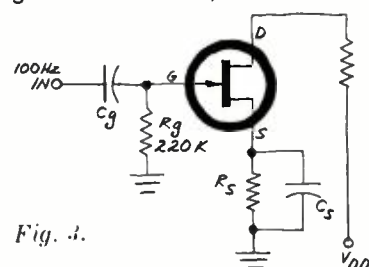

capacitor C_s prevents feedback that could cause a loss of gain in the stage.

What value of R_s is required if the operating point corresponds to a drain-source current of 15 mA and gate bias of -7.5 volts? From the formula $R_s = V_g/I_D$:

$$7.5 \div 0.15 = \text{Display: } 500$$

If the frequency response of the input network must have a cutoff of 100 Hz, what is the required value for C_g ? The -3-dB point is that frequency at which X_c is equal to R:

$$2 \times \pi \times 100 \times 22 \text{ EE } 4 = 1/x$$

$$\text{Display: } 7.234315592 \text{ -09}$$

Hence, the required value for C_g is approximately 0.007 μF . Since the actual value is not critical, a 0.01- μF capacitor will suffice here.

If the source filter is to operate efficiently at 100 Hz, the reactance of C_s must be $0.1R_s$. Therefore, the reactance must be 50 ohms ($500/10$). The value of C_s is obtained from the equation $C_s = 1/(2\pi fR)$:

$$2 \times \pi \times 100 \times 50 = 1/x$$

$$\text{Display: } 3.183098861 \text{ -05}$$

A 31.8- μF capacitor is required here.

RLC Networks. Electronic systems often contain circuits that use combinations of resistors, capacitors, and inductors in various resonant and nonresonant configurations. The simple series network shown in Fig. 4 is an example.

The voltages across the three elements in Fig. 4 are not in-phase, because the capacitive voltage lags the current by 90°, while the inductive

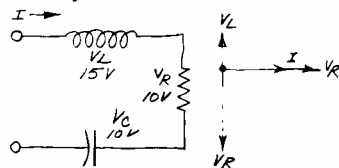

Fig. 4.

voltage leads the current by 90°, as illustrated in the vector diagram. Phase relationships depend on frequency and the relative magnitudes of R, L, and C. The equation for source voltage is $V_s = \sqrt{V_R^2 + (V_L - V_C)^2}$. For the component values given in Fig. 4, V_s becomes:

$$10 x^2 + (15 - 10) x^2 = \sqrt{x}$$

Display: 11.18033988

As in the case of the simple series RC network, the vector diagrams can be drawn in terms of reactance and resistance, as shown in Fig. 5. Capacitive reactance X_C lags resistance R by 90°, while inductive reactance X_L leads R by 90°. The equation for impedance is $Z = \sqrt{R^2 + (X_L - X_C)^2}$. The phase angle of the network is the angle between R and Z and in equation form is $\theta = \arccos R/Z$.

Notice the influence of subtracting X_C from X_L in the vector diagram. This results in a certain equivalent reactance, or X_{EQ} . Inasmuch as this reactance leads the resistance, it is in effect an equivalent inductive reactance. If X_C were greater than X_L , the network would have an equivalent capacitive reactance.

Calculate the impedance for the relevant values given in Fig. 5.

$$50 x^2 + (100 - 50) x^2 = \sqrt{x}$$

Display: 70.71067811

This means that Z is approximately 70.7 ohms. Now, what is the phase angle?

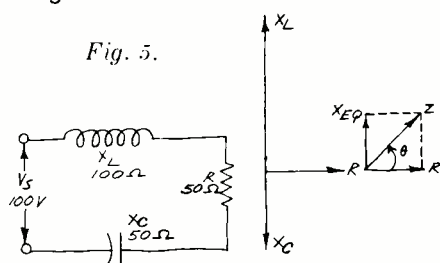

Fig. 5.

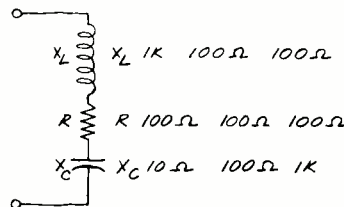

Fig. 6.

$$50 \div 70.71067811 = \cos^{-1}$$

Display: 45

Hence, the impedance angle is 45°, and Z is leading R by this amount.

Determine the source current, using the equation $I_s = V_s/Z$:

$$10 \div 70.71067811 =$$

Display: 1.414213562 -01

Once you know I_s , you can calculate V_R :

$$.141421356 \times 50$$

Display: 7.07106781

Now, how much power is dissipated by the resistor? Using the equation $P = I_s^2 R$:

$$.141421356 x^2 \times 50 =$$

Display: 9.999999965 -01

This is the true power dissipated by the network, since no power is dissipated by the ideal reactance.

Next, determine the impedance and current for each of the three sets of component values given in Fig. 6. Note that the three sets of values illustrate the three possible conditions that can exist for the network — X_L greater than X_C , X_C greater than X_L , and X_L equal to X_C . Solving for the impedances:

$$100 x^2 + (1000 - 10) x^2 = \sqrt{x}$$

Display: 995.0376877

$$100 x^2 + (100 - 100) x^2 = \sqrt{x}$$

Display: 100

$$100 x^2 + (1000 - 10) x^2 = \sqrt{x}$$

Display: 995.0376877

And solving for the currents:

$$100 \div 995.0376877 =$$

Display: 1.004987058 -01

$$100 \div 100$$

Display: 1

$$100 \div 995.0376877 =$$

Display: 1.004987058 -01

It should be noted that Z is high and I low when the reactive component is substantial. When $X_L = X_C$, impedance is low and current is high. This is the condition for a series-resonant setup, with a minimum Z and maximum I at resonance.

The resonance condition of equal reactances can be arranged to obtain the standard formula for resonance as follows: $2\pi fL = 1/(2\pi fC)$ and transposing, $f = 1/(2\pi\sqrt{LC})$. With this in mind, calculate the L and C values required to resonate the Fig. 6 circuit at 2 MHz when X_L and X_C are 100 ohms each. Since X_L , X_C , and f are known, L and C

can be calculated from the formulas $L = X_L/(2\pi f)$ and $C = 1/(2\pi fX_C)$:

$$100 \div (2 \times \pi \times 2 \text{ EE } 6) =$$

Display: 7.957747151 -06

and $2 \times \pi \times 2 \text{ EE } 6 \times 100 = 1/x$

Display: 7.957747151 -10

The L and C values required are approximately 8 μH and 800 pF, respectively.

You can prove the validity of your calculations by plugging the answers obtained into the equation for the resonant frequency.

$$2 \times \pi \times (7.957747151 \text{ EE } +/- 10) \sqrt{x} = 1/x$$

Display: 2000000 or 2 MHz

The example shown in Fig. 7 will give a better understanding of the operating conditions of the series-resonant circuit and how to use your scientific calculator to speed mathematical procedures. First, determine the circuit's resonant frequency:

$$2 \times \pi \times (6 \text{ EE } +/- 6 \times 200$$

EE +/- 12) $\sqrt{x} = 1/x$

Display: 4594407.462

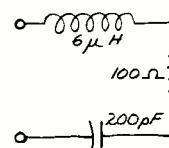

Fig. 7.

Now you can calculate X_C and X_L :

$$2 \times \pi \times 4594407.462 \times 200 \text{ EE } +/- 12 = 1/x$$

Display: 173.2050807

$$\text{and } 2 \times \pi \times 4594407.462 \times 6 \text{ EE } +/- 6 =$$

Display: 173.2050808

The reactances are almost identical at 173 ohms. Since at resonance $X_C = X_L$, the two reactances cancel out and effectively leave only the R value in the circuit. The current at resonance is determined by the formula $I = V_s/R$:

$$10 \div 100 =$$

Display: 0.1 (ampere)

In the parallel RLC network shown in Fig. 8, the current divides and the source voltage is the same across each element and is of the same phase

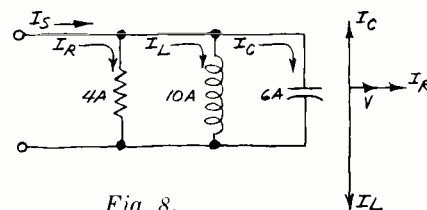

Fig. 8.

as the resistor current. As shown in the vectors, I_C leads I_R and V_s by 90°, while I_L and I_C are 180° out of phase with each other. The equation for I_s becomes $I_s = \sqrt{I_R^2 + (I_L - I_C)^2}$. Determine I_s for the Fig. 8 network:

$$4x^2 + (10 - 6)x^2 = \sqrt{x}$$

Display: 5.656854249

Because current is the quotient of voltage and the individual resistance, reactance, and impedance, the vector diagram can be redrawn as shown in Fig. 9A. Furthermore, the voltage is the same across each leg of the parallel arrangement, and the vector dia-

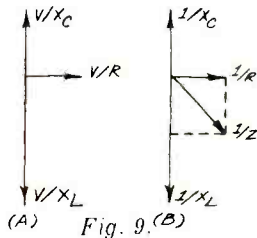

gram can be simplified as in Fig. 9B. Hence, the impedance formula is $Z = 1/\sqrt{(1/R)^2 + (1/X_c - 1/X_L)^2}$. Now you can calculate Z for the Fig. 10 circuit:

$$100 \frac{1}{x} x^2 + (20 \frac{1}{x} - 20$$

$$\frac{1}{x}) x^2 = \sqrt{x} \frac{1}{x}$$

Display: 19.61161351

Calculate I_s when V_s is 100 volts:

$$100 \div 19.61161351 =$$

Display: 5.099019514

Now, calculate Z if X_c were to be increased to 20 ohms. Since in this event X_c would be equal to X_L , the reactances cancel, leaving only R in the

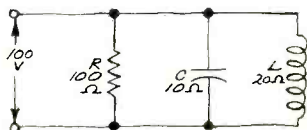

Fig. 10.

circuit. You can double check this on your calculator:

$$100 \frac{1}{x} x^2 + (20 \frac{1}{x} - 20$$

$$\frac{1}{x}) x^2 = \sqrt{x} \frac{1}{x}$$

Display: 100

The calculation proves that only the resistive element is effectively in the circuit when X_c and X_L are equal.

Summing Up. In this series of articles, we have shown how the hand-held scientific calculator lets you pursue electronics without the drudgery of inconvenient mathematical procedures. The calculator permits the solution of even lengthy problems in only a fraction of the time required by hand and with a great deal more accuracy.

As you become more familiar with the operation and capabilities of your calculator, you will in all likelihood want to dig much deeper into electronics theory. ♦

SEPTEMBER 1976

This is the Legendary

FUZZBUSTER®

POLICE RADAR MONITOR



PEACE for the Professional Driver

(Ask any long-haul trucker . . . he'll tell you about it.)

A military type radar receiver that works two to ten times farther than radar. Parametric design provides unparalleled sensitivity, but rejects false signals. No installation or antenna. Adopts to positive or negative ground vehicles.

A unique AUDIO CUEING system announces radar lock-on with a short beep. The visual indicator is then used to estimate where and what type of speed trap is being encountered. The receiver is especially effective against the new moving radar.

Proven by thousands of truckers over billions of miles, nationwide, and now available to the general public!

IF IT DOESN'T SAY:



IT'S BOGUS!

DEDUCT 10% if you have paid a SPEED RADAR TICKET in the preceding 12 MONTHS. Send ticket or cancelled check with order (\$89.95). Copies O.K.; original returned.

Please rush me a Fuzzbuster.
My check for \$99.95 is enclosed.
Wenover Associates
P.O. Box 231
Burlington, Mass. 01803

Name _____

Street _____

City _____

State _____ Zip _____

CIRCLE NO. 71 ON FREE INFORMATION CARD

LED BARGRAPH READOUTS

Measure voltage, resistance, and frequency

BY FORREST M. MIMS

IN THE ongoing revolution of digital electronics, the old-fashioned meter movement has almost been replaced by rows of plastic encapsulated LED digital display modules. Despite the accuracy and convenience of digital displays, however, the analog meter movement offers several important advantages over the more modern digital display.

Have you ever tried to observe trends on a digital voltmeter or frequency meter? Good luck, because

the trend of a slowly changing voltage or frequency is tough to follow on a digital readout. For example, a meter needle will instantly indicate a fluctuating voltage by simply bouncing back and forth while a digital readout presents a series of seemingly unrelated readings.

The LED bargraph described here bridges the gap between the conventional meter and the digital display. Bargraph readouts consist of a linear row of LED's which light up in re-

istance, and frequency sensitive readouts.

Resistor Voltage-Sensitive Bargraph. You can make a simple but reliable LED bargraph readout from a string of resistors connected across a string of LED's as shown in Fig. 1. The resistors form a voltage divider. A single LED requires a certain forward voltage to produce light, and each LED in the circuit glows when the voltage across its resistor reaches this value. Since the voltage across the larger resistors increases faster than the voltage across the smaller resistors, when a gradually increased voltage is connected to the circuit, the LED's begin glowing sequentially until all are turned on.

With the values shown in Fig. 1, LED1 will begin glowing with about

8.1 volts applied to the circuit. The remaining LED's will begin glowing at increments of about 1 volt until all 10 are illuminated. Different voltage indications can be obtained by changing the resistor values or by using green or yellow LED's.

The circuit draws about 20 milliamperes when all 10 LED's are on, and

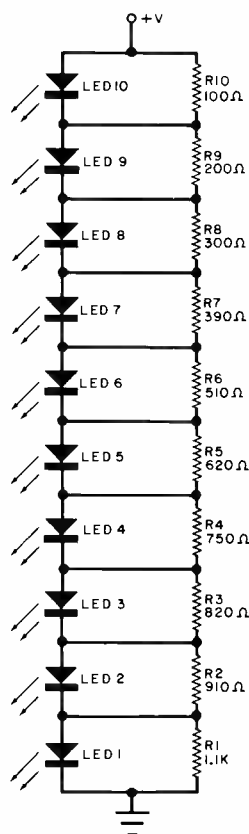

Fig. 1. Resistor voltage-sensitive bargraph.

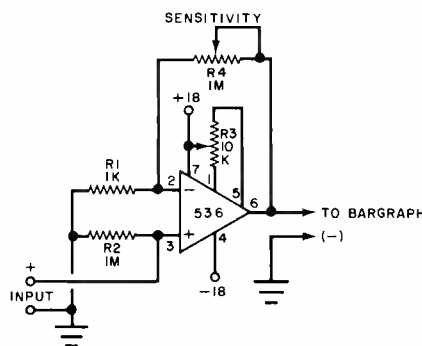

Fig. 2. Bargraph readout with op amp input.

sponse to voltage, resistance, or frequency. Like meters, they present an analog readout and can therefore show trends. And like digital displays, they are solid state and have no moving parts. This means they are "inertialless" and have responses thousands or more times faster than conventional meters. It also means an LED bargraph readout has no undershoot or overshoot and, best of all, cannot be "slammed."

If LED bargraph readouts sound interesting, read on, as we show you how to build several different voltage,

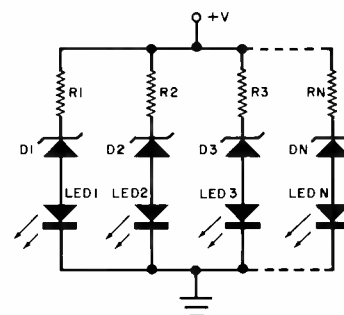

Fig. 3. Zener diode voltage-sensitive bargraph.

How 2½ Million Smart Buyers Get Superior Quality CB and Hi-Fi Equipment at Lower Prices.



With The
FREE
Lafayette
Catalog

You'll also find extraordinary values on other stereo components, radios, ham gear, scanners, cameras, watches, test equipment, calculators, hobby kits, electronic parts and accessories and much, much more. The new 1977 catalog has 164 pages filled with thousands of the newest products and better electronic values for your home, car and office. Behind every product is 56 years of experience, reliability and our money back guarantee. Enjoy shop-at-home convenience and a variety of easy payment plans. Smart buyers know that shopping around is the best way to get the best deal. Shop around in our new catalog and you'll see why so many people think so much of it. Before you buy anywhere else, check the Lafayette catalog. You'll get more for your money.

- Citizens Band
- Cameras
- Calculators
- Hobby Kits
- Watches And Clocks
- Test Equipment
- Electronic Parts And Accessories
- Musical Instruments
- Security Systems
- Power Tools
- Stereo Components
- Radios
- Ham Gear
- Scanners
- TV Accessories
- Books
- Auto Accessories
- Home And Office Communication Systems

And Much, Much More . . .

Send for your free copy today.

Lafayette
Radio Electronics & Shopping Centers

Lafayette Radio Electronics Corp.
Dept. 19
111 Jericho Turnpike, Syosset, New York 11791

Send my FREE catalog to:

Name _____

Street _____

City _____

State _____ Zip _____

CIRCLE NO. 40 ON FREE INFORMATION CARD

The better the training the better you'll

Send for
FREE
illustrated
career
guide

NTS guide
to careers in
Electronics

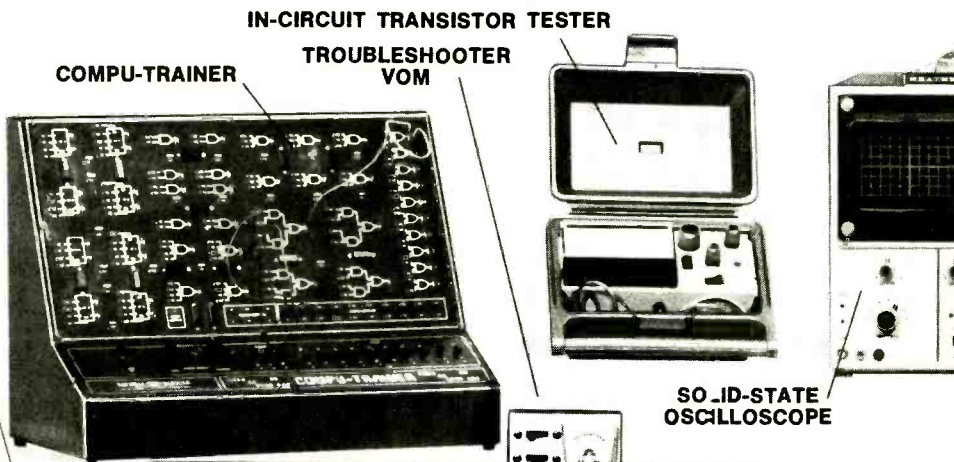
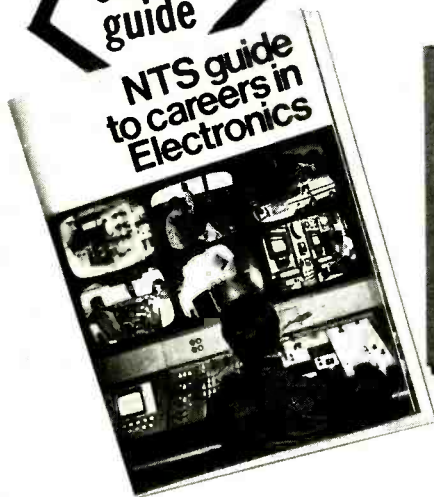

COMPU-TRAINER

IN-CIRCUIT TRANSISTOR TESTER

TROUBLESHOOTER
VOM

SOLID-STATE
OSCILLOSCOPE

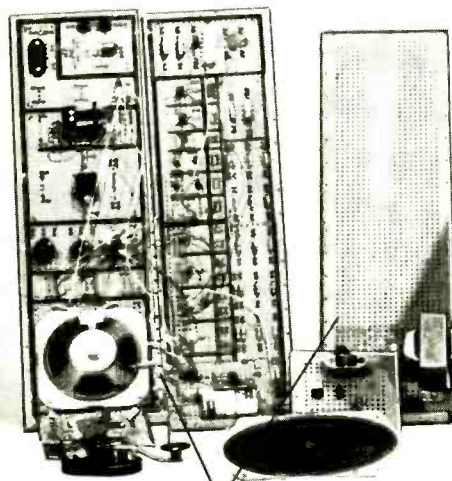

ELECTRO-LAB

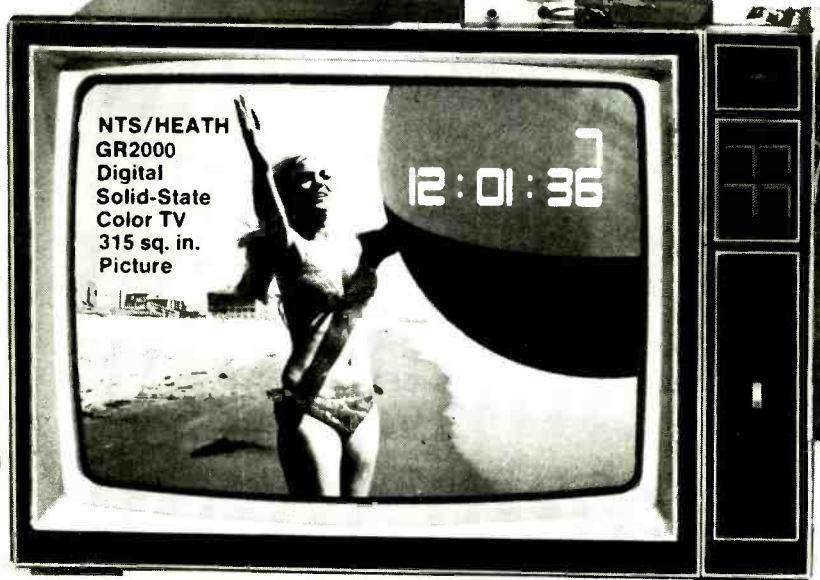

(Simulated TV Reception)

As an NTS student you'll acquire the know-how that comes with first-hand training on NTS professional equipment. **Equipment you'll build and keep.** Our courses include equipment like the **NTS/Heath Digital GR-2000 Solid State color TV** with first-ever features like silent varactor diode tuning; digital channel selection, (with optional digital clock), and big 315 sq. in. ultra-rectangular screen.

Also pictured above are other units — 5" solid state oscilloscope, vector monitor scope, solid-state stereo AM-FM receiver with twin speakers, digital multi-meter, and more. It's the kind of better equipment that gets you better equipped for the electronics industry.

This electronic gear is not only designed for training; it's field-type — like you'll meet on the job, or when you're making service calls. And with NTS easy-to-read, profusely illustrated lessons you learn the theory behind these tools of the trade.

Choose from 12 NTS courses covering a wide range of fields in electronics, each complete with equipment, lessons, and manuals to make your training more practical and interesting.

Compare our training; compare our lower tuition. We employ no salesmen, pay no commissions. You receive all home-study information by mail only. All Kits, lessons, and experiments are described in full color. Most liberal refund policy and cancella-

and the equipment be equipped.

**COMPARE OUR
KITS AND LESSONS.
COMPARE OUR
TUITION.**

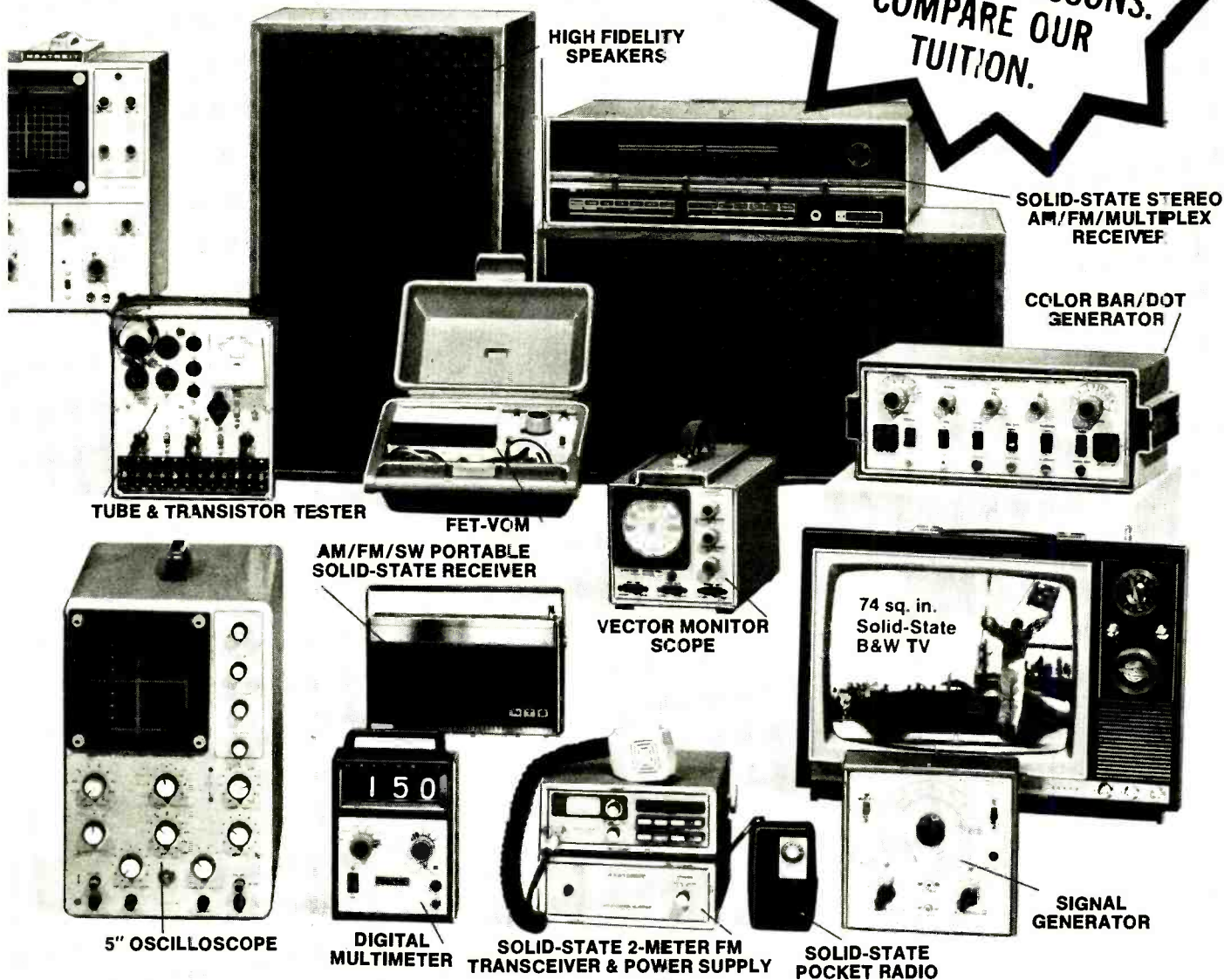

TUBE & TRANSISTOR TESTER

FET-VOM

AM/FM/SW PORTABLE
SOLID-STATE RECEIVER

HIGH FIDELITY
SPEAKERS

SOLID-STATE STEREO
AM/FM/MULTIPLEX
RECEIVER

COLOR BAR/DOT
GENERATOR

5" OSCILLOSCOPE

DIGITAL
MULTIMETER

SOLID-STATE 2-METER FM
TRANSCEIVER & POWER SUPPLY

VECTOR MONITOR
SCOPE

SOLID-STATE
POCKET RADIO

SIGNAL
GENERATOR

tion privileges spelled out. Make your own comparisons, your own decision. Mail card today, or clip coupon if card is missing.

NO OBLIGATION. NO SALESMAN WILL CALL

APPROVED FOR VETERAN TRAINING

Get facts on new 2-year extension

NATIONAL TECHNICAL SCHOOLS

TECHNICAL-TRADE TRAINING SINCE 1905

Resident and Home-Study Schools

4000 So. Figueroa St., Los Angeles, Calif. 90037

NATIONAL TECHNICAL SCHOOLS Dept. 205-096

4000 South Figueroa St., Los Angeles Calif. 90037

Please send FREE Color Catalog and Sample Lesson.
NO OBLIGATION. NO SALESMAN WILL CALL

- | | |
|---|--|
| <input type="checkbox"/> Color TV Servicing | <input type="checkbox"/> Electronics Technology |
| <input type="checkbox"/> B & W TV and Radio Servicing | <input type="checkbox"/> Computer Electronics |
| <input type="checkbox"/> Electronic Communications | <input type="checkbox"/> Basic Electronics |
| <input type="checkbox"/> FCC License Course | <input type="checkbox"/> Audio Electronics Servicing |

NAME _____ AGE _____

ADDRESS _____ APT # _____

CITY _____ STATE _____

Please fill in Zip Code for fast service _____

- Check if interested in G.I. Bill information.
 Check if interested ONLY in classroom training in Los Angeles.

you can effectively isolate the readout from a circuit under test with an op amp. Figure 2 shows a circuit with an op amp input. The op amp will increase the input impedance of the readout to a few hundred thousand ohms or more. Also, since the gain of the op amp is easily adjusted, you can measure small fractions of a volt with this modified circuit.

Zener Diode Voltage-Sensitive Bargraph. The unique voltage-sensing property of zener diodes makes them ideal for LED bargraph

ment than either of the previous two, but it works quite well.

The circuit in Fig. 4 is connected to a Darlington input stage to isolate the circuit under test from the display. Potentiometer *R2* can be used to adjust the sensitivity of the bargraph from 0.1 to 0.5 volts (0.1-volt increments) to 1.0 to 10.0 volts (2.0-volt increments). Current through the LED's is limited by *R4*, *R6*, *R8*, *R10*, and *R12*.

Even higher sensitivity and better linearity can be obtained by substituting an op amp for the Darlington input stage. See Fig. 2 for details.

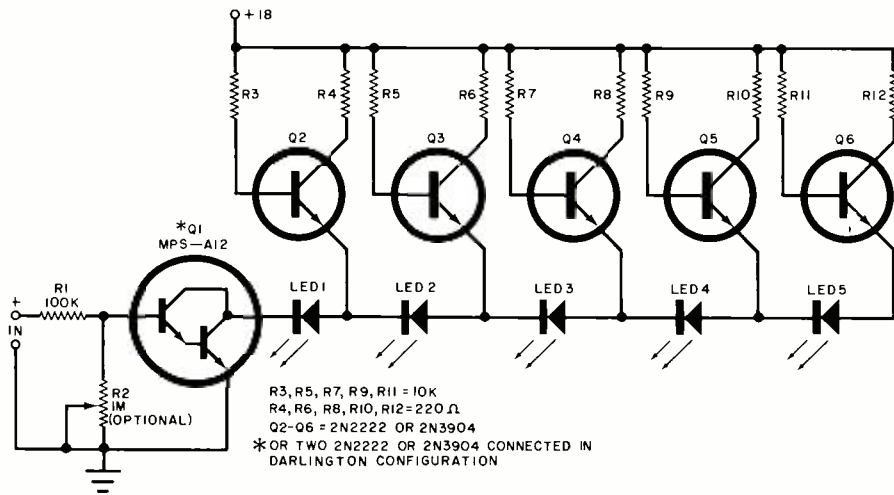

Fig. 4. Transistors can be used to switch on a series string of LED's in succession as in this circuit.

indicators. Figure 3 shows a typical circuit.

In operation, an increasing voltage applied to the circuit has no effect until the breakdown voltage of *D1* is reached. When *D1* breaks down, *LED1* receives forward current and glows, with *R1* limiting the current to a safe level.

Zener diodes *D2*, *D3* . . . *DN* break down in succession as the voltage is increased. As with the voltage-divider readout, the zener diodes can be arranged for nonlinear response and other "custom" readout roles. Any number of LED-zener diode pairs can be used. You can also connect a zener diode bargraph readout to an op amp to provide a high input impedance and increased sensitivity.

Transistorized Voltage-Sensitive Bargraph. Transistors can be used to switch on a series string of LED's in succession as shown in Fig. 4. The circuit requires more components per resolution ele-

Comparator Voltage & Resistance-Sensitive Bargraph. You can make an exceptionally versatile bargraph readout from a batch of op amp comparators. The input of each comparator is connected to one stage of a voltage divider and the output to an LED. When an increasing voltage is applied to the voltage divider, the comparators turn on in sequence and cause their LED's to glow. The same effect occurs when an external resistance is connected across the divider.

Fig. 5 shows one possible configuration of this concept. Three LM339 quad comparators are used to provide the ten comparators for the circuit. The voltage divider consists of *R1-R11*, while *R12* limits current through the LED's to about 10 milliamperes.

Potentiometer *R1* is the source of this circuit's exceptional sensitivity. When it is set for a resistance of several megohms or more, for example, the LED's will turn on in increments of a millivolt or so. By substituting a ro-

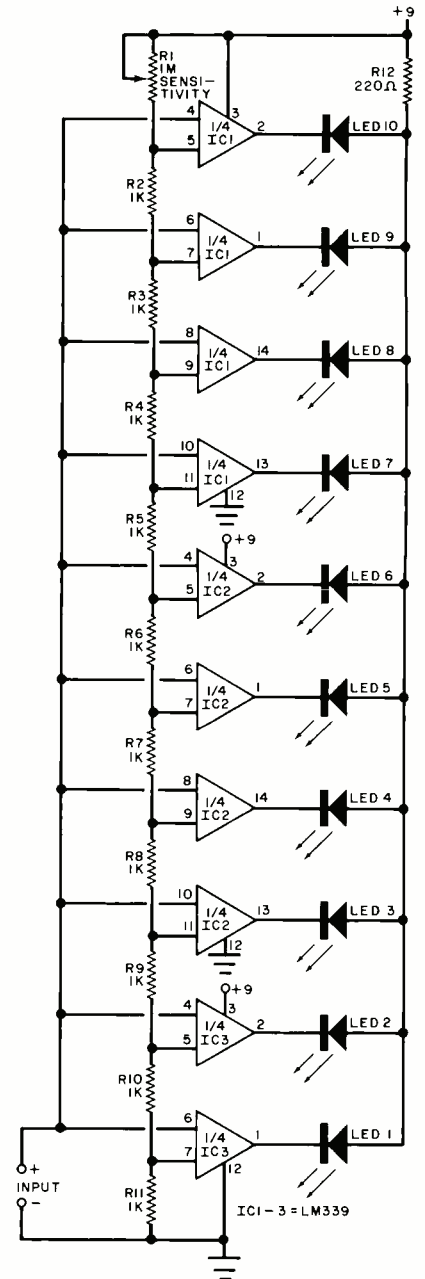

Fig. 5. Bargraph using comparator voltage and resistance-sensitive circuit.

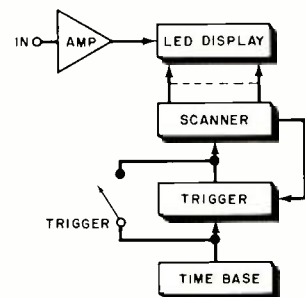

Fig. 6. Block diagram for bargraph frequency meter.

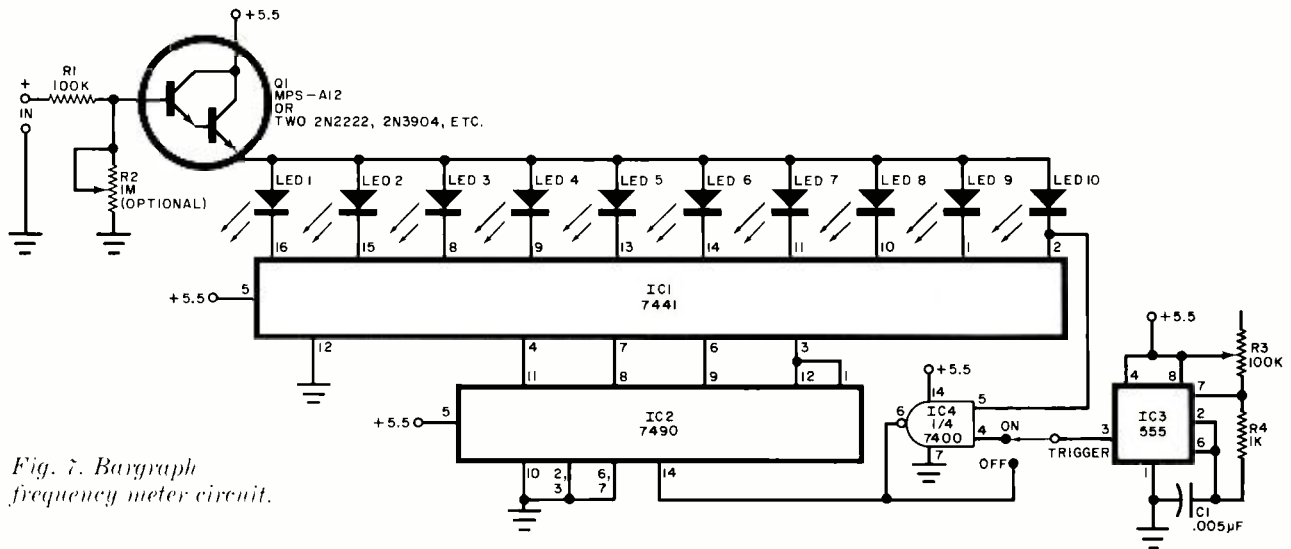

Fig. 7. Bargraph frequency meter circuit.

tary switch and several fixed precision resistors for *R1*, you can make a calibrated voltmeter which doubles as a resistance meter. In the resistance sensing mode, the circuit can be adjusted to indicate up to 10 megohms per LED.

This circuit can also be used as a timer or sensitive light meter. To operate it as a timer, connect a large-valued good-quality capacitor across the input leads. (Use at least 1 microfarad for best results.) As the capacitor charges, the LED's will glow in succession to indicate the charge on the capacitor. Intervals of a fraction of a second to more than a minute per LED can be obtained.

To use the circuit as a light meter, connect either a photovoltaic cell such as a silicon solar cell or a photoresistive cell to the input leads. The photovoltaic cell generates a voltage in response to light and the LED's glow in succession as the light level at the cell is increased. Photoresistors change their resistance in response to light, and the LED's react accordingly.

Frequency-Sensitive LED Bargraph. Believe it or not, you can make a frequency meter from a 555 timer, several TTL IC's, ten LED's, and a few miscellaneous parts. Figure 6 is a block diagram of the circuit; Fig. 7 is the schematic. Here's how it works:

The time base (555 timer) feeds clock pulses at an adjustable rate to a scanning circuit (7490 counter and 7441 decoder). An LED is connected to each of the decoder outputs.

Normally, all the LED's are off. How-

ever, a pulse applied to the input amplifier (a Darlington or FET stage) which is coincident with a clock pulse causes one or more LED's to be turned on. The number and arrangement of the LED's indicates the frequency of the incoming pulses and their width.

To view the individual pulses of the incoming signal on the display, the time base must be properly synchronized. This is accomplished by adjusting the time base's RC time constant. Calibration is accomplished in the same way.

Manual adjustment of the time base's time constant is adequate for pulses occurring at a rate of less than a few kilohertz, and faster frequencies require automatic synchronization. This is accomplished by a single NAND gate (7400 quad NAND gate) which is connected as an automatic trigger. The trigger operates much like the triggered sweep in an oscilloscope.

With the component values shown, the circuit will display frequencies ranging from about 20 microseconds per LED to 1 second per LED. You may have to increase *C1* to 0.01 or 0.1 microfarad to obtain the full operating range.

Operation of the frequency meter can be a little tricky at first. You will need to calibrate the unit by using a known frequency source. For best results, a square or rectangular pulse shape should be employed.

Begin calibration by applying a known frequency and rotating *R3* until the display resembles:

1 0 1 0 1 0 1 0 1 0

where "1" represents a glowing LED and "0" represents an LED which is off. If the input frequency is 1 kHz, each LED corresponds to 500 microseconds. Mark *R3*'s shaft position accordingly, and continue calibrating for a range of input frequencies.

During calibration, you will notice that the LED's do not always glow in a uniform pattern. For example, the following pattern may appear:

1 0 1 0 1 0 1 0 1 1

This and similar effects are caused by slight changes in either the time base frequency, the input frequency, or noise.

After you have calibrated the circuit, you can use it to measure the frequency of a pulse train and the width of square pulses. For example, to measure the width of a square pulse, simply rotate *R3* until several LED's near the center of the display are glowing. The pattern might resemble this:

1 0 0 1 1 1 0 0 1 1

The 1 1 1 pattern near the center of the display is a single pulse (ignore the other LED's) and its width is found by adding the time increment represented by each LED. If *R3* is set for 100 microseconds per LED, then the pulse is 300 microseconds wide.

Since the resolution of the 10 element readout is so limited, your measurements will not be very accurate. Nevertheless, you can get a good idea of both frequency and pulse width with the circuit. For best results, operate the frequency meter in subdued light since the LED's will not be very bright. This is especially true when measuring fast frequencies. ♦



Product Test Reports

ABOUT THIS MONTH'S HI-FI REPORTS

Truly giant advances in performance and operating characteristics of audio equipment are rare. More common than "breakthroughs" are improvements on preceding models in a company's line, especially when the earlier models are at the state-of-the-art level. This is the case with the two hi-fi units examined this month.

Crown's magnificent Model 150 stereo preamp has been improved in performance as well as operating flexibility, including the ability to switch on power amplifiers drawing a total of 25 amperes! It's called the IC-150A, and, as the name suggests, it uses integrated circuits in all its active stages, including the power-supply regulator.

Similarly, Dual replaced its excellent automatic turntable, the 1229Q, with the new 1249, retaining the features and even the external appearance of its illustrious predecessor. Under the skin, however, the 1249 is a completely different unit, employing a lower-speed motor that drives the platter through a flexible belt.

Both models emphasize how, each year it seems, there are small increments of improvement that have a way of adding up to a giant step when viewed over a period of a few years.

—Julian D. Hirsch

CROWN MODEL IC-150A PREAMPLIFIER

Has improved operating flexibility and performance.



High-power audio amplifiers are making a lot of news recently, as the popularity

of hi-fi "separates" increases. It takes two to tango, however, so we examine here a professional type of audiophile-priced preamplifier that could be a good match for a top-quality power amplifier. It's the new Crown Model IC-150A stereo preamplifier/control center.

Making full use of new integrated circuit design possibilities, the IC-150A utilizes five IC's that are equiva-

lent to 89 bipolar transistors, 25 FET's, 3 zeners and 12 diodes. The result is a low-distortion, wide-dynamic-range, versatile control center. Proper equalization, and low-level and high-level gain are provided for use with a host of sources.

Housed in an attractive walnut cabinet, the preamp measures 5¼"H × 17"W × 8⅞"D (13.3 × 43.2 × 20.6 cm). It is \$399.

General Description. The front panel of the preamp is divided horizontally into two sections. Across the upper section are grouped six rotary

controls: input SELECTOR, VOLUME, BALANCE, PANORAMA, BASS, and TREBLE. The lower section of the panel contains five pushbutton switches labelled TAPE 1 and TAPE 2 MONITOR, LOW and HIGH FILTERS, and AC ON. Also on the lower part of the panel are three standard phone jacks, two of which provide inputs for the AUX 3 input. The third jack, labelled MONITOR, is for driving a third tape deck with signals from the preamp's output, where it can be modified by the tone controls.

The selectable inputs include PHONO 1, PHONO 2, AUX 1, AUX 2, AUX 3, TUNER, TAPE 1, and TAPE 2. The VOLUME control is a 31-position step switch that permits varying the volume in 2-dB steps over a 60-dB range, starting from full off at its lowest setting. Precision resistors in the volume-control circuit maintain channel balance within 0.2 dB.

The PANORAMA control provides a means of continuously varying channel separation and orientation, from normal stereo through mono to reverse stereo as the control is rotated clockwise. The tone controls for the two channels are concentric to permit independent adjustment. Pushbuttons near the controls can be used to bypass the tone circuits and connect the loudness-compensation circuit into the VOLUME control circuit.

Recessed into the rear of the preamp are the various inputs and outputs, including two parallel sets of outputs and a slide switch for reducing the output signal level by about 10 dB, for use with high-gain power amplifiers. Two screwdriver-adjustable controls near the PHONO jacks permit the user to vary the phono gain over a 20-dB range. There are also six ac outlets on the rear panel, five of which are switched by the preamplifier, able to supply up to 1200 watts of power to external components.

The preamp is rated to deliver at least 11 volts output to a high-impedance load, with less than 0.002% IM distortion, or less than 0.0005% THD, both at 1000 Hz. The rated output into 600 ohms is 2.5 volts.

Laboratory Measurements. To the extent that our test equipment was able to measure performance, the preamplifier met all of its published specifications with room to spare. Of course, no unmodified laboratory instruments are capable of measuring THD down to 0.0005%, but we satisfied ourselves that the preamp is as nearly

POPULAR ELECTRONICS

distortionless as any piece of high-fidelity equipment we have ever used or tested.

The output clipped at 11.7 volts into 100,000-ohm loads and 4.8 volts into 600-ohm loads. The low-impedance load was used for our distortion and noise measurements, based on the maximum rated output of 2.5 volts. At 20 Hz, the THD was 0.018%, which is approximately the residual distortion of our signal generator. It decreased to less than 0.01% between 100 and 10,000 Hz and rose to 0.05% at 20,000 Hz. At most frequencies, the THD was below the minimum measurement limit of 0.003%.

The IM distortion was measured with a Crown IM analyzer, which can barely indicate its own 0.002% residual distortion. We obtained a 0.002% IM distortion at most output levels from 2.5 volts down to about 0.25 volt. At the rated output, the figure was 0.005%.

The preamp delivered a reference output of 1 volt at 1000 Hz with an input of 0.18 volt through its high-level inputs. The unweighted S/N ratio, relative to 1 volt, was 80 dB down. The phono gain is factory set at 60 dB for a 1-mV input to produce a 1-volt output. We measured a 76.5-dB S/N ratio through the phono inputs. The phono overload level occurred at 140 mV. The screwdriver-adjustable phono sensitivity controls permitted the gain to be varied from 0.27 to 3.1 mV, with corresponding overload levels occurring at 40 to 400 mV. The noise level was not significantly different at most usable settings.

The frequency response was basically flat within ± 0.25 dB (which is also

the rating of the General Radio frequency-response plotter we used during the test). The bass tone control varied the turnover frequency from about 50 to 300 Hz, making it possible to modify the low-frequency response over a considerable range without seriously affecting the midrange response. The treble control characteristic was hinged at a frequency in the range between 1000 and 1500 Hz. The low-frequency filter had a 6-dB/octave slope. Its response was down 3 dB at 90 Hz with the volume at maximum. (The filter's cutoff frequency decreases at lower volume settings.) The high-frequency filter cut off with a 12-dB/octave slope, and its response was down 3 dB at 6000 Hz. The loudness compensation was very mild (and, therefore, quite useful), producing a boost in response below 100 Hz, with no effect on the high frequencies.

The RIAA equalization was not affected by any significant amount by cartridge inductance. It was within ± 0.5 dB from 70 to 20,000 Hz, rising slightly to +1.5 dB at 25 to 30 Hz. The square-wave risetime through the high-level inputs was 2 μ s, and the slew rate was 6 volts/ μ s with a 600-ohm load.

User Comment. It would certainly be difficult to improve the noise, distortion, and frequency-response characteristics of this preamplifier. Furthermore, the preamp operates smoothly and silently, with no switching transients or other undesired side effects. (A plug-in reed relay shorts out the outputs for a few seconds when the preamp is first turned on and when

it is turned off to prevent switching transients from reaching the system's speakers.)

The preamp is very flexible, seemingly able to handle any and all program sources and accessories that one would reasonably connect to it. It represents a clear improvement over the company's IC-150, which is also a fine unit. For example, the IC-150A surpasses its predecessor in that it has lower noise, lower distortion, tighter tracking between channels, an internal reed relay, an added input, switched output attenuation, and an additional switched ac outlet (to name a few).

The preamp isn't flawless, however. One has to be careful if a signal-processing accessory (equalizer, noise reducer, dynamic expander) is connected to one of the tape-monitoring circuits. If the preamp's monitor switch is in the tape source position, setting the SELECTOR switch to the corresponding TAPE input will cause a violent oscillation ("motorboating"). Of course, with separate preamp and power amp, one can install any accessory between the components, bypassing this problem.

Additionally, the handsomely designed front panel would benefit from a visible and contrasting index mark on control knobs. In dim light, it's difficult to determine many of the control settings, a problem that is by no means unique to the IC-150A, but nevertheless a minor annoyance.

In all other respects, one could hardly ask for a finer preamplifier. The Crown Model IC-150A is also reasonably priced for a component preamp/control center in today's market.

CIRCLE NO. 80 ON FREE INFORMATION CARD

DUAL MODEL 1249 AUTOMATIC RECORD PLAYER

Uses belt drive and combines best features of automatic and manual operation.



Replacing the 1229Q at the top of Dual's automatic record player line is the Model 1249. It resembles its predecessor in many respects, but there are some important differences, both externally and beneath the motorboard. The 1249 is a two-speed (33 $\frac{1}{3}$ and 45 rpm) belt-driven turntable, able to play records singly in a fully automatic or manual mode or to play a stack of six records in sequence when the short single-play spindle is replaced by the automatic center spindle.

For speed adjustment, there are

stroboscopic marks around the edge of the full-size (12") platter, illuminated from below through a window in the motorboard. A small knob, concentric with the speed-change lever is used to make the speed adjustments. The other operating control is a conventional Dual start-stop lever.

The cueing lever raises and lowers the tonearm with a smooth, damped motion in both directions, and a small knob near the arm base adjusts the height of the lift. A two-position knob in front of the cueing lever makes it possible to repeat a single record indefinitely, or to play it once and then shut off automatically.

The Dual 1249, measuring 14 $\frac{3}{4}$ "W \times 12 $\frac{1}{4}$ "D (38 \times 31 cm), is \$279.95, less base and cover.

General Description. The tubular aluminum tonearm appears to be identical to that of the 1229Q and other Dual units. Its low-friction pivots are mounted on gimbals, for equal freedom of motion in both planes. The anti-skating dial, on the base next to the arm, is a drum with three separate scales, for conical, elliptical, and CD-4 styli.

A lever is used to raise the entire tonearm for multiple play so that the vertical stylus angle at the center of a 3-record stack will be approximately the same as when playing a single record with the arm lowered. In the

1249's belt-drive system, the 12-inch aluminum alloy platter rests on a smaller platter which is driven through a belt by an 8-pole synchronous motor turning at 900 rpm. The drive shaft provides vernier speed control.

The internal arm wiring of the Dual 1249 is low-capacitance, though the external signal cable is not. For CD-4 installations, it is only necessary to unplug the signal cable and replace it with a special CD-4 cable.

Laboratory Measurements. With an Ortofon VMS-20E cartridge installed, the tonearm of the Dual 1249 resonated at about 7 Hz. The measured vertical tracking force was identical to the settings of the dial on the tonearm, over the range of 1 to 3 grams. The tracking error was under 0.5 degrees per inch of radius over almost the entire record surface. With a 1-gram vertical tracking force, it was necessary to set the anti-skating dial to 1.5 grams for best correction.

Wow and flutter were virtually unmeasurable at 0.02 and 0.03%, which probably represents the residual of the test record. Rumble was -32 dB (unweighted), improving to -57.5 dB with RRLA audibility weighting. The speed vernier control range was about $\pm 4\%$ at 33 $\frac{1}{3}$ rpm, but less than half as much at 45 rpm. Speed was absolutely constant when the line voltage was varied from 80 to 135 volts.

CIRCLE NO. 81 ON FREE INFORMATION CARD

The automatic change cycle required 14.5 seconds, typical of record changers; and, in the single-play automatic mode, 17 seconds elapsed between the time the START lever was operated and the time the pickup reached the record.

The Dual arm-lift system is one of the best we have used, with no outward drift during the descent caused by anti-skating correction. The turntable mounting springs afforded good isolation from external vibration, comparable to what we have measured on other good automatic turntables.

User Comment. The overall level of performance of Dual's top automatic players has been so high in recent years that, quite frankly, we had difficulty pin-pointing any specific superiorities of the 1249 over its predecessors. For all practical purposes, its wow, flutter, and rumble are nonexistent, since almost any record is inherently likely to have more of these unwanted characteristics than will be contributed by the 1249.

The operating features of the 1249 combine the best parts of automatic and manual players. (It can be operated manually by picking up the tonearm, which starts the motor, and cueing it to the desired portion of a record, using the cueing lever to lower it if desired.)

HANDIC MODEL 2305 AM CB TRANSCEIVER

Attractive styling, excellent audio quality and good modulation.

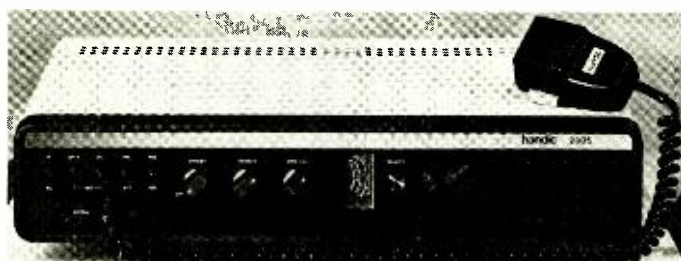

THE Handic Model 2305 AM CB base-station transceiver features a striking low-silhouette packaging design. This gives it a long, lean look and allows all controls, meter, and channel indicator to be arranged in a functional horizontal line. Another feature that makes this transceiver "different" from most others on the market is that it has a built-in priority receiver that operates separately from

(and does not interfere with) the operation of the main transceiving functions. This sub receiver can be set up to constantly or "on command" monitor any CB channel for which the correct crystal is installed.

The 23-channel transceiver can be operated from any 117- or 220-volt ac power source and uses electronic regulation in its power supply. Provisions are also made for charging up to

10 NiCd cells for use in walkie-talkies. In addition, a socket is provided for installation of a selective-call accessory, and there is a PHONE jack on the front panel for private listening. The remaining features are more or less standard for a CB base station: audio gain and squelch controls, S/R/F/SWR meter, switchable anl, PA operation, external-speaker jacks, detachable dynamic microphone, front-facing speaker, amc, and operation at full legal power.

The transceiver measures 17"W \times 8 $\frac{1}{8}$ "D \times 8 $\frac{1}{8}$ "H (43 \times 20.7 \times 8 cm). It retails for \$279.00.

The Receiver. A double-conversion design is used in the main receiver section, using the common crystal frequency synthesizing scheme to obtain a 10,595-to-10,635-kHz first i-f and a 455-kHz second i-f. The rest of the circuitry is quite conventional in de-



Ben Hyek
Edna, Texas

Brothers Ben and Vic Hyek,
Texas antenna installers agree:
Chromstar
gets the "Ayes" of Texas

Deep in the heart of Texas, the Hyek brothers, Ben and Vic, operate their separate TV service firms.*

Ben Hyek, of Ben's TV, Edna, Texas, says "I have yet to find a competitor's antenna as good as Winegard Chromstar."

Only 30 miles from the Gulf, Ben sells the anodizing feature to his customers. "The combination of heavy duty construction and anodizing makes Chromstar the best long-life antenna on the market," he states. When he sells Chromstar, he tells the customer, "If it doesn't work, I'll take it down," and he hasn't taken one down yet.

Vic Hyek operates Vic's Radio & TV, Nada, Texas, and says: "I think Chromstar is by far the greatest antenna Winegard has ever offered. UHF performance is excellent, and VHF is better, too. Now I can pick up Channel 39 out of Houston, over 60 miles away, better than I have before. UHF performance in this area doesn't require a preamp."

Both Vic and Ben like the stronger construction of Chromstar, the ease of installation, the new color combination, and the compact packaging that allows easy handling and storage.

*Copies of letters from the Hyek brothers will be sent on request.

Get Chromstar facts and free Spec Charts from your Winegard distributor.



Vic Hyek, Nada, Texas

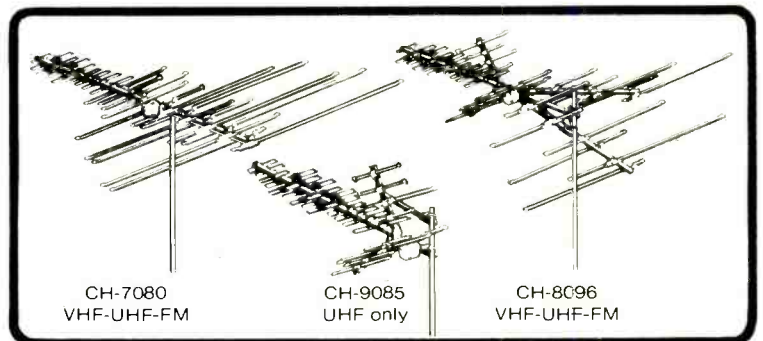

WINEGARD
C O M P A N Y

3000 Kirkwood • Burlington, Iowa 52601

TV ANTENNAS MORE PEOPLE LOOK UP TO

Should your career in electronics go beyond TV repair?

**CREI prepares you at home
for broader and more advanced
opportunities in electronics —
plus offers you special arrangements
for engineering degrees**

There is no doubt television repair can be an interesting and profitable career field. TV repair, however, is only one of the many career areas in the fast growing field of electronics.

As an indication of how career areas compare, the consumer area of electronics (of which TV is a part) makes up less than one-fourth of all electronic equipment manufactured today. Nearly twice as much equipment is manufactured for the communications and industrial fields. Still another area larger than consumer electronics is the government area. That is the uses of electronics in such areas as research and development, the space program, and others.

Just as television is only one part of the consumer field, these other fields of electronics are made up of many career areas. For example, there are computer electronics, microwave and satellite communications, cable television, even the broadcast systems that bring programs to home television sets.

As you may realize, career opportunities in these other areas of electronics are mostly for advanced technical personnel. To qualify for these higher level positions, you need college-level training in electronics. Of course, while it takes extra preparation to qualify for these career areas, the rewards are greater both in the interesting nature of the work and in higher pay. Furthermore, there is a growing demand for personnel in these areas.

Unlike most other home study schools, CREI programs are devoted exclusively to preparing you for careers in advanced electronics. All of CREI programs are college level. And CREI gives you both theory and practical experience in advanced electronics.

Unique Design Lab

A unique feature of CREI training is its Electronic Design Laboratory Program, which trains you to actually design circuits. It also helps you understand the theories of advanced electronics and gives you extensive practical experience in such areas as tests and measurements, breadboarding, prototype construction, circuit operation and behavior, characteristics of electronic components and how to apply integrated circuits.

Career Training at Home

Only CREI offers this unique Lab Program. It is a complete college lab and, we believe, better than you will find in most colleges. The "Lab" is one of the factors that makes CREI training interesting and effective. And the professional equipment in this program becomes yours to keep and use throughout your professional career after you complete the training.

Engineering Degree

CREI offers you special arrangements for earning credit for engineering degrees at certain colleges and universities as part of your home study training program. An important advantage in these arrangements is that you can continue your full time job while "going to college" with CREI. This also means you can apply your CREI training in your work and get practical experience to qualify for career advancement.

Wide Choice of Programs

CREI gives you a choice of specialization in 14 areas of electronics. You can select exactly the area of electronics best for your career field. You can specialize in such areas as computer electronics, communications engineering, microwave, CATV, television (broadcast) engineering and many other areas of modern electronics.

FREE Book

In the brief space here, there isn't room to give you all of the facts about CREI college-level, home study programs in electronics. So we invite you to send for our free catalog (if you are qualified to take a CREI program). The catalog has over 80, fully illustrated pages describing your opportunities in advanced electronics and the details of CREI home study programs.

Qualifications

You may be eligible to take a CREI college-level program in electronics if you are a high school graduate (or the true equivalent) and have previous training or experience in electronics. Program arrangements are available depending upon whether you have extensive or minimum experience in electronics.

Send for this **FREE** Book describing your opportunities and CREI college-level programs in electronics



Mail card or write describing qualifications to

CREI **CAPITOL
RADIO
ENGINEERING
INSTITUTE**

McGraw-Hill Continuing Education Center
3939 Wisconsin Avenue Northwest
Washington, D.C. 20016

Accredited Member National Home Study Council

GI Bill

CREI programs are approved for training of veterans and servicemen under the G.I. Bill.



sign. It consists of a diode-protected r-f stage, first and second mixers, two 455-kHz i-f stages, detector stage, agc stage, squelch system, and an audio section that terminates in a class-B output stage (that also serves as the transmitter modulator or provides the PA output).

The receiver's sensitivity measured 0.5 μV for 10 dB (S + N)/N. The maximum audio sine-wave output at the onset of clipping was 3.4 watts at 2.5% THD with a 1000-Hz test signal and an 8-ohm load. The overall audio frequency response was 400 to 2500 Hz at the 6-dB points. The agc system produced a relatively uniform audio output level, amounting to a change of only 8 dB with an 80-dB r-f input change at 1 to 10,000 μV . A 30- μV input signal was required to provide an S9 indication on the meter.

I-f selectivity is obtained with two cascaded 455-kHz ceramic filters that hold the ± 10 -kHz bandwidth to the area of 90 dB. However, due to r-f and mixer stage signal-handling characteristics, the adjacent-channel rejection, desensitization, and cross modulation were, in practice, on the order of 60 dB. Image and i-f signal rejection were 55 and 60 dB, respectively, while other unwanted-signal rejection was a minimum of 40 dB.

The automatic limiter, or anl, per-

formed exceptionally well, particularly during weak-signal reception, where it is most important. The squelch threshold range was 0.1 to 1000 μV .

The priority SUB receiver employs single conversion to a 255-kHz i-f. This requires a special crystal for whatever channel is to be set up. Since we did not have such a crystal, we were unable to make any performance measurements in this section. Sensitivity is rated at 0.7 μV , and with a 255-kHz i-f, the image rejection cannot be expected to be as good as the main section's. Nevertheless, this is of little consequence for the application for which this section is intended. Separate squelch and anl are provided for the SUB receiver, too.

The Transmitter. The straightforward transmitter contains a synthesizer mixer, spurious-response filtering, and predriver, driver, and final (power) amplifier stages. The output of the last stage goes into a matching network for 50-ohm loads. The output carrier power measured 4 watts.

The automatic modulation control (amc) system provides a high degree of compression (35 to 40 dB above 50% modulation) for maintaining high modulation with differing voice levels. Under dynamic conditions, the splat-ter was nominally 50 dB down. With a

1000-Hz test tone at full compression and 100% modulation, the distortion was only 5%. The overall response was 350 to 4000 Hz.

Antenna switching is performed electronically with a diode switch. Other circuits are relay switched.

The frequency tolerance of the transmitter was within 0.0025%.

User Comment. The appearance of this transceiver is enhanced by a black control panel with an orange stripe across the top. Behind the bezel, the case is all white, presenting a pleasant contrast with the front panel.

Miniature toggle switches are used for the switchable functions, while the VOLUME, SQUELCH, and SWR CAL controls and the channel selector are rotary devices. The meter movement is oriented vertically and is easy to read.

The priority SUB receiver is activated by a switch. When the switch is in the SUB position, the receiver is switched in and a light on the front panel flashes to indicate that the priority channel is on.

Attractive styling, excellent audio quality, and fine modulation characteristics make this transceiver a desirable piece of CB gear. The selective-call accessory socket and battery charging capability add unusual versatility.

CIRCLE NO. 82 ON FREE INFORMATION CARD

OAE MODEL OP-80A TTY PAPER TAPE READER

High-speed tape reader for less than \$75.

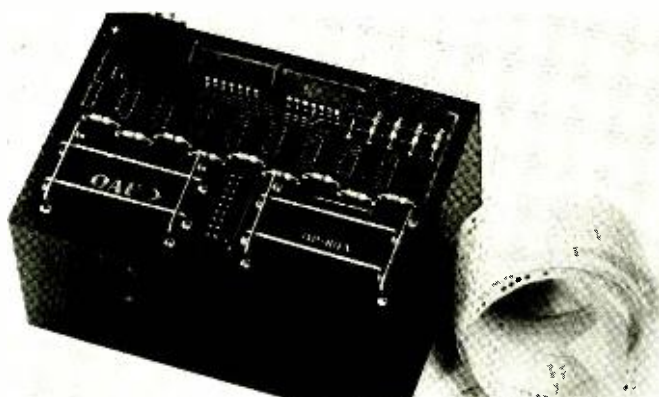

YOU CAN feed TTY paper tape programs into any computer with an 8-bit input port without having to spend \$1000 or more for a Teletype® terminal. The OAE Model OP-80A high-speed paper tape reader lets you do it for just \$74.50 if you build it from a kit or \$95 if you buy it factory assembled and tested. The reader has no

moving parts, unless you count the motion of the tape going through it. It also lets you feed tape programs into your computer at much faster speeds than a standard electro-mechanical tape reader will permit.

General Description. The tape reader can be assembled in a single

evening. The design is so simple and complete, even a neophyte should have little difficulty in putting together the kit.

The tape reader's circuit design employs several 555 timer IC's, a precision optical sensor "head," and some "handshake" logic. All parts, including the heavy solid wire that serves as the tape guides, mount on the top surface of a single printed circuit board. The board itself becomes the top of a compact box. A 48" (1.2-m) multi-color flat ribbon cable interconnects the tape reader to the computer with which it is to be used.

The actual hookup to the computer is simple. If your computer has an 8-bit parallel input port, you can feed programs in parallel from tapes directly. On the other hand, if your computer is equipped with only a TTY serial input port pegged at a slow 110 baud, the tape reader's manual gives details on how to connect the reader to the com-

puter's serial input UART so that you can load programs at high speed. No software modifications are required in either case.

Four LED's in the tape reader indicate status. One comes on when 5-volt power (obtained from the computer's power bus) is applied to the reader. A second LED comes on when the tape illumination through the sprocket hole sensor is sufficient for proper operation. The remaining two LED's are not dedicated; they can be used as signal indicators as desired. The illuminating source can be any standard 100-watt desk lamp.

The stiff wires used as tape guides on the reader maintain proper tape alignment as it passes over the optical read head. A large arrow on the top of the pc board indicates proper direc-

tion of tape motion. A smaller arrow identifies the sprocket sensor.

All internal and external connections are made to a conventional 14-pin dip socket mounted on one corner of the pc board. The color-coded ribbon cable is terminated at one end in a male connector that fits the DIP socket.

User Report. After assembling the kit, we wired it into the parallel port of our computer and connected the two required handshake leads. Then we loaded punched TTY tape in the guides, checked for the right indication of the sprocket LED, and pulled the tape through as fast as we could. It came as quite a shock to see how fast we could feed data into our computer and see it on our video monitor.

CIRCLE NO. 83 ON FREE INFORMATION CARD

Once we confirmed the operation of the parallel port, we rewired the tape reader to the UART on our 110-baud serial TTY board and made all necessary changes. During our operational test, we were able to load 8K Basic into our computer as fast as we could pull the tape through the reader's guides. According to OAE, the tape reader is designed to let you run 12K Extended Basic through in about 30 seconds! We didn't have the equipment to verify this claim, but the results of our other tests gave us no reason to doubt it.

Needless to say, we are impressed with the performance of this paper tape reader. It is reasonably priced for the average computer user, and we predict that it will become one of the hottest computer accessory items on the market.

ALPHA WIRE MODEL STRP-25 WIRE STRIPPERS

Unique cutting material permits repeated, dependable stripping.



STRIPPING insulation from wire and cable by hand has always been a chancy proposition at best. If you use diagonal cutters and don't apply enough pressure, you run the risk of tearing the insulation instead of neatly parting it. Apply too much pressure, and you nick the conductor or remove a few fine strands, weakening the structure at the connection point. Using automatic hand-type wire strippers is time consuming because you must carefully locate the wire in the proper notch in the steel jaws. But if you use Alpha Wire's new Model STRP-25 automatic strippers, you will not only produce perfect strips every time, you'll also strip wires faster than you can using any other tool we've examined on the market today.

The new strippers look and operate just like the standard steel-jawed automatic tool. What Alpha has done is redesigned the basic automatic tool to accept special Stilan® plastic cutting blades. The blades are harder than most materials used for wire and cable insulation—except Teflon and Kynar, which aren't commonly used by hobbyists and experimenters—but softer than copper.

The Model STRP-25 strippers retail for \$39.95 and come with three sets of plastic blades. A five-set replacement blade pack (No. BLD-5) can be obtained for \$11.95.

More Details. The blades are similar in size and shape to the steel blades used in injector razors. They even install in the tool the same way, with the new blades ejecting the old.

The Stilan plastic material used for the blades is tough and resilient. As the opposing knife-edges of the blades come together during the stripping procedure, they neatly slice through the insulation and then deform around the conductor. The tool then cleanly and automatically parts the insulation from the wire. Inspection of the blades after a strip will reveal small notches where the plastic deformed around the wire. If you carefully position the wire in these grooves and make repeated strips, you'll find that the blades will continue to remove insulation several hundred times before you have to move on to a "fresh" area. Of course, in actual practice, you would use all areas of the blades randomly.

The wire strippers are designed to cope with a number of problems fast and accurately. For example, when stripping insulation from 4" (10.2-cm) or shorter lengths of hookup wire, the tool will not crush the insulation, kink the wire, or pull the wire clean out of the insulation. Also, it strips insulation

from twisted-pair, speaker and line cord, and 300-ohm twin-lead cable with the same facility as single-conductor hookup wire. The tool will even strip insulation from wire bundles, multiple twisted pairs, and flat ribbon cable, whether or not the conductors are all of the same size.

User Comment. Over a period of weeks, we put the plastic-blade wire strippers through a strenuous series of tests. After performing some 10,000 strips using stranded and solid 22-gauge hookup wire with PVC insulation and several hundred strips on 300-ohm twin-lead with polyethylene insulation, we used the tool with the original blades to build two rather complex projects.

Periodic samplings of our strips were subjected to close inspection with a magnifying glass and high-intensity light. In all cases, the insulation was parted neatly at the strip points. More important, we detected no nicks in the wire, crushed conductors, or removal of fine wire strands.

Using a little bit of common sense, one can easily exceed 50,000 strips from a single pair of blades. You just start with the smallest size wire or cable with a pair of new blades and continue stripping away until the blades will no longer remove insulation. Then you use the same blades for the next larger size wire, working up to 12 gauge.

We highly recommend this new tool to anyone who is involved in electronics where speed and reliability are important.

CIRCLE NO. 84 ON FREE INFORMATION CARD

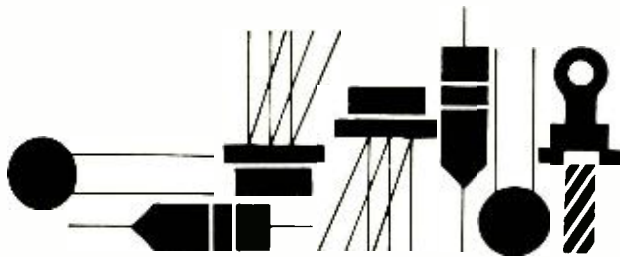

Solid State

By Lou Garner

AN IC THAT IS ALSO DANDY

DISCUSSING a voltage-tuned FM broadcast-band front end in last February's column, I referred to it as a DANDY circuit, explaining that "DANDY" was my acronym for "Discretes Are Not Dead Yet." If we broaden the basic meaning a little, the LM389 might well qualify as a *DANDY IC*, for it combines the versatility of discrete transistors with the wiring density and compactness of an integrated circuit. Manufactured by the National Semiconductor Corporation (2900 Semiconductor Drive, Santa Clara, CA 95051), the LM389 is supplied in a molded 18-pin DIP. As shown in Fig. 1, the device comprises three uncommitted npn transistors and a low-power integrated audio amplifier in a single package.

With its uncommitted transistors and overall electrical characteristics, the LM389 is one of the most versatile devices you're likely to encounter in some time and almost seems to have been "custom-designed" specifically for the experimenter/hobbyist. It can be used in hundreds of applications ranging from simple toys to sophisticated communications equipment. Its versatility, in fact, is limited only by the imagination and capabilities of the individual designer. Typically, the device might be used for such exciting and useful projects as AM or FM receivers, walkie-talkies, tape recorders, portable phonographs, games, power converters, musical instruments, and control systems. Depending on the equipment designer's skill, it may be the *only* active device needed for most of the projects in which it is used.

The LM389's three transistors are general-purpose npn types capable of operating from dc to 100 MHz. They are reasonably well matched and can function effectively at current levels from 1 μ A to their maximum ratings of 25 mA. With a maximum V_{CE} of 12 volts and a maximum power dissipation of 150 mW, each transistor has a typical dc beta of 275. As long as their currents and voltages are kept within the absolute maximum ratings and the collectors are never at a negative potential with respect to the common substrate (pin 17), there is virtually no limit to the ways in which the transistors can be used. For example, they can be employed as conventional transistors, in a Darlington configuration for increased gain, as diodes, and even as zeners, utilizing their emitter-base break-down voltage of 7.1 volts at currents of from 1 μ A to 5 mA. In addition, with a V_{CE} of only 150 mV when sinking 10 mA, they make excellent LED drivers.

The device's amplifier section comprises the equivalent of five npn and five pnp transistors together with two diodes and features a quasi-complementary power output stage capable of delivering up to 500 mW to a 16-ohm load with only 10% total harmonic distortion (THD). At the 125-mW level with an 8-ohm load, the THD drops to a typical value of 0.2%. The amplifier has a nominal bandwidth of 250 kHz, a power supply rejection ratio of 50 dB, and input impedances of, typically, 50,000 ohms. The input(s) are ground referenced while the output is biased automatically to one-half the supply voltage. The circuit's quiescent current (zero input signal) is typically a low 6 mA. Although the voltage gain is set internally at 20 (26 dB), external shunt components can be used to raise this to as much as 200 (46 dB).

Overall, the LM389 has a maximum supply voltage rating of 15 volts, a maximum power dissipation of 825 mW, and an operating temperature range of from 0°C to +70°C.

Referring to Fig. 1, the following tips are among the practical application hints suggested by the manufacturer in the 8-page technical brochure describing the LM389:

(1) The amplifier section's voltage gain is fixed at 20 by the 1350-ohm resistor between pins 4 and 12. Bypassing this resistor will raise the overall gain. With a 10- μ F, 12-V capacitor here, the gain will increase to 200. Gain values between 20 and 200 may be obtained by connecting a fixed or variable resistor in series with the shunt capacitor. Gain control also can be achieved by capacitively coupling a resistor or FET between pin 12 and circuit ground (pin 17).

(2) The circuit's overall frequency response can be tailored to meet individual requirements. For example, bass boost can be added to compensate for a small loudspeaker's poor bass response by connecting a blocking capacitor (say, 10 μ F) and series shunt resistor between pins 1 and 12, paralleling the internal 15,000-ohm resistor. A shunt resistor of 15,000 to 10,000-ohms here will provide an effective 6-dB bass boost. If pins 4 and 12 are bypassed for increased gain, shunt values as low as 2,000 ohms can be used without affecting overall stability.

Fig. 1. The equivalent circuit diagram for the LM389 shows its versatility.

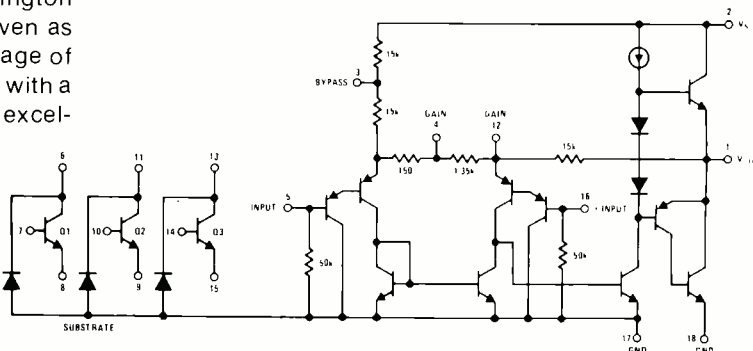

(3) Normally, both amplifier inputs (pins 5 and 16) are biased to ground via 50,000-ohm internal resistors. If capacitive coupling is used to either input or if direct coupling with a dc source resistance of more than 250,000 ohms is used, no modifications to the input circuits are needed. If direct coupling with a dc source resistance of between 10k and 250k is used, then the unused input terminal should be shunted to circuit ground with a resistor equal to the source resistance to minimize the effects of offset biasing. If the dc source resistance is less than 10k, the unused input terminal should be shorted directly to ground. In addition, when the LM389 is used at higher gain levels, it is necessary to bypass the unused input with a 0.1- μ F capacitor to ground to prevent degradation of gain.

(4) If oscillation or circuit instability occurs due to specific load characteristics, these may be eliminated by connecting a 2.7-ohm and 0.05- μ F series RC network from output pin 1 to circuit ground.

(5) Although the LM389 has excellent power supply rejection and does not require a well-regulated dc source, the supply should be decoupled to ground with a 0.1- μ F bypass capacitor to eliminate possible instability.

(6) Separate ground returns to the dc power source from the small signal (pin 17) and power stages (pin 18) are recommended to minimize possible parasitic coupling.

(7) If desired, the amplifier may be muted (turned off) without affecting the input signal either by shorting pin 3 to the supply voltage or shorting pin 12 to ground.

Typical circuit applications for the LM389 are illustrated in Figures 2 through 4. Abstracted from the company's technical bulletin, these are but representative of the hun-

dreds of ways in which the device may be used. All the circuits employ standard, readily available components, all utilize a single LM389 as their *only* active device, and all may be duplicated quite easily in the home workshop using conventional construction methods, such as perf board or pc techniques. Neither layout nor lead dress should be critical but, of course, good wiring practice should be observed, with all signal carrying leads kept short and direct, dc polarities maintained, and adequate separation provided between the input and output circuits. Unless otherwise noted, all resistors, except for potentiometers, can be either half-or quarter-watt types, at the builder's option. The smaller capacitors can be either low-voltage ceramic, paper or plastic film types, while the higher value units, identified by polarity markings, are low-voltage electrolytics. The loudspeakers are PM types with either 8- or 16-ohm voice coils. Finally, the dc power sources may be either series connected penlight or flashlight cells or well-filtered, line-operated power supplies, as preferred.

Designed for use with standard ceramic pick-ups, the phono amplifier circuit shown in Fig. 2 uses one of the uncommitted transistors as an emitter-follower preamp to achieve a high input impedance, while the other two are wired in a high-gain Darlington configuration. Parallel-tee and bridged-tee RC networks are used to provide treble and bass control, respectively. A 10k potentiometer, capacitively coupled to the Darlington's output load through a 1- μ F capacitor, serves as the circuit's gain control. The LM389's amplifier section is capacitively coupled to the loudspeaker. The output (pin 1) to ground series RC network is optional.

Consumer Tested Remedy for Sick Car Performance Sparks New Life in Pre-1975 Cars.

Owners of pre-1975 cars get better performance with less maintenance when they install one of the Mark Ten C.D. Electronic Ignition Systems. In fact, thousands of users testify the Mark Ten has noticeably improved their automobile's performance. As a California doctor stated after using the Mark Ten for 95,000 miles. "... I can 'feel' the difference in performance between my conventional ignition and the Mark Ten..."



Mark Ten Systems* spark each plug with 50,000 to 60,000 volts in secondary output compared to a mere 25,000 volts in standard and most pointless systems. This means dramatic increases in acceleration and general engine performance, and substantial increases in gasoline mileage. Points will last the lifetime of the rubbing block. Spark plug life is extended three to ten times due to the hot spark generated by the Mark Tens, which eliminates fouling and cleans dirty plugs. And the Mark Ten Systems virtually eliminate at least 2 out of 3 tuneups! Look at what Delta Customer P.S. from New York wrote, "... I might add that I had another unit of yours that has been on three cars so far. Each of the cars was driven about 50,000 miles

before it was turned in. *Not one of the cars ever had a new set of points, new plugs or a tune-up.*

Now its on the fourth car with 20,000 miles on it and going strong." The result? **BIG SAVINGS!**

Send today for your copy of the new Delta brochure and learn how a Mark Ten System can spark your car into new life.

*Only Delta Products offers a full line of C.D. ignitions: The Mark Ten and Mark Ten B, available assembled or in kit form; and the Mark Ten C, assembled only.

DELTA PRODUCTS, INC.

P.O. Box 1147
Grand Junction, Colo. 81501
(303) 242-9000 Dept. PE

I want to know more about Mark Ten CDI's. Send me complete no-nonsense information on how they can improve the performance of my car.

Name

Address

City State Zip

THE BOMAN HIGHWAY HIDE-AWAY

Remote Control Modular 23 Channel In-Dash CB Radio



CBM-6000

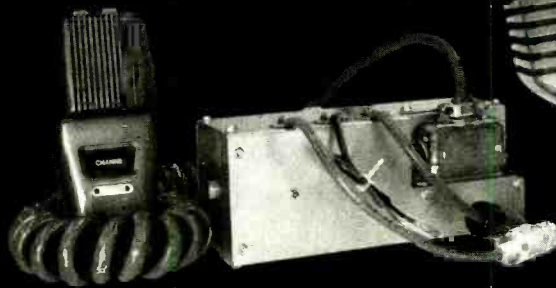

Boman offers the ultimate in CB design. The "High-way Hide-away" CB unit is engineered in a small package that mounts in any "hide-away" location: under dash, on fire wall, in glove compartment, etc. Can be attached in any position to any Boman radio, cassette player or 3-track player. Module-lation microphone — which easily detaches — contains all the CB controls: digital channel indicator, transmit and receive mode indicator lights, volume and squelch controls, standby control, up/down two-speed channel selector and push-to-talk button. The CB unit contains the most advanced technology: digital synthesis and phase lock loop circuitry for optimum frequency stability.

This module will mount on any Boman unit for any and all domestic, foreign automobiles, trucks, boats and campers.

Boman also offers a complete line of in-dash and under-dash car stereo equipment.



Boman *Astrosonix*

A DIVISION OF
BOMAN INDUSTRIES
9300 HALL ROAD, DOWNEY, CA. 90241

Toll Free Numbers: Inside California 800-352-2553; Outside California 800-421-2533

CIRCLE NO. 11 ON FREE INFORMATION CARD

www.americanradiohistory.com

**CIE has
a terrific idea
for a few people
who know what
they want.**

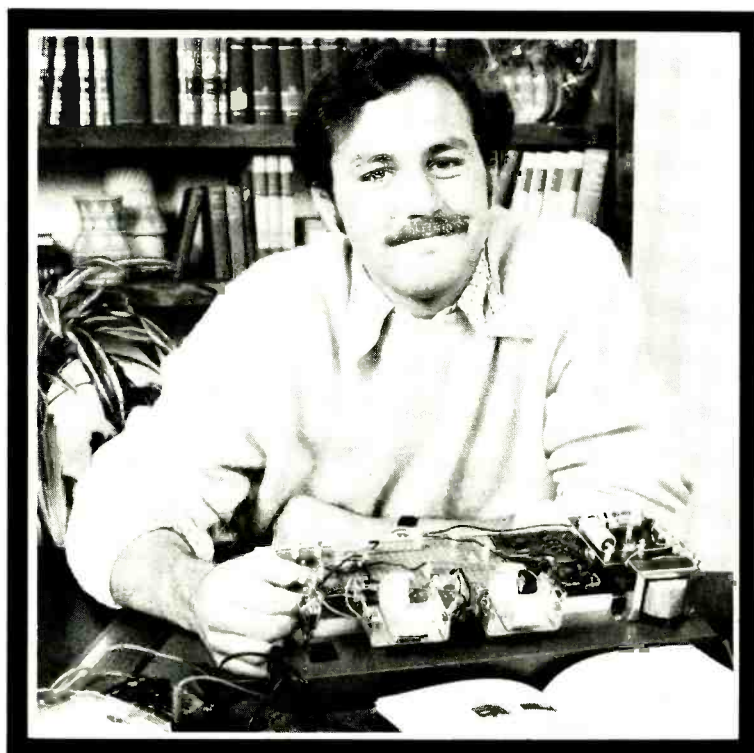

If you want success in electronics . . . if you want the skills people are glad to pay for . . . find out about CIE training. It's a terrific idea that can get you on your way to success in electronics troubleshooting.

Let's face it, learning valuable new skills isn't something you just breeze through. Especially in a modern technological field like electronics troubleshooting. You've got to really *want* success if you're going to build your skills properly.

But, oh boy, the rewards when you do! In today's world, the ones who really *know* electronics troubleshooting find that people . . . even industries . . . look for their help.

What about you? How much do you want the thrill of success . . . of being in demand? Enough to roll up your sleeves and work for it?

Why it pays to build troubleshooting skills .

Suppose the automated production controls on an assembly line break down. Imagine how much money the manufacturer can lose when help doesn't come *fast!* And it takes a skilled electronics troubleshooter to move in . . . locate the problem . . . solve it . . . and get the lines moving again.

Or take a TV station. Breakdowns are costly in broadcasting where time is money. Viewers won't sit forever waiting for sound or the picture to come back. Before they change channels, the station needs to get back on the air again — with the help of a skilled troubleshooter.

No question about it. Building new skills in electronics troubleshooting is an investment in your future. It's well worth the effort.

Why you should get CIE to help you do it .

Troubleshooting starts with *ideas* . . . principles. CIE's Auto-Programmed® Lessons help you get the idea — at your own most comfortable pace. Step by step at home, you explore each principle — each theory — until you understand it thoroughly and completely. Then you start to use it.

How CIE helps you turn ideas into reality .

If you're a beginner, you start with CIE's Experimental Electronics Laboratory. You actually perform over 200 experiments to help you grasp the basics. Plus you use a 3-in-1 Precision Multimeter to get your first taste of the testing, checking, analyzing steps you take in troubleshooting!

SEPTEMBER 1976

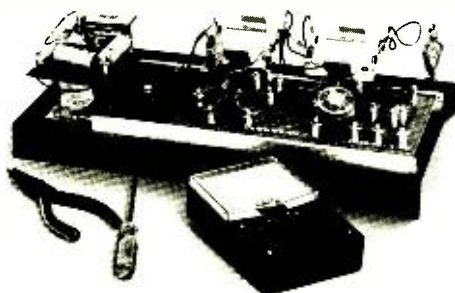

How 3 practical steps help you build troubleshooting skills .

You'll take your first practical step in professional troubleshooting when you build your own 5MHz triggered-sweep, solid-state oscilloscope.

As a trained troubleshooter, you'll use your oscilloscope the way a doctor uses his X-ray machine. As a student, you learn how to "read" waveform patterns on a big, 8cm. x 10cm. screen . . . how to "lock them in" for closer study . . . how to understand and interpret what they tell you.

Your second practical, skill-building step begins when you get your Zenith 19-inch diagonal, solid-state color TV — featuring nine removable modules! Now's your chance to apply the new skills you learned with your oscilloscope!

With CIE's guidance, you perform actual service operations — the kind you'd handle on the job as a trained troubleshooter! Using the TV, you learn to trace signal flow . . . detect and locate malfunctions . . . restore perfect operating standards . . . just as you would with any sophisticated electronics equipment.



Finally, step three rounds out your experience as you work with a completely solid-state color bar generator — actually a TV signal transmitter that produces ten different display patterns on your TV screen!

You study a gated color bar rainbow . . . crosshatch lines . . . dot patterns.

You explore digital logic circuits . . . observe the action of a crystal-controlled oscillator!

This practical, "hands on" training takes concentration and effort. But it's enjoyable and rewarding. And it's a great way to prepare for a troubleshooting career!

Why it's important to get your FCC License .

For some troubleshooting jobs, you *must* have your FCC License. For others, employers often consider it a mark in your favor. It's government-certified proof of specific knowledge and skills!

Almost 4 out of 5 CIE graduates who take the exam get their Licenses. More than half of CIE's courses can prepare you for it . . . and the broadest range of career opportunities!

Free catalog!

Mail the card. If it's gone, cut out and mail the coupon. If you prefer to write, mention the name of this magazine. We'll send you a copy of CIE's FREE school catalog — plus a complete package of independent home study information! For your convenience, we'll try to have a representative call to help you with course selection. Mail the card or coupon . . . or write: CIE, 1776 East 17th Street, Cleveland, Ohio 44114.

CIE Cleveland Institute of Electronics, Inc.

1776 East 17th Street, Cleveland, Ohio 44114
Accredited Member National Home Study Council

YES . . . I want to succeed in electronics. Send me my FREE CIE school catalog — including details about troubleshooting courses — plus my FREE package of home study information!

NAME (please print)

ADDRESS APT.

CITY

STATE ZIP

AGE PHONE (area code)

Check box for G. I. Bill information:

Veteran Active Duty

PE-13

Mail today!

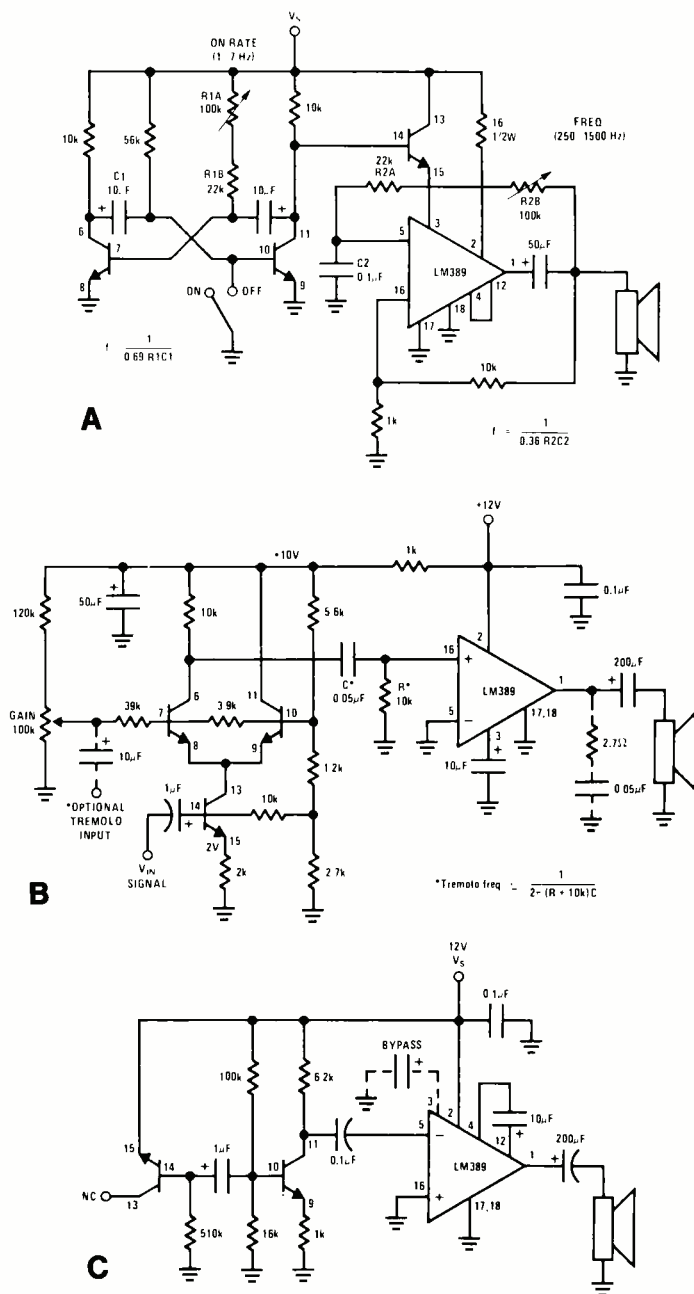

Fig. 4. Additional applications for the LM389 include: (A) a siren circuit; (B) a voltage-controlled amplifier with tremolo; and (C) a noise generator circuit.

The phonograph circuit (Fig. 2), for example, could be modified quite easily for use as an intercom. In addition, since the transistors have excellent high-frequency characteristics, the device is well suited for receiver and walkie-talkie projects. Add a suitable sensor, such as a photocell or thermistor, wire the amplifier section for operation as an oscillator (as in the siren circuit), and the LM389 can become the active part of a burglar or fire alarm system. The applications are there waiting—all that's needed is your imagination!

Reader's Circuit. Suitable for use in games, ESP experiments, and other applications, the random 4-digit number generator circuit illustrated in Fig. 5 was submitted by reader Michael S. Pyska (934 Seneca St., Lewiston, NY 14092). Requiring relatively few components, the design should be a good single evening's or weekend's project for

the average hobbyist. The "heart" of Mike's design is a four-digit counter containing integral multiplexed 7-segment output drivers. In operation, a free-running pulse generator or "clock," IC1, drives the counter continuously. Since the instantaneous count in IC2's register is changing rapidly, it is essentially a random number. Depressing and releasing the latch switch, S2, permits this number to be displayed on the readouts.

Standard components and devices are specified for the project. The clock, IC1, is a familiar type 555 timer while the counter/driver, IC2, is National Semiconductor's MM74C925. The four readouts are 7-segment common-cathode types, with the driver transistors, Q1 through Q4, type 2N2222 general-purpose npn devices. All resistors are one-quarter or one-half watt types, with the series readout current limiters, Rs, 100 to 220 ohm units (the exact value is not critical). Power switch S1 is a spst toggle, slide, or rotary unit, while the latch switch, S2, is a spdt, spring return pushbutton or lever type. Finally, the power pack consists of three or four series-connected penlight or flashlight cells.

With neither parts arrangement nor wiring dress critical, the random number generator can be assembled using any standard construction technique from simple perfboard to a carefully designed PC card. If desired, it can be used as a two or three, rather than four, digit generator, and common-anode instead of common-cathode readouts can be used by adding a pair of hex inverters.

Device/Product News. Motorola Semiconductor Products, Inc. (P.O. Box 20294, Phoenix, AZ 85036) has introduced its popular *switchmode* power transistor in low-cost plastic packages. First in the new series are the MJE13002 and MJE13003 devices, rated at 1.5 amperes and 600/700 V blocking voltage. Switchmode transistors are designed especially for switching power supplies and other circuits requiring very fast turnoff time. They are characterized at 100°C operation with *limit* specifications for critical parameters—including a complete inductive-load switching performance matrix for collector currents ranging from 0.5 to 1.5 A., and reverse biased SOA for various turn-off voltages. The devices are housed in TO-126 packages.

A new line of inexpensive GE-MOV^h varistors has been announced by GE's Semiconductor Products Department (Electronics Park, Bldg. 7-49, Syracuse, NY 13201). Ten models are available covering 14 to 250 V ac and 14 to 56 V dc. Typically, these devices are used for light-duty transient protection, such as relay-coil spike suppression.

Several products of potential interest to hobbyists and experimenters have been introduced by the Fairchild Camera and Instrument Corporation. Its Optoelectronics Division (4001 Miranda Ave., Palo Alto, CA 94304) is offering a complete digital clock module, a group of 8/10-inch high 3½- and 4-digit clock displays, and a family of 5-kV optical couplers, while its Linear Integrated Circuits Division (464 Ellis St., Mountain View, CA 94042) is manufacturing a new 5-watt, high-voltage audio amplifier IC in a molded 12-lead plastic package. The clock module, type FCS8100, contains a MOS circuit which features 10-second protection against power interruptions as well as a power failure indication, a display with a.m., p.m. and alarm set indicators and a colon in a solid-state assembly that measures only 3.5 × 1.75 inches and is 1-inch thick. The unit also incorporates power supply and output drive

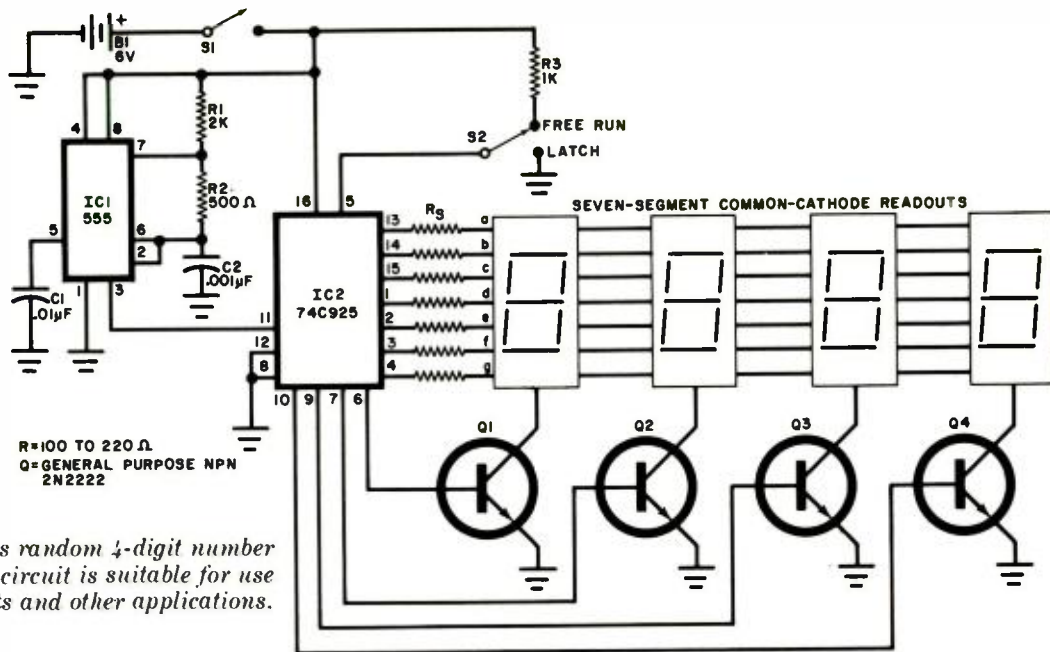

Fig. 5. This random 4-digit number generator circuit is suitable for use in games, experiments and other applications.

circuitry for alarm and clock radio operation; only the switches required by the application and a transformer with a 12.6-volt center-tapped secondary are needed to make the module a functioning clock. Similar 0.8-inch high clock displays also are available in either 3½- or 4-digit formats. The FCS8000 and FCS8001 are 3½-digit, common-cathode displays requiring only 8-mA drive current per segment and including AM/PM indicators, with the two versions offering optional spacing between digits. The

FCS8024 and FCS8025 are 0.8-inch high 4-digit displays which permit 24-hour time readouts; the two versions offer optional spacing between digits, but do not include AM/PM indicators. All the displays utilize Fairchild's patented "light-pipe" construction for maximum brightness at low drive current levels. The new line of optical couplers is intended as direct replacements for most low voltage standard units and carries corresponding type numbers.

DESIGNING OPTIMUM-Q AND SMALL INDUCTORS

BY R. E. MARTIN

Optimum Q is achieved in an inductor when its length and diameter are equal. This table will serve as a guide when designing high-Q inductors for r-f circuits. It gives maximum turns and inductance for various wire sizes when close-wound in a single layer.

Higher Q's will be obtained if the turns are spaced at one wire diameter. This results in half the turns and one quarter of the inductances listed in the table. Should an intermediate inductance or number of turns be desired, the factor, K, at the bottom of each column can be used for calculation from the formula $L=KT$

Wire AWG	Diameter & Length (inches)						
	1/8	1/4	3/8	1/2	5/8	3/4	1
16	T		6	8	10	12	16
	L*		.233	.552	1.08	1.86	4.41
18	T	5	8	10½	13	15½	21
	L*	.108	.414	.950	1.82	3.11	7.60
20	T	3	6½	10	13	16½	26
	L*	.0194	.182	.647	1.46	2.93	11.7
22	T	4	8	12	16½	20	24½
	L*	.0345	.276	.931	2.35	4.31	7.76
24	T	5	10	15	20½	25	30½
	L*	.0539	.431	1.46	3.62	6.74	12.0
26	T	6½	13	19½	25½	32½	51
	L*	.091	.728	2.46	5.61	11.4	19.2
28	T	8	16	24	32	40	48
	L*	.138	1.10	3.72	8.83	17.2	29.8
30	T	10	20	30	40	50	60
	L*	.215	1.72	5.82	13.8	27.0	46.5
	K	.00215	.00431	.00647	.00862	.0108	.0129

*Inductance, L, is in microhenries.

When small inductors are needed, for r-f chokes or h-f filter networks, it's frequently convenient to wind them on composition (carbon) resistors. The table shows inductances for various wire sizes when close-wound on common resistor bodies. The resistor value should be above 4.7 kilohms for the low-value inductances and above 47 kilohms for the higher values, unless low Q is desired.

The number of turns listed leaves a little space at the end of the resistor body to file small notches in order to guide the coil wire down to the resistor lead while not allowing the coil turns to fall off the ends. Do not use wire-wound resistors.

Wire AWG		Resistor Size			
		¼W	½W	1W	2W
20	T	3	7	11	14
	L*	.013	.097	.32	.63
22	T	4	8	13	17
	L*	.023	.13	.45	.92
24	T	5	10	17	22
	L*	.036	.20	.76	1.5
26	T	6	12	21	27
	L*	.051	.29	1.2	2.3
28	T	8	15	26	33
	L*	.092	.45	1.8	3.5
30	T	9	19	32	41
	L*	.12	.72	2.7	5.4
32	T	11	22	39	50
	L*	.17	.96	4.0	8.0
34	T	14	28	49	62
	L*	.28	1.6	6.3	12
36	T	18	34	60	77
	L*	.46	2.3	9.5	19

*Inductance, L, is in microhenries.



Tips & Techniques

EXTENDING TUBE LIFE

If you have a TV or radio receiver that uses a filament string, you can easily avoid tube failures due to current surges that occur when line power is first applied. The non-linear resistors (dubbed "lamp misers") that are sold to extend the life of incandescent lamps can be used for this purpose. These devices are inexpensive (about \$1 each), have a cold resistance of about 150 ohms, a "hot" resistance of about 2 ohms, and a load capacity of about 300 watts. Drop one of the resistors into a wall outlet-to-bulb socket adapter, and then screw in a bulb socket-to-power outlet adapter. Plug the assembly into the wall, and the receiver into this device. The surge projector stabilizes to about a 2-volt drop in about 20 seconds. It runs hot (about 2 watts dissipation), but this heat is not critical.—*Bertram A. Thiel*

FILAMENT POWER FOR FLUORESCENT READOUTS

You can supply power to the filaments of fluorescent readouts without using expensive transformers or dropping resistors that generate a lot of heat. Simply insert a

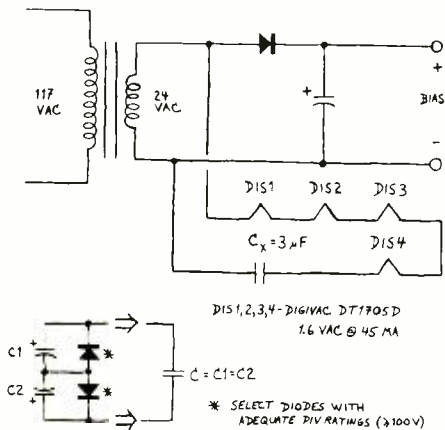

non-polarized capacitor in series with the filament string, and use the transformer in the bias supply as a voltage source. The capacitor will act as a voltage-dropping reactance without "consuming" any power. Experiment to find the value of C_x . Start with a small (about 0.5- μF) capacitance and gradually increase until the desired effect is obtained. When this idea was applied to a four-digit clock readout, as shown, only 3 μF was needed. You can buy nonpolarized electrolytics (designed for speaker crossovers), or make your own as shown.—*Gregory Whittier*

PC STICK-ON DOTS

Here's a good source of stick-on dots for pc etching work. Stick a strip of vinyl electrical tape onto drafting acetate or any clean plastic thicker than the tape itself. Then use a leather punch (multiple die starwheel type) to punch out as many dots as required in the particular size you need. With practice, you can cut through only the tape, using the backing material again and again. You can even punch a hole within a disc to surround mounting holes on the corners of the pc board.—*Bob Best*

ISOLATING COMPONENTS FROM PC BOARD

Before mounting a component on a pc board, slip a small piece of cardboard between it and the board. Then solder the leads, snip off excess, and gently pull the cardboard out from under the component. This will provide a degree of thermal insulation between component and board, and a more stable circuit.—*William Graham III*

ZERO-INSERTION-PRESSURE DEVICE FOR IC'S

IC leads can easily be damaged when they are inserted into the usual breadboarding strips. A handy device called the ZIP-DIP (Zero Insertion Pressure) from Textool Products (1410 W. Pioneer Dr., Irving, Tx 75061) can eliminate such problems. The ZIP-DIP is inserted into the breadboard, and its lever brought to the upright position. The holes of the ZIP-DIP are opened and the IC is dropped in. Firm contact to the IC pins is made when the lever is moved to the closed (horizontal) position. The adaptor sells for about \$4. It will accommodate 14-pin DIPs, 8-pin mini-DIPs, and metal-can types if the leads are bent into an in-line configuration.—*Sol D. Prenskey*

RUBBER FEET

Silastic® or RTV type silicone rubber can be used to make rubber feet for small enclosures. Drill holes in the corners of the bottom of the chassis or utility box and place self-tapping screws in each hole. (Hex-head screws work best.) Then, apply a blob of silicone rubber completely around each screw and touching the chassis. Allow the rubber to "cure" for about five minutes in an inverted position, and then turn upright onto a sheet of waxed paper for complete curing.—*Robert L. Gray*

CUTTING PC BOARDS

Using a hacksaw to cut pc boards to proper sizes can be very difficult. Fortunately, there's a much easier way. Lay the board on a flat surface and draw a line where the cut is to be made. Then score the board on both sides with a common glass cutter and a straight edge. Place the scored line over a dowel and apply firm but even pressure on both sides of the score. The board will cleanly snap along the line. A glass cutter with a carbide tip is recommended over the less costly ones.—*W.J. Prudhomme*

Operation Assist

If you need information on outdated or rare equipment—a schematic, parts list, etc.—another reader might be able to assist! Simply send a postcard to Operation Assist! POPULAR ELECTRONICS, 1 Park Ave., New York, NY 10016. For those who can help readers, please respond directly to them. They'll appreciate it! (Only those items regarding equipment not available from normal sources are published.)

Silvertone Model 1946 3-band receiver covering .55-15.5 MHz. Serial 462653. Schematic and alignment information. A.F. Schweikhard, 3422 N. 24th Dr., Phoenix, AZ 85015

Jackson Model 805 VTVM. Need a new function switch or substitute. Burt Douglas, 181 Lotus Pt. Road, Irving, NY 14081

Halicrafters S-40A receiver circa 1947. **Acton Labs** TCV-271 CB transceiver. Schematics and/or service manuals. David Newman, 418 Pleasant St., S. Weymouth, MA 02190

Symbolic Displays Inc. Model 103 Digital IC tester. Need schematic and/or owner's manual. Benny R. Maestas, 17630 Lakewood Blvd #10, Bellflower, CA 90706.

IBM Model 1571 diode tester known as IBM print 450918S 32001. Uses Weston panel meter. Need operations manual and/or data on self-contained batteries, 10-pin male plug adapter cord, etc. Fred W. Gatzke, 184 Hewes St., Brooklyn, NY 11211

Zenith Model 95244 cabinet Long Distance Radio serial R561561. Schematic diagram, operations manual, and any other information. Roz Paturick, 4201 Locust, Apt. 406, Kansas City, MO 64110

Granada Model 8000 AM FM 8-track stereo. Need drive motor for tape deck or a source of parts. Lyle W. Jenkins, Electronic Repair Service, Lakeside Acres, Rte. 2, Killen, AL 35645

Sonora Model B31 AM radio covering 550 to 1500 kHz, circa 1929-35 with LL18 dynamic speaker. Schematic needed. Barry S. Radio and TV, c/o George Barry, 89 Gilbert St., Quincy, MA 02169

Dumont Model 3290 oscilloscope, serial 4X00. Schematic and parts list. C.H. Welch, Jr., 336 Orchid Rd., Birmingham, AL 35215

Thomas Model VL-5 transistor organ. Need schematic and service information. N.M. Dietrich, Rt. 1, Box 393A, Texarkana, AR 75501

Central Electronics Model 200-V broad-band exciter/SSB transmitter. Need a set of 160-meter band (1750 to 2500 kHz) broadband coupler coils. Jack Williamson, W5PJS, 127 Patton Ave., Shreveport, LA 71105

Hickok Model 665 oscilloscope. Schematic, service and operation manuals. Joseph Planisky, 13690 Diagonal Road, Salem, OH 44460

Concertone Model 800 stereo tape recorder. Schematic, service and operation manual needed. John L. Nowack, 1326 Maple St., Bellaire, OH 43906

Philco Model 37-610 three-band receiver (1935). **Leaer** VHF-LF aircraft transceiver. Model numbers on chassis LR-6A-1 vhf receiver, LRA-6A LF receiver, RT-10E transmitter, Omni-range converter model 2214A. Schematics, operation manual, and service info needed. James Marble, 2801 Sequoia Ln., Arlington, TX 76010

E.H. Scott Allwave Model 15 receiver, circa 1933. Chrome plated two chassis, electrodynamic speaker, 2-2A3 output tubes, 5Z3 rectifier. Require Dial escutcheon tuning indicator and schematic. T.W. Scott, Box 601, Greenwood, Nova Scotia, BOP 1N0, Canada

Hickok Model 640 oscilloscope. Need power transformer or substitute info. Joe Grygar, 8816 Greyling Pl., San Diego, CA 92123

Hartman Hurricane vhf FM Marine transceiver, 5 channels, Serial 45866. Need schematic and/or service manual. Paul Smith, W1GHN, 65 West St., New London, CT 06320

Jackson Model 655 Audio Oscillator. Service manual and/or schematic. John J. Schnupp, 6464 W. 11th Lane, Hialeah, FL 33012

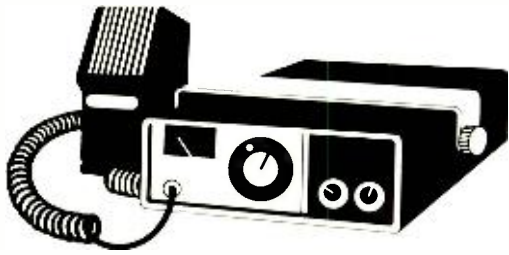

CB Scene

By Ray Newhall, KWI6010

FCC PROPOSES NEW CB RADIO CHANGES

WITH MORE than a half-million new license applications flooding the FCC mailbags each month at its new address (Gettysburg, PA 17326), you can be certain that the FCC is concerned with the future of the Citizens Band. A few months ago, I suggested that 6,000,000 to 7,500,000 CB rigs might be sold this year. Now it appears that even the most optimistic of CB marketeers may have short-changed public demands for CB. In mid-1976, a strange thing seems to be happening . . . the people who bought mobile rigs earlier this year are returning to their dealers for base units to match.

Although it may not appear that way out in CB-land, the FCC is very anxious to expand the number of CB channels, as promised last March. It was just in the nick of time that FCC technicians determined that the addition of 50 or more channels on the Class D Band would raise unbelievable havoc on AM broadcast frequencies because of a phenomenon known as "intermodulation interference." It is created whenever two basic frequencies are mixed: two new frequencies are generated in addition to the two original frequencies. This phenomenon of "heterodynes" is used as the basis of the common superheterodyne receiver, in which the desired antenna frequency is mixed with the frequency of a local oscillator to create an intermediate frequency of 455 kHz. The three other frequencies are filtered out, and the IF frequency is isolated, amplified and demodulated.

Right now it appears that 45 channels may be the viable maximum that can be assigned in the 27-MHz Class D band without creating an intolerable level of harmonic interference. We ex-

pect the FCC to authorize this expansion in 1977, but do not anticipate that such expanded-channel units will be available for some time thereafter. For one thing, the FCC will not be certifying units for "Type Acceptance" for some time afterwards. But Uncle Charlie knows that 45 channels are not nearly enough to satisfy the future needs for personal two-way radio. One or more additional band must be assigned at higher frequencies where noise, skip and sunspot activity will not hamper communications. The FCC is now searching frantically for spectrum space which could be transferred from another allocation to The Citizens Radio Service.

The FCC is examining portions of the radio spectrum which might accommodate uhf CB. A portion near 460 MHz is under examination, as is another segment at 915 MHz. I think, however, that any allocation of CB channels above 300 MHz would be very unwise within the scope of current technology. Equipment to operate at these uhf frequencies would be too costly for the average citizen and would require special installation techniques which are not currently available to the consumer. We have already seen the demise of Class B CB because of its cost.

Other New Proposals. Along with new frequency authorizations, we can expect the FCC to require closer frequency tolerances and lower spurious emissions from future CB rigs. Already there are serious problems developing out of harmonic interference between legal CB transceivers and commercial TV, AM and FM receivers and solid-state stereo devices. Congress is considering legislation which

would require these home entertainment electronic devices to be more immune to external interference, but the permissible amount of harmonic radiation from the CB transceiver itself must also be reduced.

The FCC is now considering tighter restrictions and rule changes in all of the areas listed below.

- Harmonic radiation from the transceiver cabinet and antenna terminals suppressed to at least 70 dB.
- Frequency tolerances for single-sideband transmitters to be held to less than $\pm 0.0001\%$ (about 25 Hz @ 27 MHz). This would eliminate the need for clarifier controls. The present requirement for AM transmissions (about ± 1350 Hz) would probably not be changed.
- Manufacturers would be required to engrave or stamp a serial number into the chassis of each transceiver so that it can be identified if stolen.
- Manufacturers will be required to affix a warning label informing the buyer or user that the penalty for unlicensed use is \$10,000 and/or one year imprisonment.
- FCC is proposing to reorganize all CB Radio classes under the name, "General Radio Service." Class C (remotely controlled devices) would be incorporated into Class D and called the "CB Radio Service." (The FCC is reportedly inundated by letters from Class C users objecting to this proposal, though users under 18 can still operate remote-control models under a CBers station license.) Class A would be redesignated as the "UHF CB Service."
- The designation of Channel 11 as a "hailing-only" frequency has not worked out. It is proposed that it be restored to the status of all other CB channels, leaving only Channel 9 as a designated use frequency.
- After 1976, no more 100-mW Walkie-Talkies may be manufactured to operate on 11 meters. They have been moved to 49.82 - 49.90 MHz. Use of existing units will be permitted until 1983.
- **Technological Improvements.** The recent manufacturer's CB show, "PC-76," revealed much technical development which will soon be evident on the display shelves of your local CB radio store.
Phase-locked loop (PLL) circuitry on an IC chip will come into greater

avanti ASTROPLANE CB base antennas give you patented performance



The unique construction features are so exceptional they are covered by U.S. Patent #3587109. 4.46 db gain over isotropic provides a stronger signal in and out.

To make use of the better signal, the Astroplane radiates the signal from higher up than other CB antennas and at a better angle. According to Dr. Alva Todd of the Midwest College of Engineering, "it possesses an unusually low angle of maximum radiation." This low angle of radiation means that your power is radiated at the horizon and not up into the clouds for greater efficiency.

You'll also get long lasting, trouble-free performance because it is compact in design—without long drooping radials, without coils to burn or short out, and high power capacity for lightning and static dissipation.

\$36.95 Suggested Retail
Length 12 Ft. • Dia. 30 in.

Free 24 page color catalog

Avanti makes a complete line of high performance base and mobile CB antennas from \$11.95 to \$373.95.

avanti

RESEARCH AND DEVELOPMENT, INC.
340 Stewart Avenue, Addison, IL 60101

Creators of the famous

MOONRAKER

use to determine and control r-f frequencies. This permits manufacturers to build highly versatile transceivers containing only two or three high-quality crystals instead of 14 or more as previously required. Digital displays will become more commonplace as channel indicators, and you may soon dial-in your channel selection on a ten-key pad.

These new circuitry techniques are already beginning to appear in the marketplace, and they will pave the way for extended channel allocations. But don't hold your breath waiting for rigs with extended channel capabilities. Even if 45 channels are authorized by FCC in 1977, it will be many months (or years) before they are available for use, as previously noted. And they will probably be considerably more expensive than present Class D rigs. If you buy a new rig this year, it will likely be well-worn before you can replace it with one with extended channel capability. The current channels will not become obsolete. In fact, it is possible that most of the extended channels may be reserved for SSB use, or use between units of the same station only.

New Facts To Remember. When you buy your new CB rig, file your license application (Form 505), along with your check for \$4.00, with the FCC, Gettysburg, PA 17326. This is a new address, the one on your Form 505 is obsolete.

You may use your rig immediately after you mail your *Form 505* if you complete a *Form 555-B* and hold it in your possession. You may copy the *Form 555-B* published in the July issue of PE, or you may obtain a copy by writing REST MARINE, Box 170, Old Greenwich, CT 06870. (Please enclose a self-addressed, stamped envelope.)

There is a new edition of Part 95 available for only \$1.50 from the Superintendent of Documents, Government Printing Office, Washington, DC 20402, or the Public Documents Distribution Center, Pueblo, CO 81009. This is an extract of Volume IV, published in April, 1976, and contains only Part 95. It is not a subscription. (You must have a copy of Part 95 in your possession before you are properly licensed.)

If you have any future subjects that you would like to see discussed in this column, please send your suggestions to me at POPULAR ELECTRONICS, One Park Avenue, New York, NY 10016. ♦

NOW... GET YOUR

CAPTAIN VIDEO



★ Keyboard/Display Module

Ideal for communicating with your microprocessor!

RS-232 interface x 32 characters \$400
TV/TTY kbd/display (16 lines x 64 characters) \$500
Keyboard/CRT Monitor (24 lines x 80 characters) \$700

ORDER FORM

Ship To _____

Subtotal \$ _____

Calif residents add sales tax _____

Please find a check enclosed in the amount of total order \$ _____

Bill my BankAmericard _____ exp _____

Mastercharge _____ exp _____

My signature as purchaser: _____ date _____

MICON INDUSTRIES
Micon Industries
252 Oak Street
Oakland, CA 94607
(415) 763-6033

CIRCLE NO. 44 ON FREE INFORMATION CARD

PLANNING TO MOVE?

Let us know 8 weeks in advance so that you won't miss a single issue of **POPULAR ELECTRONICS**.

Attach old label where indicated and print new address in space provided. Also include your mailing label whenever you write concerning your subscription. It helps us serve you promptly.

Write to: P. O. Box 2774, Boulder, CO 80302, giving the following information:

Change address only Extend my subscription

ENTER NEW SUBSCRIPTION

1 year \$9.98 Payment enclosed (1 extra BONUS issue) delivery. Bill me later

NEW ADDRESS HERE **0188**

Name _____ please print

Address _____

City _____

State _____ Zip _____

Additional postage per year: For Canada add \$2. For countries outside U.S. and Canada, add \$3—cash in U.S. currency only.

AFFIX OLD LABEL →

If you have no label handy, print OLD address here.

Name _____ please print

Address _____

City _____

State _____ Zip _____

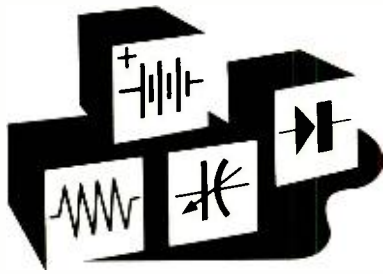

Inside Basic Electronics

By Sol D. Premsky

USING RESISTANCES

IN OUR first column, we discussed the many various types of fixed and variable resistors that are available for use by the experimenter/hobbyist. Before leaving resistors altogether, we should consider some of the problems involved with using resistance itself. For instance, how do you design a resistive voltage divider—a very common configuration in electronic circuits.

Suppose we have a device that operates at 6 volts and our available source of supply is 12 volts. (The same principles would apply for any other combination of supply and demand.) A simple resistive voltage divider can be designed as shown in Fig. 1A. Resistors R_1 and R_2 are equal so the voltage across R_2 , as measured by the meter, is 6 volts.

When we proceed to connect a lamp across R_2 (Fig. 1B) we find that the lamp glows only dimly, if at all, and that the voltage across it is now sub-

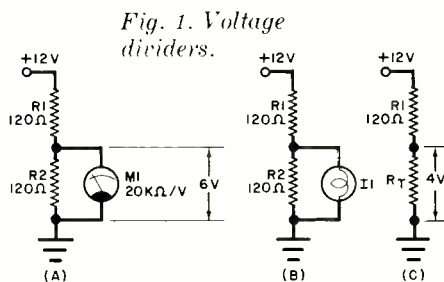

stantially less than 6 V. What has happened, of course, is that the effective resistance of the lamp in parallel with R_2 has dropped so that the voltage across the combination is not sufficient to light the lamp. The lamp is rated at 6 volts and 50 mA, which means a resistance of 120 ohms. The combination of the lamp and R_2 thus gives a total resistance of 60 ohms and the voltage across the combination is 4 V (Fig. 1C).

We realize now that the 20,000 ohm/volt meter on its 10-V range, connected across R_2 , drew only a small

amount of current and did not provide any appreciable load on the circuit. On the other hand, the current drawn by the lamp was sufficient to drag down the output voltage. As a general rule: *To avoid loading the circuit by more than 5%, the load should be at least 20 times greater than the parallel resistance.*

Variable-Voltage Dividers. It is often possible to adjust the voltage

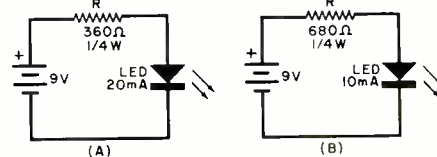

Fig. 2. LED circuits.

across a load by using a variable-voltage divider (a potentiometer as one leg of the divider), especially when in doubt about the definite current characteristics of the load. While such a technique generally seems easy, since it avoids the bother of some calculations, it can often prove to be more trouble than it is worth. This is especially true when miniature pots are used. It is very easy to exceed

the wattage rating of a pot and ruin it permanently.

Suppose, for instance, that we want to use a $\frac{1}{2}$ - or $\frac{3}{4}$ -watt pot in the example in Fig. 1. If the resistance of the pot (composition type) is 5000 ohms, the rated current turns out to be only 10 mA. Using a lower-resistance pot would provide a slightly higher current rating, but it would still be too low for a 50 mA load. So, it seems obvious that using a miniature $\frac{1}{2}$ -watt pot for a 50-mA load would exceed the pot's rating and possibly damage the pot. However, the miniature pot does have many uses in conjunction with op amps and IC's that draw less than 10 mA.

The common 2-watt composition potentiometer can usually be considered a good choice for loads up to 20 mA, with resistances up to 5000 ohms. Staying on the conservative side, the use of wirewound (or equivalent ceramic) types in the 4-to-5-watt ratings is even better. So keep this rule in mind: *For load currents larger than about 10 mA, be wary of using miniature pots in the range of $\frac{1}{2}$ to $\frac{3}{4}$ watts (especially for resistance ranges greater than 5 kilohms).*

Series Dropping—Resistor Method.

A much more direct way of reducing applied voltage is through the use of a simple series resistor. This avoids parallel-loading complications, but we must know how much voltage and current are required by the load. For instance, suppose we want to operate a low-voltage LED from a 9-volt battery. As shown in Fig. 2A, the LED is rated at 2 V and 20 mA, so we need a series resistor to drop the

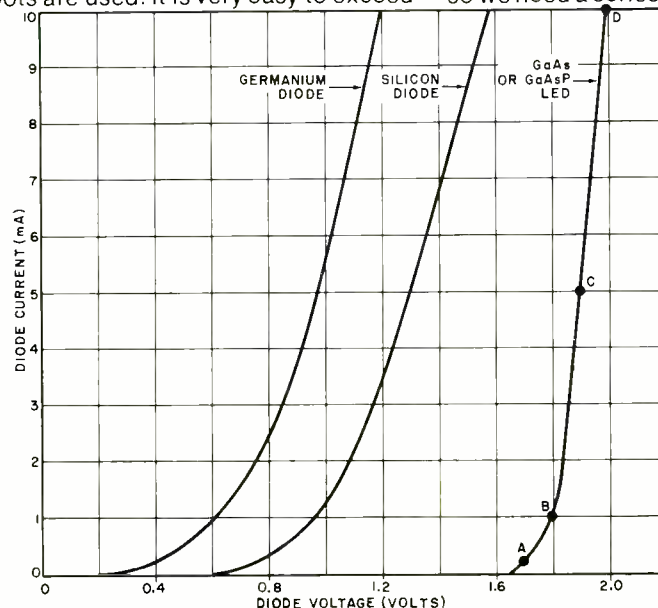

Fig. 3. Curves show dependence of resistance on applied voltage, as well as temperature for diodes.

Superb price!!! Supreme quality!

6-DIGIT
FREQUENCY COUNTERS

6995
(30mHz Kit)
\$99.95 assembled

11995
(250 mHz Kit)
\$139.95 assembled

A counter-offer you can't refuse! It's rock-bottom price and sky-high quality make it your best possible buy! We've proved it to thousands. Let us prove it to you!



Perfect for: **CBers, Hams, Service Techs, & Experimenters!**

- HAM, CB, & COMMERCIAL BANDS • WIRED & TESTED AVAILABLE • 100HZ READOUT • 6 DIGITS
- CRYSTAL TIME-BASE • 1Hz OPTIONAL • MASTER CHG. / B. AMERICARD OK • ADD \$2 SHIPPING

Hufco

Incredible counters starting at \$45.95 are also available!
All counters can be factory wired and tested. Write or call today!
Box 357, Dept. 52, Provo, UT 84601 (801) 375-8566

CIRCLE NO. 35 ON FREE INFORMATION CARD

FREE McIntosh CATALOG and FM DIRECTORY

Get all the newest and latest information on the new McIntosh Solid State equipment in the McIntosh catalog. In addition you will receive an FM station directory that covers all of North America.



MX 113

FM/FM STEREO - AM TUNER AND PREAMPLIFIER

**SEND
TODAY!**

McIntosh Laboratory, Inc.
East Side Station P.O. Box 96
Binghamton, N.Y. 13904
Dept. PE

NAME _____
ADDRESS _____
CITY _____ STATE _____ ZIP _____

If you are in a hurry for your catalog please send the coupon to McIntosh.
For non rush service send the *Reader Service Card* to the magazine.

CIRCLE NO. 42 ON FREE INFORMATION CARD

supply to 2 volts. So $IR = 7$, and $R = 7/0.02 = 350$ ohms. (Use 330 or 360 ohms.)

For a low-current LED (2 V and 10 mA as in Fig. 2B), the resistor would have to be about twice as big—say 680 ohms. The power requirement for the resistor is calculated from $P = VI$ or (for Fig. 2A) $P = 7 \times 20 = 140$ mW and (for Fig. 2B) $P = 7 \times 10 = 70$ mW.

Nonlinear Resistances. Circuits involving incandescent lamps and LED's are not always as simple as they are described above, since these components, under certain circumstances, are nonlinear resistances. In actual practice, this need not present any big problem, as long as the lamp or LED is used at its rated operating value. (A lamp rated for 6 volts with 50 mA flowing through it can be considered a resistance of 120 ohms.) However, if the applied voltage is something less than the rated voltage, the so-called "cold" resistance of the lamp must be taken into account. This will be appreciably less than 120 ohms. A rule covering this action (since an incandescent lamp filament is tungsten) is: *The resistance of a metal increases with temperature or (similarly) when operated at a high current.*

On the other hand, the rule is reversed when it comes to a semiconductor such as the LED. Semiconductors have an unusual voltage-current characteristic as shown in Fig. 3.

Considering the LED specifically, note that the LED requires a much larger threshold voltage for forward conduction to occur. Then, with each small increase in voltage, there is a large increase in current, making the effective resistance smaller. As a result, we can refer to the effective resistance of the LED (or any other semiconductor diode) in terms of specific operating voltages and currents. The rule is: *Semiconductors show a substantially decreased effective resistance with increased temperature or (equivalently) at high voltages or currents.*

The following figures for the four points called out on Fig. 3 for the LED show how rapidly the effective resistance decreases for increasing voltage.

	A	B	C	D
Voltage	1.7	1.8	1.9	2.0
Resistance (ohms)	16k	1.6k	400	200

Many LED's have been ruined by too high a voltage. ♦

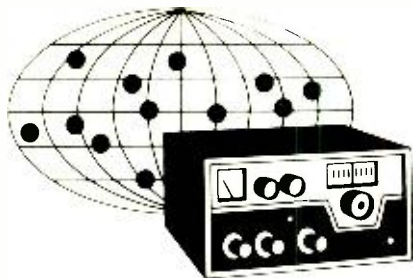

DX Listening

Glenn Hauser

LISTENING to *Deutsche Welle* does not necessarily mean that you are receiving a broadcast direct from Germany. This broadcaster is one of eight major systems which use relay stations outside their home countries. Not only can you not assume that you are listening to a broadcast from the station's home country—you can't always accept what they themselves would lead you to believe. Each has its own peculiar policies and practices with respect to relays.

Programs reach relay sites by different routes. *Deutsche Welle* feeds its Rwanda relay by satellite, which assures freedom from fades and interference, but provides only low fidelity. Its Malta base receives signals from Germany by SSB feeds outside the broadcast bands. Radio Canada International picks up in-band broadcasts at Stittsville, Ontario, and microwaves them to Montreal and then Sackville, New Brunswick, for retransmission. *Deutsche Welle* on 6085 kHz via Sackville often has the interference on 6145 kHz.

Deutsche Welle has been building (with *BBC*) a new relay site in Antigua and Montserrat, which should now be on the air. Also under construction is a site in Sri Lanka, this one to be shared with *Radio Teheran*—which will put Iran in the 'big league' of countries with external relay sites. A few years ago, *DW* tested via the *Sierra Leone Broadcasting Service*, but this failed. *DW* also has an interest in *Radio Trans-Europe*, Sines, Portugal, which is used by a number of different broadcasters but has no programs of its own.

Radio Free Europe and *Radio Liberty*, now based in the same building in Germany, transmit from low-powered stations in Germany, and high-powered sites in Portugal and Spain, respectively. *Radio Liberty*, however, has been in serious danger of losing its rights to beam to the USSR from a Barcelona beach.

How do you know whether you're hearing these stations from Germany or Iberia? Only a current frequency schedule gives the exact answer. In general, however, higher frequencies come from Iberia rather than from Germany. In fact, most *RFE* programs on 11 MHz, and all on the 15, 17 and 21 MHz bands, are from Portugal.

Multi-Site Broadcasters. The *Voice of America* is the supreme multi-site broadcaster, with 72 transmitters in nine foreign countries (as of last year) and 41 at 6 U.S. sites. Last May, *VOA* resumed a policy DX listeners had criticised before—ceasing to show the site in use on QSL cards, and ceasing to announce specific sites (just the studio location of Washington, D.C.). *VOA*'s summer schedule still lists the sites, however. It's not uncommon for two or three different sites to be used on a single frequency within a 24-hour period. Several frequencies (5955, 9650, 11805 and 11830 kHz) show four sites per day, and one—15205 kHz—is listed for five sites each day (Delano, Dixon, Munich, Kavalla, Tangier).

Rather than expanding its network, *VOA* has trouble holding on to existing sites. Okinawa's lease ran out last May, and Thailand is eyeing the megawatt *VOA* station there for its own benefit as relations with the U.S. deteriorate.

Only two of the eight *VOA* transmitters in Liberia are on the air between 2300 and 0100 GMT, and none at all from 0100 to 0300. It's a pity politics prevents these from relaying hard-to-hear Asian, African and European stations back to the USA.

Many parts of the U.S. are too far from *VOA* transmitters for ground-wave reception, yet too close for sky-wave. The central states hear all domestic *VOA* sites well by back-radiation, but on the coasts transmissions from the opposite coast or overseas sites often come in better than

backscatter from relatively close transmitters.

AFRTS uses *VOA* transmitters as backup for overseas military units depending primarily on cable or satellite feeds, 24 hours a day—despite the fact that few overseas *AFRTS* stations use much from *AFRTS*-Washington besides ball games and news. Consequently, *AFRTS* uses only one overseas relay—a Philippine transmitter beamed westward.

The *VOA* site near Bethany, Ohio, is used extensively by other organizations—for two main reasons. Bethany is at a disadvantage in reaching Europe, compared to Greenville, N.C. The latter has a much more southerly path, away from the auroral absorption zone, so the higher-priority *VOA* programs radiate from Greenville; also, *UN Radio*, *AFRTS*, and the *Voice of the OAS* are all interested in reaching Latin America, for which Bethany is as good as Greenville.

You may hear *VOA* out of band; if it's not a receiver image, it still may be a feeder, like 5745 kHz, with the carrier hardly reduced at all. However, one frequency-hour of *VOA* transmissions is officially broadcast out-of-band, via a long-established *BBC* channel—7325 kHz at 0600-0700 GMT.

BBC is another big multi-site station. Except along the East Coast, best reception in North America usually comes from *BBC* sites outside the UKOGBANI. *BBC* sites are referred to only in vague terms—"Atlantic Relay" for Ascension Island, "East Mediterranean Relay" for Cyprus; and "Far Eastern Station" for Malaysia.

Just as the *VOA* uses *BBC* facilities in England, and more recently in Ascension, the *BBC* uses *VOA* facilities in the USA. But despite *VOA*'s openhandedness about the deal, the *BBC* continues to avoid any official admission that it is depending on *VOA* for its Spanish broadcasts at 0215-0415 from Dixon-6010 and Delano-9680 kHz (*VOA* picks up the *BBC* signals at Greenville and feeds them by land line to the west coast); for Portuguese at 2200-2415 on 5995 kHz; and for the World Service at 0030-0330 from Greenville-9510 kHz, the last of which appears in *BBC* schedules as if it were from a site in England. *VOA* warms up that transmitter on 9500 to avoid interfering with an abutting *BBC* relay from Canada on 9510.

The relatively isolated Ascension site, however, uses tapes whenever possible, resulting in a much nicer

If you want a microcomputer with all of these standard features...

- 8080 MPU (The one with growing software support)
- 1024 Byte ROM (With maximum capacity of 4K Bytes)
- 1024 Byte RAM (With maximum capacity of 2K Bytes)
- TTY Serial I/O
- EIA Serial I/O
- 3 parallel I/O's
- ASCII/Baudot terminal compatibility with TTY machines or video units
- Monitor having load, dump, display, insert and go functions

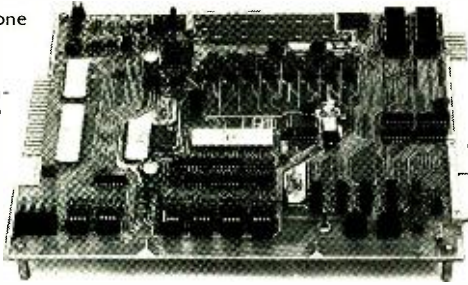

- Complete with card connectors
- Comprehensive User's Manual, plus Intel 8080 User's Manual
- Completely factory assembled and tested—not a kit
- Optional accessories: Keyboard/video display, audio cassette modem

interface, power supply, ROM programmer and attractive cabinetry... plus more options to follow. **The HAL MCEM-8080. \$375**

...then let us send you our card.

HAL Communications Corp. has been a leader in digital communications for over half a decade. The MCEM-8080 microcomputer shows just how far this leadership has taken us...and how far it can take you in your applications. That's why we'd like to send you our card—one PC board that we feel is the best-valued, most complete



microcomputer you can buy. For details on the MCEM-8080, write today. We'll also include comprehensive information on the HAL DS-3000 KSR microprocessor-based terminal, the terminal that gives you multi-code compatibility, flexibility for future changes, editing, and a convenient, large video display format.

HAL Communications Corp.
Box 365, 807 E. Green Street, Urbana, Illinois 61801
Telephone (217) 367-7373

audio sound, even though the signal may be weaker than from Sackville. Most mail to Ascension goes through Patrick AFB, Florida. There are times, such as 0100 GMT, when we can select *BBC* from any of four different countries: Canada on 6175, Britain on 5975, 7325 or 9410; USA on 9510, Ascension on 9580 kHz. A fifth is now being added, in cooperation with *Deutsche Welle*, on Antigua. This will involve some adjustments in *BBC* usage from other sites. Frequencies planned to be used from Antigua are 6010, 6065, 6085, 6175, 9545, 9590, 9605, 9735, 9765, 11765 and 11810 kHz. Not all are for *BBC-English*—some are Spanish, and some are for *DW*.

On the other side of the world, *BBC* is moving its Far Eastern Station from the southern tip of Malaysia to nearby Singapore, whence it once claimed to be operating before Singapore became independent. Christmas Island had been considered a possible replacement for Malaysia, but a Reuters report spotted by Gerry Dexter reveals why not: the phosphate island is being mined heavily.

The cable connecting Britain and Canada works both ways. *RCI* feeds some of its programs to Daventry, England. Indeed, there are no *RCI* broadcasts in Czech, Slovak, Hungarian and Polish from Canada itself; only from Britain. *Radio Trans-Europe*, Portugal, is also used for Russian and Ukrainian *RCI* programs. *RCI* once used the *DW* site on Malta, but was kicked off for political reasons. Most recently, Malta has started allowing Libya to broadcast from the station *DW* built. *RCI* probably wasn't too sorry to lose Malta; they had a lot of problems in feeding their signal there, direct and via Daventry.

However, *RCI* is the only station we know of to try beaming two *different* programs on the same frequency at the same time from the *same site*—Sackville on 9625 kHz. *RCI* European service mixed with the Northern Service two hours a day last summer, and for a few weeks this May, NS overlapped the South Pacific Service for half an hour. This kind of sharing just doesn't work!

Any *Radio Nederland* transmission you hear between 0030 and 0750 GMT is not from Holland, but from Bonaire, which is an excellent spot for reaching all of the Americas and Africa. Bonaire frequencies hardly ever change, which is another advantage for *RN*. The site has even been used for

NEWS RELEASE 1976

OFFICIAL TESTING LAB RATES ALLISON #1...

the BEST OF ALL Ignition Systems!

The ALLISON "Opto" was Officially Rated #1 by a Foreign Government Testing Laboratory as the BEST "Fuel Saving" Ignition of ALL the Ignition Systems Tested, including Systems with C.D. "add-ons"!

NEW ALLISON 'OPTO XR-700'

with the Exclusive... "Built-In" SOLID-STATE VOLTAGE REGULATOR

The "XR-700" is a NEW, redesigned, EASIER TO INSTALL version of the Allison "Opto-Electric", with the New addition of the Voltage Regulator, making it the MOST RELIABLE and Fool-Proof Ignition System ever invented.

*** Allison replaced the mechanical Breaker-Points and Condenser with a "Highly Accurate" Optical Control.** A Beam of Light, passing through a specially designed U.S. & Foreign Patents Pending "ROTOR" precisely triggers a Heavy-Duty "POWER MODULE" that BOTH "Charges and Fires" the Ignition Coil, with the "FASTEST" High Voltage RISE TIME, producing the MAXIMUM "HIGHEST ENERGY" SPARK available

*** Since there is NO Mechanical Friction, there are NO Parts to ever WEAR or need replacing, and ONCE properly Timed, it should NEVER need any Maintenance!** OWELL never needs adjustment, it is PRE-SET to supply the OPTIMUM Performance at BOTH High and Low Speeds. The RPM Capability of the "XR-700" is Factory Tested to 15,000 RPM

*** The "High-Energy" SPARK INTENSITY and DURATION... permits the Positive FIRING of Spark-Plugs, even under the MOST ADVERSE conditions, results in more COMPLETE COMBUSTION and Eliminates "Engine Misfire", hence fewer exhaust Emissions, IMPROVED Fuel Mileage, a HIGHER Performance Level...and helps keep Plugs FROM FOULING, which greatly extends the Spark-Plug LIFE!**

*** Only the Highest Grade (U.S. Made) Solid-State Components are used... UNAFFECTED by Moisture or Vibration!** The Allison "XR-700" was engineered to OUTLAST the LIFE OF YOUR CAR!

*** "EASY-TO-FOLLOW" INSTALLATION.** (Not Necessary to Dismantle your Distributor.)

*** "XR-700"...Designed for those who want the BEST in Performance, Gas Mileage, Quicker Starting, Eliminate frequent Tune-Ups and Maintenance Costs.**

FACTORY-BACKED 10-YEAR WARRANTY. FREE Unit Repair or Replacement on ANY Defects

*** ORDER WITH CONFIDENCE...** Remember, even if you PAY Three Times as much, you cannot get a better Ignition System than the "XR-700"!

*** SAVE! ORDER FACTORY DIRECT.** Send Check or M.O., Car Make, Year, No. Cyl. (4, 6, or 8-Cyl.)

*** You may use your MASTER CHARGE or BANKAMERICARD.** Send us (1) Your Number, (2) Interbank No., (3) Exp. Date.

*** MC or BA Card Holders, ORDER by TOLL FREE PHONE:** (800) 423-6525, Ext. 2. (When in Continental U.S.A.)

*** Before Buying ANY other Type Ignition System... Send Postcard for FREE BROCHURE.**

If you have already installed a "Capacitive-Discharge" Ignition...
*** Convert Your "C-D" Unit to BREAKERLESS!**
INCREASE ITS EFFICIENCY with "XR-CD"...Only \$34.95

*** America's Oldest and Largest Manufacturer of Opto-Electronic Ignition Systems. ©**

ALLISON AUTOMOTIVE CO. *** Our BEST Salesmen...are the USERS of our ALLISON Systems!**

1267 -E8, East EDNA PL., COVINA, CAL. 91722

Only \$59.95 COMPLETE (Calif. Res. add Tax) That's EVERYTHING INCLUDING... Postage & Insurance

*** "CB" USERS: The XR-700 completely ELIMINATES the Major Cause of Primary (Ignition Noise) Interference.**

broadcasts back to Europe, as Holland is in the skip zone from much of Europe; but this is now an added benefit of RN's other relay base, in Madagascar, which primarily serves Africa, Asia and Australia. RN prepares tapes weeks in advance so its relay stations can broadcast high-quality audio—except for news fed via SSB links on SW, often with incredible interference. The electronic-music version of RN's interval signal, used only on PTP feeders such as 5925 kHz, must be heard to be believed. Some RN programs are broadcast from all three sites at the same time, with tapes as much as 30 seconds apart.

The USSR is so large it doesn't need—or at least doesn't have—overseas relay bases. However, though neither country admits it, Bulgaria helps the USSR reach North America. *Radio Moscow* on 9700 and 6070 kHz has long been known to be via Sofia, but this year it has come to light that another Bulgarian site, Plovdiv, also transmits Moscow programs, scheduled when summer began on 11750 and 9530; 11870 is another Sofian. These are the conclusions of monitor Roger Legge in McLean, VA. Most of the other *R. Moscow* North American Service sites are in Simferopol' or elsewhere in the Ukraine, which is most advantageous, next to Bulgaria.

Several Far East sites reach North America from the other direction. Petropavlovsk, on the Kamchatka Peninsula, is best situated, and was used as the summer began on 17720, 15210, 12050, 11970, 11720 and 9710 kHz, as observed by Bill Davis in Laguna Niguel, CA. Vladivostok is on 15100; Nikolayevsk on 12000 and 11870; Blagoveshchensk on 11690, and Khabarovsk on 9635. Do not believe the sites *Radio Moscow* claims on its QSL cards. Discrepancies have been determined by careful study of propagation and operation. Despite a growing Orbita comsat system in the USSR, many *Radio Moscow* frequencies exhibit the characteristics of relays off shortwave. *R. Moscow*, *R. Kiev*, *R. Vilnius* and *R. Yerevan* should be thought of as programs, rather than stations, as each uses transmitters outside its own republic.

Little is known about the sites within China, but there must be several of them. However, *Radio Peking* is relayed to the Americas and Africa from Albania (on 6135, 7120, 9500 and 9780 kHz), and extensively to Europe on

Could the ultimate system be all Crown?



It depends on how you define "ultimate." But Crown may be the only top-quality, state-of-the-art manufacturer whose components could build a complete, ultimate hi-fi system.

For instance: A CX-824 tape deck, world-renowned for reliable performance. Connected to an IC-150A pre-amp. With the signal amplified by a DC-300A power amp, proved in many thousands of hours of professional use. Output controlled, monitored and switched by an OC-150. Possibly a VFX-2 for personal control of crossover points. And sound faithfully reproduced by ES-212 electrostatic speakers.

All Crown. We think that system would be somebody's ultimate. Certainly ours. Maybe yours.

Write us today for the name of your nearest Crown dealer. He'll talk to you — ultimately.

When listening becomes an art,



CROWN
Box 1000, Elkhart IN 46514

CIRCLE NO. 16 ON FREE INFORMATION CARD

Incredible! \$1,500 Video Players Now Just \$99*



BUY TWO GET ONE FREE.

Originally intended to sell for over \$1,500.00, these quality units from a major U.S. consumer electronics manufacturer are brand new (still in their original cartons), but no longer in production.

A limited supply of programmed cassettes is available from a domestic source. And large quantities may be obtained through an overseas supplier.

They're perfect for experimental projects in the lab, classroom, or home. Ideal as a T.V./electro-optical testbed; the Video Players include these components: • flying spot scanner • photomultiplier • optics • video ampli-

*FOB Reston, Virginia. All orders shipped freight collect.

fiers • chroma-circuits • stereo audio preamp • RF modulator panel • film transport assembly.

The Player can be used with any standard T.V. set. It comes with a crystal controlled oscillator for picture carrier on Channel 3, plus an FM audio carrier output. External sound and picture are available through your T.V. by connecting a standard CCTV camera and audio input (1 volt RMS).

With the exception of the flying spot CRT and photomultiplier, the system is all solid state, including transistors and integrated circuits.

All contained in a beautiful walnut case with protective cover. Plus schematics and operating manual.

Our sale price of \$99.00 is worth any one of the major components alone. Supply is limited, so hurry — they won't last long.

Send check or money order (please include necessary sales tax) or use your Mastercharge or BankAmericard. Today!

Division of Metric Resources Corp.
822 Airport Blvd., Burlingame, CA 94010
Telephone (415) 342-7111

Leasametric

FREE catalog

over 2000

unique tools,
handy kits,
precision
instruments,
technical
supplies.



Our 23rd year of service to the World's finest craftsmen and technicians.

A carefully selected and tested assortment of unique, hard-to-find tools, clever gadgets, precision instruments, bargain kits. One-stop shopping for the technician, craftsman, hobbyist, lab specialist, production supervisor. Many tools and measuring instruments available nowhere else. One of the most unusual and complete tool catalogs anywhere. Get your copy of the NC FLASHER today.



National Camera
2000 West Union Ave., Dept. GGA
Englewood, Colorado 80110
(303) 789-1893

CIRCLE NO. 45 ON FREE INFORMATION CARD

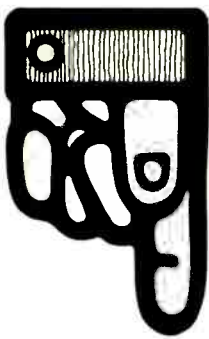

**DON'T LET
OUR NAME
FOOL
YOU**

STEREO DISCOUNTERS

WE'RE ALSO

CB DISCOUNTERS!

Save by buying from a high volume dealer.
Send for your Free Hi-Fi and CB Catalog ...
Or call for a price quote on our "Super
Service" line ...

301-252-6880

Name _____

Address _____

State _____

Zip _____

STEREO DISCOUNTERS
7A Aylesbury Rd.
Timonium, Md. 21093

PE-9

CIRCLE NO. 67 ON FREE INFORMATION CARD

1457 kHz. But you won't hear any announcements like "This is the *Radio Peking* relay in Albania!"

Smaller Stations. *Radio Budapest* was relayed, briefly, a few years ago from East Germany. This had no particular advantage and was discontinued. This summer, C.M. Stanbury, reports a "relay sound" on *Radio Bucharest's* 5990 kHz outlet to North America, but we don't yet know where this one is relayed from.

Australia has no external relay sites, but several within the continent. The newest is at Carnarvon on the west coast. One of Carnarvon's three beams eventually crosses Boston, and it's not hard to hear elsewhere in North America though intended for Asia. Interestingly, it is the most distant international broadcasting site in the world from (roughly) the Eastern and Central time zones. (*R. Nederland* in Madagascar is farther from the Mountain and Pacific time zones.) Carnarvon is fed primarily by transcontinen-

tal microwave link, but with backup on SSB at 9210 and 9450 kHz from Lyndhurst, Victoria.

Several countries broadcast from two or more sites within their own country, but seldom specify which. Among them are England, France, Spain, Sweden, Switzerland, Saudi Arabia, Israel, East Germany, Hungary, Nepal and Malaysia.

New listeners are often confused by WYFR. Is it in Oakland, CA, or Scituate, MA? Most of the programming is recorded at the studios in Oakland, but newscasts in Spanish seem to be fed across the continent to Scituate, where all transmissions radiate. However, WYFR is planning a move to Florida.

Some stations are multi-site without being relays. *Trans World Radio* broadcasts from Monaco (actually France), Bonaire, Swaziland, Cyprus, Guam, and soon Sri Lanka. *IBRA Radio* owns no stations but buys time in Portugal and Malta, despite its studio location in Sweden. ♦

ENGLISH-LANGUAGE SHORTWAVE BROADCASTS FOR SEPT. & OCT. 1976

by Richard E. Wood

TO EASTERN NORTH AMERICA				
TIME-EDT	TIME-GMT	STATION	QUAL*	FREQUENCIES, MHz
6:00-7:00 a.m.	1000-1100	**Montreal, Canada	G	5.97, 9.57
6:30 a.m.-8:00 p.m.	1030-2400	**Montreal, Canada (Northern Service)	G	9.625, 11.72 (Includes French, etc.)
7:00-7:25 a.m.	1100-1125	Tirana, Albania	F	9.48, 11.985
7:00-9:00 a.m.	1100-1300	Melbourne, Australia	G	9.58
7:00-9:30 a.m.	1100-1330	London, England	G	15.07
7:00-10:00 a.m.	1100-1400	**VOA, Washington, U.S.A.	G	9.655, 9.73
7:15-8:15 a.m.	1115-1215	Montreal, Canada	G	5.97, 9.655
8:00-8:30 a.m.	1200-1230	Jerusalem, Israel	F	11.655, 15.10, 15.485, 17.685
8:00-8:55 a.m.	1200-1255	Peking, China	F	11.685
8:15 a.m.-12:30 p.m.	1215-1630	HCJB, Quito, Ecuador	G	11.745, 15.115
9:00-11:00 a.m.	1300-1500	Trans-World Radio, Bonaire, N.A.	G	15.255 (Sat., Sun.)
9:15-9:45 a.m.	1315-1345	Berne, Switzerland	G	15.14
9:15 a.m.-4:00 p.m.	1315-2000	**London, England	G	9.41, 15.07
9:30-10:00 a.m.	1330-1400	Helsinki, Finland	F	15.11
10:00-10:30 a.m.	1400-1430	Stockholm, Sweden	G	15.305
11:00 a.m.-12:15 p.m.	1500-1615	London, England	G	17.84 (via Ascension)
12:00-1:00 p.m.	1600-1700	**Paris, France	G	9.74, 11.705, 11.89, 11.93, 11.965, 15.21, 15.30, 15.32, 15.425, 17.72, 17.80, 17.82
1:00-2:15 p.m.	1700-1815	London, England	G	9.58 (via Sackville) (Sun. to 1845)
2:45-4:00 p.m.	1845-2000	**Abidjan, Ivory Coast	F	11.92 (Mon.-Sat.)
3:45-6:30 p.m.	1945-2230	**Delhi, India	F	9.525, 9.912, 11.62
4:00-4:30 p.m.	2000-2030	**Tehran, Iran	F	9.022
		Jerusalem, Israel	G	7.395, 9.815, 11.645
4:00-5:00 p.m.	2000-2100	**Brasilia, Brazil	G	11.78
		Accra, Ghana	F	9.545, 11.85
4:00-5:15 p.m.	2000-2115	**London, England	G	9.41, 11.75, 15.07, 15.26
4:00-5:20 p.m.	2000-2120	**Hilversum, Holland	F	11.73 (via Talata)
4:45-5:00 p.m.	2045-2100	**Valletta, Malta	G	6.035 (Sat.)
5:00-5:50 p.m.	2100-2150	**Johannesburg, South Africa	G	4.875, 9.585, 11.90
5:00-6:00 p.m.	2100-2200	**Montreal, Canada	G	9.625, 11.855, 15.325

5:15-6:45 p.m.	2115 2245	London, England	G	9.58 (via Ascension), 11.78, 15.26 (via Ascension)
5:30-6:50 p.m.	2130 2250	Hilversum, Holland	G	9.715, 11.73 (Sun.: Dutch)
5:45-7:00 p.m.	2145 2300	**Cairo, Egypt	G	9.805
6:00-6:15 p.m.	2200-2215	**Belgrade, Yugoslavia	F	9.62
6:00-6:30 p.m.	2200-2230	**Montreal, Canada	G	11.855, 15.325
6:00-8:00 p.m.	2200-0000	Montreal, Canada	G	6.04, (Mon.-Fri.)
6:00-9:20 p.m.	2200-0120	**Ankara, Turkey	F	9.515, 11.88
6:30-7:00 p.m.		Jerusalem, Israel	G	7.395, 9.435, 9.815, 11.625
	2230 2300	Vilnius, U.S.S.R.	G	7.32, 7.355, 9.685, 9.735, 9.745
6:30-7:20 p.m.	2230-2320	Johannesburg, S. Africa	F	4.875, 9.585, 11.90
6:45-8:30 p.m.	2245-0030	London, England	G	5.975, 7.325, 9.58 (via Ascension), 11.78
			F	9.73
6:55-7:15 p.m.	2255 2315	Brussels, Belgium	F	6.12, 9.605, 11.705
7:00-7:30 p.m.	2300 2330	Stockholm, Sweden	F	15.11
		Helsinki, Finland	P	11.71 (Mon.-Fri.)
7:00-7:50 p.m.	2300 2350	**Buenos Aires, Argentina	G	
7:00-8:30 p.m.	2300-0030	Moscow, U.S.S.R.	G	5.905, 7.10, 7.11, 7.15, 7.205
			F	7.355, 9.685
7:45-8:00 p.m.	2345-0000	**Voice of the Org. of American States, Washington, U.S.A.	G	9.64, 11.74, 15.16
		Tokyo, Japan	F	15.27, 15.30
7:45-8:45 p.m.	2345-0045	Tirana, Albania	G	7.065, 9.78
8:00-8:25 p.m.	0000-0025	Oslo, Norway	G	6.18, 9.645, (Sun.)
8:00-8:30 p.m.	0000 0030	Peking, China	F	11.945, 15.06, 15.52, 17.673
8:00-8:55 p.m.	0000 0055	Sofia, Bulgaria	F	9.70
8:00-10:00 p.m.	0000-0200	**Luxembourg	F	6.09
		**VOA, Washington, U.S.A.	G	6.13, 9.65, 11.83
8:00 p.m.-1:05 a.m.	0000-0505	**Montreal, Canada (Northern Service)	F	5.96, 9.625 (includes French, etc.)
		Athens, Greece	F	9.76
8:15-8:30 p.m.	0015-0030	Prague, Czechoslovakia	F	6.055, 9.54
8:30-8:55 p.m.	0030-0055	Kiev, U.S.S.R.	G	7.15, 7.205, 9.685, 9.72
8:30-9:00 p.m.	0030-0100	Stockholm, Sweden	F	11.955
8:30-9:30 p.m.	0030-0130	**Trans-World Radio Bonaire, N.A.	G	11.925
8:30-11:30 p.m.	0030-0330	London, England	G	5.975, 7.325, 9.58 (via Ascension)
8:40-9:00 p.m.	0040-0100	Brussels, Belgium	F	9.73
8:40 p.m.-1:00 a.m.	0040-0500	HCJB, Quito, Ecuador	G	6.095, 9.56, 11.915 (includes some Eskimo)
9:00-9:15 p.m.	0100-0115	Vatican City	G	5.995, 6.105, 9.605
9:00-9:20 p.m.	0100-0120	Rome, Italy	G	9.575, 11.81
9:00-9:45 p.m.	0100-0145	Berlin, Ger. Dem. Rep.	F	9.73
9:00 p.m.-12 mdt.	0100-0400	Madrid, Spain	G	6.065, 11.88 (Mon.-Sat.)
9:00-9:55 p.m.	0100-0155	Peking, China	G	7.12, 9.78 (via Tirana), 11.945, 11.965, 15.06, 15.52
		Prague, Czechoslovakia	G	5.93, 7.345, 9.54, 9.74, 11.99
9:00-10:00 p.m.	0100-0200	Montreal, Canada	G	6.085, 9.655
9:00-11:00 p.m.	0100-0300	Melbourne, Australia	F	15.32, 17.795
		Moscow, U.S.S.R.	G	5.905, 7.10, 7.11, 7.15, 7.205, 7.355, 9.685, 9.70 (via Sofia)
9:00-11:30 p.m.	0100-0330	Havana, Cuba	G	11.725, 11.93
9:30-9:50 p.m.	0130-0150	Cologne, Ger. Fed. Rep.	G	6.01, 6.04, 6.075, 6.10 (via Malta), 9.565, 9.69, 9.745, 11.865 (via Malta)
9:30-9:55 p.m.	0130-0155	Tirana, Albania	G	6.20, 7.30
		Vienna, Austria	P	6.155, 9.77
9:30-10:25 p.m.	0130-0225	Bucharest, Rumania	F	5.99, 9.57, 9.68, 11.775, 11.94
9:45-10:15 p.m.	0145-0215	Berne, Switzerland	G	5.965, 6.135, 9.725, 11.715
10:00-10:30 p.m.	0200-0230	Budapest, Hungary	G	6.00, 6.115, 9.585, 9.833, 11.91, 15.22 (Ex. Sun.)
		Lisbon, Portugal	G	6.025, 11.935
		Dslo, Norway	F	6.18, 9.645, (Sun.)
		Warsaw, Poland	P	6.095, 6.135, 7.27, 9.675, 11.815, 11.84, 15.12
10:00-10:55 p.m.	0200-0255	Peking, China	F	11.965, 15.06
10:00-11:20 p.m.	0200-0320	Hilversum, Holland	G	6.165 (via Bonaire)
10:00-11:30 p.m.	0200-0330	Cairo, Egypt	G	9.475
10:30-10:55 p.m.	0230-0255	Tirana, Albania	G	6.20, 7.30
11:00-11:30 p.m.	0300-0330	Budapest, Hungary	G	6.00, 6.115, 9.585, 9.833, 11.91, 15.22
		Kiev, U.S.S.R.	G	7.15, 7.39, 9.61, 9.72
11:00-11:35 p.m.	0300-0335	Warsaw, Poland	P	6.095, 6.135, 7.27, 9.675, 11.815, 11.84, 15.12
11:00-11:55 p.m.	0300-0355	Peking, China	G	7.12, 9.78 (via Tirana)
11:00-12 mdt.	0300-0400	Buenos Aires, Argentina	G	9.69 (Mon.-Fri.)

Put Professional Knowledge and a
COLLEGE DEGREE
in your Electronics Career through
HOME STUDY

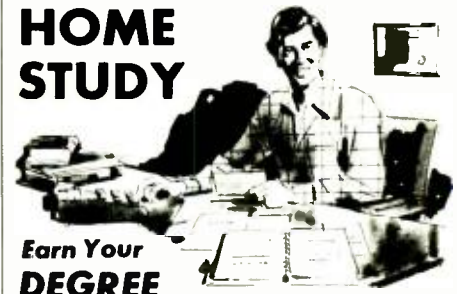

Earn Your DEGREE

by correspondence, while continuing your present job. No commuting to class. Study at your own pace. Learn from complete and explicit lesson materials, with additional assistance from our home study instructors. Advance as fast as you wish, but take all the time you need to master each topic. Profit from, and enjoy, the advantages of independent study.

The Grantham electronics degree program begins with basics, leads first to the A.S.E.T. degree, and then continues through the B.S.E.F. degree level. Our *free* bulletin gives complete details of the program itself, the degrees awarded, the requirements for each degree, and how to enroll. Write or phone (no collect calls please) and ask for BULLETIN E-76.

Grantham School of Engineering
2000 Stoner Ave., Los Angeles, CA 90025

• Telephone (213) 477-1901 •

Worldwide Career Training thru Home Study

CIRCLE NO. 31 ON FREE INFORMATION CARD

SAVE!

MONEY • TIME • FREIGHT

QUALITY STEREO EQUIPMENT
AT LOWEST PRICES.

YOUR REQUEST FOR QUOTA-
TION RETURNED SAME DAY.

FACTORY SEALED CARTONS—
GUARANTEED AND INSURED.

SAVE ON NAME BRANDS LIKE:
A.D.C. KLH
A.R. SHURE
DYNACO KOSS
SONY FISHER

PIONEER

AND MORE THAN 50 OTHERS

BUY THE MODERN WAY

BY MAIL—FROM

illinois audio

Department 217S

12 East Delaware

Chicago, Illinois 60611

312-664-0020

CIRCLE NO. 36 ON FREE INFORMATION CARD

Now
a
KIT

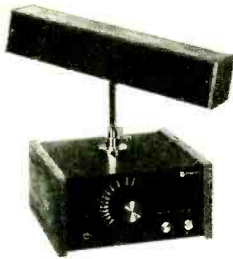

McKay Dymek-Kit — DX'ers and AM listeners — build your own ferrite loop AM antenna and **SAVE BIG MONEY.** Dymek-Kit DA5 \$119. (\$175 assembled.)

Overcomes the two most common AM reception problems: strong local stations "hiding" weaker distant stations close on the dial, and interference from TV and electrical sources.

Improves inherent long range capabilities of AM — programs listenable from a thousand miles.

Send coupon for full details in a hurry; or phone your order **Toll free: 800/854-7769 (Calif:800/472-1783)**

	McKay Dymek Co. 675 N. Park, P.O. Box 2100 Pomona, CA 91766			
	name _____			
address _____				
city _____		state & zip _____		
phone _____		area _____		

CIRCLE NO. 43 ON FREE INFORMATION CARD

DIXIE SAVE ON
Brand Name Audio Components
BY MAIL

Write Today for Our
FREE Audio Catalog

DIXIE is one of the oldest and largest audio component mail order houses in the country. Our prices on brand name components are actually LOWER than "Discounters". See our new catalog or call us for a price quote. Everything shipped factory sealed with full manufacturer's warranty.

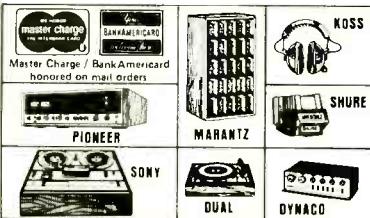

DIXIE HI-FIDELITY PE-9

5600 Second St., N. E., Washington, D. C. 20011
Phone: 1-202-635-4900

Please rush me your FREE Audio Catalog and complete information. I understand there is no obligation.

Name _____
Address _____
City _____
State _____ Zip _____

	Prague, Czechoslovakia	G	5.93, 7.345, 9.54, 9.74, 11.99
	Moscow, U.S.S.R.	G	5.905, 7.10, 7.11, 7.355, 9.665, 9.685, 9.70 (via Sofia)
		F	3.23, 3.995, 4.875
11:00 p.m.-12:25 a.m.	0300-0425	**Johannesburg	
		S. Africa	
11:30-11:55 p.m.	0330-0355	Tirana, Albania	G
		Vienna, Austria	P
11:30-12:30 a.m.	0330-0430	London, England	G
11:30-12:50 a.m.	0330-0450	Havana, Cuba	G
12 mdt.-12:15 a.m.	0400-0415	Budapest, Hungary	G
			6.20, 7.30
			6.155, 9.77
			5.975, 9.58 (via Ascension)
			11.725, 11.76, 11.93
			6.00, 6.115, 9.585, 9.833, 11.91, (Tue./Fri.)
12 mdt.-12:25 a.m.	0400-0425	Bucharest, Rumania	F
12 mdt.-12:30 a.m.	0400-0430	Sofia, Bulgaria	G
12 mdt.-1:00 a.m.	0400-0500	Moscow, U.S.S.R.	G
			5.99, 9.57, 9.68, 11.775, 11.94
			9.70
			5.905, 7.10, 7.15, 7.205, 7.355, 7.39, 9.685, 9.72
12 mdt.-2:00 a.m.	0400-0600	Montreal, Canada	G
12:30-1:00 a.m.	0430-0500	**London, England	G
12:50-2:00 a.m.	0450-0600	Havana, Cuba	G
1:00-1:15 a.m.	0500-0515	Jerusalem, Israel	G
1:00-2:00 a.m.	0500-0600	**London, England	G
1:00-3:00 a.m.	0500-0700	HCJB, Quito, Ecuador	G
			6.005, 9.58 (via Ascension)
			11.725, 11.76
			5.90, 7.413, 9.009, 9.435
			6.005, 7.27, 9.60 (via Ascension)
			6.095, 9.56

TO WESTERN NORTH AMERICA

TIME-PDT	TIME-GMT	STATION	QUAL*	FREQUENCIES, MHz
4:00-4:15 a.m.	1100-1115	Tokyo, Japan	G	5.99
4:00-5:00 a.m.	1100-1200	London, England	F	11.75 (via Tebrau)
4:00-7:00 a.m.	1100-1400	**VOA, Washington, U.S.A.	G	5.955, 9.73
5:00-5:15 a.m.	1200-1215	Tokyo, Japan	P	5.99
5:00-6:15 a.m.	1200-1315	London, England	G	5.99 (via Sackville)(opens 1300 Sun.), 11.75 (via Tebrau)
5:15-9:30 a.m.	1215-1630	HCJB, Quito, Ecuador	G	11.745, 15.115
6:00-6:15 a.m.	1300-1315	Tokyo, Japan	P	5.99
6:00-8:00 a.m.	1300-1500	Trans-World Radio, Bonaire, N.A.	G	15.255 (Sat., Sun.)
6:30-8:00 a.m.	1330-1500	**Delhi, India	F	11.81, 15.345
6:30-9:15 a.m.	1330-1615	**London, England	F	9.74, 11.75, 15.31 (via Tebrau)
7:00-7:30 a.m.	1400-1430	Tokyo, Japan	G	9.505
7:00-8:20 a.m.	1400-1520	**Hilversum, Holland	G	11.73 (via Talata)
7:00-9:55 a.m.	1400-1655	Manila, Philippines	F	9.58 (Closes 1555 Sun.)
8:00-8:15 a.m.	1500-1515	Tokyo, Japan	G	9.505
8:00-9:15 a.m.	1500-1615	London, England	G	17.84 (via Ascension)
9:00-9:15 a.m.	1600-1615	Tokyo, Japan	G	9.505
9:00-9:30 a.m.	1600-1630	Oslo, Norway	F	17.80 (Sun.)
9:45-9:51 a.m.	1645-1651	Hilversum, Holland	G	15.14, 15.19 (via Bonaire, Mon.-Fri.)
10:00-10:15 a.m.	1700-1715	Tokyo, Japan	G	9.505
10:00-11:30 a.m.	1700-1830	London, England	G	9.58 (via Sackville closes 1845 Sun.)
11:00-11:15 a.m.	1800-1815	Tokyo, Japan	G	9.505
11:30 a.m.-1:00 p.m.	1830-2000	**London, England	F	11.82 (via Ascension)
12 noon-12:07 p.m.	1900-1907	**Papëetë, Tahiti	F	11.825, 15.17 (exc. Sun.)
12 noon-12:15 p.m.	1900-1915	Tokyo, Japan	G	15.105
1:00-1:15 p.m.	2000-2015	Tokyo, Japan	G	15.105
1:00-2:20 p.m.	2000-2120	**Hilversum, Holland	G	11.73 (via Talata)
2:00-2:15 p.m.	2100-2115	Tokyo, Japan	G	15.105
2:15-4:00 p.m.	2115-2300	London, England	G	15.26 (via Ascension)
3:00-3:15 p.m.	2200-2215	Tokyo, Japan	G	15.105
3:00-5:00 p.m.	2200-0000	**VOA, Washington, U.S.A.	G	17.82, 17.895, 21.61
3:30-4:00 p.m.	2230-2300	Montreal, Canada	G	6.04 (Mon.-Fri.)
3:30-4:20 p.m.	2230-2320	Jerusalem, Israel	F	7.395, 9.815, 11.645
4:00-4:30 p.m.	2300-2330	Johannesburg, S. Africa	G	4.875, 9.585, 11.90
4:00-5:30 p.m.	2300-0030	Tokyo, Japan	G	15.105
		London, England	G	6.175, 9.51 (via Sackville), 9.58, 15.26 (via Ascension)
5:00-5:15 p.m.	0000-0015	Moscow, U.S.S.R.	G	12.05, 15.18, 17.775 (via Soviet Far East)
5:00-7:00 p.m.	0000-0200	Tokyo, Japan	G	15.105
		**VOA, Washington, U.S.A.	G	11.71, 15.205
5:30-6:30 p.m.	0030-0130	**Trans-World Radio, Bonaire, N.A.	G	11.925
5:30-8:30 p.m.	0030-0330	London, England	G	6.175 (via Sackville), 9.51 (via Greenville), 9.58 (via Ascension)
5:40-10:00 p.m.	0040-0500	HCJB, Quito Ecuador	G	6.095, 9.56, 11.915 (includes some Eskimm)

6:00-6:15 p.m.	0100-0115	Tokyo, Japan	G	15.105
6:00-8:00 p.m.	0100-0300	Moscow, U.S.S.R.	G	12.00, 12.05, 15.18, 17.775 (via Soviet Far East)
		Melbourne, Australia	G	15.32, 17.795
6:00-9:00 p.m.	0100-0400	Madrid, Spain	F	6.065, 11.88 (Mon.-Sat.)
6:30-7:30 p.m.	0130-0230	Tokyo, Japan	F	15.195, 15.39, 17.725, 17.825
7:00-7:15 p.m.	0200-0215	Tokyo, Japan	G	15.105
7:00-7:55 p.m.	0200-0255	Peking, China	G	11.965, 12.055, 15.06
7:00-8:50 p.m.	0200-0350	Taipei, Taiwan	G	11.86, 15.125, 17.72, 17.89
7:30-8:00 p.m.	0230-0300	Stockholm, Sweden	P	9.695, 11.705
8:00-8:15 p.m.	0300-0315	Tokyo, Japan	G	15.105
8:00-8:30 p.m.	0300-0330	Kiev, U.S.S.R.	G	12.05, 15.18, 17.775 (via Soviet Far East)
8:00-8:55 p.m.	0300-0355	Peking, China	G	7.12, 9.78 (via Tirana), 12.055, 15.06 15.385; 17.735, 17.855
8:00-9:25 p.m.	0300-0425	**Johannesburg; S. Africa	F	3.23, 3.995, 4.875
8:00-9:35 p.m.	0300-0435	**San José, Costa Rica	F	6.175, 9.645
8:22-8:28 p.m.	0322-0328	Erevan, U.S.S.R.	G	11.96, 15.13, 15.18, 15.455, (Sat./Tue./Wed./Fri., via Far East)
8:30-9:00 p.m.	0330-0400	Moscow, U.S.S.R.	G	6.02, 9.635, 11.72, 11.96, 12.05, 15.13, 15.18, 15.21, 15.245, (via Soviet Far East)
8:30-9:15 p.m.	0330-0415	Berlin, Ger. Dem. Rep.	P	9.73, 11.84, 11.89
8:30-9:30 p.m.	0330-0430	London, England	G	6.175 (via Sackville), 9.58 (via Ascension)
9:00-9:15 p.m.	0400-0415	Tokyo, Japan	G	15.105
9:00-9:30 p.m.	0400-0430	Sofia, Bulgaria	P	9.70
		Budapest, Hungary	P	6.00, 6.115, 9.585, 9.833, 11.91 (Tue., Fri.)
		Oslo, Norway	F	9.645, 11.87 (Sun.)
9:00-10:00 p.m.	0400-0500	Moscow, U.S.S.R.	G	6.02, 9.635, 11.69, 11.96, 12.05, 15.10, 15.13, 15.18, 15.21, 15.245 (via Far East)
9:00-11:00 p.m.	0400-0600	Montreal, Canada	G	6.135, 9.655
9:15-10:30 p.m.	0415-0530	Bangkok, Thailand	P	9.655, 11.905
9:30-10:00 p.m.	0430-0500	Lisbon, Portugal	P	6.025, 11.935
		Berne, Switzerland	F	9.725, 11.715
		Vienna, Austria	P	6.015
		**London, England	G	6.005, 9.58 (via Ascension)
9:30-10:15 p.m.	0430-0515	**Cologne, Ger. Fed. Rep.	F	7.225 (via Kigali)
10:00-10:15 p.m.	0500-0515	Jerusalem, Israel	F	9.815
		Tokyo, Japan	G	15.105
10:00-10:30 p.m.	0500-0530	Seoul, Rep. of Korea	F	9.64, 15.335
10:00-11:20 p.m.	0500-0620	Hilversum, Holland	G	6.165, 9.715 (via Bonaire)
10:00 p.m.-12 mdt.	0500-0700	HCJB, Quito, Ecuador	G	6.095, 9.56
		**London, England	G	6.005, 7.27, 9.60 (via Ascension)
10:00 p.m.-12:30 a.m.	0500-0730	Moscow, U.S.S.R.	G	6.02, 9.635, 9.71, 11.69, 11.96, 12.05, 15.10, 15.13, 15.18, 15.21 (via Soviet Far East)
10:30-10:50 p.m.	0530-0550	Cologne, Ger. Fed. Rep.	G	6.10 (via Malta), 6.185, 9.545
11:00-11:15 p.m.	0600-0615	Tokyo, Japan	G	9.505
11:00-11:30 p.m.	0600-0630	Oslo, Norway	P	9.645, 11.87 (Sun.)
11:00-12 mdt.	0600-0700	Buenos Aires, Argentina	G	9.69 (Mon.-Fri.)
11:30 p.m.-1:30 a.m.	0630-0830	Havana, Cuba	G	9.525
11:30 p.m.-1:55 a.m.	0630-0855	**Kuala Lumpur, Malaysia	G	11.90, 15.275
12 mdt.-12:15 a.m.	0700-0715	Tokyo, Japan	G	9.505
12 mdt.-12:30 a.m.	0700-0730	**London, England	G	6.005, 9.60 (via Ascension)
12:30-1:15 a.m.	0730-0815	**London, England	G	9.60, 11.86, 15.40 (via Ascension)
1:00-1:15 a.m.	0800-0815	Tokyo, Japan	G	9.505
2:00-2:15 a.m.	0900-0915	Tokyo, Japan	G	9.505
2:00-2:30 a.m.	0900-0930	Seoul, Rep. of Korea	F	9.64, 15.335
3:00-3:15 a.m.	1000-1015	Tokyo, Japan	G	5.99
3:00-3:50 a.m.	1000-1050	Pyongyang, D.P.R. Korea	G	9.42, 9.535
3:00-4:00 a.m.	1000-1100	**Montreal, Canada	G	5.97, 9.625

* Reception quality, East Coast (West Coast) location. G-good, F-fair, P-poor

** Not intended for North America, but receivable satisfactorily

Frequencies are accurate as of press time, but subject to change. Many stations broadcasting in English but not beamed to North America are often audible here depending upon conditions, locations, time, etc. Sometimes, they are more audible than those nominally beamed here. To help readers and as a sampling of what can be heard, we have added a selection of interesting stations heard here in English. The fine programs from Paris and Brasilia are particularly recommended.

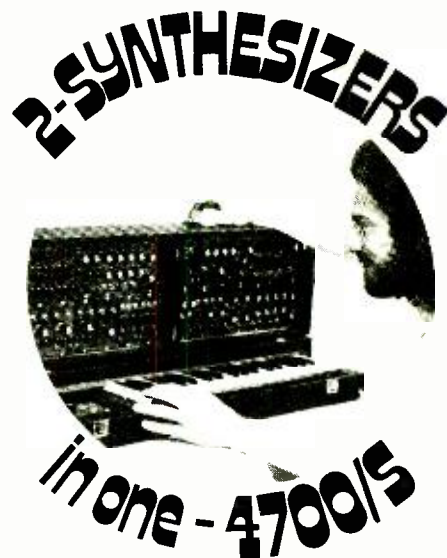

MUSIC SYNTHESIZER KIT

When you combine all of the modules that are part of this package and then throw in keyboard, 12 event sequencer and a four input stereo mixer, it's almost like having two synthesizers in a single package. Wrap them all in sturdy road cases and you have an instrument that goes anywhere and does any job. Module complement includes: Road keyboard with Glide, Two Road module cases, two Balanced Modulator/VCA's, Stereo Mixer, Reverb, three 4720 VCO's, 4730 VCF, two Envelope Generators, three Watt Blocks, Control Oscillator/Noise Source and 12-Event Sequencer.

No. 4700/S Synthesizer Kit \$499.00 *40 lbs.

FREE CATALOG

RAIA ELECTRONICS
DEPT. 9-P

1020 WEST WILSHIRE BLVD
OKLAHOMA CITY, OK 73116

CIRCLE NO. 49 ON FREE INFORMATION CARD



save on gas!
save on tune-ups!
save on maintenance!

Electronic ignition is "IN"! So says Detroit.

Update your car with either a TIGER CD or a TIGER I breakerless system.

Enjoy the benefits of better gas mileage, quicker starting, elimination of tune-ups, 50,000 miles on points and plugs, and reduced maintenance expenses.

TIGER MAX CD	\$69.95
TIGER 500 CD	59.95
TIGER SST CD	42.95
SIMPLIKIT CD	31.95
TIGER I	45.95

Postpaid U.S.A. only.

Tri-Star Corporation

Dept. ZZ, P.O. Box 1727
Grand Junction, Colorado 81501
CIRCLE NO. 69 ON FREE INFORMATION CARD



Computer Bits

By Hal Chamberlain

upper and lower sidebands corresponding to audio modulation at the pulse repetition rate. Different instructions cause pulses to appear at different places within the computer. It is therefore possible to set up program loops that execute at controlled rates and thus produce tones of different frequencies. An interesting problem with this method is that there is no way to get the radio to "shut up" for a rest or a break between two identical notes.

A more predictable way to get audio output is to connect a speaker to an output port bit. A tone may be programmed by alternately setting the bit on and off with an accurately timed loop. This has an advantage since the speaker may be silenced when desired. One commercial computer (the LINC) even had a speaker complete with volume control connected to one bit of the accumulator as standard equipment! Some hobbyist systems have a speaker installed in their surplus keyboards. It is normally clicked to signal that a character has been accepted or beeped if an error is detected. Of course, it is also available as a simple "music peripheral."

Although the above methods make interesting demonstrations and do not require any specialized hardware, they are far from being suitable for serious music performance. Early in the development of electronic music, it became apparent that any audio signal waveform could be represented as a very rapid series of discrete voltage values. With a digital-to-analog converter connected to the computer,

COMPUTER MUSIC

BEGINNING with this month, "Computer Bits" is a monthly feature of POPULAR ELECTRONICS. As a consequence, we are able to offer a two-part discussion of computer music—this month and in October.

Playing music with your computer can be a refreshing diversion, an impressive demonstration, or a mild obsession, depending on your inclination. We will discuss computer music performance first, with computer music composition to follow.

Some History. Elementary, monophonic music is just a series of tones with different frequencies and durations. Over the years, several methods have been devised by which a computer could either generate the tones directly or control tone-generating devices.

Perhaps the strangest method of output is one employed by an IBM-1401 computer program that played the line printer! Computer printers work much like a typewriter in that a metal type face strikes the paper

under computer control. A pulse of sound is emitted when the paper is struck. In a 1401, the printer was interfaced in such a way that a program could control precisely when a print hammer fired. Proper relative timing among hammer strikes in the row of 120 hammers could actually produce a tone. Different frequency tones could be produced by changing the hammer timing. A rendition of "Anchors Aweigh" was heard by the author; and, while sounding rather raspy, it was in tune!

Another unexpected way to get a computer to produce tones involves the use of a common AM broadcast-band radio. Modern computer logic circuits generate pulses having risetimes of about 10 nanoseconds. These fast risetimes imply the existence of high-frequency harmonics that may fall into the radio's tuning range. Furthermore, the harmonic frequencies are separated from each other by the pulse repetition rate. An AM receiver interprets the harmonics within its passband as a carrier with

Fig. 1. Example of a tone generation subroutine for the 8080.

					CLOCK CYCLES
	*	ENTER WITH THE FREQUENCY PARAMETER IN C			
	*	ENTER WITH THE DURATION PARAMETER IN D & E			
	*	USES SPEAKER CONNECTED TO ANY BIT OF OUTPUT PORT			
000:100	076 000	TONE MVI A,0	OUTPUT ZERO TO SPEAKER		(7)
000:102	232 XXX	OUT (port address)			(10)
000:104	101	MOV B,C	MOVE FREQ. PARAMETER TO		(5)
000:105	005	DELAY1 DCR B	B AND USE AS A DELAY COUNT		(5)
000:106	302 105 000	JNZ DELAY1	DELAY 15 X FREQ. PARAMETER CLOCK CYCLES		(10)
000:111	033	DCX D	DECREMENT DURATION PARAMETER		(5)
000:112	172	MOV A,D	TEST IF DECREMENTED TO ZERO		(5)
000:113	263	ORA E			(4)
000:114	312 136 000	JZ RETURN	GO RETURN IF SO, CONTINUE IF NOT		(10)
000:117	076 377	MVI A,377h	OUTPUT ONE TO SPEAKER		(7)
000:121	323 XXX	OUT (port address)			(10)
000:123	101	MOV B,C	DELAY AS ABOVE		(5)
000:124	005	DELAY2 DCR B			(5)
000:125	302 124 000	JNZ DELAY2			(10)
000:130	033	DCX D	DECREMENT AND TEST DURATION AS ABOVE		(5)
000:131	172	MOV A,D			(5)
000:132	263	ORA E			(4)
000:133	302 100 000	JNZ TONE	LOOP BACK FOR ANOTHER SQUARE WAVE CYCLE		(10)
000:136	311	RETURN RET	RETURN TO MAIN PROGRAM		

a series of numbers could be converted into the series of voltages and thus an audio signal. Waveforms could then be computed directly and literally any possible sound or tone produced. Some very impressive and musically important results have been obtained in this manner. Although this method has perfect generality, the number of computations needed for even a simple piece is staggering. Typically, hours of computer time are required for minutes or even seconds of musical output.

The newest method of musical output is to interface a computer to a sound synthesizer. Units such as a Moog or ARP or some of the circuits described by Don Lancaster in this magazine can be used. The amplitude, frequency, and spectrum of tones produced by the synthesizer are set with control voltages. Contrary to actual sound waveforms, control voltages typically change slowly. This greatly reduces the computational load on the computer. With only \$50 to \$100 worth of components, a multiplexed digital-to-analog converter with a dozen or more control voltage outputs can be built. Ordinary patch cords may then be used to connect the control voltages to the synthesizer.

Timed Loop Techniques. Let's look at the timed-loop technique of

Fig. 2. Table of musical notes.

Note	Frequency Hertz	Period Microseconds
C (middle)	261.62	3822.3
C#	277.18	3607.8
D	293.66	3405.3
D#	311.13	3214.2
E	329.63	3033.8
F	349.23	2863.5
F#	369.99	2702.8
G	391.99	2551.1
G#	415.30	2407.9
A	440.00	2272.8
A#	466.16	2145.2
B	493.88	2024.8
C	523.25	1911.2
C#	554.37	1803.9
D	587.33	1702.7
D#	622.25	1607.1
E	659.26	1516.9
F	698.46	1431.8
F#	739.99	1351.4
G	783.99	1275.6
G#	830.61	1204.0
A	880.00	1136.4
A#	932.33	1072.6
B	987.77	1012.4
C	1046.5	955.58

producing single tones with a computer. The two most important elements of music are pitch and rhythm. Curiously, these are the only elements that can be easily controlled in a timed-loop music program. Pitch is determined by the frequency of a tone in cycles per second (Hertz) and rhythm by the relative durations of individual tones in seconds. The computer used must have a definite clock cycle time, and most hobby computers on the market use a crystal clock which gives a very stable and accurate cycle rate. A few of the "trainer" kits may use an RC clock which is not nearly as good, but can still be used to illustrate the principles.

The basic component of a timed-loop music program is the tone-generation subroutine. The tone frequency and duration are passed to the subroutine as two arguments. The main body of the subroutine consists of two "nested" loops. The frequency argument determines how many times the inner loop is executed. The duration argument determines how many times the outer loop is executed. Note that the frequency argument is actually proportional to the period of the wave and the duration is actually the number of cycles of the wave to be played before returning for the next note.

A tone generation subroutine for an 8080 microprocessor is shown in Fig. 1. This routine generates an absolutely symmetrical square wave and uses two inner loops of identical length to accomplish it. To determine what the frequency argument value should be, it is necessary to count up the clock cycles used by the inner wait loop and by the "overhead" instructions outside of the loop. The overhead is found to be 46 cycles and the wait loop is 15 cycles times the value of the frequency parameter. Assuming that the 8080 runs at full speed (0.5 microsecond clock cycle) with no memory waits, the time for a half squarewave cycle is $23 + 7.5N$ microseconds, where N is the frequency parameter. A full cycle time is twice as long. The frequency is, of course, the reciprocal of the full cycle period. Using the routine shown, N must be between 1 and 255; if zero is given, it is interpreted as 256. Thus, the lowest possible frequency is $500,000 / (23 + 7.5 \times 256)$ Hz. or 257.33 Hz. The table in Fig. 2 may be used to determine the proper value of N for any note.

FREE EICO CATALOG

358 Ways To Save On Instruments, Citizens Band, Burglar Alarms, Automotive & Hobby Electronics!

The more you know about electronics, the more you'll appreciate EICO. We have a wide range of products for you to choose from, each designed to provide you with the most pleasure and quality performance for your money. The fact that more than 3 million EICO products are in use attests to their quality and performance.

"Build-it-Yourself" and save up to 50% with our famous electronic kits.

For latest EICO Catalog and name of nearest EICO Distributor, check reader service card or send 50¢ for fast first class mail service.

**EICO—283 Malta Street,
Brooklyn, N.Y. 11207**

*Leadership in creative electronics
since 1945.*



CIRCLE NO 23 ON FREE INFORMATION CARD

The duration parameter is actually a count of half cycles to be played before returning. As a result, the argument value is a function of both the duration in seconds and the note played. Thus $M=2TF$, where M is the argument value, T is the time in seconds, F is the frequency in Hertz, and the factor of 2 accounts for both halves of the square wave. Note that the routine of Fig. 1 uses a double precision duration argument to provide for long notes.

Fig. 3. Basic specification for music language NOTRAN.

1. **TEMPO statement**

Example: TEMPO ¼=500

TEMPO is keyword identifier.
¼ refers to a "quarter note."
500 is duration of quarter note in milliseconds.

2. **Note statement**

Example: 1C#4,½

1 refers to voice 1 (optional).
C is note name, # following is sharp, @ is flat.
4 is octave number, C4 is middle C.
½ specifies an eighth note.

3. **Rest statement**

Example: R,½

R signifies rest
½ means rest duration equivalent of half note.

4. **For monophonic music, one statement per line**

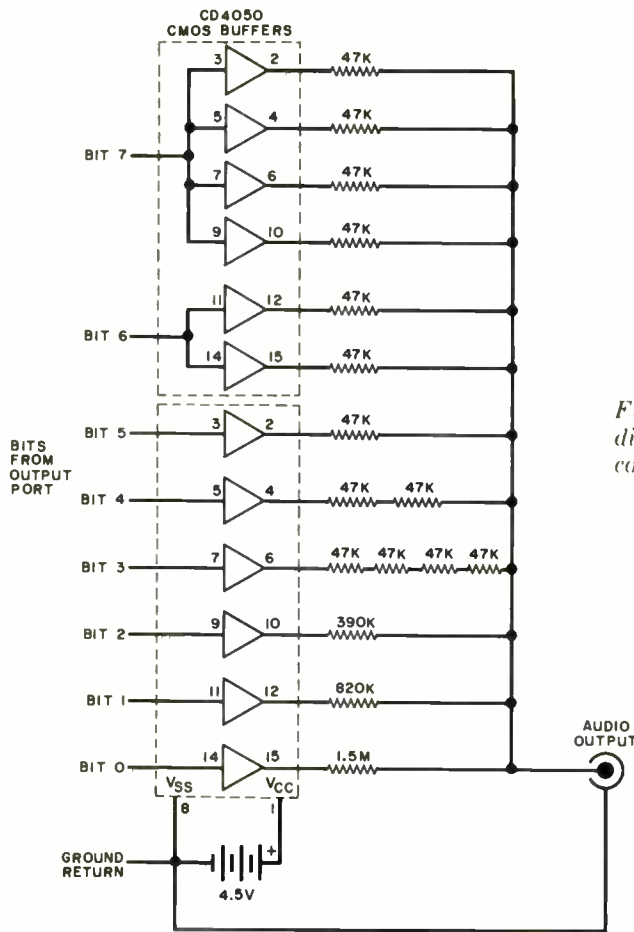

Fig. 4. Simple 8-bit digital-to-analog converter.

THINKING ABOUT YOUR OWN COMPUTER?



Join over 50,000 avid readers of BYTE, the magazine with rich, professionally edited articles on micro-computers . . . for building, expanding and having downright fun with your own system. You'll reread super articles on . . .

- detailed hardware/software designs by successful experimenters and hobbyists
- editorial on the fun of computers . . . electronic music, video games, hobbyist control systems, ideas for ham radio, model railroading and lots more
- reviews of upcoming general purpose systems
- tutorial background and sources full of ideas for home computers and computer science
- ads by firms with computer products you want
- club information and social activities

SUBSCRIBE TO BYTE NOW! IT'S FUN. . .AND GLITCH-PROOF!

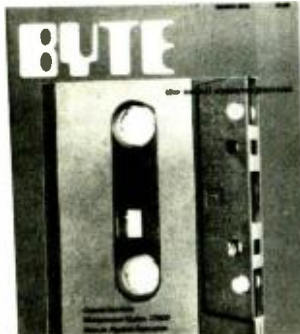

Send this coupon for a trial subscription to BYTE. Get your first issue by return mail. Read it from cover-to-cover. If it isn't everything you want, just write "CANCEL" on the bill and return it to us. The first copy is yours to keep.

BYTE PETERBOROUGH, NH 03458

Please enter my trial subscription to BYTE . . .

\$12 One Year \$22 Two Years \$30 Three Years

I understand you will send the first issue by return mail and bill me later. If I don't like BYTE, I just write "CANCEL" across the invoice and return it. I will not be charged.

Name (Please Print) _____

Address _____

City _____ State _____ Zip _____

Using the subroutine in a music program is simply a matter of calling it with the right frequency and duration arguments for each note to be played. Care must be taken to insert some silence between notes of the same frequency or else they will run together. A simple-minded program might fetch these from a hand-prepared list stored in memory. A more challenging approach is to write a program that accepts statements written in a simple "music language" and computes the tone-generation arguments (Fig. 3). Then your musically inclined wife, for example, may prepare scores for the computer herself.

Improving Basic Timed Loop Techniques. For better sounding music, a number of refinements can be made to the basic technique. It is possible to get some limited change of tone color by changing the duty cycle of the wave. This may be accomplished by inserting some "no operation" instructions in one of the wait loops. Unfortunately, the frequency arguments will have to be re-computed. Good duty cycle values to try are ⅓ and ¼, since harmonics divisible by 3 and 4, respectively, will be missing from the spectra.

Another interesting experiment is to improve the frequency accuracy of the routine. As written, the half-cycle time is in increments of 7.5 microseconds. This results in significant frequency errors, particularly for high notes. By inserting additional selected overhead instructions, it is possible to be as accurate as 0.5 microsecond. This might be accomplished by writing 15 copies of the routine with extra instructions added in increments of one clock cycle. Obtaining the right note would then be a combination of calling the proper routine with the proper frequency argument.

The computer-generated tones can be made more natural sounding if an amplitude envelope is added to the notes. All this amounts to is changing the volume in a controlled manner over the duration of the note. Additionally, there would then be some control over the dynamics (changes in loudness during a piece) of the music. At this point, some specialized hardware must be added.

The circuit in Fig. 4 may be added to an output port. This is actually a very simple 8-bit digital-to-analog converter. Best results are obtained if the 47k

resistors are 5% carbon film types from the same batch. Several mail-order firms now offer this type of resistor. A battery is used to power the circuit so that system noise will be isolated. Any type of audio amplifier can be connected to the circuit's output.

The dc output voltage of this circuit is 0.0176N volts, where N is the binary number last sent to the output port. Note, in the tone generation subroutine, that 0 and 255 (decimal) were alternately sent to the output port for a square wave. If this circuit was connected to the output port, the output voltage would alternately switch between 0 volts and +4.5 volts. If instead, 0 and 128 were alternately sent out, then the wave would switch between 0 volts and about 2.26 volts. This is only about one-half of the previous amplitude so the tone would not be as loud. Thus, amplitude control may be exercised by simply changing the values sent to the output port by the tone-generation subroutine.

Unfortunately, programming amplitude envelopes during a tone without upsetting the precise loop timing is a bit tricky. As the level of sophistication increases, a point is reached where

the effort needed to preserve the loop timing is excessive. At this point specialized hardware is needed to relieve the computer of the actual tone generation task.

Experiments with Other Sounds.

Other sounds can also be easily generated by a computer. For example, a high-speed stream of random bits will provide a good source of white noise. An 8080 program to generate white noise is given in Fig. 5. Random bits are generated by simulating a 16-stage shift register with appropriate feedback. White noise might be used in a rhythm program to approximate the sound of a snare drum.

The program in Fig. 6 produces some really "way-out" sounds. One should first try it and listen to each of the 16 possible output bits. Then study the program and see if you can figure out what it is actually doing. Finally, try to explain the weird results near the end of each repetition.

Many other interesting experiments can be performed with the simple digital-to-analog converter described earlier. Some of these will be described next time. ♦

Fig. 5. White noise generation routine for 8080

```

000:000 021 000 000  WHITEN  LXI  D,0          SET D & E TO ZERO
000:003 041 001 000  LXI  H,1          RET SHIFT REG. IN H & L NON-ZERO
000:006 174          LOOP  MOV  A,H          OUTPUT UPPER 8 BITS OF SHIFT REGISTER
000:007 323 XXX     OUT  (port address) AS A SET OF RANDOM BITS
000:011 017         RRC          FORM EXCLUSIVE-OR OF SHIFT REGISTER
000:012 254         XRA  H          BITS 15,14,12, AND 3 IN BIT 0 OF A
000:013 017         RRC
000:014 017         RRC
000:015 254         XRA  H
000:016 017         RRC
000:017 255         XRA  L
000:020 017         RRC
000:021 017         RRC
000:022 017         RRC
000:023 346 001     ANI  1          ISOLATE BIT 0 OF A
000:025 051         DAD  H          SHIFT SHIFT REGISTER LEFT 1
000:026 137         MOV  E,A        AND BRING BIT 0 OF A INTO
000:027 031         DAD  D          VACATED SHIFT REGISTER BIT 0
000:030 303 006 000 JMP  LOOP       LOOP

```

Fig. 6. Weird sound generation routine for the 8080.

```

*          CONNECT SPEAKER TO ANY BIT OF OUTPUT PORT
*          A DIFFERENT SOUND WILL BE HEARD AT EACH BIT

000:000 021 001 000  WEIRD  LXI  D,1          INITIALIZE
000:003 041 000 000  LXI  H,0
000:006 175          LOOP  MOV  A,L          CHANGE TO: MOV A,H FOR 8 MORE SOUNDS
000:007 323 XXX     OUT  (port address) OUTPUT TO SPEAKER
000:011 031         DAD  D
000:012 322 006 000 JNC  LOOP
000:015 023         INX  D
000:016 172         MOV  A,D
000:017 263         ORA  E
000:020 302 006 000 JNZ  LOOP
000:023 023         INX  D
000:024 303 006 000 JMP  LOOP

```



Electronics Library

TRANSISTOR BASICS: A SHORT COURSE (REVISED SECOND EDITION)

by George Stanley, Jr.

The revised edition of this practical guide covers recent transistors and circuit appli-

cations. Beginning with an introduction to commonly used terms, the author describes diode and transistor behavior. Circuit analysis is conducted on a practical level so that the reader will be able to determine required circuit parameters for many applications. Amplifier action, feedback, and special solid-state devices are explored. Troubleshooting information for bipolar and field-effect transistor circuits is included.

Published by Hayden Book Co., 50 Essex St., Rochelle Park, NJ 07662. 128 pages. \$4.30 soft cover.

RCA RECEIVING TUBE MANUAL

The new edition of the RCA Receiving Tube Manual, RC-30, contains chapters on basic

operational principles of vacuum tubes, electrical characteristics, and circuit applications. Technical data are included on active as well as discontinued tube types. Among the book's features are tube basing diagrams, a picture tube characteristics chart, and an expanded replacement guide for entertainment and industrial receiving tubes.

Published by RCA Distributor and Special Products Division, Box 85, Runnemede, NJ 08078. 754 pages, soft cover. \$3.45 post-paid.

TRANSISTOR THEORY FOR TECHNICIANS AND ENGINEERS

by Andrew Veronis

Semiconductor parameters, device design and fabrication, transistor operation, and circuit theory are explored in this book. The author begins with a description of atomic structure, then progresses to electron action within doped semiconductors and pn junctions. Diode and transistor behavior is explained in terms of important properties — reverse saturation current, diode resistance, current transfer, emitter injection efficiency, avalanche multiplication, etc. Transistor parameters are discussed in relation to circuit performance. Analyses of basic transistor circuits, such as common emitter, common base, and common collector, are given.

Published by Tab Books, Blue Ridge Summit, PA 17214. 224 pages. \$8.95 hard cover, \$5.95 soft cover.

SOLID-STATE CIRCUIT ANALYSIS

by Vester Robinson

Solid-state devices are analyzed from a practical circuit applications point of view. Simple pn diodes, bipolar transistors, tunnel and zener diodes, field effect transistors, unijunction transistors, and integrated circuits are examined in detail. Sample circuits include many commonly found in AM and FM transmitters and receivers. Mathematics is kept to a low level (mostly algebra) and is used only when necessary. Review questions appear at the end of each chapter.

Published by Reston Publishing Co., Box 547, Reston, VA 22090. 372 pages. \$15.95 hard cover.

ACTIVE FILTER COOKBOOK

by Don Lancaster

The compact, high-Q filters made possible by op-amp technology are described in this book. Among those covered are low- and high-pass filters, bandpass filters, and switchable and voltage-controlled designs. Thorough design information as well as ready-to-use circuits are presented. Operating ranges vary from subsonics to ultrasonics.

Published by Howard W. Sams & Co., 4300 W. 62nd St., Indianapolis, IN 46206. 192 pages. \$5.95 soft cover.

NOW FROM TEXAS INSTRUMENTS . . . three machines in one.

programmable
slide-rule calculator
SR-52

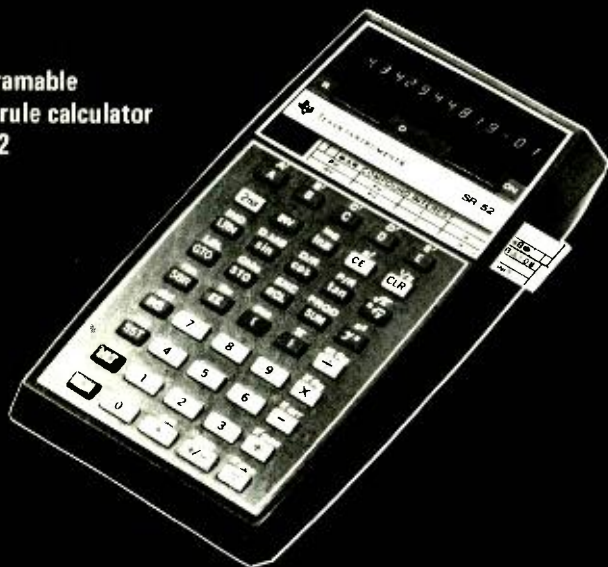

- 10 user defined keys
- 224 program storage locations
- 23 preprogrammed key functions
- 8 preprogrammed condition statements
- 20 independent addressable memory registers
- Permanent program storage on magnetic cards

It took TEXAS INSTRUMENTS to invent the SR-52 calculator. It took C & S MARKETING ASSOCIATES to offer it at a price you can afford, now only \$249.95. With such versatility and such an affordable price, you can not afford to be without the problem solving power of card programability. Now solve problems in seconds that would take hours with an ordinary calculator or slideruler if they could be done at all.

For more information or the answer to any question you may have about the SR-52 calculator, call toll free (800-251-6771)*. Tenn. residents call (800-252-6706). Other TEXAS INSTRUMENT models available from \$49.95.

Each TEXAS INSTRUMENT calculator comes with a 1-year warranty. Should your unit prove defective within 60 days, just return it for a new unit! Finally should you be dissatisfied with your calculator return it within 15 days for a prompt refund.

C & S MARKETING ASSOC.

P.O. BOX 165 ALGOOD, TENN. 38501

QTY. _____ PRICE 249.95 ea.

CHECK M.O. C.O.D.

LITERATURE INFORMATION

DIAL (800-251-6771) IN TENN. DIAL

(800-252-6706).

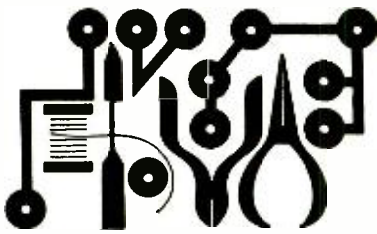

Experimenter's Corner

By Forrest M. Mims

THE LM380 POWER AMPLIFIER

FOR YEARS I've used one of the popular commercial modular amplifiers when it was necessary to beef up a weak audio signal and drive a miniature speaker. These amplifiers are available in a range of power output levels (100 mW to several watts or more) and are supplied completely preassembled on a compact pc board.

Though many of these modular amplifiers are reasonably priced and easy to use, I've recently switched over to the versatile LM380 power amplifier IC for many routine amplifier applications. This deceptively simple chip comes in both eight- and fourteen-pin versions with only six active pins. The remaining pins are all connected to ground and can be used to heat sink the chip when it is operated at high power levels.

Unlike most modular amplifiers which use discrete components, the LM380 has a very low output impedance and can be directly connected to an 8-ohm speaker. And, best of all, you can buy LM380's from several of the firms who advertise in the back pages of this magazine for less than \$1.50 each.

The twelve-transistor circuit of the LM380 incorporates several important and useful features. For example, a pnp input stage permits direct coupling of the input signal. The overall gain of the circuit is set to 50 (34 dB) by internal feedback resistors, but you can get more gain with a simple positive feedback circuit.

One of the really bothersome problems of semiconductor power amplifiers is overheating of the output stage. The LM380 solves this problem with an automatic thermal shutdown circuit which turns the amplifier off when excessive output current overheats the chip. Several times this feature has saved me from having to buy a new chip.

At room temperature, the chip dissipates up to about 1.25 watts without a heat sink. For higher power opera-

tion, the heat sink pins (3,4,5,10,11, and 12 on the fourteen-pin version) should be soldered to a common copper foil pad on a pc board. Six square inches of two-ounce foil will permit operation up to 3.7 watts (room temperature).

The pin diagrams for both the standard fourteen-pin and the miniature eight-pin versions of the LM380 are shown in Fig. 1. Since the eight-pin

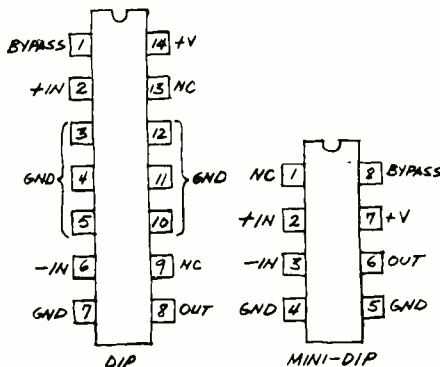

Fig. 1. Pin configurations for standard and miniature LM380.

mini-DIP version has less internal heatsinking, it is limited to about a half watt without an external heatsink.

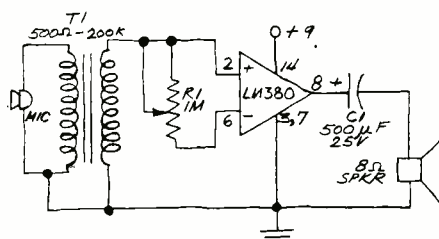

Fig. 2. Simple audio amplifier circuit using an LM380.

Fig. 2 shows one of the simplest circuits you can build with an LM380, a straightforward amplifier for an inexpensive, low-impedance microphone like those commonly used with miniature cassette tape recorders. The circuit

uses an input transformer to match the impedance of the microphone to that of the amplifier, and the resulting gain is adequate for a super-simple one-way intercom. You'll know the circuit is working properly if you place the microphone a few inches away from the speaker because of the resulting feedback sounds.

The simple circuit in Fig. 2 draws only about 4 mA from a 9-volt supply during standby operation, but loud sounds at the microphone can create drains of 70 mA or more. A drain of 100 mA at 9 volts is a power consumption of 0.9 watt, well within the maximum operating range of the fourteen-pin version of the LM380 without an external heat sink. Potentiometer *R1* serves as a volume control.

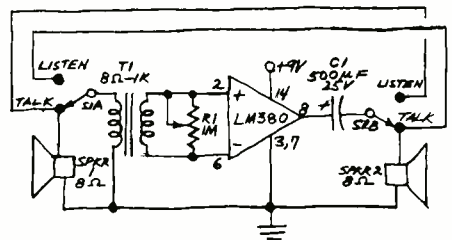

Fig. 3. Circuit for elementary two-way intercom system.

You can build a complete two-way push-to-talk intercom with a single LM380 and only six external components with the circuit in Fig. 3. The circuit uses a pair of ordinary 8-ohm speakers which double as microphones. In the TALK mode, *SPKR1* serves as the microphone and *SPKR2* as the speaker. The roles of the two speakers are reversed in the LISTEN mode.

This circuit also draws only 4 mA during standby (at 9 volts) so it can be

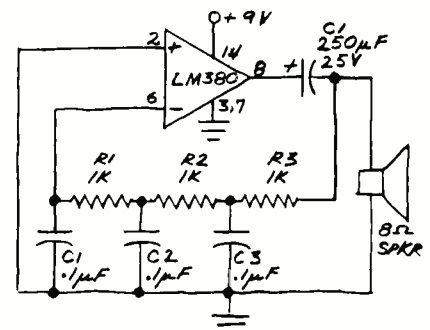

Fig. 4. LM380 phase-shift oscillator produces shrill tone.

left on for long periods of time at little expense. Since the LM380 has a wide voltage range (8-22 volts), the power supply requirements are quite flexible. I have used a 12-volt lantern battery with excellent results.

Phase-Shift Oscillator. National Semiconductor's LM380 spec sheet shows how to use the chip as a simple phase-shift oscillator. The circuit, which is shown in Fig. 4, uses a simple RC network to produce an exceptionally shrill tone from a miniature speak-

er. With the parts values shown in Fig. 4, the circuit oscillates at a frequency of 3.6 kHz and drives a miniature 2½" speaker with plenty of ear-piercing volume for a burglar alarm or other attention-getting or warning device. The output waveform is a square wave with a width of 150µs, sloping rise and fall times, and a peak-to-peak amplitude of 4.2 volts (when powered by 9 volts).

Current drain of the oscillator is a high 90 mA at 9 volts, but total power dissipation at this voltage is only 0.81

watt, well below the 1.25 watts the fourteen-pin version will absorb (at room temperature) before shutting down. Therefore you don't have to heat sink the chip for safe operation of this circuit.

If the internally set 50× gain of the LM380 isn't enough for your application, the circuit in Fig. 5 uses positive feedback (via R2) to provide a gain of 200. National Semiconductor recommends 15.2K (1%) for R1 and 2.7 ohms for R3, but I obtained excellent results with a 10%, 15K resistor for R1 and three 1-ohm resistors in series for R3. The circuit makes a very sensitive one-way intercom or you can omit T1 and connect an appropriate input device directly to pin 6 and ground.

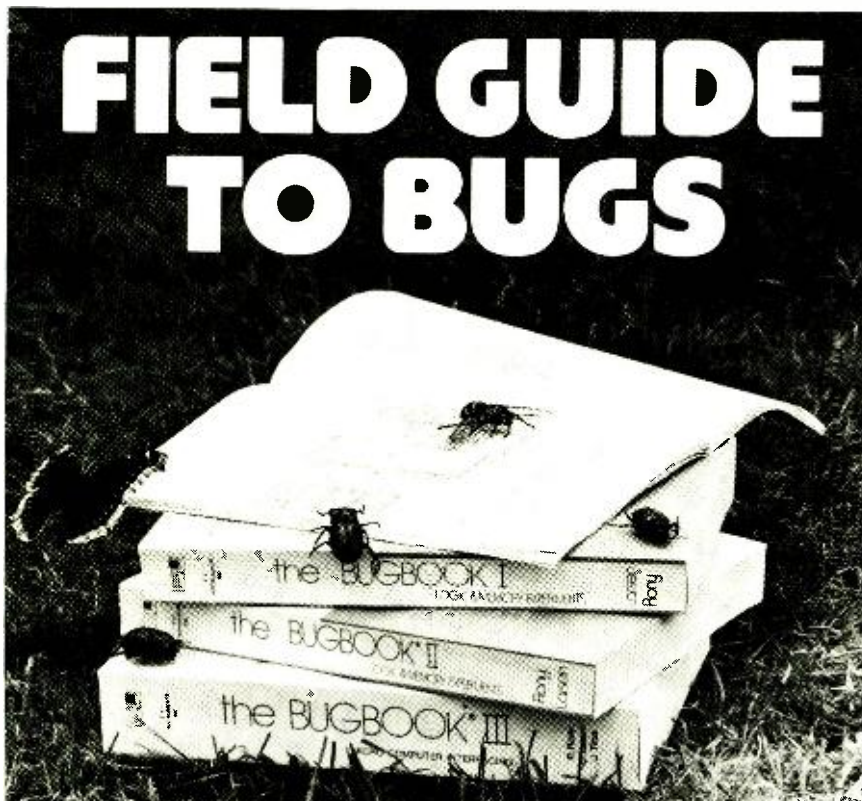

SPECIAL PRICE

The Bugbook library — Bugbooks I, II, IIA and III — are available together at the factory direct price of \$37.00 . . . save postage and handling . . . order today.
Prices applicable only in the U.S. and its possessions.

In a world crawling with bugs, it's good to have the Bugbooks by your side. Good to have just four books dedicated solely to teaching you digital electronics . . . from ground zero on up. From fundamental logic and memory experiments to interfacing with microprocessors. The Bugbooks are E&L Instruments' pioneering approach to mastering today's pulse-quick world of micro-electronics. With an approach that's simple and straightforward. Clear. Complete. Well-illustrated. And as fresh as tomorrow's circuit design. In all, some 1350 pages. They're the Bugbooks. Don't ven-

ture a step farther into the world of digital electronics without them. Because the place is crawling with bugs.

CIRCUIT DESIGN, INC.

Division of E & L Instruments, P.O. Box 24, Shelton, Conn. 06484

Gentlemen:
Please send me the set of Bugbooks for \$37.00 postpaid.
Name _____
Company _____
Address _____
City _____ State _____ Zip _____
Enclose check or money order or valid BankAmericard or Master Charge information.

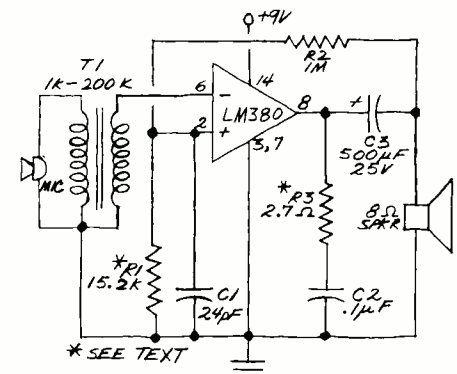

Fig. 5. An audio amplifier circuit with gain of 200.

Incidentally, when operating any of the circuits described here you may encounter a couple of undesirable problems. One is a 5-10-MHz oscillation whose presence can easily be determined (if you don't have access to a scope) by simply placing an AM radio near the circuit. If the radio hisses or if station interference occurs, connect the C2-R3 network shown in Fig. 5 to the circuit to suppress the oscillation. Oscillation may also occur if the power supply leads are too long. Connect a 0.1-µF capacitor between pins 14 and 7 to eliminate this problem.

Finally, a particularly troublesome problem is erratic circuit operation. The circuit seems to work fine for a while and then quits. After the power supply voltage is removed for a few seconds, the circuit operates in a normal manner.

You can be thankful for this "problem" since the IC is being overloaded and the thermal shutdown circuit is saving you from having to buy a new IC! Solve this problem by reducing the level of the input signal, decreasing the power supply voltage, or both. ♦

ELECTRONICS MARKET PLACE

NON-DISPLAY CLASSIFIED: COMMERCIAL RATE: For firms or individuals offering commercial products or services, \$2.00 per word (including name and address). Minimum order \$30.00. Payment must accompany copy except when ads are placed by accredited advertising agencies. Frequency discount; 5% for 6 months; 10% for 12 months paid in advance. **READER RATE:** For individuals with a personal item to buy or sell, \$1.20 per word (including name and address.) No minimum! Payment must accompany copy. **DISPLAY CLASSIFIED:** 1" by 1 column (2-1/4" wide), \$230.00. 2" by 1 column, \$460.00. 3" by 1 column, \$690.00. Advertiser to supply film positives. For frequency rates, please inquire.

GENERAL INFORMATION: First word in all ads set in caps at no extra charge. All copy subject to publisher's approval. All advertisers using Post Office Boxes in their addresses **MUST** supply publisher with permanent address and telephone number before ad can be run. Advertisements will not be published which advertise or promote the use of devices for the surreptitious interception of communications. Ads are not acknowledged. They will appear in first issue to go to press after closing date. Closing Date: 1st of the 2nd month preceding cover date (for example, March issue closes January 1st. Send order and remittance to **POPULAR ELECTRONICS**, One Park Avenue, New York, New York 10016, Attention: Hal Cymes.

FOR SALE

FREE! Bargain Catalog—I.C.'s, LED's, readouts, fiber optics, calculators parts & kits, semiconductors, parts. Poly Paks, Box 942PE, Lynnfield, Mass. 01940.

GOVERNMENT Surplus Receivers, Transmitters, Sniperscopes, Radios, Parts, Picture Catalog 25 cents. Mesna, Nahant, Mass. 01908.

LOWEST Prices Electronic Parts, Confidential Catalog Free. KNAPP, 3174 8th Ave. S.W., Largo, Fla. 33540.

ELECTRONIC PARTS, semiconductors, kits, FREE FLYER. Large catalog \$1.00 deposit. BIGELOW ELECTRONICS, Bluffton, Ohio 45817.

RADIO—T.V. Tubes—36 cents each. Send for free catalog. Cornell, 4213 University, San Diego, Calif. 92105.

AMATEUR SCIENTISTS, Electronics Experimenters, Science Fair Students... Construction plans—Complete, including drawings, schematics, parts list with prices and sources... Robot Man — Psychedelic shows — Lasers — Emotion/Lie Detector — Touch Tone Dial — Quadraphonic Adapter — Transistorized Ignition — Burglar Alarm — Sound Meter... over 60 items. Send 50 cents coin (no stamps) for complete catalog. Technical Writers Group, Box 5994, University Station, Raleigh, N.C. 27607.

METERS—Surplus, new, used, panel or portable. Send for list. Hanchett, Box 5577, Riverside, CA 92507.

MECHANICAL, ELECTRONIC devices catalog 10 cents. Greatest Values — Lowest Prices. Fertik's, 5249 "D", Philadelphia, Pa. 19120.

SOUND SYNTHESIZER KITS—Surf \$12.95, Wind \$12.95, Wind Chimes \$17.95, Electronic Songbird \$6.95, Musical Accessories, many more. Catalog free. PAIA Electronics, Box J14359, Oklahoma City, OK 73114.

BUGGED??? New locator finds them fast. Write, Clifton, 11500-L N.W. 7th Avenue, Miami, Florida 33168.

DISCOUNT PRICES

B&K, SENCORE, LEADER, RCA
EICO, FLUKE, HICKOK, SIMPSON
Test Equipment

ICC Servicemaster, RCA and Raytheon Tubes
Complete line of electronic supplies

Free Catalog

FORDHAM RADIO SUPPLY CO., INC.

855R Conklin St., Farmingdale, N.Y. 11735 (516) 752-0050

YOU WILL SAVE BIG MONEY! Surplus, Clearouts, Bankruptcy, Inventory, Deals. Catalog \$1 (redeemable). ETCOA Electronics, Box 741, Montreal, H3C 2V2. U.S. Inquiries.

HEAR POLICE/FIRE Dispatchers! Catalog shows exclusive directories of "confidential" channels, scanners. Send postage stamp. Communications, Box 56-PE, Commack, N.Y. 11725.

CD IGNITIONS, VHF/UHF monitors, crystals, CB radios, Southland, Box 3591-B, Baytown, Texas 77520.

SURPRISE! Build inexpensively, the most Unusual Test Instruments, Futuristic Gadgets using Numerical Readouts! Catalogue Free! GBS, Box 100A, Green Bank, West Virginia 24944.

TELEPHONES UNLIMITED, equipment, supplies. Catalog 50 cents. Box 1654E, Costa Mesa, Calif. 92626.

UNSCRAMBLERS: Fits any scanner or monitor, easily adjusts to all scrambled frequencies. Only 4" square \$29.95, fully guaranteed. Dealer inquiries welcomed. PDQ Electronics, Box 841, North Little Rock, Arkansas 72115.

SURPRISE! SURPRISE! Digital Piano Tuning Device tunes musical instruments Accurately! Perfectly! Inexpensively! Construction-Instruction-Plans Complete \$12.95 Airmailed Postpaid! Moonlighting quickly repays \$40 electronics investment! GBS, Box 100P, Green Bank, West Virginia 24944.

RECONDITIONED Test Equipment. \$0.50 for catalog. Walter's Test Equipment, 2697 Nickel, San Pablo, CA 94806.

IC BONANZA

*Data Sheet included on these items

*2102	1K Static RAM	\$ 1.49
*5203Q	Eraseable PROM 2K	10.95
*MM5330	National DVM Chip	9.95
*50310	Slide Rule Calculator Chip	3.95
*50250	Alarm Clock Chip	4.45
304H	Negative Regulator	95
309K	5 Volt Regulator	95
LM320K	5 Volt Neg Regulator	84
LM340K	24 Volt Pos Regulator	89
741	Op Amp - Mimirid	29
MAN 7	(HP-7730) 7 Seg Display	1.15
MAN 3	7 Segment Display	5/1 00
MCA 8	Monsanto Slotted Opto Switch	75
LED	2" Red	6/1 00
LED	2" Yellow	5/1 00
LED	2" Green	5/1 00
LED	2" Red-Right Angle	5/1 00
LED	12" Red	7/1 00
LED	12" Yellow	6/1 00
LED	12" Green	6/1 00

SEND FOR FREE CATALOG

Minimum order \$5.00, data sheets 25 cents each. Include 5% of order for postage and handling. Texas residents include 5% state sales tax

BONANZA ELECTRONICS

P. O. Box 24767 Dallas, Texas 75224

ELECTRONIC ignition: Pointless, Transistor, Capacitor. Vapor inductors, Auburn Sparkplugs. Information 10 cents. Anderson Engineering, Epsom, N.H. 03234.

6 MHZ CRYSTALS including schematic and info to generate 60 Hz-12VAC to make your digital clock run on batteries. \$10.50 pp in US. Eastern Sales, Box 510, Raleigh, N.C. 27602.

DESCRAMBLERS: Several Professional Models that work with all Scanners. Tone Encoders/Decoders, Scanmate, AAPP, Radar Detectors, Big Ears, Alarms, Books, Kits, parts. Catalog 25 cents: KRYSTAL KITS, Box 445, Bentonville, Ark. 72712.

CARBON FILM RESISTORS. Brand new as low as 1.7 cents. Discounts of 20%. Prompt delivery. FREE samples/specifications. COMPONENTS CENTER, Box 134P, N.Y., N.Y. 10038.

WHOLESALE C.B., Scanners, Antennas, Catalog 25 cents. Crystals: Special cut, \$4.95. Monitor \$3.95. Send make, model, frequency. G. Enterprises, Box 461P, Clearfield, UT 84015.



Send for your information packet today—
which also includes circuit functions, component line-up, and accessories. Information Packet \$1.00 (refundable with order).

visulex P. O. Box 4204P Mountain View, CA 94040



The Edmund BIOSONE II

turns brainwaves into an audible or visual signal. \$149.95

KNOW YOUR ALPHA FROM YOUR THETA!

For greater relaxation, concentration... monitor your alpha/theta brainwaves.

Features Normally Found Only In Units Selling For More Than \$200.00—And 3 Feedback Modes.



The portable, professional quality Edmund Biosone II boasts 3 feedback modes—LED FM tone, threshold tone; a test mode to check overall system of operation. Easy to use, this beautiful 4-pound, simulated walnut unit (9 1/2 x 5 1/2 x 4 1/4") can be operated at home, in office or clinic. It gives you outputs to allow further monitoring of logic signal, raw EEG, filter output, meter, and FM. Total brainwave monitoring capability, incl. filter select feedback, with wide range calibration sensitivity control (5-100 microvolts). Completely safe, the Edmund Biosone II is similar to an electroencephalograph (EEG), enabling you to identify the electrochemical activity that exists at all times in the human brain. In addition to letting you know when you're most relaxed, Biosone II is a great conversation piece. Included at its low price are a set of electrodes, an earphone jack for private use. Uses latest advances in linear circuitry, runs on two 9v transistor batteries (not included).

STOCK NO. 1668AV Just \$149.95 ppd.
LOW COST STARTERS' UNIT, No. 71,809AV \$55.00 ppd.

COMPLETE AND MAIL COUPON NOW

EDMUND SCIENTIFIC CO., 300 Edscorp Bldg., Barrington, N. J. 08007

Send me:

SEND FREE   164 PAGE CATALOG AV

Charge my BankAmericard

Charge my Master Charge

Interbank No. _____

Card No. _____

Expiration Date _____

30-DAY MONEY-BACK GUARANTEE. You must be satisfied or return any purchase in 30 days for full refund.

City _____ State _____ Zip _____

Service and handling charge \$ _____ \$1.00

Enclosed is check, m.o. in amount of \$ _____

Signature _____

Name _____ Please print

Address _____

GIANT FREE CATALOG!

NEW 164 Pages Over 4,500 Unusual Bargains for Hobbyists, Schools, Industry



JUST CHECK COUPON!

EDMUND SCIENTIFIC CO.
300 EDSCORP BUILDING
Barrington, N. J. 08007
(609) 547-3488

America's Greatest
Science • Optics • Hobby Mart

HELPING TO DEVELOP AMERICA'S TECHNOLOGY FOR OVER 30 YEARS.

ABOUT YOUR SUBSCRIPTION

Your subscription to POPULAR ELECTRONICS is maintained on one of the world's most modern, efficient computer systems, and if you're like 99% of our subscribers, you'll never have any reason to complain about your subscription service.

We have found that when complaints do arise, the majority of them occur because people have written their names or addresses differently at different times. For example, if your subscription were listed under "William Jones, Cedar Lane, Middletown, Arizona," and you were to renew it as "Bill Jones, Cedar Lane, Middletown, Arizona," our computer would think that two separate subscriptions were involved, and it would start sending you two copies of POPULAR ELECTRONICS each month. Other examples of combinations of names that would confuse the computer would include: John Henry Smith and Henry Smith; and Mrs. Joseph Jones and Mary Jones. Minor differences in addresses can also lead to difficulties. For example, to the computer, 100 Second St. is not the same as 100 2nd St.

So, please, when you write us about your subscription, be sure to enclose the mailing label from the cover of the magazine—or else copy your name and address exactly as they appear on the mailing label. This will greatly reduce any chance of error, and we will be able to service your request much more quickly.

NEW ADJUSTABLE THREE OUTPUT REGULATED POWER SUPPLY, plus 900 parts worth \$400.00 list. Solid state CARTRIVISION television recorder electronic unit. Schematics, parts cross reference. HEATHKIT television transistor substitutions. Power CB radios, MICRO-PROCESSORS \$17.95 plus \$3.50 S&H. USA. Free Brochure. Master Charge, BankAmericard. Satisfaction guaranteed. MADISON ELECTRONICS COMPANY, INCORPORATED, Box 369, D55, Madison, Alabama 35758.

PLANS—Video Pong...\$2.00. Laser...\$2.00. Projection TV...\$2.00. Catalog 50 cents. Technologic, Box 5262, Orchard Lake, Michigan 48033.

POLICE CODE UNSCRAMBLERS. Fits all scanners. Satisfaction Guaranteed. Jim's Two-Way, Box 275, Hot Springs, Ark. 71901.

500 MHZ Prescaler -10 or +100 \$59.95. Plans \$5.00. CBS, Box 1356, Cocoa Beach, Florida 32931.

CLASSIFIED ADVERTISING ORDER FORM

Please refer to heading on first page of this section for complete data concerning terms, frequency discounts, closing dates, etc.

1	2	3	4	5
6	7	8	9	10
11	12	13	14	15
16	17	18	19	20
21	22	23	24	25
26	27	28	29	30
31	32	33	34	35

WORD COUNT: 15 WORD MINIMUM. Include name and address. Name of city (Des Moines) or of state (New York) counts as one word each. Zip Code numbers not counted. (Publisher reserves right to omit Zip Code if space does not permit.) Count each abbreviation, initial, single figure or group of figures or letters as a word. Symbols such as 35mm, COD, P.O., AC, etc., count as one word. Hyphenated words count as two words. Telephone numbers count as one word.

Words \$2.00 (Commercial Rate) \$1.20 (Reader Rate)

Payment of \$ _____ enclosed for _____ insertion(s).

CHARGE: American Express BankAmericard Master Charge Diners Club

for _____ insertion(s). You will be billed monthly.

Account # _____ Expiration Date _____

Master Charge Interbank # (4 digits above name) _____

SIGNATURE MUST BE PROVIDED BELOW

PRINT NAME _____

ADDRESS _____

CITY _____

STATE _____

ZIP _____

SIGNATURE _____

PE-976

The BIGGEST "BRIGHTEST" BESTEST 6 Digit LED Alarm Clock & Elapsed Timer Kit available at this value anywhere \$17.95 Complete

- 6-Fairchild .50" LED Displays
- 0-60 Min. Elapsed Timer
- 12 Hr. 60 cycle oper.
- AC or DC oper.
- 5375AB Nat. Clock Chip
- "Freeze" Feature on any Mode
- 24 Hr. Alarm w/snooze
- Field Tested over 6 months

The kit contains P.C. Boards, Xformer, and EVERY Part Required for the Clock and all options except Cabinet or Crystal Time Base for D.C. Oper. If desired, see below.

Clock Cases

Wood Grain, Dark Oak Finish & Filter — \$4.00
Plexiglas (Choice: Bl. Wh. Blue. Smoke) — \$3.00

Crystal Time Base Kit

for D.C. operation
\$5.95

ELECTRONIC COMPONENTS — A small SAMPLING

LM309K · 5 Volt Regulator · Raytheon	79¢
LM340T Series Regs. - 5, 6, 12, 15, & 24 V (pos.)	99¢
LM741 Op. Amp. 14 Pin Dip Pkg.	4 for 99¢
2N3055 NPN Transistor TO-3 Pkg.	59¢
2N4904 PNP (complement to 2N3055)	69¢
25 Amp · 200 Volt Full Wave Bridge	\$1.49
10 Pk · 220 Power Tab Xistors, NPN & PNP Asst.	\$1.49
15 Pk · LED's Assorted Sizes and Colors	\$1.49
Bi-Polar LED - Red/Green	\$1.00

HOBB-Y-TRONIX, INC.

Box 511, Edison, N.J. 08817

AC/DC - ALARM Clock Kit - 12/24 Hr.

\$7.50

quantities
of 1-5

\$6.50

quantities of
6 & up

- Your choice of Display Colors - Red, Green, Blue, Amber
- Displays Hrs. & Min. - Switch to Min. & Secs. on Command.
- AM/PM Indication
- Field Tested for 6 months

The kit will include a 5316 National Clock Chip, 4 Fluorescent Display tubes, all electronic components, switches, controls & complete instructions, specs, etc. for clock and all optional Features. Other parts required or if desired are as follows:

- PC Board, Drilled & Silk Screened for Clock & all options \$3.00
- Xformer (for AC oper.) — \$1.00
- Speaker Alarm Kit — \$2.00
- Crystal Time Base Kit (for DC oper.) & cabinets — See Below
- App. (SCR output) timer kit — \$2.00
- Count Down (turn-off) timer kit — \$2.00

Dual Range DIGITAL Voltmeter Kit

0 to ±2 Volts DC \$39.95 Complete 0 to ±2 Volts DC

- Features latest Technology DVM chip set
 - High Noise Rejection
 - Non Critical Comp.
 - Accuracy to within .001
- Contains — P.C. Boards; 4-large .50 Fairchild Readouts; Display Drivers; Op-Amps; Inverter; all electronic comp; Switches, Pots; Complete Instructions and Specs; & DVM Chip Set.
- Requirements: Power Supply w/+5V, +15V and -15V.
Option Avail. — 0-200V Range Extender - \$4.95

TERMS AND CONDITIONS

Orders must include Check - No COD's. Add \$1.00 handling for orders under \$15.00. N.J. residents - add 5% tax. Shipment via UPS unless otherwise specified.

Poly Pak[®] EXCLUSIVE Avg. Ship. \$1.98 Wt. 6 ozs.



YOUR CHOICE OF ANY KIT

100'S OF BARRELS PURCHASED! TEST 'EM YOURSELF 'N SAVE!

For the first time anywhere, Poly Pak merchandisers introduce a new way in buying the economical way. Raw stock from the "barrel". Remember the "good ole days"? They're back again. The same way merchandisers

throughout the United States buy from various factories... their overruns in barrels. Poly Pak has done the same. Therefore you are getting the same type of material as the RE-TESTERS DO!

Every kit carries a money back guarantee!

BARREL KIT #1
SN7400 DIP IC'S
75 for \$1.98
Marked 14 and/or with 16 pin dips, may include gates, registers, flip flops, counters. Who knows! GUARANTEED SATISFACTION!
Cat.No. 9E2415 Untested.

BARREL KIT #2
LINEAR OP AMPS.
DIPS
75 for \$1.98
Un-
tested
May include 709's, 741's, 703's, 560 series. 555 includes marked and unmarked. Cat.No. 9E2416

BARREL KIT #3
1N4148/914
SWITCHING DIODES
100 for \$1.98
You never saw this before. Imagine famous switching diodes at these prices!
Cat.No. 9E2418 Untested.

BARREL KIT #4
"4000" RECTIFIERS
100 for \$1.98
Un-
tested
These are the famous micro miniature rectifiers of the 1N4000 series. May include 25, 50, 100, 200, 400, 600, 800 and 1000 volters. Cat.No. 9E2417

BARREL KIT #5
SCRS, TRIACS,
QUADRACS
40 for \$1.98
All the famous plastic power tab type. Raw factory stock! All the 10 amp types. Cat.No. 9E2419 Untested.

BARREL KIT #7
VOLUME CONTROL
BONANZAI
40 for \$1.98
100% good
Singles, duos, variety of values, styles, big ones — small ones. Cat.No. 9E2421

BARREL KIT #8
SUBMINIATURE
IF TRANSFORMERS
100 for \$1.98
100% good.
Amazing. Includes 455kcs, etc. antennas, who knows! From transistor radio manufacturers. Cat.No. 9E2422

BARREL KIT #10
ROMS-REGISTERS
50 for \$1.98
Un-
tested
28 to 40 pin devices, marked internal factory numbers. Cat.No. 9E2424

BARREL KIT #12
POWER TAB
TRANSISTORS
40 for \$1.98
PNP, plastic TO220 type. Assorted 2N numbers. Cat.No. 9E2426 Untested.

BARREL KIT #13
RESISTOR NETWORKS
60 for \$1.98
Un-
tested.
By Corning Glass, in 14-pin dip packs Cat.No. 9E2427

BARREL KIT #14
PRECISION RESISTORS
200 for \$1.98
Marked and unmarked 1/4, 1/2, 2 watts. No. 9E2428

BARREL KIT #15
MOSFET TRANSISTORS
60 for \$1.98
All 4 leaders TO-18 case, includes UHF transistors too! Cat.No. 9E2429

BARREL KIT #17
LINEAR & 7400 DIPS
100 for \$1.98
Un-
tested
Marked and unmarked, internal numbers of raw factory stock. Cat.No. 9E2431

BARREL KIT #19
DIPPED MYLARS
60 for \$1.98
100% good.
Finest capacitor made, shiny finish. Imagine factory dumping 'em in barrels. Cat.No. 9E2597 100% good.

BARREL KIT #20
LONG LEAD DISCS
150 for \$1.98
Un-
tested.
Factory distributor stock "auction sale" Prime, marked only. Long leads. Cat.No. 9E2598 100% good.

BARREL KIT #25
METAL CAN
TRANSISTORS
100 for \$1.98
Un-
tested.
Includes TO-5, TO-18, etc. assorted 2N numbers, unmarked etc. Cat.No. 9E2603

BARREL KIT #26
PLASTIC
TRANSISTORS
100 for \$1.98
Un-
tested.
Type TO-92 (TO-18), all manufacturers, variety of 2N's. Cat.No. 9E2604

BARREL KIT #30
PREFORMED
RESISTORS
250 for \$1.98
We got barrels of 1/4 and 1/2 watt resistors for pe use. You'll get seven amount. 100% 1/4, 100% 1/2 watt. Cat.No. 9E2608 100% good.

BARREL KIT #31
METALLIC
RESISTORS
100 for \$1.98
Made mostly by Corning, the finest resistor made. Mostly 1/2 watters, 1% to 5% tol. A barrel of values. Cat.No. 9E2609

BARREL KIT #32
TRANSISTORS
WITH A HOLE IN IT
50 for \$1.98
Un-
tested.
Can't name factory but we thought barrels of 25 watters with mtg. hole in middle. PNP's and NPN's.

BARREL KIT #35
NEON LAMPS
30 for \$1.98
100% good.
Famous NE-2's. All prime, but factory made millions and barrel of 'em. No advantage. Cat.No. 9E2613

BARREL KIT #36
GERMANIUM DIODES
200 for \$1.98
Un-
tested
Famous maker, popular item. Never grows old! But this is why the RE-TESTERS buy 'em from the factories. Cat.No. 9E2614

BARREL KIT #37
1 AMP "BULLET"
RECTIFIERS
100 for \$1.98
Un-
tested
Famous style, ass't. voltage, silicon, axial includes all types of voltages to 1kV. Cat.No. 9E2615

BARREL KIT #39
2N3055 HOBBY
TRANSISTORS
15 for \$1.98
100% good.
From factory to you, these fallouts of the famous 2N3055. We have 10 barrels. Cat.No. 9E2617

BARREL KIT #40
PNP HIGH-POWER
TRANSISTORS
20 for \$1.98
Popular germanium TO-3 case units, now available at "good ole barrel" prices. Cat.No. 9E2618 100% good.

BARREL KIT #46
6.3V 1/2 WATT
AMPLIFIERS
25 for \$1.98
Un-
tested.
Hobby type, factory fallouts, we purchased them in barrels. These are unknown. Cat.No. 9E2624

BARREL KIT #50
SIGNAL SILICON
DIODES
200 for \$1.98
Includes many, many types of switching, signal silicon types, all axial leads. Some may be zeners. Cat.No. 9E2628 Untested.

BARREL KIT #53
JUMBO RESISTOR PAK
100-pc. \$1.98
Cat.No. 9E2721
Assortm metal films, precision, carbons, metal oxide resistors, from 1/4 watt to 7 watts. Color coded & 100% good. Worth \$10.

BARREL KIT #54
8 DIGIT READOUTS
7 for \$1.98
Bargain of a lifetime! All we got was 1 barrel — the "blisidor digit" types. Multiplexed. Cat.No. 9E2722

BARREL KIT #55
SLID SWITCHES
30 for \$1.98
All shapes, sizes, spst, opt, momentaries, etc. Tremendous stock pack for 100's of switching projects. Cat.No. 9E2726 100% good.

BARREL KIT #59
POWER TRANSISTORS
40 for \$1.98
15 watt Bendix B-5000 pellet transistors, non, all glass, double plug. A pretreater, have millions of 100% good. Cat.No. 9E2727

BARREL KIT #61
POLYSTYRENE CAPS
100 for \$1.98
Finest caps made. As a gamble we bought 10 barrels from factory, mixed values, all good. Cat.No. 9E2729

BARREL KIT #65
MIXED READOUTS
15 for \$1.98
Factory returns — such numbers as MAN-1's, MAN-7's, MAN-9's, 11 barrels & no time to separate. Cat.No. 9E2733 Untested.

BARREL KIT #68
2 WATERS
100 for \$1.98
100% good.
Nobody seems to want 'em! So many suppliers don't count, but throw 'em in the barrel. It's a lil' gold mine. All marked. Cat.No. 9E2735

BARREL KIT #71
CAPACITOR SPECIAL
100 pcs. \$1.98
Empire stockroom into barrels of mylars, poly's, mica's, moldeds, plastics, ceramic's, disc's, etc. Nifty. 100% good. Cat.No. 9E2738

BARREL KIT #73
TRANSISTOR
ELECTROS
50 for \$1.98
Un-
tested.
Factory dump 'em in barrels. We don't wish to separate some ass't voltages & values up to 300 mV. Cat.No. 9E2747

BARREL KIT #75
400MW ZENERS
150 for \$1.98
Factory out of biz! Amazing offer: 6, 8, 10, 12, 15V. You test. Hermetically sealed glass pak. Double plug. Cat.No. 9E2740

BARREL KIT #76
1-WATT ZENERS
100 for \$1.98
Un-
tested.
Factory same as 400-mw's. Never-to-see-again offer: 6, 8, 10, 12, 15V, under glass, double plug. Cat.No. 9E2741

BARREL KIT #77
"BROWN" BODY
TRANSISTORS
40 for \$1.98
6-E 1-40 series; has hi-voltage. Darlington, hi-current type. Factory line discontinued. Power tabs. Cat.No. 9E2742 Untested.

BARREL KIT #81
SUBMINI RESISTORS
200 for \$1.98
100% good.
PC, upright type, color coded. Resistors marked 1/4, 1/2, 1W. Come to you in a barrel. Cat.No. 9E2746

BARREL KIT #83
LM-340T
VOLTAGE
REGULATORS
15 for \$1.98
Un-
tested.
Factory rejected them for length of leads. May include 7, 8, 9, 12, 15, 18, 24 volts. Power tab. Cat.No. 9E2635

BARREL KIT #86
HOBBY LEDS
40 for \$1.98
Un-
tested.
Wow! A Litronics dump of all the kind of mixed discrete LEDs, shapes, colors good, poor, etc. 9E2859

BARREL KIT #87
NATIONAL IC BONANZA
100 for \$1.98
Un-
tested.
Factory dumps into barrels. Types 4000, 400 series, JTL's, ROMs, registers, clock & calc. chips, linear's, etc. Cat.No. 9E2860 Untested.

BARREL KIT #88
NATIONAL IC LED
READOUTS
10 for \$1.98
Un-
tested.
747's, 747's, singles, tri-plex, etc. \$1 to 0.6. But from factory, all mixed; have fun! No. 9E2861

BARREL #91
SILVER MICAS
100 for \$1.98
Cat.No. 9E3018
For the first time silver mica so low in price! Axial, red case, variety of physical sizes & values. Big savings from distributor prices. Wt. 1 lb.

BARREL KIT #93
HALF WATERS
200 for \$1.98
Un-
tested.
Resistor factory tried to fool us by marking 100% color-coded resistors in barrel. But value is there. 4 oz. Cat.No. 9E3046

BARREL KIT #99
PHOTO ELECTRIC
CELLS
10 for \$1.98
Un-
tested.
Ass't. GE types, CDS types. Mixed by factory. Big job for us to separate. 100% good. Cat.No. 9E3052

BARREL KIT #101
RESISTOR SPECIAL
200 for \$1.98
Un-
tested.
Includes: 1/4, 1/2, 1, 2, 3 watters, carbon, 8 oz. 100% good. 9E3054

BARREL KIT #104
SLIDE VOLUME
CONTROLS
10 for \$1.98
Un-
tested.
Used in hi-fi, volume control maker unloads. Ass't. values, what a buy. Worth \$1 ea. We've got barrels of 100% material.

BARREL KIT #108
MINI VOLUME
CONTROLS
25 for \$1.98
Un-
tested.
3-Million pcs of 100%, 50K mini pots, ceramic base, long shaft. Eqpt maker unloads. 9E3058

BARREL KIT #109
TO-5 PLASTIC
TRANSISTORS
40 for \$1.98
Un-
tested.
Includes PNP, NPN, 2N-3638, 2N3641, 2N5000 series, etc. Untested, but guaranteed to a 60% yield.

BARREL KIT #109
TERMINAL STRIPS
150 for \$1.98
Un-
tested.
Wide ass't. of terminal strip connectors, from 1 contact up. Strip manufacturers barrel dump is your gain. Wt. 1 lb. Cat.No. 9E3136

BARREL KIT #112
MICRO MINI LEDS
40 for \$1.98
Un-
tested.
All the tiny leds, axial, upright of Monsanto, Litronics, variety of colors. Yield 60% or better. Cat.No. 9E3139

BARREL KIT #115
MOLEX SOCKETS
200 for \$1.98
100% good.
Calculator maker dump! We got a zillion of 'em. Used for IC sockets, etc. Cat.No. 9E3144

BARREL KIT #116
BUTTONS 'N
FEEDTHRU'S
100 for \$1.98
Un-
tested.
Truthfully, worth a small fortune. White ass't. of button-feedthru caps! HAMS TAKE NOTE! P.U.H. etc. Wt. 1 lb. Cat.No. 9E3141

BARREL KIT #118
MINI SCRS
50 for \$1.98
Un-
tested.
UNBELIEVABLE! TO-92 PLASTIC SCRS in barrels — site from factory. Includes all voltages up thru 200 priv. 9E3135

BARREL KIT #119
PRECISION
RESISTORS
100 for \$1.98
Un-
tested.
100% good. Wt. 2 ozs. PREFORMED! Designed for printed circuit work. 1/4 W. Marked values, 1 and 2% values. 9E3205

BARREL KIT #126
UPRIGHT
ELECTROS
40 for \$1.98
Un-
tested.
Made ass't. of values from 1mf to 300mf in mixture of voltages. 100% marked in good, why barrelled? Legit-a-buy! Cat.No. 9E3226

BARREL KIT #127
AXIAL ELECTROS
40 for \$1.98
Un-
tested.
These ass't. of values (by mixing 'em in barrels) do all of us a favor. WUT A BUY! Ass't. capacities and voltages. Cat.No. 9E3227

BARREL KIT #128
MINI DIP IC'S
75 for \$1.98
Un-
tested.
Large mfg dumped 100's of lbs into barrels. Includes 741's, LM-380-8, 703, 667, 655, 555 — but who knows? Factory to you. All mixed, you test. Wt. 1 lb. Cat.No. 9E3245

BARREL KIT #130
CRYSTALS!
12 for \$1.98
Un-
tested.
Larke U.S. maker dumped frequency marked 1/4, 1/2, 1, 2, 3, 4, 5, 6, 7, 8, 9, 10, 11, 12, 15, 18, 24, 30, 36, 45, 54, 60, 72, 90, 108, 120, 150, 180, 225, 270, 324, 360, 450, 540, 630, 720, 900, 1080, 1350, 1620, 1800, 2025, 2250, 2700, 3240, 3600, 4050, 4500, 5040, 5400, 6030, 6480, 7020, 7560, 8100, 8640, 9180, 9720, 10260, 10800, 11340, 11880, 12420, 12960, 13500, 14040, 14580, 15120, 15660, 16200, 16740, 17280, 17820, 18360, 18900, 19440, 19980, 20520, 21060, 21600, 22140, 22680, 23220, 23760, 24300, 24840, 25380, 25920, 26460, 27000, 27540, 28080, 28620, 29160, 29700, 30240, 30780, 31320, 31860, 32400, 32940, 33480, 34020, 34560, 35100, 35640, 36180, 36720, 37260, 37800, 38340, 38880, 39420, 39960, 40500, 41040, 41580, 42120, 42660, 43200, 43740, 44280, 44820, 45360, 45900, 46440, 46980, 47520, 48060, 48600, 49140, 49680, 50220, 50760, 51300, 51840, 52380, 52920, 53460, 54000, 54540, 55080, 55620, 56160, 56700, 57240, 57780, 58320, 58860, 59400, 59940, 60480, 61020, 61560, 62100, 62640, 63180, 63720, 64260, 64800, 65340, 65880, 66420, 66960, 67500, 68040, 68580, 69120, 69660, 70200, 70740, 71280, 71820, 72360, 72900, 73440, 73980, 74520, 75060, 75600, 76140, 76680, 77220, 77760, 78300, 78840, 79380, 79920, 80460, 80999, 81538, 82077, 82616, 83155, 83694, 84233, 84772, 85311, 85850, 86389, 86928, 87467, 88006, 88545, 89084, 89623, 90162, 90701, 91240, 91779, 92318, 92857, 93396, 93935, 94474, 95013, 95552, 96091, 96630, 97169, 97708, 98247, 98786, 99325, 99864, 100403, 100942, 101481, 102020, 102559, 103098, 103637, 104176, 104715, 105254, 105793, 106332, 106871, 107410, 107949, 108488, 109027, 109566, 110105, 110644, 111183, 111722, 112261, 112800, 113339, 113878, 114417, 114956, 115495, 116034, 116573, 117112, 117651, 118190, 118729, 119268, 119807, 120346, 120885, 121424, 121963, 122502, 123041, 123580, 124119, 124658, 125197, 125736, 126275, 126814, 127353, 127892, 128431, 128970, 129509, 130048, 130587, 131126, 131665, 132204, 132743, 133282, 133821, 134360, 134899, 135438, 135977, 136516, 137055, 137594, 138133, 138672, 139211, 139750, 140289, 140828, 141367, 141906, 142445, 142984, 143523, 144062, 144601, 145140, 145679, 146218, 146757, 147296, 147835, 148374, 148913, 149452, 150000, 150539, 151078, 151617, 152156, 152695, 153234, 153773, 154312, 154851, 155390, 155929, 156468, 157007, 157546, 158085, 158624, 159163, 159702, 160241, 160780, 161319, 161858, 162397, 162936, 163475, 164014, 164553, 165092, 165631, 166170, 166709, 167248, 167787, 168326, 168865, 169404, 169943, 170482, 171021, 171560, 172099, 172638, 173177, 173716, 174255, 174794, 175333, 175872, 176411, 176950, 177489, 178028, 178567, 179106, 179645, 180184, 180723, 181262, 181801, 182340, 182879, 183418, 183957, 184496, 185035, 185574, 186113, 186652, 187191, 187730, 188269, 188808, 189347, 189886, 190425, 190964, 191503, 192042, 192581, 193120, 193659, 194198, 194737, 195276, 195815, 196354, 196893, 197432, 197971, 198510, 199049, 199588, 200127, 200666, 201205, 201744, 202283, 202822, 203361, 203900, 204439, 204978, 205517, 206056, 206595, 207134, 207673, 208212, 208751, 209290, 209829, 210368, 210907, 211446, 211985, 212524, 213063, 213602, 214141, 214680, 215219, 215758, 216297, 216836, 217375, 217914, 218453, 218992, 219531, 220070, 220609, 221148, 221687, 222226, 222765, 223304, 223843, 224382, 224921, 225460, 226000, 226539, 227078, 227617, 228156, 228695, 229234, 229773, 230312, 230851, 231390, 231929, 232468, 233007, 233546, 234085, 234624, 235163, 235702, 236241, 236780, 237319, 237858, 238397, 238936, 239475, 240014, 240553, 241092, 241631, 242170, 242709, 243248, 243787, 244326, 244865, 245404, 245943, 246482, 247021, 247560, 248099, 248638, 249177, 249716, 250255, 250794, 251333, 251872, 252411, 252950, 253489, 254028, 254567, 255106, 255645, 256184, 256723, 257262, 257801, 258340, 258879, 259418, 259957, 260496, 261035, 261574, 262113, 262652, 263191, 263730, 264269, 264808, 265347, 265886, 266425, 266964, 267503, 268042, 268581, 269120, 269659, 270198, 270737, 271276, 271815, 272354, 272893, 273432, 273971, 274510, 275049, 275588, 276127, 276666, 277205, 277744, 278283, 278822, 279361, 279900, 280439, 280978, 281517, 282056, 282595, 283134, 283673, 284212, 284751, 285290, 285829, 286368, 286907, 287446, 287985, 288524, 289063, 289602, 290141, 290680, 291219, 291758, 292297, 292836, 293375, 293914, 294453, 294992, 295531, 296070, 296609, 297148, 297687, 298226, 298765, 299304, 299843, 300382, 300921, 301460, 302000, 302539, 303078, 303617, 304156, 304695, 305234, 305773, 306312, 306851, 307390, 307929, 308468, 309007, 309546, 310085, 310624, 311163, 311702, 312241, 31

TV GAME CHIP 6 IN ONE GAME CHIP

GI AY3-8500
Play tennis, squash, hockey, practice, and 2 shooting galleries. Selectable paddle size, ball speed and angle on screen auto match scoring and pong sounds. All on one 28 pin IC. Includes complete spec sheet, schematic and parts list for building your own one chip TV home game.
Satisfaction Guaranteed \$29.95 (Calif Res add 6% tax)
KEMEL ELECTRONICS P.O. Box 62076 Sunnyvale CA 94086

NEW! 500 MHz frequency counter, 8 digit, built in TCXO ±2 ppm (± 0.0002%). Complete kit \$249.95. Davis Electronics, 636 Sheridan Dr., Dept. C, Tonawanda, N.Y. 14150. (716) 874-5848.

TV GAMES - tennis, hockey, handball, practice. COMPLETELY ASSEMBLED, play after simple connection to your TV set. 2 rifle games extra. GUARANTEED. We service, too. \$69.95. ANGSTROMICS, 16677 Mt. Alison Circle, Fountain Valley, CA 92708.

PROFESSIONAL QUALITY PA MIXER, Six Channels, reverb. Assemble yourself and save \$\$\$. Live sound, recording, use. Lo-Hi Z inputs, stackable. \$179.50. Free Literature. Neptune Electronics, 934 N.E. 25th, Portland, Oregon 97232.

POWER SUPPLY uses three IC regulators. +15 and +5 volt outputs! Comprehensive theory and plans: \$3.50. Free catalog! LHC, Box 453, Littleton, Ma. 01460.

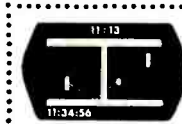

VIDEO GAME KITS DIGITAL CLOCK KITS

SEND \$ 50 FOR YOUR INFO
PACK DO IT TODAY!!!
refunded with purchase
ON SCREEN DIGITAL CLOCK KIT & DESK TOP LED ALARM CLOCK KIT
We have the BEST kits at the BEST price!
INTERFAB 27959 Cabot Rd. Laguna Niguel, Ca. 92647

ELECTRONIC IGNITION SPECIAL: Mark 10B — \$39.95, SST — \$28.45, 500 — \$37.95, MAX — \$42.95, I — \$30.95, G.E.E. Sales, 12525 SE 188 Pl., Renton, Wash. 98055.

LEARN Design Techniques. Electronics Design Newsletter, Digital, linear construction projects, design theory and procedures. Annual Subscription \$6.00, sample copy \$1.00. Valley West, Box 2119-B, Sunnyvale, CA 94087.

MOBILE IGNITION SHIELDING for Hams, CB'ers. Free literature. Estes Engineering, 930 Marine Drive, Port Angeles, Wash. 98362.

Olson electronics

Parts and Accessories

- | | | | |
|---|--------|-------|-------|
| 5-Pc. SCR Kit | TR-298 | 1.79 | 1.00 |
| 500 Mw Zeners (5 Asstd) | DI-052 | .99 | .50 |
| Unijunction Transistors (Pkg 3) | TR-441 | 1.29 | .50 |
| Red L.E.D.s. Lg. (Pkg. 5) | PL-233 | 1.19 | .60 |
| 9 Digit Sperry Display | XM-399 | 1.00 | .60 |
| 20 Key Calculator Keyboard | XM-339 | 2.49 | 1.40 |
| TI 20 Key Cal. Keyboard | XM-523 | 5.00 | 1.60 |
| Ultra-Mini Red L.E.D.s (Pkg. 5) | PL-289 | 1.29 | .70 |
| 3" 7-Seg. L.E.D. Display | XM-512 | 1.70 | .70 |
| 60 CFM Exhaust Fan | MD-390 | 5.00 | 2.50 |
| Metal TV Cart | XM-375 | 2.49 | .99 |
| 2 Volt Wet-Cell Battery | BA-329 | 6.95 | 3.00 |
| CB Rules Book with License | BK-292 | 1.00 | .30 |
| Set of 4 Easy-Roll Casters | XM-111 | 1.69 | .49 |
| "Mini" Mixie Tube | XM-107 | 1.69 | .90 |
| 5# Surprise Kit | XX-196 | 3.29 | 1.00 |
| Digital Lugs (Pkg. 13 Asstd) | XM-004 | 1.49 | .80 |
| Digital Clock Kit | XM-511 | 19.00 | 11.00 |
| 3 1/2" Digit L.C. Display | TR-511 | 1.60 | 1.10 |
| LM 309K 5V Regulator | CB-557 | 13.95 | 9.00 |
| CB Carrying Case | AA-010 | 11.95 | 8.00 |
| Disappearing CB Ant. Mount | SS-080 | 20.00 | 12.00 |
| 8" 2-Way Wood Speaker System | PH-331 | 7.00 | 3.50 |
| Hi-Fi Stereo Headphones | AU-333 | 22.00 | 15.00 |
| FM Converter For Auto Radio | CB-558 | 4.95 | 3.00 |
| CB Bump Mount | AA-999 | 15.00 | 9.00 |
| Trunk Mount CB Antenna | CB-417 | 17.00 | 11.00 |
| CB Converter for Auto Radio | BA-327 | 3.50 | 1.50 |
| Ni-Cad Battery AA Size (Pkg. 3) | BA-328 | 6.00 | 3.00 |
| 1.2 Volt Ni-Cad Battery | HF-283 | 5.00 | 2.50 |
| 8 Tr. Tape Recorder Head | SS-114 | .95 | .50 |
| 3 1/4" 8 ohm Speaker | XM-291 | 1.00 | .50 |
| 117 VAC Black Light Bulb | XM-112 | .88 | .70 |
| Window Lock Alarm | SW-839 | 1.79 | 1.00 |
| 117 VAC Heavy-Duty Solenoid | KN-030 | 1.00 | .50 |
| Assorted Knob Kit (25 Pk) | CC-210 | 1.29 | 1.00 |
| 100 Ceramic Capacitors | MO-359 | .89 | .50 |
| 1/30 RPM Timing Motor 117 VAC | HW-181 | 2.00 | 1.20 |
| 5# Hardware Kit | TI-582 | 1.49 | 1.00 |
| Post 10" Slide Rule | XM-495 | 1.49 | .60 |
| Water Temp. Thermometer (Pkg. 2) | RE-131 | 1.49 | .90 |
| 709 IC OP Amp | TR-514 | 1.00 | .50 |
| Cadmium Photocells (Pkg. 2) | SW-836 | 1.19 | .70 |
| Miniature 12 VDC Solenoid | SW-807 | 1.00 | .70 |
| Magnetic Reed Switch (Pkg. 5) | CD-407 | 5.00 | 2.70 |
| Low Voltage Elect. Capacitor (50 Asstd) | MO-395 | 2.98 | 1.50 |
| 117 VAC/D.C. 4000 RPM Motor | TT-092 | 1.09 | .70 |
| Audio Output Xfmr. 2500 to 4/8 ohms | | | |

ADD POSTAGE & SALES TAX

FREE | **FREE**
8 Olson Catalogs | Olson CB Catalog
NEXT 8 ISSUES SENT TO YOU FREE | WITH DEALERS PRICE LIST

Olson Electronics, 260 S. Forge St., Dept. I P, Akron, Ohio 44327
Please send me Olson catalog CB catalog Both Please Print

NAME _____
ADDRESS _____
CITY _____
STATE _____ ZIP _____

ADVANCED MICROCOMPUTER PRODUCTS

- NEW MOS/LSI TV GAME CHIP
GI AY3 8500 1 in Stock
6 TV Games on a single IC
Unit Qty 39.95
Qty 10 33.95
Qty 100 29.95
- TV Kit 1 PCB, Chd. Instructions 42.95
Video camera output
- TV Kit 2 PCB, Chd. Switches 59.95
Cases, pots, speaker, crystal etc. and all parts required for video output instructions
- TV Kit 3 The ultimate in TV 99.95
Games, inc. chassis, I/F modulator, battery operation, manually assembled
- FUNCTION GENERATOR KIT 27.50
PCB, function chip, instructions, and external components
- MULTITEL KIT 50.00
PCB, instructions plus GI AY5 9100 push button dialer AY5 9200 rotary dialer AY3 9400 Mult. Freq. Gen. AY5 9500 CMOS clock gen.
- TOUCHTONE CONVERTER \$54.95
Converts dial phone to touchtone completely assembled.
- ALTAIR/MSAI COMPATIBLE BK LOW POWER STATIC RAM MODULE
All the latest features at affordable prices
500 ms access time requiring no wait states, fully buffered, memory write protect, addressable on 1K boundaries ie 0.8K, 1.9K, 2.10K etc., noise free, auto. parity, flip switch address selection
Special Introductory Price Only \$29.00
JUST LIKE THE OTHER GUYS BUT LESS MONEY!!!
- AMI EVK 99 6800 Based Microcomputer Kit \$149.00
Expandable to 64K Bytes EPROM, 2048 Bytes RAM programming, 1024 Bytes RAM, 2048 Bytes ROM, 2048 Bytes EPROM, lines, TTL, interface DMA, SV, Kie computer PCB, 6800, 6850, 6820, (2) 6830, (4) 6810, operating manual and complete instructions Also Available: Tiny Basic for 6800 Coming Soon. 16K RAM add on memory Write for More Details
- 8080A Chip Set Special 79.95
1. AMD 8080A
32 AMD-91L 02 A/C (500ns) Rams

Note: our Products have been designed by People like you. If you have any ideas, drop us a line and we will show you how to participate.

ADVANCED MICROCOMPUTER PRODUCTS

IC MARKETPLACE

MICROPROCESSORS	AMD 8080A \$24.95	GENERAL INSTRUMENTS	75450 thru 453 \$.49	QUAD/DUALS/SPECIALS	RC1458 CN .89
AMD 2901 .31.00	AY5 1013A Uart \$ 5.25	74LS138 1.50	1489A 1.45	RC1556 CN .99	
AMI 6800 24.95	AY5 1203 Clockchip 9.95	8820N 1.95	RC3403AD 2.30	RC4131 CN .99	
GI CP1600 59.95	AY5 2376 Keyboard encoder 15.00	8830N 1.95	RC4358 CN 1.90	RC4136 D 1.90	
	RG-2513 Character Generator 10.95	8831 1.95	RC4151 CN 6.50	RC2556CP 2.95	
		8832 1.95	XR 2556CP 2.95	XR 2240CP 2.95	
		8T26B 2.95	XR 1310P 2.95	XR 2206CP 3.95	
6800 SUPPORT DEVICES		9601PC 1.25	XR 2207CP 3.75	XR 1800 2.95	
S680 Modem \$15.95		9614PC 1.95	XR 567CP 2.95	XR 567CP 2.95	
S6820 PIA 11.00	MEMORY DEPARTMENT	9615PC 1.95	XR 1600 2.95	XR 567CP 2.95	
S6810 1 RAM 5.25	2102APC (500ns) \$ 1.70	9616PC 4.25	XR 1600 2.95		
S6850 ACIA 9.95	2112 APC 3.90	9617PC 4.25			
S2350 USRT 7.95	2112 PC 10.90	9620PC 3.50			
S1883 UART 5.00	1702A 10.90	9621PC 3.50			
S6834 1 EPROM 22.95	DM8599 4.75	9622PC 3.50			
S6800 Prog. Manual 15.00	P3101 3.25	9623PC 3.50			
S6800 Hardware Manual 15.00	4402 (4K Static) 12.95	75107N 2.25			
	4200 (4K Static) 13.95	75108N 2.25			
	AMD9130 13.95	75109N 2.05			
	AMD9140 13.95	75110N 2.05			
	AMD9130 13.95	75207N 2.05			
		75208N 2.05			
8080 SUPPORT PRODUCTS					
8224 I/O Port \$ 3.75					
8224 Clock 5.00					
8216 Driver 4.95					
8226 Driver 5.95					
8228 Controller 8.90					
9551 Prog. Interface 19.95					
9555 Prog. Interface 19.95					

7400 TTL	LINEAR	CMOS
SN7400N 14	SN74153N 85	HTO 5 N DIP
SN7401N 14	SN74156N 105	LM105H 3.50
SN7402N 14	SN74157N 95	LM108H 3.50
SN7404N 14	SN74158N 95	LM114H 3.00
SN7408N 16	SN74159N 89	LM131H 1.20
SN7409N 21	SN74172N 39	LM309H 1.20
SN7410N 20	SN74173N 39	LM301AH 45
SN7412N 28	SN74174N 99	LM302AH 45
SN7413N 24	SN74175N 99	LM303AH 95
SN7414N 14	SN74176N 110	LM304AH 1.25
SN7415N 16	SN74177N 110	LM305AH 1.25
SN7416N 16	SN74178N 110	LM306AH 1.05
SN7417N 16	SN74179N 110	LM307AH 1.05
SN7418N 24	SN74180N 99	LM308AH 1.05
SN7419N 24	SN74181N 99	LM309AH 1.05
SN7420N 16	SN74182N 99	LM310AH 1.05
SN7421N 16	SN74183N 99	LM311AH 1.05
SN7422N 49	SN74184N 99	LM312AH 1.05
SN7423N 37	SN74185N 99	LM313AH 1.05
SN7424N 29	SN74186N 99	LM314AH 1.05
SN7425N 29	SN74187N 99	LM315AH 1.05
SN7426N 28	SN74188N 99	LM316AH 1.05
SN7427N 27	SN74189N 99	LM317AH 1.05
SN7428N 31	SN74190N 99	LM318AH 1.05
SN7429N 16	SN74191N 99	LM319AH 1.05
SN7430N 16	SN74192N 99	LM320AH 1.05
SN7431N 16	SN74193N 99	LM321AH 1.05
SN7432N 16	SN74194N 99	LM322AH 1.05
SN7433N 16	SN74195N 99	LM323AH 1.05
SN7434N 16	SN74196N 99	LM324AH 1.05
SN7435N 16	SN74197N 99	LM325AH 1.05
SN7436N 16	SN74198N 99	LM326AH 1.05
SN7437N 16	SN74199N 99	LM327AH 1.05
SN7438N 16	SN74200N 99	LM328AH 1.05
SN7439N 16	SN74201N 99	LM329AH 1.05
SN7440N 16	SN74202N 99	LM330AH 1.05
SN7441N 16	SN74203N 99	LM331AH 1.05
SN7442N 16	SN74204N 99	LM332AH 1.05
SN7443N 16	SN74205N 99	LM333AH 1.05
SN7444N 16	SN74206N 99	LM334AH 1.05
SN7445N 16	SN74207N 99	LM335AH 1.05
SN7446N 16	SN74208N 99	LM336AH 1.05
SN7447N 16	SN74209N 99	LM337AH 1.05
SN7448N 16	SN74210N 99	LM338AH 1.05
SN7449N 16	SN74211N 99	LM339AH 1.05
SN7450N 16	SN74212N 99	LM340AH 1.05
SN7451N 16	SN74213N 99	LM341AH 1.05

SEND FOR OUR NEW CATALOGUE... it contains all popular part types at competitive pricing. We are not a surplus dealer and you will appreciate our service when you get to know us.

TERMS: All shipments first class in U.S. for orders under \$25.00 add \$1.00 for handling. Minimum order \$10.00. California Residents add 6% tax.

ADVANCED MICROCOMPUTER PRODUCTS

P.O. BOX 17329
IRVINE, CALIFORNIA 92713

THE KING OF ALTAJ



6-DIGIT ALARM CLOCK

\$23.50

THE KING FEATURES

- 1) 6 digit 12 hr. 60 cycle or 24 hr. 50 cycle alarm clock.
- 2) Time sharing capability for no. play of additional information.
- 3) Simple 12v supply and a minimum of interface components.
- 4) AM/PM and automatic power fail over indications.
- 5) 10 minute snooze.
- 6) Intensity control of LEDs.

Add 10¢ for Shipping

- Kit No. 70250 1R (Red readouts)
- Kit No. 70250 1G (Green readouts)
- Kit No. 70250 1Y (Yellow readouts)
- Kit No. 70250 2R (DL727 readouts) \$29.50
- Kit No. 70250 3R (FND807 readouts) \$29.50

All kits include components, PC Boards, Transformer, case and construction manual.

THE KING'S HAREM

FATIMA 4-DIGIT TEMP. KIT

\$19.95

Features 4 digit temperature display, 1 gram or centigrade complete C/Mus application, uses 7002 4 digit counter.

Kit includes all components, PC Board and instructions for interfacing with THE KING 6 digit alarm clock. Address Number 1

DELILA APPLIANCE STARTER \$9.95

Example: Set your alarm for 7 am. Set timer for 15 min. At exactly 7 am, the appliance will start, at 7:15 your clock alarm will wake you.

Kit includes all components, PC Board and instructions for interfacing with THE KING 6 digit alarm clock. Address Number 2

TANYA 60 HZ CRYSTAL TIME BASE

ADDITIONAL FEATURES

- 1) Low Power Consumption
- 2) Directly Interfaces with King MOS Clock Chip
- 3) 60 Hz output with crystal time base accuracy
- 4) Ideal for Cus. Boards & Campers

\$5.95

Kit includes all components, PC Board and instructions for interfacing with THE KING 6 digit alarm clock. Address Number 3



FND 70
RED, 25 In. Char.
15mA per segment.
Common Cathode.
\$1.25

DL727

One of our best readouts
5 in. high, 20mA per
segment. Common anode.
\$3.75



FND 807
New 5 in. display
Common Cathode.
\$1.60

FND 800
New 5 in. display
Common Cathode.
\$1.50

ANODE CATHODE
Kit. Built on the Best on the market. Ideal for large signal applications.
\$4.95

BURROUGHS 12 DIGIT
25 in. high orange digit. 160V ic. Free socket.
\$2.50

LEDS

- 12 Mini and Jumbo red
- 15 Jumbo green
- 20 Jumbo yellow
- 25

DL33

If you like an array of diodes, we have it. Common cathode.
\$1.45



TI
Fully multiplexed common cathode. Complete. Best for mini 6 digit clocks.
\$1.30



DE TRANSISTOR ASSORTMENT
1098 Caset Darling, SCRs, NPN, PNP, ect.
50 for \$1.50
100 for \$2.50
300 for \$6.00

TTL BOARDS

MEMOREX computer boards with TTL's Diodes and Transistors, etc.

5 Boards containing 150 250 IC's \$4.50

LSI INTEGRATION

- MM5316 4 6 digit alarm clock 40 pin dip w/ spec. \$ 3.75
- 7002 4 digit counter latch decoder, 7 segment and BCD outputs, 28 pin dip w/ spec. \$12.50
- 7005 4 digit counter latch decoder, 7 segment output only, 24 pin dip w/ spec. \$ 9.50
- 7007 4 digit counter latch decoder with BCD output only, 16 pin dip w/ spec. \$ 7.00
- 70250 4 6 digit alarm clock, 28 pin dip w/ spec. \$ 5.50
- PC Board for 70250 \$ 4.25
- 70380 4 digit non multiplexed radio alarm clock featuring direct drive display, output 40 pin dip w/ spec. \$4.50
- PC Board for 70380 \$ 3.75
- 8006 8 bit parallel CPU, \$19.50
- 2102 1K static RAM for 8006, \$2.25
- MM5203 2K UV erasable PROM, \$2.25
- 75491 segment driver, \$ 0.35
- 75492 1/4 bit driver, \$ 0.45
- 7020 6 function calculator chip with direct segment drive, B drive, \$ 2.25

TTL

CMOS

7400	21	7448	94	74151	80	4000	24	4018	1-39	4037	1-50
7402	21	7453	21	74153	34	4001	24	4019	59	4040	1-59
7404	21	7473	42	74154	100	4002	24	4020	1-59	4041	1-59
7406	29	7424	42	74161	104	4006	1-39	4021	1-39	4042	7-9
7408	21	7475	70	74163	124	4007	24	4022	1-19	4043	80
7410	21	7476	48	74164	194	4008	1-15	4023	24	4044	59
7412	54	7483	90	74165	154	4009	55	4024	99	4047	50
7420	21	7489	250	74174	134	4010	55	4025	24	4049	59
7422	25	7490	74	74175	144	4011	24	4027	59	4050	59
7430	21	7492	80	74182	280	4012	24	4028	99	4066	99
7437	44	7493	80	74192	130	4013	59	4029	139	74C12	29
7438	39	7495	80	74199	84	4014	145	4030	49	74C04	29
7440	21	7496	80	74193	130	4015	115	4031	325	74C107	129
7442	74	7498	80	74199	84	4016	59	4035	139		
7444	21	74121	45			4017	129				
7447	94	74123	80								

4 & 6 DIGIT PC BOARDS

- PC Board for 4 digit display, FND 807 or 807 \$2.75
- PC Board for 6 digit display, FND 800 or 807 \$3.75
- PC Board for 4 digit display, MM5316 \$1.75
- PC Board for 6 digit display, MM5316 \$2.75
- PC Board for 4 digit display, 7002 \$2.00
- PC Board for 6 digit display, 7002 \$3.00
- PC Board for 4 digit display, DL727 \$7.50
- PC Board for 6 digit display, DL727 \$10.00
- PC Board for 4 digit display, DL727 \$2.25
- PC Board for 6 digit display, DL727 \$3.00
- PC Board for 4 digit display, FND70 \$2.25
- PC Board for 6 digit display, FND70 \$3.00



MSI

Wise move

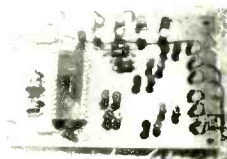

4-DIGIT DECADE COUNTER KIT \$19.95 KIT 012

One chip 4 digit decade counter kit, with both 7 segment and BCD output.

- 1) Chip features internal oscillator for scanning speed.
- 2) Over flow and count extend out puts.
- 3) Transfer, reset, count, blanking and true complement control inputs.
- 4) PC Boards can be cascaded to 8-12 16, etc. digits.
- 5) Kit includes counter chip, drive circuit for 4 cathode type displays and PC Board. (For read out board see FND70-FND503)

KIT 016 FREQ. COUNTER

Features IET input front end with trigger circuit for measuring complex waveforms. Measures from 0.1 Hz to 100MHz when used with Kit 015 or 019. Measures from 0.1Hz to 35MHz when used with Kit 013 and 014. \$24.50



KIT 030 POWER SUPPLY

Input voltage 25V max. Output current 1 amp max. Load regulation 50mV. Output voltage 5V. Line regulation 0.1% (requires B20V transformer). \$4.55

(Contains all parts except transformer)

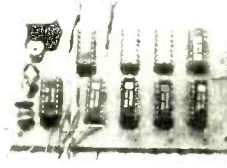

KIT 017 DVM

1.999V as base with polarity indication. 1 M ohm input impedance and accuracy to 1% if properly adjusted. \$16.50



KIT 020 RPM COUNTER

Counts from 1 to 100,000 RPM. RPM counter kit contains components and PC board. \$8.95

TIME BASES

1 Mhz crystal chain time base divider. Outputs, 1Mhz, 100Khz, 10Khz, 1Khz, 100Hz, 10Hz, 1Hz, 0.1Hz. Accuracy better than 0.05% with proper adjustment.

Kit 013 complete CMOS with PC Board Buffer Circuit for TTL Interfacing. \$15.75

Kit 014 Same as Kit 013, but with TTL output. \$13.35

Kit 015, 50Hz or 60Hz chain time base using line frequency as reference. Accuracy 0.1 to 0.05%. Outputs 10KHz, 1KHz, 0.1Hz. Complete with CMOS sharing circuit and PC Board. \$8.75

Kit 019 Same as Kit 015, but with TTL and 60Hz only. \$7.75

Kit 018 60Hz chain time base using line frequency for Kit 020 RPM counter.

*Outputs: 6 sec. = 100Hz of RPM
6 sec. = 10Hz of RPM
60 sec. = full revolution \$9.75

MSI CLUB

Send for your membership card to the Modular Scientific Instrumentation Club and receive a big 10% off on future purchases of MSI kits. Send \$3.00 with your name and address. We will promptly send you your own registered membership card. Don't miss out on the savings. Write now.

Memberships valid for one year from date of registration.

A-C-E 208 Part No. 923332

\$28.95 Add 10% for Shipping



Write for our FREE Brochure

\$\$\$ SAVE! 4-DIGIT ALARM CLOCK

Kit No. 1 \$13.95 (with PC Board)

- 1) Dual in-line clock outputs
- 2) Current control-regulation chip
- 3) Low power brightness control on the BCD eliminating sleep circuitry
- 4) Sleep Ratio feature - 24 hr. snooze alarm
- 5) Independent output setting
- 6) Non multiplexed output circuitry - 12VAC 11.2 amp transformer for Kit No. 1 \$2.00

KIT NO. 2

Complete kit with components, PC Board, Transformer, wood grain case with filter for display window. Includes 25 in. readouts. \$21.50

KIT NO. 3

Complete kit with components, PC Board, Transformer, wood grain case, and filter for display window. Includes 25 in. readouts. \$22.50

* Components for Kit No. 2 or Kit No. 3 sleep ratio feature, add \$9.50 Add 10% for Shipping

LIGHTS MUSIC 60 WATT COLOR ORGAN

Completely self contained unit with 120 watt power cord included. \$2.00

- 555 Timer Mini dip 0.65
- 8038 Functional generator 4.25
- HCA 3043 FM IF, Aud Preamp 1.20
- 565 Phase Lock Loop 1.05
- 567V Tone Decoder 1.50
- LM723 Pns. Vols. Reg. 0.55
- LM309 Sv. Lemo Reg. 1.10
- LM380 2w. Audio Amp 8 pin dip 1.00
- LM741 Operational Amp 0.25
- RCA 200V 115W 705 NPN 1.25
- GE D40C1 NPN Darl 0.25
- 2N4145CR 400MA 7020 0.65
- 2N2922 NPN Gen Amp 0.20
- 2N3904 NPN Driver 0.15
- 2N3906 PNP Compl. 2N3904 0.15
- 2N4001 NPN Low level driver 0.25
- 2N5401 PNP Nixie driver 0.25
- 1N4004 400PIV 15 for 1.00
- 1N4007 4000PIV 10 for 1.00
- 1N746 3.3Zen 4 for 1.00
- 1N4748 Switch 20 for 1.00

LOOK!

From Altaj to you, we've got it! Power Supply Kit 5 Volt 1 Amp Reg. Line regulator 005V Load regulation 50mV. Kit includes Components, PC Board, Transf. Fuse, Pilot Light. Nothing else to buy. \$6.50

ALTAJ ELECTRONICS

P.O. BOX 38544 Dallas, Texas 75238
TERMS: Check or money order. No COD
Telephone (214) 278-3561
Texas Residents Add 5%

7400N TTL

SN7400N	16	SN7400N	27	SN74150N	100
SN7401N	16	SN7401N	20	SN74151N	80
SN7402N	16	SN7402N	25	SN74152N	80
SN7403N	16	SN7403N	22	SN74154N	1.25
SN7404N	18	SN7404N	45	SN74155N	99
SN7405N	24	SN7405N	69	SN74156N	99
SN7406N	24	SN7406N	39	SN74157N	99
SN7407N	29	SN7407N	37	SN74160N	1.25
SN7408N	25	SN7408N	32	SN74161N	99
SN7409N	25	SN7409N	50	SN74162N	99
SN7410N	18	SN7410N	32	SN74164N	1.10
SN7411N	30	SN7411N	5.00	SN74165N	1.10
SN7412N	33	SN7412N	5.00	SN74166N	1.25
SN7413N	45	SN7413N	98	SN74167N	5.00
SN7414N	70	SN7414N	2.10	SN74170N	2.10
SN7415N	35	SN7415N	89	SN74172N	1.50
SN7416N	35	SN7416N	39	SN74173N	1.50
SN7420N	21	SN7420N	3.50	SN74174N	1.25
SN7421N	33	SN7421N	2.25	SN74175N	99
SN7422N	37	SN7422N	7.5	SN74177N	90
SN7423N	37	SN7423N	49	SN74180N	99
SN7424N	29	SN7424N	49	SN74181N	2.99
SN7425N	29	SN7425N	79	SN74182N	95
SN7426N	42	SN7426N	2.45	SN74184N	1.95
SN7427N	42	SN7427N	89	SN74185N	2.20
SN7428N	26	SN7428N	89	SN74186N	2.20
SN7429N	31	SN7429N	4.00	SN74188N	1.10
SN7430N	27	SN7430N	1.00	SN74187N	6.00
SN7431N	27	SN7431N	39	SN74190N	5.10
SN7432N	25	SN7432N	39	SN74191N	1.25
SN7433N	15	SN7433N	39	SN74192N	89
SN7434N	89	SN7434N	70	SN74193N	89
SN7435N	58	SN7435N	60	SN74194N	89
SN7436N	75	SN7436N	60	SN74195N	75
SN7437N	75	SN7437N	0.99	SN74196N	1.25
SN7438N	81	SN7438N	1.15	SN74197N	75
SN7439N	89	SN7439N	4.00	SN74198N	1.75
SN7440N	79	SN7440N	4.50	SN74200N	5.59
SN7441N	25	SN7441N	4.50	SN74201N	99
SN7442N	11	SN7442N	1.15	SN74202N	1.79
SN7443N	27	SN7443N	1.35	SN74204N	6.00
SN7444N	27	SN7444N	2.00	SN74205N	6.00

CONSUMER ELECTRONICS

PONG SUPER PONG

SINGLE GAME \$59.95
4 GAMES IN ONE \$89.95

FOR YOUR HOME TV

GAMES INCLUDED IN SUPER PONG ARE:
 • PONG • CATCH
 • SUPER PONG • HANDBALL

FEATURES OF PONG AND SUPER PONG

- Incremental speed on volleys increases excitement.
- Playing field adjusts to any size screen.
- Game appears in color on a black & white television set.
- Unmistakable PONG sound accompanies each volley.
- Digital scoring flashes on the screen between each point.
- 2 player challenge or Solitaire.
- Hooks up simply to any model television set. The screen actually becomes the playing field.
- English and other techniques can be used to make any member of the family a Pong champion.
- Battery operated by 4 size "D" flashlight batteries included with the Unit.

AC Adaptor (Eliminates Batteries) **\$9.95**



74LS00 TTL

74LS00	39	74LS55	39	74LS151	1.95
74LS02	39	74LS56	39	74LS152	1.69
74LS04	39	74LS74	65	74LS157	1.55
74LS05	45	74LS75	79	74LS162	2.25
74LS06	45	74LS76	65	74LS163	2.25
74LS10	39	74LS83	2.19	74LS164	2.25
74LS12	39	74LS86	65	74LS161	3.69
74LS13	79	74LS90	1.25	74LS190	2.85
74LS14	219	74LS92	1.25	74LS191	2.85
74LS20	39	74LS93	1.25	74LS192	2.85
74LS26	49	74LS96	2.19	74LS193	2.85
74LS27	45	74LS96	1.89	74LS194	2.25
74LS28	49	74LS107	65	74LS195	2.25
74LS30	39	74LS112	65	74LS267	1.89
74LS32	45	74LS120	1.58	74LS260	5.55
74LS40	49	74LS136	65	74LS279	1.79
74LS51	39	74LS138	1.89	74LS270	5.95

MANY OTHERS AVAILABLE ON REQUEST
20% Discount for 100 Combined 7400's

CMOS

CD4000	25	7400A	75
CD4001	25	74C10N	65
CD4002	25	74C20N	65
CD4003	2.50	74C30N	65
CD4007	25	74C42N	1.10
CD4009	59	74C43N	2.10
CD4010	59	74C44	1.15
CD4011	25	74C47	3.00
CD4012	25	74C50	2.00
CD4013	47	74C50	1.15
CD4016	56	74C51	2.90
CD4017	35	74C52	3.00
CD4018	35	74C53	2.15
CD4020	49	74C56	3.25
CD4022	25	74C61	3.25
CD4023	25	74C63	3.00
CD4024	50	74C64	3.25
CD4025	49	74C65	2.50
CD4027	69	74C68	2.75
CD4028	1.65	74C69	2.75
CD4029	2.90	74C70	4.50
CD4030	65	74C70	5.50

OPTO ELECTRONICS

XCITON LITRONIX MONSANTO

DISCRETE LEDES

R - RED
G - GREEN
Y - YELLOW
O - ORANGE

125" dia. 185" dia. 190" dia.

XC209R	5/51	XC526R	5/51	XC111R	5/51
XC209G	4/51	XC526G	4/51	XC111G	4/51
XC209Y	4/51	XC526Y	4/51	XC111Y	4/51
XC209O	4/51	XC526O	4/51	XC111O	4/51

200" dia. 200" dia. .085" dia.

XC229R	5/51	XC556R	5/51	MV50	
XC229G	4/51	XC556G	4/51	853" dia Micro	
XC229Y	4/51	XC556Y	4/51	red led	
XC229O	4/51	XC556O	4/51	G/S1	

DATA HANDBOOKS

7400 Pin-out & Description of 5400/7400 ICS **\$2.95**
 CMOS Pin-out & Description of 4000 Series ICS **\$2.95**
 Linear Pin-out & Functional Description **\$2.95**
ALL THREE HANDBOOKS \$6.95

MINIATURE TOGGLE

DPDT	ON	OFF	ON	221	2.95	2.55	1.87	1.70
	ON	NO	NC	223	2.95	1.25	1.58	1.43
	ON	OFF	ON	121	2.35	1.95	1.43	1.30
	ON	NO	NC	123	2.08	1.65	1.21	1.10

PUSH BUTTON

Model 1 Quantity net prices
 Number Each 2-9 10-29 30-99
 PB-123 \$2.35 \$1.95 \$1.47 \$1.30
 PB-126 \$2.35 \$1.95 \$1.47 \$1.30

LINEAR

LM300H	80	LM1351N	1.65
LM300H	35	LM1458C	1.75
LM300H	75	LM1496N	66
LM300H	100	LM1555V	1.85
LM300H	100	LM1711N	1.95
LM300H	25	LM3820N	2.30
LM300H	100	NE501K	8.00
LM300H	100	NE510A	6.00
LM300H	100	NE531H	3.00
LM300H	99	NE530T	6.00
LM300H	11	NE540L	6.00
LM300H	11	NE550N	7.00
LM300H	90	NE553	2.50
LM300H	1.50	NE555*	5.00
LM300H	1.30	NE560*	5.00
LM300H	9.00	NE561B*	4.00
LM300H	1.35	NE562B*	5.00
LM300H	2	NE565*	5.00
LM300H	1.25	NE568*	1.25
LM300H	1.25	NE569C*	1.25
LM300H	1.75	NE567H	1.25
LM300H	1.75	NE567V	1.50
LM300H	1.75	LM709H	29
LM300H	1.75	LM709N	29
LM300H	1.80	LM710N	29
LM300H	1.70	LM711N	39
LM300H	1.95	LM723N	55
LM300H	1.95	LM723H	55
LM300H	1.95	LM733N	100
LM300H	1.95	LM739N	129
LM300H	1.75	LM741C	35
LM300H	1.75	LM741CN	35
LM300H	1.75	LM741N	39
LM300H	1.75	LM747H	79
LM300H	1.75	LM747N	79
LM300H	1.75	LM748H	39
LM300H	1.75	LM748N	39
LM300H	1.75	LM748P	39
LM300H	1.00	LM783N	90
LM300H	65	LM1303N	1.19
LM300H	1.15	LM1305N	1.40
LM300H	1.15	LM1307N	85
LM300H	3.25	LM1310N	2.95

DISPLAY LEDES

FND503 FND70 DL707 MAN 2 MAN 3 MAN 7

TYPE	POLARITY	HT	TYPE	POLARITY	HT
MAN 1	COMMON ANODE	270	MAN 7A	COMMON CATHODE	300
MAN 2	5 x 7 DOT MATRIX	300	DL707	COMMON ANODE	300
MAN 3	COMMON CATHODE	125	DL747	COMMON ANODE	800
MAN 4	COMMON CATHODE	187	DL750	COMMON CATHODE	500
MAN 7	COMMON ANODE	300	DL338	COMMON CATHODE	110
MAN 7G	COMMON ANODE-GREEN	300	DL707	COMMON CATHODE	250
MAN 7Y	COMMON ANODE-YELLOW	300	FND503	COMMON CATHODE	500
MAN 7Z	COMMON ANODE	300	FND507	COMMON CATHODE	500

THUMBWHEEL SWITCHES

10 POSITION ROTARY SWITCH

2 FOR \$1.00

These switches are a 7 position, one position open, rotary switch included in a 10-5 size. They have a standard 8 pin configuration and will mount perfectly on printed circuit board.

IC SOLDERTAIL - LOW PROFILE (TIN) SOCKETS

8 pin	\$ 1.17	16	25	50	100	1.24	25-49	50	100
8 pin	20	19	18	18	28	28	45	37	36
16 pin	22	21	20	20	36	60	59	58	58
18 pin	29	28	27	27	40	63	62	61	61
22 pin	37	36	35	35					

SOLDERTAIL STANDARD (TIN)

14 pin	\$ 2.27	25	24	28	pin	\$ 9.99	90	81
16 pin	30	27	25	36	pin	1.19	1.26	1.15
18 pin	35	32	30	40	pin	1.59	1.45	1.30
24 pin	49	45	42					

SOLDERTAIL STANDARD (GOLD)

8 pin	\$ 3.00	27	24	28	pin	\$ 7.70	63	57
14 pin	35	32	32	36	pin	1.10	1.00	90
16 pin	38	35	32	36	pin	1.75	1.40	1.26
18 pin	52	47	43	40	pin	1.75	1.59	1.45

WIRE WRAP SOCKETS (GOLD) LEVEL #3

10 pin	\$ 4.55	41	37	24	pin	\$ 1.05	95	85
14 pin	39	38	37	28	pin	1.40	1.25	1.10
16 pin	43	42	41	36	pin	1.59	1.45	1.30
18 pin	75	68	62	40	pin	1.75	1.55	1.40

ZENERS - DIODES - RECTIFIERS

TYPE	VOLTS V	PRICE	TYPE	VOLTS V	PRICE		
1N746	3.3	400m	1N4005*	600 PIV	1 AMP	10.00	
1N751A	5.1	400m	1N4006*	800 PIV	1 AMP	10.00	
1N752	5.6	400m	1N4007*	1000 PIV	1 AMP	10.00	
1N753	6.2	400m	1N4008*	500 PIV	200m	61.00	
1N754	6.8	400m	1N4178	75	10m	15.10	
1N955B	15	400m	1N4154	35	10m	12.10	
1N5232	5.6	500m	28	1N4736	6.2	1w	28
1N5234	6.2	500m	28	1N4737	6.2	1w	28
1N5235	6.8	500m	28	1N4738	8.2	1w	28
1N5236	7.5	500m	28	1N4742	12	1w	28
1N5256	25	600m	61	1N4743	15	1w	28
1N485A	180	10m	51	1N4744	15	1w	28
1N4001	50 PIV	1 AMP	121	1N1184	100 PIV	35 AMP	1.60
1N4002	100 PIV	1 AMP	121	1N1185	200 PIV	35 AMP	1.60
1N4003	200 PIV	1 AMP	121	1N1186	400 PIV	35 AMP	1.80
1N4004	400 PIV	1 AMP	121				

TRANSISTORS

MPS 405	\$ 61.00	PN2219	\$ 31.00	PN2219	\$ 51.00
2N2219	\$ 31.00	2N2219	\$ 31.00	2N2219	\$ 31.00
2N2222	\$ 31.00	2N2222	\$ 31.00	2N2222	\$ 31.00
2N2907	\$ 51.00	2N2907	\$ 51.00	2N2907	\$ 51.00
2N3055	\$ 51.00	2N3055	\$ 51.00	2N3055	\$ 51.00
2N3638	\$ 51.00	2N3638	\$ 51.00	2N3638	\$ 51.00
2N3772	\$ 51.00	2N3772	\$ 51.00	2N3772	\$ 51.00
2N4349	\$ 51.00	2N4349	\$ 51.00	2N4349	\$ 51.00
2N5087	\$ 51.00	2N5087	\$ 51.00	2N5087	\$ 51.00
2N5206	\$ 51.00	2N5206	\$ 51.00	2N5206	\$ 51.00
2N5209	\$ 51.00	2N5209	\$ 51.00	2N5209	\$ 51.00
2N5209	\$ 51.00	2N5209	\$ 51.00	2N5209	\$ 51.00
2N5209	\$ 51.00	2N5209			

CRYSTALS

THESE FREQUENCIES ONLY

Part #	Frequency	Case/Style	Price
CY1A	1.000 MHz	HC33/U	\$4.95
CY2A	2.000 MHz	HC33/U	\$4.95
CY3A	4.000 MHz	HC18/U	\$4.95
CY7A	5.000 MHz	HC18/U	\$4.95
CY12A	10.000 MHz	HC18/U	\$4.95
CY14A	14.31818 MHz	HC18/U	\$4.95
CY19A	18.000 MHz	HC18/U	\$4.95
CY22A	20.000 MHz	HC18/U	\$4.95
CY30B	32.000 MHz	HC18/U	\$4.95

CLOCK CHIPS — CALCULATOR CHIPS

MM5309	6 Digit, BCD Outputs, Reset Pin	\$5.95
MM5311	4 Digit, BCD Outputs, 12 or 24 Hour	4.95
MM5312	4 Digit, BCD Outputs, 1 PPS Output	4.95
MM5313	6 Digit, BCD Outputs, 1 PPS Output	4.95
MM5314	6 Digit, 12 or 24 Hour, 50 or 60 Hz	4.95
MM5316	4 Digit, Alarm, 1 PPS Output	6.95
MM5318	Video Clock Chip, for Use With MM5311	9.95
CT7001	6 Digit, Calendar, Alarm, 12 or 24 Hour	6.95

CALCULATOR CHIPS

MM5725	6 Digit, Four Function, Less Decimal	\$2.95
MM5738	8 Digit, 5 Function, + = x %	2.95
MM5739	8 Digit, 4 Function, Floating Decimal	2.95
CT5001	12 Digit, 4 Function	3.95
CT5003	12 Digit, 4 Function with Memory	5.95
CT5030	12 Digit, 4 Function and %	7.95

MISC. MOS

MM5320	TV Camera Sync Generator	\$19.95
MM5330	4 1/2 Digit DVM Chip	4.95
MM5339	80 Hz Tripler, General From 3.58 MHz	5.00
MM5341	Video Generator, For MM5318	18.00
MC1508-L7	7 Bit Digital to Analog Converter	9.95
MC5007	4 Decade Counter, with Latches	10.95
LD110/LD111	3 1/2 Digit DVM Chip Set	23.00
95H90	100 MHz, 10 Counter, for Prescalers	13.95

THE NEW RCA CA3140 MOST USEFUL OP AMP SINCE THE 741 CA3140 vs. 741 at a glance

	CA3140'S	741CT'S
Input Resistance R _i (MΩ)	1,500,000	2
Input Current I _b (pA)	10	80,000
Slow Rate SR (V/μs)	9	0.5
Gain Bandwidth Product f _t (MHz)	4.5	1.0

\$1.25

VECTOR WIRING PENCIL

Vector Wiring Pencil P173 consists of a hand held featherweight (under one ounce) tool which is used to guide and wrap insulated wire. Fed off a self-contained reliable bobbin onto component leads or terminals isolated on pre-numbered P-Pattern Vectorbord™. Connections between the wrapped wire and component leads, pads or terminals are made by soldering. Complete with 250 FT of red wire.

\$9.50

REPLACEMENT WIRE — BOBBINS FOR WIRING PENCIL

W36-3-A-Pkg 3	250 Ft 36 AWG GREEN	\$2.40
W36-3-B-Pkg 3	250 Ft 36 AWG RED	\$2.40
W36-3-C-Pkg 3	250 Ft 36 AWG CLEAR	\$2.40
W36-3-D-Pkg 3	250 Ft 36 AWG BLUE	\$2.40

1/16 VECTOR BOARD

Part No.	Price
PHENOLIC	4.50
1689A-1 02x11P	1.50
1689A-2 02x11P	1.50
EPOXY	4.50
81P-1 02x11P	1.50
81P-2 02x11P	1.50
1689B-1 06x2	8.50
1689B-2 06x2	11.00
EPOXY GLASS COMPLY (1/4)	4.50

VECTOR TERMINALS

Series	Gold	Tinned	Paste Size	Gold	25 pcs	50 pcs
143	143-1	143-2	1.50	1.00	1.50	1.50
145	145-1	145-2	1.50	1.00	1.50	1.50
149	149-1	149-2	1.50	1.00	1.50	1.50
142-1	PKG 100	Terminals	\$3.50	C	\$13.00M	

DIP SWITCH

These switches feature seven SPST slide switches in a molded dip. They are ideally suited for microprocessor applications.

\$1.95

SCR AND FW BRIDGE RECTIFIERS

C360	15A @ 400V	SCR	\$1.95
C38M	35A @ 200V	SCR	1.95
2N2328	1.6A @ 200V	SCR	.50
MDA 980-1	25A @ 50V	FW BRIDGE REC	1.95
MDA 980-3	25A @ 200V	FW BRIDGE REC	1.95

64 KEY KEYBOARD

This keyboard features 64 open contact SPST keys, unattached to any kind of P.C.B. A very solid molded plastic 13 x 3 base suits most applications.

\$19.95

JOYSTICK

These joysticks feature four 100K potentiometers, that vary resistance proportional to the angle of the stick. Sturdy metal construction with plastic components only at the movable joint. Perfect for electronic games and instrumentation.

\$9.95 ea.

MICROPROCESSOR COMPONENTS

8080 SUPPORT DEVICES		RAM S	
8080A	8212 8 BIT INPUT/OUTPUT PORT FOR 8080	\$ 5.95	8080
\$37.95	8224 CLOCK GENERATOR AND DRIVER FOR 8080	12.95	\$24.95
	8228 SYSTEM CONTROLLER AND BUS DRIVER FOR 8080	12.95	
CPU'S			
8008	8 BIT CPU	\$19.95	
8080	Super 8008	24.95	1101 256 x 1 Static
8080A	Super 8080	31.95	1103 1024 x 1 Dynamic
	SR S		2101 256 x 1 Static
			2102 1024 x 1 Static
2501	1024 Dynamic	\$ 9.00	2107 4096 x 1 Dynamic
2518	Hex 32 Bit	7.00	2111 256 x 4 Static
2519	Hex 40 Bit	4.00	2112 1024 x 1 MMSIS
2524	512 Dynamic	2.95	2102 1024 x 1 Static
2525	1024 Dynamic	6.00	7489 16 x 4 Static
2527	Txal 256 Bit	3.95	8101 256 x 4 Static
2529	Dual 512 Bit	4.00	8111 256 x 4 Static
2532	Quad 8C Bit	3.95	8099 16 x 4 Static
2533	1024 Static	1.95	9102 1024 x 1 Static
3341	Fifo	6.95	73200 256 x 1 Static
74LS670	16 x 4 Rog	3.95	9104 256 x 1 Static
UART S			
AY-51013	30K Baud	\$ 6.95	1702A 2018 Famous
	ROM'S		5203 2048 Famous
2513	Char. Gen	\$11.00	82523 32 x 8 Open C
2516	Char. Gen	13.00	825123 32 x 8 Turbine
74S387	1024 Bit Programmable	1.95	74S287 1024 Static
			3601 256 x 4 Fast
2K RAM SPECIAL			
MM5262 Fully decoded 2K1 dynamic RAM. All inputs except clocks are TTL compatible. Provides a 635 ns minimum access time at 4 reads, a +5, -8.5, and -15V power supply. Low power provides non-volatile memory using battery back up.			
\$0.99 ea. (.05 cents per bit)			
Special Requested Items			
HC4194	Dual Track V Reg	\$ 5.95	N8197 \$ 2.00
RC4195	15V Track Reg	3.25	4024P 2.25
E9368	Decoder	3.95	D98130 3.25
LD110-111	DVM Chip Set	25.00	CD4520 5.50
CA3130	Super CMOS Op Amp	3.99	MC14016 3.50
AM1408-7	D/A	9.95	2925 6.00
17341	FIFO	6.95	2527 3.95
MM5841	Character Gen	18.00	CD4518 2.50
AY-51010	Push Button Dialer	17.50	MM5309 5.95
			45662 3.00
			MC1044 \$ 1.50
			1M3009 1.25
			MM5320 19.95
			40724E 1.50
			7422 1.50
			7497 1.00
			250 74186 5.00
			74279 4.00
			82596 4.00
			MCT-2E 2.00

WE'LL BE HAPPY TO QUOTE ON YOUR SPECIAL PARTS.

Continental Specialties

PROTO BOARD \$75

POWER FOR THE PROFESSIONAL

For the economy-minded experimenter

Proto Board 100 \$19.95

Proto Board 101 \$29.95

Proto Board 102 \$39.95

Proto Board 103 \$59.95

DESIGN MATE 1 \$49.95

LOGIC MONITOR \$84.95

OT Proto Strips \$84.95

5 FUNCTION ELECTRONIC CALCULATOR

RAODFIN MODEL 8P

\$8.95

FEATURES:

- 8 Digit Display
- 5 Functions consists of addition, subtraction, multiplication, division, percentage, with constant on all functions, with full floating decimal point
- Power source is 1 pre-preg V DC Battery 90 GP. Jack for AC adapter
- Black superline grained finish plastic cabinet

5 FUNCTION ELECTRONIC CALCULATOR WITH WALLET-NOTEBOOK AND POCKET CHECKBOOK

RAODFIN MODEL 1710

\$19.95

FEATURES:

- 8 Digit Display
- 5 Functions consists of addition, subtraction, multiplication, division, percentage, with constant on all functions, with full floating decimal point
- Power source is 6 AAA cells 9 V DC
- Wallet is 2 tone lexan, cabinet is black plastic

3 1/2 DIGIT DVM KIT

JE700 CLOCK

This 0-2 VDC 05 per cent digital voltmeter features the Motorola 3 1/2 digit DVM chip set. It has a 4 LED display and operates from a single +5V power supply. The unit is provided complete with an injection molded black plastic case complete with Bezel. An optional power supply is available which fits into the same case as the 0-2V DVM allowing 117 VAC operation.

A. 0-2V DVM with Case \$49.95

B. 5V Power Supply \$14.95

JE700 CLOCK

This large digit clock (6 1/2 hours & minutes, 3 seconds) features the MM5314 clock chip. It operates from 117 VAC and will operate in either a 12 or 24 hour mode. The clock is complete with a walnut grain case, and has fast set, slow set, and hold time set features.

\$24.95

Liquid Crystal Temperature Display

Six Digit Light Emitting Diode Display

DL 33 Display

This clock makes an attractive addition to any desk. It has an extruded, black anodized aluminum case. It displays hours, minutes, and seconds with 11 inch displays, and comes complete with a liquid crystal thermometer. It operates off 115 VAC at 50 or 60 Hz.

JE803 PROBE

The Logic Probe is a unit which is for the most part indispensable in trouble shooting logic families. TTL, DTL, RTL, CMOS. It derives the power it needs to operate directly off of the circuit under test, drawing a scant 10 mA max. It uses a MANI readout to indicate any of the following states by these symbols: 1H, 1LOW, 0, PULSE, P. The Probe can detect high frequency pulses to 15 MHz. It can't be used at MOS levels or circuit salvage will result.

\$9.95 Per Kit

printed circuit board

T-1 5V 1A Supply \$9.95 Per Kit

This is a standard TTL power supply using the well known LM309K regulator. C to provide a solid 1 AMP of current at 5 volts. We try to make things easy for you by providing everything you need in one package, including the hardware for only

exelar

This watch is manufactured by National Semiconductor. It provides 5 functions, hours, minutes, seconds, date, A.M. indicator dot. Accuracy is assured to 5 seconds per month by precision quartz crystal. If something should go wrong with the watch, repair is assured within 48 hours after it is received. Complete with steel black leather band.

ES4-Y5 3 MICRON GOLD PLATE BEZEL \$29.95

DIGITAL ALARM CLOCK

This 4 digit Novus Alarm Clock is a very reliable and smartly styled unit. It provides such features as an alarm settable to any minute of the day, a 7 minutes snooze alarm, a power failure indicator, and even an A.M./P.M. indicator.

Novus \$19.95

NOT A KIT

TV TECHNICIANS, SERVICEMEN, HOBBYISTS—Vista Model 740 Digital Crosshatch Generator. Compact crystal divider for lowest-priced ultra-stable 5x7 crosshatch or 56 dot patterns. AC powered. \$31.95 complete kit; \$41.95 assembled. Postpaid in USA, Canada. Information available free. Photolume Corporation, Dept. PE-96, 118 East 28th Street, New York, New York 10016.

ORGAN KITS KEYBOARDS
THE ULTIMATE IN DESIGN AND SOUND
FREE LITERATURE

Wurlitzer reproductions
DEVTRONIX ORGAN PRODUCTS, Dept. C
5872 Amapola Dr. • San Jose, CA 95129

ORGAN/SYNTHESIZER keyboards, pedalboards, amplifiers, consoles, etc. Free brochures. DANIELSON, 555 Richmond Road, West Chester, PA 19380.

LOW cost digital/analog test equipment. Exceptional values. Free catalog. Salen Electronics, Box 82, Skokie, Illinois 60076.

6 TV GAMES ON ONE CHIP
MOS/LSI Design/Supply Limited
Chip \$39.95 Kit \$69.95
Send \$1.00 for kit info & data sheet
Advanced Microcomputer Products
P. O. Box 17329, Irvine, CA 92713

DON'T LET VOLTAGE TRANSIENTS ZAP YOUR HI-FI. Solid state equipment protector plugs into outlet protects any transistorized equipment. \$6.95. Kopp Electronics, 1650 William St., Buffalo, N.Y. 14206. Free Brochure.

FREE CATALOG. Strobe Lights, UARTS, Memories, Digital Thermometers. Rechargeable Batteries, LEDES, Transistors, IC's, Unique Components. Chaney's, Box 27038, Denver, Colorado 80227.

RECEIVERS, Transmitters, Components, Test Equipment. Catalog 25 cents. E. French, P.O. Box 249, Aurora, Ill. 60507.

CB RADIO. Scanners, Antennas. The best for less. Free List. Capitol Sound, Box 3523, Des Moines, Iowa 50322.

Don't miss...
the next issue of the magazine that gives you the most exciting projects anywhere.

ELECTRONIC EXPERIMENTER'S HANDBOOK
Published each year by the editors of Popular Electronics, here's the one publication that helps you get it together... with a score of build-it-yourself projects.

The all-new 1977 edition goes on sale nationally October, 1976
It will again be packed with features and articles and complete lab-tested instructions that are sure to guarantee successful days and months of mind absorbing projects for fun and practicality.

YOU CAN RESERVE YOUR COPY NOW AT THE SPECIAL MONEY-SAVING PRE-PUBLICATION PRICE OF ONLY \$1.00 POSTPAID.

Regular newsstand price is \$1.50; mail order price \$1.85. Complete the Reservation Form and return it promptly with your remittance. The 1977 ELECTRONIC EXPERIMENTER'S HANDBOOK will be mailed when published from first-off-the-press copies.

PRE-PUBLICATION RESERVATION FORM

Electronics Experimenter's Handbook
Consumer Service Division
595 Broadway, N.Y., N.Y. 10012 PE-96

Enclosed is \$1.00 (outside U.S.A. \$2.00). Please reserve my copy of the 1977 ELECTRONIC EXPERIMENTER'S HANDBOOK at this special pre-publication price, to be mailed to me from first-off-the-press copies.

Name _____
Address _____
City _____
State _____ Zip _____
Residents of Calif., Colo., Fla., Ill., Mich., Mo., N.Y. State, D.C. and Texas add applicable sales tax.

QUALITY ELECTRONIC COMPONENTS
NEW DISCOUNT SCHEDULE SAVES YOU EVEN MORE!

AMD 8080A \$34.95 2102-1 \$1.99
MICROPROCESSOR 1024 Bit Random Access Memory
0-70°C 480 ns Clock Period 500 ns Max Access Time

INTEGRATED CIRCUITS — TTL, CMOS, LINEAR & MOS

7400 .21	7473 .30	74174 .98	4001 .23	4073 .23
7401 .21	7474 .30	74175 .93	4002 .23	4075 .23
7402 .21	7475 .49	74176 .79	4006 .12	4081 .23
7403 .21	7476 .32	74177 .79	4007 .73	4082 .23
7404 .21	7480 .70	74180 .70	4008 .79	4502 .79
7405 .21	7482 .70	74181 2.15	4009 .44	4510 1.14
7406 .25	7483 .70	74182 .79	4010 .44	4511 1.05
7407 .25	7485 .89	74184 2.19	4011 .23	4514 2.80
7408 .21	7486 .28	74185 2.19	4012 .23	4515 2.80
7409 .21	7489 2.19	74189 3.50	4013 .40	4516 1.23
7410 .21	7490 .44	74189 3.50	4014 .96	4518 1.14
7411 .21	7491 .70	74190 1.23	4015 .96	4520 1.14
7412 .21	7492 .44	74191 1.23	4016 .40	4527 1.68
7413 .25	7493 .44	74192 .79	4017 1.05	4528 .88
7414 .89	7494 .70	74193 .88	4018 1.05	4585 1.80
7416 .25	7495 .70	74194 .88	4019 .23	LM309K 1.23
7417 .25	7496 .70	74195 .88	4020 1.14	LM324N 1.28
7420 .21	7497 .28	74196 .88	4021 1.14	LM3401-5 1.25
7421 .25	74107 .30	74197 .88	4022 .96	LM3401-6 1.25
7423 .35	74109 .33	74198 1.49	4023 .23	LM3401-8 1.25
7425 .35	74125 .40	74199 1.49	4024 .84	LM3401-12 1.25
7426 .25	74122 .44	74201 .88	4025 .23	LM3401-15 1.25
7427 .33	74123 .61	74202 .88	4026 1.68	LM3401-18 1.25
7428 .28	74125 .40	74203 .67	4027 .40	LM3401-24 1.25
7432 .21	74132 .70	74204 .88	4028 .96	LM3909N .88
7433 .30	74141 .88	74205 .67	4029 1.14	NE536T 3.24
7437 .25	74145 .70	74206 .67	4030 .23	NE540L 2.04
7438 .25	74147 1.63	74207 .67	4033 1.61	NE555V 4.83
7440 .21	74148 1.30	74208 .67	4034 3.30	NE556A .88
7441 .88	74150 1.16	74209 .67	4035 1.14	NE560B 3.83
7442 .53	74151 1.16	74210 .67	4040 1.14	NE561B 3.83
7443 .63	74153 .65	74211 .67	4041 .79	NE562B 3.83
7444 .63	74154 1.03	74212 .67	4042 .79	NE565A 1.25
7445 .70	74155 .70	74213 .67	4043 .70	NE566V 1.38
7446 .70	74156 .70	74214 .67	4044 1.86	NE567V 1.26
7447 .70	74157 .70	74215 .67	4046 1.86	UA709CV .44
7448 .70	74160 .88	8093 .40	4049 .40	UA710CA .44
7450 .21	74161 .88	8094 .40	4050 .40	UA711CA .53
7453 .21	74162 .88	8095 .67	4051 1.26	UA722CA .60
7454 .21	74163 .88	8096 .67	4052 1.26	UA741CV .44
7456 .21	74164 .96	8097 .67	4053 .72	UA747CA .70
7470 .30	74166 1.26	8098 .67	4060 1.58	UA748CV .49
7472 .30	74170 2.64	82525 2.19	4071 .23	2102-1 .99
	74173 1.42	4000 .23	4072 .23	8080A 34.95

SPECIAL PURCHASE
NATIONAL MA1001A DIGITAL ALARM CLOCK MODULE
with Transformer and Switches
\$12.95!

MA1001A \$9.50 when purchased without transformer & switches

FEATURES:

- Bright 4 Digit 0.5" LED Display
- Assembled & Tested Module
- 12 Hour Format with PM Indicator
- 50 or 60 Hz Operation
- Power Failure Indication
- Brightness Control Capability
- Alarm and Snooze Timers
- Compact 3.0" x 1.75"

A Great Bargain, but Quantities are limited — So Order Now!

BISHOP GRAPHICS Printed Circuit Drafting
Aids are now available from Digi-Key

TRIC-0220 PACKAGE 10 AMP/100 VOLT 50c
TRANSFORMER Pri: 120 V. Sec: 12V 300 Ma. \$1.00

DATA BOOKS

TTL IC's - 592 pages \$4.00	INTERFACE IC's - 464 pages \$4.00
LINEAR IC's - 704 pages . . . \$4.00	VOLTAGE REGULATORS - 128 pages \$3.00
CMOS IC's - 256 pages . . . \$3.00	LINEAR APPLICATIONS - 432 pages \$4.00
TRANSISTORS - 288 pages . . \$3.00	
MEMORY IC's - 592 pages . . \$3.00	

REED RELAYS 1.5 Amp SPST N.O. Contacts

4.8V Coil \$1.70	\$125/C
6.0V Coil \$1.70	\$125/C
12V Coil \$1.70	\$125/C
24V Coil \$1.70	\$125/C

Sc each in multiples of 5 per value. \$1.70/100 of same value. 10 ohm to 1.0 meg

SILICON TRANSISTORS

MPF102 .36 \$30.00/C 2N5457 .48 \$41.00/C MPF413 .28 \$24.00/C 2N3055 .99 \$85.00/C

WIRE WRAPPING WIRE
Pre-cut and stripped Kynar insulated wire from 1.0" to 15.0" in red or black. Also sold in bulk lengths.

RESISTOR ASSORTMENTS

5 sec. all 10% 1/4 W. Val. from 2.2 to 22 meg (435 pcs) \$12.00
5 sec. all 10% 1/4 W. Val. from 10 to 5.6 meg (350 pcs) \$12.00

AP SUPER STRIP II—Universal Breadboarding Element with 840 Solderless Plug-In Tie-Points \$17.00

HARDWARE

2-56 1/4 Screw	99/C 7.20/M
2-56 1/2 Screw	99/C 7.65/M
4-40 1/4 Screw	55/C 3.60/M
4-40 1/2 Screw	60/C 4.05/M
6-32 1/4 Screw	65/C 4.40/M
6-32 1/2 Screw	75/C 4.85/M
8-32 3/8 Screw	90/C 5.85/M
2-56 Hex Nut	55/C 3.60/M
4-40 Hex Nut	55/C 3.75/M
6-32 Hex Nut	60/C 4.00/M
8-32 Hex Nut	60/C 4.15/M
No. 2 Lockwasher	85/C 5.75/M
No. 4 Lockwasher	45/C 3.00/M
No. 6 Lockwasher	45/C 3.00/M
No. 8 Lockwasher	45/C 3.00/M

LED DISPLAYS

FND357 C. 375" . . . \$1.75	1N5226B 3.3v .15 \$11/C	1N5236B 7.5v .15 \$11/C
FND500 C. 500" . . . \$1.75	1N5227B 3.6v .15 \$11/C	1N5237B 8.2v .15 \$11/C
FND507 C. 500" . . . \$1.75	1N5228B 3.9v .15 \$11/C	1N5238B 8.7v .15 \$11/C
FND800 C. 800" . . . \$3.50	1N5229B 4.3v .15 \$11/C	1N5239B 9.1v .15 \$11/C
FND807 C. 800" . . . \$3.50	1N5230B 4.7v .15 \$11/C	1N5240B 10.0v .15 \$11/C
	1N5231B 5.1v .15 \$11/C	1N5241B 11.0v .15 \$11/C
	1N5232B 5.6v .15 \$11/C	1N5242B 12.0v .15 \$11/C
	1N5233B 6.0v .15 \$11/C	1N5243B 13.0v .15 \$11/C
	1N5234B 6.2v .15 \$11/C	1N5244B 14.0v .15 \$11/C
	1N5235B 6.8v .15 \$11/C	1N5245B 15.0v .15 \$11/C

LED LAMPS

NSL5053 T-1 1/4 18c
NSL5056 T-1 1/4 18c

DIGI-KEY CORPORATION
P.O. Box 677 Thief River Falls, MN 56701

S. D. SALES CO.

P. O. BOX 28810 DALLAS, TEXAS 75228

ALARM CLOCK KIT SIX DIGIT LED

Thousands of hobbyists have bought and built our original clock kit and were completely satisfied. But we have received many requests for an alarm clock kit with the same value and quality that you have come to expect from S.D. So, here it is!

THE KIT INCLUDES:

- 1 Mostek 50252 Alarm Clock Chip
- 6 Hewlett Packard .30 in. common cathode readouts.
- 15 NPN Driver Transistors
- 2 Switches for time set
- 2 Slide Switches for alarm set and enable
- 1 Filter Cap
- 4 IN4002 Rectifiers
- 1 IN914 Diode
- 1 .01 Disc Cap
- 15 Resistors
- 1 Speaker for alarm
- 1 LED lamp for PM indicator.

\$9.95

PCB - 3.00
XFMR - 1.50

60 Hz. Crystal Time Base

FOR DIGITAL CLOCKS **\$5.95**
S. D. SALES EXCLUSIVE!

KIT FEATURES:

- A. 60 Hz output with accuracy comparable to a digital watch.
- B. Directly interfaces with all MOS clock chips.
- C. Super low power consumption (1.5 Ma typ.)
- D. Uses latest MOS 17 stage divider IC.
- E. Eliminates forever the problem of AC line glitches.
- F. Perfect for cars, boats, campers, or even for portable clocks at ham field days.
- G. Small size, can be used in existing enclosures.

BUY TWO FOR \$10.00

Kit includes crystal, divider IC, P.C. Board plus all other necessary parts and specs.

MOS 4 DIGIT COUNTER IC

All in one 28 PIN DIP. 4 Decade counters, latches, MUX circuits, display decoders, etc. Features: 5VDC operation, 25 MW power consumption, BOTH 7 segment and BCD outputs. Perfect for DVM's, frequency meters, tach's, etc. Can be cascaded for more digits. #5002 - \$8.95.

8008-1 MICRO PROCESSOR

New Units. High speed 8008. Almost twice as fast as units sold by others. Still a very versatile and widely used MPU. No data book, only pinout data included at this price. \$12.50 LIMITED QTY.

1101 A RAM IC

256 X 1 BITS. Perfect for 8008 or small systems such as telephone dials that do not require a lot of memory. Special 59c. 8 FOR \$4.

C & K MINI TOGGLE SWITCH

#7103 SUB MINI SPDT Center OFF. Special - 99c.



TTL INTEGRATED CIRCUITS

7400 - 19c	7430 - 19c	7476 - 35c	74153 - 75c
7402 - 19c	7432 - 34c	7480 - 49c	74154 - 1.00
74L04 - 29c	7437 - 39c	7483 - 95c	74157 - 75c
74S04 - 44c	7438 - 39c	7485 - 95c	74161 - 95c
7404 - 19c	7440 - 19c	7486 - 45c	74164 - 1.10
7406 - 29c	7447 - 85c	7490 - 65c	74165 - 1.10
7408 - 19c	7448 - 85c	7492 - 75c	74174 - 95c
7410 - 19c	7451 - 19c	7495 - 75c	74181 - 2.50
7411 - 29c	7453 - 19c	7496 - 89c	74191 - 1.25
7413 - 50c	7473 - 39c	74121 - 38c	74192 - 1.25
7420 - 19c	7474 - 35c	74123 - 65c	74193 - 1.00
	7475 - 69c	74141 - 75c	74195 - 69c

MOTOROLA POWER DARTINGTON -- \$1.99

BACK IN STOCK!
Like MJ3001. NPN 80 V., 10A., HFE 6000 TYP. TO-3 case. We include a free 723C volt. reg. with schematic for a power supply. SPECIAL - \$1.99

MOTOROLA RTL IC'S

Brand new, factory prime. Hard to find, but still used in a variety of projects. (See the RTL Cookbook by Howard W. Sams.)

MC724P-59c	MC780P-89c	MC791P-69c
MC725P-59c	MC785P-49c	MC792P-59c
MC764P-49c	MC787P-89c	MC799P-59c
MC767P-69c	MC788P-49c	MC9704P-89c
MC771P-49c	MC789P-59c	MC9709P-69c
MC775P-89c	MC790P-89c	MC9760P-69c

MV-50 TYPE LED's

by LITRONIX
10 for \$1
Factory Prime!

3 DIGIT LED ARRAY -- 75c

by LITRONIX
DL33MMB. 3 MAN-3 Size Readouts in one package. These are factory prime, not retested rejects as sold by others. compare this price! 75c 3 for \$2

SALE ON CUT LEAD SEMICONDUCTORS

Leads were cut for PCB insertion. Still very useable.

1N914/1N4148	100/\$2
1N4002 1 Amp 100 PIV	40/\$1
1N4745A 16V 1W Zener	20/\$1
EN2222 NPN Transistor	25/\$1
EN2907 PNP Transistor	25/\$1
2N3904 NPN Driver Xstr.	25/\$1
2N3392 GE Pre-amp Xstr.	25/\$1
C103Y SCR. 800MA. 60V.	10/\$1

ALL NEW.
UNUSED.
SOME ARE
HOUSE #

SLIDE SWITCH ASSORTMENT

Our best seller. Includes miniature and standard sizes. single and multi-position units. All new, first quality, name brand switches. Try one package and you'll reorder more Special! - 12 for \$1 (Assortment)



DISC CAP ASSORTMENT

PC leads. At least 10 different values. Includes .001, .01, .05, plus other standard values. 60 FOR \$1



UPRIGHT ELECTROLYTIC CAPS

47 mid 35 V-10/\$1 68 mid 25V-8/\$1 Brand new by Sprague. PC leads.

RESISTOR ASSORTMENT

1/4 W 5% and 10%. PC leads. A good mix of values. 200/\$2



1000 MFD FILTER CAPS

Rated 35 WVDC. Upright style with P.C. leads. Most popular value for hobbyists. Compare at up to \$1.19 each from franchise type electronic parts stores. S.D. Special 4 for \$1



FAIRCHILD BIG LED READOUTS

A big .50 inch easy to read character. Now available in either common anode or common cathode. Take your pick. Super low current drain, only 5 MA per segment typical.

FND - 510	Common Anode	YOUR CHOICE
FND - 503	Common Cathode	\$1.50 ea. 6 for \$7.50

DUAL 741C (5558) OP AMPS

Mini dip. New house numbered units by RAYTHEON. 4 FOR \$1

FET'S BY TEXAS INSTRUMENTS -- SPECIAL 5 for \$1

#TIS-75 but with an internal house number TO-92 plastic case. N. Channel. Junction type FET

We do not sell junk. Money back guarantee on every item. No C.O.D. Texas Res. add 5% tax. Postage rates went up 30%! Please add 5% of your total order to help cover shipping.

S. D. SALES CO.

P. O. BOX 28810
DALLAS, TEXAS 75228

ORDERS UNDER \$10
ADD 75c HANDLING.

T _ _ K _ _ _
_ _ _ _ _

ORDERS OVER \$15 CHOOSE \$1 FREE MERCHANDISE

FOREIGN ORDERS MUST BE PAID IN U.S. FUNDS

POLICE, Fire monitors, scanners, crystals, CB Transceivers, New Crystal-less scanners. Discount priced. Box 19224, Denver, CO 80219.

TELETYPE EQUIPMENT for sale for beginners and experienced computer enthusiast. Teletype machines, parts, supplies. Catalogue \$1.00 to: ATLANTIC SALES, 3730 Nautilus Ave., Brooklyn, NY 11224. Tel: (212) 372-0349.

SURPLUS 'SMART' TERMINALS, components, serious music synthesizer kits, plans, parts, and more. Send SASE for FREE INFO Package. CFR Associates, P.O.B. Newton, N.H. 03858.

YOU WANT TO BUILD IT WE WANT TO HELP WE SELL CONSTRUCTION PLANS with an Engineering Service. TELEPHONE: Answering Machines, Speakerphones, Carphones, Phonevision, Touch Button Dialers. TELEVISION: VTR, 1" Color TV Set, PONG, \$25.00 Camera, COLOR PROJECTION TV. HOBBYIST: Electron Microscope, \$75 software programmable computer. BROADCAST: Special Effects Generator, Chroma Key, Audio Board, DA's. COURSES: Telephone Engineering \$52.00, Detective Electronics \$29.50, IC Engineering \$65.00, PLUS MUCH MORE. NEW Super Hobby Catalog PLUS year's subscription to Electronic News Letter AIR MAILED \$1.00. Don Britton Enterprises, 6200 Wilshire Blvd., Los Angeles, Calif 90048.

The easy \$25 counter kit!

An easy-to-build 50MHz (6-Digit) Frequency Counter for a measly \$25! Standard easy-to-find parts, too! Uses 7segment LEDreadouts-no scarce Nixie tubes! No tricky crystal ovens! Kit includes classy cabinet with front panel, PC boards, hardware, instructions, and diagrams. A proven design! An unbeatable offer! Write or call today! (please add \$2 for postage and handling) HUFCD Box 357, Dept 58 Provo, UT 84601 (801) 375-8566



Hufco

JAPANESE TRANSISTORS, all transistors original factory made. Free catalog. West Pacific Electronics, P.O. Box 3879, Torrance, CA 90510.

BUILD YOUR OWN SPEAKERS AND SAVE UP TO 50%



You can assemble your own high quality, multi-element stereo speakers in a few hours and save up to half the cost of comparable speakers. Send for our free 32-page catalogue of speaker kits, raw speakers and accessories. SPEAKERLAB Dept. PE-9, 5500-35th N.E. Seattle, Washington 98105

Announcing the NEW STANDARD in Stereo Testing! The All-New Model SR12 STEREO TEST RECORD

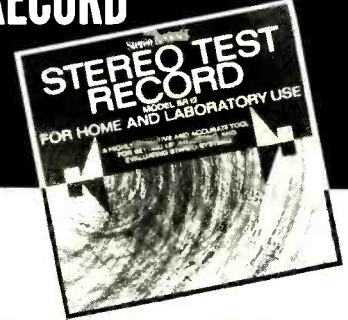

The most complete... most sophisticated... most versatile Test Disc available today...

For Just \$5.98!

Who needs the New Model SR12? You do. Whether you're an avid audiophile, a casual listener, or a professional technician... the new MODEL SR12 will be the most important disc in your entire collection. MODEL SR12 has been produced by Stereo Review Magazine for music lovers who want immediate answers to questions about the performance of their stereo systems and how to get the best possible sound reproduction. It is the most complete test record of its kind—containing the widest range of checks ever included on one test disc.

Make these important stereo checks BY EAR... (no test instruments required)

- Frequency response • Separation • Cartridge tracking • Channel balance • Hum and rumble • Flutter • Cartridge and Speaker Phasing • Anti-Skating Adjustment • "Gun Shot Test" for Stereo Spread • Multi-purpose Musician's "A" • Equal-tempered Chromatic Octave • Guitar-tuning Tones.

Attention professionals: For the ultimate in stereo testing, 7 critical TEST EQUIPMENT checks...

- 1,000-Hz square waves to test transient and high-frequency response of phono pickups.
 - 50 to 20,000 Hz frequency-response sweep
 - Sine-wave tone-bursts to test transient response of pickup
 - Intermodulation test using simultaneous 400-Hz and 4,000-Hz signals.
 - Intermodulation sweep to show distortion caused by excessive resonances in tone arm and cartridge.
 - 1,000-Hz reference tones to determine groove velocity.
 - 3,000-Hz tone for flutter and speed tests.
- Sample waveforms—illustrating both accurate and faulty responses are provided in the Instruction Manual for comparison with the patterns appearing on your own oscilloscope screen.

FREE Instruction Manual Includes Detailed Instructions, Charts, Tables and Diagrams

CHARGE YOUR ORDER TO YOUR AMERICAN EXPRESS, BANKAMERICARD, MASTER CHARGE OR DINERS CLUB ACCOUNT.



Ziff-Davis Service Division, Dept. R, 595 Broadway, New York, N.Y. 10012. PE-96

Please send the SR12 Stereo Test Record @ \$5.98, postpaid (\$8 outside U.S.A.).

Enclosed is \$_____ (Residents of Calif., Col., Fla., Ill., Mich., Mo., N.Y. State, D.C. and Tex. add applicable sales tax.)

CHARGE:
 BankAmericard Master Charge
 American Express Diners Club

Account # _____ Exp. Date _____
 Master Charge Interbank # _____
 (4 numbers over your name)

Signature _____

Print Name _____

Address _____

City _____ State _____ Zip _____

EDLIE'S BARGAIN BONANZA

ONLY HIGHEST QUALITY PRODUCTS



- (FP017) COPPER CLAD BOARDS! Copper on one side, 1/16" thick. Excellent quality for either production or experimental work. 6 3/8" x 17 1/2" \$1.19 ea 3/\$2.99
- Copper on both sides, 1/16" thick. Size 12" x 18" (FP018) \$1.99 ea 3/\$4.99
- (FP134) 8 ROTARY SWITCHES Some multiple gang \$1.00
- (FP128) 13 MINIATURE ELECTROLYTIC CAPACITORS \$1.00 Axial & upright, popular values.
- (FP144) TRANSISTOR REPAIR KIT \$1.19 Various parts used to repair transistorized devices.
- (FP336) TO-3 TRANSISTOR SOCKETS 12 for \$1.00
- 9 V. BUZZER FOR ALARMS 99c ea. 6 for \$5 
- (FP164) 4 ROLLS OF WIRE \$1.00 Approx 25 ft. per roll, 20-28ga.
- (FP140) TAPE RECORDER SPARE PARTS KIT \$2.95 Parts for repairing most tape recorders: capacitors, meter, pilot lamp, jacks, and MUCH MORE.
- (FP167) 10 MINIATURE POTENTIOMETERS \$1.00
- (FP182) 2 MISC. METERS \$1.00 Miniature.
- (FP156) 60 DISC CAPACITORS \$1.00 Asst. from .0001 to 1, most 600v, Z5U, NPO, N750, etc.

- SURPLUS TUBES**
 All guaranteed for 1 full year.
ANY 3 FOR \$1.49
 Acquired from U.S. Defense depots or removed from equipment (new and used) These are laboratory tested and guaranteed for one full year. Most are of such standard makes as RCA, GE, etc.
- | | | | |
|------|------|------|-------|
| 3A3 | 6A07 | 6CM7 | 6X4 |
| 3AF4 | 6AT6 | 6DE4 | 10EW7 |
| 3BN6 | 6AU6 | 6DR7 | 12AE7 |
| 3DG4 | 6AV6 | 6DW4 | 12AL5 |
| 3KT6 | 6AX4 | 6EB8 | 12AU7 |
| 3Q4 | 6AX5 | 6EM7 | 12AV6 |
| 4BC5 | 6AY3 | 6GF7 | 12BE6 |
| 4BN6 | 6BA6 | 6GH8 | 12BH7 |
| 4BU8 | 6BG6 | 6K6 | 18FW6 |
| 4BZ7 | 6BJ8 | 6K11 | 25L6 |
| 5V6 | 6BQ6 | 6LB6 | 35EH5 |
| 6AF4 | 6BZ6 | 6SN7 | 36AM3 |
| 6AC5 | 6CB6 | 6T8 | 50A5 |
| 6AG7 | 6CG7 | 6W4 | 50L6 |
| 6AL5 | | | |

- (FP147) 4 lb. GRAB BAG SPECIAL \$1.00 Full of exotic and exciting electronics parts
- (FP155) TUBE BONANZA! \$1.00 20 asst. popular tubes, untested.
- (FP142) 50 PRECISION RESISTORS \$1.00 All 1%, 1/2w and 1w. low and high ohmages.
- (FP150) POWER TRANSFORMER Primary 117 volts. Sec. 1-11.1 volts; Sec.2 17.7 volts; Sec.3 15.9 volts; Sec.4 27.7 volts. Each winding approx. 750 mils. Size 2 1/4" H x 2" D x 3 3/8" mounting centers. \$1.95
- (FP175) 70 1/2w CARBON RESISTORS \$1.00 Asst. values. Some 5%.
- (FP154) 150 CUT LEAD RESISTORS \$1.00 Carbon, all leads long enough for soldering.
- (FP149) 20 POLYSTYRENE TOP GRADE CAPACITORS \$1.00
- (FP132) 20 DUAL POTS \$1.00
-  24V. C.T. FILAMENT TRANSFORMER 1/2A. WITH 150V. TAP. (FP202) 99c ea 6 for \$4.99

MONEY BACK GUARANTEE
 Terms: Minimum order \$4.00. Include postage. Either full payment with order or 20% deposit, balance C.O.D.

BONUS FREE CAPACITOR KIT With Every \$5 Purchase

WRITE FOR FREE 1976 VALUE PACKED CATALOG
 Listing thousands of components, tubes, transistors, IC's, kits, test equipment.

- THIS MONTH'S SPECIALS!**
- TTL**
- | | | | |
|-------------------------------|--------|--------------------------------|-----|
| <input type="checkbox"/> 7400 | 16c | <input type="checkbox"/> 7446 | 80c |
| <input type="checkbox"/> 7401 | 18c | <input type="checkbox"/> 7447 | 80c |
| <input type="checkbox"/> 7402 | 22c | <input type="checkbox"/> 7448 | 80c |
| <input type="checkbox"/> 7403 | 23c | <input type="checkbox"/> 7473 | 49c |
| <input type="checkbox"/> 7404 | 23c | <input type="checkbox"/> 7474 | 49c |
| <input type="checkbox"/> 7405 | 23c | <input type="checkbox"/> 7475 | 85c |
| <input type="checkbox"/> 7406 | 23c | <input type="checkbox"/> 7476 | 53c |
| <input type="checkbox"/> 7410 | 23c | <input type="checkbox"/> 7490 | 79c |
| <input type="checkbox"/> 7411 | 27c | <input type="checkbox"/> 7492 | 79c |
| <input type="checkbox"/> 7413 | 40c | <input type="checkbox"/> 7493 | 69c |
| <input type="checkbox"/> 7420 | 23c | <input type="checkbox"/> 7495 | 79c |
| <input type="checkbox"/> 7430 | 23c | <input type="checkbox"/> 74121 | 57c |
| <input type="checkbox"/> 7440 | 30c | <input type="checkbox"/> 74122 | 57c |
| <input type="checkbox"/> 7442 | \$1.12 | <input type="checkbox"/> 74123 | 67c |
- LINEARS**
- LM309K 5v 1a. reg. \$1.15
 - 555 Timer .75c
 - 556 Dual 555 \$1.00
 - 566 Function gen. \$1.75
 - 567 Tone decoder \$1.95
 - 741 comp. op amp .39c
 - 2513 Char. gen. \$5.95
 - 8038 volt cont osc \$4.25

- CLOCK CHIPS WITH DATA**
- (MM5314) 6 dig clock \$4.95
 - CT7001 Alarm & Date \$5.95
- LED'S**
- (FP223) 10 Asst LEDs \$1.00
 - (FP242) 5 Jumbo Green LEDs \$1.00
 - (FP242) 5 Med Yellow LEDs \$1.00
 - (FP001) 5 Jumbo Red LEDs \$1.00
 - (FP011) 5 Med Red LEDs \$1.00
 - (FP012) 5 Mini Red LEDs \$1.00
 - (FP293) DL707 (equiv.) 7 seg red LED, 3" char., comm anode \$1.50
 - (FP006) DL 704 (equiv.) same as DL707 except comm cath \$1.50
 - (FP007) DL747 7 seg red LED, 6" char., comm anode \$2.25
 - (FP013) MAN 5 (equiv.) 7 seg green LED, .27 char., comm anode \$1.49

- IC BREADBOARDS & TERMINALS**
 Boards have .042 holes. Made of 1/16" polyester glass.
- (BB663) 3" x 4" 94c
 - (BB664) 3" x 6" \$1.29
 - (BB665) 4" x 6" \$1.65
 - (BB666) 4" x 8" \$2.12
- Push-in terminals
- (FP6601-20) pkg 20/90c
 - (FP6601-100) pkg 100/\$2.98
- Push-in flanged pins
- (BB6602-20) pkg 20/90c
 - (BB6602-100) pkg 100/\$2.98
- Push-in flea clips
- (BB6603-20) pkg 20/90c
 - (BB6603-100) pkg 100/\$2.98
- (B008) 14 pin DIP sockets 3 for \$1
 - (FP1104) IC REMOVAL AND INSERTION TOOL \$4.95 "Pul-n-seric" extracts and inserts ICs without damage.



- REED RELAYS**
- (FP203) SPST, 12V, 1000 ohms coil. Price 79c

Babylon-Pac super SALE! Each pac only \$1.98

All parts are first quality (no fallout), tested and guaranteed.

Memory pac 4 MM5016 MOS TO-5 512 BIT shift registers from NATIONAL with data \$1.98	Flip-Flop pac 10 assorted Flip-Flops, Dual JK, ST's, and low power F's, with data \$1.98	Comparator pac 5 assorted DIP's LM311, 710, 711 with data \$1.98
TTL Gates 15 assorted DIP's 7400 series-7420, 7430, 7440, etc... All prime, marked parts with data \$1.98	LED pac 10 assorted discrete LED's-green, red, and infra-red, with data \$1.98	Regulators 4 LM773 DIP variable regulate with data \$1.98
TIP31A pac 5 TIP31A NPN Power Transistor: HFE-30, 10-3A VCE-60V, 40% Power fab w/ Formed Leads \$1.98	Transistor pac 6 2N2222 discrete transistors-4N50E (HEPS3020) NPN & 4N50S (HEPS3031) PNP 4 frequencies \$1.98	Resistors 100 watt resistors of any simple standard value from 1 ohm to 1M ohms \$1.98
Linear pac 8 assorted linear op amp, LM307 op amp, LM137 op amp, LM131 op amp, with data and price \$1.98	Silicon Diode pac 10 Silicon Signal Diodes better than 200V! Leads trimmed for mounting \$1.98	Switches 8 1/2" Momentary Contact Push button 5.0" Red Button fits in approx. 1/2" panel, with lock washer and mounting nut \$1.98
LED Display pac 2 10 digit 3 digit each, 7 segment display, 1/2" wide, 1/4" high, 1/4" deep, with data \$1.98	Buy 5 pacs for \$9.90 and pic-a-pac for 10¢	
3 Amp Power Silicon Rectifiers 4 1/2" 3 Amp Power Silicon Rectifiers 110V 150V 200V 250V 100V 150V 200V 250V 100V 150V 200V 250V \$1.98	POTTER BRUMFIELD Type PHP Relay 4 PDT 3A Contacts 24V DC \$1.50 (650-111) 120V AC \$1.15 (10.5 MA coil)	Send a stamp for our flyer listing more money-saving bargains!
Capacitors PCB vertical mount electrolytic capacitors - 1000 3/4 dia 59¢ ea. 10 for \$5.00	BABYLON ELECTRONICS Mail orders to P.O. Box 21779 Sacramento, CA 95841 Phone (415) 334-2161 3911 Myrtle Ave Sacramento, CA Orders under \$7.00 add \$1.00 postage and handling. Residents of Cal add sales tax. Orders shipped promptly. SIC 3600 Non E.O.S.	

World's Lowest IC Prices

NE555... \$ 3 NE560... 2 NE565... 1 NE567... 3 55-P... 1 701... 1 702... 1 703... 1 704... 1 705... 1 706... 1 707... 1 708... 1 709... 1 710... 1 711... 1 712... 1 713... 1 714... 1 715... 1 716... 1 717... 1 718... 1 719... 1 720... 1 721... 1 722... 1 723... 1 724... 1 725... 1 726... 1 727... 1 728... 1 729... 1 730... 1 731... 1 732... 1 733... 1 734... 1 735... 1 736... 1 737... 1 738... 1 739... 1 740... 1 741... 1 742... 1 743... 1 744... 1 745... 1 746... 1 747... 1 748... 1 749... 1 750... 1 751... 1 752... 1 753... 1 754... 1 755... 1 756... 1 757... 1 758... 1 759... 1 760... 1 761... 1 762... 1 763... 1 764... 1 765... 1 766... 1 767... 1 768... 1 769... 1 770... 1 771... 1 772... 1 773... 1 774... 1 775... 1 776... 1 777... 1 778... 1 779... 1 780... 1 781... 1 782... 1 783... 1 784... 1 785... 1 786... 1 787... 1 788... 1 789... 1 790... 1 791... 1 792... 1 793... 1 794... 1 795... 1 796... 1 797... 1 798... 1 799... 1 800... 1	TTL 7400 14 7402 14 7404 16 7410 14 7420 14 7427 25 7438 25 7440 14 7445 45 7447 65 7450 14 7451 14 7473 22 7474 23 7493 50 7495 49 74107 29 74116 100 74123 50 74150 60 TRANSISTORS 2N4740 100 PNP 40V Each 15¢ 10 for \$1.00	LOW POWER SCHOTTKY 74LS00 25 74LS02 25 74LS10 25 74LS13 40 74LS15 50 74LS151 85 74LS153 95 74LS157 150 74LS163 150 74LS164 150 74LS174 150 74LS175 150 74LS193 150 74LS251 150 74LS253 150 74LS257 150 74LS258 150 CMOS 4001 16 4002 16 4006 90 4007 16 4008 70 4011 16 4012 16 4013 35 4015 80 4016 35 4019 70 4020 90 4021 95 4023 16 4024 75 4025 20 4027 40 4028 60 4030 35 4040 95 4042 60 4043 75 4044 70 4049 38 4050 38 4056 65 4068 35 4069 16 4071 16 4073 16 4075 16 4516 85 4585 85
SCHOTTKY 74S02 25 74S37 40 74S85 200 74S139 150 74S140 50 74S153 250 74S172 350 74S175 150 74S181 350 74S197 150 74S257 150	HIGH SPEED 74H00 20 74H01 20 74H04 20 74H10 20 74H11 20 74H40 20 74H51 20 74H52 20 74H74 40 74H103 50 74H106 50	LINEARS NE555V 43 NE556A 90 741V 30 1458V 52 566V 125 567V 135 540L 200 RAMS 2102 150 82S23 123 82S23 123 195 PROMS 82S23 123 195

Order Minimum \$10.00. Add \$1.00 shipping and handling charge per order. California residents add 6% sales tax. All orders shipped promptly.

Order the famous lasis 6 volume Programmed Learning Course "Microcomputer Design is a Snap" for \$99.50 and receive a special \$10.00 credit on any group of IC's.

Satisfaction 100% guaranteed.

C.O.D. Orders:
 Phone (day or night) 408/354-1448
PO Box 2542 A
Sunnyvale, CA 94087

CB SPECIALS-R.F. DRIVERS-R.F. POWER OUTPUTS-FETS

2SC481 1.85	2SC767 15.75	2SC866 5.85	2SC1449-1 1.60	40081 3.00	40082 3.00
2SC482 1.75	2SC773 .85	2SC013 1.50	2SC0475 1.50	5K3046 2.15	5K3047 3.75
2SC495 1.10	2SC774 1.75	2SC1014 1.50	2SC1678 5.50	5K3048 3.25	5K3049 1.25
2SC502 3.05	2SC775 2.75	2SC1017 1.50	2SC1679 4.75	2SK19 1.75	2SK30 1.00
2SC517 4.75	2SC776 3.00	2SC1018 1.50	2SC1728 2.15	2SK31 1.20	2SK32 1.00
2SC614 3.80	2SC777 4.75	2SC1173 1.25	2SC1760 2.15	2SK33 1.00	2SK34 2.75
2SC615 3.90	2SC778 3.25	2SC1226A 4.25	2SC1816 5.50	2SK35 2.75	2SK36 2.75
2SC616 4.15	2SC797 2.50	2SC1237 1.40	2SC1908 .70	2SK37 1.00	2SK38 1.00
2SC617 4.25	2SC798 3.10	2SC1239 3.50	2SC1957 1.50	2SK39 1.00	2SK40 2.75
2SC699 4.75	2SC781 3.00	2SC1243 1.50	2SF8 3.00	2SK41 2.75	2SK42 2.75
2SC710 .70	2SC789 1.00	2SC1306 4.75	HEP-S3001 3.25	2SK43 1.00	2SK44 2.75
2SC711 .70	2SC796 3.15	2SC1306-1.40	2SD235 1.00	2SK45 2.75	2SK46 2.75
2SC735 .70	2SC799 4.25	2SC1307 5.75	MRF8004 3.00	2SK47 2.75	2SK48 2.75
2SC756 3.00	2SC802 3.75	2SC1307-1.60	4004 3.00	2SK49 2.75	2SK50 2.75
2SC765 9.50	2SC803 4.00	2SC1377 5.50	4005 3.00	2SK51 2.75	2SK52 2.75
2SC766 10.15	2SC839 8.85	2SC1449 1.30	40080 1.25	2SK53 2.75	2SK54 2.75

JAPANESE TRANSISTORS

2SA52 .60	2SB187 .60	2SC458 .70	2SC815 .75	2SC1569 1.25
2SA316 .75	2SB235 1.75	2SC460 .70	2SC828 .75	2SC1756 1.25
2SA473 .75	2SB303 .65	2SC478 .80	2SC829 .75	2SD30 .95
2SA483 1.95	2SB324 1.00	2SC491 2.50	2SC830 1.60	2SD45 2.00
2SA489 .80	2SB337 2.10	2SC497 1.60	2SC839 .85	2SD45 2.00
2SA490 .70	2SB367 1.60	2SC515 .80	2SC945 .65	2SD65 7.50
2SA505 .70	2SB370 .65	2SC535 .75	2SC1010 .80	2SD68 .90
2SA564 .50	2SB405 .85	2SC536 .65	2SC1012 .80	2SD72 1.00
2SA628 .65	2SB407 1.65	2SC537 .70	2SC1051 2.50	2SD88 1.50
2SA643 .85	2SB415 .85	2SC563 2.50	2SC1061 1.65	2SD151 2.25
2SA647 2.75	2SB461 1.25	2SC605 1.00	2SC1079 3.75	2SD170 2.00
2SA673 .85	2SB463 1.65	2SC620 .80	2SC1096 1.20	2SD180 2.75
2SA679 3.25	2SB471 1.75	2SC627 1.75	2SC1098 1.15	2SD201 1.95
2SA682 .80	2SB474 1.50	2SC643 3.50	2SC1115 2.75	2SD218 4.75
2SA699 1.35	2SB481 1.25	2SC643 3.75	2SC1116 .70	2SD300 1.50
2SA699A 1.75	2SB481 2.10	2SC644 7.00	2SC1170 4.00	2SD313 2.10
2SA705 .55	2SB492 1.25	2SC681 2.50	2SC1172B 4.25	2SD315 7.50
2SA815 .85	2SB495 .95	2SC684 2.10	2SC1209 5.50	2SD318 9.50
2SA816 .85	2SB507 .90	2SC687 2.50	2SC1213 .75	2SD341 9.50
2SB22 .65	2SB511 .70	2SC696 2.35	2SC1226 1.25	2SD350 3.25
2SB54 .70	2SC206 1.00	2SC712 .70	2SC1243 1.50	2SD352 8.00
2SB56 .70	2SC240 1.10	2SC713 .70	2SC1293 .85	2SD380 5.70
2SB77 .70	2SC261 .65	2SC732 .70	2SC1308 4.75	2SD389 .90
2SB128 2.25	2SC291 .65	2SC733 .70	2SC1347 4.75	2SD390 7.50
2SB135 4.50	2SC291 .65	2SC739 .70	2SC1383 .75	2SD437 5.50
2SB152 4.95	2SC320 2.00	2SC715 1.75	2SC1409 1.25	2C106B1 5.00
2SB173 .75	2SC352 .75	2SC762 1.90	2SC1410 1.25	MPS-U31 4.00
2SB175 .55	2SC353 .75	2SC783 1.00	2SC1447 1.25	MPS-80001 2.50
2SB178 1.00	2SC371 .70	2SC784 .70	2SC1448 1.25	
2SB186 .60	2SC372 .70	2SC785 1.00	2SC1507 1.25	
	2SC394 .70	2SC793 2.50	2SC1509 1.25	

POWER TRANSISTORS HIGH-VOLT. TV. TYPE

BU204 1300V 3.90	BU207 1300V 5.40	2SC1172B 1100V 4.25
BU205 1500V 4.70	BU208 1500V 6.25	2SC308 1100V 4.95
BU206 1700V 5.90	2SC1170 1100V 4.00	2SC1325 1100V 4.95

OEM SPECIALS

1N270 .10	2N960 .55	2N2219A .30	2N2913 .75	2N3740 1.00	2N4401 .20
1N914 .10	2N962 .40	2N2221 .25	2N2914 1.20	2N3771 1.75	2N4402 .20
2N173 1.75	2N967 .50	2N2222 .25	2N2916A 3.65	2N3782 1.90	2N4403 .20
2N178 .90	2N967 .50	2N2222A .30	2N3019 .50	2N3773 3.00	2N4409 .20
2N327A 1.15	2N967 .50	2N2222A .30	2N3053 .30	2N3783 3.00	2N4410 .25
2N334 1.20	2N967 .50	2N2222A .30	2N3053 .30	2N3783 3.00	2N4411 .75
2N336 .90	2N967 .50	2N2222A .30	2N3055 .75	2N3783 3.00	2N4411 .85
2N338A 1.05	2N967 .50	2N2222A .30	2N3055 .75	2N3783 3.00	2N4412 .90
2N398B .90	2N967 .50	2N2222A .30	2N3055 .75	2N3783 3.00	2N4413 1.20
2N404 .30	2N967 .50	2N2222A .30	2N3055 .75	2N3783 3.00	2N4414 .55
2N443 1.75	2N967 .50	2N2222A .30	2N3055 .75	2N3783 3.00	2N4415 3.00
2N456 1.10	2N967 .50	2N2222A .30	2N3055 .75	2N3783 3.00	2N4416 .50
2N501A 3.00	2N967 .50	2N2222A .30	2N3055 .75	2N3783 3.00	2N4417 .50
2N508A .45	2N967 .50	2N2222A .30	2N3055 .75	2N3783 3.00	2N4418 .15
2N555 .45	2N967 .50	2N2222A .30	2N3055 .75	2N3783 3.00	2N4419 3.75
2N652A .85	2N967 .50	2N2222A .30	2N3055 .75	2N3783 3.00	2N4420 .50
2N677C 6.00	2N967 .50	2N2222A .30	2N3055 .75	2N3783 3.00	2N4421 .75
2N706 .25	2N967 .50	2N2222A .30	2N3055 .75	2N3783 3.00	2N4422 .50
2N706B .40	2N967 .50	2N2222A .30	2N3055 .75	2N3783 3.00	2N4423 .50
2N711 .50	2N967 .50	2N2222A .30	2N3055 .75	2N3783 3.00	2N4424 .50
2N711B .60	2N967 .50	2N2222A .30	2N3055 .75	2N3783 3.00	2N4425 .50
2N718 .25	2N967 .50	2N2222A .30	2N3055 .75	2N3783 3.00	2N4426 .40
2N720A .50	2N967 .50	2N2222A .30	2N3055 .75	2N3783 3.00	2N4427 .35
2N918 .35	2N967 .50	2N2222A .30	2N3055 .75	2N3783 3.00	2N4428 .40
2N930 .25	2N967 .50	2N2222A .30	2N3055 .75	2N3783 3.00	2N4429 .50
2N956 .30	2N967 .50	2N2222A .30	2N3055 .75	2N3783 3.00	2N4430 .40

SILICON UNIUNCTIONS	INTEGRATED CIRC.	RECTIFIERS
2N2646 .50	2N2160 65	UA703C .40
2N2647 .60	2N4870 50	709C OP. AMP. .25
2N2657 .55	2N4871 50	741C OP. AMP. .25
2N6028 .70	2N4891 50	7400 .15
D5E37 .25	2N4892 50	TA 7061P 3.50
	2N4893 50	TA 7205P 10.00
	2N4894 50	UPC 1001h2 6.00
	MU10 .40	NE 555 1.25
		IN4001 .60
		IN4002 .70
		IN4003 .80
		IN4004 .90
		IN4005 1.00
		IN4006 1.10
		IN4007 1.20

New-Tone Electronics
 P.O. Box 1738 A
 Bloomfield, N.J. 07003
 Phone: (201) 748-6171, 2, 3

ALL PARTS GUARANTEED AND TESTED ON PREMISES.

N.J. residents add 5% sales tax. Minimum order \$5.00. All orders add \$1.00 postage. Dealers write or phone for discount prices.

ARIES brought you the first calculator kit, and the first digital clock kit... and now brings you three of the most innovative electronic kits ever made. The System 300 Electronic Music Synthesizer kit is the most advanced in the world today, regardless of price. The AR-781 is a space-age beauty for any decor. And the wholly solid state AR-830 does the work of a \$400.00 tape memory unit.



WARNING... if you're interested in a music synthesizer, don't make a move until you see our catalog first. It's more like a handbook than a catalog, with hundreds of in-depth photographs and descriptions to explain electronic music principles, and to show equipment to do the job. **ARIES** now offers a complete complement of modules, keyboards, and cases, matched to the most rigorous professional standards. Starter systems priced as low as \$395.00.

A clear, ruby-red cylinder shows off all six digits of this modern calendar clock. Easy-to-read numbers show the hours, minutes, and seconds, as well as the month and day every ten seconds.



Red LED 7-segment numerals are 0.33" high, in a sturdy cylinder 2-1/2" in diameter and 4-3/4" long, with finished hardwood ends. Time and calendar are controlled by 60 Hz line frequency, with a 12-month movement. Separate time and calendar adjustments. Includes all the components, PC boards, housing, and instructions. Shipping weight 2 lbs, AR-781 Clock Kit \$34.50

Add finger-touch operation to your old-fashioned dial telephone with an **ARIES** AR-830 Automatic Digital Telephone Dialer. This has the same layout and convenience as Ma Bell, plus other features she doesn't offer yet. For instance... AR-830 always remembers the last number you dialed, in case the line was busy and you want to try again later. Not only that, but the Dialer's memory can store as many as ten of your favorite numbers for one-touch dialing. AR-830 uses standard dialing and muting contacts; consult local tariffs before connecting. Sh. wt. 2 lbs. AR-830 Dialer Kit \$69.50



ARIES INC.
119 Foster Street
Peabody, Mass., 01960
(617) 532-0450

CIRCLE NO. 9 ON FREE INFORMATION CARD

SEMICONDUCTOR AND PARTS Catalogue, \$1.00 refundable, from the semiconductor specialists, J & J Electronics, Box 1437P, Winnipeg, Manitoba, Canada. U.S. Inquiries.

COMPUTER HOBBYISTS! Bargain hunt and sell via ON_LINE. 18 issues/year — \$3.75. Free Sample. ON_LINE, 24695 Santa Cruz Hwy., Los Gatos, CA 95030.

TAPE AND RECORDERS

RENT 4-Track open reel tapes—free brochure. Stereo-Parti, P.O. Box 7, Fulton, CA 95401.

1930-1962 Radio Programs. Reels, \$1.00 Hour! Cassettes, \$1.00 Show!... Mammoth Catalog, \$1.25. AM Treasures, Box 192PE, Babylon, N.Y. 11702.

RECORDS—TAPES! Discounts to 73%; all labels; no purchase obligations; newsletter; discount dividend certificates; 100% guarantees. Free details. Discount Music Club, 650 Main St., Dept 5-976, New Rochelle, New York, N.Y. 10801.

1/2 INCH VIDEO TAPE. \$8.25 per hour on 7" reel. Free information. Oregon Magnetics, Box 13374P, Portland, Oregon 97213.

PLANS AND KITS

FREE CATALOGUE KITS, COMPONENTS. Audio equipment, Sinclair Kits, radio parts. Gladstone Electronics, 1736 Avenue RD., Toronto, Canada, M5M 3Y7. U.S. Inquiries.

AMAZING ELECTRONIC PRODUCTS

LASERS SUPER POWERED, RIFLE, PISTOL, POCKET SEE IN DARK, PYRO TECHNICAL DE BUGGING UNCRAMBLERS GIANT TESTA STUNWAND TV DISRUPTER ENERGY PRODUCING SCIENTIFIC DETECTION ELECTRICITY CHEMICAL ULTRASONIC CB AERO AUTO AND MECH DEVICES HUNDREDS MORE ALL NEW PLUS INFO UNLTD PARTS SERVICE

INFORMATION unlimited

Box 626 Lord Jeffery P2 • Amherst, N. H. 03031

CATALOG \$1

FREE KIT Catalog contains Test and Experimenter's Equipment, Dage Scientific Instruments, Box 1054P, Livermore, CA 94550.

PROJECTION TELEVISION: Ingenious idea enables you to project a six foot wide picture from your own television. Detailed diagrams with quality optic system only \$15.95. Kelly, Dept. W, Box 8, Levittown, Penna. 19059.

"CBers!" "TREMENDOUS POWER INCREASE" using NEW higher 46' all-directional CB Antenna!!! Plan \$2. (2/83). Astrobeam-3, 704 Edwards, Visalia, CA 93277.

TUBES

RADIO & T.V. Tubes—36 cents each. Send for free Catalog. Cornell, 4213 University, San Diego, Calif. 92105. TUBES receiving, factory boxed, low prices, free price list. Transleteronic, Inc., 1365 39th Street, Brooklyn, N.Y. 11218A, Telephone: 212-633-2800.

TUBES: "Oldies", Latest Supplies, components, schematics. Catalog Free (stamp appreciated). Steinmetz, 7519-PE Maplewood, Hammond, Ind. 46324.

WANTED

GOLD, Silver, Platinum, Mercury wanted. Highest prices paid by refinery. Ores assayed. Free circular. Mercury Terminal, Norwood, MA 02062.

BURGLAR ALARMS

PROTECT Your C.B., Solid State Burglar Alarm, Less than \$10.00 to build. Plans \$2.00. Ideas, Rt. No. 1, Box 361A, Gaston, S.C. 29053.

DIALING Unit automatically calls police. Immediate delivery \$29.95. Free literature. S&S Systems, 5619-C St. John, Kansas City, MO 64123. (816) 483-4612.

HIGH FIDELITY

DIAMOND NEEDLES and Stereo Cartridges at Discount prices for Shure, Pickering, Stanton, Empire, Grado and ADC. Send for free catalog. LYLE CARTRIDGES, Dept. P, Box 69, Kensington Station, Brooklyn, New York 11218.

GOVERNMENT SURPLUS

MANUALS for Govt Surplus radios, test sets, scopes. List 50 cents (coin). Books, 7218 Roanne Drive, Washington, D.C. 20021.

JEEPS, TRUCKS, Typically From \$52.40... Automobiles, Boats, Motorcycles, Airplanes, Oscilloscopes, Tools, Clothing, Sports, Camping, Photographic, Electronics Equipment... 200,000 Bid Bargains Nationwide Direct From Government... Low as 2 cents on Dollart Surplus Catalog and Sales Directory \$1.00 (refundable first order). National Surplus Center, 240 Eastcass-PEL, Joliet, IL 60432.

GOVERNMENT SURPLUS. Buy in your area. How, Where. Send \$2.00. Surplus, 30177-PE Headquarters Building, Washington, D.C. 20014.

SURPLUS ELECTRONIC EQUIPMENT, government and manufacturers' Grab Box Assortment—diverse, useful new and used parts, assemblies, etc. Carton packed: 50 lbs. \$6.00; 100 lbs. \$10.00. F.O.B. Lima. Send for BIG Free Catalog! Fair Radio, Box 1105-E, Lima, Ohio 45802.

DO-IT-YOURSELF

MODULAR TELEPHONES now available. Sets and components, compatible with Western Electric concept. Catalog 50 cents. Box 1654W, Costa Mesa, California 92626.

"SEE" MUSIC IN PULSATING COLOR



The Edmund 3-Channel Color Organ **\$17⁹⁵**

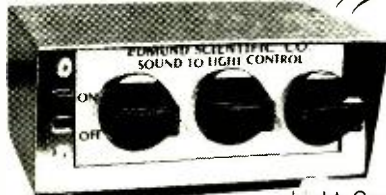

COMPLETELY ASSEMBLED! LESS THAN HALF THE PRICE OF OTHER MODELS!

Create your own audio "light show", add a new dimension to your music listening pleasure with the bargain-priced Edmund 3-Channel Sound To Light Control. Lets you modulate 3 independent strings of colored lamps with the intensity of your music. They flash and vary in brightness related to the music's rhythm, pitch and volume—a pulsating light performance to music! You get volume and frequency sensitivity to a peak rating of 300 watts per channel. Just plug in your favorite colored flood or spotlight, and turn on! Great price, too. This high quality, fully assembled unit in metal housing, with 3 individually controlled circuits, is priced at less than half that of others. Complete instructions are included with this terrific value.

ASSEMBLED \$17⁹⁵ Ppd.
NO. 42.309AV

UNASSEMBLED, IN KIT FORM \$13⁹⁵ Ppd.
NO. 42.336AV ONLY

GIANT FREE CATALOG!

NEW 164 Pages Over 4,500 Unusual Bargains for Hobbyists. Schools, Industry



JUST CHECK COUPON!
EDMUND SCIENTIFIC CO.
300 EDSCORP BUILDING
Barrington, N. J. 08007
(609) 547-3488

America's Greatest Science • Optics • Hobby Mart

COMPLETE AND MAIL COUPON NOW

EDMUND SCIENTIFIC CO. 300 Edscorp Bldg., Barrington, N. J. 08007

Send me:

SEND FREE 164 PAGE CATALOG AV

Charge my BankAmericard

Charge my Master Charge

Interbank No. _____

Card No. _____

Expiration Date _____

30-DAY MONEY-BACK GUARANTEE. You must be satisfied or return any purchase in 30 days for full refund.

City _____ State _____ Zip _____

Send me: _____

_____ COLOR ORGAN(S)
No. 42.309AV @ \$17.95 ea. \$ _____

_____ COLOR ORGAN KIT(S)
No. 42.336AV @ \$13.95 ea. \$ _____

Service and handling charge \$ _____ \$1.00

Enclosed is check, m.o. in amount of \$ _____

Signature _____

Name _____ Please print

Address _____

HELPING TO DEVELOP AMERICA'S TECHNOLOGY FOR OVER 30 YEARS.

INVENTIONS WANTED

INVENTORS: Manufacturers Need New Products. Free "Recommended Procedure," by a creative fee-based invention service company. Washington Inventors Service, 422-T Washington Building, Washington, D. C. 20005.

INVENTORS
RECOGNITION...FINANCIAL
REWARD...OR CREDIT
FOR "INVENTING IT FIRST" MAY BE YOURS!

If you have an idea for a new product, or a way to make an old product better, contact us, "the idea people." We'll develop your idea, introduce it to industry, negotiate for cash sale or royalty licensing. Write now without cost or obligation for free information. Fees are charged only for contracted services. So send for your FREE "Inventor's Kit." It has important Marketing Information, a special "Invention Record Form" and a Directory of 500 Corporations Seeking New Products.

RAYMOND LEE ORGANIZATION
 230 Park Avenue North, New York, NY 10017
 At no cost or obligation, please rush my
 FREE "Inventor's Kit No. A-112"

Name _____ Please Print
 Address _____
 City _____ State _____ Zip _____

FREE PAMPHLET: "Tips on Marketing Your Invention," from an experienced fee-based invention service company. Write United States Inventors Service Company, Dept. T, 1435 G Street NW, Washington, D. C. 20005.

INSTRUCTION

LEARN PERIPHERAL ORGAN SERVICING at home all makes including transistor. Experimental kit—troubleshooting. Accredited NHSC. Free Booklet. NILES BRYANT SCHOOL, 3631 Stockton, Dept. A, Sacramento, Calif. 95820.

EARN ELECTRONICS DEGREE by correspondence. Free information bulletin. Grantham, 2000 Stoner Avenue. Los Angeles, California 90025.

F.C.C. EXAM MANUAL
 PASS FCC EXAMS! Memorize study — Test Answers — for FCC 1st and 2nd class Radio-Tele. phone licenses. Newly revised multiple choice questions and diagrams cover all areas tested on FCC exams plus Self-Study Ability Test. \$9.95 postpaid. Moneyback Guarantee.
 COMMAND PRODUCTIONS P.O. BOX 26348-P
 RADIO EQUIPMENT DIVISION SAN FRANCISCO, CALIF. 94126

SCORE high on F.C.C. Exams — Over 300 questions and answers. Covers 3rd, 2nd, 1st and even Radar. Third and Second Test, \$14.50; First Class Test, \$15.00. All tests, \$26.50. R.E.I., Inc., Box 806, Sarasota, Fla. 33577.

UNIVERSITY DEGREES BY MAIL! Bachelors, Masters, Ph.D.'s. Free revealing details. Counseling, Box 317-PE9, Tustin, California 92680.

SELF-STUDY CB RADIO REPAIR COURSE. THERE'S MONEY TO BE MADE REPAIRING CB RADIOS. This easy-to-learn course can prepare you for a career in electronics enabling you to earn as much as \$16.00 an hour in your spare time. For more information write: CB RADIO REPAIR COURSE, Dept. PE096, 531 N. Ann Arbor, Oklahoma City, Okla. 73127.

LEARN Basic Digital Troubleshooting by correspondence. Information Free Educational Technologies, Box 224, Reynoldsburg, Ohio 43068.

LEARN WHILE ASLEEP! HYPNOTIZE! Astonishing details, strange catalog free! Autosuggestion, Box 24-ZD, Olympia, Washington 98507.

FCC LICENSE STUDY GUIDE — 377 pages, 1465 questions with answers/discussions — covering third, second, first radiotelephone examinations. \$9.95 postpaid. GSE, 2000 Stoner, Los Angeles, California 90025.

ACHIEVEMENT in Electronics-Mathematics can be yours through independent study with individualized instruction. For your trial lesson, send \$2.00 to: Vinther Institute, Box 9447P, Berkeley, CA 94709.

INTENSIVE 5 week course for Broadcast Engineers. FCC First Class license. Student rooms at the school. Radio Engineering Inc., 61 N. Pineapple Ave., Sarasota, FL 33577 and 2402 Tidewater Trail, Fredericksburg, VA 22401.

LOWEST PRICES EVER

LINEAR CIRCUITS

300	Pos V Reg (super)	10-5	\$.71	
301	Hi Perf Op Amp mDIP	10-5	.29	
302	Volt follower	10-5	.53	
304	Pos V Reg	10-5	.80	
305	Pos V Reg	10-5	.71	
307	Op AMP (super)	10-5	mDIP 10-5	
308	Moni Pot Op Amp mDIP	10-5	.89	
309K	5V 1A regulator	10-1	1.35	
110	V Follower Op Amp	mDIP	1.07	
311	Hi perf V Comp mDIP	10-5	.95	
119	Hi Speed Dual Comp	DIP	1.13	
120T	Neg Reg 5.12	10-220	1.39	
120K	Neg Reg 5.12	10-220	1.39	
122	Precision Timer	DIP	1.70	
124	Quad Op Amp	DIP	1.52	
119	Quad Comparator	DIP	1.58	
110K	Pos V Reg 15V	8V 12V 15V 18V 24V	10-1	1.69
3401	Pos V Reg 15V	8V 12V 15V 18V 24V	10-220	1.49
370	AGC/Squelch	AMPL DIP	2.20	
372	AF IF Strip	detector DIP	2.91	
373	AM 1.5 VSB Strip	DIP	2.42	
376	Pos V Reg	mDIP	.68	
380	2x Audio	AMP DIP	1.30	
480-8	2x Audio	AMP mDIP	1.25	
481	To Noise Dual	preamp DIP	1.75	
482	To Noise Dual	preamp DIP	1.75	
531	High Slew rate	Op Amp	2.95	
540	Power driver	10-5	2.95	
555	Timer	mDIP	.79	
556A	Dual 555	Timer DIP	1.49	
560	Phase Locked	loop DIP	3.39	
562	Phase Locked	loop DIP	3.39	
565	Phase Locked	loop DIP	10-5	1.18
566	Function Gen	mDIP 10-5	1.95	
567	Tone Decoder	mDIP	.49	
790	Operational AMP	10-5 or DIP	.26	
710	Hi Speed Volt	Comp DIP	.35	
711	Dual Difference	Comp DIP	.26	
723	V Reg	DIP	.62	
733	Differential	AMPL 10-5	1.02	
739	Dual Hi Perf	Op Amp DIP	1.07	
741	Comp Op Amp	mDIP 10-5	.32	
747	Hi Dual Op	AMP DIP or 10-5	.71	
748	Freq Adj	741 mDIP	.74	
1304	FAM Multis	Stereo Demod	DIP	1.07
1307	FAM Multis	Stereo Demod	DIP	.74
1456	Op Amp	mDIP	1.83	
1458	Dual Comp	Op Amp mDIP	.62	
1800	Stereo multiplexer	DIP	2.48	
1900	Quad Amplifier	mDIP	.49	
752A	Dual core	memors sense Amp	.71	
752S	Dual core	memors sense Amp	.90	
8038	Voltage control	osc DIP	4.16	
886A	9 DIG	led Cath Drive	DIP	2.25
75150	Dual Line	Driver DIP	1.75	
75451	Dual Peripheral	Driver mDIP	.35	
75452	Dual Peripheral	Driver mDIP	.35	
7553	(151) Dual	Periph Driver mDIP	.71	
75491	Quad Seq	Driver for LED	DIP	.71
75492	Hx Quad	driver DIP	.80	

CMOS

4000A	.26	4018A	1.39	4066A	.89
4001A	.25	4020A	1.72	4068A	.44
4002A	.25	4021A	1.18	4069A	.44
4003A	.25	4022A	.94	4071A	.26
4007A	.26	4023A	.25	4072A	.35
4008A	1.52	4024A	.89	4073A	.39
4009A	.57	4025A	.25	4075A	.39
4010A	.54	4027A	.59	4078A	.39
4011A	.29	4028A	.98	4082A	.35
4012A	.25	4030A	.44	4518A	1.56
4013A	.45	4035A	1.27	4528A	1.56
4014A	1.27	4040A	1.39	4585A	2.10
4015A	1.27	4042A	1.47		
4016A	.48	4049A	.59		
4017A	1.01	4050A	.59		

CLOCK KIT
 6 DIGITS (NS71L)
 MMS5314 CLOCK CIRCUIT
 2 PC BOARDS (CLOCK & DISPLAY)
 ALL TRANSISTORS, RESISTORS
 CAPACITORS & 3 SWITCHES \$14.95
 WALL TRANSFORMER \$2.95
 WOODEN CASE (UNASSEMBLED) \$3.95
 CLOCK KIT, TRANSFORMER & CASE \$20.95

DVM CHIP 4 1/2 DIGIT
 MM 5330 — P channel device provides all logic for 4 1/2 digit voltmeter. 16 pins DIP with data 9.95

SHIFT REGISTERS

MS45013	1024 bit	accum. dyn.	1.75
	8 pin		
MS45016	500	312 bit dyn.	1.59
	8 pin		
MS45025	Quad	25 bit	.99
2504	1024 bit	multiplexed dyn.	3.95
	8 pin		

IC SOCKETS
 Solder Tail — low profile

8 pin	5	17	24 pin	.42
14 pin	5	17	28 pin	.59
16 pin	22	40 pin		.69
18 pin				.29
14 pin				.49

WIRE WRAP — gold plate
 14 pin .49

Data included with order on request. Add \$.50 ea. if item is priced below \$10.00

LINEAR SEPTEMBER SPECIALS TTL

301	\$.21	7432	\$.19
311	.59	7437	.20
309K	.89	7438	.18
340T+5v	.99	7446	.69
340T+15v	.99	7474	.22
741	.1A	7490	.39
3900	.33	74121	.29
9602	.59	74123	.49
75491	.59	74164	.85
1310	1.79	74165	.85
		74193	.73

FREE RESISTOR KIT WITH EVERY \$50 ORDER
 180 carbon film resistors ± 5%, 1/4 or 1/2 watt. 15 each of 12 values. First quality resistors supplied in a durable clear styrene utility box with color code chart. Includes 15 each 100, 220, 470, 1K, 1.5K, 3.3K, 4.7K, 6.8K, 10K, 33K, 100K, 1M.

THESE DISCOUNTS APPLY TO TOTAL OF ORDER — SPECIALS INCLUDED
10% OFF ON ORDERS OVER \$25
15% OFF ON ORDERS OVER \$100
 LARGE QUANTITY PRICING AVAILABLE ON REQUEST
 PLEASE SPECIFY ITEM AND QUANTITY

POCKET CALCULATOR KIT
 5 function plus constant — addressable memory with maximum of 8 digit display plus overflow feature. saves — uses standard rechargeable batteries — all necessary parts in ready to assemble form — instructions included

Calc. Kit. & Adapter \$ 9.95
 Batteries (alkaline disp.) 2.00

MEMORIES

1101	256 bit	RAM MOS	16 pin	1.39	7451	.17	74153	.89
1103	1024 bit	RAM MOS	dynamic 18 pin	1.95	7452	.17	74154	1.20
1702A	2048 bit	PROM	static electrically programmable UV erasable 24 pin	10.95	7453	.15	74155	.97
2102	1024 bit	RAM	static 16 pin	1.95	7454	15	74156	.97
5203	2048 bit	PROM	static electrically programmable UV erasable 24 pin	10.95	7455	.19	74157	.99
5260	1024 bit	RAM	MOS dynamic 16 pin	1.95	7456	.20	74158	1.23
5261	1024 bit	RAM	MOS dynamic 16 pin	1.95	7457	.28	74159	1.39
8253	256	PROM-SCHOTTKY	16 pin	3.69	7458	.19	74160	.99
F93410	256 bit	RAM	bi-polar 16 pin	1.95	7459	.25	74161	.84
74187	1024 bit	ROM	TTL 16 pin	5.75	7460	.20	74162	.90
74200	256 bit	RAM	tri-state 16 pin	5.45	7461	.25	74163	.99

CLOCK CHIPS

CT5002	1.95	MMS5311	4.45
CT5005	2.49	MMS5312	3.95
MM5225	1.98	MMS5314	4.45
MM5376	2.95	MMS5316	4.95
MM5378	3.95	5375A	4.95
MM5379	3.95	CT7001	5.95

LOW POWER

74100	.29	74151	.29	74190	1.40
74102	.29	74155	.29	74191	1.20
74103	.23	74171	.29	74193	1.50
74104	.29	74172	.45	74195	1.50
74106	.29	74173	.56	74198	2.25
74107	.29	74174	.56	74199	2.25
74120	.29	74175	.75	74164	2.25
74130	.29	74185	1.09	74165	2.30
74142	1.39	74186	.65		

LOW POWER SCHOTTKY

741500	.36	741532	.38	741595	2.09
741502	.36	741540	.45	741507	.59
741504	.36	741542	1.00	741516A	2.20
741508	.38	741574	.50	7415193	2.20
741510	.36	741590	1.30	7415197	2.20
741520	.36	741593	1.30		

MULTIPLE DISPLAYS

NS111	1 digit	12' red LED	1.79
HP5082	5 digit	11 red LED	3.49
7405			
HP5082	4 digit	11 red LED	3.25
7414			
SP-425-09	9 digit	25 gas disch.	1.79

OPTO ISOLATORS

MC22	Opto isolator diode	1.09
MCT2	Opto isolator transistor	1.70

SPECIAL DEVICES

372	AF-IF Strip	Detector DIP	2.93
546	AM-Rcvr Receiver	Subsystem DIP	.75
1310	FM Stereo	Demodulator DIP	2.90
1496	Balance	Modulator-Demodulator	.99
1800	Stereo	multiplexer DIP	2.48
ULN2208	FM Gain	Block 34db (typ) mDIP	1.18
ULN2209	FM Gain	Block 48db (typ) mDIP	1.35
2513	Character	Generator 64x85 DIP	20.20
5046	Transistor	Array DIP-14	.73

SCHOTTKY

74500	.38	74508	.52	74522	.38
74502	.45	74510	.38	74532	.52
74503	.38	74520	.38	74574	.38

FREE CATALOG AVAILABLE ON REQUEST
 Satisfaction guaranteed. Shipment will be made postage prepaid within 3 days from receipt of order. Payment may be made with personal check, charge card (include number and exp. date), or money order. Phone Orders — BoIA and M/C card or C.O.D. Add \$1.00 to cover shipping and handling if order is less than \$10.00. California residents add sales tax. Include shipping expense for orders shipped out of U.S. and Canada approx. 15% of order.

INTERNATIONAL ELECTRONICS UNLIMITED
 P.O. BOX 3036-R MONTEREY, CA. 93940 USA
 PHONE (408) 659-3171

DELTA

DELTA ELECTRONICS CO.
P.O. BOX 2, AMESBURY, MASS. 01913

8 TRACK TAPE PLAYER

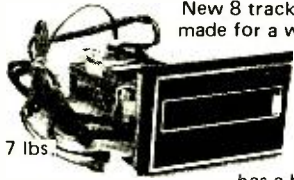

New 8 track tape players made for a well known

manufacturer of consumer electronics, who installed it in a stereo console. It

has a built in pre-amp, so that it can be plugged in the Aux. inputs of any amplifier. With flip-down door, automatic track changing, track lights, 4' power & signal cords. 6 1/2" wide, 4" high, 8 1/2" deep. We test each one before shipping. STOCK NO. P5429 \$17.95 each, 2/35.

SILICON SOLAR CELLS

Experiment with SOLAR ENERGY with these exotic silicon solar cells. Developed by Ion Physics Corp. for space applications. Each one develops 430 mv, 95 to 130 ma (40 to 56 milliwatts). .788" square x 8 to 15 mils thick. Boron doped Si base, dopant is phosphorus implanted, contacts are titanium silver. New, 1st line, with data. Applications unlimited! STOCK NO. P5433 \$2.50 each, 5/10.00, 20/35.00

Send for latest free catalog. Minimum order \$5, phone orders welcome: (617) 388-4705. Include sufficient postage; excess refunded. BankAmericard & Mastercharge welcome, ALL numbers needed for processing. Min. charge \$15.

CIRCLE NO. 17 ON FREE INFORMATION CARD

IMSAI & ALTAIR OWNERS! All IMSAI 8080 Computer Boards Completely Plug- Compatible With Altair 8800

Interchangeable MPU, Memory and I/O Boards. Full IMSAI 8080/Altair 8800 Bus Compatibility. No Hardware Modifications Required. Just Plug In!

Part #	Description	Kit	Assembled
MPU-A	8080 microprocessor board	\$190	\$350
RAM 4A-4	4K static RAM board	139	279
PR0M 4-4	4K bytes EPROM board	399	579
EXT	Extender board	39	49
PIC-8	Priority int/clock board	125	238
P10 4-1	One-port parallel I/O board	93	140
P10 4-4	Four-port parallel I/O board	156	299
S10 2-1	One-port serial I/O board	125	235
S10 2-2	Two-port serial I/O board	156	299
UCR1-1	Cassette recorder I/O board	59	99

IMSAI 8080 Computer

Basic computer includes front panel/control board, 28 amp power supply, MPU board, 6-slot expander board with 2 edge connectors, cabinet, assembler software and complete documentation. . . \$599 Kit, \$931 Assembled.

COMPLETE DOCUMENTATION

An Introduction to Microcomputers, Vol. I & II	\$12.00
IMSAI 8080 User's Manual	50.00
INTEL 8080 Assembly Language Manual	12.00
INTEL 8080 User's Manual	7.00
The T.I. TTL Handbook	10.00
Supplement to T.I. TTL Handbook	5.00
My Computer Likes Me When I Speak	
In BASIC	3.50
BASIC-PLUS Language Manual	17.00
8080 Programming for Logic Design	12.00
Pinout Handbook, 54/7400 SERIES	5.00
What To Do After You Hit RETURN (Computer Games)	11.00

SEND \$1 FOR NEW IMSAI 8080 ILLUSTRATED 16-PAGE CATALOG TODAY!

TERMS: Check, money order, BankAmericard, Master Charge (include all embossed data on card). 25% non-refundable deposit on C.O.D. 25% cancellation charge on all orders. California residents add 6% sales tax. Prices, terms and specifications subject to change without notice.

IMSAI

IMS Associates, Inc.
14860 Wicks Blvd., San Leandro, CA 94577
Phone: (415) 483-2093

For faster service

USE ZIP CODE

on all mail

Same day shipment
First line parts only. Factory tested. Guaranteed money back. Quality IC's and other components at factory prices

P.O. Box 44300 Santa Clara, CA 95054
(408) 988-1640

TERMS: \$5.00 min. order U.S. funds
Calif. residents add 6% tax.
FREE: Send for your copy of our 1976 QUEST CATALOG.



INTEGRATED CIRCUITS

7400 TTL	17	SN74ALS00	39
SN7400N	17	SN74ALS00N	39
SN7401	19	SN74ALS01	41
SN7401N	19	SN74ALS01N	41
SN7402	23	SN74ALS02	45
SN7402N	23	SN74ALS02N	45
SN7403	34	SN74ALS03	56
SN7403N	34	SN74ALS03N	56
SN7404	20	SN74ALS04	41
SN7404N	20	SN74ALS04N	41
SN7405	65	SN74ALS05	141
SN7405N	65	SN74ALS05N	141
SN7406	26	SN74ALS06	205
SN7406N	26	SN74ALS06N	205
SN7407	38	SN74ALS07	240
SN7407N	38	SN74ALS07N	240
SN7408	32	SN74ALS08	200
SN7408N	32	SN74ALS08N	200
SN7409	42	SN74ALS09	90
SN7409N	42	SN74ALS09N	90
SN7410	20	SN74ALS10	2
SN7410N	20	SN74ALS10N	2
SN7411	20	SN74ALS11	2
SN7411N	20	SN74ALS11N	2
SN7412	39	SN74ALS12	90
SN7412N	39	SN74ALS12N	90
SN7413	20	SN74ALS13	2
SN7413N	20	SN74ALS13N	2
SN7414	20	SN74ALS14	2
SN7414N	20	SN74ALS14N	2
SN7415	20	SN74ALS15	2
SN7415N	20	SN74ALS15N	2
SN7416	20	SN74ALS16	2
SN7416N	20	SN74ALS16N	2
SN7417	20	SN74ALS17	2
SN7417N	20	SN74ALS17N	2
SN7418	20	SN74ALS18	2
SN7418N	20	SN74ALS18N	2
SN7419	20	SN74ALS19	2
SN7419N	20	SN74ALS19N	2
SN7420	20	SN74ALS20	2
SN7420N	20	SN74ALS20N	2
SN7421	20	SN74ALS21	2
SN7421N	20	SN74ALS21N	2
SN7422	20	SN74ALS22	2
SN7422N	20	SN74ALS22N	2
SN7423	20	SN74ALS23	2
SN7423N	20	SN74ALS23N	2
SN7424	20	SN74ALS24	2
SN7424N	20	SN74ALS24N	2
SN7425	20	SN74ALS25	2
SN7425N	20	SN74ALS25N	2
SN7426	20	SN74ALS26	2
SN7426N	20	SN74ALS26N	2
SN7427	20	SN74ALS27	2
SN7427N	20	SN74ALS27N	2
SN7428	20	SN74ALS28	2
SN7428N	20	SN74ALS28N	2
SN7429	20	SN74ALS29	2
SN7429N	20	SN74ALS29N	2
SN7430	20	SN74ALS30	2
SN7430N	20	SN74ALS30N	2
SN7431	20	SN74ALS31	2
SN7431N	20	SN74ALS31N	2
SN7432	20	SN74ALS32	2
SN7432N	20	SN74ALS32N	2
SN7433	20	SN74ALS33	2
SN7433N	20	SN74ALS33N	2
SN7434	20	SN74ALS34	2
SN7434N	20	SN74ALS34N	2
SN7435	20	SN74ALS35	2
SN7435N	20	SN74ALS35N	2
SN7436	20	SN74ALS36	2
SN7436N	20	SN74ALS36N	2
SN7437	20	SN74ALS37	2
SN7437N	20	SN74ALS37N	2
SN7438	20	SN74ALS38	2
SN7438N	20	SN74ALS38N	2
SN7439	20	SN74ALS39	2
SN7439N	20	SN74ALS39N	2
SN7440	20	SN74ALS40	2
SN7440N	20	SN74ALS40N	2
SN7441	20	SN74ALS41	2
SN7441N	20	SN74ALS41N	2
SN7442	20	SN74ALS42	2
SN7442N	20	SN74ALS42N	2
SN7443	20	SN74ALS43	2
SN7443N	20	SN74ALS43N	2
SN7444	20	SN74ALS44	2
SN7444N	20	SN74ALS44N	2
SN7445	20	SN74ALS45	2
SN7445N	20	SN74ALS45N	2
SN7446	20	SN74ALS46	2
SN7446N	20	SN74ALS46N	2
SN7447	20	SN74ALS47	2
SN7447N	20	SN74ALS47N	2
SN7448	20	SN74ALS48	2
SN7448N	20	SN74ALS48N	2
SN7449	20	SN74ALS49	2
SN7449N	20	SN74ALS49N	2
SN7450	20	SN74ALS50	2
SN7450N	20	SN74ALS50N	2
SN7451	20	SN74ALS51	2
SN7451N	20	SN74ALS51N	2
SN7452	20	SN74ALS52	2
SN7452N	20	SN74ALS52N	2
SN7453	20	SN74ALS53	2
SN7453N	20	SN74ALS53N	2
SN7454	20	SN74ALS54	2
SN7454N	20	SN74ALS54N	2
SN7455	20	SN74ALS55	2
SN7455N	20	SN74ALS55N	2
SN7456	20	SN74ALS56	2
SN7456N	20	SN74ALS56N	2
SN7457	20	SN74ALS57	2
SN7457N	20	SN74ALS57N	2
SN7458	20	SN74ALS58	2
SN7458N	20	SN74ALS58N	2
SN7459	20	SN74ALS59	2
SN7459N	20	SN74ALS59N	2
SN7460	20	SN74ALS60	2
SN7460N	20	SN74ALS60N	2
SN7461	20	SN74ALS61	2
SN7461N	20	SN74ALS61N	2
SN7462	20	SN74ALS62	2
SN7462N	20	SN74ALS62N	2
SN7463	20	SN74ALS63	2
SN7463N	20	SN74ALS63N	2
SN7464	20	SN74ALS64	2
SN7464N	20	SN74ALS64N	2
SN7465	20	SN74ALS65	2
SN7465N	20	SN74ALS65N	2
SN7466	20	SN74ALS66	2
SN7466N	20	SN74ALS66N	2
SN7467	20	SN74ALS67	2
SN7467N	20	SN74ALS67N	2
SN7468	20	SN74ALS68	2
SN7468N	20	SN74ALS68N	2
SN7469	20	SN74ALS69	2
SN7469N	20	SN74ALS69N	2
SN7470	20	SN74ALS70	2
SN7470N	20	SN74ALS70N	2
SN7471	20	SN74ALS71	2
SN7471N	20	SN74ALS71N	2
SN7472	20	SN74ALS72	2
SN7472N	20	SN74ALS72N	2
SN7473	20	SN74ALS73	2
SN7473N	20	SN74ALS73N	2
SN7474	20	SN74ALS74	2
SN7474N	20	SN74ALS74N	2
SN7475	20	SN74ALS75	2
SN7475N	20	SN74ALS75N	2
SN7476	20	SN74ALS76	2
SN7476N	20	SN74ALS76N	2
SN7477	20	SN74ALS77	2
SN7477N	20	SN74ALS77N	2
SN7478	20	SN74ALS78	2
SN7478N	20	SN74ALS78N	2
SN7479	20	SN74ALS79	2
SN7479N	20	SN74ALS79N	2
SN7480	20	SN74ALS80	2
SN7480N	20	SN74ALS80N	2
SN7481	20	SN74ALS81	2
SN7481N	20	SN74ALS81N	2
SN7482	20	SN74ALS82	2
SN7482N	20	SN74ALS82N	2
SN7483	20	SN74ALS83	2
SN7483N	20	SN74ALS83N	2
SN7484	20	SN74ALS84	2
SN7484N	20	SN74ALS84N	2
SN7485	20	SN74ALS85	2
SN7485N	20	SN74ALS85N	2
SN7486	20	SN74ALS86	2
SN7486N	20	SN74ALS86N	2
SN7487	20	SN74ALS87	2
SN7487N	20	SN74ALS87N	2
SN7488	20	SN74ALS88	2
SN7488N	20	SN74ALS88N	2
SN7489	20	SN74ALS89	2
SN7489N	20	SN74ALS89N	2
SN7490	20	SN74ALS90	2
SN7490N	20	SN74ALS90N	2
SN7491	20	SN74ALS91	2
SN7491N	20	SN74ALS91N	2
SN7492	20	SN74ALS92	2
SN7492N	20	SN74ALS92N	2
SN7493	20	SN74ALS93	2
SN7493N	20	SN74ALS93N	2
SN7494	20	SN74ALS94	2
SN7494N	20	SN74ALS94N	2
SN7495	20	SN74ALS95	2
SN7495N	20	SN74ALS95N	2
SN7496	20	SN74ALS96	2
SN7496N	20	SN74ALS96N	2
SN7497	20	SN74ALS97	2
SN7497N	20	SN74ALS97N	2
SN7498	20	SN74ALS98	2
SN7498N	20	SN74ALS98N	2
SN7499	20	SN74ALS99	2
SN7499N	20	SN74ALS99N	2

CMOS

CD34001	42
CD34002	25
CD4001	25
CD4002	25
CD4003	25
CD4004	40
CD4005	50
CD4006	

INTEL 8080 CPU	\$29.50
2518-HEX 32 BIT SR	\$6.00
2102 1 1024 BIT RAM	\$ 2.60
5280 4K DYNAMIC RAM	\$12.50
5202A UV PROM	\$12.50
MM5203 UV PROM	\$12.50
1702A UV PROM	\$12.50
5204 4K PROM	\$24.95
MINIATURE MULTI-TURN TRIM POTS	
100 500, 5K, 10K, 100K 200K	\$ 1.25 ea.
\$.75 each	\$3.00
MULTI-TURN TRIM POTS Similar to Bouras	
3010 style 3/16"x5/8"x1 1/4", 50, 100,	
1K, 10K, 50K ohms	
\$1.50 ea.	\$3.00
LIGHT ACTIVATED SCR's	
TO 18, 200V 1A	\$ 1.75

TRANSISTOR SPECIALS

2N3585 NPN Si TO 66	\$.95
2N3772 NPN Si TO 3	\$ 1.60
2N4908 PNP Si TO 3	\$ 1.00
2N6055 NPN Si TO 3 Darlington	\$ 1.30
2N5086 PNP Si TO 92	4/5 1.00
2N4898 PNP TO 66	\$.60
2N404 PNP GF TO 5	5/5 1.00
2N3919 NPN Si TO 3 RF	\$ 1.50
MPSA 13 NPN Si TO 92	3/5 1.00
2N3767 NPN Si TO 66	\$.70
2N2222 NPN Si TO 18	5/5 1.00
2N3055 NPN Si TO 3	\$.80
2N3904 NPN Si TO 92	5/5 1.00
2N3906 PNP Si TO 92	5/5 1.00
2N5296 NPN Si TO 220	\$.50
2N6109 PNP Si TO 220	\$.55
2N3866 NPN Si TO 5 RF	\$.75
2N3638 PNP Si TO 5	5/5 1.00
2N6517 NPN TO 92 Si	3/5 1.00

CMOS (DIODE CLAMPED)

74C02	25	4016	50	4035	118
74C10	25	4017	100	4042	90
4001	19	4018	120	4047	1.80
4002	22	4019	50	4049	50
4006	120	4022	100	4050	50
4007	22	4023	25	4055	1.75
4009	47	4024	80	4066	90
4010	47	4025	22	4071	40
4011	22	4027	48	4077	35
4012	22	4028	100	4081	35
4013	30	4029	100	4076	120
4015	110	4030	45		

LED READOUTS

FND 500 5" C.C.	\$1.75
HP 7740 3" C.C.	\$1.40
MAN 7 3" C.A.	\$1.25
NS 333 3dig array	\$1.35

Send 25c for our catalog featuring Transistors and Rectifiers 145 Hampshire St., Cambridge, Mass.

PRINTED CIRCUIT BOARD

4 1/2"x6 1/2" SINGLE SIDED EPOXY BOARD 1/16" thick, unetched	\$ 50 ea.
VECTOR BOARD 1" SPACING	5/\$2.20
4 5" x 6" SHEET	\$ 1.50
4 WATT IR LASER DIODE \$7.95	
2N 3820 P FET	\$.45
2N 5457 N FET	\$.45
2N 4891 UJT	\$.45
TIS 43 UJT	\$.35
ER 900 TRIGGER DIODES	4/\$1.00
2N 6028 PROG UJT	\$.65

VERIPAX PC BOARD

This board is a 1/16" single sided paper epoxy board, 4 1/2"x6 1/2" DRILLED and ETCHED which will hold up to 21 single 14 pin IC's or 8, 16, or LSI DIP IC's with buses for power supply connector \$4.00

MV 5691 YELLOW/GREEN	\$4.00
BIPOLAR LED	\$1.25
MT 2 PHOTO TRANS	\$.60
RED, YELLOW, GREEN OR	\$ 20
AMBER LARGE LED'S	ea. \$.20
14 PIN DIP SOCKETS	\$.25
16 PIN DIP SOCKETS	\$.25
MOLEX PINS	1000/\$1.00
8 PIN MINI DIP SOCKETS	\$.25
10 WATT ZENERS 3.9, 4.7, 5.6, 8.2, 12, 15, 18 OR 22V, 100, 150, 200, . . . ea \$.60	
1 WATT ZENERS 4.7, 5.6, 10, 12, 15, 18 OR 22V	ea. \$.25

Silicon Power Rectifiers

PRV 1A	3A	12A	50A	125A
100	06	14	30	80
200	07	20	35	115
400	09	25	50	140
600	11	30	70	180
800	15	35	90	230
1000	20	45	110	275

SILICON SOLAR CELLS

2 1/4" diameter

5V at 500 ma. . . . \$5.00 ea., 6/\$27.50

REGULATED MODULAR POWER SUPPLIES

1-15 VDC AT 100ma	
115VAC INPUT	\$27.95
5VDC AT 1A, 115VAC INPUT	\$24.95
12 VDC AT .5A	\$24.95
1N 4148 1N914	15/\$1.00

TANTULUM CAPACITORS

22UF 35V 5/\$1.00	6.8UF 35V 3/\$1.00
47UF 35V 5/\$1.00	22UF 35V \$.40
68UF 35V 5/\$1.00	33UF 35V \$.40
1UF 35V 5/\$1.00	30UF 6V 5/\$1.00
3.3UF 35V 4/\$1.00	1UF 35V \$.50
4.7UF 35V 4/\$1.00	100UF 35V \$.50
	150UF 15V \$.40
	CT7001 ALARM CLOCK CHIP \$5.75

NATIONAL MOS DEVICES

MM1402 2 00	MMS057 2 25
MM1403 2 00	MMS058 2 75
MM1404 2 25	MMS060 2 75
MM5013 4 00	MMS061 2 50
MM5016 2 50	MMS555 4 75
MM5017 2 50	MMS556 4 75
MM5055 2 25	MMS210 1 95
MM5056 2 25	MMS260 2 95

TTL IC SERIES

74100 25	7442 55	74126 60
7400 16	7445 75	74150 100
7401 16	7446 80	74151 80
7402 16	7447 69	74153 79
7403 16	7448 77	74154 105
7404 18	7472 35	74155 100
7405 18	7473 37	74157 75
7406 35	7474 32	74161 100
7407 33	7475 50	74164 105
7408 18	7476 32	74165 105
7409 18	7480 48	74173 135
7410 15	7483 70	74174 120
7411 25	7485 88	74175 95
7412 30	7486 39	74177 100
7413 45	7489 200	74180 100
7414 80	7490 48	74181 210
7416 33	7491 75	74190 115
7417 33	7492 45	74191 110
7420 16	7493 49	74192 85
7426 35	7494 80	74193 85
7427 28	7495 80	74194 125
7430 16	7496 73	74195 74
7437 30	74107 34	74198 110
7437 27	74121 39	74283 150
7438 27	74123 60	75324 175
7440 18	74125 60	75491 60
7441 85		75492 60

MINIATURE DIP SWITCHES

CTS 206 4 Four SPST switches in one minidip package	\$1.50
CTS 206 8 Eight SPST switches in a 16 pin DIP package	\$2.55

AY 5 1013 A30K ser./par./bit./ser./uni. versal UART \$8.50

ALCO MINIATURE TOGGLE SWITCHES	
MTA 105 SPDT	\$1.20
MTA 206 DPDT	\$1.70

Full Wave Bridges

SANKEN AUDIO POWER AMPS

Si 1010 G 10 WATTS	\$ 6.90
Si 1020 G 20 WATTS	\$13.95
Si 1050 G 50 WATTS	\$24.95

PRV 2A	6A	25A
200	95	1.25
400	1.15	1.50
600	1.35	1.75
CD 110 LINEAR 256 XI BIT SELF SCANNING CHARGED COUPLED DEVISE		\$99.00

LINEAR CIRCUITS

LM 309K 5V 1A REGULATOR	\$1.25
723 - 40 V 40V REGULATOR	\$.50
301748 Hi Per. Op. Amp	\$.31
3201 5, 12, 15, OR 24V	
NEGATIVE REG	\$1.50
741A or 741C OP AMP	\$.31
710 COMPARATOR	\$.35
307 OP AMP	\$.31
CA 3047 Hi Per. Op. Amp	\$.95
3401 5, 6, 8, 12, 15, 18, 24V POS REG TO 220	\$1.50
101 OPEM Amp. HI PERFORM.	\$.75
LM 308 Oper. Amp. Low Power	\$.95
747 - DUAL 741	\$.65
555 DUAL TIMER	\$1.00
556 PRECISION OP AMP	\$1.70
LM 3900 QUAD OP AMP	\$.49
LM 324 QUAD 741	\$1.50
560 - PHASE LOCK LOOP	\$2.00
561 - PHASE LOCK LOOP	\$2.00
565 - PHASE LOCK LOOP	\$1.25
566 FUNCTION GEN.	\$1.65
567 TONE DECODER	\$1.50
LM 1310M FM STEREO OEMOD	\$2.75
8038 IC VOLTAGE CONT. OSC.	\$3.90
LM 370 AGC SQUELCH AMP	\$1.15
555 2w 2 HI. TIMER	\$.45
553 QUAD TIMER	\$.80
FCD 810 OPTO-ISOLATOR	\$2.50
1458 DUAL OP AMP	\$.60
LM 380 2W AUDIO AMP	\$.95
LM 377 - 2W Stereo Audio Amp	\$2.50
LM 381 - STEREO PREAMP	\$1.50
LM 382 DUAL AUDIO PREAMP	\$1.50
LM 311 HI PER. COMPARATOR	\$.90
LM 319 Dual Hi Speed Comp	\$1.25
LM 339 QUAD COMPARATOR	\$1.50

TRIACS SCR'S

PRV 1A	10A	25A	1.5A	6A	35A
100	40	70	1.30	40	1.20
200	70	110	1.75	60	1.60
400	110	160	2.60	100	2.20
600	170	230	3.60	150	3.00

Terms: FOB Cambridge, Mass. Send Check or Money Order. Include Postage, Minimum Order \$5.00, COD'S \$20.00



SOLID STATE SALES

P.O. BOX 74A
SOMERVILLE, MASS. 02143 TEL. (617) 547-4005

CIRCLE NO. 63 ON FREE INFORMATION CARD



WORLD'S SMALLEST RECHARGEABLE CALCULATOR \$19.95!

Does Everything Big Ones Do

Small but mighty! 8-digit, 4-function electronic calculator even has automatic % key . . . for only \$19.95. Take it anywhere. Carry it in your pocket or purse — it's 2/3 the size of a pack of cigarettes. This 3 1/2-ounce dynamo features floating decimal, constant key, lead zero depression, clear entry, more! At Edmund's low price, the unit comes with a Ni-Cad rechargeable battery pack that can plug into any AC outlet. No need for special recharging adapters. Calculator overall is just 2 x 3 1/2 x 1/4" with plenty of room for most fingers. *Another Edmund first with advanced technology.* **\$19.95** ppd.

STOCK NO. 1945AV Only

GIANT FREE CATALOG!

NEW 164 Pages Over 4,500 Un-usual Bargains for Hobbyists Schools, Industry



JUST CHECK COUPON!

EDMUND SCIENTIFIC CO.
300 EDCORP BUILDING
Barrington, N. J. 08007
(609) 547-3488

America's Greatest Science • Optics • Hobby Mart

COMPLETE AND MAIL COUPON NOW

EDMUND SCIENTIFIC CO. 300 Edcorp Bldg., Barrington, N. J. 08007

Send me: SEND FREE 164 PAGE CATALOG 'AV' Charge my BankAmericard Charge my MasterCard

Service and handling charge \$ 1.00

Enclosed is check, m.o. in amount of \$ _____

Signature _____ Name _____ Please print

Address _____ City _____ State _____ Zip _____

Expiration Date _____

30 DAY MONEY-BACK GUARANTEE. You must be satisfied or return any purchase in 30 days for full refund

HELPING TO DEVELOP AMERICA'S TECHNOLOGY FOR OVER 30 YEARS. CIRCLE NO. 27 ON FREE INFORMATION CARD

BOOKS AND MAGAZINES

FREE book prophet Elijah coming before Christ. Wonderful bible evidence. Megiddo Mission, Dept. 64, 481 Thurston Rd., Rochester, N.Y. 14619.

FREE CATALOG Aviation and Space Books. Aero Publishers, 329PE West Aviation, Fallbrook, California 92028.

THE AUDIO AMATEUR—A quarterly publication for the serious audio constructor. Free prospectus. The Audio Amateur, Box 176Z, Peterborough, N.H. 03458.

AVOID Speeding Tickets. Comprehensive booklet on defensive driving tactics showing countermeasures. Covers Radar and Vascar. Don't fall prey to the speed trap. \$2.25 plus 30 cents shipping. Booklet, 6728 Harvest Glen, Dallas, Texas 75248.

CRIMEFIGHTERS! SHOPLIFTING! LOCKPICKING! DEBUGGING! All 3 books for only \$5.00. Don-Q, 548-PE, Seattle, Washington 98111.

BACK ISSUE MAGAZINES, 1890 to 1976. Free list. Send stamped envelope to Everybody's Bookshelf, Dept. PE, 317 West 6th, Los Angeles, CA 90014.

ELECTRONIC SURVEILLANCE — Technology report based on government sponsored project. All telephone, laser, radio devices and debugging detectors, jammers, etc. described. Exclusive by original authors. 180 pages, illustrated — \$35.00. AASD, Suite 511, 1730 M Street, N. W., Washington, D.C. 20036.

PERSONALS

MAKE FRIENDS WORLDWIDE through international correspondence. Illustrated brochure free. Hermes-Verlag, Box 110660/Z, D-1000 Berlin 11, Germany.

Ph.D.'S, MASTER'S, BACHELOR'S — official nonresident College Degrees easily acquired through mailorder Universities. Complete Revealing Directory — \$2. Counseling Connection, 5495 Claremont, No. BPE, Oakland, CA 94618.

MUSICAL INSTRUMENTS

UP TO 60% DISCOUNT. Name brand instruments catalog. Freeport Music, 114 G. Mahan St., W. Babylon, N.Y. 11704.

WHOLESALE! Professional Guitars, PA Systems, Altav Speakers, 240W RMS Amplifiers. Free Catalog, Carvin, Escondido, Calif. 92028.

READER SERVICE NO.	ADVERTISER	PAGE NUMBER
1	A P Products Incorporated	12
2	Adva Electronics	141
61	Advanced Microcomputer Products	128
3	Allison Automotive	110
6	Alltag Electronics	129
7	Ancona Corp.	139
9	Aries Inc.	136
74	Avanti Research and Development, Inc.	104
	Babylon Electronics	135
10	Bennies Warehouse	69
11	Boman Industries	95
12	Byte	118
	CRI Capitol Radio Engineering Institute	86, 87, 88, 89
13	C&S Marketing Assoc.	120
	Circuit Design, Inc.	122
	Cleveland Institute of Electronics, Inc.	96, 97, 98, 99
14	Cobra Product of Dynascan	SECOND COVER
15	Continental Specialties Corporation	2
16	Crown	111
17	Delta Electronics Co.	138
18	Delta Products, Inc.	93
19	Digi-Key Corporation	132
20	Discwasher	52
	Dixie Hi-Fidelity Wholesalers	114
	Dynaco, Inc.	12
23	EICO	117
24	Eddie Electronics Co.	134
25	Edmund Scientific Co.	123
26	Edmund Scientific Co.	136
27	Edmund Scientific Co.	140
28	Edmund Scientific Co.	142
68	Electronics Book Club	7
29	Electronics Technical Institute	1
30	Eltron	135
31	Grantham School of Engineering	113
	Hai Communications Corp.	110
32	Handic U.S.A. Inc.	6
5	Heath Company	107, 108
34	Hewlett-Packard	21
77	Hobby-Tronix, Inc.	124
35	Hulco	106
	IMS Associates, Inc.	33, 51, 138
36	Illinois Audio	113
37	International Electronics Unlimited	137
38	Intersil, Inc.	11
39	James	130, 131
33	Johnson Co., E F	36
40	Lafayette Radio Electronics Corp.	75
41	Lesametric	111
42	McIntosh Laboratory, Inc.	106
43	McKay Dymek Co.	114
76	MCM Mfg. Company	10
73	MITS	35
44	Micon Industries	104
	NRI Schools	16, 17, 18, 19
45	National Camera	112
	National Technical Schools	76, 77, 78, 79
46	New-Tone Electronics	135
47	Non-Linear Systems, Inc.	22
48	Olson Electronics	128
49	PAIA Electronics	115
50	Pathcom, Inc.	31
51	Pickering & Co.	THIRD COVER
52	Poly Paks	127
53	Poly Paks	138
54	Polymorphic Systems	20
	Processor Technology Co.	24
55	Quest Electronics	138
	Radio Shack	9
57	Royce Electronics	23
58	SBE, Inc.	25
59	S D Sales Co.	133
60	Schober Organ Corp. The	22
62	Shure Brothers Inc.	15
63	Solid State Sales	140
64	Sound Guard	41
65	Southwest Technical Products Corp.	3
66	Sparkomatic Corporation	15
67	Stereo Discounters	112
69	Tri-Star Corporation	115
79	Turner Microphones	26
70	U.S. Pioneer Electronics	46, 47
4	United Audio Products Inc.	FOURTH COVER
71	Wenover Associates	73
72	Winegard Antennas	85

CLASSIFIED ADVERTISING
123, 124, 128, 132, 134, 136, 137, 138, 140, 141

PRO SPORTS ACTION FILMS

START YOUR SPORTS FILM COLLECTION with '76 Super Bowl X (Steelers/Cowboys) or '75 IX (Steelers/Vikings); Super 8 Color, 200' reel, \$19.95 ea; B&W, \$8.95 ea + shipping. Include 1974 & '75 World Series, official films; 200' Super 8 B&W, \$8.95 ea; Color, \$19.95 ea (add \$0.85 per film for shipping — Canada, \$1.25 ea). Round out your collection with '76 & '75 Stanley Cup (Canadiens/Flyers), (Flyers/Islanders), each 400' Mag Sound Super 8 Color, only \$49.95 ea + \$1.50 Postage, Handling. (Super 8 200' silents also available.) New Castle, Columbia catalogs, \$0.50 each; Sportlite, \$0.25 (coins, stamps, no checks, pls). SPORTLITE, Elect-9, Box 24-500, Speedway, IN 46224.

BUSINESS OPPORTUNITIES

I MADE \$40,000.00 Year by Mailorder! Helped others make money! Free Proof. Torrey, Box 318-NN, Ypsilanti, Michigan 48197.

FREE CATALOGS. Repair air conditioning, refrigeration. Tools, supplies, full instructions. Doolin, 2016 Canton, Dallas, Texas 75201.

MAILORDER MILLIONAIRE helps beginners make \$500 weekly. Free report reveals secret plan! Executive (1K9), 333 North Michigan, Chicago 60601.

PIANO TUNING LEARNED QUICKLY AT HOME! Musical knowledge unnecessary. Free information. Empire School, Box 450327, Miami 33145.

GET RICH with Secret Law that smashes debts and brings you \$500 to \$5 Million cash. Free report! Credit 4K9, 333 North Michigan, Chicago 60601.

HIGHLY PROFITABLE ONE-MAN ELECTRONIC FACTORY

Investment unnecessary, knowledge not required, sales handled by professionals. Postcard brings facts about this unusual opportunity. Write today! Barta - Pl., Box 248, Walnut Creek, CA 94597.

FREE SECRET BOOK "2042 UNIQUE, Proven Enterprises" Fabulous "Little Knowns". Work home! Haylings-B, Carlsbad, Calif. 92008.

\$178 WEEKLY, Work one hour daily. Completely Guaranteed. Free. FAS, Box 13703-R, San Antonio, Texas 78213.

HOW TO MAKE \$2,000 WEEKLY at home using other people's money. Guaranteed. Free details. Richlieu, Box 25277, Dept. F9, Houston, Texas 77005.

FREE DETAILS on how to borrow \$300-\$3,000 entirely by mail. Write Postal Finance, Dept 613-07, 6018 Maple, Omaha, Nebraska 68104.

HOW TO SAVE Thousands of Dollars & Taxes! Call Free (any time) 800-325-6400 or write Fast Incorporating Service, Box 684, Lakewood, N.J. 08701.

CASH WITH YOUR CAMERA! Earn \$5000-\$15,000 yearly selling to 4,000 clients. Details 25 cents. Pictureprofits, Box 171-PE, Island Park, N.Y. 11558.

FOR SALE—Eighty-year-old man retiring next January. Manhattan Mail-Order/Retail Store. Electronic hobby kits, gadgets, and parts. Incorporated 1962. References exchanged. Box 553, Church St. Station, New York City 10008.

\$2,000 MONTHLY by mailorder . . . evenings. Free Details. Alex D. Enterprises, 230 Rio Verde St., Daly City, CA 94014.

EMPLOYMENT OPPORTUNITIES

ELECTRONICS/AVIONICS EMPLOYMENT OPPORTUNITIES. Report on jobs now open. Details FREE. Aviation Employment Information Service, Box 240E, Northport, New York 11768.

SOLID STATE AUDIO/TV Techs needed. Resume to: Glentronics, Inc., Box 6-L Sunny Isle, St. Croix, U.S. Virgin Islands 00820.

TREASURE FINDERS

TREASURE FINDER locates buried gold, silver, coins, treasures. 6 powerful models. Instant financing available. Write or call for free catalog. Phone (713) 682-2728 day or night. Relco, Dept. AA20, Box 10839, Houston, Texas 77018.

DISCOVER true treasure hunting with world-famous deep-detecting mineral/metal detectors from White's! Locate gold, silver, rings, coins, artifacts and more! Sold, serviced, warehoused world wide. Priced from \$79.50. Free Catalog! White's Electronics, Dept. PD6W, 1011 Pleasant Valley Rd., Sweet Home, OR 97386.

RUBBER STAMPS

RUBBER ADDRESS STAMPS. Free Catalog. 45 type styles. Jackson's, Dept. K, Brownsville Rd., Mt. Vernon, Ill. 62864.



LOGIC PROBE KIT—Use with CMOS, TTL, DTL, RTL, HTL, HiNIL and most MOS IC's. Built in protection against polarity reversal and overvoltage. Draws only a few mA from circuit under test. Dual LED readout. Complete kit includes case and clip leads. \$8.95

VARIABLE REGULATED POWER SUPPLY KIT—Continuously variable from 3 to over 15 Volts. Short circuit proof with electronic current limiting at 300 mA. Compact size and typical regulation of 0.1% make this a great bench or lab power supply. \$19.95

FIXED REGULATED POWER SUPPLY KITS—Short circuit proof with thermal current limiting. Compact size and typical regulation of 0.5% make these ideal for most electronic projects. Available for 5V @ 500mA, 6V @ 500mA, 9V @ 500mA, 12V @ 400mA, 15V @ 300mA. Specify voltage when ordering. \$8.95 ea.

These easy to assemble kits include all components, complete detailed instructions and plated fiberglass PC boards. Power supply kits do not include case or meters. Add \$1.25 per kit for postage and handling.

TRANSISTORS (NPN)

2N918 TYPE RF Amp & Oscillator to 1 GHz	3/\$1.00
2N3563 TYPE RF Amp & Osc to 1 GHz (pl. 2N918)	6/\$1.00
2N3565 TYPE Gen. Purpose Gain (TO-92/106)	6/\$1.00
2N3866 TYPE RF Power Amp 1.5 W @ 450 MHz	\$0.75
2N3904 TYPE GP Amp & Sw to 100 mA hFE 100	6/\$1.00
Assort. NPN GP TYPES, e.g. 2N3694, 2N3933, etc. (15)	\$2.00
2N3638 TYPE (PNP) GP Amp & Sw to 300 mA	6/\$1.00
2N3906 TYPE (PNP) GP Amp & Sw to 30 MHz	6/\$1.00

FET's:

N-CHANNEL (LOW-NOISE)

2N4091 TYPE RF Amp & Switch (TO-18/106)	3/\$1.00
2N4416 TYPE RF Amplifier to 450 MHz (TO-72)	2/\$1.00
2N5163 TYPE Gen. Purpose Amp & Sw (TO-106)	3/\$1.00
2N5486 TYPE RF Amp to 450 MHz (plastic 2N4416)	2/\$1.00
E100 TYPE Low-Cost Audio Amplifier	4/\$1.00
ITE4868 TYPE Ultra-Low Noise Audio Amp	2/\$1.00
TIS74 TYPE High-Speed Switch 40!	3/\$1.00
Assort. RF & GP FET's, e.g. 2N5163, MPF102, etc. (8)	\$2.00

P-CHANNEL:

2N4360 TYPE Gen. Purpose Amp & Sw (TO-106)	3/\$1.00
E175 TYPE High Speed Switch 125! (TO-106)	3/\$1.00

SUPER SPECIALS:

2N2222 NPN TRANSISTOR GP Amp & Switch	6/\$1.00
2N2907 PNP TRANSISTOR GP Amp & Switch	6/\$1.00
2N3553 RF Power Amp 5 W @ 150 MHz, 7 W @ 50 MHz	\$1.50
MPF102 N-CHANNEL FET RF Amp-200 MHz	3/\$1.00
556 DUAL 555 TIMER 1 µsec to 1 hour (DIP)	\$0.90
723 VOLT. REGULATOR 3-30 V @ 1-200 mA (DIP/TO-5)	3/\$1.00
2740 FET Op Amp, Like NE536 and µA740 (TO-5)	\$1.95
µA7805 VOLTAGE REGULATOR 5 V @ 1 A (TO-220)	\$1.25
8038 WAVEFORM GENERATOR Wave w/ckts	\$4.50
1N4154 DIODE 30 V/10mA-1N914 except 30 V	25/\$1.00
BR1 BRIDGE RECTIFIER 50 V PIV, 500 mA (DIP)	4/\$1.00
MM5314 DIGITAL CLOCK CHIP-With Specs/Schematics	\$4.95

LINEAR IC's:

308 Micro-Power Op Amp (TO-5/MINI-DIP)	\$1.00
309K Voltage Regulator 5 V @ 1 A (TO-3)	\$1.25
324 Quad 741 Op Amp, Compensated (DIP)	\$1.50
3401 Volt. Reg. 1 Amp-Specify 5, 6, 12, 15 or 24 V-w/ckts	\$1.75
380 2.5 Watt Audio Amplifier 34dB (DIP)	\$1.28
555 Timer 1 µs to 1 hr. NE555, LM555, etc. (MINI-DIP)	2/\$1.00
708 Popular Op Amp (DIP/TO-5)	\$0.29
739 Dual Low-Noise Audio Preamp/Op Amp (DIP)	\$1.00
1458 Dual 741 Op Amp (MINI-DIP)	2/\$1.00
741 Freq. Comp. Op Amp (DIP/TO-5/MINI-DIP)	4/\$1.00

DIODES:

ZENERS—Specify Voltage 3.3, 3.9, 4.3, 5.1, 6.8, 8.2	400mW 4/\$1.00
9.1, 10, 12, 15, 16, 18, 20, 22, 24, 27, or 33V (-10%)	1 Watt 3/\$1.00
1N914 or 1N4148 TYPE General Purpose 100V/10mA	15/\$1.00
1N3893 TYPE RECTIFIER Stud Mount 400 V/12 A	2/\$1.00
05 VARACTOR 5-50 W Output @ 30-250 MHz, 7-70 pF	\$5.00
F7 VARACTOR 1-3 W Output @ 100-500 MHz, 5-30 pF	\$1.00

*MAIL NOW! FREE DATA SHEETS supplied with every item from this ad. FREE ON REQUEST—741 Op Amp with every order of \$5 or more—749 Dual Op Amp or two E100 FET's with every order of \$10 or more, postmarked prior to 9/20/76. One free item per order.

ORDER TODAY—All items subject to prior sale and prices subject to change without notice. All items are new surplus parts—100% functionally tested. WRITE FOR FREE CATALOG #7510 offering over 350 semiconductors carried in stock. Send 13 stamp.

TERMS: Send check or money order (U.S. funds) with order. We pay 1st Class postage to U.S., Canada and Mexico (except on kits) \$1.00 handling charge on orders under \$10. Calif. residents add 6% sales tax. Foreign orders add postage. COD orders—add \$1.00 service charge.

ADVA ELECTRONICS
BOX 4181 CB, WOODSIDE, CA 94062
Tel. (415) 851-0455

CIRCLE NO. 2 ON FREE INFORMATION CARD

MAGNETS

MAGNETS. All types. Specials-20 disc, or 10 bar, or 2 stick or 8 assorted magnets. \$1.00. Magnets, Box 192-H Randallstown, Maryland 21133.

REAL ESTATE

BIG . . . NEW . . . FALL CATALOG . . . FREE! Over 2,600 top values coast to coast! UNITED FARM AGENCY, 612-EP, West 47th, Kansas City, MO 64112.

SHORT WAVE LISTENING

LOGBOOK. 28 pages, use hourly or consecutively. \$1.25. Books, Accessories. SWL Guide, 414 Newcastle, Syracuse, New York 13219.

MISCELLANEOUS

WINEMAKERS: Free illustrated catalog yeasts, equipment. Semplex, Box 12276P, Minneapolis, Minn. 55412.

LIVE IN THE WORLD OF TOMORROW... TODAY!

And our FREE 164 PAGE CATALOG is packed with exciting and unusual values in electronic, hobby and science items — plus 4,500 finds for fun, study or profit... for every member of the family.

A BETTER LIFE STARTS HERE

OUR MYSTICAL MUSICAL MACHINE

... gets it on! Fascinates with an automatic 256-note pseudo-random tone pattern. The controls let you adjust beat, volume & pitch. Finger its 3 photocells, and you creatively vary the tone of its continuous "music". Output jack permits a patch-in to guitar or band amplifier for some really wild effects. Jack it into your stereo (use an external amplifier), or recorder for a great tape. Good executive toy? You bet! Incis. 9V tr. batt., instrs. Just 1.3 lb.



No. 72,203AV (9³/₁₆ × 5¹/₄ × 3¹¹/₁₆) \$59.95 Ppd.

SUPER POWER FOR ANY AM RADIO

New antenna assist turns a tiny transistor into a tiger, has pulled in stations up to 1000+ miles away! Just set beside radio (no wires, clips, grounding) and fine-tune Select-A-Tenna's dial to same frequency — "gangbusters"! Great for clearing weak signals in radio depressed areas, off-coast islands, crowded frequency stations. Solid state—uses no electricity, batts., tubes.



Stock No. 72,095AV \$15.95 Ppd.

ULTRA SELECT-A-TENNA
No. 72,147AV (*OVER 1000 MI.) \$22.95 Ppd.

NASA-CHOSEN FOR APOLLO/SOYUZ

157 mi. out in space, the Astronauts used this super 20×60 binocular (modified) to view Earth! Our biggest, most powerful for distance. Far-off objects come in big, clear & sharp to the edge through big 60mm objective lenses; 173-ft. field of view at 1000 yds. Relative brightness, 9.0. Fully coated optics; 20X spcl design eye lenses. Coated BK-7 Porro prism. Extra long All-American style with fold-down rubber eyecups. Includes case & straps.



No. 1556AV ... (9¹/₄ × 8¹/₂; 47.5 oz.) \$99.95 Ppd.
No. 1559AV ... (4¹/₂ × 6¹/₄; 19 oz.) \$27.50 Ppd.

PRO ELECTRONIC SOUND CATCHER

Parabolic mike w/ 18³/₄" transparent reflecting shield & 2 I.C.'s in amplifier magnifies signals 100x that of omni-direction mikes. Catch sounds never before heard! Highest signal to noise ratio poss. Earphones, tape recorder output, tripod socket; req. two 9v trans, batt. (not incl).



No. 1649AV ... (5¹/₂ LB.) \$299.00 Ppd.

LOW COST MODEL: NO EARPHONES, ELECTR. CIRC.
No. 1665AV \$149.95 Ppd.

LOWER SENSITIVITY ECON. MOD. W/O ELECTR.
No. 80,242AV \$89.50 Ppd.

WHEN YOU COME TO PHILADELPHIA BE SURE TO SEE
FREE BICENTENNIAL LIGHT SHOW
IN BARRINGTON, N.J. ONLY 10 MINUTES AWAY AT
EDMUND FACTORY STORE

4 1/4" ASTRONOMICAL TELESCOPE



FREE EYEPIECE: 12.5mm F.L., 96X w/ 48" F.L. Objective

See moon craters, rings of Saturn, double stars. Features fine f/10 mirror* (verified better than 1/10 wave with a scatter plate interferometer) to insure performance to theoretical limit of resolution.

Equatorial mount; rack & pinion focusing; aluminum tube, 6X finder, 25mm F.L. 45X Kellner achromatic eyepiece & Barlow lens to double and triple power to 135X. Incl. FREE Star Chart plus 2 Books. *Pyrex.™.

No. 85,260AV (SHPG. WT. 42 LB.) \$159.50 FOB
No. 85,261AV (CLOCK DR.; 45 LB.) \$199.50 FOB

MEASURE WIND SPEED ANYWHERE



Hold this handy (16 oz.!) low cost Anemometer into the wind, quickly read wind speed on its big dial—from a 5 mph to a 70 mph gale. Sensitive, accurate to ± 3% of full scale (2.1 mph), it req. no batts., electrical circuits, adjustments or recalibration. Fine quality unit of black plastic w/ all critical moving parts of marine bronze and brass, is always ready to use. Great for golf, boating, flying... and a terrific value. Includes security strap.

No. 42,428AV (7¹/₂" HIGH) \$19.95 Ppd.

ELECTRONIC DIGITAL STOPWATCH: \$49.95



The price alone obsoletes your wind-up timer and it's ± 0.002% accurate! Hand-held, you start, stop, reset compact 6-ounce w/one hand; times to 59 mins, 59.9 secs in 1/10 increments. Failsafe design (cannot be accidentally reset), solid-state

electronics! Incl. neckstrap, repl. batts.

No. 1671AV (5-DIGIT LED DISPLAY) \$49.95 Ppd.

SPLIT ACTION W/NICADS, RECHARGER
No. 1669AV (5-DIGIT LED DISPLAY) \$79.95 Ppd.

DELUXE SPLIT ACTION BATTERY MODEL
No. 1653AV (6-DIGIT NEON DISPLAY) \$149.95 Ppd.

LOW COST INFRA-RED VIEWER



For Infra-red crime detection surveillance, security system alignment, I.R. detection, laser checking, nite wildlife study, any work req. I.R. detection & conv. to visible spectrum. Self-cont. scope w/ everything incl. I.R. light source. 6v or 12v power. 6032 I.R. converter tube, f/3.5 objective lens, adjust. triplet eyepiece. Provides 1.6X, focuses from 10' to infinity.

No. 1659AV (11 × 14¹/₄ × 3") \$285.00 Ppd.

WITHOUT LIGHT SOURCE
No. 1663AV \$225.00 Ppd.

WOW! TR METAL DETECTOR: \$69.95



Super-sensitive transmitter/receiver unit at a never-before price, w/feats. of 150 toys. Terrific selectivity—10-turn (not just 90°) metal/mineral tuner! 6" waterproof search coil find a cent at 6"; telescoping adjust. shaft gives 44" lgh.; 1/4" stereo earphone jack; all metal constr.

Perfect balance & feather light, it incis 8 "AA" batteries. Lifetime warranty!
No. 80,251AV (JUST 38 OZ.!) \$69.95 Ppd.

STARTERS' BFO CHALLENGER I (32 OZ.)
No. 80,222AV (ALUMINUM CONSTR.) \$39.95 Ppd.

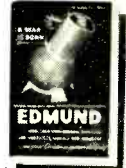

MAIL COUPON FOR GIANT FREE CATALOG!

164 PAGES • MORE THAN 4500 UNUSUAL BARGAINS

Completely new 1977 edition. New items, categories, illustrations. Dozens of electrical and electromagnetic parts, accessories. Enormous selection of Astronomical Telescopes. Unique lighting and ecological items. Microscopes, Binoculars, Magnifiers, Magnets, Lenses, Prisms. Hard-to-get-surplus bargains. Ingenious scientific tools. 1000's of components.

EDMUND SCIENTIFIC CO.
300 Edscorp Building, Barrington, N.J. 08007
Please rush Free Giant Catalog "AV"

Name _____
Address _____
City _____ State _____ Zip _____



COMPLETE & MAIL WITH CHECK OR M.O.

EDMUND SCIENTIFIC CO. 300 Edscorp Building, Barrington, N.J. 08007

How Many	Stock No.	Description (809) 547-3488	Price Each	Total
<input type="checkbox"/>		PLEASE SEND GIANT FREE CATALOG "AV"		
<input type="checkbox"/>		Charge my BankAmericard		
<input type="checkbox"/>		Charge my Master Charge		
				Add Service and Handling Charge \$1.00
Interbank No. _____		I enclose <input type="checkbox"/> check <input type="checkbox"/> money order for TOTAL \$ _____		
My Card No. Is _____		Signature _____		
Card Expiration Date _____		Name _____		
30-DAY MONEY-BACK GUARANTEE. You must be satisfied or return any purchase in 30 days for full refund. *\$15.00 minimum		Address _____		
		City _____ State _____ Zip _____		

What is your first component?

Is it your receiver?

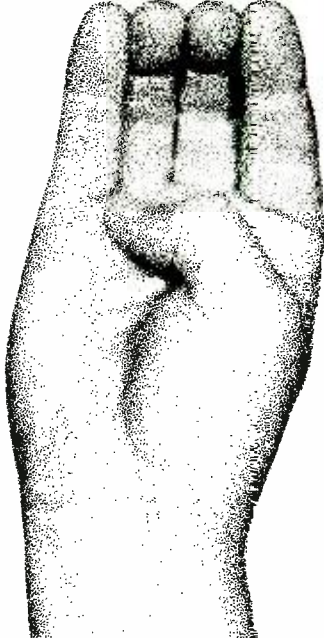

Your Turntable?



Your speakers?

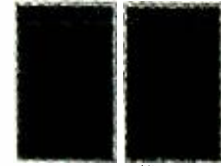

or is it your cartridge?



We have become convinced that it really is your phono cartridge, even though we have been modestly advertising it for the past few years as your *fourth*.

Let's face it, the cartridge *is* that important *first* point where the music begins, and if the stylus cannot follow its path accurately, no amount of expensive equipment . . . speakers, turntable or receiver . . . can make up for the distortion it can produce. That is why you need a cartridge you can depend on. One that's the best your money can buy. Specifically, a Pickering:

Because a Pickering cartridge has the superior ability to "move in the groove", from side to side and up and down, without shattering the sound of your music on your records.

Because a Pickering cartridge possesses low frequency tracking ability and high frequency tracing ability (which Pickering calls traceAbility™). It picks up the highest highs and the lowest lows of musical tones to reveal the distinctive quality of each instrument.

Because Pickering offers a broad range of cartridges to meet any application whether you have an automatic record changer, or a high quality manual turntable, a stereo, or a 4-channel sound system. Your Hi-Fi dealer will be able to recommend a Pickering cartridge that is just right for *your* system. Your stereo cartridge is the *first* part of your music system. It is too important to overlook, and so is a Pickering.



For further information write to Pickering & Co., Inc., Dept. PE, 101 Sunnyside Blvd., Plainview, N. Y. 11803



"for those who can hear the difference"

CIRCLE NO. 51 ON FREE INFORMATION CARD

Dual owners generally are more experienced than typical component owners. More than half have owned another brand. Usually they have spent more for records than all their audio equipment combined. Thus, they need no reminder that the turntable is the only component that handles the record. Or that to compromise with quality here can risk damage to their record collection.

What Dual owners know about their turntables that you should know about yours.

(And there is no way to repair a damaged record.)

Dual owners also know that the true measure of a turntable's quality and long-term reliability is not merely in its features, but is inherent in the materials used, the care in their assembly and the quality control employed in testing.

The mechanical feel of controls and switches, smoothness of tonearm movement and overall evidence of solidity are excellent clues to a turntable's general performance. Other clues are internal and not so easily appreciated. If you own a Dual, you know precisely what we mean. If you don't, the examples of Dual refinements described below may be of interest and enlightenment. They indicate why you will appreciate some things about Dual right away and why others may take years.

United Audio Products, 120 So. Columbus Ave., Mt. Vernon, N.Y. 10553
 Exclusive U.S. Distribution Agency for Dual



Dual 1249. Single-play/multi-play, belt-drive turntable with fully automatic start and stop, plus continuous play. Mode Selector parallels tonearm to record in single-play for accurate vertical tracking. Other features: 6% pitch control; illuminated strobe; cue-control viscous-damped in both directions; anti-skating calibrated for conical, elliptical and CD-4 styli. Less than \$280.



True, four-point gimbal centers and pivots the tonearm mass at intersection of horizontal and vertical axes. Tonearm is dynamically balanced in all planes. The four needle-point pivots are first hardened, then honed, a process which produces microscopically smooth surfaces. The precision ball-bearing races are only .0157 inch diameter.



Unique Vario-pulley used in Dual's three belt-drive models is precision-machined for perfect concentricity and balance. Speeds are adjusted by expansion and contraction of pulley circumference; belt is never twisted or distorted.



Dual single-play/multi-play models: 1225, less than \$140; 1226, less than \$170; 1228, less than \$200; 1249, less than \$280.
 Dual single-play models: 502, less than \$160; 510, less than \$200; CS704, less than \$310; CS721, less than \$400.

CIRCLE NO. 4 ON FREE INFORMATION CARD