

INS-AND-OUTS OF COMPUTERS FOR BEGINNERS

14278

Popular Electronics®

WORLD'S LARGEST-SELLING ELECTRONICS MAGAZINE

JUNE 1976/\$1

AUDIO * STEREO * MUSIC

ADJUST ROOM REVERBERATION WITH

The "Bucket Brigade" Audio Delayer

A \$59 STEREO PROJECT

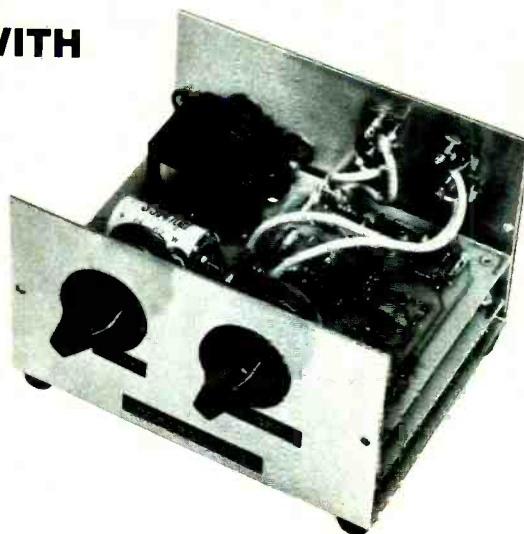

Ten Speaker-Enclosure Fallacies Exposed!

"Music Modules" Simplify Synthesizer Kit

PROJECTS FOR SUMMER USE



Now You Can Operate AC Equipment from a Battery!

SINE-WAVE INVERTER
BOOSTS 12 VDC TO 110 VAC

Build a Low-Cost Power-Failure Alarm

Test Reports:

HEATH MODULUS
AM/STEREO FM
SYSTEM

SOUND CONCEPTS
SD-50 AUDIO
DELAY SYSTEM

CRAIG 4104
CB AM MOBILE

CONTINENTAL
SPECIALTIES
DESIGN MATES



Experience is the best teacher. You might settle for any CB first time around. Understandably. A lot of people think they're all pretty much alike. But you'll soon discover that, like everything else, there are exceptions.

Ask the pros. America's long distance truckers. These guys talk CB day in and day out. And they demand the best. That's why truckers refer to the Cobra 29 as "The Diesel Mobile."

Listen to Cobra. You'll hear a big difference. Because the Cobra 29 gives you features which assure crystal clear reception. Like switchable noise limiting and blanking, to cut out practically all pulse and ignition interference. Add squelch control and RF gain and you've got exceptional — adjustable — receiver clarity. Even in the heaviest CB traffic. You also get Delta Tuning which makes up for the other guy, because even off-frequency transmitters are pulled in. Perfectly.

Talk to Cobra. And you know you're punching through. One glance at the

29's over-sized illuminated meter tells you just how much power you're punching out and pulling in. For voice modulation the DynaMike delivers at 100%. Same way with power: The 29 transmits at maximum power levels.

Sooner or later you'll get a Cobra. And you'll get engineering and craftsmanship second to none. Performance that will make your first CB seem obsolete. Reliability and durability that have set standards for the industry. Above all, you'll get power. The power to punch through loud and clear like nothing else. Because when it comes to CB radio, nothing punches through loud and clear like a Cobra.



Punches through loud and clear.

Cobra Communications, Products of Dynascan Corp.
1801 W. Belle Plaine, Chicago, Illinois 60613

CIRCLE NO. 14 ON FREE INFORMATION CARD

IF YOUR FIRST CB ISN'T A COBRA YOUR SECOND ONE WILL BE.



Is our new HP-27 an engineering work of art? Or simply the most powerful preprogrammed calculator we've ever built?

It depends whether you consider versatility artistic.

The HP-27 offers you all the log, trig and exponential functions we've preprogrammed into all our scientifics. Plus new stat and financial functions, new storage capacity, new clearing operations and engineering notation.

That's why we've dubbed it our "Scientific/Plus."

It lets you forecast, allocate resources, analyze costs.

The combination of stat functions, storage registers, selective clearing and RPN logic system with 4-register stack takes the time and trouble out of sophisticated stat calculations.

It performs valuable time-value-of-money calculations.

Whether you're looking to figure your mortgage or build a capital budget, the HP-27 makes the task easy. You might even be able to do both at the same time, thanks to its exceptional storage capacity.

19 memories simplify complex calculations.

You can store constants in 10 addressable storage registers, financial data in five financial registers. And you have four operational registers in the stack for easy data manipulation.

Six clearing operations let you do multiple calculations without destroying data.

You can clear all 10 addressable registers, or just the six used for stat calculations. You can clear the entire stack, or just the "X" register. Or you can clear the prefix keys only, or you can clear the status of the financial registers.

You get uncompromising design, assembly, support.

Three things that have made believers of the million+ people who own personal-sized HP calculators. Three prerequisites for a potential engineering work of art.

800-538-7922
(in Calif. 800-662-9862).

The toll-free numbers to call for

complete specs on our new \$200.00* HP-27 Scientific/Plus and a nearby dealer. Or send the coupon.



Sales and service from 172 offices in 65 countries. Dept. 254C, 19310 Pruneridge Avenue, Cupertino, CA 95014.

Hewlett-Packard
Dept. 254C,
19310 Pruneridge Avenue
Cupertino, CA 95014
Please send me HP-27 specs

Name _____
Company _____
Street _____
City _____
State/Zip _____

*Suggested retail price, excluding applicable state and local taxes—Continental U.S., Alaska & Hawaii. 6/16/06

Financial functions

- Number of periods
- Interest/period
- Payment amount/period
- Present value
- Future value
- Net present value
- Internal rate of return for up to 10 different uneven cash flows



Statistical functions

- Factorial
- Accumulates /deletes stat data (n, Σx, Σy, Σx² Σy² Σxy)
- Linear regression
- Standard deviation
- Correlation coefficient NEW
- Variance NEW
- Normal distribution NEW
- Linear estimate
- Mean

CIRCLE NO. 25 ON FREE INFORMATION CARD

Introducing...

SBE Touch/Com

The mike that does it all!

SBE adds the ultimate touch of sophistication to CB with the new SBE Touch/Com. It puts all the functions of CB two-way radio communication in the palm of your hand. Change channels, adjust volume and squelch, receive or transmit...all with the flick of a finger on the mike. It features up/down two-speed channel selection and a bright base-station-size LED digital channel readout for fast identification.

The Touch/Com, with the circuitry of the now-famous Formula D, incorporates all of SBE's most advanced CB technology: digital synthesis to cover all 23 channels with a single crystal; phase-lock-loop circuitry for "on-target" frequency stability; positive or negative ground for RV, boat and truck voltage systems; dual conversion for sharp selectivity and rejection of adjacent channel interference. The Touch/Com also features delta tune: crisp, clear audio output; a large, combination power output/"S" meter, night-lighted for easy viewing.

SBE'S finest CB—now made unquestionably the best by the unique convenience of Touch/Com.



SBE-32CB



Better Communications through Creative Technology

For information write: SBE, Inc., 220 Airport Blvd., Watsonville, CA 95076

INTERNATIONAL OFFICES: E. S. Gould Marketing Co. Ltd., Quebec, Canada/Linear Systems, S.A., Geneva 1, Switzerland

Popular Electronics®

WORLD'S LARGEST SELLING ELECTRONICS MAGAZINE

FEATURE ARTICLES

TEN SPEAKER-ENCLOSURE FALLACIES	David B. Weems	39
<i>Things to look for in designing or buying a speaker "box."</i>		
IN'S AND OUT'S OF COMPUTERS FOR BEGINNERS	Eugene H. Mitchell	47
<i>Understanding character codes, flags, interrupts, DMA, etc.</i>		
HOW TO USE THE HP-45 CALCULATOR AS A STOPWATCH OR ELAPSED-TIME INDICATOR	Paul E. Miller	67
UNIVERSAL INTERFACE BETWEEN LOW-POWER LOGIC AND LOAD DRIVER	Vern Gregory	94

CONSTRUCTION ARTICLES

THE "BUCKET BRIGADE" AUDIO DELAY LINE	John H. Roberts	33
<i>Simulates larger listening room and creates special effects.</i>		
BUILD A SINE-WAVE INVERTER	Martin Meyer	43
<i>Allows operation of ac appliances from 12-V vehicle battery.</i>		
POWER-FAILURE ALARM	Barton M. Bresnik	55
AUTOMATIC DIODE CHECKER	R. M. Stitt	57
<i>Makes a complete test in 1/60th of a second.</i>		
MUSIC MODULES TO BUILD YOUR OWN SYNTHESIZER	Don Lancaster	59

COLUMNS

STEREO SCENE	Ralph Hodges	20
<i>Dateline 1976.</i>		
HOBBY SCENE	John McVeigh	28
SOLID STATE	Lou Garner	82
<i>Programmable Schmitt Trigger.</i>		
CB SCENE	Ray Newhall	95
<i>Avoiding CB Ripoffs.</i>		
EXPERIMENTER'S CORNER	Forrest M. Mims	102
<i>Applications for the TTL NAND Gate.</i>		

PRODUCT TEST REPORTS

HEATHKIT MODEL AN-2016 "MODULUS" CONTROL CENTER		
HEATHKIT MODELS AA-1505 AND AA-1506 "MODULUS" POWER AMPLIFIERS		72
SOUND CONCEPTS MODEL SD-50 DELAY UNIT		76
CRAIG MODEL 4104 MOBILE AM CB TRANSCEIVER		78
CONTINENTAL SPECIALTIES "DESIGN MATES"		80

DEPARTMENTS

EDITORIAL	Art Salsberg	4
<i>The Second Golden Opportunity for CB.</i>		
LETTERS		6
OUT OF TUNE		6
<i>"An LED-Readout Audio Power Meter" (March 1976)</i>		
<i>"Space War Game" (April 1976)</i>		
NEW PRODUCTS		12
NEW LITERATURE		18
NEWS HIGHLIGHTS		30
ELECTRONICS LIBRARY		99
TIPS & TECHNIQUES		100
OPERATION ASSIST		101
ADVERTISERS INDEX		121

POPULAR ELECTRONICS, June 1976, Volume 9, Number 6, Published monthly at One Park Avenue, New York, NY 10016. One year subscription rate for U.S., \$6.98; U.S. Possessions and Canada, \$7.98; all other countries, \$8.98. Second Class postage paid at New York, NY and at additional mailing offices. Authorized as second class mail by the Post Office Department, Ottawa, Canada and for payment of postage in cash. Subscription service and Forms 3579; P.O. Box 2774, Boulder, CO 80302.

POPULAR ELECTRONICS including ELECTRONICS WORLD. Trade Mark Registered. Indexed in the Reader's Guide to Periodical Literature. COPYRIGHT © 1976 BY ZIFF-DAVIS PUBLISHING COMPANY. ALL RIGHTS RESERVED.

Ziff-Davis also publishes Boating, Car and Driver, Cycle, Flying, Modern Bride, Popular Photography, Skiing and Stereo Review.

Material in this publication may not be reproduced in any form without permission. Requests for permission should be directed to Jerry Schneider, Rights and Permissions, Ziff-Davis Publishing Co., One Park Ave., New York, NY 10016.

Editorial correspondence: POPULAR ELECTRONICS, 1 Park Ave., New York, NY 10016. Editorial contributions must be accompanied by return postage and will be handled with reasonable care; however, publisher assumes no responsibility for return or safety of manuscripts, art work, or models.

Forms 3579 and all subscription correspondence: POPULAR ELECTRONICS, Circulation Dept., P.O. Box 2774, Boulder, CO 80302. Please allow at least eight weeks for change of address. Include your old address, enclosing, if possible, an address label from a recent issue.

EDGAR W. HOPPER
Publisher

ARTHUR P. SALSBERG
Editorial Director

LESLIE SOLOMON
Technical Editor

JOHN R. RIGGS
Managing Editor

ALEXANDER W. BURAWA
Feature Editor

EDWARD I. BUXBAUM
Art Director

JOHN McVEIGH
Associate Editor

ANDRE DUZANT
Technical Illustrator

PATRICIA BROWN
Editorial Assistant

**LOU GARNER
GLENN HAUSER
JULIAN D. HIRSCH
RALPH HODGES
ART MARGOLIS
FORREST MIMS
JERRY OGDIN
WILFRED M. SCHERER**
Contributing Editors

JOSEPH E. HALLORAN
Advertising Director

JOHN J. CORTON
Advertising Sales

LINDA BLUM
Advertising Service Manager

PEGI McENEANEY
Executive Assistant

STANLEY NEUFELD
Associate Publisher

ZIFF-DAVIS PUBLISHING COMPANY
Popular Electronics

Editorial and Executive Offices
One Park Avenue New York, New York 10016
212-725-3500

Hershel B. Sarbin, President
Furman Hebb, Executive Vice President
Vincent Perry, Financial Vice President and Treasurer
Phillip T. Heffernan, Senior Vice President, Marketing
Edward D. Muhlfeld, Senior Vice President, Sports Division
Philip Sine, Senior Vice President
Frank Pomerantz, Vice President, Creative Services
Arthur W. Butzow, Vice President, Production
Lawrence Sporn, Vice President, Circulation
George Morrissey, Vice President
Sydney H. Rogers, Vice President
Sidney Holtz, Vice President
Al Traina, Vice President
Philip Korsant, Vice President
Paul H. Chook, Vice President, Market Planning
Charles B. Seton, Secretary
Edgar W. Hopper, Vice President, Electronics Div.

William Ziff, Chairman
W. Bradford Briggs, Vice Chairman

Midwestern Office

The Patts Group, 4761 West Touhy Ave.,
Lincolnwood, Illinois 60644, 312 679-1100
GERALD E. WOLFE, THOMAS HOCKNEY

Western Office

9025 Wilshire Boulevard, Beverly Hills, CA 90211
213 273-8050; BRadshaw 2-1161

Western Advertising Manager, BUD DEAN

Japan: James Yagi

Oji Palace Aoyama, 6-25, Minami Aoyama
6 Chome, Minato-Ku, Tokyo 407-1930/6821
582-2851

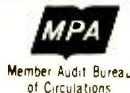

The publisher has no knowledge of any proprietary rights which will be violated by the making or using of any items disclosed in this issue.



Editorial

THE SECOND GOLDEN OPPORTUNITY FOR CB

When a market reaches the billion-dollar annual sales level, it is truly an important industry. That's where CB radio is today. Whereas unit sales in 1975 were about 4.2 million, projected unit sales for 1976 are for more than 9 million!

This huge growth has brought with it a host of problems—short supply of equipment, minimal discounting, high theft rate, and gross violations of the FCC Rules and Regulations. Solutions can be seen for all but the latter. How can CB'ers be compelled to follow the legal pattern set for them by the FCC? Even the welcome relaxed rules instituted September 15, 1975?

Without a substantial enforcement staff, which we aren't about to get, the FCC is depending heavily on self-policing by CB'ers. This is easier said than done. On sideband, it is successful for the most part. On AM, however, where most CB'ers operate, the rules are blithely ignored in many sections of the country. Some day, this practice is liable to stunt the continuing growth of the Citizens Band—unless something positive is done about it *now*.

IF CB had followed the original assumption that most users would be small-business people and "consumers" in the same household, this problem could have been handled. But now, with most communications taking place between stations with different licenses for purposes of both neighborliness and emergency motorist assistance, and with the vast number of CB'ers on the air, the situation is out of hand.

Here are some constructive steps that could be taken, with the assistance of far-sighted manufacturers, the FCC and CB'ers:

1. Establish point-of-purchase temporary licenses, making it mandatory to buy a license when the rig is purchased. (The FCC is finalizing thinking on this procedure right now.)

2. Include information with each CB rig on the obligations that go with the communication privilege and how they benefit users in the long run. Taking a page from the Boy Scouts' Merit Badge on Citizenship, an analogy could be drawn by pointing out the value of a library card and how everyone is eventually hurt when books are defaced or returned late.

3. Illustrate how local CB'ers perform self-policing for the good of all concerned. For example, in some areas, there are clubs to which a prospective member must supply name, handle, and license number before being admitted. He is then assigned a club number which is used as part of his handle (following his callsign). No member will talk to a CB'er unless he or she is a member of the club and follows the FCC rules. Other clubs reserve one night a week for a "signal hunt"—tracking down violators, getting their names or auto license numbers, and warning them that they will be reported to the FCC if another violation is heard.

4. Consider the possibility of equipping transceivers with an automatic transmitter identification system that transmits in code the CB'ers callsign everytime he presses the "talk" button. This would put the fear of God into CB'ers and also serve as a theft deterrent. This would have to be predicated on minimal cost to the manufacturer and user, or course.

At this juncture, with CB nowhere near a levelling off point and the promise of more allocated channels in 1977, there is a second golden opportunity to ensure future growth of CB.

Some manner of efficient regulation enforcement is necessary because most CB'ers are not restrained by the tradition that radio amateurs enjoy. Interestingly, if you speak to CB'ers who have lived with the *lack* of regulation enforcement, you will discover that the great majority would now welcome it. In the long run, it would be to the advantage of manufacturers as well as the citizenry.

This is the Legendary

FUZZBUSTER

Parametric Radar Receiver
with revolutionary Audio Cueing



PEACE for the Professional Driver

(Ask any long-haul trucker...he'll tell you about it.)

A military type radar receiver that works two to ten times farther than radar. Parametric design provides unparalleled sensitivity, but rejects false signals. No installation or antenna. Adopts to positive or negative ground vehicles.

A unique AUDIO CUEING system announces radar lock-on with a short beep. The visual indicator is then used to estimate where and what type of speed trap is being encountered. The receiver is especially effective against the new moving radar.

IF IT DOESN'T SAY:

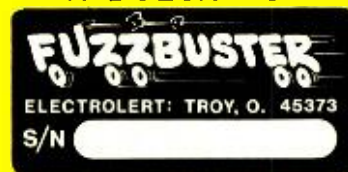

IT'S BOGUS!

Proven by thousands of truckers over billions of miles, nationwide, and now available to the general public!

DEDUCT 10%

If you have paid a SPEED RADAR TICKET in the preceding 12 MONTHS. Send ticket or cancelled check with order (\$89.95). Copies O.K.; original returned.

No Radar Ticket Yet?
TRAVEL NAKED AND QUALIFY SOON!

Please rush me a Fuzzbuster.
My check for \$99.95 is enclosed.

Name _____

Street _____

City _____

State _____ Zip _____

Wenover Associates
P.O. Box 231/Burlington, Mass. 01803

avanti's CB mobile antennas

offer:

- Quality construction
- Long range
- Mounting versatility

This is the Avanti Racer 27 mobile antenna. A first quality instrument, it is one of the most popular antennas in the entire CB field. That's because experienced CBers appreciate the benefits of a good, dependable long-range antenna that offers quiet performance.

The Racer 27 is readily adaptable to a wide variety of mounting assemblies:

- a fold-over mount for campers and vans
- a no-hole trunk mount (no drilling into your car)
- a mirror bracket mount for trucks
- a dual assembly for increased performance on all vehicles
- Avanti makes the famous MOONRAKER CB BASE ANTENNA

The Racer 27 is Avanti Model AV-327. Suggested retail \$23.95

This is only one of many Avanti antennas for car, boat or home. Send today for FREE full-color catalog.

avanti

RESEARCH AND DEVELOPMENT, INC.
340 Stewart Ave., Addison, Illinois 60101



Letters

COMMENTS ON CUTS

I am pleased to see computer-controlled tape motion for audio cassettes, to generate blocks, in the CUTS ("Computer Bits," March 1976). I had been thinking about the same thing because blocks can be very handy when they're written and read under computer control. However, it wasn't clear what would be read in the 5-second gap between blocks. I assume it is neither the 2400- nor the 1200-Hz tones. Assuming the tape has a leader, a block could then be positively identified by blank tape followed by 5 seconds of continuous 1's. (Remember that the user may rewind the tape into a previous block to find the next block and then let the computer search for a start-of-block.) If the characters are recorded asynchronously (for example, with a keyboard), a 5-second pause between characters would seem to be a start-of-block.—*Phillip J. Tubb, Lakewood, CO.*

There are no blank spaces on the tape; both leader and "gaps" are filled with the 2400-Hz tone onto which the clock can lock.

BACKWARD CHART PEN

Come now, the graph in Fig. 1 of the March 1976 "Stereo Scene" is a month early for an "April fool" joke. The output of a spectral analyzer cannot loop backward as shown at about 100 Hz. If literally interpreted, this would mean that the sound source has two values at a range of frequencies—a physical impossibility. Whatever peaks and valleys appear in a spectrum, the curve is always smooth, with no negative slope.—*James J. Schmidt, Sunnyvale, CA.*

Quite right. A slip of a draftsman's pen was responsible for the error.

CREDIT WHERE DUE

With reference to the Tate Directional Enhancement System described in "New Trends In Hi-Fi Electronics" (December 1975), I would like to point out that I am the inventor of the system and the engineer who designed and developed the IC's in cooperation with National Semiconductor Corp. Wes Ruggles, who was erroneously credited with this, has been responsible for the management of the project and the marketing effort.—*Martin Willcocks, Huntington, England.*

"CARE & FEEDING" BOOSTERS

We found "The Care and Feeding of NiCd Batteries" (March 1976) to be very pertinent and of great interest to us. Many users feel that NiCd batteries should last forever, and we find it difficult to dissuade users of our products from this belief. Alex Burr's article is a simple-to-digest, detailed answer to our problem.—*Axel M. Fritz, Jr., President, Bison Instruments, Minneapolis, MN.*

... an excellent article on NiCd's. The article was clear and very informative and didn't shy away from the more sophisticated details.—*Hugh MacDonald, Menlo Park, CA.*

APRIL (FOOL) HOBBY SCENE

Particularly intriguing was the problem of working with MOS circuitry. The geomagnetic aspect is indeed a stickler! However, after spending considerable time wrestling with this dilemma, I believe I have come up with a solution. If the device is housed in a spherical silicate material (available at your local quarry) and if it can be kept in motion (via pushing, kicking, etc.), the result will be a device which cannot accumulate any MOS difficulties. (P.S. The column was outstanding!)—*Ron Simprini, Philadelphia, PA.*

Congratulations. It took me a while (well into "Golden Oldies") to realize what was going on. But then I nearly died laughing. I haven't seen anything this funny since "Blazing Saddles."—*Frank Grether, San Francisco, CA.*

These are excerpts from only a few of the many letters Ms. Swampfelder received. By the time this is in print, April Fool's Day will have come and gone, and we hope everyone will have gone back to read the April Hobby Scene and appreciate it for the fun with which it was intended.

Out of Tune

In "An LED-Readout Audio Power Meter" (March, p 35), note an error in Table II, "Ideal Threshold Voltages" for the comparators. The right column, "Voltage," is inverted. The last entry, 4.395, refers to Pin 7 of IC1; the next to last, 3.070, refers to pin 5 of IC1; and so on. The top entry, 0.011, is the threshold for pin 11 of IC3.—*Tim Henry*

See also "Out of Tune," May 1976.

In "Space War Game" (April, p 42), the parts list omitted the type numbers for IC7 and IC8 (4023) and IC9 and IC10 (4001).—*J.A. Weisbecker.*



Motorola CB is here!

Introducing Mocat—The CB radio backed by Motorola's 40 years experience in professional radio communications. Great looks. Great performance. Everything you'd expect from a radio built by Motorola. Yet it comes at a very affordable price.

Designed and engineered in the USA, Mocat is a 100% solid-state Motorola CB radio with the very latest in technological advances, and exciting features.

Motorola CB means reliability. A digital phase lock loop synthesizer assures on-frequency perform-

ance on all channels.

Motorola CB means quality reception. Automatic gain control, cross modulation rejection circuit and optional "Extender" noise blanker circuit give Mocat superior receiver performance.

Motorola CB means power. All models feature a rugged plug-in mike with built-in amplifier for maximum transmit signal strength.

Motorola CB means good looks. Contemporary styling across the line. Selected models offer easy channel identification with high-intensity L.E.D. digital channel read-

out and dimmer.

Motorola CB also means high performance and attractively styled antennas and accessories.

Motorola CB is the biggest news and greatest value in personal communications today. Mocat from Motorola. Now is the time to own a Motorola CB. For complete details, write us at Motorola, Inc., Dept. CB-700, 1301 East Algonquin Road, Schaumburg, IL 60172.

MOTOROLA

No other TV/Audio home study school puts prices in its ads. Why?

Maybe it's because they can't match these values.

No other school gives you a choice of five ways to learn TV/Audio servicing, with complete courses starting as low as \$445 and convenient, inexpensive time payment plans. No other school includes both an engineered-for-training 25" diagonal color TV and a four-speaker Quadraphonic stereo in its best course. In fact, to even match this kind of thorough training at another school, you'd have to take an extra course costing hundreds of dollars more. We're proud to quote our prices because we believe you get top educational value from NRI.

You pay less because NRI passes its savings on to its students.

NRI pays no salesmen. We buy no outside "hobby kits" for our experiments or training kits. We design our own equipment with special Power-On features that allow you to experiment as you build. You get low tuition rates without the penalty of exorbitant interest charges for time payments. We pass the savings on to you.

More than 1 million students have come to NRI for home training.

Home study isn't a sideline with NRI. We've been its innovating leader for

over 62 years. More than one million students have enrolled in our many career courses. NRI is one of the few home study schools with a full-time staff of engineers, authors and editors to help you with any problem. NRI graduates will tell you: you can pay more, but you can't buy better training.

Widest choice of courses with digital computer, CB, and complete communications.

Send for the free NRI electronics catalog and check out the full spectrum of courses available, including Color TV, FCC License, Complete Communications Electronics—with Citizens Band radio, Computer Electronics, Marine and Aircraft Electronics, Mobile Communications, etc.

Mail the card for your Free NRI catalog.

No salesman will call.



NRI SCHOOLS
McGraw-Hill Continuing Education Center
3939 Wisconsin Avenue,
Washington, D.C. 20016

1
2
3
4
5

Available for career study under GI Bill
Check the GI Bill Box on the card for information.

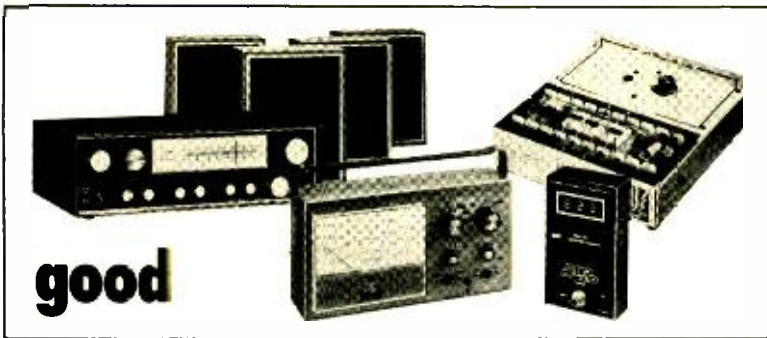

good

7 kits: Quadraphonic Stereo...

\$445 or low monthly terms

A basic TV/Audio Servicing Course including 7 training kits for your experiments. You build your own 4-speaker Quadraphonic System, solid-state volt-ohmmeter, CMOS digital frequency counter, and electronics Discovery Lab. Includes 48 bite-size lessons (18 on color TV), 10 special reference texts with hundreds of servicing shortcuts, tips on setting up your own business, etc. This completely up-to-date course covers black & white and color TV, FM multiplex receivers, public address systems, antennas, radios, tube, transistor and solid-state circuits.



better

11 kits: Quadraphonic Stereo and B/W TV...\$550

or low monthly terms

A complete course in B&W and Color TV Servicing, including 48 lessons (18 on color TV) 10 special reference texts and 11 training kits. Kits you build include 4-speaker Quadraphonic System, solid-state volt-ohmmeter, CMOS digital frequency counter, electronics Discovery Lab, plus a 12" diagonal solid-state black & white portable TV to build and use. At each assembly stage, you learn theory and "Power-On" application of that theory in typical solid-state TV sets.



better yet

11 kits: 19" diagonal Color TV...

\$880 or low monthly terms

The course includes 42 lessons and 4 reference texts plus kits and experiments to build a superb solid-state 19" diagonal color TV receiver . . . complete with cabinet, and engineered specifically for training by NRI's own engineers and instructors. This handsome set was designed from the chassis up to give you a thorough understanding of circuitry and professional troubleshooting techniques. You build your own solid state volt-ohmmeter, CMOS digital frequency counter, and experimental electronics Discovery Lab.



best

14 kits: 25" diagonal color TV and Quadraphonic Stereo...\$1195.00

or low monthly terms

The-ultimate home training in Color TV/Audio servicing with 48 bite-sized lessons, 10 reference texts, and 14 training kits . . . including kits to build a 25" diagonal color TV, complete with console cabinet; a 4-speaker Quadraphonic Center; a wide band, solid-state, triggered sweep, service type 5" oscilloscope; digital integrated circuit color TV pattern generator; a CMOS digital frequency counter, and an electronics Discovery Lab. This gives you thorough TV and Audio training for hundreds of dollars less than the separate courses you'd have to take elsewhere.

This Master Course combines theory with practice, using the "Power-On" stages for experimentation and learning. Building NRI's equipment will give you the confidence and ability to service any color TV or Audio unit on the market. And you'll have a magnificent TV and quad unit for years of trouble-free performance.



advanced

Pro Color: 19" diagonal color TV...

\$665 or low monthly terms

An advanced Color TV Servicing Course for experienced technicians, 18 lessons, 5 new "Shop Manuals", and NRI 19" diagonal Color TV receiver with cabinet.



New Products

Additional information on new products covered in this section is available from the manufacturers. Either circle the item's code number on the Reader Service Card inside the back cover or write to the manufacturer at the address given.

SAE DIGITAL FM TUNER

The SAE Mark VIII digital (stereo) FM tuner utilizes monolithic linear-phase filters and a phase-locked-loop multiplex section for alignment. The display consists of four seven-segment LED numeric indicators for

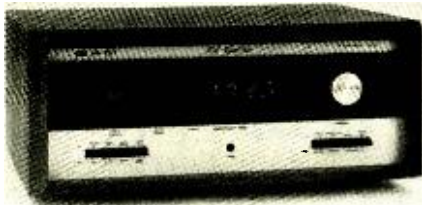

frequency readout, plus two meter movements for tuning. The tuning system is said to have a dial accuracy of 0.004%. Other ratings include: 1.6 μ V IHF sensitivity, 100 dB spurious response rejection, 120 dB alternate-channel selectivity, 100 dB AM rejection, and 4 μ V stereo switching threshold. There are eight push-push switches on the front panel, including one for selecting 25 or 75 μ s deemphasis. 17"W \times 10 $\frac{1}{2}$ "D \times 5 $\frac{3}{4}$ "H (43.2 \times 26.7 \times 14.6 cm); 23 lb (10.5 kg).

CIRCLE NO. 84 ON FREE INFORMATION CARD

CB ROOF-MOUNT MOBILE ANTENNA

Antenna Incorporated's Model 12510 is a base-loaded, stainless-steel 34" (86.4 cm) whip designed for roof mounting. Features a stainless steel impact spring, sealed base housing, and a 17-foot (5.2-m) length of RG-58U coaxial cable terminated in a PL-259 plug. Low-angle radiation and a VSWR of 1.5:1 or less are claimed. \$21.25

CIRCLE NO. 85 ON FREE INFORMATION CARD

CROWN SINGLE/DUAL-CHANNEL AMPLIFIER

The Model D 150A power amplifier from Crown International features a switch that allows the user to select either mono or stereo operation without having to make internal wiring changes. The 80-watt/channel (rms into 8-ohm loads) unit is said to have a frequency range of 1 to 20,000 Hz

at less than 0.05% harmonic and IM distortion (worst cases). Circuitry within the amplifier is designed to protect the amplifier against shorted, mismatched, and open loads without dc fuses and mode switches. Output power in mono is rated at 180 watts rms into 16 ohms at 0.1% THD. The outputs are unbalanced in stereo and balanced in mono. Overall dimensions are: 17"W \times 8 $\frac{3}{4}$ "D \times 5 $\frac{1}{4}$ "H (43.2 \times 22.2 \times 13.3 cm) and weight is 25 lb (11.4 kg). \$479.

CIRCLE NO. 86 ON FREE INFORMATION CARD

TELCO CB CONVERTER FOR CAR RADIOS

Telco's Model 10-73 Hi-Way Alert[®] converter can turn any AM car radio into a CB receiver. The converter, measuring 4 1/8"W \times 3 3/8"D \times 1 1/2"H (10.5 \times 8.6 \times 3.8 cm), is mounted by using adhesive-backed Velcro[®] pads supplied. The crystal-controlled converter provides 23-channel CB coverage and is said to provide a 1.5- μ V (For 10 dB S/N) sensitivity and better than 80 dB down AM feedthrough. Its power cord plugs into the car's cigar lighter receptacle, and the existing AM radio antenna is used. A switch on the front panel provides for CB or radio.

CIRCLE NO. 87 ON FREE INFORMATION CARD

SHURE LIGHTWEIGHT MICROPHONE

The Model SM62 by Shure Brothers is a unidirectional dynamic mike with a cardioid pickup pattern. It's designed for hand-held stage and remote interview applications, and is said to be especially suited for picking up brass, drums, guitar and vocals. Frequency response is claimed to be flat and uncolored with minimum feedback. The microphone is 4 $\frac{29}{32}$ " (124 mm) long. Other features include a "pop" filter to suppress wind noise and breath sounds, and internal shock isolation to attenuate noise caused by unstable stands, stages, etc. \$84.00

CIRCLE NO. 88 ON FREE INFORMATION CARD

TEABERRY MOBILE CB TRANSCEIVER

The Tele "T" AM CB transceiver, with 4 W r-f power output, features a telephone-type handset with a built-in transmit/receive bar. It is completely solid-state in design and has an S/r-f meter, delta tune, PA switch, hi/lo tone control switch, and au-



tomatic noise limiter switch. A loudspeaker is also built-in for use when it is not necessary to have private listening. Price is \$199.99.

CIRCLE NO. 89 ON FREE INFORMATION CARD

VECTOR TWO-SIDED DIP BREADBOARD

Model 51X Klip-Blok breadboard from Vector Electronic, on an aluminum chassis, allows components to be mounted (solderless medium) and connections made from

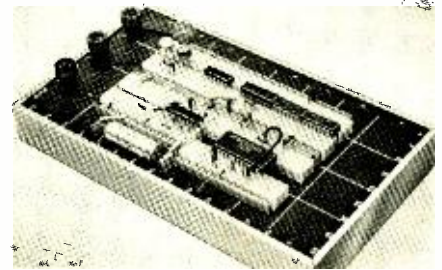

both sides of the board. With a total of eight solderless Klip-Bloks, the breadboard accommodates 12 14- or 16-pin DIP's or four 24- or 40-pin DIP's on 0.1" pin centers and 0.3" and 0.6" row spacing. Additional Klip-Bloks can be mounted on the unoccupied perforated areas of the Vectorbord[®]. Numbers along the edges of the 8" \times 4 $\frac{1}{2}$ " (20.3 \times 11.4 cm) board identify component locations. The board in the Model 51X is unclad. The breadboard is also available with a ground-plane-clad board as the Model 51X-GP. Prices are \$25.50 and \$29.95 for the Models 51X and 51X-GP, respectively.

CIRCLE NO. 91 ON FREE INFORMATION CARD

EPICURE BOOKSHELF SPEAKER SYSTEM

The new Epicure 11 is a high-efficiency, two-way bookshelf system with a bass port. Drivers used are a 6-inch (15.2-cm) controlled-excision woofer and a 1-inch (2.5 cm) cone tweeter with a claimed 180-degree dispersion. A tweeter level control is built-in. Frequency response is rated at 38 to 20,000 Hz \pm 3 dB. Recommended driving power is 15 to 80 W rms. System impedance is 8 ohms, and system resonance is at 36 Hz. Measures 21 $\frac{1}{2}$ " \times 13 $\frac{1}{2}$ " \times 9 $\frac{1}{2}$ " (54 \times 34.3 \times 24.1 cm), and weighs 36 lb. (16.4 kg). \$134.00

CIRCLE NO. 92 ON FREE INFORMATION CARD

E&L MICROCOMPUTER

The Mini-Micro Designer, introduced by E&L Instrument, is based on Intel's 8080 microprocessor chip. It has direct input via built-in keyboard and input/output buses through external card edge connections or the No. SK-10 interface/breadboarding socket that comes with the microcomputer. Internal status/data is shown by three sets of LED's. Included in the package is a memory card that accommodates 1024 bytes of read/write memory. Complete

POPULAR ELECTRONICS

From out of the blue comes a significant improvement in CB from Telex, the aviation communications experts.



Fully cushioned for comfort.

Boom pivots so headset can be used over left or right ear.

Push-to-talk switch with cushioning clip

Soft ear pieces for comfortable fit.

Noise-cancelling magnetic power mike.

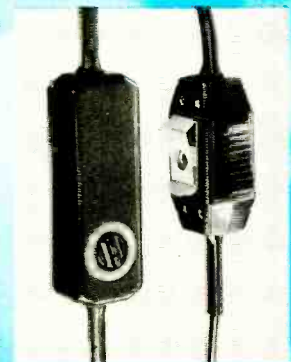

In-line variable gain power amplifier.

Boom adjusts easily for precise mike positioning.

The first "wall to wall" lightweight.

Dramatically better transmission and reception. New Telex aviation-type headset.

The first lightweight headset for CB'ers. The same style as worn by pilots around the world. So comfortable you may forget you are wearing it. Be heard better. Noise-cancelling power mike is always positioned properly. Ear piece lets you hear better. Your CB won't disturb others. And your hands are free. Try the new Telex CB-88. Made in U.S.A. You'll get the message loud and clear.



Telex CB-1200 Headset. Specially suited for high noise environments.



Telex CB-73 Double-Header. Aviation-type. Power mike and noise cancelling.

The Pilot People

TELEX
COMMUNICATIONS, INC.

9600 ALDFICH AVE. SO., MINNEAPOLIS, MN 55420 U.S.A. EUROPE: 22 rue de la Legion-d'Honneur 93200 St. Denis, France CANADA: Telak Electronics, Ltd., Scarborough, Ontario

Royce re-invents

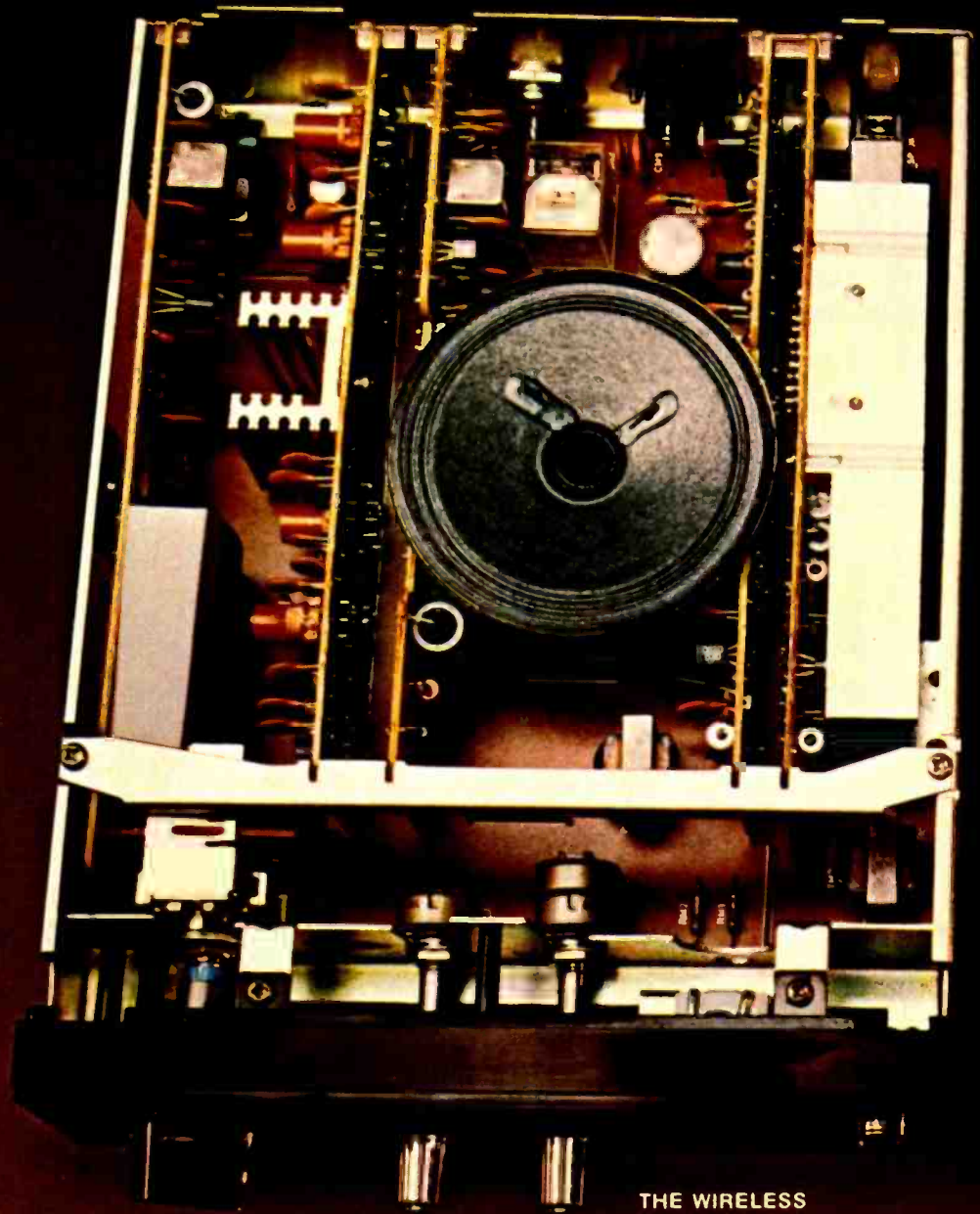

THE WIRELESS

Biggest CB breakthrough since the transistor!

THE WIRELESS is here! Royce brings computer technology to CB!

THE OLD WAY. A tangled mass of wires and hand-soldered connections.

THE WIRELESS. Automated module assembly. Computer tuned and quality controlled.

That is why THE WIRELESS chassis promises less chance of failure.

Computer tuning and testing means peak power and performance.

And, automated module assembly assures uniform quality.

Here is greater CB reliability than ever before.

That is why THE WIRELESS by Royce is turning the personal communications world upside-down!

THE WIRELESS

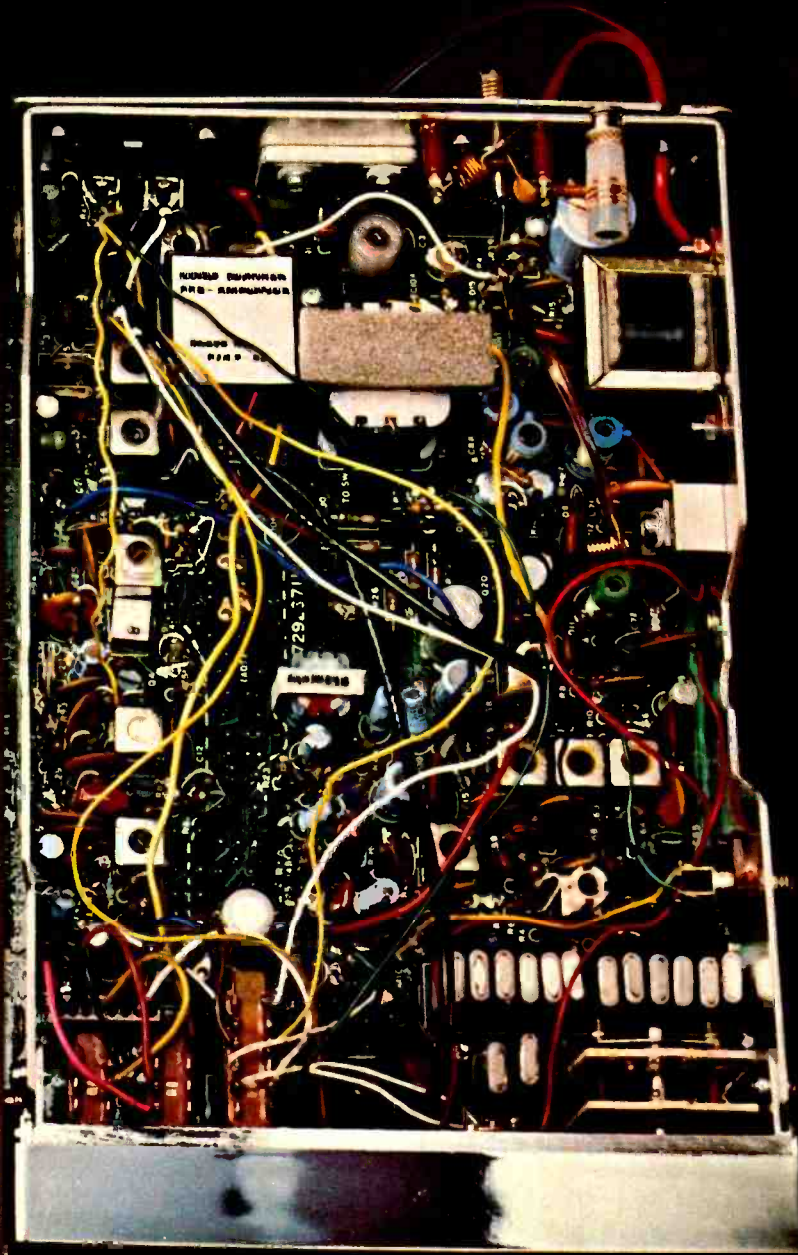

THE OLD WAY



Write today for information on
THE WIRELESS Models: 1-650;
1-653; 1-655; 1-658; 1-660, and
1-662. Plus details about the other
reliables from Royce!

Follow the new leader!

Royce

Royce Electronics Corporation
1746 Levee Road
North Kansas City, Mo. 64116
Call: (816) 842-7505 • Telex: 426-145

CIRCLE NO. 47 ON FREE INFORMATION CARD



software takes the user from assembly to system usage. \$125 for simplest kit to \$500 for completely assembled, tested system.

CIRCLE NO. 93 ON FREE INFORMATION CARD

J.I.L. UNDER-DASH CASSETTE PLAYER

J.I.L. Corporation's Model 607 is a new miniature cassette player designed for under-the-dash installation in virtually all foreign and domestic cars. It can be tucked away in most glove compartments. To assure the most dependable sound performance, the player offers a full complement of



features, including volume and tone controls, "play" indicator, left-to-right balance control, and fast-forward, rewind, and eject buttons.

CIRCLE NO. 94 ON FREE INFORMATION CARD

FIELD-STRENGTH METER

A compact, easy-to-operate field-strength meter for TV service technicians is available as the Model TVS from Castle Television Tuner Service, Inc. Called Mezzar™, the instrument measures signals from 300 to 30,000 μV ; has dial marking for quick identification of signal level for proper color reception (1 to 4 millivolts); features integrated circuit amplifier and meter driver circuits; with electronic voltage regulation. Operates from 9-V transistor batteries, and has battery status indicator.

CIRCLE NO. 95 ON FREE INFORMATION CARD



From the deep jungles of jumbled software, from the rivers of mysterious circuits, he came. Mini-Micro Designer. He was tough and smart. And he glowed with purpose. To teach the people microcomputers.

Learn from the leader in the modern electronics revolution. E&L's Mini-Micro Designer (MMD-1) comes with a series of educational "modules" that teach you how to design and use a microcomputer. And you get complete documentation and full software support. MMD-1 features the 8080A central processor chip, direct keyboard entry of data/instructions, LED status indicators, and all the apparatus needed to make your first microcomputer. Novice or expert, MMD-1 gets you into action fast. Put a revolutionary on your side. Send for more information today.

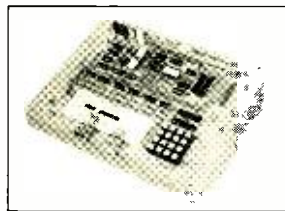

Prices start at \$125.00 in kit form.

CIRCUIT DESIGN, INC.

Division of E&L Instruments
P.O. Box 24
Shelton, Conn. 06484

CIRCLE NO. 12 ON FREE INFORMATION CARD

SENCORE BENCH-TYPE DMM

The Sencore Model DVM34 digital multimeter features a basic 0.1% accuracy and a 15-megohm input impedance that minimizes circuit loading for increased accuracy and reliability. A range/function format supplies measuring capabilities from 100 μV to 2000 volts dc, 100 μV to 1000 volts ac, 10 milliohms (using the special 20-ohm range) to 20 megohms, and 100 nA to 2 amperes ac and dc. An optional high-voltage probe permits measurements up to 50 kV dc at 1% accuracy. A high-and-low-power-ohms system is built in for increased accuracy when measuring resistance in solid-state circuits. To take full advantage of the high-accuracy 3½-digit



display, the DMM employs a single-step autoranging circuit that automatically ranges down to the next range on ac and dc volts whenever the reading is 108 or less. \$295. (\$25 for optional Model HP200 50 kV probe.)

CIRCLE NO. 96 ON FREE INFORMATION CARD

CB PREAMPLIFIER

According to Kris Inc., its "Antenna Fire" CB preamp will provide up to 20 dB receive gain and improve sensitivity when inserted in-line between the transceiver and antenna. The dual MOSFET preamp is pre-tuned. It offers two tuned circuits to improve image and spurious rejection figures. The preamp operates on 12-V mobile supply or 12-V ac adapter. It comes complete with connectors and mounting bracket and measures 5" x 4" x 3" (12.5 x 10 x 7.8 cm).

CIRCLE NO. 97 ON FREE INFORMATION CARD

POPULAR ELECTRONICS

Phase Linear 8,515,200 watts later.

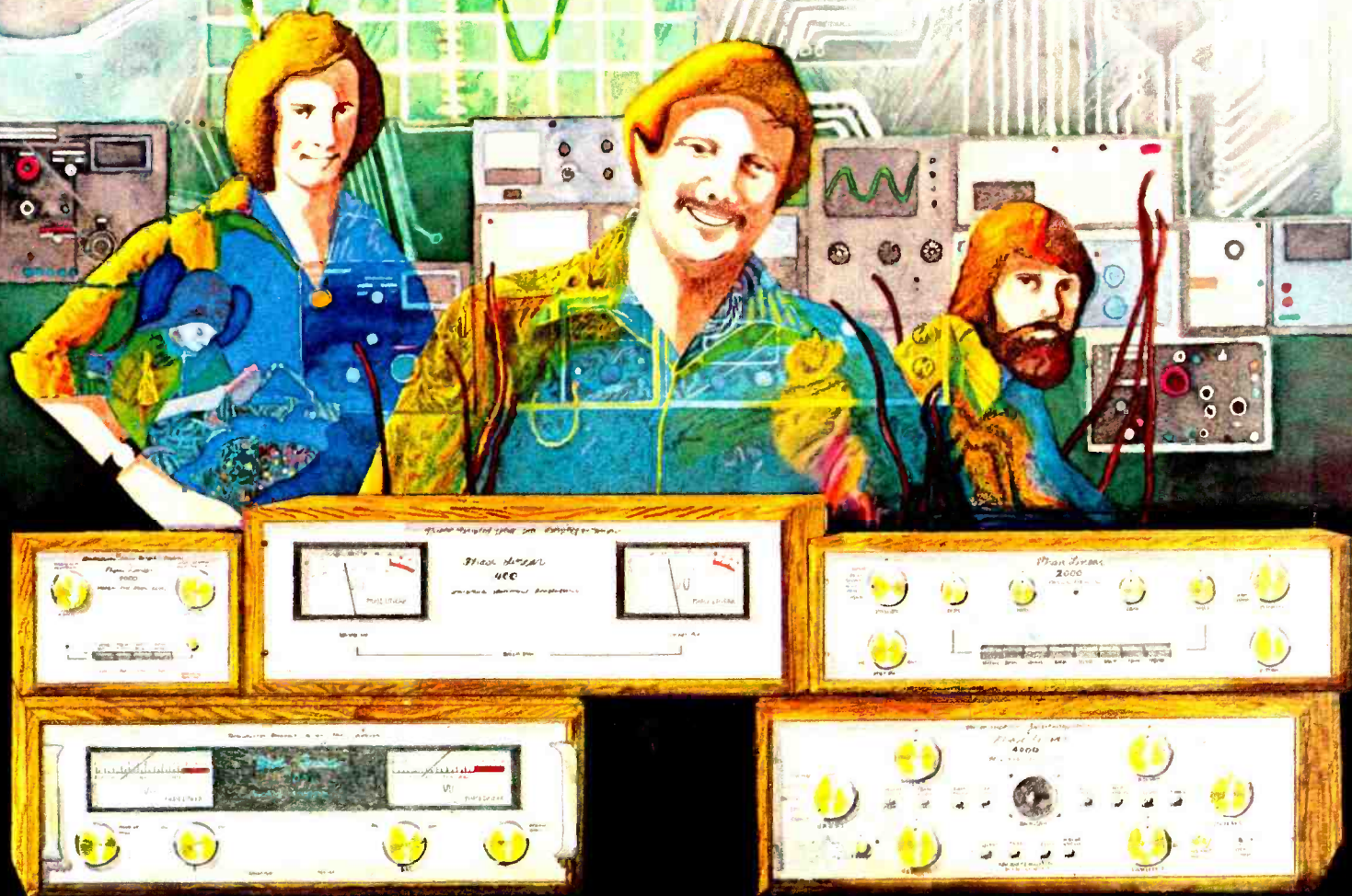

Back in '71 Phase Linear was Bob Carver, an audiophile with 200 square feet in the basement of an A & P store in the Pacific Northwest and one all-consuming obsession: to design and build the world's most powerful stereo amplifier.

Today Phase Linear Corporation is an acknowledged leader in high power technology, selling a complete line of amps and pre-amps throughout the world, operating out of one of the most advanced stereo component plants in the industry.

Phase Linear is now a household word among serious listeners, a word synonymous with power, quality, reliability and way-out-front technology.

And Bob Carver, Steve Johnson and A. P. VanMeter have come to be

recognized as the gurus of state-of-the-art amplifier design and development.

Phase Linear has dispensed over 8½ million watts of power to music lovers everywhere, starting with the famous super reliable, virtually distortion free Phase Linear 700, the first successful 700 watt amplifier. The popular Phase Linear 400 watt amplifier quickly followed. The incredible Phase Linear 4000 pre-amplifier was then perfected followed by a smaller version, the Phase Linear 2000. Recently the Phase Linear 1000 Noise Reduction System was added to the line . . . and there are many more advanced products in the wings.

Technological milestones along the way have included a unique Amplifier Protection Circuit (Patent # 3,727,148).

the first practical Expansion System, the innovative Auto Corra tor Noise Reduction System and a unique Ambience Injection System for pre-amps.

Phase Linear has come a long way from that basement lab of Bob Carver's. But products are still made one at a time, and one out of every three people in production is involved in quality control or testing.

And that's the way it'll be for the next 8,000,000 watts.

Phase Linear
A POWERFUL DIFFERENCE

Phase Linear Corporation,
20121 48th Avenue W
Lynnwood, Washington 98036

This is an echo chamber?



Yes, and much more! It is the first N-channel Bucket Brigade Device designed with the audio engineer in mind. The **SAD-1024 Serial Analog Delay** will provide reverberation, echo, tremolo, vibrato and chorus effects in electronic organs and musical instruments. It will equalize speaker systems in an auditorium, or can be used in speech compression or voice scrambling systems. The SAD-1024, which contains two independent sections of 512 analog storage elements will accomplish all of these with a signal-to-noise ratio in excess of 75 dB. The two sections may be used independently or they may be connected in sequence to provide 1024 clock periods of delay. The delay provided by the device can be continuously varied by the clock rate from less than one millisecond to more than one second.

Other performance characteristics include: Signal bandwidth from 0 to 200 KHz, less than 1% total harmonic distortion, 0 dB insertion loss, and less than 5 mW power requirements from a single 15V power supply.

You get all of these features for less than 1¢ per storage element in OEM quantities.

We also offer a complete circuit card to help you evaluate this exciting new device. Other devices for applications such as time base correction in the video bandwidth are also available.

There are over 70 salesmen and 16 distributors to serve you worldwide.

RETICON®

910 Benicia Avenue
Sunnyvale, California 94086
(408) 738-4266 • TWX: 910-339-9343

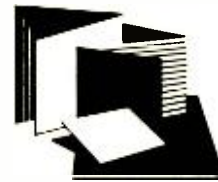

New Literature

GENERATOR AND SYNTHESIZER CATALOG

Dana Exact's new 8-page catalog describes 36 different models including function, phase, and pulse/sweep function generators. Frequency and complex waveform synthesizers are also covered. The catalog also contains a model capability cross-reference chart and prices. Address: Dana Exact Electronics, Inc., Box 160, Hillsboro, OR 97123.

LASER SAFETY GUIDE

A new laser safety guide has been published by the Laser Institute of America. The 31-page booklet covers laser, eye and skin hazards, associated hazards from high-power lasers, present laser safety standards, viewing laser radiation, eye protection, laser hazard classification, control of associated hazards, and laser calculations and measurements. Single copies are available to LIA members for \$1, and to non-members for \$2.50. Address: Laser Institute of America, 4100 Executive Park Dr., Cincinnati, OH 45241.

SOUND SYSTEMS BROCHURE

An 8-page, 3-color brochure describes the Argos Freedom Systems. Argos Sound's three portable sound systems are illustrated and described in terms of capacity, portability, and effectiveness. Address: Argos Sound, 600 South Sycamore St., Genoa, IL 60135.

ALL ABOUT CB

A new book from Radio Shack, *All About CB Two-Way Radio*, discusses what Citizens Band radio is and how to use it. Written in an easy-to-understand manner, the 116-page book is a guide to the equipment, rules and benefits of low-cost CB two-way radio. It also explains how to select and install a CB radio. Available at all Radio Shack outlets.

POWER TRANSISTOR DIRECTORY

An updated edition of the RCA Power Transistor Directory, PTD-187E, is now available from the RCA Solid State Division. This 44-page catalog lists the power transistors and power hybrid circuits currently available from RCA and provides selection charts and data on each of the devices. Also included are application information, a list of transistors which may be used as complementary pairs, and charts showing high-reliability and military-specification types. Address: RCA Solid State Division, Box 3200, Somerville, NJ 08876.

POPULAR ELECTRONICS

Realistic® gives you more than Brands J and L...



and charges about \$10 to \$20 less*

Let's talk features! Delta tune. Dual conversion receiver. Noise blander. S/Rf meter. Brand J's comparable set gives you none of those things and Brand L's gives you just one. Another fact: Realistic has Auto-Modulator for full RF power always, whether you talk loud or soft. It's Radio Shack's new look in mobile CB — the 23-channel Realistic® TRC-56. With its telephone-type handset you get two big advantages: you can listen privately; you can talk and listen with greatly reduced background noise. And you can switch to the regular built-in speaker anytime, of course. FCC Type Accepted. Usable with plus or minus ground. Universal dash/floor/cab roof mount included. The money you may save will just about pay for your (Archer) antenna! **179⁹⁵***

TRC-56 SPECIFICATIONS

Sensitivity for 10 dB S+N/N: 0.5 microvolt
 Selectivity at -6 dB: ±3 kilohertz
 Adjacent Channel Rejection: 50 dB
 Audio Power Output: 3 watts maximum
 RF Power Output: 4 watts maximum
 Size: 5" (maximum in front)x8¾x7"

ONLY WHERE YOU SEE THIS SIGN:

Radio Shack®

A DIVISION OF TANDY CORPORATION
 OVER 4600 STORES • 50 STATES • 9 COUNTRIES



Just Say "Charge It"
 at participating stores

*Retail prices may vary at individual stores and dealers.
 Prices and products may vary in Canada.



Stereo Scene

By Ralph Hodges

DATELINE 1976

JUNE is the "official" beginning of Model Year 1977 for the high-fidelity industry. But before we take on the future, let's have a final look at some of the recent developments of 1976, and some things that bode well to be of ongoing significance.

Nonlinear In, Linear Out. Except in the case of pure electronics, distortion-cancellation techniques haven't received a great deal of attention from audio designers in recent years. However, all of a sudden we have two new products that apply the principle in rather novel ways: the Nakamichi Model 600 cassette deck and the Phase Linear Andromeda III speaker system.

Nakamichi calls its version "IM suppression," and in theory at least its operation is pretty straightforward. It's based on the not-unreasonable assumption that it's possible to determine what types and amounts of distortion a recording medium (in this case tape) is going to exhibit when used under typical conditions (in other words, that you can predict with fair accuracy how the signal is going to be "bent" by the medium). Armed with this knowledge, it should then be possible to design a nonlinear circuit that will "bend" the signal by the same amount in the *opposite* direction. When put together, these two bends will have a combined effect that adds up to "straight." No doubt achieving this in practice is a little trickier than in this oversimplified theory, but the basis is sound.

According to the manufacturer, the IM suppression is aimed at compensating for nonlinearities introduced by tape saturation; and, in so doing, it reduces intermodulation and third-order harmonic distortion. Note that—again, in theory—you can apply the compensatory "bend" either before or after the signal is recorded. As it happens, Nakamichi chooses to do it

after, during playback. The claim is cheerfully made that ultimate distortion can be kept to 3 per cent or less for recording levels up to +7 dB, so effective is the technique at extending the useful range of a tape under near-saturation conditions.

Two key points should be made about the IM suppression technique. First, for optimum results, the tape used should closely match the characteristics of the circuit. Nakamichi has set up the Model 600 for two of its branded cassette tapes, EX and SX, between which the machine is switchable. (Near-equivalents of these tapes are available in other brands also.)

Second, since the circuit operates in playback (and can be switched in or out), it is possible to use it with already-recorded cassettes—even those made on a different machine. This is not a specifically recommended practice, but most tapes and machines are evidently similar enough in their behavior near the tape-saturation point to permit some improvement—if not the maximum improvement—to be realized under a variety of conditions. The manufacturer does offer one caveat in this regard, however: should you ever en-

counter a tape with significantly less distortion than the Model 600 would normally introduce in its record mode, the IM suppression becomes a liability. This is because in attempting to compensate for more distortion than actually exists on the tape, it leaves behind a "remainder" of distortion.

The Massless Tweeter. The Andromeda III, scheduled for introduction very shortly, is Phase Linear's first speaker system, and a rather innovative one. It comes in four pieces: two large mid-range tweeter panels that closely resemble several popular electrostatic designs, a separate bass "commode," and an electronic equalizer/signal "conditioner" that is installed in the tape-monitor loop of the receiver or amplifier. This last item does some pretty surprising things to the signal driving the speakers.

As Phase Linear's president Bob Carver describes it, the speaker was sonically modeled on a pair of very high-quality electrostatic headphones. However, when it came down to the final analysis, the cone mid-ranges and tweeters selected for the system were simply not able to imitate the sound of the electrostatics. Carver attributed their deficiency to the relatively high mass of their cone diaphragms, which could not start and stop with the agility of the very light electrostatic film diaphragms. Yet it was his belief that this shortcoming could be compensated for electronically, and this conviction led to what is probably the most interesting aspect of the Andromeda III's design.

If you were to take the Andromeda's equalizer unit and feed it a known input—a brief pulse with a rise and decay time typical of demanding mus-

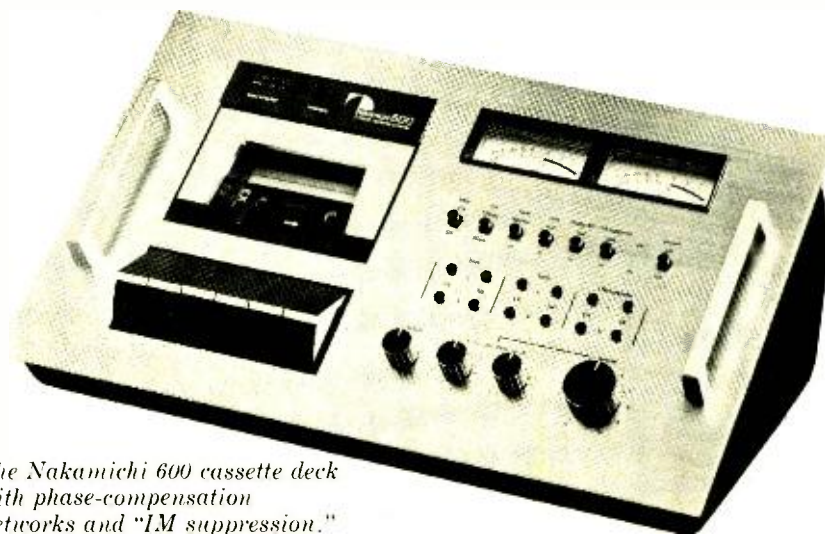

The Nakamichi 600 cassette deck with phase-compensation networks and "IM suppression."

What are your opportunities in the electronics field?

Here are some eye opening facts from ETI.

Q. What about the job market in electronics?

A. It's good. In fact, it seems to be one of the few fields that stays relatively steady in bad times. Today, for example, estimates indicate that several thousand jobs will be opening up for electronics technicians each year, for years to come. One reason for this is the fact that electronics are the basis of almost all communications, and this is a communications-oriented nation.



Q. What kind of jobs are you talking about?

A. For example, there are jobs available in electronic/industrial automation, electronic equipment repair and servicing, in the broadcast and radio telephone communications field, at airports, and even in medicine and in hospitals, where electronics are rapidly increasing in importance. And there are hundreds of other jobs opening up as electronics continues to make great strides, in new ideas and developments.

Q. Can such a complicated subject as electronics be successfully taught by the home-study method?

A. Of course it can. Electronics Technical Institute has proven that beyond a shadow of a doubt. Our graduates are working in practically every phase of electronics. This is largely due to the kind of instruction pro-

vided by ETI. For example, its course in the Fundamentals of Electronics features an exclusive teaching system called Autotext. And throughout all the courses the student is thoroughly monitored and carefully guided by a licensed instructor, whose professional and personal interest is to see that he masters every bit of information presented to him. Of course, we must give a lot of credit to our students themselves. They know that no matter how good the instructor and instruction may be, they have to make it work. So most of them apply themselves diligently, and they find the more they learn, the more they want to learn.

Q. But I have a job, and as much as I would like to get into electronics, I can't afford to take time off. How do I get around that?

A. You don't have to take time off from your job. You study at home, in your free time. We do advise, however, that you set aside a certain time for your study schedule and stick to it, even if it's only a couple of hours a day. The beauty of the ETI way of learning is that you work at your own pace, making sure you've completed your assignment thoroughly and completely. We think you'll find, as you go along, that learning the ETI way can be fun.

Q. But I was never very big on books and study. I like to work with my hands.

A. With your ETI course, you'll get plenty of work with your hands. In fact, the



ETI system of teaching combines hands-on work with study, so that you actually learn by doing. As you move along developing your technical knowledge, you will use, in many phases, specially developed Project Kits. So you apply your knowledge in logical, hands-on sequences, from the first step through completion of basic units. It all adds up to knowledge and self-confidence gained by actually *doing* the job.

Q. It all sounds very interesting and inviting. But I wouldn't want to commit myself before knowing more.

A. We wouldn't want you to. In fact, we insist that you check it out first. All you do is fill out the coupon and mail it to us. We'll send you a colorful new 48-page ETI Career Book that will give you the facts and the many opportunities ETI can open up for you. If you like electronics, you'll enjoy reading this book.

Q. Do I obligate myself in any way by sending for your book?

A. Absolutely not. The ETI Career Book is free, and it involves no responsibility on your part, nor will a salesman call on you. All we want to do is to be sure you have all the facts about ETI and what it can mean to your future. And you can get these facts and complete information about ETI's 18 different courses and programs in electronics by filling out and mailing the coupon to us today. We'll send you ETI's Career



Book by return mail. We think it will be a real eye opener for you. Mail the coupon today.

Electronics Technical Institute

Division of Technical Home Study Schools

Electronics Technical Institute • Dept. 2-473-066
Little Falls, New Jersey 07424

Send my free Career Book!

Tell me how I can get ahead in Electronics through ETI. I've checked the fields of special interest to me.

- | | | |
|---|---|---|
| <input type="checkbox"/> TV/Audio Servicing | <input type="checkbox"/> Computers | <input type="checkbox"/> Business and Engineering |
| Black & White | Digital Electronics | Electronics |
| Color | Computer Technology | Fundamentals |
| Solid State | Computer Programming | Electronics Drafting |
| CATV | <input type="checkbox"/> Communications | Industrial Electronics |
| Closed Circuit | FCC License | Advanced Electronics |
| Video Recorders | Aircraft | Industrial |
| Radio | Marine | Instrumentation |
| Hi-Fi Stereo | Mobile Two-Way | Electronics Technology |
| | Microwave | Medical Electronics |

Check here for Veteran information.

Name _____
(please print)
Address _____
City _____ State _____ Zip _____

**This is what happens
every time you play a record.**

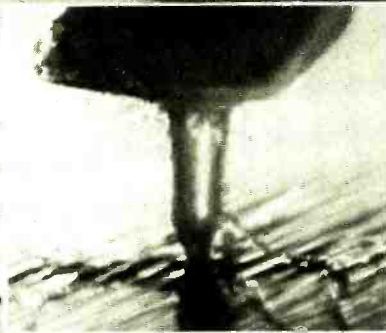

Photographed at 200X magnification with 1.5 grams tracking force on an Empire 598III turntable.

**This is what happens
after you apply Sound Guard.™**



Photographed at 200X magnification with 1.5 grams tracking force on an Empire 598III turntable.

Introducing Sound Guard.™

The first product ever that protects records against wear, without resulting loss in frequency response or fidelity.

Every time you play a record you destroy some of its sound. The culprit is friction. An inevitable result of a hard, diamond stylus tracking soft, vinyl grooves.

Under 200X magnification you can see the damage occur. Tiny shavings of vinyl curl off the record like metal off a lathe.

You literally see sound being worn away. After repeated playings your ears begin to confirm what your eyes have seen.

Until now, no product could protect records against wear without interfering with sound fidelity.

An answer from outer space

From Ball Corporation research into dry lubricants for NASA's Orbiting Solar Observatories came a breakthrough in micro-coatings that can function for long periods under extreme conditions.

One derivative of this new technology is a microscopically thin, dry film that molecularly binds itself to vinyl. Developed into a record preservative this product is now known as Sound Guard.*

How Sound Guard works

Just spray Sound Guard on (it has a non-aerosol pump sprayer). Then buff it with the soft, durable velvet buffing pad provided in the kit.

Sound Guard puts an ultra-thin, dry film on the groove surfaces to substantially reduce wear. (It's self-limiting and may be applied repeatedly without buildup. The film thickness is less than 0.000005".) One bottle will protect about 20 LP's.

Sound Guard is *dry*—not wet



over this new product. Along with audio experts who've tested it, we believe Sound Guard is the long-awaited breakthrough in sound

and sticky like silicone-type products—so dust or dirt won't accumulate on the stylus or in the grooves. And since it has an anti-stat built in, Sound Guard actually prevents records from attracting dust.

But does Sound Guard adversely affect frequency response or fidelity? For conclusive proof, we asked the most respected of the independent audio laboratories for an exhaustive evaluation. Their results were astounding!

Test results

1. The application of Sound Guard to a stereophonic or CD-4 quadrasonic disc does not in any way degrade audible frequency response.

2. Sound Guard increases the life of the records by significantly reducing record wear.

3. Sound Guard significantly retards increases in random noise content (surface noise) and total harmonic distortion caused by repeated playing.

4. Records treated with Sound Guard do not attract dust as readily as untreated discs.

(Complete test results will be mailed with every order.)

Like it or your money back

We're understandably excited

CIRCLE NO. 54 ON FREE INFORMATION CARD

fidelity protection.

As of now, the only way you can buy Sound Guard is by ordering direct. Just fill in the coupon (or write: Sound Guard, P.O. Box 3300, Muncie, IN 47302) and enclose your check or money order payable to Sound Guard. \$5.99 for one Sound Guard kit plus \$1.00 for postage and handling.

For two or more kits, pay \$5.99 each and we'll pay postage and handling. If not satisfied return the unused portion and we'll refund your money or replace the product at your option.

Sound Guard keeps your good sounds sounding good.

Sound Guard
P.O. Box 3300, Muncie, IN 47302

Yes, I'm interested in Sound Guard.
 Please send me *one* Sound Guard kit. I am enclosing a check or money order for \$6.99 (\$5.99 plus \$1.00 for postage and handling).

Please send me _____ Sound Guard kits. I am enclosing a check or money order for _____ (\$5.99 each kit—postage and handling *free*). Make check or money order payable to Sound Guard.

Name _____

Address _____

City _____ State _____ Zip _____

(please print clearly) PE-6



*Sound Guard is Ball Corporation's trademark for its record preservative. Copyright ©Ball Corporation, 1976.



The 160-W/channel Pioneer SX-1250 is 21 $\frac{7}{8}$ " W x 18 $\frac{3}{4}$ " D x 7 $\frac{3}{8}$ " H (56 x 47 x 18.5 cm) and weighs just over 6 $\frac{1}{4}$ pounds.

ical material, for example—the output would show the following significant alterations. First, the leading edge of the waveform would be steeper in slope than the input's. Second, where the input's waveform would ultimately return to the zero axis, the output signal would overshoot the axis for a brief time. What is happening is that the equalizer is attempting to offset the comparative slowness of the drivers by exaggerating the rise time of the signal (the steeper slope) and by braking the drivers (the overshoot) more drastically than the original input signal would.

Of course, the conditioning applied to the signal has been carefully adjusted to complement the characteristics of the individual drivers used. And according to Carver, conditioning is used throughout the audio range in the appropriate amounts. Certainly there will be skeptics to doubt that this kind of electrical manipulation could ever turn a cone into an electrostatic diaphragm. But to my ears, having been exposed to the Phase Linear product for about an hour, the speaker gave a very credible imitation of a good full-range electrostatic—except in the bass, where it was much more potent.

Heavyweight Receivers. The Pioneer SX-1250, at 160 watts per channel, is now the most powerful receiver generally available. Among the runners-up are the Marantz 2325 (125 watts per channel), the Kenwood KR-9400 (120 watts), the JVC S600 (110 watts), and the Sansui 9090 (110 watts). Even bigger receivers could be made, certainly, but the question being asked within the industry—especially by those who have yet to break the 100 + 100 mark—is *should* they be? The issue seems to hinge on a further question: What is the essential appeal of the receiver (as a generic

product) to the consumer? Does he buy it because it means fewer components to mess with; and if so, will he really find it a convenience to have all his electronics on a single chassis that is growing too heavy to lift and too big to fit on any shelf? Or does he choose a receiver because its built-in tuner eliminates one more agonizing buying decision he would otherwise have to make; or simply because his Uncle Fred has one? For consumers who don't want to get too deeply involved in system building, the receiver seems to have acquired a reputation as a practical, economical, good-sense approach to high-fidelity sound. Will a huge receiver with every imaginable feature and tremendous output capability miss the market by violating that image?

Many manufacturers are actively seeking answers to these questions right now. Their decisions are only complicated by the prospect (some-

time in the future) of Class D and other innovations, promising high-power capability in rather small packages. In any case, in a short time we should have some indication of whether the super-receivers of 1976 are dinosaurs or the progenitors of a new breed.

The Tape Tangle. In semi-public announcements recently, Nakamichi and Tandberg have made it clear that they are going to drop—or at least de-emphasize—chromium-dioxide capability on their future cassette decks in favor of ferric-oxide tapes with cobalt additives, such as TDK's SA. Why this dramatic break with past practice? The companies cite several reasons.

First, both manufacturers are believers in the superiority of permalloy as a material for cassette record-play heads, and prefer to use ferrite heads only in other applications. Being a softer material, permalloy is said to wear at an accelerated rate with chromium-dioxide tape. (On the other hand, Advent Corp., which also uses permalloy record-play heads, has sponsored extensive wear tests with chromium dioxide and remains committed to the tape.)

Second, both companies share the opinion that chromium dioxide has uniformity problems that defy current manufacturing procedures. And third, although chrome's performance remains essentially unsurpassed at high frequencies, there are well-documented weaknesses at mid and

Dynamic ranges of CrO₂ and SA tapes.

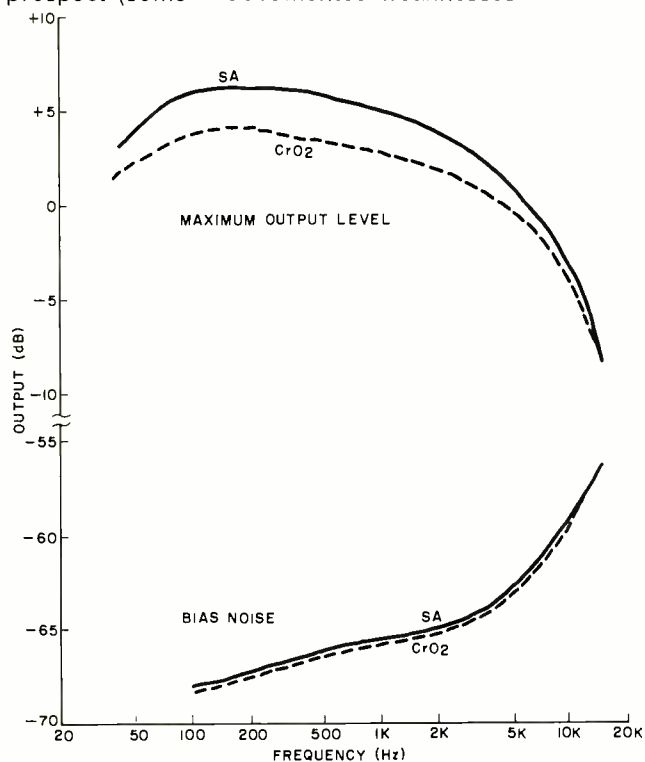

afs® / Kriket® Communications Speakers

**AFS' KC-55 BASE STATION EXTERNAL SPEAKER
FOR THE CB OPERATOR WHO DEMANDS
THE VERY BEST.**



Speakers are our only business. They have to be better!

AFS' engineers take special pride in the KC-55, our top-of-the-line speaker acoustically designed for the CB operator who demands the very best in clarity and intelligibility across the entire voice range.

Beautifully crafted, the KC-55 makes any equipment setup look better. And, by simply removing the base, our patented press snap locking positioner, mounted in mobile units, permits any directional adjustment required. Just like our best-selling KC-35 speaker.

AFS - the only company with the patented WORKING WALL® enclosure, featuring cross laminated, tubular fiberboard construction to deaden static, eliminate voice distortion.



Available at CB dealers everywhere.



World Wide Headquarters
Acoustic Fiber Sound Systems, Inc.
2831 North Webster
Indianapolis, Indiana 46219
(317) 545-2481

Exclusive Canadian Distributor
Muntz Canada Ltd.
1149 Pioneer Road
Burlington Ontario, Canada
(416) 639-5373

AFS/KRIKET® speakers are manufactured in the U.S.A. using American materials and craftsmen.

Copyright 1976 Acoustic Fiber Sound Systems, Inc.

IMSAI announces a unique 4K RAM board for just \$139.

Nobody has a 4K RAM board that gives you so much for your money. It's fully compatible with the Altair 8800.

Through the front panel or under software control, you can write protect or unprotect any 1K group of RAM's. Also under software control you can check the status of any 4K RAM board in 1K blocks to determine whether it's protected or not. The board has LED's that clearly show you the memory protect status of each 1K block and which block is active. And there's a circuit provided that will let you prevent the loss of data in the memory if there's a power failure. This low power board has a guaranteed 450 ns cycle time—no wait cycle required. There's nothing like the IMSAI 4K RAM board around.

Dealer inquiries invited.

IMS

IMS Associates, Inc.

PE-6

IMS Associates, Inc.
1922 Republic Ave.
San Leandro, CA 94577
(415) 483-2093

Order Your IMSAI 4K RAM Board For Only \$139. Use BankAmericard, Master Charge, personal check or money order.

- Send _____ 4K RAM boards today.
- Charge to my credit card.
- BAC No. _____
- MC No. _____

Signature _____

Name _____

Address _____

City/State, Zip _____

low frequencies. Overall, Tandberg and Nakamichi feel that the Super Avilyn (SA) type of formulation equals the performance of chrome at high frequencies and surpasses it for longer wavelengths, without being as abrasive on heads.

Well and good, but does this development presage any complex incompatibilities between tapes and machines? Yes and no. SA is designed for about the same bias and equalization requirements as chromium dioxide. Therefore, a cassette machine's bias and equalization switch positions should do about the same thing, whether they're labeled SA or CrO₂. However, the Dolby circuits are a different story. According to my information, SA is about 3 dB more sensitive than chrome, which is certainly enough to upset the tracking of the Dolby B noise reduction process. I have tried an SA cassette with a machine whose Dolby circuits were set up for chromium dioxide, and the compression of dynamics during playback was immediately obvious. Logically, the opposite effect should be obtained when chrome tape is used on an SA-adjusted machine. So, if you have hopes of using both types of tape on the same cassette deck, you had better choose a machine with readily accessible Dolby calibration controls.

AM Stereo. The idea of AM stereo—by no means a new one—is apparently gaining ground once more. There are several proposed methods for doing the job, all of them using the existing AM channels and employing a carrier that is both amplitude and, in effect, frequency modulated at the same time. To provide reasonable compatibility with existing mono receivers, the sum of the stereo channels (L + R) amplitude modulates the carrier and the difference (L - R) signal frequency or phase modulates it.

The only significant problem comes, predictably, from the restrictions on the spectrum space allotted each AM broadcaster. High modulation levels give rise to extensive sidebands that must be kept from interfering with adjacent stations. However, sideband limiting can result in significant amounts of distortion. A related difficulty, arising from "high" levels of frequency modulation, is distortion of the amplitude envelope. Consequently, troubles for existing receivers occur.

Arrayed in opposition to these problems (and also in more-or-less competitive stances toward one another) are the systems of CBS, RCA, General Electric, Philco, Westinghouse, Sansui, and other companies. Because none of the systems enjoys a clear margin of superiority, it looks as if we're due for another stand-off between industrial giants. However, the prospect of AM stereo seems likely to attract much more understanding and support than four-channel FM broadcasting has been able to muster so far.

Who of the general public will benefit from AM stereo? Certainly those who live in the FM fringes and can receive, at most, one or two FM stations with sufficient signal strength to permit stereo listening. Those who regularly drive long distances will have a much better chance of picking up usable stereo signals once they've installed the appropriate receiver. For those who live in urban and suburban areas well served with diverse FM programming, the direct benefits are not so obvious; but there may be some unexpected indirect ones. For example, during the recent period when the current four-channel matrix systems were taking shape, there was some fairly strong resistance to all the phase-shifting that would have to go on in matrixed recordings. Among the more vigorous protestors were some from the radio industry who argued—quite rightly—that phase shift between channels is a burden to the AM and mono FM broadcaster, who is at the mercy of the largely unpredictable cancellations and reinforcements of information that will take place when he tries to combine the signals.

I can recall some pretty feisty altercations, with the matrix proponents shouting that mono compatibility could go hang and the radio contingent saying that four-channel should go hang. However, AM stereo could be a long stride toward eliminating mono altogether. Record companies would then no longer feel constrained (if they do now) to pay special attention to phase in their products, with the possible result that more random-phase information would begin appearing on records. And it seems clear beyond a shadow of a doubt that a wealth of random-phase content greatly enhances the sonic spaciousness of a recorded performance, whether reproduced quadratically or in conventional stereo. ♦

Can anyone beat the Altair System?



We doubt it.

When it comes to microcomputers, Altair from MITS is the leader in the field.

The Altair 8800 is now backed by a complete selection of plug-in compatible boards. Included are a variety of the most advanced memory and interface boards. PROM board, vector interrupt, real time clock, and prototype board.

Altair 8800 peripherals include a revolutionary, low-cost floppy disk system, Teletype™ line printer, and soon-to-be-announced CRT terminal.

Software for the Altair 8800 includes an assembler, text editor, monitor, debug, BASIC, Extended BASIC, and a Disk Operating System. And this software is **not just icing on the cake**—it has received industry wide acclaim for its efficiency and revolutionary features.

But MITS hasn't stopped with the Altair 8800. There is also the Altair 680—complete with memory and selectable interface—built around the new 6800 microprocessor chip. And soon-to-be-announced are the Altair 8800a and the Altair 8800b.

MITS doesn't stop with just supplying hardware and software, either. Every Altair owner is automatically a member of the Altair Users Group through which he has access to the substantial Altair software library. Every Altair owner is informed of up-to-date developments via a free subscription to **Computer Notes**. Every Altair owner is assured that he is dealing with a company that stands firmly behind its products.

After all, we didn't become the leader by messing around. Shouldn't you send for more information or visit one of our Altair dealers?

Altair Coupon

Please send me the following information:

- Your latest catalog and price list
- Software information package
- Please include a list of your dealers

NAME _____

ADDRESS _____

CITY _____ STATE & ZIP _____



mits

2450 Alamo S.E. Albuquerque, N.M. 87106

Hobby Scene



Have a problem or question on circuitry, components, parts availability, etc.? Send it to the Hobby Scene Editor, POPULAR ELECTRONICS, One Park Ave., New York, NY 10016. Though all letters can't be answered individually, those with wide interest will be published.

By John McVeigh

VARIABLE DELAY POWER SHUTOFF

Q. I need a timer (preferably solid-state) to turn off my stereo after I fall asleep. Maximum delay of 1 to 1½ hours would be fine.

—David Custer, Timonium, MD

A. In the circuit shown, the 555 acts as a one-shot, providing gate current

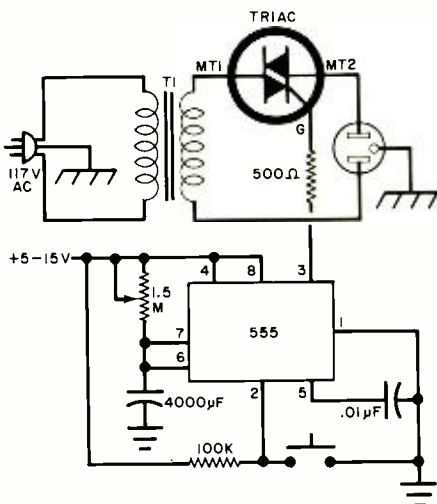

for the triac. With the 1.5-megohm pot set for maximum resistance, power cutoff will occur about 1½ hours after the normally open pushbutton switch is depressed. Use two 2000-µF electrolytics to derive the required timing capacitance (try to get close-tolerance units). The 1:1 isolation transformer is included for safety reasons. Both the transformer and triac are not specified, since they will have to be chosen to accommodate whatever load you want to power.

SINAD

Q. I was reading receiver specs the other day, and came across the word SINAD. What does it mean?

—Robert Wyatt, Oxford, CT

A. SINAD is an acronym derived from signal (S), noise (N), and distortion (AD). It is a figure of merit in communications systems. The noises referred to are Johnson or white noise; shot, thermal, and recombination noise, man-made impulses (electrical equipment, power lines, ignition systems, etc); and vibrational (microphonics). Distortion might be produced by improper amplifier conditions, detector nonlinearities, improper modulation, etc. Many consider the SINAD yardstick to be superior to the S/N and quieting ratings for communications, since it takes into account the distortion produced by the system. A SINAD ratio of 12 dB is generally considered to be the minimum acceptable figure. It is characteristically noisy and "hashy." A SINAD ratio of 20 dB or more represents a good, reliable grade for voice service.

CARRIER CURRENT AND DIGICLOCKS

Q. Will the operation of an electronic digital clock be affected by a carrier-current remote control system which injects a 120-kHz signal onto the ac line? Is there some way of keeping the signal from getting to the counters?

—Allan Silburt, Downsview, Ontario

A. In most cases, the power transformer, which has considerable reactance at 120 kHz, will provide the re-

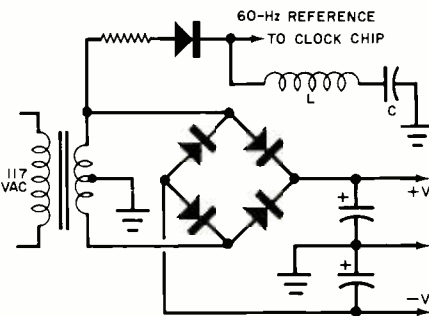

quired rejection. However, if the signal is very strong, it could cause the counting circuitry to act up. If this is the case, install the series-tuned LC trap shown in the figure at the 60-Hz reference tap-off. Use a 0.02-µF, 75-V ceramic capacitor (Lafayette 33 F 69063) for C and a 1-10-mH width coil (Miller 6322, Lafayette 34 F 88525) for L. Adjust L for normal clock counting.

MEDIUMWAVE LISTENING

Q. How can I join a mediumwave listening club and where is the one closest to me?

—W.E. Osborne, Eau Gallie, FL

A. National Radio Club, Box 127, Boonton, N.J. 07005. Also try ANARC,

557 N. Madison Ave., Pasadena, CA 91101. It's an association that can supply a list of affiliated clubs.

RECORD PLAYER RFI

Q. I've just moved to a new town, and find my record player picks up radio broadcasts as soon as it's turned on—even when no record is being played! What can I do about it?

—Harry Birdsall, Bloomfield, N.J.

A. You are experiencing RFI (radio frequency interference). Somewhere within the record player, signals are getting in and being rectified (detected). Try shielding external speaker leads and/or bypassing them to ground with 0.001-µF disc capacitors. If this doesn't work, shielding the enclosure and/or installing bypass capacitors at other points may be necessary. Does the volume control have any effect? If not, the point of rectification is between the control and the final audio amp. If it does, look back toward the cartridge. Ferrite beads on the tone arm wires might help.

COAX IMPEDANCE

Q. Why does my supposedly 52-ohm coax line read less than 1 ohm on my VTVM?

—Leon Brown, Bayside, NY

A. This type of coaxial line has an impedance (or opposition to r-f ac current) of 52 ohms, not a dc resistance of this value. That's what you're measuring with your VTVM. The impedance of a transmission line depends on the size of the conductors used, their spacing, their material composition, and that of the dielectric between them.

COMMERCIAL CODE STATION

Q. I occasionally pick up a CW station at about 8.100 MHz with the call letters WCC. While it appears to be commercial traffic, it makes excellent code practice. Where is it located?

—Grenville Beem, Silver Spring, MD

A. The station you are listening to is located in Chatham, Massachusetts, and is engaged primarily in ship-to-shore traffic with ocean-going vessels. Although it is excellent practice to copy such stations, keep FCC regulations in mind. It's illegal to divulge the contents of any message you copy to a third party, nor can you use such information for personal (financial) gain.

COMPARE

Feature	SWT [®] —6800	Theirs—Your Choice
Processor—	The best "Motorola MC6800". Two accumulators, automatic vectoring, seven addressing modes and complete set of branch instruction. The more powerful instruction set and memory orientated architecture makes programming very straight forward and easy to learn. Operates from a single +5 Volt supply.	Some are almost as good in one respect or another. None can offer all of the features of a real MC6800.
Memory—	Static 2102-1 type memories. Fast enough to allow the processor to run at full speed at all times. No refresh cycles, no problems with glitches and flakey dynamic memories.	Various types available. Often not included in the basic kit, and must be purchased as an extra cost option. (this is an option?)
Power Supply—	10 Amp. Capacity. More than enough to power a fully expanded system. Power supply uses a rugged 25 amp bridge rectifier and a 91,000 mfd computer grade filter. Regulators on the individual plug-in cards.	Some expand more than others with the supply provided. Check carefully.
Expansion—	Seven slots for processor and memory boards. Eight I/O slots. I/O's are programmable type. All decoding and clocking provided from mother board making additional interfaces very inexpensive. Baud rates may be independently selected for each interface card.	Varies from "0" to 16, or more.
Start Up—	Automatic start and reset provided by "Motorola" Mikbug [®] ROM. No fiddling with switches and status lights. Just push the button and go. Use of standard Motorola firmware makes software 100% compatible with Motorola evaluation module programs.	Anything from switch and status light to automatic ROM loading. If ROM is not a standard part, the software may be unique to that machine.
Clock—	Crystal controlled master clock oscillator with high power clock drivers. Insures reliable, consistent operation with no noise problems. Baud rate divider operating from the master clock oscillator provides the various baud rates for the I/O devices with crystal accuracy. No adjustments necessary to lock everything in at the proper frequency.	Anything from cheap dual monostable systems to crystal control. Crystal oscillators are best. Dual one-shots can develop phase overlap problems and are more susceptible to noise problems.
Buffering—	Tri-state bi-directional buffers on all data lines, address lines and clock lines on <u>ALL</u> boards. Insures trouble free noise immune operation.	Various—from full buffering to almost no buffering. Lack of full buffering can lead to noise problems.
Documentation—	Very complete. Our own notebook, plus the "Motorola" Programming Manual and Applications Manual. Detailed instructions along with sample programs help you to understand programming. You will be ready and able to write your own programs after mastering these instructions.	
Price—	\$395.00 For the whole thing. You get the case, power supply, processor 2K word memory and serial interface. No extras to buy. Just connect a terminal and start operating.	As we said—COMPARE.

© Registered Trademark Motorola



COMING ATTRACTIONS

CASSETTE INTERFACE—Our new AC-30 will make it possible to load and dump programs to cassette tape using ordinary inexpensive recorders. Uses the standard "Kansas City" recording format for compatibility.

LINE PRINTER—At last—hard copy at a reasonable price. Our new PR-40 printer will print program listings, or any other material you might want to keep in printed form. A dot matrix printer at a price you are not going to believe.

GRAPHICS TERMINAL—A universal—works with any computer—graphics terminal. With this connected to your computer you can play games in style. May be used with our CT-1024 to put both graphics and alpha-numerics on the screen simultaneously.

PLEASE—Don't call or write. We will have details on these projects in our next ad. Government regulations prevent us from giving prices, or taking orders yet.

SOFTWARE—The flood is near. Editor and assembler now available. BASIC and more games right away. Yours for the cost of copying. **WE DON'T SELL SOFTWARE—WE GIVE IT TO YOU. ENJOY IT, COPY IT, WE WON'T COMPLAIN.** . . .

SWT[®] Southwest Technical Products Corp., Box 32040, San Antonio, Texas 78284

NEWS HIGHLIGHTS

New Zenith Color Picture Tube

A cooperative venture between Zenith Radio Corp. and Corning Glass Works over a four-year period has resulted in a new color TV picture tube of decreased depth and weight. The deflection angle of the new tube is 100°. The narrow-neck tube has a striped negative guard band phosphor screen, slot-type aperture mask assembly, high-resolution electron gun, hybrid deflection yoke,

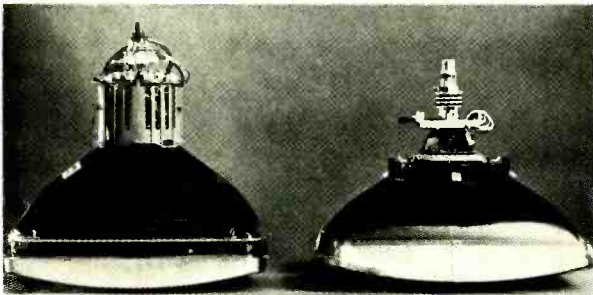

and lower-cost glass components. The tube (at right above) is 2 1/2" (6.4 cm) shorter and more than 2 lb (1 kg) lighter than other 19" (48.3-cm) color picture tubes. Zenith plans to use the new picture tube in a portion of its 19" color TV receiver line in late summer.

RFI Bill Before Senate

On February 25, Senator Barry Goldwater introduced radio-frequency interference legislation into the U.S. Senate as Bill No. S. 3033. It is virtually identical to the RFI bill introduced into the House of Representatives last year by Mr. Charles A. Vanik. The bill places the responsibility of providing RFI suppression on the manufacturers, importers, and sellers to provide interference-reducing circuits in audio and visual electronic equipment.

Tubes Live!

Though solid state appears to have taken over, vacuum-tube equipment is still very much alive, even in hi-fi. LUX Audio of America, for example, is marketing a new monophonic power amplifier and matching stereo preamplifier using tubes. The Model MB-3045 power amplifier has a new triode tube developed by LUX and NEC, which is said to be the first triode that makes possible a high-power, low-distortion (50 watts at 0.3% THD) triode amplifier. The new Model CL-35 tube-type stereo preamp is rated at 0.06% harmonic distortion at 2 volts output. LUX developed the new components to satisfy the demands of sophisticated audiophiles who prefer "tube sound" to

"transistor sound," especially when amplifiers are driven to clipping.

Heartbeat Digital Watch

A transducer capable of providing a digital read-out (on a watch, for instance) is to be marketed by Pulse Watch, Inc., of Tiburon, CA. The Orr transducer (invented by Thomas Orr, of Warsash, England) consists of a light-emitting diode in the center of an annular, thin-film photovoltaic detector. The LED illuminates the skin and penetrates the tissue. Light reflected back from the skin onto the detector is modulated by the rhythmic changes in blood absorption in the tissue. The signal is then electronically processed and can be displayed or recorded.

Citizens Band in Europe

The current boom in Citizens Band activity in the U.S. is paralleled by similar interest in West Germany, Italy and other European countries. The German authorities have allocated frequencies from 26.965 to 27.275 MHz at a spacing of 10 kHz, providing 26 channels with certain exclusions. Power is limited to two watts input, and two types of transceivers are available—one requiring a license but no payment, and the other requiring payment of a monthly fee. CB, incidentally, is not yet allowed in Great Britain.

Holographic Credit Cards

As an aid to the prevention of falsification and fraudulent alteration of credit cards, ID cards, passports, etc., Siemens has developed a system of making a hologram of the original card and incorporating it in the card. Consequently, if the original is altered in any way, the hologram is unchanged, and the two can be compared in a special reader to check validity. A helium-neon laser is used to make the hologram and must also be used to read the hologram. During the checking procedure, two pictures appear on a liquid-crystal screen on the reader: a conventionally produced image of the card and a similar-sized reconstruction of the hologram.

Home Microprocessor By 1985?

Sperry Univac thinks so! According to Dr. Val E. Herzfeld, Vice President, Business Planning and Development, within the next ten years a new type of small, inexpensive computer may be monitoring the heating and cooling systems in your home, helping your wife plan her menus, and flashing a "paperless newspaper" on a screen in your den. Such a home microprocessor should cost no more than a major appliance like a refrigerator and would be small enough to fit into a desk drawer, says Dr. Herzfeld.

The Black Watch Kit \$29.95



Dimensions: 1½" x 1" x 3/10"
Weight: ½ oz.
Strap: ¾" wide
Case: Specially designed unbreakable black matte plastic. Water resistant.
Batteries: Mallory RM41H. One year life with normal use.

THE KIT CONTAINS

- | | | |
|--------------------------------|--|---|
| 1. printed circuit board | 6. LED display | 10. black strap |
| 2. unique Sinclair-designed IC | 7. 2-part case with window in position | 11. full instructions for building and use. |
| 3. encapsulated quartz crystal | 8. batteries | All you provide is a fine soldering iron and a pair of cutters. |
| 4. trimmer | 9. battery-clip | |

The Black Watch by Sinclair is unique. Controlled by a quartz crystal...powered by two hearing aid batteries... it's also styled in the cool prestige Sinclair fashion: no knobs, no buttons, no flash... just touch the front of the case to show hours and minutes and minutes and seconds in bright red LEDs. There's a re-set control on the back.

*Guaranteed. A correctly-assembled watch is guaranteed for a year. It works as soon as you put the batteries in. On a built watch we guarantee an accuracy within a second day. In building it yourself you may be able to adjust the trimmer to achieve an accuracy within a second a week.

Take advantage of this no-risks, money-back offer today! The Sinclair Black Watch is fully guaranteed. Return your kit undamaged within 10 days and we'll refund the cost of your kit without question.

NOW ALSO AVAILABLE WITH DATE!

Sinclair Radionics Inc.
375 Park Avenue
New York, New York 10022

Please send me:
 Black Watch kit(s) at \$29.95 \$ _____
 Black Watch kit(s) with date at \$39.95 \$ _____
 Black Watch(es) assembled at \$49.95 \$ _____

Sales Tax (N. Y. residents) \$ _____

Shipping & Handling \$2.50 per unit \$ _____

Enclosed is my check/M.O. for total \$ _____

Please send me the Sinclair calculator catalog

Name _____

Address _____

City _____

State _____ Zip _____

sinclair™



Pace.
The best-selling CB in the world
introduces 5 new ones.

More people buy Pace than any other CB, based on estimates by Pathcom Inc.

We make the largest CB line in the world too — 23 models. Here are our 5 newest:

Mobiles

CB 166 — Revolutionary state-of-the-art phase lock loop (PLL) design with digital synthesizer. Suggested selling price \$229.95.

CB 161 — Striking LSI digitally-synthesized model. Single crystal handles all 23 channels. Suggested selling price \$149.95.

Base Stations

CB 2700B — AM-deluxe transceiver, includes SSB receiver.

Manufactured in the U.S. Suggested selling price \$399.95.

CB 113 — Medium-priced, full-feature model. Suggested selling price \$229.95.

CB 162 — The feature-loaded, handsome unit with an amazing price tag. Suggested selling price \$199.95. Is Pace for you? We think Number One deserves #1.

Write us —
 Pathcom Inc.,
 (Los Angeles),
 Harbor City,
 CA 90710

PACE CB

**When you've got a Pace,
 you've got the world by the ears.**

PACE TWO-WAY RADIOS, PRODUCTS OF PATHCOM INC.

BY JOHN H. ROBERTS

THE SOUND of recorded music being played is a listening experience that changes according to the room you are in. If the room is too "live" or too "dead", the sound appears to be unnatural. When the room has an ultra-modern decor and lots of glass window areas, the effect on the music is "bouncy." With heavy drapes, carpeting, and thickly padded furniture, plus a minimum of hard surfaces, the effect approaches that of an anechoic chamber—with very little sound reflection.

For the latter, you can either throw away your sofa pillows and pull down the drapes, or you can add a time-delay device to your audio system to create a more natural ambience. Since you may not care to redecorate, you can create an echo (audio signal time delay) and reverberation (later reflections) and achieve a livelier sound.

Until recently, the only means of obtaining an audio signal delay has been through the use of very expensive electronic equipment. Now there is a new type of IC—the "bucket brigade"—and you can build your own delay system for as little as \$39 in mono and \$59 in stereo. Connected between source and preamp or preamp and power amplifier (at the tape monitoring jacks possibly), it provides an adjustable, signal echo that can enhance the sound in most home listening rooms. With minor connection changes, it also can be used as a phasor/flanger, giving you a sound effect for tape recording purposes and electric-guitar playing used by the professionals.

The bucket-brigade IC is a MOS-type shift register that contains two 512-stage registers in a single 14-pin package. When an audio signal is applied to the input of the bucket brigade and a clock generator drives the IC, the signal is stepped along stage by stage until it comes out delayed a discrete interval in time. By adding this delayed signal to the original, reverberation is simulated.

In addition to providing real-time ambience, the bucket-brigade circuit can be used with a tape recorder to provide simulated stereo sound from mono sources, a means for "double voicing," and "phasor/flanging."

Technical Details. If you can delay an audio signal, you can create a number of useful sound effects. The most obvious is simulating echo, though delays provided by the bucket

THE "BUCKET BRIGADE"



AUDIO DELAY LINE

*Allows user to simulate
larger listening room.*

*Also used by recordists
and musicians for
special sound effects.*

20 100

PEAKS +6db

NOTCHES > 35db

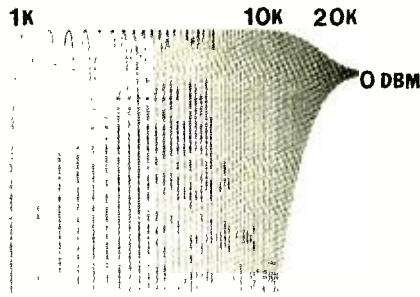

Fig. 1. Frequency between notches on a comb filter is adjusted by varying the clock frequency.

brigade are too short to be discerned as discrete echoes. Recirculating the delayed signal at reduced gain can approximate the natural decay of echoes in a reverberant room. By adding some gain during the recirculation of the delayed signal, you can create an unnatural "door-spring" effect on the music.

Delay an instrument or voice track by 30 or 40 ms and add the delayed signal back to the original signal, and you will make the output sound fuller and give it the effect of more than the original number of voices or instruments. This commonly used technique is known as "double voicing."

Another popular short-delay effect is a strange sound that results from a technique known as "phasing" or "reel flanging." The name is derived from its original implementation where a tape recorder was used to create the time delay and the friction of a well-placed hand on the outside edge of the tape-feed reel varied the delay to produce the acoustic effect. This effect can be created totally by electronic means by delaying the signal 0.5 to 5 ms while adding or subtracting the delayed signal from the original signal.

In the phasor/flanger mode, the frequency and its multiples whose wavelengths are equal to the time delay will be completely cancelled out while all other frequencies are reinforced. The result is a comb filter whose frequency between the notches is adjusted by varying the clock frequency (Fig. 1). In this manner, a tonal quality can be imparted to nontonal sound such as drums, cymbals, and even voices.

The phasor/flanger mode can be used to simulate stereophonic sound from a monophonic source. To do this, the phased output derived by adding the delayed signal goes to one channel, while the output derived by subtracting the delayed signal goes to the other. To the listener, the phasing

effect cancels leaving a reasonable pseudo-stereo effect.

The basic block diagrams of the delay-line and phasor/flanger circuits are shown in Fig. 2. The hearts of the circuits, of course, are the bucket-brigade IC's, which can directly process analog signals. The circuits do not require costly analog-to-digital and digital-to-analog converters. When the clock pulse from the flip-flop is applied to the bucket-brigade IC, the dc voltage present at the input is shifted into the register. The discrete bits are transferred stage by stage with successive clock pulses until, after 256 pulses, they reach the end of the line and provide the output.

The output waveform is smoothed by a low-pass filter and duplicates whatever signal was present at the input but delayed in time by 256 times the period of the clock frequency. (Period is equal to the reciprocal of the

frequency.) For example, if the clock frequency is 100,000 Hz, the delay would be $256 \times 1/100,000 = 2.56$ ms.

Since the audio signal at the input is being sampled at a rate determined by the clock frequency, a theoretical limit of half the clock frequency is the highest audio frequency that can be reliably passed. However, owing to practical limitations, a third of the clock frequency is a more reasonable design goal. Circuits can be cascaded to provide longer time delays at high clock rates, but the increase in noise in the series-connected circuits might outweigh the increase in bandwidth.

In the delay mode, the two shift registers are connected in series, which allows twice the clock frequency to be used. Therefore, twice the bandwidth of a single shift register can be programmed for the same time delay. Even in this double-bandwidth mode, the clock frequency required for a

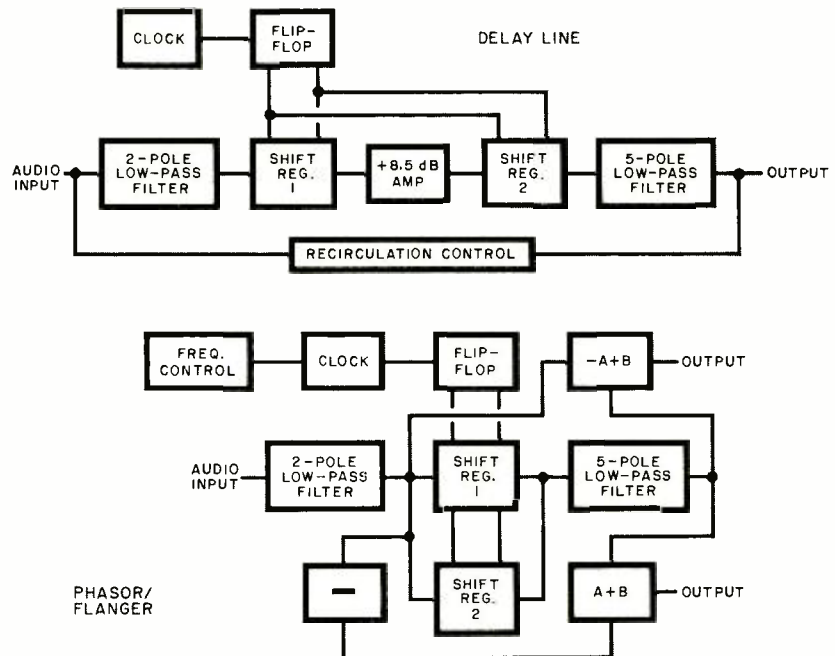

Fig. 2. Basic block diagrams of the delay line and the phasor/flanger circuits.

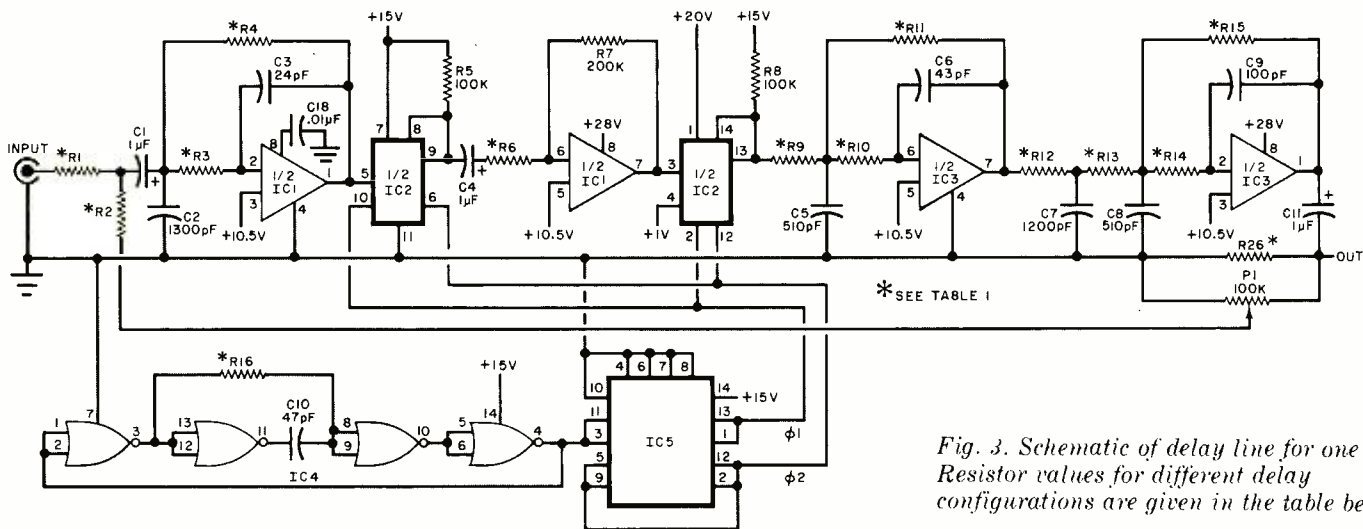

Fig. 3. Schematic of delay line for one channel. Resistor values for different delay configurations are given in the table below left.

TABLE OF FILTER RESISTOR VALUES

	A	B	C	D
	(all values in kilohms)			
R1	100	200	300	390
R2	130	270	390	510
R3	36	75	110	150
R4	100	200	300	390
R6	75	75	75	75
R9	47	91	130	180
R10	43	82	130	160
R11	120	240	360	470
R12	10	20	30	39
R13	56	110	160	220
R14	33	68	100	130
R15	68	100	200	270
R16	110	240	360	470
R26	200	200	200	200

A = 10 ms or less, -3 dB at 15,000 Hz
 B = 20 ms or less, -3 dB at 7500 Hz
 C = 30 ms or less, -3 dB at 5000 Hz
 D = 40 ms or less, -3 dB at 3800 Hz

PARTS LIST FOR FIG. 3

C1, C4, C11—1-μF, 25-volt electrolytic capacitor
 The following are 5% polystyrene capacitors:
 C2—1300 pF
 C3—24 pF
 C5, C8—510 pF
 C6—43 pF
 C7—1200 pF
 C9—100 pF
 C10—47 pF

C18—0.01-μF ceramic disc capacitor
 IC1, IC3—1458 dual operational amplifier
 IC2—MN3001 dual analog shift register (Matsushita)
 IC4—4001 CMOS quad NOR gate
 IC5—4013 CMOS dual D flip-flop
 P1—100,000-ohm potentiometer
 R1 through R4, R6, R9 through R16, R26—
 See Table
 R5, R8—100,000-ohm, ¼-watt, 5% resistor
 R7—200,000-ohm, ¼-watt, 5% resistor
 Note—See Parts List for Fig. 5 for kit information.

40-ms delay limits the bandwidth to a maximum input signal frequency of 3750 Hz, which is adequate for voice but less than adequate for many musical instruments. In most applications where the delayed signal is added to the original signal, the reduction in bandwidth will be masked by the high-frequency signals present in the original. To compensate for normal signal attenuation, an 8.5-dB amplifier is used between the shift registers. In the phasor/flanger mode, the

maximum delay required is about 5 ms, which is short enough that a single shift register can be used without compromising the bandwidth. The second shift register is therefore connected in parallel with the first to improve the S/N ratio. The signals are added in-phase, while the noise adds and subtracts randomly.

How It Works. The schematic diagrams of the delay-line and phasor/flanger configurations of the circuit

A BUCKET-BRIGADE SHIFT-REGISTER ANALOGY

The name "bucket brigade" conjures up images of a line of men passing along buckets of water to fight a fire. The bucket-brigade analog shift register operates in a similar manner, which is how it got its name. In the case of the shift register, however, the buckets are capacitors integrated right on the PMOS chip. There are more than 1000 such capacitors on each chip (one capacitor and two MOS transistors for each stage). What is being passed along are packets of electrical charge from stage to stage.

It is difficult to pour water both into and out of a bucket at the same time. So, too, it is difficult to simultaneously charge and discharge a capacitor. This problem is overcome in the shift register by utilizing two out-of-phase clocks.

While the first clock is high, the "odd" buckets are dumped into the next consecutive "even" bucket. When the second clock is high, the even buckets are dumped into the next consecutive odd buckets. In this manner, individual charges are transferred along the line one stage at a time.

The drawing is a schematic representation of four typical stages of the MN3001 analog shift register. Each MN3001 IC contains two 512-stage shift registers. Note that stages A and C are connected to one clock, while stages B and D are connected to the other clock to provide the odd/even relationship.

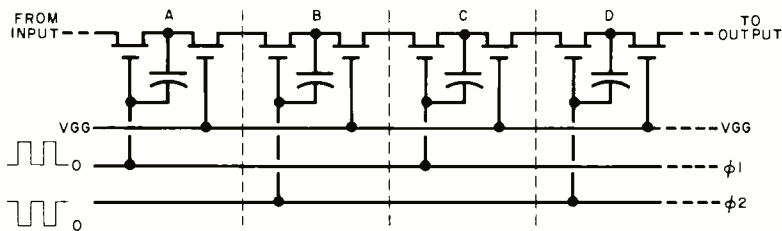

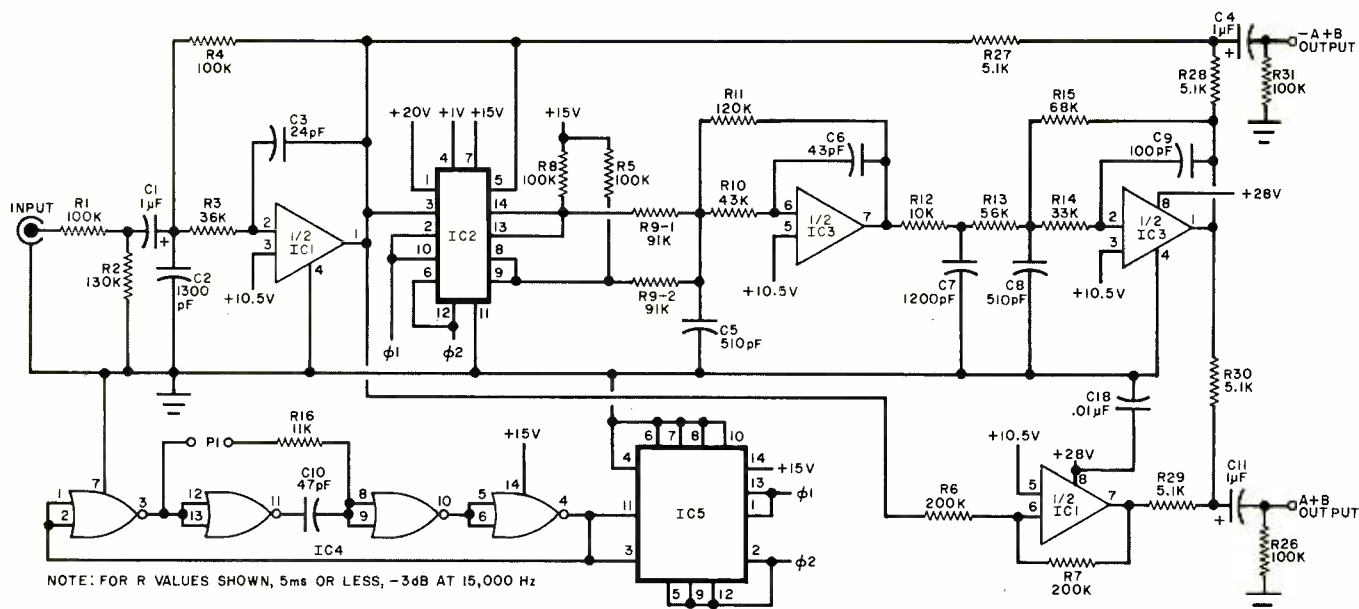

Fig. 4. Schematic of circuit for phasor/flanger.

PARTS LIST FOR FIG. 4

C1 through C11—Same as for Fig. 3
 C18—0.01-µF ceramic disc capacitor
 IC1 through IC5—Same as for Fig. 3
 The following resistors are ¼ watt, 5% tolerance:
 R1, R4, R5, R8, R26, R31—100,000 ohms
 R2—130,000 ohms

R3—36,000 ohms
 R6, R7—200,000 ohms
 R9-1, R9-2—91,000 ohms
 R10—43,000 ohms
 R11—120,000 ohms
 R12—10,000 ohms
 R13—56,000 ohms

R14—33,000 ohms
 R15—68,000 ohms
 R16—11,000 ohms
 R26—100,000 ohms
 R27 through R30—5100 ohms
 Note—See Parts List for Fig. 5 for kit information.

are shown in Fig. 3 and Fig. 4, respectively. In both cases, quad NOR gate IC4 is wired as an astable multivibrator operating at twice the desired clock rate's frequency. The output of IC4 goes to flip-flop IC5, which provides a pair of complementary (180° out of phase with each other) output clock pulses with 50% duty cycles. These pulses then "clock" the shift registers in IC2. Frequency determining resistor R16 is fixed in the delay configuration, while resistance can be added via a pair of connectors to change the clock frequency in the phasor/flanger.

The audio input signal is conditioned by seven poles of low-pass filtering in which IC3 and half of IC1 are used. The filters provide a total of 42-dB/octave attenuation above the tuning frequency. For example, if the filter were tuned for 5000 Hz, a 10,000-Hz signal would be attenuated by more than 100:1.

When filters are designed with high-gain operational amplifiers (op amps), it is possible to have their outputs increase before rolling off at the rate of 6 dB/octave per pole. Such filters are termed "under damped." By carefully selecting the proper balance of under-damped and over-damped (RC) filter sections, it is possible to design a filter that is flat in the desired

passband so that it is 3 dB down at the tuning frequency and has a roll-off rate of 6 dB times the number of poles.

This is what has been done in the delay-line and phasor/flanger circuits. Quite a bit of mathematical compu-

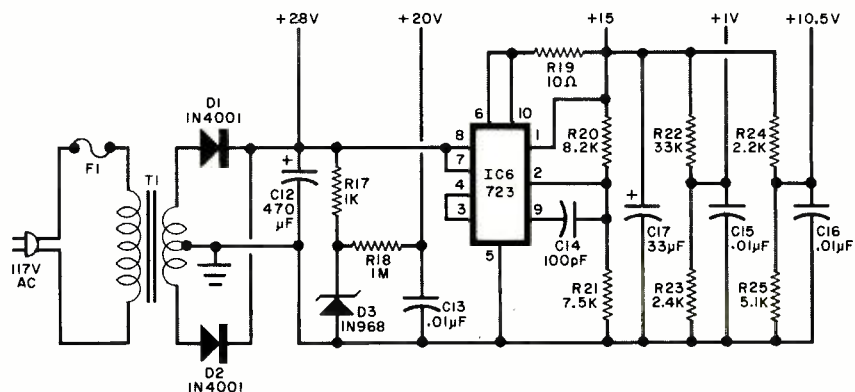

Fig. 5. Schematic of power-supply circuit. Parts List includes kit information for all circuits.

PARTS LIST FOR FIG. 5

C12—470-µF, 35-volt electrolytic capacitor
 C13, C15, C16—0.01-µF disc capacitor
 C14—100-pF disc capacitor
 C17—33-µF, 25-volt electrolytic capacitor
 D1, D2—1N4001 rectifier diode
 D3—1N968 (20-volt) zener diode
 F1—1/10-ampere fuse
 IC6—723 precision voltage regulator
 The following resistors are ¼ watt, 5% tolerance:
 R17—1000 ohms
 R18—1 megohm
 R19—10 ohms
 R20—8200 ohms
 R21—7500 ohms
 R22—33,000 ohms
 R23—2400 ohms

R24—2200 ohms
 R25—5100 ohms
 T1—Power transformer with two 28-volt secondaries at 50 mA each
 Misc.—Chassis: line cord; phono jacks (4); control knobs (2); rubber grommet; spacers; machine hardware; hookup wire; solder; etc.
 Note: The following items are available from Phoenix Systems, P.O. Box 73, Saugatuck Sta., Westport, CT 06880: Complete kit of parts (delay line or phasor/flanger) No. P-1220-M (mono) for \$39.00; complete kit of parts No. P-1220-S (stereo) for \$59.00; etched and drilled pc board No. P-1220-B for \$5.00; MN3001 analog shift register IC No. P-1220-C for \$15.00. Add \$1.00 for shipping and handling. Connecticut residents, please add sales tax.

CLAIMED SPECIFICATIONS

Delay Line:

Frequency response	15 to 15,000 Hz (+2/-3 dB)
Distortion (THD)	Typically less than 1% (1000 Hz, 1 V rms)
Input impedance	Greater than 100,000 ohms
Clipping level	1.77 V rms (5 V p-p)
Signal-to-noise	Typically 50 dB below 0 dBm

Phasor/Flanger:

Frequency response	15 to 15,000 Hz (+2/-3 dB)
Distortion (THD)	Typically less than 0.75% (1000 Hz, 1 V rms)
Input impedance	Greater than 100,000 ohms

tation is normally required to determine the values of the filter resistors to use. To simplify matters, you can select the appropriate resistor values from the Table of Filter Resistor Values. Use this Table for selecting resistor values for only the delay-line circuit. (The filter resistor values specified in Fig. 4 and its accompanying Parts List will provide an optimized 5-ms delay, with the output 3 dB down at 15,000 Hz for the phasor/flanger.)

The power supply is shown in Fig. 5. It uses a voltage regulator, IC6, to generate the main 15-volt supply output. The shift register requires supplies of both +1 and +20 volts. The +20-volt line is obtained through the

use of zener diode D3, while the +1-volt line is derived from the voltage divider consisting of R22 and R23. Since the op amps are being operated from a single-ended supply, it is necessary to have the 10.5-volt supply line serve as the reference point in the circuit for these IC's.

Construction. The actual-size etching and drilling guide, the same for both circuit configurations but wired differently as required, is shown in Fig. 6A. The parts-placement guides for the delay-line and phasor/flanger con-

figurations are shown in Figs. 6B and 6C, respectively.

Before installing any components on the board, mount and solder into place the wire jumpers. Then, wire the board as in Fig. 6B or Fig. 6C, depending on the desired mode of operation. Be careful to properly orient all semiconductor devices and electrolytic capacitors. Be sure to handle the MOS devices with care to prevent them from being damaged by static charges. You can mount the IC's directly on the board or use sockets. Use a low-power soldering iron (25 to 35

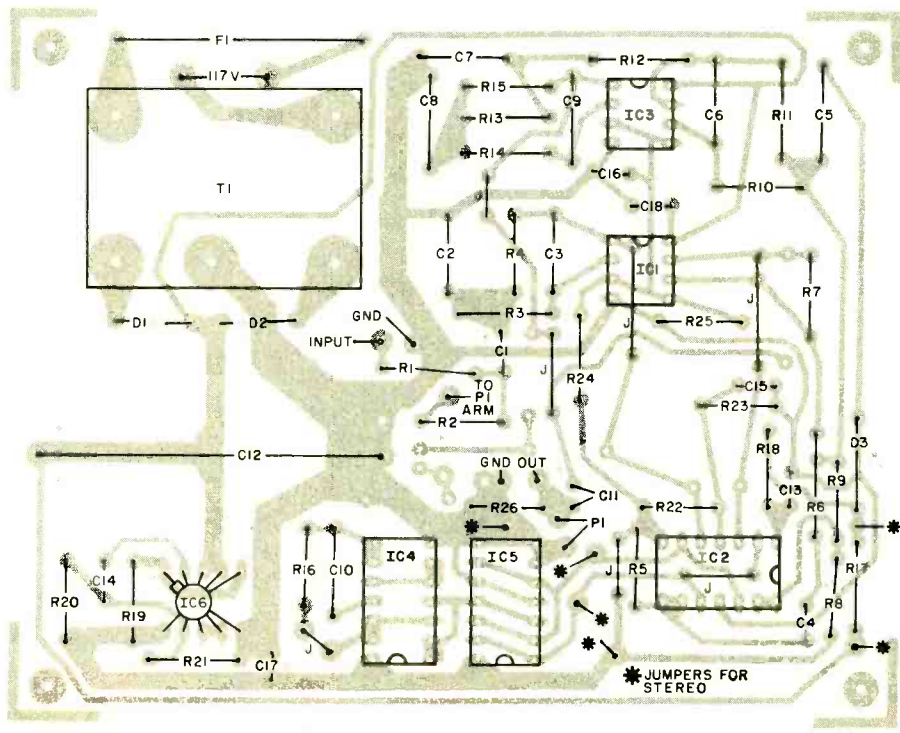
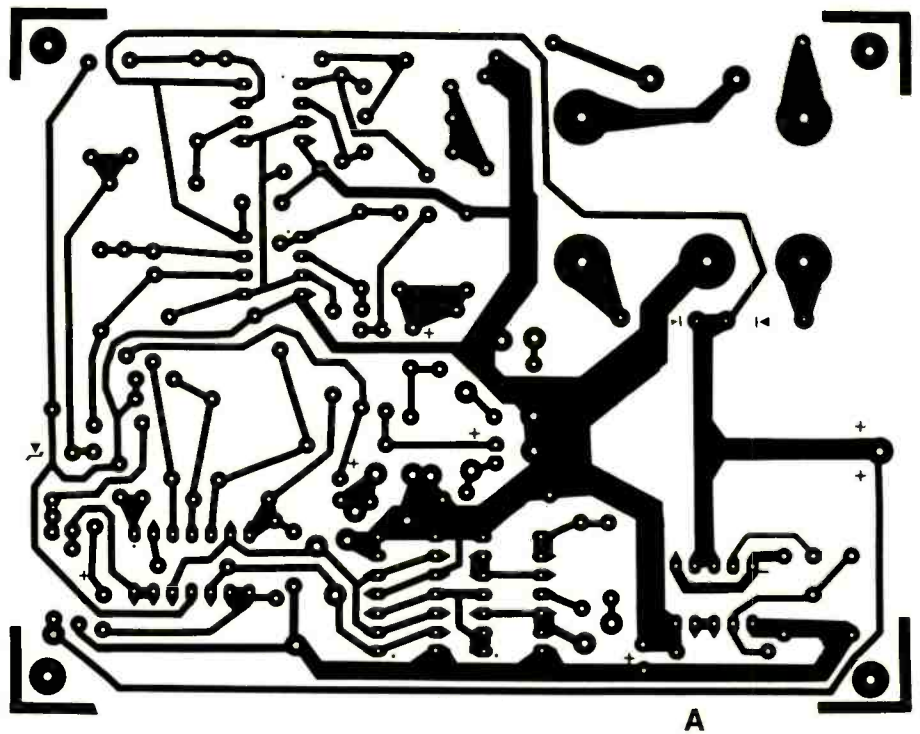

Fig. 6. Above (A) is etching and drilling guide for pc board. It can be used for either channel for delay-line circuit, or for the phasor/flanger. At left (B) is component layout for one channel of delay line. It includes the power supply. Component layouts for phasor/flanger and second channel of stereo delay line are on next page.

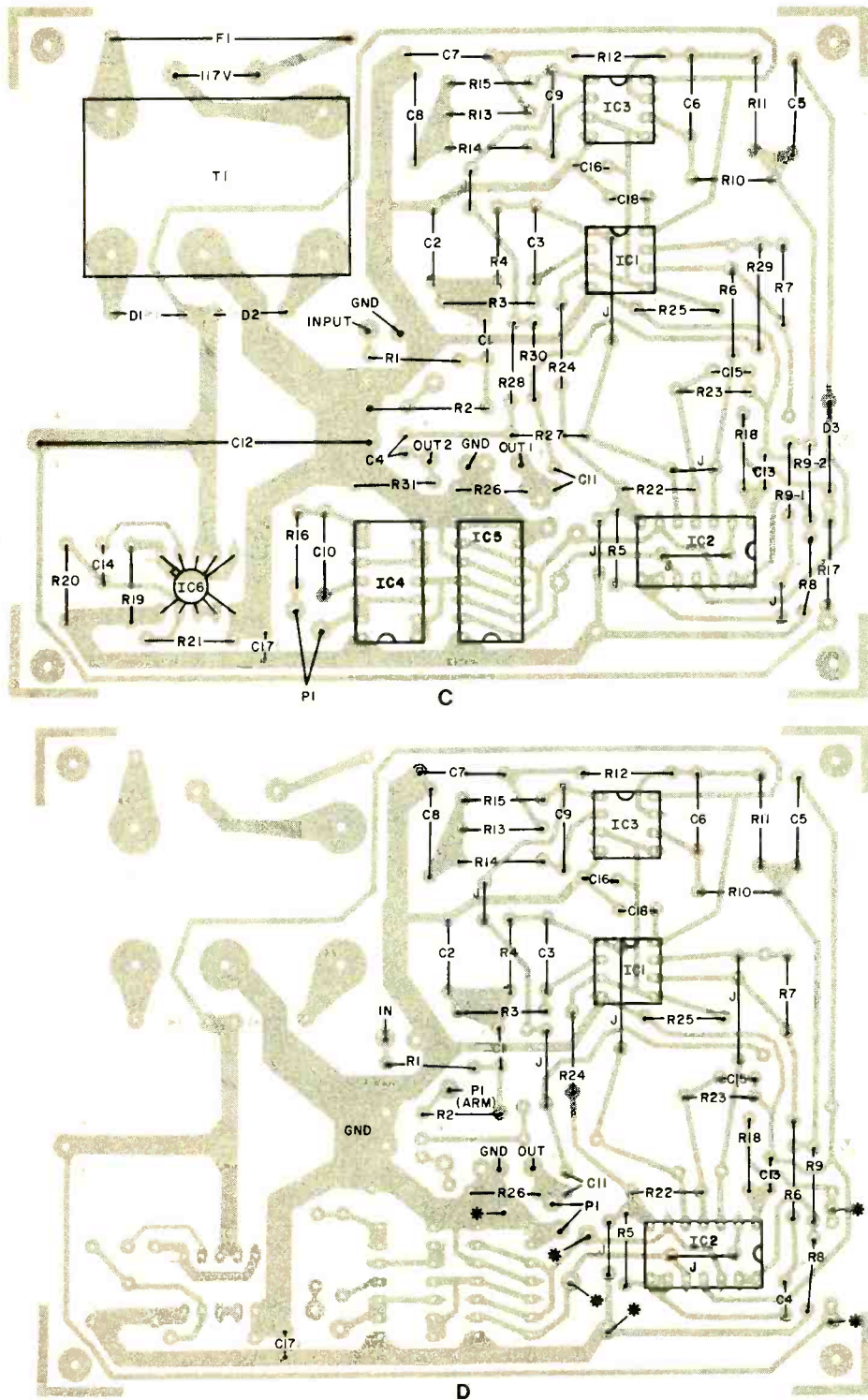

Fig. 6. Component layout at top is for phasor/flanger (C). Below (D) is for second channel of stereo system. It uses power supply in first channel.

watts) and fine solder, and watch out for solder bridges between the closely spaced pads on the board.

The wiring guide for the second pc board for a delay line for stereo is shown in Fig. 6D. Note that the power supply section is *not* repeated; you get power and clock pulses from the first board via wire interconnections.

Solder lengths of hookup wire to the pads that are to interconnect with the

off-the-board pots and jacks. Then drill holes for the line cord, jacks, pots, and board mounting in a 5" x 4" x 3" (12.7 x 10.1 x 7.6 cm) aluminum chassis box. Locate the line cord and jack holes on a wall directly opposite the wall through which the pot holes have been drilled.

Use machine hardware and spacers to mount the pc board assembly to the floor of the aluminum box. If you are

HANDS-ON EVALUATION

Both the time-delay and phasor/flanger configurations of this circuit should keep the home recordist occupied for hours, if not days. While the effects are not as apparent as those obtained with professional delay and flanging systems, this system does not cost the \$4000 or so demanded for such top-of-the-line professional system.

The flanging effect is heard only while the potentiometer is in motion, at which time the variable comb filter sweeps across the audio bandwidth to create the "flanging" sound. At rest, the comb-filtered sound is noticeable, but it is not as apparent as one would expect from looking at the peaks and dips that occur at regular intervals on the frequency response curve.

Although you might not have occasion to use the flanger as a mono-to-stereo generator, don't overlook this operating mode for the enhancement of a single-output reverberation device. Reverberation is very diffuse by nature, and the flanger outputs, when panned left and right, are a noticeable improvement over a regular mono reverb return. When used in this application, the potentiometer remains at rest.

Use only one output when applying flanging to a recording. For an interesting Doppler effect, try combining the two outputs while rapidly revolving the pot. Better still, replace the standard pot with a free-spinning pot. (Connect the resistance element in series with R16 and the wiper to either end of the element.)

On the delay line, the recirculation control must be used sparingly. A little goes a long way, and the "door spring" effect can easily get out of control. If you build both circuit configurations, you can experiment by wiring the flanger into the delay line's recirculation path. The slight additional delay in feedback creates even more echoes at the delay line's output. It also helps to keep the door spring from becoming a steady-state squeal.

—John Woram,
Woram Audio Associates

assembling a stereo delay line mount the second board assembly over the first with short spacers and machine hardware after interconnecting the power-supply and clock-drive lines with hookup wire. (Be sure to make the interconnections before fastening the boards together.) Connect and solder the free ends of the hookup wires from the board(s) to the appropriate lugs in the jacks and pots. ♦

Ten Speaker-Enclosure Fallacies

BY DAVID B. WEEMS

SEVERAL years ago the U.S. Patent Office granted a patent for a speaker enclosure that had some unique internal reflectors. Its inventor claimed that the reflectors, by bouncing the sound back and forth, enabled any speaker to reproduce longer wavelength bass in a compact box. The fact that the patent was issued shows that the inventor recognized a great need. Unfortunately it does not show that a new set of natural laws would be necessary to make the invention work.

Experimenters have contributed many interesting and imaginative (often flawed) speaker enclosures to the high fidelity and stereo scene. Many of them have been adopted and are commercially produced. But com-

mercial production is no proof of merit. How about a cheap speaker buried in a thin-walled unpadded box? This commercial flop was called a "cavity generator." It really sounded as bad as you'd expect. Then there was the bass reflex with ports shaped like f-holes on a violin for (one supposes) a more musical bass. If you like to mix pets and audio components, how about the "cat's door" speaker? This one had a small swinging door in the back. Presumably this was the answer for anyone who couldn't choose between a sealed box and one with a port.

Some bizarre speaker systems are good, but they don't always work the way their designers think they will. Novices misinterpret speaker box

theory. They overlook hidden snags, because after all, what looks easier to make than a simple box?

They are also often misled by old speaker box fallacies. Stories about speaker systems can be loaded with colorful misconceptions. Even well-known manufacturers sometimes promote them in their advertising. A current table model radio, for example, was introduced with the claim that its wooden cabinet gave it "the same mellow resonance that grandma's big console used to have." Aside from the suggestion that resonance is good, this statement gives credence to a fallacy that has been around a long time. Its roots probably go back some 300 years. In deference to its age we'll consider it first.

1ne

*Wooden speaker cabinets
have a good "tone."*

This old one is surely a hangover from the mysterious art of violin making that reached its peak in the 17th century. That's when the families of Amati and Stradivari developed methods of using certain woods which produced instruments of great esteem. But a loudspeaker is not a musical instrument. Its function is to change electrical energy into acoustic energy without adding to the original signal.

Wood is only one of many materials suitable for speaker boxes. Its popularity is based on convenience and appearance. Dense materials, such as brick or concrete, are better. Having greater rigidity, they are less likely to vibrate and add false tones. Any material that is acoustically opaque, sufficiently rigid, and reasonably well damped can be used.

2wo

*Enclosure wall panels should
have a low resonant frequency.*

This might be called a high-level fallacy because it is often believed by people who are otherwise well informed about speaker systems. They know that all panels, like speakers, have resonance. The general rule for speakers goes: low resonance, good; high resonance, bad.

For box panels the reverse is true. Unlike speakers, box walls should produce no sound at all. Making a panel more rigid helps in two ways. It reduces the amplitude of any vibration, lowering its sound level; and it raises the panel's resonant frequency. Upper-bass and midrange frequencies can be more easily absorbed by using acoustic damping material in the box.

3hree

Fig. 1. Braces are usually put across short dimension of panels (A). Lengthwise braces (B) make panels stiffer.

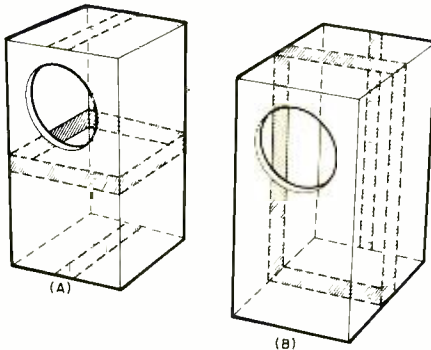

Panel braces should cross the short dimension of the panel.

There is a common belief, sometimes supported by mathematics, that braces around the mid-section of a box (Fig. 1A) add more rigidity than lengthwise braces (Fig. 1B). The reasoning is that a short brace is more rigid than a long brace. But the goal

should be to produce greater rigidity in the walls, not the braces.

Another theory says that braces should be installed diagonally. The advantage of diagonal bracing, it is said, is that one brace can resist stress in two directions.

About 15 years ago Peter Tappan did some experiments to find the effects of various kinds of bracing. He found that a panel with a fundamental resonance of 60 Hz had the resonance raised to 100 Hz by a cross brace, to 115 Hz by a diagonal brace, and to 160 Hz by a lengthwise brace. He concluded that the lengthwise brace was most effective because it divided the panel into the narrowest possible sections. Ideally, a brace should be installed slightly off center so that it breaks the panel into two unequal parts. Opposite sides, which have the same dimensions, should have dissimilar bracing.

4our

All speaker box walls should be $\frac{3}{4}$ " thick.

This is an old rule of thumb. When most speaker enclosures were floor models made of plywood, it was good enough. Now, when speaker boxes take many sizes, assume various shapes, and contain unusual materials, wall thickness should be matched to individual box requirements.

Thick plywood is a good choice for large panels. Plywood backs, for example, should usually be at least $\frac{3}{4}$ " thick. But to use $\frac{3}{4}$ " walls for a miniature speaker would be wasteful.

For other materials, weight is a good guide to adequate thickness; but there are exceptions. Consider a thin-walled enclosure made of steel, for example. It could be satisfactorily rigid and yet produce inferior sound because of poor damping. If you suspect wall damping problems, use the knuckle test. Rap the sides with your knuckles and listen. You should hear a dead thump rather than a hollow drummy sound.

5ive

Damping material is useful in eliminating bass boom, but too much can cause rolloff at high frequencies.

Various damping materials, such as fiberglass, dacron batting, and other fuzzy substances, are used to absorb unwanted sound. These absorbents are most effective in the midrange frequency band. Don't underrate this ability. Midrange reflections inside the box interact with the speaker cone to produce a rough frequency response. The proper use of damping material can greatly reduce listening fatigue.

Stuffing a box does little to control bass boom (much less than electrical damping on the speaker), but it can affect bass range. The stuffing, by absorbing and giving up heat, changes the condition of sound propagation in the box from adiabatic to isothermal. This change reduces the velocity of sound, shortening the wavelength. In effect, the enclosure "acts" larger. Because of increased acoustical resistance, a stuffed box reduces speaker efficiency.

The second part of fallacy 5, that acoustic treatment inside the box can depress the highs, is a common case of mistaken judgement. Padding the inside of a box often removes excessive brightness. Careless listeners sometimes interpret the reduction of midrange peaks as a loss of highs.

6ix

The outside shape of a speaker box has no effect on the sound.

One problem with most speaker enclosures is that they are box-shaped. Opposite parallel walls produce internal reflections, but the problem is usually treatable. Externally, sharp corners and projections at the front edge of the box cause diffraction effects as the sound waves reach those corners. The diffracted waves overlap, producing destructive interference and uneven frequency response. Ideally the front of the enclosure should curve away from the speaker, like a sphere. As a compromise solution, the front corners of box-shaped enclosures can be made free of projections and even rounded off or chamfered.

7even

A speaker should be centered on the speaker board.

A speaker in the center of a speaker board looks right. It can sound bad. Equidistant from each side, it is positioned where it will promote standing wave formation in the box. Centered speakers also aggravate the diffraction problem discussed in 6.

To insure in-phase operation, woofers and tweeters need only be wired with proper polarity and installed on the same board.

Most audio fans know that they must "phase" speakers in a stereo or 4-channel system. Polarity should also be observed when wiring woofers and tweeters into a crossover network. But there are other, more subtle, causes of phase distortion. One of these is unequal sound-path length from multiple sources.

Speaker phase distortion was first recognized in 1935 when some Hollywood sound men noticed an echo in a tap dancing sequence by film star Eleanor Powell. They traced the source of the echo to the theater speaker, a large two-way horn system. Unequal path length was the demon. The bass horn was 8 feet longer than the treble horn. The dancer's sharp transients uncovered a kind of distortion that had gone unrecognized in music and speech.

Multiple speakers on a common speaker board can produce sound with unequal path length in at least two ways. The woofer cone, because of its greater depth, is usually located a few inches behind the shallow tweeter cone. And sometimes there is a lateral distance between the cones (Fig. 2). These two distances introduce phase shift in any sound reproduced by both cones. When the difference in path lengths is equal to one-

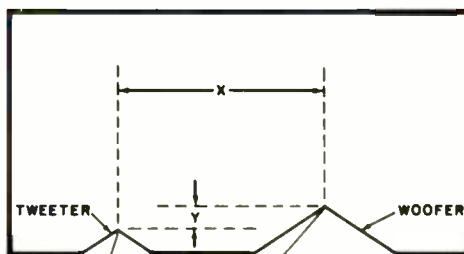

Fig. 2. Difference in sound path length due to horizontal distance between woofer and tweeter (X) and depths of cones (Y) produces phase distortion to listener.

8ight

half wavelength, the phase angle is 180° , causing cancellation. For woofers and tweeters the phase problem extends through the band of frequencies in which their response overlaps, usually about a half octave on each side of the crossover frequency.

Phase distortion can also occur when a well-designed speaker is placed on its side. If that placement puts a horizontal distance between drivers with overlapping frequency bands, it can cause phase distortion except at the one listening position where the path lengths are equal.

With proper design a small box can give both good efficiency and a full bass range.

This might be called the wishful thinking fallacy. Compact speakers can reproduce low-frequency bass (as proved by acoustic suspension speakers). But to get a woofer with an ultra-low resonance (a necessity in a small box), engineers must increase both the compliance and mass of the cone. Newton's Second Law of Motion tells us that the added mass requires more energy to accelerate it. So full-range acoustic suspension speakers are inefficient.

Can a light cone be made compliant enough to give both good efficiency and a full bass range in a small box? No. First, there are practical problems with ultra-high compliance. A floppy cone is hard to protect during shipment, for example. There are also theoretical limits. A speaker's fundamental resonance varies inversely with the square root of its compliance. So to reduce a speaker's resonant frequency by increased compliance alone from, say 60 Hz to 30 Hz, the compliance must be made 4 times as great.

To get a 15-Hz resonance with the same speaker, its compliance would have to be increased to 16 times the original value. But such a speaker, even if practical, would be defeated by a small box. An electrical circuit equivalent to the mechanical circuit of the speaker in the box (Fig. 3) shows that the compliance of the trapped air is in

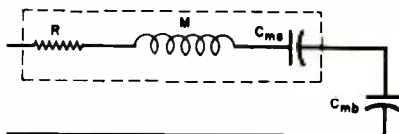
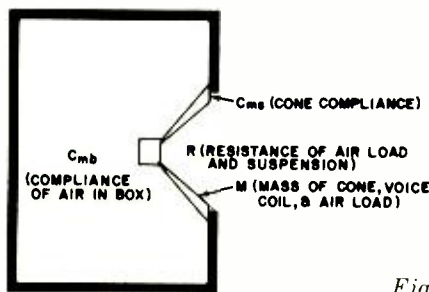

Fig. 3. Electrical schematic below is equivalent to mechanical circuit of a speaker in an enclosure.

series with the cone compliance. When two capacitances appear in series, the smaller capacitance (C_{mb}) limits the total capacitance (or compliance) no matter how great the other capacitance (compliance).

The example shown here is for a closed box speaker system. Reflex speakers have a theoretical efficiency advantage of 3 dB over closed boxes, but the minimum box volume for satisfactory reflex operation is greater than that for a closed box.

Any speaker designer faces the conflicting requirements of efficiency, low-frequency response, and space. He can make a small speaker offer high efficiency and a limited bass range, or it can have low efficiency and a full bass response. He cannot give it all three.

9ine

10en

Bass reflex enclosures always boom. That's why they are called "boom boxes."

This fallacy has been promoted by both sides in the reflex/closed-box war. "I like bass," some say, meaning that any kind of bass is desirable. Closed-box fans say, "Reflex speakers give one-note bass."

The belief that a reflex system will inevitably have more boom than closed-box systems is wrong on two counts. Any kind of dynamic woofer, particularly if its Q is high, can boom.

Cheap speakers with small magnets have a higher Q than speakers with adequate magnetic field strength in the voice-coil gap. Well-designed reflex enclosures produce no more obnoxious boom than other types.

If you have a reflex system that booms excessively, the box may be too large or too small for optimum performance. In either case, the solution is simple. Cover the port and operate the speaker as a closed-box system. If the boom persists, your problem is more basic than a mistuned bass reflex enclosure.

There are probably more fallacies having to do with speaker systems than about any other audio component. When you consider how difficult it is to measure and analyze speaker

behavior, however, that's no wonder. Sometimes it is a case of mistaken identity. Fallacies crop up when somebody mistakenly identifies effect as cause, form as function, or even

inferior performance as superior performance. The ten fallacies listed here are only a few samples. So stay alert. You may discover a brand new one yourself. ♦

Build A SINE-WAVE INVERTER

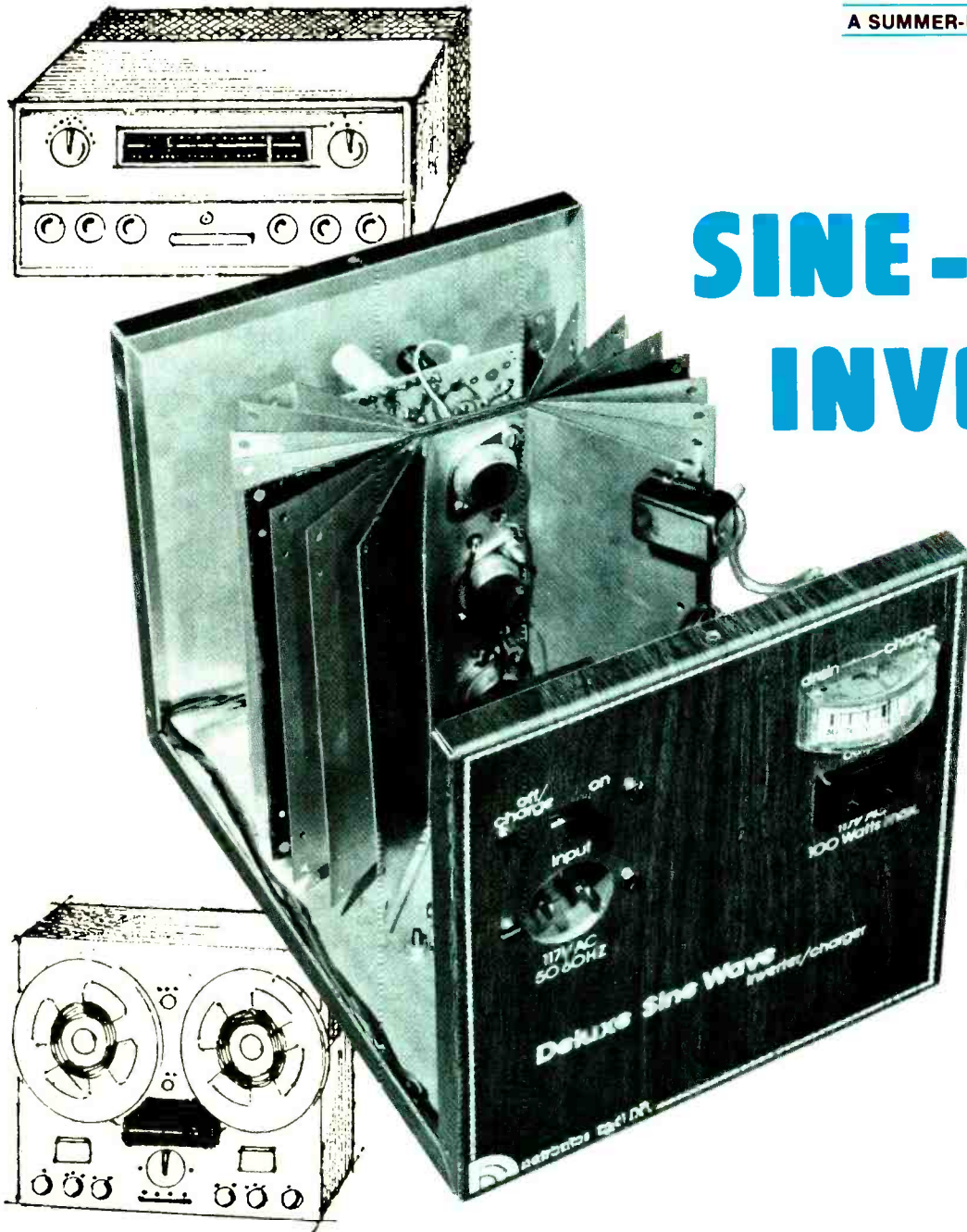

Boosts 12 volts dc to 117 volts ac at 100 watts, and also recharges storage batteries.

BY MARTIN MEYER

“CAMPING OUT,” whether it be in one of the new modern campers, a trailer, a tent, or even a boat, is one of today’s most popular ways of “getting away from it all.” There always comes a time, however, when we miss some of the creature comforts that we left at home—comforts that can only be provided by electrical appliances. Unfortunately, appliances that work on 12 volts dc are relatively expensive.

You can, however, use a dc-to-ac inverter, enabling you to utilize ac equipment you already own. As some readers might have already discovered, though, most of these devices deliver a form of square wave that prevents their use with equipment that is

sensitive to the interference caused by square waves. This includes TV receivers, audio equipment, CB gear and some test instruments. With the inverter described here, you can now get 117 volts of 60-Hz sine-wave power at 100 watts from a conventional 12-volt battery system. In addition, the in-

verter can be used to recharge vehicle batteries at 15 amperes from any 117-volt, 60-Hz power source.

The inverter can also be preset to deliver power at any frequency from 50 to 400 Hz, making it useful for operating some surplus electronic gear designed for 400 Hz. As an integrated standby power source it can even be used for power-failure emergencies in the home.

SPECIFICATIONS

Input:	12 V dc at 14 A
Output:	117 V ac, 50-400 Hz, 100 W
Distortion:	Less than 10% at 100 W
Charge Current:	15 A max. (self-limiting)

How It Works. As shown in Fig. 1, the first stage in the inverter is a low-distortion sine-wave oscillator (*IC1A*) whose frequency can be adjusted by *R1*. The output of the oscillator is amplified and isolated from the load by a combination of an op amp and

PARTS LIST

- C1—0.082- μ F Mylar capacitor
- C2—0.002- μ F disc capacitor
- C3,C5,C6,C7—47- μ F, 16-volt electrolytic capacitor
- C4—220- μ F, 16-volt electrolytic capacitor
- C8—2.2- μ F, 16-volt electrolytic capacitor
- C9—1000- μ F, 16-volt axial-lead electrolytic capacitor
- C10—1000- μ F, 16-volt, pc-type electrolytic capacitor
- C11,C12,C13—0.01- μ F disc capacitor
- CB—18-A circuit breaker (Littlefuse)
- D1 to D9—1N4001 diode
- D10,D11—1N4148 diode
- IC1—747 dual op amp
- M1—30-0-30-A meter
- P1—17-volt male socket
- Q1—2N5232 transistor
- Q2—2N5354 transistor
- Q3,Q4—60407 transistor (RCA)
- Q5 to Q10—2N3055 (matched gain at 5A)
- R1,R11—50,000-ohm potentiometer
- Following resistors are 10%, 1/4-watt:
 R2,R4—68,000 ohms
 R3—2200 ohms
 R5,R19,R22—220 ohms
 R6,R7,R12,R13,R20,R21—10,000 ohms
 R8—510 ohms
 R9—4700 ohms
 R10—1000 ohms
 R14—1 megohm
 R15—120,000 ohms
 R16—470,000 ohms
 R17—560,000 ohms
 R18—220,000 ohms

- S1—5-pole, double-throw switch
 - S01—17-volt chassis-mounting socket
 - T1—1:3 step-up driver transformer
 - T2—6-V/117-V, 18-A primary output transformer (see below)
- Misc.—Suitable chassis, rubber feet, grommet for battery lines, press-on type, silicone grease, aluminum for heat sink, 3/4" standoff insulators.
- Note—The following are available from Netronics Research and Development Ltd., Rt. 6, Bethel Meadows, Bethel, CT 06801: complete kit including case and heat sink at \$69.95, plus \$3.00 postage and handling. Also available separately are: output transformer T2 at \$27.95; driver transformer T1 at \$4.00; S1 at \$2.70; meter M1 at \$4.50; circuit breaker at \$3.00; six matched 2N3055 transistors at \$12.00; pc board at \$4.00. Separate part orders add \$2.00 postage and handling. Connecticut residents add sales tax.

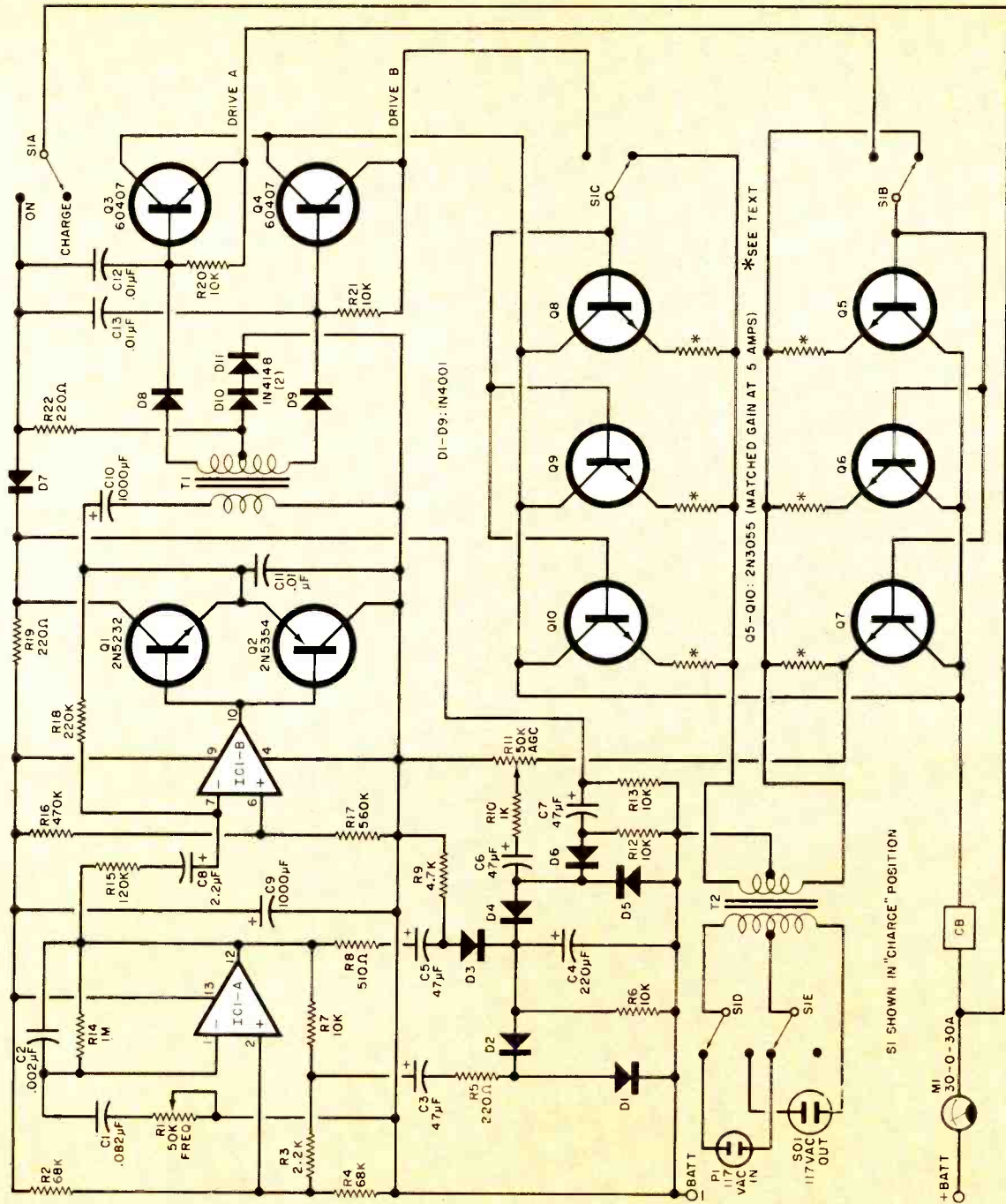

Fig. 1. A stable op amp audio oscillator is used to drive six high-power transistors, delivering 117 volts sine wave at any frequency between 50 and 400 Hz and with 100 watts of power.

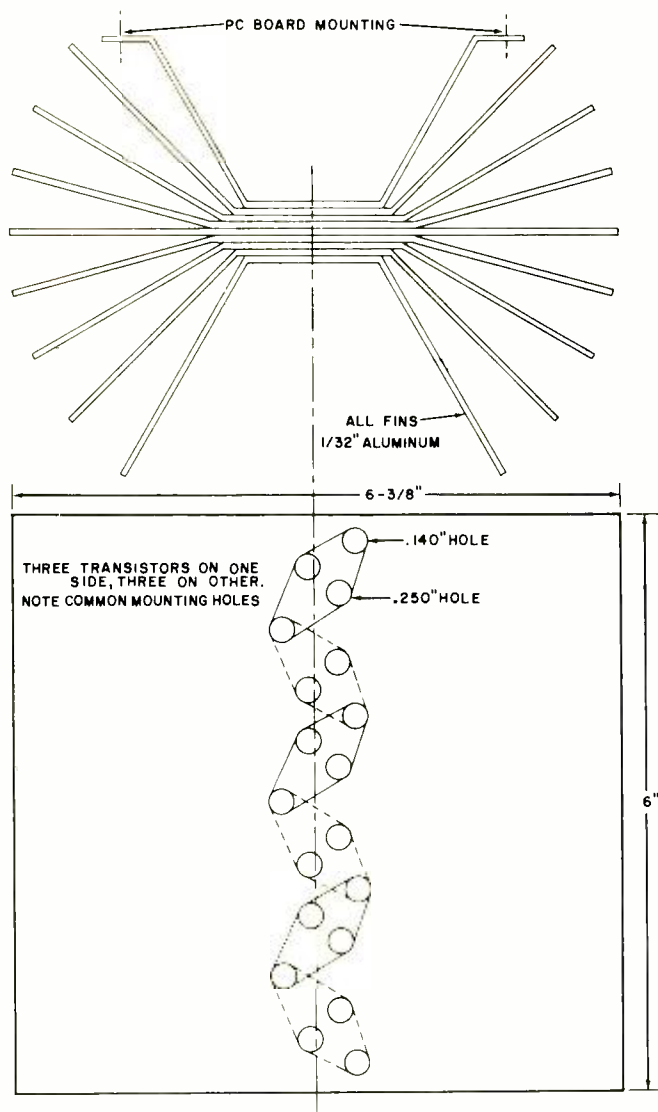

Fig. 2. Instructions and dimensions for making the heat sink. It must have at least 500 sq. in. of cooling surface.

discrete-transistor class-B pair (*IC1B*, *Q1* and *Q2*) and *T1*.

Transistors *Q3* and *Q4* are medium-power amplifiers, each one Darlington-connected to three high-power transistors (*Q8*, *Q9*, *Q10* and *Q5*, *Q6*, *Q7*). Transformer *T2* is the load for the high-power transistors and provides the 117-volt output at the preset sine-wave frequency.

Load regulation is provided by feedback from the emitter of *Q7* to potentiometer *R11* and then to the oscillator. Regulation from no load to full load is better than 6%.

When switch *S1* is set to CHARGE, the circuit (except for *Q5* through *Q10*) is disconnected from the battery, and the six high-power transistors act as rectifiers. The secondary of *T2* is connected so that the proper charging current is obtained.

An 18-ampere circuit breaker is mounted on the output stage heat sink

to monitor the temperature and current drain. If the heat sink gets too hot due to improper ventilation, the current rating of the circuit breaker reduces proportionately. Thus, the inverter is protected from improper mounting or application.

The zero-center ammeter (*M1*) indicates the current drain when the circuit is inverting and the charging current when it is recharging a battery.

Construction. The crucial element in the assembly is the construction of the heat sink. To keep the operating temperature below 100°C, the heat sink must have more than 500 square inches of area. Details of the construction are shown in Fig. 2. Note that there are nine sections of 1/32"-thick aluminum in the heat sink, with holes drilled to mount the six power transistors.

After drilling the holes for the trans-

istors, remove the burrs. The transistors share common mounting holes with three transistors on one side of the sink and three on the other. Use silicone grease under the transistors to insure intimate thermal contact with the heat sink. The transistor cases are not insulated from the sink as all collectors are connected in parallel. The heat sink is insulated from the metal case by four insulated stand-offs. Do not try to use a smaller heat sink or you will run the risk of damaging the transistors.

The remainder of the circuit is mounted on a pc board (Fig. 3). Note that the cases of diodes *D10* and *D11* are actually thermally bonded to the heat sink. The cutout in the board allows the diodes to contact the heat sink (with silicone grease to insure the contact). Transistors *Q3* and *Q4* are also mounted so they touch the heat sink. Their collectors are at the same potential as those of the power transistors. Drill suitable holes to attach the pc board to the lips on one end of the heat sink.

After selecting a chassis, mount the heat sink on four insulated stand-offs. The metal chassis must be floating, not connected to input or output.

The emitter resistors for transistors *Q5* through *Q10* are made of 14-inch lengths of #22 wire. It is important that the lengths of the resistors be as nearly the same as possible so that the transistors share equal amounts of the current. The secondary of *T2* is at 117 volts ac so use care in routing the leads. Dress leads away from the heat sink and use wire rated at 105°C.

The leads from the inverter to the battery (through the rear of the case) may carry as much as 18 amperes, so use heavy gauge wire or lengths of line cord with both leads in parallel for each side. If the connection is very long, use four parallel wires for each side to keep the voltage drop in the leads to less than 0.5 volt.

When assembly is complete, check again to make sure there is no connection between the case and the input or output.

Testing. With the cover off, set *R11* and *R11* to their mid-positions. Connect the battery leads to a high-current 12-volt source (vehicle battery). Turn the inverter on and note that the meter indicates less than 2 A drain. If this is not the case, immediately turn off the unit and determine the reason.

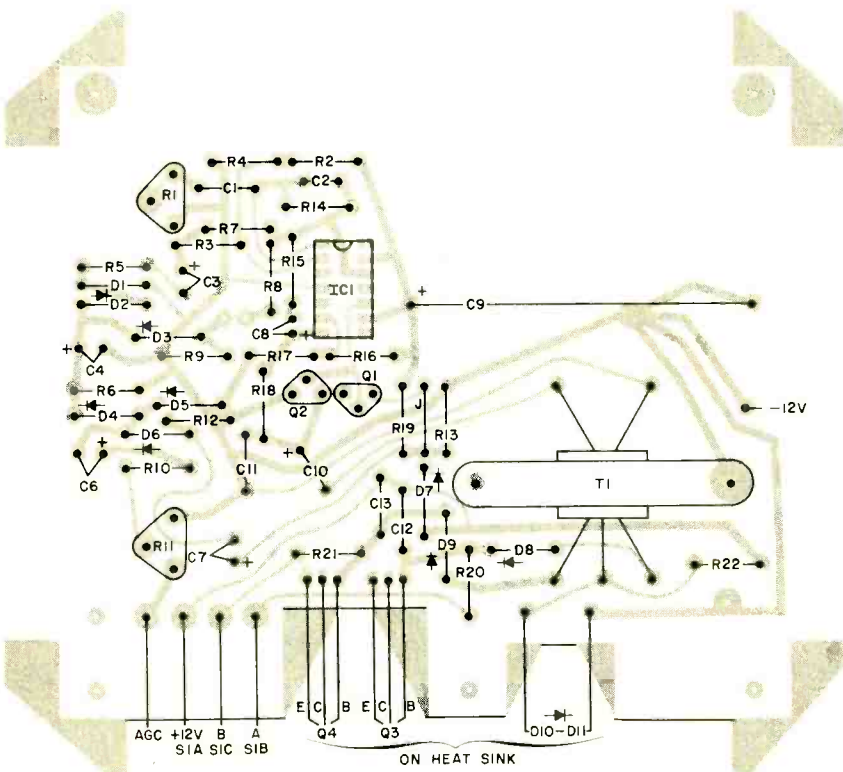
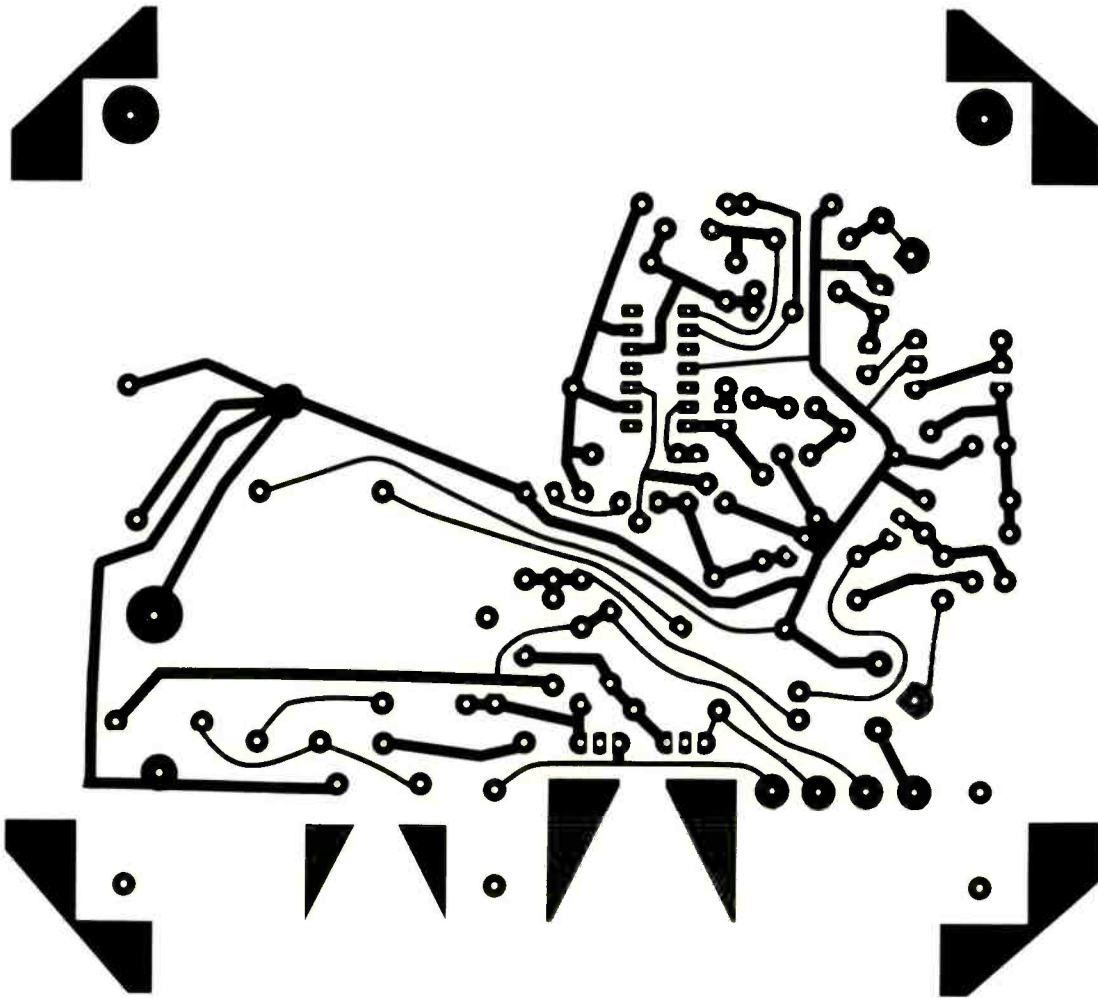

Fig. 3. Etching and drilling guide and component layout for pc board. D10, D11, Q3, and Q4 touch heat sink.

If the meter indication is correct, turn off the inverter and connect a 117-volt ac meter and a 100-watt lamp to SO1. Keep in mind that this is a hazardous voltage. Turn the inverter on and adjust R11 to obtain 117 volts at SO1.

Use a frequency counter or the circuit shown in Fig. 4 to adjust R1 for 60 Hz. In using the circuit in Fig. 4, adjust R1 until the neon lamp does not flash (zero beat).

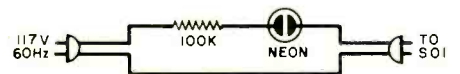

Fig. 4. Use this circuit to tune the inverter to 60 Hz.

Operation. This equipment, like any ac line-powered gear, must be treated with great care. The cabinet should be adequately ventilated at all times. The design is safe up to an ambient of 120°F. If the circuit breaker trips, check the ventilation and possibly reduce the output voltage slightly. It is good practice not to operate any electronic gear in an ambient in which a human is not comfortable. ♦

SO YOU HAVE finally found what you hope is the last solder bridge on your homebuilt computer, put the case on, and turned the dining table back to your wife. Now you are ready to start using your computer; but after one long evening of working the switches and watching the lights, you realize you don't really know how.

Did you read the operating manual? If so, you would have found that there are a number of "input/output ports" available. However, you can't just feed data through an input port and expect it to come flowing from the output port. You have to have some peripheral devices to attach to those input and output ports.

A peripheral device can be a teletypewriter, card reader, paper-tape punch, CRT terminal, etc. Magnetic tape and discs are also part of the peripheral device scene. However, these devices don't just sit there and communicate with the computer automatically. You have to know how they work and how to "talk" to them through the input/output ports.

Every device has its own idiosyncracies. There are two main characteristics that we will consider here: character codes and speed.

Character Codes. The easiest way to get a good feel for the concept of a character code is to design an input

device. First, we must decide upon its alphabet; that is, we must describe *precisely* the entire set of characters that this device will recognize. We then order these characters in whatever arrangement suits our fancy and number them from 0 to n , where n is the number of distinct characters in our alphabet.

The device is now constructed so that when it recognizes a specific character, say the 17th character in its alphabet, it transmits its *number*, 17, (in binary, of course) to the computer's input port.

The question arises: how many bits are needed to uniquely code an alphabet? The answer is that we need at

IN's and OUT's of COMPUTERS for BEGINNERS

BY EUGENE H. MITCHELL

*Understanding
character codes,
flags, interrupts,
DMA, and
other
computer terms.*



least $\log_2 n$. Conversely, if a character code contains n bits per character, then the maximum number of characters is 2^n . Thus, an 8-bit code can describe a 256-character alphabet.

Another question is: how many characters do we need in an alphabet? In English, we need 26 letters, 10 digits, a number of punctuation characters, and a *blank*. Never forget that a *blank* is a character! If we allow for eleven punctuation characters we find we need a total of 48 characters. Note that we have 26 letters with no discrimination between upper and lower case. If we want both cases, we must add another 26 characters—upper and lower case of a given English letter are two completely different characters to a computer! The total is now 74 characters.

Five bits would give us 32 characters which is not enough. Six bits would permit 64 characters, so 6 bits is the minimum number we need for a reasonable alphabet, although we need at least 7 if we are to recognize both upper and lower case letters. For years the 6-bit code was a default industry standard and the default character set was the 48 characters available on the IBM model 026 keypunch. When IBM introduced the 360 computer they went to a model 029 keypunch with 64 characters. The computer, however, used an 8-bit character code.

You may have heard of a character code known as ASCII (American Standard Computer Information Interchange) which is used in the newer teletypewriters. This has an 8-bit code and 128 characters including upper and lower case. However, most teletypewriters have only upper case letters.

To build an output device, we go through a similar procedure. The major difference is that when the computer gives it a binary number, the output device produces the corresponding character of *its* alphabet, not necessarily the same as that of the input device.

Data Rate. Let's say the output device is a typewriter with a speed of 10 characters per second. Let's type the letters "AB". First, we put the code for an "A" in the output port, followed by the code for a "B". In your computer this would take a few microseconds. But it takes the device 1/10 of a second to type the A! Thus, it would do one of

two things: type the A and never see the B, or never see the A and type out the B.

What we must do is put the code for the A in the output port, then do something else for 1/10 of a second (we may just have to waste 1/10 of a second by looping), then put the code for B in the port.

Let's leave the computer and look at the output port from the eyes of the device. First it "sees" the code for an A so it prints an A; then it looks back at the port and sees the code for a B and prints a B; then it looks back at the port and sees the code for a B (it's still there!) so it prints it. And so on, ad nauseum. We obviously need some method to avoid this. One way is to define a character code which means "do nothing" (this is NOT a blank). We will give this code a name; it is the *null* character. Then to send "AB" we output A (we really mean we output the code for an A), wait, output B, wait, then output *null*. The device prints the A, prints the B, then continuously does nothing so long as the *null* remains in the port. But this process can be improved.

One way to solve our problem is to use a special flip-flop, called a flag, for each output port. As long as the flag is reset (zero), the output device does nothing. If the flag is set, the device outputs the character from the output port and *resets the flag*. Thus, in general, we no longer need a *null* character; the flag bit takes its place. The control pulse generated by the computer to load the data into the output port is also used to set the flag.

We gained something else. If the computer can somehow determine the state of the flag bit, it can tell if the character previously in the output has yet been accepted by the device. This means that we no longer have to waste a programmed amount of time and *assume* the device has processed the character, but we can *verify*, by testing the flag. This is important when different models of the same computer run at different speeds. An Intel 8008-1 running at full speed cannot properly drive a teletypewriter using a program developed on a standard 8008, because the do-nothing loop has been programmed to waste the correct number of cycles for the 8008 clock. The do-nothing loop which tested the flag would work on either computer, because the device supplies the timing. This means that each output port

must be associated with an input port to input the flag.

We must arrange the power-up logic so that all the flags are initially reset to prevent the output devices from outputting garbage when the machine is first turned on. Also, it would be nice to have a master clear button to force all the flags to zero if we need to manually stop and restart the computer. In some cases, it would be useful to have a special output port connected to the same master clear logic so the program could reset all flags with one instruction. We may also want the ability to set or reset individual flags under program control. This would require another output port for each output device. Thus, a full-blown flag facility would require two output ports and one input port for each output device. Similarly, it would need two input ports and one output port for each input device. Actually two output ports and one input port could handle all the flags if you dedicate one input and one output port to reading a flag and writing (setting or resetting) a flag, and another output port to specifying which flag is to be read or written.

Now let's look at an input using the flag bit. The input device would read a character, place its code in the input port, and set the flag. The program would then test the flag, find it set, and then read the character from the input port, resetting the flag. The problem here is that the operation is initiated by the device, not the program (this may be desirable in some applications). Usually, we don't want the input device to function until the program invites it to. This implies that we need two bits—one to tell the device to operate, and one to tell the computer that the operation is complete. Let us use our flag bit for the latter function and add an additional bit (a control bit) to control the device.



Input keyboard?



Flag bits.

For output:

1. Set the control bit to start the device.
2. Put data in the output port, and reset the flag.
3. The device accepts the data and sets the flag.
4. The computer repeats from step 2 until all the data has been output.
5. The computer resets the control bit to stop the device.

For input:

1. Set the control bit to start the device and reset the flag bit.
2. The device puts data into the input port and sets the flag.
3. The computer reads the data from the port and resets the flag.
4. This repeats from step 2 until all the data has been input.
5. The computer resets the control bit to stop the device.

Call Me, I Won't Call You. If you are working when the phone rings, and you stop to answer it, you have been *interrupted*. The caller may have an urgent request for some information in which case you suspend what you are doing to supply the information, then return to your original task. On the other hand, the call may be simply to inform you that you are to be in a meeting at a later time. In this case, you post the request on your memo pad or calendar and at the proper time, stop what you are doing and attend the meeting. The call may also be to inform you that something you had previously requested of the caller has been completed. Such a facility, called *interrupt*, can be built into a computer.

If you have only one phone on your desk, you must ask the caller to identify himself when the phone rings, since many different people can interrupt you over the same phone. In a computer, this method is called a *basic interrupt* facility. Another method is a *vectored interrupt* facility.

To illustrate, you may have a desk full of phones, with each number known to only one prospective caller. In this case, it is not necessary to have the caller identify himself. You know who it is by which phone is ringing. Alternatively, a small number of people may be given the same number so a particular phone does not uniquely identify the caller, but limits the possible callers to a small set. To implement an interrupt facility within the computer, we do the following:

1. Save the address of the next instruction in some specific place; in machines with a stack, it is usually convenient to stack it.
2. Force the program counter to a specific address.

In a *basic interrupt* facility, the address used in step 2 is the same, regardless of who interrupted. In a *vectored interrupt* facility, the address used is a function of the particular interrupt. (See the restart instruction on Intel machines.)

Now we can produce an even better input/output system than we have to date. Just wire the flag bit *true* output to the interrupt line. Actually, we should probably AND the flag and control bits and wire this to the interrupt line. Then, when the control bit is set (the device has been invited to operate) and the flag bit is set (the device has operated) the computer will be interrupted. Thus, we no longer need a timing loop to assume the operation is complete nor a test loop to verify the operation is complete. Simply go on with the program or go into a do-nothing loop until the interrupt occurs. No test is needed since the occurrence of the interrupt will automatically tap the computer on its shoulder and give it the address of another program to execute. This other program is called the interrupt service routine.

A Mind-Reading Machine. You may have noticed that we have been sending only one character at a time. Usually, a peripheral device has a line length that it prefers. Punched cards generally use 80 characters, printers 132, typewriters 72 to 90, etc. In many cases, these are specified in terms of the maximum number of characters. Such a group of characters is called a *record*. Some devices must transmit an entire record at a time, while others transmit *incrementally*; one character

at a time. There is usually some character in a hard-copy machine's 'alphabet' which does not print, but causes the carriage to be returned, thus defining the end of the record. Some devices, such as discs, are built so that, once a transmission is started, an entire record must be transmitted. For this reason, a common method of programming prepares the entire record in the computer's memory, and then sends one character at a time. If the entire record is in memory, there must be a better way to output it!

Suppose we built an "intelligent" output port that operated as follows: In lieu of putting the individual characters in the port, we give the port the address of the first character and tell it the number of characters to transmit. Then we allow the "intelligent" port to reach into memory at its own speed to fetch the characters and pass them on to the device. Such an intelligent port is called a *direct memory access* device, since it reaches directly into memory as it performs its function.

But if the DMA is accessing memory and the computer is accessing memory, can't things get fouled up when they both attempt to access at the same time? They sure can! To use such a facility, the computer must be appropriately designed. Read your manual again. If you have a machine built around the Intel 8080 you will find a pin called HLDA (hold acknowledge) and another labeled HOLD. When HOLD is raised, the computer finishes its current cycle, switches the address and data buses to the high impedance state, and raises the HLDA line. At this point the memory bus is available to the DMA with no interference from the CPU (central processing unit). When HOLD is dropped, the CPU resumes its execution. Thus, the DMA can directly access the memory for either input or output. If the device attached to the DMA is medium- to low-speed, the HOLD line is dropped after every access to permit the CPU to operate. If the device is fast, the DMA can lock the HOLD line high and seize the memory for the duration of the transfer.

There are a number of methods to implement this DMA. The simplest assigns a particular address to each DMA when it is built or installed. The programmer must put the first character of each record for the DMA device at this address. Then, all he has to do is set the control bit and reset the flag, through an output port, to start the

Engineers design electronic circuits —so can you!

**Only CREI offers you a choice
of 18 home study programs
in electronics with circuit design,
plus special arrangements
for engineering degrees**

Circuit design is perhaps the one qualification that distinguishes advanced technical personnel and engineers from the average electronics technician.

If you can design electronic circuits, you can more readily understand the circuitry of all types of electronic equipment. Thus you can more easily handle the repair and maintenance of such equipment, as well as assist in the development of new electronic systems.

The ability to design electronic circuits to solve practical engineering problems is one of the most valuable skills you can possess. Those with this ability are sought after and command positions of far greater responsibility, prestige and pay than the average technician.

If you are going to have a worthwhile career in the field of electronics, the ability to design circuits is a skill you will want to acquire.

Circuit design in all CREI programs

CREI covers circuit design in its home study programs in electronics. This is one of the factors that makes CREI training different from most other home study schools. CREI programs, of course, are college level—the same level of training you will find in any college or university offering programs in electronic engineering technology.

CREI training, however, is designed for home study. The programs give you effective, step-by-step training to help you move up in your career in electronics by using your spare time for technical self improvement.

Unique Design Lab

CREI gives you both theory and practical experience in circuit design with its Electronic Design Laboratory Program. The professional equipment included in this program allows you to construct, test out and correct the circuits you design until you have an effective circuit.

This Lab Program helps you understand advanced electronics. It also gives you practical experience in many other important areas of electronics, as in prototype construction, breadboarding, test and measurement procedures, circuit operation and behavior, characteristics of electronic components and how to apply integrated circuits.

Career Training at Home

Only CREI offers this unique Lab Program. It is a complete college lab and, we believe, better than you will find in most colleges. The "Lab" is one of the factors that makes CREI training interesting and effective. And the professional equipment in this program becomes yours to keep and use throughout your professional career after you complete the training.

Engineering Degree

CREI offers you special arrangements for earning engineering degrees at certain colleges and universities as part of your home study training program. An important advantage in these arrangements is that you can continue your full time job while "going to college" with CREI. This also means you can apply your CREI training in your work and get practical experience to qualify for career advancement.

Wide Program Choice

CREI gives you a choice of specialization in 14 areas of electronics. You can select exactly the area of electronics best for your career field. You can specialize in such areas as computer electronics, communications engineering, microwave, CATV, television (broadcast) engineering and many other areas of modern electronics.

FREE Book

In the brief space here, there isn't room to give you all of the facts about CREI college-level, home study programs in electronics. So we invite you to send for our free catalog (if you are qualified to take a CREI program). The catalog has over 80, fully illustrated pages describing your opportunities in advanced electronics and the details of CREI home study programs.

Qualifications

You may be eligible to take a CREI college-level program in electronics if you are a high school graduate (or the true equivalent) and have previous training or experience in electronics. Program arrangements are available depending upon whether you have extensive or minimum experience in electronics.

Send for this **FREE** Book describing your opportunities and CREI college-level programs in electronics

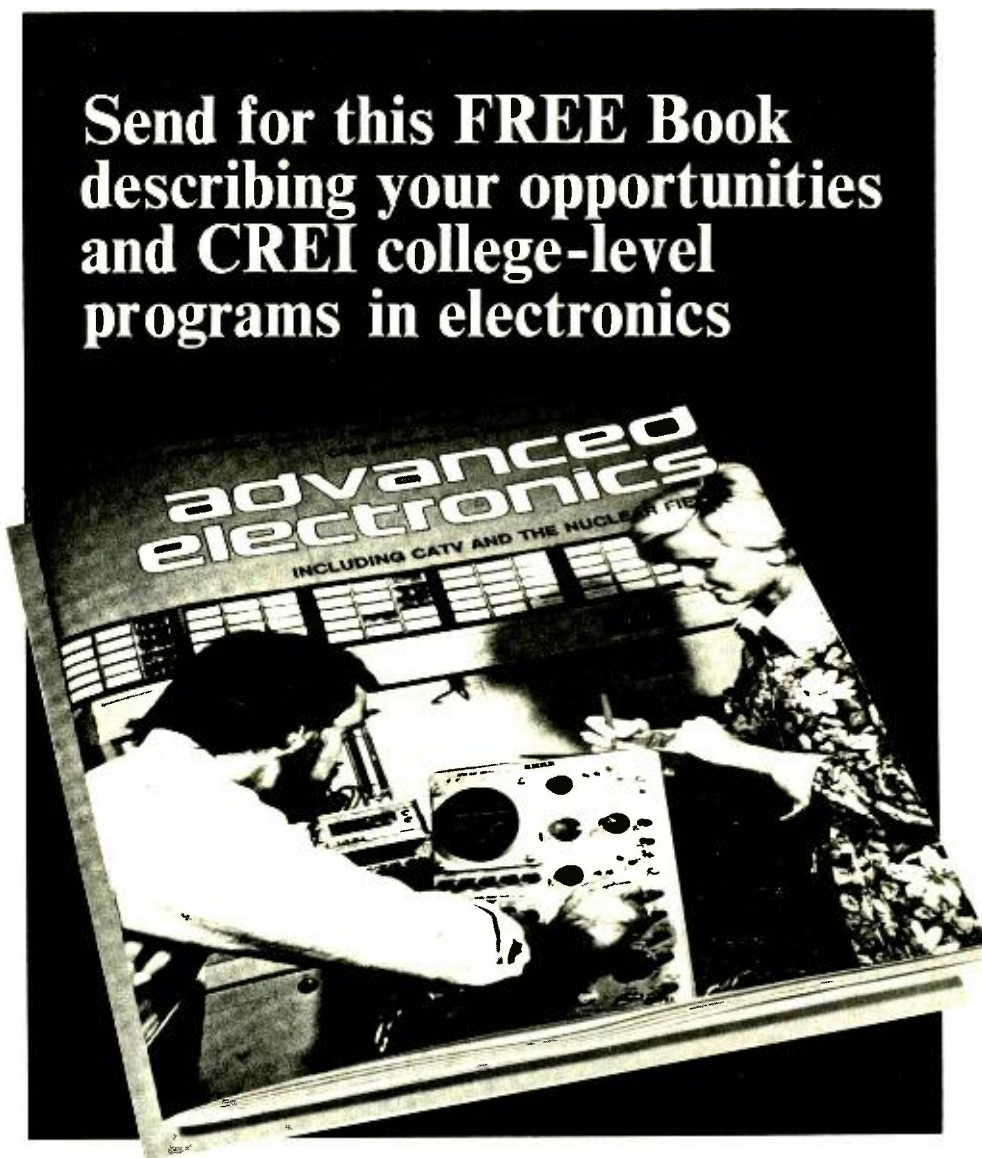

Mail card or write describing qualifications to

CREI **CAPITOL
RADIO
ENGINEERING
INSTITUTE**

McGraw-Hill Continuing Education Center
3939 Wisconsin Avenue Northwest
Washington, D.C. 20016

Accredited Member National Home Study Council

GI Bill

CREI programs are approved for training of veterans and servicemen under the G.I. Bill.

Sharpen your Altair's Memory.

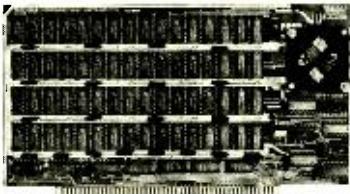

Add Processor Technology's new 8KRA Static Memory Module to your Altair or IMSAI system. You'll have 8192 eight-bit word capacity, using full speed, low power RAM's, manufactured to stringent military standards. The 8KRA uses less power per bit than any other true static memory module (including our own 4KRA); so that two flashlight "D" cells will maintain memory for 4-5 hours. (Re-charging circuitry for Ni-Cad cells and battery connectors are on the card.) The 8KRA occupies any 8K segment at 1K intervals within the 8080 addressing range. Card address is selected by a DIP switch at the top of the card. And, all 76 Integrated Circuits have their own **premium grade, low-profile IC sockets**—for reliability and easier assembly, testing, or repair.

8KRA 8192-word Static Memory Module **\$295**
4KRA 4096-word Static Memory Module **\$154**
(all sockets included)

Write Us, about our other plug-in modules, compatible with the 8800 system.

**Processor
Technology**
6200-K Hollis Street
Emeryville, CA 94608

transfer. When the operation is finished, the DMA sets the flag, and, optionally, an interrupt occurs. The problem here is that each record for the device must start in the same location and must be the same length.

A more flexible arrangement uses an output port to feed the address and the record length to the DMA. This would require a transmission of 4 characters in the proper order. At this time the DMA could start its function. Again, when the operation was finished, the flag would be set and/or an interrupt could be requested. An even more flexible arrangement would permit several devices to be attached to the DMA. The program would output 5 characters to the DMA to start it (2 characters for the address, 2 for the number of characters to transfer, and one to identify the device and specify the direction, input or output). Using an 8-bit character, we could use 1 bit to specify the direction (0 means output and 1 input, say) and the other 7 bits to specify one of 128 devices. By using an additional bit to inform the DMA whether to interrupt or not gives us more flexibility and still permits us to handle 64 devices. Of course, only one device can be in use at any given instant. A DMA such as that described above is sometimes referred to as a basic input/output channel. Note that, while the DMA is functioning, the CPU can still operate, possibly at a reduced speed due to the fact that the DMA is stealing memory cycles from the CPU. If the DMA is locking the HOLD line high, the CPU cannot operate, of course, until the transfer is complete.

Since the DMA can effectively lock out the CPU, we must arrange the power-up and master clear logic so that no DMA will attempt operation until the CPU directs it to.

Control And Status Signals.

There are two types of transmissions yet to be considered: *control* signals sent to the device, and *status* signals received from the device.

Control signals cause the device to perform non-data operations such as start a new line, start a new page, backspace, etc. There are two ways to send such signals to the device. The first is to have a separate control path to the device from the computer, while the second is to define certain alphabetic characters as control characters rather than data to be

printed. It is this second method that is used in ASCII. In many cases, the same bus which carries the data also carries the control signals, but a secondary line is raised to indicate that the information is control data and not alphabetic data. Control signals are used to cause tape drives to rewind or backspace over a record, a disc drive to select a different track, a hard-copy machine to return the carriage (and, usually, start a new line), printers to skip to a pre-defined spot on the page, erase the screen on a CRT, etc.

Status codes are sent from the device to the computer and generally are used to convey information about the device's condition. Common items of information which are conveyed to the computer are the status of the device's power supply (on or off); an indication that it is busy (for instance, a carriage return takes much longer than typing one character); that one or more characters were sent (or received) erroneously during the last transmission; that a tape drive is at the beginning of the tape and should not be backspaced further; that a tape drive is at the end of the tape and no further attempt should be made to read or write it; etc. Status information can be treated in much the same way as control information. It can be returned to the computer over a separate bus; it can come over the data bus accompanied by a signal which identifies it as status rather than data; or it can be built into the device's alphabet.

Notice that input devices now, in general, have an output type of characteristic, so we can send an input-device control signal. In the same way, output devices generally provide for input of their status. The two can also interact. A particular device may send status information to the computer only after it has been invited to do so by a command signal. In many cases, the system protocol requires a device to send status information at the end of every transmission. In some cases, the "standard" status is assumed to be that every thing is fine unless something goes wrong. In such cases, we frequently find that the status information is wired to an interrupt so that, as long as the transmission is proceeding according to plan, nothing happens; but an interrupt occurs if an unusual condition arises. At this time the interrupt program can request the status to obtain the details of what happened. ♦

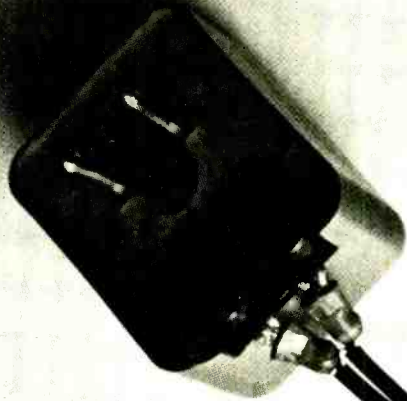

BY BARTON M. BRESNIK

POWER-FAILURE ALARM

Lets you know when a power outage occurs.

SUMMER or winter, night or day, a power outage in your local utility system can cause all sorts of problems in your home. Heating and cooling systems shut down, refrigerators and freezers come to a halt, and your electric alarm clock stops, making you late for work.

The power-failure alarm is a battery-powered device that sounds an alarm when a power failure occurs. Then you can, at least, turn off devices that might blow fuses when the power returns and take what other steps are necessary to protect your property.

How It Works. Battery *B1* (Fig. 1) gets a constant trickle charge from the transformer through *D1* and *R1*. As shown here, the battery is made up of two 1.25-V NiCd cells. Sealed NiCd or lead-acid storage cells with higher voltage ratings could be used. Vented secondary batteries can be used if the electrolyte is checked every few months. If carbon-zinc or manganese-alkaline cells are used, the value of *R1* should be increased to 47,000 ohms. Remember also that manganese-alkaline and mercury cells may burst when recharged.

The alarm generator consists of a two-transistor astable multivibrator and associated loudspeaker, while the trigger portion uses an SCR and related bias components. The SCR is in a feedback loop from the emitter of *Q2*. The gate of *SCR1* is biased low enough to keep it from firing by the combination of *R3* and *R4*. When a power outage occurs, the voltage from the battery turns on the SCR, and the multivibrator provides an audio-frequency signal to the speaker.

The time delay provided by *C1* and *R3* is used to keep the system from operating in case there is only a brief loss of power (which can be caused by lightning) or a line transient.

In standby operation, the circuit draws less than 1 mA, which is supplied by the trickle charging current. When an outage occurs, and the SCR turns on, the current increases to 15 mA for a 2.5-V battery and 50 mA for a 4.5-V source.

The lamp circuit is optional and can be used to check the battery. The lamp can also be made to glow during a power outage by connecting a silicon diode between the LAMP position of *S1* (anode of the diode) and the anode of *SCR1* (cathode of the diode).

Construction. The prototype of the alarm was assembled on a small piece of perforated board with point-to-point wiring. For transformer *T1*, use a standard recharging unit which plugs directly into a wall socket. This provides a safety feature in that only 6.3 volts is used in the chassis.

Mount the completed assembly in any type of enclosure with only *S1* and some speaker holes on the top. (The

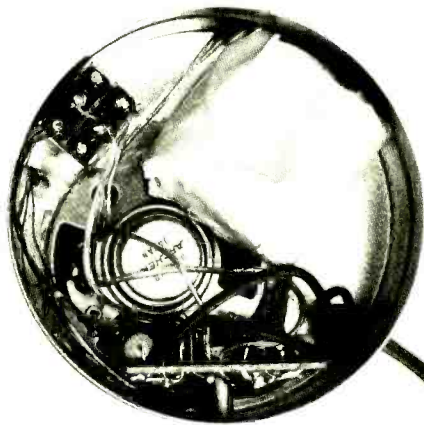

Author's prototype was assembled in a 35-mm film container.

PARTS LIST

- B1—Two 1.25-V NiCd cells (Lafayette 32F47400 or similar)
- C1—100- μ F, 10-V electrolytic capacitor
- C2—0.05- μ F disc capacitor
- D1,D2—1N4001 diode
- I1—2.5-to-3.0-V lamp (or #48)
- Q1—2N3638 transistor
- Q2—2N2621 transistor
- R1—680-ohm, 1/4-W 10% resistor (or 47,000-ohm, see text)
- R2—3300-ohm, 1/4-W 10% resistor
- R3,R4,R5—10,000-ohm, 1/4-W 10% resistor
- R6—1000-ohm, 1/4-W 10% resistor
- R7—100-ohm, 1/4-W 10% resistor
- SCR1—Silicon controlled rectifier (GE-X5 or 2N5060)
- SPKR—8- or 10-ohm speaker (Lafayette 99F60972 or similar)
- S1—Spdt switch
- T1—6.3 volt, low-current "wall-socket" transformer (Lafayette 33F37029 or similar)
- Misc.—Suitable enclosure, rubber grommet, mounting hardware, circuit board, etc.

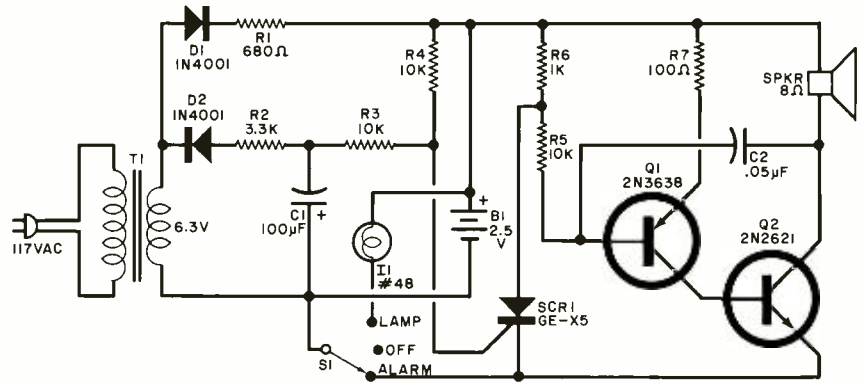

Fig. 1. The two-transistor audio oscillator is inoperable until the SCR conducts. This occurs when the power line fails and the battery voltage is applied to the SCR gate. Do not use an on-off switch with the unit.

author used a 100-ft, 35-mm film container.) The optional "grain-of-wheat" lamp can be mounted in a hole drilled in the container using epoxy glue to secure it in place. Since none of the parts is critical, feel free to experiment with "junk box" items.

To test the device, turn the switch to

OFF, plug the transformer in a power outlet, and then turn the switch to ALARM. Unplug the transformer from the wall socket. After a few seconds, the alarm should sound, continuing even when the transformer is put back in the socket. This locking feature reminds you to reset clocks if you were

not at home when the outage occurred.

If you are using rechargeable cells, connect a current meter in series with the battery and check that, with the transformer plugged in, the charging current is within the limits prescribed for the cell. ♦



Design of Digital Systems is written for the engineer seeking to learn more about digital electronics. Its six volumes — each 11-1/2" x 8-1/4" — are packed with information, diagrams and questions designed to lead you step-by-step through number systems and Boolean algebra, to memories, counters and simple arithmetic circuits, and finally to a complete understanding of the design and operation of calculators and computers.



Digital Computer Logic and Electronics is designed for the beginner. No mathematical knowledge other than simple arithmetic is assumed, though the student should have an aptitude for logical thought. It consists of four volumes — each 11-1/2" x 8-1/4" — and serves as an introduction to the subject of digital electronics. Everyone can learn from it — designer, executive, scientist, student, engineer.

Contents include: Binary, octal and decimal number systems, conversion between number systems; AND, OR, NOR and NAND gates and inverters; Boolean algebra and truth tables; De Morgan's Laws; design of logic circuits using NOR gates; R-S and J-K flip flops, binary counters, shift registers and half adders.

SEVEN-DAY MONEY-BACK GUARANTEE: If you are not satisfied with your Cambridge course, return it within 7 days for a full refund.

Understanding Digital Electronics

New teach-yourself courses

The contents of **Design of Digital Systems** include:

- Book 1** Octal, hexadecimal and binary number systems; conversion between number systems; representation of negative numbers; complementary systems; binary multiplication and division.
- Book 2** OR and AND functions; logic gates; NOT, exclusive-OR, NAND, NOR and exclusive-NOR functions; multiple input gates; truth tables; De Morgan's Laws; canonical forms; logic conventions; Karnaugh mapping; three-state and wired logic.
- Book 3** Half adders and full adders; subtractors; serial and parallel adders; processors and arithmetic logic units (ALUs); multiplication and division systems.
- Book 4** Flip flops; shift registers; asynchronous and synchronous counters; ring, Johnson and exclusive-OR feedback counters; random access memories (RAMs) and read only memories (ROMs).
- Book 5** Structure of calculators; keyboard encoding; decoding display data; register systems; control unit; program ROM; address decoding; instruction sets; instruction decoding; control program structure.
- Book 6** Central processing unit (CPU); memory organization; character representation; program storage; addressing modes; input/output systems; program interrupts; interrupt priorities; program; assemblers; compilers; executive programs; operating systems and time sharing.

The six volumes of Design of Digital Systems cost only: **\$19.88**

And the four volumes of Digital Computer Logic and Electronics cost only: **\$14.88**

But if you buy both courses, the total cost is only: **\$29.90**

a saving of over: **\$5.00**

In the years ahead the products of digital electronics technology will play an important part in your life. Calculators and digital watches are already commonplace. Tomorrow, a digital display could show your automobile speed and gas consumption; you could be calling people by entering their name into a telephone which would automatically look up their number and dial it for you.

These courses were written by experts in electronics and learning systems so that you could teach yourself the theory and application of digital logic. Learning by self-instruction has the advantages of being faster and more thorough than classroom learning. You work at your own pace and must respond by answering questions on each new piece of information before proceeding.

After completing these courses you will have broadened your career prospects and increased your fundamental understanding of the rapidly changing technological world around you.

technology trends P.O. Box 732
Manhasset, N.Y. 11030

ORDER NOW BY MAIL OR PHONE • Credit Card Orders: Call (516) 829-5858

Technology Trends		P.O. Box 732 Manhasset, N.Y. 11030	PE
Please send me:			
_____ sets of Design of Digital Systems	@ \$19.88*		
_____ sets of Digital Computer Logic and Electronics	@ \$14.88*		
_____ sets of both courses	@ \$29.90*		
Method of Payment: _____ Plus \$2.50 shipping & handling			
<input type="checkbox"/> Check or Money Order enclosed for \$ _____ Make checks payable to Technology Trends			
Charge my <input type="checkbox"/> BankAmericard <input type="checkbox"/> Master Charge		Exp. Date: _____	
Account No. _____	_____	Bank No. _____	
Name _____ Title _____			
Company _____ Address _____			
City/State/Zip _____			
Signature _____		Date _____	
New York residents add City and/or State tax			

CIRCLE NO. 58 ON FREE INFORMATION CARD

Automatic Diode Checker

*Makes a complete check
in 1/60th of a second.*

BY R. M. STITT

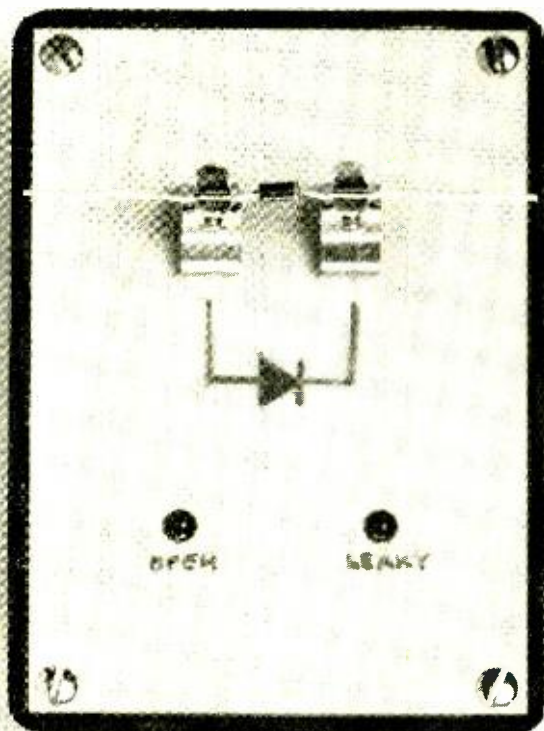

MOST EXPERIMENTERS think that using an ohmmeter is the best way to test a semiconductor diode. However, some ohmmeters supply too much current to the device, causing an "open" where one does not really exist. Other meters indicate values of forward and reverse resistance, which hopefully give an indication of the diode's condition.

In the Automatic Diode Checker described here, the diode is tested in the forward-bias condition for excessive voltage drop and then in the reverse condition for excessive leakage current. Each test is made during one half of the power-line frequency, and the results are displayed simultaneously on two LED's labeled OPEN and LEAKY. The LED marked OPEN is illuminated when there is excessive voltage drop. The other is lit when there is excessive reverse leakage. If the diode fails both tests, both LED's are on. With no diode in the clips, the OPEN indicator is on.

When a good diode is inserted in the test clips (correctly oriented), both LED's should be off. There will be no damage to either the diode being tested or the diode tester if the diode is inserted the wrong way; but both LED's will glow.

The peak reverse voltage is less than 18 volts and the peak forward current is less than 4 mA. With the values shown in Fig. 1, OPEN indicates a forward voltage drop in excess of 1.3 volts at 3 mA; and LEAKY indicates a reverse leakage current of about 0.05 mA at 16 volts.

How It Works. On one half cycle of the ac supply, the OPEN circuit is active (*D1, D2, D3, R2, R3, Q1* and *LED1*). In this half cycle the upper ac line is positive. (*D4* and *D5* are reverse-biased to isolate the other part of the circuit.) Current, limited by *R2*, flows through *D1* and the diode being tested. The voltage across the test diode is applied through *D3* to the base of *Q1*. If this voltage exceeds 1.3 V, *Q1* turns on and sinks current through *LED1*, indicating high forward drop.

When the ac supply reverses, the lower part of Fig. 1 is active, with *D1* and *D2* reverse-biased to shut out the OPEN part of the circuit. Any reverse leakage current through the test diode flows through *R1*, creating a potential across it. This voltage is applied to the base of *Q2* through *R7* and *D5*. When this voltage exceeds about 2 volts, *Q2* is energized, turning on *Q3* and *LED2*.

Since the circuit uses a conven-

Fig. 1. The "open" circuit operates when upper ac line is positive. "Leaky" circuit operates when this line is negative. Both circuits test diode at line frequency.

PARTS LIST

- D1 to D5—Silicon diode (1N914 or similar)
- LED1, LED2—Red light emitting diode*
- Q1, Q2, Q3—Transistor (2N3904 or similar)
- R1—47,000-ohm, 1/4-W, 5% resistor
- R2, R7—4700-ohm, 1/4-W, 5% resistor
- R3, R5—330-ohm, 1/4-W, 5% resistor*
- R4—2700-ohm, 1/4-W, 5% resistor
- R6—10,000-ohm, 1/4-W, 5% resistor
- T1—12.6-V, 100-mA transformer
- *R3 and R5 can be varied to change the brightness of the LED's.
- Misc.—Diode test clips, plastic case (Harry Davis #220 or similar), line cord, grommet, mounting hardware, etc.

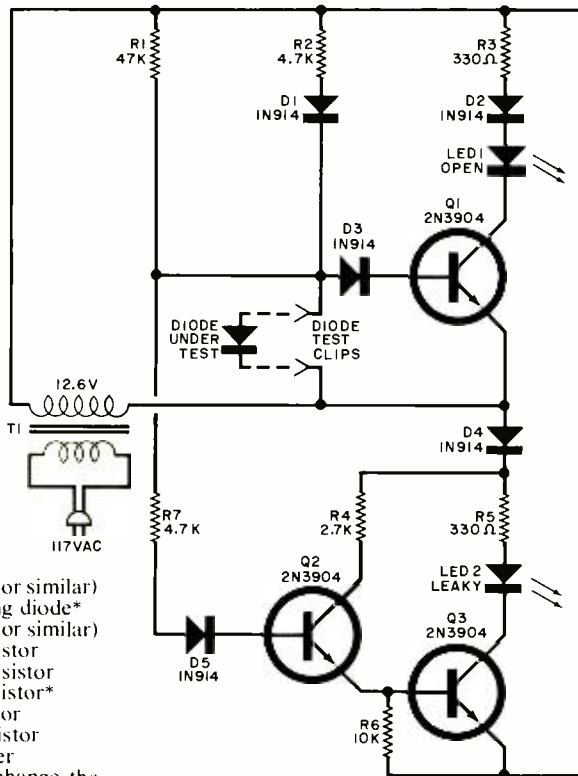

Note: A complete kit of parts is available from: Atlantis, Box 12654, Tucson, AZ 85711, for \$19.95.

tional 12-volt transformer, no dc supply is required and all switching is performed automatically at 60 Hz.

Construction. Although circuit layout is not critical and any type of construction can be used, a unique approach was used in the author's prototype as shown in the photographs. The pc board foil pattern shown in Fig. 2 can be used to make a board which has the components mounted on one side with the other side serving as the cover for the plastic case. The component holes are drilled only half-way into the board. The only holes drilled all the way through the board are those for mounting the LED's and the diode test clips. The other components are mounted by bending and cutting their leads so that they just fit on their pads. Solder must be applied quickly and properly to insure a good mechanical hold.

Transformer T1 can be attached to the bottom of the plastic case, with plastic foam insulation between the transformer and the components on the board. Use a grommet on the hole for the line cord in the side of the case.

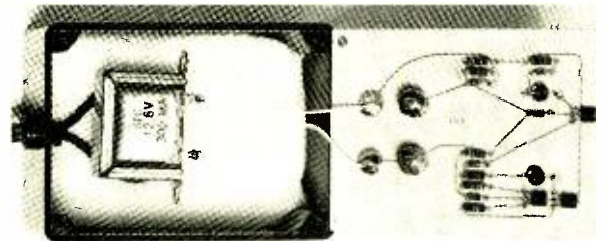
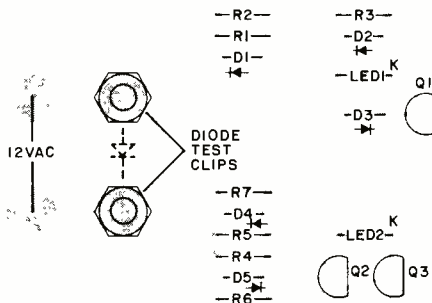
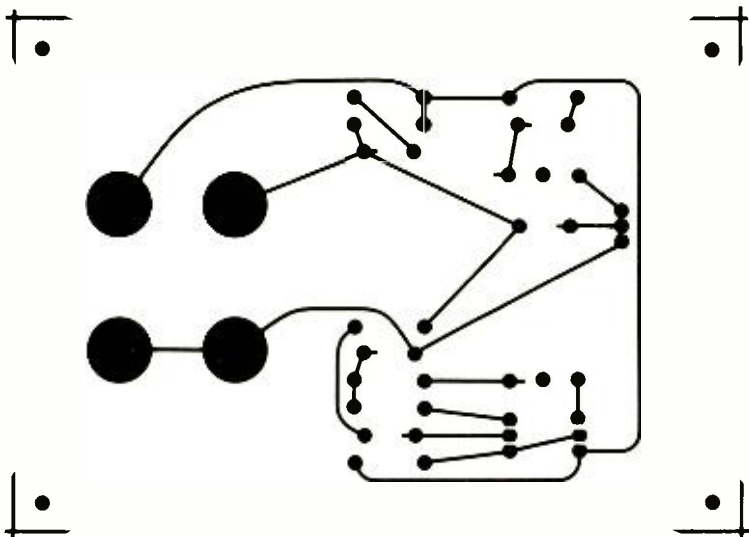

Photo shows how components are mounted on pc board with the transformer in the bottom of the case with foam insulation.

Fig. 2. Pc board can be used as case cover with component mounting as shown at left.



Identify the LED's on the front of the pc board, and draw a diode symbol between the two test clips with the anode side going to the junction of D1 and R1.

Checkout. Check the pc board for correct installation of components, and then apply power to the tester. The OPEN indicator should come on. Connect a diode that you know is good between the test clips. Note that both LED's are off. Remove the diode and connect a 100,000-ohm resistor between the test clips. Note that both LED's are on. Remove the resistor and connect two or three good diodes in series across the test clips. Only the OPEN LED should turn on. ♦

HERE is a practical, low-cost way to build your own electronic music system. The "Music Modules" presented here are a series of snap-together blocks that let you build any instrument you want, of any desired complexity, using virtually any system architecture you can dream up. Like traditional organ circuits, the system can be equally tempered and fully polyphonic, and it generates up to 97 notes simultaneously with extreme, permanently tuned stability.

As with some synthesizers, the Music Modules give you a wide range of control over the attack, sustain, fallback, decay, snubbing, bite, and echo of a note. As an option, you can have complete control over glides, slide, and portamento effects in either single or multiple voices. The system is economical enough to permit you to make simpler things like pitch references, calliopes, computer music interfaces, composers, and sideman rhythm mates.

The basic system is composed of three modules: a top-octave generator and translator, a sawtooth divider, and a dual hex vca (voltage-controlled amplifier). You can combine as many of these modules as you want with a power supply and professional keyboard to form the heart of any instrument. What we have here, in effect, is the usually difficult-to-build and expensive repetitive circuit that is the core of any quality polyphonic system reduced to a few simple CMOS circuit blocks.

Some Basics. The top-octave generator schematic diagram is shown in Fig. 1. It starts with a 2,000-240-MHz crystal for single, fixed tuning. If you want to tune another instrument, do glides or vibrato, or add noise or other frequency-modulation effects, you can break the oscillator's output circuit and add a variable master pitch reference. A seven-stage binary divider follows the oscillator to reduce the octaves down the scale.

Four possible frequencies are selected from the divider by an electronic switch. These are the crystal frequency and one-half, one-quarter, and one-eighth of the crystal's frequency. The selected frequency goes to a special IC that automatically develops all the notes of the top octave. With the electronic selector switch, you can choose the top octave, which means you can use a short keyboard and only a few vca modules and still be

MUSIC MODULES TO BUILD YOUR OWN SYNTHESIZER

Low-cost, easily assembled units

*can be used for a number of
different instruments.*

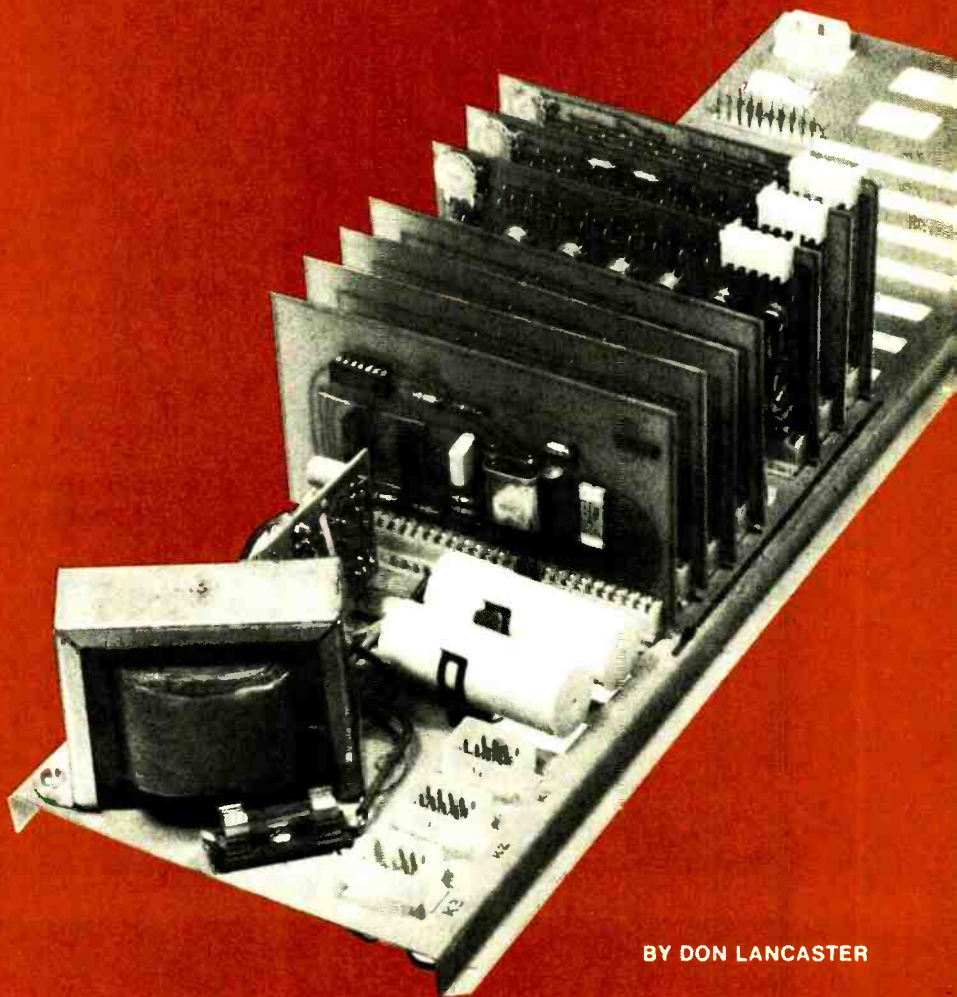

BY DON LANCASTER

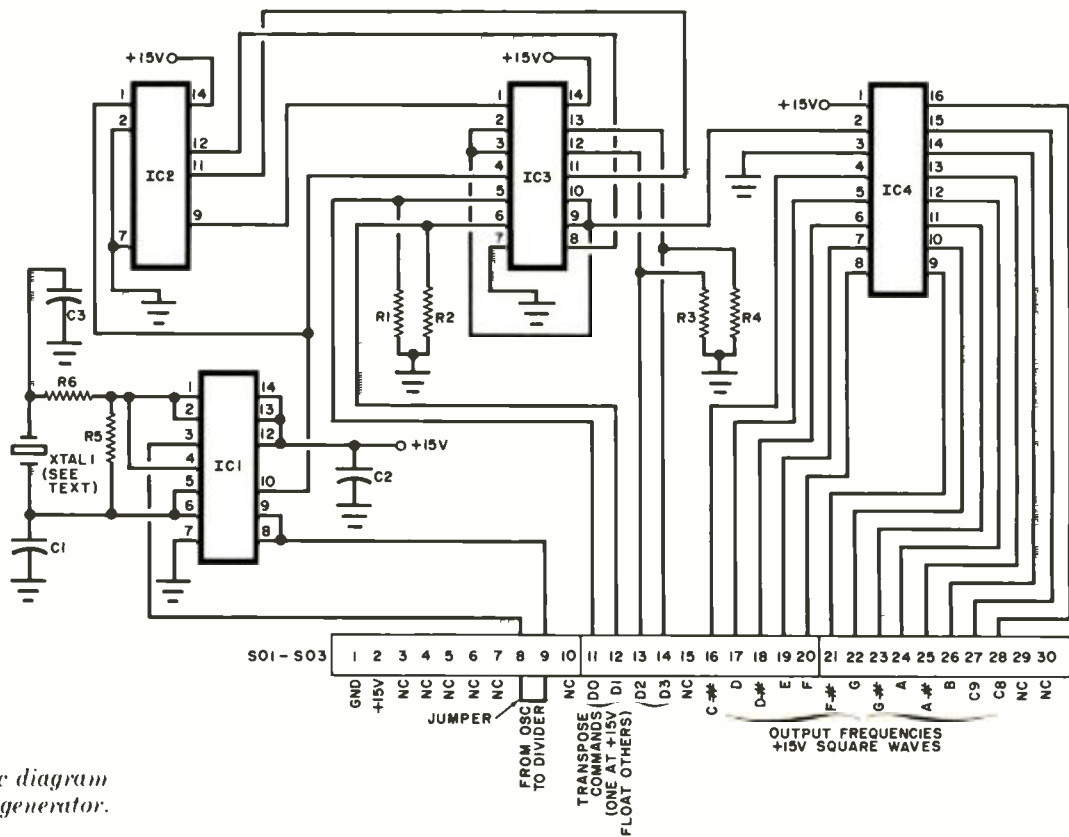

Fig. 1. Schematic diagram of the top-octave generator.

PARTS LIST

Top-Octave Generator & Translator

C1, C3—27-pF mica or polystyrene capacitor
 C2—0.1- μ F, 50-volt Mylar capacitor
 IC1—CD4001 CMOS quad NOR gate IC

IC2—CD4024 7-stage CMOS binary divider IC
 IC3—CD4016 quad CMOS switch IC
 IC4—MK5024P-AA integrated circuit
 R1 through R4—100,000-ohm, 1/4-watt resistor
 R5—10-megohm, 1/4-watt resistor

R6—10,000-ohm, 1/4-watt resistor
 SO1 through SO3—10-contact Molex No. 09-52-3153 connector
 XTAL1—2,000,240-MHz parallel-resonant crystal (30-pF load).
 Misc.—Printed circuit board, hookup wire; solder; etc.

able to generate all the notes you need.

The pitch generator divides the 2-MHz reference 13 different ways to generate the 13 notes of top octave C7 through C8 (2093.01 to 4186.02 Hz). These note divisions approximate the equally tempered music scale with an accuracy better than can be determined by the best musician. Thirteen different references, each one of which corresponds to a different note, are produced simultaneously: C7, C#7, D7, D#7, E7, F7, F#7, G7, G#7, A7, A#7, B7, and, in the next octave up, C8. (For more information on musical pitch, see "Electronic Music Pitch Standards," POPULAR ELECTRONICS, January 1974.)

There are at least two ways to use the top-octave system. In traditional organ architecture, you provide 12 outputs simultaneously and route them to divider modules so that you have all the notes you need all the time. You can also use the translator and an external 1-of-12 selector to generate any single note under digital

command. This is ideal for computer control, pitch references, and many synthesizer applications. Only an on/off keyboard without precision resistors is needed, and the normally troublesome exponential or logarithmic conversion circuitry is built into this module, which is essentially "free" and temperature, time, and voltage stable. All you do is provide a number or digital word to get the note out.

The divider module takes three of the notes of the top octave and generates all equivalent lower-octave notes down to zero (Fig. 2). For instance, suppose one input of one divider module is fed note A7. The outputs of the module will be eight notes (A7 down to A0), each one octave or 2:1 frequency lower in pitch. Each octave output is a square wave, which can be used directly for economy or where you want to imitate "woody" tones (clarinet or stopped organ pipe). The module also contains some resistor networks that convert the square waves into sawtooth outputs. More

precisely, it converts them into a stepped approximation of a sawtooth, but the two are identical once you start to filter them. A sawtooth or its stepped approximation contains nearly all harmonics, compared to a square wave that has only odd harmonics. You can also filter the outputs of this module to recover sine or near-sine waves for flute-like tones.

One top-octave generator and four divider modules are needed to generate all 97 notes either as square or sawtooth waves.

The dual hex vca module provides a means of turning on and off 12 notes combined as two groups of six notes each (Fig. 3). There are several ways you can use this module. Connect the decay bus to -15V, and you obtain simple on/off control of each note without key clicks or other undesirable effects. Grounding a keying input produces a note, while leaving it floating stops the note. Connect the decay bus to +15V, and you get a sharp attack, gradual decay, or long sustain keying characteristic. If you connect

your keying input to a source of controlled-width pulses, you gain complete control of attack, fallback, sustain, and decay of all notes simultaneously, independently and exponentially, with very little added complexity. A storage capacitor on each keying input averages out these control pulses and provides a wide range of independent control of each note.

PARTS LIST

Triple Divider Module

- C1—0.1- μ F, 20-volt disc capacitor
- IC1 through IC3—CD4024 7-stage CMOS binary divider IC
- The following resistors are 1/4-watt, 10%:
 - R1 through R8, R35 through R42, R69 through R76—220 ohms
 - R9 through R16, R43 through R50, R77 through R84—100,000 ohms
 - R17 through R23, R51 through R57, R85 through R91—200,000 ohms
 - R24 through R29, R58 through R63, R92 through R97—390,000 ohms
 - R30 through R34, R64 through R68, R98 through R102—750,000 ohms
- SO1 through SO3—10-contact Molex No. 09-52-3153 connector
- Misc.—Printed circuit board; hookup wire; solder; etc.

Fig. 2. The divider module takes three of the notes of the top octave and generates equivalent lower-octave notes.

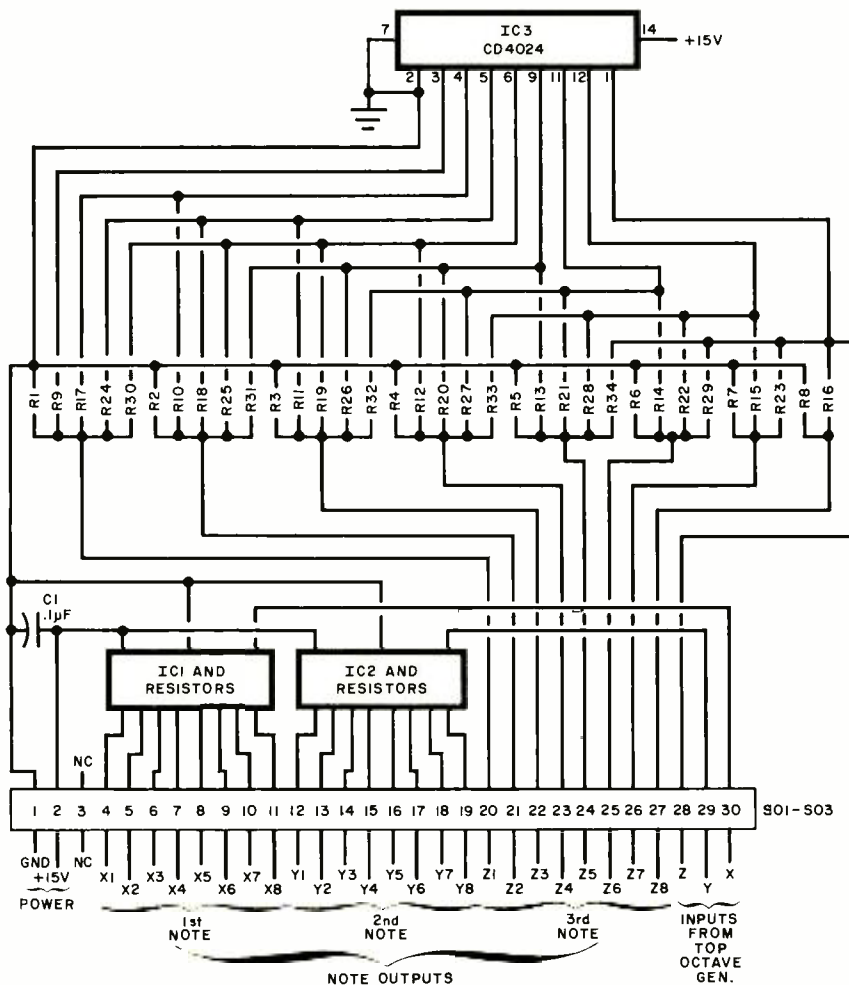

Fig. 3. The dual hex vca module provides for turning on and off 12 notes combined as two groups.

PARTS LIST

Dual Hex VCA

- C1—500- μ F, 3-volt electrolytic capacitor (14 mm maximum height)
- C2—0.1- μ F, 25-volt Mylar capacitor
- C3 through C14—1- μ F, 35-volt high-quality electrolytic capacitor with axial leads
- D1 through D36—1N914 (or similar computer-type) diode
- IC1 through IC12—CA3080 transconductance amplifier IC (RCA)*
- The following resistors are 1/4-watt, 10%:
 - R1, R2—22,000 ohms
 - R3—220,000 ohms
 - R5 through R16—10,000 ohms
 - R17 through R28—3300 ohms
 - R29 through R40—2.2 megohms
 - R41 through R52—680,000 ohms
 - R4—1000-ohm flat-mounting pc potentiometer
- SO1 through SO3—10-contact Molex No. 09-52-3153 connector
- SO4—4-contact Molex No. 09-52-3042 connector
- Misc.—Printed circuit board; hookup wire; solder; etc.

*There are several different packages available for the CA3080, which fits the TO-5 pin circle shown in the foil pattern. The CA3080S and CA3080E fit 8-pin dual inline minidip patterns. Be sure your pc layout and IC's are compatible. All three package styles remain available from RCA.

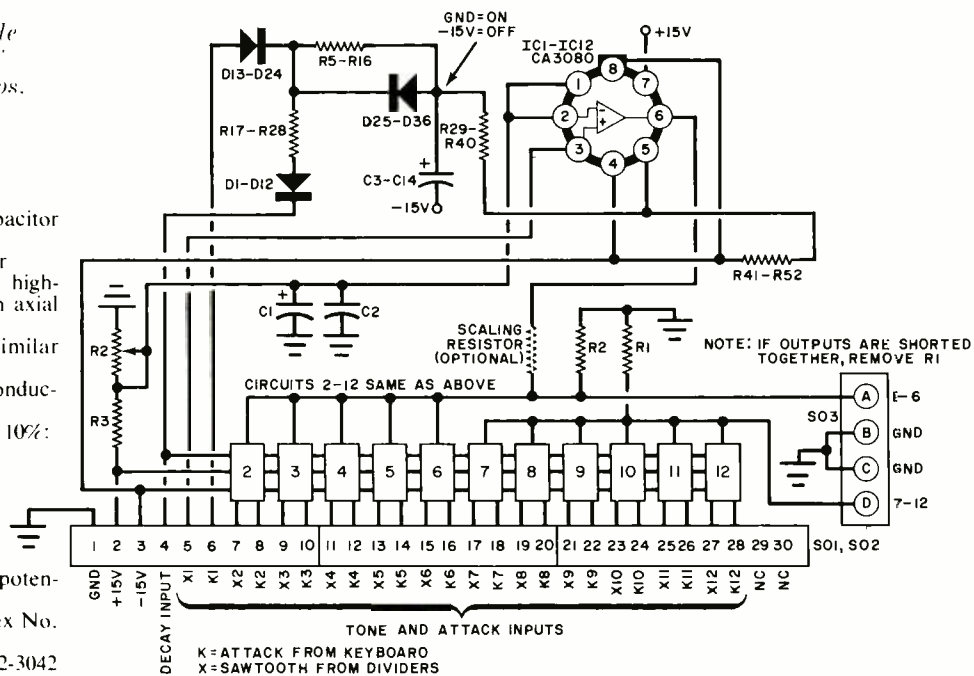

Note—The following items are available from Southwest Technical Products Corp., 219 West Rhapsody, San Antonio, TX 78216: No. TOB printed circuit board for top octave generator for \$5.50; complete top-octave generator kit, No. TO-1 for \$17.25; No. TDb pc board for triple divider for \$5.75; complete triple divider kit, No. TD-1, for \$10.50; No. TXb dual hex vca pc board for \$4.75;

complete dual hex vca kit, No. TX-1, for \$21.50; No. TP-1 regulated power supply kit for \$17.50. A fully assembled 37-note professional keyboard designed to AGO standards, No. AGO-37, is available for \$65.00 (includes \$5.00 for handling) from PAIA Electronics, P.O. Box 14395, Oklahoma City, OK 73114. Allow four weeks for delivery.

There are 12 IC's in the vca module. Each controls the gain of a single note. The outputs are normally wired so that six share a common load resistor. However, you can easily break out one or more individual vca's for such things as loudness control, quadra-sonic fading, or position modulation, or to introduce tremolo or noise amplitude modulation.

You can use as many vca modules as you want in your system, adding one for each independent, polyphonic octave. Since keyboards are one of the major expenses in any electronic music system, it pays to keep the keyboard as short as reasonably possible. This also cuts down on the number of vca modules you'll need. Remember that you can still get all the notes you want by using the translator switches on the top octave module.

A 72-note polyphonic system, using a 36-note (three octave) keyboard, the top-octave module, four sawtooth dividers, and three vca modules, is shown in Fig. 4. A four-position switch selects which three octaves are to be played at any time. Note that this is only one possible polyphonic arrangement. You can add or eliminate as many parts as you want. In addition, there are all sorts of simpler monophonic variations. A top-octave module and part of a vca module can give you the heart of a synthesizer or a computer-controlled instrument.

Construction and Checkout. In the top-octave generator, IC1 is the crystal oscillator and buffer. It is followed by the binary divider in IC2, selector in IC3, and top-octave synthesizer IC4. This circuit should be built on a double-sided pc board, using one side of the board for the foil conductors as in Fig. 5A and the other side for a grounding shield as in Fig. 5B. Component layout and orientation are as shown in Fig. 5C.

Once it is assembled, you can test the top-octave module by connecting to it a 15-volt power supply and jump-ering pad 8 to pad 9 and pad 2 to pad 11 (foil contacts that mate with the edge connector). Note that only pads 1 and 30 are labelled in Fig. 5C. Then check for the top octave note outputs at pads 16 through 28 using an oscilloscope or audio amplifier. Bear in mind that the outputs consist of 15-volt amplitude rectangular pulses that must be capacitively coupled and strongly attenuated before feeding them into an audio amplifier.

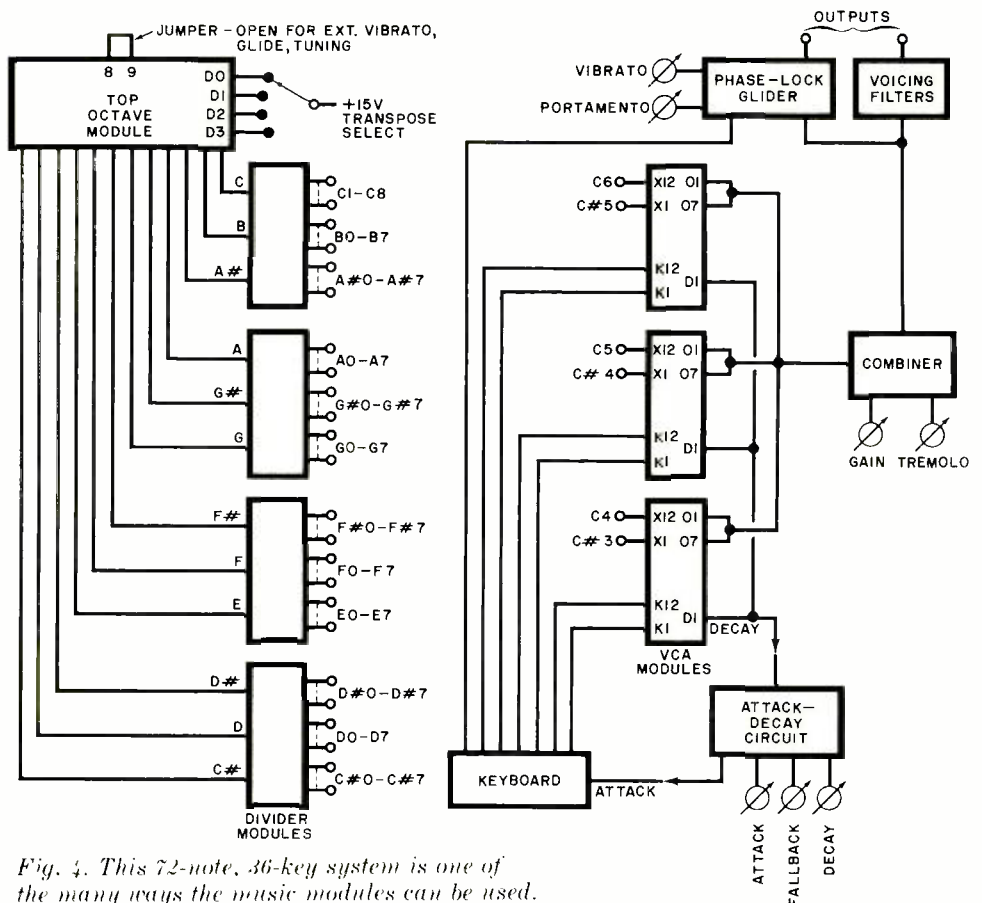

Fig. 4. This 72-note, 36-key system is one of the many ways the music modules can be used.

If you are using the internal oscillator, pads 8 and 9 must be jumpered. For external signals, break the jumper and route a 15-volt CMOS-compatible signal to pad 9. Note also that one and only one of the transpose commands must be at +15 volts at all times; the other three must be floating or grounded.

The foil-conductor etching and drilling, ground-plane, and components-placement guides for the divider

module are shown in Fig. 6. Note that the resistors on this module mount upright.

You can test the divider module by connecting to it a 15-volt power supply and applying three notes from the top-octave generator. The output sawtooth waves should be approximately 70 mV in amplitude (check with a calibrated scope), and each of the three sections of the module should produce eight octave-related notes.

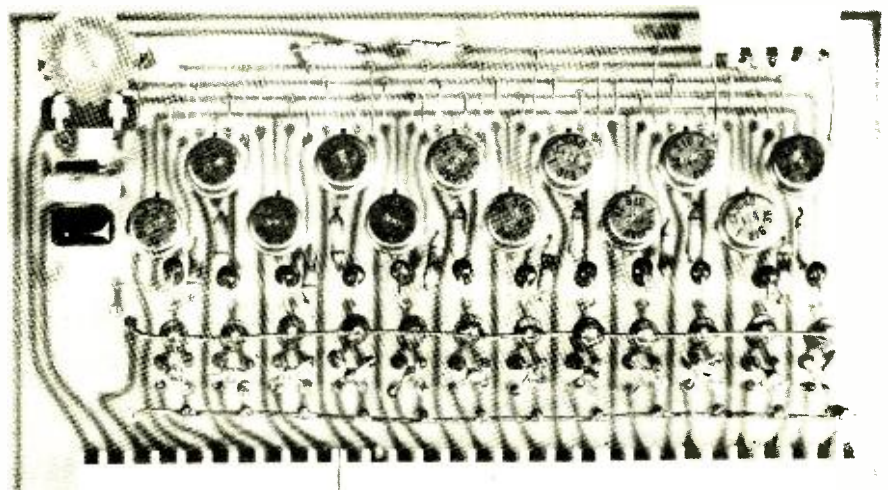

Photo shows details of upright component mounting on vca module and bus connections.

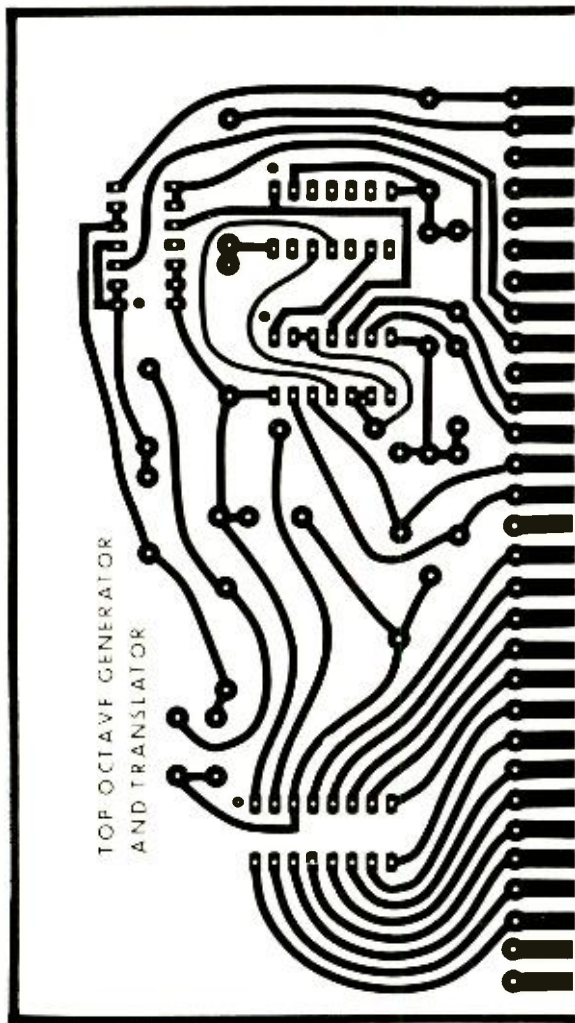
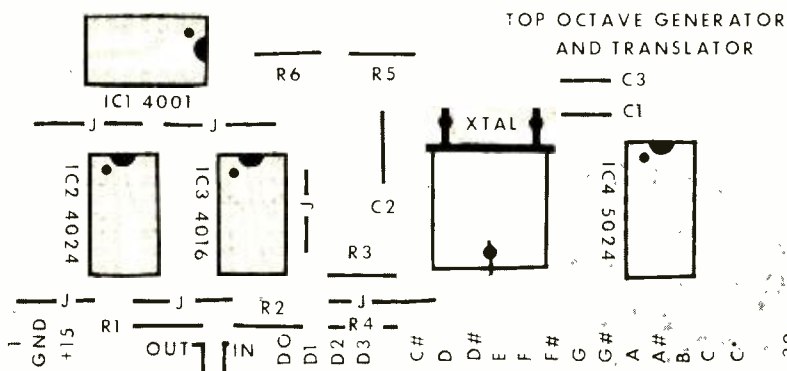
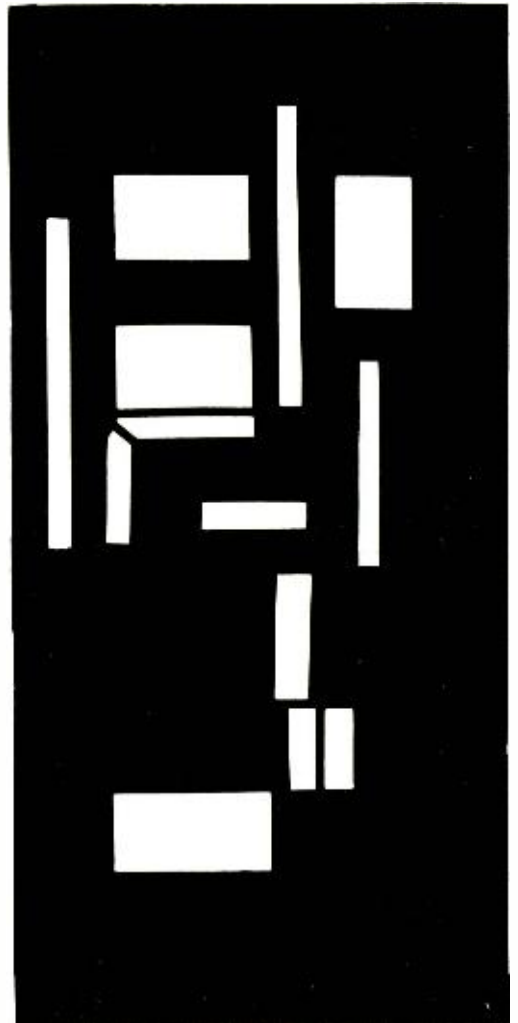

Fig. 5. Etching and drilling guide (A) for top-octave generator is at left, ground plane guide (B) right, component layout (C) below.



leads up and connected to a length of bare wire that terminates in the $-15V$ hole. Finally, mount $R29$ through $R40$ in the usual manner, without bus-joining the upright leads.

The best way to test the vca module is one stage at a time. Do this by leaving the IC pin 6 jumpers disconnected from the output buses, except for the jumper in the stage being tested. Start by connecting the dual-polarity $+15V$ $-15V$ power supply to the module via pads 1, 2 and 3 at the edge connector. Route a single note from the divider to the X1 input and monitor the output with an oscilloscope or audio amplifier. Connect the decay input to -15 volts. Now, grounding K1 should turn on the note and floating or connecting K1 to -15 volts should turn off the note. The note should turn on and off rather abruptly without key clicks, distortion, or transients. Offset potentiometer $R4$ should be adjusted to eliminate any dc in the output or set for the best sounding note. Then, check K2 and X2, K3 and X3, and so on down the line, finishing up with K12 and X12.

The highest note will be a square wave, followed by four-level and eight-level notes. Lower-frequency outputs will contain 16 levels. If one note sounds excessively loud or looks wrong on a scope, check your resistor matrix carefully for a missed solder connection or an interchanged value.

The etching and drilling and component-placement guides for the vca module are shown in Fig. 7. Note

that $D1$ through $D12$ mount with the cathode (banded) end up and the cathodes to a length of bare wire that terminates in the decay hole. Next, $D13$ through $D36$ (cathodes up) and $R5$ through $R28$ mount upright, their free ends connected together in groups of four, with $D13$, $D25$, $R5$, and $R17$ making up the first and $D24$, $D36$, $R16$, and $R28$ the last group. Then mount $C3$ through $C14$ with their negative ($-$)

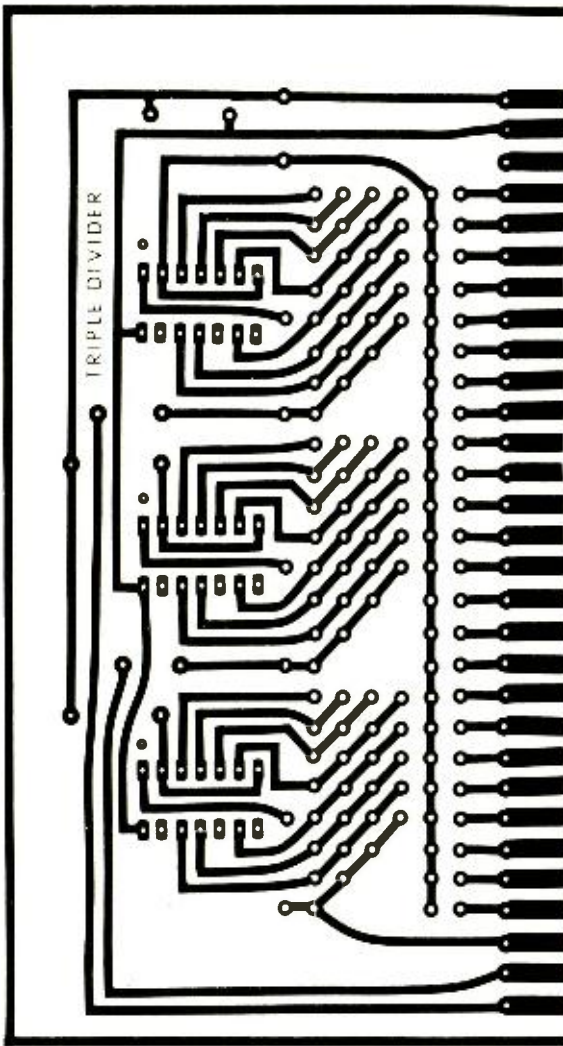
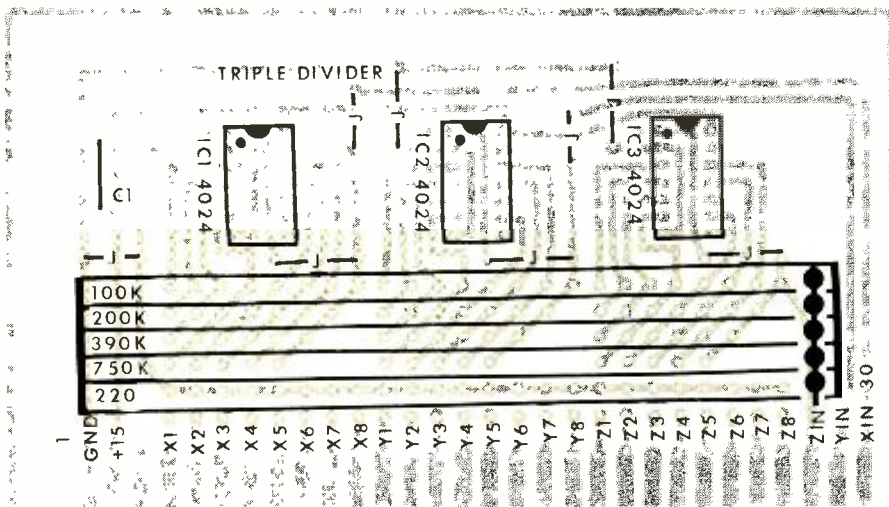
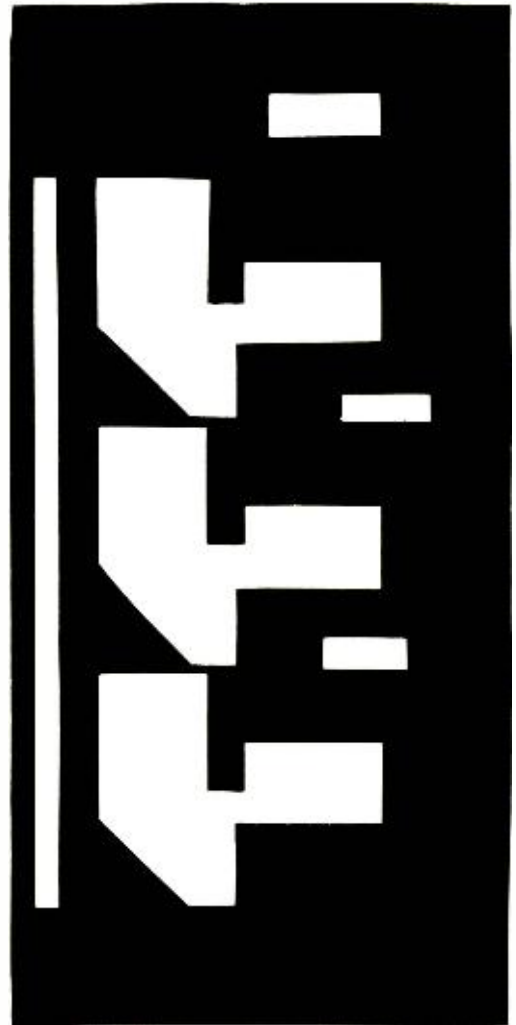

Fig. 6. Etching and drilling guide (A) for triple divider is at left, ground plane guide (B) right, and component layout (C) below.



The CA3080 IC's have a *high*-impedance (current-sourcing and -sinking) output, unlike the other op amps. This permits you to short as many outputs as you wish to a common load resistor to automatically sum all the outputs. The amount of maximum output signal is set by load resistors *R1* and *R2*. If you use both halves of the vca module, *R2* can be omitted.

An open circuit at any X input disrupts the summing process, so be sure that all connected IC's are in fact receiving tones from the divider modules. Connecting the decay input to ground should give you a fast-attack, long-decay characteristic. If any single note sounds odd or responds differently from the rest, check the resistor/diode/capacitor matrix for shorts, incorrect values, or unsol-

dered connections. All diode bands (cathodes) go up as do the negative sides of the electrolytic capacitors.

System Interconnections. No matter what arrangement you choose for your instrument, there are some important system-level things you'll have to watch for. First, be sure to use a well-regulated power supply. While CMOS devices will operate on a wide range of low voltages, the +15-V supply contributes directly to the stairsteps of the note. Hum or noise or interaction on the supply spells problems.

Be sure to use twisted-pair wiring or shielded cable between the top-octave outputs and the dividers to minimize any radiation of these high-level signals. You can put your modules on 20-mm centers, but be sure to skip one slot between the last divider and first vca modules, and place a fairly thick grounded sheet of steel between the two. Proper shielding and lead routing can mean the difference between a solid 85-dB or higher

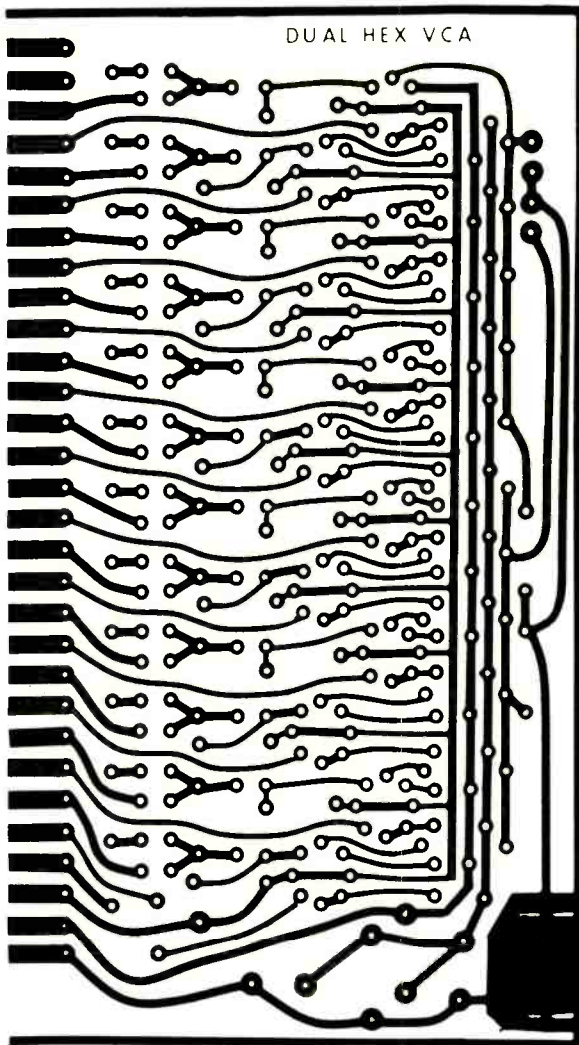

Fig. 7. Etching and drilling guide (A) for vca module is at left, component placement guide (B) at right. No ground plane is required.

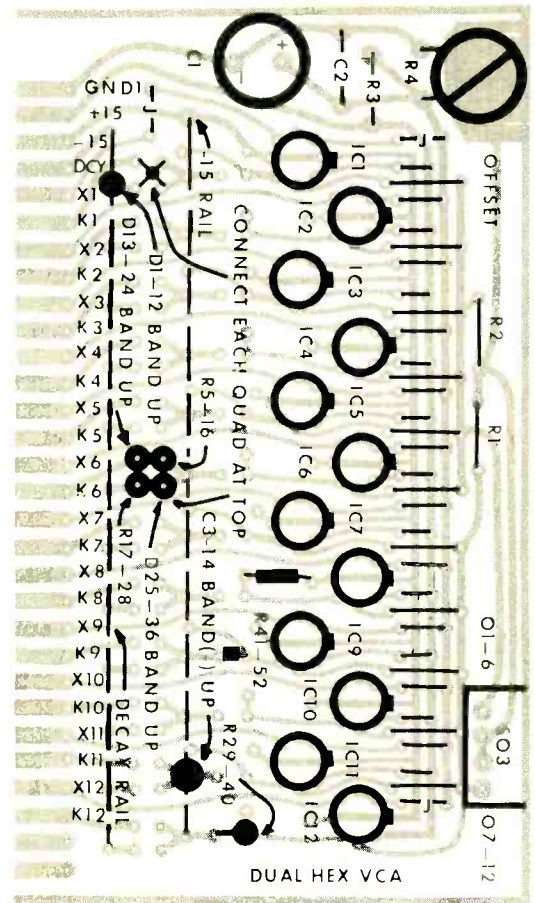

Fig. 8. Add one or more of the circuits below to basic system to build a complete music synthesizer.

crosstalk and playthrough level and an intolerable 60-dB level.

Shields are also required on the vca module's outputs because of the fairly high impedances involved. Outputs are located on the top of the vca module to keep them well away from the tone-generator signals. The same care you give to the high-level tone signals should also be given to the attack and decay control pulses.

Some add-on circuits that will get you started on your system are shown in Fig. 8. In A, a CA3080 is used as a combiner and master gain control. The outputs of as many vca modules as you want can be shorted together and routed to this stage, but be sure to use shielded cable. Resistor R_1 can be adjusted to maintain the maximum input signal level to 100 mV peak-to-peak with several notes being played simultaneously. A variable voltage ranging from +15 volts (for maximum gain) to -15 volts (for off) will control the loudness of everything in the system. You can also sum a low-frequency sine wave or noise spectrum for tremolo, wind noise, or other

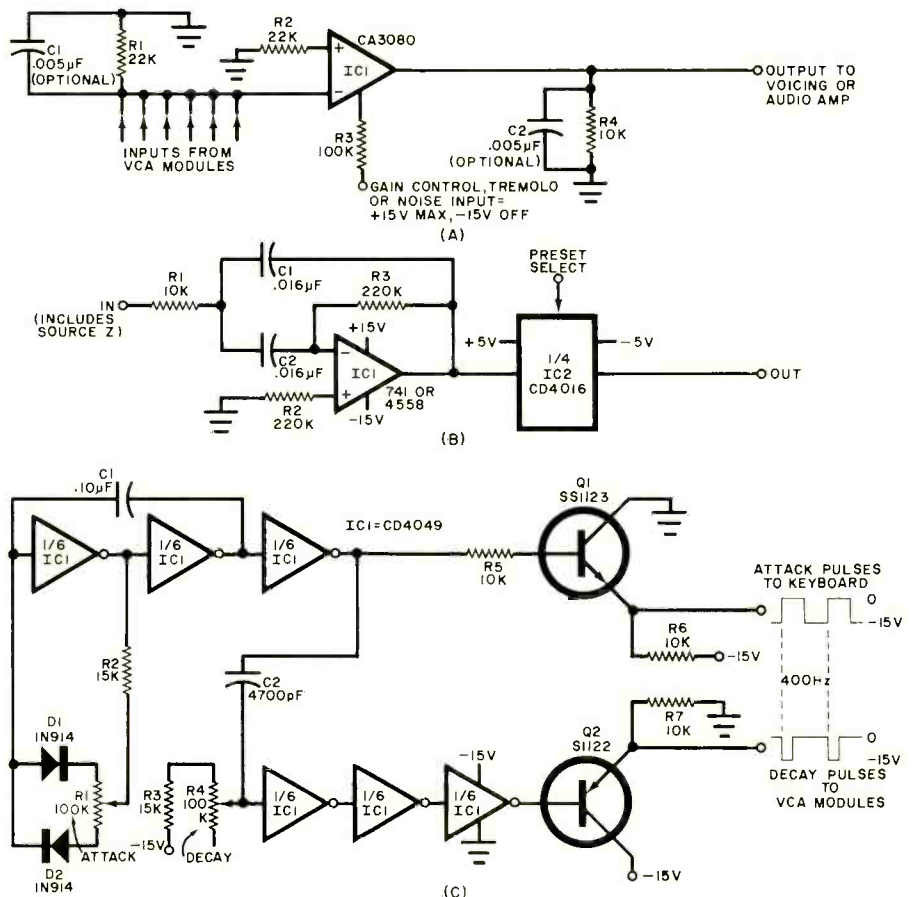
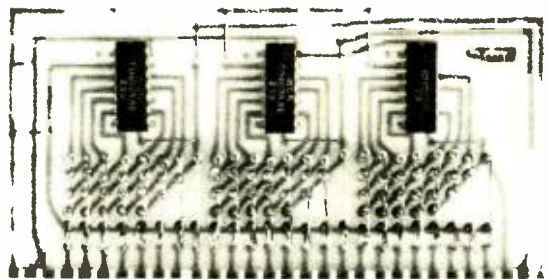

Photo of divider board shows all resistors mounted upright and bus-connected to socket pads.



amplitude-modulated effects. Capacitors C1 and C2 are optional. Installing them in the circuit yields a mellow sound; eliminating them permits the use of fancy voicing filters in the output.

A horn filter is shown in Fig. 8B. To change the center frequency, change the values of C1 and C2, but keep both capacitor values identical. To change the Q, change the values of the resistors, keeping R2 and R3 at 4Q² times the value of R1. Note that R1 must include the source impedance of the circuit or circuits from which you are tapping the signal.

You can simultaneously control the attack and decay of all notes with the pulse-width system shown in Fig. 8C. To do this, you rapidly switch the 10k attack and 3.3k decay resistors in and

out of the vca channel. (A 10k resistor in the circuit at all times has an effective value of 10,000 ohms. If it is in the circuit only 10% of the time, its effective value is 100,000 ohms.)

The circuit employs a single CMOS hex inverter and a pair of drive transistors. The attack portion is a variable-duty-cycle oscillator that operates at 400 Hz. The length of time that the attack remains grounded determines the attack time as a ratio of the total time. If you end up with too much interaction between frequency and duty cycle, a high-value resistor across one of the diodes should fix things. The frequency should remain nearly the same as you change the duty cycle.

The leading edge of the attack waveform can be shortened by operating DECAY potentiometer R4 and

capacitor C2. It is then amplified and routed to the decay inputs of the vca module. Note that attack goes to the keyboard, while decay goes to the vca's. The attack time has priority over decay, so a key fully pressed charges the vca capacitor that is storing the attack and decay information. Because of the resistor values in the vca circuit, up to a 3:1 reverse attack can be accommodated at the extremes of the control settings.

A second decay circuit connected to a driver transistor that catches at some negative voltage will provide fallback. This is important for percussive voices that simulate piano and guitar effects. With fallback, the note very rapidly decays to some low value when the key is released. It then gradually dies out.

Final Comment. With the three basic music module blocks we have presented, plus a keyboard, you have the heart of a sophisticated electronic music synthesizer. You can put additions into the system and modify it to suit your needs. In fact, you can expand it until you have a highly sophisticated and flexible polyphonic instrument. ♦

THE COMPLETE DVM

\$348

FOR FASTER, MORE RELIABLE MEASUREMENTS

A NEW STANDARD IS BORN
High accuracy you can trust
Versatile measuring capabilities
An efficient, easy to operate meter
All at an affordable price
That's the DVM38 . . . The complete DVM that sets new performance standards in 4 key areas.

A NEW ACCURACY STANDARD
The 3½ digit, .1% accuracy is backed by a 15 meg Ω input impedance, compared to 10 meg Ω input of conventional DVM's, which guarantees up to 50% greater accuracy with 1/3 less circuit loading on every measurement for high accuracy you can trust.

A STANDARD IN CAPABILITIES
The DVM38 is more accurate in MORE circuits with these versatile ranges: 100μV to 2000V DC, 1KV AC; .01 Ω to 20 meg Ω; 0.1μA to 2A . . . Plus

HI and LO ohms and a 50KVDC range with accessory Hv probe.

A NEW STANDARD IN SPEED AND EASE OF OPERATION
Large pushbuttons and callouts - no need to hunt and peck. Large 4" L.E.D.'s with direct readout, down to V and mV indicators. SINGLE STEP AUTO-RANGING for maximum resolution and efficiency. 2KV DC protection minimizes downtime.

THE AFFORDABLE STANDARD
There are few .1% DVM's less expensive - there are none as complete in this price range, plus backed by a LIFETIME guarantee against factory workmanship errors.

THE DVM38 A NEW STANDARD IN DVM'S FOR SPEED, VERSATILITY AND ACCURACY.

DVM38 BACKED BY SENCORE'S 100% MADE RIGHT LIFETIME GUARANTEE

SENCORE 3200 Sencore Drive, Sioux Falls, S.D. 57107
Phone: 1 605 338 0100 TWX: 910 660 0300

what you need...

IS A

SPHERE COMPUTER SYSTEM

- Play computer games.
- Play word and math games.
- Balance your check book.
- Complete payroll, financial statements.
- Solve research assignments.
- File valuable magazine articles, etc.
- Learn computer theory and operations.

FLEXIBLE • EXPANDABLE • VERSATILE
A SYSTEM FOR EVERY POCKETBOOK!

SPHERE CORPORATION
P.O. BOX 213 BOUNTIFUL, UTAH 84010

Write for complete information

**HOW TO USE
THE HP-45 CALCULATOR
AS A STOPWATCH OR
ELAPSED-TIME INDICATOR**

IF YOU own a Hewlett-Packard HP-45 calculator and would like to use it as a digital stopwatch and elapsed-time indicator the way the more expensive HP-55 programmable can, there's good news. You *can* use your HP-45 for these functions, even though Hewlett-Packard makes no mention of the fact in its Operator's Manual.

To gain access to the clock function in the HP-45, first clear the calculator by operating the gold alternate-function key. Then press RCL and *simultaneously* press CHS and the digits 7 and 8, or 5 and 4, or 1 and 2. (It is important that these keys be pressed simultaneously.) The display format will now be

HR MIN SEC 0.01XSEC
00. 00 00 00

To start the clock function, press the CHS key once. Pressing CHS again will stop the count without resetting the display to zero. To reset the display to zero, simply press the CLX key.

When operating the calculator on batteries, you can save power by blanking the last two digits (hundredths-of-seconds) by operating the EEX key. The clock will continue to run without upsetting the count. You can restore the blanked digits by pressing the EEX key again.

Elapsed-Time Indicator. The clock can also be used as an elapsed-time indicator for timing and storing the elapsed times of up to nine separate events. The only constraint is that all events must start simultaneously. This function can be quite handy for measurements of physical phenomena, chemical reaction experiments, etc.

While the clock is running, depressing any 1 through 9 digit key stores the displayed time up to that point in the respective register. The clock keeps running and is not otherwise affected by this action. After stopping the clock by operating the CHS key, pressing any of the digit keys recalls the time stored in the respective register.

Note that the STO key, while the clock is running, and the RCL key, after the clock is stopped, need not be operated. The "store" and "recall" functions are automatically executed, depending on whether the clock is running or stopped. (The CLX key should again be pressed after the last readout of stored time to permit the clock to continue from the reading on the display when it is again started.)

When the clock is no longer needed, you can return the calculator to normal operation by pressing ENTER or turning off and then on the power. The latter method is preferred because it clears the contents of the registers automatically. Even so, the registers don't have to be cleared if you wish to store new elapsed-time data. Whenever new data is entered into a memory location, it automatically clears previous data.

While the clock function is in operation, the only keys that have any effect are CHS, EEX, CLX... (decimal point), and 1 through 9. All other keys, including the basic arithmetic ($-$, $+$, \times , \div) keys, are inoperative.

Accuracy. It appears that the HP-45 was built with the HP-55 in mind and, hence, uses some of the same circuitry contained in the latter. However, while the HP-55 is "trimmed" for the required oscillator accuracy, the HP-45 is not. The result is that the HP-45, although reasonably accurate, will not be "on the nose." If you determine the percentage of inaccuracy by comparing the HP-45 against a known time standard and make a note of the deviation, you can calculate precise times.

Although the absolute accuracy of the HP-45 as a timer may not be equal to that of the HP-55, the time function used during relative measurements—and particularly for storing up to nine elapsed-time measurements—can be very useful indeed. At least you won't have to trade up to a more expensive calculator. ♦

FREE EICO CATALOG

346 Ways To Save On Instruments, Burglar Alarms, Automotive & Hobby Electronics!

The more you know about electronics, the more you'll appreciate EICO. We have a wide range of products for you to choose from, each designed to provide you with the most pleasure and quality performance for your money. The fact that more than 3 million EICO products are in use attests to their quality and performance.

"Build-it-Yourself" and save up to 50% with our famous electronic kits.

For latest EICO Catalog on Test Instruments, Automotive and Hobby Electronics, Eicocraft Project kits, Burglar-Fire Alarm Systems and name of nearest EICO Distributor, check reader service card or send 50¢ for fast first class mail service.

**EICO—283 Malta Street,
Brooklyn, N.Y. 11207**

*Leadership in creative electronics
since 1945.*





The United States of America

NEM31111
Pl-2-14355

FEDERAL COMMUNICATIONS COMMISSION

RADIO TELEPHONE OPERATOR LICENSE

FIRST CLASS
(General Radiotelephone Certificate)

This certifies that JOHN R. DOE

SEX M	HEIGHT 6' 2 1/2"	WEIGHT 185	COLOR OF EYES BLUE	COLOR OF HAIR BROWN	DATE OF BIRTH MAY 02 1922
----------	---------------------	---------------	-----------------------	------------------------	------------------------------

IS A LICENSED RADIO OPERATOR, AUTHORIZED, SUBJECT TO ANY SPECIAL ENDORSEMENT PLACED HEREON, TO OPERATE THE CLASSES OF LICENSED RADIO STATIONS FOR WHICH THIS CLASS OF LICENSE IS VALID UNDER THE ORDERS, RULES AND REGULATIONS OF THE FEDERAL COMMUNICATIONS COMMISSION, ANY STATUTE OF THE UNITED STATES AND ANY TREATY TO WHICH THE UNITED STATES IS A PARTY.

THIS LICENSE IS GRANTED UNDER THE AUTHORITY OF THE COMMUNICATIONS ACT OF 1934, AS AMENDED AND THE TERMS AND CONDITIONS THEREOF AND OF ALL LEGISLATIVE ACTS, EXECUTIVE ORDERS AND TREATIES TO WHICH THE UNITED STATES IS SIGNATORY, AND ALL ORDERS, RULES AND REGULATIONS OF THE FEDERAL COMMUNICATIONS COMMISSION, WHICH ARE BINDING UPON RADIO OPERATORS AND MADE A PART HEREOF AS THOUGH SPECIFICALLY SET OUT IN FULL HEREIN.

NEITHER THIS LICENSE NOR THE RIGHTS CERTIFIED TO HEREIN SHALL BE ASSIGNED OR OTHERWISE TRANSFERRED TO ANY OTHER PERSON.

PLACE AND DATE OF ISSUANCE: WASHINGTON, D. C. MARCH 31, 1975

DATE AND TIME OF EXPIRATION: MARCH 31, 1980 AT THREE O'CLOCK A. M. EASTERN STANDARD TIME

SPECIAL ENDORSEMENT:

SHEP KADAR ENDORSEMENT WASHINGTON, D. C. MARCH 31, 1975

Paul J. Harris
FEDERAL COMMUNICATIONS COMMISSION

John L. Rice
FEDERAL COMMUNICATIONS COMMISSION

SPECIMEN

NOT VALID UNTIL SIGNED

CIE's Warranty says a lot to you!

A lot about CIE's FCC License training programs...and a lot more about our school.

Our FCC License Warranty means just what it says. If you enroll in any CIE career course that includes FCC License preparation and successfully complete your training . . . you'll pass the Government FCC exam. *We warrant* that you'll succeed.

CIE can make this no-nonsense warranty because we're confident of our in-depth career training programs. You see, we have *specialized exclusively* in Electronics education-by-mail for more than 40 years. Just Electronics. And, the courses we offer today are the result of these years of teaching experience and proven methods of training.

Our courses of study are written in easy-to-understand language, so you can progress at your own learning pace, at home, in your spare time. And, there are never any classrooms to attend.

CIE courses challenge your thinking . . . help you develop your understanding of important electronics theories and applications . . . enable you to learn new skills and knowledge. Our courses are thorough. They have to be.

You see, we're training you for a career in Electronics. And, if an FCC "ticket" is part of your goal, you'll have to pass a tough licensing exam administered by the Federal Communications Commission (an agency of the U.S. Government). And you'll be prepared.

CIE is willing to warrant that you will pass! The reason is . . . we have every reason to expect that *you will* do exactly that. Based on a series of continuing surveys, *close to 9 out of 10 CIE grads pass* their FCC exams!

What's a license worth?

An FCC License can be worth a lot if you're interested in any area of Electronics involving communications. In some fields, federal law requires that you must have one. And, even in careers where a license is not required, it is

Government certification of certain electronics knowledge and skills.

What about other CIE courses?

In every CIE career course, you'll find the same time-tested instructional techniques that have made CIE's FCC License preparation programs so successful.

Each CIE career course is built on the principle that the best way for you to *learn* and *retain* what you've learned is to *explain*; then to *check* your understanding; then to *reinforce* your comprehension with practical applications. In some courses, you will perform experiments and tests with your CIE Experimental Electronics Laboratory using authentic electronic components and gear. And, if you select a course that includes Color TV technology, you will not only build and keep a 25" diagonal Color TV which features digital circuitry . . . you'll also learn how to troubleshoot your TV.

The CIE course you select (beginner, intermediate, or advanced college-level), will be a complete educational program, designed by *experts* to give you the best in Electronics home-study education.

Send for FREE school catalog

Discover more about the career opportunities open to people with electronics training. *Learn* how CIE career courses can help you build new skills and knowledge and prepare you for a meaningful, rewarding career. Whether you are just starting out in Electronics or are a college-trained engineer in need of updating, (or anywhere in between), CIE has a course designed for *you*. And, more than half of CIE's career courses include FCC License preparation.

Send today for our FREE school catalog and booklet on FCC License information. For your convenience, we will try to have a representative call to assist in course selection. Mail reply card or coupon to CIE . . . or write: Cleveland Institute of Electronics, Inc., 1776 East 17th Street, Cleveland, Ohio 44114. Do it TODAY.

G.I. Bill benefits

All CIE *career* courses are approved for educational benefits under the G.I. Bill. If you are a Veteran or in service now, check box for G.I. Bill information.

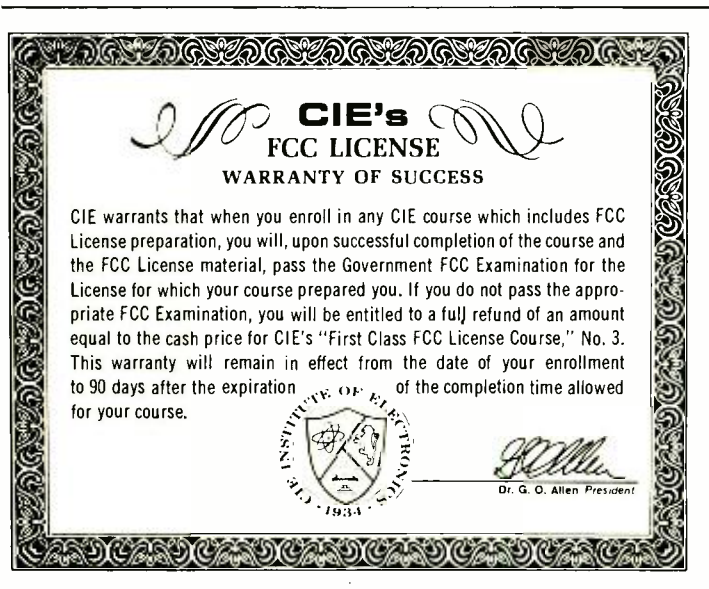

CIE Cleveland Institute of Electronics, Inc.
 1776 East 17th Street, Cleveland, Ohio 44114
 Accredited Member National Home Study Council

Yes, I want your FREE school catalog and career information package today.

I am especially interested in: PE-04

Electronics Technology Industrial Electronics
 FCC License Preparation Electronics Engineering
 Color TV Maintenance Other _____
 Mobile Communications _____

Print Name _____

Address _____ Apt. _____

City _____

State _____ Zip _____ Age _____

Check box for G.I. Bill information. Veteran On Active Duty



Product Test Reports

ABOUT THIS MONTH'S HI-FI REPORTS

In a field as varied as high-fidelity reproduction, it is difficult indeed to design a product, or a system, which has all the features needed to meet today's requirements, but is still flexible enough to handle anything that might come along in the future. Heath's ambitious Modulus system is the most impressive effort we have seen toward meeting these requirements. In addition, the Modulus system is a superb performer in all respects, with a unique combination of styling, flexibility, and just plain good sound.

One of the presumed benefits in the introduction of quadraphonic sound was the recreation of the concert hall environment in the home. With rare exceptions, this has not even been approached, let alone achieved, by existing four-channel hardware and software. Now, it appears that we may be closer to the goal with almost any stereo (or even mono) program by means of electronic time delay and reverberation techniques. The Sound Concepts SD-50 Audio Delay unit uses the "bucket-brigade" technique to restore the "liveness" that has been removed from most recorded programs — or perhaps was never there. It is, at times, startlingly effective in that role, and, to a great extent, begins to fulfill the unkept promise of quadraphony.

—Julian D. Hirsch

HEATHKIT MODEL AN-2016 "MODULUS" CONTROL CENTER

Modular sections offer 2- and 4-channel system choices.



The Heath Company's new "Modulus" series of audio components takes a bold approach to solving the problem of obsolescence resulting from constant changes in audio technology. At least in principle, the Modulus system is capable of dealing with almost any conceivable 2- or 4-channel signal encoding system without the use of add-on accessories.

The Modulus system is built around the Model AN-2016 control center that consists of an AM/stereo FM tuner with digitally generated numeric frequency readout, a two/four channel preamplifier, and full control facilities

for a highly flexible system. (See box for details on companion power amplifiers.) In its basic form, the control center is a stereo component, although it comes standard with four preamplifier channels to accommodate external discrete 4-channel program sources. It contains 11 plug-in circuit board assemblies that hinge up for adjustment and servicing without disturbing normal operation. Three additional spaces are provided for the optional plug-in modules: Dolby decoder for FM; full-logic, wave-matching, variable-blend SQ decoder; and CD-4 demodulator. All switching functions for the optional modules are standard on the control center.

The styling of the control center is

rather unique. The front panel has a black wrinkle finish and is accented with an aluminum surround. The side panels are covered with walnut grain vinyl. Slightly sloping front-panel sections and contoured top give the control center a decidedly modern look.

The Model AN-2016 control center measures 19" W × 14½" D × 6½" H (48.3 × 36.8 × 16.5 cm) and weighs 29 lb (13.2 kg). Available only in kit form, it retails for \$599.95. The optional modules include the Model AM-1503 SQ decoder for \$49.95; Model AN-1504 FM Dolby decoder for \$39.95; and Model AD-1507 CD-4 demodulator for \$79.95.

General Description. The front panel of the control center is divided into three full-width functional areas. At the top is the display section that contains four output-level meters, the numeric frequency readout system, and separate center-tune and signal strength tuning meters.

The output level meters have logarithmic scales that cover a range of more than 30 dB, with the 0-dB calibration marks corresponding to the 1.5-volt rated output of the preamplifiers. The meters have fast responses that provide true peak level indications of the signal. The 3½-digit frequency display consists of ½" (12.7-mm) high seven-segment red LED numerals. The tuning is conventional (not synthesized) so that the numbers displayed are derived from a frequency counter and can be considered as a substitute for a very accurate and easily interpreted dial. FM frequencies are displayed to the nearest 0.1 MHz in odd-value units that conform to the FM broadcasting channels in the U.S. On AM, the display indicates to the nearest 10-kHz mark. When a stereo FM program is received or the system is switched to CD-4, identifying legends next to the numeric display light up when the 19- or 30-kHz carriers are detected. The tuning meters and numeric display light up only when the AM or FM tuner is used.

Below the display section is a row of 21 pushbutton switches above which are identifying legends that light up whenever a button is pressed. Also, when a button is engaged, it is internally illuminated in yellow, except for the POWER button, which glows red. Eight buttons permit selection of PHONO, CD-4, AUX, TAPE, DUB, and tape MON sources. Five additional buttons,

labelled MONO, STEREO 2, STEREO 4, SQ, and 4 CHAN, provide for mode selection.

There are five more pushbuttons. One labelled TONE FLAT is used to switch in and out the tone controls.

The rest are labelled LO and HI FILTER, LOUD (loudness compensation), FM DOLBY, and SQUELCH DEFEAT. (Pressing the FM DOLBY button simultaneously switches in the noise reduction system and changes the de-emphasis

to the required 25 μ s.) The final button is labelled OUTPUT. It disables the pre-amplifier outputs to permit private headphone listening.

On the lower portion of the front panel are 10 control knobs and six 1/4"

HEATHKIT MODELS AA-1505 AND AA-1506 "MODULUS" POWER AMPLIFIERS

THE MODELS AA-1505 and AA-1506 basic power amplifiers flesh out the Heathkit "Modulus" system lineup. Rated at 35 and 60 watts/channel, respectively, their inputs are specifically designed for the output characteristics of the Modulus Model AN-2016 tuner/preamplifier control center. The two amplifiers are electrically and physically identical except for power transformers, ratings of output transistors, and output power rating. They are designed to deliver their rated output power over a frequency range of 20 to 20,000 Hz with less than 0.1% distortion.

The Modulus power amplifiers measure 14 5/8" D x 8" W x 5 5/8" H (37.1 x 20.3 x 14.3 cm) and weigh 21 lb (9.5 kg). Available only in kit form, they retail for \$159.95 for the Model AA-1505 and \$179.95 for the Model AA-1506.

General Description. The only controls on the power amplifiers are a pair of individual channel level potentiometers (on the rear panel) and three pushbutton switches (on the front panel). One switch is a red pushbutton that, when pressed, turns on the power and illuminates the legend POWER. The two remaining switches permit selection between two separate pairs of speaker systems. To minimize the possibility of accidental short circuits and incorrect phasing, the amplifiers are provided with special polarized speaker plugs.

The amplifier circuits are direct coupled throughout, except for a dc blocking capacitor at the input. Electronic

dissipation limiting circuits protect the output transistors. All circuits are assembled on two printed circuit boards that, together with the output transistor heat sinks, swing up to reveal a built-in test meter with attached clip leads. The meter is used only during initial setup to check resistance and voltage, after which it is not needed.

The amplifiers deliver their rated output power with 1.5-volt inputs, which is the rated output level of the Model AN-2016 control center. The input impedance is between 15,000 and 25,000 ohms, depending on the settings of the level controls. This relatively low impedance is easily driven from the 600-ohm output impedance of the control center and many other fine preamps.

With the amplifier inputs shorted, the hum and noise are rated at 95 dB below full power.

Laboratory Measurements. After the standard preconditioning period of one hour at one-third power and five minutes at full power, the amplifiers were only moderately warm. The Model AA-1505 clipped at 47.5 watts/channel into 8 ohms (69 and 27 watts into 4 and 16 ohms) at 1000 Hz.

At its rated output (35 watts) or less, the amplifier's THD was less than 0.01% at 20 Hz and 0.05% at 20,000 Hz. It measured typically between 0.005% and 0.01% over most of the audio range. At 1000 Hz, the THD was 0.005% with outputs of 1 to 30 watts and less than 0.01% from a small fraction of a watt to 40

watts. The IM distortion was 0.01% at 0.1 watt, 0.03% between 5 and 30 watts, and 0.05% at 40 watts.

An input of 0.64 volt drove the amplifier to a reference 10-watt output, and hum and noise measured 80 dB below the output level. The frequency response was \pm 0.1 dB from 5 to 30,000 Hz, -1 dB at 150,000 Hz, and -3 dB at 320,000 Hz. The slew rate was 6 volts/ μ s.

The Model AA-1506 amplifier, rated at 60 watts/channel, clipped at 75.6 watts into 8 ohms (120 watts into 4 ohms and 45.6 watts into 16 ohms) at 1000 Hz. Its distortion characteristics were essentially the same as for the Model AA-1505 (extending the high power outputs, of course), as were its frequency response and noise level. Only 0.5 volt was needed at the input for a reference 10-watt output, and the slew rate was 10 volts/ μ s.

User Comment. The only differences between the two amplifier models are in output power and price. Both are handsome amplifiers, nicely complementing the tasteful styling of the Model AN-2016 control center. They are equally fine sounding, with distortion levels so low that the finest laboratory instruments are hard pressed to measure them.

While both amplifiers are good values at their respective prices, we feel that the slight added cost of the Model AA-1506 buys a very worthwhile increase in available power. This is especially true if you plan to drive 4-ohm speaker systems, considering that the Model AA-1506 can deliver 240 clean watts of power.

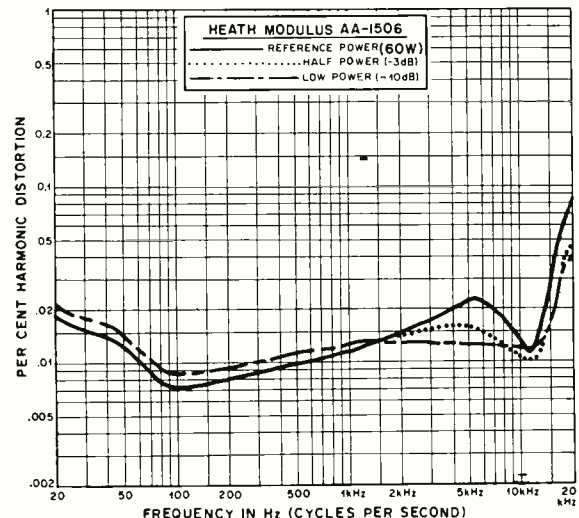
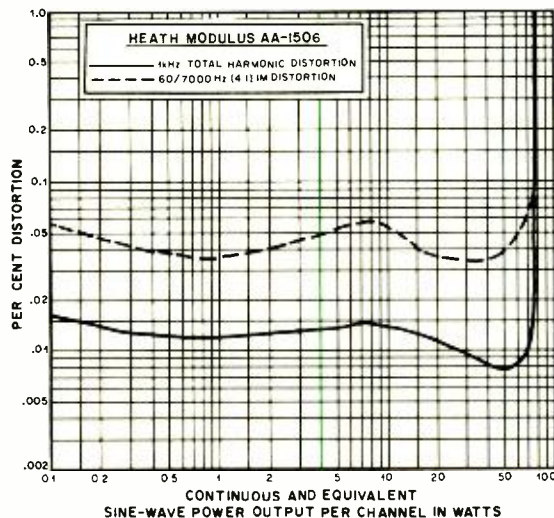

(6.35-mm) phone jacks. Four LEVEL controls permit adjustment of the individual output channels, while a separate VOLUME control serves as the master gain control. Four BASS and TREBLE tone controls are provided for the front and rear channels. A large TUNING knob operates the smooth tuning system for both AM and FM reception. Separate front and rear PHONE jacks permit the use of 4-channel headphones. The four IN and OUT DUBBING jacks located at the bottom center of the front panel are for using a stereo or 4-channel tape deck, making copies of tapes played on the system's regular tape deck (and vice versa), recording the normal program source, or listening to pre-recorded tapes.

On the rear apron of the control center are all the standard input and output jacks, vertical and horizontal outputs for a multipath indicator oscilloscope, and two switched and two unswitched ac convenience outlets. In addition, there are screw terminals for 75- and 300-ohm FM antennas, a phono jack for an external shielded AM loop antenna (supplied with the kit), and a HI/LO PHONO SENSITIVITY switch. The AM loop antenna is used instead of the usual ferrite rod antenna to eliminate most of the electrical interference that can affect AM.

The circuits contained in the control center are so extensive that space does not permit a detailed description. But to give you an idea of how complex the system is, it contains 28 IC's, 134 transistors, and 55 diodes. The FM front end employs dual JFET r-f stages, and a linear-phase multipole LC filter in the i-f section provides high selectivity and stereo separation. A digital discriminator and phase-locked-loop multiplex demodulator contribute to the excellent distortion and stereo separation characteristics of the tuner. The AM section is also designed to give above-average performance. It features a dual-gate MOSFET front end and a nine-pole LC filter for i-f selectivity.

The preamplifier section uses differential amplification and is designed for low noise and distortion. The feedback-type tone controls permit adjustment at the frequency extremes with minimum effect on mid-range response. The audio filters have 12-dB/octave slopes for minimum loss of program content.

Laboratory Measurements. The tuner/control center we tested came completely assembled and aligned. Looking over the supplied manuals, however, we determined that it should

be possible for anyone to obtain the specified performance without having to resort to external test instruments.

The IHF usable sensitivity of the FM tuner measured 10.8 dBf (1.9 μ V) in mono and 16.1 dBf (3.5 μ V) in stereo. The 50-dB quieting sensitivity was 34 dBf (27.5 μ V) with 0.4% THD. The ultimate signal-to-noise ratio was 68 dB in mono, 63 dB in stereo. Distortion at 65 dBf (1000 μ V) was 0.35% and 0.2% in mono and stereo, respectively.

The capture ratio was 1.9 dB at a 45-dBf (100 μ V) input. AM rejection was an excellent 71.5 dB, image rejection a very good 94 dB, and alternate-channel selectivity 80 dB. The internally set FM muting threshold was 22 dBf (7 μ V), while the stereo switching threshold was 11 dBf (2 μ V). The stereo frequency response was ± 0.4 dB from 30 to 15,000 Hz. Channel separation was 35 to 36 dB over most of the audio range, diminishing to 24 dB at 15,000 Hz. The 19-kHz pilot carrier leakage in the audio outputs was 63 dB below 100% modulation.

The frequency response of the AM tuner was ± 2 dB from 20 to 7000 Hz, which is considerably better than the performance of the AM tuners in most receivers we have tested, regardless of price. Whistles and the usual interstation noises were notably absent.

In the audio section of the control center, the turnover frequency of the bass control varied from about 100 to 300 Hz, while the treble response was hinged at about 3000 Hz. The loudness compensation boosted both the lows and the extreme highs (above 10,000 Hz) to a moderate extent. It could easily be adjusted to individual tastes by setting the channel level and volume controls. The 3-dB frequencies of the filters were at 37 and 6500 Hz, beyond which their 12-dB/octave slopes could remove appreciable amounts of rumble and hiss without serious loss of program content.

With tone controls bypassed, the frequency response of the preamplifier section was ± 0.25 dB from 20 to 20,000 Hz. It did not change appreciably when the tone controls were switched into the circuit and mechanically centered. The RIAA equalization was very accurate, changing less than 1 dB at any frequency when measured through the inductance of a phono cartridge coil.

To develop a reference 1-volt output, a 90-mV signal was required at the aux inputs, while 3.7 or 1.3 mV (depending on the setting of the phono

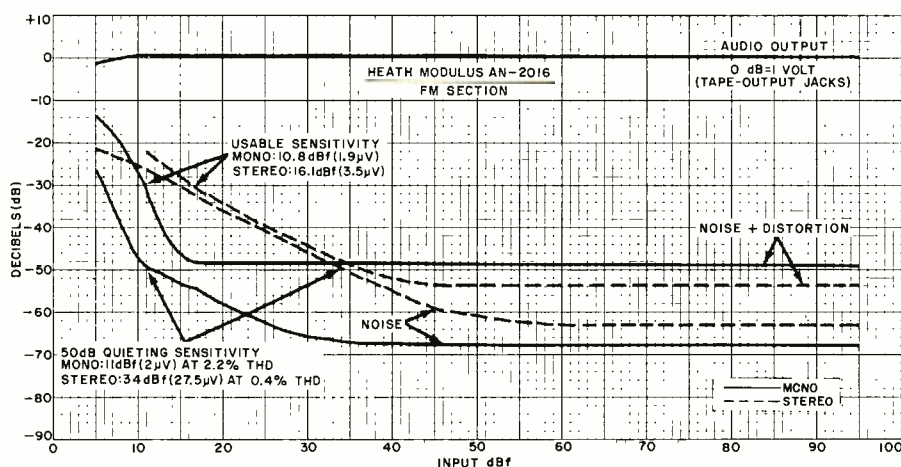
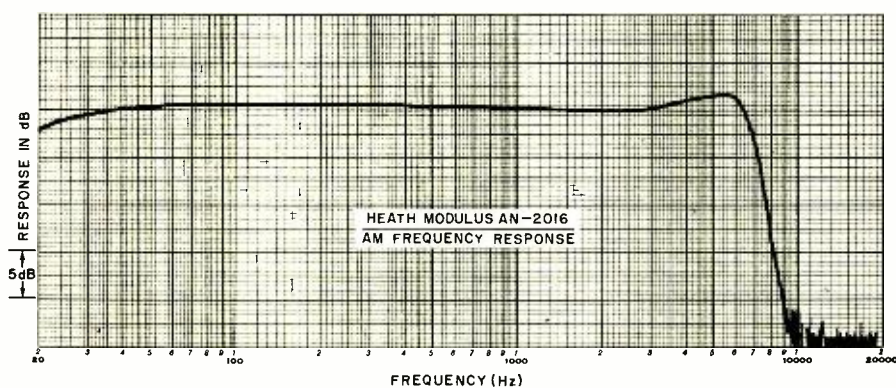

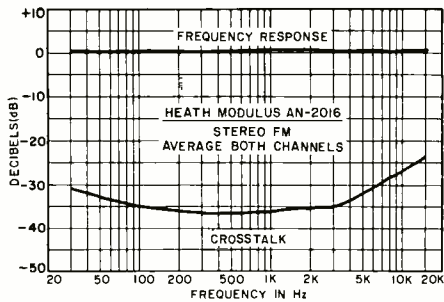

sensitivity switch) was required at the PHONO inputs. The S/N ratio through any input was 67 to 69 dB referred to a 1-volt output. The PHONO inputs overloaded at 55 and 175 mV with the HI and LO sensitivity settings. The overload level at the AUX inputs was 4.4 volts, a figure not likely to be encountered in practice.

The phono sensitivity through the CD-4 inputs was about 1 mV for a 1-volt output when the separation was optimized and using the CD-4 test record supplied with the demodulator. As is the case with most CD-4 demodulators, this one overloaded at a rather low 9 mV input. Although this would be intolerable for stereo operation, it is not a problem with CD-4 discs and cartridges. (The recorded level on most CD-4 discs is relatively low, and most CD-4 cartridges have a low output.)

The 1.5-volt output rating of the tuner/control center's preamplifiers proved to be quite conservative, since we measured 5.9 volts into a high-impedance load and 3.15 volts into a 600-ohm load at the clipping point. The 1000-Hz THD and IM were between 0.01% and 0.02% at all outputs from 0.1 to 3 volts.

We performed no measurements on the FM Dolby, SQ, and CD-4 modules. We judged performance subjectively with normal program material.

User Comment. The tuner/preamplifier system proved to be exceptionally easy to operate with maximum effectiveness. Both AM and FM tuning were smooth and not critical, and there was never any doubt as to the frequency or channel to which we were listening.

The FM tuner is extremely sensitive and has the selectivity, distortion figures, and frequency response characteristics typical of today's fine-quality tuners. The FM muting was positive and noise-free. The Dolby noise reduction system performed effectively with the stations using Dolby encoding. The effect produced was a sense

of improved high-frequency response with reduced noise — a most unusual and welcome combination.

The AM tuner could legitimately be called "hi-fi" when compared with the other AM tuners we have tested. The background noise was negligible, and the frequency response was wide enough to eliminate the usual muffled quality AM reception.

The illuminated pushbutton switches and digitally generated numeric display allow you to see at a glance — even from across the room — the operating mode and station being heard. We also appreciated the headphone outputs, which were able to drive both high- and low-impedance phones to a healthy level. This is not the case with most preamplifier headphone output systems. Of course, electrostatic and other voltage-operated phones must still be driven by a power amplifier.

When playing SQ discs, the decoder produced the quality of separation and total sound effect that we have come to expect from modern logic decoders. Although we made no direct comparison between the Heath system and other good SQ decoders, our impression was that it was at least as good as the others we have used.

We were especially critical in our listening to the CD-4 operation of the system because of its apparently low overload limits. Using a couple of the latest and best cartridges and making A-B comparisons with a very good accessory CD-4 demodulator, we never heard anything that could be attributed to input overloading. The rare instances of breakup distortion were all on early disc releases and were almost certainly the fault of the records.

The high-frequency response through the Heath system was strikingly superior to the demodulator we used as a comparison. It was apparently one octave greater in range and gave some of our discs an entirely different sound character. All in all, when good discs and cartridges were used, we felt that the Heath system gave the best CD-4 reproduction we have ever heard through a home-entertainment system. Our only criticism of Heath's CD-4 design is the need for separate record players (or a well-shielded external switch box) for playing stereo or matrixed 4-channel and CD-4 records. A number of recent CD-4 cartridges are also outstanding stereo reproducers. It seems a pity that these fine and very expensive car-

SAVE!

MONEY • TIME • FREIGHT

- ♪ QUALITY STEREO EQUIPMENT AT LOWEST PRICES.
 - ♪ YOUR REQUEST FOR QUOTATION RETURNED SAME DAY.
 - ♪ FACTORY SEALED CARTONS—GUARANTEED AND INSURED.
 - ♪ SAVE ON NAME BRANDS LIKE:
- | | |
|--------|--------|
| A.D.C. | KLH |
| A.R. | SHURE |
| DYNACO | KOSS |
| SONY | FISHER |

PIONEER
AND MORE THAN 50 OTHERS
BUY THE MODERN WAY
BY MAIL—FROM

illinois audio

Department 217S
12 East Delaware
Chicago, Illinois 60611
312-664-0020

CIRCLE NO. 27 ON FREE INFORMATION CARD

New AM/FM-CB Receiver!

Low Price
\$29⁹⁵



- Built in ferrite AM antenna
- 45" telescoping swivel FM/CB antenna
- All 23 CB channels
- Slide rule tuning
- Volume and Tone controls
- Batteries included
- 7" x 4" x 2"
- Manufacturer's Warranty
- \$29.95 plus \$3 shipping and insurance
- Optional AC Adapter @ \$4.95 each

Get in on all the CB Action, anywhere, with this new portable 23 Channel Receiver (plus AM/FM) by Hanimec. It's a quality built, solid-state unit in a handsome, high-styled case. The convenience of a portable radio—the excitement of all the CB happenings—all in one at an amazing price. Order today for a 2-week no obligation trial.

TWO WEEK RETURN PRIVILEGE PE
Check, Money Order or Charge Cards. Please give Account No., Bank No., (if any), Expiration Date, Signature. Conn. residents only add 7% Sales Tax.
ORDER TOLL FREE 24 HOURS, 7 DAYS
800-243-6006 Conn. res: 1-800-882-6500
new concepts 158 Silvermine Ave. Norwalk, Ct. 06850

CIRCLE NO. 35 ON FREE INFORMATION CARD

tridges cannot be used for both functions in the Heath system.

It is clear that the combination of extreme flexibility and top-notch performance in a single hi-fi component is a noteworthy achievement. In our judgement, Heath comes very close to creating the ultimate obsolescence-free control center with the Model AN-2016. Perhaps because it comes so close to being the ultimate control center, we must note a few instances where it falls short of that goal. First, there is only one tape monitoring system where there should be a minimum of two. The user with two tape decks cannot connect both of them into the system with full flexibility. (The DUBBING jacks are not equivalent to a regular in/out monitor connection.) Also,

some external signal-processing accessories, such as graphic equalizers, volume expanders, noise-reduction units, etc., are best connected into tape monitoring loops.

The Model AN-2016 would have been *the* complete 4-channel control center. However, it has no facilities for a QS decoder. Of course, if the choice of only one matrix decoder was possible, the much greater availability of SQ-encoded discs justifies Heath's choice of the full-logic, wave-matching SQ decoder. But it would have been nice to have the QS Vario-Matrix as well.

One final note about the kit itself. Although we did not assemble the tuner/preamp control center or the power amplifiers that make up the

Modulus system, we know from past experience that this is a major assembly project that is likely to take a considerable amount of time. Fortunately, Heath's excellent manuals and the fact that no test equipment is needed for alignment make it possible for the kit builder to obtain full performance from this highly complex system.

While the Modulus is not exactly an economical hi-fi system approach, it is a highly sophisticated, nearly state-of-the-art product whose features simply cannot be purchased factory-wired from any source. The Model AN-2016 is also a strikingly handsome unit, especially when flanked by its matching power amplifiers.

CIRCLE NO. 90 ON FREE INFORMATION CARD

SOUND CONCEPTS MODEL SD-50 DELAY UNIT

Time-delay system creates "concert-hall" effect in home.



The time-delay device used in home audio systems to provide reverberation has traditionally been the economical coil-spring type. Unfortunately, this type of delay device has a severely irregular frequency response and tends to obliterate the transient characteristics of the input signal. Recently, all-electronic delay techniques have become feasible with the development of suitable IC's.

One way to delay a signal through all-electronic means involves analog-to-digital (A/D) conversion, passing the digitized signal through a series of shift registers to delay it, and converting the delayed signal back to analog form. The delayed signal then is amplified and fed to the rear or side speaker systems. Another technique employs analog techniques, with a "bucket-brigade" IC serving as the delay device. The analog signal is

passed along through a series of capacitive elements at a rate determined by a clock (timing) signal. A consumer version of this approach to delaying a signal is the Model SD-50 delay unit developed by Sound Concepts, Inc.

The Model SD-50 processes stereo (and mono) signals available at the preamplifier or tape recording outputs of amplifiers and receivers. The front-channel (input) program is passed unchanged through the delay unit to the front-channel inputs of a power amplifier to drive the speakers. The delayed signals are then fed to the rear-channel amplifier for the rear speakers. For compatibility with 4-channel systems, whose rear-channel amplifiers and speaker systems can be used for the reverb signal, the delay unit also has a set of rear-channel inputs that accept the line-level, rear-channel outputs from a 4-channel preamp or receiver.

The Model SD-50 delay unit is 12" W

× 7½" D × 3¾" H (30.5 × 19.1 × 9.5 cm). Designed to be powered continuously from the ac line to avoid problems with start-up transients, it consumes only 3.5 watts of power. Contained on its single printed circuit assembly are some 30 IC's, which should convey some idea of the circuit complexity. Price is \$600.00.

General Description. The front panel of the delay unit has five control knobs. Calibrated from 5 to 50, the DELAY control introduces a time delay of the indicated number in milliseconds to signals available at the rear-channel outputs. These delays correspond roughly to acoustic path length differences of 5.5 to 55 feet (1.7 to 16.8 m). The program content of the rear signal is essentially the same as the input to the delay unit, except that it is delayed and modified as explained below. The two channels are separately processed, but the setting of the DELAY control applies to both channels.

Next is the REVERB control, which adjusts the proportion of the output of each rear channel that is fed back to the input of the opposite channel's delay circuit. This simulates the effect of multiple reverberations in the hall. Since room surfaces vary widely in reflective properties, the REVERB control provides the means of varying the "liveness" of the total sound by cross-coupling from zero to 90% of the delayed signal. The effect is multiple echoes of successively lower amplitude.

The MODE switch causes the delay unit to operate as described above

only when it is set to the STEREO position. Setting it to MONO causes the front-left and front-right channels to be mixed, producing a mono signal that is passed through both delay circuits in succession. The delay time calibrations around the DELAY control are, therefore, doubled to give a range of 10 to 100 ms. Both rear outputs carry the same signal. The delay unit does not modify the program delivered to the front speakers in any way.

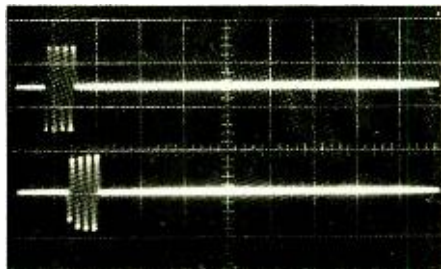

5 ms

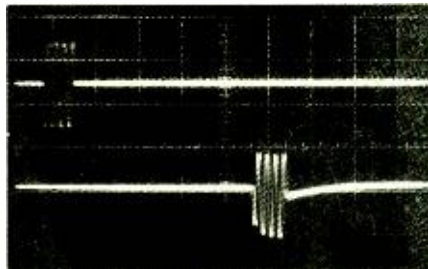

50 ms

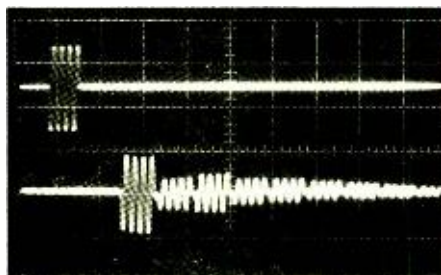

20 ms with reverb

Tone bursts of 500 Hz show delay for 5 ms, 50 ms, and 20 ms with reverb.

The EXT position of the MODE switch bypasses all circuits in the delay unit and passes the front and rear input signals directly to the outputs without modification. In this mode, a 4-channel system can be operated in the normal manner.

In a real concert hall, the reflected sound has a reduced high-frequency content that is a result of the greater absorption of higher frequencies by the acoustically treated surfaces and the occupants of the hall. The rear outputs of the delay unit are, therefore, designed with a high-frequency roll-off that increases with the setting of the DELAY control. In addition, there is a ROLLOFF switch that can be used to reduce the high-frequency response of the rear channels by nominal 3-, 6-, or 9-dB amounts at 7000 Hz with a 6-dB octave slope.

The final control, labelled LEVEL, is for adjusting the rear, or delayed outputs. When set to 30% of maximum, the rear-channel gain is unity (the same as the front channels). The reason for providing the LEVEL control is to allow the user to make adjust-

ments for differences in amplifier gain and speaker sensitivity. A red PEAK LED flashes whenever there are excessive input signal levels.

All input and output connectors are located on the rear apron of the delay unit, including a pair of outputs labelled 2CH MIX. These connectors make available the regular front-channel program mixed with an amount of the delayed signal set by the LEVEL control. If the combined signals are used

to drive the regular stereo speaker systems (through an amplifier), some of the benefits of the delay system can be realized without the need of a 4-channel playback system. The effect, of course, is not as dramatic as with a 4-channel playback system.

A more subtle use of the 2CH MIX outputs is to drive stereo headphones, which can be done directly or through an amplifier. It is possible to give stereo headphones a sense of spaciousness that is usually obtained only with the better 4-channel headphones. The effect is completely under the listener's control. Unfortunately, the 2CH MIX jacks are standard phono jacks; it would have been more convenient if they were standard phone jacks to accept the phone plugs normally fitted to the cords of headphones.

Laboratory Measurements. As rated, the gain through the delay unit at a LEVEL setting of 3 was 1.0 (unity). The gain was 3.5 at the maximum setting of the control. The PEAK LED began to glow as the signal input level

The IMSAI 8080.

A commercial yet personally affordable computer.



If you thought you could never afford a computer at home, think again. The IMSAI 8080 is built for rugged industrial performance. Yet its prices are competitive with Altair's hobbyist kit. Fully assembled, the 8080 is \$931. Unassembled, it's \$599.

The IMSAI 8080 is made for commercial users, and it looks it. Inside and out. The cabinet is attractive, heavy gauge aluminum. The heavy duty lucite front panel has an extra 8 program controlled LED's. It plugs directly into the Mother Board without a wire harness. And rugged commercial grade paddle switches are backed up by reliable debouncing circuits.

The system is optionally expandable to a substantial system with 22 slots in a single printed circuit board. And the durable card cage is made of commercial-grade anodized aluminum.

The IMSAI 8080 power supply produces a true 20 amp current, enough to power a full system. You can expand to a powerful system with 64K of software protectable memory plus an intelligent floppy disk controller. You can add an audio tape cassette input device, a printer plus a video terminal and a teletype. And these peripherals will function with an 8-level priority interrupt system. BASIC software is available in 4K, 8K and 12K.

Get a complete illustrated brochure describing the IMSAI 8080, options, peripherals, software, prices and specifications. Send one dollar to cover handling to IMS. The IMSAI 8080. From the same technology that developed the HYPERCUBE Computer architecture and Intelligent Disk systems.

Dealer inquiries invited.

IMS

IMS Associates, Inc.
1922 Republic Avenue
San Leandro, CA 94577
(415) 483-2093

approached 5 volts. The output noise referred to 1 volt was 66 dB down unweighted and below our minimum measurement capability of -80 dB (100 μ V) with IEC A weighting.

The 1000-Hz harmonic distortion at the rear outputs was less than 0.5% for outputs of up to 1 volt. It reached 1% at 1.4 volts, after which it rapidly increased to 20% at 5 volts output. At a fixed 1-volt level, the distortion was about 0.5% over most of the audio range, 2% at 20 Hz, and 1.4% at 20,000 Hz.

Our rear-channel frequency response measurements confirmed the data supplied in the comprehensive operator's manual. The response varies with the amount of delay used. With longer delays, there is a reduction in high-frequency response, as required for a realistic effect. At the minimum delay of 5ms, the response was down 3 dB at 7800 Hz. Using a delay of 50 ms, the -3-dB frequency was 3000 Hz, while at the extreme setting of 100 ms (mono), the 3-dB down frequency was 1700 Hz. The ROLLOFF switch reduced the output at 7000 Hz by approximately the 3-, 6-, and 9-dB amounts indicated on the settings for the switch.

The delay characteristics of the unit can be best appreciated by examining the tone-burst photos, which were taken with a four-cycle burst of a 500-Hz signal. The time scale in the photos is 10 ms/cm. The upper burst in each photo is the input to the delay unit; the lower burst, the delayed output. Note that the delayed signal is not distorted in the manner that is typical of inexpensive spring-type delay units.

When reverberation is added, a series of output bursts that decay in amplitude is obtained.

User Comment. Our laboratory tests confirmed that the delay unit performed according to its published specifications, with the single exception that the maximum output available was considerably less than the rated 10 volts.

The real value of this type of hi-fi accessory can be judged only by listening tests using a broad variety of program material. When we first used the delay unit, we yielded to the temptation to use relatively large delays combined with reverberation. While this is not the way the delay system would be used for normal listening, it is a good way to convince yourself that the system is working. (A properly adjusted delay system should normally be so unobtrusive that you are not consciously aware of its presence.)

After a familiarization period, we began to use smaller delay times (20 to 30 ms) for our more critical listening tests. The enhancement of almost any stereo (or mono) program by the proper combination of delay and reverb is unmistakable and impressive. On complex orchestral music, the contribution of the delayed signals is often difficult to detect when the recording contains sufficient ambience content. However, with chamber music and vocals, the effect is more apparent. In fact, a combination of long delay and reverb can make an announcer appear to be speaking in a huge empty hall or cavern. We obtained our most impressive results

with organ music and a long 100-ms delay and reverb.

To some extent, a good quadraphonic system can give a similar subjective spatial effect only if the recording was made with this goal in mind. Few recordings are. The delay unit makes almost *any* stereo or mono program sound more real than 99% of the available quadraphonic programs. Also, unlike quadraphonic listening, the delay system does not alter the front speaker system imaging or place special demands on the listening environment or speaker placement. Although we used good-quality speaker systems in the rear and a fairly powerful amplifier to drive them, the low power and restricted frequency range of the delayed signal suggests that a relatively low-power amplifier and inexpensive speaker systems could be used effectively for the rear channels.

We enjoyed listening to the mixed headphone outputs, but the lack of standard phone jacks for plugging in the phones was an annoyance. We hope that, in the future, Sound Concepts will add phone jacks in parallel with the 2CH MIX phono jack outputs.

A nearly infinite number of acoustic perspectives can be created with headphones, but the special advantage of using the delay system is its ability to reduce the unnatural left-to-right separation effects of stereo programs heard through phones and the "center-of-the-head" effect with mono programs. Instead, the delay unit gives headphone listening a realistic spacious effect that is not unlike what we have heard through some of the best 4-channel phones.

CIRCLE NO. 80 ON FREE INFORMATION CARD

CRAIG MODEL 4104 MOBILE AM CB TRANSCEIVER

Moderately priced unit includes quick-release mounting and modern styling.

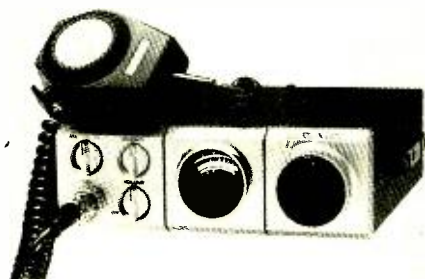

THE frequency-synthesized 23-channel Model 4104 AM CB transceiver from Craig features a quick-release mounting bracket that allows it to be conveniently removed

for security or transfer to another vehicle. What sets this transceiver apart from most other mobile rigs is its rather unconventional, modernistic front-panel design. Instead of the usual edgewise S/r-f meter, there is a round, dark-faced area in the middle of the control panel that, when the transceiver is turned on, illuminates the meter face. The back-lighted channel selector gives a similar appearance.

The transceiver has a full-time automatic noise limiter (ANL), switchable noise blanker (NB), and PA operation,

all selectable by a single switch. There are also separate VOLUME and SQUELCH controls. Among the other transceiver features are: external-speaker jacks, operation at full legal power, automatic modulation compression (amc), LED modulation indicator, detachable microphone with quick-connect plug, operation from a nominal 12-volt dc (positive or negative ground) source, and dual line filtering.

The transceiver measures 8 $\frac{1}{4}$ " D \times 7" W \times 2 $\frac{5}{8}$ " H (21 \times 17.8 \times 6.7 cm). It retails for \$169.95.

The Receiver. The dual-conversion receiver section is conventional. It uses paired synthesizer crystals in the 37.700- and 10.160-MHz range to provide a 10.635-to-10.595-MHz first i-f and 455-kHz second i-f. An r-f input amplifier precedes the two mixers. This arrangement provided a measured sensitivity of 0.55 μ V for 10 dB (S + N)/N with 30% modulation at 1000 Hz.

The receiver's selectivity is obtained with the aid of a 455-kHz ceramic filter, which provided good adjacent-channel rejection, measuring an average of 56 dB. Primary-image (CB frequency plus two times the first i-f) rejection measured 75 dB, while i-f and other unwanted spurious-signal rejection measured 75 and 55 (minimum) dB, respectively.

The anl is a series-gate configuration. The noise-blanker functions between the two mixers. It employs a FET pulse amplifier and a dual-diode gate.

The three-stage audio system employs a push-pull final stage whose output measured 4 watts with 5.5% THD at the start of clipping, using a 1000-Hz test tone and an 8-ohm load. The overall frequency response, including the i-f passband, was down 6 dB at 300 and 3500 Hz.

The characteristics of the agc varied, with negligible agc action at 1 to 10 μ V (20-dB input range) on channels 1 through 16. On channels 17 through 23, the agc held the audio output to within 10 dB with a 20-dB input variation at 1 to 10 μ V. Otherwise, the output change was around 8 dB for a 60-dB input change at 10 to 10,000 μ V. An S9 indication was obtained with signals in the 50-to-100- μ V range. The squelch range was nominally 0.5 to 500 μ V.

The Transmitter. Crystals in the 10.615-MHz range paired with crystals in the 37.700-MHz range in the synthesizer provide the carrier at a mixer. A buffer, driver, and power amplifier complete the r-f transmitter circuit that terminates in a 50-ohm output-matching and harmonic-reduction network.

Modulation is obtained from the receiver section's audio system. The modulation scheme employs a compression-type amc in which a voltage-doubled potential from the modulator is fed back to the first audio stage (used as the speech amplifier on transmit). An LED, located just below the movement in the meter's blackout

Saving the best for last.

The chances are good that when you first bought a stereo system, it was a "package" that included a receiver, 2 speakers, and a record player with cartridge. But how much time was spent selecting the cartridge? Most probably it was just a minor element of the package. Even if it had a famous name, it probably was not a truly first-rank model.

Yet the cartridge is more important than that. It can limit the ability of the entire hi-fi chain to properly reproduce your records. It can affect how many times you will enjoy your favorite records without noise and distortion. And it can determine whether you can play and enjoy the new four-channel CD-4 records.

Consider the advantages of adding an Audio-Technica AT15Sa to your present system. You start with response from 5 to 45,000 Hz. Ruler flat in the audio range for stereo, with extended response that assures excellent CD-4 playback if desired. Tracking is superb at all frequencies and distortion is extremely low. The sound is balanced, transparent, effortless. Stereo separation is outstanding, even at 10kHz and higher where others fall short. Our Dual Magnet design* assures it.

And the AT15Sa has a genuine nude-mounted Shibata stylus. Which adds a host of advantages. Like longer record life. Better performance from many older, worn records. Exact tracing of high frequencies, especially at crowded inner grooves. And tracking capability—at a reasonable 1-2 grams—that outperforms and outlasts elliptical styli trying to track at less than a gram.

We're so certain that an AT15Sa will improve your present system that we'd like to challenge you. Take several of your favorite records to an Audio-Technica dealer. Have him compare the sound of your present cartridge (or any other) with the AT15Sa. Listen. We think you'll be impressed. And convinced.

*T.M. Audio-Technica Dual Magnet cartridges protected by U.S. Patent Nos. 3,720,796 and 3,761,647.

The AT15Sa. Very possibly the last phono cartridge you'll ever need.



 **audio-technica**[®]
INNOVATION □ PRECISION □ INTEGRITY

AUDIO-TECHNICA U.S., INC., Dept. 66P, 33 Shiawassee Ave., Fairlawn, Ohio 44313
Available in Canada from Superior Electronics, Inc.

area, blinks in step with the modulation. Transmit/receive switching is accomplished with a solid-state circuit.

Powering the transceiver from a 13.8-volt dc source, the measured r-f carrier output was 3.75 watts. Starting at 50% modulation and without compression, a 6-dB rise in the audio input level would normally cause the modulation to go up to 100%. With this transceiver, the amc held the modulation to just short of the 100% mark with a 16-dB rise above the same initial input level. This indicates a high degree of compression. Under this condition, sine-wave modulation was obtained with 6% THD at 1000 Hz. A further increase gave the transmitter a tendency to clip at 100% modulation, with distortion rising to about 20%.

With a 400-Hz test tone, the THD was somewhat higher. Adjacent-channel splatter, with voice operation, was

down 55 to 60 dB. The audio response was nominally 225 to 6000 Hz, while the transmitter frequency tolerance was within 0.00185% on any channel.

User Comment. The transceiver's meter is calibrated in S units and relative power in watts, the accuracy of the latter depending on the SWR. The meter scales are recessed, which can make the S-unit scale, located at the top, difficult to read under some viewing conditions. The illuminated channel numbers on the selector dial are small and may be difficult to read.

Under most noise conditions, the full-time anl was less effective than the noise blanker. The noise blanker was good; however, it had the disadvantage of dropping the signal level quite a bit when 1-to-2- μ V signals were being received.

The lower-than-usual rolloff point at

CIRCLE NO. 81 ON FREE INFORMATION CARD

the low end of the frequency response curve gave to transmitted signals a more natural sound than is usually the case.

The transceiver slides in and out of its mounting bracket relatively easily. Mating connectors at the back of the transceiver and mounting bracket automatically engage and disengage when the rig is slid into and removed from the bracket. This is true only for the dc power leads; the antenna connection must still be made through its own connector. The bracket itself is designed to be mounted above or below the dashboard.

The Model 4104 CB transceiver represents honest performance for its price and features. This, plus the fact that it has a distinct modern appearance, will make it appealing to CB'ers who are looking for something "different" in CB rigs.

CONTINENTAL SPECIALTIES "DESIGN MATES"

Breadboards with power supply, meter, function generator and resistance/capacitance bridge.

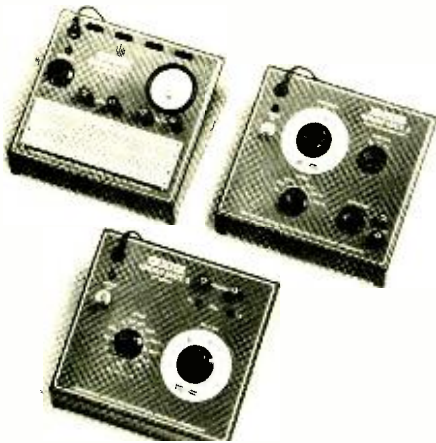

WHETHER you're an avid experimenter or do circuit prototyping for a living, you'll appreciate the Design Mates from Continental Specialties Corp. The Design Mate 1 circuit designer is a solderless breadboarding system with its own built-in power supply and voltmeter. The Design Mate 2 function generator provides a source of sine, square, and triangle waves over a frequency range of 1 Hz to 100 kHz. The Design Mate 3 resistance/capacitance bridge measures resistances from 10 ohms to 10 megohms and capacitances from 10 pF to 1 μ F. While each can be used independently of the others, the three Design Mates together comprise a highly flexible designer/experimenter lab.

Each Design Mate is in an enclosure that measures 7 $\frac{1}{2}$ " W \times 6 $\frac{3}{4}$ " D (19.1 \times

17.1 cm) and slopes from 3 $\frac{1}{4}$ " to 1 $\frac{1}{2}$ " (8.3 to 3.8 cm) high. All three units are designed for operation on 117-volt ac line power.

The Design Mate 1 solderless breadboard sells for \$49.95, the Design Mate 2 function generator for \$64.95, and Design Mate 3 R/C bridge for \$54.95.

General Descriptions. The heart of the Design Mate 1 breadboard is its large solderless breadboarding socket, which contains a 59 \times 10 hole matrix. Component leads and stripped hookup wires are plugged into the holes to make electrical (and mechanical) contact during circuit setup. The matrix is arranged in two 59 \times 5 sets, with each of the 59 columns containing five electrically common contacts to provide multiple connection points for each component lead. The column-to-column and row-to-row hole spacing is 0.1" (2.54 mm), with 0.3" (7.62 mm) between matrix sets to accommodate standard DIP (dual in-line package) IC's. Above and below the main solderless socket are bus strips (each with 50 holes).

The internal regulated power supply delivers from 5 to 15 volts at 600 mA to the breadboarding system. The supply's ripple and noise are rated at less than 20 mV full load. Both line and load regulation are specified at less than 1%. The output of the power sup-

ply is available at a pair of color-coded binding posts (red for +, black for -). The 15-volt full-scale dc voltmeter is accessed through another pair of binding posts with the same color coding. Needless to say, the power supply and/or meter can be used for purposes other than simple breadboarding.

The Design Mate 2 function generator is built around an 8038 function generator IC and uses a 301 op amp and five transistors to generate the sine, square, and triangle waves. The 1-Hz to 100-kHz signal frequencies are tuned by first setting the RANGE switch to the desired range and then fine adjusting with the continuously tunable FREQUENCY control. The only other controls are the three-position FUNCTION switch and output signal AMPLITUDE control. The output from the function generator is available through color-coded OUTPUT binding posts on the control panel.

The sine-wave output has less than 2% THD; triangle-wave linearity is better than 1%; and the square-wave output rise and fall times are less than 0.5 μ s into a 600-ohm, 2-pF termination. Output signal amplitude is variable from 0.1 to 10 volts peak-to-peak into an open circuit. The output impedance of the function generator is 600 ohms, constant over the amplitude and frequency range. The output circuit can easily be modified for driving TTL, HTL, RTL, DTL, and CMOS logic.

The resistance and capacitance measuring accuracy of the Design Mate 3 is stated at better than 5%. A pair of HI and LO LED's are used as a unique NULL indicator that instantly tells the user whether the resistor or capacitor under test (connected via a pair of binding posts labelled UNKNOWN) has a value above or below the dial setting. The null is quite sharp to minimize ambiguities. The bridge circuit features a bootstrapped op amp whose high input impedance permits checking small capacitances without introducing loading errors.

The RANGE switch has separate positions for resistance and capacitance. The positions are labelled in decade steps from 10 to 10M and from 10PF to 1UF. The NULL ADJ control provides the means for producing the null condition in each range. When the null condition is obtained, the user merely checks the position to which the RANGE switch is set and reads the resistance or capacitance value directly from the NULL ADJ's calibrated scale.

User Report. We were anxious to see how well the Design Mates performed separately and as a team on our workbench. After living with these three units for several weeks, we have come to the conclusion that they do indeed make the task of breadboarding and testing a design simpler and less time consuming. In terms of frequency of use, the Design Mate 1 breadboarding system came out on top, followed closely by the Design Mate 2 function generator. Although we didn't have as much call for the Design Mate 3 R/C bridge, we found that there wasn't a better instrument for determining resistance and capacitance values and for matching components.

With a small circuit addition, spelled out in the manual that accompanied the Design Mate 2, we used the function generator as a variable-rate clock for several of our digital experiments. We have since used this unit for general-purpose audio testing and to check filters in our RTTY and slow-scan ham equipment. In all cases, it did a creditable job of testing.

The Design Mates, whether used singly or as a team, are a very practical addition to any workbench. They are relatively low in cost, simple to use, and eliminate much of the clutter normally attendant upon experimenting and design work.

CIRCLE NO. 82 ON FREE INFORMATION CARD

The time you save may be your own.

Used to be you'd get a circuit idea, lay out a pc board, print it, solder everything together, troubleshoot, change your layout, try a new board, and spend absolutely too much time breadboarding. Now A P ACE All Circuit Evaluators let you breadboard in a fraction of the time. Make your changes immediately. Keep full leads on your components. Avoid the heat damage possible with repeated soldering and desoldering. And have a pattern for your board—if you need a board—sitting in front of you. In about as long as it takes to sketch a schematic. Get cooking with ACE. ACE. The All Circuit Evaluator from A P Products.

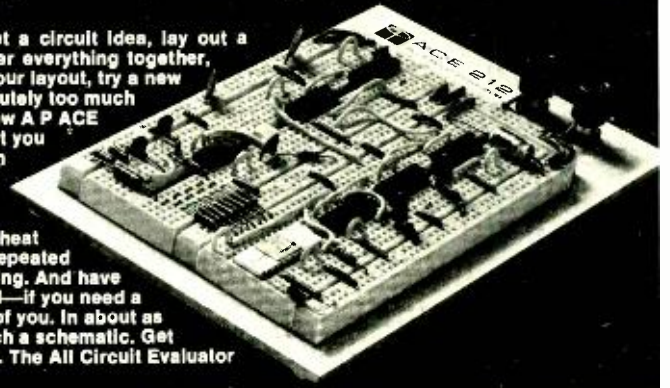

Order No.	ACE Model No.	Tie Points	DIP Capacity	No. Buses.	No. Posts	Board Size (inches)	Price Each	Qty.	Total
923333	200-K (kit)	728	8 (16's)	2	2	4"x5 1/16"	\$18.95		
923332	208 (assem.)	872	8 (16's)	8	2	4"x5 1/16"	28.95		
923334	201-K (kit)	1032	12 (14's)	2	2	4"x7"	24.95		
923331	212 (assem.)	1224	12 (14's)	8	2	4"x7"	34.95		
923326	218 (assem.)	1760	18 (14's)	10	2	6 1/2" x 7 1/8"	46.95		
923325	227 (assem.)	2712	27 (14's)	28	4	8"x9 1/4"	59.95		
923324	236 (assem.)	3648	36 (14's)	36	4	10 1/4" x 9 1/4"	79.95		

ACE solderless breadboards feature gold-anodized aluminum base/ground plates. non-corrosive nickel-silver terminals and four rubber feet.

Check or M.O. enclosed
 Charge BAC
 Charge MC
 Send catalog

Credit Card Number _____
 4 Numbers Above Name (MC) Good Thru _____
 Signature _____
 Print Name _____
 Address _____
 City _____ State _____ Zip _____

TOTAL for merchandise _____
 Sales Tax (OH and CA) _____
 Shipping (see table) _____
TOTAL ENCLOSED _____

Shipping/Handling
 Up to \$10.00 \$1.00
 10.01 to 25.00 1.50
 25.01 to 50.00 2.00
 50.01 to 100.00 2.50
 100.01 to 200.00 3.00

Company PO's FOB Painesville
 No COD orders
DEALER INQUIRIES INVITED.

AP PRODUCTS INCORPORATED
 Box 110-H Painesville, OH 44077 (216) 354-2101

CIRCLE NO. 1 ON FREE INFORMATION CARD

FREE McIntosh CATALOG and FM DIRECTORY

Get all the newest and latest information on the new McIntosh Solid State equipment in the McIntosh catalog. In addition you will receive an FM station directory that covers all of North America.



MX 113

FM/FM STEREO - AM TUNER AND PREAMPLIFIER

SEND TODAY!

McIntosh Laboratory, Inc.
 East Side Station P.O. Box 96
 Binghamton, N.Y. 13904
 Dept. PE

NAME _____
 ADDRESS _____
 CITY _____ STATE _____ ZIP _____

If you are in a hurry for your catalog please send the coupon to McIntosh. For non rush service send the Reader Service Card to the magazine.

CIRCLE NO. 31 ON FREE INFORMATION CARD



Solid State

By Lou Garner

PROGRAMMABLE SCHMITT TRIGGER

THERE is never a lack of new IC's on the market. Many of the latest ones are in the microprocessor area, but there are plenty of others that are also of interest to the imaginative experimenter or hobbyist. RCA's Solid State Division (Box 3200, Somerville, NJ 08876), for example, has recently introduced a versatile programmable Schmitt trigger with memory suitable for use in a variety of control circuit applications. Depending on its accessory devices and peripheral circuitry, the new IC, designated type CA3098, can be used to activate relays, heaters, LEDs, incandescent lamps, thyristors, solenoids, and similar units. It can serve as an on/off switch for pump, fan or positioning motors and in signal reconditioning, phase or frequency modulator, and square or triangular-wave generator circuits. The CA3098 can be used, too, for time-delay operations, for level control and sensing, or to provide overvoltage, overcurrent, or over/under temperature protection. With relatively low power requirements, it can be used effectively in either battery-powered or line-operated projects.

A monolithic silicon IC comprising more than 20 transis-

tors and a number of diodes and resistors, as shown schematically in Fig. 1A, the CA3098 can be operated with either a single (16 volts max.) or a dual (± 8 volts max.) power source. It can control currents up to 150 mA, having only microwatt power dissipation under standby conditions when the controlled current is less than 30 mA. Offered in three different package styles—an 8-lead DIP (type CA3098E), an 8-pin TO-5 case (type CA3098T), and an 8-pin TO-5 case with formed inline leads (type CA-3098S), as well as in chip form (type CA3098H)—the new device has an operating temperature range of -55 to $+125^\circ\text{C}$, and can dissipate up to 630 mW at an ambient temperature of 55°C or, with a suitable heat sink, up to 1.6 W at the same temperature. When used at temperatures above 55°C , it is derated linearly at 6.67 mW/ $^\circ\text{C}$ without a heat sink and at 16.67 mW/ $^\circ\text{C}$ with a heat sink. It will accept sensors ranging in value from 100 ohms to 100 megohms, offers a programmable hysteresis characteristic from 20 mV to the supply-voltage level, and has an extremely low output leakage current of 10 μA max. As a switching device, the CA3098 has a low delay time of 600 ns, with fall and rise

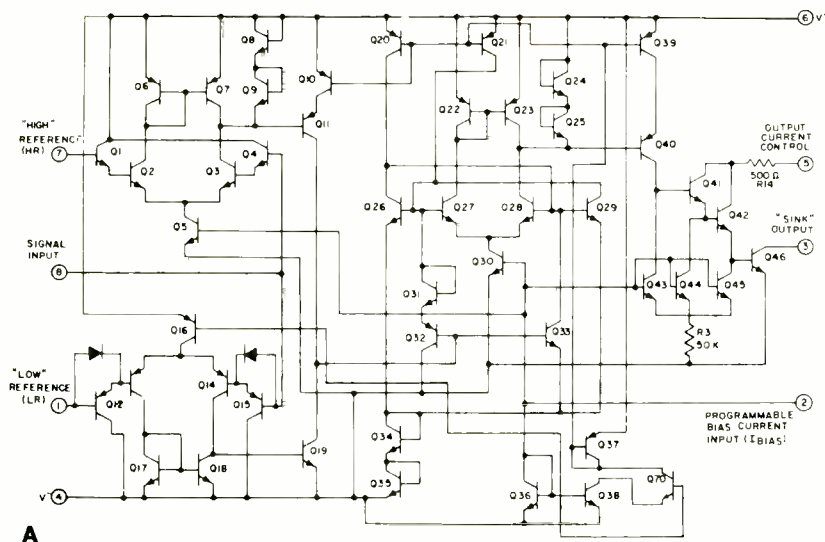
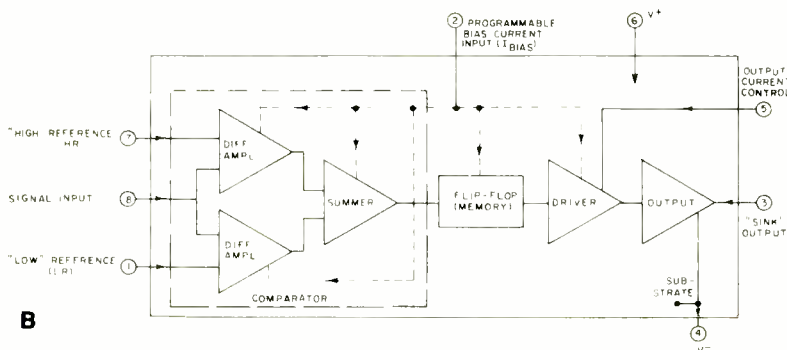

Fig. 1. RCA's CA3098 programmable Schmitt trigger: (A) internal schematic; (B) functional diagram.



HOW TO SAVE HUNDREDS OF DOLLARS ON PARTS. PAINLESSLY.

At CSC, we've developed a family of ingenious Design Mate™ test equipment that gives you professional quality and precision at very *unprofessional* prices. Each unit can save you money—and time—in a number of interesting ways.

For more information on these, or any other CSC products, see your dealer or write for our catalog and distributor list.

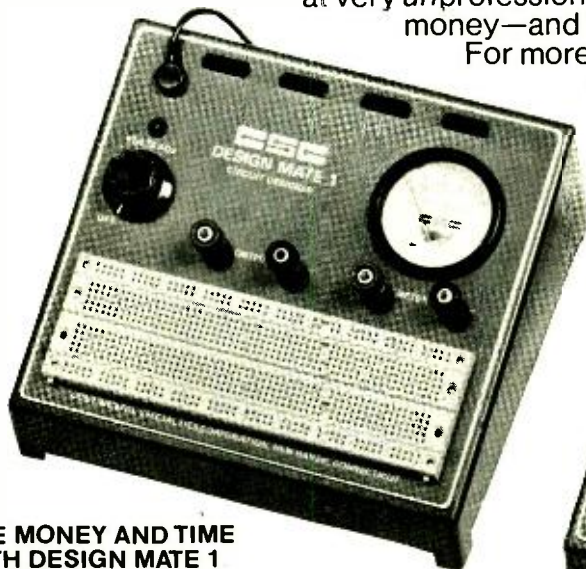

SAVE MONEY AND TIME WITH DESIGN MATE 1

This precision all-in-one unit combines a solderless plug-in breadboarding system with a built-in better-than-1%-regulated variable 5-15V supply and 0-15V voltmeter. Gives you everything you need to design and test circuits faster than you ever could before. Saves money by eliminating lead damage and heat damage to components. Lets you re-use parts over and over again, to save even more. All for just \$49.95*

STRETCH YOUR BUDGET FURTHER WITH DESIGN MATE 2

Precision function generator lets you test all kinds of equipment, with 1Hz-100kHz signals. Low-distortion sine waves, high-linearity triangle waves, fast-rise-time square waves. Five decade ranges, accurate to 5% of dial setting, with variable 100mV-10V P-P output and constant 600-ohm impedance. At \$64.95*, it's a lot of signal for very little money.

SAVE MORE MONEY AND TIME WITH DESIGN MATE 3

Accurate R/C bridge helps you use "bargain" components. Quickly and easily measures resistance 10 ohms-10 meg; capacitance 10pF-1μF—both in decade ranges to within 5% of dial setting. Simple, 2-control operation and positive LED indication make measurements in seconds. At \$54.95*, it pays for itself in no time.

CONTINENTAL SPECIALTIES CORPORATION

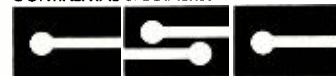

EASY DOES IT

44 Kendall Street, Box 1942
 New Haven, CT 06509 • 203-624-3103 TWX: 710-465-1227
 West Coast office: Box 7809, San Francisco, CA
 94119 • 415-421-8872 TWX: 910-372-7992
 Canada: Len Finkler Ltd., Ontario

*first
time ever
published!*

POPULAR ELECTRONICS' \$1.75
**CITIZENS BAND
HANDBOOK 1976**
COMPLETE BUYER'S AND USER'S GUIDE TO CB RADIO

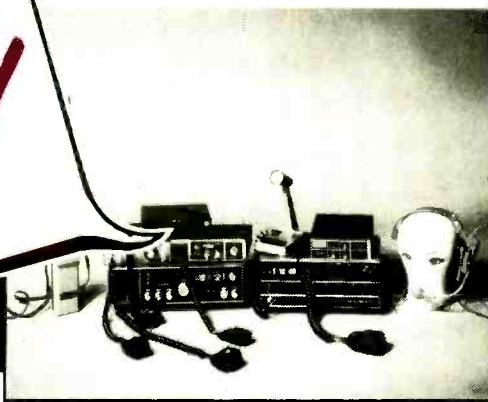

**THIS
SPECIAL ADVANCE
PUBLICATION NOTICE
APPEARS IN POPULAR
ELECTRONICS MAGAZINE
ONLY. YOU CAN
RESERVE YOUR COPY
OF CITIZENS BAND
HANDBOOK NOW, TO BE
MAILED TO YOU FROM
FIRST-OFF-THE-PRESS
COPIES WHEN
PUBLISHED.**

CITIZENS BAND HANDBOOK

CITIZENS BAND HANDBOOK, by the editors of POPULAR ELECTRONICS, has it all . . . all the authoritative information you need on CB two-way radios to make an intelligent buying decision for transceivers, antennas and accessories . . .

Here's a partial look at what the experts have packed into one volume:

- * You'll have over 500 CB models at your fingertips, fully described with technical specifications, features, latest prices and photographs.
- * Lab test evaluations on mobile and base-station transceivers, both AM and SSB, spell out what the rigs can *really* do.
- * The latest FCC Rules and Regulations are discussed in down-to-earth language, so you truly know what you can and cannot do legally.
- * Manufacturers' specifications are "decoded" so that you will be able to read a "spec sheet" with ease.
- * All about CB antennas — the true key to "talk power."
- * CB language translation chart.
- * How emergency CB associations can save your life!
- * How phase-lock-loop digital synthesizers work.
- * The latest Flash Report on upcoming CB units presented at the first all-CB-manufacturers show.

Regular price by mail for the 1976 CITIZENS BAND HANDBOOK will be \$2.00 including postage and handling charges. **WE ARE RESERVING COPIES NOW AT \$1.50 FOR ALL ORDERS RECEIVED NO LATER THAN JULY 31, 1976. SAVE MONEY** and enjoy the convenience of receiving your copy by mail. Complete the Pre-Publication Reservation Form at right and return it with your remittance. We'll see to it that the new Citizens Band Handbook is mailed to you when published.

PRE-PUBLICATION RESERVATION FORM

CITIZENS BAND HANDBOOK, Consumer Service Division,
595 Broadway, New York, N.Y. 10012. PE-676
Enclosed is \$1.50.* Please reserve my copy of the 1976
CITIZENS BAND HANDBOOK to be mailed to me from first-
off-the-press copies when published in August, 1976.

Print Name _____

Address _____

City _____

State _____

Zip _____

*Residents of Calif., Colo., Fla., Ill., Mich., Mo., N.Y. State, D. C. and Texas add applicable sales tax.

All the practical essentials of electronics engineering... right at your fingertips!



FIRST-OF-ITS-KIND VOLUME

Provides technicians and engineers with a complete guide to the fundamentals of electronics engineering.

HANDBOOK FOR ELECTRONICS ENGINEERING TECHNICIANS

Edited by M. Kaufman and A. Seidman
560 pages, 695 illustrations, \$19.50

This practical volume gives you instant access to details on every vital aspect of the electronics field: component selection, circuit analysis, power supplies, the characteristics and use of integrated circuits, operational amplifiers, transistors, batteries, tubes, and much more.

MANY SPECIAL FEATURES

- Explains how to compute ampere turns and how to make various other types of magnetic circuit calculations
- Compares the isolation transformer and the auto transformer
- Analyzes important transformer cores
- Explains impedance and admittance, and phasor diagrams
- Describes ammeters, voltmeters, and ohmmeters
- Analyzes the classification of filters by frequency, shape of response, type of construction, and method of design
- Covers operation of sinusoidal oscillators
- Explains bistable, monostable, astable multivibrators
- Details special applications of power supplies
- Provides a detailed analysis of diodes, including electron flow geometry
- Compares vacuum tubes and transistors.

ALSO OF INTEREST

Three famed volumes by John Markus that give you access to more than 9,700 different electronic circuits! Fully indexed and cross referenced, illustrated, and with values and exact source locations, for fast, sure selection of the circuits that best meet your needs at the moment, whatever your project. *Absolutely no duplication of circuits in these three volumes.*

GUIDEBOOK OF ELECTRONIC CIRCUITS

1068 pages, \$24.50

ELECTRONIC CIRCUITS MANUAL

892 pages, \$24.75

SOURCEBOOK OF ELECTRONIC CIRCUITS

888 pages, \$23.50

At your local bookstore or use coupon for

FREE 10-DAY EXAMINATION

McGraw-Hill Book Company

1221 Avenue of the Americas, New York, N.Y. 10020

Please send me the book(s) checked below for a free 10-day examination. In that time I will remit the price, plus local tax, postage and handling, or return the book(s) with no further obligation. I understand that if I remit in full, plus local tax, with this order, McGraw-Hill pays postage and handling, and a 10-day return privilege still applies. This order subject to acceptance by McGraw-Hill.

- Handbook for Electronics Engineering Technicians (033401-3) \$19.50
- Guidebook of Electronic Circuits (040445-3) \$24.50
- Electronic Circuits Manual (040444-5) \$24.75
- Sourcebook of Electronic Circuits (040443-7) \$23.50

Name _____

Address _____

City _____

State _____

Zip _____

This order good only in the U.S. and Canada

23-A889-4003-3

CIRCLE NO. 30 ON FREE INFORMATION CARD

85

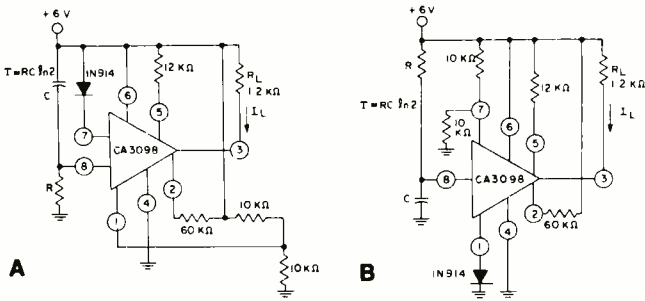

Fig. 2. CA3098 time-delay circuits: (A) switches on after delay; (B) switches off after delay.

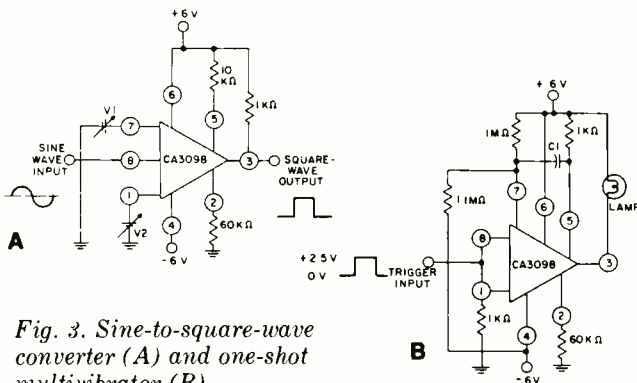

Fig. 3. Sine-to-square-wave converter (A) and one-shot multivibrator (B).

times of 50 and 500 ns, respectively, coupled with a storage time of only 4.5 μ s under typical operating conditions.

Functionally, the device consists of two differential input amplifiers, a summing circuit, a flip-flop which serves as a bistable "memory" element, a driver amplifier, and a power output stage (Fig. 1B). The input signal voltage (pin 8) is compared to a prefixed higher reference voltage (HR, pin 7) by one differential amplifier and to a lower reference voltage (LR, pin 1) by the other, with the resultant output signals applied to the summer. The latter delivers a trigger signal to a flip-flop that changes state in response to each trigger command. The flip-flop, in turn, supplies a signal to the driver amplifier which controls the power output stage. The output stage serves to "sink" current from the power supply through an external load device, such as a lamp, relay, solenoid, or thyristor gate circuit. When the applied signal voltage is equal to or less than the present low

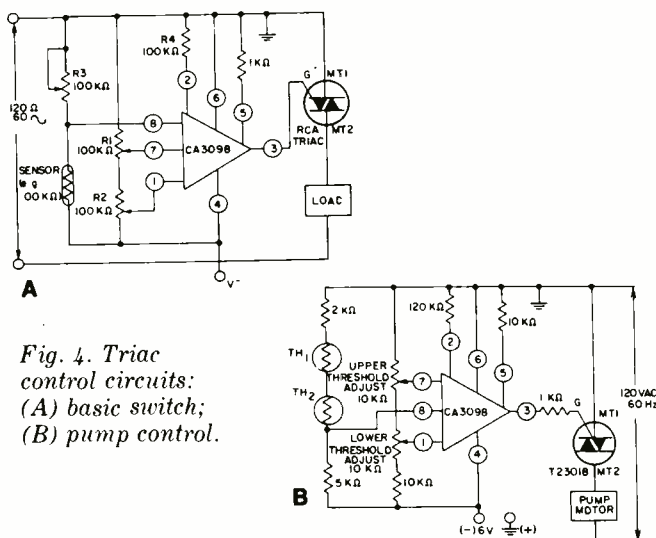
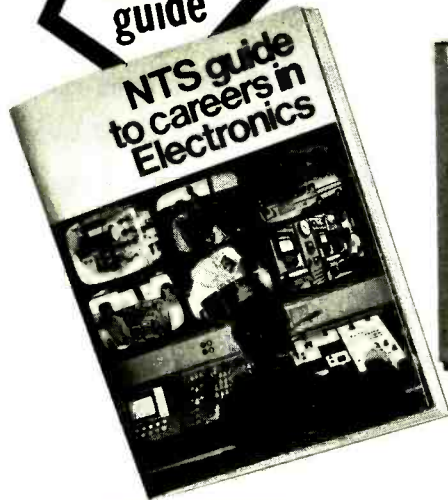

Fig. 4. Triac control circuits: (A) basic switch; (B) pump control.

JUNE 1976

We'd like to compare our But there's no

Send for
FREE
illustrated
career
guide



COMPU-TRAINER

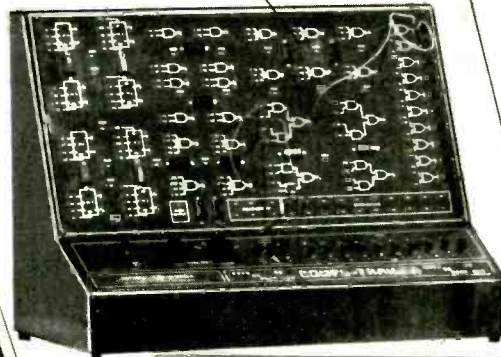

IN-CIRCUIT TRANSISTOR TESTER

TROUBLESHOOTER
VOM

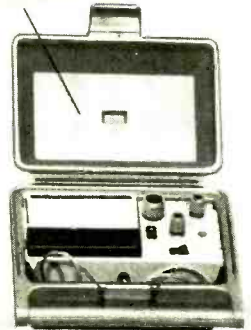

SOLID-STATE
OSCILLOSCOPE

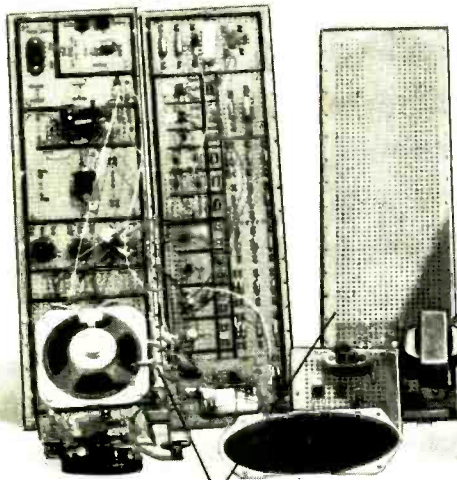

ELECTRO-LAB



(Simulated TV Reception)

COMPARE OUR TRAINING PROGRAMS: NTS Electronics programs are considerably different from those of other schools, and, we believe, better designed to prepare you for entry-level opportunities in the field of your choice. For example, our Master Course in Electronics Technology includes over 170 lessons; another school offers fewer than half that many in a course with the same title. Our course includes 26 kits to build an Electro-Lab, a Solid-State Digital Computer-Trainer with transistor-diode logic circuits; a 5" wide-band solid-state Heath Oscilloscope; a Heath FET-VOM, and slide rule. Their course offers 10 kits to build a private label VOM and 2 experimental circuit chassis. And even though you need an oscilloscope to perform their experiments, they don't provide it. You have to buy your own. And their course does not even include a Digital

Computer-Trainer. The closest thing to our program they offer costs over \$200 more than ours. Another school's course in Electronics Technology offers even fewer lessons, and kits to build only a VOM. That's all. Think it over, and check it out, course by course, program by program. There's no comparison.

COMPARE OUR EQUIPMENT: NTS selected Heath equipment because of Heath's international reputation as a prime designer of commercial and professional electronic equipment in kit form. Cooperation between Heath and NTS assures you of highest quality components, design, function and training. What's more, Heath equipment is the kind you'll meet in the field - not limited to training only. For instance, the Heath GR 2000 25" (diagonal) Color TV included in our Color TV courses is acclaimed as ahead of its time in features and engineering. And the Heath AM-FM

school to other schools. comparison.

COMPARE OUR
KITS AND LESSONS.
COMPARE OUR
TUITION.

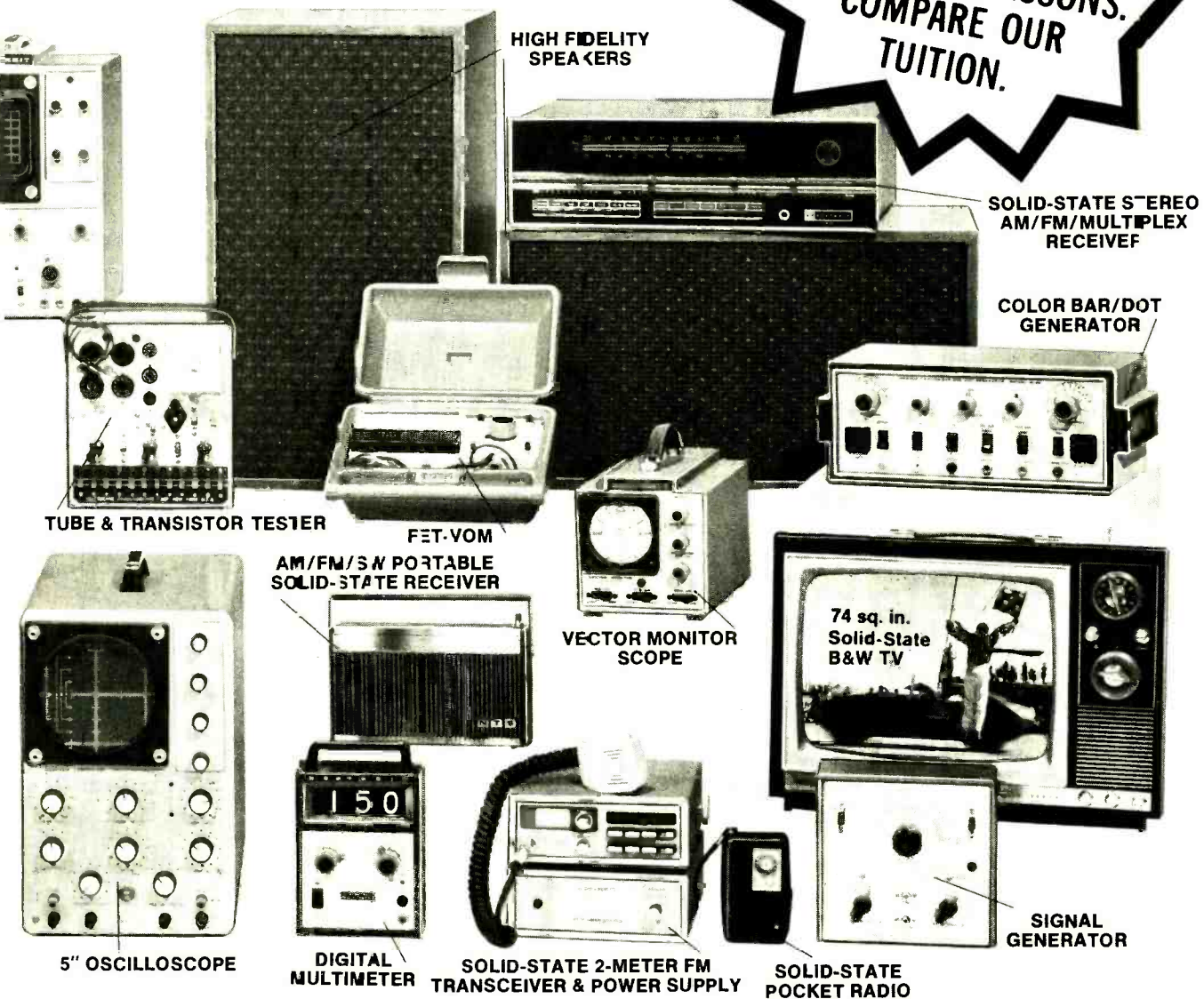

Multiplex/Receiver offered in our Audio course is a 30-Watts-RMS-per-channel set that's designed for true High Fidelity performance, not built for training only. As for reliability, that's another word for Heath.

The same holds true for Heath Oscilloscopes, FET-VOM, Digital Multimeter, In-Circuit Transistor Tester, Solid-State 2-Meter FM Transceiver, and much more included in over a dozen NTS courses. Check it out! There's just no comparison.

COMPARE OUR LOW TUITION: We employ no salesmen, pay no commissions. You receive all home study information by mail. All kits, lessons and experiments are fully described in our Catalog and all equipment needed for your training is included in the tuition price. Nothing extra to buy for your training with NTS. Liberal refund policy and cancellation privileges spelled out.

Make your own comparisons. Check the number of lessons, check the subjects covered and check the amount and value of training equipment you will receive for your tuition dollars. Then make your own decision. Mail card today, or write for FREE Electronics catalog if card is missing. **FIND OUT!**

NO OBLIGATION. NO SALESMAN WILL CALL
APPROVED FOR VETERAN TRAINING

Get facts on new 2-year extension

NATIONAL TECHNICAL SCHOOLS

TECHNICAL-TRADE TRAINING SINCE 1905
Resident and Home-Study Schools
4000 So. Figueroa St., Los Angeles, Calif. 90037

Mark Ten Electronic Ignitions put lightning under the hood.

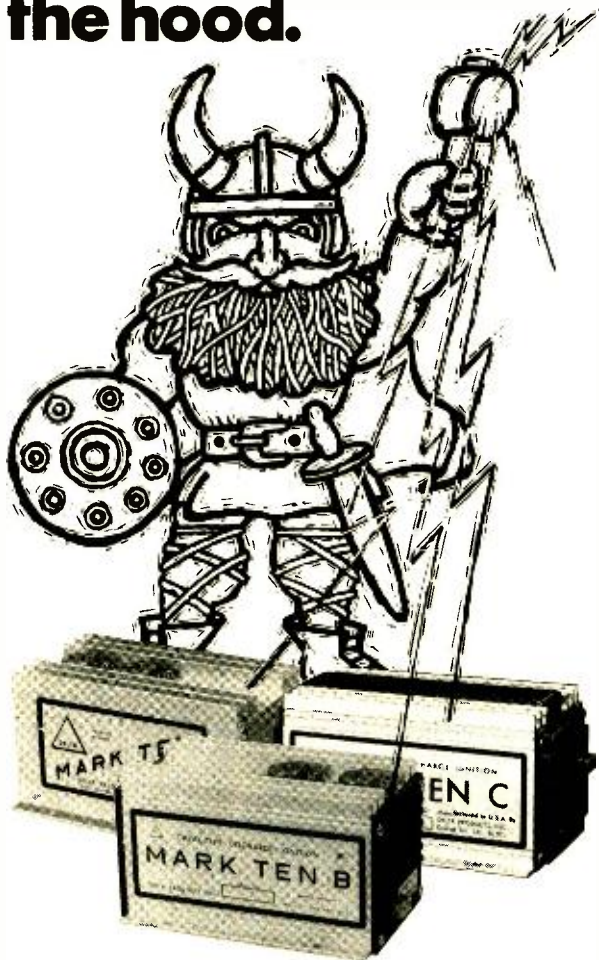

It's like having a bolt of lightning under the hood of your car when you feel it burst into action. And that's not all you'll feel with one of Delta's three HOT, HOT ignition systems. You'll feel the contentment of knowing your car will start INSTANTLY no matter how hot or cold the weather, the relief of fast, safe entry onto teeming freeways with POWERFUL ACCELERATION, and the satisfaction of pocketing all that money you'll save, not only from INCREASED GAS MILEAGE, but from all the TUNE-UPS you can forget about (at least 2 out of 3). And that's just for starters. Send today for free, color brochure jam-packed with helpful facts on how Delta's Mark Ten, Mark Ten B and Mark Ten C Capacitive Discharge Electronic Ignitions can help make driving a better experience for you.

I want to know more about Mark Ten CDI's. Send me complete non-sense information on how they can improve the performance of my car.

Name _____
 Address _____
 City _____ State _____ Zip _____

DELTA PRODUCTS, INC.
 P.O. Box 1147, Grand Junction, Colo. 81501
 (303) 242-9000 Dept. PE

reference voltage, the output stage is in a conducting state. This state is maintained until the input voltage rises to or exceeds the high reference voltage, at which point the output state switches to a nonconducting or "open" state. The "open" condition is maintained until the input signal again drops to or below the LR level, and the output stage is switched back to a conducting state. In addition to establishing the switching points by presetting the HR and LR levels, the device's operation may be programmed for optimum performance by means of an external bias current applied to the differential amplifiers, summer, flip-flop and driver stages through pin 2, while the maximum load current can be limited by the application of a separate bias current to the output stage through pin 5.

Representative examples of the CA-3098's potential circuit applications are illustrated in Figs. 2 through 4. These can be used either for the development of a specific projects or, if preferred, simply as guides in the design of original circuits. Abstracted from RCA's 8-page data bulletin for the CA3098, File No. 896, the circuits use standard components and, in most cases, can be duplicated quite easily in the home laboratory or workshop, for neither layout nor lead dress should be overly critical. Of course, good technical practice should be followed when wiring the circuits, with care taken not to overheat semiconductor device leads, and all dc polarities carefully observed.

The circuit shown in Fig. 2A is designed to switch the load current on following a predetermined delay after power is applied. The circuit in 2B switches the load current off after a suitable delay. Although resistive output loads are shown, relays, lamps, or other devices might be used in the circuits. In both, the time delay is dependent upon the time constant of the RC input network. Large values of either R or C will provide a longer time delay. If adjustable time delays are required, several capacitor values can be provided, selected as needed by a rotary switch. A fine adjustment can be provided by using a small trimmer rheostat in series with a fixed resistor for the R component.

Typical signal conditioning circuits featuring the CA3098 are illustrated in Fig. 3. The square-wave converter (Fig. 3A) features an adjustable duty cycle, achieved through the use of variable bias levels (V1 and V2) applied to the HR and LR inputs. The one-shot delivers an output pulse of fixed amplitude and duration to its lamp load when triggered by a positive-going input pulse. The output pulse width is determined by the value of the feedback capacitor C1. With a 0.01- μ F unit, the pulse width is 15 ms, while a

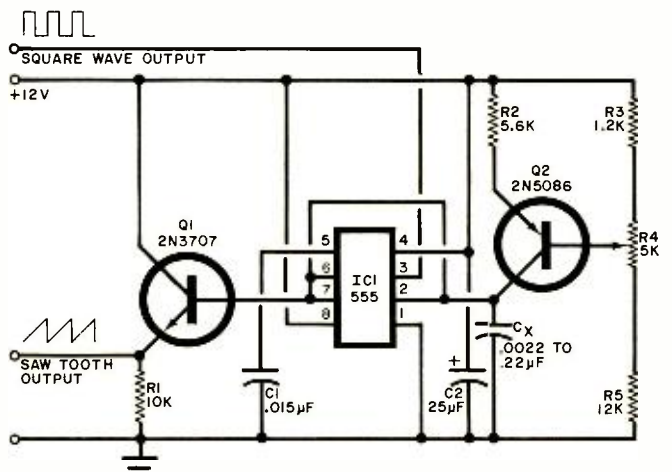

Fig. 5. Design for a function generator.

Who learns electronics the easy, effective, low-cost way?

You Do! when you study using the exclusive Heathkit Individual Learning Programs.

What better way to learn electronics than from people whose *business depends* on making it as easy to understand and work with as possible?

These Heathkit Individual Learning Programs will give you a thorough background in basic electronics, while letting you study and learn at your own pace. There are four programs presently available: DC electronics, AC electronics, Semiconductor devices, and for the advanced, Digital Techniques. Each program includes a text written by the same people who write the world-famous Heathkit instruction manuals, audio records to reinforce and "personalize" text materials, and parts for hands-on experiments using low-cost electronic trainers which provide signal sources, power supplies and controls. Find out more about them, send for the FREE catalog below.

HEATHKIT
CONTINUING
EDUCATION

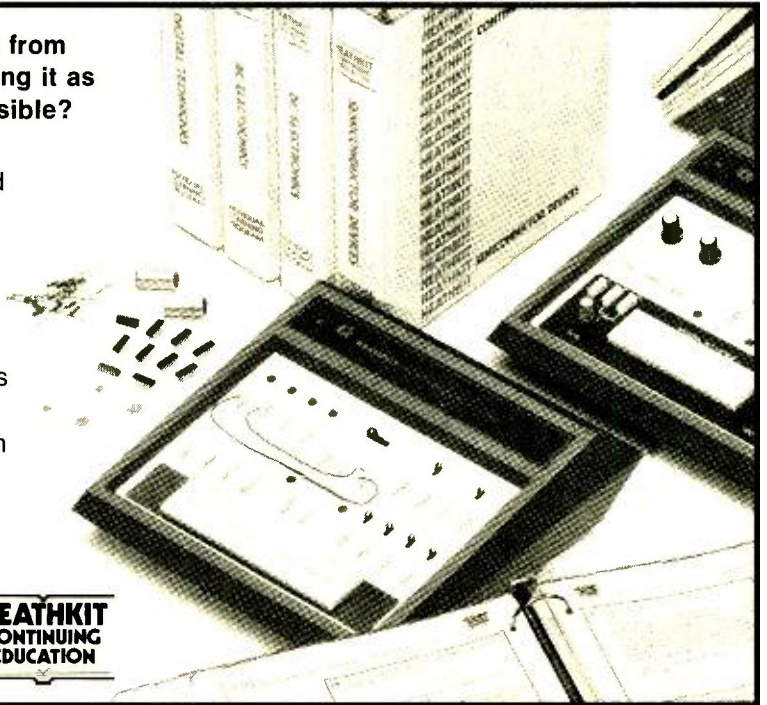

FREE!



Complete, accurate, **HONEST** descriptions of over 400 electronic kits including:

- Test Instruments
- Educational Self-Study
- Stereo Hi-Fi Components
- Amateur and Shortwave Radio
- Color TV • Security Systems
- Automotive, Aircraft and Boating Aids

Use coupon today!



Read all about them!

The new Spring '76 Heathkit catalog describes programs above, plus over 400 other money-saving electronic kits that are easy and fun to build! Send coupon today for your FREE copy.

Heath Company, Dept. 10-18, Benton Harbor, Michigan 49022

HEATH Schlumberger	Heath Company, Dept. 10-18, Benton Harbor, Michigan 49022
Send me my FREE Heathkit Catalog.	
Name _____	
Address _____	
City _____	
State _____	
ED-101	Zip _____

300-ms pulse is obtained with a 0.2- μ F capacitor. For optimum performance with the circuit values specified, the input pulse should have an amplitude of at least 2.5 volts and a duration greater than 1 ms, but less than the output circuit's "on" time. Naturally, other output loads can be used in place of the lamp shown on the diagram.

Finally, circuits featuring the use of the CA3098 in conjunction with bidirectional thyristors (triacs) are shown in Fig. 4. In both examples, ac line power is supplied to the thyristor and its load, with a separate dc source provided for the CA3098 control circuit. In the basic switching circuit (Fig. 4A), a voltage divider made up of a single sensor (such as a photoresistive cell or thermistor) in series with a rheostat supplies the input control signal, while potentiometers $R1$ and $R2$ serve to preset the HR and LR levels, respectively. A modified version of the basic circuit intended specifically for maintaining the water level in a storage tank is given in Fig. 4B. Here, two thermistors, $TH1$ and $TH2$, operated in self-heating modes, are used as sensors and the triac controls a pump-out motor. The thermistors are mounted in the tank on each side of the desired mean water level, with $TH2$ at the top. In operation, the pump-out motor is activated when the water level rises above $TH2$ and switched off when the water level falls below thermistor $TH1$.

Readers' Circuits. Most experimenters probably can discover a half-dozen or more applications for the simple function generator circuit illustrated in Fig. 5. Capable of supplying linear sawtooth and square-wave signals simultaneously, it might be used, typically, in test equipment, as a tone source for a basic electronic musical instrument, or as a linear sweep generator for an oscilloscope. Submitted by reader Craig K. Sellen (48 Briarwood Road, Wayne, NJ 07470), the design offers yet another application for the ubiquitous and inexpensive 555 timer IC. The circuit has an emitter-follower ($Q1$) as a buffer amplifier and an adjustable constant-current source ($Q2$) for the timing capacitor (Cx) to insure good linearity and optimum overall performance. Intended for operation on a 12-volt dc source, the circuit can be powered either by batteries or a well-filtered line-operated power supply.

Depending on individual preferences, the circuit can be breadboarded for experimental tests or duplicated on a perf or pc board, for neither the parts placement nor wiring arrangement should be especially critical. Aside from the active devices, $IC1$ (type 555), $Q1$ (2N3707), and $Q2$ (2N5086), the fixed resistors can be 1/4- or 1/2-watt types, potentiometer $R4$ a standard linear control, bypass capacitor $C1$ a paper or low-voltage ceramic type, and power-supply decoupler $C2$ a 12-to-15-volt electrolytic

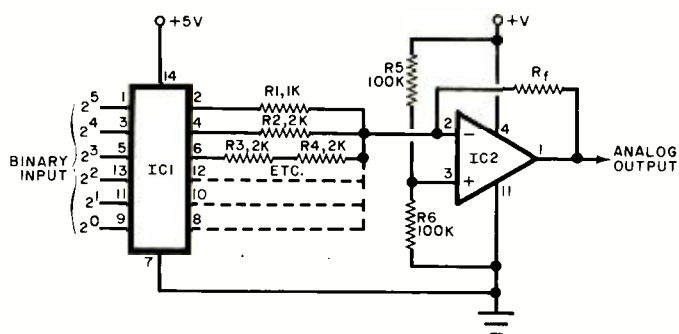

Fig. 6. Digital-to-analog converter circuit.

capacitor. The circuit's operating frequency is determined primarily by timing capacitor Cx , which can be a plastic film, paper or ceramic type, with values from 0.0022 to 0.22 μ F, depending on application requirements. According to Craig, the circuit will deliver a linear sawtooth of approximately 4 volts, p-p.

Recognizing that many of today's hobbyists are working with digital projects, reader Robert L. Schuman (R.R. #2, Winthrop, IA 50682) has suggested the circuit given in Fig. 6 as an inexpensive solution for those requiring a simple digital-to-analog (D/A) converter. Using only two IC's, a hex inverter ($IC1$) and an operational amplifier ($IC2$), the circuit accepts digital binary input pulses and converts these to an equivalent analog signal. In operation, the actual conversion process takes place in a weighted resistive divider network ($R1$, $R2$, $R3$, $R4$, etc.) connected to the hex inverter's output terminals and which, in turn, becomes part of the op amp's inverting input feedback/bias circuit. The output resistance for each binary digit from 2^3 (32) to 2^0 (1) is doubled in value so that the summed resistive output connected to the op amp is inversely proportional to the input binary signal, thereby insuring that the op amp's output is directly proportional to the original binary number.

Robert has specified standard components in his design, with hex inverter $IC1$ a type 7406 and $IC2$ one section of a 324 quad op amp, a type amenable to operation on a single-ended power source. For optimum performance, precision resistors (1% or better) must be used in the divider network. Op amp input bias resistors $R5$ and $R6$ may be standard 1/4- or 1/2-watt types, while feedback/bias resistor Rf should have a value less than half that of the smallest resistor connected to the hex inverter outputs (i.e., less than 500 ohms). The D/A converter circuit can be assembled using any construction technique, for neither layout nor wiring dress should be critical.

Data Sources. If our mail is any criterion, one problem plaguing many experimenters is that of finding technical data on IC's and discrete devices acquired through surplus stores and other outlets. As a general rule, of course, the best source of data is the original manufacturer, for virtually all of them publish detailed specification sheets, data bulletins, and, often, application notes covering their products. A number of the larger firms, including Motorola, RCA, and National Semiconductor, also publish comprehensive data books covering their entire product lines which are available at modest cost. Unfortunately, not all manufacturers will honor individual requests for data. This is often true of small-to-medium-size firms catering primarily to the large OEM market, even though their products may be available through surplus outlets and local distributors. In addition, original data sheets may not be available on obsolete or discontinued devices. However, if the need for information is great enough to justify the relatively high cost, complete specification data on virtually every semiconductor device ever manufactured is available from D.A.T.A., INC. (32 Lincoln Avenue, Orange, NJ 07050). This firm publishes a series of data books covering devices in every basic category from diodes to microcomputers. Each book is offered on an annual subscription basis and separate books are available covering discontinued devices. Prices range from, typically, \$12.75 for the book on *Discontinued Thyristors* to \$54.50 for the book on *Op-toelectronics*.

Device/Product News. Fairchild Semiconductor (4001 Miranda Ave., Palo Alto, CA 94304) has announced a new 190 x 244-element charge-coupled device (CCD) area image sensor for use in imaging and video systems. The second member of Fairchild's family of area sensors, the new solid-state device, type CCD211, contains 46,360 sensing elements organized in an array of 190 vertical columns and 244 horizontal lines, which is equivalent to one-quarter of the standard television resolution. The X-Y format of the array provides a 3:4 vertical to horizontal ratio, which is ideal for use with Super 8 movie camera lenses. Converting light focused by a camera lens into a video signal, the new CCD211 can operate at data rates up to 15 MHz, providing a picture frame rate up to 200 frames per second, in contrast to the 30 frames per second rate of broadcast TV and 18 frames per second rate of movie cameras. In addition to the image sensing elements, the device, which dissipates only 100 mW, includes 190 columns of 2-phase vertical analog transport registers, a 200-element horizontal analog transport register and a

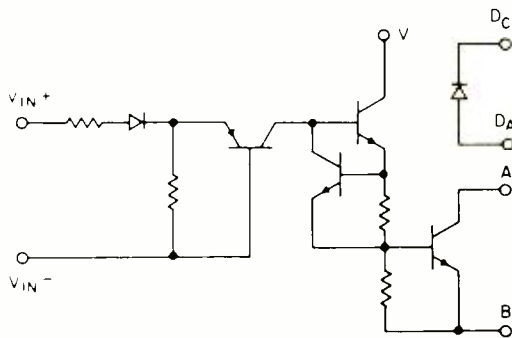

Fig. 7. Schematic of Dionics' power driver.

low-noise output amplifier. Featuring Fairchild's ion-implanted buried n-channel technology, the new CCD211 is offered in a 24-pin DIP.

A high-voltage, high-current power driver designed for use as an interface device between low-power MOS or TTL circuits and higher-power system elements, such as relays, lamps, and actuators, is now available from Dionics, Inc. (65 Rushmore St., Westbury, NY 11590). With an 80-volt maximum rating and the capability of controlling load currents up to 125 mA, the new device, designated type DI-445, has a power dissipation rating of 500 mW and features an adjustable logic threshold voltage. A monolithic silicon device comprising four transistors and several resistors, as shown in Fig. 7, the DI-445 includes an isolated high-current diode for transient suppression when used to drive inductive loads. The unit is supplied in a standard 8-pin plastic miniDIP.

Featuring an aluminum chassis and offering optional two-sided wiring, a versatile new breadboard system is now available from the Vector Electronic Co., Inc. (12460 Gladstone Ave., Sylmar, CA 91342). Designed for solderless interconnections, the new system includes eight *Klip-Bloks* capable of accommodating a maximum of twelve 14- or 16-pin DIP's, or four 24- or 40-pin devices, such as microprocessors and calculator or memory IC's. Additional *Klip-Bloks*, sockets, or discrete components can be added to expand the basic system's capacity. Two versions are currently available: the Model 51X, priced at \$25.50 and featuring a 4.5-by-8-inch glass-epoxy board,

and the Model 51X-GP, which includes an etched ground plane on the underside of the board for improved high-frequency performance, priced at \$29.95.

The Hildreth Engineering Company (P.O. Box 3, Sunnysvale, CA 94088) has added a new member to its family of op amp design instruments, the Quadri QUICK-OP, a four position unit. Featuring 38 quad solderless connectors providing 152 tie-points, the new type is available in two versions, the Model 440-741, which includes four type 741 op amps, and the Model 440-MD, which offers 8-pin miniDIP sockets in each position, permitting the user to work with his choice of devices. Both models are priced at \$39.95 each, less batteries.

An exciting new *three terminal* adjustable voltage regulator IC has been announced by the National Semiconductor Corp. (2900 Semiconductor Drive, Santa Clara, CA 95051). Capable of supplying over 1.5 A output current at any output level from 1.2 to over 37 volts, the new device is supplied in *standard* power transistor packages which may be heat-sinked easily using conventional hardware. Functionally, the device comprises a constant current source, a 1.2-volt band-gap reference diode, a voltage comparator, and a Darlington pass transistor. The new IC offers 0.01%/volt line regulation, 0.1% load regulation over its full range, 80-dB ripple rejection, 0.1% load regulation over its full range, 80-dB ripple rejection, full overload protection, and a minimum input/output differential of 2.5 volts. Two external resistors are needed to set the output voltage. The new IC is offered in three basic versions: the LM117, rated for operation from -55°C to 150°C , the LM217, -25°C to 150°C , and the LM317, 0°C to 124°C . All three devices are available in both TO-3 and TO-5 packages, while the LM317 also is furnished in a TO-220 Epoxy package. ♦



Put more punch in your work.

With a Greenlee Chassis Punch you can punch clean, true holes in seconds. Round, square, key or D. In 16-ga. metal, hard rubber, plastic or epoxy. Available at radio and electronics parts dealers. Write for catalog E-730. Greenlee Tool Co, Rockford, Ill. 61101.

GREENLEE TOOL CO



CIRCLE NO. 71 ON FREE INFORMATION CARD

Flexible alternative

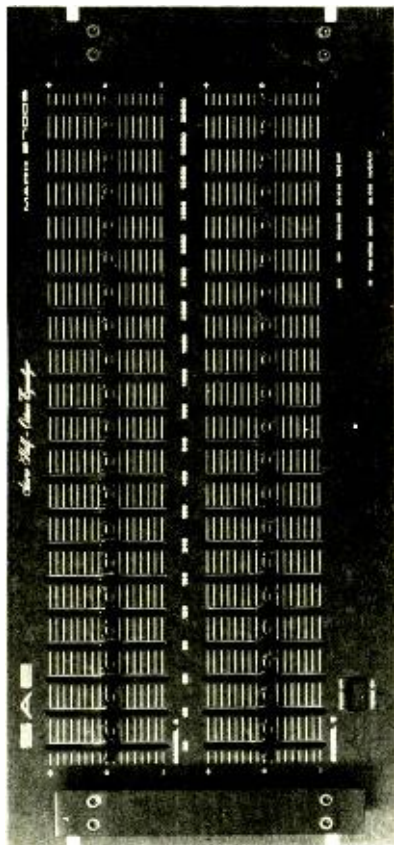

The SAE 2700B Half-Octave Stereo Equalizer

The 2700B can bring to your system the clarity & definition you have been looking for. Wayward sounds (booming bass, missing highs, blaring horns, or stifled solos) are all put in their place with the SAE 2700B Half-Octave Equalizer. The flexibility of 20 controls per channel only begins to tell the story. Some facts:

- * 0.02% THD & IM
 - * -100dB S/N Ratio
 - * Can drive any system
 - * FREE 5 YEAR Service Contract PLUS, long-throw oil-damped slide pots for better accuracy, precision wound toroid inductors for low distortion & a pink noise generator for system balance. Built with SAE quality, the 2700B is value packed with the capability and performance you need to control your system.
- PRICE: \$550.00 (suggested list)

SAE

Scientific Audio Electronics, Inc.

P.O. Box 60271, Terminal Annex
Los Angeles, Calif. 90060

Please send me more information on the
SAE 2700B Half-Octave Equalizer.

NAME _____
ADDRESS _____
CITY _____ STATE _____ ZIP _____

UNIVERSAL INTERFACE BETWEEN LOW-POWER LOGIC AND LOAD DRIVERS

BY VERN GREGORY

A PROBLEM that confronts the designer of MOS logic circuits is coupling these low-power devices to heavy loads. The job need not be too complicated, however, since there is a relatively simple circuit that can be used easily. It consists primarily of a conventional junction FET (JFET).

The basic circuit is shown at (A). The p-channel JFET is a normally conducting, depletion-mode device. That is, it conducts a fixed current (I_{DSS}) with

transistor, without a current-limiting resistor, as shown at (B). Here, the interfaced voltage can be at any level within the ratings of the JFET and the bipolar transistor. The base current is selected to be about 1/15 of the required load current, by choosing the proper JFET. The load current is in phase with the input to the inverter driving the JFET. Since the JFET draws no gate current, the logic element is not loaded.

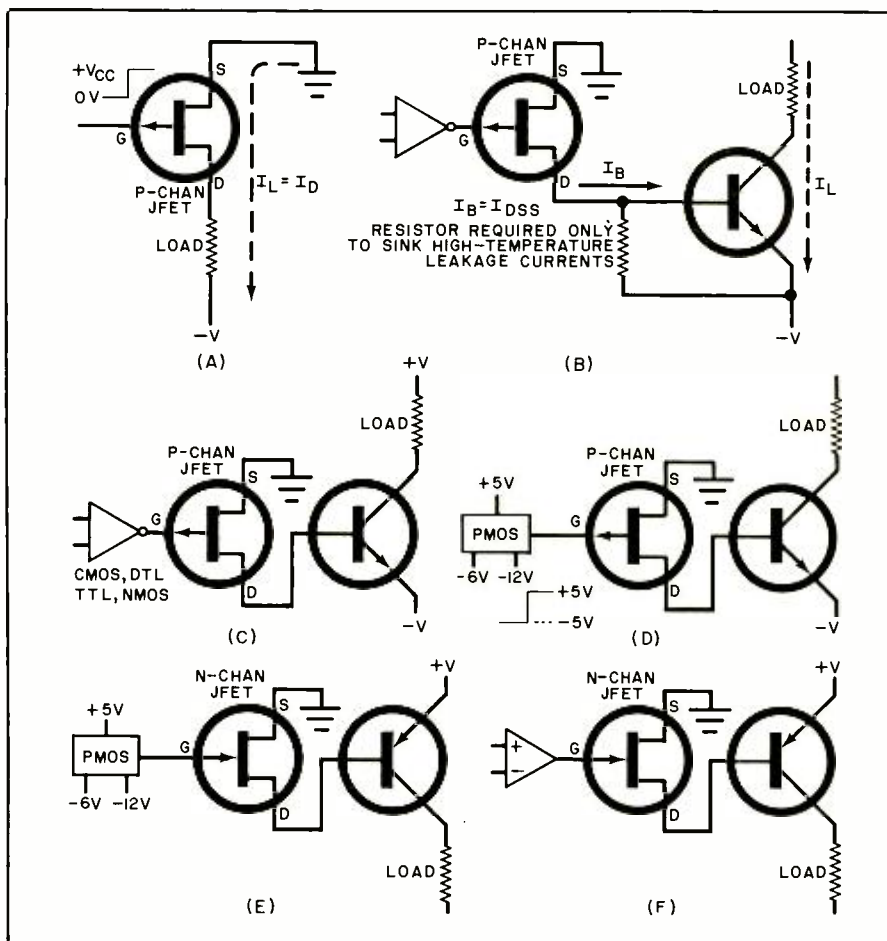

zero gate voltage. When the gate voltage is increased toward positive V_{cc} , I_D drops until pinch-off is reached. Then the current is zero.

The important feature is the fixed current at zero gate voltage. This means that the current is limited and can be selected to drive the base of a

Circuit (C) shows how to connect a 5-volt logic element (inverter shown) to a load, while (D) is a way to connect PMOS logic to a load on the negative supply. Circuit (E) is the same thing for a positive supply. The circuit at (F) illustrates an op amp or comparator interface.



CB Scene

By Ray Newhall, KW16010

AVOIDING CB RIPOFFS

THE THEFT of CB rigs from boats and vehicles has grown to epidemic proportions during the past year, and is becoming even more prevalent as each month goes by. There are few statistics available from official sources, but it is believed that as many as one in twenty mobile transceivers were stolen last year. Most CB marketers believe that about 80% of the estimated 10,000,000 CB transceivers now in use are installed in mobile environments. This could mean that nearly one-half million rigs, valued at more than \$25 million on the street, were stolen from CB'ers in 1975. *That's not peanuts!*

The increase in CB larceny is inevitable, considering the increasing demand and the short supply. By EIA estimates, the demand for CB in 1975 resulted in 4.2 million units sold. Sales in 1976 are expected to surpass that figure by a wide margin. Manufacturers and distributors have simply been unable to keep up with the demand. So, when that guy from out-of-state promises you any rig you want at 50% of list price, within 24 hours, where do you think it will come from?

This subject was selected for discussion in this month's column after my own rig was neatly lifted from my car while it was parked in my driveway. After driving around "blind" for a few months, I recently installed a new CB

radio. However, I couldn't complete an auto intrusion alarm installation to prevent a repeat theft because I was missing a few parts. But that was no problem (I thought), because the needed items could be easily obtained on Monday morning. But the new mobile didn't last that long! It was ripped off Sunday night, less than 36 hours after installation! Although my research has been somewhat more thorough than originally intended, I have learned a few lessons that I want to pass on to you.

Official Attitudes. I asked several local, state, and federal law enforce-

Fig. 1. Use a tag similar to that below to identify your rig and warn repairmen.

NOTICE TO CB REPAIRMAN

If the name and address on your repair order do not agree with those below, this set may be stolen. Please ask your local police to check the serial number through NCIC for possible theft. If it is stolen, please call collect the owner (number below) to notify him and arrange for a return.

(Owner's name, address and telephone)
(Date of purchase)

ment agencies for their ideas on how the average CB'er can protect his investment in mobile equipment. Their unanimous answer was, "We are doing what we can, but we must have the help of the CB'ers themselves to stem this growing type of larceny." Most officials doubt that there is a single, foolproof countermeasure, but they believe that if each of us would take a few simple, common-sense precautions, CB larceny would soon become too risky to practice.

Some officials pointed out that insurance companies could do more than anyone to curb the rising tide of CB thefts, simply by insisting that those caught be charged and, if convicted, punished by the courts. All too often, the officials complain, the insurers of stolen property refuse to press charges against a thief who is caught because of trial expenses. Thus, the thief is out on the streets again in a few hours, ready to steal again. An alternative suggestion is that the insurance carriers relinquish their subrogation rights and urge owners with insurance to press charges, even though their claims have already been paid.

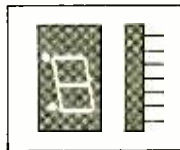

OPCOA SLA 1.33" character
Common anode (left DP) LED
display fits standard 14 pin
dual in-line sockets. \$1.15 each
6 for \$5.95

CM4-83 Jumbo LED Lamps
.200" diameter Red. Prime
factory units including plastic
mounting clips. 20c each 6 for
\$1.00



Board No. 1		Board No. 2		Board No. 3	
qty.	name	qty.	name	qty.	name
4	7400	1	7400	2	7400
2	7402	2	1402	2	7402
2	7404	2	7404	3	7404
2	7410	2	8233	1	7410
3	7420	1	7440	1	7430
1	7474	2	7438	3	7438
1	74151	1	7416	1	7474
2	7493	2	7474	1	74151
1	7486	1	7451	2	7475
Plus caps and resistors. Values over \$20.00 just \$1.99		1	MH0025C	3	74193
		1	7420	1	1302
		1	7402	3	7493
		Plus caps, diode and resistors. Values over \$30. just \$2.99		1	74121
				1	75451A
				Plus caps, diodes and resistors. Values over \$50. just \$4.99	

Texas residents add 5% sales tax. We pay postage on orders over \$5.00. For orders under \$5.00, include 50¢ postage. Money back guarantee. Many more boards available. Please send 25¢ for a complete listing

C D Two
● P.O. Box 111 ●
Richardson, Texas 75080

I found little statistical information of value collected by these companies; but apparently, so many claims are being made that it is not profitable to insure mobile radios. As a result, many have advised that by the

time this column is published, most policies will exclude *all* two-way radios (including CB, amateur, and vhf transceivers) from coverage.

Chief Francis Virgulak of the Norwalk (Connecticut) Police Depart-

ment, his chief Crime Prevention Officer, Lieutenant Doug Lamb, and other department heads spent several hours in research and conferences to provide material and technical assistance for this column. In that city, the incidence of Auto Break and Entry cases increased only 9.4% in 1975, compared to the previous year. In the same period, however, the theft of tape decks increased 40.5%, and the theft of "radios" rose 425%. This police department does not differentiate between the types of radios stolen, but acknowledges that most of these were CB rigs.

Most sources I consulted indicated that, from personal experience, many (and possibly the majority) of CB thefts are not reported to the police. They could not explain why, but believed that many people feel that the police can do nothing about it, or that "illegal" (unlicensed) operators are afraid that the police will turn them in to the FCC. Lieutenant Lamb was quick to point out that the Police Department's concern was the prevention of larceny. No request to see a license is made when a theft is reported. He also said that any report of theft *which includes the serial number* of the stolen property will be put into the state and federal (NCIC) computers and remain on record for at least a year. Although authorities admit that the chances of a successful recovery are not great, they point out that their only hope of catching the thief is through these records. So they really depend on the cooperation of the CB'er to report all thefts.

Steps You Can Take. With the help of the police, we developed a list of "Do's and Don'ts" to reduce your chances of getting ripped off. In the long run, if followed by most CB'ers, they will make CB larceny so unprofitable that it will be reduced to a minor problem.

- When you buy a rig, deal with a reputable dealer and get a sales slip on a printed letterhead form. Be wary of any deal that offers much more than a 10% discount (based on list price), unless it's a "clearance" sale, an obviously hard-to-move unit, a sales "leader," a discount based on having a base-station antenna installed (antenna materials plus labor), or an older non-type-accepted unit.

- Save that sales slip! When you take your new rig out of the box, record the serial number on the slip. Put it in a

FUN AND PRIDE BUILDING YOUR OWN ELECTRONIC "ALPHAKITS", AND SAVE BIG DOLLARS

RALLY
Digital Stopwatch Kit



\$39.95
+ \$2.00 P&H
NICADS &
CHARGER
\$10.00
ADDITIONAL

- * .003% Xtal Accuracy
- * 6 Digit LED Display
- * 4 Functions for Versatile Timing
- * Easy Assembly

DMM - 2 Auto-Zero Polarity
2½ Digit Multimeter Kit



\$49.95
+ \$2.95 P&H
LESS TEST
LEADS &
BATTERIES

DC Volts 1% 3V - 300V
OHMS 1% 3K - 3 meg.
DC I 5% 3ma - 300 ma
Battery operated; 4 - AA Cells



ALPHA ELECTRONICS

P. O. Box 1005
Merritt Island, FL 32952

Telephone In Your
'ALPHAKIT' Order
305 - 636-6951



If you want a microcomputer with all of these standard features...

- 8080 MPU (The one with growing software support)
- 1024 Byte ROM (With maximum capacity of 4K Bytes)
- 1024 Byte RAM (With maximum capacity of 2K Bytes)
- TTY Serial I/O
- EIA Serial I/O
- 3 parallel I/O's
- ASCII/Baudot terminal compatibility with TTY machines or video units
- Monitor having load, dump, display, insert and go functions

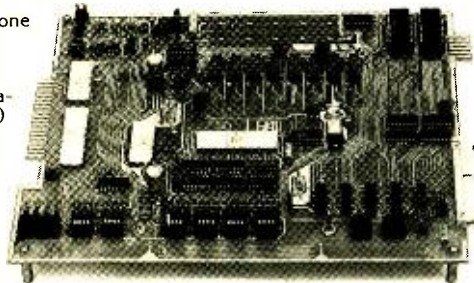

- Complete with card connectors
- Comprehensive User's Manual, plus Intel 8080 User's Manual
- Completely factory assembled and tested—not a kit
- Optional accessories: Keyboard/video display, audio cassette modem interface, power supply, ROM programmer and attractive cabinetry...plus more options to follow. **The HAL MCEM-8080. \$375**

...then let us send you our card.

HAL Communications Corp. has been a leader in digital communications for over half a decade. The MCEM-8080 microcomputer shows just how far this leadership has taken us...and how far it can take you in your applications. That's why we'd like to send you our card—one PC board that we feel is the best-valued, most complete



microcomputer you can buy. For details on the MCEM-8080, write today. We'll also include comprehensive information on the HAL DS-3000 KSR microprocessor-based terminal, the terminal that gives you multi-code compatibility, flexibility for future changes, editing, and a convenient, large video display format.

HAL Communications Corp.
Box 365, 807 E. Green Street, Urbana, Illinois 61801
Telephone (217) 367-7373



WARNING!

OPERATION IDENTIFICATION

ALL ITEMS OF VALUE ON THESE PREMISES HAVE BEEN MARKED FOR READY IDENTIFICATION BY THE NORWALK POLICE DEPT.

safe place, and remember where it is. Besides its usefulness in case of theft, it is a valid proof of purchase for warranty purposes.

- Remove the chassis from the cabinet and paste in a label that identifies you as the owner, requesting the technician to compare your name with that on his repair slip. (Be sure not to hamper convection cooling.) If the two names do not match, request on the slip that the technician report the serial number to the police for a check against NCIC records. A sample label is shown in Fig. 1. Many service techs will cooperate, either because they are dealers hurt by the black market, or because of warranty problems. Most manufacturers insist that their authorized service stations check all serial numbers against a "hot list." A more permanent ID can be engraved with a suitable stylus on the chassis itself.

- If your rig is stolen, report it immediately to your local police department. Include the serial number in your report and ask them to have it registered with NCIC.

- Consider investing a few dollars in a locking security mount, such as SHUR-LOK's, which accommodates almost any transceiver and vehicle. These mounts usually require a key to gain access to the mounting bolts. An alternative, of course, is to remove your rig whenever you leave the vehicle. There are power-disconnect brackets sold by some auto radio and tape recorder installation companies that can accommodate some CB rigs.

- If you live in a high-theft area, you might choose a CB transceiver that is installed out of sight. For example, Royce has a model with a control head separate from a remotely mounted electronics package. The remote unit can be locked in your trunk.

- There is no questioning the value of an intrusion alarm installed in your vehicle. It not only protects your CB equipment, but may even save the car itself! These are available from many

sources, but you might prefer to build your own. They take many forms, varying from a simple "lock-in relay" to sophisticated time-delay devices for both trip and automatic recycling. Some CB rigs incorporate a security mounting circuit which can be connected to the intrusion alarm to trigger it when the transceiver's mounting bolts are removed. It is also possible to have an alarm trigger when the transceiver's ground return lead is disconnected, though I'm not aware of a commercially available one.

- Check with your local police department to see if they have an "Operation Identification" plan. Some offer free decals similar to the one shown in Fig. 2. These decals, identifiable with a specific police organization, can be installed on a vehicle window. They are generally more effective deterrents than alarm warning decals that identify the type of alarm installed. (Here, the manufacturer's "advertisement" might be the tip-off to a smart burglar who knows how to bypass that particular alarm!)

- Efficient antennas are essential to effective mobile communications; but they tend to be very visible. For example, a pair of 108-inch phased whips mounted on a rear bumper practically "shouts out" the existence of a fancy rig. If you are willing to sacrifice performance, there are CB antennas that resemble the standard electric-powered auto antenna. Lowering the whip electrically into the cowl when you leave the car will hide the fact that you have a CB rig. (There are also nonelectrical whips that can be pushed into the cowl manually.)

- There are certain "booby trap" devices marketed that I believe should not be used. One is a tear-gas canister that is widely advertised. It is attached to the back of the set, and a mechanical trigger releases the gas when the transceiver is removed. Even though some cities and states may not consider installation of this device a violation of its criminal code, you are need-

Fig. 2. A tag like this from your local police and affixed to your vehicle window can be a theft deterrent.

TEST SEMICONDUCTORS ANYWHERE

Portable, in-circuit tester for all bipolar transistors, Darlingtons, FETs, SCRs

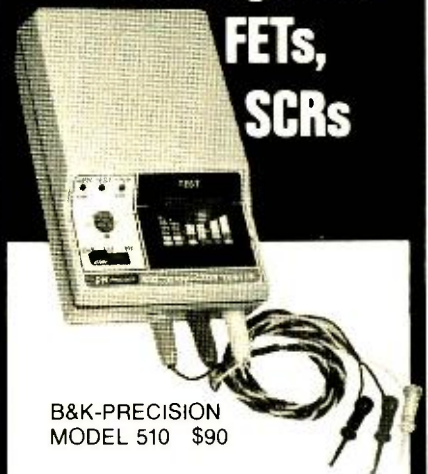

B&K-PRECISION MODEL 510 \$90

- Combines Dynapeak™ testing method with HI/LO power drive
- Tests semiconductors and identifies all leads; base, emitter, collector in LO drive
- Provides GOOD/BAD indicator in circuits with shunt resistance as low as 10Ω; shunt capacitance up to 25 μF, in HI drive
- Test performed as quickly as one can turn the switch
- Measures 6⅞" x 3¾" x 1¾"
- Weighs 1/2 pound, less four "AA" batteries
- Price includes test clips and carrying case
- Available from local B&K-PRECISION distributors

B&K PRECISION
PRODUCTS OF DYNASCAN

1801 West Belle Plaine Avenue
Chicago, Illinois 60613 312/525-3990
In Canada: Atlas Electronics, Toronto

**- A TOTALLY NEW
CONCEPT IN
MUSICAL INSTRUMENTS**



**OZ IS ...
POLYTONIC
WITH 7 OCTAVE RANGE,
BUILT IN SPEAKER AND AMP,
LED STATUS INDICATORS &
UNIQUE PRESSURE SENSITIVE
PITCH BENDER. OZ CAN BE
USED ALONE OR INTERFACE
TO ANY SYNTHESIZER
INCLUDING THE GNOME
MICRO-SYNTHESIZER! FOR
UNDER \$80.00 IN KIT FORM.
CALL OUR 24HR. DEMO-LINE
(405) 843-7396
FREE CATALOG**

**PASA ELECTRONICS, INC.
DEPT. 6 - P**

**1020 WEST WILSHIRE BLVD.
OKLAHOMA CITY, OK 73116
CIRCLE NO. 39 ON FREE INFORMATION CARD**



**You can build a better
organ than you can buy!**

A magnificent Schober Electronic Organ

What a marvelous way to put your special talents to work! With our Schober Electronic Organ Kits and your skill, you can build yourself some very special satisfaction, and a lifetime of great music!

Schober Organs are literally far superior to comparably-priced "ready-made" units. You could actually pay twice as much and get no better organ ... and miss the fun of assembling it yourself. A PC board at a time, component by component, you'll assemble your own "king of instruments." And when you're done, you'll wish there was more to do. And there is! For then, Schober will help you learn to play, even if you've never played a note before!

Schober Organ Kits range from \$650 to \$2850, and you can purchase in sections to spread costs out...or have two-year time payments.

Just send the coupon for the fascinating Schober color catalog (or enclose \$1 for a record that lets you hear as well as see Schober quality.)

**The Schober Organ Corp., Dept. PE-66
43 West 61st Street, New York, N.Y. 10023**

- Please send me Schober Organ Catalog.
- Enclosed please find \$1.00 for 12-inch L P record of Schober Organ music.

NAME _____
ADDRESS _____
CITY _____ STATE _____ ZIP _____

lessly endangering yourself by installing it. First of all, the unit might faultily trigger itself, giving you a dose of teargas while driving—an invitation to disaster. Secondly, an inquisitive child, an innocent auto mechanic, or even a would-be thief might trip it, leaving you open to a civil lawsuit. If the thief is thus injured in pursuit of his "trade," it's very likely that, as soon as he is released on bond, he will file suit for personal injury. He might even win, and get a \$100,000 judgment.

● There is a company in Oklahoma City which has advertised to register the serial number of your rig for a small fee. I asked this company in a letter how their service could help one recover a stolen rig. So far, they haven't responded. I have discussed this type of "protection" with law enforcement officers, and their concensus was that it could be a bonanza for the thief who got hold of a registry listing. Unless tightly controlled, it would provide him with all the information he needed to find the exact type of rig his "fence" requested him to acquire.

● How and where you leave your vehicle will have a great effect on how long you keep your rig. If you lock all doors, it will slow down the honest thieves. But car door locks offer no real barrier to professionals, who can open them faster than you can get your key in the lock! Your best bet is to park the car out of sight of the street. If you can't lock it in a garage at night, you might consider setting up an area alarm around your parking spot, using photo-relays, etc. (The Heathkit Model 1021 is just the ticket.) In addition to an intrusion alarm, I now have a system that floodlights my parking area and sounds an audible alarm. A garage door control disarms the system when moving vehicles in or out.

Conclusion. I believe that the growing threat of CB theft is one of the strongest possible arguments in favor of automatic transmitter identification, which is now under consideration by the FCC. I can't think of a better deterrent to putting a stolen rig on the air than the knowledge that each time the mike is keyed, the rig will transmit its very own ID number to any monitoring station within communications range. The operator will never know when someone is feeding his unit's number into a computer. But the automatic identifier concept may not be adopted. ◆

POLY-88

(MICRO-ALTAIR)

A Complete Computer System for \$575 requires just a Keyboard and TV Monitor for use.

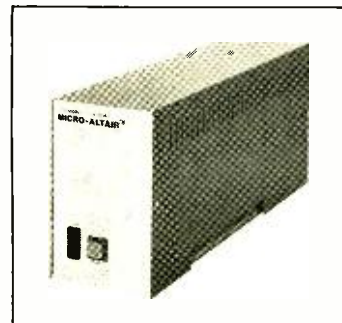

Polymorphic Systems new Poly 88 System is a complete expandable powerful microcomputer system with dozens of personal and industrial uses. Applications include smart terminals data acquisition systems games accounting, front end for larger computers — anywhere some computer processing is required. The Poly-88 hardware includes our Video Terminal Interface circuit card CPU/ROM/RAM card, and Backplane/Power Supply in a 4 1/4" W x 6 1/4" H x 17" cabinet. The Video Terminal Interface displays 16 lines of up to 64 characters of text, or a 48 x 128 graphics grid on a TV monitor. Processor card includes 8080A processor, ROM, RAM, and a serial or cassette option. Software supplied on ROM includes Video Driver, Debugger, and Operating Kernel. The wide range of IMSAI/Altair circuit boards are compatible with this system! For complete details send to:

POLYMORPHIC SYSTEMS
737 S. Kellogg, Goleta, CA 93017 (805) 967-2351
CIRCLE NO. 72 ON FREE INFORMATION CARD

ISOATIP

**QUICK
CHARGE**

Recharges in 1/3rd the time of any other cordless iron.

Complete line of accessories available:

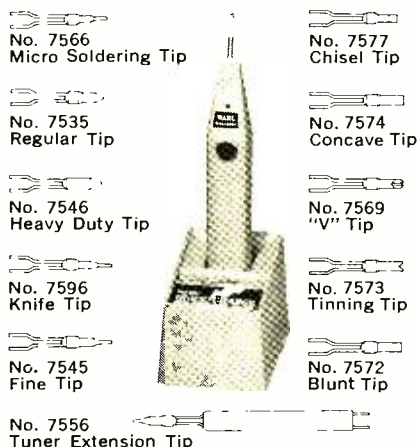

WAHL CLIPPER CORPORATION
ORIGINATORS OF PRACTICAL CORDLESS SOLDERING
Sterling, Illinois 61081 (815) 625-6525
"Manufacturing Excellence Since 1919"

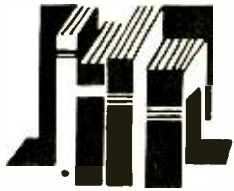

Electronics Library

WTFDA TV STATION GUIDE

The Worldwide TV-FM DX Association's new publication is a reference work of North and Central American television data. Features include maps (by channel) showing location, call letters, network, and offset frequency for most active stations; a station list giving city of license, state of transmitter location, satellite (rebroadcasting) information, effective radiated power, and antenna height.

Published by the Worldwide TV-FM DX Association, Box 163, Deerfield, IL 60015. 62 pages (8 1/2" x 11"). \$5.00.

INTEGRATED CIRCUIT PROJECTS

by Charles Rakes

Useful, fun-to-build, and educational circuits using IC's are described in this book. Among the areas covered are operational amplifiers, TTL circuits, and tone-signalling circuits. Basic design equations and device schematics are included. Commonly available parts are used.

Published by Howard W. Sams & Co., 4300 W. 62nd St., Indianapolis, IN 46206. 128 pages. \$4.95 soft cover.

BASIC TELEVISION: PRINCIPLES AND SERVICING (Fourth Edition)

by Bernard Grob

This is an old friend but one which has undergone extensive "facelifting" to the point where it is scarcely recognizable. Not only has there been a complete redesign of the book itself but the contents have been updated with greater emphasis on color television, solid-state circuitry, and newer, more imaginative applications of TV. Written for the electronics or TV technician, the book can be used in the classroom or by those wanting to upgrade their skills. Each chapter carries a summary, a series of test questions, and suggestions for essays.

Published by McGraw-Hill Book Company, New York, N.Y. 10020. 718 pages. \$13.95 hard cover.

ERRATUM

The book "Microcomputer Design Systems and Hardware for the 8008/8080," by Donald P. Martin, was incorrectly listed in this column in April 1976 as costing \$75. It is \$25. The publisher's correct address is: Martin Research, 3336 Commercial Ave., Northbrook, IL 60062.

WANT TO HOOK UP A CIRCUIT QUICK?

The PB-100 is only one of our family of solderless Proto-Board breadboarding units, designed to help you assemble, test and modify circuits as fast as you can push in or pull out a lead. *Preassembled* sockets with durable 5-point terminals provide low-resistance interconnections you can arrange and re-arrange at will.

Resistors, capacitors, transistors, DIP's, TO-5's, LED's etc. plug in without damage to leads. And jumper connections, where required, are lengths of #22 AWG solid wire. Models from 630 to 3060 tie-point (6 to 32 14-pin DIP) capacity available. For more information, see your CSC dealer, or write for our catalog and distributor list.

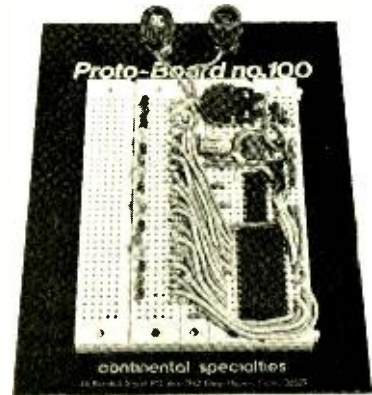

Proto-Board® 100. 760 solderless tie-points. Kit, \$19.95*

CONTINENTAL SPECIALTIES CORPORATION



EASY DOES IT

44 Kendall Street, Box 1942
New Haven, CT 06509 • 203-624-3103 TWX 710-465-1227
West Coast office Box 7809, San Francisco, CA
94119 • 415-421-8872 TWX 910-372-7992
Canada Len Finkler Ltd., Ontario

© 1976. CSC

*Mfrs. sugg. list

CIRCLE NO. 66 ON FREE INFORMATION CARD

SOLID STATE...BREAKERLESS ELECTRONIC IGNITION.

The BEST...The ULTIMATE of All Ignition Systems

ALLISON 'OPTO-ELECTRIC'



★ No Breaker-Points or Condenser to EVER wear out or need any maintenance.



★ Once installed and properly timed your Distributor will give you CONTINUOUS PEAK PERFORMANCE!



● The Allison OPTO-ELECTRIC System ELIMINATES the Points and Condenser, replacing them with an OPTO-Electronic Trigger, using a Light-Emitting Diode and Phototransistor. This System operates on a BEAM of LIGHT. There is NO "Breaker-Point Wiper-Arm" to wear down. Point bounce and erosion are completely eliminated thereby giving longer Timing ACCURACY than any System using "Mechanical" Breaker-Points (and No Timing Fluctuation as with Magnetic Impulse Units). ACCURATE Timing gives the BEST in Engine EFFICIENCY, and that's the name of the Game for the BEST in GAS MILEAGE and ECONOMY.



★ PROVEN RELIABILITY
Factory Tested to 15,000 RPM
Road and Race PROVEN
(Opto-Electric Systems Won at INDY Two Years in a Row)

★ ORDER with CONFIDENCE...
FACTORY-BACKED 10-YEAR
Free Repair or Replacement on ANY
Defects in Materials or Workmanship

Only \$59.95
COMPLETE
(Calif. Res. add Tax)
...that's EVERYTHING!
including
Postage & Insurance.

★ SAVE! ORDER FACTORY DIRECT

● Send Check or M.O.
State Make, Year, Engine Size, (4, 6, or 8-cylinder)
● You may use your MASTER CHARGE or BANKAMERICARD
Send us (1) Your Number (2) Interbank No. (3) Exp. Date
MC or BA Card Holders, ORDER by TOLL FREE PHONE:
(800) 423-6525, Ext. 2 (When in Continental U.S.A.)

★ Before Buying any other Type ignition system
Send Postcard for our FREE BROCHURE.

★ If you have already installed a "Capacitive-Discharge" Ignition
Modernize and Increase its Efficiency...
CONVERT YOUR "C-D" UNIT TO BREAKERLESS!
Opto-Electric "TRIGGER UNIT"... Only \$34.95.

★ Installed in your Distributor in same location as Points
COMPLETE INSTRUCTIONS FURNISHED.
(Not Necessary to Dismantle your Distributor)

● America's Oldest and Largest Manufacturer of Opto-Electronic Ignition Systems.



ALLISON
AUTOMOTIVE COMPANY 1267 - E8 East EDNA PL., COVINA, CAL. 91722
Our BEST Salesmen are the USERS of our ALLISON System!

Put Professional Knowledge and a COLLEGE DEGREE in your Electronics Career through HOME STUDY

Earn Your DEGREE

by correspondence, while continuing your present job. No commuting to class. Study at your own pace. Learn from complete and explicit lesson materials, with additional assistance from our home study instructors. Advance as fast as you wish, but take all the time you need to master each topic. Profit from, and enjoy, the advantages of independent study.

The Grantham electronics degree program begins with basics, leads first to the A.S.E.T. degree, and then continues through the B.S.E.E. degree level. Our free bulletin gives complete details of the program itself, the degrees awarded, the requirements for each degree, and how to enroll. Write or phone (no collect calls please) and ask for BULLETIN E-76.

Grantham School of Engineering
2000 Stoner Ave., Los Angeles, CA 90025

• Telephone (213) 477-1901 •

Worldwide Career Training thru Home Study

CIRCLE NO. 24 ON FREE INFORMATION CARD



Tips & Techniques

CASSETTE WINDER

Want to get to a specific point on a cassette without putting it in the deck? Just insert a 19-cent BIC pen barrel into the hole for the motor shaft. It fits very well, and you can easily twirl the pen barrel to wind the tape.—*Daniel Eddins, Jr.*

ADD MISSING SEGMENTS TO DIGITAL CLOCK

The "clock on a chip" IC's are very popular, but some of the displayed figures (6 and 9)

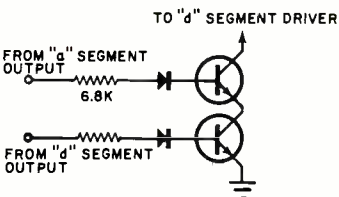
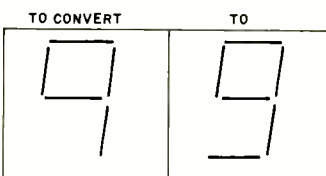
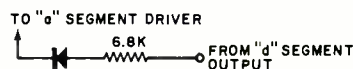
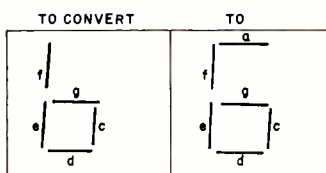

look a bit awkward. Here's a simple way to restore the missing segments which can also be used on any seven-segment display (DVMs, counters, etc.). Semiconductors are not critical—"junk box" silicon diodes and transistors will work fine.—*Alan Kong*

JAPANESE TRANSISTOR MARKINGS

While troubleshooting an audio amplifier, I came across an open transistor marked C1060. I checked several substitution guides and could not even find a listing for this number. After some research, I discovered that C1060 is actually an abbreviated

FREQUENCY?

MEASURE IT ANYWHERE
To 60 MHz with the FM-7.

NLS proudly announces a NEW Frequency Meter.



With Rechargeable Batteries & Charger Unit **\$195**

Features Include:

- Portable, battery operated for measurement anywhere! • 10 Hz to 60 MHz input with LED 7-digit resolution. • High sensitivity; 30 mV - 50 Hz to 30 MHz (100 mV - 10 Hz to 60 MHz). • Input overload protection. • Small, only 1.9"H x 2.7"W x 4"D. • High stability internal time base. • For field application, servicing or production testing.

See your local distributor!

Distributor inquiries invited.



Non-Linear Systems, Inc.

Originator of the digital voltmeter.

Box N, Del Mar, California 92014

Telephone (714) 755-1134 TWX 910-322-1132

CIRCLE NO. 37 ON FREE INFORMATION CARD

form of 2SC1060. Each guide listed several replacements for this type number. I then inspected several pieces of equipment using Japanese transistors and found many devices using this kind of "shorthand." A note of caution—when making any substitution, check the parameters of the device to make sure that it is in fact a suitable replacement. Substitutes are often wide-tolerance devices.—*Alan W. Otto*

RTL POWER FROM OLD CAR RADIOS

Transformers salvaged from the vibrator supplies in old auto radios can often be put to use in noncritical RTL or other low-voltage supplies. However, they must be connected "backwards." When line voltage is applied across half of the secondary, an open-circuit voltage of 3.3 to 3.9 V ac will appear across the primary. Since both windings are usually center-tapped, various voltages are available through combinations of connections. The low-voltage windings can handle 4 to 6 amps dc, so fairly hefty loads can be used with them. (If the laminations get too warm to touch, you're overdoing it.) The reduced operating frequency and applied voltage will offset each other to forestall saturation problems. Of course, the method and degree of filtering needed depends directly on the particular load.—*Parke S. Barnard*

POPULAR ELECTRONICS

DIXIE SAVE ON Brand Name Audio Components BY MAIL

Write Today for Our FREE Audio Catalog

DIXIE is one of the oldest and largest audio component mail order houses in the country. Our prices on brand name components are actually LOWER than "Discounters". See our new catalog or call us for a price quote. Everything shipped factory-sealed with full manufacturer's warranty.



DIXIE HI-FIDELITY

PE-6

5600 Second St., N. E., Washington, D. C. 20011
Phone: 1-202-635-4900

Please rush me your FREE Audio Catalog and complete information. I understand there is no obligation.

Name _____
Address _____
City _____
State _____ Zip _____

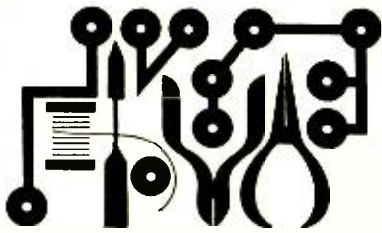

Experimenter's Corner

By Forrest M. Mims

APPLICATIONS FOR THE TTL NAND GATE

BECAUSE they have so many complex applications, digital IC's may intimidate some electronics hobbyists. Impressive microphotographs of tiny silicon chips, complicated schematics, and a unique vocabulary sometimes combine to discourage both electronic novices and old hands.

This month we're going to expose the myth that digital IC's possess mysterious, even magical abilities by building several practical circuits from one of the simplest digital logic circuits, the NAND gate.

As most of you probably know, the gate is a circuit with two or more inputs and one output. A signal will appear at the output only if the appropriate combination of signals is present at the inputs.

The three basic logic gates are the AND, OR, and NOT circuits. The AND gate will provide an output signal only if an input signal is present at each of its inputs. The OR gate will provide an output signal only if an input signal is present at either or both of its inputs. The NOT gate is simply an inverter which reverses the phase of an input signal. Two compound circuits made by connecting an inverter to the output of an AND gate and OR gate are the NAND gate and NOR gate.

The logic symbols for each of the gates as well as their truth tables are shown in Fig. 1. Since a single gate usually has a couple of transistors plus a few resistors, the gate symbol



A	B	OUT	A	B	OUT	A	OUT	A	B	OUT	A	B	OUT
0	0	0	0	0	0	0	1	0	0	1	0	0	1
0	1	0	0	1	1	1	0	0	1	1	0	1	0
1	0	0	1	0	1	1	1	1	0	1	1	0	0
1	1	1	1	1	1			1	1	0	1	1	0

Fig. 1. The five gates and their truth tables.

greatly simplifies circuit diagrams. The truth table is simply a list of the output signals which result from various combinations of input signals. (For more details on digital logic, gates, and truth tables, see the "Basic Digital Logic Course," Parts 1 and 2, in the October and November 1974 issues of POPULAR ELECTRONICS.)

So you can see just how versatile and easy to use gates can be, let's assemble three versions of one of the most important circuits in electronics, the multivibrator. We will use only two of the gates in a TTL 7400 quad NAND gate (Fig. 2). The multivibrator is a two-state circuit, and each circuit will include one or two LED's to indicate

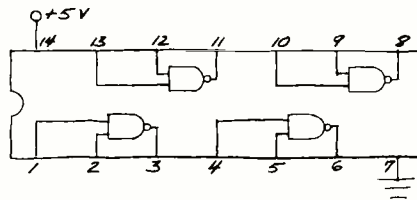

Fig. 2. The 7400 pin layout.

which logic state the circuit is in. Incidentally, if you've gotten this far, but still have reservations about working with digital IC's, maybe this fact will turn you on: The 7400 is available for well under a nickel per gate from most of the dealers who advertise in the back of this magazine!

One-Shot. The first circuit is the *monostable multivibrator* shown in

Fig. 3. Sometimes called a one-shot or single-shot, this useful circuit supplies a stable and predictable output pulse each time it receives an input signal, and this operating feature gives rise to several important applications.

Have you ever pressed a single digit key on a calculator and obtained a string of identical digits? This common phenomenon is usually the result of contact bounce in the calculator keyboard. A mechanical switch does not turn a circuit on or off in one clean operation since rough contact sur-

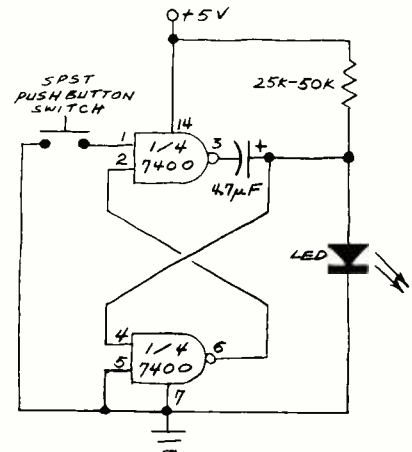

Fig. 3. Monostable multivibrator.

faces, pressure differences, wear, humidity, and dust interfere to produce a burst of on-off pulses each time the switch is actuated. A digital circuit will respond to each of these bounce-induced pulses as separate signals.

The one-shot circuit conveniently eliminates the bounce problem by providing a single, uniform pulse each time a mechanical switch connected to it is pressed. By adjusting the one-shot's pulse width to last longer than the bounce time, the bounce effects are completely eliminated.

Another important application for the one-shot is frequency division. Since you can adjust the one-shot for a variety of pulse widths by simply changing the value of its capacitor, you can block equal intervals of pulses in a pulse train. This application has uses in frequency generation and electronic music.

Flip-Flop. The second NAND gate circuit is the *bistable multivibrator* or, as it is more commonly known, flip-flop. The flip-flop can be switched back and forth between its two states by means of an input signal. This fea-

ture makes possible numerous applications including shift registers, memories, dividers, and counters. For example, the popular TTL 7490 de-

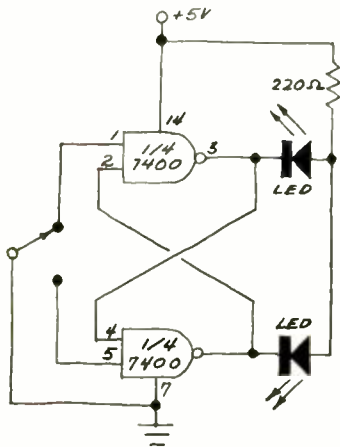

Fig. 4. Flip-flop circuit.

cade counter consists of four flip-flops on a single chip.

You can breadboard the flip-flop (Fig. 4) in just a few minutes since only three external components are required. When you first apply power to the circuit, one of the LED's will glow. By using the switch to ground first one and then the other input lead, the two LED's will alternately switch on and off as the circuit "flip-flops."

The one-shot has only one stable state, and it quickly resumes that state after each time it is called upon to supply an output pulse. But the flip-flop "remembers" the last input signal by keeping the appropriate LED on until the second input is activated or power is removed from the circuit. This operating principle is the basis for the memory, shift register, and counter applications for flip-flops.

Astable Multivibrator. The third NAND gate circuit is the *astable multivibrator* shown in Fig. 5. This circuit is a free-running multivibrator which oscillates back and forth between its two permissible states automatically. Two LED's are used to show when the circuit changes state, but they are effective only when the multivibrator operates at a frequency below about 18 Hz. The human eye does not respond to a flicker rate any faster than this.

The circuit's period of oscillation is determined by capacitors C1 and C2 and a value of about 50 μF each will give you a rate of one or two flashes per second—and an inexpensive "quick-and-dirty" dual flasher with lots of attention-getting applications.

Smaller values for C1 and C2 will give you much faster flash rates, but you won't be able to see them. Here are some flash rates I measured with a frequency counter for two capacitor sizes:

Capacitance	Power Supply	Frequency
0.001 μF	4.5 volts	92.4 kHz
0.001 μF	5.0 volts	165.0 kHz
0.1 μF	4.5 volts	950.0 Hz
0.1 μF	5.0 volts	1610.0 Hz

As you can see, gates are not all that complicated, and they can be used to build some simple but useful circuits. By assembling and experimenting with these circuits, you'll be well on the way to understanding many of the more advanced digital construction projects which appear each month in

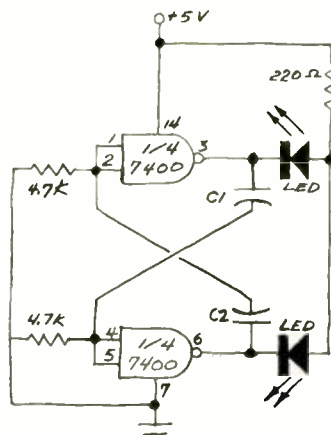

C1, C2 = .001 - 50 μF (SEE TEXT)

Fig. 5. Astable multivibrator.

POPULAR ELECTRONICS. Remember, if it's a digital project its operation is almost entirely dependent upon the gate!



"I've narrowed down the problem. It's either a fuse or something else."

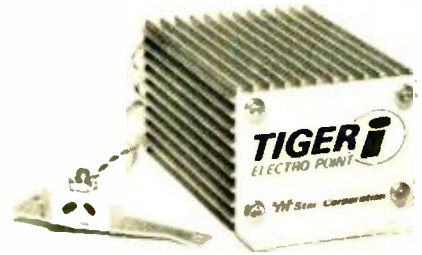

**save on gas!
save on tune-ups!
save on maintenance!**

Electronic ignition is "IN"! So says Detroit.

Update your car with either a TIGER CD or a TIGER I breakerless system.

Enjoy the benefits of better gas mileage, quicker starting, elimination of tune-ups, 50,000 miles on points and plugs, and reduced maintenance expenses.

TIGER MAX CD	\$69.95
TIGER 500 CD	59.95
TIGER SST CD	42.95
SIMPLIKIT CD	31.95
TIGER I	45.95

Postpaid U.S.A. only.

Tri-Star Corporation

Dept. ZZ, P.O. Box 127
Grand Junction, Colorado 81501

CIRCLE NO. 60 ON FREE INFORMATION CARD

LISTEN!

We're one of the country's largest Mail Order Houses of Stereo Equipment and now CB Equipment

Our volume buying power enables us to pass the savings on to you. Listen to us ... You can't go wrong.

Fill out this coupon and mail to address below for our latest Free Catalogs.

Name _____

Address _____

City _____

State _____ Zip _____

AUDIO CATALOG

PE-6

STEREO DISCOUNTERS

7A AYLESBURY ROAD □ TIMONIU, MD. 21093
[301] 252-6880

CIRCLE NO. 57 ON FREE INFORMATION CARD

103

ELECTRONICS MARKET PLACE

NON-DISPLAY CLASSIFIED: COMMERCIAL RATE: For firms or individuals offering commercial products or services, \$2.00 per word (including name and address) Minimum order \$30.00 Payment must accompany copy except when ads are placed by accredited advertising agencies. Frequency discount; 5% for 6 months; 10% for 12 months paid in advance. **READER RATE:** For individuals with a personal item to buy or sell, \$1.20 per word (including name and address.) No minimum! Payment must accompany copy. **DISPLAY CLASSIFIED:** 1" by 1 column (2 1/4" wide), \$230.00. 2" by 1 column, \$460.00. 3" by 1 column, \$690.00. Advertiser to supply film positives. For frequency rates, please inquire.

GENERAL INFORMATION: First word in all ads set in caps at no extra charge. All copy subject to publisher's approval. All advertisers using Post Office Boxes in their addresses **MUST** supply publisher with permanent address and telephone number before ad can be run. Advertisements will not be published which advertise or promote the use of devices for the surreptitious interception of communications. Ads are not acknowledged. They will appear in first issue to go to press after closing date. Closing Date: 1st of the 2nd month preceding cover date (for example, March issue closes January 1st. Send order and remittance to **POPULAR ELECTRONICS**, One Park Avenue, New York, New York 10016. Attention: Hal Cymes

FOR SALE

FREE! Bargain Catalog IC's, LED's, readouts, fiber optics, calculators parts & kits, semiconductors, parts Poly Paks Box 942PE Lynnfield, Mass 01940

GOVERNMENT Surplus Receivers Transmitters Snooperscopes, Radios, Parts Picture Catalog 25 cents Meshna, Nahant, Mass 01908

ELECTRONIC PARTS, semiconductors, kits FREE FLYER Large catalog \$1.00 deposit BIGELOW ELECTRONICS Bluffton, Ohio 45817

LOWEST Prices Electronic Parts Confidential Catalog Free KNAPP, 3174 8th Ave S.W., Largo, Fla 33540

RADIO TV Tubes--36 cents each Send for free catalog Cornell 4213 University, San Diego, Calif 92105

AMATEUR SCIENTISTS Electronics Experimenters, Science Fair Students Construction plans--Complete, including drawings, schematics, parts list with prices and sources Robot Man - Psychedelic shows Lasers - Emotion/Lie Detector Touch Tone Dial - Quadraphonic Adapter Transistorized Ignition Burglar Alarm - Sound Meter over 60 items Send 50 cents coin (no stamps) for complete catalog Technical Writers Group, Box 5994, University Station, Raleigh, N.C. 27607

METERS - Surplus, new, used, panel or portable Send for list, Hanchett, Box 5577, Riverside, CA 92507

MECHANICAL ELECTRONIC devices catalog 10 cents Greatest Values - Lowest Prices Fertik S, 5249 "D", Philadelphia, Pa 19120

SOUND SYNTHESIZER KITS - Surf \$12.95, Wind \$12.95, Wind Chimes \$17.95, Electronic Songbird \$6.95, Musical Accessories many more Catalog free PAIA Electronics, Box J14359, Oklahoma City, OK 73114

BUGGED??? New locator finds them fast Write, Clifton, 11500-L N.W. 7th Avenue, Miami, Florida 33168

DISCOUNT PRICES
B&K, SENCORE, LEADER, RCA
EICO, FLUKE, HICKOK, SIMPSON
 Test Equipment
 IGC Service-master RCA and Raytheon Tubes
 Complete line of electronic supplies
Free Catalog
FORDHAM RADIO SUPPLY CO., INC.
 855R Conklin St., Farmingdale, N.Y. 11735 (516) 752-0050

YOU WILL SAVE BIG MONEY! Surplus, Clearouts, Bankruptcy Inventory, Deals Catalog \$1 (redeemable) ETCOA Electronics Box 741 Montreal, H3C 2V2 U.S. Inquiries

TELEPHONE "BUGGED"? Don't be Watergated! Countermeasures Brochure \$1.00, NEGEVE LABORATORIES, Drawer 547, Pennsboro, W. VA 26415

HEAR POLICE/FIRE Dispatchers! Catalog shows exclusive directories of confidential channels, scanners Send postage stamp Communications, Box 56-PE, Commack, N.Y. 11725

CD IGNITIONS, VHF/UHF monitors, crystals, CB radios, Southland, Box 3591-B, Baytown, Texas 77520

SURPRISE! Build inexpensively the most Unusual Test Instruments, Futuristic Gadgets using Numerical Readouts! Catalogue Free! GBS, Box 100A, Green Bank, West Virginia 24944

TELEPHONES UNLIMITED, equipment, supplies Catalog 50 cents Box 1654E, Costa Mesa, Calif. 92626.

UNSCRAMBLERS Fits any scanner or monitor, easily adjusts to all scrambled frequencies Only 4" square \$29.95, fully guaranteed Dealer inquiries welcomed PDQ Electronics, Box 841, North Little Rock, Arkansas 72115

SURPRISE! SURPRISE! Digital Piano Tuning Device tunes musical instruments Accurately! Perfectly! Inexpensively! Construction-Instruction-Plans Complete \$12.95 Airmailed Postpaid! Moonlighting quickly repays \$40 electronics investment! GBS, Box 100P, Green Bank, West Virginia 24944

RECONDITIONED Test Equipment, \$0.50 for catalog Walter's Test Equipment, 2697 Nickel, San Pablo, CA 94806

FREE giant bargain electronic catalog listing thousands of components, tubes, transistors, IC's, kits, test equipment EDLIE'S, 2700-PD Hempstead Tpke., Levittown, N.Y. 11756

POLICE, Fire monitors, scanners, crystals, CB Transceivers, New Crystal-less scanners Discount priced Box 19224, Denver, CO 80219

TELETYPE EQUIPMENT for sale for beginners and experienced computer enthusiast Teletype machines, parts, supplies Catalogue \$1.00 to ATLANTIC SALES, 3730 Nautlius Ave., Brooklyn, NY 11224 Tel (212) 372-0349

ACE OF THE MONTH SPECIALS

ASCII COMPUTER KEYBOARDS
 These keyboards were manufactured for use on Texas Instruments line of Silent 700 series data terminals. They are fully encoded with TTL large scale integrated circuits (TTL) MS 5000 in 28 pin socket! Additional IC provides a parallel 7 bit, without parity code plus a strobe signal indicating valid data and six other independent outputs for those special keys which are not encoded. The keys are read type with a format similar to typewriter. Internal circuitry provides for two key rollover and de-bounce. Output is on standard 10 pin double readout connector for data and power input. And 8 pin double readout connector for six special switch functions.

KB 6 Clare/Pendar 720627 1 New tested \$39.95
 T1 Part number 959327 1 Used tested \$29.95
 A 56 key ASCII encoded alphanumeric keyboard with six extra switch closures to ground marked HERE IS PAPER ADV, BREAK REPEAT TAPE - TAPE

KB 7 Clare/Pendar 720731 1 New tested \$49.95
 T1 Part number 959326 1 Used tested \$39.95
 This is a 64 key full ASCII encoded keyboard

All keyboards supplied with wiring diagrams code tables, and other useful documentation

ACOUSTIC COUPLER
 This coupler was manufactured by Navation, Inc. Tarzana, California for use in Texas Instruments model 725 Electronic Data Terminal. It is compatible with Bell 103 and 113 data sets or equivalent. The coupler operates asynchronously to a maximum speed of 450 baud in the full or half duplex mode coupled to a standard telephone handset. Transmits freq. is 1270hz for mark and 1070hz for space. Receive frequency is 2225hz for mark and 2025hz for space. Unit required 1.2 VOLTS and - 5 VOLTS for operation. Complete with schematic & all pertinent information fully reconditioned calibrated and guaranteed. \$59.95

Kynar solid silver-plated wire wrap wire
 30 AWG Blue Or Yellow 1000 FT SPOOL 9.95
 26 AWG Red or Black 1000 FT SPOOL 10.95

MOLEX I.C. PINS
 100's 1000 6.95

BISMUTH LEAD
 Meters 1000 ea. 1.00
 400 2.00
 100 4.00

74S201N
 13 ns 256 Bit RAM
 Three State Output
 Plug-In Replacement
 \$3.95 ea. 10 for \$25.00

2N5449 50v 800 mA 6/\$1.00 100 for 12.50
 1N914B 100 for 6.95
 LM301AH 100 for \$25.00

TMS5000 ASCII keyboard encoder with data \$17.95 Black or White 5 for \$1.98 30 for \$10.00

6' 2 CONDUCTOR 18 GA MOLDED VINYL CABLE FOR FOUND PINS Mates with Recessed panel mounting TV type plug 10 For \$1

PRINTED CIRCUIT BOARD G-10 Size 1 10 100
 116 thick, unetched copper 3x6" .50 2.50 19.95
 4x12" 1.00 5.00 39.95
 8x8" 1.50 9.95 59.75

BURROUGHS PANAPLEX II 12 DIGIT 25 pin
 BR 16254 16v DC limitation voltage
 with socket \$2.95 ea. 10 for \$25.00

SLIDE SWITCH ASSORTMENT standard and miniature 40 for \$5.00

SEMICONDUCTOR	10	100	1000	10,000
IN753A	2.40	19.00		
IN914B		6.98	60.00	
IN966	2.50	19.95		
IN4448		5.60	48.00	394.45
SZ13709 - IN749A	1.95	14.95	99.95	250.00
2N3640	2.50	19.95	150.00	
2N930	2.50	19.95	150.00	
MPS3704	2.00	12.50	99.95	750.00
2N3705	1.75	9.95	75.00	
MPS3904	2.94	24.95	175.00	
SN7400N	1.50	12.50	99.95	
SN7412N	4.50	39.95	250.00	
SN74165N	12.50	99.95	750.00	
SN74S251N	19.95	175.00	950.00	

KEYBOARD ASSORTMENT 5 for \$9.95
CALCULATOR & COMPUTER All new first quality

DISC CAP ASSORTMENT
 includes 220 22k 220k 2.2M Prime
 these 4.25 4.75 5.00
 value 100 200 200 200 PCS FOR \$3.95

200 ELECTROLYTIC ASSORTMENT \$9.95
 MINIATURE ALUMINUM Anodized 50V 100V
 KEMET CK06BX 104K
 0.1 uF 100 VDC Epoxy dipped
 1-9-.50 15 uF 50V monolithic
 10-.40 1-49-.90 50-99-.48
 100-.34

AC adapter \$3.00 ea. INPUT 115 Volts, 50-60 Hertz OUTPUT 8 VAC 100 Ma. 10 for \$22.95 100 for \$149.50

NE-2 NEON 100 - 9.95 1000 - 49.95 10M - \$350.00

SWITCHCRAFT Micro-Jax 10 - \$2.95 100 - 25.00 TR-2A 1000 - 199.50 10M - 1250.00

P.C. Mount

CLAIREX Res. Ratio 1:1000 Volt 170 Type 4 CdSe, peak spectral response 6900 angstroms, very low resistance photocells. Can be used for "on-off" applications when low resistance is desired. For use with either incandescent or neon lamps. 10 for \$13.75

3/4" O.D. 7 1/2" High Boxes of 100 \$4.95
G-C No. 5788-C

RECESSED BUMPERS (STEEL WASHER INSETS)

ELECTRONIC PARTS
 TWX 910-881-2411
 5400 MITCHELLEDALE B-B HOUSTON, TEXAS 77092

SPEEDY BEND by PRODUCTION DEVICES \$1.95 \$2.95

CLOCK POWER TRANSFORMER PRIMARY 117 VOLT 60 Hz
 OUTPUT 1 OUTPUT 2
 VAC DCMA VAC DCMA
 20CT 50 80 20
 10 for \$15.00 We Ship ORDERS OVER 10 pcs Weight, 5 1/2 oz Collect
 100 for \$69.95 1000 for \$595.00

Do Not Write in this Space

TERMS We pay postage unless otherwise specified. Include check or money order, no COD. Texas residents add 5% sales tax. Canada and Mexico add \$2.50 overseas countries add \$5.00

Poly Pak's BUY 'EM FROM THE "BARREL" AND SAVE!

100'S OF BARRELS PURCHASED!



EXCLUSIVE 'BARREL' SALE

Every kit carries money back guarantee.

THE BIGGEST INFLATION-FIGHTING VALUE EVER! TEST 'EM YOURSELF 'N SAVE!

For the first time anywhere, Poly Pak merchandisers introduce a new way in buying the economical way. Raw stock from the "barrel". Remember

the "good ole days"? They're back again. The same way merchandisers throughout the United States buy from various factories... their over-

runs in barrels. Poly Pak has done the same. Therefore you are getting the same type of material as the RE-TESTERS DO!



NEVER BEFORE!

U-TEST EM-N-CHOOSE EM IC'S

Order by Cat. No. and Type No.

7400 SERIES

- Cat. No. 6E3170
- | | |
|---------|---------------|
| Type | Sale |
| SN7400 | 50 for \$1.98 |
| SN7402 | 50 for 1.98 |
| SN7404 | 40 for 1.98 |
| SN7410 | 50 for 1.98 |
| SN7412 | 25 for 1.98 |
| SN7420 | 50 for 1.98 |
| SN7440 | 50 for 1.98 |
| SN7475 | 25 for 1.98 |
| SN7474 | 40 for 1.98 |
| SN7475 | 30 for 1.98 |
| SN7476 | 30 for 1.98 |
| SN7483 | 40 for 1.98 |
| SN7486 | 40 for 1.98 |
| SN7490 | 25 for 1.98 |
| SN7492 | 30 for 1.98 |
| SN7495 | 30 for 1.98 |
| SN74107 | 40 for 1.98 |
| SN74112 | 40 for 1.98 |
| SN74123 | 30 for 1.98 |
| SN74125 | 40 for 1.98 |
| SN74150 | 30 for 1.98 |
| SN74157 | 30 for 1.98 |
| SN74173 | 30 for 1.98 |
| SN74173 | 30 for 1.98 |
| SN74192 | 30 for 1.98 |
| SN74193 | 30 for 1.98 |
| SN74198 | 30 for 1.98 |

NEW FACTORY ARRANGEMENTS by mix 'em? They decided to buy in same types, then throw backs into barrels. WE DON'T TEST! You test 'em yourself! Buy types of your choice at BARREL PRICES!

LINEARS

- Cat. No. 6E3171
- | | |
|----------|---------------|
| LM300H | 30 for \$1.98 |
| LM301V | 50 for 1.98 |
| LM307V | 40 for 1.98 |
| LM308V | 30 for 1.98 |
| LM311V | 30 for 1.98 |
| LM318V* | 30 for 1.98 |
| LM319V | 30 for 1.98 |
| LM324N | 30 for 1.98 |
| LM339N | 30 for 1.98 |
| LM351V | 30 for 1.98 |
| LM358V | 30 for 1.98 |
| LM367N | 30 for 1.98 |
| LM380N | 30 for 1.98 |
| LM380V* | 30 for 1.98 |
| LM381N | 30 for 1.98 |
| LM382N | 25 for 1.98 |
| LM555V | 30 for 1.98 |
| LM709H | 50 for 1.98 |
| LM733N | 30 for 1.98 |
| LM737N | 30 for 1.98 |
| LM747N | 30 for 1.98 |
| LM1303N | 30 for 1.98 |
| LM1304N | 30 for 1.98 |
| LM1310N | 30 for 1.98 |
| LM1458V | 30 for 1.98 |
| LM1810N | 30 for 1.98 |
| LM2002N | 30 for 1.98 |
| LM2111N | 50 for 1.98 |
| LM2901N | 30 for 1.98 |
| LM2902N | 30 for 1.98 |
| LM2903N | 30 for 1.98 |
| LM3320N | 30 for 1.98 |
| LM3612V* | 30 for 1.98 |
| LM3900N | 30 for 1.98 |
| LM3901N | 30 for 1.98 |
| LM7534N | 40 for 1.98 |
| LM7535N | 40 for 1.98 |
| LM7538N | 40 for 1.98 |
| LM7541V* | 30 for 1.98 |
| LM75491N | 30 for 1.98 |
| LM75492N | 30 for 1.98 |

MONEY BACK GUARANTEE PER PART!

BARREL KIT #1
SN7400 DIP IC'S
75 for \$1.98

Marked 14 and/or with 16 pin dips, may include gates, registers, flip flops, counters. Who knows? GUARANTEED SATISFACTION!
Cat. No. 6E2415 Untested.

BARREL KIT #2
MARK STAR OP AMPS, DIPS
75 for \$1.98

Un tested
May include 700's, 741's, 703's, 560 series. 555 includes marked and unmarked. Cat. No. 6E2416

BARREL KIT #3
1N4745/914
SWITCHING DIODES
100 for \$1.98

You never saw this before. Imagine famous switching diodes at these prices!
Cat. No. 6E2418 Untested.

BARREL KIT #4
"4000" RECTIFIERS
100 for \$1.98

Un tested.
These are the famous micro miniature rectifiers of the 1N4000 series. May include 25, 50, 100, 200, 400, 600, 800 and 1000 voltages. Cat. No. 6E2417

BARREL KIT #5
SCRS, TRIACS, QUADRACS
40 for \$1.98

All the famous plastic power tab type. Raw factory stock! All the 10 amp types.
Cat. No. 6E2419 Untested.

BARREL KIT #7
VOLUME CONTROL BONANZAS!
40 for \$1.98

100% good
Singles, duals, variety of values, styles, big ones, small ones. Cat. No. 6E2421

BARREL KIT #8
SUBMINIATURE IF TRANSFORMERS
100 for \$1.98

100% good.
Amazing, includes 455kcs, etc. antenna, who knows? From transistor radio manufacturers. Cat. No. 6E2422

BARREL KIT #10
ROMS-REGISTERS
50 for \$1.98

Un tested
28 to 40 pin devices, marking internal factory numbers. (c) Cat. No. 6E2424

BARREL KIT #12
POWER TAB
40 for \$1.98

PNP plastic 10220 type. Assorted 2N numbers.
Cat. No. 6E2426 Untested.

BARREL KIT #13
RESISTOR NETWORKS
60 for \$1.98

Un tested.
By Corning Glass, in 14-pin dip paks. Cat. No. 6E2427

BARREL KIT #15
MOSFET TRANSISTORS
60 for \$1.98

All 4 leaders TO-18 case, includes UHF transistors too! Cat. No. 6E2429

BARREL KIT #17
LINEAR & 7400 DIPS
100 for \$1.98

Un tested
Marked and unmarked, internal numbers of raw factory stock. Cat. No. 6E2431

BARREL KIT #19
DIPPED MYLARS
60 for \$1.98

Finest capacitors made, slinging finish. Imagine factory dumping 'em in barrels. Cat. No. 6E2597 100% good.

BARREL KIT #20
LONG LEAD DISCS
150 for \$1.98

Factory distributor stock. Auction sale. Prime marked only. Long leads.
Cat. No. 6E2598 100% good

BARREL KIT #25
HEAT CAN TRANSISTORS
100 for \$1.98

Un tested.
Includes TO-5, TO-18, TO-18, etc., assorted 2N numbers. Cat. No. 6E2603

BARREL KIT #26
TRANSISTORS
100 for \$1.98

Un tested.
Type TO-92 (TO-18), all manufacturers, variety of 2N's. Cat. No. 6E2604

BARREL KIT #30
PREFORMED RESISTORS
250 for \$1.98

We got barrels of 1/4 and 1/2 watters for pe use. You'll get clean amount. 100 1/4, 100 1/2 watters. Cat. No. 6E2608 100% good

BARREL KIT #31
METALLIC RESISTORS
100 for \$1.98

100% good.
Made mostly by Corning, the finest resistor made. Mostly 1/2 watters, 1/4 to 5/8 tol & a barrel of values. Cat. No. 6E2609

BARREL KIT #32
TRANSISTORS WITH A HOLE IN IT
50 for \$1.98

Un tested.
Can't name factory, but we bought barrels of 25 watters with mfg. hole in middle. PNP's and NPN's.

BARREL KIT #35
NEON LAMPS
40 for \$1.98

100% good.
Factory NE-2's. All prime, but famous made millions and barrelled 'em. Your advantage. Cat. No. 6E2613

BARREL KIT #36
GERMANIUM DIODES
200 for \$1.98

Un tested.
Famous maker, popular item. Never grows 'em in barrel. It's the way the RE-TESTERS buy 'em from the factories. Cat. No. 6E2614

BARREL KIT #37
1 AMP "BULLET" RECTIFIERS
100 for \$1.98

Un tested.
Famous style, ass'td. includes ages, silicon, axial includes all types of voltages to 1KV. Cat. No. 6E2615

BARREL KIT #39
2N3055 HOBBY TRANSISTORS
15 for \$1.98

100% good.
From factory to you, these fellows of the famous 2N3055. We have 10 barrels. Cat. No. 6E2617

BARREL KIT #40
PNP HIGH-POWER TRANSISTORS
20 for \$1.98

Popular germanium TO-3 case units, now available at "good ole barrel" prices. Cat. No. 6E2618 100% good

BARREL KIT #46
G.E. 3.5 WATT AMPLIFIERS
25 for \$1.98

Un tested.
Hobby type, factory fallouts, we purchased them in barrels. These are unknown. Cat. No. 6E2624

BARREL KIT #80
SIGNAL SILICON DIODES
200 for \$1.98

Un tested.
Includes many, many types of switching, signal silicon types, all axial. Leads, some may be center. Cat. No. 6E2628

BARREL KIT #51
HOBBY OPTO COUPLERS
40 for \$1.98

Un tested.
We got 1,000's unknown both the sensor or transmitter may be good or both. WE DON'T KNOW! We don't know the types. 2N005 (assorted) Cat. No. 6E2629

BARREL KIT #52
DISCS!
500 for \$1.98

Cat. No. 6E2630 100% good
The bargain of a lifetime! Put time ever offered by Poly Pak for the economy-minded bargain hunters.

BARREL KIT #53
JUMBO RESISTOR PAK
100-pc. \$1.98

Cat. No. 6E2721
Assorted metal film, precision, carbon, metal oxide powers, from 1/4 watt to 7 watts. Color coded. 400 & 100% good. Worth \$10.

BARREL KIT #58
SLIDE SWITCHES
30 for \$1.98

Un tested.
All shapes, sizes, spat, dip, momentaries, etc. Treadmill, office shop pak for 100's of switches. Includes 100's. Cat. No. 6E2726 100% good.

BARREL KIT #59
POWER TRANSISTORS
40 for \$1.98

15 watt Bendix R-5000 pellet transistors, npn, all color, purchased from a factory. Includes 100's of 100% good. Cat. No. 6E2727

BARREL KIT #60
DTL'S IC'S
75 for \$1.98

Un tested.
This is prime barrel material. Who wants DTL's? 930, 936, 946's. Your gain is our loss. They're marked too. Cat. No. 6E2728

BARREL KIT #61
POLYSTYRENE CAPS
100 for \$1.98

100% good.
Finest caps made. As a kammie, we bought 10 barrels of factory mixed values, all good. Cat. No. 6E2729

BARREL KIT #65
MIXED READOUTS
15 for \$1.98

100% good.
Factory returns — such numbers as MAN-4's, MAN-7's, MAN-3's, 11 barrels. A no time to separate. Cat. No. 6E2733 Untested.

BARREL KIT #68
2 WATTERS
100 for \$1.98

100% good.
Nobody seems to want 'em! So many suppliers don't count, but they're in the barrel. It's a 1/4 gall mine! All marked. Cat. No. 6E2735

BARREL KIT #71
CAPACITOR SPECIAL
100 pcs. \$1.98

Un tested.
Emptied stockrooms into barrels of various, poly's, ceramic, mica, etc. Plastics. 100% good. Cat. No. 6E2738

BARREL KIT #73
SILICON DIODES
50 for \$1.98

Un tested.
It bugs us why the factories throw 'em in barrels. We don't wish to separate wide asst values & values up to 400 mf. Cat. No. 6E2747

BARREL KIT #75
400MW ZENERS
150 for \$1.98

Un tested.
Factory out of biz! Amazing! 600, 800, 10, 12 to 15V. You test. Hermetically sealed glass pak. Double plug. Cat. No. 6E2740

BARREL KIT #76
1-WATT ZENERS
100 for \$1.98

Un tested.
Factory same as 400mw's. Never to separate. 10, 12, 15V. Under glass. Double plug. Cat. No. 6E2741

BARREL KIT #77
"BROWN" BODY TRANSISTORS
40 for \$1.98

Un tested.
G.E. 10-10 series. Has 100's of 5 digit resistors, hi-current, npn's. Factory line discontinued. Power tabs. Cat. No. 6E2742 Untested.

BARREL KIT #78
"RED" BODY TRANSISTORS
40 for \$1.98

Un tested.
D-12 series. You test—go into your own biz! High current, hi-volts, NPN. Cat. No. 6E2743 Untested.

BARREL KIT #81
SUBMINI RESISTORS
200 for \$1.98

100% good.
P1, upright type, color coded, 1/4 watt. Ass't values. Come to us in a barrel. Cat. No. 6E2746

BARREL KIT #83
LM-340T VOLTAGE REGULATORS
15 for \$1.98

Un tested.
Factory rejected them for length of leads. May include 5, 6, 8, 12, 15, 18, 24 volts. Power tab. Cat. No. 6E2635

BARREL KIT #87
NATIONAL IC BONANZA
100 for \$1.98

Un tested.
Factory dumps into barrels. Types 8000, 7400 series, DTL's, ROM's, registers, clock & other chips, linears, etc. Cat. No. 6E2860 Untested.

BARREL #91
SILVER MICAS
100 for \$1.98

Cat. No. 6E3018
For the first time silver mica's are low in price! Axial, red case variety of physical sizes & values. Big savings from distributor prices. Wt. 1 lb.

BARREL KIT #94
"BUBBLE" READOUTS
12 for \$1.98

Un tested.
DL-33B bubble magnifiers. Needs missing. Truthfully so many of 'em we don't care. Untested. 3 oz. No. 6E3046

BARREL KIT #99
PHOTO ELECTRIC CELLS
10 for \$1.98

Un tested.
Asst. GE types, CDS types. Mixed by factory. Big job for us to separate. 100% good. Cat. No. 6E3052

BARREL KIT #102
CLOCK CHIPS
5 for \$1.98

No. 6E3055
National is dumping! MM-5316 — what's wrong with 'em, we don't know, but we got barrels. Hobby special. Wt. 2 oz.

BARREL KIT #104
SLIDE VOLUME CONTROL
10 for \$1.98

Cat. No. 6E3057
Used in hi-fi, volume control maker unloads. Ass't values, what a buy. Worth \$1 ea. We've got barrels of 100% material.

BARREL KIT #107
SQUARE OHMS
60 for \$1.98

Cat. No. 6E3096
Factory people are sometimes "squares" when they topple prime square ohms mix 'em up in barrels. Ass't values wats. Wt. 1 lb.

BARREL KIT #108
TO-18 PLASTIC TRANSISTORS
40 for \$1.98

Cat. No. 6E3101
Includes PNP, NPN, 2N-3638, 2N3441, 2N5000 series, etc. Un tested, but guaranteed to a 60% yield.

BARREL KIT #109
TERMINAL STRIPS
150 for \$1.98

Un tested.
Wide asst. of terminal strip connectors, from 1 contact up. Strip manufacturers barrel dump. Cat. No. 6E3136

BARREL KIT #110
SUPPRESSOR DIODES
50 for \$1.98

Cat. No. 6E3137
Keeps ignition noises out axial. Un tested, but the of your eqpt., car, industrial, etc. Double plug.

BARREL KIT #111
MULTI DIGIT READOUTS
8 for \$1.98

Un tested.
Barrels of bismuthed 3, 4 digit, 5 digit resistors, to USA for "dump". Un tested. Cat. No. 6E3138

BARREL KIT #112
MICRO MINI LEDS
40 for \$1.98

Un tested.
All the tiny leds, axial, up-right of Monsanto. Litrohi variety of colors. Yield 50% or better. Cat. No. 6E3139

BARREL KIT #113
STABISTORS
50 for \$1.98

Cat. No. 6E3140
Regulator, sensing and computer circuitry. Axial double plug type. Discontinued factory line. PIV 20 volts. 80% yield. U test 'n save!

BARREL KIT #115
MOLEX SOCKETS
300 for \$1.98

100% good.
Calculator maker dump! We got a barrel of 'em. Used for IC sockets, etc. Cat. No. 6E3144

BARREL KIT #116
BUTTONS 'N FEEDTHRU'S
100 for \$1.98

100% good.
Truthfully worth a small fortune. Wide asst. of buttons, feedthru's, etc. BMS TAKE NOTE! RF, UHF, etc. Wt. 1 lb. Cat. No. 6E3143

BARREL KIT #117
20-MIL OPTICAL FIBERS
200-Ft. \$1.98

Un tested.
Fiber optics factory bankruptcy purchase! High quality, low cost, commonly used size (20-mil). CLEAR! Lowest price. 6E3206

BARREL KIT #118
MINI SCRS
50 for \$1.98

Unbelievable! TO-92 plastic SCRS in barrels... site from factory. Includes all voltages up thru 200 mv. 6E3135

BARREL KIT #119
MODULAR SWITCHES
25 for \$1.98

Un tested.
Centralab "push-ON" switches. TV-makers excess. Dpdt, 6pdt, etc. Brand new. Cat. No. 6E3150

BARREL KIT #120
TRIGGER DIODES
25 for \$1.98

Un tested.
Type ER-900, same type used to trigger scrs, triacs. Sometimes called "diacs". Un tested. Cat. No. 6E3160

BARREL KIT #121
"MINI" MAGNETS
100 for \$1.98

Un tested.
Magnet circular and rectangular cutouts from a major maker — For road switches & micro-circuitry. Cat. No. 6E3168

BARREL KIT #122
PLASTIC OPTICAL FIBERS
500-Ft. \$1.98

Un tested.
Poplr 10-mil size. Excellent for making life pipes, experiments, lamp sprays. Cat. No. 6E3159

BARREL KIT #123
CD-4002 C-MOS IC
15 for \$1.98

Un tested.
magnificent. But we have 250,000. Cat. never sell 'em out. YOUR GAIN! Their number is CD-5027. Cat. No. 6E3217

BARREL KIT #126
UPRIGHT ELECTROCS
40 for \$1.98

Un tested.
Wide asst. of values from 1mf to 100mf. mixture of voltages. 100% marked 'n good. Why barrelled? (got-a-buy!) Cat. No. 6E3226

BARREL KIT #127
AXIAL ELECTROCS
40 for \$1.98

Un tested.
Truthfully the factories by mixing 'em in barrels do all of us a favor. WUT A BUY! Ass't. capacities and voltages. Cat. No. 6E3227

BARREL KIT #128
MINI DIP IC'S
75 for \$1.98

Un tested.
Large offer dumped 100's of the into barrels. Includes 741's, LM-380's, 701, 767, 555, 555's—but who knows? Factory to you. All mixed, no test. Wt. 1 lb. Cat. No. 6E3245

BARREL KIT #131
TANTALUM ELECTROCS
30 for \$1.98

Un tested.
Mixed, marked prime, top grade ass't. values, voltages. 50, 100, 200, etc. Cat. No. 6E3255

BARREL KIT #133
C-MOS IC'S
60 for \$1.98

Un tested.
Deliberately thrown in barrels, so we can't test 'em! The famous CD4000 series. How good? Who knows? Who tests? Only 3c ea. Cat. No. 6E3257

Terms: Add postage. Rated: net 30
Phone: Wakefield, Mass. (617) 245-3829
Retail: 16-18 Del Carmine St., Wakefield, MA
MINIMUM ORDER — \$6.00

POLY PAKS Send for FREE Spring-Summer CATALOG

C.O.D.'s MAY BE PHONED

VIDEO CAMERA KIT

A UNIQUE ALL SOLID STATE CAMERA KIT
FEATURING A... 100 x 100 BIT
SELF SCANNING CHARGED
COUPLED DEVICE

INCLUDES THE FOLLOWING
UNIQUE FEATURES...
FOUND IN FAR MORE
EXPENSIVE CAMERAS
IF AVAILABLE

- LOW VOLTAGE SUPPLY (FOR BATTERIES) - 5 AND 15 VOLTS
- SENSITIVE TO INFRARED AS WELL AS VISIBLE LIGHT
- MAY BE USED FOR IR SURVEILLANCE WITH AN IR LIGHT SOURCE
- EXCELLENT FOR STANDARD SURVEILLANCE WORK BECAUSE OF ITS LIGHT-WEIGHT AND SMALL SIZE
- ALL COMPONENTS MOUNTED ON TWO PARALLEL 3" x 5" SINGLE SIDED BOARDS TOTAL WEIGHT UNDER 2 LBS
- MAY BE VIEWED BY PERSON WITH SOME TECHNICAL EXPERIENCE IN 4-6 HRS



SUPER UNBELIEVABLE ONLY \$225.00

ADD \$2.00 POSTAGE AND HANDLING, PLUS \$1.00 FOR ALL IC SOCKETS (OPTIONAL)

MAY BE USED WITH A MATEUR RADIO FOR VIDEO

USED FOR CHARACTER RECOGNITION FOR COMPUTERS WITH EXTERNAL CIRCUITS

MAY BE USED IN A VACUUM, UNDER WATER, HIGH ALTITUDE, AND IN MAGNETIC ENVIRONMENT BECAUSE THERE IS NO HIGH VOLTAGE OR MAGNETIC DEFLECTION

WE SUPPLY ALL SEMICONDUCTORS, BOARDS, DATA SHEETS, DIAGRAMS, RESISTORS AND CAPACITORS

SORRY, WE DO NOT SUPPLY THE CASE, BATTERIES (OR SUPPLY) THE LENS (NOT SUPPLIED) DEPENDS UPON THE USE

F8 MICROPROCESSOR KIT

WE'VE GOT THE F8 MICROPROCESSOR KIT, ONE OF THE MOST ADVANCED MCU SYSTEMS ON THE MARKET TODAY FOR ONLY **\$159.00**

- This three chip microprocessor system has the following advantages:
- 1) Driven by +5 and +12 volt power supply.
 - 2) Two I/O ports on the CPU chip, and ROM, making 32 bidirectional lines.
 - 3) 64 bytes of fast RAM scratchpad built into the CPU chip.
 - 4) A built in clock generator and power-on reset built into the CPU chip.
 - 5) A programmable internal timer built into the ROM chip.
 - 6) 60% of the instructions are 1 byte.
 - 7) TTL I/O compatibility.
 - 8) Consumes less than 300mw of power per chip.
 - 9) A local interrupt with automatic address vector.
 - 10) Expandable to 64K bytes (2102-1) of memory.
 - 11) 20 mil loop and RS-232 included.
- The F8 Kit has enough parts and instructions to demonstrate microprocessor programs up to 1K byte, and to debug those programs.

We supply:

- 1) 3850 CPU
 - 1) 3851 A FAIR 8100 program storage unit, provides the programmer with all its I/O subroutines, and allows the programmer to display or alter memory, and register contents via a teletype terminal.
 - 1) 3853 Static memory interface
 - 8) 2102
- Plus CMOS gates and buffers, PC card, instruction manuals, programming guide, and time sharing guide.

4K MEMORY KIT \$159.00

Memory Board: Our unique memory card features:

- 1) 8 bit bidirectional port, outputs buffered
 - 2) On board decoding for any four of 64 pages.
 - 3) Address buffered
 - 4) 4K bytes of 2102-1 static RAM's
 - 5) No on board regulation to cause heat problems
- The memory card, like our other computer cards, has a 44 pin gold plated edge (1.56 spacing). This feature makes the system completely stackable to save space, service problems, and hard wiring. It will also allow plug-in capability for our other cards when they become available.

EXPANDER BOARD

This board will expand the memory capability to 16 kilobytes with full buffering. Individual power terminals for each memory card are available. This system can be expanded to the full 64 kilobytes of memory by plugging other expander cards into this one with the 44 pin connector options.

To the best of our knowledge, ours is the only kit on the market designed for easy expansion to full memory capability.

EXPANDER KIT WITH ONE EDGE CONNECTOR \$59.00 Extra 44 Pin Connectors

IC BONANZA

Data Sheet included on these items

*MM5330	National DVM on a chip	\$ 9.95
*2102	1K Static Ram 450 NS	1.60
*5203 Q	Erasable Prom 2K	11.95
*50310	Slide rule calculator chip	3.95
*50240	Ten octave organ chip	5.95
*50250	Alarm clock chip	4.45
LM340K-5	5 Volt pos regulator	.89
LM340K-12	12 Volt pos regulator	.89
LM340K-15	15 Volt pos regulator	.89
LM340K-24	24 Volt pos regulator	.89
LM320K-5	5 Volt neg regulator	.84
LM320-5.2	5.2 Volt neg regulator	.84
LM320K-12	12 Volt neg regulator	.84
N8252B	BCD to decimal decoder	.79
962	Triple 3 input NAND gate	.09
2N6050	Darlington	.75
2N6051	Darlington	.79
2N6285	Darlington	.99
2N6286	Darlington	1.04

SEND FOR FREE CATALOG

Minimum order \$5.00, data sheets 25 cents each include 5% of order for postage and handling. Texas residents include 5% state sales tax.

BONANZA ELECTRONICS
P O Box 24767 Dallas Texas 75224

TV PING PONG game Plays through your set's antenna terminals: Plans \$3.25 ARS SYSTEMS Box 1922 Sunnyvale, CA 94088

6 MHZ CRYSTALS including schematic and info to generate 60 hz-12VAC to make your digital clock run on batteries \$10.50 pp in US Eastern Sales, Box 510, Raleigh, N.C. 27602

INTEL 8080 CPU	\$29.50
8008 8 BIT MICRO PROCESSING CHIP (with Data Book)	\$19.00
2102-1 1024 BIT RAM	\$ 2.60
5202A UV PROM	\$12.50
MM5203 UV PROM	\$12.50
1702A UV PROM	\$12.50
5204-4K PROM	\$24.95
MINIATURE MULTI-TURN TRIM POTS 100, 50K, 10K, 25K, 50K, 100K, 200K, \$.75 each	\$32.00
MULTI-TURN TRIM POTS Similar to Bourns 3010 style 3/16"x5/8"x1.1/4", 50, 100, 1K, 10K, 50K ohms	\$34.00
\$1.50 ea.	
LIGHT ACTIVATED SCR's	
TO-18, 200V 1A.	\$ 1.75

PRINTED CIRCUIT BOARD

4 1/2" x 6 1/2" SINGLE SIDED EPOXY BOARD 1/16" thick, unetched	\$5.00 ea.	5/\$22.20
VECTOR BOARD 1" SPACING 4.5"x6.5" SHEET		\$1.50

4 WATT IR LASER DIODE \$7.95

2N 5460 P FET	\$.45
2N 5457 N FET	\$.45
2N 4891 UJT	\$.45
TIS 43 UJT	\$.35
ER 900 TRIACGER DIODES	4/\$1.00
2N6028 PROG. UJT	\$.65

VERIPAX PC BOARD

This board is a 1/16" single sided paper epoxy board, 4 1/2" x 6 1/2" DRILLED and ETCHED which will hold up to 21 single 14 pin IC's or 8, 16, or LSI DIP IC's with buses for power supply connector. \$5.25

MV 5691 YELLOW-GREEN BIPOLAR LED	\$1.25
MT-2 PHOTO TRANS	\$.60
RED, YELLOW, GREEN OR AMBER LARGE LED's	ea. \$.20
14 PIN DIP SOCKETS	\$.35
16 PIN DIP SOCKETS	\$.35
MOLEX PINS	1000/\$9.00
8 PIN MINI DIP SOCKETS	\$.30
10 PIN TO 5 TEFLOX PC SOCKETS	\$.60
10 WATT ZENERS 3.9, 4.7, 18 OR 22V	ea. \$.60
1 WATT ZENERS 4, 7, 5, 6, 10, 12, 15, 18 OR 22V	ea. \$.25

Silicon Power Rectifiers

PRV 1A 3A 12A 50A 125A	
100 .06 .14 .30 .80	
200 .07 .20 .35 1.15 4.25	
400 .09 .25 .50 1.40 6.50	
600 .11 .30 .70 1.80 8.50	
800 .15 .35 .90 2.30 10.50	
1000 .20 .45 1.10 2.75 12.50	

REGULATED MODULAR POWER SUPPLIES

+ 15 VDC AT 100ma	
115VAC INPUT	\$27.95
5VDC AT 1A 115VAC INPUT	\$24.95
12 VDC AT .5A	\$24.95
IN 4148 (1N914) 15 \$1.00	
251R-HEX 32 BIT SR	\$6.00
SILICON SOLAR CELLS 2 1/2" diameter 5V at 500 ma.	\$5.00 ea., 6/\$27.50
7 POLE 1 THROW TO 5 MINIATURE ROTARY SWITCH	\$.95

TRANSISTOR SPECIALS

2N3585 NPN Si TO-66	\$.95
2N3772 NPN Si TO-3	\$ 1.80
2N4901 PNP Si TO-3	\$.85
2N5086 PNP Si TO-92	4/\$ 1.00
2N4898 PNP TO-66	\$.60
2N404 PNP GE TO-5	5/\$ 1.00
2N3919 NPN Si TO-3 RF	\$ 1.50
MPSA 12 NPN Si TO-92	3/\$ 1.00
2N3767 NPN Si TO-66	\$.70
2N2222 NPN Si TO-18	5/\$ 1.00
2N3055 NPN Si TO-3	\$.80
2N3904 NPN Si TO-92	5/\$ 1.00
2N3906 PNP Si TO-92	5/\$ 1.00
2N5296 NPN Si TO-220	\$.55
2N6109 PNP Si TO-220	\$.55
2N3866 NPN Si TO-5	\$.75
2N3638 NPN Si TO-5	5/\$ 1.00
2N6517 NPN TO-92 Si	3/\$ 1.00

TANTALUM CAPACITORS

22UF 35V 5/\$1.00	6.8UF 35V 3/\$1.00
47UF 35V 5/\$1.00	33UF 25V \$.40
68UF 35V 5/\$1.00	30UF 6V 5/\$1.00
1UF 35V 5/\$1.00	150UF 20V \$.50
4.7UF 35V 4/\$1.00	

CT7001 ALARM CLOCK CHIP \$5.75
PPA 711-7 LEVEL Diode Array Optical Tape Readers \$5.95

NATIONAL MOS DEVICES

MM1402-3-20	MM5057-4-00
MM1403-3-20	MM5058-4-95
MM1404-2-50	MM5060-4-95
MM5011-7-75	MM5061-4-30
MM5016-3-50	MM5555-6-25
MM5017-4-75	MM5556-6-25
MM5505-4-00	MM5210-1-95
MM5056-4-00	MM5260-2-95

TTL IC SERIES

74L00-30	7483-90
7400-18	7485-105
7401-18	7486-45
7402-18	7489-180
7403-18	7490-60
7404-22	7491-79
7405-22	7492-60
7406-35	7493-60
7407-33	7494-90
7408-22	7495-85
7409-25	7496-79
7410-18	74107-34
7411-25	74121-50
7412-30	74123-85
7413-60	74125-70
7414-145	74126-90
7416-33	74150-100
7417-33	74151-90
7420-18	74153-79
7425-35	74154-140
7426-35	74155-140
7427-35	74157-75
7430-18	74161-120
7432-24	74164-150
7437-35	74165-150
7438-35	74173-35
7440-18	74175-95
7441-95	74177-100
7442-70	74180-105
7445-85	74181-230
7446-100	74191-150
7447-87	74192-110
7448-100	74193-125
7472-35	74194-125
7473-40	74195-74
7474-40	74196-120
7475-60	75324-175
7476-40	75491-80
7480-48	75492-80

ALCO MINIATURE TOGGLE SWITCHES
MTA 106 SPDT \$1.20
MTA 206 DPDT \$1.70

CMOS (DIP CODE CLAMPED)

74C02-30	4016-60	4035-175
74C01-30	4017-30	4042-100
4001-30	4018-140	4046-275
4002-30	4019-60	4047-300
4006-160	4022-140	4049-75
4007-30	4023-30	4050-75
4009-60	4024-125	4055-195
4010-60	4025-30	4066-110
4011-30	4027-75	4071-30
4012-30	4028-120	4077-30
4013-50	4029-145	4081-30
4015-140	4030-55	

LED READOUTS

FND 500-5" C.C.	\$1.75
HP 712-12 1/2" C.C.	\$1.40
MAN 4-25" C.C.	\$1.20
MAN-7-3" C.A.	\$1.25
DL747-6" C.A.	\$1.95
NS 33-3 dig. array	\$1.35

Full Wave Bridges

PRV 2A 6A 25A	
200 95 1.25 2.00	
400 1.15 1.50 3.00	
600 1.35 1.75 4.00	

CD 110 LINEAR 256 X1 BIT SELF SCANNING CHARGED COUPLED DEVICE \$125.00

SANKEN AUDIO POWER AMPS

Si 1010 G 10 WATTS	\$ 6.90
Si 1020 G 20 WATTS	\$13.95
Si 1050 G 50 WATTS	\$24.95

LINEAR CIRCUITS

LM 309K 5V 1A REGULATOR	\$1.00
723-40 +40V V REGULATOR	\$.54
301/748-Hi Per. Op. Amp.	\$.35
3207-5, 12, 15, 019 24V	
NEGATIVE REG.	\$1.35
741A or 741C OP. AMP.	\$.35
709C OPER. AMP.	\$.32
307 OP. AMP.	\$.25
CA 3047 Hi Per. Op. Amp	\$.95
3407-5, 6, 12, 15, 18, 24V POS REG. TO-220	\$1.20
101 OPER. AMP. HI PERFORM.	\$.75
LM 308 OPER. Amp., Low Power	\$1.05
747-DUAL 741	\$.65
556-DUAL TIMER	\$.95
537-PRECISION OP. AMP.	\$2.80
540-70W POWER DRIVE	\$2.75
LM 3900-QUAD OP. AMP.	\$.49
LM 324-QUAD 741	\$.50
561-PHASE LOCK LOOP	\$2.50
561-PHASE LOCK LOOP	\$2.50
565-PHASE LOCK LOOP	\$1.50
566-FUNCTION GEN.	\$2.50
567-TONE DECODER	\$2.00
LM 1310N FM STEREO DEMOD.	\$2.75
8038 IC VOLTAGE CONT. OSC.	\$3.90
LM 370-AGC SQUELCH AMP.	\$1.75
555-2ur-2 HR. TIMER	\$.53
553 QUAD TIMER	\$2.50
FCD 810 OPTO-ISOLATOR	\$.80
1458 DUAL OP. AMP.	\$.55
LM 380-2W AUDIO AMP.	\$.95
LM 377-2W Stereo Audio Amp.	\$2.50
LM 381-STEREO PREAMP	\$1.75
LM 382-DUAL AUDIO PREAMP	\$1.25
LM 311-HI PER. COMPARATOR	\$.95
LM 319-Dual Hi Speed Comp.	\$1.25
LM 339-QUAD COMPARATOR	\$1.40

TRIACS SCR'S

PRV 1A 10A 25A 1.5A 6A 35A	
100 40 70 1.30 40 50 1.20	
200 70 1.10 1.75 60 70 1.60	
400 1.10 1.60 2.60 1.00 1.20 2.20	
600 1.70 2.30 3.60 1.50 3.00	

Send 25c for our catalog featuring Transistors and Rectifiers 145 Hampshire St., Cambridge, Mass.

Planning to move?

Let us know 8 weeks in advance so that you won't miss a single issue of POPULAR ELECTRONICS. Attach old label where indicated and print new address in space provided. Also include your mailing label whenever you write concerning your subscription. It helps us serve you promptly. Write to: P.O. Box 2774, Boulder, CO 80302, giving the following information:

- Extend subscription. Enter new subscription.
- 1 year \$6.98
- Payment enclosed (1 extra BONUS issue)
- Bill me later

AFFIX LABEL

If you have no label handy, print OLD address here.

name _____ address _____ city _____ state _____ zip code _____

name _____ address _____ city _____ state _____ zip code _____

name _____ address _____ city _____ state _____ zip code _____

name _____ address _____ city _____ state _____ zip code _____

Add'l postage per year: Add \$1 for Canada; \$2 for all other countries outside the U.S.

N-RAMS		PREMIUM COMPONENTS		PROMS	
2102-1.50		INTRODUCTORY OFFER		8223/S123-1.95	
TTL		SCHOTTKY		CMOS	
7400	14 74123	50 74S02	25 74LS153	95 4001	16 4030 35
7402	14 74150	60 74S37	40 74LS163	150 4002	16 4040 95
7404	16 74151	60 74S85	2 00 74LS164	150 4006	90 4042 60
7410	14 74157	60 74S140	50 74LS174	150 4007	16 4044 70
7420	14 74160	75 74S172	3 50 74LS175	150 4011	16 4049 38
7427	25 74161	75 74S175	1 50 74LS193	150 4012	16 4050 38
7438	25 74163	75 74S181	3 50 74LS251	150 4013	35 4066 65
7440	14 74165	80 74S197	1 50 74LS253	150 4021	95 4068 35
7445	45 74174	75 74S257	1 50 74LS257	150 4023	16 4071 16
7450	14 74175	75	74LS258	1 50 4024	75 4073 16
7451	14 74177	70	Low Power	4025	20 4075 16
7473	22 74180	80	Schottky	4027	40 4516 95
7474	23 74181	150	74LS00	25	
7493	50 74191	100	74LS02	25	
7495	49 74192	70	74LS10	25	
74116	100 74193	70	74LS73	40	
		74198	100 74LS75	50	
			74LS151	85	

ELTRON—P O Box 2542
SUNNYVALE, CA 94087
Min Order \$10.00 Add \$1.00
P & H Calif Res add 6% Tax

CARBON FILM RESISTORS. Brand new as low as 1.7 cents. Discounts of 20%. Prompt delivery. FREE samples/specifications. COMPONENTS CENTER. Box 134P, N.Y., N.Y. 10038.

KEYBOARDS, for synthesizers, organs. Three octave, \$65. Info for interfacing with Gnome Micro-synthesizer. Brinkwood Electronics, Box 26, Sandy Spring, MD 20860.

CANADA'S LOWEST PRICED MAIL ORDER SUPPLIER
IC Sockets, Rectifiers, LEDs, TTL, CMOS, Linear, Transistors.

some typical prices include
 min-dip 741. \$.45 SN7400 \$.29 CD4002 \$.29
 CD4025 29 CD4001 29 CD4027 1.05
 SN74LS279. 1.22 SN7433 49 SN7443 93

For complete catalogue, send 25¢ for handling, or a stamped, self-addressed, 9X12 envelope to P O Box 181, Station G, Toronto, Ontario. M4M 3G7

Minicircuits Limited

50W RMS from your CB P.A. or car stereo — No modifications to set — Schematics \$3.00 ppd. Solar Electronics Enterprises. Box 778, Edmonton, Alberta, Canada T5J 2L4. U.S. Inquiries.

UNIVERSAL TTL/DTL/CMOS IC TESTER. Tests 16/14 pin ICs! Illustrated Info/Plans: \$2.00. NORTHSTAR ENGINEERING. 3617 NORTHCREDE DRIVE. CHARLESTON, WV 25302.

ELECTRONICS DESIGN NEWSLETTER

- ★ Logic Design Techniques
- ★ Digital & Linear Design Theory & Procedures
- ★ Construction Projects

Learn Design Techniques!
Write for FREE CATALOG of parts & kits!

Subscription \$6 Sample Copy \$1
VALLEY WEST Box 2119-V Sunnyvale, CA 94087

WHOLESALE C.B., Scanners, Antennas, Catalog 25 cents. Crystals Special cut. \$4.95. Monitor \$3.95. Send make, model, frequency G. Enterprises Box 461P, Clearfield, UT 84015.

COMPUTER HOBBYISTS! Bargain hunt and sell via ON.LINE. 18 issues/year — \$3.75. Free Sample. ON.LINE. 24695 Santa Cruz Hwy — Los Gatos, CA 95030.

POLICE CODE UNSCRABLERS. Fits all scanners. Satisfaction Guaranteed. Jim's Two-Way, Box 275, Hot Springs, Ark. 71901.

TV CAMERAS \$125 (new); Cartrivision front panels \$12, five heads \$12. Robert Allen, 124 Lundy Lane, Palo Alto, California 94306.

CB RADIO, Scanners, Antennas. The best for less. Free List. Capitol Sound, Box 3523, Des Moines, Iowa 50322.

YOU WANT TO BUILD IT: WE WANT TO HELP WE SELL CONSTRUCTION PLANS with an Engineering Service. TELEPHONE: Answering Machines, Speakerphones, Carphones, Phonevision, Touch Button Dialers. TELEVISION: VTR, 1" Color TV Set. PONG. \$25.00 Camera, COLOR PROJECTION TV. HOBBYIST: Electron Microscope. \$75 software programmable computer. BROADCAST: Special Effects Generator, Chroma Key, Audio Board, DA's. COURSES: Telephone Engineering \$52.00, Detective Electronics \$29.50, IC Engineering \$65.00, PLUS MUCH MORE. NEW Super Hobby Catalog PLUS year's subscription to Electronic News Letter AIR MAILED \$1.00. Don Britton Enterprises, 6200 Wilshire Blvd., Los Angeles, Calif. 90048.

SEMICONDUCTOR AND PARTS Catalogue from the semiconductor specialists. J & J Electronics, Box 1437, Winnipeg, Manitoba, Canada. U.S. Inquiries.

ELECTRONIC Ignition: Pointless, Transistor, Capacitor, Vapor inductors, Auburn Sparkplugs. Information 10 cents. Anderson Engineering, Epsom, N.H. 03234.

DESCRAMBLERS: Several Professional Models that work with all Scanners. Tone Encoders/Decoders, Scanmate, AAPP, Radar Detectors, Big Ears, Alarms, Books, Kits, parts. Catalog 25 cents: KRYSTAL KITS, Box 445, Bentonville, Ark. 72712.

NEW*FROM*VECTOR*NEW*FROM*VECTOR*NEW*FROM*VECTOR*NEW*FROM*VECTOR*NEW*FROM*VECTOR

GODBOUT

BILL GODBOUT ELECTRONICS
BOX 2355, OAKLAND AIRPORT, CA 94614

TERMS: Add 50¢ to orders under \$10. No COD. Cal res add tax. Bankamericard® / Mastercharge®. Call (415) 357-7007 anytime.

WIRE PENCIL \$9.50 This handy & time-saving tool has drawn raves from hobbyist magazines, and we have them in stock for you. With tool, instructions, 500 ft. wire.

BRAND NEW! MANUAL WRAPPER STRIPS INSULATION AND WRAPS for \$24.95. Makes top quality wraps & saves you lots of time. Add 1 lb. shp.

UNIVERSAL PROTOTYPE BOARD ➡ ➡ ➡ **\$19.95**

For Altair 8800 or homebrew computers. Accepts any DIP package; power & ground planes on opposite sides of board; on-board room for two regulators (1 heat sink provided free). Universally useful for peripherals. Add 1 lb. shipping (sockets for illustration only)

NEW*FROM*VECTOR*NEW*FROM*VECTOR*NEW*FROM*VECTOR*NEW*FROM*VECTOR*NEW*FROM*VECTOR

CIRCLE NO. 23 ON FREE INFORMATION CARD

ABOUT YOUR SUBSCRIPTION

Your subscription to POPULAR ELECTRONICS is maintained on one of the world's most modern, efficient computer systems, and if you're like 99% of our subscribers, you'll never have any reason to complain about your subscription service.

We have found that when complaints do arise, the majority of them occur because people have written their names or addresses differently at different times. For example, if your subscription were listed under "William Jones, Cedar Lane, Middletown, Arizona," and you were to renew it as "Bill Jones, Cedar Lane, Middletown, Arizona," our computer would think that two separate subscriptions were involved, and it would start sending you two copies of POPULAR ELECTRONICS each month. Other examples of combinations of names that would confuse the computer would include: John Henry Smith and Henry Smith; and Mrs. Joseph Jones and Mary Jones. Minor differences in addresses can also lead to difficulties. For example, to the computer, 100 Second St. is not the same as 100 2nd St.

So, please, when you write us about your subscription, be sure to enclose the mailing label from the cover of the magazine—or else copy your name and address exactly as they appear on the mailing label. This will greatly reduce any chance of error, and we will be able to service your request much more quickly.

For faster service

USE ZIP CODE

on all mail

DELTA ELECTRONICS CO.
P.O. BOX 2, AMESBURY, MASS. 01913
Phone (617) 388-4705

ELECTRONIC TIMER
(.5 sec to 120 sec)

A sophisticated timer used by a large camera maker for timing "Instant Pictures". Range about .5 sec to 2 min., adjustable with variable control. Operates from 3v source. Elapsed time is indicated by a small incandescent bulb, which goes on when the timer is started, off at end of time. The bulb could be replaced by a sensitive reed relay or SCR to control other equipment. Useful for all kinds of timing, security devices, etc. 2" x 2". All units tested before shipping.
STOCK NO. P6312 \$1.75 each, 4/6.00

HONEYWELL HUMIDITY CONTROLLER

Made by HONEYWELL for automatic control of humidifiers or de-humidifiers. Control range 10% RH to 60% RH, sensing by means of a nylon ribbon. Snap action switch with 240v AC contacts. Ideal for home lab, or greenhouse. 3½ x 2½ x 1½.
STOCK NO. P6263 1 lb. \$4.95 each, 3/14.00

VERSATILE POWER TRANSFORMER

This versatile power transformer has a primary tapped for 115v or 230v operation, and 4 secondaries: 34v CT @ 3 amps, 17v @ 4 amps, 11v @ 5 amps, and 6.3v @ 1.5 amps. Ideal for a +5v, 5 amps, + and - 15v supply for general lab use or computer supply, or for a stereo amplifier. 3¾" x 4½" x 4½". Shipping weight 10 lbs.
STOCK NO. P9397 \$12.95 each, 2/24.00

Send for our latest free catalog. BANKAMERICARD and MASTERCHARGE welcome; we must have ALL numbers on the card for processing. Include sufficient postage (2 lbs min); excess will be refunded. Minimum order \$5. Phone orders OK.

7400N TTL

SN7400N*	13	SN7453N	27	SN74150N	100
SN7401N	16	SN7454N	29	SN74151N	79
SN7402N	21	SN7459A	25	SN74153N	89
SN7403N	16	SN7460N	22	SN74154N	1.25
SN7404N*	16	SN7470N	45	SN74155N	99
SN7405N	24	SN7471N*	39	SN74157N	99
SN7406N	20	SN7472N	39	SN74157A	99
SN7407N	29	SN7473N*	37	SN74160N	1.25
SN7408N	25	SN7474N*	32	SN74161N	99
SN7409N	25	SN7475N*	50	SN74163N*	99
SN7410N	18	SN7476N*	50	SN74164N	1.10
SN7411N	35	SN7479N*	5.00	SN74165N	1.10
SN7412N	33	SN7480N	5.00	SN74166N	1.25
SN7413N	35	SN7482N	96	SN74167N	5.50
SN7414N	70	SN7483N	7.00	SN74170N	2.10
SN7415N	35	SN7485N	89	SN74172N	18.00
SN7417N	75	SN7486N	39	SN74173N	1.50
SN7420N	31	SN7488N	3.50	SN74174N	1.25
SN7421N	23	SN7489A	2.25	SN74175N	99
SN7422N*	49	SN7490N*	45	SN74176N	90
SN7423N	37	SN7491N	75	SN74177N	90
SN7424N	29	SN7492N	49	SN74180N	99
SN7426N	39	SN7493N*	49	SN74181N	2.49
SN7427N	27	SN7494N	79	SN74182N	99
SN7428N	42	SN7495N	79	SN74184N	1.95
SN7429N	26	SN7496N	89	SN74185N	2.20
SN7432N	31	SN7497N*	4.00	SN74186N*	5.00
SN7437N	27	SN74100N*	3.00	SN74187N	6.00
SN7438N	27	SN74107N	39	SN74190N	1.75
SN7439N	24	SN74121N*	39	SN74191N	1.19
SN7440N	15	SN74122N	39	SN74192N*	89
SN7441N	89	SN74123N*	70	SN74193N*	89
SN7442N	59	SN74125N	60	SN74194N	1.25
SN7443N	75	SN74126N	60	SN74195N	75
SN7445N	71	SN74132N	1.09	SN74196N	1.25
SN7446N	85	SN74136N	95	SN74197N	75
SN7447N*	69	SN74141N	1.15	SN74198N	1.75
SN7448N	79	SN74142N*	4.00	SN74199N	1.75
SN7450A	26	SN74143N*	4.50	SN74200N	5.59
SN7451N	66	SN74144N*	4.50	SN74207N*	90
SN7452N	27	SN74145N	1.15	SN74251N	1.79
SN7453N	27	SN74147N	2.25	SN74254N	6.00
SN7454N	27	SN74148N	2.00	SN74255N	6.00

MANY OTHERS AVAILABLE ON REQUEST
20% Discount for 100 Combined 7400's

CONSUMER ELECTRONICS

exelar



DIGITAL WATCH
This watch is manufactured by National Semiconductor. It provides 5 functions: hours, minutes, seconds, date, A.M. indicator, dot. Accuracy is assured to 5 seconds per month by precision quartz crystal. If something should go wrong with the watch, repair is assured within 48 hours after it is received. Complete with steel black leather band.

ES4-YS
3 MICRON GOLD PLATE BEZEL

\$29.95
NOT A KIT

Novus



DIGITAL ALARM CLOCK
This 4 digit Novus Alarm Clock is a very reliable and smartly styled unit. It provides such features as an alarm settable to any minute of the day, a 7 minutes snooze alarm, a power failure indicator, and even an A.M. P.M. indicator.

\$19.95
NOT A KIT

XCITON OPTO ELECTRONICS

LITRONIX MONSANTO

DISCRETE LEDS

R - RED
G - GREEN
Y - YELLOW
O - ORANGE

XC209R	5/51	XC526R	5/51	XC111R	5/51
XC209G	4/51	XC526G	4/51	XC111G	4/51
XC209Y	4/51	XC526Y	4/51	XC111Y	4/51
XC209O	4/51	XC526O	4/51	XC111O	4/51

125" dia. 185" dia. 190" dia.

200" dia. 200" dia. 085" dia.

74LS00 TTL

74LS00	39	74LS55	39	74LS151	1.55
74LS02	39	74LS73	65	74LS153	1.89
74LS03	39	74LS74	65	74LS157	1.95
74LS04	45	74LS75	70	74LS159	2.25
74LS05	45	74LS76	65	74LS163	2.25
74LS08	39	74LS83	2.19	74LS164	2.25
74LS10	39	74LS86	65	74LS181	3.89
74LS13	79	74LS90	1.25	74LS190	2.85
74LS14	2.19	74LS92	1.25	74LS191	2.85
74LS20	39	74LS93	1.25	74LS192	2.85
74LS26	49	74LS95	2.19	74LS193	2.85
74LS27	45	74LS96	1.89	74LS194	2.25
74LS28	79	74LS99	65	74LS195	2.25
74LS30	39	74LS112	65	74LS207	1.89
74LS32	45	74LS132	1.55	74LS260	55
74LS40	49	74LS136	65	74LS279	79
74LS51	39	74LS138	1.89	74LS270	5.95

DL728

The DL728 is a dual 0-5 common cathode red display. It is ideal for use with clock chips as segments are already multiplexed.

\$2.95

MINIATURE TOGGLE

DPDT	ON	OFF	NO	NC	1	2	3	4	5	6	7	8	9	10	11	12	13	14	15	16
ON	ON	OFF	NO	NC	1	2	3	4	5	6	7	8	9	10	11	12	13	14	15	16
OFF	OFF	ON	NO	NC	1	2	3	4	5	6	7	8	9	10	11	12	13	14	15	16
NO	NO	NO	ON	NC	1	2	3	4	5	6	7	8	9	10	11	12	13	14	15	16
NC	NC	NC	NC	ON	1	2	3	4	5	6	7	8	9	10	11	12	13	14	15	16

PUSH BUTTON

Model PB-123 \$2.35 \$1.95 \$1.47 \$1.30
Model PB-126 \$2.35 \$1.95 \$1.47 \$1.30

THUMBWHEEL SWITCHES

These switches are a 7 position one position rotary switch enclosed in a 1.05" case. They have a standard 8 pin configuration and will mount perfectly on printed circuit board.

\$7.99

ZENERS-DIODES-RECTIFIERS

TYPE	VOLTS	W	PRICE	TYPE	VOLTS	W	PRICE	
1N4751A	3.3	400m	4.10	1N4005*	600	PIV	1 AMP	10.00
1N751A	5.1	400m	4.10	1N4006*	800	PIV	1 AMP	10.00
1N752A	5.6	400m	4.10	1N4007*	1000	PIV	1 AMP	10.00
1N753A	6.2	400m	4.10	1N3600	50	200M	6.10	
1N754A	6.8	400m	4.10	1N4184	75	10m	2.10	
1N9658	15	400m	4.10	1N4154	35	10m	2.10	
1N9659	16	400m	4.10	1N4731	5	1w	28	
1N2324	6.2	500m	28	1N4735	6	1w	28	
1N5235	6.8	500m	28	1N4735	6	1w	28	
1N5236	7.5	500m	28	1N4735	6	1w	28	
1N4550	25	40m	6.10	1N4742	12	1w	28	
1N4551	25	40m	6.10	1N4743	12	1w	28	
1N4552	25	40m	6.10	1N4744	12	1w	28	
1N4553	25	40m	6.10	1N4745	12	1w	28	
1N4554	25	40m	6.10	1N4746	12	1w	28	
1N4555	25	40m	6.10	1N4747	12	1w	28	
1N4556	25	40m	6.10	1N4748	12	1w	28	
1N4557	25	40m	6.10	1N4749	12	1w	28	
1N4558	25	40m	6.10	1N4750	12	1w	28	
1N4559	25	40m	6.10	1N4751	12	1w	28	
1N4560	25	40m	6.10	1N4752	12	1w	28	
1N4561	25	40m	6.10	1N4753	12	1w	28	
1N4562	25	40m	6.10	1N4754	12	1w	28	
1N4563	25	40m	6.10	1N4755	12	1w	28	
1N4564	25	40m	6.10	1N4756	12	1w	28	
1N4565	25	40m	6.10	1N4757	12	1w	28	
1N4566	25	40m	6.10	1N4758	12	1w	28	
1N4567	25	40m	6.10	1N4759	12	1w	28	
1N4568	25	40m	6.10	1N4760	12	1w	28	
1N4569	25	40m	6.10	1N4761	12	1w	28	
1N4570	25	40m	6.10	1N4762	12	1w	28	
1N4571	25	40m	6.10	1N4763	12	1w	28	
1N4572	25	40m	6.10	1N4764	12	1w	28	
1N4573	25	40m	6.10	1N4765	12	1w	28	
1N4574	25	40m	6.10	1N4766	12	1w	28	
1N4575	25	40m	6.10	1N4767	12	1w	28	
1N4576	25	40m	6.10	1N4768	12	1w	28	
1N4577	25	40m	6.10	1N4769	12	1w	28	
1N4578	25	40m	6.10	1N4770	12	1w	28	
1N4579	25	40m	6.10	1N4771	12	1w	28	
1N4580	25	40m	6.10	1N4772	12	1w	28	
1N4581	25	40m	6.10	1N4773	12	1w	28	
1N4582	25	40m	6.10	1N4774	12	1w	28	
1N4583	25	40m	6.10	1N4775	12	1w	28	
1N4584	25	40m	6.10	1N4776	12	1w	28	
1N4585	25	40m	6.10	1N4777	12	1w	28	
1N4586	25	40m	6.10	1N4778	12	1w	28	
1N4587	25	40m	6.10	1N4779	12	1w	28	
1N4588	25	40m	6.10	1N4780	12	1w	28	
1N4589	25	40m	6.10	1N4781	12	1w	28	
1N4590	25	40m	6.10	1N4782	12	1w	28	
1N4591	25	40m	6.10	1N4783	12	1w	28	
1N4592	25	40m	6.10	1N4784	12	1w	28	
1N4593	25	40m	6.10	1N4785	12	1w	28	
1N4594	25	40m	6.10	1N4786	12	1w	28	
1N4595	25	40m	6.10	1N4787	12	1w	28	
1N4596	25	40m	6.10	1N4788	12	1w	28	
1N4597	25	40m	6.10	1N4789	12	1w	28	
1N4598	25	40m	6.10	1N4790	12	1w	28	
1N4599	25	40m	6.10	1N4791	12	1w	28	
1N4600	25	40m	6.10	1N4792	12	1w	28	

TRANSISTORS

2N2222	5.51	2N3055	5.51	2N4339	5.51
2N2907	5.51	2N3055	5.51	2N4340	5.51
2N2907	5.51	2N3055	5.51	2N4341	5.51
2N2907	5.51	2N3055	5.51	2N4342	5.51
2N2907	5.51	2N3055	5.51	2N4343	5.51
2N2907	5.51	2N3055	5.51	2N4344	5.51
2N2907	5.51	2N3055	5.51	2N4345	5.51
2N2907	5.51	2N3055	5.51	2N4346	5.51
2N2907	5.51	2N3055	5.51	2N4347	5.51
2N2907	5.51	2N3055	5.51	2N4348	5.51
2N2907	5.51	2N3055	5.51	2N4349	5.51
2N2907	5.51	2N3055	5.51	2N4350	5.51
2N2907	5.51	2N3055	5.51	2N4351	5.51
2N2907	5.51	2N3055	5.51	2N4352	5.51
2N2907	5.51	2N3055	5.51	2N4353	5.51
2N2907	5.51	2N3055	5.51	2N4354	5.51
2N2907	5.51	2N3055	5.51	2N4355	5.51
2N2907	5.51	2N3055	5.51	2N4356	5.51
2N2907	5.51	2N3055	5.51	2N4357	5.51
2N2907	5.51	2N3055	5.51	2N4358	5.51
2N2907	5.51	2N3055	5.51	2N4359	5.51
2N2907	5.51	2N3055	5.51	2N4360	5.51
2N2907	5.51	2N3055	5.51	2N4361	5.51
2N2907	5.51	2N3055	5.51	2N4362	5.51
2N2907	5.51	2N3055	5.51	2N4363	5.51
2N2907	5.51	2N3055	5.51	2N4364	5.51
2N2907	5.51	2N3055	5.51	2N4365	5.51
2N2907	5.51	2N3055	5.51	2N4366	5.51
2N2907	5.51	2N3055	5.51	2N4367	5.51
2N2907	5.51	2N3055	5.51	2N4368	5.51
2N2907	5.51	2N3055	5.51	2N4369	5.51
2N2907	5.51	2N3055	5.51	2N4	

SAVE ELECTRIC POWER!

Save up to 80% electrical power with this unique, inexpensive, portable, permanent and legal method applicable for shops, homes, factories, businesses, farms, sites. 100% Refund Guaranteed if not scientifically sound or if it employs gimmicks.

Information \$1.00

CONSUMERTRONICS CO.

P.O. Box 542E Alamogordo, N.M. 88310

RADIO REMOTE CONTROLS. Door Openers, Alarms, etc. Receivers \$29.95; Transmitters \$13.95. Chasco, 9124 Tripp, Skokie, Illinois 60076.

ELECTRONIC IGNITIONS — Mark 10B — \$36.95. Tri-Star SST — \$28.95. 500 — \$33.95. Fire-Smoke Detector \$29.95. Pace CB 133 \$99.95. SBE 23 CB \$72.95. G.E.E. Sales, 12525 SE 188 Pl., Renton, WA 98055.

COMPUTER 8 BIT Complete (assembled) \$198.00. Details \$1.00. Refundable Nibot Enterprises, Box 2103, Escondido, CA 92025.

SUPREME Television-Radio Diagram Servicing manuals discounted 50%. Information Supreme Publications, 1760 Balsam, Highland Park, Illinois 60035.

LOADS OF JUNE GOODIES — 100 1% precision resistors/\$1 — 100 mica capacitors/\$1 — 1/4 lb. semiconductors \$1 — 75 1/2W carbon resistors/\$1 — DL 707/95 cents — 7400, 7402/10 cents — transistors, IC's, zeners, optoelectronics, pots, pilot lamps, solar cells, kits, assortments WOW! Catalog 25 cents. DIAMONDBACK ENGINEERING, PO Box 194, Spring Valley, Ill. 61362.

YOUR CB HANDLE and sign engraved. Woodgrain color 1X3" panel. \$1.75. 2/\$3. Reelway, Box 793-E, Mattoon, Illinois 61938.

ALTAIR 8800 Assembled and working for sale. W/4k RAM + 1k board w/256 bytes. W/BASIC and assembler. Home built cabinet and power supply. \$700 or best offer. Charles Skeldon, 5753 27th Ave., So., Mpls., Minn. 55417.

Etcetera, etcetera

COMPUTER SYSTEM

Multiprocessor design allows 8080/8080 F8/6502 G othersto work together, share memory 1K RAM 1 Proc essor basic systems with ROM Power Cabinet Display ITTY interfaces under \$500. Many options. Electronic Tool Co., 4736 W. El Segundo Blvd., Hawthorne, CA 90250

OSCILLOSCOPES, Signal Generators and other test equipment for sale. Free information. American Calibration Services, Box 8104, Athens, Georgia 30601.

PROGRAMMING — Octal Calculator: \$14.95. Hexadecimal Calculator: \$35.95. Literature free. Radix Precision, Box 13861-PE, Atlanta, Georgia 30324.

BUILD YOUR OWN SPEAKERS AND SAVE UP TO 50%



You can assemble your own high quality multi-element stereo speakers in a few hours and save up to half the cost of comparable speakers. Send for our free 32 page catalogue of speaker kits, raw speakers and accessories.

SPEAKERLAB
Dept. PE 8, 5500-35th N.E.
Seattle, Washington 98105

ALTAIR 8800 & IMSAI 8080 Plug-ins 8K Static Memory, exceptionally low power fast no wait states or refresh Prototyping Board Extender Card 8800 Octal Encoder IC Sockets Microprocessor Coding Pads low prices. ELECTRONIC CONTROL TECHNOLOGY Box 6, Union, N.J. 07083.

PC BOARDS \$10.00 less than 5x7" 200 holes. \$15.00 less than 8x10" 300 holes. 062 Glass Epoxy. Send 2/1 or 1/1 artwork turn-around 5 days ARO add \$5.00 for 24hr. Check or money order plus \$1.00 for shipping. KNOL ENTERPRISES, P.O. Box 402, San Luis Obispo, CA 93401.

WHY RENT EXTENSION TELEPHONES? Save hundreds of dollars by connecting your own legally New FCC ruling eliminates monthly rentals completely. Details \$1.00. QVTS, Box 29002-R, Queens Village, NY 11429.

ELECTRONIC Voltage Regulator for your car. Free information. W.J. Prudhomme, 1405 Richland, Metairie, LA 70001.

STOP C.B. tape deck rip-offs with Shur-Lok. Can't be picked or pried. Free information. Pruitt Enterprises, Box 41P5, Tonopah, Nevada 89049.

T.V. GAMES LSI Chip Plays 8 exciting games with wound and score. One to four players. Plugs straight into your T.V. Antenna socket. Full constructional Data included. Cost including Postage 1 to 10 Chips \$40 each. 11 to 50 Chips \$30.51 plus on application. Orders with Money Order or Cash to Television Sports Ltd, 6 Half Moon Street, Mayfair, London, England W1Y 7RA.

AUDIO PROGRAM CONTROL CENTER



\$19.95 PPD USA
10 inputs, 4 outputs. Switch TV, Short-Wave, Ham, FM to Stereo Amplifier & Recorder. Listen & Record.

POWERCOM CORPORATION

Box 454 Dept 4 Troy, N.Y. USA 12181

NEW ADJUSTABLE THREE OUTPUT REGULATED POWER SUPPLY, plus 900 parts worth \$400.00 list. Solid state CARTRIVISION television recorder electronic unit. Schematics, parts cross reference. HEATHKIT television transistor substitutions. Power CB radios, MICRO-PROCESSORS \$17.95 plus \$3.50 S&H USA. Free Brochure. MADISON ELECTRONICS COMPANY INCORPORATED, Box 369, D55, Madison, Alabama 35758.

BUILD YOUR OWN TV CAMERA!

— Ideal for home & business —

THE ECONOMIC ANSWER TO HOME MONITORING OF NURSERIES, ENTRANCES, DRIVEWAYS... BUSINESS and INDUSTRIAL SECURITY... TV... AMATEUR TV PLUS SO MANY OTHER APPLICATIONS: MODEL IT-1A, SERIES D - KIT FORM SING ASSEMBLED \$275. SOLID-STATE. WORKS ON ANY TV SET. OPTIONAL SOUND KIT \$28.95. PHONE or WRITE for catalog. Dial 482-987-3771

1301 BROADWAY ATV Research DAKOTA CITY, NE 68721

FREE! Catalog of Audio Equipment. Great prices on Sansui, Pioneer, Sony, Akai, and more G L M Appliances. Dept. K, 82 East Old Country Road, Hicksville, New York 11801.

LINEAR AMPLIFIER for C.B. Walkie-Talkie. Tiny Solid-State Portable Unit produces 100 Watt PEP from Milli-watts and can be inserted inside existing unit. Build for about \$20. Send \$5.00 for plans to: J. Martin Peter, P.O. Box 07071, Milwaukee, WI 53207.

Send for your information packet today — which also includes circuit functions, component line-up, and accessories. Information Packet \$1.00 (refundable with order).

visulex P.O. Box 4204P Mountain View, CA 94040

PLANS—Video Pong \$2.00 Laser \$2.00. Projection TV \$2.00. Catalog 50 cents. Technologic, Box 5262, Orchard Lake, Michigan 48033.

EDLIE'S BARGAIN BONANZA

ONLY HIGHEST QUALITY PRODUCTS



(CP017) COPPER CLAD BOARDS!
Copper on one side, 1/16" thick. Excellent quality for either production or experimental work.
B) 4" x 16 1/2" \$9c ea. 3/\$2.69
D) 8" x 16 1/2" \$1.19 ea. 3/\$2.99
E) 6 3/4" x 17 1/2" \$1.19 ea. 3/\$2.99

JUST ARRIVED

Copper on both sides. 1/16" thick. Size 12" x 18"

(CP018) \$1.99 ea. 3/\$4.99

(CP134) 8 ROTARY SWITCHES
Some multiple gang. \$1.00

(CP128) 13 MINIATURE ELECTROLYTIC CAPACITORS \$1.00
Axial & upright, popular values.

(CP144) TRANSISTOR REPAIR KIT \$1.19
Various parts used to repair transistorized devices.

(CP336) TO-3 TRANSISTOR SOCKETS 12 for \$1.00

(CP298) 1 WATT ZENERS 60c
Available in 5V, 9.1V, 12V, 20V.

(CP164) 4 ROLLS OF WIRE \$1.00
Approx 25 ft. per roll, 20-28ga.

(CP140) TAPE RECORDER SPARE PARTS KIT \$2.95
Parts for repairing most tape recorders: capacitors, meter, pilot lamp, jacks, and MUCH MORE.

(CP167) 10 MINIATURE POTENTIOMETERS \$1.00

(CP182) 2 MISC. METERS \$1.00
Miniature.

(CP156) 60 DISC CAPACITORS \$1.00
Asst. from .0001 to .1, most 600v, 25U, NPO, N750, etc.

SURPLUS TUBES

All guaranteed for 1 full year.
ANY 3 FOR \$1.25

Acquired from U.S. Defense depots or removed from equipment (new and used). These are laboratory tested and guaranteed for one full year. Most are of such standard makes as RCA, GE, etc.

- | | | | |
|------|------|------|-------|
| 3A3 | 6AQ7 | 6CM7 | 6X4 |
| 3AF4 | 6AT6 | 6DE4 | 10EW7 |
| 3BN6 | 6AU6 | 6DR7 | 12AE7 |
| 3DG4 | 6AV6 | 6DW4 | 12AL5 |
| 3KT6 | 6AX4 | 6EB8 | 12AU7 |
| 3Q4 | 6AX5 | 6EM7 | 12AV6 |
| 4BC5 | 6AY3 | 6GF7 | 12BE6 |
| 4BN6 | 6BA6 | 6GH8 | 12BH7 |
| 4BU8 | 6BG6 | 6K6 | 18FW6 |
| 4BZ7 | 6BJ8 | 6K11 | 25L6 |
| 5V6 | 6BQ6 | 6LB6 | 35EH5 |
| 6AF4 | 6BZ6 | 6SN7 | 36AM3 |
| 6AG5 | 6CB6 | 6T8 | 50A5 |
| 6AG7 | 6CG7 | 6W4 | 50L6 |

(CP147) 4 lb. GRAB BAG SPECIAL

Full of exotic and exciting electronics parts

(CP155) TUBE BONANZA! \$1.00
20 asst. popular tubes, untested.

(CP142) 50 PRECISION RESISTORS \$1.00
All 1%, 1/2w and 1w. low and high ohmages.

(CP150) 15 HI-FI KNOBS \$1.00
Every one superb! Purchased from Harmon, Kardon, Fisher, etc.

(CP102) CALCULATOR KEYBOARD \$2.95
Wild Rover C-1380. Can be used with CT5001. 4 function, clear, clear entry and constant. 7 cm x 9 cm.

(CP175) 70 1/2w CARBON RESISTORS \$1.00
Asst. values. Some 5%.

(CP154) 150 CUT LEAD RESISTORS \$1.00
Carbon, all leads long enough for soldering.

(CP149) 20 POLYSTYRENE TOP GRADE CAPACITORS \$1.00

(CP132) 20 DUAL POTS \$1.00

24V. C.T. FILAMENT TRANSFORMER 1/2A. WITH 150V. TAP.
(CP202) 99c ea 6 for \$4.99

MONEY BACK GUARANTEE
Terms: Minimum order \$4.00. Include postage. Either full payment with order or 20% deposit, balance C.O.D.

BONUS FREE CAPACITOR KIT With Every \$5 Purchase

WRITE FOR FREE 1976 VALUE PACKED CATALOG
Listing thousands of components, tubes, transistors, IC's, kits, test equipment.

THIS MONTH'S SPECIALS!

- TTL**
- | | | | |
|-------------------------------|--------|--------------------------------|-----|
| <input type="checkbox"/> 7400 | 16c | <input type="checkbox"/> 7446 | 80c |
| <input type="checkbox"/> 7401 | 18c | <input type="checkbox"/> 7447 | 80c |
| <input type="checkbox"/> 7402 | 22c | <input type="checkbox"/> 7448 | 80c |
| <input type="checkbox"/> 7403 | 23c | <input type="checkbox"/> 7473 | 49c |
| <input type="checkbox"/> 7404 | 23c | <input type="checkbox"/> 7474 | 49c |
| <input type="checkbox"/> 7405 | 23c | <input type="checkbox"/> 7475 | 55c |
| <input type="checkbox"/> 7406 | 23c | <input type="checkbox"/> 7476 | 83c |
| <input type="checkbox"/> 7410 | 23c | <input type="checkbox"/> 7490 | 79c |
| <input type="checkbox"/> 7411 | 27c | <input type="checkbox"/> 7492 | 79c |
| <input type="checkbox"/> 7413 | 40c | <input type="checkbox"/> 7493 | 69c |
| <input type="checkbox"/> 7420 | 23c | <input type="checkbox"/> 7495 | 79c |
| <input type="checkbox"/> 7430 | 23c | <input type="checkbox"/> 74121 | 57c |
| <input type="checkbox"/> 7440 | 30c | <input type="checkbox"/> 74122 | 57c |
| <input type="checkbox"/> 7442 | \$1.12 | <input type="checkbox"/> 74123 | 67c |

- LINEARS**
- | | | |
|---------------------------------|---------------|--------|
| <input type="checkbox"/> LM309K | 5v 1a. reg. | \$1.15 |
| <input type="checkbox"/> 555 | Timer | 75c |
| <input type="checkbox"/> 556 | Dual 555 | \$1.00 |
| <input type="checkbox"/> 566 | Function gen. | \$1.75 |
| <input type="checkbox"/> 567 | Tone decoder | \$1.95 |
| <input type="checkbox"/> 741 | comp. op amp | 39c |
| <input type="checkbox"/> 2102 | 1024 bit RAM | \$4.95 |
| <input type="checkbox"/> 8038 | volt cont osc | \$4.25 |

CLOCK CHIPS WITH DATA

<input type="checkbox"/> (MM5314)	6 dig clock	\$4.95
<input type="checkbox"/> CT7001	Alarm & Date	\$5.95

LED'S

<input type="checkbox"/> (CP223)	10 Asst LEDs	\$1.00
<input type="checkbox"/> (CP242)	5 Jumbo Green LEDs	\$1.00
<input type="checkbox"/> (CP242)	5 Med Yellow LEDs	\$1.00
<input type="checkbox"/> (CP001)	5 Jumbo Red LEDs	\$1.00
<input type="checkbox"/> (CP011)	5 Med Red LEDs	\$1.00
<input type="checkbox"/> (CP012)	5 Mini Red LEDs	\$1.00
<input type="checkbox"/> (CP293)	DL707 (equiv.) 7 seg red LED, 3" char., comm anode	\$1.00
<input type="checkbox"/> (CP006)	DL 704 (equiv.) same as DL707 except comm cath	\$1.35
<input type="checkbox"/> (CP007)	DL747 7 seg red LED, 6" char., comm anode	\$1.95
<input type="checkbox"/> (CP013)	MAN 5 (equiv.) 7 seg green LED, .27 char., comm. anode	\$1.49

IC BREADBOARDS & TERMINALS
Boards have .042 holes. Made of 1/16" polyester glass.

- | | | |
|----------------------------------|---------|--------|
| <input type="checkbox"/> (BB663) | 3" x 4" | 94c |
| <input type="checkbox"/> (BB664) | 3" x 6" | \$1.29 |
| <input type="checkbox"/> (BB665) | 4" x 6" | \$1.65 |
| <input type="checkbox"/> (BB666) | 4" x 8" | \$2.12 |
- Push-in terminals.
- | | | |
|---------------------------------------|-----|------------|
| <input type="checkbox"/> (CP6601-20) | pkg | 20/90c |
| <input type="checkbox"/> (CP6601-100) | pkg | 100/\$2.98 |
- Push-in flanged pins
- | | | |
|---------------------------------------|-----|------------|
| <input type="checkbox"/> (BB6602-20) | pkg | 20/90c |
| <input type="checkbox"/> (BB6602-100) | pkg | 100/\$2.98 |
- Push-in flea clips
- | | | |
|---------------------------------------|-----|------------|
| <input type="checkbox"/> (BB6603-20) | pkg | 20/90c |
| <input type="checkbox"/> (BB6603-100) | pkg | 100/\$2.98 |
- (B008)** 14 pin DIP sockets 3 for \$1
- (CP1104) IC REMOVAL AND INSERTION TOOL** \$4.95
"Pul-n-tertic" extracts and inserts IC's without damage.

REED RELAYS

<input type="checkbox"/> (CP203)	SPST, 12V, 1000 ohms coil.	Price 79c
<input type="checkbox"/> (CP204)	DPDT, 12V, 500 ohm coil.	Price 99c



S. D. SALES CO.

P. O. BOX 28810 DALLAS, TEXAS 75228

ALARM CLOCK KIT SIX DIGIT LED

Thousands of hobbyists have bought and built our original clock kit and were completely satisfied. But we have received many requests for an alarm clock kit with the same value and quality that you have come to expect from S.D. So, here it is!

THE KIT INCLUDES:

- 1 Mostek 50252 Alarm Clock Chip
- 6 Hewlett Packard .30 in. common cathode readouts.
- 15 NPN Driver Transistors
- 1 Etched and Drilled P.C. Board set
- 1 Step Down Transformer
- 2 Switches for time set
- 2 Slide Switches for alarm set and enable
- 1 Filter Cap
- 4 IN4002 Rectifiers
- 1 IN914 Diode
- 1 .01 Disc Cap
- 15 Resistors
- 1 Speaker for alarm
- 1 LED lamp for PM indicator.

\$16.50
(COMPLETE KIT)

Why pay **MORE MONEY** for our competitor's clock that has **LESS DIGITS** that are **SMALLER** in size?

Please take note that we use only first run parts in our kits and include ALL the necessary parts. Not like some of our competitors who use retested readouts and chips or who may not even include switches in their kits.

60 Hz. Crystal Time Base

FOR DIGITAL CLOCKS

\$5.95

S. D. SALES EXCLUSIVE!

The kit you have been waiting for is here **NOW**, and at an unbelievable price! Thanks to S.D. Sales you can turn that digital clock of yours into a superbly accurate, DC operated, time piece.

KIT FEATURES:

- A. 60 Hz output with accuracy comparable to a digital watch.
- B. Directly interfaces with all MOS clock chips.
- C. Super low power consumption (1.5 Ma typ.)
- D. Uses latest MOS 17 stage divider IC.
- E. Eliminates forever the problem of AC line glitches.
- F. Perfect for cars, boats, campers, or even for portable clocks at ham field days.
- G. Small size, can be used in existing enclosures.

BUY TWO FOR \$10.00

Kit includes crystal, divider IC, P.C. Board plus all other necessary parts and specs.

ORDERS OVER \$15 CHOOSE

\$1 FREE MERCHANDISE

2102 1K RAM's - 8 FOR \$12.95

New units _____ We bought a load on a super deal, hence this fantastic price.
Units tested for 500NS Speed.

MOTOROLA RTL IC'S

Brand new, factory prime. Hard to find, but still used in a variety of projects. (See the RTL Cookbook by Howard W. Sams.)

MC724P-59c	MC780P-89c	MC791P-69c
MC725P-59c	MC785P-49c	MC792P-59c
MC764P-49c	MC787P-89c	MC799P-59c
MC767P-69c	MC788P-49c	MC9704P-89c
MC771P-49c	MC789P-59c	MC9709P-69c
MC775P-89c	MC790P-89c	MC9760P-69c

MV-50 TYPE LED's

by LITRONIX
10 for \$1
Factory Prime!

3 DIGIT LED ARRAY - 75c

by LITRONIX
DL33MMB. 3 MAN-3 Size Readouts in one package. These are factory prime, not retested rejects as sold by others. compare this price! 75c 3 for \$2.

SALE ON CUT LEAD SEMICONDUCTORS

Leads were cut for PCB insertion. Still very useable.

1N914/1N4148	100/\$2
1N4002 1 Amp 100 PIV	40/\$1
1N4745A 16V 1W Zener	20/\$1
EN2222 NPN Transistor	25/\$1
EN2907 PNP Transistor	25/\$1
2N3904 NPN Driver Xstr.	25/\$1
2N3392 GE Pre-amp Xstr.	25/\$1
C103Y SCR 800MA. 60V.	10/\$1

**ALL NEW.
UNUSED.
SOME ARE
HOUSE #**

SLIDE SWITCH ASSORTMENT

Our best seller. Includes miniature and standard sizes, single and multi-position units. All new, first quality, name brand switches. Try one package and you'll reorder more. Special - 12 for \$1 (Assortment)



DISC CAP ASSORTMENT

PC leads. At least 10 different values. Includes .001, .01, .05, plus other standard values.
60 FOR \$1



UPRIGHT ELECTROLYTIC CAPS

47 mid 35V-10/\$1 68 mid 25V-8/\$1
Brand new by Sprague. PC leads.

RESISTOR ASSORTMENT

1/4 W 5% and 10% . PC leads.
A good mix of values. 200/\$2



1000 MFD FILTER CAPS

Rated 35 WVDC. Upright style with P.C. leads. Most popular value for hobbyists. Compare at up to \$1.19 each from franchise type electronic parts stores. S.D. Special 4 for \$1



FAIRCHILD BIG LED READOUTS

A big .50 inch easy to read character. Now available in either common anode or common cathode. Take your pick. Super low current drain, only 5 MA per segment typical.

FND - 510	Common Anode	YOUR CHOICE \$1.50 ea. 6 for \$7.50
FND - 503	Common Cathode	

DUAL 741C (5558) OP AMPS

Mini dip. New house numbered units by RAYTHEON.
4 FOR \$1

FET'S BY TEXAS INSTRUMENTS - SPECIAL 5 for \$1
#TIS-75 but with an internal house number. TO-92 plastic case. N. Channel. Junction type FET.

We do not sell junk. Money back guarantee on every item. No C.O.D. Texas Res. add 5% tax. Postage rates went up 30%! Please add 5% of your total order to help cover shipping.

S. D. SALES CO.

P. O. BOX 28810
DALLAS, TEXAS 75228

ORDERS UNDER \$10
ADD 75c HANDLING.

--- E --- G
--- E ---

CIRCLE NO. 50 ON FREE INFORMATION CARD

FND 807 cathode.
FND 800 anode.



.8 in. High. The Best on the market. Ideal for large readout application. \$4.95

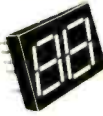

DL727
One of our best readouts .5 in. high, 20mA per segment. Common anode. \$3.75



DL33
If you like an array of displays, we have it! Common cathode. \$1.45

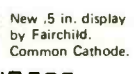

New .5 in. display by Fairchild. Common Cathode. \$1.60 \$5/7.50



DL707
Red, .30 in. high 15mA per segment. Common anode.... \$1.25



HP7730
.33 in. high red very bright 25mA per seg. Common anode. \$1.25

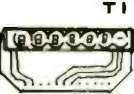

TI
Fully multiplexed common cathode. Goldplated. Ideal for mini 6 digit clock. \$1.30



Why not make a clock in 3 diff. colors. .27 in. high Common anode. \$1.25



BURROUGHS 12 DIGIT
.25 in. high orange digit. 160V dc. Free socket. \$2.50



LEDS
Mini red .12
Jumbo red .15
Jumbo green .20
Jumbo yellow .25

4 & 6 DIGIT PC BOARDS

- PC Board for 4 digit display FND 800 or 807 \$2.75
- PC Board for 6 digit display FND 800 or 807 \$3.50
- PC Board for 4 digit display MAN series or DL707 \$1.75
- PC Board for 6 digit display MAN series or DL707 \$2.25
- PC Board for 4 digit display FND503 \$2.00
- PC Board for 6 digit display FND503 \$3.00
- PC Board for 4 digit display DL747 \$2.50
- PC Board for 6 digit display DL747 \$3.00
- PC Board for 4 digit display DL727 \$2.25
- PC Board for 6 digit display DL727 \$3.00
- PC Board for 4 digit display FND70 \$1.75



All PC display boards are multiplexed for adding additional digits.

TRANSISTORS-DIODES

- RCA200V 115W TOS NPN 1.25
- GE D40C1 NPN Darl. 0.25
- 2N4443SCR 400V/8A T0220 0.65
- 2N2222 NPN Gen. Ampl. 0.20
- 2N3904 NPN Driver 0.15
- 2N3906 PNP Compl. 2N3904 0.15
- 2N4400 NPN Low level noise 0.20
- 2N5401 PNP Nixie driver 0.25
- 1N4004 400PIV 15 for 1.00
- 1N4007 400PIV 10 for 1.00
- 1N746 3.3 Zen. 4 for 1.00
- 1N4148 Switch 20 for 1.00

GE TRANSISTOR ASSORTMENT

- T098 case Darling., SCRs, NPN,PNP, etc.
- 50 for \$0.95
- 100 for \$1.75
- 300 for \$5.00

TTL BOARDS

MEMOREX computer boards with TTL's Diodes and Transistors, etc.
5 Boards containing 150-250 IC's. \$3.95

THE KING OF ALTAJ

INTRODUCING: DELILA APPLIANCE STARTER



OPERATION: \$9.95

(Example) Set your alarm for 7: a.m., set timer for 15 min. At exactly 7: a.m., the appliance will start; at 7:15, your clock alarm will wake you.

Kit includes all components, PC Board and instructions for interfacing with THE KING 6-digit alarm clock. Addition Number 2

FATIMA \$19.95 4-DIGIT TEMP. KIT

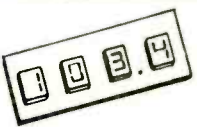

Features 4-digit temperature display; farenheit or Centigrade; complete C-Mos application; uses 7002 4-digit counter.

Kit includes all components, PC Board and instructions for interfacing with THE KING 6 digit alarm clock. Addition Number 1

THE KING 6-DIGIT ALARM CLOCK



\$23.50

THE KING FEATURES:

- 1) 6 digit, 12 hr. 60 cycle or 24 hr. 50 cycle alarm clock.
- 2) Time sharing capability for display of additional information.
- 3) Single 12v. supply and a minimum of interface components
- 4) AM-PM and automatic power failure indications
- 5) 10 minute snooze
- 6) Intensity control of LEDs.

- Kit No. 70250-1R (Red readout)
- Kit No. 70250-1G (Green readout)
- Kit No. 70250-1Y (Yellow readout)
- Kit No. 70250-2R (DL727 readout)... \$28.50
- Kit No. 70250-3R (FND807 readout)... \$29.50

All kits include components, PC Boards, Transformer, case, and construction manual.

TTL

7400	-16	7483	-85
7402	-16	7490	-69
7404	-16	7492	-75
7406	-24	7493	-75
7408	-16	7495	-75
7410	-16	7496	-75
7413	-49	74121	-38
7420	-16	74123	-75
7427	-24	74151	-75
7430	-16	74153	-89
7437	-39	74154	-95
7438	-35	74161	-99
7440	-16	74163	-119
7442	-69	74164	-169
7447	-89	74165	-149
7448	-89	74174	-129
7453	-16	74175	-139
7473	-37	74181	-275
7474	-37	74192	-125
7475	-65	74193	-125
7476	-39	74195	-79
		74197	-79

CMOS

4000	-24	4026	-149
4001	-24	4027	-59
4002	-24	4028	-99
4006	-149	4029	-139
4007	-24	4030	-49
4008	-115	4032	-24
4009	-59	4033	-149
4010	-55	4034	-325
4011	-24	4035	-139
4012	-24	4037	-450
4013	-59	4040	-159
4014	-149	4041	-89
4015	-119	4042	-79
4016	-59	4043	-80
4017	-129	4044	-59
4018	-149	4047	-59
4019	-59	4049	-59
4020	-159	4050	-55
4021	-149	4066	-99
4022	-119	4077	-39
4023	-24	74C92	-29
4024	-99	74C04	-29
4025	-24	74C107	1.29

LSI INTEGRATION

MM5316	-4-6 digit alarm clock 40 pin dip w/spec.....	\$ 4.25
7002	-4 digit counter/latch decoder, 7 segment and BCD outputs. 28 pin dip w/spec.....	\$12.50
7005	-4 digit counter/latch decoder, 7 segment output only. 24 pin dip w/spec.....	\$ 9.50
7007	-4 digit counter/latch decoder with BCD output only. 16 pin dip w/spec.....	\$ 7.00
70250	-4-6 digit alarm clock 28 pin dip w/spec.....	\$ 5.50
PC Board for 70250.....		\$ 4.25
70380	-4 digit non-multiplexed radio alarm clock featuring direct drive display output 40 pin dip w/spec.....	\$3.50
PC Board for 70380.....		\$ 3.75
8008	-8 bit parallel CPU.....	\$19.50
2102	-1K static RAM for 8008.....	\$ 2.25
MM5203	-2K UV erasable PROM.....	\$12.25
75491	-segment driver.....	\$ 0.35
75492	-digit driver.....	\$ 0.45
7020	-6 function calculator chip with direct segment drive. 8 digit.....	\$ 2.25

\$\$\$ SAVE! 4-DIGIT ALARM CLOCK



KIT NO. 1 \$13.95 (with PC Board)

FEATURES:

Direct drive display outputs, *Current control regulation-on chip, *Low power brightness control-on chip, *RFI eliminating stopwup circuitry, *Sleep radio feature, *24 hour snooze alarm, *Independent digit setting, *Non multiplexed output circuitry. 12VAC CT 1/2 amp transformer for Kit No. 1

*KIT NO. 2

Complete kit with components, PC Board, Transformer, wood grain case, and filter for display window. Includes .25 in. readouts. \$21.50



*KIT NO. 3

Complete kit with components, PC Board, Transformer, wood grain case, and filter for display window. Includes 5 inch readouts. \$22.50

*Components for Kit No. 2 or Kit No. 3 sleep radio feature, add \$.95



Proto Board \$19.95
(Complete Kit)
(Allow 2 weeks for delivery)

We now offer a full line of Continental Specialties Proto Boards, Clips, Monitors, etc.

LOOK!

From Altaj to you, a special offer.

Power Supply Kit; 5 Volt 1 Amp. Reg. Line regulation .005% Load regulation 50mV

Kit includes Components, PC board, Transf., Fuse, Pilot Light
Nothing else to buy: \$5.50

GOT A CASE? HERE'S THE CURE!

Ideal for Frequency counter case, function generator, etc. Overall height 4", length 12", width 7 1/2".

(Includes top, bottom, and hardware.)

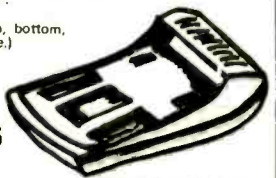

\$5.95

MASTER II

LIGHTS MUSIC 60 WATT COLOR ORGAN

Completely self contained unit with 120 volt power cord included. \$1.50

ALTAJ ELECTRONICS

P.O. BOX 38544, Dallas, Texas 75238
TERMS: Check or money order. No COD.
Telephone (214) 278-3561
Texas Residents Add 5%

MSI

Wise move



MODULAR SCIENTIFIC INSTRUMENTATION

Now you can build some of the most advanced digital electronic instruments with our new series of low-cost modular scientific kits. These kits will expand the range of your electronic applications enormously—and all at a surprisingly low cost.

The heart of the system is our 4-digit Decade Counter (Kit 012) which features a full 4-digit LED readout (you choose the size best suited to your application). Combine this with a 5-volt regulated power supply (Kit 030) and you have the basis of a wide range of sophisticated electronic instruments, including:

A Digital Voltmeter (DVM) .. Kit 012 + Kit 030 + Kit 017
Frequency Counter..... Kit 012 + Kit 030 + Kit 016
RPM Counter..... Kit 012 + Kit 030 + Kit 020 + Kit 018



4-DIGIT DECADE COUNTER KIT \$19.95 KIT 012

One chip 4 digit decade counter kit, with both 7 segment and BCD output.

1. Chip features internal oscillator for scanning speed.
2. Overflow and count extent outputs.
3. Transfer, reset, count, blanking and true compliment control inputs.
4. PC Boards can be cascaded to 8-12-16, etc. digits.
5. Kit includes counter chip, drive circuit for 4 cathode type displays and PC Board. (For read-out board see (FND70-FND503))



KIT 016 FREQ. COUNTER

Features FET input front end with trigger circuit for measuring complex waveforms. Measures from 0.1Hz to 10MHz when used with Kit 015 or 019. Measures from .01Hz to 35MHz when used with Kit 013 and 014. **\$24.50**

KIT 017 DVM

1.999V as basic, with polarity indication. 1 M ohm input impedance and accuracy to 1% if properly adjusted **\$13.50**

KIT 020 RPM COUNTER

Counts from 1 to 100,000 RPM. RPM counter kit contains components and PC board. **\$8.95**

KIT 030 POWER SUPPLY

*Input voltage: 25V max. *Output current: 1 amp max.
*Load regulation: 50mV. *Output voltage: 5V. *Line regulation: .01%. (requires 8-20V transformer) **\$4.55**

(Contains all parts except transformer)

TIME BASES

1 Mhz crystal chain time base divider. Outputs: 1Mhz-100Khz-10Khz-1Khz-100Hz-10Hz-1Hz-0.1Hz. Accuracy better than .005% with proper adjustment.

Kit 013 complete CMOS with PC board **\$15.75**
Buffer Circuit for TTL Interfacing

Kit 014 Same as Kit 013, but with TTL..... **\$13.75**

Kit 015 50Hz or 60Hz chain time base using line frequency as reference. Accuracy 0.1-0.05%. Outputs 10Hz 1Hz-0.1Hz. Complete with CMOS shaping circuit and PC Board..... **\$9.75**

Kit 019 Same as Kit 015, but with TTL and 60Hz only..... **\$7.75**

Kit 018 60Hz chain time base using line frequency for Kit 020 RPM counter.

*Outputs: .6 sec. = 100th of RPM
6 sec. = 10th of RPM
60 sec. = full revolution

\$9.75

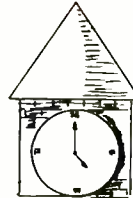

MORE TO COME

Watch this space in future issues for additional kits, including Multimeter, Timer, Capacitance Meter, Thermometer and many more. With our kits and your imagination, you'll find dozens of new and exciting applications.

ALTAJ ELECTRONICS

P. O. Box 38544, Dallas, Texas 75238

TERMS - Check or money order. No COD.

Telephone (214) 278-3561

Texas Residents Add 5%

MSI CLUB

Send for your membership card to the Modular Scientific Instrumentation Club and receive a big 10% off on future purchases of M.S.I. kits. Send \$3.00 with your name and address. We will promptly send you your very own registered membership card. Don't miss out on the savings. Write now.

Memberships valid for one year from date of registration.

NEW MANAGEMENT!

- Free Postage
- No Minimum Order
- 48 Hour Service
- 24 Hour Phone Service



WE ARE EAGER TO SERVE YOU!

CIRCLE NO. 68 ON FREE INFORMATION CARD

FREE Catalog Ultrasonic Devices, LEDs, Transistors, IC's, Strobe Lights, UARTS, Memories, Digital Thermometers, Unique Components Chaney S, Box 15431, Lakewood, Colo 80215

TV TECHNICIANS, SERVICEMEN, HOBBYISTS - Vista Model 740 Digital Crosshatch Generator Compact crystal divider for lowest-priced ultra-stable 5x7 crosshatch or 56 dot patterns AC powered \$31.95 complete kit; \$41.95 assembled Postpaid in USA, Canada. Information available free. Photolum Corporation, Dept. PE-66, 118 East 28th Street, New York, New York 10016.

TV-GAMES, construction plans Pong series - 5 game set \$5.00, big 12 game set \$12.00. Jaws-2 and Space Race - both games for \$8.00. ANTI-AIRCRAFT 1 & 2 - both for \$8.00. Full description and specs - \$1.00. ADVANCED ELECTRONICS, P.O. Box 1128, Cupertino, Calif 95014.

AUDIO POWER Amplifier assemblies 50W - \$35, 100W - \$50. Details 25 cents Progressive Sound Engineering, 357 Richfield No. 16, San Jose, Calif 95129

BURGLAR-PROOF, one way slotted, chromium plated steel screws, install with regular screwdriver, price sheets, send 26 cents in stamps. Fastening Products, Box 151, Cheltenham, PA 19012

GOVERNMENT SURPLUS

MANUALS for Govt Surplus radios, test sets, scopes List 50 cents (coin). Books, 7218 Roanne Drive Washington, D.C. 20021.

JEEPS, TRUCKS, Typically From \$52.40 Automobiles, Boats, Motorcycles, Airplanes, Oscilloscopes, Tools, Clothing, Sports, Camping, Photographic, Electronics Equipment 200,000 Bid Bargains Nationwide Direct From Government Low as 2 cents on Dollar! Surplus Catalog and Sales Directory \$1.00 (refundable first order). National Surplus Center, 240 Eastcass-PEL, Joliet, IL 60432

GOVERNMENT SURPLUS Buy in your area How, Where Send \$2.00 Surplus, 30177-PE Headquarters Building, Washington, D.C. 20014

SURPLUS ELECTRONIC EQUIPMENT, government and manufacturers' Grab Box Assortment - diverse, useful new and used parts, assemblies, etc Carton packed 50 lbs. \$6.00; 100 lbs. \$10.00 F O B Lima. Send for BIG Free Catalog! Fair Radio, Box 1105-E, Lima, Ohio 45802



WORLD'S SMALLEST RECHARGEABLE CALCULATOR \$19.95!

Does Everything Big Ones Do

Small but mighty! 8-digit, 4-function electronic calculator even has automatic % key . . . for only \$19.95. Take it anywhere. Carry it in your pocket or purse - it's 2/3 the size of a pack of cigarettes. This 3 1/2-ounce dynamo features floating decimal, constant key, lead zero depression, clear entry, more! At Edmund's low price, the unit comes with a Ni-Cad rechargeable battery pack that can plug into any AC outlet. No need for special recharging adapters. Calculator overall is just 2 x 3 1/2 x 3/8" with plenty of room for most fingers. *Another Edmund first with advanced technology.* **\$19.95** ppd.

STOCK NO. 1945AV..... Only

GIANT FREE CATALOG!

NEW 172 Pages
Over 4,500 Un-
usual Bargains
for Hobbyists,
Schools, Industry



JUST CHECK
COUPON!

**EDMUND
SCIENTIFIC CO.**
300 EDSCORP BUILDING
Barrington, N. J. 08007
(609) 547-3488

America's Greatest
Science • Optics • Hobby Mart

COMPLETE AND MAIL COUPON NOW

EDMUND SCIENTIFIC CO. 300 Edscorp Bldg., Barrington, N. J. 08007

SEND FREE Send me:
172 PAGE CATALOG 'AV' ELECTRONIC CALCULATOR(S)

Charge my BankAmericard @ \$19.95 ea. (No 1945AV) \$
 Charge my Master Charge Service and handling charge \$ \$1.00

Interbank No. Enclosed is check, m.o. in amount of \$

Card No. Signature

Expiration Date Name Please print

30-DAY MONEY-BACK GUARANTEE. You must be satisfied or return any purchase in 30 days for full refund

Address City State Zip

HELPING TO DEVELOP AMERICA'S TECHNOLOGY FOR OVER 30 YEARS.

JUNE SPECIALS

POCKET CALCULATOR

3 function plus constant addressable memory with individual recall — 8 digit display plus overflow battery save — uses standard on rechargeable batteries — all necessary parts in ready-to-assemble form — instructions included



Calc. Kit, Kit only \$10.95
Batteries (alkaline, disp.) 2.00
Adapter 50Hz 3.95
Kit, Batteries & Adapter \$15.95

UNIVERSAL BREADBOARD

Size-glassed copper circuit board 1-1/2" x 5-1/2" — 2 rows of 27 holes for DIP IC's — space for transistors, resistors & capacitors — versatile and simple for breadboarding IC circuits \$1.50 ea. 100 pcs \$1.00 ea.



UV ERASABLE PROM 1702A — 2048 bit static PROM 256x8 elect programmable & erasable TTL/DTL comp. \$12.95

8038 FUNCTION GENERATOR

Variable controlled oscillator — sine, square, triangular output, 16 pin DIP with data \$3.95

7001 CLOCK CHIP

4.4 digit, 12-24 hr. alarm, timer and date circuits — with data \$6.95

MM5378

8 digit multiplexed — five functions — chain operation 2 hrs memory — floating decimal — independent constant — interfaces with led with only digit driver — 9 V batt. oper. 24 pin \$3.95

CT5005 CALCULATOR CHIP

12 digit — 4 function with memory — chain operation \$1.39

8 DIGIT LED CLOCK KIT

INCLUDES: MM4314 clock circuit & 16D70 LED displays (120° red 7 segment) All necessary transistors, resistors & capacitors 1 double sided PCB board accommodates LED's & clock circuit Schematic & instructions Does not include 12V-100 ma transformer, switches & case \$11.95

DVM CHIP 4 1/2 DIGIT

MM5330 — P channel device provides all logic for 4 1/2 digit volt meter, 16 pin DIP with data \$12.99

RESISTOR KIT

CARBON FILM 1% 1/4 WATT

455 RESISTORS 44 VALUES

SUPPLY IN A 15 DRAWER

W/ COMPARTMENT STORAGE

COUNT — TABLE OR WALL

MONUMENT, READY TO USE

18 10 20 30 40 50 60 70 80 90 100 110 120 130 140 150 160 170 180 190 200 220 240 270 300 330 360 390 430 470 510 560 620 680 750 820 910 1000

\$24.95 ea.

\$2.00 SHIPPING & HANDLING

SHIPPED VIA UPS OR PARCEL POST



1/4 WATT

1/2 WATT

RESISTOR ASSIGNMENT

R (OHMS)

QTY

QTY

QTY

QTY

QTY

QTY

QTY

QTY

QTY

QTY

QTY

QTY

QTY

QTY

QTY

QTY

QTY

QTY

QTY

QTY

QTY

QTY

QTY

QTY

QTY

QTY

QTY

QTY

QTY

QTY

QTY

QTY

QTY

QTY

QTY

QTY

QTY

QTY

QTY

QTY

QTY

QTY

QTY

QTY

QTY

QTY

QTY

QTY

QTY

QTY

QTY

QTY

QTY

QTY

QTY

QTY

QTY

QTY

QTY

QTY

QTY

QTY

QTY

QTY

QTY

QTY

QTY

QTY

QTY

QTY

QTY

QTY

QTY

QTY

QTY

QTY

QTY

IC SOCKETS

Solder tail - low profile

8 pin \$1.28 24 pin \$4.42

14 pin .20 28 pin .59

16 pin .22 40 pin .69

18 pin .32

wire wrap - gold plate

14 pin \$4.49

LOW POWER, SCHOTTKY

741500 \$.36 741574 .59

741502 .36 741590 1.30

741504 .36 741593 .94

741508 .38 741595 .79

741510 .36 7415107 .59

741520 .36 7415164 2.20

741532 .38 7415193 2.50

741540 .45 7415197 2.20

741542 1.40

MISC. DEVICES

546 AM radio receiver subst. DIP \$.75

CA3046 Transistor array 14 pin DIP .89

2513 64 x 8 x 5 character generator \$11.00

METAL FILM RESISTORS

1% 1/4 WATT

QTY PRICE EACH MINIMUM 10 PFR VALUE

0 - 10 \$.20

10 - 100 .20 \$.15

100 - 1000 .10 \$.09

1000 .10 \$.08

RESISTANCE (OHMS)

22.6 71.5 182 807 11.8K 40.2K

23.7 78.7 187 1.15K 13.0K 45.3K

25.5 84.5 191 1.5K 15.0K 48.7K

29.0 105 205 2.49K 18.2K 54.9K

34.8 110 232 3.57K 19.1K 60.4K

40.2 115 243 4.75K 19.6K 64.9K

45.1 137 499 5.49K 22.6K 69.8K

51.1 147 604 6.04K 24.9K 84.5K

61.9 158 715 7.15K 28.0K

64.9 178 806 8.25K 37.4K

733 Diff. video AMPL TO-5 .89

MC1456 Int. compensated Op Amp mDIP 1.59

7525 Dual core mem. sense AMP DIP .98

TANALDUM CAPACITORS

SOLID-DIPPED 20%

1 mfd 35V .25 ea. 6.8 mfd 6V .30 ea.

3.3 mfd 35V .25 ea. 6.8 mfd 50V .40 ea.

1 mfd 35V .25 ea. 10 mfd 25V .40 ea.

2.2 mfd 20V .25 ea. 15 mfd 10V .40 ea.

2.2 mfd 35V .30 ea. 33 mfd 10V .40 ea.

4.7 mfd 16V .30 ea. 47 mfd 6V .40 ea.

Zener Diodes, Diodes & Rectifiers

IN 4868 Diode 250V \$.25 ea. 10/ \$1.50

IN 715A Zener 11V .25 10/ 1.50

IN 747A Zener 3.6V .25 10/ 1.50

IN 754A Zener 6.8V .25 10/ 1.50

IN 756A Zener 8.2V .25 10/ 1.50

IN 904 Sw. Diode 30V .10 10/ .65

IN 914 Sw. Diode 100V .10 10/ .75

IN 967B Zener 18V .25 10/ 1.50

IN 2900A Zener 33V (Stud Mt.) 1.25 10/ 7.50

IN 3064 Sw. Diode 75V .20 10/ 1.40

IN 3600 Sw. Diode 50V .20 10/ 1.40

IN 3604 Sw. Diode 75V .20 10/ 1.40

IN 4148 Sw. Diode 75V .10 10/ .65

IN 4858 Zener 120V .25 10/ 1.50

IN 5230A Zener 4.7V .25 10/ 1.50

IN 5242B Zener 12V .25 10/ 1.50

TTL

7400 \$.14 7492 .71

7401 .16 7493 .60

7402 .15 7495 .79

7403 .16 7496 .79

7404 .19 74100 1.30

7405 .19 74105 .44

7406 .35 74107 .40

7407 .35 74121 .42

7408 .18 74122 .45

7409 .19 74123 .85

7410 .16 74125 .54

7411 .25 74126 .63

7413 .55 74141 1.04

7416 .35 74145 1.04

7417 .35 74150 .97

7420 .16 74151 .79

7422 .38 74153 .99

7423 .29 74154 1.25

7425 .27 74155 1.07

7426 .26 74156 1.07

7427 .29 74157 .99

7430 .20 74158 1.79

7432 .23 74160 1.19

7437 .35 74161 1.25

7438 .35 74162 1.49

7440 .17 74161 1.39

7441 .98 74164 1.59

7442 .77 74165 1.59

7443 .87 74166 1.49

7444 .87 74170 2.30

7445 .89 74173 1.49

7446 .93 74174 1.62

7447 .89 74175 1.39

7448 1.04 74176 .89

7450 .17 74177 .84

7451 .17 74180 .90

7453 .17 74181 2.98

7454 .17 74182 .79

7460 .17 74184 2.29

7464 .35 74185 2.29

7465 .35 74187 5.95

7470 .30 74190 1.35

7472 .30 74191 1.35

7473 .35 74192 1.25

7474 .35 74193 1.25

7475 .57 74194 1.19

7476 .39 74195 .89

7483 .79 74196 1.25

7485 1.10 74197 .89

7486 .40 74198 1.79

7489 2.48 74199 1.79

7490 .59 74200 5.90

Data included with order on request. Add \$1.00 per item in price and \$1.00 per \$40.00 order in shipping and handling.

Satisfaction guaranteed. Shipment will be made via first class mail in U.S., Canada and Mexico within 5 days from receipt of order. Add \$.75 to cover shipping and handling for orders under \$25.00. Minimum order: \$5.00. California residents add sales tax.

INTERNATIONAL ELECTRONICS UNLIMITED

P.O. BOX 3036 / MONTEREY, CA. 93940 USA

PHONE (408) 659-3171



PLANS AND KITS

FREE CATALOGUE KITS, COMPONENTS. Audio equipment, Sinclair Kits, radio parts. Gladstone Electronics, 1736 Avenue RD., Toronto, Canada, MSM 3Y7, U.S. Inquiries.

AMAZING ELECTRONIC PRODUCTS

Spring-Pac super SALE! Each pac only

All pacs are first quality (no fallout), tested and guaranteed. **\$1.98**

Memory pac 4 MM5016 MOS TO-5 512 BIT shift registers from NATIONAL - with data \$1.98	Flip-Flop pac 10 assorted Flip-Flops, Dual JK's, JST's, and low power FF's, with data \$1.98	Comparator pac 5 assorted OIP's--LM311, 710, 711, with data \$1.98
--	---	---

TTL Gates 15 assorted DIP's 7400 series-7420, 7430, 7440, etc.--All types, marked parts, with data \$1.98	LED pac 10 assorted discrete LED's-green, red, and infra-red, with data \$1.98	Transistor pac 40 assorted TO-92 plastic transistors--PNP's and NPN's, mostly Fairchild house marked \$1.98
--	---	--

Regulators 4 LM723 DIP variable regulators, 2-40V, with data \$1.98	Diodes 100 germanium computer signal diodes with leads trimmed for PCB mounting \$1.98	Resistors 100 1/2 watt 5% resistors of any single standard value from 2.7 ohm to 1M ohm \$1.98
--	---	---

Linear pac 8 assorted linears in mini-DIP or TO-6/741 on amp, LM307 op amp, LM 703 RF-IF amp, with data and circuits \$1.98	DIP RC Network 50 assorted 14 and 16 pin IC packages containing precision resistors and capacitors-no data available \$1.98	Switches 8 SPST momentary contact push button N.O. Red button fits in approx. "1" panel, with lock washer and mounting nut \$1.98
--	--	--

LED Display pac 2 DL33 - 3 digits each, approximately .1" magnified digits in a 12 pin DIP, with data \$1.98	Buy 5 pacs for \$9.90 and pic-a-pac for 10c	
---	--	--

SEND A STAMP FOR OUR FLYER LISTING MORE BARGAINS!!

CERAMIC DISC CAPACITORS 8 for \$1.00	POTTER BRUMFIELD Type KHP Relay 4 POT 3A CONTACTS 24V DC - \$1.50 (650 coil) 120V AC - \$1.75 (10.5 MA coil)	Memories 93410-256x1 RAM, fully de-loaded, high speed (40 ns) open collector output. 16 pin DIP with data. \$1.75 each 10 for \$14.95
--	---	--

Capacitors
PCB vertical mount electrolytic capacitors. 2" long, 3/4" dia.
59c ea. 10 for \$5.00

Mail orders to: P.O. Box 41778 Sacramento, CA 95841
Phone (916) 334-2161
FAX # 916-367-3521

BANKAMERICARD
welcome here

BABYLON ELECTRONICS
All IC's are new and fully tested. Leads are plated with gold or silver. Due to increased costs, orders under \$7.00 add \$1.00 postage and handling. Residents of California add sales tax. Orders are shipped within 2 workdays--kits are shipped within 10 days. \$10 minimum order on C.O.D.'s.

CIRCLE NO. 10 ON FREE INFORMATION CARD

P.O. Box 4430C Santa Clara, CA 95054

Integrated Circuits

TERMS:
\$5.00 min. order U.S. funds.
Calif. residents add 6% tax.



Same Day Shipment

First line parts only, guaranteed satisfaction. Broad line of IC's and other components at low factory prices. Try us. You'll like the quality and service.

7400 TTL	SN74ALS00	2.00
SN74ALS01	2.20	
SN74ALS02	2.00	
SN74ALS03	1.50	
SN74ALS04	1.00	
SN74ALS05	1.00	
SN74ALS06	1.00	
SN74ALS07	1.00	
SN74ALS08	1.00	
SN74ALS09	1.00	
SN74ALS10	1.00	
SN74ALS11	1.00	
SN74ALS12	1.00	
SN74ALS13	1.00	
SN74ALS14	1.00	
SN74ALS15	1.00	
SN74ALS16	1.00	
SN74ALS17	1.00	
SN74ALS18	1.00	
SN74ALS19	1.00	
SN74ALS20	1.00	
SN74ALS21	1.00	
SN74ALS22	1.00	
SN74ALS23	1.00	
SN74ALS24	1.00	
SN74ALS25	1.00	
SN74ALS26	1.00	
SN74ALS27	1.00	
SN74ALS28	1.00	
SN74ALS29	1.00	
SN74ALS30	1.00	
SN74ALS31	1.00	
SN74ALS32	1.00	
SN74ALS33	1.00	
SN74ALS34	1.00	
SN74ALS35	1.00	
SN74ALS36	1.00	
SN74ALS37	1.00	
SN74ALS38	1.00	
SN74ALS39	1.00	
SN74ALS40	1.00	
SN74ALS41	1.00	
SN74ALS42	1.00	
SN74ALS43	1.00	
SN74ALS44	1.00	
SN74ALS45	1.00	
SN74ALS46	1.00	
SN74ALS47	1.00	
SN74ALS48	1.00	
SN74ALS49	1.00	
SN74ALS50	1.00	
SN74ALS51	1.00	
SN74ALS52	1.00	
SN74ALS53	1.00	
SN74ALS54	1.00	
SN74ALS55	1.00	
SN74ALS56	1.00	
SN74ALS57	1.00	
SN74ALS58	1.00	
SN74ALS59	1.00	
SN74ALS60	1.00	
SN74ALS61	1.00	
SN74ALS62	1.00	
SN74ALS63	1.00	
SN74ALS64	1.00	
SN74ALS65	1.00	
SN74ALS66	1.00	
SN74ALS67	1.00	
SN74ALS68	1.00	
SN74ALS69	1.00	
SN74ALS70	1.00	
SN74ALS71	1.00	
SN74ALS72	1.00	
SN74ALS73	1.00	
SN74ALS74	1.00	
SN74ALS75	1.00	
SN74ALS76	1.00	
SN74ALS77	1.00	
SN74ALS78	1.00	
SN74ALS79	1.00	
SN74ALS80	1.00	
SN74ALS81	1.00	
SN74ALS82	1.00	
SN74ALS83	1.00	
SN74ALS84	1.00	
SN74ALS85	1.00	
SN74ALS86	1.00	
SN74ALS87	1.00	
SN74ALS88	1.00	
SN74ALS89	1.00	
SN74ALS90	1.00	
SN74ALS91	1.00	
SN74ALS92	1.00	
SN74ALS93	1.00	
SN74ALS94	1.00	
SN74ALS95	1.00	
SN74ALS96	1.00	
SN74ALS97	1.00	
SN74ALS98	1.00	
SN74ALS99	1.00	
SN74ALS00	1.00	

DISPLAY LEADS	PRDM	ALSO AVAILABLE
MAN1 1.00	112A 15.20	Switches
MAN2 1.00	NB2512 2.30	Sockets
MAN3 1.00	NB2512J 4.80	Capacitors
MAN4 1.00	NB2512K 4.80	Resistors
MAN5 1.00		Transistors
MAN6 1.00		Diodes
MAN7 1.00		Rectifiers
MAN8 1.00		
MAN9 1.00		
MAN10 1.00		
MAN11 1.00		
MAN12 1.00		
MAN13 1.00		
MAN14 1.00		
MAN15 1.00		
MAN16 1.00		
MAN17 1.00		
MAN18 1.00		
MAN19 1.00		
MAN20 1.00		
MAN21 1.00		
MAN22 1.00		
MAN23 1.00		
MAN24 1.00		
MAN25 1.00		
MAN26 1.00		
MAN27 1.00		
MAN28 1.00		
MAN29 1.00		
MAN30 1.00		
MAN31 1.00		
MAN32 1.00		
MAN33 1.00		
MAN34 1.00		
MAN35 1.00		
MAN36 1.00		
MAN37 1.00		
MAN38 1.00		
MAN39 1.00		
MAN40 1.00		
MAN41 1.00		
MAN42 1.00		
MAN43 1.00		
MAN44 1.00		
MAN45 1.00		
MAN46 1.00		
MAN47 1.00		
MAN48 1.00		
MAN49 1.00		
MAN50 1.00		
MAN51 1.00		
MAN52 1.00		
MAN53 1.00		
MAN54 1.00		
MAN55 1.00		
MAN56 1.00		
MAN57 1.00		
MAN58 1.00		
MAN59 1.00		
MAN60 1.00		
MAN61 1.00		
MAN62 1.00		
MAN63 1.00		
MAN64 1.00		
MAN65 1.00		
MAN66 1.00		
MAN67 1.00		
MAN68 1.00		
MAN69 1.00		
MAN70 1.00		
MAN71 1.00		
MAN72 1.00		
MAN73 1.00		
MAN74 1.00		
MAN75 1.00		
MAN76 1.00		
MAN77 1.00		
MAN78 1.00		
MAN79 1.00		
MAN80 1.00		
MAN81 1.00		
MAN82 1.00		
MAN83 1.00		
MAN84 1.00		
MAN85 1.00		
MAN86 1.00		
MAN87 1.00		
MAN88 1.00		
MAN89 1.00		
MAN90 1.00		
MAN91 1.00		
MAN92 1.00		
MAN93 1.00		
MAN94 1.00		
MAN95 1.00		
MAN96 1.00		
MAN97 1.00		
MAN98 1.00		
MAN99 1.00		
MAN00 1.00		

FREE—Send for your copy of our 1976 Quest Catalog.

IC Update Master Manual
1976 integrated circuit data manual with free quarterly updates. Complete IC data from all manufacturers directly. 14,000 cross references. Everything you need to select IC's in one handbound manual. **\$30.00 complete with Update service.**
Money Back Guaranteed if not satisfied within first week.

Digital Clock Kit \$12.95
6 digit 05 in LED readout. Add \$1.50 for transformer and \$3.00 for PC board. A tremendous value!
Wood grain and plexiglas cases available.

CIRCLE NO. 45 ON FREE INFORMATION CARD

CB SPECIALS—R.F. DRIVERS—R.F. POWER OUTPUTS—FETS

25C481 1.85	25C767 15.75	25C866 5.85	25C1449 1.60	40081 1.50
25C482 1.75	25C773 8.5	25C013 1.50	25C475 1.50	40082 3.00
25C495 1.10	25C774 1.75	25C1014 1.50	25C1678 5.50	25C608 4.85
25C502 3.75	25C775 2.75	25C1017 1.50	25C1679 4.75	SK3046 2.15
25C517 4.75	25C776 3.00	25C1018 1.50	25C1728 2.15	SK3047 3.75
25C614 3.80	25C777 4.75	25C1173 1.25	25C1860 2.15	SK2095 3.50
25C615 3.90	25C778 3.25	25C1226A 1.25	25C1876 5.50	SK3048 3.25
25C616 4.15	25C797 2.50	25C1237 4.50	25C1908 .70	SK3054 1.25
25C617 4.25	25C798 3.10	25C1239 3.50	25C1957 1.50	
25C699 4.75	25C781 3.00	25C1243 1.50	25F8 3.00	25K19 1.75
25C710 1.70	25C789 1.00	25C1306 4.75	HEP-S3001 3.25	25K30 1.00
25C711 1.70	25C796 3.15	25C1307 4.90	25D235 1.00	25K33 1.20
25C735 .70	25C799 4.25	25C1307 5.75	MRF8004 3.00	
25C756 3.00	25C802 3.75	25C1307-16 0.00	4004 3.00	35K40 2.75
25C765 9.50	25C803 4.00	25C1377 5.50	4005 3.00	35K45 2.75
25C766 10.15	25C839 .85	25C1449 1.30	40080 1.25	35K49 2.75

JAPANESE TRANSISTORS

2SA52 .60	2SB187 .60	2SC458 .70	2SC815 .75	2SC1569 1.25
2SA316 .75	2SB235 1.75	2SC460 .70	2SC828 .75	2SC1756 1.25
2SA473 .75	2SB303 .65	2SC478 .80	2SC829 .75	
2SA483 1.95	2SB324 2.00	2SC491 2.50	2SC830 1.60	2SD30 .95
2SA489 .80	2SB337 1.10	2SC492 1.60	2SC839 .85	2SD45 2.00
2SA490 .70	2SB367 1.60	2SC515 .80	2SC945 .65	2SD65 .75
2SA505 .70	2SB370 .65	2SC535 .75	2SC1010 .80	2SD68 .90
2SA564 .50	2SB405 .65	2SC536 .65	2SC1012 .80	2SD72 1.00
2SA628 .65	2SB407 1.85	2SC537 .70	2SC1051 2.50	2SD88 1.50
2SA643 .85	2SB415 .85	2SC563 2.50	2SC1061 1.65	2SD151 2.25
2SA647 2.75	2SB461 1.25	2SC605 1.00	2SC1079 3.75	2SD170 2.00
2SA673 .85	2SB463 1.65	2SC620 .80	2SC1096 1.20	2SD180 2.75
2SA679 3.75	2SB471 1.75	2SC627 1.75	2SC1098 1.15	2SD201 1.95
2SA682 .85	2SB474 1.50	2SC642 3.50	2SC1115 2.75	2SD218 4.75
2SA699 1.30	2SB476 1.25	2SC643 3.75	2SC1166 7.00	2SD300 2.50
2SA699A 1.75	2SB481 2.10	2SC644 .70	2SC1170 4.00	2SD313 1.10
2SA705 .55	2SB492 1.25	2SC681 2.50	2SC1172B 4.25	2SD315 1.75
2SA815 .85	2SB495 .95	2SC684 2.10	2SC1209 5.5	2SD318 1.95
2SA816 .85	2SB507 .90	2SC687 2.50	2SC1213 .75	2SD341 1.95
	2SB511 .70	2SC696 2.35	2SC1226 1.25	2SD350 3.25
2SB22 .65		2SC712 .70	2SC1243 1.50	2SD352 .80
2SB54 .70	2SC206 1.00	2SC713 .70	2SC1293 .85	2SD380 5.70
2SB56 .70	2SC240 1.10	2SC732 .70	2SC1308 4.75	2SD389 .90
2SB77 .70	2SC261 .65	2SC733 .70	2SC1347 .80	2SD-390 7.75
2SB128 2.25	2SC291 .65	2SC739 .70	2SC1383 .75	2SD437 5.50
2SB135 .95	2SC320 2.00	2SC715 1.75	2SC1409 1.25	
2SB152 4.50	2SC352 .75	2SC762 1.90	2SC1410 1.25	C106B1 5.0
2SB173 .55	2SC353 .75	2SC783 1.00	2SC1447 1.25	
2SB175 .55	2SC371 .70	2SC784 .70	2SC1448 1.25	MPS-U31

TREASURE FINDERS

TREASURE FINDER locates buried gold, silver, coins, treasures. 6 powerful models. Instant financing available. Write or call for free catalog. Phone (713) 682-2728 day or night. Dealer inquiries invited. Relco. Dept. AA20. Box 10839. Houston, Texas 77018.

DISCOVER true treasure hunting with world-famous deep-detecting mineral/metal detectors from White's! Locate gold, silver, rings, coins, artifacts and more! Sold, serviced, warehoused world wide. Priced from \$79.50. Free Catalog! White's Electronics, Dept. PD6T, 1011 Pleasant Valley Rd., Sweet Home, OR 97386.

RUBBER STAMPS

RUBBER ADDRESS STAMPS. Free Catalog. 45 type styles. Jackson S. Dept. K. Brownsville Rd., Mt. Vernon, Ill. 62864.

NEW Pocket Case Address STAMPER. \$11.95 100,000 Impressions without Re-Inking! 25 Yr. Unconditional Guaranty. NO INK PAD! LEE GARLAND, Box 17056, San Diego, CA 92117.

MUSICAL INSTRUMENTS

UP TO 60% DISCOUNT. Name brand instruments catalog. Freeport Music, 114 N. Mahan St., W. Babylon, N.Y. 11704.

WHOLESALE! Professional Guitars, PA Systems, Altec Speakers. 240W RMS Amplifiers. Free Catalog. Carvin, Escondido, Calif. 92028.

DULCIMERS and other musical kits also completed. Instrument makers woods. Catalog 50 cents. RemBrand Company, R.R.3. Newton, Iowa 50208.

PERSONALS

MAKE FRIENDS WORLDWIDE through international correspondence. Illustrated brochure free. Hermes, Berlin 11, Box 110660/2D, Germany.

Ph.D.S. MASTER S. BACHELOR S. — official nonresident College Degrees easily acquired through mailorder Universities. Complete Revealing Directory — \$2. Counseling Connection, 5495 Claremont, No. BPE, Oakland, CA 94618.

QUALITY ELECTRONIC COMPONENTS

NEW DISCOUNT SCHEDULE SAVES YOU EVEN MORE!

AMD 8080A \$34.95 **2102 \$1.99**

MICROPROCESSOR 1024 Bit Random Access Memory 500 ns Typical, 1000 ns Max Access Time

INTEGRATED CIRCUITS — TTL, CMOS, LINEAR & MOS

7400 .21	7473 .30	74174 .70	4001 .23	4073 .23
7401 .21	7474 .30	74175 .93	4002 .23	4075 .23
7402 .21	7475 .49	74176 .79	4006 .123	4081 .23
7403 .21	7476 .32	74177 .79	4007 .23	4082 .23
7404 .21	7480 .70	74180 .70	4008 .79	4502 .79
7405 .21	7482 .70	74181 2.15	4009 .44	4510 1.14
7406 .25	7483 .70	74182 .79	4010 .44	4511 1.05
7407 .25	7485 .89	74184 2.19	4011 .23	4514 2.80
7408 .21	7486 .28	74185 2.19	4012 .23	4515 2.80
7409 .21	7489 2.19	74188 3.50	4013 .40	4516 1.23
7410 .21	7490 .44	74189 3.50	4014 .96	4518 1.14
7411 .21	7491 .70	74190 1.29	4015 .96	4520 1.14
7412 .21	7492 .44	74191 1.23	4016 .40	4527 1.68
7413 .25	7493 .44	74192 .88	4011 .05	4528 .88
7414 .89	7494 .70	74193 .88	4018 .65	4565 1.23
7416 .25	7495 .70	74194 .88	4019 .23	LM309K 1.80
7417 .25	7496 .70	74195 .88	4020 1.14	LM324N 1.28
7420 .21	7499 .44	74196 .88	4021 1.14	LM3401-5 1.25
7421 .25	74100 1.28	74197 .88	4022 .23	LM3401-5 1.25
7422 .35	74109 .33	74198 .49	4023 .23	LM3401-8 1.25
7423 .35	74109 .33	74199 1.49	4024 .84	LM3401-12 1.25
7425 .35	74121 .65	74201 1.09	4025 .23	LM3401-15 1.25
7426 .25	74122 .44	74202 .88	4026 1.68	LM3401-18 1.25
7427 .33	74123 .61	74203 .88	4027 .40	LM3401-24 1.25
7428 .28	74125 .40	74365 .67	4027 .40	LM3401-24 1.25
7430 .21	74126 .40	74366 .67	4028 .89	LM3900N .88
7432 .25	74132 .70	74367 .67	4029 1.14	NE520V 3.24
7433 .30	74141 .88	74368 .67	4030 .23	NE540L 2.04
7437 .25	74145 .50	75150 1.31	4033 1.51	NE555V .48
7438 .25	74147 1.63	75150 .88	4034 1.50	NE556A .88
7440 .21	74148 1.30	75451 .61	4035 .11	NE5608 3.83
7441 .88	74150 1.16	75452 .61	4040 1.14	NE561B 3.83
7442 .53	74151 .70	75453 .61	4041 .79	NE562B 3.83
7443 .63	74152 .65	75454 .61	4042 .79	NE565A 1.25
7444 .63	74154 1.03	75455 .61	4043 .70	NE566V .28
7445 .70	74155 .70	75492 .84	4044 .70	NE567V 1.36
7446 .70	74156 .70	75493 1.09	4046 1.86	UA709CV 44
7447 .70	74157 .70	75494 1.19	4049 .40	UA709CA 44
7448 .70	74160 .88	8093 .40	4050 .40	UA711CA 53
7450 .21	74161 .88	8094 .40	4051 .26	UA723CA 60
7453 .21	74162 .88	8095 .67	4052 .26	UA741CV 44
7454 .21	74163 .88	8096 .67	4053 .79	UA747CA 70
7460 .21	74164 .96	8097 .67	4060 1.58	UA748CV 49
7470 .30	74166 1.26	8098 .67	4066 .79	MC1458V 53
7472 .30	74170 2.64	8099 2.19	4065 .23	217 (asem.) 27
	74173 1.42	4000 .23	4072 .23	8080A 49.95

AP SUPER STRIP II—Universal Breadboarding

Element with 840 Solderless Plug-in Tie-Points

\$17.00

IC TEST CLIPS

14 pin TC-14 \$4.50
16 pin TC-16 \$4.75
24 pin TC-24 \$13.85

TC-16 TC-24

In a hurry? Try these high-performance All-Circuit Evaluators

7 models for fast building and testing of circuits

photo ACE 201K

On all models... simply plug in your components and interconnect with 22-ga. solid wire. All models accept all DIP's, TO-5's and discretes with leads up to .032" diameter.

Multiple buses can easily be linked for power and ground distribution, reset and clock lines, shift command, etc. Bases: gold-anodized aluminum. Terminals: non-corrosive nickel-silver. Four rubber feet included.

ACE Model No.	Tie Points	DIP No.	No. Capacity Buses	Posts	Board Size (inches)	Price Each
200-K (kit)	728	8 (16's)	2	4	4.9/16x5.9/16	\$18.95
208 (asem.)	872	8 (16's)	8	2	4.9/16x5.9/16	28.95
201-K (kit)	1032	12 (14's)	2	2	4.9/16x7	24.95
212 (asem.)	1224	12 (14's)	8	2	4.9/16x7	34.95
218 (asem.)	1760	18 (14's)	10	2	6.1/2x7-1/8	46.95
227 (asem.)	2712	27 (14's)	28	4	8.9/14	71.95
236 (asem.)	3648	36 (14's)	36	4	10.1/16x11/4	79.95

BISHOP GRAPHICS Printed Circuit Drafting

Aids are now available from Digi-Key

CMOS DATABOOK \$1.50

Specifications and pin-outs for 80 different 4000 series parts

DATA BOOKS

TTL IC's - 592 pages... \$4.00
INTERFACE IC's - 464 pages \$4.00
LINEAR IC's - 704 pages... \$4.00
VOLTAGE REGULATORS - 128 pages... \$3.00
CMOS IC's - 256 pages... \$3.00
TRANSISTORS - 288 pages... \$3.00
LINEAR APPLICATIONS - 432 pages... \$4.00
MEMORY IC's - 592 pages... \$3.00

REED RELAYS

1.5 Amp SPST N.O. Contacts

4.8v Coil \$1.70 \$125/C
6.0v Coil \$1.70 \$125/C
12v Coil \$1.70 \$125/C
24v Coil \$1.70 \$125/C

1/4 WATT 5% CARBON FILM RESISTORS

See each in multiples of 5 per value
\$1.70/100 of same value. 10 ohm to 1.0 meg

SILICON TRANSISTORS

MPS918, MPS930, MPS2222A, MPS2369A, MPS2712, MPS2907A, MPS3392, MPS3393, MPS3394, MPS3395, MPS3563, MPS3565, MPS3638, MPS3638A, MPS3640, MPS3641, MPS3643, MPS3645, MPS3646, 2N3904, 2N4124, 2N4124A, 2N4126, 2N4401, 2N4403, 2N4410, PN4888, 2N5087, 2N5089, PN5129, PN5133, PN5134, PN5137, PN138, PN5139, 2N5210, PN5994 16, \$1.55/100, \$13.60/100 of same part no.

MPF102 36 \$30.60/C 2N5457 48 \$41.00/C MPF413 28 \$24.00/C 2N3055 99 \$85.00/C

I.C. SOCKETS

8 Pin Solder Tab .17
14 Pin Solder Tab .20
16 Pin Solder Tab .22
18 Pin Solder Tab .29
24 Pin Solder Tab .38
28 Pin Solder Tab .45
40 Pin Solder Tab .63
8 Pin Wire-Wrap .24
14 Pin Wire-Wrap .36
16 Pin Wire-Wrap .30
18 Pin Wire-Wrap .60
24 Pin Wire-Wrap .66
28 Pin Wire-Wrap 1.23
40 Pin Wire-Wrap 1.00

RESISTOR ASSORTMENTS

5 ea. all 10% 1/4 W. Val. from 2.2 to 22 meg (425 pcs) \$12.00
5 ea. all 10% 1/4 W. Val. from 10 to 5.6 meg (350 pcs) \$12.00

ELECTROLYTIC CAPACITORS

— Radial Lead — — Axial Lead — — Axial Lead —

1uF/50v	08 65/10	1uF/50v	11 90/10	47uF/25v	17 1.30/10
2.2uF/50v	08 65/10	2.2uF/50v	12 90/10	100uF/16v	17 1.30/10
3.3uF/50v	08 65/10	3.3uF/25v	12 95/10	100uF/25v	20 1.55/10
4.7uF/50v	08 65/10	3.3uF/50v	12 1.00/10	100uF/50v	29 2.30/10
4.7uF/50v	08 70/10	4.7uF/25v	11 90/10	220uF/16v	20 1.55/10
10uF/25v	08 65/10	4.7uF/50v	12 95/10	220uF/25v	29 2.35/10
10uF/50v	10 75/10	10uF/16v	11 90/10	330uF/16v	29 2.35/10
22uF/25v	09 70/10	10uF/25v	12 1.00/10	330uF/25v	32 2.55/10
22uF/50v	12 1.00/10	10uF/50v	14 1.15 10	470uF/16v	32 2.55/10
100uF/6.3v	09 75/10	22uF/16v	12 1.00/10	470uF/25v	37 3.00/10
100uF/16v	11 85/10	22uF/25v	13 1.05/10	1000uF/16v	39 3.15/10
100uF/25v	13 1.10/10	33uF/16v	12 1.00/10	1000uF/25v	56 4.50/10
		33uF/25v	14 1.15/10	2200uF/16v	62 4.95/10
		47uF/16v	14 1.15/10		

HARDWARE

2-56 1/4 Screw .99/7.20/M
2-56 1/4 Screw .99/7.65/M
4-40 1/4 Screw .55/2.50/M
4-40 1/4 Screw .60/2.40/M
6-32 1/4 Screw .65/2.40/M
6-32 1/4 Screw .75/2.45/M
8-32 3/8 Screw .90/5.85/M
2-56 Hex Nut .55/3.60/M
2-56 Hex Nut .60/4.00/M
4-40 Hex Nut .60/4.15/M
No. 2 Lockwasher .85/3.75/M
No. 4 Lockwasher .45/3.00/M
No. 6 Lockwasher .45/3.00/M
No. 8 Lockwasher .45/3.00/M

VOLUME DISCOUNT SCHEDULE

Merchandise	Discount	Merchandise	Discount
Total	\$ 100.00-9.99	Total	\$ 100.00-999.99 LESS 15%
\$ 100.00-5.99	NET	\$ 500.00-999.99 LESS 20%	
\$ 100.00-2.99	LESS 5%	\$ 1000.00 & up LESS 25%	
\$ 250.00-99.99	LESS 10%		

— Then Add the Standard Charge Below

STANDARD SHIPPING/HANDLING CHARGE

If your merchandise total after discount is between:

\$ 0.00-4.99	add \$2.00	\$ 50.00-99.99	add \$0.25
\$ 5.00-24.99	add \$0.75	\$ 100.00 & up	No Charge
\$ 25.00-49.99	add \$0.50		

Includes shipping & insurance to USA & Canada

COD ORDERS ACCEPTED FOR SAME DAY SHIPMENT — CALL 218-681-8674

DISC CAPS

100uF/500v .04 36/10
220uF/500v .04 36/10
470uF/500v .04 36/10
1000uF/500v .04 37/10
2200uF/500v .04 37/10
01uF/500v .06 32/10
01uF/500v .06 32/10
01uF/500v .03 24/10
022uF/25v .03 28/10
047uF/25v .03 42/10
1uF/25v .08 62/10

1/4 WATT ZENER DIODES

1N5226B 3.6v .15 \$11/C	1N5226B 7.5v .15 \$11/C
1N5227B 3.3v .15 \$11/C	1N5227B 8.2v .15 \$11/C
1N5228B 3.9v .15 \$11/C	1N5228B 8.7v .15 \$11/C
1N5229B 4.3v .15 \$11/C	1N5229B 9.1v .15 \$11/C
1N5230B 4.7v .15 \$11/C	1N5230B 10v .15 \$11/C
1N5231B 5.1v .15 \$11/C	1N5241B 11v .15 \$11/C
1N5232B 5.6v .15 \$11/C	1N5242B 12v .15 \$11/C
1N5233B 6.0v .15 \$11/C	1N5243B 13v .15 \$11/C
1N5234B 6.2v .15 \$11/C	1N5244B 14v .15 \$11/C
1N5235V 6.8v .15 \$11/C	1N5245V 15v .15 \$11/C

Send for free catalog on all new products. "Only Quality Components Sold!"

DIGI-KEY CORPORATION

Thief River Falls, MN 56701

Popular Electronics

1975 ANNUAL INDEX

Hundreds of references to subjects, products, equipment, and technical tips that you know are in the magazine but can never find when you want them—all arranged for fast easy reference.

Prepared in cooperation with the magazine editors, each of these handy indexes covers a full year (12 issues) and is an indispensable companion to your magazine collection.

\$1.50 per copy plus \$.25 per order for postage and handling.

1972, 73 and 74 indexes also still available at \$1.50 each or \$5.50 for the complete set of four (1972 thru 1975).

POPULAR ELECTRONICS INDEX
Box 2228, Falls Church, Va., 22042

CB-HAM-SWL... they come through loud and clear in the all-new 1976 COMMUNICATIONS HANDBOOK

Here's everything you want to know—need to know—about Citizens' Band, Amateur Radio, Shortwave Listening, Police-Fire Monitoring, Marine Radio. This vital "how-to" guide will help you get greater value, greater enjoyment out of every minute you spend with your equipment. CITIZEN'S BAND—What it is, how it's used, how to get a low-cost no-test license; new, easier-to-follow rules for legal operation of CB 2-way radios; guides to choosing and operating CB equipment... TWO-WAY RADIO-TELEPHONES FOR PLEASURE CRAFT—What VHF-FM and SSB marine radio equipment offers; new FCC rules; getting a marine license... PUBLIC SERVICE BAND—Monitor radios for listening in on police, fire, pilot communications... GOVERNMENT PUBLIC SERVICE BROADCASTS... OXING THE FM BAND—How to get long-distance reception of FM frequencies... SHORTWAVE 1976—Listening to utility frequencies, including SAC communications; new stations; old stations with super-power; what to expect on all the SW bands... HOW TO BECOME A HAM—Includes all the special communication options you have as an amateur... "working" 2-meter FM, fast-scan TV, and space satellites. ONLY \$1.50!

Ziff-Davis Publishing Company
Consumer Service Division, PE-676
595 Broadway, New York, N.Y. 10012

Please send the 1976 COMMUNICATIONS HANDBOOK, I'm enclosing \$1.85 (\$1.50 plus 35c for postage and handling). Outside U.S.A. \$3.00, postpaid.

Residents of Calif., Col., Fla., Ill., Mich., Mo., N.Y. State, D.C. and Tex. add applicable sales tax (postage and handling charges non-taxable).

print name _____
address _____
city _____
state _____ zip _____

ZENER DIODES		500 mW - 5%	
V	1.9 10up	V	1.9 10up
IN5223B	2.7 45	IN5246B	16 45 40
IN5224B	2.8 45 40	IN5247B	17 45 40
IN5225B	3.0 45 40	IN5248B	18 45 40
IN5226B	3.3 45 40	IN5249B	19 45 40
IN5227B	3.6 45 40	IN5250B	20 45 40
IN5228B	3.9 45 40	IN5251B	22 45 40
IN5229B	4.3 45 40	IN5252B	24 45 40
IN5230B	4.7 45 40	IN5253B	25 45 40
IN5231B	5.1 45 40	IN5254B	27 45 40
IN5232B	5.6 45 40	IN5255B	28 45 40
IN5233B	6.0 45 40	IN5256B	30 45 40
IN5234B	6.2 45 40	IN5257B	33 45 40
IN5235B	6.8 45 40	IN5258B	36 45 40
IN5236B	7.5 45 40	IN5259B	39 45 40
IN5237B	8 45 40	IN5260B	43 45 40
IN5238B	8.7 45 40	IN5261B	47 45 40
IN5239B	9.1 45 40	IN5262B	51 45 40
IN5240B	10 45 40	IN5263B	55 55 50
IN5241B	11 45 40	IN5264B	60 55 50
IN5242B	12 45 40	IN5265B	62 55 50
IN5243B	13 45 40	IN5266B	66 55 50
IN5244B	14 45 40	IN5267B	75 55 50
IN5245B	15 45 40		

7400N TTL			
1.9 10up	1.9 10up	1.9 10up	1.9 10up
7400N	14 13	7470N	40 30
7401N	18 16	7472N	40 30
7402N	18 16	7473N	42 38
7403N	18 16	7474N	44 40
7404N	21 19	7475N	44 40
7405N	20 19	7476N	44 40
7406N	36 28	7480N	80 72
7407N	36 28	7481N	1.30 1.25
7408N	24 24	7482N	98 96
7409N	28 21	7483N	82 76
7410N	22 19	7484N	1.80 1.70
7411N	26 20	7485N	1.20 1.08
7412N	34 32	7486N	44 40
7413N	45 42	7487N	2.20 2.10
7414N	98 95	7490N	56 51
7416N	35 32	7491N	84 76
7417N	35 32	7492N	56 50
7418N	30 27	7493N	62 56
7419N	15 12	7494N	88 76
7421N	30 26	7495N	80 72
7422N	50 45	7496N	75 68
7423N	37 36	7497N	5.00 4.50
7425N	30 23	74100N	1.10 1.00
7426N	28 26	74104N	1.00 90
7427N	28 25	74105N	1.00 90
7428N	40 33	74107N	40 36
7430N	26 20	74109N	40 36
7432N	32 30	74110N	40 36
7433N	44 40	74111N	1.00 90
7437N	29 20	74116N	2.00 1.80
7438N	29 27	74118N	2.20 2.00
7439N	44 44	74119N	4.00 3.60
7440N	17 16	74121N	88 80
7441N	85 83	74122N	48 43
7442N	40 39	74123N	68 62
7443N	72 65	74125N	50 45
7444N	72 65	74126N	42 40
7445N	90 81	74128N	50 45
7446N	90 81	74132N	92 85
7447N	98 90	74136N	80 72
7448N	98 90	74141N	1.70 1.60
7449N	14 13	74142N	55 50
7451N	14 13	74147N	1.90 1.70
7453N	14 13	74148N	1.50 1.35
7454N	14 13	74150N	1.52 1.40
7459N	20 18	74151N	1.02 92
7460N	14 13	HIGH SPEED TTL	

LOW POWER TTL			
1.9 10up	1.9 10up	1.9 10up	1.9 10up
74100N	24 24	74101N	34 34
74102N	24 24	74103N	34 34
74103N	39 39	74104N	39 39
74104N	33 33	74105N	33 33
74105N	33 33	74106N	33 33
74106N	40 40	74107N	40 40
74110N	33 33	74108N	33 33
74111N	33 33	74109N	33 33
74100N	24 24	74101N	34 34
74102N	24 24	74103N	34 34
74103N	39 39	74104N	39 39
74104N	33 33	74105N	33 33
74105N	33 33	74106N	33 33
74106N	40 40	74107N	40 40
74110N	33 33	74108N	33 33
74111N	33 33	74109N	33 33

74LS00			
1.9 10up	1.9 10up	1.9 10up	1.9 10up
74LS00N	36 35	74LS55N	39 38
74LS01N	44 40	74LS73N	58 55
74LS02N	36 35	74LS74N	56 54
74LS03N	45 44	74LS75N	65 64
74LS04N	44 40	74LS78N	92 90
74LS05N	45 44	74LS95N	2.08 2.00
74LS06N	38 37	74LS107N	59 58
74LS08N	44 40	74LS109N	92 86
74LS10N	36 35	74LS127N	89 85
74LS11N	46 42	74LS113N	92 85
74LS15N	58 54	74LS114N	92 85
74LS20N	44 40	74LS123N	160 150
74LS21N	58 54	74LS131N	160 150
74LS22N	58 54	74LS139N	2.00 1.80
74LS27N	44 40	74LS151N	1.68 1.50
74LS30N	39 38	74LS153N	1.80 1.79
74LS32N	44 40	74LS171N	1.58 1.54
74LS38N	58 53	74LS183N	1.68 1.60
74LS51N	39 38	74LS160N	2.00 1.70
74LS54N	58 54	SCHOTTKY TTL	

LINEAR IC'S					
H-TO-5	N-DIP	M-MINI-DIP	D-CER-DIP	K-TO-3	
LM105H	3.90	LM311H	1.20	LM710CH	90
LM108H	4.90	LM312H	.90	LM710CN	90
LM114H	3.00	LM313H	.75	LM711CH	90
LM1300H	1.20	LM314H	1.20	LM713CN	90
LM300N	1.20	LM318H	1.50	LM715CH	3.50
LM301AH	50	LM318M	2.40	LM715CD	4.60
LM301AM	80	LM324N	1.90	LM723CN	60
LM301AN	1.10	LM331N	1.20	LM723CN	65
LM302N	1.30	LM339N	2.40	LM725CD	60
LM302H	1.40	LM320 5K	2.90	LM733CH	1.40
LM304H	1.20	LM320 5K	2.90	LM733CD	1.50
LM305H	1.20	LM320 1K	2.90	LM733CN	1.30
LM305AH	1.05	LM320 12T	2.50	LM741CH	4.20
LM305AN	1.00	LM340 5K	2.60	LM741CD	4.20
LM306N	95	LM340 6K	2.60	LM741CM	.39
LM307H	60	LM340 8K	2.60	LM747CH	90
LM307M	1.50	LM340 12K	2.60	LM747CN	90
LM308H	85	LM340 15K	2.60	LM748CM	55
LM308AH	5.00	LM340 18K	2.60	LM777CH	2.15
LM308D	2.25	LM340 24K	2.60	LM777CM	2.10
LM308M	1.00	LM355 2.0	70	LM3046CN	95
LM309H	1.50	LM556CM	1.30	LM3054CN	1.50
LM309L	1.50	LM567CM	1.70	SG4501T	2.40
LM310H	1.50	LM709CH	75	SG4501N	2.40
LM310M	1.80	LM709CN	75	LM5000K	7.50

CMOS					
1.9 10up	1.9 10up	1.9 10up	1.9 10up	1.9 10up	1.9 10up
4000AE	1.9 10up	4021BE	1.9 10up	4056AE	1.9 10up
4000AF	28 24	4022AE	1.05 1.00	4056BE	2.04 2.03
4000BE	19 18	4022BE	1.10 1.05	4060AE	1.70 1.68
4001AE	24 20	4023AE	24 22	4063AE	2.50 2.49
4001BE	27 24	4023BE	30 28	4066AE	90 89
4002AE	24 20	4024AE	95 85	4068AE	53 48
4002BE	30 18	4024BE	85 75	4069AE	44 43
4004AE	4.00 3.80	4025AE	24 20	4069BE	53 48
4007AE	3.0 1.20	4025AF	30 28	4070BE	60 59
4006AF	15.0 1.30	4025BE	30 28	4072AE	34 33
4006BE	1.35 1.25	4026AE	1.50 1.49	4072BE	40 39
4007AE	24 23	4027AE	55 50	4073AE	40 39
4007AF	40 35	4027BE	60 55	4075AE	40 39
4007BE	27 28	4028AE	95 85	4076AE	44 43
4008AE	1.15 1.14	4028BE	1.00 95	4077AE	40 39
4008AF	1.30 1.25	4029AE	1.20 1.10	4077BE	44 43
4009AE	50 45	4029BE	1.25 1.15	4078AE	40 39
4009BE	50 45	4029AE	48 45	4078BE	44 43
4010AE	50 45	4030AF	65 60	4078AE	40 39
4010BE	55 50	4030BE	55 50	4082AE	39 38
4011AE	24 23	4030AE	2.00 1.90	4082BE	43 42
4012AE	24 22	4035AE	1.20 1.10	4093AE	1.65 1.64
4012BE	29 27	4035AF	1.25 1.15	4093BE	1.24 1.22
4013AE	30 28	4040AE	1.20 1.10	4098AE	1.30 1.29
4013AF	45 43	4040AF	1.50 1.40	4099AE	2.90 2.89
4014AE	1.05 1.00	4041AE	1.25 1.10	4099BE	1.50 1.49
4014AF	1.10 1.05	4043AE	95 90	4510AE	1.40 1.39
4015AE	1.15 1.10	4044AE	95 90	4510BE	1.45 1.44
4015BE	1.20 1.15	4046AE	3.10 3.05	4511BE	2.00 1.99
4016AE	1.25 1.20	4046AF	3.20 3.15	4512BE	1.84 1.83
4016BE	60 54	4048AE	1.43 1.40	4514AE	5.00 4.99
4017AE	1.05 1.00	4049AE	.58 53	4515AE	5.00 4.99
4017BE	1.10 1.05	4049BE	.63 58	4516AE	1.75 1.74
4018AE	1.24 1.23	4050AE	.58 53	4518AE	1.28 98
4018BE	1.25 1.20	4051AE	1.15 1.10	4518BE	1.28 98
4019AE	54 49	4052AE	1.40 1.39	4528AE	2.25 2.19
4019AF	70 68	4052BE	1.45 1.44	4528BE	2.25 2.24
4019BE	60 55	4053AE	1.40 1.39	4585AE	2.05 1.95
4020AE	45 43	4054AE	1.35 1.34	4514AE	32 31
4021AE	1.30 1.20	4055AE	1.95 1.94	4511AE	32 31

INDUSTRIAL QUALITY COMPONENTS
 What is more important?
 QUALITY OR PRICE?
 We have decided to offer only the highest quality components. When quality counts, you can count on Ancrona.

IC SOCKETS		TEFLON TO-5		SOLDER-TIN DIP	
WIRE-WRAP GOLD DIP				1.24 25 100	
PIN 1.24 25 100	4 PIN .55 EA	8 21 19 17			
14 28 41 37	4 PIN .65 EA	16 25 22 20			
16 54 49 44	8 PIN 1.10 EA	16 28 31 28			
	8 PIN 1.40 EA	22 37 36 35			
		22 47 43 40			
		28 38 80 70			
		36 1.09 98 89			
		16 37 34 31	8 PIN 4.0EA	4.00 1.12 12.90	

1-AMP RECTIFIERS			
Part No.	1.9 10up	10up	10up
INTERSIL 8038			
PRECISION WAVEFORM GENERATOR & VCO			
For simultaneous sine, square and triangle waveforms C_{001}			
Hz to 1MHz:			
8038CCPD	\$3.90	\$3.70	\$4.00

HYBRID POWER AMPLIFIERS			
Model No.	Vdc	Amps	Price
SI-1010G	10W	\$6.40	\$2.00
SI-1020G	20W	9.90	\$2.00
SI-1050G	50W	24.90	\$2.00
SI-1050G	50W	24.90	\$2.00

HIGH VOLTAGE TRANSISTORS			
Model No.	Vdc	Amps	Price
Bu204	3A	1300V	\$4.14
Bu205	3A	1500V	4.95
Bu206	3A	1700V	5.94
Bu207	6A	1300V	5.85
Bu208	6A	1500V	6.93
Bu209	6A	1700V	8.64

ANCRONA CORP.
 Mail order: P.O. Box 2208P, Culver City, CA 90230. Phone order: (213) 641 4064
 Prices may vary at over the counter locations.

MICROPROCESSOR SPECIAL

8080A \$34.90
 8080 27.50
 AM2901 31.50

F8 MICROPROCESSOR KIT . . . \$185.00

RAM'S		SHIFT REGISTER	
1.9 10up	1.9 10up	1.9 10up	1.9 10up

Olson

Electronics Parts and Accessories



- TL-477. Soldering Iron 2.99
- VC-274. 12-Pc. Volume Control Kit 49c
- XM-501. 40-Pc. Terminal Strip 79c
- XM-370. 7 Seg. L.E.D. Display 1.29
- TR-446. 25-Pc. Ass'd. SCR 1.49
- SW-555. 90-120 V AC Relay 59c
- SW-156. Ctr.-Off Toggle Switch DPDT. Pkg. 2 2.49
- SW-460. 3 Button Push Switch 24c
- SW-636. Thermostatic Switch 50-600 NO 39c
- SW-752. Unimax 15A Switch SPST 49c
- SW-587. 5A Toggle SPST NO 39c
- SW-431. Phone Type Lever Switch 4 SPST 62c
- SW-632. Reed Switch W/Magnet SPST. Pkg. 10 1.29
- MD-359. 1/30 RPM Timing Motor 120V AC 49c
- TT-092. 2500 OHM Output Transformer 64c
- TF-047. 6 V 1/2 A. Filament Transformer 44c
- TF-050. 12V .2A Filament Transformer 47c
- KN-030. 25-Pcs. Assorted Knobs 49c
- ME-182. 0-1 Ma Panel Meter 1 3/8" Mtg. Hole 89c
- ME-205. 0-200 UA. Panel Meter 1 5/16 x 5/8" 74c
- ME-204. 0-150 UA. Panel Meter 1 x 1 x 7/8" 74c
- ME-203. 100-0-100 UA. 1"x1"x7/8" Meter 74c

When ordering allow for postage. CDD 20% Deposit. Residents of the following states please add Sales Tax: Ca. 5%, Fl. 4%, GA. 3%, Il. 4%, Ky. 5%, Ma. 5%, Mi. 4%, Mo. 3%, N.Y. 4%, Oh. 4%, Pa. 6%, Tx. 4%.

FREE 7 Olson Catalogs
FREE Olson CB Catalog
 NEXT 7 ISSUES SENT TO YOU FREE
 WITH DEALERS PRICE LIST

Olson Electronics, 260 S. Forge St., Dept. IM, Akron, Ohio 44327
 Please send me Olson catalog CB catalog Both. Please Print

NAME _____
 ADDRESS _____
 CITY _____
 STATE _____ ZIP _____

CIRCLE NO. 38 ON FREE INFORMATION CARD

REAL ESTATE

BIG SUMMER CATALOG Free! Over 2,600 top values coast to coast! UNITED FARM AGENCY, 612-EP West 47th, Kansas City, MO 64112

RECORDS

RECORD RATERS WANTED! Anyone qualifies. We ship you nationally released LP's to rate. We pay postage and handling. You pay nothing for LP's. All you pay is small membership fee. Applicants accepted "first come basis." Write: E.A.R.S., Inc., Dept. PE, Box 10245, 5521 W. Center Street, Milwaukee, Wisconsin 53210.

SERVICES

CANADIAN CB Mail Order Service, discount prices. Send for List. L. W. Electronics, Box 42, Strathroy, Ontario, Canada. U.S. Inquiries.

INVENTIONS WANTED

INVENTORS: Manufacturers Need New Products. Free "Recommended Procedure," by a creative fee-based invention service company. Washington Inventors Service, 422-T Washington Building, Washington, D. C. 20005.

INVENTORS WANTED

RECOGNITION... FINANCIAL REWARD... OR CREDIT
 for "inventing it first" may be yours!

If you have an idea for a new product, or a way to make an old product better, contact us, "the idea people." For a fee, we'll develop your idea, introduce it to industry, negotiate for cash sale or licensing. Send for our FREE "Inventor's Kit." It has a Directory of 500 Corporations Seeking New Products, a special "Invention Record Form," and important Marketing Information.

RAYMOND LEE ORGANIZATION
 230 Park Avenue North, New York, NY 10017
 Yes, I'd like to find out how to take action on my idea. Rush your FREE INVENTOR'S KIT No. A-112

Name _____ Please Print
 Address _____
 City _____ State _____ Zip _____
 A Fee-Based Invention Service Company

FREE PAMPHLET: "Tips on Marketing Your Invention," from an experienced fee-based invention service company. Write United States Inventors Service Company, Dept. T, 1435 G Street NW, Washington, D. C. 20005.

HYPNOTISM

SLEEP learning. Hypnotic method. 92% effective. Details free. ASR Foundation, Box 23429EG, Fort Lauderdale, Florida 33307.

FREE Hypnotism. Self-Hypnosis. Sleep Learning Catalog! Drawer H400, Ruidoso, New Mexico 88345.

AMAZING self-hypnosis record releases fantastic mental power. Instant results! Free trial. Write: Forum (AA6), 333 North Michigan, Chicago 60601.

INSTRUCTION

LEARN ELECTRONIC ORGAN SERVICING at home all makes including transistor. Experimental kit—trouble-shooting. Accredited NHSC. Free Booklet, NILES BRYANT SCHOOL, 3631 Stockton, Dept. A, Sacramento, Calif. 95820.

EARN ELECTRONICS DEGREE by correspondence. Free information bulletin. Grantham, 2000 Stoner Avenue, Los Angeles, California 90025.

INTENSIVE 5 week course for Broadcast Engineers. F.C.C. First Class license. Radio Engineering Incorporated, 61 N. Pineapple Ave., Sarasota, Florida 33577 and 2402 Tidewater Trail, Fredericksburg, VA 22401.

NO FCC LICENSE? Tried every way but the right way? It's time for Genn Tech. Home Study. Free Catalog, 5540 Hollywood Blvd., Los Angeles, Calif. 90028.

LEARN Basic Digital Troubleshooting by correspondence. Information Free. Educational Technologies, Box 224, Reynoldsburg, Ohio 43068.

LEARN WHILE ASLEEP! HYPNOTIZE! Astonishing details. strange catalog free! Autosuggestion, Box 24-ZD, Olympia, Washington 98507.

SCORE high on F.C.C. Exams. Over 300 questions and answers. Covers 3rd, 2nd, 1st and even Radar. Third and Second Test. \$14.50; First Class Test, \$15.00. All tests. \$26.50. R.E.I., Inc., Box 806, Sarasota, Fla. 33577.

UNIVERSITY DEGREES BY MAIL! Bachelors, Masters, Ph.D's. Free revealing details. Counseling, Box 1162-PE6, Tustin, California 92680.

SELF-STUDY CB RADIO REPAIR COURSE. THERE'S MONEY TO BE MADE REPAIRING CB RADIOS. This easy-to-learn course can prepare you for a career in electronics enabling you to earn as much as \$16.00 an hour in your spare time. For more information write: CB RADIO REPAIR COURSE, Dept. PE066, 531 N. Ann Arbor, Oklahoma City, Okla. 73127.



LOGIC PROBE KIT Use with CMOS TTL, DTL, RTL, HTL, HNHL and most MOS IC's. Built-in protection against polarity reversal and overvoltage. Draws only a few nA from circuit under test. Dual LED readout. Complete kit includes case and clip leads. \$8.95

VARIABLE REGULATED POWER SUPPLY KIT Continuously variable from 3 to over 15 Volts. Short circuit proof with electronic current limiting at 300 mA. Compact size and typical regulation of 0.1% make this a great bench or lab power supply. \$11.95

FIXED REGULATED POWER SUPPLY KITS Short circuit proof with thermal current limiting. Compact size and typical regulation of 0.05% make these great for most electronic projects. Available for 5V @ 900mA, 6V @ 900mA, 9V @ 600mA, 12V @ 400mA, 15V @ 300mA. Specify voltage when ordering. \$8.95 ea.

These easy to assemble kits include all components, complete detailed instructions and plated fiberglass PC boards. Power supply kits do not include case or meters. Add \$1.25 per kit for postage and handling.

- TRANSISTORS (NPN)
- 2N918 TYPE RF Amp & Oscillator to 1 GHz 3/S1.00
 - 2N3563 TYPE RF Amp & Osc to 1 GHz (pl. 2N918) 6/S1.00
 - 2N3565 TYPE Gen. Purpose Gain (TD-92/106) 6/S1.00
 - 2N3866 TYPE RF Power Amp 1.5 W @ 450 MHz \$0.75
 - 2N3904 TYPE GP Amp & Sw to 100 mA IFE 100 6/S1.00
 - Assort. NPN GP TYPES, e.g. 2N3694, 2N3903, etc. (15) \$2.00
 - 2N3638 TYPE (PNP) GP Amp & Sw to 300 mA 6/S1.00
 - 2N3906 TYPE (PNP) GP Amp & Sw to 30 MHz 6/S1.00

- FET's:
- N-CHANNEL (LOW-NOISE)
- 2N4091 TYPE RF Amp & Switch (TD 18/106) 3/S1.00
 - 2N4416 TYPE RF Amplifier to 450 MHz (TD 12) 2/S1.00
 - 2N5163 TYPE Gen. Purpose Amp & Sw (TD 106) 3/S1.00
 - 2N5486 TYPE RF Amp to 450 MHz (plastic 2N4416) 2/S1.00
 - E100 TYPE Low-Cost Audio Amplifier 4/S1.00
 - 1TE4868 TYPE Ultra-Low Noise Audio Amp 2/S1.00
 - T1574 TYPE High-Speed Switch 40! 3/S1.00
 - Assort. RF & GP FET's, e.g. 2N5163, MPF102, etc. (8) \$2.00
- P-CHANNEL:
- 2N4360 TYPE Gen. Purpose Amp & Sw (TD-106) 3/S1.00
 - E175 TYPE High-Speed Switch 125! (TD 106) 3/S1.00

SUPER SPECIALS:

- 2N2222 NPN TRANSISTOR GP Amp & Switch 6/S1.00
- 2N2907 PNP TRANSISTOR GP Amp & Switch 6/S1.00
- 2N3553 TYPE GP Power Amp 5 W @ 150 MHz, 3 W @ 50 MHz \$1.50
- MPF102 N-CHANNEL FET RF Amp 200 MHz 3/S1.00
- 556 DUAL 555 TIMER 1 μsec to 1 hour (DIP) \$0.90
- 723 VOLT. REGULATOR 3-30 V @ 1-200 mA (DIP/TD-5) 3/S1.00
- 2740 FET Op Amp, Like NE536 and μA740 (TD-5) \$1.95
- μA7805 VOLTAGE REGULATOR 5 V @ 1 A (TD-220) \$1.25
- 8038 WAVEFORM GENERATOR Wave w/ckts \$4.50
- 1N4154 DIODE 30 V/10mA IN914 except 30 V 25/S1.00
- BR1 BRIDGE RECTIFIER 50 V PIV, 500 mA (DIP) 4/S1.00
- MM5314 DIGITAL CLOCK CHIP With Specs/Schematics \$4.95

- LINEAR IC's:
- 308 Micro-Power Op Amp (TD-5/MINI-DIP) \$1.00
 - 309K Voltage Regulator 5 V @ 1 A (TD-3) \$1.25
 - 324 Quad 741 Op Amp, Compensated (DIP) \$1.50
 - 340T Volt. Reg.-1 Amp Specify 5, 6, 12, 15 or 24 V-w/ckts \$1.75
 - 380 2.5 Watt Audio Amplifier 34 dB (DIP) \$1.29
 - 555 Timer 1 μs to 1 hr. NE555, LM555, etc. (MINI-DIP) 2/S1.00
 - 709 Popular Op Amp (DIP/TD 5) \$0.29
 - 739 Dual Low-Noise Audio Preamp/Op Amp (DIP) \$1.00
 - 1458 Dual 741 Op Amp (MINI-DIP) 2/S1.00
 - 741 Freq. Comp. Op Amp (DIP/TD-5/MINI-DIP) 4/S1.00

- DIODES:
- ZENERS—Specify Voltage 3.3, 3.9, 4.3, 5.1, 6.8, 8.2, 400mW 4/S1.00
 - 9.1, 10, 12, 15, 18, 20, 22, 24, 27, or 33V (10%) 1 Watt 3/S1.00
 - 1N914 or 1N4148 TYPE General Purpose 100V/10mA 15/S1.00
 - 1N3893 TYPE RECTIFIER Stud Mount 400 V/1/2 A 2/S1.00
 - D5 VARACTOR 5-50 W Output @ 30-250 MHz, 7 70 pF \$5.00
 - F7 VARACTOR 1-3 W Output @ 100-500 MHz, 5-30 pF \$1.00

*MAIL NOW! FREE DATA SHEETS supplied with every item from this ad. FREE ON REQUEST. 741 Op Amp with every order of \$5 or more. 749 Dual Op Amp or two E100 FET's with every order of \$10 or more. Postmarked prior to 8/31/76. One free item per order.
 ORDER TODAY! All items subject to prior sale and prices subject to change without notice. All items are new surplus parts. 100% functionally tested. WRITE FOR FREE CATALOG. 7510 offering over 350 semiconductor catalog items. Send \$3.00.
 TERMS: Small check or money order (U.S. funds) with order. We buy 1st Class postage in U.S. Canada and Mexico (except on kits). \$1.00 handling charge on orders under \$10. Calif. residents add 6% sales tax. Foreign orders add postage-COD orders add \$1.00 service charge.

ADVA ELECTRONICS
 BOX 4181 BT, WOODSIDE, CA 94062
 Tel. (415) 851-0455
 CIRCLE NO. 3 ON FREE INFORMATION CARD

F.C.C. EXAM MANUAL

PASS FCC EXAMS! Memorize, study — "Test Answers" for FCC 1st and 2nd class Radio Telephone licenses. Newly revised multiple choice questions and diagrams cover all areas tested on FCC exams plus "Self-Study Ability Test." \$9.95 postpaid. Moneyback Guarantee.

LOWMAN PRODUCTIONS P.O. BOX 26348-P
 SALES ENGINEERING DIVISION SAN FRANCISCO, CALIF. 94126

BURGLAR/FIRE ALARM EXPERTS NEEDED for cars, homes, industry. Learn high profit systems installation at home spare time. Simple, quick, complete. Free information by mail. No salesmen. Security Systems Management School (homestudy), Dept. 7373-066, Little Falls, N.J. 07424.

BROADCAST STATION: Start your own! Learn how. Details Free! "Radio Opportunities," Box 5516-AE, Walnut Creek, CA 94596.

FCC LICENSE STUDY GUIDE — 377 pages, 1465 questions with answers/discussions — covering third, second, first radiotelephone examinations. \$9.95 postpaid. GSE, 2000 Stoner, Los Angeles, California 90025.

Popular Electronics

JUNE 1976

ADVERTISERS INDEX

READER SERVICE NO.	ADVERTISER	PAGE NUMBER
1	A P Products	81
70	Ace Electronics	104
	Acoustic Fiber Sound	25
3	Adva Electronics	120
4	Allison Automotive Company	99
	Alpha Electronics	96
6	Altaj Electronics	114
68	Altaj Electronics	115
7	Ancrona Corp.	119
8	Aries Inc.	121
	Audio Technica U.S. Inc.	79
9	Avanti Research & Development	6
65	B&K Product of Dynascan	97
10	Babylon Electronics	117
11	C D Two	95
	CREI Capitol Radio Engineering Institute	50, 51, 52, 53
12	Circuit Design, Inc.	16
	Cleveland Institute of Electronics	68, 69, 70, 71
14	Cobra, Product of Dynascan	SECOND COVER
13	Continental Specialties Corporation	83
66	Continental Specialties Corporation	99
15	Delta Electronics Co.	109
16	Delta Products, Inc.	96
17	Digi-ty Corporation	118
	Dixie Hi-Fidelity Wholesalers	100
18	EICO	67
19	Eddie Electronics	112
20	Edmund Scientific Co.	115
21	Edmund Scientific Co.	122
22	Electronics Technical Institute	21
23	Godbout Elecs. Bill	109
24	Grantham School of Engineering	100
71	Greenlee Tool Co.	93
64	Hal Communications	96
5	Health Company	91
25	Hewlett-Packard	1
26	IMS Associates Inc.	26
63	IMS Associates Inc.	77
27	Illinois Audio	75
28	International Electronics Unlimited	116
29	James	110, 111
33	Johnson Company, E.F.	FOURTH COVER
30	McGraw-Hill Book Company	85
31	McIntosh Laboratory Inc.	81
	MITS	27
34	Motorola	7
	NRI Schools	8, 9, 10, 11
	National Technical Schools	86, 87, 88, 89
35	New Concepts	75
36	New-Tone	117
37	Non Linear Systems	100
38	Olson Electronics	120
39	PAIA Electronics, Inc.	98
40	Pathcom Inc.	32
41	Phase Linear Corporation	17
43	Poly Paks	107
72	Polymorphic Systems	98
	Processor Technology Co.	54
45	Quest Electronics	117
46	Radio Shack	19
69	Reticom	18
47	Royce Electronics	14, 15
48	S A E	94
49	SBE, Inc.	2
50	S.D. Sales Co.	113
51	Schober Organ Corp.	98
52	Senecore	66
	Sinclair Radionics, Inc.	31
53	Solid State Sales	108
54	Sound Guard	22, 23
62	Southern California Computer Society	101
55	Southwest Technical Products Corporation	29
	Sphere	66
42	Stanton Magnetics Inc.	THIRD COVER
57	Stereo Discounters	103
58	Technology Trends	56
59	Telex Communications, Inc.	13
60	Tri-Star Corporation	103
61	Wahl Chipper Corporation	98
67	Wenover Associates	5
	CLASSIFIED ADVERTISING	104, 108, 109, 112, 115, 116, 118, 120, 121

AMATEUR RADIO. Complete no-textbook correspondence Code and Theory license courses. Ron Reed Electronics Institute, 12217 Santa Monica Blvd., Los Angeles, CA 90025.

PASS FCC EXAMINATIONS! First Phone question — answers. Proven results. \$7.00, guaranteed. Exams. Box 5516AE, Walnut Creek, CA 94596.

BUSINESS OPPORTUNITIES

I MADE \$40,000.00 Year by Mailorder! Helped others make money! Free Proof. Torrey, Box 318-NN, Ypsilanti, Michigan 48197.

FREE CATALOGS Repair air conditioning, refrigeration. Tools, supplies, full instructions. Doolin, 2016 Canton, Dallas, Texas 75201.

MAILORDER MILLIONAIRE helps beginners make \$500 weekly. Free report reveals secret plan! Executive (1K6), 333 North Michigan, Chicago 60601.

PIANO TUNING LEARNED QUICKLY AT HOME! Musical knowledge unnecessary. Free Information. Empire School, Box 450327, Miami 33145.

GET RICH with Secret Law that smashes debts and brings you \$500 to \$5 Million cash. Free report! Credit 4K6, 333 North Michigan, Chicago 60601.

HIGHLY PROFITABLE ONE-MAN ELECTRONIC FACTORY

Investment unnecessary, knowledge not required, sales handled by professionals. Postcard brings facts about this unusual opportunity. Write today! Barta-DF, Box 248, Walnut Creek, CA 94597.

FREE, SECRET BOOK "2042 UNIQUE. Proven Enterprises! Fabulous "Little Knowns" Work home! Haylings-B. Carlsbad, Calif. 92008

OPERATE your own profitable human relations success groups. Free brochure AIM, Box 2446F, San Leandro, CA 94577.

\$178 WEEKLY. Work one hour daily. Completely Guaranteed. Free FAS, Box 13703-R, San Antonio, Texas 78213

MAIL ORDER dealers wanted. Earn outstanding profits! Free information. Star Enterprise, RR No 4-PE, Van Wert, Ohio 45891

HOW TO MAKE \$2,000 WEEKLY at home using other people's money. Guaranteed. Free details. Richlieu Reports, Box 25277-F, Houston, Texas 77005

EMPLOYMENT OPPORTUNITIES

ELECTRONICS/AVIONICS EMPLOYMENT OPPORTUNITIES. Report on jobs now open. Details FREE. Aviation Employment Information Service, Box 240E, Northport, New York 11768.

CALIFORNIA companies hiring Engineers and Technicians. Current openings bulletin \$3 Dynamics, Box 1867-K, Covina, Calif 91722

DO-IT-YOURSELF

TV PROBLEMS? Send symptoms / copy schematic / self addressed-stamped envelope with \$3.00. Troubleshooter, Box 4553-PE, Downey, Calif. 90241

MODULAR TELEPHONES now available. Sets and components, compatible with Western Electric concept. Catalog 50 cents. Box 1654W, Costa Mesa, California 92626

BOOKS AND MAGAZINES

FREE book prophet Elijah coming before Christ. Wonderful bible evidence. Megiddo Mission, Dept 64, 481 Thurston Rd., Rochester, N.Y. 14619

FREE CATALOG. Aviation and Space Books. Aero Publishers, 329PE West Aviation, Fallbrook, California 92028

THE AUDIO AMATEUR—A quarterly publication for the serious audio constructor. Free prospectus. The Audio Amateur, Box 176Z, Peterborough, N.H. 03458

CB SLANG DICTIONARY—Most complete CB Dictionary Handbook available. Hundreds of slang terms plus part 95 mandatory FCC rules. Great gift. Order NOW. Send \$5.00 to: Communication Books, Inc., Dept. PE, Box 10198, Milwaukee, WI 53210.

CBese SLANG DICTIONARY of 600 CB and Truckers terms. \$1.25 postpaid. Big Bear Enterprises, 1932 East Eucalyptus, Unit P, Brea, Calif. 92621.

ARIES brought you the first calculator kit, and the first digital clock kit . . . and now brings you three of the most innovative electronic kits ever made. The System 300 Electronic Music Synthesizer kit is the most advanced in the world today, regardless of price. The AR-781 is a space-age beauty for any decor. And the wholly solid state AR-830 does the work of a \$400.00 tape memory unit.



WARNING . . . if you're interested in a music synthesizer, don't make a move until you see our catalog first. It's more like a handbook than a catalog, with hundreds of in-depth photographs and descriptions to explain electronic music principles, and to show equipment to do the job. **ARIES** now offers a complete complement of modules, keyboards, and cases, matched to the most rigorous professional standards. Starter systems priced as low as \$395.00.

A clear, ruby-red cylinder shows off all six digits of this modern calendar clock. Easy-to-read numbers show the hours, minutes, and seconds, as well as the month and day every ten seconds.



Red LED 7-segment numerals are 0.33" high, in a sturdy cylinder 2-1/2" in diameter and 4-3/4" long, with finished hardwood ends. Time and calendar are controlled by 60 Hz line frequency, with a 12-month movement. Separate time and calendar adjustments. Includes all the components, PC boards, housing, and instructions. Shipping weight 2 lbs, **AR-781 Clock Kit** \$34.50

Add finger-touch operation to your old-fashioned dial telephone with an **ARIES AR-830 Automatic Digital Telephone Dialer**. This has the same layout and convenience as Ma Bell, plus other features she doesn't offer yet. For instance . . . **AR-830** always remembers the last number you dialed, in case the line was busy and you want to try again later. Not only that, but the Dialer's memory can store as many as ten of your favorite numbers for one-touch dialing. **AR-830** uses standard dialing and muting contacts; consult local tariffs before connecting. Sh. wt. 2 lbs. **AR-830 Dialer Kit** \$69.50



ARIES INC.
119 Foster Street
Peabody, Mass., 01960
(617) 532-0450

CIRCLE NO. 8 ON FREE INFORMATION CARD

PRO SPORTS ACTION FILMS

SUMMER ENTERTAINMENT FILM FUN—Start or add to your collection with SportLite specials: Tunney/Gibbons & Tunney/Heehey on 1 Super 8 B&W 200' reel, \$6.95 ea PPD '69 NBA — its greatest year! Celtics vs. Lakers — see Russell star! Super 8 B&W, \$6.95 ea PPD. '74 Stanley Cup Playoffs (Flyers/Bruins) Standard 8 B&W, \$6.95 ea or Color, \$16.95 ea PPD, can be shown on Dual 8 projector. Or buy Apollo 15, The Ride of the Rover, official NASA footage, a Columbia Picture. Super 8 B&W, \$5.95 ea while they last. 40 cents for new Castle catalog; 30 cents each for Columbia or SportLite order forms (coins, stamps, no checks pls). **SPORTLITE.** Elect-6, Box 24-500, Speedway, Indiana 46224

MISCELLANEOUS

WINEMAKERS Free illustrated catalog yeasts, equipment. Semplex, Box 12276P, Minneapolis, Minn. 55412.

LIVE IN THE WORLD OF TOMORROW... TODAY!

And our FREE 164 PAGE CATALOG is packed with exciting and unusual values in electronic, hobby and science items — plus 4,500 finds for fun, study or profit... for every member of the family.

A BETTER LIFE STARTS HERE

WORLD'S SMALLEST RECHARGEABLE CALCULATOR!

Small but mighty! 8-digit, 4-function *electronic* calculator does everything big ones do—even has automatic % key... for only \$19.95. Take it anywhere. Fits in your pocket— $\frac{1}{2}$ size of cigarette pack. $3\frac{1}{2}$ oz. dynamo features floating decimal, constant key, lead zero depression, more! Includes plug-in rechargeable Ni-Cad battery pack, $2 \times 3\frac{1}{2} \times \frac{9}{16}$ " with plenty of room for most fingers. Another Edmund first with advanced technology.



Stock No. 1945AV \$19.95 Ppd.

SUPER POWER FOR ANY AM RADIO

New antenna assist turns a tiny transistor into a tiger, has pulled in stations up to 1000+ miles away! Just set beside radio (no wires, clips, grounding) and fine-tune Select-A-Tenna's dial to same frequency — "gangbusters"! Great for clearing weak signals in radio depressed areas, off-coast islands, crowded frequency stations. Solid state — uses no electricity, batts., tubes.



Stock No. 72,095AV \$15.95 Ppd.

ULTRA SELECT-A-TENNA
No. 72,147AV (*OVER 1000 MI.) \$22.95 Ppd.

KNOW YOUR ALPHA FROM THETA!

For greater relaxation, concentration, monitor your Alpha/Theta brainwaves w/ audible or visible signal on Biosone II. Has 3 feedback modes, outputs to monitor logic signal, filter sel. feedback, broad sensitivity control; other professional feats. of \$200+ up units. Easily operated 4-lb. portable has total brainwave monitoring capability! Req. 2 9v tr. batteries.



No. 1668 ($9\frac{1}{2} \times 5\frac{1}{2} \times 4\frac{1}{4}$ ") \$149.95 Ppd.
LOW COST STARTERS' UNIT (PORTABLE)
No. 71,809 AV ($4\frac{1}{2} \times 2\frac{3}{4} \times 4\frac{1}{4}$ ") \$55.00 Ppd.

SEE MUSIC IN PULSATING COLOR

New 3-Channel Color Organ adds to music listening pleasure, lets you modulate 3 independent strings of colored lamps with intensity of your music to create an audio "light show." They flash, vary in brightness related to music's rhythm, pitch, volume—pulsating lighting performance to music! Fully assembled & priced half that of others, the Edmund Sound To Light Control is a terrific value. Plug in, turn on!



No. 42,309AV... (ASSEMBLED) \$17.95 Ppd.
No. 42,336AV... (UNASSEMBLED) \$13.95 Ppd.

WHEN YOU COME TO PHILADELPHIA BE SURE TO SEE
FREE BICENTENNIAL LIGHT SHOW
IN BARRINGTON, N. J. ONLY 10 MINUTES AWAY AT
EDMUND FACTORY STORE

INCLUDED FREE
\$33.50 ORTHOSCOPIC
EYEPIECE
(TIL 7/31/76)



4 1/4" ASTRONOMICAL TELESCOPE

FREE EYEPIECE: 12.5mm F.L., 96X w/ 48" F.L. Objective
See moon craters, rings of Saturn, double stars. Features fine f/10 mirror (verified better than 1/10 wave with a scatter plate interferometer) to insure performance to theoretical limit of resolution. Equatorial mount, rack & pinion focusing; aluminum tube, 6X finder, 25mm F.L. 45X Kellner achromatic eyepiece & Barlow lens to double and triple power to 135X. Incl. FREE Star Chart plus 2 Books. *Pyrex.®.

No. 85,260AV (SHPG. WT. 42 LB.) \$159.50 FOB
No. 85,261AV (CLOCK DR.; 45 LB.) \$199.50 FOB

LOW-COST DIGITAL MULTIMETER

World's smallest, with accuracy of .1 to .3% of full scale! Measures up to 500V DC or AC, up to 10 megohms—3 digit LED reading seen 8 ft. away! Performance & acc. of a digital volt-ohm-meter; very high impedance better than most VTVM's, great for TV. 9-oz. "pocket" unit has 13 ranges (4V DC, 4V AC & 5 ohms), operates form 0-45°C. Overload indicator, more! Req. 3 AA batts.



No. 72,192AV... (1.9x2.7x4") \$115.00 Ppd.
WITH RECHARGEABLE BATTs. & RECHARGER
No. 72,179AV \$129.95 Ppd.

ELECTRONIC DIGITAL STOPWATCH: \$49.95

The price alone obsoletes your wind-up timer and it's .0002% accurate! Hand-held, you start, stop, reset compact 6-ounce w/one hand; times to 99 mins, 59.9 secs in 1/10 increments. Failsafe design (cannot be accidentally reset), solid-state



electronic! Incl. neckstrap, repl. batts.
No. 1671AV (5-DIGIT LED DISPLAY) \$49.95 Ppd.
SPLIT ACTION W/NICADS, RECHARGER
No. 1669AV (5-DIGIT LED DISPLAY) \$79.95 Ppd.
DELUXE SPLIT ACTION BATTERY MODEL
No. 1653AV (6-DIGIT NEON DISPLAY) \$149.95 Ppd.

LOW COST INFRA-RED VIEWER

For Infra-red crime detection surveillance, security system alignment, I.R. detection, laser checking, nite wildlife study, any work req. I.R. detection & conv. to visible spectrum. Self cont. scope w/ everything incl. I.R. light source, 6v or 12v power, 6032 I.R. converter tube, f/3.5 objective lens, adjust. triplet eyepiece. Provides 1.6X, focuses from 10' to infinity.



No. 1659AV ($11 \times 14\frac{1}{4} \times 3\frac{1}{2}$ ") \$285.00 Ppd.
WITHOUT LIGHT SOURCE
No. 1663AV \$225.00 Ppd.

WOW! TR METAL DETECTOR: \$69.95

Super-sensitive transmitter/receiver unit at a never-before price, w/feats. of \$150 types. Terrific selectivity—10-turn (not just 90°) metal/mineral tuner! 6" waterproof search coil find a cent at 6"; telescoping adjust. shaft gives 44" lgh., $\frac{1}{4}$ " stereo earphone jack; all metal constr.



Perfect balance & feather light, it incl. 8 "AA" batteries. Lifetime warranty!
No. 80,251AV (JUST 38 OZ.!) \$69.95 Ppd.
STARTERS' BFO CHALLENGER I (32 OZ.)
No. 80,222AV (ALUMINUM CONSTR.) \$39.95 Ppd.



MAIL COUPON FOR GIANT FREE CATALOG!

164 PAGES • MORE THAN
4500 UNUSUAL BARGAINS

Completely new 1976 edition. New items, categories, illustrations. Dozens of electrical and electromagnetic parts, accessories. Enormous selection of Astronomical Telescopes. Unique lighting and ecological items. Microscopes, Binoculars, Magnifiers, Magnets, Lenses, Prisms. Hard-to-get surplus bargains. Ingenious scientific tools. 1000's of components.

EDMUND SCIENTIFIC CO.
300 Edscorp Building, Barrington, N. J. 08007
Please rush Free Grant Catalog "AV"

Name _____
Address _____
City _____ State _____ Zip _____



COMPLETE & MAIL WITH CHECK OR M.O.

EDMUND SCIENTIFIC CO. 300 Edscorp Building, Barrington, N.J. 08007

How Many Stock No.	Description (609) 547-3488	Price Each	Total
<input type="checkbox"/>	PLEASE SEND GIANT FREE CATALOG "AV"		
<input type="checkbox"/>	Charge my BankAmericard		
<input type="checkbox"/>	Charge my Master Charge		
		Add Service and Handling Charge \$1.00	

Interbank No.

My Card No. is

Card Expiration Date

I enclose check money order for TOTAL \$

Signature _____

30-DAY MONEY-BACK GUARANTEE. Name _____
You must be satisfied or return any purchase in 30 days for full refund. *\$15.00 minimum Address _____
City _____ State _____ Zip _____

WKLS, Atlanta, broadcasts 100% disc-to-air. That's why it uses Stanton's 681 series... exclusively.



Chuck Ealston DJ, on the air at WKLS.

Top notch broadcasters who capture a large share of the listening audience, are critically aware of the necessity to achieve a superior quality of sound. Station WKLS is just such a station.

As Bob Helbush, chief engineer, states: "We broadcast 100% disc-to-air except for some commercials. So, for maximum quality sound and phase stability, we use the Stanton 681 SE for on-the-air use. We consider it the ideal answer for that application. And our program director uses Stanton's 681 Triple-E for auditioning new releases before we air them".

And Don Waterman, General Manager, added: "Today, every station in the SJR Communications group . . . all eight of them, all in Major Markets . . . use Stanton 681 cartridges on every turntable".

There are good reasons for this vast acceptance. Stanton's 681 Calibration Series cartridges offer improved track-

ing at *all* frequencies. They achieve perfectly flat frequency response to beyond 20 Kc. And the top-of-the-line, superb 681 Triple-E has an ultra miniaturized stylus assembly with substantially less mass than previously, yet it possesses even greater durability than had been thought possible to achieve.

Each 681 Series cartridge is guaranteed to meet its specifications within exacting limits and each one boasts the most meaningful warranty. An individually calibrated test result is packed with each unit.

Whether your usage involves recording, broadcasting or home entertainment, your choice should be the choice of the professionals . . . the STANTON 681.

Write today for further information to Stanton Magnetics, Terminal Drive, Plainview, N.Y. 11803.



CIRCLE NO. 42 ON FREE INFORMATION CARD

New Horizons In CB Performance

The Johnson solid-state meter.

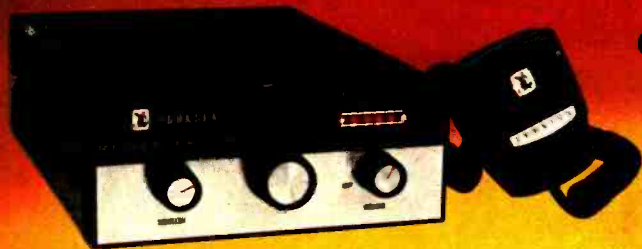

Clearly an improvement! Bright ruby red LED readouts let you read signal strength, transmitter power and modulation precisely ... at a glance! All solid-state, it's completely reliable regardless of temperature, dust or humidity. Solid-state metering — exclusive in the Messenger 123SJ.

Engineer's triumph ... Operator's dream.

Improving what is already the best is the ultimate challenge for the engineer. And the ultimate reward for the CB operator. Now you can experience the incredible interference rejection of the only dual cascaded crystal filtering system in CB — plus a new fully automatic noise limiter and RF-type noise blanker. It's a dream rig you can own! Messenger 323A.



Johnson sideband. Again!



Nearly 10 years ago we introduced the first CB sideband radio ... now Johnson offers the most advanced SSB performance on-the-air! With color-keyed lights for USB/LSB/AM modes, individual controls for every function, and famous Johnson quality, performance, warranty and service. Viking 352.

Write for free catalog



JOHNSON

E. P. JOHNSON COMPANY, WASECA, MINNESOTA 56093

In Canada: A. C. Simmonds & Sons, Ltd.