

EXCLUSIVE! \$50 CD-4 QUADRAPHONIC DEMODULATOR KIT

Popular Electronics®

WORLD'S LARGEST-SELLING ELECTRONICS MAGAZINE SEPTEMBER 1975/75¢

A PE TESTED! BREAKTHROUGH!

NOW...EXCHANGE COMPUTER DATA EASILY, INEXPENSIVELY

Introducing PE's Hobbyist Interchange Tape (HIT) System

KARNAUGH MAPS FOR FAST DIGITAL DESIGN

A neat, simple method for working with logic

HOW TO GET EXTRA FUNCTIONS FOR SIMPLE HAND CALCULATORS

Add memory, constant, % at little cost

BUILD A DIRECT-READING LOGIC PROBE

Readout displays high, low, open and pulse

TEST REPORTS:

- Heathkit "Digital" Color TV ● Realistic Portable Scanner
- Pickering Discrete 4-Channel Cartridge
- Crown Electronic Crossover ● Hickock Curve Tracer

What Does Your Stereo Receiver Dollar Buy?

Hirsch-Houck Labs compares performance and cost



Pioneer's new 9191...the best cassette deck under \$450[†] that money can buy.

Here is a magnificent cassette deck with specifications that are beyond what our industry had been aware were possible; specs that surpass anything that a deck of this price, performance and quality has ever been able to come up to before. Unbelievably low wow and flutter; solenoid controls that operate at a touch with almost magical precision, and a unique, truly-visible horizontal front loading system by which the cassette is effortlessly set into place with two fingers, are only a few highlights.

Pioneer's new 9191 incorporates a cascade of features and innovations: automatic CrO₂ tape detector and indicator light; an illuminated panel scale that lets you see at a glance the amount of tape remaining on a cassette; and an advanced memory rewind circuit that permits quick and easy location of (and automatic re-start from) any point on a cassette tape. It also has two independent drive motors; including an electronically-controlled DC unit for recording and playback.

Our engineers took into consideration the many types of tapes available and included superior bias and equalization circuitry and switching (in addition to the automatic CrO₂ detection system) so that the 9191's recording capability is



Unique, effortless front-loading system.



Selectable equalization and bias switches.

optimized for any kind of cassettes you want to use. And, of course, there's built-in Dolby B* to bring the 9191's S/N ratio up to 62 dB, even with standard tapes. We've also included separate mic/line mixing, and an extra pair of input and output jacks.

By now you realize that here is a cassette deck rivaling the performance of decks costing hundreds of dollars more; a deck whose controls make it respond faster than many reel-to-reel machines, and which offers greatly-extended frequency response and dynamic range. And it's the only front-loading, front-

control, stackable deck to have all the features we've mentioned.

But of all the ingredients that make up the 9191: performance, reliability, style and features, the most important of all is its value. We set out to build a cassette deck that was better, but less costly, than any deck built previously. We know we have succeeded. We know that you'll agree when you see and handle the Pioneer CT-F9191 at your Pioneer dealer.

CT-F9191 Specifications:

Frequency Response: Standard, LH tape: 25-16,000 Hz (35-13,000 Hz \pm 3dB); CrO₂ tape: 20-17,000 Hz (30-14,000 Hz \pm 3dB)

Signal-to-Noise Ratio: Dolby OFF: More than 52 dB; Dolby ON: More than 62 dB (Over 5,000 Hz, Standard and LH tapes) More than 66.5 dB over 5,000 Hz with CrO₂ tape

Harmonic Distortion: No more than 1.7% (OdB)

Wow and Flutter: No more than 0.07% (WRMS)

U.S. Pioneer Electronics Corp.,
75 Oxford Drive, Moonachie,
New Jersey 07074.

West: 13300 S. Estrella, Los Angeles
90248 / Midwest: 1500 Greenleaf, Elk
Grove Village, Ill. 60007 / Canada:
S.H. Parker Co.

PIONEER[®]
when you want something better



*Dolby is a trademark of Dolby Laboratories, Inc.

[†]\$449.95 is manufacturer's suggested resale price only and includes walnut grained vinyl top & side panels. Actual selling price is set by Pioneer dealer at his option.

CIRCLE NO. 66 ON FREE INFORMATION CARD

www.americanradiohistory.com

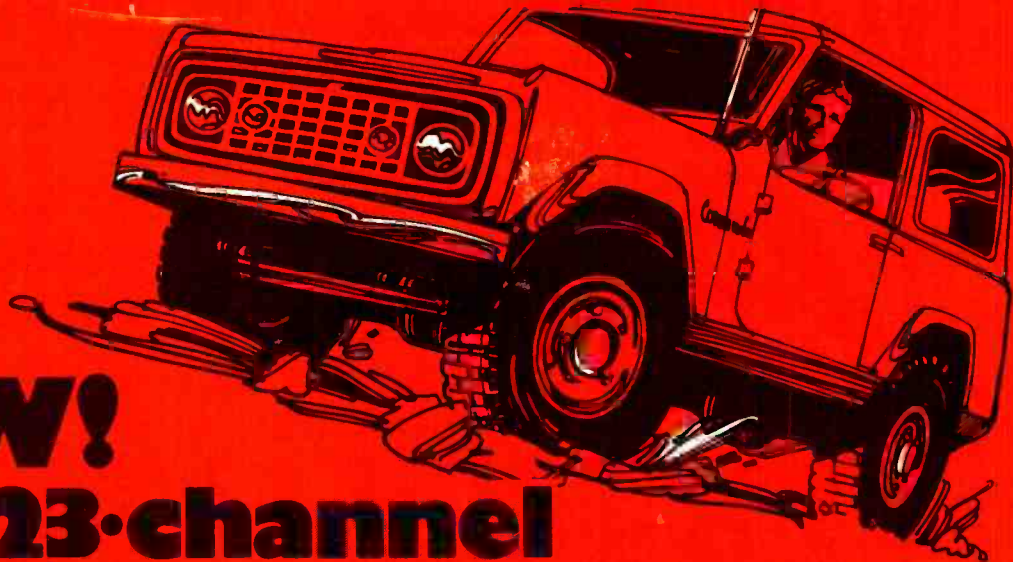

NOW! Full 23-channel operation from only 2 crystals!



Other Model 1-612 features:

- **LARGE (1 $\frac{3}{8}$ " x $\frac{3}{8}$ ") S-RF METER.** Offers visual signal input and power output indication.
- **TWIN LED LIGHT** indicate transmit (red) and receive (green).
- **VARIABLE TONE CONTROL.** You adjust audio response level to compensate for high noise levels.
- **LOCAL-DISTANT RF GAIN SWITCH** prevents overload and distortion from nearby transmitters.
- **AUTOMATIC NOISE ELIMINATOR SWITCH**—with On-Off feature.
- **PLUS THESE OTHER GREAT FEATURES AND CONVENIENCES:** CB-PA switch converts unit into powerful, 5-watt P.A./Hailer system . . . full-size, plug-in mike . . . illuminated channel dial . . . AMC circuit to prevent overmodulation . . . Tuned RF stage . . . Positive and negative ground operation . . . Full 4 watts power to antenna . . . Dual conversion superheterodyne receiver . . . External speaker jack.

Royce Model 1-612 Gyro-Lock Citizens Band Transceiver

That's Gyro-Lock! An amazing new innovation in CB engineering design. Imagine—full, 23-channel operation from only 2 crystals. Advanced, integrated circuits (10 of them) replace other crystals formerly needed. So, unlike old synthesizers which can be affected by temperature changes—with Royce Gyro-Lock you are always on channel, on every channel.

Reason enough to choose the Royce Model 1-612. But, your Royce Dealer has many other features to show you. Stop by and see them all—soon!



Royce
electronics
corporation

1142 Clay Street

North Kansas City, Missouri 64116

CALL (816) 842-0252 • TELEEX: 426-145

Send for full-line color brochure today!

CIRCLE NO. 46 ON FREE INFORMATION CARD

NEW... from A P Products

A·C·E

ALL-CIRCUIT EVALUATOR

OBSOLETE ordinary breadboards — for fast, solderless, plug-in circuit building and testing

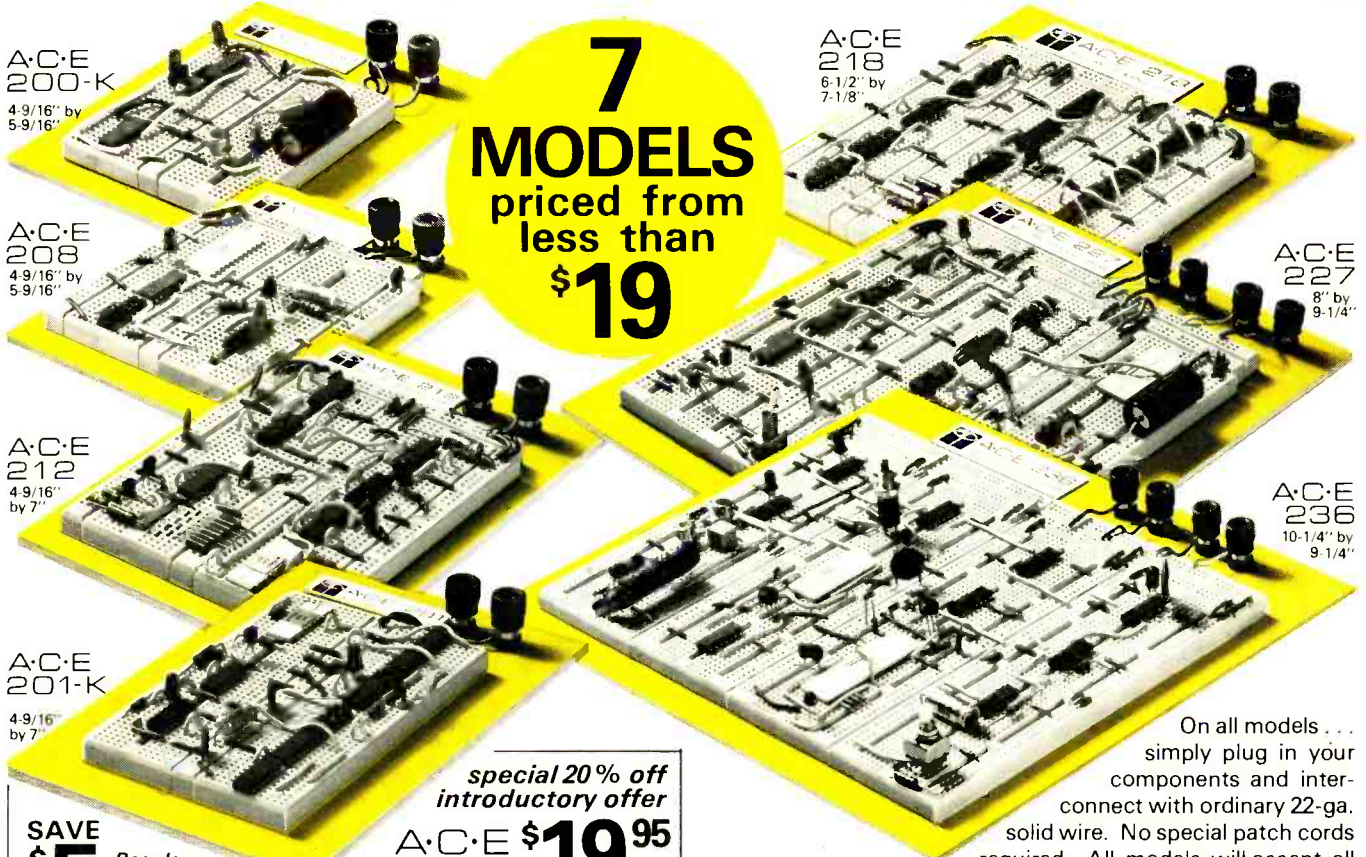

7
MODELS
priced from
less than
\$19

A·C·E
200-K
4-9/16" by
5-9/16"

A·C·E
218
6-1/2" by
7-1/8"

A·C·E
208
4-9/16" by
5-9/16"

A·C·E
227
8" by
9-1/4"

A·C·E
212
4-9/16" by
7"

A·C·E
236
10-1/4" by
9-1/4"

A·C·E
201-K
4-9/16" by
7"

special 20% off
introductory offer

A·C·E \$19⁹⁵
201-K

ASSEMBLE-IT-YOURSELF KIT

SAVE \$5
Regular \$24.95
value

Now you can enjoy the pleasure and convenience of checking out your circuits on an ACE from A P Products at this special low price! Just plug in and power up... no soldering required! Incorporates the famous A P multi-tie-point plug-in feature throughout for optimum circuit design flexibility.

OFFER EXPIRES SEPT. 30, 1975

ORDER TODAY AND SAVE

No. ACE's	Model No.	Total Price
Total cost of ACE's		
Residents of California and Ohio add sales tax		
Postage and Shipping		1 50
ORDER TOTAL \$		

- CASH: check or M.O. enclosed
 CHARGE: Master Charge
 CHARGE: BankAmericard  Send FREE catalog

Acct. No. _____
 Expiration date _____
 Master Charge Interbank No.: _____
 _____ 4 NUMBERS OVER YOUR NAME
 SIGNATURE _____
 PRINT NAME _____
 ADDRESS _____
 CITY _____
 STATE _____ ZIP _____

Send order to:
A P PRODUCTS INCORPORATED
 Box 110-H, 72 Corwin Dr.
 Painesville, Ohio 44077

On all models... simply plug in your components and interconnect with ordinary 22-ga. solid wire. No special patch cords required. All models will accept all DIP's, TO-5's and discrete components with leads up to .032" diameter. Multiple buses can easily be linked for power and ground distribution, reset and clock lines, shift command, etc.

- ACE 200-K... 728 tie points, holds up to 8 16-pin DIP's, two buses, two 5-way binding posts, kit form... \$18.95
- ACE 208... 872 tie points, holds up to 8 16-pin DIP's, 8 buses, two 5-way binding posts, assembled... \$28.95
- ACE 201-K... 1032 tie points, holds up to 12 14-pin DIP's, two buses, two 5-way binding posts, kit form... \$24.95
- ACE 212... 1224 tie points, holds up to 12 14-pin DIP's, 8 buses, two 5-way binding posts, assembled... \$34.95
- ACE 218... 1760 tie-points, holds up to 18 14-pin DIP's, ten buses, two 5-way binding posts, assembled... \$46.95
- ACE 227... 2712 tie points, holds up to 27 14-pin DIP's, 28 buses, four 5-way binding posts, assembled... \$59.95
- ACE 236... 3648 tie points, holds up to 36 14-pin DIP's, 36 buses, four 5-way binding posts, assembled... \$79.95

MATERIALS

Anodized aluminum bases (also serve as ground plane); acetal copolymer dielectric; non-corrosive nickel/silver tie-point terminals; rubber bench feet.

A P PRODUCTS INC. • Box 110-H • Painesville, OH 44077

CIRCLE NO. 2 ON FREE INFORMATION CARD

POPULAR ELECTRONICS

Popular Electronics®

WORLD'S LARGEST SELLING ELECTRONICS MAGAZINE

FEATURE ARTICLES

WHAT DOES YOUR STEREO RECEIVER DOLLAR BUY?..... Julian D. Hirsch **33**
Hirsch-Houck Labs compares performance and price.

KARNAUGH MAPS FOR FAST DIGITAL DESIGN Art Davis **50**
A neat, simple method for working with logic.

ENGLISH-LANGUAGE SHORTWAVE BROADCASTS FOR SEPT. & OCT. 1975 Richard E. Wood **82**

CONSTRUCTION ARTICLES

HOW TO ADD FUNCTIONS TO SIMPLE HAND CALCULATORS Donald Shapiro **38**
If it contains the right IC, your calculator can be made more useful.

BUILD A HIGH-PERFORMANCE CD-4 DEMODULATOR Louis Dorren **39**
Low-cost demodulator for playing discrete 4-channel discs.

BUILD A DIRECT-READING LOGIC PROBE R. M. Stitt **54**
Seven-segment readout displays high, low, open, and pulse.

SKIN TEMPERATURE THERMOMETER C. Shakespeare **62**
Consciously controlling blood flow is said to improve body functions.

COLUMNS

STEREO SCENE Ralph Hodges **22**
Starting With a Lacquer Disc.

COMPUTER BITS Jerry Ogdin **57**
Hobbyist Interchange Tape System.

TEST EQUIPMENT SCENE Leslie Solomon **79**
Checking the Sweep Generator "Birdie."

DX LISTENING Glenn Hauser **80**
Antarctica Calling.

SOLID STATE Lou Garner **84**
New IC's for Digital Watches.

HOBBY SCENE Editorial Staff **91**

PRODUCT TEST REPORTS

PICKERING MODEL XUV/4500Q CD-4 PHONO CARTRIDGE **68**

CROWN MODEL VFX2 ELECTRONIC STEREO CROSSOVER SYSTEM **69**

HEATHKIT MODEL GR-400 "DIGITAL" COLOR TV RECEIVER KIT **71**

REALISTIC MODEL PRO-6 PORTABLE SCANNING RECEIVER **72**

HICKOCK MODEL 440 TRANSISTOR CURVE TRACER **78**

DEPARTMENTS

EDITORIAL Art Salsberg **4**
About Editorial Bull Sessions.

LETTERS **6**

OUT OF TUNE **6**
Build a Muscle Feedback Monitor (May 1975)

NEW PRODUCTS **12**

NEW LITERATURE **16**

NEWS HIGHLIGHTS **26**

TIPS & TECHNIQUES **90**

ELECTRONICS LIBRARY **92**

OPERATION ASSIST **94**

COVER PHOTO Photographed at Grand Central Radio, New York City

POPULAR ELECTRONICS, September 1975, Volume 8, Number 3 Published monthly at One Park Avenue, New York, NY 10016. One year subscription rate for U.S., \$6.98. U.S. Possessions and Canada \$7.98, all other countries, \$8.98. Second Class postage paid at New York, NY and at additional mailing offices. Authorized as second class mail by the Post Office Department, Ottawa, Canada and for payment of postage in cash. Subscription service and Forms 3579, P.O. Box 2774, Boulder, CO 80302. POPULAR ELECTRONICS including ELECTRONICS WORLD, Trade Mark Registered. Indexed in the Reader's Guide to Periodical Literature. COPYRIGHT © 1975 BY ZIFF-DAVIS PUBLISHING COMPANY. ALL RIGHTS RESERVED.

Ziff-Davis also publishes Boating, Car and Driver, Cycle, Flying, Modern Bride, Popular Photography, Skiing and Stereo Review.
Editorial correspondence: POPULAR ELECTRONICS, 1 Park Ave., New York, NY 10016. Editorial contributions must be accompanied by return postage and will be handled with reasonable care, however, publisher assumes no responsibility for return or safety of manuscripts, art work, or models.
Forms 3579 and all subscription correspondence: POPULAR ELECTRONICS, Circulation Dept., P.O. Box 2774, Boulder, CO 80302. Please allow at least eight weeks for change of address. Include your old address enclosing, if possible, an address label from a recent issue.

EDGAR W. HOPPER
Publisher

ARTHUR P. SALSBERG
Editorial Director

LESLIE SOLOMON
Technical Editor

JOHN R. RIGGS
Managing Editor

ALEXANDER W. BURAWA
Associate Editor

EDWARD I. BUXBAUM
Art Director

JOHN McVEIGH
Assistant Editor

ANDRE DUZANT
Technical Illustrator

HERBERT S. BRIER
LEN BUCKWALTER
LOU GARNER
GLENN HAUSER
JULIAN D. HIRSCH
RALPH HODGES
ART MARGOLIS
WILFRED M. SCHERER
Contributing Editors

JOSEPH E. HALLORAN
Advertising Director

JOHN J. CORTON
Advertising Sales

LINDA BLUM
Advertising Service Manager

PEGI McENEANEY
Executive Assistant

STANLEY NEUFELD
Associate Publisher

FURMAN H. HEBB
Group VP, Electronics & Photo

ZIFF-DAVIS PUBLISHING COMPANY
Popular Electronics
Editorial and Executive Offices
One Park Avenue New York, New York 10016
212-725-3500
Hershel B. Sarbin, President
Furman Hebb, Executive Vice President
Vincent Perry, Financial Vice President and Treasurer
Phillip T. Heffernan, Senior Vice President, Marketing
Edward D. Muhlfeld, Senior Vice President, Sports Division
Philip Sine, Senior Vice President
Frank Pomerantz, Vice President, Creative Services
Arthur W. Butzow, Vice President, Production
Lawrence Sporn, Vice President, Circulation
George Morrissey, Vice President
Sydney H. Rogers, Vice President
Sidney Holtz, Vice President
Charles B. Seton, Secretary
Edgar W. Hopper, Vice President, Electronics Div.
William Ziff, Chairman
W. Bradford Briggs, Vice Chairman

Midwestern Office
The Patis Group, 4761 West Touhy Ave.
Lincolnwood, Illinois 60644, 312 679-1100
GERALD E. WOLFE THOMAS HOCKNEY
Western Office
9025 Wilshire Boulevard, Beverly Hills, CA 90211
213 273-8050, BRadshaw 2-1161
Western Advertising Manager, BUD DEAN

Japan James Yagi
Oji Palace Aoyama, 6-25, Minami Aoyama
6 Chome, Minato-Ku, Tokyo 407-1930/6821,
582-2851



The publisher has no knowledge of any proprietary rights which will be violated by the making or using of any items disclosed in this issue



Editorial

ABOUT EDITORIAL BULL SESSIONS

The editors here at POPULAR ELECTRONICS get together on a regular and irregular basis to ruminate about the state of the art, where it's headed, and sundry editorial problems and challenges. Here's a minuscule sampling of what we typically discuss at these bull sessions.

Why do two audio amplifiers with identical performance specifications sometimes sound different? One consideration, we concluded, may be "transient intermodulation distortion" or TIM. Essentially, this concerns the delay that occurs between a transient input signal to an amplifier and its output signal. Because of the delay, there is no feedback to modify the momentary high input as occurs under steady-state conditions. The upshot is often some degree of overload clipping, compounded by an extension of cut-off time by the feedback mechanism. Such a short burst of intermodulation distortion is said to resemble momentary crossover distortion in solid-state amplifiers, which is revealed as a harshness of sound.

Unfortunately, TIM is undetectable at the output. To measure it requires disconnecting the feedback loops, a job that's easier said than done. Conclusive tests on this elusive distortion mechanism have not been made, to our knowledge. So you can be sure that we'll be kicking this one around again.

We naturally follow electronic developments very closely, keeping each other posted on what we learn. For instance, moderately priced erasable PROM's for hobbyists do not appear to be too far down the road. Also of interest, fusible-link PROM's (see our July 1975 issue), which in effect allow you to make your own ROM's, are obviously untested by the manufacturer in final form. As a result, some 2% are likely to be defective. So add an extra device or two to your order to cover this possibility.

Our readers are a major subject of discussion, too. What do you want to hear about: microprocessors, shortwave listening, hi-fi? Your letters help us answer this question and you'll sometimes see editorial changes reflecting them. For example, it's clear that our recently introduced quarterly column, "Computer Bits," will be increased in frequency due to its enormously favorable response and the many requests for more coverage. Also, we'll be resurrecting "Operation Assist" for readers who can't locate the schematics or parts for an old product. Other pleasant surprises are in store for you, too.

And, of course, we chat about problems with some reader mail. So there are a few requests we'd like to make of you. They concern letters that you hope to have answered. To help ensure a reply, please enclose a stamped, self-addressed envelope. Due to the tremendous volume of mail received, we can't respond if this is not done. Furthermore, we simply cannot modify or troubleshoot circuits by mail, as much as we'd like to. To answer complicated design questions would jeopardize our schedule, which must be met monthly to satisfy all of our nearly 400,000 readers.

Art Salsberg

no strings attached

NEW **Weller**[®] CORDLESS SOLDERING IRON GOES ANYWHERE

A professional quality tool, Weller's feather-light and fingertip-handly WC-100 Cordless Soldering Iron allows you to make connections anywhere...without dependence on an AC cord and outlet.

The heart of the WC-100 is its high-energy, long-life, nickel-cadmium battery which springs into action at the touch of your finger, heating the tip to over 700°F in just 6 seconds. And no danger of accidental discharge. Weller's exclusive sliding safety switch breaks the circuit when your finger is removed, won't lock in "on" position, and does lock in "off" position for added safety while restoring energy with fast-power recharger (UL listed).

Loosen two slotted set screws and you've got instant choice of four tips... regular, long-reach, fine-point, or miniature...each mounted on an extra-strong stainless tube to resist bending. Tip is continuously illuminated by the built-in light which focuses on the work area, a special advantage under poor lighting conditions.

Try this for size! It's a full-scale photo of the compact WC-100. And the real thing is waiting for you at your dealer or distributor...right now. Need to know more? Request literature.

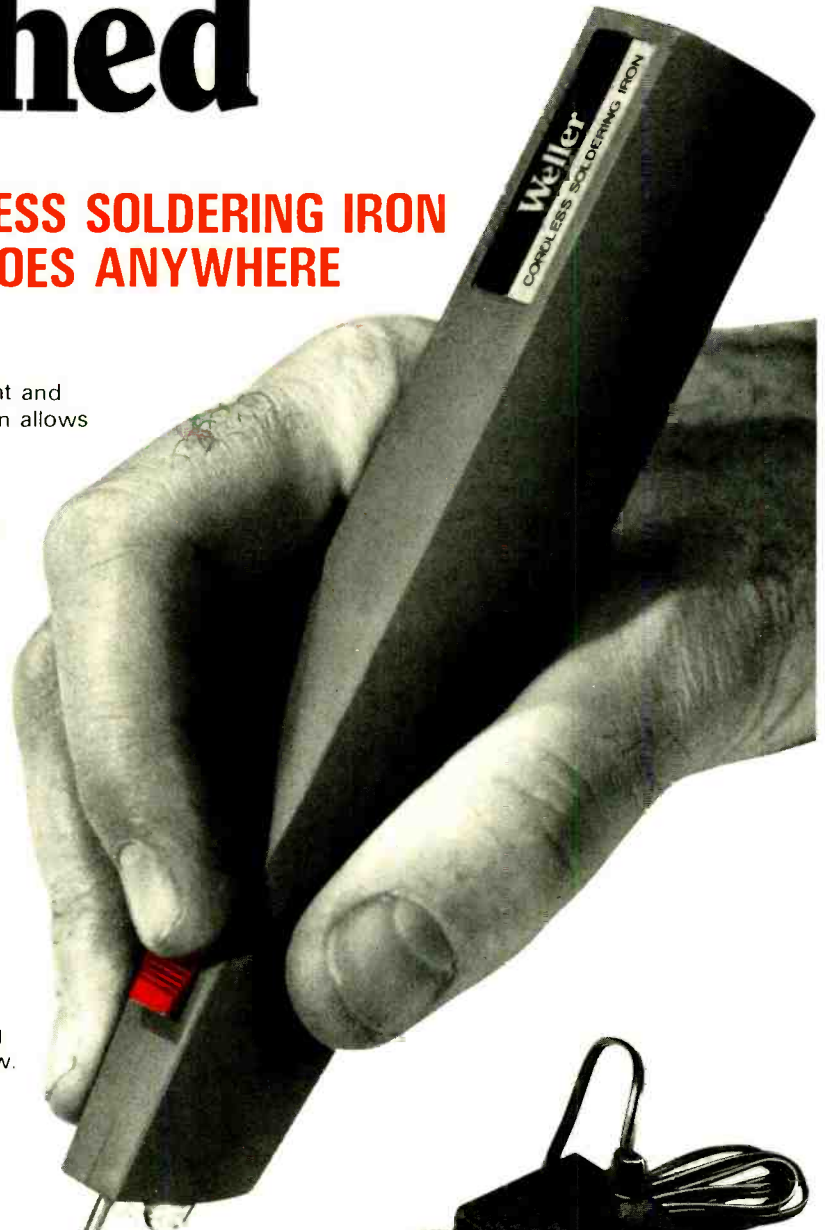

Weller-Xcelite Electronics Division
The Cooper Group

P. O. BOX 728, APEX, NORTH CAROLINA 27502

All New
PROBE IV

CAT. NO.
5104



CHECK FOUR FUNCTIONS WITH ONE INSTRUMENT!

- Continuity
- Polarity
- Voltage
- Digital Logic

LIGHTWEIGHT - POCKET SIZE
PROTECTIVE VINYL CARRYING
POUCH. SEE YOUR FAVORITE
ELECTRONICS DISTRIBUTOR.

LIFT-IT!

"COPY ANY CIRCUIT"

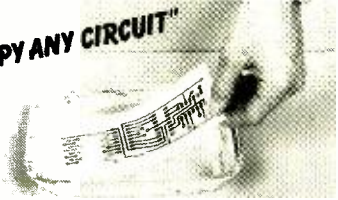

The All-New,
Quick And Easy
Way To Reproduce
Printed Circuits.
Get Your Kit From
Your Favorite
CALECTRO Electronics
Distributor Today!

CAT. NO.
J4-828

GC ELECTRONICS
DIVISION OF HYDROMETALS, INC.
ROCKFORD, ILLINOIS 61101 U.S.A.



Coming Up In The October

Popular Electronics[®]

THE "SENIOR SCIENTIST" CALCULATOR
DESIGNING SOLID-STATE OSCILLATORS
USING PHASE-LOCKED LOOPS
RHOMBIC ANTENNAS FOR TV
WHAT'S NEW FOR HI-FI IN 1976



Letters

BITS ON COMPUTER BITS

The response to Jerry Ogdin's first *Computer Bits* column (in the June issue) has been tremendous. Here are excerpts from just a few of the letters:

Thanks for your new column. I am interested in being a member of a computer hobbyist group. — *John F. Sprague, Allendale, N.J.* . . . Make it monthly instead of quarterly as soon as possible. I am a reasonably good programmer but need support in electronics. — *Peter Nevius, Niskayuna, N. Y.* . . . Because of this, I have just subscribed to your magazine. — *Howe C. Fong, Los Angeles, Calif.* . . . I have years of experience with hardware, but none with software. Please continue the column. — *J. E. Kircher, Hannibal, Mo.* . . . I would like to see this column become regular, instead of a quarterly thing. Glad to see somebody's in touch with 1975. — *R. M. Bash, Fairbanks, Alaska.* . . . We found your new column very interesting. We will be using your magazine as a "textbook" starting next fall. The wide variety of articles, new components, career opportunities, basic design projects, quizzes, printed and digital circuit projects all fit into our introductory electronics course. — *J. W. Craig, St. Louis, Mo.* . . . I welcome the appearance of "Computer Bits." However, I resent your statement that there are those who know hardware but nothing of programming and those who know software but not hardware. I know both very well and fully believe that you can't understand all implications of either without knowing both. — *H. J. Kuhman, Pittsburgh, Pa.* . . . I am guessing that your "neat, inexpensive solution" to the program-sharing problem will be achieved with cassettes. I am planning to buy a microcomputer. When asked why I wanted one, I came up with the following planned uses: Files Management (adaptation for record-keeping in a small business); Teaching Programs (programmable learning via teletype or CRT display); Software Experience; Academic and Job Augmentation (doing work at home with a phone hook-up to a big plant); Home Recreation (for the sheer fun of it). — *Gary Walker, Gilroy, Calif.*

We're still gathering computer club info and will alert respondents to them in the near future. Commencing with this issue's "Computer Bits," the column will be bimonthly instead of quarterly.

CREDIT FOR CONVERTER CIRCUIT

I was pleased to see a good application for a V-to-f converter in the article "Converter Turns Counter into a Digital VOM" (May 1975). However, I was disappointed to see that a reference was not given for the source of this circuit. I developed the circuit shortly after the NE 555 timer became available. — *H. Klement, White Plains, N.Y.*

The author included the reference in his manuscript. It was dropped in editing.

RED IS OK

In the article "Build a Digital Marine/Auto Tachometer" (June 1975), it was stated that the use of red displays for anything other than emergency indicators in automobiles is illegal.

We checked this out with the National Highway Transportation Safety Administration, which is responsible for Federal Standard 101 (covering the subject), and also with the Motor Vehicles Manufacturers Association in Detroit, which provides automobile industry standards. We find no basis for the prohibition mentioned. — *David K. Bradley, E. F. Johnson Co., Waseca, Minn.*

Thanks for bringing us up to date. Our statement was based on information we received several years ago when the NHTSA was with the Department of Commerce.

THE LONG CONNECTION

In your July 1975 editorial (The ATIS Connection), you said that transmission of the identifying code would take about 1/4 to 1/5 of a second. Using the most common implementation of the ASCII code, including framing bits for synchronization, a total of ten or eleven bits is required per character. Thus a 22-character message (suggested for ATIS) means the transmission of 220 or 242 bits. At 100 bits per second, each ATIS would take just under 2½ seconds.

Even more discouraging (about ATIS) is that the suggested frequency is smack-dab in the middle of the speech band. Of course, that's where you want it for use with equipment designed for spoken communication, but ATIS will sound like a canary. — *Bob Brown, Atlanta, Ga.*

Identification would require 176 bits of information. Transmitting this at 100 baud would require 1.76 seconds. — *Stuart Goldberg, Warrington, Pa.*

How right you are! It's 22 characters times 8 bits divided by 100 baud equals 1.76 seconds. That's a SMOP (small matter of programming) for you.

Out of Tune

In "Build a Muscle Feedback Monitor" (May 1975), the polarity of B2 in Fig. 2 should be reversed.

Our reliable 15MHz scope syncs to 30MHz

RESPONSE CURVE

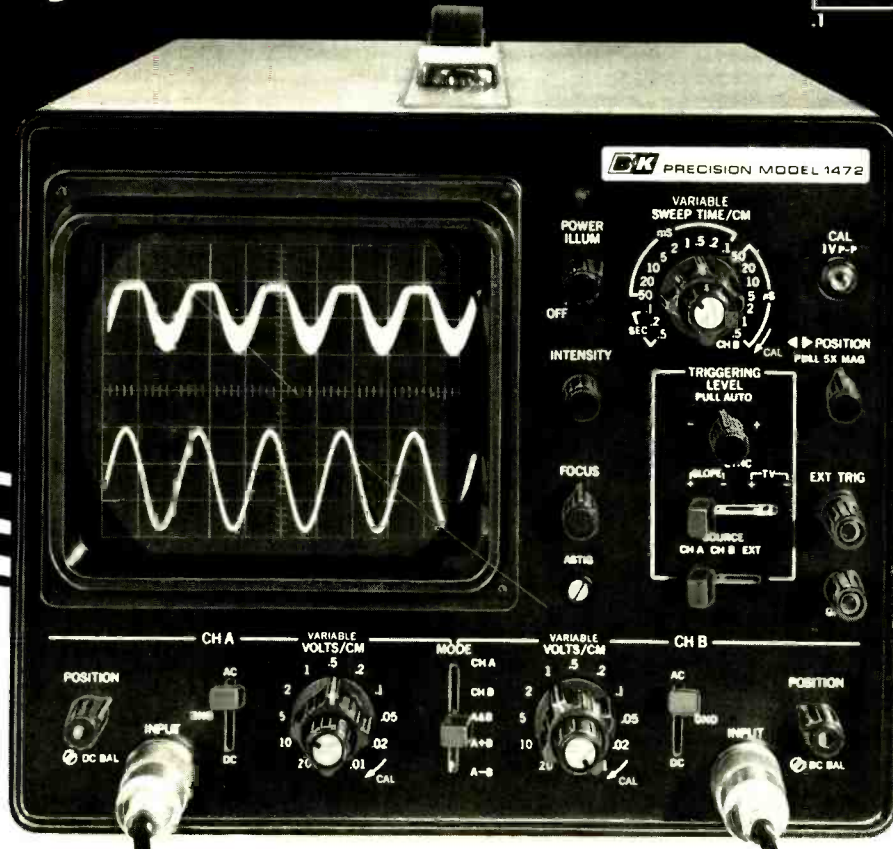
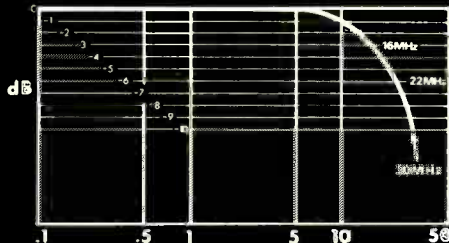

B&K PRECISION

Model 1472 Dual Trace
Oscilloscope: 27MHz modu-
lated carrier and original
audio displayed . . \$599.00

Model 1472 Dual Trace Scope has reliable automatic sync and plenty of deflection for waveform analysis at frequencies far beyond its nominal range. Look at its actual, smooth roll-off curve and you can see how you can do an expensive scope's job with our far less costly but equally reliable, easy-to-use counterpart. Model 1472 lengthens the B&K-Precision complete line of 2 to 10MHz bandwidth scopes—a line of scopes that now outsells every other 10 to 15MHz scope because our users have discovered our reliability, performance and instant delivery from our distributors.

Model 1472 has 19 calibrated sweeps—.5 μ SEC/cm to .5SEC/cm and sweep to .1 μ SEC/cm with 5x and to 1.5SEC/cm with uncalibrated vernier. Deflection factor is 0.01V/cm to 20V/cm \pm 5% in 11 ranges plus fine adjustment. Regulation maintains calibration accuracies over 105-130VAC range. Rise time is 24nSEC, fast enough to check most digital logic circuitry, including CMOS. Automatic triggering is

obtained on waveforms with as little as 1cm deflection. Dual trace display has algebraic addition and subtraction and differential input capability. Mode automatically shifts between CHOP and ALTERNATE as you change sweep time, speeding set-up. Extremely flat in-band response is particularly useful for demanding applications like adjusting color video to close tolerances in TV broadcast studios.

Front panel X-Y operation uses matched vertical amplifiers, preserving full calibration accuracy for both amplitude and phase. The intensity modulation input (Z axis) is available for time or frequency markers. Bright blue P31 phosphor and variable illuminated graticule make any waveform easy to see.

In Stock For Free Trial

Model 1472 or any B&K-Precision oscilloscope can be obtained from your local distributor for a free trial. You'll find the scope you need in stock today. Write for detailed specifications.

B&K PRECISION

PRODUCTS OF DYNASCAN

1801 W. Belle Plaine Avenue Chicago, IL 60613

CIRCLE NO. 10 ON FREE INFORMATION CARD

Where do the pros get their training?



Almost half of the successful TV servicemen have home study training and with them, it's NRI 2 to 1. It's a fact! Among men actually making their living repairing TV and audio equipment, more have taken training from NRI than any other home study school. More than twice as many!

Not only that, but a national survey,* performed by an independent research organization, showed that the pros named NRI most often as a recommended school and as the first choice by far among those who had taken home study courses from *any* school. Why? Perhaps NRI's 60-year record with over a million students...the solid training and value built into every NRI course...and the designed-for-learning equipment originated by NRI provide the answer. But send for your free NRI catalog and decide for yourself.



25" Diagonal Color TV... Professional Instruments

As a part of NRI's Master Course in TV/Audio servicing, you build a big-screen solid state color TV with every modern feature for great reception and performance. As you build it, you perform stage-by-stage experiments designed to give you actual bench experience while demonstrating the interaction of various stages of the circuitry. And your TV comes complete with console cabinet, an optional extra with other schools. Likewise, NRI's

instruments are a cut above the average, including a 3½ digit precision digital multimeter, triggered sweep 5" oscilloscope, and integrated circuit TV pattern generator. They're top professional quality, designed to give you years of reliable service. You can pay hundreds of dollars more for a similar course and not get a nickel's worth extra in training and equipment.

Widest Choice of Courses and Careers.

NRI doesn't stop with just one course in TV/Audio servicing. You can pick from five different courses (including an advanced color course for practicing technicians) so you can fit your training to your needs and your budget. Or, you can go into Computer Technology, learning on a real, digital computer you build yourself. Communications with famous Johnson transceiver. Aircraft or Marine Electronics. Mobile radio, and more.

Free Catalog... No Salesman Will Call.

Send the postage-paid card for our free color catalog showing details on all NRI electronics courses. Lesson plans, equipment, and career opportunities are fully described. Check card for information on G.I. benefits. No obligation, no salesman will call. Mail today and see for yourself why the pros select NRI two to one!

If card is missing, write to:



Two Famous Educators... NRI and McGraw-Hill.

NRI is a part of McGraw-Hill, world's largest publishers of educational material. Together, they give you the kind of training that's geared for success...practical know-how aimed at giving you a real shot at a better job or a business of your own. You learn at home at your convenience, with "bite-size" lessons that ease learning and speed comprehension. Kits designed to give you practical bench experience also become first-class professional instruments you'll use in your work.

*Summary of survey results upon request.



NRI SCHOOLS

McGraw-Hill Continuing Education Center
3939 Wisconsin Avenue,
Washington, D.C. 20016



New Products

Additional information on new products covered in this section is available from the manufacturers. Either circle the item's code number on the Reader Service Card inside the back cover or write to the manufacturer at the address given.

AP PRODUCTS BREADBOARDING STRIPS

A new series of terminal and distribution strips is available from AP Products. These solderless, plug-in strips are available in three basic configurations of terminal strips and two versions of distribution

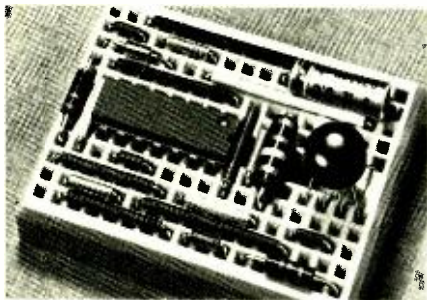

strips. The Model L terminal strips contain two rows of 5-tie-point terminals, are available in four lengths, and are said to accommodate all components and jumpers with leads up to 0.032" (0.8 mm) diameter. The full-length model will hold eight 14-pin DIP's. The Model R terminal strips are available with either one or two rows of 4-tie-point terminals and are useful in breadboarding circuits using standard DIP's. Distribution strips are available in two models. The first consists of two continuous bus strips (three lengths available), and the second consists of two groups of three-bus strips. All buses are comprised of 4-tie-point terminals. All contacts are a nickel-silver copper alloy. Price varies from \$2.00 to \$12.50, depending on model.

CIRCLE NO. 70 ON FREE INFORMATION CARD

MAGNAVOX MX 4-2-CHANNEL AM/FM STEREO RECEIVER

The MX Model 1620 receiver from Magnavox features four power amplifiers, SQ and RM decoders, and a full complement of controls. The tuner section features the ASNC system (which reduces noise level on weak stereo stations,) and three dual-gate MOSFET's in the front end. The amplifier section has a direct-coupled output, a power boost circuit to double power out-

put in stereo mode, and an Automatic Protection Circuit for amplifiers and speakers. Claimed FM sensitivity is 1.8 μ V (IHF), stereo separation 50 dB @ 10,000 Hz, harmonic distortion 0.3% (stereo), and capture ratio 1.5 dB. The amplifier is rated at 12 W rms/ch (30 W/ch stereo), over a power bandwidth of 20-20,000 Hz with 0.5% THD into 8 ohms. The Model 1620 measures 22 $\frac{3}{4}$ " W \times 15" D \times 6" H (57.2 \times 38.1 \times 15.2 cm) and weighs 33 lb (15 kg). Includes grained walnut veneer enclosure. \$499.95.

CIRCLE NO. 71 ON FREE INFORMATION CARD

INFINITY MONITOR II LOUDSPEAKER SYSTEM

Infinity System's new Monitor II is a floor-standing, four-way loudspeaker system. Program material ranging from 23 to 450 Hz is reproduced by a patented long-throw 12-inch (30.5-cm) damped woofer. A 1 $\frac{1}{2}$ -inch (3.8-cm) enclosed midrange driver is active in the 450-5000-Hz range, while a 1-inch dome tweeter covers 5000 to 10,000 Hz. A Walsh Transmission Line Tweeter, which looks like an ice cream cone, handles material in the 10,000- to 28,000-Hz range with 360° horizontal dispersion. The Monitor II's floor-standing, oiled walnut enclosure comes with two tops—one oiled walnut and one cloth-wrapped. The system is not recommended for use with amplifiers rated at less than 60 W rms/channel. Nominal impedance is 8 ohms. The Monitor II measures 50" H \times 17" W \times 16" D (127 \times 43.2 \times 40.6 cm) and weighs 94 lb (42.7 kg).

CIRCLE NO. 72 ON FREE INFORMATION CARD

GEMTRONICS MOBILE CB TRANSCEIVER

The newest addition to Gemtronics' line of CB transceivers is the Model GTX-23 mobile rig. Among its features are a fre-



quency synthesizer providing 23 crystal-controlled transmit and receive channels, three-position delta tune, PA/CB operation, S/r-f meter, a modulation indicator lamp and noise limiter.

CIRCLE NO. 73 ON FREE INFORMATION CARD

OVER-VOLTAGE PROTECTION FOR MOBILE EQUIPMENT

The Voltector, by D.R. Corbin Manufacturing Co., is a solid-state over-voltage protection device for 12-V dc mobile equipment. A PUT is used in a voltage comparator that is said to track \pm 0.5 volt from 20°F to 200°F (-6.7°C to 93.3°C). The comparator output feeds a high-current thyristor switch that crowbars the supply line. Voltage on the

line is clamped to about 1 volt, which blows the line fuse normally used with the equipment. The unit is housed in a waterproof enclosure with aluminum r-f shielding, and looks much like a small electrolytic capacitor with two flexible leads. The Voltector can be used with either positive- or negative-ground 12-V systems. \$29.50

CIRCLE NO. 74 ON FREE INFORMATION CARD

HELECTRONIX FUNCTION GENERATOR KIT

The Model L-10 Function Generator kit by Helectronix has a pre-wired and pre-tested circuit board to facilitate assembly. Fre-



quency range is claimed at 1 Hz to 100 kHz with amplitude constant \pm 0.5 dB. Sine output with variable amplitude up to 10 V_{pp} into 600 ohms is said to contain less than 2% distortion. The generator's triangle wave is claimed to have a typical linearity of 0.1%, with variable amplitude output up to 12 V_{pp} into a 600-ohm load. The square wave and pulse (variable width) output has a fixed amplitude at TTL logic one (greater than 3 V) levels. Rise and fall times are said to be less than 15 ns. Duty cycle of the pulse output can be varied from 5 to 95%. Fanout is 30 gates, according to the manufacturer. The L-10 weighs 2 lb (0.9 kg) and measures 7" \times 5" \times 4.5" (17.8 \times 12.7 \times 11.4 cm). \$49.95

CIRCLE NO. 75 ON FREE INFORMATION CARD

UHER LIGHTWEIGHT STEREO HEADPHONES

Uher of America is offering a pair of open-air headphones in three configurations. The Model W674 has a two-pin plug for use with Uher open reel decks, the Model W675 has a 5-pin plug for use with Uher cassette decks, and the Model W676 has a phone plug termination for use with amplifiers having the standard headphone jack. The headphones have a frequency response of 20 to 20,000 Hz. It is said that they weigh only 2.2 oz (62 g), and permit you to hear external sounds as well as the program material. An eight-foot (2.4-m) cord is included. \$49.95

CIRCLE NO. 76 ON FREE INFORMATION CARD

MAXELL RECORDING TAPES

Maxell has introduced two new lines of recording tape. A family of premium cassettes will be known as the UDXL series, available in 60- and 90-minute packages. Epitaxial blending techniques of pure and alloy ferrites provide large dynamic range,

MIT S Announces Lower Memory Prices!

On July 1, 1975, MIT S lowered the price of the Altair 1K Static Memory Card (88-1MCS). The kit price was dropped from \$176 to just \$97 while the assembled price was dropped from \$209 to \$139.

This price reduction was made possible by a reduction in the price of the Altair 1K 8101 memory chips.

Also affected was the price of 88-MM 256 byte (word) memory modules. The \$53 kit price was lowered to just \$14 and the \$61 assembled price to \$26.

Altair BASIC—Not Just Anybody's BASIC

Altair BASIC is an easy-to-use programming language that can solve applications problems in business, science and education.

You will find that with only a few hours of using BASIC that you can already write programs with an ease that few other computer languages can match.

Altair BASIC doesn't compromise power for simplicity. While it is one of the simplest computer languages in existence, it is also a very powerful language.

ALTAIR BASIC comes in three versions. The first of these is a 4K BASIC designed to run in an Altair with as little as 4,000 words of memory. This powerful BASIC language has 6 functions (RND, SQR, SIN, ABS, INT, and SGN) in addition to 15 statements (IF . . . THEN, GOSUB, RETURN, FOR, NEXT, READ, INPUT, END, DATA, GOTO, LET, DIM, REM, RESTORE, PRINT, STOP) and 4 commands (LIST, RUN, CLEAR, SCRATCH).

The second ALTAIR BASIC option is the 8K BASIC designed to run in an Altair with as little as 8,000 words of memory. This BASIC language is the same as the 4K BASIC only with 8 additional functions (COS, LOG, EXP, TAN, ATN, INP, FRE, POS) and 4 additional statements (ON . . . GOTO, ON . . . GOSUB, OUT, DEF) and 1 additional command (CONT). This BASIC has a multitude of advanced STRING functions and it can be used to control low speed devices—features not normally found in many BASIC languages.

The third ALTAIR BASIC is the EXTENDED BASIC version designed to run on an Altair with as little as 12,000 words of memory. It is the same as the 8K BASIC with the addition of PRINT USING, DISK I/O, and double precision (13 digit accuracy) add, subtract, multiply and divide.

Altair BASIC is only the beginning. MIT S is currently engaged in an extensive software development program. Other software now available includes an Assembler, System Monitor, and Text Editor.

Altair software comes with complete documentation.

One Month Specials

The Altair Users Group is quite possibly the largest computer hobbyist organization in the World. It is both a means of communication among Altair Users and a method of building a comprehensive library of Altair programs. All Altair 8800 owners are entitled to a free, one year membership in this group.

For one month only, you can become an Associate Member for one year at a reduced rate of \$10 (regularly \$30). Among other benefits you will receive a subscription to the monthly publication, Computer Notes, which contains complete update information on Altair hardware and software developments, programming tips, general computer articles and other useful information.

Now available is the Altair Software Documentation Book I which contains technical data on the Altair Assembler, Text Editor, System Monitor and BASIC language software. This documentation is free to purchasers of Altair BASIC. For one month only, it is being offered for only \$7.50 (regularly \$10).

Offers good until September 30, 1975.

The 1K Static Memory Card contains 1024 bytes of memory with a maximum access time of 850 nanoseconds.

Now ready for production is the new Altair 2K Static Memory Card (88-2MCS) with 2048 bytes of memory. Like the 1K Static Memory this new card contains memory protect features and provisions for disabling the ready.

It has a maximum access time of 850 nanoseconds and is engineered with the finest components available. It is inexpensively priced at \$145 kit and \$195 assembled.

HARDWARE PRICES:

Altair Computer kit with complete assembly instructions	\$439
Assembled and tested Altair Computer	\$621
1,024 Byte Static Memory Card	\$97 kit and \$139 assembled
2,048 Byte Static Memory Card	\$145 kit and \$195 assembled
4,096 Byte Dynamic Memory Card	\$264 kit and \$338 assembled
Full Parallel Interface Card	\$92 kit and \$114 assembled
Serial Interface Card RS232C	\$119 kit and \$138 assembled
Serial Interface Card (TTL or Teletype)	\$124 kit and \$146 assembled
COMTER II*	\$780 kit and \$920 assembled

*The Comter II Computer Terminal has a full alpha-numeric keyboard and a highly readable 32-character display. It has its own internal memory of 256 characters and complete cursor control. Also has its own built-in audio cassette interface that allows you to connect the Comter II to any tape recorder for both storing data from the computer and feeding it into the computer. Requires an RS232C Interface Card.

SOFTWARE PRICES:

Altair 4K BASIC	\$350
Purchasers of an Altair 8800, 4K of Altair Memory, and Altair Serial I/O or Audio-Cassette I/O	ONLY \$60
Altair 8K BASIC	\$500
Purchasers of an Altair 8800, 8K of Altair Memory, and Altair Serial I/O or Audio-Cassette I/O	ONLY \$75
Altair EXTENDED BASIC	\$750
Purchasers of an Altair 8800, 12K of Altair Memory, and Altair Serial I/O or Audio-Cassette I/O	ONLY \$150

Altair PACKAGE ONE (assembler, text editor, system monitor)
Purchasers of an Altair 8800, 8K of Altair Memory, and Altair I/O ONLY \$30

NOTE: When ordering software, specify paper tape or cassette tape.

Warranty: 90 days on parts for kits and 90 days on parts and labor for assembled units. Prices, specifications, and delivery subject to change.

MAIL THIS COUPON TODAY!

Enclosed is check for \$_____

BankAmericard # _____ or Master Charge # _____

Altair 8800 Kit Assembled Options
Include \$8 for postage & handling (list on separate sheet)

Altair Users Group Associate Software Documentation

Please send free literature

NAME _____

ADDRESS _____

CITY _____ STATE & ZIP _____

MIT S/6328 Linn N.E., Albuquerque, NM 87108 505/265-7553 or 262-1951

MIT S
"Creative Electronics"

MIT S/6328 Linn N.E., Albuquerque, NM 87108 505/265-7553 or 262-1951

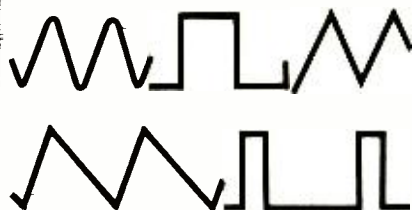

0.1 Hz. to 100 KHz.



For only \$39.95

Our new FG-2 Function Generator kit gives you all five of the most useful waveforms for design and testing at one fourth the cost of previous similar instruments. Thanks to improved IC's the FG-2 now features amplitude stability of ± 1 db over any range, Sine wave distortion of less than 1% from 20 Hz. to 20,000 Hz. and an output of 4.0 Volts peak-to-peak with adjustable offset. The offset selector lets you put the positive peak, negative peak, or the center of the waveform on DC ground. The DC coupled circuit keeps the waveforms in exactly the same position no matter what the level control setting.

Gray impact plastic case $5\frac{1}{4} \times 6\frac{3}{4} \times 2\frac{1}{2}$.
115 Volts 60 cycle power supply included.

FG-2 Function Generator Kit
shipping weight 3.0 lbs.....\$39.95 PPD

GET OUR NEW 1975 CATALOG

listing this and other unique kits

"FREE"

by simply circling our number
on the reader service card.



SOUTHWEST TECHNICAL
PRODUCTS CORPORATION

DEPT. PE

219 W. Rhapsody
San Antonio, Texas 78216

CIRCLE NO. 53 ON FREE INFORMATION CARD

high sensitivity, uniform distribution and wide frequency response, according to Maxell. Other features are a redesigned package with side and tape travel indications, a built-in 5-second cueing line, and a head cleaning leader. Also being introduced is a new high-level mastering tape known as Ultra Dynamic back-coated tape. Maxell claims that this tape can provide a flat response over the range of 20 to 24,000 Hz when properly biased (about 115% bias current). The conductive back coating is said to provide good capstan traction and bleedoff of static charges. The new UD back coated tape will be marketed in 7- and 10-inch reel formats.

CIRCLE NO. 77 ON FREE INFORMATION CARD

SANSUI CASSETTE DECK

Sansui's new Model SC363 stereo cassette deck boasts a magni-crystal ferrite head, a 4-pole hysteresis synchronous drive motor, high-inertia flywheel, and belt-



driven capstan. The transport has fail-safe devices, which according to Sansui eliminate tape jamming, stretching, and breakage. A photoelectric sensor stops the tape automatically when it reaches either end. Other features are low-noise circuitry, Dolby-B noise reduction, a line/mic shorting circuit to eliminate hum, provisions for a stereo headphone, and a no-click pause button. Wow and flutter are claimed at less than 0.12% (WRMS) and tape speed accuracy at 1.5%. Winding time is less than 70 seconds for a C60 cassette. Frequency response is 30 to 13,000 Hz for standard tape, and 30 to 16,000 for CrO₂. \$279.00

CIRCLE NO. 78 ON FREE INFORMATION CARD

B&K 6-DIGIT AUTORANGING FREQUENCY COUNTER

B&K's new model 1801 is a six-digit autoranging frequency counter with a guaranteed measurement range of 20 Hz to 40 MHz with a typical accuracy of 10 PPM. A front panel switch selects either a "1 SEC" preset gate interval or the "AUTO" range. The display consists of 7-segment solid-state numerical digits, and three LED's for units (kHz and MHz) and over-range indication. A 10-MHz crystal time base is incorporated, but an external time base can also be used. The 1801 measures $10\frac{1}{2}''$ D \times $8\text{-}11\frac{1}{16}''$ W \times $3\text{-}5\frac{1}{16}''$ H (26.7 \times 22.1 \times 8.4 cm), and weighs 4 lb (1.8 kg). \$230.00

CIRCLE NO. 83 ON FREE INFORMATION CARD

SCOTT DIGITAL FM TUNER

The Scott T33S digital stereo FM tuner uses MSI and phase-locked-loop circuitry, digital frequency readout, a MOSFET r-f front end, two pre-tuned phase-linear i-f filters, and a quartz crystal reference standard. Frequency selection is accomplished by automatic or manual scan, or by using prepunched cards for preferred stations. Channel spacing is set at 100 kHz, and de-emphasis is switch-selected (50 or 75 μ sec), which allows the tuner to be used in either the U.S. or Europe. The tuner will work on 120 or 240 V ac. Among other features are a front panel Tape Out jack, both upscale and downscale scanning, a mute control, hiss filter, and gas-discharge display. Specifications include 1.8 μ V IHF sensitivity; frequency response, 20-15,000 Hz \pm 1 dB; tuning accuracy, 0.001%; and an image rejection of 85 dB. The tuner measures $17.5'' \times 11.6'' \times 5.3''$ (44.5 \times 29.5 \times 13.5 cm). \$999.95.

CIRCLE NO. 79 ON FREE INFORMATION CARD

HEATH PORTABLE DIGITAL MULTIMETER

Heathkit's IM-2202 DMM uses a rechargeable NiCd battery pack (included) and a built-in charging circuit for portable opera-



tions. Up to eight hours of continuous operation can be obtained from each charge. Its 26 ranges include full scales of 100 mV to 1000 V dc, 100 mV to 750 V ac, 100 μ A to 1000 mA, and 100 ohms to 1000 kilohms. The meter's 100% over-ranging capacity operates on all ranges except 1000 V dc and 750 V ac, giving full 2-A and 2-megohm capability. According to Heath, internal standards supplied with the kit allow field calibration to 0.5% (dc) and 1% (ac). Better accuracy can be obtained using lab standards. The $3\frac{1}{2}$ -digit display features automatic polarity indication and decimal point placement. \$179.95.

CIRCLE NO. 5 ON FREE INFORMATION CARD

E&L MICROPROCESSOR SYSTEM

A new Microprocessor System is being introduced by E&L Instruments. The basic system provides a CPU and interface control built around Intel's 8080 microprocessor chip, a memory card featuring 1K of read and write memory space and a 256×8 PROM, a front panel, power supply, and an interface board. The front panel controls have priority over software. load 16 bits of address data. reset and suspend functions over the system program. The system is

POPULAR ELECTRONICS

SBE®

scans any station in the nation

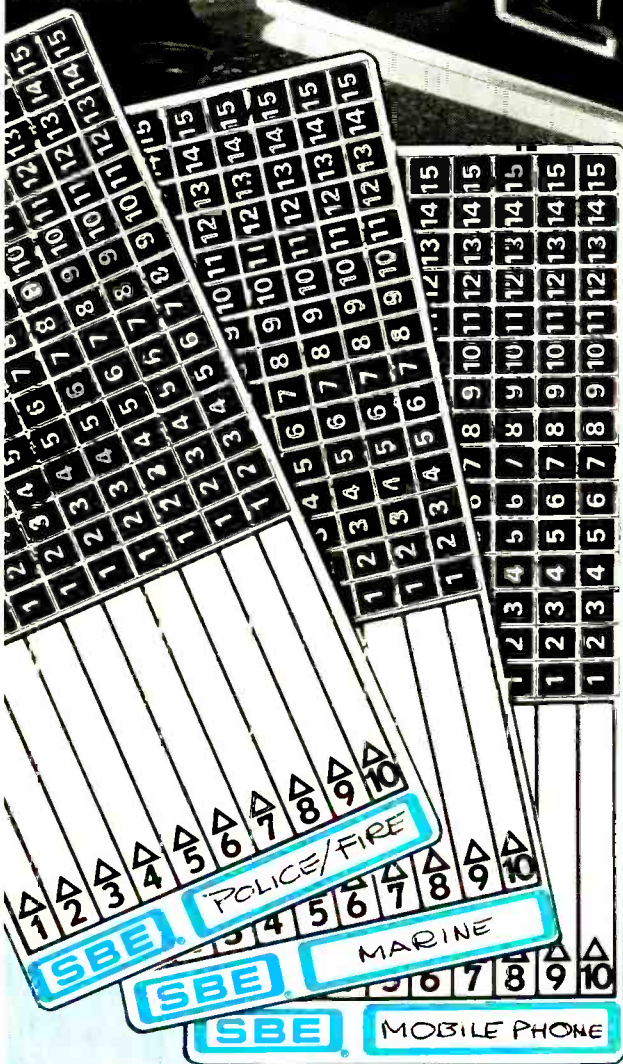

- 16,000 different, digitally-derived frequencies instantly at your command. Hear every "action" station within range, 30-50MHz, 153-170MHz, 450-470MHz and 490-510MHz.
- Cards easily programmed from list supplied. Simple visual check of program.
- Insert card in slot for instant 10 channel program change **even while mobile**. Without equal when traveling by car, truck, RV, boat.
- Smallest size and only crystal-less scanner with integral power supply for 12VDC and 115VAC. **USE FOR BASE OR MOBILE.**
- No confusing, error-prone switches, tabs, mechanical gadgetry. Permanent card memory eliminates need for continual re-programming.
- Get the complete story on OPTISCAN — write now for 4-color descriptive brochure.

SBE®

LINEAR SYSTEMS, INC.

220 Airport Blvd. Watsonville, CA 95076

INTERNATIONAL OFFICES:

E. S. GOULD MARKETING CO., LTD.
Quebec, Canada H4T, 1S9

LINEAR SYSTEMS, S.A.
5 Rue des Alpes, P.O. Box 163,
1211 Geneva 1, Switzerland

Sound reasons 1 thru 5 why an SAE gives you what you pay for.

You are an audio connoisseur. You know exactly what you are looking for in audio components. The right features. The right functions. The right power. But you can't find one at the right price. And you won't. What you're looking for costs plenty to produce. Some build additional price right into their units. We build additional unit into our price. Here are some reasons why an SAE gives you what you pay for.

5 YEAR FREE SERVICE CONTRACT
SAE — first in the industry to offer a **TRANSFERABLE FULL 5 YEAR* FREE SERVICE CONTRACT** on parts, labor and performance specifications. This contract covers SAE's complete line of audio products when returned to the factory or an authorized service agency.

*except oscilloscope and tube tubes—one year.

1

We start with a Free Five Year Transferable Service Contract. It's on parts, labor and specifications. If you're a connoisseur, you'll demand it.

We design each product from the strict requirements of professionals. After a unit has passed our rigid engineering and quality control standards, it must meet the demands of professional use. Road testing. Testing that requires extreme power handling for longer periods of time. Testing that requires surviving continual movement from place to place. All of which simply means that each unit will work that much better in your home.

2

3

The professional approach led to the development of the "Steady-State" audio component. A component that lasts longer because it's built as an efficient package to perform perfectly under highest demand conditions.



4

Our product, its professional appearance and its unique features, create their own reasons for costing more. Like our Mark XXV Stereo Power Amplifier. It features Parallel-Series-Output circuitry (PSO). Forced air cooling. Triple diffused output transistors. Dual relay protection circuits. As if these were not enough to justify its \$1250 price, the unit delivers a minimum of 300 Watts RMS per channel into 8 Ohms, both channels driven from 20Hz-20kHz, $\pm 25\text{dB}$, with no more than 0.05% total harmonic distortion from 250mW to rated output. Yet it weighs less than 60 pounds (lift others with the same specs).

5

It all started here with our 2500 professional version shown with rack mount for professional use.

There are many other reasons. Send us the attached coupon and we'll send you an additional 25, plus literature, and the location of a dealer who'll be able to supply even more.

Components for the Connoisseur



Scientific Audio Electronics, Inc. PE-9/75
P.O. Box 60271 Terminal Annex,
Los Angeles, California 90060
I want more reasons, thank you.
Name _____
Address _____
City _____ State _____ Zip _____

CIRCLE NO. 47 ON FREE INFORMATION CARD

16

easily expanded, with the following options available: synchronous communications interface; printer output; priority interrupt with a real-time clock; D/A converters; A/D converter with 8 channels of MPX; 4K of read-write memory (up to 64K total); 2K PROM (ultraviolet erasable) memory, and cassette I/O. Computer interfacing, hardware development and software are taught through the "Bugbooks" III and IV (included).

CIRCLE NO. 80 ON FREE INFORMATION CARD

DRAKE GENERAL COVERAGE RECEIVER

R.L. Drake's new Model SSR-1 is a synthesized radio receiver capable of desk-top or portable operation over a range of 500 kHz to 30 MHz on AM, Upper or Low-



er Sideband (selectable), and CW. The receiver is supplied with a built-in speaker, removable telescoping whip antenna, holders for 8 D cells, and a built-in, switchable 117/234 V ac power supply. With batteries installed, the SSR-1 will automatically switch to battery operation if ac power fails or the line plug is pulled. For reduced current drain on battery power, the dial lamps do not light up unless a red pushbutton on the front panel is depressed. Include coarse and fine tuning controls, preselector, clarifiers, S meter, and headphone jack.

CIRCLE NO. 81 ON FREE INFORMATION CARD

EICO CONVERTER/CHARGER

A solid-state power supply, Model 1040, which permits auto stereo tape players or mobile CB rigs to be operated at home, has been introduced by Eico Electronic Instrument. Twelve-volt dc equipment can be operated from 120-V ac lines or can be checked out prior to installation in a car or boat. It can also be used as a charger for 12-V batteries. Input: 120-V ac, 50-60 Hz; output: 12-V dc at 4 A continuous. \$19.95 (wired only).

CIRCLE NO. 82 ON FREE INFORMATION CARD

RECORDING TAPE/TIME SLIDE RULE

The Tape Measure[®] is a double-slide cardboard slide rule which computes the amount of recording or playing time left on a given length of tape. The slide rule can be used with regular 5-, 7- and 10½-inch open-reel tapes. Calibrated time scale ranges from 2 minutes to 24 hours. Available for \$1.84 from the Rothchild Printing Co., 7900 Barnwell Avenue, Elmhurst, NY 11373.



New Literature

SHAKESPEARE WHIP ANTENNA CATALOG

Shakespeare has released its latest catalog of the Royal line of fiberglass whip antennas. Radiators for CB mobile, base station, and marine operation, as well as mounting hardware, co-phasing harnesses, and gutter clips are described. The White Knight base-loaded whip is representative of the line, featuring a tuning-screw adjustment for minimum SWR, and a helical coil in a sealed enclosure, which the company claims helps keep feedpoint impedance constant. For base operation, the Greyhound, a 5/8-wave antenna, uses a capacitive "hat" to reduce static and radiation angle. All Shakespeare antennas are rated to full legal power without burn outs. Address: Shakespeare Industrial Fiberglass Div., Jefferson Sq., P.O. Drawer 246, Columbia, SC 29202.

CB RADIO ACCESSORIES CATALOG

An 8-page catalog from GC Electronics illustrates and describes its line of CB and amateur radio replacement parts and accessories. Items such as base and mobile microphones, SWR meters, noise filters and suppressors, and mike and antenna connectors are featured. Address: GC Electronics, 400 South Wyman, Rockford, IL 61101.

CTS SPEAKER LINE

An 8-page catalog featuring CTS of Paducah's line of high-fidelity loudspeakers. Twenty-four models are now available, ranging from a 1¼-inch tweeter with a frequency response of 2000 to 20,000 Hz to a 12-inch woofer with a 50-watt power rating and a response of 20 to 2000 Hz. All CTS speakers are designed with an 8-ohm nominal impedance measured at 400 Hz. Address: CTS of Paducah, Inc., 1565 N. 8th St., Paducah, KY. 42001.

WATTS RECORD CARE BOOKLET

A new 27-page booklet entitled, "Watts, Just For The Record," is available for \$1 from Elpa Marketing. The booklet discusses static and dust build-up on phonograph discs and styli, and how to keep them clean. The Watts line of record care products is illustrated, and explicit directions are given for their use. The booklet also gives tips on handling records, storing and washing them, and how to keep the stylus in good condition. Address: Elpa Marketing Industries, Inc., New Hyde Park, NY 11040.

POPULAR ELECTRONICS

five new breadboard testers from

Continental Specialties Corp. offers a total line of breadboard test devices ... everything from inexpensive kits to high-power professional units and logic monitors too. Each high quality, compact unit comes with a guarantee of complete satisfaction or your money back within 10 days. Here are but five of the "hottest" items we make...

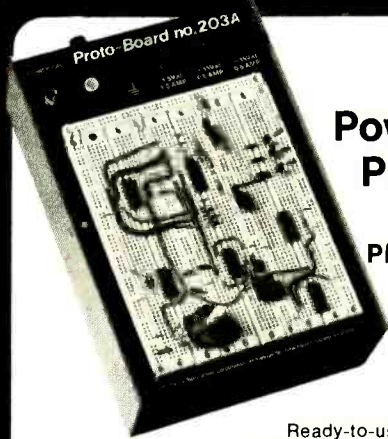

Power for the Professional!

**New Proto Boards
PB-203 and PB-203A
with built-in
regulated
short-proof
power supplies!**

Ready-to-use. Just plug in and start building! 2 extra floating 5-way binding posts for external signals (PB-203 only). Completely self-contained with power switch, indicator lamp and power fuse. 24 14-pin DIP capacity. All metal construction... no chipping or cracking as with plastic cases. Two-tone quality case makes both PB-203 and PB-203A aesthetically, as well as technically attractive.

PB-203

- 3 QT-59S Sockets
- 4 QT-59B Bus Strips
- 1 QT-47B Bus Strip
- Fuse • Power Switch
- Power-On Light
- 9.75"L x 6.6"W x 3.25"H
- Weight: 5 lbs.
- 5V, 1 AMP regulated power supply

75.

Add \$2.50 shipping/handling

OUTPUT SPECIFICATIONS

Output Voltage 5V \pm 1/4V
Ripple & Noise @ 1/2 AMP
10 millivolts
Load Regulation Better than 1%

PB-203A

- 3 QT-59S Sockets
- 4 QT-59B Bus Strips
- 1 QT-47B Bus Strip
- Fuse • Power Switch
- Power-On Light
- 9.75"L x 6.6"W x 3.25"H
- Weight: 5 lbs.
- 5V, 1 AMP regulated power supply (same as PB-203)
- +15V, 1/2 AMP regulated power supply
- -15V, 1/2 AMP regulated power supply

120.

Add \$2.50 shipping/handling

OUTPUT SPECIFICATIONS

Output Voltage 15V, internally adjustable
Ripple & Noise @ 1/2 AMP,
10 millivolts
Load Regulation Better than 1%

PROTO BOARD 100



PE-100
Complete Kit...

**A complete mini-
breadboard budget
kit with full IC capacity**

19⁹⁵

Add \$1.50
shipping/handling

The PB-100 is a low cost, big 10 IC capacity breadboard kit, complete down to the last nut, bolt and screw. Includes 2 QT-35S Sockets; 1 QT-35B Bus Strip; 2 5-way binding posts; 4 rubber feet; screws and easy assembly instructions. 4.50" (114.3mm) wide x 6.00" (152.4mm) long x 1.35" (34.3mm) high. Order your PB-100 kit! Start building and testing now!

PROTO-CLIP offers power-on... hands-off signal tracing... under \$5!

Trace signals or troubleshoot fast. Inject signals or wire unused circuits into existing boards. Flexible plastic web* construction eliminates springs and pivots. Plus, the narrow throat is perfect for high density PC boards.

Order now!
PC-14 14-pin Proto-Clip: \$4.50 ea.
PC-16 16-pin Proto-Clip: \$4.75 ea.

Add \$1.00 shipping
and handling

**Scope probes,
test leads lock
onto unique
toothed grips**



© COPYRIGHT CONTINENTAL SPECIALTIES CORPORATION 1975

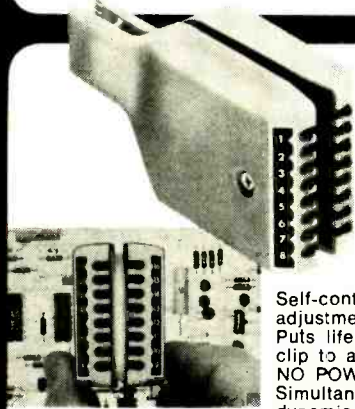

**Continental
Specialties Corp.
LOGIC MONITOR
brings ICs to life
faster than a scope...
safer than a
voltmeter**

LM-1 **84⁹⁵** each

Add \$2.50 shipping/handling

Self-contained, pocket size. No adjustments or calibrations needed. Puts life into digital designs. Just clip to any DIP IC up to 16 pins. NO POWER SUPPLY NEEDED!

Simultaneously displays static and dynamic logic states of DTL, TTL,

HTL or CMOS on 16 large high intensity LEDs. Watch signals work through counters, shift registers, timers, adders, flip flops, decoders, entire systems. Concentrate on signal flow and input/output truth tables. Forget probe grounds, pin counting or sync polarity. Precision plastic guides and flexible plastic web* insure positive connections. Versatile. Fast. Accurate. Indispensable. Order yours today!

All Continental Specialties breadboard test devices are made in the USA, and are available off-the-shelf from your local distributor or CSC. Direct purchases may be charged on BankAmericard, Master Charge or American Express. You get a FREE English/Metric conversion slide rule with each order. Foreign orders please add 10% for shipping/handling. Prices are subject to change. Write or phone for complete illustrated catalog, plus the name and address of the CSC dealer nearest you.

*Patents Pending



CONTINENTAL SPECIALTIES CORP.

44 Kendall St., Box 1942, New Haven, CT 05519 • 203/624-3103

West Coast Office: Box 7809, San Francisco, CA 94119 • 415/383-4207

CANADA: available thru Len Finkler Ltd., Ontario

You can tear out all the cards in this magazine...

But this is the one you should mail!

**If you're thinking of investing your money
in a learn-at-home program in electronics, there are
a few things you should know first.**

Selecting a home electronics program isn't easy. It could be one of the most important decisions you'll ever make for your future. So you want to decide carefully and get the best education you can.

After all, you're investing your time and money, and you want a full return on that investment.

What should you look for before you select a school?

You probably want a school with a proven track record of quality and performance. You want personal attention plus, the convenience of learning at home. You want the most up-to-date technical texts...teaching aids and learning methods.

But most of all you want to actually learn what electronics is all about. Not just theory, but actual hands-on experience with the latest and best technical equipment available today!

At Bell & Howell Schools, you get all that...and so much more!

Bell & Howell Schools has been in the home-study electronics business a long time. Almost half a century. In that time, we have developed teaching techniques that provide our students with the most vital and comprehensive learning system available for at-home study.

Techniques like our "step-by-step" concept of learning.

At Bell & Howell Schools, we start you off with the basics. Then take you step by step through the learning process. You work at a comfortable pace—not too fast...not too slow. If you already have some learning or experience, we'll arrange advanced standing in the program so you can skip the beginning lessons. And don't worry if you don't have any electronics background. 25% of our graduates never

even had any electronics training before enrolling with Bell & Howell Schools. (Based on a recent survey of our graduates conducted by an independent research firm. Survey results available on request.)

Or our system of personal contact.

No course is without its problems. And when you get hung up on a problem, you want answers and you want them fast. Here at Bell & Howell Schools, we combine the convenience and pleasure of learning at home with a system of personal contact with faculty and other students that rivals—if not beats—any other program available.

For problems that "just can't wait" we have a toll-free "hot-line" that you can call and discuss your questions with an experienced instructor. You get real attention—someone whose only job is to see to it that your individual questions are answered. And answered quickly and clearly!

To help you develop your thoughts and understand electronics principles more thoroughly, Bell & Howell Schools has developed a unique feature that no other learn-at-home program has—In-Person Help Sessions in 50 major cities throughout the United States. These let you get together with instructors and other fellow students. There you can talk shop with other people who share your interests... explore your problems further... and get additional assistance.

But that's not all that Bell & Howell Schools will do for you! In addition to our vast experience and expertise, is a philosophy that the best learning comes from working with the best equipment available. And that's exactly what our students do!

What better way to learn electronics than to actually work with electronics equipment?

And what better way to find out how things fit together... how they work and why they work than to actually build the equipment? And we don't mean gadgets that will be worthless to you later.

We mean equipment like the Bell & Howell Schools exclusive "Electro-LabSM" electronic training system including design console, digital multimeter and oscilloscope, that you can use professionally after you've graduated.

The design console will allow you to set up and examine circuits without having to solder them in place.

The digital multimeter measures voltage, current and resistance and displays its findings in big clear numbers for easier reading.

And the solid-state "triggered sweep" oscilloscope is similar in principle to the kind used in hospital operating rooms to monitor heartbeats. But you'll use it to monitor and analyze tiny integrated circuits. And you'll find the "triggered sweep" feature locks in signals for easier observation.

That's not all you build when you choose a course from Bell & Howell Schools!

To learn the most advanced electronics technology, you have to work with the most advanced training tools.

So in addition to the exclusive "Electro LabSM" system that you will build as part of Bell & Howell's Home Entertainment Electronics program, you'll also build a 25" diagonal color TV with digital features.

Sounds exciting, doesn't it? Well, digital electronics is exciting! Its growth and application are giving us new and better products and a whole new realm of split-second accuracy that was just a dream a few years ago. And this new technology is being applied more and more to TV's, clocks, radios and other home entertainment equipment.

By studying with Bell & Howell Schools—one of the first schools to introduce digital electronics as part of its training program—you can actually get in on the ground floor of this new technology while learning all the basic electronics principles and skills you'll need to detect and troubleshoot problems professionally on digital and other electronic equipment.

Make no mistake about it! As you build your digital color TV, you'll get a thorough grounding in electronics principles. You'll develop a working knowledge of "state of the art" integrated circuitry and the 100% solid-state chassis. Plus you'll actually know how to program a special automatic channel selector to skip over "dead" channels and how to build a remarkable on-the-screen digital clock that flashes the time in hours, minutes and seconds.

But most importantly, you'll have the skills that could lead you to a brighter future...

And isn't that what education is supposed to be all about? At Bell & Howell Schools we've always thought so although no school can guarantee you a job or income opportunity. Get full details about us, our courses, our philosophy of education by mailing the postage-paid card today. If you take one of our courses for vocational purposes, this program is approved by the state approval agency for Veterans' Benefits.

Mail card today for full details!



If card has been removed, write:

An Electronics Home Study School

DEVRY INSTITUTE OF TECHNOLOGY

ONE OF THE

BELL & HOWELL SCHOOLS

4141 Belmont, Chicago, Illinois 60641

763/4R1

"Electro-LabSM" is a registered trademark of the Bell & Howell Company. Simulated TV test pattern.

SEPTEMBER 1975



Stereo Scene

By Ralph Hodges

STARTING WITH A LACQUER DISC

ACCORDING to my sources, two United States companies, Capitol (formerly Audio Devices) and Transco, are responsible for at least 90 per cent of the world's blank lacquer discs for record cutting. Capitol has the larger share of the market—maybe 55 to 60 per cent. Recently, I joined other members of the press on a trip to the Capitol plant in Winchester, Virginia, where the pictures shown here were taken. (I can't take credit for the photography since that belongs to a professional, Thomas Bancroft, who was employed for the expedition).

The blank lacquer disc is of course the modern equivalent of the wax- or tinfoil-covered surfaces on which the first phonograph and gramophone

records were cut. Today's cutting (inscribing) device is a precision cutting head mounted on a heavy worm-gear-driven lathe (Fig. 1). The inscribing stylus, a tiny jewel arrowhead with complex facets, is heated to ease its passage through the lacquer material, while the coils of the cutting head, which must dissipate enormous amounts of power, are cooled, usually by a flow of liquid helium.

The lacquer records made on this device are used to produce metal molds for vinyl disc pressing. They are not intended to be played, although they can be with high-quality pickups (keeping in mind that the stylus mass and damping of pickup cartridges are designed for vinyl, not lacquer, and

some differences in high-frequency response can be expected as a result). When they are, they provide an eerily quiet background—quite obviously the best signal-to-noise ratio, audibly and measurably, of any recording medium in current use. Unfortunately, their durability under any practical playing situation is extremely poor.

Lacquer Noise. This outstanding noise performance depends, of course, on a good master tape (tape noise is usually dominant on any lacquer disc, as you soon become aware), good electronics, and a very consistent and well-defined interaction between cutting stylus and lacquer material. How quiet is a lacquer master that is not limited by tape noise? Well, Capitol claims to measure signal-to-noise ratios that are typically about 65 dB with A weighting. Hardly astonishing, you say, and in fact well within the proven capability of the tape medium. But the difference is that tape S/N is rated at a recorded level that comes rather close to the saturation point of the tape, while the lacquer S/N is referred to a recorded velocity of 3.54 centimeters per second—a very moderate level indeed. Recorded velocities briefly exceeding 20 centimeters per second have been found on commercial disc records, and some of the better playback cartridges (the consumer's cartridge, not the recording system, determines the upper limit for levels on discs) are capable of around 30 centimeters per second at mid-frequencies before mistracking. If the lacquer has a 65-dB S/N at 3.54 centimeters per second, the equivalent S/N at 20 centimeters per second would be about 80 dB. Now you begin to understand how quiet the disc medium can really be.

Basically, lacquer noise is low because the groove wall is smooth, with a grain so fine that only the finest scanning electron microscopes can resolve it. This exquisite polish is acquired through the action of the heated cutting stylus on the lacquer material. It is not known whether the heat actually melts (briefly) the material or simply softens it to facilitate a smooth passage for the stylus, but it is known that the right stylus temperature is critical for a quiet cut. (In fact, temperature requirements change from the outer grooves to the inner, where linear velocities are lower, so that a compromise must be made.)



Fig. 1. Disc-cutting lathe used for evaluation of lacquers. Test cuts can be seen on the lacquer's surface.



II'nd only to the III.

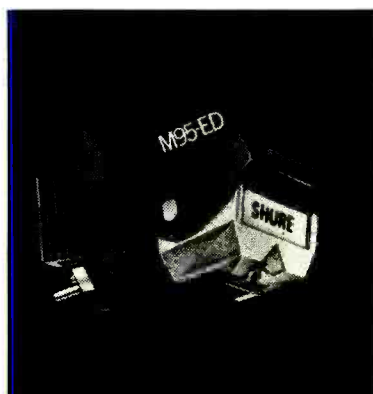

The new Shure M95ED phono cartridge combines an ultra-flat 20-20,000 Hz frequency response and extraordinary trackability with an utterly affordable price tag! To achieve this remarkable feat, the same hi-fi engineering team that perfected the incomparable Shure V-15 Type III cartridge spent five years developing a revolutionary all-new interior pole piece structure for reducing magnetic losses. The trackability of the M95ED is second only to the Shure V-15 Type III. In fact, it is the new "Number 2" cartridge in *all* respects and surpasses much higher priced units that were considered "state of the art" only a few years ago. Where a temporary austerity budget is a pressing and practical consideration, the M95ED can deliver more performance per dollar than anything you've heard to date.

Shure Brothers Inc.
222 Hartrey Ave., Evanston, IL 60204
In Canada: A. C. Simmonds & Sons Limited



Manufacturers of high fidelity components, microphones, sound systems and related circuitry.



Fig. 2. After coating, steps are carried out under clean-room conditions, including inspection.

What Makes a Good Lacquer? A

blank lacquer disc is a rather impressive product to behold. It is mirror-finished (Fig. 2), solid and stiff, and has an intriguing chemical aroma. The mirror qualities are not so important to performance, although they do imply precision (and they give some indication of the degree of polish the finished groove walls will take on). The near-perfect flatness is. With many modern disc-cutting lathes the depth of the groove cut will of course vary if the recording surface rises and falls beneath the cutting stylus. Since deeper grooves must be spaced further apart, it becomes difficult to decide on the appropriate average groove spacing, and on how many grooves (i.e., how long a program) the



Fig. 3. In curing tunnel, counter measures airborne particles.

disc side will accommodate. It has even been suggested that a non-flat cutting surface may introduce a slight "warp wow," since the cutter head has a certain amount of freedom to ride up and down.

What else? To a significant extent the motion of the cutting stylus is controlled by the compliance and damping the lacquer material presents, so that linear performance of the system requires a material that is both correctly constituted and homogeneous. The material should behave properly under the stress of cutting, so that forces "stored" during the modulation of one groove do not work themselves through the material to an adjacent groove, causing the phenomenon called "groove echo." Consistent performance of the lacquer under the temperatures involved in cutting is vital. Otherwise the cut will be noisy, or the thin thread of material (the "swarf") thrown up by the stylus will not separate cleanly from the groove. Occasionally deposits of lacquer material will bake right onto the stylus, scoring the groove. And, of course, impurities or irregularities in the lacquer coating are verboten.

By now all these requirements are pretty much known and understood, but now and then a bizarre problem surfaces. For example, a cartridge manufacturer recently drew my attention to a fault in a test record's stereo separation that he tentatively attributed to the lacquer/cutting-stylus interaction. Apparently the cutting situation involved too much friction, distorting the drive impulses from the cutter and altering the included angle of the groove being cut.

How It's Done. However complicated it may be, the making of a blank lacquer disc certainly looks simple enough. It begins with a disc of aluminum alloy, its surfaces prepared either by calendering or polishing, followed by whatever cleansing and chemical treatment the manufacturer deems appropriate. Then comes the lacquer, composed of a nitrocellulose base with various (often proprietary) additives. It is made up in controlled batches, filtered, de-aerated, and then stored in special tanks that keep its highly volatile contents stable until the moment of use.

British recording pioneer Cecil Watts acquired a certain reputation for eccentricity through his initial scheme for coating his own recording

blanks. Reportedly he built up the coating in thin layers, letting each one cure for a precise period of time, and so had to rise at all hours of the night to perform a fresh application. The Capitol technique (which we were not allowed to view) is a one-step process, taking only a second or so for each side. After each side is done there is a trip through a curing tunnel (Fig. 3) that is monitored constantly for temperature and cleanliness. Then it's all over except for inspection, center-hole punching, and packaging, all of which involve clean-room environments and elaborate handling precautions. During inspection, blanks for the various record sizes are sorted into both-sides-usable or one-side-usable categories. As might be im-



Fig. 4. Separating the metal master from the lacquer disc.

aged, there is a lot of feedback from customers about the performance and consistency of the product, and this is taken quite seriously.

The Lacquer's Fate. While we were there, Capitol permitted us a look at the Winchester pressing plant—a real treat for me, since I had never been admitted within the doors of such a facility before. Although I am not as a rule an admirer of pressing plants, I did manage to work up some genuine sympathy for their problems, considering that they're expected to keep intact every nuance of a recording they won't even get a chance to hear until it's half way to the mass-production stage.

There is not enough space here for a detailed description of the record-making process (many of you are probably familiar with it anyway), but I can present some photographs of sights that few in the outside world have seen first-hand. Figure 4 shows the lacquer's fate. Here, in the



Fig. 5. Metal mother is played and imperfections are marked for later removal through "microsurgery."

TAKE YOUR CHOICE



Mini-Scan™
is the pocket scanner that works a week on just 4 penlight cells.



A breakthrough we call "mini-miser circuitry" makes it possible . . . and it's actually 2½ to 5 times more efficient than any other pocket scanner we tested!* Just 4 alkaline penlight cells power it for a full week, 8 hours a day, on a tough 50-50 duty cycle (50% full volume, 50% squelched). And its performance is bred from our experience in public safety two-way radio . . . so it also gives you the crispest, clearest messages possible. Just \$119.95 with built-in ferrite antenna (batteries, crystals and optional flexible antenna extra.)

*Test results gladly supplied on request.



Johnson
MINI-SCAN™

... the professional pocket scanner

E. F. JOHNSON CO., WASECA, MINNESOTA 56093
IN CANADA: A. C. SIMMONDS & SONS, LTD.
CIRCLE NO. 33 ON FREE INFORMATION CARD

operator's right hand, the lacquer is being separated from a rather thick metal coating that has been built up on it through an electroplating process. The coating, called a "metal master," is a negative of the lacquer. It will in turn be electroplated to create a metal part that can actually be played on a turntable (Fig. 5), so that flaws can be detected. When okay, it is itself plated, creating the die that will mold side one or side two of the record you'll ultimately have a chance to buy. Before it is mounted in the press, however, its edges will be trimmed and crimped to mold the contour of the record's edge. It will also have a

hole punched in the precise center of the groove spiral (Fig. 6). I say "precise" bemusedly, since I too have had my share of off-center records. But from the look of this process, it couldn't miss if performed properly.

The presses that mold the vinyl records are becoming automated more and more. The ones I saw require little more than an attendant to pick up the stacks of finished discs and cart them away. And that, after inspection (I hope) and packaging, is the last intended thing that happens to the offspring of the blank lacquer disc before you have it in your own quivering and anticipatory hands. ♦



Fig. 6. Locating center hole for stamper involves spinning disc until groove pattern appears stationary.

NEWS HIGHLIGHTS

International Digital Data Service

Western Union International has applied to the FCC for permission to start a new international data communications service (IDDS). IDDS features simultaneous digital transmission over both satellite and submarine cable links for greater assurance of continuous service. Equipment will sample incoming data signals up to 6000 times each minute and select the preferred path at each instant. Transmission rates of 50 to 9600 bits/second will be used. A real-time link between New York and Paris using IDDS has already been demonstrated.

RCA Demonstrates AM Stereo System

RCA conducted live demonstrations of a proposed AM stereo transmitting system at the National Association of Broadcasters convention in Las Vegas. The system is said to be compatible with existing monophonic receivers, with the capability of multiplexing two discrete left and right channels. Appropriate industry standards and FCC approval would be necessary before AM stereo broadcasts could become a reality.

Talking Computers

An expert in human and computer-synthesized speech predicts that computers will someday be talking to man and helping him to do certain tasks. Dr. James Flanagan of Bell Labs says that talking laboratory computers can already read out stored information, verify the identity of a caller by checking his voice, and respond to simple spoken commands. Computers speak in their own distinctive voices and accents, Dr. Flanagan says, which they assemble from the speech resonances and rules of syntax with which they are programmed. The voices can exchange fairly complex information with a questioner. The machines' capacities are still restricted to recognizing single words from a limited vocabulary. One system handles about 200 words, and another responds to spoken digits.

CB Mobile Use

The EIA's Citizens Radio Section reports that 1 in 5 long-haul trucks is equipped with CB radios and that 1 out of every 28 American families (1 of 15 farm families) uses the Citizens Band in one way or another, with over 6¼ million CB radios now in use. Through the use of emergency channel 9, approximately 20 million emergencies are said to be reported every year.

Self-Healing Fuse

NASA has developed a self-healing fuse, primarily for use in remote locations. It is a very fast-acting, current-limiting device that provides current overload protection for vulnerable circuit elements. It then re-establishes the conduction path within a few milliseconds. It also performs as a fast-acting switch to clear transient overloads. The fuse has a current-time curve almost identical to that of an SCR. Life tests indicate at least 500 operations before failure with fuse ratings from 4 to 40 amperes and 50 to 100 volts dc.

Production-Line CCD

Fairchild Camera and Instrument Corp. is now producing a charge-coupled memory device on a production-line basis. The high-density CCD 450, a 1-kilobyte serial storage element, is expected to be incorporated into terminals, video displays, and electronic switching networks for data communications. It is organized as 1024 words by 9 bits. OEM sample pricing is \$90 in quantities of 1 to 10.

Artificial Sky-Wave Propagation

Scientists at the Stanford Research Institute have demonstrated that a temporary bubble can be produced in the ionosphere which reflects radio signals back to earth. The bubble is produced by heating the atmosphere with radio signals from a ground-based "heating transmitter." The heating is based on principles similar to those employed by microwave ovens. The bubble is typically about 100 miles in diameter and 10 miles thick directly above the transmitter, and is invisible to the naked eye. Space-charge irregularities within the bubble act as radio reflectors. When the heating transmitter is turned off, the bubble disappears without a trace. The technique will be most useful for reflecting vhf signals, particularly those from public service radios and mobile radio telephones. Existing 500-kW shortwave transmitters can be used for heat sources.

GE Marketing Transient Protector

A solid-state device will be introduced by GE to protect home entertainment equipment against potentially dangerous voltage spikes on ac power lines. The GE-MOV™ is a voltage-sensitive metal-oxide varistor said to be able to respond to line transients in 50 billionths of a second. It absorbs them and dissipates the energy in the form of heat. Voltage spikes can be caused by the starting of pumps, oil burners, fluorescent lights, as well as lightning-induced effects. The device will not protect equipment against a direct lightning hit, however. Voltage transients are believed to be responsible for as many as one-half the component failures in solid-state television receivers and other home entertainment equipment.

Transmitting Technique for "Ghosts"

RCA Broadcast Systems has demonstrated that circular polarization of television transmission virtually eliminates ghosting—an effect caused by reflected signals. RCA says that the use of matching transmitting and receiving antennas (both circularly polarized) provides "polarization discrimination" rejecting a reflected signal. An application has been made to the FCC to permit special antennas to be used for TV broadcasting. If approved, the use of such antennas (and special receiving antennas) should provide relief to viewers whose screens are haunted by "ghosts."

The new Sansui LM Loudspeakers that set the AES Convention on its ears.



LM 330
CUT-A-WAY

At the Convention of the Audio Engineering Society in Los Angeles last May, Sansui demonstrated a new concept in loudspeaker design.

The reception from these experts—chief engineers of radio and TV stations, record producers, recording engineers and sales executives of audio companies—was even more sensational than we ourselves expected.

And these are the reasons:

Unlike conventional speakers, the LM design incorporates a multi-radiational tweeter device. High frequencies instead of being lost through encapsulation, are diverted through three special exponential horns and recovered into sound energy that

adds a breathtaking sense of ambience, and realism. The LM speakers also display extremely stable and well-defined stereo images. At the same

time, both the transient response and efficiency of the system are greatly increased. An extra large woofer assembly gives exceptionally strong bass response ordinarily available only in much larger and more expensive speakers.

Hear any of the 3 models available at your nearest Sansui franchised dealer. You never heard music so alive before.



Multi-radiational
tweeter

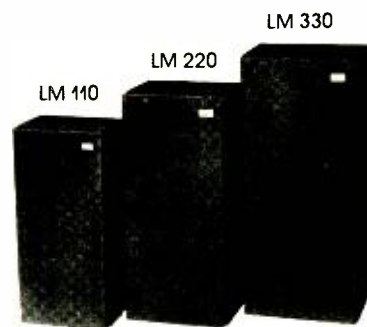

SANSUI ELECTRONICS CORP.

Woodside, New York 11377 • Gardena, California 90247
SANSUI ELECTRIC CO., LTD., Tokyo, Japan • SANSUI AUDIO EUROPE S.A.,
Antwerp, Belgium • ELECTRONIC DISTRIBUTORS (Canada) Vancouver 9, B.C.



CIRCLE NO. 48 ON FREE INFORMATION CARD

The better the training the better you'll

Send for
FREE
illustrated
career
guide

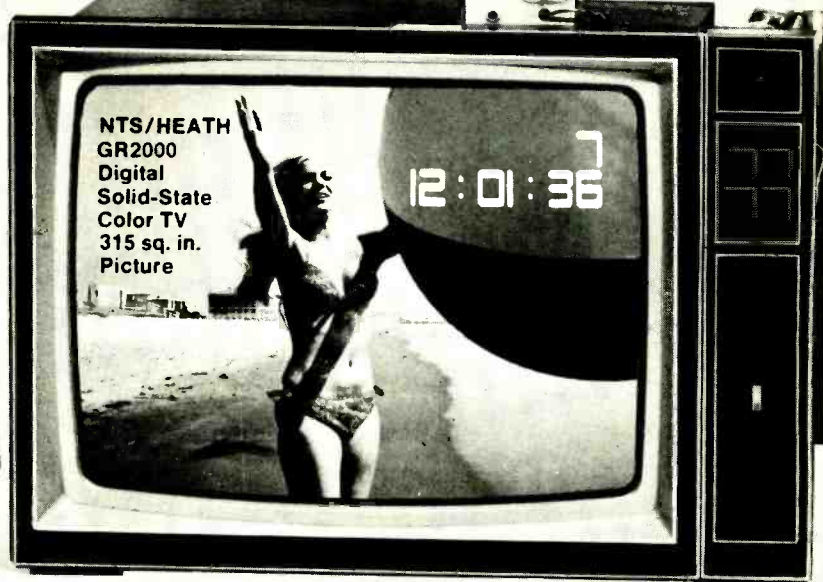
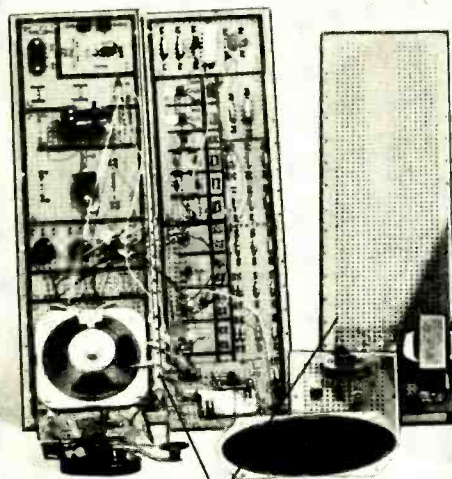
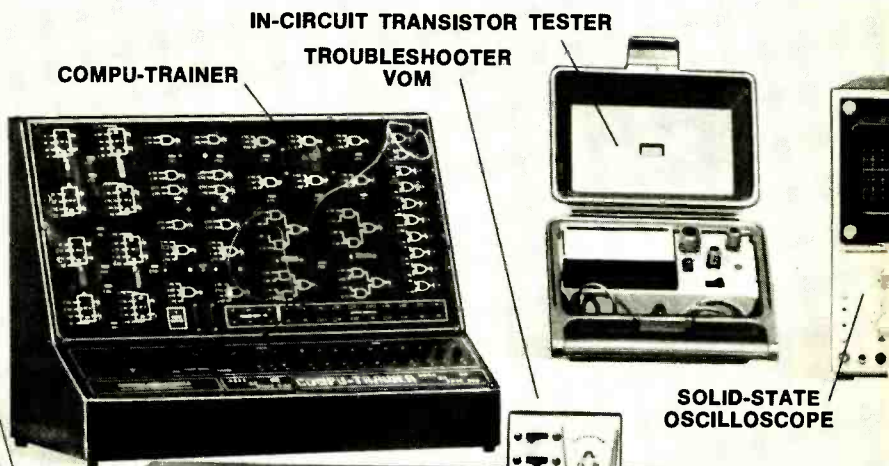
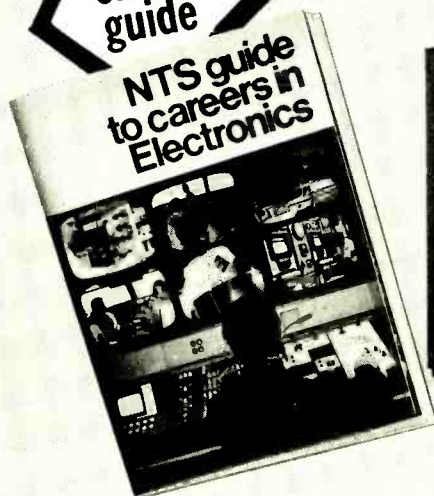

ELECTRO-LAB

(Simulated TV Reception)

As an NTS student you'll acquire the know-how that comes with first-hand training on NTS professional equipment. **Equipment you'll build and keep.** Our courses include equipment like the **NTS/Heath Digital GR-2000 Solid State color TV** with first-ever features like silent varactor diode tuning; digital channel selection, (with optional digital clock), and big 315 sq. in. ultra-rectangular screen.

Also pictured above are other units — 5" solid state oscilloscope, vector monitor scope, solid-state stereo AM-FM receiver with twin speakers, digital multi-meter, and more. It's the kind of better equipment that gets you better equipped for the electronics industry.

This electronic gear is not only designed for training; it's field-type — like you'll meet on the job, or when you're making service calls. And with NTS easy-to-read, profusely illustrated lessons you learn the theory behind these tools of the trade.

Choose from 12 NTS courses covering a wide range of fields in electronics, each complete with equipment, lessons, and manuals to make your training more practical and interesting.

Compare our training; compare our lower tuition. We employ no salesmen, pay no commissions. You receive all home-study information by mail only. All Kits, lessons, and experiments are described in full color. Most liberal refund policy and cancella-

and the equipment be equipped.

COMPARE OUR
KITS AND LESSONS.
COMPARE OUR
TUITION.

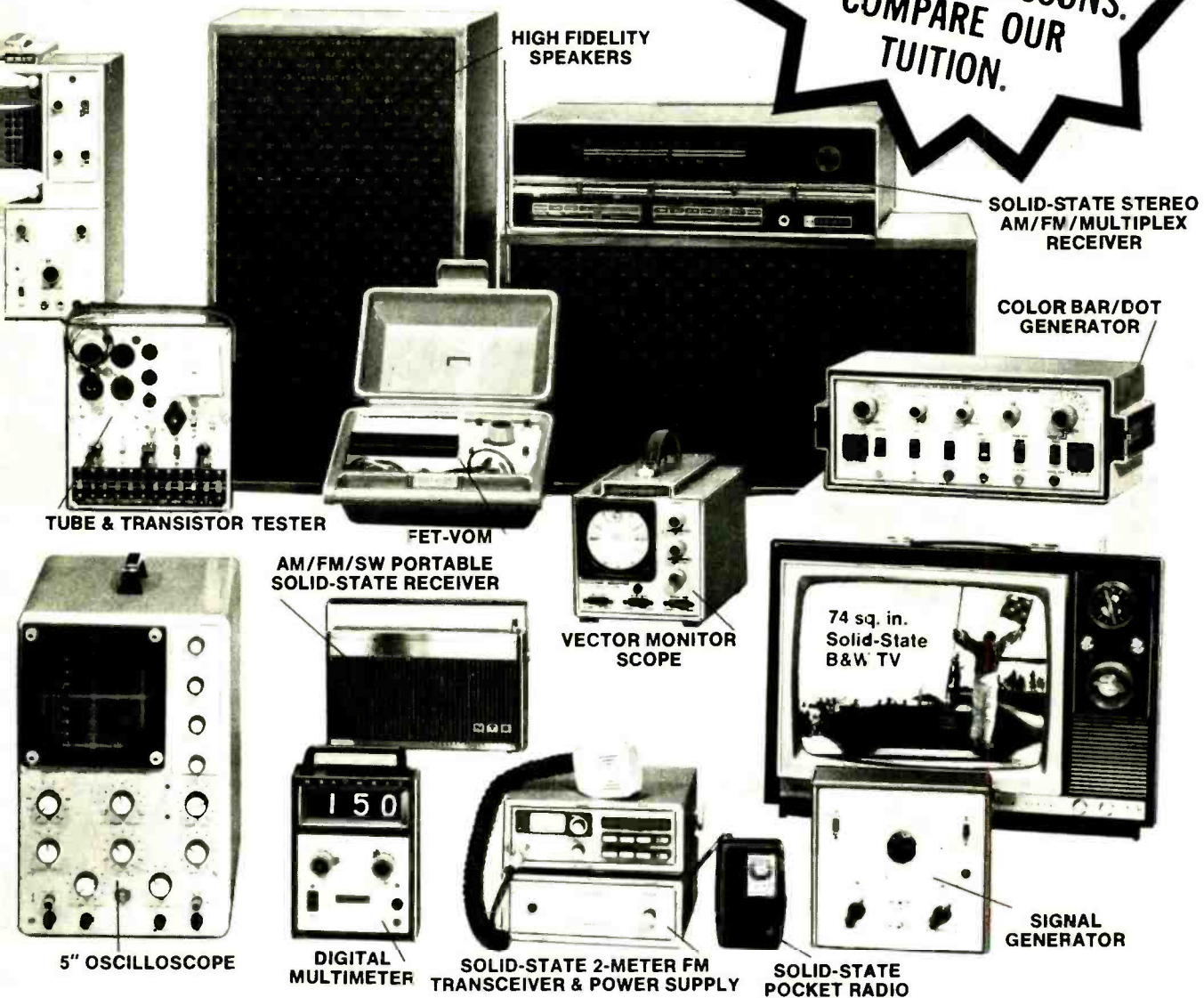

tion privileges spelled out. Make your own comparisons, your own decision. Mail card today, or clip coupon if card is missing.

NO OBLIGATION. NO SALESMAN WILL CALL

APPROVED FOR VETERAN TRAINING
Get facts on new 2-year extension

NATIONAL TECHNICAL SCHOOLS

TECHNICAL-TRADE TRAINING SINCE 1905
Resident and Home-Study Schools
4000 So. Figueroa St., Los Angeles, Calif. 90037

NATIONAL TECHNICAL SCHOOLS Dept. 205-095
4000 South Figueroa St., Los Angeles, Calif. 90037
Please send FREE Color Catalog and Sample Lesson.
NO OBLIGATION. NO SALESMAN WILL CALL.

Color TV Servicing Electronics Technology
 B & W TV and Radio Servicing Computer Electronics
 Electronic Communications Basic Electronics
 FCC License Course Audio Electronics Servicing

NAME _____ AGE _____

ADDRESS _____ APT # _____

CITY _____ STATE _____

Please fill in Zip Code for fast service _____

Check if interested in G.I. Bill information.
 Check If interested ONLY in classroom training in Los Angeles.

New Mallory Ni-Cad Batteries. Rechargeable 1000 times.



Economical recharging—
Mallory RC-1 Charger draws only two watts.

Team these long-life nickel-cadmium cells with an automatic Mallory Charger, and you can recharge them 1000 times, or more.

You'll be sure of having fresh D, C, and AA batteries, while saving money, time and trouble. Mallory Rechargeable Nickel-Cadmium Batteries keep on coming back for more in electronic calculators, tape recorders, radios, cameras, toys, other battery-powered products.

Keep a spare set of Mallory Ni-Cads on hand,

and you'll never run out of battery power again. They recharge to full strength, two or four at a time. And unlike ordinary dry cells that lose voltage during discharge, Mallory Ni-Cads with a full charge maintain operating voltage during the entire work cycle. You get maximum power, continuously, for top product performance.

For the long run, Mallory Rechargeable Ni-Cads... the 1000-time batteries. Get them now at your Mallory Distributor.

MALLORY

MALLORY DISTRIBUTOR PRODUCTS COMPANY

a division of P. R. MALLORY & CO. INC.
Box 1284, Indianapolis, Indiana 46206; Telephone: 317-856-3731

Batteries • Capacitors • Controls • Security Products • DURATAPE® • Resistors • Semiconductors • SONALERT® • Switches • Fastening Devices
DURATAPE® and SONALERT® are registered trademarks of P. R. Mallory & Co. Inc.

WITH stereo receiver prices ranging from less than \$200 to more than \$1000, choosing a model around which to build your hi-fi system is no easy task. The difficulty lies in the wide variety of features, functions, and performance offered by the literally hundreds of receiver models available. Obviously, a major consideration when you are out shopping is what you get for your money. If you have settled on a \$400 to \$500 receiver, for example, you'll want to know what it will give you that you can't obtain with a receiver selling at a lower price and what you'll be missing that a costlier receiver offers you.

We have studied the characteristics of stereo receivers typical of each price category. Bar graphs provide at-a-glance performance expectations versus price. Obviously, there are many other factors to consider—operating and control features, cosmetic styling, warranty policies, etc.—and we will touch on these also in this report.

Features. A basic hi-fi system might consist of a stereo receiver, two speaker systems, and a record turntable. Naturally, one should expect the

What Does Your Stereo Receiver Dollar Buy?

receiver to have a magnetic phono input. This should be supplemented by at least one high-level (AUX) input through which the audio output from an eight-track cartridge tape player or a TV receiver can be played.

The basic hi-fi receiver should also have inputs and outputs for a tape recorder and a tape monitor switch for simultaneous listening to the playback from the tape deck while recording. The latter feature is important even if you don't plan to use a tape player because it protects your receiver from obsolescence. Furthermore, a variety of accessories—including noise-reduction units, active equalizers, and quadraphonic decoders and adapters—can be connected to a receiver via its tape monitoring jacks. The accessories permit you to update your system.

Common to every receiver are volume and tone controls. Each receiver has at least one tone control for the bass range and another for the treble. Some of the more expensive receivers have tone-control circuits that are more elaborate, permitting more flexibility in tailoring the sound to the listener's preferences.

Almost all volume-control circuits

Hirsch-Houck Labs compares performance and price.

BY JULIAN D. HIRSCH

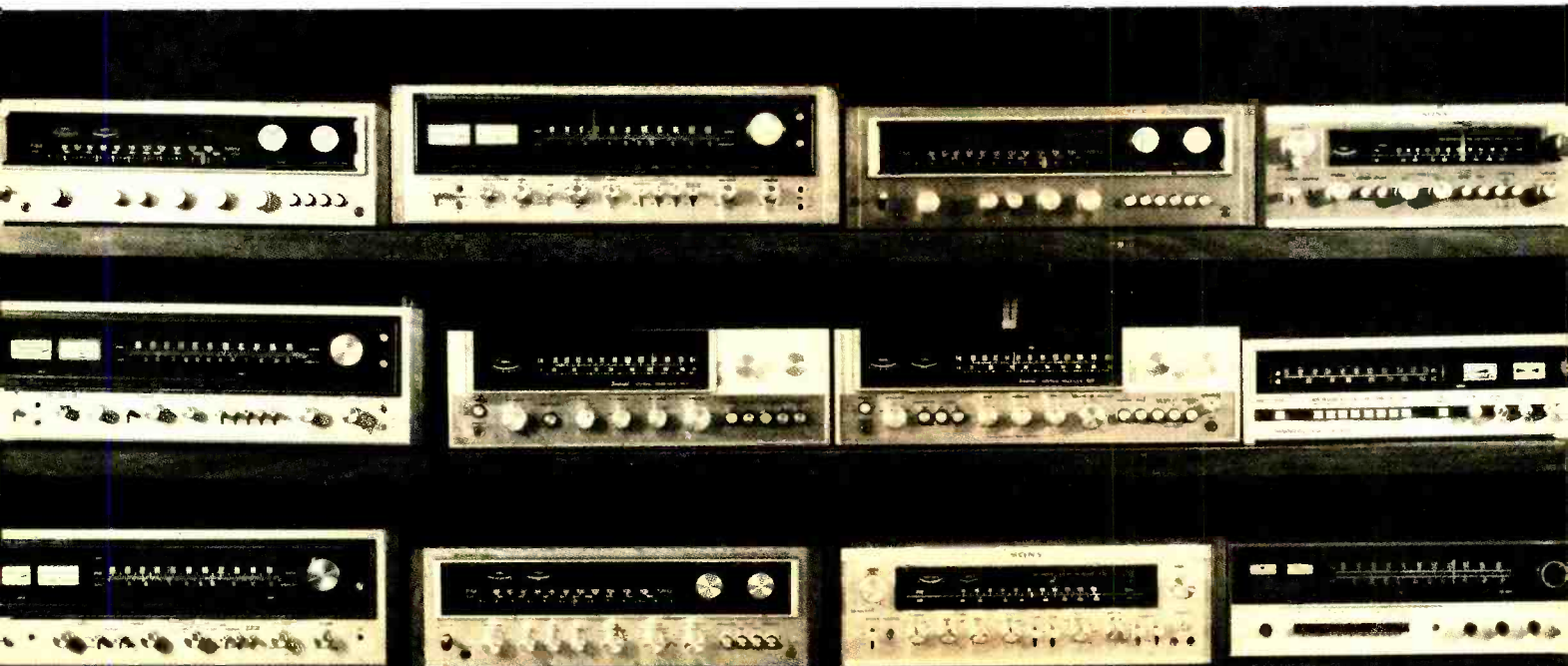

are supplemented by loudness compensation systems that boost the low frequencies relative to the midrange and high frequencies when the volume level is reduced. Unfortunately, it has been our experience that fully 95% of all such systems either do not have the best response characteristics or lack the provisions for matching the volume-control settings to the actual volume of the sound.

Almost all stereo receivers have a headphone jack on the front panel for private listening. The rear apron usually contains output connectors for at least two speaker systems (one per channel).

Most receivers that sell for more than \$200 feature interstation noise muting that removes the between-station hiss when tuning across the FM band. Since some muting circuits are more effective than others, it pays to perform a listening test before you buy.

The great majority of receivers have at least one meter to aid in tuning. In lower-priced receivers, the meter gives a broad indication when a station is properly tuned. Better receivers might use a zero-center meter instead, while still better models are likely to have both types of meters for unambiguous tuning indication.

Other control features, such as rumble or hiss filters, microphone inputs, multiple-speaker-system switching, and the like, may or may not be important to you. On higher-priced receivers, it is not unusual to find additional input facilities, for a second phono cartridge, one or two more high-level sources, and a second tape monitoring system. The last is nice to have if you plan to use a tape deck and some other accessory that would normally use the receiver's tape-monitoring facilities.

Electrical Performance. Perhaps the most advertised electrical specification, and the one most closely related to price, is the receiver's output power. The greater the output power, the larger and more expensive the output transistors, the larger the heat sinks, and the larger the power transformer and filter capacitors. All of this costs money and adds to the sale price of the receiver. Determining how much power you need depends on your speaker systems, the size and acoustical properties of your listening room, and your musical preferences.

Any receiver that costs more than

\$200 should be able to drive acoustic-suspension speaker systems of moderately low efficiency to a more than comfortable volume level in your listening room. Bear in mind that the human ear requires a considerable increase in power for a modest increase in subjective volume level. A ten-fold power increase will roughly double the apparent loudness. Fortunately, typical home listening levels can be obtained with surprisingly little audio power—on the order of one watt or less. So, if you do not know how much power you need, play it safe and err on the high side.

The recent FTC ruling regarding advertised amplifier power rating requires manufacturers to specify distortion level at any output power between 0.25 watt and maximum at any frequency limits specified by the manufacturer. Furthermore, all channels must be driven into the loads specified by the manufacturer (usually 8 ohms). The low and high frequency limits most often set for hi-fi products are 20 and 20,000 Hz.

The rated distortion is the *maximum* figure. One can expect that, at most frequencies and power levels, it will be much lower than the published figure. In fact, it is often less than a tenth of the receiver's rated distortion level. In any event, the distortion should not be

particularly audible as long as the amplifier is operated within its design ratings.

It is not our purpose to go into detail here on frequency response, noise level, input sensitivity, and so on. Though these are important considerations, our experience suggests that just about all modern receivers are compatible with good hi-fi standards in these characteristics.

One amplifier characteristic that is often overlooked is its phono overload level: the input signal amplitude at which the phono preamplifier stage begins to distort significantly. With some combinations of heavily recorded discs and high-output cartridges, it is possible for the phono preamp to severely distort if it is poorly designed. This one minor rating appears to correlate very well with the overall quality of the amplifier.

In the FM tuner section, sensitivity is really not a very important specification, especially in view of the way it is presently defined. However, it does give a clue to the over-all caliber of the tuner's performance. Much more important is the signal input required to achieve a listenable signal-to-noise (S/N) ratio. One might assume that higher FM sensitivity (a lower number of microvolts in the specifications) would go hand-in-hand with higher

TABLE: 1 TABULATION OF SURVEY DATA (AVERAGE PERFORMANCE LEVEL)

Survey Parameter	PRICE RANGE (\$)							
	200-250	251-300	301-350	351-400	401-450	451-500	501-600	600+
Power (watts)	15.4	16.8	23	40	46	53	49	79
THD (%)	1.1	0.8	0.6	0.4	0.4	0.4	0.4	0.2
Phono Overload (mV)	77	88	102	117	87	144	152	210
FM Sensitivity (µV)	2.5	2.3	2.1	1.8	1.9	1.8	1.9	1.7
Mono FM THD (%)	0.63	0.39	0.42	0.34	0.36	0.29	0.24	0.18
Stereo FM THD (%)	1.0	0.58	0.73	0.64	0.60	0.53	0.42	0.30
Capture Ratio (dB)	2.7	2.5	2.1	1.6	1.8	1.7	1.5	1.5
Alternate-Channel Selectivity (dB)	51.2	51.2	55	65	66	68	78	83
Image Rejection (dB)	53.4	60	65	77	70	86	88	95
Average Price*	\$225	\$268	\$334	\$368	\$442	\$488	\$564	\$714
Receivers Surveyed	26	6	19	20	8	11	8	9

*Fall, 1974

"quieting" sensitivity (a higher dB number). This is not necessarily true, especially when comparing tuners with roughly the same IHF sensitivity rating. However, only the listener with severe weak-signal problems is likely to need all the sensitivity built into any modern receiver.

An excellent indicator of the quality of an FM tuner's front-end design is its image rejection. A good image rejection figure is needed to eliminate interference on certain frequencies. If you are located near a busy airport, or on a flight path into or out of an airport, you may already be aware of the problem of interference. The only cure is a receiver with a higher (in dB) image rejection characteristic.

Another source of interference is alternate-channel signals from a strong FM carrier 400 kHz removed from a weaker signal you are trying to tune. This can happen in locations very close to a powerful FM transmitter. (It is unlikely to occur if you are more than a few miles from the nearest transmitter.) Again, the best cure is high alternate-channel selectivity (the higher the dB number, the better), which is a function of the receiver's i-f amplifier design.

Many manufacturers emphasize the capture ratio of their receivers. This is an indication of how completely the stronger of two signals on the same frequency will take over (or capture) and prevent the weaker from being heard. A low number is better. Some receivers have a capture ratio as low as 1 dB. This means that with a signal level difference of only 1 dB, the stronger will suppress the weaker by 30 dB, and if the signals are more than 1 dB apart, it is possible that the weaker will not be heard at all. In most geographical areas, it is unlikely that two receivable signals will occupy the same channel.

The greater significance of capture ratio is in its ability—together with AM rejection, to which it is somewhat related—to reduce multipath distortion. This distortion can deteriorate the quality of stereo FM reception. It occurs in many urban and suburban locations, where signals are received from stations via several different paths. The direct signal arrives first, followed by one or more delayed signals reflected from obstacles in the surrounding terrain. The time differences between the arrivals of the signals cause severe cancellations and amplitude modulation of the re-

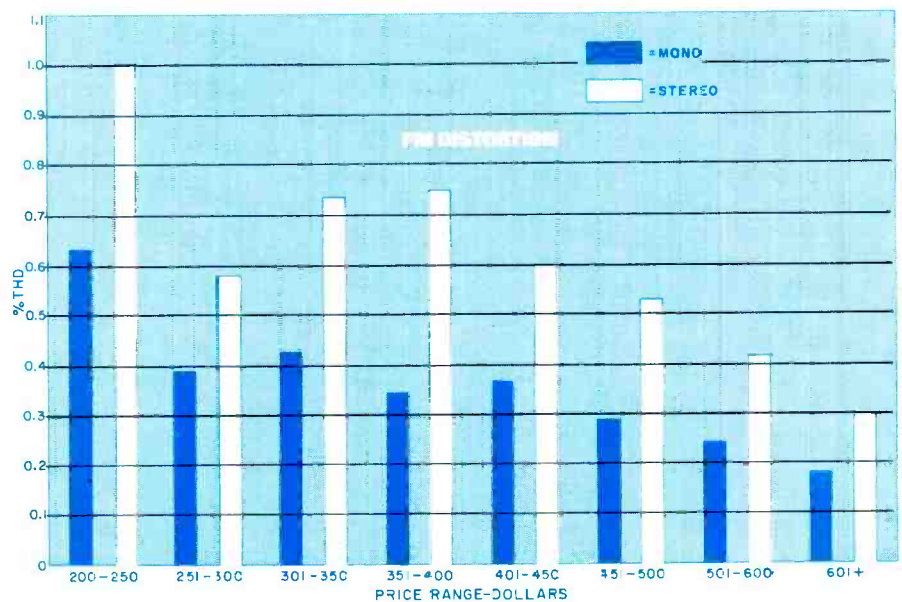
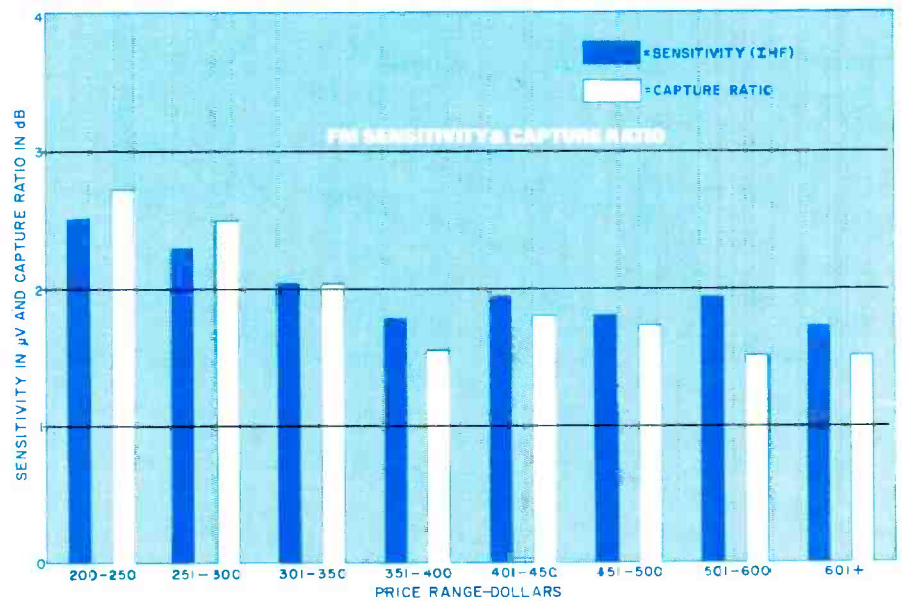
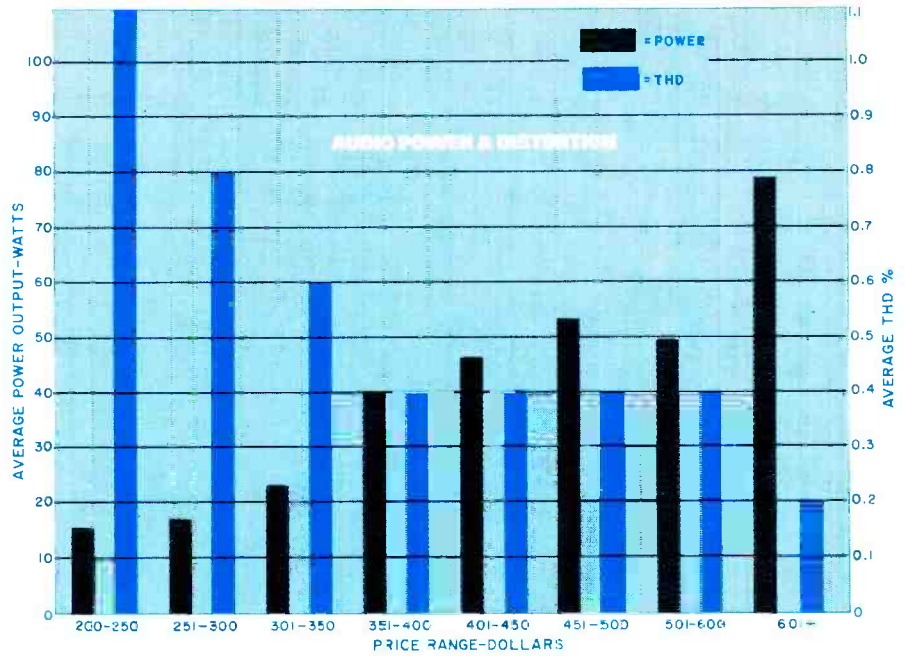

ceived signal. The ultimate solution to severe multipath distortion is a directional antenna, but a receiver with a good capture ratio will tend to discriminate against the weaker portions of the multiple signal and reduce the distortion.

The distortion imparted to signals by the FM tuner section of the receiver is a function of the amplitude and phase characteristics of the i-f amplifier and detector. Elaborate and expensive components are needed to provide the nearly ideal characteristics that minimize distortion in the finest tuner designs. In stereo, distortion problems are compounded because the stereo demodulator adds distortion of its own. As a result, stereo distortion is almost always greater (by an average of twice as much) than mono distortion.

Performance vs Cost Study. The performance categories we analyzed in our study were: output power per channel into 8-ohm loads with both channels driven over the audio range (usually but not always 20 to 20,000 Hz); maximum THD at full power within the frequency range; phono input overload signal level; FM sensitivity (IHF usable); FM distortion in both mono and stereo; FM capture ratio; FM alternate-channel selectivity; and FM image rejection. There are many other specifications that could have been included, but not all were available for a sufficient number of receivers to provide meaningful results. However, we consider the specifications selected to give a good picture of the overall quality of a receiver's amplifier and FM tuner sections.

The performance ratings were taken directly from the figures published by the various manufacturers. Some people might question this approach, but it has been our experience that, for the most part, most manufacturers honestly and even conservatively rate their receivers. A receiver's performance will often surpass its published ratings by a comfortable margin. Even when it fails to meet a particular specification, the difference is rarely serious.

The objective of our survey was to determine the average level of performance offered in each price range. If you want to know which receiver is inferior or superior to the average, you should examine manufacturer spec sheets or the listings in the STEREO DIRECTORY & BUYING GUIDE. Due to the

TABLE 2: COMPARISON OF MEASURED RECEIVER PERFORMANCE

Parameter	BRAND NAME AND MODEL			
	Pioneer SX-836	Rotel RX-402	Sherwood S-7110	Sylvania RS-4744
Price (\$)	350	290	230	400
Power (W)	23/25/25*	16.8/25/25	15.4/17/17**	40/60/60
THD (%)	0.6/0.5/0.06	0.8/0.5/0.6	1.1/0.9/0.1**	0.4/0.25/0.13
Phono Overload (mV)	102/110/100	88/85/87	77/90/88	117/NA/82
FM Sensitivity (µV)	2.1/1.9/1.8	2.3/2.0/1.8	1.8/2.0/2.1	1.8/1.8/2.0
Capture Ratio (dB)	2.1/1.0/0.7	2.5/2.0/3.3	2.7/1.5/0.7	1.6/1.5/0.7
Selectivity (dB)	55/60/63	51/70/71	51/60/61	65/55/51
Image Rejection (dB)	60/60/70	60/60/53	53/60/51	77/53/56
Mono THD (%)	0.42/0.20/0.12	0.39/0.20/0.65	0.63/0.44/0.22	0.34/0.40/0.27
Stereo THD (%)	0.73/0.40/0.48	0.58/NA/0.45	1.0/0.6/0.28	0.64/0.40/0.63

*Three-figure entries in each column are interpreted, left to right, as follows: Averaged value from Table 1/manufacturer specification/Hirsch-Houck Labs measurement. NA means information not available.

**Specified at 40 to 20,000 Hz. All others 20 to 20,000 Hz

spread in performance within each of the arbitrary price ranges we selected, you can expect some overlap in performance. The best receivers in one range may well be superior to the lowest ranks in the next higher range.

The results of the study are tabulated in Table 1 and graphically via the bar graphs. The graphs clearly illustrate the relationship of each performance rating to price. Starting with the lowest-priced receivers, audio power gradually increases with increasing price, although not significantly until the \$450 point. The most notable increment comes in the most expensive (\$600-plus) category, where the average power rating of almost 80 watts/channel is at least 50% greater than in any of the lower-priced groups. It is striking to note the rapid drop in rated distortion with increase in price and the leveling-off at the \$350 mark, above which there is no significant reduction in distortion until the \$600-plus point is reached.

Phono overload level rises steadily

with price, except for a drop in the \$401 to \$450 range, which may reflect an inadequate sample lot. Even the lowest-priced receivers can typically handle 80 mV (the higher the mV the better) without overloading. Only a few years ago, such a high overload level was available in a very few of the highest-priced receivers.

FM sensitivity improves slightly with price. This is partially because today's receivers approach the theoretical limit, which is variously stated to be between 1.5 and 1.8 µV. Since it is relatively easy to achieve a 2.5-µV sensitivity in a low-priced receiver, the gap between the least and most expensive models is slight. Although the quieting sensitivity for a 50-dB S/N ratio is more meaningful, this information wasn't available for a sufficient number of the receivers surveyed to be included in our calculations. Our experience with actual receiver performance indicates that there are appreciable differences among receivers with respect to quieting sensitivity, especially when weak-

signal FM reception is required. Naturally, the more expensive receivers tend to be better in quieting sensitivity. In most strong-signal areas, the differences in quieting, or ultimate S/N ration, are usually difficult to detect without critical listening.

Capture ratio seems to follow sensitivity as price goes up. But here, too, the differences are slight. FM distortion, like audio distortion, decreases steadily with increasing price, with the major improvements taking place between \$200 and \$300 and again above \$500. Selectivity and image rejection go hand in hand, although they are related to completely different parts of the tuner circuitry, with little change up to the \$301 to \$350 range, where a steady and significant improvement occurs all the way to the most expensive receivers.

Receivers often surpass their published specifications in many respects. To illustrate this, we have reviewed our recent laboratory tests and have chosen representative receiver models in each of the four lowest-priced ranges in our survey. There wasn't sufficient choice of receivers in the high-priced range, since most \$500-plus models tested in the recent past have been 4-channel models. As it happens, the receivers we selected all surpassed many of their published ratings and were above the average specifications in their respective price groups.

Conclusions. The most interesting result (which we weren't entirely prepared for) of our survey was that the greatest incremental improvement for the extra cost can be obtained by going to the \$351 to \$400 range. It is in this price range that all facets of receiver performance seem to be optimum. Lower-priced receivers are less advanced in their performance, to say nothing of control feature limitations, while a worthwhile improvement would probably require a jump to over \$500.

There is a danger in reading too much into the above because of the overlap between ranges and the wide variations within each range among receivers from different manufacturers. Of course, there is the matter of features and control flexibility, which, although they are not among the tabulated parameters, are the major differences between models in adjacent price ranges where electrical performance differs very little.

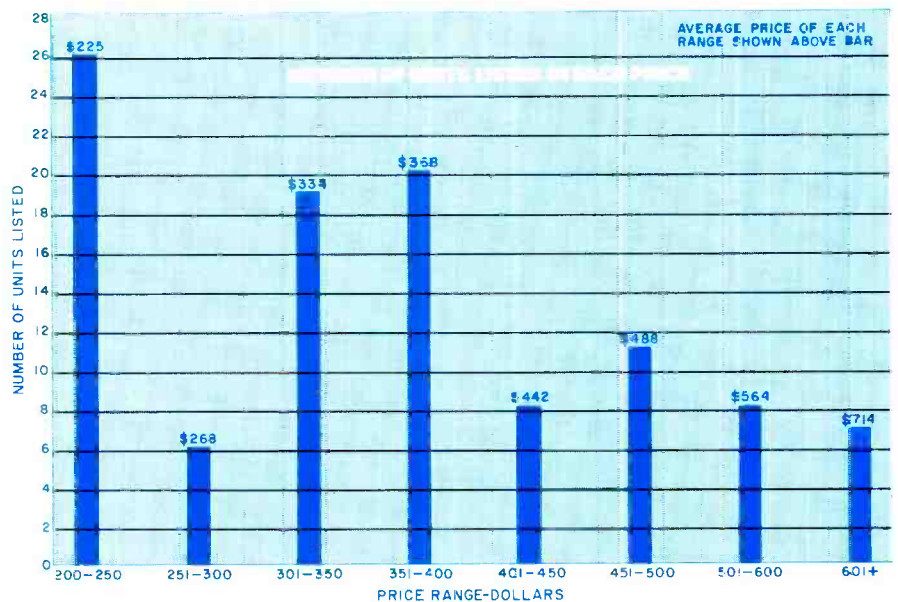
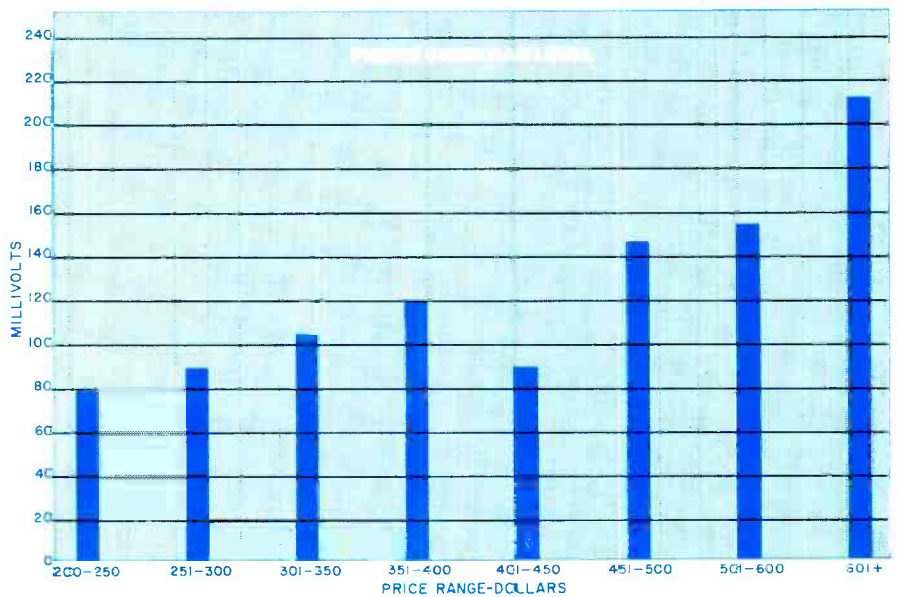
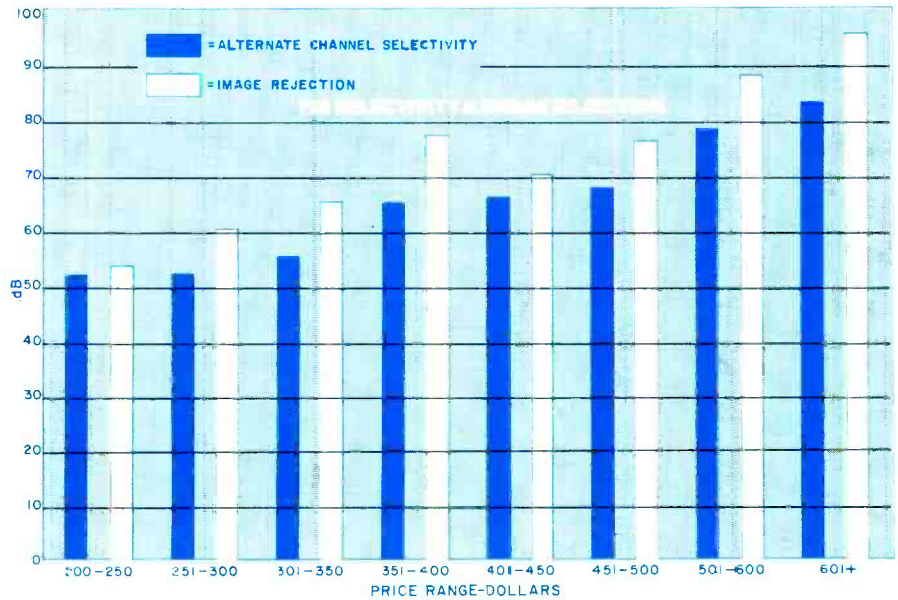

HOW TO ADD FUNCTIONS TO SIMPLE HAND CALCULATORS

If it contains the right IC, you can turn your calculator into a more useful one at little extra cost

BY DONALD SHAPIRO

CALCULATOR manufacturers often stock just one type of IC and use it in a range of units—from a simple four-banger to one having memory, constant, percent, and battery-saver functions. So it is possible that your inexpensive calculator can be modified to include the extra functions. We say possible because if the "bare-bones" MM5737 is used, there are no extra functions available. With an MM5738 IC, however, there may be one or more extra functions available. The basic arithmetic functions will be intact but the extra functions are inoperative. In the latter case, the IC manufacturer usually indicates an inoperative function by marking the case near the pin with a dot.

A simple test can be performed from the calculator keyboard to determine if the extra functions are available. This test is based on the ability of the MM5738 IC to perform repeated squares. Press: 3, ×, =, =. An answer of 9 indicates that no modifications are possible, but if the answer is 81, extra functions can be used.

Modifying the Calculator. It would be an unrealistically expensive ap-

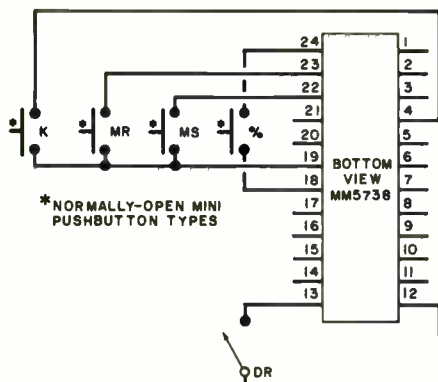

Where to add switches to IC.



Photo at left shows switches mounted on top of calculator

proach to replace the keyboard in an inexpensive calculator with one that has extra keys to accommodate the extra functions. It would be far more practical to mount several miniature pushbutton switches on the outside of the calculator's case for the constant, storage memory, and percent functions and make one minor printed circuit board change to activate the battery-saver feature. The photos show how a Novus Model 850 calculator was modified to take advantage of the constant (K) and memory-store (MS) and memory-recall (MR) functions that were operational in its MM5738 IC.

To perform this type of modification, the calculator case must be disassembled to allow access to the bottom of the printed circuit board and provide working room for mounting the extra-function switches on the top of the case. First, isolate pin 13 of the IC from the rest of the circuit by carefully cutting through the copper foil near the IC pin; this will activate the battery-saver feature. Then, carefully drill holes for and mount the switches.

Now, referring to the schematic diagram, solder lengths of hookup wire to the extra-function IC pins that are operational. Route the wires along the bottom of the board, and reassemble the case, with the wires exiting through the battery compartment cutout. Solder the free ends of the wires to the appropriate switch lugs.

Cut a shallow groove in the case, making it just deep enough to accommodate the wires when the battery-compartment cover is in place. Then neatly arrange the wires in the battery well so that they will not be in the way of the battery. Plug the battery into its connector, set it into the well, and replace the well cover.

Checkout and Use. Turn on the calculator and push the numeral keys at random to just fill the display. Allow the display to remain undisturbed for about 60 seconds. If the battery-saver feature is operational, the seven most significant figures in the display will blank out. Depress the = key; the same random number should instantly reappear in the display. You can depress any of the arithmetic-function keys to restore the display in this manner. Alternatively, you can use an externally mounted switch to restore the display; label this switch DR, for display recall.

Depress keys C, 1, 2, and 3. The display should now have the number 123 showing. Now, depress %; the display should now indicate 1.23. (Any time



Arrange wires in battery well so they do not interfere.

the % key is operated, the calculator automatically multiplies the displayed number by 0.01.)

To check the memory function, feed in the keystrokes in the following order: C, 2, ×, 3, = (a 6 should now be displayed), MS, 3, ×, 5, = (15 should now be displayed), ×, MR, =. The answer displayed at the last = key-stroke should be 90.

Finally, check out the constant function for both the × and ÷ functions. Start by pressing C. Then turn on K and press 2, ×, 2, =, K, K, K, K. The answer displayed, if the constant function is working properly, should be 64. Hit C, 8, 8, 8, ÷, 2, =, K, K; the display should now read 111. The constant function works on only the × and ÷ functions. The number used as the constant in either case is the one fed into the calculator after the arithmetic command is entered. ♦

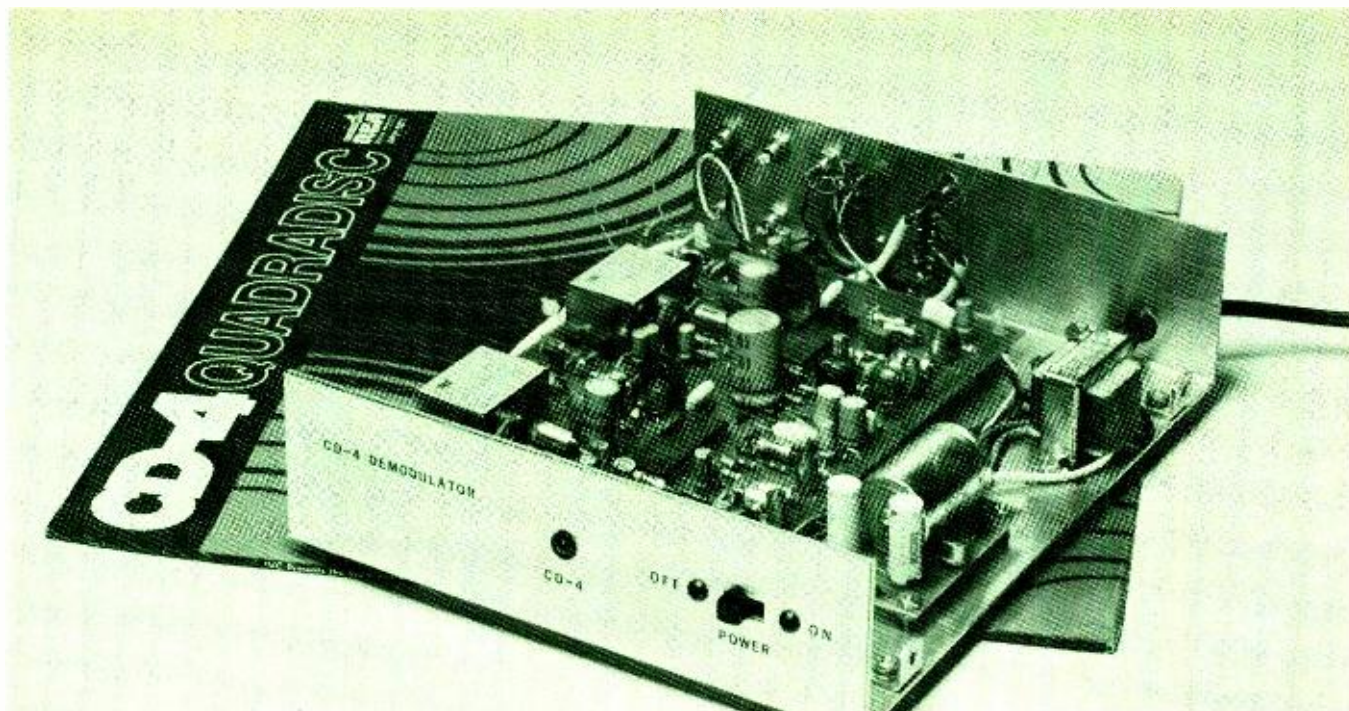

BUILD A

HIGH-PERFORMANCE CD-4 DEMODULATOR

Low-cost add-on unit for playing discrete 4-channel discs.

BY LOUIS DORREN

THE Compatible Discrete 4-channel sound system, called CD-4, permits four fully separate channels of sound to be reproduced, starting with discrete channel information incorporated right into the record groove. This contrasts with SQ[®] or QS matrix 4-channel sound, where channel information is encoded.

Some four-channel receivers today are akin to multiple-speed record players that play 33-1/3 or 45 rpm discs. The receivers can quite often handle information from either discrete or matrix discs. There are many 4-channel receivers, however, that only have a CD-4 input jack for adding a demodulator that's needed to play CD-4 discs (which includes RCA's "Quadrads," among other labels), while incorporating decoding circuits for SQ and/or QS matrix discs. If this is the case with your receiver, you will want to build the high-performance,

low-cost demodulator described here. With the demodulator plugged into your receiver and a CD-4 cartridge on your record player, you will be able to play all types of 4-channel discs including discrete.

CD-4 Operation. The CD-4 system was designed to utilize the standard V-shaped record groove to assure compatibility of quadrasonic disc recordings with conventional stereo and mono playing equipment. So, all of the information contained in the four signal channels had to be combined to physically fit on the two walls of the record groove. In the process, the left-front and left-back signals are combined and impressed on one wall, while the right-front and right-back signals are combined and impressed on the other wall of the record groove.

To facilitate separation (demodulation) of the front and back channels

from the combined right and left signals, separate 30-kHz subcarriers are used. One carrier contains the difference of left-front and left-back signals and the other contains the difference of the right-front and right-back signals. By mixing the signals in an appropriate resistive network, each of the originally recorded channels can be extracted, resulting in the four discretely different channels originally recorded.

While the CD-4 system is basically very simple, special techniques developed to minimize signal degradation require a complex demodulator circuit design. Pre-emphasizing the carrier is one such technique. Unlike the case in standard FM broadcasting, the pre-emphasized signal is frequency modulated from 0 to 630 Hz and from 6000 to 15,000 Hz, and audio information between these two ranges is phase modulated (PM) to provide a

DEMODULATOR PARTS LIST

BPF1, BPF2—30-kHz bandpass filter (EUL-BPF006)
 C1, C8, C13, C16, C19, C22, C25, C28, C39, C40, C43, C44, C45, C57, C61—3.3- μ F, 25-volt electrolytic capacitor
 C2, C46—220- μ F, 25-volt electrolytic capacitor
 C3, C47—0.0047- μ F capacitor
 C4, C48—0.002- μ F capacitor
 C5, C49, C64, C76—0.47- μ F capacitor
 C6, C50—0.033- μ F capacitor
 C7, C51, C59, C73, C74, C75—0.01- μ F capacitor
 C9, C52—0.0027- μ F capacitor
 C10, C36, C53, C70—0.0031- μ F capacitor
 C11, C14, C17, C20—0.0062- μ F capacitor
 C12, C15, C18, C21—820-pF capacitor
 C23, C38, C55, C68—960-pF capacitor
 C24, C37, C56, C69—0.0039- μ F capacitor
 C26, C35, C58, C71—0.0068- μ F capacitor
 C27, C60—0.0072- μ F capacitor
 C29, C30, C41, C42, C54, C62, C63—100-pF capacitor
 C31, C65—0.0022- μ F capacitor
 C32, C66—0.68- μ F capacitor
 C33, C67—4.7- μ F, 25-volt electrolytic capacitor
 C34, C72—33-pF capacitor
 CR1 to CR4—Diode (1N914 or similar)
 DS1—Low-current red LED (20-mA max.)
 IC1, IC2—Demodulator (QSI-5022)
 L1, L2—100-mH inductor
 Q1 to Q8—Transistor (2N5210 or similar)
 The following resistors are 1/2 watt, 10% tolerance:
 R1, R24, R28, R32, R36, R58, R97, R98—47,000 ohms
 R2, R18, R59—100,000 ohms
 R3, R46, R60, R90—10,000 ohms
 R4, R14, R61—150,000 ohms
 R5, R6, R7, R20, R45, R62, R63, R64, R75, R88, R101, R102—15,000 ohms
 R8, R11, R13, R65, R68, R70—2200 ohms
 R10, R67, R99, R100—20 ohms
 R12, R69, R77, R78—330 ohms
 R15, R71—6800 ohms
 R17, R40, R73, R83—8200 ohms
 R19, R74—7500 ohms
 R21, R22, R23, R25, R26, R29, R30, R31, R33, R34, R35, R37, R38, R39, R41, R43, R47, R50, R51, R52, R53, R80, R81, R82, R84, R86, R89, R93, R94, R95, R96—4700 ohms
 R27—Not used
 R42, R85—27,000 ohms
 R44, R48, R87, R91—220,000 ohms
 R49, R92—3300 ohms
 R54, R57—470,000 ohms
 R55, R56—1800 ohms
 R76, R79—1000 ohms
 R9, R66—500-ohm trimmer potentiometer
 R16, R72—5000-ohm trimmer potentiometer
 S1—5-pole, double-throw switch
 S2—Spdt switch
 Misc.—Printed circuit board; suitable chassis (see text); phono jacks for inputs and outputs (6); spacers or plastic stand-offs; 28-pin IC socket or Molex Soldercons (optional); hookup wire; machine hardware; solder; etc.
 Note—The following are available from Southwest Technical Products Corp., 219 West Rhapsody, San Antonio, TX 78216: BPF1, BPF2, IC1, IC2, L1, and L2 for \$24.50; etched and drilled power supply and demodulator printed circuit boards for \$13.00; complete kit of parts, including chassis and power supply, for \$50.00.

Fig. 1. Schematic, left, shows how two IC's, with added components make up circuit.

better signal-to-noise (S/N) ratio as well as other advantages from the standpoint of higher level-capacity to the overall system.

Audio level compression is also applied in the modulation technique. It reduces the harmonic distortion of second-, third-, and fourth-order components. In some cases, it even reduces noise.

How It Works. Each specialized IC used in this project contains all of the subsystems required for demodulating one pair of channels. These include a phono preamplifier to increase signal levels from the phono cartridge; a high-gain limiter FM detector; a phase-locked-loop (PLL) FM detector; and a high-speed carrier dropout cancellation circuit. Also present on-chip are an FM/PM/FM amplifier, mid- and high-band audio expanders, resistive combining output networks (true matrix), output buffer amplifiers, a drive circuit for a quadrasonic indicator LED, a complete power-supply regulator, and automatic changer transient muting circuits. By combining two IC's, with appropriate filters and other related components, in a single system (see Fig. 1), we can obtain a CD-4 demodulator of advanced design.

The input signal from a magnetic phono cartridge is applied to pins 26 of IC1 and IC2. Equalization networks between pins 24 and 25 of each integrated circuit shape the frequency responses of the amplifiers to produce the RIAA curve characteristic. In the case of a semiconductor phono cartridge input, the equalization is flat for the preamplifier. The preamplifier has both inverting and non-inverting outputs. The inverting network is used in one IC and the noninverting network is used in the other IC because the semiconductor outputs are out-of-phase with each other and only one must be inverted before the signal is passed to the rest of the demodulating system.

The outputs of the preamps (pins 23) go through 30-kHz bandpass filters that isolate the subcarriers and eliminate unwanted signals from the main, or audio, channels. The filter outputs go to the circuit limiters (pins 22). Then, pins 21 serve as the bypasses for the limiter stages.

The outputs from the limiters (inside the IC's) feed the phase detectors of the PLL's.

Because the fidelity of the 4-channel

output relies on precise tracking of the 30-kHz carrier that is present—along with the standard stereo information—even the smallest variation in turntable speed can significantly degrade the overall signal. Hence the need for the PLL. The other reason why the PLL is needed is the very wide deviation of the 30-kHz subcarriers, which presents extreme difficulties for low-distortion demodulation to other types of FM detectors.

Whenever an input signal differing from the 30-kHz free-running loop frequency is applied to the phase detector, a corresponding error voltage is produced in the loop filter (RC networks R12/C6 and R69/C50) that is set to the bandwidths of the PLL's. This output information causes the vco to swing toward the input frequency, reducing the error voltage until the vco and input signal frequencies are equal. At this point, the PLL is "locked" and remains so in spite of minor input variations. Pins 17 of IC1 and IC2 connect to timing capacitors C9 and C52 of the vco's while pins 16 connect to potentiometers R16 and R72 that are used to set the center frequency of the vco's.

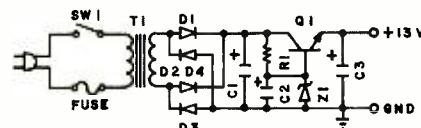

POWER SUPPLY PARTS LIST

C1—2000- μ F, 25-volt electrolytic capacitor
 C2, C3—50- μ F, 25-volt electrolytic capacitor
 D1 to D4—Diode (1N4001 or similar)
 F1—1/2-ampere fuse
 Q1—40406 (RCA) or similar transistor
 R1—330-ohm, 1/2-watt resistor
 S1—Spst switch
 T1—15-volt, 300-mA transformer
 Z1—15-volt, 500-mW zener diode (HEP Z0225 or similar)
 Misc.—Printed circuit board; spacers; fuse holder; line cord; rubber grommets; grounding lug; hookup wire; machine hardware; solder; etc.

Fig. 2. Conventional power supply uses zener regulation.

The audio output signals from the IC's, at pins 15, are coupled to 15-kHz low-pass emitter-follower filters and the networks required in the sub-channel systems for delay equalization (see small dashed boxes to the right of the IC's). The vco's also feed back to the phase detectors to yield a locked condition when the carrier is present. The outputs of the limiters are

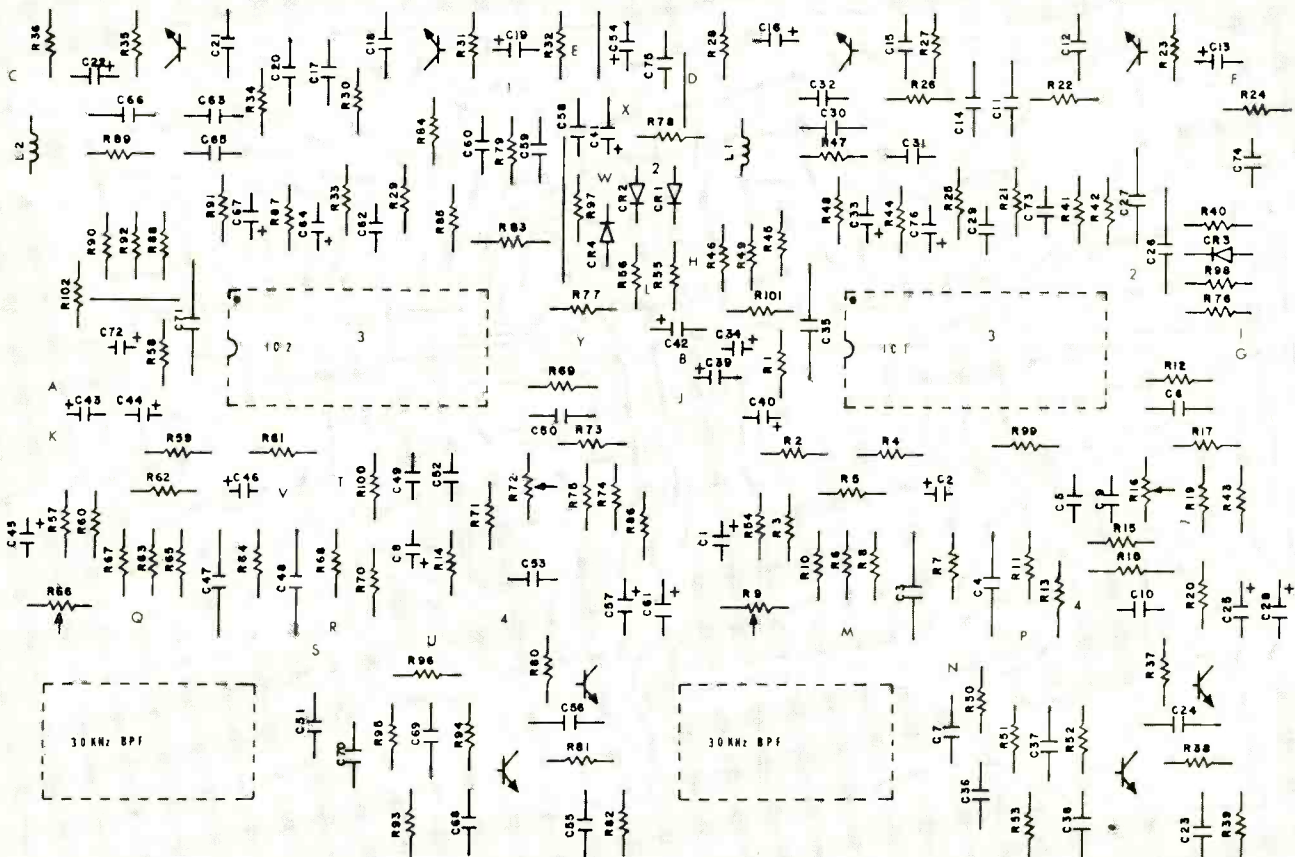
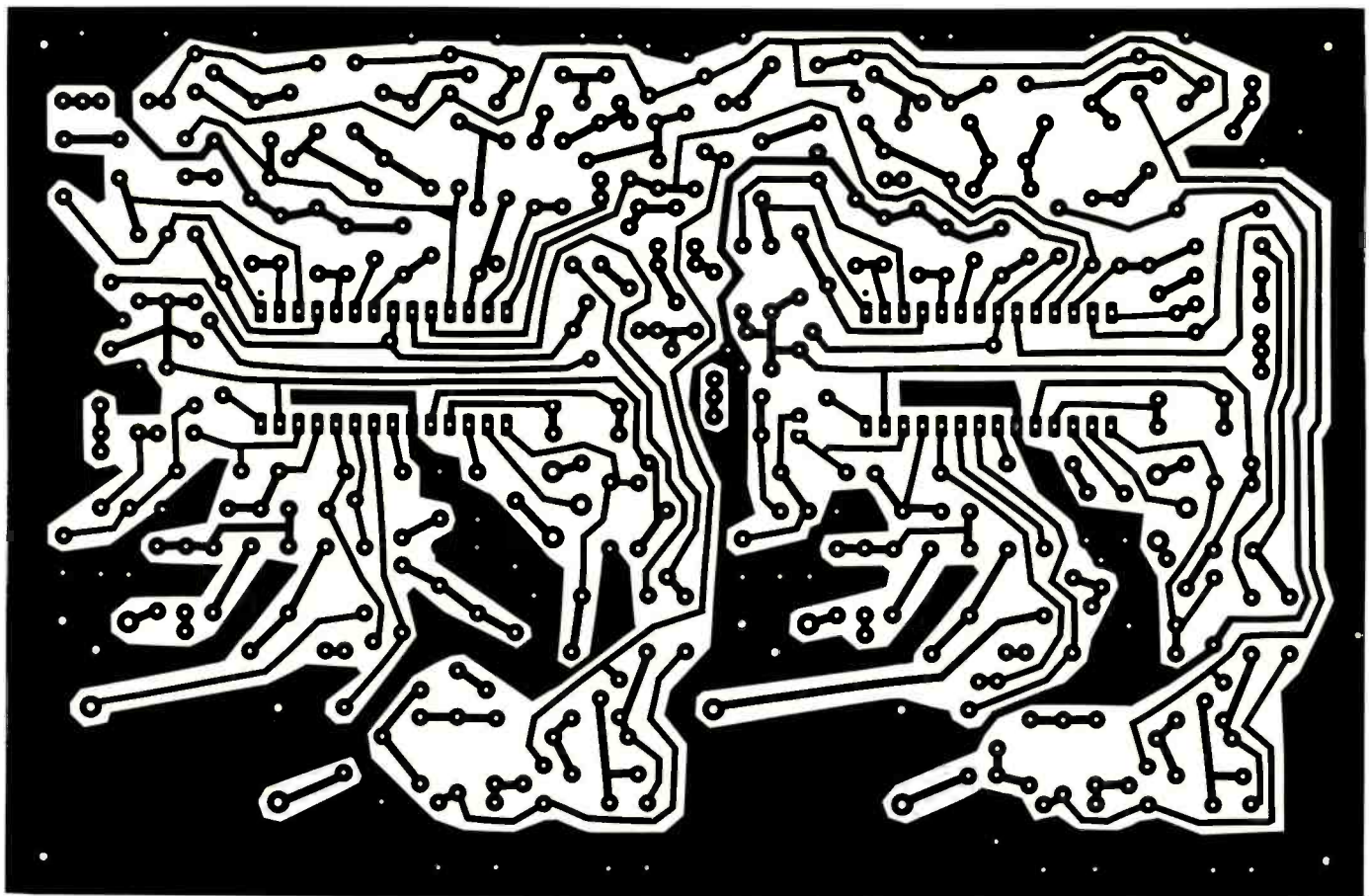

Fig. 3. External connection guide: A-LEFT IN, F-RB OUT, L-S1B-2, R-S1D-2, W-S2-2, B-RIGHT IN, G-DS-1, M-S1C-1, S-S1D-3, X-13 VDC, C-LF OUT, H-S1A-1, N-S1C-2, T-S1E-1, Y-GND, D-RF OUT, J-S1A-2, P-S1C-3, U-S1E-2, E-LB OUT, K-S1B-1, Q-S1D-1, V-S1E-3. Jumpers from 1 to 1, 2 to 2, 3 to 3, and 4 to 4.

also passed to the carrier-level (C.L.) detectors, which consist of quadrature phase detectors. These are fed from the limiters, vco's, and carrier dropout cancellation circuits. When the signal is locked, the quadrature detectors sense the 90° quadrature differences between the vco and input signals, turning on 4-channel LED *DS1* and allowing the audio from the subchannel detectors to pass to the expanders.

Pins 14 of each IC can be used to select between 4-channel and 4-channel/auto operation as they are grounded or left floating, respectively, via *S2*. The output circuits that drive *DS1*, accessed through pins 13 on the IC's, provide a current sink of no more than 20 mA. So, it is important that you use a low-current LED for *DS1*.

Pins 12 are the signal inputs to the audio shaping networks in the subcarrier system. They are fed from the 15-kHz low-pass filter and delay networks. Audio-frequency shaping networks for FM/PM/FM equalization are connected to the IC's via pins 11 and 12. Pins 11 also drive the expander controls and audio inputs. Pins 2 and 5 are used for the expander time-constant controls, while pins 1, 3, 4, and 28 serve as audio and control inputs for the expanders.

The outputs from the expanders feed the resistive combining networks (true matrices), which are also fed by the subsystem amplifier and automatic changer muting circuits. Pins 10 are the control inputs for the automatic changer muting detectors, while pins 9 are the audio inputs and bias terminals for the amplifiers. Pins 8 are the

"CD-4 HANDBOOK" AVAILABLE

A comprehensive 28-page "CD-4 Handbook" available from Matsushita Electric Corp. explains what quadraphonic sound is all about. It especially explains how the CD-4 format differs from the matrixed disc formats. Topics included in the booklet include a quick look at the disc from Thomas Edison to the present; how quadraphonic systems work; information on quadraphonic FM broadcasts; a roster of CD-4 equipment manufacturers; a complete list of CD-4 Quadradisc artists and albums; suggested speaker placement for the optimum listening environment; etc. To Obtain a copy of the "CD-4 Handbook," write to: Matsushita Electric Corp. of America, 1 Panasonic Way, Secaucus, NJ 07094 or JVC America, Inc., 50-35 56 Road, Maspeth, NY 11378.

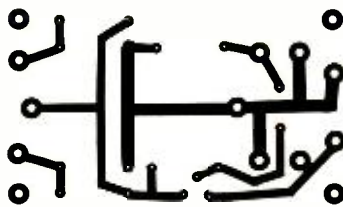
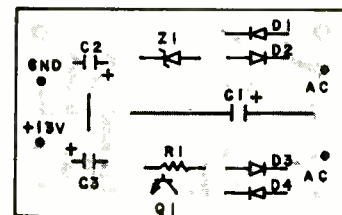

Fig. 4. Etching and drilling guide (above) and component layout for power supply (right)



positive-voltage inputs for the IC's, while pins 6 and 7 are the audio outputs. These outputs are fed to the final 15-kHz emitter-follower low-pass filters.

The power supply for the demodulator is shown schematically in Fig. 2. It is quite conventional in design, employing bridge (*D1* through *D4*) rectification, zener-diode (*Z1*) regulation, and a series-pass transistor (*Q1*).

Construction. Owing to the complexity of the circuit that makes up the demodulator, printed circuit board assembly is highly recommended. An actual-size etching and drilling guide for the pc board is shown in Fig. 3, along with the component placement diagram **shown from foil side**.

Start assembly by installing and soldering into place on the board the resistors, capacitors, and inductors (coils). Follow with the diodes, transistors, and bandpass filters. Pay careful attention to the polarities of the electrolytic capacitors and diodes and the basing of the transistors.

Last to be installed on the pc board should be the two IC's. You can directly mount the IC's and solder their pins to the pads on the board, or you can install sockets or Molex Soldercons® into which the IC's can be plugged.

Next, wire the power supply board. (The etching and drilling and component placement guides for this subassembly are shown in Fig. 4.) Again, pay careful attention to diode and electrolytic capacitor polarities and the transistor's basing.

The prototype of the CD-4 demodulator was mounted in a 9"D × 7"W × 2"H (23 × 18 × 5.1-cm) U-shaped metal chassis. The six INPUT and OUTPUT jacks, *S1*, *S2*, and a grounding lug mount on the rear panel. A hole drilled through this panel through which the line cord exits must be rubber grommet lined.

The POWER switch and 4-CHANNEL

LED indicator *DS1* mount on the front panel. Use a small rubber grommet in the hole for the LED. Mount the power transformer and fuse holder, side by side, to the floor of the chassis, locating them to one side and near the rear panel.

Solder lengths of hookup wire to both boards to facilitate interconnections. Keep tabs on where the free end of each wire is to terminate. Immediately interconnect the two circuit board assemblies and the power transformer with the power supply board. Mount the boards on the floor of the chassis with machine hardware and spacers or plastic standoffs. Then, referring back to Fig. 1, connect and solder the free ends of the wires to the appropriate jacks, switches, and LED. (Note: Before completing the wiring, refer to the Test Procedure outlined below.)

Test Procedure. Temporarily connect a milliammeter between the positive terminal of the power supply and the positive voltage input of the demodulator board. Remove *DS1* from the circuit. Plug the line cord into an ac outlet. Turn on the power and observe the meter indication. The current drain should be less than 100 mA. If you obtain a higher reading, a short circuit exists and must be corrected. In this event, turn off the power and unplug the line cord from the ac socket. Carefully examine all your wiring and soldering, particularly around the closely spaced pads to which the IC pins or sockets are soldered.

Once you obtain a normal current reading, connect a voltmeter from pin 27 of each IC and ground. You should obtain a 5.8-volt reading in both cases. Turn off the power, disconnect the line cord, remove the milliammeter from the circuit. Then wire the positive leads from the power supply and demodulator boards together and the LED back into the circuit.

Connect a 4-channel (CD-4) phono

don't miss...

the next issue of the magazine that gives you the most exciting build-it-yourself projects anywhere.

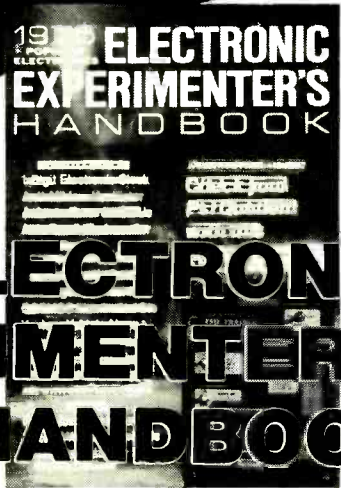

ELECTRONIC EXPERIMENTER'S HANDBOOK

You can always count on ELECTRONIC EXPERIMENTER'S HANDBOOK. Published each year by the editors of Popular Electronics, it's the one publication that helps you get it together . . . with a score of build-it-yourself projects.

The all-new 1976 edition goes on sale nationally September 18, 1975.

It will again be packed with features and articles and complete lab-tested instructions that are sure to guarantee successful hours and months of mind absorbing projects for fun and practicality.

This offer is being made to readers of POPULAR ELECTRONICS Magazine only.

Regular newsstand price is \$1.50; mail order price \$1.85. You can reserve your copy now at this special pre-publication price of only \$1 by completing the Reservation Form and returning it promptly along with your remittance. The 1976 ELECTRONIC EXPERIMENTER'S HANDBOOK will be mailed to you on or before publication date from first-off-the-press copies.

YOU CAN RESERVE YOUR COPY NOW AT THE SPECIAL MONEY-SAVING PRE-PUBLICATION PRICE OF ONLY \$1.00 POSTPAID.

PRE-PUBLICATION RESERVATION FORM ▶

Electronic Experimenter's Handbook
Consumer Service Division
595 Broadway, N.Y., N.Y. 10012.

PE-975

Enclosed is \$1.00 (outside U.S.A. \$2.00). Please reserve my copy of the 1976 ELECTRONIC EXPERIMENTER'S HANDBOOK at this special pre-publication price, to be mailed to me from first-off-the-press copies on or before September 18, 1975.

Print Name _____

Address _____

City _____

State _____

Zip _____

Residents of Cal., Col., Fla., Ill., Mich., Mo., N.Y. State, D.C. and Tex. add applicable sales tax.

cartridge to the demodulator via the audio input jacks. Make certain that switch *S1* is set to SEMICONDUCTOR or MAGNETIC, according to the type of cartridge you are using. Use the setup tone provided on a CD-4 test record for an audio signal at all four outputs from the demodulator. (A CD-4 test record can be obtained for \$5.00 from the source given in the Parts List.) The absolute levels of the individual channel outputs are not critical at this point, but the left-front level should be the same as the left-back level and the right-front level should be the same as the right-back level.

When the system is properly detecting, *DS1* will glow brightly. If it glows dimly or does not glow at all, one or both of the phase-locked loops may be too far out of adjustment. In this case, any of the following procedures can be used to set the PLL's on the correct 30-kHz frequency:

1. With the cartridge stylus tracking the setup band of the test record, adjust the vco's via *R16* and *R72*. Adjust first one vco until the LED glows, then adjust the other until the LED glows at maximum brightness. Because of the high-level subcarrier modulation, you should now hear severe signal distortion. Now, adjust *R16* and *R72* for minimum audible distortion.

2. Using an accurate 30-kHz sine-wave source, feed this signal to pin 22 of *IC1* through a 1000-pF capacitor. Adjust the vco's center frequency via *R16* until the LED glows. Then couple the test signal to pin 22 of *IC2* and adjust the other vco via *R72* for maximum brightness.

3. Connect a high-impedance frequency counter to pin 16 of *IC1* and ground and adjust the vco to 30 kHz (*R16*) without an input signal. Repeat the procedure for *IC2* (*R72*).

Any of the above procedures will work successfully, but be sure that you adjust the center frequency of both IC's.

Once the vco's have been properly adjusted, use the test record to check out the entire demodulator. Carefully listen to the rear channels and adjust separation controls for minimum volume level of these channels. Once these adjustments have been made, they do not have to be touched again unless you decide to replace the phono cartridge.

The CD-4 demodulator is now ready to use. Fasten the case cover to the chassis, and connect the demodulator into your 4-channel hi-fi system. ♦

SEPTEMBER 1975

THE MISSING LINK

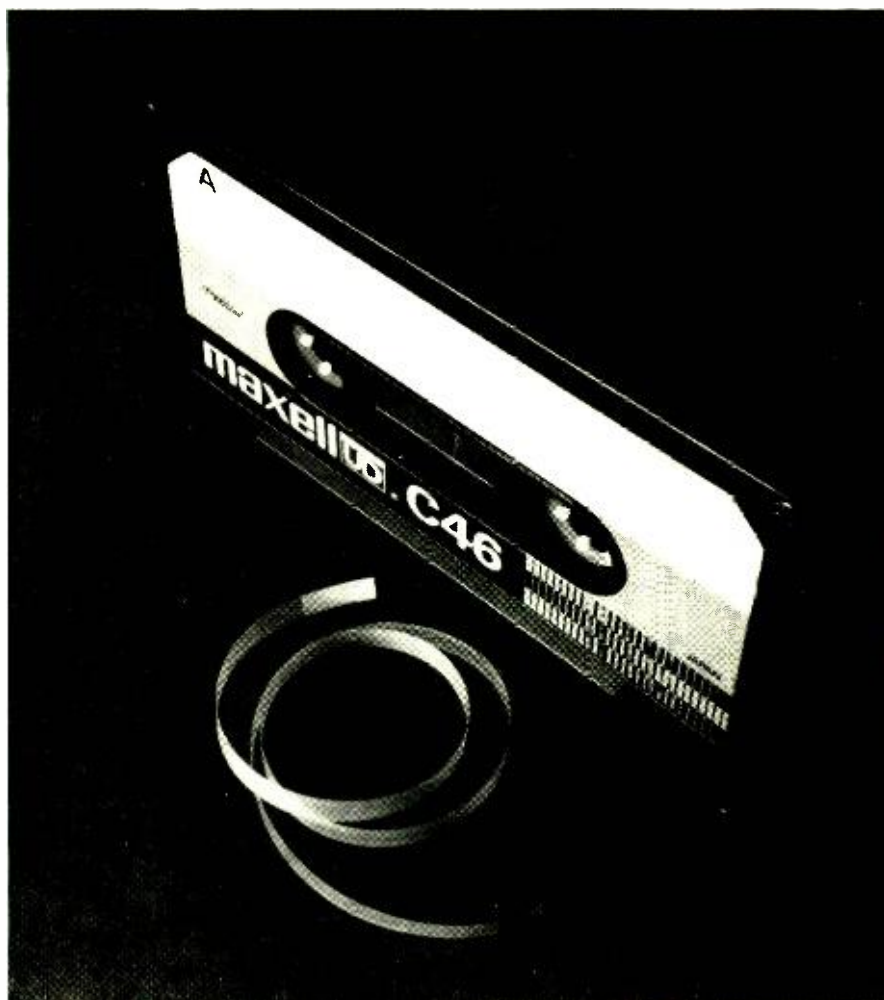

The first five seconds of every Maxell UD cassette cleans your recorder heads. Another Maxell exclusive.

The leader in our UD cassettes sweeps dust and debris off your recorder heads before they can foul-up a recording. And it sweeps gently, with no damaging abrasives to ruin your equipment.

Our head-cleaning leader is also calibrated, so you can use it to cue your recordings.

It's on both ends of all Maxell Ultra Dynamic cassettes. It's another reason you can record the very best sounds (both high and low) your equipment produces, without tracking dust all over your music.

Maxell Corporation of America, Moonachie, New Jersey 07074. Also available in Canada.

maxell.

For professional recordings at home.

CIRCLE NO. 35 ON FREE INFORMATION CARD



**Communications
Engineering**

**Aeronautical
& Navigational**

**Television
Engineering**

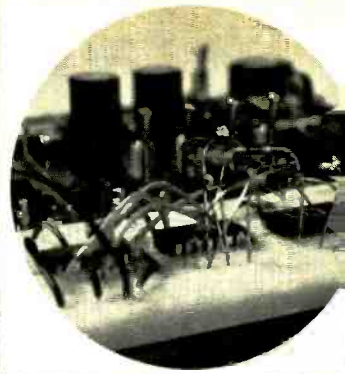

**Automatic
Control
Engineering**

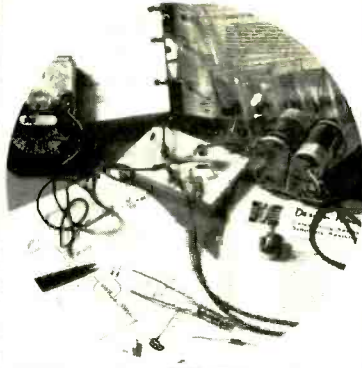

**Missile &
Spacecraft
Guidance**

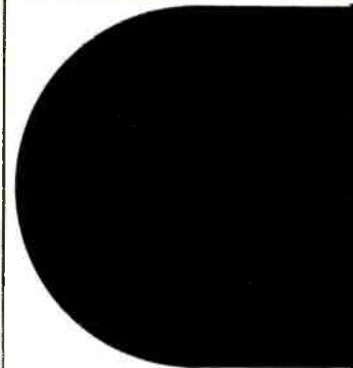

**Radar &
Sonar
Engineering**

**Digital
Communications**

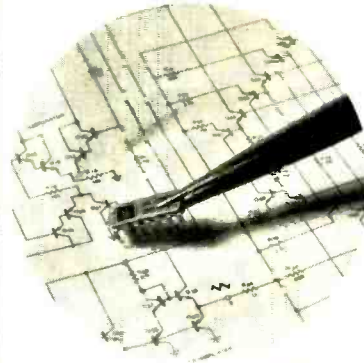

**Industrial
Electronics**

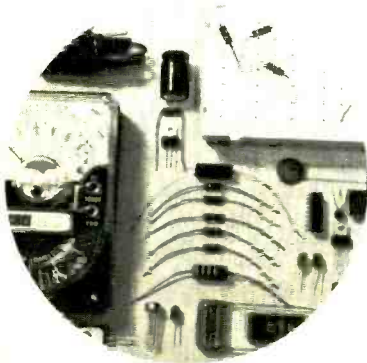

**Microwave
Engineering**

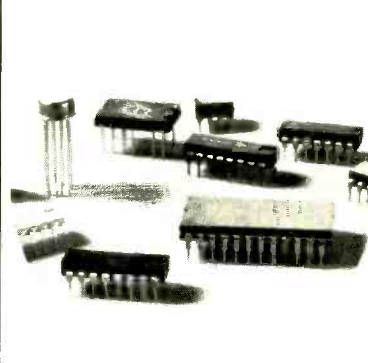

**Satellite
Communications**

**Cable
Television
Engineering**

**Electronic
Engineering
Technology**

**Nuclear
Instrumentation
& Control**

**Special Programs
for Electronic
Engineers**

Computer
Engineering

If you are too busy to go to college to learn advanced electronics, CREI brings college level training to you. CREI programs give you practical engineering training that you can apply in your work to move ahead to higher paying jobs. And CREI lets you specialize in exactly the area of electronics you want. You have a choice, depending on your qualifications, of 18 different programs.

Not only are CREI programs college-level but arrangements are available for you to earn college credit applicable to advanced degrees.

Only CREI offers you a choice of 18 programs in advanced electronics

Electronic
Systems
Engineering

For over 45 years CREI programs have been recognized by leading technical organizations as effective home study training in advanced electronics.

NEW OPTIONAL LAB PROGRAM



CREI now offers a supplementary ELECTRONIC DESIGN LABORATORY PROGRAM to make learning advanced electronics easier and to give you actual experience to use in your work. Only CREI offers this complete college type laboratory program. You learn to actually design electronic circuits. At the same time you get extensive experience in tests and measurements, breadboarding, prototype building and other areas important to your career.

Qualifications to Enroll. To qualify for enrollment in a CREI program, you must be a high school graduate (or equivalent). You should also be working in electronics or have previous training in this field.

Send for FREE book. If you are qualified, send for CREI's newly published book describing your career opportunities in advanced electronics. This full color book is filled with facts about career opportunities for you.

Nuclear
Engineering
Technology



Accredited Member, National Home Study Council

CREI, Dept. E1209F
3939 Wisconsin Avenue
Washington, D. C. 20016

Rush me your FREE book describing my opportunities in advanced electronics. I am a high school graduate.

Name _____ Age _____

Address _____

City _____ State _____ ZIP _____

If you have previous training in electronics, check here

Employed by _____

Type of Present Work _____

Veterans and servicemen, check here for G. I. Bill information

CREI
**CAPITOL
RADIO
ENGINEERING
INSTITUTE**

A Division of McGraw-Hill
Continuing Education Co.
3939 Wisconsin Avenue,
Washington, D. C. 20016

Special Programs
for
Non Electronic
Engineers

HAVE you ever tackled a digital design project with vim and vigor—only to find yourself entangled in a morass of logic ones and zeros and a “this goes up, and that goes down” nightmare? If you have, don’t despair. There is a much neater, much simpler method than the brute force approach. This article provides a coherent approach to digital design. The method is not a substitute for intuition and practical seat-of-the-pants experimentation, but a tool for getting the end results quickly.

Before getting down to actual techniques, it might be wise to do a little reviewing. The truth tables for the AND, OR, and NOT (or COMPLEMENT, or INVERTER) functions are shown in Fig. 1. The function a AND b is written ab ; a OR b is written $a + b$; and NOT a is written \bar{a} . Note that $+$ as defined here is different from ordinary addition, and merely symbolizes

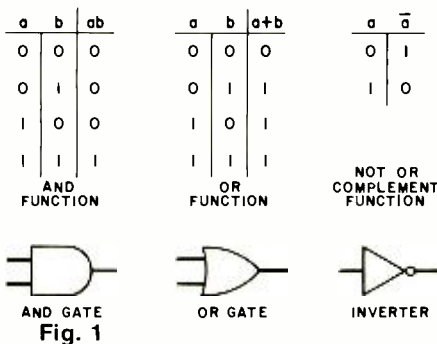

the function defined by the truth table of Fig. 1. A truth table is simply an array, one side of which contains all possible combinations of the input variables and the other side of which contains the corresponding values of a logic function—or output. Figure 1 also shows the digital logic gate symbols for the three functions.

Any logic function can be constructed from these three basic types of functions or gates. It is often convenient, though, when working with a particular type of logic family (TTL, DTL, etc.) to use two other types of function, the NAND and the NOR. The NAND function of a and b is written \overline{ab} , and the NOR function, $\overline{a + b}$. Their truth tables and logic symbols are illustrated in Fig. 2. All of these functions except the NOT, or INVERTER, can be extended in an obvious way to include more than two inputs. With these functions at hand, it becomes possible to construct any logic function desired.

In manipulating the basic functions

KARNAUGH MAPS FOR FAST DIGITAL DESIGN

A neat, simple method for working with logic.

BY ART DAVIS

to form more complex ones, it is expedient to have available two important, yet simple, rules of basic logic theory known as DeMorgan's Laws. Figure 3 contains truth tables for the logic functions \overline{ab} , $\overline{a + b}$, $\overline{a} + \overline{b}$, and $\overline{\overline{a} + \overline{b}}$. Comparing them yields the formulas of DeMorgan's Laws:

- 1) $\overline{ab} = \overline{a} + \overline{b}$
- 2) $\overline{a + b} = \overline{a} \overline{b}$

These formulas are useful in implementing digital functions using only NAND or only NOR gates.

Why Map Techniques? A truth table is one way of specifying a logic function—the Karnaugh map (pronounced Kar-no) is another. To get an idea of what such a map is, and why it is a convenient tool, let's look at a practical digital design problem.

Suppose we are faced with designing the digital black box of Fig. 4, which has three inputs a , b and c , and a single output $f(a,b,c)$. The black box is to provide a logic one output under the following input conditions:

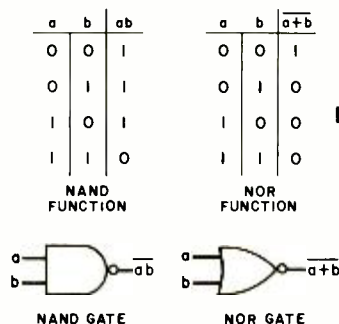

Fig. 2

$a=b=c=1$, $a=c=1$ and $b=0$, $a=0$ and $b=c=1$, or $a=b=0$ and $c=1$. How can we manufacture the digital logic inside the box from this specification?

One possible answer is to be methodical. A person unfamiliar with map techniques—but very methodical—might reason in the following way.

“The output function $f(a,b,c)$ is logic one whenever $a=b=c=1$. An AND gate puts out a one whenever all inputs are logic one, so let's use an AND. But the AND output is zero for all other input combinations, and $f(a,b,c)$ is a one for several other input conditions.

“Well, the AND gate did pretty well for the first input combination, so why not try it for the second? Let's take the complement of b by passing it through an INVERTER and run it into an AND gate with a and c . This AND will put out a one when $a=c=1$ and $b=0$, as desired. This seems to be working well, so let's do the same with each of the other two combinations.”

With all the AND gates and INVERTERS arranged as above, our methodical experimenter will then observe that, since $f(a,b,c)$ is to be a logic one whenever the input variables form the first combination, or the second, or the third, or the fourth, all he has to do is OR the outputs of the four ANDs to generate $f(a,b,c)$. The resulting logic is shown in Fig. 5.

Now this logic design works. It will do the digital job, but it is inefficient. It requires four AND gates, one OR, and two INVERTERS. This is costly, and it would cause quite a few layout problems because of the numerous interconnections. In addition, the design procedure outlined above is slow and, for more complicated circuits, error prone. What can be done to streamline the procedure?

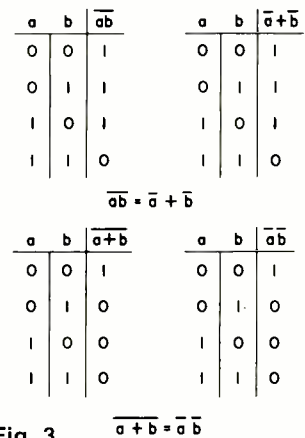

Fig. 3

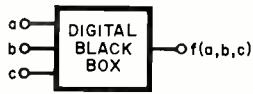

Fig. 4

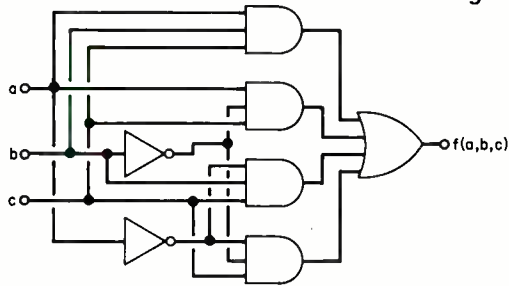

Fig. 5

The answer is the Karnaugh map. This is just a rectangle divided up into a number of squares, each square corresponding to a given input combination. The Karnaugh map of our function $f(a,b,c)$ is shown in Fig. 6. The right half of the map corresponds to $a=1$, the left half to $a=0$ ($\bar{a}=1$), the middle half to $b=1$, and so on. The basic idea is that there is one square for each input combination. If we write into that square the value of the output function for that particular input combination, we will have completely specified the function. The ones and zeros in Fig. 6 are the values which $f(a,b,c)$ assumes for the associated input variable combinations.

Now recalling our methodical design procedure, it is easy to see that each square which has a one in it corresponds to the AND function of those input variables, and $f(a,b,c)$ can be generated as the OR function of all of the ANDs.

A key factor arises here. It isn't necessary to include all of these AND functions, and the Karnaugh map tells us how to eliminate some of the terms. For example, looking at Fig. 6, we see that $f(a,b,c)$ is a one for four adjacent boxes forming the bottom half of the map. (We will consider squares on opposite edges to be adjacent.) It is also easy to see the following: The only variable which does not change as we go from one square with a one to another with a one is c . It remains at one. What this means is that $f(a,b,c)$ cannot depend on a and b because, regardless of their values, $f(a,b,c)$ is a one as long as $c=1$. Therefore we can forget about a and b , and

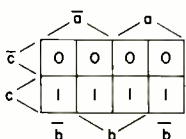

Fig. 6



Fig. 7

implement our black box as shown in Fig. 7. We have grouped together the four adjacent squares to eliminate a and b . Notice that we have simplified things a great deal, since we now need no gates at all.

Using a Karnaugh Map. Maps of one, two, three, and four variables are shown in Fig. 8. Maps of one variable are rarely used, and maps with more than four variables are seldom needed—even if such a problem were to chance along, the Karnaugh map would not be the tool to use. Its value depends on the pattern recognition capability of the user, and it becomes hard to recognize pattern groupings in maps of more than four variables.

Using the three-variable map as an example, note that there is one box for abc , one for $\bar{a}bc$, another for $\bar{a}\bar{b}c$, and so on, with abc corresponding to the input combination $a=1, b=1, c=1$; $\bar{a}bc$ to $a=1, b=0, c=1$; and $\bar{a}\bar{b}c$ to $a=0, b=1, c=0$; etc. Each box, then, corresponds to a single row in the truth table. The map is arranged in such a way that half of it corresponds to the uncomplemented form of a given variable and the other half to its complemented form; and the variables are interleaved so that every input combination corresponds to exactly one square, and conversely. Usually only the uncomplemented form of each variable is written—it being clear that the other half of the map corresponds to the complemented form.

Now, a logic function is displayed by placing ones and zeros in the boxes on the map. If a given input combination produces an output, or function value, of one, a one is placed in the corresponding square on the map. If the output is zero, a zero is placed in the square. As an example, look at the logic function in Fig. 9. On the Karnaugh map, the box given by abc has a 1 in it. This means that f is a logical one when the input variables have the value $a=1, b=1, c=1$. The box given by $\bar{a}b\bar{c}$ has a 0 in it. This means that $f=0$ when $a=1, b=1, c=0$. These entries, as well as all the others, can be verified by looking at the truth table.

The logic function in Fig. 9 is not at all simple looking. The question is, how can the function be reduced to its simplest form? Variables can be eliminated from the function by use of the following definition and rules:

Definition: Two boxes are adjacent if the corresponding variables differ in only one place, for example if one box corresponds to $\bar{a}b\bar{c}$ and the other to $\bar{a}bc$. Notice that boxes on opposite edges of the map are adjacent under this definition.

Rule 1: If two boxes containing ones are adjacent, the single variable which differs between the two (uncomplemented for one, complemented for the other) can be eliminated and the two boxes combined. These two boxes correspond to the AND function of all the variables except the one eliminated.

Rule 2: If four boxes containing ones are adjacent in such a way that each box is adjacent to at least two others, these boxes can be combined and the two variables eliminated—those two which appear in both complemented and uncomplemented form somewhere within the group. The group of four corresponds to the AND function of all the variables except for the two which have been eliminated.

Rule 3: The same procedure holds for eight, sixteen, and so on, adjacent boxes. Each box in a grouping must be adjacent to three, four, etc., others within that group.

Rule 4: The various AND functions produced by the above groupings are "ORed" together to yield the simplest function.

It should be noted that a given box can be included in more than one grouping if that will simplify the overall function, but each grouping should contain at least one box which doesn't belong to an existing group-

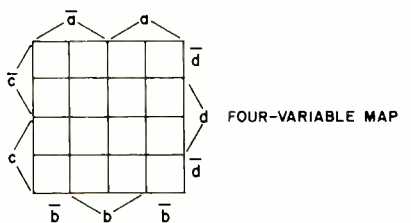
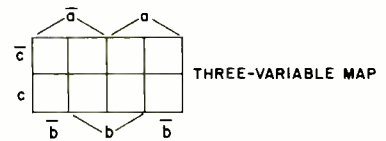
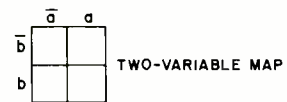

Fig. 8

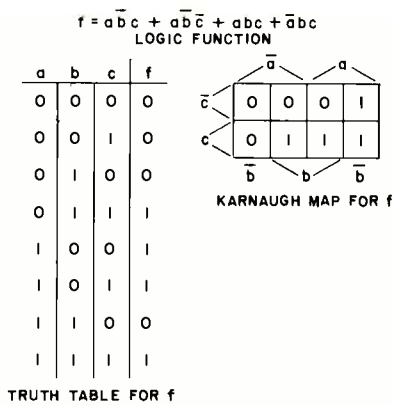

Fig. 9

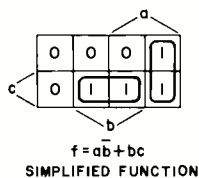

Fig. 10

ing (otherwise, this would lead to redundancy).

To illustrate, the Karnaugh map of Fig. 9 is repeated in Fig. 10, along with the adjacency groupings and the resulting simplified function. Note the contrast in simplicity. The boxes represented by abc and $a\bar{b}c$, although adjacent, are not grouped together because each is already included in an existing grouping. Now we are equipped to tackle a real-life problem.

BCD-to-Decimal Decoder. Consider the BCD counter of Fig. 11, with the four output variables a , b , c , and d . Suppose we need to decode the count of decimal eight and provide a control pulse, lasting one clock period, to some other digital circuit. We must build a logic function f_8 ,

DECIMAL	a	b	c	d	f_8
0	0	0	0	0	0
1	0	0	0	1	0
2	0	0	1	0	0
3	0	0	1	1	0
4	0	1	0	0	0
5	0	1	0	1	0
6	0	1	1	0	0
7	0	1	1	1	0
8	1	0	0	0	1
9	1	0	0	1	0
?	1	0	1	0	X
?	1	0	1	1	X
?	1	1	0	0	X
?	1	1	0	1	X
?	1	1	1	0	X
?	1	1	1	1	X

TRUTH TABLE FOR f_8

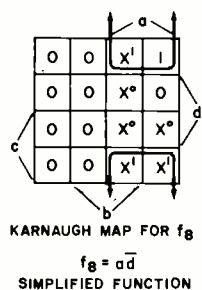
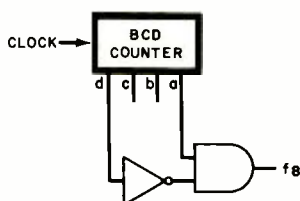

Fig. 11



defined by the truth table of Fig. 11. This truth table introduces a new variable, called a *don't care* and given the symbol "X." The don't care means that we can define the output function f_n to be either zero or one for that particular input combination—simply because the input combination will never occur. A BCD counter never counts above decimal nine. The X's can be given values of zero or one so as to simplify the resulting function. In our case, the don't cares have been chosen as indicated by the smaller ones and zeros on the map. Notice the very simple form for the function f_n , which can be constructed from a single AND gate and an INVERTER.

The preceding was an example of what is called combinational logic. The outputs at a given time are dependent only upon the inputs at that time. Actually, the gates used to build up a logic function have some delay. In the case of combinational logic, though, this just means that after the input values are established, there is some flat delay before the output value is established. The delay is critical only if we have to compare the output value with another being similarly generated. If this is the case, we could encounter problems with the timing margins.

In the digital game we are playing, though, the gate delays can be important for a different reason. They allow us to build so-called sequential machines for storing information, as well as for a myriad of other useful things. The general idea of a sequential machine is illustrated in Fig. 12.

The R-S Flip-Flop. An R-S flip-flop is a one-bit digital memory whose output is set to the one state by a one on an input set (S) line and to the zero state by a one on another line, called the reset (R). An incomplete truth table for this device is sketched in Fig. 13. It is incomplete because the output stable state is specified not only in terms of ones, zeros, and don't cares, but depends in addition on the present (unstable) state q . We can form a complete truth table by including q as one of the input variables, thus creating a feedback situation. The complete truth table is also shown in Fig. 13, along with the resulting Karnaugh map and the derived logic equation for the state Q . Note that we must always have $RS=0$ (called the RS flip-flop constraint) to

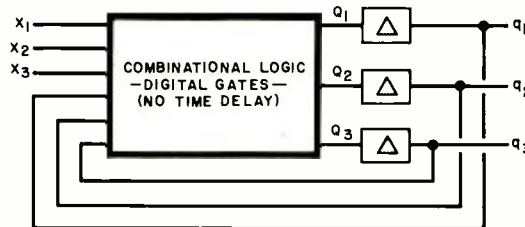

Fig. 12

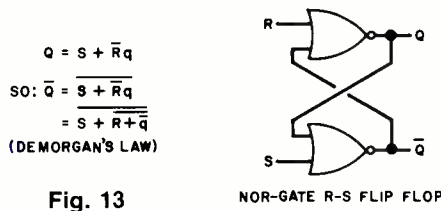
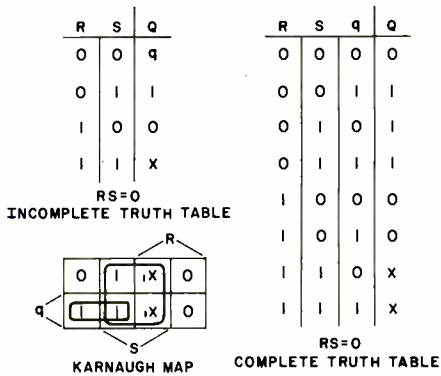

Fig. 13

keep from violating the condition that $R=S=1$ must never occur. Figure 13 also shows how DeMorgan's Law is used to get the function into a form requiring only NOR gates for its construction. By assuming all three possible combinations of input variables (remembering the $R=S=1$ is disallowed from ever occurring) and computing outputs, the truth table can easily be verified. It is also easy to show in this way that the output labeled Q is, indeed, the complement of the output labeled \bar{Q} for all input conditions except the disallowed $R=S=1$.

The Clocked R-S Master-Slave Flip-Flop. It is often desirable to have available an R-S flip-flop which changes state only on, for example, the trailing edge (or 1-0 transition) of a clock signal. It is possible to use the Karnaugh map to derive the form of such a flip-flop, but the end result, although economical in number of gates and number of inputs per gate, would not shed much light on the internal workings.

This type of sequential machine is depicted in Fig. 14. When the clock goes high, the R and S inputs are passed through the input gates and stored in the master. When the clock goes low, the input gates are disabled, and the information is coupled through the transfer gates into the slave flip-flop. The function of the preset and clear inputs is evident. Try assuming a set of input values for R and S , and trace the information flow, letting the clock change as described

above, to convince yourself that the unit performs the R-S function.

The J-K Flip-Flop. Let's return to our newly developed map technique now and develop the (clocked) J-K flip-flop as a last example. For convenience, since output changes are allowed only on clock transitions, let's denote the unstable state q by Q_n and the stable state Q by Q_{n+1} . This is reasonable, because Q_n is the stable state just prior to the n^{th} 1-0 clock transition, and is the unstable state just afterward, with the flip-flop settling down into the stable state Q_{n+1} before the next clock transition occurs.

The incomplete and complete truth tables are shown in Fig. 15, along with the Karnaugh map and the resulting simplified function. The J serves as the S and K as the R , respectively, of an R-S flip-flop. The only difference is that the $J=K=1$ output is now defined (\bar{Q}_n).

Let's use the clocked R-S flip-flop to build the J-K from our derived equation. For this purpose, let $S=J\bar{Q}_n$ and $R=KQ_n$ be the inputs to the clocked R-S. According to the R-S equation,

$$Q_{n+1} = S + \bar{R}Q_n = JQ_n + (\bar{K}\bar{Q}_n)Q_n$$

Now, applying DeMorgan's law to $\bar{K}\bar{Q}_n$, we get

$$Q_{n+1} = JQ_n + (\bar{K} + \bar{Q}_n)Q_n = JQ_n + \bar{K}Q_n + \bar{Q}_nQ_n$$

But $\bar{Q}_nQ_n = 0$ always, so

$$Q_{n+1} = JQ_n + \bar{K}Q_n$$

which is the J-K flip-flop equation. Notice that the R-S constraint is satisfied, since

$$RS = (J\bar{Q}_n)(KQ_n) = JK(\bar{Q}_nQ_n) = 0$$

Fig. 16 shows the construction of the J-K from the R-S using two AND gates. Again, test the operation by assuming a set of conditions for J and K and tracing the logic flow. A glance back at the incomplete truth table will reveal that if $J=K=1$ (J and K inputs tied to a logic one) the J-K forms a toggle flip-flop.

The preceding examples have been intended to accomplish two things. In the first place, knowledge of the logical operation of the various types of flip-flops is essential in order to use them intelligently in an original design. As a second objective, they have provided an effective demonstration of the economy of thought which results when the Karnaugh map is used in a digital design effort. ♦

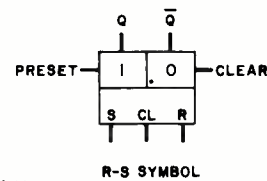
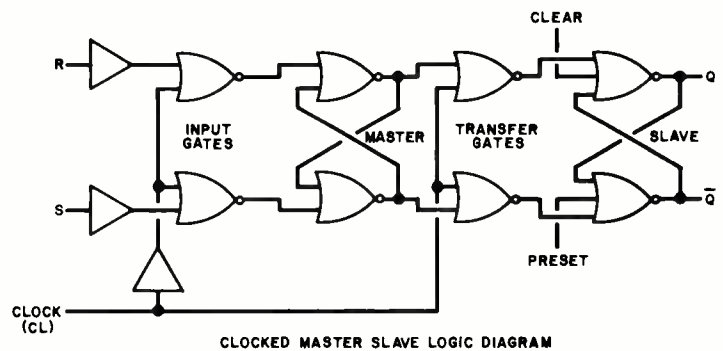

Fig. 14

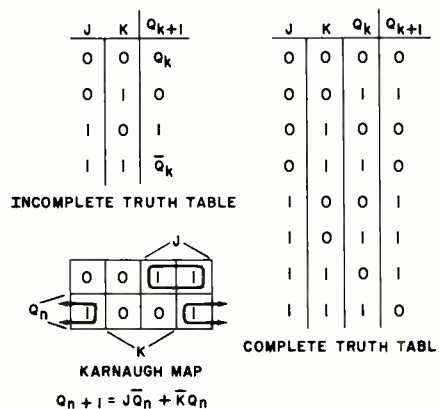

Fig. 15

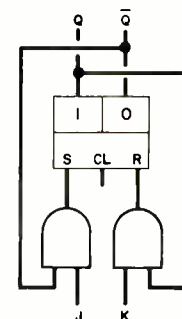
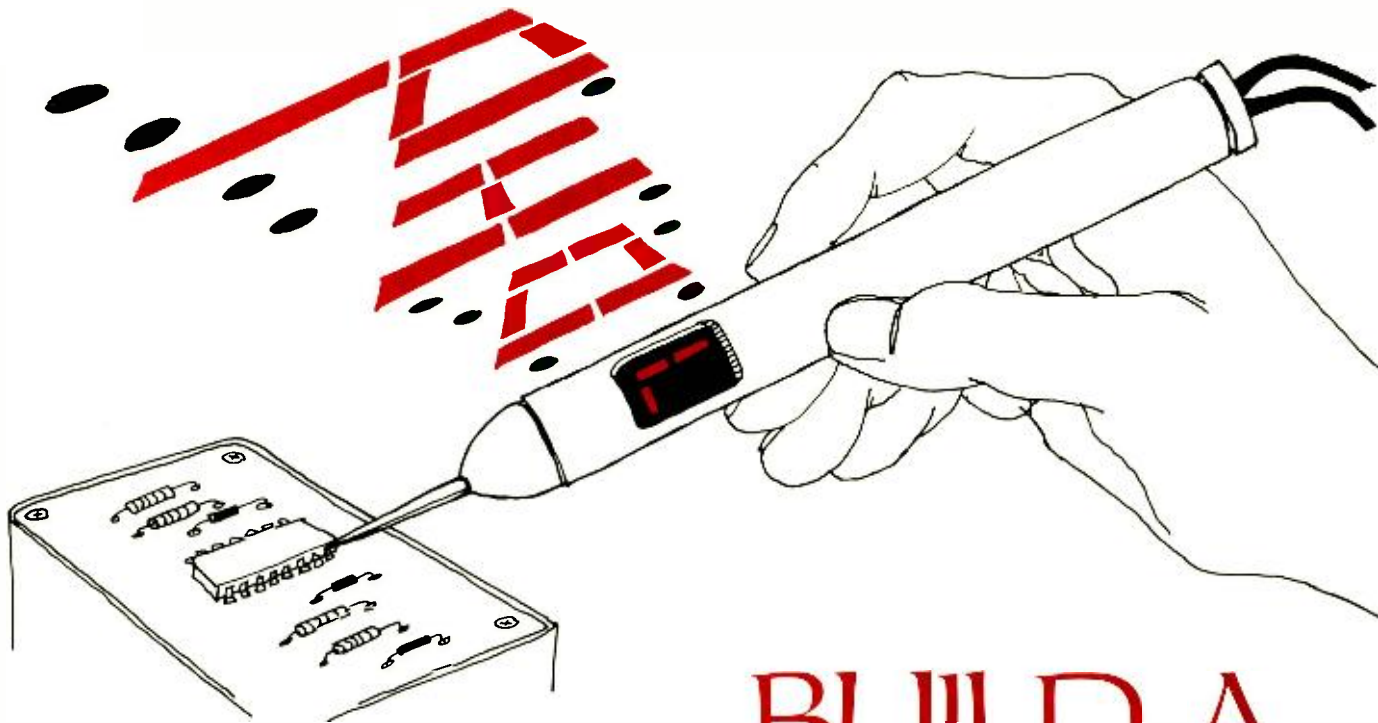

Fig. 16



BUILD A DIRECT-READING LOGIC PROBE

Seven-segment readout displays high, low, open, and pulse.

BY R. M. STITT

THE LOGIC probe is almost a necessity in checking digital circuits. Usually the probe detects and discriminates between high-level, low-level, and pulse conditions at various points in a digital circuit. The results are then displayed on miniature lamps or discrete light-emitting diodes.

If you want a more advanced logic probe, try the one described here. It does what the conventional probe does, but has the additional capability of being able to sense an open circuit or an out-of-tolerance high or low logic level. And the indicator is a single seven-segment LED display. The four possible test conditions are shown as actual letters on the seven-segment display.

The letters are: H (high logic level), L (low logic level), O (open), and P (pulse). This type of display makes testing faster and improves accuracy in reading the results.

How It Works. Shown in Fig. 1 is the logic probe's schematic diagram. Transistor *Q1* functions as a voltage comparator and buffer with a threshold of approximately 0.6 volt. Transistor *Q2* and diodes *D1*, *D2*, and *D3* function as a voltage comparator and buffer with an approximate 2.4-volt threshold. These thresholds are slightly wider apart than is standard for TTL devices, thus providing a safety margin.

Resistors *R4* and *R5* and transistor *Q3* shift the level of *Q2* to make it TTL

compatible. The outputs of the two comparator circuits are further buffered and conditioned by *IC2*, the high (H) and low (L) outputs of which are decoded by the remaining circuitry. Assuming that the point under test is either at a constant high or a constant low, the end result will be an H or an L displayed on *DIS1*.

In the event of any pulse activity at the point under test, one-shot multivibrator *IC1* will trigger and generate a P (for pulse) on *DIS1*. If a single pulse occurs at the test point, *IC1* will still cause a P to be displayed, but only for about 0.5 second. (The probe is capable of "capturing" pulses as short as 10 ns in duration.)

Any time the probe tip is not touching a point in the test circuit or is

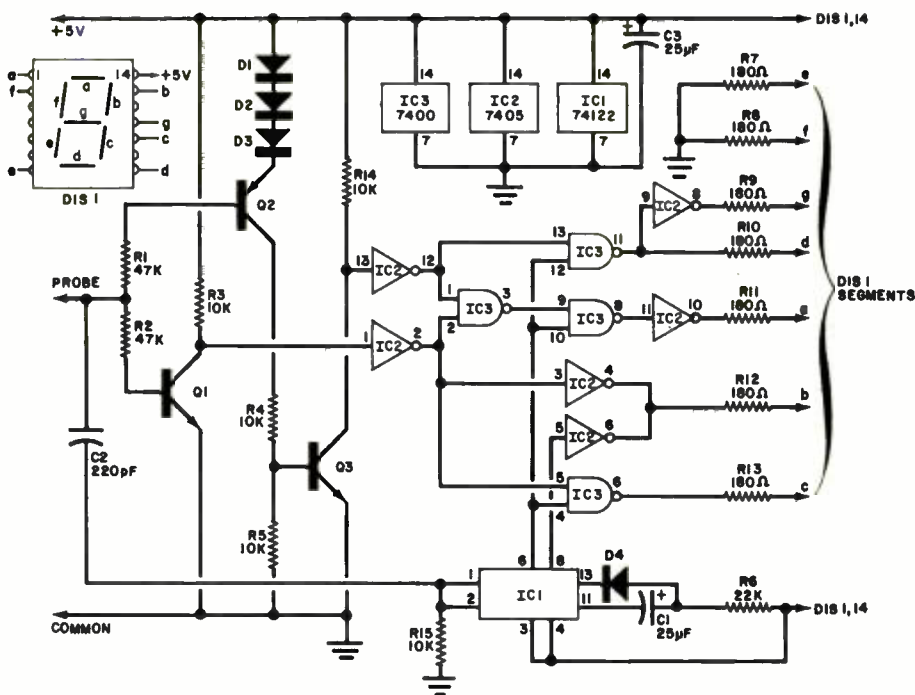

PARTS LIST

- C1, C3—25- μ F, 6-volt tantalum electrolytic capacitor
- C2—220-pF ceramic disc capacitor
- D1 thru D4—Signal diode (1N914 or similar)
- DIS1—Common cathode seven-segment LED display (Opcoa SLA-7 or similar)
- IC1—Retriggerable monostable multivibrator (74122)
- IC2—Hex inverter (7405)
- IC3—Quad two-input NAND gate (7400)
- Q1, Q3—Npn silicon switching transistor (2N3904 or similar)
- Q2—Pnp silicon switching transistor

- (2N3906 or similar)
- The following are 1/4-watt, 5% tolerance resistors
- R1, R2—47,000 ohms
- R3, R4, R5, R14, R15—10,000 ohms
- R6—22,000 ohms
- R7 thru R13—180 ohms
- Misc.—Printed circuit board; 7/4" \times 1/2" inner diameter CPVC plastic tubing; 5/8" or 1/2" diameter hardwood dowel stock (see text); one red- and one black-booted alligator clips; 72" length of No. 18 test lead cable; 6d finishing nail; solder; etc.

Fig. 1. Schematic diagram of the logic probe. Transistors Q1 and Q2 are in comparator circuits which set the logic levels. IC2 and IC3 decode the signal.

touching a point that is electrically isolated from the circuit. DIS1 will display an o. Furthermore, any logic level that is within the range set by the comparators will also result in an o being displayed.

In operation, H indicates a high TTL state (greater than 2.5 volts); L indicates a low TTL state (less than 0.6 volt); o indicates an open circuit or an out-of-tolerance TTL state (high impedance or less than 2.5 volts but greater than 0.6 volt); and P indicates a pulse train or single pulse.

Construction. When assembling the probe, parts layout and lead dress are not particularly critical. The test prod lead should be kept as short and direct as possible through the junction of R1 and R2.

To keep the electronic assembly as compact as possible, a printed circuit board is a must for component mounting. The etching and drilling and component placement guides are shown in Fig. 2. Since you will be making your own double-sided board and will not be able to plate through the holes, it is important to solder connections on both sides of the board. Consequently, you must install the components in a set sequence. Install and solder into place R7, R9, R13, and R15 before you install R8, R10, R11, and R12. Likewise, install C2 before C1. All remaining components can be installed in whatever sequence you desire. (Note: The component placement guide shown in Fig. 2 is the view from the top, or component, side of the board. The items to be installed first

are indicated in phantom in Fig. 2.)

After wiring the circuit board, solder a 1" (25 mm) length of insulated wire to the pad under DIS1 nearest the end of the board. The free end of this wire goes to the probe's test tip. Prepare the ends of two 36" (about 1-m) lengths of test-lead cable, and solder one end to the +5-volt and ground pads on the board.

Now, cut a 3/4" long by 5/32" deep (19 \times 3.8-mm) window 1/2" (13 mm) from one end of the tube. Use CPVC tubing; it has thinner walls to provide a slenderer assembly than is possible with ordinary PVC tubing. CPVC tubing is available from most hardware and building supply stores.

You can fabricate the end caps for the tube to the dimensions given in Fig. 3 by turning on a lathe or whittling with a knife 5/8" (16-mm) diameter hardwood dowel stock. If you don't have access to a wood-turning lathe or don't relish whittling, you can fashion blunt end caps from 1/2" hardwood dowel stock and use small screws to hold them in place. In either case, drill a 1/4" (6.5-mm) diameter hole through the rear end cap and a hole just large enough to require force fitting a 6d finishing nail into it through the front end cap.

Pass the power leads for the probe through the hole in the rear end cap. Connect and solder a red-booted alligator clip to the +5-volt and a black-booted alligator clip to the ground cables.

Test the probe by connecting its power cables to the +5-volt and common buses of a known good circuit and touching the probe lead to the +5-volt bus, common bus, and a point in the circuit where there are pulses. When the power leads are initially hooked up, the display should indicate 0. Touching the probe lead to the +5-volt and common buses should cause an H and an L to be displayed, respectively. With the probe lead touching a point in the circuit where pulse activity is taking place, the display should indicate a P.

The circuit board is deliberately wider than the inside diameter of the plastic tube. To get the board into the tube, you will have to deform the latter. To do this, place the tube between two blocks of wood in a vise and very carefully close the vise just enough to permit the board to slip into place. Before opening the vise, make certain that the display is centered in the window of the tube.

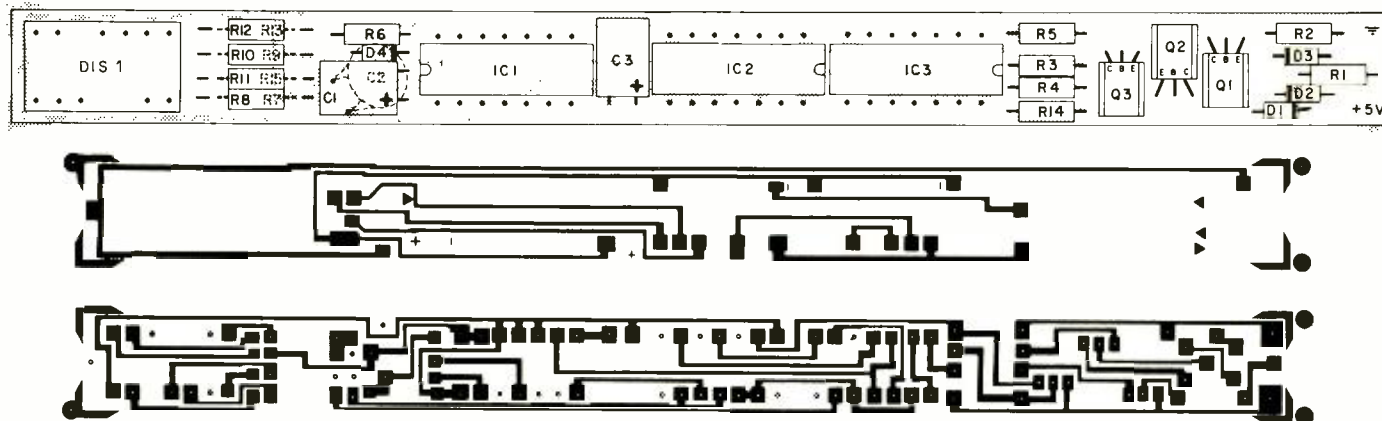
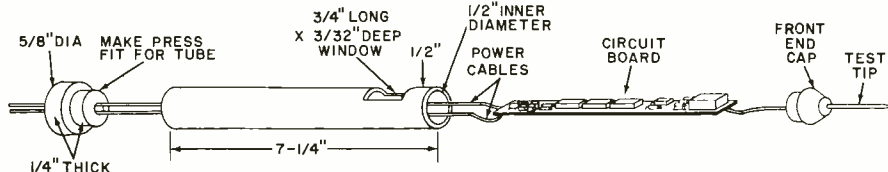

Fig. 2. Etching and drilling guides and component layout for pc board are above.

Fig. 3. Diagram shows how to assemble the probe. Be sure display shows in the window.



File or grind the point of the finishing nail to a sharp tip, contouring it like a standard test-probe point. Drive the nail into the front end of the cap, leaving about 1/4" of the nail head free. Locate the free end of the probe tip wire coming from the circuit board. Strip away about 3/8" of insulation from the wire, wrap the exposed wire around the nail head, and drive the nail home in the end cap. Push both end caps into the tube (and secure them with small screws if necessary), and the probe is ready to use. ♦

You don't have to buy a new car to get an electronic ignition.



Most of you know the evaluation of automotive electrical systems . . . an evaluation characterized only occasionally by efficiency and performance. I know that, and that's why I use the Delta Mark Ten B CDI on all my cars, new and old. And believe me, you don't have to have a new car to appreciate the best electronic ignition available today. Study these features and you'll know what I mean.

1. Mark Ten and Mark Ten B Capacitive Discharge Ignition Systems are manufactured by Delta Products, Inc., a company with a conscience, and with a proven record of reliability both in product and in customer relations.
2. The Mark Ten CDI's really do save money by eliminating the need for 2 out of 3 tune-ups. Figure it out for yourself. The first tune-up or two saved pays for the unit, the rest is money in your pocket. No bunk!
3. Because the Mark Ten CDI's keep your car in better tune, you actually can save on expensive gasoline.
4. With a Mark Ten, spark plugs stay clean and last longer . . . fouling is virtually eliminated.



No matter what kind of car you drive, it too can use a Delta quality lift.

I want to know more about Mark Ten B CDI's. Send me complete no-nonsense information on how they can improve the performance of my car.

Name _____
 Address _____
 City _____ State _____ Zip _____



DELTA PRODUCTS, INC.

P.O. Box 1147, Dept. PE, Grand Junction, Colo. 81501
 303-242-9000

Mark Ten B, assembled	\$64.95 ppd	Standard Mark Ten, assembled	\$49.95 ppd
Mark Ten B, kit	\$49.95 ppd	Deltakit®	\$34.95 ppd

CIRCLE NO. 18 ON FREE INFORMATION CARD



Computer Bits

By Jerry Ogdin

HOBBYIST INTERCHANGE TAPE SYSTEM

COMPUTER hobbyists have an insatiable appetite for new programs. Consequently, they are increasingly using the practice of sharing their programs.

But efficient sharing requires a common communications medium. Short programs can be exchanged easily by correspondence on a typewriter or even longhand. As software becomes more complex, however, the possibility of translation error increases so it is essential that a universally recognized exchange medium be used. Further, price and simplicity are of great importance since many hobbyists can't afford expensive commercial equipment.

With no such common exchange medium available to hobbyists today, we have taken the bull by the horns and developed a standard which we think meets all of the foregoing requirements. We call it the Hobbyists Interchange Tape System or simply HIT. The system uses an ordinary low-cost audio cassette tape recorder as the hardware/software interface; and it can be adapted for use with any computer. In the following discussion, HIT is used with an 8080 CPU-design microcomputer.

HIT is probably not the most efficient nor simplest possible system, but we think it is the best compromise for public interchange of software. At the tape speeds used, data will appear on the tape at rates between 30 and 360 bits per second—not a blindingly fast speed, but reliable! However, by changing some of the circuit and software values and using a high-quality recorder, 2500 bits per second can be achieved.

The technique does not depend on frequency, amplitude, or phase. Indeed, the low-cost cassette recorder does not even have to handle digital pulses directly. In practice, short and long bursts of tone are used, with each

zero bit represented by a short burst and each one bit by a long burst. Here is how it works.

Basic Theory. Every digital pulse has a leading and trailing edge; a bit interval extends from the leading edge of one bit to the leading edge of the next. If we synchronously count up during the time from the leading edge to the trailing edge, as shown by the dotted line in Fig. 1, and then count

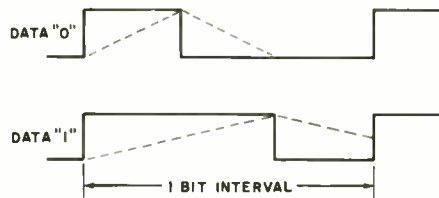

Fig. 1. Pulse waveforms show how zero and one bits differ in length.

down from the trailing edge to the next leading edge, we can determine whether the pulse is long or short. If, as shown in the upper waveform of Fig. 1, we can count down to zero before the next leading edge, we know that the data bit was a "0". If, however, the counter is stopped by the leading edge of the next pulse (lower waveform), we know that the bit was long and the data was a "1."

Unfortunately, steep-edged pulses are unacceptable to most cassette recorders. So we convert them into audio tones, with a data pulse represented by a burst of approximately 2000 Hz, which is compatible with most low-cost recorders. The schematic for the complete HIT translator is shown in Fig. 2, and the associated waveforms are shown in Fig. 3.

The output of the computer consists of two data lines from an output port latch. One (Fig. 3A) is called the envelope and is true during the tone burst. The other (B) is called modulation and is a software-controlled 2000-Hz square wave. Op amp IC1A converts the TTL-level signals into an approximate 2-kHz sine-wave burst (D) which can be recorded easily on any tape machine. The output of IC1A is about 2 volts peak-to-peak at the AUX output jack and about 50 mV at the MIC jack. When recording on a stereo cassette, write this data into the right channel.

The playback circuit takes the re-

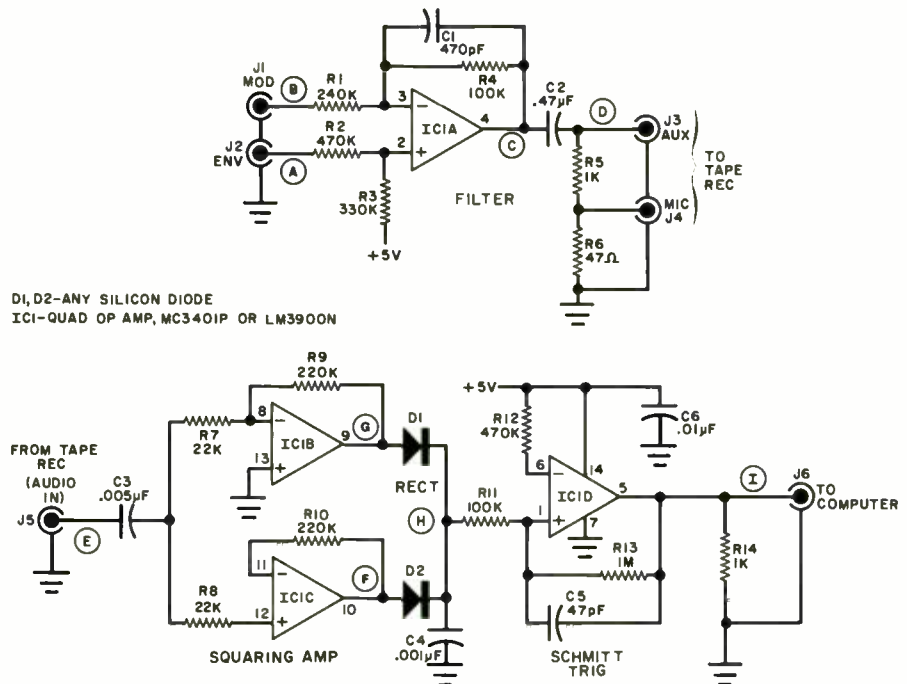

Fig. 2. At top is schematic for recording end of HIT system. Circuit at bottom reads from cassette into computer.

recorded data signal from the tape recorder (Fig. 3E) and converts it back to the original digital signal. This circuit, consisting of IC1B, C, and D, works with an input signal level from 0.75 V to 4 V, although 2 to 2.5 V is ideal. The input is squared up in IC1B and IC1C (Figs. 3F and G) and then rectified by diodes D1 and D2. The combined output (H) is then applied to a Schmitt trigger (IC1D) which produces the output signal (I), an exact reproduction of the original envelope input.

The frequency of the tone burst is not critical. In writing a tape to be mailed to another person, use a frequency near 2 kHz as the modulating input. The reliability of the recorded data depends on how long each pulse is written. With very brief tone bursts, the data rate is high, but the reliability can be adversely affected by poor-quality tape and inexpensive cassette recorders. Each bit may be as short as 1250 microseconds or as long as 35 milliseconds, depending on the writer of the tape. In the programs that follow, 2.75 milliseconds is used as the bit time. The playback circuit and software should be capable of adapting automatically to pulse lengths since it is the ratio of the first half to the second half that determines the data value.

With this wide range of permissible pulse lengths, virtually any computer can be used to write these standard format tapes. Even the slower 8008 CPU can write out bits that have 1-m-

seconds durations and still be able to recover them successfully.

Programs. The software we have used with an 8080 is shown in Program 1 (overleaf). The output port (named TAPEO in the program) puts the envelope signal on the most-significant bit and the modulation on the least-significant bit. Since most output ports are TTL-compatible, the simple writing circuit of Fig. 2 can be directly connected. Each data bit is shifted into the CARRY flag of the computer, where the decision to emit a short or long pulse is made. The least-significant bit of the counter is used to determine how long to emit the tone burst (modulation) signal. After all of the tone burst has been sent out, we wait in a counting loop (built into the program) for some tape to move past the recording head before starting the next output bit.

Nine bits are written for each 8-bit byte. Since this new recording scheme uses the leading edge of a burst as the "clock," it is necessary to assure that there is a data bit after the eighth bit of a byte. This ninth bit is always written as a "0". The time that it takes this bit to move past the recording head is the time that we can use to process the character and store it away in memory.

The data rate is 364 bits per second, using all the values in the illustrations. This writing routine, like the reading routine of Program 2, is critically

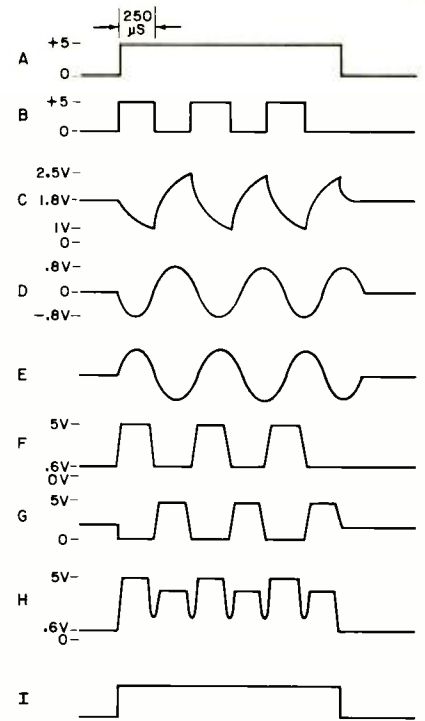

Fig. 3. Waveforms at various points in the writing and reading circuits of the HIT.

timed. Consequently, do not change the instruction sequences unless you fully understand the timing relationships of the instructions.

In reading the data back in, the input port (the least significant bit is used) is examined until a zero-to-one transition is found; that is the leading edge of the burst. We now count up (in the B register) until the trailing edge is

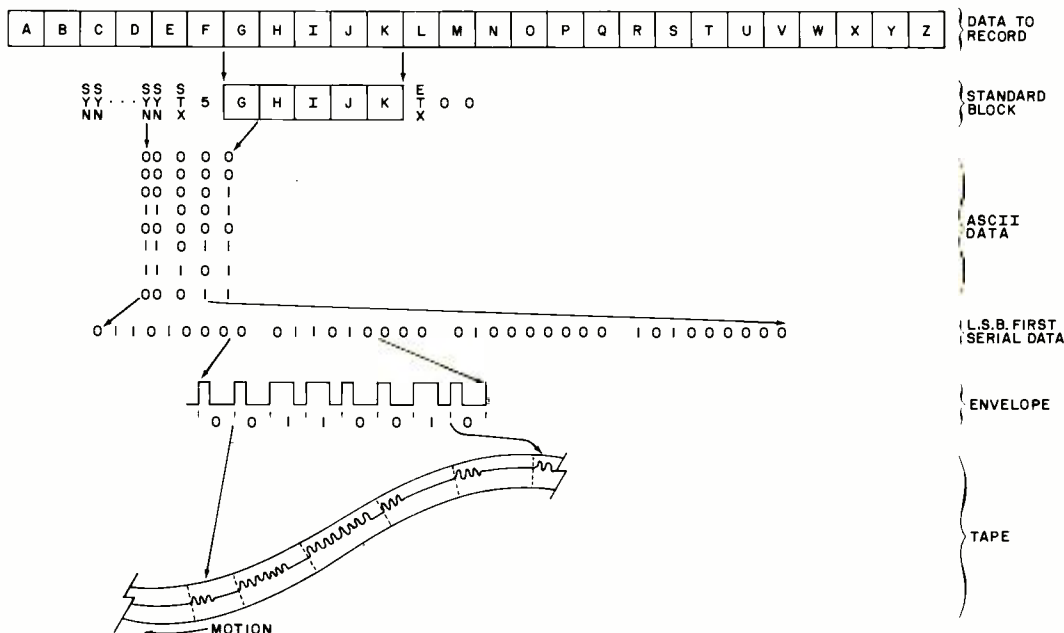

Fig. 4. How data to be recorded is first translated to ASCII code and then put on tape as tone bursts.

found. After that, we count down until either a new leading edge is detected (making the data bit a 1), or the counter goes to zero (data is a 0). Note that each bit condition must be sensed two times in succession to be considered valid. This provides noise protection.

Each time a bit is found, it is shifted into place. After eight bits are located, the return is taken. When the character reading routine returns, the leading edge of the ninth bit has thus always been sensed.

Data Format. Having a standard medium and a standard recording form is not enough for successful computer data exchange. We must all agree on the code and format of the data. As far as possible, the method described here uses national and international data communications standards. All data is written in ASCII code unless otherwise agreed upon by writer and reader. It is possible, for example, to agree on the transmission of actual eight-bit object code. All data is recorded with the least-significant bit first.

The record format we use is shown in Fig. 4. This technique is synchronous, and from the beginning of the data to the end, there should be no dead spots. At this time, it should be pointed out that cassette recorders have agc or limiter circuits. When the data first appears at the record input of such a machine, the agc does cruel things to the waveshape. By not allowing this to happen, except in the first part of the data where it is permissible, many problems can be avoided. This is done as follows: Each data block begins with at least 32 ASCII SYN (synchronizing codes 0001 0110). The SYN codes repeat long enough to allow the recorder's agc to settle down and the software to go into character "sync." A special character signal at the start of text (ASCII STX code 0000 0010) appears next, followed by an eight-bit count word. That count specifies how many more characters appear in the data record. If the count is zero, then this is called an end-of-file block. If it is not zero, it specifies how many eight-bit bytes appear in the data record. At the end of the data bytes (if any), is an ASCII ETX (end-of-text 0000 0011) character and two block-check characters. These two characters are normally zero, but can be used to hold the CRC code, or a check-sum, or whatever error protec-

tion the writer wishes to employ here.

If the block-check characters are used, the writer of the original tape is expected to provide a computer program in the first few data blocks for the machine of interest that will read and utilize them. This program should appear at the front of the tape and be terminated by an end-of-file block. The data to be read in should then follow on the tape. This front-end program is called a "bootstrap leader."

Programs for reading and writing standard format data tapes from memory of an 8080 are shown in Program 3. We can read or write 1024 bits in about 30 seconds using the standard format.

Higher Speed. This cassette interface can also be used locally for normal input/output needs. However, in your own computer, you may be able to go substantially faster. Our experiments have shown that you can expect to have a data bit rate about one-fourth of the modulation frequency. If your tape recorder will faithfully reproduce a 10-kHz signal, as many better decks do, you can expect to handle 2500 bits (240 characters) per second.

You may also want to add some additional hardware to eliminate some of the software. A simple gated oscillator can be used instead of performing the modulation in software. The envelope signal can drive the gate of an oscillator. You can even go so far as to have an eight-bit parallel output bit port and perform all of the timing and serialization external to the computer. You will probably want to have two versions of these circuits: one to be used to write standard tapes at standard frequencies and rates, and the other to write at whatever speed your own tape recorder can handle without errors.

The playback circuitry can also be expanded. The count-up/count-down software can be converted into a couple of timers that control ramps. Similarly, you may want to assemble incoming bits into eight-bit characters in hardware. With all this hardware installed (it takes about 10 IC's), the software becomes only a few input and output statements.

What is needed now is a central exchange point. Perhaps some of the emerging hobbyist groups (or even individuals) will agree to create a library of tapes for exchange or have them available at a nominal charge. A brief listing of program function,

The MIKE Family



Introducing the family of modular micros from Martin Research!

Choose either the economical 8008 processor, or the powerful 8080. Either CPU is compatible with our advanced bus structure! Plus, a convenient monitor program, in PROM memory, allows you to enter instructions with the ease of a handheld calculator. Six large digits display data in octal format.

Modularity makes for easy expansion. First quality parts throughout. Professionally made PC boards with plated holes, solder-mask protection. 8080 CPU board features versatile interrupt structure, multiprocessing capability. Easy interfacing to input and output ports.

MIKE 303A: CPU board with 8080, key-board/display board, PROM/RAM board monitor PROM (256 bytes of RAM), breadboard, hardware, and instructions: \$395.00 kit, \$495.00 assembled and tested.

MIKE 203A: CPU board with 8008, key-board/display, PROM/RAM, breadboard, hardware, and instructions: \$270.00 kit, \$345.00 A&T.

MIKE 3-5 or 2-5: 4K RAM board with 450 ns static RAM: \$165.00 kit, \$190.00 A&T.

FREE CATALOG!

Kits: US & Canada only.
Master Charge accepted.
OEMs: write for quantity prices.

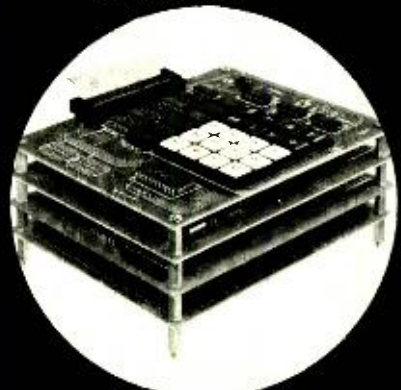

MARTIN RESEARCH
Microcomputer Design
1825 S. Halsted St.
Chicago, IL 60608
(312) 829-6932

PROGRAM 1

```

;WRITE THE BYTE IN THE -C- REGISTER OUT TO TAPE,
; LEAST-SIGNIFICANT BIT FIRST. AFTER EIGHTH BIT
; WRITE OUT A DATA '0'. REGISTERS (A & B) ARE
; DESTROYED. OCCUPIES 74 BYTES.
;
; VARIABLES -WRWAI- AND -WRLEN- CONTROL DATA RATE.
; -WRWAI- DEFINES PERIOD OF EACH MODULATION HALF-
; CYCLE; -WRLEN- DEFINES LENGTH OF EACH DATA BIT.
; DATA RATE IN BPS IS:
;
;           1000000
;           -----
;           BPS = (15 WRWAI + 64) (6 WRLEN - 1) C
;
; WHERE -C- IS 8080 CYCLE TIME IN MICROSECONDS
WRWAI EQU 29 ;2004 HZ IF C=500 NANOSECONDS
WRLEN EQU 2 ;REDUNDANCY = 2
; GET NEXT DATA BIT TO TRANSMIT
WRCHA: MOV A,C
;
; JAM IN STOPPER BIT
WRCHX: STC
; GET LEAST-SIGNIFICANT BIT
MOV C,A ;SAVE ALL OTHER BITS FOR LATER
LDA WRLNG ; (FOR DATA '1')
JC WRBST
LDA WRSHT ; (FOR DATA '0')
; WRITE TONE BURST OUT TO TAPE
WRBST: CALL WRTIM ;WRITE OUT FIRST HALF-CYCLE
JZ WRFIN ; (GO DO LONG PART NOW)
CALL WRTIM ;WRITE OUT SECOND HALF-CYCLE
JNZ WRBST ; (KEEP GOING)
OUT TAPEO ;TERMINATE MODULATION
LDA WRSHT ; (GO DO SHORT PART NOW)
JMP WRDLY-1
WRFIN: OUT TAPEO ;TERMINATE MODULATION
LDA WRLNG
; WRITE OUT NO MODULATION FOR REST OF BIT TIME
MOV B,A
WRDLY: CALL WRTIM+3 ;JUST DELAY
JMP $+3 ; (WASTE MORE TIME)
MOV A,A
JNZ WRDLY
; PREPARE NEXT BIT FOR OUTPUT
MOV A,C
ORA A
RZ ;IF ZERO, CHARACTER'S ALL DONE
CPI 1 ;IF 1, WE'VE FOUND STOPPER BIT
JNZ WRCHX ;(JUST ANOTHER DATA BIT)
XRA A ;EMIT A TERMINAL '0'
JMP WRCHX
; TIMING DELAY LOOP FOR CONTROLLING MODULATION
WRTIM: MOV A,B ;GET COUNTER WORD
OUT TAPEO ;WRITE OUT CARRIER
MVI A,WRWAI ;SET UP WAIT
DCR A
JNZ $-1
INR B ;UPDATE COUNTER
RET
; SHORT- AND LONG-BURST CONSTANTS
WRSHT: DB 255-WRLEN-WRLEN+2 ; (MUST BE ODD)
WRLNG: DB 255-WRLEN-WRLEN-WRLEN-WRLEN+1 ; (EVEN)

```

PROGRAM 2

```

;READ A BYTE FROM TAPE INTO THE -C- REGISTER.
; -C- IS LOADED LEAST-SIGNIFICANT BIT FIRST
; INTO THE MOST-SIGNIFICANT POSITION. 122 BYTES
;
; SAMPLE PERIOD FOR INCOMING DATA IS SET BY -RDTIM-,
; WHICH IS COMPUTED AS:
;
;           T - 100C      (T IS TIME IN USEC,
;           -----      C IS 8080 CYCLE TIME
;           15C          IN USEC)
RDTIM EQU 7 ; TO SAMPLE EACH 100 USEC
; SET UP NORMAL WORD-SIZE STOPPER
RDCHA: MVI C,128
IN TAPEI ;AWAIT DATA '0' CONDITION
RRC ; BEFORE LOOKING FOR
JC RDCHA+2 ; LEADING EDGE
MVI A,RDTIM+2
CALL RDBIT ;WAIT FOR SAMPLE PERIOD,
JC RDCHA+2 ; THEN CONFIRM '0'
; FIND AND CONFIRM LEADING EDGE OF DATA BURST
RDCHC: IN TAPEI ;LOOK FOR LEADING EDGE
RRC
JNC RDCHC
MVI B,1 ;INITIALIZE RAMP COUNT
MVI A,RDTIM+2
CALL RDBIT ;GO CONFIRM LEADING EDGE
JNC RDCHC
MVI A,1 ;CONFIRMED. START COUNTING
RAMP UP (-B- REGISTER) UNTIL TRAILING EDGE
RDCH3: ADD B ;INCREMENT RAMP COUNT
MOV B,A ;SAVE RAMP COUNT
JC RDCHC ; (BAD DATA; PULSE TOO LONG)
MVI A,RDTIM+1
RDCHR: CALL RDBIT ;GO READ NEXT SAMPLE
MVI A,1
JC RDCH3 ;IF SAMPLE = '1', CONTINUE COUNT
CONFIRM TRAILING EDGE

```

```

NOP
MVI A,RDTIM+2
CALL RDBIT ;CONFIRM
MVI A,2
JC RDCH3 ;EARLIER '0' WAS NOISE
MVI A,-2 ;BEGIN TO COUNT DOWN
; COUNT DOWN AFTER TRAILING EDGE
RDCH5: ADD B ;DECREMENT RAMP COUNT
MOV B,A
JNC RDCH0 ;DATA BURST WAS SHORT. DATA='0'
MVI A,RDTIM+1
CALL RDBIT ;READ NEXT SAMPLE
MVI A,-1
JNC RDCH5 ;STILL '0', CONTINUE COUNT DOWN
CONFIRM CLOCK (NEXT LEADING EDGE)
NOP
MVI A,RDTIM+2
CALL RDBIT ;GET SAMPLE TO CONFIRM
MVI A,-2
JNC RDCH5 ;EARLIER '1' WAS NOISE
; FOUND NEW LEADING EDGE; DATUM = '1'
MOV A,C
RAR ;INSERT '1' INTO BYTE
MOV C,A
RC ;IF STOPPER BIT IN -CY-, QUIT
MVI B,2
MVI A,RDTIM
JMP RDCHR ;GO CATCH THIRD SAMPLE
; COUNTED DOWN TO ZERO; DATUM = '0'
RDCH0: MOV A,C ;INSERT '0' INTO BYTE
RAR
MOV C,A
JNC RDCHC ;GO WAIT FOR LEADING EDGE
IN TAPEI ;AT END OF BYTE, BE SURE
RRC ; TO AWAIT LEADING EDGE
JNC $-3 ; OF TERMINAL '0' BIT
RET
; TIMING DELAY FOR READ SAMPLE PERIOD
RDBIT: DCR A ;DELAY
JNZ RDBIT
IN TAPEI
RRC ;PUT SAMPLE INTO CARRY BIT
RET
; ERROR ROUTINE. CLEAR CARRY TO REPORT ERROR
RDCHC: XRA A
RET

```

PROGRAM 3

```

;READ A BLOCK OF DATA FROM TAPE INTO LOCATIONS
; NAMED IN (H,L). REGISTER -E- WILL BE SET
; TO THE INPUT BLOCK SIZE; (A,B,C,D) ARE ALL
; USED. OCCUPIES 60 BYTES.
; UPON RETURN, FLAGS REPORT CONDITIONS FOUND:
; ZERO CARRY CONDITION
; -----
; 1 1 NORMAL DATA BLOCK
; 1 0 END-OF-FILE BLOCK
; 0 1 BAD BLOCK FORMAT READ
XXSTX EQU 2 ;ASCII START-OF-TEXT (STX)
XXETX EQU 3 ;ASCII END-OF-TEXT (ETX)
XXSYN EQU 20 ;ASCII SYNC CODE (SYN)
; SET WORD-SIZE STOPPER BIT IN -C-
RDBLK: MVI C,128
CALL RDCHC ;AT OUTSET, READ ANYTHING
MOV A,C
CPI XXSYN ;SEE IF SYN FOUND YET
JZ RDSYN
; GET ONE MORE BIT TO SEE IF SYNC CODE YET
RDNXT: ORI 1 ;SET TO READ ONLY ONE BIT
MOV C,A
JMP RDBLK+2
; CONFIRM THE SYNC CODE FOUND
RDSYN: CALL RDCHA ;READ A SECOND SYNC CODE
MOV A,C
CPI XXSYN
JNZ RDNXT
; FIND THE STX AND COUNT WORDS
CALL RDCHA
MOV A,C
CPI XXSTX
JNZ RDNXT ;LOST SYNC. TRY AGAIN
CALL RDCHA ;READ IN BLOCK SIZE
MOV A,C
MOV D,C ;SAVE FOR OUR COUNTING
MOV E,C ;SAVE FOR THE CALLER
ORA A
RZ ;IF ZERO, RETURN END-FILE.
; READ IN DATA BYTES AND STORE THEM AWAY
RDATA: CALL RDCHA ;READ NEXT DATA BYTE
MOV M,C ; AND PUT INTO STORAGE
INX H ;ADDRESS NEXT BYTE
DCR D ;SEE IF WE'RE DONE YET
JNZ RDATA ; (NO)
READ AND PROCESS BLOCK EPILOG
CALL RDCHA ;READ IN ETX CODE
MOV A,C
SUI XXETX ;SET ERROR FLAG
STC ;MARK NOT-EOF
RET

```

PROGRAM 3 (Continued)

```

;WRITE A BLOCK OF DATA TO TAPE FROM THE ARRAY
; STARTING AT ADDRESS IN (H,L). DATA IS
; ASSUMED TO BE IN ASCII AND THE NUMBER OF
; CHARACTER TO WRITE IS IN -E-. IF -E- = 0,
; WRITE A NULL BLOCK AS END-OF-FILE.
; (A,B,C,D,E) ARE USED. (H,L) WILL END UP
; POINTING TO END OF ARRAY + 1. USES 50 BYTES.
;
; RECORD FORMAT:
; SS      SSSN      EBB
; YY...32...YYTN...DATA...TCC
; NN      NNXN      XCC
XXBCC EQU 0 ;DUMMY BLOCK-CHECK WORD
; WRITE OUT SYNC CODES AT FRONT OF BLOCK
WRBLK: MVI D,32
        MVI C,XXSYN
        CALL WRCHA ;WRITE OUT NEXT SYN CODE
        DCR D
        JNZ WRBLK+2
        WRITE OUT STX AND THEN COUNT WORD (NNN)
        MVI C,XXSTX

```

```

CALL WRCHA ;WRITE OUT THE STX CODE
MOV C,E
CALL WRCHA ;WRITE OUT COUNT
DETERMINE WHETHER DATA NEEDS TO BE WRITTEN
MOV A,E
ORA A ;IF COUNT=0,
JZ WRBLF ; DON'T WRITE ANY DATA
; WRITE OUT DATA BLOCK
WRBLL: MOV C,M ;GET DATA BYTE
        INX H
        CALL WRCHA ;WRITE BYTE OUT
        DCR E
        JNZ WRBLL ;REPEAT UNTIL DONE
; WRITE OUT BLOCK EPILOG
WRBLF: MVI C,XXETX
        CALL WRCHA ;WRITE OUT END-TEXT CODE
        MVI C,XXBCC
        CALL WRCHA ;WRITE OUT BLOCK CHECK BYTES
        MVI C,XXBCC
        CALL WRCHA
        RET

```

machine, and source could be highly useful. For starters, reader David Yulke, 121 Liberty Ave., Selden, NY 11784, wants to trade software at no cost and offers PROM programming and assembling service at nominal cost to cover his time and postage. He has a home-designed 8008 system with cassette, CRT terminal, ASR-33 Teletype, and 1702A or 5203 programmer. Software includes MON-8 modified for UART operation and a RAM test feature; modified cassette routine, octal loader and hex loader (paper tape), all on 3 PROM's with an error routine. He is working on a "black-jack" program and a home accounting program. So let us hear from any other readers who wish to list such information.

Response. Thanks for the overwhelming response to our first column in June. We're gathering material on hobbyist computer clubs and will alert writers as soon as our input is complete. (POPULAR ELECTRONICS will be increasing the frequency of this column shortly as a result of so many reader requests to do so. —Ed.)

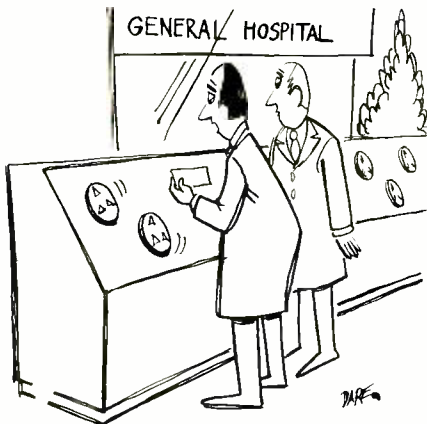

"He wants to call in a few other computers for consultation."

SEPTEMBER 1975

20 hi-fi watts in 1.2 cubic inches

What a powerhouse! SK3154 packs a 20-watt RMS audio amplifier in one small module. With virtually flat response from 15 Hz to 70 kHz. In the SK3154 package you'll find all the information you need. Just follow the instructions for adding 12 easy-to-get

passive components, power supply and hardware — and you've got one channel of a fine stereo or quad amplifier. The fun — and a super finished product — are yours. (Ten and 15-watt SK modules also available.) Start now! See your RCA electronics distributor.



Solid fun in 399 pages
Electronic organ, temperature alarm, tachometer, light-operated switch — 68 useful solid-state projects in one book. Complete instructions plus some theory. \$2.95 optional price. At your RCA electronics distributor.

**Solid State
Hobby
Circuits**



RCA

RCA Solid State, Box 3200,
Somerville, N.J. 08876.

CIRCLE NO. 45 ON FREE INFORMATION CARD

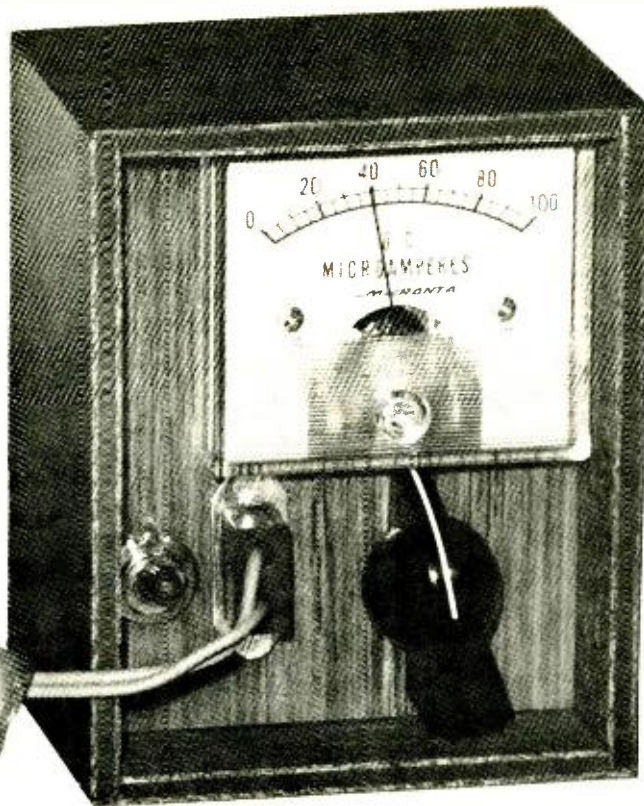
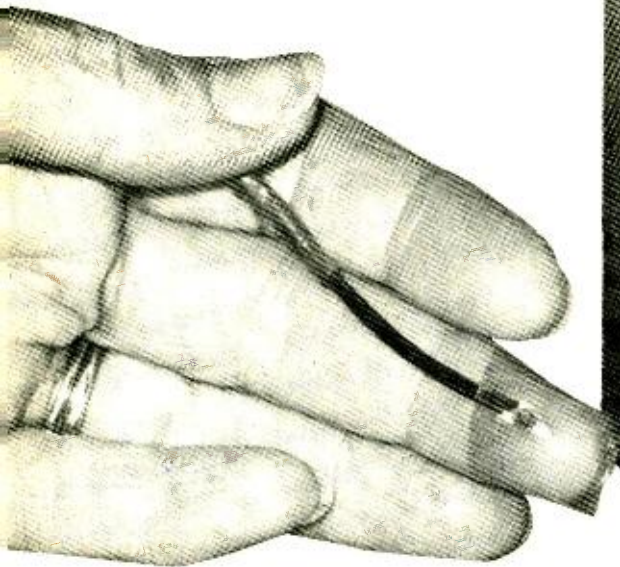

SKIN TEMPERATURE THERMOMETER

Consciously controlling the blood flow by measuring skin temperature is said to improve several body functions.

BY COLIN SHAKESPEARE

DURING the past few years, a lot of research has been directed at learning how to consciously control some of the "involuntary" body functions. Electronics has played a major role in this research, providing the means for both sensing and monitoring body functions. Among the more commonly measured and, hence, controlled body functions are skin resistance, potential, and temperature, as well as alpha, beta, theta, and delta brain waves.

Our interest, in this article, is in skin temperature, which is an indication of the flow of blood in the peripheral parts of the body (hands and feet). We want a skin temperature thermometer that will serve to teach the user how to increase and decrease the flow of blood to his limbs. With training, it is even possible to control the flow of blood in each hand independently.

Controlling the flow of blood is one way of solving the problem of cold hands and feet. Another use for this technique is the control of migraine headaches. Working on the theory that the throbbing headache pain is caused by the blood vessels in the

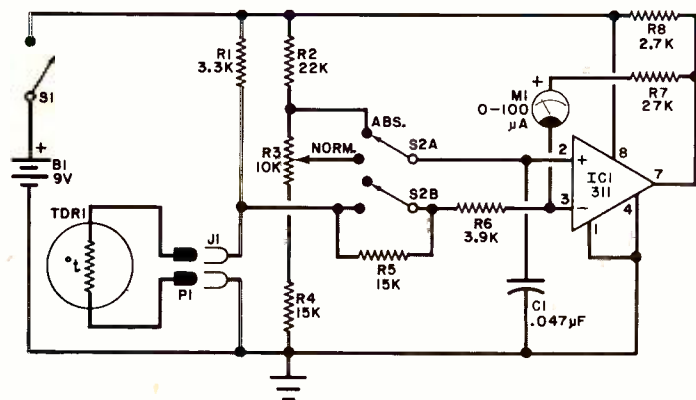

PARTS LIST

- B1—9-volt transistor battery
- C1—0.047- μ F capacitor
- IC1—Comparator integrated circuit (311)
- J1—Two-contact jack
- M1—0-100- μ A meter movement
- P1—Two-contact plug
- The following are 1/8-watt, 10% tolerance resistors:
- R1—3300 ohms
- R2—22,000 ohms
- R4, R5—15,000 ohms

- R6—3900 ohms
- R7—27,000 ohms
- R8—2700 ohms
- R3—10,000-ohm linear-taper potentiometer
- S1—Spst switch (part of R3)
- S2—Dpdt switch
- TDR1—Thermistor (Fenwal No. JA33J1)
- Misc.—Perforated board and solder clips; socket for IC1; contact clip for B1; suitable box to house circuit; machine hardware; zip cord; hookup wire; solder; etc.

Difference between drop across TDR1 and reference is shown on M1.

head being stretched (vasodilated) by the flow of blood, when more blood is diverted to the limbs, there is less to go to the head and the rest of the body. This reduces the pressure of the blood in the vessels of the head, which, in turn, diminishes the pressure pain.

Once a person learns how to increase the flow of blood in one limb while reducing it in others, it is possible that he can control bleeding from a wound. However, a great deal of physical and mental self control must be exercised — which may be impossible in the heat of the moment — for success. The uses to which such control can be put are almost limitless. If a person persists with regular training over a period of weeks, considerable control can be achieved.

About the Circuit. As shown in the schematic, the skin temperature thermometer's circuit is a simple configuration. Temperature sensor *TDR1* is an ordinary thermistor, while microammeter movement *M1* is the monitor indicator. Voltage variations, resulting from variations in temperature, from *TDR1* are fed to the inverting input of comparator integrated circuit *IC1*. Inside the IC, this voltage is compared with a reference voltage applied to the IC's noninverting input. The output from *IC1* then provides an amplified voltage that drives *M1*.

For training purposes, two meter ranges (scales) are useful. One must be fairly sensitive; so, for this, a zero-center scale with a range of $\pm 2^\circ\text{C}$ was chosen. An absolute scale, covering the range from room temperature to blood temperature is also required. This is important because once a subject's hands are within a few degrees of blood temperature, no amount of control will get them any warmer. (Most users will find that there is an upper temperature limit that will vary from person to person by a degree or so. From a training point of view, then, you must pick a time when the subject's hands are cool or start with training to reduce blood flow.)

With *S2* in the position shown, *M1* is on the ABSOLUTE scale, indicating nominally from 20° to 40°C . In this position, potentiometer *R3* has no effect, and at room temperature, the pointer of *M1* would be near the zero index on the scale. Setting *S2* to its alternate position puts the meter on the SENSITIVE scale ($\pm 2^\circ\text{C}$), in which case, the pointer of *M1* will peg at the left end of its travel. (This is a normal

condition and will not harm the meter movement.)

Construction. The skin temperature thermometer project can be made very compact, as shown in the lead photo. With the exception of *B1*, *M1*, *R3/S1*, *S2*, and *TDR1*, all parts can be mounted on a piece of perforated board that has holes on 0.1" (2.54-mm) centers. Use a socket for *IC1* and, if you want, solder clips for the rest of the components.

The meter movement, switched potentiometer, range switch, and input jack for the thermistor mount on the front panel of a suitable enclosure. At one end of a 3' (about 1 m) long piece of thin zip cord, solder plug *P1*. At the other end of this cable goes the thermistor. Put insulating tubing over the leads of the thermistor, and heat sink *TDR1* during the soldering operation. Slide the sleeving right up to the thermistor's disc. As a final touch, apply a thin coat of lacquer or other insulating material over the probe. Keep the coating as thin as possible to avoid increasing the time constant of the sensor.

When making hookups to the circuit board assembly, keep the leads to the two inputs of the IC as short as possible. If oscillation problems are encountered during checkout, which would appear as a high reading on the meter, reroute the IC's input wires away from the other leads and components in the circuit.

Checkout and Use. As potentiometer *R3* is adjusted through its range with *S2* in the RELATIVE position, a balance point will be found. The voltage appearing across *TDR1* during this test should fall between 3.0 and 4.7 volts.

Due to the tolerance of the thermistor used in the thermometer, the actual scale reading for blood temperature must be obtained by experiment. The absolute value of the temperature is not particularly important. What is of importance is to learn by trial and error the maximum temperature that you can normally achieve.

To use the skin temperature thermometer, the thermistor should be lightly taped to a finger. Then sit in a relaxed, comfortable position. The more relaxed you become, the better results you will achieve. Any tension will completely override attempts to increase the flow of blood in the hands. ◆

Stravinsky made us do it.



Stravinsky . . . and every composer who has ever written music with the range, power and majesty of "Rites of Spring" . . . music that demands far more than any stereo can deliver without adequate amplifier power.

The Phase Linear 700B Power Amplifier faithfully reproduces the most difficult passages of the most demanding recorded music. It lets *all* of the music through at realistic volume levels. You never have to reach for your volume or tone controls to prevent clipping.

The 700B has the highest power, widest frequency response and lowest distortion of any stereo amplifier in the world. Take Stravinsky to your dealer and listen to what we mean.



Phase Linear 700-B

THE POWERFUL DIFFERENCE

PHASE LINEAR CORPORATION,
P. O. BOX 1335,
LYNNWOOD, WASHINGTON 98036

CIRCLE NO. 42 ON FREE INFORMATION CARD



The United States of America

FEDERAL COMMUNICATIONS COMMISSION

RADIO TELEPHONE OPERATOR LICENSE

FIRST CLASS
General Radiotelephone Certificate

This certifies that JOHN R. DUB

SEX	HEIGHT	WEIGHT	HAIR COLOR	EYES	COMPLEXION	DATE OF BIRTH	CLASSIFICATION
M	5, 11	175	BLUE	BROWN	02	20, 1, 1946	

IS A LICENSED RADIO OPERATOR AUTHORIZED SUBJECT TO ANY SPECIAL ENDORSEMENT PLACED HEREON TO OPERATE THE CLASSES OF LICENSED RADIO STATIONS FOR WHICH THIS CLASS OF LICENSE IS VALID UNDER THE ORDERS, RULES AND REGULATIONS OF THE FEDERAL COMMUNICATIONS COMMISSION AND STATUTES OF THE UNITED STATES AND ANY TREATY TO WHICH THE UNITED STATES IS A PARTY.

THIS LICENSE IS GRANTED UNDER THE AUTHORITY OF THE COMMUNICATIONS ACT OF 1934 AS AMENDED AND THE TERMS AND CONDITIONS THEREOF AND OF ALL LEGISLATIVE ACTS, EXECUTIVE ORDERS AND TREATIES TO WHICH THE UNITED STATES IS A PARTY AND ALL ORDERS, RULES AND REGULATIONS OF THE FEDERAL COMMUNICATIONS COMMISSION WHICH ARE BINDING UPON RADIO OPERATORS AND MADE A PART HEREOF AS THOUGH SPECIFICALLY SET OUT IN THIS LICENSE.

NEITHER THIS LICENSE NOR THE RIGHTS THEREIN SHALL BE ASSIGNED OR OTHERWISE TRANSFERRED TO ANY OTHER PERSON.

PLACE AND DATE OF ISSUANCE: WASHINGTON, D. C. MARCH 31, 1975

DATE AND TIME OF EXPIRATION: MARCH 31, 1980 AT THREE O'CLOCK A. M. EASTERN STANDARD TIME

SPECIAL ENDORSEMENT: SHIP KADAN ENDORSEMENT WASHINGTON, D. C. MARCH 31, 1975

Paul J. Harris
Commissioner

John R. Lee

SPECIMEN

NOT VALID UNTIL SIGNED

CIE's Warranty says a lot to you!

A lot about CIE's FCC License training programs...and a lot more about our school.

Our FCC License Warranty means just what it says. If you enroll in any CIE career course that includes FCC License preparation and successfully complete your training . . . you'll pass the Government FCC exam. We *warrant* that you'll succeed.

CIE can make this no-nonsense warranty because we're confident of our in-depth career training programs. You see, we have *specialized exclusively* in Electronics education-by-mail for more than 40 years. Just Electronics. And, the courses we offer today are the result of these years of teaching experience and proven methods of training.

Our courses of study are written in easy-to-understand language, so you can progress at your own learning pace, at home, in your spare time. And, there are never any classrooms to attend.

CIE courses challenge your thinking . . . help you develop your understanding of important electronics theories and applications . . . enable you to learn new skills and knowledge. Our courses are thorough. They have to be.

You see, we're training you for a career in Electronics. And, if an FCC "ticket" is part of your goal, you'll have to pass a tough licensing exam administered by the Federal Communications Commission (an agency of the U.S. Government). And you'll be prepared.

CIE is willing to warrant that you will pass! The reason is . . . we have every reason to expect that *you will* do exactly that. Based on a series of continuing surveys, *close to 9 out of 10 CIE grads pass their FCC exams!*

What's a license worth?

An FCC License can be worth a lot if you're interested in any area of Electronics involving communications. In some fields, federal law requires that you must have one. And, even in careers where a license is not required, it is

Government certification of certain electronics knowledge and skills.

What about other CIE courses?

In every CIE career course, you'll find the same time-tested instructional techniques that have made CIE's FCC License preparation programs so successful.

Each CIE career course is built on the principle that the best way for you to *learn* and *retain* what you've learned is to *explain*; then to *check* your understanding; then to *reinforce* your comprehension with practical applications. In some courses, you will perform experiments and tests with your CIE Experimental Electronics Laboratory using authentic electronic components and gear. And, if you select a course that includes Color TV technology, you will not only build and keep a 25" diagonal Color TV which features digital circuitry . . . you'll also learn how to troubleshoot your TV.

The CIE course you select (beginner, intermediate, or advanced college-level), will be a complete educational program, designed by *experts* to give you the best in Electronics home-study education.

Send for FREE school catalog

Discover more about the career opportunities open to people with electronics training. *Learn* how CIE career courses can help you build new skills and knowledge and prepare you for a meaningful, rewarding career. Whether you are just starting out in Electronics or are a college-trained engineer in need of updating, (or anywhere in between), CIE has a course designed for *you*. And, more than half of CIE's career courses include FCC License preparation.

Send today for our FREE school catalog and booklet on FCC License information. For your convenience, we will try to have a representative call to assist in course selection. Mail reply card or coupon to CIE . . . or write: Cleveland Institute of Electronics, Inc., 1776 East 17th Street, Cleveland, Ohio 44114. Do it TODAY.

G.I. Bill benefits

All CIE *career* courses are approved for educational benefits under the G.I. Bill. If you are a Veteran or in service now, check box for G.I. Bill information.

CIE's FCC LICENSE WARRANTY OF SUCCESS

CIE warrants that when you enroll in any CIE course which includes FCC License preparation, you will, upon successful completion of the course and the FCC License material, pass the Government FCC Examination for the License for which your course prepared you. If you do not pass the appropriate FCC Examination, you will be entitled to a full refund of an amount equal to the cash price for CIE's "First Class FCC License Course," No. 3. This warranty will remain in effect from the date of your enrollment to 90 days after the expiration of the completion time allowed for your course.



Dr. G. O. Allen President

CIE Cleveland Institute of Electronics, Inc.

1776 East 17th Street, Cleveland, Ohio 44114

Accredited Member National Home Study Council

Yes, I want your FREE school catalog and career information package today.

I am especially interested in:

PE-86

- | | |
|--|--|
| <input type="checkbox"/> Electronics Technology | <input type="checkbox"/> Industrial Electronics |
| <input type="checkbox"/> FCC License Preparation | <input type="checkbox"/> Electronics Engineering |
| <input type="checkbox"/> Color TV Maintenance | <input type="checkbox"/> Other _____ |
| <input type="checkbox"/> Mobile Communications | _____ |

Print Name _____

Address _____

Apt. _____

City _____

State _____

Zip _____

Age _____

Check box for G.I. Bill information. Veteran On Active Duty



Product Test Reports

ABOUT THIS MONTH'S HI-FI REPORTS

On testing Pickering's new "second generation" CD-4 cartridge, we found it to be one of the finest stereo cartridges on the market — not to mention its ability as a superb transducer for playing CD-4 quadraphonic discs. Thus, it overcomes the "stereo-playing" shortcomings exhibited by many earlier CD-4 cartridges made in the U. S., which did not equal the tracking ability and general performance of the same manufacturer's top stereo models.

The second hi-fi product examined this month is Crown's new electronic crossover system. There has long been a school of thought that passive crossover networks were a significant weakness in conventional speaker systems. A bi-amplifier or tri-amplifier system, with electronic crossover networks preceding separate amplifiers for the different frequency ranges, is an ideal solution to this "problem." One of the most versatile accessories we have seen in some time is Crown's VFX2 electronic crossover. Its independently adjustable low-pass and high-pass filters can be set to cross over at any frequency between 20 and 20,000 Hz. They can also be connected to form a three-way crossover or a band-pass filter. The VFX2 should be an invaluable aid to anyone brewing his own speaker system, as well as to those wishing to experiment with loudspeaker crossovers.

—Julian D. Hirsch

PICKERING MODEL XUV/4500Q CD-4 PHONO CARTRIDGE

Plays CD-4 and matrix 4-channel records, as well as being a superb stereo transducer.



In the company's own words, the Pickering Model XUV/4500Q is a "second-generation" discrete phono cartridge that is designed to play all types of mono, stereo, matrixed, and CD-4 records at a very low 1-gram tracking force. In short, this is a universal-program cartridge. The "first generation" of CD-4 cartridges required at least 1.5 or 2 grams of tracking force for proper op-

eration, although their specially shaped styli actually caused less record wear at these forces than do ordinary elliptical styli operating at 1 gram.

Pickering's "Quadrilateral" stylus assembly has a built-in hinged brush that removes dust from the surface of the record. This brush exerts a 1-gram upward vertical force that must be cancelled out. To do this, you just set the downward vertical force to 2 grams to yield a 1-gram net tracking force on the record's grooves. Other stylus assemblies for playing mono LP's and 78-rpm discs are available from Pickering, and they can be interchanged with the Quadrilateral.

As is the case with most CD-4 cartridges, the output of the XUV/4500Q must be operated into a low-capacitance load (100 pF or less in parallel with 100,000 ohms) to obtain the full 50,000-Hz response of the cartridge. For 2-channel stereo opera-

tion, the load requirement is less stringent, with typical values being 275 pF in parallel with 47,000 ohms.

Although most CD-4 cartridges have the wide frequency response required for playing CD-4 discs, very few of them can play the highest recorded levels on stereo discs without distortion. Pickering has taken pains to eliminate this shortcoming in the new cartridge to allow it to perform at its best with all types of discs.

The Pickering Model XUV/4500Q phono cartridge retails for \$139.95.

Laboratory Measurements. We tested the cartridge in the tonearm of a Garrard Zero 100 record player, using the recommended 100-pF in parallel with a 100,000-ohm load. The 30-cm/s, 1000-Hz tones of the Fairchild 101 test record were played with negligible distortion at an extremely low 0.5-gram tracking force, but we had to go to 1 gram to track the high-level 32-Hz portion of the Cook Series 60 test record. For all subsequent tests, we used the 1-gram tracking force.

At 1 gram, the cartridge was able to track the 80- μ m (micrometer), 300-Hz tones of the German Hi-Fi Institute test record. This is a very severe test of a cartridge's midrange tracking ability. No other CD-4 cartridge has passed this test, and only a couple of the very finest stereo cartridges have squeaked by. Even more impressive was the fact that the Pickering cartridge played the highest level on this record (100 μ m) at its maximum rated tracking force of 1.5 grams.

The output voltage from the cartridge measured 3.95 mV at a 3.54-cm/s velocity, which is a relatively high level for a CD-4 cartridge. That this output performance was identical for both channels is a very unusual occurrence in our experience. The 1000-Hz square-wave response of the CBS STR-111 test record revealed a single cycle of ringing at about 10,000 Hz. The output distortion was checked with the aid of two Shure test records. The TTR-102 is a conventional IM (intermodulation) distortion record, containing 400- and 4000-Hz test tones recorded at velocities up to 27.1 cm/s. The IM measured 1.5% at all levels except the highest where it reached 2.5%. This is not only exceptionally low distortion, but it also indicates a very good contact between the stylus and the record groove walls at levels that cause most pickups to lose contact on modulation peaks.



1000-Hz square wave.

The TTR-103 test record has specially shaped 10,800-Hz tone bursts at a 270-Hz repetition rate, with velocities from 15 to 30 cm/s. The 270-Hz content of the cartridge's output is an indication of the high-frequency non-linearity of its tracking performance. In this test, the cartridge was comparable to the best stereo cartridges on the market and distinctly superior to the average for CD-4 cartridges.

Next, we measured the frequency response of the cartridge from 1000 to 50,000 Hz with a JVC TRS-1005 test record. The response was exceptionally uniform, varying by only ± 3 dB in one channel and ± 1.5 dB in the other channel over the full range. The channel separation reached a minimum of 15 to 20 dB in the vicinity of 10,000 to 12,000 Hz. It was typically 25 to 30 dB at the lower and higher frequencies.

When the audio frequency response of the cartridge was checked with the CBS STR-100 record, the output was flat to within ± 2 dB from 40 to 20,000 Hz. In this range, the frequency response was not changed measurably when we changed the cartridge load to the typical stereo load of 335 pF in

parallel with 47,000 ohms. The low-frequency tonearm/phono cartridge resonance had a "double-humped" shape with the maxima at 5 and 6.5 Hz and an amplitude of only 4 dB or less. These figures, of course, might be different with other tonearms, but they are essentially what we would expect from a high-compliance cartridge.

User Comment. Our 4-channel listening tests were conducted with a Panasonic Model SE-405H CD-4 demodulator. In general, we feel that the Pickering cartridge delivered quadraphonic reproduction that was at least as good as, and usually better than, we have heard from our CD-4 records with any other cartridge.

With stereo records, the cartridge was easily the peer of today's finest and most advanced stereo cartridges. The most heavily modulated recordings played without strain at only 1 gram of tracking force, and the slightly elevated signal output from the cartridge in the 10,000-to-12,000-Hz

range provided an ideal complement to the falling response of most speaker systems in this range. At all times, the sound was smooth.

This is one of the most expensive phono cartridges on the market and, as such, is obviously intended for a select listening audience. Offsetting the high price is the fact that this cartridge is one of the very few that can deliver flawless CD-4 performance at the maximum inherent fidelity in the program at a 1-gram tracking force. Add to this the cartridge's ability to track the highest levels on stereo discs without significant distortion and the bonus of extremely low record wear.

We were impressed with the close matching of such important operating characteristics as output level, frequency response, crosstalk, and distortion between the two channels. All things considered, we must agree with Pickering's claim that the XUV/4500Q represents a genuine advance in cartridge performance.

CIRCLE NO. 65 ON FREE INFORMATION CARD

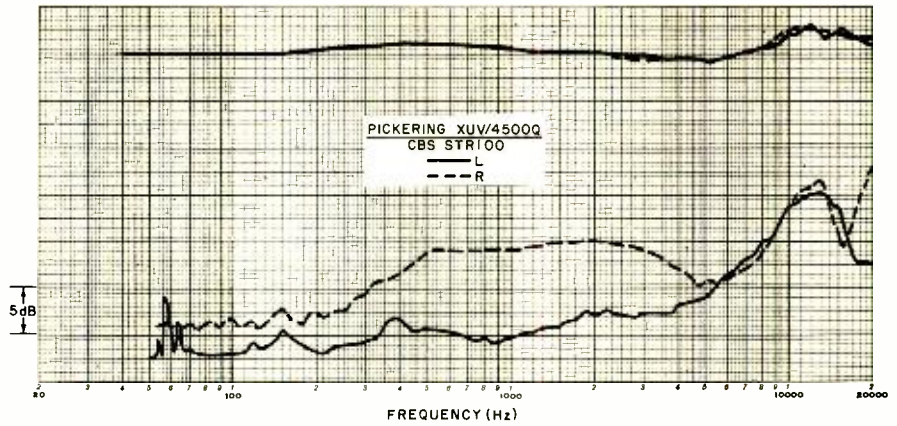

CROWN MODEL VFX2 ELECTRONIC CROSSOVER STEREO SYSTEM

Features active IC filters and continuously variable crossover from 20 to 20,000 Hz.



Some years ago, before the advent of stereophonic sound and solid-state

electronics, there was considerable interest in electronic crossover systems among audiophiles who built their own speaker systems. The crossover systems were designed to be installed between the preamplifier and the power amplifiers that drove the appropriate portions of the speaker system. This permitted the listener to vary crossover frequencies over a wide range (not practical with fixed networks) and eliminated subtle distortions thought to have been created by crossover network components in the speaker system.

As stereo sound came into being,

the development of small and relatively inexpensive high-quality speaker systems eliminated most of the incentive to home-brew speaker systems. Most modern speaker systems do not provide electrical access to their individual drivers. Fortunately, there are a few systems that do provide such access, and when they are used with one of the new electronic crossover systems now being marketed, they make excellent choices for bi- and triamplification systems. One of the new electronic crossover systems available is the Model VFX2 from Crown International.

The Model VFX2 contains two independent but identical signal channels, each of which employs active operational-amplifier IC filters in low- and high-pass configurations. The cutoff slopes of the filters are fixed at 18 dB/octave. Each filter, of which there are two per channel, has a step switch, supplemented by a continuously variable control, to permit adjusting its 3-dB down frequency over a full 20-to-20,000-Hz range (as well as providing a flat frequency response).

The crossover system is physically compact. It is designed for standard rack mounting and measures 19"W × 5¾"D × 3½"H (48 × 15 × 9 cm) and weighs 6 pounds (2.7 kg). Retail price is \$249.

General Information. The front panel control complement consists of a switch and control for the high- and low-pass filters in each of two channels. The only other control on the panel is the POWER switch.

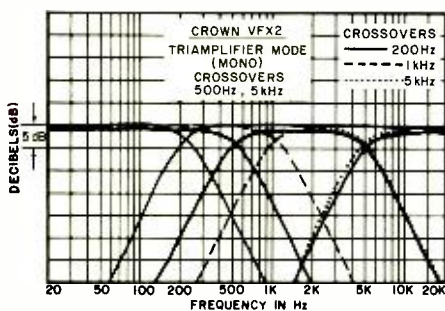

On the rear apron are 12 phone jacks that give complete access to all parts of the crossover system's circuitry. A functional block diagram is silk-screened onto the panel to clearly illustrate how the signal is modified by plugging it into any of the jacks. Each channel has separate unity-gain and balanced (transformerless) inputs. Screwdriver controls can be adjusted to increase the gain of the balanced

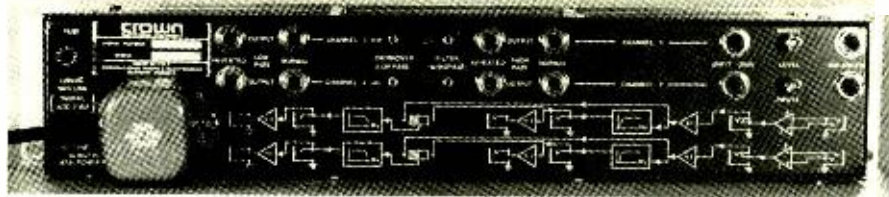

Back panel of network.

inputs by about 15 dB. Each low- and high-pass filter section has two outputs, one that is in-phase with the input and the other that is 180° out-of-phase with the input. Slide switches for each channel can be used to connect the two filter sections for parallel input, the normal method for electronic crossover applications, or in tandem for use as an adjustable bandpass filter.

By patching the signal between channels, the system can be used as a three-way crossover system for triamplification. In this mode, two crossover systems are needed for stereo operation. Another function, suggested for Crown amplifiers but also suitable for many other amplifiers, makes use of the normal and inverting outputs to drive the amplifier inputs and create a mono signal at a much higher power level across the two "hot" output terminals of a stereo power amplifier.

The comprehensive instruction manual that comes with the crossover system includes curves that illustrate the typical phase and frequency characteristics of the filters, as well as complete specifications and technical data. The maximum unclipped output is rated at 10 volts into a high-impedance load, and the low output impedance makes it possible to develop 6.4 volts rms across 600 ohms.

The rated output of the system, with typical Crown conservatism, is 2.5 volts, with hum and noise stated to be 100 dB below 2.5 volts. The IM distortion is rated at less than 0.01% at 2.5 volts output. The unity-gain inputs have 1-megohm impedances, and the balanced inputs are rated at 20,000 ohms (10,000 ohms from either side to ground) impedance.

Laboratory Measurements. The filters have ideal shapes, with identical gains above and below the crossover frequency, no passband ripple, an intersection within 0.5 dB of the ideal -3-dB response point, and a crossover frequency generally within 10% of the value indicated by the control

knobs. The steep slopes also make the crossover filter highly suitable for conventional audio filtering applications, and the continuously variable cutoff frequencies can easily be adjusted to suit the program.

For distortion and output level tests, we set up the crossover system as a 20-to-20,000-Hz bandpass filter, using the unity-gain inputs. The output clipped at 9.7 volts into a high-impedance load and exactly at the rated 6.4 volts into 600 ohms. The gain was unity (1), except through the balanced inputs, where it could be increased by as much as 16.5 dB. Somewhat unconventionally, the screwdriver adjustment controls on the rear apron, labelled LEVEL, increase the gain as they are turned counter-clockwise. The output noise level was well below the 100-μV minimum indication point of our meter, which corresponds to 88 dB below 2.5 volts.

The distortion of the system can be measured, even approximately, with only the most advanced test equipment. With the Crown IMA intermodulation analyzer, the IM readings were the residual of the instrument at 0.001% up to 1 volt output. It increased to 0.003% at the rated 2.5 volts and to 0.07% at 8.5 volts output, which is just below the clipping level. The 1000-Hz THD was less than the noise level up to 0.5 volt, measuring between 0.004% and 0.008% from 1 to 9 volts output.

User Comment. It is hardly necessary to comment on the electrical performance of the electronic crossover system, which could hardly be more ideal with respect to frequency response, distortion, and noise characteristics. To determine how well the system performed its intended functions, we connected it between a preamplifier and two power amplifiers in a biamp setup. Lacking any speaker systems designed for biampification, we combined two full-range systems, using one as the "tweeter" and the other as the "woofer."

Simply varying the crossover frequency made dramatic differences in the overall sound quality. Needless to say, the optimum frequencies will depend on the specific drivers used. One thing that was immediately obvious was the need for gain controls on the power amplifiers, not all of which have them. The reason for this is that the crossover system supplies the same

signal level at both outputs and one cannot reasonably expect the woofer and tweeter to have the same efficiency.

Setting up the system in a bandpass configuration, its performance in this filter mode was excellent in every respect. Of course, this would be an expensive way of using the system.

Whether or not you can benefit from

a multi-amplifier system is difficult to say with certainty, since there are differing points of view on the subject. But one thing is certain: if you decide to go the bi-amplifier route, the Crown Model VFX2 electronic crossover system will give you the utmost in operating versatility and superb electrical performance.

CIRCLE NO. 66 ON FREE INFORMATION CARD

HEATHKIT MODEL GR-400 DIGITAL COLOR TV RECEIVER KIT

Ultra-rectangular 17-inch CRT provides bright, clear picture.

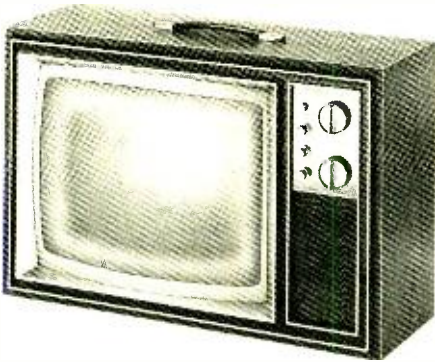

THE Model GR-400 is the mid-size version of three new small-screen color TV receivers being marketed by Heath. This 17" (43.2-cm) diagonal measurement, "ultra-rectangular" receiver employs virtually every state-of-the-art feature currently available in small-screen models, plus a few that are exclusive to Heathkit receivers.

One of the new "digital" receivers on the market, the Model GR-400 features on-screen channel numbers. An optional digital clock accessory (pioneered with the company's top-of-the-line Model GR-2000 color receiver) also places digitally generated numerals on-screen.

The receiver comes as an all-inclusive kit at a retail price of \$489.95. This includes walnut-grained cabinet, adjustable telescoping vhf antenna, and ring-type uhf antenna. Optional items available are the \$29.95 Model GRA-2000-1 clock kit, \$24.95 Model GRA-500-3 pedestal stand, and \$21.95 Model GRA-403-18 roll-around cart.

General Information. Among the latest features employed in the receiver are all-solid-state modular assembly, extensive use of IC's, and the latest in picture tubes. The solid-state design keeps energy requirements down, while the modular assembly simplifies kit construction and service.

Ten IC's are used in the receiver.

One is in the power supply, where it regulates the 24-volt line. Two more are in the on-screen readout assembly for gating and character generation. (If the optional clock is used, the digital system uses a total of three IC's.) In the i-f section are two IC's, one for wider than usual bandwidth i-f amplification and the other for video detection. A fixed LC filter in the i-f section virtually eliminates the need for future realignment.

The aft and agc/sync sections each have an IC to eliminate almost all other active devices. Sound i-f amplification and detection are accomplished by another IC. Finally, there are two IC's on the color demodulator board. One is for chroma demodulation; the other performs all remaining chroma functions.

By far the most important feature of this receiver is its picture tube. It replaces the familiar dot triad format with three in-line electron guns, a slotted mask, and color stripes. The stripes are surrounded by a negative-guard-band black matrix. Furthermore, the tube itself is designed to be operated at higher anode voltage (from a voltage tripler in this receiver). The result is brighter pictures with increased contrast and excellent color fidelity.

The precision static toroid yoke assembly comes permanently bonded to the neck of the picture tube. It is factory adjusted and sealed, which reduces the number of convergence and purity adjustments during setup to zero. The new tube design has even done away with another potential source of trouble: pins. Metal contacts on the base of the tube pressure-mate with contacts on the tube socket for positive electrical contact.

The vhf tuner used in this receiver borrows heavily from the top-of-the-line Model GR-2000 color TV receiver,

including a four-circuit design for improved selectivity. The dual-gate MOSFET r-f amplifier is designed for low-noise performance, high gain, and low cross modulation. A dual-gate MOSFET is also used in the mixer circuit.

Both the vhf and uhf tuners are detented for all channels in their respective ranges. Extensions on the rears of the control shafts of both tuners accommodate code wheels. The plastic wheels work with three printed circuit board assemblies (two on vhf, one on uhf) to electro-mechanically decode the channel numbers. Coded voltages are then fed to the character generator board for incorporation into the video signal.

On the character generator board are three controls and three wire jumpers. Two of the controls permit the display to be positioned anywhere on the CRT screen, while the third control can be adjusted for the desired display time. One jumper lets you display the numbers on-screen either continuously or for a predetermined period of time before they blank out. (The display automatically activates whenever the receiver is turned on or a channel change is made.) A second jumper allows you to select between four- and six-digit time display format. The final jumper lets you select between channel-only or channel-and-time display format. The brightness level of the display can be adjusted as desired. When the display comes on and blanks out, it is simultaneous channel and time (if you are using the clock accessory and the jumpers are set for this format). With the receiver in the instant-on mode, the clock is always keeping time, even though there is no raster.

A welcome convenience feature for families that have children who like to play with front-panel knobs is the one-button preset picture control (PPC) system. Duplicated on a small panel buried inside the receiver are the front-panel brightness, contrast,

color, and tint controls. You preset these controls according to your own tastes. Then, whenever you push in the PPC button on the front panel, it disables the primary controls and switches their functions to the preset controls.

The receiver has built-in service features, backed up by Heath's exclusive troubleshooter instrument that accompanies the GR-400 as a kit. There is a sound-output jack for operating the receiver through a hi-fi system. (A switch on the tuner bracket lets you defeat the speaker when the hi-fi hookup is made.)

Both 75- and 300-ohm vhf antenna inputs are provided. The 75-ohm input is for direct feed with low-loss coaxial cable, such as from a CATV or an MATV system. The 300-ohm input has built in Balun coils for proper impedance match between receiver and twin-lead transmission line.

About the Kit. This was a very simple kit to assemble. We see no reason why a rank amateur to electronic kit building could not assemble it, assuming that he follows the soldering and assembly instructions carefully. This is due in no small part to the excellently written and profusely illustrated assembly manuals. Some credit must also be given to the modular design and the fact that very few of the components in the receiver mount on the chassis. Also, the high-voltage assembly and both tuners come factory wired and tuned.

Assembly starts off with Book 1, which covers the details for wiring the 11 plug-in printed circuit board sub-assemblies and the aft board. Each board and its components are packed separately to avoid confusion. Noteworthy is the fact that all IC's and on-board transistors plug into sockets, rather than having their pins and leads solder directly to the pads on the pc boards. The board-wiring portion of the assembly procedure took us some 10 hours to complete.

Next came chassis and front panel assembly, covered in detail in Book 2. This consisted mostly of putting together the metal chassis, mounting the circuit board connectors and the few chassis-mounted components, and interconnecting the factory-prepared wiring harnesses in the main chassis. It also included the putting together and wiring of the tuner bracket subassembly and the wiring of the three identical pc boards that make up the decoder for the character generation system. The metal parts that make up the chassis went together without our having to force screw holes and panels to line up. By the time we finished this portion of the assembly, another 18 hours had passed.

Another five hours were spent on picture tube mounting and final assembly. A separate assembly manual details this portion of the assembly procedure.

We spent another hour assembling the troubleshooter instrument kit. All

told, we put in about 35 hours of assembly time over a period of about two weekends and five week nights. Add another two hours for doublechecking all wiring and soldering.

Finally, working from Book 3, we performed the initial tests to assure that everything was okay, after which we plugged in the circuit board assemblies and made the circuit adjustments according to instructions. When we were finished, we had a picture that was truly superb.

User Comment. Although this is a very easy kit to assemble, if you take it in bite-size pieces, it does require considerable time to complete. But when you are finished with assembly and tuning, you are rewarded with a picture quality that is second to none.

The pictures provided by this receiver are indeed brighter and sharper than was possible with old receiver technology. In fact, the brighter, sharper picture and ultra-rectangular screen design make this receiver appear larger than it really is. We proved this in a side-by-side comparison with a large-screen console.

We particularly like the PPC system. From a service point of view, the modular assembly and slide-out chassis permit easy access to every point in the receiver's circuitry.

In summation, this is a first-class color TV receiver, well worth the effort of assembling it from a kit.

CIRCLE NO. 5 ON FREE INFORMATION CARD

REALISTIC MODEL PRO-6 PORTABLE SCANNING RECEIVER

Scans four crystal-controlled frequencies in low or high bands.



IN RESPONSE to the growing popularity of vhf narrow-band FM monitoring, Radio Shack is marketing

the very compact portable Realistic Model PRO-6 scanning receiver. It is designed to receive up to four crystal-controlled, fixed-frequency channels. The channels can be divided between the 30-to-50-MHz low and 148-to-174-MHz high bands. Any single channel can be continuously monitored, or the receiver can be set to scan any or all of the four channels, at a rate of six channels per second.

The receiver is powered by four penlight cells. It also has a jack for connecting any suitable external 6-volt dc power source. A second jack, located next to the first on the side of the receiver, is provided for connecting a charger when nickel-cadmium batteries are installed. An attached clip is

provided for hanging the receiver on a belt. Crystals and batteries can be installed through separate covered compartments. A 2" (5.1-cm) loud-speaker is built in for completely self-contained operation.

Resembling a CB walkie-talkie, the receiver measures a compact 6½"L × 2¾"W × 1½"D (16.5 × 7 × 3.8 cm) and weighs only about 12 ounces (0.37 kg). It retails for \$119.95, which includes earphone, antenna, and batteries. Crystals do not come with the receiver and are not included in the retail price. This is because crystals must be selected according to the specific frequency allocations in the listener's area.

General Description. All operating controls are located on the top panel of the receiver's case. The VOLUME-control/power-switch and the

POPULAR ELECTRONICS

SQUELCH control are thumbwheel operated. Four light-emitting diodes (LED's) are provided, one assigned to each of the four channels. They come on sequentially as the scanner stops at each channel. Four slide switches are used to lock out any unwanted channel or channels from the scanning sequence as desired. A separate toggle switch has positions to put the receiver into the scanning mode or to manually advance one channel at a time (in the same sequence as on scan).

As with other scanning receivers, this monitor begins to scan when the SQUELCH control is advanced to the point where interstation hiss drops out. It stops scanning when a signal is detected on any of the channels. When the transmission ends, scanning resumes after about a one-second delay.

Two miniature phone jacks are provided for the antenna and private-listening earphone. Built into the receiver is a loop antenna that is suitable for reception where transmitted signals are strong. Better reception can be obtained in areas where the signals are not so strong by use of the external 20" (50-cm) wire antenna. For best results, a mobile whip or a fixed-station antenna is advisable. (An antenna of about 36", or roughly 1 meter, in length is preferable for low-band reception.)

The receiver features a double-conversion superheterodyne design. The first conversion is to a 10.7-MHz i-f, while the second is to a 455-kHz i-f. Separate front ends are employed for the low and the high bands. Each front end has its own r-f amplifier, mixer, and oscillator. Except for the input and output transformers and the 10.7-MHz ceramic filter in the i-f strip, all of the i-f stages are RC coupled. Two integrated circuits are employed in the scanning section.

Laboratory Measurements. Only limited laboratory measurements were possible on the receiver. The input impedance is not stated in the manual, but with a 50-ohm resistor connected across the antenna jack, 20 dB of quieting required an input signal level of 2.5 to 3 μ V on both the low and the high bands.

Signal deviations of at least 11,000 Hz could be accommodated without serious distortion. (The rated deviation is \pm 7000 Hz maximum.) The squelch threshold could be adjusted from less than 3 to greater than 20 μ V.

Our new cartridges will turn your good record player into a great record player.

Perhaps you've tried to track your records at the lowest advertised setting for your elliptical stylus. In the hopes of optimizing performance and reducing record wear. But every footstep threatens to bounce the stylus out of the groove. And big crescendos are simply fuzzy. Should you get a better player? No. Get a better stylus.

We have a sensible new approach. A stylus shape that contacts more of the groove wall, to spread tracking force over a greater vertical area. The Shibata

stylus. It safely tracks your records at up to 2 grams while maintaining response to 45,000 Hz, offering great stereo separation, and *reducing* record wear... even compared with an elliptical stylus at less than a gram.

Put an Audio-Technica Dual Magnet* UNIVERSAL cartridge with genuine Shibata stylus in your good old record player today. It's a great combination for better sound today and tomorrow, and tomorrow.



UNIVERSAL™

*T.M. Audio-Technica. Dual Magnet cartridges are protected by U.S. Patent Nos. 3,720,796 & 3,761,647. Shibata stylus Patent No. 3,774,918.



audio-technica®

AUDIO-TECHNICA U.S., INC., Dept. 95P, 33 Shiawassee Ave., Fairlawn, Ohio 44313
Available in Canada from Superior Electronics, Inc.

CIRCLE NO. 9 ON FREE INFORMATION CARD

FREE McIntosh CATALOG and FM DIRECTORY

Get all the newest and latest information on the new McIntosh Solid State equipment in the McIntosh catalog. In addition you will receive an FM station directory that covers all of North America.



MX 113

FM/FM STEREO - AM TUNER AND PREAMPLIFIER

SEND TODAY!

McIntosh Laboratory, Inc.
East Side Station P.O. Box 96
Binghamton, N.Y. 13904
Dept. PE

NAME _____
ADDRESS _____
CITY _____ STATE _____ ZIP _____

If you are in a hurry for your catalog please send the coupon to McIntosh.
For non rush service send the Reader Service Card to the magazine.

CIRCLE NO. 30 ON FREE INFORMATION CARD

Your NEW Heathkit Catalog is ready



Now over 400 do-it-yourself electronic kits for home, hobby, and industry. All designed to give you more for your money...more value, more performance, more satisfaction. All designed so even beginners can build them. Send for your free catalog today.

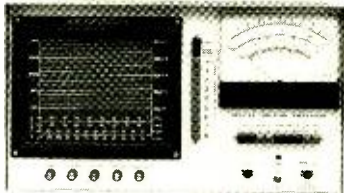

New Professional 12" Ignition Scope — Kit or Wired

Does more than others for \$1000 less. Spots tough ignition problems on all types of systems in 3, 4, 6, 8 cyl. or 2-rotor Wankel engines; sets itself automatically for no. of cylinders. Big 12" screen has 2 calibrated primary and secondary voltage grids plus dwell angle indications. Special circuit maintains trace length regardless of RPM. Displays "superimposed" patterns, single cyl. pattern, primary or secondary "parade" patterns. "Power balance" feature even helps spot bad valves or rings. 8" meter with tach & DCV ranges. Optional low cost timing light, alternator adaptor & cart. Kit CO-2500 \$379.95; Assembled WO-2500 \$695.



New Automobile Intrusion Alarm Kit

Total Protection. Alarm mounts anywhere; connects to switches on doors, hood, & trunk. Underdash switch arms or disables unit. Adjustable delay time allows you to quickly enter or leave car without triggering alarm, but opening trunk or hood triggers alarm instantly. Alarm sounds car horn in repeated 2-minute cycles. Kit GD-1157 Alarm \$24.95; Kit GDA-1157-1 Siren (gives yelping sound louder than car horn) \$19.95.

waiting to serve you with more values, more new kits, than ever before



New Programmable Digital Stop Watch Kit

Another "first" from Heath. 2 IC counters, 8 digits & 7 functions with typical accuracy to $\pm 0.003\%$ and resolution to 1/100th of a second. Function 1 (Start/Stop Elapsed) times individual events while also counting total. Function 2 (Sequential) times each part of event & displays each separately while timing overall event. Function 3 (Total Activity) accumulates total elapsed time of a series, excluding time between events. Function 4 (Split) displays cumulative time to each "split" point while continuing overall event time. Function 5 (Start/Stop Activity) shows separate time for each event & totals all individual times. Function 6 (Programmed Upcount) counts up to "learned" time. Function 7 (Programmed Downcount) counts down from "learned" time. Stop watch can "learn" time from other functions or be programmed up to 9 hours, 59 minutes, 59 seconds. Has jacks for external triggering devices and alarms. Includes nickel-cadmium batteries & charger. Kit GB-1201, \$99.95.



New Digital Wind Speed & Direction Indicator Kit

Unique. Two big, bright digits show wind speed to 99 mph. As you build, choose 2 readout modes: miles, knots, or kilometers per hour; front panel light shows mode in use. 8 incandescent lights show wind direction at principal compass points; adjacent lighted bulbs give 16 point resolution. Remote transmitter boom clamps to TV mast. Styled in black plastic to match Heathkit GC-1005 Digital Clock and ID-1390A Digital Thermometer. Kit ID-1590, \$69.95 less cable.



New — Two-Way Telephone Amplifier Kits

Now, hands-free telephone use with amplified "talk" and amplified "listen" — with or without dialer. Talk & listen from 10' away. Voice-actuated circuitry switches from talk to listen without feedback or clipped words. Listen button lets you monitor line without built-in microphone activated. Dialer model may be used with or without regular telephone. Includes 4-prong jack & phone coupler connector. Battery powered. Kit GD-1112 (no dial) \$49.95; Kit GD-1162 (w. dial) \$69.95.

New Public Address Sound System Kits

Outperforms those costing twice as much. TA-1620 Control/Amp. takes 6 low impedance mikes, each with level, bass & treble controls & reverb sw. Has VU meter, 4 switched response "shaper" circuits, exclusive bass filter, 100 rms watts drives 2 speaker columns. TA-1625 Booster Amp. 100 rms watts to drive 2 extra speaker columns. TS-1630 Speaker Column. Six 8" full-range drivers response tailored for voice; 60 watt rms rating; 12 ohm impedance. Kit TA-1620 \$449.95; Kit TA-1625 \$179.95; Kit TS-1630 \$199.95.



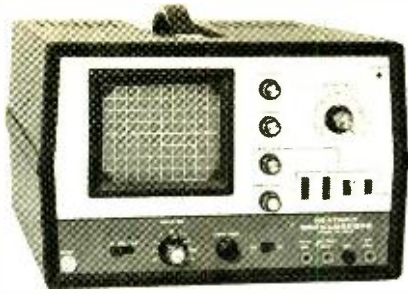

New DC-5 MHz Triggered Scope — Kit or Wired

Best scope value today. Wide bandwidth, 20 mV sensitivity, & stable triggering — ideal for TV, audio and RF servicing. Easy-to-use controls. Trigger circuit (not recurrent type) has normal & automatic modes, switched AC & DC coupling, & front panel external inputs (special TV position allows low freqs. to pass while rejecting high freqs. for easy triggering on complex TV signal. 7 calibrated time bases from 200 ms to 0.2 μ s/cm. 20 mV/cm vertical sensitivity with 9 calibrated attenuator positions up to 10 v/cm, plus variable control. 5" round flat-face CRT (8 x 10 cm graticle). Lightweight, durable blue plastic cabinet with white panel. Kit IO-4540 \$179.95; Assembled SO-4540 \$275.

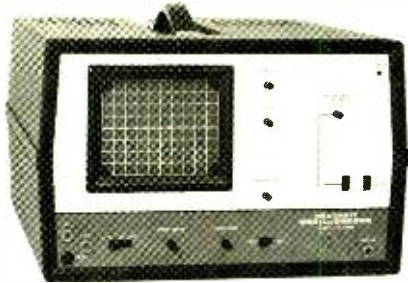

New — Lowest cost Triggered 5 MHz Scope Kit

The scope everyone can afford, and it has the performance you need. DC-5 MHz band width, 100 mV vertical sensitivity with X1, X10 & X100 attenuation, AC or DC. Automatic, positive locking horizontal sweep continuously adjustable from 20 ms to 200 ns/cm. Stable displays due to zener regulated amplifiers and sweep. 5" round flat-face CRT with 8 x 10 cm graticle. Simplified controls and switches make it easy to use. Lightweight, durable blue plastic cabinet; white panel. It's the best instrument buy in years. Kit IO-4560 \$119.95

New catalogs and kits also available at

HEATHKIT ELECTRONIC CENTERS —
Units of Schlumberger Products Corporation
Retail prices slightly higher.

ARIZ.: Phoenix; CALIF.: Anaheim, El Cerrito, Los Angeles, Pomona, Redwood City, San Diego (La Mesa), Woodland Hills; COLO.: Denver; CONN.: Hartford (Avon); FLA.: Miami (Hialeah), Tampa; GA.: Atlanta; ILL.: Chicago, Downers Grove; IND.: Indianapolis; KANSAS: Kansas City (Mission); KY.: Louisville; LA.: New Orleans (Kenner); MD.: Baltimore, Rockville; MASS.: Boston (Wellesley); MICH: Detroit; MINN.: Minneapolis (Hopkins); MO.: St. Louis (Bridgeton); NEB.: Omaha; N.J.: Fair Lawn; N.Y.: Buffalo (Amherst), New York City, Jericho (L.I.), Rochester, White Plains; OHIO: Cincinnati (Woodlawn), Cleveland, Columbus, Toledo; PA.: Philadelphia, Pittsburgh; R.I.: Providence (Warwick); TEXAS: Dallas, Houston; VA.: Norfolk (Va. Beach); WASH.: Seattle; WIS.: Milwaukee.

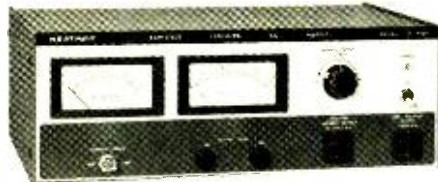

New variable Isolated AC Supply

What every tech & hobbyist needs. The IP-5220 isolates equipment under test from the AC power line and provides an AC output which is variable from zero to 140 volts. Great for locating circuit faults caused by high or low voltage or testing equipment with unknown power requirements. Power rating is 360 volt-amperes, continuous. Variable output current rating: 3A. max. Direct output current rating: 10A. Two meters: voltmeter 0-150 VAC; ammeter: 0-1 & 0-3A. Ammeter and variable output socket are fused. Kit IP-5220, \$109.95

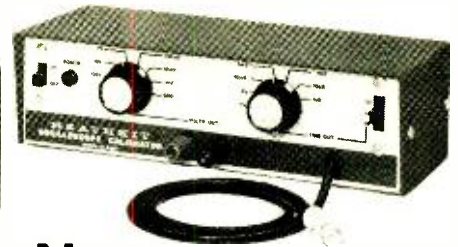

New Oscilloscope Calibrator Kit

For time calibration, it generates a 0.5 second to 1 μ sec square wave in 1-2-5 sequence accurate to 0.01% with 200 mV peak (\leq 3% overshoot) and \leq 4 ns rise time. Voltage calibration ranges are 1 mV to 100 v. in decade sequence, accuracy within 2%, DC plus variable 2 Hz to 10 kHz in 1-2-5 sequence (internal std. accuracy within 1%). Use it to calibrate scopes up to 35 MHz and voltmeters; it's also a fast rise time squarewave generator and good bench freq. standard. Kit IG-4505 \$44.95

New 21" (diag.) Digital Design Color TV Kit

All the advanced technology of digital circuitry in a smaller screen size. **Electronic touch-to-tune** varactor front end (nothing mechanical to wear out) with computer-like programming board for up to 16 channels. **On-screen channel numbers**, adjustable in brightness, position, and duration. **On-screen digital clock**; a low-cost option; programmable in 12 or 24 hour format, displays 4 or 6 digits. **Fixed-filter IF**, a Heath exclusive that assures better pictures longer, never needs instrument alignment. **100% solid state** — more ICs than any other — sophisticated circuitry that results in less interference, better color tints, improved sensitivity, greater noise immunity, improved picture definition. **Black negative matrix 21V picture tube** for brighter, sharper pictures. **Total touch-tune remote control** — low cost option that operates all functions, including recall of time & channel.



Easier to build & service — thanks to extensive modular design and built-in servicing tools including digital-design dot generator, front access slide-out Service Drawer, new picture centering and pin-cushioning correction circuits, and Test Meter. **Enjoy the best in TV design** — now in smaller size at lower cost. Kit GR-2050 \$599.95. Kit GRA-2000-6, remote control, \$89.95. Kit GRA-2000-1, digital clock accessory, \$29.95. Contemporary or Mediterranean cabinets from \$119.95.

Use coupon below to order your favorite new kit or to get your FREE new Heathkit Catalog.

HEATH Schlumberger	Heath Company Dept. 10-09 Benton Harbor, MI 49022
<input type="checkbox"/> Please send my free 1975 Heathkit Catalog.	
<input type="checkbox"/> Enclosed is \$ _____ plus shipping. Please send model(s) _____	
NAME _____	
ADDRESS _____	
CITY _____	STATE _____ ZIP _____
<small>PRICES ARE FACTORY MAIL ORDER, FOB PRICES & SPECIFICATIONS SUBJECT TO CHANGE WITHOUT NOTICE.</small>	
CL-571	

The audio frequency response, relative to the 400-Hz input, varied by ± 6 dB between 230 and 4000 Hz. Into a 16-ohm load, such as the accessory earphone, the maximum undistorted output power was 62 mV.

User Comment. We fitted our test receiver with crystals for the NOAA

Weather Transmissions on 162.55 MHz and several fire and police channels employed in the metropolitan New York area. No transmitting stations were nearer to our listening location than 10 miles (16 km) and several were at least 20 miles (32 km) away.

We heard strong signals on all channels. The audio volume was

good, and received signals had excellent clarity and intelligibility.

The PRO-6 should prove to be ideal for receiving local Civil Defense units, volunteer fire department calls, etc. For these purposes, its light weight and compactness provide a big advantage.

CIRCLE NO. 68 ON FREE INFORMATION CARD

HICKOCK MODEL 440 TRANSISTOR CURVE TRACER

Identifies and matches transistors by displaying characteristic curves.



AN ORDINARY in/out-of-circuit transistor tester is sufficient if all you want to do is track down a defective transistor. But when you have to identify an unlisted or unmarked transistor by its performance characteristics or to match two devices of the same type, there is no substitute for a transistor curve tracer.

While the simple go/no-go tester is a self-contained instrument, the curve tracer must be used in conjunction with an oscilloscope to display a family of characteristic curves for the semiconductor under test. One such instrument recently put on the market by Hickock Electrical Instrument Company is the Model 440 transistor curve tracer, retailing for \$165.

This instrument performs the usual curve tracing functions for germanium and silicon bipolar signal and power transistors. In addition, it can also test FET's, SCR's, UJT's, and signal, switching, rectifier, and zener diodes.

The 4¼-pound (2-kg) transistor curve tracer measures 8¼" W × 7½" D × 4⅝" H (21 × 19 × 12 cm).

General Information. The curve tracer has a unique feature, which Hickock calls "Insta-Beta," that takes the guesswork out of transistor beta and FET parameter calculations. In

the transistor mode, this function displays a single full-range I_C/I_B curve from which ac and dc beta can be instantly determined. This curve also shows beta linearity at a glance. Switching to the FET mode, the Insta-Beta function displays the entire transfer curve, including pinch-off voltage (V_{p}), full-on current (I_{DSS}), and the active portion for easy transconductance (G_m) calibration.

In conventional semiconductor testing, the tracer features a variable step control that provides up to 10 steps per family. The steps are in base current for bipolar transistors and gate voltage for FET's.

A horizontal volts/division control is provided for changing oscilloscope sensitivity without having to recalibrate the scope. The maximum sensitivity of 1 V/division is especially useful for measurements in the semiconductor threshold or turn-on region.

The collector supply is variable from zero to 100 volts peak via a knob on the curve tracer's control panel.

A pull-out card at the lower edge of the instrument's front panel provides a ready reference for information for calibration, setup, and operation of the curve tracer.

Two transistor sockets on the control panel provide a convenient means for testing and matching devices by the A-B comparison method. The sockets are supplemented by two sets of color-coded banana jacks for in-circuit tests and for connecting physically large transistors to the curve tracer for out-of-circuit testing. All operational controls are clearly labelled as to function and setup. Fast setup positions on the legends for each control are marked by small arrowheads when the user does not know the actual starting parameters.

User Comment. The first test to which we put the Model 440 curve

tracer was in troubleshooting. We had on our bench an expensive oscilloscope that had resisted all of our efforts to repair. We had not had a curve tracer to help us, although we did know that one transistor of a differential pair was bad. We replaced that transistor, but there was still a problem with stability.

Since we now had on hand a transistor curve tracer, we pulled both the good transistor and the supposedly exact replacement transistor and ran an A-B comparison. Both transistors had the same 2N numbers stamped on them, but when their characteristic curves were displayed, they were worlds apart in performance. We then sorted through a number of transistors until at last we had a matched pair. Upon installing the pair in the scope and performing the recommended tuning, the scope worked perfectly.

Our scope problem is just one type of job the curve tracer can tackle in short order in a service shop. Another job is identifying transistors marked with foreign numbers in imported radios, recorders, etc., according to performance characteristics. The method of identification is to run A-B comparisons with domestic transistors until you find the proper substitute. Of course, a transistor manual helps enormously for this operation by providing families of curves that match those displayed for the unknown transistor.

The curve tracer is an extremely useful tool for sorting through a collection of unmarked or house-marked devices. We quickly sorted through several semiconductor devices we have been collecting. Transistors were graded according to type, beta, etc., and diodes according to type (silicon or germanium and signal or rectifier) and, for zeners, according to voltage. We even found a few expensive FET's in the collection. In this one instance alone, the curve tracer more than paid for itself.

CIRCLE NO. 69 ON FREE INFORMATION CARD



Test Equipment Scene

By Leslie Solomon

CHECKING THE SWEEP GENERATOR "BIRDIE"

THERE are many uses for sweep generators in aligning FM, TV, and other r-f systems. Most of these sweepers include some form of variable-frequency oscillator to produce the "birdie" markers used to identify particular points along the viewed trace.

Obviously, the more accurate these marker frequencies are, the more accurate the alignment. So, the question is, just how accurate are your markers? It should be noted that some sweeper manufacturers include crystal-controlled frequencies (4.5, 10.7, TV frequencies, etc.), but here we are discussing those older sweepers that use a vfo and do not have the crystal-controlled provision.

Possibly, you have stored away in a small cardboard box a number of quartz crystals obtained from long-forgotten CB rigs, ham gear, or old test equipment. Here is your chance to determine their frequencies and make use of them.

Determining the Frequency. First you have to make sure just what the crystals' frequencies are. Despite the markings that may be on them, many crystals have fundamental frequencies far different. The identification process is quite simple. All you need is a conventional r-f signal generator (a sweeper will do if you can tune it manually without sweep), a frequency counter, and a scope.

Connect the signal generator ground to the scope's ground. Then connect the unknown crystal between "hot" leads of the generator and scope. A quartz crystal is a very-high-Q device, and when the generator is tuned to the frequency of the crystal, the scope will suddenly display a waveform (should be a sine wave). There will be almost no waveform when the generator is not tuned to the crystal frequency.

Starting at a low frequency, tune the signal generator until you see the dis-

play on the scope. This will be (roughly) the fundamental frequency of the crystal (despite what it may say on the box). Now couple the frequency counter to the r-f generator; and, as you carefully tune for maximum waveform display on the scope, note and record the frequency. Use a felt-tipped marker pen to identify each crystal. As we said, however, this is a rather rough frequency value; so it is necessary to take one more step to refine the value. At least this test has given you a "ballpark" figure

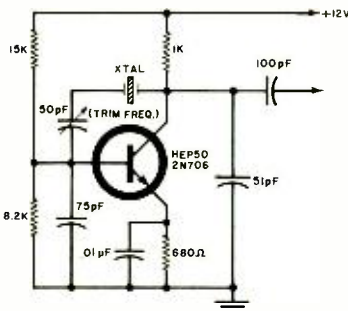

In the *Radio Amateurs Handbook*, we found a good transistor crystal-oscillator circuit. We built the oscillator circuit on a small pc board and "stole" the required power from the solid-state r-f generator we were using.

With the oscillator circuit operating, we plugged the known good crystals in and checked the operation on the scope. Then we used the frequency counter to get the exact frequency. Once we had a decent selection of frequencies, we used a multiple-pole rotary switch for crystal selection and marked the switch with the frequencies. Using the same approach as that of the vfo within the sweeper, we coupled the crystal oscillator to the sweeper mixer.

Tuning the Birdie. If you are lucky, you will have some good frequencies to use. (Of course, you can always buy a low-cost crystal with a useful frequency.) Now, with the sweeper work-

ing with a scope and an r-f circuit to be swept, turn on the sweeper's vfo and tune the birdie. Then turn on the crystal oscillator to a frequency that is within the swept range and note its birdie. Operate the vfo dial until you get a zero beat between the two birdies. The vfo dial should now indicate the exact frequency of the selected crystal. If not, you can make the necessary adjustments to the vfo dial so that it is correct. You can use harmonics of a crystal or higher-frequency crystals to check the other ranges of your sweeper. ♦

ACE OF THE MONTH SPECIALS



ASCII COMPUTER KEYBOARDS

These keyboards were manufactured for use on Texas Instrument's line of Silent 700 series data terminals. They are fully encoded with TTL large scale integrated circuits (T.I. TMS-5000 in 28 pin socket). Additional IC's provide a parallel 7 bit, without parity, code plus a strobe signal indicating "valid" data and six other independent outputs for those special keys which are not encoded. The keys are read type with a format similar to typewriter. Internal circuitry provides for two key rollover and de-bounce. Output is on standard 10 pin double readout connector for data and power input. And 8 pin double readout connector for six special switch functions.

KEYBOARDS

KB-6 - Clare/Pendar 720627-1

T.I. Part number 959327-1

A 56 key ASCII encoded Alphanumeric keyboard with six extra switch closures to ground marked HERE IS, PAPER ADV., BREAK, REPEAT, TAPE → TAPE ← code 1 - \$47.50 2 - \$37.50 3 - \$17.50

KB-7 - Clare/Pendar 720731-1

T.I. Part number 959326-1 as used on T.I. Silent 700 data Terminals. This is a 64 key full ASCII encoded keyboard. code 1 - \$49.95 2 - \$39.95 3 - \$19.95

1. All keyboards supplied with wiring diagrams, code tables, and other useful documentation.

PRICE:

1. New - tested and guaranteed w/test record
2. Used - tested and guaranteed w/test record
3. Used - untested - appear to be in good condition. LSI Chip missing - may have a few bad or broken switches. Good for parts.

ACOUSTIC COUPLER

This coupler was manufactured by Novation, Inc. Tarzana, California for use in Texas Instrument's model 725 Electronic Data Terminal. It is compatible with Bell 103 and 113 data sets or equivalent. The coupler operates asynchronously to a maximum speed of 450 baud in the full or half-duplex mode coupled to a standard telephone handset. Transmit freq. is 1270hz for mark and 1070hz for space. Receive frequency is 2225hz for mark and 2025hz for space. Unit required ± 12 VOLTS and + 5 VOLTS for operation. Complete with schematic & all pertinent information, fully reconditioned, calibrated, and guaranteed - \$59.95.



MEMORY CHIP

SN74S201N 256-BIT RAM with 3 state output. Plug in replacement for SN74 200 & SN74S200.

\$3.95 ea. 10 for \$25.00
NEW GUARANTEED



METER

EMICO Model *3 - 0-1 ma edgewise meter. Scale is marked 0-10 relative output. Mounts in a 3/4 X 1 7/8 rectangular hole with a press on clip supplied with the meter. New \$1.95 each 10 for \$15.00

TERMS: We pay postage, unless otherwise specified. Orders over \$50.00 subtract 10%. Include check or money order, no COD. Texas residents add 5% sales tax.



ELECTRONIC PARTS
3303 Mangum Road
Houston, Texas 77018

CIRCLE NO. 14 ON FREE INFORMATION CARD

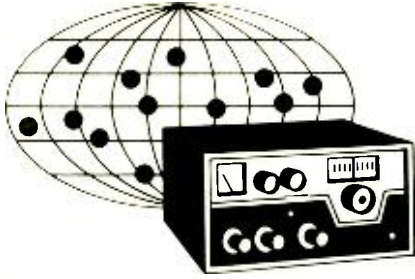

DX Listening

By Glenn Hauser

ANTARCTICA CALLING

AFTER a long, hot summer, how about an armchair trip to Antarctica? Just a year ago, North American DX'ers began picking up the American Forces Antarctic Network on 6.012 MHz (not to be confused with a spur from AFRTS, Ohio on 6.018 MHz or a spur from HCJB, Ecuador, on 6.012 MHz). Reception of AFAN peaked in October and November, especially on the West Coast around 1100 GMT. Then, last April, from his ideally situated monitoring post at the southern tip of New Zealand, Arthur Cushen flashed news of a change for AFAN to 7.050 MHz. It is possible that AFAN may have returned to 6.012 MHz, by now.

DX'ers speculate that other nations with Antarctic bases may initiate their own broadcasts since radio news and entertainment help diminish the sense of isolation. Meanwhile, North American DX'ers can hear, with some effort, a handful of programs beamed on shortwave from the home country toward Antarctica.

For instance, Radio RSA has a program for the South African National Antarctic Expedition, Sundays at 0956-1045 GMT on 15.220 (alternate: 15.155) and 11.970 MHz. Radio New Zealand also broadcasts weekly toward Antarctica, Sundays GMT at 0015-0045 (that's Saturday evening here) on 15.280 MHz.

Radio Australia calls its men in Antarctica on Fridays GMT at 0300-0330 on 15.290; 0400-0430 on 15.240; and 0915-0945 on 6.005 MHz. Radio Moscow transmits (in Russian) twice a week toward Antarctica—Mondays and Thursdays at 1530-1600. Frequencies often change, but try 12.000, 11.630, 9.510, 9.490 or 7.135 MHz. Now for the easy ones: BBC designates 7.130 MHz exclusively for Atlantic Islands and Antarctica, at 2245-0430 GMT daily, with the same World Service programs heard elsewhere. But on Sundays "Calling the Falkland Islands" approaches an Antarctic service, at 2200-2245 on 9.915 and 12.040 MHz.

Antarctica happens to be in the same direction as the Caribbean, viewed from Bethany, Ohio, so AFRTS transmissions from there serve both regions, 24 hours a day, on 6.030, 9.755 or 15.330 MHz.

Less and Less English? The Voice of Germany, on April Fool's Day, cut its English broadcasts to North America from three hours a day to 40 minutes—the same amount as Belgium. Radio Finland soon launched trial balloons on eliminating its English programs completely and then was crippled by a June strike of English-language freelance program producers. One nation where English broadcasting is secure is Australia. By Dec. 20, the abandoned U.S. tracking base at Carnarvon is to become the temporary replacement transmitter site for Darwin, which was blown off the air last Christmas.

Spanish and Portuguese dominate Latin American airwaves. This year's big story is the extensive rearrangement of Brazilian frequencies in the 60- and 90-meter bands—so don't jump to conclusions by referring to an outdated list. A new Colombian shortwaver appeared on 5.9618 MHz

with the romantic name of La Voz de los Centauros—and then attained its nominal channel of 5.990.

Nicaragua happens to be a rare country for shortwave broadcasts, so DX'ers welcomed the reappearance of Radio Atlántico, Bluefields, on 6.1182 MHz. The station does have an English program, but it's during the daytime. Mexico City's cultural outlet, Radio Universidad, went to 9.7672 MHz from its nominal 9.600 last November, and then went silent. This summer it returned, on 9.60945 MHz, facing stiff interference from the world's most distant SWBC station, ABC-Perth, on 9.610 MHz—until the Australian closes down at 1602 GMT.

Publications. The only major club specializing in SWBC DX news is the North American Shortwave Association, Box 13, Liberty, IN 47353. Dues are \$12 per year; or send \$1 for a sample of the monthly journal *FRENDX*. Long-needed and now available is a *TV Station Guide*, with channel-by-channel maps and accompanying tables showing location, call, net, power, offset (even on UHF!), plus extensive listings and maps of stations as far south as Ecuador. You can order it for \$5 from WTFDA, Box 163, Deerfield, IL 60015.

The QSL Flap. Tuning in broadcasts from all over the world is exciting enough—but many DX listeners aren't satisfied with just hearing a station, perhaps taping it, and above all *knowing* they heard it. They want something tangible to "prove" their reception. Since it's good public relations, and a way to encourage listeners to send in reception reports, most major broadcasters go along with the practice (derived from ham radio) of 'verifying' reports with QSL cards.

I have quite a QSL collection myself. They're great for display at conventions and make nice, often artistic souvenirs. But a reputable DX'er shouldn't really *need* anything beyond his word of honor to convince others of what he has heard. In addition, an unhealthy aura can surround these QSL cards. There is tendency to judge a DX listener by the extent of his QSL collection, *which is actually an option*. And this leads to narrow definitions of just what constitutes a valid QSL.

When Radio Canada International announced that it would cease specifying the frequency or any other details on its QSL's, howls of protest

We are pleased to verify your report on the reception of Radio Canada International.

Thank you and best wishes from Canada.

Nous sommes très heureux de vous remercier pour votre rapport de réception de Radio Canada International.

Merci de nos meilleurs vœux du Canada.

GLENN HAUSER
1312 W. Oak
Enid OK
73701 USA

Radio Canada International
P.O. Box / Case postale 2020
Montreal, Canada H3C 3H8

Radio Canada has simplified their QSL to save money.

were heard from avid QSL collectors. (RCI made the move to cut down its operating expenses.) At issue, actually, is the real purpose of international broadcasting: filling QSL albums or propagating a nation's news and image. Would we rather have detailed QSL's or quality programming?

Conventions. Coincidentally, RCI is co-hosting this year's Association of North American Radio Clubs convention, in Montreal, Aug. 22-24. All DX'ers are cordially invited, though by now it's a bit late to secure hotel reservations. For details, call (514) 486-9614. Among many other topics, RCI's new QSL policy will be discussed by Ian McFarland, the RCI DX program producer.

If you're at the other end of the continent over the Labor Day weekend (Aug. 29-Sept. 1), you're invited to drop in for the NORCAL get-together, at El Rancho Inn, Millbrae, California. For information, contact Rick Heald, 17412 Rolando Ave., Castro Valley, CA 94546.

Handicapped Aid. RCI's support of both the Canadian and American Handicapped Aid Programs (CHAP and HAP-US) shows its heart is in the right place, whatever its QSL policy. Reel or cassette tapes of RCI's African ident and interval signals series are available through either group for \$3.50. Tapes covering other regions of the world are soon to follow.

HAP and CHAP deserve the support both of benefactors and of handicapped people already enjoying the shortwave and DX listening hobbies. If you know someone whose handicap has led to a contracting world, you can help expand it by putting her or him in contact with HAP, c/o Ted Poling, Box 163, Mt. Sterling, IL 62353; or CHAP, c/o Harold T. Sellers, 122 Giroux St., Apt. 20, North Bay, Ont. P1B 7Y7. HAP and CHAP offer to loan SW receiving equipment and a half-price DX club membership to deserving handicapped applicants.

In addition to the tapes, HAP financing comes from a translation service and sales of happy-face rubber stamps. CHAP also sells stamps for collectors. When inquiring, please enclose a self-addressed stamped envelope. Regular HAP progress reports are broadcast on the Saturday DX programs of RCI and HCJB, and via Radio Nederland each third Thursday of the month. ♦

SEPTEMBER 1975

Could the ultimate system be all Crown?



It depends on how you define "ultimate". But Crown may be the only top-quality, state-of-the-art manufacturer whose components could build a complete ultimate system.

For instance: A CX-824 tape deck, world-renowned for reliable performance. Connected to an IC-150 pre-amp. With the signal amplified by a DC-300A power amp, proved in many thousands of hours of professional use. Output controlled, monitored and switched by an OC-150. Possibly a VFX-2 for personal control of crossover points. And sound faithfully reproduced by ES-212 electrostatic speakers.

All Crown. We think that system would be somebody's ultimate. Certainly ours. Maybe yours.

Write us today for the name of your nearest Crown dealer. He'll talk to you — ultimately.

When listening becomes an art,



CROWN

Box 1000, Elkhart IN 46514

CIRCLE NO. 16 ON FREE INFORMATION CARD

NEW, FULL-FEATURE PERSONAL 2-WAY RADIO



STYLED FOR THE CB'ER WHO IS BUDGET MINDED, YET WANTS A COMBINATION OF PERFORMANCE, STYLE AND RUGGEDNESS FOR HIS CB RADIO.

PACE CB 144 is a fully synthesized 23 channel AM transceiver offering full legal transmit power.

Maximum control at your fingertips: Noise blanker switch • Automatic noise limiter switch • RF gain control • PA control • Delta tune • Illuminated S/RF meter • transmit indicator light • Plug-in microphone.

Operates on 12V DC (+) or (-) ground.

Suggested retail price \$179.95

See your distributor today.



PACE COMMUNICATIONS, Div. of Pathcom Inc., 24049 S. Frampton Ave., Harbor City, CA. 90710, Dept. 62

Available in Canada from Superior Electronics Ind. Export: 2200 Shames Dr., Westbury, N.Y. 11590

CIRCLE NO. 39 ON FREE INFORMATION CARD

81



ALL TYPES OF SPEAKERS,
SPEAKER SYSTEMS AND
OTHER ELECTRONIC PARTS
SEEK IMPORTER AND
DISTRIBUTOR



**CHIEN CHANG INDUSTRIAL
CO. LTD.**

241 Wanta Road, Taipei 109, Taiwan
Republic of China TELEX 22416

PACE 16 BIT MICROPROCESSOR

FROM NATIONAL SEMICONDUCTOR, "THE SECRET MICROCOMPUTER CO": THIS 40 PIN DIP FEATURES TRI-SHARE AND A POWERFUL INSTRUCTION SET. WE ARE PROUD TO OFFER THIS EXCITING IC TO THE COMPUTER ENTHUSIAST STARTING SEPTEMBER 1st.

...and 16 BIT basic kit ★ Microcomputer! ★

IT SEEMED LOGICAL TO WRAP A COMPUTER KIT AROUND OUR PACE IC, AND HERE IT IS. WE'VE PUT A LOT OF THOUGHT INTO THIS ONE AND WE THINK YOU'LL LIKE IT; OUR ONLY PROBLEM IS WE DON'T HAVE A NAME FOR THE BEAST YET. SEND US YOUR IDEA--IF WE USE IT, YOU'LL GET ONE OF OUR KITS. AVAILABLE SEPT. 1ST; WRITE FOR DETAILS AND PRICING.

...AND 8 BITS, TOO! 8008 - \$27.95!

GODBOUT

BILL GODBOUT ELECTRONICS
BOX 2355, OAKLAND AIRPORT, CA 94614

THIS AD IS ONLY THE TIP OF THE ICEBERG; OUR FLYER TELLS ALL ABOUT OUR TTL (7400 & 8200 SERIES), CMOS, MOS, LINEARS, COMPONENTS, READOUTS, POWER SUPPLIES, MUSICIAN'S KITS & MORE. SEND FOR IT.... BE SURPRISED!

TERMS: Cal + tax. BankAmericard®/Mastercharge® call (415) 357-7007 24 hr. No COD.

CIRCLE NO. 24 ON FREE INFORMATION CARD

ENGLISH-LANGUAGE SHORTWAVE BROADCASTS FOR SEPT. & OCT. 1975

by Richard E. Wood

TO WESTERN NORTH AMERICA

TIME-PDT	TIME-GMT	STATION	QUAL*	FREQUENCIES, MHz
4:00-5:15 a.m.	1100-1215	London, England	G	5.99 (via Sackville), 11.75 (via Tebrau)
5:15-6:15 a.m.	1215-1315	London, England	F	11.75 (via Tebrau)
6:00-6:15 a.m.	1300-1315	Tokyo, Japan	G	5.99
7:00-7:30 a.m.	1400-1430	Tokyo, Japan	G	9.505
7:00-9:00 a.m.	1400-1600	**VDA, Washington, U.S.A.	G	6.185, 9.565
8:00-8:30 a.m.	1500-1530	Tokyo, Japan	G	9.505
9:00-10:15 a.m.	1600-1715	London, England	G	15.365 (via Sackville)
9:42-9:51 a.m. (Mon.-Fri.)	1642-1651	Hilversum, Holland	G	15.14, 15.19 (via Bonaire; mixed English/Dutch)
10:00-10:15 a.m.	1700-1715	Tokyo, Japan	G	9.505
11:00-11:15 a.m.	1800-1815	Tokyo, Japan	G	9.505
12 noon-12:15 p.m.	1900-1915	Tokyo, Japan	G	15.105
1:00-1:15 p.m.	2000-2015	Tokyo, Japan	G	15.105
2:00-2:15 p.m.	2100-2115	Tokyo, Japan	G	15.105
2:15-4:00 p.m.	2115-2300	London, England	F	9.58 (via Ascension)
3:00-3:15 p.m.	2200-2215	Tokyo, Japan	G	15.105
4:00-4:30 p.m.	2300-2330	Tokyo, Japan	G	15.105
4:00-5:30 p.m.	2300-0030	London, England	G	6.175, 9.51 (via Sackville), 9.58 (via Ascension)
5:00-5:15 p.m.	0000-0015	Tokyo, Japan	G	15.105
5:00-7:00 p.m.	0000-0200	**VDA, Washington, U.S.A.	G	15.29, 17.895
5:30-8:30 p.m.	0030-0330	London, England	G	6.175 (via Sackville), 9.51 (via Greenville), 9.58 (via Ascension)
5:30-6:00 p.m.	0030-0100	HCJB, Quito, Ecuador	G	5.97, 9.56
6:00-6:15 p.m.	0100-0115	Tokyo, Japan	G	15.105
6:00-7:00 p.m.	0100-0115	Peking, China	G	9.94, 11.945, 15.06
6:00-8:00 p.m.	0100-0300	Melbourne, Australia	G	15.32, 17.795
		Moscow, U.S.S.R.	G	12.05, 15.18, 17.775 (via Soviet Far East)
6:00 p.m.-12 mdt.	0100-0700	HCJB, Quito, Ecuador	G	5.97, 9.56, 11.915 (includes Eskimo)
6:30-7:30 p.m.	0130-0230	Tokyo, Japan	G	15.195, 15.42, 17.725, 17.825
7:00-7:15 p.m.	0200-0215	Tokyo, Japan	G	15.105
7:00-8:00 p.m.	0200-0300	Peking, China	G	11.455, 11.965, 12.055, 15.06
7:00-8:50 p.m.	0200-0350	Taipei, Taiwan	F	11.86, 15.125, 17.72
7:30-8:00 p.m.	0230-0300	Stockholm, Sweden	F	9.695, 11.705
8:00-8:15 p.m.	0300-0315	Tokyo, Japan	G	15.105
8:00-8:30 p.m.	0300-0330	Seoul, Korea	P	15.355
8:00-8:45 p.m.	0300-0345	Madrid, Spain	P	6.065, 11.925
8:00-9:00 p.m.	0300-0400	Peking, China	G	7.12, 9.78 (via Tirana), 11.445, 12.055, 15.06, 15.385, 17.735, 17.855
8:30-9:30 p.m.	0330-0430	London, England	G	9.58 (via Ascension)
8:30 p.m.-12 mdt.	0330-0700	Moscow, U.S.S.R.	G	11.72, 12.05, 15.18
9:00-9:15 p.m.	0400-0415	Tokyo, Japan	G	15.105
9:00-9:30 p.m.	0400-0430	Sofia, Bulgaria	F	9.70
		Oslo, Norway	F	9.645, 11.87 (Sun.)
9:00-9:15 p.m. (Tue., Fri.)	0400-0415	Budapest, Hungary	F	6.00, 7.22, 9.833, 11.91
9:00-10:00 p.m.	0400-0500	Montreal, Canada	G	6.135, 9.655
9:30-10:00 p.m.	0430-0500	Lisbon, Portugal	F	6.025, 11.935
		Berne, Switzerland	F	9.725, 11.715
10:00-10:15 p.m.	0500-0515	Tokyo, Japan	G	15.105
		Jerusalem, Israel	F	12.025
10:00-11:00 p.m.	0500-0600	Montreal, Canada	G	6.135, 9.655
10:00-11:20 p.m.	0500-0620	Hilversum, Holland	G	6.165, 9.715 (via Bonaire)
10:30-10:50 p.m.	0530-0650	Cologne, Ger. Fed. Rep.	F	6.075, 6.185, 9.545
11:00-11:15 p.m.	0600-0615	Tokyo, Japan	G	9.505
11:00-11:30 p.m.	0600-0630	Oslo, Norway	F	9.645, 11.87 (Sun.)
11:00 p.m.-12 mdt.	0600-0700	Buenos Aires, Argentina	G	9.69 (Mon.-Fri.)
11:30 p.m.-1:00 a.m.	0630-0800	Havana, Cuba	G	9.525
12 mdt.-12:15 a.m.	0700-0715	Tokyo, Japan	G	9.505
1:00-1:15 a.m.	0800-0815	Tokyo, Japan	G	9.505
2:00-2:15 a.m.	0900-0915	Tokyo, Japan	G	9.505
3:00-3:30 a.m.	1000-1030	Tokyo, Japan	G	9.505

*Reception quality, East Coast location: G-good, F-fair, P-poor

**Not intended for North America, but receivable satisfactorily

Frequencies are accurate as of press time, but subject to change especially for Sweden, U.S.S.R. and Lebanon.

TO EASTERN NORTH AMERICA

TIME-EDT	TIME-GMT	STATION	QUAL*	FREQUENCIES, MHz
7:00-8:15 a.m.	1100-1215	London, England	G	5.990 (via Sackville), 15.07
7:00-7:30 a.m.	1100-1130	Tirana, Albania	F	9.48, 11.985
7:00-9:00 a.m.	1100-1300	**VOA, Washington, U.S.A.	G	6.185, 9.565
7:15-8:15 a.m.	1115-1215	Montreal, Canada	G	5.97
7:15-8:45 a.m.	1115-1245	Melbourne, Australia	G	9.58
8:00-8:55 a.m.	1200-1255	Peking, China	F	11.685
8:15-9:00 a.m.	1215-1300	London, England	G	15.07
8:30-9:00 a.m.	1230-1300	Stockholm, Sweden	G	17.71
9:00-10:30 a.m.	1300-1430	London, England	G	15.07, 17.79
9:15-9:45 a.m.	1315-1345	Berne, Switzerland	G	15.14
10:00-10:30 a.m.	1400-1430	Stockholm, Sweden	G	17.71
		Oslo, Norway	F	17.80 (Sun. only)
		Helsinki, Finland	G	15.185
10:30-11:00 a.m.	1430-1500	London, England	G	15.07, 17.79, 17.84 (via Ascension)
11:00-11:15 a.m.	1500-1515	London, England	G	15.07, 15.26, 17.79, 17.84 (via Ascension)
11:15 a.m.-12:15 p.m.	1515-1615	London, England	G	15.07, 17.79, 17.84 (via Ascension)
12 noon-12:30 p.m.	1600-1630	Oslo, Norway	F	15.17, 17.80 (Sun. only)
4:00-4:55 p.m.	2000-2055	Jerusalem, Israel	G	7.395, 9.815, 12.025
5:15-6:45 p.m.	2115-2245	London, England	G	9.58 (via Ascension), 11.78, 15.26
5:30-6:50 p.m.	2130-2250	Hilversum, Holland	G	9.715, 11.73 (Sun.: Dutch)
6:30-7:00 p.m.	2230-2300	Vilnius, U.S.S.R.	F	7.32, 7.355
6:30-7:20 p.m.	2230-2320	Johannesburg, S. Africa	G	5.985, 9.525, 9.695, 11.90
6:45-11:30 p.m.	2245-0330	London, England	G	5.975, 7.325, 9.58 (via Ascension)
6:55-7:15 p.m.	2255-2315	Brussels, Belgium	G	9.73
7:00-7:30 p.m.	2300-2330	Stockholm, Sweden	F	6.035, 9.605, 11.705
7:00-8:30 p.m.	2300-0030	Moscow, U.S.S.R.	G	7.15, 7.205, 7.355, 7.39, 9.685
7:45-8:45 p.m.	2345-0045	Tokyo, Japan	F	15.27, 15.30
8:00-8:30 p.m.	0000-0030	Tirana, Albania	G	7.065, 9.78
		Oslo, Norway	F	6.18, 9.645 (Sun.)
8:00-9:00 p.m.	0000-0100	Peking, China	F	11.945, 15.06, 15.52, 17.673
		Sofia, Bulgaria	F	9.70
8:00-10:00 p.m.	0000-0200	**VOA, Washington, U.S.A.	G	6.13, 9.65, 11.710, 11.83, 15.205
8:30-9:00 p.m.	0030-0100	Kiev, U.S.S.R.	G	7.15, 7.205, 9.685 (Mon./Thu./Sat.)
8:30-9:00 p.m.	0030-0100	Vilnius, U.S.S.R.	F	7.32, 7.355 (Fri./Sat.)
8:30-9:00 p.m.	0030-0100	HCB, Quito, Ecuador	G	5.97, 9.56
8:40-9:00 p.m.	0040-0100	Brussels, Belgium	G	6.08
9:00-9:15 p.m.	0100-0115	Vatican City	G	5.995, 6.165, 9.605
9:00-9:20 p.m.	0100-0120	Rome, Italy	G	9.575, 11.81
9:00-9:45 p.m.	0100-0145	Berlin, Ger., Dem. Rep.	P	9.73
		Madrid, Spain	G	6.065, 11.925
9:00-10:00 p.m.	0100-0200	Peking, China	G	7.12, 9.78 (via Tirana), 11.945, 11.965, 15.06, 15.52
		Prague, Czechoslovakia	G	5.93, 7.345, 9.54, 11.99
9:00 p.m.-3 a.m.	0100-0700	HCB, Quito, Ecuador	G	5.97, 9.56, 11.915 (includes some Eskimo)
9:00-10:00 p.m.	0100-0200	Montreal, Canada	G	6.085
9:00-10:30 p.m.	0100-0230	Moscow, U.S.S.R.	G	7.15, 7.205, 7.355, 9.685
9:30-9:50 p.m.	0130-0150	Cologne, Ger. Fed. Rep.	G	6.01, 6.04, 6.10 (via Malta), 9.565, 9.69, 9.745, 11.865 (via Malta)
9:30-9:55 p.m.	0130-0155	Tirana, Albania	G	6.20, 7.30
		Vienna, Austria	P	6.155, 9.77
		Bucharest, Rumania	P	5.99, 9.57, 11.94
9:45-10:15 p.m.	0145-0215	Berne, Switzerland	G	5.965, 6.135, 9.725, 11.715
10:00-10:30 p.m.	0200-0230	Budapest, Hungary	F	6.00, 7.22, 9.833, 11.91 (Ex. Sun.)
		Oslo, Norway	F	6.18, 9.645 (Sun.)
10:00-11:00 p.m.	0200-0300	Peking, China	F	11.965, 15.06
10:00-11:20 p.m.	0200-0320	Hilversum, Holland	G	6.165 (via Bonaire)
10:00-11:30 p.m.	0200-0330	Cairo, Egypt	G	9.475
10:00 p.m.-12 mdt.	0200-0400	Warsaw, Poland	P	6.095, 6.135, 7.27, 9.675, 11.815 (mixed Polish/English)
10:30-11:00 p.m.	0230-0300	Beirut, Lebanon	P	9.675
11:00-11:30 p.m.	0300-0330	Budapest, Hungary	F	6.00, 7.22, 9.833, 11.91
11:00 p.m.-12 mdt.	0300-0400	Buenos Aires, Argentina	G	9.69 (Mon.-Fri.)
		Peking, China	G	7.12, 9.78 (via Tirana)
		Prague, Czechoslovakia	G	5.93, 7.345, 9.54, 11.99
11:30 p.m.-12 mdt.	0330-0400	Tirana, Albania	G	6.20, 7.30
		Kiev, U.S.S.R.	G	7.205, 7.39, 9.685 (Mon./Thu./Sat.)
11:30 p.m.-12:30 a.m.	0330-0430	London, England	G	5.975, 9.58 (via Ascension)
11:30 p.m.-2:00 a.m.	0330-0600	Havana, Cuba	G	11.76
12 mdt.-12:30 a.m.	0400-0430	Bucharest, Rumania	P	5.99, 6.19, 9.57, 11.94
12 mdt.-2:00 a.m.	0400-0600	Moscow, U.S.S.R.	G	7.15, 7.205, 7.355, 7.39
1:00-1:15 a.m.	0500-0515	Jerusalem, Israel	G	5.90, 7.395, 9.009, 9.815

Olson

Electronics Parts and Accessories

SALE

DUAL IN-LINE IC'S

Made in U.S. These IC's are guaranteed against defects. With diagram. Shpg. wt. 1/4 lb.

LOW AS **29c**

Type 7400 Quad 2-input Pos. NAND Gate. High speed diode-clamped inputs

TR-431. Reg. 69c Sale 29c

Type 7402 Quad 2-input Pos. NOR Gate. Low noise Propagation delay 12 ns

TR-432. Reg. 69c Sale 29c

Type 7404 Hex inverter. Low noise, low power dissipation

TR-433. Reg. 79c Sale 29c

Type 7410 Triple 3-input Pos. NAND Gate. Low output impedance, diode-clamped inputs

TR-434. Reg. 69c Sale 29c

Type 7447 BCD to 7-Segment Decoder/Driver. With common anode displays

TR-435. Reg. 2.99 Sale 59c

Type 7473 Dual J-K Master/Slave Flip-Flop

TR-436. Reg. 1.19 Sale 39c

Type 7474 Dual D-Type Edge Triggered Flip-Flop

TR-438. Reg. 69c Sale 39c

Type 7475 4-Bit Latch. Temp. stores binary coded info

TR-437. Reg. 1.89 Sale 79c

TR-437. Reg. 79c Sale 29c

Type 7410 Triple 3-input Pos. NAND Gate. Low output impedance, diode-clamped inputs

TR-434. Reg. 69c Sale 29c

Rechargeable Battery With Charger

6 VDC alkaline rated @ 5 amp hr. Max. current 1.25 amp. Eveready #565 4 lbs. 9.98 BA-307. Sale 4.99

4.99

Reg. 2.98

BIG 1 LB. Resistor Kit

Over 400 pieces of 1/4, 1/2, 1 watt sizes. All color coded. 2 1/2 lbs. RS-239. 99c

99c

500-ft. Hook-Up Wire

For almost any type of printed circuit or wiring project. 2 lbs. WW-579. Sale 1.69

1.69

Reg. 2.98

PNP Transistors

Big 10 pc kit. For general to & hi-gain & audio. Germanium types. Untested 1/4 lb. TR-445. Sale 39c

39c

Reg. 99c

3-6 VDC Motors

Kit 1/5 Small 1/2 lb. MO-333. Sale 55c

Kit 4. Med. 1 lb. MO-334. Sale 79c

Kit 4 Ass'd 2 lbs. MO-335. Sale 99c

59c

LOW AS

Three 60-Min. Cassettes

Pkg 3 quality cassette recording tapes. 60-Min. each 1/2 lb. TA-879. Sale 99c

99c

Reg. 1.49

12-Digit IC Calculator Chip

40-pin DIP single CAL Tech #CT-5001. 7-seg de-coded display output overflow lock-out. Spacs Incl. 5.98 XM-330. Sale 1.59

1.59

Reg. 5.98

8-T Blank Tape

Famous manufacturer's high quality. Low priced tapes. 1/2 lb. TA-854. 40-Min. 89c

89c

Reg. 1.19

50-Pc. 1 Amp Diode Kit

Polarity is unmarked but easily identified with ohm meter. 200 PIV rated. 1/2 lb. Di-051. Sale 69c

69c

REG. 1.69

Silicon Rectifiers

1 Amp Epoxy Type Pkg 5, 4 oz. Reg Sale

Di-028 50 PIV IN4001 89c 39c

Di-029 100 PIV IN4002 99c 39c

Di-030 200 PIV IN4003 1.19 39c

Di-031 400 PIV IN4004 1.39 39c

Switching Diodes

Pkg 10 IN4148 for low current applications. 10 mA-75 PIV 1/2 lb. XM-382. Sale 59c

59c

Reg. 1.29

LED'S 2V 10 mA

Gallium phosphide. Large red, high quality LED. Wt. 1/4 lb. Pkg. 5

59c

Reg. 1.19

SCR Assortment

Hobby Pak of asst. values & case types. Pkg. of 25. Untested. Wt. 1 lb. TR-446. Sale 99c

99c

Reg. 2.69

FREE Olson Catalogs

WITH THOUSANDS OF ELECTRONIC BARGAINS

Next 7 Issues FREE!

FREE Sent Today!

ORDER TODAY! Send to Olson Electronics, 260 S. Forge St., Akron, Ohio 44327. Allow for postage. C.O.D. 20% Deposit. Ohio Residents Add 4% Sales Tax.

Olson electronics

Dept. IB
260 S. Forge St., Akron, Ohio 44327

NAME _____

ADDRESS _____

APT _____

CITY _____

STATE _____

ZIP _____



Solid State

By Lou Garner

NEW IC'S FOR DIGITAL WATCHES

WITH the entertainment equipment market well covered and the calculator market approaching saturation in many areas, several semiconductor manufacturers are concentrating their big guns on the digital electronic watch market. The result? Improved quality, better distribution, much lower prices, and a plethora of designs to suit virtually every need and desire.

As predicted in my January column, digital electronic watch prices have taken a nose dive. Today, you can buy any of a number of calendar digital watches for less than \$100.00, and I've seen standard (time only) watches offered for less than sixty dollars retail. If you shop at discount houses, you may be able to pick up a digital electronic watch for less than \$50.00, despite inflation.

More and more major semiconductor manufacturers are offering digital-watch IC's as stock, rather than custom, products. In last June's column, you may recall, I discussed the DF111 CMOS LSI watch chip introduced by Siliconix, Inc. (2201 Laurelwood Road, Santa Clara, CA 95054). Suitable for operation on dc sources of 2.7 to 3.4 volts, the DF111 requires only a 32.768-kHz crystal, batteries, a LED display with drivers, and three small switches, plus a case and hardware for watch assembly.

The *ne plus ultra* of digital watch devices, however, is probably the WM series recently introduced by the National Semiconductor Corporation (2900 Semiconductor Drive, Santa Clara, CA 95051). The electronic equivalent of

the legendary "Swiss watch movements," the WM devices are complete electronic digital modules ready to slip into a basic watch case. All that is required for final watch assembly is a suitable standard 13 ligne case (1.152 inches in diameter), pushbutton actuators aligned to contact the module's integral switches, and a pair of small battery cells.

Currently, three standard models are offered by the manufacturer—the WM 01, WM 02 and WM 03. All three are pretested and precalibrated for an accuracy of better than 5 seconds per month. As illustrated in Fig. 1, the WM modules include a CMOS timer chip, a 2.5-mm four-digit LED display, segment and digit LED driver chips, a 32.768-kHz quartz crystal, an oscillator, a timing adjustment capacitor, battery contacts, and built-in spring switch elements with special debounce circuitry to insure positive contact actuation. Designed for rugged service, the oscillator crystal is potted in a compound that absorbs shock, while another specially developed compound coats all the semiconductor components and protects them from handling and environmental damage.

In operation, the circuit's low power consumption permits more than twenty time checks per day for one year with a single pair of 1.5-volt batteries. A special extra feature permits the user to turn off the module during shipment or periods of storage and thus to obtain an indefinite shelf life.

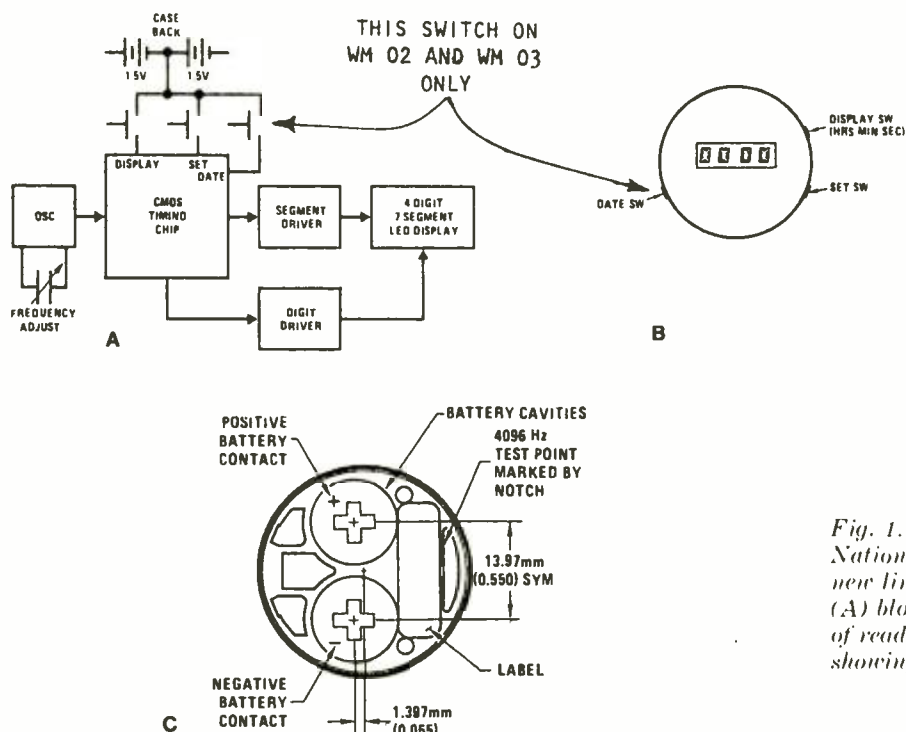

Fig. 1. Basic design of National Semiconductor's new line of watch modules: (A) block diagram; (B) view of readout; (C) rear view showing battery cavities.

The basic WM 01 module is designed to display the time in hours, minutes and seconds upon pushbutton command. Models WM 02 and WM 03 are generally identical to the WM 01 except for an additional capability of displaying the date of the month on command. The WM 02 displays time in a 12-hour format with an AM/PM indicator, while the WM 03 displays time in a 24-hour format.

Siliconix and National Semiconductor are not the only major semiconductor manufacturing firms making waves in the digital watch market, of course. Litronix, Inc. (19000 Homestead Road, Cupertino, CA 95014) has recently announced a new CMOS circuit chip for LED watches that displays hours, minutes, seconds, day and date. Designated type LMC-6130, the Litronix chip requires a 32.768-kHz quartz crystal, two capacitors, two resistors, bipolar driver chips, a suitable LED display, and external spst switches. In practice, up to eight modes of operation may be selected by switch actuation: display off, display time, display date and day, advance hours, advance minutes, advance day, advance date, and zero seconds while holding hours and minutes. Designed for operation on 2.7-to-3.2-volt dc, the LMC-6130 requires only 15 μ W, and will function from 0° to 50° C.

Motorola Semiconductor Products, Inc. (Box 20912, Phoenix, AZ 85036) is now offering a pair of low-power liquid-crystal watch displays, types MLC500 and MLC501. Differing slightly in overall size, both feature a 3½-digit, center-colon readout. Both offer a typical contrast ratio of 25:1 at 3 volts bias, both feature turn-on and turn-off times of 290 and 250 ms, respectively, and both are compatible with standard CMOS watch IC's.

Reader's Circuit. Combining magnetic reed switches and semiconductor devices, the circuit illustrated in Fig. 2 is suitable for an electronic game or puzzle. Adapted from a design submitted by reader Joel Grodstein (400 South Fourth Ave., Highland Park, NJ 08904), the game can be made simple enough for children to enjoy or so difficult that even an adult would have trouble winning.

Referring to the schematic diagram, SCR1 serves as an electronic switch supplying power to the LED used as a win indicator through current limiting resistor R1. Power is furnished by battery B1, controlled by switch S1. The actual game circuit consists of from 3 to 9 (or more, at the builder's option) magnetic reed switches and SCR2. Game circuit power is supplied by C1, charged by B1 when momentary contact switch S2 is depressed. Capacitor C1 discharges through R2, providing a time limit on play. Optional rotary switches S3 and S4 are used to program the game, making it more difficult for the player. One or more reed switches are included as PENALTY switches which, if actuated accidentally, will discharge C1, thus causing the player to lose. With the arrangement shown, the PENALTY switches are SC1, SC2, and SC3. Resistors R3 and R5 limit the gate currents of silicon controlled rectifiers SCR2 and SCR1, respectively, while R4 serves as SCR2's cathode load.

The circuit's operation can be followed most easily by considering the moves that a player would make in winning the game. First, of course, S1 would be closed. Next, S2 would be depressed (charging C1) and released. The player would then touch his *playing piece* (small permanent magnet) to reed switch SB1, closing this switch momentarily, supplying a gate current to SCR2, and causing the SCR to switch to a conducting state. He would then

NEW FROM TECO

TRI Model 6355 Digital Multimeter \$279

TRI Model 5163 250 MHz Frequency Counter \$295

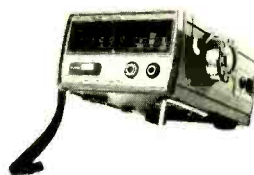

MODEL 6355



MODEL 5163

High resolution 10 μ V on DCV/High accuracy 0.15% of rdg.
5 functions in one — DCV ACV OHM DCI ACI
Fully automatic for easiness of operations
Truly portable — Free from power cord
Common input for all measurements
Safety design protects from high voltage.

NEW!
\$279

* 250 MHz

25mV sensitivity
8 digits/LED

NEW!
\$295

NOW AVAILABLE FROM TECO!
CALL OR WRITE FOR COMPLETE SPECIFICATIONS



P. O. Box 1050 • Garland, Texas 75040

TOLL-FREE CALL
800-527-4642
(In Texas call collect 214-348-8800)

CIRCLE NO. 58 ON FREE INFORMATION CARD

FREE

1975 CATALOG OF CIRCUIT DESIGN AND BREADBOARDING EQUIPMENT

Send for your free copy of Circuit Design's new 1975 catalog. In it, you'll find lots of new ideas in solderless breadboarding aids and instrumentation (in kit form or assembled), as well as a host of hard to find components. If you are involved in any aspect of electronics, you can't do without it.

For your free copy, write to:

CIRCUIT DESIGN, INC.
Div. of E&L Instruments
P.O. Box 24 • Shelton, Connecticut 06484

CIRCLE NO. 12 ON FREE INFORMATION CARD

touch his *playing piece* to reed switch SA1, closing this switch, supplying a gate current to SCR1, and causing the SCR to fire and supply current to the win light (LED1) through R1. However, he *must* touch the switches in *proper order*, since they remain closed only as long as the magnet is held against (or near) them, and *within the time limit* established by C1-R2's time constant. In addition, when SCR2 fires, R4 is an additional load across C1 in parallel with R2, thus causing a sharp reduction in the available playing time.

BETTER THAN A THIRD HAND!

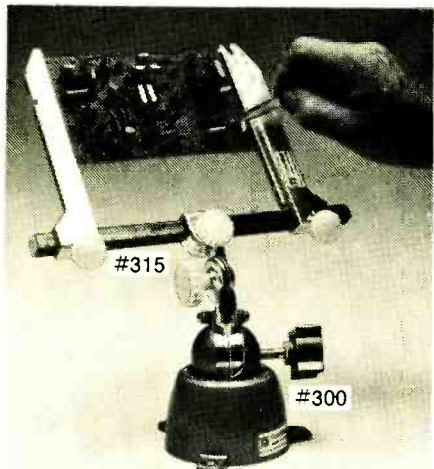

PANAVISE TILTS, TURNS, AND ROTATES TO ANY POSITION. IT HOLDS YOUR P.C. BOARD EXACTLY WHERE YOU WANT IT.

Quite possibly the finest new tool you will buy this year. PanaVise is built to exacting professional standards. We guarantee it!

Illustrated is P.C. Board Holder #315 in the #300 Base. This combination has exclusive multiple positioning ability. Boards are gently but firmly locked in place with one arm spring loaded to facilitate quick board changes.

Three other bases and a wide variety of heads are available. All interchangeable! Buy a basic unit, then add on to create your system.

FREE Write for the latest PanaVise catalog, prices, and dealer listing.

Available through your dealer.

PANAVISE® Dept. 15E

A Division of Colbert Industries
10107 Adella Ave., South Gate, CA 90280

CIRCLE NO. 41 ON FREE INFORMATION CARD

In practice, of course, the game can be quite difficult. The programming switches (S3 and S4) are hidden. The player is confronted with an array of reed switches arranged in a row, rectangular matrix, or random pattern, depending on the builder's choice of layout. He doesn't know which two switches will win. If he accidentally actuates one of the penalty switches (SC1 to SC3), he'll lose. And, once he depresses S2, he has a limited amount of time to complete his moves. And *only two* switches, actuated in *proper order*, will register a win.

Ideally, the game should be assembled in a wooden, plastic or metal case, with only the ON-OFF, PUSH-TO-PLAY and reed switches available to the player and the programming switches hidden. The silicon controlled rectifiers, SCR1 and SCR2, are low-voltage types similar to HEP 320. The LED may be any standard type. Resistors R1 to R5 are ½-watt types. The capacitor, C1, is a 10-to-15-volt electrolytic. A 9-volt battery is used for B1. The power switch is a spst toggle, rotary or slide type, while S2 is a momentary contact spdt pushbutton or lever type. Programming switches S3 and S4 are rotary types, with the "play" switches all small magnetic reed types similar to Calctro type E2-102.

Neither layout nor lead dress is critical and the circuit may be assembled on a pc board, on perf board, or using point-to-point wiring, as preferred. The reed switches may be left exposed on the playing surface or, if desired, hidden behind a thin panel on which locations are marked by dots or circles. Depending on the SCR's used, some experimentation with R4's value

may be necessary. Normally, this resistor should have as large a value as is practicable while maintaining SCR2's holding current.

If you wish to simplify the game for children, omit the penalty switches (SC1 to SC3), increase the size of C1 and/or R2 to lengthen the playing time, omit the programming switches, and provide only a single reed switch in each playing position. On the other hand, if you wish to make the game more difficult, add additional penalty and play switches (changing the programming switches as needed to 4, 5, 6 or more positions), and replace R2 with a 10,000-ohm resistor in series with a 50,000-ohm potentiometer to provide a variable time delay.

Once the project is completed and tested, it can be used in a variety of ways. You can use it as a simple puzzle to challenge your friends, for example, or in competitive play, where different players take turns resetting the programming switches for their opponents, with the player having the greatest number of "wins" in a given number of attempts declared the winner.

The Lit Bit. Recent publications by semiconductor manufacturers which you may wish to add to your library:

Power Transistor Users Guide

—Published by General Electric, this is a 120-page, 8½ × 11 manual filled with practical data on power transistor circuit applications, handling and mounting. The book covers GE's broad line of power transistors, including complementary pairs, Darlington's, and high-voltage types, as well as both metal and plastic encap-

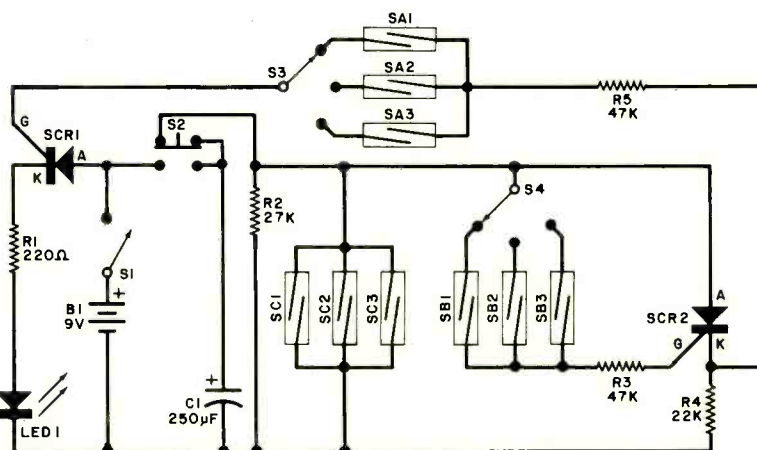

Fig. 2. Schematic of versatile game circuit suggested by reader.

sulated devices. Two items we found of particular value were a 16-page interchangeability guide referencing GE devices to standard industry types and a component chart which illustrates basic devices, symbols, construction, and characteristic curves. The book carries a nominal price of \$1.50, but may be available without charge to quantity device users. It is stocked by GE Electronic Components Sales Offices and authorized GE Electronic Components distributors.

Small-Signal Multiple Transistor Selection Guide & Cross-Reference, Publication SG31—A 24-page booklet covering Motorola's broad line of quad, dual and Darlington transistors. Complete specification tables are included together with device outlines and a competitive cross-reference index. Notes are provided on power ratings and general applications are suggested for various product categories. Contact your local Motorola distributor for copies.

Opto-Couplers at Work—A 20-page booklet chock full of practical application circuits for Motorola's line of Opto-Couplers. Each circuit includes a brief description and all parts values are noted directly on the schematics. Among the projects described are a *digitally programmed dc voltage regulator*, a *high-voltage, complementary output switching amplifier*, and a variety of *solid-state relay* circuits. The booklet also includes a cross-reference guide to the products of other manufacturers. (Motorola Semiconductor Products, Inc., Box 20912, Phoenix, AZ 85036).

Semiconductor Data Book 1975—A massive 418-page, 8½ × 11 handbook covering the Unitorde line of semiconductor devices. Full specification data sheets are provided for such devices as power hybrid circuits, rectifiers, rectifier assemblies, power zeners, power switching transistors, power Darlingtons, SCR's, photo-sensitive devices, PUT's, and pin diodes. Available without charge on letterhead request, the volume also includes an index of available Application Notes and a detailed discussion of thermal design considerations. (Unitorde Corp., 580 Pleasant St., Watertown, MA 02172)

Device/Product News. Experimenters and hobbyists working with digital displays should be in-

terested in a new high-current decoder/driver recently introduced by NEC Microsystems (1150 N. W. 70th St., Fort Lauderdale, FL 33309). Identified as the Model 1001, the new device is a thick-film hybrid microcircuit designed to operate incandescent 7-segment readouts. Socket interchangeable with the popular SN7447, the Model 1001 utilizes individual output transistor chips which are rated at maximums of 40 volts and 100 mA, each output, in continuous operation. Both plastic-encapsulated and hermetically sealed metal versions are offered by the manufacturer.

An unusual solid-state vane sensor that should spark the imaginations of more advanced experimenters has been announced by Micro Switch (Division of Honeywell, 11 W. Spring St., Freeport, IL 61032). Capable of functioning at speeds up to 100,000 times per second, the device, designated the AV, can be used as a tachometer sensor, a shaft-position encoding sensor, a limit switch and a cam-operated programming switch. Based on the Hall Effect and with no mechanical contacts, the AV "no-touch" sensor is actuated by the passage of a ferrous vane through a gap between a magnet and a Hall sensor. The vane prevents the magnetic flux from reaching an IC chip, developing a digital output signal. When the space between the ferrous blades of the vane appears in the switch gap, the output returns to zero. Both linear and rotary vanes may be used with the device. With a 20-mA output, the AV interfaces directly with most electronic circuitry, eliminating the need for additional amplification in most applications. Internal regulation permits the device to be used on dc power sources of 6 to 16 volts.

If you like to build amplifiers that can rattle teeth, shake walls, and shatter sanity, you'll want to investigate a new high-power transistor recently introduced by RCA's Solid State Division. An npn silicon homotaxial-base device offered in a TO-3 package, the new transistor, type RCS258, has a power dissipation rating of 250 watts! Its other specifications include a continuous collector current rating of 20 A, a peak collector current of 30 A, and a collector-to-emitter voltage rating of 80 volts. In addition to applications as an audio amplifier, the RCS-258 can be used in power-switching circuits, driver and output stages for series and shunt regulators, dc-to-dc converters, inverters, and solenoid/relay drivers. ♦



LOOKING FOR INNOVATION? LOOK TO PAIA KITS.

Some recent examples . . .
The GNOME, The only Electronic Music Micro-Synthesizer available in a hand held, battery powered package.
 \$48.95 shipping wt. 4 lbs.
The PYGMY, battery powered practice/headphone/stage amp. 8 watts peak power driving super-efficient 5" acoustic suspension speaker.
 \$39.95 shipping wt. 6 lbs.
NEW 24 HOUR DEMO-LINE for a one-minute recorded demo of PAIA Synthesizers (405) 843-7396. Catalog requests or charge orders also accepted.

FREE CATALOG
 PAIA Electronics, Dept. 9P, 1020 West
 Wilshire Blvd., Oklahoma City, OK 73116

CIRCLE NO. 40 ON FREE INFORMATION CARD

DIXIE **SAVE ON**
Brand Name Audio Components
BY MAIL

**Write Today for Our
 FREE Audio Catalog**

DIXIE is one of the oldest and largest audio component mail order houses in the country. Our prices on brand name components are actually LOWER than "Discounters". See our new catalog or call us for a price quote. Everything shipped factory-sealed with full manufacturer's warranty.

 Master Charge / BankAmericard honored on mail orders		 KOSS
 PIONEER	 MARANTZ	 SHURE
 SONY	 DUAL	 DYNACO

DIXIE HI-FIDELITY
 5600 Seconc St., N. E., Washington, D. C. 20011
 Phone: 1-202-635-4900

Please rush me your FREE Audio Catalog and complete information. I understand there is no obligation.

Name _____
 Address _____
 City _____
 State _____ Zip _____ PE-9

ALLISON 'OPTO-ELECTRIC' The BEST...the ULTIMATE of ALL Ignition Systems!

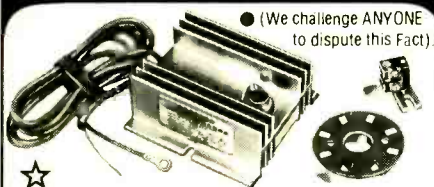

● (We challenge ANYONE to dispute this Fact)

★ Never wears out or needs any Maintenance!



● gives you Maximum Power with continuous PEAK PERFORMANCE ...while reducing Maintenance and Operating Costs!

★ The Allison OPTO-ELECTRIC System eliminates the Points and Condenser, replacing them with an OPTO-ELECTRONIC TRIGGER, using a Light-Emitting Diode and Photo Transistor. The System operates on a beam of Light. As there are NO moving parts in rubbing contact, "Friction-wear" is completely eliminated. Timing adjustments are PERMANENT.

● Gives 40-Times more Timing accuracy than ANY system using "Mechanical" Breaker-Points! UNLIMITED RPM! "Electronically-Controlled" DWELL automatically supplies HIGHEST Performance at both Low and High speeds. Spark strength does not fall off at high RPM. POSITIVE SPARK helps eliminate "Misfire" for faster acceleration and improved Engine Performance. Sparkplugs LAST 3 to 10-Times LONGER.

● Easier Starting under any condition! Smoother running... (NO TIMING FLUCTUATION as with Magnetic Impulse Units) All SOLID-STATE Components UNAFFECTED By Temperature, Moisture, or Vibration! Only Highest grade materials used. Guarantees you Solid, Dependable Performance!

● PERFECT TIMING INCREASES Engine Efficiency and Gas Mileage SAVES Precious Fuel! Allison gives you MAXIMUM Engine Efficiency 100% of the Time and that's the name of the game for the BEST in GAS MILEAGE AND ECONOMY

★ Perfect Timing and Dwell never change.

● Pays for itself! Eliminates ignition Tune-Ups forever! "INFINITE LIFE" Once installed...Never needs replacing!



★ PROVEN RELIABILITY!
Each Unit Tested to 15,000 RPM.

● Road and Race Proven.
(Opto-Electric Systems won at INDY Two years in a row!)

★ You CAN install the ALLISON System in ALL the U.S. made & Foreign Cars! (4, 6, or 8-Cylinder).

"EASIEST-TO-INSTALL" UNIT ON THE MARKET.
(Not necessary to dismantle Distributor as with other systems).

★ If you want the BEST, and SAVE! This is IT!

ORDER with CONFIDENCE...
SATISFACTION GUARANTEED
or Full Refund

Only \$49.95
COMPLETE.

10-YEAR FACTORY WARRANTY!
(Free Repair or Replacement)

that's EVERYTHING!
including
Postage & Insurance

● Send Check or M/O
State Make, Year, Engine Size. (Calif. Res. add Tax).

★ (So New...it's Sold ONLY FROM FACTORY DIRECT).

● You may use your MASTER CHARGE or BANKAMERICARD.
Send us (1) Your Number, (2) Interbank No., (3) Exp. Date

★ Before buying any other Type ignition system...

Send Postcard for our FREE BROCHURE.

★ If you have already installed a C-D ignition system,
Modernize and Increase its Efficiency...
CONVERT YOUR "C-D" UNIT TO BREAKERLESS!
Opto-Electric "TRIGGER UNIT"...Only \$34.95

● Our BEST Salesmen are the users of our ALLISON System!

● America's Oldest and Largest Mfg. of
Opto-Electronic Ignition Systems.



ALLISON
AUTOMOTIVE COMPANY

1267-P, East EDNA PL., COVINA, CAL. 91722

CIRCLE NO. 68 ON FREE INFORMATION CARD

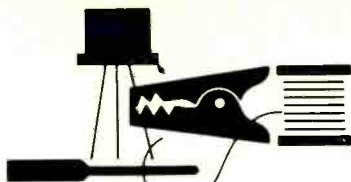

Tips & Techniques

60-Second Interval Timer

In some situations, such as timing Polaroid™ scope photos, it is useful to have a 60-second timer. In the circuit

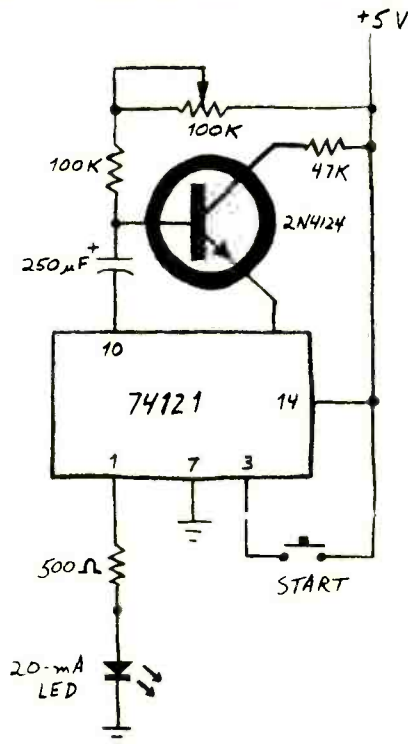

shown, depressing the pushbutton will cause the LED to go off (it is normally on), and then light again after 60 seconds. Adjust the time interval to exactly one minute by varying the 100-k pot.

—Mitch Cohen, Union, NJ

Unclogging A Desoldering Bulb

If you use a desoldering bulb, you might find that the Teflon™ nozzle clogs with solder occasionally. To prevent this, place a drop or two of heaving mineral oil into the nozzle before use. While the oil might smoke slightly from contact with hot solder, this is harmless and eliminates frequent cleaning of the nozzle.

—Edward Brown, N. Miami Beach FL.

Plastic "Clips" Identify Cables

The plastic "clips" commonly used for closing plastic bags can double as cable identifiers. Properly label each clip, using a permanent felt-tip marker, and slip onto the cable. This will keep the many cables of your antenna farm, hi-fi system, etc. from becoming mixed up.

—Alan Prosser, New Brunswick, Canada.

VIDEO PING PONG

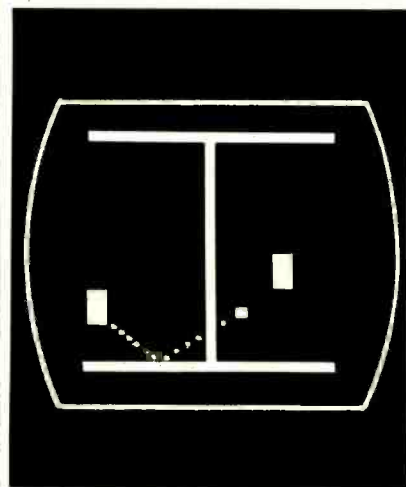

- ATTACHES TO TV ANTENNA
- PLANS, PC CARD, COMPLETE KIT AVAIL.
- ONLY 14 IC'S (7400 FAMILY)

HOTEST ELECTRONIC GAME IN TOWN - NOW CUSTOMIZE YOUR OWN HOME TV - SEND 50¢ FOR INFO PACK - REFUNDED WITH PURCHASE

VIDEO GAMES
20650 RUNNYMEDE, CANOGA CA 91306

CIRCLE NO. 61 ON FREE INFORMATION CARD

EDI

THE SHOPPING CENTER
FOR ELECTRONICS

●HOBBYISTS... EXPERIMENTERS...
SERVICE TECHNICIANS... ENGINEERS●

YOUR SATISFACTION
IS OUR TARGET!

Top Name Brands... Low Prices

AMPLE STOCKS - Including those hard-to-find Parts whether you want a 15¢ capacitor, or a \$50 FET-VOM — you can get it at EDI!

Transistors, ICs, Modules,
Speakers, Stereo, Hi-Fi,
Photo cells and thousands
of other Electronic Parts...

SEND FOR YOUR
FREE CATALOG TODAY!
(updated 5 times a year)

ELECTRONIC DISTRIBUTORS, INC.
DEPT. PE-1 4900 Elston
Chicago, Ill. 60630

NAME _____
Address _____
City _____ State _____ Zip _____

CIRCLE NO. 23 ON FREE INFORMATION CARD

Hobby Scene

CAPACITANCE MULTIPLIER

Q. I've heard that it's possible to use a transistor to "amplify" the capacitance of a fixed capacitor. What does the circuit look like, and how much capacitance can be gotten from it?—Philip Alfonso, Highlands, NJ

A. A capacitance multiplier (Fig. A) can be used. It smooths a pulsating dc voltage into a ripple-free one. The effective filter capacitance, C_F , is equal to the product of C_r , the base filter capacitor, and β , the current gain of the transistor. It is possible to simulate capacitance values up to one farad or more by using medium-size electrolytics and high-beta transistors.

BROADCAST INTERFERENCE FILTER

Q. I have a small shortwave receiver and am experiencing interference from a new AM radio station on 1170 kHz. I pick up the AM station at many points on the shortwave bands. Is there any way I can stop this interference?—Doug Wirth, Somerville, N.J.

A. The interference you are experiencing is due to receiver overloading. Because you are so close to the broadcast station, its field strength at your home is very high. The shortwave receiver just can't cope with the strong signal levels and is generating false signals on the shortwave bands. A simple signal trap should be installed as shown (Fig. B). The coil can be a

ferrite loop antenna coil for the AM band (Lafayette 34 F 87485). The capacitor should be a 365-pF variable unit. The Lafayette 99 F 62176 is ideal for this purpose since it has a calibrated dial. Install L and C in a metal utility box, which is bonded to a good earth ground. Be sure to use coaxial cable from the antenna to the trap, and from the trap to the receiver, and tie all chassis together by means of the coax braid. Adjust C for a null at the broadcast station's frequency and most of its signal will be shunted to ground. When listening on the AM broadcast band, (when filtering is not desired) open the switch.

REGULATED CURRENT SOURCE

Q. I need a current source with a regulated output covering 50 to 200 mA. Do you have a circuit?

—R. Crumb, Gary, Ind.

A. If you apply 50 V to the input of the circuit shown (Fig. C) 50 to 200 mA of regulated current can be obtained at the output. Adjust the potentiometer for the desired value. Use a good heat sink on the pass transistor to avoid thermal instability.

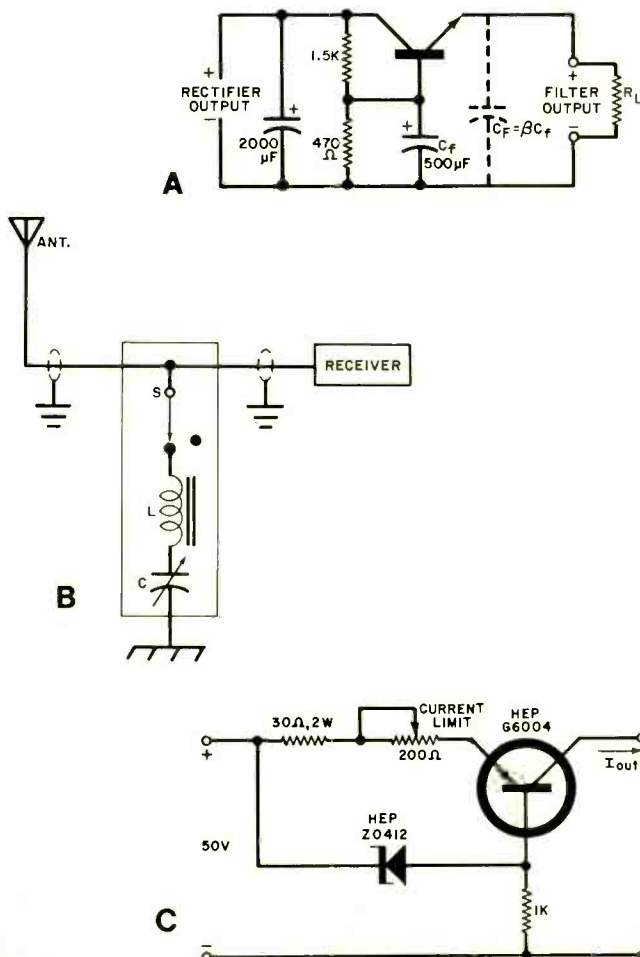

SENCORE'S DVM32

THE FIRST COMPLETE PORTABLE DIGITAL MULTIMETER



\$198 Less batteries and optional AC adaptor.

IT'S ACCURATE

- Industry standard 3½ digit, L.E.D. readout.
- Complete measuring capabilities:
 - DC Volts: 1mV to 1999V, 4 ranges.
 - AC Volts: 1mV to 1000V, 4 ranges
 - AC, DC Current: 1µA to 1.999A, 4 ranges
 - Ohms: .1 ohms to 19.99 megohms, 6 ranges
 - 50Kv capabilities using optional 1% High Voltage Probe
- Digital Accuracy
 - DC Volts: ± .5%
 - AC Volts, Current: ± 1.5%
 - DC Current and Ohms: ± 1%
- Complete High and Low Power ohms functions.
- High 15 megohm input impedance to minimize circuit loading

IT'S AUTOMATIC AND FAST

- Fast response time with 2½ updates a second.
- Automatic polarity, decimal and overrange indication.

TAKE IT ANYWHERE

- True portability using "C" cells, rechargeables or AC adaptor.
- Patent pending "Auto-Off" blanks bright L.E.D. display between measurements, drawing only 15mA, for the first, long life, battery operated L.E.D. digital multimeter.
- Portable protection. Tough Cyclocac® case withstands field use.
- Overload protection to 2000V on DCV, 1000V on all other ranges.

BACKED BY OUR 100% MADE RIGHT LIFETIME GUARANTEE

Available at your Sencore Full Line Promotional Distributor.

SENCORE 3200 Sencore Drive, Sioux Falls, S.D. 57107
Phone: 605-339-0100 TWX: 910-660-0300

Now the most enjoyable, do-it-yourself project of your life— a Schober



Electronic Organ!

You'll never reap greater reward, more fun and proud accomplishment, more benefit for the whole family, than by assembling your own Schober Electronic Organ.

You need no knowledge of electronics, woodwork or music. Schober's complete kits and crystal-clear instructions show you— whoever you are, whatever your skill (or lack of it)— how to turn the hundreds of quality parts into one of the world's most beautiful, most musical organs, worth up to twice the cost of the kit.

Five superb models, with kit prices from \$575 to around \$2,300, each an authentic musical instrument actually superior to most you see in stores.

Join the thousands of Schober Organ builder-owners who live in every state of the Union. Often starting without technical or music skills, they have the time of their lives— first assembling, then learning to play the modern King of Instruments through our superlative instructions and playing courses.

Get the full story FREE by mailing the coupon TODAY for the big Schober color catalog, with all the fascinating details!

The Schober Organ Corp., Dept. PE-61
43 West 61st Street, New York, N. Y. 10023

- Please send me Schober Organ Catalog.
 Enclosed please find \$1.00 for 12-inch L.P. record of Schober Organ music.

NAME _____

ADDRESS _____

CITY _____ STATE _____ ZIP _____

CIRCLE NO. 49 ON FREE INFORMATION CARD



LISTEN!

We're one of the country's largest Mail Order Houses of Stereo Equipment and Musical Instruments.

Our volume buying power enables us to pass the savings on to you. Listen to us ... You can't go wrong.

Fill out this coupon and mail to address below for our latest Free Catalogs.

Name _____

Address _____

City _____

State _____ Zip _____

- AUDIO CATALOG
 MUSICAL INSTRUMENT CATALOG

PE-9

STEREO DISCOUNTERS
7A AYLESBURY ROAD □ TIMONIUM, MD. 21093
(301) 252-6880

CIRCLE NO. 55 ON FREE INFORMATION CARD



Electronics Library

TRANSISTOR SUBSTITUTION HANDBOOK No. 14

The fourteenth edition of the Transistor Substitution Handbook has been updated by the Howard Sams Engineering Staff to include the latest type numbers. Section 1 contains substitutions for American and foreign transistors, arranged in numerical and alphabetical order. Types recommended by the manufacturers of general-purpose replacement transistors are included at the end of each list of substitutes. Additional data on the general-purpose types—the manufacturer, polarity, material (Ge or Si), and the recommended applications—are reviewed in Section 2. When an exact replacement is impossible, the closest match is listed. Over 10,000 bipolar types are included.

Published by Howard W. Sams and Co.,
4300 W. 62nd Street, Indianapolis, IN 46206. 152 pages (8½ x 11). \$2.95 soft-bound.

RCA COLOR TV SERVICE HANDBOOK

The fifth volume of RCA's Color TV Service Handbook provides service data for 1973 and 1974 models of 16 manufacturers, including Admiral, GE, Hitachi, Magnavox, Motorola, Panasonic, Philco, RCA, Sony, Sylvania and Zenith. A Chassis Index guides the user to information on chassis layouts, hot and cold leakage current checks, RCA tube and SK semiconductor replacements, and several adjustment procedures, such as those for purity, convergence, agc, horizontal hold, color killer, pin cushion, black-and-white set-up, color APFC (field), and high voltage. Information in the book is based on each manufacturer's service notes.

Published by RCA Commercial Engineering, Harrison, NJ 07029. 276 pages. Soft cover. \$3.75.

DIAL 911: MODERN EMERGENCY COMMUNICATIONS NETWORKS

by Leo Sands and George Leon

The communications networks used to handle emergency traffic by public service agencies are described in this book. Dispatching techniques, hardware aspects of these systems, and detailed information about systems in operation in New York, Philadelphia, and other cities are highlighted. Also covered are foot patrolman's communications, electronic surveillance, "bugging," polygraphs, voice identification, and call box systems. Citizens' participation in these networks (by CB and

WE'LL YOU SAVE MONEY



ON FAMOUS BRAND NATIONALLY ADVERTISED

STEREO COMPONENTS, VIDEO & PROFESSIONAL PRODUCTS EQUIPMENT

WRITE TODAY FOR OUR QUOTE AND OUR COMPLETE AUDIO CATALOG.

FAST DELIVERY IN FACTORY SEALED CARTONS

FOR IMMEDIATE QUOTE

CALL (202) 723-6060

THE COST OF YOUR CALL WILL BE DEDUCTED FROM ANY ORDER OVER \$200.00.



A.D.R. AUDIO VIDEO
6200 CHILLUM PLACE N.W.
WASHINGTON, D.C. 20011

Master Charge/BankAmericard Honored on Mail Orders

CIRCLE NO. 1 ON FREE INFORMATION CARD

A Major Advance...

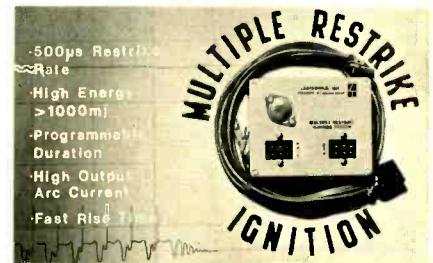

- *INSURES PROPER COMBUSTION
- *EASIER STARTING
- *LONGER POINTS and PLUG LIFE
- *INCREASE MILEAGE up to 40%
- *EASY INSTALLATION (12v neg. gnd.)

Labtronics' Multiple Restrike (M-R) Ignition produces a high energy repetitive spark on each power stroke to effectively ignite the air/fuel mixture. M-R statistically insures more complete combustion - resulting in greater energy and increased efficiency. Send for Labtronics' free literature on the M-R system. Better yet, experience M-R and enjoy the pleasure and the economy of a well-performing engine.

Model VI \$79.95 • 1 Year Warranty •

Model VI-B \$59.95

Brochure

30 Day Money

P.P.D. in U.S.A.

Back Guarantee

Send Check or Money Order to:

Labtronics, Incorporated
3635 Hillside, Ypsilanti, Michigan 48197

DEDICATED TO EFFICIENCY

CIRCLE NO. 27 ON FREE INFORMATION CARD

LED WRISTWATCH

MODULE BASIC PARTS KIT

FEATURING AN LSI CMOS INTEGRATED CIRCUIT WITH HOURS, MINUTES, SEC. AND DATE. YOUR CHOICE OF 12 OR 24 HOUR IC. PLEASE SPECIFY



\$ 29.95 + 1.00 P & H

FOR JUST 29.95 YOU WILL RECEIVE THE BASIC ESSENTIALS. YOU NEED ONLY SUPPLY A FEW CAPACITORS AND RESISTORS AND THE READILY AVAILABLE MAN 3 DISPLAYS. THE MODULE HOUSING IS UP TO YOU.

THE BASIC PARTS KIT CONTAINS PC FOIL LAYOUT, IC, INSTRUCTIONS, TRIMMER, CRYSTAL AND 4 DRIVERS



ALPHA ELECTRONICS
DEPT 1 PO BOX 1005
MERRITT ISLAND, FLA. 32952

TO ORDER OR FOR INFORMATION
CALL TOLL FREE
800 - 327 - 2084

CIRCLE NO. 6 ON FREE INFORMATION CARD

ISOATIP®

QUICK CHARGE

Recharges in 1/3rd the time of any other cordless iron.

Complete line of accessories available:



No. 7566
Micro Soldering Tip



No. 7535
Regular Tip



No. 7546
Heavy Duty Tip



No. 7596
Knife Tip



No. 7545
Fine Tip

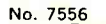

No. 7556
Tuner Extension Tip



No. 7577
Chisel Tip



No. 7574
Concave Tip



No. 7569
"V" Tip



No. 7573
Tinning Tip



No. 7572
Blunt Tip

WAHL CLIPPER CORPORATION
ORIGINATORS OF PRACTICAL CORDLESS SOLDERING
Sterling, Illinois 61081 (815) 625-6525
"Manufacturing Excellence Since 1919"

CIRCLE NO. 60 ON FREE INFORMATION CARD

SEPTEMBER 1975

amateur radio operators) is described. A list of police radio frequencies forms an appendix.

Published by Hayden Book Co., 50 Essex Street, Rochelle Park, NJ 07662. 118 pages. \$3.95 soft cover.

HOW IT WORKS... HOW TO FIX IT HOME/ENTERTAINMENT PRODUCTS

Written for the home handyman, this book explains in simple language how televisions, audio products, photographic equipment, typewriters and power tools operate. Tips on making minor repairs are given, supplemented with illustrations and glossaries. To keep those products operating before and after you fix them, suggestions are made on routine maintenance. With the cost of skilled repair services mounting, this book will be of interest to those with the desire and basic mechanical aptitude to repair these devices in their own home.

Published by Rand McNally and Co., 10 E. 53rd St., New York, NY 10022. 98 pages (8½" x 11"). \$1.95 soft cover.

THE CALCULATING BOOK

by James Rodgers

Subtitled "Fun and Games with Your Pocket Calculator," this book presents puzzles, tricks, and games for a four-banger with floating decimal and a chain/constant switch. Following the instructions set down by the author, you can make your calculator say "hello" (enter 07734 and read upside-down), compute famous dates in American history, guess numbers that your friends make up, and approximate square roots and π. Basic calculator functions and operations are also explained for more serious applications.

Published by Random House, Inc., 201 E. 50th St., New York, NY 10022. 81 pages. \$2.95 soft cover.

ELECTRONIC CIRCUIT BEHAVIOR

by Daniel Metzger

An overview of electronics, including a capsule history and fundamental concepts and theorems, introduces this work. Using simple algebra and right-triangle trigonometry, the author describes how actual electronic components work in a circuit, rather than going into deep theoretical analyses. Among the areas covered are diodes, power supplies, transistors (bipolar), switching and amplifier circuits, FET's, oscillators, linear and digital IC's, and feedback circuits. The final chapter highlights typical circuits that appear in commercial equipment. Appendices include schematic symbols, popular packages, charts, tables, formula derivations, and selected device specifications.

Published by Prentice-Hall, Inc., Englewood Cliffs, NJ 07632. 426 pages. \$15.95 hard cover.

FREE EICO CATALOG

346 Ways To Save On Instruments, Burglar Alarms, Automotive & Hobby Electronics!

The more you know about electronics, the more you'll appreciate EICO. We have a wide range of products for you to choose from, each designed to provide you with the most pleasure and quality performance for your money. The fact that more than 3 million EICO products are in use attests to their quality and performance.

"Build-it-Yourself" and save up to 50% with our famous electronic kits.

For latest EICO Catalog on Test Instruments, Automotive and Hobby Electronics, Eicocraft Project kits, Burglar-Fire Alarm Systems and name of nearest EICO Distributor, check reader service card or send 50¢ for fast first class mail service.

**EICO—283 Malta Street,
Brooklyn, N.Y. 11207**

Leadership in creative electronics since 1945.



CIRCLE NO. 20 ON FREE INFORMATION CARD



12 REASONS YOUR CAR NEEDS TIGER CDI

Instant starting in any weather - Eliminates tune-ups - Increases gas mileage - Increases horsepower 15% - Improves acceleration and performance - Spark plugs last up to 70,000 miles - Reduces engine maintenance expense - Amplifies spark plug voltage to 45,000 volts - Maintains spark plug voltage to 10,000 RPM - Reduces exhaust emissions - Dual ignition switch - An Unconditional LIFETIME GUARANTEE Installs in 10 minutes on any car with 12 volt negative ground - No rewiring - Most powerful, efficient and reliable Solid State Ignition made.

SATISFACTION GUARANTEED or money back

TIGER 500 assembled \$53.95
TIGER SST assembled \$42.95
 Post Paid in U.S.A.

Send check or money order with order to:

Tri-Star Corporation
 P. O. Box 1727 C
 Grand Junction, Colorado 81501

DEALER INQUIRIES INVITED

CIRCLE NO. 57 ON FREE INFORMATION CARD



send for your **FREE** copy now!!!

In it you'll find hundreds of quality consumer electronic products. Amateur radios, CB radios, scanners, antennas, masts, towers, rotors, tools, components, electronic kits, technical books, test gear, digital watches, calculators, portable radios, televisions, microphones, speakers, audio equipment, high fidelity, stereo systems, tape recorders, and much, much more. If it's electronic and it's quality, TECO has it.

WRITE FOR YOUR FREE COPY TODAY.



P. O. Box 1050 • Garland, Texas 75040

CIRCLE NO. 59 ON FREE INFORMATION CARD

Operation Assist

If you need information on outdated or rare equipment—a schematic, parts list, etc.—another reader might be able to assist. Simply send a postcard to Operation Assist: POPULAR ELECTRONICS, 1 Park Ave., New York, NY 10016. For those who can help readers, please respond directly to them. They'll appreciate it. (Only those items regarding equipment not available from normal sources are published.)

York 4-Band Portable Radio, Model G34. Schematic. L. Paliser, c/o Pecan Manor, Central State Hospital, Milledgeville, GA 31062.

Precision Apparatus Tube & Battery Tester, Series 612. Source or copies of tube update rollers. Albert Stock, RD 1, Bushkill, PA 18324.

General Electronic Music Napoli Organ (468203) and **Hyler Ignition Scope Model 326-A.** Schematics. Peter Donneau, 11 Blanche Avenue, Cumberland, RI 02864.

Craig Electronic Notebook Model 490. Recording Tapes. Paul Chance, 17990 Graystone Lane, San Jose, CA 95120.

Federal Telephone & Radio AM/SW Receiver Model 1030-T. Schematic. Robert Remes, 813 N. Noland, Independence, MO 64050.

Jackson Electrical Instrument Dynamic Tube Tester Model 636 and **Winston Research Automatic Gain Control Model C.** Service manuals and/or schematics. Leo Krebs, Box 842, Apple Valley, CA 92307.

Jackson Electrical Instrument AM-FM Signal Generator Model 641A. Schematic. J. James, 1187 W. 23rd St., Vancouver, BC V7P 2H2.

E.H. Scott 6-Band (150 kHz to 80 MHz) Receiver Serial E-706. Schematic and/or service manual. Jim Segrave, 5987 Franklin Ave., Apt. 201, Los Angeles, CA 90028.

General Household Utility Cabinet Model Grunow Radio (1935). Any available information. Ted Jensen, 33 Field Road, Silver Bay, MN 55614.

Fisher X-101 Stereo Amplifier. Schematic. Delbert Cox, 205 Y St., Newburgh, NY 12550.

A.H. Grebe Cabinet Radio (serial 212048) and/or **Atwater Kent Model 55.** Any available information. Gerald Linden, 407 Longfield Rd., Erdenheim, PA 19118.

Wardle-Davenport Free Precision Proton Magnetometer. Schematic and/or service info. C. Fred Goodwin, Coordinator, SMVTI, 2 Fort Road, South Portland, ME 04106.

Blaupunkt (Kofferradio) Derby Receiver Model 94770. Tuning capacitor or source for same. Edward Dygert, RD 1, Box 262, Mohawk, NY 13407.

Scintillonics (Ft. Collins, CO) Radiation Detector (meter calibrated in microrentgens/hour). Battery placement data, calibration and operating instructions. C.J. Orciuch, 982 Rosada Ct., Camarillo, CA 93010.

Clairtone Solid-State 17 Stereo Receiver. Schematic and/or service info. Wayne Berg, 1691 Garland Ave., Tustin, GA 92680.

Argus Model AV800 CCTV Cameras. Schematic and specs. Robert Hastings, 4650 E. Fulton # 109, Tulsa, OK 74135.

Note: Supreme Publications offers schematics and service information on many old radio and TV receivers. Usual cost is \$1 for radio material and \$1.50 for TV material, covering a specific set. Address: 1760 Balsam Road, Highland Park, Ill.

For more information on items mentioned in editorial copy or ads, circle appropriate number on the "Free Information" Card.

ABOUT YOUR SUBSCRIPTION

Your subscription to POPULAR ELECTRONICS is maintained on one of the world's most modern, efficient computer systems, and if you're like 99% of our subscribers, you'll never have any reason to complain about your subscription service.

We have found that when complaints do arise, the majority of them occur because people have written their names or addresses differently at different times. For example, if your subscription were listed under "William Jones, Cedar Lane, Middletown, Arizona," and you were to renew it as "Bill Jones, Cedar Lane, Middletown, Arizona," our computer would think that two separate subscriptions were involved, and it would start sending you two copies of POPULAR ELECTRONICS each month. Other examples of combinations of names that would confuse the computer would include: John Henry Smith and Henry Smith; and Mrs. Joseph Jones and Mary Jones. Minor differences in addresses can also lead to difficulties. For example, to the computer, 100 Second St. is not the same as 100 2nd St.

So, please, when you write us about your subscription, be sure to enclose the mailing label from the cover of the magazine—or else copy your name and address exactly as they appear on the mailing label. This will greatly reduce any chance of error, and we will be able to service your request much more quickly.

SAVE!

MONEY • TIME • FREIGHT

- ♪ QUALITY STEREO EQUIPMENT AT LOWEST PRICES.
- ♪ YOUR REQUEST FOR QUOTATION RETURNED SAME DAY.
- ♪ FACTORY SEALED CARTONS—GUARANTEED AND INSURED.
- ♪ SAVE ON NAME BRANDS LIKE:

A.D.C.	KLH
A.R.	SHURE
DYNACO	KOSS
SONY	FISHER

PIONEER

AND MORE THAN 50 OTHERS
 BUY THE MODERN WAY
 BY MAIL—FROM

illinois audio

Department 217S
 12 East Delaware
 Chicago, Illinois 60611
 312-664-0020

CIRCLE NO. 63 ON FREE INFORMATION CARD

POPULAR ELECTRONICS

LIVE IN THE WORLD OF TOMORROW ... TODAY!

And our **FREE 164 PAGE CATALOG** is packed with exciting and unusual values in electronic, hobby and science items — plus 4,500 finds for fun, study or profit ... for every member of the family.

A BETTER LIFE STARTS HERE

He-Ne LASERS FROM \$115.00

Edmund quality. TEM₀₀ mode. cold cathode for long life. Completely self-contained units: solid state power supply, 110v AC. 0.3mW min — GREAT GENERAL PURPOSE LASER: 1.2mm beam dia., 2.0mRad beam Diverg.

- Stock No. 79,061AV \$115.00 Ppd.
1.0mW min — HI-PERFORMANCE LAB LASER: 1.2mm beam dia., 1.0mRad beam Diverg.
- Stock No. 79,050AV \$180.00 Ppd.
3.0mW min — PENDABLE HI-POWERED LASER: 1.0mm beam dia., 0.8mRad beam Diverg.
- Stock No. 79,052AV \$350.00 Ppd.



The MOST POWERFUL SOLAR CELL!

World's biggest (3" dia.), strongest silicon cell delivers over 1 amp. @ .5v D.C. or 1/2W. 5 times more efficient per cost than ever before! Only 1 mil thick. Tab leads for any circuit, 100's of applications. Hook in series for more voltage; parallel—more current. Real breakthrough!

- No. 42,270AV \$19.95 Ppd.
2" DIA. 500 mA. @ .5v
- No. 42,145AV \$9.95 Ppd.
PIE-SHAPED 1/4 2" DIA. 100 mA. @ .5v
- No. 42,146AV \$5.50 Ppd.

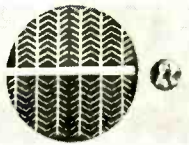

PRO ELECTRONIC SOUND CATCHER

Parabolic mike w/ 18-3/4" reflecting shield & 2 I.C.'s in amplifier magnifies signals 100X that of omni-directional mikes. Catch a songbird 1/2 mile off; QB's huddle strategy; sounds never before heard. Super directivity gives highest signal to noise ratio poss. Safe: auto. cuts off ear damaging noises. Earphones, taperecorder output, tripod socket. Req. two 9v trans. batt. (not incl).

- No. 1649AV ... (5 1/2 LB.) \$299.00 Ppd.
- BIG EAR "TOY" MODEL #80,176AV \$32.25 Ppd.



SUPER POWER FOR ANY AM RADIO

New antenna assist turns a tiny transistor into a tiger, has pulled in stations 1000 miles away! Just set it beside your radio (no wires, clips, grounding) and fine-tune Select-A-Tenna's dial to same frequency — "Gangbusters"! Terrific for sportsmen, vacationers. Great for clearing weak signals in radio depressed area, off-coast islands, stations in crowded frequencies. Solid state—uses no electricity, batts., tubes. Works almost forever.

- Stock No. 72,095AV \$15.95 Ppd.



WHEN YOU COME TO PHILADELPHIA BE SURE TO SEE
FREE BICENTENNIAL LIGHT SHOW
IN BARRINGTON, N.J. ONLY 10 MINUTES AWAY AT
EDMUND FACTORY STORE

"POP" YOUR OWN BUTTONS

Make customized badges in minutes! Create your own, reproduce photos with name affixed. Great anywhere, from kindergarten to business meetings, to school sports. Sell for profit! Ingenious badge machine makes permanent buttons; kit includes precision



cast hand die press, matching color dies, starter asst. for 25 complete badges including plastic protectors. Sold nationally for several dollars each, yours will pay off fast. Step-by-step instrs.

- Stock No. 71,974AV \$31.50 Ppd.
- 100 EXTRA BADGE PARTS \$13.50 Ppd.
- Stock No. 71,976AV

AN ALPHA MONITOR FOR \$34.95?

Yes, because you build it! Use your ability to tune in your brainwaves, an aid to relaxation, concentration. Kit incl.: everything you need (except 9v trans. batt.) to own a portable self-cont. BIOFEEDBACK unit for



steth. earphones, electrode headband, solid-state circuitry; 5 microvolt sensitivity, more! Compl. assembly instructions & op. manual. With basic electronics knowledge, you can do it!

- No. 61,069AV ... (KIT) \$34.95 Ppd.
- No. 71,809AV ... (FULLY ASSEMBLED) \$55.00 Ppd.

BUILD A SOLAR HOME AND SAVE!

Beat the energy crisis—build a modern 70 room solar heated & air conditioned home designed by famous ecological architect Malcolm B. Wells! Its 10-yr.-proven Thomason "Solaris System" can cut conventional heating costs as much as 2/3! Your builder can modify or use as-is the complete blueprints included with "Solar House Plans III" (by Edmund, Homan Thomason & Wells). Estimated \$40,000 building cost. 48-pg book shows all pro's and cons. Illustr.



- No. 9469AV ... (8 1/2 x 11" PPRBK) \$24.95 Ppd.

WHICH ARE YOUR CRITICAL DAYS?

Can Bio-rhythm tell you? We're not sure, but we're told that vast mood shifts are caused by your body's internal Time Clock whose rhythms can be charted ahead to possibly warn you of "critical" days. Some are great, some blah. Maybe it's your physical, emotional & intellectual rhythms converging at the right or wrong time. Compute your cycles with our Bio-rhythm kit and judge for yourself. Incl. Charting kit, metal Dialgraft Calc. instrs.



- Stock No. 71,949AV \$14.50 Ppd.
- 1 YR. PERSONALIZED REPORT BY COMPUTER
- Stock No. 19,200AV ... (send Birthdate) \$15.95 Ppd.

CAN'T SLEEP, RELAX? TRY THIS!

Electronic sound conditioner simulates 4 kinds of soothing sounds of ocean surf and rain. "White sound" helps mask unwanted noise, adds restful, intriguing background sound. Program the solid-state unit to your own need: 2 surf, 2 rain, or "white sound", proven by medical tests to have analgesic effects. Great for meditation, restlessness, sleeplessness psychology.

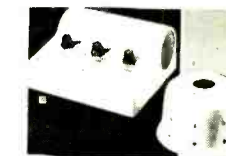

- (A)-No. 71,997AV ... (7 1/2 x 7 x 3 1/2") 110V AC \$79.95 Ppd.
- (B)-AS ABOVE, BUT "WHITE SOUND" ONLY
- No. 71,980AV ... (6" Rd. x 3 1/2" Hi) \$28.00 Ppd.



MAIL COUPON FOR GIANT FREE CATALOG!

164 PAGES • MORE THAN **4500 UNUSUAL BARGAINS**

Completely new 1975 edition. New items, categories, illustrations. Dozens of electrical and electromagnetic parts, accessories. Enormous selection of Astronomical Telescopes. Unique lighting and ecological items. Microscopes. Binoculars. Magnifiers. Magnets. Lenses. Prisms. Hard-to-get-surplus bargains. Ingenious scientific tools. 1000's of components.

EDMUND SCIENTIFIC CO.
300 Edscorp Building, Barrington, N.J. 08007
Please rush Free Giant Catalog "AV"

Name _____
Address _____
City _____ State _____ Zip _____



COMPLETE & MAIL WITH CHECK OR M.O.

EDMUND SCIENTIFIC CO. 300 Edscorp Building, Barrington, N.J. 08007

How Many	Stock No.	Description	Price Each	Total
<input type="checkbox"/>		PLEASE SEND GIANT FREE CATALOG "AV"		
<input type="checkbox"/>		Charge my BankAmericard		
<input type="checkbox"/>		Charge my Master Charge		
Add Handling Chg.: \$1.00, Orders Under \$5.00, 50¢, Orders Over \$5.00				
Interbank No. _____				
My Card No. Is _____				
Card Expiration Date _____				
30-DAY MONEY-BACK GUARANTEE				
You must be satisfied or return any purchase in 30 days for full refund. *\$15.00 minimum				
Signature _____				
City _____			State _____ Zip _____	

ELECTRONICS MARKET PLACE

NON-DISPLAY CLASSIFIED: COMMERCIAL RATE: For firms or individuals offering commercial products or services. \$1.80 per word (including name and address). Minimum order \$27.00. Payment must accompany copy except when ads are placed by accredited advertising agencies. Frequency discount; 5% for 6 months; 10% for 12 months paid in advance. **READER RATE:** For individuals with a personal item to buy or sell, \$1.10 per word (including name and address.) No minimum! Payment must accompany copy. **DISPLAY CLASSIFIED:** 1" by 1 column (2-1/4" wide), \$215.00. 2" by 1 column, \$430.00. 3" by 1 column, \$645.00. Advertiser to supply cuts. For frequency rates, please inquire.

GENERAL INFORMATION: First word in all ads set in bold caps at no extra charge. All copy subject to publisher's approval. All advertisers using Post Office Boxes in their addresses **MUST** supply publisher with permanent address and telephone number before ad can be run. Advertisements will not be published which advertise or promote the use of devices for the surreptitious interception of communications. Closing Date: 1st of the 2nd month preceding cover date (for example, March issue closes January 1st. Send order and remittance to **POPULAR ELECTRONICS**, One Park Avenue, New York, New York 10016. Attention: Hal Cymes.

FOR SALE

FREE! Bargain Catalog—I.C.'s, LED's, readouts, fiber optics, calculators parts & kits, semiconductors, parts. Poly Paks, Box 942PE, Lynnfield, Mass. 01940.

GOVERNMENT Surplus Receivers, Transmitters, Snooperscopes, Radios, Parts. Picture Catalog 25 cents. Meshna, Nahant, Mass. 01908.

LOWEST Prices Electronic Parts. Confidential Catalog Free. KNAPP, 3174 8th Ave. S.W., Largo, Fla. 33540.

ELECTRONIC PARTS, semiconductors, kits. FREE FLYER. Large catalog \$1.00 deposit. BIGELOW ELECTRONICS, Bluffton, Ohio 45817.

RADIO—T.V. Tubes—36 cents each. Send for free catalog. Cornell, 4213 University, San Diego, Calif. 92105.

AMATEUR SCIENTISTS, Electronics Experimenters, Science Fair Students. Construction plans—Complete, including drawings, schematics, parts list with prices and sources. Robot Man — Psychedelic shows — Lasers — Emotion/Lie Detector — Touch Tone Dial — Quadrasonic Adapter — Transistorized Ignition — Burglar Alarm — Sound Meter over 60 items. Send 50 cents coin (no stamps) for complete catalog. Technical Writers Group, Box 5994, University Station, Raleigh, N.C. 27607.

METERS—Surplus, new used, panel or portable. Send for list. Hanchett, Box 5577, Riverside, CA 92507.

TELEPHONE "BUGGED"? Countermeasures Brochure \$1.00. Negeye, Drawer 547, Pennsboro, W. VA 26415.

ALTAIR 8800 USERS!

DID YOU KNOW . . .

- that our 4K memory board can remember things after you pull the plug!
- that our I/O module will interface two TV typewriters, with keyboards, a teletype and modem, all at the same time!
- that all of our modules are 100% compatible with the 8800 computer!
- that our Software is FREE! or close to it
- that we deliver on time!!

INPUT/OUTPUT

This one card will meet all common I/O requirements. Interface your Altair with the TV Typewriter and at the same time a teletype or modem, plus other devices.

- Two parallel input and output ports
- One serial I/O for any teletype and/or EIA RS-232C device, uses a UART
- Two special ports for any imaginable control needs
- Serial data rate from 35 to 9600 baud
- Full I/O handshaking provided

ORDER KIT No. 3P+S . . . \$125.

MEMORIES

Our high speed, low power static read write memory (RAM) allows the 8800 to run at top speed. All our memory IC's are 100% tested to Military STD-8831. Each card accepts up to 4096 8 bit words.

ORDER KIT No. 4KRA
4KRA-4, w/4096 8-bit words . . . \$215.
4KRA-2, w/2048 8-bit words . . . \$135.

Our PROM card accepts up to eight 1702A or 5203 erasable programmable read only memories. All necessary 8800 interface logic is provided but NO PROM's.

ORDER KIT No. 2KRO . . . \$ 50.

Write for assembled unit pricing. Send for our FREE flyer or order now from:

PROCESSOR TECHNOLOGY CO.
2465P Fourth St., Berkeley, Calif. 94710
(415) 549-0857

Terms: All items postpaid if full payment comes with order. Calif. residents add sales tax. COD orders must include 25% deposit. Discounts: 5% orders over \$375; 10% orders over \$600.

WE SELL CONSTRUCTION PLANS. TELEPHONE: Answering Machine, Speakerphone, Carphone, Phonevision, Auto Dialer, Touch Button Dialer, Central Dial System. **TELEVISION:** \$35.00 Color Converter, Video Tape Recorder, \$25.00 Camera. **HOBBYIST:** Electron Microscope, 96 Hour Tape Music System, Ultrasonic Dishwasher, Radar-Oven, Plans \$4.95 each. **NEW ITEM:** \$75. Electronic Pocket Calculator, \$7.50. **COURSES:** Telephone Engineering \$39.50. Detective Electronics \$22.50. Integrated Circuit Engineering, \$49.50. **NEW SUPER HOBBY CATALOG** plus year's subscription to Electronic News Letter AIRMAILED \$1.00. Don Britton Enterprises, 6200 Wilshire Blvd., Los Angeles, Calif. 90048.

MECHANICAL, ELECTRONIC devices catalog 10 cents. **Greatest Values — Lowest Prices.** Fertik's, 5249 "D", Philadelphia, Pa. 19120.

SOUND SYNTHESIZER KITS—Surf \$12.95, Wind \$12.95, Wind Chimes \$17.95, Electronic Songbird \$6.95, Musical Accessories, many more. Catalog free. PAIA Electronics, Box J14359, Oklahoma City, OK 73114.

BUGGED??? New locator finds them fast. Write, Clifton, 11500-L N.W. 7th Avenue, Miami, Florida 33168.

DISCOUNT PRICES

B&K, SENCORE, LEADER, RCA, EICO, FLUKE and HICKOK

Test Equipment

ICC/Servicecenter, RCA and Raytheon Supplies
Complete line of electronic supplies

Free Catalog

FORDHAM RADIO SUPPLY CO., INC.

558 Morris Ave. • Bronx, N.Y. 10451

FREE CATALOG. Parts, circuit boards for POPULAR ELECTRONICS projects. PAIA Electronics, Box C14359, Oklahoma City, OK 73114.

YOU WILL SAVE BIG MONEY! Surplus, Clearouts, Bankruptcy, Inventory, Deals. Catalog \$1 (redeemable). ETCOA Electronics, Box 741, Montreal, H3C 2V2. U.S. Inquiries.

HEAR POLICE/FIRE Dispatchers! Catalog shows exclusive directories of "confidential" channels, receivers. Send 10 cent stamp. Communications, Box 56-PE, Commack, N.Y. 11725.

CONVERT any television to sensitive, big-screen oscilloscope. Only minor changes required. No electronic experience necessary. Illustrated plans \$2.00. Sanders, Dept. A-33, Box 92102, Houston, Texas 77010.

CD IGNITIONS, VHF/UHF monitors, crystals, CB radios, Southland, Box 3591-B, Baytown, Texas 77520.

CRYSTALS, Scanners, \$3.88, include make and frequency. G Enterprises, P.O. Box 461PC, Clearfield, UT 84105.

ALPHA/THETA BRAINWAVE biofeedback instruments. Analog instruments from \$125; digital processing systems from \$225. BioScan, Box 14168-E, Houston, Texas 77021.

SURPRISE! Build inexpensively, the most Unusual Test Instruments, Futuristic Gadgets using Numerical Readouts! Catalogue Free! GBS, Box 100A, Green Bank, West Virginia 24944.

WHOLESALE Scanners, CB, Crystals, Directories, SSB/AM. Catalog 25 cents. G—Enterprises, Box 461P, Clearfield, Utah 84105.

LEARN DESIGN TECHNIQUES. Electronics Design Newsletter. Digital, linear construction projects, design theory and procedures. Annual subscription \$6.00, sample copy \$1.00. Valley West, Box 2119-B, Sunnyvale, California 94087.

TELEPHONES UNLIMITED, equipment, supplies. Catalog 50 cents. Box 1654E, Costa Mesa, Calif. 92626.

SURPRISE! SURPRISE! Digital Piano Tuning Device tunes musical instruments Accurately! Perfectly! Inexpensively! Construction-Instruction-Plans Complete \$12.95 Airmailed Postpaid! Moonlighting quickly repays \$40 electronics investment! GBS, Box 100P, Green Bank, West Virginia 24944.

PYROTECHNICAL chemicals, casings, fuse, tools, literature, supplies. Catalog-50 cents, with samples — \$2.00. Westech, Logan, Utah 84321.

DIGITAL ELECTRONICS! Highly effective course brings immediate results, \$10.00. Satisfaction or \$11.00 refunded! Plans, Projects, Free Literature. DYNASIGN, Box 60A7, Wayland, Mass. 01778.

UNSCRAMBLERS: Fits any scanner or monitor, easily adjusts to all scrambled frequencies. Only 4" square \$29.95, fully guaranteed. Dealer inquiries welcomed. PDQ Electronics, Box 841, North Little Rock, Arkansas 72115.

ELECTRONIC parts, low prices, free flyer: DARTEK ELECTRONICS, Box 2460, Dartmouth, Nova Scotia, Canada. U.S. Inquiries.

ELECTRONICS SUPERMARKET

GE TYPE C108BI SCR
400V 200PIV 50A 5221070801
55c ea. or \$55.00/100

SPT X OPEN B SWITCH
300V 10A 50C

1N4001 1N4004 DIODES
1N4001 1N4004 50C 5000
1N4002 1N4003 50C 5000
1N4004 1N4005 50C 5000

DUAL IN-LINE SOCKETS
DIP-16 50C
DIP-18 50C
DIP-24 50C
DIP-28 50C

PC STYLE ELECTROLYTIC CAPACITORS
50C 1000µF
50C 2200µF
50C 4700µF

Are YOU doing our mailing list?
CALL TODAY FOR YOUR
FREE CATALOG

RESISTORS 5%
1000 10K 100K 1M 2K 20K 200K
ONLY \$3.00/100

SOLID STATE RELAYS
50C 10A 120V
50C 15A 120V
50C 20A 120V
50C 25A 120V
50C 30A 120V

MINIATURE AUDIO OUTPUT TRANSFORMERS
100W 50C
200W 50C
300W 50C
400W 50C
500W 50C

WOAS ELECTRONICS
PO. BOX 9437
EL CAJON CA 92031

PHONE: (714) 449-3421

RECONDITIONED Test Equipment. \$40.50 for catalog. Walter, 2697 Nickel, San Pablo, CA 94806.

7400 SERIES TTL PINOUT HANDBOOK

COVERS ENTIRE 7400/7400 SERIES D.L.E. I.C.'S

MINI CONNECTIONS — FUNCTIONAL SPEED

CROSS REFERENCE — ONLY \$2.95 FROM:

THE PINOUT HANDBOOK, INC.
708 E. 14TH ST., SAN LEANDRO, CALIF. 94577
N.B.: SEE P.O. BOX 185, N.H. 204 9-5 FAX.

FREE giant bargain electronic catalog listing thousands of components, tubes, transistors, IC's, kits, test equipment. EDLIE'S, 2700-PG Hempstead Tpke., Levittown, N.Y. 11756.

CONSTRUCTION PROJECTS: Laser, \$2.00. TV Camera, \$3.95. Catalog, Technologic, Box 5262, Orchard Lake, Michigan 48033.

FREE Bargain Catalog. Ultrasonic devices, LEDs, transistors, IC's, keyboards, Xtals, unique components. Chaney's, Box 15431, Lakewood, CO 80215.

CARBON FILM RESISTORS. Brand new as low as 2-1/4 cents. FREE samples and specifications. COMPONENTS CENTER—PE, Box 134, New York, NY 10038.

ALPHA BRAINWAVE MONITOR—New from EICO. Model BW300 Kit, \$34.95; Wired, \$59.95 Postpaid. Send check or money order. M&K Electronic Corp., 135-33 Northern Blvd., Flushing, N.Y. 11354.

wanted Citizens Band DEALER-DISTRIBUTORS

Send this ad with Letterhead to

PAL ELECTRONICS CO.

2962 W. WELDON - PHOENIX, ARIZ. 85017

FOR A New Electronic Experience. learn to control your brainwaves. Aquarius Electronics, Box 96ZE, Albion, CA 95410.

TEST EQUIPMENT—DISCOUNT PRICES: B&K, Sencore, Leader, EICO, Lectrotech, M&K Electronic Corp., 135-33 Northern Blvd., Flushing, N.Y. 11354.

PART OR PACKAGE

TERMINAL COMPONENTS FOR YOUR SYSTEM OR OURS



Baudot Keyboard (Order: RMK)

Micro Switch Hall effect solid-state keyboard manufactured by Honeywell - no contacts or parts to wear out - 51 keys and two special direct control keys plus 16 additional encoded keys. NEW. 5 volt supply, 8 level Baudot code. Add \$1.50 for shipping, handling, insurance. **\$44.50**

Baudot-ASCII Keyboard (Order: RMKA)

With plug in conversion board to ASCII code, including lower case, and ASCII control functions. Custom encoding and new custom key tops will be available. Add \$1.50 for handling, shipping, insurance. **\$54.50**

PACKAGE ONE

TV Terminal III (Order: RM TVT)

A complete I/O device - our RM Terminal unit using the case, keyboard, (combination Baudot or ASCII code), power supply, the complete RM terminal, and including our TV TERMINAL III kit of parts and PC boards, including all IC's, transistors, memories, resistors, caps. The display terminal is an improved version of the device described in February, March, April issues of Radio-Electronics. Complete RM terminal and TV Terminal III. Add \$5.00 for shipping, handling, and insurance. **\$229⁹⁵**

PACKAGE TWO

Altair-TV Terminal III (Order: RM TVALT)

Same as above but includes interface to Altair 8800* in parallel I/O card (kit version) for complete input and output display capabilities. Add \$5.00 for handling, shipping, and insurance. **\$274⁹⁵**

PACKAGE THREE

Mark 8 Minicomputer (Order: RM MK8)

The Famous Mark 8, as described in July, 1974 Radio-Electronics (construction manual available from them at \$5.00) using the 8008 8 bit micro processor IC - includes PC boards, 8008, all TTL, resistors, caps (no switches, hardware, or Memory IC's, or Memory Boards). Memory listed separately below. Does include input and output boards. **\$249⁹⁵**

Memory Boards For Any Above Systems

These can also be used with Mark 8, Mod 8, (also Sclebi, Altair 8800* with proper adaptation).

C-MOD 8-9 board with 256 x 8 of memory	\$33.95
C-MOD 8-5 board with 1 K x 8 memory	49.95
C-MOD 8-5 board with 2K x 8 memory	77.95
C-MOD -6 Accomodates 4 - eight bit inputs	24.95
C-MOD -7 Accomodates 4 - eight bit outputs	24.95

Please note - above boards quoted with normal speed memory - 1000 ns. For 8080 based systems 500 ns memory is recommended - please add \$2 per each 256 bytes (256 x 8) of memory ordered.

*TradeMark

C.O.D. orders will be accepted (\$1 extra charge), if a 20% deposit is sent with the order.

All prices subject to change without notice; all offers subject to withdrawal. N.Y. residents add 7% tax.

PACKAGE FOUR

C-MOD 8 Minicomputer (Order: RM C8)

Introducing the C-MOD 8 in conjunction with the RM Terminal unit - a second generation system based on a design of an 8008 system originally developed by Microsystems International, called the MIL Mod 8. The system offered is a minimum system, priced less memory, and consists of a CPU and address latch board, and an interface board to the RM Terminal. Comes with plated-through hole PC boards, all TTL, 8008, resistors, caps, and the RM terminal as described, and a backplane with 6 connectors. **\$249⁹⁵**

PACKAGE FIVE

C-MOD 80 Minicomputer (Order: RM C80)

Introducing the new C-MOD 80 system - the 8080 version of the system above featuring faster processing times and twice as many instructions, the minimum system is offered - A CPU board and an interface board to the RM terminal, (Memory, and other input and output cards extra - see below) but comes with backplane with 6 connectors, all TTL, the famous 8080 8 bit CPU chip, resistors, capacitors, in combination with the RM Terminal described below. **\$349⁰⁰**

Riker-Maxson Terminal (Order: RMT)

MiniMicroMart has obtained a quantity of new Riker-Maxson computer reservation terminals. Complete, less teletype printer. Contains Micro Switch keyboard, shown above, and a panel of 11 push-button illuminated momentary contact Dialco switches, as well as power supply, Boxer fan, all enclosed in an attractive housing - could be used to house complete minicomputer system. Also contains complete terminal electronics, 7 PC boards [TTL logic]; it transmits a distinct code of its own, responds to being polled by central computer, provides for special formatting, and has capability of STORING and EDITING 512 eight bit words, then transmitting them on command. Unit can be used as is or modified for your requirements. Originally sold for more than \$3000. Add \$4.00 for handling, shipping, insurance. **\$109.95**



Power Supply Module (Order: RMPS)

The modular power supply is available separately. It will supply 5 amps at 5 volts, with overvoltage crowbar protections. Furnishes -5 volts [regulated] and two windings offering 24 volts DC unregulated. When our RM Terminal is offered with a kit, we supply necessary components to alter the PS to supply needed voltages. NEW. Add \$2.00 for handling, shipping, insurance. **\$42.50**

Other Combination Offers

We will be offering the terminal units with the world famous DEC PDP-8A and LSI-11 systems - perhaps the two most popular minicomputer systems ever introduced - featuring brand new boards, fully built, tested, and guaranteed by the Digital Equipment Corp. The PDP-8A is a 12 bit machine - the LSI-11-s a 16 bit machine. The backplane and the interface to the RM Terminal is of our design. Please write for prices and details.

MiniMicroMart

1618 James Street, Syracuse, N.Y. 13203, Phone: (315) 422-4467

POTTER BRUMFIELD
Type KHP Relay
4 PDT 3A Contacts
24 VDC (650 coil) \$1.50 EA.
120 VAC (10.5 MA coil) \$1.75 EA.

DIP SOCKETS	TTL SPECIAL
8 PIN PCB * .22	7400 DIP TTL Snetic/ House Numbered
14 PIN PCB .26	
16 PIN PCB .30	7404 DIP TTL Hex Inverter Snetic/House Numbered
24 PIN PCB .75	Each \$.17 Ten for \$1.50
40 PIN PCB 1.25	
14 PIN WIRE WRAP .35	

FAIRCHILD "TRIMPOTS"

Brand new 20 turn precision trimmers. These are prime parts mostly individually packed in sealed envelopes. These values in stock:

50 OHM	1K	5K	25K
500 OHM	2K	10K	

Each only \$.89 10 for \$7.50

CARBON RESISTORS

Carbon Resistors 1/2-Watt 5%-full prime All values in stock. 10 per value (minimum quantity).

10 for \$.45

2102-2 MOS 1024 BIT MEMORY (DIP)

FULLY DECODED STATIC RANDOM ACCESS MEMORY DIRECTLY TTL COMPATIBLE INPUTS AND OUTPUT SINGLE V5 SUPPLY -- NO CLOCKS OR REFRESH

\$5.00 each 8 for \$34.95

DIODE ARRAY

10 - 1N914 Silicon Signal Diodes in one package. 20 leads spaced .1"; no common connections. Each \$.25 10 for \$2.25

Numeric Display 1/4" Single Digit GaAsP LED	SPECIAL 8 8 8 8 PROM
COMMON CATHODE WITH RH DECIMAL SUPER SPECIAL \$.59 TEN for \$4.95	8 BIT 32 WORD MEMORY \$3.00 EA. 10 - \$29 WE PROGRAM FOR \$5 EACH

Compact - 10 digits in 3" panel width highly legible - bright red 1/4" character easily read within 10 feet over a wide viewing angle (140°) Low power - 125 mW per digit at typical brightness

RECTIFIER SPECIAL! 1N4007 - 1 AMP - 1000 volt PRV \$.13 each 10 for \$1.00

SEND FOR FREE FLYER! C.O.D. PHONE ORDERS ACCEPTED--\$10 MINIMUM

All IC's new and fully tested, leads plated with gold or solder. Orders for \$5.00 or more are shipped prepaid, smaller orders--add 55c. California residents add Sales Tax....IC's shipped within 24 hours. P.O. BOX 41727 SACRAMENTO, CA 95841

BABYLON ELECTRONICS 916 334 2161

CIRCLE NO. 11 ON FREE INFORMATION CARD

DIGITAL IC MANUAL-3rd edition-more than 3000 latest types / pinout diagrams-cross references. \$6.95-IC APPLICATIONS MANUAL-Analog/Digital-\$3.95. Electronetics-PE, P.O. Box 127, Hopedale, Mass. 01747.

WAREHOUSE DISCOUNTS ON NATIONALLY ADVERTISED

- C.B. RADIOS
- MONITOR SCANNERS FIRE POLICE IN FACTORY SEALED CARTONS

BUSINESS - RECREATION - PERSONAL SATISFACTION GUARANTEED

WRITE FOR QUOTE
ELECTRONICS WAREHOUSE, INC.
6234 LITTLE RIVER TURNPIKE (DEPT. 5)
ALEXANDRIA, VA. 22312
OR PHONE: (703) 256-1300

BUILD THAT ELECTRONIC ORGAN YOU ALWAYS WANTED AT A PRICE YOU CAN AFFORD. Third edition of "Organ Builder's Guide," pictured product kit line, circuits, block diagrams, design rationale using IC divider and independent generators with diode keying. \$3.00 postpaid. Also, free brochure on keyboards. DEVTRONIX ORGAN PRODUCTS, Dept. C, 5872 Amapola Dr., San Jose, CA 95129.

HYBRID AUDIO AMPLIFIER
EPITEK Model 1240
12 Watts RMS
Distortion 0.6% at 12W
Price: \$6.95 + 50 cents postage.
(CA Residents add 6% tax)

ROYER COMPONENTS
P.O. Box N
Bellflower, CA 90706

Send Money Order or COD

DIGITAL CONSTRUCTION PLANS: IC Tester, Pulse Generator, others. Free info. T. Wong, 103 E. Bway, Dept. 4D, New York, N.Y. 10002.

MEMORIES. Prime 2101. No surplus, \$4.45. Plug in compatibility with Altair systems; superior specifications. BankAmericard accepted. JK Electronics, Box 352, Davis, CA 95616.

ELECTRONIC MUSICAL CHIME. Program any 10 note melody: Plans \$3.50. TV PING PONG game. Plays through your set's antenna terminals: Plans \$3.25. ARS SYSTEMS, Box 1922K, Sunnyvale, CA 94088.

JAPANESE TRANSISTORS, all transistors original factory made. Free catalog. West Pacific Electronics, P.O. Box 25837, W. Los Angeles, CA 90025.

UNIVERSAL TTL/DTL/CMOS IC TESTER 100,000 test operations in 0.66 seconds. Will test 16/14 Pin Digital ICs. Circuit is easy to understand and build. ICs needed cost less than \$20.00; All are TTL. Plans \$1.40: NORTHSTAR ENGINEERING, 3617 North Crede Drive, Charleston, WV 25302.

INTEL 8080: \$125.00; INTEL 8008: \$25.00; TV-II KIT: \$112.00 (less power supply and case). ELECTRONIC DISCOUNT SALES, 138 N 81st Street, Mesa, Arizona 85207.

FREE FLYER. Semis. Components. Electronic Hardware. Lowest Prices. Vanguard Electronics, Ltd., Box 1193, Edmonton, Alberta, Canada. T5J 2M5.

UNUSUAL ELECTRONIC PLANS. Projects, Security Equipment, etc. Catalog \$1.00. McCord Electronics, Box 276-PE, Sylvania, Ohio 43560.

EXCITING, high-paying jobs in communications electronics are opened when you get an FCC License! Just published research report reveals best type of license to get, how to get it, much more. Order Report R102/E1, \$3 postpaid. Radio Research, Box 50406, Nashville, Tennessee 37205.

CONSTRUCTION MANUALS - GOLD recovery - SILVER recovery - Alternator adapter (120 volts from alternator) - Inverter (12vdc to 120vac) - Electronic insect trap - Burglar alarm system - Chemical formulary - manuals \$5.00 each - HIGHLY PROFITABLE BUSINESS COURSES!! - "How to start a Silver recovery business" - "How to find Precious metals!!" - Courses \$9.95 each - color catalog 25 cents - Airmailed 50 cents. Creative Products, Dept. PE-975, 4913 Northridge NE, Albuquerque, New Mexico 87111.

GO METRIC! It's easy with booklet-conversion tables. Only \$1.00. Wilhelm, 1524 Blvd., Dept. D, Jersey City, N.J. 07305.

TV TECHNICIANS, SERVICEMEN, HOBBYISTS - Vista Model 740 Digital Crosshatch Generator. Compact crystal controlled digital divider for lowest-priced ultra-stable 5x7 crosshatch or 56 dot patterns. AC powered. \$31.95 complete kit; \$41.95 assembled. Postpaid in USA, Canada. Information available free. PHOTOLUPE CORPORATION, 118 East 28th Street, New York, N.Y. 10016.

MICRO 440-MICROCOMPUTER ON ONE CIRCUIT BOARD! Four-bit 4040 CPU performs decimal, binary arithmetic, logic. 256-word memory on board, expandable to 8K. Board only, partial or complete kits, or assembled. Send 25 cents for details, \$10 (refundable) for complete documentation. COMP-SULTANTS, INC., P.O. Box 1016, Huntsville, Alabama 35807. (205) 837-5100.

TELEVISION SERVICING MANUALS, \$4.00. Sample typical volume, \$1.00. Supreme Publications, 1760 Balsam, Highland Park, Illinois 60035.

QUALITY SURPLUS ELECTRONIC BARGAINS. Catalog 25 cents refunded with order. Atlantis, P.O. Box 12654, Tucson, Arizona 85711.

MEMORY-2102-1K Static RAM, \$3.75. Quantity discount, computer components, digital clock kits. Send for free list. Digitex, 2603 West Davis, Dallas, Texas 75211.

SAVINGS TO 91%! LATEST BOOKS. ANY SUBJECTS! Sams, Tab. Hayden, Wiley! \$6.50 Digital Techniques. \$1.00! "Cookbooks": \$9.95, Opamps \$7.79, Lancaster's TTL. \$6.95! FREE CATALOGS. TECHNIBOOKS-EI, Box 81, Maplewood, New Jersey 07040.

BUG DETECTORS!!! Locates transmitters and phone taps fast. Serco. P.O. Box 73, East Haddam, Conn. 06423.

STEREO TV

The TE 200 TELEADAPTER EASILY CONNECTS TO ANY TV & STEREO SYSTEM Using our coupling and matrix circuit, teleadapter takes a low impedance output from the television and delivers two HIGH IMPEDANCE CHANNELS OF SIMULATED STEREO, to drive any amplifier. Frequency response is maintained so you can hear the tinkle of bells or booming bass sounds as it happens on TV. With service warranty and hookup instructions \$19.95 pdd. Guaranteed to make your TV 100% more enjoyable.

OUR NEW TE 300 VHF UHF TELEVISION High Fidelity AUDIO TUNER is now available. Completely solid-state Recording and amp output jacks. Anodized Aluminum front panel and simulated Walnut Cabinet. 110 volt operation. \$169.95 pdd.

SEND CHECK, M.O., MASTERCHARGE or BANKAMERICARD NO and Expiration date TO RHOADES NATIONAL CORP DEPT NO 5B BOX 817 HENDERSONVILLE TENNESSEE 37075.

NAME _____
ADDRESS _____
CITY _____

PLANS AND KITS

ATTENTION AUDIO FREAKS!! Audio Processing Circuits designs, kits, units. Laboratory tested designs for hobbyist through professional use--limiters, compressors, equalizers, phasers, mixers and more! Send now--\$1.00 (refundable) for complete catalog--CIRCUIT RESEARCH LABS, 3920 E. Indian School, Phoenix, AZ 85018.

AMAZING ELECTRONIC PRODUCTS--Pocket Laser. See-In-The-Dark, Scramblers, Penlight Strobe, Energy Devices, TV Disruptor, Many More, All New. Catalog \$1.00. INFORMATION UNLTD., Lord Jeffrey Drive, Box 626, Amherst, N.H. 03031.

CYCLOPS TV CAMERA KIT, featured on cover of February PE, available from CROMEMCO, 26655 Laurel, Los Altos, California 94022.

NEW FROM EICO--Listen to official FCC-Licensed background music (SCA) on your FM radio without commercials. EC5000 Kit, \$12.95 Postpaid. M&K Electronic Corp., 135-33 Northern Blvd., Flushing, N. Y. 11354.

DIGITAL CLOCK KIT \$22.50. Frequency Counter kit, PC boards only silk screened for component mounting double sided, no jumpers, full instructions \$25.00. New 2N4424 or 2N4248 or 1N5391, mixed or not 7 for \$1.00. EAST COAST ELECTRONICS, 50 Scott, Hamburg, NY 14075.

Planning to move?

Let us know 8 weeks in advance so that you won't miss a single issue of POPULAR ELECTRONICS. Attach old label where indicated and print new address in space provided. Also include your mailing label whenever you write concerning your subscription. It helps us serve you promptly. Write to: P.O. Box 2774, Boulder, CO 80302, giving the following information:

Change address only.
 Extend subscription. Enter new subscription.
 1 year \$6.98
 Payment enclosed (1 extra BONUS issue)
 Bill me later

AFFIX LABEL

If you have no label handy, print OLD address here.

name	address	city	state	zip code
name	address	city	state	zip code

0176

Add'l postage per year: Add \$1 for Canada; \$2 for all other countries outside the U.S.

Wow!
INCREDIBLE
PRICES

**BUY ANY 10
TAKE 15%**
**BUY 100
TAKE 25%**



SN7400 \$1.16	SN7462 \$2.22	SN74122 .48
SN7401 .16	SN7470 .29	SN74123 .85
SN7402 .16	SN7471 .49	SN74125 .59
SN7403 .16	SN7472 .29	SN74126 .59
SN7404 .19	SN7473 .36	SN74127 1.75
SN7405 .19	SN7474 .36	SN74140 2.10
SN7406 .35	SN7475 .59	SN74145 1.05
SN7407 .35	SN7476 .39	SN74148 2.25
SN7408 .19	SN7478 .79	SN74150 .98
SN7409 .19	SN7480 .52	SN74151 .75
SN7410 .16	SN7481 .59	SN74153 .90
SN7411 .25	SN7482 .89	SN74154 1.35
SN7413 .59	SN7483 1.25	SN74155 .95
SN7414 1.65	SN7485 1.25	SN74156 .95
SN7416 .34	SN7486 .37	SN74157 .95
SN7417 .34	SN7488 1.95	SN74158 .95
SN7420 .16	SN7489 2.45	SN74160 1.35
SN7422 .45	SN7490 .59	SN74161 2.25
SN7423 .29	SN7492 1.10	SN74164 1.50
SN7425 .29	SN7493 .59	SN74166 1.50
SN7426 .25	SN7493 .59	SN74173 1.45
SN7427 .29	SN7494 .95	SN74174 .39
SN7430 .16	SN7495 .79	SN74175 1.30
SN7432 .25	SN7496 .79	SN74176 1.20
SN7433 .49	SN74100 1.40	SN74177 1.20
SN7437 .34	SN74104 .44	SN74180 .95
SN7438 .34	SN74105 .44	SN74181 2.98
SN7440 .16	SN74106 .52	SN74182 .74
SN7441 1.00	SN74107 .44	SN74184 1.98
SN7442 .70	SN74108 .89	SN74185 1.98
SN7444 1.25	SN74112 .89	SN74190 1.40
SN7445 1.65	SN74113 .89	SN74191 1.40
SN7446 1.15	SN74119 1.75	SN74193 1.25
SN7447 .99	SN74121 .49	SN74194 1.20
SN7448 .99		SN74195 .85
SN7450 .16		SN74196 1.80
SN7451 .17		SN74197 .90
SN7452 .17		SN74200 4.95
SN7453 .17		
SN7454 .17		
SN7455 .22		
SN7460 .17		

\$4.95 6-VOLT NICAD BATTERY POWER PAK
Includes 4 "A" cell nicad batteries hooked up to give you 6-volts for all types of energy uses. The best batteries made. Rechargeable.

9-FUNCTION, 8-DIGIT MEMORY CALCULATOR KIT

It's the easiest multi-function kit today!

Lightweight, 5 1/4 x 3 x (2" at back side) x 1 1/4" front side of angular display panel black case. Nifty unit for business, school, home, and for the youngsters. Under and pictorial instruction booklet and how-to-use-book. **AC/DC tool**
KIT INCLUDES: case, 22-key keyboard kit, ON-OFF switch (part of keyboard) PC board, driver and memory calculator chips, 9-digit "bubble" magnifier LED array, array cable, AC adapter, battery case, 6 battery card display, instruction and pictorial step-by-step construction booklet.

DOUBLE MEMORY
Percent Constant
Display Restore

\$16.95



4-Function Arithmetic
22 KEYS!

8 BRITE DIGITS 6-FUNCTION AC-DC CALCULATOR KIT!

The entire kit is even packed in a multicolor attractive designed box that in itself tells the mini calculator story. Kit includes: attractive black case with red filter; Flex Key (type 20SK-66) 18 key keyboard that measures only 2 1/2 x 2 1/2 inch; part assembly board; famous Gal Tech 5030 28-pin calculator chip; two 75491 ic drivers; 9 digit array; 1000's of 100 ohm 1/4 watt resistors; two transistors; back protective plate; necessary wire plugs; easy instructions. (Less 9 volt standard battery and AC adapter)

EASIEST KIT TO BUILD

THE SIMPLEST! FINEST! SMALLEST!

\$13.95

Simplified Indexing
Mark up and Mark down
Constant multiplication and division
AC adaptor jack
Lightweight, pocket size
Extra large display
6 functions plus, minus, times, percentage, constant
Floating decimal
Chain and Mix calculations

4-DIGIT AM-PM FLUORESCENT CLOCK PANEL \$9.99

"PANEL OPTICS"

YOU ASKED FOR IT! Found only at Poly Paks at this low price! It's ONLY 1 3/4" x 1 3/16" x 8/8" deep panel. Designed specifically for our MM-5316 fluorescent driving clock chip. Indicates 4-digits, AM-PM, pulsating second indicator, requires minimum 250V ac to build. Color: BLUE-GREEN; you can use RED or GREEN filters. Character height: 0.5". Filament voltage is 1.75 VAC or DC @ 160 milli. Anode voltage 25V @ 250 microamps per segment. With spec sheets, clock construction diagrams, P.C. board layouts, specs. A DIGITAL CLOCK BUILDER'S SPECIAL.



Made By TUNG-SOL D2004

\$2.50 24V FILAMENT TRANSFORMERS
Scarce and very popular. 115 vac primary 24VCT secondary at 500 mils. Color-coded leads. 1000's of low voltage ideas. Metal encased. 2 1/2 x 2 x 2". Wt. 1 lb. 3 for \$6

LED Revolution!

MONSANTO! XCITONI! LITRONIX! OPCOA!

5 for \$1

340x.260 Jumbo	240x.200 Medium
Red	Red
Yellow	Yellow
Green	Green
Amber	Amber
Clear	Clear
Micro	210x.125
Red	Yellow
Green	Amber

Micro (Axial) MV-50 style
MV-50 Clear 10 for \$1.
MV-55 Red 6 for \$1.

This unit is not advertised anywhere! Made for Motorola Communications at the original cost of \$4.50 each (for insertion in their Walkie Talkie Program). It's a 80-ohm imp MIKE. It's an excellent speaker

POSTAGE STAMP MOBILE SPKR MIKE \$1.98
too covering broad range in sound. Extremely well-made.

LOWEST PRICES IN U.S.A.!

"BLASTAWAY" ON IN4000 RECTIFIER PRICES

Type	Piv	Sale
IN4001	50 10 for 85c	
IN4002	100 10 for 55c	
IN4003	200 10 for 65c	
IN4004	400 10 for 75c	
IN4005	600 10 for 85c	
IN4006	800 10 for 95c	
IN4007	1000 10 for 1.29	

INDUSTRIAL SPEED CONTROL \$4.95
A \$30 item from G.E. Model 533A (made for Xerox) that controls home, shop and industrial lighting too! A very elaborate circuit for controlling many electrical and electronic devices. Easily controls speeds of electric drills, brush type motors, etc. 115vac, rated at 1100 watts. With variable speed or dimming control in heavy-duty aluminum case. 3 x 2 3/4 x 2. With diagram and hookups.

4 1/2 DIGIT DIGITAL VOLTMETER DVM CHIP

Type MM5330 by National utilizes P channel low-threshold enhancement mode devices and ion implanted depletion mode devices. Provides logic circuit for 4 1/2 digit DVM. All logic for four decade counters, a divide by four counter, a divide by two counter for over-range blanking, latches for all counter stages, an output ROM to generate BCD to 9's complement BCD of the latches and a module 4 counter to sequentially present each of decade latches thru ROM to the BCD outputs plus four outputs to indicate which decade is display. A reset for all counter stages, transfer pulse generator to set the latches. To 400 KHz operation. TTL compatible. With instruction sheets and diagram on "how-to-build a 4 1/2 digit DVM". Ideal with our Litronix 1/4" single, 1 1/2" and dual digits. 16-pin DIP.

MICROPROCESSORS! ROMS! RAMS! MEMORIES!

8008 Microprocessor	\$44.00
8080 Super 8008	250.00
2102 1024 Static RAM	3.95
1101 256 bit RAM	1.50
1103 1024 bit RAM	2.95
1105 2048 bit RAM	2.95
MMS260 2048 bit RAM	6.50
2513 Character generator	12.50
MMS203Q Erasable PROM	19.95
MMS202Q Erasable PROM	19.95
1702A Erasable PROM	19.95
8223 Programmable ROM	2.95

7-SEGMENT READOUT SALE!

Up to 20 mils per seg. at 5V. MAN-1
All fit into 14-pin IC socket.

Type	Size	Color	Sale	3 for
MAN-1	.27	Red	\$2.50	\$6.00
MAN-3MA	.12	Red	.69	2.00
MAN-4AB	.27	Red	1.95	5.00
MAN-5	.27	Green	1.50	4.00
MAN-6	.6	Red	4.50	12.00
MAN-64	.4	Red	3.50	9.00
MAN-7	.27	Red	1.00	2.50
MAN-8	.27	Yellow	1.50	4.00

ALL ABOVE BY MONSANTO

Fabulous POLY PAKS

Here is what Poly Paks is Famous for...

25 BARRELS PURCHASED FOR THIS SALE! BUY 'EM FROM THE "BARREL" AND SAVE!

For the first time anywhere, Poly Pak merchandisers introduce a new way in buying the economical way. Raw stock from the "barrel". Remember the "good ole days"? They're back again! The same way merchandisers throughout the United States buy from various factories... their overruns in barrels. Poly Pak has done the same. Therefore you are getting the same type of material as the RE-TESTERS DO!

Your choice of any kit **\$1.98**

BARREL KIT 23 POWER TAB TRANSISTORS 40 for \$1.98	BARREL KIT 24 RESISTOR NETWORKS 40 for \$1.98	BARREL KIT 25 LINEAR & TRANS DIODES 100 for \$1.98	BARREL KIT 26 DISC CAPACITORS 100 for \$1.98	BARREL KIT 27 MOSFET TRANSISTORS 30 for \$1.98	BARREL KIT 28 LINEAR & TRANS DIODES 100 for \$1.98	BARREL KIT 29 SCRs, TRIACS, QUADRACs 30 for \$1.98	BARREL KIT 30 RELAYS, RECTIFIERS 30 for \$1.98	BARREL KIT 31 ZENER RECTIFIER MIX 100 for \$1.98	TEST 'EM YOURSELF AND SAVE!
---	---	--	--	--	--	--	--	--	-----------------------------

LITRONIX "JUMBO'S"

Singles size: 1 x 3/4 x 5/16
DUALS size: .8 x .9 x .29
7-Segment, 25-mils per segment

Type	Size	Color	Sale	3 for
721D	.5	Red	\$5.95	\$15.00
727E	.5	Red	5.95	15.00
748F	.6	Red	3.95	11.00
747	.6	Red	3.95	11.00

D—Plus or Minus 1 plus a digit (1 1/2 digits)
E—Dual digits
F—Plus or Minus 1

Terms: add postage. Rated: net 30
Phone Orders: Wakefield, Mass. (617) 245-8829
Retail: 16-18 Del Carmine St., Wakefield, Mass. (off Water Street) C.O.D.'S MAY BE HIJACKED

20c CATALOG on Fiber Optics, IC's, Semi's, Parts
MINIMUM ORDER — \$4.00

POLY PAKS
P.O. BOX 942E, LYNNFIELD, MASS. 01940



QUALITY ELECTRONIC COMPONENTS - SAME DAY SERVICE -

NEW DISCOUNT SCHEDULE SAVES YOU EVEN MORE!

1024 BIT STATIC MOS RAM 2102...\$3.50

INTEGRATED CIRCUITS - TTL, CMOS, LINEAR & MOS

Table listing various integrated circuits with part numbers, descriptions, and prices.

SILICON TRANSISTORS

Table listing silicon transistors with part numbers, descriptions, and prices.

ELECTROLYTIC CAPACITORS

Table listing electrolytic capacitors with values, voltages, and prices.

DISC CAPS

Table listing disc capacitors with values, voltages, and prices.

HARDWARE

Table listing hardware items like screws and nuts with prices.

SILICON DIODES

Table listing silicon diodes with part numbers and prices.

1/2 & 1/4 WATT CARBON COMP. RESISTORS

5 each of the 85 standard 10% values (2.2-22M) 1/2 W Resistors (425 pcs.) Sorted by value \$13/set 2-4 are \$12/set 5-9 are \$11/set

MOLEX SOLDERCON IC TERMINALS

Table listing Molex soldercon IC terminals with prices.

VOLUME DISCOUNT SCHEDULE

Table showing volume discount percentages for different order quantities.

STANDARD SHIPPING/HANDLING CHARGE

If your merchandise total after discount is between: \$ 0.00-4.99 add \$2.00 \$ 5.00-99.99 add \$2.50

COO ORDERS ACCEPTED FOR SAME DAY SHIPMENT - CALL 218-681-6674

DIGI-KEY CORPORATION

P.O. BOX 677 Thief River Falls, MN 56701

CIRCLE NO. 19 ON FREE INFORMATION CARD

INSTRUCTION

LEARN ELECTRONIC ORGAN SERVICING at home all makes including transistor. Experimental kit--trouble-shooting. Accredited NHSC. Free Booklet. NILES BRYANT SCHOOL, 3631 Stockton, Dept. A, Sacramento, Calif. 95820.

LEARN WHILE ASLEEP. Hypnotize! Strange catalog free. Auto-suggestion, Box 24-ZD, Olympia, Washington 98501.

DEGREE IN ELECTRONICS through correspondence. Free catalog. Grantham, 2000 Stoner Avenue, Los Angeles, California 90025.

INTENSIVE 5 week course for Broadcast Engineers. F.C.C. First Class license. Radio Engineering Incorporated, 61 N. Pineapple Ave., Sarasota, Florida 33577 and 2402 Tidewater Trail, Fredericksburg, VA 22401.

Advertisement for F.C.C. Manual, Exam Manual, and Test Answers for FCC First and Second Class Commercial Licenses.

SCORE high on F.C.C. Exams Over 300 questions and answers. Covers 3rd, 2nd, 1st and even Radar. Third and Second Test, \$14.50; First Class Test, \$15.00. All tests, \$26.50. R.E.I., Inc., Box 806, Sarasota, Fla. 33577.

UNIVERSITY DEGREES BY MAIL! Bachelors, Masters, Ph.D.'s. Free revealing details. Counseling, Box 1162-PE9, Tustin, California 92680.

SELF-STUDY CB RADIO REPAIR COURSE. THERE'S MONEY TO BE MADE REPAIRING CB RADIOS. This easy-to-learn course can prepare you for a career in electronics enabling you to earn as much as \$16.00 an hour in your spare time.

DRAFTING--Blueprint Reading (Mechanical, Electronic, Architectural). Home Courses \$25.00. Send \$2.00 first lesson. Prior, Inc., 23-09 169th Street, Whitestone, N.Y. 11357.

UPDATE your electronics knowledge and add a FCC first class license. Home study. Free catalog. Genn Tech., 5540 Hollywood Blvd., Los Angeles, CA 90028.

FM BROADCAST STATION. Start your own. Learn how. Details free. Broadcaster, Box 5516AK, Walnut Creek, CA 94596.

UNDERSTAND DIGITAL ELECTRONICS--Calculators, Microprocessors, clocks. New programmed learning courses. Design of Digital Systems, 6 volumes, only \$14.95. Digital Computer Logic, 4 volumes, \$9.95. Both \$19.95. Unconditional refund if dissatisfied. Cambridge Learning, 300 East 56th Street, New York, N.Y. 10022.

TREASURE FINDERS

FREE FACT-FILLED CATALOG! World's largest selection! Metal detectors starting at \$79.50. Two year guarantee! Three factories, U.S.-Canada. 1,200 dealers - Service Centers nationwide. Finest instruments at any price! Budget Terms. Dealer inquiries invited. Write: White's Electronics, Inc. Dept. PD5W, 1011 Pleasant Valley Road, Sweet Home, Oregon 97386.

TREASURE FINDER locates buried gold, silver, coins, treasures. 6 powerful models. Instant financing available. Write or call for free catalog. Phone (713) 682-2728 day or night. Dealer inquiries invited. Relco, Dept. AA20, Box 10839, Houston, Texas 77018.

REAL ESTATE

BIG . . . NEW . . . FREE. FALL CATALOG! Over 2,600 top values in 40 states coast to coast! UNITED FARM AGENCY, 612-EP, West 47th St., Kansas City, Mo. 64112.

RECORDS

OLDIES. 45rpm. Free Catalog. Corry's Record Shop, Box 166TM, Mason, Ohio 45404.

FREE RECORD COLLECTION Reviewers wanted. Anyone qualifies. We ship you new records to review. You pay postage. Records are free. Applicants accepted "first come" basis. Write: Research PE, 6162 Washington Circle, Milwaukee, Wisconsin 53213.

RUBBER STAMPS

RUBBER address stamps. Free catalog. 45 type styles. Jackson's, Box 443G, Franklin Park, Ill. 60131.

NEW KITS! NEW KITS! JAMES ELECTRONICS P.O. BOX 822 BELMONT, CALIFORNIA 94002 (415) 592-8097

DIGITAL VOLTMETER This is a 3 1/2 digit, 0-2 volt Digital Voltmeter, with a 5% full scale accuracy. It is based around the Siliconix LD110, LD111 DVM chip set. The voltmeter uses MAN7 readouts (3" high) to provide a highly readable display. The unit requires the following supply voltages: 12, -12, 5. The unit comes complete with all components to build the unit pictured at the left, that is a complete DVM less power supply.

\$39.95 Per Kit

LOGIC PROBE The Logic Probe is a unit which is for the most part indispensable in trouble shooting logic families: TTL, DTL, RTL, CMOS. It derives the power it needs to operate directly off of the circuit under test, drawing a scant 10 mA max. It uses a MAN5 readout to indicate any of the following states by these symbols: (H)=1 (LOW)=0 (PULSE)=P. The Probe can detect high frequency Pulses to 45 MHz. It can't be used at MOS levels or circuit damage will result.

\$9.95 Per Kit

DIGITAL COUNTER This is a 4 digit counter unit which will count up to 9999 and then provide an overflow pulse. It is based around the Mostek MK5007 digital counter chip. The unit performs the following functions: Count Input, RESET, Latch, Overflow. The counter operates up to 250 KHz. The counter is an ideal unit to be used as a frequency counter, where the only extra components needed would be a trimbase, divider chain and gate. The unit requires 5V, and -12V. The unit comes complete as shown on the left less power supply.

\$29.95 Per Kit

ONE KILOBYTE RANDOM ACCESS MEMORY This memory card is for the most part a universal unit that can be used in almost any microcomputer from a HOME BREW to an ALTAR 8800. It uses an array of 2102 1k x 1 static random access memories to produce a 1024 x 8 memory compatible with most standard microcomputer systems. We provide everything from the super low noise vector logic card, to fine quality low profile sockets, to the eight 2102's. We even include timing diagrams and tantalum bypass capacitor.

\$69.95 Per Kit

5 VOLT 1 AMP T²L SUPPLY 5 VOLT 1 AMP T²L SUPPLY This is a standard TTL power supply using the well known LM309K regulator IC to provide a solid 1 AMP of current at 5 volts. We try to make things easy for you by providing everything you need in one package, including the hardware for only

\$9.95 Per Kit

PLASTIC INSTRUMENT CASE These cases are fine quality units made by a German manufacturing firm which fit to the dimensions of our DVM and COUNTER kit with room enough left for power supply or batteries. Excellent for many other projects as well. Dimensions 2" x 3-1/8" x 5-7/8".

\$5.95 Per Case

Satisfaction Guaranteed. \$5.00 Min. Order. U.S. Funds. Add \$1.25 for Postage -- Write for FREE 1975 Catalog California Residents -- Add 6% Sales Tax

JAMES P.O. BOX 822, BELMONT, CA. 94002 PHONE ORDERS - (415) 592-8097

CIRCLE NO. 62 ON FREE INFORMATION CARD

Altaj Electronic Bargains

PRICES SLASHED! WE WANT YOUR BUSINESS. SATISFACTION GUARANTEED ON EVERY ITEM

COMPUTER BOARD BONANZA

We bought over 4 tons of assorted boards. Contains TTL, diodes, transistors, etc. 5 board assmt. with 150 to 250 IC's — \$3.95.

C - MOS			
CD4000 - .24	CD4015 - 1.19	CD4026 - 1.49	CD4044 - .59
CD4001 - .24	CD4016 - .59	CD4027 - .59	CD4047 - .59
CD4002 - .24	CD4017 - 1.29	CD4028 - .99	CD4049 - .59
CD4006 - 1.49	CD4018 - 1.49	CD4029 - 1.39	CD4050 - .59
CD4007 - .24	CD4019 - .59	CD4030 - .49	CD4066 - .99
CD4008 - 1.15	CD4020 - 1.59	CD4032 - .24	CD4077 - .39
CD4009 - .59	CD4021 - 1.49	CD4033 - 1.49	74C02 - .29
CD4011 - .24	CD4022 - 1.19	CD4035 - 1.39	74C04 - .29
CD4012 - .24	CD4023 - .24	CD4040 - 1.59	74C107 - 1.29
CD4013 - .59	CD4024 - .99	CD4041 - .89	
CD4014 - 1.49	CD4025 - .24	CD4042 - .79	



LM309K
TO-3 Case. 1 AMP 5 VDC Voltage Regulator Brand New By National \$1.19



3 DIGIT LED READOUT ARRAY
Like Litronix DL-33 3 MAN-3 style readouts in one package. Factory new units. Designed for calculators. Special — \$1.39 (3 Digits)



LITRONIX DL707 READOUTS
30 IN. CHAR. Common Anode. SPECIAL — \$1.19



MAN-3 LED READOUTS
Brand new, factory prime units. 12 in. character. Common cathode. Perfect for calculators 39c ea. Best Price Anywhere!

CALCULATOR CHIP BONANZA PRICES SLASHED!

The newest and easiest to use chips available today. Made by famous US mfg. All are 28 pin DIP. Features: direct LED segment drive, low power consumption, internal keyboard debounce, internal clock oscillator, single supply voltage, internal keyboard encoding, and floating decimal point. Does not require many external components as do older types like CT5001, 5002, 5005, etc. We offer the most sophisticated functions for the lowest price anywhere.

Chip #1 — 8 Digit, Constant, Six Function (-, ., x, +, %, √) — \$2.49

MOTOROLA MJE 3055
Plastic version of 2N3055. NPN Silicon. 90 Watts 15 Amps. SPECIAL — 69c

8008 MICROPROCESSOR
Computer on a chip. 8 Bit Parallel CPU. Can address 16k x 8 bits of memory. With specs. Factory tested units. \$24.95

2102-1K RAM's for above — \$4.95 or 8 For \$30

TTL SUPER SPECIAL
74121 — ONE SHOT 4/\$1

DIGITAL ALARM CLOCK IC

The newest and easiest to use alarm chip on the market today. Features:

1. Single supply voltage.
2. LED intensity control
3. Simple time set.
4. 4 or 6 Digit LED Display
5. AM-PM Indication
6. 24 Hr. Alarm.
7. 10 minute snooze.
8. Outperforms MM5318

Order #70250 — \$6.95 (2 FOR \$12)



MM5314 NATIONAL CLOCK CHIP
The most popular clock chip around. We made a huge special purchase of factory fresh, prime units. Lowest price in USA. 24 Pin DIP. 4 or 6 Digits. With Specs. \$3.95

CT7001 BY CAL-TEX
Digital alarm clock chip with calendar feature. 4 or 6 digits. Also has timing circuitry for radio ON-OFF control factory fresh. \$6.95

JUMBO LED READOUT
Twice the size of regular readouts. .65 inches. Like Litronix DL747. Outperforms and easier to read than SLA-3, only 20 MA per segment. Our best readout for digital clocks. \$2.95 ea (6 FOR \$15) Common Anode

FLOURESCENT READOUT TUBES
7 Segments. Blue-Green in color. Mfg. by ISE. #DG8F. The most popular display used in many imported clocks and calculators. Perfect for use with MMS316 clock chips. SUPER SPECIAL 69c ea. 12 For \$5.95



DIGITAL WRIST WATCH CRYSTAL
Brand new, mfg. by CTS-KNIGHT. 32.768 KHZ. Standard, most popular type. Special \$1.95

COLOR ORGAN CONTROL MODULE
Completely self-contained. Has SCR circuitry, AC line cord, etc. From a close out by a mfg. of color organs. New, unused. \$1.49

MOTOROLA SCR
2N4443 8 Amp 400PN, Plastic Power Case. 69c

GE POWER DARLINGTON
NPN, Plastic Power Tab Case. VCE-30 HFE-30,000 TYP. Brand new units, but leads are slightly trimmed for P.C.B. #D40C1 — SPECIAL 39c 3 For \$1

1024 BIT SIGNETICS P-ROM
82S1291-256X4 bipolar, field programmable ROM. Fully TTL compatible. 50 ns. max address access time. Much faster than MOS type units. Perfect for code conversions, microprogrammers, hand-wired algorithms, controllers, etc. With specs. Regular \$35 ea. SPECIAL — 3.95
BEST MEMORY BUY IN USA!

1 AMP RECTIFIER RIOT!
We bought over 10 million pieces untested. 1N4000 series. Also a few 1 watt ZENERS mixed in. Sample tests show this lot contains many useable devices, some even up to 1 KV. Sold as is assorted, but you will be happy. 100 PCS — \$1.29 500 PCS — \$4.95

Free 28 Pin Socket with purchase of any clock or calculator chip. \$1 VALUE-FREE BONUS

SILICON TRANSISTORS
EN2222 — NPN — 8 For \$1
2N2369 — NPN — 8 For \$1
2N3638 — PNP — 8 For \$1
2N3904 — NPN — 6 For \$1
2N3906 — PNP — 6 For \$1
2N4400 — NPN — 6 For \$1

IN4004 RECTIFIERS
1 AMP 400PIV — SPECIAL 15/\$1

7805 STYLE REGULATORS
TO-220 Plastic Case 5VDC Regulator. Brand New by National — 99c

FACTORY NEW LED'S
Jumbo Red-Like MV5024-8/\$1
Jumbo Green-Like MV5222-5/\$1
Jumbo Yellow-5/\$1
Mini Red-Like MV50-10/\$1

FORD SOLID STATE MODULES
Mfg. by Centralab for Ford car radios. Each module contains 2 transistors plus other components. These modules were used as audio pre-amps. We include specs. — 4 For \$1

TTL IC ASSORTMENT
Various types. Most are marked. Our best selling assortment. Untested but includes many useable devices. 200 PCS FOR \$3.95

FM TRANSFORMERS
We bought a load of coils and transformers that were used in Ford AM-FM car radios. Includes 19KHZ, 36KHZ, OSC. Coils, etc. All New. Perfect for experimenters or repairmen. 10 Pc Assjt. — 99c

ALTAJ ELECTRONICS
P.O. BOX 38544
DALLAS, TEXAS 75238

TERMS: Check or money order. No COD. Add 10% Patg. and Hdg. Tex Res. add 5%.

LINEAR IC SPECIALS
555V-75c 567V-\$1.95 723CH-59c 741CV-39c
LM324 by National — Quad 741C in one DIP — \$1.19

12VDC REED RELAY
Coil is 500 OHM. SPST-No. \$1.49 Sub-Mini.

FILTER CAPS
1000 MFD 16VDC upright style. 4 FOR \$1

PRIME TTL DIP IC'S

7400-16c	7448-89c	74151-75c
7402-16c	7453-16c	74153-89c
7404-16c	7473-37c	74154-95c
7406-24c	7474-37c	74157-99c
7408-16c	7475-65c	74161-99c
7410-16c	7476-39c	74163-1 19
7413-49c	7483-85c	74164-1 29
7420-16c	7490-69c	74165-1 49
7427-24c	7492-75c	74174-1 29
7430-16c	7493-75c	74175-1 39
7437-39c	7495-75c	74181-2 75
7438-35c	7496-75c	74192-1 25
7440-16c	74121-38c	74193-1 25
7442-69c	74123-75c	74195-79c
7447-89c	74150-70c	74197-79c

8038 FUNCTION GENERATOR
Brand new Voltage controlled oscillator. Has sine, square wave, and triangular outputs. \$4.50 each.

IN4148 DIODES
Brand New Units. Same as IN914. Full Leads. 6c each

MONSANTO COLORED READOUTS
27 IN. Character. Common Anode
MAN 5 — GREEN — \$1.29
MAN 8 — YELLOW — \$1.29

PHASE LOCKED LOOP
565A by Signetics. Extremely stable. High linearity, wide frequency range. TTL compatible. Perfect for tone decoders, FSK, SCA receivers, frequency multiplication and division — \$1.75. WITH SPECS

LOOK MOS 4 DIGIT COUNTER
An ALTAJ exclusive. These are the latest state of the art, MOS chips. By a famous US mfg. Contains a complete 4 digit counter, including 4 decade counters, latches, multiplexing circuits, display decoders, etc. Features: 5 VDC operation, 25 MW power consumption, both 7 segment and BCD outputs. Perfect for making DVM's, frequency meters, tachometers, stopwatches, or any other device requiring 4 or more digits. Complete with specs. 28 PIN DIP. QTY Limited. SPECIAL — \$12.50 BACK IN STOCK!

RCA CA3043 — FM IC
Used in FM stereos. Contains IF Amp, Limiter, FM Detector, and an Audio Preamp and Driver all in one 12 lead TO-5 package. With Spec Sheets. A \$3.00 Valve — 99c

P & B RELAYS
4P. D.T Miniature Size
24VDC Coil — 1.49
115VAC Coil — 1.79

LIVE IN THE WORLD OF TOMORROW... TODAY!

And our FREE 164 PAGE CATALOG is packed with exciting and unusual values in electronic, hobby and science items — plus 4,500 finds for fun, study or profit... for every member of the family.

A BETTER LIFE STARTS HERE

TOTAL KIRLIAN PHOTOGRAPHY SET

Explore "aura" photography w/ superb new self-contained Kirlian Electrophotography Research Unit. Terrific value — introduced at \$99.95 (\$140 in Sept.!) Has everything but vinyl photo changing bag. Ideal for color or b&w 35mm. sheet or Polaroid film for photos up to 5" x 7" all without camera or lens. Variable voltage 12v to 32kv. Ultimate safety design—fully encased in plastic; patented electronics. Instrs.

No. 72.104AV (3" x 5 7/8" x 7 7/8") \$99.95 Ppd.
No. 42.240AV (CHANGING BAG) \$ 6.50 Ppd.

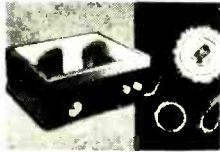

ELECTRONIC DIGITAL STOPWATCH: \$69.95

A price breakthrough! New pocket size 4 oz. timer acc. to -2% of last digit (1/100 sec. increments). Compares with others twice the price! Instant error-free readouts to 9999.99 sec. (over 2 3/4 hr). Starts, stops re-starts (accumulates). Mechanical pushbutton & electrical remote on/off w/any 3.5-150v AC/DC source. Plug-in jack. incis. 9v batt. Solid state.



No. 1943 AV (2 1/4 x 4 1/4 x 7/8") \$69.95 Ppd.
DELUXE 2 EVENT STOPWATCH (-0.01% OF LAST DIGIT)
No. 1653 AV \$149.95 Ppd.

FUEL MISER RECLAIMS HEAT

Save your 40% wasted heat to warm a basement, garage or rec room at no extra cost! Instead of going "up the chimney" it goes where you want it. Remove part of furnace exhaust pipe, slip Heat Exchanger in. At 125 fan automat. forces clean air through unit which heats to over 200° F., can be ducted to 20 ft. from unit. 110v AC. Inst.



No. 19.194AV (5/8" DIA.) Shpg. 17 lb. \$106.00 FOB
No. 19.195AV (6" DIA.) Shpg. 17 lb. \$106.00 FOB
No. 19.198AV (7" DIA.) Shpg. 17 lb. \$106.00 FOB

3-CHANNEL COLOR ORGAN KIT

Easy to build low-cost kit needs no technical knowledge. Completed unit has 3 bands of audio frequencies to modulate 3 independent strings of colored lamps (i.e. "lows"-reds, "middles"-greens, "highs"-blues. Just connect hi-fi, radio, power lamp etc. & plug ea. lamp string into own channel (max. 300w ea.). Kit features 3 neon indicators, color intensity controls, controlled indivd SCR circuits; isolation transformer; custom plastic housing; instr.

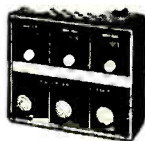

Stock No. 41.831AV \$18.95 Ppd

WHEN YOU COME TO PHILADELPHIA BE SURE TO SEE
FREE BICENTENNIAL LIGHT SHOW
IN BARRINGTON, N.J. ONLY 10 MINUTES AWAY AT
EDMUND FACTORY STORE

OWN A WORKING DUTCH WINDMILL



Easily build a charming 1/5 scale replica of the real thing with our detailed plans, blueprints, list of materials needed and explicit instructions. 8" size can generate 1000w (12v current) of free electricity from the wind! 2', 4' & 8' sizes stand 36", 7' & 14' high, respectively. Get kudos from your neighbors for the beauty & practicality. If you're the least bit handy you can do it for \$250-\$350 (est. complete material cost). Go Dutch!
Stock No. 9130AV \$15.95 Ppd.

AM RADIO FITS IN/ON YOUR EAR!



Wear it inconspicuously everywhere, listen as you work (lawn, yard, office), watch (game, beach) or wait. Instant music, news, sports. No gimmick-6/10 oz. technological wonder w/integrated circuit, 11 transistors, patented ferrite antenna/tuner/volume dial. Works best outdoors. Uses hearing aid batt. (incl.) up to 100 hrs. playing. New batt. to slip in avail. at drug stores (about 50c). No lengthy wires, bulky cases, or power-packed!
Stock No. 42.275AV \$14.95 Ppd.

KNOW YOUR ALPHA FROM THETA!



For greater relaxation, concentration, listen to your Alpha-Theta brainwaves. Ultra-sensitive electrode headband slips on/off in seconds—eliminates need for messy creams, etc. Atch'd to amplifier, filters brainwaves, signals beep for ea. Alpha or Theta wave passed. Monitoring button stimulates Alpha sound; audio & visual (L.E.D.) feedback. Reliable, easy-to-use unit comparable to costlier models. Completely safe. Comprehensive instruction booklet

No. 1635AV (8" x 3" x 4"; 24 oz.) \$149.50 Ppd.
DELUXE "ON" TIME MONITOR—Measures and records %
No. 1652AV (15" x 10" x 6") \$299.50 Ppd.
No. 71809AV LDW COST "STARTER" UNIT \$55.00 Ppd.
DO-IT-YOURSELF KIT No. 61.069AV \$34.95 Ppd.

THE FINAL OPTICAL ILLUSION!



Now you see it, but you don't. Put a coin, ring, rock, any small thing inside the unit—it seems to be resting on the mirrored top. Look at it, smell it, shine a light on it, even photograph it AND it's really there. Try to touch it, you'll get only thin air! You & everyone else will be astounded by this Parabolic Display Unit (it's

science and art) that produces an amazing optical effect. Scientists call it a 3 dimensional real image. Very exciting!

No. 72.074AV (w/4" dia. displ. stand) \$45.00 Ppd.

4 1/4" ASTRONOMICAL TELESCOPE



See moon craters, rings of Saturn, double stars. New equatorial mount. f/10. 1/4 wave mirror (Pyrex). Gives theoretical limit of resolution. Rack & pinion focusing. Aluminum tube, 6X finder. 1" F.L. 45X Kellner achromatic eyepiece and Barlow lens to double & triple power up to 135X. Free Star Chart plus 2 Books.

Stock No. 85.105AV (Shipping Wt. 42 lbs.) \$149.50 FOB
4 1/4" WITH CLOCK DRIVE No. 85.107AV \$189.50 FOB
6" REFLECTOR TELESCOPE (48X to 360X) No. 85.187AV \$249.50 FOB
6" WITH CLOCK DRIVE No. 85.086AV \$285.00 FOB
3" DELUXE REFLECTOR (30X to 90X) No. 80.162AV \$ 79.95 Ppd.
STANDARD 3" REFLECTOR No. 85.240AV \$ 49.95 Ppd.



MAIL COUPON FOR GIANT FREE CATALOG!

164 PAGES • MORE THAN 4500 UNUSUAL BARGAINS

Completely new 1976 edition. New items, categories, illustrations. Dozens of electrical and electromagnetic parts, accessories. Enormous selection of Astronomical Telescopes. Unique lighting and ecological items. Microscopes, Binoculars, Magnifiers, Magnets, Lenses, Prisms. Hard-to-get-surplus bargains. Ingenious scientific tools. 1000's of components.

EDMUND SCIENTIFIC CO.
300 Edscorp Building, Barrington, N.J. 08007
Please rush Free Giant Catalog "AV"

Name _____
Address _____
City _____ State _____ Zip _____



COMPLETE & MAIL WITH CHECK OR M.O.

EDMUND SCIENTIFIC CO. 300 Edscorp Building, Barrington, N.J. 08007

How Many	Stock No.	Description	Price Each	Total
<input type="checkbox"/>		PLEASE SEND GIANT FREE CATALOG "AV"		
<input type="checkbox"/>		Charge my BankAmericard		
<input type="checkbox"/>		Charge my Master Charge		

Add Handling Chg.: \$1.00, Orders Under \$5.00, 50¢, Orders Over \$5.00

Interbank No. _____ My Card No. is _____
 BankAmericard Master Charge Enclose check money order for TOTAL \$ _____

Card Expiration Date _____ Signature _____

30-DAY MONEY-BACK GUARANTEE. You must be satisfied or return any purchase in 30 days for full refund. *\$15.00 minimum

Name _____ Address _____
City _____ State _____ Zip _____

THE SOURCE OF PERFECTION IN SOUND...

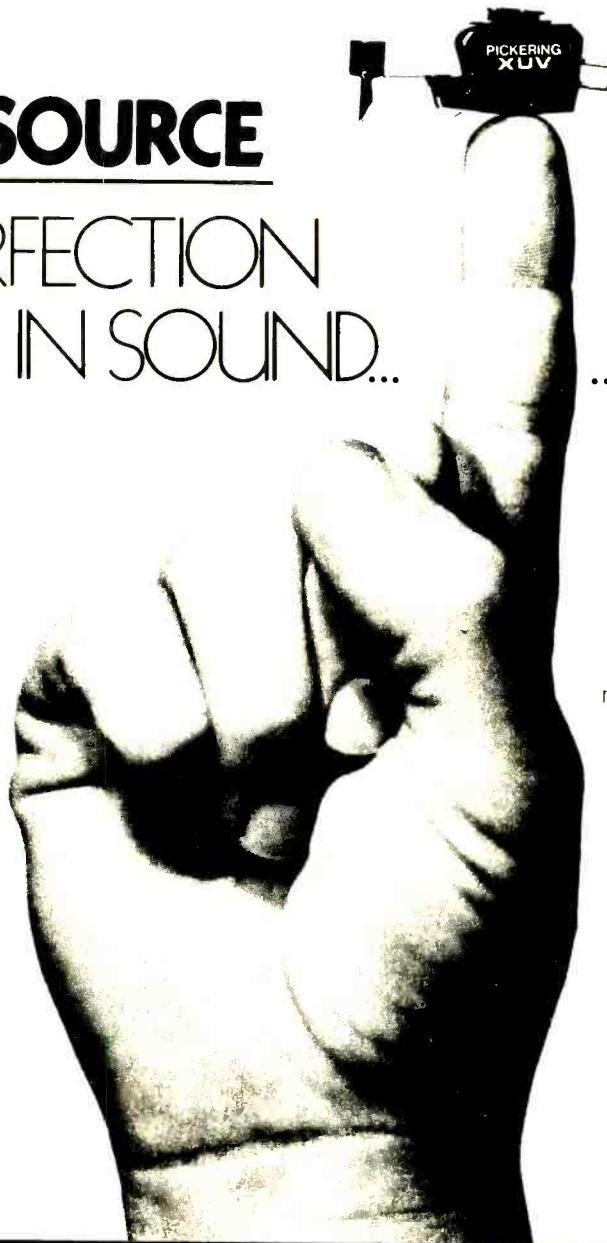

...tracks at one gram (or less)
in stereo and discrete

Pickering's engineers pursued the idea of a totally new departure in cartridge design with all the zeal of true crusaders. They had a reason . . . there was a demand for a pickup to play both stereo and discrete (as well as SQ and QS) with *total and absolute precision* at one gram. That they succeeded is a remarkable achievement because this cartridge successfully tracks all types of records at forces even lighter than one gram. It is a real *first* to do it this accurately.

The XUV/4500-Q features Pickering's patented Quadrahedral® stylus assembly. The Quadrahedral stylus assembly incorporates those features that produce extended *traceAbility™* for 4-channel as well as stereo. This means that it possesses not only superior performance in low frequency tracking, but also in high frequency *tracing ability*. When combined with the exclusive Quadrahedron™ stylus tip, a brand new shape, it can truly be called: "the *Source* of perfection in Sound", whether the playback requirement is stereo, SQ, QS, or discrete 4-channel.

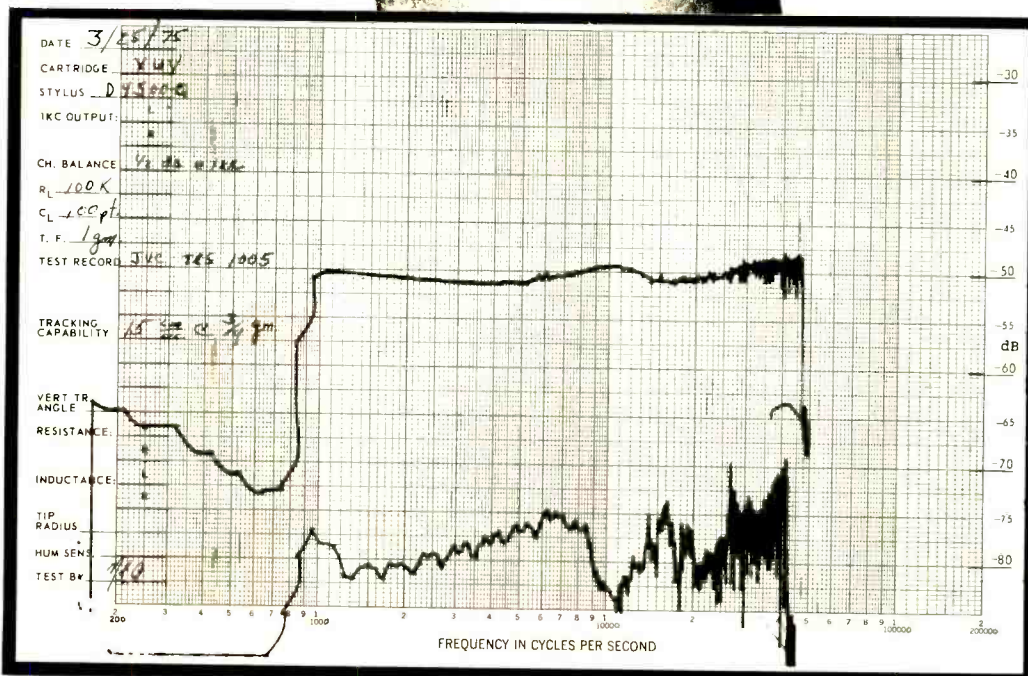

a typical curve of the XUV/4500-Q

Shown at left is a printout graph from Pickering's testing apparatus. The top line is a frequency response curve (note that it starts at 1,000 cycles for the sake of simplicity). It depicts the unusually flat frequency response throughout the spectrum. The bottom line, which also starts at 1,000 cycles, shows the separation characteristics of this new cartridge.

Believe us, you have never seen one quite like this because Pickering's exclusive new design development also makes it superior to other cartridges in the playback of stereo records, as well as discrete.

The specifications are so exciting that we hope you will write to Pickering and Company, Inc., Dept. PE, 101 Sunnyside Blvd., Plainview, New York 11803 for further information.

PICKERING
"for those who can hear the difference"

CIRCLE NO. 54 ON FREE INFORMATION CARD

Now you can have Dual precision any way you like.

Every Dual, from the 1225 to the CS701, is designed to fulfill one basic concept: to provide more precision than you are ever likely to need.

Perhaps this is why more component owners—audio experts, hifi editors, record reviewers and readers of the music/equipment magazines—own Duals than any other turntable. These serious music lovers, whose investment in records typically exceeds their investment in equipment, prefer Dual for only one reason. Quality.

Until recently, Dual quality has been available only with fully automatic turntables with both single-play and multi-play facility. Now the choice is much broader. Of the seven Dual models, three are single-play only. Two of these are fully automatic: one is semi-automatic. Dual turntables also use all three types of drive systems: belt, rim and direct.

The way a tonearm is moved to and from the record is not critical. Nor is the type of drive system. What is critical is how faithfully the tonearm permits the stylus to follow the contours of the groove and how accurately and quietly the platter rotates.

If precision performance and reliability are of primary importance to you—as they should be—you'll find them in every Dual.



Dual 1225

Dual 1225. Fully automatic, single-play/multi-play. Viscous damped cue-control, pitch-control. 10 $\frac{1}{2}$ " platter. \$139.95, less base.
Dual 1226, with cast platter, rotating single-play spindle, \$169.95.
Dual 1228, with gimballed tonearm, synchronous motor, illuminated strobe, variable tracking angle, \$199.95.

Dual 1249. Fully automatic, single-play/multi-play. Belt drive. 12" dynamically-balanced platter. \$279.95, less base. Full size belt-drive models include: Dual 510, semi-automatic, \$199.95; Dual 601, fully automatic, \$249.95 (Dual CS601, with base and cover, \$270.)

Dual CS701. Fully automatic, single-play. D.C. brushless, electronic direct drive motor; tuned anti-resonance filters. \$400, including base and cover.



Dual 1249



Dual CS701

United Audio Products, 120 So. Columbus Ave., Mt. Vernon, N.Y. 10553

CIRCLE NO. 4 ON FREE INFORMATION CARD

www.americanradiohistory.com

Exclusive U.S. Distribution Agency for Dual

Dual