

Popular Electronics

WORLD'S LARGEST-SELLING ELECTRONICS MAGAZINE FEBRUARY 1975/75c

HOW PHASE-LOCKED LOOPS WORK

A VU Meter with
No Moving Parts

Shortwave Newscasts
in English

Build a Minicomputer,
Part II

"Tug of War"
Electronics Game

TEST REPORTS:

Marantz 4270
Receiver

Garrard Zero 100SB
Turntable

Ortofon VMS-20E
Phono Cartridge

Lafayette Com-Phone 23
CB Transceiver

Data Technology
Models 20 & 21 DMMs

Build the first Low-cost ALL-SOLID-STATE TV Camera!

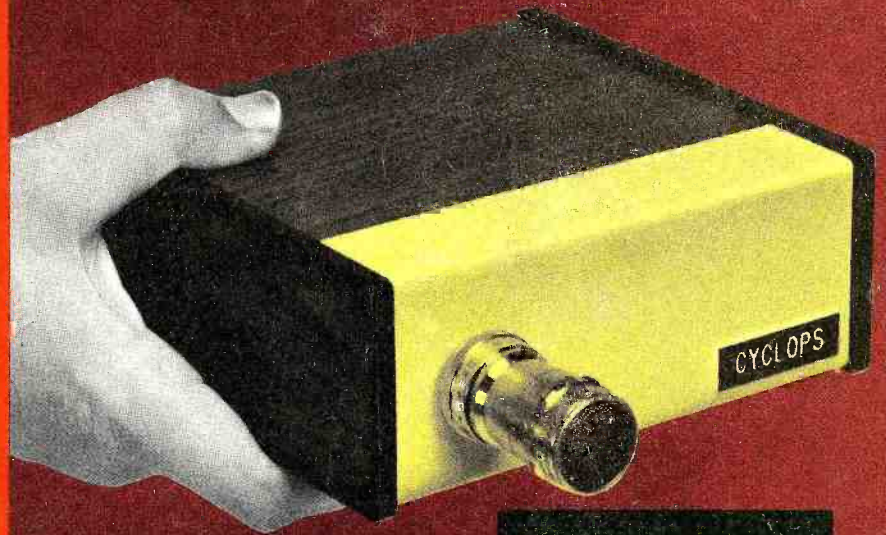

- Uses MOS Sensor
- All Digital



692108 JNK 11024002 APR78 1 10
R JENKINS
1102 S 45TH ST
TEMPLE TX 76501
L
20

Your sure-fire smoke detector is here...the Mallory SDA3 Alarm.

Automatically, 'round the clock, when hazardous smoke fumes threaten, it sounds a life-saving intermittent blast—so loud it can break through the deepest sleep.

The Mallory Smoke Detector Alarm is completely self-contained, battery-powered. It installs easily on ceilings—in hallways, bedrooms, wherever warning for escape from lethal combustion products (visible or invisible) is needed.

And the 12.6-volt Mallory battery is specially designed for added security. It changes characteristics after a life of approximately one year and the Alarm then emits a burst of sound at one-minute intervals, signaling that a fresh battery is needed.

All for a price so affordable, every home, apartment, trailer, office can have sure-fire smoke-alarm protection.

For details, see your Mallory distributor.



The SDA3 Alarm is compact, unobtrusive—only 6" x 1 1/16".

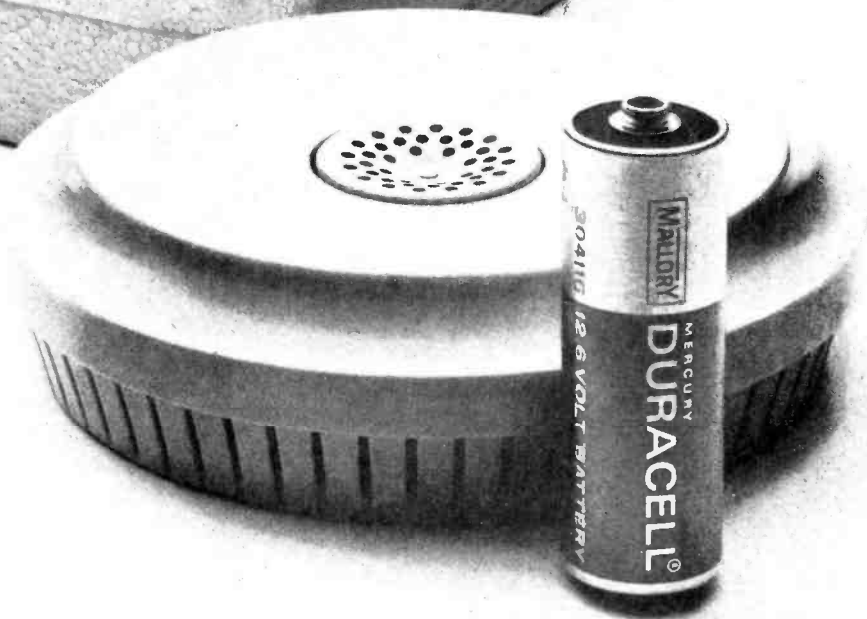

MALLORY

MALLORY DISTRIBUTOR PRODUCTS COMPANY

a division of P. R. MALLORY & CO. INC.
Box 1284, Indianapolis, Indiana 46206; Telephone: 317-856-3731

Batteries • Capacitors • Controls • Security Products • DURATAPE® • Resistors • Semiconductors • SONALERT® • Switches • Timing Devices and Motors
DURACELL®, DURATAPE® and SONALERT® are registered trademarks of P. R. Mallory & Co. Inc.

CIRCLE NO. 24 ON READER SERVICE CARD

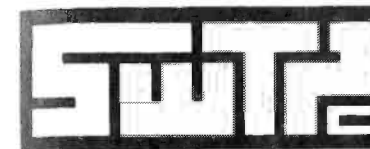

IS PROUD TO ANNOUNCE: THE CT-1024 TERMINAL SYSTEM

- * DISPLAYS UP TO 16 LINES (of 32 Characters) AT ONE TIME.
- * 1,024 Character — Two Page Memory Capacity — STANDARD.
- * Plug-In Circuits to adapt the terminal to any requirement at lowest possible cost.
- * Requires +5 Volts DC @ 2.5 Amps, -5 and -12 Volts @ 20 Ma.
- * Use with any TV set

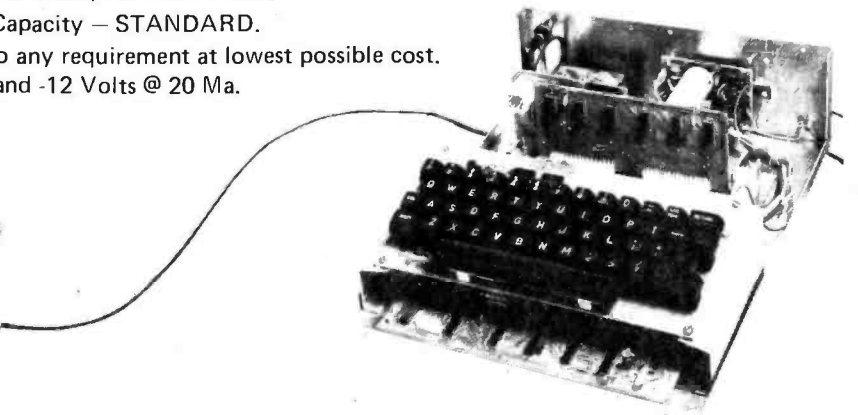

- * Up to date, low power consumption STATIC type MOS Memory.
- * No complicated refresh or power-down circuits needed.

At last we can tell you about the most versatile, video-display terminal kit available anywhere; the Southwest Technical CT-1024. Our terminal is designed around a basic mother board and a 6,144 bit memory that will display two pages of data on any standard television set, or monitor. The two pages consist of 16 lines with 32 characters on each line. Input may be any source of parallel ASCII code; keyboard, computer, etc. If the system is to be used for a display, teaching aid, deaf communicator, or other similar purpose; this is all you will need.

Other applications of a terminal system such as remote time share, RTTY, etc require an interface having a serial output. For these applications you add our # CT-S plug-in UART card to the mother board. This allows you to transmit and receive ACSCII coded data in serial form at a rate of 110 baud. (300 and 600 baud options are available). The standard RS-232 type interface connects directly to your transmitter FSK modulator, modem system, or what have you.

If you are going to use the CT-1024 directly with a computer I/O port that requires a parallel ACSCII input, then you will want our parallel interface card, #CT-P which

allows either the keyboard, or the computer to access the terminals memory and display data on the screen.

For those applications where it is useful, we also have an "off line edit", or "screen read" plug-in circuit #CT-E. This allows you to compose a program, or message on the terminals display screen and transmit it out a line at a time when you are finished and satisfied that everything is correct.

If you would like the convenience of complete cursor control, we have our #CT-CM plug-in board. This gives you Move Right, Move Left, Move Up, Move Down, Home Up, Erase to end of line and Erase to end of frame functions. These are operated by keyswitches, or any other type switches you may wish to use, giving you complete manual control of the cursor.

If the terminal is to be part of a computer system, you might prefer our automatic cursor control circuit #CT-CA. This plug-in not only allows you to control the cursor and to perform the functions listed above, but makes possible computer control of these same functions through the machines software.

# CT-1024 Terminal System Kit with 1024 Memory Card—less cabinet or power supply	\$175.00 Ppd
# CT-E Screen Read Plug-in Card Kit.	\$ 17.50 Ppd
# CT-M Manual Cursor Control Plug-in Card Kit	\$ 11.50 Ppd
# CT-P Power Supply for CT-1024—115-230 Volt Primaries.	\$ 15.50 Ppd
# KBD-2 Keyboard Kit — 53 Keys	\$ 39.95 Ppd

FREE—1975 Catalog—Circle our number on the "Bingo" card.

SOUTHWEST TECHNICAL PRODUCTS CORPORATION

219 W. RHAPSODY

SAN ANTONIO, TEXAS 78216
CIRCLE NO. 35 ON READER SERVICE CARD

Now there's a CB radio with too much talk power.



Put punch in your voice, from a block away to the fringes of your range. New Dyna-Mike gain control puts out absolute modulation. So much talk power you'll have to turn it down.

An important feature, but only one that makes this fantastically low-priced CB radio the best CB value on today's market.

The Cobra 21 with crystal filter, dual conversion receiver; transmits and receives on all 23 AM channels.

Features 60 dB adjacent channel rejection that completely eliminates bleedover.

Extra large Power S Meter let's you monitor your set's performance easily even when it's tucked under the dashboard.

And you get switchable automatic noise limiter, P.A./external speaker jack, large built-in speaker and detachable mike.

It's all wrapped up in a beautiful, compact cabinet only 6" wide x 2 1/2" wide x 7 1/2" deep. Meets FCC requirements.

Ask your CB Dealer for the Cobra 21. The radio with too much talk power for not much money.



COBRA 21
WITH EXCLUSIVE DYNA-MIKE

Product of DYNASCAN CORPORATION • 1801 W. Belle Plaine • Chicago, Illinois 60613

CIRCLE NO. 8 ON READER SERVICE CARD

POPULAR ELECTRONICS

FEBRUARY 1975 VOLUME 7, NUMBER 2

Popular Electronics®

WORLD'S LARGEST-SELLING ELECTRONICS MAGAZINE

FEATURE ARTICLES

HOW PHASE-LOCKED LOOPS WORK	Herb Cohen	32
<i>Theory and applications of a circuit revitalized by IC technology.</i>		
SHORTWAVE NEWSCASTS IN ENGLISH	Richard E. Wood	35
KEYING AND VCA CIRCUITS FOR ELECTRONIC MUSIC INSTRUMENTS, PART II	Don Lancaster	37
POWER SURGES AND SEMICONDUCTORS	Leslie Solomon	42
ALTAIR 8800 MINI COMPUTER, PART 2	H. Edward Roberts & William Yates	56
<i>Practical use of the computer, including programming.</i>		

CONSTRUCTION ARTICLES

BUILD CYCLOPS	Terry Walker, Harry Garland & Roger Melen	27
<i>First all solid-state TV camera for experimenters.</i>		
A VU METER WITH NO MOVING PARTS	Terry L. Mayhugh	40
<i>New bar-graph device provides signal-strength readouts, accurate peak signals.</i>		
TUG-OF-WAR	Robert C. Frosthalm & Roger Lundegard	43
<i>An electronic game project to challenge your reflexes.</i>		
BUILD A "UNIVERSAL" DIGITAL PROBE	James P. Tierney	48
<i>Tests virtually any digital logic family at speeds to 10 MHz.</i>		
UPDATE YOUR DIGITAL CLOCK WITH ADD-ONS	Jeffrey Glick, Jerry McElwee & Wilbur Marky	50
<i>An hourly chimer, alarm for heavy sleepers, and grandfather's tick-tock.</i>		
ZERO-TO-30V EXPERIMENTER'S SUPPLY	Thomas McGahee	70

COLUMNS

HOBBY SCENE	Editorial Staff	17
STEREO SCENE	Ralph Hodges	22
<i>Tape-head alignment.</i>		
SOLID STATE	Lou Garner	76
<i>Using thermoelectric devices.</i>		
CB SCENE	Len Buckwalter	80
<i>Taking the bark out of spark.</i>		
ART'S TV SHOP	Art Margolis	86
<i>Mystery of the pocket power supply.</i>		
TEST EQUIPMENT SCENE	Leslie Solomon	88
<i>Learning to live with digital.</i>		

PRODUCT TEST REPORTS

MARANTZ MODEL 4270 AM/FM STEREO 2-QUADRADIAL 4 RECEIVER	59
GARRARD ZERO 100SB TURNTABLE	61
ORTOFON MODEL VMS-20E PHONO CARTRIDGE	66
LAFAYETTE COM-PHONE 23 MOBILE CB TRANSCEIVER	67
DATA TECHNOLOGY MODEL 20 BENCH-TYPE AND MODEL 21 PORTABLE DIGITAL MULTIMETERS	68

DEPARTMENTS

EDITORIAL	Art Salsberg	4
<i>It's a Tough World Out There.</i>		
LETTERS		6
NEW PRODUCTS		12
NEW LITERATURE		16
NEWS HIGHLIGHTS		25
ELECTRONICS LIBRARY		89

POPULAR ELECTRONICS, February 1975, Volume 7, Number 2. Published monthly at One Park Avenue, New York, NY 10016. One year subscription rate for U.S., Possessions and Canada, \$7.98; all other countries, \$8.98. Second class Postage paid at New York, NY and at additional mailing offices. Authorized as second class mail by the Post Office Department, Ottawa, Canada and for payment of postage in cash. Subscription service and Forms 3579; P.O. Box 2774, Boulder, CO 80302. POPULAR ELECTRONICS including ELECTRONICS WORLD, Trade Mark Registered. Indexed in the Reader's Guide to Periodical Literature. COPYRIGHT ©1975 BY ZIFF-DAVIS PUBLISHING COMPANY. ALL RIGHTS RESERVED.

Ziff-Davis also publishes Boating, Car and Driver, Cycle, Flying, Modern Bride, Popular Photography, Skiing and Stereo Review. Forms 3579 and all subscription correspondence should be addressed to POPULAR ELECTRONICS, Circulation Dept., P. O. Box 2774, Boulder, CO 80302. Please allow at least eight weeks for change of address. Include your old address, as well as new—enclosing, if possible, an address label from a recent issue. Editorial contributions must be accompanied by return postage and will be handled with reasonable care; however publisher assumes no responsibility for return or safety of art work, photographs, models, or manuscripts.



Editorial

EDGAR W. HOPPER
Publisher

ARTHUR P. SALSBERG
Editorial Director

LESLIE SOLOMON
Technical Editor

JOHN R. RIGGS
Managing Editor

EDWARD I. BUXBAUM
Art Director

ALEXANDER W. BURAWA
Associate Editor

JOHN McVEIGH
Assistant Editor

ANDRE DUZANT
Technical Illustrator

HERBERT S. BRIER
LEN BUCKWALTER
LOU GARNER
GLENN HAUSER
JULIAN D. HIRSCH
RALPH HODGES
WALTER G. JUNG
ART MARGOLIS
Contributing Editors

JOSEPH E. HALLORAN
Advertising Director

JOHN J. CORTON
Advertising Sales

LINDA BLUM
Advertising Service Manager

PEGI McENEANEY
Executive Assistant

STANLEY NEUFELD
Associate Publisher

FURMAN H. HEBB
Group VP, Electronics & Photo

ZIFF-DAVIS PUBLISHING COMPANY
Popular Electronics
Editorial and Executive Offices
One Park Avenue New York, New York 10016
212-725-3500

Hershel B. Sarbin, President

Furman Hebb, Executive Vice President and Treasurer
Phillip T. Heffernan, Senior Vice President, Marketing
Edward D. Muhfeld, Senior Vice President, Sports Division
Phillip Sine, Senior Vice President
Frank Pomerantz, Vice President, Creative Services
Arthur W. Butzow, Vice President, Production
Lawrence Sporn, Vice President, Circulation
George Morrissey, Vice President
Sydney H. Rogers, Vice President
Sidney Holtz, Vice President
Charles B. Seton, Secretary
Edgar W. Hopper, Vice President, Electronics Div.

William Ziff, Chairman
W. Bradford Briggs, Vice Chairman

Midwestern Office
The Patis Group, 4761 West Touhy Ave.,
Lincolnwood, Illinois 60464, 312 679-1100
GERALD E. WOLFE, GEORGE B. MANNION
DAVID ALLEN

Western Office
9025 Wilshire Boulevard, Beverly Hills, CA 90211
213 273-8050; BRadshaw 2-1161
Western Advertising Manager, BUD DEAN

Japan: James Yagi
Oji Palace Aoyama; 6-25, Minami Aoyama
6 Chome, Minato-Ku, Tokyo 407-1930/6821,
582-2851



The publisher has no knowledge of any proprietary rights which will be violated by the making or using of any items disclosed in this issue.

IT'S A TOUGH WORLD OUT THERE

An electronics editor sometimes gets spoiled. Parts are almost always available, delivery is generally speedy, etc. However, to corroborate some reader reports that it isn't as easy as it once was to be an electronics hobbyist, I set out to build some projects without my protective cloak. Here are some of my experiences.

Failing to find a particular \$3 component locally—retail electronics stores didn't stock it and industrial distributors wouldn't sell me just one—I found an industrial mail-order supplier that carried it. However, since I didn't meet a minimum purchase requirement, I had to pay a 50% premium (\$1.50 handling charge) on the part, plus postage. I also used mail order for a single 750k-ohm, 5%, 1/2-watt resistor because it wasn't available at local outlets. And I purchased a 556 dual timer that turned out to be defective (which I learned after troubleshooting an inoperative module). After quickly wiring in a replacement without referring to an application note, I discovered that the second device had a different pin configuration.

Running out of solder, I hurried to a local electronics retailer and asked for a pound. The clerk's eyes widened as he advised me that tin prices had gone sky-high and a pound would cost \$9.85, plus tax. Nine-eighth-five indeed, I thought! So I tried another electronics store, where I was able to buy a pound of name-brand, rosin-core solder for only \$4.95. Happily, I took my bargain home, only to discover that the solder required more time than usual to melt. Furthermore, spread was poor, the liquified alloy looked slurry and the solidified joint was dull and crusty rather than bright and shiny. Distressed, I examined the spool. It was 40/60. What I wanted, naturally, was 60/40, which has a lower melting point (370°F vs. 460°F).

I could go on, but the idea is clear. It is more difficult today than it used to be to gather parts at the right price—for a variety of reasons. But in many ways, our lot today is better than it ever was. We have many more devices available, with numerous circuit application possibilities. Prices on many devices are low and getting lower (an anomaly in today's inflationary market). Using pc boards and multi-function chips, it is easier to assemble a complicated circuit today than it was to put together a simple one years ago. The result is more satisfactory also.

Facing up to the fact that no single outlet carries all parts and that some suppliers are not interested in small-quantity orders, how can one ease the parts procurement problem? One sensible way is to write to all companies that sell components and have catalogs available. Many of them advertise in this magazine. Be sure, also, to check mail-order suppliers at the back of the magazine. Arm yourself with cross-reference and replacement guides, too. This may sound basic, but we recently received a host of letters asking where one could get 200-PIV diodes for a solder-iron heat reducer hint we published, when practically every electronic parts catalog lists them!

Also, there's nothing wrong with using higher-rated components (a 2-watt resistor if a 1-watt isn't available); totem-poling zeners; paralleling capacitors; etc. Yankee ingenuity can often provide a helpful assist.

Art Salsberg

Get the news before it's news... with a "behind-the-scenes" Scanner Radio from Radio Shack!

Realistic® scanners seek and lock-in on exciting police, fire and emergency calls, even continuous weathercasts! There's one to cover the "action" in your area—10 models in all.

PRO-6—VHF-Hi and VHF-Low

Continuously, automatically scans up to 4 crystal-controlled channels on 148-174 or 30-50 MHz. It stops on each active channel until the conversation ends, then resumes scanning. You don't miss a thing—it's like 4 radios in one! Lighted channel indicators, switches for bypassing any channels, scan/manual switch, variable volume and squelch, built-in speaker and antenna, earphone jack. With 4 "AA" cells. Requires up to 4 crystals. #20-171.

PRO-5—UHF "Metro" Band

Same as the PRO-6, but covers 450-470 MHz now used in many larger cities. Requires up to 4 crystals. #20-169.

Accessories Available. Plug-in antenna, 12VDC adapter or AC adapter/battery charger, nickel cadmium batteries.

Pocket Size,
Both Models **119⁹⁵** each



FREE New 1975 Radio Shack Catalog

OVER 2000 PRODUCTS
EXCLUSIVES ON EVERY PAGE
BEAUTIFUL FULL COLOR

Stereo • Quadraphonic • Phonographs
TV Antennas • Radios • Citizens Band
Kits • Recorders • Tape • Tools
Auto Tune-Up • Electronic Parts
Test Instruments • More!



164 pages of the finest in home and hobby electronics. Respected brand names like Realistic, Micronta, Archer, Science Fair—and they're available only at Radio Shack stores and dealers nationwide! See what's really new in electronics by getting this catalog now.

SEND FOR YOURS TODAY!
FILL OUT COUPON BELOW

1975 Mail to Radio Shack, P. O. Box 1052, 479
Catalog Ft. Worth, Texas 76101. (Please print.)

Name _____ Apt. No. _____

Street _____

City _____

State _____ ZIP _____

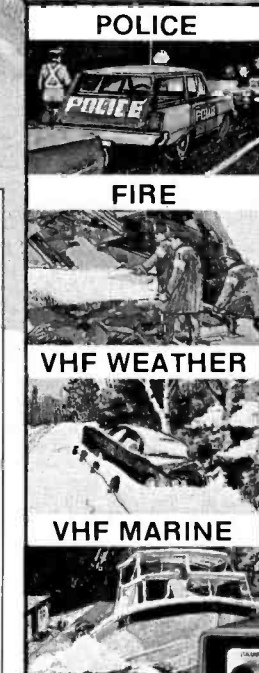

*On VHF Hi-Band. Stations not in all localities.

The PRO-16—a Super Scanner
for the ultimate at-home
or mobile listening post



229⁹⁵

Scans up to 16 crystal-controlled channels, in any combination, on 30-50 and 148-174 MHz VHF and 450-470 MHz UHF. Like 16 radios in one! Lockout buttons and indicator lights for each channel, manual selector, squelch, variable scan rate, scan-delay in/out button, 12 VDC/120 VAC operation, mobile mounting bracket. Requires up to 16 crystals. U.L. listed. #20-165



Master Charge or
Bank Americard at
participating stores

REALISTIC®
at
Radio Shack®

A TANDY CORPORATION COMPANY
OVER 3000 STORES • 50 STATES • 7 COUNTRIES
Retail prices may vary at individual stores

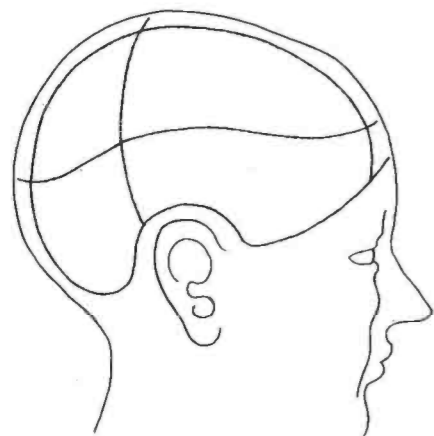

'GET INTO YOURSELF'

Discover your Alpha Brainwaves with this professional Biofeedback System.

Lowest Cost Brainwave Monitor
EICO introduces a price breakthrough in the fantastic new field of brainwave biofeedback... a completely safe, battery operated, biofeedback system that offers features and sensitivity comparable to professional models costing much more.

You Will Be Amazed At What You Hear
The BW-300 will detect your alpha brainwaves (which occur when you are totally relaxed) and produce a tone varying in frequency according to your mental state.

100% Solid State Circuitry
Reliable All Solid State IC Circuit Design features an active filter that isolates alpha brainwaves and a high-gain low-noise amplifier providing 5-microvolt sensitivity for easy alpha recognition. The BW-300 is supplied with stethoscopic earphones, electrodes headband, contact cream and instructions.

KIT 3495
WIRED 59.95

FREE EICO CATALOG

For latest EICO Catalog on Test Instruments, Automotive and Hobby Electronics, Eicocraft Project kits, Burglar-Fire Alarm Systems and name of nearest EICO Distributor, check reader service card or send 50¢ for fast first class mail service.

EICO—283 Malta Street, Brooklyn, N.Y. 11207

Leadership in creative electronics **EICO**

CIRCLE NO. 14 ON READER SERVICE CARD



Letters

FEEDBACK ON SALT METER

The data on sodium chloride content of baby foods and other hypothetical intake cited in the POPULAR ELECTRONICS article ("An Electronic Salt Meter For Family Health," October 1974) are not unreasonable, but they do not give an accurate or complete picture of the salt intake of infants.

About 20 years ago, one of our physical chemists designed and built conductance meters for controlling salt addition in our production operations. Although these meters represented an advance at the time, their use has been abandoned because conductance is influenced by too many food factors other than salt. Salt addition is carefully controlled by weighing or accurate metering devices. The sodium levels in Gerber Foods are determined by atomic absorption or electron emission methods and have been published periodically for more than 20 years.

ROBERT A. STEWART, PH.D.
Director of Research
Gerber Products Company
Fremont, Mich.

PRO'S AND CON'S OF TECH REPPING

I enjoyed your article about tech reps ("Career Opportunities for the Tech Rep," November 1974). I feel it was a straightforward and honest account of the profession. Let me encourage anyone contemplating such a career—the future looks good. I would suggest an associate degree in electronics or computer science for the first-rate positions, as this would be a distinct advantage over either military or trade school training, with the added plus of having college hours should further education be desired. With "sheep-skin" in hand, you can literally write your own ticket.

MICHAEL P. TOWERS
Field Engineer
Singer Aerospace & Marine Systems
Binghamton, N.Y.

I have just finished reading "Career Opportunities for the Tech Rep," and as a former tech rep, my message to all is to stay out of the business. Tech repping is a job whose duration is only as long as the contract you are on lasts. Your job experience will not be recognized when you look for employment back in the U.S. — no matter what your title was as a tech rep. The pay

offered for tech reps is not all that hot either.

BERNHARDT SANDLER
Gardena, Calif.

AND NOW A WORD FROM AN SWL

I am happy to see that the "Shortwave Broadcasts to North America" schedules are again being published quarterly in POPULAR ELECTRONICS. However, there is one criticism I feel I must make. The experienced DX'er knows that stations periodically change their schedules of operating frequencies—often without previous notice. To help correct this fault, a simple note should be prominently placed on the page to inform the reader that frequencies might be changed without notice.

I also question the use of a Collins receiver in preparing this listing. After all, how many newcomers to SWL'ing have an expensive Collins? With the receivers neophytes do have, they are lucky they can receive HCJB with good quality.

Kenneth Zichi, WDX8KWT
Bay City, Mich.

Your recommendation about a word of caution on frequency changes is hereby adopted. Thanks. With regard to the use of a Collins receiver, the information is supplied simply as a frame of reference. Unless one is seeking out a 5-kW station, less costly gear should display similar reception quality. The antenna is only a simple end-fed Hertz type. If one can't receive HCJB, which boasts one of the strongest and cleanest signals, he must have a defective receiver and/or antenna.

ERRATUM

A drafting error seems to have slipped into Fig. 2 of my "Photo Tachometer" story (August 1974). For transistor Q2 (in Fig. 2), the S and G legends were shown transposed. Most people who build this project will correctly place the leads of Q2 in the proper holes (they conform to the transistor's lead basing configuration), but we should clear up this confusion for anyone who may have doubts.

A.A. MANGIERI
New Kensington, Pa.

WHEN DOES \$10 EQUAL \$100?

I have built the "Large-Port Speaker System" described in the August 1974 issue and have only words of praise. This is not only the most unique speaker system that I know of, but it is also the best sounding system I have heard next to \$100 and \$200 systems with which I compared it. Considering that my Large-Port Speaker System cost only \$10 to build, the results are remarkable.

SCOTT E. PERSSON
Omaha, Neb.

POPULAR ELECTRONICS

"ELECTRONICS AUSTRALIA" SCOOPS PE

In "Build a Laser TV System" (November 1974), it was claimed that POPULAR ELECTRONICS published details of the world's first hobbyist/experimenter's laser in December 1969. I beg to differ! We published construction details for such a project in our August 1969 issue and gave details of the modifications necessary to use it for light-beam communications in our October 1969 issue.

J. ROWE
Editor
ELECTRONICS AUSTRALIA
Sydney, Australia

We were surprised to learn that we were scooped on another continent back in 1969. Congratulations EA.

SETTING UP CB SERVICE SHOP

I enjoyed "How to Set Up a Home TV Service Shop" (August 1974). Now, I would like to see you publish an article on how to set up a home CB service shop.

BOB J. LATHIM
Dwight, Ill.

DISCRETE IS BETTER THAN INTEGRATED

In Don Lancaster's article on selecting an electronic music synthesizer (October 1974), our company was omitted from the list of manufacturers.

There is one portion of the article to which we would take exception. That is his statement that present-day IC's will provide economies in future synthesizers. Our engineering staff has yet to find an integrated circuit currently on the market (except for the 741 op amp) that will perform as well in EM circuits as do our discrete designs. We have been told by almost all our competitors that they have found the same thing in their research.

O. D. WILLIAMS
General Manager
Steiner-Parker
Salt Lake City, Utah

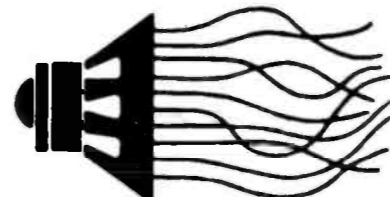

Out of Tune

In "Measure Low Millivolts with a Multimeter" (November 1974), capacitor C1 is listed correctly as 3 pF in the Parts List, but is shown incorrectly as 33 pF in the schematic. Resistor R10 is a 100,000-ohm fixed resistor, not a potentiometer.

FEBRUARY 1975

BUILD & TEST CIRCUITS AS FAST AS YOU THINK!

- POWER FOR THE PROFESSIONAL
- ECONOMY KITS FOR THE HOBBYIST
- A MODEL AND A PRICE FOR EVERYONE



PROTO BOARD 203

Breadboard Prototyping with 5 Volt, 1 AMP Regulated Power Supply included! A total ready-to-use power breadboard prototyping device with a built-in regulated, short-proof power supply. Just plug-in and start building! 2 extra floating 5-way binding posts for external signals. Self-contained with power switch indicator lamp and power fuse. 24-14 pin DIP capacity. Attractive two-tone quality case. All metal construction. 9 3/4" L x 6 1/2" W x 2 3/4" H. 5 lbs. Order today!

\$75

Add \$2.50 shipping/handling

A modestly priced kit for the economy-minded experimenter . . .

PROTO BOARD 100

A low cost, big 10 IC capacity breadboard kit with all the quality of QT sockets and the best of the Proto Board series . . . complete down to the last nut, bolt and screw. Includes 2 QT-35S Sockets; 1 QT-35B Bus Strip; 2 5-way binding posts; 4 rubber feet; screws, nuts, bolts; and easy assembly Instructions.

19⁹⁵

Add \$1.50 shipping/handling.

PROTO-CLIP for Power-On, Hands-Off Signal Tracing. No more shorting leads. Costs less than . . .

\$5

Bring IC leads from pc board for fast signal tracing and troubleshooting. Inject signals. Wire unused circuits into boards. Scope probes and test leads lock onto Dynagrip inset (see circle) for hands-off testing. Plastic construction eliminates springs, pivots. Non-corrosive nickel/silver contacts for simultaneous low resistance connections.
PC-14, 14-pin Proto Clip, \$4.50 ea.
PC-16, 16-pin Proto Clip, \$4.75 ea.
Add 75¢ shipping/handling.

Order today off-the-shelf from CSC or local distributor. Charge: BAC, MC, AX. Write for free catalog. Free English/Metric Slide Rule with each order. Dealer inquiries invited. Foreign orders add 15%.

CSC Continental Specialties Corp.

Box 1942, New Haven, CT 06509 • 203/624-3103

Patents Pending Made in USA
Prices subject to change

W. Coast Off.: Box 7809, S. Francisco, CA 94119 • 415/383-4207
Canada: Available thru Len Finkler Ltd., Ontario

CIRCLE NO. 9 ON READER SERVICE CARD

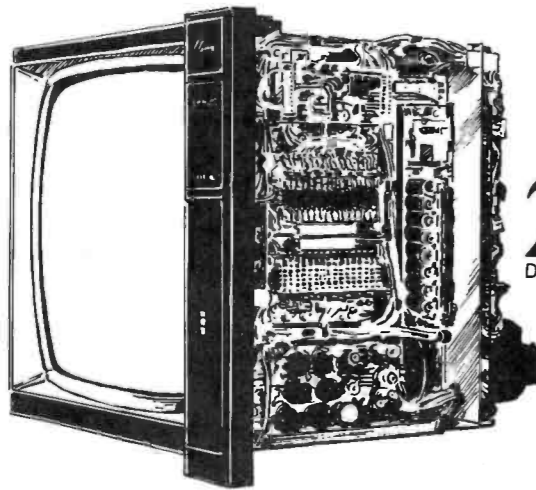

**You get the same
25" hobby-kit color
TV from three
different schools.**



**You get
this designed-
for-learning
25" color TV only
with NRI training.**

No other home-study school gives you a TV like the one you build with NRI's Master Course in Color TV/Audio servicing. Some schools give you three or four plug-in sub-assemblies off the production line to put together a commercial set. Others give you a hobby-kit bought from outside sources. And because neither type was originally designed to train people for TV servicing, lessons and experiments must be "retro-fitted" to the set as it comes.

That's why we went to the trouble to engineer our own, exclusive solid-state TV. It's the only way a student can (1) get the feel of typical commercial circuitry, (2) learn bench techniques while building a complete set from the "ground" up, (3) perform over 25 "in-set" experiments during construction, and (4) end up with a 25" diagonal solid-state color TV with console cabinet and all the modern features you'll find on sets you'll service. Nobody else can give you this combination of advantages because nobody else invested the time and money to design a set with learning in mind.



More know-how per dollar

That's what it all boils down to, the quality of training you get for the money you spend. In our 60-year history, more than a million students have come to NRI and we're fully approved for career study under the G.I. Bill. We must be teaching something right.

Some of those "right" things are bite-size lessons to ease understanding and speed learning . . . personal grading of all tests, with comments or explanations where needed . . . a full-time staff of engineer/instructors to help if you need it . . . plenty of "real-life" kits and experiments to give you hands-on training . . . and fully professional programs oriented to full- or part-time career needs.

Widest choice of career opportunities

NRI offers not one, but five excellent TV/Audio servicing courses so you can tailor your training to your budget. Or, you can study other opportunity fields like Computer Electronics, Communications, Aircraft or Marine Electronics, Mobile Radio, and more. Free catalog describes them all, showing lesson plans, equipment and kits, and career opportunities. There's no obligation and no salesman will ever call, so send for your copy today. See for yourself why NRI experience, selection, and exclusives give you something no other school can.

If card is missing, write to:



NRI SCHOOLS
McGraw-Hill Continuing Education Center
3939 Wisconsin Avenue,
Washington, D.C. 20016

NRI passes the savings on to you

You don't pay a big premium to get this unique TV as part of your training, because NRI engineering eliminates the cost of buying from an outside source. And we pay no salesman's commission. We enroll students by mail only. We pass the savings along to you in the form of low tuition fees, extras like a cabinet for the TV, a solid-state radio you learn on as you build, and actual instrument kits for servicing TVs . . . triggered sweep oscilloscope, integrated circuit TV pattern generator, and 3½ digit digital multimeter. You can pay hundreds of dollars more for a similar course and not get a nickel's worth more in training and equipment.

LARGE-LARGE DISCOUNTS LOW - LOW PRICES

NATIONALLY
ADVERTISED STEREO EQUIPMENT
AT LOWEST PRICES!

TURNABLES • SPEAKERS • RECEIVERS
AMPLIFIERS • TAPE RECORDERS

WRITE FOR QUOTE ON
NATIONALLY ADVERTISED BRANDS OF STEREO
COMPONENTS. SATISFACTION
GUARANTEED!

Clifford's
HI-FI WHOLESALE
P. O. Box 809
Kankakee, Illinois 60901
(815)-939-7868

CIRCLE NO. 7 ON READER SERVICE CARD

Now the most enjoyable, do-it-yourself project of your life—a Schober Electronic Organ!

You'll never reap greater reward, more fun and proud accomplishment, more benefit for the whole family, than by assembling your own Schober Electronic Organ. You need no knowledge of electronics, woodwork or music. Schober's complete kits and crystal-clear instructions show you—whatever you are, whatever your skill (or lack of it)—how to turn the hundreds of quality parts into one of the world's most beautiful, most musical organs, worth up to twice the cost of the kit. Five superb models, with kit prices from \$575 to around \$2,300, each an authentic musical instrument actually superior to most you see in stores.

Join the thousands of Schober Organ builder-owners who live in every state of the Union. Often starting without technical or music skills, they have the time of their lives—first assembling, then learning to play the modern King of Instruments through our superlative instructions and playing courses. Get the full story FREE by mailing the coupon TODAY for the big Schober color catalog, with all the fascinating details!

The Schober Organ Corp., Dept. PE-58
43 West 61st Street, New York, N. Y. 10023
 Please send me Schober Organ Catalog.
 Enclosed please find \$1.00 for 12-inch L.P. record of Schober Organ music.

NAME _____
ADDRESS _____
CITY _____ STATE _____ ZIP _____

CIRCLE NO. 31 ON READER SERVICE CARD

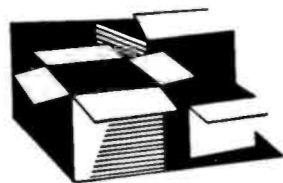

New Products

Additional information on new products covered in this section is available from the manufacturers. Either circle the item's code number on the Reader Service Card inside the back cover or write to the manufacturer at the address given.

PEARCE-SIMPSON COUGAR 23B TRANSCEIVER

This mobile CB transceiver by Pearce-Simpson features 23-channel capability, built-in SWR bridge, r-f noise blanker with manual override and a multi-purpose meter that indicates r-f output and acts as a receive/transmit indicator, S-meter, modulation monitor, and forward/reflected



power meter. Other features are a high-Q ceramic filter, PA capability, squelch, receiver offset tuning, and noise limiter. Specifications include 5 watts input power and a rated sensitivity of 0.5 μ V for 10 dB S+N/N. A noise-cancelling dynamic microphone is included with the rig. It measures 6 $\frac{7}{8}$ " x 2 $\frac{3}{16}$ " x 9 $\frac{1}{4}$ " (17.3 cm x 5.5 cm x 23.2 cm) and operates from a 13.8-V positive or negative ground source.

CIRCLE NO. 70 ON READER SERVICE CARD

BLONDER-TONGUE FM ANTENNAS

Two new antennas for the FM broadcast band have been introduced by Blonder-Tongue. Both the eight-dipole Stereo-8 and the five-dipole Stereo-5 are log-periodic designs whose dipole elements operate in the half-wave mode. This design is said to provide good gain and directivity and an impedance that is essentially uniform across the band. The Stereo-5 has a claimed average gain of 4 dB across the band, 16-dB front-to-back ratio, and 70° horizontal beamwidth. The respective figures for the Stereo-8 are 6.5 dB, 26 dB, and 60°. For rotor-equipped installations, the turning radii are 52 in. (1.32 m) for the Stereo-5 and 65 in. (1.65 m) for the Stereo-8. The respective retail prices are \$27.28 and \$40.29.

CIRCLE NO. 71 ON READER SERVICE CARD

DYNASCAN RF SIGNAL GENERATOR

Dynascan announces introduction of the B & K Model 2050 RF Signal Generator. The unit is totally solid-state, and provides



three outputs—r-f, 400-Hz modulated r-f, and externally modulated r-f. Accuracy is said to be 1.5% of dial setting. A combination high-low switch, plus continuously variable r-f output control provides up to 20-dB change in output level. Features include zener-regulated power supply, FET oscillators, 4 $\frac{1}{2}$ -in. dial with anti-backlash drive, and shielded leads terminated with a banana plug and insulated clip. Measures 7 $\frac{1}{2}$ " x 6 $\frac{1}{8}$ " x 9 $\frac{3}{4}$ " (19.1 x 15.6 x 24.8 cm). Price is \$107.00

CIRCLE NO. 72 ON READER SERVICE CARD

HEATHKIT EXHAUST GAS ANALYZER

With the new Heathkit CI-1080, persons can check exhaust emissions of their own cars, and adjust engine tuning for minimum pollution levels and maximum operating efficiency. The Exhaust Gas Analyzer indicates air-fuel ratio, percentage of carbon monoxide present, and relative combustion efficiency of four-cycle automotive engines. Color-coded battery clips attach to any 6- or 12-volt auto battery. A flexible stainless steel tubing directs exhaust gas from the tailpipe to the sensor. The kit is mail-order priced at \$59.95.

CIRCLE NO. 5 ON READER SERVICE CARD

CASTLE MASTER TUNER SUBBER

The Master Subber Mark V is the latest addition to Castle's line of instruments for TV service technicians. It is a signal-substitution type of analyzer that can be used to test all signal stages of color and monochrome TV receivers. Substitution signals allow tests of: vhf tuner, uhf tuner, video i-f amplifiers, video detectors, video amplifier, 4.5-MHz sound i-f amplifier, sound limiter, sound detector, audio amplifier. A loudspeaker, video-carrier level meter, and telescoping antenna are included with the subber. The unit can be operated from the 117-volt ac line or from its internal 9-volt alkaline battery supply.

CIRCLE NO. 73 ON READER SERVICE CARD

BURWEN NOISE FILTER

The Burwen Model DNF 1200 is a dynamic noise filter that is compatible with any program source. Thus, it does not require encoded program sources. Employing a fil-

POPULAR ELECTRONICS

ter whose bandwidth is varied according to the spectral content of the program material, the filter attenuates the high-frequency content when the program level is low—when the noise is most noticeable. At other times, the spectral configuration of the program material is not disturbed since the level of the signal is sufficient to mask the noise. The threshold at which dynamic filtering is engaged is determined by a sensitivity control. Switches are provided for program source selection, switching the filter in and out of the signal path, and for power. A slide control is used for setting the filter's threshold. Two LED's monitor the activity of the filter: dynamic filtering (suppression) and unaltered spectral balance (Wide Band). The noise filter is claimed to produce only 0.2 percent harmonic distortion.

CIRCLE NO. 74 ON READER SERVICE CARD

SOUNDCRAFTSMEN TAPE RECORD/PLAYBACK EQUALIZER

The Model RP 2212 stereo 10-octave equalizer allows the owner of a hi-fi system to introduce flexible audio response without loss of tape-monitoring facilities when

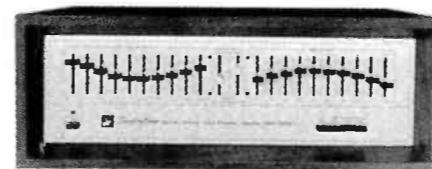

only one set of jacks is available for patching purposes. In addition to extra outputs for tape recording and playback, the equalizer features LED indicators for

input/output balance adjustments, front-panel pushbutton selectors, separate equalized zero-gain controls with a range of +6 to -12 dB and \pm 12-dB response adjustments for each octave. The RP2212 is packaged in a walnut-grained vinyl case. Price is \$349.50.

CIRCLE NO. 75 ON READER SERVICE CARD

ASCOM MULTITESTER FOR VHF

Ascom Electronic Products has introduced a new multitester for use with vhf communications systems. The Model AMSR100 tester is useful for monitoring transmitter and antenna operation over a frequency range of 144 to 174 MHz (contains vhf marine band, land mobile channels, and 2-meter amateur band). The instrument functions as a wattmeter, field-strength meter, and VSWR indicator. It has 0-25- and 0-50-watt power ranges. Transmitter output power is read directly on either scale with a claimed \pm 8-percent accuracy. VSWR is measured, with meter calibration from 1:1 to 3:1. Using this function, antenna adjustments and matching network operations can be checked. To monitor overall system operation and antenna directivity characteristics, the field-strength meter is used. Price is \$69.95.

CIRCLE NO. 76 ON READER SERVICE CARD

KENWOOD DOLBYIZED CASSETTE DECKS

Kenwood has introduced two new high-performance cassette decks with Dolby noise reduction. The decks, KX-910 and KX-710, boast a number of special features, including a high-torque motor, belt-driven large (90 mm) flywheel, and precision-machined capstan. Flutter and wow is

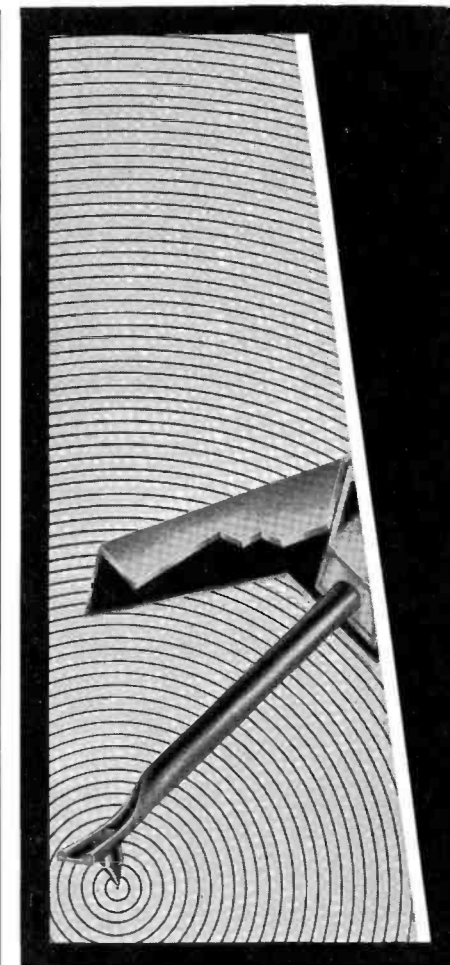

Straight talk about a stylus

You can still hear some audiophiles refer to the record stylus as... "the needle." The fact is that the stylus of today bears no more resemblance to a needle than it does to a ten-penny nail. In fact, a Shure stylus is probably the most skillfully assembled, critically important and carefully tested component in any high fidelity system. It must maintain flawless contact with the undulating walls of the record groove—at the whisper-weight tracking forces required to preserve the fidelity of your records. We put everything we know into Shure Stereo Dynetic Stylus Assemblies—and we tell all about it in an informative booklet. For your copy, write:

Shure Brothers Inc.
222 Hartrey Ave., Evanston, Ill. 60204
In Canada: A. C. Simmonds & Sons Limited

SHURE



CIRCLE NO. 32 ON READER SERVICE CARD



FEBRUARY 1975

SAVE!

MONEY • TIME • FREIGHT

QUALITY STEREO EQUIPMENT AT LOWEST PRICES.

YOUR REQUEST FOR QUOTATION RETURNED SAME DAY.

FACTORY SEALED CARTONS—GUARANTEED AND INSURED.

SAVE ON NAME BRANDS LIKE:
 A.D.C. KLH
 A.R. SHURE
 DYNACO KOSS
 SONY FISHER

AND MORE THAN 50 OTHERS

BUY THE MODERN WAY
 BY MAIL—FROM

illinois audio

Department 217S
 12 East Delaware
 Chicago, Illinois 60611
 312-664-0020

CIRCLE NO. 17 ON READER SERVICE CARD

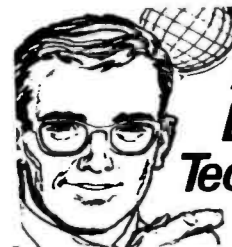

Attention Electronic Technicians!

SCHOOLING OF EXCELLENCE in ELECTRONICS ENGINEERING

If you have adequate schooling and experience at the technician level you may be able to qualify to enter our college-level Home Study Program in Electronics Engineering. The CIEE Program is OUTSTANDING, and up-to-date in every respect. CIEE is a forward-looking school, and Engineering is taught on the basis of application and understanding rather than on the basis of memorization. All lesson material and texts are thorough and easy-to-understand. Through this Highly Effective Home Study Program in Electronics Engineering you can raise your status and pay to the Engineering level. No residence classes required for those who qualify. If you are an electronics technician with above-average ambition, and not willing to settle for anything less than the best home study Engineering Schooling available anywhere, then you should write TODAY for our free revealing descriptive literature. There is no obligation, and no salesman will call on you.

COOK'S INSTITUTE of Electronics Engineering

Raymond Road
 P. O. Box 10634
 Jackson, Miss. 39209
 Established 1945
 Formerly Cook's School of Electronics

CIRCLE NO. 10 ON READER SERVICE CARD



specified as 0.1%. Use of a special ferrite head extends high-frequency response to 16 kHz. Automatic tape selector and Auto Memory, an Automatic Level Control, and LED peak-level indicators add to operating flexibility and performance.

CIRCLE NO. 77 ON READER SERVICE CARD

GLENBURN RECORD CHANGER

A new record changer, the Model 351, has been introduced by the Glenburn Corp. A wide umbrella spindle has been incorporated into the unit to correct double record drop, record hang-ups and unbalanced-record slanting tendencies. Other features



include bi-directional viscous-damped cueing, slide-in cartridge adapter, dual anti-skating scales, gravity stylus pressure adjustment, and a four-pole synchronous motor. The unit is equipped with a Shure M91E elliptical stylus. Price is \$160.

CIRCLE NO. 78 ON READER SERVICE CARD

ADD-ON FOAM SPEAKER GRILLES

Do-it-yourself speaker grille kits with sculptured-foam speaker material are offered by Republic Systems. This flexible urethane foam can be sprayed with latex paint if the standard black color is not suitable to the user's decor, and cut with scissors for a custom fit. Foam is available in 8" x 15" (20.3 x 38.1 cm) and 14" x 24" (35.6 x 61 cm) sizes. Each kit contains sculptured foam grille, self-sticking attachment material, and instructions. Address: Republic Systems Corp., 9160 Green St., Chicago, IL. 60620.

MIDLAND 23-CHANNEL HAND-HELD CB RIG

Midland Electronics' Model 13-796 is a 23-channel, hand-held transceiver with 5 watts input power. The dual-conversion superhet receiver includes agc and a

three-way meter for indicating signal strength, output power and battery condition. Includes a jack for use with an optional external microphone/speaker. The transmitter can be run at full legal power input or in a "battery saver" 2.5-watt input mode. It operates on 12-V dc penlight cells (dry-cells or nickle-cadmium), ac adapter, or auto cable. \$190.95.

CIRCLE NO. 79 ON READER SERVICE CARD

FLUKE MULTI-FUNCTION FREQUENCY COUNTER

The John Fluke Co.'s new Model 1900A frequency counter has an upper limit of 80 MHz, and contains autoranging and autoreset functions. Autoreset controls all functions and gate times, and autoranging is available in both the frequency and period measurement modes. The 1900A

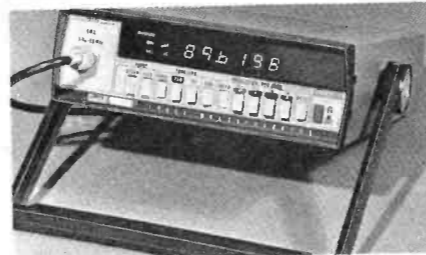

uses advanced LSI/MOS circuitry, has four over-riding gate times for manual selection of resolution down to 0.1 Hz. The frequency counter can also be used to totalize, with event counting up to 10⁶ events. Results are displayed on six LED digits with leading zero suppression, automatic annunciation and overflow. A switchable 1-MHz low-pass filter and attenuator are included. Sensitivity is 25 mV, and dynamic range is 5 Hz to 80 MHz. An optional rechargeable internal battery pack is available. \$349.

CIRCLE NO. 80 ON READER SERVICE CARD

SOLDERING IRON TIP CLEANER

The RE-TIP (No. 9482) from GC Electronics is designed to instantly clean any contam-

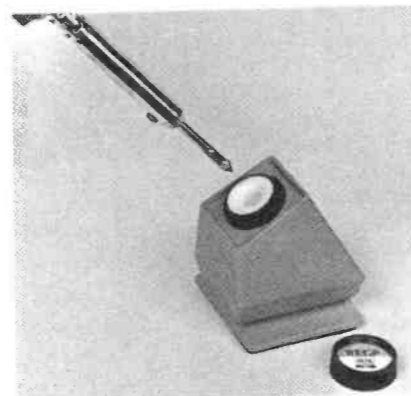

inants or excess solder from iron and pencil tips. It accommodates tips up to 1/4-inch diameter. The tip cleaner has a self-adhesive bottom for workbench installation. A refill cartridge, catalog No. 9484, is also available.

CIRCLE NO. 81 ON READER SERVICE CARD

POPULAR ELECTRONICS

if you've been wondering what the next great step in CB will be... you're off the hook.

Messenger 130... so radically new in design and performance that citizens band radio will never be the same again. Inside this prestigious "radiotelephone" package is a unique all solid-state chassis that provides unparalleled operating advantages. From handset reception clarity... to automatic speaker silencing for private listening... this is truly an innovation in CB mobile radio performance. An innovation that's available only from your E. F. Johnson dealer.

Messenger[®] 130

CB mobile radio will never be the same again.

HANDSET CLARITY... PRIVATE LISTENING OPTION

POWERFUL, ALL SOLID-STATE 23-CHANNEL CIRCUITRY

BUILT-IN PA FUNCTION... EXTERNAL SPEAKER FUNCTION LETS YOU HEAR CALL OUTSIDE VEHICLE

UNIVERSAL MOUNTING... TRANSMISSION HUMP, UNDER DASH, OVERHEAD

E. F. Johnson Co.

Waseca, Minnesota 56093

Excellence through half a century of experience.

CIRCLE NO. 33 ON READER SERVICE CARD

free

The "NEW LOOK" 1975 LAFAYETTE Radio Electronics CATALOG

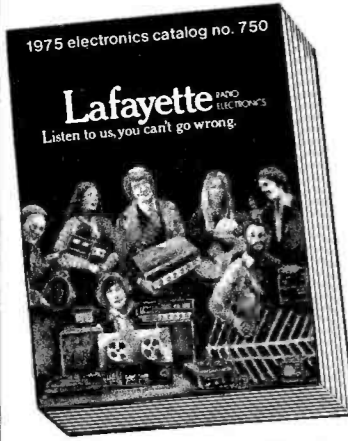

The ONLY Nationally Distributed Full-line Catalog with a Major Showing of the Newest NAME-BRAND electronics products for 1975.

FREE
SEND TODAY

SAVE on exclusive Lafayette Products plus MAJOR BRANDS

• Stereo and 4-Channel Systems • Tape Equipment • Car Stereo • CB and Ham Gear • Police/Public Service Receivers • Antennas • Cameras • TV • PA and Test Equipment • Musical Instruments and Amplifiers • Books • Electronic Calculators • Security Systems • PLUS PARTS, TUBES, BATTERIES, HARDWARE, MORE!

Lafayette

Listen to us, you can't go wrong.

Dept. 35025

Lafayette Radio Electronics
111 Jericho Tpke., Syosset, L.I., N.Y. 11791

Send me your FREE 1975 Catalog

Name _____ Apt. _____

Street _____

City _____ State _____

Zip _____

Send a 1975 Catalog to my friend

Name _____ Apt. _____

Street _____

City _____ State _____

Zip _____

CIRCLE NO. 21 ON READER SERVICE CARD

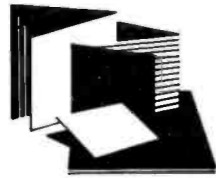

New Literature

EDSYN SOLDERING TRAINING MANUAL

A new training manual for soldering techniques has been prepared by the Edsyn Company, a manufacturer of soldering tools. Using the Fanovision™ method (flipping the pages creates a nickelodeon effect), correct soldering practices are illustrated, supplemented by text. Also included in the 144-page publication are Color codes for resistors, Ohm's law, Series and Parallel Resistance tables, and inch/millimeter conversion tables. Available at participating dealers for \$7.95, or free with a \$7.95 or more purchase.

NATIONAL LED DRIVER SELECTION GUIDE

National Semiconductor offers a short-form device summary to designers in selecting LED drivers. The LED Driver Selection Guide lists 23 National driver types. Organized as a four-unit matrix, the guide has rows for common anode and common cathode configurations, and columns for segment and digit drivers. Thus the user can tell at a glance exactly which LED driver is needed. Available from Marketing Services, National Semiconductor Corp., 2900 Semiconductor Drive, Santa Clara, CA 95051.

PACE COMMUNICATIONS CATALOG

A new four-color, full-line catalog from Pace Communications, displays its equipment for CB, Marine, Scanning Monitor, and Business/Industry Communications. Each unit is illustrated, described, and specifications and available accessories are listed. Available from Pace Communications, 24049 S. Frampton Avenue, Harbor City, CA 90710.

FORDHAM SERVICEMAN/TECHNICIAN CATALOG

A new 48-page, illustrated discount mail-order catalog is available from the Fordham Radio Supply Company. This catalog has been designed as a quick reference ordering guide for Radio/TV Servicemen, Electronic Technicians, and Hobbyists. Included are tools, repair kits, tubes, test equipment, phono cartridges, speakers and mikes, antennas, and components. Available from Fordham Radio Supply, 558 Morris Avenue, Bronx, N.Y. 10451.

EICO TEST EQUIPMENT CATALOG

A 6-page condensed catalog featuring a broad line of electronic test and measuring

devices is now available from Eico. The publication includes a large selection of oscilloscopes, VTVM's, FET VOM's, signal tracers, signal injectors, bridges, grid dip meters, automotive engine analyzers, and battery eliminators/inverters. Accessories such as test probes, and carrying cases are also listed. In all, more than 100 electronic kits and factory-assembled units are described. Address: Eico Electronic Instrument Co., Inc., 283 Malta St., Brooklyn, NY 11207.

EDMUND SCIENTIFIC CATALOG

The latest in items that conserve energy, save money, plus things that are unusual or just plain fun are crammed into Edmund Scientific's Catalog No. 751. Over 300 new products and a total of 4500 items are included in the 164-page publication. Products include devices for reclaiming chimney heat, brain-wave monitoring, metal detection and Kirlian photography, as well as Edmund's well-known line of telescopes. Address: Edmund Scientific Co., 555 Eds-corp. Bldg., Barrington, NJ 08007.

SPRAGUE INTEGRATED CIRCUIT GUIDE

Sprague Electronic's Semiconductor Division has published a guide to its line of "ion-implanted" integrated circuits, designed for application in the audio, radio, and TV fields. IC's are offered to implement many functions — from chroma demodulators and oscillators, TV sound systems, to stereo decoders for FM receivers and audio amplifiers and preamplifiers. Includes "quick selector" and cross-reference tables. Address: Sprague Electric Co., 115 Northeast Cutoff, Worcester, MA 01606.

SWITCHCRAFT SHORT-FORM CATALOG

Switchcraft, Inc. announces the publication of its 1974/75 Short-Form Catalog. Contains more than 4000 product listings, with a special alphabetical/numerical index. The 42-page booklet provides product data and prices of major Switchcraft product lines, including telephone jacks, plugs, switches, connectors, molded cable assemblies, and audio accessories. Available from Switchcraft, Inc., 5555 No. Elston Ave., Chicago, Ill. 60630.

HEATH/SCHLUMBERGER INSTRUMENTS CATALOG

Test instruments for the advanced electronics experimenter, engineer, and scientist are listed and fully described in the latest Heath/Schlumberger catalog. Featured are such instruments as frequency/events counters, oscilloscopes, multimeters (both digital and analog), signal generators, substitution boxes, etc. For the engineering and science labs, there are chart recorders and accessories, an analog/digital designer breadboarding system, plug-in circuit cards, and pH meters. Address: Heath/Schlumberger Instruments, Benton Harbor, MI 49022.

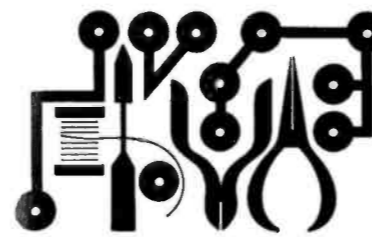

Hobby Scene

BEAT OSCILLATOR FOR CODE

Q. I have an excellent AM-FM-Shortwave receiver that I would like to use to help me learn Morse code. How could I arrange a low-cost beat oscillator to use with my set?

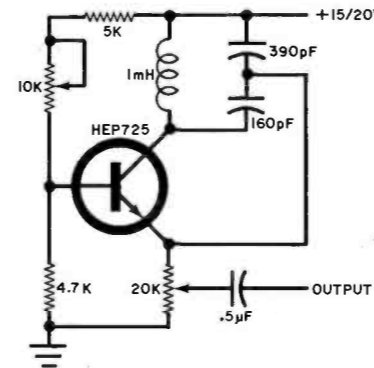

A. The circuit shown here can be added to your receiver either at the antenna, the i-f strip, or the detector. Adjust the 10,000-ohm potentiometer for maximum output amplitude and

the 20,000-ohm potentiometer for the desired level. The coil shown is for a 455-kHz i-f.

CDI INTERFERENCE

Q. I have installed a CDI system in my 1967 VW Bug and have the typical problem of ignition interference with my AM radio (Sapphire V). I've shielded all CDI leads, the ignition coil, and installed "Mag Wire." The noise is the distinct sound of the unit's multivibrator, which varies with engine speed, and seems to come through the speaker even when the radio is off. Any suggestions?—R. Schweder, La Habra, Cal.

A. CDI systems do not use variable-frequency multivibrators, but run at a fixed frequency set by an RC combination. You must be hearing something else. More likely the voltage regulator, the generator, or the ignition coil is the trouble source. Add 0.5-µF feed-through (coaxial) capacitors to the armature and battery connectors on

the regulator, and attach the leads to them. Connect a 5-ohm, 1-watt resistor and a 0.002-µF capacitor in series from the regulator's field terminal to ground. Generator leads to the regulator should be well shielded. If interference is still a problem, install a 0.5-µF bypass capacitor from the battery terminal of the ignition coil to ground, and/or a 0.1-µF coaxial feed-through capacitor to the coil's battery terminal, attaching the battery lead to the capacitor's top post. That should take care of any interference problems. It is not unusual for a solid-state radio to produce audible interference at the speaker when power is off, because a transistor junction can rectify an r-f signal even when not supplied with operating voltage.

ULTRASONIC INSECT REPELLER

Q. I live in an area where the mosquitoes are ferocious. Could you show me a simple circuit for an ultrasonic insect repeller. I have seen them advertised and would like to construct one. P.S. Where can I get a 1N3716 tunnel diode?—M. Rehorst, Cudahy, Wis.

A. See "Electronic Pest Control," a construction project in POPULAR ELECTRONICS July 1972. The tunnel diode is listed in the Newark Electronics catalog. Nearest branch is at 3695 No. 126th Street, Brookfield, Wis., 53005. (414) 781-2450. However, a \$25 minimum order must be sent.

SQUARE WAVES FROM SINE WAVES

Q. I have a decent solid-state sine-wave generator that I use quite often. Is there a simple circuit that I can use with the generator to get clean square waves? The circuit should be small enough to mount within the present case.

A. There are several approaches to this problem. You can use a low-cost TTL flip-flop (with a +5-volt supply)

driven from the sine-wave source. Although the square waves will be clean, they will be at half the dial frequency. (The flip-flop divides by two.) You can also use a TTL Schmitt trigger; or, you can use the simple circuit shown here. Any decent silicon switching transistors can be used. Set the potentiometer for the desired symmetry. Once adjusted, this potentiometer should not have to be reset. The circuit will cover the audio range from about 10 Hz to

100 kHz. It requires a drive of about 2 volts.

Another reader asked the same question, but he was also concerned with the loading of the square-wave converter on his audio generator. The second circuit shows a high-input-impedance Schmitt trigger using a MOS front end. Because of the high input impedance, the circuit should not load the generator. The trip point is between 3 and 3.5 volts.

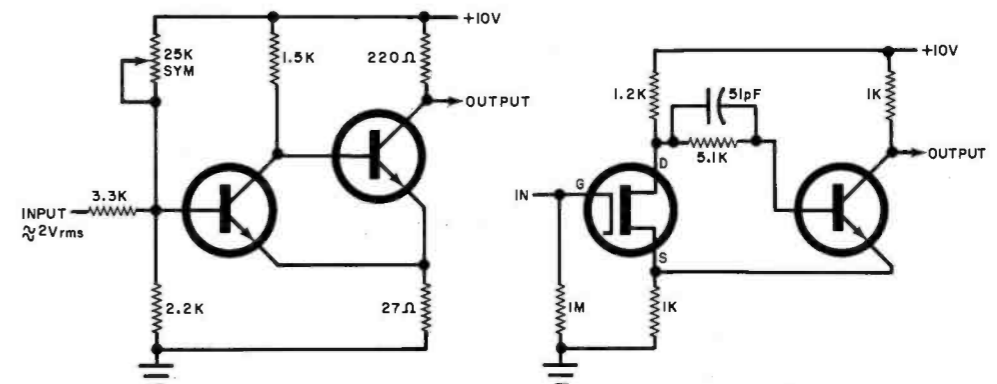

Hunting for
a better job?

CIE will
help you get
the license
you need



A Government FCC License can help you qualify for an exciting, rewarding career in ELECTRONICS, the Science of the Seventies. Read how you can prepare for the license exam at home in your spare time — with a passing grade assured or your money back.

IF YOU'RE OUT TO BAG A BETTER JOB in Electronics, you'd better have a Government FCC License. It will help you track down the choicest, best-paying jobs in the growing field of Electronics.

Demand for people with technical skills is growing twice as fast as any other group, while jobs for the untrained are rapidly disappearing. Right now there are thousands of new openings every year for electronics specialists. And you don't need a college education to qualify!

But you *do* need knowledge, knowledge of electronics fundamentals. And there is only one nationally accepted method of measuring this knowledge . . . the licensing program of the FCC (Federal Communications Commission).

Why a license is important

An FCC License is a legal requirement if you want to become a Broadcast Engineer, or get into servicing any other kind of transmitting equipment — two-way mobile radios, microwave relay links, radar, etc. And even when it's not legally required, a license proves to the world that you understand the principles involved in any electronic device. Thus, an FCC "ticket" can open the doors to thousands of exciting, high-paying jobs in communications, radio and TV broadcasting, the aerospace program, industrial automation, and many other areas.

So why doesn't everyone who wants a good job in Electronics get an FCC License?

It's not that simple. You must pass a Government licensing exam. A good way to prepare for your FCC exam is to take a licensing course from Cleveland Institute of Electronics.

Our training is so effective that, in a recent survey of 787 CIE graduates, better than 9 out of 10 CIE grads passed the Government FCC License exam. That's why we can offer this famous Money-Back Warranty: when you complete any CIE licensing course, you'll be able to pass your FCC exam or be entitled to a full refund of all tuition paid. This warranty is valid during the completion time allowed for your course. You get your FCC License — or your money back!

And with CIE, you learn at home in your spare time. With AUTO-PROGRAMMED® Lessons, you'll pick up the facts, figures and electronics theories you

CIE HAS CAREER COURSES TO FIT YOUR BACKGROUND

ELECTRONICS TECHNOLOGY with LABORATORY . . . teaches you the fundamentals. With a 161-piece laboratory you apply the principles you learn by analyzing and trouble-shooting electronics equipment.

ELECTRONICS ENGINEERING . . . A college-level course for men already working in Electronics. Covers steady-state and transient network theory, solid-state physics and circuitry, pulse techniques, computer logic and mathematics through calculus.

may have considered "complicated" . . . even if you've had trouble studying in the past.

CIE Grads get licenses . . . better jobs

The value of CIE training has been demonstrated time and again by the achievements of our thousands of successful students and graduates.

An outstanding example is Ed Dulaney of Scottsbluff, Nebraska. He passed his 1st Class FCC License exam soon after completing his CIE course. Today, he owns two companies . . . one to manufacture and distribute two-way radio equipment, the other to maintain and repair such equipment along with home radio, TV and stereo sets. He says: "In the last three years we sold more than \$1,500,000 worth of equipment through dealers in every state plus Canada, South America and Europe."

Richard Kihn, Anahuac, Texas, worked in the engine room of a tugboat when he started his CIE training. He reports, "Before finishing, I got my FCC License and landed a job as broadcast engineer at KFDM-TV in Beaumont, Texas. I was able to work, complete my CIE course and get two raises . . . all in the first year of my new career in broadcasting."

Send for FREE books

If you'd like a chance to succeed like these men, send for our FREE book, "How To Get A Commercial FCC License." It tells you all about the FCC License . . . requirements for getting one . . . types of licenses available . . . how the exams are organized and what kind of questions are asked . . . where and when the exams are held, and more.

With it, you will also receive a second FREE book, "Succeed in Electronics." For your convenience, we will try to have a representative call. Send for both books today.

APPROVED UNDER G. I. BILL

All CIE career courses are approved for educational benefits under the G.I. Bill. If you are a Veteran or in service now, check box for G.I. Bill information.

**CIE Cleveland Institute
of Electronics, Inc.**

1776 East 17th Street, Cleveland, Ohio 44114
Accredited Member National Home Study Council

Cleveland Institute of Electronics, Inc.

1776 East 17th Street, Cleveland, Ohio 44114

Please send me your two FREE books:

1. Your book on "How To Get A Commercial FCC License."
2. Your school catalog, "Succeed in Electronics."

I am especially interested in:

- Electronics Technology Electronic Communications
 Broadcast Engineering Industrial Electronics
 First Class FCC License Electronics Engineering
 Electronics Technology with Laboratory

Name _____
(PLEASE PRINT)

Address _____

City _____

State _____ Zip _____ Age _____

Veterans and Servicemen:

Check here for G.I. Bill information.

PE-75

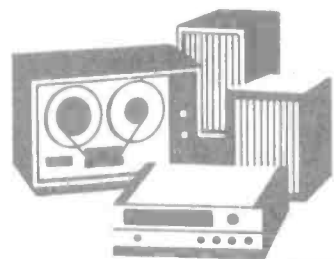

Stereo Scene

By Ralph Hodges

TAPE HEAD ALIGNMENT

WHEN it comes to aligning tape recorders, I favor the support-your-factory-serviceman approach. A practiced technician with a bench equipped for alignment can make short work of even a complicated machine; but an untrained amateur taking his first crack at the job is almost certain to find it tedious and outrageously time consuming. So there's no disgrace, as I see it, in saving the alignment (and other routine chores of maintenance) for a periodic factory return, where your machine can be fussed over by capable and sympathetic hands.

But how do you know when your recorder needs such care? And worse, once it's given, how do you know it was administered properly, or that it survived the trip back to your local freight depot, the ride home in the trunk of the car, or the fall from the coffee table that took place several days later?

Many experts suggest that, as a check on the day-to-day health of your recorder, you make and save a reference recording (a dubbing of a phonograph record, for example), and assure yourself periodically that the machine is still capable of recording the same disc with equal fidelity. This is actually a fairly sensitive test. But some people are reluctant to trust their ears that far, and others will have long since updated their phono cartridges or other components in the

system, changing the reference point. Finally, the reference-recording test is not at all diagnostic; you may hear that something is wrong, but you won't necessarily know what. Clearly it would be good to have some additional techniques for isolating specific problems.

The alignment of a tape recorder refers to both electrical and mechanical adjustments, and these affect its frequency response (particularly high-frequency response), signal-to-noise ratio, distortion, and drop-out rate (drop-outs are brief signal losses caused by imperfect tape-to-head contact). Many of the adjustments are interdependent. Therefore, if you ever feel ambitious enough to make one, you may find yourself forced to make all the rest.

This is precisely what you're trying to avoid. So the idea behind recorder check-ups at home is to find out as much as possible about what's right and wrong with the machine without disturbing any of its adjustments too much. This is not easy, I assure you, but there are ways.

Mechanical Alignment. This refers to the orientation of the tape heads relative to the tape passing over their faces. Not only should each head be positioned properly, but, since most serious recordists' tape recorders have at least three interdependent heads (erase, record, and playback),

they should all be positioned properly relative to one another. The *azimuth* adjustment—getting the record and playback head gaps precisely perpendicular to the edge of the passing tape—has been well publicized because it is critical for extended high-frequency response. However, there are other alignment factors (Fig. 1) that can affect audible performance much more. The *height* adjustment, for example, which determines how accurately the playback and erase heads line up with the tracks the record head lays down, is vital for a good signal-to-noise ratio, and can even affect the drop-out rate. The same is true of the *tilt* adjustment.

As a preliminary check on alignment, put a reel of tape on the machine and record a 1,000-Hz tone from your audio generator on both channels, watching the recorder's output on a scope. Use a fresh reel of good tape for this, since any deformation of the tape edges will grossly influence results. It's also a good idea, in this and subsequent tests, to run through the reel at least once beforehand at normal playing speed, so that the machine has had a chance to wind the tape the way it normally does on the take-up reel. Do not use a fast-wound tape for this test and watch out for any rubbing of the tape on the reel flanges.

Set the scope for a slow sweep so that you can observe the envelope of the signal rather than individual cycles. As you switch the scope from one channel to the other, small differences in level will be readily apparent, and you'll also see drop-outs as momentary gashes in the envelope. The ideal is for both channels to be equal in level and drop-out severity—an achievable goal for a half-track machine, but not always for a quarter-track recorder, which may have a consistently poorer left channel.

The level difference between the two channels should be well within one decibel. Otherwise, some electri-

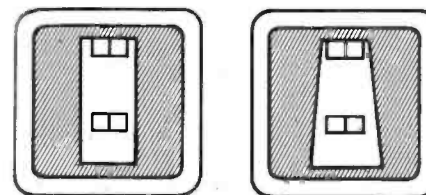

Fig. 2. A tilt error produces a trapezoidal wear pattern on the head. Correct pattern is at left.

cal portions of the machine—meters, or recording or playback electronics—are miscalibrated, or there is a tilt problem with one of the heads. If, on a quarter-track machine, the right channel is lower in level (and all other possible causes have been eliminated), the trouble is very likely tilt, which causes the top edge of the tape to press closer to a head than the bottom. A tilt error should also produce more drop-outs on the weaker channel.

A height misalignment is less likely to show up as a level difference between channels. What can happen, however, is a high drop-out rate on the left channel of a quarter-track machine, usually caused by a record or playback head that is too low (and therefore recording or playing right on the upper edge of the tape, which is the most irregular part).

The Magic Marker Test. To get an idea of the tilt situation, as well as a general picture of tape-to-head contact, try gently painting the head faces with dark-color ink from a felt-tip pen and running a few seconds worth of tape over them. Once the tape has worn away some of the ink, you'll be able to see a contact patch, which should be perfectly rectangular in shape and well centered on the head face (Fig. 2). If the patch is trapezoidal (i.e., wider at the top or bottom of the head), there is a tilt misalignment, although it may not be obvious which head is misaligned. Any head of the three can give the tape a little skew that will show up in the contact patterns of the other two. But probably

the responsible head will have a patch that is larger in area. (As a general rule, you can expect patches of equal size on the record and playback heads of a properly aligned machine.)

On a brand new recorder, or an especially old one, the contact patches may be roughly rectangular, but irregular in shape or even streaky. In the new machine's case, this is caused by a slight roughness of the head faces that will disappear after a few reels of tape have polished them down. With an older machine, it may indicate severe and uneven head wear.

A tilt misalignment may be responsible for an error in height, since the tilt can bow the tape away from its proper path, or even cause it to "ride up" on the angled head surface. Conversely, if the machine was originally aligned with a tilted head, correcting the condition may cause a height error to appear. You can readily appreciate from this how head alignment tends to be an "all or nothing" task.

After you've completed the magic marker test, clean the heads according to the manufacturer's recommendations and, since it's probably not a good idea to reuse it, snip off and discard the length of tape used to develop the contact patch.

Looking at the Recording. When you suspect a height problem, the first question is: which head is responsible, the record or playback head? About the only way you can determine this (short of buying an expensive test tape and fiddling with playback-head alignment) is to invest in the Soundcraft Magna-See kit, which costs about \$7 and is not always easy to find. The main ingredient of the kit is a can of volatile (but not flammable) solvent in which is suspended a gray iron-oxide powder. Swirl a bit of recorded tape around in this fluid, let it dry, and Shazam! the recorded tracks appear in a dusty pattern on the tape surface. An alternative to the Magna-See, less messy and easier to obtain (through mail order) but more expensive, is

3M's Plastiform Magnetic Viewer Type BX-1022. With this device, the fluid is contained in a thin-wall plastic case that is placed directly on the tape surface. One drawback, according to a 3M spokesman, is that the case's seal, critically thin to ensure adequate sensitivity, must be maintained by storage in a moist environment (such as a sponge in the viewer's box). Order from 3M Industrial Electrical Products Div., P.O. Box 33365, 3M Center, St. Paul, MN 55101. Price is \$24.95 plus 75 cents for postage.

For a half-track machine with both channels of the tape recorded, a height misalignment of the record head exists if the guard band between tracks is not perfectly centered on the tape (Fig. 3). A quarter-track tape, which should be recorded on both channels in both directions, shows a record-head height error when all three guard bands are not of the same width. A too-wide center guard band means the head is too low, which may actually give acceptable performance as long as the tracks don't touch or overlap. A too-narrow center band indicates a high head, which risks drop-outs of the tracks near the edge of the tape. (If your recorder is a four-channel machine, you'll find this test easier to interpret if you record only the two front channels, in both directions.)

So much for the record head. If it passes this test and you still suspect a height problem, you'll have to start thinking of the playback head, or possibly some misalignment of the tape guides.

Some Simple Adjustments. The only way you can learn much more about the alignment condition of your machine is to start fiddling with the head adjusting screws. This can be a tempting idea, particularly if you believe that only one head is at fault, and that fixing it might cause everything else to snap into place. Well, it doesn't always work that way. It may be, for example, that at one time the other heads were aligned to the incorrectly

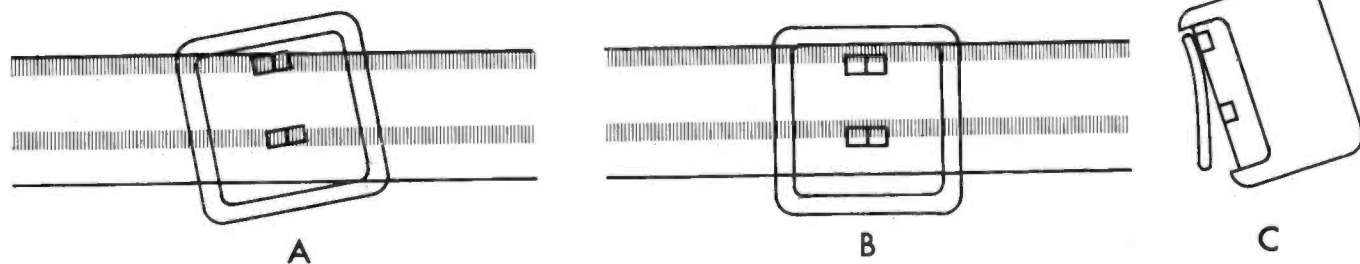

Fig. 1. An azimuth error, as indicated at (A) is a common cause of losses at the extreme high frequencies. A height error is shown at (B), with the head gaps missing the tracks somewhat. At (C) is a tilt error. All illustrations are exaggerated for clarity.

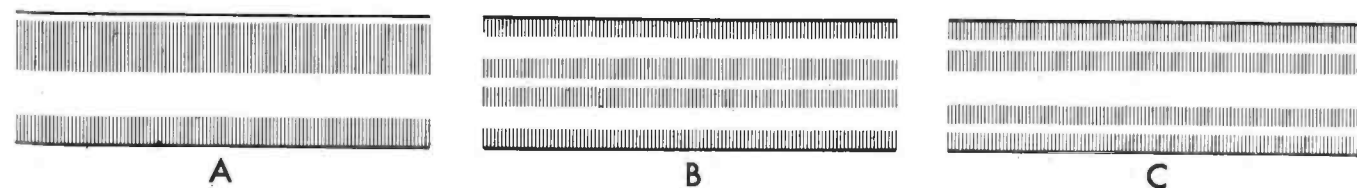

Fig. 3. A height error of the record head on a half-track machine creates an off-center guard band (A). Diagrams (B) and (C) show results of a quarter-track record head positioned too high and too low, respectively.

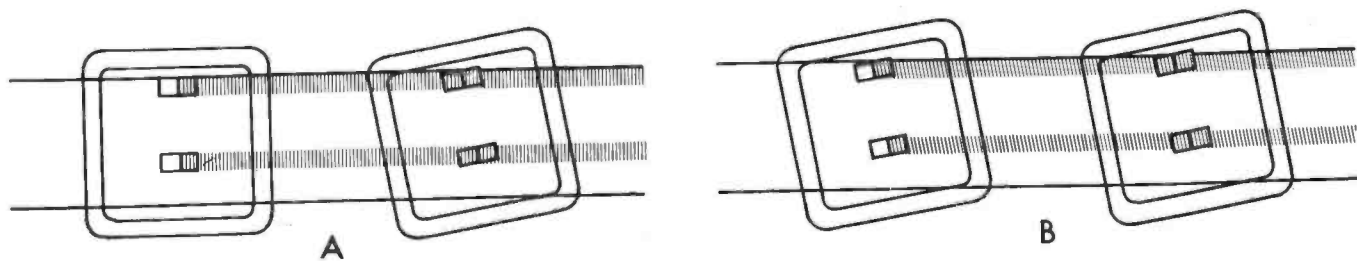

Fig. 4. Azimuth errors between record and playback heads produce high-frequency losses (A). Misalignment of both heads (B) causes no losses for tapes made on that machine.

positioned head, in which case a change in any one of them is likely to degrade the performance of the rest. Also, there's the problem of making sure that when you change one alignment factor—height, for example—you don't also change tilt or azimuth. (As far as I know there is no way to be sure of this, except by going back and checking tilt and azimuth after you've made the adjustment.) Finally, depending on the way the manufacturer has set up the machine, a readjustment of equalization or bias may be necessary.

Looking at the brighter side, however, it is true that you usually have the option of returning to the original adjustment if your attempted improvements do more harm than good—provided you have marked the original screw positions carefully! When you take off the cover to expose the heads, you'll probably find some or all of the alignment screws (protruding through the little platform on which each head is mounted) sealed with lacquer or whatever. If not, you can apply your own at this point, since the broken edges of the disturbed seal are a much better guide for returning to the starting point than a pencil mark.

Next, it's a great comfort to have on hand the recorder's service manual (frequently an expensive item), or at least some specific instructions from the manufacturer on head alignment. Sometimes the screws are readily identifiable as to their precise function, but there may be some sequence in setting them that will greatly simplify the whole business.

And now to proceed. With the simple checks described above and a few others, you're in a position to do a respectable alignment job on every parameter *except* the azimuth of the playback head. Playback azimuth must be set with a reproducer alignment test tape if it is to conform to tapes made on other, properly adjusted machines. If this is not a re-

quirement, you can get by with a reasonable error in playback-head azimuth as long as the record head has exactly the same error (Fig. 4). But where possible, it's best to avoid touching the playback head at all, on the assumption that whatever its actual azimuth alignment, it is more accurate than you could achieve without a test tape.

In making height and tilt adjustments on the record head, you'll have to resort to the magic marker test on both the record and playback heads to make sure that what you're doing isn't adversely affecting either one. If one contact patch changes appreciably in size relative to the other, it means that one head is beginning to lose contact with the tape. Shifting the entire record head closer to or farther away from the tape will usually serve to equalize things again.

You'll also have to keep constant tabs on the playback head, making sure that what you do to the record head does not diminish its output (indicating that the tracks laid down by the record head are beginning to miss the playback-head gaps). To do this you must have tape running through the machine virtually at all times, and being recorded with a steady 1000-Hz tone. Monitoring the playback-head output on a scope or meter will alert you to any loss of level (an *increase* in level is a good sign, provided it takes place in both channels). There will be a short delay before any adjustment you make on the record head shows up in the playback-head output, and you'll simply have to get used to that. On the other hand, if the playback-head gaps are significantly longer than the width of the recorded tracks, you may be able to make minor height adjustments on the record head without observing any changes in playback level.

Assuming you can get the height and tilt of the record head squared away without introducing further

problems, you can go on to matching the record head's azimuth to the playback head. For a test signal, I just use the audio generator to drive the record head, running it up in frequency until the playback-head output begins to drop. Then I tweak the record-head alignment to see if I can raise the output level at that point. (Note that the results may well be different for the two channels, necessitating an intermediate setting.) Usually I use the 7½-ips tape speed, although the other speeds should work as well on most machines. (The one exception I can think of had its response electronically rolled off above 20 kHz. Since the heads were presumably capable of going beyond that at 7½ ips, I probably would have chosen a slower tape speed to make sure I was seeing the effects of head alignment and not electronic filtering.) However, be sure to keep the recording level for the test tone down to -20 dB or lower. Otherwise, high-frequency tape losses are likely to occur at most speeds.

I've saved the erase head for last because it's easy. Azimuth doesn't really matter, and tilt can be handled through the magic marker test. The height adjustment is best accomplished by running a previously recorded tape with the machine in the record mode (record-level controls at minimum and no input signal being fed to the machine) and going for minimum playback output.

The Last Word. So it is possible to perform a good deal of recorder alignment with a minimum of specialized equipment. This is not to say, however, that all these tests will give you nice, neat, unambiguous results, or that you'll find satisfaction in devoting to them the time they require. Those seeking the last word in tape performance regularly go to greater lengths, and are often rewarded by audibly improved performance. For others, these tests can serve as indicators of something wrong. ♦

FCC CB & Experimenter Proposals

In response to a ruling by the Supreme Court, the agency has proposed a reduction in station license fees for CB operations from the present \$20 to \$6. The new amount is based on recovery of the cost associated with application processing. In another move, the Commission has proposed the establishment of a license-free, 5-channel band adjacent to the 6-meter (50-54 MHz) amateur band. Transmitters would operate on 49.91, 49.93, 49.97 and/or 49.99 MHz. AM, SSB, and FM emissions would be allowed, when confined within a 20-kHz channel centered on each of the above frequencies. Total input power would be limited to 100 mW and the antenna (single element, one meter or less in length) would have to be permanently attached to the transmitter or transceiver enclosure.

Plug-In P-ROM Calculator

Using a P-ROM (Programmable-Read Only Memory) system, Sharp Electronics introduced a calculator that can be designed to a user's specialized interest. The first "customer-designed" calculator, Model PC-1002, is a fifteen-function scientific unit with four extra-function keys and a receptacle for accommodating a P-ROM plug-in module. The program of the P-ROM, which is tailored to the user's application, is controlled by the



extra-function keys. While the "design-your-own" calculators can be programmed for a wide range of specialized scientific, engineering, and business uses, standard chips are now available for four basic applications: statistics, mathematics, metric conversion, and surveying. Additional programs are currently being readied, covering the structural and electrical engineering, and financial fields, among others.

Information Bank

Individuals can now retrieve general information from the Information Bank of the New York Times. The computerized on-line, time-shared system provides the user

with an abstract of a wide range of material published every day in the newspaper and in a number of other magazines and periodicals. The abstract includes the date of publication and page number so that the user may obtain the complete article. One taps into the computer, a System 370/145, via a video display terminal. The abstract appears on the display screen, but a hard-print copy is also available. The entire process of locating a desired abstract is said to take about a minute. The user can begin his search with a broad category and narrow the field down until the specific subject is reached. The number of subject terms is about 11,000, not including names of people, places and organizations.

CMOS Prices Drop 20 to 51%

Two major manufacturers of CMOS logic, RCA and National Semiconductor, are reducing the prices on gates to a point where they are competitive with TTL on a piece-by-piece basis. RCA has reduced gate prices more than 30% and MSI prices more than 20% for standard CD4000 series devices in quantities of 100 to 999 units. National has reduced prices on two product lines, the MM7CXXN series, and Series-4000 equivalent MM56XXAN, from 25 to 51%. Price reductions affect every Series 74C molded, commercial-grade and Series-4000-equivalent devices. Price cuts are attributed to increased efficiency in high-volume production.

NYC Doubling Voice Communication Boxes

The City of New York is adding 3000 two-way voice communication boxes to its emergency reporting system. This brings to about 6000 the number of Norelco voice communications devices ordered since 1971. The city plans to replace all of its 15,000 older fire alarm boxes with such two-way voice boxes over the next few years. The audio boxes allow the user in the street to speak directly with fire or police officers simply by depressing a button on the call box. The system also provides a printed record (time, operator and box number) of all incoming calls. Each box can be tested automatically from the central station.

An Electronic Weed Killer

Zapper III, a device which kills weeds by electronic rather than chemical means, has been developed by the Oceanography International Corporation. The editorial board of *Industrial Research*, which includes rocket pioneer Werner Von Braun and inventor William Lear, has selected the weed killer as one of the 100 most significant new technical products of the year. The Zapper III is a 13-ton, self-propelled machine with a 155-kW diesel generator and two Klystron microwave sources which produce 60 kW of microwave energy. Microwaves cause the molecules of an organism to rotate very rapidly. This causes fatal internal structural damage to the organism. The effects on plants, seeds, and fungi are said to be immediate and lasting.

MITTS

A COMPUTER CONCEPT BECOMES AN EXCITING REALITY.

Not too long ago, the thought of an honest, full-blown computer that sells for less than \$500 would have been considered a mere pipe dream.

Everyone knows that computers are monstrous, box-shaped machines that sell for 10's and 100's of thousands of dollars.

Pipe dream or not, MITTS, the quality engineering oriented company that pioneered the calculator market, has made the Altair 8800 a reality. It is the realization of that day when computers are accessible to almost anyone who wants one.

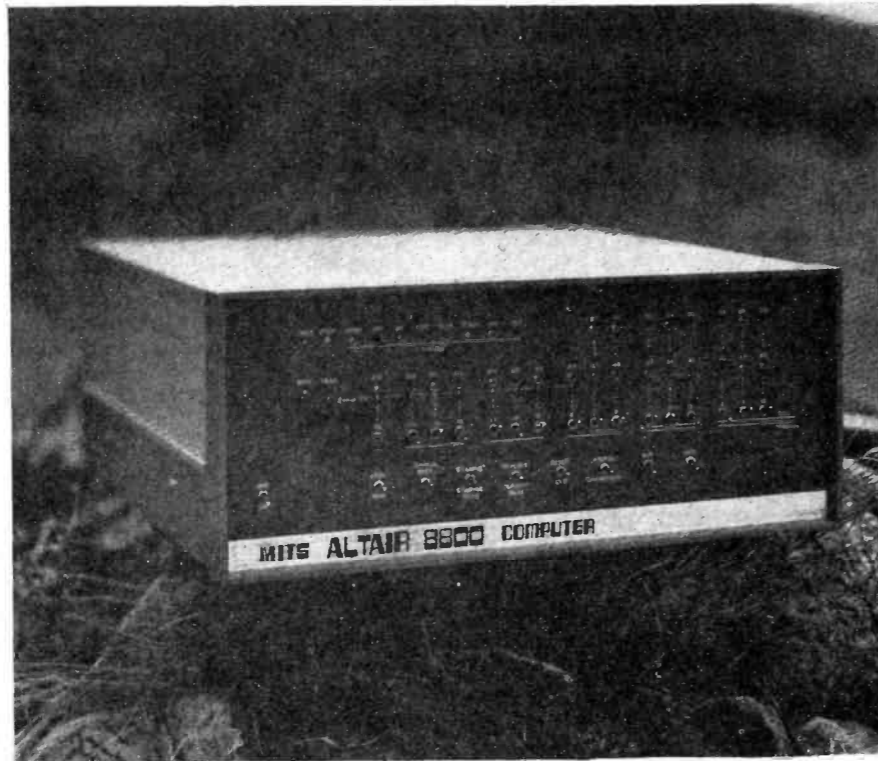

The heart (and the secret) of the MITS Altair 8800 is the Intel 8080 processor chip. Thanks to rapid advances in integrated circuit technology, this one IC chip can now do what once took thousands of electronic components (including 100's of IC's) and miles of wire.

Make no mistake about it. The MITS Altair 8800 is a lot of brain power. Its parallel, 8-bit processor uses a 16-bit address. It has 78 basic machine instructions with variances up to 200 instructions. That's more than enough to program all the street lights in a major city.

And the MITS Altair 8800 Computer is fast. Very fast. Its basic instruction cycle time is 2 microseconds.

Combine this speed and power with the Altair's flexibility (it can directly address 256 input and 256 output devices) and you have a computer that's competitive with most mini's on the market today. And sells for a fraction of their cost.

The Altair 8800 has been designed to fulfill a wide variety of computer needs. It is ideal for the hobbyist who wants to get involved with computers. Yet, it has the power and versatility for the most advanced data processing requirements.

Its basic memory of 256 words of static RAM memory can be expanded to 65,000 words of directly addressable memory. Static OR dynamic memory. OR PROM or ROM memory. OR a floppy disc system. All supplied by MITTS.

Using standard MITTS interface cards, the Altair 8800 can be connected to MITTS peripherals (computer terminals, line printers, audio-cassette interface) to form

the core of a sophisticated time-share system.

The Altair 8800 can be a process controller. It can be an educational device. Or it can be expanded to be an advanced, custom intrusion system. A programmable scientific calculator. Automatic IC tester. Automated automobile test analyzer. Complete accounting system. "Smart" computer terminal. Sound and light system controller.

OR it can be all of these things at the same time. It could be the beginning of new business opportunities. The list of applications is literally endless.

MITTS wants to service your individual computer needs.

You can buy an assembled Altair 8800. Or you can start by building the computer yourself. The MITS Altair 8800 is the ultimate kit. Its assembly isn't much more difficult than assembling a desktop calculator.

OR you can start with an Altair 8800 complete data processing system. Altair Systems come in 4 basic configurations.

MITTS INC.
"Creative Electronics"

Warranty: 90 days on parts and labor for assembled units. 90 days on parts for kits. Prices, specifications and delivery subject to change without notice.

CIRCLE NO. 23 ON READER SERVICE CARD

For those users who are not familiar with computers, MITTS offers free consultation service. Just describe your requirements to our engineering staff and we will specify the additional cards and the system configuration you need to do the job.

The MITS Altair 8800 is backed by complete peripheral and software development programs. There is even a high level language available.

Order your Altair 8800 Computer today. As a special introductory offer, MITTS is offering the Altair 8800 at a discount of \$100. This offer is good on all orders postmarked prior to March 1, 1975.

PRICES:

Altair 8800 Computer (assembled with complete operation instructions) **\$750.00**
Altair 8800 Computer (kit form) **\$495.00**
Subtract **\$100.00** from above prices on all orders postmarked prior to March 1, 1975.

Enclosed is a Check for \$ _____
or Bank Americard # _____
or Master Charge # _____
Credit Card Expiration Date _____ Kit
Include \$8.00 for Postage and Handling Assembled
 ALTAIR 8800
 Please send complete Altair System Catalogue.

NAME _____
ADDRESS _____
City _____
STATE & ZIP _____
MITTS / 6328 Linn, N.E., Albuquerque, New Mexico
87108 505/265-7553

POPULAR ELECTRONICS

Popular Electronics

FEBRUARY 1975

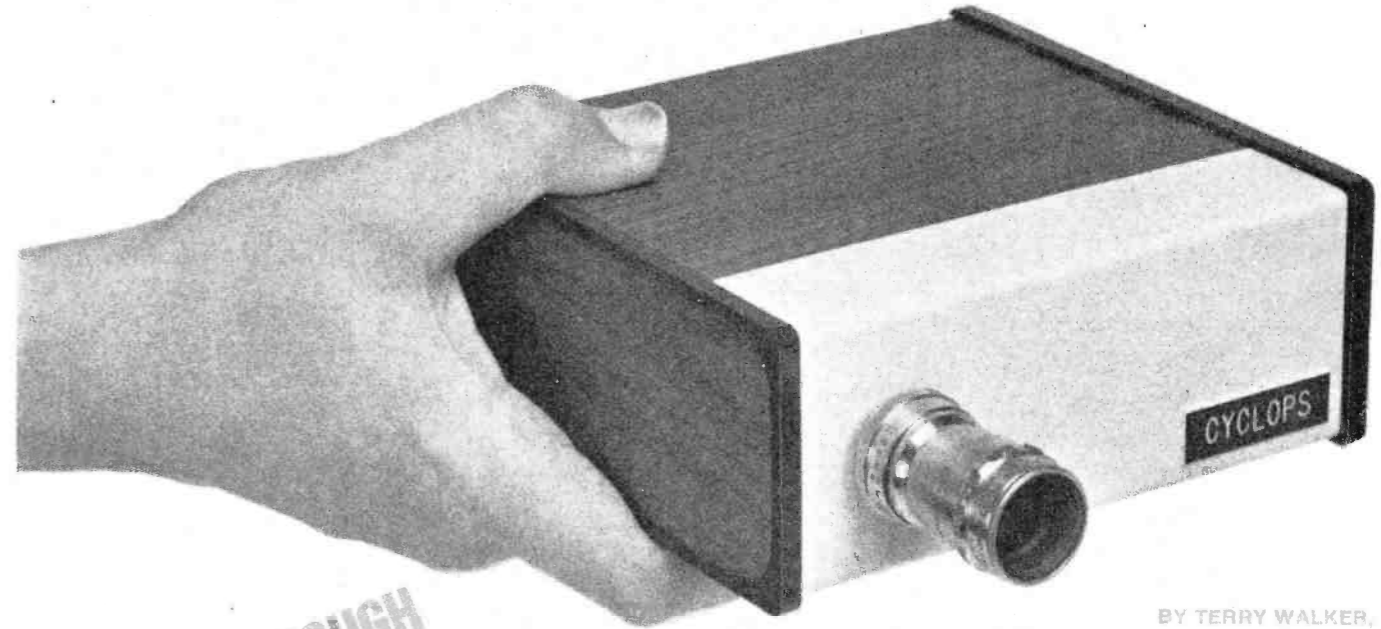

BY TERRY WALKER,
HARRY GARLAND & ROGER MELEN

CYCLOPS

BREAKTHROUGH PROJECT!

Using an MOS array and digital electronics eliminates vidicon and yoke.

SOLID-STATE image sensors, which were discussed in detail last month, may one day supplant vidicon tubes in TV cameras. They promise small size and easy camera construction, have a low power requirement and operate in a wide range of light conditions. Cost, however, has been prohibitive—until now!

Presented here is "Cyclops," the first all-solid-state TV camera project using a special MOS photoelement array as the image sensor—and, it can be built by electronics experimenters at an affordable price. (A complete kit of semiconductors, including the MOS device, is available for \$55, for example.)

Any image that can be picked up by a conventional TV (or movie) camera

can be picked up by Cyclops. Unlike conventional cameras, however, Cyclops is sensitive to infrared radiation and is thus able to "see" in the dark when an infrared light is used to illuminate the scene.

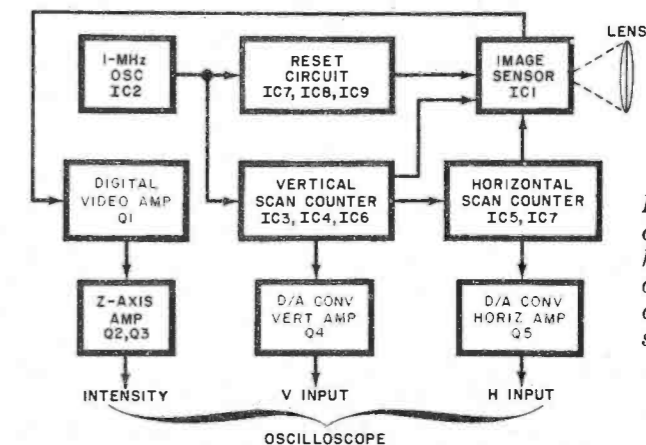

Fig. 1. Logic diagram of the camera shows how scan counters address camera and also generate sweep signals for the scope.

PARTS LIST

C1, C2—0.001- μ F disc capacitor
 C3, C4, C5—0.1- μ F disc capacitor
 C6—330-pF disc capacitor
 C7, C8, C9—0.01- μ F disc capacitor
 D1 to D4—1N914 diode
 D5—1N5242 12-volt zener diode
 IC1—1024-element image sensor
 IC2, IC9—7402 TTL quadruple 2-input NOR gate
 IC3, IC5, IC6, IC7—7493 TTL 4-bit binary counter
 IC4—7404 TTL hex inverter
 IC8—7400 TTL quadruple 2-input NAND gate
 IC10—MC7805CP 5-volt regulator
 I1, I2—#47 pilot light
 J1 to J4—Banana jacks
 Q1, Q2, Q3—2N3640 transistor
 Q4, Q5—2N3904 transistor
 R1—100-ohm, 1/2-watt miniature potentiometer
 R2—100-ohm, 1/2-watt resistor
 R3—560-ohm, 1/4-watt resistor
 R4 to R18 and R52—1000-ohm, 1/4-watt resistor
 R19—15,000-ohm, 1/4-watt resistor
 R20 to R31—20,000-ohm, 1/4-watt 5% resis.
 R32 to R39—10,000-ohm, 1/4-watt 5% resis.
 R40 to R44—100-ohm, 1/4-watt resistor
 R45, R46—68,000-ohm, 1/4-watt resistor
 R47, R48—5600-ohm, 1/4-watt resistor
 R49—1800-ohm, 1/4-watt resistor
 R50—18,000-ohm, 1/4-watt resistor
 R51—2200-ohm, 1/4-watt resistor
 Misc.—IC socket (9), 3/4" variable-length spacers, lens (see text), suitable chassis, mounting hardware, line cord, etc.
 Note—The following are available from

H. Garland and R. Melen, 26655 Laurel Lane, Los Altos, CA 94022: kit of all IC's (including image sensor), diodes, and transistors at \$55; pc board at \$5; all postpaid. California residents, please add sufficient sales tax.

Fig. 2. Complete schematic of the camera. Letters between sections are merely for showing interconnections. Letters in circles are terminals for use with optional circuits.

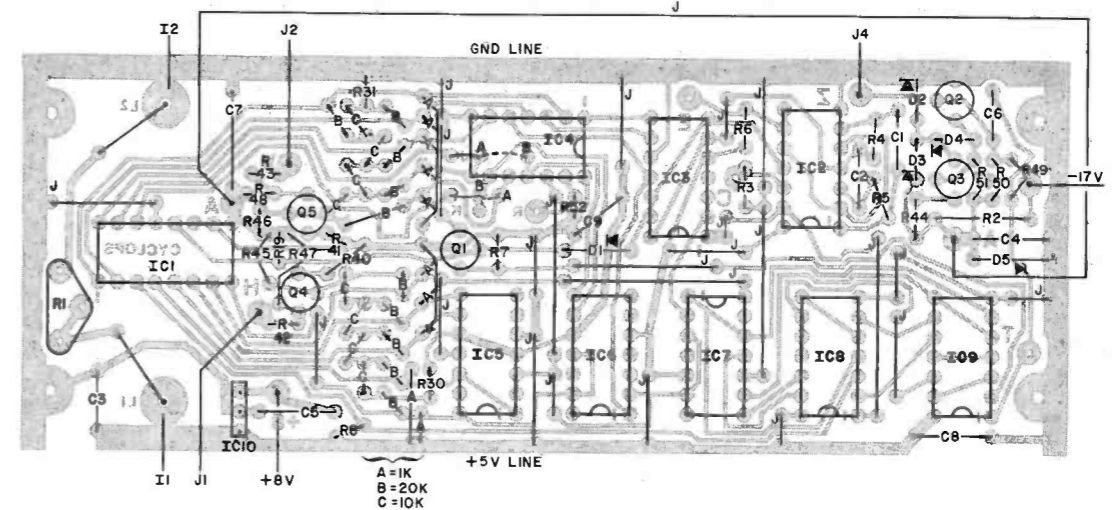
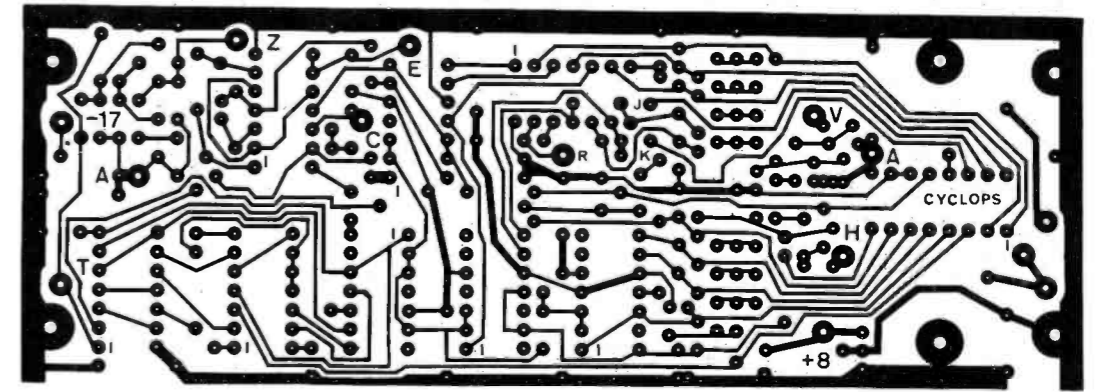
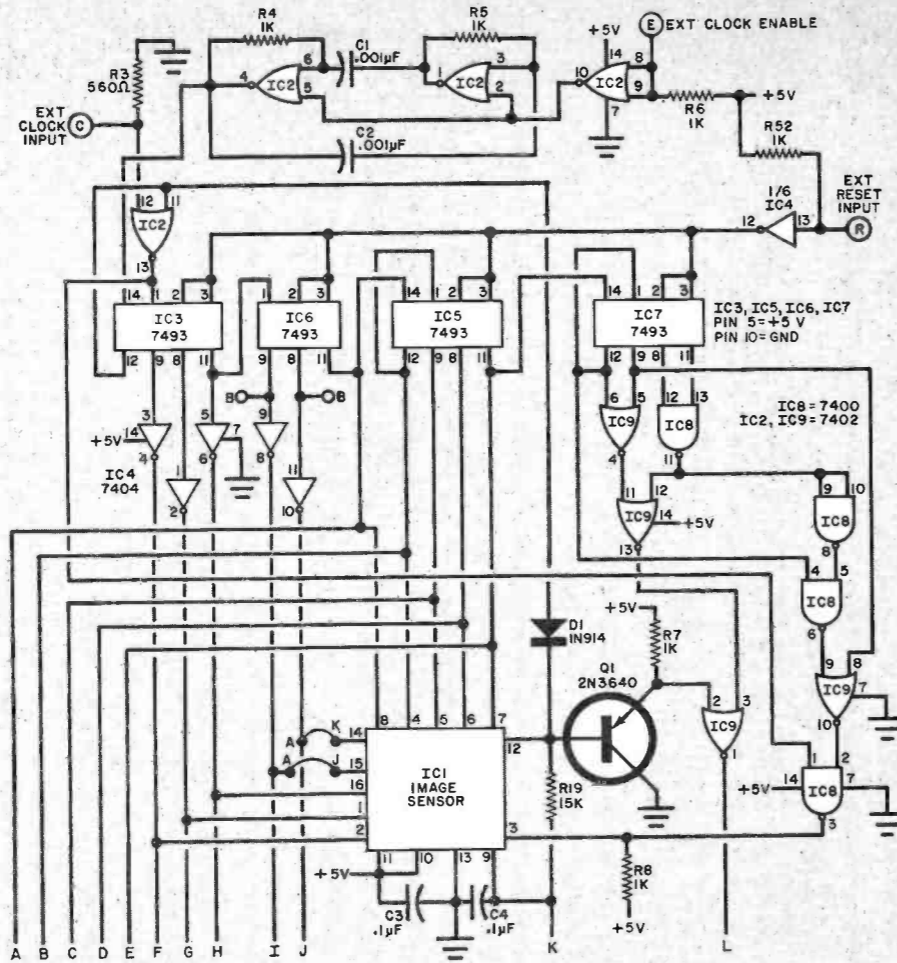
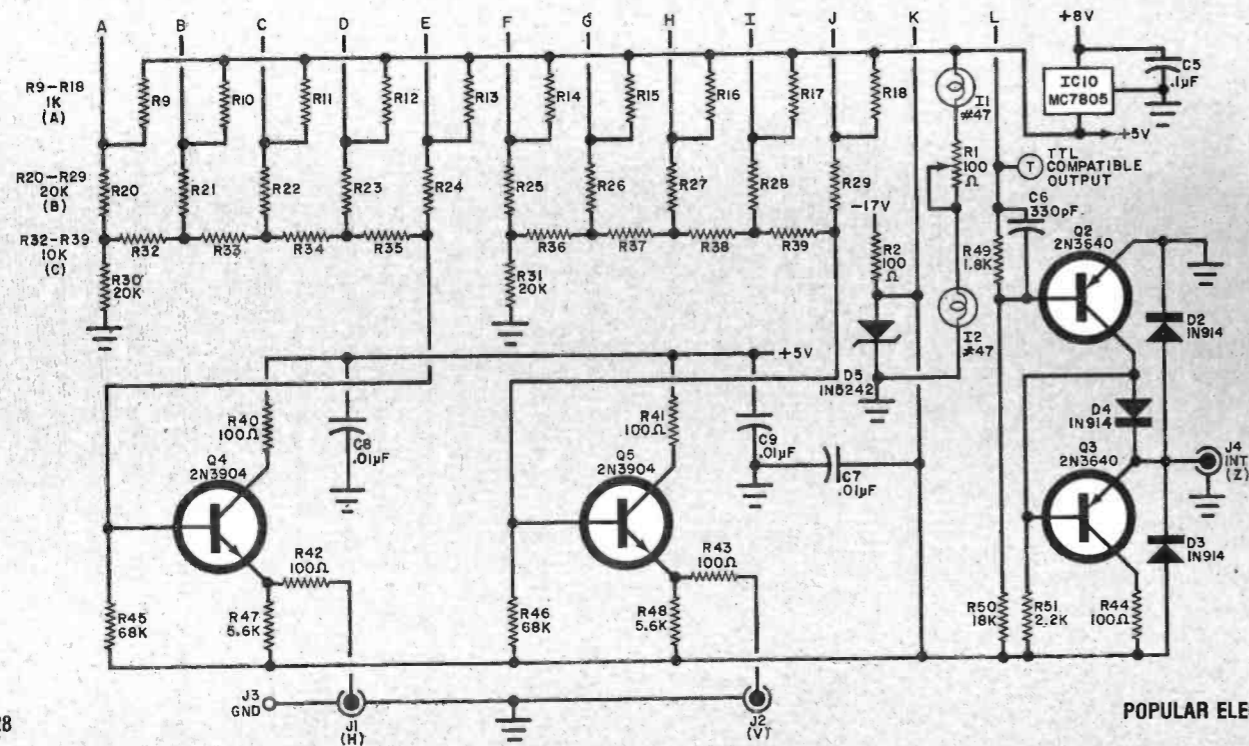

Fig. 3. Actual-size foil pattern (top) and component placement. Note that most resistors are mounted on end to conserve space.



The MOS array has 1024 separate photosensitive elements fabricated on a single chip and mounted in a conventional 16-pin DIP case with a transparent cover. Although similar sensing devices have cost up to several hundred dollars in the past, new techniques and volume production have made it possible to reduce prices. With just 1024 elements (in a 32 by 32 array), Cyclops can't be expected to match the resolution of a vidicon camera; but it is quite useful for many applications. The circuit described here is for using Cyclops with a conventional oscilloscope, but it could be altered for a display on a TV tube. (Among other things, a sync generator would be needed.)

A little imagination will enable the experimenter to come up with a number of novel uses for Cyclops. For example, if a fiber-optic light pipe is used with the sensor, it could pick up conventional printed material for transmission or to excite a type of tactile device for use by the blind. Consider also the possibility of using Cyclops in conjunction with the

Altair 8800 Minicomputer (POPULAR ELECTRONICS, January 1975). The combination could be used to build a security system that would operate on the basis of a person's appearance. This approach also opens up a brand new and exciting area for the advanced experimenter—a digital computer that has "vision." For example, the Cyclops/Altair combination, with 256 independent inputs/outputs could be the basis for a robot that could be programmed to do a number of things, while also being able to "see" its environment and make any necessary corrections in its actions.

Circuit Operation. The Cyclops logic diagram is shown in Fig. 1. A part of IC2 is used as a 1-MHz timing oscillator. One output of the oscillator drives the vertical scan counter, which drives the horizontal scan counter. The binary outputs of the scan counters are used to address the rows and columns of the MOS array.

As each of the 1024 elements is addressed, two events occur within a period of less than two microseconds.

First, the outputs of the vertical and horizontal scan counters are processed by a ladder-type digital-to-analog (D/A) converter, then amplified by Q4 and Q5, respectively, to produce the scope vertical and horizontal sweep. This creates the raster on the CRT. The second event occurs when the video information on the image sensor is read out, amplified and used to vary the brightness of each of the 1024 dots that make up the raster and produce the intensity-modulated image on the CRT. Since both sweeps (H and V) and the video (brightness) information are "in step" at all times, each of the 1024 elements on the sensor has a corresponding point on the raster, and the charge on each element determines the brightness of its raster dot.

A novel coding scheme is used for the video information. Thirty completely new frames are displayed on the scope each second, with each frame made up of 16 separate and complete scans of the image sensor. The first of these 16 scans is used to reset the 1024 photoelements, with

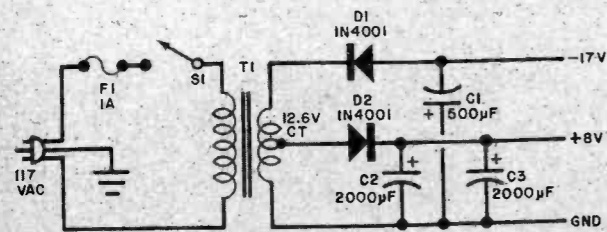

PARTS LIST

- C1—500-µF, 15-volt electrolytic capacitor
- C2, C3—2000-µF, 15-volt electrolytic capacitor
- D1, D2—1N4001 diode
- F1—1-ampere fuse and holder
- S1—Spst switch
- T1—12.6-VCT filament transformer (Triad F-25X or similar)

Fig. 4. Power supply for camera can be wired point-to-point and mounted anywhere in chassis.

the reset pulses generated by IC7, IC8, and IC9. On subsequent scans, the video information is read out.

When a particular photoelement is illuminated by a bright light (from the image being sensed), a video output pulse is developed each time that element is addressed. The video output pulses are amplified by Q1 and, after gating, by Q2 and Q3 to produce the scope intensity (Z) axis signal. If there is no light on a particular element, no video pulse is generated when that element is addressed. For grey portions of the picture, the number of video pulses generated for each frame is determined by the intensity of the grey in the original image.

Several inputs and outputs are provided on the pc board as shown in Fig. 2. These are for possible use in advanced projects. For normal operation, no connection is necessary at these points. Point "T" provides a TTL-level signal to facilitate interfacing with external digital circuits. By connecting point "E" to ground, the 1-MHz oscillator is disabled and an external oscillator can be applied to point "C". An external reset pulse can be applied through point "R" to reset the scan counters at any point in the scan cycle. Since both position and intensity information are available in digital form, Cyclops can very easily be interfaced with a digital computer.

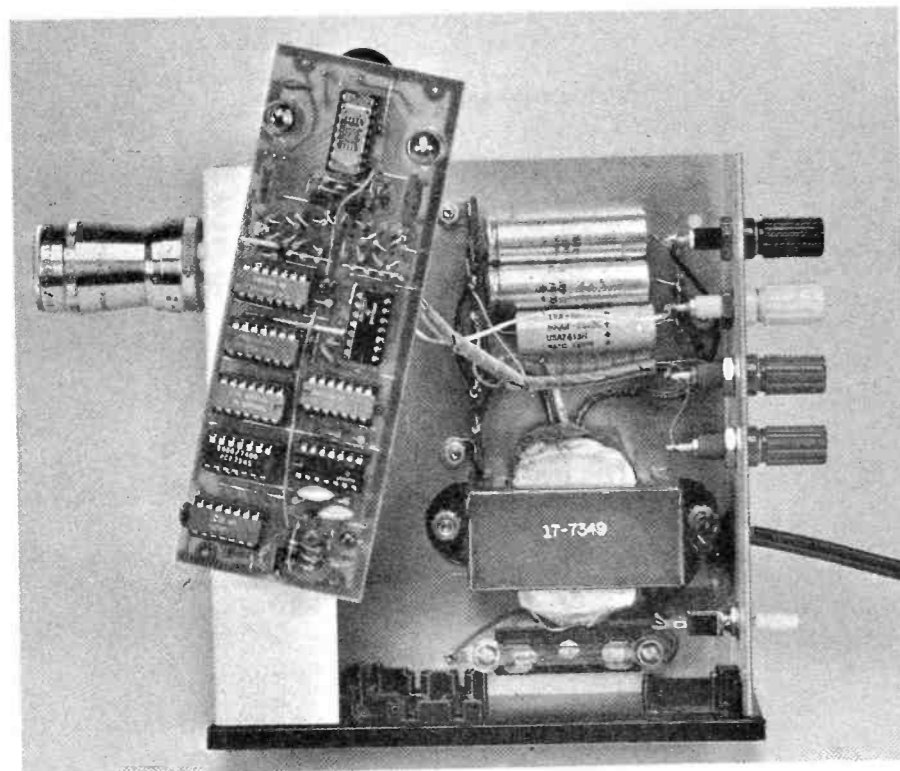

Photo shows chassis with the printed circuit board pulled out.

The external oscillator input can be used to synchronize Cyclops with the computer or with a TV display.

Construction. The logic circuits of Cyclops are on a single pc board (Fig. 3). Use sockets for all of the IC's except IC10 which is soldered in place. Be sure to observe the correct polarities on all IC's, diodes, and transistors.

For the pilot lamps (I1 and I2), drill holes in the board just large enough to accommodate the metal portions of the lamps so that, when they are inserted from the nonfoil side, the glass portion just touches the board. The metal portions of the lamps are then soldered to the pads, and small lengths of wire are soldered to the center connectors on the lamps and the appropriate pads.

Miniature potentiometer R1 is mounted on the foil side of the board so that the two lamps can be adjusted when the pc board is mounted in place. The purpose of I1 and I2 is to bias the image sensor with a dim, uniform background light. Although this is not absolutely necessary, the bias light improves the low-light-level sensitivity and provides better picture contrast.

Note that many resistors are mounted on-end to conserve space on the board.

The power supply circuit is shown in Fig. 4. This supply is wired point-to-point (using a terminal strip) and can be mounted anywhere within the selected chassis.

The pc board is mounted on 3/4" adjustable standoffs behind the front of the chassis. Mount the board temporarily and mark a spot on the front panel that is directly in line with the center of the image sensor (IC1). Remove the board and drill (or cut) a hole just large enough to accommodate the selected lens. Before mounting the board permanently, make sure that the distance between it and the lens can be adjusted slightly to permit focussing.

Connect the ground, +8-volt and -17-volt lines from the power supply to the board. Connect the four leads from the board (ground, vertical, horizontal, and intensity) to their respective color-coded jacks on the rear panel. The power switch (S1) is also mounted on the rear panel, and the line cord goes through a grommeted hole in the same panel.

Either one of two image sensors



Jacks for scope connections and on/off switch are on chassis rear.

may be supplied for use in Cyclops. The two are identical except for the way pins 14 and 15 are connected to the circuit. Note that, on the pc board, IC1 pin 15 goes to pad J, and pin 14 goes to pad K. If your image sensor is marked "Type A," connect pad J to pin 8 of IC4 and pad K to pin 10 of IC4. If the image sensor is marked "Type B," connect pad J to pin 9 of IC4 and pad K to pin 11 of IC4.

Lens Selection. Almost any movie camera lens will work with Cyclops. The two important factors to consider in choosing a lens are focal length and

f-number. The focal length determines the viewing angle of the camera, while the f-number determines how much light can be collected.

The lens used with Cyclops should have a variable aperture so that the f-number can be adjusted to suit the lighting conditions. The minimum f-number, when the aperture is wide open, determines the lowest light level at which Cyclops will operate. An f-2.8 lens should be adequate for most applications, though some additional lighting may be required for indoor operation. (We purchased an under-\$10 used f-2.8 normal motion-

picture-camera lens with variable stops for this project.)

Both new and used movie camera lenses are available from photography stores and mail-order houses. A 12.5-mm, f-27 lens is available from Edmund Scientific (300 Edscorp Bldg., Barrington, NJ 08007) for less than \$10 (stock No. 41,146).

Setup and Operation. Connect Cyclops to an oscilloscope (set to external horizontal) as follows: J1 to horizontal input, J2 to vertical input, J3 to ground, and J4 to intensity input. If your scope does not have provision for an intensity input, modify it according to Fig. 5.

With power applied to both Cyclops and the scope, adjust the scope's horizontal and vertical gain until a 32-by-32 pattern of dots forms a square array on the screen. Cover the lens of Cyclops and then turn the scope's intensity control down until the dots just disappear. Now, expose the lens to a lamp. The dots on the CRT will illuminate.

To adjust the focus between the image sensor and lens, turn the bias lamps down (R1 at maximum resistance) and expose the lens to a simple, illuminated test pattern such as a black cross on a white background. If the lens can be focussed, adjust it for the distance between the lens and the test pattern. Set the lens to its widest opening (smallest f-number). Use a 50-watt lamp to illuminate the test pattern and position the lamp until an image appears on the screen. Adjust the distance between the image sensor and the lens by varying the spacers until the test pattern is in the sharpest focus. Then secure the pc board in place.

To adjust the bias lamps, darken the room so that no ambient light reaches the image sensor. Make sure that R1 is at maximum resistance (lamps out). Adjust the scope's brightness control until the dot pattern can just be seen, and then increase the brightness of the bias lamps until the scope pattern just starts to get brighter. This is the correct setting of R1. Place the cover on the chassis so that no ambient light reaches the image sensor.

Cyclops is now ready for use. Although the resolution may seem to be on the low side for observing fine details, you will note that the apparent resolution seems to increase when viewing a "live" scene—especially one with motion.

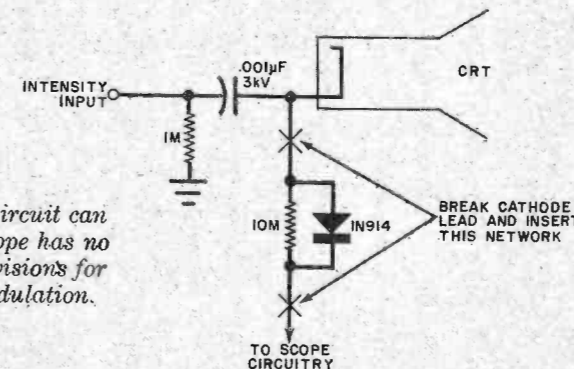

Fig. 5 This circuit can be used if scope has no internal provisions for intensity modulation.

PHASE-LOCKED loop circuitry has been popularized by its current use in high-quality FM stereo tuners and by publicity accompanying the Dorren Quadraplex system of discrete 4-channel FM (a quadrasonic FM broadcasting contender).

Though the advantages of PLL in FM reception have been used for many years in sophisticated military and space applications, integrated-circuit versions weren't introduced until 1970. Lowered costs have spurred applications in many consumer-electronics areas.

The phase-locked loop is analogous to a servo system—in the FM range. Its behavior as a servo permits it to find and lock on signals, tracking them 6 dB under the noise level. As an electronic filter, it can present a 1% passband to any frequency from 0.1 Hz to the r-f region with excellent stability. Using programmable dividers in its oscillator loop, the PLL becomes a frequency synthesizer that can reproduce practically any frequency from only one crystal. This throws the door open to digital tuning of receivers and transmitters.

These are only a few of the areas where PLL is useful. There are, in addition: frequency shift keying for RTTY, motor control, FM generators, touch-tone telephone, and stereo and four-channel decoding. Now that the price of PLL IC's has dropped below \$5.00, the hobbyist and experimenter can add the PLL to their store of basic building blocks.

PLL Basics. The PLL is a feedback system comprised of four basic elements (Fig. 1): a phase detector or comparator; an external low-pass filter; an error correction amplifier; and a voltage controlled oscillator (vco).

The vco is a free-running form of multivibrator whose center frequency is determined by an external timing capacitor and resistor. The vco output is presented to the phase comparator, where it is compared to the incoming signal. The result is an error correction voltage whose magnitude is a function of the phase and frequency differences of the two signals.

This signal is then filtered in an external low-pass filter and amplified in the error correction amplifier. The output of the latter is fed back to the voltage-control input of the vco to complete the loop and cause the oscillator frequency to approach more closely the frequency of the input.

Once the vco starts to change fre-

HOW PHASE-LOCKED LOOPS WORK

BY HERB COHEN

Theory and applications of an old circuit, revitalized and refined by IC technology.

quency, it is in the "capture" state; and it continues to change frequency until its output is exactly the same frequency as the input. The circuit is then "locked" so that the loop frequency varies exactly with the input frequency.

Thus, the loop has three states: free-running, capture, and locked or tracking. The capture state is highly complex. Interestingly, the capture range (frequency band above and below the vco center frequency) is not as wide as the locking range.

A closer look at the capture state will provide an explanation. Figure 2 shows the waveform of the voltage at the output of the error-correction amplifier. As capture starts, a small sine wave appears. This is the "beat" between the vco and the input signal. Note that the negative half of the waveform is slightly larger than the positive half. This is the dc component of the beat, which drives the vco toward lock. Each successive cycle causes the vco to move closer to the input signal.

There are two results of this action which help the vco to lock. First, the closer the vco approaches the input signal, the lower the beat frequency. This allows the low-pass filter to pass more of the beat frequency to the vco with a correspondingly larger portion of the dc component. The vco is now skipping two steps toward lock and one step back. At the same time, the closer the vco nears lock, the longer it wants to stay there, and the more reluctant it is to move away. This extends the negative half of the cycle, reduces the positive half, and increases the dc component to speed up the process. The vco finally locks and the beat frequency is zero.

The low-pass filter is an important factor in controlling the capture range. If the vco is too far away from the signal, the beat frequency will be too high to pass through the filter and the signal is out of the capture band.

Once lock has been achieved, the filter no longer restricts the PLL. It can track a signal well past the capture band, being restricted only by the output range of the phase comparator. However, the filter does limit the speed at which the PLL can track. If the signal frequency changes too rapidly, the PLL can become "unlocked."

The low-pass filter is an engineering trade-off. On one hand, it restricts the capture band and reduces tracking speed; but, without it, the PLL would have great difficulty locking. The filter supplies the PLL with a short-term "memory" of where it was with respect to the signal, providing a sort of fly-wheel effect. It also "memorizes" the rate-of-change of the signal frequency. Even if the signal should drop into a noise level for several cycles, the filter will continue to shift the vco at the same rate until it picks up the signal again. This produces a high noise immunity and locking stability.

The 560 Family. The most popular family of PLL IC's is the Signetics 560 series. The table lists the important specifications for various units in the series. The first three are high-frequency devices, with typical vco operation of 15 MHz and a maximum of 30 MHz. Above 15 MHz, its opera-

Fig. 1. Four basic elements of a phase-locked loop.

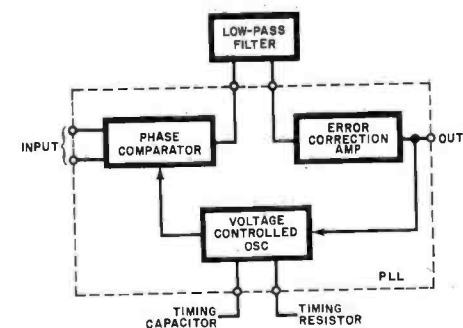

POPULAR ELECTRONICS

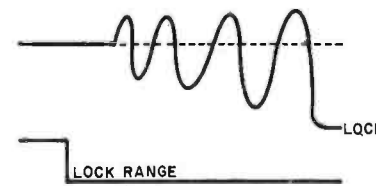

Fig. 2. Upper trace shows beat between vco and input. Lower trace is the lock range.

tion becomes critical, and great care is needed to get them to perform properly. Its input sensitivity is very good—the device can lock on to signals of 100 to 200 microvolts. The 561 is a duplicate of the 560, but it has an added product detector for synchronous demodulation. The 565 has an exceptional lock range (typically $\pm 60\%$); however, its input sensitivity is only fair (1 millivolt for lock). The 565 has one added advantage over the high-frequency units: its vco is tuned with an RC network, and frequency is directly proportional to the change in the resistance. This permits tuning over a 10-to-1 frequency range using a potentiometer.

The 567 is primarily a narrow-band filter. Its interesting feature is a built-in synchronous switch which turns on when the unit goes into lock. The switch is able to handle up to 100 mA and can be used to turn on an SCR, a relay, or a lamp for indication of the lock condition. Another feature of the 567 is its low power-supply voltage (4 volts minimum), making it ideal for battery operation. However, it is less input-sensitive than the others in the series.

Working with the 565. The 565 PLL is the only member of its family that is not internally stabilized with a zener diode. Therefore, a well-regulated supply or a zener diode should be used to keep the power stable.

Suppose you want to use a 565 as an SCA background music decoder. A suggested circuit is shown in Fig. 3.

The SCA signal is 14-kHz FM on a 67-kHz subcarrier. Note that a single-ended power supply is used and the resistor network made up of R_3 through R_6 is used to bias the inputs at 3.2 volts. Thus only one comparator input (pin 2) is used for the signal.

The two input capacitors (C_2 and C_3) and resistor R_2 act as a high-pass filter to remove the lower-frequency stereo subcarrier from the SCA input. Capacitor C_1 and resistor R_1 determine the operating frequency of the internal vco by the expression $1.2/(4R_1C_1)$. Since we know that the vco should operate at the SCA frequency of 67 kHz, and we would like R_1 to be about 5000 ohms, we can

The demodulated output (pin 7) is passed through a three-stage low-pass filter (C_5 to C_7 and R_7 to R_9) to provide the necessary de-emphasis and attenuate the high-frequency noise that often accompanies the SCA transmission. The demodulated output signal is approximately 50 mV and the frequency response extends to 7 kHz.

The locking range is determined from $\pm 8F_o/V_{cc}$ which comes out ($\pm 8 \times 67$)/10 or ± 53.6 kHz. Since the bandwidth of the SCA subcarrier is only 14 kHz, there is more than enough locking range available. This expression applies only when the input signal is high enough to saturate the com-

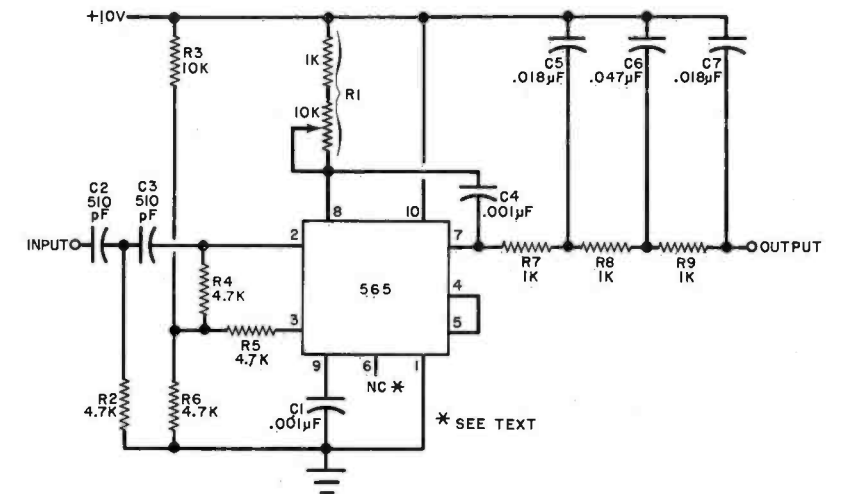

Fig. 3. Typical phase-locked circuit for decoding SCA background music on FM broadcast.

calculate the value of C_1 needed. This works out to be 0.000895 or 0.001 μF .

Tuning resistor R_1 is made up from a 1000-ohm fixed resistor in series with a 10,000-ohm potentiometer. (Remember that we assumed a value of 5000 ohms for R_1 .) Using this larger potentiometer will enable tuning over a wide range around the center frequency (in case the tolerance of C_1 is very broad), while the 1000-ohm fixed resistor will act as a current limiter if the potentiometer resistance is reduced to zero.

If the input signal decreases, the correction voltage also decreases, thereby reducing the locking and capture ranges.

The curve in Fig. 4 shows the locking range versus the input signal level. Since the SCA decoder requires a 20% locking range, the curve shows that a 10-mV input will be enough to drive the phase lock.

The 565 provides a method of limiting the locking range. A tap on an internal voltage divider is used as a reference output (pin 6). This voltage is the same as the output voltage (pin 7) when F_o is equal to the incoming signal. Connecting a resistor between pins 6 and 7 differentially loads the output without changing the dc level or shifting the vco. A resistance change from 25,000 ohms to zero between these points will shift the locking range from $\pm 60\%$ to $\pm 20\%$. Since the output is loaded, one can expect a corresponding decrease in the level of the output signal.

PLL SPECIFICATIONS

Type	Min. Input For Lock	VCO Freq. (MHz)	Lock Range	V _{cc}	
				Min.	Max.
560	120 μV	15	15%	16	26
561	120 μV	15	15%	16	26
562	200 μV	15	15%	16	30
565	1 mV	0.5	60%	10	26
567	20 mV	0.1	12%	4	10

FEBRUARY 1975

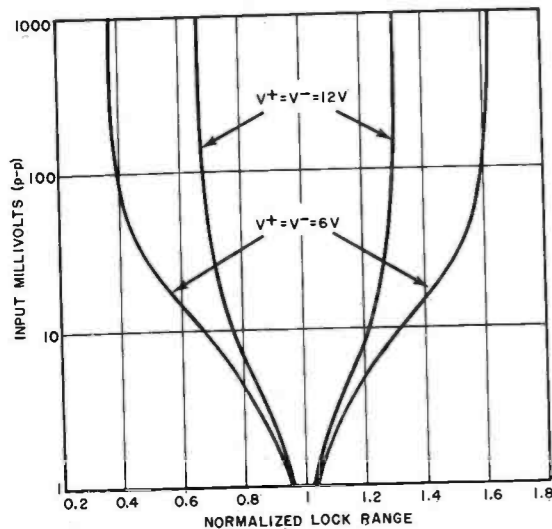

Fig. 4. Lock range versus input signal level for the 565 phase-locked loop.

HISTORY OF PHASE-LOCKED LOOPS

In 1932, a group of British physicists was working on a new method of radio reception to compete with the superheterodyne system. This new approach would require only one tuned circuit and would have greater fidelity and selectivity than the superhet circuit.

The theory was deceptively simple. When an r-f oscillator and an incoming signal are mixed at the same phase and frequency, the output product will be a perfect audio reproduction of the transmitted modulation. An adjacent carrier, 20 kHz away, will be demodulated as a 20-kHz signal and could easily be filtered out of the desired audio.

The system was constructed using a simple untuned r-f amplifier to feed the mixer. The results were astonishing—perfect reception with no adjacent-channel interference. The only problem was that the local oscillator would slowly drift off frequency, producing a beat note which made reception intolerable.

One member of the group then theorized that if the oscillator frequency could be compared to the signal frequency in a phase-detector circuit, a correction voltage could be produced to return the oscillator. This could be done by having the correction voltage drive a Miller-effect (electronic variable capacitance) amplifier connected across the tuning circuit of the oscillator. The same feedback idea had worked in servo systems. So, why not an electronic servo?

The new oscillator circuit was built and connected to the receiver system. It not only stayed in frequency with the incoming signal, it locked itself in. When the tuning was changed to a new

signal, the oscillator would hold onto the old until the new one got too strong and then it would switch to the new signal. When the system was tuned between carriers, it hunted for the stronger one and locked on to it.

The receiving system, which originally had been named the homodyne circuit, was renamed the syncrodyne circuit.

The circuit, though superior to the superhet in many ways, could not compete where cost was concerned. The oscillator locking circuitry was too expensive. Though the syncrodyne receiver circuit was never used in AM receivers, it attracted the attention of FM receiver designers who were looking for a method of stabilizing the mixer/oscillator at 100 MHz. The FM receiver already had a form of phase discriminator to demodulate the i-f signal. By connecting the dc component of the discriminator output to a Miller-effect tube across the local oscillator, the latter could be forced to lock in 10.7 MHz above the incoming signal to produce an exact 10.7-MHz i-f. The system was called automatic frequency control.

The budding TV-receiver industry, looking for a way of locking the horizontal oscillator, developed several phase-locked circuits—notably the "Syncro-Guide" and "Syncro-Lock."

By the mid 1940's, phase-lock was being used in military microwave and radar receivers. When NASA fired the first space capsule, its 10-milliwatt, 108-MHz transmitter signals were received by a phase-locked receiver, whose ability to follow a signal below the noise level was considered phenomenal.

The differential output (pins 6 and 7) is useful in frequency-shift keying. This is a method of reproducing digital pulses by shifting the frequency of the input signal, generally 1 kHz for a zero state and 2 kHz for a one state. By connecting a voltage comparator across pins 6 and 7, the output pulses are cleaned and shaped. They can then be interfaced with the following digital circuitry.

The 565 has two outputs that can be useful in some applications. A triangle waveform is available at pin 9 with an output of 2.4 V and 0.5% linearity. Because even light loading at the output will distort the triangle wave, a high-impedance buffer is recommended when using it.

Note that there is a short between pins 4 and 5. Pin 5 is the output of the vco while pin 4 is the input to the comparator. In the SCA adapter, these two pins are not used. The output at pin 5 is a square wave with an impedance of 5000 ohms and a level of 5.4 V p-p.

As shown in Fig. 5, pins 4 and 5 provide a convenient way to insert a programmable frequency divider for frequency synthesis. If the input, F_{REF} , is a

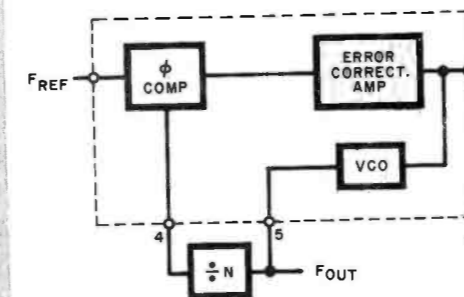

Fig. 5. Adding a divider permits frequency synthesis.

10-kHz crystal-controlled source, and the divider is programmable from 1 to 10, the vco output, F_{OUT} , is 10 to 100 kHz in steps of 10 kHz, all having the same stability as the crystal. If a divider is programmed from 100 to 110, the vco becomes programmable from 1 MHz to 1.1 MHz in 10-kHz steps. Unfortunately, the 565 can only operate to 1 MHz, so this discussion serves only to illustrate how you can use a phase-locked loop and a programmable counter to synthesize almost any desired frequency.

This, in essence, is how frequency-synthesized CB and FM devices work. If you have a synthesized local oscillator, you can receive almost any channel on any band, provided they are evenly spaced. ♦

SHORTWAVE NEWSCASTS IN ENGLISH

BY RICHARD E. WOOD

A SHORTWAVE receiver is a passport to a world of information. On the shortwave bands, headline news stories can be heard as they happen. Try listening to some of the broadcasts listed here. Though frequencies are subject to change without notice, this list includes most of the major newscasts (in English) copyable in North America. These broadcasts are not necessarily beamed here and recep-

tion will depend on many factors—your receiver and antenna, ionospheric conditions at any given moment, and your location.

In addition to the stations listed, the Voice of America, the AFRTS (Armed Forces Radio and Television Service), and the CBC Northern Service provide many newscasts, throughout the day, on a number of frequencies.

The listings here are based on the author's experience and proven reception—with one exception. The Israel BA station has done many flip-flops in scheduling in the past few months (perhaps as a result of the installation of a new 300-kW transmitter). So the times and frequencies listed for this station are the latest obtainable.

Time (GMT)	Station	Frequency (MHz)	Station	Frequency (MHz)
0000	BBC	15.260*, 11.750, 9.740†, 9.580, 9.510*, 9.410	R. Bangladesh	15.520, 11.650
		7.325, 6.175†, 5.975	R. Berlin Int.	9.730
	R. Japan	15.105	R. Moscow	See 0200 listings
	R. Norway	11.860, 9.645 (Mon)	R. Beirut	9.675 (may be changed)
	R. Moscow	9.665, 7.440, 7.355, 7.205, 7.185, 7.150, 7.105, 5.940	R. Cairo	9.475
		15.520, 15.060, 11.945, 11.685, 8.300, 6.810	UN Radio	21.630, 17.850, 15.365
	R. Peking	9.755, 7.065	R. Australia (Australian Newsreel)	See 0230 listings (weekdays)
		9.700		
		6-MHz band (subject to change)		
		15.150, 9.590, 9.560, 6.190		
0030	R. Tirana	9.655, 9.530, 9.520, 7.150, 5.940 (Tu, Fri, Sat)	Voice of Chile	15.150, 9.590, 9.560, 6.190
	R. Sofia	9.540	BBC	15.260*, 9.580, 9.510*, 7.325, 6.175*, 5.975
	R. Sweden	9.685, 7.105 (Sun, Mon)		
	V. of Chile	9.605, 6.165, 5.995	R. Japan	15.105
	HCJB, Quito	9.690, 9.545, 6.040, 6.010	R. RSA	9.525, 7.270, 5.980, 3.995
	R. Kiev	15.105	R. Finland	9.720 (Subject to change)
		11.915, 9.560, 5.970 (weekdays)	R. Moscow	9.700††, 7.440, 7.355, 7.205, 7.185, 7.150
		9.655, 9.530, 9.520, 7.150, 5.940 (Tu, Fri, Sat)	R. Kiev	9.610, 9.520, 7.205 (may be changed) (Tu, Fri, Sat)
		9.540	R. Peking	15.095, 15.060, 12.055, 11.650, 11.445, 9.780**, 7.120**
		9.685, 7.105 (Sun, Mon)		
0100	Vatican R.	9.605, 6.165, 5.995	RAE, Argentina	9.690
	Deutsche Welle	9.690, 9.545, 6.040, 6.010	R. Budapest	9.833, 7.220, 6.165
	R. Japan	15.105	R. Portugal	11.840
	R. Canada	9.755, 6.085	R. Prague	11.990, 9.630, 9.540, 7.345, 5.930
	RAI, Rome	9.575, 6.010		
	R. Berlin Int.	9.730	R. Bucharest	11.940, 9.570, 6.190, 5.990
	R. Havana	11.930, 11.725	Spanish Nat. R.	11.925, 6.065
	R. Moscow	See 0000 listings.	Deutsche Welle	9.545, 6.185, 6.075, 6.040
	R. Peking	17.855, 17.715, 15.060, 11.945, 11.445, 9.780**, 9.390, 7.120**	R. Erevan	17.900, 17.720, 15.180 (via Soviet Far East) (Mon, Wed, Fri, Sun)
		11.925, 6.065		
0130	Spanish Nat. R.	9.833, 7.220, 6.165	R. Berlin Int.	11.970, 11.840
	R. Budapest		R. Havana	11.930, 11.760, 11.725
	R. Television	9.505 (weekdays, irregular)	R. Moscow	See 0300 listings, plus 17.775, 15.180, 15.140, 11.860, 11.690, 9.785, 9.735, 9.700††, 9.610, 9.580, 9.540
	Dominicana	11.815***		
	Trans-World R.	11.990, 9.630, 9.540, 7.345, 5.930	R. Austria	9.770, 6.155
	R. Prague		R. Tirana	7.300, 6.200
		17.825, 17.725, 15.235, 15.195	R. Portugal	11.935, 6.025 (not Mon)
	R. Japan	17.795, 15.320, 11.970	BBC	11.750, 9.580, 9.510*, 5.975
	R. Australia	See 0100 listings, with 9.700††	R. Japan	9.505
	R. Moscow	9.700††	R. Canada	9.655, 6.135
0145	R. Austria	9.770, 6.155	R. Sofia	9.700
	R. Bucharest	11.940, 9.570, 6.190, 5.990	R. Norway	9.645, 6.180 (Mon)
	R. Tirana	7.300, 7.070, 6.200 (7.300 may vary to 7.290, all times)	R. Portugal	11.935, 6.025 (Mon)
		11.715, 9.535, 6.120, 5.970	R. Moscow	See 0330 listings but delete 9.700, add 9.655, 5.940
	Swiss BC	15.260*, 11.750, 9.580, 9.510*, 7.325, 6.175*, 5.975		
	BBC	15.105	New Zealand BC	15.110
		11.935, 6.025	R. Peking	15.385, 15.060, 11.650, 9.640
	R. Japan	11.975 (weekdays)	R. Budapest	9.833, 7.220, 6.000
	R. Portugal	11.915, 9.560, 5.970 (weekdays)	RAI, Rome	7.265, 5.990
	R. Grenada	9.785, 9.700††, 9.665, 9.610, 7.440, 7.355, 7.205, 7.185, 7.150	R. Tirana	7.300, 5.945
R. Moscow	17.715, 15.060, 12.055, 11.945, 11.445	R. Bucharest	11.940, 9.570, 6.190, 5.990	
0200	R. Peking	11.925, 6.025	Swiss BC	11.715, 9.725
		6.165*** (weekdays)	R. Moscow	See 0400 listings
	Spanish Nat. R.	9.645, 6.180 (Mon.)	Deutsche Welle	9.545, 6.185, 6.075
	R. Nederland	17.795, 15.320, 11.970	BBC	11.750, 9.580, 9.510*, 6.050, 5.975
	R. Norway	6.135		
	R. Australia		Israel BA	12.000, 9.495, 9.009, 7.395
	R. Sweden		R. Japan	9.505

Time (GMT)	Station	Frequency (MHz)	Station	Frequency (MHz)
	R. Korea, Seoul	9.640	R. Japan	9.505
	R. Canada	9.655, 6.135	R. Sweden	17.710
	HCJB	11.915, 9.560, 5.970 (Tu, Th, Sat)	R. Finland	15.185
	R. Nederland	9.715***, 6.165*** (weekdays)	R. Tashkent	15.460, 15.115, 11.925, 11.730
	R. Moscow	17.775, 15.180, 15.140, 11.860, 11.690, 9.785, 9.735, 9.610, 9.580, 9.540, 7.260, 7.170, 7.150, 5.985, 11.915, 9.560, 5.970 (Wen, Fri)	1415 Trans-World Radio	15.255*** (Sun)
0515	HCJB		1450 Vatican Radio	11.825
	ORTF, Paris	11.735, 11.710, 9.710, 9.680, 7.135	1500 BBC	21.710, 17.840*, 17.790, 15.260, 15.070 (Radio Newsreel)
0530	R. Kuwait	15.345		9.505
	R. Moscow	See 0500 listings, but delete 17.775, 15.140, 11.860, 11.690, 11.890, 9.730	R. Japan	17.880, 15.115, 11.740 (weekdays)
0535	ETLF, Addis Abeba	9.765, 9.605†, 9.545, 6.145, 6.085†, 6.075	R. Bucharest	15.250, 11.940
	Deutsche Welle	15.185, 11.900, 7.255	R. Belgrade	15.240, 11.735
0600	V. of Nigeria	15.400*, 15.070, 11.750, 9.640, 9.600*, 9.580, 6.005*	R. Hanoi	7.038
	BBC	9.505	BBC	17.840*, 17.790, 15.070, 12.095
	R. Japan	11.860 (Mon)	R. Japan	9.505
	R. Norway	See 0530 listings, add 11.690, 7.300	R. RSA	15.155, 11.900
	R. Moscow	11.780, 9.540 (BBC News)	R. Norway	17.825, 15.175 (Sun)
0615	New Zealand BC	9.690	BBC	15.070, 12.095, 9.410
	RAE, Argentina	17.780, 15.220, 11.900	R. Japan	9.505
0630	R. RSA	9.525	R. Tahiti	15.170, 11.825 (except Sun)
	R. Havana	11.730*** (weekdays)	Vatican Radio	17.900, 15.210, 11.705
	R. Nederland	See 0600 listings	R. Kuwait	15.415
	R. Moscow	15.295, 11.900	BBC	15.070, 12.095, 9.410
	V. of Malaysia	9.530, 6.055 (Tu-Sat)	R. Canada	15.325, 11.865, 9.480, 5.930
0700	UN Radio	15.400*, 15.070, 11.750, 9.640, 9.600*, 9.580, 6.005*	R. Japan	9.505
	BBC	9.505	R. Finland	21.670, 18.275, 15.410 (weekdays)
	R. Japan	See 0600 listings	V. of Nigeria	15.210, 11.770
0707	UN Radio	9.520, 6.055 (Tu-Sat)	Vatican Radio	17.900, 15.210, 11.705
0715	R. Australia	9.570, 7.280	R. Belgrade	9.620
0745	UN Radio	9.520, 6.055 (Tu-Sat)	R. Japan	9.505
0800	BBC	15.070, 11.955, 11.860*, 9.640, 9.600*, 7.150	R. Algiers	17.745, 15.420 (both variable)
	R. Japan	9.505	R. Baghdad	9.745
	R. Moscow	See 0600 listings	BBC	15.400*, 15.260*, 15.195, 15.070, 11.750, 9.410
	UN Radio	9.520, 6.055 (Tu-Sat)		9.505
0815	V. of Malaysia	15.295, 11.900	R. Nederland	11.730††† (weekdays)
0845	UN Radio	9.565, 5.955 (Tu-Sat)	R. Belgrade	9.620
0900	BBC	15.400*, 15.070, 11.955, 9.640, 7.150	R. Ghana	11.850
	R. Canada	9.625, 5.970	V. of Iran	15.084, 6.022
	R. Japan	9.505	Israel BA	17.690, 15.490, 15.100, 12.025, 9.815, 9.495, 9.009, 7.395
	R. Korea, Seoul	15.335, 9.640		15.155
1000	R. Japan	9.505	2010 R. Havana	15.105 (weekdays)
	R. Pyongyang	12.075, 9.895, 7.405	2030 R. Grenada	15.105 (weekdays)
	R. Hanoi	15.012	2035 Vatican Radio	15.260, 11.740, 9.625
	UN Radio	9.650, 6.145	2045 ELWA, Monrovia	11.940
1040	V. of Chile	15.150, 9.590, 9.560, 6.190	R. Havana	17.705, 11.970
1100	BBC	15.070, 12.095, 11.905	R. Japan	9.505
	R. Japan	9.505	R. Canada	9.480, 5.930
	Vatican Radio	21.485, 17.840 (weekdays)	R. RSA	15.155, 11.900
	R. RSA	21.535, 15.220, 11.900	Swiss BC	15.430, 15.305, 11.870, 11.720
	R. Korea	15.335, 9.640	All India Radio	11.620, 9.912, 9.525
	R. Tirana	11.985, 9.500	R. Nederland	9.715, 5.965 (weekdays)
	V. of Indonesia	11.715 (varies)	BBC	15.260*, 15.195, 11.780, 11.750, 9.580, 9.410, 5.975
1115	R. Canada	11.825, 9.655, 5.970		15.105
1130	Israel BA	17.690, 15.130, 15.100, 12.025, 9.009	R. Norway	15.175 (Sun)
1145	Vatican Radio	21.485, 17.840 (weekdays)	R. Moscow	7.390
1200	R. Japan	9.505	R. Belgrade	9.620, 7.240, 6.100
	R. Tashkent	15.460, 15.115, 11.925, 11.730	R. Cairo	9.805
	R. Peking	11.685, 9.480, 8.260, 5.250, 4.130	All India Radio	11.620, 9.912, 9.525
1205	Trans-World Radio	11.815*** (Sat, Sun)	R. Canada	11.990, 9.480, 5.930
1220	R. Ulan Bator	17.780 (variable), 15.440, 8.990	RAI, Rome	11.905, 9.710, 5.990
1230	R. Australia	9.580	V. of Turkey	11.880
1245	Vatican Radio	21.485, 17.840 (weekdays)	V. of Chile	15.150, 9.590, 9.560
1300	BBC	21.710, 17.790, 15.070	R. RSA	15.155, 11.900, 9.695, 9.525
	R. Japan	9.505	R. Vilnius	11.980, 9.655, 9.530, 7.105 (may be changed) (Sat, Sun)
	R. Pyongyang	9.515		15.260*, 11.780, 11.750, 9.740†, 9.580, 9.510*, 7.325, 6.175†, 5.975
	R. RSA	21.535, 15.220, 11.900		15.105
	R. Hanoi	10.040	R. Japan	9.665, 7.440, 7.400, 7.355, 7.205, 7.185, 7.150, 7.105, 5.940
	Trans-World Radio	15.255***, 11.815*** (Sat)		See 2300 listings
1315	Swiss BC	21.520, 15.140	2330 R. Moscow	15.445, 15.270
1400	BBC	21.710, 17.840*, 17.790, 15.070 (Sat)	2345 R. Japan	

*Via Ascension
 **Via Tirana
 ***Via Bonaire
 †Via Sackville
 ††Via Sofia
 †††Via Madagascar
 ★Via Greenville

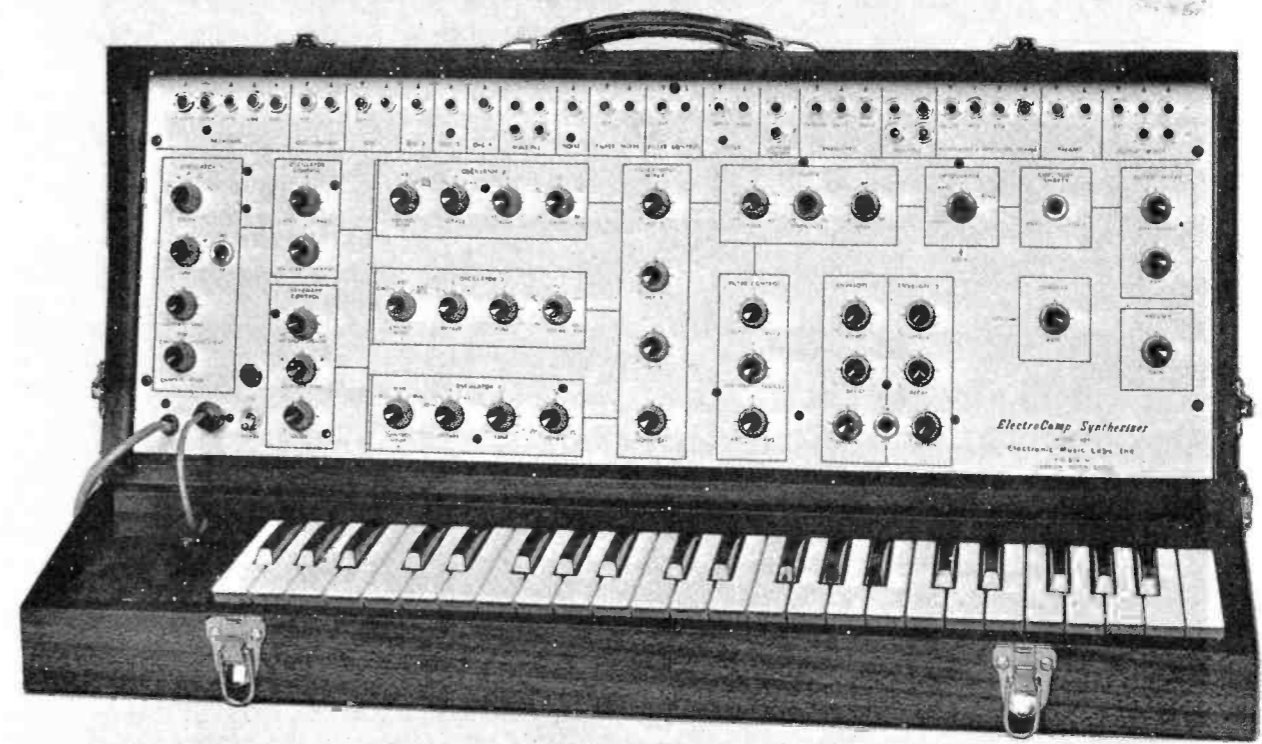

FOR ELECTRONIC MUSIC INSTRUMENTS PART 2

Gain-block IC, JFET, MOSFET, CMOS and digital keyers

By DON LANCASTER

LAST MONTH, Part I discussed what a keyer does and several different types of keyers and vca's used in electronic musical instruments. We continue here with descriptions of other types of keyers, including the digital variety.

First, the output is a bilateral current coming from a very high impedance source. Second, the internal current gain is linearly variable from zero up

by controlling the current fed into pin 5 of the IC. Zero current provides zero gain, while +100 μA provides a maximum useful gain.

A Special Gain Block. The CA3080 is a special, inexpensive gain-block IC made by RCA. It can serve either as a voltage-controlled amplifier (vca) or as a two-quadrant multiplier, making it almost ideal for use in electronic musical instruments.

A typical circuit in which the CA3080 is used is shown in Fig. 1. While the IC looks like an ordinary operational amplifier (the connections are about the same as for the 741 op amp, in fact), there are some important differences.

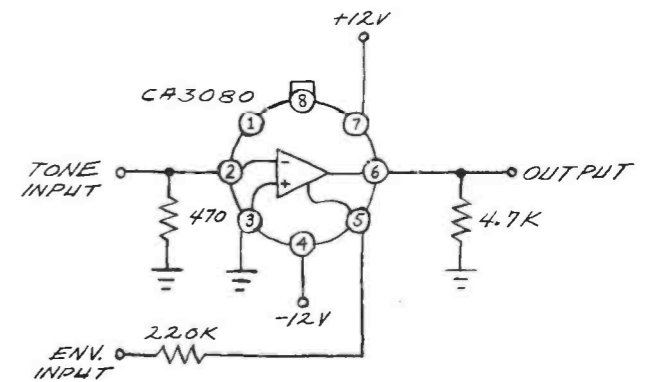

Fig. 1. The CA3080 gain-block IC used as a vca. Cost of unit in large quantities is about 50 cents.

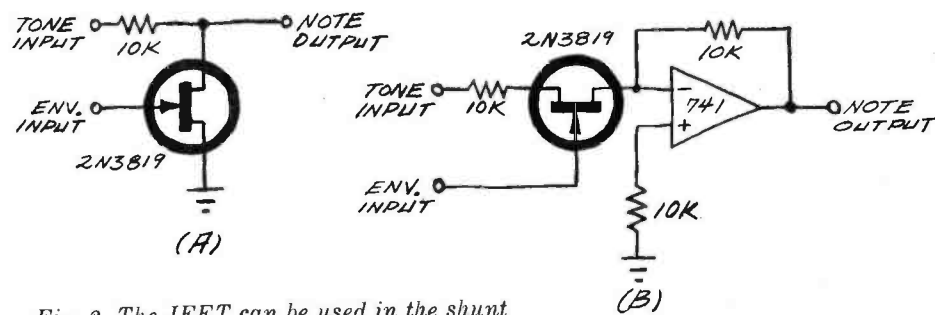

Fig. 2. The JFET can be used in the shunt mode (A) or the series mode (B).

There are two inputs to the IC, inverting (-) and noninverting (+). The IC amplifies the difference voltage on these inputs and converts it to an output current. When an output load resistor is put into the circuit as shown, the output current is converted to an output voltage. Therefore, the overall voltage gain is set by the load resistor and the control current fed into pin 5.

There are three important things to remember when using the CA3080: (1) always keep input signal levels below 100 mV to prevent distortion and clip-

ping; (2) always current-limit the input to pin 5 with not less than 100,000 ohms; (3) the voltage gain obtained depends on the output load resistor.

more and more negative, the equivalent resistance increases until the cutoff voltage is reached, at which point the JFET acts as an open circuit. A JFET must be used in a shunt mode (Fig. 2A), or the signal into the virtual ground of an operational amplifier in the series mode (Fig. 2B) must be summed to keep the control or envelope voltage from appearing at the output.

The input impedance on the control line is very high because a reverse-biased diode is being driven as an

input. One problem is that the cutoff voltage varies quite a bit from one JFET to another. Thus, it may be necessary to adjust the envelope amplitude and off level to suit the particular JFET in use.

The MOSFET. Enhancement-mode MOS (metal-oxide silicon) FET's with insulated gates can also be used as variable resistors. MOSFET's cost a bit more than conventional JFET's, but they have a number of distinct advantages.

Shown in Fig. 3 are typical circuits in which the 2N4351 MOSFET is used in the shunt (A) and series (B) modes. If the substrate lead is permitted to float and the two-resistor feedback network is used exactly as shown, the circuits can be operated with up to 10 volts of peak-to-peak audio signal.

A voltage must be applied to the gate of a MOSFET to drive the device (unlike the depletion-mode JFET that requires that a voltage be removed from the gate to turn it off). This permits the use of positive envelope and control voltages.

The MOSFET remains cut off until the envelope input signal reaches +4 volts or so. Between +4 and +8 volts, control of gain and resistance is more or less linear. Any potential beyond +8 volts or so does not significantly change the resistance.

The input impedance to the MOSFET is essentially infinite on the envelope line. However, the feedback resistors reduce the impedance to about 6 megohms, a value low enough to permit the use of small capacitors in the envelope shaping circuitry. At \$2

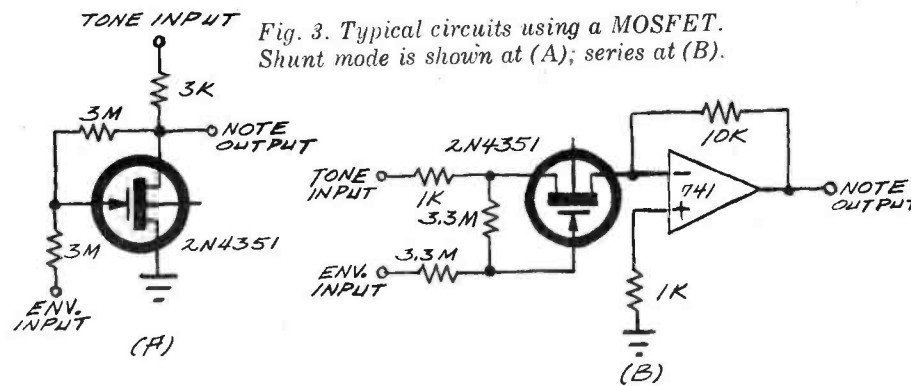

Fig. 3. Typical circuits using a MOSFET. Shunt mode is shown at (A); series at (B).

ping; (2) always current-limit the input to pin 5 with not less than 100,000 ohms; (3) the voltage gain obtained depends on the output load resistor.

The JFET. The junction field effect transistor (JFET) can serve as a small-signal, electrically variable resistor. JFET's are low in cost. Texas Instruments' 2N3819 is a typical example of such devices. Also, there is a wide variety of custom JFET's for variable-resistance applications, with Siliconix offering several devices and some good application notes.

The ac input signal to a JFET must be kept very low in amplitude, preferably less than 10 mV peak-to-peak. Grounding the gate input of an n-channel JFET causes the device to conduct heavily. As the gate is made

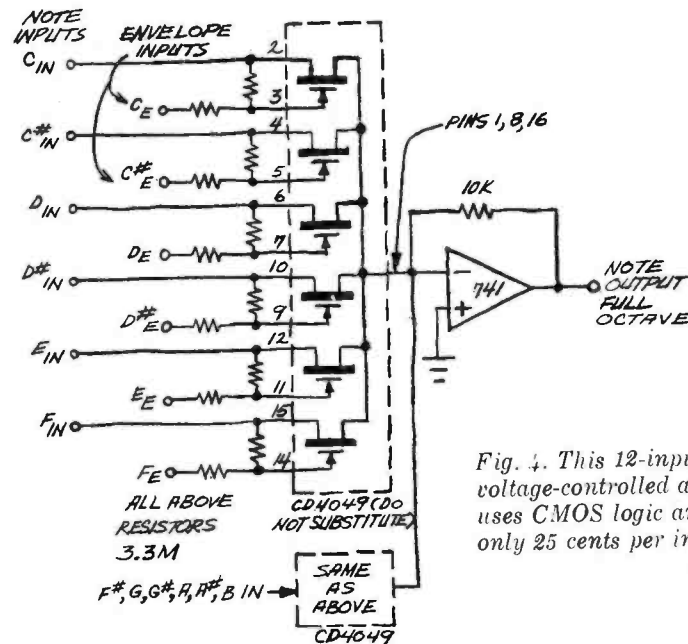

Fig. 4. This 12-input voltage-controlled amplifier uses CMOS logic and costs only 25 cents per input.

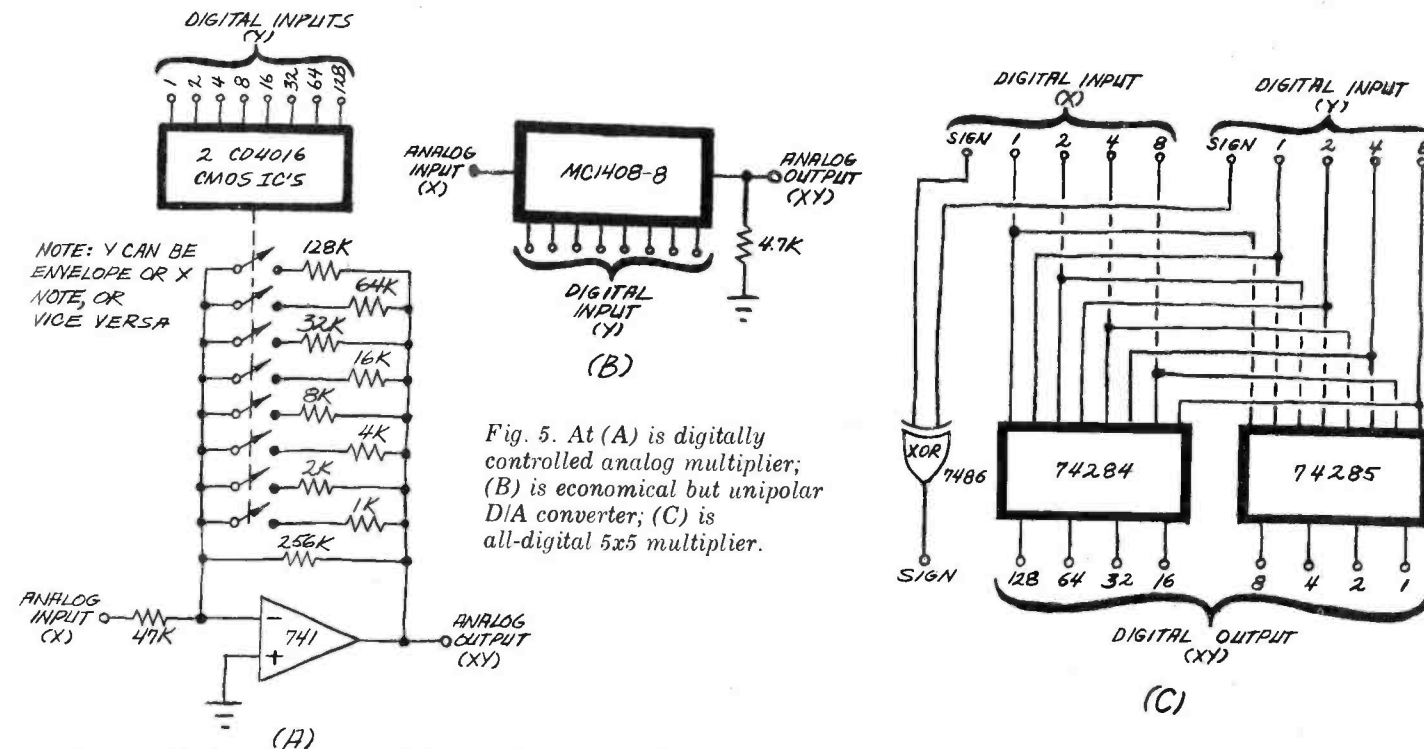

Fig. 5. At (A) is digitally controlled analog multiplier; (B) is economical but unipolar D/A converter; (C) is all-digital 5x5 multiplier.

or so per device, the MOSFET technique can be economically used on smaller polyphonic instruments.

The CMOS Technique. There are many games you can play with the CMOS digital-logic family of devices, especially the industry standard CD4000 series. One obvious thing to do is to bias a hex inverter to obtain six n-channel MOSFET's, yielding six keyers in a \$1 or \$2 package. The resultant unit keyer cost will then be 15c to 30c, which is the pricing you must aim for when considering a fully polyphonic keying system on a large but reasonably priced instrument.

The only catch to the above is that ordinary CMOS hex inverters contain input-protection diodes that make this essentially impossible. But the new RCA CD4049 or Motorola MC14049 IC's eliminate the problem. The circuit for using these new IC's is shown in Fig. 4. It is simply the circuit shown in Fig. 3 repeated 12 times for a full octave's worth of keying (12 notes), accomplished with three low-cost integrated circuits.

The signals must be limited to very low levels at the note inputs, preferably to between 50 and 100 mV rms from a 400-ohm source. Thanks to the operational amplifier, the output impedance from the system is low. The output signal level is 2 volts peak-to-peak. The resistors provide a linearizing effect. Depending on your system, however, you may be able to eliminate the resistors. It all depends on the dis-

tortion permissible at this point in your system. Since each keyer works on only one note, distortion changes the harmonic structure of only the one note and does not intermodulate.

The most important advantages of the CMOS keying approach include very simple circuit design, low parts cost and, electronically, very high impedance on the envelope input lines. (A fully custom version of the Fig. 4 circuit technique is used by one major electronic organ manufacturer.)

While you are looking at CMOS devices, check out the quadrature analog gate CD4016 IC. It cannot be used in a variable-gain mode, but it is great for on/off control of electronic music signals. Even in single-quantity prices, it costs only about 25¢ per channel.

Going Digital. So far, only analog keying and control techniques have been described. Digital techniques can also be used in electronic music. You will be seeing more EM digital circuitry in the future. Let us take a brief look at some of the possibilities:

In Fig. 5A, eight stages of CD4016 CMOS IC switching are used to set the gain of an operational amplifier to one part in 256. The gain can be set to any of 256 discrete values that are close enough that they appear to continuously change in amplitude.

The tone signal is fed to the input of the operational amplifier, and envelope information is derived from a mask or a digital memory. The mem-

ory can be in the form of a permanent store, program card, or programmable information store. One benefit of this approach is the ability to generate any envelope you want, including impossible with conventional acoustical instruments. Precision resistors are required for this particular circuit.

In Fig. 5B, all switching is accomplished inside the Motorola MC1408P-8 IC. An analog input current and a digital word are applied to the inputs. The output current is a ratio of the input current from zero to full value in one of 256 discrete steps. This circuit is also useful for changing a digital to an analog envelope waveform, or for converting digital timbre information into an equivalent analog waveshape. One limitation of the device is that the input current must be single-directional with respect to ground; so, an MC1408P-8 cannot be used directly for keying operations.

In Fig. 5C is a 5-bit by 5-bit (5X5) digital multiplier that provides a digital word as the product of an input envelope word and an input tone word. The five bits are derived from a pair of 4X4 multipliers and an exclusive-OR gate to take care of the sign bits. Though we would like to see more bits than this, the cost rises considerably if you shoot for greater accuracy.

There you have the keying and vca techniques commonly used in electronic musical instruments. Good luck in applying these to your own instrument designs.

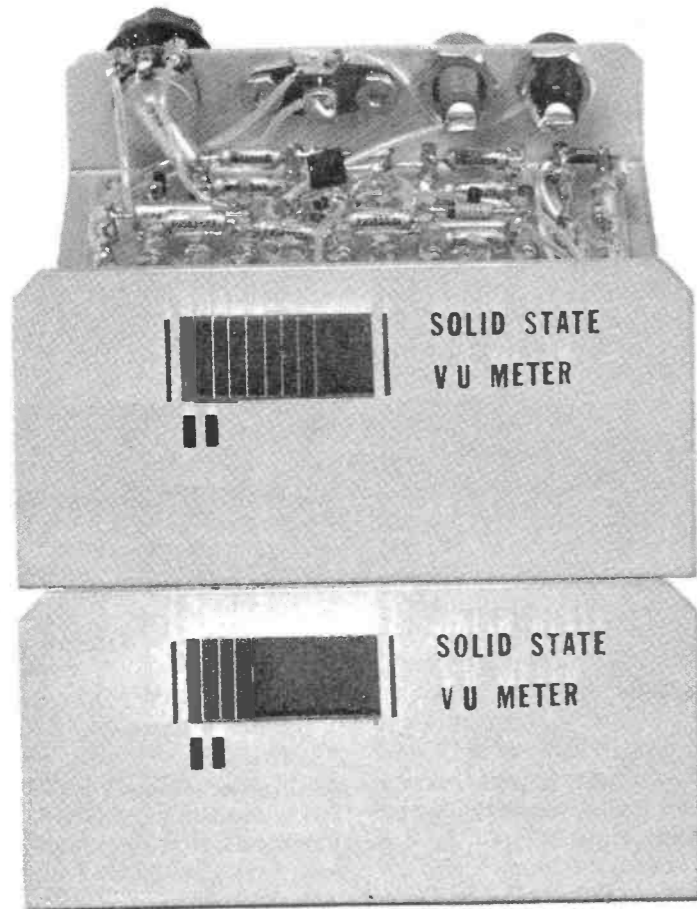

CONSTRUCTION

New bar-graph device provides signal-strength readouts, accurate peak signals

BY TERRY L. MAYHUGH

VU METERS cannot accurately read out momentary peaks due to meter-movement inertia. For example, the ballistics of a professional VU meter is standardized so that about 0.30 second is required before a steady-state reading is reached. Obviously, this is too slow to register the fast peaks that occur in music. A peak-responding LED is sometimes used to indicate the presence of such transients.

Here is a "VU" meter that combines the features of a standard VU and the peak indicator. It is a meter with no moving elements. The all-solid-state circuit is designed around a new incandescent bar indicator that instantaneously shows relative signal strength, including sharp peaks, over

a wide dynamic range.

The readout element resembles a conventional DIP IC (in shape) and displays up to ten discrete signal levels on parallel filaments. In this case, it has a dynamic range of 30 dB, with each sequential filament illuminating fully at 3 dB over the preceding one. The tenth filament (the final 3dB) is the peak signal indicator.

Circuit Operation. As shown in Fig. 1, potentiometer *R1* sets the level of the audio input to a precision full-wave rectifier that uses both halves of *IC1*. The rectified output is coupled to 10 parallel voltage comparators in *IC2*, *IC3*, and *IC4*.

Each of the 10 filaments in the display operates at 5 volts and 10 mA. The

first nine are driven directly by the comparators. The tenth is controlled by a one-shot multivibrator (*IC5*) to indicate the peaks.

Two other comparators in *IC2* are used as voltage regulators to supply a reference voltage. A third regulator made up of *D3* and *Q1* supplies the higher current required for the display filaments.

The resistor network made up of *R24* through *R42* is arranged as an R-2R ladder that allows a precision voltage divider to be constructed using only two different values of precision resistors. The consecutive reference voltages for the noninverting inputs of the comparators are selected to increase in 3-dB steps from the low end to the high end of the range. As the rectified audio voltage to each comparator's inverting (-) input reaches that of the associated noninverting (+) input, the comparator switches to turn on its associated display filament. Thus, the number of filaments turned on (illuminated) at any instant is determined by the level of the audio input.

Construction. The circuit can be assembled on a pc board or a perforated board. All of the components except for the power supply and the display can be on the board. Sockets should be used for the IC's.

When laying out the board, be sure that wires carrying the comparator outputs and inputs are not too close to each other to avoid oscillation. Since the output pins of the comparators are at one end of the package, there should be no problem in getting a satisfactory layout. The +*V_{cc}* pin of each IC should be bypassed to ground by a 0.1- μ F disc capacitor mounted as close to the pin as possible.

Output indicator *DIS1* and its socket are cemented in a suitable rectangular cutout on the front panel. Since the incandescent filaments emit a white light, a filter of almost any color can be used in front of the display. In the prototype, a green filter was used.

Any power supply delivering 12 volts at 200 mA can be used.

Diode *D3* must be selected by trial and error. First, tack-solder a standard 1N914 into the circuit. Apply an input audio signal of about 1 or 2 volts rms to *J1* and adjust *R1* until all 10 segments are lit. All 10 segments should be bright, but there is a possibility that the first nine may not have equal brightness due to different current-sinking capabilities of the com-

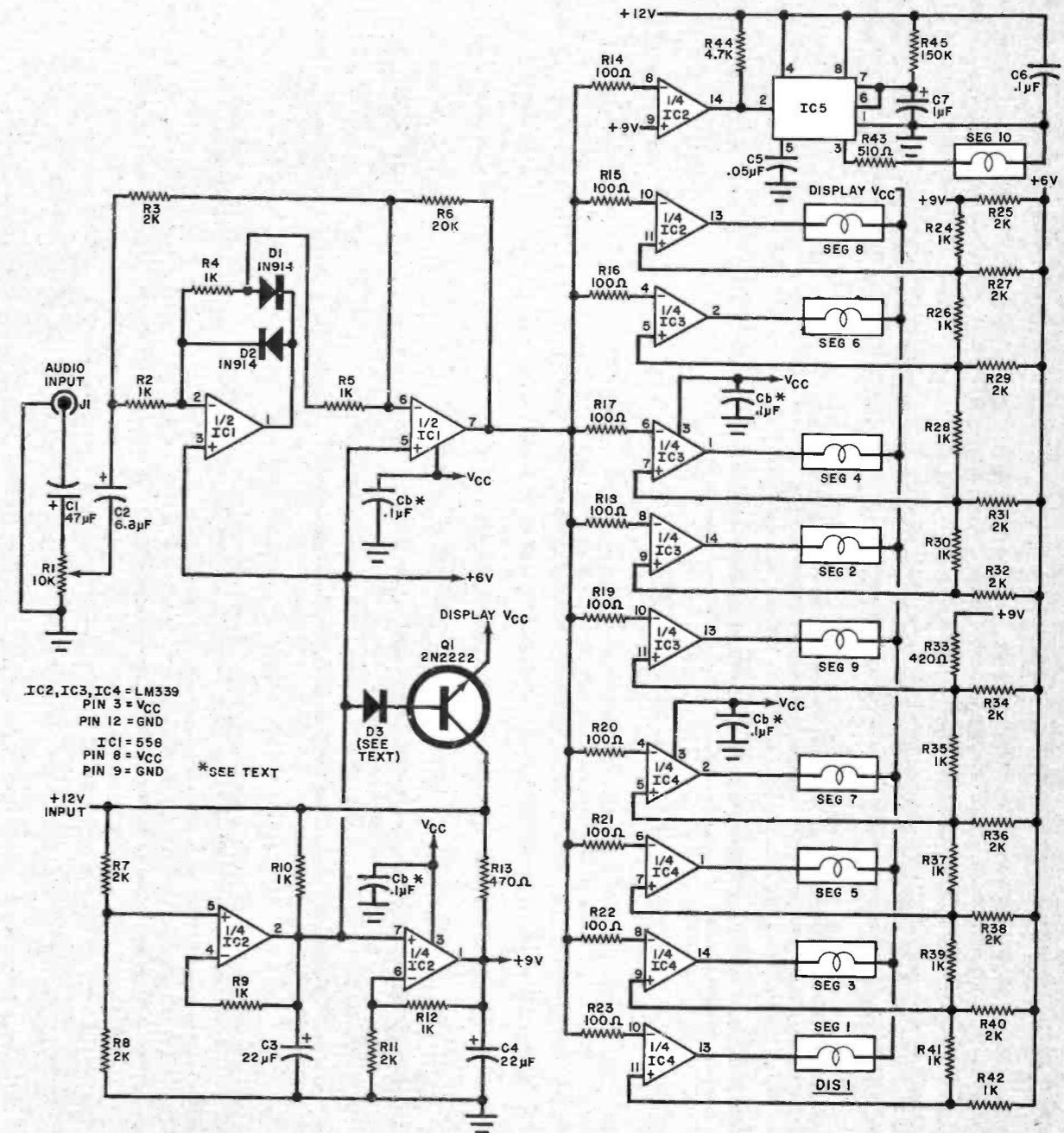

Fig. 1. The audio signal is rectified and applied to sequential comparators, which turn on filaments in display.

PARTS LIST

(Two of each needed for stereo)
 C1—47- μ F tantalum capacitor
 C2—6.8- μ F tantalum capacitor
 C3, C4—22- μ F tantalum capacitor
 C5—0.05- μ F ceramic capacitor
 C6—0.1- μ F ceramic capacitor
 C7—1- μ F tantalum capacitor
 D1, D2—1N914 diode
 D3—See text
 DIS1—Bar indicator light (see note)
 IC1—558 dual op amp
 IC2, IC3, IC4—LM339 quadruple comparator (National)
 IC5—555 timer
 J1—Phono connector
 Q1—2N2222 transistor (or similar)
 R1—10,000-ohm potentiometer
 R2, R4, R5, R9, R12, R26, R28, R30, R32,

R35, R37, R39, R41, R42—1000-ohm, 1% resistor
 R3, R7, R8, R11, R25, R27, R29, R31, R34, R36, R38, R40—2000-ohm, 1% resistor
 R6—20,000-ohm, 5% resistor
 R10—1000-ohm, 5% resistor
 R13—470-ohm, 5% resistor
 R14 to R23—100-ohm, 5% resistor
 R33—420-ohm, 1% resistor
 R43—510-ohm, 5% resistor
 R44—4700-ohm, 5% resistor
 R45—150,000-ohm, 5% resistor
 Misc.—IC sockets (6), transparent filter, cement, mounting hardware, power supply.
 Note—Bar indicator (3015Q) is available from Readouts, Inc., Box 149, Del Mar, CA 92014, for \$4.25, plus postage.

parators. If there is a noticeable difference in segment brightness, use two diodes in series for *D3*. Recheck the brightness. At least one diode must be used for *D3*; but as many as three (connected in series) may be used to get the desired brightness.

Use. Since the meter has a relatively high input impedance, it can be connected directly across the speaker terminals of any audio amplifier. In fact, two meters can be used for stereo balance tests.

Adjust potentiometer *R1* so that the last segment flickers on the required audio peaks.

POWER SURGES AND SEMICONDUCTORS

BY LESLIE SOLOMON
Technical Editor

MOST repair problems on electronic equipment can be traced to failures of parts due to simple things like overheating, vibration, or even sheer carelessness—as when a screwdriver gets stuck in the wrong place. These faults are relatively easy to locate and correct; but sometimes (particularly when semiconductors are involved) we hit a real "puzzlement." These problems can't be solved even with the aid of the most sophisticated test gear.

In such cases, the problem is; though semiconductors have no known wear-out mechanism when operated within specified limits, how can they suddenly fail catastrophically? How can a piece of equipment containing all the correct components, with a well-regulated power supply and proper voltages, suddenly drop dead? It can happen anywhere, even in mobile equipment located far from an ac power line.

Line Surges. The answers to some of these questions were provided in a recent paper written by engineers at General Electric. Their findings are worth bearing in mind.

In monitoring the power lines of about 400 locations in 20 cities, these engineers found some astoundingly high voltage surges. A few were as high as 2500 or even 5600 volts and in six locations, there were surges over 1200 volts more than once a day. These were not prolonged peaks, of course, but extremely short transients that suddenly appeared on the power line.

What causes these sudden surges? In some cases, they have been traced to the operation of an oil burner, a fluorescent lamp bank, a pump motor, a refrigerator, etc. In other cases, no amount of deliberate load switching could produce the transients. Some surges were traced to local lightning storms. (Film recordings, made on oscilloscopes, showed distinct oscillatory characteristics of approximately 300 kHz. This suggests shock oscillation of the home power system.)

The question of the amount of

energy involved in the surge is related to the impedance of the system, which usually falls in the range of 100 to 300 ohms for a branch circuit. This means that, in a typical home, the impedance at the common service entrance could be about 5 to 10 ohms. However, this low value exists only for a small fraction of a microsecond of pulse travel time. Connected loads have a lower impedance than a branch circuit and will be dependent on frequency where inductive components are present. These loads will absorb part of the energy, thus lowering the peaks. Electric motors and transformers have substantial insulation, which may account for their rare failures. Defective wiring practices may cause flashover, without the 60-Hz power follow.

Other Types of Surges. High-voltage surges also spring from other than power-line sources. For example, take the simple case of an on-off switch in the primary circuit of a transformer. If the transformer is suddenly energized, or de-energized, at the peak of the input power waveform, a transient of approximately twice the normal peak voltage of the secondary can occur. If there is any contact bouncing when energizing the transformer, much higher transients may occur. These transient voltages are due to the interruption of the magnetizing current. Transients in excess of 10 times the normal voltage have been observed across rectifiers if there is no load on the system. Unless a low-impedance path is provided, this can be generated across the load. If the rectifiers have insufficient PRV ratings, they can be destroyed.

If there is any inductance in a power-supply circuit (such as a choke), interrupting the power line can produce transients as the magnetic field collapses. It is also possible to get large transient voltages on the dc side of the rectifier as opening the dc load circuit can produce an amount of energy proportional to the stored energy of the ac line and transformer. This is greatest when the dc circuit is opened with a high current flowing.

The stored energy in the ac circuit is the source of the destructive energy as the dc stored energy is dissipated through the forward path of the rectifiers. If high-current rectifiers are used, a higher dc current will flow in the load circuit; and if this is suddenly interrupted, large transients can be generated.

Keep in mind that these sudden transients may be many times larger than the maximum peak voltages of the various semiconductor junctions. Also keep in mind that semiconductors are not like vacuum tubes that can tolerate some overvoltage without sustaining permanent damage. A fast peak, that may occur only once, may be enough to blast a semiconductor junction out of existence, yet not damage any other parts. That is why, in some inoperable circuits, all components except the semiconductors, are in good condition. This is also one reason diode protection is found in some signal circuits. The diodes allow up to 0.5 V to pass, yet look like shorts when the voltage exceeds this value.

Mobile Equipment. Consider a whip antenna mounted on a fast-moving vehicle in dry air. Think of the amount of static voltage being built up on the antenna. Couple this with the possibility of lightning-produced charges in the air. Or consider what happens if the car passes under a high-tension line just as a large transient goes down the line. To protect mobile equipment, a neon lamp can be connected between the antenna and ground to act as a "short" when the static voltage exceeds a certain value. An r-f choke can also be connected between the antenna and ground to act as a short to the static voltage, yet present a high impedance to received signals.

As for power-line transients in the home or shop, it is pretty difficult to turn a power supply on or off exactly at the zero crossing. One solution is to use one of the transient suppressors now being offered by a number of manufacturers. These can be found in the pages of most of the larger electronics catalogs. ♦

POPULAR ELECTRONICS

FOR THE person who likes a challenge, the spirit of friendly competition, and tinkering in electronics, here is a new electronic game to build. It's called "Tug-of-War."

When the START button is pressed, the middle light in a chain of nine LED's lights up. At approximately five-second intervals, a GO LED blinks on for a moment. Each player has a pushbutton which he operates to try to "pull" the illuminated LED over to his side. This is accomplished by being the first one to push the PLAYER button after the GO light comes on. However, there is a catch. If a player pushes his button before the GO light, the lit LED will advance one position toward the opponent's end.

BY ROBERT C. FROSTHOLM AND ROGER LUNDEGARD
Signetics Corp.

TUG-OF-WAR

When one player succeeds in advancing the lit LED all the way to his end, the WINNER light comes on and the game is over. A new game can be started by pushing the START button. You can also add a circuit and speaker to give an audible signal indicating who won the game.

Circuit Operation. The project uses a total of 10 timing circuits (built around three dual 555 timers), an up-down counter, and some logic gates. As shown in Fig. 1, IC1A is a clock oscillator that generates a pulse approximately every five seconds. The timing is determined by R1, R2, and C1. During the short period of time

Built around popular 555 timer devices, this electronic game project will challenge your reflexes.

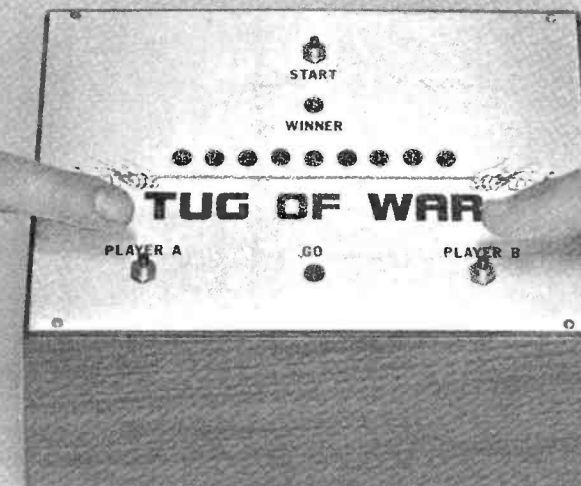

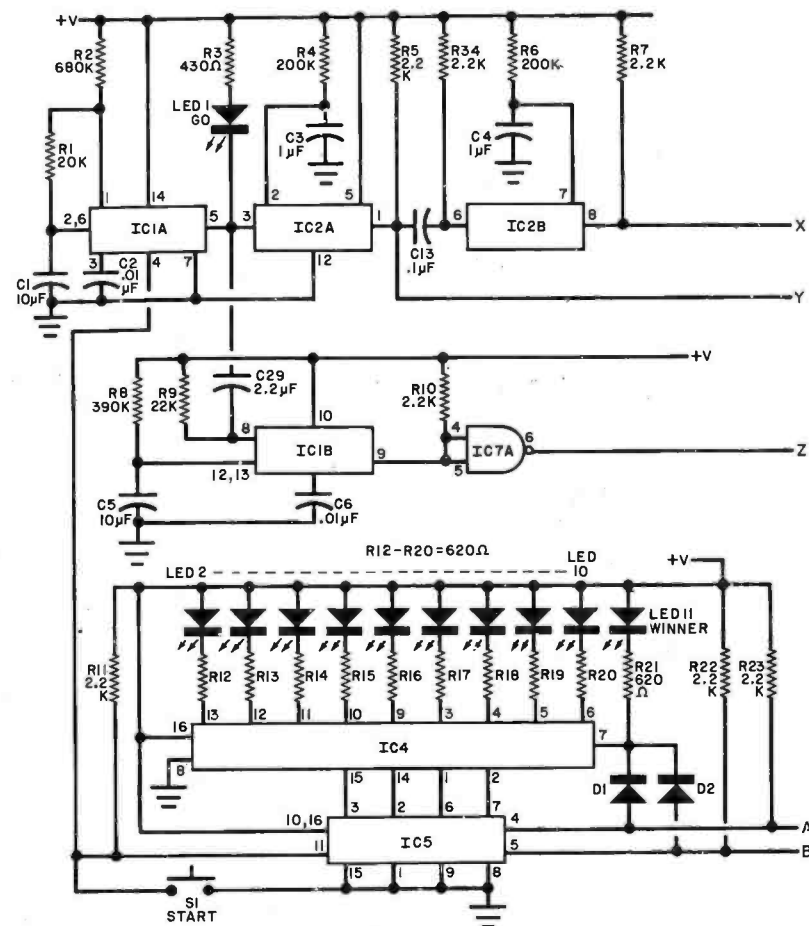

Fig. 1. Clock oscillator IC1A drives IC2A and IC2B to generate two successive gate intervals. Output of IC1B is 4.3-s pulse, inverted to a 0.7-s pulse by IC7A. Up/down counter (IC5) and BCD-to-decimal circuit (IC4) drive LED's.

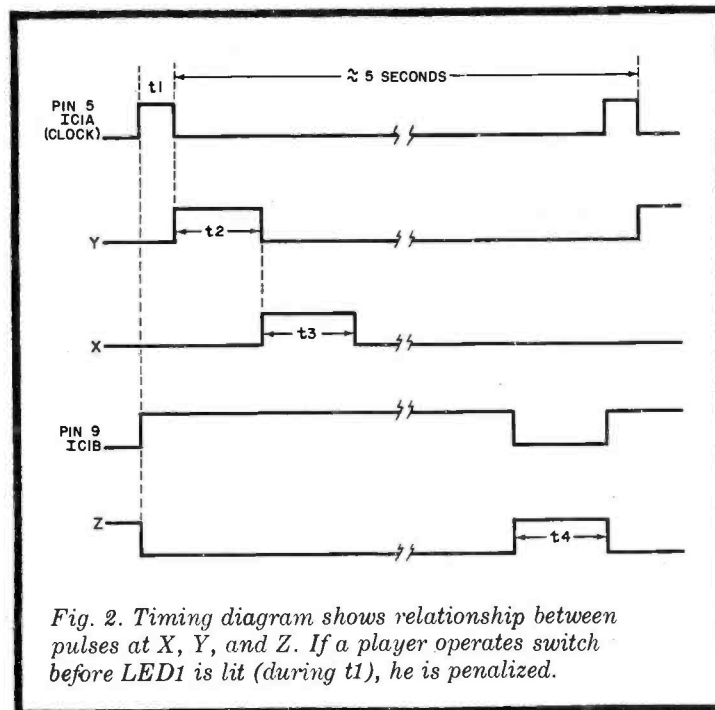

Fig. 2. Timing diagram shows relationship between pulses at X, Y, and Z. If a player operates switch before LED1 is lit (during t1), he is penalized.

PARTS LIST

- C1, C5—10- μ F electrolytic capacitor
 C2, C6, C17, C19 to C23—0.01- μ F capacitor
 C3, C4, C8, C11—1- μ F electrolytic capacitor
 C7, C10, C13, C14, C15, C16, C27, C28—0.1- μ F capacitor
 C9, C12—0.001- μ F capacitor
 C18—Not used.
 C24, C25, C26—47- μ F, 15-volt electrolytic capacitor
 C29—2.2- μ F electrolytic capacitor
 C30—500-1000 μ F, 15-volt electrolytic capacitor
 D1 to D8—1N914 diode
 D9 to D12—1N2071 diode
 IC1, IC8, IC9—556A dual timer (Signetics)
 IC2—553B quadruple timer (Signetics)
 IC3, IC7—7400 quadruple NAND
 IC4—8251B BCD-to-decimal (Signetics)
 IC5—74192 up/down counter
 IC6—8241A quadruple exclusive OR (Signetics)
 IC10—LM309DB 5-volt regulator (Signetics)
 LED1, LED11—Green MV5253 (Monsanto)
 LED2 to LED10—Red MV5053 (Monsanto)
 R1—20,000-ohm, 1/4-watt 10% resistor
 R2—680,000-ohm, 1/4-watt 10% resistor
 R3—430-ohm, 1/4-watt, 10% resistor
 R4, R6—200,000-ohm, 1/4-watt 10% resistor
 R5, R7, R10, R11, R22, R23, R27, R32, R34—2200-ohm, 1/4-watt 10% resistor
 R8—390,000-ohm, 1/4-watt 10% resistor
 R9, R25, R30—22,000-ohm, 1/4-watt 10% resistor
 R12 to R21—620-ohm, 1/4-watt 10% resistor
 R24, R29—2700-ohm, 1/4-watt 10% resistor
 R26, R31, R38, R40—2000-ohm, 1/4-watt 10% resistor
 R28, R33—510-ohm, 1/4-watt 10% resistor
 R35, R36—130,000-ohm, 1/4-watt 10% resistor
 R37—75,000-ohm, 1/4-watt 10% resistor
 R39—120,000-ohm, 1/4-watt 10% resistor
 S1, S2, S3—Spst temporary-contact push-button switch
 Spkr—8-ohm speaker
 T1—6.3-volt filament transformer (Triad F-14X or similar)
 Misc.—Suitable Cabinet, line cord, rubber grommets (11), press-type, mounting hardware, IC sockets (9), clip-on heat sink for IC10, solder, wire, etc.
 Note—The following are available from Four Seasons Mfg. Corp., 1071 Peninsular, Los Altos, CA 94022: IC package containing IC1 through IC10 for \$24; etched and drilled pc board (TW202) for \$6.95; wood case with metal top plate screened and drilled (TW206) for \$9.95. California residents add sales tax. All prices include shipping in U.S. only.

that this oscillator "sinks" current, LED1 is turned on. The pulse also triggers IC2A and IC1B. The former is a one-shot multivibrator whose "on" time is determined by R4 and C3. Since this timer is edge-triggered and the state of the trigger has no effect on the output pulse, IC2A can be coupled to IC2B to provide a second pulse of equal duration (determined by R6 and C4). The outputs at points X and Y are sequential pulses of equal duration.

When IC1B is triggered, it produces a one-shot output pulse of about 4.3 seconds, determined by R8 and C5. This pulse is inverted by IC7A to produce a pulse of about 0.7 second duration just prior to each clock pulse. The pulse at point Z is used to penalize the player who attempts to anticipate the clock and jumps the gun. The timing diagram in Fig. 2 shows the sequence of events.

The circuitry for the players is shown in Fig. 3. The two circuits are identical except that their outputs are reversed to enable one to drive an up/down counter (IC5 in Fig. 1) in one direction and vice versa. The players' positions are keyed around one-shots (IC2C and IC2D).

To see how the circuits work, assume player B does not touch his button when the go light comes on or that player A is very fast and is able to press his button during time period t2 (Fig. 2). Then the pulse generated by IC2C is applied to an AND gate with the pulse from point Y. Two exclusive OR gates (IC6A and IC6B) act as a frequency doubler and provide two pulses at point A, which are applied to pin 4 of IC5. This causes IC5 to count down two steps. The BCD-to-decimal decoder (IC4) takes the output of IC5 and causes the lit LED to move two positions toward the A end.

If player A is not quite as fast and pushes his button during period t3, the output of IC2C and the pulse at

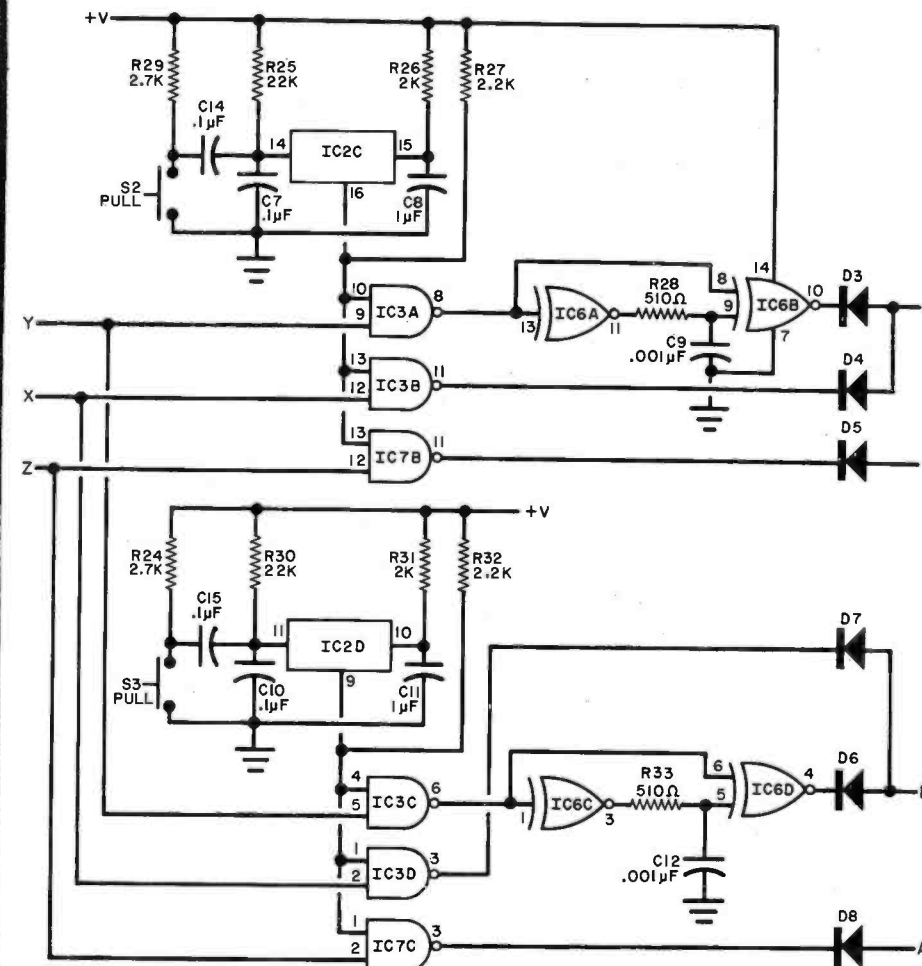

Fig. 3. Player circuits are identical. Outputs of one-shot circuits are compared with timing pulses on X, Y and Z.

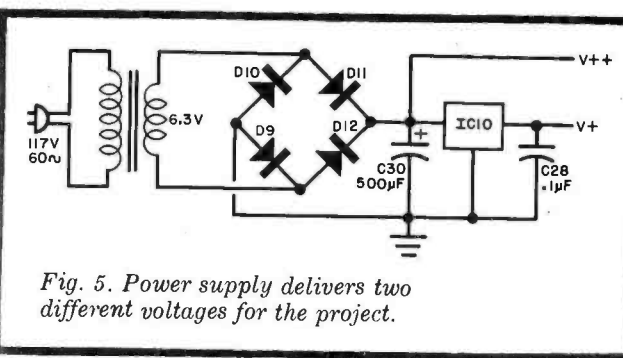

Fig. 5. Power supply delivers two different voltages for the project.

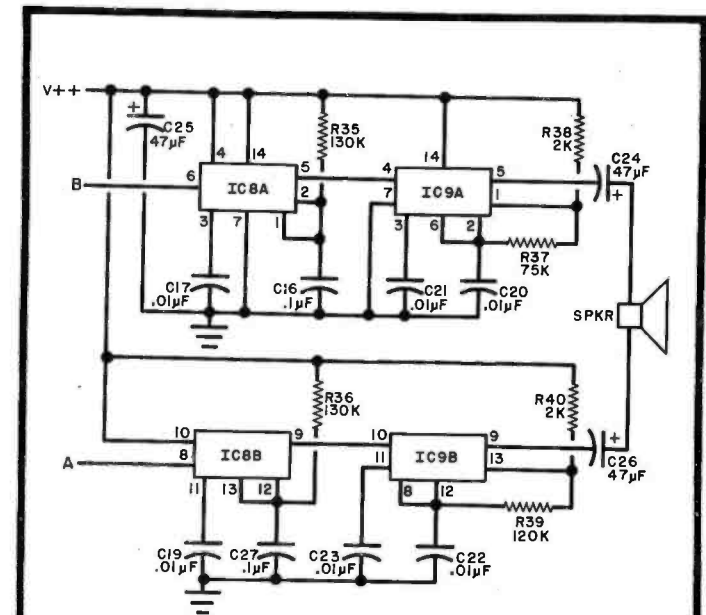
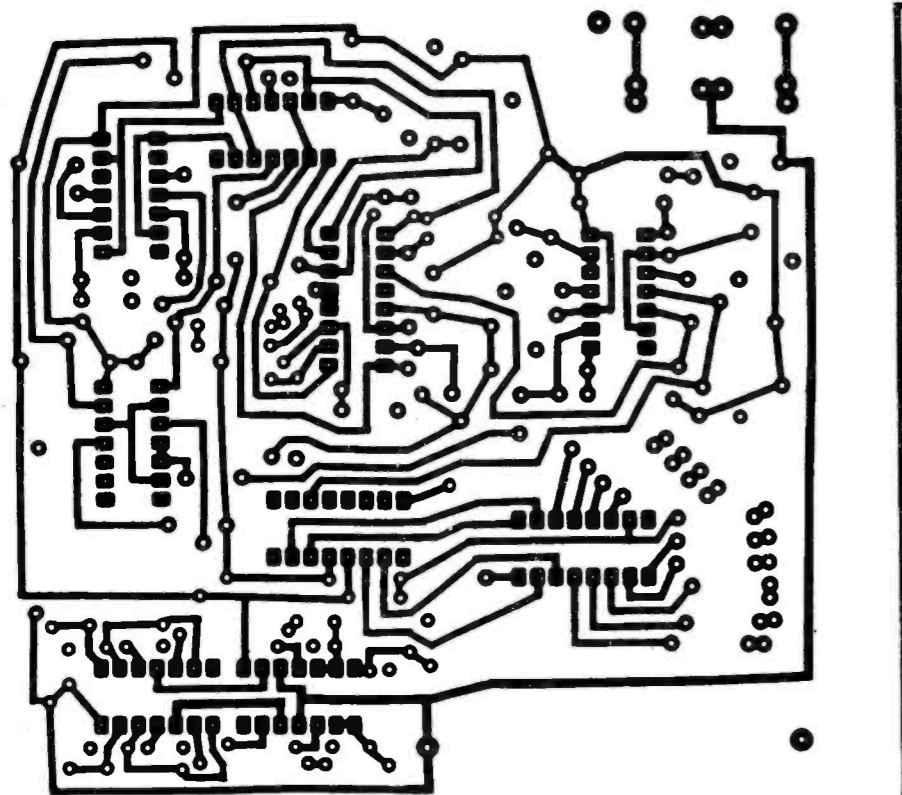
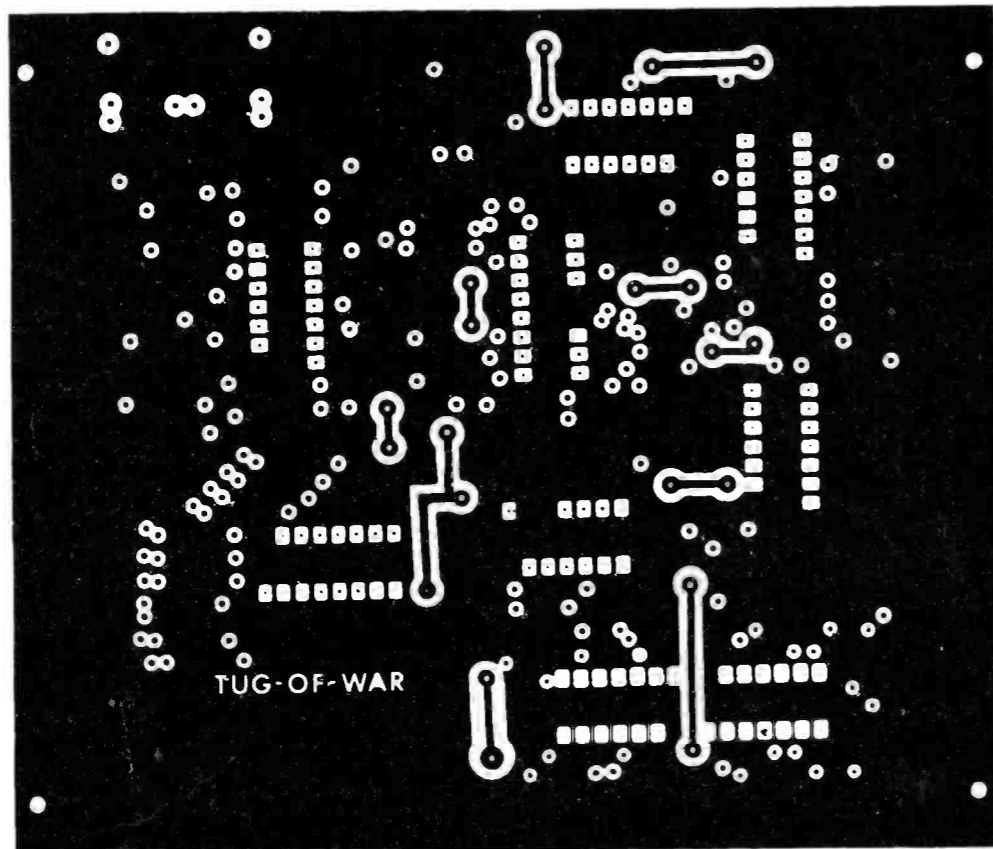

Fig. 4. Optional sound-output circuit is two gated tone-burst generators, each having a different frequency to create separate sounds for players.

Fig. 6. Foil patterns for the double-sided pc board are shown at right and below.



both players press their buttons at the same time, the signals cancel each other. After playing the game for some time, the players' reflexes will appear to have improved to the point where the game becomes a standoff. In this event, reduce the values of $R4$ and $R6$ to shorten $t2$ and $t3$. Resistors $R26$ and $R31$ should be reduced by the same percentage as $R4$ and $R6$ to reduce the possibility of confusion in the AND gates, since the pulses at X and Y will be much shorter.

When one player has moved the lit LED to his end, $LED11$ is lit and diodes $D1$ and $D2$ prevent any further action until the START button is operated.

The game can be made more exciting by adding a circuit to provide an audible indication of which player has won. The circuit is shown in Fig. 4. Tone bursts are generated by $IC8$ and $IC9$. Each half of $IC8$ acts as a one-shot which determines how long the associated half of $IC9$ is activated. The two halves of $IC9$ are oscillators with outputs of different frequencies. When a player wins a game, the signal at A or B causes the appropriate circuit to provide a sound through the loudspeaker.

The simple power supply shown in Fig. 5 can be used for the Tug-of-War.

point X are applied to AND gate $IC3B$. Then only one pulse appears at point A, and the lit LED advances only one position toward A.

When player A tries to anticipate the GO light and presses his button too

soon, the pulses from $IC2C$ and point Z are applied to AND gate $IC7B$ and the output at point B causes the counter to go in the other direction.

The circuit for player B operates in the same way as that for player A. If

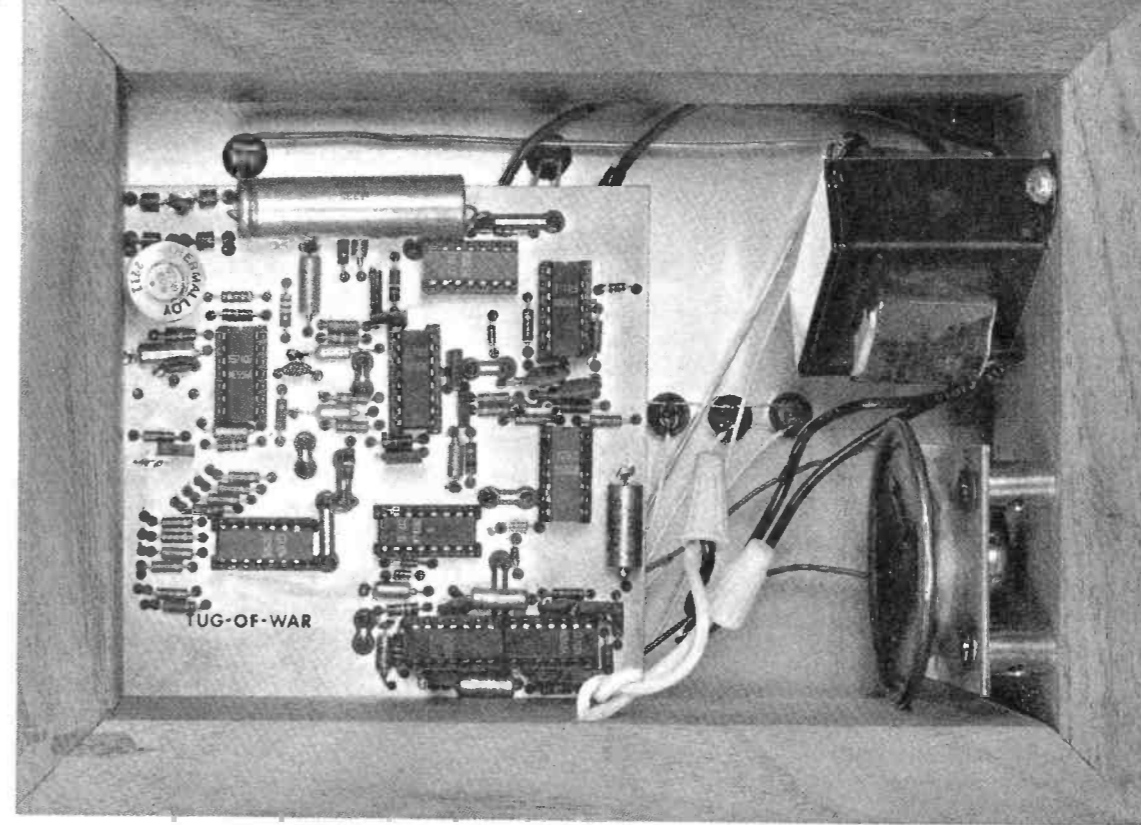

Photograph of interior of the Tug-Of-War shows mounting of printed circuit board with power supply transformer and optional speaker for sound at right.

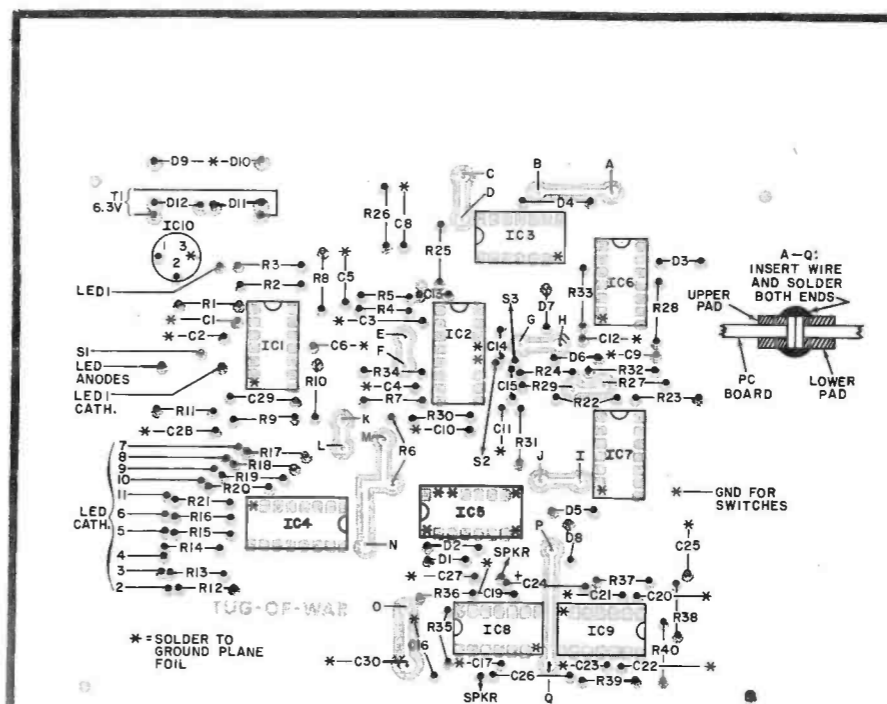

Fig. 7. Components must be mounted carefully since the top of the pc board is primarily a ground plane. Some connections, however, are made to the top side of board (asterisk).

Construction. A double-sided pc board such as that shown in Fig. 6 can be used for the Tug-of-War. Don't use sockets for the IC's. Since the top of the pc board is primarily a ground plane, it is important to remember that components must be carefully mounted so that their leads do not touch the ground, though some components and IC pins are soldered on the top side of the board to provide a ground. These points are indicated in Fig. 7 with an asterisk.

Since the board does not have plated-through holes, coincident pads (A-Q) on both sides should be interconnected by small lengths of wire through the holes and soldered on both sides. Use a clip-on heat sink for integrated circuit $IC10$.

The LED's and switches are mounted on the top cover as shown in the photograph. All use $1/4$ " holes with grommets for the LED's. Short lengths of insulated wire are used to connect the LED's and switches to the board.

Mount the LED's so that proper positioning and polarity are observed—with $LED6$ at the center of the line, $LED2$ toward player A end, and $LED10$ at the other end. Green LED's are used for the WINNER and GO indicators, while the others are red.



BUILD A "UNIVERSAL" DIGITAL PROBE

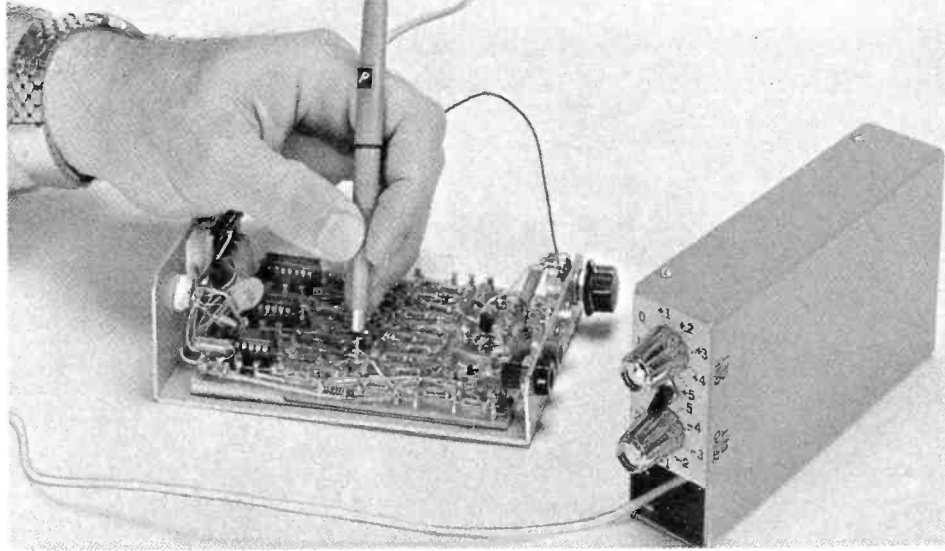

Tests virtually any digital logic family at speeds to 10 MHz.

BY JAMES P. TIERNEY

MANY different designs for digital logic test probes have appeared in the past few years. Most tend to favor a specific logic family, with TTL getting the most attention. Few, if any, are capable of checking ECL and MOS devices and circuits. The logic probe described here is designed for testing virtually all the logic families currently in use, including RTL, DTL, TTL, ECL, and MOS devices and circuits.

The universal logic probe, while larger than "ordinary" testers, is also completely self-contained. It has its own built-in battery power supply to simplify test hookups. (Most popular test probes derive their power from the circuit under test.)

An important factor to be consid-

ered in logic probe design is frequency response. Most testers will not respond to high frequencies. Thus extremely short duration pulses are lost and, in some cases, cause signal degradation in the circuit being tested. The universal probe solves this problem by being able to respond to frequencies in excess of 10 MHz. Furthermore, it will check for a logic 1 or logic 0 within 5 mV of a set value.

About the Circuit. The tester is made up of two parts: a small case containing all of the electronics (including two controls that permit you to preset the logic levels) and a probe assembly with attached cable. The probe itself contains a 7-segment LED display. The ground lead is at-

tached to the body of the probe for easy connection to the circuit being tested.

The heart of the circuit is dual differential comparator integrated circuit *IC1* in Fig. 1. The *IC1B* half checks for a logic 1. Its pin-8 output is held low until the input on pin 5 from the probe is 5 mV (or greater) above the voltage applied to pin 6. The latter is determined by the setting of *R5* and ranges from -1 V to +5.25 V dc. When the input is greater than the voltage on pin 6, the output of the comparator sends *Q1* into conduction to cause a 1 to be displayed.

The 0 part of the circuit operates in the opposite manner. The input on pin 13 must be more negative than the preset voltage on pin 12, determined

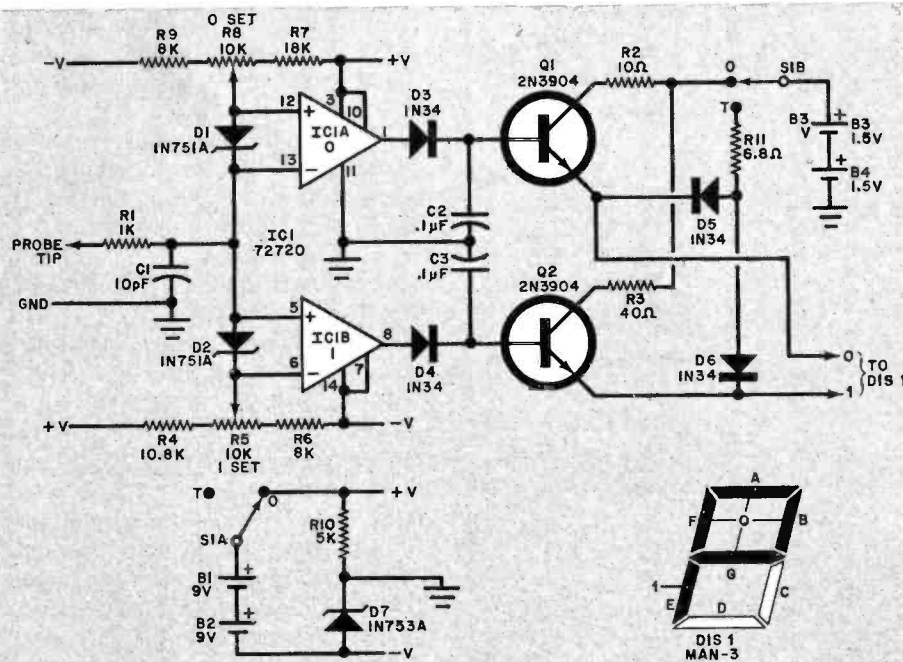

Fig. 1. Dual comparators sense the voltage at probe tip.

PARTS LIST

- B1, B2—9-volt battery
- B3, B4—1.5-volt battery (AA cell)
- C1—10-pF, 10-volt capacitor
- C2, C3—0.1- μ F, 10-volt capacitor
- D1, D2—1N751A zener diode
- D3 to D6—1N34 diode (or similar)
- D7—1N753A zener diode
- DIS1—Seven-segment LED display (Monsanto MAN-3 or similar)
- IC1—72720 dual differential comparator
- Q1, Q2—2N3904 transistor (or similar)
- The following resistors are 1/2 watt:
- R1—1000 ohms
- R2—10 ohms
- R3—40 ohms
- R4—10,800 ohms
- R6, R9—8000 ohms
- R7—18,000 ohms
- R10—5000 ohms
- R11—6.8 ohms
- R5, R8—10,000 ohm miniature potentiometer
- Misc.—Length of three-conductor shielded cable, plastic felt-tipped pen, cement, needle tip, knobs (2), press-on type, battery connectors, chassis, mounting hardware, etc.

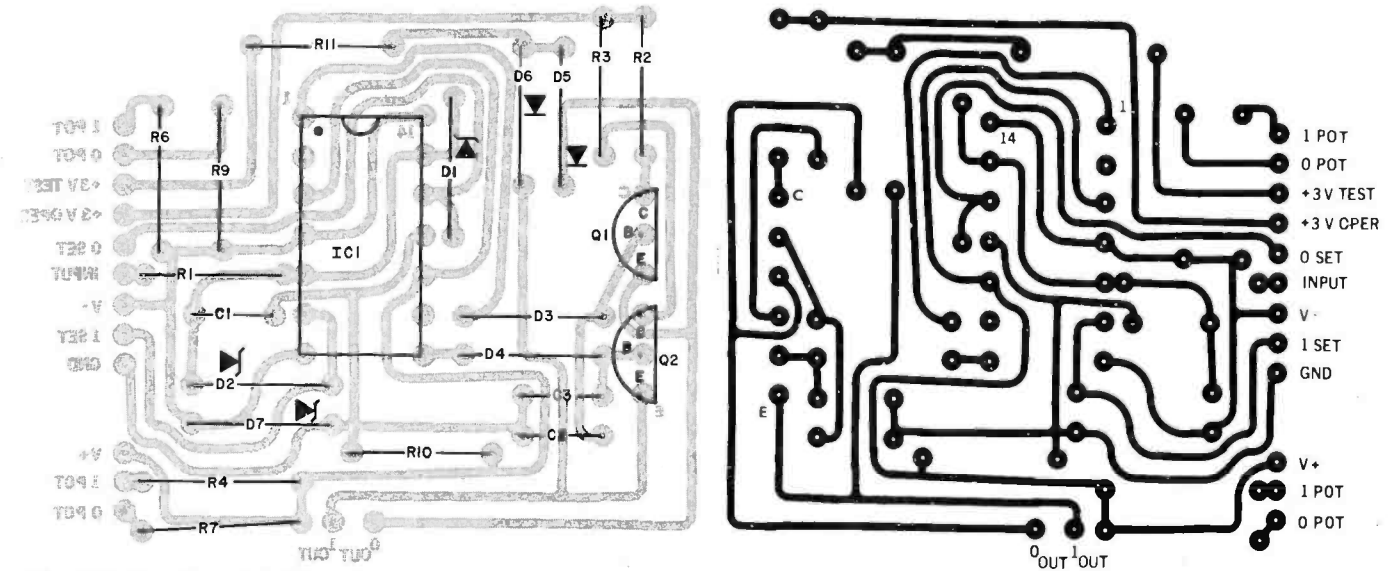

Fig. 2 Foil pattern (right) and component installation.

by the setting of *R8*. The range here is from -2 V to +3 V dc. When this section of the comparator turns on, *Q1* saturates, and the 0 portion of the display is illuminated.

Diodes *D3* and *D4*, in conjunction with capacitors *C2* and *C3*, ensure that, once the indicator is activated, it will remain on long enough to be seen, even with reasonably high pulse repetition frequencies. Resistors *R2*, *R3*, and *R11* provide current limiting for the display. Diodes *D5* and *D6* form a gate that allows testing the indicator before operation. Diodes *D1* and *D2* protect the IC inputs. Resistor *R10*, with *D7*, converts the 18 V from batteries *B1* and *B2* to -6 V and +12 V for the IC. Batteries *B3* and *B4* provide the

higher current required for the seven-segment display.

Construction. The tester can be assembled on a printed circuit board using the actual-size etching and drilling guide shown in Fig. 2. However, if care is exercised, the circuit could be assembled on perforated board using point-to-point wiring.

Mount the board and batteries in an enclosure approximately 1 1/2" by 3" by 5 1/2" as shown in Fig. 3. Note that part of the box is used to store the probe and cable when not in use. The two potentiometers and switch are mounted on one end of the chassis

out and wrap it around the plastic case. Feed the tip lead through the front opening on the case. Seat the display in place and cement it securely. Fabricate a needle tip and solder it to the probe tip lead. Cement this in place.

When assembly is complete, connect a voltmeter between the rotor of potentiometer *R5* and ground. Rotate this potentiometer between its two extremes and mark the 1-volt calibration points on the front panel at the rotor of *R5*. Do the same for *R8*. Don't forget to indicate the polarity. Also make sure that the rotor of *R8* is always more negative than the rotor of *R5*.

Fig. 4. The probe can be fabricated from a plastic felt-tipped pen case.

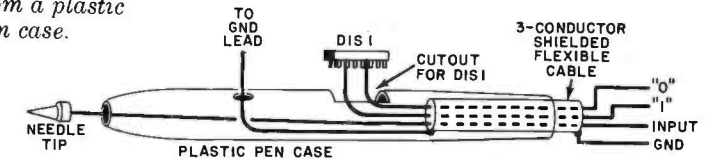

with appropriate identifications made with press-on type.

The probe can be made from a used plastic felt-tipped pen case as shown in Fig. 5. Using a three-conductor shielded flexible cable, identify the leads as 0, 1, and tip. Make the tip lead long enough to go through the end of the plastic case. Cut an opening on the side of the case slightly smaller than the LED display. Feed the 0 and 1 leads through this hole. On the display, interconnect segment leads A, B, F, and G. Solder the 0 lead to this combination. Solder the 1 lead to the E segment. Connect the display common to the coax shield. Feed the shield lead through a small hole below the read-

Operation. To check a logic circuit, determine the high and low voltages for the 1's and 0's of the circuit being tested. Set the two potentiometers accordingly. Attach the probe ground to the circuit ground. Place *S1* in the test position (T). The display should indicate both a 0 and a 1 (which looks like the letter P). Place *S1* in the operate position and touch the probe tip to the circuit being tested. A logic 0 or a logic 1 should be properly displayed; or, if the circuit is transitioning between 0 and 1, both sections of the display will light. If the display remains blank, the test point is operating somewhere between 1 and 0, which means something is wrong.

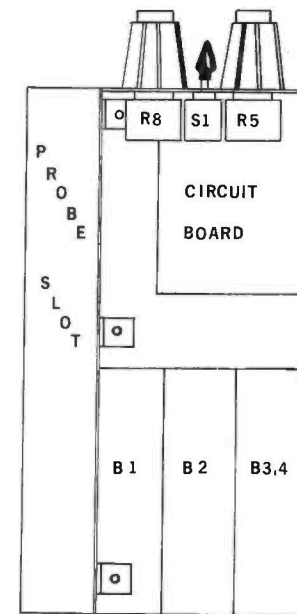

Fig. 3 Layout of chassis as used in prototype.

UPDATE YOUR DIGITAL CLOCK WITH ADD-ONS

AN HOURLY CHIMER

BY JEFFREY GLICK

The proliferation of digital electronic clocks in the last few years has been phenomenal. Particularly popular was the "Low-Cost Digital Clock" project published in these pages in March 1973. Never satisfied with the status quo, electronic experimenters have come up with all kinds of add-ons for their clocks—alarms, power supplies, etc. Now,

we have a circuit that provides hourly chimes (at least, an audible tone) for your clock.

The circuit for the chimer uses the 1-Hz counting frequency from a digital clock, the 1-2-4-8 outputs of the ones-of-hours counter and the 10 and 20 outputs of the tens-of-hours counter. The latter must be high when the tens-of-hours readout indicates a

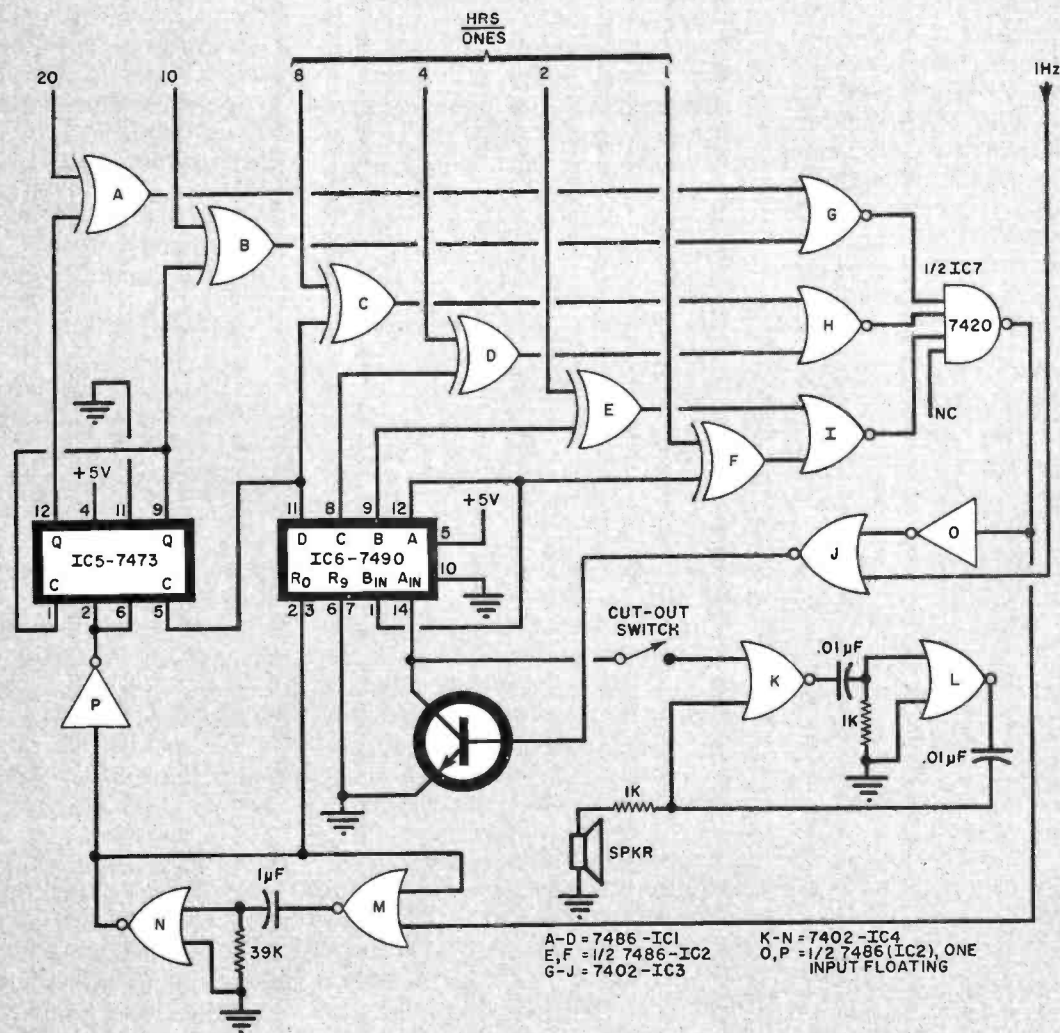

10 or 20, but low otherwise. The operating power can also be taken from the digital clock.

The exclusive-OR gates (A-F) normally have low signals on their inputs but when the clock changes the hour, the signal to one of the gates changes. This produces a high output from the NAND gate (1/2 IC7). The latter triggers a one-shot multivibrator (M, N) to reset the counter (IC5, IC6) to zero. Simultaneously the 1-Hz clock signal is gated through gates O and J to start the count on IC5 and IC6.

The 1-Hz clock signal also turns on a tone generator (K, L) which provides a beep once per second. Audio output is through a small (1"), low-impedance speaker.

When the counter reaches the state that disables the functioning exclusive-OR gate, the NAND gate is inhibited stopping the 1-Hz toggle, which stops the counter and the beep. Thus, the beep occurs once per second until it has indicated the number of hours.

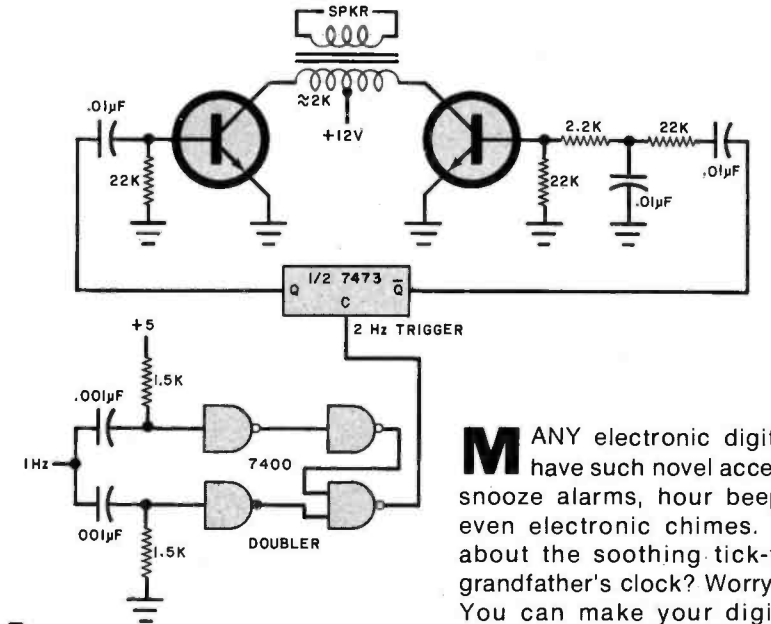

A GRANDFATHER'S TICK-TOCK

BY WILBUR MARKY

MANY electronic digital clocks have such novel accessories as snooze alarms, hour beepers, and even electronic chimes. But what about the soothing tick-tock of a grandfather's clock? Worry no more! You can make your digital clock sound like a grandfather's clock very easily with the aid of the logic circuit shown here. It can be assembled on perforated board or a pc board, and the power can be obtained from your existing clock.

If you have a clock that indicates seconds, then the 1-Hz timing signal can be found at the toggle input of the first decade counter. If the smallest indication you have is minutes, you will have to locate the 1-Hz signal in the countdown that feeds the units of minutes counter. If you have a single-chip clock, and there is no access to a 1-Hz signal, you can build a divide-by-60 from a couple of 7490's to produce the synchronized 1-Hz signal from the ac side of the transformer.

The 1-Hz signal (square wave) is coupled to a 7400 TTL chip arranged as a digital frequency doubler. The 2-Hz signal is then passed to a conventional divide-by-2 flip-flop (which can be any TTL chip having a single flip-flop available). The output of this flip-flop is then passed to a two-transistor sound generator, with one transistor having a simple capacitor coupling to generate the "tick," and the other having a filter to remove the high-frequency components and generate the "tock." Any type of npn switching transistor can be used. The transformer can be a standard unit for push-pull output transistors with a 2000-ohm center-tapped primary and a secondary impedance to match the speaker.

Connect the circuit as shown, install the board in the present clock case and attach the speaker to the wall of the case.

AN ALARM FOR HEAVY SLEEPERS

BY JERRY McELWEE

IN THE December 1973 issue of POPULAR ELECTRONICS (p. 61), a 10-minute alarm add-on for digital

clocks was described. Unfortunately, a lot of people can drift back to sleep after the alarm first goes off and completely miss the 10 minutes. To prevent this, the circuit shown here can be added to keep the alarm going beyond 10 minutes.

Circuit (A) was used in the original alarm. The 7411 IC operated off of the tens-of-hours, ones-of-hours and tens-of-minutes signals from the clock. When the signals agreed with the set time, the output of the 7411 was used to drive some type of external alarm. However, as soon as the tens-of-minutes signal stopped, the output signal stopped.

Circuit (B) shows how to extend the length of time that the alarm is on, no matter what happens on the selected input signals. It uses three OR gates (in a 7432) and a switch wired as shown. When the switch is closed, and at the selected time, the OR gates are turned on and the 7411 delivers the alarm signal. However, the output signal is fed back to the second input of the OR gates which keeps them on until the switch is opened. If the switch is located far enough from the bed, the sleeper will have to get up to turn off the alarm.

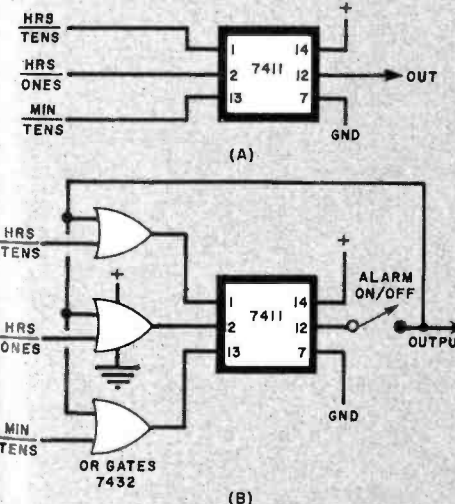

The better the equipment the better you'll be equipped.

Compare what we offer in kits and lessons. Compare our tuition

COMPU-TRAINER

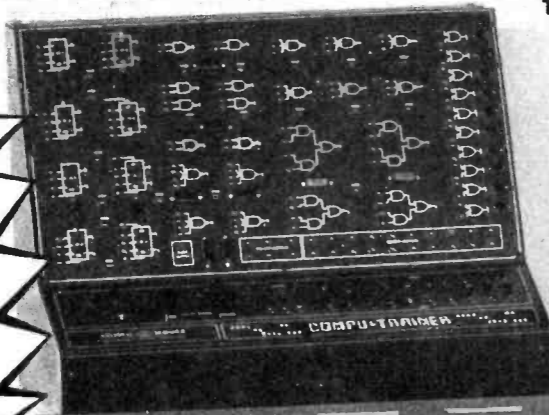

TUBE & TRANSISTOR TESTER



SOLID STATE OSCILLOSCOPE

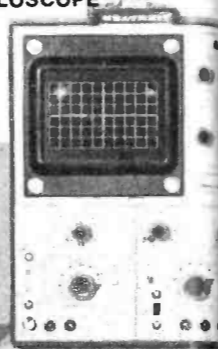

IN-CIRCUIT TRANSISTOR TESTER



DIGITAL MULTIMETER



HIGH FIDELITY SPEAKERS



SOLID STATE STEREO AM FM RECEIVER AMPLIFIER

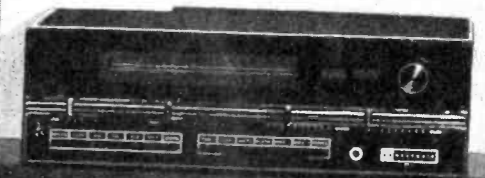

COLOR BAR/DOT GENERATOR



LO-SILHO SUPERHET RADIO



VECTOR MONITOR SCOPE

SOLID STATE B&W TV

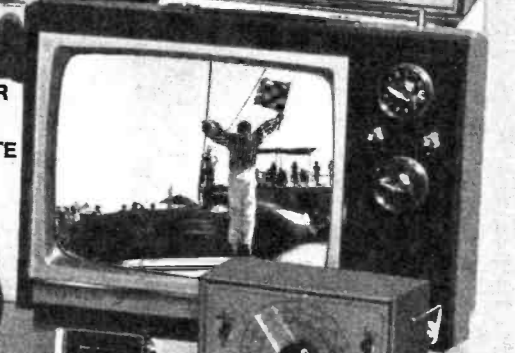

ELECTRO-LAB

NTS DIGITAL GR-2000 SOLID STATE COLOR TV WITH 315 SQ. IN. PICTURE AND VARACTOR DIGITAL TUNING

TROUBLESHOOTER VOM



5" OSCILLOSCOPE

SIGNAL TRACER



FET - VOM

SOLID STATE 2-METER FM TRANSCEIVER AND POWER SUPPLY



SOLID STATE POCKET RADIO

SIGNAL GENERATOR

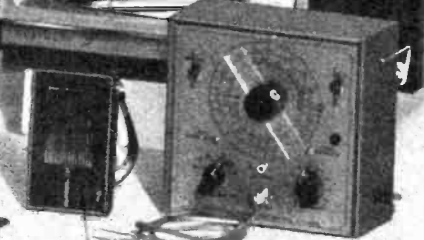

As an NTS student you'll acquire the know-how that comes with first-hand training on NTS professional equipment. Equipment you'll build and keep. Our courses include equipment like the 5" solid-state oscilloscope, transistor and tube-tester, vector monitor scope, 74 sq. in. B&W TV, and solid state stereo AM-FM receiver. The unique NTS **Digital GR-2000 color TV** with first ever features like silent varactor diode tuning; digital channel selection, (with optional digital clock,) and big 315 sq. in. ultra rectangular screen. This is just a sampling of the kind of

better equipment that gets you better equipped for the electronics industry. This electronic gear is not only designed for training; it's field type — like you'll meet on the job, or when you're making service calls. And with NTS easy-to-read, profusely illustrated lessons you learn the theory behind these tools of the trade. **Choose from 12 NTS courses** covering a wide range of fields in electronics, each complete with equipment, lessons, and manuals to make your training more practical and interesting.

Compare our training; compare our tuition. We employ no middlemen because we need no salesmen. We believe you have the right to make your own decisions based on the facts, and you'll find these all spelled out in our catalog mailing. Lessons, kits, and experiments are described in full color. Most liberal refund policy and cancellation privileges — it's all in writing. And our low tuition is another big advantage. No frills, no commissions to pay. This means lower tuition for you. You receive solid training value. NTS puts more into your training, so you get more out of

it. Make your own decision. Mail the card, or write if card is missing. There's no obligation, ever, and no salesman will call. **Approved for Veteran Training.** Get facts on new 2-year extension.

NATIONAL TECHNICAL SCHOOLS
 TECHNICAL-TRADE TRAINING SINCE 1905
 Resident & Home Study Schools
 4000 South Figueroa St., Los Angeles, Calif. 90037

BUILD THE ALTAIR 8800 MINICOMPUTER

PART TWO

Practical use of the computer, including programming

BY H. EDWARD ROBERTS AND WILLIAM YATES

LAST MONTH, we discussed the various subassemblies used in the basic Altair 8800 computer, went into details on how it is assembled, and listed a few applications. Here, we will describe a test program to be used in checking operation and then focus on practical uses and go through a software example to familiarize you with some operating procedures.

Test Program. The following simple program is used for initial testing of the computer's operation. It also illustrates how a program is loaded and run. The selected program will add two numbers stored at address locations 128 and 129 and store the result at address location 130. The procedure is as follows:

1 Set the power switch to ON and momentarily toggle the RESET switch. (Note: Excluding the power switch, all bottom-row switches on the front panel are spring-loaded, momentary-action types. The switches automatically return to their center-off positions when released from either of their operate positions. When instructed to operate any of the bottom row switches, momentarily throw it to the position indicated and release it.)

2 Set address switches A0 through A15 all to the 0 positions (down). Operate the EXAMINE switch, which should cause address LED's A0

through A15 to extinguish to indicate that location 0 is ready. (Some of the data LED's, D0 through D7, might be illuminated, indicating the current contents at location 0.)

3 Next, store the load accumulator instruction at location 0 by using the binary number for 58 (00111010). Set this binary input up by using switches D0 through D7, with a 1 represented by the switch in the up position and a 0 with the switch in the down position. Hence the switch sequence for 00111010 would be: D7 down, D6 down, D5 up, D4 up, D3 up, D2 down, D1 up, D0 down. Store this number at location 0 by operating the DEPOSIT switch. The D0 through D7 LED's should now match these settings, with a lighted LED indicating a 1 and a darkened LED indicating a 0. None of the A0-A15 LED's should be on indicating location 0. The load accumulator instruction now tells the computer that the next two entries will be an address number (16 bits). Upon program execution, the data stored at that address number will be transferred to the accumulator.

4 Address numbers, such as address 128, are expressed in 16-bit binary format. The least-significant bits (last eight) are stored in the first memory location following the load accumulator instruction, while the most-significant bits are stored in the

second memory location. Set D0 through D7 for 10000000 (128) and operate the DEPOSIT NEXT switch. This number is now stored, in binary form, at memory location 1. (A0 LED should be lit indicating location 1.) Set D0 through D7 all to 0 and operate the DEPOSIT NEXT switch. The all-zero binary number is now stored at memory location 2 (A1 LED is lit) and the computer has been instructed to put the contents of address 128 into the accumulator.

5 To add a second number to the current number stored in the accumulator, the computer must be instructed to transfer the current number to one of the general-purpose registers. In this example, we will use register B. The instruction used is "move A to B," where A is the accumulator. The code for this instruction is 01000111, set up with switches D0 through D7. Operate the DEPOSIT NEXT switch. The instruction "move A to B" is now stored at memory location 3. (A1 and A0 lit.)

6 Now, instruct the computer to load the data from address 129 into the accumulator. This procedure is identical to that outlined in steps 3 and 4 above. Set switches D0 through D7 for 00111010 and operate the DEPOSIT NEXT switch. The load accumulator instruction is now stored at memory location 4. (A2 lit.) Set D0 through D7 for

10000001 (129) and operate the DEPOSIT NEXT switch to store this number at memory location 5. (A2, A0 lit) Then set D0 through D7 all to 0 and operate the DEPOSIT NEXT switch to store the all-zero number at memory location 6 (A2, A1 lit).

7 Store the add instruction at memory location 7 by setting D0 through D7 for 10000000 (128) and operating the DEPOSIT NEXT switch. When executed, this instruction adds the number in the accumulator to the number stored in register B and places the result in the accumulator (A2, A1, A0 lit).

8 To store the result at address 130, first store the instruction at memory location 8 by setting D0 through D7 for 00110010 and operating the DEPOSIT NEXT switch (A3 lit). Set D0 through D7 for 10000010 and operate the DEPOSIT NEXT switch. The least-significant eight bits of address 129 are now stored at memory location 9 (A3, A0 lit) Set D0 through D7 to 0 and operate the DEPOSIT NEXT switch. The most-significant eight bits of address 129 are now stored at memory location 10 (A3, A1 lit).

9 A program that adds the contents of address 128 to the contents of address 129 and stores the result in address 130 has now been loaded into the computer. With the use of a "jump" instruction, you can now create a program loop that will direct the computer back to memory location 0 and allow repeating this addition procedure continuously for as long as desired. Store the jump instruction at memory location 11 by setting D0 through D7 for 11000011 and operating the DEPOSIT NEXT switch (A3, A1, A0 lit). Set D0 through D7 to 0 and operate the DEPOSIT NEXT switch twice. The 16-bit address 0 is now stored at memory locations 12 and 13 (A3, A2, A0 lit).

Before we can run this program, we

have to load the two numbers we want added into addresses 128 and 129. For example, if we wanted to add 12 to 8, the procedure would be as follows:

Set address switches A0 through A15 for 0000000010000000 (128) and operate the EXAMINE switch (A7 lit). Set D0 through D7 for binary 12 (00001100) and operate the DEPOSIT switch (A7 still lit). Set D0 through D7 for binary 8 (00001000) and operate the DEPOSIT NEXT switch. The binary numbers for 12 and 8 are now stored at address locations 128 and 129, respectively (A7, A0 lit).

Set address switches A0 through

A15 to 0 and operate the EXAMINE switch (all A LED's are off). Operate the RUN switch, and the program will execute at a rate of about 30,000 times per second. Operate the STOP switch. Set the address switches to address 130 (10000010) and operate the EXAMINE switch. LED's D0 through D7 will display the sum of the two numbers added, which is 20, in binary format (00010100).

Basics of Programming. If you have never done any programming, it may seem a little mysterious at first, but the basic ideas of programming

GLOSSARY OF COMPUTER JARGON

Access time — Time interval between the instant at which information is called for storage and the instant at which delivery is complete.

Accumulator — Part of the logical-arithmetic unit of a computer used for intermediate storage, to form algebraic sums, or other intermediate operations.

Address — Label, name, or number identifying a register, location, or unit where information is stored.

Assembler — Translates input symbolic codes into machine instructions.

Bit — Abbreviation of binary digit; a single character in a binary number.

Buffer — Isolating circuit used to avoid reaction of a driven circuit upon its driving circuit.

Byte — Group of binary digits usually operated upon as a unit. Usually shorter than a word.

Clock — Time-keeping device used to synchronize the computer.

Data — Basic elements of information which can be processed or produced by a computer.

Hold — Function of retaining information in one storage device after transferring it to another device, in contrast to clear.

Instruction — Coded program step that tells the computer what to do for a single operation in a program.

Interrupt — Break in the normal flow of a system or routine such that the

flow can be resumed from that point at a later time.

Jump — Depart from the normal sequence of executing instruction in a computer (synonymous with branch).

Memory — Storage. A device that holds information that can be extracted at a later time.

Processor — Device capable of receiving data, manipulating it, supplying results usually of an internally stored program.

Programming — Art of reducing the plan for the solution of a problem to machine-sensible instructions.

Register — Device for the temporary storage of one or more words to facilitate arithmetical, logical, or transferral operations.

Stack — Portion of a computer memory and/or registers used to temporarily hold information.

Subroutine — Set of instructions in machine code to direct the computer to carry out a well-defined mathematical or logical operation; a part of a routine.

Word — Set of characters that occupies one storage location and is treated by the computer as a unit and is transported as such. Word lengths are fixed or variable, depending on the particular computer being used.

Definitions were extracted from "Computer Dictionary" by Charles J. Sippl and Charles P. Sippl, published by Howard W. Sams & Co., Inc., The Bobbs-Merrill Co. Inc., Number 20943, 484 pages, \$8.95 (in Canada \$11.95).

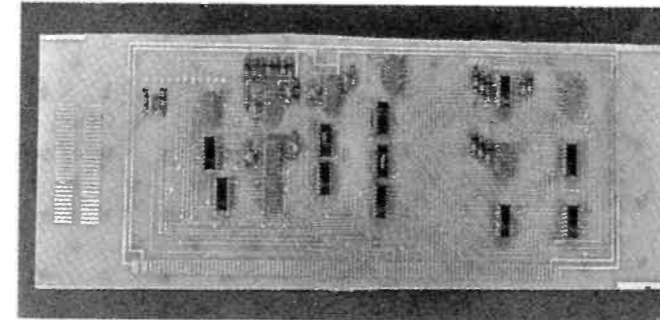
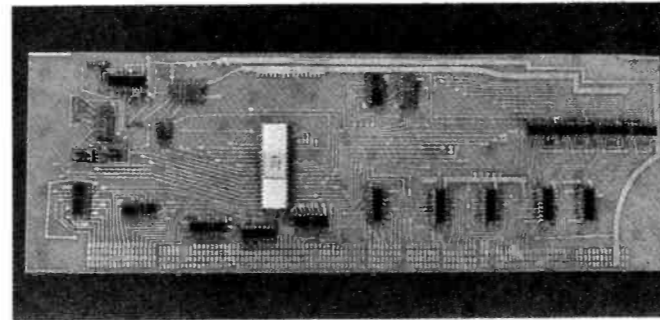
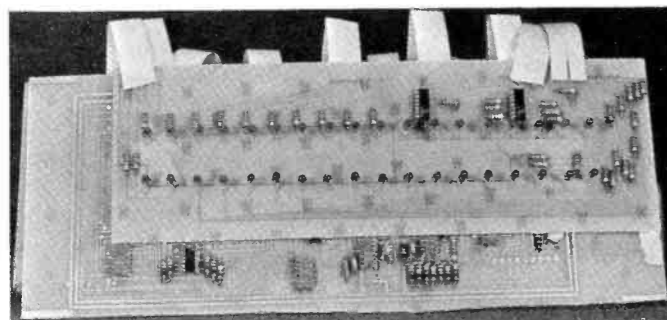

Shown at far left is the display board atop the control board, with cables that connect to other boards. The central processor unit is shown in the center, and the control board at near left. Not shown is memory board, which holds 17 IC's.

MACHINE INSTRUCTIONS

Instruction	Binary Code (for instruction)	Octal	Comment
IN 6	11011011 (IN)	333,006	Bring data from input 6 and store in register A (accumulator).
MOV B,A	01 (MOVE) 000 (B) 111 (A)	107	Take A and move its contents to B.
IN 30	11011011 (IN) 00011110 (30)	323,036	Bring input 30 into accumulator
ADD B	10000 (ADD) 000 (B)	200	Add contents of A to B. Put results in A.
OUT 128	11010011 (OUT) 10000000 (128)	323,200	Transmit contents of accumulator to output 128.

are really very straightforward and easy to master. The procedures that are always used consist of the following:

Defining the Problem. This is by far the hardest part of the programming. Don't worry about the computer or the computer language when doing this part of the preparation. Simply decide what is required to do the job you want to accomplish.

Establishing an Approach. The computer and computer language have nothing to do with this step, either. It involves outlining a step-by-step procedure to achieve the desired results and getting it down on paper.

Writing the Program. Once you are familiar with programming, you will find that this step is the simplest. It is merely a matter of translating step 2 into the appropriate language.

There are many books available on programming. Some of them are quite good and are particularly useful for learning techniques such as flow programming, looping, etc. However, in essence, they can all be boiled down to the three steps above.

Software Example. To get a feel for what programming the Altair 8800 is like, let's go through a sample program, which is similar to the test program that we first went through to check out the computer operation. Assume that we want to take the data available from input channel 6 and input channel 30 and add them, placing the result in output channel 128. The machine instructions are shown in the box.

The first instruction simply stores the data from channel 6 in register A (the accumulator). The next instruction moves this data from register A to register B. This clears A for the next

input. The third instruction brings the data from input channel 30 into the A register. The fourth instruction adds the contents of register A (data from channel 30) to register B (data from channel 6) and puts the results back into register A. The final instruction transmits the answer from A to output channel 128. Total computer time used to perform this operation with the Altair 8800 is 18 microseconds. To put it another way, the computer could perform 56,000 of these operations in one second.

The instructions could be entered into the processor in one of three ways. The first and easiest would be with the use of an assembler. This is essentially a piece of software that converts alphanumeric symbols to machine language (binary code). For example, the assembler would convert our first instruction (IN 6) to the correct binary code. The problem with using an assembler is that you need a computer terminal for an input device and the assembler itself requires about 6000 words of memory storage. If extensive program development is to take place, the assembler is a good tool to have.

The next easiest method of entering the instructions is with the use of



EXPANDING THE COMPUTER

In describing the assembly of the Altair 8800 Minicomputer in last month's article, it was noted that the interior of the cabinet provides plenty of room for expansion. The room can be used to add many functions to the basic computer. For example, the present memory board in the Altair 8800 can be expanded with the addition of three 256-word memories (Kit 8802-MS available from the manufacturer, MITS at \$34 per 256-word memory). Further additions require an expansion mother board having four connectors that can accommodate any four memory or input-output (I-O) cards. This expansion board (Kit 8800-EB) is available for \$44, while a 4K dynamic memory card (Kit 8840-MC) costs \$198. Various other kits—a vectored interrupt card and a real-time clock, among them—are also available.

the Very Low Cost Terminal featured in the December 1974 issue of POPULAR ELECTRONICS. With this terminal, the instructions could be entered by using the octal code. The procedure would be to write the program in assembly language and then enter the corresponding code for each instruction. This system, while not being as fast as the use of an assembler is less expensive.

The third method, using front panel entry, is of course inexpensive but time consuming.

This has been only a brief summary of the programming procedures for the computer. Complete programming information is provided with the Intel 8080 integrated circuit and with the Altair 8800 computer kit. ♦

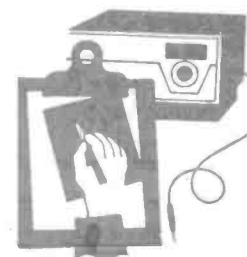

Product Test Reports

ABOUT THIS MONTH'S HI-FI REPORTS

The three components covered in this month's hi-fi equipment reports could easily form the heart of a very fine stereo or quadraphonic system. The general performance qualities of the Marantz 4270 receiver are more comparable to those of the better separate components than those of a receiver. Not only is it equally at home in a two-channel or four-channel system, it has built-in Dolby circuits for either FM decoding or tape recording and playback.

As for the Garrard Zero 100SB, this fine single-play record player combines the "zero tracking error" tonearm made famous by that company's Zero 100 record changer, with a new belt-driven turntable whose performance rivals more expensive units.

Finally, the new Ortofon VMS-20E cartridge is almost a twin of the highly regarded Ortofon M15E Super, with essentially the same performance (and sound) at a much lower price.

—Julian D. Hirsch

MARANTZ MODEL 4270 AM/FM STEREO 2—QUADRADIAL 4 RECEIVER

70 W/ch stereo, 25 W/ch 4-channel with built-in decoding matrix and Dolby NRS.

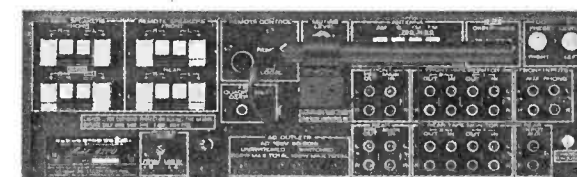
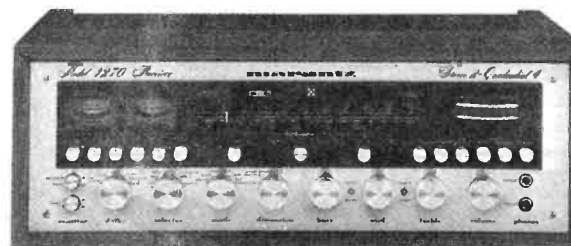

The Marantz Model 4270 shares many features of the other receivers in the company's "Stereo 2—Quadradial 4" line. It's a medium power quadraphonic receiver (25 W rms/channel) that preserves a user's ability to opt for one or more of the four-channel systems through plug-in matrix decoders and/or connection of an external CD-4 demodulator. In the stereo mode, the 4270 is transformed

into a powerful 70 W rms/channel receiver.

Furthermore, the 4270 features a host of refinements, such as Dolby noise-reduction circuitry for tapes and FM broadcasts; a built-in quadraphonic synthesizer for stereo software; and an optical remote control, among others.

The receiver is approximately 17 3/8 in. wide by 5 3/8 in. high by 14 3/8 in. deep (44.1x13.7x36.5 cm) and weighs 40.2 lb. (18.2 kg). Price is \$699.95. SQ and QS decoders (ranging from basic SQ

to full-logic SQ and SQ/QS models) are \$49.95 to \$79.95; CD-400 adapter, \$99.95 (when purchased with receiver); remote control, \$39.95.

General Description. In addition to the conventional complement of controls and switches, the 4270 features separate tone controls—bass, mid-range, and treble—for the front and rear channels. Further, complete Dolby noise-reduction facilities are available, controlled by a DOLBY switch.

When this switch is placed in one of the RECORD positions, program material is encoded or decoded for input to a tape recorder, depending on the noise-reduction capabilities of the particular tape deck. When FM DOLBY is selected, a decoder processes the FM signal for proper reception, with the added advantages of higher S/N ratio and dynamic range. Unusually complete Dolby system calibration facilities are incorporated into the receiver, including a level generator and calibrating meter that doubles as the signal-strength monitor.

Two sets of inputs and outputs for tape monitoring are included, selectable from the front panel. If only one set is used for a recorder, the other provides a convenient circuit interruption point for patching in a graphic equalizer or signal monitor.

A "flywheel" tuning control, protruding through the front panel selects the operating frequency of the tuner. Two meters, an AM/FM signal strength indicator and an FM zero-center monitor make precise tuning adjustments possible. Three slide-type controls adjust balance between the front, rear, and front/rear channels.

Among the rear-panel inputs and outputs is an FM QUADRADIAL output. This jack supplies the composite detector output for possible use with a discrete four-channel adapter, should an FCC-approved FM system be developed. Also included are screwdriver adjustments for FM Dolby level, muting, and a socket for an optional remote control unit for volume, loudness, and balance adjustments. The PREAMP OUT and AMP IN jacks, normally bridged by jumpers, provide another circuit-interruption point for signal processors, or for using the 4270 with a super-powered amp. A slide switch changes the normal 75-μs deemphasis characteristic to 25 μs, for proper reception of FM Dolby broadcasts. A power mode switch selects

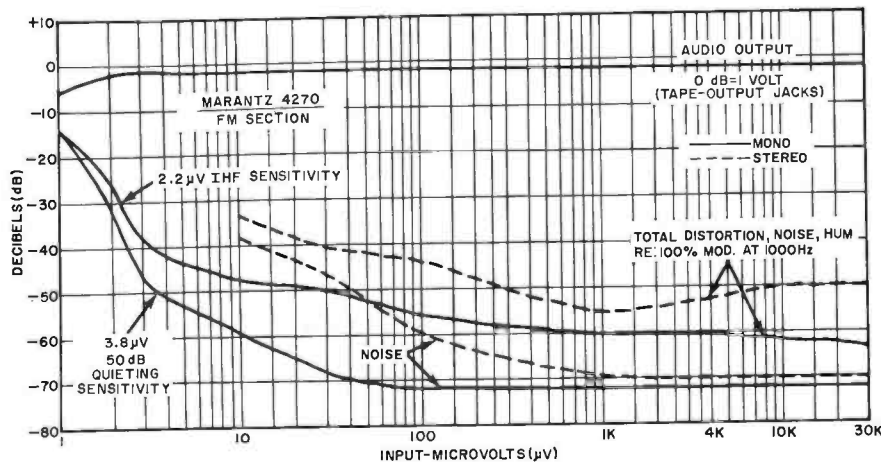

either "strapped" stereo (70 W/channel) or four-channel (25 W/channel) amplifiers. Two ac outlets, one switched, are included.

Laboratory Measurements. In virtually every respect, the Marantz 4270 met or exceeded the manufacturer's published specifications. In the four-channel mode, the amplifiers, rated at 25 W/channel, delivered 35.7 W at the clipping level with all channels driven into 8-ohm loads at 1000 Hz. Into 4 ohms, the amplifiers clipped at 52 W/channel. The clipping level of the two-channel "bridged" mode was 100 W/channel, 30 W/channel higher than the rated figure. Amplifier distortion at rated output was under 0.03% from 20 Hz to 10 kHz, and 0.04% at 20 kHz. At lower output the figure rose, but at no time exceeded 0.07%. THD at 0.1 W, 1 kHz, was 0.1%, falling to about 0.02% between 10 and 30 W, and reaching 0.1% at 35 W. (Below 1 W, distortion was less than figures imply, since it was masked by circuit noise.) IM distortion behaved similarly, declining from 0.15% at 0.1 W to 0.06% between 10 and 30 W.

Input sensitivity for a reference 10-W output was 80 mV at the AUX inputs, and 1.0 mV at the PHONO inputs.

S/N ratios were very good: 78 dB and 68 dB, respectively (at 10 W output). Phono overload occurred at 115 mV, an output rarely, if ever, reached with today's pickups. Tone controls offered a wide variety of response curves, so that almost any tonal coloration could be obtained. The HI Filter response, which had a gradual -6 dB/octave slope, was down 3 dB at 5500 Hz.

RIAA phono equalization was within ± 0.5 dB from 30 Hz to 20 kHz. Though phono cartridge inductance affected the equalization appreciably above 15 kHz, it had little or no effect below 10 kHz.

The FM tuner section displayed an IHF usable sensitivity of 2.2 μ V, with a steep limiting curve that reached 50 dB of quieting at 3.8 μ V in mono and 43 μ V in stereo. Mono FM distortion at 1000 μ V was very low, less than 0.1%, and in stereo was an excellent 0.17% to 0.33%. The ultimate quieting of the tuner was 72 dB in mono and 70 dB in stereo. These figures are close to the residual noise level of the signal generator used.

Stereo FM frequency response was flat within ± 0.5 dB from 30 Hz to 15 kHz. The 19-kHz pilot carrier leakage was 67 dB below the 100% modulation

level. Channel separation was 35 dB from 30 Hz to 8 kHz, peaking to 55 dB in the midrange, and 30 dB at 15 kHz. Capture ratio was 1.1 dB at 1000 μ V, and AM rejection was a good 60 dB. The signal threshold for muting and automatic stereo switching was 10 μ V. Image rejection was 76 dB, and alternate-channel selectivity was measured to be a very good 78 dB. The response of the AM tuner was better than average. It was flat over most of its range, down 3 dB at 33 Hz and 6000 Hz.

User Comment. The operation of the Marantz 4270 was flawless in every respect. Its many functions may prove overwhelming to a new owner, so a careful study of the instruction manual is recommended for most enjoyable use of the receiver.

Although no measurements were made on the Dolby circuitry, we did cross-check its performance with that of an accurately adjusted Dolby unit and found it to be subjectively identical and completely compatible. The FM Dolby function worked properly with the one Dolbyized station in our area. Interestingly, we found that it is possible to leave the de-emphasis switch in the 25- μ sec position at all times, obtaining correct frequency response with all FM stations. This is possible because of the relationship between the switching functions of the DOLBY and de-emphasis switches. The FM muting operated with pleasing smoothness, free of thumps and noise bursts.

Our test receiver was not fitted with one of the plug-in SQ decoders, so its four-channel performance was judged using its Vari-Matrix. This proved to be effective in supplying four-channel ambience enhancement to stereo material and matrixed records, but as expected, did not provide the inherent directional response of a

logic-assisted decoder, which is a moderately priced option.

In view of its versatility and features, not to mention its outstandingly fine performance, it is clear that the Marantz 4270 can serve as a first-class stereo receiver. Its price is not at all inconsistent with its overall quality and flexibility. It can be upgraded in stages to quasi-four-channel operation by merely adding rear speakers and to full four-channel with one or more decoders, depending on the owner's desires.

CIRCLE NO. 65 ON READER SERVICE CARD

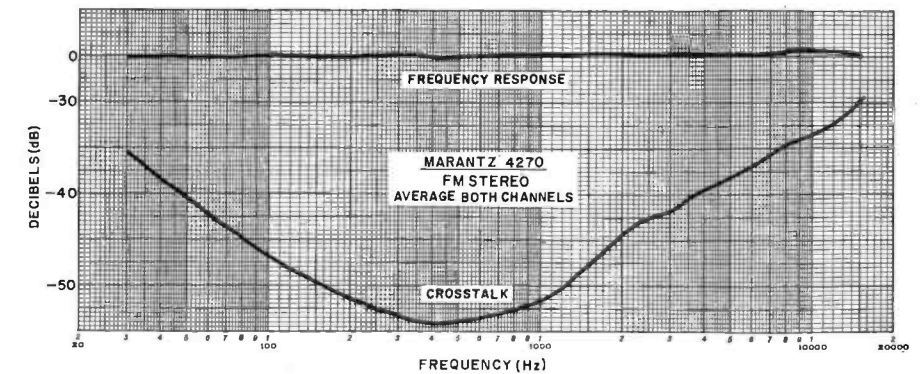

GARRARD ZERO 100SB TURNTABLE

Automatic single-play machine with belt drive.



Manual record players were once the popular choice of hi-fi buffs. Interest in this type of machine died out, however, when record changers were introduced to combine high-quality, single-play provisions with automatic features. Turnabout is fair play, so more recently, a new breed of record player—the *automatic* single-play machine—has again captured the imagination of hi-fi music listeners. The Garrard Zero 100SB is one of a host of automatic single-play entries this year.

It's supplied as a complete turntable and arm, with wood base (black with teak side panels), removable hinged dust cover and all connecting leads attached. Adding a cartridge turns it into a functioning record player. Price is \$209.95.

General Description. The Garrard Zero 100SB utilizes a belt-drive system instead of the idler-wheel drive used in the manufacturer's older Zero 100 model. With two speeds—33 1/3 and 45 rpm—a combined speed selector and record diameter indexing control shifts the belt on a stepped synchronous motor shaft for "automatic" single-play operation. (Records of any

size can be played manually at any speed.) The 100SB employs a cast non-ferrous turntable platter that is 11 1/2 inches in diameter and weighs 5 1/2 pounds. Overall dimensions are 18 in. wide by 16 in. deep by 7 1/2 in. high (with cover in place).

Operating controls are three levers. The AUTO lever starts the turntable and indexes the arm automatically while the MAN lever merely turns on the platter drive. Each has an OFF setting, which in the case of the AUTO lever, also returns the arm to its rest. In either mode, after a record is played, the arm returns to the rest and the motor shuts off. The third lever, CUE, raises and lowers the arm with damped control in both directions. Unlike most other cueing devices, it can lift the arm by any amount up to the maximum, and hold it at that point, which can reduce the lowering time considerably.

A clear plastic tonearm pivot housing contains the magnetic repulsion system used to supply anti-skating bias. A magnetic shield is moved between two magnets (one on the fixed section and one on the movable arm body) to vary the torque. Separate scales are provided for conical and elliptical styli.

The adjustable counterweight is elastically mounted to damp the low-frequency arm resonance. A unique feature of the Zero 100SB arm is the automatic record play counter built into the transparent pivot support. A red pointer moves up slightly every time the arm returns to its rest after playing a record, and the index marks on the plastic correspond to various numbers of plays from 400 to 1600. A knurled knob below the scales resets the pointer to zero.

Tracking force is set by a sliding weight on the arm body, calibrated at 0.25-gram intervals from 0 to 3 grams.

Laboratory Measurements. When the test cartridge (in this instance an Ortofon VMS-20E) was installed using the jig supplied with the Zero 100SB, tracking error was unmeasurably low (under 0.5 degree) over the entire record surface. The stylus force indications were very accurate, with less than 0.05 gram error at 1- and 2-gram settings, and only 0.1 at 3 grams. The anti-skating calibration was correct for equal playback distortion in both channels (a very unusual occurrence among the many arms we have tested).

To obtain visible waveform clipping on the 30 cm/s test tones we use for setting anti-skating, it was necessary to operate the Ortofon VMS-20E cartridge at 0.5 gram, and the corresponding anti-skating setting proved to be exact. This test, incidentally, established that the Zero 100SB arm, in spite of its multiple pivots, had negligible friction. As we see it, any cartridge made today can be operated in this arm at the lowest tracking force consistent with the design of the cartridge, without encountering difficulties of excessive arm friction.

The turntable wow and flutter were 0.06% and 0.04% at 33 1/3 rpm, and 0.04% and 0.035% at 45 rpm. The unweighted rumble was ± 38 dB; with relative audibility weighting, it was a very low ± 61 dB. Operating speeds were within 0.2% of the correct values, and did not vary measurably over a line voltage shift from 95 to 135 volts. The operating cycle in the AUTO mode required 14 seconds, from the time the lever was moved until the stylus set-

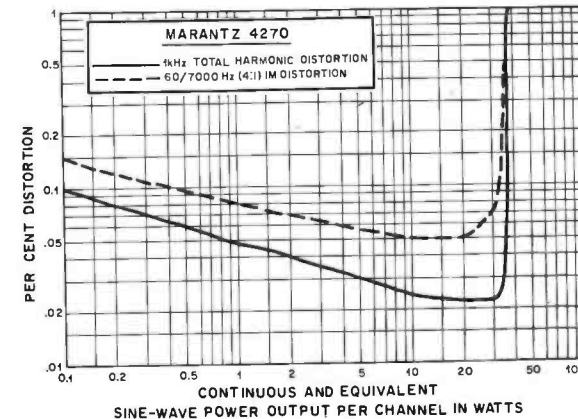
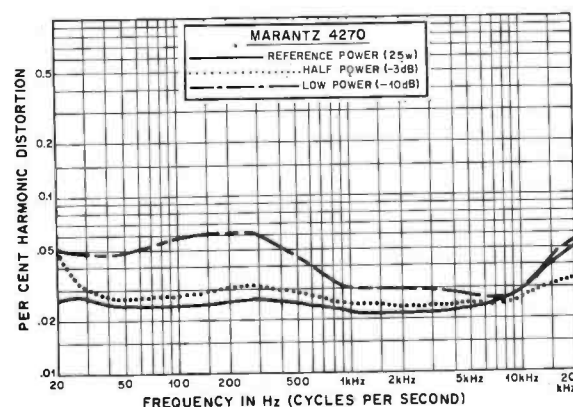

The whole neighborhood wondered what Frank Mallon was up to in his workshop.

Word had it he was up to something mighty peculiar. And when he didn't show up for bowling practice one Wednesday night, the Wabash Cannonballs (that was the name of his neighborhood team) began to wonder, too.

So it was that a bunch of the boys decided to pay their "star" a visit, and talk him out of his workshop and back into action.

It didn't happen that way, though.

Matter of fact, it was Frank Mallon who talked the Wabash Cannonballs out of their bowling night and down into his workshop. What was it... what could be exciting enough to keep a bunch of ten-pin tigers from their favorite pastime? One of the most fascinating learn-at-home programs in the world, that's what!

Actually build and experiment with the new generation color TV in Bell & Howell Schools' fascinating learn-at-home program. It will help you develop new occupational skills as an electronics troubleshooter.

You'll set up your own electronics laboratory to learn first-hand, the technology behind such innovations as digital-display wrist-watches and tiny pocket calculators.

In fact, as part of the program, you'll actually build and experiment with a 25" diagonal color TV incorporating digital features.

But most important of all will be the new skills you'll develop all along the way... the kind of skills that could lead you in exciting new directions. While we cannot offer assurance of income opportunities, once you've completed the program you can use your training:

1. To seek out a job in the electronics industry.
2. To upgrade your current job.
3. As a foundation for advanced programs in electronics.

Go exploring at home, in your spare time. No traveling to class. No lectures. No one looking over your shoulder.

Bell & Howell Schools wants to introduce you to the modern way to learn. It means you'll be able to develop new skills in your own home—on whatever days and hours you choose. So you don't have to give up your present job or paycheck just because you want to learn new occupational skills.

What's more, we believe that when you're exploring a field as fascinating as electronics, reading about it is just not enough.

That's why you'll get lots of "hands on" experience with some of the most impressive electronic training tools you've ever seen.

No electronics background necessary.

That's one of the advantages of this program. We start you off with the basics and help you work your way up, one step at a time. In fact, with your first lesson you receive a Lab Starter Kit to give you immediate working experience on equipment.

You build and perform exciting experiments with Bell & Howell's Electro-Lab®. An exclusive electronics training system.

First comes the design console. After you assemble it, you'll be able to set up and examine circuits without soldering.

Next, you'll put together a digital multimeter. This instrument measures voltage, current and resistance, and displays its findings in big, clear numbers like on a digital clock.

Then comes the solid-state "triggered sweep" oscilloscope. An instrument similar in principle to the kind used in hospital operating rooms to monitor heartbeats. You'll use it to analyze the "heartbeats" of tiny integrated circuits. The "triggered sweep" feature locks in signals for easier observation.

You'll build and work with Bell & Howell's new generation color TV... investigating digital features you've probably never seen before!

This 25" diagonal color TV has digital features that are likely to appear on all TV's of the future.

As you build it, you'll probe into the technology behind all-electronic tuning. And into the digital circuitry of channel numbers that appear right on the screen! You'll also build in a remarkable on-the-screen digital clock that will flash the time in hours, minutes and seconds.

And you'll program a special automatic channel selector to skip over "dead" channels and go directly to the channels of your choice.

You'll also gain a better understanding of the exceptional clarity of the Black Matrix picture tube, as well as a working knowledge of "state-of-the-art" integrated circuitry and the 100% solid-state chassis.

After building and experimenting with this TV, you'll be equipped with the kinds of skills that could put you ahead of the field in electronics know-how.

We try to give more personal attention than other learn-at-home programs.

1. Toll-free phone-in assistance. Should you ever run into a rough spot, we'll be there to help. While many schools make you mail in your questions, we have a toll-free line for questions that can't wait.

2. In-person "help sessions". These are held in 50 major cities at various times throughout the year, where you can talk shop with your instructors and fellow students.

So take a tip from Frank Mallon. Find out more about the first learn-at-home program that could stir up your neighborhood!

Mail this postage-paid card today for full details, free!

Taken for vocational purposes, this program is approved for Veterans' Benefits.

If card has been removed, write:

An Electronics Home Study School
DEVRV INSTITUTE OF TECHNOLOGY
ONE OF THE

BELL & HOWELL SCHOOLS
4141 Belmont, Chicago, Illinois 60641

Electro-Lab is a registered trademark of the Bell & Howell Company.

696 R2



On-screen digital clock



Channel numbers that flash on the screen

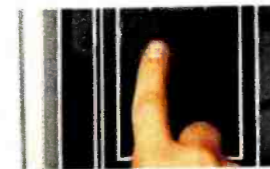

Automatic pre-set channel selector

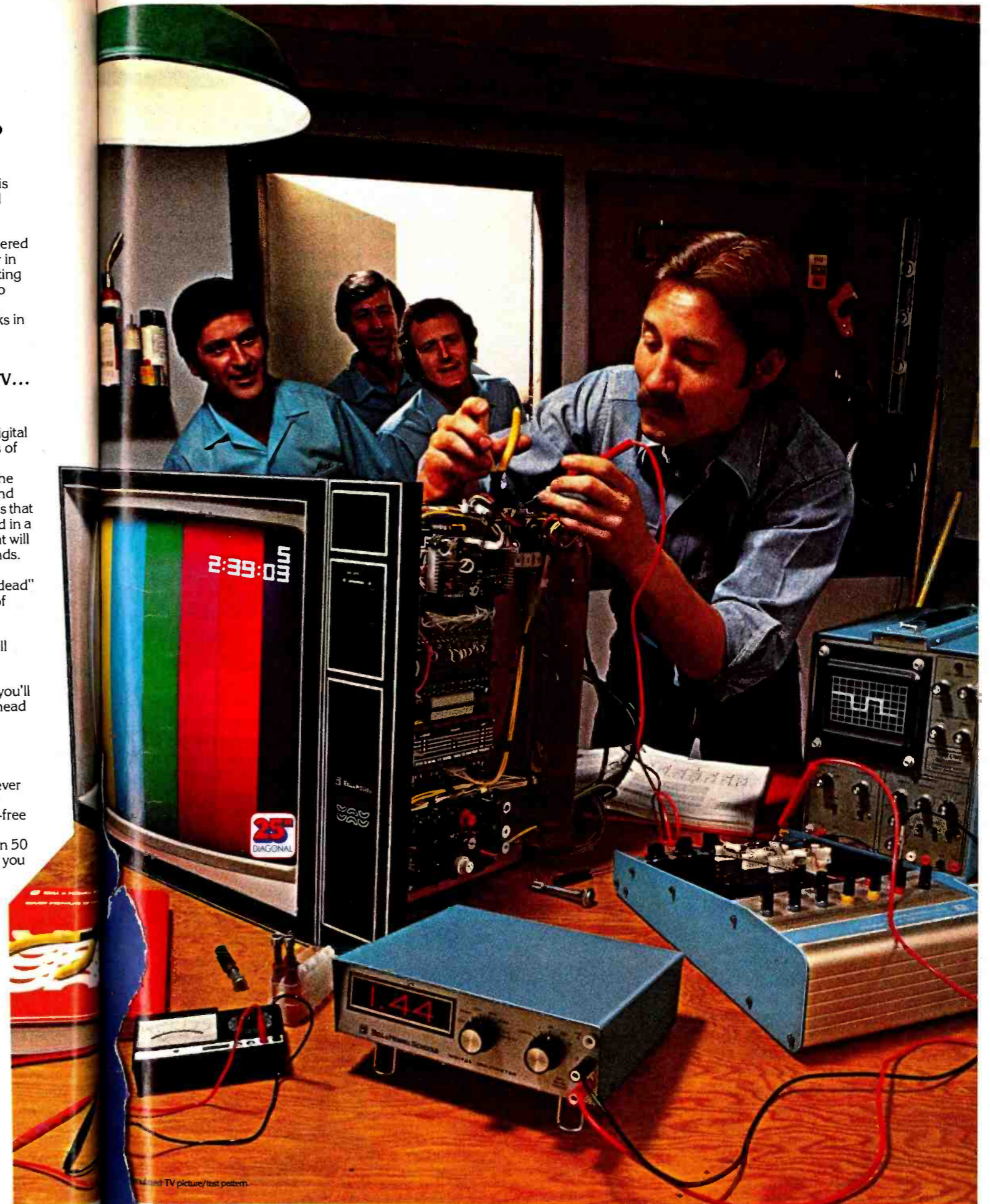

tled into the lead-in groove. There was no lateral drift during descent when using the cue control. The low frequency arm/cartridge resonance was at 5 Hz (indicating a moderately high arm mass), and an amplitude of about 10 dB.

User Comment. The Garrard Zero 100SB combines a number of useful operating conveniences. It boasts high performance in its basic characteristics at a price that matches or betters other record players of comparable quality. For example, only a few of the most expensive direct-drive turntables we have tested have shown lower rumble than the Zero 100SB.

ORTOFON MODEL VMS-20E PHONO CARTRIDGE

Moderately priced variable-magnetic-shunt design offers neutral sound quality.

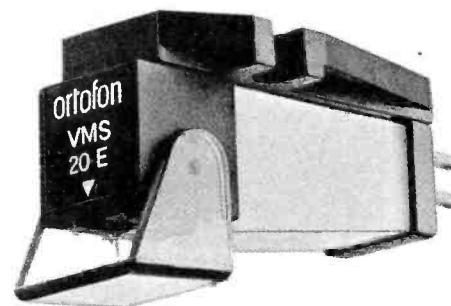

Ortofon first introduced its variable magnetic shunt (VMS) principle a couple of

years ago in its still top-of-the-line Model M-15E Super stereo cartridge. In this cartridge, a magnetic armature is moved in the field of a light ring magnet. It varies the flux distribution through the internal pole pieces and coils, while reducing the flux through the pole pieces to zero when the stylus is in its neutral position. This design is claimed to greatly reduce nonlinearities in the magnetic system, resulting in lower distortion than was previously possible in magnetic cartridges of conventional design.

Now, Ortofon has brought the M-15E Super's essential qualities within reach of the many users of good-quality automatic turntables with the introduction of the Model VMS-20E cartridge. It also uses the variable magnetic shunt principle and has an 8- x 18-micron (0.3- x 0.7-mil) user-replaceable elliptical diamond stylus.

When the M-15E Super was intro-

duced, a 15° vertical tracking angle was in general use. The standard has since been changed to 20°, and the design of the VMS-20E reflects that change.

Physically, and in most of its other characteristics, the VMS-20E appears to be identical to the M-15E Super cartridge. It is a lightweight 5 grams and is rated to track at between 0.75 and 1.5 grams. (One gram is the recommended tracking force.) Ortofon specifies the loading of the cartridge at the standard 47,000 ohms and recommends a 400-pF shunt capacitance.

Aside from its vertical tracking angles, the VMS-20E appears to differ from the M-15E Super in only three specifications: It has about 25% greater output voltage; its tracking ability at 300 Hz is 70 microns, as opposed to 80 microns for the M-15E Super; and its lateral compliance is reduced from the M-15E Super's 50×10^{-6} cm/dyne to 40×10^{-6} cm/dyne.

Another very important feature is the VMS-20E's relatively inexpensive cost—\$65. This sharply contrasts with

the \$90 figure asked for the M-15E Super cartridge.

Laboratory Measurements. We tested the VMS-20E in a Pioneer Model PL-71 record player/tonerarm combination, using a 47,000-ohm load shunted by 340 pF. The low-frequency tracking ability of the cartridge was tested with a Cook Series 60 record at a 0.75-gram tracking force. The 1000-Hz, 30-cm/s test tones of a Fairchild 101 record revealed symmetrical clipping at 0.5 gram, with no improvement from the use of a higher force. This suggests that the amplitude limits of the stylus system rather than its dynamic tracking abilities were being exceeded in this very severe test. A 1-gram force was used throughout subsequent tests.

Ortofon's 300-Hz tracking specification for the VMS-20E is based on the use of a German hi-fi test record we also use in our test program. The cartridge easily tracked the 80-micron band of this record at 1 gram. By careful adjustment of the tonearm's anti-

skating compensation, the 100-micron (highest-level) band could be played without significant distortion. It should be noted that very few cartridges can even approach this performance at any tracking force.

The output of the cartridge was 3.2 mV at a 3.54-cm/s velocity. A 1000-Hz square wave from the CBS STR-111 record was played with only a single small overshoot and no sign of ringing. As with the M-15E Super, the VMS-20E had an exceptionally flat response, varying only ± 1.5 dB from 500 to 20,000 Hz on one channel and ± 1 dB over the same range on the other channel when tested with the CBS STR-100 record.

The channel separation was typically 25 to 30 dB up to about 4000 Hz. It reduced smoothly to 15 dB at 10,000 Hz and 5 to 10 dB at 20,000 Hz. Both channels had very similar characteristics with respect to frequency re-

duced, a 15° vertical tracking angle was in general use. The standard has since been changed to 20°, and the design of the VMS-20E reflects that change.

Physically, and in most of its other characteristics, the VMS-20E appears to be identical to the M-15E Super cartridge. It is a lightweight 5 grams and is rated to track at between 0.75 and 1.5 grams. (One gram is the recommended tracking force.) Ortofon specifies the loading of the cartridge at the standard 47,000 ohms and recommends a 400-pF shunt capacitance.

Aside from its vertical tracking angles, the VMS-20E appears to differ from the M-15E Super in only three specifications: It has about 25% greater output voltage; its tracking ability at 300 Hz is 70 microns, as opposed to 80 microns for the M-15E Super; and its lateral compliance is reduced from the M-15E Super's 50×10^{-6} cm/dyne to 40×10^{-6} cm/dyne.

Another very important feature is the VMS-20E's relatively inexpensive cost—\$65. This sharply contrasts with

the \$90 figure asked for the M-15E Super cartridge.

Laboratory Measurements. We tested the VMS-20E in a Pioneer Model PL-71 record player/tonerarm combination, using a 47,000-ohm load shunted by 340 pF. The low-frequency tracking ability of the cartridge was tested with a Cook Series 60 record at a 0.75-gram tracking force. The 1000-Hz, 30-cm/s test tones of a Fairchild 101 record revealed symmetrical clipping at 0.5 gram, with no improvement from the use of a higher force. This suggests that the amplitude limits of the stylus system rather than its dynamic tracking abilities were being exceeded in this very severe test. A 1-gram force was used throughout subsequent tests.

Ortofon's 300-Hz tracking specification for the VMS-20E is based on the use of a German hi-fi test record we also use in our test program. The cartridge easily tracked the 80-micron band of this record at 1 gram. By careful adjustment of the tonearm's anti-

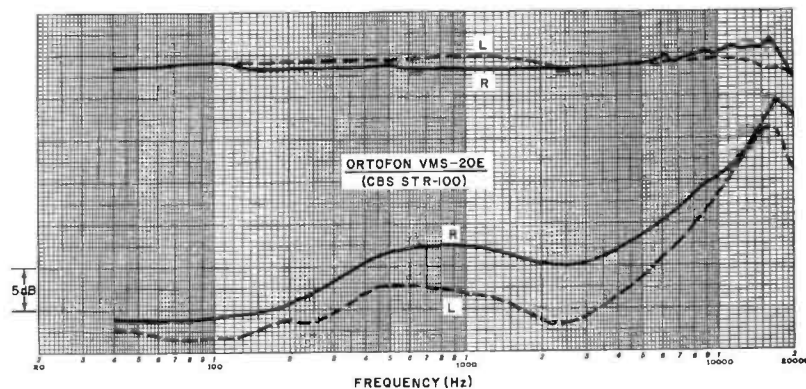

skating compensation, the 100-micron (highest-level) band could be played without significant distortion. It should be noted that very few cartridges can even approach this performance at any tracking force.

The output of the cartridge was 3.2 mV at a 3.54-cm/s velocity. A 1000-Hz square wave from the CBS STR-111 record was played with only a single small overshoot and no sign of ringing. As with the M-15E Super, the VMS-20E had an exceptionally flat response, varying only ± 1.5 dB from 500 to 20,000 Hz on one channel and ± 1 dB over the same range on the other channel when tested with the CBS STR-100 record.

The channel separation was typically 25 to 30 dB up to about 4000 Hz. It reduced smoothly to 15 dB at 10,000 Hz and 5 to 10 dB at 20,000 Hz. Both channels had very similar characteristics with respect to frequency re-

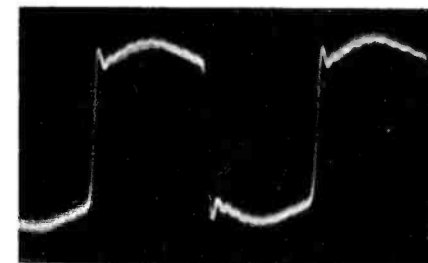

1000-Hz square wave.

LAFAYETTE COM-PHONE 23 MOBILE CB TRANSCEIVER

Handset receiver provides mounting versatility and communication privacy.



LAFAYETTE's Com-Phone 23 is a 23-channel mobile AM transceiver using a telephone-type handset instead of a conventional grip mike. Adaptable to a variety of mounting positions, it can be installed horizontally above a transmission hump, mounted vertically on the wall of a van or camper, or similar to a wall phone in the home (with an ac adapter).

The use of a handset reduces interference from background noise. Additionally, the Com-Phone 23 retains "talk" flexibility with a PTT switch incorporated into the handset, and a panel-mounted switch to allow operation of a built-in speaker or a handset earphone.

Circuitry is all-solid-state, including a crystal-governed frequency synthesizer. Using only 14 crystals, the Com-Phone 23 produces 23 transmitting and receiving channels. A 12-volt, negative- or positive-ground power

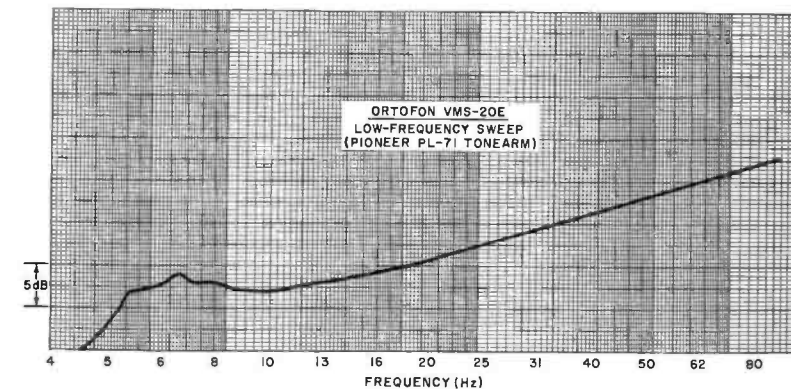

source can be used, and an optional ac supply allows the radiotelephone to be used as a base-station rig. Other features of the transceiver include adjustable squelch, always-on noise limiter, "range boost" circuitry, adjustable TVI trap, and an external speaker jack for receiving or PA work. The Com-Phone 23 draws only 100 mA on receive (no signal) and 1 A on transmit (modulated).

The transceiver measures 4 in. by 5 in. by 9½ in. (10 cm x 12.6 cm x 23.8 cm) and weighs 3.25 lb (1.47 kg). Price is \$189.95.

The Receiver. Dual-conversion circuitry is used, with i-f's at 10.6 MHz and 455 kHz. Two uncommon circuit configurations are employed—the r-f amplifier is a grounded-base stage, instead of the usual grounded-emitter mode, and a crystal diode is used as the second mixer, rather than a tran-

quality, with no audio peaking or coloration in any part of the audio range. As Ortofon implies, the VMS-20E and M-15E Super cartridges have virtually identical performance in all respects. We could hear no differences between the two in side-by-side comparisons.

The major difference between the two cartridges appears to be that the M-15E Super will play anything we have seen on record without difficulty at 1 gram, while the VMS-20E might have to be operated at 1.5 grams in the most severe cases. We would still opt for 1-gram operation, assuming the tonearm is capable of it. (The VMS-20E should not be used in tonearms incapable of tracking at 1 gram.) At that force, it can still outperform most cartridges on the market.

CIRCLE NO. 67 ON READER SERVICE CARD

sistor. A ceramic filter in the second i-f stage affords good selectivity. The noise limiter is a series-gate type, and the squelch is agc-activated. Audio output is obtained from a class-B, push-pull stage which doubles as the transmitter modulator. The frequency synthesizer employs six 37-MHz and four 10-MHz crystals for all-channel operations.

Sensitivity measured 0.3 μ V for a 10-dB S+N/N ratio, three times better than the 1.0 μ V claimed by the manufacturer! Two watts of audio output was obtained from a 1- μ V input signal. Image rejection was 80 dB, i-f signal rejection measured 60 dB at the first i-f frequency and 100 dB at 455 kHz. Spurious-signal and adjacent-channel rejection were 50 dB and 40 dB, respectively. The overall a-f bandpass was 350-2900 Hz at the 6-dB points, while threshold range for squelching action was 0.3 μ V to 30 mV.

The agc held the audio output to within 14 dB for a 20-dB r-f input range (1 to 10 μ V). However, input levels above 10 μ V tended to drop 4 to 6 dB, apparently due to overload somewhere before the volume control. Any distortion generated at these levels was not audibly significant. In the ab-

sence of any input signal, the receiver was exceptionally quiet. In the PA mode, 3.25 watts of output power into 8 ohms was delivered, with 10 percent distortion at 1000 Hz at the start of limiting.

The Transmitter. To enhance performance, the transmitter features a two-section matching network, an adjustable series-tuned TVI trap, and a "range boost" automatic modulation control with a-f compression. Antenna changeover is accomplished by a diode. Other switching functions are handled by a relay.

A standard 13.8-V power supply provided 4 watts of carrier output. Distortion at full modulation was 4 percent using a 1000-Hz signal. With further mic-input level increases of 6 and 10 dB, distortion rose to 9 and 14 percent, respectively.

Unlike some other compressors, Lafayette's "range boost" circuitry prevented overmodulation on both positive and negative peaks. Adjacent-channel splatter was under 50 dB using a 2500-Hz tone at a level 10 dB higher than that required for full modulation. Audio response of the transmitter was 450 to 4800 Hz at the 6-dB

points, and frequency tolerance for any one channel was within 275 Hz.

General. Audio output will appear at the handset or internal or external speaker, depending on the position of the panel-mounted switch. In the SPEAKER position, both the handset and the speaker receive audio; in the HANDSET position, the speaker is silenced when the handset is lifted from its cradle. Another switch selects CB or PA operation. When the latter mode is selected, both the internal speaker and the handset earphone are silenced, and output appears only at the external speaker jack. The connecting cables plug in at the top edge of the enclosure, which is convenient. In some mounting positions, however, special wiring may be necessary.

Summing up the attributes of the Lafayette Com-Phone 23 CB transceiver, its telephone-style design offers communications privacy, as well as mounting flexibility. Equally important, users will appreciate its good signal punch, made possible by the "Range Boost" circuit, and clean talk power without spurious products spilling over into nearby channels.

CIRCLE NO. 68 ON READER SERVICE CARD

remaining two jacks, coded white, are for the resistance and capacitance functions. A pair of banana plugs equipped with spring clips are provided with the instrument. These are convenient to use for measuring discrete, out-of-circuit resistors and capacitors. For in-circuit tests, the usual test leads can be plugged into the jacks.

Unlike most DMM's, the Model 20 can be disassembled in just a few minutes by pulling back on two plastic knobs located on the rear apron. This allows the DMM to be disassembled for access to all parts in the event service or repairs must be performed or when calibration is required. (Calibration is a snap when performed according to the instructions printed on the inside of the instrument case lid.)

We put the Model 20 through our usual tests, checking accuracy with a voltage standard and precision-tolerance resistors. It performed well within its published specifications. After a few weeks of use, we again checked accuracy and found no deviations.

Model 21. Next, we turned our attention to the Model 21 hand-held DMM.

This instrument is identical in performance to the Model 20 (including the capacitance-measuring function) except that it is battery powered, much



more compact, and uses 6.86-mm seven-segment LED readouts. The battery pack is rechargeable, providing more than 1000 measurements before recharging is required. (The

charger is provided with the instrument.)

Operation of the Model 21 is initiated by a fingertip switch located on the left side of the instrument case. The switch has three positions: off, momentary-on, and full-on. For momentary-on operation, the switch is depressed for as long as desired. For full-on, it is slid forward, where it locks in place until slid back to off.

The Model 21 comes with a soft carrying case, which is equipped with a belt clip. It also has a built-in pocket in which the test leads are stored when the instrument is not in use. As far as actual performance is concerned, we could find no difference between the Model 21 and the Model 20 in accuracy and flexibility, and the Model 21 is built to take the rough-and-tumble life of a tool-box/service-vehicle environment.

The Model 20 bench DMM measures 9 in. by 6 1/4 in. by 2 1/2 in. (22.7 x 15.9 x 6.4 cm) and weighs slightly more than 2 lb (1 kg). Its total power consumption is 3.5 watts. The compact Model 21 measures 6 3/4 in. by 3 1/4 in. by 1 3/4 in. (17.1 x 8.3 x 4.4 cm).

CIRCLE NO. 69 ON READER SERVICE CARD

DATA TECHNOLOGY MODEL 20 BENCH-TYPE AND MODEL 21 PORTABLE DIGITAL MULTIMETERS

Bench and portable units have 3 1/2 digits and can measure capacitance.



MOST digital multimeters offer a broad range of measurement and function features coupled with an easy-to-read numeric display. The most popular display is one of the various types of seven-segment character formats, usually consisting of 3 1/2 decades (digits).

Ever since the DMM first began to appear in the market in quantity, we have been anticipating new functions to appear as competition grew. Hence, it did not overly surprise us when Data Technology Corp. announced no less than two "extra-feature" DMM's. One is the Model 20 bench-type DMM and the other is the Model 21 battery-

powered portable DMM that is about the size of a pocket calculator. (Each one is \$269.) Both instruments feature capacitance-measuring functions in addition to the usual ac and dc voltage and resistance functions.

The capacitance function covers a range of from 0.002 μ F to 2 μ F full-scale in four decade-step ranges. Resolution is 1 pF on the 0.002- μ F, 10 pF on the 0.02- μ F, 100 pF on the 0.2- μ F, and 0.001 μ F on the 2- μ F ranges. Consequently, you can now measure unknown capacitances with a high degree of accuracy.

Model 20. In the Model 20, there are four dc-voltage ranges that go from 0 to 2, 20, 200, and 1000 V full-scale. Input resistance is 10 megohms, and polarity indication is automatic. The ac-voltage ranges are the same as on dc, except for the highest range, which goes to 800 volts. The input impedance is 10 megohms shunted by 40 pF, while the frequency range is 50 to 500 Hz.

Resistance can be measured in decade steps in four ranges from 2000 ohms to 2 megohms full-scale. Test currents on the ranges are 5, 0.5, 0.05, and 0.005 mA respectively from the lowest to the highest range.

Any time the measurement capability of the DMM is exceeded, the over-range condition is indicated by the display blinking on and off.

The numeric readouts in the Model 20 are 1/3 in. (8.47 mm) high. They form a bright orange gas-discharge seven-segment display that is easy to read over a very wide range of viewing angles and from quite a number of feet away. The plus and minus signs used to display the polarity of the dc voltage being measured are also gas-discharge devices.

Aside from the RANGE and FUNCTION control knobs and display window, the only other things on the front panel of the DMM are the power switch and four banana jacks. Two jacks, color-coded red and black, are for the ac and dc voltage inputs. The

POPULAR ELECTRONICS

You don't have to buy a new car to get an electronic ignition.

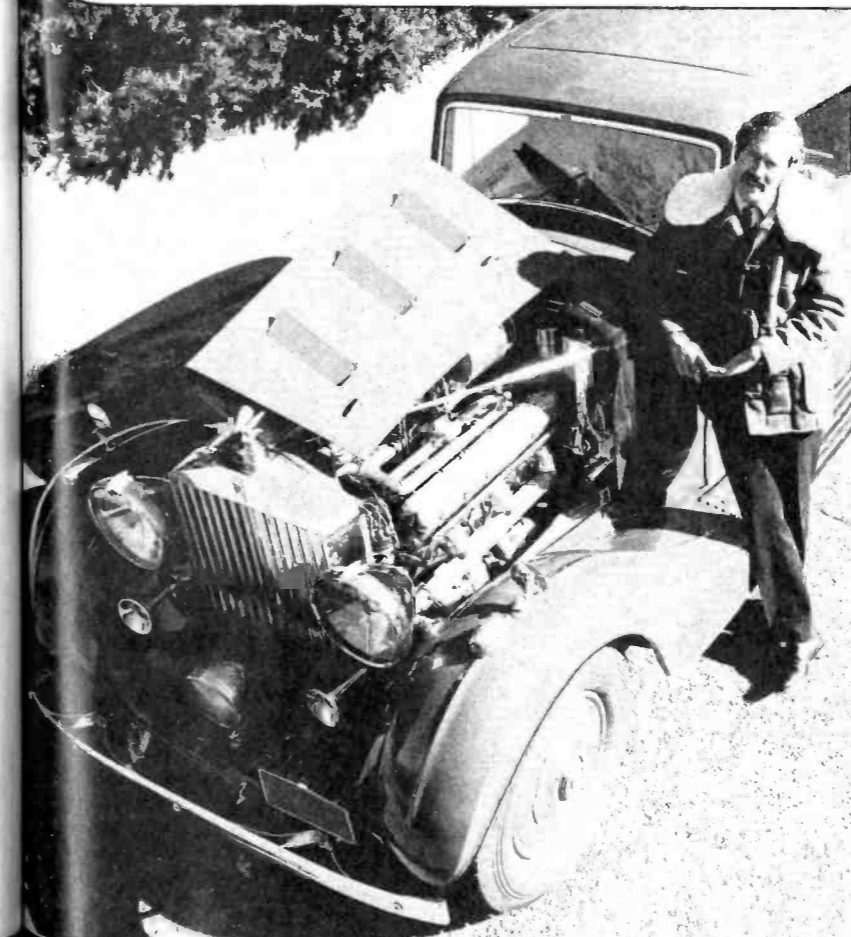

Let's face it. After 37 years, even a Phantom III can use a lift. That's why I put a Delta Mark Ten B Capacitive Discharge Ignition on my Phantom . . . to give her a spark I'd pit against any '75 model car. I went to Delta because they aren't Johnny-come-latelays. Delta's been making electronic ignition systems for over a decade.

Whatever kind of car you drive, you can give it the same great Delta performance I gave mine.

- Mark Ten B Capacitive Discharge Ignition Systems are manufactured by Delta Products, Inc., a company with a conscience, and with a proven record of reliability both in product and in customer relations.

- The Mark Ten B really does save money by eliminating the need for 2 out of 3 tune-ups. Figure it out for yourself. The first tune-up or two saved pays for the unit, the rest is money in your pocket. No bunk!

- Because the Mark Ten B keeps your car in better tune, you actually can save on expensive gasoline.

- With a Mark Ten B, spark plugs stay clean and last longer . . . fouling is virtually eliminated.



I want to know more about Mark Ten B CDI's. Send me complete no-nonsense information on how they can improve the performance of my car.

Name _____

Address _____

City _____ State _____ Zip _____

DELTA PRODUCTS, INC.

P.O. Box 1147, Dept. PE, Grand Junction, Colo. 81501
303-242-9000

Mark Ten B,
assembled . . . \$64.95 ppd
Mark Ten B, kit . . . \$49.95 ppd

Standard Mark Ten,
assembled . . . \$49.95 ppd
Deltakit® . . . \$34.95 ppd

CIRCLE NO. 12 ON READER SERVICE CARD

ZERO-TO-30V EXPERIMENTER'S SUPPLY

BY THOMAS McGAHEE

MOST power supplies that employ the popular 723 precision voltage regulator IC do not permit the output voltage to go down to zero. By using a bias supply (IC3 in the schematic) to reference the main regulator (IC1), the power supply described here is able to use a full 7 volts for its reference supply, while maintaining the ability to go to a 0-volt output. Top output is 30 volts.

The power supply employs a split output, providing both positive and negative output voltages referenced

to a common point. The voltage splitter circuit is composed of IC2, Q2, Q3, and R6 through R8. With the values given for R6 and R8, the positive output voltage swing at BP1 can be varied from 10 to 85 percent of the total available voltage, leaving a negative voltage swing at BP3 of 15 to 90 percent.

Transistors Q2 and Q3 change their dynamic resistance to keep the output voltage properly split for loads of up to 1 ampere. Accurate tracking occurs for all output voltages where the total adds up to at least 3 volts. Below the

3-volt output level, operational amplifier IC2 does not track exactly. For single-ended outputs, BP1 is used as the positive and BP3 the negative output connector; Q2 and Q3 then draw only a few milliamperes of quiescent current.

Because of the circuit's unique design, potentiometer R3 permits a linear adjustment in the output from 0 to 30 volts. The voltage splitter circuit is also designed to perform in a linear fashion. The output current is limited by R2 to 1 ampere at all outputs up to

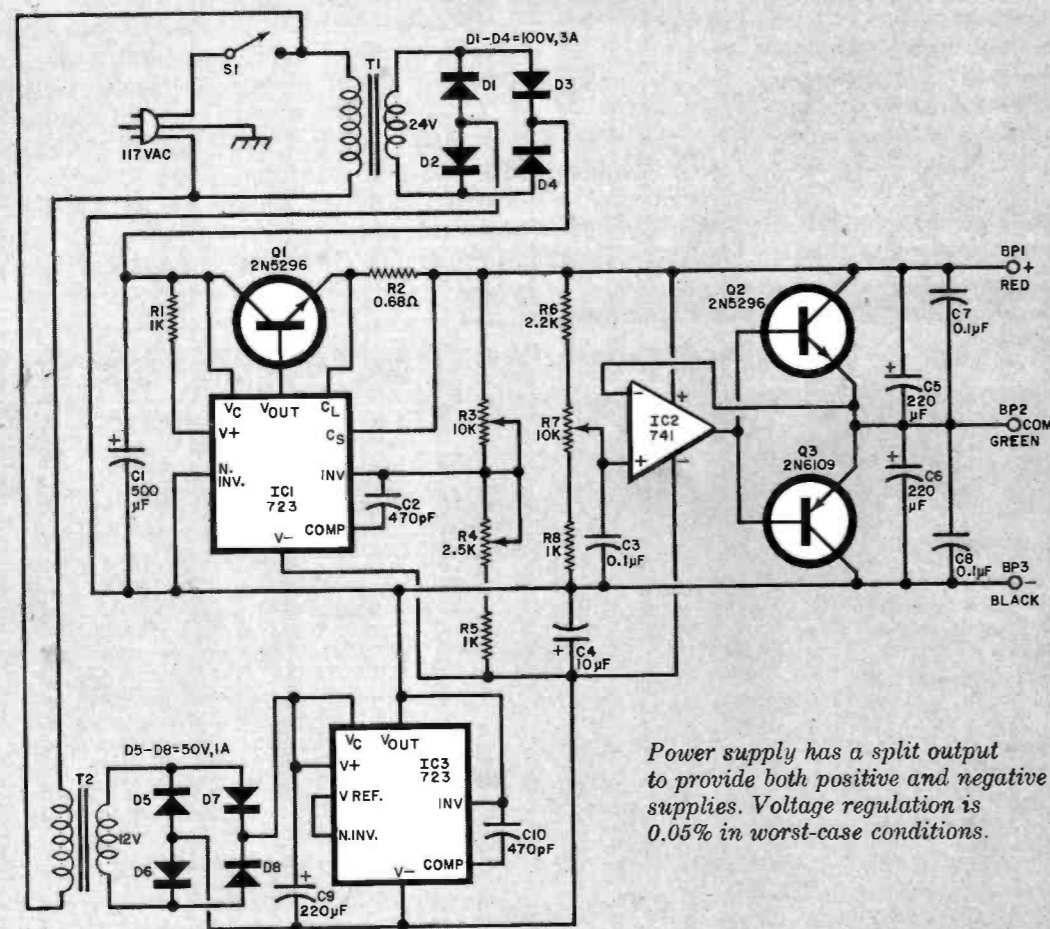

Power supply has a split output to provide both positive and negative supplies. Voltage regulation is 0.05% in worst-case conditions.

PARTS LIST

BP1-BP3—Color-coded binding post
C1—500- μ F, 50-volt electrolytic capacitor
C2, C10—470-pF ceramic capacitor
C3, C7, C8—0.1- μ F ceramic capacitor
C4—10- μ F, 15-volt electrolytic capacitor
C5, C6, C9—220- μ F, 35-volt electrolytic capacitor
D1-D4—100-volt, 3-ampere silicon diode
D5-D8—50-volt, 1-ampere silicon diode
IC1, IC3—723 precision voltage regulator integrated circuit

IC2—741 operational-amplifier integrated circuit.
Q1, Q2—2N5296 transistor
Q3—2N6109 transistor
R1, R5, R8—1000-ohm, 1/2-watt resistor
R2—0.68-ohm, 5-watt resistor
R3, R7—10,000-ohm, linear-taper potentiometer.
R4—2500-ohm, linear-taper trimmer or standard potentiometer (see text)

R6—2200-ohm, 1/2-watt resistor
S1—Spst power switch
T1—24-volt, 1.5-ampere filament transformer
T2—12-volt, 1/2-ampere filament transformer
Misc.—Suitable chassis box; three-conductor line cord; heat sinks and insulators for transistors; line-cord strain relief; pc or perforated phenolic board with solder clips; spacers for mounting board; machine hardware; hook-up wire; solder; etc.

POPULAR ELECTRONICS

25 volts and 800 mA between 25 and 30 volts. The entire available current is delivered between BP1 and BP3 in single-ended applications, or it can be split as needed between the BP1/BP2 positive and BP3/PB2 negative outputs.

Voltage regulation under the worst-case conditions in the power supply measured 0.05 percent in both the single-ended and split modes. The power supply can withstand short circuits across its outputs indefinitely if the three transistor heat sinks are large and mounted on the outside of the supply's case. With the power supply delivering 1 ampere at 24 volts, the ripple measured slightly less than 10 mV. Delivering 950 mA at 28 volts, the ripple was 30 mV—its worst-case condition. (The exact values for regulation and ripple appear to be due mainly to the particular 723 IC used. With some 723 IC's, the regulation can be as bad as 0.7 percent.)

The power supply is best assembled using a printed circuit board, owing to the fact that it utilizes three IC's. However, if you prefer, you can use perforated phenolic board and push-in solder clips—in which case, use sockets for IC1 through IC3. The three transistors *must* be mounted on heat sinks, preferably on the outside of the case in which you build the power supply. (Note that, in the schematic, no pin numbers are given for the IC's. Each IC is available in a variety of package configurations with different pin-designation formats. Hence, pin functions are given so that you can design your pc board for the package configuration used.)

The power supply can be built into a 5 $\frac{7}{8}$ -in. x 5 $\frac{1}{4}$ -in. x 3-in. (14.9-cm x 13.3-cm x 7.6-cm) metal utility box. The transistors, with their heat sinks, go on the rear outside wall of the box, while the front accommodates voltage control potentiometer R3, voltage split control R7, and power switch S1. Zero-set potentiometer R4 can also be mounted on the front panel, or it can be located inside the supply's case, with access provided to it through a hole in the front panel.

In use, R4 must be adjusted until the minimum output from the power supply is exactly zero. Then, potentiometer R3 controls the output over the 0- to 30-volt range. Potentiometer R7 permits the power supply to be operated in the split mode with both sides balanced or with different positive and negative voltages. \diamond

FEBRUARY 1975

PACE...The Two-Way Radio Specialists
Others Try To Keep Pace With

Move Up To The "SIDETALKS"

The dependables! A matched pair that will make you "BIG" in the rapidly expanded 55B mode.

- 23 channels Citizens Band AM — with full 4 watts of maximum legal output power.
- 46 channels Single Side Band 55B — with 12 watts PEP of maximum legal power output.
- Full netting clarifier.
- Highly sensitive performance on receive — more limiting circuitry in AM and blanking circuitry in 55B mode.
- Base unit features a built-in SWR/Watt Meter with mounting bracket and 12V DC input for mobile installations for constant check of antenna performance.



Clean and clear sound in both talking and listening. A full 100% modulation with PACE's unique compression. And a sensitivity of 1.0 μ V on AM and .5 μ V on 55B. Squelch sensitivity is .3 μ V.

ABOVE ALL: MORE TALK POWER FOR YOUR DOLLAR — ONLY \$329.95 and \$389.95 — the price that has lasted all year (but may not last much longer).

TAKE ADVANTAGE NOW! SEE YOUR DEALER TODAY!

((P)) PACE COMMUNICATIONS

Division of PATHCOM INC., 24049 South Frampton Avenue, Harbor City, California 90710
Export: 2200 Shames Drive, Westbury, New York 11590. Available in Canada.

CIRCLE NO. 26 ON READER SERVICE CARD

Who Says Audiophile Components have to be Expensive?

No one really says so, but most people think so. The SAE Mark XXX Stereo Preamplifier and Mark XXXIB Stereo Power Amplifier offer the highest engineering excellence and quality parts available at a moderate price.

To find out what makes these units the most sought after components, fill out the coupon and mail today.

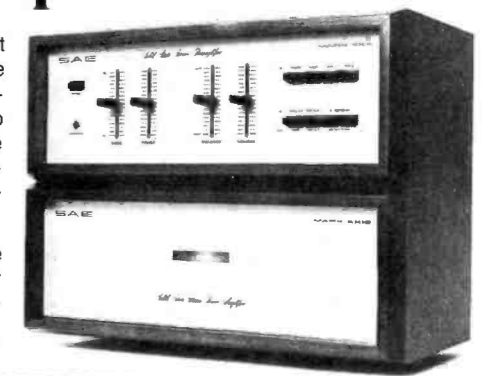

SAE
Components for the Connoisseur

SAE, Inc., Electronics Division (574)
P.O. Box 60271, Terminal Annex, Dept. PE-275
Los Angeles, California 90060

Gentlemen:

Please rush free information on the Mark XXX and Mark XXXIB by return mail.

Name _____

Address _____

City _____ State _____ Zip _____

CIRCLE NO. 30 ON READER SERVICE CARD

IF YOU ARE READY FOR SERIOUS CAREER

Learn College-Level

ADVANCEMENT NOW—

Electronics at Home

With CREI's unique Electronic Design Laboratory Program

There is only one way to a career in advanced electronics—through advanced training. You can get such training through a resident engineering college or you can take a CREI specialized college level electronics program at home.

Wide Choice of Programs. CREI offers you program arrangements with *fourteen* areas of specialization in advanced electronics. You can select exactly the area of specialization for the career you want.

CREI also offers program arrangements *both* for those with extensive experience in electronics *and* for those with only limited experience. All programs are college-level, except for a brief introductory level course, which is optional.

Unique Laboratory Program. CREI now offers a unique *Electronic Design Laboratory Program* to train you in the actual design of electronic circuits. You also get extensive experience in tests and measurements, breadboarding, prototype building and in other areas important to your career. The Lab Program makes it easier for you to understand the principles of advanced electronics. Only CREI offers this complete college type laboratory program.

The Lab Program includes professional equipment which becomes yours to keep. You will especially appreciate the Electronic Circuit Designer, which is available only through this program and which you will find extremely valuable throughout your professional career.

College Credit. You can actually earn college credit through CREI programs, which you can use at recognized colleges for an engineering degree. CREI maintains specific credit transfer arrangements with selected colleges in the U. S.

Industry Recognized Training. For nearly 50 years CREI programs have been recognized throughout the field of electronics. CREI students and graduates hold responsible positions in every area of electronics and are employed by more than 1,700 leading organizations in industry and government.

Qualifications to Enroll. To qualify for enrollment, you should be employed in electronics or have previous experience or practical training in the use of electronic equipment. You must also be a high school graduate or true equivalent.

All CREI Programs are available under the G.I. Bill

Send for FREE Book. If you are qualified, send for CREI's full color catalog describing these college-level programs and your career opportunities in advanced electronics. Mail card or write for your copy of this book.



CREI CAPITOL
RADIO
ENGINEERING
INSTITUTE

McGraw-Hill Continuing Education Center
3939 Wisconsin Avenue Northwest
Washington, D. C. 20016



Accredited Member, National Home Study Council

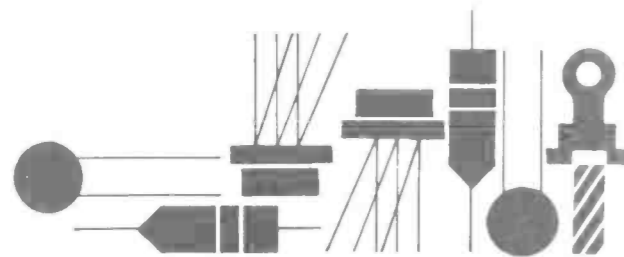

Solid State

By Lou Garner

USING THERMOELECTRIC DEVICES

MOST electronics buffs find great delight in demonstrating their latest hobby project to friends and neighbors, be it a newly constructed audio amplifier, a special-purpose receiver, or whatever. Now you can flabbergast your friends and astonish your acquaintances just by demonstrating the operation of a single, relatively simple solid-state device. And you won't need a bench full of extra equipment to accomplish this marvelous feat. All you'll need is a standard *thermoelectric* (TE) module and a suitable dc power source.

Call in the friend you wish to impress. Place an aluminum cookie sheet on the kitchen table to "protect the surface" (you don't have to mention that its real purpose is to serve as a heat sink). Produce the TE module with a suitable flourish and a few well-chosen comments. Place the module on the cookie sheet and ask your friend to hold it flat in place while you connect the power leads to a dc power supply (in some cases, an ordinary lantern battery). Then ask your friend to continue to hold the module down until it starts to "warm up."

Within seconds, the module's top surface will start to get cold (unless you goofed and placed it on the cookie sheet upside down). Chances are your friend will move his (her?) hand away from the device with some degree of astonishment. Continue watching and, within minutes, a thin film of frost will start to form on the module's top surface. At this point, you can: (a) tell your friend about the device; (b) tell him it's a subminiature air conditioner for pygmy space capsules; or (c) tell him it's a defective heater that gets cold instead of hot.

After you've had your fun demonstrating the device to all your friends, you can use it in a variety of practical applications, from cooling the output devices in a power amplifier to keeping potables at a reasonable drinking temperature. If you're a high school student, you can incorporate the TE device in any of a number of exciting Science Fair projects or, if in college, use it in scientific research work.

Interestingly, TE devices, in themselves, are not new.

Scientists have been working with these units in one form or another for over a century and a half, dating back to 1821, when a German, Thomas Seebeck, discovered that an electric current will flow in a closed circuit made up of two dissimilar metals as long as the junction between the two is maintained at different temperature levels. Named, appropriately, the *Seebeck effect*, this discovery has been utilized for decades in the manufacture of meter and temperature sensing *thermocouples*.

The next major breakthrough was made in 1834, when a French scientist, Jean Peltier, observed that heat energy could be transferred across a junction of dissimilar metals when an electric current was passed through the junction. The junction became, in effect, an electrical "heat pump." This is known as the *Peltier effect*.

Today, TE modules are manufactured using semiconductors and are classified as solid-state devices. The modern Peltier TE cell (Fig. 1A) consists of short sections of p-type and n-type semiconductor materials bonded together with a heavy metallic strap on one side, with electrical connections made to the free ends of the semiconductor elements. Most commercial units are multi-element modules made up by connecting a number of individual cells in series electrically, but in parallel as far as heat transfer characteristics are concerned, as shown in Fig. 1B.

In operation, a dc voltage is applied to the module (or cell), with the positive supply terminal connected to the n-type element, the negative to the p-type. Heat transfer from one side of the module to the other occurs as a result of the continuous formation of new current carriers and their migration through the semiconductor elements to the power terminals. Within limits, the greater the current flow, the greater the heat transfer, provided the transferred heat is dissipated by a suitable heat sink. Unfortunately, internal heating occurs as a result of the current flow, just as in a resistor.

At some point, therefore, the heat generated internally

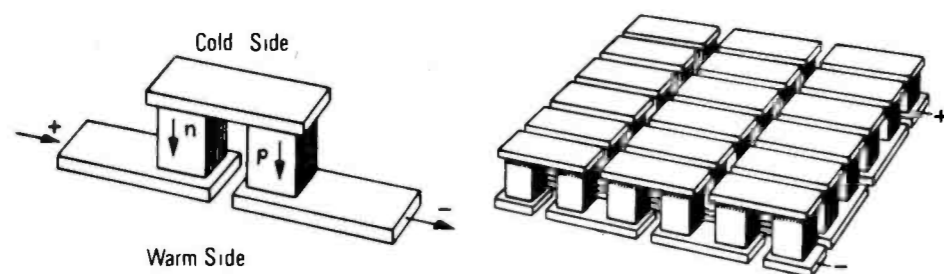

Fig. 1. Thermoelectric devices: single junction (left) and multi-element (right).

offsets the heat transfer and the unit will no longer operate efficiently as a heat pump. In practice, then, each module, depending on its size and construction, has an optimum current rating and maximum heat transfer capability. The direction of heat transfer can be reversed simply by reversing the applied voltage polarity. Thus, a single device can serve either as a cooling or a heating element.

As the legendary two-faced god, Janus, a TE device has two facets to its operation. It can "pump" heat or it can serve as a low-power electrical generator when heat is "pumped" through it. This can be accomplished by heating one side of the module while cooling the other. This technique has been used in commercial and military applications to generate electrical power in remoter areas.

Peltier-type TE modules are available from a number of major manufacturers, with some models carried as stock items by industrial electronics distributors and the larger mail-order supply houses. Prices vary, of course, depending on type and capacity; but in general they are comparable to the prices of medium-power uhf transistors. In addition to the modules themselves, several manufacturers also offer detailed application notes and handbooks.

The Jermyn type A1357 is typical of the medium-power units. It has a maximum cooling capacity of 20 watts and a maximum current rating of 9 A at 2 V dc. It can be powered by line-operated dc supplies provided the ac ripple does not exceed 15% and can develop a maximum temperature gradient of 60°C when the warm face is no hotter than +45°C. The A1357 sells for \$40 each in quantities of up to four units.

Space limitations prohibit our listing all of the firms now manufacturing thermo-electric devices, but the following offer a number of types which should be of particular interest to experimenters and hobbyists:

Borg-Warner Thermoelectrics
Wolf & Algonquin Roads
Des Plaines, IL 60018

Cambridge Thermionic Corporation
445 Concord Avenue
Cambridge, MA 02138

Jermyn
712 Montgomery Street
San Francisco, CA 94111.

Reader's Circuits. Apparently, my discussion of LED's and their applications in last October's column struck a responsive chord among our readers. A number have suggested modifications of the basic circuits I discussed, several have written of their own experiences with these intriguing devices, and others have submitted original designs for new applications. The LED flasher circuit given in Fig. 2, for example, was submitted by Michael E. Lindsey (2625 Fairgreen Drive, Pittsburgh, PA 15241).

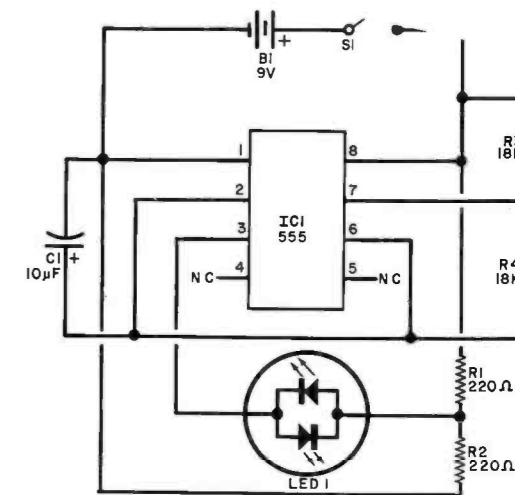

Fig. 2. Reader's flasher circuit uses a 555 timer and a dual-element LED.

Featuring a single IC timer, a minimum of additional components, and a dual (red/green) LED, Lindsey's design alternately flashes red and green at a rate determined by the timing capacitor's (C1) value. The circuit can be used in toys, displays, and models or, if preferred, as a unique type of visual alarm for a control system or intrusion detector.

With neither layout nor lead dress critical and readily available components specified, Lindsey's design can be duplicated quite easily in the home workshop. A standard 555 is used for IC1; the resistors are 1/4 or 1/2-watt types, C1 is a 10 µF, 10-to-15-volt electrolytic capacitor, and LED1 is a MV5491 red/green dual LED. Operating power is supplied by a 9-volt transistor battery, controlled by a spst toggle, slide or rotary switch, S1. A pair of individual LED's may be substituted for the MV5491, if preferred, provided they are connected with reverse polarity, as shown, while the circuit's flashing rate can be changed by using different values for C1.

"How simple can you get?" was my initial reaction to the circuit illustrated in Fig. 3. Submitted by reader James C. Graves, Jr. (11A Lin Drive, Eglin AFB, Valparaiso, FL 32542), this square-wave oscillator requires a hex inverter IC, a feedback capacitor, a dc power source, and . . . that's all!!! The basic design may be used as part of a function generator, in a test square-wave generator, as a tone source for electronic musical instruments, in a signal injector for radio-TV servicing, as a simple clock source for digital applications, or even as a code-practice oscillator if a hand key is used in series with the power supply.

James suggests a 7404 for IC1 and a 30-µF, 6-to-12-volt electrolytic capacitor for C1, with the power supply furnishing 4.5 to 5.5 V dc. However, I suspect that other

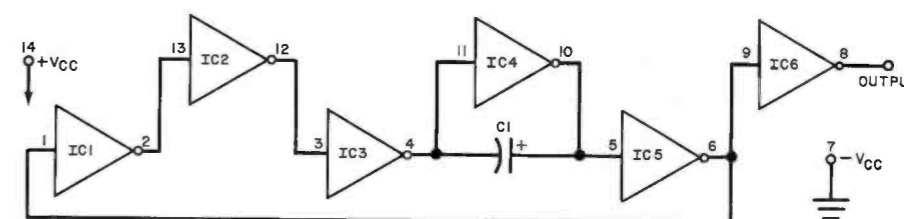

Fig. 3. Square-wave generator uses only a hex inverter IC, a feedback capacitor and a dc power source.

standard hex inverters will work equally well in the basic design, although the supply voltage may have to be changed to match device specifications. When duplicating the circuit, some builders may wish to modify the original design by adding a two-pole, multi-position switch to provide a choice of feedback capacitor values and, thus, a selection of different output frequencies.

The Lit Bit. Aside from your favorite technical magazines, the best sources of up-to-date literature on semiconductor devices and their applications are the reams of material published each year by the major semiconductor manufacturers. While a good deal of this material is directed primarily toward the advanced design engineer or to specialists in specific fields, many of the publications are of general interest and can be particularly valuable to the student as well as to the serious hobbyist and experimenter.

A fair amount of the material will be found on the literature shelves of local distributors. Some is available through area manufacturer representatives, while other items must be requested directly from the manufacturer. Although much of the literature is available without charge, there may be a nominal price for larger items, such as bound handbooks. Among the recent publications which, I feel, should be of special interest to our readers (some of which have been called to your attention in PE's *New Literature* section) are the following:

**From RCA's Solid State Division
(Box 3200, Somerville, NJ 08876):**

Understanding CMOS, publication CPI-279. An 80-page programmed text structured as a self-teaching aid to familiarize engineers and technicians with CMOS technology. Sells for \$2.00/copy.

Thyristors/Rectifiers Pocket Directory, publication TRP-440A. A 68-page pocket-size directory describing over 500 RCA devices, including SCR's, ITR's, triacs, diacs, and rectifiers.

RCA Solid State IR Emitters, Isolators, and Laser Diodes, publication OPT-113A. An interesting 6-page brochure designed so that it can be inserted in a loose-leaf note-book or opened for use as a wall-chart, this publication provides basic information on RCA's line of subject devices.

Linear IC Wall Chart, form LIC-247A. Printed on heavy paper stock, this large wall chart features condensed technical data and functional diagrams for RCA's line of linear IC's.

**From Siliconix, Inc.
(2201 Laurelwood Road, Santa Clara, CA 95054):**

Designing Junction FET Input Op Amps, application note AN74-3. This 18-page application note deals with the design criteria for FET input op amps.

**From Motorola Semiconductor Products Division
(Box 20912, Phoenix, AZ 85036):**

Generate Custom Waveforms Digitally, application note AN-589. Prepared by Karl Huehne, this 6-page publication discusses a method for generating custom waveforms using IC counters, a read-only memory (ROM), and a monolithic digital/analog converter, and a review of possible applications.

Battery-Powered 5-MHz Frequency Counter, application note AN-717. By Don Aldridge, this 10-page application

note describes a battery-powered 5-MHz frequency counter featuring CMOS logic circuitry to achieve low-power operation. Designed for use on a 12-volt power source, the basic counter can be used with any of several readouts.

**From Hamlin, Inc.
(Lake and Grove Streets, Lake Mills, WI 53551):**

Liquid Crystal Display Application Manual—Written as an introduction to liquid crystal displays and their application, this 12-page, 8½ x 11 booklet covers such topics as: "What are liquid crystal displays?" "What is liquid crystal?" "How do LCD's work?" "How many types are there?" "Applications," and "Other displays." It includes one of the best explanations we've seen on the difference between dynamic scattering and field-effect liquid crystals.

Device/Product News.

The Amperex Electronic Corp. (230 Duffy Ave., Hicksville, NY 11802) has introduced a moderately priced solid-state product which should offer interesting possibilities in the

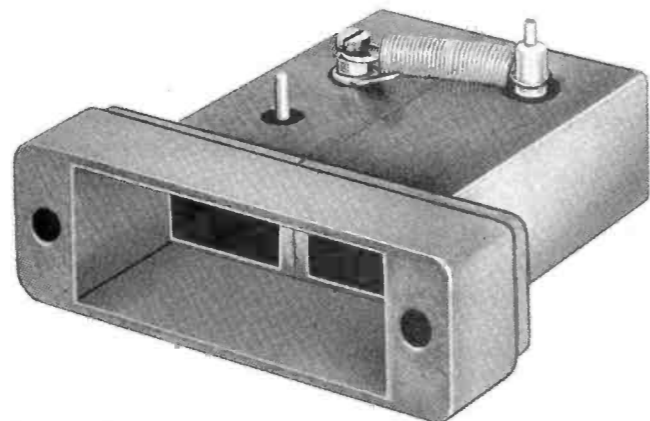

Amperex's low-cost solid-state doppler radar proximity and motion detector.

hands of an imaginative hobbyist—a self-contained microwave module designed for X-band doppler radar proximity and motion detector systems. Priced at only \$47.50 F.O.B. Hicksville in single quantities, the module includes an integral antenna, Gunn oscillator transmitter and low noise Schottky diode detector. Identified as the DX-489 Microwave Module, the new Amperex device is capable of detecting a moving man at a distance of 100 feet, and is suitable for a variety of applications, including intrusion alarm systems and "back-up" safety alarms for trucks, buses and cars. The DX-489 requires a 7-volt dc power source and consumes less than 1 watt while radiating approximately 8 mW at 10.525 GHz. Because of the low-gain antenna, extremely wide angle coverage is possible. The unit can be flush-mounted in a ceiling or wall and still effectively monitor an entire room for "intrusion alarm" applications. External deflectors can be used to shape the radiated pattern; and the vertical beam width can be reduced without reducing horizontal width.

Three new plastic encapsulated devices have been added to General Electric's (Semiconductor Products Dept., Bldg 7, MD49, Electronics Park, Syracuse, NY 13201) growing line of power Darlington transistors. Designated types D41K, D44E and D45E, the new units feature high current gains and low saturation voltages, and may be

used as drivers, regulators and amplifiers. The D41K has a current rating of 2 amperes, with a minimum beta of 10,000 at 200 mA, and is the pnp complement to the earlier D40K. Types D44E and D45E, npn and pnp units, respectively, are complementary pairs in the 10-ampere range, and have minimum betas of 1,000 at 5 amperes. Each type is color-coded for easy pnp-npn identification.

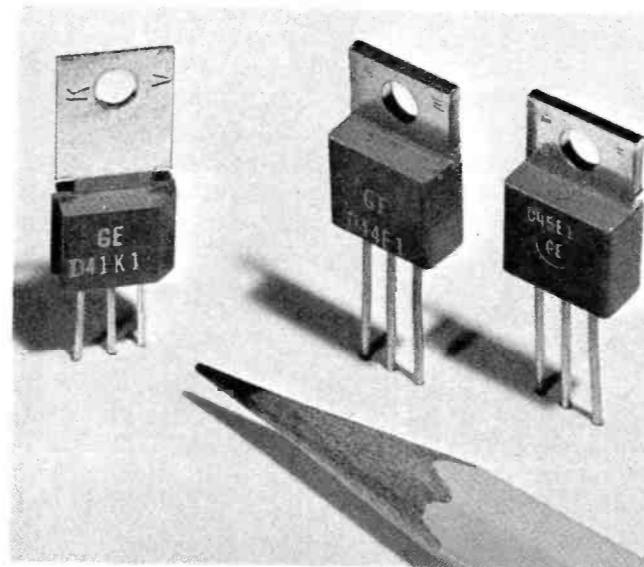

GE's new series of complementary power Darlington's have high current gains.

As a complement to the MPC1000 positive voltage regulator, Motorola's Semiconductor Products Division (P.O. Box 20294, Phoenix, AZ 85036) has introduced the MPC900 negative voltage regulator. Requiring a minimum of external components for operation, as illustrated in Fig. 4, the new device has a maximum input voltage rating of

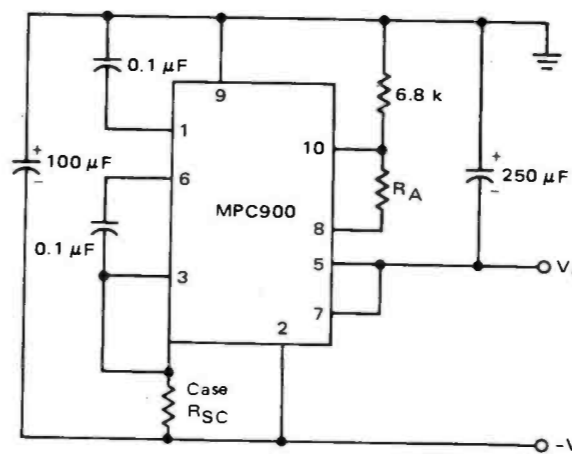
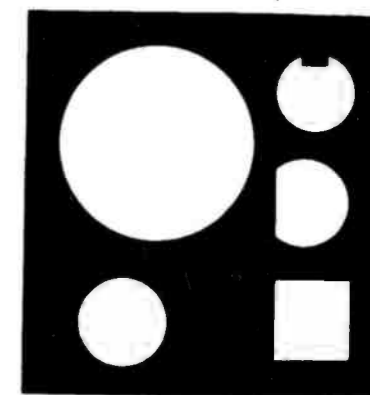

Fig. 4. Typical circuit connections for Motorola's MPC900 negative voltage regulator.

—35 V dc, and can supply an adjustable output voltage from -4 to -30 volts. Housed in a TO-3 style package, the MPC900 can deliver load currents of up to 10 A without an external current-boost transistor and has an internal power dissipation capability of 100 W. Device protection is provided by an adjustable overload circuit. The MPC900 and the MPC1000 can be used together in applications that require complementary regulated supply voltages with a common ground.



Put more punch in your work.

With a Greenlee Chassis Punch you can punch clean, true holes in seconds. Round, square, key or D. In 16-ga. metal, hard rubber, plastic or epoxy. Available at radio and electronics parts dealers. Write for catalog E-730. Greenlee Tool Co, Rockford, Ill. 61101.

GREENLEE TOOL CO



CIRCLE NO. 16 ON READER SERVICE CARD

EVERYTHING YOU WANTED TO KNOW ABOUT CD IGNITION SYSTEMS BUT DIDN'T KNOW WHOM TO ASK.

Send for FREE Tiger booklet (20 pages) which answers all your questions.

Name _____
Address _____
City _____
State _____ Zip _____

CLIP OUT THIS AD AND SEND TO—

TRI-STAR CORP.
P. O. Box 1727 Dept. E
Grand Junction, Colo. 81501
CIRCLE NO. 38 ON READER SERVICE CARD

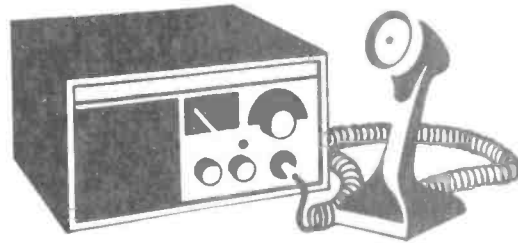

CB Scene

By Len Buckwalter

TAKING THE BARK OUT OF SPARK

I THOUGHT I knew something about ignition noise until I met Harry Bichsel. He probably knows more about the snaps, crackles and pops that tear up our mobile rigs than any other CB'er around today. Harry's a retired electrical engineer (from Westinghouse) and he's spent 25 years tracking down the nasty noises that disable the communications of a mobile rig. As I drove up to his home, he was puttering with a huge contraption that looked like a barn door painted black and covered with plumbing pipes. I soon found out it was designed to capture energy from the sun. But I was more interested in the two vehicles parked next to Harry's infernal solar machine—a 1971 Ford LTD and a perky Mustang. They looked like ordinary cars, but something beneath their bonnets made them the most interference-free mobiles for miles around. They had shielded ignition systems.

CB manufacturers have already done their part in trying to lick mobile radio's greatest problem. Noise limiters on today's sets are a far cry from the simple diode clippers of an earlier time. The diode simply clips the sharp spike created by a noise pulse just before it passes into the receiver's audio circuits. Since the pulse is almost always stronger than the voice modulation, the desired audio goes through unaffected. Well, almost, because clippers aren't perfect and they can reduce the set's intelligibility. If you get one of the newer r-f noise-silencer circuits, chances are it does a better job by attacking noise much earlier in the receiver, before those spikes slop up the i-f circuits. But noise limiters aside, it's generally agreed that in mobile rigs it's best to suppress the noise where it begins—in the car's electrical system. Let the noise limiters in the receiver deal with noise from the other fellow's car.

Harry had tried the usual suppression measures years ago. He had installed filters, bypass capacitors and other items to short-circuit offending r-f hash to ground before it rides into the receiver through antenna or power leads. If ignition noise causes an S-meter reading of S7, he explains, that's about 42 dB, considering that each S-unit might be equivalent to 6 dB. It means an incoming signal must rise to considerable strength to override the noise. The weak ones are never heard. As he demonstrated the point, I recalled a friend of mine who runs a vending-machine route and calls his office on CB to get messages. It's a great moneysaver in his busi-

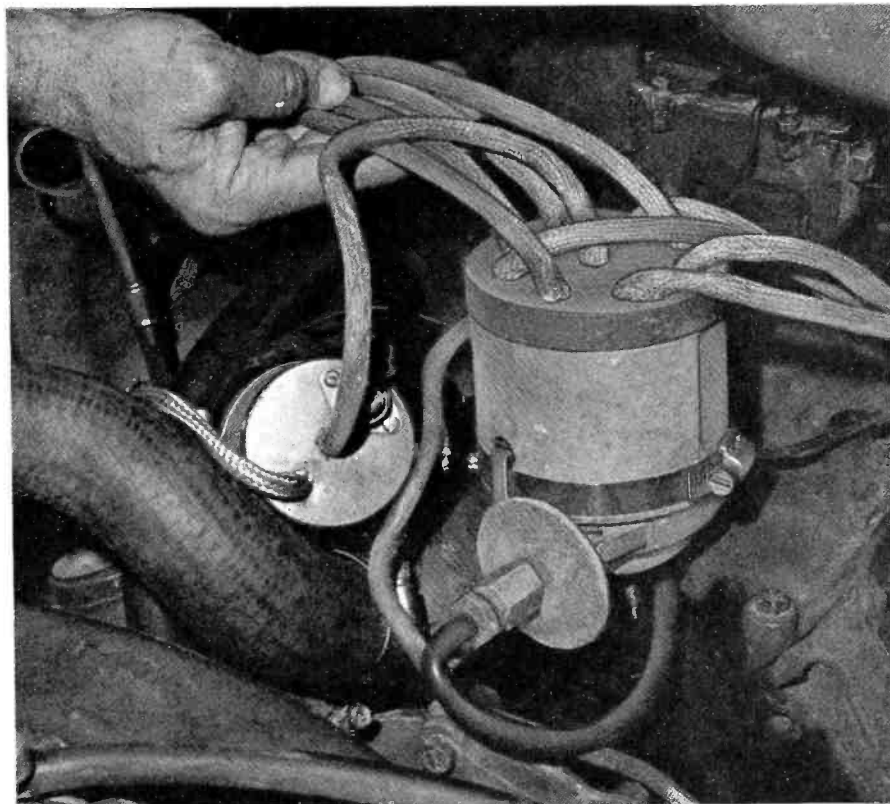

At center is the distributor with a shield can clamped over it. In the technician's hand are high-tension wires encased in shield braid.

ness. But he has to stop and turn off his truck engine to hear anything! Harry found he could reduce an S7 noise reading to about S5, mostly by treating the voltage regulator and instruments (such as the gas gauge). But a whopping difference happened when he went all the way and shielded the ignition system.

The big culprit is the spark plug, and it's easy to see why. If you could somehow bring back Heinrich Hertz and show him the diagram of a car's ignition, he'd likely say, "Looks like the radio transmitter I built around 1890." There's a high-voltage generator and spark-discharge gap reminiscent of turn-of-the-century radio apparatus. A steeply peaked electrical discharge across an air gap creates a wave rich in harmonics that easily extends to 27 MHz. To make matters worse, the wires from each spark plug to the car's distributor act as a multi-element transmitting antenna. You can't bypass high-tension wires because it would warp the clean waveform needed for good ignition, and cost a fortune anyway. In a high-compression engine, spark-plug voltages occasionally reach 30 to 40 kilovolts. Thus, the practical answer is to shield the ignition wires.

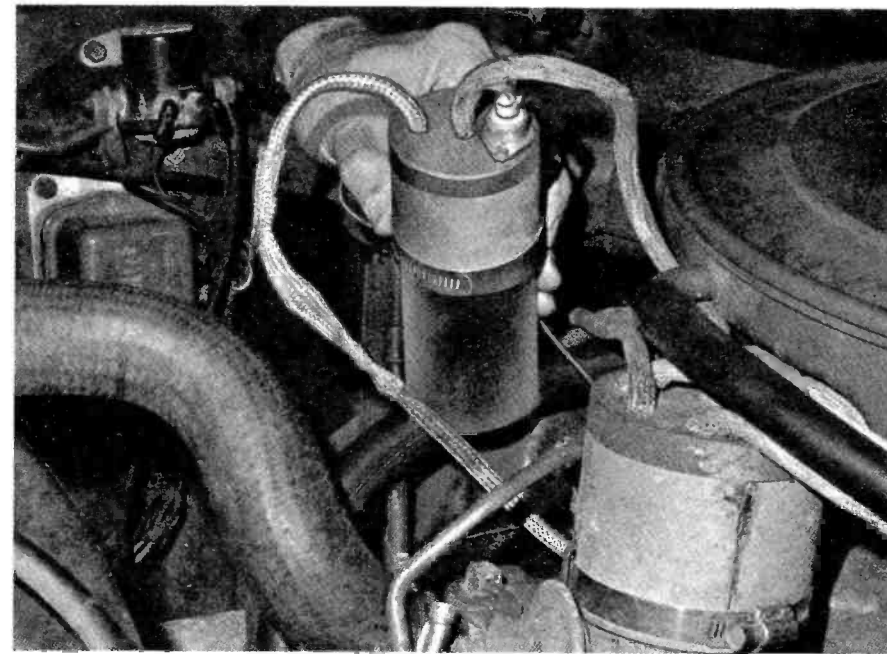

The ignition coil is shielded where the wires connect to it. Shield braids are pulled over the primary wires going to the coil.

How to Shield. Harry has some good pointers on how the job is done. The first is to draw your own diagram that shows where each spark plug and coil wire are connected in your car. Also find the indexing mark on the distributor that orients the wires with respect to the ignition timing. (If you reverse a spark plug wire, it'll mess up the firing order.) All the old spark plug wires should be removed and replaced because these leads must be in excellent condition in a shielded system. Any cracks in the insulation will surely cause an engine miss, since the spark is attracted to the easy ground afforded by the copper braid pulled over each wire. One end of the braid is soldered to a metal shield that covers the spark plug. The other end of the braid is soldered to a can fitted over the distributor cap. (That cap is plastic and radiates considerable noise.) Another metal cap is fitted over the plastic end of the ignition coil to contain noise emitted from that area. Shielded braid is also pulled over the primary wires to the coil, and a 0.1- μ F bypass capacitor is fastened to a coil lead.

That's the basic routine for shielding an ignition system. Good insulation around the plugs inside the shield is important to avoid any possibility of arcing. The bypass capacitor on the ignition coil is needed to establish a good r-f short for noise currents cir-

culating in the shield braids. Since Harry does his own ignition tuneups, he overlaps some braid on one lead to the ignition coil so he can slide back the braid and attach a tach or dwell meter. He's found no difference in engine performance or distributor point life after shielding the ignition system.

Is it worth all the trouble? I'd always thought shielding an ignition system was something done only in airplanes and text books. Much too exotic for us civilians. The answer came as Harry fired up the big V-8 and turned on a CB transceiver that had a plastic case, no less. The little radio hardly protested.

Of course, some cars are quiet, while another of the same make can create the sound of hail on a tin roof. I challenged Harry to remove some of the shielding. All he did was slide back the shield braid from a coil wire and the radio made noises like Baron Frankenstein's laboratory. The receiver's S-meter, which had been idling at a gentle reading of 1 or 2 units swung to S7.

Maybe the time and trouble to shield the ignition are worth it after all. I recall only one mobile rig I operated in the past that wasn't troubled in some way by ignition interference. It was aboard a boat a couple of years ago. Boats, like cars, are prolific noise generators. But come to think of it, that boat was powered by a diesel engine. It had no spark plugs! ♦

**SAVES GAS!
REDUCES
MAINTENANCE!**



★ **The Most Advanced
IGNITION SYSTEM.**

Never wears out or needs any Maintenance.

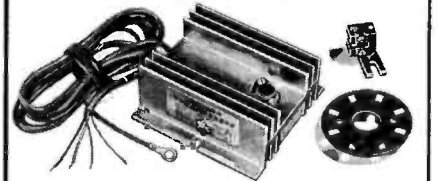

Perfect Timing and Dwell never change!

The Allison OPTO-ELECTRIC System eliminates the Points and Condenser, replacing them with an OPTO-ELECTRONIC TRIGGER, using a Light-Emitting Diode and Phototransistor. Completely eliminates Point and wiper-arm "Friction" wear. The only "TRUE" Electronic Ignition... that you can buy for under \$100. Gives 40-times more Timing Accuracy than ANY system Using "Mechanical" Breaker-Points! Unlimited RPM. Smoother running (No timing fluctuation as with Magnetic Units). All SOLID-STATE Components. UNAFFECTED by Temperature, Moisture, or Vibration! Easier Starting under any condition! Increased Horsepower. Sparkplugs last 3 to 10-times Longer. PERFECT TIMING INCREASES Engine Efficiency and Gas Mileage up to 30%! Pays for itself! Eliminates ignition Tune-Ups forever!

● Quick and Easy Installation!
★ Tested and Proven reliability.

Only **\$49.95** ● SATISFACTION GUARANTEED!

● Complete. ● 1-YEAR FACTORY WARRANTY.
(State Make, Year, Engine Size). (Calif. Res. add Tax).

● CONVERT YOUR "C-D" UNIT TO BREAKERLESS!
Opto-Electric "TRIGGER UNIT" ... Only \$34.95

★ Send Postcard for FREE BROCHURE Today.

ALLISON AUTOMOTIVE CO.
1269-P, East EDNA PL., COVINA, CAL. 91722

CIRCLE NO. 2 ON READER SERVICE CARD

HUGE SAVINGS ON FAMOUS BRAND STEREO COMPONENTS

DISCOUNTS

ON NATIONALLY ADVERTISED

TURNTABLES • CARTRIDGES

COMPACTS • RECEIVERS

AMPLIFIERS • TAPE RECORDERS

Wholesale Prices! Audio Warehouse Sales, One of the Capitals largest stereo wholesalers will fill and deliver all your mail orders promptly in factory sealed cartons, at prices that will amaze you.

Write for quote on Famous Brand, Stereo Components. We guarantee satisfaction.

AUDIO WAREHOUSE SALES
3310 NEW YORK AVE. N.E.
WASHINGTON, D.C. 20002
(202) 832-1616

CIRCLE NO. 39 ON READER SERVICE CARD

15 exciting new projects for '75

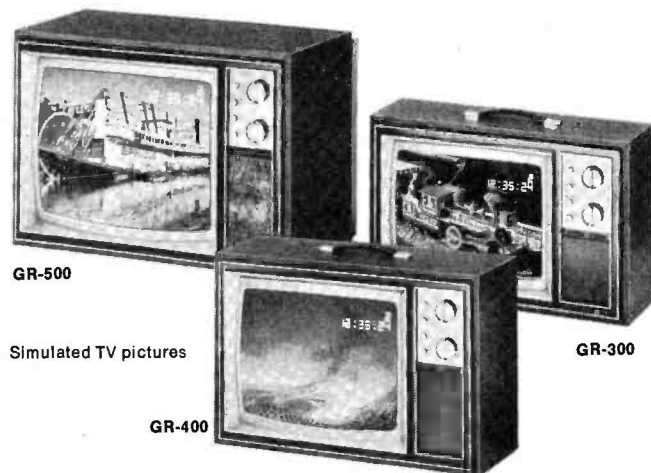

GR-500

Simulated TV pictures

GR-300

GR-400

15, 17 & 19" (diagonal) Color TVs with On-Screen Digital Readout

Advanced Heath engineering and outstanding picture quality. All feature on-screen channel readout & optional plug-in clock modules. In-line picture tubes with slotted shadow masks provide exceptionally bright, sharp pictures. In the GR-400 and 500, black matrix tubes improve contrast. And here's something new—static toroid yoke & magnet assemblies never require convergence & fixed LC filters eliminate instrument IF alignment. GR-300 & 400 come with walnut veneer cabinets; cabinets for the GR-500 start at \$39.95.*

- Kit GR-300 (15" diag.), with cabinet 449.95*
- Kit GR-400 (17" diag.), with cabinet 489.95*
- Kit GR-500 (19" diag.), less cabinet 499.95*
- Kit GRA-2000-1, Digital Clock Module 29.95*

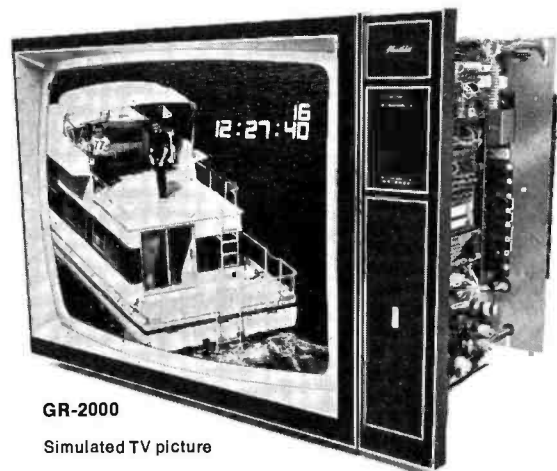

GR-2000

Simulated TV picture

Highly Acclaimed GR-2000 Digital-Design Color TV

The set that brought TV into the digital age—and still one of the finest made. Tuning is totally digital solid-state & the channel number appears right on the big, 25" (diagonal) screen. The optional clock module also displays the time on the screen. For the ultimate in convenience, add the optional wireless remote control. Can be custom mounted; optional cabinets start at \$119.95*.

- Kit GR-2000, less cabinet 669.95*
- Kit GRA-2000-1, Digital Clock Module 29.95*

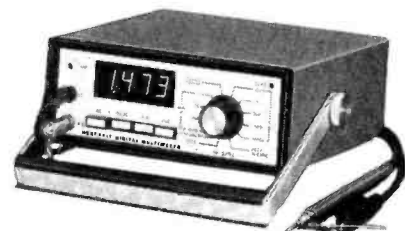

NEW Portable Digital Multimeter

Professional performance at a budget price. 26 ranges resolve voltages to 100 μ V, currents to 100 nA, measures AC & DC current up to 2 A, resistance from 100 to 1000K ohms. Big, bright 3 1/2-digit readout with automatic over-range & polarity indications. Built-in reference standards for easy field calibration. With rechargeable batteries & AC line cord. Kit IM-2202 179.95*



NEW DC-10MHz Oscilloscope

A great scope—a great value! Perfect for TV servicing. 10 mV vertical input sensitivity, time bases from 200 ms/cm to 200 ns/cm, internal or external digital triggering, two input channels. Mu-metal shielded tube with 8x10 cm graticule. Kit IO-4530 299.95*

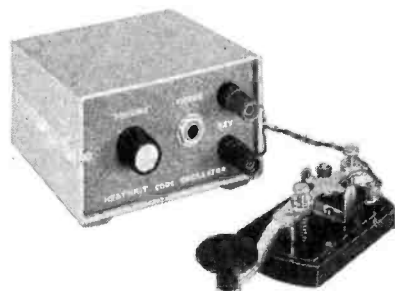

NEW Code Practice Oscillator

As much fun to build as it is to use. It's battery operated for complete portability. Built-in speaker, adjustable tone & volume, head-phone jack. With key. Less battery. Kit HD-1416 9.95*

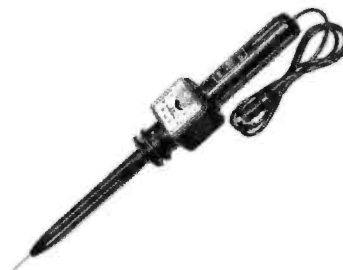

NEW 40 kV Metered Probe

Ideal for high-voltage TV measurements—up to 40 kV with \pm 3% accuracy. On/off switch. Kit IM-5210 17.95* Assembled SM-5210 24.95*



NEW Emergency Car Strobe Light

Highly visible amber flash warns other drivers when your car stalls or breaks down. Non-marring magnetic base, 12' cord, plug fits cigarette lighter. For 12 VDC. Kit GD-1026 28.95*



NEW Solid-State Dip Meter

Fully portable, fits in your hand. Covers 1.6 to 250 MHz in fundamentals. MOS-FET paraphrase amp, hot-carrier diodes, Q-multiplier. With case, 7 plug-in coils. Less battery. Kit HD-1250 59.95*



NEW Windshield Wiper Delay

Provides exactly the wiper speed you need for safe driving in any weather, from light mist to heavy rain. Works with most 12 VDC positive or negative ground cars. Kit CH-1068 14.95*

at traditional Heathkit savings

There are 350 more in the new FREE Heathkit catalog!

Who can build our kits? Anybody!

For over 27 years we've made superb electronic equipment that anyone can build—even with no prior knowledge of electronics or kit building. Famous Heathkit assembly manuals guide you step by step, showing you exactly what to do—even how to solder like a pro.

And we back every Heathkit purchase with people. Expert technical consultants at the factory and trained service personnel from coast to coast are ready to help every step of the way.

Thousands of Heath customers will tell you—**we won't let you fail!**

When you're finished, you'll own one of the finest products available—kit or assembled. But don't take our word for it, independent reviewers consistently praise their quality.

You'll enjoy the satisfaction—and savings—of building a useful product with your own hands. And for years to come, you'll enjoy its unexcelled quality and performance. Build it yourself—with a little help from Heath.

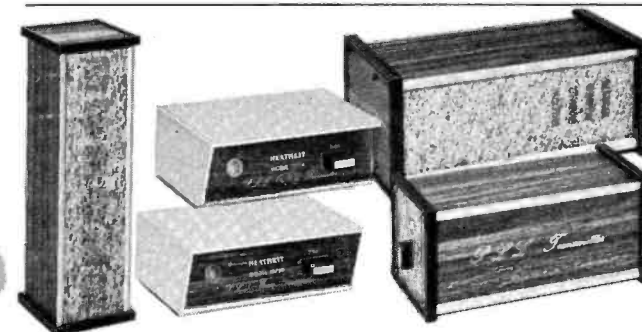
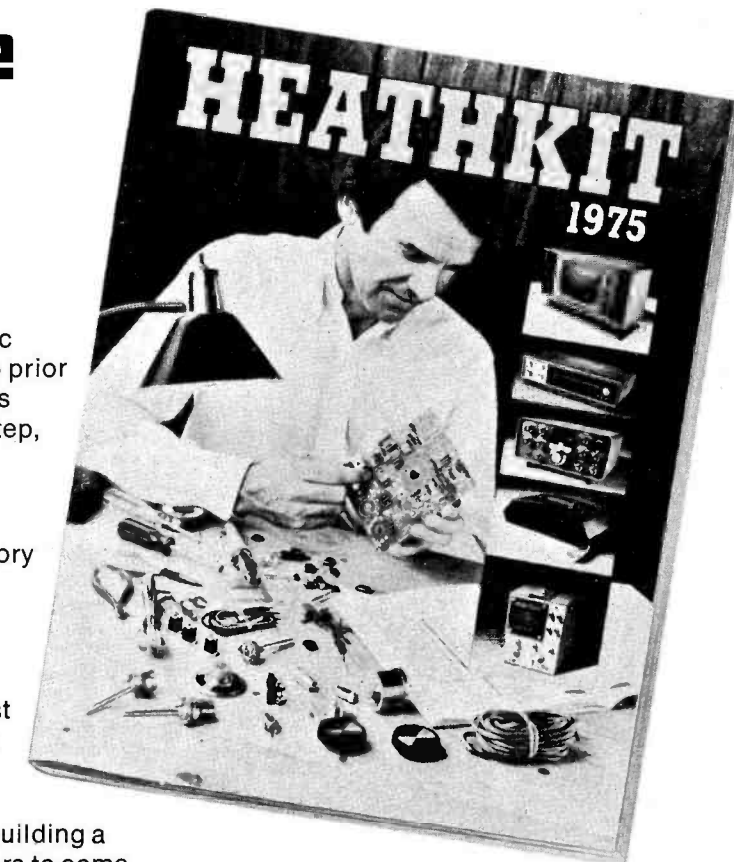

NEW Heathkit/Delta Home Security System

Everything you need for a complete home security system. Remote detectors connect to Central Processor through your home's electrical wiring. Inputs for ultrasonic intrusion detector, heat & smoke detectors plus "panic button" & remote on/off switch. Central Processor features built-in speaker; output for an external speaker. Sounds alarm during power failure.



AM/FM Digital Alarm Clock Radio

One of the world's most sophisticated radios. Big, bright Beckman planar gas discharge tubes display the time, automatically adjusting their brightness as room lighting changes. Standby battery power keeps the clock—and you—on time (without the display) even if the electricity is interrupted. It wakes you to your favorite station or a gentle, electronic beep with adjustable volume. The radio section uses fixed ceramic filters for AM and FM and a factory-assembled and aligned FM front-end with 5 μ V sensitivity.

Kit GR-1075, less batteries 129.95*

Send for your free 1975 Heathkit Catalog today!

HEATHKIT ELECTRONIC CENTERS—Units of Schlumberger Products Corporation
Retail prices slightly higher.

ARIZ.: Phoenix; CALIF.: Anaheim, El Cerrito, Los Angeles, Pomona, Redwood City, San Diego (La Mesa), Woodland Hills; COLO.: Denver; CONN.: Hartford (Avon); FLA.: Miami (Hialeah), Tampa; GA.: Atlanta; ILL.: Chicago, Downers Grove; IND.: Indianapolis; KANSAS: Kansas City (Mission); KY.: Louisville; LA.: New Orleans (Kenner); MD.: Baltimore, Rockville; MASS.: Boston (Wellesley); MICH.: Detroit; MINN.: Minneapolis (Hopkins); MO.: St. Louis (Bridgeton); NEB.: Omaha; N.J.: Fair Lawn; N.Y.: Buffalo (Amherst), New York City, Jericho (L.I.), Westchester; OHIO: Cincinnati (Woodlawn), Cleveland, Columbus, Dayton; PA.: Philadelphia, Pittsburgh; R.I.: Providence (Warwick); TEXAS: Dallas, Fort Worth; VA.: Norfolk (Va. Beach); WASH.: Seattle; WIS.: Milwaukee.

HEATH Schlumberger	
Heath Company Dept. 10-02 Benton Harbor, Michigan 49022	
Name _____	_____
Address _____	
City _____	State _____ Zip _____
*PRICES & SPECIFICATIONS SUBJECT TO CHANGE WITHOUT NOTICE. *MAIL ORDER PRICES; P.O.B. FACTORY.	
CL-555	

CIRCLE NO. 5 ON READER SERVICE CARD



Art's TV Shop

By Art Margolis

MYSTERY OF THE POCKET POWER SUPPLY

AS I OPENED the door of my shop one morning, I was startled by the barking of a white toy poodle. A little old lady, obviously the tiny dog's owner, said sternly, "Quiet Killer." She then picked up Killer, put him in her large pocket book, and followed me into the store.

Strolling up to the counter, she pulled a 4-inch (measured diagonally) black-and-white Sony TV out of the same large pocket book. I shrugged, wrote up a service ticket and placed it in line for the bench.

I didn't get to it until late afternoon. Plugging it in and turning it on, the sound snapped on instantly. Some light struggled to appear on the screen, and finally pushed its way out. At the same time, I heard a buzz in the sound. Examining the raster, it was shrunk in on all four sides and badly bowed. The bowing then moved slowly through the picture and, as the bend reached the bottom of the screen some flopover occurred.

I slid the chassis out of the tiny cabinet and frowned at the tightly packed conglomeration of tuner, three printed boards and a CRT assembly. There were no tubes except the CRT and high-voltage quintupler. The classical symptoms. There was visible hum in the picture, audible hum in the sound and four-sided shrink. This indicated that a filter in the power supply had failed. The line-voltage pulsations, if they weren't filtered, would raise the dickens in the picture and sound, while lowering B+ voltages enough to cause vertical and horizontal shrinking of the picture.

The filters in the power supply are needed to smooth out pulsations after the rectifier changes the input to pulsating output. As the rectifier conducts, the filter charges near the peak voltage of the rectifier's output. Then as the cycle approaches the zero base line, the filter discharges a bit of elec-

tron storage to keep the output near the peak. If the filter is large enough, it keeps on discharging, with little lowering of voltage until the next peak.

A glance at the schematic of the Sony showed that, while the ac input was 117V, the power supply B+ output was supposed to be way down at 10 volts. For receivers having a high B+ input (in the hundreds), a filter size like 20, 50, or 100 μ F is ample. In small transistor sets where the B+ is so low, a large storage device is needed (1,000 μ F or higher is common).

The Sony had two 1000- μ F filters at the dc output and a 1900- μ F at the ac input. These were the prime suspects. I located them quickly on the power supply board and decided to test them by direct replacement.

About ten minutes later, I had them out, new ones in and then the old ones back in place. They were all good. Unhappily, the test didn't work!

A closer look at the schematic, which I fortunately had, showed that there were three transistors in the power supply for further filtering. Operating as filters and voltage regulators, they noise-cancel the ripple and keep voltage at the prescribed level. In addition, they clean out any 60 Hz or 15,750 Hz from the vertical and horizontal sweep circuits that might be coupled into the supply and redistributed throughout the TV.

How They Operate. As electrons are drawn from the TV circuits to the B+ source in the supply, the electrons encounter the collectors of an active power filter system and the emitter of a filter driver, two pnp's and an npn.

The active power filters have their emitters connected to the rectifier. Electrons can thus flow easily through the collector to the emitter and on to the rectifier. Ripple, of course, pulses the electron flow.

Meanwhile, the filter driver has its collector attached to the bases of the active power filters. The base of the driver, however, is connected to a network between the +10 volt line and ground. It takes a steady sample of the rectifier ripple. The ripple enters the base of the driver and is amplified and inverted 180 degrees. Since its collector is attached directly to the bases of the active filter, the inverted ripple modulates the B+ passing through the active filter. The inverted ripple, 180 degrees out of phase with the active filter's ripple, cancels all ripple.

Schematic and layout of the power supply board.

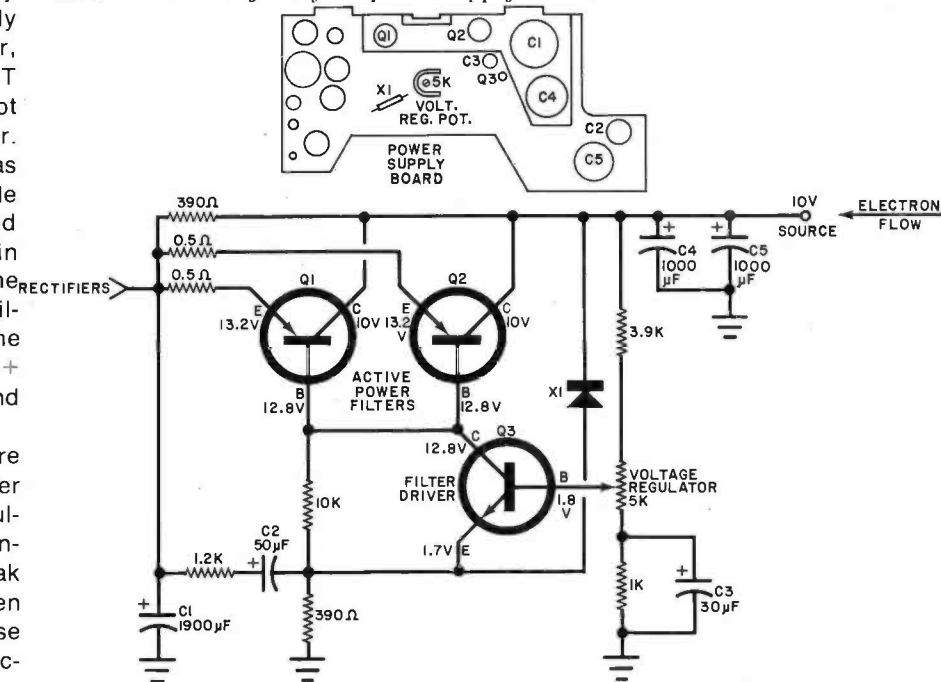

In the base circuit of the driver is a potentiometer used to adjust the size of the amplified ripple. The adjustment is a screwdriver type, accessible through a hole on the center of the power supply board. I took my miniature screwdriver and tried the pot. No effect. Symptoms were unchanged.

I then read the dc voltage at source. Instead of 10 V there was about eight. I turned the control again, noting that the eight volts did not vary. Aha! The trouble was apparently in this pocket power supply.

Turning off the TV, I began resistance readings. When I tested the resistance across the 390-ohm resistor in the +10 volt line, the meter read almost zero. The resistor looked clean and shiny however, which meant it was probably good. The short circuit appeared to be across the resistor, but two active power filters paralleled it!

I had to unsolder them for the final test. But it was worth it! They were both shorted. Zero ohms from E to C.

In a few minutes I had new ones installed. The picture spread out both vertically and horizontally, the visible hum was gone and the buzz in the sound was eliminated. Also, flop-over disappeared and the vertical hold locked the picture tightly.

It was closing time now and I could hear Harry Harris whistling as he swept the front of the store.

I called the number on the little old lady's ticket. "Ma'am, your TV is completed," I told her. "we're closing in a few minutes."

"Killer and I would be so pleased if we could have it for tonight. Could you deliver it?"

Since it was on my way home, and it was probably her only TV, I said yes.

I knocked on her door. She came to the window, and waved me to the garage. When the overhead door squeaked open, Killer was there and started his high-pitched bark. Walking in, I saw a four-foot high doll house with its roof lying on the floor. On the second story was a tiny dog's bedroom and a miniscule TV table that was perfectly sized for the Sony I had in my hand.

I placed the TV on the table, as directed by the woman, plugged it in an actual electric outlet on the doll house wall and attached an antenna wire that came through the wall near the outlet. Video and sound came on, and Killer quickly snuggled down in front of it. Guess a dog's life isn't so bad nowadays.

OEMorsco

An OEM Distributor Of
Certified Integrated Circuits

TTL	7460	.33	74158	1.38	74L51	.39	74S113	1.03	DTL	930	.42	LINEAR	703LH	.90	LM306H	5.28
7400	.29	7470	.38	74160	1.89	74L54	.39	74S114	1.03	932	.42	703LN	.80	LM307H	.65	
7401	.27	7472	.36	74161	1.89	74L55	.39	74S140	3.45	935	.46	709CH	.70	LM307N	.60	
7402	.29	7473	.49	74162	1.93	74L71	.52	74S153	2.00	936	.48	709CN	.44	LM308H	1.75	
7403	.29	7474	.49	74163	1.99	74L73	.68	74S157	2.90	937	.46	710CH	.60	LM308AH	5.88	
7404	.31	7475	.83	74164	1.43	74L74	.68	H SERIES		944	.39	710CN	.55	LM309H	1.80	
7405	.31	7476	.65	74165	1.43	74L75	2.90	74H00	.51	945	.63	711CN	.70	LM309K	2.10	
7406	.48	7480	.66	74166	1.85	74L78	.74	74H01	.51	946	.39	711CN	.65	LM311H	2.60	
7407	.47	7482	1.11	74170	4.02	74L85	1.80	74H04	.57	948	.51	723CH	.95	LM311N-14	2.15	
7408	.33	7483	1.55	74173	2.99	74L86	.74	74H05	.57	949	.41	723D	3.88	LM320	3.00	
7410	.28	7485	2.37	74174	2.85	74L90	1.88	74H08	.57	961	.42	741CH	.68	LM320K	3.30	
7411	.33	7486	.48	74175	2.00	74L91	1.83	74H08	.57	962	.42	741CN	.48	LM340T	1.88	
7413	.59	7489	4.29	74176	1.29	74L93	1.77	74H10	.48	963	.45	LM107H	6.85	LM340K	2.75	
7414	2.90	7490	.81	74177	1.29	74L95	1.69	74H11	.74	1800	.37	LM300H	3.30	LM380N	1.35	
7416	.45	7492	.84	74181	2.85	74L164	1.45	74H12	.47	1808	.37	LM301AH	.68	LM380N-8	1.75	
7417	.29	7493	.82	74182	.88	74L165	1.45	74H22	.47	1812	.59	LM301AN	.53	LM381	2.15	
7420	.73	7494	1.19	74190	1.77	74L192	2.10	74H40	.47	LSI	1103	7.75	LM302H	2.97	LM382N	1.70
7423	.40	7495	1.10	74191	1.77	74L193	2.10	74H50	.47				LM304H	3.00	LM3900N	.95
7425	.70	7496	1.13	74192	1.77	S SERIES		74H51	.47				LM305H	1.65		
7426	.37	7497	.53	74193	1.77	74S00	49	74H52	.47				NE501A	Video Amp	2.87	
7427	.41	7499	.85	74194	1.75	74S03	49	74H53	.47				NE555V	Timer	.77	
7430	.29	74109	.63	74195	1.25	74S04	52	74H54	.47				NE560B	PLL	2.51	
7432	.31	74123	1.06	74196	1.50	74S05	52	74H55	.47				NE562B	PLL	2.43	
7437	.65	74125	.68	74197	1.50	74S10	49	74H61	.47				NE565A	PLL	1.80	
7438	.65	74126	.68	74198	2.75	74S11	49	74H62	.47				NE566V	Func. Gen.	1.55	
7440	.31	74132	1.85	74199	2.75	74S15	49	74H71	.73				NE567V	Tone Dec.	2.50	
7441	1.18	74141	1.37	74200	9.00	74S15	49	74H72	.73							
7442	1.03	74145	1.66	L SERIES		74S20	49	74H73	.73							
7445	1.37	74150	1.33	74L00	.39	74S22	49	74H74	1.20							
7446	1.09	74151	1.02	74L02	.39	74S40	49	74H74	1.20							
7447	1.09	74153	1.39	74L04	.41	74S64	49	74H76	1.19							
7448	1.22	74154	1.91	74L05	.40	74S65	49	74H78	1.19							
7450	.33	74155	1.33	74L10	.39	74S74	98	74H103	1.18							
7451	.33	74156	.99	74L20	.39	74S86	.99	74H106	1.21							
7453	.33	74157	1.01	74L42	1.81	74S112	1.03	74H108	1.36							
7454	.33															

Please inquire about DM8090 through DM8880, F9300 series, Signetics 2500 and BT series, and CMOS. We also offer burn-in and custom testing (e.g. LM308AN-0.1mv) to OEM's. DISCOUNTS: \$100-12%, \$350-18%, \$1000-26%, \$3500-36%, \$10K-43%. TERMS: Cash, check, or your favorite credit card. 25% on C.O.D. CIRCLE NO. 25 ON READER SERVICE CARD

FREE McIntosh CATALOG and FM DIRECTORY

Get all the newest and latest information on the new McIntosh Solid State equipment in the McIntosh catalog. In addition you will receive an FM station directory that covers all of North America.



MX 113 FM/FM STEREO - AM TUNER AND PREAMPLIFIER

SEND TODAY!

McIntosh Laboratory, Inc.
East Side Station P.O. Box 96
Binghamton, N.Y. 13904
Dept. PE

NAME _____
ADDRESS _____
CITY _____ STATE _____ ZIP _____

If you are in a hurry for your catalog please send the coupon to McIntosh. For non rush service send the Reader Service Card to the magazine. CIRCLE NO. 22 ON READER SERVICE CARD

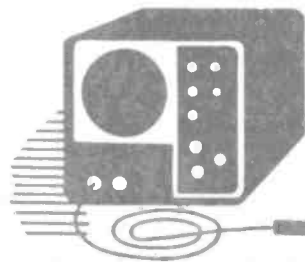

Test Equipment Scene

By Leslie Solomon

LEARNING TO LIVE WITH DIGITAL

If I had to make a guess, I would say that most electronics service technicians are afraid to tackle jobs involving digital circuits. More than likely, this fear comes from a feeling that the technician knows almost nothing about digital electronics and is preconditioned by the "science fiction" surrounding it. Yet, these same technicians think nothing of tackling a complex color-TV problem, armed with nothing more than some basic test equipment and a service manual that may or may not be correct for the particular receiver.

However, the most important tool that the service technician has—problem solving "savvy" gleaned from many years of experience—is an attribute that can make any digital circuit just as easy to service as a five-tube radio.

Let's consider a few facts. During all the years that most service technicians were ignoring digital circuits—leaving them to the computer experts and the "wild-eyed" electronics hobbyists who build strange digital projects—designers of all kinds of consumer devices were putting digital circuits to use in their products. Last year, the Heath Co. introduced a color TV receiver that uses digital logic for tuning and displaying channel number and time on the CRT. This receiver also uses quite a bit of digital logic in its remote control. Magnavox has now introduced the "Star" system in its latest color TV receivers, with heavy use of digital circuits. Soon, we will see FM tuners with 100% digital front ends and numeric channel read-out using LED's or liquid crystal displays. A digital power amplifier will soon find its way to the market; and frequency synthesizers using digital logic are already an important part of CB rigs. Lastly, we have recently been inundated by all types of digital cal-

culators, clocks, and even wrist-watches—some of which are going to need servicing one of these days.

The Altair 8800 Minicomputer introduced in this magazine last month shows promise of wide use in many areas—schools, homes, garages, shops, etc.—presenting a challenge that the service technician must accept for the sake of his future livelihood.

Furthermore, audio equipment can not be expected to remain a bastion of linear equipment for long. Digital recording of music is a reality. Using analog-to-digital and digital-to-analog techniques, tapes have been produced that rival present-day analog recorded versions.

Where to Start. How does one learn the principles of digital logic? One way is through reading the articles on the subject in this or other magazines. Another is to take a course through one of the schools advertised here. The latter approach will give you a long-term knowledge that can be applied to any digital service job you might encounter in the future.

What does the service technician do when faced with a repair job on a digital circuit? The first thing is to arm yourself with a simple digital probe. There are several commercial models available, or plans for building your own have been published in this magazine (for example: "IC Digital Logic Memory Probe," March 1974 and "Digiviewer," March 1971). With a probe and the timing diagram of the equipment to be serviced, the technician can use his savvy to take on most any job. Actually, a digital probe is easier to use than either a scope or a VTVM. For example, the sketch shows a typical digital waveform as seen on a MITS MitScope Model 416 (a four-channel digital probe with memory).

Like most other digital probes, the Model 416 has a lit LED for a logic 1 and a dark LED for logic 0.

At first, the waveforms may appear confusing but they are far easier to interpret than a scope waveform. The four lines represent the logic 1's and 0's that are present at four different points in the particular circuit. The circles within the waveforms represent the LED's in the probe display. There are only two states—on and off. If you were using a digital probe with a single LED, it would blink on and off depending on whether the probe tip was at a point that was 0 or 1 at that instant. Clean decisions are being made at all times. There are no questions of linearity, biasing, harmonic distortion, trap adjustments, etc. There are no scope sweep rates to adjust, no vertical gain to be set, no triggering point to be found, and no time-consuming alignments to be made.

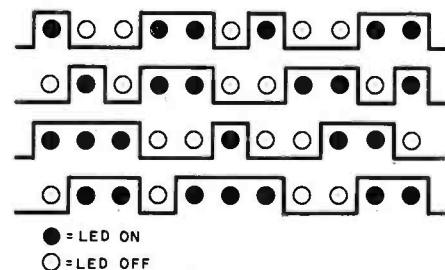

When it comes to digital IC's, we have all learned by now to ignore their internal circuits and deal with them on a black-box level. Some pins are inputs, and some are outputs. All you need is some way to indicate the input and output relationships (logic states), all of which are available from the circuit schematic or the supplier of the device. Add to this a basic knowledge of some simple logic (AND, NAND, OR, NOR, etc.) and the mysterious circuit starts to yield its secrets.

All that remains is to follow the 1's and 0's down the line (just as you would follow a signal through the circuit of a TV receiver), looking for the correct signal. When an improper logic state is found, the defective stage is pinpointed. When you consider the numerous voltages and waveforms encountered in troubleshooting a TV receiver, digital logic circuits become almost elementary.

Essentially, what we are saying is that we must learn to live with digital electronics or prepare to live with the servicing standards (and income) of the five-tube radio days. ♦

Electronics Library

PRACTICAL TRIAC/SCR PROJECTS FOR THE EXPERIMENTER

by Richard W. Fox

There are many works with "Practical Projects" titles that are no more than compilations of schematics, with little or no explanation of circuit operation. This book is a notable exception. Starting with basic pn junction theory, the author progresses through BJT and UJT theory to three-junction devices—SCR's and Triacs. Practical projects are incorporated, utilizing the developed theory. These range from flip-flops to light organs. Also included are switching and voltage control circuits for a variety of ac and dc loads. The book is written for the technician and advanced hobbyist.

Published by Tab Books, Blue Ridge Summit, PA. 17214, 192 pages. \$7.95 hard cover; \$4.95 paper back.

RESISTIVE AND REACTIVE CIRCUITS

by Albert P. Malvino

This textbook is equally suited to formal classroom and home study. As its title implies, it is presented in two parts. Part 1 deals with resistive circuits, covering both series and parallel configurations, theorems and laws, basic measurements, and time. Part 2 is devoted to reactive circuits, including capacitance, inductance, transients, reactance, phasor analysis, resonance, instantaneous ac analysis, switching circuits, etc. The student should have some familiarity with algebra and trigonometry, although reviews of math are given where needed. Each section finishes with a series of questions related to the subject covered, and answers to odd-numbered questions are provided in the back of the book.

Published by McGraw-Hill Book Co., 1221 Avenue of the Americas, New York, NJ 10020. Hard cover. 592 pages. \$12.95.

HANDBOOK OF MODERN SOLID-STATE AMPLIFIERS

by John D. Lenk

This handbook covers the theory, proven design practices, test procedures, and troubleshooting techniques of modern solid-state amplifiers. The first chapter deals with basic amplifier theory. The next five chapters are devoted to the theory and simplified design for a-f, r-f, dc, and operational amplifiers, while the final chapter details amplifier testing and trouble-

FEBRUARY 1975

shooting procedures and techniques. The text and diagram coverage takes in both discrete-transistor and selected integrated-circuit amplifier designs. The text assumes specific design goals and conditions, then presents simple, practical approaches to designing circuits that meet the assumed requirements.

Published by Prentice-Hall, Inc., Englewood Cliffs, NJ 07632. Hard cover. 414 pages. \$15.00.

POLICE CALL

by Gene C. Hughes, Editor

Here is a series of handbooks which list police, fire, ambulance, paramedic, rescue squad, and government radios by frequencies and call letters and by city, county, and state.

Those who have taken up Public Safety Radio monitoring as a hobby will find these comprehensive lists a real help in identifying transmissions or in seeking stations in their immediate area.

The series, which is updated annually, covers the 48 states and the District of Columbia. The nine volumes are divided so as to provide area coverage of contiguous states. In addition to the actual listings, the handbook provides detailed instructions for using the data and a "beginner's" guide to radio monitoring.

Available from Police Call, Lebanon, NJ 08833. 88 pages. \$3.95 each volume plus 50 cents First Class postage and 20 cents sales tax for New Jersey residents (specify geographical location).

HANDBOOK OF ELECTRONIC TABLES AND FORMULAS (FOURTH EDITION)

by D. Herrington and S. Meacham

The revised edition of the Handbook is a thorough listing of most of the commonly used formulas in the field of electronics. Basic formulas and laws, including Ohm's law, Kirchoff's laws, resistance, capacitance, and inductance relationships, are covered in Part One. Constants, and government and industry standards are included in the second section. A table of conversion factors is helpful in changing a value into another measuring system. Symbols, abbreviations, coaxial line characteristics, hardware data, filter and attenuator configurations, and mathematical tables and formulas are included in other sections.

Published by Howard W. Sams and Co., 4300 W 62nd Street, Indianapolis, Ind. 46206. 264 pages. \$6.95, hardbound.

SOLID STATE DEVICES: ANALYSIS AND APPLICATION

by William D. Cooper

Presented in this book is a comprehensive, logically organized treatment of the major solid-state devices used in electronics.

The text starts off with an introduction to

ABOUT YOUR SUBSCRIPTION

Your subscription to POPULAR ELECTRONICS is maintained on one of the world's most modern, efficient computer systems, and if you're like 99% of our subscribers, you'll never have any reason to complain about your subscription service.

We have found that when complaints do arise, the majority of them occur because people have written their names or addresses differently at different times. For example, if your subscription were listed under "William Jones, Cedar Lane, Middletown, Arizona," and you were to renew it as "Bill Jones, Cedar Lane, Middletown, Arizona," our computer would think that two separate subscriptions were involved, and it would start sending you two copies of POPULAR ELECTRONICS each month. Other examples of combinations of names that would confuse the computer would include: John Henry Smith and Henry Smith; and Mrs. Joseph Jones and Mary Jones. Minor differences in addresses can also lead to difficulties. For example, to the computer, 100 Second St. is not the same as 100 2nd St.

So, please, when you write us about your subscription, be sure to enclose the mailing label from the cover of the magazine—or else copy your name and address exactly as they appear on the mailing label. This will greatly reduce any chance of error, and we will be able to service your request much more quickly.

BIG DISCOUNTS

STEREO COMPONENTS

Largest selection of top name brands... try us and see.

It's worth a call
(301) 488-9600



DEPT. D
6330 Frankford Ave.
Baltimore, Md. 21206

All mail answered within 24 hours

Phone Daily 9 AM to 9 PM
Saturday 9 AM to 4 PM
Phone (301) 488-9600

CIRCLE NO. 19 ON READER SERVICE CARD

LOOK IT UP in the Popular Electronics INDEX

1974 Edition Now Available

A complete and detailed subject index to POPULAR ELECTRONICS Magazine containing hundreds of references to equipment, theory, components, and those special circuits that you remember seeing but can't find.

An essential companion to your POPULAR ELECTRONICS Magazine collection, and a must for the audiophile, ham, gadgeteer, and service technician.

The index covers one full year (12 issues) and was prepared in cooperation with the editors of POPULAR ELECTRONICS.

ORDER NOW!

ONLY \$1.50 per copy, postpaid

1972 and 1973 INDEXES

still available at \$1.50 per copy also

SPECIAL DISCOUNT OFFER

All three INDEXES (1972, 1973 & 1974) ONLY \$4.00

POPULAR ELECTRONICS INDEX
Box 2228, Falls Church, Va. 22042

Enclosed please find \$_____ for the following INDEXES, postpaid:

— Sets (1972, 1973 & 1974 INDEXES) \$4.00 per set

— Copies 1974 INDEX, \$1.50 ea.
— Copies 1973 INDEX, \$1.50 ea.
— Copies 1972 INDEX, \$1.50 ea.

Print name _____

Address _____

City _____

State _____ Zip _____

Please enclose payment with order. Make checks payable to INDEX.

semiconductor electronics then proceeds to the junction diode, bipolar transistors, FET's, IC's, etc. Separate chapters are devoted to multistage amplifiers, power amplifiers, rectifiers and filters, power, supply regulators, and oscillators. The behavior of solid-state devices in practical circuit applications is covered by using both graphical and mathematical methods of circuit analysis. Frequent reference is made to actual device ratings and characteristics.

Published by Reston Publishing Co., Inc., P.O. Box 547, Reston, VA 22090. Hard cover. 453 pages. \$14.00.

ELECTRONIC MUSIC PRODUCTION

by Alan Douglas

In providing a practical guide to the production of electronic music, this book will appeal to anyone involved in technical research in EM or in the practical experimentation with musical forms. The book deals first with the properties of conventional instruments, then goes on to demonstrate how their limitations can be overcome by electronic means. Three principle methods of synthesizing music electronically are described. This is both a user's guide and a builder's manual. Well illustrated, it contains tables, waveform drawings, photos of equipment, and schematic diagrams (most with component values indicated) for the basic electronic circuits used in EM generation and processing.

Published by Tab Books, Blue Ridge Summit PA 17214. 148 pages. \$7.95 hard cover; \$3.95 soft cover.

BASIC ELECTRICITY FOR ELECTRONICS

by Richard Blitzer

Although designed as a text for technical training, this work will introduce the more casual reader to basic electrical principles. Algebra and right-triangle trigonometry are used in the presentation. Among the chapter topics are Basic Theory of Electricity, Electrical Units, Series and Parallel Resistor Circuits, Networks, Magnetism and Electromagnetism, and Capacitors and Resistors in DC and AC Circuits. Also included are Introductions to Vacuum Tubes and Semiconductors. Appendices contain trigonometric functions, logarithms and exponents, color codes, and a capsulized mathematics for electronics.

Published by John Wiley & Sons, Inc., 605 Third Avenue, New York, NY 10016. Hard cover, 727 pages, \$14.95.

WIRELESS TELEGRAPHY

edited by Sir Eric Eastwood

The Royal Institution in London sponsored a series of lectures for many years on subjects related to the physical sciences. In this volume, many of the discourses that stand as landmarks in the development of tele-communications are reproduced. The

earliest talks, given in the 1850's, deal with telegraphy, telephony, and the Atlantic cable. At the turn of the century, attention turned to "Signalling Through Space Without Wires," a talk by William Preece, and "Wireless Telegraphy" by Guglielmo Marconi. From 1900 to the end of the series in 1932, the expansion of electronic communications is heralded in talks by Marconi on improvements and new techniques, such as microwaves, and by Fleming's expositions on the thermionic valve. Anyone interested in the history of electronic communications should find these lectures entertaining and educational.

Published by Halsted Press, 605 Third Avenue, New York, NY 10016. 391 pages. \$32.50 hardbound.

ESSENTIAL FORMULAE FOR ELECTRICAL ENGINEERS

by Noel Morris

The continued growth of electrical and electronic engineering has increased the demands on students' and graduate engineers' memories to the point where it is practically impossible to memorize all the formulas they need. This 8 1/4" x 11 1/2" page-size book contains the essential formulas in electronics, control systems, measurements, logic, telecommunications, mathematics, and fields. Also included are color codes, a list of dimensions, and a summary of mechanics.

Published by Halsted Press, 605 Third Avenue, New York, NY 10016. 26 pages. Soft cover, \$2.95.

COMING UP IN THE MARCH

Popular Electronics

How To Choose Electronic Organs

Build A Lady's Led Time/Date Wristwatch

Two Night-Light Projects For Cyclists

TEST REPORTS:

Philips RH-532 Motional Feedback Speaker System
Pioneer PL-71 Single-Play Turntable
Regency ACT-C4H Scanning Monitor
Heathkit TO-1260 Electronic Organ

ELECTRONICS MARKET PLACE

NON-DISPLAY CLASSIFIED: COMMERCIAL RATE: For firms or individuals offering commercial products or services, \$1.80 per word (including name and address). Minimum order \$27.00. Payment must accompany copy except when ads are placed by accredited advertising agencies. Frequency discount; 5% for 6 months; 10% for 12 months paid in advance. **READER RATE:** For individuals with a personal item to buy or sell, \$1.10 per word (including name and address.) No minimum! Payment must accompany copy. **DISPLAY CLASSIFIED:** 1" by 1 column (2-1/4" wide), \$215.00. 2" by 1 column, \$430.00. 3" by 1 column, \$645.00. Advertiser to supply cuts. For frequency rates, please inquire. **GENERAL INFORMATION:** First word in all ads set in bold caps at no extra charge. All copy subject to publisher's approval. All advertisers using Post Office Boxes in their addresses **MUST** supply publisher with permanent address and telephone number before ad can be run. Advertisements will not be published which advertise or promote the use of devices for the surreptitious interception of communications. Closing Date: 1st of the 2nd month preceding cover date (for example, March issue closes January 1st. Send order and remittance to **POPULAR ELECTRONICS**, One Park Avenue, New York, New York 10016, Attention: Hal Cymes.

FOR SALE

FREE! Bargain Catalog—I.C.'s, LED's, readouts, fiber optics, calculators parts & kits, semiconductors, parts. Poly Paks, Box 942PE, Lynnfield, Mass. 01940.

GOVERNMENT Surplus Receivers, Transmitters, Sniperscopes, Radios, Parts, Picture Catalog 25 cents. Meshna, Nahant, Mass. 01908.

LOWEST Prices Electronic Parts. Confidential Catalog Free. KNAPP, 3174 8th Ave. S.W., Largo, Fla. 33540.

ELECTRONIC PARTS, semiconductors, kits. FREE FLYER. Large catalog \$1.00 deposit. BIGELOW ELECTRONICS, Bluffton, Ohio 45817.

RADIO—T.V. Tubes—36 cents each. Send for free catalog. Cornell, 4213 University, San Diego, Calif. 92105.

AMATEUR SCIENTISTS, Electronic Experimenters, Science Fair Students... Construction plans—Complete, including drawings, schematics, parts list with prices and sources... Robot Man — Psychedelic shows — Lasers — Emotion/Lie Detector — Touch Tone Dial — Quadrasonic Adapter — Transistorized Ignition — Burglar Alarm — Sound Meter... over 60 items. Send 25 cents coin (no stamps) for complete catalog. Technical Writers Group, Box 5994, University Station, Raleigh, N.C. 27607.

METEERS—Surplus, new, used, panel or portable. Send for list. Hanchett, Box 5577, Riverside, CA 92507.

WE SELL CONSTRUCTION PLANS. TELEPHONE: Answering Machine, Speakerphone, Carphone, Phonevision, Auto Dialer, Touch Button Dialer, Central Dial System. **TELEVISION:** \$35.00 Color Converter, Video Tape Recorder. \$25.00 Camera. **HOBBYIST:** Electron Microscope, 96 Hour Tape Music System, Ultrasonic Dishwasher, Radar-Oven, Plans \$4.95 each. **NEW ITEM:** \$75. Electronic Pocket Calculator, \$7.50. **COURSES:** Telephone Engineering \$39.50. Detective Electronics \$22.50. Integrated Circuit Engineering, \$49.50. **NEW SUPER HOBBY CATALOG** plus year's subscription to Electronic News Letter AIRMAILED \$1.00. Don Britton Enterprises, 6200 Wilshire Blvd., Los Angeles, Calif. 90048.

LOOKING FOR A NEW CHALLENGE?
... then build a TV camera!
ONLY SOLID-STATE CAMERA AVAILABLE IN KIT FORM OR FACTORY ASSEMBLED. COMPLETE KIT WITH VIDEO TUBE ONLY \$166.00. POSTPAID DELIVERY ANYWHERE IN U.S., CANADA AND MEXICO. OPTIONAL AUDIO SUBCARRIER \$185. WRITE OR PHONE NOW FOR COMPLETE CATALOG OF KITS, PARTS AND PLANS. DIAL 402-387-3771.



MECHANICAL, ELECTRONIC devices catalog 10 cents. Greatest Values — Lowest Prices. Fertik's, 5249 "D", Philadelphia, Pa. 19120.

SOUND SYNTHESIZER KITS—Surf \$12.95, Wind \$12.95, Wind Chimes \$17.95, Electronic Songbird \$6.95, Musical Accessories, many more. Catalog free. PAIA Electronics, Box J14359, Oklahoma City, OK 73114.

DISCOUNT PRICES
B & K, SENCORE, LEADER and RCA
Test Equipment
RAYTHEON, ICC/MULLARD Tubes
TELEMATIC Test Jigs
Free Catalog
FORDHAM RADIO SUPPLY CO., INC.
558 Morris Ave. • Bronx, N.Y. 10451

FREE CATALOG. Parts, circuit boards for POPULAR ELECTRONICS projects. PAIA Electronics, Box C14359, Oklahoma City, OK 73114.

YOU WILL SAVE BIG MONEY! Surplus, Clearouts, Bankruptcy, Inventory, Deals. Catalog \$1 (redeemable). ETCOA Electronics, Box 741, Montreal, H3C 2V2. U.S. Inquiries.

BURGLAR-FIRE alarm supplies and information. Free catalog. Protecto Alarm Sales, Box 357-G, Birch Run, Michigan 48415.

TELEPHONE "BUGGED"? Countermeasures Brochure \$1.00. Nageye, Drawer 547, Pensboro, W. VA 26415.

HEAR POLICE/FIRE Dispatchers! Catalog shows exclusive directories of "confidential" channels, receivers. Send 10 cent stamp. Communications, Box 56-PE, Commack, N.Y. 11725.

CONSTRUCTION PLANS: Laser... \$2.00. Rocket Tracking Transmitter... \$2.00. Space Monitor-Missile Tracker... \$2.00. Free Catalog. Electro-Research, P.O. Box 20285, Ferndale, Michigan 48220.

CD IGNITIONS, VHF/UHF monitors, crystals, CB radios, Southland, Box 3591-B, Baytown, Texas 77520.

INTERNATIONAL ELECTRONICS UNLIMITED

MICROPROCESSORS

IEU is making available for the first time anywhere an extremely versatile 16 bit microprocessor kit. The basic kit includes all necessary components to build a 16 bit microprocessor. Optional memory boards are available allowing possible expansion of the basic system to microcomputer or minicomputer proportions.

Basic Kit Includes: A printed circuit boards (compatible with 22 pin edge connectors — not supplied) B microprocessor chip set C gates, interface elements, clock drivers, etc. D transistors, diodes, capacitors E 75 page data package which includes an Introduction to microprocessors, all necessary data sheets and extensive data on the workings and applications of microprocessor chips.

PRICE (basic kit) \$349.50

Available Options:
1 power supply component pkg
2 memory board #1 (16kbytes 1101 rams)
3 memory board #2 (40kbytes 1101 rams and 5203 erasible PROMS)

Basic Data Package available separately refundable with purchase of basic kit \$5.00

TTL		LINEAR CIRCUITS	
7400	\$.19	7485	\$ 1.39
7401	.19	7486	.44
7402	.19	7489	2.75
7403	.19	7490	.76
7404	.22	7491	1.29
7405	.22	7492	.79
7406	.39	7493	.79
7407	.39	7494	.89
7408	.25	7495	.89
7409	.25	7496	.89
7410	.19	74105	.49
7411	.29	74107	.57
7413	.79	74121	.49
7415	.39	74122	.53
7416	.39	74123	.99
7417	.39	74125	.69
7420	.19	74126	.79
7422	.29	74141	1.23
7423	.35	74145	1.15
7425	.39	74150	1.09
7426	.29	74151	.89
7427	.35	74153	1.29
7430	.22	74154	1.59
7432	.29	74155	1.19
7437	.45	74156	1.29
7438	.39	74157	1.29
7440	.19	74161	1.39
7441	1.09	74163	1.59
7442	.99	74164	1.89
7443	.99	74165	1.89
7444	1.10	74166	1.65
7445	1.10	74173	1.65
7446	1.15	74175	1.89
7447	1.15	74176	1.65
7448	1.15	74177	.99
7450	.24	74180	1.09
7453	.27	74181	3.65
7454	.39	74182	.89
7460	.19	74190	1.59
7464	.39	74192	1.49
7465	.39	74193	1.39
7472	.36	74194	1.39
7473	.43	74195	.99
7474	.43	74196	1.85
7475	.75	74197	1.15
7476	.47	74198	2.19
7483	1.11	74199	2.19

FEBRUARY SPECIALS

930	Dual 4 input gate w/exp	\$.10
936	Hex inverter	.10
937	Hex inverter	.10
311	Hi perf volt comp mDIP	.89
322	Prec timer. Operates on unreg supply 4.5-40v	1.59
709	Op amp	.21
739	Dual hi perf op amp	.99
40411	Audio pwr amp	3.40
40594	Audio driver	1.33
40595	Audio driver	1.49
2N2219A	Audio-UHF amp/sw	.89
5001	12 dig calculator chip	3.39
5312	4 dig clock chip	5.25
7404	Hex inverter	.18
7410	Triple 3-input NAND gate	.16
7420	Dual 4-input NAND gate	.16
7437	Quad 2-input NAND buffer	.29
7440	Dual 4-input buffer	.17
7445	BCD-dec ddr-drvr	.90
7489	64 Bit RAM	2.35
7490	Decade counter	.69
74154	4-6 line ddr demux	1.19
74181	Arithmetic logic unit	2.95
74L00	Dual 2 input gate (l.p.)	.27
74L74	Dual D flip flop (l.p.)	.49
MAN1	Red 7 seg LED	2.19
MCT2	Opto iso trans	.59

ALL DUAL-IN-LINE

1101	256 bit RAM MOS	\$1.75
1103	1024 bit RAM MOS	4.95
5203	2048 bit eras. PROM	24.95
5260	1024 bit RAM low power	3.95
7489	64 bit RAM TTL	2.75
8223	Programmable ROM	4.95
74200	256 bit Ram-tri-state	7.95

LED'S AND OPTO ISOLATORS

MV10B	Red TO 18	\$.25 ea.
MV50	Axial leads	.33
MV5020	Jumbo visible red	.33
ME4	Infra red diff. dome	.60
MAN1	Red 7 seg. .270"	2.50
MAN2	Red alpha num. .32"	4.95
MAN3A	Red 7 seg. .127"	1.79
MAN3M	Red 7 seg. .127" claw	.75
MAN4	Red 7 seg. .190"	2.15
MAN5	Green 7 seg. .270"	2.95
MAN7	Yellow 7 seg. .270"	1.35
MAN8	Yellow 7 seg. .270"	3.95
MAN6	60° high disp. view	4.65
DL707	Red 7 seg. .3"	2.15
MCT2	Opto-iso transistor	.69

CALCULATOR & CLOCK CHIPS w/data

5001	12 DIG 4 funct fix dec	3.95
5002	Same as 5001 6xc btry pwr	7.95
5005	12 DIG 4 funct w/mem	8.45
MM5725	8 DIG 4 funct chain & dec	2.79
MM5736	18 pin 6 DIG 4 funct	4.95
MM5738	8 DIG 5 funct K & Mem	7.95
MM5739	9 DIG 4 funct (btry sur)	6.95
MM 5311	28 pin BCD 6 dig mux	6.95
MM 5312	24 pin 1 pps BCD 4 dig mux	6.95
MM 5313	28 pin 1 pps BCD 6 dig mux	7.95
MM 5314	24 pin 6 dig mux	8.95
MM 5316	40 pin alarm 6 dig	8.95

4000 SERIES RCA-EQUIV.

CD4001	\$.55	CD4017	2.95
CD4009	.85	CD4019	1.35
CD4010	.85	CD4022	2.75
CD4011	.55	CD4023	.55
CD4012	.55	CD4025	.55
CD4013	1.20	CD4027	1.35
CD4016	1.25	CD4035	2.85

(408) 659-4773

ON ORDERS OVER \$25.00 DEDUCT 10%
All items are new, unused surplus parts — tested functional. Satisfaction is guaranteed. Shipment will be made via first class mail — postage paid — in U.S., Canada and Mexico within three days from receipt of order. Minimum order — \$5.00. California residents add sales tax.

INTERNATIONAL ELECTRONICS UNLIMITED
P.O. BOX 1708 MONTEREY, CALIF. 93940 USA

FREE DATA SHEETS WITH EVERY ITEM 739/749 IC WITH EVERY \$10 ORDER*

- REDUCE YOUR PROJECT COSTS
- MONEY-BACK GUARANTEE
- 24-HOUR SHIPMENT
- ALL TESTED AND GUARANTEED

- TRANSISTORS (NPN):**
- 2N3563 TYPE RF Amp & Osc to 1 GHz (pl.2N918) 6/\$1.00
 - 2N3565 TYPE Gen. Purpose Hgh Gain (TO-92/106) 6/\$1.00
 - 2N3567 TYPE Hgh-Current Amplifier/Sw 500 mA 4/\$1.00
 - 2N3866 TYPE RF Pwr Amp 1-2 W @ 100-600 MHz \$1.50
 - 2N3903 TYPE GP Amp & Sw to 100 mA and 30 MHz 6/\$1.00
 - 2N3904 TYPE GP Amp & Sw to 100 mA (TO-92/106) 5/\$1.00
 - 2N3919 TYPE RF Pwr Amp 3-5 W @ 3-30 MHz \$3.00
 - 2N4274 TYPE Ultra-High-Speed Switch 12 ns 4/\$1.00
 - MPS5615 TYPE High-Gain Amplifier hys. 250 3/\$1.00
 - Assort. NPN GP TYPES, 2N3565, 2N3641, etc. (15) \$2.00
 - 2N4249 TYPE (PNP) Low-Noise Amp 1 µA to 50 mA 4/\$1.00
- FETs:**
- N-CHANNEL (LOW-NOISE):
 - 2N4401 TYPE RF Amp & Switch (TO-18/106) 3/\$1.00
 - 2N4416 TYPE RF Amplifier to 450 MHz (TO-72) 2/\$1.00
 - 2N5486 TYPE RF Amp to 450 MHz (Plastic 2N4416) 3/\$1.00
 - E100 TYPE Low-Cost Audio Amplifier 4/\$1.00
 - ITE4868 TYPE Ultra-Low Noise Audio Amp. 2/\$1.00
 - T1574 TYPE High-Speed Switch 40Ω 3/\$1.00
 - Assort. RF & GP FETs, 2N5163, 2N5486, etc. (8) \$2.00
- P-CHANNEL:**
- 2N4360 TYPE Gen. Purpose Amp & Sw (TO-106) 3/\$1.00
 - E175 TYPE High-Speed Switch 125Ω (TO-106) 3/\$1.00

- FEBRUARY SPECIALS:**
- IN3644 TYPE PNP TRANSISTOR GP Amp & Switch 4/\$1.00
 - MPF102 TYPE N-CHANNEL FET RF Amp 3/\$1.00
 - 741 Freq. Compensated Op Amp (DIP/TO-S/MINI-DIP) 3/\$1.00
 - IN914 or IN4148 TYPE GP DIODE 100 V/10 mA 15/\$1.00
 - MM5316 Digital Alarm Clock-Snooze/Alarm/Timer Hrs, Mins, Secs — with Special Schematics \$11.95
 - MM5736 6-Digit 4-Function Calculator 18 PIN DIP \$ 3.95

- LINEAR ICs:**
- 308 Micro-Power Op Amp (TO-5/MINI-DIP) \$1.00
 - 309K Voltage Regulator 5 V @ 1 A (TO-3) \$1.50
 - 324 Quad 741 Op Amp, Compensated (DIP) \$1.90
 - 380 2-5 Watt Audio Amplifier 34 dB (DIP) \$1.29
 - 555X Timer 1 µs-1 hr, Dif. plout from 555 (DIP) \$.85
 - 709 Popular Op Amp (DIP/TO-5) \$.29
 - 723 Voltage Regulator 3-30 V @ 1-250mA (DIP/TO-5) \$.58
 - 739 Dual Low-Noise Audio Preamp/Op Amp (DIP) \$1.00
 - 1458 Dual 741 Op Amp (MINI-DIP) \$.65
 - 2556 Dual 555 Timer 1 µsec to 1 hour (DIP) \$1.55

- DIODES:**
- IN3600 TYPE Hi-Speed Sw 75 V/200 mA 6/\$1.00
 - IN3893 TYPE RECTIFIER Stud Mount 400 V/12 A 2/\$1.00
 - IN4608 TYPE GP & Sw 80 V/400 mA 6/\$1.00
 - IN749 ZENER 4.3 Volt (±10%) 400 mW 4/\$1.00
 - IN753 ZENER 6.2 Volt (±10%) 400 mW 4/\$1.00
 - IN755 ZENER 7.5 Volt (±10%) 400 mW 4/\$1.00
 - IN757 ZENER 9.1 Volt (±10%) 400 mW 4/\$1.00
 - IN758 ZENER 10 Volt (±10%) 400 mW 4/\$1.00
 - IN965 ZENER 15 Volt (±10%) 400 mW 4/\$1.00
 - IN968 ZENER 20 Volt (±10%) 400 mW 4/\$1.00
 - D5 VARACTOR 5-50 W Output @ 30-250 MHz, 7-70 pF \$5.00
 - F7 VARACTOR 1-3 W Output @ 100-500 MHz, 5-30 pF \$1.00

*MAIL NOW! FREE DATA SHEETS supplied with every item from this ad. FREE 739 or 749 Low-Noise Dual Op Amp included (\$1.00 value) with every order of \$10 or more, postmarked prior to 3/31/75. ORDER TODAY—All items subject to prior sale and prices subject to change without notice. WRITE FOR FREE CATALOG offering hundreds of semiconductors not listed here. Send 10¢ stamp. TERMS: All orders must be prepaid. We pay postage. \$1.00 handling charge on orders under \$10. Calif. residents add 6% sales tax.

ADVA ELECTRONICS
BOX 4181 V, WOODSIDE, CA 94062
Tel. (415) 851-0455
CIRCLE NO. 1 ON READER SERVICE CARD

CONVERT any television to sensitive, big-screen oscilloscope. Only minor changes required. No electronic experience necessary. Illustrated plans. \$2.00. Sanders, Dept. A-33, Box 92102, Houston, Texas 77010.

BUGGED??? New locator finds them fast. Write, Clifton, 11500-L N.W. 7th Avenue, Miami, Florida 33168.



PAIA HAS... modular SYNTHESIZER KITS

demo record \$1.00 free catalog

PAIA ELECTRONICS, INC.
BOX P14369, OKLAHOMA CITY, OK 73114

CRYSTALS, Scanners, \$3.88, include make and frequency. G Enterprises, P.O. Box 461PC, Clearfield, UT 84105.

FREE CATALOG. Kits, Components, audio equipment. Electronic Supply Pacs, Box 175, Floral Park N.Y. 11001.

SUBSCRIBE NOW!

LEARN THE SECRETS OF YOUR TELEPHONE

Telephone Electronics Line

FACTS NEVER PUBLISHED FOR THE PUBLIC

A UNIQUE REFERENCE GUIDE TO THE INSIDE STORY FROM THE HOBBIST TO THE TECHNICIAN

Current News Items • Plans • Illustrations Stories • History • Comics • Facts • Games Code Numbers • Projects • And Many More

— One year subscription only \$ 3.00 —

TELEPHONE ELECTRONICS COMPANY OF AMERICA P.O. BOX 3486 LOS ANGELES, CA 90028

ALPHA/THETA BRAINWAVE biofeedback instruments. Analog instruments from \$125; digital processing systems from \$225. BioScan, Box 14168-E, Houston, Texas 77021.

SURPRISE! Build inexpensively, the most Unusual Test Instruments, Futuristic Gadgets using Numerical Readouts! Catalogue Free! GBS, Box 100A, Green Bank, West Virginia 24944.

ELECTRONIC IGNITION: Capacitor, transistor, pointless. Auburn sparkplugs. Information 10 cents. Anderson Engineering, Epsom, N.H. 03234.

WHOLESALE Scanners, CB, Crystals, Directories, SSB/AM, Catalog 25 cents. G—Enterprises, Box 461P, Clearfield, Utah 84105.

CALCULATOR OWNERS: Use Your +x- calculator to compute square roots, trigonometric functions, logarithms, and more! Quickly, Accurately, Easily! Send today for the First and Best Calculator Manual... now in use throughout the world... still only \$2.00 Postpaid with Unconditional Money-Back Guarantee! Mallmann Optics and Electronics, Dept. 24A, 836 South 113, West Allis, Wisconsin 53214.

FREE 1975 Electronics Catalog. McCord Electronics, Box 276-N, Sylvania, Ohio 43560.

AUTORANGING DMM, deluxe VOM's, logic probes and more. Lowest prices. Free catalog. Electro Industries, 4201 Irving Park, Chicago, Illinois 60641.

PYROTECHNICAL chemicals, casings, tools, supplies, fuse. Price List 50 cents. Westech, Logan, Utah 84321.

BURGLAR—FIRE ALARM components, hardware. Free Catalog—Information. Silmur, 133 S. W. 57 Ave., Miami, Florida 33144.

CARBON FILM RESISTORS. Brand new as low as 2-1/4 cents. FREE samples and specifications. COMPONENTS CENTER—PE, Box 134, New York, NY 10038.

7,000 SEMICONDUCTORS, 100's Electronic Circuit Kits, Technical Reports, Energy Conservation, Computers. Cat. 50 cents. E/S Lab, Box 738, College Park, MD 20740.

LEARN DESIGN TECHNIQUES. Electronics Monthly Newsletter. Digital, linear construction projects, design theory and procedures. Sample copy \$1.00. Valley West, Box 2119-B, Sunnyvale, California 94087.

TELEPHONES UNLIMITED, equipment, supplies. Catalog 50 cents. Box 1654E, Costa Mesa, Calif. 92626.

WE SELL MONEY MAKING CONSTRUCTION MANUALS!!! — Reclaim GOLD, SILVER for EXCELLENT full or part time money!!! — PLUS, we buy scrap gold & silver — ALSO, we sell 99.999% pure SILVER BARS!!! — Color Catalog 25 cents — Airmailed 50 cents — Creative Products, Dept. PE-275, 4913 Northridge NE, Albuquerque, New Mexico 87111.

DIGITAL IC Manual—Latest Edition—1500 types by types/diagram number \$3.95. 32—function digital computer kit—IC, transistors, instructions, \$14.00. IC applications manual—numerous circuits—Analog/Digital, \$3.95. Electronics, P. O. Box 127, Hopedale, Mass. 01747.

COMPUTER countless uses. 8 bit word, powerful instruction set. Complete \$225. Brochure 10 cents. RAECO, Box 14, Readville, Mass. 02137.

ELECTRONIC COMPONENTS—all kinds, send for free catalog. Epic, Box 20152A, Minneapolis, Minn. 55420.

QUALITY military and industrial surplus electronics. Send 25 cents for last 3 of our monthly picture flyers. US only. Startrons, Box 17127, Portland, OR 97217.

COMPUTER SCHEMATICS. 256 bits, expandable to several K. Many other schematics available. SP Electronics, Box 5E, Prospect Heights, Illinois 60070.

ELECTRONICS parts, low prices, free flyer: DARTEK ELECTRONICS, Box 2460, Dartmouth, Nova Scotia, Canada. U.S. Inquiries.

FREE BARGAIN CATALOG. Transistors, LED's, Readouts, Micro-Miniature Parts, Unusual Electronic Components. Chaney's, Box 15431, Lakewood, Colorado 80215.

QUARTZ CRYSTALS CB-Amateur. \$1.10 ea., catalog 10 cents. Quaker, Hunlock Creek, PA 18621.

DIGITAL Transistor Tester, LED Display, plans \$2.50. Photoelectronics, Box 343, Geyserville, CA 95441.

PICTURE TUBE rebuilding equipment. Complete. J. Brand, 2416 W. N. Front, Grand Island, Nebraska 68801.

FREE TELEPHONE PRICE LIST. Flemco, 20272 37th Ave., N.E., Seattle, Wash. 98155.

AUTHENTIC, INSTRUMENTED, FLYING ROCKETS for casual or serious experimenters. Over 80 scale original, multi-stage or ready-to-fly models. Solid-propellant engines for safe, electric launch system liftoffs up to 2,500 feet. Measure altitude, temp. inversions, more. Real telemetry, electronic tracking, aerial still and movie photography with super-miniaturized equipment. New, detailed tech manual and full-color catalog. 25 cents from ESTES INDUSTRIES Dept. 18F, Penrose, Colo. 81240.

FOR A New Electronic Experience, learn to control your brainwaves. Aquarius Electronics, Box 96ZE, Albion, Calif. 95410.

LIQUID CRYSTAL display price breakthrough! 3-1/2 digit, designed for digital wristwatches, miniature test instruments, etc. 30uw at 15v. mounts directly on PC board, with diagrams. \$8.95 postpaid. Bargain catalog 50 cents. Diamondback Engineering, P.O. Box 194, Spring Valley, Illinois 61362.

ALPHA Biofeedback Instruments. DIGITAL: Heart Monitor, Thermometer, VOM, Frequency Counter, Logic Probe with readout, etc. Free Catalog. COSMIC ELECTRONICS, BOX 282, Lawrence, NY 11559.

LIFE-GUARD: The finest HEAT-SMOKE-GAS Alarm available, 100% solid state. COSMIC ELECTRONICS, Box 282, Lawrence, NY 11559.

100 PRECISION RESISTORS, assorted values all 1%. Send 1.00 + 25 cents postage to P.O. Box 3081, Granada Hills, Calif. 91344.

ANTIQUA RADIO SCHEMATICS. SASE Please. Sterling, Box 202, 06878.

SUSPECT ELECTRONIC SPYING???...By Officials, Detectives, Business Competitors, etc.?...Protect Your Privacy. Details \$1.00. CAL-TRONIX, Box 1502, Santa Rosa, Calif. 95403.

ELECTRONIC ORGAN KITS, KEYBOARDS for organs and synthesizers. Independent and divider organ tone generators, diode keying. 35 cents for catalog. DEVTRONIX ORGAN PRODUCTS, Dept. C, 5872 Amapola Dr., San Jose, CA 95129.

"BASIC TELEPHONE WIRING" — Unique report gives complete details. \$3.50 postpaid. Queens Village Telephone Supply, Box 29002-G, Queens Village, NY 11429.

I.Q. TEST Questions and Answers. Send \$2.00 to Ruden Enterprises, Box 944, Frazer, PA 19355.

DIGITAL ELECTRONICS! Highly effective course brings immediate results. \$10.00. Satisfaction or \$11.00 refunded! Plans, Projects, Free Literature. DYNASIGN, Box 60A7, Wayland, Mass. 01778.

COMPLETE CONSTRUCTION PLANS—TELEPHONE: Answering Device, Automatic Dialer, "Black Boxes", Call Diverter, Call Limiter, Conference Bridge, Central Dial Exchange, Melodic Ringing, Recorder-Actuator, Remote Control, Schematics, Speakerphone, Teletink Burglar Alarm, Voice Scrambler, \$3.00 each. **ELECTRONIC:** Biofeedback Conditioner, Horticulture Stimulator, Multifrequency Encoder Network (Speeds telephone calling 100%). \$5.00 each. **ONE YEAR SUBSCRIPTION:** Telephone-Electronics Newsline \$3.00. Super illustrated 16 page catalog of plans, many more, 50 cents. All of the construction plans above, \$19.95. TELETRONICS COMPANY OF AMERICA, P.O. Box 3486, Hollywood, California 90028. USA.



DESCRAMBLERS

Several models to choose from... operates with all scanner and monitor receivers.

WRITE OR CALL for Catalog Phone (501) 273-5340

KRYSTAL KITS, Box 445, BENTONVILLE, ARK. 72712

POLICE, FIRE Monitors, scanners, crystals. Discount Priced. Some CB. Box 19224, Denver, Colorado 80219.

THE BEST Electronics Systems in the country at wholesale prices. Duke Engineering, 51 Granger Street, Dor, Mass. 02122.

BUILD DIGITAL KITS, I.C. Tester \$29.95, 20 MHZ Counter \$119.95, 200 MHZ prescaler \$24.95, Miniature FM Transmitter \$2.00. Free Flyer, Kits and Parts. DAVIS ELECTRONICS, 6 W. Oakwood, Buffalo, N.Y. 14214.

WANTED QUICKSILVER, Platinum, Silver, Gold, Ores Analyzed. Free Circular. Mercury Terminal, Norwood, Mass. 02062.

FREE INFORMATION:

Learning more about a product that's advertised or mentioned in an article in this month's issue is as simple as one, two, three. And absolutely free.

Print or type your name and address on the attached, postage-paid card. Use only one card per person.

Circle the number(s) on the card that correspond to the number(s) at the bottom of the advertisement or article for which you want more information. (Key numbers for advertised products also appear in the Advertisers' Index.)

Simply mail the postage-paid card.

Use only one card per person

POPULAR ELECTRONICS PE2753
Use only one card per person.
NAME _____

ADDRESS _____

CITY _____ STATE _____ ZIP _____

[Zip Code must be included to insure delivery.] [Void after Apr. 30, 1975]
How much reel-to-reel audio tape have you bought in the past 90 days? (Please check one.)
A None D 11-15
B 1-5 E 16-20
C 6-10 F over 20

- | | | | | | | | | | | | | | | |
|----|----|----|----|----|----|----|----|----|----|----|----|----|----|----|
| 1 | 2 | 3 | 4 | 5 | 6 | 7 | 8 | 9 | 10 | 11 | 12 | 13 | 14 | 15 |
| 16 | 17 | 18 | 19 | 20 | 21 | 22 | 23 | 24 | 25 | 26 | 27 | 28 | 29 | 30 |
| 31 | 32 | 33 | 34 | 35 | 36 | 37 | 38 | 39 | 40 | 41 | 42 | 43 | 44 | 45 |
| 46 | 47 | 48 | 49 | 50 | 51 | 52 | 53 | 54 | 55 | 56 | 57 | 58 | 59 | 60 |
| 61 | 62 | 63 | 64 | 65 | 66 | 67 | 68 | 69 | 70 | 71 | 72 | 73 | 74 | 75 |
| 76 | 77 | 78 | 79 | 80 | 81 | 82 | 83 | 84 | 85 | 86 | 87 | 88 | 89 | 90 |

POPULAR ELECTRONICS PE2752
Use only one card per person.
NAME _____

ADDRESS _____

CITY _____ STATE _____ ZIP _____

[Zip Code must be included to insure delivery.] [Void after Apr. 30, 1975]
How much reel-to-reel audio tape have you bought in the past 90 days? (Please check one.)
A None D 11-15
B 1-5 E 16-20
C 6-10 F over 20

- | | | | | | | | | | | | | | | |
|----|----|----|----|----|----|----|----|----|----|----|----|----|----|----|
| 1 | 2 | 3 | 4 | 5 | 6 | 7 | 8 | 9 | 10 | 11 | 12 | 13 | 14 | 15 |
| 16 | 17 | 18 | 19 | 20 | 21 | 22 | 23 | 24 | 25 | 26 | 27 | 28 | 29 | 30 |
| 31 | 32 | 33 | 34 | 35 | 36 | 37 | 38 | 39 | 40 | 41 | 42 | 43 | 44 | 45 |
| 46 | 47 | 48 | 49 | 50 | 51 | 52 | 53 | 54 | 55 | 56 | 57 | 58 | 59 | 60 |
| 61 | 62 | 63 | 64 | 65 | 66 | 67 | 68 | 69 | 70 | 71 | 72 | 73 | 74 | 75 |
| 76 | 77 | 78 | 79 | 80 | 81 | 82 | 83 | 84 | 85 | 86 | 87 | 88 | 89 | 90 |

POPULAR ELECTRONICS PE2751
Use only one card per person.
NAME _____

ADDRESS _____

CITY _____ STATE _____ ZIP _____

[Zip Code must be included to insure delivery.] [Void after Apr. 30, 1975]
How much reel-to-reel audio tape have you bought in the past 90 days? (Please check one.)
A None D 11-15
B 1-5 E 16-20
C 6-10 F over 20

- | | | | | | | | | | | | | | | |
|----|----|----|----|----|----|----|----|----|----|----|----|----|----|----|
| 1 | 2 | 3 | 4 | 5 | 6 | 7 | 8 | 9 | 10 | 11 | 12 | 13 | 14 | 15 |
| 16 | 17 | 18 | 19 | 20 | 21 | 22 | 23 | 24 | 25 | 26 | 27 | 28 | 29 | 30 |
| 31 | 32 | 33 | 34 | 35 | 36 | 37 | 38 | 39 | 40 | 41 | 42 | 43 | 44 | 45 |
| 46 | 47 | 48 | 49 | 50 | 51 | 52 | 53 | 54 | 55 | 56 | 57 | 58 | 59 | 60 |
| 61 | 62 | 63 | 64 | 65 | 66 | 67 | 68 | 69 | 70 | 71 | 72 | 73 | 74 | 75 |
| 76 | 77 | 78 | 79 | 80 | 81 | 82 | 83 | 84 | 85 | 86 | 87 | 88 | 89 | 90 |

FREE INFORMATION:

First Class
Permit No. 217
Clinton, Iowa

BUSINESS REPLY MAIL

No postage necessary if mailed in the United States

POSTAGE WILL BE PAID BY

Popular Electronics

P.O. Box 2905
Clinton, Iowa 52732

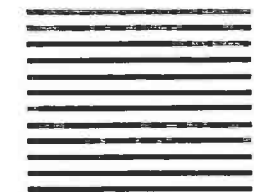

First Class
Permit No. 217
Clinton, Iowa

BUSINESS REPLY MAIL

No postage necessary if mailed in the United States

POSTAGE WILL BE PAID BY

Popular Electronics

P.O. Box 2905
Clinton, Iowa 52732



First Class
Permit No. 217
Clinton, Iowa

BUSINESS REPLY MAIL

No postage necessary if mailed in the United States

POSTAGE WILL BE PAID BY

Popular Electronics

P.O. Box 2905
Clinton, Iowa 52732



Stereo Review is proud to announce an important new set of recordings created to help you expand your understanding of music.

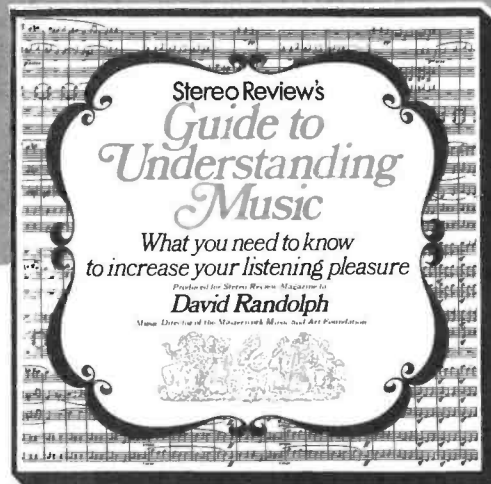

This unique four-disc album is interesting, easy to comprehend, and instructive. It is the first project of its kind to approach the understanding of music through its basic elements:
rhythm . . . melody . . .
harmony . . . texture.

Written and narrated exclusively for Stereo Review by David Randolph, Music Director of the Masterwork Music and Art Foundation, this fascinating set of stereo records will help you become a more sophisticated, more knowledgeable listener—and a more completely satisfied one as well. It will give you an "ear for music" you never thought you had.

In the GUIDE TO UNDERSTANDING MUSIC, David Randolph first discusses, by means of recorded narration, how the composer uses and unifies all the basic musical elements. After each musical point is made in the narration, a musical demonstration of the point under discussion is provided. Thus you become a part of the creative musical process by listening, by understanding, by seeing how music's "raw materials" are employed by composers and performers to attain their highest level of expressivity and communication through musical form.

FOUR LONG-PLAY STEREO RECORDS:

Record I—The Elements of Music.
1. Rhythm, 2. Melody, 3. Harmony, 4. Texture.

Record II—Sense and Sensation in Music. (The Instruments of the Orchestra.) How Music is Unified.

Record III—Form in Music. Words and Music.

Record IV—Can Music Tell a Story or Paint a Picture? The Interpretation of Music.

The GUIDE TO UNDERSTANDING MUSIC contains

OVER 200 MUSICAL EXAMPLES which have been carefully chosen from among thousands of recordings by major record companies as the best illustrations of musical points made in the recorded narration. In addition, supplementary musical demonstrations were specially recorded for this album.

FREE BOOKLET INCLUDED. The accompanying booklet is a valuable complement to the album. It presents David Randolph's straightforward professional approach to music, and shares the insights and understanding of his many years of experience in bringing music to listeners . . . as well as advice on how you can make the best use of the album.

FIRST TIME EVER OFFERED

The Guide to Understanding Music has been several years in the planning and production stages to assure that it would be as complete, as up-to-date, and as effective a presentation of its subject as possible. The exclusive four-disc recording is now ready, available for the first time through Stereo Review. The special low price is just \$19.98, available for all four 33 1/3 rpm stereo long-play records, a price made possible by the availability of the consultative and production facilities of Stereo Review and its staff. Under ordinary auspices, a work of this nature and importance would cost much more.

SPECIAL SCHOOL AND LIBRARY OFFER

Of particular importance is the role the GUIDE TO UNDERSTANDING MUSIC can play as a teaching tool for music departments in schools throughout the country. Orders for 3 sets or more are available to schools and libraries at the SPECIAL DISCOUNT PRICE of only \$17.98 per album, a savings of 10% off the regular price of \$19.98. This special quantity price is also available to individuals and organizations who may have a need for more than one album. Schools may submit orders on standard purchasing forms.

HERE'S HOW TO ORDER:

CASH: Mail your order along with your name, address and remittance in the amount of \$19.98, postpaid.

CHARGE: Your American Express or BankAmericard account! Mail your order, name, address and credit card number. You will be billed at \$19.98, postpaid.

MAIL ALL ORDERS TO: RECORDS, ZIFF-DAVIS SERVICE DIVISION,
595 BROADWAY, NEW YORK, N.Y. 10012

Altaj Electronic Bargains

PRICES SLASHED! WE WANT YOUR BUSINESS. SATISFACTION GUARANTEED ON EVERY ITEM



CALCULATOR BASIC KIT WITH TI CHIP
Includes case with matching all function keyboard, and 9 digits of LED readouts plus a Texas Instruments TMS 103 NC calculator chip. (Same style chip as in TI Datamath calculator). All the basics for building your own hand held calculator. Special — \$11.95 Kit Quantity Limited.



BURROUGHS PANAPLEX II 12 DIGIT READOUT

#BR13251 Neon 7 segment readout. Latest design for calculators, etc. Requires 160 VDC. Right hand decimals. Brand new, factory fresh. We include mating socket FREE. Special — \$5.95 NOTE: With purchase of above readout array we offer motorola 2N5401 PNP High Voltage driver transistor for 10¢ each.



LM309K
TO-3 Case, 1 AMP 5 VDC Voltage Regulator. Brand New By National 95¢

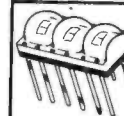

3 DIGIT LED READOUT ARRAY
Like Litronix DL-33. 3 MAN-3 style readouts in one package. Factory new units. Designed for calculators. Special — \$1.19 (3 Digits)

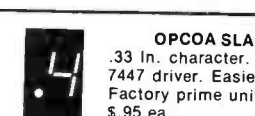

OPCOA SLA-1 LED READOUT
.33 in. character. Left decimal pt. Uses 7447 driver. Easier to read than MAN-1. Factory prime units. Best Price in USA! \$.95 ea.

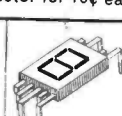

MAN-3 LED READOUTS
Brand new, factory prime units. .12 in. character. Common cathode. Perfect for calculators. 3 FOR \$1 Best Price Anywhere!

CALCULATOR CHIP BONANZA PRICES SLASHED!
The newest and easiest to use chips available today. Made by famous US mfg. All are 28 pin DIP. Features: direct LED segment drive, low power consumption, internal keyboard debounce, internal clock oscillator, single supply voltage, internal keyboard encoding, and floating decimal point. Does not require many external components as do older types like CT5001, 5002, 5005, etc. We offer the most sophisticated functions for the lowest price anywhere.
Chip #1 — 8 Digit, Constant, Six Function (+, -, x, +, %, √) — \$5.95
Chip #2 — 8 Digit, Memory, Six Function (+, -, x, +, %, √) — \$7.95
Chip #3 — 8 Digit, Memory, Six Function (+, -, x, +, %, 1/x) — \$6.95

DIGITAL ALARM CLOCK IC
The newest and easiest to use alarm chip on the market today. Features:
1. Single supply voltage.
2. LED Intensity control
3. Simple time set.
4. 4 or 6 Digit LED Display
5. AM-PM Indication
6. 24 Hr. Alarm.
7. 10 minute snooze.
8. Outperforms MM5316
Order #70250 — \$6.95 (2 FOR \$12)

MINI CORE MEMORY SPECIAL
Mfg. by DATARAM. Stores 180 words of 18 bits each. With sense amps and associated drive circuits. A complete memory system. We include 50 pages of data and schematics. Data only \$2.50 Brand New. Special \$24.95

SOLID STATE MEMORY ARRAY
Brand new, MFG. by Monolithic Systems Corp. Consists of 16-1101 (256 Bit Ram) and associated drive circuits. Drive circuits include 24 assorted 7400 series devices and various transistors, diodes, etc. Array is mounted on two stacked 6 x 8 in. PC boards. Original cost \$300 ea. With schematic. These are recommended for experienced hobbyists only. Limited quantity — \$29.95 ea.

MM5314 NATIONAL CLOCK CHIP
The most popular clock chip around. We made a huge special purchase of factory fresh, prime units. Lowest price in USA. 24 Pin DIP. 4 or 6 Digits. With Specs. \$3.94 EACH [3 FOR \$10]

CT7001 BY CAL-TEX
Digital alarm clock chip with calendar feature. 4 or 6 digits. Also has timing circuitry for radio ON-OFF control factory fresh.
\$8.95

COLOR ORGAN CONTROL MODULE
Completely self-contained. Has SCR circuitry, AC line cord, etc. From a close out by a mfg. of color organs. New, unused.
\$3.95 ea. (3 FOR \$9)

NI-CAD BATTERY SPECIAL
Two cell battery packs. 2.75 V. capacity is 250 MA HRS. Two of these make a great power pack for TTL. Special 95c

MOS 4 DIGIT COUNTER IC
An ALTAJ exclusive. These are the latest, state of the art. MOS chips. By a famous US mfg. Contains a complete 4 digit counter, including 4 decade counters, latches, multiplexing circuits, display decoders, etc. Features: 5 VDC operation, 25 MW power consumption, both 7 segment and BCD outputs. Perfect for making DVM's, frequency meters, tachometers, stopwatches, or any other device requiring 4 or more digits. Complete with specs. 28 PIN DIP. QTY Limited.
Special — \$12.50

JUMBO LED READOUT
Twice the size of regular readouts. .65 inches. Like Litronix DL747. Outperforms and easier to read than SLA-3, only 20 MA per segment. Our best readout for digital clocks.
\$2.95 ea (6 FOR \$15) Common Anode

GE POWER TRANSISTOR ASSORTMENT
Plastic power devices. Includes NPN and PNP, darlington, high voltage, high current, and various other types. Cases are color coded for easy sorting. Un-tested but includes many useable units.
SPECIAL — 20 FOR \$1

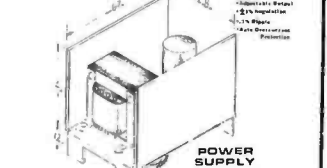

REGULATED DC POWER SUPPLY
Brand new by wanlass. DC output 17 to 30 V. Rated 60 WATTS out. Our tests show these units will put out 12 VDC by changing one resistor. #OEM 60-3. Original cost \$57.50. In original factory boxes, with specs. Special \$14.95

FREE SPECIAL BONUS
With purchase of any of our clock or calculator chips we will include a free 28 pin IC socket. A \$1 value Free.

MINIATURE SWITCH
Rocker style. Small size. SPDT. Perfect for use on digital clocks.
4 FOR \$1

CALCULATOR KEYBOARD SWITCH KIT
Kit of 16 brand new switches with tops. Each switch has a smooth, quiet, key travel. Internally the switches consist of a magnet and read switch for low contact bounce. Kit has 0-9 CL, decimal point, and four functions, perfect for use with our calculator chips.
COMPLETE SET — \$3.95

7805 STYLE REGULATORS
TO-220 Plastic Case 5VDC Regulator. Brand New by National — 89¢

ELECTROLYTIC CAPACITOR SPECIAL
220 MFD at 25 WVDC. AXIAL Leads by GI. Brand New 8 FOR \$1

8038 FUNCTION GENERATOR
Brand new by Intel. Voltage controlled oscillator. Has sine, square wave, and triangular outputs. \$4.50 each.

MOTOROLA POWER TRANSISTOR
MJ3029 — T03 Case — NPN Silicon High Voltage — VCEO — 250V Used in horiz. and vert. TV Circuits. Regular Price \$4. Our Price 95c

ZENERS
IN746 — 400MW — 3.3V
IN752 — 400MW — 5.6V
YOUR CHOICE
8 FOR \$1

PRIME TTL DIP IC'S

7400-16c	7448-85c	74157-1.19
7402-16c	7473-39c	74161-1.15
7404-16c	7474-38c	74164-1.29
7406-24c	7475-69c	74165-1.50
7408-16c	7476-42c	74174-1.75
7410-16c	7483-88c	74175-\$1.50
7413-49c	7490-75c	74181-\$2.95
7420-16c	7492-85c	74192-\$1.25
7430-16c	7493-85c	74193-\$1.25
7437-39c	74121-38c	74195-95c
7438-39c	74123-75c	74197-\$1.25
7440-16c	74150-70c	
7442-69c	75151-75c	
7445-69c	74153-95c	
7447-85c	74154-95c	

IN4148 DIODES
High speed switching diodes. Brand new units, however, leads are cut and bent for PC board insertion, still plenty long. 30 For \$1

ELECTROLYTIC CAPACITORS
10MFD 25WVDC — Upright — 7c
50MFD 15WVDC — Upright — 10c
50MFD 15WVDC — Axial — 10c
100MFD 15WVDC — Upright — 14c

TTL IC ASSORTMENT
Various types. Most are marked. Our best selling assortment. Un-tested but includes many useable devices.
200 PCS FOR \$3.95

TIP-3055 BY TI
Plastic version of 2N3055. NPN Silicon 89¢

POLAROID FILTERS
The real thing by Polaroid Corp. Pale green in color. 2.3 x 12 inches. Use with various readouts or for optical experiments, limited Qty. 2 For \$1.

POLAROID FILTERS
The real thing by Polaroid Corp. Pale green in color. 2.3 x 12 inches. Use with various readouts or for optical experiments, limited Qty. 2 For \$1.

OUR LOWER PRICES AND SUPERIOR QUALITY
have made ALTAJ one of the fastest growing electronic suppliers in the USA. Put your trust in our unconditional money back guarantee.

1 AMP SILICON RECTIFIERS
IN4002 — 100 PIV — 8¢
IN4007 — 1000 PIV — 17¢

MOTOROLA AUDIO AMP
MFC 4000. 4 lead mini DIP. 250 MW. 9 volt operation. Hobbyist Special
59c

YOUR CHOICE 6 FOR \$1 ALL NEW UNITS
Use for drivers in clock or calculators.
MPS2222A — NPN
MPS2714 — NPN
MPS3704 — NPN
2N 3904 — NPN
2N 3906 — PNP
2N 4249 — PNP

ALTAJ ELECTRONICS
P.O. BOX 38544
DALLAS, TEXAS 75238
TERMS: Check or money order. No COD. Add 10% Pstg. and Hdq. Tex Res. add 5%.

PLANS AND KITS

ATTENTION AUDIO FREAKS!... Audio Processing Circuits... designs, kits, units. Laboratory tested designs for hobbyist through professional use—limiters, compressors, equalizers, phasers, mixers and more! Send now—\$1.00 (refundable) for complete catalog—CIRCUIT RESEARCH LABS, 3920 E. Indian School, Phoenix, AZ 85018.

FREE CATALOG. 200+ unique electronic projects. Bio-feedback, acupuncture, more! Cimarron Labs, 4183A Springfield St., Burton, Michigan 48509.

USE your transistor radio as a sensitive direction finder. Great for emergencies. Detailed plans. Guaranteed results. \$1.00. RADIO COMPASS, Dept. B, Box 606, Webb City, Missouri 64870.

AMAZING ELECTRONIC PRODUCTS—Pocket Laser, See-In-The-Dark, Scramblers, Penlight Strobe, Energy Devices, TV Disruptor, Manny More, All New. Catalog \$1.00. INFORMATION UNLTD., West St., Milford, N.H. 03055.

CONSTRUCTION PLANS. Digital tachometer, aircraft strobe, others. Send 25 cents for listing. MIKRONICS, P.O. Box 338, Dundee, Ill. 60118.

ELECTRONICS plans and formulas list. DeepSouth, 4641 Kawanee, Metairie, Louisiana 70002.

TUBES

RADIO & T.V. Tubes—36 cents each. Send for free Catalog. Cornell, 4213 University, San Diego, Calif. 92105.

RECEIVING & INDUSTRIAL TUBES, TRANSISTORS. All Brands—Biggest Discounts. Technicians. Hobbyists. Experimenters—Request FREE Giant Catalog and SAVE! ZALYTRON, 469 Jericho Turnpike, Mineola, N.Y. 11501.

TUBES receiving, factory boxed, low prices, free price list. Transletronic, Inc., 1306 40th Street, Brooklyn, N.Y. 11218A, Telephone: 212-633-2800.

TUBES "Oldies", latest. Lists free. Steinmetz, 7519 Maplewood, Hammond, Indiana 46324.

TUBES 60% OFF LIST PRICE. McCord Electronics, Box 276-T, Sylvania, Ohio 43560.

CASH PAID FOR OBSOLETE RECEIVING TUBES WE300B, WE300A, WE350B, WE252A, WE27A/B, WE284D, RCA45, RCA50, Small and large quantities, and movie theatre equipment, amplifier WE86A, WE59A, WE30A, WE91A/B, pick-up WE9A, WE10A, etc. Contact: M. Takabe, 303 Fifth Ave., N.Y.C. 10016. Tel: (212) 679-1970.

HIGH FIDELITY

DIAMOND NEEDLES and Stereo Cartridges at Discount prices for Shure, Pickering, Stanton, Empire, Grado and ADC. Send for free catalog. LYLE CARTRIDGES, Dept. P, Box 69, Kensington Station, Brooklyn, New York 11218.

SAVE 50%. Build your own speaker systems featuring Nor-elco, Eminence and CTS. Famous brands from world's largest speaker factories at lowest wholesale prices. Write for free catalog of speakers and electronic accessories. McGee Radio Company, 1901 McGee Street, Kansas City, Missouri 64108.

POWER AMP modules: Direct-coupled Op-Amp design produces 50 watts rms, 10hz-100khz, negligible distortion. Requires simple power supply. \$28; 2/\$54 p.p.d. or send for specs. R. Brown, 1233 Somerset Dr., San Jose, Calif. 95132.

SHOTGLASS. As seen in Esquire. Glasscane Columnar Speaker. \$129.50 each. F.O.B. Moneyback Guarantee. TACHYON™, Box 1012, Roselle, Illinois 60172.

LISTEN TO SPECTACULAR 4 CHANNEL SOUND! Expand your stereo to quadrasonic Hi-Fi. Build the VISTA Full Logic "SQ" Decoder.

Latest CBS licensed circuitry using 3 IC's to provide Full Logic and Wave Matching. Exclusively ours. Kit SQ-1 \$37.50. Shipped prepaid in USA & CANADA. Send for information.

PHOTOLUOME CORPORATION 118 East 28th Street, New York, N.Y. 10016

MOVIE FILMS 8MM-SUPER 8-16MM MOVIES! Biggest Selection! Lowest Prices! Free Catalog! Cinema Eight, Box PE, Chester, Connecticut 06412.

ELECTRICAL SUPPLIES & EQUIPMENT PLATING Equipment, Portable Platers, Supplies and "Know-How." Build your own tanks for nickel, chrome, etc. Easy-to-install PVC liners. Rectifier components—all sizes. Schematics, parts lists, formulas, operating instructions for all plating. Guaranteed to save you 25%-75%. Some good units for sale. Write for details. Platers Service Company, 1511-PE Esperanza, Los Angeles, Calif. 90023.

SHORTWAVE LISTENING SWLs MAGAZINE, 50 cents. SWLs QUARTERLY, 75 cents. Books, Antennas. SWL Guide, 414 Newcastle, Syracuse, NY 13219.

TAPE AND RECORDERS RENT 4-Track open reel tapes—all major labels—3,000 different—free brochure. Stereo-Part, 55 St. James Drive, Santa Rosa, Ca. 95401.

1930-1962 Radio Programs. Reels, \$1.00 Hour! Cassettes, \$2.00 Hour!... Mammoth Catalog, \$1.25. AM Treasures, Box 192F, Babylon, N.Y. 11702.

CASSETTE LABELS Plain white cassette labels, Norelco cassette cleaners, paper mailer boxes hold Norelco-type plastic box, famous brand cassettes. "Use now" 10-1/2" metal or fiberglass reels. Send for open reel and cassette discount catalog. 1-9 10-99 100 1000

SAXITONE TAPE SALES WE have a few competitively priced used Revox A77 decks available. These have been completely reconditioned by Revox, are virtually indistinguishable from new and have the standard Revox 90 day warranty for rebuilt machines. Satisfaction guaranteed. One example is an A77 Dolby for \$675 plus shipping. Please write stating your requirements to ESSi, Box 854, Hicksville, N.Y. 11802 (212) 895-9257.

GOVERNMENT SURPLUS GOVERNMENT Surplus. How and Where to Buy in Your Area. Send \$2.00. Surplus 30177-PE Headquarters Bldg., Washington, D.C. 20014.

MANUALS for Govt Surplus radios, test sets, scopes, radar, teletype. List 50 cents (coin). Books, 7218 Roanne Drive, Washington, D.C. 20021.

COMMUNICATIONS Equipment Catalog. Colonel Russell, 9410 Walhampton, Louisville, Kentucky 40222.

C-MOS

Table listing C-MOS components with part numbers and prices.

Waveform Generator Kit

XR205K Only \$28.00 Here's a highly versatile lab instrument at a fraction of the cost of conventional unit. Kit includes two XR205 IC's, data & applications, PC board (etched & drilled, ready for assembly) and detailed instructions.

Digital Watch

with liquid crystal display. Beautiful, reliable and accurate. \$149.00 plus \$2.50 for shipping and handling.



FM Stereo Demodulator

XR1310 \$3.90

Audio Amps

Table listing Audio Amps components with part numbers and prices.

DUAL LOW NOISE OP AMP

LM331N: Vio = 6mV, Ie = 1000nA, Ip = 2000nA, Noise = 1.5dB, \$2.20

Power Transistors

Table listing Power Transistors components with part numbers and prices.

Memories

Table listing Memories components with part numbers and prices.

Displays

Table listing Displays components with part numbers and prices.

Optoisolator

Table listing Optoisolator components with part numbers and prices.

Voltage Regulators

Table listing Voltage Regulators components with part numbers and prices.

Decoded Read Write RAM

Table listing Decoded Read Write RAM components with part numbers and prices.

HYBRID POWER AMPLIFIERS

Table listing Hybrid Power Amplifiers components with part numbers and prices.

IC sockets Teflon

Table listing IC sockets Teflon components with part numbers and prices.

PREMIUM QUALITY COMPONENTS

We've been buying and selling top quality components for nearly ten years. Our annual volume exceeds \$3 million. We handle only original parts, from the world's leading manufacturers and our customers include some of the largest and most quality-conscious companies.

Solder

Table listing Solder components with part numbers and prices.

1024 Bit N-Channel RAM

Table listing 1024 Bit N-Channel RAM components with part numbers and prices.

7400N TTL

Table listing 7400N TTL components with part numbers and prices.

LOW POWER TTL

Table listing Low Power TTL components with part numbers and prices.

HIGH SPEED TTL

Table listing High Speed TTL components with part numbers and prices.

Model 4440 A PORTABLE 4 1/2 DIGIT MULTIMETER FOR \$299.

A 10 MHz COUNTER OPTION FOR \$50.

I-Amp Rectifiers

Table listing I-Amp Rectifiers components with part numbers and prices.

Interface Modules

Table listing Interface Modules components with part numbers and prices.

LED's

Table listing LED's components with part numbers and prices.

1.125" dia.

Table listing 1.125" dia. LED's components with part numbers and prices.

1.60" dia.

Table listing 1.60" dia. LED's components with part numbers and prices.

2.00" dia.

Table listing 2.00" dia. LED's components with part numbers and prices.

Linear IC's

Table listing Linear IC's components with part numbers and prices.

Phase Locked Loops

Table listing Phase Locked Loops components with part numbers and prices.

IC Power Regulators

Table listing IC Power Regulators components with part numbers and prices.

Pulse Generator

Interdesign 1101: 0.1Hz-2MHz. 0-5V Output, var. width, line or battery operation. \$159.00.

2524V Recirculating 512 Bit Dynamic Shift Register

1-24: \$4.00 / 25 up: \$3.90

Shift Registers

Table listing Shift Registers components with part numbers and prices.

9300 SERIES

Table listing 9300 SERIES components with part numbers and prices.

TEKTRONIX 321A PORTABLE ALL-TRANSISTORIZED 3", 5MHZ TRIGGERED SCOPES WITH 10:1 PROBE \$450.00

MINIATURE TRIM POTS 5K, 10K, 25K, 50K, 100K, \$7.5 EA. 3/\$22.00

MULTI-TURN TRIM POTS Similar to Bourns 3010 style 3/16" x 5/8" x 1 1/4" 50, 100, 500, 2000, 5000, 10,000 ohms. \$1.50 ea. 3/\$4.00

PRINTED CIRCUIT BOARD 4 1/2" x 6 1/2" single sided EPOXY board, 1/16" thick, unetched \$5.50 ea. 5/\$22.00

LIGHT ACTIVATED SCR'S, TO-18 200V 1A \$1.75

NIXIE TUBES Similar to Raytheon 8650 tubes, with socket & data sheet \$2.25 3/\$6.00

4 WATT IR LASER DIODES \$6.95

TIS 73 N FET \$1.50 2N4891 UJT \$1.50 ER900 TRIGGER DIODES 4/\$1.00 2N6028 PROG. UJT \$1.75

VERIPAX PC BOARD This board is a 1/16" single sided paper epoxy board, 4 1/2" x 6 1/2" (standard veripax), DRILLED and ETCHED which will hold up to 21 single 14 pin IC's or 8, 16 or LSI DIP IC's with busses for power supply connections. Is also etched for 22 pin connector \$5.25

FLY 100 VISIBLE LED \$1.50 ME-4 IR LED \$1.40 MCD-2 OPTO-ISOL \$1.90 GREEN GAP OSL-16 LED \$1.60 RED GAP OSL-3 LED \$1.40 14 PIN DIP SOCKETS \$1.40 16 PIN DIP SOCKETS \$1.50

10 WATT ZENERS 3.9, 4.7 OR 5.6 V \$1.75 EA 4 WATT ZENERS 3.9, 5.6, 6.8 OR 12 V \$1.30 EA

Silicon Power Rectifiers PRV 1A 3A 12A 50A

REGULATED MODULAR POWER SUPPLIES + -15VDC AT 100 ma, 115VAC INPUT \$19.95 5VDC AT 1A, 115VAC INPUT \$19.95 IN 4148 \$14/\$1.00

8038C IC VOLTAGE CONTROLLED OSCILLATOR \$4.95

TRANSISTOR SPECIALS 2N256 PNP GE TO-3 \$1.50 2N404 PNP GE TO-5 4/\$1.00 2N1137B PNP GE TO-3 \$1.95 2N5137 NPN Si TO-106 \$5/1.00 2N3904 NPN Si TO-92 4/\$1.00 MPS3393 NPN Si TO-92 4/\$1.00 2N3906 PNP Si TO-92 4/\$1.00 MPS A13 NPN Si TO-92 3/\$1.00 2N3767 NPN Si TO-66 \$1.70 2N2222 NPN Si TO-18 5/\$1.00 2N3055 NPN Si TO-3 \$1.00 2N5296 NPN Si TO-220 \$1.50 2N6109 NPN Si TO-220 \$1.55 2N4898 PNP Si TO-66 \$1.60 M2252 NPN Si TO-66 \$1.90 2N3638 PNP Si TO-5 5/\$1.00 2N2184 NPN Si TO-5 4/\$1.00

C/MOS (DIODE CLAMPED) 74C 02 \$1.55 74C 10 \$1.60 74C 157 \$2.15 74C 165 \$3.50 CD 4001 \$1.55 CD 4002 \$1.65 CD 4009 \$1.80 CD 4010 \$1.65 CD 4011 \$1.55 CD 4012 \$1.55 CD 4013 \$1.20 CD 4016 \$1.25 CD 4019 \$1.35 CD 4022 \$2.25 CD 4023 \$1.55 CD 4025 \$1.55 CD 4027 \$1.35 CD 4030 \$1.65 CD 4050 \$1.35

CAPACITORS 6V 30 UF TANT. 5/\$1 20V 4.7UF TANT. 5/\$1 12V 10UF ELECT. 5/\$1 50V 100UF ELECT. \$1.40 25V 30UF ELECT 4/\$1.00

MAN-1, RED OR YELLOW LED READOUT \$2.50 MAN-3 READOUTS \$1.75 MAN-4 READOUTS \$2.00

5311-CLOCK CHIP 6-DIGIT BCD HOLD COUNTER, OUTPUT STROBE \$7.75 5314-CLOCK CHIP 6-DIGIT HOLD COUNTER, OUTPUT STROBE \$7.75 5316-ALARM CLOCK CHIP \$8.50

2513-64x7x5 CHARACTER GEN \$9.95 2516-64x6x8 STATIC CHARACTER GEN \$9.95

SANKEN AUDIO POWER AMPS Si 1010 Y 10 WATTS \$6.40 Si 1015 E 25 WATTS \$17.95 Si 1050 E 50 WATTS \$24.95

LINEAR CIRCUITS LM 309K 5V 1A REGULATOR \$1.65 723-40 +40V REGULATOR \$1.58 301748-HI Per. Op. Amp. \$1.35 LM 320 -5 or -15V REGULATOR \$1.75 LM 376 -V to 37V POS REG. \$1.58 741A or 741C OP. AMP. \$1.35 709C OPER AMP \$2.29 340T-5, 12, 15, 18, 24V POS. REG. TO-220 \$1.75 101 OPER. AMP., HI PERFORM. \$1.75 LM 308 OPER. AMP., LOW POWER \$1.05 747-DUAL 741 \$1.75 536-FET INPUT OPER. AMP. \$2.60 537-PRECISION OP. AMP. \$2.60 LM 3900-QUAD OP. AMP. \$1.58 LM 324-QUAD 741 \$2.20 560-PHASE LOCK LOOP \$2.60 561-PHASE LOCK LOOP \$2.60 565-PHASE LOCK LOOP \$2.60 567-TONE DECODER \$2.95 703-RF-IF AMP. \$3.95 LM 370-AGC SQUELCH AMP. \$1.15 555-2 us - 2 HR. TIMER \$1.98 1458 DUAL OP. AMP. \$1.60 1456 OPER. AMP. \$1.95 LM 380-2W AUDIO AMP. \$1.45 LM 377-2W STEREO AUDIO AMP. \$2.60 LM 381-STEREO PREAMP \$1.75 LM 382-DUAL AUDIO PREAMP \$1.75 LM 311-HI PER. COMPARETOR \$1.95 LM 319-DUAL HI SPEED COMP. \$1.25 LM 339-QUAD COMPARETOR \$1.65

TRIACS SCR'S PRV 1A 10A 25A 15A 6A 35A

8038C IC VOLTAGE CONTROLLED OSCILLATOR \$4.95

SOLID STATE SALES WE SHIP OVER 95% OF OUR ORDERS THE DAY WE RECEIVE THEM P.O. BOX 74A SOMERVILLE, MASS. 02143 TEL. (617) 547-4005

POPULAR ELECTRONICS

FEBRUARY 1975

ANCRONA CORP. SEND CHECK OR MONEY ORDER (NO. C.O.D.) TO: P.O. Box 2208P, Culver City, CA. 90230

Planning to move?

Let us know 8 weeks in advance so that you won't miss a single issue of POPULAR ELECTRONICS.

Attach old label where indicated and print new address in space provided. Also include your mailing label whenever you write concerning your subscription. It helps us serve you promptly.

Write to: P.O. Box 2774, Boulder, CO 80302, giving the following information:

- Change address only.
- Extend subscription. Enter new subscription.
- 1 year \$6.98
- Payment enclosed (1 extra BONUS issue)
- Bill me later

AFFIX LABEL

If you have no label handy, print OLD address here.

name	address	city	state	zip
name	address	city	state	zip

0169 please print

12 DIGIT BASIC #4 — Key parts include: CT5001 chip, 4-3 digit readouts, factory etched PC board, case, carrying cable, 2-resistor network, 100 ohm resistor, Wild Rover Keyboard with ON-OFF switch diagrams.

Add'l postage: \$2 per year outside U.S., its poss. & Can.

T T L	CMOS
7400* 6/\$1 200 7488 4.00	CD4001 \$.55
7401 .23 7489* 2.75	CD4002 .55
7402 .23 7490* .75	CD4007 1.25
7403 6/1 .00 7491* 1.00	CD4009 1.40
7404* .25 7492 .95	CD4010 .60
7405 .24 7493 .95	CD4011 .55
7406 .50 7494 .95	CD4012 1.55
7407 .50 7495 .95	CD4013 1.55
7408 .25 7496 .95	CD4016 1.40
7409 .25 74100 1.50	CD4017 2.75
7410* 6/1 .00 74107 1.25	CD4019 1.55
7411 .30 74121 .55	CD4020 1.50
7412 .40 74122 .47	CD4022 2.50
7413 .89 74123 1.05	CD4023 .55
7416 .45 74125 .60	CD4025 .55
7417 .45 74126 .80	CD4027 1.25
7418 .25 74141 1.15	CD4030 .60
7420 .23 74145 1.15	CD4035 2.75
7421 .27 74150 .95	CD4049 1.25
7423 .32 75151 1.20	CD4050 1.25
7425 .27 74153 1.50	74C00 .45
7426 .31 74154 1.25	74C02 .45
7427 .32 74155 1.30	74C04 .70
7429 .40 74156 1.30	74C20 .65
7430 .33 74157 1.55	74C74 1.15
7432 .26 74160 1.65	74C160 3.25
7437 .45 74161 1.65	74C161 3.25
7438 .50 74163 2.50	74C107 1.50
7439 .50 74164 2.50	74C151 2.90
7440 .23 74165 2.50	74C154 3.50
7441 .10 74166 1.75	74C163 3.25
7442 1.05 74170 3.00	74C164 3.50
7443 1.10 74173 1.75	74C173 3.90
7444 1.15 74174 1.85	74C195 2.90
7445 1.10 74175 1.85	
7446 1.25 74176 .85	
7447 1.00 74177 .85	
7448 1.25 74180 1.00	
7450 .25 74181 3.75	IN746 4/\$1
7451 .27 74182 1.00	IN752 4/\$1
7453 .27 74184 2.30	IN5232 .28c
7454 .40 74185 2.30	IN5234 .28c
7459 .25 74187 7.00	IN4734 .28c
7460 .25 74190 1.50	IN4735 .28c
7470 .45 74191 1.50	IN3600 6/\$1
7472 .41 74192 1.25	IN4148 15/\$1
7473 .47 74193 1.25	IN4154 12/\$1
7474 .47 74194 1.50	IN456 6/\$1
7475 .90 74195 1.05	IN458 6/\$1
7476 .47 74196 1.25	IN485A 5/\$1
7480 .50 74197 1.05	IN4001 .09
7482 1.75 74198 2.25	IN4002 .10
7483 1.15 74199 2.75	IN4004 .10
7485 1.10 74200 7.00	IN1183 1.60
7486 .47	IN1184 1.70
	IN1186 1.80

20% Discount for 100 Pieces Combined 7400

PERSONALS

MAKE FRIENDS WORLDWIDE through international correspondence. Illustrated brochure free. Hermes, Berlin 11, Box 110660/ZD, Germany.

INSTRUCTION

LEARN ELECTRONIC ORGAN SERVICING at home all makes including transistor. Experimental kit—troubleshooting. Accredited NHSC. Free Booklet. NILES BRYANT SCHOOL, 3631 Stockton, Dept. A, Sacramento, Calif. 95820.

LEARN WHILE ASLEEP. Hypnotize! Strange catalog free. Auto-suggestion, Box 24-ZD, Olympia, Washington 98501.

DEGREE IN ELECTRONICS through correspondence. Free catalog. Grantham, 2000 Stoner Avenue, Los Angeles, California 90025.

INTENSIVE 5 week course for Broadcast Engineers. F.C.C. First Class license. Radio Engineering Incorporated, 61 N. Pineapple Ave., Sarasota, Florida 33577.

F.C.C. EXAM MANUAL

PASS FCC EXAMS! Memorize, study—"Test Answers" for FCC 1st and 2nd class Radio Telephone license. Newly revised multiple-choice questions and diagrams cover all areas tested in FCC exams plus "Self-Study Ability Test." \$9.95 postpaid. Moneyback Guarantee.

COMMAND PRODUCTIONS P.O. BOX 26348-P
FIELD ENGINEERING DIVISION SAN FRANCISCO, CALIF. 94126

SCORE high on F.C.C. Exams. Over 300 questions and answers. Covers 3rd, 2nd, 1st and even Radar. 3rd and Second Test, \$14.50; First Class Test, \$15.00. All tests, \$26.50. R.E.I., Inc., Box 806, Sarasota, Fla. 33577.

FCC LICENSE through tape recorded lessons. Also Radar endorsement. Radio License Training, 1060D Duncan, Manhattan Beach, Calif. 90266.

FCC LICENSE, electronics design, satellite communications, through correspondence. Free catalog. Genn Tech, 5540 Hollywood Blvd., Los Angeles, CA 90028.

FCC License, electronics design, satellite communications, through correspondence. Free catalog. Genn Tech, 5540 Hollywood Blvd., Los Angeles, CA 90028.

★ FEBRUARY — SPECIALS

Miniature Aluminum Electrolytic Capacitors

— AXIAL LEAD TYPE —

— RADIAL LEAD TYPE —

MFD-VOLTS	1-9	10-100	MFD-VOLTS	1-9	10-100
1 UFD/50V	14c	12c	11c	100 UFD/16V	19c
2.2 UFD/50V	14c	12c	11c	100 UFD/25V	24c
3.3 UFD/25V	14c	12c	11c	220 UFD/16V	24c
4.7 UFD/25V	14c	12c	11c	220 UFD/25V	35c
10 UFD/16V	14c	12c	11c	330 UFD/16V	35c
10 UFD/25V	14c	12c	11c	330 UFD/25V	44c
22 UFD/16V	14c	12c	11c	470 UFD/16V	37c
22 UFD/25V	15c	13c	12c	470 UFD/25V	49c
33 UFD/16V	15c	13c	12c	1000 UFD/16V	49c
33 UFD/25V	17c	13c	12c	1000 UFD/25V	75c
47 UFD/16V	17c	14c	13c	2200 UFD/16V	75c
47 UFD/25V	19c	15c	14c		

*50 VOLT CERAMIC DISC CAPACITORS

.001 mf. 5c	3.5c	3c	.033 mf. 6c	4c	3.5c
.0047 mf. 6c	4c	3.5c	.047 mf. 6c	4c	3.5c
.01 mf. 5c	3.5c	3c	.1 mf. 12c		7.5c
.022 mf. 6c	4c	3.5c			

MPS-A05 5/\$1 *TRANSISTORS

2N918	25	2N2906A	4/\$1	2N3906	4/\$1
2N2219A	3/\$1	2N2907A	5/\$1	PN4249	4/\$1
2N2221A	4/\$1	2N3053	2/\$1	PN4250	4/\$1
2N2222A	5/\$1	2N3724A	2/\$1	2N4409	5/\$1
2N2369	5/\$1	2N3725A	2/\$1	2N5129	19
2N2369A	4/\$1	2N3903	5/\$1	2N5139	19
2N2484	4/\$1	2N3904	4/\$1	CT106B1-SCR-2	\$1

CALCULATOR & CLOCK CHIPS w/data

5001 LSI 40 pin DIP 4 funct	\$3.95
5005 LSI 28 pin DIP 4 funct w/mem	7.95
MM5311 28 pin BCD 6 dig mux	7.95
MM5312 24 pin 1 pps BCD 4 dig mux	6.95
MM5313 28 pin 1 pps BCD 6 dig mux	7.95
MM5314 24 pin 6 dig mux	7.95
MM5316 40 pin alarm 6 dig	7.95

Satisfaction Guaranteed. All Items 100% Tested \$5.00 Min. Order — 1st Class Mail — No Charge California Residents — Add 6% Sales Tax Wholesale Outlets — Write for Special Discounts Write for FREE 1975 Catalog — Data Sheets .25¢ each

JAMES

P.O. BOX 822, BELMONT, CA. 94002
PHONE ORDERS — (415) 592-8097
CIRCLE NO. 20 ON READER SERVICE CARD

SELF-STUDY CB RADIO REPAIR COURSE. THERE'S MONEY TO BE MADE REPAIRING CB RADIOS. This easy-to-learn course can prepare you for a career in electronics enabling you to earn as much as \$16.00 an hour in your spare time. For more information write: CB Radio Repair Course, Dept. PE-0275, 531 N. Ann Arbor, Oklahoma City, Okla. 73127.

LEARN to do fast mental calculations of time and frequency nanoseconds, etc. used in electronics. Newsletter \$2. GLOBE, 1304 Midland Avenue, Yonkers, N.Y. 10704. ANY Tech problems answered by experts, \$1. Globe, 1304 Midland Ave., Yonkers, N.Y. 10704.

DRAFTING—Blueprint Reading (Mechanical, Electronic, Architectural). Home Courses \$25.00. Send \$2.00 first lesson. Prior Inc., 23-09 169th Street, Whitestone, New York 11357.

MUSICAL INSTRUMENTS

30% DISCOUNT name brand musical instruments. Free Catalog. Freepart Music, 455N, Route 110, Melville, N.Y. 11746.

WHOLESALE! Professional Guitars, PA Systems, Altecc Speakers, 240W RMS Amplifiers. Free Catalog, Carvin, Escondido, Calif. 92028.

30%+DISCOUNT. Name Brand Musical Instruments. Free Catalog. Continental Music, Dept. H, P.O. Box 3001, Garden City, New York 11530.

BUSINESS OPPORTUNITIES

MADE \$40,000.00 Year by Mailorder! Helped others make money! Free Proof. Torrey, Box 318-NN, Ypsilanti, Michigan 48197.

FREE CATALOGS. Repair air conditioning, refrigeration. Tools, supplies, full instructions. Doolin, 2016 Canton, Dallas, Texas 75201.

MAILORDER MILLIONAIRE helps beginners make \$500 weekly. Free report reveals secret plan! Executive (1K2), 333 North Michigan, Chicago 60601.

\$200.00 DAILY In Your Mailbox! Your opportunity to do what mail-order experts do. Free details. Associates, Box 136-J, Holland, Michigan 49423.

\$178.00 WEEKLY. Work one hour daily. Free brochure. FAS, Box 13703-A, San Antonio TX, 78213.

LINEAR

LM300	\$.79
LM301H/N*	3/1.00
LM302H	Volage Follower .79
LM304H	Negative Volt Reg .89
LM305H	Positive Volt Reg 1.00
LM307H/N	Op Amp (Super 741) .35
LM308H/N	Micro Power Op Amp 1.15
LM309K*	5 Volt Regulator/Amp 1.25
LM310H	Imprd Volt Follower 1.19
LM311H/N	Hi-perform Volt Comp. 1.99
LM318N	Hi-Speed Op Amp 2.00
LM320K	-5V 5.2V 12V 15V-24 Neg. Reg. 1.75
LM324N	Quad 741 Qp Amp 1.90
LM339N	Quad Comparator 2.35
LM340K	+5V 12V 15V 24V Pos. Reg. 1.89
LM340T	+5V 12V 15V 24V Pos. Reg. 1.75
LM370N	A 6 C - Squelch Amp 1.15
LM373N	AM/FM \$ \$ B Strip 3.15
LM380N*	2 Watt Audio Power Amp 1.25
LM380-8N*	.6 Watt Audio Amp 1.00
NE531T	OP ^ mp 3.00
NE550N	Volt. Reg. .79
LM.555V*	Timer .75
NE565H*	Phase Lock Loop (T05) 1.75
LM565N*	Phase Lock Loop (DIL) 2.00
LM566CN*	Function Generator 2.00
LM567H*	Tone Generator (T05) 1.75
LM567CN	Tone Generator (MINI) 2.00
LM703H	RF/IF Amp .45
LM723H/N*	Voltage Regulator .55
LM741H/N*	Comp. Op Amp 3/1.00
LM747H/N	Dual Compn. Op Amp .90
LM1310P	Stereo Demodulator 4.10
LM1458N	Dual Comp. Op Amp .65
LM1556N*	5 Times Faster 741 1.85
LM2307P	Current Controlled 3.15
LM3065N	T.V. - FM Sound System .75
LM3900N*	Quad Amp .50
LM3905N*	Precision Timer .65

PROJECTS

8263 \$ 7.00	MV 10	5/1	8090-98	.55
8267 4.00	MV 50	6/1	8123	1.50
2513* 11.00	MM 5024	5/1	8223	4.00
2518 7.00	MAN-1	1.95	8263	7.00
2519 4.00	MAN-3	.95	8267	4.00
2524* 5.00	MAN-4	1.95	8280	.75
2525 7.00	MAN-7	1.50	8281	1.85
2529* 4.00	DL 33	1.95	8288	1.15
4024P 3.00	DL747	2.50	8880	1.35

"ALL LED" MONSANTO READOUTS

MAN-1 MAN-3 MAN-6 MAN-64

MONSANTO TYPE	CHAR. HT.	SALE PRICE	Quantity Discounts
MAN-1	.27	\$3.50	3 for \$ 9.
MAN-2	.32*	4.95	3 for \$14.
MAN-3	.12	1.00	3 for \$ 2.50
MAN-6	.60	4.50	3 for \$12.
MAN-64	.4	3.50	3 for \$ 9.
MAN-7	.27	1.50	3 for \$ 3.

* 35 LED matrix

20-Years of Business INTEGRITY
20-Years of Money-Back GUARANTEES
20-Years of Economy! LOWEST PRICES!

48-HR. SERVICE

REFLECTIVE BAR TYPES

SLA-1**	.33	2.10	3 for \$5.
SLA-3**	.70	4.95	3 for \$13.
SLA-11**	.33†	2.50	3 for \$6.
SLA-21**	.33††	2.50	3 for \$6.

MAN-1 or MAN-4 spec. Color - RED
*By Opcoa, equal to
†Green. †† yellow

GAS DISCHARGE DISPLAY POWER SUPPLIES Only \$3.95

NATIONAL NUMERICAL DISPLAY PANEL \$5.95 3 for \$15

Type NDP1252 cold cathode gas discharge, 7-segment/8-digit symbols minus overflow and dot. Properly multiplexed. Like Burroughs Panplex-Two. Color: ORANGE. Used in calculators, equipment etc. Anode supply voltage 190 vdc. We have listed miniature power supply for them. With schematic, 3 x 1 1/4 x 1/2".

35 WATT AUDIO AMPLIFIER BASIC 2 for \$7

For Class AB use. Basic includes: Signetic 540 30 transistor high power driver TO-5 "IC", with a pair of complementary 35-watt plastic transistors, i.e. 2N5296 nnp and 2N6109 pnp. With schematics, printed circuit and parts board layout.

BRAND NEW LOWEST PRICES GENERAL ELECTRIC 3-WATT \$2.50 AUDIO AMP 3 for \$6.00

Delivers 3.5 watts continuous, 9-watts peak. With heat sinks; micro-mini size: 3/4 x 1/2 x 1/2". 9 to 30V supply. High sensitivity. 8 to 16 ohms.

THREE QUARTER INCH DIGITS BY OCOA

0 to 9
• 0.7 character
• 7 Segments
30 mils

Any color \$4.95

Type Color
SLA-3H RED
SLA-4H*RED
SLA-13 GREEN
SLA-14 GREEN
SLA-23 YELLOW
SLA-24 YELLOW

+Plus or Minus one

CLOCK CHIPS ON A "CHIP" as low as \$3.95

WITH DATA SHEETS

MM5311	6-digit 28-Pin	\$6.99
MM5312	4-digit 24-Pin	6.99
MM5313	6-digit 28-Pin	6.99
MM5314	6-digit 24-Pin	6.99
MM5316	4-digit 40-Pin, alarm	6.99
MM5316-A	no alarm	3.95

8 WATT STEREO AUDIO AMP

The factory "snipped" most of the cables to this compact 8 watt stereo unit with aluminum escutcheon plate. It's easy to use because we have all the cables marked ready to use. With power supply, 1.5 vac, 3 controls, LEFT and RIGHT VOLUME controls for two speakers for balancing and center TONE control. With knobs. 7 x 3 1/2 x 3 1/2. Hookup spec sheets.

MINI-COMPUTER PARTS

8008 micro - \$79.95

Kit of 9 IC's \$129

8008 Microprocessor with 8-2102/2602 n channel "STATIC" 1000 BIT RAM's. Requires single 5 VDC power supply. Specs.

35 WATT AUDIO AMPLIFIER BASIC 2 for \$7

For Class AB use. Basic includes: Signetic 540 30 transistor high power driver TO-5 "IC", with a pair of complementary 35-watt plastic transistors, i.e. 2N5296 nnp and 2N6109 pnp. With schematics, printed circuit and parts board layout.

60-WATT STEREO AM-FM-MULTIPLEX TUNER WITH AMPLIFIER

All Solid State, Printed Circuitry
Slide Rule Dial
All Purpose, All Family System!

INTEGRATED CIRCUIT SOCKETS

14-Pin, DIP	\$.45
14-Pin, Side Mount	1.00
16-Pin, DIP	.50
18-Pin, DIP	.50
8-Pin, SO (10-Pin)	.29
14-Pin, Wire Wrap	.39
16-Pin, Wire Wrap	.60c

Buy Any 3
Take 10%
Discount!

6995 WITH ESCUTCHEON

INTEGRATED CIRCUIT SOCKETS

Buy Any 3
Take 10%
Discount!

THE SIMPLEST! FINEST! SMALLEST

SELL MAGNETIC SIGNS—Free Information—Write Today
—Magnetic Signs, Box 76F, Villas, New Jersey 08251.

wanted CITIZENS BAND
DEALER-DISTRIBUTORS
Send this Ad to:
PAL ELECTRONICS CO.
P. O. Box 778 • Westminster, Ca. 92683

PIANO TUNING LEARNED QUICKLY AT HOME!
Tremendous field! Musical knowledge unnecessary. GI approved. Information free. Empire School, Box 450327, Miami 33145.

HIGHLY PROFITABLE ONE-MAN ELECTRONIC FACTORY
Investment unnecessary, knowledge not required, sales handled by professionals. Postcard brings facts about this unusual opportunity. Write today!
Barta-DN, Box 248, Walnut Creek, CA 94597.

SELL TO GOVERNMENT—Complete instruction package \$4. RMP, Box 33071, District Hts., MD 20028.

WANT MORE MONEY, BETTER JOB? Get valid College Degrees without studying...legally! Complete details for stamp. Counseling, Box 1162-PE1, Tustin, Calif. 92680.

FREE BOOK "2042 unique proven enterprises." Work home! Hayling-B, Carlsbad, CA 92008.

POVERTY to riches in six easy steps. Invest \$2 for our money making booklet. P.O. Box 8071, Cranston, R.I. 02920.

FREE BOOK "999 Successful, Little-Known Businesses." Work Home! Plymouth-TFD, Box 1056, Weston, CT 06880.

UNIVERSITY DEGREES BY MAIL! Free Details. Counseling, Box 1162-PE2, Tustin, California 92680.

RECORDS

OLDIES. 45rpm. Free Catalog. Corny's Record Shop, Box 166TC, Mason, Ohio 45040.

TIME DELAY RELAYS

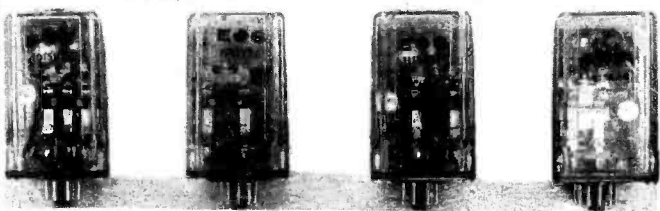

We have 2 time delay relays, similar, except that one has a delay of 10 seconds, and the other has a variable delay from 3 to 10 seconds. Each relay is enclosed in a clear plastic case, with an octal base. We provide the octal socket. Relays operate from 24 to 60 volts. The relays are DPDT, Potter & Brumfield KA series, with 10 Amp contacts. Time delay is solid state with Unijunction circuitry, all built into the plastic case. Provision is made for adding external capacitance or resistance to change or increase the time delay. Data sheet provided.

STOCK NO.P5229 Fixed delay (10 sec.) 2.95 ea. 2/5.00
STOCK NO.P5230 3-10 second delay 3.95 ea. 2/7.00



STEREO AMPLIFIER

Small 10 transistor STEREO AMPLIFIER is complete, except for speakers and small AC transformer. Contains tone, balance and volume controls. 6"x2"x1 1/4", 2 units make a quadraphonic amplifier. Makes a good basic unit for an intercom. The transformer for above is available.

STOCK NO.P5228 \$9.95 ea. 2/19.00
STOCK NO.P9713, Transformer for above. \$1.50

HIGH POWER TRANSFORMER 64 volts ct @ 5 volts, tapped @ 32 volts 8 amp., 18 volts ct @ 8 amp., 400 volts @ .15 amp.
STOCK NO. P9905 wt. 10 lbs. 9.95 Ea. 11.95 ea. 2/22.00

Include sufficient postage; Excess refunded. Write for new catalog 13, just of the press & loaded.

DELTA ELECTRONICS CO.
BOX 1, LYNN, MASSACHUSETTS 01903
Phone (617) 388-4705

CIRCLE NO. 11 ON READER SERVICE CARD

INVENTIONS WANTED

CASH-ROYALTIES for patented, unpatented inventions. Global Marketing Service, 139-P Lake Merced Hill South, San Francisco, California 94132.

INVENTORS: Protect your ideas! Free "Recommended Procedure". Washington Inventors Service, 422T Washington Building, Washington, D.C. 20005.

FREE PAMPHLET: "Tips on Safeguarding Your Invention." Write: United States Inventors Service Company, 708-T Carry Building, Washington, D.C. 20005.

Inventors
...Manufacturers Need New Products

If you have an idea for a new product, or a way to make an old product better, contact us, "the idea people." We'll develop your idea, introduce it to industry, negotiate for cash sale or licensing.
Send for our FREE "Invention Kit." It has a special "Invention Record Form," an important brochure, "Your Invention—Its Development, Protection & Marketing," and a Directory of 500 Corporations Seeking New Products. You'll learn how ideas become a reality!



RAYMOND LEE ORGANIZATION
230 Park Avenue, New York, N.Y. 10017
I'd like to find out how to take action on your idea. Send Free "Invention Kit No. A-112"

Name _____ Please Print
Address _____
City _____ State _____ Zip _____
SAN FRANCISCO LOS ANGELES TORONTO VANCOUVER DENVER CHICAGO

MR. INVENTOR: Manufacturers need inventions. For development assistance, patent searches, sales for cash or royalty, free "Proof of Invention" forms and other important information, write: Charles S. Prince, Invention Consultant, 509-E 5th Avenue, NYC 10017.

FILE your own patent application. Complete information and materials. Write: Inventor's Guide, 468-R, Goodspeed Road, Virginia Beach, Virginia 23451.

MAGAZINES

ZILLIONS OF SUPER ARTICLES every issue of Pop 'Tronics. Oct '54 thru July '74, for sale, no cutouts, make offer. Jiffy, 1874 Cheshire, Cheyenne, Wyo. 82001.

EINSTEIN'S THEORY OF RELATIVITY REPUTED in excerpt from the "Steel Ball" by Stan White. \$1 P.D. Tachyon™, P.O. Box 1012, Roselle, Illinois 60172.

EMPLOYMENT OPPORTUNITIES

ELECTRONICS/AVIONICS EMPLOYMENT OPPORTUNITIES. Report on jobs now open. Details FREE. Aviation Employment Information Service, Box 240, Northport, New York 11768.

TREASURE FINDERS

FREE FACT-FILLED CATALOG! World's largest selection! Metal detectors starting at \$79.50. Two year guarantee! Three factories, U.S.-Canada. 1,200 dealers - Service Centers nationwide. Finest instruments at any price! Budget Terms. Dealer Inquiries invited. Write: White's Electronics, Inc. Dept. PD5P, 1011 Pleasant Valley Road, Sweet Home, Oregon 97386.

TREASURE FINDER locates buried gold, silver, coins, treasures. 6 powerful models. Instant financing available. Write or call for free catalog. Phone (713) 682-2728 day or night. Dealer Inquiries invited. Relco, Dept. AA20, Box 10839, Houston, Texas 77018.

REAL ESTATE

BIG...FREE...SPRING '75 CATALOG! Over 2,500 top values in FARMS, RANCHES, ACREAGES, RECREATIONAL PROPERTIES, BUSINESSES, TOWN and COUNTRY HOMES in 40 states coast to coast! Over 4,100 PHOTOS! UNITED FARM AGENCY, 612-EP West 47th St., Kansas City, MO 64112.

Popular Electronics

JANUARY 1975

ADVERTISERS INDEX

READER SERVICE NO.	ADVERTISER	PAGE NUMBER
1	Adva Electronics	92
2	Allison Automotive	81
3	Altaj Electronics	95
	Ancrona Corp	97
39	Audio Warehouse Sales	81
	Bell & Howell Schools	62, 63, 64, 65
	CREI Capitol Radio Engineering Institute	72, 73, 74, 75
6	Cleveland Institute of Electronics	18, 19, 20, 21
7	Clifford's Hi-Fi Wholesalers	12
8	Cobra Product of Dynascan Corporation	2
9	Continental Specialties Corp	7
10	Cook's Institute of Electronics Engineering	14
11	Delta Electronics Co	100
12	Delta Products, Inc	69
13	Digi-Key Corporation	101
14	EICO	6
15	Edmund Scientific Co	102
16	Greenlee Tool Co	79
5	Heath Company	82, 83, 84, 85
17	Illinois Audio	14
18	International Electronics Unlimited	91
19	International Hifi Distributors	89
20	James Electronics	98
23	Johnson Co., E.F.	15
21	Lafayette Radio Electronics	16
22	McIntosh Laboratory, Inc	87
23	MITS, Inc	26
24	Mallory & Co., P.R.	SECOND COVER
	NRI Schools	8, 9, 10, 11
	National Technical Schools	52, 53, 54, 55
25	OEMorsco	87
26	Pace Communications	71
27	Pickering & Co., Inc.	THIRD COVER
28	Poly Paks	99
29	Radio Shack	5
30	S A E, Inc	71
31	Schober Organ Corp., The	12
32	Shure Brothers Inc	13
34	Solid State Sales	96
35	Southwest Technical Products Corporation	1
36	Technics by Panasonic	FOURTH COVER
37	Tracy Design Corp	100
38	Tri-Star Corp	79

CLASSIFIED ADVERTISING .91, 92, 96, 98, 100, 101
FEBRUARY 1975

HOME ENTERTAINMENT FILMS

ENJOY A GOOD FIGHT RIGHT AT HOME! All-Foreman Championship—Watch the knockout! 200' reel, \$19.95 color; \$9.95 B&W; Super 8 or Standard 8. We pay the postage. Or the '74 Indy "500," just out, 200' Super 8 color only, \$17.95 each plus 50 cents postage. Catalog, 25 cents. SPORTLITE, Elect. Dept.-2, 20 North Wacker Drive, Chicago, Illinois 60606.

RUBBER STAMPS

RUBBER address stamps. Free catalog, 45 type styles. Jackson's, Box 443G, Franklin Park, Ill. 60131.
MADE-TO-ORDER STAMPS. Low Prices. Free Catalog. Al-legheny, Box 14A, East McKeesport, PA 15035.

BOOKS

FREE catalog aviation/electronic/space books. Aero Publishers, 329PE Aviation Road, Fallbrook, California 92028.
FREE book prophet Elijah coming before Christ. Wonderful bible evidence. Megiddo Mission, Dept. 64, 481 Thurston Rd., Rochester, N.Y. 14619.
BOOKS—thousands titles, bargains. Catalog Free. Cassiano, 92-27 New York Blvd., Jamaica, New York 11433.

POPULAR ELECTRONICS INDEXES. Detailed and complete subject indexes now available to both 1972 and 1973 magazines. Hundreds of subject references to help you quickly find that special project, article, or product test. 1972 and 1973 editions \$1.00 each. INDEX, box 2228, Falls Church, Va. 22042.

PLASTICS

CASTOLITE pours like water, hardens like glass without heat. Crystal clear, colors. Embed flowers, seashells, mementos, anything. Make fine gifts. Form flexible molds over patterns of any shape, size. Reproduce your own designs in plastics, candlewax, metal, plaster, cement. Free Brochure. Or send \$1.00 for Illustrated Manual, Catalog. Profitable. CASTOLITE, Dept. 75B/PE, Woodstock, Ill. 60098.

REPAIRS AND SERVICES

ELECTRONIC PROTOTYPE Models Built. Wire-Wrap, Hand solder, P.C. Boards. Engineering consultation and drafting service available. ACE Technical Services, 23-13 Steinway St., Astoria, N.Y. 11105. Phone: (212) 728-8284.

HYPNOTISM

SLEEP learning. Hypnotic method. 92% effective. Details free. ASR Foundation, Box 23429EG, Fort Lauderdale, Florida 33307.

FREE Hypnotism. Self-Hypnosis. Sleep Learning Catalog! Drawer H400, Ruidoso, New Mexico 88345.

AMAZING self-hypnosis record releases fantastic mental power. Instant results! Free trial. Write: Forum (AA2), 333 North Michigan, Chicago 60601.

STAMPS

WOW! 110 ALL DIFFERENT GERMANY 10 CENTS. Commemorative, Airmails, High Values, Big Catalog, bargain lists. Also, fine stamps from our approval service, which you may return without purchases and cancel service at any time. Jamestown Stamp, Dept. A25EG, Jamestown, N.Y. 14701.

DO-IT-YOURSELF

TELEPHONES UNLIMITED, equipment, supplies. Catalog 50 cents. Box 1654E, Costa Mesa, Calif. 92626.

MISCELLANEOUS

WINEMAKERS: Free illustrated catalog yeasts, equipment. Simplex, Box 12276P, Minneapolis, Minn. 55412.

QUIT SMOKING! Multi-colored Illustrated Book Reveals How...Includes PRE-PAID Magazine Subscription Application, \$1.50. Guaranteed. Communique, Box 1988-E, Hollywood, CA 90028.

Quality Electronic Components

SPECIAL SAVINGS DISCOUNT ON LINEAR AND DIGITAL INTEGRATED CIRCUITS
Discount 4% from the total of your I.C. order if it exceeds \$25.00 based on single lot prices. 7% for \$50.00 or more, 10% for \$100.00 or more. Additional lots quantity discounts offered.

DIGITAL INTEGRATED CIRCUITS			
7400N . 25.5c	7437N . 42.0c	7480N . 70.5c	74154N . \$2.22
7401N . 25.5c	7438N . 42.0c	7482N . 99.0c	74155N . \$1.17
7402N . 25.5c	7440N . 25.5c	7483N . \$1.17	74156N . \$1.14
7403N . 25.5c	7441N . \$1.40	7485N . \$1.40	74157N . \$1.11
7404N . 30.0c	7442N . 90.0c	7486N . 45.0c	74158N . \$1.53
7405N . 30.0c	7445N . \$1.49	7489N . \$4.47	74160N . \$1.50
7406N . 48.0c	7446N . \$1.14	7490N . 66.0c	74161N . \$1.50
7407N . 48.0c	7447N . \$1.11	7491N . \$1.05	74162N . \$1.50
7408N . 28.5c	7448N . \$1.22	7492N . 66.0c	74163N . \$1.50
7409N . 28.5c	7450N . 25.5c	7493N . 66.0c	74164N . \$1.58
7410N . 25.5c	7451N . 25.5c	7494N . \$1.10	74165N . \$2.45
7411N . 25.5c	7453N . 25.5c	7495N . \$1.14	74166N . \$2.00
7413N . 60.0c	7454N . 25.5c	7496N . \$1.14	74175N . \$1.00
7416N . 46.5c	7459N . 28.5c	74107N . 45.0c	74180N . \$1.17
7417N . 46.5c	7460N . 25.5c	74121N . 46.5c	74181N . \$3.42
7418N . 31.5c	7470N . 33.0c	74122N . 49.5c	74182N . \$1.14
7420N . 25.5c	7472N . 36.0c	74123N . \$1.08	74192N . \$1.73
7421N . 25.5c	7473N . 43.5c	74141N . \$1.10	74193N . \$1.73
7423N . 72.0c	7474N . 43.5c	74150N . \$1.53	74198N . \$2.75
7426N . 33.0c	7475N . 69.0c	74151N . \$1.17	74199N . \$2.75
7430N . 25.5c	7476N . 46.5c	74153N . \$1.17	

LINEAR INTEGRATED CIRCUITS			
555V MINIDIP TIMER . 82.5c	558V MINIDIP DUAL AMP . 75.0c	565A DIP PLL . \$3.38	567V MINIDIP DECODER . \$3.38
709V MINIDIP OP AMP . 36.0c	723A DIP VOLTAGE REG . 82.5c	741V MINIDIP OP AMP . 50.0c	747A DIP DUAL AMP . 97.5c
748V MINIDIP OP AMP . 42.0c	LM3900 DIP QUAD AMP . 60.0c	LI29 5 VOLT REG . \$1.80	LI30 12 VOLT REG . \$1.80
LI31 15 VOLT REG . \$1.80			

MINIATURE ALUMINUM ELECTROLYTIC CAPACITORS — AXIAL LEAD TYPE —
40°C plus 85°C Tolerance. 10 plus 50% (greater than 4.7 uFd) 10 plus 75% (4.7 uFd or less)

1 AMP SILICON RECTIFIERS			
1N4001 50 PIV 12/51 100/56 1000/548	1N4005 600 PIV 6/51 100/109 1000/570		
1N4007 1000 PIV 6/51 100/511 1000/588			

SILICON SIGNAL & SWITCHING DIODE			
1N4148 (1N914 equiv.) 12/51 100/57 1M/550 5M/520			

MOLEX SOLDERCON IC TERMINALS			
100/51 500/54.20	1000/58.20	5000/538.20	50,000/5275

LED 7 SEGMENT DISPLAYS			
DATALIT-704 . \$1.00	DATALIT-707 . \$1.50		

IC SOCKETS 4 AMP SLIDE SWITCHES			
8 Pin DIP Solder 35c	SPST . . . 12c	10/51 DPDT . . . 25c	10/52
14 Pin DIP Solder 45c			
16 Pin DIP Solder 50c			
24 Pin DIP Solder \$1.25			

REED RELAY			
6 AMP CONTACT 5 VOLT/20MA COIL			
\$2.00	10/515	100/5125	

25 V. DISC CAPS			
Value 1 10 100 1000			
.01 1c	3c	3.5c	3c 2.4c
.022 6c	4c	3.5c	2.75c
.047 9c	6c	5.3c	4.25c
.1 12c	9c	7.5c	6c

½ & ¼ WATT CARBON COMP. RESISTORS			
5 each of the 85 standard 10% values (2.2-22M) ¼ W Resistors (425 pcs.) Sorted by value \$12/set 2-4 are \$11/set 5-9 are \$10/set.			
5 each of the 70 standard 10% values (10-5.6M) ¼ W Resistors (350 pcs.) Sorted by value \$12/set 2-4 are \$11/set 5-9 are \$10/set.			

SILICON TRANSISTORS			
EN918 . TO-106	1.9 10.99 100	2N3645 . TO-105	20c 17.5c 16.0c
EN930 . TO-106	21c 18.5c 16.5c	2N3646 . TO-106	22c 19.0c 17.5c
EN922 . TO-106	21c 18.5c 16.5c	2N3694 . TO-92	22c 19.0c 17.5c
EN2569A . TO-106	21c 18.5c 16.5c	2N3696A . TO-92	22c 19.0c 17.5c
EN2907 . TO-106	21c 18.5c 16.5c	2N4124 . TO-92	22c 19.0c 17.5c
2N2712 . TO-98	18c 16.0c 14.5c	2N4126 . TO-92	22c 19.0c 17.5c
2N3391A . TO-98	22c 19.0c 17.5c	2N4401 . TO-92	22c 19.0c 17.5c
2N3392 . TO-98	22c 19.0c 17.5c	2N4403 . TO-92	22c 19.0c 17.5c
2N3393 . TO-98	22c 19.0c 17.5c	2N5057 . TO-92	22c 19.0c 17.5c
2N3394 . TO-98	22c 19.0c 17.5c	2N5059 . TO-92	22c 19.0c 17.5c
2N3563 . TO-106	20c 17.5c 16.0c	2N5129 . TO-106	19c 17.0c 15.0c
2N3565 . TO-106	20c 17.5c 16.0c	2N5133 . TO-106	19c 17.0c 15.0c
2N3638 . TO-106	20c 17.5c 16.0c	2N5134 . TO-106	19c 17.0c 15.0c
2N3638A . TO-105	20c 17.5c 16.0c	2N5136 . TO-106	19c 17.0c 15.0c
2N3640 . TO-106	22c 19.0c 16.0c	2N5138 . TO-106	19c 17.0c 15.0c
2N3641 . TO-105	20c 17.5c 16.0c	2N5139 . TO-106	19c 17.0c 15.0c
2N3642 . TO-105	20c 17.5c 16.0c	2N3055 . TO-3	\$1.00 95.0c 85.0c

FIELD EFFECT TRANSISTORS			
MPT102 . TO-92	.44 .380 .350	2N5457 . TO-92	.47 .420 .375

NPN DARLINGTON TRANSISTOR
MPS-A13 . TO-92 Min. DC Current Gain of 5,000 at 10mA. .36 .320 .290
Send for Free Catalog or Mail Readers Service Card
COD ORDERS ACCEPTED FOR SAME DAY SHIPMENT
CALL 218-681-6674
Orders Less than \$10.00 add 50c Service Charge—Others Postpaid
"Only Quality Components Sold!"
DIGI-KEY CORPORATION
P.O. Box 126 Thief River Falls, MN 56701
CIRCLE NO. 13 ON READER SERVICE CARD

LIVE IN THE WORLD OF TOMORROW... TODAY!

And our FREE 180 PAGE CATALOG is packed with exciting and unusual values in electronic, hobby and science items — plus 4,500 finds for fun, study or profit... for every member of the family.

A BETTER LIFE STARTS HERE

TEST YOUR DEGREE OF ESP!

Which light comes on when you push the button—Star, Square, Triangle or Circle? If you've got ESP you or your subject will guess right, significantly. Solid state ESP Tester has guaranteed random circuit for accuracy—you can't beat the machine by memorizing! Run classic ESP, precognition, Probability, telepathy experiments. Portable. Req. 4 "D" batt.



No. 72,090AV... (6 1/4 x 3 3/4 x 2")\$29.95 Ppd.
EXTRA PADS TO RECORD 250 EXPERIMENTS
Stock No. 72,092AV\$3.50 Ppd.

"FISH" WITH A MAGNET

Go treasure hunting on the bottom! Fascinating fun & sometimes profitable! Tie a line to our powerful new specially designed 150 lb. pull PVC coated Magnet—drop it overboard in bay, river, lake or ocean. Troll it along bottom—your "treasured" haul can be outboard motors, anchors, other metal valuables. Has 6 stacked ceramic magnets. Lifts over 150 lbs. under water!

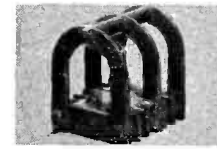

No. 71,135AV... (3-1/4 x 3-7/8")\$17.50 Ppd.
75-LB. PULL (1 LB) W/ 3 CERAMIC MAGNETS
No. 71,150AV... (1-11/16 x 3-1/4")\$11.00 Ppd.

NEW! KIRLIAN PHOTOGRAPHY KIT!

Experiment in the fascinating new field of "Kirlian electrophotography"—images obtained on film without camera or lens by direct recording of electric charge transmitted by animate & inanimate objects. Each "aura" differs—animate aura said to change corresponding to physical changes. Kit incs. portable darkroom, double transformer isolated from power source; instrs.



Stock No. 71,936AV\$49.95 Ppd.
"HIGH VOLTAGE PHOTOGRAPHY" by H.S. Dakin
No. 9129AV (60-PC. PAPERBACK BOOK)\$5.00 Ppd.
DELUXE KIRLIAN PHOTOGRAPHY SET
No. 72,053AV\$399.00 Ppd.

SEE
FEATURE ARTICLE
JANUARY 1975

GET A CHARGE FROM THE SUN!

Our 12V Solar Battery Charger allows direct conversion of light-to-electricity. Compact panel put on a boat can automatically charge its 12V battery over entire daylight period. Use anywhere for a trickle charge. Big value, it comprises 30 1/2V silicon solar cells in series w/diode.

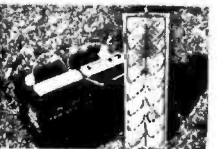

No. 71,971AV (AB, 30 W-HRS./WK.)\$89.95 Ppd.
9 x 18" HI CURRENT MODEL (6W, 12V, 500 mA)
No. 72,010AV (AB, 150 W-HRS./WK.)\$349.95 Ppd.
6 x 6" LO VOLTAGE MODEL (1.5V, .38W, 250 mA)
No. 42,172AV\$49.95 Ppd.

3-CHANNEL COLOR ORGAN KIT



Easy to build low-cost kit needs no technical knowledge. Completed unit has 3 bands of audio frequencies to modulate 3 independent strings of colored lamps (i.e. "lows"-reds, "middles"-greens, "highs"-blues. Just connect hi-fi, radio, power lamp etc. & plug ea. lamp string into own channel (max. 300w ea.). Kit features 3 neon indicators, color intensity controls, controlled individ SCR circuits; isolation transformer; custom plastic housing; instr.

Stock No. 41,831AV\$18.95 Ppd

AM RADIO FITS IN/ON YOUR EAR!

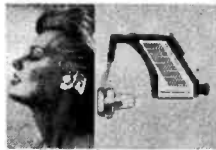

Wear it inconspicuously everywhere, listen as you work (lawn, yard, office), watch (game, beach) or wait. Instant music, news sports. No gimmick, our 6/10 oz. technological wonder has integrated circuit, 11 transistors, patented ferrite antenna/tuner/volume dial. Uses normal siber oxide hearing aid batt.

(incl) for approx. 100 hrs. playing. New batt. to slip in avail. at drug stores (about 50¢). No lengthy wires, bulky cases, or power-packs!
Stock No. 42,275AV\$14.95 Ppd.



KNOW YOUR ALPHA FROM THETA!

For greater relaxation, concentration, listen to your Alpha-Theta brainwaves. Ultra-sensitive electrode headband slips on/off in seconds—eliminates need for messy creams, etc. Atch'd to amplifier, filters brainwaves, signals beep for ea. Alpha or Theta wave passed. Monitoring button stimulates Alpha sound; audio & visual (L.E.D.) feedback. Reliable, easy-to-use unit comparable to costlier models. Completely safe. Comprehensive instruction booklet.

No. 1635AV (8x3x4"; 24. oz.)\$134.50 Ppd.
LOW COST "STARTER" UNIT
No. 71809AV\$55.00 Ppd.
DELUXE "ON" TIME MONITOR—Measures and records %
No. 1652AV... (15x10x6")\$349.50 Ppd.

WHICH ARE YOUR CRITICAL DAYS?



Can Bio-rhythm tell you? We're not sure, but we're told that vast mood shifts are caused by your body's Internal Time Clock whose rhythms can be charted ahead to possibly warn you of "critical" days. Some are great, some blah. Maybe it's your physical, emotional & intellectual rhythms converging at the right or wrong time. Compute your cycles with our Bio-rhythm kit and judge for yourself. Incis Charting kit, metal Dialgraft Calc., instrs.

Stock No. 71,949AV\$11.50 Ppd.
1 YR. PERSONALIZED REPORT BY COMPUTER
Stock No. 19,200AV... (send Birthdate)\$15.95. Ppd.

3" ASTRONOMICAL REFLECTING TELESCOPE



See stars, moon, planets close-up! 30 to 90X. Famous Mt. Palomar Type. Aluminized & overcoated 3" diameter f/10 primary mirror, ventilated cell. Fork type equatorial mount. Durable PVC tube. Includes 1" F.L. 30X Ramsden, Barlow lens to triple power, 3X finder telescopes, hardwood tripod. FREE: "STAR CHART", "HOW TO USE" book.

Stock No. 85,240 AV\$49.95 Ppd.
DELUXE 3" REFLECTOR TELESCOPE\$79.95 Ppd.
4 1/4" REFLECTOR (45X to 135X)\$149.50 FOB
4 1/4" REFLECTOR W/CLOCK DRIVE\$189.50 FOB
6" REFLECTOR (48X to 360X)\$249.50 FOB
6" REFLECTOR W/CLOCK DRIVE\$285.00 FOB

DISCRETE 4-CHANNEL

UV-15 2400 Q

DCF 2400



UV-15 2000 Q

DCF 2000

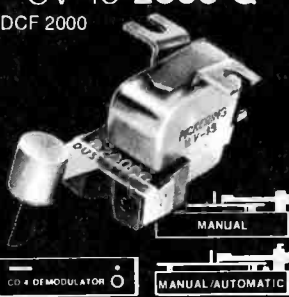

STEREO AND MATRIX

XV-151200E

DCF 1200

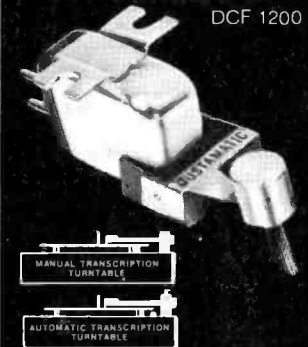

XV-15750E

DCF 750



XV-15400E

DCF 400

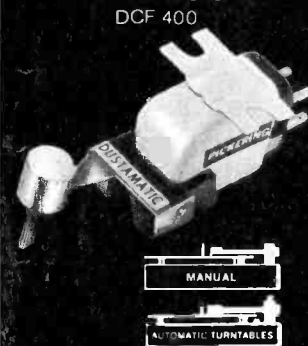

XV-15350

DCF 350



XV-15200E

DCF 200



XV-15150

DCF 150

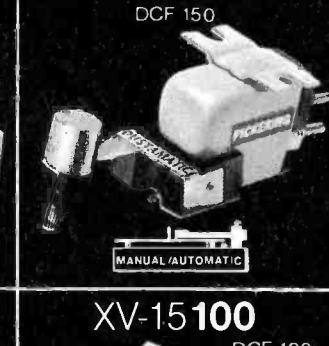

XV-15140E

DCF 140

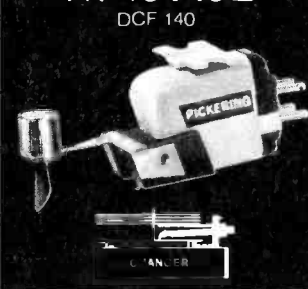

XV-15100

DCF 100

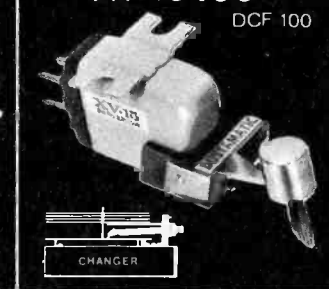

The right PICKERING cartridge for your equipment is the best cartridge money can buy.

They feature low frequency tracking and high frequency tracing ability*!

Pickering offers you "The Best of Both Worlds" in discrete 4-channel and in stereo cartridges. These cartridges have been specifically designed and engineered not only to peak specifications and performance characteristics, but also to achieve total compatibility with your music system to help you get the most out of it.

Only Pickering has developed a way for you to be absolutely certain you select the "right" cartridge for your music system. We did it first for stereo by developing our Dynamic Coupling Factor rating system—DCF for short—which identifies pick-up performance in terms of a quantitative measurement. The value of a DCF rating lies not only in its merit to define low frequency tracking ability but also in its measure as an index of high frequency (8 to 50 kHz) tracing ability. Pickering's DCF-rated pick-ups have exceptional high frequency tracing characteristics, vital for both stereo and discrete 4-channel performance. The Pickering cartridge exactly "right" for maximum performance with your equipment is simple to select because of this rating method.

Now, Pickering is also applying application engineering techniques and DCF ratings to its discrete cartridges. They fulfill the stringent requirements necessitated by the sophisticated nature of discrete discs.

So, whether stereo or discrete is your preference, choose from "The Best of Both Worlds" the Pickering cartridge exactly right for your equipment.

For further information write to Pickering & Co., Inc. Dept. PE, 101 Sunnyside Blvd., Plainview, New York 11803

* traceAbility™



"for those who can hear the difference"

MAIL COUPON FOR GIANT FREE CATALOG!

180 PAGES • MORE THAN 4500 UNUSUAL BARGAINS

Completely new 1975 edition. New items, categories, illustrations. Dozens of electrical and electromagnetic parts, accessories. Enormous selection of Astronomical Telescopes. Unique lighting and ecological items. Microscopes, Binoculars, Magnifiers, Lenses, Prisms. Hard-to-get-surplus bargains. Ingenious scientific tools. 1000's of components.

EDMUND SCIENTIFIC CO. 300 Edscorp Building, Barrington, N. J. 08007 Please rush Free Giant Catalog "AV"

Name _____
Address _____
City _____ State _____ Zip _____

PLEASE SEND GIANT FREE CATALOG "AV"

30 DAY MONEY-BACK GUARANTEE
YOU MUST BE SATISFIED OR RETURN ANY PURCHASE IN 30 DAYS FOR FULL REFUND

COMPLETE & MAIL WITH CHECK OR M.O.

EDMUND SCIENTIFIC CO. 300 Edscorp Building, Barrington, N.J. 08007

How Many	Stock No	Description	Price Each	Total

Add Handling Chg.: \$1.00, Orders Under \$5.00, 50¢, Orders Over \$5.00

I enclose check money order for \$ _____ TOTAL \$ _____

NAME _____

ADDRESS _____

CITY _____ STATE _____ ZIP _____

Introducing the SL-1300. The precision of direct drive. The convenience of automation.

Now Technics adds convenience to perfection.

The SL-1300. The fourth and newest Technics direct-drive turntable. And the first with convenient, fully automatic operation.

Auto-Start. Auto-Stop. Auto-Return. Auto-Repeat. And the kind of outstanding specifications that are normally found only in a manual turntable.

The SL-1300, like all Technics turntables, uses our electronically controlled DC motor. But with an improvement. The platter is part of the motor. Making the drive even more direct. It also reduces parts, increases reliability and produces an ultra-thin profile.

The gimbal-suspended automatic arm is $9\frac{1}{16}$ " pivot to stylus. For extremely low tracking error. And its four pairs of pivot bearings increase the rotational sensitivity

while maintaining flawless balance.

Our anti-skating control requires only one scale for all types of styli. While gold-plated contacts in the head shell assure reliable contact and help prevent hum.

And we haven't forgotten the more refined details. Like Memo-Repeat. So you can play a record from one to five times. Or indefinitely. There's also a

new prism strobe. Two-speed variable pitch controls. Dust cover. Feedback-insulated legs. And low capacitance phono cables for CD-4 records.

The concept is simple. The execution is precise. The performance is outstanding. The name is Technics.

200 PARK AVE., NEW YORK, N.Y. 10017. FOR YOUR NEAREST AUTHORIZED TECHNICS DEALER, CALL TOLL FREE 800 447-4700. IN ILLINOIS, 800 322-4400.

Technics

by Panasonic

WOW & FLUTTER	0.03% WRMS
RUMBLE	-50dB (DIN A), -70dB (DIN B)
LONG-TERM DRIFT	Less than 0.1% (over 30 min.)
MIN. STYLUS PRESSURE	0.25 grams
TRACKING ERROR	$\pm 1.6^\circ$



CIRCLE NO. 36 ON READER SERVICE CARD