





According to Audio Times, a leading publication devoted to audio manufacturing and retailing: "No piece of audio equipment is as eagerly awaited as the 'one four-channel unit that does everything — i.e., the receiver with built-in circuitry for SQ, RM and CD-4 record decoding.'"

**It's here!**

Pioneer has taken another giant step forward. Our new collection of quadraphonic receivers — QX-949, QX-747, QX-646 — has this total capability. They reproduce CD-4, SQ, RM and discrete four-channel sound without adaptors, add-on decoders or demodulators. And they're specifically designed to fully meet all of the standards established for these matrix and discrete program sources.

Bearing in mind that two-channel is, and will continue to be, a tremendous source of listening pleasure for many years to come, these new units are designed for it, along with their total quadraphonic capabilities. The QX-949 and QX-747 reproduce two-channel with augmented power due to Pioneer's new Power Boosting circuitry.

**A whole new world of discrete sound with the built-in CD-4 demodulator**

While many quadraphonic receivers have limited degrees of four-channel capabilities, Pioneer offers maximum versatility with built-in CD-4. Without

it you can't enjoy the increasing number of CD-4 discrete discs (the true four-channel record) from leading recording companies like RCA, Warner, Atlantic, Elektra, and others. CD-4 is a 'must' for optimum quadraphonic listening enjoyment.

Since the CD-4 circuit incorporates FET's and IC's, continuous, stable performance is assured. In addition, it uses a 30KHz subcarrier similar to that used in FM multiplex broadcasting. The subcarrier is demodulated by a Phase Lock Loop (PLL) circuit for each channel. The result is optimum channel separation — absolutely necessary to achieve the full, rich impact of quadraphonic reproduction. Convenient and simple-to-use front/rear left and right separation controls are on the front panels of all three models.

**SQ and RM decoding bring to life the hidden ambience of matrixed and stereo records**

With built-in RM circuitry, you can experience new brilliance from your present collection of two-channel stereo records and tapes. FM broadcasts, too. Also, new vistas of enjoyment unfold when you play the new four-channel SQ matrix records being released by Columbia, Capitol, Epic and Vanguard, to mention just a few of the prominent SQ record producers. No matter what the quadraphonic program source or the record label, Pioneer's new quadraphonic receivers flawlessly reproduce them all.

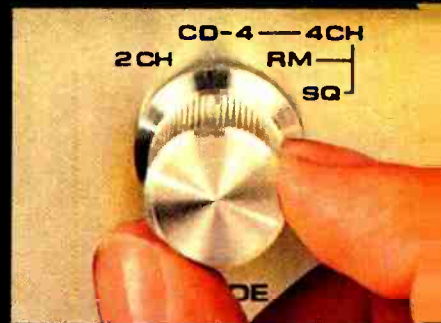

**Total Capability Mode Switch — Fingertip switching to CD-4, SQ, RM quadraphonic sources, as well as two-channel stereo.**

**Matchless performance with powerhouse capabilities**

As is traditional with all Pioneer receivers, these quadraphonic units have power to spare. For example, the top model, QX-949 has a power output in four-channel operation, of 40 watts per channel, minimum continuous power, 20Hz—20,000Hz, with maximum total harmonic distortion 0.3% at 8 ohms.

Switching to two-channel operation, the Pioneer Power Boosting circuit delivers 60 watts per channel, minimum continuous power, 20Hz—20,000Hz, maximum total harmonic distortion 0.3% at 8 ohms.

By using super-size power transformers in the QX-949, in combination with four 10,000 microfarad electrolytic capacitors, this high power output is obtained at very low frequency. And it's further insured by direct-coupling in the output stage.

**No overload with speaker protector circuit**

Since direct-coupling feeds the signal directly to the speakers, an automatic







**The best way** to find out how well a receiver performs is to listen to it. The next best way is to listen to the opinions of qualified critics who have listened to it. Pioneer quadraphonic receivers have earned the unanimous praise of the critics. Visit a Pioneer dealer and listen to these receivers. Once you've heard them yourself, we're confident you'll agree.

**STEREO REVIEW:** "The QX-949 has built-in decoding circuits for all the major types of four-channel records — SQ, RM and CD-4 . . . electrical performance of its tuner and amplifier rivals some of the finest separate component systems."

**MODERN HI-FI & STEREO GUIDE:** "The QX-949 is commensurate with all the fine receivers we have learned to expect from Pioneer and it stands as the model for present-day quadraphonic receivers."

**AUDIO:** "(The QX-949 is) one of the most impressive receivers (visually and technically) we have ever tested . . . It would be very difficult to come up with any features in a four-channel receiver that Pioneer hasn't already thought of in this powerful unit."

**POPULAR ELECTRONICS:** "The Pioneer Model QX-747 receiver is clearly a superb unit when judged by all normal performance standards. In fact, its power capabilities in the 2-channel mode make it a fine value even as a stereo-only receiver."

**HIGH FIDELITY:** "The tuner section is one of the best we've seen in a quadraphonic receiver . . . All told, the QX-949 strikes us as typical of Pioneer's relatively uncompromising approach to receiver design."

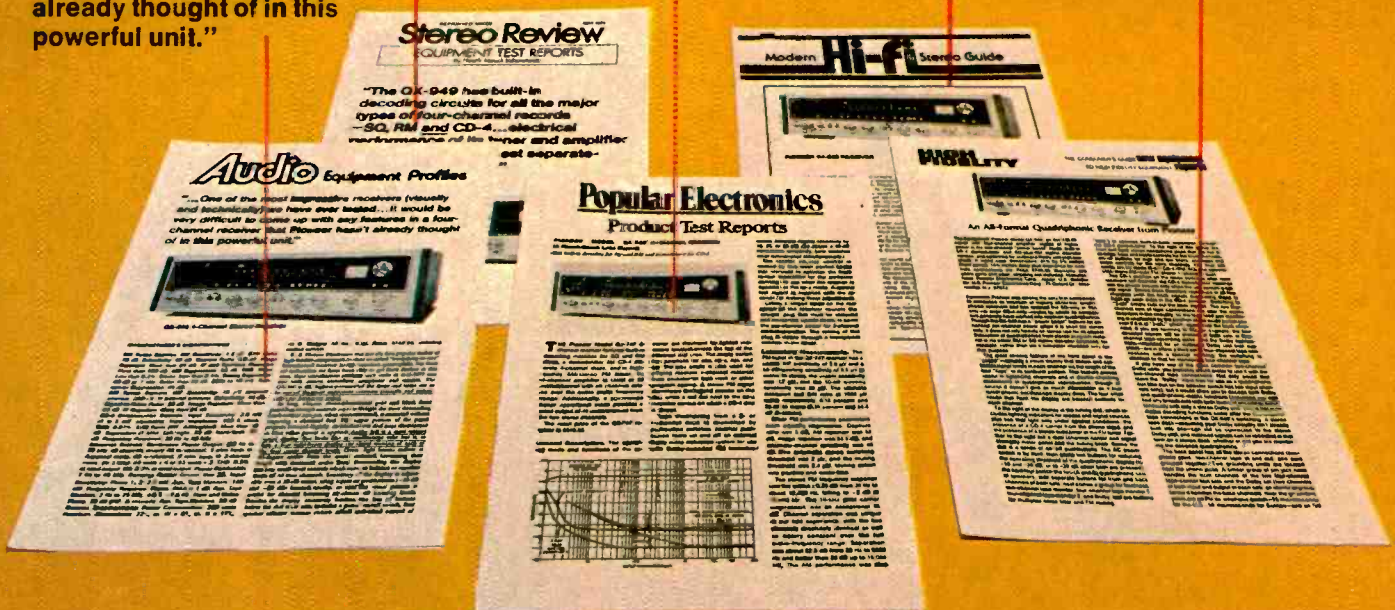



# Pioneer.

# The very best.





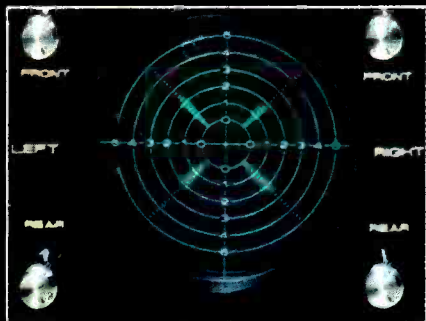

**Four-Channel Level Indicator** — See what you hear. Make instant adjustments with left/right, front/rear level controls.

electronic trigger relay system is used to protect the speakers from DC leakage or overload.

#### **New and exclusive Power Boosting circuit**

When switching from four-channel to two-channel reproduction, power is substantially increased with the new and advanced Power Boosting circuit, as described above. This exclusive circuit is built into both the QX-949 and QX-747 models.

Another plus feature attributable to the Power Boosting circuit is simplified switching from four-channel to two-channel operation. It can be instantly achieved without the usual re-connecting of speaker wires. This, too, is a Pioneer exclusive.

#### **A tuner section the equal of separate components**

The FM tuner section of the QX-949 is truly an engineering accomplishment. It incorporates two dual-gate MOS FET's in the front end, plus three ceramic filters and 6-stage limiters in a monolithic IC in the IF stage. The result is superb sensitivity and selectivity, and excellent signal to noise ratio.

#### **Advanced circuitry includes Dolby adaptor input/output and 4-channel broadcasting multiplex output terminal**

In anticipation of the future use of discrete quadraphonic broadcasting, the QX-949 and QX-747 include a quadraphonic multiplex output terminal. Depending on the system finally approved, all that ever will be required is a simple adaptor unit. And speaking of adaptor units, both the QX-949 and QX-747 highlight an input/output for a Dolby noise reduction adaptor unit.

#### **Unique 4-channel level indicator**

Regardless which quadraphonic

source is in operation, the sound level of each channel can be monitored by viewing the large scope-type level indicator on the top two models. Left and right front/rear controls permit instant adjustment. Indicator sensitivity controls allow for a maximum of -30dB adjustments at any sound level. The level indicator may also be used to view CD-4 channel separation adjustments made with the CD-4 separation controls.

#### **Inputs/Outputs for total versatility**

Pioneer has endowed these models with terminals for a wide range of program sources. The only limitation is your own listening interests and your capability to experiment with sound.

#### **Convenient features increase listening enjoyment**

Along with the total capability of these receivers, Pioneer has incorporated a wide array of additional, meaningful features. All three instruments include: loudness contour, FM muting, an extra wide tuning dial, two sets of bass/treble

controls for front and rear channels, function and mode selector with multi-colored indicator lights. Further refinement is offered with the QX-949's multiplex noise and high/low filters, plus signal strength and center tuning meters in one housing.

Admittedly, these new Pioneer quadraphonic receivers, like fine sports cars or cameras, are not inexpensive. However, they represent the high fidelity industry's most outstanding value. We have built them with the same quality, precision and performance you've come to expect from Pioneer stereo equipment. We offer them to you with the same pride and conviction that has always compelled you to say — "Pioneer, the very best."

QX-949 — \$749.95; QX-747 — \$649.95; QX-646 — \$499.95. Prices include walnut cabinets.

U.S. Pioneer Electronics Corp.,  
75 Oxford Drive, Moonachie,  
New Jersey 07074  
West: 13300 S. Estrella, Los Angeles  
90248 / Midwest: 1500 Greenleaf,  
Elk Grove Village, Ill. 60007  
Canada: S. H. Parker Co.

#### **Specifications**

<b>Amplifier</b>	<b>QX-949</b>	<b>QX-747</b>	<b>QX-646</b>
* 4-ch. minimum continuous power per channel, 8 ohms	40 watts/ channel (20Hz-20kHz)	20 watts/ channel (20Hz-20kHz)	9 watts/ channel (40Hz-20kHz)
* 2-ch. minimum continuous power per channel, 8 ohms	60 watts/ channel (20Hz-20kHz)	40 watts/ channel (20Hz-20kHz)	13 watts/ channel (40Hz-20kHz)
* Maximum total harmonic distortion	0.3% (20Hz-20kHz)	0.5% (20Hz-40kHz)	1% (40Hz-20kHz)
<b>FM Tuner</b>			
FM Sensitivity (IHF) (the lower the better)	1.8uV	1.9uV	2.2uV
Selectivity (the higher the better)	80dB	60dB	40dB
Capture Ratio (the lower the better)	1dB	1dB	3dB
S/N Ratio (the higher the better)	70dB	70dB	65dB
<b>Inputs</b>			
Phono	2	1	1
Tape Monitor	2 (4-ch.) 1 (2-ch.)	1 (4-ch.) 1 (2-ch.)	1 (4-ch.) 1 (2-ch.)
Dolby adaptor input	1 (4-ch.)	1 (4-ch.)	—
Auxiliary	1	1	1
<b>Outputs</b>			
Speakers	2 (Front) 2 (Rear)	1 (Front) 2 (Rear)	1 (Front) 2 (Rear)
Headset	1 (Front/Rear)	1 (Front/Rear)	1 (Front)
Dolby adaptor output	1 (4-ch.)	1 (4-ch.)	—
Tape Rec.	2 (4-ch.) 1 (2-ch.)	1 (4-ch.) 1 (2-ch.)	1 (4-ch.) 1 (2-ch.)
4-ch. MPX output	1	1	—

\* In accordance with F.T.C. regulations

**PIONEER**  
when you want something better

CIRCLE NO. 43 ON READER SERVICE CARD

www.americanradiohistory.com



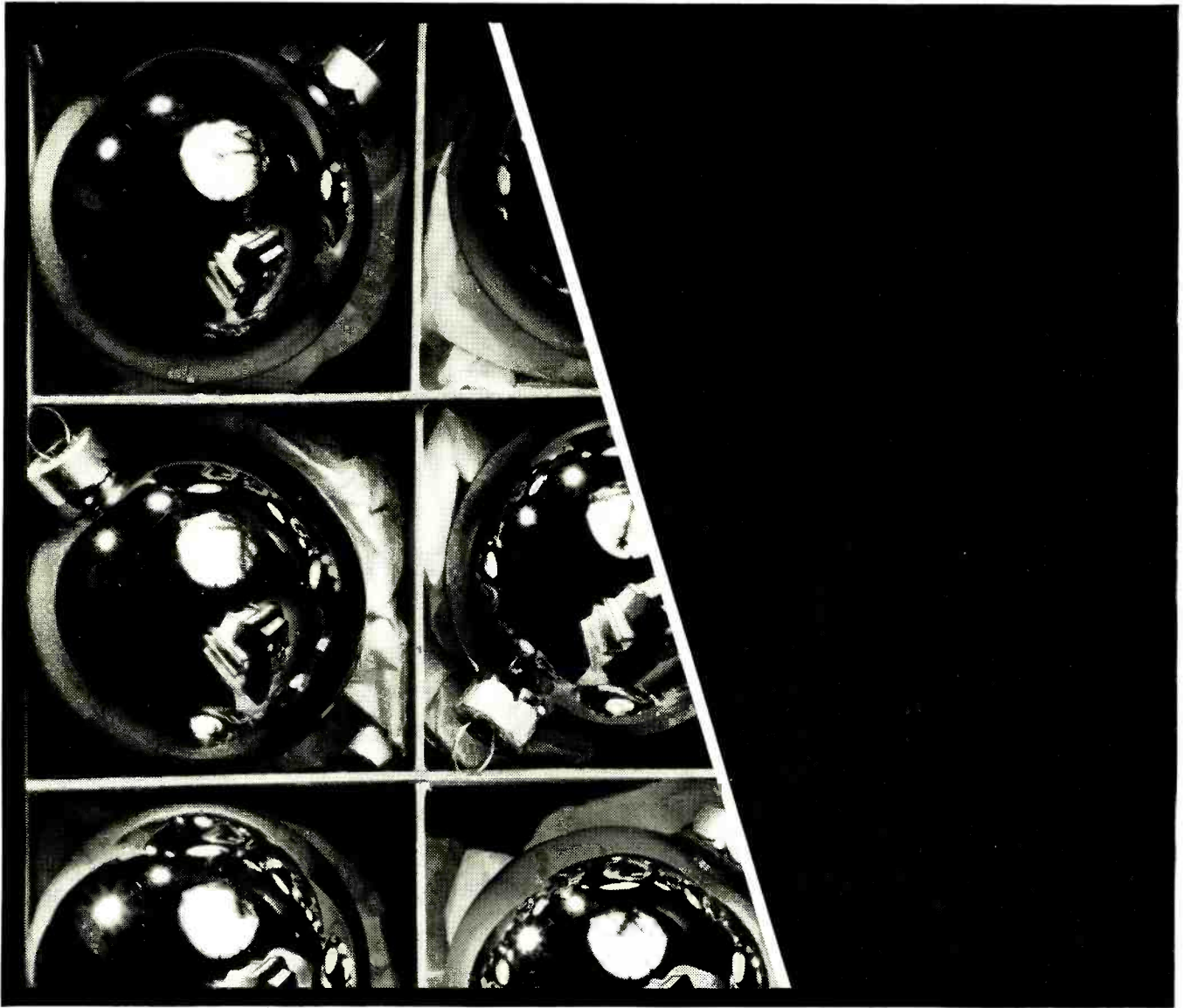

## A cartridge in a pear tree.

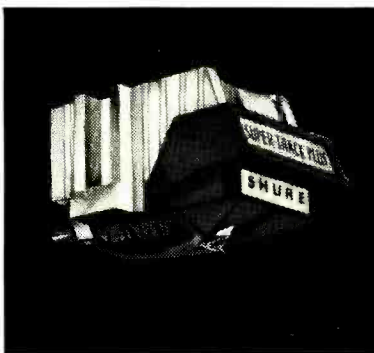

A gift of the *Shure V-15 Type III* stereo phono cartridge will earn you the eternal endearment of the discriminating audiophile who receives it. What makes the V-15 such a predictable Yuletide success, of course, is its ability to extract the real sound of pipers piping, drummers drumming, rings ringing, et cetera, et cetera. In test reports that express more superlatives than a Christmas dinner, the performance of the V-15 Type III has been described as "... a virtually flat frequency response ... Its sound is as neutral and uncolored as can be desired." All of which means that if you're the giver, you can make a hi-fi enthusiast deliriously happy. (If you'd like to receive it yourself, keep your fingers crossed!)

Shure Brothers Inc.  
222 Hartrey Ave., Evanston, IL 60204  
In Canada: A. C. Simmonds & Sons Limited



**Manufacturers of high fidelity components, microphones, sound systems and related circuitry.**



# Popular Electronics

WORLD'S LARGEST-SELLING ELECTRONICS MAGAZINE

## FEATURE ARTICLES

<b>PAY TV—PRESENT AND FUTURE</b> .....	<i>Shel Kagan</i>	<b>44</b>
<i>Will it be by cable or over-the-air?</i>		
<b>A SPECIAL REPORT ON HI-FI</b> .....		<b>51</b>
<b>RECEIVERS, AMPLIFIERS, AND TUNERS</b> .....	<i>Leonard Feldman</i>	<b>51</b>
<b>FOUR-CHANNEL DISC SYSTEMS</b> .....	<i>Julian D. Hirsch</i>	<b>53</b>
<b>RECORD PLAYING EQUIPMENT</b> .....	<i>Julian D. Hirsch</i>	<b>55</b>
<b>TAPE RECORDERS</b> .....	<i>Julian D. Hirsch</i>	<b>57</b>
<b>SPEAKER SYSTEMS</b> .....	<i>George W. Tillet</i>	<b>59</b>
<b>DIGITAL FILTERING</b> .....	<i>Leslie Solomon</i>	<b>63</b>
<i>A new technique with many uses.</i>		
<b>STANDING WAVE RATIO</b> .....	<i>Carl C. Drumeller</i>	<b>69</b>
<i>What it is and how to deal with it.</i>		

## CONSTRUCTION STORIES

<b>BUILD AN AUTO POLARITY, AUTO ZERO</b>		
<b>DIGITAL MULTIMETER FOR UNDER \$100</b> .....	<i>W. L. Green</i>	<b>33</b>
<i>Pocket-Size instrument with 3½-digit readout.</i>		
<b>BASIC DIGITAL LOGIC COURSE</b> .....	<i>H. Edward Roberts &amp; David Bunnell</i>	<b>38</b>
<i>Part 3: Flip-flops and how to build a very low cost computer terminal.</i>		
<b>LOW-COST, EASY-TO-BUILD POWER SUPPLY</b> .....	<i>Craig Anderton</i>	<b>78</b>
<i>12-V/6-A supply for mobile and portable equipment.</i>		
<b>THE EXECUTIVE DIGITAL TEMPER COUNTDOWNER</b> .....	<i>Robert D. Pascoe</i>	<b>92</b>
<i>Lets you know when to blow your top.</i>		

## COLUMNS

<b>STEREO SCENE</b> .....	<i>Ralph Hodges</i>	<b>22</b>
<i>Reflections on a session at AES.</i>		
<b>HOBBY SCENE</b> .....	<i>Editorial Staff</i>	<b>68</b>
<b>SOLID STATE</b> .....	<i>Lou Garner</i>	<b>79</b>
<i>Some projects for holiday giving.</i>		
<b>TEST SCENE</b> .....	<i>Leslie Solomon</i>	<b>94</b>
<i>Uses for your multimeter.</i>		
<b>ART'S TV SHOP</b> .....	<i>Art Margolis</i>	<b>96</b>
<i>The case of the booby-trapped tube.</i>		
<b>CB SCENE</b> .....	<i>Len Buckwalter</i>	<b>98</b>
<i>New antenna rules.</i>		

## PRODUCT TEST REPORTS

<b>ESS MODEL 200 STEREO POWER AMPLIFIER</b> .....	<b>73</b>
<b>SYLVANIA MODEL RS-4744 STEREO RECEIVER</b> .....	<b>74</b>
<b>REALISTIC MODEL TRC-24B CB TRANSCEIVER</b> .....	<b>75</b>
<b>WAVETEK MODEL 30 AUDIO SWEEP GENERATOR</b> .....	<b>76</b>
<b>MURA MODEL 250-M MULTIMETER</b> .....	<b>77</b>

## DEPARTMENTS

<b>EDITORIAL</b> .....	<i>Art Salsberg</i>	<b>4</b>
<i>Salt in the Wound</i>		
<b>LETTERS</b> .....		<b>6</b>
<b>NEW PRODUCTS</b> .....		<b>12</b>
<b>NEW LITERATURE</b> .....		<b>16</b>
<b>NEWS HIGHLIGHTS</b> .....		<b>26</b>
<b>ELECTRONICS LIBRARY</b> .....		<b>105</b>
<b>EDITORIAL INDEX TO VOLUMES 5 AND 6 (1974)</b> .....		<b>107</b>

POPULAR ELECTRONICS, December 1974, Volume 6, Number 6 Published monthly at One Park Avenue, New York, NY 10016. One year subscription rate for U.S., Possessions and Canada, \$6.98; all other countries, \$8.98. Second class Postage paid at New York, NY and at additional mailing offices. Authorized as second class mail by the Post Office Department, Ottawa, Canada and for payment of postage in cash. Subscription service and Forms 3579; P.O. Box 2774, Boulder, CO 80302.  
POPULAR ELECTRONICS including ELECTRONICS WORLD, Trade Mark Registered. Indexed in the Reader's Guide to Periodical Literature.  
COPYRIGHT © 1974 BY ZIFF-DAVIS PUBLISHING COMPANY. ALL RIGHTS RESERVED

Ziff-Davis also publishes Boating, Car and Driver, Cycle, Flying, Modern Bride, Popular Photography, Skiing and Stereo Review.  
Forms 3579 and all subscription correspondence should be addressed to POPULAR ELECTRONICS, Circulation Dept., P.O. Box 2774, Boulder, CO 80302. Please allow at least eight weeks for change of address. Include your old address, as well as new—enclosing, if possible, an address label from a recent issue.  
Editorial contributions must be accompanied by return postage and will be handled with reasonable care; however publisher assumes no responsibility for return or safety of art work, photographs, models, or manuscripts.



# Popular Electronics

**EDGAR W. HOPPER**  
Publisher

**ARTHUR P. SALSBERG**  
Editorial Director

**LESLIE SOLOMON**  
Technical Editor

**JOHN R. RIGGS**  
Managing Editor

**EDWARD I. BUXBAUM**  
Art Director

**ALEXANDER W. BURAWA**  
Associate Editor

**JOHN McVEIGH**  
Assistant Editor

**ANDRE DUZANT**  
Technical Illustrator

**LEN BUCKWALTER**  
**LOU GARNER**  
**JULIAN D. HIRSCH**  
**RALPH HODGES**  
**WALTER G. JUNG**  
**MILTON S. SNITZER**  
Contributing Editors

**JOSEPH E. HALLORAN**  
Advertising Director

**JOHN J. CORTON**  
Advertising Sales

**LINDA BLUM**  
Advertising Service Manager

**PEGI McENEANEY**  
Executive Assistant

**STANLEY NEUFELD**  
Associate Publisher

**FURMAN H. HEBB**  
Group VP, Electronics & Photo

ZIFF-DAVIS PUBLISHING COMPANY, INC.  
Popular Electronics  
Editorial and Executive Offices  
One Park Avenue New York, New York 10016  
212-725-3500

Hershel B. Sarbin, President  
Furman Hebb, Executive Vice President and Treasurer  
Phillip T. Heffernan, Senior Vice President, Marketing  
Edward D. Muhlfeld, Senior Vice President, Sports Division  
Philip Sine, Senior Vice President  
Frank Pomerantz, Vice President, Creative Services  
Arthur W. Butzow, Vice President, Production  
Lawrence Sporn, Vice President, Circulation  
George Morrissey, Vice President  
Sydney H. Rogers, Vice President  
Sidney Holtz, Vice President  
Charles B. Seton, Secretary  
Edgar W. Hopper, Vice President, Electronics Div.

William Ziff, Chairman  
W. Bradford Briggs, Vice Chairman

Midwestern Office  
The Patis Group, 4761 West Touhy Ave.,  
Lincolnwood, Illinois 60644, 312 679-1100  
GERALD E. WOLFE, GEORGE B. MANNION  
DAVID ALLEN  
Western Office  
9025 Wilshire Boulevard, Beverly Hills, CA 90211  
213 273-8050, BRadshaw 2-1161  
Western Advertising Manager, BUD DEAN

Japan: James Yagi  
Oji Palace Aoyama: 6-25, Minami Aoyama  
6 Chome, Minato-Ku, Tokyo 407-1930/6821,  
582-2851



The publisher has no knowledge of any proprietary rights which will be violated by the making or using of any items disclosed in this issue.



## Editorial

### SALT IN THE WOUND

Love/hate reactions to an article we publish are rare. That's why reader response to Art Margolis's August article, "How to Set Up a Home TV Service Shop," was so interesting. Readers who yearned for such guidelines were especially pleased by the article; professional full-time service technicians were less than enchanted.

The latter's displeasure had to do with two areas of concern: the unleashing of unqualified TV technicians on the public and the encouragement of competition. Concerning the former, the article was directed to readers who are trained in electronics and have a satisfactory knowledge of TV servicing through experience and/or training.

There would have been less distress, I believe, if there were a greater awareness of just who our readers are. For example, about 52% are engaged full time in electronics-related employment. Based on a reader study made last year, some 150,000 of our readers repaired a TV set within the past 60 days, excluding installing picture tubes and TV antennas. The average number of sets serviced was eight per respondent.

Of equal interest is the vast number and types of test equipment owned by 82% of our readers. The total investment here was \$236.8 million(!) or an average of \$740 per owner. Of these, 12.9% (50,000) own color bar/dot generators; 41.3% (161,000) own scopes; 68.9% (269,000) own VOM's; 52.4% (204,000) own VTVM's; 33.5% (131,000) own tube testers; 28.6% (112,000) own transistor testers; 34.3% (134,000) own r-f signal generators; and 32.5% (127,000) own audio signal generators. Additionally, the study showed that 121,290 readers planned to spend over \$52 million (\$430 per buyer) on test equipment in the next 12 months. From the above figures, it's clear that POPULAR ELECTRONICS readers are not largely electronics neophytes. And that we were not addressing the article to the "general public."

I fully share the professional TV service technicians' concern about the possibility of an incompetent servicer ruining a receiver and blackening the eye of an industry. Certainly, TV circuitry is becoming increasingly complex, often challenging the technical acumen of the most experienced technician. Furthermore, the equipment investment to maintain a full-time service shop is enormous, not to mention store rental and expenses for such things as a business phone, a car or truck, advertising, taxes, et al. For this investment in money and experience, one generally obtains efficient, reliable TV service at a fair price.

Doubtlessly, the article was salt in the wound to professionals who are already smarting as a result of unfair pricing tactics, botched chassis repairs, etc., by tyros. However, since our readers now probably own close to \$1/3 billion worth of test equipment, we hardly expect much botching from TV-service-trained readers who enter the field. As for unfair pricing, the choice of servicer will necessarily have to rest with the set owner, unless a stringent licensing law is instituted. With the assistance of fine TV service associations, the many benefits of using the services of full-time shops are being brought to the attention of the public.

*Art Salsberg*

Best Wishes for a Joyous Holiday Season  
and a Happy New Year

POPULAR ELECTRONICS



# Radio Shack **FIRST!**

## New Realistic Microphone with Switchable REVERB

Sound Like the Pro's!  
Create Your Own  
Reverb and Echo



With Desk Stand,  
Floor Stand Adapter,  
20' Cable and  
1/4" Phone Plug

### **FREE** New 1975 Radio Shack Catalog

OVER 2000 PRODUCTS  
EXCLUSIVES ON EVERY PAGE  
BEAUTIFUL FULL COLOR

Stereo • Quadraphonic • Phonographs  
TV Antennas • Radios • Citizens Band  
Kits • Recorders • Tape • Tools  
Auto Tune-Up • Electronic Parts  
Test Instruments • More!



164 pages of the finest in home and hobby electronics. Respected brand names like Realistic, Micronta, Archer, Science Fair — and they're available only at Radio Shack stores and dealers nationwide! See what's really new in electronics by getting this catalog now.

SEND FOR YOURS TODAY!  
FILL OUT COUPON BELOW

1975 Mail to Radio Shack, P. O. Box 1052,  
Catalog Ft. Worth, Texas 76101. (Please print.)

Name \_\_\_\_\_ Apt. No. \_\_\_\_\_

Street \_\_\_\_\_

City \_\_\_\_\_

State \_\_\_\_\_ ZIP

only  
**29<sup>95</sup>**

### One of the Biggest Mike Developments in Years

Now you can create studio-type audio effects at the flick of a microphone switch—as you talk, sing or play. No special, expensive equipment is required. The Realistic® reverb mike has *dual* dynamic elements that produce a 1.5-second time delay for the echo effect. And you get a wide 50-10,000 Hz response in both reverb and normal modes. It's "the" mike for vocalists, musicians, standup comedians, all kinds of recording and public address work. In the normal mode you've got a high-quality omnidirectional, dynamic mike for everyday use, too. Lightweight non-reflective housing, Reverb In-Out switch, 200 ohms impedance, —80 dB output level. Fully self contained, no batteries required. 8" long x 1½" diameter. Fitted vinyl carrying case included. #33-1049. There's only one place you can find it . . . Radio Shack!



Master Charge or  
BankAmericard at  
participating stores

# Radio Shack®

A TANDY CORPORATION COMPANY

OVER 3000 STORES • 50 STATES • 7 COUNTRIES  
Retail prices may vary at individual stores

# LARGE-LARGE DISCOUNTS LOW - LOW PRICES

NATIONALLY  
ADVERTISED STEREO EQUIPMENT  
AT LOWEST PRICES!

TURNABLES · SPEAKERS · RECEIVERS  
AMPLIFIERS · TAPE RECORDERS

WRITE FOR QUOTE ON  
NATIONALLY ADVERTISED BRANDS OF STEREO  
COMPONENTS. SATISFACTION  
GUARANTEED!

*Clifford's*  
**HI-FI WHOLESALERS**  
231 W. COURT ST.  
Kankakee, Illinois 60901  
(815)-939-7868

CIRCLE NO. 8 ON READER SERVICE CARD



## BUILD YOUR OWN BIOFEEDBACK MONITOR

BioFeedback Training (BFT) has unexplored potential. Our low cost Brain Wave Monitor kit EDC-1 (featured in Jan. '73 Pop. Elect.) has been praised by amateurs and researchers. IC design performance exceeds cost. Complete with stainless steel and disposable electrodes, contact gel, and instructions; \$68.95, guaranteed, postpaid.

- 4 pole filter
- Alpha, Beta, Theta bandswitch
- Direct or integrated feedback mode
- Permanent Ag/AgCl electrodes as illustrated available @ \$14.95
- Complete Line of BioFeedback supplies, kits

Extended Digital Concepts, Box 9161E,  
Berkeley, CA 94709

- \$68.95 enclosed, ship EDC-1 BioFeedback Monitor Kit.
- \$14.95 enclosed; ship Ag/AgCl permanent electrodes.

Name \_\_\_\_\_

Street \_\_\_\_\_

City \_\_\_\_\_

State \_\_\_\_\_ Zip \_\_\_\_\_

Calif. Res. add Sales Tax.

CIRCLE NO. 21 ON READER SERVICE CARD

# Letters

## ANOTHER FILM FOR CB'ERS

Len Buckwalter's coverage of films for CB Club viewing (CB Scene, September 1974) omitted what is possibly the only 16-mm sound film about CB Radio. It is all about REACT and is titled "Where Seconds Count."

The film runs 12 minutes and includes general information about CB, with emphasis on emergency communication. A variety of base and mobile equipment is shown operated by actual REACT team members. The film is available on free loan from: General Motors Film Library, General Motors Bldg., Detroit, MI 48202.

GERALD H. REESE  
Managing Director  
REACT National Headquarters  
Chicago, Ill.

## ORCHIDS AND ONIONS

Orchids to you for your new larger format. I feel sure that you will now be able to explain things in greater detail and will have more room for full-size etching and drilling printed circuit board guides. But onions to you for timing! I keep a library of POPULAR ELECTRONICS that goes back about five years. Your size change in the middle of a publishing year is going to make a mess of my filing system. I wish you had made the change to the new format at the beginning of 1974 or held off until the January 1975 issue.

WILLIAM C. RICHTER  
Palo Alto, Calif.

## WANTS TO DO Nth ROOTS

I enjoyed the article on the use of the basic four-function calculator (Mac's Service Shop, May 1974) very much. The comments given were meaningful, particularly the square-root formula. Now, I would like to know if you have a workable formula for finding the cube root—or, for that matter, any root—of a number on a basic four-function calculator.

ROBERT J. WUEST  
APO New York

*You will either have to trade your four-banger in for a calculator with nth-root or log/antilog capability or get your hands on a set of logarithm tables. Assuming you are using log tables and your four-banger, the procedure is to look up the log of the number for which you want to find the root, divide the log by the number of the*

*root, and convert the result to the proper number with the aid of antilog tables. For example, if you want to find the 8th root of 458, look up the common log (2.66086) and divide it by 8 (0.33261), and look up the antilog (2.151). If you were to raise 2.151 to the 8th power, you would obtain 458.27196, which is very close to your starting point.*

## WHAT EVER HAPPENED TO "LOW-COST"?

During the past three or four years, I have seen construction plans published in POPULAR ELECTRONICS for some great IC projects. Unfortunately, every time I see a phrase like "Build . . . for under \$40," I just keep on dreaming. I remember the projects of the 1950's when prices were more in line with the experimenter's budget. What ever happened to those low-cost projects?

KEITH SCHAEFER  
Fenton, Mo.

*The unfortunate thing about this situation is that inflation has hit all areas of the economy—including electronics experimenting. On the positive side is the fact that today's projects are easier to build, smaller in size, more sophisticated in design and performance, and less power hungry than projects of the 1950's. They may be more expensive to build, but they are dirt cheap for what you ultimately get.*

## 555 TIMER IC AND ITS ENDLESS USES

Thank you for introducing me to the 555 IC timer ("The IC Time Machine," November 1973). I am including the schematic diagram of my latest 555 application—a delayed-action wind-

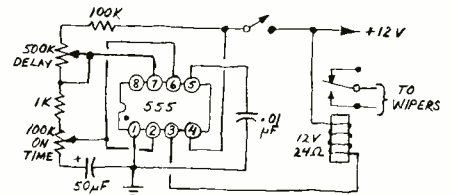

shield-wiper control. I originally planned on using transistor switching, but too much power was wasted in base current. So, I opted for relay switching.

DAVID R. MCKEEN  
Wallingford, Conn.

## THE AVAILABILITY PROBLEM

It seems that every time I decide to build an electronic project featured in POPULAR ELECTRONICS—and most other magazines as well—I have considerable difficulty in locating stores that sell the parts for them. Years ago, I would go into a local electronics store and be able to buy just about anything I wanted. Today, the situation has changed drastically. Even the big outlets seem to have veered away from the experimenter market. Therefore, when you publish construction plans, it would



be greatly appreciated if you also indicate where exact parts can be obtained.

FRANK BERNSTEIN  
Maspeth, N.Y.

Most solid-state devices and a great many passive components (resistors, capacitors, etc.) can be obtained from the various mail-order houses whose ads appear in the back of this magazine. For parts that could not be substituted and are available from only one or two sources, it has been our policy to indicate the sources.

#### ELECTRONIC MUSIC BOOSTER

I must commend Mr. Lancaster on the excellent presentation he made in his "How to Select Electronic Music Keyboards" (July 1974). This article aroused my interest because over the past year, I have been engaged in designing and building my own rather unique synthesizer.

You may wish to pass on to your readers that a very good source of conventional keyboards for electronic music is the electronic organ service repairman. Most music stores that deal in electronic organs have service departments that can usually provide new or used keyboards at very reasonable cost.

DAN SCHREIBER  
Cedar Lake, Ind.

#### 8-TRACK CARTRIDGES AND DOLBY

In "4-Channel Tape Machines" (July 1974), it was stated Dolby processing has not been used on pre-recorded 8-track cartridge tapes. I believe this statement to be incorrect. I have in my 8-track cartridge library five Columbia cartridges mastered to the Dolby B Standard.

TOMMY FRANKLIN  
Nashville, Tenn.

#### HEARTILY SUPPORTS METRICATION

Congratulations on being one of the first—if not *the* first—American hobby magazines to metricate. I refer specifically

to "Build a Large-Port Speaker System" in the August 1974 issue. Once again, POPULAR ELECTRONICS has taken the lead, giving the metric system the recognition it deserves. That alone made our first 21-cm by 27.6-cm issue worthwhile. Keep the new size and the metrics, and you have a permanent subscriber.

ARTHUR YASSUR  
Palo Alto, Calif.

#### EQUATION WRONG, VALUES RIGHT

In "Applications For the IC 'Time Machine'," there appears to be an error. In the SW oscillator circuit on page 74, the equation for the operating frequency was

given as  $1.43/(R_2C_1)$ , which is incorrect. The correct equation is  $f \approx 1.43/(2R_2C_1)$ .

ALFRED GNAEDIG  
Mexico City, Mexico

The author replies: "Assume  $t_1$  to be the time during which the signal is at 'high' and  $t_2$  the time during which it is at 'low.' Then,  $t_1 = 0.7(R_1 + R_2)C_1$  and  $t_2 = 0.7R_2C_1$ . If  $R_1 \ll R_2$ ,  $t_1 = t_2 = 0.7R_2C_1$  and  $T = t_1 + t_2 = 2(0.7R_2C_1)$ . Therefore  $f = 1/T = 1/0.7(2R_2C_1)$  or  $1.43/(2R_2C_1)$  exactly as Mr. Gnaedig states. The  $f$  and  $T$  expressions on page 74 of the article are incorrect, but the values in the example are correct for 100 Hz as given."

# This Christmas give your car a Mark Ten B Capacitive Discharge Ignition. You and your car will enjoy it all year.



The Mark Ten B keeps your car in tune. That means increased mileage, less maintenance and a better running car. A well-tuned car also decreases emission contaminants. All this adds up to more driving enjoyment for you. Mark Ten B, the perfect gift—for cars—and their owners.

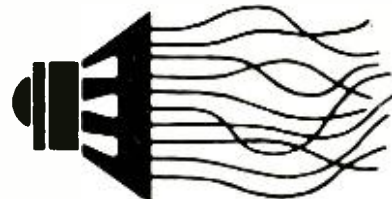

## Out of Tune

In "Build a Versatile Nickel-Cadmium Battery Charger" (October 1974), the schematic should be modified as follows: The bottom of the secondary of  $T_1$  should be connected to the B1-BP1-negative node, rather than R1-S2A.

DECEMBER 1974

### DELTA PRODUCTS, INC.

P.O. Box 1147, Dept. PE  
Grand Junction, Colo. 81501  
(303) 242-9000

Here's my Christmas order. Please rush!

Please send me free literature.

Enclosed is \$ \_\_\_\_\_  Ship ppd.  Ship C.O.D.

Please send: \_\_\_\_\_ Mark Ten B assembled @ \$64.95 ppd. \_\_\_\_\_ Mark Ten B Kit @ \$49.95

ppd. 12 volt negative ground only • \_\_\_\_\_ Standard Mark Ten, assembled, @ \$49.95 ppd.

\_\_\_\_\_ 6 Volt: Neg. Ground Only \_\_\_\_\_ 12 Volt: Specify \_\_\_\_\_ Pos. Ground \_\_\_\_\_ Neg.

Ground • \_\_\_\_\_ Standard Mark Ten Deltakit" @ \$34.95 ppd. (12 Volt Positive or Negative Ground Only)

Car Year \_\_\_\_\_ Make \_\_\_\_\_

Name \_\_\_\_\_

Address \_\_\_\_\_

City/State \_\_\_\_\_ Zip \_\_\_\_\_

CIRCLE NO. 13 ON READER SERVICE CARD

# Prepare for a high-paying career in Complete Communications

Including CB design, installation  
and maintenance...in actual practice



The field of communications is bursting out all over. In Citizens Band alone, estimates predict a growth in equipment sales from \$514 million in 1973 to \$1.2 billion dollars in 1982! That means a lot of openings in service and maintenance jobs. NRI can train you at home to fill one of those openings... including your FCC license and solid-state 2-way radio service.

NRI's Complete Communications Course will qualify you for a First Class Commercial License or you get your money back! It covers AM and FM Transmission Systems, Teletype, Radar Principles, Marine Electronics, Mobile Communications, and Aircraft Electronics.

You will learn to service and/or adjust CB equipment... using your own 23-channel Johnson Transceiver and AC power supply for hands-on experience as well as your own personal use.

With NRI's training program, you can learn this important skill easily, at home in

Get 2-way radio training with this solid-state  
23-channel transceiver and power supply!



Your CB training will be up-to-the-minute when you experiment with this solid-state transceiver unit. Mount it in your car or use it with your AC power as a base station. You get "hands-on" experience that puts your course theory into practice the practical way.

your spare time. You get 8 training kits, including your own 3½ digit digital multimeter for digital experiments and precise measurements. You'll learn from bite-size lessons, progressing at your own speed to your FCC license and then into the communications field of your choice.



POPULAR ELECTRONICS



## Only NRI offers five choices in TV/Audio Servicing



NRI can train you at home to service and repair commercially-built color and black-white TV, hi-fi equipment, AM-FM radios and sound systems.

You can choose from 5 courses, starting with a basic servicing course with 65 lessons... up to a Master Color TV course, complete with 25" diagonal solid state color TV in handsome woodgrain cabinet. All courses are available with low down payments and convenient monthly payments to fit your budget. And all courses provide professional equipment along with NRI-designed kits for hands-on training. With the Master Course, for instance, you receive your own 5" wide band, solid-state triggered sweep oscilloscope, TV pattern generator, 3½ digit digital multimeter, and a high quality NRI 25" diagonal solid state television receiver expressly designed for color TV training.

### YOU PAY LESS WITH NRI TRAINING AND YOU GET MORE FOR YOUR MONEY

NRI employs no salesmen, pays no commissions. We pass the savings on to you in reduced tuition costs and extras in the way of professional equipment, testing instruments, etc. You can pay more, but you can't get better training.

## Step into the digital age with NRI's Complete Computer Electronics Course



Digital electronics is the career area of the future... and the best way to learn it is with NRI's Complete Computer Electronics Course. You can become a computer or digital technician with NRI's unique

and fascinating home training... while you build and use a real digital computer in your home! This is no beginner's "logic trainer". It's a complete programmable digital computer. And it's just one of ten kits you receive, including a professional digital multimeter for experiments and precise measurement. It's the quickest and best way to learn digital logic, and computer operation.

### NEARLY ONE MILLION STUDENTS IN 60 YEARS HAVE LEARNED AT HOME THE NRI WAY...

Mail the insert card and discover for yourself why NRI is the recognized leader in home study training. No salesman will call. Do it today and get started on that new career.

#### APPROVED UNDER GI BILL

For the career minded, we are approved for veterans benefits. Check box on card for details.

### MAIL THE INSERT CARD FOR YOUR FREE NRI CATALOG

No salesman will call



#### NRI SCHOOLS

McGraw-Hill Continuing Education Center  
3939 Wisconsin Avenue,  
Washington, D.C. 20016

# FREE EICO CATALOG

## 346 Ways To Save On Instruments, Burglar Alarms, Automotive & Hobby Electronics!

The more you know about electronics, the more you'll appreciate EICO. We have a wide range of products for you to choose from, each designed to provide you with the most pleasure and quality performance for your money. The fact that more than 3 million EICO products are in use attests to their quality and performance.

**"Build-it-Yourself" and save up to 50% with our famous electronic kits.**

For latest EICO Catalog on Test Instruments, Automotive and Hobby Electronics, Eicocraft Project kits, Burglar-Fire Alarm Systems and name of nearest EICO Distributor, check reader service card or send 50¢ for fast first class mail service.

**EICO—283 Malta Street,  
Brooklyn, N.Y. 11207**

*Leadership in creative electronics  
since 1945.*



**CIRCLE NO. 16 ON READER SERVICE CARD**



## New Products

*Additional information on new products covered in this section is available from the manufacturers. Either circle the item's code number on the Reader Service Card inside the back cover or write to the manufacturer at the address given.*

### GENAVE 2-METER FM TRANSCEIVER

General Aviation Electronics has introduced the GTX-2 amateur transceiver, featuring a dual-gate MOSFET front-end for high sensitivity and immunity from overload. The transmitting section of the GTX-2 is rated at 30 watts output, nominal, @ 14 V



dc input. Ten pushbutton switches are mounted on the front panel for channel selection. Eight-pole second i-f filters are incorporated for selectivity, and r-f output devices are VSWR-protected. The GTX-2 comes with quick-disconnect power cable, SO239 antenna connector, a mobile mounting bracket and a ceramic plug-in microphone. Optional accessories include the TE-1 tone pad for autpatching, a variety of power supplies, antennas, receiver preamp, and auxiliary speaker.

**CIRCLE NO. 70 ON READER SERVICE CARD**

### RCA XL-100 COMPONENTS KIT

Parts Kit No. 199006 from RCA is designed to aid service technicians who are called upon to repair XL-100 color TV receivers. It contains 29 of the most frequently replaced components (a variety of transistors, diodes, and resistors) to facilitate fast, efficient receiver service. A tube of silicone heat-sink compound is included for transistor and diode protection while soldering. The kit contains a parts location diagram and crossreference chart. Price of the kit is \$59.60.

**CIRCLE NO. 71 ON READER SERVICE CARD**

### JERROLD TV REMOTE CONTROL

Jerrold Electronics is marketing a new type of remote control system that works with any TV receiver. Called the Model TRC-12, it is all-solid-state in design. Instead of

using a motor for channel selection, the TRC-12 uses a varactor-diode-controlled oscillator to govern a heterodyne mixer. The system consists of a converter and the remote control, both interconnected by a 25-ft (7.62-m) control cable. By means of 12 pushbutton switches, the remote-control unit can be used to select discrete voltages that bias the varactor diode and cause the oscillator to produce various output signal frequencies. The incoming signal is mixed with the oscillator's output to produce the proper channel, frequency translated for display on channel 2 or 3 (whichever is not in use in your area). Aside from channel selection, the system fine tunes and turns on and off receiver power. Price is \$100.  
**CIRCLE NO. 72 ON READER SERVICE CARD**

### PACE PORTABLE VHF MONITOR

The Scanmate 150, produced by Pace Communications, is a miniature scanning monitor covering the 144-to-174-MHz band. FM communications may be monitored with the Scanmate 150, and any four channels within a 10-MHz band can be scanned at a rate of 10 to 12 channels per second. It measures 2½" × 6" × 1", and weighs 1 pound. Circuitry is all solid-state, and can be powered by either 110 V ac, an internal 9-V battery supply, or a mobile power source by use of an optional cigarette-lighter adapter.

**CIRCLE NO. 73 ON READER SERVICE CARD**

### PIONEER BELT-DRIVE TURNTABLE

The PL-10 belt-drive turntable by Pioneer employs a four-pole synchronous motor and belt drive for stable speed rotation. An anti-skating control independent of the S-shaped tonearm provides accurate adjustment without disturbing tonearm



parameters. A direct-reading stylus force scale is incorporated on the adjustable counterweight to provide accurate tracking of cartridges weighing from 4 to 8 grams with a 0.61" stylus overhang. The tubular tonearm has an oil-damped cueing mechanism, and low-capacitance shielded cables allow CD-4 cartridges to be used. The wood-grain cabinet of the PL-10 is lined with aluminum foil to shield the unit from electrical noise, and a spring suspension inhibits vibration. A removable, hinged dust cover can be closed during record play. The PL-10 operates on 117 V,

**POPULAR ELECTRONICS**



60 Hz and consumes 10 watts. The unit measures 16-15/16" x 6-17/32" x 13-11/32" and weighs 14 lb, 12 oz. Retail price is \$99.95.

**CIRCLE NO. 74 ON READER SERVICE CARD**

### DYNASCAN 3 1/2-DIGIT, AUTOMATIC-POLARITY DMM

The B&K Model 282 by Dynascan features a claimed dc accuracy of 0.5%, automatic polarity, automatically positioned decimal point, positive out-of-range indication, and 100% overrange capability on all ranges.



The totally solid-state circuitry of the 282 incorporates overload protection on all ranges, 1-mV resolution, and the unit presents a 10-megohm input impedance on both ac and dc volts. Large (0.55"), non-blinking Beckman-Sperry gas-discharge seven-segment red displays are used. The 282 measures ac and dc volts up to 1000 V, dc and ac current to 1000 mA, and resistance to 10 megohms. Included with the 282 DMM are a three-position handle which also serves as a stand, and the B&K PR-21 probe, with a switchable 100 kilohm isolation resistor to prevent capacitive loading when measuring dc in r-f circuits. The unit measures 3 1/2" x 7" x 9", operates on 105 to 125 V ac, 50 to 60 Hz, and costs \$200.

**CIRCLE NO. 75 ON READER SERVICE CARD**

### BEYER "OPEN AIRE" HEADPHONES

A new, light-weight stereophone has been added to the Beyer line. The DT302, distributed by Revox, features wide-range response (20 to 20,000 Hz) and has soft acoustical-sponge ear cushions. Impedance is 600 ohms per transducer, and the phones may be connected directly to high- or low-impedance outputs. The DT302 weighs only 2.3 ounces (less cord). Rated power is 7 mW (2.1 V for 600 ohms). The phones come with a cord terminated in a stereo plug. Price is \$29.95.

**CIRCLE NO. 76 ON READER SERVICE CARD**

### TEKELEC DIGITAL MULTIMETER

A low-cost (\$179) digital multimeter, introduced by Tekelec, Inc., as its Multex Model TA357, features a liquid-crystal display, seven functions, 27 ranges, automatic polarity, and automatic decimal positioning. The claimed basic dc accuracy is 0.05 percent of full scale, plus 0.1 percent of range.

DECEMBER 1974

Voltages can be measured on scales as low as 100 V (ac or dc). The included high-voltage probe extends the voltage-measuring limit to 20 kV. A two-range conductance function permits leakages as low as 10<sup>-12</sup> mho to be measured. A built-in bias supply allows measurement of three ranges of leakage currents, with a sensitivity of 10<sup>-11</sup> amperes on the lowest range. Other features include interlocked range and function pushbutton selection, input protection to 848 V p-p, and a thumb-wheel zero-compensation control.

**CIRCLE NO. 77 ON READER SERVICE CARD**

### GC PRINTED CIRCUIT KIT

The Professional Printed Circuit Kit by GC Electronics, Cat. No. 22-297, contains everything needed to make high-quality pc boards. Included are drafting aids, a tray set, etch-resist sensitizer, etch-resist lacquer, developing solution, stripping solution, layout film (2 sheets—8 1/2" x 11"), contact frames and two copper-clad boards (3" x 5" x 1/16" and 4" x 6" x 1/16"). GC also offers a complete line of pc materials—tools, chemicals, boards and drafting aids.

**CIRCLE NO. 78 ON READER SERVICE CARD**

### LAFAYETTE 4-CHANNEL STEREO RECEIVER

The LR-111 is a 4-channel AM/FM 30-watt rms "SQ" stereo receiver. It has four amplifiers for SQ, discrete, and derived quadraphonic program material, through use of an optional CD-4 demodulator and the incorporated "Composer" circuitry. The rear panel has 2- and 4-channel speaker outputs, auxiliary and phono inputs with adjustable sensitivity, and an FM detector output for discrete FM reception hardware should transmissions be approved. Amplifier frequency response is 20 to 20,000 Hz ± 1.5 dB @ 1 watt, THD less than 1% @ 1 watt. Tuner sensitivity is 5 µV (IHF) and 35 dB stereo separation at 400 Hz. The LR-111 is packaged in a walnut-finish wood cabinet, and measures 16" x 4 1/4" x 12". Weight is 15 lb. and it costs \$229.95.

**CIRCLE NO. 79 ON READER SERVICE CARD**

### COURIER BASE MIKE WITH PREAMP

Fanon/Courier has introduced a new base station microphone, the Model BTM-4. It features a dynamic element with cardioid response to minimize background noise and an acoustical damper to preserve voice quality. A solid-state preamp with an adjustable output of 0-30 dB gain provides enough drive to satisfy the requirements of most transceivers. A slide switch on the underside of the base permits selection of relay or electronic switching. The push-to-talk bar can be locked in the TALK position. Frequency response is 100-8000 Hz, and output impedance is 1000 ohms. A six-foot (1.83-m) coiled cable, with a three conductor plug, is included.

**CIRCLE NO. 80 ON READER SERVICE CARD**

SOLDERING + DESOLDERING + RESOLDERING

**SOLDER Ability**  
A NEW AND UNIQUE METHOD OF VISUAL EDUCATION - IT'S FUN TO LEARN!

VISUAL APPLICATIONS OF THE *World's*  
*Most Practical* SOLDER HANDLING TOOLS

**SOLDAPULL**  
DESOLDERING TOOLS

**UNIVERSAL**  
US140

**ATMOSCOPE**  
VACUUM TIP  
AV125

**LOWER**  
SOLDERING INSTRUMENT  
Model 950  
CLOBO

**Idle-REST**  
ENERGY SAVER!  
HOLDER  
TK089

**SOLDAVAC**  
DESOLDERING TOOLS

STANDARD SVO26

**TWP**  
SOLDER AND WICK  
TW108  
AT FINGER TIPS

**Triple Mate**  
PERFECT SOLDERING TIPS  
Work Rated

**ERSA**  
INDUSTRIAL SOLDERING TOOL  
ER140

VACUUM PUMP  
SN104

**SNORT**  
MINI VACUUM PUMP  
MV124

**SOLDASIP**  
RESOLDERING WICK  
SW091

Covered by U.S. and Foreign Patents and Pending Applications

**NEW... 144 PAGE TRAINING MANUAL**  
**OVER 1,000 ILLUSTRATIONS**

EDSYN pioneer in Solder-ABILITY, presents FANOVISION—graphic motion in a training manual designed to stimulate the mind to **SAVE TIME** on the line. Available at \$7.95

**FANOVISION** T.M.

— AT PARTICIPATING DISTRIBUTORS ONLY —

Send **FREE** information on EDSYN Products

Send **FANOVISION** Manual (\$ 7.95)\*

\*NOTE: FANOVISION Manual will be sent **FREE** with purchase of \$7.95 (or more) of any EDSYN Products. Limit one **FREE** MANUAL to a customer.

Name \_\_\_\_\_

Address \_\_\_\_\_

City \_\_\_\_\_ State \_\_\_\_\_ Zip \_\_\_\_\_

SEND TO: EDSYN, Inc.  
15958 ARMINTA STREET, VAN NUYS, CALIFORNIA 91406

**CIRCLE NO. 20 ON READER SERVICE CARD**





TEAC

TEAC

TEAC 2300S

POWER  
OFF ON  
SPEED  
HIGH LOW

MIC

LINE

OUTPUT

STOP

REC



# There are 159,090 reasons to buy it.

159,090 owners had their reasons for choosing a TEAC 1200/2300 series over any other tape deck. Universities, record companies, audiophiles, musicians, audio testing labs and recording studios – all with different reasons.

Yet all with the same reason: Reliability.

The innovation behind this unparalleled performance record? TEAC's 3-motor/3-head tape transport system. (Three heads for the individual functions of erase, record and playback. And three motors, driving feed and takeup reels, and the capstan.) Our 1230 became the yardstick of the industry.

Our 2300S is the same but better, with significant electronic improvements.

Total touch-button control with logic circuitry

now enables you to shift instantly from fast forward to fast rewind, and to record from pause or directly from playback. With total remote capability.

Bias and EQ switches adjust for the new tapes. And there's more.

Check out the classic 2300S. And if you decide that it is unbeatable in performance and price, just remember – you're not alone.



## The classic 2300S.

# TEAC®

The leader. Always has been.

TEAC Corporation of America – Headquarters: Dept. A-23, 7733 Telegraph Road, Montebello, California 90640 – TEAC offices in principal cities in the United States, Canada, Europe, Mexico and Japan.

DECEMBER 1974

CIRCLE NO. 41 ON READER SERVICE CARD

©TEAC 1973

15

# free

## The "NEW LOOK" 1975 LAFAYETTE Radio Electronics CATALOG

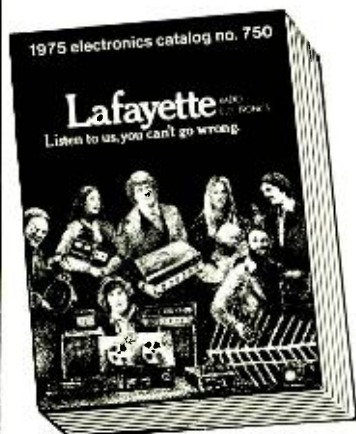

The ONLY Nationally Distributed Full-line Catalog with a Major Showing of the Newest NAME-BRAND electronics products for 1975.

**FREE  
SEND TODAY**

### SAVE on exclusive Lafayette Products plus MAJOR BRANDS

• Stereo and 4-Channel Systems • Tape Equipment • Car Stereo • CB and Ham Gear • Police/Public Service Receivers • Antennas • Cameras • TV • PA and Test Equipment • Musical Instruments and Amplifiers • Books • Electronic Calculators • Security Systems • PLUS PARTS, TUBES, BATTERIES, HARDWARE, MORE!

# Lafayette

Listen to us, you  
can't go wrong.

Dept. 35124  
Lafayette Radio Electronics  
111 Jericho Tpke., Syosset, L.I., N.Y. 11791

Send me your FREE 1975 Catalog

Name ..... Apt. ....  
Street .....  
City ..... State .....  
Zip .....

Send a 1975 Catalog to my friend

Name ..... Apt. ....  
Street .....  
City ..... State .....  
Zip .....

CIRCLE NO. 27 ON READER SERVICE CARD  
16



## New Literature

### CORNELL-DUBILIER ROTOR DATA SHEETS

Cornell-Dubilier has issued a 4-page data sheet describing their new Amateur Beam Antenna Rotor Systems. Control features, such as clockwise, counterclockwise, and brake release governors, are described and operating hints are given which will extend the life span of the rotor and the supporting system. An exploded view of each unit is shown and complete mechanical and electrical specifications are given. Address: Cornell-Dubilier, 150 Avenue L, Newark, NJ

### FACTS ABOUT F.A.C.T.

The Electronics Division of Kurz-Kasch, Inc. has published a brochure describing their Failure Analysis by Color Tracing system (F.A.C.T.). This troubleshooting system for digital circuits is based on the use of a three-color code to specify states—logic one, zero, and transition. Color overlays are placed on the pc board corresponding to the logic states at the various nodes. Test probes equipped with three lamps may be used to check the equipment. This procedure becomes a simple task of comparing the color of the overlay to the color of the indicator which is activated. Address: Kurz-Kasch, Electronics Division, 2876 Culver Avenue, Dayton, OH 45429.

### RCA'S "UNDERSTANDING CMOS"

An 80-page programmed text, entitled "Understanding CMOS," publication No. CPI-279, is now available from RCA's Solid State Division. The booklet has been structured as a self-teaching aid to familiarize design engineers with CMOS technology. The six chapters of the text deal with such topics as CMOS fundamentals and features, basic circuit configurations and characteristics, packaging and specifications, design considerations, and custom circuits and LSI. Price is \$2.00. Address: RCA Solid State Division, Box 3200, Somerville, NJ 08876.

### INTERPRETING LOUDSPEAKER POWER RATINGS

The Altec Corporation's Sound Products Division offers a free 12-page information booklet entitled, "Loudspeaker Power Ratings," which can help the reader extend the life span of his quality loudspeaker systems. This booklet explains how loudspeaker power is rated, why loudspeakers fail, and how this failure may be avoided.

The important do's and don'ts in the care and feeding of loudspeakers are presented. Address: Altec Corp., 1515 S. Manchester, Anaheim, CA 92803.

### INTRODUCTION TO HOLOGRAPHY

This 34-page booklet, published by Metrologic Instruments, is designed to be an instruction manual for the use of its holography systems. Seven pages are devoted to the theory of holograms, and 15 diagrams and three pictures of basic setups for recording three-dimensional images are included. The two basic types of holograms are discussed—planar holograms, 3-D images viewed as if from a window, and round holograms, which can be viewed at any angle. Introduction to Holography is included in each of the company's holographic system outfits, but is also available separately for \$3.00 from Metrologic Instruments, 143 Harding Avenue, Bellmawr, NJ 08030.

### INCANDESCENT FLATPACK DISPLAY LITERATURE

Industrial Electronic Engineers, Inc. announces the availability of their IEE-AURORA Product Profile. This detailed technical catalog enables prospective users to evaluate and/or specify and order units of this series of slim-line profile, flat-pack digital displays. They are suited for applications where panel depth, wide-angle readability, and high brightness are major design criteria. There is a choice of character sizes and they may be easily adapted to a full range of colors through the use of filters. The IEE-AURORA series is designed to operate with a wide variety of standard driver decoders. Address: Opto-Components Division, IEE, 7740 Lemona Avenue, Van Nuys, CA. 91405.

### BUCKEYE KNOB CATALOG

A complete listing of the various types of knobs made by the Buckeye Stamping Company is now available. Sizes range from 1/2-inch diameter to 3 inches. Drawings and dimensional lists are included for single, concentric, bar, and bar-concentric knobs. A line of finger-tip spinners is also offered. A "Quick Reference Chart" is incorporated for simple selection of a particular type and size. Address: Buckeye Stamping Co. 555 Marion Road, Columbus, OH. 43207.

### MAGNEPLANAR SPEAKER DATA

Audio Research Corporation has introduced a two-color data sheet on its Magnepanar Tympani line of loudspeakers. It describes five different speaker models and includes detailed specifications on performance as well as physical factors. The loudspeakers incorporate several patented design innovations and resemble folding screens. Address: Audio Research Corp. 2843 26th Ave. South, Minneapolis, MN 55406.

POPULAR ELECTRONICS



# mitScope

Our 25 lb., \$2000.00  
four channel scope is  
handheld, digital,  
weights 10 ozs.  
and costs \$189.50\*



SIZE: 5 3/4" x 3 1/4" x 1 1/4"

The mitScope MS-416 is a valuable tool in analyzing circuits. With the increasing use of digital circuitry in home entertainment equipment (stereo receivers, television sets, etc.), the MS-416 will be indispensable for every electronic service department. Digital circuitry is becoming more and more commonplace, and the mitScope is designed to handle this requirement. The MS-416 can be extremely useful in digital circuit design in electronic research and development situations. With its memory capability the mitScope can outperform oscilloscopes many times its price.

A few of the areas where the mitScope is an excellent tool for diagnosing problems are: electronic calculators; digital clocks and timers; digital automotive electronics; and many more.

**DISPLAY:** LED Matrix: 4x16 LED Matrix. 4 channels; with 16 divisions per channel useful for determining extensive time relationships.

**TIME BASE:** Range: from .5 u sec. to .2 sec.

**Triggering:** from channel one input signal; positive or negative edge selection using SYNC switch; also an automatic sweep for checking DC steady-state signals.

**Range Selection:** using three controls—a potentiometer for initial sweep rate and two switches for X1000 and X20 selection.

\* **OR, IF YOU REALLY WANT TO SAVE, BUILD YOUR OWN MS-416 FOR JUST \$127.50**

**MODES:** Normal: for most troubleshooting and testing applications. Storage: on all 4 channels stores the information in a 16x4 bit high speed RAM and displays the signal continuously.

**PULSE CATCHING:** Single-shot storage capability: can catch and store a one-time occurring pulse in the memory and display it for as long as desired.

**POWER:** Battery: operation using rechargeable NiCads. AC: operation using an AC-(Adapter/Charger) for use with normal 110 v.a.c.

PRICE: MS-416 (fully assembled) ..... \$189.50  
MS-416 (kit with easy-to-follow manual) ..... \$127.50

Warranty: One year on parts and labor on assembled units. 90 days on parts for kits.

Prices, specifications and delivery subject to change without notice.

**mits** INC.

"Creative Electronics"

Enclosed is a Check for \$ \_\_\_\_\_  
or  BankAmericard # \_\_\_\_\_  
or  Master Charge # \_\_\_\_\_  
Credit Card Expiration Date \_\_\_\_\_  Kit  
Include \$3.00 for Postage and Handling  Assembled  
 MS-416  
 Please send information on Entire MITS Line.  
NAME \_\_\_\_\_  
ADDRESS \_\_\_\_\_  
CITY \_\_\_\_\_  
STATE & ZIP \_\_\_\_\_  
MITS / 6328 Linn, N.E., Albuquerque, New Mexico 87108 505/265-7553



# When you're exploring technology... books





# a fascinating new alone are not enough.

If you're like most men, deep down inside there's still a bit of the boy who loved to go exploring . . . and who'd love to go again. Well, now you can.

Only this time you'll explore the expanding world of electronics . . . a world more fascinating than any you ever dreamed of as a boy.

**Learn by exploring . . . Bell & Howell Schools offers an exciting way for you to gain new occupational skills in electronics.**

Everybody enjoys learning something new, but why learn it the old way? Classes to go to. Lectures to sit through. And only a bunch of books to keep you interested.

Bell & Howell Schools' adventure in learning is a far cry from all that.

You can probe into electronics and learn exciting new occupational skills right in your own home, in your spare time. On whatever days and whatever hours you choose. So there's no need to give up your present job and paycheck just because you want to learn something new.

What's more, when you're exploring a field as fascinating as electronics, reading about it is just not enough. That's why throughout this program you'll get lots of "hands on" experience with some of today's latest electronic training tools.

**You'll be stimulated for hours on end as you build, experiment and learn while using the latest ideas and techniques in this fascinating field.**

As part of the program you'll actually learn to build and work with your own electronics laboratory. Using it to put many of today's most dynamic electronic discoveries to the test . . . including electronic miniaturization.

Among the things you'll discover is how the development of tiny integrated circuits has made possible an electronic calculator small enough to fit into a shirt pocket! And a wristwatch that flashes the time with the push of a button.

You'll investigate the concept of "logic circuits." An idea that has been with us for centuries but only in recent years put to use as the "brain" behind all the new digital consumer appliances we see today.

But more important than anything else is the new occupational skills you'll develop in electronics troubleshooting. While no assurance of income opportunities can be offered, you'll develop skills that could lead you in exciting new directions. Use your training:

1. To seek out a job in the electronics industry.
2. To upgrade your current job.
3. As a foundation for advanced programs in electronics.

**You build and perform many exciting experiments with Bell & Howell's Electro-Lab.®**

**An exclusive electronics training system.**

Using our successful step-by-step method,

you'll build:

1. A design console, for setting up and examining circuits.
2. A digital multimeter for measuring voltage, resistance and current (it displays its findings in big, clear numbers like a digital clock).
3. A solid-state "triggered sweep" oscilloscope—similar in principle to the kind used in hospital operating rooms to monitor heartbeats. You'll use it to monitor the "heartbeats" of tiny integrated circuits. The "triggered sweep" feature locks in signals for easier observation.

**Step-by-step you'll build and experiment with Bell & Howell's new generation color TV—investigating digital features you've probably never seen before!**

This 25" diagonal color TV has digital features that are likely to appear on all TV's of the future. As you build it you'll probe into the technology behind all-electronic tuning. And into the digital circuitry of channel numbers that appear right on the screen! You'll also build in a remarkable on-the-screen digital clock, that flashes the time in hours, minutes and seconds. Your new skills will enable you to program a special automatic channel selector to skip over "dead" channels and go directly to the channels of your choice.

You'll also gain a better understanding of the exceptional color clarity of the Black Matrix picture tube, as well as a working knowledge of "state of the art" integrated circuitry and the 100% solid-state chassis.

After building and experimenting with this TV, you'll be equipped with the skills that could put you ahead of the field in electronics know-how.

**We try to give more personal attention than other learn-at-home programs.**

1. Toll-free phone-in assistance. Should you ever run into a rough spot during the program, we'll be there to help. While many schools make you mail in your questions, we have a toll-free line for questions that can't wait.
2. In-person "help sessions." These are held in 50 major cities at various times throughout the year where you can talk shop with your instructors and fellow students.

**No electronics background needed.**

What you really need is the thing you've never lost. A boy's love for exploring. Now you can go again, only this time learning new occupational skills all along the way.

**Mail the postage-paid card today for more details, free!**

Taken for vocational purposes, this program is approved by the state approval agency for Veterans' Benefits.

If card has been removed, write:

An Electronics Home Study School  
DEVRY INSTITUTE OF TECHNOLOGY

ONE OF THE  
**BELL & HOWELL SCHOOLS**  
4141 Belmont, Chicago, Illinois 60641

Simulated TV picture/test pattern.

"Electro-Lab" is a registered trademark of the Bell & Howell Company.





# Stereo Scene

By Ralph Hodges

## REFLECTIONS ON A SESSION AT AES

**T**HE concluding event of this year's Audio Engineering Society convention in New York was a panel discussion entitled "How Valid Are Hi-Fi Equipment Tests?" A fitting subtitle, to judge from the composition of the panel, would have been "How helpful (or necessary) are the numbers now being derived from test instruments in predicting the audible performance of sound equipment?" Representing the faction that uses tests extensively in published product reports were: Julian Hirsch of Hirsch-Houck Labs (which prepares the audio test reports for this magazine and *Stereo Review*); Leonard Feldman, whose product evaluations appear in several magazines; Edward Foster and Emil Torick, both of whom are or have been associated with the CBS Labs' testing program; and long-time hi-fi writer J. Gordon Holt, who was the advocate for "subjective" (by ear) evaluation. Larry Klein of *Stereo Review* moderated.

A good show was in prospect it seemed. Unfortunately, in short order, the proceedings got diverted into other matters—subjects that were stimulating, to be sure, but somewhat afield of the panel's proper business. After the meeting ended, I had a chance to look at the written questions submitted by the audience, and was immediately sorry that more didn't receive their due in the debate. So I'm going to take the liberty of reviving some of them here, and appending a few remarks of my own just to get the discussion started. Look upon what follows as a Question and Comment (Q & C) rather than a Question and Answer (Q & A) dialogue. Heaven knows I don't have any answers, and since I don't prepare component

evaluations for magazines, I'm in no position to offer any.

**Question. It is commonly known (at least in my circles) that amplifiers X and Y sound distinctly different in the bass region. What accounts for this, and why have none of the major magazines taken on this issue?**

**Comment.** By now it must be obvious to every reader of the U.S. audio magazines that the reviewers who use test instruments extensively almost never cite audible differences between *good* amplifiers, while the sub-

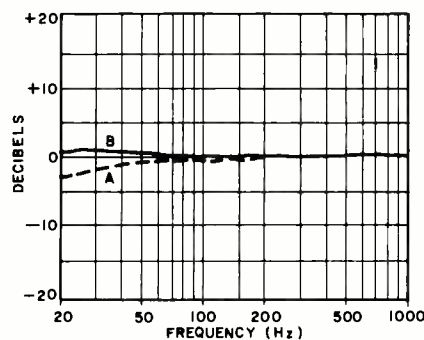

*Fig. 1. Curve A shows frequency response with amplifier adjusted for 10-kilohm input impedance; while B is response with 50-kilohm impedance.*

jective testers rarely do anything but. Interestingly, information I've gathered indicates that both may be correct in some instances. I suspect the fellow who hears differences between amps X and Y could be right. He may very well hear them! I have this feeling because, for several months, I had amplifier Y in my home. I also had on hand several preamplifiers commonly used in conjunction with it. Figure 1 reveals two differing low-frequency

response curves taken with one preamp/amp combination. What accounts for this difference? Curve A was made with the amp's gain controls turned up fully, presenting a load of 10 kilohms to the preamp. Curve B was taken with the controls at half rotation, resulting in about a 50-kilohm input impedance for Y. It's obvious that the *preamp* in question, despite its undisputed merits, cannot successfully drive a 10-kilohm load; the low frequency response of the amp/preamp combination rolls off. The difference would, I think, be quite audible to anyone. So would the difference in sound between amps X and Y with this preamp, X having a somewhat higher minimum input impedance.

This situation is by no means unique with these equipment combinations, which is why I refrain from naming the products involved. Provided I have diagnosed his problem correctly, I think the poser of the question was quite astute in isolating the differences between X and Y to the bass region. Many listeners in similar straits would have accused Y of having a "hard" top end, since the lows were not there to round out the overall balance.

It would be meaningful if reviewers would go a bit deeper in considering such equipment mismatch possibilities in their product reports. Obviously, a reviewer cannot test a product in tandem with *every* component with which it might be used. However, he could establish the range of satisfactory load impedances for a preamplifier, and the limitations of a power amplifier in driving highly reactive speaker loads (as some reviewers attempt to do). Specs of good separate preamps and amps may also alert one to possible mismatch problems. But the adequacy of specs in predicting how a component will sound is sometimes open to question, particularly in the case of speakers. To paraphrase Julian Hirsch, the only way you can find out how a speaker sounds is to listen to it.

**Question. J. Gordon Holt states he can hear the difference between amplifiers having very low measured harmonic distortion. Listening tests by Stereo Review appear to disprove this possibility. Comments?**

**Question. What about a weighted total harmonic distortion test to compensate for masking phenomena? Ideally, high frequencies would be**



# The most sideband money can buy

Built-in illuminated digital clock turns on your unit at any time you select—just like a clock radio

CB/PA switch lets you use audio output to drive a PA horn

AM/Upper Sideband/Lower Sideband illuminated mode switches for 69-channel versatility

Transmit light shows you're on the air

Large illuminated channel selector

Automatic on-switch lets you use clock to turn unit on at any time

REV/FWD switch lets you measure reverse and forward SWR on the built-in meter

SWR calibration control

Extra-large illuminated meter also shows SWR

Squelch threshold adjustable below 1  $\mu$ V

RF Gain cuts back strong signals

Volume control

Voice Lock helps you tune in off-frequency signals

## MAXIMUM LEGAL POWER PLUS...

Convenient plug-in microphone, output for extension speaker, capability for operating on 13.8VDC and the rugged quality and precision that COBRA is famous for! Send for your copy of our detailed full color brochure today!



**Cobra 135**

PRODUCT OF DYNASCAN CORPORATION • 1801 W. Belle Plaine • Chicago, Ill. 60613

**HUGE SAVINGS** ON FAMOUS BRAND STEREO COMPONENTS

**DISCOUNTS**

ON NATIONALLY ADVERTISED  
 TURNTABLES • CARTRIDGES  
 COMPACTS • RECEIVERS  
 AMPLIFIERS • TAPE RECORDERS

Wholesale Prices! Audio Warehouse Sales. One of the Capitols largest stereo wholesalers will fill and deliver all your mail orders promptly in factory sealed cartons, at prices that will amaze you.

Write for quote on Famous Brand, Stereo Components. We guarantee satisfaction.

**AUDIO WAREHOUSE SALES**  
 3310 NEW YORK AVE. N.E.  
 WASHINGTON, D.C. 20002  
 (202) 832-1616

CIRCLE NO. 4 ON READER SERVICE CARD

**INCREASE GAS MILEAGE 10-20%**



INSTALL A BAY CAPACITIVE DISCHARGE IGNITION SYSTEM!  
**\$23.88**

\$28.88 with By-Pass Switch as Pictured

**FIELD-TESTED FOR 5 YEARS!**

- Increase Engine Power
- Reduce Engine Maintenance
- Instant Starting in All Climates
- Thousands of Satisfied Users

**NO FINER CD SYSTEM AVAILABLE!**

- Completely wired, ready-to-install (not a kit)
- Install in 10 minutes (use original coil)
- Solid state reliability
- Distributor points last lifetime of car
- Spark Plugs last 3 to 10 times longer
- For 12-volt negative ground systems only
- 1-year written guarantee

**Write For Quantity Purchase Prices**

BAY PRODUCTS Division of V-J Products, Inc.  
 P.O. BOX 9562, HOUSTON, TEXAS 77011

Please send \_\_\_\_\_ Model J15 CD Ignition Systems with By-Pass Switch @ \$28.88.

Please send \_\_\_\_\_ Model SW101 CD Ignition Systems without By-Pass Switch @ \$23.88.

Enclosed is \$ \_\_\_\_\_ plus \$1 per unit for shipping.

Name \_\_\_\_\_

Address \_\_\_\_\_

City/State \_\_\_\_\_ Zip \_\_\_\_\_

CIRCLE NO. 44 ON READER SERVICE CARD

**boosted to emphasize high-order distortion products.**

Comment. I put these two questions together because they may be related. As a participant in the mentioned distortion listening tests, I can describe in some detail the conditions and results. The distortion, which we were trying to categorize in terms of its smallest audible amounts, was injected by a rigged amplifier that intro-

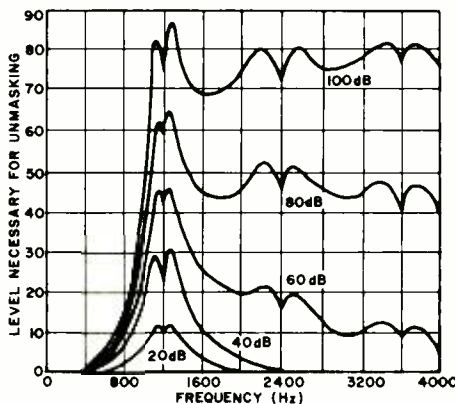

Fig. 2. For 1200-Hz tones at the levels indicated (100, 80, 60, 40 and 20 dB), the curves show the levels any other tones have to achieve before they are "unmasked" (that is, heard). Data according to Moir in High Quality Sound Reproduction.

duced known increments of so-called "notch" or "crossover" distortion. The gain of the amplifier had to be carefully adjusted so that the distortion percentage was "as calibrated" for all inputs, and this process was carried out very systematically. The tests began with a single sine-wave tone, on which the listeners were able to hear as little as 0.2 per cent distortion. Then a second sine-wave was added, and a third. With the addition of each tone any given percentage of distortion became much less audible. With two tones, the panel's threshold of perception was 2.5 per cent. With three it was 4 per cent. And on program material it was much higher—6 to 12 per cent.

What we couldn't really determine was the spectral (frequency) content of the distortion at any particular moment during the tests. In my recollection, although the distortion I heard frequently had a buzzy, bristly quality suggesting high-order products, I was mostly aware of it as a spurious tone—something like the difference tone you get from the intermodulation of two fundamentals. This might indicate

that low-order products constituted much of the distortion, which opens the door to the possibility of masking effects. In fact, Bob Carver of Phase Linear, who designed the test and reported on the results, attributed much of their significance to masking.

Figure 2 illustrates the operation of masking, in which sounds can be rendered inaudible by louder sounds of lower frequency. Note that masking is generally less effective as the masked sound gets higher in frequency. I tend to conclude, then, that high-order distortion products, as they move out of the masking region, may be more audible than low-order products still well within it.

Another piece of data may have relevance here. In his book *Modern Sound Reproduction*, Harry F. Olson describes tests conducted with a listening panel to determine the threshold, clear audibility, and even the objectionability of various distortion levels. To do this he varied both the percentage of distortion and the bandwidth of the reproduced sound, and determined his parameters through measurement of the entire reproduction system. Figure 3 shows the spectral distribution of the harmonic distortion introduced, and fig-

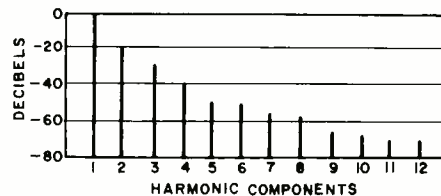

Fig. 3. The distribution and relative strengths of harmonic-distortion products introduced by Olson during his listening tests. Relative to fundamental, a level of 12 percent THD is shown here.

ure 4 presents the results. Note that there are significant high-order distortion products present in his signal, and also that, as he extends bandwidth to the highest audible frequencies (so that high-order products are brought out), any distortion that is audible is almost equally objectionable. Note also that on full-range program material Olson's listeners heard much smaller amounts of distortion than we.

On the basis of this evidence, I concur with the gentleman who recommends frequency-weighted distortion measurements. Or at least I feel that the proposal deserves prompt further



study. On the other hand, if you consider Olson's results across most of the audio spectrum, you'll notice that the percentage of distortion deemed audible is the same order of magnitude as the SR tests. When we get down to distortion levels approaching

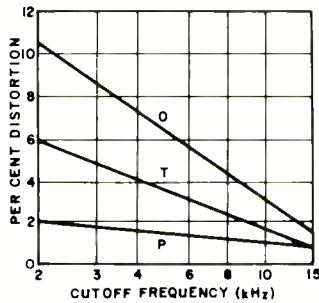

Fig. 4. Results of Olson's distortion listening tests on music. For the three curves, P means just perceptible; T is tolerable; and O is objectionable. Horizontal calibrations show the various high-frequency cutoffs used.

one tenth of one per cent (and most high-quality amplifiers do), I have to be a little skeptical about claims asserting the gross audibility thereof to those with educated ears. I prefer Olson's figures.

**Question. Has anyone found any conclusive correlation between measured phase "distortion" and subjective effects?**

Comment. I think the answer to this question has to be yes. Phase distortion (or "time-delay" distortion, which refers to the same thing, but which many authorities feel is closer to describing what it really is that offends the ear) has received some concentrated study of late. Recently, the highly respected E.R. Madsen of Denmark devised a test signal that could be phase shifted without altering its spectral (frequency balance) characteristics. Tests with listening panels gave evidence that the phase shifts were audible—sometimes quite surprisingly so. In conversations with me and others, he has said he believes that phase distortion is a primary factor in the listening quality of a speaker system. And further listening tests conducted by one of his colleagues, Henrik Staffeldt, indicate a correlation between the phase integrity and listener preference in loudspeakers. There is further evidence. At this same AES convention, Mr. K. Nakabayashi, of NHK Technical Research Laboratories in Japan, presented a paper in

which he stated that no current four-channel system—discrete or otherwise—is capable of producing a satisfactory "side" stereo image. (i.e., effectively localizing a sound source between the left-front and left-rear speaker pairs, or the right-front and right-rear). All attempts to localize sources in those areas sound "very unnatural", according to Nakabayashi, and I, if I correctly grasp his meaning, tend to agree.

Again, I can't provide details on the content of this paper, since the presentation level was so technically complex. However, the "fix" proposed by NHK involved complex and various adjustments of amplitude and phase throughout the frequency spectrum to achieve the desired side imaging. Personally, I'm anxious to hear the result. I'm half convinced already because I can recall reading a carefully documented paper from some years back (I can't recall where), in which phase manipulation of signals going to a mere two front speakers successfully located sound images to the side of and behind volunteer listeners.

There's really no doubt that certain phase effects are audible, and therefore significant. A problem remains in fully qualifying and quantifying the effects. For example, it appears that an abrupt, narrow-band frequency response aberration is not particularly disturbing to listeners. But many authorities seem to feel that an abrupt, narrow-band phase shift (as might provoke such a frequency-response aberration) is. So, while some hard correlation between phase and subjective effects has been demonstrated to the satisfaction of most, you've got to pity those unfortunates who will try to work out all the details of the matter, and the reviewers who will try to test for it.

I've got several more questions, but no space in which to deal with them. Perhaps, if the response to the foregoing is overwhelming, I'll put them into a later column.

As for the AES panel discussion, I don't think there was anyone present who really doubted the validity of measurements in evaluating hi-fi. Instead, the doubts were whether we might, in effect, be peeking through the wrong keyholes into the wrong rooms. Could be, because the real nature of a room is maddeningly difficult to judge through a keyhole. But at least we're fairly sure that the keyholes we're investigating do not give entry to rooms in the wrong house! ◆

# FREE Olson Catalog

**VALUE PACKED WITH THOUSANDS OF ELECTRONIC BARGAINS**

**We Will Send You The Next 7 Issues FREE! You'll Find The Best Of the Name Brands Plus Exclusive Olson Products at Low, Low Prices!**

Olson Electronics Dept. I2  
260 S. Forge St., Akron, Ohio 44327

Name \_\_\_\_\_  
Street \_\_\_\_\_  
City \_\_\_\_\_  
State \_\_\_\_\_ Zip \_\_\_\_\_  
Apt. No. \_\_\_\_\_

**CIRCLE NO. 31 ON READER SERVICE CARD**

**Now...the most enjoyable, do-it-yourself project of your life—a Schober Electronic Organ!**

You'll never reap greater reward, more fun and proud accomplishment, more benefit for the whole family, than by assembling your own Schober Electronic Organ.

**You need no knowledge of electronics, woodwork or music.** Schober's complete kits and crystal-clear instructions show you—whatever your skill (or lack of it)—how to turn the hundreds of quality parts into one of the world's most beautiful, most musical organs, worth up to twice the cost of the kit.

Five superb models, with kit prices from \$575 to around \$2,300, each an authentic musical instrument actually superior to most you see in stores.

Join the thousands of Schober Organ builders—owners who live in every state of the Union. Often starting without technical or music skills, they have the time of their lives—first assembling, then learning to play the modern King of Instruments through our superlative instructions and playing courses.

Get the full story FREE by mailing the coupon TODAY for the big Schober color catalog, with all the fascinating details!

The Schober Organ Corp., Dept. PE-57  
43 West 61st Street, New York, N. Y. 10023

Please send me Schober Organ Catalog.

Enclosed please find \$1.00 for 12-inch L.P. record of Schober Organ music.

NAME \_\_\_\_\_  
ADDRESS \_\_\_\_\_  
CITY \_\_\_\_\_ STATE \_\_\_\_\_ ZIP \_\_\_\_\_

**CIRCLE NO. 37 ON READER SERVICE CARD**

# NEWS HIGHLIGHTS

## Chip Manufacturers on the Move

Two more major manufacturers have introduced lines of consumer products utilizing the MSI and LSI chips they previously sold only to assemblers. Rockwell International announces its "Answer" line of calculators, ranging from basic four-function units to scientific slide rule, universal conversion, and desk-top printout models.

At the same time, National Semiconductor's Consumer Products division has entered the electronic timepiece market with its Novus line of six quartz crystal/digital wristwatches and three digital alarm clocks. The Novus watches use LED displays to show hours, minutes, and seconds on push-button command. Novus 4- and 6-digit alarm clocks and a 6-digit executive desk model will also be produced by the Company. The heart of each watch is a new ceramic hybrid IC.

## Computer-Monitored Solar Home

A solar-heated home has been built by the Homewood Corporation and Ohio State University, under a grant from the National Science Foundation. Incorporated into the house is an IBM System/7 computer, which compiles data obtained from sensors located throughout the house. The computer takes readings every 15 minutes of such data as weather, ground temperature, heat flow through walls, the number of times the doors are opened and closed, and air temperature in the attic, crawl spaces, and slab. The four-bedroom, one-story home will be occupied by a typical family for two to three years. Solar panels (37) on the roof collect and transfer energy from the sun to a water-antifreeze solution, which will heat the home through a forced-air system, provide hot water, and drive a heat-exchange air conditioning system.

## New TV Developments

Sharp Electronics has demonstrated a new, flat electroluminescent panel (thinner than a pane of glass) that is capable of reproducing a television picture. Sharp's "Thin Film Electroluminescent Television Panel" is constructed of three layers of crisscrossing conductors. When an impulse is sent to a point on the matrix, that area emits a bright glow. The panel is directly compatible with digital circuitry, and will probably be applied first in computer terminal displays.

A second development heralds the return of Earl "Madman" Muntz to the television industry, in which he was a prominent figure in its infancy. He has brought with him a self-contained giant (1200 square inches) home screen projection television set. The Muntz Home Television Theatre is 68 inches high and 25 inches deep. Muntz's system joins in competition with two other projection systems being marketed—the Advent Videobeam system, which uses a three-color projection unit and a 4 x 5-foot screen, and the Sony Color Video Projection system, which uses a Trinitron™ projection unit and a 30 x 40-inch screen.

## "True Hi-Fi" Cassettes?

BASF expects true high-fidelity reproduction from its still experimental Unisetite ¼-in. tape cassette, assuming there are tape decks to handle it. The Unisetite looks like an oversized compact cassette, measuring 5.82 in. x 3.7 in. x 0.77 in. (148 x 94 x 19.5 mm)—1.4 in. longer and wider and slightly thicker than the conventional compact cassette to accommodate the wider tape. . . . Cassettes have always suffered in a direct comparison with open-reel tape, requiring special tape formulations and noise-reduction systems to overcome deficiencies. Their poorer audio qualities are due to: reduction of tape speed, reduction of tape width and base and magnetic coating thickness, and tape guidance and tape run influenced by the cassette casing. These tend to cause a reduction of dynamic range, especially in the highs; reduction of S/N; jamming problems; reduced high-frequency response; azimuth difficulties that reduce interchangeability; and wow and flutter from frictional forces.

## Electronic Music Tutor

Warner Communications has unveiled a new means of learning musical instruments, called the Music Learning System. MLS was developed by Dr. Peter Goldmark, who invented the long-playing phonograph record. A compact, 4-track tape-cassette system enables one to play along with recorded musical groups, while substituting his own instrument for one in the group. Accompanying sheet music is synchronized with electronic voice signals and beat instructions from the tape.

The cassette tracks include an Ensemble track (pre-recorded without the instrument the student is studying), a Soloist track (with the sound of the instrument, but minus the rest of the group), an Index Voice track (containing voice instructions and beats), and the Student track for recording alone to compare with the professional artist.

A library of MLS tapes and sheet music is being assembled to bring into the classroom or home a wide variety of famous bands and orchestras, performing classical, popular, and rock music.

## Unaware of Electricity's Sources

Although Americans use the lion's share of the world's electrical power, many of us have an incredible lack of knowledge about the sources of electricity. A national sampling among Americans over age 18, commissioned by the National Electrical Manufacturers Association during last winter's energy crisis, noted the following: (a) One out of three people questioned cannot name a single fuel used to generate electricity; (b) Six out of 10 failed to mention coal; (c) Less than two out of 10 mentioned nuclear power as a fuel; (d) Three out of 10 mention oil, in spite of the fact that oil-fired generators account for only 17 percent of the electrical power generated in the U.S.



# new breadboard test equipment

... with power for the professional... with economy for the hobbyist!  
 Fresh, from the laboratories of Continental Specialties, whose QT Sockets and Proto-Boards have taken the electronics market by storm... here are exciting NEW ideas to make your circuit design and testing faster, safer, easier and less expensive!

## NOW...PROTO POWER! NEW PROTO BOARD-203

New Proto Board 203 with built-in regulated short-proof 5V, 1AMP power supply. Ready-to-use. Just plug-in and start building!  
 2 extra floating 5-way binding posts for external signals. Completely self-contained with power switch indicator lamp and power fuse. 24-14 pin DIP capacity. All metal construction... no chipping or cracking like plastic cases. Two-tone gold/black quality case makes PB203 as well as technically, pleasing.

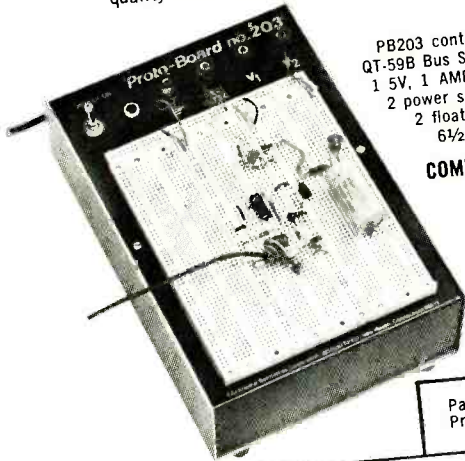

PB203 contains: 3 QT-59S Sockets; 4 QT-59B Bus Strips; 1 QT-47B Bus Strip; 1 5V, 1 AMP regulated power supply; 2 power supply 5-way binding posts; 2 floating binding posts; 9 3/4" L x 6 1/2" W x 2 3/4" H. Weight: 5 lbs.

COMPLETE  
**\$75**  
 ORDER TODAY!

Patents Pending • Made in U.S.A.  
 Prices subject to change

Build and test circuits as fast as you can think without soldering or patch cords with NEW

## Proto Board Breadboard Assemblies

Here are four versatile new Continental Specialties' Proto Boards, made from convenient combinations of QT Sockets and Bus Strips, that let you make all circuit and power interconnections with common solid #22 wire, while power distribution busses make wiring a snap. Aluminum base plates offer solid work surfaces and perfect ground plane. Rubber feet prevent scratching. Each Proto Board features one or more 5-way binding posts to tie into system or power supply ground. And all are compatible with digital and linear ICs, in T05s, DIP packs and discrete components. Each is assembled and ready-to-use.

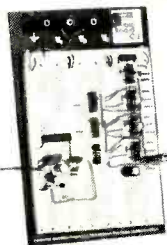

**Proto Board 103.**  
 2,250 solderless tie points. (4) 5-way binding posts. 24-14 pin DIP capacity. 9" x 6". **59<sup>95</sup>**



**Proto Board 101.**  
 Compact. Inexpensive. 10-14 pin DIP capacity. 5.8" long x 4.5" wide. **29<sup>95</sup>**

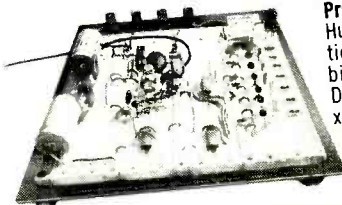

**Proto Board 104.**  
 Huge. 3,060 solderless tie points. (4) 5-way binding posts. 32-14 pin DIP capacity. 9 1/2" long x 8" wide. **79<sup>95</sup>**

Available off-the-shelf at your local distributor or order directly from Continental Specialties. Phone charges accepted for BankAmericard, Master Charge, American Express. Write for Free catalog. Dealer inquiries invited.



**Continental Specialties Corporation**

44 Kendall St., New Haven, CT 06509  
 Telephone: 203/624-3103

CANADA:  
 Available thru Len Finkler, Ltd.  
 Ontario

## For the economy-minded student or experimenter... NEW PROTO BOARD-100

Here's a low cost, big 10 IC capacity breadboard kit with all the quality of QT Sockets and the best of the Proto-Board series... complete down to the last nut, bolt and screw. Includes 2 QT-35S Sockets; 1 QT-35B Bus Strip; 2 5-way binding posts; 4 rubber feet; screws, nuts, bolts; and easy assembly instructions.

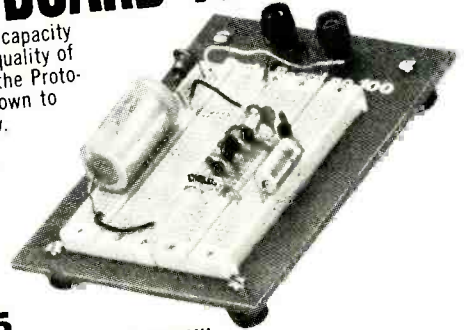

COMPLETE KIT...

**\$19<sup>95</sup>** ORDER YOURS TODAY!

## NEW! PROTO-CLIP for power-on, hands-off signal tracing. Eliminates shorting leads... and costs under \$5!

Bring IC leads up from pc board for fast signal tracing and troubleshooting. Inject signals. Wire unused circuits into boards. Scope probes and test leads lock onto Dynagrip (see circle) inset for hands-off testing. New plastic construction eliminates springs, pivots. Non-corrosive nickel/silver contacts for simultaneous low resistance connections. Narrow throat for high density pc boards.



14-pin Proto-Clip ... \$4.50 each  
 16-pin Proto-Clip ... \$4.75 each



**Proto Board 102.** Compact. 12-14 pin DIP capacity. 7" x 4 1/2". **39<sup>95</sup>**

**FREE!** Metric-to-English SLIDE RULE. Convert lengths, area, weight, volume instantly. Yours FREE with a minimum \$5.00 order!

# One of our most successful students wrote this ad!

**Harry Remmert decided he needed more electronics training to get ahead. He carefully "shopped around" for the best training he could find. His detailed report on why he chose CIE and how it worked out makes a better "ad" than anything we could tell you. Here's his story, as he wrote it to us in his own words.**

## By Harry Remmert

**A**FTER SEVEN YEARS in my present position, I was made painfully aware of the fact that I had gotten just about all the on-the-job training available. When I asked my supervisor for an increase in pay, he said, "In what way are you a more valuable employee now than when you received your last raise?" Fortunately, I did receive the raise that time, but I realized that my pay was approaching the maximum for a person with my limited training.

"Education was the obvious answer, but I had enrolled in three different night school courses over the years and had not completed any of them. I'd be tired, or want to do something else on class night, and would miss so many classes that I'd fall behind, lose interest, and drop out.

### The Advantages of Home Study

"Therefore, it was easy to decide that home study was the answer for someone like me, who doesn't want to be tied down. With home study there is no schedule. I am the boss and I set the pace. There is no cramming for exams because I decide when I am ready, and only then do I take the exam. I never miss a point in the lecture because it is right there in print for as many re-readings as I find



Harry Remmert gives his CIE Electronics course much of the credit for starting him on a rewarding career. He tells his own story on these pages.

necessary. If I feel tired, stay late at work, or just feel lazy, I can skip school for a night or two and never fall behind. The total absence of all pressure helps me to learn more than I'd be able to grasp if I were just cramming it in to meet an exam deadline schedule. For me, these points give home study courses an overwhelming advantage over scheduled classroom instruction.

"Having decided on home study, why did I choose CIE? I had catalogs from six different schools offering home study courses. The CIE catalog arrived in less than one week (four days before I received any of the other catalogs). This indicated (correctly) that from CIE I could expect fast service on grades, questions, etc. I eliminated those schools which were slow in sending catalogs.

### FCC License Warranty Important

"The First Class FCC Warranty\* was also an attractive point. I had seen "Q" and "A" manuals for the FCC exams, and the material had always seemed just a little beyond my grasp. Score another point for CIE.

\*CIE backs its courses with this famous Money-Back Warranty: when you complete a CIE license preparation course, you'll be able to pass your FCC exam or be entitled to a full refund of all tuition paid. Warranty is valid during completion time allowed for your course.



"Another thing is that CIE offered a complete package: FCC License and technical school diploma. Completion time was reasonably short, and I could attain something definite without dragging it out over an interminable number of years. Here I eliminated those schools which gave college credits instead of graduation diplomas. I work in the R and D department of a large company and it's been my observation that technical school graduates generally hold better positions than men with a few college credits. A college degree is one thing, but I'm 32 years old, and 10 or 15 years of part-time college just isn't for me. No, I wanted to *graduate* in a year or two, not just *start*.

"When a school offers both resident and correspondence training, it's my feeling that the correspondence men are sort of on the outside of things. I wanted to be a full-fledged student instead of just a tag-a-long, so CIE's exclusive home-study program naturally attracted me.

"Then, too, it's the men who know their theory who are moving ahead where I work. They can read schematics and understand circuit operation. I want to be a good theory man.

"From the foregoing, you can see I did not select CIE in any haphazard fashion. I knew what I was looking for, and only CIE had all the things I wanted.

### Two Pay Raises in Less Than a Year

"Only eleven months after I enrolled with CIE, I passed the FCC exams for First Class Radiotelephone License with Radar Endorsement. I had a pay increase even before I got my license and *another* only ten months later.

"These are the tangible results. But just as important are the things I've learned. I am smarter now than I had ever thought I would be. It feels good to know that I know what I know now. Schematics that used to confuse me completely are now easy for me to read and interpret. Yes, it is nice to be smarter, and that's probably the most satisfying result of my CIE experience.

### Praise for Student Service

"In closing, I'd like to get in a compliment for my Correspondent Counselor who has faithfully seen to it that my supervisor knows I'm studying. I think the monthly reports to my supervisor and generally flattering commentary have been in large part responsible for my pay increases. My Counselor has given me much more student service than "the contract calls for," and I certainly owe him a sincere debt of gratitude.

"And finally, there is Mr. Tom Duffy, my instructor. I don't believe I've ever had the individual attention in any classroom that I've received from Mr. Duffy. He is clear, authoritative, and spared no time or effort to answer my every question. In Mr. Duffy, I've received everything I could have expected from a full-time private tutor.

"I'm very, very satisfied with the whole CIE experience. Every penny I spent for my course was returned many

times over, both in increased wages and in personal satisfaction."

Perhaps you too, like Harry Remmert, have realized that to get ahead in Electronics today, you need to know much more than the "screwdriver mechanics." They're limited to "thinking with their hands" . . . learning by taking things apart and putting them back together . . . soldering connections, testing circuits, and replacing components. Understandably, their pay is limited—and their future, too.

But for men like Harry Remmert, who have gotten the training they need in the fundamentals of Electronics, there are no such limitations. He was recently promoted, with a good increase in income, to the salaried position of Senior Engineering Assistant working in the design of systems to silence submarines. For trained technicians, the future is bright. Thousands of men will be needed in virtually every field of Electronics from two-way mobile radio to computer testing and troubleshooting.

### Send for Complete Information — FREE

Many men who are advancing their Electronics career started by reading our illustrated school catalog, "Succeed in Electronics." It tells of the many electronics careers open to men with the proper training. And it tells which courses of study best prepare you for the work you want.

If you're "shopping around" for the training you need to move up in Electronics, this interesting book may have the answers you want. We'll send it to you FREE. With it, we'll also include our other helpful book, "How To Get A Commercial FCC License."

To get both FREE books, just fill out and mail the reply card. For your convenience, we will try to have a representative call. If card is missing, use coupon below.

#### APPROVED UNDER G.I. BILL

All CIE career courses are approved for educational benefits under the G.I. Bill. If you are a Veteran or in service now, check box for G.I. Bill information.

## CIE Cleveland Institute of Electronics, Inc.

1776 East 17th Street, Cleveland, Ohio 44114

Accredited Member National Home Study Council

### Cleveland Institute of Electronics, Inc.

1776 East 17th Street, Cleveland, Ohio 44114

Please send me your two FREE books:

1. Your school catalog, "Succeed in Electronics."
2. Your book on "How To Get A Commercial FCC License."

I am especially interested in:

- |   |  |
|---|--|
| <input type="checkbox"/> Electronics Technology                 | <input type="checkbox"/> Electronic Communications |
| <input type="checkbox"/> Broadcast Engineering                  | <input type="checkbox"/> Industrial Electronics    |
| <input type="checkbox"/> First Class FCC License                | <input type="checkbox"/> Electronics Engineering   |
| <input type="checkbox"/> Electronics Technology with Laboratory |  |

Name \_\_\_\_\_ (Please Print)

Address \_\_\_\_\_

City \_\_\_\_\_

State \_\_\_\_\_ Zip \_\_\_\_\_ Age \_\_\_\_\_

Veterans & Servicemen: Check here for G. I. Bill information

PE-69

### For men with prior electronics training . . . Electronics Engineering Course

. . . Covers steady-state and transient network theory, solid-state physics and circuitry, pulse techniques, computer logic and mathematics through calculus. A college-level course for men already working in Electronics.

# SWTC - POWER FROM -25 TO 250 WATTS

No matter what your power requirements. No matter what your budget. Now there is a Southwest Technical power amplifier that will fit your requirements.

NEW— #215 Stereo Amplifier



Now those who don't need the power output of our famous "Tiger .01" can have the same super low distortion in a 25 Watt per channel amplifier. This amplifier has all of the features of "Tiger .01". Our unique cross coupled, complementary differential input system; an output triple and IM distortion of less than .01% up to rated output. It also has the same beautiful bronze anodized chassis with a perforated metal cover and two meters to indicate the output level. Frequency response is -3.0 dB at 0.1 Hz and 250 KHz. Rise time is less than a microsecond. As usual nothing but first quality parts and fibreglass circuit boards are used in the kit. Wiring pictorials and step-by-step instructions are provided.

#215 Stereo Amplifier Kit \$69.50 PPD

The first of the super low distortion amplifiers, our famous "Tiger .01". The first amplifier to be designed with our complementary differential input system. Rated at 60 Watts continuous sine wave output into either 4.0 or 8.0 Ohms, "Tiger .01" is 3.0 dB down at 0.1 Hz and 250 KHz. Power bandwidth is 10 Hz to 75 KHz; and IM distortion is of course less than .01% up to rated output. The circuit is housed in a bronze anodized chassis and has an output meter, overheat indicator

lamp and power switch on the front panel. Parts are our usual name brand first quality stuff. In this kit you will find things like RCA, and Motorola transistors, Sprague capacitors and like that. The kit comes with the usual pictorial wiring diagrams, wiring tables and step-by-step instructions.

#207 Amplifier Kit \$77.50 PPD



New—#275 Tiger B

Our latest version of the amplifier that started it all, the faithful old "Universal Tiger". We have switched to our new complementary differential input circuit and put him in a fancy new chassis, but this is still the most economical, low distortion power you can get. Rated at 75 Watt with an 8.0 Ohm load, or 90 Watts with a 4.0 Ohm load with IM distortion less than 0.1% up to rated output. Typically less than .02% at low power levels. Frequency response is -3.0 dB at 0.1 Hz and 250 KHz and rise time is less than 1.0 microsecond. "Tiger B" is the ideal BASIC amplifier for all type of applications Hi-Fi system, public address, instrument amplifier; you name it. As in all of our amplifiers, we have provided all of the protection that we know how to put into a circuit. The outputs stages have volt-amp limiting systems, there are two supply fuses, a line fuse, a speaker fuse and a thermal cutout. "Tiger B" comes in the same chassis as our #207, but the finish is alodine instead of anodize. For those of you who insist on gilding the lilly, we will have an accessory kit to add an

output level meter, input level control, etc.

#275 Amplifier Kit \$64.50 PPD



Tigersaurus is our answer to those who want, or need tremendous amounts of power, but insist on it being clean. This amplifier uses the same basic circuit as "Tiger .01", but uses stacked parallel output devices and of course a higher supply voltage. This amplifier can supply 200 Watts continuous sine wave power into 8.0 Ohms and 250 Watts into 4.0 Ohms at less than .05% distortion. Below 100 Watts distortion is typically less than .01%. Output at clipping is typically 300 Watts. Bandwidth is the same as our other amplifiers. The eight output transistors are mounted on over 500 square inches of heat sink for cool reliable operation even at these power levels. There is a large illuminated meter to indicate power output on the front panel and the entire case is finished in a bronze anodized finish for durability and scratch resistance. If you need "beastly" amounts of power this is the amplifier for you.

#210 Tigersaurus

Amplifier Kit

\$154.50 PPD



## SOUTHWEST TECHNICAL PRODUCTS CORPORATION

219 W. RHAPSODY - SAN ANTONIO, TEXAS 78216



# Build an Auto Polarity, Auto Zero Digital Multimeter for Under \$100

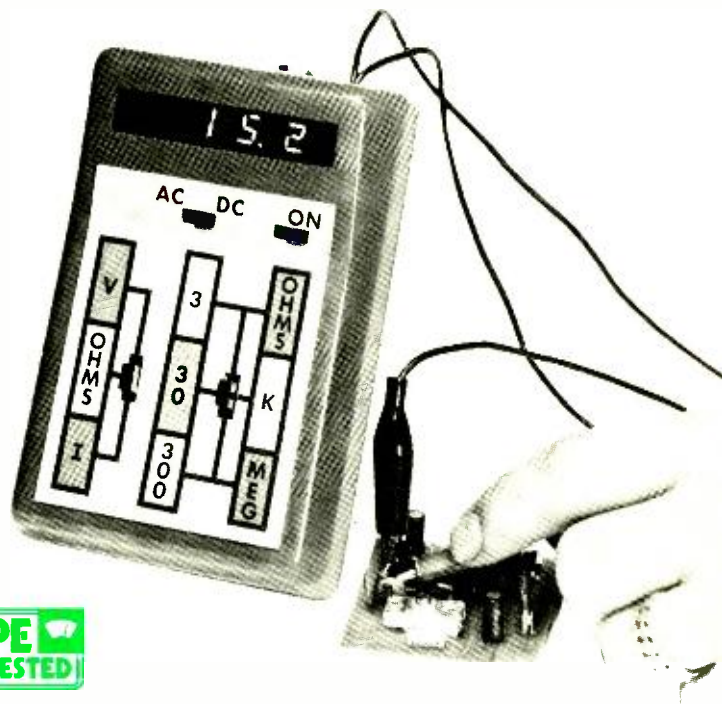

BY W. L. GREEN

**T**HERE are many advantages to be gained from using digitally generated decimal readouts in test and measurement equipment. Besides being inherently more accurate than meter movements, decimal readouts are unambiguous to read and interpret and do not suffer from "parallax" error. Also, the circuits used in digital instruments have long-term stability, and tests performed using them are easily repeatable.

All of these advantages are available in the pocket-size digital multimeter (DMM) described here. It has a bright yellow 3½-digit display and is battery-powered. The resistance and ac and dc voltage and current ranges

are shown in the table. Other features include automatic zeroing and polarity indication on dc volts, automatic zeroing on ohms and an accuracy of 0.1 percent on most ranges.

Ordinarily, this DMM would cost several hundred dollars. However, you can assemble it for less than \$100.

**About the Circuit.** The complete schematic diagram of the DMM is shown in Fig. 1. The heart of the instrument is contained in IC1 and IC2, a pair of new PMOS LSI integrated circuits. The first is a monolithic bipolar analog processor, while the latter is a digital processor. These two IC's provide input buffering of the voltage to

be measured and create an analog-to-digital (A/D) conversion for a binary-coded-decimal (BCD) output to the decoder and driver IC's, IC3 and IC4.

The circuit uses a modified dual-slope integrating conversion technique that gives the basic A/D converter an accuracy of 0.05 percent. Although 1-percent tolerance resistors are used in the input voltage divider, the design employed in this instrument improves the accuracy on the 3- and 30-volt ranges to close to 0.05 percent, or as close as your calibration standards and care in calibration will allow. The resistance-range accuracy is limited to about 0.1 percent under any conditions without redesigning the resistance current source to improve linearity.

Accuracy on the current ranges is 1 percent for the 3- and 30-mA ranges and 5 percent on the 300-mA range. This accuracy can be improved by judicious selection of input shunt resistors R8, R7, and R6.

The instrument's full-scale range is 3½ digits with a 50-percent overrange. The overrange is indicated by the display digits blinking on and off. Discrete light-emitting diode LED1, located on the extreme left of the dis-

## TECHNICAL SPECIFICATIONS

**Dc volts:** 1 mV to 300 volts in three ranges. Accuracy better than 0.1 percent on 3- and 30-volt ranges, 1 percent on 300-volt range. Input resistance 10 megohms on all ranges.

**Ac volts:** Ranges and input impedance same as on dc. 0 to full-scale voltage between 40 and 100 Hz; 0 to 2.4 volts between 100 and 10,000 Hz; 0 to 1.5 volts between 10,000 and 50,000 Hz. Accuracy within these limits is 1 percent.

**Resistance:** 1 ohm to 3 megohms in three ranges. Accuracy is 0.1 percent on all ranges.

**Current (ac and dc):** For ac, 1 mA to 300 mA in three ranges, with accuracy and frequency the same as for ac volts, except 5-percent accuracy on 300-mA range. For dc, ranges same as for alternating current, with accuracy 1 percent on 3- and 30-mA ranges and 5 percent on 300-mA range.

## PARTS LIST

- B1—Five AA nickel-cadmium cells  
 C1 to C5—10- $\mu$ F, 16-V electrolytic capacitor  
 C6—0.1- $\mu$ F, 15-V polyester capacitor  
 C7—0.01- $\mu$ F, 15-V polyester capacitor  
 C8, C10—0.0027- $\mu$ F, 15-V polycarbonate capacitor  
 C9—5-pF ceramic capacitor  
 DIS1 to DIS4—Seven-segment LED numeric readout (Monsanto MAN-8)  
 D1—1N4001 silicon rectifier  
 D2—Diode (Siliconix E507, no substitute)  
 D3 to D8—1N914 diode  
 IC1—Integrated circuit (Siliconix LD111)  
 IC2—Integrated circuit (Siliconix LD110)  
 IC3—7416 TTL hex inverter IC  
 IC4—Seven-segment driver (Fairchild 9368)  
 IC5—Op amp (Signetics N5308)  
 IC6—Timer IC (Motorola MC1455)  
 J1—Miniature phone jack  
 LED1—Light-emitting diode (Motorola MLED50 or Monsanto MV50)  
 Q1—Transistor (Motorola MPF161)  
 Q2—Transistor (National 2N4274—do not substitute)  
 Q3—Transistor (Motorola MPSD05)  
 Q4—2N4400 transistor  
 Q5—2N5139 transistor  
 R1—4.22-megohm, 1% resistor  
 R2—4.87-megohm, 1% resistor  
 R3—909,000-ohm 1% resistor  
 R4, R25—100,000-ohm, 1% resistor  
 R5—1000-ohm, 1% resistor  
 R6—100-ohm, 1% resistor  
 R7—10-ohm, 1% resistor  
 R8—1-ohm, 5% resistor  
 R9, R28—1000-ohm, 10% resistor

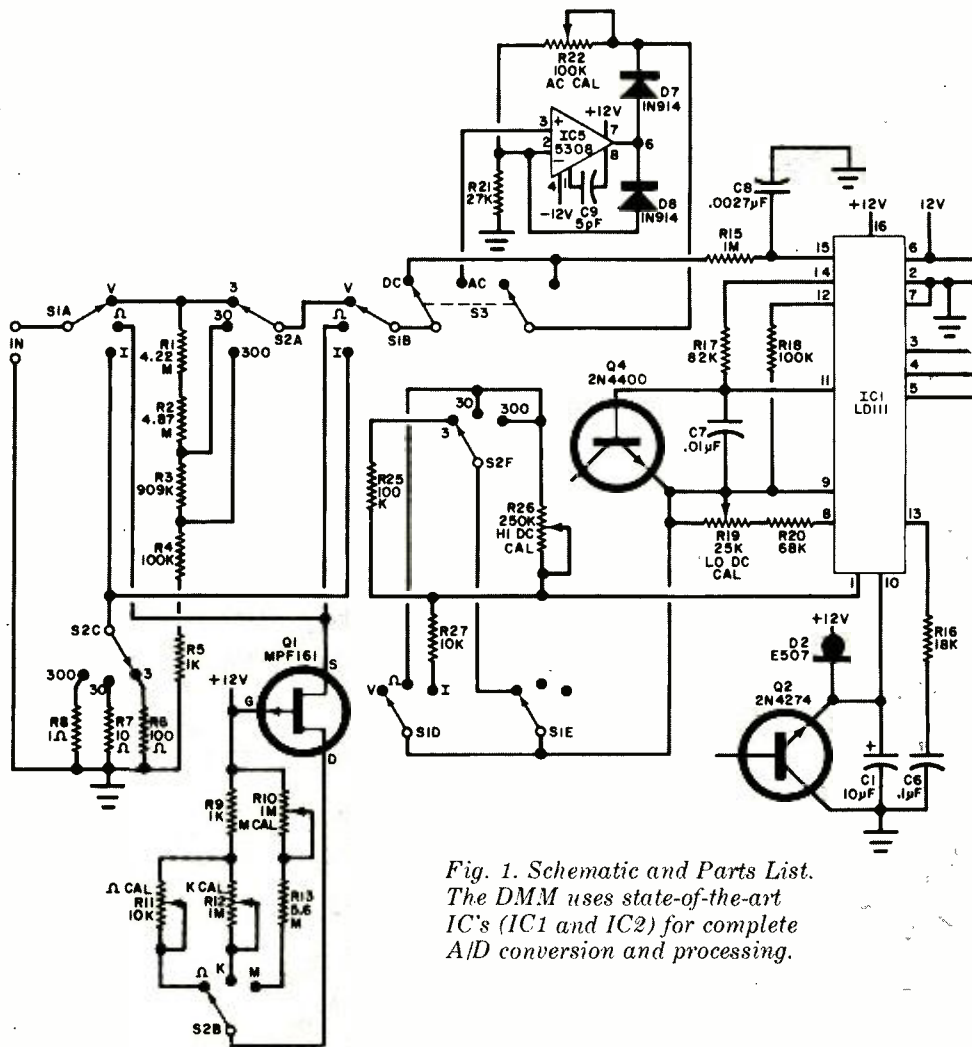

Fig. 1. Schematic and Parts List. The DMM uses state-of-the-art IC's (IC1 and IC2) for complete A/D conversion and processing.

## ABOUT THE A/D CONVERTER

The LD110 and LD111 PMOS LSI circuits used in this digital multimeter project were developed by Siliconix Inc. to create a complete analog-to-digital (A/D) converter in two directly interfacing chips. The A/D technique, called "quantized feedback" by Siliconix, is an integrating scheme in which two sets of charges are summed—the charge supplied by the analog input voltage and the discrete (quantized) units of charge provided by the digital feedback system. This technique, while providing high accuracy ( $\pm 0.05$  percent of the reading  $\pm 1$  count), has excellent noise rejection due to the noise-averaging property of integration.

Automatic-zeroing circuitry, an es-

sential component of the quantized feedback technique, provides a drift-resistant conversion scheme that is highly immune to temperature effects. The zero is automatically established prior to each conversion, and no external zeroing adjustment is required.

A further refinement offered by this technique is that an input voltage of either polarity can be applied to the instrument and the circuit will automatically determine and display the proper polarity. Ordinarily, this would require complex switching systems, two reference voltages, and two full-scale adjustments. In this new approach, only one reference voltage and one full-scale adjustment is used to cover the range from  $-200$  mV to  $+200$  mV (or

$-2.000$  volts to  $+2.000$  volts).

The two new IC's utilize advanced LSI processing techniques. The LD111 combines bipolar npn and pnp transistors with p-channel MOSFET's in a single monolithic IC. The MOSFET's provide the high input impedance (greater than 1000 megohms) necessary to prevent loading the signal source. The MOSFET's are also used as switches within the integrated circuit.

The LD110 IC uses approximately 1400 p-channel MOSFET's combined into logic elements to provide counting, storage, multiplexing, and control operations. The digital output of this chip is multiplexed for use by the LED readouts.



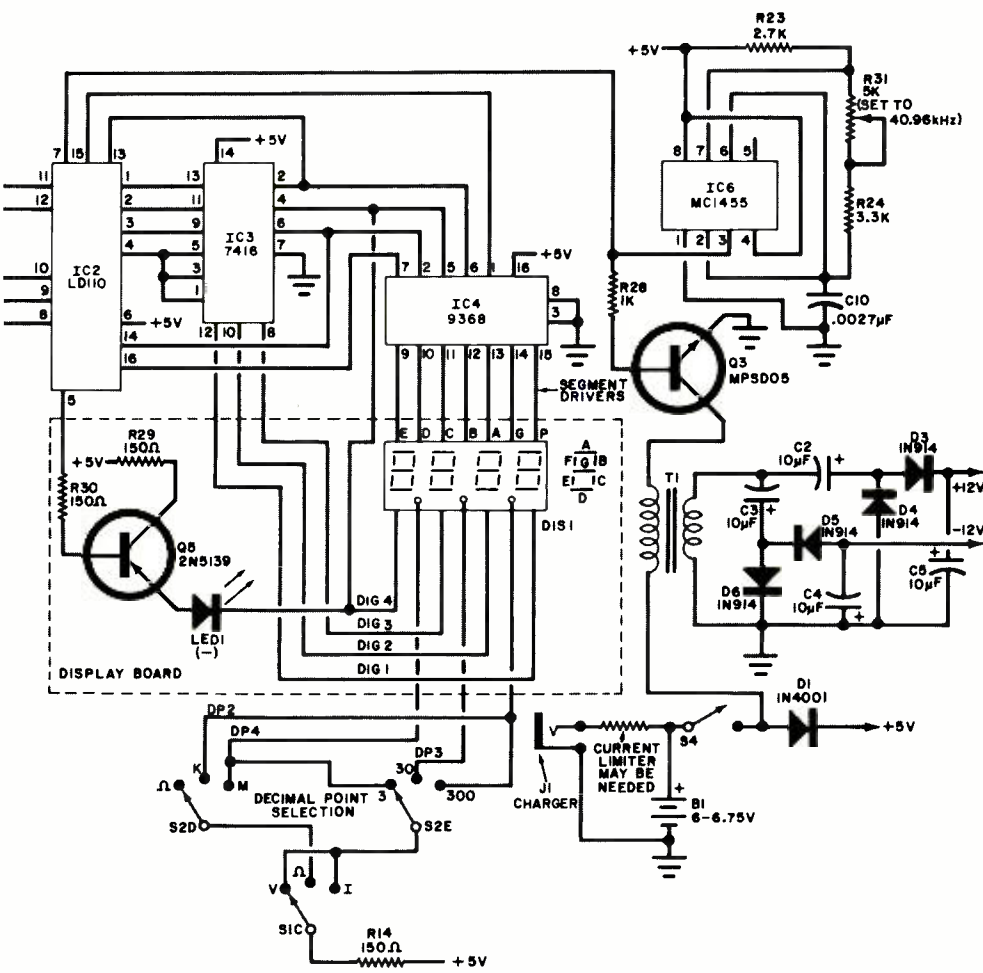

- R10, R12—1-megohm mini-pot
- R11—10,000-ohm mini-pot
- R13—5.6-megohm, 10% resistor
- R14, R29, R30—150-ohm, 10% resistor
- R15—1-megohm, 10% resistor
- R16—18,000-ohm, 10% resistor
- R17—82,000-ohm, 10% resistor
- R18—100,000-ohm, 10% resistor
- R19—25,000-ohm mini-pot
- R20—68,000-ohm, 10% resistor
- R21—27,000-ohm, 10% resistor
- R22—100,000-ohm mini-pot
- R23—2700-ohm, 10% resistor
- R24—3300-ohm, 10% resistor
- R26—250,000-ohm mini-pot
- R27—10,000-ohm, 1% resistor
- R31—5,000-ohm mini-pot
- S1, S2—6-pole, 3-position slide switch
- S3—Dpdt slide switch
- S4—Spst slide switch
- T1—10,000-ohm to 2000-ohm miniature transformer (see text for modification)
- Misc.—Suitable instrument case; plastic filter for display; main and display printed circuit boards; battery charger (plus current-limiting resistor if needed); insulated test leads with probes (one red, one black); dry-transfer lettering kit; etc.

Note: The following items are available from Alpha Electronics, P.O. Box 1005, Merritt Island, FL 32952: complete kit of parts, including case but less batteries and test leads (No. DMM-1) for \$99.95 plus \$2 shipping and handling; set of printed circuit boards (No. DM-1PC), \$10 postpaid; one each LD110 and LD111 integrated circuits, \$49.90 postpaid; one case, \$10.00 postpaid.

play, shows when the voltage is negative.

Ac-to-dc conversion is performed by an active half-wave rectifier formed by operational amplifier IC5. This rectifier differs from the classic half-wave rectifier in that the ac signal is applied to the noninverting (+) input of the op amp instead of the inverting (-) input. This permits the input impedance to be more than 30 megohms.

The clock generator (IC6) is set to 40,960 Hz ±200 Hz (by R31) for maximum up-converter efficiency and to reduce normal mode rejection when measuring ac voltages. The operating frequency was selected to be 2048 times the nominal 60-Hz line frequency, then dividing by three.

Constant current for the resistance mode is supplied by p-channel field effect transistor Q1. Range resistors R9 through R13 determine the magnitude of the constant current supplied, which is 1 mA for ohms, 10 μA for kilohms, and 1 μA for megohms.

The multimeter then measures the voltage drop across the test resistor.

Current is measured by taking the voltage drop across the selected shunt resistor (R6 through R8). The sensitivity of the A/D converter is changed from 2V full scale to 0.2 V full scale when measuring current to allow the use of shunt resistors of smaller values, which lowers the voltage drop. The full-scale voltage drop is 0.19 volt.

Because IC1, IC2, and IC5 require a dual-polarity supply in excess of the nominal 6 volts supplied by battery B1, the positive and negative voltages are generated in an "up-converter" formed by Q3 and its associated components. The output of clock generator IC6 provides the base drive for Q3, whose collector load is the primary of transformer T1. The secondary of T1 feeds a voltage-doubling network to generate the positive and negative 12 volts needed for the three IC's.

**Construction.** Because of the complexity of the circuit and the packaging density required of a pocket-sized multimeter, the use of a printed circuit board is mandatory (see Fig. 2).

Start construction by cementing the amber-colored plastic window in the display cutout in the top half of the case. Bend the lugs of S3 and S4 flat as shown in Fig. 3. Install the switches in their respective locations and, using a soldering iron, melt down the plastic posts to hold the switches firmly.

Next, carefully cut the slots for the switches in the metal front panel of the instrument. Then use a dry-transfer lettering kit to label the switches and their positions as shown in the lead photograph. Epoxy the prepared front panel to the top of the case.

Now, referring to Fig. 4, solder a 5-in. (12.7-cm) length of insulated hookup wire to each of the four cathode pads and each of the three decimal point pads. Install displays DIS1-DIS4 in their respective loca-

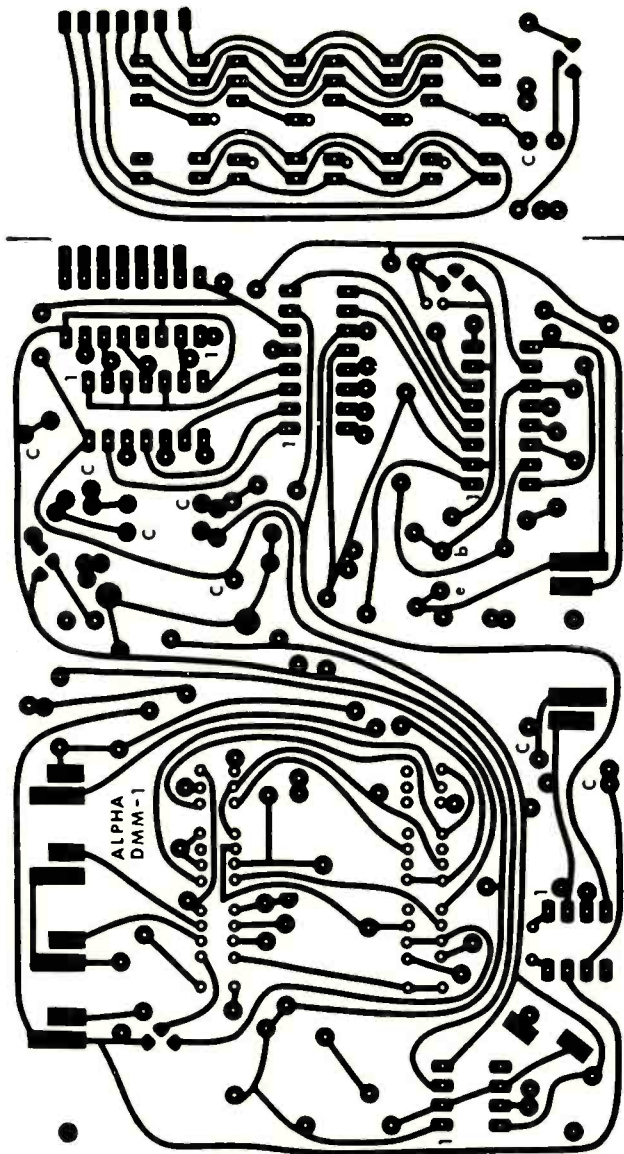

Fig. 2. Actual-size foil patterns for display (top) and main (below) boards.

tions. (Note: The displays have three semicircular notches on their faces. The edges with the two notches identify the tops, while the single-notch edges are the bottoms. Make sure you install these displays in the proper orientation on the board.)

Install and solder into place on the display board *LED1* (the wider lead identifies the cathode), *Q5*, *R29*, and *R30*. Solder tin the seven pads, identified with the letters A through G, on the upper edge of the board. Solder a 2-in. (5.1-cm) length of bare wire to each of these pads. Finally, connect and solder a 4-in. (10.2-cm) length of insulated hookup wire to the +5-volt and - sign pads.

Transformer *T1* must be disassembled and rewound. When you disassemble it, save the wire. Then use a 7-ft (2.14-m) length of the wire and fold it 3 ft (0.915 m) from one end and bifilar wind it on the transformer's bobbin.

Insulate the winding with electrical tape. The primary will be the 3-ft long winding and the secondary the 4-ft long winding. Cut the windings at the fold, scrape away the enamel coating from the ends of the wire, and use color-coded (for example, red for the primary and black for the secondary windings) stranded hookup wire for connections. Insulate the connections with tape or heat-shrinkable tubing. Reassemble transformer.

As can be seen in Fig. 5, components are mounted on both sides of the main board. Mount and solder into place the components exactly as shown, taking care to observe polarities and orientations. Also, use soldering heat sparingly, and be particularly careful to avoid solder bridges between closely spaced conductors. When you mount *T1*, make absolutely certain that the transformer's metal frame does not contact

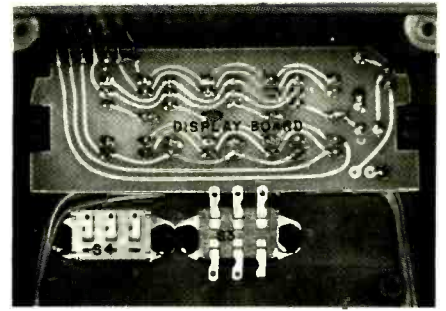

Fig. 3. Photo shows installation of *S3* and *S4*.

any but the foil conductors shown.

Before mounting *S1* and *S2* in their respective locations on the board, cut off the four mounting tabs. Install the switches and solder their lugs to the foil pattern.

Referring back to Fig. 3, install the display board in the top half of the instrument case, dressing the leads as shown. The board mounts in place in a manner similar to that used for *S3* and *S4*. Use a soldering iron to melt the plastic bosses on the case down over the right and left edges of the board, taking care to avoid damaging the case.

Place the main board in position in the case, and wire and solder the nine insulated digit, decimal-point, minus-sign, and +5-volt leads coming from the display board to the appropriate points on the main board. Route the leads carefully to allow the main board

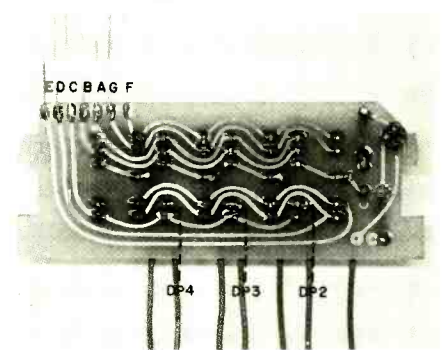
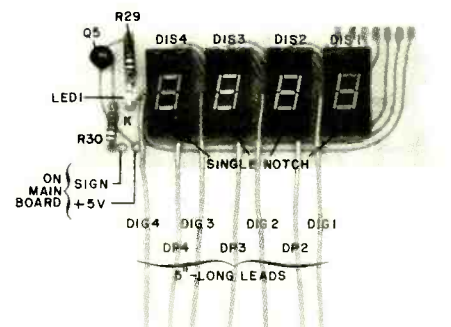

Fig. 4. Component layout for the display board.





to sit against its mounting bosses without pinching them.

Drill a small hole in the top of the case and pass the two insulated test leads through. Use a red lead for the "hot" and a black lead for the "common" lines. Connect these leads to their respective pads on the main board.

Drill a second hole and mount charger jack *J1* in place. Use insulated wire to interconnect power switch *S4*, *J1*, and the main board and to wire *S3* to the main board.

With four small screws, mount the main board in place, making sure that the range and function switches protrude through their holes in the front panel and can be moved from position to position without binding. Solder tin

the seven (segment) pads at the upper left of the main board. Slide thin insulating sleeving over the seven bare wire leads on the display board and solder their free ends to their respective pads on the main board. Trim away any excess from these leads.

Connect the battery pack, which consists of five rechargeable AA-size nickel-cadmium cells, to the charger jack. Then wrap the battery pack with electrical tape to completely insulate it. Position the battery pack against the foil side of the main board and lower the bottom cover of the instrument into place. If the fit is satisfactory, remove the bottom of the case and temporarily set it aside.

Select a battery charger that has a recharging rate suitable for your bat-

tery pack. If necessary, connect a current-limiting resistor in series with *J1* to maintain the charging current at a safe level. (See Fig. 1 for installation details.)

Carefully recheck the entire assembly for correct wiring and component installation and orientation. Check also for solder bridges and bits of wire.

**Calibration.** The calibration procedure for the DMM should be accomplished exactly as follows, since adjustments of *R19* and *R26* will affect the accuracy and calibration of the entire instrument.

Turn on the power and observe the display. There should be some indication that the system is working. Set *S1* to VOLTS, *S2* to position 3, and *S3* to DC. Apply any known accurate source of 1.5 volts dc to the test leads and adjust *R19* for an exact reading on the display.

Set *S3* to 30. Now, apply a known accurate 15-volt dc source to the DMM's test prods. Adjust *R26* for an exact reading on the display. The 300-volt range requires no calibration.

Prior to calibrating the ac ranges, it is necessary to adjust the frequency of clock oscillator *IC6* to 40,960 Hz  $\pm 200$  Hz) with the aid of a frequency counter connected to pin 3 of the IC, adjusting *R31*. If you do not have access to a frequency counter, set *S1* to VOLTS, *S2* to 3, and *S3* to AC. Connect the test leads to a 1-volt or so 60-Hz source, which you can derive from a filament transformer with a potentiometer voltage divider. Observe the display while adjusting *R31* for a stable reading, noting that the wiper of *R31* will be clockwise of its center position.

Connect the DMM's test leads to a 1-volt rms, 1000-Hz sinewave source and adjust *R22* for the correct reading on the display.

Set *S1* to OHMS, *S2* to  $\Omega$ , and *S3* to DC. Connect a known accurate resistor of about 1000 ohms across the test leads and adjust *R11* for the correct reading on the display. Set *S2* to K and, using a known accurate 100,000-ohm resistor, adjust *R12* for the correct reading. Then use a known accurate 1-megohm resistor to calibrate the megohm range with *R13*.

Once the calibration procedure has been performed, tighten down any loose hardware, position the battery pack, and attach the bottom half of the instrument case with flathead machine screws.  $\diamond$

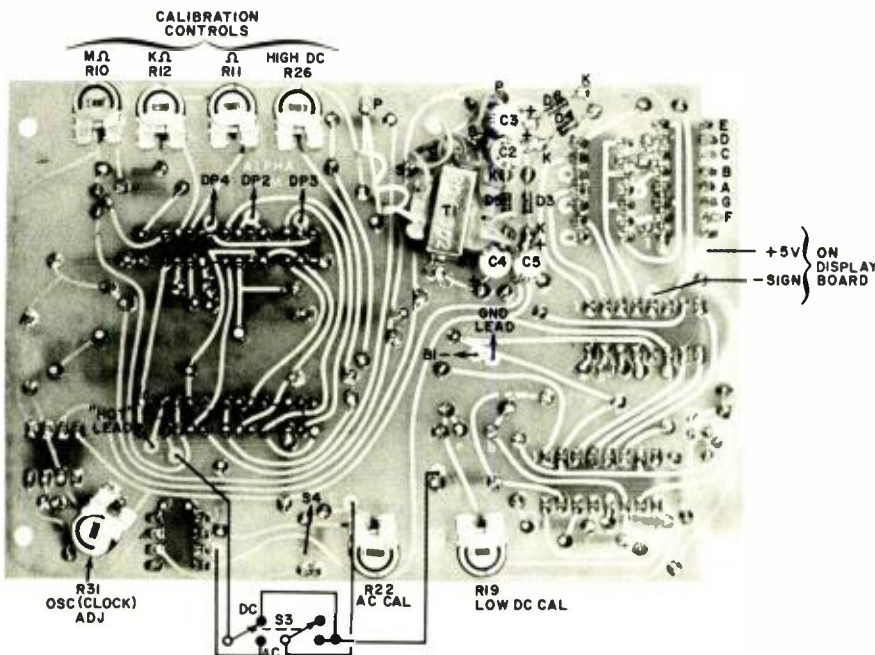
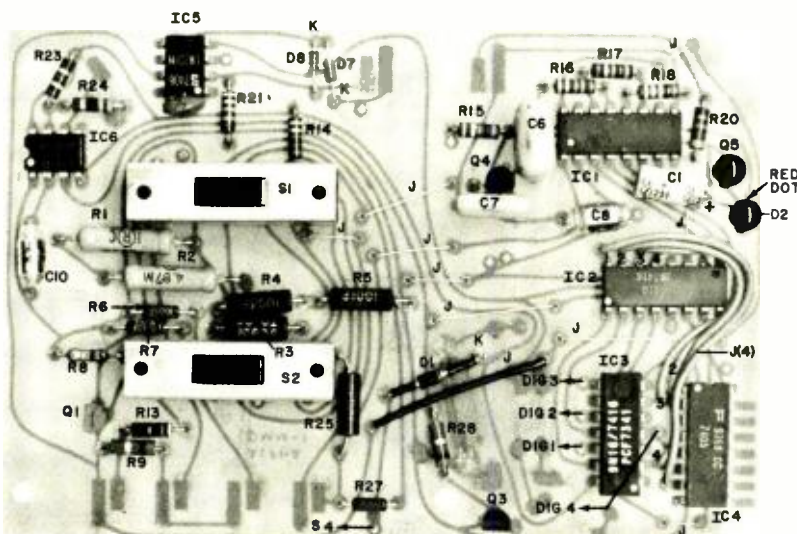

Fig. 5. Components mount on both sides of main board—foil side above, blank side below.



# BASIC DIGITAL LOGIC COURSE

## PART 3: FLIP-FLOPS

### AND HOW TO BUILD A VERY LOW COST COMPUTER TERMINAL

IN Parts 1 and 2 of our short course in digital logic, published in October and November, we discussed number systems, principles of logic, and some basic logic circuits. This

month we will talk about flip-flops and describe the design and construction of a very low cost terminal (VLCT) for use with computers.

Once you understand the material presented here, you should find that designing digital circuits—even complex ones—is mostly a matter of common sense and familiarity with what each element does.

**Flip-Flops.** The flip-flop is the basic memory circuit used in digital electronics. It has two stable states that can be simulated by the two-switch analogy shown in Fig. 1A. The switches are arranged in such a way that, if one is closed, the other must be open, with control circuits determining the states.

The logic diagram of a toggle flip-flop is shown in Fig. 1B. When a pulse appears at the toggle, or T, input, the Q and  $\bar{Q}$  (said "not-Q") outputs will change state. The small circle at the T

input indicates that, to toggle the flip-flop, the input must go from "high" (logic 1) to "low" (logic 0). The other two inputs are labelled P for preset and C for clear. These allow the flip-flop to be set to a specified condition no matter what was the previous condition. For example, if a 0 is applied to the P input, the Q output would be 0. Bear in mind that the two outputs are complementary; that is, if Q is at 0,  $\bar{Q}$  will be at 1.

Semiconductor manufacturers make at least 50 different types of flip-flops. Do not be intimidated by this number. The flip-flops are still flip-flops, and all you need to understand any specific one is its data sheet, which you can obtain from the manufacturer.

#### Designing a Computer Terminal.

Combining what you now know about flip-flops with what you learned in Parts 1 and 2, you have the knowledge

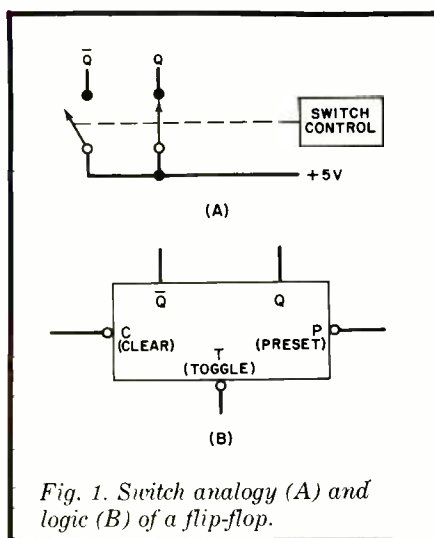

Fig. 1. Switch analogy (A) and logic (B) of a flip-flop.



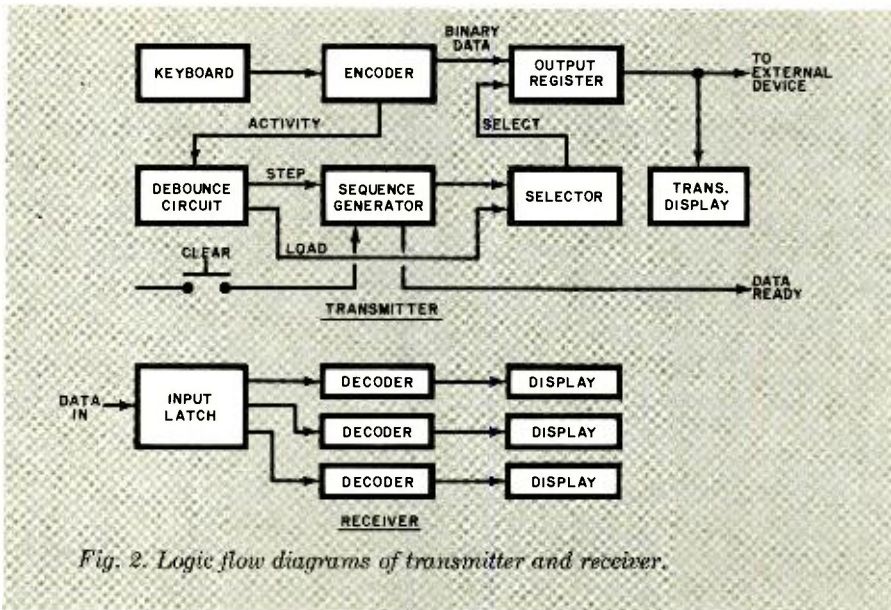

Fig. 2. Logic flow diagrams of transmitter and receiver.

needed for designing a VLCT. In the following pages, we will design a VLCT that will allow you to convert from octal to binary and back to octal, decimal, or hexadecimal logic. Not only will the VLCT prove instructive in terms of digital logic, it will also be invaluable for interfacing with other digital devices. (In particular, it can be used with the POPULAR ELECTRONICS minicomputer that will be introduced in the January 1975 issue.)

The VLCT performs seven functions: (1) converts the operator's octal input to binary format; (2) eliminates any bounce that might be present in the key switches; (3) loads the binary data into and retrieves it from a register and stores it until transmission; (4) determines where each piece of data goes in the output register; (5) transmits a "ready" signal after the third octal number is entered; (6) receives and stores binary data from the computer; and (7) decodes this computer data in either octal, decimal, or hexadecimal display format. The overall block diagram of the terminal shown in Fig. 2 should be consulted whenever any question concerning functions arises.

The complete logic diagram for the transmitter portion of the terminal is shown in Fig. 3. The terminal employs transistor-transistor-logic, or TTL, devices—by far the most widely used logic family. It has the following basic characteristics: a logic 1 is any potential level between 2.4 and 5 volts, and a logic 0 is any potential between 0 and 0.4 volt. A detailed discussion of TTL can be found in a number of books devoted to the subject, but a brief ex-

planation of how a typical TTL NAND gate works is on page 00.

**Keyboard Encoder.** In Fig. 3 the key switches labelled 1 through 7 are grouped together at the upper left, while the 0 key is located in the center of the diagram. NAND gates *NG1*, *NG2*, and *NG3* provide the encoding for key switches 1 through 7, while *NG4* detects the activation of any key.

Before any key switch is depressed, note that *NG1*, *NG2*, and *NG3* have a 0 output due to the 1 being applied to each of the four inputs. Note also that *NG4* has a 0 output as a result of the 1-level signals applied to its four inputs.

Now, to understand the logic used, assume that key switch 3 has been de-

*Front view of the computer terminal.*



pressed. When this happens, one of the inputs of *NG1* and *NG2* is placed at logic 0 by grounding. This forces both of these gates to have a logic 1 at their outputs. (A 0 output of a NAND gate can occur only when all its inputs are a logic 1.) Keyboard output lines *B0*, *B1*, and *B2* then have the following conditions:

$$\begin{matrix} B_0 & B_1 & B_2 \\ 0 & 1 & 1 \end{matrix} = 3_8 = 3_{10}$$

As you can see, the octal input has been converted to a binary code. Note also that the output of *NG4* has gone to a 1, signalling that keyboard activity has occurred.

Depressing key switch 0 causes the output of *NG4* to go to 1, indicating that keyboard activity has occurred. However, this signal will have no effect on *NG1*, *NG2*, or *NG3*, all of whose outputs remain at 0. If you were to read the binary number at *B0*, *B1*, and *B2*, it would still be 000 (binary zero). But there would be a signal from activity gate *NG4* to indicate that a switch closure has occurred.

**Debounce Circuit.** The problem with many keyboard switches is that they have a mechanical "bounce." This bounce must be allowed enough time to damp out before attempting to load data into the output-register flip-flops (*FF3* through *FF10*). This delay is accomplished in the debounce circuit in which *NG5* and *NG6* form an RS flip-flop—the simplest form of flip-flops. To understand its operation, you need to realize that only one input at a time can be activated by a 0. If a 0 is

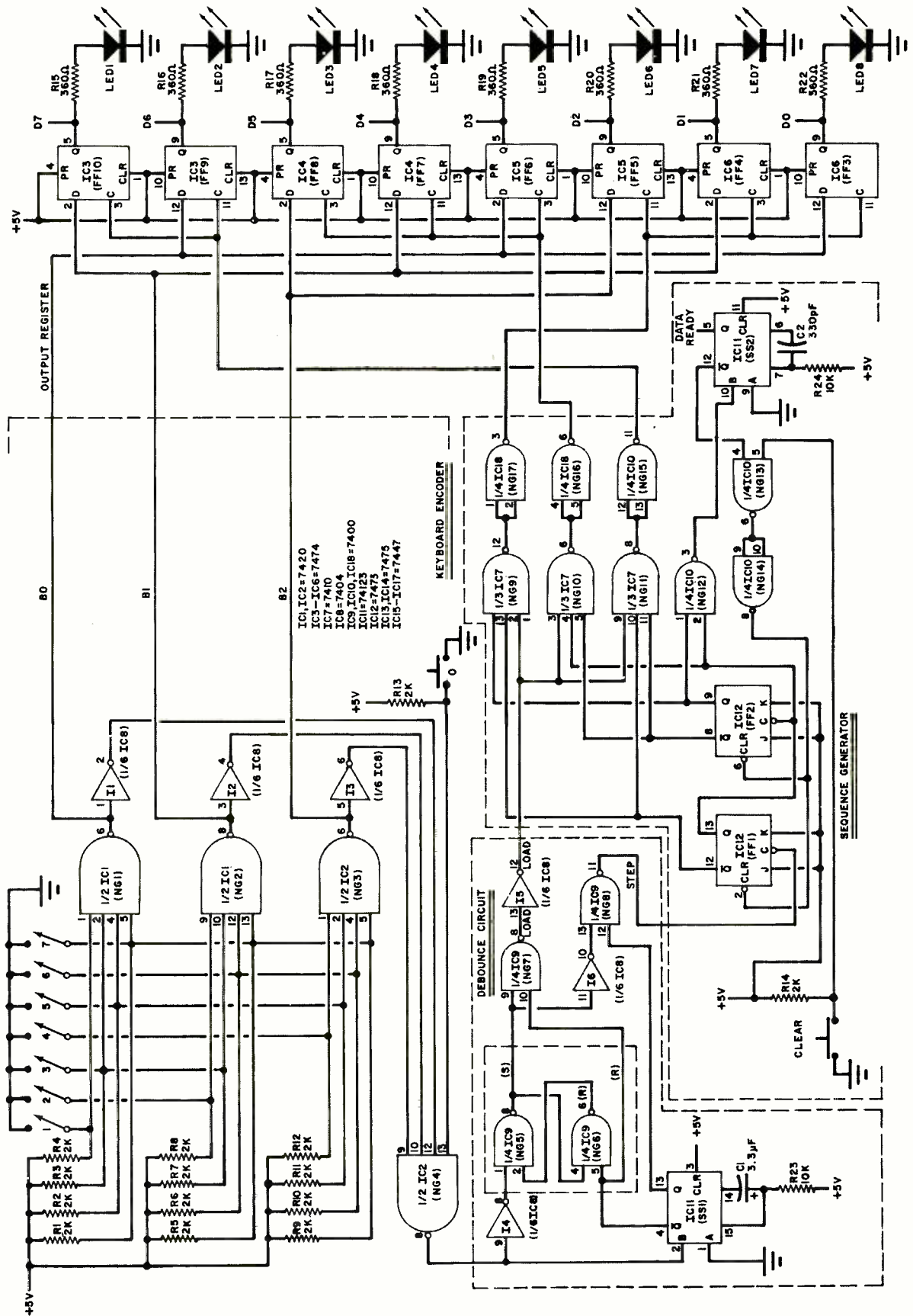



## PARTS LIST

- C1—3.3- $\mu$ F, 25-volt electrolytic capacitor  
 C2—330-pF disc capacitor  
 C3, C5—0.01- $\mu$ F, 1-kV disc capacitor  
 C4—1500- $\mu$ F, 16-volt electrolytic capacitor  
 D1 thru D4—1N4004 silicon rectifier  
 DIS1 thru DIS3—7-segment numeric LED display  
 F1—1-ampere fuse  
 IC1, IC2—7420 dual 4-input NAND gate integrated circuit  
 IC3 thru IC6—7474 dual D flip-flop integrated circuit  
 IC7—7410 triple 3-input NAND gate integrated circuit  
 IC8—7404 hexinverter integrated circuit  
 IC9, IC10, IC18—7400 quadrature 2-input NAND gate integrated circuit  
 IC11—74123 dual retriggerable monostable multivibrator integrated circuit  
 IC12—7473 dual JK flip-flop integrated circuit  
 IC13, IC14—7475 dual bistable latch integrated circuit  
 IC15, IC16, IC17—7447 BCD to 7-segment decoder/driver integrated circuit  
 IC19—LM309 5-volt regulator integrated circuit (Signetics)  
 LED1 thru LED8—Light-emitting diode (Monsanto RL-50 or similar)  
 R1 thru R14—2000-ohm, 1/4-watt resistor  
 R15 thru R22—360-ohm, 1/4-watt resistor  
 R23, R24, R27—10,000-ohm, 1/4-watt resistor  
 R25—15-ohm, 1/2-watt resistor  
 R26—47-ohm, 1/4-watt resistor  
 R28—100-ohm, 1/4-watt resistor  
 T1—8-volt, 1-ampere transformer  
 Misc.—Suitable enclosure; key-switch pad with 0-7, clear, and ready switches; red display filter; filter bezel; fuse holder; line cord; printed circuit boards; IC sockets (optional); insulated hookup wire; machine hardware; solder; etc.

Note: The following are available from MITS, Inc., 6328 Linn, N.E., Albuquerque, NM 87108 (Tel.: 505-265-7553; Telex: 660401): Main pc board at \$6.50; display board at \$5.50; kit of all IC's, pc boards, LED's, numeric displays, and assembly manual for \$38.00; complete kit, including power supply regulator and transformer, key-switch pad, hardware, case and filter bezel for \$57.00. **Copies of the pc foil patterns and component layouts can be obtained free upon request.**

Fig. 3. Complete logic diagram of the terminal is on opposite page.

applied to both inputs at the same time, the device will not operate as a flip-flop.

The activity line (output from NG4) goes to a logic 1 if any key switch is depressed. This signal is fed through inverter I4 to one of NG5's inputs. A 0 into NG5 generates a 1 at the gate's output, which is then fed to one of NG6's inputs. Assuming that the other input (pin 5) is also at 1, a 0 will appear at the output of NG6. If both inputs were allowed to go to 1, the RS flip-flop would remain as set by the previous 0. If a 0 is applied to NG6, while a 1 is applied to NG5, the device will flip, causing a 0 output to be generated at NG5 and a 1 output at NG6.

The mechanical-bounce switch problem occurs whenever a mechanical device is interfaced with digital electronics. The bounce time of the mechanical switch is very fast (say, 10 pulses during a 10-ms interval), but it is exceedingly slow from an electronics viewpoint, since each individual pulse can be detected. A debounce circuit, therefore, should be included to remove any extraneous pulses.

The debounce circuit employed in the VLCT consists of an RS flip-flop made up of NG5 and NG6 and a retriggerable monostable multivibrator (sometimes called a single-shot multivibrator), SS1. The SS1 circuit is basically a form of unstable flip-flop. When a trigger pulse is applied to it, the multivibrator changes states only for a period determined by an external-time-delay network, which in this case consists of C1 and R23 to yield a 10-ms delay. After the delay, SS1 switches back to its initial state.

Let us trace a signal through the debounce circuit. With a 1 coming from the output of NG4, the output of I4 is 0. This causes the RS flip-flop to change

states, with the S output going to 1. The logic-1 activity signal from NG4 is also fed to the B (trigger) input of SS1, causing the multivibrator to go into its unstable state for 10 ms and apply a 0 to the other input of the RS flip-flop—which is a violation of the rules for this circuit. But the violation can be disregarded because SS1 applies this signal for only 10 ms before control reverts back to the activity input, which sets the S output of the flip-flop to 1. This signal is then applied to one of the inputs of NG7, while the other input comes from SS1 which, after 10 ms will apply a 1 to completely enable this gate and generating a 0 at its output.

The 0 output is inverted by I5 to produce the "load" signal for the output register. It is important to note that the load command did not occur until 10 ms after the keyswitch was originally closed. This assumes that the switches will not be bouncing for more than 10 ms. If there were any bouncing after the 10-ms delay, a longer time constant would be needed at SS1 by selecting appropriate C1 and/or C2 values.

When the key switch is released, SS1 is reset and a "step" pulse is generated by NG8 for use by the sequence generator.

**Sequence Generator.** To load eight bits of data into the output register with an octal keyboard, three switches must be operated because each key depression generates only two or three bits. For example, assume you want to load the octal number 365 into the output register. The first step is to load the 3 into the first two bits, the 6 into the next three bits, and the 5 into the bottom (least-significant) three bits. Note that the first key depressed can use only two bits. This means that

### IC POWER CONNECTIONS

IC No.	Type	V <sub>CC</sub>	Gnd	Function
1,2	7420	14	7	Dual 4-input NAND gate
3,4,5,6	7474	1,4,10,13,14	7	Dual D flip-flop
7	7410	14	7	Triple 3-input NAND gate
8	7404	14	7	Hex inverter
9,10,18	7400	14	7	Quadrature 2-input Nand gate
11	74123	3,11,16	8	Dual retriggerable multivibrator
12	7473	14,3,4,7,10	11	Dual JK flip-flop
13,14	7475	5	12	Bistable latch
15,16,17	7447	3,4,5,16	11	BCD-7-segment decoder
19	LM309		3	5-volt regulator

a 3 is the largest digit allowable on the first key depression. The next two key positions can be any octal number.

The sequence generator consists of FF1, FF2, NG9 through NG14, and SS2. Let us assume that at the beginning of the cycle FF1 and FF2 are both cleared so that the Q output of each is 0 and the  $\bar{Q}$  output is 1. Under these conditions, NG11 has a 1 at two of its three inputs. Now, when a load pulse occurs, caused by a key switch depression, the third input goes to 1 and the output of NG11 goes to 0. After inversion by NG15, a clock pulse is applied to FF9 and FF10 to cause the data on B0 and B1 to be loaded into FF9 and FF10.

When the key switch is released, a "step" pulse is generated at NG8 and is fed to the C (clock) input of FF1, causing this flip-flop's Q output to go from 0 to 1; FF2 will be unaffected because the change is positive-going. When the next key switch is depressed, NG10 will be the gate selected. This will load FF6, FF7, and FF8 with data from the keyboard. When the switch is released, the step pulse will again cause FF1 to change states. But this time, the change will be from 1 to 0 at the Q output.

The Q output of FF1 is now 0 and the Q output of FF2 is 1. This selects NG9, which will load FF3, FF4, and FF5 on the next key switch depression.

When the 3 key is released, the step pulse will again cause the FF1/FF2 counter to step, resulting in a 1 on

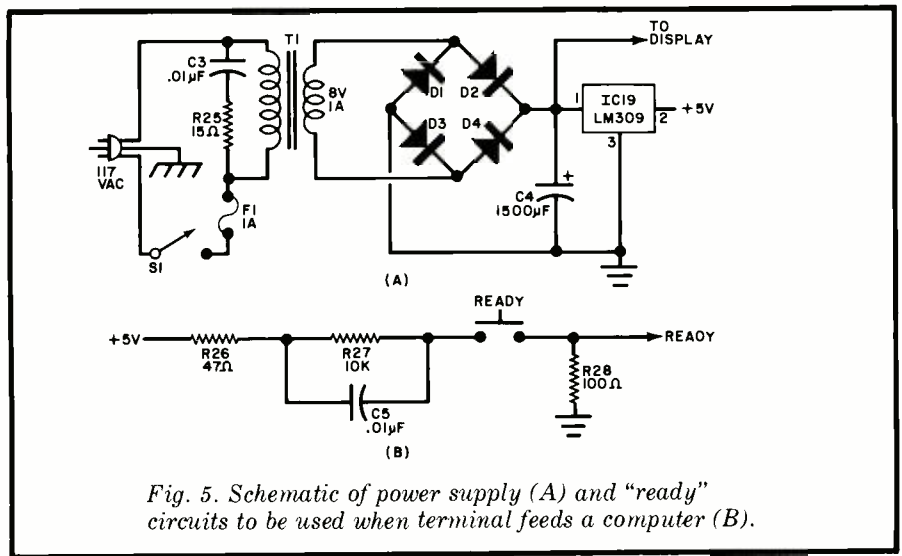

Fig. 5. Schematic of power supply (A) and "ready" circuits to be used when terminal feeds a computer (B).

both Q outputs. This is detected by NG12 and causes SS2 to be triggered for 1 μs. Then SS2 clears FF1 and FF2 and transmits a "data-ready" signal to the computer or other digital devices connected to the output. The CLEAR button can be used to reset the counter in the event an error was made during entry.

**Output Register.** The output register consists of FF3 through FF10. These eight flip-flops store data until the three key entry sequences are completed. They are called data flip-flops, or D flip-flops. Their function is to load the bit present at the D input whenever the C (clock) line goes to 1. This data then appears at the Q out-

puts. The flip-flops ignore anything on the D inputs unless the clock pulse is present.

The output display consists of light-emitting diodes LED1 through LED8. The LED's glow whenever their respective data lines are at logic-1. This provides a binary readout. It is these data lines that are coupled to the external computer or other digital device.

**Receiver.** Shown in Fig. 4 is the receiver portion of the system, consisting of latches IC13 and IC14 (each with four D flip-flops for a total of eight flip-flops); IC15, IC16, and IC17 4-bit binary to 7-segment decoders; and DIS1, DIS2, and DIS3 7-segment display readouts.

Assume that the transmitter drives the receiver directly (receiver inputs directly connected to transmitter outputs). Each time the transmitter receives three key switch operations during number entry, it transmits a "data-ready" signal to the receiver. This signal is coupled to the LOAD inputs of quadrature latches IC13 and IC14 and causes the eight input signals to be read into the two latches and stored. The outputs of the latches are connected to the 7-segment decoders, each of which consists of approximately 80 gates arranged to convert a 4-line binary signal into a 7-segment drive signal for a numeric readout on the displays.

Since the system under discussion is octal-based, one of the inputs of each decoder is not used. Therefore, each readout displays only the digits 0 through 7. If desired, the fourth input can be used, resulting in a full decimal and hexadecimal format.

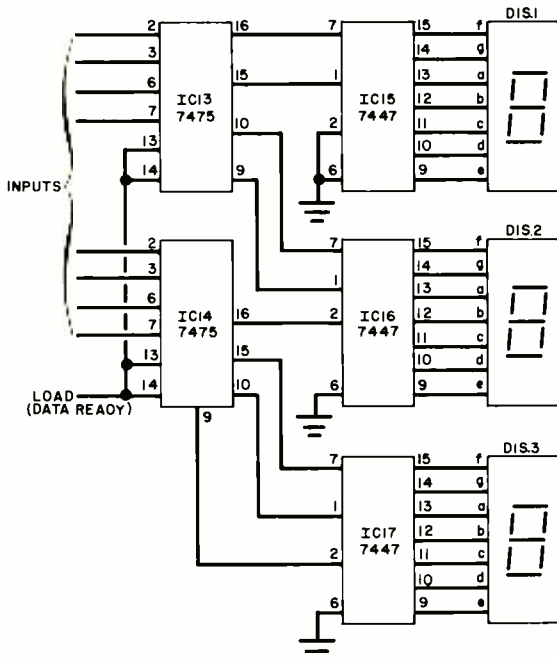

Fig. 4. Complete logic of the receiver with 7-segment readouts.



## HOW TTL WORKS

Transistor-transistor logic (TTL) is a positive-logic system. The circuit of a typical gate, in this case one gate in a 7400 quadrature NAND IC, is shown below.

If neither input of the gate is grounded, or both are connected to a positive-voltage source, the base-collector junction of  $Q1$  is forward biased so that current can flow through  $R1$  and the B-C junction of  $Q1$  into the base of  $Q2$ . Transistor  $Q2$  goes into saturation, producing a voltage drop across  $R3$ . This provides a bias to turn on  $Q3$  and at the same time the voltage at the collector of  $Q2$  drops.

For  $Q4$  to conduct, its base must be at

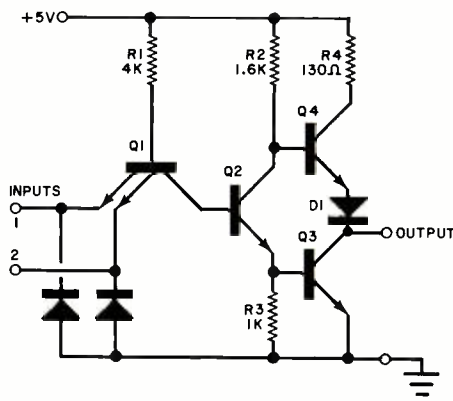

about 1.8 volts. The values of  $R2$  and  $R3$  are selected so that, when  $Q2$  is conducting, the voltage drop across  $R3$  is high enough to turn on  $Q3$ . But the voltage at the collector of  $Q2$  is not high enough to cause  $Q4$  to conduct. The "0" output is then only a junction away from ground (through  $Q3$ ). Note that in this state, the output (via  $Q3$  to ground) can sink a reasonable amount of current—approximately 16 mA. This is why TTL is sometimes referred to as "current-sinking logic."

If one or both inputs of the gate is grounded,  $Q1$  conducts and its collector voltage drops to near ground potential, cutting off  $Q2$ . Almost no current flows through  $Q2$ 's C-E junction, and the base voltage of  $Q3$  (voltage drop across  $R3$ ) is close to zero. Transistor  $Q3$  then forms an open circuit. The collector of  $Q2$  approaches +5 volts, which causes  $Q4$  to conduct. The output (1) is then a function of  $R4$ , the C-B resistance of  $Q4$ , and the forward resistance of  $D1$ . The output voltage is then about 3.5 volts.

In the regular TTL family, about 1.6 mA flows through any input grounding circuit. In the event grounding is through a resistor, there will be a voltage drop across the resistor. Because the maximum permissible low-state input voltage is about 0.8 volt, the ex-

ternal resistor cannot have a value in excess of 500 ohms, and any low input connection must hold the input below 0.8 volt.

In some TTL devices, a protective diode is connected from each input to ground. If a negative voltage (with respect to ground) greater than 0.6 volt is accidentally applied to either input, the diodes conduct to protect the gate. The protective diodes also prevent high-frequency ringing when long connection leads or sharp risetime pulses are used.

The truth table for a two-input NAND gate is as follows:

INPUT		OUTPUT
1	2	
0	0	1
1	0	1
0	1	1
1	1	0

The 0's and 1's represent "low" or logic 0 and "high" or logic 1 conditions, respectively. Note that the only time the output of the gate changes state from its normal 1 output condition to 0 is when both inputs are "enabled" (have a 1 applied to them simultaneously). If neither input, or only one input, is enabled, the output of the gate remains at 1.

**Power Supply.** Shown in Fig. 5 is the power supply for the VLCT. The dc voltage from  $T1$  and the bridge rectifier consisting of  $D1$  through  $D4$  is applied to 5-volt regulator  $IC19$ . (The +5-volt and ground lines go to the IC's as shown in the table.) The regulator is current and temperature protected. Capacitor  $C4$  filters the output of the bridge.

The VLCT requires about 500 mA of regulated current for the logic elements and about 150 mA of unregulated current for the LED displays, both at 5 volts dc.

**Construction.** The VLCT is assembled on two double-sided printed circuit boards, too large to be published. The actual-size foil patterns and component layouts can be obtained by writing to the supplier noted in the Parts List. Carefully install the components on the boards exactly as shown in the component-placement diagrams. Pay particular attention to the polarities of the electrolytic capacitors, LED's, and rectifiers and the orientations and indexing of the integrated circuits and 7-segment displays.

When soldering the component

leads to the pc boards, use a low-power soldering iron and fine solder. Be particularly careful to avoid solder bridges between closely spaced foil conductors. Note also that the use of sockets or Molex Soldercons<sup>®</sup> for the IC's and 7-segment displays is recommended but not absolutely necessary to assembly.

It is good practice to handle the IC's as little as possible and to install them as the last step in construction.

The terminal should be housed in a case that allows the display board to be viewed easily through some form of window. Each LED (indicators for the output register) should be identified by digit on the cover plate or lens filter as shown in the photo.

Power transformer  $T1$  should be mounted on the floor or bottom plate of the case, while regulator  $IC19$  goes on the rear wall, its case exposed to the outside.

**Checkout.** The checkout procedure consists of making certain that the transmitter is connected to the receiver and that power is delivered to both circuits. Once it is verified that power is properly delivered to the cir-

uits, depress three keys on the transmitter and note that the displays indicate the proper sequence. This procedure checks all transmitter and receiver logic. ♦



"Now, what do they mean by female connection."

# PAY TV

## PRESENT AND FUTURE

BY SHEL KAGAN

**“FREE” TELEVISION** (paid for by the advertisers) has coexisted with various forms of “pay” (by the viewer) TV ever since cable TV or Community Antenna Television (CATV) was introduced some twenty years ago. Cable TV was originally conceived to benefit homes nestled in mountainous areas, where signal reception was extremely poor. (The system got its name from the fact that 75-ohm coaxial cable was—and still is—used to bring signals from the central antenna to individual receivers.)

It is estimated that there are about 2500 cable systems in operation in the U.S. They serve approximately 8 mil-

lion homes, roughly 12% of those having TV receivers. Subscription rates for cable TV service have stabilized at around \$6 per month, plus an installation charge.

**Pay TV.** Though the user pays for cable TV in order to receive free broadcast TV, the words “pay TV” now connote special programming that is not available on standard broadcasts (prize fights, blacked-out football games, dramatic performances, etc.). The signals may come by cable or “over-the-air.” We will consider the cable systems first since, at the moment, they are more preval-

ent; though, in the long run, over-the-air may prove to be more important.

Special programming might be called second-generation cable TV. Recent technological advances have increased its desirability by providing up to 30 channels instead of the original 12. Cable TV systems also originate some local programs—including civic meetings, news, and weather—and they can “import” signals from distant stations (though the FCC has a complex set of rules governing this practice).

**Pay for What You Want.** The third generation of cable TV is a form of letting the subscriber choose programs he wants and pay an additional charge for them. In 1972, a company called Home Box Office leased a cable channel in Allentown, Penn. and began to show first-run, uninterrupted motion pictures and sports events that were not available on broadcast channels and ordinary cable-TV systems. For \$6 a month, Home Box Office offered this program fare, which was received on Channel H by means of a special converter that was designed to supplement the 12-channel converter installed by the local cable-TV company.

About the same time, other pay-TV systems were being introduced. Optical Systems introduced its “Channel 100” operation in San Diego. First-run films and basketball games were among the offerings in the program lineup. Channel 100’s home terminal was more complex than a converter, consisting of an optically-triggered gate. On the top of the unit was a slot into which a viewer inserted his individual cardboard credit card that had a series of holes punched in it. The hole pattern formed the viewer’s own

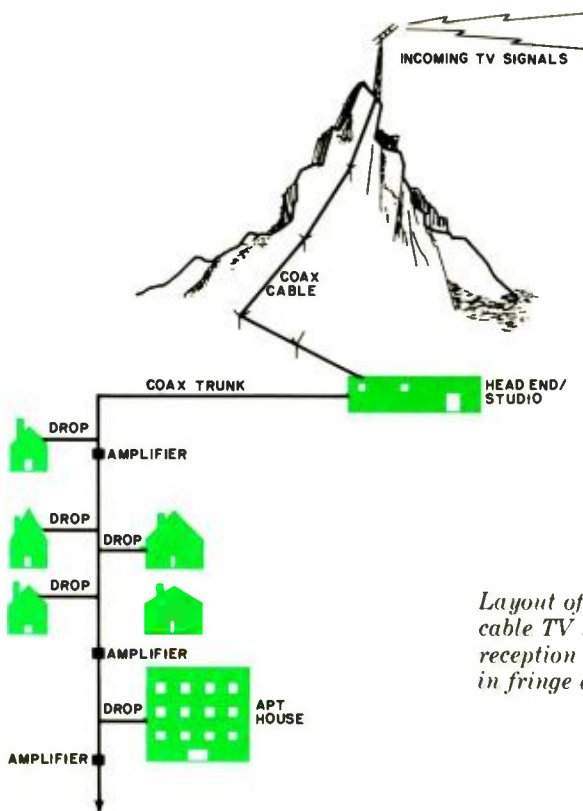

*Layout of the classic cable TV system to provide reception to customers in fringe areas.*



unique combination, while the terminal was designed for only that combination and no other.

Light beams passing through the credit card's hole pattern unlocked the gate and allowed the decoded program to enter the receiver from the cable system. Customers paid the usual \$6 per month for the cable service, plus \$1 extra for maintenance. A refundable \$20 deposit for the gate was also paid upon installation.

Optical Systems has since terminated the use of the optical gate in which card alignment was too critical to assure reliable service. The company had TRW, its hardware designer, produce a new unit that uses a tone pad on which the viewer punches his code. Both the card and tone pad are compatible with standard converters.

Based in Sarasota, Florida, Theater-Vision developed a box that used actual theatre-type tickets. Viewers purchased the tickets through the mail and selected outlets. Inserted into the box, the tickets were shredded to prevent re-use, and the decoder was "unlocked," unscrambling the program. Viewers paid for only the shredded tickets (unused tickets could be returned for credit).

Cooperating with Tele-Prompter Cable Corp., Magnavox conducted a short-term experiment in San Bernardino, California called IDEM (for Interactive Data Exchange Module). When a viewer elected to watch a program, a digital pulse was sent from the viewer's terminal to an IDEM mounted on a pole outside his home that served about 30 customers. Once a month, the program and billing information was transferred from the IDEM to a cassette tape and brought to the central cable office for tabulation.

Although technology has provided many different methods of distribution, cable pay TV has yet to settle on a standardized system. Much of the engineering effort has been directed toward cleaning up distortion on the pic-

ture signal. Many systems are prone to a condition known as "skew" or "flagging" in which the top 3 in. (7.62 cm) of the picture leans or waves, usually to the right. This is the result of uneven passage of the program tape past the capstan of the videocassette player in the pay TV studio, causing improper contact with the playback head. It is similar to flutter in audio tape transports. Dr. Peter Goldmark, inventor of the LP disc and stereo, invented a skew corrector that provides one solution to the problem. Another solution was to ventilate the closets in which the transports were mounted to reduce the heat buildup that altered the operation of the transport capstans.

The skew problem plagued pay TV systems in hotels most severely, since there was usually no technician on duty to track down the problems. Introduction of the remedies mentioned above alleviated the problem, allowing the growth of the hotel pay TV market. The largest hotel TV company, Trans-World Communications, has wired about 25,000 rooms across the country. Films are transmitted to each hotel over leased telephone lines from studios that look like network control rooms. Using 1-in. (2.54-cm) videotape, Trans-World produces a picture that is visibly superior to that obtained from 3/4-in. (1.91-cm) videocassettes. When a guest wants to see a program, he simply calls room service, which unlocks the decoder that sits atop the TV receiver and bills the guest \$3.

Computer Television is currently wiring most of the units of the Hilton hotel chain for pay TV. Similar to the Trans-World system, Computer Television's system will offer two channels of films for \$3 per program. Another form of hotelvision, sponsored by such firms as First Cine-Tel and MGM's Metrovision, offers films continuously at no charge—at least in theory; usually, room rates have been increased by 50¢ to \$1 to cover equipment and film rental costs. The slight additional cost will hardly be noticed in these days of inflation.

**Rate Scheduling.** The most heated controversy in the payvision ranks today is the route to choose in scheduling programs. Presently, except for two limited systems, all pay TV is on a per-channel basis; programs run continuously and monthly payment is a flat rate that is independent of the

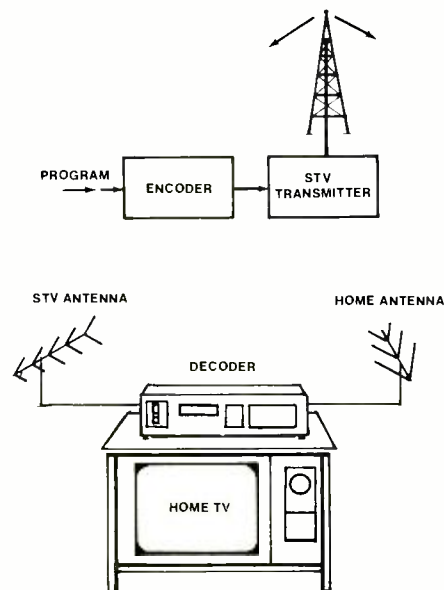

*Diagram shows how a typical subscription system works.*

number of programs viewed. In the per-program scheme, the subscriber pays for only those programs viewed. The problem with the per-program scheme is that it requires some way for the subscriber to communicate his request to the head end to activate his channel at the proper time.

In the Cablerama (Columbus, Ohio) and ViaCode (Smithtown, N.Y.) systems that offer per-program scheme options, some two-way capability is employed. In the ViaCode system, the subscriber dials the head-end operator on the telephone and gives a special code number. The engineer punches the code into a mini-computer that unscrambles the individual TV receiver and bills the subscriber in the process.

Eventually, as traffic builds up, the man at the head end will be replaced by the computer itself. The computer will receive thousands of calls at one time, decipher the codes, turn on the receivers, and bill the subscriber, all in a matter of microseconds.

In the Cablerama system in Columbus, true two-way operation is featured. The subscriber simply pushes a button on the converter to activate a switching unit at the head end, sending the signal down the line. The problem, however, is that signals going back up the cable have a tendency to run into noise buildup. Even with bypass filters that jump around cable amplifiers, the loss in gain is so great, even for a digital pulse, that the range of two-way operation has been limited to only a few blocks.

*Blonder-Tongue decoder for subscription TV.*



# The better the the better you

Compare  
what we  
offer in kits  
and lessons.  
Compare  
our  
tuition

COMPU-TRAINER



TUBE & TRANSISTOR  
TESTER

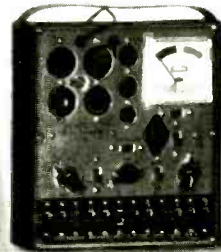

SOLID STATE  
OSCILLOSCOPE

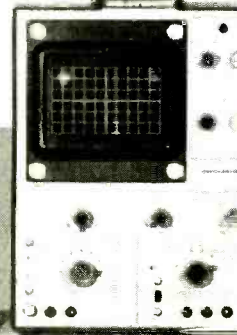

DIGITAL  
MULTIMETER

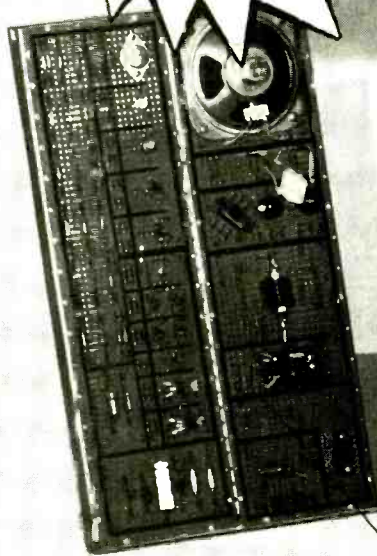

ELECTRO-LAB

NTS DIGITAL GR-2000 SOLID STATE  
COLOR TV WITH 315 SQ. IN. PICTURE  
AND VARACTOR DIGITAL TUNING

TROUBLESHOOTER  
VOM

As an NTS student you'll acquire the know-how that comes with first-hand training on NTS professional equipment. Equipment you'll build and keep. Our courses include equipment like the 5" solid-state oscilloscope, transistor and tube-tester, vector monitor scope, 74 sq. in. B&W TV, and solid state stereo AM-FM receiver. The unique NTS **Digital GR-2000 color TV** with first ever features like silent varactor diode tuning; digital channel selection, (with optional digital clock,) and big 315 sq. in. ultra rectangular screen. This is just a sampling of the kind of

better equipment that gets you better equipped for the electronics industry. This electronic gear is not only designed for training; it's field type — like you'll meet on the job, or when you're making service calls. And with NTS easy-to-read, profusely illustrated lessons you learn the theory behind these tools of the trade. **Choose from 12 NTS courses** covering a wide range of fields in electronics, each complete with equipment, lessons, and manuals to make your training more practical and interesting.

Simulated TV reception



# equipment will be equipped.

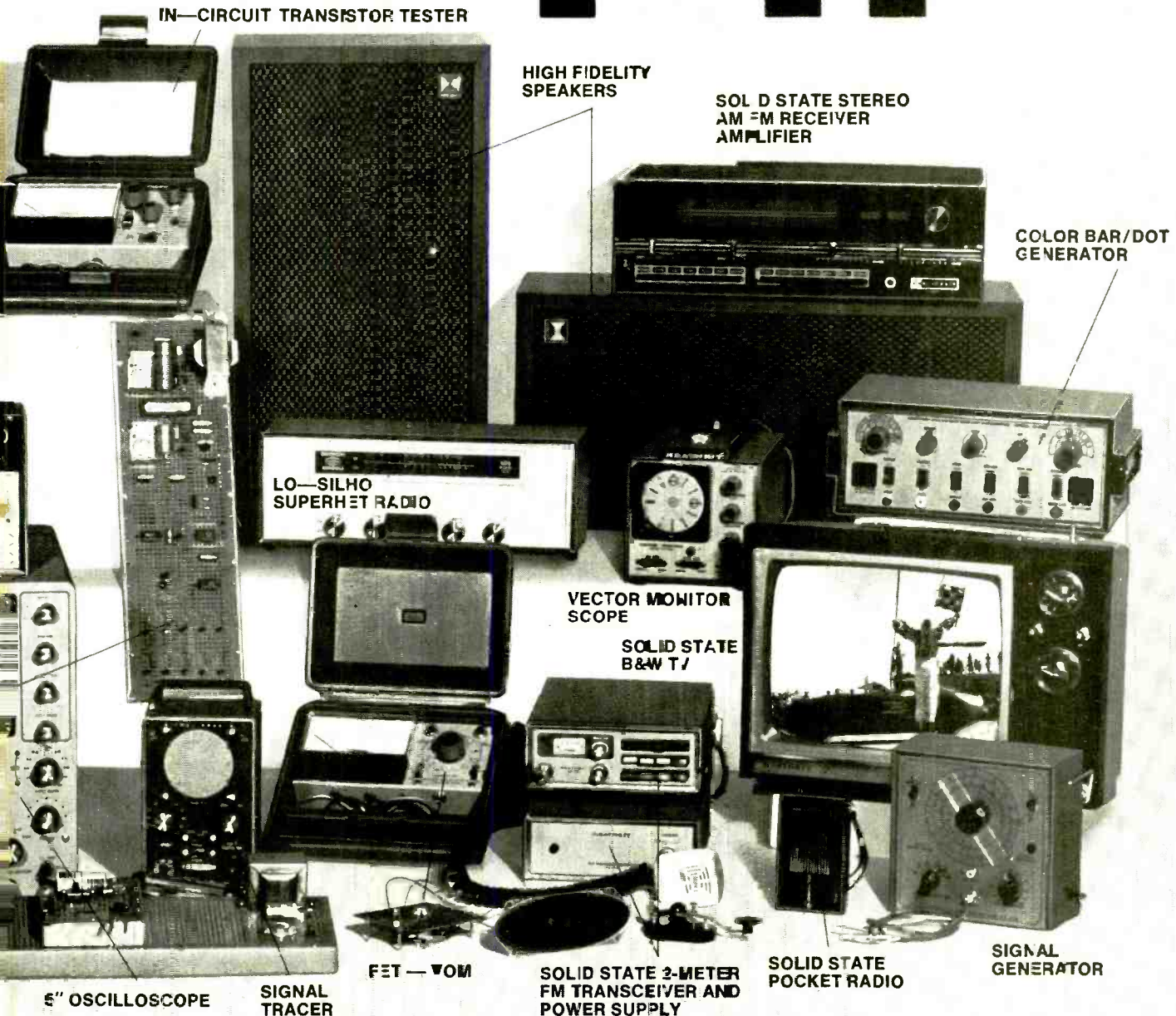

Compare our training; compare our tuition. We employ no middlemen because we need no salesmen. We believe you have the right to make your own decisions based on the facts, and you'll find these all spelled out in our catalog mailing. Lessons, kits, and experiments are described in full color. Most liberal refund policy and cancellation privileges — it's all in writing. And our low tuition is another big advantage. No frills, no commissions to pay. This means lower tuition for you. You receive solid training value. NTS puts more into your training, so you get more out of

it. Make your own decision. Mail the card, or write if card is missing. There's no obligation, ever, and no salesman will call.

**Approved for Veteran Training.** Get facts on new 2-year extension.

**NATIONAL TECHNICAL SCHOOLS**

TECHNICAL-TRADE TRAINING SINCE 1905  
Resident & Home Study Schools  
4000 South Figueroa St., Los Angeles, Calif. 90037

**Fourth Generation.** Two-way cable, which is undoubtedly the "fourth generation" of the industry's development, is referred to as "blue sky" because it seems to be far off in the future. Some provision has been made for two-way operation systems built with a "shadow" cable for upstream communication. But since this doubles cable expenditures, it is not a long-term solution.

What has yet to be developed is what some engineers call the "handshake" system in which signals can be passed up- and downstream without interfering with each other. Once this can be accomplished, the blue-sky idea will become a reality and all manner of services become possible. Not only will you be able to order movie viewing at will, but your TV receiver will become your morning newspaper, airport arrival/departure schedule, department-store catalog, fire and intruder alarm, and even your remote "eyes" in your local library.

A small hand-held unit, much like today's electronic calculators (Jerrold Electronics has already developed the prototype) will enable each household to order merchandise and pay bills by punching up the code numbers on the control unit.

**Over-the-Air.** The first over-the-air pay-TV format was called "subscription television," or STV. In some quarters, STV is given higher marks than cable pay TV, simply because there are no cables involved. It has been predicted that 1-million homes will be watching some form of STV by 1976.

Basically, STV puts out a scrambled signal that can be decoded only by a box connected to the TV receiver's antenna terminals. It in no way affects any other broadcast signal.

Of the several proposed methods for transmitting STV, two are slated to go on the air at about the time you are reading this. The system devised by Blonder-Tongue Labs will transmit into New York City and environs from a Newark, N.J. transmitter. The encoding circuits at the transmitter suppress the horizontal and alter the vertical syncpulses. This causes the received picture to have a continuous random horizontal tear with a 10-Hz vertical oscillation. The program's sound is placed on a sub-carrier frequency, leaving the audio channel clear for a continuous announcement of what program is available.

In the home, the decoder is acti-

vated by a single button that restores the original signal. Each time the decoder button is pushed, a real-time ticket is generated by an internal strip printer. The ticket, marked with the program identification number and price, is taken from the box and mailed in with the monthly payment.

Telesat, another STV broadcaster, will be operating a 5-megawatt transmitter to cover a 50-mile area around Milwaukee, Wisconsin. The decoders for the system will rent for \$5 per month, while estimated average program cost will be \$2.50 per selection.

The potential interest in such an operation was investigated by a Roper Organization poll taken last year. The study indicated that 24 percent of those people queried would pay up to \$45 a month for programming not available on "regular" TV. Considering the current number of homes in the U.S. with TV receivers (estimated at 66-million), the total revenue from pay TV could amount to \$8.5-billion a year—more than double the total an-

nual amount of advertising revenues broadcast television receives annually.

The only possible limitations on STV arise from FCC regulation. The format is allowed only one station per market. With most of the vhf broadcasters already locked into either network or network-affiliated programming, that leaves only the more limited uhf stations available to carry the programming. Furthermore, STV operators are restricted to a limited amount of hours per day for their pay programming. The rest of the time must be in the "clear." With such constraints, it will be more difficult for STV to establish itself in the face of cable-TV's head start.

Over-the-air proponents, however, are staunchly optimistic. Licenses are pending for all major cities, with Los Angeles, New York, Philadelphia, Milwaukee, and Chicago the likeliest first locations.

**Where Pay TV Stands.** Recently, broadcast networks have again put pay TV under fire. The networks appear to live in fear that pay TV will siphon away their programming, even though FCC rulings strictly forbid pay-TV companies from using any programming that is presently in the domain of "free" TV. Pay cable will undoubtedly survive the broadcast attack because studies have revealed that where it is available, pay TV has been welcomed by people who are willing to pay a little extra for uninterrupted, uncut movies that can be seen in the comfort of their own living rooms.

All told, there are currently more than 40,000 home TV receivers and some 60,000 hotel rooms wired into various types of pay systems. This is a modest beginning to be sure. But it is an impressive one in the light of the fact that the entire industry is little more than a year old. The demand for pay TV increases daily and shows no sign of slackening.

The long-awaited Office of Telecommunications Policy Report, issued in January 1974, advocated the removal of restraints on pay and cable TV. While the restraints might not be removed immediately, the report's optimistic approach to the future of pay TV means that all of us might someday have a living room that will be a combination library/shopping center/movie theatre/sports arena—the possibilities are virtually unlimited. ♦

### PAY-TV COMPANIES

The following is a partial list of the pay-TV companies now in operation:

#### Private-Home:

- American Multi-Cinema (Columbus, Ohio)
- American Video (Fort Lauderdale, Fla.)
- Cinca Communications (Long Beach, San Clemente, and Escondido, Calif.)
- Digital Communications (Pensacola and Palm Beach, Fla.; Decatur, Ga.)
- Home Box Office (Allentown-Bethlehem, Wilkes-Barre, Hazelton, and Stroudsburg, Pa.; Ithaca, Mt. Vernon, Babylon Village, and Vestal, N.Y.)
- Optical Systems (San Diego and Santa Barbara, Calif.; Toledo, Ohio; Harrisburgh, Pa.; Wayne, N.J.)
- Telecommunications, Inc. (Hamilton, Ohio)
- TheatreVision (Sarasota, Fla.)
- Warner Cable (Reston, Va.; Pottsville, Warren, and Clearfield, Pa.; Coos Bay, Ore.; Winter Haven, Fla.; Fayetteville, Ark.; Pittsfield, Mass.)
- Viacom (Smithtown, N.Y.)

#### Hotel:

- Adams-Russell Corp.
- Athena Communications
- Computer Television
- Digital Communications
- First Cine-Tel Corp.
- Metrovision
- Trans-World Communications
- Transcom



*POPULAR ELECTRONICS examines the state of high-fidelity components as we move into 1975. Authoritative reports by respected authors in the audio field explore equipment trends.*

RECEIVERS, AMPLIFIERS, AND TUNERS .....	51
FOUR-CHANNEL MATRIX SYSTEMS .....	53
RECORD PLAYING EQUIPMENT .....	55
TAPE RECORDERS .....	57
SPEAKER SYSTEMS .....	59

# SPECIAL REPORT ON HI-FI

## RECEIVERS, AMPLIFIERS AND TUNERS

BY LEONARD FELDMAN

**A**S IF to reinforce the unchallenged conviction that 1975 will be a good year for hi-fi sales (in spite of inflation), the major electronic component manufacturers offer an ever-expanding choice of the electronic modules that make up a hi-fi system.

Although the preferences of most buyers of hi-fi components are still the all-in-one receivers, which offer certain economies because of the single power supply and one-piece chassis construction, a surprising number of manufacturers are introducing or re-introducing a variety of separate tuners, integrated amplifiers and even separate preamplifier and basic power amplifier units, in wide price ranges. Generally, the potential purchaser of a hi-fi component system in 1975 can expect to pay from 10 to 15 percent more for electronics than he would have a year ago. Unlike other commodities, the increase in prices stems not so much from rising parts costs (often significantly offset by the increased use of integrated circuits which combine the functions of many transistors and passive components into a single chip), but from the addition of an increasing number of control and convenience features.

**Receiver Trends.** Not too long ago, a receiver was considered to be "high powered" if it could produce 50 watts of continuous power per channel when driving 8-ohm speaker loads. This year there are top-powered receivers that produce 100 watts per channel, while retaining reasonable physical dimensions, fully protected output circuitry, and complete thermal stability.

But high power alone is not the sole justification for spending \$600 or even \$700 for a two-channel integrated receiver. In the case of some top models, it becomes increasingly difficult to differentiate between the performance specifications and extra control features of these self-contained units and separate amplifier/preamp/tuner systems of recent vintage.

For example, the lowly tape-monitoring circuit conceived originally as a handy "circuit interruption point" for owners of three-head tape decks, has taken on new importance. Tape monitor "in" and "out" jacks provide a convenient access point for connection of such diverse outboard accessories as equalizers (which offer more refined control of frequency response often through the use of octave-by-octave or even third-octave-by-third-octave levers or controls.) Dolby noise reduction accessories (or similar devices manufactured by dbx and others) and, of course, matrix 4-channel decoders with various degrees of separation logic. As a result, even low-cost receivers are now equipped with more than one set of tape monitoring facilities.

Some receivers, for example, have as many as four sets of tape monitoring jacks. These pairs are specifically labelled for certain applications (such as "4-channel" and "Dolby NR"), but are no different from an ordinary circuit interruption point. The growing popularity of tape recording (and the improved performance of both cassette and open-reel tape decks) has also given rise to multiple tape jacks with switching arrangements that permit recording one tape deck from another, often while listening to still another program source.

Multiple tone controls (beyond the conventional bass and treble knobs) are showing up on receivers, too. Where such niceties as variable crossover point selection, midrange controls, and even segmented tone controls (in which five or more knobs or levers divide up the audio spectrum for finer adjustment) were once found only on integrated amplifiers or preamplifier chassis, such arrangements are now appearing on the front panels of the new breed of receivers.

Almost all of the major receiver manufacturers have opted for direct-coupled output circuitry which eliminates the need for the coupling capacitors between the output stages and the loudspeakers. Manufacturers employing such circuitry maintain that the improvement in low-frequency damping and power bandwidth is worth the somewhat higher cost entailed in providing dual-polarity voltage supplies required by this configuration.

More and more IC's are finding their way into the new receivers in such stages as i-f sections, complete AM tuners and phono preamplifiers, although critical output circuits continue to rely on discrete transistors. It is now just as likely that sophisticated single-IC phase-locked loop circuitry will be found in the multiplex section of a receiver as in separate tuners, so that receiver FM stereo performance (channel separation, low distortion, and long-term stability) is hardly distinguishable from that obtained with the "separates."

**Tuner Trends.** Faced with the growing sophistication in receiver designs, manufacturers of separate tuners (many of whom are engaged in receiver manufacture) have had to add features and performance to their products in order to justify their existence as separates. Having reached what amounts to the ultimate in sensitivity (there is a limit as to how few microvolts of signal are needed to produce a marginal signal-to-noise ratio of 30 dB), tuner designers have concentrated their efforts on lower distortion, greater circuit stability and better capture ratios and selectivity. Since the distortion of received FM signals is greatly dependent upon accuracy of tuning, major efforts have been devoted to developing very accurate tuning schemes.

The digital-readout, frequency-synthesizing AJ-1510 tuner introduced by Heath more than two years ago stood alone as an example of crystal-controlled tuning accuracy until the introduction of tuners from an assortment of manufacturers this year. Mere digital readout does not, of course, mean accurate tuning. In some in-

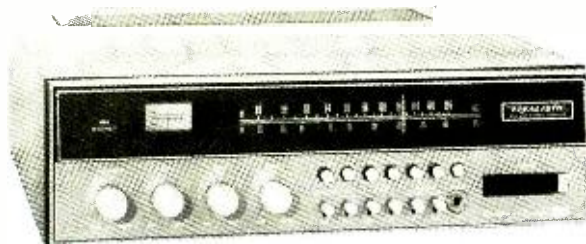

*Pushbutton and lever-switch control flexibility plus built-in synthesized 4-channel versatility with Radio Shack's STA-250 stereo receiver.*



*Receivers with direct-coupled amplifiers and phase-locked loop FM circuitry, exemplified by Pioneer's SX-535 stereo receiver.*



*Four-channel versatility is represented by Lafayette Radio's LA-74 built-in Full Logic Wavematching SQ and other matrix decoding, with demodulator provisions for CD-4 (below).*

*Phase Linear's 4-channel Autocorrelation Preamp boasts special hiss- and noise-reduction circuits, dynamics restorer and active equalizer (left).*

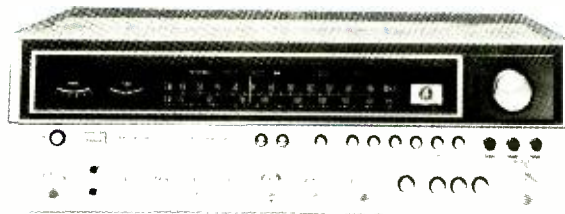

*Multiple tape monitor provisions, QS Vario-Matrix and other 4-channel matrix and CD-4 capabilities are features in Sansui's QRX 7001 receiver (above).*



*Super-power stereo basic amplifiers such as Marantz's 400M (above) are on the rise.*

*Digital readout FM tuning sections, as in SAE'S Mark VIB FM stereo tuner, exhibit growing popularity (below).*



stances, the digital readout tubes simply replace the conventional dial scale and pointer, introducing nothing to ensure tuning accuracy or prevent possible drift. A state-of-the-art frequency synthesizer can ensure tuning accuracy to a high degree. Such a circuit is a sophisticated feedback control system which uses a built-in crystal oscillator and a variety of logic circuits borrowed from computer technology to set the tuner's operating frequency in a manner that is as precise as the broadcast station's own frequency.

As an indication of the limits to which manufacturers have gone in designing high-end FM tuners, some products feature spectrum analyzers which provide visual inspection of the station's signals as well as those signals up to 1 MHz away on either side of the desired signal—all displayed on an instrument-quality oscilloscope.

**Dolby FM Broadcasting.** The big news 52

this year involves two major technological breakthroughs. One is still under consideration by the FCC and the NQRC industry committee—the choice of systems for discrete 4-channel FM broadcasting. The issue is not likely to be decided in 1975, even though engineering field tests in San Francisco are well under way. Anticipation of an approved system has led most manufacturers to include a special jack on the back of the tuner's chassis (also to be found on most new receivers) which will accept the "4-channel adapter" of the future.

Meanwhile, a proposal to the FCC suggested by Dr. Ray Dolby was unexpectedly approved in the summer of 1974, catching most every tuner manufacturer by surprise. Dolby FM broadcasts have been a regular feature of many FM stations throughout the country for more than a year, but listeners who were not equipped with a proper decoder have heard such broadcasts reproduced with shrill high-frequency re-

sponse unless they turned down their treble tone controls. Even this corrective measure did not fully solve the problem because the amount of extra treble emphasis introduced at the broadcast end is a function of the level of the program material and varies from instant to instant.

Dolby suggested to the FCC some time ago that stations employing his system be allowed to alter their pre-emphasis (amount of fixed treble boost introduced at the transmitter and compensated for by the de-emphasis network in the tuner, reducing fixed residual noise level) from its prescribed value of 75 microseconds to 25 microseconds. This, according to the inventor, would increase the "headroom" or dynamic range of music that stations transmit and would reduce the "treble" effect when heard on receivers or tuners not equipped for Dolby reception.

The latter objective is probably adequately met for listeners equipped with less-than-hi-fi FM receivers, but the un-



pected approval of this proposal by the FCC leaves owners of present hi-fi FM equipment in somewhat of a quandary. A few tuners were already equipped with built-in Dolby decoding circuits. Those owning tuners not so equipped, but sufficiently interested in hearing these broadcasts perfectly reproduced, might have gone out and purchased a separate "Dolby box." Now, however, as stations start broadcasting Dolby using the new 25-microsecond pre-emphasis characteristics, even those audiophiles equipped with Dolby will have to alter the de-emphasis characteristics of tuners or receivers if they are to get the exact results intended. (See POPULAR ELECTRONICS, November 1974, for de-emphasis adapter circuit.)

A few manufacturers find themselves in the fortunate position of already having switches for selecting 25 or 75 microsecond de-emphasis built into their products. They also have included Dolby decoders so their products are ready for this new type of transmission. No doubt other manufacturers will scramble quickly to find room on their front or rear panels for the simple two-position switch to be incorporated. The change in de-emphasis applies only to Dolby broadcasts; and the switch is needed because all other FM broadcasting will continue to employ the 75-microsecond pre-emphasis standards.

**Amplifier Trends.** The trend to higher power in separate amplifiers (particularly in the case of separate power amplifiers) continues as more and more low-efficiency loudspeaker systems appear on the market. Manufacturers of these massive amplifiers are enjoying increased sales in the 200-watt-plus categories.

Speaking of size and weight, at least one U.S. manufacturer has already shown prototypes of a so-called "class D" solid-state amplifier which uses pulse or digital techniques to reconstitute audio waveforms. Power-supply requirements in this kind of design are lower and overall size of such products camouflages their power output

capability. We are likely to see more effort directed toward this approach to higher power in the months ahead. Meanwhile, the "brute force" approach, using higher-dissipation transistors for increased power, continues; and with this increase comes the realization that speakers have physical limitations as to how much power they can absorb before being damaged or destroyed. Some amplifier designs incorporate a power limiting switch which is set to suit the capabilities of associated speaker systems.

New FTC rules governing advertised statements of power output capability of audio products (see POPULAR ELECTRONICS, November 1974) will hopefully make the consumer's task of comparing competitive products simpler in the months ahead.

**Four-Channel Systems.** Home quadraphonic sound systems captured some 15% of the new system market, falling somewhat short of industry expectations last year. The picture has been confused by the variety of four-channel record systems, lack of proper demonstration facilities in most audio salons, and the relatively small selection of available records.

Nevertheless, significant improvements in 4-channel components are evident this year. Previous "do-everything" 4-channel receivers generally lacked sophisticated logic circuitry in their SQ matrix decoders, even though many had built-in CD-4 demodulator circuitry. Cost and circuit complexity had prevented most manufacturers from going all out in 1973 and 1974 models. Now, integrated circuits for both SQ full-logic decoding and QS Vario-Matrix are available at reasonable cost. Consequently, manufacturers finally have what may be termed truly universal 4-channel receivers. QS Vario-Matrix, long deemed an also-ran in the matrix battle, has gained ground since some manufacturers offer receiver models that contain this advanced matrix form as well as SQ and CD-4. Some recording companies in this country continue to show interest in this system as well, so that resolution of the QS versus SQ bat-

tle, let alone the matrix versus discrete approach seems unlikely to occur in 1975. Manufacturers of playback equipment presently have no choice but to try to incorporate the best circuitry they can for all the available systems, and this has kept high-powered 4-channel receivers priced considerably higher than similarly powered stereo models.

Very few manufacturers are offering quadraphonic integrated amplifiers. The reasoning here probably is that, if "separates" constitute less than 20% of the total component system market and 4-channel represents a mere 15% of all system sales, catering to a mere 3% of the market hardly justifies the tooling and design expense involved in creating a line of quadraphonic power amplifiers or preamplifiers.

Many manufacturers, and audiophiles too, point to the absence of a broadcast 4-channel system as another obstacle to mass acceptance of quadraphonics in the home. They cite the example of stereo's greatest increase in popularity and distribution after the FCC approved stereo broadcasting methods in the early 1960's. Not wanting to imply any sense of eventual obsolescence of their stereo products, manufacturers are stressing the ease of adaptability of good stereo products to 4-channel via the "add on" route. Most 4-channel receivers being marketed this year also feature the 'strapped' mode circuit, whereby the product can be operated with just two speakers (at more than twice the power available per channel) until such time as the user elects to add two or more speakers and the accessories that are required for full quadraphonic conversion.

Stimulated by the continuing refinement of hi-fi components and growing public reliance on home entertainment, the audio scene in 1975 should be more appealing than ever before. ♦

## FOUR-CHANNEL DISC SYSTEMS

BY JULIAN D. HIRSCH

**T**HE jockeying for commercial dominance between the major contenders in the 4-channel record field appears to be no nearer resolution today than it was a year ago. But the lot of the prospective buyer of quadraphonic equipment is a bit better now, since most current 4-channel amplifiers and receivers have provisions for more than one of the existing competitive systems.

There is no compatibility between the CD-4 discrete 4-channel disc system and the various matrix systems. Hence, it is

necessary to have completely different "decoding" (actually "demodulating") circuits for CD-4 discs. A number of receivers presently on the market have CD-4 demodulators built into them for just this reason.

With matrix systems such as the SQ and the QS, some compromise is possible. A decoder can be designed to favor one of the matrices and still do a tolerable job of decoding the other. In any event, every 4-channel receiver and amplifier should have at least one of the basic matrix decoders.

**The SQ System.** When getting into 4-channel sound, making a choice between the various matrix systems available is no easy task. SQ would, at first glance,

appear to be the obvious choice since the quadraphonic section of most record shops is dominated by SQ discs; but when it comes to the matrix decoder in a receiver or amplifier, it would be erroneous to assume that all SQ decoders are the same. Over the past few years, there has been a constant evolution of the SQ system—at least in the reproduction process. The purpose of the changes has been to improve the overall channel separation of the basic SQ matrix to give it a more "discrete" 4-channel character.

Theoretically, the simplest SQ decoding matrix has infinite side-to-side (left-to-right across the front and rear) separation. In reality, the separation is limited by the normal stereo separation of the phono car-

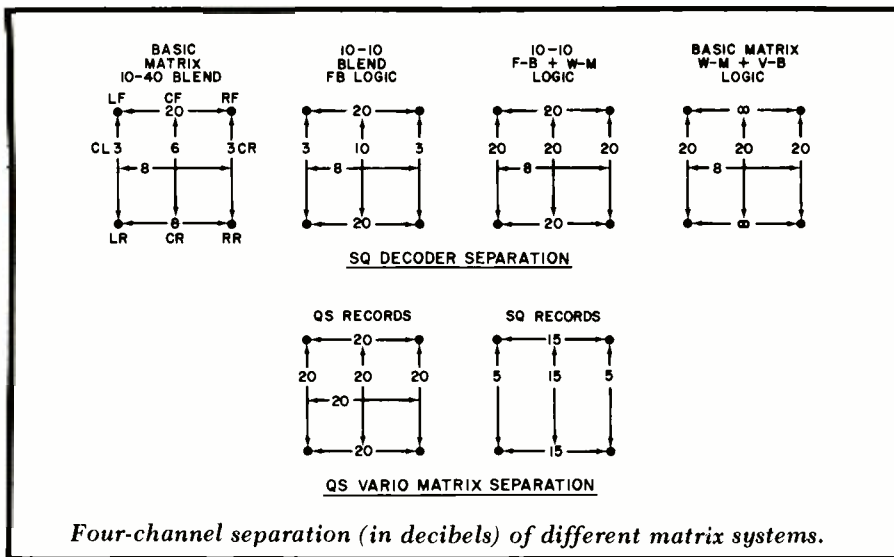

Four-channel separation (in decibels) of different matrix systems.

tridge in use, which may be a minimum of 20 or 30 dB. However, the separation from side-front to side-rear and from center-front to center-rear in the basic SQ matrix system is only 3 dB—an inadequate figure for meaningful 4-channel directionality.

Most of the lower-priced 4-channel equipment with SQ decoding capability employs the basic matrix scheme. This fails to do justice to the intent of the recording engineer. Fortunately, it is possible to substantially improve the center-front to center-rear separation at negligible sacrifice of separation in other directions.

By blending some of the front-left and front-right and some of the rear-left and rear-right signals, it is possible to increase front-to-rear center separation with a slight loss of side-to-side separation. The most popular SQ system uses a 10-percent front- and a 40-percent rear-channel blend (known as a "10-40" blend). This reduces the front lateral separation to 20 dB (a change that is undetectable except with instruments) and the rear lateral separation to 8 dB. Since the rear channels—particularly in classical music reproduction—carry mostly ambience and reverberation information with little side-to-side directionality, the reduction does not represent a serious compromise in performance. However, the center-front to center-rear is improved to 6 dB. This reduces some of the vagueness of positioning associated with center-front soloists heard through a basic matrix decoder.

It is possible to increase front-to-rear separation further by blending, but only at the expense of side-to-side separation. A predominantly center-front signal differs from a center-rear signal in the amplitude and phase of its encoded components. By shifting the phase of one of the input signals with respect to the other by 90° and then adding and subtracting them, one can derive "logic" control signals whose presence indicates the predominance of either a center-front or a center-rear signal.

The logic signals can be used to control the gains of the four individual output amplifiers in the decoder. If the logic circuit

senses that the center-front signal is strongest, the gains of the front channels are increased by 3 dB, while the gains in the rear channels are reduced by about 14 dB. The result is a net effective separation of 20 dB along the center front-to-rear axis, with no change in overall sound volume. (The front-channel levels have been increased by 3 dB to compensate for the virtually total attenuation of the rear channels.)

There are other ways to achieve center-front-to-rear enhancement. Some result in less separation than in the example cited above. Typically, however, one can expect a center front-to-rear separation of 10 to 20 dB from the relatively inexpensive front-back (F-B) logic system sometimes referred to as "partial logic."

**Enter Wave Matching.** The next evolutionary step in SQ decoder development was the addition of wave-matching (W-M) logic. In this system, the control signals are processed to obtain new signals that indicate the relative levels of the signals in each of the four channels. This is accomplished by rectifying and comparing the rectified outputs. In effect, this is a "matching" of waveforms in the different channels; hence, the term "wave-matching" logic.

The W-M system is usually combined with a F-B logic system to give a nearly discrete character to the sound. It is capable of about 20-dB separation in every direction, except center-left to center-right, which remains at about 8 dB in all current SQ decoding systems.

The original "full-logic" SQ decoders used the combination of F-B and W-M logic and represented such a dramatic improvement over unaided matrix decoding that it was easy to overlook some shortcomings. Any such "gain-riding" system depends on critically controlled operating speeds if it is to remain unobtrusive.

In the case of F-B and W-M logic, CBS Laboratories (developer of the SQ system) has found that an attack time of about 1 to 3 ms and a decay time of 50 ms give a strong sense of directionality, while the control

action remains relatively inaudible. This is due to the fact that the direction from which a sound first reaches the ear determines its apparent direction, even if it subsequently comes from other directions. This allows a fast-acting gain-riding system to "steer" the listener to the correct azimuth position for any sound. Even when a subsequent change in program directionality requires a gain shift to favor another channel, the ear "remembers" the direction from which the sound first arrived.

The quadraphonic effect from such a decoder can often seem to be perfectly "discrete"—provided one does not listen too carefully and avoids a listening position too close to one of the speakers. Although it is obvious that a well-designed logic system can produce these effects when the program is principally concentrated in one direction at a time, how can it cope with the situation where all four channels are carrying equal signal levels simultaneously? The answer is that it cannot! But simultaneous directionality in all four channels rarely occurs in actual musical recordings. Even when all channels appear to be fully occupied, they have slightly different program contents at any given instant.

The decoder can sense the differences in a matter of milliseconds and direct the listener's attention to the appropriate corner with remarkable effectiveness. The end result is not really equal to a fully discrete 4-channel program, but it is so close that one rarely is aware of the lack of simultaneous but different signals in all four channels.

When the gain of an uncontrolled or boosted channel is suddenly reduced to favor one of the other channels, any low-level sound (such as room reverberation or the decay of a musical note) appears to be abruptly cut off. This effect has been minimized in the latest decoders by careful selection of operating time constants and is to some degree under the control of the recording engineer, who can time his record mix-down to avoid audible anomalies. Under certain conditions, the rapid shifting of channel gains can also give a "pumping" action that can be detected as a level modulation rather than a change in position.

More recent decoders have combined F-B with a variable-blend (V-B) logic. Here, the logic control signals actually vary the amount of side-to-side blending to dynamically control the center front-to-rear separation. In combination with a W-M system, the latest V-B decoders can provide a full 20 dB of front-to-rear separation either along the sides or in the center of the listening area, with no significant dilution in side-to-side separation. There has also been a noticeable reduction in audible "pumping," so that it is rarely heard.

In addition to the operational shortcomings of various logic systems, there was for some time an even more serious



disadvantage: high cost. A full-logic system was initially very expensive due to the considerable circuit complexity and the lack of suitable integrated circuits. Much effort has gone into the development of IC's to go with the inexpensive basic SQ matrix decoder IC's that appeared some time ago. Presently, a full-logic W-M and V-B decoder can be made with only three IC's at a small fraction of the cost of discrete-component systems.

Through the first half of 1974, very few quadrasonic receivers included any form of logic enhancement for their SQ decoding. Most of those that did had only a simple F-B system. At present, a number of manufacturers have announced availability of full-logic receivers, usually in models in the upper price brackets. As the SQ IC's become more widely available, other manufacturers and models will surely join the list.

**The QS System.** Acceptance by the American recording industry of QS or RM (for regular matrix) system has not matched the CBS SQ system; but the former has enjoyed considerable popularity in Japan. Sansui's Vario-Matrix "logic" system has followed a path of development that parallels that of the SQ system. More important, it has attributes that make it noteworthy, as you will see. Also, the system has made significant inroads in four-channel FM broadcasting.

The Vario-Matrix system, which operates very differently from the SQ system, has gradually been converted to a simple three-IC design. It senses the phase rela-

tionships between the two composite input signals and uses a derived control signal to continuously alter the decoding matrix's coefficients in such a manner as to shift the apparent directionality to favor the preferred azimuth.

Since the Vario-Matrix system does not vary channel gains, it is quite free of pumping effects and is capable of a degree of "discreteness" that hardly seems possible with a matrix system. The first Vario-Matrix decoders used mostly individual components and achieved about 12 dB of separation in the basic directions. An IC version of the Vario-Matrix system is now available. It has a full 20 dB of separation between all channels.

In view of the predominance of SQ discs in the U.S., it is fortunate that the Vario-Matrix system can be switched to a "Phase Matrix" mode that decodes SQ discs quite well. The separation along the sides of the listening area is about 6 dB in this setup. But from center-front to center-rear and along any left-right axis, it is 15 dB or more.

Any matrix decoder can be used to synthesize pseudo-quadrasonic programs from stereo sources. Depending on the matrix and the nature of the program, the result can be anything from a vague ambience in the rear speakers (often a very pleasing effect) to a distinctly separated 4-channel distribution, although the latter may not conform to any predetermined spatial configuration. It is worth noting, however, that the Vario-Matrix has a "Synthesizer" mode that combines the stereo channels in an enclosing matrix to create a 4-channel program that is then

## SPECIAL REPORT ON HI-FI

decoded with impressive effect by the decoder itself. Often, this produces a 4-channel spatial effect that is the equal of that from any quadrasonic record.

**Discrete Discs.** RCA/JVC's CD-4 discrete disc is in a ballpark of its own. It is not at all compatible with the matrix systems, but does offer the potential for the best 4-channel disc sound. The result can be similar to that of a 4-channel tape—four separate signals. Instead of inserting more information into record grooves, CD-4 uses ultrasonic frequencies in a stereo groove to develop rear channels. However, to reproduce quadrasonic sound from a CD-4 disc, a demodulator and a special phono cartridge must be used. Another consideration is the need to maintain a high order of stylus and disc cleanliness.

As for the broadcasting on FM of 4-channel CD-4 discs, experiments are being conducted, but the possibility is still unresolved. Many stations broadcast matrix-type discs, which are compatible with the present FM broadcast system; but CD-4 broadcasting would require modifications of the system.

There are currently a number of receivers with built-in CD-4 demodulators plus full-logic SQ decoders. Further, many receivers have input provisions for outboard CD-4 demodulators. So, CD-4, backed by RCA's potential record library, appears to be a long-range contender. ♦

## RECORD PLAYING EQUIPMENT

BY JULIAN D. HIRSCH

**T**HE single-play record player is coming back strong. Current lines of players indicate an increasing trend toward single-play models that span a price range from less than what you would expect to pay for a moderately priced changer to as much as \$400. Except for the least expensive units, most of these players have some degree of automation, which might be simply an automatic motor shut off at the end of play. On the other hand, the automation might be very sophisticated, including a complete arm indexing/play/return-to-rest: shut-off cycle—all initiated at the touch of a button or lever.

Most single-play turntables are belt-driven. This is the least expensive method of rotating a turntable platter with a minimum of vibration or momentary speed fluctuation, which could result in rumble, wow, or flutter. Virtually every currently manufactured single-play turntable operates at 33 $\frac{1}{3}$  and 45 rpm.

**Enter Electronic Drive.** A couple of years ago, the first successful direct-drive turntables were introduced by a few manufacturers. Now, most of the major manufacturers feature at least one direct-drive model. With the direct-drive system, there are no stepped drive shafts, idler wheels, or belts.

The motor of a direct-drive system rotates at 33 $\frac{1}{3}$  or 45 rpm. It is rigidly fastened to the platter that supports and rotates the record. In fact, in one model, the platter is actually the motor's rotor.

The motor speed in a direct-drive system is controlled, and tightly regulated, by electronic means, the specific operating principles of which vary from manufacturer to manufacturer.

The major advantages of direct-drive include virtual elimination of mechanical parts that can wear out or require replacement, reduction of rumble-producing vibration to an absolute minimum, and a record speed entirely independent of line voltage and frequency fluctuations. All of this has its price in the amount of money paid for the player. They cost roughly from \$250 to \$400. Since turntables that are much less expensive have rumble and flutter levels that are inaudible and often below those inherent in many recordings,

not everyone will want the added cost of a direct-drive system. But for those who want direct-drive, there are a number of models from which to choose.

**The Tonearm.** From time to time, new tonearm designs are announced. They purport to cure the ills of phonograph reproduction, the great majority of which have nothing to do with the tonearm. Few of these "revolutionary" designs prove useful in the long run. Hence, the conventional pivoted and offset tonearm is used almost universally in record players.

The differences among tonearms used with most record players, where they exist, are principally in the important area of low bearing friction (which costs money) and secondarily in the matter of operating conveniences, such as cartridge overhang adjustment, damped cueing lifts (now almost universal except on the least expensive players), and accurately calibrated tracking and anti-skating force adjustments.

The radial tonearm received much publicity a few years ago when Rabco introduced the first truly successful design. It is still around, available only from Rabco. (A radial tonearm is also featured in a new and very expensive record player from Bang &

Examples of popular multiple-play (below) and single-play (right) automatic turntables.



**BIC 980**



**Dual 701**



**Technics SL-1300**



**BSR 810**



**Pioneer PL-51**

Olufsen, soon to be introduced in this country.)

The radial arm essentially eliminates the small amount of horizontal tracking error left in today's conventional tonearms—not really a significant factor—and is also free of skating force effects, which is an important advantage. However, as with the direct-drive turntable, radial tonearms are costly and may not return enough improvement in listening quality to justify the cost to many people.

Although it is not widely heralded in advertising literature, most tonearms have enough internal wiring capacitance to be a potential source of difficulty with many of the CD-4 cartridges used for playing the RCA/JVC "discrete" 4-channel discs. Most of these cartridges should be operated with a total load capacitance of less than 100 pF.

Special connecting cables supplied with some CD-4 demodulators have a capacitance of less than that of the record player's internal wiring capacitance of about 30 pF. So, the player's internal wiring capacitance should be less than 70 pF. Unfortunately, many players we have measured have wiring capacitances in the 150-to-200-pF range, which would not be suitable for CD-4 service with most cartridges.

Recent models of record players from several manufacturers have low-capacitance arm wiring. This fact is not always stated in the literature. So, check on this if you are making the change to CD-4.

**Record Changers.** The record changer is still alive and thriving. It will probably always be a major factor in the record-playing world. "New" record changers appear on the scene with great regularity, but much of the newness appears to be cosmetic in nature. Among exceptions is a new line of "programmed" players. These are set by the user to play in sequence up to six records. This eliminates a large portion of the mechanical complexity from the record-changing mechanism and makes it possible to use the more desirable belt-drive system instead of the idler wheel that other changers require.

**Cartridges.** The most noteworthy advance in phono cartridges during the past 12 months has been in the development of a number of new models for playing CD-4 discs. Most manufacturers here and abroad seem to have been proceeding with caution in this respect; but in recent months, a number of new models have made their appearance.

A few Japanese cartridges use a spe-

cially shaped stylus to achieve a greater area of contact with the record groove's walls in the interest of reduced disc wear while being able to trace high frequencies up to 45 kHz. They all require about 2 grams of tracking force, which is higher than that needed by most top-grade stereo cartridges. However, due to the shape of the stylus, the actual force per unit of area contacted is less than that exerted by conventional conical or elliptical styli operating at about 1 gram.

A different approach is taken in a CD-4 cartridge that uses semiconductor strain-gauge elements. It requires a special preamplifier (with no equalization) that is able to supply dc to the cartridge. The stylus is similar in shape to those mentioned above. It, too, operates at about 2 grams.

A new cartridge from Denmark appears to combine the best of the stereo and CD-4 worlds. Its shaped stylus, called the Pramanik after its inventor, has the essential qualities of the other specially contoured styli, but it is able to operate at only 1 gram. It is also one of the very few cartridges made today that does not have a user-replaceable stylus. The entire cartridge must be returned to the factory for stylus replacement when the need arises.

Many people have concluded from the



wide frequency response inherent in a CD-4 cartridge that it should be an outstandingly good performer when used for stereo reproduction. Although many CD-4 cartridges are good stereo performers, this does not necessarily follow for all CD-4 cartridges. The reason for this is that the required tracking ability as a function of frequency is not the same for the two modes of service.

The special styli used with most CD-4 cartridges are expensive. This accounts for

their high prices, which are typically from \$50 to \$100. It happens that some medium-priced stereo cartridges selling for between \$20 and \$40 can outperform most of the much more expensive CD-4 cartridges when playing stereo records, with respect to tracking ability and flatness of response within the audio-frequency range.

The finest stereo cartridges, which are priced competitively with the CD-4 cartridges, are definitely superior for stereo-

## SPECIAL REPORT ON HI-FI

only applications. This statement should not be misinterpreted to denigrate the CD-4 cartridge in any way. If there is any reasonable likelihood that you will be converting to CD-4 in the next few years, one of the better CD-4 cartridges on today's market would be an excellent addition to your system. ♦

### TAPE RECORDERS

BY JULIAN D. HIRSCH

**T**HE DEATH knell that was supposed to have sounded for open-reel tape recorders when high-quality cassette decks appeared has never materialized. Open-reel machines continue to attract buyers for a variety of reasons. Among them are: extended frequency response, greater signal-to-noise (S/N) ratio, ease of editing, and such recording versatility as sound-on-sound, sound-with-sound, etc.

At the same time, cassette recorders have made the full transition to true hi-fi, thanks to noise reduction circuits, special raw tape mixes, and improved transport design.

Here are details of what has happened in the past and what the near future promises in the tape equipment field.

**Open-Reel Recorders.** Although cassette recorders initially superseded open-reel machines selling at comparable prices, the continuing upward spiral in prices has brought us to the point where many cassette decks retail for as much as \$500. This has had the effect of raising the "floor" of open-reel recorder pricing to roughly the same level. Fortunately for the consumer, there has been a simultaneous upgrading of the equipment, in both features and performance. You might have to pay more for your recorder than you did formerly, but you also get more.

One clear trend in open-reel tape recorders is the use of the large 10½-in. (26.7-cm) "professional" tape reels. Once a feature only of recorders costing \$1000 or more, it is now available in machines selling for \$600 or less. So far, tape is more generally available on 7-in. (17.8-cm) reels. But the growing popularity of the larger reel will inevitably bring a greater number of tapes and machines to the market in the larger format.

One of the basic objections to quarter-track open-reel tape is the need to interchange the supply and takeup reels to play the second pair of tracks. For some years, there have existed automatic-reversing machines that eliminate this shortcoming

in the playback mode. (Very few recorders are equipped for bidirectional recording.) There is a slow but steady growth in the number of automatic-reversing machines on the market, but it can hardly be considered a trend. At one time, there were several systems for initiating the tape reversal process, including recorded subsonic tones, sensing unrecorded portions of the tape, and foil conductors attached to the tape's ends. Only the last appears to have survived.

In spite of the dearth of commercially recorded 4-channel tapes, almost every manufacturer now has one or more quadraphonic machines in his line. Sometimes the machine can play but not record in the 4-channel format. This is a relatively inexpensive addition to a standard stereo recorder.

Among the true 4-channel recorders currently available, we see an indisputable trend toward providing a synchronous dubbing capability. Each manufacturer has his own trade name for this feature, which allows the recording head on a selective track-by-track basis to be used as a playback head. After some musical part has been recorded on track one, for example, that portion of the recording head is used to play it back through headphones while one or more of the remaining three tracks is recorded with new material in exact synchronization with the original track. This technique is useful for creating special effects, such as having several instrumental or vocal parts played by the same person but recorded at different times.

Strange as it may seem, the Dolby noise reduction system, long since a standard in better-quality cassette recorders, has made few inroads into the open-reel format. There are several machines with built-in Dolby circuits. But in spite of the growing availability of Dolby B-encoded commercial open-reel tapes, the situation seems to be static. A three-head deck needs four Dolby sections, which adds about \$200 to the deck's selling price. Most good open-reel recorders, particularly when operated at 7½ ips (19.05 cm/s), have such low inherent noise that the Dolby B system cannot provide enough improvement to justify its added cost. Professional recorders, of course, use the much more

sophisticated, effective, and costly Dolby A system.

Recognizing the existence of several different types of magnetic tape that have different bias and equalization requirements, a number of tape recorder manufacturers have provided tape bias or equalization (or both) switches on their decks. These are usually labelled for "normal" and "low-noise" tapes. Since with some decks there are as many as six choices of operating conditions, it might be necessary to experiment a bit if the manufacturer does not supply specific information.

Most three-motor recorders continue to use the hysteresis synchronous motor for capstan drive. This ties the accuracy (and constancy) of the speed to the power line frequency, which is subject to short-term variations. A few of the best and most expensive tape recorders employ servo-operated tape drives that are independent of the frequency of the power line. One goes as far as to use a crystal-controlled oscillator, to which the capstan motor is phase locked, to provide a constant, precise, and independent speed reference.

Among today's quarter-track open-reel tape decks, it is not uncommon to find the frequency response extending to 20,000 Hz or higher at 7½ ips and sometimes even at 3¾ ips (9.525 cm/s). An S/N ratio of 60 dB or better (sometimes as high as 70 dB) can be expected. There is often little difference in performance between the two speeds, except for the easier editing made possible by the higher speed. For the home recordist, 15 ips (38.1 cm/s), available with some of the high-priced decks, offers only editing convenience. Probably the best justification for a 15-ips speed in a home recorder is the playing of master tapes that were made at this speed. A 10½-in. reel capacity is essential for the 15-ips speed. In some cases, it is necessary to have the recorder fitted with half-track heads.

**Cassette Recorders.** Externally, the big change in cassette recorders this year is the appearance of front-loading models. Until recently, all or most of the operating controls, meters, and the tape-loading well were located on the top surface of the deck. This made it necessary to install the deck in a location that permitted unobstructed access to the deck's top.



*Representative examples of tape machine types now available to consumers (clockwise): Akai auto-reverse CXC-75D cassette deck; Wollensack 8-track player/recorder with Dolby NRS; Pioneer 10 1/2" reel capacity, 3-motor, 3-head RT-1011L open-reel deck; and Teac auto-reverse play, Dolby NRS open-reel deck.*

A number of cassette deck manufacturers have now developed machines that resemble in size and style their tuners, receivers, and integrated amplifiers. Usually, a hinged door on the front panel opens for tape loading and a mirror and internal lamp make the cassette visible from the front while it is in use. The transport's controls, meters, and level controls are also located on the front panel. Hence, the cassette deck can be placed next to other system components or stacked with them if desired.

As the prices of cassette recorders have moved upward to fill the gap left by the disappearance of low-priced open-reel decks, they have acquired many of the deluxe features and conveniences of the better open-reel machines. Solenoid-operated transports are offered in a few cassette machines, with the feather-touch and logic control systems that add so much to the pleasure of using a good, well-adjusted tape recorder.

We have heard much about three-head cassette recorders. However, so far, only one company has produced a true three-head deck with full-fidelity capability. These machines are very expensive. Other "three-head" recorders have a separate monitor head whose frequency response is usually inferior to that of the regular record/play head. These machines do not

have the separate recording and playback Dolby noise reduction system that is necessary if the monitored playback is to have the same sound quality as the regular tape playback.

Dolby B noise reduction is now standard in all cassette recorders with a claim to high-fidelity performance. A growing number of machines are designed to switch to the Dolby circuits to decode Dolby-encoded FM broadcasts. Some of the latest models have circuits that can convert the normal 75- $\mu$ s FM tuner deemphasis characteristic to the 25- $\mu$ s characteristic recently approved by the FCC for Dolby-encoded broadcasts. Not all cassette recorders with FM Dolby decoding circuits are able to record the encoded signal as received from the tuner while allowing you to listen to the signal in decoded form at the same time. Check this out if you plan to do much listening to or taping from a Dolby FM station.

A number of cassette recorders have a "memory-rewind" feature. This permits the index counter to be set to 000 at any point on the tape to permit the tape to automatically stop at that point when rewound. In one case, this has been expanded to a "memory-play" mode, with the tape going into normal play after stopping.

The ease with which cassette tape can be overloaded by excessive signal levels

makes the relatively slow response of the level meter a less-than-adequate indicator of recording levels. Many decks now have small light-emitting diodes (LED's) that flash red on short-duration peaks that might not register on a meter. Some recorders have fast-response peak-level meters that serve the same function as the LED's.

There are a few cassette recorders with automatic-reversing systems, which sometimes include the recording as well as the playback modes. Nevertheless, we see no sign of a growing trend in this direction. Perhaps the relative ease of flipping over a cassette has reduced the incentive for manufacturers to incorporate this feature, which would inevitably raise the price of the deck.

Most cassette recorders now have switches for optimizing them for ferric-oxide and chromium-dioxide tape formulations. Most of them also change the playback equalization to the industry standard of 70  $\mu$ s with CrO<sub>2</sub> tape (120  $\mu$ s is used for standard ferric-oxide tapes). A couple of machines have sensors that automatically change the deck's circuits for CrO<sub>2</sub> tape when a suitably designed cassette is loaded. Unfortunately, the specially notched cassettes needed for using this feature are available from only a few manufacturers, and we see no move on the part of others to go along with it.



For the most part, today's cassette recorders are only slightly improved, with respect to actual performance, over those of a year or two ago. Reduced wow and flutter would appear to be the most significant area of advance this year. Most of the changes are directed toward making the machine easier to operate or more versatile in its operation. The only real "break-through" has been in the deluxe three-head machines, whose quality rivals that of top-grade open-reel recorders in most respects. Unfortunately, their prices are very high, in the \$700 to \$1100 range.

A modern cassette recorder should have a frequency response extending from 40 Hz to beyond 15,000 Hz with less than 3 dB variation and an S/N of about 60 dB (with Dolby). Flutter, once considered a serious problem, is down to 0.1 percent or less in a number of machines. As a general rule, you should be able to copy any broadcast over FM or disc recording on a cassette with no discernible difference between the original and the cassette's playback. Only in certain "live" recording situations will the cassette's limited dynamic "headroom" and lack of easy editing capability prove to be a serious disadvantage.

**Cartridge Recorders.** Two noteworthy developments in 8-track cartridge recorders for the home (as distinguished from players or purely automotive machines) have appeared on the market in the past year. One is the incorporation of Dolby circuits to eliminate or reduce the hiss that has until recently kept the cartridge from acceptance in high-fidelity home music systems. Not only does this allow you to

make your own cartridge tapes with relative freedom from noise, but many commercial tapes will be issued with Dolby processing. Of course, this offers no particular advantage in an automobile environment where ambient noise usually masks the hiss. But even in a car, the slight added "brightness" heard when playing a Dolby tape without decoding will most likely enhance the sound through the limited bandwidth of the mobile speakers.

The second change is the development of a new tape, which for the first time brings the fidelity of the 8-track cartridge into direct competition with cassettes. The "Special" tape, as it is known, requires a higher bias than do previous cartridge tapes. Some of the machines will have a switch with which to set the bias for regular or Special tape. With the Special tape, a frequency response up to 15,000 Hz has been achieved, which, in combination with the 60-dB S/N ratio afforded by the Dolby system, brings the 8-track cartridge into the high-fidelity class for the first time. In the cartridge medium, even to a greater extent than with cassettes, the ultimate wow and flutter are determined as much by the cartridge itself as by the tape transport.

**Tape Developments.** In open-reel tape, the trend is toward higher-energy tapes with a finer grain structure to reduce noise. Several manufacturers have introduced new "premium" grade tapes. While we have not yet had the opportunity to use any of these new tapes, we would expect them to have improved frequency response, better distortion characteristics, and lower inherent noise.

Now that cassettes have settled down into the distinct categories of ferric-oxide and chromium-dioxide formulations, and most recorders are designed to use both types effectively, we have a newcomer with which to contend. A few tape producers are offering a two-layer tape with a layer of ferric oxide next to the backing and an outer layer of chromium dioxide. It is claimed to offer most of the advantages of both types of tapes with few of the disadvantages of either. In particular, this FeCr tape can operate with the same bias used for ferric-oxide tape and will produce a higher output level and an enhanced high-frequency response. In one playback scheme, the playback equalization is changed to the 70- $\mu$ s CrO<sub>2</sub> standard when using FeCr tape, but the bias is at the "standard" level. The result is an improved high-frequency response, greater output level, lower distortion, and less noise than with any of the other types of tape.

As these tapes become more readily available, more recorders will be designed to use them with full effectiveness. But in the meantime, our experience indicates that they can be used to improve the high-frequency performance of many older recorders, especially those that were not designed for CrO<sub>2</sub> tape. As might be expected, however, the new tape is somewhat more expensive than the other types. ♦

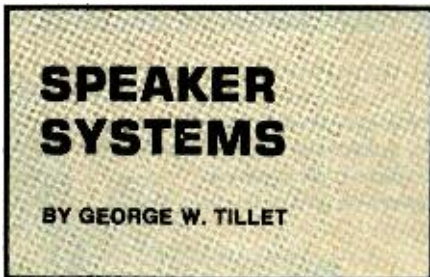

**I**F, AFTER a hiatus of a few years, you decide to buy new speaker systems, you'll discover the market to be a "whole new ballpark." It will be different in terms of new shapes, new grille treatments, new finishes, new coloring. And it will, to a lesser degree, be new in terms of design concepts—novel driver units and improved variations on old themes.

A visit to any hi-fi salon will confirm that today's speaker system displays are no longer merely row on row of rectangular boxes. Dealers are now likely to display speakers in square, triangular, octagonal, pentagonal, and spherical shapes; with here and there a planed-off rectangle or a dodecahedron (a lopped sphere with a dozen "firing" surfaces). You'll also see flat speaker systems in the form of decorative pictures, mirrors, and even fireplace

screens, plus vertical columnar models.

Many of the grilles in today's speaker systems are of light-weight, air-through foam plastic that can be colored and shaped to a variety of patterns, either flat or steeply sculptured. Some of today's speaker systems feature a choice of grilles, in terms of colors as well as designs. Some are engineered so that the user, whatever his reasons, may "unlatch" them (generally from Velcro® pinions), remove the old grille cloth, and replace it with another fabric in a new color or design. In the case of some plastic foam types, one may even slip off the grille to spray-paint it in a new hue to suit his fancy or new room decor.

Oiled-walnut wood veneer has been the favorite speaker system finish for over a decade. It still is, but to a lesser degree. Today, with walnut veneer in critically short supply and astronomically priced, substitutes are being used—including other wood veneers such as pecan, oak, teak and rosewood. Also coming on the scene are walnut-grain-surface materials of a plastic that fools many an eye because it looks so much like wood. Also popular are painted and lacquered finishes—with antique or off-white especially well-liked.

Some of the new speaker systems found

in audio stores are being made of "space-age" materials such as high-impact, light-weight moldable plastic, as in the new Advent/2 systems with contoured corners and bone-white finish. Use of such materials enables manufacturers to escape the high cost of wood and create new cabinet silhouettes. Many manufacturers are also using particle-board made up of pressure-fabricated wood particles to offset the high cost of solid woods. Ironically, the particle-board is often superior in certain speaker applications because it is far less resonant than wood.

Before going into the details of some of the new unusual speaker systems gracing the displays of hi-fi emporiums, let's consider some behind-the-scenes elements that play a part in today's speaker system technology and trends.

**Impact of Four Channels.** Quadraphonic sound has had a big impact on the audio industry, and especially on speaker systems. A sound buff, out to buy his first quadraphonic rig, faces some harsh realities. At any given budget point, a 4-channel receiver offers less power per channel than a stereo unit of comparable price. This means that the buyer must in-

the system houses a radically new concept in loudspeaker design—the Heil air-motion transformer. The inventor of the unit claims that the acceleration of the air is increased by a factor of five over a conventional driver. The diaphragm of the air-motion transformer is made of a light, conductive material and is driven over its entire area, radiating through slots which form extensions to the magnetic polepieces. The company's models use dynamic speakers for the bass and midrange, but they are dipolar above 700 or 1000 Hz, with the exception of a new bookshelf system. Work is proceeding on a full-range air-motion transformer.

Infinity Systems uses an unusual tweeter in two of its models. Shaped like an ice-cream cone, the driver is mounted vertically, affording 360-degree horizontal dispersion.

Another interesting high-frequency driver, made by Motorola, is comprised of piezoelectric material. That is, these materials physically deform when a voltage is placed across them, and conversely generate a potential difference between the crystal boundaries when subjected to a deforming physical stress. The first audio application of this principle was in crystal phono cartridges, which would produce a varying voltage that was analogous to the movements of the stylus in the groove. Modern ceramic materials have replaced the sodium-potassium-tartrate that was first used.

Piezo-electric speakers have been made in the past, but they never achieved popularity.

Lead-zirconate-titanium, a ceramic material, is used in the latest piezo speakers.

Two discs of this compound are formed, and a brass separator is epoxied between them to form a three-layer device. The discs are polarized so that an applied signal will cause one disc to expand while the other contracts. A cone is coupled to the center, and on some models this is loaded with a small, folded compression horn. The impedance of these devices is quite high—300 ohms at 5 KHz, falling to 100 ohms at 10 KHz. No special precautions need be taken to prevent low frequencies from being applied.

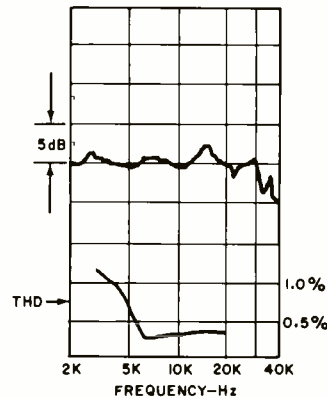

**Fig. 2. Frequency response and distortion for piezo speaker.**

Figure 2 shows the frequency response and distortion characteristics of a typical Motorola unit. A number of manufacturers, including Polk, Dahlquist, RTR and STR, are using at least one of these transducers in their top-quality models, usually active above 6 kHz or more. Because of their

many advantages—no voice coil, high power-handling capacity and good transient response—many manufacturers of high-power PA systems used by rock groups will be incorporating these units into their products in the near future.

In addition to the ESS/Heil and the Infinity Systems units mentioned earlier, there are some two dozen other column speaker systems now available. Notable are eight such units in the EPI line of Towers and Micro-Towers, and the new JBL Aquarius Q and the Altec Stonehenges I and III. New column models are also being produced by Fairfax, KLH, Polk, Stradivari, Onkyo, Technisound, Equasound, and Design Acoustics, among others. Most of the columnar systems take up a minimum of floor space.

**Other Design Approaches.** The recently introduced Philips Motional Feedback System is of interest. It has an 8" motional-feedback woofer in a three-way speaker system that includes two integrated power amplifiers and a bass comparator with a feedback loop.

In other design developments, there is a bumper crop of hybrid dynamic /electrostatic systems available. These include those from RTR, Electronic Industries, SAE, Soundcraftsmen, Crown, and infinity Systems. Arthur Jantzen has just announced his return to the industry with a downward-facing 10-in. woofer and an array of 10 small ES tweeters. Koss and a few other companies are working on full-range ES systems. Dayton-Wright, a Canadian group, has an interesting system that puts out a fair amount of power at 40 Hz. The system is filled with an inert gas to obtain maximum efficiency, and the matching transformer weighs 35 lb. Predictably, the system is quite expensive.

**In Conclusion.** In spite of the high-efficiency and/or unique-design syndrome apparent in the speaker system industry (focused on here because of "newness"), one should not dismiss the low-efficiency speaker systems. Their strength in the marketplace has not diminished; nor has the number of air-suspension system adherents who want good bass response from a small enclosure. It's just that the marketplace is bigger than ever before and new design departures and revivals of old ones have joined in an effort to meet certain needs—whether those needs are efficiency, appearance or dispersion characteristics. In addition, some of the traditional low-efficiency designs are not really so low. Some require only 10 watts rms power to drive woofers satisfactorily. Truth is, air-suspension woofers outnumber other designs two to one in number of models available.

So it is apparent that 1975 will offer consumers more of a choice than ever before with traditional designs, new design entries and a range of prices to fit most anyone's budget. ♦

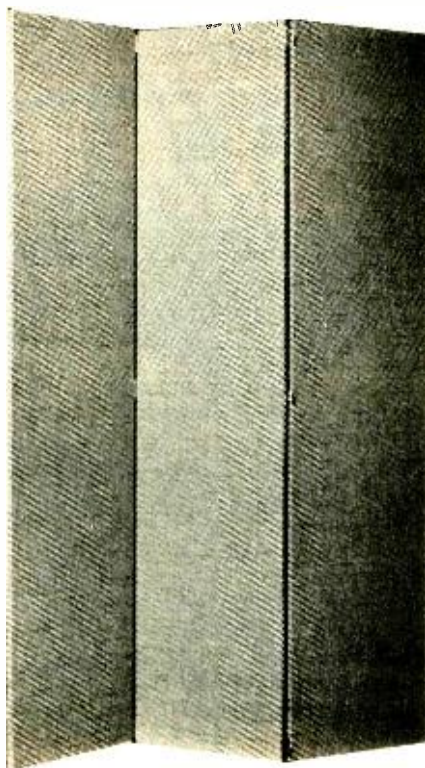

*Screen-like appearances illustrate the new unusual shapes of speaker systems. Below, Dahlquist DQ-10. At left, Magneplanar by Audio Research.*





# Digital Filtering

*New technique operates from a digital oscillator and uses no critical elements*

BY LESLIE SOLOMON  
Technical Editor

**S**INGLE-FREQUENCY filters are important in a number of areas—RTTY, SSTV, radio control, etc. There are two approaches that are usually used to accomplish such filtering: either multi-element passive systems (which use precision components and are somewhat bulky physically) or active filters (which use a few passive components and an op amp). Even with the active filter, to obtain careful control of the selected frequency, it is necessary to select precision passive elements.

Though either of the two approaches works well, there is a new filtering method that is unique and should be of interest to the serious electronics experimenter. Called digital filtering, the new method uses no critical elements and is "tuned" with a digital oscillator. High-Q filters (even at low audio frequencies) can be realized and the circuit is very stable since no regeneration is used. These filters use low-cost TTL logic and some conventional switching transistors.

In the simple circuit shown in Fig. 1A, with the six-position switch in position 1, and with an audio sine wave applied to the input, the first capacitor will start to charge up toward the signal's peak voltage. If S1 is switched to the next capacitor when the voltage across the first capacitor has reached the average value for that portion of the sine wave, the switch makes another step.

Therefore, as S1 rotates around the six capacitors, each capacitor receives a charge whose value depends on the average value of the sine wave at its portion of the wave-form. The charges on the capacitors can be represented by the step curve in Fig. 1B. Of course, the switch must be synchronized with the input sine wave. If

the input and switching frequencies are not synchronized, the average voltages stored in each capacitor will differ and will drop very rapidly on each side of the switching frequency. This is the basis of digital filtering; and because of the synchronization system, tuning the filter to any desired frequency is primarily a matter of "tuning" the switching oscillator. Component values for the resistance and capacitance are not very critical.

The circuit of an experimental digital filter for the audio range is shown in Fig. 2. This circuit consists of a conventional mod-6 counter (7490) driving a BCD-to-decimal counter (7442).

The audio input to be filtered is passed through a simple clipper and then coupled to the digital filter consisting of R1 and the six transistor-switched capacitors (C1 through C6). The digital logic and transistors form the switch in Fig. 1A. The digital clock that actually tunes the filter can be any variable-frequency triggering source at six times the required filter frequency.

To tune the filter, connect the audio input to the clipper and a scope to the output. For a dual-channel scope, use the second channel to observe the sine-wave input. Care must be taken in tuning the variable clock since the Q of the circuit is high and the filtering action might be missed.

As the input is tuned up further in

frequency, a peaking in the digitized waveform will be reached at the harmonics of the original setup, with the steps getting coarser each time. This will happen until the harmonic number corresponding to the number of switching positions is reached (six, in this case). There will then be no output, but there will be at the next harmonic. As each harmonic is viewed, it will be lower in amplitude and coarser.

The filtered output signal is a distorted version of the original input so the output can not be used as a sine wave. However, it is useful for triggering other circuits. The bandwidth of the filter remains substantially the same even when the filter frequency is changed. Once built, to change the filter's center frequency, it is only necessary to change the clock frequency to the TTL counter (7490), with the frequency six times the input.

The number of switched capacitors is not limited to six but can be any number from a minimum of three to as many as required. The larger the number of capacitors, the smoother the displayed waveform. The number of capacitors also determines the clock frequency. With six capacitors, the clock must be six times higher in frequency than the input. With five switched capacitors, the clock must be five times higher than the input signal, etc. ♦

Fig. 1. At (A) below is a simple switch circuit which generates the stepped waveform shown at (B) from a sine wave.

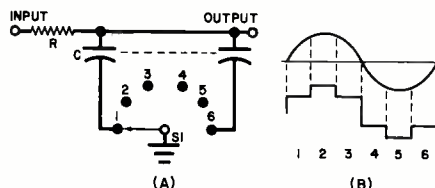
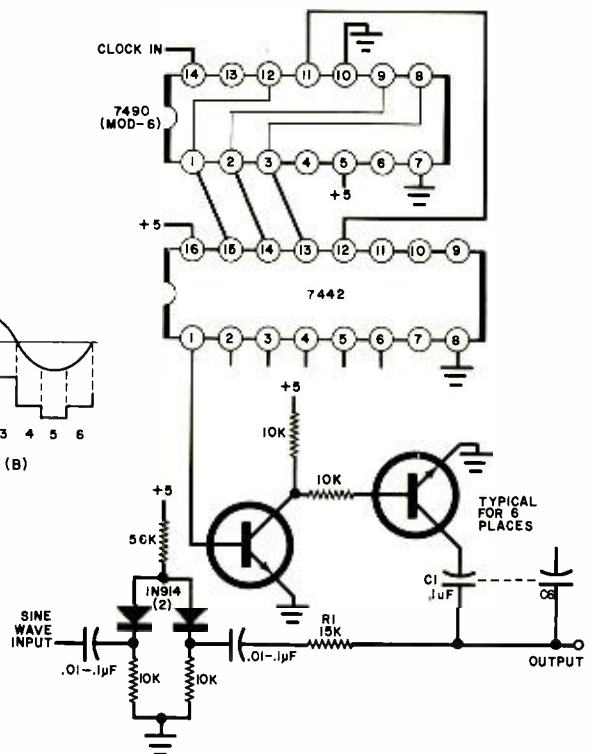

Fig. 2. Circuit of an experimental digital filter for the audio range (right).



IF YOU ARE READY FOR SERIOUS CAREER

# Learn College-Level





ADVANCEMENT NOW—

# Electronics at Home

## With CREI's unique Electronic Design Laboratory Program

There is only one way to a career in advanced electronics—through advanced training. You can get such training through a resident engineering college or you can take a CREI specialized college level electronics program at home.

**Wide Choice of Programs.** CREI offers you program arrangements with *fourteen* areas of specialization in advanced electronics. You can select exactly the area of specialization for the career you want.

CREI also offers program arrangements *both* for those with extensive experience in electronics *and* for those with only limited experience. All programs are college-level, except for a brief introductory level course, which is optional.

**Unique Laboratory Program.** CREI now offers a unique *Electronic Design Laboratory Program* to train you in the actual design of electronic circuits. You also get extensive experience in tests and measurements, breadboarding, prototype building and in other areas important to your career. The Lab Program makes it easier for you to understand the principles of advanced electronics. Only CREI offers this complete college type laboratory program.

The Lab Program includes professional equipment which becomes yours to keep. You will especially appreciate the Electronic Circuit Designer, which is available only through this program and which you will find extremely valuable throughout your professional career.

**College Credit.** You can actually earn college credit through CREI programs, which you can use at recognized colleges for an engineering degree. CREI maintains specific credit transfer arrangements with selected colleges in the U. S.

**Industry Recognized Training.** For nearly 50 years CREI programs have been recognized throughout the field of electronics. CREI students and graduates hold responsible positions in every area of electronics and are employed by more than 1,700 leading organizations in industry and government.

**Qualifications to Enroll.** To qualify for enrollment, you should be employed in electronics or have previous experience or practical training in the use of electronic equipment. You must also be a high school graduate or true equivalent.

**All CREI Programs are available under the G.I. Bill**

**Send for FREE Book.** If you are qualified, send for CREI's full color catalog describing these college-level programs and your career opportunities in advanced electronics. Mail card or write for your copy of this book.



**CREI** CAPITOL  
RADIO  
ENGINEERING  
INSTITUTE

McGraw-Hill Continuing Education Center  
3939 Wisconsin Avenue Northwest  
Washington, D. C. 20016



Accredited Member, National Home Study Council

# Planning to move?

Let us know 8 weeks in advance so that you won't miss a single issue of **POPULAR ELECTRONICS**.

Attach old label where indicated and print new address in space provided. Also include your mailing label whenever you write concerning your subscription. It helps us serve you promptly.

Write to: P.O. Box 2774, Boulder, CO 80302, giving the following information:

- Change address only.
- Extend subscription.  Enter new subscription.
- 1 year \$6.98
- Payment enclosed (1 extra BONUS issue)
- Bill me later

**AFFIX LABEL**

If you have no label handy, print OLD address here.

name please print  
address  
city state zip code

0889

name please print  
address  
city state zip code

Add'l postage: \$2 per year outside U.S., its poss. & Can.

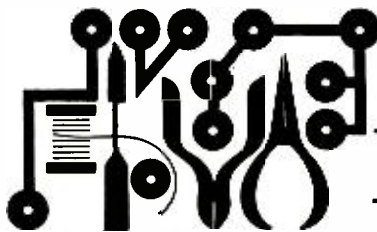

# Hobby Scene

## PUT AN ALARM ON PA SYSTEM

**Q.** We have an audio system in our plant (for background music, announcements, etc.). We would like to add some kind of alert signal to the system to be used in case of fire or other emergencies. The sound should be distinctive and capable of cutting through normal noise.

**A.** Try this circuit, using a pair of 555 timers or a single dual timer (if you use the correct pins). Capacitor C1 controls the speed of the warble, while C2

determines the pitch. The values shown should produce quite a distinctive signal. The output of the circuit goes to your audio amplifier.

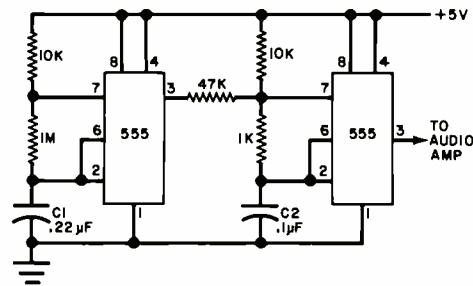

## CONVERTING TRANSISTORS TO PHOTODEVICES

**Q.** Somewhere I read that almost any transistor can be converted into a photodevice. Is this true? I would like to experiment along these lines. How do I go about it?

**A.** Although it does not make the greatest photodevice in the world, you can convert an ordinary metal-encased transistor into a light-sensitive device. Select a silicon type having a high beta and a high  $f_T$ . Preferably it should be planar passivated.

Very carefully cut away the case to expose the silicon chip—don't break the chip leads. Cut off the base lead. You will use only the collector and emitter leads. Seal the device in clear epoxy. That's all there is to it; if you were lucky enough to choose the right transistor, you will have a good photodevice. In one example we heard of, a 2N699 was converted and has a rise time of about 0.4  $\mu$ s and a fall time of about 0.6  $\mu$ s. You will need some form of amplification to get any useful output.

## HEAT-SENSITIVE TRANSISTORS

**Q.** Since many transistors are heat-sensitive, is there any way to use a transistor as a temperature-indicating device—with a simple circuit, of course?

**A.** Try the circuit shown here. The transistor should be a silicon, high-beta type. (We used a 2N2222.) The output is measured on a dc voltmeter, that could be calibrated in degrees F. Set the potentiometer for an output of 4 volts at 70°F. The transistor case should be exposed to the ambient temperature. As the case heats up, the output voltage goes down. Conversely, as the case cools, the output

goes up. The output swing can range from about 5 V at -30° or -40° to 2.5 V at 212° F.

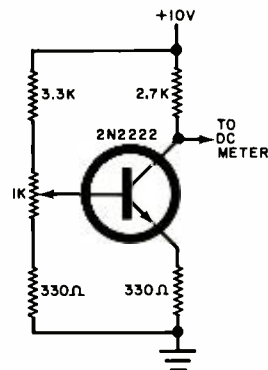

## SAVE!

**MONEY • TIME • FREIGHT**

- 🎵 QUALITY STEREO EQUIPMENT AT LOWEST PRICES.
- 🎵 YOUR REQUEST FOR QUOTATION RETURNED SAME DAY.
- 🎵 FACTORY SEALED CARTONS—GUARANTEED AND INSURED.
- 🎵 SAVE ON NAME BRANDS LIKE:
 

A.D.C.	KLH
A.R.	SHURE
DYNACO	KOSS
SONY	FISHER

AND MORE THAN 50 OTHERS

BUY THE MODERN WAY  
BY MAIL—FROM

**illinois audio**

Department 217S  
12 East Delaware  
Chicago, Illinois 60611  
312-664-0020

CIRCLE NO. 24 ON READER SERVICE CARD  
68



# STANDING WAVE RATIO

*What it is.*

*How it affects  
communications.*

*How and when to take  
corrective steps.*

**S**WR is a term used often in amateur and CB communications. Usually, it sounds as if the conversants were referring to an electromagnetic "bogeyman" which wreaks all manner of havoc in communications systems. Many strange powers are attributed to SWR, including the ability to destroy output tubes or transistors, make proper loading of transmitters difficult or impossible, neutralize a large portion of the output power, cause distortion, and even cause coaxial cable to heat up and melt its insulation.

Here's what SWR really is, how it affects communication systems and what can be done about it.

**What It Is.** SWR is an abbreviation for Standing Wave Ratio, and comes in three varieties: Voltage Standing Wave Ratio (VSWR), Current Standing Wave Ratio (CSWR), and Power Standing Wave Ratio (PSWR). It is defined as the ratio of the maximum parameter (voltage, current, or power) to the minimum, when sampled along a length of transmission line. Why do waves "stand" on a line? Let us consider a typical transmitter installation.

The transmitter sends a train of sine waves down the transmission line (the radio "hose" which carries power toward the load). If the impedance of the antenna is the same as the output impedance of the transmitter and that of the line, then the impedance of the entire system is constant, and since  $V = IZ$  (voltage equals current times impedance), the effective voltage and current are constant along the line, the maxima equal the minima, and the

SWR is one, or as commonly said "one to one."

However, if the impedance of the antenna is different from the transmitter output impedance and that of the line, the wave train, which was "used" to the  $V = IZ$  relationship of the line, experiences a new relationship at the abrupt change of impedance. In order to fit within the constraints of the laws electromagnetic waves obey, some of the power is sent back into the line, and a new wave train appears heading down the line toward the transmitter. When two waves headed in opposite directions meet, the result is a wave which stands still on the line. You can verify this with a simple experiment (see Fig. 1).

Tie a rope or string to some solid, stationary object (a tree or post will do). Grasp the free end and start waving the rope up and down. You are now generating a train of waves down

the rope, much in the way that a transmitter sends waves down a transmission line. When the waves reach the point where the rope is anchored, they experience a new condition—the post can't allow them to propagate, since it is a stationary, inflexible object, so the waves are reflected and propagate back down the length of the rope. This situation is analogous to the termination of a transmission line with an impedance different from that of the line. You will see a wave appear on the rope that does not move. It is generated by the combination of the forward and reflected waves, and is called a standing wave. The points on the rope that appear to be free of vibration are called nodes, and the points of maximum vibration are called loops or antinodes.

**What SWR Does.** When an imped-

*Fig. 1. Standing waves on a rope. Such waves are generated by the combination of travelling waves headed in opposite directions.*

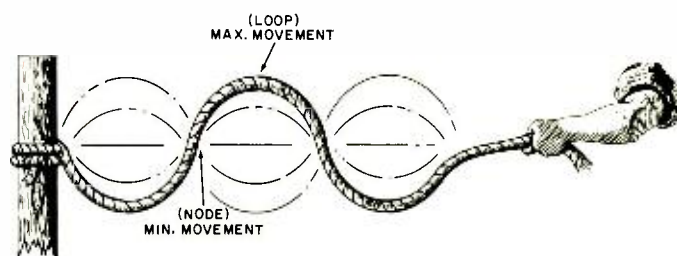

ance mismatch generates a standing wave on a line, the voltage and current distribution along the line is upset. In Fig. 2, we have plotted the voltage between the conductors of a transmission line as a function of the length of the line. A family of curves appears when various impedances are used to terminate the line. When  $Z_L$  (load impedance) is 50 ohms, we see that the effective value of the voltage along the line remains a constant 150 volts. This figure is determined by the equation  $P = V^2/Z$ , where  $P$  is 450 watts and  $Z$  is 50 ohms. The maximum and minimum voltage ( $V_{max}$  and  $V_{min}$ ) are both 150 volts, and the SWR, defined as  $V_{max}/V_{min}$ , is 150V/150V, or 1:1 (Spoken as "one to one").

When a 25-ohm load terminates the line, a standing voltage wave appears on the line.  $V_{min}$  equals 100 volts, and appears at the transmitter end of the line, and at integral multiples of one-half of a wavelength.  $V_{max}$  is 200 volts, and appears at odd multiples of one-quarter wavelength. The SWR is 200 V/100V, or 2:1. When a 100-ohm load is connected to the line, the values of  $V_{max}$  and  $V_{min}$  are the same as the case above, except that the 200-volt  $V_{max}$  appears at the transmitter end of the line, and at whole multiples of a half-wavelength.  $V_{min}$  (100V) appears at odd multiples of a quarter-wavelength.

A more extreme case is shown when a 500-ohm load terminates the 50-ohm

line. In this case,  $V_{max}$  equals 272 volts, and it appears at the transmitter end of the line.  $V_{min}$ , 27.2 volts, appears at odd multiples of a quarter-wavelength. The SWR is 272V/27.2V, or 10:1. We see that a large voltage is found at the transmitter—transmission line connection. This voltage may exceed the voltage rating of the active device(s) in direct-coupled final amplifier and destroy it. Transistors are much more intolerant of voltage overloads than tubes, and most will be destroyed instantly under such conditions. Even hardy vacuum tubes will blow when subjected to prolonged operation under these conditions.

If we terminate the line with a 5-ohm impedance, we note a  $V_{min}$  of 27.2 volts, at the transmitter feed point, and at integral multiples of a half-wavelength, and a  $V_{max}$  of 272 volts located at odd multiples of a quarter wavelength. As above, the SWR is 10:1.

High SWR will cause certain points along the transmission line to have a high r-f potential difference between conductors. In VHF or UHF systems, depending on the power rating of the cable, transmitter output power, and the SWR, this potential difference will be great enough to cause "hot spots" due to dielectric losses, or even arcing between conductors. "Hot spots" appear at current maxima in HF systems due to  $I^2R$  effects. High SWR can make transmitter tuning very critical,

necessitating large changes in control setting for a slight change in frequency. This occurs because the reactive effects of a mismatched line change with frequency, as does SWR.

Reactance, for the sake of review, is the opposition to ac offered by an inductance or capacitance. It is expressed in ohms, but is not a resistance—pure reactance does not dissipate any power, but returns a portion of the power to the generator during each cycle. A line not terminated in its characteristic impedance behaves in this manner by setting up a backward-travelling wave train. Equal amounts of capacitive and inductive reactance cancel each other out. For example, 25 ohms of inductive reactance combined with 25 ohms of capacitive reactance produce a net reactance of zero ohms.

The tuning and loading controls of a transmitter introduce amounts of inductive or capacitive reactance to cancel out the reactive properties of the line. If these adjustments are made correctly, the transmitter "sees" a purely resistive load. Impedance, the term we have used to describe the relationship between voltage and current in transmission lines and loads, is the phasor or vector sum of the resistance and reactance in a circuit.

If the characteristic impedance of the line ( $Z_0$ ) and the impedance of the load ( $Z_L$ ) are purely resistive, then the SWR may be obtained from:

$SWR = R_L/R_0$  for  $R_L > R_0$ , and  $SWR = R_0/R_L$  for  $R_0 > R_L$ . For example, if  $R_0$  is 50 ohms, and  $R_L$  is 25 ohms, the SWR is 50 ohms/25 ohms, or 2:1.

So far, we have not mentioned power loss as one of the seriously harmful effects of SWR on a communications system. Many operators look upon output power as a commodity more precious than gold, and develop ulcers at the thought of losing any of it to resistive or reactive elements in the system. While it is true that SWR indicates that a part of the transmitter output is not reaching the antenna, the amount of power lost in most situations does not justify the degree of concern it generates.

How can we determine what fraction of the power is being returned to the transmitter? A quantity called the reflection coefficient,  $\rho_r$ , gives this information. The reflection coefficient is defined as:

$$\rho_r = \frac{Z_L - Z_0}{Z_L + Z_0} = \frac{SWR - 1}{SWR + 1}$$

Fig. 2. Voltage measured along a 50-ohm transmission line fed with 450 watts of 20-MHz r-f when connected to various loads. Voltage Standing Waves are generated when the line is mismatched.

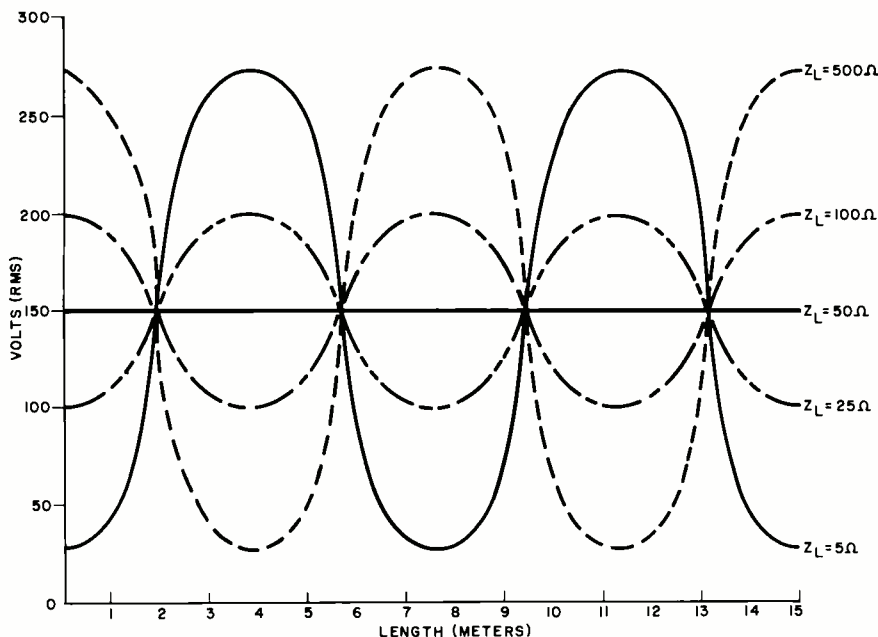



If a line has an SWR of 2:1, then the reflection coefficient is  $(2 - 1)/(2 + 1)$ , or  $1/3$ . This means that  $1/3$  of the voltage wave sent down the line by the transmitter is returned. Since the power  $P$  equals  $V^2/Z$ , the fraction of the power returned is equal to  $\rho_r^2$ , or  $1/9$ . The portion of the power which is delivered to the antenna (neglecting line losses) may be expressed as the ratio of  $P$ , the power which reaches the load, to  $P_m$ , the power which would

monitor the magnitudes of the parameter we choose to measure.

There are many units available which will monitor SWR. The most common type is called a reflectometer or SWR bridge. A typical reflectometer includes two jacks, to which cables from the transmitter output and the antenna are connected, a sensitive meter with a direct SWR scale calibration, a sensitivity control which is used to calibrate the unit, and a selector

1.5:1. Then, for one reason or another, you permanently move the transmitter and have to add on a piece of transmission line, or trim the line to fit the new operating location. The next time you tune up, you find you have an SWR of 3:1. "What's going on here?" you might wonder, since frequencies haven't changed or the antenna altered.

The answer to the higher SWR reading lies in the properties of a mismatched transmission line. Not only does a mismatch set up voltage, current and power standing waves, but an impedance one as well. If the mismatch is severe, but the transmission line is an odd multiple of a quarter-wavelength, the reactive effects of the line are hidden from the reflectometer and the transmitter (if the meter is inserted into the line close to the transmitter). In the first case, the line was close to this special length. But when the length was changed the true situation on the line was no longer hidden.

You may have noticed that some mobile antennas come with a length of transmission line attached, and the manufacturer's instructions clearly advise that the line not be cut, but that the excess be rolled up and stowed somewhere along the path the line will follow. This length is a quarter-wavelength or an odd multiple. Such antennas normally operate with a high SWR, but the length of the line is chosen to hide this from the transmitter. As you can see, you can't put absolute faith in a reflectometer reading.

There is an easy way to make sure that the SWR reading that the reflectometer is showing you is a close approximation of the actual SWR. Fig. 3 shows a typical installation configuration for a reflectometer.

The reflectometer may be inserted at any point along the transmission line, but as noted it may give different readings at various points. Which one is the true SWR? If the bridge is located at the antenna feed point, with the antenna connected directly to the output jack of the SWR bridge, then the reflectometer will indicate the true SWR on the line. This is an inconvenient place to connect the bridge, however, since most antennas are mounted a considerable distance away from the transmitting equipment, out of the operator's view.

Because of this difficulty, almost all SWR meters are inserted into the line near the transmitter or the operating position. If this is the case at your in-

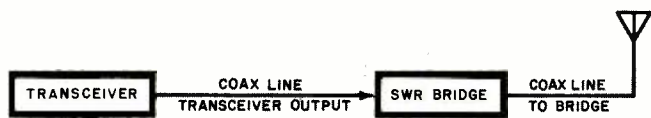

*Fig. 3. Typical SWR bridge installation. Bridge is placed in series with coaxial line along the way to the antenna at a convenient spot.*

reach the load if the system were matched, by the formula:

$$\frac{P}{P_m} = (1 - \rho_r)$$

$$= \frac{4 \times \text{SWR}}{(\text{SWR} + 1)^2}$$

The power loss with a 2:1 SWR is not great (11% or  $1/2$  db). The human ear, or most S meters for that matter, could not tell the difference. Only when the SWR reaches 5:1 do we note a reflection of one half of the transmitter output power. This may sound like a large power loss, but it will only register as a 3-dB decrease in signal strength on an S meter. When such a meter is properly calibrated, one S unit equals 6 dB, so the decrease in signal strength caused by a 5:1 SWR will amount to only one half of an S unit. Many operators would be hard pressed to detect the differences using just their ears. However, as we have noted, this does not mean you should allow such a state of affairs to exist.

**How To Measure SWR.** If, at a certain point along the transmission line, we sample the magnitude of the forward-going voltage wave, and then the reflected voltage wave, we can take the ratio of these magnitudes (forward to reflected) and obtain the VSWR. We could also sample power and obtain the PSWR. Devices which pass energy in only one direction are called directional couplers. An SWR monitor can be made by inserting two directional couplers into the line, and connecting them to meters which will

switch which connects the meter to one of two directional couplers. Prices of these reflectometers are usually \$15 to \$20, and the following comments pertain only to these types of reflectometers, not the more expensive, well engineered units.

**The Truth About Reflectometers.** Reflectometers of this type are adequate for most amateur and CB purposes, but there are a few realities that must be recognized before attempting to use one and obtain meaningful results. Reflectometers are designed to give a relative indication of SWR, but accuracy varies from unit to unit, and they are easily "fooled" into giving readings which do not truly reflect the conditions on the line.

If it were possible to connect the reflectometer to the line at any point (which is not convenient, since the line has to be interrupted to insert the reflectometer), we might get a wide range of values of SWR from the meter. Does this mean that the SWR varies from point to point? No, it merely means that the line at certain points "hides" the true value of SWR from the reflectometer. If you already have an SWR Bridge, and have done some antenna experimentation, you might have encountered the following situation.

After installing a new antenna, a feedline is connected and run down to the transmitter. At the transmitter input, you connect the bridge and tune up the transmitter. After adjusting the bridge, you read an SWR of

stallation, you should connect a piece of transmission line, using a dual-female adapter and properly installed coaxial plugs between the line and the bridge. The extension should be less than  $\frac{1}{8}$  wavelength long. After installing the extension, tune up the transmitter (legally!) and note the SWR. If it has changed radically from the previous reading, you can be certain that a high SWR exists on the line and that any low readings are false. The test may also be run by trimming the feedline, but usually this is inconvenient, since any cuts in the cable are permanent.

**What To Do About SWR.** Now that you've made sure your SWR bridge is telling the truth and you find that you have an SWR of 3:1, what should be done? Should you fool around with the feedline or antenna or just leave things as they are? The answer depends on the type of feedline you have and the limitations of your transmitter.

If your transmitter is built to withstand "infinite SWR," then you can tolerate such a mismatch, and the power lost will not seriously degrade the strength of your signal. However, if you are using a transmitter which can take a maximum SWR of 2:1 (consult the spec sheet for this), and/or you are running an output close to the maximum power rating of the coaxial feedline, then you should take steps to make the mismatch less severe or make things appear that way.

Perhaps the easiest way to do this, if the load is highly reactive (a miniwhip or other loaded antenna), is to trim the length of coaxial feedline for a tolerable sending-end impedance. This does not really solve the mismatch problem, however.

The best way to correct a mismatch

is to adjust the antenna or the feedline impedance for a good SWR. Most commonly available transceivers and transmitters are designed to work into 50-to-75-ohm loads, and are tolerant of a maximum mismatch of 2:1. The range of impedances that the transceiver can work into is therefore from 25 to 150 ohms. If you are operating on one band only, 11 meters or one of the amateur bands between 7 and 30 MHz, you can use a simple dipole for edge-to-edge coverage. The maximum SWR should be 2:1, although it varies with the height above ground.

Most verticals can also cover an entire band with the same range of SWR. There is one trick to the successful operation of all vertical antennas. To obtain a decent SWR and efficient radiation, a good ground system *must* be used. If the vertical is roof-mounted, a radial system using at least five quarter-wave wires must be installed. The radials should droop slightly toward the roof.

A good radial system will include as many as 200 or more radial wires. Since copper wire is expensive these days, it is economically wise to use aluminum radials in your ground system.

By adjusting the radial system of a vertical, a dipole's height above ground, or a "gamma match" on a beam, you are changing the antenna feedpoint impedance to a value which is closer to the characteristic impedance of the feedline, thus reducing the mismatch. This is the most effective way to reduce SWR.

There is another approach, however—matching networks or "transmatches." These devices act as variable impedance transformers, converting a wide range of loads to the ideal 52 ohms. Transmatches also

tune out any reactance that the feedline may present to the transmitter, making it easier to load up the output stage. If a transmitter has a pi-network output, or a transmatch is used, SWR does not contribute to a power loss in the system. The network is adjusted to present the right amount of reactance necessary to cancel that at the load. Any power that is reflected down the line from the load will simply be rerouted back to the load. A forward-power measurement would show a greater amount than the transmitter output due to this compensation.

Figure 4 shows two configurations for transmatches. At "A" we see that a transmatch has been installed at the antenna end of a stretch of 50-ohm transmission line. A 100-ohm resonant antenna has been connected directly to the output of the transmatch. If we adjust the matching network to step down the 100-ohm impedance to a 50-ohm one, the SWR bridge will read 1:1. This is a true reading, since the transmitter output impedance, the line characteristic impedance, and the transformed antenna impedance are all 50 ohms. There are no standing waves on the line.

At "B" we have a second case. The transmatch is located at the transmitter end, right after the SWR bridge. Between the transmatch and the antenna, whose impedance is 100 ohms, a 50-ohm transmission line is connected. If we adjust the transmatch to give a 1:1 SWR reading on the reflectometer, do we have the perfectly matched condition at "A"? No, we don't! Although the transmatch fools the transmitter into thinking so, by presenting a 50-ohm impedance for the transmitter output, we still have an SWR on the transmission line due to the feeder/antenna mismatch.

When can SWR be ignored? If you are running output power well below the maximum rating of the feedline, and do not exceed the mismatch toleration of the transmitter, then you can safely ignore the SWR. If transmitter tuning becomes balky, feedlines heat up, or output amplifiers pop, then you should put into action one of the above-mentioned plans.

Try adjusting the antenna first. If you still have problems, make sure your transmission line and its connectors are in good shape. An antenna matcher should be used as a last resort (for coaxial lines). Above all, don't listen to the old wives' tales about SWR!

*Fig. 4. Transmatch configurations. Matching networks are adjusted to present a 50-ohm impedance to the transmitter. A mismatch can still appear at the antenna depending on where the transmatch is inserted.*

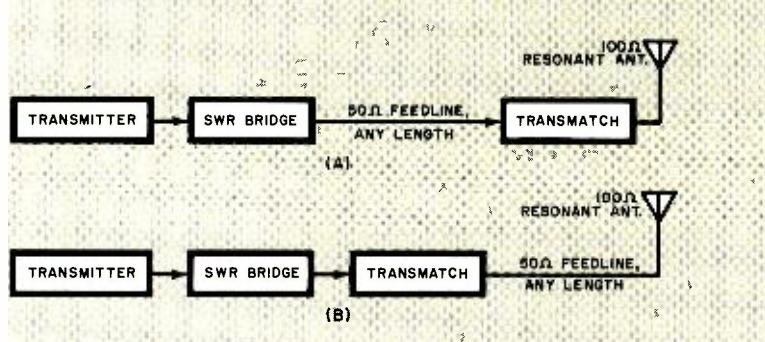





# Product Test Reports

## ESS MODEL 200 STEREO POWER AMPLIFIER (A Hirsch-Houck Labs Report)

Low-dollar-per-watt "super-power" amplifier

**T**HE ESS Model 200 stereo power amplifier brings to the hi-fi purist high power, extremely low distortion, wide bandwidth, and stability under varying reactive loads at an attractive price. It is conservatively rated at 100 watts/channel over a frequency range of 20 Hz to 20,000 Hz. This is backed by less than 0.5 percent IM and harmonic distortion figures. All of which are certainly enough to satisfy the most critical home listening needs.

This is a basic power amplifier, lacking any type of user controls. In fact, it doesn't even have a power switch; it is designed to be switched on and off by the preamplifier with which it is used (which means that the preamp's switched outlet system must be hefty enough to accommodate the heavy surge of current drawn by the power amplifier). The only thing on the front panel is a pilot lamp located behind the ESS logo where it glows a soft blue when power is on. The signal inputs and outputs, fuse holders, and an accessory ac outlet are located on the rear apron of the amplifier.

The amplifier measures 16 3/16 in. (41.1 cm) wide by 11 3/4 in. (29.8 cm)

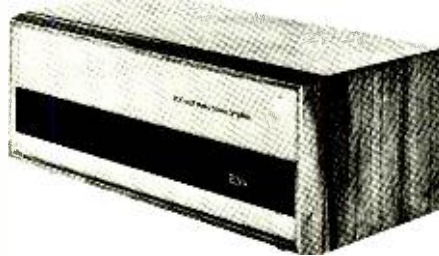

deep by 6 in. (15.2 cm) high. It weighs 23 lb (10.5 kg). The retail price of the ESS Model 200 stereo power amplifier is \$399.

**Laboratory Measurements.** With both channels driven at 1000 Hz into 8-ohm loads, the output waveforms clipped at 136 watts/channel. Into 4-ohm loads, clipping power measured 196 watts, while into 16-ohm loads it was 81 watts/channel.

At 1000 Hz, the THD was less than 0.01 percent — typically 0.007 percent — from 1 watt to about 125 watts output. The IM distortion was below 0.01 percent from 10 mW to 100 watts output, indicating a total absence of "crossover" distortion. The IM distortion reached 0.4 percent at 140 watts output.

At full power (100 watts), the distortion was a maximum of 0.04 percent at 20 Hz. It fell off steadily to 0.005 percent or less in the range between 1500 Hz and 16,000 Hz. The half-power distortion was essentially the same, and at one-tenth of rated power, it measured between 0.007 and 0.009 percent from 60 Hz to 20,000 Hz. At lower frequencies, the distortion was the same at all power levels.

An input of 0.55 volt drove the amplifier to 10 watts output, our standard reference level. The unweighted noise was 85 dB below the 10-watt level. The frequency response was +0.1/-0.3 dB from 20 Hz to 20,000 Hz. It fell to -3 dB at 6 Hz and 150,000 Hz.

**User Comment.** The ESS Model 200 amplifier obviously belongs in the same category as most of the far more expensive (and slightly more powerful) "super-power" amplifiers on the market. It has totally clean, distortionless sound. We could never detect, by ear, any difference between the ESS amplifier and several of the super-power amplifiers in a direct A-B comparison, so long as we did not exceed its maximum power capabilities. But even with low-efficiency speaker systems, exceeding the amplifier's power capabilities is no easy task.

The amplifier runs only slightly warm to the touch in normal service. For operation at high sustained power levels, especially with 4-ohm loads, however, a fan is recommended for additional cooling.

The amplifier is protected against damage by electronic dissipation limiters. It also has separate fuses in its dual-polarity dc power supply and in the ac line. Although we did not damage the amplifier by extended high-power operation or occasional

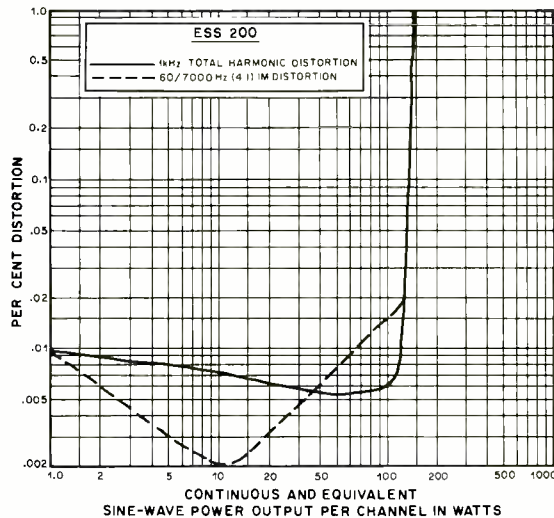
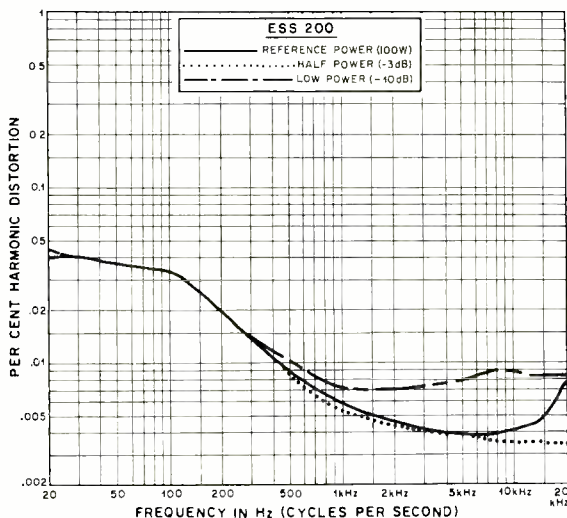

overload, the dc power supply fuses did blow, particularly when we tried to make full-power measurements into 4-ohm loads.

The ESS Model 200 stereo power

amplifier is, in our opinion, a notable value in today's market for critical listeners who want a state-of-the-art amplifier with enough power to make peak clipping a rare occurrence. This

is especially true if you balk at having to pay \$500 or more for the performance you get from the Model 200 for only \$279.

**CIRCLE NO. 65 ON READER SERVICE CARD**

## SYLVANIA MODEL RS-4744 STEREO RECEIVER (A Hirsch-Houck Labs Report)

*Features PLL FM decoder and direct-coupled 60-W/channel amp.*

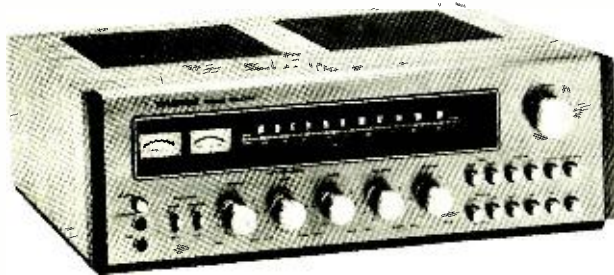

**T**HE MODEL RS-4744 is Sylvania's finest AM/stereo FM receiver. Its FM tuner section features a phase-locked loop (PLL) multiplex decoder and direct-coupled 60-watt/channel power amplifier. Switching is provided for two pairs of speaker systems and for driving rear speaker systems with a modified difference signal for a simulated 4-channel effect from stereo programs.

**General Description.** A group of 12 pushbutton switches provide for a selection of the program source and the mode of operation. The source selection includes two magnetic phono cartridge inputs (one can be switched, in the rear of the receiver, to operate with ceramic cartridges), FM, AM, and AUX. Two tape monitor switches permit playback from either of two tape decks or monitoring from either while recording the program being played through the receiver, as well as copying a tape from one machine onto another.

When both phono input switches are activated, signals from a microphone plugged into a front-panel jack appear at both speaker outputs as well as at the tape recording outputs. Other pushbutton switches control FM muting, loudness compensation, mono/stereo mode selection, and the high- and low-cut filters. (The filters employ active circuits to produce cutoff slopes of 12 dB/octave instead of the simpler and more common 6 dB/octave slopes provided by the filters in most stereo receivers.)

In addition to the usual bass and treble tone controls, this receiver also

has a midrange control whose action is centered at about 1000 Hz. The tone controls are slightly detented at their center (flat) positions.

The receiver has all the normal signal inputs and outputs of a stereo setup. There are also separate preamplifier outputs and power-amplifier inputs. These are joined by jumpers that can easily be removed to connect into the system an electronic crossover, active equalizer, etc. Inputs for 300-ohm and 75-ohm FM antennas and an external AM antenna, as well as a rod-type AM antenna, are also provided. Insulated spring connectors are used for the speaker outputs. A third set of outputs (marked PQ4), with an adjacent slide switch, is used for supplying synthetic rear-channel programs through a separate pair of speaker systems.

The receiver is protected against damage by internal electronic circuits and three push-to-reset circuit breakers. One circuit breaker is for the ac

line circuit, while the other two are for the speaker-output lines. For convenience, there are two unswitched and one switched ac outlets on the rear apron.

Supplied with a walnut-finished cabinet, the receiver measures 17¾ in. wide by 15 in. deep by 6 in. high (45.1 × 38.1 × 15.2 cm) and weighs 26 lb (11.8 kg). It retails for \$429.95.

**Laboratory Measurements.** The receiver met or surpassed all the published specifications we were able to test. The FM tuner section has a 2- $\mu$ V IHF usable sensitivity in mono (8  $\mu$ V in stereo, which is also the input threshold for automatic mono/stereo switching as well as for the FM muting circuit). The 50-dB quieting sensitivity was a very good 3  $\mu$ V in mono and 35  $\mu$ V in stereo.

Distortion at 1000  $\mu$ V was 0.5 percent in mono and 1.0 percent in stereo. (These figures could have been halved by retuning the receiver at each input level, but this is not in accordance with the IHF test procedure.) The ultimate S/N ratio was 70 dB in mono and 63 dB in stereo.

The PLL multiplex decoder produced exceptionally uniform stereo separation—about 32 dB across most of the audio-frequency range, 28.5 dB at 30 Hz, and 29.5 dB at 15,000 Hz. The FM frequency response was within  $\pm 0.5$  dB from 30 Hz to 13,000 Hz. It fell to  $-2$  dB at 15,000 Hz due to the low-pass filters in the audio outputs. These were very effective in removing 19-kHz pilot carrier leakage, which was 72 dB below the output from a 100-

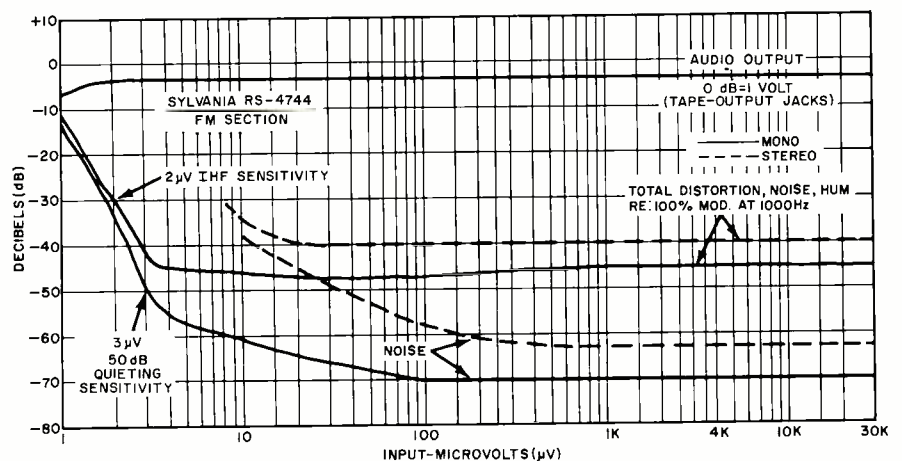



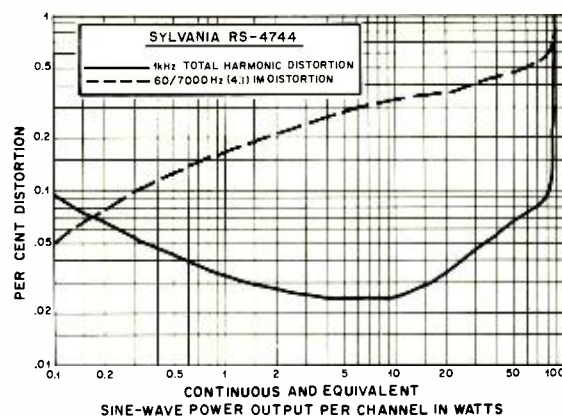
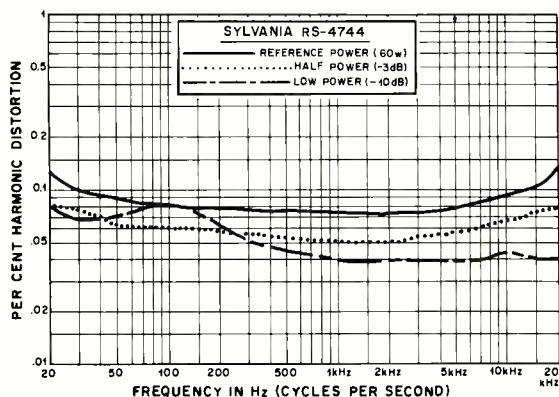

percent-modulated signal. The AM frequency response was down 6 dB at 85 Hz and 3400 Hz.

The audio amplifier was conservatively rated. It clipped at about 81.5 watts/channel with both channels driven simultaneously into 8-ohm loads at 1000 Hz. The 4-ohm clipping power was 87.5 watts, and the 16-ohm power was 56.5 watts/channel.

At 1000 Hz., the THD was less than 0.1 percent from 0.1 watt to about 80 watts/channel. At most power levels, it was less than 0.03 percent. The IM increased from 0.05 percent at 0.1 watt to 0.3 percent at 10 watts and 0.5 percent at the rated 60 watts. At very low outputs (3 mW or so), the IM was still only 0.25 percent. At the rated 60 watts or less output, the THD was typically less than 0.08 percent. It reached a maximum of 0.13 percent at 20 Hz and 20,000 Hz, with 60 watts/channel output.

A high-level input of 88 mV was needed to drive the amplifiers to 10 watts output with a 77.5-dB S/N ratio. Through the phono inputs, the sensitivity was a very good 0.82 mV; yet, the overload point was a high 82 mV. The phono S/N ratio measured 72.5 dB, referred to 10 watts output. The RIAA equalization was very accurate, within  $\pm 0.5$  dB from 20 Hz to 20,000 Hz.

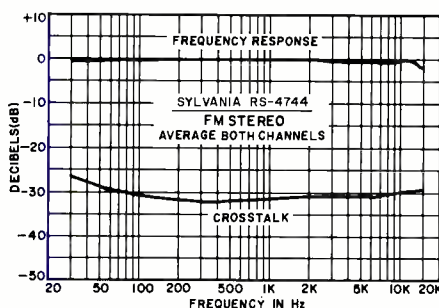

(We were pleased to note that the equalization was not affected significantly by cartridge inductance, unlike the case with most amplifiers, which exhibit loss of several decibels at 10,000 Hz or higher from this interaction.)

The loudness compensation boosted only the low frequencies to a moderate degree. With their excellent 12-dB/octave slopes, the filters had -3-dB points at 70 Hz and 4000 Hz. The bass and treble tone controls had the familiar characteristic of feedback-type controls, with a variable bass turnover frequency and a high-frequency action hinged at about 1500 Hz. The midrange control had its maximum effect at about 500 Hz with partial settings, sliding up to about 1200 Hz when the full 10-dB boost or cut was used.

**User Comment.** The Sylvania Model RS-4744 receiver revealed itself in our tests to be well above average in the important performance aspects. Its FM tuner is competent, with an accurately calibrated dial (within 100 kHz of the indicated setting across the full FM band). The FM muting action is very positive, with a distinct click or thump when it operates, but without bursts of noise or program modulation.

The receiver's audio amplifiers must be considered outstanding for a receiver in the RS-4744's price range. Usually one must pay considerably more money to match the power output of this receiver, and the variety and flexibility of its control functions should be sufficient to satisfy most critical users.

The PQ4 mode of operation gives an excellent sense of ambience with most stereo programs. Its operation depends on having four speaker systems of roughly equal efficiency, since there is no differential front-rear level control.

If the Model RS-4744 is any sample of what Sylvania has in store for the high-fidelity market, the company should soon be a force with which to reckon.

**CIRCLE NO. 66 ON READER SERVICE CARD**

## REALISTIC MODEL TRC-24B CB TRANSCEIVER

*Mobile rig operates on 23 channels with effective noise blanking.*



**T**HE Realistic Model TRC-24B is an FCC type-accepted CB transceiver that operates at the full legal

power on all 23 AM channels by means of a frequency synthesizer. It is a compact solid-state rig that features a very effective noise-silencing system. This system consists of an r-f series-gate and that can be turned on or off, along with a noise blanker. Other features include the usual adjustable squelch, external-speaker jacks, PA operation, Delta tuning, signal-strength/relative r-f output metering, and transmitter-indicator.

The transceiver is supplied with a detachable dynamic microphone and mobile mounting hardware. The retail price is \$159.95.

**The Receiver.** The receiver employs double conversion, with the i-f's located at 11,275 and 455 kHz. The r-f input amplifier is neutralized to insure good stability and sensitivity, the latter measuring in our lab as 0.4  $\mu$ V for 10 dB (S + N)/N with a 1000-Hz signal at 30-percent modulation.

The high first i-f provides good image rejection, found to be 60 dB in

our tests. The second mixer is a bit unusual in that it is a balanced type that employs two transistors. This type of circuit enhances the minimizing of spurious responses (down 50 dB in our tests). Unwanted signal rejection is aided by bandpass-coupling circuits between the two mixers. The i-f signal rejection was 80 dB.

The second mixer is also used as the noise-blanker switching circuit that momentarily interrupts the signal path during each noise pulse. Since it is a balanced configuration, noise that might otherwise be due to switching transients is eliminated. This makes the whole setup more effective.

The blanker is somewhat different from the usual. The noise pulses that trigger the switching are detected after being picked up directly from the antenna through two cascaded r-f amplifiers tuned just outside the CB range.

Two ceramic filters at the 455-kHz i-f determine the selectivity, which provided a good minimum adjacent-channel rejection figure of 50 dB. The overall bandpass response, including that of the audio system, was 450 to 2000 Hz at the 6-dB points.

The squelch threshold sensitivity

could be varied from 0.5 to 1000  $\mu\text{V}$ . The agc held the a-f output to within 6 dB with a 20-dB r-f input change at 1 to 10  $\mu\text{V}$ , and to 5 dB with an input change of 60 dB at 10 to 10,000  $\mu\text{V}$ . The S meter required 300 $\mu\text{V}$  for an S-9 reading.

The Delta-tune system is handled by a three-position toggle switch that shifts the receiver frequency a fixed amount above or below the center frequency. In our sample unit, it provided a change of +1425 Hz and -2450 Hz.

The receiver's frequency-determining system consists of 12 crystals. Six are cut for around 23,390 kHz, four for around 14,960 kHz, one at 11,730 kHz for receive, and one at 11,275 kHz for transmit. Bandpass filters are used where needed to minimize spurious responses.

The maximum audio output from the class-B output stage on receive or PA operation was 3.5 watts with 5-percent distortion at the start of clipping, using a 1000-Hz signal and 8-ohm load.

**The Transmitter.** The transmitter is a conventional affair, with the r-f driver and power amplifier collector-modulated by the receiver section's a-f

system. It employs an output-matching and filtering network, along with a TVI trap. Transmit/receive transfer is accomplished without relays.

Operating at 13.8 volts dc, the transmitter's carrier output was 4 watts. A 100-percent modulation level was attainable with 4 percent distortion (at 1000 Hz) and 10 percent distortion with a 6-dB increase of the speech input level beyond that needed for 100-percent modulation. Amc is employed, which provides a degree of compression between 50 and 100 percent modulation. Although it holds the modulation within 100 percent on the positive peaks, it does not limit the negative peaks. Nevertheless, with the EIA standard test at 2500 Hz, the adjacent-channel splatter was at least 45 dB down. Otherwise, the overall a-f response was 225 to 4800 Hz at the 6-dB points. The frequency tolerance varied between -174 and -678 Hz, depending on the channel in use.

The transceiver is designed to be operated from only negative-ground systems. Reverse-polarity protection is provided, and a line filter is engaged to minimize noise picked up through the supply leads.

**CIRCLE NO. 67 ON READER SERVICE CARD**

## WAVETEK MODEL 30 AUDIO SWEEP GENERATOR

*Battery-operated unit has three ranges from 2 to 200,000 Hz.*

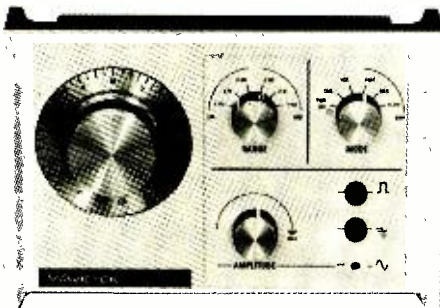

**N**OT TOO long ago, the only economical way of plotting the response of an audio amplifier, filters, and the like was by point-by-point entry on graph paper at various frequencies obtained from a signal generator. The process was time-consuming and tedious. No matter how you approached the problem, you had to look forward to many hours of dial "twiddling," reading and recording an output meter indication, and laboriously plotting the resulting curve.

The introduction of the low-cost (\$149.95) Model 30 precision audio sweep/function generator by Wavetek

has eliminated the tedium and reduced the time required for frequency response plotting to only a few minutes. This instrument has a frequency range of from 2 Hz to 200,000 Hz in three overlapping ranges that include 2 to 2000 Hz, 20 to 20,000 Hz, and 200 to 200,000 Hz. Dial accuracy is 2 percent of the range out to 20,000 Hz. And the output is available in either a linear or a logarithmic sweep.

**General Description.** Flexibility of the Model 30 is enhanced by five modes of operation. When the MODE switch is set to DIAL, the instrument operates as an excellent manually variable signal generator, with the main tuning dial used to set the desired frequency. In the VCG position, the generator's output frequency is a function of an external voltage applied to a rear-apron connector, permitting use in either a linear or a logarithmic mode. The three selectable sweep times range from FAST (2.5 ms) to MEDIUM (250 ms) to SLOW (25 s). For greater sweep-rate versatility, connectors are provided on the rear apron for

tying in external timing capacitors for virtually unlimited increase in sweep speed.

There are a number of different outputs available from this instrument. In addition to the usual sine-wave output that is variable in amplitude to about 1 volt rms from a 600-ohm source, there is a pulse output connector on the front panel, the signal from which can directly drive TTL devices. Output connectors on the rear apron deliver a 1-volt peak-to-peak triangle signal and a sync signal that is in parallel with the front panel output.

The power source for the instrument is a conventional 9-volt transistor battery that can operate the generator for a full eight hours. For \$25 over the cost of the basic instrument, you can buy an optional nickel-cadmium battery pack and plug-in charger. The battery pack provides three hours of continuous operation from full charge, and the recharger doubles as a battery eliminator (ac power supply) when the generator is used on a test bench.

**User Report.** To merely describe the Model 30 cannot do justice to this instrument. One must actually operate it



to appreciate its unique features. For example, the instrument case is designed to permit the instrument to be laid flat or stood upright, while providing full access to all controls and connectors. The side members of the case act as excellent hand grips.

The controls and switches, particularly the main tuning dial, have the positive action generally associated with good-quality test gear. The control knobs are recessed below the level of the handgrips, while the main tuning control's dial is further recessed into the front panel itself. The uncluttered control panel has a no-nonsense look about it, with all controls and connectors clearly marked according to function and position.

Within a couple of hours after opening the carton in which the instrument

arrived, there was very little in the way of filters and audio systems within our reach that we did not put to the test. The generator was very simple to use. Its output is simply connected to the device to be tested, an oscilloscope is connected to the output of the device under test, the generator's controls and switches are set as desired, and the results appear on the scope's CRT. Total elapsed time to make a frequency-response check is about three minutes—including checking out the performance of bass and treble controls and even some multi-range frequency equalizers.

Because of its relatively low price and great use potential, we feel that the Model 30 sweep function generator fills a long-overdue purpose.

**CIRCLE NO. 68 ON READER SERVICE CARD**

### MURA MODEL 250-M MULTIMETER

*Low-cost, compact instrument for bench or portable use.*



**B**ENCH-TYPE multimeters are becoming more versatile with every passing year. Some new VOM's offer more measurement ranges than before—at prices the same as demanded for older instruments. As more and more versatility is being built into them, the VOM's themselves are becoming more and more compact. One good example of these trends is the Model 250-M multimeter from the Mura Corp. (It retails for \$42.95 from electronic instruments distributors.)

The Model 250-M is physically small, measuring only 7<sup>3</sup>/<sub>8</sub> in. by 4<sup>1</sup>/<sub>2</sub> in. by 3<sup>1</sup>/<sub>2</sub> in. (17.8 × 11.4 × 8.9 cm). It has a taut-band meter movement, 23 measurement ranges, meter reversal, etc. Operation is from a single C cell.

The instrument's basic dc sensitivity is 30,000 ohms/volt. There are eight dc voltage ranges that span from 0.5 volt to 2500 volts full-scale with an accuracy of 3 percent. Five ac voltage ranges cover from 15 volts to 1000 volts full-scale at 10,000 ohms/volt

sensitivity and with 4% accuracy. Direct current is measured in six ranges from 50 μA to 5 A full-scale with 3% accuracy. Three overlapping resistance ranges cover from 0 to 3 megohms with a 3% accuracy. Finally, a built-in decibel scale uses a capacitor-coupled input to the ac-voltage circuit to provide a measurement range of -20 dB to +62 dB in 5 ranges.

The instrument presents a pleasing appearance with its brushed-aluminum control panel and clean black range/function markings. Separate banana jack inputs are provided for 2.5-kV dc, 5-ampere, and capacitor-coupled inputs.

The 4-in. (10.2-cm) meter movement is diode protected. The instrument's circuitry has an internal fast-acting fuse. (An extra fuse is provided.) The range selector knob is large and comfortable to use. The rotary switch to which it is attached has positive detent action. A small knob, centered below the meter movement, provides a convenient zero-centering mechanism for the meter's pointer.

We tested the Model 250-M multimeter, using voltage, current, and resistance standards. The instrument's ranges on each function tested fell within the published specifications. After a few weeks using the multimeter on our workbench, we tested it again with the same standards. It checked out exactly as before.

**CIRCLE NO. 69 ON READER SERVICE CARD**

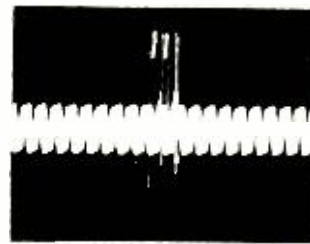

Actual, unretouched photo of an oscillograph test.

The oscillograph you see is an actual photo of a high-quality audio system "playing" a fingerprint.

You're hearing fingerprints now through your speaker system. Instead of the sound your precious discs are capable of. And no vacuum record cleaner, brush-arm or treated cloth will remove them. None.

## The sound of your fingerprint

But Discwasher™—with new **du** fluid—removes fingerprints completely. Along with dust. And manufacturing lubricants (added to make pressing faster) that can act like grove-blocking fingerprints. All this cleaning without pulling polymer stabilizers from your vinyl discs.

Discwasher™. The only safe, effective way to silence the printed finger. At Audio specialists world wide.



**Discwasher, Inc.**

909 University,  
Columbia, Mo. 65201

**CIRCLE NO. 15 ON READER SERVICE CARD**



# LOW-COST, EASY-TO-BUILD POWER SUPPLY

## 12-V/6-A SUPPLY FOR MOBILE AND PORTABLE EQUIPMENT

BY CRAIG ANDERTON

**A** NUMBER of electronic devices today require a stable 12-volt dc power source capable of delivering several amperes of current. For such items as mobile CB and ham transceivers, car tape decks and radio receivers, portable TV receivers, etc., you need a power supply like the 6/12 circuit shown in the schematic.

This ac power supply is designed to deliver 12 volts dc at 6 amperes continuous. (Hence the name 6/12.) The supply will also deliver 8 amperes on a 50-percent duty cycle or, with very

good heat sinking and ventilation, 8 amperes continuously. Additionally, a simple modification will provide a 13.6- or 15-volt output. You get all of this, plus better than 1 percent regulation from no load to full load, for about \$18 in parts, plus chassis.

To achieve stable regulation from the 6/12 power supply an LM309 IC is used. This integrated circuit is specifically designed for voltage regulation over a wide range of load conditions.

When assembling the supply, good construction procedures must be ob-

served. Use mica insulators, coated on both sides with silicone grease, when mounting the transistors and regulator IC to electrically isolate them from the heat sink. Provide adequate heat sinking for the power diodes and good ventilation for the entire circuit. When you interconnect the components, use only heavy-gauge wire. And when you finish assembling the power supply, double check your work to make certain that the components are properly polarized.

To change the output voltage, all you have to do is change the zener diode. The LM309 IC normally provides 5 volts output with pin 3 grounded. By raising pin 3 above ground, the output of the power supply will be the original 5 volts plus the potential "seen" by pin 3. So, for 15 volts output, use a 10-volt zener diode. For 13.6 volts out, use a 7.6-volt zener.

With a 6-8-volt zener in the circuit, the output of the power supply is 11.8 volts. To increase this by another 0.7 volt, all you have to do is connect a 1N4001 diode in series with the zener diode. This diode is shown phantomed in the schematic. It is installed in the power supply's circuit at the point marked with an X.

Any center-tapped 30-volt transformer capable of delivering 4 amperes or more to a load can be used for T1. Alternatively, you can use a transformer with two 12-volt secondary windings (each capable of 4 amperes); connect the secondaries in series and properly phase them to yield the desired 24 volts.

One note of caution: The output of the 6/12 power supply is not short-circuit protected. We suggest that you install a 6- or 8-ampere fuse, depending on the output current desired. ♦

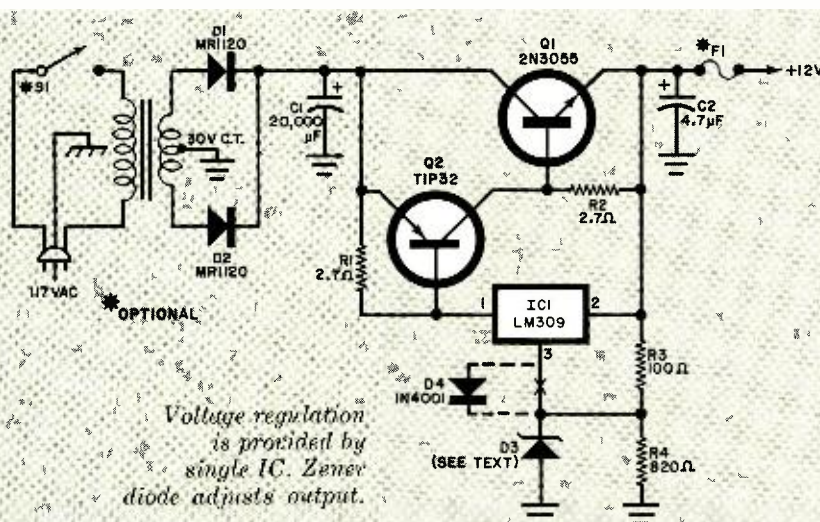

### PARTS LIST

C1—20,000-µF, 20-volt electrolytic capacitor  
C2—4.7-µF, 15-volt tantalum capacitor  
D1, D2—MR1120 (Motorola) or equivalent power diode  
D3—Zener diode (see text)  
D4—1N4001 diode (optional, see text)  
F1—Fuse (optional, see text)  
IC1—LM309 voltage regulator integrated circuit (National Semiconductor)  
Q1—2N3055 transistor  
Q2—TIP32 (Motorola) or equivalent transistor  
R1, R2—2.7-ohm, 1/2-watt resistor

R3—100-ohm, 1-watt resistor  
R4—820-ohm, 1-watt resistor  
S1—Spst switch (optional)  
T1—30-volt, center-tapped, 4-ampere transformer (see text)  
Misc.—Mica insulators (3) and silicone paste; suitable chassis; fuse holder (optional); line cord; machine hardware; heavy-gauge hookup wire; etc.  
Note: A kit of all parts listed above except chassis box and optional items is available for \$17.95, plus postage on 8 pounds and insurance, from Bill Godbout Electronics, Box 2673, Oakland Airport, CA 94614.





# Solid State

By Lou Garner

## USEFUL PROJECTS FOR HOLIDAY GIFTS

**E** NCOMPASSING two important religious festivals, Christmas and Hanukkah, both of which traditionally involve gifts for children, the holiday season—between Thanksgiving and New Year's Day—accounts for the overwhelming majority of annual toy sales in the U.S.

If there are one or more children on your holiday gift list (an offspring, a younger brother or sister, a favorite niece or nephew, a neighbor's child) and you are considering current toy prices, there's a good chance you can save money by assembling and giving electronic toys this year. What's more, you'll be giving something of yourself in each gift—your time and labor. This always makes the gift more important.

An electrical or electronic toy should meet certain basic criteria, whether home-assembled or purchased factory-built.

- First, it should be *safe*. This rules out, for the most part, line-powered projects and high-power designs which may have overly warm components.

- Second, it should be reasonably *sturdy*. Children are great destroyers. I read about a military tank recently that had survived several battles in two wars and had been placed on a local playground. The kids managed to wreck it completely within a couple of weeks. Therefore, assemble your projects in sturdy housings and avoid the use of delicate components, such as meters.

- Third, the toy should be *complete* in itself. An amplifier designed to be used with a separate microphone and loudspeaker can pose problems for the younger child (and, occasionally, even for older ones and adults). Ear-phones, probes, indicators, or any separate accessories which have to be plugged in or connected have a tendency to "get lost."

- Fourth, it should *do something*—make a noise, make music (some adults may tend to equate these two), flash lights, operate a model car, control a mechanical gadget, or whatever.

- Fifth, unless intended for the very young, the toy should require some *effort* on the part of the child. Buttons or keys to press, switches to close, or knobs to turn.

- Sixth, it should have *high play value*. The child should be able to use it in its intended function; but at times, should also be able to adapt it, using his or her imagination, to other types of play.

There are a number of electronic gifts that are not considered "toys" in the conventional sense, but children enjoy them and they can be modified to enhance play value. In this category are AM radio receivers, wireless microphones (or "home broadcasters"), low-power CB walkie-talkies, portable phonographs, and inexpensive tape and cassette recorders. Any of these, excellent gifts in themselves, can be modified slightly to delight the child.

For example, you might devise a sturdy bracket for securing a small transistor radio to handlebars, permitting its use as a tricycle or bike radio.

Another possibility is combining a small receiver and wireless microphone (or CB unit) on a fancy control panel, adding a few switch-controlled pilot lamps and perhaps even an inexpensive buzzer. To the child, such an assembly could become, depending on his (her) mood, the *communications center* for a hospital, the *command post* for an imaginary army, or even the *control panel* of a space ship, time machine, or submarine.

Of course, the real challenge is not in modifying a commercial product, but in assembling a complete and unique electronic toy from "scratch," allowing your imagination

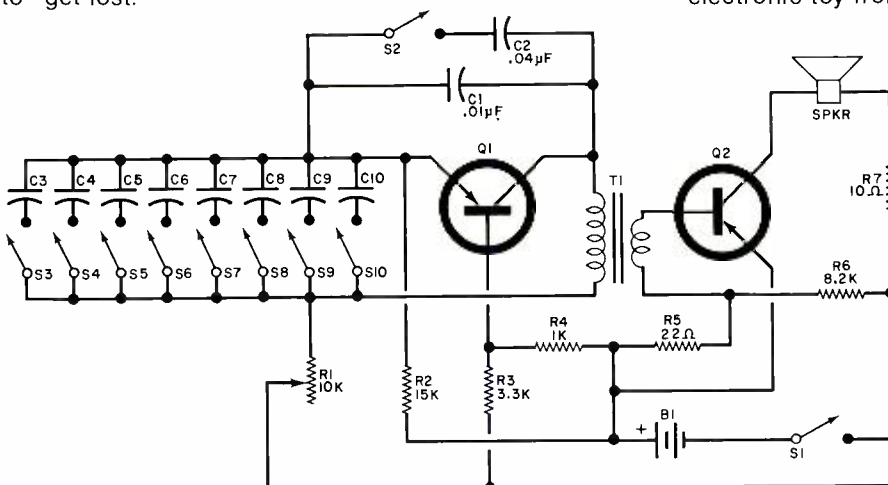

Fig. 1. This toy electronic organ covers a full octave and has a treble-bass switch to shift range.

# There's a new Heathkit everyone on

## Introducing a new generation of Heathkit small-screen color TV



- On-screen digital channel readout
- Optional on-screen Digital Clock
- New one-button Preset Picture Control (PPC) restores perfect picture at a touch
- New precision in-line gun picture tube with new slotted shadow mask for greater light output
- No convergence or purity adjustments — ever
- 3 popular screen sizes — 15, 17, & 19 in. (diagonal)

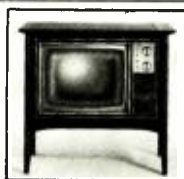

Floor model cabinet for GR-500



Optional digital clock module



Optional roll-around cart

In the new Heathkit GR-500, GR-400 and GR-300, Heath brings you another industry first — a new generation of small-screen color TV receivers featuring on-screen digital channel readout, an optional digital clock accessory, and a host of other exciting new design innovations. The new precision in-line gun tube uses a slotted shadow mask for far greater light output. And, in the GR-400 & 500, a negative matrix screen is used for greater contrast and brightness. A wider bandwidth IF amplifier with fixed LC filter was added. This, coupled with luminance and video circuits with black level clamps maintains the true brightness level of the televised scene, with picture realism you never dreamed possible.

**Convergence and purity adjustment a thing of the past.** A new precision static toroid yoke offers vastly improved convergence. And the factory adjusted and sealed yoke and magnet assemblies completely eliminate the need for convergence and purity adjustments, yet the results are superior to previous methods requiring manual adjustments.

**Improved VHF tuner design.** Another area receiving special attention was the VHF tuner. It was given a new mixer circuit featuring a dual gate FET to achieve better cross modulation performance. The RF amplifier is also a dual gate FET, resulting in a low noise figure, high gain and low cross modulation. The four circuits of the tuner (most have only three) offer far greater selectivity than ordinary sets.

**Total VHF/UHF detent tuning convenience — with on-screen channel display.** Every VHF and UHF channel is selectable simply by turning the channel selection knobs until they click to your favorite channel with precision detent action. As you turn the knobs, every channel number is displayed on the TV screen in big bright digits, completely adjustable as to brightness, position on the screen, and length of display time. And the same goes for the optional digital clock. Fine tuning (AFT) is automatic.

**New one-button Preset Picture Control (PPC).** An important new convenience feature is the PPC button located on the front panel. Once the brightness, contrast, color and tint have been correctly set by the rear preset controls, a touch of the PPC button returns the picture to perfection instantly — no matter how much the front-panel controls have been disturbed.

**Other design innovations include** Instant-On operation with a front-panel defeat switch for vacation-time shutdown; hi-fi output jack and TV speaker defeat switch; 75-ohm VHF antenna input; a new high voltage power supply with voltage tripler circuit for plenty of reserve power; a new quasi-complementary-symmetry vertical deflection circuit that eliminates the need for an output transformer; new slide-out chassis, plus interconnecting cables using plugs and sockets, for easier adjustment and servicing.

Get with the new generation of Heathkit small-screen Color TV now ... in time for the holiday fun!

**Kit GR-500**, less cabinet, 88 lbs., Exp./Frt. .... **499.95\***

**GRA-500-1**, table model cabinet for GR-500 (main illus.), 35 lbs., Exp./Frt. .... **39.95\***

**GRA-500-2**, floor model cabinet for GR-500 (inset), 45 lbs., Exp./Frt. .... **89.95\***

**Kit GR-400**, with cabinet, 104 lbs., Exp./Frt. .... **489.95\***

**Kit GR-300**, with cabinet, 90 lbs., Exp./Frt. .... **449.95\***

**GRA-403-18**, roll-around cart for GR-300, -400 & -500, 23 lbs., Exp./Frt. .... **21.95\***

**GRA-2000-1**, optional digital clock module, 1 lb., mailable ..... **29.95\***

POPULAR ELECTRONICS



# Christmas gift for your list

Give your scientist, engineer or student a gift he'll use all year long. Finger-sized keys and 8 bright 1/2" digits make it easier to use than pocket calculators. Cumulative memory and register exchanges virtually eliminate scratchpad work. Performs arithmetic plus trig and arc trig in degrees or radians, common and natural logs,

powers of e, square roots, inverses, pi and exponential functions. Kit IC-2100, 4 lbs., available . . . 119.95\*

## Unique New Heathkit AM/FM Digital Clock Radio

Our outstanding clock radio makes even sleepy Santas happy.



The electronic clock with snooze alarm features a gentle "beep" with adjustable volume. Or wake to the component-quality AM/FM radio. Standby batteries (not included) keep the clock on time during power interruptions. Kit GR-1075, 10 lbs., available . . . 129.95\*

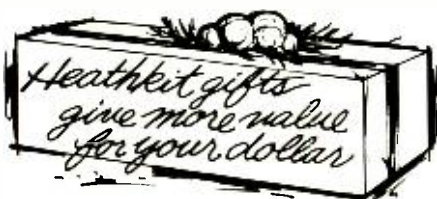

## Our new Heathkit Desktop Electronic Sliderule Solves Your Gift-Giving Problems

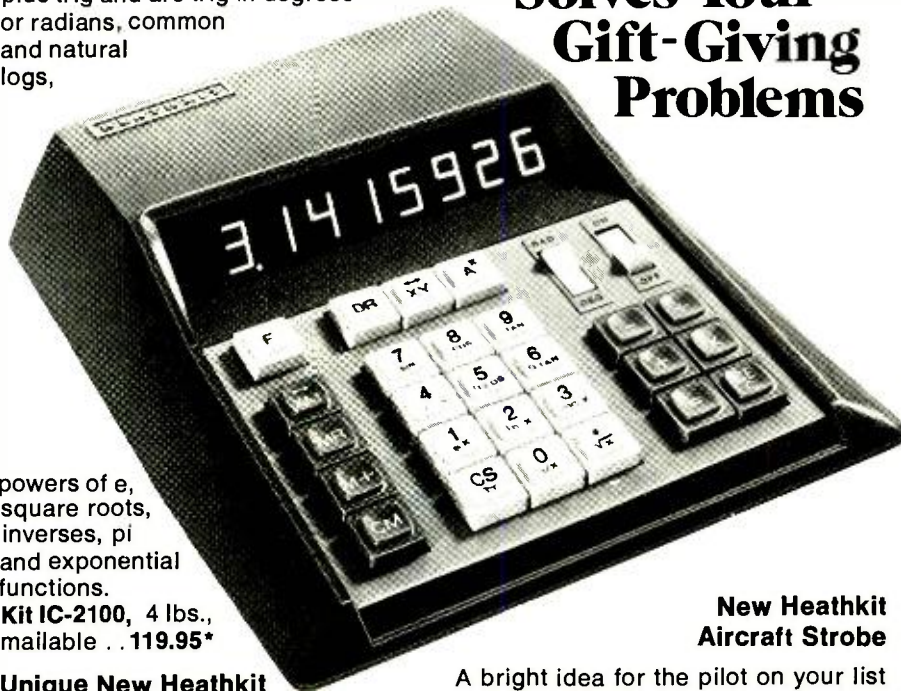

## New Heathkit Aircraft Strobe

A bright idea for the pilot on your list—or for anyone who needs an emergency marine or marker light. It meets FAR 23.1401 and assembles easily in just one evening. For 12 VDC neg. ground. With clear lens, optional red and red/clear lenses available. Kit OL-1155, 3 lbs., available . . . 54.95\*



## Learning's Fun With Our New Heathkit "Electronics Workshop"

The JK-18A teaches kids electronics the easy learn-by-doing way. 35 exciting projects include light meter, sound meter, transistor radios. For safety, it's battery powered and requires no soldering. (Batteries not included) Kit JK-18A, 10 lbs., available . . . 34.95\*



## New Heathkit Electronic Clock/Timer for Car, Boat or Plane



A timely gift—

an electronic clock and a 20-hour rally timer, both with quartz crystal accuracy. Bright 1/2"-tall digits dim automatically at night. 12 VDC, mounts on or under dash. Kit GC-1093, 2 lbs., available . . . 62.95\*

## Two Heathkit Electronic Clocks with Standby Power

Two beautiful gifts—the GC-1092A is a clock with a snooze alarm; the GC-1092D reads the time in 6 digits, the month and date in 4 digits. Both have standby power to keep the clock on time without the display even during temporary power interruptions. (Batteries not included.) Kit GC-1092A or D, 5 lbs., available . . . . . each 82.95\*

Time/Alarm



Time/Date



## Heathkit Exhaust Analyzer Checks Your Car's Tune Up

Make everyone's Christmas whiter and cleaner—be sure your tune up is helping clean up the environment. Big 4 1/2" meter reads relative combustion efficiency, air-fuel ratio and percentage carbon monoxide. Kit CI-1080, 6 lbs., available . . . 61.95\*



# Exciting new Heathkit Christmas giving



## new Heathkit dual-trace DC-15MHz scope



### Compare the features:

- Dual-trace with true X-Y capability
- 1 mV/cm vertical sensitivity over the full bandwidth
- Post-deflection accelerated CRT for bright trace, fast writing
- Vertical amplifier delay lines for pulse analysis capability
- Digitally controlled triggering for exceptional stability
  - Typically triggers up to 45 MHz—guaranteed to 30 MHz

**It offers a  
lot more than  
just a low price**

The Heathkit IO-4510 is your best 'scope buy for two good reasons—it does more and it costs less.

**Time base sweep up to 100 nsec/cm.** There's always a reference baseline, even when there's no trigger signal. The time base can be precisely triggered at any point along the positive or negative slope of the trigger signal. In automatic mode, it triggers at the zero crossing point.

**Modes of display.** Either channel can be displayed as a function of time or both can be displayed together. In X-Y operation, channel 1 provides horizontal deflection and channel 2

provides vertical deflection. There are 22 calibrated time bases from 0.2 sec/cm to 0.1  $\mu$ sec/cm. The sweep speed is continuously variable between switch positions. Any speed can be expanded five times by pulling out the control knob.

**For easy calibration,** a 1 volt peak-to-peak square wave is available on the front panel. The regulated supply operates from 100-280-volt AC power. **Kit IO-4510,** 34 lbs., mailable **549.95\***

**Assembled SO-4510,** factory-wired & calibrated version of the IO-4510, 34 lbs., mailable **750.00\***



### New Low-Cost Heathkit Function Generator

A true function generator, not an oscillator, delivers sine, square and triangle waveforms from 0.1 Hz to 1 MHz. Short-proof output supplies 10 volts peak-to-peak into 50-ohm load. A calibrated step attenuator adjusts from 0-50 dB (10V to 30 mV) in 10 dB steps. A variable control provides up to 20 dB of additional attenuation at

each step. Attenuator accuracy is  $\pm 1$  dB; frequency accuracy is  $\pm 3\%$ . Non-linearity of the triangle waveform is 5% max., symmetry is within 10%. Sine wave THD is 3% max. from 5-100k Hz. Square wave rise and fall times are 100 nsec max. 105-130 or 210-260 VAC. **Kit IG-1271,** 7 lbs., mailable **99.95\***

**Assembled SG-1271,** factory-wired & calibrated version of IG-1271, 7 lbs., mailable **140.00\***



# projects - timed for

Coming in December...

## A new generation of Heathkit ham radio equipment

### New Heathkit SB-104 transceiver

**Years ahead in design & features** — the SB-104 is a complete rethinking of what a CW/SSB transceiver should be. It utilizes the latest digital & solid-state technologies. The "104" is completely solid-state from the front end to the RF output.

**Totally broadbanded.** You can switch from 3 to 30 MHz without preselector, load or tune controls.

**True digital readout** with 6 bright digits to indicate the frequency with accuracy to 100 Hz.

**Mobile-ready.** The SB-104 operates from 12 VDC, so it's ready to go mobile when you are. Optional features include a plug-in digital noise blander and 400 Hz crystal filter for CW.

Just about the only things that aren't totally new about the "104" are the quality and easy assembly that have made Heath famous. **Kit SB-104**, 31 lbs., mailable ..... **669.95\***

**Kit SBA-104-3**, 400 Hz CW crystal filter for SB-104, 1 lb., mailable ..... **34.95**

**Kit SBA-104-1**, digital noise blander for SB-104, 1 lb., mailable ..... **24.95\***

**Kit SBA-104-2**, mobile mount, 6 lbs., mailable ..... **34.95\***

### New Heathkit SB-230 1 kW conduction-cooled linear

**High-power match for the SB-104.** Lowest cost conduction cooled linear on the market. 1200 watts PEP and 1000 watts CW from less than 100 watts input. It's also rated at 400 watts input for slow-scan TV and RTTY. And absolutely silent — no blowers, no fans.

**Full metering** of relative power, plate current, grid current and plate high voltage. Safety features include microswitch interlocks for top and bottom shells, thermal shutdown, fused cathode, on/off switch with circuit breaker for power transformer.

**On the air in 15 to 20 hours.** Fast, easy assembly, then check it out with an ohmmeter — no alignment necessary. **Kit SB-230**, 40 lbs., mailable ..... **319.95\***

### New Heathkit SB-614 station monitor scope

**How clean is your signal?** The bright 1½ x 2" screen helps you keep your rig in peak condition. Reveals a wide variety of operating problems — nonlinearity, insufficient or excessive drive, carrier or sideband suppression problems, regeneration and key clicks. Monitors AM, SSB and CW signals up to 1 kW from 80 to 6 meters. **Kit SB-614**, 17 lbs., mailable ..... **139.95\***

### New Heathkit 5-Function SB-634 station console

**Five accessories in one** — a 24-hour 6-digit electronic clock, a ten-minute digital ID timer with visual and/or audible alarms, RF wattmeter, SWR bridge, hybrid phone patch with manual and VOX controls. **Kit SB-634**, 14 lbs., mailable ..... **179.95\***

### New Heathkit SB-644 remote VFO

**Designed exclusive for SB-104**, it provides the ultimate in multi-mode operation with two crystal sockets for fixed frequencies. No modifications — just plug the VFO into the "104" and go — VFO frequency even reads out on the 104's digital display. **Kit SB-644**, 10 lbs., mailable ..... **119.95\***

### New Heathkit Fixed station AC power supply

**Powers the SB-104** from 120 or 240 VAC. Sophisticated regulation assures almost no change in voltage from no load to full load. Entire supply fits inside SB-604 speaker cabinet. **Kit HP-1144**, 28 lbs., mailable ..... **89.95\***

### New Heathkit SB-604 station speaker

**Response-tailored to SSB** and designed to match the SB-104. Large enough to house HP-1144 AC power supply. **Kit SB-604**, 8 lbs., mailable ..... **29.95\***

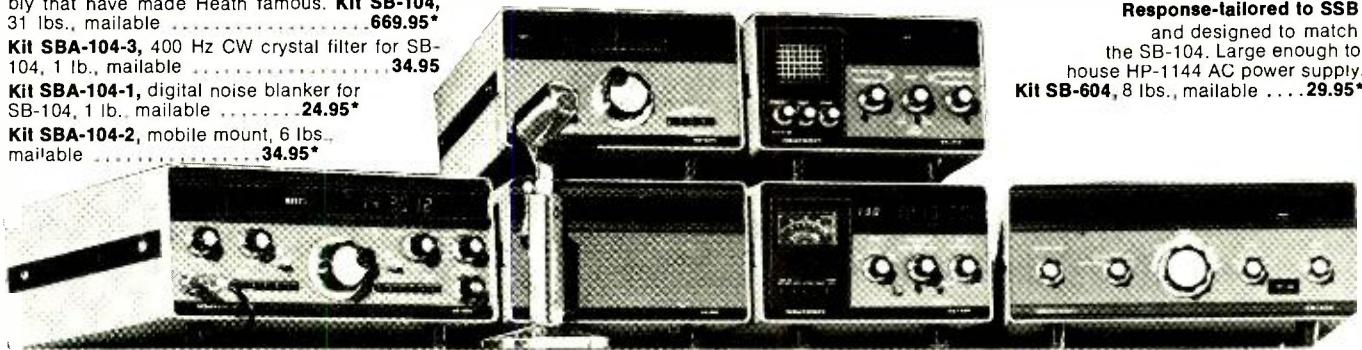

**HEATHKIT ELECTRONIC CENTERS** — Units of Schlumberger Products Corporation Retail prices slightly higher.

ARIZ.: Phoenix; CALIF.: Anaheim, El Cerrito, Los Angeles, Pomona, Redwood City, San Diego (La Mesa), Woodland Hills; COLO.: Denver; CONN.: Hartford (Avon); FLA.: Miami (Hialeah), Tampa; GA.: Atlanta; ILL.: Chicago, Downers Grove; IND.: Indianapolis; KANSAS: Kansas City (Mission); KY.: Louisville; LA.: New Orleans (Kenner); MD.: Baltimore, Rockville; MASS.: Boston (Wellesley); MICH.: Detroit; MINN.: Minneapolis (Hopkins); MO.: St. Louis (Bridgeton); NEB.: Omaha; N.J.: Fair Lawn; N.Y.: Buffalo (Amherst), New York City, Jericho, L.I., Rochester, White Plains; OHIO: Cincinnati (Woodlawn), Cleveland, Columbus; PA.: Philadelphia, Pittsburgh; R.I.: Providence (Warwick); TEXAS: Dallas, Houston; WASH.: Seattle; WIS.: Milwaukee.



**Heath Company, Dept. 20-12**  
Benton Harbor, Michigan 49022

**HEATH**  
**Schlumberger**

Send for your FREE 1975 catalog today.

- Please send my free 1975 Heathkit Catalog.  
 Please send the merchandise checked below. I've enclosed \$ \_\_\_\_\_, plus shipping, in payment.

- |  |   |   |
|--|---|---|
| <input type="checkbox"/> GR-500 Color TV                 | <input type="checkbox"/> GC-1093 Digital car clock/timer          | <input type="checkbox"/> SG-1271 Function generator (assembled) |
| <input type="checkbox"/> GRA-500-1 TV Cabinet            | <input type="checkbox"/> JK-18A Junior electronics workshop       | <input type="checkbox"/> SB-104 Transceiver                     |
| <input type="checkbox"/> GRA-500-2 TV Cabinet            | <input type="checkbox"/> GC-1092A Digital clock with snooze alarm | <input type="checkbox"/> SB-104-1 Noise blander                 |
| <input type="checkbox"/> GR-400 Color TV                 | <input type="checkbox"/> GC-1092D Digital clock with date display | <input type="checkbox"/> SB-104-2 Mobile mount                  |
| <input type="checkbox"/> GR-300 Color TV                 | <input type="checkbox"/> IO-4510 Oscilloscope (kit)               | <input type="checkbox"/> SB-104-3 CW crystal filter             |
| <input type="checkbox"/> GRA-403-18 TV Cart              | <input type="checkbox"/> SO-4510 Oscilloscope (assembled)         | <input type="checkbox"/> SB-230 1 kW linear                     |
| <input type="checkbox"/> GRA-2000-1 Digital clock module | <input type="checkbox"/> IG-1271 Function generator (kit)         | <input type="checkbox"/> SB-614 Monitor scope                   |
| <input type="checkbox"/> IC-2100 Calculator              |   | <input type="checkbox"/> SB-634 Station monitor                 |
| <input type="checkbox"/> CI-1080 Exhaust analyzer        |   | <input type="checkbox"/> SB-644 Remote VFO                      |
| <input type="checkbox"/> GR-1075 Digital clock radio     |   | <input type="checkbox"/> HP-1144 AC power supply                |
|  |   | <input type="checkbox"/> SB-604 Station speaker                 |

Name \_\_\_\_\_  
 Address \_\_\_\_\_  
 City \_\_\_\_\_ State \_\_\_\_\_ Zip \_\_\_\_\_

\*Mail order prices, FOB factory  
 Prices and specifications subject to change without notice.

CL-548

# READ WHAT THE EXPERTS SAY ABOUT THE NEW HEATHKIT DIGITAL COLOR TV

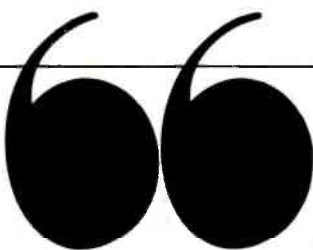
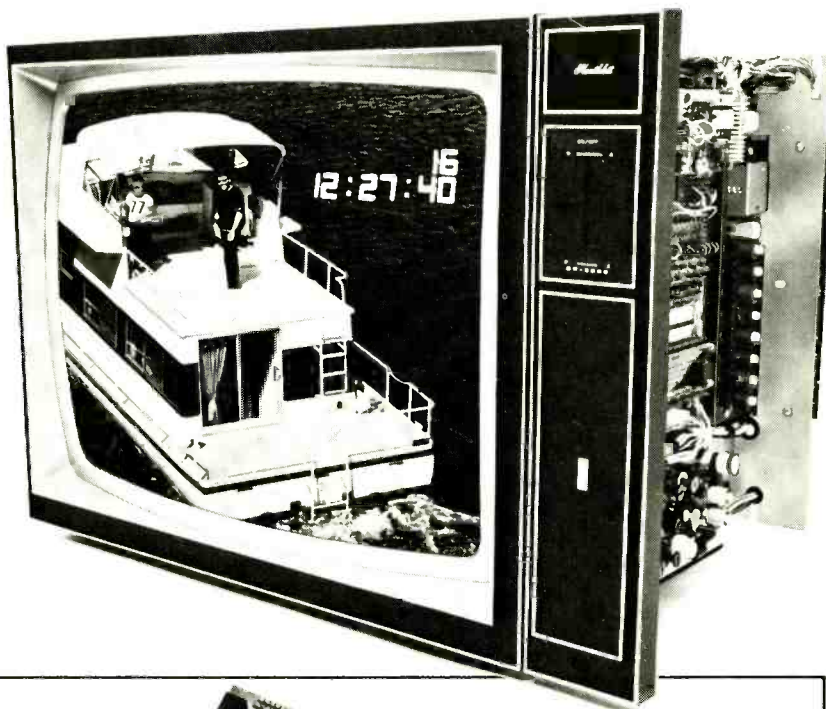

The editors of RADIO-TV REPAIR said, "With manufacturers only now beginning to get the color excellence Heath has featured for years, it was time for Heathkit to once again move ahead of the industry, and move they did..."

According to RADIO-ELECTRONICS, the Heathkit GR-2000 Digital Color TV "uses so much digital design and so many integrated circuits... it sets new standards for state-of-the-art in color TV".

The RADIO-ELECTRONICS editors said the Heathkit Digital TV has "features that are not to be found in any other production color TV being sold in the U.S."



*"On-screen electronic digital channel readout... numbers appear each time you switch channels or touch the RECALL button... On-screen electronic digital clock... an optional low cost feature... will display in 12- or 24-hour format... Silent all-electronic tuning. It's done with uhf and vhf varactor diode tuners... Touch-to-tune, reprogrammable, digital channel selection... up to 16 channels, uhf or vhf... in whatever order you wish... there's no need to ever tune to an unused channel. LC IF amplifier with fixed ten-section LC IF bandpass filter in the IF strip... eliminates the need for critically adjusted traps for eliminating adjacent-channel and in-channel carrier beats. No IF alignment is needed ever. Touch volume control... when the remote control is used... touch switches raise or lower the volume in small steps."*

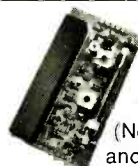
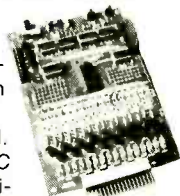

POPULAR ELECTRONICS took a look at the 25-in. (diagonal) picture and said it "can only be described as superb. The Black (Negative) Matrix CRT, the tuner and IF strip, and the video amplifier provide a picture equal to that of many studio monitors..."

Furthermore, the Heathkit GR-2000 is an easier kit-form TV to build. POPULAR ELECTRONICS pointed out that "Each semiconductor has its own socket and there are 12 factory-fabricated interconnecting cables... The complete color adjustments can be performed in less than an hour."

And here's what RADIO-TV REPAIR said about service: "...virtually every function of the TV receiver has been broken down to a miniature plug-in circuit assembly... if trouble develops you simply pop out the correct board and check it yourself... Heath provides free technical consultation, and if you do need factory service, as we said, the costs are low, well below that for (conventional color TV) insurance protection."

To sum up, POPULAR ELECTRONICS concluded its study by stating, "In our view, the color TV of the future is here — and Heath's GR-2000 is it!"

Why not see what the experts have seen? The Heathkit Digital Color TV — without question the most remarkable TV available today. Mail order price for chassis and tube, \$669.95. Remote Control, \$89.95 mail order. Clock, \$29.95 mail order. Cabinets start at \$154.95. (Retail prices slightly higher).

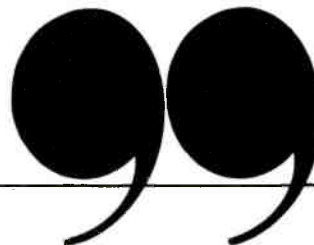
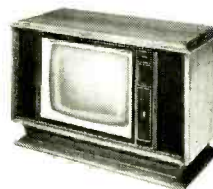



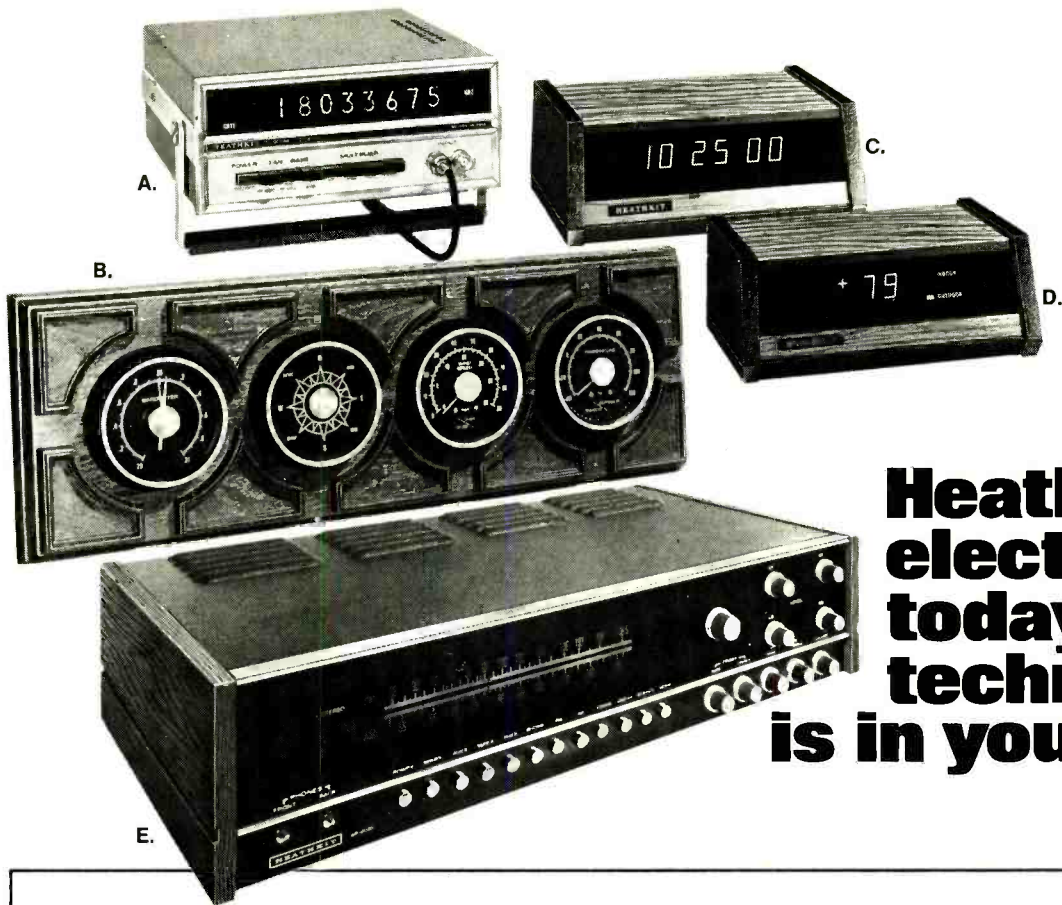

# Heathkit electronics—today's technology is in your hands

**A. Heathkit IB-1103 180 MHz Counter** has phase-locked multiplier, extremely high resolution with 8½-digit readout. Pushbuttons permit multiplication by 1 (direct), 10, 100 or 1000. Also has temperature compensated crystal oscillator (TCXO) and pushbutton selection of 1 msec., 100 msec. and 1 sec. gate times. Input sensitivity is 50 mV to 120 MHz and 100 mV to 180 MHz. Has lighted indicators for MHz, kHz, Hz, Gate, Overrange and unlocked conditions. \$349.95\*. Shipping weight, 12 lbs.

**B. Heathkit ID-1290 Weather Station** has Uni/Mag® barometer for 2½ times greater pointer deflection; 8 wind-direction compass points that light-up in combination to give you 16-point resolution; wind speed indicator with 2 switch selectable ranges, 0-30 and 0-90 mph; dual-sensor thermometer with switch selection of indoor and outdoor temperatures. Includes weather cup and wind vane assembly, simulated walnut housing. \$99.95\*. Weight, 9 lbs., 50' cable, 6.95\*, 2 lbs.; 100', 12.95\*, 4 lbs.; 150', 17.95\*, 6 lbs.

**C. Heathkit GC-1005 Electronic Alarm Clock.** A six-digit timepiece that displays hours, minutes and seconds on highly visible cold-cathode readout tubes. Gentle "beeper" alarm can be set for 24-hour cycle, features snooze switch for seven more minutes of sleep. Displays time in 12-hour, or 24-hour format. \$59.95\*. Mailing weight, 4 lbs.

**D. Heathkit ID-1390 Digital Thermometer.** A solid-state device that monitors indoor and outdoor temperatures. Switches set thermometer for alternate display of indoor/outdoor temperature at 4-second intervals, for constant display, and for readout in either degrees Fahrenheit or degrees Centigrade. Includes 85' cable and 2 sensors. \$62.95\*. Mailing weight, 5 lbs.

**E. Heathkit AR-2020 4-Channel Receiver** offers 15 watts per channel†, built-in decoder for reproducing

matrixed 4-channel material, and an AM/FM tuner that boasts 2μV sensitivity, 2dB capture ratio. Pushbuttons for all modes of operation and inputs to accommodate phono, tape and auxiliary source in stereo or 4-channel combinations. The solid-state circuitry mounts on plug-in boards for easy assembly and self-service. And the low kit price includes the cabinet, too! \$259.95.\* Mailing weight, 31 lbs. †Power measured at 8 ohms with less than 0.5% total harmonic distortion from 20-20,000 Hz, all channels driven.

**Send for your FREE '74 Heathkit Catalog—world's largest selection of electronic kits**

#### HEATHKIT ELECTRONIC CENTERS

Units of Schlumberger Products Corporation

Retail prices slightly higher

ARIZ.: Phoenix; CALIF.: Anaheim, El Cerrito, Los Angeles, Pomona, Redwood City, San Diego (La Mesa), Woodland Hills; COLO.: Denver; CONN.: Hartford (Avon); FLA.: Miami (Hialeah), Tampa; GA.: Atlanta; ILL.: Chicago, Downers Grove; IND.: Indianapolis; KANSAS: Kansas City (Mission); KY.: Louisville; LA.: New Orleans (Kenner); MD.: Baltimore, Rockville; MASS.: Boston (Wellesley); MICH.: Detroit; MINN.: Minneapolis (Hopkins); MO.: St. Louis; NEB.: Omaha; N.J.: Fair Lawn; N.Y.: Buffalo (Amherst), New York City, Jericho (L.I.), Rochester, White Plains; OHIO: Cincinnati (Woodlawn), Cleveland, Columbus; PA.: Philadelphia, Pittsburgh; R.I.: Providence (Warwick); TEXAS: Dallas, Houston; WASH.: Seattle; WIS.: Milwaukee.

<b>HEATH</b>	
<b>Schlumberger</b>	
<b>Heath Company</b>	
Dept. 10-12	
Benton Harbor, Michigan 49022	
<input type="checkbox"/> Please send my free 1974 Heathkit Catalog.	
<input type="checkbox"/> Enclosed is \$ _____, plus shipping.	
Please send model(s) _____	
Name _____	
Address _____	
City _____ State _____ Zip _____	
Prices & specifications subject to change without notice.	
*Mail order prices; F.O.B. factory.	
CL-549	

full rein. Several possibilities are illustrated schematically in Figs. 1 to 4.

Regardless of your choice, remember that the toy's housing (case) often is as important as its basic function. Sturdiness is essential, naturally, but eye appeal means a lot. A chassis-built toy, for example, may work just as well as a fancier version. However, it generally will not have the same appeal to a child. A little paint, a suitable decal or two, special switches and similar touches will do wonders.

Adapted from an older Motorola applications bulletin, the toy electronic organ circuit given in Fig. 1 covers a full octave, features a treble-bass switch to shift range, and has sufficient power output to please most children and, after a while, antagonize most parents. It can be assembled easily on a weekend, even if you take the time to build an attractive case from plywood and fashion key-type switches from scraps of wood and strips of phosphor bronze or spring copper.

In operation, *Q1* serves as a modified Colpitts common-base oscillator, driving the output transistor, *Q2*, through an impedance matching step-down transformer, *T1*. Switches *S3* through *S10* determine the oscillator's basic frequency by selecting different series capacitor *C3* to *C10* to tune *T1*'s primary winding in conjunction with *C1*. A simple spst switch, *S2* acts to switch shunt capacitor *C2* across *C1* to lower the scale a full octave. Base bias is provided for *Q1* by voltage divider *R3-R4*, for *Q2* by *R5-R6*. Resistor *R2* serves as *Q1*'s emitter load, while *R7* limits the speaker's voice coil current. Adjustable collector resistor *R1* permits *Q1*'s collector current to be set for optimum performance. Finally, operating power is supplied by *B1*, controlled by *S1*.

With standard components used throughout the design, the electronic organ can be assembled using a combination of stock or salvaged and purchased parts to save money. Type 2N653 is specified for *Q1*, type 2N554 for *Q2*; HEP types 631 and 230 may be used as replacements, respectively. Except for *R7*, a 2-watt unit, the fixed resistors can be 1/4-, 1/2- or 1-watt types, with *R1* a standard potentiometer. Either ceramic, plastic film, or tubular paper capacitors can be used. The loudspeaker should have a 10-ohm voice coil, but may be any size from 2 1/2" to 8". While the original diagram specified transformer *T1* as a Triad type T42X with a 5000-ohm primary and 8-ohm secondary, other types may be used; but it will be necessary to readjust individual tuning capacitor values for optimum operation. If the original transformer is used, capacitors *C3*, *C4*, *C5*, *C6*, *C7*, *C8*, *C9* and *C10* should have values of 0.6, 0.33, 0.2, 0.15, 0.1, 0.068, 0.05 and 0.04  $\mu$ F, respectively. Power switch *S1* and bass-treble switch *S2* can be toggle, slide or rotary units, but momentary contact key-type switches, whether commercial or homebrew, are preferred for the note selector switches, *S3* through *S10*. The power supply, *B1*, consists of four to six series-connected size C or D flashlight cells.

Neither layout nor lead dress is critical and any standard construction technique, including perforated board or point-to-point wiring, can be used for project assembly. As suggested previously, the circuit should be housed in a sturdy cabinet, preferably designed to look like a miniature organ or piano. For a different approach, however, you might wish to give the project the appearance of an "electronic accordion." Mount the speaker and basic circuitry in a large center section, the key switches on one small side section and the bass-treble switch (*S2*) and power switch

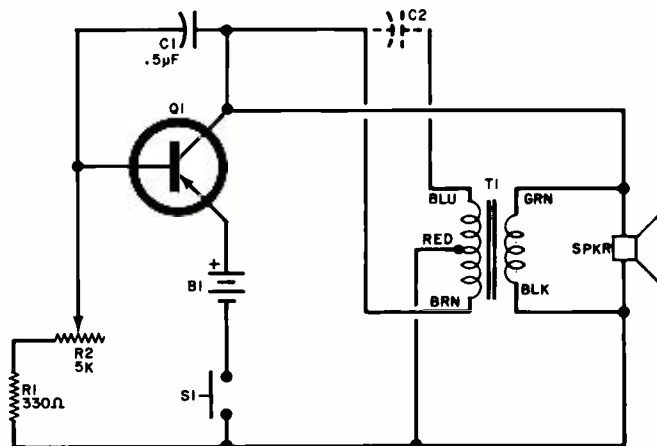

Fig. 2. Audio oscillator provides continuous frequency coverage of more than two octaves.

(*S1*) on the other. Regardless of the type of cabinet you use, be sure to provide an access panel for easy battery replacement.

The general-purpose audio oscillator circuit in Fig. 2 may be used for a number of toy electronic "musical" instruments. Unlike the toy organ, which supplies a single note when a specific key is depressed, this design provides continuous frequency coverage of better than two octaves. Any desired note within its range, including sharps and flats, can be sounded by adjusting frequency control *R2* and switching the instrument on by means of *S1*. It is even possible for the user to slide from one note to another and to create vibrato and other special effects by manipulating the frequency control.

A single power transistor, *Q1*, serves both as a blocking oscillator and output driver, with the feedback needed to start and maintain oscillation provided by a miniature step-up transistor transformer, *T1*. This mode of operation develops a harmonic-rich signal and permits the circuit's operating rate (frequency) to be controlled by a simple R-C network, *R1-R2-C1*. Operating power is supplied by battery pack *B1*, controlled by spst switch *S1*.

Transistor *Q1* is a general-purpose pnp medium-power type, such as the RCA 2N301 or HEP 230. Transformer *T1* has a 500-ohm CT primary and 8-ohm secondary (typically, Lafayette type AR-164). Any standard PM loudspeaker with a 4-to-8-ohm voice coil can be used. Resistor *R1* is a half-watt type, frequency control *R2* is a conventional potentiometer, and feedback capacitor *C1* a 0.5- $\mu$ F low-voltage ceramic or tubular paper unit. Used to modify the tone quality and frequency range, *C2* is optional; its value determined experimentally. The power pack, *B1*, consists of from two to six penlight or flashlight cells. A momentary-contact spst pushbutton switch is used for *S1*.

Several modifications can be made in the basic circuit to meet special needs. For example, *C2* can be included, but switched in and out of the circuit by a separate spst toggle or slide switch. A slide type, rather than rotary, potentiometer can be used for *R2*. Finally, a single 3.0-, 4.5-, 6.3-, or 9-volt battery can be used for the power supply in place of series-connected individual cells.

With a bit of imagination, you can use the oscillator circuit to create a variety of toy musical instruments. Typically, the circuit could be mounted in a round cake pan to which a piece of aluminum tubing has been attached to form an arm—an "electronic banjo." Here, realism can be achieved by mounting the control switch, *S1*, at the far end



of the arm. Use a pan of a different shape for a "violin," "uke," or other instrument.

In practice, the operator presets  $R2$  for the desired musical note and depresses  $S1$  as long as is needed to sound a  $1/16$ ,  $1/8$ ,  $1/4$ ,  $1/2$  or full note. If desired, the control ( $R2$ ) setting can be calibrated to indicate specific musical notes, but a talented user can learn to preset the control by "feel" after using the instrument for a while.

In this column, in October, I described a collector-coupled multivibrator circuit using LED loads to provide an alternate flashing action. This circuit, repeated in Fig. 3, is ideal for toys for younger children.

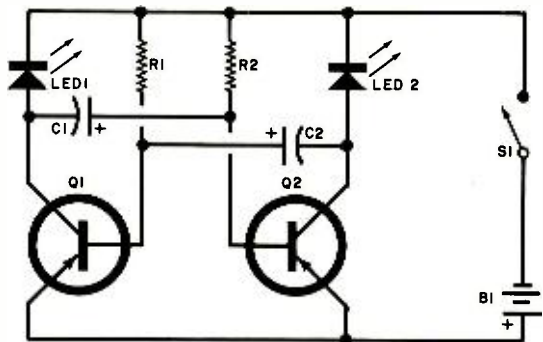

Fig. 3. Flashing LED's can be used in a variety of different toys.

Typical values for resistors  $R1$  and  $R2$  are 100 kilohms to 1 megohm ( $1/4$  or  $1/2$  watt); and for capacitors  $C1$  and  $C2$ , from 50 to 100  $\mu\text{F}$ . Transistors  $Q1$  and  $Q2$  are general-purpose, small-signal pnp units. If desired, npn types may be used by reversing all dc polarities. The control switch is a spst type, while  $B1$  is a standard 9-volt transistor battery, although series-connected penlight or flashlight cells are preferred for maximum battery life.

Using a jigsaw or coping saw, cut the outline of a clown's or favorite cartoon character's head out of plywood or hardboard. Drill small openings for the eyes. Paint in suitable colors, install the flasher circuit with the LED's as eyes, provide a secure cover, and you have a "winking clown" (or cartoon character) which a small child can watch and enjoy for hours. You can even mount the circuit in a stuffed animal if you're clever with a needle (or have someone to help who has sewing skills), but don't forget to provide a zipper pouch for replacing the battery! If desired, a mercury switch can be used for  $S1$ , arranged so that the animal's eyes "wink" when the stuffed toy is erect, but go dark when it is laid in a horizontal position to "rest."

Remote controlled vehicles or toys are fascinating to children of all ages. While elaborate ultrasonic or radio remote controls may be used to assemble some rather sophisticated (and expensive) toys, a simple flashlight operated control can be almost as intriguing and just as much fun for most children. An inexpensive and virtually fool-proof circuit is shown in Fig. 4.

In operation,  $Q1$  serves as a series resistor to control power transistor  $Q2$ 's base bias. Control transistor  $Q1$ , in turn, receives its base bias from a photovoltaic cell,  $PC1$ . As long as  $PC1$  is dark,  $Q1$ 's emitter-collector resistance remains high and  $Q2$ 's base bias low. When light is applied to the photocell, it generates a small current, forward biasing  $Q1$  and causing a corresponding drop in its emitter-collector impedance, providing forward base bias to  $Q2$  through  $R1$  and permitting this device to conduct and supply power to the small battery motor.

## COMING UP IN THE JANUARY Popular Electronics

### BUILD YOUR OWN

#### State-Of-The-Art Minicomputer

For accounting, scientific, many other applications

#### Scientific Calculator for Under \$90

Has 10 digits, 99 exponents, and nested parenthesis

### AND ...

#### Electronic Music Keyer Circuits

How to control loudness of individual notes

#### CCD Devices—

#### The TV Camera Tube's Successor?

#### The Identometer—

#### A Simple Transistor Identifier

### Product Test Reports

Pioneer RT-1011L Open-Reel Stereo Tape Recorder

Technics 200 Speaker System

Hewlett-Packard 5381 Frequency Counter

Tram Diamond 40 CB AM Transceiver

Edmund Scientific Kirlian Photo Kit

**EVERYTHING YOU  
WANTED TO KNOW  
ABOUT CD IGNITION  
SYSTEMS BUT DIDN'T  
KNOW WHOM TO ASK.**

*Send for FREE Tiger booklet (20 pages) which answers all your questions.*

Name \_\_\_\_\_

Address \_\_\_\_\_

City \_\_\_\_\_

State \_\_\_\_\_ Zip \_\_\_\_\_

CLIP OUT THIS AD AND SEND TO—

**TRI-STAR CORP.**

P. O. Box 1727 Dept. E

Grand Junction, Colo. 81501

CIRCLE NO. 42 ON READER SERVICE CARD

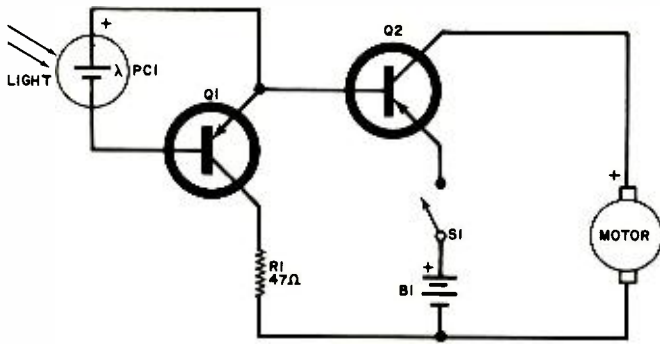

Fig. 4. Inexpensive circuit for remote control has a photocell which senses signals from a flashlight to operate the motor.

Except for the motor, which can be obtained from a hobby shop, together with any necessary reduction gears and coupling shafts, all the parts should be available at most local and mail order parts distributors. The photocell, PC1, is a self-generating type similar to International Rectifier's B3M; Q1 is a general-purpose, small-signal pnp transistor; Q2 a medium-power pnp type; R1 a half-watt resistor; and S1 a spst toggle, slide or rotary switch. The battery, B1, consists of two or more series-connected flashlight cells, as determined by the type of motor used in the project.

You can use the basic light control circuit to operate a toy tank, truck, car, or other vehicle, and to provide remote control for a movable display or other toy. If you're so inclined, and finances permit, you can duplicate the circuit to provide a variety of controls in a single toy. For example, one circuit could be used to control a steering motor, another a drive motor, and yet another to initiate special action, such as a rotating turret or crane.

**Reader's Circuit.** Seeking a solid-state preamp to use with an old vacuum tube amplifier recorder for playback purposes, reader Bill Roberts (Rt. 3, Highway 81, Winder, GA 30680) tried a number of different approaches, but found

that each lacked something. He finally settled on a published design using an IC op amp supplied with a "poly" kit he had purchased. After preliminary tests, however, Bill concluded that the circuit's response was, in his words, "from 1000 to 2000 Hz, soaking wet!!!"

Undaunted, Bill dug out his old reliable sine/square-wave generator, his soldering iron, and a few thousand assorted parts, and started experimenting, finally developing the circuit illustrated in Fig. 5. He liked its performance so well that he's now using a stereo version of the preamp with his expensive hi-fi system.

Referring to Fig. 5, Bill's design employs a Fairchild type  $\mu A739$  dual operational amplifier, IC1. Supplied in a 14-pin DIP, the  $\mu A739$  features low distortion, excellent channel separation, relatively low power consumption, high gain, and extremely low noise. Both sections are used for stereo applications, with the IC connections to the second op amp section identified by the pin numbers given in parentheses. Component values are identical for both channels, but a 220- $\mu F$ , 35-volt electrolytic bypass capacitor should be added between pins 7 and 14 in stereo versions. All resistors are 1/4 or 1/2 watt. Capacitors C1 and C2 are 25-volt electrolytics, C5 and C8 are 15-volt electrolytics, and the remaining capacitors are low-voltage ceramic or plastic film units.

The circuit's frequency response, rolloff, and turn-over characteristics will vary with component values, of course. According to Bill, the specified values develop an RIAA playback curve suitable for use with magnetic phono pickups. For an NAB tape curve, change R1 to 120 kilohms, C6 to 0.001  $\mu F$ , and omit C7.

Bill assembled his original model on a 2 1/2" x 3" etched circuit board, providing a socket for the integrated circuit. Other construction techniques may be used, of course, provided good layout and lead dress procedures are observed by the builder. Operating power can be obtained from the amplifier with which the preamp is used or from a separate well-regulated, adequately filtered, line-operated dc power supply.

**Device/Product News.** General Electric's Semiconduc-

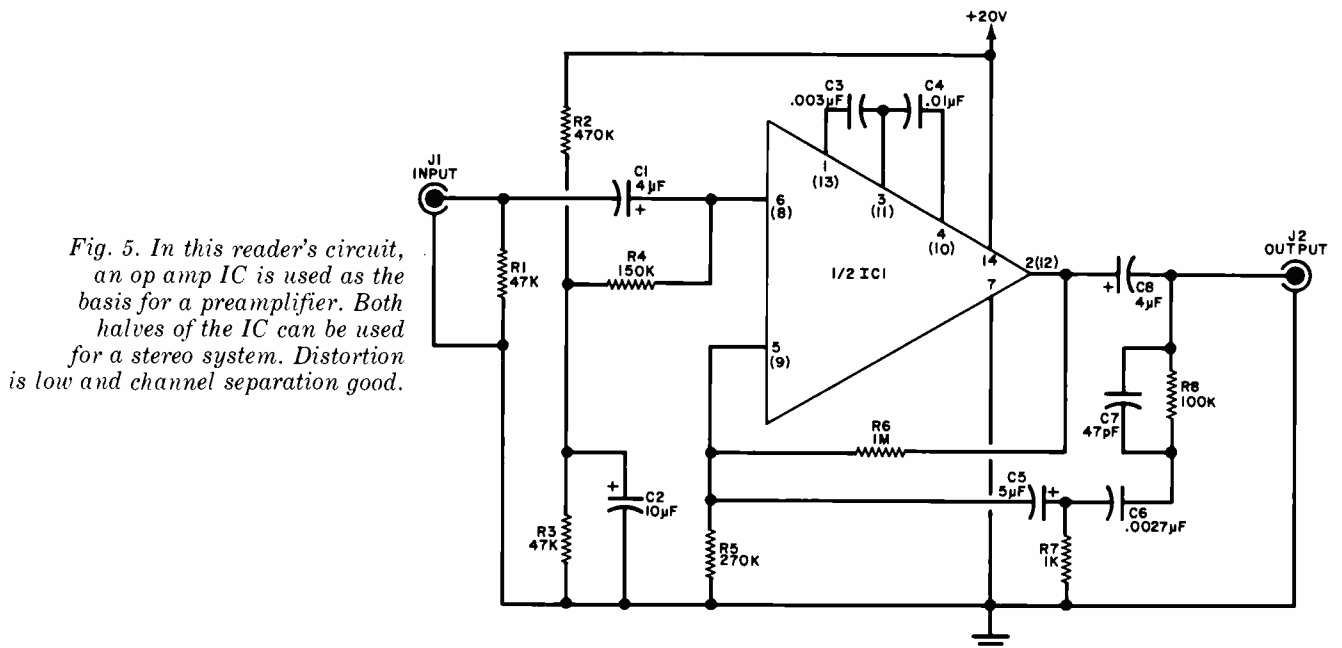

Fig. 5. In this reader's circuit, an op amp IC is used as the basis for a preamplifier. Both halves of the IC can be used for a stereo system. Distortion is low and channel separation is good.



tor Products Department (Building 7, Mail Drop #49, Electronics Park, Syracuse, NY 13201) has introduced two new devices which should be of particular interest to experimenters and hobbyists working with control circuits—a threshold switch and a bi-directional coupler. Both devices are supplied in 6-pin miniDIP packages.

The new threshold switch is essentially a programmable photocoupler which allows the separation of high-level noise from switching signals. Designated type H11A10, the new device "turns on" a transistor electrically remote from the input when the input current exceeds a tightly specified threshold level. This threshold may be programmed over a ten-to-one range, from four to forty mA. The unit provides an isolation voltage of 1,500 V and a minimum current transfer ratio of 10% in the "on" state.

Designed for ac inputs, GE's new bi-directional photocoupler will operate on either positive or negative input cycles. This action is achieved by providing two light-emitter diodes in an anti-parallel connection coupled to a phototransistor output. Identified as the H11AA, the new coupler features 1500 V isolation and up to 20% minimum current transfer ratio.

The National Semiconductor Corporation (2900 Semiconductor Drive, Santa Clara, CA 95051) is also in there swinging with two new photocouplers (optocouplers, if you prefer), types NCT 200 and NCT 260. Having pin-for-pin compatible with such devices as the MCT2, MCT26, ISO-LIT 16, 4N26, 4N27 and FCD820, the new units offer a higher guaranteed minimum isolation voltage of 2000 V and an isolation capacitance of only 0.5 pF.

If you're working with LED digital displays, as used in clocks and calculators, you should be interested in a new hex digit driver just introduced by Bowmar Arizona, Inc. (2355 West Williams Field Road, Chandler, AZ 85224). Designated type BD5021, the new IC consists of six MOS-compatible digit drivers, with each driver capable of sinking up to 320 mA. A separate pin is provided for drive current input, permitting the use of an external resistor to optimize input current versus display brightness, thereby reducing battery drain. The circuit is designed to prevent current flow if the input potential becomes negative, providing improved performance in multiplexed applications. The BD5021 is supplied in a 16-pin plastic DIP.

Motorola's Semiconductor Products Division (P. O. Box 20924, Phoenix, AZ 85036) has some good news for hams and others working with high-frequency circuits—a new die-mounting technique which significantly improves the power dissipation and gain capabilities of uhf and vhf transistors offered in the popular TO-39 style package. These improvements enable a designer to use medium-power devices in r-f applications with a price savings of up to two-to-one over stud-mounted units. In practice, the transistor die is mounted in a beryllium insulator, electrically isolating the collector while still allowing heat to be conducted to the case header. The emitter is connected directly to the case, which is normally soldered to circuit ground, thus providing lower emitter inductance and reduced parasitics in the common-emitter configuration. In a typical installation, the device is mounted *directly* to a heat sink, chassis, or the equipment's case. The first device offered using the new package is the MRF227, a 225-MHz transistor rated at 3W with a power gain of 13.5 dB minimum and an efficiency of 60%. Future devices expected to follow the MRF227 are the MRF237 vhf driver and the MRF629 uhf driver. ♦

DECEMBER 1974

# New

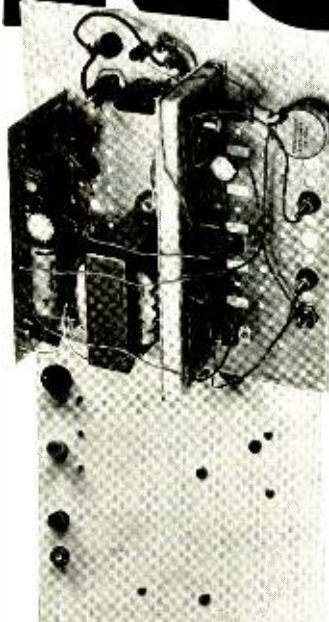

... UNIVERSAL  
ELECTRONIC  
INSTRUMENT  
DESIGN AND BUILD  
YOUR OWN  
ELECTRONIC  
INSTRUMENT  
IN HOURS, NOT DAYS!

Think of it. No circuit board to assemble or solder; just push your electronic components into the SK-10; no panels to lay out and machine — simply mount your parts . . . combine your design with the self-contained power supplies and you've got a finished instrument.

Available in 3 kit versions to meet your unique requirements, it combines the SK-10 socket with the UMP-01 universal panel and gives the designer an instrument in 1/10th the time it would take with custom instruments.

From \$50.00 to \$85.00 depending on the power supplies you want. Write for free literature.

## CIRCUIT DESIGN, INC.

Div. of E&L Instruments  
P.O. Box 24  
Shelton, Conn. 06484

CIRCLE NO. 17 ON READER SERVICE CARD

**Allied Electronics**  
Allied stocks every item in this guide

1975 ENGINEERING MANUAL & PURCHASING GUIDE No. 750

## New

### The 1975 Engineering Manual & Purchasing Guide!

A "must" for  
hobbyists, experimenters,  
repairmen and technicians!  
Thousands of hard-to-get electronic  
parts and supplies. Order now!

Send \$1 to Allied Electronics  
Dept. PE75, 401 East 8th St.  
Fort Worth, Texas 76102

NAME \_\_\_\_\_

ADDRESS \_\_\_\_\_

CITY \_\_\_\_\_

STATE \_\_\_\_\_ ZIP \_\_\_\_\_

**ALLIED ELECTRONICS**  
A DIVISION OF TANDY CORPORATION

# THE EXECUTIVE DIGITAL TEMPER COUNTDOWNER

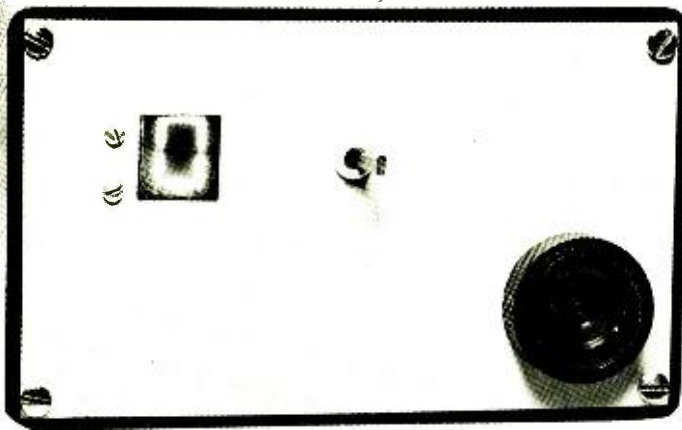

Counts and displays for ten seconds— followed by an audible “blow-your-top” signal

BY ROBERT D. PASCOE

“COUNT to ten before you blow your top” is familiar advice to help avoid losing one’s temper. Here’s a novel temper controller—a perfect gift for the executive who has everything—that does the counting for you.

Activating the temper timer starts the visual display of ten numerals (0 to 9), followed by an audible sound that means “now you can blow your top.”

**About the Circuit.** The temper timer is a clock, whose pulse rate is 1 Hz;

a decade counter and seven-segment display; and a Sonalert beeper. The schematic is shown below.

When switch *S1* is closed, power is supplied to the temper timer. Resistor *R4* and capacitor *C3* form a differentiator which is connected to the reset

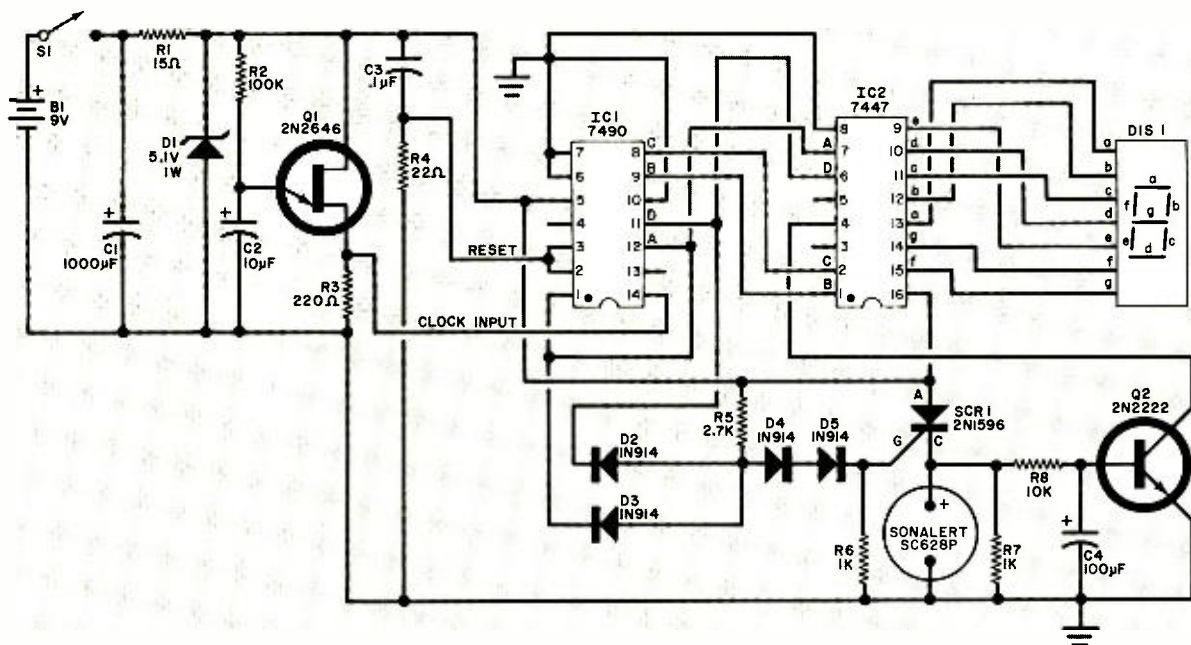

## PARTS LIST

B1—Six C or D cells in series (see text)  
C1—1000- $\mu$ F, 25-volt electrolytic capacitor  
C2—10- $\mu$ F, 25-volt electrolytic capacitor  
C3—0.1- $\mu$ F, 50-volt disc capacitor  
C4—100- $\mu$ F, 25-volt electrolytic capacitor  
D1—5.1-V, 1-W zener diode (Motorola HEP Z0406)  
D2, D3, D4, D5—1N914 diode  
DIS1—Numitron (2000 series) or other

7447-compatible seven-segment display  
IC1—7490 integrated circuit  
IC2—7447 integrated circuit  
Q1—2N2646 unijunction transistor (Motorola HEP 310)  
Q2—2N2222 transistor (Motorola HEP 736)  
R1—15-ohm, 1-watt resistor  
R2—100,000-ohm,  $\frac{1}{2}$ -watt resistor  
R3—220-ohm,  $\frac{1}{2}$ -watt resistor  
R4—22-ohm,  $\frac{1}{2}$ -watt resistor

R5—2700-ohm,  $\frac{1}{2}$ -watt resistor  
R6, R7—1000-ohm,  $\frac{1}{2}$ -watt resistor  
R8—10,000-ohm,  $\frac{1}{2}$ -watt resistor  
S1—Spst switch  
SCR1—2N1596 silicon controlled rectifier (Motorola HEP R1102)  
1—Mallory No. SC628P Sonalert®  
Misc—Suitable plastic enclosure, battery holder, machine hardware, hookup wire, pc board or perforated board, solder, etc.



terminal of the decade counter. This arrangement insures that the counter starts at zero every time the sequence is initiated.

The UJT timing oscillator, *Q1*, generates one pulse per second which is fed to the clock input of the counter (*IC1*). The outputs of the 7490 up-counter are introduced into the inputs of the BCD-to-seven-segment decoder, *IC2*. A 7447 chip is used for this function. The outputs of *IC2* are connected to the display. A Numitron (2000 series) was used in this project, but any seven-segment display compatible with the 7447 decoder can be substituted.

A diode AND gate, composed of *D2*, *D3*, and *R5*, controls the beeper and display-off sequence. When a 9 appears at the output of the 7447, the output of the AND gate goes high, and *SCR1* is triggered. Once *SCR1* is on, the Sonalert is activated, and audible beeps are emitted until the power switch is opened. The output of the gate also is connected to an inverter (*Q2*). When the output of the inverter goes low, the display is turned off. This is done to reduce power consumption. A small delay is introduced by *C4* to allow the last digit (9) of the count to appear on the display.

Any 5-volt supply capable of delivering 250 mA to the temper timer is suitable. For portability, six C or D cells can be used in the zener-regulated supply shown in the schematic. If longer battery life is desired, alkaline cells should be used.

**Construction.** The placement of components is not critical. Parts may be mounted on perforated board or a pc board. Leads should be run from the board to the display, rather than soldering the display directly to the board. This will afford a large degree of flexibility in mounting the board and display in an enclosure. The author used a plastic box (6¼" × 3" × 2") with an aluminum cover panel. A ¾" square hole was cut out of the panel for the display, and a bracket made from scrap aluminum was used to hold the Numitron securely.

**Operation.** The device may be used any place and any time that your temper flares up. It is a good conversation piece for the home or office, and correct use of the temper timer, in conjunction with self-restraint, may well keep some conversations going that otherwise would have led to blows. ♦



The reason you get **more** from our LR-5000 4-Channel Receiver is simple.

Control. We design it, we manufacture it, we distribute it. So we can build in 35 watts RMS per channel power (four channels driven, 8 ohms, 20-20,000 Hz, 0.5% THD) and 1.65  $\mu$ V IHF FM sensitivity. We can design an exclusive full-logic wavematching circuit with Variblend that provides the best SQ 4-channel separation available today. We can include every control, input and output you're ever likely to need (accessory CD-4 package available). And we can make it look as good as any receiver you're ever likely to see. We can even price it at \$599.95 and give it our AAA 2-year guarantee.\* That's what WE can do. You can buy it, make it the heart of your music system, and enjoy the finest 4-channel sound you EVER HEARD—for years to come!

\*Parts and labor.

# Lafayette

RADIO ELECTRONICS

## Listen to us, you can't go wrong.

111 Jericho Turnpike, Syosset, L.I., N.Y. 11791

54 Years of Leadership and Integrity in Electronics • Write for FREE Catalog • Stores Coast-to-Coast

CIRCLE NO. 28 ON READER SERVICE CARD



**NEW ALPHA**  
**QUARTZ TIMED DIGITAL WATCH KIT**  
 HOUR & MINUTES 69.99  
 WITH SECONDS ON DEMAND 79.99  
 +2.00 handling  
 complete kit except band and battery...

HIGH VISIBILITY FIELD EFFECT DISPLAY  
 TIME SETTING BY REED SWITCHES  
 STAINLESS CASE INCLUDED  
 (CASE REQUIRES SOME ASSEMBLY)

ALPHA ELECTRONICS 305-636-6951  
 P.O. BOX 1005 • MERRITT ISLAND • FLORIDA 32952



# Test Equipment Scene

By Leslie Solomon

## PUTTING YOUR MULTIMETER TO USE

**A** COUPLE of months back, we were discussing some valuable uses for the VOM and other multimeters—aside from using them to check just voltages, currents, and resistances. Now, we will finish up on this subject with several more uses for the ubiquitous multimeter.

Let us start with some semiconductor tests. The simple circuit shown in the schematic diagram can be em-

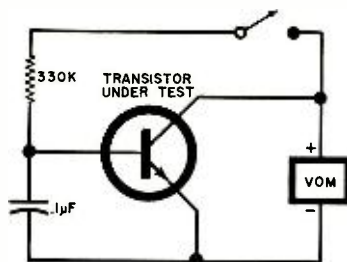

ployed to make a low-cost transistor tester that can be used to check leakage and give a rough idea of the beta of an unknown transistor. The circuit is shown in the test setup for npn transistors, but all you have to do is reverse the leads of the VOM when checking pnp devices.

To check collector-emitter leakage, leave the switch open and set the multimeter to the resistance function and a high range. With decent silicon transistors, negligible meter pointer deflection should occur, even when the VOM is set to the RX100K range. The best transistors will exhibit the least leakage (highest resistance). To obtain a rough idea of the transistor's beta, set the multimeter to the RX100 range and close the switch. The meter's pointer will deflect from infinity towards the zero index. Open transistors cause no deflection (shorted devices will have shown up during the leakage tests). Although this test will not reveal the actual beta of the transistor, it will reveal whether or not the transistor is good. If you have a transistor of known beta, you can come up

with an approximate beta scale for your multimeter.

To test a semiconductor diode, connect the multimeter (set to the RX100 range) across the diode, take a reading, and then reverse the leads and take another reading. If the diode is good, you should observe two different readings—one relatively low, and the other high, depending on the polarity of the diode when connected to the meter's leads. This is one way to check the front-to-back ratio and to determine if the diode is open or shorted. If you know the polarity of the voltage on your multimeter's leads in the resistance function, you can also identify the anode and cathode leads of the diode. If the meter's pointer swings to the low-resistance point on the scale, the positive-voltage lead of the meter is connected to the diode's anode lead.

Power transistors can be easily checked for quality with a couple of simple tests. The collector-emitter leakage of silicon power transistors can be measured on either the RX10K or RX100K range, while germanium types are best checked on the RX1K range. Most power transistors fail catastrophically; they usually have direct emitter-collector shorts or are completely open. The most common "bad" transistor indication is a direct short, regardless of the polarity of the meter's leads in the test setup.

Bear in mind that most power transistors use the metal case for the collector lead. When mounted in metal enclosures, some thin insulating material is used to isolate the collector (case) from the metal chassis. You can use your multimeter to probe between the metal case and chassis to check the effectiveness of the insulator. (If you find a bad power transistor and replace it in a piece of equipment, do not forget to use silicone grease between transistor case and insulator

and insulator and chassis to assure efficient heat conduction.)

You can use your multimeter (assuming it has the usual 1.5-volt ohmmeter voltage) to check zener diodes. Use the RX10 range and check the continuity through the diode in both polarities. A near zero indication for both hookups of the meter's leads usually indicates a shorted junction, while a very high indication in both directions indicates an open-circuit condition.

To determine the zenering voltage of an unknown zener diode, connect a high dc voltage (50 volts or so) in series with the diode and a 22,000-ohm, 1-watt resistor. Connect the positive supply lead to the *cathode* and the negative lead to the anode lead of the zener diode. Connect the multimeter, set to dc volts and an intermediate range, across the zener diode. When power is applied, the multimeter will indicate the zener voltage. To check this reading, momentarily shunt the resistor with another 22,000-ohm, 1-watt resistor. The meter reading should not change.

You can make a simple check of UJT's with a conventional VOM. Using the multimeter on the RX100 range, connect it between the emitter and base-1 leads. Forward conduction is indicated by a mid-scale pointer deflection. Reversing the test leads should produce essentially an open-circuit reading. Then check the resistance between the base-1 and base-2 connections with nothing connected to the emitter. Most UJT's will exhibit between several thousands of ohms to 10,000 ohms. The exact value is unimportant. This inter-base resistance should remain the same when the meter's leads are transposed.

**Testing SCR's and Triacs.** To check SCR's, you can use a multimeter that can deliver several ten's of milliamperes of test current to insure sufficient "holding" current supplied to the SCR under test. The first test is resistance, measured directly between the anode and cathode of the SCR with the gate left open. A low resistance, independent of polarity, is an indication of a shorted SCR.

To check the unknown SCR's triggering, connect the positive test lead of the meter to the anode and the negative test lead to the cathode of the SCR. Use the RX1 range. Then connect the parallel combination of a 220,000-ohm resistor and 0.22- $\mu$ F



capacitor between the anode and gate of the SCR. The resulting gate spike should trigger on the SCR, and the meter should indicate a relatively low resistance. Momentarily breaking the anode circuit should result in a high-resistance reading once again. If the SCR does not trigger on with the small gate spike, add a 1.5-volt penlight cell in series with the RC circuit, with the positive side of the cell toward the SCR's gate. If the SCR still does not trigger on, discard it.

Most triacs can be checked by connecting the multimeter (set to RX1), in both polarities, between the anode-1 and anode-2 terminals with the gate left open. No current should flow through the triac, a condition indicated by high resistance. With the multimeter connected across the two anode leads, momentarily connect a low-value resistor (10 to 15 ohms) between anode-1 and the gate. One half of the triac should conduct, producing a multimeter pointer deflection. Switch the meter leads and once again momentarily connect the resistor between anode-1 and the gate. The meter should now indicate that the second half of the triac is operating properly. A good triac will exhibit negligible leakage in both directions when the gate is left floating.

If you happen to have a triac that has a built-in diac gate firing element, replace the 10- to 15-ohm resistor with a 220-ohm resistor. Switch the multimeter to its 100-mA range, and insert another 220-ohm resistor in series with the meter and a 22.5-volt battery. (Battery polarity is unimportant.) Test the triac as outlined above.

**The VOM and Your Car.** The multimeter is a handy device to have around when it comes time to work on your car. One example of its use in cars is in checking out the distributor system. Remove the distributor cap and check the resistance between the center "hot" terminal and all other terminals. Use the high-resistance range of the meter for this operation. This test will reveal any leakage due to conducting dust clinging to the interior wall of the distributor cap. Clean away any film you discover. In some cases, the cap will exhibit some leakage even in the absence of a visible film. This can be caused by a leakage path existing *inside* the material of the cap. So, next time you cannot figure out why your engine is misfiring, check the distributor cap.

Using the high-resistance range of your meter, check each spark plug—without removing it from the engine block. Simply remove the ignition cable from the end of the plug. If the points are fouled, or if there is a conducting crack in the porcelain insulator of the spark plug, the meter test will tell you which plugs to remove for further inspection. This test will not reveal burned-up electrodes or wrong gaps, but it will point the way to a faulty plug.

Next, use the multimeter to check

out ignition wiring, especially any interference-suppression cables. Connect the meter between the conducting ends and flex the cable. If you observe an erratic indication on the ohmmeter, replace the cable.

Another simple engine test is for the "condenser." The usual metal case of this capacitor should make good contact with the car's ground system, via the capacitor clamp. Use the meter to determine if this is the case, since even a fraction of an ohm can prevent proper operation. ♦

**PHOTO ETCH PRINTED CIRCUIT KIT**  
**MAKES PRINTED CIRCUITS THREE WAYS!**

1 FULL SCALE ARTWORK MASTER

2 MAGAZINE ART ILLUSTRATION → FILM POSITIVE → NEGATIVE → DEVELOPED PHOTO RESIST IMAGE ON COPPER CLAD CIRCUIT BOARD → ETCHED CIRCUIT BOARD

3 DIRECT ETCH DRY TRANSFERS APPLIED TO COPPER CLAD BOARD

**The revolutionary photographic way that makes PERFECT printed circuits from YOUR ARTWORK or a PRINTED PAGE! No camera. No darkroom. No tracing. No film cutting. Simple and fast.**

KIT CONTAINS 5" x 6" steel printing frame 4 sheets 5" x 6" photocopy film yellow filter chemicals for 1 pint film developer and 1 pint film fixer 5" x 6" copper clad board 3" x 4" copper clad board spray can of photo etch resist 1 pint resist developer 2 sheets 8 1/2" x 11" layout film 1 roll 1/16" printed circuit tape 1 roll 1/32" printed circuit tape 8 sheets dry transfer direct etch PC patterns including pads transistors round can and flat pack ICs DIP ICs edge card connectors lines circles jogs etc. 1/4 lb anhydrous ferric chloride to make 1 pint etchant instructions

ER-4 COMPLETE PHOTO ETCH SET ..... postpaid \$24.95  
 (N. J. residents add sales tax)

AT YOUR DISTRIBUTOR OR DIRECT

the DATAK corp. • 65 71st Street • Guttenberg, New Jersey 07093

CIRCLE NO. 11 ON READER SERVICE CARD

for only \$19.95\* this ugly little space-age device makes your FM/AM mobile stereo sound like it's always parked near the radio station

model ASC-100 stereo x-pander

ascom electronic products

Division of OR ON INDUSTRIES, INC., 12435 Euclid Ave., Cleveland, Ohio 44106  
 Export 2200 Snames Drive, Westbury, L.I. New York 11590  
 Canada: A.C. Simmonds & Sons, Ltd.

CIRCLE NO. 3 ON READER SERVICE CARD



# Art's TV Shop

By Art Margolis

## THE CASE OF THE BOOBY-TRAPPED TUBE

**S**EEMS like you got a bad batch of tubes there, Art," burly detective sergeant Haines smiled in a cool fashion.

"It's not indicated, Joe," I grinned back.

"That's the third bad 6GH8 old boy," he returned with some of the smile gone.

"Let's review it," I answered, trying to be patient.

He began, "I brought in all the tubes from my TV and tested them," he waved a finger at the self-service tube tester. "The 6GH8 was bad. You sold me a new one."

"Right you are," I nodded, "I made sure you tested the new one before taking it home, right?"

He sighed, "Yeh, but the new one didn't work, so I brought it back. It tested bad then."

"I gave you another new one, that you also tested before you took it home," I answered, trying to keep smiling.

He gave a long sigh a second time, "That one didn't work either." He held the tube up. "It tests bad too."

I pointed at our Service Charge List. "Joe I'll tell you what. Bring in the TV. If there is nothing wrong but a tube, I'll pay you the service charge. If there is trouble, then you pay for the job."

He smiled. "Be back in a while," and he strode out to his unmarked patrol car.

I took the three 6GH8's—his original and the two new ones I sold him—and tested them carefully. All three had the same problem. The pentode section of the triode-pentode was dead.

I pulled out Joe Haines's file card. He owned an Emerson 29P03 color TV. He had described the symptom of the trouble, the first time he was in. The color-killer control was inoperative and rainbows were going through the picture instead of the colors locking into place. I pulled the schematic

for the TV and looked over the circuit.

The tube in question had the triode section doing color-killer work, while the pentode part was the burst amplifier. The burst amplifier was connected into the color killer. If the burst amplifier was defective, it could ruin the performance of the color killer.

As I mused, Joe walked back into the store and gingerly placed the 19-inch color TV on the service counter.

I set it in place, removed the back and plugged it in. I took a new 6GH8 off the shelf and tested it in the tube tester. Both the triode and pentode sections showed Good.

Joe was watching closely. He didn't say a word, so I remained silent. I plugged the new, known good 6GH8 into its socket and turned the TV on. I could see the face in the counter mirror.

The audio blasted forth and a bright picture pushed its way satisfactorily across the screen. The colors came in momentarily but then began rotating down through the picture. The flesh tones changed continually from green through normal through purple. A clear case of colors out of sync. The color burst-oscillator circuits were indicated as being in trouble.

I looked at the burst amplifier I had just installed. It seemed normal. I watched it. Then it began. One of the black plates was turning pinkish. I pulled the plug. That is not permissi-

ble. A plate in a tube should never run hot enough to glow. If it does, it is drawing more plate current than it is rated for and will burn up quickly.

Now what could be causing this 6GH8 to be drawing too much current? There are three immediate possibilities (Fig. 1). One, B-plus could have bled through to a control grid from the preceding plate. When that happens, the valve action of the tube causes too much current to pass the control grid vicinity. Instead of a normal negative bias, the control grid is positive, exercising no control. The tube runs wide open.

A second possibility is loss of cathode positive bias. When the cathode loses bias, the control grid-cathode voltage difference acts as if a positive voltage were on the grid, as in the number one possibility. Here again the tube runs wide open and passes more current than the plate can absorb.

The third reason could be too much positive attraction voltage on the plate. Should plate voltage go more positive, it affords a stronger attraction to the cathode current, and plate current rating could be exceeded.

I looked at the schematic and zeroed in on the pentode part of the 6GH8. Joe watched over my shoulder. The plate and screen were supposed to have plus 250 volts on them. The control grid is at zero volts, while the cathode has plus 25 volts. The plus 25 on the cathode effectively gives a minus 25 volts bias on the control grid. This high negative bias allows little current to flow. Surely not enough to make the plate glow.

I plugged in the TV, grabbed the probe of my voltmeter and began reading voltages (Fig. 2).

Pin 3 the screen grid had plus 250 as prescribed. Pin 6 the plate was about 175 volts, somewhat low. Pin 2 the control grid had the zero voltage shown on the schematic. Pin 7 the cathode was wrong! It had plus 2 volts

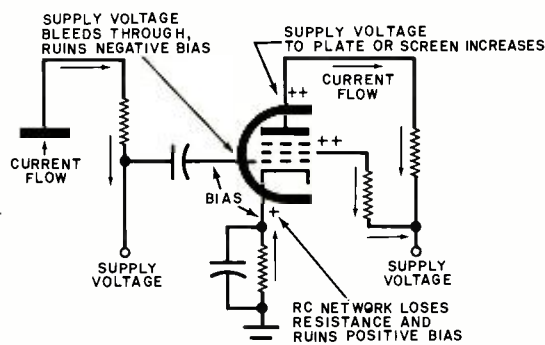

Fig. 1. Three possible reasons for excessive plate current are shown.



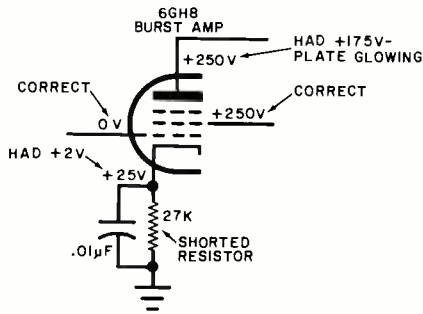

Fig. 2. Voltage readings showed a shorted resistor.

instead of plus 25, which is required.

In the cathode was a small RC network consisting of a 0.01-µF capacitor and a 27,000-ohm resistor in parallel to ground. They both looked good.

I turned off the TV and took a resistance reading from pin 7 to ground. Aha, it was under a hundred ohms. There was not enough bias resistance to develop the plus 25 volts between ground zero and pin 7. The hundred ohms only developed about 2 volts. Either the capacitor or the resistor had shorted down to the low ohmage.

I unsoldered one end of the capacitor. Joe was now watching carefully. I measured the capacitor. It had infinite resistance. It wasn't shorted, it was good. I disconnected one end of the resistor and took a resistance reading. That was it! Instead of 27,000, it read under a hundred ohms.

I turned to Joe with the little colored carbon body between my fingers, "Here's the trouble, a shorted resistor." Then I took a new one out of the drawer and soldered it in.

The TV was turned on and the newest 6GH8 plugged in. I watched the plates carefully. They stayed black, no glow.

I tried the color-killer control. It was now working properly. A good picture showed with all the colors locked into place.

I laid the box of the last 6GH8 I used alongside his other three. He looked at them all ruefully, then put both his elbows on the counter and cupped his chin in his open palms. He smiled coolly, "Seems like you got a bad batch of tubes there, Art."

I took a deep breath and said, "Joe ----"

He laughed, "Don't get up-tight there old boy, it's a bad batch, but it was a booby trap in my TV that did it. I could have been buying tubes forever if you didn't catch it. Pretty tricky." ♦

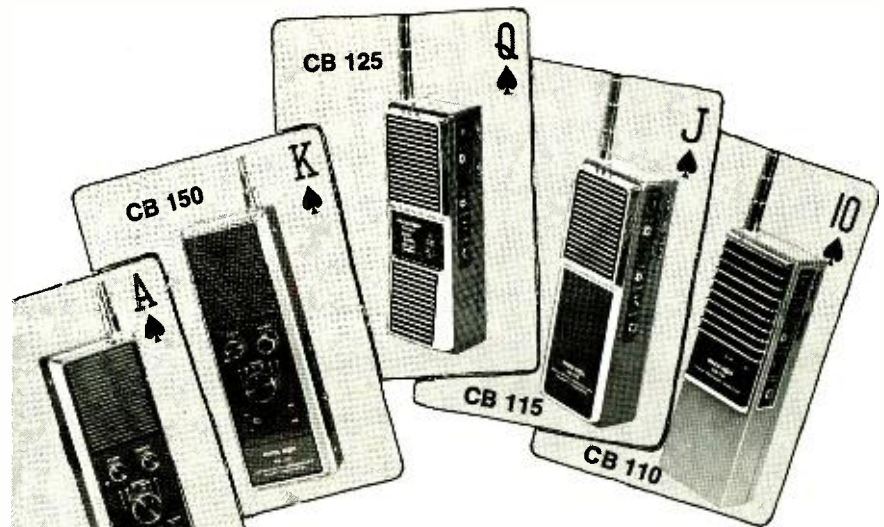

## Pace's Best Bet for Handheld CB

Your communications "stakes" are on the table, when you need CB 2-way radio. Play it safe with any one of the experience-proven veterans from PACE — one of the largest selections of handheld CB transceivers in the industry. All are guaranteed and all have PACE's U.S. Factory Service Program. See your PACE Dealer soon or write for new full product line catalog.

### ((P)) PACE COMMUNICATIONS

Division of Pathcom Inc., 24049 S. Frampton Ave., Harbor City, Calif. 90710  
EXPORT: 2200 Shames Drive, Westbury, New York 11590. Available in Canada.  
CIRCLE NO. 32 ON READER SERVICE CARD

38

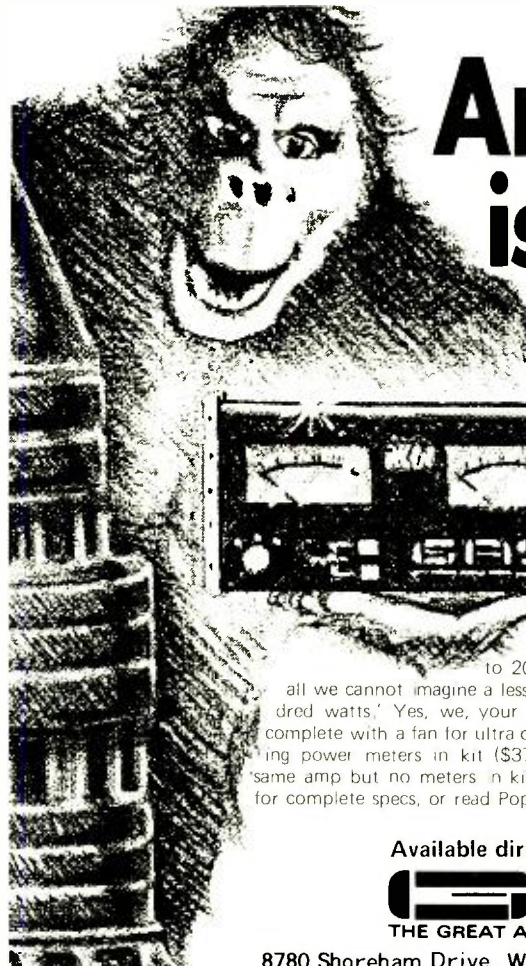

## Ampzilla is here...

Why spend \$750 to \$1200 dollars for an amplifier? The Great American Sound Company sells one with a full complementary series connected output for much less. In short AMPZILLA is here. In the September 1974 Popular Electronics, Hirsch-Houck Labs says "... solidly in the audio monster amplifier class ... using 8 ohm loads ... THD was less than 0.01% for all power levels ... up to 200 watts ... (per channel) ... all in all we cannot imagine a less expensive way of obtaining several hundred watts." Yes, we, your friendly GAS company, have the goods complete with a fan for ultra cool operation. Available with direct reading power meters in kit (\$375) or fully assembled (\$525). Also the same amp but no meters in kit (\$340) and assembled (\$475). Write us for complete specs, or read Popular Electronics, September 1974

Available directly from

**GAS**  
THE GREAT AMERICAN SOUND COMPANY, INC.

8780 Shoreham Drive, West Hollywood, California 90069  
CIRCLE NO. 23 ON READER SERVICE CARD



# CB Scene

By Len Buckwalter, K10DH

## NEW ANTENNA RULES

**C**B has finally won a substantial change in its antenna rules. After laboring under a severe 20-foot height restriction for 16 years, the medium has gained FCC approval to raise its antennas to 60 feet. The new regulations, proposed back in 1973, not only boost antenna height but allow a piece of once-forbidden hardware: a tower. The new law officially took effect on September 6, 1974.

The changes include several technical details of interest to any CB'er planning to install a new antenna or improve an old one. Consider, first, that 60-foot figure. According to the old rule, a CB antenna could not rise higher than 20 feet above a man-made or natural mounting point. Since most base antennas are almost 20 feet tall, the rule limited the antenna to such locations as a roof or chimney. Today, you can install the antenna on a much higher mast so long as it does not exceed 60 feet above *ground* level. Note that key word *ground*. It means you can't put a 40-foot pole on your roof and top it with a 20-foot CB antenna.

As Fig. 1 shows, it creates an overall 80-foot combination that violates the ground rule. Practically speaking, the new rule means you may install a 40-foot tower in your backyard to support a 17-foot, or so, base antenna. The rules, incidentally, don't specifically spell out "tower" but refer to "supporting structure." Since towers have always been illegal in CB, we checked with an FCC engineer in Washington to be certain of the wording. It's true—"supporting structure" means a mast, pole or tower.

Before you raise a giant sky hook with more elements than a NASA tracker, watch out for an important restriction in the new regulation. Any antenna mounted on a tower *must be omnidirectional* (or, as sometimes stated, "all-directional" or "non-directional".) Beams or any other "gain" antennas are not allowed. If some engineer comes up with a revolutionary antenna that promises, say, 6-dB "gain" in all directions, the FCC could submit it to a simple test to solve any disputes. According to usual en-

gineering practice, the antenna is slowly rotated while its radiated signal is picked up on a nearby receiver that plots signal strength over 360 degrees. If strength varies by more than 3 dB over a full circle, the antenna is considered directional. This is how the restriction appears in the FCC definition of an omnidirectional antenna: "An antenna designed so the maximum radiation in any horizontal direction is within 3 dB of the minimum radiation in any horizontal direction."

Now if someone comes up with a new omnidirectional antenna—one that has more than 3-dB gain under that definition—he will probably become as famous as Dr. Yagi himself. It is still an axiom of gain antennas that, to put a stronger signal in one direction you must steal it from another. This shows up in "front-to-back ratio" and even a simple beam may display a 12-dB difference as it swings around.

Thus, the new rule promises to bring relief to the CB'er who suffers from poor range. It doesn't, on the other hand, give the go-ahead to huge, lofty arrays that work into the next state. If you still want to use a beam or other directional antenna, it's permitted; just follow the earlier rule which limits antenna height to 20 feet above a man-made or natural formation (Fig. 3).

The major reason for the original 20-foot rule was to keep CB a short-range service. The trouble was, it was too short to be of practical value in many applications, so the new rules should provide some relief.

**Airplane Considerations.** There is yet another height consideration besides range. It's the airplane. The FCC has always been concerned about

Fig. 1. This combination is illegal.

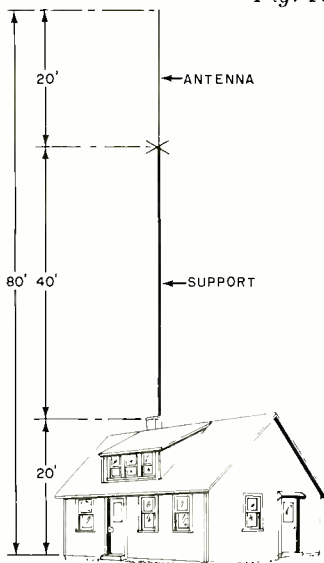

Fig. 2. Either of these installations would be within new specifications.

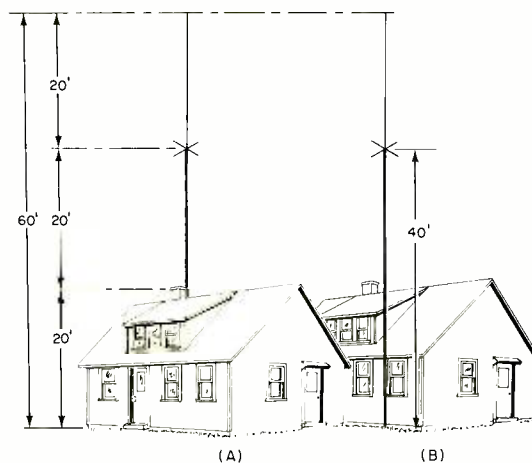
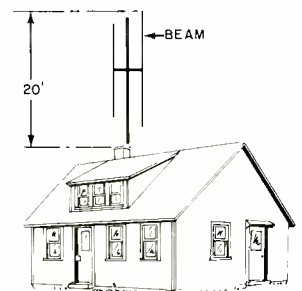

Fig. 3. The 20-foot rule is still applicable for beam antennas.





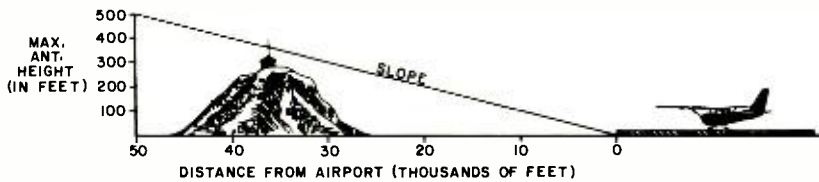

Fig. 4. This antenna near an airport would be against the rules.

several hundred thousand citizens poking their antennas into the navigable airspace (and some citizens have erected some monumental hazards to aircraft). When the Commission originally adopted a blanket 20-foot rule, no legal antenna could pose an aerial threat. It also eliminated a lot of paperwork, engineering services, surveying and other complications that now confront broadcasters and other communicators when they erect their towers. But the new 60-foot height for CB renews the threat to air navigation and the FCC has specific words about it in the new regulation. Let's look at it in some detail.

The crucial new antenna restrictions say: "...the highest point ... does not exceed one foot in height above the established airport elevation for each 100 feet of horizontal distance from the nearest point of the nearest airport runway." Translated to practicality it means, in many instances, that you won't have to be concerned about it unless you are less than about 2 miles from an airport. The reason is that if a runway is slightly over a mile away (6,000 feet) the antenna may rise to 60 without threatening air safety. Just divide distance to the airport in feet by 10 to get your maximum antenna height.

In some areas, though, you could violate the airspace at greater distances. Let's say the airport is 3 miles away—or about 16,000 feet, horizontally. According to the rule, this means your antenna may not be mounted more than 1,600 feet higher than the airport elevation. If you live on high ground overlooking a nearby airport, you may intrude into the "slope pattern" the FCC wishes to create in the vicinity of airports. This is shown in Fig. 4.

The Commission's concern about interfering with aircraft had, in fact, raised the possibility of prohibiting CB'ers from erecting antennas more than 20 feet high if they lived within several miles of an airport. The FCC, however, dropped it as being an unnecessary hardship on a great number of people and, instead, urges that an-

tenna manufacturers and dealers provide the buyer with enough installation advice to avoid the problem.

Is it really that great a threat? Maybe so. The commercial airlines use only some 300 airports in the U.S., but there are approximately 12,000 airports registered with the FAA and one could be near you. Add this to the fact that a vast proportion of aircraft accidents happen in the last moments before landing during conditions of low visibility and these antenna restrictions start to make sense. If you don't know what the various heights are, inquire at the airport and ask for its "field elevation," which is height above sea level. Then check at your town hall for a contour map of your vicinity and note the elevation of your home (or office). This should help you figure your height above (or below) the airport at any distance.

In the early deliberations about the 60-foot rule, the FCC believed the change might reduce television interference. The reasoning was that increased space between the higher CB antenna and the typical roof-top TV antenna would weaken the radio field and thus disturbances to the TV receiver. Others believed these distances would be negligible and argued that too many other variable factors enter the picture. So whether you'll calm an irate neighbor by raising your antenna will (as in many instances of TVI) be strictly a matter of individual cases.

**New Antennas?** Don't expect a rash of novel antenna types to bow in with the new regulations. A query of several manufacturers revealed that none has such plans (at this moment, anyway). They say that any of today's non-directional base station antennas will fill the bill. They also recommend that if you do go to 60 feet, the antenna should be installed with heavy coaxial cable—RG/8, for example—to hold down transmission line losses over the longer run. One antenna-maker cautions that RG/8 should be purchased from a reliable source; he's seen some with 50 percent less copper

## BETTER THAN A THIRD HAND!



**PANAVISE TILTS, TURNS, AND ROTATES TO ANY POSITION. IT HOLDS YOUR WORK EXACTLY WHERE YOU WANT IT.**

**PanaVise has great strength yet is gentle enough to firmly hold delicate objects.**

Quite possibly the finest new tool you will buy this year, PanaVise is built to exacting professional standards. We guarantee it!

Illustrated is the Electronics Vise Model 396. Three other bases and a wide variety of heads are available. All interchangeable! Buy a basic unit, then add on to create your system.

Available through your dealer.  
Write for a free catalog.

**PANAVISE®** Dept. 22E

10107 Adella Ave., South Gate, CA 90280  
In Canada: 25 Toro Rd., Downsview, Ont. M3J 2A6



A Division of Colbert Industries

CIRCLE NO. 33 ON READER SERVICE CARD

in its shield braid than a high-quality cable selling at the same price.

If you decide to exploit the new regulation and raise your antenna to new heights, don't expect to flood the county with two or three times more operating range. It's generally believed that an increase from 20 to about 60 feet will improve range by approximately 30 percent. It may not sound dramatic, but should certainly fill in many difficult and dead spots, and encircle a few hundred more square miles into your range. ◆

Why a Sylvania home training program may be

# your best investment for a rewarding career in electronics

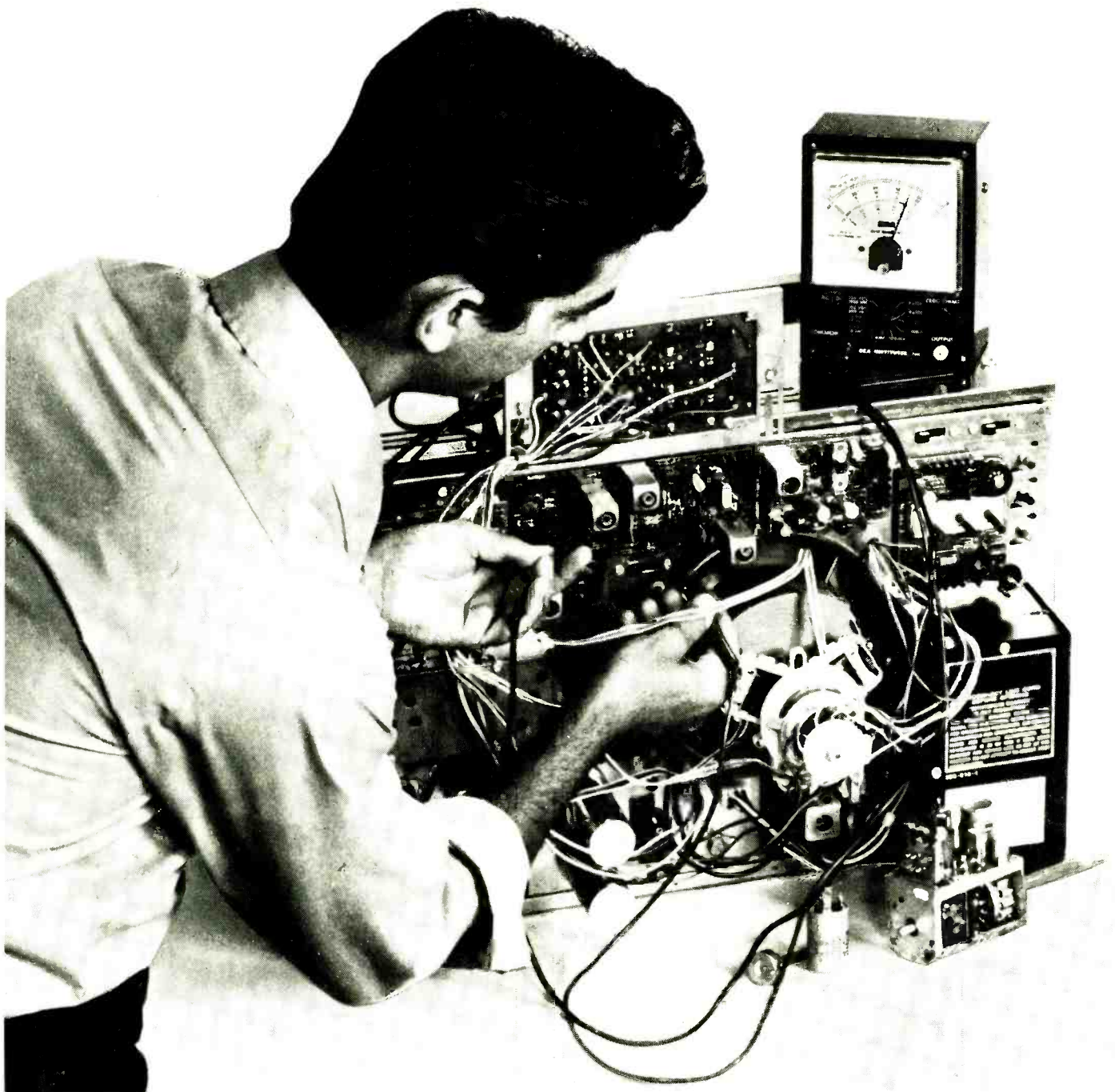



## 1 LEADER IN ELECTRONICS TRAINING

Over the years, Sylvania Resident Schools have trained thousands of men and women for key positions in the electronics field. Now, through Sylvania Home Training, you can receive the same high-quality career training at home. In your spare time. While you hold your present job. Remember, this training is designed with one purpose in mind — to give you the background you need to land the electronics job you really want!

## 2 AUTOTEXT TEACHES YOU ELECTRONICS RAPIDLY, EASILY.

AUTOTEXT, offered exclusively by Sylvania, is the proven step-by-step method of home training that can help you learn the basics of electronics quickly and easily.

## 3 CASSETTE SYSTEM

This innovative learning-by-hearing approach is a special option that adds an extra dimension to AUTOTEXT. It's almost like having an instructor in your own home. As you play the cassette tapes, you'll have an instructor guiding you through your AUTOTEXT lessons. Explaining the material as you read it. Going over schematics with you, reinforcing the basic electricity and electronics study materials with you. Everything you need to know to get you started towards a highly regarded position as an electronics technician — all in an easy-to-understand, conversational tone.

## 4 SPECIALIZED ADVANCED TRAINING

For those already working in electronics or with previous training, Sylvania offers advanced courses. You can start on a higher level without wasting time on work you already know.

## 5 PERSONAL SUPERVISION THROUGHOUT

All during your program of home study, your exams are reviewed and your questions are answered by Sylvania instructors who become personally involved in your efforts and help you over any "rough spots" that may develop.

## 6 HANDS-ON TRAINING

To give practical application to your studies, a variety of valuable kits are included in many programs. In Sylvania's Master TV/Radio Servicing Program, you will actually build and keep an all solid-state black and white TV set, and a color TV set. You also construct an oscilloscope which is yours to keep and use on the job.

## 7 FCC LICENSE TRAINING — MONEY BACK AGREEMENT

Take Sylvania's Communications Career Program — or enter with advanced standing and prepare immediately for your 1st, 2nd, or 3rd class FCC Radio Telephone License examinations. Our money-back agreement assures you of your money

back if you take, and fail to pass, the FCC examination taken within 6 months after completing the course.

## 8 CONVENIENT PAYMENT PLANS

You get a selection of tuition plans. And, there are never any interest or finance charges.

SEND ATTACHED POSTAGE PAID CARD TODAY! FREE DESCRIPTIVE BOOK YOURS WITHOUT OBLIGATION!

Sylvania Technical Systems, Inc.

If reply card is detached send this coupon

<b>SYLVANIA TECHNICAL SCHOOL</b>	
Home Study	694-412-0
909 Third Avenue	
New York, N.Y. 10022	
Please send me FREE illustrated career catalog. I understand that I am under no obligation.	
Name _____	
Address _____	
City _____	
State _____	Zip _____
Age _____	
Veterans: Check here <input type="checkbox"/>	

**GTE SYLVANIA**

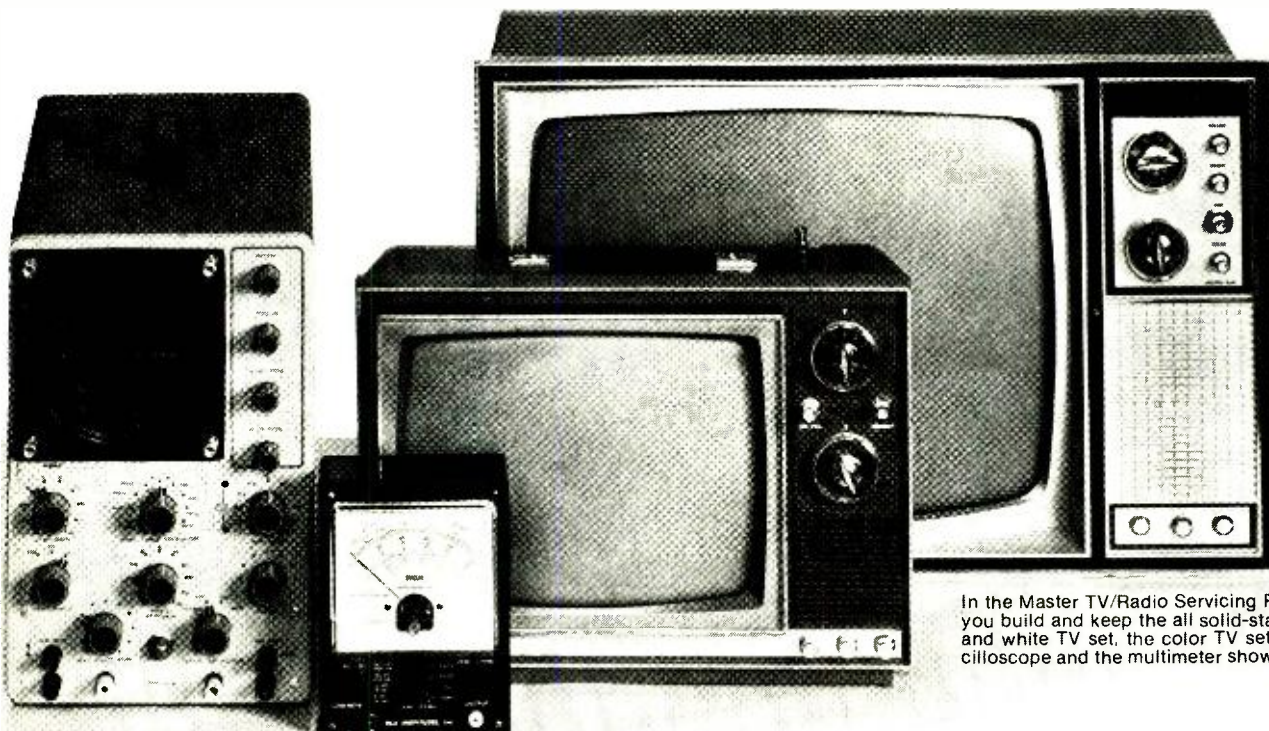

In the Master TV/Radio Servicing Program, you build and keep the all solid-state black and white TV set, the color TV set, the oscilloscope and the multimeter shown above.



# Electronics Library

## SOPHISTICATED ELECTRONICS FOR FUN

by Joe Urschel

If you've been turned off by the dry nature of electronic projects books, here is a work

that will amuse, instruct, and provide construction tips for a variety of unusual and entertaining projects utilizing BJT's, FET's, and IC's. The basics of component and circuit operation are explained, and then practical advice is given for the assembly of the project.

Many of the projects employ digital logic, and this subject is treated very lucidly, without unnecessary complications. Plans are included for electronic slot machines, a juke box with no moving parts, and a game-playing computer against which you can test your skills. The book is well illustrated with many photos and diagrams, and will be easily understood by even a neophyte to electronic circuits.

Published by Vale Communications, Box 272, Valparaiso, Indiana 46383. \$6.95 soft cover.

## MICROPHONES: DESIGN AND APPLICATION

by Lou Burroughs

This volume, by one of the pioneers in microphone research and development, treats the basic practical use of microphones. For adequate comprehension, fundamentals of microphone theory are discussed. Polar response, types of microphones, impedance, phase, and noise cancellation are thoroughly discussed. The emphasis throughout the book is applications in practical situations. Techniques for individual environments—musical, dramatical, and outdoors—are treated separately and completely. The book is written in a personal and interesting way, and will be easily understood by the amateur, as well as the professional recordist.

Published by the Sagamore Publishing Company, Inc., Plainview, N.Y. 11803. 260 pages. \$20.00 hard cover.

## THE ROLLING STONE GUIDE TO HIGH FIDELITY SOUND

by Len Feldman

This book concentrates on how to put together a fine high-fidelity system, rather than on why one manufacturer chose one type of design over another. It is based on the premise that there are a lot of good hi-fi components on the market mixed in with lots of junk that masquerades as "high-fidelity" equipment. The book begins with an introduction to audio dynamics, moves into the debate over components versus the "orange-crate" approach, and then gets into nuts-and-bolts considerations: turntables, speaker systems, amplifiers, receivers, etc.

Published by Straight Arrow Books, 625 Third St., San Francisco, CA 94107. Soft cover. 160 pages. \$4.95.

## COMMUNICATIONS ELECTRONICS FOR TECHNICIANS

by Lloyd Temes

This book covers the basics of communications without the mathematical intricacies

of Fourier Transforms and Bessel Functions. The relationships of sidebands, carriers, and power, as well as band-widths are described for AM, as well as FM, in the opening chapters. Methods of generating such signals and detecting them are described using both the block diagram and schematic approaches. Samples of commercially available transmitting and receiving equipment are presented for consideration, as well as typical schematics of home-brew devices. Studio consoles receive special attention. TV is presented in a straightforward and thorough manner, as is pulse modulation. Fundamentals of tuned circuits, r-f. amplifiers, and transmission lines are explained algebraically to give the technician an insight into the behavior of communications systems in ideal and practical situations. The book was written as a technical institute textbook, but its lucid tone will be appreciated by those using it for less formal education.

Published by McGraw-Hill Book Company, New York, St. Louis, San Francisco. 318 pages. Hard cover.

## THE RADIO AMATEUR'S HANDBOOK, Fifty-First Edition

The 1974 edition of this popular ham radio handbook contains revisions and updates in almost every area of radio communication. Many descriptions of solid-state devices, portable and emergency equipment, and test equipment have been modified to include the latest techniques used in the field.

The manual reflects a primary emphasis on the practical approaches to the radio communication art. Among the newly revised sections are those covering high-frequency transmitters, measurements and test equipment, mini-sized antennas, vhf converters, and automatic transmitter keyers. Nearly 75 new drawings and charts have been included to help in carefully explaining all technical facets of communication for the radio amateur.

Published by The American Radio Relay League, Inc., Newington, CT 06111. 694 pages. \$7.50 hard cover; \$4.50 soft cover.

## MANUAL OF LINEAR INTEGRATED CIRCUITS: OPERATIONAL AMPLIFIERS AND ANALOG IC'S

by Sol D. Prenskey

Today many manufacturers are utilizing linear IC's, rather than discrete forms for their amplifier requirements. In this volume the author discusses the underlying principles of LIC design and application, while supplying many schematics to illustrate the content of the text. Concepts essential to design, such as common mode rejection ratio and differential gain, are explored for monolithic configurations. Throughout such treatment, comparison is made to discrete circuits, allowing those unfamiliar with LIC techniques to compare them to the already familiar forms.

**CALECTRO®**  
**DIGITAL DISPLAYS AND LOGIC**

**ATTENTION HOBBYISTS!**  
BUILD THIS DIGITAL COUNTER/ L.E.D. DISPLAY KIT.

Everything needed to build a complete decade counter (0-9) including a printed circuit board. Operates from a 5 Volt D.C. supply. Can be used in hundreds of applications.

See your nearby CALECTRO distributor for all the most popular digital displays and integrated circuits. Also, get your copy of the new CALECTRO DIGITAL PROJECTS HANDBOOK!

**GC ELECTRONICS**  
Division of Hydrometals, Inc.  
Rockford, Illinois 61101 U.S.A.



Op amps are rigorously treated, starting with basics like loop gain, frequency response, selection of parameters from IC data sheets, and basic amplifier configurations—inverting and non-inverting modes, summing, integrating, and differentiating amplifiers. Exposure to the physical realities of testing and breadboarding IC op amps is given. Extensive discussion of applications in dc and audio power amplifiers, communications circuits, regulators, digital interfaces, precision instrumentation, and active filters is supplemented by a wealth of schematics, including model types and component values. The text is profusely annotated with references to manufacturer's manuals and the text bibliography. A cross reference index describes over 300 manufacturers' type numbers with identifying codes for second-source types, easing the task of model selection.

*Published by the Reston Publishing Company, Inc., Reston, VA. 22090. 289 pages. \$16.95 hard cover.*

#### MATHEMATICS OF ELECTRICITY AND MAGNETISM

by L.G. Chambers

Although primarily intended for applied mathematicians, this book will also prove useful to physicists, chemists, and electrical engineers. The text discusses electromagnetic theory as far as Maxwell's equations and their more important elementary solutions. A welcome feature of the book is its very large number of worked-out examples that include treatment of such topics as non-conservation of charge, calculus of variations as applied to electrostatics, superconductivity, and an alternative approach to postulating Maxwell's equations. Prior knowledge of electronics theory and advanced mathematics to basic differential and integral calculus are assumed.

*Published by Halsted Press, Div. of John Wiley & Sons, Inc., 605 Third Ave., New York, NY 10016. Soft cover. 271 pages. \$12.50.*

#### HOW TO LISTEN TO THE WORLD, Eighth Edition

Included in this book are articles on the BBC International News Service, sports coverage, and popular and classical programs. Both technical and program matters are discussed in detail in this section, as are articles of general interest for those who are new to shortwave listening. The book also contains hints on how to gain maximum benefit from shortwave receivers, the pleasure that can be obtained from SWL'ing, suggestions for improving reception, and a chapter devoted to long-distance TV reception. Included for the first time is an International Buyer's Guide that lists by country the manufacturers of all-wave communications receivers, antennas,

headsets, tape recorders, microphones, and accessories.

*Published by Billboard Books, c/o Watson-Guptill Publications, 2160 Patterson St., Cincinnati, OH 45214. Soft cover. \$4.95.*

#### ELECTRIC NETWORKS

by Hugh H. Skilling

The focus in this book is primarily on linear networks. It starts out with differential equation descriptions of electrical currents in networks. This lays the groundwork for chapters devoted to alternating current, complex algebra, the frequency and time domains, and network functions. Later chapters discuss state-variable and loop and node equations, matrix solutions, network theorems, mutual inductance, and two-port networks. The final chapters deal with the Fourier series; Laplace transformation, applications, and theorems; translation, convolution, and the impulse function; and three-phase systems.

*Published by John Wiley & Sons, Inc., 605 Third Ave., New York, NY 10016. Hard cover, 483 pages, \$15.95.*

#### CET LICENSE HANDBOOK

by Joseph J. Carr

The National Electronics Association has a

program for testing and accrediting electronics technicians: the Certified Electronics Technicians series. The book's basic format is to present theory in a few pages and then list a series of questions and answers on the material just presented. The text deals with basic circuit laws and theory, basic circuit math, amplifiers, detectors, communications signals and waveforms, antennas and transmission lines, test equipment, solid-state devices, television, and waveform analysis. A sample test and answer key is included for home practice.

Two supplementary sections deal with optional parts of the exam, the Audio Option and the Industrial Electronics Option. The Audio Section deals with power ratings of amplifiers, distortion, and program sources. Industrial Electronics includes servomechanisms, diacs and triacs, and digital electronics. Sample tests are also provided for these sections.

The book is a thorough review of all basic electronic theory, as well as practical considerations, written in a clear style. The text is well illustrated, and there are many schematics included. The practice exams cover the material very well, and the two combined provide a thorough means of preparing for the CET license exams.

*Published by Tab Books, Blue Ridge Summit, PA. 17214. 276 pages. \$8.95 hard cover.*

## FREE McIntosh CATALOG and FM DIRECTORY

Get all the newest and latest information on the new McIntosh Solid State equipment in the McIntosh catalog. In addition you will receive an FM station directory that covers all of North America.



### MX 113

#### FM/FM STEREO - AM TUNER AND PREAMPLIFIER

**SEND TODAY!**

McIntosh Laboratory, Inc.  
East Side Station P.O. Box 96  
Binghamton, N.Y. 13904  
Dept. PE

NAME \_\_\_\_\_

ADDRESS \_\_\_\_\_

CITY \_\_\_\_\_ STATE \_\_\_\_\_ ZIP \_\_\_\_\_

If you are in a hurry for your catalog please send the coupon to McIntosh. For non rush service send the *Reader Service Card* to the magazine.

**CIRCLE NO. 29 ON READER SERVICE CARD**

# Popular Electronics

## INDEX VOLUMES 5 AND 6 JANUARY TO DECEMBER 1974

### COMMUNICATIONS

AM/WWV Receiver, The Simplest (Drumeller) .....	58 June
Antenna Sitching Methods (Moody) .....	99 Mar.
Deluxe Frequency Standard, Build a (Rolf) .....	80 Jan.
Direct-Conversion Communication Receiver, Build a (White) .....	48 Nov.
DX'ing Clandestine Shortwave Stations (Stanbury) .....	53 Oct.
English-Language Shortwave Broadcasts (Legge) .....	41 May
English-Language Shortwave Broadcasts (Legge) .....	98 Sept.
English-Language Shortwave Broadcasts (Legge) .....	79 Nov.
FAA Weather Receiver, An (Robbins) .....	60 June
Ham Antenna, Flag-Pole (McMahan) .....	98 Jan.
Ham Antenna, Indoor 20-Meter (McMahan) .....	52 Oct.
How the New FTC Hi-Fi Rules Affect You! (Feldman) .....	39 Nov.
How to Break the 10-Words-Per-Minute Code Barrier (Humphrey) .....	67 July
Laser TV System, Build a (Punis & O'Donnell) .....	32 Nov.
Light Beam Communications (Mims) .....	52 Feb.
Microphones for CB'ers and Hams (Humphrey) .....	52 Jan.
Mobile CB Antennas, A User's Guide to (Evanzia) .....	51 Aug.
Mobile CB Radios, Buying Guide to .....	51 Sept.
Mobile CB Radios, Directory of .....	52 Sept.
Shortwave Receiver, Noise & Interference Filter for (Wicklund) .....	56 Jan.
Q Multiplier Boosts SW Selectivity & Gain (Rolf) .....	32 Apr.
Single-LED Transceiver (Mims) .....	66 Mar.
Single Sideband, A Primer on (Trulove) .....	41 Sept.
Shortwave Broadcast Bands—And What to Find on Them, The (Wood) .....	92 Feb.
Shortwave Receiver, What to Look for in a (Wood) .....	33 May
Single-IC AM Receiver Projects, Two	
The Simplest AM/WWV Receiver (Drumeller) .....	58 June
An FAA Weather Receiver (Robbins) .....	60 June
Standing Wave Ratio (Drumeller) .....	69 Dec.
VHF/UHF Scanning Monitors (Friedman) .....	46 Feb.
Voice Scrambler, Enjoy Private Messages with a (Wicklund) .....	56 Sept.
Walkie-Talkies: Something for Everyone (Friedman) .....	35 Apr.
Whistlers and Other Strange R-F Noises (Hofford) .....	97 Mar.

### CONSTRUCTION

Ampzilla, Get 400 Watts of Clean Stereo Power with (Bongiorno) .....	22 Sept.
ASCII Keyboard and Encoder (Lancaster) .....	27 Apr.
Automatic Photo Enlarger Controller (Giannelli) .....	51 Apr.
Basic Digital Logic Course, Part 3, Build a VLC computer Terminal (Roberts & Bunnell) .....	38 Dec.
Capacitance Meter, Single IC (Garland & Meten) .....	44 Feb.
Capacitor Meter, High-Value Electrolytic (Richard) .....	45 June
Car, Three Projects for Your (Caso) .....	69 Jan.
CMOS Microlab, Build The (Lancaster) .....	40 June
Custom Meters from Salvaged Parts, How to Make (Koval) .....	41 Apr.
Deluxe Frequency Standard, Build a (Rolf) .....	80 Jan.
"De-Shockers," A Pair of (Wels) .....	113 Jan.
Digital Clock, Add a 10-Minute "Beeper" to Your (Olsen) .....	48 Aug.
Digital Clocks, Portable Base for	

(Michael) .....	91 July
Digital LED Thermometer, Build a Versatile (Fox) .....	54 Nov.
Digital Multimeter for Under \$100, Build an Auto Polarity, Auto Zero (Green) .....	33 Dec.
Digiviewer II, Build (Lancaster) .....	63 Sept.
Direct-Conversion Communication Receiver, Build a (White) .....	48 Nov.
Double-Sided PC Boards, How to Make (Burawa) .....	27 June
Electronic Digital Wristwatch, Build Your Own (Green) .....	29 Jan.
Electronic Salt Meter for Family Health, An (Lawrence) .....	33 Oct.
ESP Testing Machine, Build an (Spector) .....	27 July
Executive Digital Temper Countdown, The (Pascoe) .....	92 Dec.
Fast-Acting Resettable Electronic Fuse (Russo) .....	67 Feb.
Ground Fault Interrupter, Eliminate Risk of Fatal Electric Shock with the (Lo) .....	44 Apr.
Guitar Sound Intensifier, Build a (Lang) .....	45 July
Ham Antenna, Flag-Pole (McMahan) .....	98 Jan.
Ham Antenna, Indoor 20-Meter (McMahan) .....	52 Oct.
How the 741 Op Amp Becomes Super-Op (Laughlin) .....	62 Feb.
IC Digital Logic Memory Trouble (May) .....	33 Mar.
IC Timer, Making Noises with the 555 (Robbins) .....	50 July
Laser TV System, Build a (Punis & O'Donnell) .....	32 Nov.
Measure Low Millivolts with a Multimeter (Hollabaugh) .....	52 Nov.
Metal Locator, Low-Cost (Rolf) .....	47 July
Nickel-Cadmium Battery Charger, Build a Versatile (Lincoln) .....	68 Oct.
Nine Uses for the 99: Wonder (Rolf) .....	67 June
Op-Amp Designer, Build the (Cazes) .....	59 Mar.
Osci-Tester, Build the Low-Cost (Hollabaugh) .....	64 Mar.
Photo Tachometer, Measure RPM of Rotating Elements with the IC (Mangieri) .....	54 Aug.
Photoflash Tripper, 3-Way (Sound, Light, Manual) (Robbins) .....	52 July
Poisoned-Air Detector (Cohen) .....	55 Feb.
Polarity-Sensing Continuity Tester, Build a (Graf) .....	66 Oct.
Power Line Monitor, Build an ac (McClellan) .....	36 Oct.
Power Supply, Low-Cost, Easy-to Build (Anderton) .....	78 Dec.
Power Supply, Three-Way (Laughlin) .....	62 Jan.
Precision Seconds/Minutes Internal Timer, Build a (Collin) .....	47 Apr.
Q Multiplier Boosts SW Selectivity & Gain (Rolf) .....	32 Apr.
R-F Transistor Tester (Metzger) .....	58 Aug.
SCA Adapter Reveals Hidden Music & News on FM Receivers (Karkota) .....	43 Oct.
Scopewriter, The (Steinbaugh) .....	33 Aug.
Semiconductor Junction Tester, In-Circuit/Out-of-Circuit (Marks) .....	58 July
Shirt-Pocket Metronome, Build a (Mangieri) .....	69 Apr.
Shortwave Receiver, Noise & Interference Filter for (Wicklund) .....	56 Jan.
Simple Testers from "Junkbox" Parts (Taylor) .....	67 Jan.
Single-IC AM Receiver Projects, Two	
The Simplest AM/WWV Receiver (Drumeller) .....	58 June
An FAA Weather Receiver (Robbins) .....	60 June
Single-LED Transceiver (Mims) .....	66 Mar.
Speaker System, Build a Large-Port (Weems) .....	43 Aug.
Tape Recorder/Amplifier FET VU Meter, Build a (Berglas) .....	52 June
Test Ideas, A Pair of Useful Check & Select PUT's (Tenny) .....	37 Oct.

Use VOM as Dwell-Angle Indicator (Cameron) .....	37 Oct.
Torture Box, Build the (Tenny) .....	34 Feb.
Tremolo Adapter, Build a (Gardner) .....	40 Mar.
Voice Scrambler, Enjoy Private Messages with a (Wicklund) .....	56 Sept.
Voltage Indicator Using LED's (Graf) .....	71 Apr.
VU Meter, Lamp-Readout (Cohen) .....	44 Jan.

### DEPARTMENTS AND COLUMNS

Amateur Radio (Brier)	
Getting Started in Amateur Radio .....	98 Oct.
Art's TV Shop (Margolis)	
Checking Tube Nationality .....	92 Sept.
The Case of the Booby-Trapped Tube .....	96 Dec.
CB Scene (Spinello)	
The Full-Time Communicator .....	109 Jan.
CB Scene (Buckwaller)	
Antennas & Towers .....	109 Feb.
Type Acceptance .....	101 Mar.
Patches Come to CB .....	97 Apr.
Hearing and Speaking Accessories .....	86 May
Who Repairs CB Rigs? .....	85 June
Antennas for Cars .....	89 July
Lightning and the CB Boater .....	86 Aug.
How to Boost Club Attendance .....	102 Sept.
Mayday, Pan, Security .....	86 Oct.
CB to the Rescue .....	86 Nov.
New Antenna Rules .....	98 Dec.
DX Listening (Hauser)	
TV and FM DX'ing .....	100 Oct.
"Secret" Shortwave Stations .....	80 Nov.
Editorial (Snitzer)	
A Service to Our Readers .....	6 Jan.
Looking Over the Issue .....	6 Feb.
The Energy Crisis and Electronics .....	6 Mar.
The CB Pleasure Seekers .....	6 Apr.
Qualifying TV Service Technicians .....	6 May
The Home "Pay TV" Connection .....	6 June
Communications for the Boat Owner .....	6 July
Editorial (Salsberg)	
Our "New Look" .....	4 Aug.
Electronics Show Biz .....	4 Sept.
Twenty Years Ago .....	4 Oct.
Run It Up the Flagpole .....	4 Nov.
Salt in the Wound .....	4 Dec.
Solid State (Garner)	
Predictions for 1974 .....	100 Jan.
Consumer Products Engineering .....	102 Feb.
Semiconductors in Medicine .....	84 Mar.
Using MOS Devices .....	101 Apr.
Blow-Out-Proof Transistor .....	82 May
Interpreting Schematic Diagrams .....	81 June
Designing with Ingenuity .....	81 July
Using Surplus Diodes .....	89 Aug.
Rewarding Projects with Medium-Power Transistors .....	81 Sept.
Experimenting with Light Emitting Diodes .....	88 Oct.
Circuits Using Field-Effect Transistors .....	90 Nov.
Some Projects for Holiday Giving .....	79 Dec.
Stereo Scene (Holt)	
Electronic-Drive Turntables .....	12 Jan.
Stereo Scene (Hodges)	
Cassette Recording Levels .....	10 Feb.
Noise on Records .....	12 Mar.
Legislating Power Output Claims .....	12 Apr.
Do You Need Super-power? .....	10 May
New Speaker Designs .....	12 June
Matching Tonearms and Cartridges .....	14 July
Speakers and Rooms .....	22 Aug.
Some Unfinished "Noise" Business .....	22 Sept.
Promises for 1975 .....	22 Oct.
Blazing Speakers .....	22 Nov.
Reflections on a Session at AES .....	22 Dec.
Test Equipment Scene (Solomon)	
Some Odds and Ends .....	111 Jan.
Oscilloscope Vertical Amplifiers .....	106 Feb.
Digital Frequency Counters .....	104 Mar.
4-Channel CRT Viewing .....	99 Apr.
A Triangle Waveform Generator .....	88 May
Checking Antenna Efficiency .....	88 June
Testing Internal Combustion Engines .....	92 July
Grid-Dip Meters .....	88 Aug.
Uses for the VTVM or VOM .....	90 Sept.
Digital Multimeter Turned Frequency Counter .....	100 Oct.
Uses for Your Multimeter .....	94 Dec.

### FEATURES & TUTORIALS

Anatomy of a Stereo Phone Cartridge (Hirsch) .....	62 Sept.
Antenna Switching Methods (Moody) .....	99 Mar.



Audio Sweep Generators Save Time & Increase Accuracy, How (Paul) .....	44 Mar.
Basic Logic Course, Pt. 1 (Mims) .....	56 Oct.
Basic Logic Course, Pt. 2 (Mims & Roberts) ..	57 Nov.
Basic Digital Logic Course, Part 3 Build a VLC Computer Terminal (Roberts & Bunnell) .....	38 Dec.
Bass Reflex Hi-Fi Speaker Systems, Design Your Own, Pt. 1 (Weems) .....	34 Jan.
Bass Reflex Hi-Fi Speaker Systems, Design Your Own, Pt. 2 (Weems) .....	70 Feb.
Career Opportunities for the Tech Rep (Stover) .....	69 Nov.
Cassette, An Introduction to the (Waverly) ..	33 June
Cassette Tapes, Hirsch-Houck Labs Tests the New "Premium" (Hirsch) .....	39 Aug.
CMOS Operation, A Guide to, Pt. 1 (Jung) .....	27 Mar.
CMOS Operation, A Guide to, Pt. 2 (Jung) .....	59 Apr.
CMOS Operation, A Guide to, Pt. 3 (Jung) .....	61 Aug.
Color TV Receivers for 1975, What's new in (Margolis) .....	41 Nov.
Computer Terminals Are Coming (Solomon) .....	78 Nov.
Decibels, Understanding (Board) .....	94 Apr.
Development of a Modern ECG (Frye) .....	83 Jan.
Digital Filtering (Solomon) .....	63 Dec.
Double-Sided PC Boards, How to Make (Burawa) .....	27 June
DX'ing Clandestine Shortwave Stations (Stanbury) .....	53 Oct.
Electronic Geriatrics (Frye) .....	96 Oct.
Electronic Music, Pitch Generators for, Pt. 1 (Lancaster) .....	98 Feb.
Electronic Music, Pitch Generators for, Pt. 2 (Lancaster) .....	50 Mar.
Electronic Music Pitch Standards (Lancaster) .....	39 Jan.
Electronics Music Synthesizer, Selecting an (Lancaster) .....	50 Oct.
Electronic Sensory Aids for the Blind (Mims) .....	59 July
Electronics and the Energy Crisis (Frye) .....	87 Apr.
Electronics Crossword Puzzle (Kimsey) .....	46 Jan.
Electronics in Modern Sound Studios (Anderton) .....	65 Apr.
Electronics Physics Quiz (Balin) .....	89 Mar.
EM Keyboards & Controllers, How to Select (Lancaster) .....	42 July
English-Language Shortwave Broadcasts (Legge) .....	41 May
English-Language Shortwave Broadcasts (Legge) .....	98 Sept.
English-Language Shortwave Broadcasts (Legge) .....	79 Nov.
General Electric Color TV Sets (Frye) .....	94 Mar.
Home TV Service Shop, How to Set Up a (Margolis) .....	75 Aug.
How to Break the 10-Words-Per-Minute Code Barrier (Humphrey) .....	67 July
IC "Time Machine", Applications for the (Jung) .....	72 Jan.
Industrial Noise Levels .....	55 Jan.
Light Beam Communications (Mims) .....	52 Feb.
Light Up Your Circuits with LED's (Jung) .....	58 Oct.
Microphones for CB'ers and Hams (Humphrey) .....	52 Jan.
Mobile CB Antennas, A User's Guide to (Evanzia) .....	51 Aug.
Mobile CB Radios, Buying Guide to .....	51 Sept.
Mobile CB Radios, Directory of .....	52 Sept.
Pay TV—Present and Future (Kagan) .....	44 Dec.
Quiz: What Do You Know About Resistors (Balin) .....	76 Apr.
Radio Control Modeling, How to Get Started in (Marks) .....	29 Feb.
Random Tone Generator .....	58 Mar.
Secrecy Through Electronics (Tatom) .....	56 Sept.
Servicing Without Service Data (Frye) .....	89 Feb.
Shortwave Broadcast Bands—And What to Find on Them, The (Wood) .....	92 Feb.
Shortwave Receiver, What to Look for in a (Wood) .....	33 May
Single Sideband, A Primer on (Trulove) .....	41 Sept.
Solid-State Photocells for Hobbyists, Pt. 1 (Lawrence) .....	48 June
Solid-State Photocells for Hobbyists, Pt. 2 (Lawrence) .....	64 July
Speakers in Phase?, Are Your (Weems) .....	41 Mar.
Standing Wave Ratio (Drumeller) .....	69 Dec.
Status Report: 4-Channel Tape Machines (Feldman) .....	33 July
Suppressing Transients in Solid- State Equipment .....	50 July
Tape Recorder Specs, How to Evaluate (Hirsch) .....	46 Oct.
Test Instruments, A New Wave of (Evanzia) .....	38 Oct.
Tips on Kit Building (Frye) .....	84 Aug.
Transistor Selection Guide for Experimenters (Turino) .....	64 June

Triac, Why Use a (Solomon) .....	86 Apr.
VHF/UHF Scanning Monitors (Friedman) .....	46 Feb.
Walkie-Talkies: Something for Everyone (Friedman) .....	35 Apr.
Whistlers and Other Strange R-F Noises (Hofford) .....	97 Mar.

## HI-FI/STEREO

Ampzilla, Get 400 Watts of Clean Stereo Power with (Bongiorno) .....	22 Sept.
Anatomy of a Stereo Phono Cartridge (Hirsch) .....	62 Sept.
Bass Reflex Hi-Fi Speaker Systems, Design Your Own, Pt. 1 (Weems) .....	34 Jan.
Bass-Reflex Hi-Fi Speaker Systems, Design Your Own, Pt. 2 (Weems) .....	70 Feb.
Cassette, An Introduction to the (Waverly) ..	33 June
Cassette Tapes, Hirsch-Houck Labs Tests the New "Premium" (Hirsch) .....	39 Aug.
Decibels, Understanding (Board) .....	94 Apr.
Dobly-Encoded FM Broadcasts, New .....	46 Nov.
Electronics in Modern Sound Studios (Anderton) .....	65 Apr.
Four-Channel Disc Systems, Special Report on (Hirsch) .....	53 Dec.
Receivers, Amplifiers, and Tuners Special Report on (Feldman) .....	51 Dec.
Record Playing Equipment Special Report on (Hirsch) .....	55 Dec.
SCA Adapter Reveals Hidden Music & News on Your FM Receivers (Karkots) .....	43 Oct.
Speaker System, Build a Large-Port (Weems) ..	43 Aug.
Speaker Systems, Special Report on (Tillet) .....	59 Dec.
Speakers in Phase?, Are Your (Weems) .....	41 Mar.
Status Report: 4-Channel Tape Machines (Feldman) .....	33 July
Tape Recorder Specs, How to Evaluate (Hirsch) .....	46 Oct.
Tape Recorder/Amplifier FET VU Meter, Build a (Berglas) .....	42 June
Tape Recorders, Special Report on (Hirsch) .....	57 Dec.
VU Meter, Lamp-Readout (Cohen) .....	44 Jan.

## PRODUCT TEST REPORTS

American Circuits & Systems Model MK1 Function Generator .....	68 Nov.
Antenna Specialists Model MON-41 VHF Converter .....	78 June
Avid Model 103 Speaker System .....	69 July
Ballantine Model 3/24 Digital Multimeter ..	86 Feb.
Bang & Olufsen Model 3000 Turntable/Tonearm .....	82 Feb.
Branson Model B-220 Ultrasonic Cleaner .....	87 Feb.
Browning Ltd AM/SSB Mobile CB Transceiver .....	77 July
Calectro Mini Mounts .....	83 Mar.
Caringella Model TCG-1 Semicon- ductor Curve Tracer .....	84 Apr.
Concord Model CR-400 AM/Stereo FM 4-Channel Receiver .....	65 May
Courier Spartan SSB CB Transceiver .....	84 Feb.
Data Precision Models 134 and 245 Digital Multimeters .....	78 Oct.
dbx Model 119 Dynamic Range Enhancer .....	71 July
Design Acoustics Model D-6 Speaker System .....	76 Oct.
Digital Concepts Model CX-100 Electronic Clock Kit .....	68 Aug.
Drake Model SPR-4 Communications Receiver .....	66 Nov.
Dual Model 701 Single-Play Automatic Turntable .....	76 June
Dynascan Cobra CAM 89 CB Transceiver .....	77 Oct.
E.F. Johnson Messenger 250 CB Base Station .....	73 Sept.
EL Instruments Model DD1-K Digi-Designer ..	92 Jan.
Electro-Voice Interface: A Speaker System ..	76 Mar.
EPI Microtower II Speaker System .....	88 Jan.
ESS Model 200 Stereo Power Amplifier .....	73 Dec.
Heathkit Model AD-1013 Audio Oscilloscope .....	78 July
Heathkit Model AR-2020 4-Channel Receiver .....	70 Oct.
Heathkit Model GR-2000 Digital Color TV Receiver with Optical Remote Control & Clock .....	77 Apr.
Helpmate Model CB-5 Automatic Garage Door Opener .....	70 May

HM Electronics Model HM0310 VOM Plus .....	79 June
International Components Model IC-500 FET VOM .....	90 Jan.
Kenwood Model KR-5340 4-Channel Receiver .....	64 Aug.
Koss Model HV-1 Stereo Headphones .....	67 May
Lafayette Model LR-221 4-Channel Receiver .....	80 Feb.
Leader Model LBO-302 Dual-Channel Oscilloscope .....	80 Mar.
Linear Systems Model SBE-18 CB Transceiver .....	91 Jan.
Mallory Model CA3 Ultrasonic Alarm .....	80 Oct.
Micro Electronic Systems Mini Drill .....	85 Apr.
Mura Model 250-M Multimeter .....	77 Dec.
Onkyo Model TX-555 AM/Stereo FM Receiver .....	86 Jan.
Pace Sidetalk Model CB-1023 AM/SSB CB Transceiver .....	69 May
Pickering Model OA-3 Stereo Headphones .....	61 Nov.
Pioneer Model QX-747 4-Channel Receiver .....	70 Sept.
Pioneer Model SX-636 Stereo Receiver .....	59 Nov.
RCA Model WR-525A TV Marker/Signalyst ..	68 May
RCA Model WT-540A Leakage Current Tester .....	67 Aug.
Realistic Model TRC-24B CB Transceiver .....	75 Dec.
Robyn Porta-Scan 1000 Monitor Receiver .....	78 Sept.
Royce Model 1-408 Hand-Held CB Transceiver .....	66 Aug.
Royce Model 1-600 Mobile CB Transceiver .....	60 Nov.
Sansui Model QRX-3500 4-Channel Receiver .....	81 Apr.
Sony Model NR-115 Noise Reduction Adapter .....	78 Mar.
Sony Model STR-7045 Stereo Receiver .....	70 June
Sylvania Model RS-4744 Stereo Receiver .....	74 Dec.
Tag Electronics Water Alarm .....	80 June
Tandberg Model 3341X Stereo Tape Deck .....	65 Aug.
Tram Diamond-60 AM/SSB Transceiver .....	81 Mar.
Triplett Model 615-K Maintenance Tester Kit .....	80 Sept.
Wavetek Model 30 Audio Sweep Generator .....	76 Dec.
Wollensak Model 8074 8-Track Cartridge Deck .....	72 Sept.

## TEST EQUIPMENT & TV SERVICING

Audio Sweep Generators Save Time & Increase Accuracy, How (Paul) .....	44 Mar.
Capacitance Meter, Single-IC (Garland & Melen) .....	44 Feb.
Capacitor Meter, High-Value Electrolytic (Richard) .....	45 June
Case of the Booby-Trapped Tube, The (Margolis) .....	96 Dec.
Checking Tube Nationality (Margolis) .....	92 Sept.
Custom Meters from Salvaged Parts, How to Make (Koval) .....	41 Apr.
Digital LED Thermometer, Build a Versatile (Fox) .....	54 Nov.
Digital Multimeter for Under \$100 Build an Auto Polarity, Auto Zero (Green) .....	33 Dec.
Digiviewer II, Build (Lancaster) .....	63 Sept.
Electronic Geriatrics (Frye) .....	96 Oct.
General Electric Color TV Sets (Frye) .....	94 Mar.
Home TV Service Shop, How to Set Up a (Margolis) .....	75 Aug.
IC Digital Logic Memory Probe (May) .....	33 Mar.
Measure Low Millivolts with a Multimeter (Hollabaugh) .....	52 Nov.
Osci-Tester, Build the Low-Cost (Hollabaugh) .....	64 Mar.
Photo Tachometer, Measure RPM of Rotating Elements with the IC (Mangieri) ..	54 Aug.
Polarity-Sensing Continuity Tester, Build a (Graf) .....	66 Oct.
Power Line Monitor, Build an AC (McClellan) .....	36 Oct.
Power Supply, Three-Way (Laughlin) .....	62 Jan.
R-F Transistor Tester (Metzger) .....	58 Aug.
Semiconductor Junction Tester, In-Circuit/Out-of-Circuit (Marks) .....	58 July
Servicing without Service Data (Frye) .....	89 Feb.
Simple Testers from "Junkbox" Parts (Taylor) .....	67 Jan.
Simplest Test Gear, The (Frye) .....	88 Nov.
Test Ideas, A Pair of Useful: Check & Select PUT's (Tenny) .....	37 Oct.
Use VOM as Dwell-Angle Indicator (Cameron) .....	37 Oct.
Test Instruments, A New Wave of (Evanzia) .....	38 Oct.
Voltage Indicator Using LED's (Graf) .....	71 Apr.





# C-MOS

4000AE	\$ .55
4001AE	.54
4002AE	.59
4004AE	5.90
4006AE	3.90
4007AE	.65
4008AE	3.60
4009AE	.95
4010AE	.95
4011AE	.54
4012AE	.54
4013AE	1.19
4014AE	3.80
4015AE	3.80
4016AE	1.15
4017AE	2.94
4018AE	3.20
4019AE	1.30
4020AE	4.20
4021AE	3.80
4022AE	2.75
4023AE	.54
4024AE	2.30
4025AE	.54
4026AE	9.90
4027AE	1.35
4028AE	2.95
4029AE	5.40
4030AE	1.25
4035AE	1.80
4037AE	4.00
4040AE	4.70
4041AE	3.35
4042AE	2.95
4043AE	2.95
4044AE	2.95
4048AE	1.50
4049AE	1.35
4050AE	1.35
4051AE	5.40
4056AE	4.95
4060AE	3.50
4069AE	.90
4076AE	4.30

# Schottky TTL

SN74S00N	\$.80
SN74S02N	.80
SN74S03N	.80
SN74S04N	.80
SN74S08N	.80
SN74S10N	.80
SN74S11N	.80
SN74S20N	.80
SN74S30N	.80
SN74S32N	.80
SN74S40N	.80
SN74S41N	.80
SN74S64N	.80
SN74S74N	1.30
SN74S85N	6.10
SN74S86N	2.90
SN74S112N	2.50
SN74S113N	1.50
SN74S133N	1.00
SN74S138N	4.50
SN74S139N	3.90
SN74S140N	1.00
SN74S151N	3.30
SN74S153N	3.30
SN74S154N	3.40
SN74S157N	2.00
SN74S158N	3.70
SN74S160N	6.60
SN74S161N	6.60
SN74S174N	6.60
SN74S175N	4.00
SN74S181N	11.50
SN74S189N	5.10
SN74S194N	3.30
SN74S195N	4.40
SN74S251N	4.20
SN74S253N	4.20
SN74S275N	3.20
SN74S258N	3.70
SN74S260N	.90
SN74S280N	5.70
SN74S289N	5.00
93S10	6.80
93S16	6.80
93S21	3.50
93S22	3.20
93S48	3.70

# HIGH SPEED TTL

74H00N	.34
74H01N	.49
74H04N	.36
74H05N	.38
74H08N	.44
74H10N	.44
74H11N	.44
74H15N	.38
74H20N	.39
74H40N	.36
74H74N	.69



## Waveform Generator Kit

XR205K Only \$28.00

Here's a highly versatile lab instrument at a fraction of the cost of conventional unit. Kit includes two XR205 IC's, data & applications, PC board (etched & drilled, ready for assembly) and detailed instructions.

## Audio Amps

LM352	6-15V, 1.15W, 8Ω	1.60
LM354A	6-27V, 2.80W, 8Ω	2.50
TAA611B12	6-15V, 1.15W, 8Ω	1.60
TAA621A12	6-27V, 1.40W, 8Ω	2.00
TBA611B11	6-18V, 2.20W, 4Ω	3.00
TBA800	5-30V, 4.70W, 8Ω	2.20
TBA810AS	4-20V, 2.50W, 4Ω	3.00
TBA820	3-16V, 0.75W, 4Ω	1.70
TCA830	5-20V, 2.00W, 4Ω	2.20
TCA940	6-24V, 6.50W, 8Ω	4.40

## Power Transistors

BU204	3A	1300V	\$4.14
BU206	3A	1500V	4.95
BU206	3A	1700V	5.94
BU207	6A	1300V	5.85
BU208	6A	1500V	6.93
BU209	6A	1700V	8.64

2N512B	\$3.00
2N1136	1.50
2N1483	1.20
2N1534	1.00
2N1540	1.10
2N1544	.90
2N3053	.35
2N3055	.95
2N3375	5.50
2N3442	2.20
2N3730	1.70
2N3731	2.00
2N3732	1.50
2N3771	2.20
2N3772	2.30
2N3773	3.40
2N3789	3.00
2N3866	.95
2N4347	1.60
2N4348	2.00
2N4395	1.30
2N4427	1.10
2N5109	2.10
2N5322	.92
2N5323	.70
2N6099	.80
2N6101	.80
2N6103	.90

## DUAL LOW NOISE OP AMP

LM331N:  $V_{io} = 6mV$ ,  $I_{ie} = 1000nA$ ,  $I_b = 2000nA$ , Noise = 1.5dB \$2.20

## HYBRID POWER AMPLIFIERS

Power	RMS	Price
SI-1010Y	10W	\$ 6.40
SI-1025E	25W	18.00
SI-1050E	50W	25.40

## Voltage Regulators

LM100H	\$5.50
LM104H	6.50
LM105H	5.10
LM105F	8.50
LM109H	9.50
LM109K	6.30
LM200H	3.80
LM204H	4.70
LM205H	3.00
LM209H	3.50
LM209K	3.70
LM300H	.90
LM300N	1.40
LM304H	1.40
LM305H	1.10
LM305AH	1.40
LM305N	1.20
LM309H	1.75
LM309K	1.95
LM340-05K	2.60
LM340-06K	2.60
LM340-08K	2.60
LM340-12K	2.60
LM340-15K	2.60
LM340-18K	2.60
LM340-24K	2.60
LM723H	1.30
LM723D	3.90
LM723CN	.75
L129	1.50
L130	1.50
L131	1.50

## Digital Watch

with liquid crystal display. Beautiful, reliable & accurate. \$149.00 plus \$2.50 for shipping & handling.

## Memories

P1101A	\$6.90
P1101A1	8.50
P1402A	7.90
P2102	15.00
P3101	5.50
P3101A	5.50
MM6560N	5.00
MM6561N	5.00
DM8599N	5.00
93403	5.00

## Decoded Read/Write RAM

P1103	\$6.20
-------	--------

## LED's

.125" dia.

209	Red	\$.25
209	Yellow	.35
209	Green	.35

.160" dia.

216	Red	.25
216	Yellow	.30
216	Green	.30

.200" dia.

220	Red	.25
220	Yellow	.30
220	Green	.30

## Displays

SLA1	Red	\$2.25
SLA11	Green	4.25
SLA21	Orange	4.25
SLA2	±1 Red	2.25
SLA12	±1 Grn	2.25
SLA22	±1 Org	2.25
SLA3	Red	7.50
SLA4	Red	7.50
XAN72	Red	2.50
XAN52	Green	2.50

## Optoisolator

MCT2	1.45
------	------

## Linear IC's

LM301A	TO-5	\$.90
LM301AM	Mini-dip	.75
LM301AN	Dip	1.10
LM302H	TO-5	.95
LM302N	Dip	1.40
LM306H	TO-5	2.80
LM307H	TO-5	.90
LM307M	Mini-dip	.90
LM308H	TO-5	1.20
LM308AH	TO-5	5.00
LM310H	TO-5	1.40
LM311H	TO-5	1.70
LM318H	TO-5	2.50
LM555CM	Mini-dip	.95
LM709CH	TO-5	.45
LM709CN	Dip	.45
LM710CH	TO-5	.60
LM710CN	Dip	.75
LM715CH	TO-5	4.30
LM725CH	TO-5	5.00
LM733CH	TO-5	1.50
LM733CN	Dip	1.50
LM741CH	TO-5	.45
LM741CM	Mini-dip	.44
LM747CH	TO-5	1.90
LM747CN	Dip	.90
LM748CN	Dip	.40
LM3046CN	Dip	.95
LM3054CN	Dip	1.50

## Phase Locked Loops

LM567CM	Mini-dip	2.10
---------	----------	------

## IC Power Regulators

LM335K	5V, 600mA	2.40
LM336K	12V, 500mA	2.90
LM337K	15V, 450mA	2.90



## Pulse GENERATOR

Interdesign 1101: 0.1Hz-2MHz, 0-5V Output, var. width, line or battery operation. \$159.00.

## Shift Registers 9300 SERIES

1402A	\$ 7.90	9300PC	\$1.00
1403A	6.00	9301PC	1.20
1404A	6.00	9304PC	1.50
1405A	4.50	9306PC	6.90
1406A	6.00	9308PC	2.50
1407A	6.00	9309PC	2.50
1506	3.00	9310PC	1.50
1507	3.00	9311PC	2.50
2505K	4.00	9312PC	1.20
2512K	5.50	9314PC	1.30
2524V	4.00	9316PC	1.30
2525V	5.50	9318PC	2.50
2533V	10.90	9321PC	1.20
2807	4.00	9322PC	1.30
2808	5.50	9324PC	2.00
2814DC	8.20	9328PC	2.50
MM5055N	5.00	9334PC	2.95
MM5056H	5.00	9338PC	3.30
MM5057N	5.00	9340PC	5.00
MM5058N	10.90	9341PC	4.10
TMS3114J	9.50	9342PC	1.15
TMS3133NC	10.90	9360PC	1.75
		9366PC	1.75

TWO PHASE MOS CLOCK DRIVER MH0026CN \$6.50

# You deserve PREMIUM QUALITY COMPONENTS

When you order from us, that is what you receive! We've been buying and selling top quality components for nearly ten years. Our annual volume exceeds \$3 million. We handle only original parts, from the world's leading manufacturers and our customers include some of the largest and most quality-conscious companies.

Now you can take advantage of our component buying skills and power. Select from a broad range of advanced devices. Enjoy competitive and often amazingly low prices. Depend on shipment in 48 hours or less and rely on our guarantee of complete satisfaction --- ANCRONA CORPORATION.

## 7400N TTL

7400N	.16	7475N	.68	74150N	1.14
7401N	.23	7476N	.59	74151N	.75
7402N	.22	7480N	.66	74152N	2.25
7403N	.22	7481N	1.21	74153N	1.12
7404N	.25	7482N	1.01	74154N	1.63
7405N	.29	7483N	1.01	74155N	1.49
7406N	.38	7484N	3.01	74156N	1.49
7407N	.48	7485N	2.49	74157N	1.19
7408N	.24	7486N	.49	74158N	1.54
7409N	.54	7489N	2.99	74160N	1.50
7410N	.24	7490N	.75	74161N	1.35
7411N	.29	7491N	1.29	74162N	1.50
7412N	.51	7492N	.84	74163N	1.50
7413N	.78	7493N	.84	74164N	1.89
7414N	2.81	7494N	1.29	74165N	1.89
7416N	.46	7495N	.88	74166N	1.98
7417N	.64	7496N	.88	74170N	2.55
7420N	.19	7497N	1.51	74173N	1.79
7421N	.51	74100N	1.45	74174N	1.52
7422N	.49	74105N	.54	74175N	1.50
7425N	.39	74107N	.48	74176N	1.69
7426N	.29	74108N	.91	74177N	1.69
7427N	.35	74109N	.91	74180N	2.49
7428N	.51	74110N	.71	74181N	3.85
7430N	.22	74111N	.91	74182N	1.19
7432N	.28	74114N	.91	74184N	2.89
7433N	.61	74115N	.91	74185N	2.29
7437N	.44	74118N	.91	74189N	2.89
7438N	.44	74119N	.81	74191N	2.89
7439N	1.01	74121N	.54	74192N	1.49
7440N	.19	74122N	.89	74193N	1.39
7441AN	1.16	74123N	.95	74194N	1.35
7442N	.98	74125N	1.39	74195N	.99
7445N	.98	74126N	1.39	74196N	2.39
7447N	1.39	74128N	1.21	74197N	2.39
7448N	1.29	74132N	2.05	74198N	2.59
7450N					

# Quality Electronic Components

## MINIATURE ALUMINUM ELECTROLYTIC CAPACITORS

— AXIAL LEAD TYPE —

-60°C plus 85°C Tolerance, 10 plus 50% (ignore), (than 4.7 UFD) 10 plus 75% (4.7 UFD or less)

1 UFD/50V	14c	12c	11c	33 UFD/16V	15c	12c	11c	330 UFD/16V	35c	25c	24c
2.2 UFD/50V	14c	12c	11c	33 UFD/25V	17c	15c	13c	330 UFD/25V	44c	35c	32c
3.3 UFD/25V	14c	12c	11c	47 UFD/16V	17c	15c	13c	470 UFD/16V	37c	26c	27c
4.7 UFD/25V	14c	12c	11c	47 UFD/25V	19c	15c	14c	470 UFD/25V	49c	39c	35c
10 UFD/16V	14c	12c	11c	100 UFD/16V	19c	15c	14c	1000 UFD/16V	49c	39c	35c
10 UFD/25V	14c	12c	11c	100 UFD/25V	24c	18c	17c	1000 UFD/25V	75c	60c	55c
22 UFD/16V	14c	12c	11c	220 UFD/16V	24c	18c	17c	2200 UFD/16V	75c	60c	55c
22 UFD/25V	15c	13c	12c	220 UFD/25V	35c	25c	24c				

### 1 AMP SILICON RECTIFIERS

1N4001 50 PIV	12/\$1	100/\$6	1000/\$48	1N4005 600 PIV	8/\$1	100/\$9	1000/\$70
1N4007 1000 PIV	6/\$1			1N4007 1000 PIV	6/\$1	100/\$11	1000/\$88

### SILICON SIGNAL & SWITCHING DIODE

1N4148 (1N914 equiv.)	12/\$1	100/\$7	1M/\$50	5M/\$220
-----------------------	--------	---------	---------	----------

### LED 7 SEGMENT DISPLAYS

DATALIT 704 .31"	\$1.40	10/\$13	100/\$100
DATALIT 707 .31"	\$3.50	10/\$33	100/\$280

### REED RELAY

6 AMP CONTACT 5 VOLT/20MA COIL	\$2.00	10/\$15	100/\$125
--------------------------------	--------	---------	-----------

### 4 AMP SLIDE SWITCHES

SPST . . . . . 12c	10/\$1	100/\$8	DPDT . . . . . 25c	10/\$2	100/\$15
--------------------	--------	---------	--------------------	--------	----------

### MOLEX SOLDERCON IC TERMINALS

100/\$1	500/\$4.20	1000/\$8.20	5000/\$38.20	50,000/\$275
---------	------------	-------------	--------------	--------------

### 1/2 & 1/4 WATT CARBON COMP. RESISTORS

5 each of the 85 standard 10% values (2.2-22M) 1/2 W Resistors (425 pcs.) Sorted by value \$12/set 2-4 are \$11/set 5-9 are \$10/set.

5 each of the 70 standard 10% values (10-5.6M) 1/4 W Resistors (350 pcs.) Sorted by value \$12/set 2-4 are \$11/set 5-9 are \$10/set.

Resistors also available individually, in other assortments or in boxes of 1000 pcs. per value. 1/2 W are hot molded MIL-R-11F specification types.

### Litronix 1100 Calculator



PRICE \$29.95

### IEE-APOLLO DISPLAY \$5.00

5 V. common 9 pin tube base

### IC SOCKETS

8 Pin DIP Solder	35c
14 Pin DIP Solder	45c
16 Pin DIP Solder	50c
24 Pin DIP Solder	\$1.25

### VOLTAGE REGULATORS

L129	5V	600mA	\$1.80 ea.
L130	12V	400mA	
L131	15V	450mA	

### 25 V. DISC CAPS

Value	1	10	100	1000
.01 . . . . .	5c	3.5c	3c	2.4c
.022 . . . . .	6c	4c	3.5c	2.75c
.047 . . . . .	9c	6c	5.3c	4.25c
.1 . . . . .	12c	9c	7.5c	6c

### SILICON TRANSISTORS

2N3918	10-106	21	185	165	2N3930	10-106	21	185	165
2N2722	10-106	21	185	165	2N2904A	10-106	21	185	165
2N2712	10-98	18	160	145	2N2907	10-106	21	185	165
2N3391A	10-98	22	190	175	2N3392	10-98	22	190	175
2N3393	10-98	22	190	175	2N3394	10-98	22	190	175
2N3553	10-106	20	175	160	2N3565	10-106	20	175	160
2N3638	10-105	20	175	160	2N3638A	10-105	20	175	160
2N3640	10-106	22	190	175	2N3641	10-105	20	175	160
2N3643	10-105	20	175	160	2N3645	10-105	20	175	160
2N3646	10-106	22	190	175	2N3904	10-92	25	225	200
2N3906	10-92	25	225	200	2N4124	10-92	27	240	220
2N4126	10-92	27	240	220	2N4403	10-92	32	290	260
2N4403	10-92	32	290	260	2N5087	10-92	27	240	220
2N5089	10-92	27	240	220	2N5129	10-106	19	170	150
2N5133	10-106	19	170	150	2N5134	10-106	19	170	150
2N5137	10-106	19	170	150	2N5138	10-106	19	170	150
2N5138	10-106	19	170	150	2N5355	10-3	1.35	1.20	1.09

### FIELD EFFECT TRANSISTORS

MPT102	10-92	44	380	350	2N5457	10-92	47	420	375
--------	-------	----	-----	-----	--------	-------	----	-----	-----

### NPN DARLINGTON TRANSISTOR

MPS-A13	10-92	Min DC Current Gain of 5 000 at 10mA	36	320	290
---------	-------	--------------------------------------	----	-----	-----

### LINEAR INTEGRATED CIRCUITS

555 Minidip TIMER	\$1.00	10/\$ 9.50	565 DIP PLL	\$3.57	10/\$30.00
558 Minidip DUAL AMP	80c	10/\$ 7.50	567 Minidip DECODER	\$3.57	10/\$30.00
723 Dip VOLTAGE REG	\$1.15	10/\$10.00	741 Minidip OP AMP	50c	10/\$ 4.50
747 Dip DUAL OP AMP	\$1.10	10/\$10.50	748 Minidip OP AMP	60c	10/\$ 5.30

### DIGITAL TTL

7400N	32c	28c	7437N	51c	46c	7476N	60c	55c	74153N	\$1.58	\$1.40
7401N	32c	28c	7438N	51c	46c	7480N	74c	65c	74154N	\$2.25	\$2.00
7402N	32c	28c	7439N	51c	46c	7482N	\$1.02	91c	74155N	\$1.46	\$1.29
7403N	32c	28c	7441N	\$1.45	\$1.27	7483N	\$1.58	\$1.40	74156N	\$1.17	\$1.04
7404N	35c	31c	7442N	\$1.20	\$1.07	7489N	60c	55c	74157N	\$1.56	\$1.39
7405N	35c	31c	7445N	\$1.62	\$1.44	7489N	\$4.50	\$4.00	74158N	\$1.56	\$1.39
7406N	52c	46c	7446N	\$1.30	\$1.10	7490N	85c	72c	74160N	\$1.95	\$1.74
7407N	52c	46c	7447N	\$1.30	\$1.10	7491N	\$1.37	\$1.22	74161N	\$1.95	\$1.74
7408N	36c	32c	7448N	\$1.35	\$1.15	7492N	85c	72c	74162N	\$1.95	\$1.74
7409N	36c	32c	7450N	32c	28c	7493N	85c	72c	74163N	\$1.95	\$1.74
7410N	32c	28c	7451N	32c	28c	7494N	\$1.20	\$1.07	74164N	\$1.95	\$1.74
7411N	35c	31c	7453N	32c	28c	7495N	\$1.20	\$1.07	74165N	\$2.48	\$2.20
7412N	35c	31c	7454N	32c	28c	7496N	\$1.20	\$1.07	74166N	\$2.03	\$1.80
7413N	63c	56c	7459N	32c	28c	7497N	55c	50c	74180N	\$1.20	\$1.07
7414N	50c	44c	7459N	32c	28c	74121N	70c	60c	74181N	\$3.38	\$3.00
7417N	50c	44c	7460N	32c	28c	74122N	72c	62c	74182N	\$1.17	\$1.04
7418N	32c	28c	7470N	46c	35c	74123N	\$1.11	99c	74192N	\$1.80	\$1.60
7423N	75c	67c	7473N	52c	45c	74141N	\$1.61	\$1.43	74193N	\$1.80	\$1.60
7426N	36c	32c	7474N	52c	45c	74150N	\$1.56	\$1.39	74198N	\$2.78	\$2.47
7430N	32c	28c	7475N	85c	72c	74151N	\$1.20	\$1.07	74199N	\$2.78	\$2.47

### Send for Free Catalog or Mail Orders

### Service Card

COD ORDERS ACCEPTED FOR SAME DAY SHIPMENT  
CALL 218-681-6674

Orders less than \$10.00 add 50c Service Charge—Others Postpaid

"Only Quality Components Sold"

### DIGI-KEY CORPORATION

P.O. Box 126 Thief River Falls, MN 56701

CIRCLE NO. 14 ON READER SERVICE CARD

110

CRYSTALS, Scanners, \$3.88, include make and frequency. G Enterprises, P.O. Box 461PC, Clearfield, UT 84105.

FREE CATALOG. Kits, Components, audio equipment. Electronic Supply Pacs, Box 175, Floral Park N.Y. 11001.

ALPHA/THETA BRAINWAVE biofeedback instruments. Analog instruments from \$125; digital processing systems from \$225. BioScan, Box 14168-E, Houston, Texas 77021.

SURPRISE! Build inexpensively, the most Unusual Test Instruments, Futuristic Gadgets using Numerical Readouts! Catalogue Free! GBS, Box 100A, Green Bank, West Virginia 24944.

ELECTRONIC ORGAN KITS, KEYBOARDS and many components. Independent and divider tone generators. All diode keying. I.C. circuitry. Supplement your Artisan Organ, 35 cents for catalog. DEVTRONIX ORGAN PRODUCTS, Dept. C., 5872 Amapola Dr., San Jose, Calif. 95129.

ELECTRONIC IGNITION: Capacitor, transistor, pointless. Auburn sparkplugs. Information 10 cents. Anderson Engineering, Epsom, N.H. 03234.

WHOLESALE Scanners, CB, Crystals, Directories, SSB/AM, Catalog 25 cents. G—Enterprises, Box 461P, Clearfield, Utah 84105.

ELECTROENCEPHALOPHONE: Brainwave monitor. Professional biofeedback instruments. J & J, 8102-E, Bainbridge, WA 98110.

CALCULATOR OWNERS: Use Your +x- calculator to compute square roots, trigonometric functions, logarithms, and more! Quickly, Accurately, Easily! Send today for the First and Best Calculator Manual . . . now in use throughout the world . . . still only \$2.00 Postpaid with Unconditional Money-Back Guarantee! Mallmann Optics and Electronics, Dept. 22A, 836 South 113, West Allis, Wisconsin 53214.

FREE 1975 Electronics Catalog. McCord Electronics, Box 276-N, Sylvania, Ohio 43560.

AUTORANGING DMM, deluxe VOM's, logic probes and more. Lowest prices. Free catalog. Electro Industries, 4201 Irving Park, Chicago, Illinois 60641.

ARE YOU PREPARED? 10,000 cubic foot, pull ring ignited emergency smoke grenades are now available! 3 for \$7.50, 9 for \$20.00. Postpaid. Pacific Aero Supply, Box 601, Malibu, Calif. 90265.

PYROTECHNICAL chemicals, casings, tools, supplies, fuse. Price List 50 cents. Westech, Logan, Utah 84321.

BURGLAR—FIRE ALARM components, hardware. Free Catalog—Information. Silmar, 133 S. W. 57 Ave., Miami, Florida 33144.

CARBON FILM RESISTORS. Brand new as low as 2-1/4 cents. FREE samples and specifications. COMPONENTS CENTER—PE, Box 134, New York, NY 10038.

7,000 SEMICONDUCTORS. 100's Electronic Circuit Kits. Technical Reports, Energy Conservation, Computers. Cat. 50 cents. E/S Lab, Box 738, College Park, MD 20740.

UNSCRAMBLERS: Fits any scanner or monitor, easily adjusts to all scrambled frequencies. Only 4" square \$29.95, fully guaranteed. Dealer inquiries welcomed. PDQ Electronics, Box 841, North Little Rock, Arkansas 72115.

TROUBLE getting parts for projects? Let us buy them for you. Parts Buying Service. Box 1026-F2, Fremont, Calif. 94538.

COMPONENTS. 8038CC \$5.75; SN7400 10/\$1.75; LM709 39 cents; JAN2222A 39 cents; 1/4w 5% Resistors 10/45 cents; MC7805 \$2.50; Clocks, MM5314 \$8.50; MM5316 \$10; LM703 55 cents; LM3900 75 cents; MAN3 Size Readout 85 cents; DTL 930, 946, 962 10/\$1.75. Postpaid, minimum \$5. Latest Flyer 10 cents. Tri-Tek, Inc., Box 14206, Phoenix, AZ 85063.

LEARN DESIGN TECHNIQUES. Electronics Monthly Newsletter. Digital, linear construction projects, design theory and procedures. Sample copy \$1.00. Valley West, Box 2119-B, Sunnyvale, California 94087.

FREE BARGAIN CATALOG. Leds, Transistors, IC's, Puts, Relays, Xtals, Unique Micro Miniature components, misc. Chaney's, Box 15431, Lakewood, Colo. 80215.

RECONDITIONED Test Equipment. \$0.50 for catalog. Walter, 2697 Nickel, San Pablo, CA 94806.

TELEPHONES UNLIMITED, equipment, supplies. Catalog 50 cents. Box 1654E, Costa Mesa, Calif. 92626.

COMPLETE CONSTRUCTION PLANS—TELEPHONE: Answering Device, Automatic Dialer, "Black Boxes", Call Diverter, Call Limiter, Conference Bridge, Centrif Dial Exchange, Melodic Ringing, Recorder-Actuator, Remote Control, Schematics, Speakerphone, Telelink Burglar Alarm, Voice Scrambler, \$3.00 each. ELECTRONIC: Biofeedback Conditioner, Horticulture Stimulator, Multifrequency Encoder Network (Speeds telephone calling 100%!), \$5.00 each. ONE YEAR SUBSCRIPTION: Telephone-Electronics Newsline \$3.00. Super illustrated 16 page catalog of plans, many more, 50 cents. All of the construction plans above, \$19.95. TELETRONICS COMPANY OF AMERICA, P.O. Box 3486, Los Angeles, California 90028. USA.

INGENIOUS NEW APPLICATION of computer concepts. Memorize twenty random true-false answers in less than thirty seconds, mathematically! Send \$2.00 for complete description. FOATSP, Box 1144, Forest Park, GA 30050.

For faster service

USE ZIP CODE

on all mail

### 3 OCTAVE TONE GENERATOR BOARD



MAGNUS model 1700 3 octave tone generator board, contains 12 separate tunable oscillators, for a total of 37 notes, plus 3 oscillators for chords. Includes 5 watt amplifier, & power supply except transformer. Requires 36 volts ct @ 1.0 amp. A great basic start for your electronic organ or synthesizer. Boards new, but spring contacts may be bent, or a component broken. Component parts alone are worth many times the price. 27" x 4 1/4". Weight 3 lbs.

STOCK NO.F5200 with data sheets \$14.95 ea 2/27.00

### 37 KEY KEYBOARD FOR MAGNUS TONE BOARD



This keyboard is designed for the Model 1700 TONE GENERATOR BOARD above. Limited quantity, so we can only sell to purchasers of the TONE BOARD, or those who have recently purchased a tone board from us.

KEYBOARD & TONE GENERATOR BOARD  
STOCK NO.F5200 A 24.95 2/47.00

For those previous purchasers of TONE BOARD  
STOCK NO.F5200 B Key board only \$10.95 2/20.00





# FREE IC

## With Every \$10 Order\*

- REDUCE YOUR PROJECT COSTS
- MONEY-BACK GUARANTEE
- 24-HOUR SHIPMENT
- ALL TESTED AND GUARANTEED

<b>TRANSISTORS:</b>	
NPN:	
2N3563 TYPE RF Amp & OSC to 1 GHz (pl. 2N918)	6/\$1.00
2N3565 TYPE Gen. Purpose High Gain (TO-106)	6/\$1.00
2N3567 TYPE High-Current Amplifier/Sw 500mA	3/\$1.00
2N3691 TYPE GP Amp to 25mA and 50 MHz	6/\$1.00
2N3866 TYPE RF Pwr Amp 1-2 W @ 100-600 MHz	\$1.50
2N3903 TYPE GP Amp & Sw to 100mA and 30 MHz	6/\$1.00
2N3904 TYPE GP Amp & Sw to 100mA (TO-92)	5/\$1.00
2N3919 TYPE RF Pwr Amp 3-5 W @ 30 MHz	\$3.00
2N4274 TYPE Ultra-High Speed Switch 12ns	4/\$1.00
MPS6515 TYPE High-Gain Amplifier h <sub>FE</sub> 250	3/\$1.00
Assort. NPN GP TYPES, 2N3565, 2N3641, etc. (15)	\$2.00
PNP:	
2N3638 TYPE Gen. Purpose Amp & Switch	4/\$1.00
2N4249 TYPE Low-Noise Audio Amp 1uA to 50mA	4/\$1.00
<b>FET's:</b>	
<b>N-CHANNEL (LOW-NOISE):</b>	
2N4416 TYPE RF Amplifier to 450 MHz (TO-72)	2/\$1.00
2N5486 TYPE RF Amp to 450 MHz (plastic 2N4416)	3/\$1.00
2N5163 TYPE Gen. Purpose Amp & Sw (TO-106)	3/\$1.00
2N4091 TYPE RF Amp & Switch (TO-106)	3/\$1.00
E100 TYPE Low-Cost Audio Amplifier	4/\$1.00
ITE4868 TYPE Ultra-Low Noise Audio Amp.	2/\$1.00
TS174 TYPE High-Speed Switch 40ns	3/\$1.00
Assort. RF & GP FET's, 2N5163, 2N5486, etc. (8)	\$2.00
<b>P-CHANNEL</b>	
2N4360 TYPE Gen. Purpose Amp & Sw (TO-106)	3/\$1.00
E175 TYPE High-Speed Switch 125ns	3/\$1.00
M104 TYPE MOS FET (Diode protected) 0.3 pF	\$3.00
<b>LINEAR IC's:</b>	
309K Voltage Regulator 5V @ 1A (TO-3)	\$1.90
380 2-5 Watt Audio Amplifier 34dB (DIP)	\$1.50
555X Timer 1us-1 hr, Dif. pinout from 555 (DIP)	\$ .90
709 Popular OP AMP (DIP/TO-5)	\$ .39
723 Voltage Regulator 3-30 V @ 1-250mA (DIP/TO-5)	\$ .75
739 Dual Low-Noise Audio Preamp/OP AMP (DIP)	\$1.00
741 Freq. Compensated OP AMP (DIP/TO-5/MINI/DIP)	\$ .45
2556 Dual 555 Timer 1 us to 1 hour (DIP)	\$1.55
LM305 Positive Voltage Regulator (TO-5)	\$1.25
MC1458 Dual 741 OP AMP (MINI-DIP)	\$ .95
Assorted Linear-741/709/723, etc. (4)	\$2.00
<b>DIODES:</b>	
1N914 TYPE Gen. Purpose 100V/10mA	10/\$1.00
1N3600 TYPE Hi Speed Sw 75V/200mA	6/\$1.00
1N4608 TYPE GP & SW 80V/400mA	6/\$1.00
1N3893 TYPE RECTIFIER Stud Mount 400 V/12 A	2/\$1.00
1N749 ZENER 4.3 Volt 400mW	3/\$1.00
1N753 ZENER 6.2 Volt 400mW	4/\$1.00
1N755 ZENER 7.5 Volt 400mW	4/\$1.00
1N757 ZENER 9.1 Volt 400mW	4/\$1.00
1N758 ZENER 10 Volt 400mW	4/\$1.00
1N965 ZENER 15 Volt 400mW	4/\$1.00
1N968 ZENER 20 Volt 400mW	4/\$1.00
D5 VARACTOR 5-50 W Output @ 30-250 MHz, 7-70 pF	\$5.00
07 VARACTOR 1-3 W Output @ 100-500 MHz, 5-30 pF	\$1.00

\*MAIL NOW! With every order of \$10 or more, postmarked prior to 1/31/75. FREE 739 or 749 Low-Noise Dual OP AMP included—\$1 VALUE.

ORDER TODAY—All items subject to prior sale and prices subject to change without notice. DATA SHEETS included with all items. WRITE FOR FREE CATALOG offering hundreds of semiconductor not listed here. Send 10¢ stamp.

TERMS: All orders prepaid. We pay postage. \$1.00 handling charge on orders under \$10. Calif. residents add 6% sales tax.

# ADVA ELECTRONICS

BOX 4181-M, WOODSIDE, CA 94062

Tel. (415) 851-0455

CIRCLE NO. 1 ON READER SERVICE CARD

EAVESDROPPING Countermeasure Equipment Catalog \$1.00. SECURITY, Box 671, Westwood, New Jersey 07675. CITIZENS BAND equipment discount prices. Free List. CRS Communications, 2271 Morris Avenue, New York, N.Y. 10453.

PROJECTS TEENAGERS ENJOY. New plans every month. Send for complimentary copy. Electronic Projects Newsletter. Box 1026E, Fremont, California 94538.

TRANSISTOR and DIODE Tester displays operating curves on your oscilloscope. Schematic \$1.00. All parts \$7.00. Scherr, P. O. Box 4039, Petersburg, VA 23803.

DESCRAMBLERS—Two Models, operates with all scanners and monitors. Free Brochure. Krystal Kits, P.O. Box 445, Bentonville, Arkansas 72712.

1101A RAM: \$2.25; 1103 RAM: \$3.00 2513, 2516: CHAR. GEN: \$12.75. ELECTRONIC DISCOUNT SALES, 138 N. 81st St., Mesa, Arizona 85207.

WE SELL MONEY MAKING CONSTRUCTION MANUALS!!! — Reclaim GOLD, SILVER for EXCELLENT full or part time money!!! — PLUS, we buy scrap gold & silver — ALSO, we sell 99.999% pure SILVER BARS!!! — Color Catalog 25 cents — Airmailed 50 cents — Creative Products, Dept. PE-1274, 4913 Northridge NE, Albuquerque, New Mexico 87111.

DIGITAL IC Manual—Latest Edition—1500 types by types/diagram number \$3.95. 32—function digital computer kit—IC, transistors, instructions, \$14.00. IC applications manual—numerous circuits—Analog/Digital, \$3.95. Electronics, P. O. Box 127, Hopedale, Mass. 01747.

### The Soft Touch: Electronic Touch Switch by A-2-M

Patented Electronic Receiver for Lamp or Wall. New 300mA Capability for Any Type Load With Lightning Arrestor Circuitry. Responds to Body Contact With No Pressure Necessary. Eliminates Arcing, Switch Bounce and Mechanical Wear. Designed to Fit Standard Wall Box. \$14.95 - Kit - \$12.95 60 Day Guarantee

A-2-M Electronics, Box 768, Pittsboro, N.C. 27560

PRINTED CIRCUIT TECHNIQUES for the Hobbyist. Booklet: \$2.00. Trumbull, 833 Balra Drive, El Cerrito, Calif. 94530.

CIRCUIT board service. Circuit boards made from your layouts. Send for information. Printed Circuits, 22 Maple Avenue, Lackawanna, New York 14218.

FIREPLACE heat exchanger. Use All Heat. Plans \$3.00. Jannell, 6030 O'Day Dr., Centreville, VA 22020.

LASER TUBE—\$23.50; Five Laser Plans—\$4.00; Catalog—\$1.50, "PE 1074", Plasma Scientific, Box 1005 Claremont, Calif. 91711.

**SUBSCRIBE NOW!**

**LEARN THE SECRETS OF YOUR TELEPHONE**



**FACTS NEVER BEFORE PUBLISHED FOR THE PUBLIC**  
— One year subscription \$ 3.00 — Sample copy 25¢ —

TELETRONICS  
COMPANY OF AMERICA P.O. BOX 3486  
LOS ANGELES, CA. 90028

FREQUENCY COUNTER for under \$75.00; provisions to 200MHz, Nixie or LED readout 8 digit; uses standard IC's, complete details \$3.00, postpaid. East Coast Electronics, 50 Scott, Hamburg, New York 14075.

FREE FLYER, Resistors, Capacitors, Diodes, IC's, Sockets, more. Save Money. PRASAD ELECTRONICS, Box 32, Addison, Ill. 60101.

**7400 SERIES T.T.L. PINOUT HANDBOOK**

COVERS ENTIRE 5400/7400 SERIES D.I.P. I.C.'S

PIN CONNECTIONS — FUNCTIONAL SPECS  
CROSS REFERENCE — ONLY \$1.95 FROM!

TTL PINOUT HANDBOOK: IMS ASSOCIATES, INC.  
298 E 14TH ST., SAN LEANDRO, CAL. 94577  
POSTAGE PAID IN U.S.



ELECTRONIC COMPONENTS—all kinds. send for free catalog. Epic, Box 20152A, Minneapolis, Minn. 55420.

### PLANS AND KITS

AMAZING ELECTRONIC PRODUCTS—Pocket Laser. See-In-The-Dark, Scramblers, Penlight Strobe, Energy Devices, TV Disruptor, Many More, All New. Catalog \$1.00. INFORMATION UNLTD., West St., Milford, N.H. 03055.

ATTENTION AUDIO FREAKS!! Audio Processing Circuits designs, kits, units. Laboratory tested designs for hobbyist through professional use—limiters, compressors, equalizers, phasers, mixers and more! Send now—\$1.00 (refundable) for complete catalog—CIRCUITS RESEARCH LABS, 3920 E. Indian School, Phoenix, AZ 85018.

BRAINWAVE FEEDBACK schematics & parts list. Unit has 5 sect. adj. filter, modulated & level controlled white noise, threshold det. \$3 to John Hill, 1201 E. 117, Kansas City, Mo. 64131.

FREE CATALOG. 200+ unique electronic projects. Bio-feedback, acupuncture, more! Cimarron Labs, 4183A Springfield St., Burton, Michigan 48509.

# KITS

UNIQUE  
CANADIAN  
ELECTRONICS  
CATALOGUE  
\$1.00  
(refundable on 1st purchase)



*featuring*

- SINCLAIR hi fi modules and calculator kits. We will include the new 32-page Project 80 hi-fi module construction manual.
- AMTRON electronic kits—over 100 types!
- Speaker kits and components

American enquiries welcome!

**GLADSTONE ELECTRONICS**

1736 AVENUE RD., TORONTO, ONT.  
M5M 3Y7, DEPT. PE-12

# FOR A SOUND INVESTMENT

## You Need Sound Advice...

### 1975 STEREO DIRECTORY & BUYING GUIDE

The complete guide to everything you need for your home music system. It features all the latest information on stereo systems and components—4-Channel Components • Amplifiers • Tuners • Receivers • Hi-Fi Compacts • Changers and Turntables

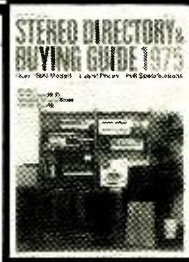

• Speaker Systems • Phono Cartridges and Arms • Cassette, Open-Reel and Cartridge Tape Machines • Headphones and Microphones • Raw Tape and Accessories • PLUS —4-Channel Section. More than 1500 products in all—listed by manufacturer, each with model number, complete specifications, description and price—and a BONUS FEATURE on What Every Hi-Fi Shopper Should Know Before Buying.

The Directory tells you what to look for, what to avoid, how to decide what's best for you at a price you can afford. Now you can know what you want before you visit the dealer and what to listen for when you get there

### 1974 TAPE RECORDING & BUYING GUIDE

WITH THE WORLD OF TAPE IN FAST-FORWARD, HOW CAN YOU KEEP UP?



All the changes and advances in the tape market could make your head spin. Here's the magazine that unearls the facts. It records all the changes, choices and facts you need to make a clear-cut buying decision. Complete directories and buying guides compare products feature by feature, cost by cost—Open-Reel Tape Machines • Cassette Tape Machines • 8-Track Tape Machines • 4-Channel Components—decoders; headphones; microphones; raw tape; accessories and more. Special features and articles—by the authorities—to keep you up-to-date—Solving the Tape Recorder Specifications Puzzle • What's the Story on 4-Channel Tape Machines? • How to Pick a Microphone • Proper Cassette Recording Levels Reduce Distortion and Noise • Guide to Buying Your First Tape Recorder • Plus a host of other informative features. If the fast-forward world of tape has you going around in circles, STOP. Order your copy now, only \$1.50

ZIFF-DAVIS SERVICE DIVISION—Dept. W PE-1274 595 Broadway, New York, N.Y. 10012

- Please send the following:
- 1975 STEREO DIRECTORY & BUYING GUIDE, \$1.50
  - 1974 TAPE RECORDING & BUYING GUIDE, \$1.50

In U.S.A., add 35c per copy for postage and handling. Outside U.S.A., copies are \$2.50 each

TOTAL ENCLOSED \$ \_\_\_\_\_

print name \_\_\_\_\_

address \_\_\_\_\_

city \_\_\_\_\_

state \_\_\_\_\_ zip \_\_\_\_\_

— PAYMENT MUST BE ENCLOSED WITH ORDER —



BUILD your own Digital Electronic Clock/Calendar in 2 hours. "Boeing 747 Readout" Hour - Minute - Second-Month/Day. Assembly divided steps - corresponding parts envelopes U. S. made - Walnut Cabinet. Details Free! Professional Merchandise Center, 220 Fifth Avenue, New York, N.Y. 10001.

ELECTRONIC Yelping Siren for your Child's Toy. Fascinates Kids Plans \$1.00. Hadley Enterprises, Route 6, Box 512, Rogers, Arkansas 72756.

CONSTRUCTION PLANS. Digital tachometer, miniature transmitters, others. Send 25 cents for listing. MIKRONICS, P.O. Box 338, Dundee, Ill. 60118.

### HIGH FIDELITY

DIAMOND NEEDLES and Stereo Cartridges at Discount prices for Shure, Pickering, Stanton, Empire, Grado and ADC. Send for free catalog. LYLE CARTRIDGES, Dept. P, Box 69, Kensington Station, Brooklyn, New York 11218.

SAVE 50%. Build your own speaker systems featuring No-elco, Eminence and CTS. Famous brands from world's largest speaker factories at lowest wholesale prices. Write for free catalog of speakers and electronic accessories. McGee Radio Company, 1901 McGee Street, Kansas City, Missouri 64108.

### LISTEN TO SPECTACULAR 4-CHANNEL SOUND!

Expand your stereo to quadraphonic Hi-Fi. Build the VISTA Full Logic "SQ" Decoder.

Latest CBS licensed circuitry using 3 IC's to provide Full Logic and Wave Matching.

Exclusively ours. Kit SQ-1 \$37.50. Shipped prepaid in USA & CANADA. Send for information.

### PHOTOLUME CORPORATION

118 East 28th Street, New York, N.Y. 10016

ARP Synthesizers—Low Prices. Dan Keen, Dept. X, 219 19th Street, Avalon, N. J. 08202.

### WANTED

QUICKSILVER, Platinum, Silver, Gold, Ores Analyzed. Free Circular. Mercury Terminal, Norwood, Mass. 02062.

### TUBES

RADIO & T.V. Tubes—36 cents each. Send for free Catalog. Cornell, 4213 University, San Diego, Calif. 92105.

RECEIVING & INDUSTRIAL TUBES, TRANSISTORS. All Brands - Biggest Discounts. Technicians, Hobbyists, Experimenters - Request FREE Giant Catalog and SAVE! ZALYTRON, 469 Jericho Turnpike, Mineola, N.Y. 11501.

TUBES receiving, factory boxed, low prices, free price list. Transleteronic, Inc., 1306 40th Street, Brooklyn, N.Y. 11218A, Telephone: 212-633-2800.

TUBES "Oidies", latest Lists free. Steinmetz, 7519 Maplewood, Hammond, Indiana 46324.

TUBES 60% OFF LIST PRICE. McCord Electronics, Box 276-T, Sylvania, Ohio 43560.

### MOVIE FILMS

8MM-SUPER 8-16MM MOVIES! Biggest Selection! Lowest Prices! Free Catalog! Cinema Eight, Box PE, Chester, Connecticut 06412.

### ELECTRICAL SUPPLIES & EQUIPMENT

PLATING Equipment, Portable Platers. Supplies and "Know-How." Build your own tanks for nickel, chrome, etc. Easy-to-install PVC liners, Rectifier components—all sizes. Schematics, parts lists, formulas, operating instructions for all plating. Guaranteed to save you 25%-75%. Some good units for sale. Write for details. Platers Service Company, 1511-PE Esperanza, Los Angeles, Calif. 90023.

### GOVERNMENT SURPLUS

GOVERNMENT Surplus. How and Where to Buy in Your Area. Send \$2.00. Surplus information, Headquarters Bldg., Box 30177-PE, Washington, D.C. 20014.

ELECTRONIC Equipment and Parts. Big 36 page Free Catalog. Send for your copy today! Fair Radio Sales, Box 1105-P, Lima, Ohio 45802.

MANUALS for Govt Surplus radios, test sets, scopes. List 50 cents (coin). Books. 7218 Roanne Drive, Washington, D.C. 20021.

### PERSONALS

MAKE FRIENDS WORLDWIDE through international correspondence. Illustrated brochure free. Hermes, Berlin 11, Germany.

DECEMBER 1974

### TAPE AND RECORDERS

RENT 4-Track open reel tapes—all major labels—3.000 different - free brochure Stereo-Parti, 55 St. James Drive, Santa Rosa, Ca. 95401.

1930-1962 Radio Programs. Reels, \$1.00 Hour! Cassettes, \$2.00 Hour! Mammoth Catalog, \$1.25. AM Treasures, Box 192F, Babylon, N.Y. 11702.

CASSETTE—TAB Erase defeat. Record over recording \$1.00. H. Hodges, Sholola, Penn. 18458.

### CASSETTE LABELS

Plain white cassette labels, Norelco cassette cleaners, paper mailer boxes hold Norelco 10 plastic box, famous brand cassettes. 144 new 10 1/2 metal or fiberglass reels. Send for open reel and cassette discount catalog. 1-9 10-99 100 1000  
Cassette Labels (Multiples of 10) 65 02 015 01  
Norelco Cassette Cleaner 65 60 55 50  
Cassette Paper Mailer Boxes 03 025 022 02  
Scotch Cassette 3090H Buy 2 get ONE FREE 272 255 244 239  
10 1/2 Fiberglass Reels Used 50 50 40 35  
10 1/2 Metal NAB Hole Used 100 100 90 80  
Plus Postage by Weight and Zone Minimum Order: \$5.00  
1776 COLUMBIA ROAD, N.W.  
WASHINGTON, D.C. 20009

OLD RADIO SHOWS on cassettes \$1.50 per show. Free Catalog, Radio Classics, Box 804, Mattituck, NY 11952.

### MUSICAL INSTRUMENTS

30% DISCOUNT name brand musical instruments. Free Catalog, Freeport Music, 455N, Route 110, Melville, N.Y. 11746.

WHOLESALE! Professional Guitars, PA Systems, Allied Speakers, 240W RMS Amplifiers. Free Catalog, Carvin, Escondido, Calif. 92028.

30% + DISCOUNT. Name Brand Musical Instruments. Free Catalog, Continental Music, Dept. H, P.O. Box 3001, Garden City, New York 11530.

### TREASURE FINDERS

FAMILY FUN! OUTDOOR ADVENTURE! Find valuable coins and treasure with world famous metal detectors. Free illustrated booklet. Detection, Dept. PE, Box 243, San Gabriel, Calif. 91778.

TREASURE FINDER locates buried gold, silver, coins, treasures. 5 powerful models. \$19.95 up. Instant financing available. Free catalog. Dealer inquiries invited. Relco, Dept. A-33, Box 10839, Houston, Texas 77018.

<p><b>TEKTRONIX 321A</b> PORTABLE ALL-TRANSISTORIZED 3.5MHz TRIGGERED SCOPES WITH 10:1 PROBE \$495.00</p> <p><b>MINIATURE TRIM POTS</b> 5K, 10K, 25K, 50K, 100K. \$.75 EA. 3/\$2.00</p> <p><b>MULTI-TURN TRIM POTS</b> Similar to Bourns 3010 style 3/16" x 9/16" x 1 1/4" 50, 100, 500, 2000, 5000, 10,000 ohms \$1.50 ea. 3/\$4.00</p> <p><b>PRINTED CIRCUIT BOARD</b> 4 1/2" x 6 1/2" single sided fiber glass board, 1/16" thick, un- etched \$4.00 ea. 5/\$1.75</p> <p><b>LIGHT ACTIVATED SCR's,</b> T018, 200PRV 1A \$1.75</p> <p><b>NIXIE TUBES</b> Similar to Raytheon 8650 tubes, with socket &amp; data sheet \$2.25 3/\$6.00</p> <p>FPA 711 - THESE PHOTO DIODE ARRAYS ARE USED TO READ SEVEN LEVEL TAPE 100 ma SPACING \$5.95</p> <p>TIS 73 N FET \$5.00 2N4891 UJT \$5.00 ER900 TRIGGER DIODES 4/\$1.00 2N6027 PROG. UJT \$7.75</p> <p><b>VERIPAX PC BOARD</b> This board is a 1 1/8" single sided paper epoxy board. 4 1/2" x 6 1/2" (standard veripax). DRILLED and ETCHED which will hold up to 21 single 14 pin IC's or 8, 16 or LSI DIP IC's with busses for power supply con- nections is also etched for 22 pin connector \$5.25</p> <p>FLV 100 VISIBLE LED \$5.00 ME-4 IR LED \$4.00 MCD-2 OPTO-ISOL \$9.00 GREEN GAP OSL-16 LED \$6.00 RED GAP OSL-3 LED \$4.00 14 PIN DIP SOCKETS \$4.00 16 PIN DIP SOCKETS \$5.00</p> <p>10 WATT ZENERS \$7.50 EA 3.9, 4.7 OR 5.6 V 4 WATT ZENERS \$3.00 EA 3.9, 5.6, 6.8 OR 12 V</p> <p><b>Silicon Power Rectifiers</b></p> <table border="1"> <tr> <th>PRV</th> <th>1A</th> <th>3A</th> <th>12A</th> <th>50A</th> </tr> <tr> <td>100</td> <td>.06</td> <td>.11</td> <td>.30</td> <td>.80</td> </tr> <tr> <td>200</td> <td>.07</td> <td>.16</td> <td>.35</td> <td>1.15</td> </tr> <tr> <td>400</td> <td>.09</td> <td>.20</td> <td>.50</td> <td>1.40</td> </tr> <tr> <td>600</td> <td>.11</td> <td>.25</td> <td>.70</td> <td>1.80</td> </tr> <tr> <td>800</td> <td>.15</td> <td>.35</td> <td>.90</td> <td>2.20</td> </tr> <tr> <td>000</td> <td>.20</td> <td>.45</td> <td>1.10</td> <td>2.60</td> </tr> </table> <p><b>REGULATED MODULAR POWER SUPPLIES</b> +15VDC AT 100 ma, 115VAC INPUT \$19.95 5VDC AT 1A, 115VAC INPUT \$19.95</p> <p>IN 4148 \$14/\$1.00</p>	PRV	1A	3A	12A	50A	100	.06	.11	.30	.80	200	.07	.16	.35	1.15	400	.09	.20	.50	1.40	600	.11	.25	.70	1.80	800	.15	.35	.90	2.20	000	.20	.45	1.10	2.60	<p><b>TRANSISTOR SPECIALS</b></p> <table border="1"> <tr> <td>2N256 PNP GE TO-3</td> <td>\$ .50</td> </tr> <tr> <td>2N404 PNP GE TO-5</td> <td>\$ 1.00</td> </tr> <tr> <td>2N1137B PNP GE TO-3</td> <td>\$ .95</td> </tr> <tr> <td>2N1016A NPN Si TO-82</td> <td>\$ 1.95</td> </tr> <tr> <td>2N2226 NPN Si TO-82</td> <td>\$ 2.50</td> </tr> <tr> <td>MPS3393 NPN Si TO-92</td> <td>\$ 4.10</td> </tr> <tr> <td>2N3866 NPN Si TO-5</td> <td>\$ .75</td> </tr> <tr> <td>2N2369 NPN Si TO-18</td> <td>\$ 1.00</td> </tr> <tr> <td>2N3767 NPN Si TO-66</td> <td>\$ .70</td> </tr> <tr> <td>2N2222 NPN Si TO-18</td> <td>\$ 1.00</td> </tr> <tr> <td>2N3055 NPN Si TO-3</td> <td>\$ 1.00</td> </tr> <tr> <td>2N5296 NPN Si TO-220</td> <td>\$ .50</td> </tr> <tr> <td>2N6109 PNP Si TO-220</td> <td>\$ .55</td> </tr> <tr> <td>2N4898 PNP Si TO-66</td> <td>\$ .60</td> </tr> <tr> <td>MJ2252 NPN Si TO-66</td> <td>\$ .90</td> </tr> <tr> <td>2N3638 PNP Si TO-5</td> <td>\$ 1.00</td> </tr> <tr> <td>2N2218A NPN Si TO-5</td> <td>\$ 4.10</td> </tr> </table> <p><b>CAPACITORS</b></p> <table border="1"> <tr> <td>6V 30 UF TANT. 5% 1</td> <td>MAN-1 RED OR YELLOW</td> </tr> <tr> <td>20V 4.7UF TANT. 5% 1</td> <td>LED READOUT \$2.50</td> </tr> <tr> <td>12V 10UF ELECT. 5% 1</td> <td>MAN-3 READOOTS \$1.75</td> </tr> <tr> <td>50V 100UF ELECT. 5% 4</td> <td>MAN-4 READOOTS \$2.00</td> </tr> <tr> <td>25V 300UF ELECT. 5% 1</td> <td></td> </tr> </table> <p>1103 1024 bit RAM \$4.75 NEC 6003 2048 bit RAM \$9.50 1101 256 bit RAM \$1.75 8225 64 bit-write RAM \$2.75 8223 PROGRAMMABLE ROM \$4.75</p> <p>Conductive Elastometer low profile calculator keyboard A 2 1/2" x 3 1/2" flex key. 19SK-6 keyboard having 0-9 + K-C buttons with off. on switch. \$6.00</p> <p><b>TTL IC SERIES</b></p> <table border="1"> <tr> <td>74L00-30</td> <td>7476-47</td> </tr> <tr> <td>7400-18</td> <td>7480-65</td> </tr> <tr> <td>7401-18</td> <td>7483-110</td> </tr> <tr> <td>7402-18</td> <td>7485-130</td> </tr> <tr> <td>7403-18</td> <td>7486-48</td> </tr> <tr> <td>7404-22</td> <td>7489-2.75</td> </tr> <tr> <td>7405-22</td> <td>7490-75</td> </tr> <tr> <td>7406-37</td> <td>7491-130</td> </tr> <tr> <td>7407-37</td> <td>7492-75</td> </tr> <tr> <td>7408-24</td> <td>7493-75</td> </tr> <tr> <td>7410-18</td> <td>7495-99</td> </tr> <tr> <td>7411-30</td> <td>7496-95</td> </tr> <tr> <td>7412-45</td> <td>8220-1.50</td> </tr> <tr> <td>7413-75</td> <td>74107-50</td> </tr> <tr> <td>7416-37</td> <td>74121-60</td> </tr> <tr> <td>7417-37</td> <td>74123-1.00</td> </tr> <tr> <td>7420-18</td> <td>74125-1.40</td> </tr> <tr> <td>7426-30</td> <td>74126-1.40</td> </tr> <tr> <td>7427-33</td> <td>74150-1.15</td> </tr> <tr> <td>7430-18</td> <td>74151-95</td> </tr> <tr> <td>7432-30</td> <td>74153-1.10</td> </tr> <tr> <td>7437-44</td> <td>74154-1.65</td> </tr> <tr> <td>7438-37</td> <td>74157-1.25</td> </tr> <tr> <td>7440-21</td> <td>74163-1.60</td> </tr> <tr> <td>7441-05</td> <td>74164-2.05</td> </tr> <tr> <td>7442-1.00</td> <td>74165-2.05</td> </tr> <tr> <td>7445-1.10</td> <td>74173-1.80</td> </tr> <tr> <td>7446-1.15</td> <td>74177-1.80</td> </tr> <tr> <td>7447-1.15</td> <td>74181-3.60</td> </tr> <tr> <td>7448-1.20</td> <td>74192-1.50</td> </tr> <tr> <td>7450-18</td> <td>74193-1.45</td> </tr> <tr> <td>7472-40</td> <td>74195-1.00</td> </tr> <tr> <td>7473-43</td> <td>75324-1.75</td> </tr> <tr> <td>7474-43</td> <td>75491-1.10</td> </tr> <tr> <td>7475-75</td> <td></td> </tr> </table> <p>Similar to 8038C IC Voltage controlled oscillator, as featured in Oct. 73 P.E. they have sine, square and triangular outputs good to 1MHz. Two of them can be used to make an FM generator. \$4.95</p>	2N256 PNP GE TO-3	\$ .50	2N404 PNP GE TO-5	\$ 1.00	2N1137B PNP GE TO-3	\$ .95	2N1016A NPN Si TO-82	\$ 1.95	2N2226 NPN Si TO-82	\$ 2.50	MPS3393 NPN Si TO-92	\$ 4.10	2N3866 NPN Si TO-5	\$ .75	2N2369 NPN Si TO-18	\$ 1.00	2N3767 NPN Si TO-66	\$ .70	2N2222 NPN Si TO-18	\$ 1.00	2N3055 NPN Si TO-3	\$ 1.00	2N5296 NPN Si TO-220	\$ .50	2N6109 PNP Si TO-220	\$ .55	2N4898 PNP Si TO-66	\$ .60	MJ2252 NPN Si TO-66	\$ .90	2N3638 PNP Si TO-5	\$ 1.00	2N2218A NPN Si TO-5	\$ 4.10	6V 30 UF TANT. 5% 1	MAN-1 RED OR YELLOW	20V 4.7UF TANT. 5% 1	LED READOUT \$2.50	12V 10UF ELECT. 5% 1	MAN-3 READOOTS \$1.75	50V 100UF ELECT. 5% 4	MAN-4 READOOTS \$2.00	25V 300UF ELECT. 5% 1		74L00-30	7476-47	7400-18	7480-65	7401-18	7483-110	7402-18	7485-130	7403-18	7486-48	7404-22	7489-2.75	7405-22	7490-75	7406-37	7491-130	7407-37	7492-75	7408-24	7493-75	7410-18	7495-99	7411-30	7496-95	7412-45	8220-1.50	7413-75	74107-50	7416-37	74121-60	7417-37	74123-1.00	7420-18	74125-1.40	7426-30	74126-1.40	7427-33	74150-1.15	7430-18	74151-95	7432-30	74153-1.10	7437-44	74154-1.65	7438-37	74157-1.25	7440-21	74163-1.60	7441-05	74164-2.05	7442-1.00	74165-2.05	7445-1.10	74173-1.80	7446-1.15	74177-1.80	7447-1.15	74181-3.60	7448-1.20	74192-1.50	7450-18	74193-1.45	7472-40	74195-1.00	7473-43	75324-1.75	7474-43	75491-1.10	7475-75		<p><b>C/MOS (DIODE CLAMPED)</b></p> <table border="1"> <tr> <td>74C 02</td> <td>\$ .55</td> </tr> <tr> <td>74C 10</td> <td>\$ .60</td> </tr> <tr> <td>74C 157</td> <td>\$ 2.15</td> </tr> <tr> <td>74C 165</td> <td>\$ 3.50</td> </tr> <tr> <td>CD 4001</td> <td>\$ .55</td> </tr> <tr> <td>CD 4002</td> <td>\$ .65</td> </tr> <tr> <td>CD 4009</td> <td>\$ .80</td> </tr> <tr> <td>CD 4010</td> <td>\$ .65</td> </tr> <tr> <td>CD 4011</td> <td>\$ .55</td> </tr> <tr> <td>CD 4012</td> <td>\$ .55</td> </tr> <tr> <td>CD 4013</td> <td>\$ 1.20</td> </tr> <tr> <td>CD 4016</td> <td>\$ 1.25</td> </tr> <tr> <td>CD 4022</td> <td>\$ 2.25</td> </tr> <tr> <td>CD 4023</td> <td>\$ .55</td> </tr> <tr> <td>CD 4025</td> <td>\$ .55</td> </tr> <tr> <td>CD 4027</td> <td>\$ 1.35</td> </tr> <tr> <td>CD 4030</td> <td>\$ .65</td> </tr> </table> <p><b>Full Wave Bridges</b></p> <table border="1"> <tr> <th>PRV</th> <th>2A</th> <th>6A</th> <th>25A</th> </tr> <tr> <td>200</td> <td>.95</td> <td>1.25</td> <td>4.00</td> </tr> <tr> <td>400</td> <td>1.15</td> <td>1.50</td> <td>5.00</td> </tr> <tr> <td>600</td> <td>1.35</td> <td>1.75</td> <td>6.00</td> </tr> </table> <p>5311—CLOCK CHIP 6 DIGIT BCD HOLD COUNT OUTPUT STROBE \$7.75 5314—CLOCK CHIP 6 DIGIT HOLD COUNT OUTPUT STROBE \$7.75 5316—ALARM CLOCK CHIP \$9.95</p> <p>2513 64-7-5 CHARACTER GEN \$11.50 2516 64-6-8 STATIC CHARACTER GEN \$11.50</p> <p><b>SANKEN AUDIO POWER AMPS</b></p> <table border="1"> <tr> <td>Si 1010 Y 10 WATTS</td> <td>\$ 7.95</td> </tr> <tr> <td>Si 1025 E 25 WATTS</td> <td>\$ 18.88</td> </tr> <tr> <td>Si 1050 E 50 WATTS</td> <td>\$ 29.95</td> </tr> </table> <p><b>LINEAR CIRCUITS</b></p> <table border="1"> <tr> <td>LM 309K 5V 1A REGULATOR</td> <td>\$1.65</td> </tr> <tr> <td>723 40 -40V REGULATOR</td> <td>\$ .58</td> </tr> <tr> <td>301/748 Hi Per Op Amp</td> <td>\$ .35</td> </tr> <tr> <td>LM 320 5 or 15V REGULATOR</td> <td>\$1.75</td> </tr> <tr> <td>LM 375 V 10 37v POS REG</td> <td>\$ .58</td> </tr> <tr> <td>714 or 741C OP AMP</td> <td>\$ .35</td> </tr> <tr> <td>709C OPER AMP</td> <td>\$ .29</td> </tr> <tr> <td>340T-5 12, 15, 18 24V POS REG TO-220</td> <td>\$1.75</td> </tr> <tr> <td>101 OPER AMP. HI PERFORM</td> <td>\$ .75</td> </tr> <tr> <td>LM 308 OPER AMP. LOW POWER</td> <td>\$1.05</td> </tr> <tr> <td>747-DUAL 741</td> <td>\$ .75</td> </tr> <tr> <td>536-FET INPUT OPER AMP</td> <td>\$2.60</td> </tr> <tr> <td>537-PRECISION OP AMP</td> <td>\$2.60</td> </tr> <tr> <td>LM 3900-QUAD OP AMP</td> <td>\$ .58</td> </tr> <tr> <td>LM 324-QUAD 741</td> <td>\$2.20</td> </tr> <tr> <td>560-PHASE LOCK LOOP</td> <td>\$2.60</td> </tr> <tr> <td>561-PHASE LOCK LOOP</td> <td>\$2.60</td> </tr> <tr> <td>565-PHASE LOCK LOOP</td> <td>\$2.60</td> </tr> <tr> <td>567-TONE DECODER</td> <td>\$2.95</td> </tr> <tr> <td>703-RF IF AMP</td> <td>\$ .55</td> </tr> <tr> <td>LM 370-AGC SQUELCH AMP</td> <td>\$1.15</td> </tr> <tr> <td>555-2 μs - 2 HR TIMER</td> <td>\$ .98</td> </tr> <tr> <td>1458 DUAL OP AMP</td> <td>\$ .88</td> </tr> <tr> <td>1456 OP AMP</td> <td>\$ .95</td> </tr> <tr> <td>LM 380-2W AUDIO AMP</td> <td>\$1.45</td> </tr> <tr> <td>LM 377-2W STEREO AUDIO AMP</td> <td>\$2.60</td> </tr> <tr> <td>LM 381-STEREO PREAMP</td> <td>\$1.75</td> </tr> <tr> <td>LM 382-DUAL AUDIO PREAMP</td> <td>\$1.75</td> </tr> <tr> <td>LM 311-HI PER COMPARATOR</td> <td>\$ .95</td> </tr> <tr> <td>LM 319-DUAL HI SPEED COMP</td> <td>\$1.25</td> </tr> <tr> <td>LM 339-QUAD COMPARATOR</td> <td>\$1.65</td> </tr> </table> <p><b>TRIACS</b></p> <table border="1"> <tr> <th>PRV</th> <th>1A</th> <th>10A</th> <th>25A</th> <th>1.5A</th> <th>6A</th> <th>35A</th> </tr> <tr> <td>100</td> <td>.40</td> <td>.70</td> <td>1.30</td> <td>.40</td> <td>.50</td> <td>1.20</td> </tr> <tr> <td>200</td> <td>.70</td> <td>1.10</td> <td>1.75</td> <td>.60</td> <td>.70</td> <td>1.60</td> </tr> <tr> <td>400</td> <td>1.10</td> <td>1.60</td> <td>2.60</td> <td>1.00</td> <td>2.0</td> <td>2.20</td> </tr> <tr> <td>600</td> <td>1.70</td> <td>2.30</td> <td>3.00</td> <td></td> <td></td> <td></td> </tr> </table> <p><b>SCR'S</b></p> <table border="1"> <tr> <th>PRV</th> <th>1A</th> <th>10A</th> <th>25A</th> <th>1.5A</th> <th>6A</th> <th>35A</th> </tr> <tr> <td>100</td> <td>.40</td> <td>.70</td> <td>1.30</td> <td>.40</td> <td>.50</td> <td>1.20</td> </tr> <tr> <td>200</td> <td>.70</td> <td>1.10</td> <td>1.75</td> <td>.60</td> <td>.70</td> <td>1.60</td> </tr> <tr> <td>400</td> <td>1.10</td> <td>1.60</td> <td>2.60</td> <td>1.00</td> <td>2.0</td> <td>2.20</td> </tr> <tr> <td>600</td> <td>1.70</td> <td>2.30</td> <td>3.00</td> <td></td> <td></td> <td></td> </tr> </table>	74C 02	\$ .55	74C 10	\$ .60	74C 157	\$ 2.15	74C 165	\$ 3.50	CD 4001	\$ .55	CD 4002	\$ .65	CD 4009	\$ .80	CD 4010	\$ .65	CD 4011	\$ .55	CD 4012	\$ .55	CD 4013	\$ 1.20	CD 4016	\$ 1.25	CD 4022	\$ 2.25	CD 4023	\$ .55	CD 4025	\$ .55	CD 4027	\$ 1.35	CD 4030	\$ .65	PRV	2A	6A	25A	200	.95	1.25	4.00	400	1.15	1.50	5.00	600	1.35	1.75	6.00	Si 1010 Y 10 WATTS	\$ 7.95	Si 1025 E 25 WATTS	\$ 18.88	Si 1050 E 50 WATTS	\$ 29.95	LM 309K 5V 1A REGULATOR	\$1.65	723 40 -40V REGULATOR	\$ .58	301/748 Hi Per Op Amp	\$ .35	LM 320 5 or 15V REGULATOR	\$1.75	LM 375 V 10 37v POS REG	\$ .58	714 or 741C OP AMP	\$ .35	709C OPER AMP	\$ .29	340T-5 12, 15, 18 24V POS REG TO-220	\$1.75	101 OPER AMP. HI PERFORM	\$ .75	LM 308 OPER AMP. LOW POWER	\$1.05	747-DUAL 741	\$ .75	536-FET INPUT OPER AMP	\$2.60	537-PRECISION OP AMP	\$2.60	LM 3900-QUAD OP AMP	\$ .58	LM 324-QUAD 741	\$2.20	560-PHASE LOCK LOOP	\$2.60	561-PHASE LOCK LOOP	\$2.60	565-PHASE LOCK LOOP	\$2.60	567-TONE DECODER	\$2.95	703-RF IF AMP	\$ .55	LM 370-AGC SQUELCH AMP	\$1.15	555-2 μs - 2 HR TIMER	\$ .98	1458 DUAL OP AMP	\$ .88	1456 OP AMP	\$ .95	LM 380-2W AUDIO AMP	\$1.45	LM 377-2W STEREO AUDIO AMP	\$2.60	LM 381-STEREO PREAMP	\$1.75	LM 382-DUAL AUDIO PREAMP	\$1.75	LM 311-HI PER COMPARATOR	\$ .95	LM 319-DUAL HI SPEED COMP	\$1.25	LM 339-QUAD COMPARATOR	\$1.65	PRV	1A	10A	25A	1.5A	6A	35A	100	.40	.70	1.30	.40	.50	1.20	200	.70	1.10	1.75	.60	.70	1.60	400	1.10	1.60	2.60	1.00	2.0	2.20	600	1.70	2.30	3.00				PRV	1A	10A	25A	1.5A	6A	35A	100	.40	.70	1.30	.40	.50	1.20	200	.70	1.10	1.75	.60	.70	1.60	400	1.10	1.60	2.60	1.00	2.0	2.20	600	1.70	2.30	3.00			
PRV	1A	3A	12A	50A																																																																																																																																																																																																																																																																																																																																															
100	.06	.11	.30	.80																																																																																																																																																																																																																																																																																																																																															
200	.07	.16	.35	1.15																																																																																																																																																																																																																																																																																																																																															
400	.09	.20	.50	1.40																																																																																																																																																																																																																																																																																																																																															
600	.11	.25	.70	1.80																																																																																																																																																																																																																																																																																																																																															
800	.15	.35	.90	2.20																																																																																																																																																																																																																																																																																																																																															
000	.20	.45	1.10	2.60																																																																																																																																																																																																																																																																																																																																															
2N256 PNP GE TO-3	\$ .50																																																																																																																																																																																																																																																																																																																																																		
2N404 PNP GE TO-5	\$ 1.00																																																																																																																																																																																																																																																																																																																																																		
2N1137B PNP GE TO-3	\$ .95																																																																																																																																																																																																																																																																																																																																																		
2N1016A NPN Si TO-82	\$ 1.95																																																																																																																																																																																																																																																																																																																																																		
2N2226 NPN Si TO-82	\$ 2.50																																																																																																																																																																																																																																																																																																																																																		
MPS3393 NPN Si TO-92	\$ 4.10																																																																																																																																																																																																																																																																																																																																																		
2N3866 NPN Si TO-5	\$ .75																																																																																																																																																																																																																																																																																																																																																		
2N2369 NPN Si TO-18	\$ 1.00																																																																																																																																																																																																																																																																																																																																																		
2N3767 NPN Si TO-66	\$ .70																																																																																																																																																																																																																																																																																																																																																		
2N2222 NPN Si TO-18	\$ 1.00																																																																																																																																																																																																																																																																																																																																																		
2N3055 NPN Si TO-3	\$ 1.00																																																																																																																																																																																																																																																																																																																																																		
2N5296 NPN Si TO-220	\$ .50																																																																																																																																																																																																																																																																																																																																																		
2N6109 PNP Si TO-220	\$ .55																																																																																																																																																																																																																																																																																																																																																		
2N4898 PNP Si TO-66	\$ .60																																																																																																																																																																																																																																																																																																																																																		
MJ2252 NPN Si TO-66	\$ .90																																																																																																																																																																																																																																																																																																																																																		
2N3638 PNP Si TO-5	\$ 1.00																																																																																																																																																																																																																																																																																																																																																		
2N2218A NPN Si TO-5	\$ 4.10																																																																																																																																																																																																																																																																																																																																																		
6V 30 UF TANT. 5% 1	MAN-1 RED OR YELLOW																																																																																																																																																																																																																																																																																																																																																		
20V 4.7UF TANT. 5% 1	LED READOUT \$2.50																																																																																																																																																																																																																																																																																																																																																		
12V 10UF ELECT. 5% 1	MAN-3 READOOTS \$1.75																																																																																																																																																																																																																																																																																																																																																		
50V 100UF ELECT. 5% 4	MAN-4 READOOTS \$2.00																																																																																																																																																																																																																																																																																																																																																		
25V 300UF ELECT. 5% 1																																																																																																																																																																																																																																																																																																																																																			
74L00-30	7476-47																																																																																																																																																																																																																																																																																																																																																		
7400-18	7480-65																																																																																																																																																																																																																																																																																																																																																		
7401-18	7483-110																																																																																																																																																																																																																																																																																																																																																		
7402-18	7485-130																																																																																																																																																																																																																																																																																																																																																		
7403-18	7486-48																																																																																																																																																																																																																																																																																																																																																		
7404-22	7489-2.75																																																																																																																																																																																																																																																																																																																																																		
7405-22	7490-75																																																																																																																																																																																																																																																																																																																																																		
7406-37	7491-130																																																																																																																																																																																																																																																																																																																																																		
7407-37	7492-75																																																																																																																																																																																																																																																																																																																																																		
7408-24	7493-75																																																																																																																																																																																																																																																																																																																																																		
7410-18	7495-99																																																																																																																																																																																																																																																																																																																																																		
7411-30	7496-95																																																																																																																																																																																																																																																																																																																																																		
7412-45	8220-1.50																																																																																																																																																																																																																																																																																																																																																		
7413-75	74107-50																																																																																																																																																																																																																																																																																																																																																		
7416-37	74121-60																																																																																																																																																																																																																																																																																																																																																		
7417-37	74123-1.00																																																																																																																																																																																																																																																																																																																																																		
7420-18	74125-1.40																																																																																																																																																																																																																																																																																																																																																		
7426-30	74126-1.40																																																																																																																																																																																																																																																																																																																																																		
7427-33	74150-1.15																																																																																																																																																																																																																																																																																																																																																		
7430-18	74151-95																																																																																																																																																																																																																																																																																																																																																		
7432-30	74153-1.10																																																																																																																																																																																																																																																																																																																																																		
7437-44	74154-1.65																																																																																																																																																																																																																																																																																																																																																		
7438-37	74157-1.25																																																																																																																																																																																																																																																																																																																																																		
7440-21	74163-1.60																																																																																																																																																																																																																																																																																																																																																		
7441-05	74164-2.05																																																																																																																																																																																																																																																																																																																																																		
7442-1.00	74165-2.05																																																																																																																																																																																																																																																																																																																																																		
7445-1.10	74173-1.80																																																																																																																																																																																																																																																																																																																																																		
7446-1.15	74177-1.80																																																																																																																																																																																																																																																																																																																																																		
7447-1.15	74181-3.60																																																																																																																																																																																																																																																																																																																																																		
7448-1.20	74192-1.50																																																																																																																																																																																																																																																																																																																																																		
7450-18	74193-1.45																																																																																																																																																																																																																																																																																																																																																		
7472-40	74195-1.00																																																																																																																																																																																																																																																																																																																																																		
7473-43	75324-1.75																																																																																																																																																																																																																																																																																																																																																		
7474-43	75491-1.10																																																																																																																																																																																																																																																																																																																																																		
7475-75																																																																																																																																																																																																																																																																																																																																																			
74C 02	\$ .55																																																																																																																																																																																																																																																																																																																																																		
74C 10	\$ .60																																																																																																																																																																																																																																																																																																																																																		
74C 157	\$ 2.15																																																																																																																																																																																																																																																																																																																																																		
74C 165	\$ 3.50																																																																																																																																																																																																																																																																																																																																																		
CD 4001	\$ .55																																																																																																																																																																																																																																																																																																																																																		
CD 4002	\$ .65																																																																																																																																																																																																																																																																																																																																																		
CD 4009	\$ .80																																																																																																																																																																																																																																																																																																																																																		
CD 4010	\$ .65																																																																																																																																																																																																																																																																																																																																																		
CD 4011	\$ .55																																																																																																																																																																																																																																																																																																																																																		
CD 4012	\$ .55																																																																																																																																																																																																																																																																																																																																																		
CD 4013	\$ 1.20																																																																																																																																																																																																																																																																																																																																																		
CD 4016	\$ 1.25																																																																																																																																																																																																																																																																																																																																																		
CD 4022	\$ 2.25																																																																																																																																																																																																																																																																																																																																																		
CD 4023	\$ .55																																																																																																																																																																																																																																																																																																																																																		
CD 4025	\$ .55																																																																																																																																																																																																																																																																																																																																																		
CD 4027	\$ 1.35																																																																																																																																																																																																																																																																																																																																																		
CD 4030	\$ .65																																																																																																																																																																																																																																																																																																																																																		
PRV	2A	6A	25A																																																																																																																																																																																																																																																																																																																																																
200	.95	1.25	4.00																																																																																																																																																																																																																																																																																																																																																
400	1.15	1.50	5.00																																																																																																																																																																																																																																																																																																																																																
600	1.35	1.75	6.00																																																																																																																																																																																																																																																																																																																																																
Si 1010 Y 10 WATTS	\$ 7.95																																																																																																																																																																																																																																																																																																																																																		
Si 1025 E 25 WATTS	\$ 18.88																																																																																																																																																																																																																																																																																																																																																		
Si 1050 E 50 WATTS	\$ 29.95																																																																																																																																																																																																																																																																																																																																																		
LM 309K 5V 1A REGULATOR	\$1.65																																																																																																																																																																																																																																																																																																																																																		
723 40 -40V REGULATOR	\$ .58																																																																																																																																																																																																																																																																																																																																																		
301/748 Hi Per Op Amp	\$ .35																																																																																																																																																																																																																																																																																																																																																		
LM 320 5 or 15V REGULATOR	\$1.75																																																																																																																																																																																																																																																																																																																																																		
LM 375 V 10 37v POS REG	\$ .58																																																																																																																																																																																																																																																																																																																																																		
714 or 741C OP AMP	\$ .35																																																																																																																																																																																																																																																																																																																																																		
709C OPER AMP	\$ .29																																																																																																																																																																																																																																																																																																																																																		
340T-5 12, 15, 18 24V POS REG TO-220	\$1.75																																																																																																																																																																																																																																																																																																																																																		
101 OPER AMP. HI PERFORM	\$ .75																																																																																																																																																																																																																																																																																																																																																		
LM 308 OPER AMP. LOW POWER	\$1.05																																																																																																																																																																																																																																																																																																																																																		
747-DUAL 741	\$ .75																																																																																																																																																																																																																																																																																																																																																		
536-FET INPUT OPER AMP	\$2.60																																																																																																																																																																																																																																																																																																																																																		
537-PRECISION OP AMP	\$2.60																																																																																																																																																																																																																																																																																																																																																		
LM 3900-QUAD OP AMP	\$ .58																																																																																																																																																																																																																																																																																																																																																		
LM 324-QUAD 741	\$2.20																																																																																																																																																																																																																																																																																																																																																		
560-PHASE LOCK LOOP	\$2.60																																																																																																																																																																																																																																																																																																																																																		
561-PHASE LOCK LOOP	\$2.60																																																																																																																																																																																																																																																																																																																																																		
565-PHASE LOCK LOOP	\$2.60																																																																																																																																																																																																																																																																																																																																																		
567-TONE DECODER	\$2.95																																																																																																																																																																																																																																																																																																																																																		
703-RF IF AMP	\$ .55																																																																																																																																																																																																																																																																																																																																																		
LM 370-AGC SQUELCH AMP	\$1.15																																																																																																																																																																																																																																																																																																																																																		
555-2 μs - 2 HR TIMER	\$ .98																																																																																																																																																																																																																																																																																																																																																		
1458 DUAL OP AMP	\$ .88																																																																																																																																																																																																																																																																																																																																																		
1456 OP AMP	\$ .95																																																																																																																																																																																																																																																																																																																																																		
LM 380-2W AUDIO AMP	\$1.45																																																																																																																																																																																																																																																																																																																																																		
LM 377-2W STEREO AUDIO AMP	\$2.60																																																																																																																																																																																																																																																																																																																																																		
LM 381-STEREO PREAMP	\$1.75																																																																																																																																																																																																																																																																																																																																																		
LM 382-DUAL AUDIO PREAMP	\$1.75																																																																																																																																																																																																																																																																																																																																																		
LM 311-HI PER COMPARATOR	\$ .95																																																																																																																																																																																																																																																																																																																																																		
LM 319-DUAL HI SPEED COMP	\$1.25																																																																																																																																																																																																																																																																																																																																																		
LM 339-QUAD COMPARATOR	\$1.65																																																																																																																																																																																																																																																																																																																																																		
PRV	1A	10A	25A	1.5A	6A	35A																																																																																																																																																																																																																																																																																																																																													
100	.40	.70	1.30	.40	.50	1.20																																																																																																																																																																																																																																																																																																																																													
200	.70	1.10	1.75	.60	.70	1.60																																																																																																																																																																																																																																																																																																																																													
400	1.10	1.60	2.60	1.00	2.0	2.20																																																																																																																																																																																																																																																																																																																																													
600	1.70	2.30	3.00																																																																																																																																																																																																																																																																																																																																																
PRV	1A	10A	25A	1.5A	6A	35A																																																																																																																																																																																																																																																																																																																																													
100	.40	.70	1.30	.40	.50	1.20																																																																																																																																																																																																																																																																																																																																													
200	.70	1.10	1.75	.60	.70	1.60																																																																																																																																																																																																																																																																																																																																													
400	1.10	1.60	2.60	1.00	2.0	2.20																																																																																																																																																																																																																																																																																																																																													
600	1.70	2.30	3.00																																																																																																																																																																																																																																																																																																																																																

**SOLID STATE SALES**  
P.O. BOX 74A  
SOMERVILLE, MASS. 02143 TEL. (617) 547-4005

WE SHIP OVER 95% OF OUR ORDERS THE DAY WE RECEIVE THEM

CIRCLE NO. 39 ON READER SERVICE CARD

## ALTAJ ELECTRONIC BARGAINS

### MOS 4 DIGIT COUNTER IC

An ALTAJ exclusive. These are the latest, state of the art, MOS chips. By a famous US mfg. Contains a complete 4 digit counter, including 4 decade counters, latches, multiplexing circuits, display decoders, etc. Features: 5 VDC operation, 25 MW power consumption, both 7 segment and BCD outputs. Perfect for making DVM's, frequency meters, tachometers, stopwatches, or any other device requiring 4 or more digits. Complete with specs. 28 PIN DIP. QTY Limited.

Special --- \$12.50

### PRIME TTL DIP IC's

7400-16c	7448-85c	74157-1.19
7402-16c	7473-39c	74161-1.15
7404-16c	7474-38c	74164-1.29
7406-24c	7475-69c	74165-1.50
7408-16c	7476-42c	74174-1.75
7410-16c	7483-88c	74175-\$1.50
7413-49c	7490-75c	74181-\$2.95
7420-16c	7492-85c	74192-\$1.25
7430-16c	7493-85c	74193-\$1.25
7437-39c	74121-38c	74195-95c
7438-39c	74123-75c	74197-\$1.25
7440-16c	74150-70c	
7442-69c	75151-75c	
7445-69c	74153-95c	
7447-85c	74154-95c	

### RCA STYLE — CMOS IC's

CD4001-44c	CD4012-44c
CD4002-44c	CD4013-89c
CD4009-75c	CD4017-\$1.95
CD4011-44c	

### NI-CAD BATTERY SPECIAL

Two cell battery packs. 2.75 V. capacity is 250 MA HRS. Two of these make a great power pack for TTL. Special 95c

### CALCULATOR KEYBOARD SWITCH KIT

Kit of 16 brand new switches with tops. Each switch has a smooth, quiet, key travel. Internally the switches consist of a magnet and read switch for low contact bounce. Kit has 0-9 CL, decimal point, and four functions, perfect for use with our calculator chips

COMPLETE SET — \$3.95

### MAN-3 LED READOUTS

Brand new. Common cathode. 12 in. character. Prime factory fresh units. Best Price in USA!

49c ea. (10 FOR \$3.95)

### COLOR ORGAN CONTROL MODULE

Completely self-contained. Has SCR circuitry, AC line cord, etc. From a close out by a mfg. of color organs. New, unused.

\$3.95 ea. (3 FOR \$9)

### SOLID STATE MEMORY ARRAY

Brand new, MFG. by Monolithic Systems Corp. Consists of 16-1101 (256 Bit Ram) and associated drive circuits. Drive circuits include 24 assorted 7400 series devices and various transistors, diodes, etc. Array is mounted on two stacked 6 x 8 in. PC boards. Original cost \$300 ea. With schematic. These are recommended for experienced hobbyists only. Limited quantity — \$29.95 ea.

### FACTORY NEW LED'S — SALE!



Jumbo Red-Like MV5024 — 8 for \$1  
Jumbo Green-Like MV5222 — 5 for \$1  
Mini Red-Like MV50 — 10 for \$1

### CALCULATOR CHIP BONANZA! THREE VERSIONS TO CHOOSE FROM

Never before offered in USA. These are the newest and easiest to use chips available to the hobbyist today. Features: direct segment drive for LED's, low power consumption, single supply voltage, internal encoding of keyboard inputs, internal keyboard debounce, internal clock oscillator. Made by famous US mfg. No one but ALTAJ offers calculator chips with these sophisticated functions. All are 28 Pin DIP. with specs. FLOATING DEC.

CHIP #1 — 8 DIGIT READOUT, CONSTANT, SIX FUNCTION (+, -, x, ÷, %, √) — \$7.95

CHIP #2 — 8 DIGIT READOUT, MEMORY, SIX FUNCTION (+, -, x, ÷, √, π) — \$8.95

CHIP #3 — 8 DIGIT READOUT, MEMORY, SIX FUNCTION (+, -, x, ÷, %, 1/x) — \$8.95

### 3 DIGIT LED READOUTS

Perfect for use with our calculator chips. 3 MAN-3 Readouts in one DIP. Properly multiplexed. New prime units. Like Litronix DL-33. \$1.25 ea. 3 for \$2.95

### DIGITAL ALARM CLOCK IC

Through a special arrangement with a famous U.S. MFG. we can offer these MOS chips. This is the newest and easiest to use alarm chip on the market today. Features:

1. Single supply voltage
2. Led intensity control
3. Simple time set
4. 4 or 6 digit led display
5. AM-PM indication
6. 24 hr alarm with 10 min. snooze
7. Outperforms MM5316

COMPARE THIS PRICE — \$7.95 ea. WITH SPEC. SHEETS

### JUMBO LED READOUT

.65 in. character. Twice the size of regular readouts. Like Litronix DL747. Outperforms SLA-3. Easy to read. Draws only 20 MA per segment. Perfect for giant digital clocks. \$2.95 ea.

### REGULATED DC POWER SUPPLY

Brand new mfg. by WANLASS. Open Style. DC Output 17 to 30 V. Rated 60 watts. Our tests show these units will put out 12 VDC by changing one resistor. Wanlass #OEM60-3. Original cost \$57.50. In original factory boxes, with specs and schematic. Special — \$19.95

### OPCOA SLA-1 LED READOUT

.33 in. Character. Left DEC. point. Uses 7447 driver. Easier to read than MAN-1 types. Factory prime units \$1.19 ea.

### LM 309K — 95c

1 AMP 5VDC TO-3 Voltage regulator new by national. Prime units.

### ALTAJ ELECTRONICS

P.O. BOX 38544

DALLAS, TEXAS 75238

TERMS: Check or M.O. NO COD. Add 10% for PSTG and HDLG. Tex. Res. Add 5%

## INVENTIONS WANTED

CASH-ROYALTIES for patented, unpatented inventions. Global Marketing Service, 2354-P Telegraph, Oakland, California 94612.

INVENTORS: Protect your ideas! Free "Recommended Procedure". Washington Inventors Service, 422T Washington Building, Washington, D.C. 20005.

FREE PAMPHLET: "Tips on Safeguarding Your Invention." Write: United States Inventors Service Company, 708-T Carry Building, Washington, D.C. 20005.

FILE your own patent application. Complete information and materials. Write: Inventor's Guide, 468-R, Goodspeed Road, Virginia Beach, Virginia 23451.

# inventors

## ...Manufacturers Need New Products

If you have an idea for a new product, or a way to make an old product better, contact us, "the idea people." We'll develop your idea, introduce it to industry, negotiate for cash sale or licensing.

Send for our FREE "Invention Kit." It has a special "Invention Record Form," an important brochure, "Your Invention — Its Development, Protection & Marketing," and a Directory of 500 Corporations Seeking New Products. You'll learn how ideas become a reality!



### RAYMOND LEE ORGANIZATION

230 Park Avenue, New York, N.Y. 10017

I'd like to find out how to take action on my idea. Send Free "Invention Kit No. A-112"

Name  Please Print

Address

City  State  Zip

SAN FRANCISCO LOS ANGELES TORONTO VANCOUVER DENVER CHICAGO

## BUSINESS OPPORTUNITIES

I MADE \$40,000.00 Year by Mailorder! Helped others make money! Free Proof. Torrey, Box 318-NN, Ypsilanti, Michigan 48197.

FREE CATALOGS. Repair air conditioning, refrigeration. Tools, supplies, full instructions. Doolin, 2016 Canton, Dallas, Texas 75201.

MAILORDER MILLIONAIRE helps beginners make \$500 weekly. Free report reveals secret plan! Executive (1K12), 333 North Michigan, Chicago 60601.

PIANO TUNING LEARNED QUICKLY AT HOME! Tremendous field! Musical knowledge unnecessary. GI approved. Information free. Empire School, Box 450327, Miami 33145.

FREE Secret Book "2042 Unique Proven Enterprises." Fabulous "Little Knowns." Work home! Haylings-BH, Carlsbad, California 92008.

\$200.00 DAILY in Your Mailbox! Your opportunity to do what mail-order experts do. Free details. Associates, Box 136-J, Holland, Michigan 49423.

\$178.00 WEEKLY. Work one hour daily. Free brochure. FAS, Box 13703-A, San Antonio TX, 78213

wanted

CITIZENS BAND

DEALER-DISTRIBUTORS

Send this Ad to:

PAL ELECTRONICS CO.

P. O. Box 778 • Westminster, Ca. 92683

EARN \$15,000 annually plus. Full year trial plan Import-Mailorder business. Postcard brings details: Northeast Imports, Box 121PE12, Fremont, N.H. 03044.

HOW TO SELL BOOKS BY MAIL. FREE INFORMATION. McCord, Box 276-D, SYLVANIA, OHIO 43560.

\$1,000 MONTH Mailorder. Send Stamp. Fiddes, Box 1242F, Glen Burnie, MD 21061.

OPPORTUNITY PACKAGE! Three amazing business plans. Free details: Gray Bros., 4830 So. 137 St., Suite 72U-12, Omaha, Nebraska 68137.

\$60 HOURLY POSSIBLE. Free Brochure shows how. Write Creative, Dept. PE, 160 So. Robertson, Beverly Hills, CA 90211.

\$50,000 YEARLY—Amazing plan reveals mailorder methods! \$3.00—A.R. Mis, 730 Hicks Road, No. 816E, Palatine, Illinois 60067.



### 60-WATT STEREO AMPLIFIER

**6995**

All Solid State, Printed Circuitry  
Slide Rule Dial  
All Purpose, All Family System!

Features: 4-speaker system, built-in FM antenna, record player jacks on separate panel. Another external panel consists of provisions for external FM and AM antenna, "satellite" speakers to provide 4-speaker ground, jacks for connecting a tape recorder to radio tuner or phono of systems to record. Lower inputs for connecting tape deck that will play back through the internal amplifier for systems. AC jack for phono power connection. RED, GREEN and CLEAR indicators for Phono, AM, and FM respectively. Includes red indicator on front panel for STEREO indicator. Has separate input to plug into mike, guitar and other musical instruments as well as another jack for plugging in a pair of stereo headphones.

Has controls on front panel. PHONO-STEREO-AM-FM. MONO, FM STEREO, GUITAR, TAPE, MIKE master control switch. LOUDNESS, BALANCE, TREBLE, BASS controls, with power ON-OFF rocker switch, and AFC ON-OFF. Designed for audio-philosophers to use as wall unit in DEN or FAMILY ROOM, or control unit by easy chair in family room, or for those who wish to design their own console or modular system. With 6 ft. 11 1/2" VAC cord and plug. Only 13 x 7 x 1 1/2" deep. No escutcheon, but we include template for one, plus diagram. Shpg. wt. 3 lbs. With knobs.



### AM-FM-MULTIPLYER WITH ESCUTCHEON

### 4 WATT GUITAR AMP SOLID STATE With Tremolo \$7.95 AMPEREX

Musical instrument amplifier at low price! Peak power output 10 watts. Two input circuits are equalized for normal or solo guitar. The four controls are VOLUME, TONE, TREMOLO INTENSITY and TREMOLO SPEED. There are terminals on board for normally open foot switch connection. Supply voltage 18vdc. Output to 8 ohm hi-quality speaker. Input impedance 33,000 ohms. Current drain 20 ma. External power supply required. Wt. 1 lb. With instructions, hookups and diagrams. Size 8 x 2 3/4 x 3.



### 60-WATT STEREO HIGH FIDELITY AMPLIFIER

Wall "Slim-Line" Type  
Tape, Record Player, PA & Musical Instruments!

The most amazing audio offer for the hi-fiers, PA men, and an ideal unit for the family den, or any room in the house, office, etc. Comes complete with hookup, escutcheon, and knobs. Separate controls: LOUDNESS, BALANCE, TREBLE, BASS, circuits switch for PHONO, TUNER, TAPE, MIKE, AUX. 3 switches for SCRATCH FILTER, RUMBLE FILTER, and POWER "ON-OFF" with built-in tie. 4-output transistors, each 30 watts. Separate accessories: mounting panel for 4 speaker attachment, mike and musical instrument jack, tuner, and power jacks. 6-ft. cord set for 115VAC, 60 cycles. Measures only 13 x 7 x 3 1/2". Wt. 3 lbs. With attractive multi-color escutcheon. Made by leading US maker.

20-20,000 Cycles Resp • 4-Channel Spkr. System!

**\$3995**

### 7-SEGMENT LED Readouts (All "LED" Types)

Type	Char.	Each	Special
MAN-1	.27	\$3.75	3 for \$9;
MAN-3	.12	1.40	3 for \$3.
MAN-4	.19	2.50	3 for \$6.

SLA-1**	3.33	2.10	3 for \$5.
SLA-3**	.70	4.95	3 for \$13.
SLA-11**	.331	2.50	3 for \$6.
SLA-21**	.331	2.50	3 for \$6.

\*\*By Optec, equal to MAN-1 or MAN-4 specs. Color - RED, GREEN, + Yellow



### SANKEN HYBRID AUDIO POWER AMPS

Used extensively in hi-fi systems, tape decks, FM tuners, record players, stereo components, musical instruments, PA, etc. All amplifiers, flat within 1/2 db from 20 to 20,000 Hz. Each unit properly heat-sinked, with heavy-duty connecting the lug connections. Single-ended pushpull output. Power supply required 24VDC. Output to 8 ohms. Order by Stock No.

### CLOCK CHIPS as low as ON A "DIP" \$7.77

MMS5311	6-digit 28-Pin	8.88
MMS5312	4-digit 24-Pin	8.88
MMS5313	6-digit 28-Pin	8.88
MMS5314	6-digit 24-Pin	8.88
MMS5316	4-digit 40-Pin	8.88
MMS5316-A	no alarm	4.95



### GENERAL ELECTRIC 3-WATT \$2.50 AUDIO AMP

Delivers 3.5 watts continuous, 10 watts peak. With heat sinks; micro-mini size: 3/4 x 2 1/2". 9 to 30V supply. High sensitivity. 8 to 10 ohms.

### 6-8-12 DIGIT Your Choice \$16.95 Calculator Basics

**BASIC KIT #1** — includes case, all-function Flex Key Keyboard, Cal Tech CT5002 calculator chip, 9-digit Antex LED display with built-on individual magnifiers, plus sheets.

**BASIC KIT #2** — same as Basic #1 except calculator chip is National 8-digit MM5726.

**BASIC KIT #3** — same as Basic #1 except calculator chip is National 6-digit MM5736 and 75492.

**12 DIGIT BASIC #4** — Key parts include: CT5001 chip, 4-3 digit readouts, factory etched PC board, case, curving case, 2-resistor networks, decimal switch, Wild Rover Keyboard with ON-OFF switch diagrams. Sale \$24.95

**12" DIGIT BASIC "MEMORY" KIT #5** — Key parts for 4-memory calculator. On with "slight touch" board, CT5005 memory chip, 6 MAZ 3's, ON-OFF switch, book, (\*extend key allows 12 digits), pc boards. \$19.95

**POLY PAKS BLUE RIBBON Policy**

20-Years of Business INTEGRITY

20-Years of Money-Back GUARANTEES

20-Years of Economy! LOWEST PRICES!

### 48-HR. SERVICE



## First Time! BUY ANY 10 IC'S TAKE 15% BUY 100 TAKE 25%

# Inflation-Fighting ECONOMY IC PRICES

Type	Sale	Order by type number! Spec sheets on request "ONLY"	Factory Marked
SN7400	\$1.19	SN7430	.24
SN7401	.19	SN7432	.28
SN7402	.24	SN7437	.28
SN7403	.19	SN7438	.49
SN7404	.27	SN7440	.19
SN7405	.24	SN7441	1.00
SN7406	.79	SN7442	1.00
SN7407	.48	SN7443	1.00
SN7408	.27	SN7444	1.00
SN7409	.27	SN7445	1.00
SN7410	.19	SN7446	1.10
SN7411	.31	SN7447	1.10
SN7412	.55	SN7448	1.45
SN7413	.89	SN7449	.27
SN7414	2.25	SN7451	.28
SN7415	.45	SN7453	.28
SN7416	.45	SN7454	.39
SN7417	.50	SN7455	.28
SN7420	.22	SN7460	.26
SN7422	.29	SN7461	.26
SN7423	.32	SN7462	.39
SN7425	.35	SN7464	.39
SN7426	.31	SN7465	.39
SN7427	.35	SN7470	.49
		SN7471	.55
		SN7472	.42
		SN7473	.52
		SN7474	.39
		SN7475	.91
		SN7476	.52
		SN7477	.79
		SN7480	.59
		SN7481	1.25
		SN7482	1.00
		SN7483	1.19
		SN7485	2.50
		SN7486	.49
		SN7490	2.95
		SN7491	1.35
		SN7492	.99
		SN7493	.99
		SN7495	1.05
		SN7496	.99
		SN74100	1.55
		SN74104	1.25
		SN74105	.95
		SN74106	.95
		SN74107	.49
		SN74108	.95
		SN74112	.95
		SN74113	.95
		SN74114	.95
		SN74122	.55
		SN74123	1.09
		SN74125	.65
		SN74139	1.25
		SN74140	2.50
		SN74141	1.19
		SN74145	1.19
		SN74150	1.19
		SN74151	.99
		SN74153	1.39
		SN74154	1.69
		SN74155	1.29
		SN74156	1.29
		SN74157	1.45
		SN74158	1.45
		SN74160	1.85
		SN74161	1.59
		SN74163	1.75
		SN74164	2.85
		SN74165	2.85
		SN74166	1.85
		SN74173	1.85
		SN74174	2.25
		SN74175	1.99
		SN74176	1.25
		SN74177	1.25
		SN74180	1.10
		SN74181	3.95
		SN74182	1.05
		SN74185	2.34
		SN74187	2.34
		SN74192	1.59
		SN74193	1.59
		SN74194	1.89
		SN74195	1.10
		SN74196	1.20
		SN74197	1.10
		SN74198	1.10
		SN74199	2.45
		SN74200	7.50

### JUMBO 0.6" MITY DIGIT DCM \$9.99

NEVER BEFORE OFFERED! Digital counting module kit using the big "M" Monsanto MAN-6 "ALL LED" readout. Same electrical specs as the MAN-1. Measures 1 x 1/8 x 1/8" encapsulated in red epoxy lens. Outperforms all reflective bar types. MORE BRILLIANT! Made for distance and wide-angle viewing. Fits into standard 14 pin DIP socket. Kit includes MAN-6, right angle IC socket, edge connector, pc board, assorted resistors and capacitors. SN7475, SN7447, SN7490. Molex sockets and booklet.

Same as above except uses MAN-64, 0.4 ALL LED readout. MAN-1 characteristics... Only \$8.88

### SCRS! TRIACS! QUADRACS!

PRV	Sale
50	\$ .75
100	.95
200	1.25
300	1.50
400	1.98
500	2.25
600	2.50

### LINEAR Op Amps

BRAND NEW LOWEST PRICES (A) TO-6 or DIP	FACTORY GUARANTEED	FACTORY TESTED	FACTORY MARKED
531 Hi slow rate op-amp (TO-5)			\$2.50
532 Micro power 741 (TO-5)			2.50
533 Micro power 709 (TO-5)			2.50
536 FET input op amp (TO-5)			2.95
555 Timer 2 u Seconds to 1-hr. (A)			1.25
556 5 Times faster than 741C			2.10
558 Dual 741 (DIP)			1.00
560 Phase lock loops (DIP)			2.95
561 Phase lock loops (DIP)			2.95
562 Phase lock loops (DIP)			2.95
565 Phase lock loops (A)			2.95
566 Function generator (TO-5)			2.95
567 Tone decoder (A)			2.95
702C Hi-grain. DC amp (TO-5)			.49
704 TV sound inf system			1.50
711C Dual DM. comp (A)			.33
723C Voltage regulator (A)			.69
741C Freq. comp 705 (Mini DIP)			.44
748C Freq. adj. 741C (A)			.44
753 Gain Block			1.75
739-739 Dual stereo preamp			1.98
741-741 Dual 741C (TO-5)			.89
UL2300 Op amp with SCR			1.00
CA3065 Vid. Audio system			1.00
RC4195 Dual 15V Tracking V.R.			2.50
4136 Quad 741's (DIP)			2.50
RC-2586 Dual 555's			2.25
TVR-2000 Super 723, TO-5			1.00

### NATIONAL LINEAR OP AMPS

(A) TO-5, Dip, or Mini Dip	PRICE
LM-300 POS V.R. (super 723) TO-5	\$.81
LM-301 Hi-performance op amp (A)	.39
LM-302 Voltage follower TO-5	.81
LM-304 Neg. Volt. Reg. TO-5	1.15
LM-305 Pos. Voltage Reg. TO-5	.95
LM-307 Super 741 op amp (A)	.39
LM-308 HI-Q fet type op amp TO-5	1.09
LM-309H 5V Volt-Regulator TO-5	1.05
LM-309K 5V Volt-Reg. 1 Amp TO-3	1.65
LM-310 Voltage Follower TO-5	1.25
LM-311 Hi-perf. Volt. Comp. (A)	1.09
LM-318 Prec. Hi-Speed DIP	1.95
LM-319 Hi-speed dual Comp. DIP	1.50
LM-320 MINUS S, 12 or 24V V.R. TO-3	1.50
LM-321 Prec. Timer	1.75
LM-324 Quad (4-741's in DIP)	2.29
LM-339 Quad Comparator, DIP	1.75
LM-340 Pos. V.R. TO-3-1-Amp 5, 6, 12, 15, 18, 24V	2.95
LM341T SV, 6V, 8V, 12V, 15V, 24V	1.75
LM-350 Dual Peripheral Driver DIP	.69
LM-370 AQC Squeal op amp. TO-5	1.50
LM-371 *F, I-F, op amp	1.25
LM-373 AM-FM 558 I.A.D. TO-5	3.50
LM-374 AM-FM 558 I.V.A.D. TO-5	3.50
LM-376 Pos. V. Reg.	.65
LM-377 Dual 2-watt audio amp	2.69
LM-380 600mw LM-380, mini DIP	1.69
LM-381 Low noise dual pre amp DIP	1.69
LM-382 Low noise dual pre amp DIP	1.89
LM-383 RF-IF amp, TO-5	.59
LM-703M RF-IF op. amp, mini DIP	.51
LM-709 Operational amplifier (A)	.36
LM-710 Differential amplifier (A)	.45
LM-711 Dual Differential Amp (A)	.36
LM-712 Voltage Regulator (A)	.39
LM-725 Instrument Op Amp	.69
LM-733 Differential Video	1.75
LM-741 Freq. Comp. 709 (A)	.41
LM-741C Mini DIP 741C	.41
LM-742 Dual 741 (A)	.41
LM-748 Freq. adjustable 741C (A)	.41
LM-1303 Stereo pre amp DIP	.91
LM-1304 FM Stereo Multiplexer	1.25
LM-1307 FM Multi. Stereo dem. DIP	.91
LM1800 Phase L. Loop w/FM demodul	3.50
LM-1458 Dual 741's mini DIPs, TO-5	.63
LM-1496 Modulator, Demodulator	1.00
LM-3028 Differential M/r/amp	1.50
LM-3900 Quad "current mirror" amp	.95
LM-4250C Programmable op amp	2.50
LM-4951 Dual peripheral driver	1.75
LM-75453 Dual peripheral driver	.44
LM-75491 Quad seg. driver, LED (DIP)	1.45
LM-75492 Hex digit driver, 250ma, DIP	1.55

### 35 WATT AUDIO AMPLIFIER BASIC \$3.98

For Class AB use. Basic includes: Signetic 540 30 transistor high power driver TO-5 "IC", with a pair of complementary 35-watt plastic transistors, i.e. 2N5296 npn and 2N6109 pnp. With schematics, printed circuit and parts board layouts.

### LOWEST PRICES ON NATIONAL CALCULATOR CHIPS

CT5002	9-Volt version of 5001	7.77	3 for \$21
CT5005	12-Digits, 28-Pin	8.88	3 for \$24.
MMS725	8-Digits, 4-Function, LED	4.95	3 for \$12.
MMS736	6-Digits, 28-Pin, 9V	4.95	3 for \$12.

### NEW! NATIONAL LM-340T VR's

Type	Volts	Price
LM-340-05T	5V	\$1.75 each
LM-340-06T	6V	
LM-340-08T	8V	
LM-340-12T	12V	
LM-340-15T	15V	
LM-340-18T	18V	
LM-340-24T	24V	

Buy Any 3 Take 10% Positive Voltage

### INTEGRATED CIRCUIT SOCKETS

14-Pin, DIP	\$4.45
14-Pin, Side Mount	1.00
16-Pin, DIP	1.00
TO-5, 8 or 10-Pins	.29
8-Pins (Mini DIP)	.39
14-Pin, Wire Wrap	.69c
16-Pin, Wire Wrap	.89c

Terms: add postage. Rated: net 30. Phone Orders: Wakefield, Mass. (617) 245-3829. Retail: 16-18 Del Carmine St., Wakefield, Mass. (off Water Street) C.O.D.'S MAY BE PHONED.

20c CATALOG on Fiber Optics, 'IC's, Semi's. Parts MINIMUM ORDER — \$4.00

## POLY PAKS

P.O. BOX 942E LYNNFIELD, MASS. 01940

CLASSIFIED ADVERTISING ORDER FORM

1	2	3	4	5
6	7	8	9	10
11	12	13	14	15
16	17	18	19	20
21	22	23	24	25
26	27	28	29	30
31	32	33	34	35

\_\_\_\_\_ Words @ \$ 1.00 (Reader Rate)  
 @ \$ 1.60 (Commercial Rate) \$ \_\_\_\_\_  
 Insert \_\_\_\_\_ time(s) Total Enclosed \$ \_\_\_\_\_

NAME \_\_\_\_\_  
 ADDRESS \_\_\_\_\_  
 CITY \_\_\_\_\_ STATE \_\_\_\_\_ ZIP \_\_\_\_\_

Signature \_\_\_\_\_

**WORD COUNT:** Include name and address. Name of city (Des Moines) or of state (New York) counts as one word each. Zip Code numbers not counted. (Publisher reserves right to omit Zip Code if space does not permit.) Count each abbreviation, initial, single figure or group of figures or letters as a word. Symbols such as 35mm, CDD, PD, AC, etc., count as one word. Hyphenated words count as two words. PE-1274

**INSTRUCTION**

LEARN ELECTRONIC ORGAN SERVICING at home all makes including transistor. Experimental kit—trouble-shooting. Accredited NHSC, Free Booklet. NILES BRYANT SCHOOL, 3631 Stockton, Dept. A, Sacramento, Calif. 95820.

LEARN WHILE ASLEEP. Hypnotize! Strange catalog free. Auto-suggestion, Box 24-ZD, Olympia, Washington 98501.

DEGREE IN ELECTRONICS through correspondence. Free catalog. Grantham, 2000 Stoner Avenue, Los Angeles, California 90025.

INTENSIVE 5 week course for Broadcast Engineers. F.C.C. First Class license. Radio Engineering Incorporated, 61 N. Pineapple Ave., Sarasota, Florida 33577.

FCC LICENSE through tape recorded lessons. Also Radar Endorsement. Radio License Training, 1060D Duncan, Manhattan Beach, Calif. 90266.

LOGIC MICRO/MINI-COMPUTER NEWS

**LOGIC NEWSLETTER** ©

SAMPLE COPY \$1.00  
 LOGIC NEWSLETTER  
 POB 252  
 WALDWICK, N. J. 0746 J

SCORE high on F.C.C. Exams. Over 300 questions and answers. Covers 3rd, 2nd, 1st and even Radar. Third and Second Test, \$14.50; First Class Test, \$15.00. All tests, \$26.50. R.E.I., Inc., Box 806, Sarasota, Fla. 33577.

SHORTCUTS To Success! Highly Effective, Profitable Short Courses (75 Choices). Study At Home. Diploma Awarded. Our 29th Year. Free Literature. CIEE-D. Box 20345, Jackson, Miss. 39209.

**F.C.C. EXAM MANUAL**

PASS FCC EXAMS! Memorize, study—"Test Answers" for FCC 1st and 2nd class Radio-Telephone licenses. Newly revised multiple-choice questions and diagrams cover all areas tested in FCC exams plus "Self-Study Ability Test." \$9.95 postpaid. Moneyback Guarantee.

TESTS ANSWERS FOR FCC First and Second Class Commercial License

COMMAND PRODUCTIONS P.O. BOX 26348-P  
 5411 EXETER BLVD. SAN FRANCISCO, CALIF. 94126

DEGREE Program in Electronics Engineering. Our 29th Year! Free literature. Cook's Institute, Dept. 13, Box 20345, Jackson, Miss. 39209.

LEARN ELECTRONICS at home. FCC license. Communications Electronics, Satellite Communications. Free Catalog. Genn Tech, 5540 Hollywood Blvd., Los Angeles, CA 90028.

FREE SUBSCRIPTION! Newsletter reviews worldwide electronics book releases. Technical Documentation, Box 340E, Centreville, VA 22020.

FCC FIRSTPHONE—4 Tests, Formulas, Aids. Guaranteed! \$10. Engineer, DWR 570, Mars, PA 16046.

WRITE BETTER PROPOSALS, reports, letters. Take "Basic Clear Writing for Technical People" correspondence course. Information Free. Communications Workshop, Suite 21, 7318 Lugary, Houston, Texas 77036.

**MAGAZINES**

**CRAFT AUDIO**

isn't a lost art. Readers of the Audio Amateur magazine are customizing and scratch building their equipment with gusto and great results. Free prospectus tells all. Box 30P, Swarthmore PA 19081

**EMPLOYMENT OPPORTUNITIES**

ELECTRONICS/AVIONICS EMPLOYMENT OPPORTUNITIES. Report on jobs now open. Details FREE. Aviation Employment Information Service, Box 240, Northport, New York 11768.

7400 \$ .18	<b>TTL</b>	74182	1.00
7401 .23		74184	2.30
7402 .23	7475 .90	74185	2.30
7403 .23	7476 .47	74187	7.00
7404 .25	7480 .50	74190	1.50
7405 .24	7482 1.75	74191	1.50
7406 .50	7483 1.15	74192	1.50
7407 .50	7485 1.10	74193	1.50
7408 .25	7486 .47	74194	1.50
7409 .25	7488 4.00	74195	1.05
7410 .23	7489 3.00	74196	1.25
7411 .30	7490 .89	74197	1.05
7412 .40	7491 1.15	74198	2.25
7413 .89	7492 .95	74199	2.75
7416 .45	7493 .95	74200	7.00
7417 .45	7494 .97		
7418 .25	7495 .95	<b>CMOS</b>	
7420 .23	7496 .95	CD4001	\$ .55
7421 .27	74100 1.50	CD4002	.55
7423 .32	74107 .47	CD4007	1.25
7425 .27	74121 .55	CD4009	1.40
7426 .31	74122 .47	CD4010	.60
7427 .32	74123 1.05	CD4011	.55
7429 .40	74125 .60	CD4012	.55
7430 .33	74126 .80	CD4013	1.50
7432 .26	74141 1.15	CD4016	1.40
7437 .45	74145 1.15	CD4017	2.75
7438 .50	74150 .95	CD4019	1.25
7439 .50	74151 1.20	CD4020	1.50
7440 .23	74153 1.50	CD4023	.55
7441 1.10	74154 1.25	CD4025	.55
7442 1.05	74155 1.30	CD4027	1.25
7443 1.10	74156 1.30	CD4030	.60
7444 1.15	74157 1.55	MC3022	2.00
7445 1.10	74160 1.65	74C00	.45
7446 1.25	74161 1.65	74C04	.70
7447 1.25	74163 2.50	74C20	.65
7448 1.25	74164 2.50	74C173	2.60
7450 .25	74165 2.50		
7451 .27	74166 1.75		
7453 .27	74170 3.00		
7454 .40	74173 1.75		
7459 .25	74174 1.85		
7460 .25	74175 1.85		
7470 .45	74176 .85		
7472 .41	74177 .85		
7473 .47	74180 1.05		
7474 .47	74181 3.75		

20% Discount for 100 Pieces Combined 7400

**Christmas SPECIALS**



**Digital LCD Watch**  
 Liquid Crystal Display  
 Constant on-Shock Proof  
 uses Field effect display  
 Accuracy to 1 Minute-a-Year.

**5 Year Warranty \$149.95ea**  
**Unassembled Kit 99.95ea**  
 California Res. Add 6% Tax

**CALCULATORS**  
 5m8-4 Function 9V \$29.95 ea  
 6 Month Warr. Red Led ea  
 SL8M-4 Function Memory \$53.00 ea  
 -Add on Disc.-Tilt Lens ea  
 5m-20-5 Function Memory \$39.95 ea  
 Constant-9V-1 Yr.W.

**TIME-Temp Display**  
 6 digit LED Display  
 Liquid Crystal Temp. Display  
 115 Volt-1 Yr. Warr. \$39.95  
 -Kit from \$29.95

**IC sockets**  
 8 pin DIL .22  
 14 pin DIL .26  
 16 pin DIL .29  
 24 pin DIL .75  
 28 pin DIL 1.10  
 36 pin DIL 1.70  
 40 pin DIL 1.90

**Shift Registers**  
 LM500H-dual 25 bit DSR \$2.00  
 LM503H-dual 50 bit DSR 2.00  
 LM504H-dual 16 bit SSR 4.00  
 LM506H-dual 100 bit DSR 2.00  
 LM507H-dual 100 bit DSR 2.00  
 LM5016H - 512 bit DSR 2.00  
 MM5230-2048 bit R.O. Mem 5.00

Satisfaction Guaranteed. All Items 100% Tested  
 \$5.00 Min. Order - 1st Class Mail - No Charge  
 California Residents - Add 6% Sales Tax  
 Wholesale Outlets - Write for Special Discounts  
 Write for FREE Catalog - Data Sheets .20¢ each

**JAMES**  
 P.O. Box 822, Belmont, CA 94002  
 PHONE ORDERS (415) 592-8097  
 CIRCLE NO. 26 ON READER SERVICE CARD

LM300	<b>LINEAR</b>	\$ .85
LM301H/N		3/1.00
LM302H	Voltage Follower	.85
LM304H	Negative Volt Reg	1.10
LM305H	Positive Volt Reg	1.00
LM307H/N	Op Amp (Super 741)	.40
LM308H/N	Micro Power Op Amp	1.15
LM309K	5 Volt Regulator/Amp	1.25
LM310H	Improved Volt Follower	1.35
LM311H/N	Hi-perform Volt.Comp.	1.15
LM318N	Hi-Speed Op Amp	2.00
LM320K	To 3 Neg. Regulator	1.75
LM324N	Quad 741 Op Amp	1.90
LM339	Quad Comparator	2.35
LM340K	Positive Volt Regulator	2.00
LM370N	A 6 C - Squelch Amp	1.55
LM373N	AM/FM \$ B Strip	3.30
LM380N	2 Watt Audio Power Amp	1.25
LM555N	Timer	.75
LM565-LM566-LM567	Phase L.L.	2.50ea
LM703H	RF/IF Amp	.45
LM709H/N	Op Amp	.29
LM723H/N	Voltage Regulator	.55
LM741H/N	Comp. Op Amp	3/1.00
LM747H/N	Dual Compen. Op Amp	.90
LM748N	Freq. Adj. 741	.40
LM1310P	Stereo Demodulator	4.10
LM1458N	Dual Comp. Op Amp	.65
LM1556N	5 Times Faster 741	1.85
LM2307P	Current Controlled 05 Cil.	3.15
LM3065N	T.V.-FM Sound System	.75
LM3900N	Quad Amp	.65
LM3905N	Precision Timer	.65
LM7522	Core Memory Sense Amp.	2.50
LM7524	Core Memory Sense Amp.	1.50
LM7535	Core Memory Sense Amp.	1.00
LM75451	Dual Peripheral Driver	.49
LM75452	Dual Peripheral Driver	.49
LM75453	Dual (LM351)	.65

PROJECTS	LEDS	8000 Series
8263 \$ 7.00	MV 10 5/1	8091-9 .55
8267 4.00	MV 50 6/1	8223 5.00
2513 12.00	MV 5024 5/1	8280 .75
2518 7.00	MAN-1 1.95	8288 1.15
2424 6.00	MAN-3 .95	8880 1.35
2425 7.00	MAN-4 1.95	Many Other
4024 2.25	MAN-7 1.50	8000 Series
	DL 33 1.95	
	Variable Power Supply	
	5 to 25 V	1 Amp \$19.95 per Kit



DECEMBER 1974

## ADVERTISERS INDEX

READER SERVICE NO.	ADVERTISER	PAGE NUMBER
1	Adva Electronics	114
	Allied Electronics	91
	Alpha Electronics	93
2	Altaj Electronics	116
	Ancrona Corp.	109
3	Ascom Electronic Products	95
4	Audio Warehouse Sales	24
5	Babylon Electronics	119
	Bell & Howell Schools	18, 19, 20, 21
	CREI Capitol Radio Engineering Institute	64, 65, 66, 67
6	Circuit Design, Inc.	91
7	Cleveland Institute of Electronics Inc.	28, 29, 30, 31
8	Clifford's Hi-Fi Wholesalers	6
9	Cobra Division Dynascan Corporation	23
10	Continental Specialties Corp.	27
11	Datak Corp., The	95
12	Delta Electronics Co.	110
13	Delta Products, Inc.	7
14	Digi-Key Corporation	110
15	Discwasher, Inc.	77
16	EICO	12
17	Edmund Scientific Co.	113
18	Edmund Scientific Co.	120
19	Edsyn, Inc.	13
20	Extended Digital Concepts	6
	GC Electronics	104
22	GTE Sylvania	100, 101, 102, 103
23	Great American Sound Company, Inc., The	97
24	Heath Company	80, 81, 82, 83, 84, 85, 86, 87
25	Illinois Audio	68
26	International Electronics Unlimited	108
27	James Electronics	118
28	Koss Corporation	FOURTH COVER
29	Lafayette Radio Electronics	16
30	Lafayette Radio Electronics	93
31	McIntosh Laboratory Inc.	105
32	MITS Inc.	17
	NRI Schools	8, 9, 10, 11
	National Technical Schools	46, 47, 48, 49
33	Olson Electronics	25
34	Pan-View Communications	97
35	PanaView	99
36	Pickering & Co., Inc.	THIRD COVER
37	Poly Paks	117
38	Radio Shack	5
39	Schober Organ Corp., The	25
40	Shure Brothers Inc.	2
41	Solid State Sales	115
42	Southwest Technical Products Corporation	32
43	TEAC Corporation of America	14, 15
44	Tri-Star Corp.	89
45	U.S. Pioneer Electronics Corp.	SECOND COVER, 1
46	V-J Products, Inc.	24

DECEMBER 1974

check nos 11, 44  
Reorder when available

## HOME ENTERTAINMENT FILMS

COLOR ACTION SPORTS AND TRAVEL FILMS MAKE GREAT GIFTS! Available in Super & Standard 8, silent or sound. Treat yourself or a friend to film enjoyment. Only \$16.95 each in color, silent, 200' reels + 50 cents mailing or \$7.95 + 50 cents each B&W. CHRISTMAS SPECIAL: Wonderful Israel—The Holy Land (while they last). \$15.95 in Super 8, color, silent—you save \$2.05. NHL '71 & '72 Stanley Cup & Seasonal Highlights, Standard or Super 8 (send first choice & alternate), \$7.45 each B&W—you save \$1.00. Revised Sportlite, Castle & Columbia catalogs available. 25 cents each (coins or stamps, please). SPORTLITE, ELECT-12 Dept., 20 North Wacker, Chicago, Illinois 60606.

## RUBBER STAMPS

RUBBER address stamps. Free catalog, 45 type styles. Jackson's, Box 443G, Franklin Park, Ill. 60131.

MADE-TO-ORDER STAMPS. Low Prices. Free Catalog. Allegheny, Box 14A, East McKeesport, PA 15035.

## BOOKS

FREE catalog aviation/electronic/space books. Aero Publishers, 329PE Aviation Road, Fallbrook, California 92028.

FREE book prophet Elijah coming before Christ. Wonderful bible evidence. Megiddo Mission, Dept. 64, 481 Thurston Rd., Rochester, N.Y. 14619.

BOOKS—thousands titles, bargains. Catalog Free. Cassiano, 92-27 New York Blvd., Jamaica, New York 11433.

POPULAR ELECTRONICS INDEXES. Detailed and complete subject indexes now available to both 1972 and 1973 magazines. Hundreds of subject references to help you quickly find that special project, article, or product test. 1972 and 1973 editions \$1.00 each. INDEX, box 2228, Falls Church, Va. 22042.

INSTRUCTION MANUALS—Thousands available for test equipment, military electronics. Send \$1.00 (Refundable first order) for listing. A service of Tucker Electronics, Box 1050, Garland, Texas 75040.

## REAL ESTATE

NEW FREE SPRING CATALOG! Over 2,500 top values in FARMS, RANCHES, ACREAGES, RECREATIONAL PROPERTIES, BUSINESSES, TOWN and COUNTRY HOMES in 40 states coast to coast! Over 3,800 PHOTOS! UNITED FARM AGENCY, 612-EP West 47th St., Kansas City, MO 64112.

## RECORDS

OLDIES. 45rpm. Free Catalog. Corny's Record Shop, Box 335TZ, Mason, Ohio 45040.

REMEMBER RADIO? Relive those bygone years with recordings of actual broadcasts from the "Golden Age of Radio." Complete programs from the 1930's and '40's. ANY show you can remember—the comedies, dramas, whodunnits, soap operas, big band remotes, and those great kid shows you used to listen to. THOUSANDS of different titles are available including YOUR old favorite. For a FREE CATALOGUE AND A FREE LP DEMONSTRATION RECORD that will bring back many memories, write to: RADIO YESTERYEAR, BOX H-88, CROTON-ON-HUDSON, N. Y. 10520.

## REPAIRS AND SERVICES

ELECTRONIC PROTOTYPE Models Built. Wire-Wrap. Hand solder. P.C. Boards. Engineering consultation and drafting service available. ACE Technical Services, 23-13 Steinway St., Astoria, N.Y. 11105. Phone: (212) 728-8284.

## HYPNOTISM

SLEEP learning. Hypnotic method. 92% effective. Details free. ASR Foundation, Box 23429EG, Fort Lauderdale, Florida 33307.

FREE Hypnotism. Self-Hypnosis. Sleep Learning Catalog! Drawer H400, Ruidoso, New Mexico 88345.

AMAZING self-hypnosis record releases fantastic mental power. Instant results! Free trial. Write: Forum (AA12), 333 North Michigan, Chicago 60601.

## IC SOCKETS PBC Mounting

8 pin--\$ .25  
14 " " .26  
16 " " .30  
24 pin--\$ .75  
40 " " \$1.25

## POTTER & BRUMFIELD



Type KHP Relay 4 PDT 3A Contacts  
24 VDC (650 coil) ea. \$1.50 10/\$14.00  
120 VAC (10.5 MA coil) ea. \$1.75 10/\$15.75

## CARBON RESISTORS

Carbon Resistors 1/4-Watt 5%-full prime, all values in stock. 10 per value (minimum quantity). ten for \$4.5

## FAIRCHILD "TRIMPOTS"

ea. only \$.89 10 for \$7.50  
Brand new 20 turn precision trimmers. These are prime parts mostly individually packed in sealed envelopes. These values in stock:  
50 OHM 1 K 5 K 25 K  
500 OHM 2 K 10 K

## DIODE ARRAY



10 1N914 Silicon Signal Diodes in one package. 20 leads spaced .1"; no common connections. ea. \$.25 10 for \$2.25

## 8270 DIP 4-BIT SHIFT REGISTER

4-Bit Shift Register---parallel and serial input and output; data entry is synchronized with clock pulse.  
ea. \$.50 10 for \$3.95

## 2N3055 NPN TRANSISTOR

2N3055 Transistor (power): PD-115W, VCE-60V, HFE-50, FT-30K; Case-TO-3  
ea. \$1.15 10 for \$6.95

## HEWLETT PACKARD 7-SEGMENT READOUT



7 Segment, Man-1, Pin Compatible, Super-Bright .33" W/LH decimal.  
ea. \$1.75 10 for \$16.00

## 7400 DIP TTL SPECIAL

7400 DIP TTL Special Signetic/House Numbered. ea. \$.17 10 for \$1.50

## 7404 DIP TTL

7404 DIP TTL Special Hex Inverter, Signetic/House Numbered.  
ea. \$.17 10 for \$1.50

## SEND FOR FREE FLYER!

C.O.D. PHONE ORDERS ACCEPTED--\$10 MINIMUM

All parts surplus and tested; leads plated with gold or solder. Orders for \$5 or more are shipped prepaid; smaller orders add 55¢. California residents add Sales Tax. ICs shipped within 24 hours.

## BABYLON ELECTRONICS

P. O. Box 41727  
Sacramento, Ca. 95841  
(916) 334-2161

CIRCLE NO. 6 ON READER SERVICE CARD

## DO-IT-YOURSELF

MOST TV problems are simple to repair. We'll show you how. \$1. William Morgan, Bruce, Miss. 38915.

## PLASTICS

CASTOLITE pours like water, hardens like glass without heat. Crystal clear, colors. Embed flowers, seashells, mementos, anything. Make fine gifts. Form flexible molds over any pattern, size. Reproduce your own designs in plastics. candlewax, metal, plaster, cement. Send 50 cents for illustrated Manual and New Mold Catalog. Profitable. CASTOLITE, Dept. 74PIPE, Woodstock, Ill. 60098.

## MISCELLANEOUS

WINEMAKERS: Free illustrated catalog yeasts, equipment. Semplex, Box 12276P, Minneapolis, Minn. 55412.





*The traceAbility<sup>TM</sup> of Pickering's cartridges makes possible...*

# The best of both worlds

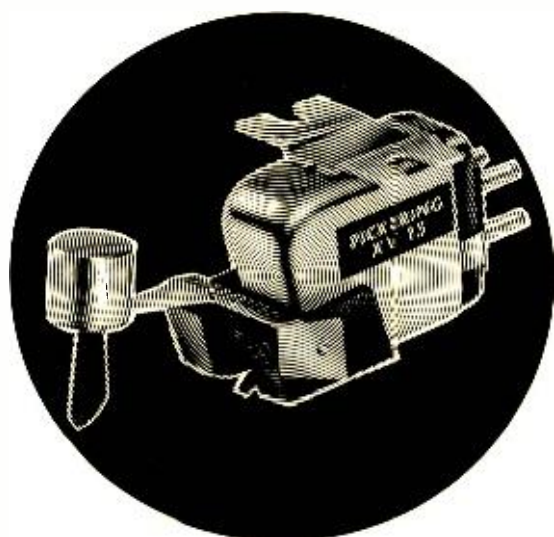

## For the World of STEREO AND MATRIX — XV-15 SERIES

At the top of the XV-15 Series of 8 fine cartridges is the 1200E, the furthest advance achievable today — and perhaps in the foreseeable future — in stereo cartridge design and performance. Its exceptional ability to pick up all the material recorded at the lightest possible tracking forces plus its tracing ability at high frequencies make it totally unique.

And all of Pickering's exhaustive testing shows that the 1200E is superior in the flatness of its frequency response and channel separation in comparison to competitive cartridges.

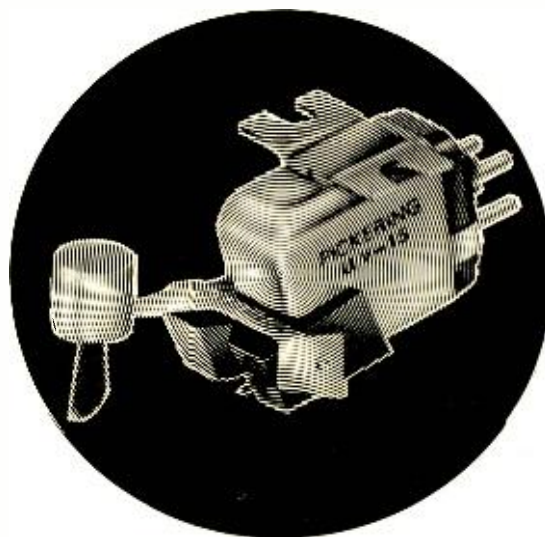

## For the World of DISCRETE 4-CHANNEL — UV-15 SERIES

The discrete 4-channel system requires completely new cartridges that could not only faithfully reproduce the 20 Hz to 20 kHz AM signals, but also the 30 kHz FM modulated signals. This requires exceptional ability to trace high frequency signals. The UV-15 Series cartridges perform in a superior manner by every test, and are capable of satisfying all technical and aesthetic requirements for playback of both discrete and stereo discs. Moreover, the stylus on UV-15 cartridges is designed to reduce record wear.

*TM — Pickering Trademark*

For further information write to Pickering & Co., Inc., Dept. PE, 101 Sunnyside Blvd., Plainview, New York 11803

*The Best of Both Worlds...*



 **PICKERING**

*"for those who can **hear** the difference"*

CIRCLE NO. 34 ON READER SERVICE CARD



# "Yes. There is a Santa Koss."

"This Christmas, instead of another paisley tie from Aunt Martha, remind her that there really is a Santa Koss. And this year, he'll be delivering a whole new phase in personal listening that's just what the 'Doctor' ordered. A new Stereophone so unique even the engineers at Koss had to call it Phase/2™.

For the first time you'll be

able to do things to your favorite music that only a recording engineer could do at the original recording session. Flip the Ambience Expander switch to the N position and rotate the world's first Panoramic Source Controls.™ You'll feel yourself moving toward the performing musicians much like a zoom lens on a camera. Now

flip the switch to the E position. What you'll hear is a breathtaking expansion of the center channel. And as you turn the Panoramic Source Controls, you'll actually move from one position to another with in the orchestra.

So this year, after Aunt Martha gets the hint, start your Christmas shopping at your

Audio Specialist. And write for our free, full-color catalog, c/o Doc 'Santa Koss' Severinsen. From \$15.95 to \$175, Christmas never sounded so good."



New Koss Phase/2 Stereophones



©Koss Corporation

 **KOSS** stereophones  
from the people who invented Stereophones.

KOSS CORPORATION, 4129 N. Port Washington Ave., Milwaukee, Wisconsin 53212 • Koss S.p.A., Milan, Italy • Koss Limited, Ontario  
CIRCLE NO. 45 ON READER SERVICE CARD