

HOW NEW FTC HI-FI RULES AFFECT YOU

Popular Electronics

WORLD'S LARGEST-SELLING ELECTRONICS MAGAZINE NOVEMBER 1974/60¢

What's New in 1975 Color TV Receivers

Build a Multimeter Range Extender

Career Opportunities for Tech Reps

A Direct-Conversion AM/SSB Project

Test Reports

Pioneer SX-636 Stereo Receiver

Pickering OA-3 Stereo Headphones

American Circuits & Systems MK1 Function Generator

Royce 1-600 CB Mobile Transceiver

Drake SPR-4 Communications Receiver



**Build Your Own
Laser TV
System**

PE
TESTED

644204 BSS 0090P091 JAN60 1 1D
6 E BOSLER
96 PEPPER AVE
ENOLA PA 17025



speed while a record is playing. Both of these sophisticated units are even equipped with a strobe light directed at the strobe marks for easy viewing. Pioneer's engineers really think of everything.



Electronic speed adjustment for each speed

Automatic features without automatic drawbacks

If you prefer to let your tonearm and turntable do all the work, consider Pioneer's all new PL-A45D. With it you can play your records without ever touching the tonearm. Unlike other single play automatics which depend upon complicated mechanical

linkages to provide the necessary tonearm cycling motion, the PL-A45D uses a separate precision gear motor just to move the tonearm in accordance with your instructions. Its other 4-pole synchronous

motor is free to drive only the 12-inch aluminum alloy die-cast platter without interruption or change of torque and speed.



Automatic operation—manual precision

Superb S-Shaped tonearms for better tracking

The tonearm of every Pioneer turntable system is the "S-shaped" design, for optimum groove tracking. All are statically balanced and all use adjustable counterweights with direct read-out of tracking force. All have adjustable anti-skate control and oil-damped cueing for the gentlest application of stylus tip to record groove. Lightweight plug-in cartridge shells insure positive electrical contact and optimum stylus position and angle for lower distortion and reduced record wear.



S-shaped tonearm for ideal tracking

The tradition of unexcelled performance

Still, all of these features and refinements alone do not guarantee the performance specifications of Pioneer's new turntables. Each tonearm and turntable platter combination is shock mounted in its specially designed natural grain cabinet (with hinged dust cover). Precision machining of all rotational parts of each unit, plus a program of continuous quality control insure that each Pioneer turntable will meet or exceed its published specifications — a time honored tradition with all Pioneer components.

Manual turntables—choice of the professionals

Engineers, experts and enthusiasts agree: to get the best performance, you need a manual turntable. And to get the best manual turntable, you need a Pioneer. Every Pioneer manual turntable offers a level of precision and performance unparalleled in its price range. And every one is a total system — complete with dust cover and base — and designed for years of professional trouble-free sound reproduction.

able that's right for you.

PL-A45D	PL-51A	PL-71
Belt	Direct	Direct
4-pole synch.	DC Servo	DC Servo
—	±2%	±2%
More than 47dB	More than 55dB	More than 60dB
0.1% (WRMS)	0.06% (WRMS)	0.05% (WRMS)
Static Bal. "S"	Static Bal. "S"	Static Bal. "S"
8 1/16"	8 1/16"	8 3/4"
12"	12 1/4"	12 1/4"
2 lbs. 3 oz.	3 lbs. 1 oz.	3 lbs. 8 oz.
\$169.95	\$249.95	\$299.95



For the best manual turntable get a Pioneer.

The manual turntable is rapidly becoming the first choice of hi-fi enthusiasts everywhere. The reason why is quite simple. Today's enthusiasts are more knowledgeable, more sophisticated and more involved with their music. And only the manual turntable can provide the involvement and performance they demand.

At Pioneer, this trend comes as no surprise. We have long recognized the superiority of the manual turntable. And long recognized a simple fact: a record changer in no way improves performance. It can detract from it.

As a result, we now offer the finest and most complete line of manual turntables available. Manual turntables that are designed with the needs of today's hi-fi enthusiast in mind. Turntables that are engineered for precision response.

When you get right down to it, good record playing equipment really has only two requirements: uniform rotation of a turntable, and accurate tracing of a record groove by a tonearm and its cartridge.

Pioneer's engineers have long recognized that these requirements are best met by single-play turntables and precision engineered tonearms. Our five new belt-drive and direct-drive turntable systems mean you needn't settle for the higher wow

and flutter and the poorer signal-to-noise ratios (rumble) of record changers. Whether you've budgeted \$100 or \$300 for this vital element of your high fidelity system, there's a Pioneer turntable that outperforms any record changer in its price class.

Consider the performance advantages

Belt-drive, featured in Pioneer's PL-10, PL-12D and PL-A45D, means smoother, more uniform platter rotation than can be achieved with typical idler-wheel/pulley arrangements normally found in record changers. Even changers equipped with synchronous motors transmit vibration to the turntable platter. This is picked up as low-frequency rumble by the tonearm and cartridge. By driving the platter with a precision-finished belt, vibration is effectively absorbed before it can be translated to audible rumble.



Belt-drive for rumble-free rotation



Direct-drive motor reduces friction

Pioneer's direct-drive models, PL-51A and PL-71 go even a step further in achieving noise-free, precision platter rotation. The DC electronically controlled servomotors used in these models rotate at exactly the required 33 $\frac{1}{3}$ or 45 rpm platter speed. Their shafts are directly connected to the center of the turntable, with no intermediate pulleys or other speed reduction devices. This means no extra friction-producing bearing surfaces.

Because of the unique technology embodied in these new, direct-drive motors, it's possible to control their speed electronically. This is more precise than any mechanical drive system. Both our PL-51A and PL-71 offer individual pitch control for both 33 $\frac{1}{3}$ and 45 rpm speeds. Their turntable platters are edge-fitted with stroboscopic marks, so you can adjust precise

Choose the Pioneer turntable

Model	PL-10	PL-12D
Drive system	Belt	Belt
Drive motor	4-pole synch.	4-pole synch.
Speed control	—	—
S/N (Rumble)	More than 47dB	More than 47dB
Wow & Flutter	0.1% (WRMS)	0.1% (WRMS)
Tonearm Type	Static Bal. "S"	Static Bal. "S"
Tonearm Length	8 $\frac{1}{2}$ "	8 $\frac{1}{2}$ "
Turntable Diameter	12"	12"
Turntable Weight	2 lbs. 3 oz.	2 lbs. 3 oz.
Price:	\$99.95	\$119.95



**For the
best performance,
get a manual
turntable.**



PIONEER
when you want something better

U.S. Pioneer Electronics Corp., 75 Oxford Drive, Moonachie, New Jersey C7074
West: 13300 S. Estrella, Los Angeles 90248/Midwest: 1500 Greenleaf, Elk Grove Village, Ill. 60007/Canada: S.H. Parker Co.

CIRCLE NO. 41 ON READERS SERVICE CARD

*traceAbility™

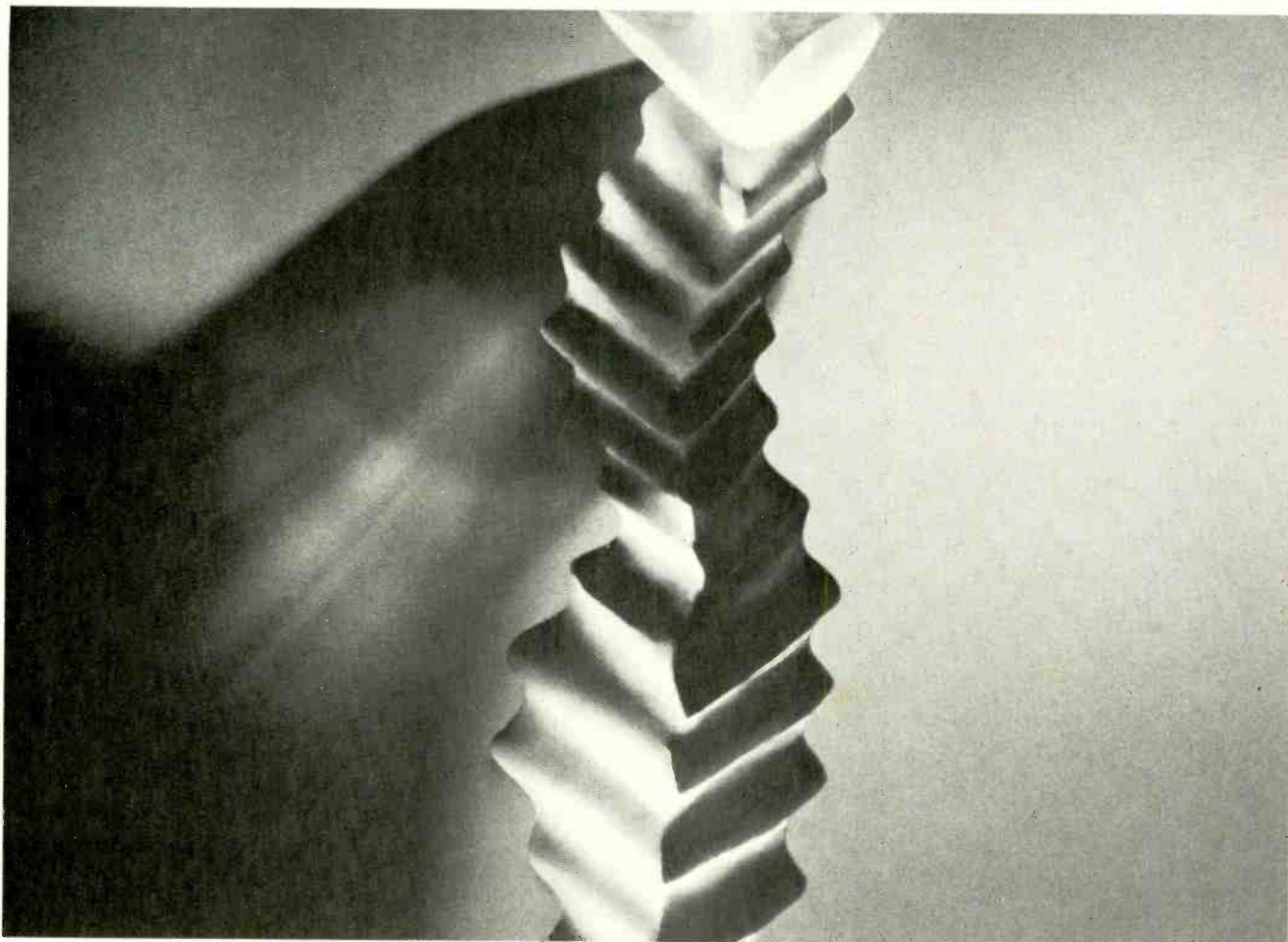

Pickering cartridges feature low frequency tracking and high frequency tracing ability*

Pickering offers you "The Best of Both Worlds" in discrete 4-channel and in stereo cartridges. These cartridges have been specifically designed and engineered to peak specification and performance characteristics. They possess traceAbility, vital for both stereo and discrete playback.

For example, take the case of discrete

playback. You are looking at a model of a discrete groove, magnified 3,000 times (figure A). You can see it is made up of complex groove undulations. This makes the demands on the cartridge and its stylus much greater than ever before. The left side of the groove possesses all of the information recorded on the left side of the room, and the right side likewise. The stereo signals for the front speakers are represented by the broad sweeps (figure B), and the special discrete high frequency tone carrier is represented by the wiggles on the same groove walls (figure C). This high frequency carrier centered at 30,000 Hz, demands a superior stylus assembly (and shape of the tip) which we call our Quadrahedral™ another Pickering exclusive which makes it possible for the stylus to trace both the stereo and discrete signals in the groove.

So, the Quadrahedral™ stylus picks up
CIRCLE NO. 30 ON READERS SERVICE CARD

all 4 signals, which the computerized demodulator sorts for the amplifier, which in turn transmits the sound to the proper speaker.

So, whether you look forward to the fabulous reality of discrete 4-channel sound in your home, or the finest stereo to satisfy your listening taste — depend on the traceAbility of Pickering cartridges to make possible "The Best of Both Worlds". . . . the world of stereo and matrix, and the world of discrete 4-channel.

For further information write to
Pickering & Co., Inc., Dept. PE
Sunnyside Blvd., Plainview, New York 11803



"for those who can hear the difference"

TM-PICKERING TRADEMARK

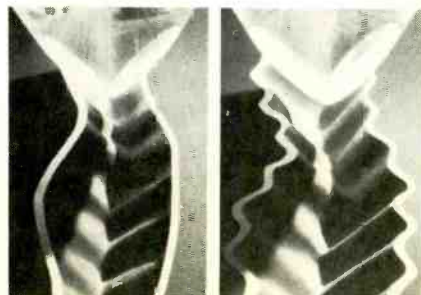

(B)

(C)

Popular Electronics

WORLD'S LARGEST-SELLING ELECTRONICS MAGAZINE

FEATURE ARTICLES

HOW THE NEW FTC HI-FI RULES AFFECT YOU!	Leonard Feldman	39
<i>The buyer must still be wary of power claims.</i>		
WHAT'S NEW IN COLOR TV RECEIVERS FOR 1975	Art Margolis	41
NEW DOLBY-ENCODED FM BROADCASTS		46
<i>How new FCC rules affect FM reception</i>		
BASIC DIGITAL LOGIC COURSE	Forrest M. Mims & H. Edward Roberts	57
<i>Part 2: Concepts and circuits</i>		
CAREER OPPORTUNITIES FOR THE TECH REP.	Allan C. Stover	69
COMPUTER TERMINALS ARE COMING	Leslie Solomon	78
<i>Time savers for the home and small business</i>		
ENGLISH LANGUAGE SHORTWAVE BROADCASTS	Roger Legge	79
<i>November to February</i>		
THE SIMPLEST TEST GEAR	John T. Frye	88
<i>Test probes can solve many service problems</i>		

CONSTRUCTION STORIES

BUILD A LASER TV SYSTEM	Giancarlo Punis & Joseph O'Donnell	32
<i>Transmit and receive BW pictures on a laser beam</i>		
BUILD A DIRECT-CONVERSION COMMUNICATION RECEIVER	Jim White	48
<i>Good performance at a fraction of the cost of a superhet</i>		
MEASURE LOW MILLIVOLTS WITH A MULTIMETER	John F. Hollabaugh	52
<i>Range expander increases sensitivity by X10 or X100</i>		
BUILD A VERSATILE DIGITAL LED THERMOMETER	Thomas R. Fox	54

COLUMNS

HOBBY SCENE	Editorial Staff	17
STEREO SCENE	Ralph Hodges	22
<i>Blazing speakers</i>		
DX LISTENING	Glenn Hauser	80
<i>"Secret" shortwave stations</i>		
CB SCENE	Len Buckwalter	88
<i>CB to the rescue</i>		
SOLID STATE	Lou Garner	90
<i>Circuits using field-effect transistors</i>		

PRODUCT TEST REPORTS

PIONEER MODEL SX-636 AM/STEREO FM RECEIVER	59
ROYCE MODEL 1-600 MOBILE CB TRANSCEIVER	60
PICKERING MODEL OA-3 STEREO HEADPHONES	61
DRAKE MODEL SPR-4 COMMUNICATIONS RECEIVER	66
AMERICAN CIRCUITS & SYSTEMS MODEL MK1 FUNCTION GENERATOR	68

DEPARTMENTS

EDITORIAL	Art Salsberg	4
<i>Run It Up The Flagpole</i>		
LETTERS		6
NEW PRODUCTS		12
NEW LITERATURE		16
NEWS HIGHLIGHTS		27

POPULAR ELECTRONICS, November 1974, Volume 6, Number 5 Published monthly at One Park Avenue, New York, NY 10016. One year subscription rate for U.S., Possessions and Canada, \$6.98; all other countries, \$8.98. Second class Postage paid at New York, NY and at additional mailing offices. Authorized as second class mail by the Post Office Department, Ottawa, Canada and for payment of postage in cash. Subscription service and Forms 3579; P.O. Box 2774, Boulder, CO 80302.

POPULAR ELECTRONICS Including ELECTRONICS WORLD. Trade Mark Registered. Indexed in the Reader's Guide to Periodical Literature.

COPYRIGHT © 1974 BY ZIFF-DAVIS PUBLISHING COMPANY. ALL RIGHTS RESERVED.

Ziff-Davis also publishes Boating, Car and Driver, Cycle, Flying, Modern Bride, Popular Photography, Skiing and Stereo Review.

Forms 3579 and all subscription correspondence should be addressed to POPULAR ELECTRONICS, Circulation Dept., P. O. Box 2774, Boulder, CO 80302. Please allow at least eight weeks for change of address. Include your old address, as well as new—enclosing, if possible, an address label from a recent issue.

Editorial contributions must be accompanied by return postage and will be handled with reasonable care; however publisher assumes no responsibility for return or safety of art work, photographs, models, or manuscripts.

EDGAR W. HOPPER
Publisher

ARTHUR P. SALSBERG
Editorial Director

LESLIE SOLOMON
Technical Editor

JOHN R. RIGGS
Managing Editor

EDWARD I. BUXBAUM
Art Director

ALEXANDER W. BURAWA
Associate Editor

JOHN McVEIGH
Assistant Editor

ANDRE DUZANT
Technical Illustrator

ELLEN S. FINKELSTEIN
Editorial Assistant

LEN BUCKWALTER
LOU GARNER
JULIAN D. HIRSCH
RALPH HODGES
WALTER G. JUNG
MILTON S. SNITZER
Contributing Editors

JOSEPH E. HALLORAN
Advertising Director

JOHN J. CORTON
Advertising Sales

LINDA BLUM
Advertising Service Manager

PEGI McENEANEY
Executive Assistant

STANLEY NEUFELD
Associate Publisher

FURMAN H. HEBB
Group VP, Electronics & Photo

ZIFF-DAVIS PUBLISHING COMPANY
Popular Electronics
Editorial and Executive Offices
One Park Avenue New York, New York 10016
212-725-3500

William Ziff, President
W. Bradford Briggs, Executive Vice President
Hershel B. Sarbin, Senior Vice President,
Secretary, and Treasurer
Phillip Sine, Senior Vice President
Phillip T. Heffernan, Vice President, Marketing
Frank Pomerantz, Vice President, Creative Services
Arthur W. Butzow, Vice President, Production
Edward D. Muhfeld, Vice President, Aviation
and Automotive Divisions
George Morrissey, Vice President
Sydney H. Rogers, Vice President
Sidney Holtz, Vice President
Lawrence Sporn, Vice President, Circulation
Edgar W. Hopper, Vice President, Electronics Div.

Midwestern Office
The Patis Group, 4761 West Touhy Ave.,
Lincolnwood, Illinois 60644, 312 679-1100
GERALD E. WOLFE, GEORGE B. MANNION

Western Office
9025 Wilshire Boulevard, Beverly Hills, CA 90211
213 273-8050; BRadshaw 2-1161
Western Advertising Manager, BUD DEAN

Japan: James Yagi
Oji Palace Aoyama; 6-25, Minami Aoyama
6 Chome, Minato-Ku, Tokyo 407-1930/6821,
582-2851



Editorial

RUN IT UP THE FLAGPOLE

As some readers know, a Notice of Proposed Rule Making by the FCC is simply the Commission's public pronouncement that it is *considering* a change in Rules and Regulations. Of course, some proposals never come to fruition, while others are severely modified before adoption, depending on comments received by interested persons and groups.

For example, the FCC created a furor almost two years ago when it invited comments on its proposal to transfer the 220-MHz amateur radio band to CB to relieve congestion. We haven't heard a word since, and suspect that hamdom's vociferous outcry against it has shelved it for a while. Now there are some startling, new proposals concerning CB, plus some action. To keep you abreast of what's going on, here are some current developments.

In the action area, CB'ers can now use omnidirectional antennas and support structures that are 60 feet above ground! (Present 20-foot restrictions on *directional* antennas remain.)

On the proposal side, the FCC proposes to allocate the 27.230-MHz to 27.540-MHz band to the Class D Citizens Radio Service as a means of relieving congestion. This would add 47 channels to the existing 23 channels if eventually adopted. Further, the Commission is toying with the idea of allowing hobby-type activities to be communicated via CB so long as it doesn't relate to use of the radiotelephone equipment . . . considering deletion or modification of rules on relaying messages by licensees . . . reducing the age requirement from 18 years to 16 years . . . using Channel 11 (27.085 MHz) as a calling channel to establish contact for communicating on another channel . . . reducing the communications silent period from five minutes to one minute (that's five on and one off) . . . and modifying the requirement of a transmitting station to use both its call sign and that of the station being contacted to the sender's call sign only, among other proposals issued.

In another recent proposal, the FCC admits its failure to eliminate extensive use of r-f power amplifiers (those illegal "linears") by Class D stations. As a consequence, the Commission wishes to prohibit sale or lease of linears in the 20- to 40-MHz band, excepting multiband equipment for use in the Amateur Radio Service and single-band amplifiers made on a single-unit basis. Until further clarification, I presume that the latter allows one to build his own linear. Under any circumstance, of course, linears cannot be used legally for Class D communications.

It's clear from the proposed major rule amendments that the Commission intends to enhance two-way short-range radio communications for individual citizens. Offhand, we like some of the proposals and have reservations on others. Nonetheless, we're pleased to learn of some positive FCC action concerning CB. Ignored, however, was a way to compel CB'ers to obtain a license and to use call signs.

Running such proposals up the flagpole provides the FCC with input from a variety of public sources. Therefore, proposals generally take considerable time to finalize, if acted upon at all. And should additional channels actually be added at some future time, you can be sure that manufacturers will be delighted to sell you an add-on adapter to expand your radio service. So go ahead and buy that CB rig, if that's what you're planning to do. It's the same suggestion offered here when Class E, now apparently dormant, was proposed. And it proved to be a sound one.

Art Salsberg



Member Audit Bureau
of Circulations



The publisher has no knowledge of any proprietary rights which will be violated by the making or using of any items disclosed in this issue.

Earn an extra \$2000 per year

Find out how you can earn an extra \$2000 or more per year restoring only a few color and black and white tubes per week. Full color brochure shows you how to make more money and satisfy more customers on almost every call. **Write today!**



New



467 CRT
Restorer/Analyzer
\$279*

With the profit restorer!

Profit in the home. After replacing a component you've often noticed a less than perfect picture. It's almost always due to a weak picture tube. The few minutes you spend with the 467 Restorer will give your customer brilliance and sharpness that will make her pleased to pay for the improved picture.

Profit in the shop. "Sixty-five dollars and the picture still doesn't look as good as it used to!" How many times have your customers said that to you? You need not hear it again! Use the 467 Restorer on every major job and your customer will thank you for returning his set working like new.

Most-Powerful Rejuvenation, but most gentle too. There's only one CRT Restorer that restores the picture to like new and analyzes tube condition so accurately that you can safely guarantee restoration for up to five years. You get extra safety from our automatic restoration method that prevents cathode stripping.

TriDynamic true test. The B & K TriDynamic method tests all three guns simultaneously. It measures true beam current that passes through G1 aperture, unlike other testers that measure meaningless cathode to G1 current. Leakage indication even includes cathode-to-cathode and there's an exclusive B & K focus continuity test.

Simplest operation. Exclusive integrated circuitry lets you test all picture tubes with the same, defined-on-the-front-panel procedure . . . including "in-line", Trinitron and tubes with common G1 and G2. See your distributor or write Dynascan.

*Six sockets included; optional sockets also shown.

B & K PRODUCTS OF
DYNASCAN
1801 W. Belle Plaine Ave.
Chicago, IL 60613 • (312) 327-7270



SUPER CB TALK POWER!

What gives Johnson CB two-way radios their "extra sock" for longer range? Built-in Electronic Speech Compression, that's what! It's the kind of engineering you expect from U.S.-made Johnson radios . . . backed by a full 1-year parts and labor warranty with over 700 service centers nationwide.

PRICES START AT UNDER \$100!
SEND COUPON FOR FREE CATALOG!



E. F. Johnson Co.

Dept. PE Waseca, Minn. 56093

Name _____

Address _____

City _____ State _____ Zip _____

In Canada: A. C. Simmonds & Sons, Ltd.

CIRCLE NO. 33 ON READERS SERVICE CARD

**EVERYTHING YOU
WANTED TO KNOW
ABOUT CD IGNITION
SYSTEMS BUT DIDN'T
KNOW WHOM TO ASK.**

Send for FREE Tiger booklet (20 pages) which answers all your questions.

Name _____

Address _____

City _____

State _____ Zip _____

CLIP OUT THIS AD AND SEND TO—

TRI-STAR CORP.

P. O. Box 1727 Dept. E

Grand Junction, Colo. 81501

CIRCLE NO. 39 ON READERS SERVICE CARD



Letters

IT TAKES TECHNICAL KNOW-HOW

The implication in "How to Set Up a Home TV Service Shop" (August 1974) that anyone with a small amount of electronics knowledge and an investment in the neighborhood of \$50 can start his own business in color TV servicing is ridiculous. Although I am not aware of author Margolis' competence or history in color TV servicing, I challenge his statement that only a small percentage of TV troubles require great skill and expensive test equipment. On the contrary, it has been my experience and the experience of my associates with whom I have discussed this article that a correct statement of fact would be that only a small percentage of TV troubles are simple and easy to repair.

EWELL A. FERGUSON, JR., CET, Executive Director
North Carolina Electronic Technicians Assoc. Inc.

The article did not focus on color TV servicing only - nor even solid-state receivers only. We know service technicians who have started with as little as \$50, though they continually added to their parts inventory and test equipment. The article was directed to readers who have a good technical knowledge of TV receiver circuits, are presently employed in another area of electronics, and who yearn for their own business. (We apologize if our reader target was not clear.) For these skilled people, most TV troubles are easy to isolate and correct. For untrained persons, this is, of course, untrue.

LEGALITY OF CB "PHONE PATCHES"

The Commission's (FCC) Rules contain no prohibition against the manual interconnection of a Citizens Class D radio station to commercial telephone facilities under conditions whereby a properly authorized operator is available to monitor and control the operation of the Citizens Radio station. Particular attention should be given to the provisions of Paragraph (d) of Section 95.119 which prohibits remote control of a Class D station and Section 95.87 (a) which requires a licensee to maintain control at all times over the transmitters operated under his license. "Phone patch" devices which permit telephone calls to automatically actuate a Class D station are in violation of both stated sections. Messages from a commercial telephone can be fed directly into a Citizens Class D transmitter through a phone patch only if an authorized operator had direct manual control of the transmitter.

Attention should also be given to Section 95.83(a)(14) of the FCC Rules which states in essence that a Citizens radio station shall not be used for relaying messages or transmitting communications for a person other than the licensee or members of his immediate family.

The connection of a phone patch to the telephone lines for interstate and intrastate communication is governed by tariff regulations filed by the telephone companies with the FCC and the state regulatory agencies. Generally, these regulations permit the connection of customer-provided communications systems. Connection by acoustic/inductive means is subject to the condition that certain "minimum protection criteria" regarding signal input power are met. Local telephone companies will explain these criteria to interested licensees and operators. On the other hand, direct electrical connection can be made only through a connecting arrangement provided by the telephone company.

CHARLES A. HIGGINBOTHAM
Chief, Safety & Special Radio Services Bureau,
Federal Communications Commission, Washington, D.C.

FEEDBACK ON DOUBLE-SIDED PC BOARDS

The process detailed in "How To Make Double-Sided PC Boards" (June 1974) can be simplified in the following manner:

First, photo-reverse the exposure masks. Use IC-pad holes as references to align the reversed films, and tape the edges together along three sides. Punch holes through both films in unused areas (preferably in each corner) of the layout.

In a safe-lighted area, slide the pc blank between the films and apply small squares of transparent tape over the punched holes to secure the film to both sides of the blank. Expose the board, one side at a time, using a photographic contact printer with foam backing. Finally, remove the tape and develop and etch the blank.

GERALD G. CRAMM
Quantico, Va.

I feel I must criticize Mr. Burawa's statement that "If you can trace a circuit, you can design any type of pc board." I am afraid that many readers are going to get themselves into difficulties if they follow this advice. Pc boards are not a toy for the unskilled. Having been in the pc-board design field since its inception, I can attest that it takes many hours of training to acquire the design knowledge required for making pc boards.

Also lacking in the article was any mention of the fact that pads or land areas are chosen in relation to the hole size for the component lead or that there are strict rules on clearances between components and the foil conductors. The greater the packaging density, the more problems will be encountered and the more you must rely upon the rules that govern pc designs. Hence, without a formal education in design, expensive trial and error are going to cause short tempers.

RICHARD MAYER
Crown Point, N.Y.

"I do not deny that formal training would better prepare the experimenter for tackling pc board design and fabrication. But I also feel that it is not absolutely necessary in the great majority of cases. I contend that if you can trace a circuit, you can design just about any type of pc board. I would only add that good layout procedures be practiced in high-gain, r-f, and other critical designs to avoid crosstalk, feedback, etc.

—Author

LINEARS ON CB ARE A NO-NO

I would very much appreciate any information you can pass on with regard to using a linear amplifier with my CB transceiver.

Name Withheld

The best information we can pass on is don't. The use of a linear power amplifier with a CB transceiver is forbidden by the FCC rules.

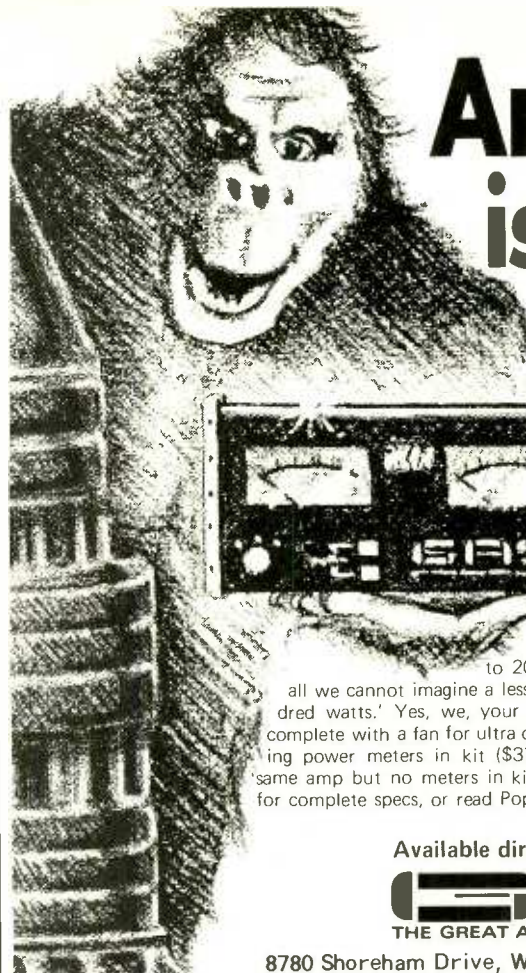

Ampzilla is here...

Why spend \$750 to \$1200 dollars for an amplifier? The Great American Sound Company sells one with a full complementary series connected output for much less. In short AMPZILLA is here. In the September 1974 Popular Electronics, Hirsch-Houck Labs says "...solidly in the audio monster amplifier class

using 8 ohm loads . . . THD was less than 0.01% for all power levels . . . up to 200 watts '(per channel)' . . . all in

all we cannot imagine a less expensive way of obtaining several hundred watts.' Yes, we, your friendly GAS company, have the goods complete with a fan for ultra cool operation. Available with direct reading power meters in kit (\$375) or fully assembled (\$525). Also the same amp but no meters in kit (\$340) and assembled (\$475). Write us for complete specs, or read Popular Electronics, September 1974.

Available directly from

GAS
THE GREAT AMERICAN SOUND COMPANY, INC.

8780 Shoreham Drive, West Hollywood, California 90069
CIRCLE NO. 18 ON READERS SERVICE CARD

The New Electronics Book

Sophisticated Electronics For Fun

By Joe R. Urschel

A totally new step by step guide to the "how to" of modern electronics, with 190 illustrations in this big 8 1/2" X 11" book.

Now, whether you're a novice or an expert you can benefit from this fact filled, easy to read book. Plus how to use TTL logic, in a non-academic approach to analog and digital electronics.

Special Bonus

Complete tried and proved plans to build • two electronic slot machines • electronic clock with chimes • juke box with no moving parts • computer game.

Available in the Chicago area at Kroch's & Brentano's bookstores.

Order Today

KROCH'S & BRENTANO'S 29 S. Wabash Ave., Chicago, IL 60603
Please send me _____ copies of Sophisticated Electronics For Fun, \$6.95 each. If not completely satisfied. I may return the book(s) within ten days for credit or refund.

PE

Name _____

Address _____

City/State/Zip _____

Charge my K & B account _____ Payment in amount of \$ _____ enclosed

Charge my Master Charge or Bank Americard _____ Expiration date _____

Illinois residents add 5% tax. Free delivery in Chicago and suburbs. Elsewhere add 40¢ per book mailing & handling charge. Sorry, no C.O.D.'s.

CIRCLE NO. 23 ON READERS SERVICE CARD

Where do the pros get their training?



Almost half of the successful TV servicemen have home study training and among them, it's NRI 2 to 1. It's a fact! Among men actually making their living repairing TV and audio equipment, more have taken training from NRI than any other home study school. More than twice as many!

Not only that, but a national survey,* performed by an independent research organization, showed that the pros named NRI most often as a recommended school and as the first choice by far among those who had taken home study courses from *any* school. Why? Perhaps NRI's 60-year record with over a million students...the solid training and value built into every NRI course...and the designed-for-learning equipment originated by NRI provide the answer. But send for your free NRI catalog and decide for yourself.



25" Diagonal Color TV... Professional Instruments

As a part of NRI's Master Course in TV/Audio servicing, you build a big-screen solid state color TV with every modern feature for great reception and performance. As you build it, you perform stage-by-stage experiments designed to give you actual bench experience while demonstrating the interaction of various stages of the circuitry. And your TV comes complete with console cabinet, an optional extra with other schools. Likewise, NRI's



Two Famous Educators... NRI and McGraw-Hill.

NRI is a part of McGraw-Hill, world's largest publishers of educational material. Together, they give you the kind of training that's geared for success...practical know-how aimed at giving you a real shot at a better job or a business of your own. You learn at home at your convenience, with "bite-size" lessons that ease learning and speed comprehension. Kits designed to give you practical bench experience also become first-class professional instruments you'll use in your work.

instruments are a cut above the average, including a 3½ digit precision digital multimeter, triggered sweep 5" oscilloscope, and integrated circuit TV pattern generator. They're top professional quality, designed to give you years of reliable service. You can pay up to \$800 more for a similar course and not get a nickel's worth extra in training and equipment.

Widest Choice of Courses and Careers.

NRI doesn't stop with just one course in TV/Audio servicing. You can pick from five different courses (including an advanced color course for practicing technicians) so you can fit your training to your needs and your budget. Or, you can go into Computer Technology, learning on a real, digital computer you build yourself. Communications with famous Johnson transceiver. Aircraft or Marine Electronics. Mobile radio, and more.

Free Catalog... No Salesman Will Call.

Send the postage-paid card for our free color catalog showing details on all NRI electronics courses. Lesson plans, equipment, and career opportunities are fully described. Check card for information on G.I. benefits. No obligation, no salesman will call. Mail today and see for yourself why the pros select NRI two to one!

If card is missing, write to:



NRI SCHOOLS
McGraw-Hill Continuing Education Center
3939 Wisconsin Avenue,
Washington, D.C. 20016

*Summary of survey results upon request.

I got it free!

Me too.

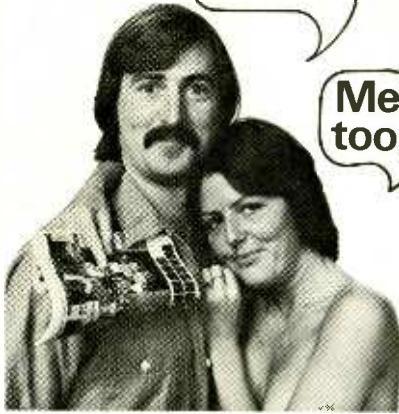

I, Dick Blake, sent off to the Warehouse Sound Co. and quickly received a full-color catalog of stereo components and complete music systems. I testify that they carry every major brand and offer super discounts! Furthermore, if you'll include \$1 for postage, those great people will also send either one of the following: their new 64-page catalog of professional products for musicians, or the 1975 edition of the Music Machine Almanac, which is a 185-page institutional guide to stereo equipment, complete with photos, prices, and specifications for over 40 brands! Sells on the newsstands for \$1.95 — so it's a good deal. Do it today!

WAREHOUSE SOUND CO.
BOX S SAN LUIS OBISPO
CA. 93405 (805) 543-2330

**WAREHOUSE
SOUND Co.**

Railroad Square, Box S
San Luis Obispo, CA. 93405
(805) 543-2330

name _____

address _____

city/state _____

zip _____

Also enclosed is \$1.00 for:
(check one)

Professional Products Catalog

1975 Music Machine Almanac

K-2

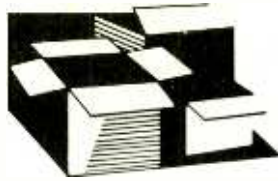

New Products

Additional information on new products covered in this section is available from the manufacturers. Either circle the item's code number on the Reader Service Card inside the back cover or write to the manufacturer at the address given.

FISHER 4-CHANNEL RECEIVER

The Fisher Studio Standard Model 334 4-channel receiver boasts 40 watts rms/channel with all channels driven into 8-ohm loads and an IHF power bandwidth of 30 to 22,000 Hz at 1 percent IM and 0.8 percent THD. It features built-in SQ and

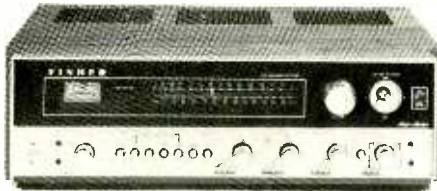

CD-4 decoding circuitry. Besides husky power rating, the receiver also has a "joystick" channel-balance control, loudness contour that is automatically disengaged when the output level is raised, and a sensitive (2- μ V) tuner. If stereo operation is desired, the amplifiers can be "strapped" to double the power per channel. Other features include Baxandall-type tone controls, FM muting, tape monitoring circuitry, output jacks for 4-channel recorders, tuning meter with Fisher's "Stereo Beacon," and an AM tuner.

CIRCLE NO. 70 ON READER SERVICE CARD

PEARCE-SIMPSON CB TRANSCEIVER

The Puma 23B is a 23-channel AM mobile CB rig (crystals supplied) from Pearce-Simpson. Its S/r-f meter glows amber on receive, red on transmit, and flashes bright red when fully modulated. A switch permits selection of r-f or PA output. The transmitter operates at the legal power limit. A dual-conversion receiver with 0.5- μ V sensitivity, with a crystal filter for selectivity and an automatic noise limiter, simplify the task of receiving signals on the crowded



channels. A noise-cancelling microphone, mobile mounting bracket, and external power cord are supplied with the transceiver.

CIRCLE NO. 71 ON READER SERVICE CARD

JBL DECADE SERIES SPEAKER SYSTEM

The Model L36 is a moderately-priced three-way speaker system that incorporates some of the hardware that comprises the JBL Century L100 and professional Model 4311 Studio Monitor systems. The L36 contains a 10-in. (25.4-cm) woofer with a 2.5-lb (about 1-kg) magnet, 5-in. (12.7-cm) midrange driver, and a 1.4-in. (3.56-cm) tweeter. Crossover frequencies are at 1500 and 6000 Hz. Nominal impedance of the system is 8 ohms. Power capacity is rated at 50 watts rms of continuous program material, requiring 10 watts rms minimum drive power. The enclosure uses a ducted-port design and comes finished in natural oak with fabric color options. The system measures 24 in. by 13 $\frac{1}{2}$ in. by 13 $\frac{1}{2}$ in. (61 \times 34.6 \times 34.3 cm) and weighs 45 lbs (20.5 kg). Retail price is \$198.

CIRCLE NO. 72 ON READER SERVICE CARD

TECHNICS SPEAKER SYSTEM

Technics by Panasonic has introduced a new series of speaker systems that includes bookshelf and floor-standing models. The top-of-the-line Model T-500 is a

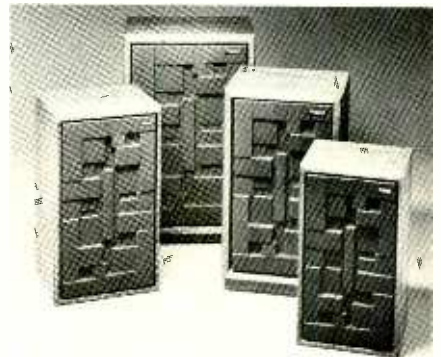

four-way, seven-driver system that features a frequency response of 35 to 20,000 Hz \pm 3 dB and handles between 10 watts minimum and 100 watts maximum program power. Frequencies up to 2000 Hz are covered by two 10-in. (25.4-cm) woofers, a 5-in. (12.7-cm) driver handles the midrange, and a pair of wide-dispersion tweeters take care of the highs. Frequencies above 8000 Hz are reproduced by an angled super tweeter assembly composed of two 2-in. (5.1-cm) transducers with a 180° dispersion angle. Two-position level controls are provided for the midrange and tweeter.

CIRCLE NO. 73 ON READER SERVICE CARD

CONWAY MASTERANGER

The Model 639 Masteranger from Conway is an unusually versatile multimeter that covers 93 ranges and 11 parameters. It features a FET front end for dc volts, 100-

C-MOS

4000AE	\$.55
4001AE	.55
4002AE	.60
4004AE	5.90
4006AE	3.90
4007AE	.65
4008AE	3.60
4009AE	.95
4010AE	1.20
4011AE	.55
4012AE	.55
4013AE	1.40
4014AE	3.80
4015AE	3.80
4016AE	1.15
4017AE	2.95
4018AE	3.20
4019AE	1.30
4020AE	4.20
4021AE	3.80
4022AE	2.95
4023AE	.55
4024AE	2.30
4025AE	.55
4026AE	9.90
4027AE	1.85
4028AE	2.95
4029AE	5.40
4030AE	1.25
4035AE	1.80
4037AE	4.00
4040AE	4.70
4041AE	3.35
4042AE	2.95
4043AE	2.95
4044AE	2.95
4048AE	1.50
4049AE	1.35
4050AE	1.35
4051AE	5.40
4056AE	3.50
4060AE	4.95
4069AE	.90
4076AE	4.30



Waveform Generator Kit

XR205K Only \$28.00

Here's a highly versatile lab instrument at a fraction of the cost of conventional unit. Kit includes two XR205 IC's, data & applications, PC board (etched & drilled, ready for assembly) and detailed instructions.

Audio Amps

LM352: 6-15V, 1.15W, 8Ω	1.60
LM354A: 6-27V, 2.80W, 8Ω	2.50
TAA611B12: 6-15V, 1.15W, 8Ω	1.60
TAA621A12: 6-27V, 1.40W, 8Ω	2.00
TBA641B11: 6-18V, 2.20W, 4Ω	3.00
TBA800: 5-30V, 4.70W, 8Ω	2.20
TBA810AS: 4-20V, 2.50W, 4Ω	3.00
TBA820: 3-16V, 0.75W, 4Ω	1.70
TCA830: 5-20V, 2.00W, 4Ω	2.20
TCA940: 6-24V, 6.50W, 8Ω	4.40

DUAL LOW NOISE OP AMP

LM331N:
V_{io} = 6mV
I_{ie} = 1000nA
I_{ib} = 2000nA
Noise = 1.5dB
\$2.20

FM Stereo Demodulator

XR1310 \$3.90



HYBRID POWER AMPLIFIERS

Power	RMS	IHF	Price
SI-1010Y	10W	25W	\$ 6.40
SI-1025E	25W	65W	18.00
SI-1050E	50W	120W	25.40

Voltage Regulators

LM100H	\$ 5.50
LM104H	6.50
LM105H	5.10
LM105F	8.50
LM109H	9.50
LM109K	6.30
LM200H	3.80
LM204H	4.70
LM205H	3.00
LM209H	3.50
LM209K	3.70
LM300H	.90
LM300N	1.40
LM304H	1.40
LM305H	1.10
LM305AH	1.10
LM305N	1.20
LM309H	1.75
LM309K	1.95
LM335	2.30
LM336	2.40
LM337	2.40
LM340-05K	2.60
LM340-06K	2.60
LM340-08K	2.60
LM340-12K	2.60
LM340-15K	2.60
LM340-18K	2.60
LM340-24K	2.60
LM723H	1.30
LM723D	3.90
LM723CH	.80
LM723CN	.75
L129	1.50
L130	1.50
L131	1.50



Digital Watch

with liquid crystal display. Beautiful, reliable & accurate. \$149.00 plus \$2.50 for shipping & handling.

Memories

P1101A	\$7.00
P1101A1	8.50
P1402A	8.50
P2102	16.00
P3101	5.50
P3101A	5.50
MM6560N	5.00
MM6561N	5.00
DM8599N	5.00
93403	5.00

Decoded Read/Write RAM

P1103 \$7.50

LED's .125" dia.

209 Red	\$.25
209 Yellow	.35
209 Green	.35

.160" dia.

216 Red	.25
216 Yellow	.30
216 Green	.30

.200" dia.

220 Red	.25
220 Yellow	.30
220 Green	.30

Displays

SLA 1	Red	2.25
SLA 11	Green	4.25
SLA 21		4.25
SLA 2	±1 Red	2.25
SLA 12	±1 Green	2.25
SLA 22		2.25
SLA 3	Red	7.50
SLA 4	Red	7.50

Optoisolator

MCT2	1.45
------	------

Linear IC's

LM301A	TO-5	\$.90
LM301AM	Mini-dip	.75
LM301AN	Dip	1.10
LM302H	TO-5	.95
LM302N	Dip	1.40
LM306H	TO-5	2.80
LM307H	TO-5	.90
LM307M	Mini-dip	.90
LM308H	TO-5	1.20
LM308AH	TO-5	5.00
LM310H	TO-5	1.40
LM311H	TO-5	1.70
LM318H	TO-5	2.50
LM555CM	Mini-dip	.95
LM709CH	TO-5	.45
LM709CN	Dip	.45
LM710CH	TO-5	.60
LM710CN	Dip	.75
LM725CH	TO-5	5.00
LM733CH	TO-5	1.50
LM733CN	Dip	1.50
LM741CH	TO-5	.45
LM741CM	Mini-dip	.44
LM747CH	TO-5	1.90
LM747CN	Dip	.90
LM748CN	Dip	.40
LM3046CN	Dip	.95
LM3054CN	Dip	1.50

Phase Locked Loops

LM567CM	Mini-dip	2.00
---------	----------	------

IC sockets

8 pin DIL	.22
14 pin DIL	.26
16 pin DIL	.29
24 pin DIL	.75
28 pin DIL	1.10
36 pin DIL	1.70
40 pin DIL	1.90

Teflon

3 pin TO-5	.55
4 pin TO-5	.65
6 pin TO-5	.90
8 pin TO-5	1.10
10 pin TO-5	1.40

Shift Registers

1402A	\$ 8.50
1403A	6.00
1404A	6.00
1405A	4.50
1406	6.00
1407	6.00
1506	3.00
1507	3.00
2505K	4.00
2512K	5.50
2524V	4.00
2525V	5.50
2807	4.00
2808	5.50
TMS3114	8.20
MM5055N	5.00
MM5056H	5.00
MM5057N	5.00

Schottky TTL

SN74S00N	\$.80
SN74S02N	.80
SN74S03N	.80
SN74S04N	.80
SN74S08N	.80
SN74S10N	.80
SN74S11N	.80
SN74S20N	.80
SN74S30N	.80
SN74S32N	.80
SN74S40N	.80
SN74S41N	.80
SN74S64N	.80
SN74S74N	1.30
SN74S85N	6.10
SN74S86N	2.90
SN74S112N	2.50
SN74S113N	1.50
SN74S133N	1.00
SN74S138N	4.50
SN74S139N	4.20
SN74S140N	1.00
SN74S151N	3.30
SN74S153N	3.30
SN74S154N	3.40
SN74S157N	3.00
SN74S158N	3.00
SN74S160N	6.60
SN74S161N	6.60
SN74S174N	4.75
SN74S175N	5.00
SN74S181N	12.50
SN74S189N	5.10
SN74S194N	4.40
SN74S195N	4.40
SN74S251N	4.20
SN74S253N	4.20
SN74S275N	3.20
SN74S258N	3.70
SN74S260N	.90
SN74S280N	5.70
SN74S289N	5.00
93S10	6.80
93S16	6.80
93S21	3.50
93S22	3.20
93S48	3.70

HIGH SPEED TTL

74H00N	.34
74H01N	.49
74H04N	.36
74H05N	.38
74H08N	.44
74H10N	.44
74H11N	.44
74H15N	.38
74H20N	.39
74H40N	.36
74H74N	.69

You deserve PREMIUM QUALITY COMPONENTS

When you order from us, that is what you receive! We've been buying and selling top quality components for nearly ten years. Our annual volume exceeds \$3 million. We handle only original parts, from the world's leading manufacturers and our customers include some of the largest and most quality-conscious companies.

Now you can take advantage of our component buying skills and power. Select from a broad range of advanced devices. Enjoy competitive and often amazingly low prices. Depend on shipment in 48 hours or less and rely on our guarantee of complete satisfaction — ANCRONA CORPORATION.

7400N TTL	
7400N	.18
7401N	.27
7402N	.23
7403N	.23
7404N	.25
7405N	.29
7406N	.42
7407N	.49
7408N	.24
7409N	.54
7410N	.24
7411N	.29
7412N	.51
7413N	.79
7414N	2.81
7416N	.47
7417N	.64
7420N	.25
7421N	.51
7423N	.49
7425N	.49
7426N	.49
7427N	.54
7428N	.51
7430N	.23
7432N	.29
7433N	.61
7437N	.49
7438N	.49
7439N	1.01
7440N	.23
7441AN	1.16
7442N	.99
7445N	1.14
7447N	1.39
7448N	1.29
7450N	.23
7451N	.29
7453N	.26
7454N	.26
7460N	.24
7470N	.31
7472N	.39
7473N	.47
7474N	.47

74150N	1.14
74151N	.89
74152N	2.25
74153N	1.12
74154N	1.64
74155N	1.49
74156N	1.49
74157N	1.26
74158N	1.54
74160N	1.89
74161N	1.59
74162N	2.05
74163N	1.59
74164N	1.89
74165N	1.89
74166N	1.98
74170N	2.55
74173N	1.79
74174N	1.52
74175N	1.92
74176N	1.69
74177N	1.69
74180N	2.49
74181N	3.85
74182N	1.19
74184N	2.89
74185N	2.29
74190N	2.89
74191N	2.89
74192N	1.49
74193N	1.39
74194N	1.89
74195N	.99
74196N	2.39
74197N	2.39
74198N	2.59
74199N	4.48
74200N	5.05
74221N	1.75
74251N	1.75
74278N	2.95
74279N	.92
74293N	.92
74298N	2.55

LOW POWER TTL

74L00N	.34
74L02N	.34
74L03N	.39
74L04N	.39
74L10N	.34
74L20N	.39
74L42N	1.62
74L47N	1.62
74L51N	.34
74L73N	.74
74L74N	.89
74L90N	1.62
74L93N	1.74
74L95N	1.62
93L00	1.50
93L01	1.60
93L08	3.40
93L09	1.80
93L10	2.80
93L11	4.20
93L12	1.80
93L14	1.70
93L16	3.20
93L18	3.50
93L21	1.50
93L22	1.80
93L24	2.80
93L28	3.90
93L34	4.00
93L38	4.20
93L40	6.50
93L41	6.50
93L60	3.00
93L66	2.70

COMPUTER INTERFACE

DM8820N	4.00	9602	2.00
DM8820AN	6.50	9614	3.00
DM8830N	4.50	9615	3.00
DM8831N	5.00	9616	4.50
DM8832N	5.00	9617	3.00
9600	1.30	9620	3.50
9601	1.30	9621	3.00

Pulse Generator



Interdesign 1101: 0.1Hz-2MHz, 0.5V Output, var. width, line or battery operation. \$159.00.

Power Regulators

LM335K: 5V, 600mA	2.40
-------------------	------

Incredible.

How else would you describe a preamplifier with:

- A **Peak Unlimiter** that restores dynamics lost in recording to closely approximate the original.
- A **Downward Expander** that reads "gain riding" and expands dynamics down to precisely the intended level.
- An **AutoCorrelator** that makes record/tape hiss and FM broadcast noise virtually vanish without affecting musical content.
- **Plus an Active Equalizer** that gives you flat energy distribution over the full audio spectrum, Joystick Balance and Step Tone Controls that allow precise music tailoring to your listening environment and SQ* and Phase Linear differential logic for Quad Sound.

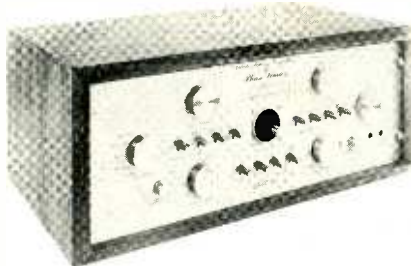

The 4000 is an advanced stereo preamp that actually puts back in what recording studios take out... lets your music (at last) reach life-like levels without distortion... lets you (for the first time) hear your music from a silent background. It is, in a word, incredible. Ask your dealer for an audition.

Price: \$599

Cabinet: \$37

Warranty: 3 years, parts & labor.

Phase Linear 4000

THE POWERFUL DIFFERENCE

PHASE LINEAR CORPORATION
P.O. Box 1335 • Lynnwood, Wash. • 98036

*SQ is a trademark of CBS Labs, Inc.
CIRCLE NO. 45 ON READERS SERVICE CARD

14

megohms input impedance, and an exceptionally large mirrored meter movement scale. Although the instrument is designed to be battery operated, an accessory power supply permits line operation. With optional probes, ranges are further extended, and they permit r-f voltage and temperature to be measured. A zero scale permits null detection and galvanometer operation. The tester can also be used for in-circuit resistance checks on semiconductors without damaging them. Accuracy is claimed to range from ± 1.5 percent for ac and dc voltages up to 1500 volts to ± 5 percent for r-f. R-f, HV, and peak-to-peak probes, external high-current shunt, ac power supply, capacitive HF voltage divider, and temperature probe are available as optional accessories.

CIRCLE NO. 74 ON READER SERVICE CARD

JERMYN DUAL-TRACE 10-MHZ SCOPE

The dual-trace Scopex Model 4D-10 oscilloscope from Jermyn features 10 mV/cm sensitivity and a dc to 10-MHz bandwidth. The all-solid-state circuitry includes MOS devices. Direct calibration is in V/cm and

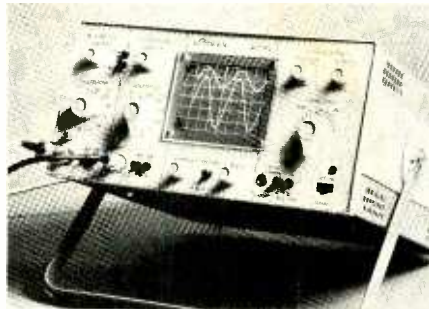

s/cm. A horizontal control incorporates a $\times 5$ expansion function that holds the trace under observation in the display when activated. Triggering is regulated by a single control that governs both level and polarity. In the absence of a trigger signal, the trace operates in the free-running mode. All other controls are pushbutton and chop modes, external trigger, and ac and dc coupling. Price of the scope is \$450.

CIRCLE NO. 75 ON READER SERVICE CARD

HEATH TELEPHONE AMPLIFIER

The Heathkit Model GD-1024 telephone amplifier kit makes it possible to carry on a conversation without being tied to the phone or to conduct "conference" calls with many individuals participating in one location. The amplifier operates with virtually any type of telephone instrument. To use it, the handset of the telephone instrument is placed on the amplifier's cradle. The incoming signal is then acoustically coupled to the amplifier where it undergoes amplification and is reproduced by the amplifier's speaker. Volume can be adjusted to suit the listening area. Other features include all solid-state circuitry for low no-signal load, 8-ft (2.44-m) speaker cord to reduce feedback, and low-cost battery operation. Mail-order price is \$14.95.

CIRCLE NO. 5 ON READER SERVICE CARD

LAFAYETTE DOLBY CASSETTE DECK

Lafayette Radio Electronics' new No. 99-16156W stereo cassette deck features built-in Dolby noise reduction circuitry. A



three-position bias switch is provided for adjusting equalization for standard and high-output ferric-oxide and chromium-dioxide tape formulations. Other features include dual VU meters, slide controls for microphone and line inputs and line outputs, three-digit tape counter with reset button, memory rewind, and total automatic mechanism shutoff. The deck is capable of performing sound-with-sound mixing. Frequency response is 30-12,000 Hz ± 3 dB at 20 dB below 0 VU. S/N is rated at 49 dB (59 dB with Dolby circuit switched in). Wow and flutter is 0.12 percent. Retail price is \$239.95.

CIRCLE NO. 76 ON READER SERVICE CARD

LECTROTECH COLOR SIGNAL GENERATOR

The compact Model BG-10 color signal generator from Lectrotech, Inc., is small enough to fit into a shirt pocket. Yet, it is a full-function instrument that provides crosshatch, dots, single horizontal/vertical lines, center-screen dot, and three- and 10-bar color test patterns. The 10-oz (283.5-g) instrument employs CMOS LSI chips for all counting functions for minimal drain from inexpensive 9-volt transistor batteries. The generator's r-f output is on TV Channel 4 or 5. Overall size is 5½ in. by 3 in. by 1½ in. (14 × 7.6 × 2.9 cm). List price is \$89.50.

CIRCLE NO. 77 ON READER SERVICE CARD

INSTANT BREADBOARDING

Instant Instruments, Inc., has developed Instant Circuit Breadboarding for the designer who requires a fast, simple, low-cost method of transferring his ideas from paper to wired electronics. This simple breadboarding method is said to allow instant assembly of a prototype circuit without drilling or insertion of components, cutting pc boards, or installing jumpers as required in conventional systems. The designer solders to pre-etched component pads. Both boards and components are easily salvaged for reuse. Four basic patterns are available for discrete components and IC's. All have pre-punched front panels. All patterns are solder-plated to prevent oxidation and to give good copper-to-solder connection bonds. Prices range from \$2 to \$8.60.

CIRCLE NO. 78 ON READER SERVICE CARD

POPULAR ELECTRONICS

MARK TEN B, THE GAS SAVING, PLUG SAVING, TUNE-UP SAVING, ELECTRONIC IGNITION FROM DELTA. NOW AS LOW AS \$49.95.



Years of testing and use by race car drivers in all categories have proven Delta's Mark Ten B the most advanced ignition system on the market today.

Prove it to yourself. Give your car vroom! With a Mark Ten B Capacitive Discharge Ignition System under the hood of your car great things will happen...like reducing costly tune-ups by as much as 75%. Further, you get better all-weather starts, quicker acceleration and better mileage.

Many operational problems caused by emission control devices, poor manifold or improper fuel mixtures disappear. Delta's Mark Ten B even improves the performance of brand-new factory installed electronic ignitions (Chrysler and Ford). Factory systems merely eliminate points and condenser, but the Delta Mark Ten B combines the advantages of capacitive discharge with solid state

electronics to give real performance and increased energy.

Are you a do-it-yourselfer?

Build your own Mark Ten B...it's available in low-cost

kit form. Or, if you prefer,

get the complete ready-to-install

unit. Either way, you can install it yourself in minutes with no rewiring, even

over Chrysler and Ford systems. Mail the coupon today and discover how to enjoy happy motoring with Delta's Mark Ten B. The do-it-yourselfer's dream that really pays off.

 **DELTA PRODUCTS, INC.**
P.O. Box 1147, Dept. PE Grand Junction, Colo. 81501
303-242-9000

Please send me free literature.

Enclosed is \$ _____ Ship ppd. Ship C.C.D. Please send: _____ Mark Ten B assembled @ \$64.95 ppd. _____ Mark Ten B Kit @ \$49.95 ppd. (12 volt negative ground only) _____ Standard Mark Ten assembled, @ \$49.95 ppd. _____ 6 Volt: Neg. Ground Only _____ 12 Volt: Specify _____ Pos. Ground _____ Neg. Ground _____ Standard Mark Ten Deltakit® @ \$34.95 ppd. (12 Volt Positive or Negative Ground Only)

Car Year _____ Make _____

Name _____

Address _____

City/State _____ Zip _____

Incomparable!

Incomparable is not a term to take lightly. In test after test the Mark IB Stereo Preamplifier and Mark IIIICM Stereo Power Amplifier have led the industry in every respect. At SAE, engineering excellence is not a goal, it's a reality! See the Mark IB and Mark IIIICM at your nearest SAE authorized dealer.

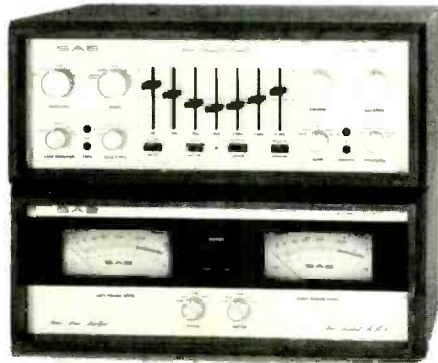

SAE
*Components
for the
Connoisseur*

SAE, Inc., Dept. PE 11/74
P.O. Box 60271, Terminal Annex,
Los Angeles, California 90060

Gentlemen:

Please rush free information on the Mark IB Stereo Preamplifier and Mark IIIICM Stereo Power Amplifier by return mail.

Name _____

Address _____

City _____ State _____ Zip _____

CIRCLE NO. 34 ON READERS SERVICE CARD

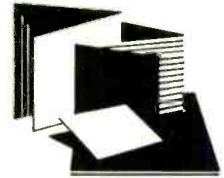

New Literature

ALTEC ENCLOSURE DESIGN MANUAL

"Loudspeaker Enclosures—Their Design and Use" is a well-illustrated 32-page publication for the do-it-yourself audio enthusiast. It is a rich source of information to aid in the design and construction of systems of predictable and satisfactory performance. Topics include the function of the enclosure, loudspeaker design theory, and types of enclosures—from infinite baffles to base reflex enclosures to tuning the bass reflex port. Details on selection of materials are abundant—types of board, acoustic damping material, stiffeners, and grille material. Other useful information includes a chart of common sound pressure levels, frequency ranges of musical instruments, and a glossary of audio terms. Available for \$2 from Altec Corp., 1515 S. Manchester, Anaheim, CA 92803.

ELPA TAPE RECORDER TESTING BOOKLET

"Tape Recorder Clinic Procedures" offered by Elpa Marketing is a 21-page booklet that describes the step-by-step methods for conducting a tape recorder test clinic using the Ferrograph Ferrotester. The booklet lists sources from which test tapes are available and includes a sample Tape Recorder Clinic Test Report sheet. Address: Elpa Marketing Industries, Inc., Thorens & Atlantic Aves., New Hyde Park, NY 11040.

VACTEC PHOTOTRANSISTOR BULLETIN

A bulletin featuring the company's complete line of phototransistors and photo-Darlington is available from Vactec. The 8-page No. VTTA-1 bulletin describes the two basic chip sizes and various packaging configurations. In addition to mechanical data, it also covers electro-optical parameters and provides 24 graphs of characteristics and environmental information. Address: Vactec, Inc., 2423 Northline Industrial Blvd., Maryland Hts., MO 63043.

STANCOR TRANSFORMER CATALOG

The new Stancor Transformer Catalog (No. 407) available from Essex Controls, lists 1600 standard transformers and gives full technical data, mounting dimensions, and other specifications on the company's complete line of audio and power transformers and chokes and inductors. Address: Essex Int'l., Inc., Controls Div., Stancor Prods., 3501 W. Addison St., Chicago, IL 60618.

Inside each of our 4-channel cartridges

AT12S
\$64.95

AT15S \$100.00 ■ AT20SL \$175.00

AT14S
\$75.00

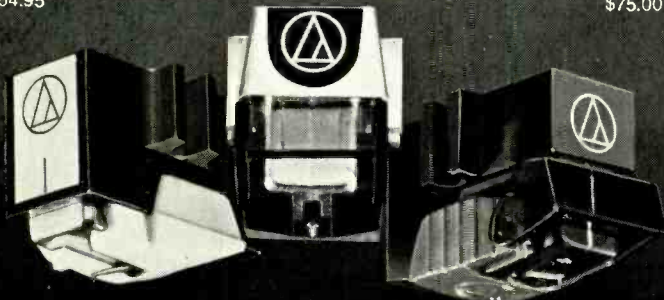

lurks a Dual Magnet stereo cartridge waiting to please you.

Our sophisticated four-channel cartridges* are also stereo cartridges at heart. Very good ones. With ruler flat response, outstanding stereo separation (especially above 1 kHz where it counts), and truly impressive high frequency tracking.

All these advantages are as important to good stereo as they are essential to CD-4. And they can be achieved

only by paying very close attention to detail. And using only the best. Like a genuine Shibata† stylus. Nothing less.

The results are good for any record... whether stereo, matrix, or discrete 4-channel. But you should really hear for yourself. Write today for our dealer list. No matter how many channels you want to hear best.

*J.S. Pat. Nos. 3,720,796; 3,761,647
†Shibata stylus Pat. No. 3,774,918



audio-technica®

AUDIO-TECHNICA U.S., INC., Dept. 33 Shawnee Ave., Fairlawn, Ohio 44131
In Canada: Superior Electronics, Inc.

CIRCLE NO. 3 ON READERS SERVICE CARD

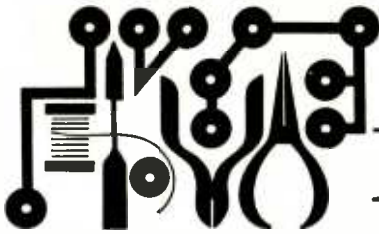

Hobby Scene

Voltage Warning Device

Q. I would like some type of warning device that will alert me in the event the dc voltage from my bench power supply exceeds some predetermined level. I am looking for something simple that can be put together quickly.

A. The circuit shown here is a zener-controlled relay. Select the zener

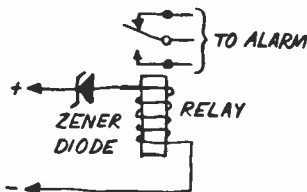

diode for the maximum voltage you want from your power supply. Then use a relay whose coil current is similar to the zener current of the diode. When the voltage is below the zener point, nothing happens. But when the voltage exceeds the zener diode's breakdown voltage, the relay will energize and trigger on the external alarm connected across the relay's contacts. The relay will remain on for all voltages above the zener point, and will immediately drop out at voltages below the zener point.

Alarm Delay Circuit

Q. I need a time-delay circuit for my car that will arm an intruder alarm a minute or so after I leave the vehicle. It must work on dc and use a minimum of parts.

A. The simple timer circuit shown here should suit your needs. When the

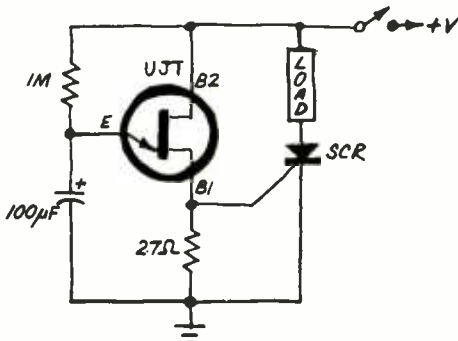

switch is closed and power is applied to the system, the capacitor starts to charge through the 1-megohm resistor. When the voltage at the emitter of the UJT reaches the firing potential of the UJT used, a positive spike will appear at the gate of the SCR, at which point the SCR fires. Because the circuit employs only dc voltages, the SCR will remain conducting until the power switch is opened.

Electronic Door Bell

Q. I have repaired my front doorbell so many times that I'm getting fed up with it. Isn't there some simple electronic substitute for the mechanical buzzer?

A. There are many oscillator circuits that will deliver a pleasant sounding

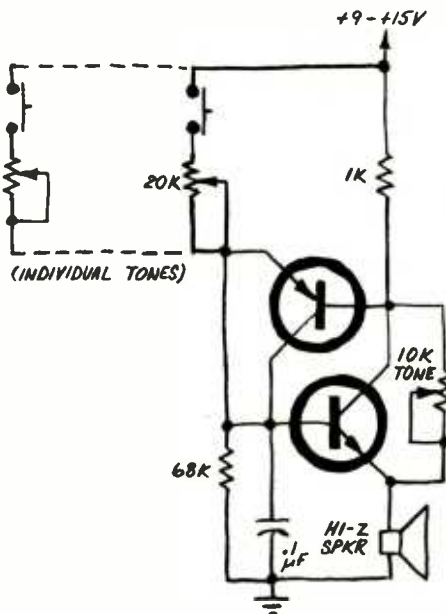

tone when a switch is closed. The one shown here uses a pair of transistors and as many switches as you wish. Each switch is associated with its own tone-control potentiometer so you can adjust each one differently. If you don't have a high-impedance speaker, try an ordinary transistor output transformer and speaker. Any general-purpose transistors can be used.

INCREASE GAS MILEAGE

10-20%



INSTALL A BAY CAPACITIVE DISCHARGE IGNITION SYSTEM!

\$23.88

\$28.88 with By-Pass Switch as Pictured

FIELD-TESTED FOR 5 YEARS!

- Increase Engine Power
- Reduce Engine Maintenance
- Instant Starting in All Climates
- Thousands of Satisfied Users

NO FINER CD SYSTEM AVAILABLE!

- Completely wired, ready-to-install (not a kit)
- Install in 10 minutes (use original coil)
- Solid state reliability
- Distributor points last lifetime of car
- Spark Plugs last 3 to 10 times longer
- For 12-volt negative ground systems only
- 1-year written guarantee

Write For Quantity Purchase Prices

BAY PRODUCTS Division of V-J Products, Inc.
P.O. BOX 9562, HOUSTON, TEXAS 77011

Please send _____ Model J15 CD Ignition Systems with By-Pass Switch @ \$28.88.

Please send _____ Model SW101 CD Ignition Systems without By-Pass Switch @ \$23.88.

Enclosed is \$_____ Plus \$1 per unit for shipping.

Name _____

Address _____

City/State _____ Zip _____

CIRCLE NO. 43 ON READERS SERVICE CARD

FREE Olson Catalog

VALUE PACKED WITH THOUSANDS OF ELECTRONIC BARGAINS

We Will Send You The Next 7 Issues FREE! You'll Find The Best Of The Name Brands Plus Exclusive Olson Products at Low, Low Prices!

FREE Send Today

Olson Electronics Dept. 12
260 S. Forge St., Akron, Ohio 44327

Name _____

Street _____

City _____

State _____ Zip _____

Apt. No. _____

CIRCLE NO. 29 ON READERS SERVICE CARD

If you can use any of these tools...

You can gain exciting new skills as an electronics troubleshooter in Bell & Howell Schools' fascinating learn-at-home program that includes building and experimenting with the new generation color TV.

Simulated TV picture/test pattern



You may already have some of the skills you need.

Most of us at one time or another have put a screwdriver, a pair of pliers or some other basic tool to work. Fixing a bicycle wheel, tightening a window latch, putting up a bookshelf, or what have you.

But here's a thought.

Using these same simple tools as a starting point, you can develop the ability to put them to work for you in far more ways than you ever dreamed of. And Bell & Howell Schools' fascinating home learning adventure in electronics will show you how.

These days when it seems like there's an "electronic everything," it makes good sense to have occupational skills in the servicing and repair of such products as TV's and other home electronic equipment. If you're a person who recognizes a future in this field, Bell & Howell Schools is ready to help you develop the specialized ability you need to become an electronics troubleshooter. While no assurance of income or employment can be offered, we can assure you that no better at-home training in electronics is available anywhere.

We have an exciting way for you to pick up these specialized skills in your spare time.

Don't think for a moment that we want you to spend your off-hours just reading a bunch of "how-to" books. That would bore anyone after awhile. What we at Bell & Howell Schools offer is the modern way to learn... a very different approach from the way you've been used to.

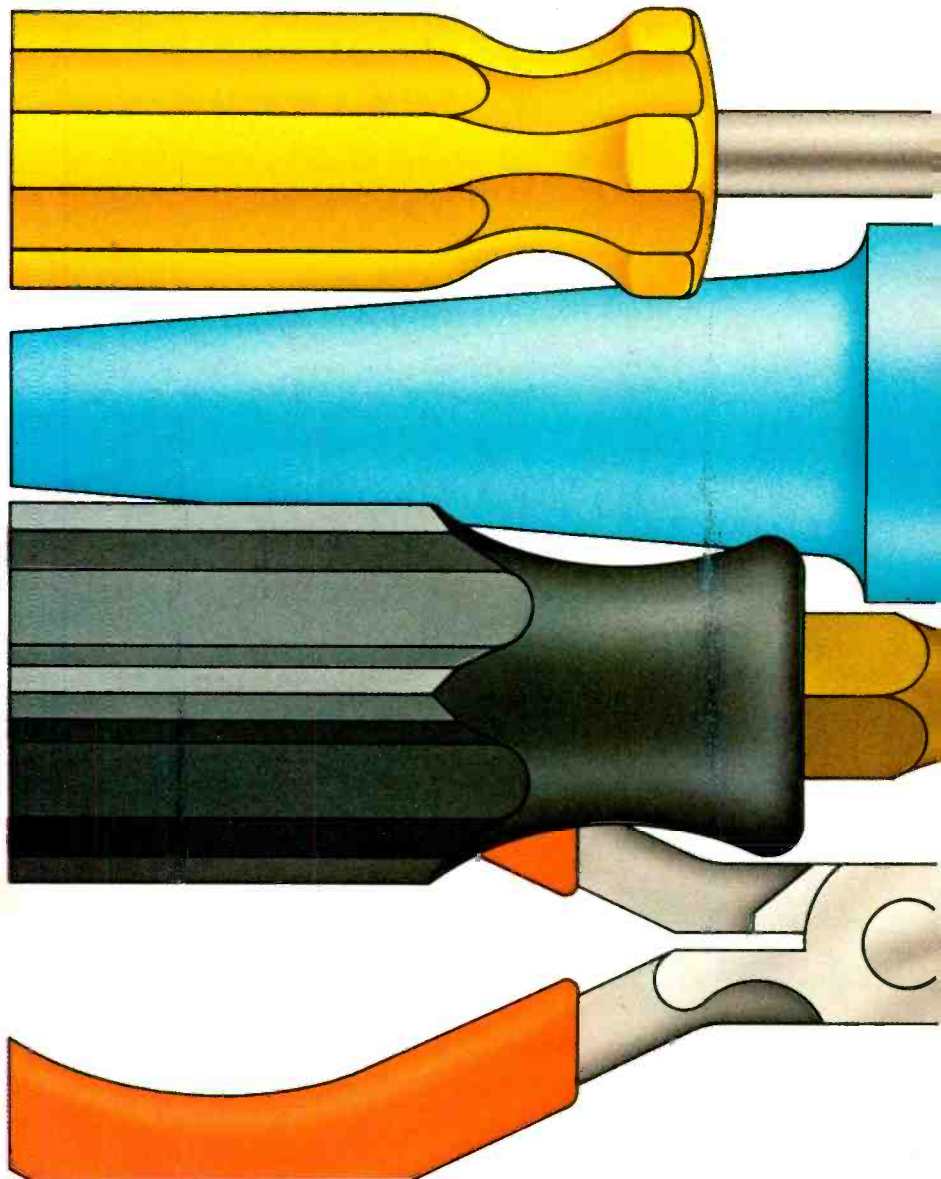

First of all, we believe that when you're exploring a field as fascinating as electronics, reading about it is just not enough. That's why throughout this learning adventure you'll get lots of "hands on" experience with some of the latest electronic training tools available today. You'll test and experiment with them and gain exciting new skills all along the way.

Once you've completed this program a number of directions are open to you:

1. Use your training to seek out a job in the electronics industry.
2. Use your training to upgrade your current job.
3. Use your training as a foundation for advanced programs in electronics.
4. Use your training in a business of your own—a few of our graduates are even doing this now!

No electronics background necessary.

That's one of the many attractions of this program. We start you off with the basics and help you work your way up one step at a time. As a matter of fact, with your very first lesson you receive a special Lab Starter Kit to give you immediate working experience on equipment as you are picking up the fundamentals.

It makes the learning process faster and certainly a lot more interesting.

You'll build and perform exciting experiments with Bell & Howell's Electro-Lab™ electronics training system.

You build the Electro-Lab step-by-step, too. First, the design console. After you assemble it, you'll be able to set up and examine circuits without having to solder them in place.

Next, you'll enjoy building a digital multimeter. This important instrument measures voltage, current and resistance and displays its findings in big, clear numbers like on a digital clock. Far easier to read than "needle pointer" meters.

Then comes the solid-state "triggered sweep" oscilloscope which is similar in principle to the kind used in hospital operating rooms to monitor heartbeats. You'll use it to analyze tiny integrated circuits. The "triggered sweep" feature locks in signals for easier observation.

You'll actually build and work with Bell & Howell's new generation color TV... investigating features you've probably never seen before!

This 25" diagonal color TV has digital features that are likely to appear on all TV's of the future. Features made possible by the applications of digital electronics

to home entertainment.

You'll probe into the technology behind all-electronic tuning and into the digital circuitry of channel numbers that appear big and clear, right on the screen!

You'll also build-in a remarkable on-the-screen digital clock, that will flash the time in hours, minutes and seconds. Your new skills will enable you to program a special automatic channel selector to skip over "dead" channels and go directly to the channels of your choice.

You'll also gain a better understanding of the exceptional color clarity of the Black Matrix picture tube, as well as a working knowledge of "state of the art" integrated circuitry and the 100% solid-state chassis.

Having actually built and experimented with this TV, you'll come away equipped with the kinds of skills that could put you ahead of the field in electronics know-how.

We try to give more personal attention than other learn-at-home programs.

1. Toll-free phone-in assistance. The program is designed so that you can proceed through it smoothly, step-by-step. However, should you ever run into a rough spot, we'll be there to help. Many schools make you mail in all your questions. We have a toll-free line you can call when you have a question that can't wait.
2. In-person "help sessions." These are held in 50 major cities at various times throughout the year where you can talk shop with your instructors and fellow students.

Why wait?

Find out more on how you can pick up new skills in electronics troubleshooting as you work with Bell & Howell's new generation color TV. You've got the tools to do it!

Mail the postage-paid card today for full details, free!

Taken for vocational purposes, this program is approved by the state approval agency for Veterans Benefits.

If card has been removed, please write to:

An Electronics Home Study School
 DEVRY INSTITUTE OF TECHNOLOGY
 ONE OF THE
BELL & HOWELL SCHOOLS
 4141 Belmont Chicago Illinois 60641



Channel numbers that flash on the screen



On-screen digital clock



Automatic pre-set channel selector

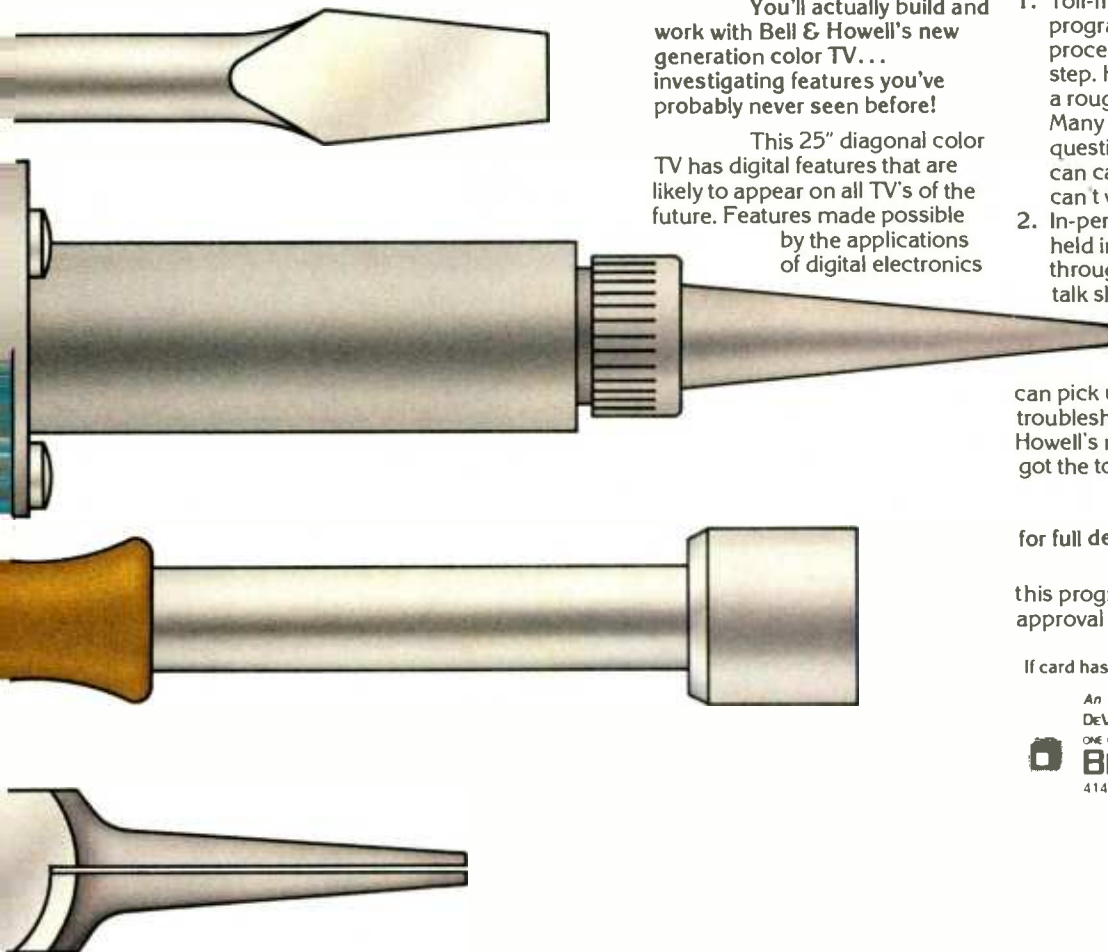

"Electro-Lab" is a registered trademark of the Bell & Howell Company.



Stereo Scene

By Ralph Hodges

BLAZING SPEAKERS

HAVE you blown out any good loudspeakers lately? The question is not frivolous, because the factory return rates for many high-quality speaker systems, certified safe for *loud* home listening, are apparently on the rise. Manufacturers have even begun encouraging the press to print more stories about loudspeaker failure, presumably in the hope of educating the consumer and forestalling disaster. The trouble is, such stories have a way of growing into "pageants," to use the word of one company spokesman. Although most speaker blow-outs result from a simple causation—an attempt on the speaker's part to absorb more electrical energy than is good for it—it is next to impossible to be both exhaustive and concise about all the ways in which this can happen. There are

more, it seems, than meet the eye (figuratively) or the ear (literally).

Big Amps and Small. One cause of speaker failure is obvious, you'd think: the proliferation of super-power amplifiers. And yes, I'm sure there are and will continue to be those who over-power their systems into occasional attacks of silence, although the likelihood is that this comes about most often through accidental signals—a loose ground connection, a severe switching transient, a dropped tone arm, or even (as used to plague rock groups when setting up) a sudden outbreak of acoustic feedback to the microphones when no one can get to the controls in time to save the situation. Now and again someone does destroy a speaker by playing loud music through it. But since the speaker almost certainly exhibited audible signs of distress before succumbing, he usually can't say that he wasn't warned.

Excessive amplifier power isn't always to blame, however. From the latest reports, one of the serious and growing problems is the blowing out of speakers by *under*-powered amplifiers. This was first brought to my attention in an article by Peter Mitchell, who among other distinctions is the president of the Boston Audio Society. His written explanation was so plausible in a theoretical sense that I was first tempted to think the whole business was just that: a theoretical possibility that doesn't occur much in real life. A few phone calls to manufacturers set me straight. It's not a rarity. Naturally, the resulting customer unhappiness is worse, as a rule, than when one of the super-power aficionados does *his* direful deed. The under-powered customer, you see, thought he was taking pains to stay within the power limitations specified by the speaker manufacturer, and yet he still got into trouble.

This is what evidently takes place. An amplifier called upon to operate at its limits much of the time will clip frequently, squaring off the tops and bottoms of any waveforms it can't pass. According to waveform analysis, these flat tops and bottoms represent odd-order harmonics of a sine-wave fundamental: i.e., spurious high frequencies of significant amplitude (see Figs. 1 and 2). These harmonics—and some of them can be very high in frequency—get routed to the tweeter, which has to cope with them in some way. If clipping is frequent, the tweeter has an almost continuous input of distortion products to handle. In time its relatively fragile voice coil, given no chance to cool off, shorts, or opens up, and that's it.

The putative problem here is that there's more (and more frequent) high-frequency energy in the clipping distortion than in most music, and therefore more energy than the tweeter's designer anticipated its having to take. Of course, you wouldn't expect the distortion to sound too good. But perhaps, if it were high enough in frequency, and if the recording had a typically hard, wiry top end and a continuous background of high-hat cymbal, it wouldn't be especially annoying. In any case, it evidently happens, as the man says, and audiophiles are advised to give a close listen to the high frequencies whenever they run their systems up near maximum levels to make sure things don't sound worse than they should. This is a particularly good idea with pop music having heavily compressed dynamics, since a constant level means constant clipping when the amplifier is operating at its design limits.

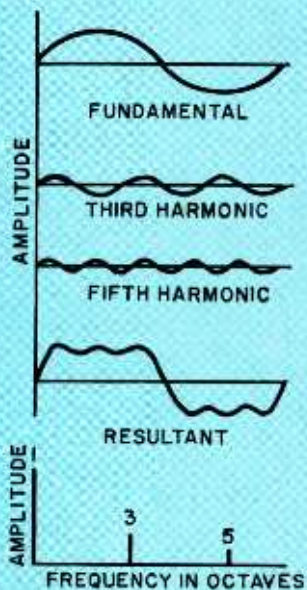

Fig. 1. Sine-wave fundamental with two harmonics results in a waveform approaching a square wave, which ideally would have an infinite series of odd-order harmonics.

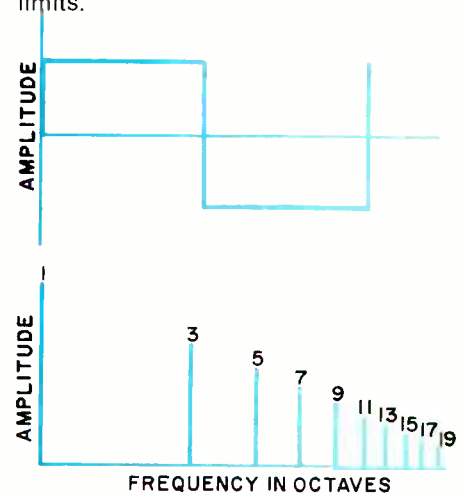
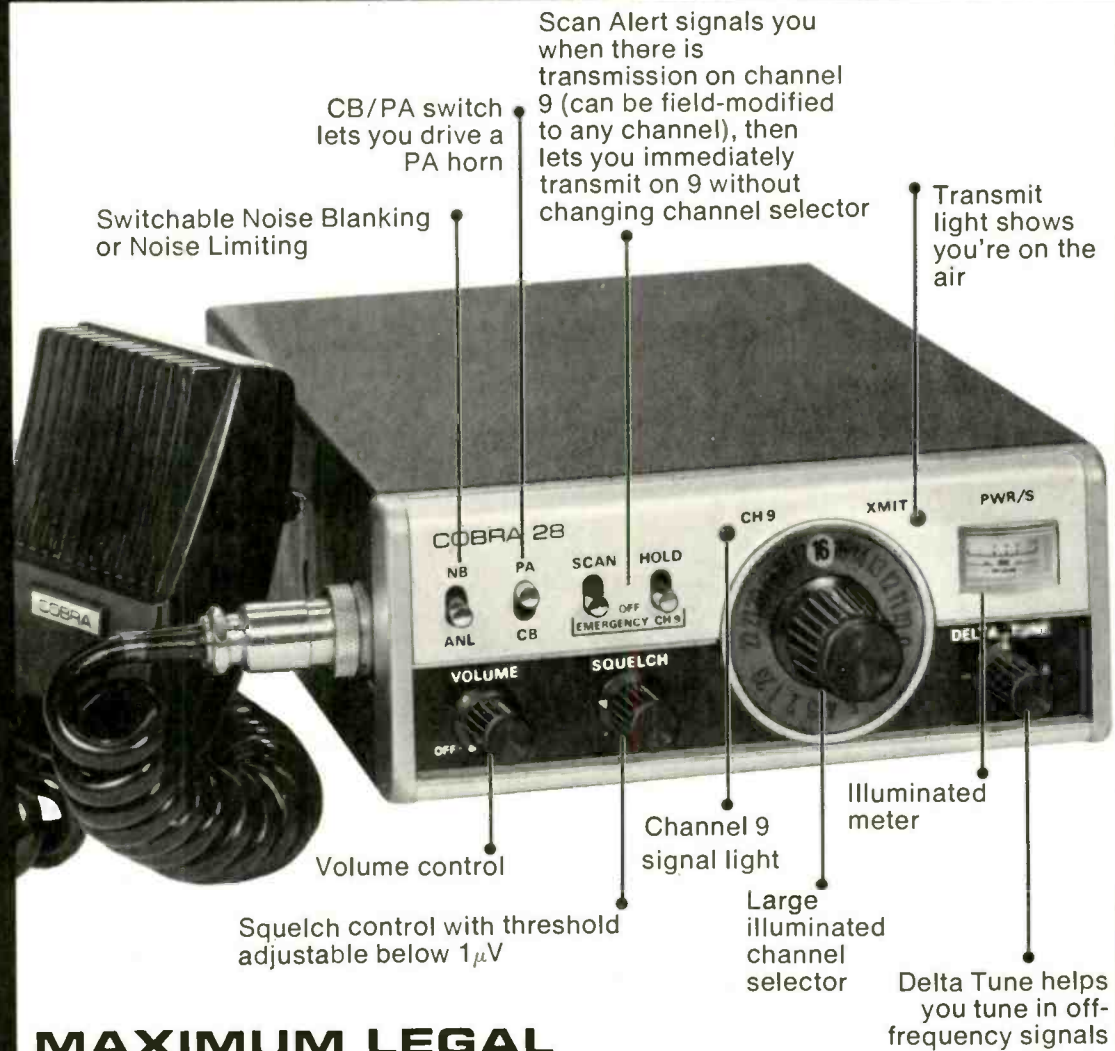

Fig. 2. Part of the spectrum for a perfect square wave.

Monitor 9 or any channel you choose



MAXIMUM LEGAL POWER PLUS...

Convenient plug-in microphone, output for extension speaker and the rugged quality and precision that COBRA is famous for! Send for your copy of our detailed full color brochure today!



PRODUCT OF DYNASCAN CORPORATION • 1801 W. Belle Plaine • Chicago, Ill. 60613

COLLECTORS!

Here's how to enjoy
Old-Time Radios—
A fascinating hobby!



VINTAGE RADIO tells you how to collect valuable old radios, and is the standard reference for collectors. Over 1,000 pictures. 263 pages, \$6.95 hard-cover, \$4.95 handbook.

S. GERBACH'S 1927 RADIO ENCYCLOPEDIA is your deluxe illustrated technical book on early radio. 175 pages, \$12.95 hard-cover, \$9.95 hand-book.

RADIO COLLECTOR'S GUIDE is your data book with 50,000 facts, 1921-1932. 264 pages, \$3.95. **MOST-OFTEN-NEEDED RADIO DIAGRAMS** gives circuits of 600 models, 1926-1938. 240 pages, \$7.00.

SEND CHECK TODAY to Vintage Radio, Dep't P,
Box 2045 Palos Verdes Peninsula, CA. 90274
Postage Paid. Ten Day Guarantee, Calif. add 6%

_____	\$ _____
_____	\$ _____
_____	\$ _____
_____	\$ _____
TOTAL	\$ _____
NAME _____	
STREET _____	
CITY _____ ST _____ ZIP _____	

COLLECTORS!



spend a
dime,
save a mint.

Invest a dime and send for our catalog. We'll prove to you that you can have selection and convenience and still get a great price.

For an immediate
FREE copy of our
64-page catalog, in-
cluding pull-out
"Hifi Primer" sec-
tion, mail the coupon
below to the location
nearest you.
Please print.



Midwest Hifi Wholesale

& MAIL ORDER DIVISION

1626 Ogden Ave. (US 34), Downers Grove, Ill. 60515
3309 E. Carpenter Frwy. (Texas 183), Irving, Tex. 75062

NAME _____	
ADDRESS _____	
CITY/STATE _____ ZIP _____ (PE4-11)	

CIRCLE NO. 28 ON READERS SERVICE CARD

Bandwidth. If excessive amplifier power is sometimes a problem, excessive amplifier frequency response (bandwidth) can be worse. Now and again a speaker manufacturer will refer nostalgically to the carefree days when amplifiers had output transformers, those wonderful low-pass filters that blocked dc and never let anything much higher in frequency than the ear could hear (and sometimes not even that much) get through to the speakers.

Today it almost seems as if many transistorized amplifiers have power responses from dc to practically infinity. Occasionally a defective unit is found with so much ultrasonic oscillation running around inside that it almost violates the FCC's regulations on illegal r-f radiation. Ultrasonic stuff, particularly when it's a constant, steady-state signal, is extremely hard on tweeters. At some high frequency the mass of any tweeter will prevent it—or at least parts of it—from moving in response to the signal. This means that the entire input is converted into heat; being unable to move, the voice coil doesn't even have the benefit of the circulating currents of cooling air that are set up to some extent during normal operation. Recently, I heard of a case in which an amplifier so afflicted, when hooked up to speakers of extremely high power-handling capability, wiped out all the tweeters before the music even had a chance to start. The preventive measure you should take here—and I've been observing it ever since the big, wide-bandwidth amplifiers started to arrive—is to connect up the oscilloscope before you connect up the speakers. This will enable one to check for ultrasonic output, and also to inspect any low-frequency turn-on pulses. It's best to have the rest of the system hooked up too, since certain combinations of components seem occasionally able to set up oscillations that other combinations avoid.

Most woofers today are quite sturdy, physically and electronically. You've got to be in a position to deliver really brutal amounts of power to them before they'll sustain much damage. Still, this is a possibility that must be considered. I have not heard lately of any woofers being hurt by record warps and such perturbations, although the amount of subsonic energy they can generate is sometimes startling. But amplifier misbehavior is another subject.

Any decent amplifier should be stable within the limits of its power-output capabilities, and even beyond them. And yet stories persist about certain designs that are believed to produce horrendous, speaker-destroying pulses of subsonic energy when overdriven, presented with an unfortunate type of speaker load, or otherwise mistreated. True enough, some early amplifiers were subsonically unstable, and probably the remembrance of them feeds the fires of suspicion about modern units. Furthermore, there are undoubtedly numerous cases of amplifier defects that have caused strange, unpredictable signals to appear at the outputs. But from what I've been able to learn, no such misbehavior can clearly be attributed to any of the modern, popular models. Speakers are returned to their manufacturers daily with the woofer voice coils torn out by the roots, among other sorts of mayhem. But it's rarely possible to tell whether the blame lies with the amplifier or the user.

Needless to say, an amplifier would have to be a big one to destroy a woofer in such dramatic fashion. Cautionary notes are always in order with high-power amplifiers. Whether he suspects trouble or not, it's probably a good idea for any owner of one to spend an evening listening with the speaker grilles off, just to familiarize himself with the degrees of excursion the woofer cones routinely go through.

Another point worth discussing is the matter of dc voltages (or dc "offsets") that may appear at the output capacitors. In a paper presented several years ago, Kerry Gaulder, who has served in design and engineering capacities with several major companies, treated this subject at length. An amplifier with dc offset will, of course, produce a constant current through the woofer voice coil. But this source of voice-coil heating is rarely of sufficient magnitude to concern anyone. What is problematic, according to Gaulder, is the possibility of serious woofer-cone offset. In other words, the dc current displaces the voice coil in the magnetic gap (either forward or back, depending on polarity), so that it is approaching the limits of its excursion in one direction, even when it's not reproducing any sound and is presumably at rest.

If this theoretical possibility is true, acoustic-suspension woofers might

be more susceptible to this effect than others. Whereas other woofers have relatively springy mechanical suspensions that resist offset, acoustic-suspension designs depend largely on the air cushion within their sealed enclosures to restore the voice coil to its proper "rest" position. Slow leaks in the enclosure could cause air pressures within and without the enclosures to be equalized, after a time, for any position the woofer cone cares to assume, and that becomes the new "rest" position. But theory aside, I have no in-practice facts to support such a supposition.

A voice coil offset significantly in the rearward direction is in danger of striking the bottom of the magnetic gap with even moderate low-frequency signals. Aside from the distortion and noise generated, this may do no immediate harm. But in time the edge of the voice-coil former (usually cardboard) may become flattened or turned over so that it can no longer clear the magnetic gap freely. An offset in the forward direction may launch the voice coil out of the gap entirely when a strong signal comes along, and a safe return cannot be guaranteed. Both these mishaps may

also occur when a woofer is overdriven by a powerful amplifier, but voice-coil offset greatly increases the probability.

Intrigued by Gaulder's paper, I managed to dig up a direct-coupled amplifier with a relatively high dc offset on one channel. (Gaulder suggests 25 millivolts as the maximum permissible value.) After letting it work over an acoustic-suspension speaker with some pipe-organ music for about an hour, I measured the offset as 0.16 volt across 4 ohms (the dc resistance of the speaker system). Despite this unacceptable voltage I was unable to detect any displacement of the woofer cone after the ordeal, which may prove something or nothing. My inclination is to defer to Gaulder's greater experience in this area, and so I suggest you pay some attention to dc voltages when present. Many amplifier manufacturers now routinely specify permissible offset values, and others would probably give you the figures they allow if requested.

TIM. Some investigations are currently being made into a new type of amplifier distortion—"new" in the sense that it hasn't been seriously

studied or quantified up to now. It goes by the name of transient intermodulation distortion or TIM. Its cause appears to be lateness of the negative feedback signal in getting back to its assigned earlier stage of amplification and engaging properly the signal being processed. The effect is too brief to be detected by conventional distortion measuring techniques with steady-state test signals, it is said. But, in effect, what happens is that the initial onset of an abrupt new signal within the amplifier (a transient, in other words) gets through without being correctly processed by negative feedback. This results not only in the feedback's failing to do its distortion-compensating job, but also in possible overload of subsequent amplifier stages.

I don't understand all the aspects of TIM, or even whether it is the problem it's been trumped up to be. But if it is, indications point to the generation of large amounts of high-frequency energy and the existence of frequent overload conditions within the amplifier. (Perhaps I should point out here that some amplifiers are considered to be more subject to TIM than others.) There's really no reason to suspect



A little Traveling Music, Please

Daily frustrations make a person want to get away from it all. And, the UTAH MP-3000 Speaker will take you there better, faster than any comparable unit. With the MP-3000, you **know** you are in Tahiti, Paris or even Nashville. Your day becomes more pleasant, too, as the MP-3000 conquers the sound barriers.

MP-3000 combines the rare attributes of sound and styling. Clean, undistorted sound comes from this 4-speaker, 3-way speaker system. The oiled and hand-rubbed walnut veneer cabinets, and unique grille of sculptured foam are both acoustically and geometrically beautiful. The system contains a 15" high compliance woofer with a 2" voice coil, as well as two horn-loaded-dome-tweeters. It's a distinguished combination of well-defined, distortion-free sound reproduction. Size: 27" x 20½" x 14" deep, excluding base. Shipping weight: 70#.

Come travel with us. Get complete information about the exciting MP-3000 Speaker System.



UTAH ELECTRONICS

Huntington, Ind. 46750

CIRCLE NO. 42 ON READERS SERVICE CARD

that it's directly responsible for any kind of speaker failure, since its duration is so brief. However, all the results are not in as yet. Readers interested in pursuing the subject further should consult the papers by Dr. Matti Otala in past issues of the *Journal of the Audio Engineering Society*.

The Stitch in Time. The readiest protection you can give a speaker from excesses of the amplifier is a fuse—preferably a fast-blow instrument fuse of the correct value inserted in series with the speaker. But what is the correct value? The individual drivers in a multi-way speaker system are not likely to have the same power-handling capacity. Nor should they. A few speaker manufacturers are now fusing some of the drivers in their systems individually, which is a great help. But in all frankness I should mention that I hear frequent complaints about blown fuses from people who religiously follow manufacturer's fusing recommendations. Probably the manufacturers, with worst-case situations uppermost in their minds, have tended to be a little conservative. Still, their advice is the best you can get for your particular speakers.

For over a year I have used 1½-amp fuses in my speaker lines and have never (fortunately) lost a speaker. I do lose fuses however—sometimes as many as three sets a month, although I have never blown a fuse on music signals except on one occasion when I was asking for it. This is not, I emphasize, a recommendation, and if you blow out a speaker following my practice you can't sue. But if you have no idea on how to go about fusing your speaker, this may be a good way to start. Pay no attention to the nominal impedance of your speaker system, because it is in most cases "nom-

inal," having little or nothing to do with the impedance over most of its frequency range.

There are on the market a few electronic speaker-protection devices that work very well, if you can accept the way in which they work. Usually they're connected in parallel with the power amplifier, so that they can sense the amplifier output and limit the amplifier input when a certain level is exceeded. Their thresholds are adjustable, with very approximate calibrations provided. But what they do, in fact, is convert your 100-watt amplifier into a 50-watt amplifier, or a 10- or 1-watt amplifier. This is because they act so fast—faster than a fuse, which will usually pass high-level signals of a brief, transient nature. (The comparative slowness of fuses is a controversial issue when speaker safety is considered, but it definitely makes more sense musically.)

More sophisticated devices are also available. Several years ago SAE began equipping some *speakers* with active, transistorized "black boxes" that electronically disconnected the amplifier when hostile signals appeared. (This made sense because the tweeters in these systems were electrostatics and had to be plugged into a wall socket anyway.)

An elaborate protective mechanism operating at the amplifier is the "Dynaguard" circuit built into the Dynaco Stereo 400 power amp. It is adjustable to limit the steady-state output of the amplifier from anything from 20 to 200 watts per channel in five steps. But its attack time is slow enough to permit short, "safe" signal peaks to get through. Perhaps more important, its action, which affects only the signal peaks, does not lop off the tops and bottoms of waveforms but merely rounds them, curtailing the

generation of high-frequency distortion products (see Fig. 3). The circuit, by the way, is rarely obvious to the ear in operation.

Finally, relays that disconnect the speakers in the presence of dc or

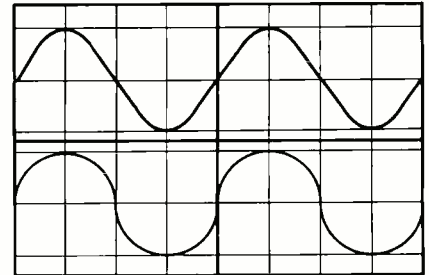

Fig. 3. Lower waveform shows effect of Dynaguard action on sine wave and lack of high-order harmonics.

strong subsonic signals are being incorporated in some amplifiers now. Basically they function to prevent "thumps" and other noises from the speakers when the equipment is turned on, but they will also serve in a protective capacity, blocking other hazardous signals that might be generated any time during operation.

Small Comforts. Articles on speaker failure always risk stirring up a lot of anxiety that is frequently unjustified. Speaker systems are rugged devices, and have to be. It is understood that they'll be used hard by anyone enthusiastic about music listening, and thus they're generally designed to hold together under any drive conditions capable of producing an undistorted, listenable output. If in spite of this they begin failing chronically, then manufacturers have to begin considering every possibility, since consumers are frequently not competent to diagnose what went wrong, and sometimes their complaint reports are not honest for fear of falling outside warranty terms. This is why the list of *potential* hazards has grown so long.

This discussion concentrates on the relatively obscure hazards—the ones that can't readily be heard or otherwise detected, and which therefore can't be prevented with a little bit of common sense. It's possible, even likely, that not one in a thousand of you will ever encounter a single one of them. But if someone, somewhere is helped by the above to discover a problem in time, or tipped off as to the cause of a mishap that has already occurred, then perhaps the telling of this grisly tale is worthwhile. ♦

NEW ALPHA
QUARTZ TIMED DIGITAL WATCH KIT
 HOUR & MINUTES 69.99
 WITH SECONDS ON DEMAND 79.99
 +2.00 handling
 complete kit except band and battery...

HIGH VISIBILITY FIELD EFFECT DISPLAY
 TIME SETTING BY REED SWITCHES
 STAINLESS CASE INCLUDED
 (CASE REQUIRES SOME ASSEMBLY)

ALPHA ELECTRONICS 305-636-6951
 P.O. BOX 1005 MERRITT ISLAND FLORIDA 32952

NEWS HIGHLIGHTS

Computer Pen

A new type of data input device that utilizes a special ballpoint pen and recognition circuitry that immediately translates hand-printed data into computer language has been announced by the Stanford Research Institute. The Alphabec-70 system, developed at SRI, is being introduced by Xebec Systems, a California company in computer peripheral equipment. Using the Alphabec-70, it will be possible to instantaneously enter hand-printed data into a processing system. In remote locations, the data can be recorded for later transmission to the data processing center. . . . The first Alphabec-70 system will have a 16-character capability (10 digits and six control characters). A company spokesman estimates that the system will replace many of the 700,000 or so keyboard entry devices now in use. The pen system eliminates keyboard-based procedures in data entry—and with them, document re-transcription, a source of human error, delay, and expense. It is expected to expedite field data collection in such applications as utility meter reading and sales order entry by routemen. The system is also applicable to banking, telephone-call logging, inventory control, and industrial data collection.

Purchase Only 53% of TV Receiver Cost

According to a study released by MIT, the purchase price of a color TV receiver accounts for only 53 percent of the total amount spent on the receiver during its useful life. Servicing accounts for 35 percent, and electrical power required for the receiver's operation claims 12 percent over the estimated 10-year lifetime of the receiver. "This means that the owner of a \$400 color TV [receiver] can expect to spend another \$400 during its usable life," according to the study. These figures do not take into consideration future inflation; so, the total cost of ownership could go progressively higher. . . . The purpose of the study was to "examine alternatives for increasing appliance service productivity in the context of what the consumer pays for a product during its usable life." The study notes a substantial increase in product reliability as evidenced by a 50-percent decline in the need for color receiver servicing during the last eight years. However, service costs have increased so greatly as to offset what would have been a sharply reduced life-cycle cost.

UA Releases 10-in. 78-rpm Disc

In keeping with the present popularity of "nostalgia," United Artists has released a 78-rpm disc containing two selections from its *Golden Age of the Hollywood Musical* album. "We're in the Money" and "Lullaby of Broadway" (both from Busby Berkeley film musicals of the 1930's) were pressed on a 10-in. mold and fitted with record labels that mirror the typographic and design style of the period. This necessitated the retooling of UA's pressing plant since 10-in., 78-rpm discs had not been pressed there in more than a decade and there was only one 10-in. die to be found in all of Los Angeles. . . . The reported vinyl shortage did not hamper progress on the project because 78-rpm discs are composed mainly of shellac and filler materials. ♦



Good time capsule.

Saving fleeting moments requires a quality tape recorder. But, just as a camera can be no better than its lens, tapes can be no better than the microphone. Whether it costs \$200, \$500—even \$1,000—a tape recorder can be significantly improved by the addition of a Shure *unidirectional* microphone—a mike that can be "aimed" so that only the target sounds will be recorded. Microphone misers who ignore this will never hear the *true* sound of recorded music lessons, parties, classes, speech therapy, sound movies and rehearsals. With Shure microphones, creating tomorrow's treasures is today's pleasure.



Shure Brothers Inc.
222 Hartrey Ave.,
Evanston, Ill. 60204
In Canada: A. C. Simmonds
& Sons Limited

 SHURE®

Manufacturers of high fidelity components, microphones, sound systems and related circuitry.
CIRCLE NO. 46 ON READERS SERVICE CARD

Why a Sylvania home training program may be

your best investment for a rewarding career in electronics

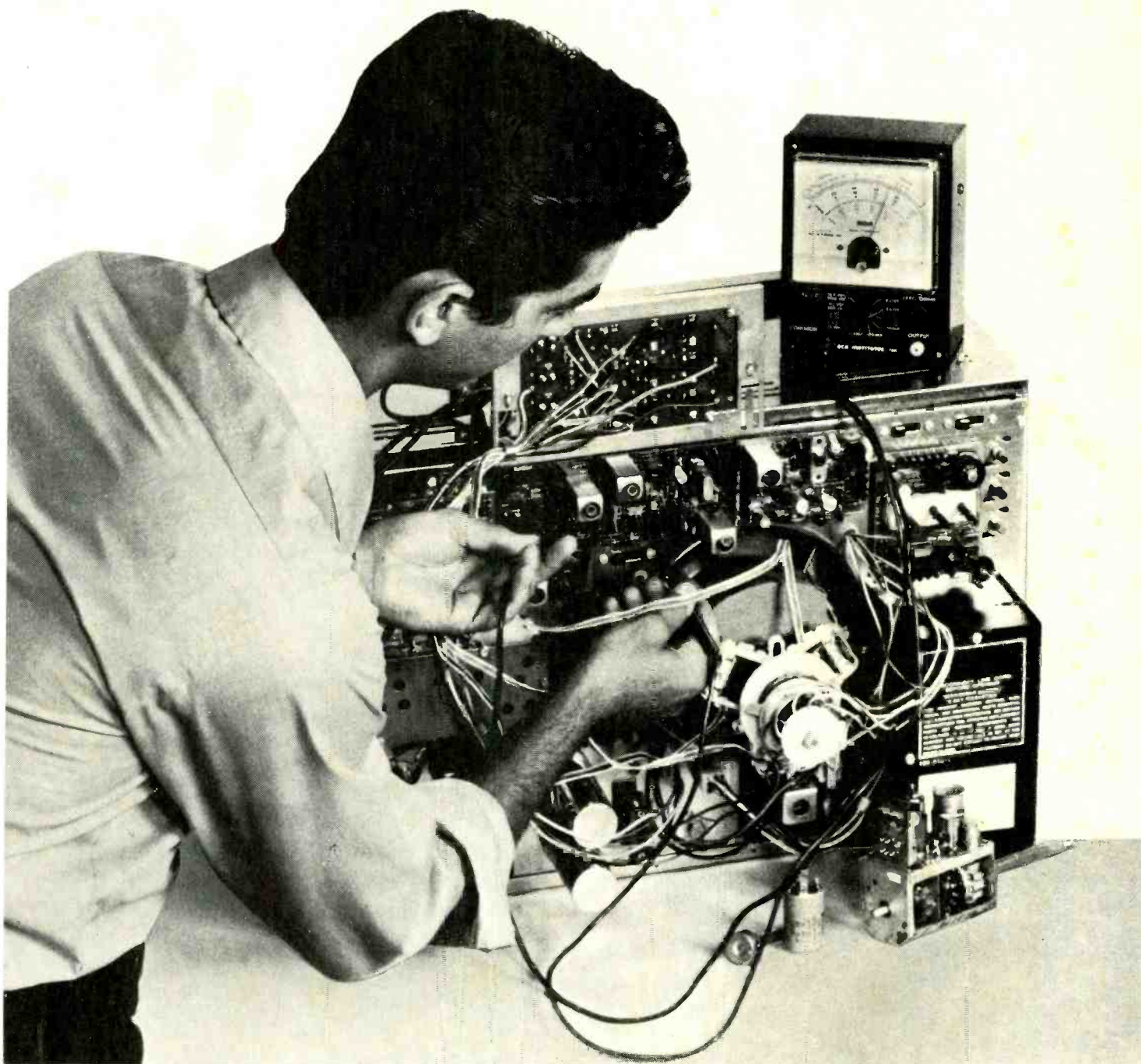

1 LEADER IN ELECTRONICS TRAINING

Over the years, Sylvania Resident Schools have trained thousands of men and women for key positions in the electronics field. Now, through Sylvania Home Training, you can receive the same high-quality career training at home. In your spare time. While you hold your present job. Remember, this training is designed with one purpose in mind — to give you the background you need to land the electronics job you really want!

2 AUTOTEXT TEACHES YOU ELECTRONICS RAPIDLY, EASILY.

AUTOTEXT, offered exclusively by Sylvania, is the proven step-by-step method of home training that can help you learn the basics of electronics quickly and easily.

3 CASSETTE SYSTEM

This innovative learning-by-hearing approach is a special option that adds an extra dimension to AUTOTEXT. It's almost like having an instructor guiding you through your AUTOTEXT lessons. Explaining the material as you read it. Going over schematics with you, reinforcing the basic electricity and electronics study materials with you. Everything you need to know to get you started towards a highly regarded position as an electronics technician — all in an easy-to-understand, conversational tone.

4 SPECIALIZED ADVANCED TRAINING

For those already working in electronics or with previous training, Sylvania offers advanced courses. You can start on a higher level without wasting time on work you already know.

5 PERSONAL SUPERVISION THROUGHOUT

All during your program of home study, your exams are reviewed and your questions are answered by Sylvania instructors who become personally involved in your efforts and help you over any "rough spots" that may develop.

6 HANDS-ON TRAINING

To give practical application to your studies, a variety of valuable kits are included in many programs. In Sylvania's Master TV/Radio Servicing Program, you will actually build and keep an all solid-state black and white TV set, and a color TV set. You also construct an oscilloscope which is yours to keep and use on the job.

7 FCC LICENSE TRAINING — MONEY BACK AGREEMENT

Take Sylvania's Communications Career Program — or enter with advanced standing and prepare immediately for your 1st, 2nd, or 3rd class FCC Radio Telephone License examinations. Our money-back agreement assures you of your money

back if you take, and fail to pass, the FCC examination taken within 6 months after completing the course.

8 CONVENIENT PAYMENT PLANS

You get a selection of tuition plans. And, there are never any interest or finance charges.

SEND ATTACHED POSTAGE PAID CARD TODAY! FREE DESCRIPTIVE BOOK YOURS WITHOUT OBLIGATION!

Sylvania Technical Systems, Inc.

If reply card is detached send this coupon

SYLVANIA TECHNICAL SCHOOL	
Home Study	694-411-0
909 Third Avenue	
New York, N.Y. 10022	
Please send me FREE illustrated career catalog. I understand that I am under no obligation.	
Name _____	
Address _____	
City _____	
State _____	Zip _____
Age _____	
Veterans: Check here <input type="checkbox"/>	

GTE SYLVANIA

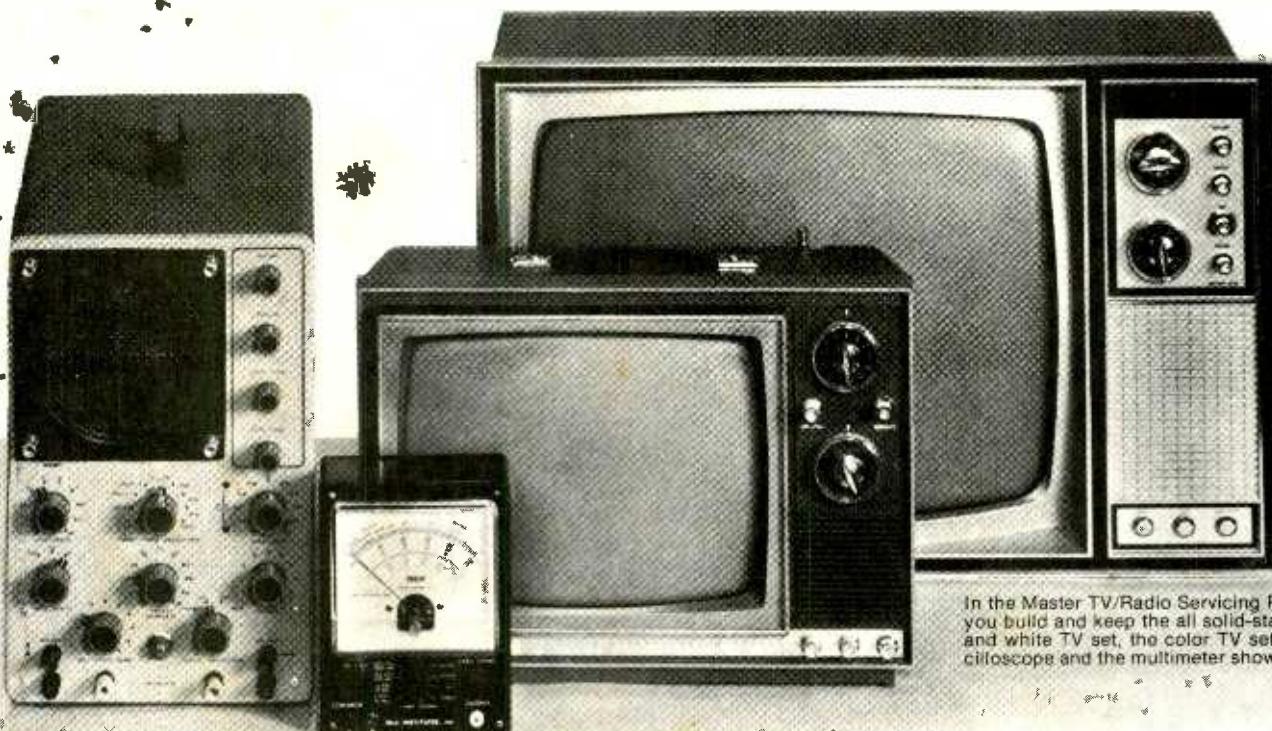

In the Master TV/Radio Servicing Program, you build and keep the all solid-state black and white TV set, the color TV set, the oscilloscope and the multimeter shown above.

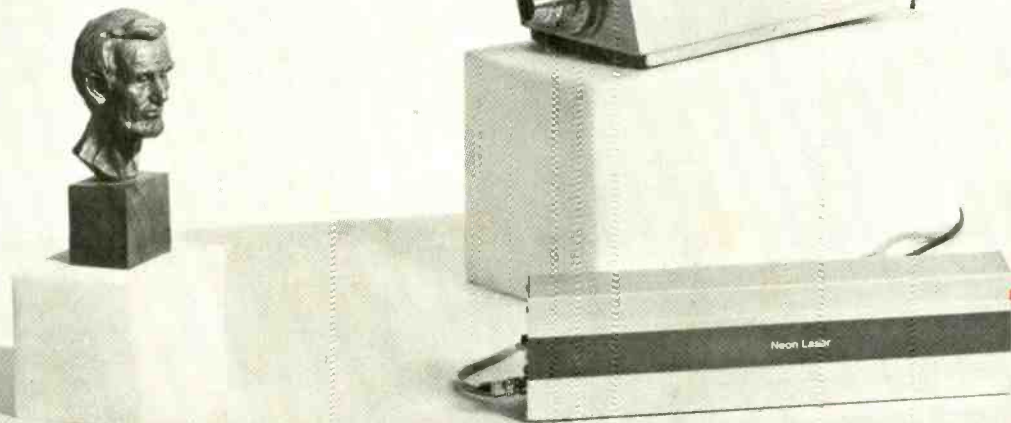

EVER since we published construction plans for the world's first hobbyist experimenter's laser in December of 1969, POPULAR ELECTRONICS has kept readers abreast of laser developments. For example, in January 1970, we gave details on how to use the laser for making three-dimensional holograms. Then, in May 1970, we published plans for assembling a laser voice communicator (which, incidentally, was featured for several weeks in the Smithsonian Institution)

Now, we have another breakthrough—plans for building the world's first experimenter's laser video (TV) system for a moderate \$150. (The TV camera and receiver are extra items.)

THE POPULAR ELECTRONICS laser TV system gives you an advance look at a communication system of the future. There are two key devices in the system. One is the composite laser tube, video modulator "transmitter" that works in conjunction with a low-cost TV camera. The other is the detector/r-f modulator "receiver" that feeds an ordinary TV receiver. (See box on Class-1 requirements.)

The helium-neon laser tube used in the system employs the latest aluminum cathode design. The tube is used in conjunction with solid-state modulation and detection circuits.

With the laser TV system, you can expect a range up to 50 ft without special optics. For extended range, you can use a telescope and/or a converging lens. More about range later in the article.

Overall System. The block diagram of the overall laser TV system is shown in Fig. 1. The video (or audio, not both simultaneously) output signal from the TV camera is typically on the order of 1 volt peak-to-peak. This signal is fed to the laser modulator, which is designed to provide a gain of 2 mA/volt. Hence, the 1-volt p-p video output signal from the camera, after passing through the modulator, is converted to a 2-mA p-p signal that current-drives the laser tube.

The gain of the laser tube is about 0.1 mW/mA, while the laser detector has a gain of 1.25 mA/mW. The r-f oscillator in the detector is tunable over a 60- to 72-MHz range to permit the system to operate on

TV channel 3 or channel 4, whichever is not in use in your area.

The output of the r-f modulator is an amplitude-modulated (AM) signal that is adjustable from 0 to 5 mV rms. This signal can be fed into an ordinary TV receiver through its vhf antenna terminals by means of 300-ohm twin-lead cable.

Laser/Modulator Circuit. In the laser/modulator power supply, shown schematically in Fig. 2, *T1*, *C5-C8*, and *D9-D14* are arranged in a voltage doubler configuration that serves as the main high-voltage supply. This supply delivers about 1700 volts to the laser tube. Diodes *D1-D8* and capacitors *C1-C4* form two more voltage doublers that are "stacked" on top of the main high-voltage supply for ionizing the gas in the laser tube. As soon as ionization is complete, current starts to flow through the laser tube. However, the values of *C1-C4* are too low to support the 5-mA tube current. So, the starting voltage collapses and only the main sustaining voltage remains.

Transformer *T2* and its associated rectifiers (*D15-D18*) and filter capacitors (*C9-C14*) make up

ANOTHER

EXCLUSIVE

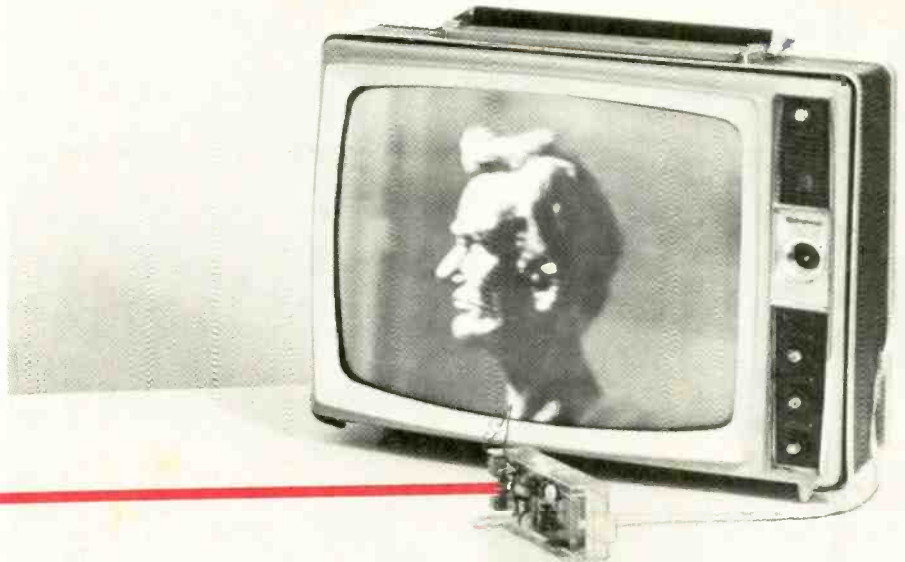

BUILD A
**Laser
TV
System**

BY GIANCARLO PUNIS
AND JOSEPH O'DONNELL

*Now you can
transmit and
receive black and white
TV pictures over
a substantial
distance with a
license-free
laser beam
video link*

the low-voltage supply that delivers the +20- and -20-volt lines for the low-voltage portions of the modulator.

High-impedance amplifier Q1 preamplifies low-level microphone signals of about 0.1 volt p-p to the 1-volt p-p level required to drive Q2 to obtain the full 15-percent modulation. (See Fig. 3 for the modulator schematic diagram.) The high-level 1-volt p-p video input at J2 and the collector of Q1 are both ac-coupled to the base of Q2 and, therefore, to each other. Hence, when using either of the J1 (audio) or J2 (video) inputs, it will be necessary to disconnect the unused input. This is important to prevent interference between the two signals as well as to prevent loading Q1's collector.

Transistors Q2-Q4 each provide some gain at the lower frequencies and one stage each of high-frequency boost, starting at about 250 kHz and ending at about 1 MHz. The boost characteristics are achieved by the RC networks used as emitter loads for the transistors. In addition, there are two broadly tuned traps consisting of C24/L1/R16 and C25/L2/R22, centered at 160 kHz and 330 kHz.

The frequency response of the laser tube only is shown in Fig. 4A. The strong peak at 170 kHz would cause severe overshoots and ringing on the fast edges of TV sync pulses or any sharp white-to-black transitions. In addition, the -3-dB bandwidth is only 250 kHz wide, with corresponding poor picture resolution. So, to smooth out the frequency response and to extend it beyond 500 kHz, the modulator combines boost circuitry and traps to yield the compensating response shown in Fig. 4B. Combining the A and B response curves, the overall laser tube/modulator system has the frequency response characteristic shown in Fig. 4C, which is adequate for most applications.

The frequency-compensated signal is coupled to Q5, which acts as a current source for both the dc bias (trimmed to 5 mA by R33) and the ac signal currents for the laser tube. Except for a small amount of current through R27 and R28, the current sourced by Q5 also flows through Q6 and Q7, ballast resistor R26, and the laser tube. Each rated at 300 volts, Q6 and Q7 are cascaded to act as one transistor with a 600-volt break-down rating.

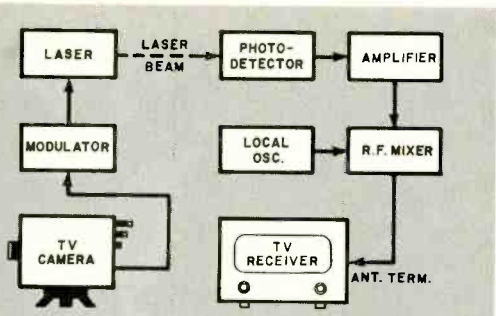
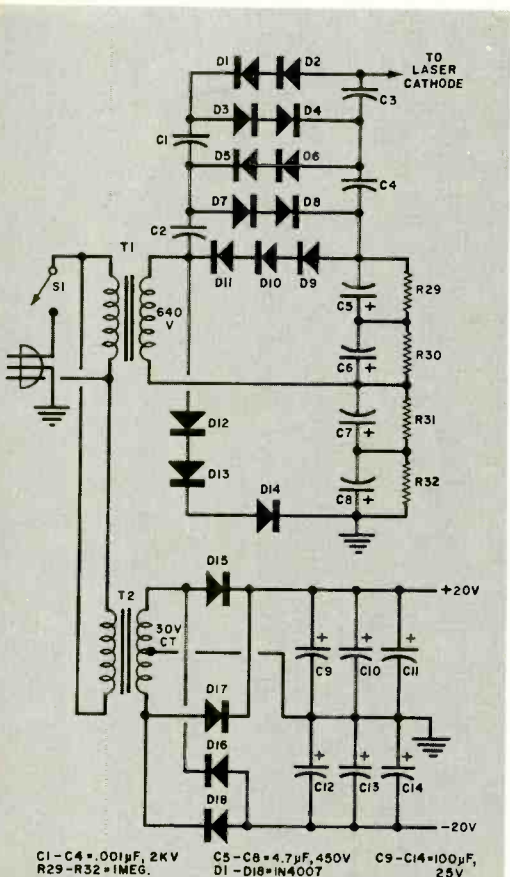

Fig. 1. Block shows the basic arrangement of the laser video link.

Detector Circuit. Phototransistor Q1 in Fig. 5 is connected as a photodiode, providing a 40- μ A p-p signal, depending on the intensity of the laser beam. This results in a 200-mV video signal at the base of Q2.

Transistor Q3 is a Hartley oscillator stage, whose operating frequency is determined by L1 (printed on the circuit board as part of the conductor pattern), C7, and C8. Capacitor C7 is adjustable to permit the circuit to operate on either the TV channel 3 or channel 4 frequency.



C1-C4 = .001 μ F, 2KV
R29-R32 = 1MEG.
C5-C8 = 4.7 μ F, 450V
D1-D18 = 1N4007
C9-C14 = 100 μ F,
25V

Fig. 2. Half of high-voltage supply "drops out" when laser starts. Low-voltage supply is more conventional.

The vhf carrier is ac-coupled to mixer diode D1 through C6, resulting in a video-modulated vhf signal of about 5 mV rms with r-f level control set for maximum output. The r-f signal goes directly to the vhf antenna input terminals through 300-ohm twin-lead antenna cable. Note, however, that when the output of the detector circuit is connected to the TV receiver's antenna terminals, the regular TV antenna cable must be removed.

Zener diode D2 provides a 3.6-volt dc bias supply for Q2 and serves as the dc supply regulator for the Q3 oscillator circuit.

Assembling the System. Except for the laser tube, jacks J1 and J2, transformer T1, and power switch S1, all components shown in Figs. 2 and 3 mount on a single printed circuit board. The actual-size etching and drilling guide and components placement diagram for the laser/modulator system are shown in Fig. 6. To permit the etching and drilling guide to be reproduced without reduction, it is shown in two parts. The left edge of the lower portion butts against the right edge of the upper portion, with the ground bus (heavy black areas) aligned.

When wiring the circuit board according to the diagram in Fig. 6, take care to properly orient the components. Pay particular attention to electrolytic capacitor polarities, transistor basing, and T2's lead routing. Bear in mind that T2 and the laser tube mount on the foil side of the board. Also, all resistors (except R26 and R29-R32) and L1 and L2 mount on-end. The rest of the components mount on the board in the conventional manner. Note that only C5-C8 are axial-lead capacitors, designed to mount flat on the board, while all other electrolytic capacitors are upright types.

Potentially lethal voltages are developed in the laser circuit. Consequently, it is imperative that the entire assembly be mounted inside a rugged — preferably metal — enclosure. Use only nylon screws when mounting anything inside the enclosure to prevent access to any high-voltage points in the circuit once the system is assembled. Select an enclosure that is large enough to accommodate the laser tube, pc board assembly, and transformer T1. Mount closed-circuit miniature phone jack J1, BNC jack J2, and power switch S1 on the rear wall of the enclosure. In another hole on this wall should be the three-

conductor power cord, held in place with a plastic strain relief. (Or line the hole with a rubber grommet, pass the line cord through, and tie a knot in the cord.)

The exit hole for the laser beam must be drilled through the enclosure's front wall, directly in line with the beam's travel. Use a 1/4-in. (6.35-mm) diameter drill bit. If possible, mount a tubular flange with a ferrous outer ring as a bezel over the hole. The ferrous ring is a convenience feature that supports the various lenses that come mounted in circular magnets in the event you decide to perform other experiments using the laser.

Solder push-on connectors to one end of a red and a black 3-in. (7.72-cm) or less pieces of 5-kV test-lead cable. Shrink tubing over the connections. Then solder the free end of the red cable to point A and the black cable to point C on the foil side of the pc board.

Drill 1/8-in. (3.27-mm) holes through the donuts marked X on the pc board. Mount a tube mounting clamp at each hole location. Orient the laser tube so that its pin-connector end is toward T2 and the anode pin on the narrow neck points toward the red cable. Set the tube down in the clamps and anchor it in place with rubber hold downs. Caution: Do not mount or handle the laser tube by its narrow necks.

Slip the red cable connector onto the anode pin of the laser tube. Then locate the cathode pin on the opposite side of the tube from the anode pin, and slip the black cable's connector onto it.

Solder 10-in. (25.4-cm) long pieces of hookup wire, preferably color coded for easy identification, to the remaining holes in the pc board. Slip 1-in. (2.54-cm) long pieces of heat-shrinkable tubing over the wires connected to the T1 secondary points. Then mount the board in the enclosure with nylon screws and insulated spacers.

Mount T1 on the floor of the enclosure. Then locate the leads with the shrinkable tubing on them. Route these leads along the component side of the board, and connect and solder them to T1's secondary winding, trimming as necessary. Shrink the tubing tightly over the connections. Complete the wiring, referring to Figs. 2, 3, and 6.

Assembling the detector is a very simple, straightforward process. Except for phototransistor Q1 (Fig. 5), output connector, and power switch,

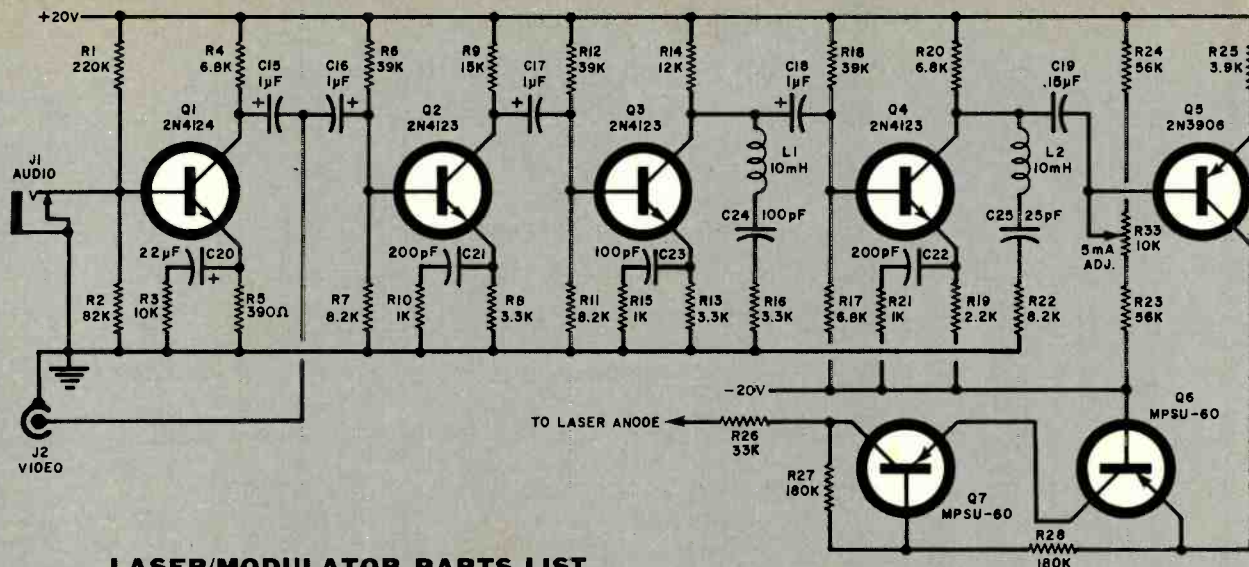

LASER/MODULATOR PARTS LIST

- C1-C4—0.001- μ F, 2-kV ceramic disc capacitor
- C5-C8—4.7- μ F, 450-volt axial-lead electrolytic capacitor
- C9-C14—100- μ F, 25-volt upright electrolytic capacitor
- C15-C18—1- μ F, 50-volt upright electrolytic capacitor
- C19—0.15- μ F disc capacitor
- C20—22- μ F, 10-volt upright electrolytic capacitor
- C21, C22—200-pF, 100-volt disc capacitor
- C23, C24—100-pF, 100-volt disc capacitor
- C25—25-pF, 100-volt disc capacitor
- D1-D18—1000-P1V, 1-A rectifier (1N4007 or similar)
- J1—Miniature shorting-type phone jack
- J2—BNC jack
- L1, L2—10-mH choke
- Q1—2N4124 transistor
- Q2-Q4—2N4123 transistor
- Q5—2N3906 transistor
- Q6, Q7—MPSU-60 transistor (Motorola)
- R1—220,000-ohm
- R2—82,000-ohm
- R3—10,000-ohm
- R4, R17, R20—6800-ohm
- R5—390-ohm
- R6, R12, R18—39,000-ohm
- R7, R11, R22—8200-ohm
- R8, R13, R16—3300-ohm
- R9—15,000-ohm
- R10, R15, R21—1000-ohm
- R14—12,000-ohm
- R19—2200-ohm
- R23, R24—56,000-ohm
- R25—3900-ohm
- R27, R28—180,000-ohm
- R29-R32—1-megohm
- R26—33,000-ohm, 2-watt resistor
- R33—10,000-ohm upright pc trimmer potentiometer

All resistors
1/2-watt, 10%

- S1—Spst switch
- T1—640-volt, 25-mA power transformer
- T2—Dual 15-volt, 25-mA power transformer
- Misc.—Metal enclosure; printed circuit board; laser tube No. PE719; mounting clamps for laser tube mounting; 5-kV test-lead cable; three-conductor line cord; pin connectors (2) for anode and cathode cables; heat-shrinkable tubing; rubber grommet or plastic cable clamp/strain relief; nylon mounting hardware and insulated spacers; 1000-ohm, 1/2-watt resistor (for transmitter checkout); hookup wire; solder; etc.

Note: The following items are available from Metrologic Instruments, Inc., 143 Harding Ave., Bellmawr, NJ 08030: No. PE719 laser tube (\$96); No. PE640 640-volt power transformer (\$7); No. PE101 etched and drilled transmitter pc board (\$6); No. PE201 etched and drilled detector/modulator pc board (\$3); No. PE669 complete kit of transmitter parts, including laser tube, pc board, transformers, metal housing, etc. (\$124.50); No. PE301 complete kit of detector/modulator parts, including housing (\$25); No. PE500 complete kits of transmitter and detector/modulator parts (not including TV camera) (\$148). All prices postpaid. Canadian readers can order from Merlan Scientific, Ltd., 825 Lake Shore Rd., Port Credit, Ontario, Canada.

Fig. 3. Frequency response of video amplifier is "tailored" to improve laser tube's response. Resulting video modulates laser beam.

CAUTION
Never look into the laser beam proper or directly into its reflection.

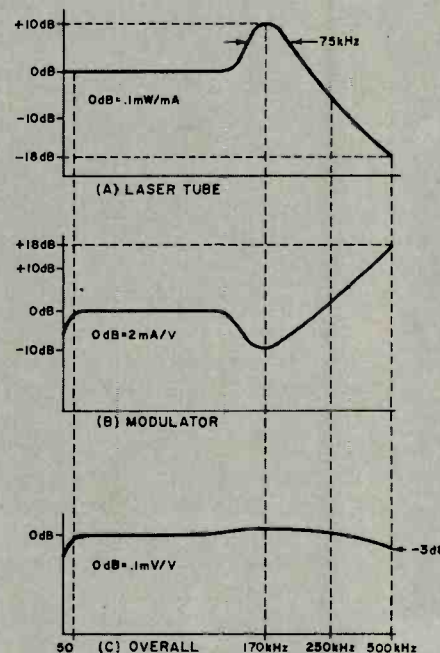

Fig. 4. Response curves of laser tube (A) and modulator (B) combine to provide flat overall system response (C).

everything mounts on a small pc board. The actual-size etching and drilling guide and components placement diagram for the detector are shown in Fig. 7. Note that coil L1 is part of the printed wiring.

The on-board components mount in the conventional manner. Just be sure to properly polarize the electrolytic capacitors and transistors. Transistor Q1 mounts in a hole on one wall of the metal enclosure, its lens "looking" to

the outside world. The phototransistor can be held in place with a bead of clear epoxy or plastic glue.

Install the battery on the floor of the enclosure, under the pc board assembly, in a battery clip. And power switch

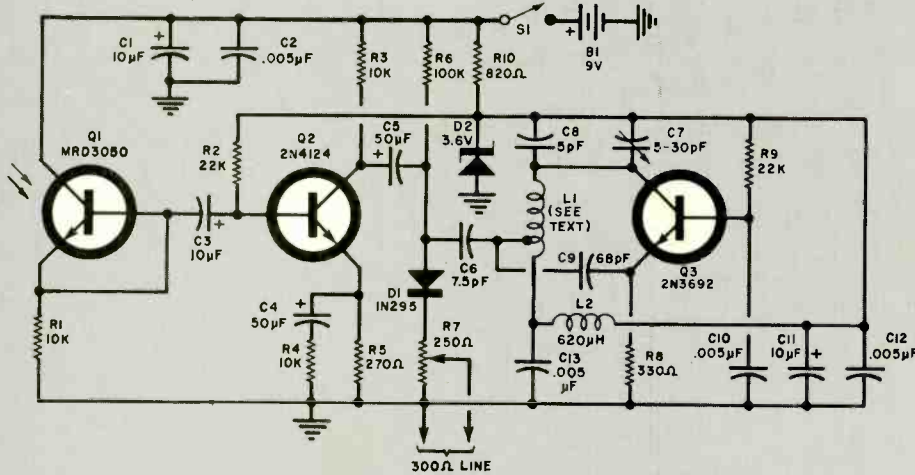

DETECTOR/R-F MODULATOR PARTS LIST

- | | |
|---|--|
| B1—9-volt battery | Q2—2N4124 transistor |
| C1, C3, C11—10- μ F, 10-volt electrolytic capacitor | Q3—2N3692 transistor |
| C2, C10, C12, C13—0.005- μ F disc capacitor | R1, R3, R4—10,000-ohm |
| C4, C5—50- μ F, 10-volt electrolytic capacitor | R2, R9—22,000-ohm |
| C6—7.5-pF silver-mica capacitor | R5—270-ohm |
| C7—5-30-pF miniature ceramic trimmer capacitor | R6—100,000-ohm |
| C8—5-pF silver-mica capacitor | R8—330-ohm |
| C9—68-pF silver-mica capacitor | R10—820-ohm |
| D1—1N295 diode | R7—250-ohm vertical pc-type trimmer potentiometer |
| D2—3.6-volt zener diode (1N747 or similar) | S1—Spst switch (optional) |
| L1—R-f coil (etched on pc board) | Misc.—Chassis box; printed-circuit board; battery clip; output cable connector (optional); 300-ohm twin-lead cable; hookup wire; spacers (2); hardware; etc. |
| L2—620- μ H choke | (Note: For kit information, see Laser/Modulator Parts List.) |
| Q1—MRD-3050 phototransistor (Moto-rola) | |

Fig. 5. Photodetector modulates oscillator on channel 3 or 4 to generate signal that goes via 300-ohm line to television receiver's antenna terminals.

S1 and the output cable connector mount on the rear wall of the enclosure.

System Checkout. Before applying any power to the laser/modulator, double check all components for proper installation. Check particularly for cold solder joints and solder bridges. If everything checks out okay, disconnect the primary of T1, Q6, and the laser tube from the circuit.

Temporarily connect a 1000-ohm, 1/2-watt resistor between Q5's collector and the -20-volt bus. Turn on the power. Now, using a high-impedance multimeter (a 20,000-ohms/volt VOM will do), check to verify that +20 and -20 volts dc is available from the power supply. Because of the temporary collector load, Q5's collector will be at about -15 volts. Adjust R33 for a reading of exactly 5 volts across the temporarily installed 1000-ohm resistor.

Alternatively, insert a milliammeter in series with the resistor and adjust R33 for a reading of exactly 5 mA. Turn off the power and disconnect the line cord from the ac receptacle.

Wire T1 into the circuit. Before applying power, remember that potentially lethal voltages are present at the negative end of C5 and the cathode (black) lead. Keep the latter well away from ground and the low-voltage circuits. The starting voltage at the top of C3 can be checked, but the meter has a loading effect on the circuit. So, do not expect to read more than about 3.5 kV when making measurements on the 5-kV range with a 20,000-ohms/volt meter. Turn off the power, and remove the plug from the ac receptacle. After power is removed, *do not touch any part of the circuit for about five minutes* until the high-voltage charges on the capacitors dissipate.

When the circuit is safe to handle

again, remove the temporary resistor from Q5's collector circuit and reconnect Q6. Connect the anode lead to the tube and a 0-10-mA meter in series with the tube's cathode pin and the cathode (black) lead. Make certain that the milliammeter and its leads are well separated from ground and the low-voltage circuits.

Plug in the line cord and turn on the power. After a short lag, the gas in the laser tube should ionize and glow

CLASS-1 TV DEVICES

There has recently been a proliferation of electronic games designed to be used with a conventional TV receiver. These so-called "Class-1" devices apply a modulated low-level r-f carrier signal directly to the receiver's antenna terminals. Because they might produce interference, the FCC has placed restrictions on the manufacture, sale, and use of Class-1 devices, of which the laser detector/r-f modulator in this article is one.

Class-1 TV device requirements are:

1. They must operate on a channel allocated for vhf or uhf broadcast TV.
2. They must transmit the r-f signal to the TV receiver by wire or cable.
3. The r-f output level must be less than 6 mV rms into a 300-ohm output.
4. A transfer switch with 60 dB of isolation must be used for switching the antenna terminals between the TV antenna and the Class-1 device.

5. The peak envelope power of any spurious emission at frequencies 3 MHz or more from either edge of the standard TV channel being used must be 30 dB or more below the peak envelope power of the in-band signal.

6. Radiated EMI from the device must be less than 15 μ V/meter at 2.6 ft. (0.79 m) from the detector modulator.

7. The device must be formally type approved by the FCC. In the case of a kit-form Class-1 device, only the manufacturer of the kit is required to obtain type approval.

The above list of regulations applies only to the detector/r-f modulator portion of the laser TV system. No specific restrictions are placed on the laser transmitter. With regard to the isolating switch, the laser TV system has none, but removing the TV receiver's antenna will satisfy the requirement. (Bear in mind that it is illegal to have the detector's output cable and the TV antenna hooked up to the TV receiver at the same time.)

The detector/r-f modulator has been type approved by the FCC. However, it is strongly urged that if you build your own instead of buying the kit from Metrologic, you faithfully follow the pc layout and assembly instructions presented in this article.

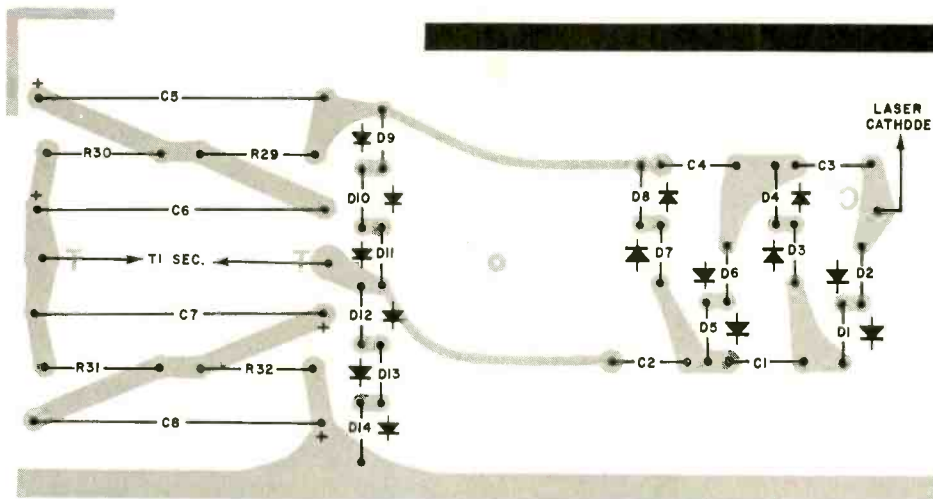
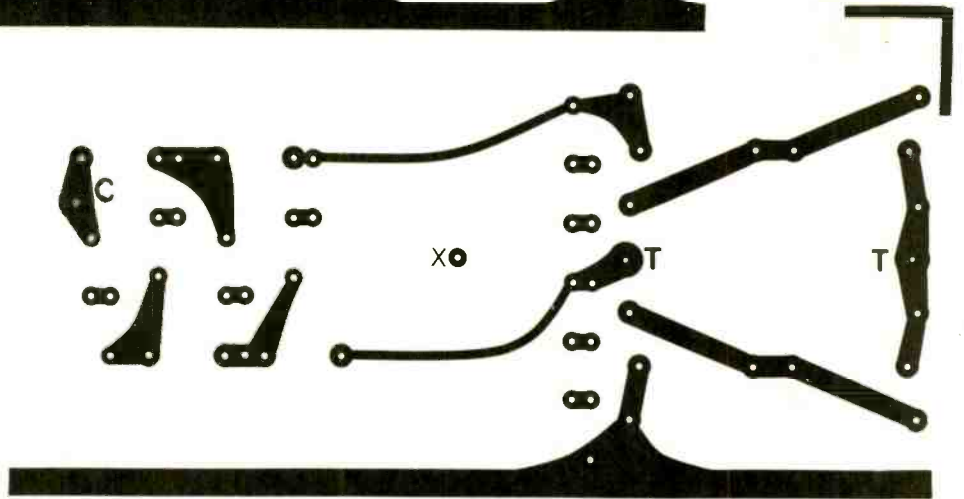
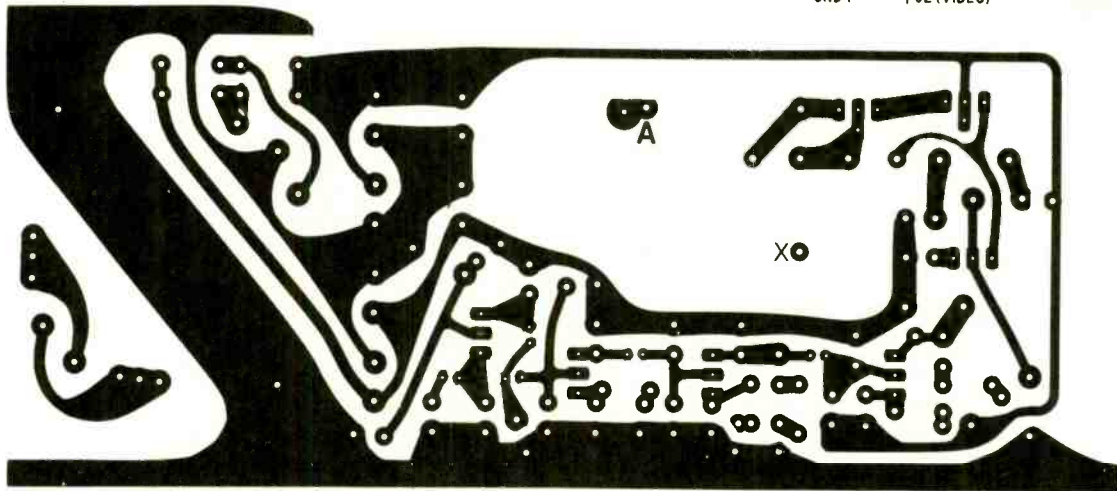
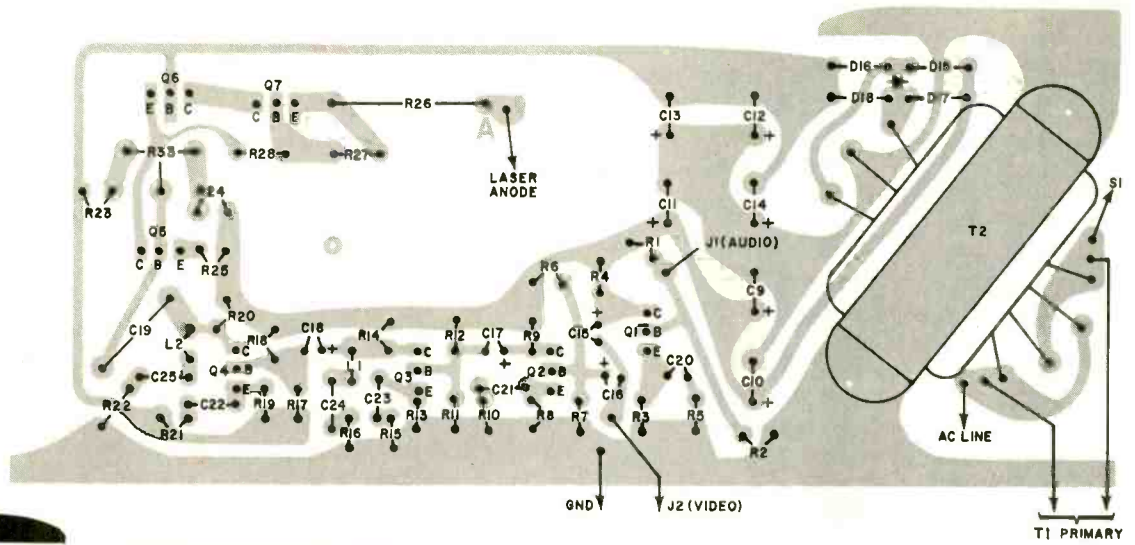

Fig. 6. Actual-size etching and drilling guide for power supply and modulator is shown in two parts (center). The component-placement guides are shown above (top) and below (left) their respective etching guides.

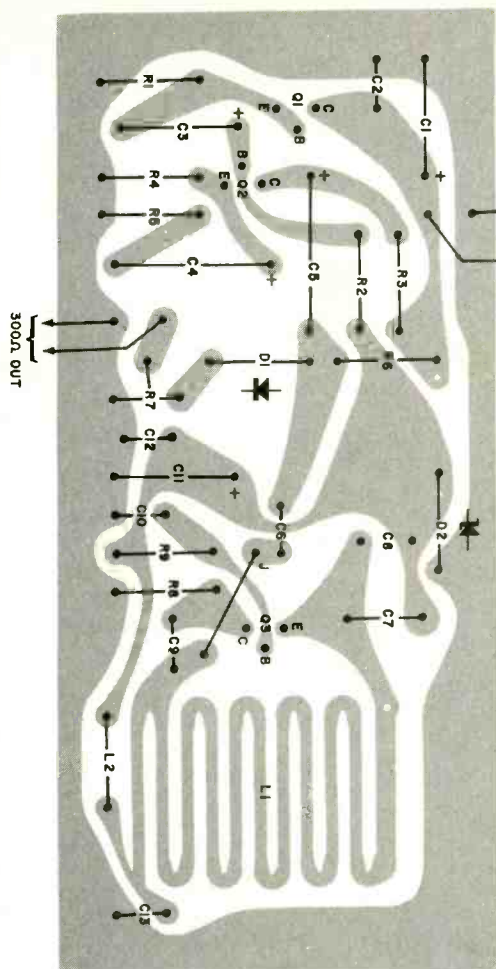

Fig. 7. Actual-size etching guide for detector/modulator (bottom) features printed r-f oscillator coil. Component-placement guide is at left.

orange. (Caution: Never look into the laser beam or directly into the reflected beam.) The milliammeter at this time should indicate a 5-mA current flow. If necessary, touch up the setting of R33 to obtain a 5-mA reading. Then turn off the power and remove the line cord from the ac line. Again, do not touch the assembly until the high-voltage charges have bled off the electrolytic capacitors. Then remove the milliammeter and reconnect the black cable to the cathode pin on the laser tube.

Reapply power to the system. Now, exercising extreme caution, measure the collector-emitter voltages on Q6 and Q7. Both transistors should have approximately the same voltage drop. An unequal drop indicates that something is wrong, meaning that you will have to troubleshoot the circuit.

Since the detector employs only a low-voltage battery supply, it is safer to work on than the laser/modulator. The emitter of Q1 should be at 0 volt with no light entering the phototransistor through its lens. With the laser beam impinging on the sensitive surface of Q1, the emitter will be at about 2 volts. (Note: A 20,000-ohms/volt meter will load this down to about 1.6 volts.)

Connect the r-f output line to the antenna terminals of a conventional TV receiver, after first removing the TV antenna cable. Adjust C7 for operation on either channel 3 or channel 4, whichever is not in use in your area. Now, modulating the laser with a TV camera, an oscilloscope should reveal the composite video signal at the emitter of Q1 at a level of about 220 mV p-p. (Almost any type of oscilloscope can be used here.) The waveform at the cathode of D1 will be the video-modulated r-f signal operating at about a 5-mV p-p level. It may be necessary to adjust R6 to obtain the correct signal level.

If you do not have access to a scope, set potentiometer R7 to the middle of its range. Set the TV receiver to the unused channel 3 or 4. Very slowly adjust C7 for the clearest, sharpest

picture on the screen of the TV receiver, while video-modulating the laser. Then adjust pot R7, and the TV receiver's brightness and contrast controls for the best picture quality. Also, if the TV camera does not have a wide agc light range, its lens should be adjusted as well for best picture.

Setup and Use. In setting up the laser TV system, bear in mind that adequate light must be on the subject to be televised. Avoid subjects (pictures) that have very bright and very dark contrasts close to each other. Focus the camera carefully, and select the best lens opening for the subject to be televised.

When mounting the laser/modulator and receiver, use solid supports to obviate vibrations and shifts that might cause the laser beam to miss the phototransistor in the detector and result in transmission drop-outs.

The uncollimated beam from the laser has a 1-milliradian divergence characteristic that causes the spot to spread to about 1 meter in diameter at 1000 meters. So, if you plan on long-distance transmission of the laser beam, you must use collimation to keep the beam as narrow as possible. The collimator is simply a telescope used backwards, with the laser beam fed into the eye-piece and exiting through the large end of the telescope. You can use either a reflecting or a refracting telescope.

The greater the power of the telescope used, the greater the range you can expect and the tighter the laser beam. However, with increasing range, optical alignment becomes a critical factor. So use a solid mount for the telescope.

Range can also be increased with a light-gathering lens at the detector end. This is comparable to using a high-gain antenna for radio waves. You can buy lightweight plastic Fresnel lenses measuring up to 11 in. (27.94 cm) square at very reasonable prices. Such lenses make excellent light gatherers. They must be focused on the sensitive surface of the phototransistor in the detector.

Long-distance alignment can be simplified in several ways. Use a rigid mounting system and some form of vernier positioner (for fine adjustment) for aiming the laser. Perform the alignment at night when the bright red laser beam is easier to see. For night setups, a bicycle safety reflector will prove useful in following the beam to the detector target. ♦





HOW THE NEW FTC HI-FI RULES AFFECT YOU!

BY LEONARD FELDMAN

EFFECTIVE November 4, 1974, new rules governing the disclosure of the output power of audio amplifiers and receivers go into effect. The new rules were promulgated by the Federal Trade Commission after several years of study. They follow a long period of advertising abuse by some segments of the electronic home-entertainment industry.

Well-known "low-fi" products claiming output power capabilities of as much as 100 watts "instantaneous peak power (IPP)" have been measured by reputable laboratories and have consistently produced no more than a few watts of output power per channel at best. Meaningless terms such as IPP, peak power, peak music power, and dynamic music power—if they are to be used in the future at all—will have to be given less typographical prominence in all advertising media.

Still Room for Ambiguities. Will the FTC rule end the confusion about

NOVEMBER 1974

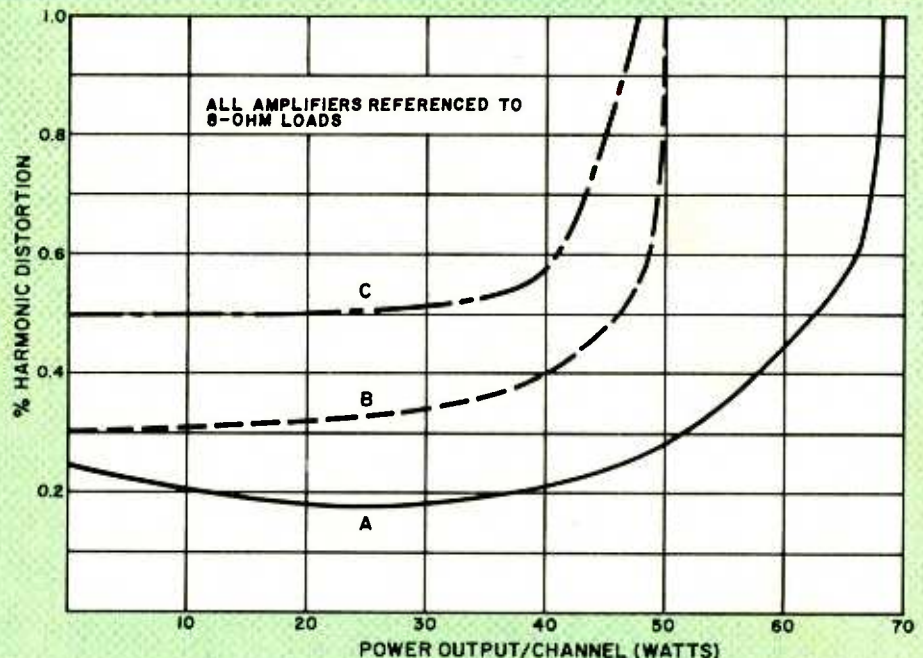

Fig. 1. When all three amplifiers are measured the same way, "lower spec" amplifier A turns out to be the highest powered unit among the three.

power ratings in the minds of all consumers? Unfortunately, the answer is a resounding "No!" While the rule goes a long way towards enforcing honesty in audio equipment advertising, adherence to its requirements will not, in and of itself, make everyone's power specifications read like everyone else's. The consumer can still be thoroughly confused when reading specification sheets describing competitive amplifiers and receivers. Here is why confusion can arise:

Henceforth, manufacturers will be required to state continuous output power delivered by their products into a specified impedance, at a specified harmonic distortion, and over a specified power bandwidth. The power specified in this manner must be delivered by the amplifier or receiver when all its channels are driven simultaneously. For a stereo receiver or amplifier, this means that both channels must be going at the same time, while in a 4-channel setup, all four amplifier channels must deliver the rated power to all four loads at the same time.

Let us consider the following sets of competitive specifications, all of which would comply with the "letter of the law":

AMPLIFIER A: 50 W/channel output power into 8 ohms at 0.3 percent harmonic distortion from 20 Hz to 20,000 Hz.

AMPLIFIER B: 60 W/channel into 4 ohms at 0.5 percent harmonic distortion from 60 Hz to 400 Hz.

AMPLIFIER C: 65 W/channel into 4 ohms at 1.0 percent harmonic distortion from 60 Hz to 4000 Hz.

Reading these three descriptions, the uninitiated consumer might conclude that Amplifier C has the greatest output power capability. He would be wrong. Nearly all solid-state amplifiers produce their greatest output power

levels when connected to 4-ohm speaker loads. Connected to more popular 8-ohm speaker system, Amplifier C might well produce less than 50 watts.

Notice, too, that the rated distortion of Amplifier C is 1.0 percent. How much less power would it be able to deliver—even into its 4-ohm specified loads—if distortion were limited to 0.5 or 0.3 percent, as in the cases of Amplifiers B and A? For that matter, we have no way of knowing from the figures given whether or not the distortion level will ever go down to the 0.3-percent level. Perhaps 1.0 percent is the best Amplifier C can do even at low output power levels.

The new FTC rule merely requires that the amplifier be able to deliver its specified power at a harmonic distortion that does not exceed the published figure. Doing some hypothetical calculation based on typical measurements observed with "real" amplifiers, Fig. 1 plots power versus distortion curves for our three fictitious amplifiers. The parameters were changed so that each amplifier was operated into 8-ohm loads, and all three were permitted to reach a distortion level of 1.0 percent, so that the comparison would be fair.

As you can see, the results are just the reverse of what is implied by an uninformed reading of the specification listings given earlier. Amplifier A produced 68 watts under these conditions, Amplifier B produced 50 watts, while the amplifier with the highest "published" power rating—Amplifier C—produced only 48 watts.

In the example, we were dealing with only a single middle-of-the-band audio frequency. However, the FTC rule requires that the power bandwidth over which the rated power can be developed at rated (or less) distortion must be specified as well. Refer-

ring again to the "published" specifications given above, each manufacturer has complied with this requirement. The maker of Amplifier C has honestly stated that his amplifier will deliver 65 watts at any frequency between 400 and 3000 Hz. But most of us know that the real test of a good amplifier is its ability to deliver maximum power at the frequency extremes. This is particularly important at low bass frequencies where musical energy demands are usually greatest. The thundering beat of a bass drum calls for more power than is required when reproducing the sounds of instruments and voices in the midrange register.

Reading the specifications of Amplifier C, we have no way of knowing how much power the product can deliver (if any) at 40 Hz and lower frequencies, or at what level of distortion. The curves in Fig. 2 show what the distortion of each of our fictitious amplifiers might look like even if we were to use 50 watts/channel as a reference power level. Again, contrary to first impressions, Amplifier A comes up the winner as far as distortion is concerned.

Buyer Beware—Still. So, while the new FTC rule may alleviate some of the worst abuses of the industry, it does not entirely correct them. In fact, many consumers may falsely conclude that, with the FTC in the act, all product specification sheets are going to read the same—that they will be comparing apples to apples.

You can be sure that manufacturers who have reason to "gimmick" their specifications will still find enough ways to obscure the facts. The component manufacturers who have always sought to tell the true performance story of their products did not have to wait for federal legislation to adhere to truth-in-advertising doctrines. They have been specifying continuous power over the entire audio range, from 20 Hz to 20,000 Hz, at low distortion levels and with all impedances defined since long before the FTC ever heard about watts, decibels, and THD.

The Institute of High Fidelity (IHF) hopes, before long, to publish more complete measurement standards for amplifiers. If adhered to, the new standards would help to eliminate the many ambiguities that still remain prevalent, even in the face of the new FTC requirements. ♦

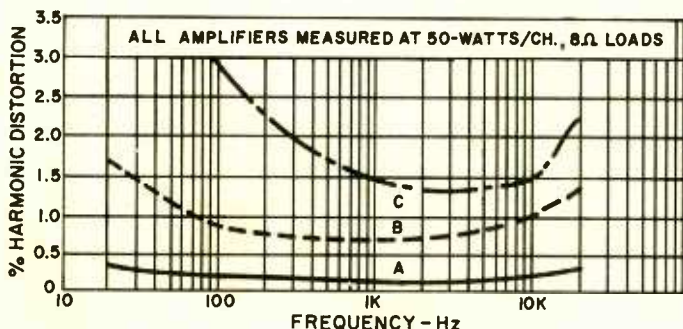

Fig. 2. Again, amplifier A proves to be much lower in distortion than amplifiers B and C, in spite of its more conservative published spec.

What's New in Color TV Receivers for 1975

MANUFACTURERS of TV receivers unveiled many innovations in their 1975 models. For example, major moves have been made toward providing brighter, sharper color pictures; tuning is getting closer to the one-button concept; power-supply designs indicate a trend toward compensation for anticipated voltage fluctuations caused by power shortages; and serviceability has been improved with modular designs and other niceties. Here are details on what each major color TV manufacturer is offering in their 1975 all-solid-state chassis lines.

Admiral. The latest in Admiral's line of color TV receivers is the Touch Tuning M25 chassis. Its main feature is a tuning system programmed with toothed cards. Six printed-circuit cards are used to program uhf channel number readouts. A seventh is for programming the remote control channel selector to go to the next higher active channel, bypassing all inactive channels. The cards are prepared for individual viewing situations with the aid of longnose pliers.

Once the cards are prepared, they are inserted into connectors in the tuner. This permits the viewer to select a channel from the keyboard or the remote control transmitter. The channel appears on the screen, and a separate readout indicator displays the channel number.

In the companion M30 chassis, a special transformer provides voltage regulation. The transformer is wound in such a way that its secondary pro-

duces fixed-amplitude square waves, with the transformer operated at saturation. The transformer is tuned to resonate at the line frequency with the aid of a capacitor.

When the input voltage is nominally 117 volts ac, the clipped output voltage is a fixed-amplitude square wave. Should the line voltage vary (within ± 10 percent of nominal), any change produces an inverse change in the clipping action. The peak-to-peak square wave applied to the rectifiers then remains at about the same amplitude.

While the Admiral chassis does not tilt (it is horizontal), it does slide out for easy servicing.

General Electric. MB, MC, QB, and YA are the designations given by General Electric to its 1975 chassis. The stress is on reliability, quality, and performance. For 1975, GE is introducing the third generation of its Quadline color picture tube. In-line gun arrangements are featured in the Porta-Color 13- and 15-in. picture tubes. The tubes have short necks and 90° deflection angles. The necks are up to 2 in. shorter than comparable tubes with triangular gun arrangements, which eliminates the bump on the rear of the cabinet. Also, the in-line arrangement reduces from 12 to 8 the

number of convergence adjustments that must be made.

In addition to manual and preset color, tint, and brightness controls, there is a Custom Picture Control. Coupled to the contrast, color, and brightness circuits, it adjusts all three parameters simultaneously to maintain a balanced ratio.

A One-Touch Color system incorporates tint lock, avc, and the preset color tint and brightness. The tint lock widens the demodulation angle by cross-coupling B-Y and G-Y at the output of the chroma demodulator IC.

The seven models in the YA series have chassis that accommodate about 90 percent of all the electrical components. Off-the-module components are overrated to increase reliability. More than 95 percent of component failures are claimed to be repairable by module replacement, and all IC's plug in for easier servicing. To further endear itself to the serviceman, GE has a lot of the service information pasted on the inside of the cabinet and printed on the circuit boards. This includes layouts, catalog part numbers, detailed adjustment instructions, and even the schematic.

In the larger chassis (like the MC series), a high-voltage quadrupler that develops 30 kV is used instead of the usual tripler. Regulation of the 30 kV is achieved with a three-winding saturable reactor circuit.

Heath Company. The latest kit marvel from Heath is its Model GR-2000 digital color TV receiver. The tuner uses a varactor diode that eliminates

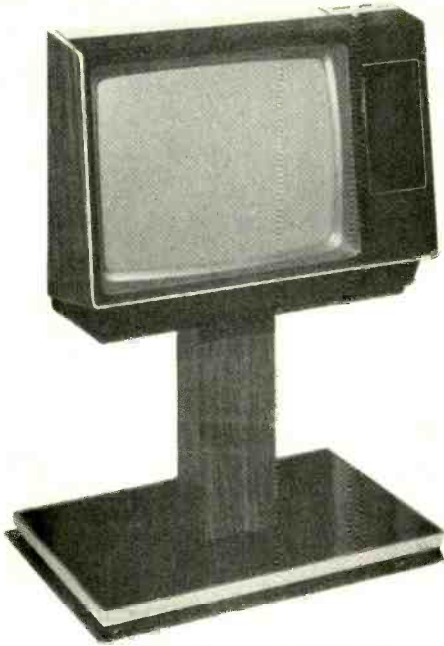

Philco Model C1922FRW

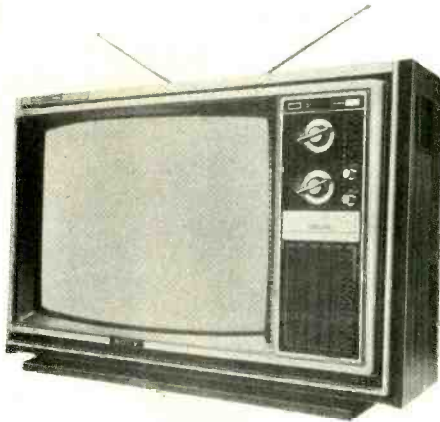

Sony Model KV-1920

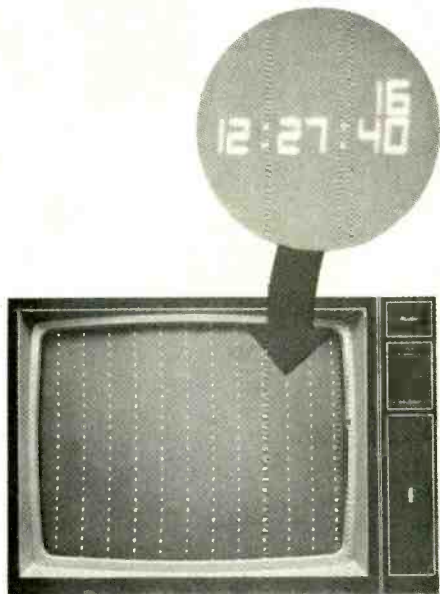

Heath Model GR-2000 with on-screen channel and optional time

moving parts. An up/down counter digital programming board has provisions for presetting up to 16 channels in the vhf and/or uhf bands in any sequence, even repeating channels if desired. The tuning, activated by a front-panel control or a button on the optional remote control transmitter, sweeps up or down through the 16 preset channels.

The number of the channel selected can be placed anywhere on the screen for a preset time of up to 90 seconds, or it can be set permanently on. The brightness of the display is adjustable. And the numerals can be instantly recalled at any time by tapping the volume-down button on either the receiver or the remote control transmitter. The numeral readout is digitally generated by a special character generator IC on one of the receiver's modular boards.

As icing on the readout cake, Heath offers an optional 12/24-hour digital clock accessory that fits into the receiver. It generates the time in an hours/minutes/seconds format. The time is displayed on the screen, simultaneously with the channel number.

The receiver's plug-in IC amplifier/fixed-tuned LC filter i-f strip eliminates the need for periodic sweep alignment. Serviceability is aided by such niceties as modular circuit boards, built-in dot generator, slide-out service drawer, and an illustrated troubleshooting guide in one of the manuals. A test meter also comes as a basic part of the receiver kit.

Magnavox. The latest color TV receiving system from Magnavox is called the STAR (for Silent Tuning At Random), which refers to its varactor-diode tuner. The viewer can call up any vhf or uhf channel by punching buttons on a compact remote control transmitter. The receiver instantly and silently tunes to the selected channel. The tuning system is not sequential; it goes directly to the selected channel without having to clunk through all the in-between channels. A special circuit in the receiver displays the channel's number in bright numerals on the upper left of the screen for about 3 seconds.

Depressing the M (for mute) button on the remote control transmitter turns off the sound for 1 minute without disturbing the picture.

The latest in negative guard band color picture tubes is used in the 13-through 19-in. STAR chassis. These tubes have a black matrix surrounding color stripes (not dots). The electron guns are arranged in-line (rather than in the usual triad configuration), reducing the number of convergence adjustments that must be made. Finally, the picture tubes' necks are shorter than usual. (The 25-in negative guard band picture tube requires a wide deflection angle that precludes an in-line gun arrangement.)

The power supply employs a new voltage-regulating transformer in a special circuit whose output maintains relatively constant voltage during minor changes (a few percent) in

THE NEW 1975 ALL-SOLID-STATE TV RECEIVER CHASSIS

Company	Chassis	Tuner	I-F Strip	Channel Indicator	Muting
Admiral	M25	Varactor	Transistor	Selector dial	Yes
General Electric	MC	Varactor	IC	Digital (on control panel)	No
Heath	GR-2000	Varactor	IC/Fixed-tuned LC	On screen (Time optional)	Yes
Magnavox	Star	Varactor	MOSFET	On screen	Yes
Panasonic	Quatre-color	Detent	IC	Selector dial	No
Philco	Boss	Varactor	—	Selector dial	No
Quasar	QS-3000	Detent vhf Varactor uhf	IC	Selector dial	Yes
RCA	XL-100	Detent	—	Digital (on control panel)	No
Sony	KV series	Detent	—	Selector dial	—
Sylvania	GT-matic II	Varactor	Transistor	Digital	Yes
Zenith	Chroma-color II	Varactor	Transistor	Selector dial	Yes

Note: All chassis are solid-state and modular and have negative guard band picture tubes, aft. audio output jacks, automatic degaussing, and 300/75-ohm antenna inputs. All have electronic remote control except Zenith (see text).

NEGATIVE vs POSITIVE GUARD BAND COLOR PICTURE TUBES

In a standard color picture tube, 85 percent of the screen is covered with phosphor dots, with nothing between them but an aluminized coating that covers the entire face of the tube. The dots are 17 mils across, while the electron beams are 13 mils in diameter. This means that the beams cannot completely excite the dots. In fact, only about half the area of each dot ever becomes excited. The part not excited is required as a "guard band" to prevent degradation of color purity resulting from the beams overlapping onto adjacent dots.

Ambient light is reflected from the aluminized coating and tends to wash out the picture. So, a tinted face glass must be used to reduce glare. Tinting works, but it also kills about half of the light from the dots. This system is referred to as "positive guard band" because the unexcited portions of the dots protect purity.

In the "negative guard band" system, as employed in many of the latest color picture tubes, the dots are surrounded by an opaque black material. The electron beams are allowed to become thicker than the diameter of the dots by increasing the sizes of the holes in the shadow mask. The entire dot can now be excited, while the black material serves as the guard band. Tinting is not required because ambient light is not reflected by the black surround. Hence, a full 85 percent of the light produced by the excited dots comes through the picture tube's face plate.

the line voltage. The high-impedance MOSFET i-f module gives the i-f strip improved sensitivity and reduces any tendency to overload.

The STAR's modular design caters to serviceability. And the vertical chassis has 20° and 45° tilt positions.

Panasonic. Quatrecolor is the name of Panasonic's line. The new Quintrix color picture tube employs a negative guard band black matrix with an additional pre-focus lens to make the picture sharper and brighter by bunching the electrons into a narrower beam. The featured Q-lock one-button color system is like the preset control systems, except that the color and tint are adjusted on a continuous basis, while brightness and contrast adjustments are made via preset potentiometers with a fixed control.

The electronic remote control system permits up/down channel selec-

tion. A "vacation" switch on most models defeats the Speed-O-Vision instant-on feature. The vhf dipole antenna is detachable to permit it to be moved around the room to where it exhibits the best signal-gathering performance. This is a convenience if the TV receiver is set into a permanent location.

Philco. The solid-state modular color TV receiver chassis from Philco is called BOSS (for Best Of the Solid States). It features a 37- to 47-percent power saving over last year's hybrid receiver models, tilt-out front controls, and a built in Invis-A-Tenna with its own reception selector.

Voltage regulation and suppression are accomplished by Picture Guard and Surge Guard in the Philco receivers. In the event of a sudden voltage spike, due to lightning or voltage transients on the power line, a filter capacitor absorbs the temporary overload.

Hands-off tuning is accomplished by a network of automatic circuits. The viewer engages the Philco Master Control button and selects a channel. When the Philcomatic COLOR Control light comes on, he pulls his hand away and the receiver automatically tunes itself.

Quick On replaces Instant Play to eliminate power wastage by not having the picture tube's filaments continuously powered. The audio still comes on immediately, while the picture follows a few seconds later.

Quasar. The "works in a drawer" people are featuring more serviceability, line-voltage regulation, a picture system responsive to ambient lighting, and more simplified and reliable modules. A special twist-lock connector is used to simplify removal of the power supply by the serviceman. This connector eliminates multiple wire leads that could have been potential trouble spots.

Quasar's Insta-Matic system employs a patented demodulator IC that works in conjunction with a light-dependent resistor. The LDR is mounted behind a honeycomb lens located on the front panel of the receiver where it measures the ambient light and allows more or less current to flow into the video-chroma circuit. This automatically raises or lowers the brightness, contrast, and color to suit the light level in the viewing location.

On the remote control panel is a

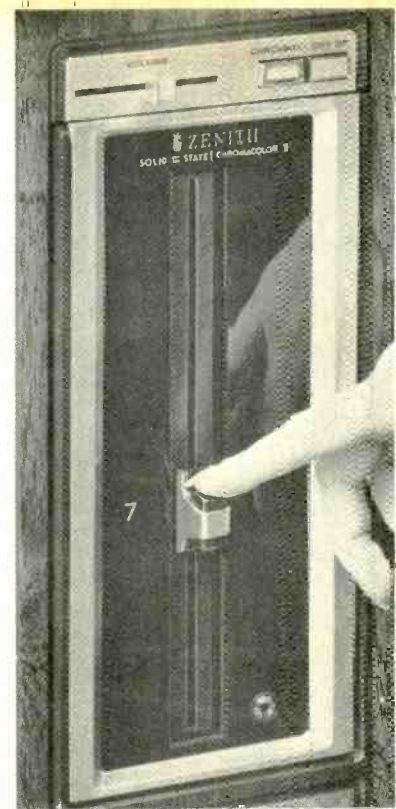

Choosing channels on Zenith's color TV receiver line is accomplished with non-detented slide control



RCA XL-100 Model GT-795



Panasonic Model CT-934

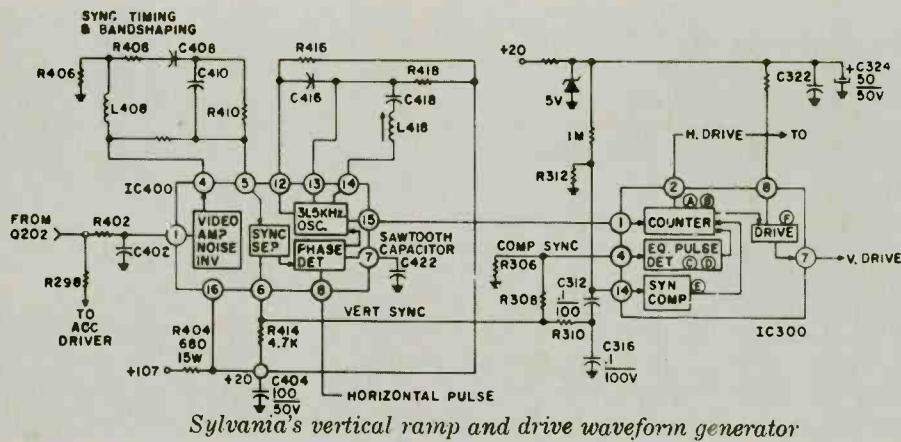

Sylvania's vertical ramp and drive waveform generator

volume-step IC/LED system. Volume is muted or varied by the differences in brightness produced by the LED's glow. In the receiver is a Slumber Sentry circuit. It samples the vertical and composite sync pulses. If the receiver is left on after the station signs off, the Slumber Sentry detects the loss of sync pulses. Then it automatically shuts off the receiver following a short delay. [Panasonic recently purchased Quasar from Motorola—Ed]

RCA. Continuing its XL-100 color TV receiver system, RCA has shaped up the 1975 line by installing an electronic digital display for the vhf and uhf channel numbers. The display is on the control panel, rather than on-screen.

There are no more tubes (except for the latest negative guard band color picture tube) in the RCA lineup. The instant-on feature common in earlier XL-100 models has been eliminated in a move toward energy conservation. Going all solid state and eliminating instant-on, RCA claims an energy savings of 27.5 percent over its tube-type receivers.

The concentration in the XL-100 line is on the Acculine portable color TV receivers. The deflection yoke is permanently bonded to the Acculine picture tube (which, incidentally, has an inline electron gun arrangement) to prevent it from shifting position. Hence, the yoke is an integral part of the picture tube.

Between the Acculine tube and the bonded yoke, there are only four dynamic convergence adjustments instead of the usual 12 that must be made for setting up the receiver. There is also only one purity adjustment—the purity magnet—instead of the usual two. The second purity adjustment—the yoke—is already fixed in the correct position.

Sony. Sony this year offers the KV color series, featuring its Trinitron system, which uses color stripes in a negative guard band matrix, and an in-line gun arrangement, and the TV transportable lifestyles line. Sony incorporates 114° wide-angle deflection picture tubes and Econoquick instant-on features for greater viewer pleasure and convenience. One of the major benefits of the Trinitron system is the elimination of costly, time-consuming set-up adjustments that conventional three-gun color systems require.

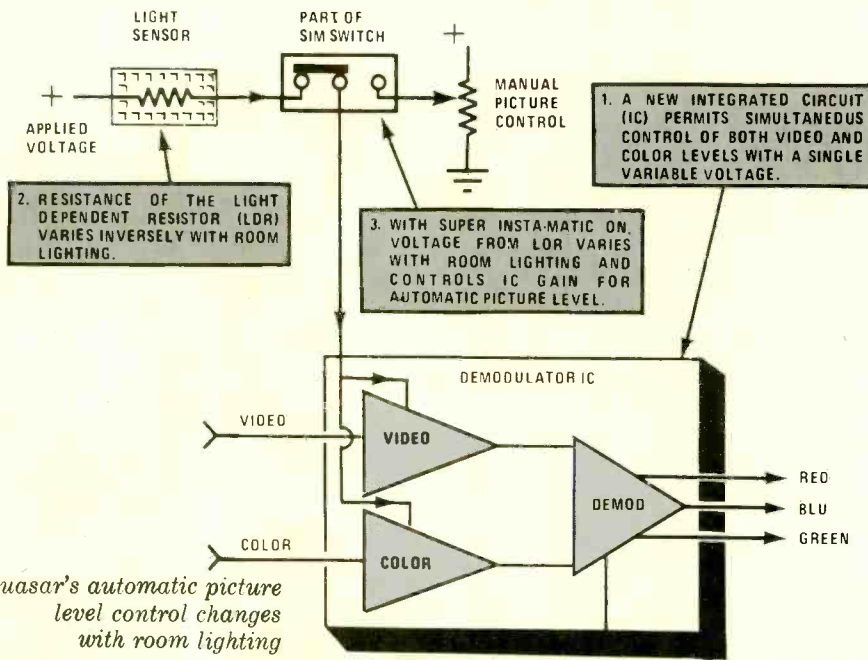

Quasar's automatic picture level control changes with room lighting

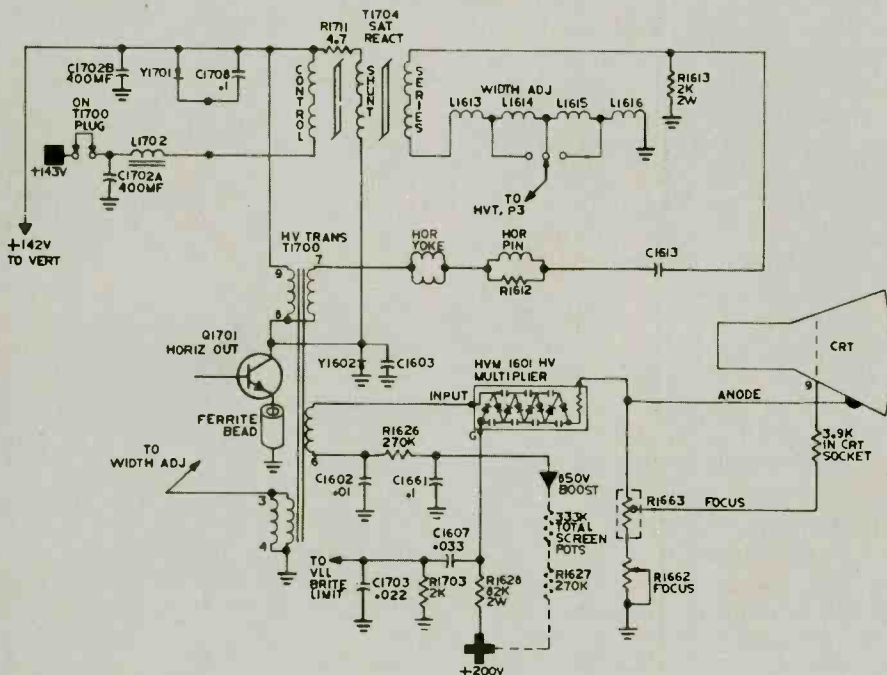

GE's MB chassis uses saturable reactor (T1704) for high-voltage regulation.

The KV series features one button control for Automatic Fine Tuning, Color and Hue for accurate and simple color reception adjustment. Optional accessories for the Sony line include rechargeable battery packs, car battery cords, sun glare filters and auto and home antennas.

Sylvania. The new Sylvania chassis, called GT-matic II, is said to add another dimension to no-button tuning. Parroting preset adjustments, the viewer simply turns on the power and selects the channel. Then, the receiver automatically sets the proper volume, brightness, contrast, color, tint, and other major tuning requirements. Automatic vertical and horizontal holds and Perma Tint supplement the preset controls. A pushbutton varactor tuner, muting, instant-on, remote control, and 100-percent solid-state chassis round out the GT-matic II's features.

The automatic vertical and horizontal holds are controlled by a six-section IC that produces a synchronized horizontal and vertical scan system. Other automatic circuits work on reducing airplane flutter, maintaining a constant voltage, etc.

The Perma Tint circuit acts as a monitor to maintain color at preset levels. It attempts to reduce flesh-tone changes. Once the hidden controls are adjusted as desired, the Perma

Quasar's 100-percent solid-state chassis' modular design system

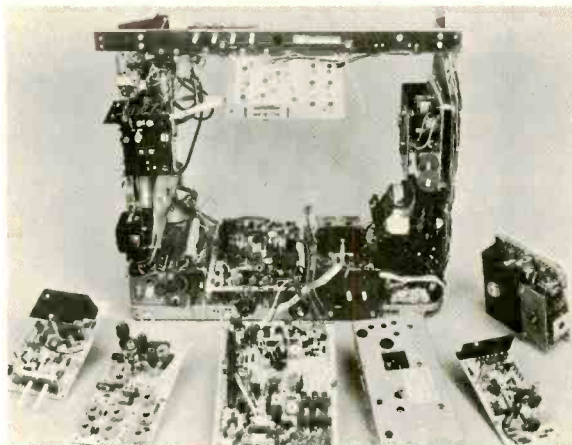

Tint control can be activated, increasing the demodulation angle between R-Y and B-Y to provide a wider range of phase angles for determining the actual color of the flesh tone.

The red demodulator IC gates the Perma Tint on only when there is a positive component of R-Y present. This limits the effect of the increased angle to only those colors in the flesh-tone range without affecting the yellow-green, green, cyan, and blue colors.

Serviceability in the GT-matic II chassis is supported by plug-in devices and modular arrangement of the pc boards.

Zenith. For 1975, Zenith is introducing its Chromacolor II receiver line. It

features an all-solid-state vertical chassis, voltage regulation, and one-button preset controls.

The Space Command remote control transmitter still uses a mechanical, rather than an electronic, scheme. A tiny hammer in the transmitter strikes a rod that then vibrates at a specific frequency. The sound thus produced (it's beyond human hearing) activates the specific control channel in the remote control receiver.



Magnavox's remote-control system features on-screen channel number in seven-segment format.

Zenith calls its modular construction "plug-in/pull-out" Dura-Modules. Eight modules accommodate 75 percent of the circuitry in the receiver.

Tuning in the Zenith receivers is accomplished with 14 preset channels and a slide-switch arrangement. The presetting need not be sequential.

In Conclusion. So it is obvious that the consumer has many new features to look for when buying a 1975 TV receiver. Of course, he will have to expect to pay a little more for these innovations. But, in the long run, the initial investment may be returned to him in the form of fewer service charges and an increase in the life of the set. ♦

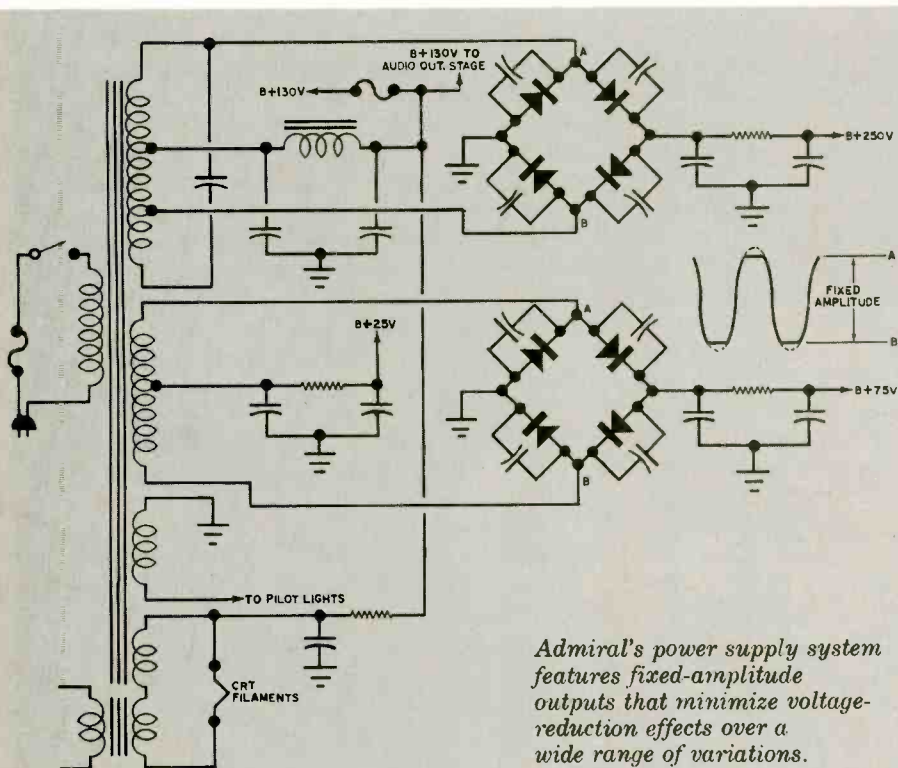

Admiral's power supply system features fixed-amplitude outputs that minimize voltage-reduction effects over a wide range of variations.

THE FCC now allows FM stations to use a combination of Dolby B-Type noise reduction and reduced pre-emphasis in their signal processing. Here's why the new proposal was accepted and how it affects the performance of your FM tuner.

For years, many responsible people in the broadcasting field have privately or publicly suggested a reduction in pre-emphasis. This process was introduced in the early days of FM. It boosts the level of high-frequency content by passing the baseband signal through an RC high-pass filter with a 75- μ s time constant, a break frequency of 2.123 kHz, and a 6-dB/octave slope. In this way, the S/N (signal-to-noise) ratio of the FM channel is increased. At the receiver, de-emphasis must be introduced to balance the spectral content of the received signal as in the original information. The de-emphasis network is a simple low-pass RC filter, with a -6-dB/octave slope, a 75- μ s time constant and 2.123-kHz break frequency. The time constant was chosen at a time when there was marginal high-frequency content, by today's standards, in recorded sound. A low break frequency was required to radically boost the highs to prevent them from being lost in the high-frequency noise that is characteristic of FM.

Today, we have reached a point where the recording media can give much flatter frequency response. Anyone who has compared an old and a recent recording of a certain piece will note a dramatic increase in high-frequency content, or a more "brilliant" sound. This presents problems to FM broadcasters, though. They are constrained to a frequency deviation of 75 kHz, and with increased high-frequency content, they must either lower the modulation index, or use high-frequency limiting. Stations with integrity will not color the sound of the modulating signal, and thus lose some of their potential audience to less scrupulous, but louder competitors who shape the spectral content of the baseband signal to achieve higher levels of modulation while staying within the law.

The proposal by Dr. Dolby will redress the inequities of the situation. If the level of pre-emphasis were reduced, using a 25- μ s time constant and 6.36-kHz break frequency, stations could modulate their carriers more fully, and their signal strengths

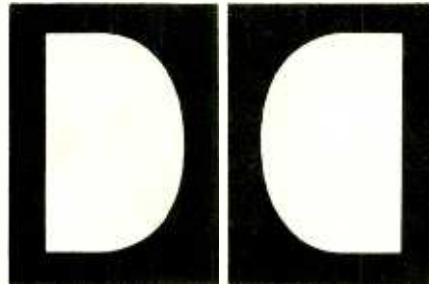

NEW DOLBY- ENCODED FM BROADCASTS

would increase an average of 4 dB. However, the sound from the millions of FM tuners already in use, with their 75- μ s de-emphasis networks, would be exceedingly dull. Obviously, the FCC could not allow such incompatibility to be introduced. If FM stations simultaneously change the time constant of their pre-emphasis networks to 25 μ s and incorporate Dolby B-Type noise reduction, an interesting situation arises.

The reduction of high-frequency brilliance caused by pre-emphasis re-

duction is almost completely counterbalanced by the effects of B-type compression. In low-to-medium-quality equipment, there is no noticeable difference, and the increase in the highs noticed from medium-to-high-quality equipment can be compensated for by a slight reduction of high response of the amplifier using the treble control(s).

Brilliance is a subjectively measured quantity, and to ascertain the effects of B-type encoding, several stations switched unannounced to the new system. Many listeners wrote letters praising the increased quality of the sound. Not one complaint was received.

For those with conventional receivers and no noise reduction, there will be a reduction of high-frequency distortion, and an increase in brilliance and program level. Listeners equipped with 25- μ s de-emphasis and Dolby B-Type noise reduction, as produced now by Dolby licensees as per Dolby's advice, will receive four benefits: improved signal to noise ratio; full program dynamic range, even at high frequencies; better reception in weak-signal areas; and reduced likelihood of SCA interference.

Some tuners and receivers are already equipped to receive the 25- μ s Dolby encoded FM broadcasts. If a 75/25 switch is on the back of the unit it should be set at 25 during reception of all subsequent Dolby FM broadcasts. Otherwise, ordinary B-Type noise reduction units can be easily adapted to take advantage of the new broadcast technique by installing the FM Compensator shown in the diagram. Only one channel is illustrated; two will be required for stereo reception. Anyone may build a compensator for personal use or manufacture it for resale without a license. The parts are inexpensive and may be obtained from any electronics supply house. The unit does not require a power supply.

The PLAY CAL controls on the noise reduction unit should be turned to

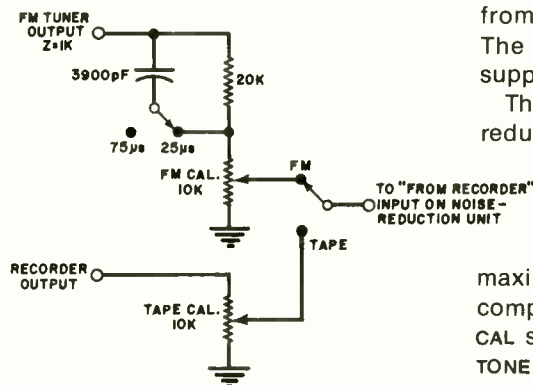

FM compensator provides choice of 75- or 25- μ s time constant.

maximum, and TAPE CAL control on the compensator used in their place. FM CAL should be set so that the DOLBY TONE broadcast by the desired station gives a DOLBY LEVEL reading on the meters of the noise reduction unit.

The perfect gift for anyone who's "into" electronics ...now even more perfect at **30% OFF!**

For guys who like nothing better than to tackle a challenging electronic project... or just learn what makes equipment "tick"... there's nothing better than Popular Electronics.

You know that — because you're reading it! But what about all the other people you know who share your interest in electronics? Like the business associate who's fascinated by pocket calculators... the neighbor who keeps refining his hi-fi system... the young relative who can't be parted from his 2-way radio. Are *they* getting Popular Electronics, too?

If they aren't, there's a way you can help them out... and save yourself a few dollars at the same time. How? By giving them Popular Electronics for Christmas — at *30% off the regular rate!*

That's right! We'll give you a whole \$2.09 off the price of each one-year gift subscription. You pay only \$4.89 for each one you send, instead of the regular rate of \$6.98.

At that great rate, why wait? Order as many gift subscriptions as you like — and save \$2.09 on each one! To do so, just detach the accompanying bound-in reply card. Fill in the names and addresses of the people you'd like to send Popular Electronics to. Then just mail the card.

No need to send money now... we'll bill you later. And we'll also announce your gift to each person on your list with an attractive gift card sent in your name.



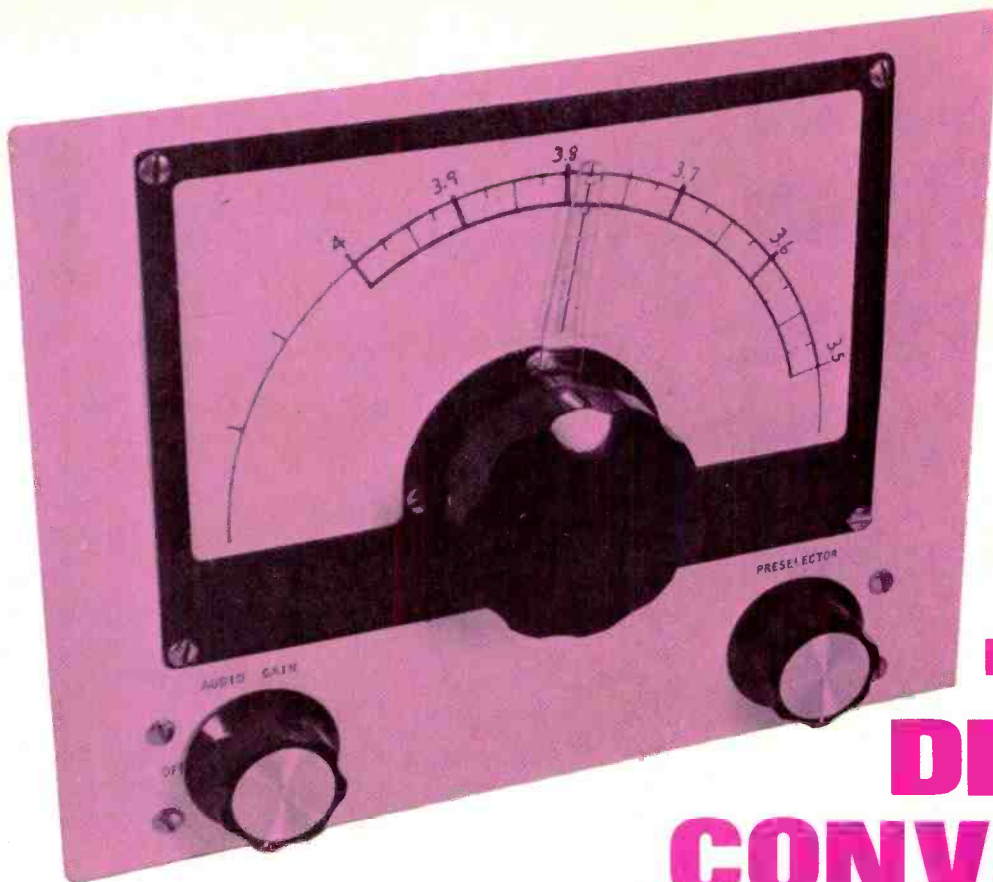

Good AM-SSB-CW performance at a fraction of a superhet's cost

BUILD A DIRECT- CONVERSION COMMUNICATION RECEIVER

BY JIM WHITE, W5LET

AN essential ingredient for the neophyte in amateur radio is a good receiver—one that is sensitive enough to pick up signals that are down near the noise level and selective enough to separate adjacent signals and provide clear copy. Without such a receiver, one can only look forward to “unanswered” CQ’s and lots of frustration. However, a good communications receiver can cost anywhere from \$250 to \$500, and most beginners don’t have that kind of money. Even a good used receiver can cost \$150. As an alternative, a direct-conversion receiver should be tried. It performs well over a range of 3.5 to 4.3 MHz on AM, SSB, and CW and is easily constructed at a cost near \$30.

Direct conversion is a much-neglected type of design that can best be described by comparing it to the more common system, superheterodyning. In the superhet system (Fig. 1), the first stage is an r-f amplifier. This is followed by a mixer where the signal is

combined with the output of a local oscillator. The frequency of the latter is a certain amount above or below that of the r-f and the difference is called the intermediate frequency. The output of the mixer contains a high-frequency component and a low-frequency component.

These two signals are produced by superheterodyning; that is, combining two signals to produce one at a frequency equal to the sum of the frequencies of the original signals, and one at a frequency equal to their difference. At this point we filter out the high-frequency component and amplify the lower in a stage that has high gain and a narrow passband, which affords selectivity. The output of the i-f amplifier is sent to a detector, which may be of two types: for AM reception, it is an envelope detector (a diode followed by a low-pass filter); for SSB and CW, a product detector, which is really a second mixer, fed by a beat frequency oscillator (BFO), is

used. The difference component of this heterodyning process is an audio signal, which is then amplified through one or more stages and passed on to phones or a speaker.

As you can see, there are usually four or more stages that must be properly tuned in conjunction with each other for proper signal recovery in a superhet receiver. Most quality communications receivers have two or three i-f stages, with separate mixers, local oscillators, and tuned amplifiers for each stage. These complications drive the cost of receivers out of the reach of a large portion of newcomers to the hobby.

The direct-conversion technique is a much simpler process. The block diagram of this system is shown in Fig. 1. The r-f amp supplies the mixer with an amplified version of the signal received from the antenna. The mixer is also fed an r-f signal of the same frequency as the incoming carrier from a local oscillator whose frequency is ad-

justed by the main tuning dial. The output of the mixer contains one audio frequency signal and one r-f signal at twice the frequency of the original. The r-f signal is then filtered out by a low-pass filter and we are left with an audio signal. This is then amplified by one or more stages of high gain and the output is connected to a speaker or a pair of phones. That's all there is to it. We have none of the complexities of dual- or triple-conversion superhet receivers; but do have good sensitivity, and if we use a high-quality, narrow audio filter, we have selectivity that will rival that of a superhet unit costing ten to twenty times more. The simplicity of operation is reflected in the ease of construction.

Circuit Operation. A comparison of the block diagram (Fig. 1) and the schematic diagram (Fig. 2) will point out a few differences. For economy's sake, an r-f amplifier has been omitted from this receiver. However, the receiver is still sensitive enough to pick up many signals that would be missed with a cheap "communications-type" superhet model. Signals from the antenna are coupled to the MOSFET mixer, Q1, over the tuned LC circuit composed of L1, C1, and C2. Transistor Q4 is the local oscillator and its output is coupled through a small silver mica capacitor, C28, to the second gate of Q1. The antenna coil, L1, and the oscillator coil, L2, are wound on small toroidal cores, which is an effective way of attaining high Q cir-

cuits, which are the basis of the selectivity of the receiver's front end.

The other contributor of selectivity in a direct conversion receiver is the audio filter. This filter performs two functions. It rejects the high-frequency component of the mixer output, passing the audio signal, and it provides a large part of the receiver's selectivity by virtue of its audio band-pass characteristics. In this circuit, L3, C5, C7, and C8 comprise the low pass filter. Coil L3 is a variable TV width coil, and the capacitors are of the Mylar type.

Transistors Q2 and Q3 are conventional audio amplifiers, and almost any npn silicon transistor will work well in this circuit. Variable resistor R10 serves as a volume control in the standard voltage divider mode and IC1 serves as a high-gain audio output amplifier. Any one of the common audio modules furnishing 0.5 to 1 watt output can be utilized for this purpose. If desired, a headphone jack can be installed as in Fig. 2.

A power supply was not incorporated into the receiver. A suitable source supplying 500 mA at 9 volts should be used. If you intend to use the receiver for portable operation, or don't wish to construct a supply, six D cells in series will work perfectly. An inexpensive plastic holder can be obtained for handling them. It is important to take care in observing polarities while connecting the supply. To protect the sensitive semiconductors, diode D2 has been incorporated. If the wrong polarity is applied to the re-

ceiver, D2 is reverse biased and will not conduct. If this diode was not installed, the transistors and the IC would be destroyed in the event of accidental reversal of power supply polarity. However, when incorrect polarity is applied, the receiver simply will not work, thanks to the protective action of D2.

Construction Details. The receiver was assembled on a 7" x 9" x 2" aluminum chassis. Two separate circuit boards were used, and laid out on the chassis as seen in Fig. 3. The two cutouts for the boards should be made following this scheme, but layout is not critical. The use of individual boards for the r-f and audio stages eases troubleshooting as well as construction.

Mount the components on the audio board first. When you have done this, position the board in its cutout and secure it to the chassis. Connect the positive lead of the power supply to the center-tap of the transformer and the negative lead to the chassis ground. Then connect a speaker to the secondary of transformer T1. If you have correctly assembled this board, you will hear a hum or buzz from the speaker when you touch the base lead connection of Q3. The remaining board can then be assembled and mounted on the chassis. Try to keep all leads as short as possible.

After the boards are in place, spray a 7" x 10" piece of 1/4" masonite with aluminum paint. When it has dried, mount the tuning dial on the panel, and secure the panel to the chassis. Mount the oscillator tuning capacitor, C26, on a small bracket, and insert the shaft of C26 into the dial drive mechanism. After you have made sure that the shaft is correctly lined up, fasten the bracket to the chassis. Using a pair of pliers, turn the tuning capacitor's shaft until the plates are fully meshed. Then turn the dial to the 9 o'clock position and tighten the setscrew on the shaft receptacle. You can then log frequencies on the dial using a crystal calibrator or an accurate VFO. The audio gain control, R10, and the preselector capacitor, C2, are mounted in 3/8" holes in the front of the chassis. Drill the holes all the way through the front panel. Three holes must be drilled through the back of the chassis, for the antenna and speaker jacks, and the power supply leads. If you choose to include a headphone jack, it can be mounted either on the front or the rear of the chassis.

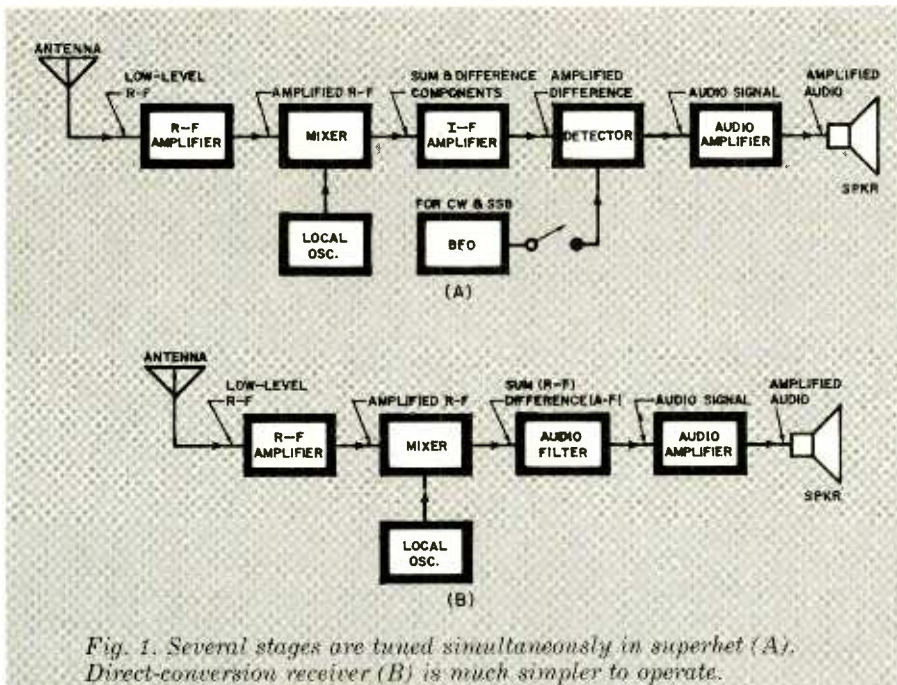
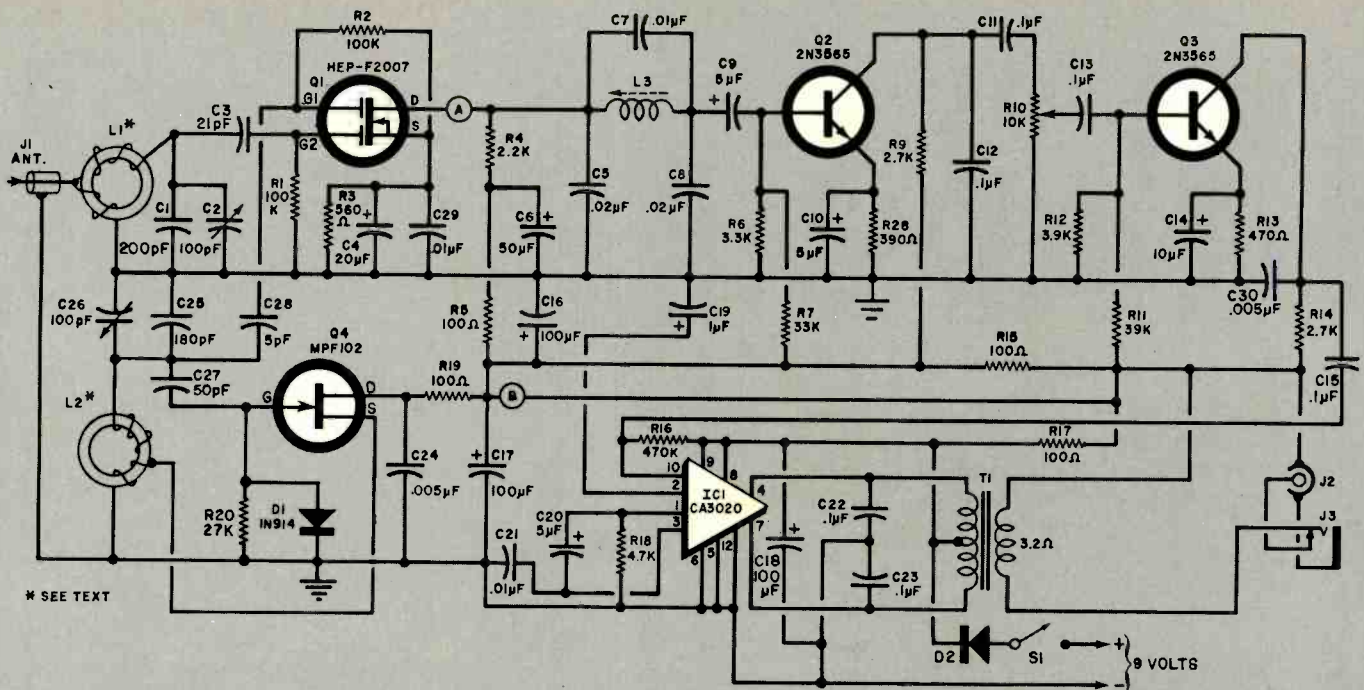

Fig. 1. Several stages are tuned simultaneously in superhet (A). Direct-conversion receiver (B) is much simpler to operate.



PARTS LIST

C1—200-pF, 500-V silver mica capacitor
 C2, C26—Variable 100-pF capacitor
 C3—21-pF, 50-V disc ceramic capacitor
 C4—20- μ F, 15-V electrolytic capacitor
 C5, C8—0.02- μ F, 100-V Mylar capacitor
 C6—50- μ F, 15-V electrolytic capacitor
 C7—0.01- μ F, 100-V electrolytic capacitor
 C9, C10, C20—5- μ F, 15-V electrolytic capacitor
 C11, C12, C13, C15, C22, C23—0.1- μ F, 50-V disc ceramic capacitor
 C14—10- μ F, 15-V electrolytic capacitor
 C16, C17, C18—100- μ F, 15-V electrolytic capacitor
 C19—1- μ F, 15V electrolytic capacitor
 C21, C29—0.01- μ F disc capacitor
 C24, C30—0.005- μ F disc capacitor
 C25—180-pF, 500-V silver mica capacitor
 C27—50-pF, 500-V silver mica capacitor

C28—5-pF, 500-V silver mica capacitor
 D1—1N914 diode
 D2—Silicon power diode (100 PIV, 750 mA)
 IC1—Integrated circuit (RCA CA3020)
 J1—Chassis-mounting coax connector
 J2—Phono jack
 J3—Two-circuit phone jack (optional)
 L1—34 turns No. 22 wire tapped 11 turns from ground end
 L2—34 turns No. 22 wire tapped 5 turns from ground end
 L3—TV width coil, 10-50 mH (Miller 6319 or equivalent)
 Q1—Dual-gate MOSFET (Motorola HEPF2007)
 Q2, Q3—2N3565 transistor
 Q4—JFET (Motorola MPF102)
 R1—100,000-ohm
 R3—560-ohm

R4—2200-ohm
 R5, R15, R17, R19—100-ohm
 R6—3300-ohm
 R7—33,000-ohm
 R8—390-ohm
 R9, R14—2700-ohm
 R11—39,000-ohm
 R12—3900-ohm
 R13—470-ohm
 R16—470,000-ohm
 R18—4700-ohm
 R20—27,000-ohm
 R10—10,000-ohm potentiometer
 S1—Spst switch (part or RIO)
 T1—Transformer: 200-ohm CT primary; 3.2-ohm secondary (Calectro D1-729)
 Note—Q1 (\$1.65) and T50-2 toroids (3 for \$1) are available from Circuit Specialists, Box 3047, Scottsdale, AZ 85257.

All resistors
 1/2-W, 10%

Fig. 2. Receiver employs toroid-wound coils for L1 and L2. Q1 is a dual-gate MOSFET.

Other Frequencies. The receiver can also be used on other frequency bands. Only the LC combination at the input of the mixer and the tuned circuit of the local oscillator need modification.

For forty-meter operation, remove C7. Remove L2 and replace it with 15 turns of No. 22 enamelled wire, wound uniformly spaced on a T50-2 toroid, and tapped 7 turns from the ground end. Also, connect a 225-pF silver mica, 500-V capacitor in parallel with C25.

For twenty meters, remove C1, and wind a new oscillator coil, L2, on a T50-2 toroid core. It should be 7 1/2 turns of No. 22 enamelled wire, evenly spaced, and tapped 2 1/2 turns from the ground end. Remove the 225-pF capacitor across C25, if it was installed for 40-meter operation.

For ten and fifteen meters, L1, the antenna coil, must be replaced with 8 turns of No. 22 enamelled wire, wound on a T50-2 toroid core. Then L2 must be replaced with 5 turns of No. 22 enamelled wire, tapped 2 turns from the ground end. In winding both coils, spread the turns to space them evenly around the forms.

Alignment. Making sure that you observe correct polarities, connect a 9-volt power supply to the receiver. Connect a speaker and antenna to their respective jacks. Turn the audio gain control until you feel it click, and then advance it further until you hear the "rushing" sound of atmospheric noise. Rotate the preselector capacitor, C2, slowly. At one point there will be a noticeable increase in sound from the speaker. Carefully ad-

just C2 for this peak. There is only one adjustment for receiver alignment, setting the value of inductance of L3. This prevents any r-f components from local oscillator feedthrough or the heterodyne process from entering the audio stages of the receiver. The procedure is very simple. Adjust L3 until the tuning slug is positioned about half-way into the coil. This completes receiver alignment.

Operating the Receiver. As you tune across a band, keep the front end of the receiver resonant by adjusting the preselector capacitor. You will notice one basic difference in receiver operation between the direct conversion receiver and a superhet. On the conventional receiver, there is a mode switch which must be adjusted for the type of signal you want to receive.

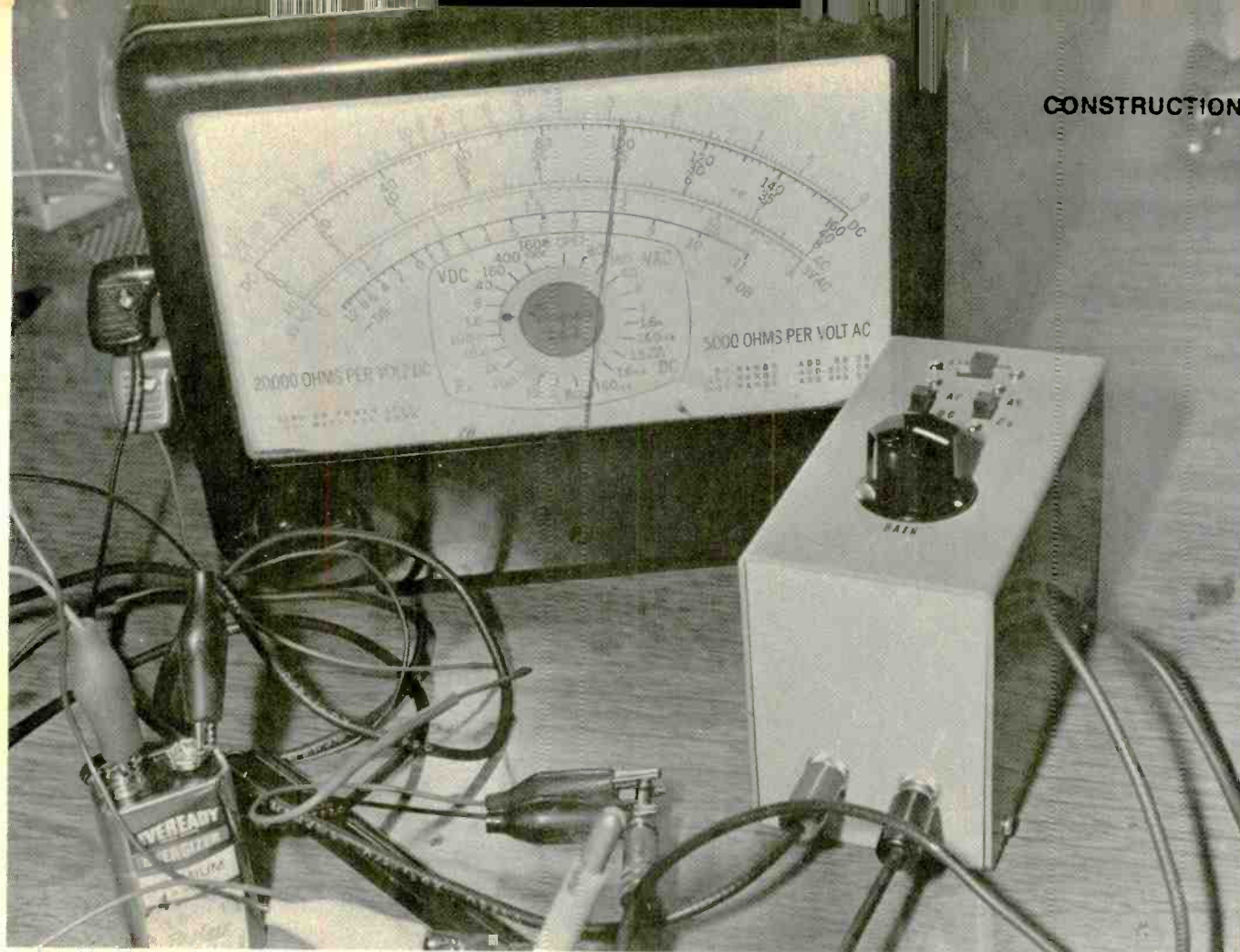

Measure Low Millivolts with a Multimeter

Range expander increases sensitivity by X10 or X100

BY JOHN F. HOLLABAUGH

HAVE you ever needed a simple device that would let you expand the ranges of your multimeter so that you could measure low-millivolt ac and dc voltages? Perhaps you need a small amplifier for checking out the high-level inputs of an audio amplifier. Well, the decade meter range expander described here will do both and more.

The decade range expander can be used to increase the usefulness of a multimeter by adding ranges divided by 10 and 100. It can also be used on decibel scales, subtracting 20 or 40 dB from the existing ranges in your VOM. Use the expander as a sensitive signal tracer to obtain quantitative measurements of the signal level at points of interest, or to read voltage amplifier stage gain directly in decibels on your

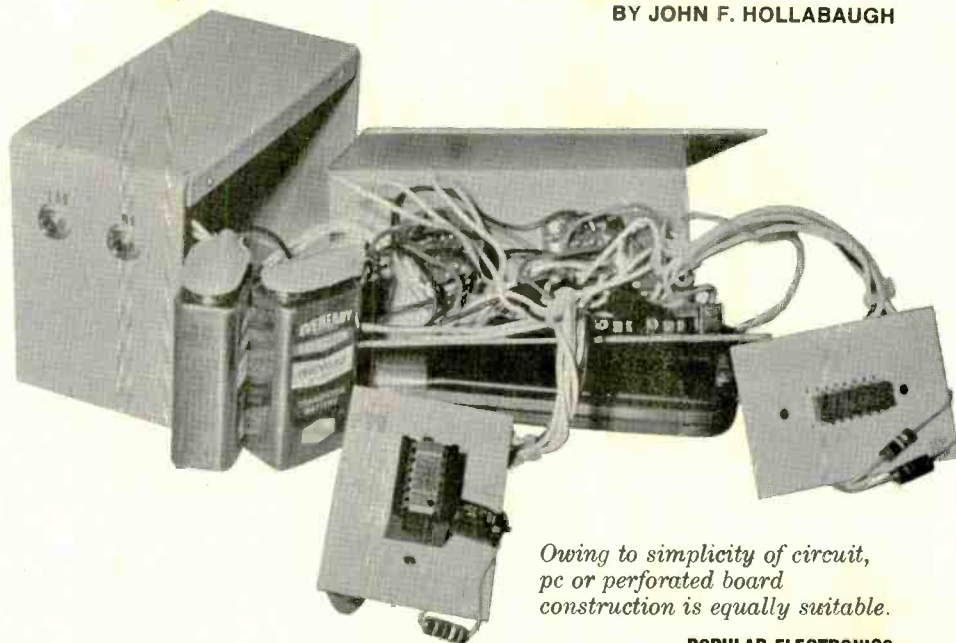

Owing to simplicity of circuit, pc or perforated board construction is equally suitable.

PARTS LIST

B1, B2—9-volt battery
 C1—3-pF capacitor
 C2, C4—1- μ F, 15-volt electrolytic capacitor
 C3—100-pF capacitor
 IC1—709 operational amplifier
 IC2—741 operational amplifier
 J1, J2—Phono jack
 R1—3900-ohm, 1/4-watt resistor
 R2—37-ohm, 1/2-watt resistor
 R3—1500-ohm, 1/4-watt resistor
 R4, R11—1-megohm, 1/4-watt resistor
 R5, R6—10,000-ohm, 1/4-watt resistor
 R7—10,000-ohm trimmer potentiometer
 R8, R9—25,000-ohm trimmer potentiometer
 R10—100,000-ohm potentiometer
 R12—100,000-ohm linear potentiometer
 S1—Spdt toggle or slide switch
 S2—Dpdt slide or toggle switch
 S3—Spst toggle or slide switch
 S4—4-position, double-throw slide switch
 Misc.—Chassis box, 9-volt transistor battery clips, shielded cable and audio phono plugs (for test cables). IC sockets or Molex Soldercons[®], pc board or perforated phenolic board and solder clips, hookup wire, solder, hardware, control knob, etc.

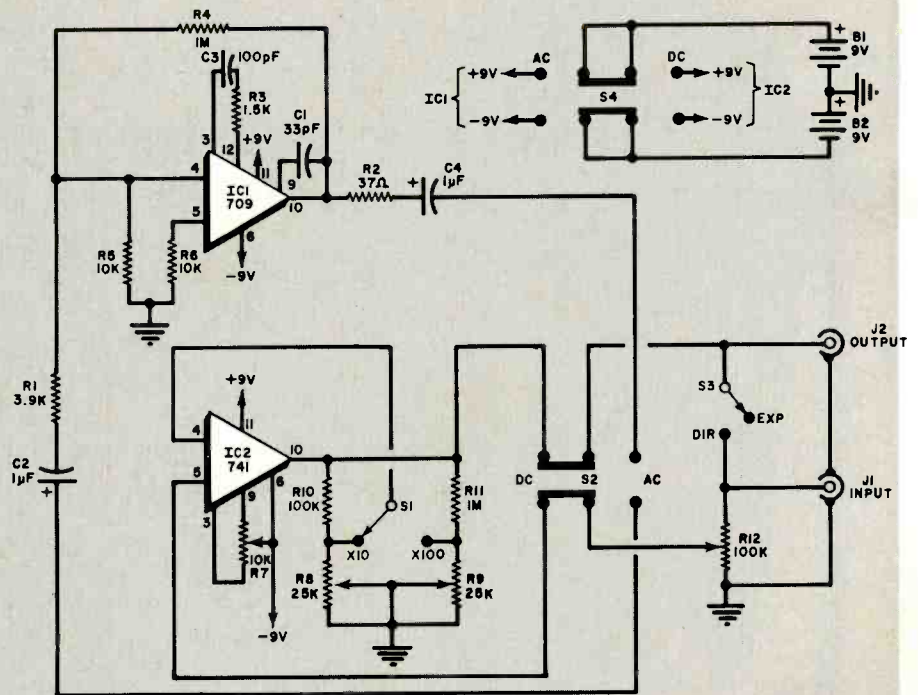

Two operational amplifiers (IC1 and IC2) form heart of expander.

meter. You can even use the range expander to measure the output voltage of a phono cartridge. Try that with an ordinary multimeter.

About the Circuit. The range expander makes use of two operational amplifier IC's (IC1 and IC2 in the schematic), exploiting the particular advantages of the types 709 and 741 op amps. A monolithic amplifier using bipolar transistors appears to the signal being processed as a series of resistances and shunting capacitances. An RC system like this forms a phase-shift network that at some frequency will cause the amplifier to oscillate.

Compensation is required to insure low gain at the frequency at which oscillation occurs. The 741 op amp is unconditionally compensated. (Gain is reduced to unity at the point where oscillation is possible.) The 709 op amp is not internally compensated, requiring external components to obtain the necessary compensation. However, it can be compensated for frequencies up to 1 MHz, while the 741 is restricted to a top-end frequency of about 1 kHz by its internal compensation.

The 741 op amp has provisions for input offset nulling, which makes it operate well as a dc amplifier. In the range expander, the 741 (IC2) is used as a dc amplifier with output nulling

and a feedback network that minimizes drift. The 741 has input overvoltage protection and output short-circuit protection, while the 709 has neither. To provide input overvoltage and output short-circuit protection for the 709, R1 and R2 are used.

The 709 (IC1) in the range expander is compensated for a 40-dB gain up to about 200 kHz by C1, C3, and R3. It has a feedback network consisting of R4 and R5. Both ac and dc amplifiers (IC1 and IC2) have a common vernier control (R12) that can be used where exact values of gain are not required.

The incoming signal (or voltage) is applied via J1, while the mode of operation (ac or dc) is selected with S2. Switch S1 permits selection of X10 or X100 in the dc mode, while switch S3 applies power to either the IC1 or the IC2 circuit. The final switch, S3, permits the range expander to be bypassed when in the DIR position. In this position, it routes the incoming signal at J1 directly to output jack J2. (Note: When S3 is in the DIR position, S4 can be switched to off to conserve battery life.)

Construction. Assembling the range expander is relatively easy, owing to the simplicity of the circuit. The entire circuit can be easily accommodated inside a 4 in. by 2 3/4 in. by 2 in. metal utility box, with the four switches and vernier control R12 mounted on the

top of the box for convenience.

You can use a printed circuit board of your own design or perforated phenolic board and solder clips for mounting the IC1 and IC2 amplifier circuits inside the box. Jacks J1 and J2 can be mounted at one end of the box.

When the circuit has been fully assembled and all parts are mounted in place, use dry-transfer letters to label the control, switches, and jacks.

Calibration. With the range expander switched to DC (both S2 and S4 must be set to this position) and R12 set for maximum sensitivity, connect a multimeter set to a low-voltage range across J2. Adjust R7 for a zero indication on the multimeter's scale.

Connect a variable-output power supply or a potentiometer in parallel with a 1.5-volt battery to J1 and adjust the supply or pot for a 0.1- to 0.5-volt indication on the multimeter's scale. Adjust R8 for an indication of 10 times the reading of the input voltage level. (Use the multimeter to monitor both the input and output voltage levels.)

Now, decrease the output voltage of the power supply (or battery/pot setup) again for a meter reading of 0.1 to 0.5 volt and switch S1 to the X100 position. Adjust R9 for a reading of 10 times the previous meter reading. With the input disconnected, recheck the null produced by adjustment of R7. If necessary, readjust the null. ♦

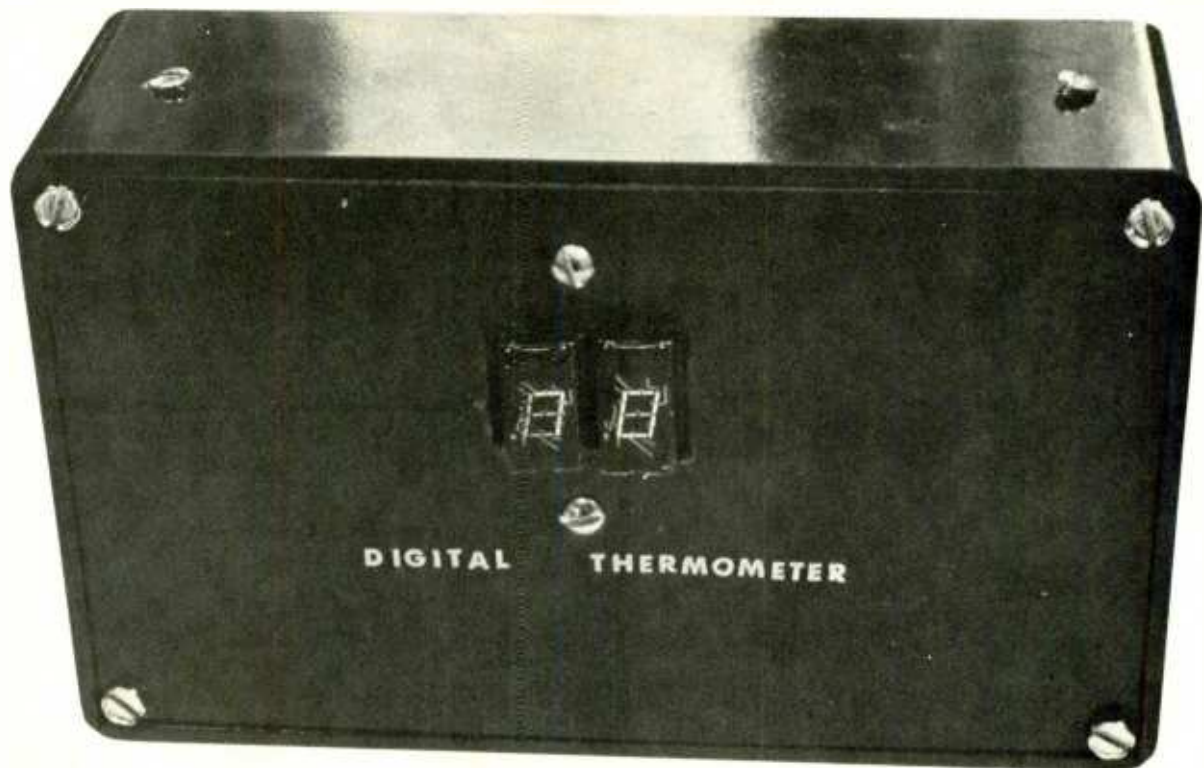

Build a VERSATILE DIGITAL LED THERMOMETER

Low-cost, accurate device can be used as

- *indoor/outdoor thermometer*
- *heater/cooler thermostat*
- *temperature alarm*
- *fishing thermometer*

BY THOMAS R. FOX

THE digital thermometer described here was designed for low cost and simplicity, as well as accuracy. If you check the semiconductor sales ads in this magazine and use a conventional thermistor, you can build the thermometer for about \$15. If you decide to use a precision thermistor, the cost will be about \$20. Since the thermometer operates from a +5-volt line, it can be used in a car,

boat, or camper. With a line-powered 5-volt supply, it can be used in the home.

It is possible to use two switchable thermistors to check temperature differentials—such as between the outside and inside, or between two rooms. If a long lead is used between the thermistor and the electronic circuit, the project can be used as a fishing thermometer.

How It Works. The frequency of the CMOS multivibrator (Fig. 1) depends on the resistance of thermistor *TDR1*, which is determined by the ambient temperature. Thus, if the temperature goes up, the frequency of the multivibrator goes up, and vice versa. Trimmer potentiometer *R23* is used to adjust the linearity.

The two-transistor multivibrator (*Q1* and *Q2*) automatically resets the two

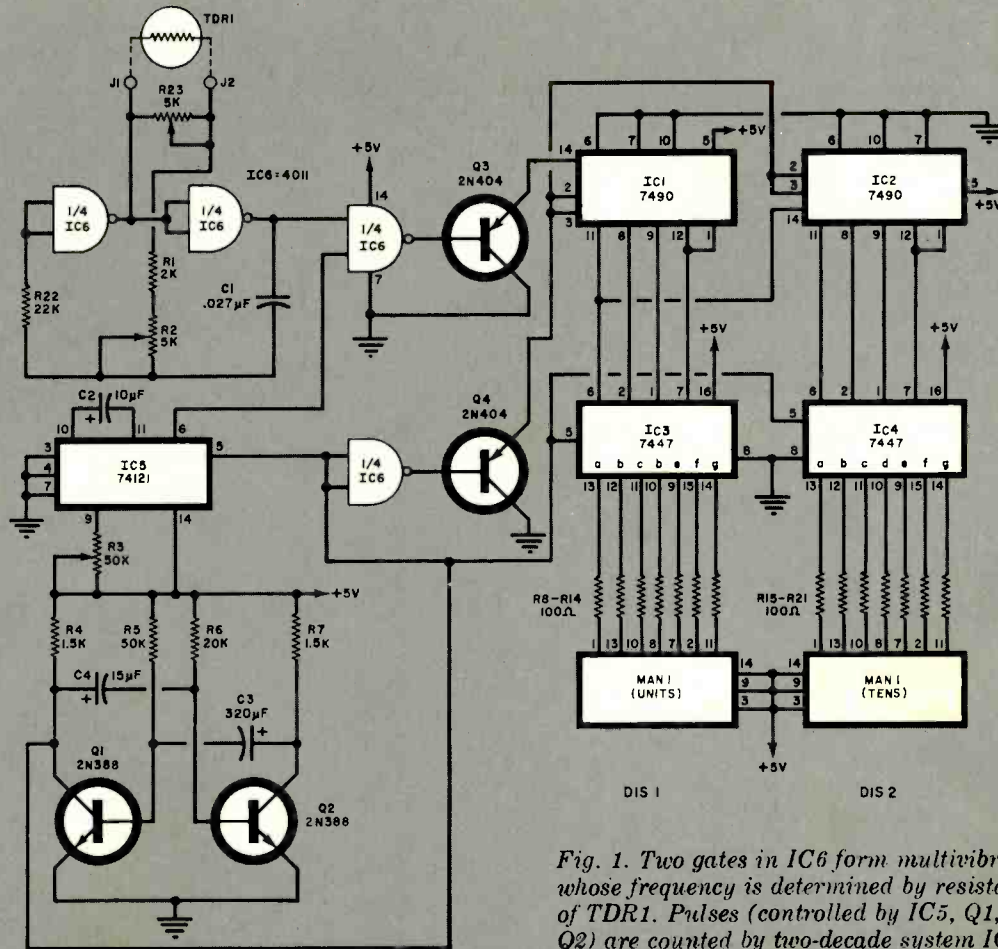

Fig. 1. Two gates in IC6 form multivibrator whose frequency is determined by resistance of TDR1. Pulses (controlled by IC5, Q1, and Q2) are counted by two-decade system IC1, IC2.

PARTS LIST

C1—0.027- μ F silver mica capacitor
 C2—10- μ F, 10-V tantalum capacitor
 C3—320- μ F, 10-V electrolytic capacitor
 C4—15- μ F, 10-V electrolytic capacitor
 DIS1, DIS2—LED display (Monsanto MAN-1 or similar)
 IC1, IC2—7490 TTL decade counter
 IC3, IC4—7447 TTL decoder/7-segment driver
 IC5—74121 TTL monostable multivibrator

IC6—Quad NAND gate (RCA CD4011 or similar).
 J1, J2—Banana jacks
 Q1, Q2—2N388, HEP641 or similar
 Q3, Q4—2N404, HEP739 or similar
 R1—2000-ohm, 5%, 1/4-watt resistor
 R2, R23—5000-ohm miniature trimmer potentiometer
 R3—50,000-ohm miniature trimmer potentiometer
 R4, R7—1500-ohm, 1/4-watt resistor
 R5—50,000-ohm, 1/4-watt resistor

R6—20,000-ohm, 1/4-watt resistor
 R8-R21—100-ohm, 1/4-watt resistor
 R22—22,000-ohm, 5% 1/4-watt resistor
 TDR1—1000-ohm, negative coefficient thermistor (US1 44004, available from Yellow Springs Instruments, Box 279, Yellow Springs, OH 43587)
 Misc.—Suitable enclosure, flexible wire for thermistor leads, rubber glue, optional 9-oz plastic jar and cover, optional switch for two thermistors, mounting hardware and sockets.

decade counters (IC1 and IC2) and IC5, which triggers the monostable multivibrator. When IC5 operates, it closes the CMOS AND gate and allows the output of the temperature-dependent multivibrator to pass to the counters. The length of time that IC5 is on is determined by the value of C2 and the setting of R3.

Construction. The circuit can be assembled on perforated board, using sockets for the IC's and transistors. Everything is on one board except the power supply and thermistor.

Choose an enclosure that will accommodate the board, the power

supply, and the two readouts. Be sure you have access to the three trimmer potentiometers (R2, R3, and R23) through suitable holes. If you use the thermistor called for in the Parts List, you can use an 1800-ohm fixed resistor for R23. Other 1000-ohm thermistors will require some adjustment of R23. For stability, C1 should be silver mica and C2 should be tantalum.

The on and off times of the display are determined by the values of R5/C3 and R6/C4, respectively. These can be varied to suit individual choice of times.

If the temperature of more than one area is to be measured, a simple

switching scheme can be arranged between J1 and J2.

Carefully solder the flexible two-wire cable to the thermistor and insulate the joints. If the thermistor is to be used only indoors, coat it with some rubber glue. If it is to be used outside, it must be protected from the direct rays of the sun and other weather conditions. In this case, mount the thermistor in a plastic jar (about 9-oz capacity), being sure to drill many ventilation holes. The thermistor (mounted through the cover) should not come in contact with the jar. The jar must be positioned so that it does not get the direct rays of the sun.

Power Supplies. Three possible power supplies are shown in Fig. 2. Select the one that suits your needs. Any 5-volt supply that can deliver at least 300 mA can be used. If the digital thermometer is for fishing, use the ac-powered circuit. In this case, omit the transformer and diodes and use a battery holder to mount four 1.35-volt mercury cells, with an spst switch to control power.

Calibration. Connect the thermistor to *J1* and *J2* and apply power to the circuit. Allow it to warm up for at least 30 minutes. You will see a numerical display that will "blink" as the multivibrator operates every few seconds.

Fill a glass with ice cubes and top it off with cold water. Fill another glass with water that is as close to 90 degrees as possible. (Use an accurate mercury thermometer.) Set *R23* to its midpoint; and place the thermistor in the ice water adjacent to an ice cube. Without disturbing the glass or thermistor, adjust *R3* until the display indicates 33. Place the thermistor in the 90° water. If the display shows greater than 90, increase the value of *R2* until a reading of 90 is obtained. If the display indicates below 90, decrease the value of *R2*.

Insert the thermistor back in the ice water and touch up *R3* if the reading is less than 33. These adjustments will have to be repeated several times to

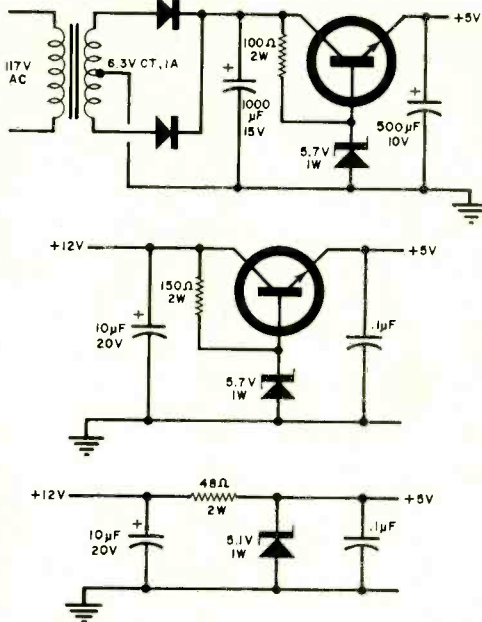

Fig. 2. Three typical power sources for thermometer. Top is for line power, other two are for mobile operation.

THERMOSTAT CONTROL MODIFICATION

You can convert the digital thermometer described in this article into a multipurpose heating/cooling thermostatic control with a 0° to 99° F temperature range by adding to it the circuit shown below. Relay *K1* and any alarm or circuit connected to it can be made to trip at any temperature selected by switches *S1* through *S8*.

The reference temperature selected by the switches is the sum of the closed-switch designations. For example, to set the system up for 34° F, you would close *S3*, *S5*, and *S6* ($4° + 10° + 20° = 34°$). If the sensed temperature falls below 34°,

K1 will sound an alarm or turn on the heat. Conversely, if the reference temperature is 99° and the sensed temperature rises to 101°, *K1* can sound a different type of alarm or turn on the cooling system.

The use of a 5-volt relay for *K1* and suitable connections for its contacts to the heating/cooling controls produces a state-of-the-art environmental control system that eliminates troublesome mechanical thermostats. For the most reliable thermostatic operation, increase the value of *C3* to at least 2000-µF and change the value of *R5* to 100,000 ohms. Also surround thermistor *TDR1* with ¼-in. (6.35 mm) of insulating material and protect it from drafts.

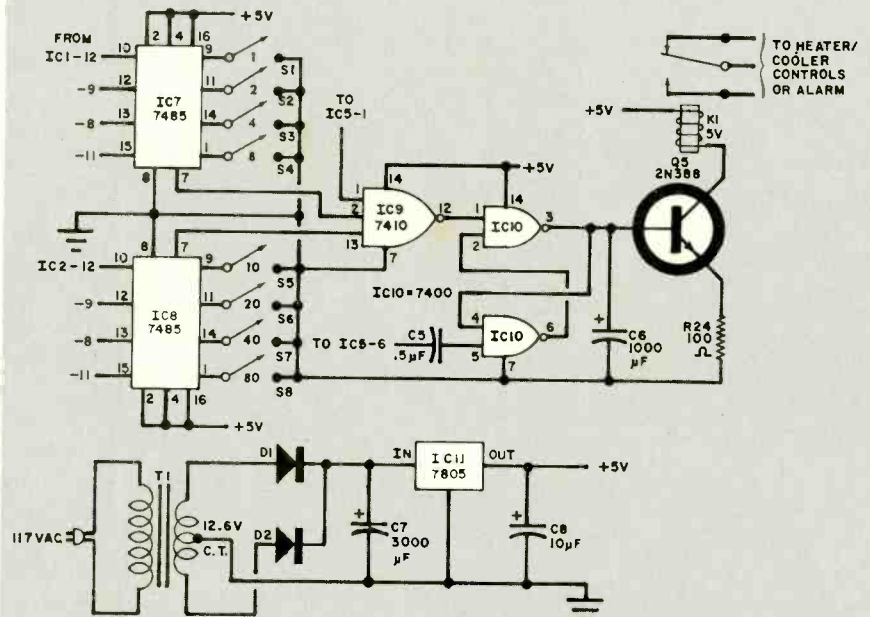

ADD-ON PARTS LIST

- C5—0.5-µF disc capacitor
- C6—1000-µF, 10-volt electrolytic capacitor
- C7—3000-µF, 20-volt electrolytic capacitor
- C8—10-µF, 15-volt electrolytic capacitor
- D1, D2—1-ampere silicon diode (1N4001 or similar)
- IC7, IC8—7485 magnitude comparator integrated circuit

- IC9—7410 triple 3-input NAND integrated circuit
- IC10—7400 quad 2-input NAND integrated circuit
- IC11—7805 5-volt regulator integrated circuit
- K1—5-volt relay with spdt contacts
- Q5—2N388 (or similar) transistor
- R24—100-ohm, ½-watt resistor
- S1-S8—Spst switch
- T1—12.6-volt, 1-ampere filament transformer

get the readings as accurate as possible. If you encounter difficulty in attaining a linear display, adjust *R23*. In general, a decrease of resistance in *R23* results in an increase in sensitivity near the high end and a decrease in sensitivity at the low end.

Once calibration is complete, the digital thermometer should be within 1 degree between 0° and 90° F and

usable between -50° and 130° F. Although this project was designed for the 0-90 range, it could be used to take readings of temperatures below zero and above 100° F. A reading of 90 on a bitter-cold winter day would mean that the true temperature is $-(100-90)$ or -10°F. A display of 5 on a hot summer day means the temperature is $100 + 5$ or 105° F. ♦

BY FORREST M. MIMS
AND H. EDWARD ROBERTS

BASIC DIGITAL LOGIC COURSE

PART 2: CONCEPTS AND CIRCUITS

IN PART 1 of our short course in digital logic, we discussed the binary number system, binary arithmetic, and the octal number system. In Part 2, we are concerned with logic concepts and circuits.

Boolean Logic. In 1847, George Boole, a British mathematician, published his *Mathematical Analysis of Logic*. This booklet did not equate mathematics with logic, but it did demonstrate how any logic statement can be analyzed with basic mathematical relationships. Boole published a much longer and refined version of his theory of logic in 1854. To this day, all practical digital computers and countless other electronic digital circuits are based on the concepts pioneered by Boole.

Boolean logic (or algebra) makes the important assumption that a logic statement is either true or false. Since electronic circuits can easily be made

to operate in either of two states, on or off, it is convenient to equate "true" with "on" and "false" with "off." Similarly, we can equate the binary 1 with on and the binary 0 with off. With the foregoing in mind, let us review Boole's basic logic concepts.

The mathematical explanation of

logic put forth by Boole can be simplified into three basic logic functions: AND, OR, and NOT. The AND function requires that one logic state or condition *and* at least one other be true before the entire statement is true. The OR function requires that one logic state *or* at least one other be true before the

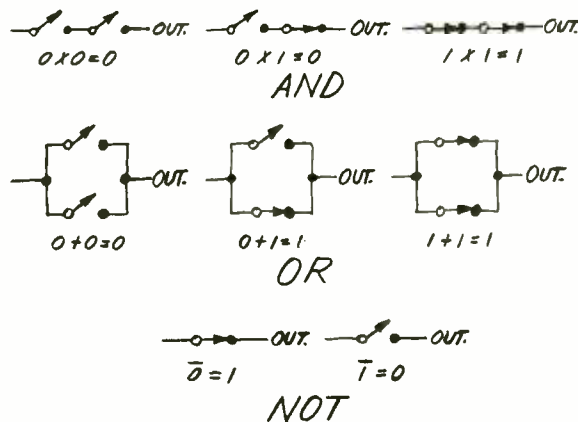

Fig. 1. Switches are arranged to illustrate three basic digital electronic functions.

entire statement is true. The NOT function simply reverses a statement from true to false, or vice versa. Electronic NOT circuits are commonly referred to as "inverters" because their function is to invert the polarity of the signal.

The above definitions can be tabulated into a table such as shown in Fig. 1. Such a table is useful in showing the relationships among Boole's three logic functions and their electronic and arithmetic counterparts. This type of table is sometimes called a "truth table" since it sets forth the various logic conditions for which each statement is true. Generally, truth tables are arranged in a more compact form similar to those shown for the three basic logic functions in Fig. 2.

Truth tables can be created for any logic function. Specification sheets for digital logic circuits almost always include a truth table.

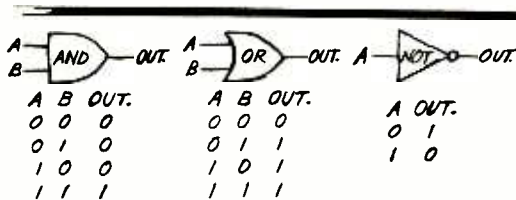

Fig. 2. AND, OR, and NOT symbols are shown with truth tables.

Logic Symbols. Boolean logic statements can be implemented by simply writing them on paper, using alphabetic symbols to correspond to "true" and "false" conditions. Electronic logic diagrams, however, are much easier to design and interpret if a sort of block diagram of the circuit is presented. For this reason, standardized logic-block symbols have been devised for the three basic logic functions. They are shown in Fig. 2.

Compound Logic Circuits. Two circuit combinations (the NOT-AND and the NOT-OR) are used so frequently that they are treated as basic logic elements and given their own logic symbols and truth tables.

When the AND function is followed by a NOT statement, the meaning of the AND function is reversed to NOT-AND, commonly called a NAND function. Similarly, when the OR function is followed by a NOT statement, the meaning of the OR statement is reversed to NOT-OR, commonly referred to as a NOR function. The logic symbols and truth tables for the NAND and NOR functions are shown in Fig. 3.

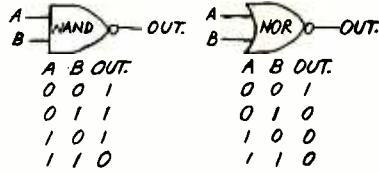

Fig. 3. NAND and NOR symbols with associated truth tables.

DeMorgan's Theorem. About the same time Boole developed his logic theories, Augustus DeMorgan was also developing some fundamental theories of logic. His most important contribution, known as DeMorgan's Theorem, relates the AND, OR, and NOT functions as follows:

$$\overline{A + B} = \overline{A} \times \overline{B}.$$

$$\overline{A \times B} = \overline{A} + \overline{B}.$$

The arithmetic symbols + and \times mean OR and AND, respectively. The bar, or vinculum, over a letter indicates the NOT function. Thus \overline{A} means NOT A.

The importance of DeMorgan's Theorem is that an AND circuit containing a NOT at each input corresponds to an OR circuit followed by a NOT. Similarly, an OR circuit with a NOT at each input corresponds to an AND circuit followed by a NOT. This does not equate the NAND and NOR functions, but it does mean that NAND circuits can be used to implement NOR functions, and vice versa.

Complex Logic Systems. Logic systems that contain three or more basic logic elements are termed "complex." One of the simplest of the complex logic systems is the EXCLUSIVE OR (sometimes written XOR) function shown diagrammatically in Fig. 4. From the truth table, note that this function is identical to the OR function with one important exception: A true condition exists only when one or the other condition, but not both, is true.

The EXCLUSIVE OR function completes the connection between Boolean logic, the binary number system, and electronic switching circuits, for it can be used to add two binary bits. To see how this is accomplished, assume a logic 1 at input A and a logic 0 at

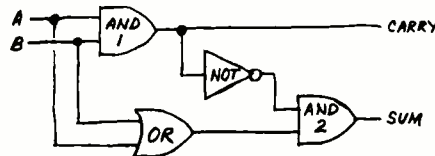

Fig. 4. Logic array for XOR circuit.

input B in the EXCLUSIVE OR circuit shown in Fig. 4. Since only one input is enabled (input A), AND circuit 1 does not turn on. Hence, a 0 is present at the CARRY output. OR circuit 1 does turn on, since only one input need be present. Since the NOT circuit inverts the 0 from AND circuit 1 into a logic 1, AND circuit 2 has two input signals and is therefore turned on. The result is a logic 1 at the SUM output. (The circuit has added 0 + 1 to obtain 1.)

The EXCLUSIVE OR circuit is often called a "half-adder." Try verifying its operation yourself by adding 1 + 1 in binary.

Practical Logic Circuits. Figure 1 demonstrated how simple switching circuits can be used to implement each basic logic function. However, it is usually not practical to employ switches in real systems. Instead, transistors, SCR's, tunnel diodes, or other solid-state switches are employed.

The most commonly used switch in digital electronics is the transistor. Relatively simple circuits that combine diodes, resistors, and transistors can be used to implement the AND, OR, and NOT functions. Thanks to integrated circuit (IC) technology, several or even dozens of individual logic circuits can be placed on a single compact silicon chip. Resistor-transistor logic (RTL) was once the most popular type of digital IC, but it has been largely replaced by the more noise-immune transistor-transistor logic (TTL) type.

In recent years, field-effect transistor (FET) technology has been adapted to integrated logic circuits of amazing complexity. By insulating the gate of a FET with a layer of silicon dioxide, extremely high impedances are made possible. The result is a logic circuit that requires microamperes or nanoamperes of operating current at relatively low voltages.

Insulated-gate fabrication techniques are collectively known as MOS (for metal oxide semiconductor) technology. Since MOS transistors are unipolar (p- or n-type) and do not require separate p and n sections like conventional bipolar pnp and npn transistors, MOS IC's can have a much higher component density than most conventional IC's. The result is large-scale integration (LSI). So, the next time you read or hear the phrase "MOS LSI," you will know that it refers to a large-scale integrated circuit employing metal oxide semiconductors. \blacklozenge



Product Test Reports

PIONEER MODEL SX-636 AM/STEREO FM RECEIVER (A Hirsch-Houck Labs Report)

25-watts/channel receiver with superlative stereo FM tuner section

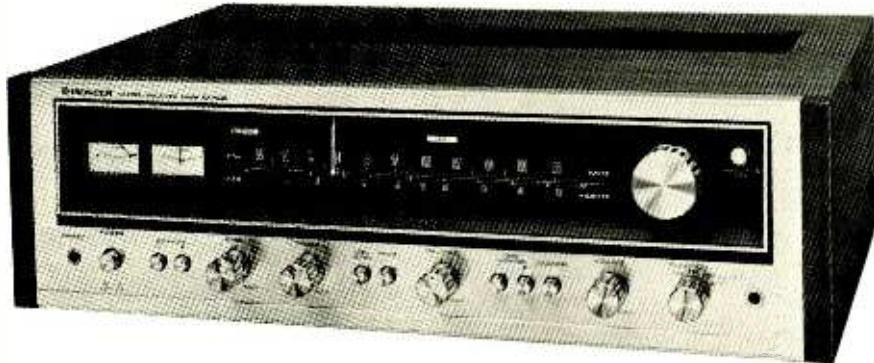

ROUGHLY in the middle of the current line of stereo receivers from Pioneer, the Model SX-636 features a tuner section that makes the most effective use of integrated circuit technology that we have yet seen in a hi-fi component. The result is a level of performance, in a moderate-priced receiver, that in some respects surpasses that of most separate components—to say nothing of far more expensive receivers.

The receiver's audio amplifiers are rated at 25 watts/channel over the entire audio range, with less than 0.5 percent THD. They are operated from balanced positive and negative power supplies and are direct-coupled to the speakers. The preamplifier section features tone controls with 11 lightly detented click-stop settings, and a balance control with a detented center setting. The phono preamplifier, whose gain allows the rated output to be developed with only a 2.5-mV input, can handle signals greater than 100 mV in amplitude without distortion.

The FM tuner section employs a fairly conventional front end containing a FET r-f amplifier followed by a dual ceramic i-f filter featuring linear phase characteristics. All other FM functions are performed by a single large-scale integrated (LSI) circuit—a proprietary development of Pioneer, containing circuitry that provides i-f amplification, five stages of limiting,

and FM (apparently quadrature) detection. The detected signal then goes to a phase-locked loop IC for multiplex demodulation. The entire AM tuner consists of only one IC, plus a handful of external components. Consequently, Pioneer has made an AM/FM tuner with only three IC's and a relatively small number of discrete components, the performance of which proved quite exceptional in our laboratory tests.

The receiver has two pushbutton switches labelled TAPE MONITOR that allow two tape decks to be used simultaneously, with off-the-tape monitoring from either deck and the ability to copy tapes from one deck to the other. The FUNCTION switch has a PHONO/MIC position, in addition to the usual AM,

FM, and Aux positions. Plugging a microphone into its jack automatically disconnects the phono pickup and applies a monophonic microphone signal to the preamplifiers of both channels. Another pushbutton switch is for the high-cut filter. And for maximum convenience, there are two ac outlets on the rear apron, one of which is switched.

The Pioneer Model SX-636 AM/stereo FM receiver comes complete with a walnut-finished cabinet for a fair-trade retail price of \$349.95.

Laboratory Measurements. The audio amplifiers of the Model SX-636 receiver clipped at 29.7 watts/channel with both channels driven simultaneously at 1000 Hz into 8-ohm loads. Into 4 ohms, the power was 36.7 watts, while into 16 ohms, it was 20.5 watts/channel. The 1000-Hz THD was less than 0.1 percent from 0.1 to 30 watts, typically measuring less than 0.03 percent. The IM distortion was also less than 0.1 percent from 25 watts all the way down to less than 5 mW output.

At the rated 25-watt output level, and at one-half and one-tenth of rated power, the distortion was typically 0.025 percent or less over most of the audio-frequency range. It never exceeded 0.055 percent, this at full power and 20,000 Hz. At normal listening levels, the THD was about 0.01 percent. Our figures were a great deal better than Pioneer's very conservative 0.5-percent published figure.

A 10-watt reference output level was obtained with an input of 75 mV (AUX), 1.25 mV (PHONO), and 3.6 mV (MIC). The respective hum and noise levels were -81 dB, -75 dB, and -61 dB. The PHONO inputs overloaded with a 100-mV input, and the MIC input overloaded with a 275-mV input.

The bass tone controls had a sliding

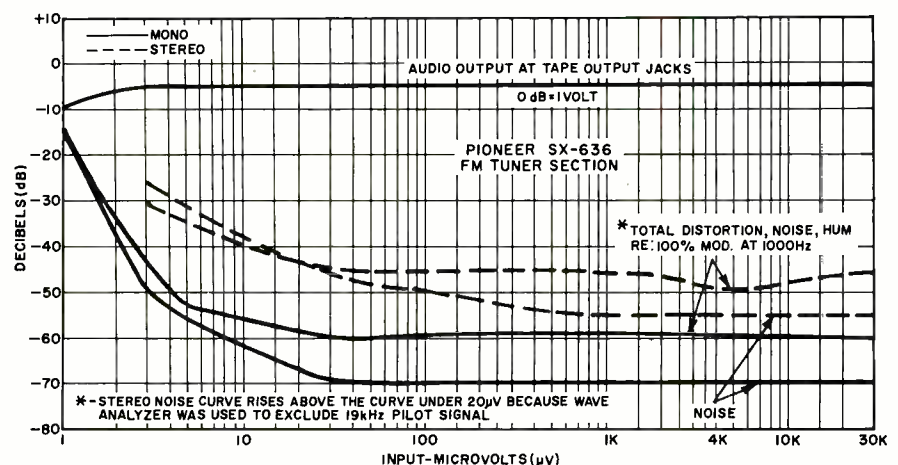

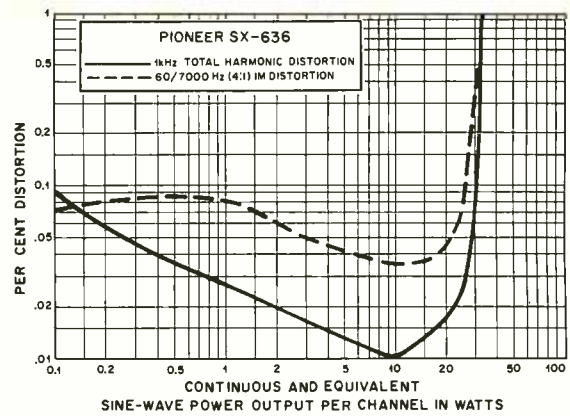
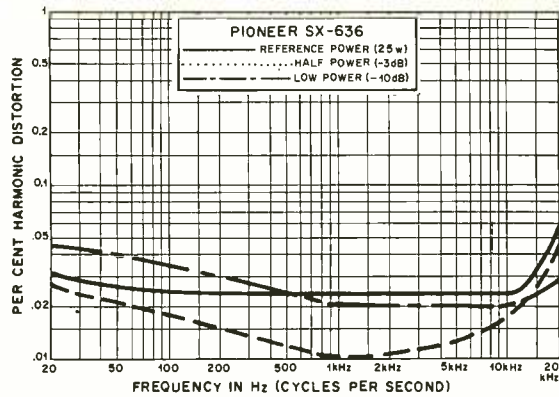

turnover frequency that allowed appreciable correction at the lower frequencies with no effect on the mid-range. The treble tone control's characteristic was hinged at about 2000 to 3000 Hz. Loudness compensation boosted both the low and the high frequencies. The high-cut filter had a 6-dB/octave slope, with the -3-dB point at 4700 Hz, while the RIAA equalization was virtually perfect over most of its range (less than ± 0.25 dB variation between 50 and 20,000 Hz).

There was a very slight bass roll-off caused by the loading of the 10,000-ohm input impedance of our graphic level recorder on the tape recording outputs where we made the RIAA measurement. The cartridge inductance had only a moderate effect on the equalization, about as much as we have found on most other good amplifiers. The microphone response was essentially flat, within ± 0.5 dB from 25 to 6000 Hz, falling off to -1.5 dB at 10,000 Hz.

The FM tuner had an IHF usable sensitivity of 1.8 μ V in mono and 10 μ V in stereo. The 50-dB quieting sensitivity was 3 μ V in mono and 100 μ V in stereo. Ultimate quieting was 70 dB in mono and 55 dB in stereo, while ultimate distortion was about 0.11 percent in mono (very low) and about 0.5 percent in stereo.

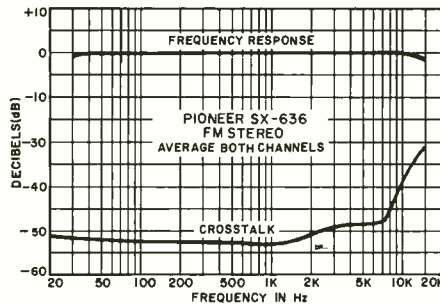

The capture ratio was an impressive 0.7 dB, about the best we have ever measured in a tuner. AM rejection was 51 dB. Image rejection was 75.5 dB, alternate-channel selectivity was 63 dB, and muting threshold was 2.2 μ V—the last low enough to exclude noise but not any receivable signals. Automatic mono/stereo switching occurred at 2.5 μ V. The 19-kHz pilot carrier leakage into the audio outputs was 41 dB below full modulation.

The stereo FM frequency response was within ± 0.25 dB from 30 to 13,500 Hz. It was down only 1.5 dB at 15,000 Hz. The channel separation was extraordinary, measuring between 50 and 53 dB over a frequency range of 30 to 2500 Hz. It reduced to 40 dB at 10,000 Hz and was still an extraordinary 31.5 dB at 15,000 Hz. Clearly, this must be credited to the linear-phase i-f filters and the phase-locked loop de-

modulator, which operate with remarkable effectiveness. The AM tuner's frequency response was down 6 dB at 100 Hz and 5300 Hz.

User Comment. As the above test data shows, the Pioneer Model SX-636 receiver merits the use of superlatives in describing some of its characteristics. In particular, the stereo FM separation taxed the abilities of our signal generator. In this one respect, the system's tuner performed in a manner that has been matched only by a component tuner that sells for \$2500!

Impressive as our measurements may appear to be, they cannot adequately describe the performance of this receiver. It is not enough to state that the receiver surpassed every one of its published specifications during our tests, even though this in itself is a rather unusual event in our experience. The real proof is in the using. The operation of the receiver is totally smooth, with noise-free muting, very accurate dial calibration, and not a trace of switching transients or other undesirable side effects. One can easily be lulled into taking these things for granted, but it is surprising how many audio components—in all price ranges—are deficient in some of these important respects.

CIRCLE NO. 65 ON READER SERVICE CARD

ROYCE MODEL 1-600 MOBILE CB TRANSCEIVER

Moderately priced unit features crisp speech quality



THE moderately priced Model 1-600 solid-state mobile CB transceiver from Royce Electronics features crystal-synthesized operation at full legal power on all 23 AM channels. It has a meter that indicates relative signal strength on receive and relative output power on transmit. Additionally, the transceiver incorporates only the main essentials: adjustable squelch, a-f volume control, au-

tomatic noise limiting (anl), and external-speaker jacks for receiver or PA operation. Supplied with the transceiver are a detachable dynamic microphone and mobile mounting hardware. The rig is designed to be operated from 12- to 13.8-volt dc, negative- or positive-ground, electrical systems. Retail price is \$124.95.

The Receiver. The receiver section

of the transceiver employs double conversion. The first i-f is nominally at 10.6 MHz, while the second i-f is at 455 kHz. The r-f stage ensures good sensitivity, which measured out at 0.3 μ V for 10 dB (S + N)/N. This is enhanced by low-noise first and second mixers.

Six synthesizer crystals cut for frequencies between 37.600 MHz and 37.850 MHz provide heterodyning signals for the first-conversion i-f, which occurs over a 40-kHz-wide spread from 10.595 MHz to 10.635 MHz according to the heterodyning crystal frequency used in relation to the CB channel frequencies. Four synthesizer crystals between 10.140 MHz and 10.180 MHz provide the heterodyning signals for the second conversion to the 455-kHz i-f.

Selectivity is obtained at the second i-f amplifier with a ceramic band-pass filter which, together with the receiver's a-f response, provided a total response of 300 to 4200 Hz at the 6-dB points.

Adjacent-channel rejection was found to be at least 45 dB. Two 455-kHz i-f stages are used in an unusual setup that has two direct-coupled transistors in lieu of the usual transformer coupling. This permits high gain to be obtained with good stability.

The diode detector furnishes an agc voltage that maintained an a-f output within 12 dB with a 20-dB r-f input change (1-10 μ V) and 7 dB with a 60-dB input change (10-10,000 μ V). A second diode provides a dc voltage in accordance with the signal strength

and actuates the S meter, which registered S9 with a 100- μ V input signal.

The squelch, driven from the emitter of the second mixer, was exceptionally smooth in operation. It eases nicely in and out of operation without "plopping." The squelch threshold range was less than 0.5 μ V to 1000 μ V.

The a-f section consists of two cascaded stages, followed by a class-B push-pull output stage that developed a bit more than 4 watts with 11 percent distortion at the start of limiting when driven by a 1000-Hz signal into an 8-ohm load in both the receive and the PA modes. When the a-f system is used for PA work or for modulating the transmitter, an extra speech amplifier is switched into the system.

The Transmitter. On transmit, one of the four crystal signals, spotted between 10.595 MHz and 10.635 MHz, is mixed with one of the six nominal 32.7-MHz signals from the synthesizer to generate the on-channel carrier. A three-section bandpass filter at the mixer's output minimizes spurious responses.

The rest of the transmitter consists of an r-f amplifier, a driver, and the power amplifier, with the two last stages collector-modulated as usual. A three-section antenna-matching network, plus a TVI trap, are incorporated into the power amplifier's output. Antenna switching is accomplished electronically. And no relay is used for send/receive transfer.

The output power of the carrier into a 50-ohm dummy load measured 3.5

watts when the transceiver was operated from a 13.8 volt source. Complete modulation of the carrier was obtained with 9.5 percent distortion at 1000 Hz. However, the positive peaks did not reach the point where peak power would normally be four times the carrier power. On the other hand, further raising the speech level extended the positive peaks to nearer the full amount, with clipping occurring on both positive and negative peaks to just 100 percent without crossing over or overmodulation. Under these conditions with the EIA standard test tone of 2500 Hz, the adjacent-channel splatter was 35 dB down. With normal voice operation, it was at least 55 dB down.

The normal overall a-f response was 300 to 4200 Hz at the 6-dB points. The frequency tolerance was 450 Hz or better on any channel.

Comment. The Model 1-600 Royce CB transceiver is attractively styled, with a wood-grain-finished control panel and a chrome-finished bezel. The edgewise-mounted S/power meter is somewhat easier to read than usual. It is illuminated in white on receive and switches to red on transmit where it varies in brilliance in step with the percentage of modulation.

The receiver is a relatively quiet one which, with an effective and crisp speech quality on both transmit and receive, make this transceiver well suited for Citizens Band communication.

CIRCLE NO. 66 ON READER SERVICE CARD

PICKERING MODEL OA-3 STEREO HEADPHONES (A Hirsch-Houck Labs Report)

Comfortable open-air phones provide "airy" sound quality



THE Pickering Model OA-3 "open-air" stereo headphones provide little or no isolation from room sounds. Unlike conventional isolating-type phones that have air-tight seals between the ear-cups and the listener's head, the Model OA-3

phones are fitted with vinyl-covered foam rings that rest lightly over the ears. The lack of sound isolation works in both directions. The program being played through the phones can be audible to others in the immediate vicinity, as well as letting outside sounds in.

Open-air phones have a distinctly different sound quality than conventional phones. The quality might be described as "airy" or "light," perhaps because the normal room ambience is not excluded from the listener's ears (although it does not directly interact with the musical program as it does when listening through loudspeakers). This type of headphone is also exceptionally com-

fortable to wear, owing to its very light weight of only 8.5 ounces (about 0.86 kg) and the slight pressure it exerts on the ears and head of the person listening with them.

It is generally recognized that good low-bass response through headphones requires a tight phone-to-ear seal. While this statement appears to contradict accepted acoustical theory in the open-air design, it is not really so. The bass response of an open-air phone may extend down to 60 Hz or so, but subjectively appear to go to a much lower frequency. Since there is little music content in the lowest octave of hearing, one is not aware of any lack of deep bass sound when listening with good open-air headphones.

Join "THE TROUBLESHOOTERS"

**They get paid top salaries
for keeping today's
electronic world running**

Suddenly the whole world is going electronic! And behind the microwave towers, push-button phones, computers, mobile radio, television equipment, guided missiles, etc., stand THE TROUBLESHOOTERS – the men needed to inspect, install, and service these modern miracles. They enjoy their work, and get well paid for it. Here's how you can join their privileged ranks – without having to quit your job or go to college in order to get the necessary training.

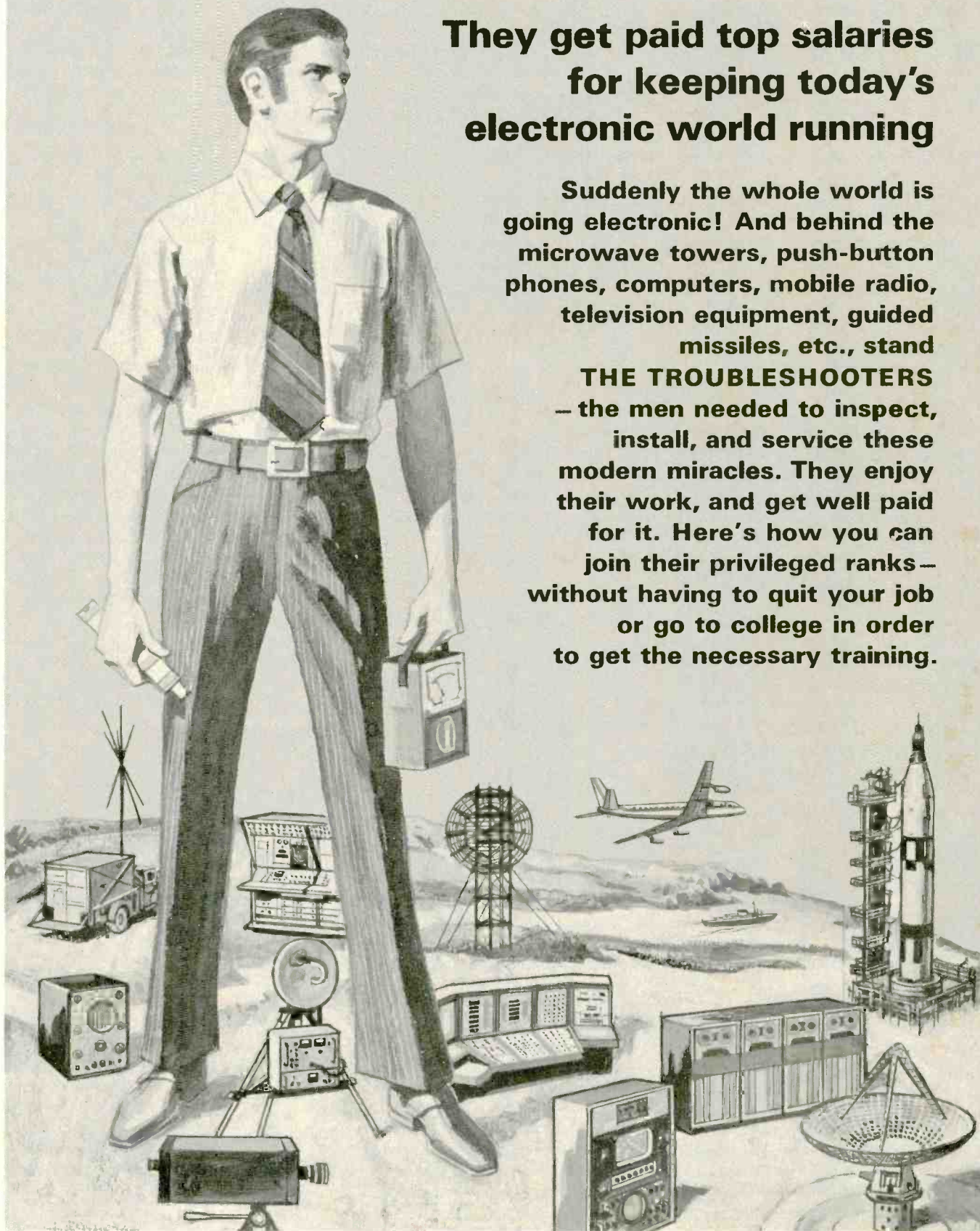

Just think how much in demand you would be if you could prevent a TV station from going off the air by repairing a transmitter . . . keep a whole assembly line moving by fixing automated production controls . . . prevent a bank, an airline, or your government from making serious mistakes by servicing a computer.

Today, whole industries depend on Electronics. When breakdowns or emergencies occur, someone has got to move in, take over, and keep things running. That calls for one of a new breed of technicians — The Troubleshooters.

Because they prevent expensive mistakes or delays, they get top pay — and a title to match. At Xerox and Philco, they're called Technical Representatives. At IBM they're Customer Engineers. In radio or TV, they're the Broadcast Engineers.

What do you need to break into the ranks of The Troubleshooters? You might think you need a college degree, but you don't. What you need is know-how—the kind a good TV service technician has—only lots more.

Learn at Home . . . In Your Spare Time

As one of The Troubleshooters, you'll have to be ready to tackle a wide variety of electronic problems. You may not be able to dismantle what you're working on — you must be able to take it apart "in your head." You'll have to know enough Electronics to understand the engineering specs, read the wiring diagrams, and calculate how the circuits should test at any given point.

Learning all this can be much simpler than you think. In fact, you can master it without setting foot in a classroom . . . and without giving up your job!

For over 37 years, the Cleveland Institute of Electronics has specialized in teaching Electronics at home. We've developed special techniques that make learning easy, even if you've had trouble studying before. Our AUTO-PROGRAMMED® Lessons build your knowledge as easily and solidly as you'd build a brick wall — one brick at a time. And our instruction is personal. Your teacher not only grades your work, he analyzes it to make sure you are thinking correctly. And he returns it the same day it is received, while everything is fresh in your mind.

The Science of the Seventies

To keep up with the latest developments, our courses are constantly being revised. CIE students receive lessons in Field Effect Transistors, Digital Switching Units, Microwave Systems, Lasers, Binary Coding and Computer Arithmetic.

In addition, CIE offers an exciting Electronics Technology with Laboratory course that includes 161 space-

age components to let you perform 242 fascinating electronics experiments. You learn the "how" as well as the "why" of Electronics . . . the Science of the Seventies. Many leading companies use CIE courses to train their own employees who are working on the latest electronic equipment.

Get an FCC License — or Your Money Back!

Two-way mobile work and many other types of troubleshooting call for a Government FCC License, and our training is designed to get it for you. But even if your work doesn't require a license, it's a good idea to get one. Your FCC License will be accepted anywhere as proof of good electronics training.

A good way to prepare for your FCC exam is to take a licensing course from CIE. Our training is so effective that, in a recent survey of 787 CIE graduates, better than 9 out of 10 CIE grads passed the Government FCC License examination. That's why we can offer this famous Money-Back Warranty: when you complete any CIE licensing course, you'll be able to pass your FCC exam or be entitled to a full refund of all tuition paid. This warranty is valid during the completion time allowed for your course. You get your FCC License — or your money back.

Mail Card for 2 Free Books

Want to know more? Then fill out and mail reply card or coupon today. We'll send you our two FREE books on opportunities in Electronics. For your convenience, we will try to have a representative call. Act now, and get a high-paying job that much sooner.

APPROVED UNDER G.I. BILL

All CIE career courses are approved for educational benefits under the G.I. Bill. If you are a veteran or in service now, check box for G.I. Bill information.

CIE Cleveland Institute of Electronics, Inc.

1776 East 17th Street, Cleveland, Ohio 44114

Accredited Member National Home Study Council

Cleveland Institute of Electronics, Inc.

1776 East 17th Street, Cleveland, Ohio 44114

Please send me your two FREE books:

1. Your school catalog, "Succeed in Electronics."
2. Your book on "How To Get A Commercial FCC License."

I am especially interested in:

- | | | |
|---|---|--|
| <input type="checkbox"/> Electronics Technology | <input type="checkbox"/> Broadcast Engineering | <input type="checkbox"/> First Class FCC License |
| <input type="checkbox"/> Electronic Communications | <input type="checkbox"/> Industrial Electronics | <input type="checkbox"/> Electronics Engineering |
| <input type="checkbox"/> Electronics Technology with Laboratory | | |

Name _____
(PLEASE PRINT)

Address _____

City _____ State _____ Zip _____

Veterans and Servicemen:

Check here for G.I. Bill information.

PE-66

Learn By Doing...

Electronics Technology with Laboratory Course teaches you the fundamentals. Using space-age components and testing techniques you will apply the principles you learn . . . actually analyze and troubleshoot modern electronics equipment.



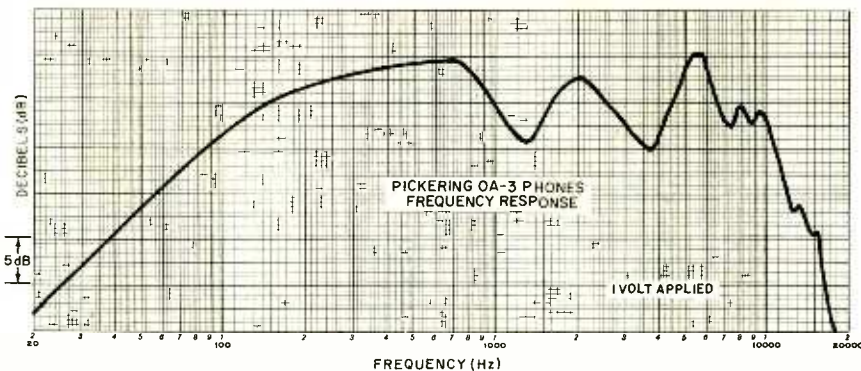

The published specifications of the Model OA-3 phones indicate that they are quite efficient, requiring only 0.1 volt across their nominal 15-ohm impedance to produce a 100-dB sound pressure level (SPL) at 1000 Hz. The maximum rated input power is 0.2 watt/channel, but the series resistors built into all amplifier headphone output circuits will provide adequate protection even with a high-powered amplifier. The distortion is specified at 0.5 percent for a 110-dB SPL output.

The Pickering Model OA-3 headphones are supplied with an adapter plug to permit them to be used with small transistor radios and cassette decks. Retail price of the phones is \$39.95.

Laboratory Measurements. We tested the frequency response of the phones on a Koss-designed coupler, which is a slightly modified version of an accepted standard earphone coupler. The measured frequency response of any headphone is closely connected with the dimensions of the coupler (or artificial ear) on which it is

mounted so that it is virtually impossible to compare data on different coupler designs, especially at the higher frequencies. However, one can obtain a reasonably valid picture of the headphone's overall response even though the specific peaks and dips on the response curve may be as much a property of the coupler as of the phone (and would certainly be still different through the ears of any individual wearing the phones).

The measured frequency response was relatively uniform from 100 Hz to 11,000 Hz, with a total variation of only ± 5 dB over that range. The output fell rather quickly at frequencies beyond 11,000 Hz and at a smooth 6 dB/octave at low frequencies. The response was measured with 1 volt applied to the phones, producing an average 120-dB SPL over the measurement range, which happens to agree exactly with the published specifications.

Normally, one would expect distortion to be a function of frequency, but the published specifications do not specify the test frequency. We measured the distortion at several fre-

quencies between 200 Hz and 1000 Hz, where the output was both strong and smooth, at a 110-dB SPL. The distortion was typically between 1.2 and 1.6 percent and was principally second harmonic. In view of the high SPL used, this amount of distortion cannot be considered serious, even if it does slightly exceed the published rating.

The electrical impedance of the phones was an almost constant 20 ohms across the audio range. It gently rose to 25 ohms at 150 Hz and underwent a slight drop to a 16-ohm minimum at 20 Hz.

Comment. Since our first experience with open-air phones several years ago, we have enjoyed their special qualities—which eliminate many of the objections voiced about headphone listening (heavy weight and pressure exerted, inability to hear desired outside sounds, such as the ring of a telephone, etc.). The Model OA-3 phones embody all the virtues of a good open-air headphone and have a smooth response and the ability to handle high volume levels without objectionable distortion.

The vinyl-coated ear cushions make the Pickering phones a little less "open" to outside noises than are some other types that feature simple foam pads. In fact, in a quiet room, one might almost believe that the phones are the isolating type.

The low impedance and high efficiency of the phones makes them exceptionally well suited for use with small radio receivers and tape recorders.

CIRCLE NO. 67 ON READER SERVICE CARD

DRAKE MODEL SPR-4 COMMUNICATIONS RECEIVER (A Hirsch-Houck Labs Report)

Versatile solid-state receiver for shortwave, amateur radio, CB

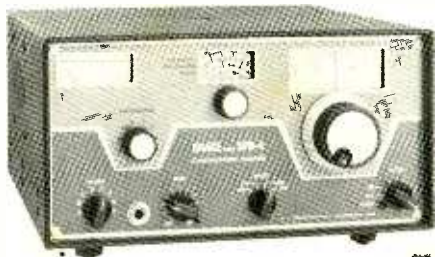

THE Drake Model SPR-4 solid-state communications receiver covers any 23 bands (each 100-kHz wide) between 150 kHz and 30 MHz. Thus, it offers the user reception of international SW, amateur radio, and CB radio transmissions, among others.

The receiver measures 12¼ in. deep by 10¾ in. wide by 5½ in. high (31.1 × 27.3 × 14 cm) and weighs 18 lb (8.2 kg). Its built-in 5-in. by 3-in. (12.7 × 7.6-cm) speaker is mounted on the left side of the metal receiver cabinet. The price of the Model SPR-4 receiver is \$579. Various crystal kits are available for the amateur radio, marine, aeronautical, MARS, Citizens Radio, and other special-interest bands. The external optional speaker, 100-kHz calibrator, and noise blanker are priced at, respectively, \$22, \$20, and \$65.

Technical Details. The receiver employs a double-conversion superheterodyne design. Its first i-f of 5645

kHz is obtained by the mixed product of a crystal oscillator selected by the band switch, while a stable permeability-tuned oscillator (PTO) takes care of the 4955-kHz to 5466-kHz range. The PTO alone is used for the lowest-frequency band.

Following the first mixer, selectivity is provided by a crystal filter, and the signal goes without further amplification to the second mixer. Here, it is converted by a crystal oscillator (with switched crystals for USB and LSB reception) to 50 kHz. Then a four-pole LC filter and a tunable-notch filter provide additional selectivity. After two stages of i-f amplification, the signal goes to a product detector for

SSB and CW or a separate diode detector for AM. The audio amplifier is rated at 3 watts output into a 4-ohm speaker load.

The PTO's dial is calibrated at 1-kHz intervals from 0 to 500, with about 50 kHz of "overrun" at each end. The dial's reference mark can be shifted to calibrate the receiver precisely to any known frequency. At the upper center of the receiver's front panel is a small opening for the frequency range dial, which is marked to indicate each of the 10 basic bands, together with the appropriate settings of the RANGE switch and the PRESELECTOR control knob. Decals are supplied for the 13 blank spaces on the dial, to be added when other crystals are installed.

The front-panel controls include concentric a-f and r-f gain controls, mode switch (with positions for AM CW, LSB, and USB), and an accessory switch. The last activates an optional 100-kHz crystal calibrator and i-f noise blanker when they are installed. Concentric with the accessory switch is a knob that is used to tune the rejection notch filter through the i-f passband to reduce interference from heterodynes.

On the rear apron of the receiver are phono jacks for the antenna and muting connections and an audio in/out jack that can be used either to supply a signal to a tape recorder, ahead of the volume control, or to amplify an external signal through the SPR-4's amplifier. There is also a 120/240-volt line selector and a switch that disables the dial lights for low battery drain (only 2.5 watts at 12 volts).

Laboratory Measurements. The Model SPR-4 receiver has sensitivity ratings for a 10-dB (S + N)/N ratio of 0.25 μ V on CW and SSB and 0.5 μ V for AM at 30 percent modulation. We measured the sensitivity at the center of each band (except the two lowest where the input impedance is too high to match our signal generator). It proved to be substantially better than claimed and varied little from band to band.

The CW sensitivity measured better than 0.15 μ V throughout and about 0.1 μ V on most bands. The SSB sensitivity was typically about 0.18 μ V and reached 0.22 μ V on the highest and lowest frequency bands tested. The AM sensitivity was better than 0.35 μ V

and was typically a little better than 0.30 μ V.

The agc is stated to hold the audio level within 6 dB for an input signal variation of 100 dB. We were able to check it over only an 86-dB signal range, where it varied by only 3.2 dB. The i-f bandwidths at the -6-dB points were essentially as rated: 4.8 kHz on AM, 2.4 kHz on SSB, and 0.4 kHz on CW.

The dial calibration was within 1 kHz on all bands, even without "zeroing" the dial on each range as recommended. When we set the zero at either end of the tuning range, the dial was about as accurate as it could be read—certainly within 200 Hz at all points. And there was no discernible drift over extended periods; the rating, incidentally, is less than ± 100 Hz.

The S meter is, of course, a relative signal strength indicator. On the 7-MHz band, an input of 1.8 μ V gave an S2 indication, while S9 was attained with only 17 μ V of input signal strength. This is by any standards a most "generous" meter. Furthermore, a reading of S9 + 20 dB required 38 μ V, which is only about 6 dB greater than the S9 input. To reach S9 + 40

TIGER "B" — BASIC POWER

Now available, our latest version of the amplifier that started it all; the faithful old "Universal Tiger". We have put him in a fancy new chassis and added our famous complementary differential input circuit, but this is still the rugged, low distortion, economical amplifier that thousands of you out there love so well. With a power output of 75 Watt into an 8.0 Ohm load, or 90 Watt into 4.0 Ohms the "Tiger B" is the ideal BASIC amplifier for all types of applications; from HiFi systems to public address work, to instrument amplifiers; you name it. With its tremendous frequency response, -1.0 dB at 1.0 Hz and 100KHz and super low distortion of .05% IM at rated output, Tiger "B" is ideal for almost any application using an audio amplifier.

Nothing but the best components and first quality fibre-glass circuit boards are used in this kit. The chassis is bronze anodized and the perforated metal cover is standard.

For those who insist on "gilding the lilly" we have an accessory kit to add an output meter, input level control, overheat indicator lamp, front panel power switch, etc.

Circle our reader service number for your free copy of our latest catalog.

275 Amplifier Kit (single channel).....\$64.50 PPd
AC-275 Accessory Kit.....\$ 7.90 PPd



Southwest Technical Products Corp.
219 W. Rhapsody,
San Antonio, Texas 78216

dB, we had to supply a 5500 μ V input, which is actually 50 dB over the S9 input and 43 dB over the S9 + 20 input.

Comment. The Drake Model SPR-4 receiver, in spite of its deceptively simple appearance, is a highly sophisticated unit. It is not to be confused with the many low-priced "communication receivers" directed toward the young SWL and novice ham. It may be

simple enough to be operated by beginners, but it is obviously meant for the advanced SWL, while also offering excellent flexibility for the intermediate and advanced operator.

The SWL in search of an elusive DX station can set the dial to the station's frequency with complete assurance that he is tuned to what the dial says. In addition, if his antenna and propagation conditions are right, he will surely

hear the station he is after—assuming, of course, it is on the air.

If you plan to buy the Model SPR-4 receiver, we feel you should seriously consider including the optional crystal calibrator in your order. Without it, the receiver will probably be tuned to within a kilohertz of the indicated frequency, but why settle for that when it can be "on the nose?"

CIRCLE NO. 68 ON READER SERVICE CARD

AMERICAN CIRCUITS & SYSTEMS MODEL MK1 FUNCTION GENERATOR

Sine, square, or triangle waveforms from 6 Hz to beyond 1.25 MHz

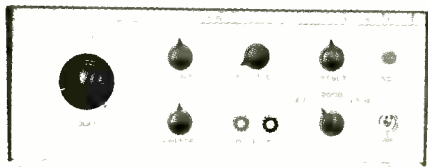

THANKS to low-cost integrated circuits and new approaches in design, a very important change is taking place in audio (and digital) signal generators. Until fairly recently, audio signal generators simply provided sine and square waves that were variable in level and covered a frequency range of about 20 Hz to 100,000 Hz. The new "function" generators that have begun to make their appearance, by contrast, provide sine, square, and triangle (or ramp) waves over a range of about 10 Hz to 1 MHz and beyond.

One good example of a low-cost function generator is the Model MK1 made by American Circuits & Systems, Inc. The MK1 sells for \$135 in kit form. It is also available factory-wired, tested, and adjusted for \$195.

The Model MK1 function generator features sine-, square-, and triangle-wave outputs that are selectable by a WAVEFORM switch. The waveforms, available at a pair of color-coded binding posts on the front panel, are continuously variable from 0 to 20 volts peak-to-peak via an AMPLITUDE control. Another control, labelled ATTENUATE, can be used to provide 0, 20, or 40 dB or attenuation.

Built into the instrument is a dc OFFSET control that permits the ac signal to be dc biased anywhere from +10 to -10 volt into an open circuit (± 5 volts into 600 ohms).

Selecting a frequency is a two-step process: First, the RANGE switch must be set to the desired position (X10, X100, X1K, X10K, X100K). Then, the FREQUENCY control, calibrated in equally spaced increments from 0.9 to

11, is set for the desired frequency. Hence, if you wanted a 5000-Hz output frequency, you would set the RANGE switch to X1K and the FREQUENCY control to 5. (The actual range of the MK1 is from less than 10 Hz to beyond 1.1 MHz.)

On the rear panel of the instrument is a TTL output jack that provides a TTL-compatible signal of the same frequency as that at the OUTPUT binding posts on the front panel. The logic-0 and logic-1 levels of this signal are 0 and +5 volts, respectively. (CMOS logic can be driven directly from the OUTPUT binding posts.)

Also on the rear panel is a vco input jack that virtually doubles the versatility of the function generator. With the appropriate inputs applied to this jack, the output can be swept through a range of frequencies, be frequency modulated with tone or voice, or be frequency shift keyed.

Within the instrument itself are six IC's, two of which are precision voltage regulators, with the remainder being linear devices. The power supply employs circuit-protecting fusing and operator-protected three-conductor line cord.

Kit Details. We selected the Model MK1 function generator kit for our test report. Upon opening the carton in which it arrived, we were gratified to note that all components were of premium quality. Most of the resistors, even some in noncritical parts of the circuit, were of 5-percent tolerance, while the trimmer potentiometers that serve as hidden set-up controls were of OEM quality. The large printed circuit board on which the majority of the components are mounted is made from G-10 epoxy fiberglass.

Assembly is simple and straightforward, guided by clear step-by-step instructions and detailed drawings.

The only test instruments needed to put the function generator into service order are a multimeter (for the voltage checks) and an oscilloscope (for distortion adjustments). A frequency counter comes in handy, but is not necessary, for calibration. (Three methods of calibration are detailed in the instructions.) Using the scope, the sine-wave distortion can be set within a few percent of optimum, while it can be fully optimized with the aid of a distortion meter.

After Assembly. Once the function generator was ready to be put into service, we subjected it to a few tests. Using a precision frequency counter, we determined that its frequency range was from 6 Hz to 1.254 MHz in five overlapping bands. The FREQUENCY control's dial calibration was well within the specified ± 5 -percent figure over almost the entire range.

The amplitude of the output signals could be adjusted from 0 to slightly more than 20 volts peak-to-peak, while the dc offset was adjustable to its specified ± 10 -volt limits into an open circuit. Triangle waveform linearity was better than 1 percent between 10 Hz and 100 kHz and about 2.8 percent maximum from 100 kHz to 1 MHz. Without using a distortion meter, the distortion in the sine-wave function averaged an excellent 6 percent. When a distortion meter was used, the figure could be optimized at 2.4 percent. All other specifications were met or exceeded.

Comment. The American Circuit & Systems Model MK1 function generator is an excellent buy, particularly in kit form. It offers a quality and versatility that should appeal to the audio or digital experimenter and service technician.

CIRCLE NO. 69 ON READER SERVICE CARD

WANTED
TECHNICIAN with three years experience for assignment in Asia or Europe. No college necessary. Salary: \$12,000 to \$19,000 per year, tax-free. Challenging work, with opportunity to move into management or engineering. Paid transportation. Privileges of U.S. Air Force Captain, including PX and Officers Club.

CAREER OPPORTUNITIES FOR THE TECH REP

BY ALLAN C. STOVER

If you read an ad like the above in the classified section of your newspaper, you might think it was too good to be true. However, it accurately describes many technical representative and field engineering opportunities available in the electronics field. On the whole, a tech rep job pays well, offers excellent opportunities for travel, and encompasses a number of duties.

A tech rep is hired by an electronics company which, in turn, sells his services where needed. The U.S. Government, private industry, and local and foreign governments sometimes need electronics technicians for special projects. So, they often sign a contract for enough tech reps to get the job done. The contract might call for the tech reps to do anything from teaching a Job Corps class in New Jersey to manning a lonely tropospheric scatter site in Thailand.

On the job, a tech rep's work varies from assignment to assignment. On one assignment, he might be an advisor, telling a crew of workers what to do. On his next assignment, his job might be to teach a group of students or working technicians the theory and operation of new avionics equipment. Then again, he might operate and maintain a communications system. Most tech reps are called upon to do a bit of everything. In a typical month, he might spend a few days each at teaching a class in electronics theory and practices, helping out on installing or

renovating electronics gear, and repairing a radio or radar system.

Tech reps have been known to operate, maintain, and repair computers, avionics equipment, radar gear, communications systems, test equipment, navigational aids, and just about everything else that uses electronic circuitry. One tech rep might specialize, his duties confined to repairing a single complex transceiver model, while another might be called upon to repair a dozen or so different models and types of equipment. Some tech reps specialize in teaching.

An assignment might put a tech rep in the heart of downtown Manila, right in the midst of civilization. On the other hand, assignment locations can be lonely and far from the amenities of civilization, such as in the heart of a jungle or atop a mountain. Assignments can be almost permanent or highly mobile, depending on the contract. Some tech reps stay in the same location for years, while others must pack up and move to a new location every few months.

Most tech reps enjoy their assignments, but few find "paradise." The Manager of International Recruiting for Page Communications Engineers says, "One word of caution to those who are tempted to cast all aside and dash off to unknown places: To the neophyte who expects to find all the creature comforts he is accustomed to, my advice is to look before he leaps. Instead of some pleasurable

off-duty relaxation in exotic Bangkok, he might find himself repairing a radio (transmitter) on an isolated mountaintop in Iran."

Electronics companies employ thousands of tech reps, stationing them in every corner of the world. You can find tech reps in almost every state of the Union, Germany, on the island of Crete, in Taiwan, Ethiopia, and Iran, Vietnam and Korea, Spain, Turkey, the Philippines, New Guinea, Jamaica, the Arctic, and on some Pacific islands, and aboard ships and submarines.

RCA Service Co. Technical Services representative works on radar unit.

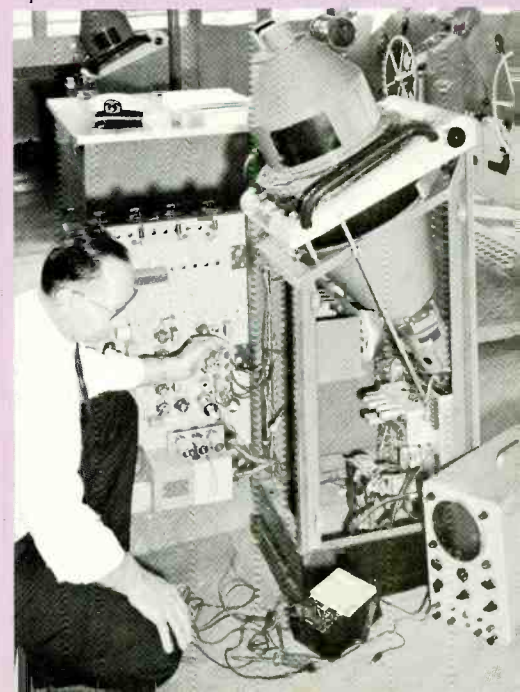

What and Where. ITT's Federal Electric Corporation ships their tech reps all over the world. Sometimes they include tech rep services as part of a contract for new equipment. In December 1973, Federal Electric signed \$56-million worth of new contracts and renewals, which gives an idea of the size of the corporation's operations. Here are a few of the hundreds of jobs the Federal Electric tech reps have handled:

They have installed a microwave communications system in South Vietnam. (The South Vietnam government issued a stamp in their honor.) In Italy, Germany, France, Belgium, England, and the Netherlands, they installed a tropospheric scatter system. For years, they have operated and maintained DEWLine (Distant Early Warning Line) sites ranging from Iceland and Greenland to northern Alaska in some of the bleakest and frostiest locations inhabited by man. The Federal Electric Corporation has held this contract since 1956—almost two decades.

Federal Electric tech reps per-

RCA Service Co. Government Services Technician works on Meteorological Data Handling System Center's computer control console at the Goddard Space Flight Center.

formed operational and maintenance services as the prime contractor on the Air Force's Western Test Range, where they manned range tracking ships and stations, among other things. They installed a computerized reservations system in the British Overseas Airways Corporation's offices in New York.

Tech reps from RCA Service Company have tackled hundreds of different jobs in as many different places all over the world.

A satellite ground station was installed in the People's Republic of China. They operated and maintained a tracking site in the Arctic, and they operated and maintained missile tracking stations on islands in the Atlantic Ocean for the Air Force's Eastern Test Range.

The RCA tech reps gave technical assistance and training to the Philippine, South Korean, Ethiopian, and Spanish air forces.

Salaries and Extras. Most companies pay their tech reps well. Base pay usually is on an average with a

good technician, but "extras" can push the total-package up to more than what the average electronics engineer earns, from \$10,500 to \$19,000 per year. Overtime can run these figures even higher. The extras depend on the company the tech rep works for and the assignment on which he is sent. Examples of extras include:

Per Diem: A daily allowance that is designed to repay the tech rep for most of his extra expenses. It covers hotels, meals, cleaning bills, tips, and other expenses. Per diem is usually a flat rate; so, if a tech rep cuts corners, he can pocket the money he saves. The per diem rate runs from a few dollars up to and beyond \$25 per day. Some companies pay per diem for as long as the tech rep remains on the assignment, while others pay it for three to six months only. Still other companies pay per diem only when the tech rep travels on business away from his regular assignment. A few companies pay the tech rep's actual expenses instead of per diem.

Cost-of-Living Allowance (COLA): A few companies pay COLA to cover the difference in living costs between a U.S. city and an overseas location. The COLA in Tokyo, the world's most expensive city in which to live, can run hundreds of dollars a month. One company gives a flat 30 percent of base pay no matter where they assign a tech rep. Some U.S. Air Force contracts direct the local military disbursement officer to pay a COLA to each rep. COLA can start at \$7 per day on some contracts.

Bonuses: Some companies pay a flat bonus for overseas service. It can be 10 percent of base pay or \$125 per month, depending on the company for which the tech rep works. Some companies pay a bonus that depends on the location of the assignment; a tech rep who lives in a soggy tent in South Vietnam gets a bigger bonus than one who works in downtown Brussels.

This patchwork of pay and allowances makes it difficult to predict a tech rep's pay package. But the average paycheck for tech reps, all extras considered, runs from \$12,000 to \$16,000 per year, with some reps receiving salaries above and other below these figures.

The tech rep who works overseas has an opportunity to take advantage of one of the juiciest Internal Revenue tax laws ever written. If he spends 510 days (about 17 months) out of 18 months outside the U.S., up to \$20,000

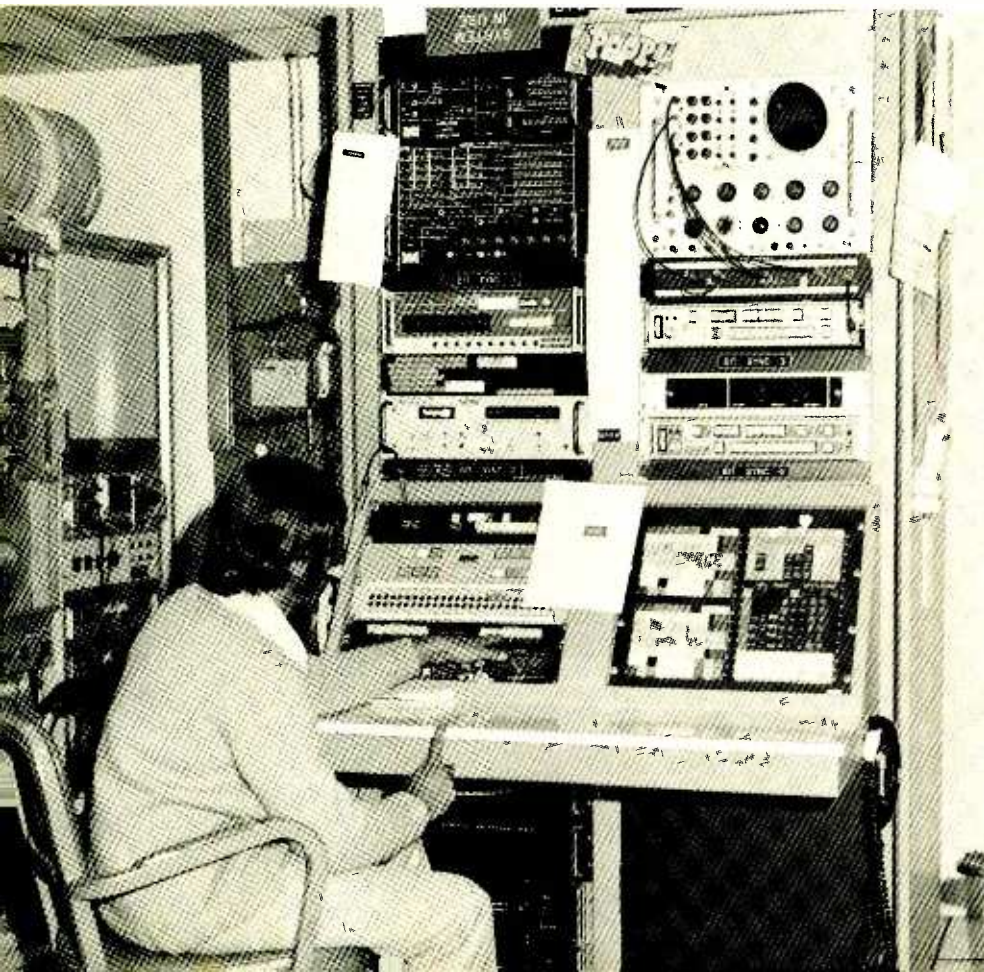

of his yearly income during that period is tax-free! If his company withholds any taxes, the tech rep claims a refund.

Other privileges sweeten the picture even more. Most military contracts with overseas assignments grant the tech rep most of the privileges of a captain. This means that he can live in the Bachelor Officers Quarters, eat and drink in the Officers Club, and shop in the PX and commissary.

The company handles the tech rep's transportation to his assignments. In return for paying per diem while the man is en route to his assignments, the company requires him to spend at least a year on assignment. Should the tech rep decide to terminate his employment before the year is up, he must pay back all the company spent on getting him to his assignment.

Becoming a Tech Rep. The qualifications for becoming a tech rep are surprisingly light. Only a handful of positions call for an engineering degree. Most require only technician-level electronics training and three to five years of specialized practical experience. If you worked on a new system in the armed forces, no matter what your rank, you stand an excellent chance of landing a tech rep job. Many companies train some tech reps, but most prefer to hire the man who already has the knowledge and practical experience to go right to work.

If you live near an electronics company that hires men for tech rep positions, apply in person. Alternatively, you can type up a resume and mail it to the companies that hire tech reps and field engineers. (Consult the want ads in your newspaper for addresses.) If your background fits in with a company's needs, you will receive a job application form in the mail or be hired on the spot. (When making up your resume, keep it down to two pages. Just give the facts about education and experience and some personal data.)

The personal data in your resume should include full name, age and date of birth, marital status, state of health, and dates of military service, if any. Under education, list all schools you attended in which you received training for the type of work you are applying for. Include resident, home-study, and military courses taken, detailing the titles of the courses and types of equipment you studied.

When giving details of your work

experience, start with your present position and work back in time. List job titles, the dates you held the positions, and short descriptions of your work duties. List the names and model numbers of all the equipment with which you are familiar. Also, mention any achievements and awards you have received or earned.

Who Needs Tech Reps? Scores of large and small companies need qualified men to serve as tech reps. As a rule of thumb, try the large companies first. If you think you can qualify for

the work, you might try the following three companies first:

Federal Electric Corp., 621 Industrial Ave., Paramus, NJ 07652. (Address correspondence to the attention of Mr. Ridings, Director, Field Services.)

Page Communications Engineers, Inc., Vienna, VA 22180. (Attn.: Manager, International Recruiting)

RCA Service Co., Camden, NJ 08101.

If these companies do not need your talents, try Bendix, Philco-Ford, and Kentron. ♦

Walt Ostrander, Audioanalyst, As Seen Through The Eyes Of His A-100X Speaker



His tortures drive drivers to drink.

Walt Ostrander, New York



Warranty on every speaker in the Audioanalyst line. \$94 to \$249.

Everyone boasts clean highs, low bass, a better driver. Fact. The best drivers are pretty much alike. It's what our Audio-

This perfectionist believes results justify the individual bench testing of every single assembly. "Unusually flat toward the top of its price range" says High Fidelity of our A-100X bookshelf speaker. We say, a Six Year

analysts do with them that's different. Is there a percentage in this kind of obsession? A sound one to be sure. To test our speakers, simply write to us. All we ask is that you give them what we give them. The works.

Meet the Audioanalyst Master of Torture. Live! At the Boston High Fidelity Music Show-Room 412.

Audioanalyst

P.O. Box 262, Brookfield, Conn. 06804
Monstrous About Perfection

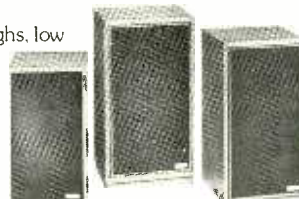

CIRCLE NO. 44 ON READERS SERVICE CARD

There's a new Heathkit everyone on

The Heathkit Digital Color TV is for two kinds of people

... those who understand electronics, and those who don't

People who understand electronics will appreciate the GR-2000's advanced digital design, incorporating on-screen channel readout and optional clock. Digital logic circuitry programs up to 16 stations in any sequence. Then just press a button—you'll never have to switch through a "dead" channel again.

And our exclusive VHF/UHF varactor tuner eliminates clunking contacts that corrode and noisy motors that break down.

The GR-2000 also has the industry's first fixed-filter IF amplifier. There's no need for instrument IF alignment ever, so the picture stays bright and clear year after year. And even in urban areas where stations are packed closely together, there's virtually no adjacent channel interference.

The 100% solid-state chassis uses 19 integrated circuits—more than any other TV around. You'll get superior performance and reliability no conventional set can match.

A built-in dot generator and test meter make it easy to keep the GR-2000 in peak condition without expensive service calls. The slide-out service drawer and hinged, swing-out chassis



put everything in easy reach. If anything ever goes wrong, an extensive trouble-shooting guide will help you fix it.

And people who don't understand electronics will enjoy the best looking picture around. *Popular Electronics* said the picture on the 25" (diagonal) screen "can only be described as superb. The Black (Negative) Matrix CRT, the tuner and IF strip, and the video amplifier provide a picture equal to that of many studio monitors..."

Everyone likes the on-screen readout that puts the channel number into the picture whenever you want it. When you change channels or touch the recall button, the big, bright digits reappear. Add the optional clock module and you'll see the time as well as the channel.

The optional wireless remote control makes the GR-2000 even more enjoyable. Change channels, adjust the volume, set tint and color intensity and turn the set on or off from across the room. And, a touch of the Volume bar automatically returns the digital readout to the screen momentarily. It's an amazing handful of convenience.

Even if you don't have a lot of kit-building experience, you'll enjoy the GR-2000. Illustrated step-by-step in-



structions, prefabricated wiring harnesses, transistor and IC sockets and modular circuit boards greatly simplify assembly.

See the TV the experts are talking about. *Popular Electronics* summed it all up: "In our view, the color TV of the future is here—and Heath's GR-2000 is it!"

GR-2000—the TV everyone can appreciate.

Mail order price for chassis and tube, \$669.95. Remote control, \$89.95, mail order.

Cabinets start at \$154.95, mail order. (Retail prices slightly higher.)

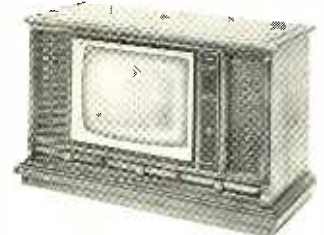

Christmas gift for your list

Give your scientist, engineer or student a gift he'll use all year long. Finger-sized keys and 8 bright 1/2" digits make it easier to use than pocket calculators. Cumulative memory and register exchanges virtually eliminate scratchpad work. Performs arithmetic plus trig and arc trig in degrees or radians, common and natural logs,

powers of e, square roots, inverses, pi and exponential functions. **Kit IC-2100**, 4 lbs., mailable .. **119.95***

Unique New Heathkit AM/FM Digital Clock Radio

Our outstanding clock radio makes even sleepy Santas happy.

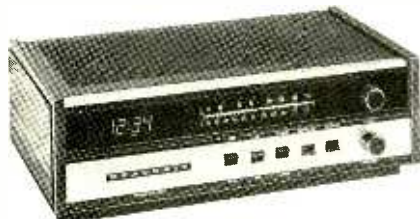

The electronic clock with snooze alarm features a gentle "beep" with adjustable volume. Or wake to the component-quality AM/FM radio. Standby batteries (not included) keep the clock on time during power interruptions. **Kit GR-1075**, 10 lbs., mailable **129.95***



Our new Heathkit Desktop Electronic Sliderule Solves Your Gift-Giving Problems

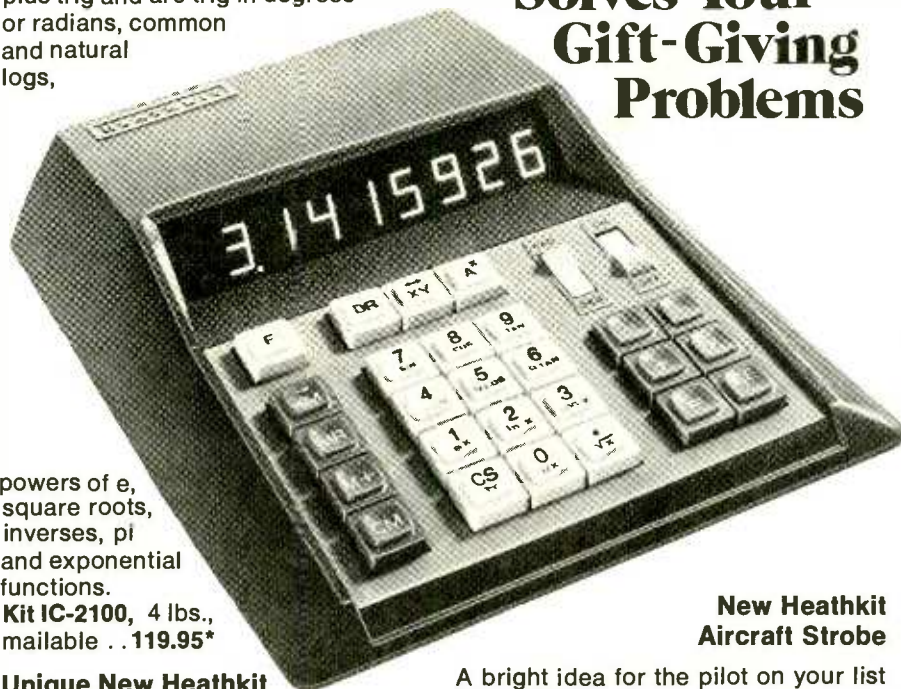

New Heathkit Aircraft Strobe

A bright idea for the pilot on your list—or for anyone who needs an emergency marine or marker light. It meets FAR 23.1401 and assembles easily in just one evening. For 12 VDC neg. ground. With clear lens, optional red and red/clear lenses available. **Kit OL-1155**, 3 lbs., mailable **54.95***



Learning's Fun With Our New Heathkit "Electronics Workshop"

The JK-18A teaches kids electronics the easy learn-by-doing way. 35 exciting projects include light meter, sound meter, transistor radios. For safety, it's battery powered and requires no soldering. (Batteries not included) **Kit JK-18A**, 10 lbs., mailable .. **34.95***



New Heathkit Electronic Clock/Timer for Car, Boat or Plane



A timely gift—

an electronic clock and a 20-hour rally timer, both with quartz crystal accuracy. Bright 1/2"-tall digits dim automatically at night. 12 VDC, mounts on or under dash. **Kit GC-1093**, 2 lbs., mailable **62.95***

Two Heathkit Electronic Clocks with Standby Power

Two beautiful gifts—the GC-1092A is a clock with a snooze alarm; the GC-1092D reads the time in 6 digits, the month and date in 4 digits. Both have standby power to keep the clock on time without the display even during temporary power interruptions. (Batteries not included.) **Kit GC-1092A or D**, 5 lbs., mailable each **82.95***



Time/Alarm



Time/Date

Heathkit Exhaust Analyzer Checks Your Car's Tune Up

Make everyone's Christmas whiter and cleaner—be sure your tune up is helping clean up the environment. Big 4 1/2" meter reads relative combustion efficiency, air-fuel ratio and percentage carbon monoxide. **Kit CI-1080**, 6 lbs., mailable .. **59.95***

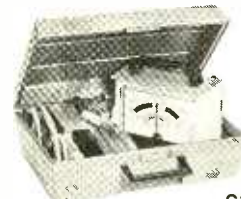

Exciting new Heathkit Christmas giving



new Heathkit dual-trace DC-15MHz scope



Compare the features:

- Dual-trace with true X-Y capability
- 1 mV/cm vertical sensitivity over the full bandwidth
- Post-deflection accelerated CRT for bright trace, fast writing
- Vertical amplifier delay lines for pulse analysis capability
- Digitally controlled triggering for exceptional stability
- Typically triggers up to 45 MHz—guaranteed to 30 MHz

It offers a lot more than just a low price

The Heathkit IO-4510 is your best 'scope buy for two good reasons—it does more and it costs less.

Time base sweep up to 100 nsec/cm. There's always a reference baseline, even when there's no trigger signal. The time base can be precisely triggered at any point along the positive or negative slope of the trigger signal. In automatic mode, it triggers at the zero crossing point.

Modes of display. Either channel can be displayed as a function of time or both can be displayed together. In X-Y operation, channel 1 provides horizontal deflection and channel 2

provides vertical deflection. There are 22 calibrated time bases from 0.2 sec/cm to 0.1 μ sec/cm. The sweep speed is continuously variable between switch positions. Any speed can be expanded five times by pulling out the control knob.

For easy calibration, a 1 volt peak-to-peak square wave is available on the front panel. The regulated supply operates from 100-280-volt AC power. **Kit IO-4510,** 34 lbs., mailable **549.95***

Assembled SO-4510, factory-wired & calibrated version of the IO-4510, 34 lbs., mailable **750.00***



New Low-Cost Heathkit Function Generator

A true function generator, not an oscillator, delivers sine, square and triangle waveforms from 0.1 Hz to 1 MHz. Short-proof output supplies 10 volts peak-to-peak into 50-ohm load. A calibrated step attenuator adjusts from 0-50 dB (10V to 30 mV) in 10 dB steps. A variable control provides up to 20 dB of additional attenuation at

each step. Attenuator accuracy is ± 1 dB; frequency accuracy is $\pm 3\%$. Non-linearity of the triangle waveform is 5% max., symmetry is within 10%. Sine wave THD is 3% max. from 5-100k Hz. Square wave rise and fall times are 100 nsec max. 105-130 or 210-260 VAC. **Kit IG-1271,** 7 lbs., mailable **99.95***

Assembled SG-1271, factory-wired & calibrated version of IG-1271, 7 lbs., mailable **140.00***

projects - timed for

Coming in December...

A new generation of Heathkit ham radio equipment

New Heathkit SB-104 transceiver

Years ahead in design & features — the SB-104 is a complete rethinking of what a CW/SSB transceiver should be. It utilizes the latest digital & solid-state technologies. The "104" is completely solid-state from the front end to the RF output.

Totally broadbanded. You can switch from 3 to 30 MHz without preselector, load or tune controls.

True digital readout with 6 bright digits to indicate the frequency with accuracy to 100 Hz.

Mobile-ready. The SB-104 operates from 12 VDC, so it's ready to go mobile when you are. Optional features include a plug-in digital noise blanker and 400 Hz crystal filter for CW.

Just about the only things that aren't totally new about the "104" are the quality and easy assembly that have made Heath famous. **Kit SB-104**, 31 lbs., mailable **669.95***

Kit SBA-104-3, 400 Hz CW crystal filter for SB-104, 1 lb., mailable **34.95**

Kit SBA-104-1, digital noise blanker for SB-104, 1 lb., mailable **24.95***

Kit SBA-104-2, mobile mount, 6 lbs., mailable **34.95***

New Heathkit SB-230 1 kW conduction-cooled linear

High-power match for the SB-104. Lowest cost conduction cooled linear on the market. 1200 watts PEP and 1000 watts CW from less than 100 watts input. It's also rated at 400 watts input for slow-scan TV and RTTY. And absolutely silent — no blowers, no fans.

Full metering of relative power, plate current, grid current and plate high voltage. Safety features include microswitch interlocks for top and bottom shells, thermal shutdown, fused cathode, on/off switch with circuit breaker for power transformer.

On the air in 15 to 20 hours. Fast, easy assembly, then check it out with an ohmmeter — no alignment necessary. **Kit SB-230**, 40 lbs., mailable **319.95***

New Heathkit SB-614 station monitor scope

How clean is your signal? The bright 1 1/2 x 2" screen helps you keep your rig in peak condition. Reveals a wide variety of operating problems — nonlinearity, insufficient or excessive drive, carrier or sideband suppression problems, regeneration and key clicks. Monitors AM, SSB and CW signals up to 1 kW from 80 to 6 meters. **Kit SB-614**, 17 lbs., mailable **139.95***

New Heathkit 5-Function SB-634 station console

Five accessories in one — a 24-hour 6-digit electronic clock, a ten-minute digital ID timer with visual and/or audible alarms, RF wattmeter, SWR bridge, hybrid phone patch with manual and VOX controls. **Kit SB-634**, 14 lbs., mailable **179.95***

New Heathkit SB-644 remote VFO

Designed exclusive for SB-104, it provides the ultimate in multi-mode operation with two crystal sockets for fixed frequencies. No modifications — just plug the VFO into the "104" and go — VFO frequency even reads out on the 104's digital display. **Kit SB-644**, 10 lbs., mailable **119.95***

New Heathkit Fixed station AC power supply

Powers the SB-104 from 120 or 240 VAC. Sophisticated regulation assures almost no change in voltage from no load to full load. Entire supply fits inside SB-604 speaker cabinet. **Kit HP-1144**, 28 lbs., mailable **89.95***

New Heathkit SB-604 station speaker

Response-tailored to SSB and designed to match the SB-104. Large enough to house HP-1144 AC power supply. **Kit SB-604**, 8 lbs., mailable **29.95***

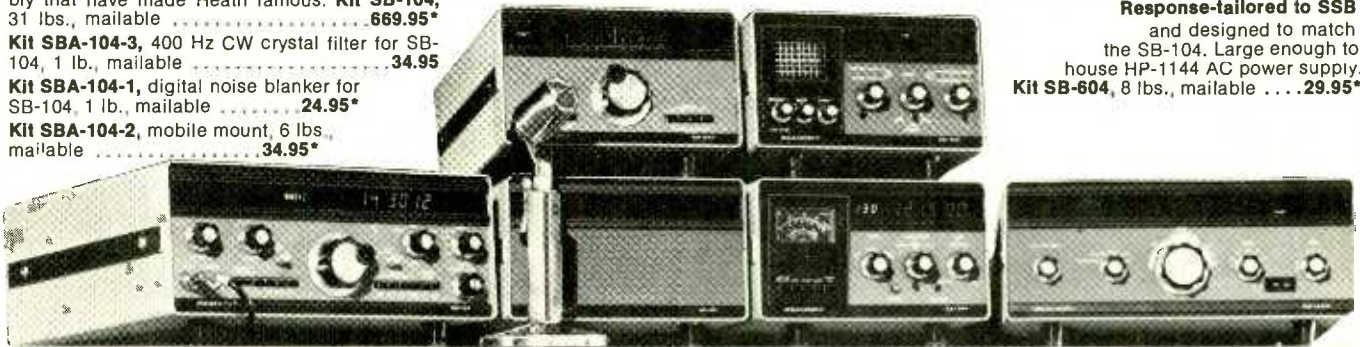

HEATHKIT ELECTRONIC CENTERS — Units of Schlumberger Products Corporation
Retail prices slightly higher.

ARIZ.: Phoenix; CALIF.: Anaheim, El Cerrito, Los Angeles, Pomona, Redwood City, San Diego (La Mesa), Woodland Hills; COLO.: Denver; CONN.: Hartford (Avon); FLA.: Miami (Hialeah), Tampa; GA.: Atlanta; ILL.: Chicago, Downers Grove; IND.: Indianapolis; KANSAS: Kansas City (Mission); KY.: Louisville; LA.: New Orleans (Kenner); MD.: Baltimore, Rockville; MASS.: Boston (Wellesley); MICH.: Detroit; MINN.: Minneapolis (Hopkins); MO.: St. Louis (Bridgeton); NEB.: Omaha; N.J.: Fair Lawn; N.Y.: Buffalo (Amherst), New York City, Jericho, L.I., Rochester, White Plains; OHIO: Cincinnati (Woodlawn), Cleveland, Columbus; PA.: Philadelphia, Pittsburgh; R.I.: Providence (Warwick); TEXAS: Dallas, Houston; WASH.: Seattle; WIS.: Milwaukee.



Heath Company, Dept. 10-11
Benton Harbor, Michigan 49022

HEATH
Schlumberger

Send for your FREE 1975 catalog today.

- Please send my free 1975 Heathkit Catalog.
 Please send the merchandise checked below. I've enclosed \$ _____, plus shipping, in payment.

- | | | |
|--|---|---|
| <input type="checkbox"/> GR-2000 Color TV | <input type="checkbox"/> JK-18A Junior electronics workshop | <input type="checkbox"/> SG-1271 Function generator (assembled) |
| <input type="checkbox"/> GRA-2000-1 Digital clock module | <input type="checkbox"/> GC-1092A Digital clock with snooze alarm | <input type="checkbox"/> SB-104 Transceiver |
| <input type="checkbox"/> GRA-2000-6 TV remote control | <input type="checkbox"/> GC-1092D Digital clock with date display | <input type="checkbox"/> SB-104-1 Noise blanker |
| <input type="checkbox"/> IC-2100 Calculator | <input type="checkbox"/> IO-4510 Oscilloscope (kit) | <input type="checkbox"/> SB-104-2 Mobile mount |
| <input type="checkbox"/> CI-1080 Exhaust analyzer | <input type="checkbox"/> SO-4510 Oscilloscope (assembled) | <input type="checkbox"/> SB-104-3 CW crystal filter |
| <input type="checkbox"/> GR-1075 Digital clock radio | <input type="checkbox"/> IG-1271 Function generator (kit) | <input type="checkbox"/> SB-230 1 kW linear |
| <input type="checkbox"/> GC-1093 Digital car clock/timer | | <input type="checkbox"/> SB-614 Monitor scope |
| | | <input type="checkbox"/> SB-634 Station monitor |
| | | <input type="checkbox"/> SB-644 Remote VFO |
| | | <input type="checkbox"/> HP-1144 AC power supply |
| | | <input type="checkbox"/> SB-604 Station speaker |

Name _____

Address _____

City _____ State _____ Zip _____

*Mail order prices, FOB factory
Prices and specifications subject to change without notice.

CL-541

COMPUTER TERMINALS ARE COMING

BY LESLIE SOLOMON
Technical Editor

THE sales and complexity of electronic calculators seem to be rising exponentially. Practically every month, new models appear with more functions available. Some of the new ones are more like mini-computers than calculators.

Where will it all end? Someday, each of us will probably have his own full-blown computer. For the foreseeable future, however, such a computer would be a trifle large for the average home; and the price would be out of reach for almost everyone. But there is a way of having the use of a full-blown computer without buying your own. All you need is a "computer terminal."

A computer terminal looks like a desk calculator, has a typewriter keyboard with a few extra keys, and is equipped with alphanumeric readout. The terminal shown in the photo is typical of those now being made available at reasonable cost. The input/output connections to the terminal are made through some form of conventional telephone-line coupler. For the unit shown here, the coupling is made by dropping the phone into a special cradle.

To operate a terminal, the user simply dials his local time-shared computer company (usually found in the Yellow Pages) and places the phone in the cradle. The remote computer then "answers" the phone; and after the terminal operator enters his private billing number and the computer verifies it, the operator is signalled to start his entry. What can the operator do? Just about anything of which the expensive computer on the other end is capable—which is quite a bit.

Since the computer is expensive, operating time costs would be very high if it were not for the use of "time-sharing" techniques. This means that a number of terminals are using the same computer but sharing its time. The computer switches from one terminal to another so fast that it appears that each terminal is the only one using the computer. This lowers the user price to between \$9 and \$30 per month installation fee plus anywhere from \$2 to \$8 per hour of actual computer time. The user also pays conventional telephone rates for the use of

the line, just as he would if he were making a conventional call.

It might appear that the hourly use charge is high. However, if a problem is laid out first, it takes very little time for it to be typed in; and then the answer should return within seconds. A lot of information can pass through such a system in a couple of minutes. Then, the time used is cumulative. That is, the user pays only for the accumulated computer time—a couple of minutes here, a couple of minutes later, etc. The system does not have to be operated for an hour at a time.

What can a computer do for you? Obviously it can provide a complete household or business accounting system in which all purchases, sales, etc., are broken down into various areas for tax purposes. A record of all financial statements, income, expenses, material, etc., is kept in the electronic files. With an available memory of up to 100,000,000 words, quite a bit of information can be stored for future recall by the customer.

How good is security? Can some outsider get a look at your private files? Precautions are generally taken to prevent unauthorized readout. Each customer has a private entry code that he alone can use to gain entry to his portion of the computer. This private code is never displayed on the alphanumeric readout so it remains a secret even if someone is watching the operator at his console.

Some time-sharing companies have special "programs" for their subscribers. Some companies, for example, specialize in engineering areas, supplying subscribers with a list of programs available. The program might be a complete analysis of a particular problem, and all you do is insert your own numbers. You do not have to be familiar with the mathematics involved; the computer takes care of that. For example, assume a transistor amplifier is to be designed or a band-pass filter using an op amp is needed. When you call the program, the terminal readouts will "ask" certain questions regarding input, voltages, stage gain requirements, output desired, and so forth. Once you insert your requirements in answer to the computer, your circuit will be designed in

seconds, with all components identified. It is like having an engineering textbook come to life, solving all the problems and supplying all the answers.

There are educational programs for children in which the computer takes on the role of teacher. Children can learn math or other subjects and ask all the questions they want from a teacher having infinite patience. The computer will "talk back" when the student does something wrong, explain the problem, or give the correct answer.

There are also "game" programs in which various sports or games can be played between the computer and the operator. This is a powerful learning tool for students and an intellectual exercise. There will be programs in almost every area; and, as the library is expanded, notification will be sent to each subscriber.

What about cost? The MITS Computer 256 terminal is \$595, complete with the acoustic coupler. This particular terminal will store 256 characters with expansion to 1026. Options to expand up to 3 pages are available.

An auto-transmit feature allows the user to transmit data or program material line-by-line instead of typing it directly into the computer, thus saving actual computer use time. The terminal also has a tape play/record feature that gives it a virtually unlimited memory capability. Almost any type of tape recorder can be used.

If you already have a digital computer, a hard wire connector is provided for direct connection to your own computer. If you don't own a computer, this connector will be used for some future add-on features to further expand the terminal. ♦



The MITS Comter 256.

ENGLISH-LANGUAGE SHORTWAVE BROADCASTS FOR NOVEMBER 1974 TO FEBRUARY 1975

by Roger Legge

TO EASTERN NORTH AMERICA

(If Standard Time is restored, EDT times are one hour earlier than listed except the Melbourne 7:15 a.m. transmission.)

TIME-EDT	TIME-GMT	STATION	QUAL*	FREQUENCIES, MHZ
7:00-8:15 a.m.	1100-1215	London, England	G	11.905, 15.07
7:00-9:00 a.m.	1200-1400	**VOA, Washington, U.S.A.	G	6.185, 9.565
7:15-8:45 a.m.	1115-1245	Melbourne, Australia	G	7.295, 9.58
7:30-8:00 a.m.	1130-1200	Jerusalem, Israel	F	12.025, 15.13
8:00-8:15 a.m.	1200-1215	Tokyo, Japan	F	5.99
8:00-8:55 a.m.	1200-1255	Montreal, Canada	G	5.97, 11.825
9:00-9:30 a.m.	1300-1330	**Bucharest, Romania	F	15.25
9:15-9:45 a.m.	1315-1345	Berne, Switzerland	G	15.14
10:00-10:30 a.m.	1400-1430	Helsinki, Finland	G	15.185
		Stockholm, Sweden	G	17.71
10:30 a.m.-12:15 p.m.	1430-1615	London, England	G	17.84 (via Ascension Is.)
4:00-4:45 p.m.	2000-2045	Jerusalem, Israel	F	7.395, 9.495, 9.815
5:15-7:00 p.m.	2115-2300	London, England	G	5.975, 9.58, 15.26
5:30-6:50 p.m.	2130-2250	Hilversum, Holland	F	9.715, 11.73 (Sun.: Dutch)
6:30-8:20 p.m.	2230-0020	Johannesburg, S. Africa	G	9.585, 9.695, 11.90, 11.97
6:55-7:15 p.m.	2255-2315	Brussels, Belgium	F	6.055
7:00-8:30 p.m.	2300-0030	Moscow, U.S.S.R.	F	5.94, 7.15, 7.205, 9.685
7:45-8:45 p.m.	2345-0045	Tokyo, Japan	P	15.27, 15.445
8:00-8:30 p.m.	0000-0030	Tirana, Albania	G	7.065, 9.78
8:00-9:00 p.m.	0000-0100	Peking, China	F	9.94, 11.945
		Sofia, Bulgaria	F	6.07, 9.70
8:00-10:00 p.m.	0000-0200	**VOA, Washington, U.S.A.	G	6.13, 9.65, 11.83
8:30-9:00 p.m.	0030-0100	Stockholm, Sweden	P	6.00
8:30-9:00 p.m.	0030-0100	Kiev, U.S.S.R.	G	5.94, 7.15, 7.205
		Tu/Th/Sa		
8:30 p.m.-3:00 a.m.	0030-0700	HCJB, Quito, Ecuador	G	5.965, 9.56, 11.915
8:40-9:00 p.m.	0040-0100	Brussels, Belgium	F	6.055
9:00-9:15 p.m.	0100-0115	Vatican City	F	5.995, 9.605
9:00-9:20 p.m.	0100-0120	Rome, Italy	P	6.01, 9.575
9:00-9:30 p.m.	0100-0130	Budapest, Hungary	P	6.00, 9.833
9:00-9:45 p.m.	0100-0145	Berlin, DDR	F	5.955, 9.73
		Madrid, Spain	F	6.065
9:00-10:00 p.m.	0100-0200	Montreal, Canada	G	6.085, 9.755
		Peking, China	F	7.12, 9.78 (via Tirana)
		Prague, Czechoslovakia	F	5.93, 7.345, 9.54
9:00-11:00 p.m.	0100-0300	Melbourne, Australia	P	11.97, 15.32
9:00-11:30 p.m.	0100-0330	London, England	G	5.975, 7.325, 9.51
9:00-11:30 p.m.	0100-0330	Havana, Cuba	F	11.725, 11.93
9:00 p.m.-1:00 a.m.	0100-0500	Moscow, U.S.S.R.	F	5.94, 7.15, 7.165, 7.205
9:30-9:55 p.m.	0130-0155	Tirana, Albania	F	6.70, 7.30
		Vienna, Austria	P	6.155, 9.77
9:30-10:30 p.m.	0130-0230	Bucharest, Romania	P	5.99, 9.57

* Reception quality (Virginia location, Collins Communications Receiver, L antenna): G-good, F-fair, P-poor
 Reception quality of Western North America broadcasts is expected reception in California.

** Not intended for North America, but receivable satisfactorily.

Reception of many evening broadcasts are expected to be fair or poor during the winter months, due to low MUF's (Maximum Usable Frequencies), associated with the winter low of the 11-year sunspot cycle.

TIME-EDT	TIME-GMT	STATION	QUAL*	FREQUENCIES, MHZ
9:30-10:50 p.m.	0130-0250	Cologne, Germany	F	6.04, 6.075, 9.545, 9.69
9:45-10:15 p.m.	0145-0215	Berne, Switzerland	F	5.98, 6.12, 9.535
10:00-10:45 p.m.	0200-0245	Lisbon, Portugal	G	6.025
10:00-11:20 p.m.	0200-0320	Hilversum, Holland	F	6.165 (via Bonaire)
10:00-11:30 p.m.	0200-0330	Cairo, Egypt	P	9.475
10:30-11:00 p.m.	0230-0300	Beirut, Lebanon	P	9.66
11:00 p.m.-12 mdt	0300-0400	Buenos Aires, Argentina	F	9.69 (Mon.-Fri.)
		Peking, China	F	7.12, 9.78 (via Tirana)
		Prague, Czechoslovakia	F	5.93, 7.345, 9.54

TO WESTERN NORTH AMERICA

(If Standard Time is restored, PDT times are one hour earlier than listed.)

TIME-PDT	TIME-GMT	STATION	QUAL*	FREQUENCIES, MHZ
7:00-9:00 a.m.	1400-1600	**VOA, Washington, U.S.A.	G	6.185, 9.565
8:00-8:15 a.m.	1500-1515	Tokyo, Japan	G	5.99
4:00-5:30 p.m.	2300-0030	London, England	G	6.175, 9.74 (via Canada)
5:00-7:00 p.m.	0000-0200	London, England	F	9.51, 15.26 (via Ascension Is.)
5:30 p.m.-12 mdt	0030-0700	HCJB, Quito, Ecuador	G	9.56, 11.915
6:00-7:00 p.m.	0100-0200	Peking, China	G	9.94, 11.945
6:00-8:00 p.m.	0100-0300	Melbourne, Australia	G	11.97, 15.32, 17.795
6:00-8:00 p.m.	0100-0300	Moscow, U.S.S.R.	G	12.05, 15.18 (via Khabarovsk)
6:30-7:30 p.m.	0130-0230	Tokyo, Japan	F	15.235, 15.445, 17.825
7:00-8:50 p.m.	0200-0350	Taipei, Taiwan	F	11.86, 15.125, 17.72
7:00-9:15 p.m.	0200-0415	London, England	F	9.51, 15.26 (via Ascension Is.)
7:30-8:00 p.m.	0230-0300	Stockholm, Sweden	P	6.045
8:00-8:30 p.m.	0300-0330	Seoul, Korea	F	11.925
8:00-10:00 p.m.	0300-0500	Peking, China	G	15.06, 17.735, 17.825
8:30 p.m.-12:30 a.m.	0330-0730	Moscow, U.S.S.R.	G	11.72, 12.05, 15.18 (via Khabarovsk)
9:00-9:15 p.m.	0400-0415	Tokyo, Japan	G	15.105
9:00-10:55 p.m.	0400-0555	Montreal, Canada	G	6.135, 9.655
9:30-10:00 p.m.	0430-0500	Berne, Switzerland	P	5.98, 9.75
9:35-10:55 p.m.	0435-0555	Cologne, Germany	G	6.085, 9.605 (via Canada)
10:00-11:20 p.m.	0500-0620	Hilversum, Holland	G	6.165, 9.715 (via Bonaire)
11:00-11:15 p.m.	0600-0615	Tokyo, Japan	G	9.505
11:00 p.m.-12 mdt	0600-0700	Buenos Aires, Argentina	F	9.69 (Mon.-Fri.)
11:30 p.m.-1:00 a.m.	0630-0800	Havana, Cuba	F	9.525



DX Listening

By Glenn Hauser

"SECRET" SW STATIONS

AS winter approaches, static on the 2-3-MHz band declines, allowing us to hear some well-known broadcasters. Low-powered stations in Latin America, Africa and the Pacific inhabit the 120-meter tropical band (2300-2495 kHz); high-powered outlets in China and both Koreas spread beyond this range.

Usually closer but offering no less a challenge to DX are the *secret* short-wave stations! So secret are they that even the people operating them are in the dark (or if they are aware, they hope no one will notice).

We're talking about *harmonics* of mediumwave (standard AM broadcast) stations. By combining a good antenna and receiver system with lots of diligent delving into the residual noise level, you too can intercept these secret flea-powered broadcasts.

Even in the central USA, the great majority of harmonics heard originate in Latin America; this speaks highly for the harmonic-suppression standards of the FCC, probably the most rigid in the world.

A harmonic is not just *any* off-frequency reception of a station. It must be an exact integral multiple of the fundamental. Second harmonics (twice the fundamental) are by far the most common, since progressively smaller amounts of power are radiated as harmonic numbers go up.

The way to DX harmonics successfully is to *know* the 1.6-3.2-MHz band—so you can quickly eliminate everything that *isn't* a DX harmonic. If you live near a nighttime MW station, you probably can't help but hear its second and/or third harmonic. Whether transmitted, or the result of receiver overload on the fundamental, local harmonics are of no DX interest.

If you live near two or more nighttime MW stations, their mixing products may be audible. You can predict where most of them will show by summing each pair of fundamental frequencies, and by doubling one, and then subtracting another, in all possible combinations.

You can also eliminate any transmission not consisting of programming, such as hams, LORAN, radiolocation beeps, time signals, ship and shore, military nets, aircraft, RTTY, etc., etc.

This leaves the legit 120-m broadcasters. In the evenings, you'll hear mostly Venezuela, Brazil and Haiti; and Mexico and Guatemala fight it out only on 2390 kHz. Any other pro-

gramming just about *has* to be harmonic!

When you suspect a harmonic, divide the measured frequency by 2 or 3 to see if its fundamental matches up with a known station. Then tune to the fundamental frequency; chances are you won't hear it there, but if you do, it should be under entirely different conditions of interference, fading and strength. Such a check will prove that you are receiving a transmitted harmonic, propagated on the frequency where you find it.

Don't give up if at first you don't succeed; the selection of harmonics is continually changing as different stations tweak their traps. *Do* report your harmonic DX to other enthusiasts, but *not* to the station! Once they learn their harmonic is getting out, they just might be moved to eliminate it permanently. Let's keep the secret.

DX Monographs. The National Radio Club has become quite a publisher, not only for its members but for a wider readership. Over the past few years, NRC has published many technical articles about antennas suitable for mediumwave reception. Now, they're compiled in the *NRC Antenna Book*, the first of many reprint books to be issued. You'll find everything from the portable ferrite rod to the mile-long Beverage wave antenna, including much ado about loops: direct coupled, degenerate, balanced, unbalanced and box. The 60-page book is \$2.25; and many other individual article reprints are available too. For a list, send an SASE to NRC, Box 127, Boonton, NJ 07005.

DX Courtesy. Back in the heyday of radio, many MW stations went on the air in the wee hours with special programs for DX listeners. The practice still continues, thanks to a small band of enthusiasts in the NRC, International Radio Club of America, and Newark News Radio Club—the clubs most involved in MW DX. Each has its own "Courtesy Programs Committee" (CPC), but they coordinate their efforts to avoid duplication. Most CPC broadcasts occur on Monday mornings during the winter season, when 24-hour stations take a few hours off. But the tests are scheduled for the most open "window," as determined from the NRC Log's schedule section and continually revised "condition of frequencies" lists. Each club publishes calendars of upcoming spe-

SAVE!

MONEY • TIME • FREIGHT

- ♪ QUALITY STEREO EQUIPMENT AT LOWEST PRICES.
- ♪ YOUR REQUEST FOR QUOTATION RETURNED SAME DAY.
- ♪ FACTORY SEALED CARTONS—GUARANTEED AND INSURED.
- ♪ SAVE ON NAME BRANDS LIKE:
A.D.C. KLH
A.R. SHURE
DYNACO KOSS
SONY FISHER

AND MORE THAN 50 OTHERS
BUY THE MODERN WAY
BY MAIL—FROM



illinois audio

Department 217S
12 East Delaware
Chicago, Illinois 60611
312-664-0020

CIRCLE NO. 20 ON READERS SERVICE CARD
80

cial. The astute late-night MW DX'er can add stations and states he might never hear any other way. It's all arranged by volunteers, which means there would be more such DX specials if there were more volunteers (hint, hint).

Europe on Your Clock Radio? Trans-Atlantic (TA) MW DX usually peaks during October and November; the exact dates depend on solar variations. Several days of low A-indices (below 10) broadcast on WWV at 18 past the hour signal optimum conditions. You'll have a much better chance to hear Europe on the BCB if you're in the eastern half of the continent. Most European channels are "split" between ours, so powerhouses of 300 to 1200 kW can even come through an 'all-American five' if you tune just right. The band usually opens from the top downward, so check 1586 for West Germany, 1554 for France and 1466 kHz for Monaco just after local sunset and again around midnight. But watch out for buzzes from nearby TV sets which also show up on split frequencies. Later on in November or December the so-called "Midwinter Anomaly" puts a damper on this high-latitude MW DX.

Pings & Bursts. Before we go, some tips for vhf people. November and December are among the best months for meteor scatter DX'ing. High-gain antennas on FM and TV will reveal 'pings' every few minutes on just about any morning; the diurnal peak of MS is at 6 a.m. local mean time. Chances for more strong, long 'bursts' are markedly greater during the meteor showers: Orionids, October 18-23; Leonids, November 14-18; and best of all, the Geminids, December 10-14. If you're lucky enough to catch a burst during a test pattern or ID break, you've bagged a new station—even if the reception only lasts a few seconds. This happens more often than you might think. If you're not equipped for this esoteric signal snatching, you can still look out for winter sporadic E openings; check the lowest open TV channels each evening, especially in December and January. For vhf DX'ers in Gulf coastal states, this is the time for thousand-mile uhf hauls or trans-Gulf Mexican vhf. You'll find much more on television DX'ing in the POPULAR ELECTRONICS 1975 COMMUNICATIONS HANDBOOK, available soon. ◆

NOVEMBER 1974



PAT. PENDING

without soldering
for as little as \$3.00



New Continental Specialties QT SOCKETS® and BUS STRIPS offer expanded, flexible breadboarding without shorts or burnt fingers. Simply SNAP/LOCK together as many QTs as you need and you can test ICs, transistors, resistors, capacitors and more. Just plug-in, connect with solid #22 AWG hook-up wire — no soldering or patch cords needed! And QTs are totally reusable. 10 different sizes. Prices from \$3 for QT Sockets . . . from \$2 for Bus Strips.

Write or phone today for FREE Selection Guide, with applications, photos, drawings, specs, socket sizes and ordering information.



Continental Specialties Corporation
44 Kendall St., New Haven, CT 06509. 203/624-3103
CIRCLE NO. 10 ON READERS SERVICE CARD

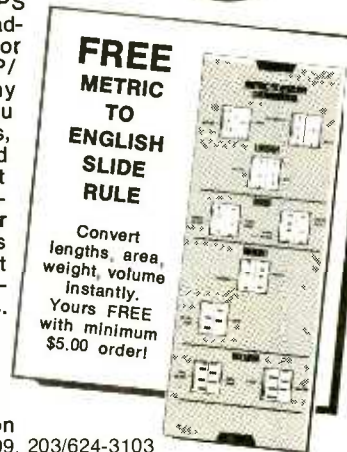

FREE McIntosh CATALOG and FM DIRECTORY

Get all the newest and latest information on the new McIntosh Solid State equipment in the McIntosh catalog. In addition you will receive an FM station directory that covers all of North America.



MX 113

FM/FM STEREO - AM TUNER AND PREAMPLIFIER

SEND TODAY!

McIntosh Laboratory, Inc.
East Side Station P.O. Box 96
Binghamton, N.Y. 13904
Dept. PE

NAME _____
ADDRESS _____
CITY _____ STATE _____ ZIP _____

If you are in a hurry for your catalog please send the coupon to McIntosh.
For non rush service send the Reader Service Card to the magazine.
CIRCLE NO. 26 ON READERS SERVICE CARD

The better the the better you'

SOLID STATE
OSCILLOSCOPE

COMPU-TRAINER

TUBE & TRANSISTOR
TESTER

Compare
what we
offer in kits
and lessons.
Compare
our
tuition

DIGITAL
MULTIMETER

ELECTRO - LAE

NTS DIGITAL 3F-2000 SOLID STATE
COLOR TV WITH 315 SQ. IN. PICTURE
AND VARACTOR DIGITAL TUNING

TROUBLESHOOTER
VOM

As an NTS student you'll acquire the know-how that comes with first-hand training on NTS professional equipment. Equipment you'll build and keep. Our courses include equipment like the 5" solid-state oscilloscope, transistor and tube-tester, vector monitor scope, 74 sq. in. B&W TV, and solid state stereo AM-FM receiver. The unique NTS **Digital GR-2000 color TV** with first ever features like silent varactor diode tuning; digital channel selection, (with optional digital clock,) and big 315 sq. in. ultra rectangular screen. This is just a sampling of the kind of

better equipment that gets you better equipped for the electronics industry.

This electronic gear is not only designed for training; it's field type — like you'll meet on the job, or when you're making service calls. And with NTS easy-to-read, profusely illustrated lessons you learn the theory behind these tools of the trade.

Choose from 12 NTS courses covering a wide range of fields in electronics, each complete with equipment, lessons, and manuals to make your training more practical and interesting.

equipment will be equipped.

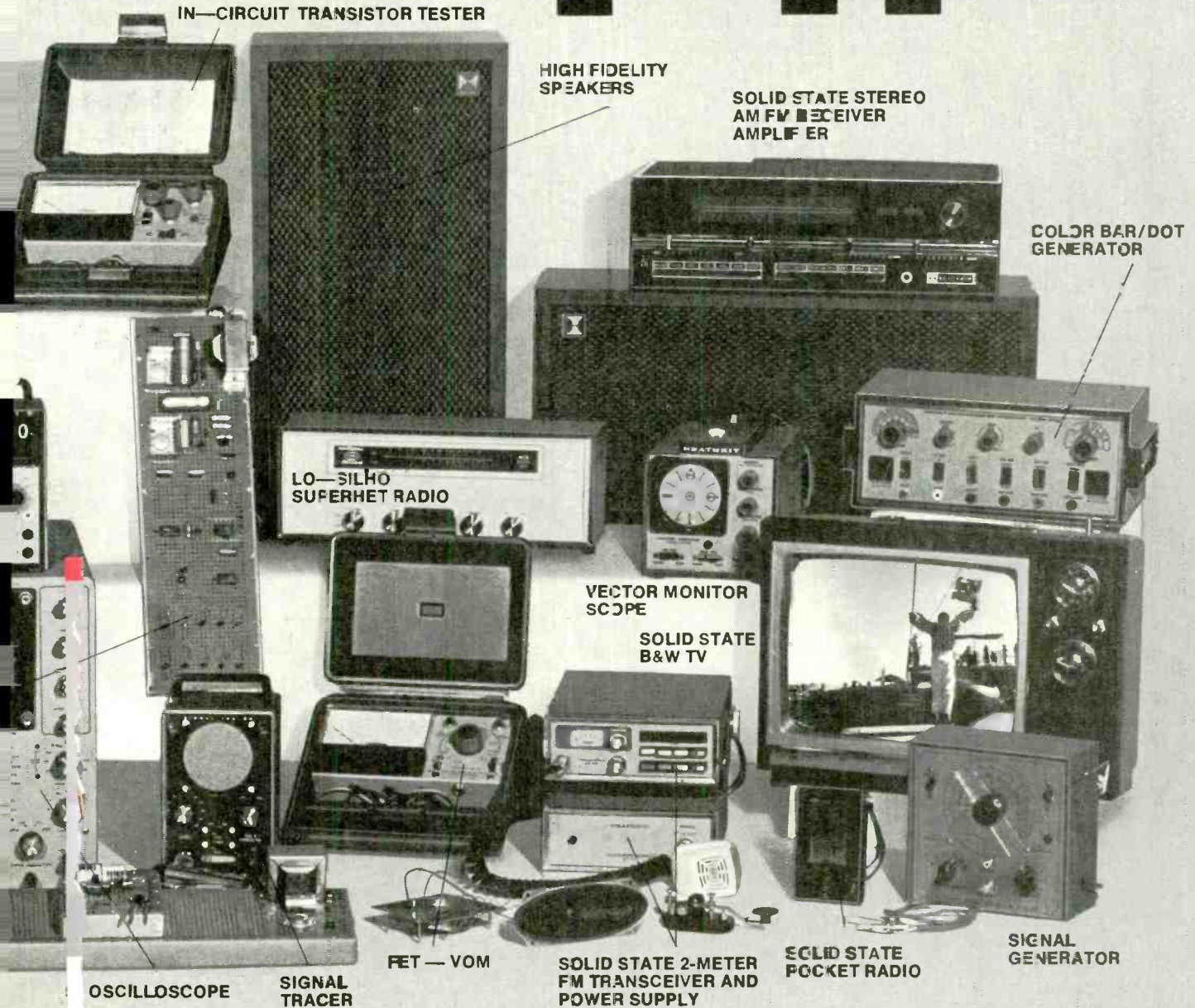

Compare our training; compare our tuition. We employ no middlemen because we need no salesmen. We believe you have the right to make your own decisions based on the facts, and you'll find these all spelled out in our catalog mailing. Lessons, kits, and experiments are described in full color. Most liberal refund policy and cancellation privileges — it's all in writing. And our low tuition is another big advantage. No frills, no commissions to pay. This means lower tuition for you. You receive solid training value. NTS puts more into your training, so you get more out of

it. Make your own decision. Mail the card, or write if card is missing. There's no obligation, ever, and no salesman will call.

Approved for Veteran Training. Get facts on new 2-year extension.

NATIONAL TECHNICAL SCHOOLS

TECHNICAL-TRADE TRAINING SINCE 1905
Resident & Home Study Schools
4000 South Figueroa St., Los Angeles, Calif. 90037

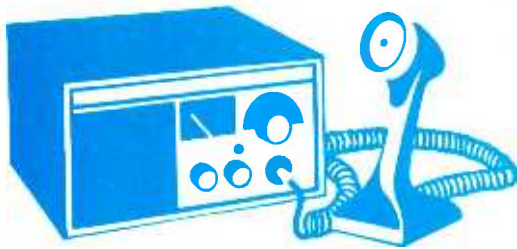

CB Scene

By Len Buckwalter

CB TO THE RESCUE

AFTER holding a license for 16 years it finally happened. I was saved by CB! In a remarkable boating incident last summer, I got a first-hand look at CB's vast power to do good and evil. Good because CB sped to the rescue faster than the U.S. Coast Guard. Evil because of the Neanderthal types who prowl the band tearing up communications, emergencies included. But let's start at the beginning.

It is the end of a hot Sunday in July on Long Island Sound, a body of water east of New York City and between Long Island and Connecticut. After a weekend of cruising aboard a rented 32-foot houseboat, two happy, tired families gather in the bow to witness our arrival in the harbor. The entrance at the breakwater is alive with craft converging on a narrow channel that leads to a crowded anchorage over the next two miles. As the houseboat penetrates a few hundred yards into the harbor the steady rumble of the engines stutters, then weakens. I glance down at the tachometers just in time to see the needle for the starboard engine flicker, then fall over and die on zero. Not much cause for alarm because a twin-diesel boat like ours can easily limp home on one good engine. Ten seconds later the port engine also expires.

Late Sunday afternoon in summer is no time to lose power near the entrance to Stamford harbor, known as the "boating capital of the Sound." It is home for some of the country's most glittering corporations and boasts more Sir Thomas Lipton types than you'd find at the Queen's Tea. Woe betide any craft under 40 feet that's bobbing in the right-of-way. But there was just enough momentum in the houseboat's lumbering hull to swing the craft in a semicircle and pull its prow to the edge of the busy channel. Luckily, the anchor bit the bottom before the wind could smash us against a sailboat moored a few yards away.

Miraculously, within minutes, a flashy cabin cruiser glides alongside and asks what's the matter. High on its flying bridge a lady captain grips the handset of a marine radiotelephone, ready to call the harbor police, the Coast Guard or anyone else we want. We're so awed by this Amazonian Marine that our grateful mumblings are drowned by the sound of her orders barked into the handset. Within a few seconds she triumphantly announces, "The Coast Guard is on its way!" Worried wives breathe easier, children return to their play and the men stand proudly on the deck of the crippled vessel, knowing that everyone will soon be safe at home.

Ten minutes later a rickety putt-putt with "Coast Guard Auxiliary" hand-painted on its side pulls up. It was a far cry from the 40-foot government cutter we were expecting to take us in tow. What's more, the two lads aboard this brave, but hardly adequate, launch were enroute to more serious business offshore. A cruiser had run out of gas and demanded immediate assistance, which meant our rescuers would not return for two hours.

But the surging stream of yachts, hot-rodders and hundreds of other Sunday drivers brushing past our bow was clearly dangerous. In the waning twilight there would be a sharply increased threat of collision. As the houseboat wallowed in the wake of passing boats, I decided to try my hand at the two radios aboard—a marine two-way rig and a CB set—and attempt to reach the owner of the boat. Maybe he could tell me how to restart the engines. We had already poured in 5 gallons of reserve fuel from a jerry can with no luck.

The vhf marine radio was hopeless. The circuits to the New York Marine Operator were jammed with returning boats wanting to call home, forcing the besieged operator to put new callers on standby. It might take hours to reach the owner. I switched off the

marine radio and turned the CB transceiver to channel 9. Even as I blindly called for help I knew it was futile. The channel was clobbered with meaningless conversation and interference. Seven pairs of eyes watched me work the radio, expecting some official response that would deliver us from an increasingly threatening situation. I flicked from channel 9 to explore the rest of the band, searching for a strong carrier of any station, but the CB speaker emitted a persistent chorus of squeals, static and fragmented voices. Then, as the selector indented on channel 11, the S-meter shot up the scale. A strong, clear voice filled the cabin. I knew I must land this station or I'd be lost.

"Break-break," I said, then waited.

After monitoring this station a few minutes, it was clear that nothing about its operation was legal. The communications were chit-chat, its callsign just a contrived fake. But the operator answered my break and I suppressed any thought of rules and regulations. The voice, which sounded like that of a 16-year old boy, said he'd gladly help me out of the emergency—but then uttered the words I dreaded. The young man wanted me to stand by while he contacted a volunteer team located closer to me. This was the last thing I'd do. We would almost certainly lose each other in the nightmare of interference washing over the band that evening. Somehow I'd have to convince him of this.

Suddenly a third voice moved on the frequency. "What's the emergency?" it asked. Some goon had been listening to me describe our plight and committed the cardinal sin of any distress communications; getting on the frequency without being called and interfering with communications. I couldn't hear what the young man replied but the goon didn't like it. He used foul language and held his carrier steadily on to block our signals.

The young man knew what to do, He ignored the carrier and shrewdly said several times, "Switch to channel 12." His powerful signal punched through just enough so I could understand the words. It worked. We rejoined on channel 12 and heard no more interference. Now the only problem was to convince the young man to stay with me and not attempt to raise a closer station. My plan was to give him the phone number of the boat's owner and have him put through a collect call. Somehow he balked at the idea.

By now the sun dipped below the

horizon and boats crossing our bow had switched on their running lights. The gathering darkness was adding yet another problem, I didn't want to dock the houseboat in the dark. Even in daylight, maneuvering this big tub at slow speed called for plenty of engine reversing and bursts of power to keep it from splintering the dock.

"Do not turn me over to any other station. I'd like you to make a collect call for me."

I shot those words at the young operator with the sting and authority of an army drill sergeant. It was my only hope. I must have shook up the kid because he came back on, no longer sounding like a NASA space communicator. I assured him several times that a long-distance telephone call placed collect would cost him nothing.

"I have Jim on the line. He says try the lift pump." A wave of excitement flooded over the houseboat. The young man had raised Jim, the boat's owner, on the landline and the first instructions were coming through.

"Where's the lift pump?" I asked. Questions and answers went back and forth over our primitive phone patch. Jim, the owner, would say something to the young man on the phone, and the information was relayed to me via CB radio. It worked well, except for the tense moments when Jim and the young man spoke to each other on the landline and no carrier filled the air. I grew apprehensive at the possibility of some other spoiler getting on the open channel and jamming us. To prevent it, I turned on my carrier during the pauses and made blind announcements about emergency communications in progress. It kept the channel clear.

In the stern of the boat, hatches were raised to expose the two dead Volvo diesels. Following Jim's CB-sent directions, we rammed the lift pump up and down by foot until it forced fuel into the starved engines. I turned the starter key and watched the tachometer. It bounced crazily as the engine fired, but dropped back to zero. I gripped the CB mike, shot my next question at Jim. My words raced over water by radio for a dozen miles, were repeated by the young CB operator on the phone, then travelled by landline over 60 miles to Jim's home.

"Keep pumping while the engine is turning," Jim said. He was right; the houseboat shuddered, made several explosive sounds then throbbed with

the steady power of its 310 horses. "Up anchor," I shouted, and within minutes the houseboat melted into the endless stream of other boats heading up the channel to a safe landing.

Later that night I learned what killed the engines. Fifty gallons were in the fuel tank but this boat had a quirk; when the tank was about a quarter full, the fuel line would gobble air and not feed unless the passengers stood at the stern. Those lift pumps purged the trapped air in the lines to get the fuel flowing again and, with the crew herded on the stern, the engines ran perfectly.

I wanted to thank the anonymous young operator. He had done an excellent job of extricating us from a tight situation, especially when he switched us away from the QRM. But I can't express much gratitude because he has no call, no license and no CB status. He legally doesn't exist.

The second hero of this adventure is CB itself. Our lives were not in immediate danger, but each passing minute increased the risk from scores of other craft that careened down the narrow channel in the dimming twilight. CB, in fact, came through when about a half-dozen other resources failed. First, it outdid that vigilante who was first to arrive on the scene. She was a well-meaning Good Samaritan, but she couldn't provide our most immediate need—a tow into port. Then there's the U.S. Coast Guard and its auxiliary. Despite their heroic work in boating areas, our dilemma held too low a priority. Next, the marine telephone system—it, too, was seriously overloaded. Then there was harbor police, but the men in blue never materialized. This is one happy instance where CB outdid them all! ♦



"I need a replacement part. Call 471-3481 in Hong Kong."

LARGE-LARGE DISCOUNTS

LOW - LOW PRICES

NATIONALLY ADVERTISED STEREO EQUIPMENT AT LOWEST PRICES!

TURNABLES • SPEAKERS • RECEIVERS
AMPLIFIERS • TAPE RECORDERS

WRITE FOR QUOTE ON NATIONALLY ADVERTISED BRANDS OF STEREO COMPONENTS. SATISFACTION GUARANTEED!

Clifford's
HI-FI WHOLESALERS
231 W. COURT ST.
Kankakee, Illinois 60901
(815)-939-7868

CIRCLE NO. 8 ON READERS SERVICE CARD



free

TRIGGER

MONEY-SAVING CATALOG

FOR THE MAN IN ELECTRONICS

SEE **TRIGGER'S GREAT SELECTIONS**

Send for this reliable buying guide to carefully selected:
Amateur Gear • Stereo Hi-Fi • Electronic Kits • CB Radio • Tape Recording • Electronic Parts • Antennas • Tubes • Transistors • Tools • Books • Test Gear

Count on TRIGGER for the best in electronics. Write for this Free Catalog today!

A MONEY-SAVER

SEND FOR IT TODAY! **FREE Catalog**

TRIGGER Electronics, Dept. 12-NO
 7361 North Ave., River Forest, Ill. 60305

Send FREE TRIGGER Catalog

Name _____
PLEASE PRINT

Address _____

City _____ State _____ Zip _____

CIRCLE NO. 40 ON READERS SERVICE CARD



The Simplest Test Gear

By John T. Frye, W9EGV

"H EY, Mac, what are you doing with the tattle lights?" Barney asked his employer, who was examining several small objects spread out on the service bench.

"Taking them with me on vacation," Mac replied. "Some of the folks in Florida we visit are sure to say, 'Mac, our electric or electronic what-chamacallit isn't working. Wonder if you'll look at it.' These lights will let me find anything simple, which is all I intend to tackle on vacation. Actually, it's amazing what a fellow can do with some simple, rugged, inexpensive test lights and a little gray matter."

"For instance?"

"Well, take this Ne-O-Lite Test Light put out by GC Electronics, a division of Hydrometals, Inc., Rockford, Ill. It carries Audiotex catalogue No. 30-245 or Calectro No. H3-452 and sells for just under a buck. As you can see, it consists of a special two-inch-long, red, high-impact plastic socket carrying a neon bulb protected by a tough clear plastic cone in one end. A current-limiting resistor of—I'd guess—about 200,000 ohms is contained in the socket, and red and black flexible, sharp-pointed leads come out the bottom. The lamp glows with any voltage from 90 to 550 volts, ac or dc. The higher the voltage, the brighter the glow.

"The neon lamp itself has almost infinite resistance until the contained gas is ionized by over 90 volts. Until then, there's no voltage drop across the series resistor, so the full voltage across the test leads is applied to the lamp. Once the gas is ionized by a voltage in excess of 90 V, current through the lamp and series resistor is a function of the voltage across the leads, but it never exceeds 3 mA, even with the full 550 volts applied.

"What can you do with it?"

"A zillion things. If one lead is attached to a spark plug of a running motor, a bright flash will indicate a good plug; a dim flash, a fouled plug; and no flash, a dead plug. Hold on to

one test lead and probe the two sides of a 120-volt outlet receptacle with the other. When you touch the 'hot' side of the line, the lamp will glow. If a device controlled by a wall switch will not turn on and you don't know if the trouble lies in the device or the switch, turn the switch on and bridge the test lamp across the switch terminals. If the lamp glows, the switch is bad. Do the same thing to locate a blown fuse. With a device on the fused line switched on, check across the fuse with the lamp. If it glows, the fuse is open. Alternately, you can check from the grounded side of the line or the cabinet of the fuse box to the output sides of the fuses, one at a time. Failure of the lamp to glow with full 120-V brilliance will indicate the bad fuse.

"This little sketch shows how the test lamp can be used for a continuity

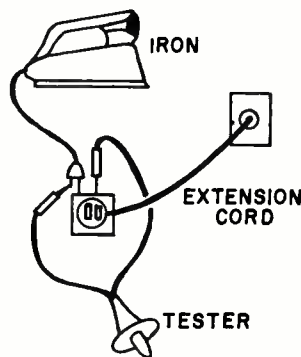

indicator. Plug an extension cord into a wall receptacle and locate the hot side of the cube tap on the end of the cord. Plug one lamp lead into this side. Now plug one prong of the cord of the device you want to test for continuity into the other, grounded, side of the cube tap. Touch the free lamp test lead to the free prong of the line cord of the device. A glow of the lamp indicates continuity.

"The test light will indicate the presence of leakage current. As you know, one side of the 117-volt line is grounded. If there's current leakage from the hot side of the line to the case of a device, say a hedge-trimmer, electric drill, refrigerator, dishwasher, etc.,

a person touching the device while in contact with the ground or a grounded device may receive a severe and perhaps fatal shock. With a clip lead, connect one side of the test lamp to a good ground, such as a water faucet, and touch the other lead to the case of the device being tested while the device is operating. Reverse the plug of the device in the wall socket and test again. If the lamp glows in either case, you know there's some leakage. It may not exceed 0.5 mA through 1500 ohms of noninductive resistance shunted by 0.15 μ F, which represents the average impedance of the human body and the current is considered permissible for most devices; but if the lamp glows at full 120-V brilliance, you can be suspicious. In all the devices I checked at home, only the electric drill, some fifteen years old, lit the light dimly."

"What's this thing?" Barney asked, picking up a small round plastic object with three prongs on one end to fit a standard 15-A, 120-V grounding receptacle.

"That's a GT-20 'Grounded Outlet' Tester made by Alco Electronic Products, 1551 Osgood Street, North Andover, Mass. 01845. It sells, in single lots, for \$7.95 and reveals instantly if a receptacle into which it is plugged has current available and is properly and safely wired. Note the three little round windows in the end. Two of them, labelled NEUTRAL and POWER, are amber, and the bottom one, labelled DANGER, POLARITY is red. When the GT-20 is plugged into a grounding receptacle, one or more of the lights behind the windows light if power is available at the socket. If the socket is correctly wired, the two amber windows glow. Any other combination of lights indicates a potentially dangerous receptacle that is improperly wired or has a broken connection.

"What's inside the thing?"

"Not being like the little boy who cut open his drum to find what made the noise, I didn't take it apart to see; but I'd guess there are three neon lamps with accompanying current-limiting resistors, each wired between a pair of prongs. Can you figure out which lamp is wired between which prongs to produce the conditions shown in the little charts?"

"Child's play!" Barney scoffed. "Will it work on 2-hole outlets?"

"The Code requires that, in all new construction, only grounding receptacles may be installed. If you replace a defective receptacle in an existing

installation, the new one must be the grounding type if you can effectively ground it. If this is difficult or impossible, the receptacle may *not* be of the grounding type. You don't want a receptacle with a dummy grounding orifice that seems to promise but does not actually provide grounding of a device with a 3-wire cord plugged into it. You can use the GT-20 as a 2-wire tester by using an adapter plug with the pigtail fastened to the outlet box by placing it under a *metal* screw holding the receptacle plate in place. If the red light of the GT-20 glows when the adapter is plugged in, reverse the position of the two blades. If the red light still glows, a ground fault is indicated and repairs should be made. The only fault the GT-20 will not reveal is switching of the neutral and ground wires, since both are normally at ground potential; but this very rarely occurs.

"How come you've got two neon test lights?"

"I haven't. That one you're holding looks like the H3-452, but it is really a Calectro No H3-454. About the only difference you can see is that the plastic is blue instead of red. It is called a Lo-Volt Test Light and will light with 5 to 50 volts ac or dc. If you look closely, however, you'll see the bulb in the end is a filament type instead of neon. I've found this filament will glow dimly with 3 volts across the test leads while it is drawing 18 mA. At 12 volts the filament is a very bright yellow and draws 45 mA. This goes to 110 mA at 50 volts, and the filament is incandescent white. Filament resistance goes from 80 ohms cold to 550 ohms at 50 volts, which explains the wide range of lighting voltage.

"The Lo-Volt Tester is especially useful in trouble-shooting auto electrical problems. Failure to light across the battery terminals indicates a dead battery. If the battery is OK, you can trace the voltage from it right to an accessory that fails to work. With the accessory turned on, the lamp will light across a defective switch or fuse. It will also light across a high resistance connection, say a battery cable connection or starter solenoid contacts, when the starter is actuated and tries to draw heavy current through the connection. By connecting the lamp between an insulation-piercing needle and ground, you can pinpoint a break in a wire. The lamp will indicate generator output. It can be used with the 12-volt battery to in-

dicate continuity, since it will glow with any series resistance from 500 ohms down.

"The Lo-Volt Tester is also useful in the home for checking out low-voltage door-bell circuits, electric trains, and slot cars. With a 9-volt transistor battery, it can be used as a continuity indicator. With a little practice, you can also use it to indicate the condition of 6- and 9-volt batteries."

"Well," Barney said as Mac paused, "that only leaves this little red bulb no bigger than a match head."

"That's a brand new RLC-400 Battery Status Indicator just released by Litronix, Inc., 19000 Homestead Road, Cupertino, Calif. 95014. It sells for a dollar at Litronix representatives all over the country. A GaAsP LED and a voltage-sensing IC are both packed inside that itty-bitty T-1 lamp package designed to warn of imminent battery failure in cameras, tape recorders, calculators, and similar battery-powered equipment. The LED lights brightly at 3 V, glows dimly at 2.5 V, and is completely dark at 2 V. It draws about 300 microamperes at 2.5 V, 8 mA at 3 V, and 20 mA at 4 V. Five volts, forward or reverse, is maximum.

"To use the RLC-400 with higher voltage batteries presented a bit of a problem. A series resistor subjected the device to a high turn-on voltage and separated on on-off points too much. A zener took care of the first problem, but the on-off points were only a half-volt apart. I finally worked out the circuit shown to let me use the

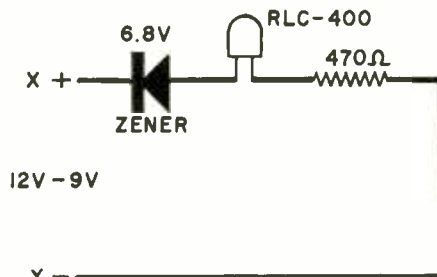

RLC-400 with any battery voltage and make the on-off span proportional to that voltage. With the values shown, 3 V appears across the LED with 12 V across points X and Y. There is 2.5 V across the LED with 9 V at X-Y. Other zeners and resistor values can accommodate other battery voltages and provide any desired span between new and discard battery voltage. This little lamp has a lot of exciting possibilities," he concluded.

"You know," Barney mused, "a knowledgeable guy can do a lot with comparatively simple equipment." ♦

FREE EICO CATALOG

346 Ways To Save On Instruments, Burglar Alarms, Automotive & Hobby Electronics!

The more you know about electronics, the more you'll appreciate EICO. We have a wide range of products for you to choose from, each designed to provide you with the most pleasure and quality performance for your money. The fact that more than 3 million EICO products are in use attests to their quality and performance.

"Build-it-Yourself" and save up to 50% with our famous electronic kits.

For latest EICO Catalog on Test Instruments, Automotive and Hobby Electronics, Eicocraft Project kits, Burglar-Fire Alarm Systems and name of nearest EICO Distributor, check reader service card or send 50¢ for fast first class mail service.

**EICO—283 Malta Street,
Brooklyn, N.Y. 11207**

*Leadership in creative electronics
since 1945.*



CIRCLE NO. 14 ON READERS SERVICE CARD

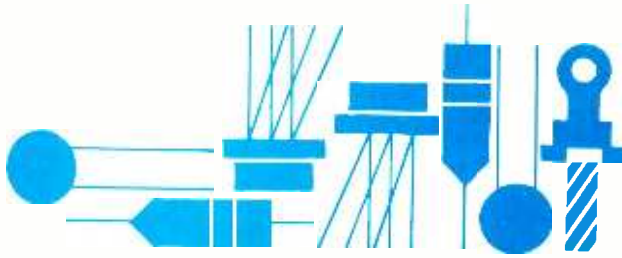

Solid State

By Lou Garner

USEFUL CIRCUITS FOR FIELD EFFECT TRANSISTORS

THOUGH more versatile than bipolar types, except in some power applications, field effect transistors—FET's—have never been overly popular with experimenters and hobbyists. True, FET's have been featured in magazine construction articles from time to time, and there have even been several project booklets published featuring FET circuits but, somehow, these devices have never really "caught on."

There are probably several reasons for the FET's lack of popularity. One may be the paucity of application data compared to what is available on bipolar devices. Another reason, perhaps equally important, may be the somewhat confusing situation regarding types. FET's are manufactured in two general categories and six major sub-categories, *in addition* to variations relating to electrical specifications. The two broad categories are insulated gate types, or IGFET's, and junction types, or JFET's. Since many insulated gate FET's are manufactured using MOS technology, these are often designated MOS-FET's, while junction FET's frequently are identified simply as FET's (without the J prefix). But there's more. IGFET's may be manufactured for use in either *depletion* or *enhancement* modes, each of which has its own technical advantages, but which may require somewhat different application techniques, depending on the circuit in which it is used. Finally, both IGFET's and junction FET's are available as either n-channel or p-channel devices. These are analogous to npn and pnp bipolar transistors, in that they may be used in similar applications, but require opposite dc polarities.

Poor availability may be another reason for the FET's lack of popularity. The first low-cost experimenter's transistor, the famous Raytheon CK722, was a bipolar device. FET's, on the other hand, were comparatively late arriving on the scene and, by the time inexpensive FET's were available, a mass of application literature and project articles had been published featuring bipolar devices, resulting in a much larger demand by users for these types. As a result, suppliers offering general-purpose semiconductor devices today may list scores of different bipolar transistors but maybe only from one to a half-dozen FET's. As of the present writing, for example, there are only five different FET's listed in Sylvania's ECG line, two types in RCA's SK line, eight in Motorola's HEP line, three in GC Electronic's *Calectro* line, and one in Radio Shack's *Archer* line. There are many other types of FET's in production of course, but the prospective user will not find these in a general line on a self-service sales rack. Instead, he'll have to buy them across the counter, specifying manufacturer's name and type number, and perhaps even seek out a broad line or industrial electronics distributor

stocking the units needed. In extreme cases, the user may find it necessary to order specific devices from a large mail-order or semiconductor specialty house.

The FET has been called the "semiconductor equivalent of the vacuum tube." This analogy is pretty close to the truth. The FET offers high input and output impedances. It is a voltage, rather than a current, amplifier. It can be self-biased via a source resistor and its characteristics curves are quite similar to those of a pentode vacuum tube.

The basic FET has three terminals—gate (G), source (S) and drain (D). These correspond, generally, to the base, emitter and collector of a bipolar transistor, or to the grid, cathode and plate of a vacuum tube, respectively.

The IGFET (or MOSFET) has an extremely high input impedance. The junction FET also has a high input impedance, although not nearly as great as the IGFET; but, from an experimenter's viewpoint, it is by far the easier device to use in practical circuits. Except for those types with internal protection, the IGFET (MOSFET) requires special treatment. It is particularly susceptible to damage from static charges or transient voltages applied to its gate electrode, even during the simple processes of handling and installation. Some types, in fact, are supplied wrapped in metal foil or with their leads shorted by a metal eyelet or spring to prevent accidental damage. The short can be removed safely only *after* the device is installed in its circuit.

Perhaps the best way to become familiar with the FET is to try the device in a few practical projects. Several useful and easily constructed junction FET circuits are illustrated in Figs. 1 and 2. These were adapted from a FET applications bulletin published several years ago by Siliconix, Inc.

Fig. 1. Useful FET circuits: (A) Crystal oscillator; (B) Tone control.

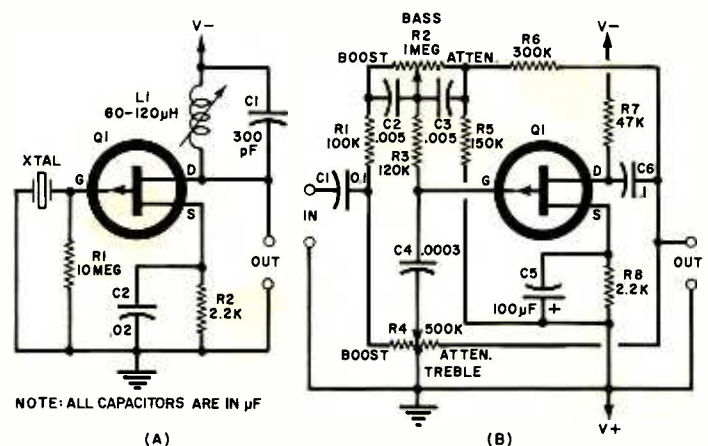

(2201 Laurelwood Road, Santa Clara, CA 95054). In each circuit, resistors are rated for 1/4 or 1/2 watt, while the capacitors may be ceramic, mica, plastic or tubular paper types, except where a dc polarity is shown, in which case an electrolytic should be used. Capacitor working voltages should be chosen on the basis of the dc supply voltage used, of course, with 50-volt, or better, units adequate for all four circuits. Although p-channel devices are indicated, comparable n-channel FET's may be substituted in each design if dc polarities are reversed and if bias and supply voltages are readjusted for optimum performance.

Suitable for use as the first stage of a transmitter, as a marker generator, and in similar applications, the FET crystal-controlled oscillator shown in Fig. 1A requires relatively few components. The original design specified a type 2N2608 for Q1, a 1-MHz crystal, and a 22-volt dc power supply. It may be assembled on a perf board, etched circuit board, or even on a small chassis using point-to-point wiring techniques.

In operation, the drain-gate feedback needed to start and sustain oscillation is provided by stray interelectrode and wiring capacities. Gate bias is established by source resistor R2, shunted by bypass capacitor C2. Drain tuning is provided by adjustable inductance L1, shunted by C1. The L and C values specified are for 1-MHz operation but these may be changed, of course, for other frequencies.

Featuring separate treble and bass controls, the tone-control circuit illustrated in Fig. 1B may be used with virtually any audio amplifier—phonographs, tape recorders or playbacks, or PA systems. Depending on application, it can be assembled as a separate control or incorporated as part of more complete amplifiers. Except for the treble control, R4, standard components are used throughout the design. As in the previous circuit, a 22-volt dc power supply should be used, and Q1 is specified as type 2N2843.

In operation, Q1 serves as a conventional common-source amplifier, with gate bias provided by source resistor R8, bypassed by C5. Resistor R7 serves as the drain load and C1 and C6 as the input and output coupling capacitors, respectively. A variable frequency response characteristic is achieved by a combination of attenuation and negative feedback techniques. When bass control R2 is shifted toward its BOOST position, it serves as a shunt across C2, increasing the amplitude of the bass portion of the applied signal. When R2 is set toward its ATTEN position, its shunting effect across C2 is reduced and, at the same time, a negative feedback signal coupled back from the drain through R6 serves to reduce effective stage gain at the lower frequencies. A similar technique is used for the treble control. With treble control R4 in its maximum boost position, C4 serves as a high-frequency shunt across the bass control network. With R4 set for maximum attenuation, high-frequency negative feedback from Q1's drain is applied through C4 to the gate electrode, effectively reducing stage gain.

You can use the phase shifter circuit shown in Fig. 2A in test instruments, such as oscilloscopes, in demonstration projects, and in musical synthesizers. It requires a 12-volt dc supply when 2N2609 FET's are used for Q1 and Q2.

In operation, Q1 and Q2 are used as cascaded split-load amplifiers, with R3 and R6 serving as the drain loads and R2 and R7 as the source loads, respectively. Networks C1-R4 and C2-R5 provide a control over the signal phase shifts, with each stage supplying a controllable shift from 0° to 180°.

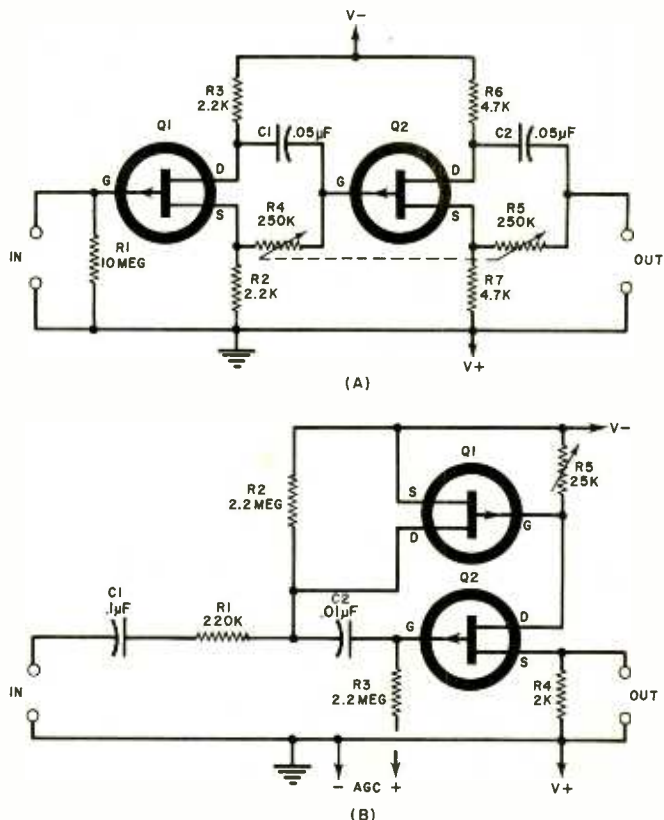

Fig. 2. Phase shifter (A) and automatic gain control (B).

ALLIED ELECTRONICS
A Division of Tandy Corporation

Allied stocks every item in this guide

1975 ENGINEERING MANUAL & PURCHASING GUIDE No. 750

New

The 1975 Engineering Manual & Purchasing Guide!

A "must" for
hobbyists, experimenters,
repairmen and technicians!
Thousands of hard-to-get electronic
parts and supplies. Order now!

Send \$1 to Allied Electronics
Dept. PE75, 401 East 8th St.
Fort Worth, Texas 76102

NAME _____

ADDRESS _____

CITY _____

STATE _____ ZIP _____

ALLIED ELECTRONICS
A DIVISION OF TANDY CORPORATION

IF YOU ARE READY FOR SERIOUS CAREER

Learn College-Level



ADVANCEMENT NOW—

Electronics at Home

With CREI's unique Electronic Design Laboratory Program

There is only one way to a career in advanced electronics—through advanced training. You can get such training through a resident engineering college or you can take a CREI specialized college level electronics program at home.

Wide Choice of Programs. CREI offers you program arrangements with *fourteen* areas of specialization in advanced electronics. You can select exactly the area of specialization for the career you want.

CREI also offers program arrangements *both* for those with extensive experience in electronics *and* for those with only limited experience. All programs are college-level, except for a brief introductory level course, which is optional.

Unique Laboratory Program. CREI now offers a unique *Electronic Design Laboratory Program* to train you in the actual design of electronic circuits. You also get extensive experience in tests and measurements, breadboarding, prototype building and in other areas important to your career. The Lab Program makes it easier for you to understand the principles of advanced electronics. Only CREI offers this complete college type laboratory program.

The Lab Program includes professional equipment which becomes yours to keep. You will especially appreciate the Electronic Circuit Designer, which is available only through this program and which you will find extremely valuable throughout your professional career.

College Credit. You can actually earn college credit through CREI programs, which you can use at recognized colleges for an engineering degree. CREI maintains specific credit transfer arrangements with selected colleges in the U. S.

Industry Recognized Training. For nearly 50 years CREI programs have been recognized throughout the field of electronics. CREI students and graduates hold responsible positions in every area of electronics and are employed by more than 1,700 leading organizations in industry and government.

Qualifications to Enroll. To qualify for enrollment, you should be employed in electronics or have previous experience or practical training in the use of electronic equipment. You must also be a high school graduate or true equivalent.

All CREI Programs are available under the G.I. Bill

Send for FREE Book. If you are qualified, send for CREI's full color catalog describing these college-level programs and your career opportunities in advanced electronics. Mail card or write for your copy of this book.



CREI CAPITOL
RADIO
ENGINEERING
INSTITUTE

McGraw-Hill Continuing Education Center
3939 Wisconsin Avenue Northwest
Washington, D. C. 20016



Accredited Member, National Home Study Council

mitScope

FOUR CHANNEL DIGITAL HANDHELD MEMORY SCOPE

MS-416 is a valuable tool for circuit analysis: TV - stereo receivers - electronic calculators - digital clocks - digital auto electronics and more. • The MITS MS416 digital pocket scope is a four-channel, digital logic oriented, handheld scope with full memory capability. • The clock time-base is from .5 sec. to 200 m sec. • The scope may be operated in two modes, selected by another switch. Besides the normal mode, there is a store mode which enables the scope to remember the information on all four channels within the time-base range and display it continuously.



SIZE: 5 1/2" x 3 1/4" x 1 1/2"

SPECIAL OFFER
MS-416 regular price \$189.50
order now for \$161.50

MITS INC.
"Creative Electronics"

Prices, specifications and delivery subject to change without notice. WARRANTY: 1 year

Enclosed is a Check for \$ _____
or BankAmericard # _____
or Master Charge # _____
Credit Card Expiration Date _____
Include \$5.00 for Postage and Handling

MS-416
 Please send information on Entire MITS Line.

NAME _____
ADDRESS _____
CITY _____
STATE & ZIP _____

MITS / 6328 Linn, N.E., Albuquerque, New Mexico 87108 505/265-7553 Telex #660401

PE-11-74

CIRCLE NO. 27 ON READERS SERVICE CARD

There are probably many uses you can devise for the audio automatic gain control (agc) circuit illustrated in Fig. 2B. Use it to maintain a constant level in a tape recorder, to prevent overmodulation in a transmitter, or as part of an expander or compressor. According to Siliconix, the circuit will provide an effective agc range of 60 dB and has a frequency response flat to within 1 dB from 1.0 Hz to better than 10 kHz. Type U112 devices are specified for both Q1 and Q2, with a 12-volt dc power supply.

In operation, Q1 serves as a variable resistance, Q2 both as a gate bias control for Q1 and as a source-follower amplifier. Series resistor R1 and Q1's source-drain resistance, shunted by R2, form a simple voltage divider. FET Q1's source-drain resistance, in turn, is determined by its gate bias, which is established by Q2's drain current and the agc voltage applied to Q2's gate. As increasing agc voltage is applied, Q2's drain current is reduced, increasing Q1's negative gate bias and thus reducing Q1's effective source-drain resistance, thus reducing the effective level of the input signal applied through C2 to Q2's gate and, therefore, the output signal developed across Q2's source load, R4. As the agc voltage is reduced, the opposite action takes place, increasing the output signal level.

Although the parameters of the agc circuit are not critical, one simple adjustment is required for optimum performance. With the circuit wiring completed and checked, apply the dc supply voltage, a small input signal, and zero agc voltage. Adjust drain load R5 for a maximum output signal across source load R4.

If you've been intrigued by our discussion of the versatile FET and would like to explore the subject in greater detail, we can recommend any (or all) of the following books:

An Introduction to Field Effect Transistors, by J. Watson, published by Siliconix, Inc.

FET Circuits and abc's of FET's, both by Rufus P. Turner, published by Howard W. Sams & Co., Inc.

Field Effect Transistor Projects, published by Motorola, Inc., Semiconductor Products Division, and offered through HEP distributors.

Reader's Circuit. Featuring a popular IC op amp and a pair of zener diodes, the portable scope calibrator circuit given in Fig. 3 was submitted by reader Ted Reiter (1442 Brook Drive, Titusville, FL 32780). Layout and lead dress are not critical and the project can be duplicated quite easily in a single evening or on a weekend by the average hobbyist.

In this circuit, IC1 serves as a simple relaxation oscillator, supplying an output signal which is clipped by zener diodes D1 and D2 in conjunction with series resistor R4,

Fig. 3. Reader's circuit for portable scope calibrator.

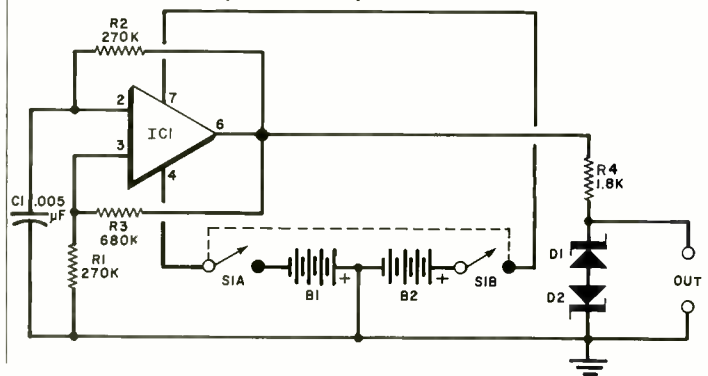

Put more punch in your work.

With a Greenlee Chassis Punch you can punch clean, true holes in seconds. Round, square, key or D. In 16-ga. metal, hard rubber, plastic or epoxy. Available at radio and electronics parts dealers. Write for catalog E-730. Greenlee Tool Co, Rockford, Ill. 61101.

GREENLEE TOOL CO



CIRCLE NO. 19 ON READERS SERVICE CARD

free

1975 electronics catalog no. 750

Lafayette RADIO ELECTRONICS
Listen to us, you can't go wrong.



**IT'S THE ONLY NATIONALLY DISTRIBUTED
FULL-LINE CATALOG WITH A MAJOR
SHOWING OF THE NEWEST NAME-BRAND
ELECTRONICS PRODUCTS
FOR 1975!**

The "NEW LOOK"

1975

LAFAYETTE RADIO ELECTRONICS CATALOG

If you're interested in electronics you NEED this catalog! Completely re-designed for easier-than-ever ordering, with the newest and best Lafayette and national-brand products for '75. And you get the same quality and service that has made Lafayette a leader for 55 years. Iron-clad guarantees! Lowest Prices! Professional Service! State-of-the-art Equipment! Pick and choose from over 18,000 quality electronics products! Now, more than ever, we're your "Single-trip" shopping center for everything in electronics.

SAVE ON EXCLUSIVE LAFAYETTE PRODUCTS PLUS THE BEST MAJOR BRAND NAMES

- Stereo and 4-Channel Music Systems
- Tape Recording Equipment • Car Stereo and Accessories • CB and Ham Gear • Police/Public Service Receivers • Car Stereo and Accessories • Antennas • Cameras • TV • PA and Test Equipment • Music Instruments and Amplifiers • Books • Electronic Calculators • Security Systems
- PLUS PARTS, TUBES, BATTERIES, HARDWARE — ALL YOU NEED FOR QUALITY LIVING THROUGH ELECTRONICS

Lafayette

Listen to us, you can't go wrong.

STORES COAST TO COAST Check Your Yellow Pages or Shop by Mail

NEW!

Bigger Pages

NEW!

More Full Color

NEW!

Easier-to-Read Type

free

MAIL TODAY!

Lafayette Radio Electronics

111 Jericho Tpke., Syosset, L.I., N.Y. 11791

35114

Send me your FREE 1975 Catalog.

Send a 1975 Electronics Catalog to my friend.

Name _____ Apt. _____

Name _____ Apt. _____

Street _____

Street _____

City _____

City _____

State _____ Zip _____

State _____ Zip _____

CIRCLE NO. 24 ON READERS SERVICE CARD

developing a fixed-level square-wave output signal with a peak-to-peak amplitude equal to the total zener voltage. Operating power is supplied by batteries *B1* and *B2* controlled by a dpst switch, *S1*.

Readily available standard components are used in the design. Ted chose a type 741 op amp for *IC1*. The terminal numbers shown are for the "minidip" version used in his original model. The resistors may be either 1/4 or 1/2 watt, while *C1* is a low-voltage

ceramic capacitor. Batteries *B1* and *B2* are conventional 9-volt transistor units, with *S1* a toggle, slide or rotary switch. Ideally, the zener diodes should be matched, with a total voltage of 10 volts. Unable to obtain a perfect match, Ted assembled his model using a 5.6-volt zener for *D1*, a 4.5 volt device for *D2*, providing a nominal 10.1-volt output signal. The actual output voltage, of course, will depend on the zener diode voltage tolerances.

If a particular application requires an accurately known output voltage, a simple test will establish this value. Disconnect *R4*'s upper lead (pin 6, *IC1*). Reverse *D2*. Connect *R4*'s free lead to the positive terminal of a 15-18-volt dc source, negative to circuit ground. Finally, measure the dc voltage across the series zeners using an accurate voltmeter. Restore the circuit to its original condition for normal operation.

Device/Product News. We've received a number of inquiries from readers asking what LED's have the lowest current ratings. Actually, most LED's will operate at currents much lower than their maximum ratings, and we've obtained satisfactory light outputs with levels as low as 8 to 10 mA using commercial 50-mA (max) devices. However, the results are not consistent. One LED of a given type may provide a good output at a 7-mA level, while another of the same type may require 10mA, and still another 12 or 15 mA. At least one firm, however, Data Display Products (5428 W. 104th St., Los Angeles, CA 90045), offers complete LED panel-light assemblies designed to be used at a mere 5-mA current level. Available colors are green, yellow, amber and red, at voltages from 1.8 to 28 V. Single unit prices range from \$1.58 for a 1.8-volt device (requiring an external current limiting resistor) to \$1.76 for a 28-volt type (with built-in resistor). Each unit is supplied with a mounting clip and Neoprene washer.

You can add another name to the roster of firms manufacturing dual 555-type timer IC's: Silicon General, Inc. (2712 McGaw Ave., Irvine, CA 92705). Packaged in 14-pin DIPs, the Silicon General version is identified as the SG556/SG556C.

Perhaps a dual timer is not enough for your application. If this is the case, you might check the new *quad* timers now available from Signetics (811 E.

Arques Ave., Sunnyvale, CA 94048). Identified as Models 553 and 554, the new units are supplied in a 16-pin DIP. The 553 and 554 are not exact duplicates of the industry standard, the familiar 555, however. They have no reset control line and a common control voltage pin is provided for all four timers in the package. Basically similar in application, the 553 is rated to sink 100 mA, the 554 to source an equivalent current, compared to the 200 mA ratings of the 555/556 types. Another interesting difference between the 553/554 devices and the 555/556 types is a simplification of their timing equations, from $T = 1.1RC$ to $T = RC$ for the new units.

How many watts in a dollar? If this seems like a silly question, comparable to a mixing of apples and oranges, it is, however, the type of question that a transmitter designer must ask himself. According to Motorola, its new MRF621 uhf power transistor can deliver an output signal in the 406-to-512-MHz band for less than a dollar per watt. Designed for 12.5-V dc operation, the new device can deliver 45 W at 470 MHz with a minimum power gain of 4.8 dB and collector efficiency of 55%. Featuring an internal MOS capacitor chip for "controlled-Q" operation, the MRF621 sells for \$39.00 each in unit quantities, even less if you want to buy 25 or more at a time.

RCA's Solid State Division (Box 3200, Somerville, N.J. 08876) has introduced a new linear IC and added another COS/MOS device to its expanding line. Designated type CA3127E, the new linear device consists of 5 independent general-purpose silicon npn transistors constructed on a common monolithic substrate to provide close electrical and thermal matching. Suitable for low-power applications at frequencies up to 500 MHz, the CA3127E, supplied in a 16-lead plastic DIP, can be used in vhf amplifiers, mixers and oscillators, in i-f converters and amplifiers, and in sense amplifiers, synthesizers, and cascade amplifiers. RCA's latest COS/MOS device, identified as the CD4093AE, is a quad 2-input NAND gate consisting of four identical Schmitt trigger circuits, each of which functions as a two-input NAND gate. The CD4093AE, packaged in a 14-pin plastic DIP, is suitable for use in wave-shapers and pulse-shapers, monostable and astable multivibrators, and NAND functional logic circuits. ♦



CALECTRO®

DIGITAL DISPLAYS AND LOGIC

ATTENTION HOBBYISTS!

BUILD THIS DIGITAL COUNTER/ L.E.D. DISPLAY KIT.



Everything needed to build a complete decade counter (0-9) including a printed circuit board. Operates from a 5 Volt D.C. supply. Can be used in hundreds of applications.



See your nearby CALECTRO distributor for all the most popular digital displays and integrated circuits. Also, get your copy of the new CALECTRO DIGITAL PROJECTS HANDBOOK!





GC ELECTRONICS
Division of Hydrometals, Inc.
Rockford, Illinois 61101 U.S.A.

ELECTRONICS MARKET PLACE

NON-DISPLAY CLASSIFIED: COMMERCIAL RATE: For firms or individuals offering commercial products or services, \$1.60 per word (including name and address). Minimum order \$16.00. Payment must accompany copy except when ads are placed by accredited advertising agencies. Frequency discount; 5% for 6 months; 10% for 12 months paid in advance. **READER RATE:** For individuals with a personal item to buy or sell, \$1.00 per word (including name and address). No minimum! Payment must accompany copy. **DISPLAY CLASSIFIED:** 1" by 1 column (2-1/4" wide), \$200.00. 2" by 1 column, \$400.00. 3" by 1 column, \$600.00. Advertiser to supply cuts. For frequency rates, please inquire.

GENERAL INFORMATION: First word in all ads set in bold caps at no extra charge. All copy subject to publisher's approval. All advertisers using Post Office Boxes in their addresses **MUST** supply publisher with permanent address and telephone number before ad can be run. Advertisements will not be published which advertise or promote the use of devices for the surreptitious interception of communications. Closing Date: 1st of the 2nd month preceding cover date (for example, March issue closes January 1st. Send order and remittance to **POPULAR ELECTRONICS**, One Park Avenue, New York, New York 10016, Attention: Hal Cymes.

FOR SALE

FREE! bargain catalog. Fiber optics. LED's, transistors, diodes, rectifiers, SCR's, triacs, parts. Poly Paks. Box 942, Lynnfield, Mass. 01940.

GOVERNMENT Surplus Receivers, Transmitters, Sniperscopes, Radios, Parts. Picture Catalog 25 cents. Meshna. Nahant, Mass. 01908.

LOWEST Prices Electronic Parts. Confidential Catalog Free. KNAPP, 3174 8th Ave. S.W., Largo, Fla. 33540.

ELECTRONIC PARTS. semiconductors. kits. FREE FLYER. Large catalog \$1.00 deposit. BIGELOW ELECTRONICS. Bluffton, Ohio 45817.

RADIO—T.V. Tubes—36 cents each. Send for free catalog. Cornell, 4213 University, San Diego, Calif. 92105.

AMATEUR SCIENTISTS. Electronics Experimenters. Science Fair Students Construction plans—Complete, including drawings, schematics, parts list with prices and sources Robot Man—Psychedelic Shows—Lasers—Emotion/Lie Detector—Touch Tone Dial—Quadrasonic Adapter—Transistorized Ignition—Burglar Alarm—Sound Meter over 60 items. Send 25 cents coin (no stamps) for complete catalog. Technical Writers Group. Box 5994, University Station, Raleigh, N.C. 27607.

METERS—Surplus, new, used, panel or portable. Send for list. Hanchett, Box 5577, Riverside, CA 92507.

WE SELL CONSTRUCTION PLANS. TELEPHONE: Answering Machine, Speakerphone, Carphone, Phonevision, Auto Dialer, Touch Button Dialer, Central Dial System. TELEVISION: \$35.00 Color Converter, Video Tape Recorder, \$25.00 Camera. HOBBYIST: Electron Microscope, 96 Hour Tape Music System, Ultrasonic Dishwasher, Radar-Oven. Plans \$4.95 each. NEW ITEM: \$75. Electronic Pocket Calculator, \$75.00. COURSES: Telephone Engineering \$39.50. Detective Electronics \$22.50. Integrated Circuit Engineering, \$49.50. NEW SUPER HOBBY CATALOG plus year's subscription to Electronic New Letter AIRMAILED \$1.00. Don Britton Enterprises, 6200 Wilshire Blvd., Los Angeles, Calif. 90048.

JAPAN HONG KONG DIRECTORY. World products information, \$1.00 today. World Trade Inquiries, Hilliard, Washington 99207.

FREE CATALOG. IC's, Puts, Transducers, Thermocouples, Led's, Transistors. Circuit Boards, parts. Chaney's, Box 15431, Lakewood, Colo. 80215.

WAVEFORM GENERATOR KIT 8038 Function Generator IC Producing Sine, Square, Triangular Waveforms, \$10.95 PPD. 8038 IC, \$6.75 each PPD. PHOTOLUMINE CORPORATION, 118 East 28th Street, New York, NY 10016.

LOOKING FOR A NEW CHALLENGE?
... than build a TV camera!

ONLY SOLID STATE CAMERA AVAILABLE IN KIT FORM OR FACTORY ASSEMBLED. COMPLETE KIT WITH VIDEO CORD. ONLY \$189.95. PREPAID DELIVERY ANYWHERE IN U.S.A., CANADA AND MEXICO. OPTIONAL AUDIO SUBCARRIER \$189.95. WHITE or PHONE MON. FOR COMPLETE CATALOG OF KITS, PARTS AND PLANS. Call 802-587-3777.

3001 BROADWAY ATV Research DAKOTA CITY, NEBR. 68721

DIGITAL ELECTRONICS: Complete schematics, parts lists, theories — Discrete Component Digital Clock, \$3.00 — Sound Sensitive Switch, \$1.50. Increase technical competence, hobby skills — Complete Course in Digital Electronics is highly effective, \$10.00. Free literature. DYNASIGN, Box 60A7, Wayland, Mass. 01778.

MECHANICAL, ELECTRONIC devices catalog 10 cents. Greatest Values — Lowest Prices. Fertik's, 5249 "D", Philadelphia, Pa. 19120.

SOUND SYNTHESIZER KITS—Surf \$12.95, Wind \$12.95, Wind Chimes \$17.95, Electronic Songbird \$6.95, Musical Accessories, many more. Catalog free. PAIA Electronics, Box J14359, Oklahoma City, OK 73114.

FREE CATALOG. Parts, circuit boards for POPULAR ELECTRONICS projects. PAIA Electronics, Box C14359, Oklahoma City, OK 73114.

COMPLETE CONSTRUCTION PLANS— TELEPHONE: Answering Device, Automatic Dialer, "Black Boxes", Call Diverter, Call Limiter, Conference Bridge, Central Dial Exchange, Melodic Ringing, Recorder-Actuator, Remote Control. Schematics, Speakerphone, Telemink Burglar Alarm, Voice Scrambler. \$3.00 each. ELECTRONIC: Biofeedback Conditioner, Horticulture Stimulator, Multifrequency Encoder Network (Speeds telephone calling 100%), \$5.00 each. DODECAHEDRON Speaker Enclosure \$7.50. Photographic Pinhole Camera \$2.00. ONE YEAR SUBSCRIPTION: Telephone-Electronics Newsline \$3.00. COURSES: Telecommunications, Electronic Protective Systems, F. E. T. Theory and Application, \$24.95 each. Catalog of plans 50 cents. All of the construction plans above, \$19.95. TELETRONICS COMPANY OF AMERICA, P.O. Box 3486, Los Angeles, California 90028, USA.

DISCOUNT PRICES
B & K, SENCORE, LEADER and RCA
Test Equipment
RAY THEON, ICC/MULLARD Tubes
TELEOMATIC Test Jigs
Free Catalog
FORDHAM RADIO SUPPLY CO., INC.
558 Morris Ave. • Bronx, N.Y. 10451

BURGLAR-FIRE alarm supplies and information. Free catalog. Protecto Alarm Sales, Box 357-G, Birch Run, Michigan 48415.

PAIA HAS... modular SYNTHESIZER KITS

demo record \$1.00 free catalog

PAIA ELECTRONICS, INC.
BOX P14359, OKLAHOMA CITY, OK 73114

AUTHENTIC, INSTRUMENTED, FLYING ROCKETS for casual or serious experimenters. Over 80 scale original, multi-stage or ready-to-fly models. Solid-propellant engines for safe, electric launch system liftoffs up to 2,500 feet. Measure altitude, temp, inversions, more. Real telemetry, electronic tracking, aerial still and movie photography with super-miniaturized equipment. New, detailed tech manual and full-color catalog, 25 cents from ESTES INDUSTRIES Dept. 18B, Penrose, Colo. 81240.

ELECTRONIC Parts wholesale, Catalog 10 cents. Donlynn Electronics, P.O. Box 15421, Phoenix, Arizona 85060.

INTERNATIONAL ELECTRONICS UNLIMITED

TTL		LINEAR CIRCUITS		LOGIC PROBE KIT	
7400 \$.19	7474 \$.43	301 Hi perf. op amp	mDIP \$.32	<ul style="list-style-type: none"> Ten nano/sec capability Checks TTL & DTL logic Dual slope memory Internal 5V regulator Kit is complete with all necessary components, case, probe, complete instructions and logic chart... \$19.95	
7401 .19	7475 .75	307 Op amp	mDIP .35	POWER SUPPLY SPLITTER KIT <ul style="list-style-type: none"> Ground reference for positive & negative output from single supply — any DC source to 20V Balanced output adjustment 1 amp-current capability with sink Increase usefulness of your power supply Complete with all components & instructions... \$4.95	
7402 .19	7476 .47	308 Micro-pwr op amp	mDIP 1.10	MEMORIES	
7403 .19	7483 1.11	309K 5V reg 1A	TO-3 1.65	1101 256 bit RAM MOS	\$1.75
7404 .22	7486 .44	311 Hi perf. V comp	mDIP 1.06	1103 1024 bit RAM MOS	4.95
7405 .22	7489 2.75	319 Hi-speed dual comp	DIP 1.29	5260 1024 bit RAM low power	3.95
7406 .39	7490 7.6	324 Quad op amp	DIP 1.96	7489 64 bit RAM TTL	2.75
7407 .39	7491 1.29	339 Quad comp	DIP 1.69	8223 Programmable ROM	4.95
7408 .25	7492 .79	340S Pot V reg (5V, 6V, 8V, 12V, 15V, 18V, 24V)	TO-220 1.95	LED'S AND OPTO ISOLATORS	
7409 .25	7493 .79	380 2w audio amp	DIP 1.49	MV10B Red To 18	\$.25 ea.
7410 .19	7494 .89	380-8 .6w audio amp	mDIP .89	MV50 Axial leads	20
7411 .79	7495 .89	381 No noise dual preamp	DIP 1.79	MV5020 Jumbo visible red	.33
7412 .39	7496 .89	550 Prec. V reg	DIP .79	ME4 Infra red diff. dome	.60
7413 .39	7497 .89	555 Timer	mDIP .99	MAN1 Red 7 seg. .270"	2.50
7414 .39	7498 .89	560 Phase locked loop	DIP 2.75	MAN2 Red alpha num. .32"	4.95
7415 .39	7499 .89	565 Op amp	DIP 2.65	MAN3A Red 7 seg. .127"	.75
7416 .39	7500 .89	709 Volt reg.	DIP .29	MAN3M Red 7 seg. .127" claw	1.19
7417 .39	7501 .89	723 Comp. op amp	mDIP .69	MAN4 Red 7 seg. .190"	2.15
7418 .39	7502 .89	741 Dual 741	DIP .79	MAN5 Green 7 seg. .270"	2.95
7419 .39	7503 .89	748 Freq adj 741	mDIP .39	MAN7 Red 7 seg. .270"	1.35
7420 .19	7504 .89	1458 Dual Comp op amp	mDIP .69	MAN8 Yellow 7 seg. .270"	3.95
7421 .35	7505 .89	3900 Quad amp	DIP .65	MAN6G 60" high dir. view	4.85
7422 .29	7506 .89	3905 Prec. timer	DIP .65	DL707 Red 7 seg. .3"	2.15
7423 .35	7507 .89	8038 Function gen.	DIP 5.95	MC02 Opto-iso diodes	1.09
7424 .35	7508 .89	70451 Dual pri. driver	mDIP .39	MCT2 Opto-iso transistor	.69
7425 .39	7509 .89	75452 Dual pri. driver	mDIP .39	ON ORDERS OVER \$25.00 DEDUCT 10%	
7426 .29	7510 .89	75453 Dual pri. driver	mDIP .39	All items are new, unused surplus parts — tested functional. Satisfaction is guaranteed. Shipment will be made via first class mail — postage paid — in U.S., Canada and Mexico within three days from receipt of order. Minimum order — \$5.00. California residents add sales tax.	
7427 .35	7511 .89	75491 Quad seq driver	DIP .79	INTERNATIONAL ELECTRONICS UNLIMITED P.O. BOX 1708 MONTEREY, CALIF. 93940 USA	
7428 .35	7512 .89	75492 Hex dig. driver	DIP .89	(408) 659-4773	
7429 .22	7513 .89	DATA SUPPLIED ON REQUEST WITH ORDER. ADD \$5.00 PER DATA FOR ITEMS PRICED UNDER \$1.00		CALCULATOR & CLOCK CHIPS w/data	
7430 .22	7514 .89	5001 LSI 40 pin DIP 4 funct	\$ 3.95	5001 LSI 40 pin DIP 4 funct	\$ 3.95
7431 .22	7515 .89	5002 LSI Same as 5001 exc batt pwr	8.95	5002 LSI Same as 5001 exc batt pwr	8.95
7432 .29	7516 .89	5005 LSI 28 pin DIP 4 funct w/mem	8.45	5005 LSI 28 pin DIP 4 funct w/mem	8.45
7433 .45	7517 .89	MM 5311 28 pin BCD 6 dig mux	9.95	MM 5311 28 pin BCD 6 dig mux	9.95
7434 .39	7518 .89	MM 5312 24 pin 1 pps BCD 4 dig mux	6.95	MM 5312 24 pin 1 pps BCD 4 dig mux	6.95
7435 .39	7519 .89	MM 5313 28 pin 1 pps BCD 6 dig mux	7.95	MM 5313 28 pin 1 pps BCD 6 dig mux	7.95
7436 .19	7520 .89	MM 5314 24 pin 6 dig mux	8.95	MM 5314 24 pin 6 dig mux	8.95
7437 .19	7521 .89	MM 5316 40 pin alarm 6 dig	12.95	MM 5316 40 pin alarm 6 dig	12.95
7438 .39	7522 .89	4000 SERIES RCA-EQUIV.		CD4001 \$.55 CD4017 2.95 CD4009 .85 CD4019 1.35 CD4010 .85 CD4022 2.75 CD4011 .55 CD4023 .55 CD4012 .55 CD4025 .55 CD4013 1.20 CD4027 1.35 CD4016 1.25 CD4035 2.85	

**DIP SOLDER TAIL SOCKETS
DUAL IN-LINE SOLDER TAIL SOCKETS
GOLD CONTACTS**

8 PIN44	18 PIN74	28 PIN1.30
14 PIN52	22 PIN1.00	36 PIN1.55
16 PIN54	24 PIN1.05	40 PIN1.75

Also available - wire wrap sockets - 1/2/3 Levels write or call for large volume DISCOUNTS

T T L

7400 \$.18	7453 \$.27	74157 \$ 1.55	CD4001 \$.55
7401 .23	7454 .40	74160 1.65	CD4002 .55
7402 .23	7459 .25	74161 1.65	CD4009 1.40
7403 .23	7460 .25	74163 2.50	CD4010 .60
7404 .25	7470 .45	74164 2.50	CD4011 .55
7405 .24	7472 .41	74165 2.50	CD4012 .55
7406 .50	7473 .47	74166 1.75	CD4013 1.50
7407 .50	7474 .47	74170 3.00	CD4016 1.40
7408 .25	7475 .90	74173 1.75	CD4023 .55
7409 .25	7476 .47	74174 1.85	CD4025 .55
7410 .23	7480 .50	74175 1.85	CD4027 1.25
7411 .30	7482 1.75	74176 .85	CD4030 .60
7413 .89	7483 1.15	74177 .85	74C00 .45
7416 .45	7485 1.10	74180 1.05	74C04 .70
7417 .45	7486 .47	74181 3.75	74C20 .65
7418 .25	7488 4.00	74182 1.00	74C173 2.60
7419 .23	7489 3.00	74184 2.30	
7421 .27	7490 .89	74185 2.30	
7423 .32	7491 1.15	74187 7.00	8090 \$.35
7425 .27	7492 .95	74190 1.50	8091-8098 .55
7426 .31	7493 .95	74191 1.50	8223 5.00
7427 .32	7494 .97	74192 1.50	8280 .75
7429 .40	7495 .95	74193 1.50	8288 1.15
7430 .33	7496 .95	74194 1.50	8880 1.35
7432 .26	74100 1.50	74195 1.05	
7437 .45	74107 .47	74196 1.25	
7438 .50	74121 .55	74197 1.05	
7439 .50	74122 .47	74198 2.25	
7440 .23	74123 1.05	74199 2.75	
7441 1.10	74125 .80	74200 7.00	
7442 1.05	74126 .80		
7443 1.10	74141 1.15		
7444 1.15	74145 1.15	8263 Sig. 7.00	
7445 1.10	74150 .95	8267 4.00	
7446 1.25	74151 1.20	2513 14.00	
7447 1.25	74153 1.50	2518 7.00	
7448 1.25	74154 1.25	2424 7.00	
7450 .25	74155 1.30	2425 7.00	
7451 .27	74156 1.30	4024 2.25	

CMOS

8000 Series

LEDS

PROJECTS

Many Other 8000 Series

LEDS

MV 10 5/1

MV 50 6/1

MV 5024 5/1

MAN-1 1.95

MAN-3 .95

MAN-4 1.95

MAN-7 1.50

DL 33 1.95

20% Discount for 100 Pieces Combined - Above 7400 Series
NOVEMBER SPECIALS NOVEMBER

IN4148 Silicon Signal Switching Diode	15/1.00
TIS97 - TIS98 NPN Transistor	10/1.00
7400 - 7401 - 7403 GATES	6/1.00
7404 - 7410 - 7420 GATES	5/1.00
LM301H/LM301N OP. AMP.	3/1.00
LM309K 5 V 1 AMP	1.25
LM311H/LM311N Comparators	1.00
LM380N 2 Watt Audio AMP	1.25
LM3900N Quad AMP DIP	.55
LM3905N Precision Timer	.65
LM741CH/LM741CN OP. AMP.	3/1.00
MM5314 24 Pin Digital Clock Chip	7.95
MM5316 40 Pin Alarm Clock Chip	11.95
MM5016H 512 Bit Dynamic Shift Reg.	2.00
MM1103 1024 X 1 Bit Dynamic RAM	3.95
2519 40 X 6 Static Shift Register	4.00
2529 240 X 2 Static Shift Register	5.00

LINEAR

LM300 Pos. V Reg To 5	\$.85
LM301H/N Improved Op Amp	.40
LM302H Voltage Follower	.85
LM304H Negative Voltage Regulator	1.10
LM305H Positive Voltage Regulator	1.00
LM307H/N Op Amp (Super 741)	.40
LM309H/N Micro Power Op Amp	1.15
LM309K 5 Volt Regulator / Amp	1.70
LM310H Improved Volt. Follower Op Amp	1.35
LM311H/N Hi-performance Volt. Comp.	1.15
LM319H Hi-Speed Dual Comp.	1.55
LM320K-5V-15V - To 3 Neg. Regulator	1.75
LM324N Quad 741 Op Amp	1.90
LM339 Quad Comparator	2.35
LM340K-5V-12V-15V-24 Positive Volt Regulator	2.00
LM370N A 6 C - Squelch Amp.	1.55
LM373N AM/FM \$\$ B Strip	3.30
LM380N 2 Watt Audio Power Amp	1.50
LM703H RF/IF Amp	.45
LM5558V Dual Op Amp	1.00
LM741H/N Comp. Op Amp	.40
LM747H/N Dual Comp. Op Amp	.90
LM748N Freq. Adj. 741	.40
LM1458N Dual Comp. Op Amp	.65
LM3065N T.V.-FM Sound System	.75
LM3900N Quad Amp	1.65
LM555N Timer	1.00
LM565-LM566-LM567 Phase Locked Loops	2.50ea
LM 7522 Core Memory Sense Amp.	2.50
LM 7524 Core Memory Sense Amp.	1.50
LM 7535 Core Memory Sense Amp.	1.00
LM75451 Dual Peripheral Driver	.49
LM75452 Dual Peripheral Driver	.49
LM75453 Dual (LM351)	.65

Satisfaction Guaranteed. All Items 100% Tested
\$5.00 Min. Order - 1st Class Mail - No Extra Charge
California Residents - Add 6% Sales Tax
Wholesale Outlets - Write for Special Discounts
Write for FREE Catalog - Data Sheets .20 ea each

JAMES Electronics
P. O. Box 822 - Belmont, Ca. 94002
PHONE ORDERS WELCOME
(415) 692-8097

CIRCLE NO. 22 ON READERS SERVICE CARD
100

WE SELL MONEY MAKING CONSTRUCTION MANUALS!—Reclaim refined GOLD and SILVER for EXCELLENT full time or part time money!—Color Catalog 25 cents—Airmailed 50 cents. Creative Products, Dept. PE-1174, 8415 Lofland, Houston, Texas 77055.

BUGGED??? New locator finds them fast. Write, Clifton, 11500-L N.W. 7th Avenue, Miami, Florida 33168.

TELEPHONE "BUGGED"? Countermeasures Brochure \$1.00. Negeye, Drawer 547, Pennsboro, W. VA 26415.

HEAR POLICE/FIRE Dispatchers! Catalog shows exclusive directories of "confidential" channels, receivers. Send 10 cent stamp. Communications, Box 56-PE, Commack, N.Y. 11725.

YOU WILL SAVE BIG MONEY! Surplus, Clearouts, Bankruptcy, Inventory, Deals, Catalog \$1 (redeemable). ETCOA Electronics, Box 741, Montreal, H3C 2V2, U.S. Inquiries.

CONVERT any television to sensitive, big-screen oscilloscope. Only minor changes required. No electronic experience necessary. Illustrated plans, \$2.00. Sanders, Dept. A-33, Box 92102, Houston, Texas 77010.

CONSTRUCTION PLANS: Laser \$2.00, Rocket Tracking Transmitter \$2.00, Space Monitor-Missile Tracker \$2.00, Free Catalog, Electro-Research, P.O. Box 20285, Ferndale, Michigan 48220.

CD IGNITIONS, VHF/UHF monitors, crystals, CB radios. Southland, Box 3591-B, Baytown, Texas 77520.

CRYSTALS, Scanners, \$3.88, include make and frequency. G Enterprises, P.O. Box 461PC, Clearfield, UT 84105.

PRACTICAL Applications of Digital IC's. 100's of tips, circuits, projects, on TTL. 443pp \$19.95. Money Back Guarantee. GEA, P.O. Box 285, Northfield, Ohio 44067.

FREE CATALOG, Kits, Components, audio equipment. Electronic Supply Pacs, Box 175, Floral Park N.Y. 11001.

ALPHA/THETA BRAINWAVE biofeedback instruments. Analog instruments from \$125; digital processing systems from \$225. BioScan, Box 14168-E, Houston, Texas 77021.

SURPRISE! Build inexpensively, the most Unusual Test Instruments. Futuristic Gadgets using Numerical Readouts! Catalogue Free! GBS, Box 100A, Green Bank, West Virginia 24944.

ELECTRONIC ORGAN KITS, KEYBOARDS and many components. Independent and divider tone generators. All diode keying. I.C. circuitry. Supplement your Artisan Organ. 35 cents for catalog. DEVTRONIX ORGAN PRODUCTS, Dept. C., 5872 Amapola Dr., San Jose, Calif. 95129.

ELECTRONIC IGNITION: Capacitor, transistor, pointless. Auburn sparkplugs. Information 10 cents. Anderson Engineering, Epsom, N.H. 03234.

WHOLESALE Scanners, CB, Crystals, Directories. SSB/AM, Catalog 25 cents. G—Enterprises, Box 461P, Clearfield, Utah 84105.

ELECTROENCEPHALOPHONE: Brainwave monitor. Professional biofeedback instruments. J&J, 8102-E, Bainbridge, WA 98110.

HOBBYISTS—For all your electronic parts requirements at low prices, send for free flyer to: Dartek Electronics, Dept. P, Box 2460, Dartmouth, Nova Scotia, Canada. U.S. Inquiries.

CALCULATOR OWNERS: Use Your +x÷ calculator to compute square roots, trigonometric functions, logarithms, and more! Quickly, Accurately, Easily! Send today for the First and Best Calculator Manual now in use throughout the world still only \$2.00 Postpaid with Unconditional Money-Back Guarantee! Mallmann Optics and Electronics, Dept. 21A, 836 South 113, West Allis, Wisconsin 53214.

FREE 1975 Electronics Catalog. McCord Electronics, Box 276-N, Sylvania, Ohio 43560.

BUBBLE ETCHER. Etches 6"x8" board in half time. Acrylic construction. Complete photo process instructions. Requires inexpensive aquarium pump. \$12.00. ETCHER, Box 25066, Northgate Station, Seattle, WA 98125.

AUTORANGING DMM, deluxe VOM's, logic probes and more. Lowest prices. Free catalog. Electro Industries, 4201 Irving Park, Chicago, Illinois 60641.

ARE YOU PREPARED? 10,000 cubic foot, pull ring ignited emergency smoke grenades are now available! 3 for \$7.50, 9 for \$20.00. Postpaid. Pacific Aero Supply, Box 601, Malibu, Calif. 90265.

DIGITAL/ANALOG PLANS for Home and Lab!!! Send for free 16-page ideas catalog featuring the EXPERIMENTER'S COMPUTER SYSTEM, practical plans, tutorials, etc. M.P. Publishing Co., Box 378-P, Belmont, Massachusetts 02178.

PYROTECHNICAL chemicals, casings, tools, supplies, fuse. Price List 50 cents. Westech, Logan, Utah 84321.

VIDEO GAMES—attaches to your TV. Ping-Pong plans \$3.50, Information 25 cents. Duncan Electronics, 20650 Rynnmede, Canoga Park, Calif. 91306.

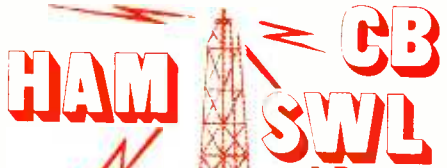

they come through LOUD AND CLEAR in the all-new 1975 COMMUNICATIONS HANDBOOK

Here is everything you want to know need to know about Citizens' Band, Amateur Radio, Shortwave Listening.



DON'T TURN A DIAL. In fact don't even buy a dial or anything else until you've checked out the 1975 Communications Handbook. Whatever your radio specialty—whether you're an old hand or just getting started—this vital "how-to" guide will help you get greater value, greater enjoyment out of every minute you spend with your equipment.

The all-new 1975 COMMUNICATIONS HANDBOOK is scheduled to go on sale nationally November 21, 1974.

YOU CAN RESERVE YOUR COPY NOW AT THE SPECIAL PRE-PUBLICATION PRICE OF ONLY \$1.00 POSTPAID.

Regular newsstand price is \$1.25, mail order \$1.60.

So to make sure you come through "Loud and Clear" in 1975...
RESERVE YOUR COPY NOW AND SAVE WITH THIS SPECIAL PRE-PUBLICATION OFFER AVAILABLE TO READERS OF POPULAR ELECTRONICS MAGAZINE ONLY.

PRE-PUBLICATION RESERVATION FORM

Communications Handbook PE-1174
Ziff-Davis Service Division
595 Broadway
New York, New York 10012

Enclosed is \$1. Please reserve my copy of the 1975 Communications Handbook at the special pre-publication price to be mailed to me on or before November 21, 1974.

Print Name _____
Address _____
City _____
State _____ Zip _____

PAYMENT MUST BE ENCLOSED WITH ORDER

GOVERNMENT SURPLUS

GOVERNMENT Surplus. How and Where to Buy in Your Area. Send \$2.00. Surplus Information, Headquarters Bldg., Box 30177-PE, Washington, D.C. 20014.

ELECTRONIC Equipment and Parts. Big 36 page Free Catalog. Send for your copy today! Fair Radio Sales, Box 1105-P, Lima, Ohio 45802.

MANUALS for Govt Surplus radios, test sets, scopes. List 50 cents (coin). Books, 7218 Roanne Drive, Washington, D.C. 20021.

N.A.S.A. SURPLUS EQUIPMENT, rack chassis, P.C. Connectors etc.. Catalog 25 cents. Computer Boards 10/\$2.75 pp.. ORION, Box 145, Springfield, Virginia 22150.

PERSONALS

MAKE FRIENDS WORLDWIDE through international correspondence. Illustrated brochure free. Hermes, Berlin 11, Germany.

INVENTIONS WANTED

CASH-ROYALTIES for patented, unpatented inventions. Global Marketing Service, 2354-P Telegraph, Oakland, California 94612.

inventors

...Manufacturers Need New Products

If you have an idea for a new product, or a way to make an old product better, contact us, "the idea people." We'll develop your idea, introduce it to industry, negotiate for cash sale or licensing.

Send for our FREE "Invention Kit." It has a special "Invention Record Form," an important brochure, "Your Invention - Its Development, Protection & Marketing," and a Directory of 500 Corporations Seeking New Products. You'll learn how ideas become a reality!



RAYMOND LEE ORGANIZATION
230 Park Avenue, New York, N.Y. 10017

I'd like to find out how to take action on my idea. Send Free "Invention Kit No. A-112"

Name _____ Please Print
Address _____
City _____ State _____ Zip _____
SAN FRANCISCO LOS ANGELES TORONTO VANCOUVER DENVER CHICAGO

INVENTORS: Protect your ideas! Free "Recommended Procedure." Washington Inventors Service, 422T Washington Building, Washington, D.C. 20005.

PATENT Searches including Maximum speed, full airmail report and closest patent copies. Quality searches expertly administered with complete secrecy guaranteed. Free Invention Protection form and "Patent Information." Write Dept. 911, Washington Patent Office Search Bureau, Benjamin Franklin Substation, P.O. Box 7167, Washington, D.C. 20044.

FREE PAMPHLET: "Tips on Safeguarding Your Invention." Write: United States Inventors Service Company, 708-T Carry Building, Washington, D.C. 20005.

FILE your own patent application. Complete information and materials. Write: Inventor's Guide, 468-R, Goodspeed, Road, Virginia Beach, Virginia 23451.

INVENTORS! FREE BROCHURE LISTING 1,000 CORPORATIONS which may be interested in your invention. Many well-known manufacturers have engaged us to locate new products. For Free brochure and information regarding the promotion of your invention, contact: Gilbert Adams Organization, Dept. 20L, 80 Wall Street, New York, New York 10005.

INVENTORS! Don't sell or license your invention until you receive our offer. Eagle Development Company, Dept. P-11, 82 Wall Street, New York City 10005.

TAPE AND RECORDERS

RENT 4-Track open reel tapes—all major labels—3,000 different — free brochure. Stereo-Parti, 55 St. James Drive, Santa Rosa, Ca. 95401.

1930-1962 Radio Programs. Reels, \$1.00 Hour! Cassettes, \$2.00 Hour! Mammoth Catalog, \$1.25. AM Treasures, Box 192F, Babylon, N.Y. 11702.

CASSETTE LABELS

Plain white cassette labels. Norelco cassette cleaners, paper mailer boxes hold Norelco-type plastic box, famous brand cassettes. "Like new" 10-1/2" metal or fiberglass reels. Send for open reel and cassette discount catalog. 1-9 10-99 100 1000
Cassette Labels (Multiplies of 10) .02 .015 .01
Norelco Cassette Cleaner .65 .60 .55 .50
Cassette Paper Mailer Boxes .03 .025 .022 .02
Scotch Cassette SC90HC, Buy 2, get ONE FREE 2.72 2.55 2.44 2.39
10-1/2" Fiberglass Reels, Used .50 .50 .40 .35
10-1/2" Metal, NAB Hole, Used 1.00 1.00 .90 .80
Minimum Order, \$5.00
Plus Postage by Weight and Zone
1776 COLUMBIA ROAD, N.W.
WASHINGTON, D.C. 20009

SAXITONE TAPE SALES

OLD RADIO SHOWS on cassettes \$1.50 per show. Free Catalog. Radio Classics, Box 804, Mattituck, NY 11952.

1/2 INCH VIDEO TAPE \$7.25 per hour on 7" reel. Free information. Oregon Magnetics, Box 13374, Portland, Oregon 97213.

INSTRUCTION

LEARN ELECTRONIC ORGAN SERVICING at home all makes including transistor. Experimental kit—trouble-shooting. Accredited NHSC. Free Booklet. NILES BRYANT SCHOOL, 3631 Stockton, Dept. A, Sacramento, Calif. 95820.

LEARN WHILE ASLEEP. Hypnotize! Strange catalog free. Auto-suggestion, Box 24-Z, Olympia, Washington 98501.

DEGREE IN ELECTRONICS through correspondence. Free catalog. Grantham, 2000 Stoner Avenue, Los Angeles, California 90025.

INTENSIVE 5 week course for Broadcast Engineers. F. C. C. First Class license. Radio Engineering Incorporated, 52 S. Palm Ave., Sarasota, Florida 33577.

SHORTCUTS TO Success! Highly Effective. Profitable Short Courses (75 Choices). Study At Home. Diploma Awarded. Our 29th Year. Free Literature. CIEE-D, Box 20345, Jackson, Miss. 39209.

F.C.C. EXAM MANUAL

Tests Answers for FCC First and Second Class Commercial License

PASS FCC EXAMS! Memorize, study — "Test Answers" for FCC 1st and 2nd class Radio Telephone Licenses. Newly revised multiple-choice questions and diagrams cover all areas tested in FCC exams plus "Self-Study Ability Test." \$9.95 postpaid. Moneyback Guarantee.

COMMAND PRODUCTIONS P.O. BOX 26348-P
RADIO ENGINEERING DIVISION SAN FRANCISCO, CALIF. 94126

DEGREE Program in Electronics Engineering. Our 29th Year! Free literature. Cook's Institute, Dept. 13, Box 20345, Jackson, Miss. 39209.

DIGITAL THEORY DESIGN & CONSTRUCTION

LOGIC NEWSLETTER

SAMPLE COPY \$1.00
LOGIC NEWSLETTER
POB 252
WALDWICK, N.J. 07463

<p>TEKTRONIX 321A PORTABLE ALL-TRANSISTORIZED 3" 5MHZ TRIGGERED SCOPES WITH 10:1 PROBE \$495.00</p> <p>MINIATURE TRIM POTS 5K, 10K, 25K, 50K, 100K \$.75 EA. 3/\$2.00</p> <p>MULTI-TURN TRIM POTS Similar to Bourns 3010 style 3/16" x 3/8" x 1/4" 50, 100, 500, 2000, 5000, 10,000 ohms. \$1.50 ea. 3/\$4.00</p> <p>PRINTED CIRCUIT BOARD 4 1/2" x 6 1/2" single sided fiber glass board, 1/16" thick, un- etched \$.40 ea. 5/\$1.75</p> <p>NIXIE TUBES Similar to Raytheon 8650 tubes, with socket & data sheet \$2.25 3/\$6.00</p> <p>FPA-711 — THESE PHOTO DIODE ARRAYS ARE USED TO READ SEVEN LEVEL TAPE 100 ma SPACING \$5.95</p> <p>TIS 73 N FET \$5.50 2N4891 UJT \$5.50 ER900 TRIGGER DIODES 4/51.00 2N6027 PROG. UJT \$2.75</p> <p>VERIPAX PC BOARD This board is a 1/16" single sided paper epoxy board, 4 1/2" x 6 1/2" (standard veripax). DRILLED and ETCHED which will hold up to 21 single 14 pin IC's or 8, 16 or LSI DIP IC's with busses for power supply con- nections. Is also etched for 22 pin connector \$5.25</p> <p>FLV 100 VISIBLE LED \$5.50 ME-4 IR LED \$4.00 MCD-2 OPTO-ISOL \$9.90 GREEN GAP OSL-16 LED \$6.90 RED GAP OSL-3 LED \$4.40 14 PIN DIP SOCKETS \$4.40 16 PIN DIP SOCKETS \$5.50</p> <p>10 WATT ZENERS 3.9, 4.7 OR 5.6 V \$7.5 EA 4 WATT ZENERS 3.9, 5.6, 6.8 OR 12 V \$3.0 EA</p> <p>Silicon Power Rectifiers</p> <table border="1" style="width: 100%; font-size: x-small;"> <tr><th>PRV</th><th>1A</th><th>3A</th><th>12A</th><th>50A</th></tr> <tr><td>100</td><td>.06</td><td>.11</td><td>.30</td><td>.80</td></tr> <tr><td>200</td><td>.07</td><td>.16</td><td>.35</td><td>1.15</td></tr> <tr><td>400</td><td>.09</td><td>.20</td><td>.50</td><td>1.40</td></tr> <tr><td>600</td><td>.11</td><td>.25</td><td>.70</td><td>1.80</td></tr> <tr><td>800</td><td>.15</td><td>.35</td><td>.90</td><td>2.20</td></tr> <tr><td>000</td><td>.20</td><td>.45</td><td>1.10</td><td>2.60</td></tr> </table> <p>REGULATED MODULAR POWER SUPPLIES + -15VDC AT 100 ma, 115VAC INPUT \$19.95 5VDC AT 1A, 115VAC INPUT \$19.95</p> <p>IN 4148 14/\$1.00</p> <p>Terms: FOB Cambridge Mass. Send check or Money Order. Include Postage. Minimum Order \$3.00</p> <p>Send 20c for our catalog featuring Transistors and Rectifiers;</p>	PRV	1A	3A	12A	50A	100	.06	.11	.30	.80	200	.07	.16	.35	1.15	400	.09	.20	.50	1.40	600	.11	.25	.70	1.80	800	.15	.35	.90	2.20	000	.20	.45	1.10	2.60	<p>TRANSISTOR SPECIALS</p> <table border="1" style="width: 100%; font-size: x-small;"> <tr><td>2N256 PNP GE TO-3</td><td>\$.50</td></tr> <tr><td>2N404 PNP GE TO-3</td><td>4/\$1.00</td></tr> <tr><td>2N1137B PNP GE TO-3</td><td>\$.95</td></tr> <tr><td>2N1016A PNP Si TO-82</td><td>\$ 1.95</td></tr> <tr><td>2N2226 NPN Si TO-82</td><td>\$ 2.50</td></tr> <tr><td>MPS3393 NPN Si TO-92</td><td>4/\$1.00</td></tr> <tr><td>2N3866 NPN Si TO-5</td><td>\$.75</td></tr> <tr><td>2N2369 NPN Si TO-18</td><td>5/\$1.00</td></tr> <tr><td>2N3767 NPN Si TO-66</td><td>\$.70</td></tr> <tr><td>2N2222 NPN Si TO-18</td><td>5/\$1.00</td></tr> <tr><td>2N3055 NPN Si TO-3</td><td>\$ 1.00</td></tr> <tr><td>2N5296 NPN Si TO-220</td><td>\$.50</td></tr> <tr><td>2N6109 PNP Si TO-220</td><td>\$.55</td></tr> <tr><td>2N4898 PNP Si TO-66</td><td>\$.60</td></tr> <tr><td>MJ2252 NPN Si TO-66</td><td>\$.90</td></tr> <tr><td>2N3638 PNP Si TO-5</td><td>5/\$1.00</td></tr> <tr><td>2N2218A NPN Si TO-5</td><td>4/\$1.00</td></tr> </table> <p>CAPACITORS</p> <table border="1" style="width: 100%; font-size: x-small;"> <tr><td>6V 30UF TANT. 5% 1/4"</td><td>\$1.00</td></tr> <tr><td>20V 4.7UF TANT. 5% 1/4"</td><td>\$1.00</td></tr> <tr><td>12V 10UF ELECT. 5% 1/4"</td><td>\$1.00</td></tr> <tr><td>50V 100UF ELECT. 4.0 1/4"</td><td>\$1.00</td></tr> <tr><td>25V 30UF ELECT. 4.0 1/4"</td><td>\$1.00</td></tr> </table> <p>MAN-1, RED OR YELLOW</p> <table border="1" style="width: 100%; font-size: x-small;"> <tr><td>LED READOUT \$2.50</td><td>PRV</td><td>2A</td><td>6A</td><td>25A</td></tr> <tr><td>MAN-3 READOUTS \$1.75</td><td>200</td><td>95</td><td>1.25</td><td>4.00</td></tr> <tr><td>MAN-4 READOUTS \$2.00</td><td>400</td><td>1.15</td><td>1.50</td><td>5.00</td></tr> <tr><td></td><td>600</td><td>1.35</td><td>1.75</td><td>6.00</td></tr> </table> <p>Full Wave Bridges</p> <table border="1" style="width: 100%; font-size: x-small;"> <tr><td>5311-CLOCK CHIP 6 DIGIT BCD HOLD COUNT, OUTPUT STROBE</td><td>\$8.50</td></tr> <tr><td>5314-CLOCK CHIP 6 DIGIT HOLD COUNT, OUTPUT STROBE</td><td>\$8.50</td></tr> <tr><td>5316-ALARM CLOCK CHIP</td><td>\$12.50</td></tr> </table> <p>1103 1024 bit RAM \$4.75 NEC 6003 2048 bit RAM \$9.50 1101 256 bit RAM \$1.75 8225 64 bit-write RAM \$2.75 8223 PROGRAMMABLE ROM \$4.75</p> <p>Conductive Elastometer low profile calculator keyboard. A 2 3/4" x 3 3/4" x 1/2" flex key. 19SK-6 keyboard having 0-9, ., +, -, *, /, =, K+C buttons with off. on switch. \$6.00</p> <p>TTL IC SERIES</p> <table border="1" style="width: 100%; font-size: x-small;"> <tr><td>74L00-30</td><td>7476-47</td></tr> <tr><td>7400-18</td><td>7480-65</td></tr> <tr><td>7401-18</td><td>7483-1.10</td></tr> <tr><td>7402-18</td><td>7485-1.30</td></tr> <tr><td>7403-18</td><td>7486-48</td></tr> <tr><td>7404-22</td><td>7489-2.75</td></tr> <tr><td>7405-22</td><td>7490-75</td></tr> <tr><td>7406-37</td><td>7491-1.30</td></tr> <tr><td>7407-37</td><td>7492-75</td></tr> <tr><td>7408-24</td><td>7493-75</td></tr> <tr><td>7410-18</td><td>7495-99</td></tr> <tr><td>7411-30</td><td>7496-95</td></tr> <tr><td>7412-45</td><td>8220-1.50</td></tr> <tr><td>7413-75</td><td>74107-50</td></tr> <tr><td>7416-37</td><td>74121-60</td></tr> <tr><td>7417-37</td><td>74123-1.00</td></tr> <tr><td>7420-18</td><td>74125-1.40</td></tr> <tr><td>7426-30</td><td>74126-1.40</td></tr> <tr><td>7427-33</td><td>74150-1.15</td></tr> <tr><td>7430-18</td><td>74151-95</td></tr> <tr><td>7432-30</td><td>74153-1.10</td></tr> <tr><td>7437-44</td><td>74154-1.65</td></tr> <tr><td>7438-37</td><td>74157-1.25</td></tr> <tr><td>7440-21</td><td>74163-1.60</td></tr> <tr><td>7441-05</td><td>74164-2.05</td></tr> <tr><td>7442-100</td><td>74165-2.05</td></tr> <tr><td>7445-1.10</td><td>74173-1.80</td></tr> <tr><td>7446-1.15</td><td>74176-1.80</td></tr> <tr><td>7447-1.15</td><td>74177-1.80</td></tr> <tr><td>7448-1.20</td><td>74181-3.60</td></tr> <tr><td>7450-18</td><td>74192-1.50</td></tr> <tr><td>7472-40</td><td>74193-1.45</td></tr> <tr><td>7473-43</td><td>74195-1.00</td></tr> <tr><td>7474-43</td><td>75491-1.10</td></tr> <tr><td>7475-75</td><td></td></tr> </table> <p>Similar to 8038C IC Voltage controlled oscillator, as featured in Oct. 73 P.E. they have sine, square and triangular outputs good to 1MHz. Two of them can be used to make an FM generator...\$4.95</p> <p>TRIACS</p> <table border="1" style="width: 100%; font-size: x-small;"> <tr><th>PRV</th><th>1A</th><th>10A</th><th>25A</th><th>1.5A</th><th>6A</th><th>35A</th></tr> <tr><td>100</td><td>.40</td><td>.70</td><td>1.30</td><td>.40</td><td>.50</td><td>1.20</td></tr> <tr><td>200</td><td>.70</td><td>1.10</td><td>1.75</td><td>.60</td><td>.70</td><td>1.60</td></tr> <tr><td>400</td><td>1.10</td><td>1.60</td><td>2.60</td><td>1.00</td><td>2.0</td><td>2.20</td></tr> <tr><td>600</td><td>1.70</td><td>2.30</td><td>3.00</td><td></td><td></td><td>3.00</td></tr> </table> <p>SCR'S</p> <table border="1" style="width: 100%; font-size: x-small;"> <tr><th>PRV</th><th>1A</th><th>10A</th><th>25A</th><th>1.5A</th><th>6A</th><th>35A</th></tr> <tr><td>100</td><td>.40</td><td>.70</td><td>1.30</td><td>.40</td><td>.50</td><td>1.20</td></tr> <tr><td>200</td><td>.70</td><td>1.10</td><td>1.75</td><td>.60</td><td>.70</td><td>1.60</td></tr> <tr><td>400</td><td>1.10</td><td>1.60</td><td>2.60</td><td>1.00</td><td>2.0</td><td>2.20</td></tr> <tr><td>600</td><td>1.70</td><td>2.30</td><td>3.00</td><td></td><td></td><td>3.00</td></tr> </table> <p>145 NORFOLK ST. Cambridge, Mass.</p>	2N256 PNP GE TO-3	\$.50	2N404 PNP GE TO-3	4/\$1.00	2N1137B PNP GE TO-3	\$.95	2N1016A PNP Si TO-82	\$ 1.95	2N2226 NPN Si TO-82	\$ 2.50	MPS3393 NPN Si TO-92	4/\$1.00	2N3866 NPN Si TO-5	\$.75	2N2369 NPN Si TO-18	5/\$1.00	2N3767 NPN Si TO-66	\$.70	2N2222 NPN Si TO-18	5/\$1.00	2N3055 NPN Si TO-3	\$ 1.00	2N5296 NPN Si TO-220	\$.50	2N6109 PNP Si TO-220	\$.55	2N4898 PNP Si TO-66	\$.60	MJ2252 NPN Si TO-66	\$.90	2N3638 PNP Si TO-5	5/\$1.00	2N2218A NPN Si TO-5	4/\$1.00	6V 30UF TANT. 5% 1/4"	\$1.00	20V 4.7UF TANT. 5% 1/4"	\$1.00	12V 10UF ELECT. 5% 1/4"	\$1.00	50V 100UF ELECT. 4.0 1/4"	\$1.00	25V 30UF ELECT. 4.0 1/4"	\$1.00	LED READOUT \$2.50	PRV	2A	6A	25A	MAN-3 READOUTS \$1.75	200	95	1.25	4.00	MAN-4 READOUTS \$2.00	400	1.15	1.50	5.00		600	1.35	1.75	6.00	5311-CLOCK CHIP 6 DIGIT BCD HOLD COUNT, OUTPUT STROBE	\$8.50	5314-CLOCK CHIP 6 DIGIT HOLD COUNT, OUTPUT STROBE	\$8.50	5316-ALARM CLOCK CHIP	\$12.50	74L00-30	7476-47	7400-18	7480-65	7401-18	7483-1.10	7402-18	7485-1.30	7403-18	7486-48	7404-22	7489-2.75	7405-22	7490-75	7406-37	7491-1.30	7407-37	7492-75	7408-24	7493-75	7410-18	7495-99	7411-30	7496-95	7412-45	8220-1.50	7413-75	74107-50	7416-37	74121-60	7417-37	74123-1.00	7420-18	74125-1.40	7426-30	74126-1.40	7427-33	74150-1.15	7430-18	74151-95	7432-30	74153-1.10	7437-44	74154-1.65	7438-37	74157-1.25	7440-21	74163-1.60	7441-05	74164-2.05	7442-100	74165-2.05	7445-1.10	74173-1.80	7446-1.15	74176-1.80	7447-1.15	74177-1.80	7448-1.20	74181-3.60	7450-18	74192-1.50	7472-40	74193-1.45	7473-43	74195-1.00	7474-43	75491-1.10	7475-75		PRV	1A	10A	25A	1.5A	6A	35A	100	.40	.70	1.30	.40	.50	1.20	200	.70	1.10	1.75	.60	.70	1.60	400	1.10	1.60	2.60	1.00	2.0	2.20	600	1.70	2.30	3.00			3.00	PRV	1A	10A	25A	1.5A	6A	35A	100	.40	.70	1.30	.40	.50	1.20	200	.70	1.10	1.75	.60	.70	1.60	400	1.10	1.60	2.60	1.00	2.0	2.20	600	1.70	2.30	3.00			3.00	<p>C/MOS (DIODE CLAMPED)</p> <table border="1" style="width: 100%; font-size: x-small;"> <tr><td>74C 02</td><td>\$.55</td></tr> <tr><td>74C 10</td><td>\$.60</td></tr> <tr><td>74C 157</td><td>\$ 2.15</td></tr> <tr><td>74C 165</td><td>\$ 3.50</td></tr> <tr><td>CD 4001</td><td>\$.55</td></tr> <tr><td>CD 4002</td><td>\$.65</td></tr> <tr><td>CD 4009</td><td>\$.80</td></tr> <tr><td>CD 4010</td><td>\$.65</td></tr> <tr><td>CD 4011</td><td>\$.55</td></tr> <tr><td>CD 4012</td><td>\$.55</td></tr> <tr><td>CD 4013</td><td>\$ 1.20</td></tr> <tr><td>CD 4016</td><td>\$ 1.25</td></tr> <tr><td>CD 4022</td><td>\$ 2.25</td></tr> <tr><td>CD 4023</td><td>\$.55</td></tr> <tr><td>CD 4025</td><td>\$.55</td></tr> <tr><td>CD 4027</td><td>\$ 1.35</td></tr> <tr><td>CD 4030</td><td>\$.65</td></tr> </table> <p>2513-64, 7 x 5 CHARACTER GEN \$11.50 5116-64 x 6 x 8 STATIC CHARACTER GEN \$11.50</p> <p>SANKEN AUDIO POWER AMPS</p> <table border="1" style="width: 100%; font-size: x-small;"> <tr><td>SI 1010 Y 10 WATTS</td><td>\$ 7.95</td></tr> <tr><td>SI 1025 E 25 WATTS</td><td>\$ 18.88</td></tr> <tr><td>SI 1050 E 50 WATTS</td><td>\$ 29.95</td></tr> </table> <p>LINEAR CIRCUITS</p> <table border="1" style="width: 100%; font-size: x-small;"> <tr><td>LM 309K 5V +1A REGULATOR</td><td>\$1.65</td></tr> <tr><td>723-40 +40V REGULATOR</td><td>\$5.58</td></tr> <tr><td>301748-Hi Per. Op. Amp</td><td>\$3.35</td></tr> <tr><td>LM 320-5 or -15V REGULATOR</td><td>\$1.75</td></tr> <tr><td>LM 376-+10 37V PDS REG.</td><td>\$5.58</td></tr> <tr><td>741A or 741C OP. AMP.</td><td>\$3.35</td></tr> <tr><td>709C DPER AMP.</td><td>\$2.29</td></tr> <tr><td>340T-5, 12, 15, 18, 24V POS. REG. TO-220</td><td>\$1.75</td></tr> <tr><td>101 DPER AMP., HI PERFORM</td><td>\$7.75</td></tr> <tr><td>LM 308 OPER. AMP., LOW POWER</td><td>\$1.05</td></tr> <tr><td>747-DUAL 741</td><td>\$7.75</td></tr> <tr><td>566-FET INPUT DPER AMP</td><td>\$2.60</td></tr> <tr><td>537-PRECISION OP AMP</td><td>\$2.60</td></tr> <tr><td>LM 3900-QUAD OP. AMP.</td><td>\$5.58</td></tr> <tr><td>LM 324-QUAO 741</td><td>\$2.20</td></tr> <tr><td>560-PHASE LOCK LOOP</td><td>\$2.60</td></tr> <tr><td>561-PHASE LOCK LOOP</td><td>\$2.60</td></tr> <tr><td>565-PHASE LOCK LOOP</td><td>\$2.60</td></tr> <tr><td>567-TONE DECOUER</td><td>\$2.95</td></tr> <tr><td>703-RF AMP.</td><td>\$5.58</td></tr> <tr><td>LM 370-AGC SQUELCH AMP</td><td>\$11.15</td></tr> <tr><td>555-2 us - 2 HR TIMER</td><td>\$9.98</td></tr> <tr><td>3822-TRANSISTOR ARRAY</td><td>\$9.95</td></tr> <tr><td>LM 380-2W AUDIO AMP.</td><td>\$1.45</td></tr> <tr><td>LM 377-2W STEREO AUDIO AMP</td><td>\$2.60</td></tr> <tr><td>LM 381-STEREO PREAMP</td><td>\$1.75</td></tr> <tr><td>LM 382-DUAL AUDIO PREAMP</td><td>\$1.75</td></tr> <tr><td>LM 311-HI PER. COMPARATOR</td><td>\$9.95</td></tr> <tr><td>LM 313-DUAL HI SPEED COMP</td><td>\$1.25</td></tr> <tr><td>LM 339-QUAD COMPARATOR</td><td>\$1.65</td></tr> </table>	74C 02	\$.55	74C 10	\$.60	74C 157	\$ 2.15	74C 165	\$ 3.50	CD 4001	\$.55	CD 4002	\$.65	CD 4009	\$.80	CD 4010	\$.65	CD 4011	\$.55	CD 4012	\$.55	CD 4013	\$ 1.20	CD 4016	\$ 1.25	CD 4022	\$ 2.25	CD 4023	\$.55	CD 4025	\$.55	CD 4027	\$ 1.35	CD 4030	\$.65	SI 1010 Y 10 WATTS	\$ 7.95	SI 1025 E 25 WATTS	\$ 18.88	SI 1050 E 50 WATTS	\$ 29.95	LM 309K 5V +1A REGULATOR	\$1.65	723-40 +40V REGULATOR	\$5.58	301748-Hi Per. Op. Amp	\$3.35	LM 320-5 or -15V REGULATOR	\$1.75	LM 376-+10 37V PDS REG.	\$5.58	741A or 741C OP. AMP.	\$3.35	709C DPER AMP.	\$2.29	340T-5, 12, 15, 18, 24V POS. REG. TO-220	\$1.75	101 DPER AMP., HI PERFORM	\$7.75	LM 308 OPER. AMP., LOW POWER	\$1.05	747-DUAL 741	\$7.75	566-FET INPUT DPER AMP	\$2.60	537-PRECISION OP AMP	\$2.60	LM 3900-QUAD OP. AMP.	\$5.58	LM 324-QUAO 741	\$2.20	560-PHASE LOCK LOOP	\$2.60	561-PHASE LOCK LOOP	\$2.60	565-PHASE LOCK LOOP	\$2.60	567-TONE DECOUER	\$2.95	703-RF AMP.	\$5.58	LM 370-AGC SQUELCH AMP	\$11.15	555-2 us - 2 HR TIMER	\$9.98	3822-TRANSISTOR ARRAY	\$9.95	LM 380-2W AUDIO AMP.	\$1.45	LM 377-2W STEREO AUDIO AMP	\$2.60	LM 381-STEREO PREAMP	\$1.75	LM 382-DUAL AUDIO PREAMP	\$1.75	LM 311-HI PER. COMPARATOR	\$9.95	LM 313-DUAL HI SPEED COMP	\$1.25	LM 339-QUAD COMPARATOR	\$1.65
PRV	1A	3A	12A	50A																																																																																																																																																																																																																																																																																																																																																							
100	.06	.11	.30	.80																																																																																																																																																																																																																																																																																																																																																							
200	.07	.16	.35	1.15																																																																																																																																																																																																																																																																																																																																																							
400	.09	.20	.50	1.40																																																																																																																																																																																																																																																																																																																																																							
600	.11	.25	.70	1.80																																																																																																																																																																																																																																																																																																																																																							
800	.15	.35	.90	2.20																																																																																																																																																																																																																																																																																																																																																							
000	.20	.45	1.10	2.60																																																																																																																																																																																																																																																																																																																																																							
2N256 PNP GE TO-3	\$.50																																																																																																																																																																																																																																																																																																																																																										
2N404 PNP GE TO-3	4/\$1.00																																																																																																																																																																																																																																																																																																																																																										
2N1137B PNP GE TO-3	\$.95																																																																																																																																																																																																																																																																																																																																																										
2N1016A PNP Si TO-82	\$ 1.95																																																																																																																																																																																																																																																																																																																																																										
2N2226 NPN Si TO-82	\$ 2.50																																																																																																																																																																																																																																																																																																																																																										
MPS3393 NPN Si TO-92	4/\$1.00																																																																																																																																																																																																																																																																																																																																																										
2N3866 NPN Si TO-5	\$.75																																																																																																																																																																																																																																																																																																																																																										
2N2369 NPN Si TO-18	5/\$1.00																																																																																																																																																																																																																																																																																																																																																										
2N3767 NPN Si TO-66	\$.70																																																																																																																																																																																																																																																																																																																																																										
2N2222 NPN Si TO-18	5/\$1.00																																																																																																																																																																																																																																																																																																																																																										
2N3055 NPN Si TO-3	\$ 1.00																																																																																																																																																																																																																																																																																																																																																										
2N5296 NPN Si TO-220	\$.50																																																																																																																																																																																																																																																																																																																																																										
2N6109 PNP Si TO-220	\$.55																																																																																																																																																																																																																																																																																																																																																										
2N4898 PNP Si TO-66	\$.60																																																																																																																																																																																																																																																																																																																																																										
MJ2252 NPN Si TO-66	\$.90																																																																																																																																																																																																																																																																																																																																																										
2N3638 PNP Si TO-5	5/\$1.00																																																																																																																																																																																																																																																																																																																																																										
2N2218A NPN Si TO-5	4/\$1.00																																																																																																																																																																																																																																																																																																																																																										
6V 30UF TANT. 5% 1/4"	\$1.00																																																																																																																																																																																																																																																																																																																																																										
20V 4.7UF TANT. 5% 1/4"	\$1.00																																																																																																																																																																																																																																																																																																																																																										
12V 10UF ELECT. 5% 1/4"	\$1.00																																																																																																																																																																																																																																																																																																																																																										
50V 100UF ELECT. 4.0 1/4"	\$1.00																																																																																																																																																																																																																																																																																																																																																										
25V 30UF ELECT. 4.0 1/4"	\$1.00																																																																																																																																																																																																																																																																																																																																																										
LED READOUT \$2.50	PRV	2A	6A	25A																																																																																																																																																																																																																																																																																																																																																							
MAN-3 READOUTS \$1.75	200	95	1.25	4.00																																																																																																																																																																																																																																																																																																																																																							
MAN-4 READOUTS \$2.00	400	1.15	1.50	5.00																																																																																																																																																																																																																																																																																																																																																							
	600	1.35	1.75	6.00																																																																																																																																																																																																																																																																																																																																																							
5311-CLOCK CHIP 6 DIGIT BCD HOLD COUNT, OUTPUT STROBE	\$8.50																																																																																																																																																																																																																																																																																																																																																										
5314-CLOCK CHIP 6 DIGIT HOLD COUNT, OUTPUT STROBE	\$8.50																																																																																																																																																																																																																																																																																																																																																										
5316-ALARM CLOCK CHIP	\$12.50																																																																																																																																																																																																																																																																																																																																																										
74L00-30	7476-47																																																																																																																																																																																																																																																																																																																																																										
7400-18	7480-65																																																																																																																																																																																																																																																																																																																																																										
7401-18	7483-1.10																																																																																																																																																																																																																																																																																																																																																										
7402-18	7485-1.30																																																																																																																																																																																																																																																																																																																																																										
7403-18	7486-48																																																																																																																																																																																																																																																																																																																																																										
7404-22	7489-2.75																																																																																																																																																																																																																																																																																																																																																										
7405-22	7490-75																																																																																																																																																																																																																																																																																																																																																										
7406-37	7491-1.30																																																																																																																																																																																																																																																																																																																																																										
7407-37	7492-75																																																																																																																																																																																																																																																																																																																																																										
7408-24	7493-75																																																																																																																																																																																																																																																																																																																																																										
7410-18	7495-99																																																																																																																																																																																																																																																																																																																																																										
7411-30	7496-95																																																																																																																																																																																																																																																																																																																																																										
7412-45	8220-1.50																																																																																																																																																																																																																																																																																																																																																										
7413-75	74107-50																																																																																																																																																																																																																																																																																																																																																										
7416-37	74121-60																																																																																																																																																																																																																																																																																																																																																										
7417-37	74123-1.00																																																																																																																																																																																																																																																																																																																																																										
7420-18	74125-1.40																																																																																																																																																																																																																																																																																																																																																										
7426-30	74126-1.40																																																																																																																																																																																																																																																																																																																																																										
7427-33	74150-1.15																																																																																																																																																																																																																																																																																																																																																										
7430-18	74151-95																																																																																																																																																																																																																																																																																																																																																										
7432-30	74153-1.10																																																																																																																																																																																																																																																																																																																																																										
7437-44	74154-1.65																																																																																																																																																																																																																																																																																																																																																										
7438-37	74157-1.25																																																																																																																																																																																																																																																																																																																																																										
7440-21	74163-1.60																																																																																																																																																																																																																																																																																																																																																										
7441-05	74164-2.05																																																																																																																																																																																																																																																																																																																																																										
7442-100	74165-2.05																																																																																																																																																																																																																																																																																																																																																										
7445-1.10	74173-1.80																																																																																																																																																																																																																																																																																																																																																										
7446-1.15	74176-1.80																																																																																																																																																																																																																																																																																																																																																										
7447-1.15	74177-1.80																																																																																																																																																																																																																																																																																																																																																										
7448-1.20	74181-3.60																																																																																																																																																																																																																																																																																																																																																										
7450-18	74192-1.50																																																																																																																																																																																																																																																																																																																																																										
7472-40	74193-1.45																																																																																																																																																																																																																																																																																																																																																										
7473-43	74195-1.00																																																																																																																																																																																																																																																																																																																																																										
7474-43	75491-1.10																																																																																																																																																																																																																																																																																																																																																										
7475-75																																																																																																																																																																																																																																																																																																																																																											
PRV	1A	10A	25A	1.5A	6A	35A																																																																																																																																																																																																																																																																																																																																																					
100	.40	.70	1.30	.40	.50	1.20																																																																																																																																																																																																																																																																																																																																																					
200	.70	1.10	1.75	.60	.70	1.60																																																																																																																																																																																																																																																																																																																																																					
400	1.10	1.60	2.60	1.00	2.0	2.20																																																																																																																																																																																																																																																																																																																																																					
600	1.70	2.30	3.00			3.00																																																																																																																																																																																																																																																																																																																																																					
PRV	1A	10A	25A	1.5A	6A	35A																																																																																																																																																																																																																																																																																																																																																					
100	.40	.70	1.30	.40	.50	1.20																																																																																																																																																																																																																																																																																																																																																					
200	.70	1.10	1.75	.60	.70	1.60																																																																																																																																																																																																																																																																																																																																																					
400	1.10	1.60	2.60	1.00	2.0	2.20																																																																																																																																																																																																																																																																																																																																																					
600	1.70	2.30	3.00			3.00																																																																																																																																																																																																																																																																																																																																																					
74C 02	\$.55																																																																																																																																																																																																																																																																																																																																																										
74C 10	\$.60																																																																																																																																																																																																																																																																																																																																																										
74C 157	\$ 2.15																																																																																																																																																																																																																																																																																																																																																										
74C 165	\$ 3.50																																																																																																																																																																																																																																																																																																																																																										
CD 4001	\$.55																																																																																																																																																																																																																																																																																																																																																										
CD 4002	\$.65																																																																																																																																																																																																																																																																																																																																																										
CD 4009	\$.80																																																																																																																																																																																																																																																																																																																																																										
CD 4010	\$.65																																																																																																																																																																																																																																																																																																																																																										
CD 4011	\$.55																																																																																																																																																																																																																																																																																																																																																										
CD 4012	\$.55																																																																																																																																																																																																																																																																																																																																																										
CD 4013	\$ 1.20																																																																																																																																																																																																																																																																																																																																																										
CD 4016	\$ 1.25																																																																																																																																																																																																																																																																																																																																																										
CD 4022	\$ 2.25																																																																																																																																																																																																																																																																																																																																																										
CD 4023	\$.55																																																																																																																																																																																																																																																																																																																																																										
CD 4025	\$.55																																																																																																																																																																																																																																																																																																																																																										
CD 4027	\$ 1.35																																																																																																																																																																																																																																																																																																																																																										
CD 4030	\$.65																																																																																																																																																																																																																																																																																																																																																										
SI 1010 Y 10 WATTS	\$ 7.95																																																																																																																																																																																																																																																																																																																																																										
SI 1025 E 25 WATTS	\$ 18.88																																																																																																																																																																																																																																																																																																																																																										
SI 1050 E 50 WATTS	\$ 29.95																																																																																																																																																																																																																																																																																																																																																										
LM 309K 5V +1A REGULATOR	\$1.65																																																																																																																																																																																																																																																																																																																																																										
723-40 +40V REGULATOR	\$5.58																																																																																																																																																																																																																																																																																																																																																										
301748-Hi Per. Op. Amp	\$3.35																																																																																																																																																																																																																																																																																																																																																										
LM 320-5 or -15V REGULATOR	\$1.75																																																																																																																																																																																																																																																																																																																																																										
LM 376-+10 37V PDS REG.	\$5.58																																																																																																																																																																																																																																																																																																																																																										
741A or 741C OP. AMP.	\$3.35																																																																																																																																																																																																																																																																																																																																																										
709C DPER AMP.	\$2.29																																																																																																																																																																																																																																																																																																																																																										
340T-5, 12, 15, 18, 24V POS. REG. TO-220	\$1.75																																																																																																																																																																																																																																																																																																																																																										
101 DPER AMP., HI PERFORM	\$7.75																																																																																																																																																																																																																																																																																																																																																										
LM 308 OPER. AMP., LOW POWER	\$1.05																																																																																																																																																																																																																																																																																																																																																										
747-DUAL 741	\$7.75																																																																																																																																																																																																																																																																																																																																																										
566-FET INPUT DPER AMP	\$2.60																																																																																																																																																																																																																																																																																																																																																										
537-PRECISION OP AMP	\$2.60																																																																																																																																																																																																																																																																																																																																																										
LM 3900-QUAD OP. AMP.	\$5.58																																																																																																																																																																																																																																																																																																																																																										
LM 324-QUAO 741	\$2.20																																																																																																																																																																																																																																																																																																																																																										
560-PHASE LOCK LOOP	\$2.60																																																																																																																																																																																																																																																																																																																																																										
561-PHASE LOCK LOOP	\$2.60																																																																																																																																																																																																																																																																																																																																																										
565-PHASE LOCK LOOP	\$2.60																																																																																																																																																																																																																																																																																																																																																										
567-TONE DECOUER	\$2.95																																																																																																																																																																																																																																																																																																																																																										
703-RF AMP.	\$5.58																																																																																																																																																																																																																																																																																																																																																										
LM 370-AGC SQUELCH AMP	\$11.15																																																																																																																																																																																																																																																																																																																																																										
555-2 us - 2 HR TIMER	\$9.98																																																																																																																																																																																																																																																																																																																																																										
3822-TRANSISTOR ARRAY	\$9.95																																																																																																																																																																																																																																																																																																																																																										
LM 380-2W AUDIO AMP.	\$1.45																																																																																																																																																																																																																																																																																																																																																										
LM 377-2W STEREO AUDIO AMP	\$2.60																																																																																																																																																																																																																																																																																																																																																										
LM 381-STEREO PREAMP	\$1.75																																																																																																																																																																																																																																																																																																																																																										
LM 382-DUAL AUDIO PREAMP	\$1.75																																																																																																																																																																																																																																																																																																																																																										
LM 311-HI PER. COMPARATOR	\$9.95																																																																																																																																																																																																																																																																																																																																																										
LM 313-DUAL HI SPEED COMP	\$1.25																																																																																																																																																																																																																																																																																																																																																										
LM 339-QUAD COMPARATOR	\$1.65																																																																																																																																																																																																																																																																																																																																																										

SCORE high on F.C.C. Exams. Over 300 questions and answers. Covers 3rd, 2nd, 1st and even Radar. Third and Second Test. \$14.50; First Class Test. \$15.00. All tests. \$26.50. R.E.I., Inc., Box 806, Sarasota, Fla. 33577.

LEARN design techniques. Electronics Monthly Newsletter. Digital, linear construction projects, design theory and procedures. Sample copy \$1.00. Valley West, Box 2119-B, Sunnyvale, California 94087.

FCC LICENSE through tape recorded lessons. Also Radar Endorsement. Radio License Training, 1060D Duncan, Manhattan Beach, Calif. 90266.

LEARN ELECTRONICS at home. FCC license, Communications Electronics, Satellite Communications. Free Catalog. Genn. 5540 Hollywood BV., Los Angeles, CA 90028.

MUSICAL INSTRUMENTS

30% DISCOUNT name brand musical instruments. Free Catalog. Freeport Music, 455N. Route 110, Melville, N.Y. 11746.

WHOLESALE! Professional Guitars. PA Systems. Altec Speakers, 240W RMS Amplifiers. Free Catalog. Carvin, Escondido, Calif. 92028.

30% + DISCOUNT. Name Brand Musical Instruments. Free Catalog. Continental Music, Dept. H, P.O. Box 3001, Garden City, New York 11530.

SPECIAL interest records available, produced by the editors of the world's leading special interest magazines. Send for free catalog. Record Catalog, CL, Ziff-Davis Publishing Co., One Park Avenue, New York, N.Y. 10016.

BUSINESS OPPORTUNITIES

MADE \$40,000.00 Year by Mailorder! Helped others make money! Free Proof. Torrey, Box 318-NN, Ypsilanti, Michigan 48197.

FREE CATALOGS. Repair air conditioning, refrigeration. Tools, supplies, full instructions. Doolin, 2016 Canton, Dallas, Texas 75201.

MAILORDER MILLIONAIRE helps beginners make \$500 weekly. Free report reveals secret plan! Executive (1K11), 333 North Michigan, Chicago 60601.

PIANO TUNING LEARNED QUICKLY AT HOME! Tremendous field! Musical knowledge unnecessary. GI approved. Information free. Empire School, Box 450327, Miami 33145.

FREE Secret Book "2042 Unique Proven Enterprises." Fabulous "Little Knowns." Work home! Haylings-BH, Carlsbad, California 92008.

\$200.00 DAILY In Your Mailbox! Your opportunity to do what mail-order experts do. Free details. Associates, Box 136-J, Holland, Michigan 49423.

\$178.00 WEEKLY. Work one hour daily. Free brochure. FAS, Box 13703-A, San Antonio TX, 78213.

wanted CITIZENS BAND
DEALER-DISTRIBUTORS

Send this Ad to:
PAL ELECTRONICS CO.
P. O. Box 778 • Westminster, Ca. 92683

EARN \$15,000 annually plus. Full year trial plan Import-Mailorder business. Postcard brings details. Northeast Imports, Box 121PE10, Fremont, N.H. 03044.

HOW TO SELL BOOKS BY MAIL. FREE INFORMATION. McCord, Box 276-D, SYLVANIA, OHIO 43560.

\$1,000 MONTH Mailorder. Send Stamp. Fiddes, Box 1242F, Glen Burnie, MD 21061.

OPPORTUNITY PACKAGE! Three amazing business plans. Free details: Gray Bros., 4830 So. 137 St., Suite 72U-11, Omaha, Nebraska 68137.

EARN UP TO \$500 WEEKLY OR MORE — EASY!

- Now needed — Vinyl Repair Specialists/Dealers!
- Sensational opportunity available! Operate your own profitable business. Write today!

FREE SAMPLE & DETAILS

GT PRODUCTS, INC., Dept. H-K
6156 Mission Gorge Rd.
San Diego, Calif. 92120

ALTAJ ELECTRONIC BARGAINS

CALCULATOR CHIP BONANZA! THREE VERSIONS TO CHOOSE FROM

Never before offered in USA. These are the newest and easiest to use chips available to the hobbyist today. Features: direct segment drive for LED's, low power consumption, single supply voltage, internal encoding of keyboard inputs, internal keyboard debounce, internal clock oscillator. Made by famous US mfg. No one but ALTAJ offers calculator chips with these sophisticated functions. All are 28 Pin DIP. with specs. FLOATING DEC.

CHIP #1 — 8 DIGIT READOUT, CONSTANT, SIX FUNCTION (+, -, x, ÷, %, √) — \$7.95

CHIP #2 — 8 DIGIT READOUT, MEMORY, SIX FUNCTION (+, -, x, ÷, √, π) — \$8.95

CHIP #3 — 8 DIGIT READOUT, MEMORY, SIX FUNCTION (+, -, x, ÷, %, 1/x) — \$8.95

3 DIGIT LED READOUTS

Perfect for use with our calculator chips. 3 MAN-3 Readouts in one DIP. Properly multiplexed. New prime units. Like Litronix DL-33. \$1.25 ea. 3 for \$2.95

PC BOARD SPECIAL #3

Boards from computer eqmt. with the following items: 1-3.600 MHz Oscillator 5 VDC, 2-Monsanto MCT2 Opto Isolator, 4-2N3642 Transistors, 1-2N2646 Unijunction, 2-7400, 1-7402, 1-7404, 2-7408, 1-7410, 1-7438, 1-7474, 2-7476, 1-7486, 3-7490, 1-7492, 3-7493, 1-74164, 1-74165, 1-74180, 1-9601 Plus 17 other DIP IC's. Limited quantity. Special Price — \$4.95

REGULATED DC POWER SUPPLY

Brand new mfg. by WANLASS. Open Style. DC Output 17 to 30 V. Rated 60 watts. Our tests show these units will put out 12 VDC by changing one resistor. Wanlass #OEM60-3. Original cost \$57.50. In original factory boxes, with specs and schematic. Special — \$19.95

JUMBO LED READOUT

.65 in. character. Twice the size of regular readouts. Like Litronix DL747. Outperforms SLA-3. Easy to read. Draws only 20 MA per segment. Perfect for giant digital clocks. \$2.95 ea.

AC LINE CORDS

7 Ft. Black. 2 wire. 4 for \$1

HOBBYIST LINEAR SPECIAL

We bought too many too test. Includes many useable devices. Buy untested and save. LM380 2 watt audio AMP 8 for \$1
LM3900 QUAD OP AMP 8 for \$1
709C OP AMP — 10 for \$1
741C Mini DIP OP AMP 10 for \$1

MINI CORE MEMORY SYSTEM

Mfg. by Dataram. Stores 180 words of 18 bits each. With sense AMP's and associated electronic drive circuits. A complete memory system. We include 50 pages of data and schematics. BRAND NEW — \$24.95 Data Only \$2.50

MALLORY FILTER CAPS

2000MFD 30VDC — 39c SMALL SIZE

SOLID STATE MEMORY ARRAY

Brand new, MFG. by Monolithic Systems Corp. Consists of 16-1101 (256 Bit Ram) and associated drive circuits. Drive circuits include 24 assorted 7400 series devices and various transistors, diodes, etc. Array is mounted on two stacked 6 x 8 in. PC boards. Original cost \$300 ea. With schematic. These are recommended for experienced hobbyists only. Limited quantity — \$29.95 ea.

FACTORY NEW LED'S — SALE!

Jumbo Red-Like MV5024 — 8 for \$1
Jumbo Green-Like MV5222 — 5 for \$1
Mini Red-Like MV50 — 10 for \$1

OPCOA SLA-1 LED READOUT

.33 in. Character. Left DEC. point. Uses 7447 driver. Easier to read than MAN-1 types. Factory prime units \$1.19 ea.

DIGITAL ALARM CLOCK IC

Through a special arrangement with a famous U.S. MFG. we can offer these MOS chips. This is the newest and easiest to use alarm chip on the market today. Features: 1. Single supply voltage
2. Led intensity control
3. Simple time set
4. 4 or 6 digit led display
5. AM-PM indication
6. 24 hr alarm with 10 min. snooze
7. Outperforms MM5316

COMPARE THIS PRICE — \$7.95 ea. WITH SPEC. SHEETS

FAIRCHILD STYLE VOLTAGE REGULATORS

1 AMP Output — Your Choice — \$1.25 Ea.

7805 — 5VDC 7815 — 15VDC
7806 — 6VDC 7818 — 18VDC TO-220
7812 — 12VDC 7824 — 24VDC CASE

RCA STYLE — C-MOS IC'S — NEW!

CD4001 — 44c CD4016 — 89c
CD4002 — 44c CD4020 — 1.49
CD4011 — 44c CD4049 — 49c
CD4013 — 95c

7400 SERIES STYLE — C-MOS

74C04 — 49c 74C83 — 1.25
74C107 — 95c

LM 309K — 95c

1 AMP 5VDC TO-3 Voltage regulator new by national. Prime units.

ALTAJ ELECTRONICS

P.O. BOX 38544
DALLAS, TEXAS 75238

TERMS: Check or M.O. No COD. Add 10% for PSTG and HDLG. Tex. Res. Add 5%

EXCLUSIVE for readers of Popular Electronics

STOP PRESS

FREE DIGITAL CLOCK/CALENDAR KIT!!

With all the options as described at left. FREE with each order totaling \$250.00 or more if postmarked before December 1, 1974. PLEASE ORDER BY CATALOG NUMBER 03-12241.

Dear Customer:

Are you confused with the wide range of prices you see while reading through this or other hobby magazines? Well, allow us to explain! We at Solid State Systems are proud to offer our customers ONLY factory FIRST-RUNS, marked and identified with FULL manufacturer's name and part numbers. We have never purchased a single "reject" or "seconds" unit. The best we know, only one other hobby supplier, also in Mid-West, has the same policy. Most others usually buy below-spec, "functional only" units as scraps at a fraction of the price and therefore are able to offer them at lower prices.

The best test of this, is the fact that in the past three years, we have never offered any "Didn't have a chance to check them all" or "For Experimenter's Only" items for sale in any of our advertisements or Catalogs. So, when shopping for parts, please remember: Manufacturers test all their production units and FACTORY TESTED is NOT the same as FIRST RUN PRIME. Defective units were tested too!

LED'S GET THE 'LED' OUT & SAVE!

The most fantastic prices for 7-Segment and overflow LED displays. These are guaranteed to be BRAND NEW, manufacturer's FIRST RUN, yet thanks to our huge purchasing power, we are able to offer them to you at prices well below what other charges for fail-outs and rejects.

Catalog Number	Description	Character Height	Color	Price
21-00001	DPDPA 31A-1, 7-Segment, 20mA, left decimal	0.33"	Red	1.50
21-00002	DPDPA 31A-2, 7-Segment, 20mA, left decimal	0.33"	Red	1.10
21-10007	DPDPA 31A-1, 7-Segment, 10mA, left decimal	0.33"	Green	1.10
24-01000	DPDPA 31A-1, 7-Segment, 20mA, left decimal	0.33"	Red	1.10
16-00704	DPDPA 31A-1, 7-Segment, 20mA, right decimal	0.33"	Red	1.00
16-00005	DPDPA 31A-1, 7-Segment, 20mA, left decimal	0.33"	Red	1.00

All displays have common anodes except DL-704 which has common cathodes.

INTEGRATED CIRCUITS

Catalog Number	Any Quantity Per (insert 1)				Multiples of 10 (insert 1)				Grouping Code
	1-99	100-999	1000-9999	10000-99999	100-999	1000-9999	10000-99999	100000-999999	
7400	34	32	30	28	26	24	22	20	
7401	34	32	30	28	26	24	22	20	
7402	34	32	30	28	26	24	22	20	
7403	34	32	30	28	26	24	22	20	
7404	36	34	32	30	28	26	24	22	
7405	36	34	32	30	28	26	24	22	
7406	56	53	50	47	44	41	38	35	
7407	56	53	50	47	44	41	38	35	
7408	36	34	32	30	28	26	24	22	
7409	36	34	32	30	28	26	24	22	
7410	34	32	30	28	26	24	22	20	
7411	34	32	30	28	26	24	22	20	
7412	34	32	30	28	26	24	22	20	
7413	60	57	54	51	48	45	42	39	
7414	64	61	58	55	52	49	46	43	
7415	54	51	48	45	42	39	36	33	
7416	34	32	30	28	26	24	22	20	
7417	34	32	30	28	26	24	22	20	
7418	34	32	30	28	26	24	22	20	
7419	34	32	30	28	26	24	22	20	
7420	34	32	30	28	26	24	22	20	
7421	34	32	30	28	26	24	22	20	
7422	34	32	30	28	26	24	22	20	
7423	54	51	48	45	42	39	36	33	
7424	54	51	48	45	42	39	36	33	
7425	54	51	48	45	42	39	36	33	
7426	34	32	30	28	26	24	22	20	
7427	34	32	30	28	26	24	22	20	
7428	34	32	30	28	26	24	22	20	
7429	34	32	30	28	26	24	22	20	
7430	34	32	30	28	26	24	22	20	
7431	34	32	30	28	26	24	22	20	
7432	34	32	30	28	26	24	22	20	
7433	34	32	30	28	26	24	22	20	
7434	34	32	30	28	26	24	22	20	
7435	34	32	30	28	26	24	22	20	
7436	34	32	30	28	26	24	22	20	
7437	34	32	30	28	26	24	22	20	
7438	34	32	30	28	26	24	22	20	
7439	34	32	30	28	26	24	22	20	
7440	34	32	30	28	26	24	22	20	
7441	34	32	30	28	26	24	22	20	
7442	134	127	120	113	106	99	92	85	
7443	134	127	120	113	106	99	92	85	
7444	134	127	120	113	106	99	92	85	
7445	134	127	120	113	106	99	92	85	
7446	134	127	120	113	106	99	92	85	
7447	134	127	120	113	106	99	92	85	
7448	134	127	120	113	106	99	92	85	
7449	134	127	120	113	106	99	92	85	
7450	34	32	30	28	26	24	22	20	
7451	34	32	30	28	26	24	22	20	
7452	34	32	30	28	26	24	22	20	
7453	34	32	30	28	26	24	22	20	
7454	34	32	30	28	26	24	22	20	
7455	34	32	30	28	26	24	22	20	
7456	34	32	30	28	26	24	22	20	
7457	34	32	30	28	26	24	22	20	
7458	34	32	30	28	26	24	22	20	
7459	34	32	30	28	26	24	22	20	
7460	34	32	30	28	26	24	22	20	
7461	34	32	30	28	26	24	22	20	
7462	34	32	30	28	26	24	22	20	
7463	34	32	30	28	26	24	22	20	
7464	34	32	30	28	26	24	22	20	
7465	34	32	30	28	26	24	22	20	
7466	34	32	30	28	26	24	22	20	
7467	34	32	30	28	26	24	22	20	
7468	34	32	30	28	26	24	22	20	
7469	34	32	30	28	26	24	22	20	
7470	34	32	30	28	26	24	22	20	
7471	34	32	30	28	26	24	22	20	
7472	34	32	30	28	26	24	22	20	
7473	52	49	46	43	40	37	34	31	
7474	52	49	46	43	40	37	34	31	
7475	52	49	46	43	40	37	34	31	
7476	52	49	46	43	40	37	34	31	
7477	52	49	46	43	40	37	34	31	
7478	52	49	46	43	40	37	34	31	
7479	52	49	46	43	40	37	34	31	
7480	52	49	46	43	40	37	34	31	
7481	52	49	46	43	40	37	34	31	
7482	172	164	156	148	140	132	124	116	
7483	172	164	156	148	140	132	124	116	
7484	172	164	156	148	140	132	124	116	
7485	60	57	54	51	48	45	42	39	
7486	60	57	54	51	48	45	42	39	
7487	60	57	54	51	48	45	42	39	
7488	60	57	54	51	48	45	42	39	
7489	60	57	54	51	48	45	42	39	
7490	60	57	54	51	48	45	42	39	
7491	60	57	54	51	48	45	42	39	
7492	60	57	54	51	48	45	42	39	
7493	60	57	54	51	48	45	42	39	
7494	60	57	54	51	48	45	42	39	
7495	60	57	54	51	48	45	42	39	
7496	60	57	54	51	48	45	42	39	
7497	60	57	54	51	48	45	42	39	
7498	60	57	54	51	48	45	42	39	
7499	60	57	54	51	48	45	42	39	
7500	60	57	54	51	48	45	42	39	
7501	60	57	54	51	48	45	42	39	
7502	60	57	54	51	48	45	42	39	
7503	60	57	54	51	48	45	42	39	
7504	60	57	54	51	48	45	42	39	
7505	60	57	54	51	48	45	42	39	
7506	60	57	54	51	48	45	42	39	
7507	60	57	54	51	48	45	42	39	
7508	60	57	54	51	48	45	42	39	
7509	60	57	54	51	48	45	42	39	
7510	60	57	54	51	48	45	42	39	
7511	60	57	54	51	48	45	42	39	
7512	60	57	54	51	48	45	42	39	
7513	60	57	54	51	48	45	42	39	
7514	60	57	54	51	48	45	42	39	
7515	60	57	54	51	48	45	42	39	
7516	60	57	54	51	48	45	42	39	
7517	60	57	54	51	48	45	42	39	
7518	60	57	54	51	48	45	42	39	
7519	60	57	54	51	48	45	42	39	
7520	60	57	54	51	48	45	42	39	
7521	60	57	54	51	48	45	42	39	
7522	60	57	54	51	48	45	42	39	
7523	60	57	54	51	48	45	42	39	
7524	60	57	54	51	48	45	42	39	
7525	60	57	54	51	48</				

IF YOU CAN SOLDER, YOU CAN BUILD YOUR OWN Clock/Calendar

SOLID STATE SYSTEMS, INC. has available a **CLOCK/CALENDAR** kit containing over 120 separate electrical components.

The clear, simplified instructions include step by step construction procedures and ample illustrations which will quickly take you through construction of this versatile Clock/Calendar.

THE KIT FEATURES:

- ★ **DISPLAY OF DATE WITH MONTH AND DAY** - displays month and day automatically, through year, except for February 29.
- ★ **DISPLAY OF TIME ON 12 HOUR CYCLE** - hours and minutes displayed with A.M. and P.M. indicators.
- ★ **A 24 HOUR ALARM OPTION** - this also includes a snooze button which delays alarm an additional 10 minutes.
- ★ **A 9 HOUR 59 MINUTE TIMING OPTION** - this allows operation of any pluggable 600 watt, 120 volt, 5 amp, 60 Hz electrical device such as a radio, room light, stereo or coffee pot.
- ★ **EASILY VISIBLE SPERRY® DISPLAY** - this display is highly visible in a well lighted room.

An attractive case may be fabricated of wood, plexiglas, metal or whatever you feel would make an appropriate show-case for your finished kit.

TO ORDER:

Order Number **01-12241** - **BASIC CLOCK** - This kit does not include the 24 hour alarm option or the 9 hour 59 minute appliance timer option. Price\$49.95.

Order Number **02-12241** - **COMPLETE CLOCK** - This kit includes all available options. Price\$65.00.

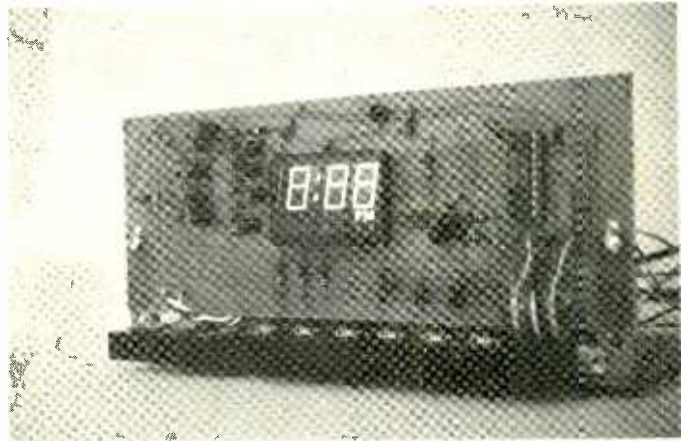

PLEASE NOTE: These kits do not include cases.

This kit when completed is a sophisticated device which offers many additional features due to its flexibility, here are two examples of what can be done with this device:

1. You may set the timer to play your radio for 15 minutes at bedtime, then the alarm allows you the option of waking up to the radio in the morning all automatically.
2. You may set the alarm to later start an appliance which will operate for the duration of the setting on the timer.

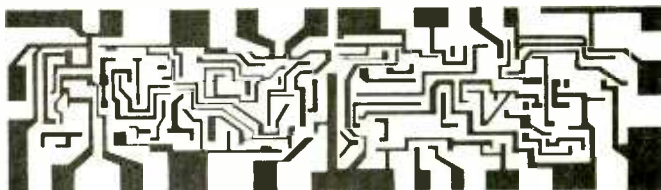

SOLID STATE SYSTEMS, INC.

NOVEMBER 1974

CIRCLE NO. 36 ON READERS SERVICE CARD

SEND YOUR ORDERS TO:
SOLID STATE SYSTEMS, INC.
P. O. BOX 617
COLUMBIA, MISSOURI 65201



OR PHONE (TOLL FREE)
800-325-2981 - 800-325-2983

FREE IC

With Every \$10 Order*

- REDUCE YOUR PROJECT COSTS
 - MONEY-BACK GUARANTEE
 - 24-HOUR SHIPMENT
 - ALL TESTED AND GUARANTEED
- TRANSISTORS:
- NPN:**
- | | |
|---|----------|
| 2N3563 TYPE RF Amp & OSC to 1 GHz (pl. 2N918) | 6/\$1.00 |
| 2N3565 TYPE Gen. Purpose High Gain (TO-106) | 6/\$1.00 |
| 2N3567 TYPE High-Current Amplifier/Sw 500mA | 3/\$1.00 |
| 2N3691 TYPE GP Amp to 25mA and 50 MHz | 6/\$1.00 |
| 2N3866 TYPE RF Pwr Amp 1-2 W @ 100-600 MHz | \$1.50 |
| 2N3903 TYPE GP Amp & Sw to 100mA and 30 MHz | 6/\$1.00 |
| 2N3904 TYPE GP Amp & Sw to 100mA (TO-92) | 5/\$1.00 |
| 2N3919 TYPE RF Pwr Amp 3-5 W @ 3-30 MHz | \$3.00 |
| 2N4274 TYPE Ultra-High Speed Switch 12ns | 4/\$1.00 |
| MPS6515 TYPE High-Gain Amplifier hFE 250 | 3/\$1.00 |
| Assort. NPN GP TYPES, 2N3565, 2N3641, etc. (15) | \$2.00 |
- PNP:**
- | | |
|---|----------|
| 2N3638 TYPE Gen. Purpose Amp & Switch | 4/\$1.00 |
| 2N4249 TYPE Low-Noise Audio Amp 1 μ A to 50mA | 4/\$1.00 |
- FET's:
- N-CHANNEL (LOW-NOISE):**
- | | |
|---|----------|
| 2N4416 TYPE RF Amplifier to 450 MHz (TO-72) | 2/\$1.00 |
| 2N5486 TYPE RF Amp to 450 MHz (plastic 2N4416) | 3/\$1.00 |
| 2N5163 TYPE Gen. Purpose Amp & Sw (TO-106) | 3/\$1.00 |
| 2N4091 TYPE RF Amp & Switch (TO-106) | 3/\$1.00 |
| E100 TYPE Low-Cost Audio Amplifier | 4/\$1.00 |
| ITE4868 TYPE Ultra-Low Noise Audio Amp. | 2/\$1.00 |
| TIS74 TYPE High-Speed Switch 40ns | 3/\$1.00 |
| Assort. RF & GP FET's, 2N5163, 2N5486, etc. (8) | \$2.00 |
- P-CHANNEL**
- | | |
|--|----------|
| 2N4360 TYPE Gen. Purpose Amp & Sw (TO-106) | 3/\$1.00 |
| E175 TYPE High-Speed Switch 125ns | 3/\$1.00 |
| M104 TYPE MOS FET (Diode protected) 0.3 pF | \$3.00 |
- LINEAR IC's:
- | | |
|---|--------|
| 309K Voltage Regulator 5V @ 1A (TO-3) | \$1.90 |
| 380 2-5 Watt Audio Amplifier 34dB (DIP) | \$1.50 |
| 555X Timer 1 μ s-1 hr, Dif. pinout from 555 (DIP) | \$.90 |
| 709 Popular OP AMP (DIP/TO-5) | \$.39 |
| 723 Voltage Regulator 3-30 V @ 1-250mA (DIP/TO-5) | \$.75 |
| 739 Dual Low-Noise Audio Preamp/OP AMP (DIP) | \$1.00 |
| 741 Freq. Compensated OP AMP (DIP/TO-5/MINIDIP) | \$.45 |
| 2556 Dual 555 Timer 1 μ sec to 1 hour (DIP) | \$1.55 |
| LM305 Positive Voltage Regulator (TO-5) | \$1.25 |
| MC1458 Dual 741 OP AMP (MINI-DIP) | \$.95 |
| Assorted Linears-741/709/723, etc. (4) | \$2.00 |
- DIODES:
- | | |
|---|-----------|
| 1N914 TYPE Gen. Purpose 100V/10mA | 10/\$1.00 |
| 1N3600 TYPE Hi Speed SW 75V/200mA | 6/\$1.00 |
| 1N4608 TYPE GP & SW 80V/400mA | 6/\$1.00 |
| 1N3893 TYPE RECTIFIER Stud Mount 400 V/12 A | 2/\$1.00 |
| 1N749 ZENER 4.3 Volt 400mW | 3/\$1.00 |
| 1N753 ZENER 6.2 Volt 400mW | 4/\$1.00 |
| 1N755 ZENER 7.5 Volt 400mW | 4/\$1.00 |
| 1N757 ZENER 9.1 Volt 400mW | 4/\$1.00 |
| 1N758 ZENER 10 Volt 400mW | 4/\$1.00 |
| 1N965 ZENER 15 Volt 400mW | 4/\$1.00 |
| 1N968 ZENER 20 Volt 400mW | 4/\$1.00 |
| 05 VARACTOR 5-50 W Output @ 30-250 MHz, 7-70 pF | \$5.00 |
| 7F VARACTOR 1-3 W Output @ 100-500 MHz, 5-30 pF | \$1.00 |

*MAIL NOW! With every order of \$10 or more, postmarked prior to 12/31/74. FREE 739 or 749 Low-Noise Dual OP AMP included—\$1 VALUE.

ORDER TODAY—All items subject to prior sale and prices subject to change without notice. DATA SHEETS included with all items. WRITE FOR FREE CATALOG offering hundreds of semi-conductors not listed here. Send 10¢ stamp.

TERMS: All orders prepaid. We pay postage. \$1.00 handling charge on orders under \$10. Calif. residents add 6% sales tax.

ADVA ELECTRONICS

BOX 4181-J, WOODSIDE, CA 94062
Tel. (415) 851-0455
CIRCLE NO. 1 ON READERS SERVICE CARD

TREASURE FINDERS

FAMILY FUN! OUTDOOR ADVENTURE! Find valuable coins and treasure with world famous metal detectors. Free illustrated booklet. Detectron, Dept. PE, Box 243, San Gabriel, Calif. 91778.

TREASURE FINDER locates buried gold, silver, coins, treasures. 5 powerful models. \$19.95 up. Instant financing available. Free catalog. Dealer inquiries invited. Relco, Dept. A-33, Box 10839, Houston, Texas 77018.

ELECTRICAL SUPPLIES & EQUIPMENT

PLATING Equipment, Portable Platers, Supplies and "Know-How." Build your own tanks for nickel, chrome, etc. Easy-to-install PVC liners. Rectifier components—all sizes. Schematics, parts lists, formulas, operating instructions for all plating. Guaranteed to save you 25%-75%. Some good units for sale. Write for details. Platers Service Company, 1511-PE Esperanza, Los Angeles, Calif. 90023.

MAGAZINES

CRAFT AUDIO
isn't a lost art. Readers of the Audio Amateur magazine are customizing and scratch building their equipment with gusto and great results. Free prospectus tells all.
Box 30P, Swarthmore PA 19081

MOVIE FILMS

8MM-SUPER 8-16MM MOVIES! Biggest Selection! Lowest Prices! Free Catalog! Cinema Eight. Box PE, Chester, Connecticut 06412.

EMPLOYMENT OPPORTUNITIES

ELECTRONICS/AVIONICS EMPLOYMENT OPPORTUNITIES Report on jobs now open. Details FREE. Aviation Employment Information Service, Box 4240E, Northport, New York 11768.

EMPLOYMENT INFORMATION

JOBS, Electronic Technicians, EE's, Tech Reps. Address 100 companies. US and overseas. Send \$2.00. Marshburn, Box 655, Wylie, Texas 75098.

REAL ESTATE

BIG FREE CATALOG! 272 pages! Over 2,500 top values in FARMS, RANCHES, ACREAGES, RECREATIONAL PROPERTIES, BUSINESSES, TOWN and COUNTRY HOMES in 40 states coast to coast! Over 3,800 PHOTOS! UNITED FARM AGENCY, 612-EP West 47th St., Kansas City, MO 64112.

RECORDS

OLDIES, 45rpm. Free Catalog. Corny's Record Shop, Box 335TP, Mason, Ohio 45040.

RUBBER STAMPS

RUBBER address stamps. Free catalog. 45 type styles. Jackson's, Box 443G, Franklin Park, Ill. 60131.

MAGNETS

MAGNETS. All types. Specials-20 disc. or 10 bar. or 2 stick, or 8 assorted magnets, \$1.00. Magnets, Box 192-H, Randallstown, Maryland 21133.

DO-IT-YOURSELF

FREE WINDPOWER HEAT Cuts fuel bills, beats shortages. Encyclopedic windmill/generator report gives sources, costs, instructions, capacities, specifications. Now \$2.98 from Energy Unlimited, Dept. 611, 219 Thorndike Street, Palmer, Mass. 01069.

PLASTICS

CASTOLITE pours like water, hardens like glass without heat. Crystal clear, colors. Embed flowers, seashells, mementos, anything. Make fine gifts. Form flexible molds over any pattern, size. Reproduce your own designs in plastics, candlewax, metal, plaster, cement. Send 30 cents for illustrated Manual and New Mold Catalog. Profitable. CASTOLITE, Dept. 74M/PE, Woodstock, Ill. 60098.

HYPNOTISM

SLEEP learning. Hypnotic method. 92% effective. Details free. ASR Foundation, Box 23429EG, Fort Lauderdale, Florida 33307.

FREE Hypnotism. Self-Hypnosis. Sleep Learning Catalog! Drawer H400, Ruidoso, New Mexico 88345.

AMAZING self-hypnosis record releases fantastic mental power. Instant results! Free trial. Write: Forum (AA11), 333 North Michigan, Chicago 60601.

ABOUT YOUR SUBSCRIPTION

Your subscription to POPULAR ELECTRONICS is maintained on one of the world's most modern, efficient computer systems, and if you're like 99% of our subscribers, you'll never have any reason to complain about your subscription service.

We have found that when complaints do arise, the majority of them occur because people have written their names or addresses differently at different times. For example, if your subscription were listed under "William Jones, Cedar Lane, Middletown, Arizona," and you were to renew it as "Bill Jones, Cedar Lane, Middletown, Arizona," our computer would think that two separate subscriptions were involved, and it would start sending you two copies of POPULAR ELECTRONICS each month. Other examples of combinations of names that would confuse the computer would include: John Henry Smith and Henry Smith; and Mrs. Joseph Jones and Mary Jones. Minor differences in addresses can also lead to difficulties. For example, to the computer, 100 Second St. is not the same as 100 2nd St.

So, please, when you write us about your subscription, be sure to enclose the mailing label from the cover of the magazine—or else copy your name and address exactly as they appear on the mailing label. This will greatly reduce any chance of error, and we will be able to service your request much more quickly.

Planning to move?

Let us know 8 weeks in advance so that you won't miss a single issue of POPULAR ELECTRONICS.

Attach old label where indicated and print new address in space provided. Also include your mailing label whenever you write concerning your subscription. It helps us serve you promptly.

Write to: P.O. Box 2774, Boulder, CO 80302, giving the following information:

- Change address only.
- Extend subscription. Enter new subscription.
- 1 year \$6.98
- Payment enclosed (1 extra BONUS issue)
- Bill me later

0888

name please print

address

city

state

zip-code

name please print

address

city

state

zip code

name

address

city

state

zip code

Add'l postage: \$2 per year outside U.S., its poss. & Can.

POPULAR ELECTRONICS

NOVEMBER 1974

ADVERTISERS INDEX

READER SERVICE NO.	ADVERTISER	PAGE NUMBER
1	Adva Electronics	110
	Allied Electronics	91
	Alpha Electronics	26
2	Altaj Electronics	107
	Ancrona Corp	13
44	Audioanalyst, Inc	71
	Audio-Technica U.S., Inc	16
6	B&K Products of Dynascan	5
	Bell & Howell Schools	18, 19, 20, 21
	CREI Capitol Radio Engineering Institute	92, 93, 94, 95
7	Cleveland Institute of Electronics Inc	62, 63, 64, 65
8	Cliiford's Hi-Fi Wholesalers	87
	Cobra Product of Dynascan Corporation	23
10	Continental Specialties Corp	81
11	Delta Electronics Co	102
12	Delta Products, Inc	15
	Digi-Key Corporation	111
14	EICO	89
15	Edmund Scientific Co	105
16	Edmund Scientific Co	112
	GC Electronics	98
	GTE Sylvania	28, 29, 30, 31
18	Great American Sound Company, Inc., The	7
19	Greenlee Tool Co	96
5	Heath Company	72, 73, 74, 75, 76, 77
20	Illinois Audio	80
21	International Electronics Unlimited	99
22	James Electronics	100
33	Johnson Co., E.F.	6
23	Kroch's & Brentano's	7
24	Lafayette Radio Electronics	97
26	McIntosh Laboratory, Inc	81
27	MITS, Inc	96
28	Midwest Hifi Wholesale	24
	NRI Schools	8, 9, 10, 11
	National Technical Schools	82, 83, 84, 85
29	Olson Electronics	17
45	Phase Linear Corporation	14
30	Pickering & Co	2
31	Poly Paks	101
32	Radio Shack	THIRD COVER
34	S A E, Inc	16
46	Shure Brothers Inc	27
35	Solid State Sales	106
36	Solid State Systems, Inc	108, 109
37	Southwest Technical Products Corp	67
38	Tracy Design Corporation	102
39	Tri-Star Corp	6
40	Trigger Electronics	87
41	U.S. Pioneer Electronics Corp	SECOND COVER, 1
4	United Audio Products, Inc	FOURTH COVER
42	Utah Electronics	25
43	VJ Products	17
	Vintage Radio	24
	Warehouse Sound	12
CLASSIFIED ADVERTISING ... 99, 100, 102, 106, 107, 110, 111		

HOME ENTERTAINMENT FILMS

COLOR ACTION SPORTS FILMS (Also B&W) — make great gifts in Super 8 and Standard 8. Treat yourself — a friend. In color, \$16.95 each plus 50 cents postage; \$7.95 plus 50 cents B&W for 200' reel. Select from Columbia, Castle and SportLite Catalogs at 25 cents each (stamps or coins, please). Be on time for Christmas, send your quarters today. SPORTLITE, Elect-11 Dept., 20 North Wacker Drive, Chicago, Illinois 60606.

TUBES

RADIO & T.V. Tubes—36 cents each. Send for free Catalog, Cornell, 4213 University, San Diego, Calif. 92105.

RECEIVING & INDUSTRIAL TUBES, TRANSISTORS. All Brands — Biggest Discounts, Technicians, Hobbyists, Experimenters — Request FREE Giant Catalog and SAVE! ZALYTRON, 469 Jericho Turnpike, Mineola, N.Y. 11501.

TUBES receiving, factory boxed, low prices, free price list. Transletronic, Inc., 1306 40th Street, Brooklyn, N.Y. 11218A, Telephone: 212-633-2800.

TUBES "Oldies", latest. Lists free. Steinmetz, 7519 Maplewood, Hammond, Indiana 46324.

TUBES 60% OFF LIST PRICE. McCord Electronics, Box 276-T, Sylvania, Ohio 43560.

BOOKS

FREE catalog aviation/electronic/space books. Aero Publishers, 329PE Aviation Road, Fallbrook, California 92028.

FREE book prophet Elijah coming before Christ. Wonderful bible edition. Megiddo Mission, Dept. 64, 481 Thurston Rd., Rochester, N.Y. 14619.

BOOKS—thousands titles, bargains. Catalog Free. Cassiano, 92-27 New York Blvd., Jamaica, New York 11433.

UNUSUAL BOOKS! Catalogue Free! International Imports, Box 7789PE, Atlanta, Georgia 30309.

LEARN RADIO ANNOUNCING! Books, Magazines: DeeJay, Box 1355-C, Sioux Falls, South Dakota 57101.

POPULAR ELECTRONICS INDEXES. Detailed and complete subject indexes now available to both 1972 and 1973 magazines. Hundreds of subject references to help you quickly find that special project, article, or product test. 1972 and 1973 editions \$1.00 each. INDEX, box 2228, Falls Church, Va. 22042.

INSTRUCTION MANUALS—Thousands available for test equipment, military electronics. Send \$1.00 (Refundable first order) for listing. A service of Tucker Electronics, Box 1050, Garland, Texas 75040.

MISCELLANEOUS

WINEMAKERS: Free illustrated catalog yeasts, equipment. Semplex, Box 12276P, Minneapolis, Minn. 55412.

NATIONAL TATTOO SUPPLIES send \$3.00 for our catalog. P. O. Box 2063, New Hyde Park, New York 11040.

1975 Electronic Experimenter's Handbook Winter Edition



This latest edition helps you get it together with a score of mind-absorbing, build-it-yourself projects—all with complete construction plans, including parts lists and printed circuit board patterns. Many products are unique designs, not available anywhere else. And in all cases, you save money by building your own!

1975 Winter Edition \$1.25 #46.
Back issues available: 1974 Spring \$1.25 #41, 1974 Winter \$1.25 #44, 1973 Spring \$1.25 #2, 1970 Winter \$1.50 #33, 1970 Spring \$1.50 #14.

Order by number from Ziff-Davis Service Div., 595 Broadway • N.Y., N.Y. 10012. Enclose an additional 35¢ per copy for postage and handling. (Outside U.S.A. all magazines are \$2.50 per copy, postpaid.)

PAYMENT MUST BE ENCLOSED WITH ORDER

FREE!
SPECIAL INTEREST RECORD CATALOG

Spectacular sound! Stereo testing! Background music and sound effects! Special Interest Records available exclusively from Ziff-Davis. Send for your free Record Catalog — Ziff-Davis Publishing Co., Dept. 23, One Park Ave., New York, N.Y. 10016

Quality Electronic Components

MINIATURE ALUMINUM ELECTROLYTIC CAPACITORS — AXIAL LEAD TYPE —

	1	10	100		1	10	100
1 UFD/50V	14c	12c	11c	100 UFD/16V	19c	15c	14c
2.2 UFD/50V	14c	12c	11c	100 UFD/25V	24c	18c	17c
3.3 UFD/35V	14c	12c	11c	220 UFD/16V	24c	18c	17c
4.7 UFD/35V	14c	12c	11c	220 UFD/25V	35c	25c	24c
10 UFD/16V	14c	12c	11c	330 UFD/16V	35c	25c	24c
10 UFD/25V	14c	12c	11c	330 UFD/25V	44c	35c	32c
22 UFD/16V	14c	12c	11c	470 UFD/16V	37c	30c	27c
22 UFD/25V	15c	13c	12c	470 UFD/25V	49c	39c	35c
33 UFD/16V	15c	12c	11c	1000 UFD/16V	49c	39c	35c
33 UFD/25V	17c	13c	12c	1000 UFD/25V	75c	60c	55c
47 UFD/16V	17c	14c	13c	2200 UFD/16V	75c	60c	55c
47 UFD/25V	19c	15c	14c				

SILICON TRANSISTORS

	10	100	100		10	100	100		
EN918	10-106	21	185	165	EN930	10-106	21	185	165
EN222	10-106	21	185	165	EN2369A	10-106	21	185	165
ZN2712	10-98	18	160	145	2N2907	10-106	21	185	165
2N3391A	10-98	22	190	175	2N3392	10-98	22	190	175
2N3393	10-98	22	190	175	2N3394	10-98	22	190	175
2N3563	10-106	20	175	160	2N3565	10-106	20	175	160
2N3538	10-105	20	175	160	2N3538A	10-105	20	175	160
2N3640	10-106	22	190	175	2N3641	10-105	20	175	160
2N3643	10-105	20	175	160	2N3645	10-105	20	175	160
2N3646	10-106	22	190	175	2N3904	10-92	25	225	200
2N3906	10-92	25	225	200	2N4124	10-92	27	240	220
2N4126	10-92	27	240	220	2N4401	10-92	32	290	260
2N4403	10-92	32	290	260	2N5087	10-92	27	240	220
2N5089	10-92	27	240	220	2N5129	10-106	19	170	150
2N5133	10-106	19	170	150	2N5134	10-106	19	170	150
2N5137	10-106	19	170	150	2N5138	10-106	19	170	150
2N5139	10-106	19	170	150	2N3055	10-3	1.35	2.20	1.99

FIELD EFFECT TRANSISTORS

MPF102	10-92	.44	.380	.350	2N5457	10-92	.47	.420	.375
--------	-------	-----	------	------	--------	-------	-----	------	------

NPN DARLINGTON TRANSISTOR

MPS-A13	10-92	Min DC Current Gain of 5,000 at 10mA.	.36	.320	.290
---------	-------	---------------------------------------	-----	------	------

1/2 & 1/4 WATT CARBON COMP. RESISTORS

5 each of the 85 standard 10% values (2.2-22M) 1/2 W Resistors (425 pcs.) Sorted by value \$12/set 2-4 are \$11/set 5-9 are \$10/set.

5 each of the 70 standard 10% values (10-5.6M) 1/4 W Resistors (350 pcs.) Sorted by value \$12/set 2-4 are \$11/set 5-9 are \$10/set.

Resistors also available individually, in other assortments or in boxes of 1000 pcs. per value. 1/2 W are box marked MIL-R-11F specification types.

25 V. DISC CAPS

Value	1	10	100
.001	5c	3.5c	3c
.022	6c	4c	3.5c
.047	6c	4c	3.5c
.047	9c	6c	5.3c
.1	12c	9c	7.5c

SGS-ATEL
VOLTAGE REGULATORS
\$1.80 ea.
1L29 5V 600mA
1L30 12V 500mA
1L31 15V 450mA



IEE-APOLLO DISPLAY

\$5.00

5 V., common 9 pin tube base

IC SOCKETS

8 Pin DIP Solder 35c
14 Pin DIP Solder 45c
16 Pin DIP Solder 50c
24 Pin DIP Solder \$1.25



Litronix 1100 Calculator
4 digit display
Selectable 2 or 4 decimal places
Reference account
Memory

LINEAR INTEGRATED CIRCUITS

555 Miniidp TIMER	\$1.00	10/S 9.50	565 DIP PLL	\$3.57	10/\$30.00
567 Miniidp TON DECODER	\$3.57	10/\$30.00	558 Miniidp DUAL OP AMP	8W	10/S 7.50
723 Dip VOLTAGE REG	\$1.15	10/\$10.00	741 Miniidp OP AMP	50c	10/S 4.50
747 Dip DUAL OP AMP	\$1.15	10/\$10.00	748 Miniidp OP AMP	60c	10/S 5.50

DIGITAL TTL

	1	100		1	100		1	100
7400N	32c	28c	7407N	51c	46c	7479N	60c	55c
7401N	32c	28c	7408N	51c	46c	7480N	74c	65c
7402N	32c	28c	7409N	32c	28c	7482N	\$1.02	91c
7403N	32c	28c	7410N	\$1.45	\$1.27	7483N	\$1.58	\$1.40
7404N	35c	31c	7411N	\$1.45	\$1.27	7484N	\$1.58	\$1.40
7405N	35c	31c	7412N	\$1.45	\$1.27	7485N	\$1.58	\$1.40
7406N	52c	46c	7413N	\$1.30	\$1.10	7486N	85c	72c
7407N	52c	46c	7414N	\$1.30	\$1.10	7487N	\$1.30	\$1.10
7408N	36c	32c	7415N	\$1.35	\$1.15	7488N	85c	72c
7409N	36c	32c	7416N	32c	28c	7489N	85c	72c
7410N	32c	28c	7417N	32c	28c	7490N	\$1.20	\$1.07
7411N	35c	31c	7418N	32c	28c	7491N	\$1.20	\$1.07
7412N	35c	31c	7419N	32c	28c	7492N	\$1.20	\$1.07
7413N	63c	56c	7420N	32c	28c	7493N	\$1.20	\$1.07
7414N	50c	44c	7421N	32c	28c	7494N	\$1.20	\$1.07
7415N	50c	44c	7422N	32c	28c	7495N	\$1.20	\$1.07
7416N	50c	44c	7423N	32c	28c	7496N	\$1.20	\$1.07
7417N	50c	44c	7424N	32c	28c	7497N	\$1.20	\$1.07
7418N	35c	31c	7425N	32c	28c	7498N	\$1.20	\$1.07
7420N	32c	28c	7426N	40c	35c	74122N	\$1.11	99c
7423N	75c	67c	7427N	52c	45c	74141N	\$1.61	\$1.43
7426N	36c	32c	7428N	52c	45c	74151N	\$1.58	\$1.39
7428N	32c	28c	7429N	85c	72c	74151N	\$1.20	\$1.07

Send for Free Catalog or Mail Readers Service Card

COD ORDERS ACCEPTED FOR SAME DAY SHIPMENT
CALL 218-681-6674

Orders Less than \$10.00 add 50c Service Charge—Others Postpaid
"Only Quality Components Sold!"

DIGI-KEY CORPORATION
P.O. Box 126 Thief River Falls, MN 56701

CIRCLE NO. 13 ON READERS SERVICE CARD

LIVE IN THE WORLD OF TOMORROW... TODAY!

And our FREE 164 PAGE CATALOG is packed with exciting and unusual values in ecological and physical science items — plus 4,500 finds for fun, study or profit... for every member of the family.

A BETTER LIFE STARTS HERE

LIE DETECTOR TYPE METER

Amazing Emotion Meter reveals hidden likes, dislikes. Easy to use; sensitive, accurate. Measures changes in body resistance caused by changes in emotional state. Needle movement indicates emotional response (not whether favorable or unfavorable). Effectiveness depends on questions asked and interpretation. Unique 10-cz. set ideal for entertainment and education — parties, science projects, psychological experiments. Requires 9V transistor battery (not included). Instructions.



No. 42,1974AV (2 7/8 x 4 x 1 3/4") \$19.95 Ppd.

LOW-COST ULTRASONIC CLEANER

Full pint capacity at price of old 1/3 pt model. For home, industry! Makes grimy, small delicate parts & objects sparkle — from diamonds to dentures, electronic items to coins & combs. Fully transistorized metal & stainless steel cabinet (6 x 4 x 4") with built-in tank has frequency control, item platform. Incls. cleaning powder, mfrs. 1-yr guar. 110-120v AC.



Stock No. 71,003AV \$65.95 Ppd.
No. 71, 198AV 1 1/4 Qt. Sz. \$115.00 Ppd.
#85, 128AV (33 lb.) 1 1/2 Gal. Sz. \$299.50 FOB

NEW! KIRLIAN PHOTOGRAPHY KIT!

Experiment in the fascinating new field of "Kirlian electrophotography"—images obtained on film without camera or lens by direct recording of electric charge transmitted by animate & inanimate objects. Each "aura" differs—animate aura said to change corresponding to physical changes. Kit incls. portable darkroom, double transformer isolated from power source; instrs.



Stock No. 71,938AV \$49.95 Ppd.
"HIGH VOLTAGE PHOTOGRAPHY" by H.S. Dakin
No. 9129AV. (60-PG. PAPERBACK BOOK) \$5.00 Ppd.

GET A CHARGE FROM THE SUN!

Our 12V Solar Battery Charger allows direct conversion of light-to-electricity. Compact panel put on a boat can automatically charge its 12V battery over entire daylight period. Use anywhere for a trickle charge. Big value, it comprises 30 1/2 V silicon solar cells in series w/diode.



No. 71,971AV (AB, 30 W-HRS./WK.) \$89.95 Ppd.
9 x 18" HI CURRENT MODEL (6W, 12V, 500 mA)
No. 72,010AV (AB, 150 W-HRS./WK.) \$420.00 Ppd.
6 x 6" LO VOLTAGE MODEL (1.5V, .38W, 250 mA)
No. 42,172AV \$49.95 Ppd.



"POP" YOUR OWN BUTTONS

Make customized badges in minutes! Create your own. Reproduce photos with name affixed. Great anywhere, from kindergarten to business meetings, to school sports. Sell for profit! Ingenious badge machine makes permanent buttons; kit includes precision cast hand die press, matching color dies, starter asst. for 25 complete badges including plastic protectors. Sold nationally for several dollars each, yours will pay off fast. Step-by-step instrs.

Stock No. 71,974AV \$31.50 Ppd.



KNOW YOUR ALPHA FROM THETA!

For greater relaxation, concentration, listen to your Alpha-Theta brainwaves. Ultra-sensitive electrode headband slips on/off in seconds—eliminates need for messy creams, etc. Atch'd to amplifier, filters brainwaves, signals beep for ea. Alpha or Theta wave passed. Monitoring button stimulates Alpha sound; audio & visual (L.E.D.) feedback. Reliable, easy-to-use unit comparable to costlier models. Completely safe. Comprehensive instruction booklet.

No. 1635AV (8x3x4"; 24. oz.) \$134.50 Ppd.
LOW COST "STARTER" UNIT
No. 71809AV \$55.00 Ppd.



3-CHANNEL COLOR ORGAN KIT

Easy to build low-cost kit needs no technical knowledge. Completed unit has 3 bands of audio frequencies to modulate 3 independent strings of colored lamps (i.e. "lows"—reds, "middles"—greens, "highs"—blues. Just connect hi-fi radio, power lamp etc. & plug ea. lamp string into own channel (max. 300w ea.). Kit features 3 neon indicators, color intensity controls, controlled individ SCR circuits; isolation transformer; custom plastic housing; instr.

Stock No. 41,831AV \$18.95 Ppd



ASTRONOMICAL MIRROR KITS

Grind your own mirror for powerful telescopes. Kit contains fine annealed pyrex mirror blank, tool, abrasives, diagonal mirror, and eyepiece lenses. Instruments you build range in value from \$75.00 to hundreds of dollars.

Stock No. 70,003AV ... 4 1/4" diam. 3/4" thick \$13.75 Ppd.
Stock No. 70,004AV ... 6" diam. 1" thick \$19.75 Ppd.
Stock No. 70,005AV ... 8" diam. 1 1/2" thick \$32.75 Ppd.
Stock No. 70,006AV ... 10" diam. 1 3/4" thick (30 lbs.) \$58.00 FOB
Stock No. 70,007AV ... 12 1/2" diam. 2 1/4" thick (46 lbs.) \$98.50 FOB



3" ASTRONOMICAL REFLECTING TELESCOPE

See stars, moon, planets close-up! 30 to 90X. Famous Mt. Palomar Type. Aluminized & overcoated 3" diameter f/10 primary mirror, ventilated cell. Fork type equatorial mount. Durable PVC tube. Includes 1" F.L. 30X Ramsden Barlow lens to triple power, 3X finder telescopes, hardwood tripod. FREE: "STAR CHART", "HOW TO USE" book.

Stock No. 85,240AV \$49.95 Ppd.
DELUXE 3" REFLECTOR TELESCOPE #80,162AV \$79.95 Ppd.
4 1/4" REFLECTOR (45X to 135X) #85,105AV \$149.50 FOB
6" REFLECTOR (48X to 360X) #85,187AV \$249.50 FOB



MAIL COUPON FOR GIANT FREE CATALOG!

164 PAGES • MORE THAN 4500 UNUSUAL BARGAINS

Completely new Catalog. Packed with huge selection of telescopes, microscopes, binoculars, magnets, magnifiers, prisms, photo components, ecology and Unique Lighting items, parts, kits, accessories — many hard-to-get surplus bargains. 100's of charts, illustrations. For hobbyists, experimenters, schools, industry.

EDMUND SCIENTIFIC CO.
300 Edscorp Building, Barrington, N. J. 08007
Please rush Free Giant Catalog "AV"

Name _____
Address _____
City _____ State _____ Zip _____



COMPLETE & MAIL WITH CHECK OR M.O.

EDMUND SCIENTIFIC CO. 300 Edscorp Building, Barrington, N.J. 08007

How Many	Stock No.	Description	Price Each	Total

Add Handling Chg.: \$1.00. Orders Under \$5.00, 50¢. Orders Over \$5.00

I enclose check money order for \$ _____ TOTAL \$ _____

NAME _____

ADDRESS _____

CITY _____ STATE _____ ZIP _____



CIRCLE NO. 16 ON READERS SERVICE CARD

POPULAR ELECTRONICS

99.9% Pure!

New Radio Shack/Realistic AM/FM Receiver



319⁹⁵

including 29.95-value walnut veneer case

FREE New 1975 Radio Shack Catalog

OVER 2000 PRODUCTS
EXCLUSIVES ON EVERY PAGE
BEAUTIFUL FULL COLOR

**Stereo • Quadraphonic • Phonographs
TV Antennas • Radios • Citizens Band
Kits • Amateur Radio • Tools
Auto Tune-Up • Batteries • Wire
Test Instruments • More!**

164 pages of the finest in home and hobby electronics. Respected names like Realistic, Micronta, Archer, Science Fair — and they're available only at Radio Shack stores and dealers nationwide! See what's really new in electronics by sending for this exciting catalog.



**SEND FOR
YOURS TODAY!
FILL OUT
COUPON
BELOW**

1975 Catalog Mail to Radio Shack, P. O. Box 1052, 443 Ft. Worth, Texas 76101. (Please print.)

Name _____ Apt. No. _____

Street _____

City _____

State _____ ZIP _____

The Realistic[®] STA-250 delivers 44 watts RMS per channel at 8 ohms (202 watts IHF ± 1 dB total). Its THD at half power (1 kHz) is actually less than 0.1%. Obviously the STA-250 keeps music pure even at "live performance" volume. With triple-ganged tuning, two FET's in the front end and two IC's, the FM is exceptional too. Muting eliminates tuning noise and a center-channel meter assures lowest distortion. Even the AM is triple-ganged and has a signal strength meter. Other features include high and low filters, inputs for two changers and a mag/ceramic switch. When you're ready, exclusive Quatravox[®] lets you add a second speaker pair for synthesized 4-channel. U.L. listed. #31-2052. A great value, that's for pure. There's only one place you can find it . . . Radio Shack.

Complete Realistic STA-250 System

save 79⁸⁵

regular 579.80

499⁹⁵

- Realistic STA-250 Receiver
- Two Optimus-1B Speaker Systems
- LAB-36A Changer, Base.
- \$22.95-Value Elliptical Cartridge



Mastercharge or Bank Americard at participating stores

Radio Shack[®]

A TANDY CORPORATION COMPANY

OVER 3000 STORES • 50 STATES • 8 COUNTRIES

Retail prices may vary at individual stores

CIRCLE NO. 32 ON READERS SERVICE CARD

Why you should select your turntable more carefully than any other component.

Every component is important to the total performance of an audio system, but the turntable is critical. It is the only component that physically handles your biggest investment in musical enjoyment: your record collection.

In time, your changing tastes can outgrow your present amplifier and speakers. But regardless of how these components affect the reproduction of music, they cannot do anything to harm your records.

Not so the turntable. A tonearm that does not allow the stylus to track the grooves lightly, accurately and with perfect balance can turn the stylus into a destructive instrument easily capable of lopping off the sharp contours which carry the high frequencies. When that happens, the clean high notes become fuzzy memories. Permanently. There's just no way to restore a damaged record. Even the best equipment can't replace notes once they're gone.

After considering what your records require for longevity,

you should consider what you require of operating convenience and flexibility. For example, if you don't relish risking your stylus and records by handling the tonearm each time you play a record, you will want an automatic turntable. And if you desire to play two or more records in sequence, you will want a turntable with record changing ability.

All Dual turntables easily fulfill every requirement for record playback and preservation — and every requirement for user convenience.

Which is why the readers of the leading audio and music magazines own more Duals than any other turntable. It's also why so many audio professionals are quite satisfied with even the lowest-priced Dual.

Please write for our very informative brochures and complete reprints of independent test reports. The more carefully you read them, the more likely you are to select a Dual.

Any Dual.

The logo for Dual, consisting of the word "Dual" in a white, sans-serif font inside a dark square.

United Audio Products
120 So. Columbus Ave.,
Mt. Vernon, N.Y. 10553
Exclusive Distribution Agency for Dual



From front to rear: Dual 1229C, \$259.95; Dual 1228, \$189.95; Dual 1226, \$159.95; Dual 1225, \$129.95.

CIRCLE NO. 4 ON READERS SERVICE CARD