

Popular Electronics

WORLD'S LARGEST-SELLING ELECTRONICS MAGAZINE

AUGUST 1974 / 60¢

Starting this issue:
NEW BIG SIZE

Hi-Fi

Build a Reflex/Omni Speaker System

Service

How to Set Up A Home TV Shop

CB

Guide to CB Mobile Antennas

Experimenters

Linear CMOS Applications

Hams

Build a GMT Digital Clock with "Beeper"

Test Reports

Kenwood KR-5340 4-Channel Receiver

Grundberg 3341X Open-Reel Tape Deck

Royce 1-408 CB "Walkie Talkie"

RCA WT-540A Leakage Tester

Digital Concepts CK-100 Clock Kit

A Breakthrough Project!

Add the **PE TESTED** "Scopewriter" to any Oscilloscope



receivers the world

Pioneer believes that any objective comparison of quality/performance/price between our new SX-1010, SX-939 and SX-838 AM-FM stereo receivers and any other fine receivers will overwhelmingly indicate Pioneer's outstanding superiority and value.

The most powerful ever

Pioneer uses the most conservative power rating standard: continuous power output per channel, with both channels driven into 8 ohm loads, across the full audio spectrum from

20Hz to 20,000 Hz. Despite this conservatism, the SX-1010 far surpasses any unit ever produced with an unprecedented 100 + 100 watts RMS at incredibly low 0.1% distortion. Closely following are the SX-939 (70 + 70 watts RMS) and the SX-838 (50 + 50 watts RMS) both with less than 0.3% distortion. Dual power supplies driving direct-coupled circuitry maintain consistent high power output with positive stability. A fail-safe circuit protects speakers and circuitry against damage from overloading.

Outstanding specifications for flawless reception

FM reception poses no challenge to the exceptionally advanced circuitry of these fine instruments. Their FM tuner sections are designed with MOS FETs, ceramic filters and phase lock loop circuitry. The result is remarkable sensitivity, selectivity and capture ratio that brings in stations effortlessly, clearly and with maximum channel separation.

	SX-1010	SX-939	SX-838
FM Sensitivity (IHF) (the lower the better)	1.7uV	1.8uV	1.8uV
Selectivity (the higher the better)	90dB	80dB	80dB
Capture Ratio (the lower the better)	1dB	1dB	1dB
Signal/Noise Ratio (the higher the better)	72dB	70dB	70dB

Total versatility plus innovations

Only your listening interests limit the capabilities of these extraordinary receivers. They have terminals for every conceivable accommodation: records, tape, microphones, headsets — plus Dolby and 4-channel multiplex adaptors. Completely unique on the SX-1010 and SX-939 is tape-to-tape duplication while listening simultaneously to another program source. The SX-838 innovates with its Recording

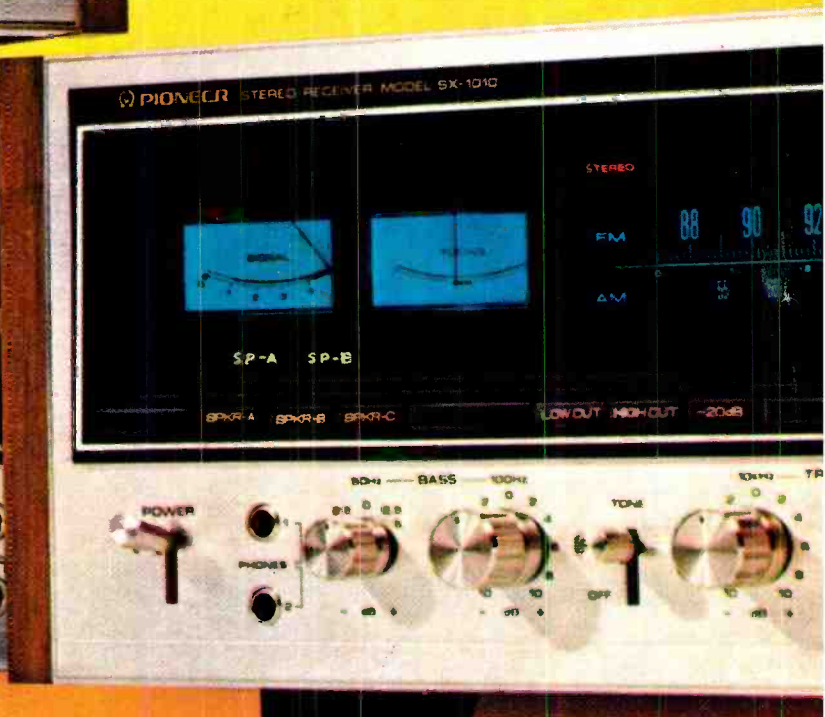

The finest stereo receiver has ever known.

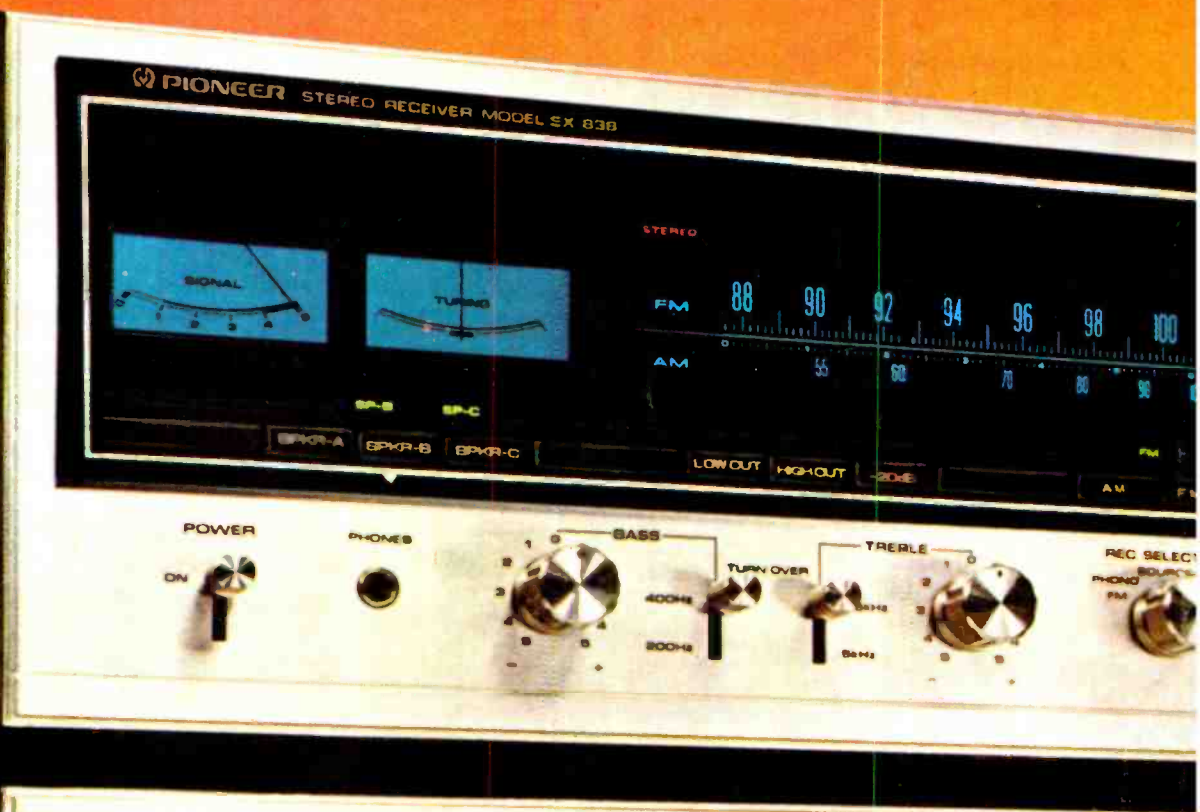

There can be only one best.

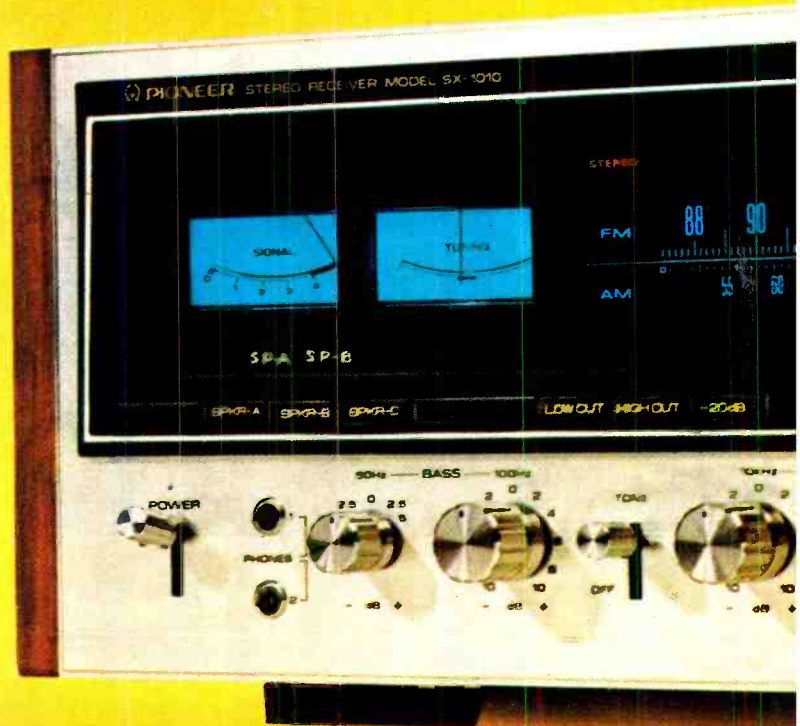



3,025 possible tonal compensations with unique twin stepped tone controls (SX-1010, SX-939)

Selector that permits FM recording while listening to records and vice versa. Up to three pairs of speakers may be connected to each model.

INPUTS	SX-1010	SX-939	SX-833
Tape monitor/4-ch. adaptor	3	2	2
Phono	2	2	2
Microphone	2	2	1
Auxiliary	1	1	1
Noise reduction	1	1	1
OUTPUTS			
Speakers	3	3	3
Tape Rec./4-ch. adaptor	3	2	2
Headsets	2	2	1
Noise reduction	1	1	1
4-channel MPX	1	1	1

Master control system capability

Pioneer's engineers have surpassed themselves with a combination of control features never before found in a single receiver. All three units include: pushbutton function selection with illuminated readouts on the ultra wide tuning dial, FM and audio muting, loudness contour, hi/low filters, dual tuning meters and a dial dimmer.

Never before used on a receiver are the twin stepped bass and treble tone controls found on the SX-1010 and SX-939. They offer over 3,000 tonal variations. A tone defeat switch provides flat response instantly throughout the audio spectrum. The SX-838 features

switched turnover bass and treble controls for more precise tonal compensation for room acoustics and other program source characteristics.

In their respective price ranges, these are unquestionably the finest values in stereo receivers the world has ever known. Audition their uniqueness at your Pioneer dealer. SX-1010 — \$699.95; SX-939 — \$599.95, SX-838 — \$499.95. Prices include walnut cabinets.

Also new and more moderately priced.

Pioneer's most complete and finest line of receivers ever, presents equally outstanding values starting at \$239.95. Shown here are the SX-535 — \$299.95, SX-636 — \$349.95, SX-737 — \$399.95. All with walnut cabinets.

U.S. Pioneer Electronics Corp., 75 Oxford Drive, Moonachie, New Jersey 07074
West: 13300 S. Estrella, Los Angeles 90248/Midwest: 1500 Greenleaf, Elk Grove Village, Ill. 60007/Canada: S.H. Parker Co.

PIONEER
where you want something better



SX-535



SX-636



SX-737





The editors' choice:

Heathkit Digital Design Color TV!



At **ELEMENTARY ELECTRONICS** they said: "The fact is, today's Heathkit GR-2000 is the color TV the rest of the industry will be making tomorrow... there is no other TV available at any price which incorporates what Heath has built into their latest color TV."

The **FAMILY HANDYMAN** reviewer put it this way: "The picture quality of the GR-2000 is flawless, natural tints, excellent definition, and pictures are steady as a rock. It's better than any this writer has ever seen."

POPULAR SCIENCE pointed out "more linear IC's, improved vertical sweep, regulators that prevent power supply shorts, and an industry first: the permanently tuned I.F. filter."

The **RADIO-ELECTRONICS** editors said the Heathkit Digital Design TV has "features that are not to be found in any other production color TV being sold in the U.S.:

"On-screen electronic digital channel readout... numbers appear each time you switch channels or touch the RECALL button... On-screen electronic digital clock... an optional low cost feature... will display in 12- or 24-hour format... Silent all-electronic tuning. It's done with uhf and vhf varactor diode tuners... Touch-to-tune, re-

programmable, digital channel selection... up to 16 channels, uhf or vhf... in whatever order you wish... there's no need to ever tune to an unused channel. LC IF amplifier with fixed ten-section LC IF bandpass filter in the IF strip... eliminates the need for critically adjusted traps for eliminating adjacent-channel and in-channel carrier beats. No IF alignment is needed ever. Touch volume control... when the remote control is used... touch switches raise or lower the volume in small steps."



POPULAR ELECTRONICS took a look at the 25-in. (diagonal) picture and said it "can only be described as superb. The Black (Negative) Matrix CRT, the tuner and IF strip, and the video amplifier provide a picture equal to that of many studio monitors..."

To sum up, **POPULAR ELECTRONICS** concluded its study by stating, "In our view, the color TV of the future is here—and Heath's GR-2000 is it!"

Why not see what the experts have seen? The Heathkit Digital Design Color TV—without question the most remarkable TV available today.

Mail order price for chassis and tube, \$659.95. Remote Control, \$89.95, mail order. Clock, \$29.95 mail order. Cabinets start at \$139.95. (Retail prices slightly higher).



Send for your **FREE '74 Heathkit Catalog**—world's largest selection of electronic kits

HEATHKIT ELECTRONIC CENTERS
Units of Schlumberger Products Corporation
Retail prices slightly higher.

ARIZ.: Phoenix; CALIF.: Anaheim, El Cerrito, Los Angeles, Pomona, Redwood City, San Diego (La Mesa), Woodland Hills; COLO.: Denver; CONN.: Hartford (Avon); FLA.: Miami (Hialeah), Tampa; GA.: Atlanta; ILL.: Chicago, Downers Grove; IND.: Indianapolis; KANSAS: Kansas City (Mission); KY.: Louisville; LA.: New Orleans (Kenner); MD.: Baltimore, Rockville; MASS.: Boston (Wellesley); MICH.: Detroit; MINN.: Minneapolis (Hopkins); MO.: St. Louis; NEB.: Omaha; N.J.: Fair Lawn; N.Y.: Buffalo (Amherst), New York City, Jericho, L.I., Rochester, White Plains; OHIO: Cincinnati (Woodlawn), Cleveland, Columbus; PA.: Philadelphia, Pittsburgh; R.I.: Providence (Warwick); TEXAS: Dallas, Houston; WASH.: Seattle; WIS.: Milwaukee.



Heath Company, Dept. 10-8 Benton Harbor, Michigan 49022	HEATH Schlumberger
<input type="checkbox"/> Please send FREE Heathkit Catalog.	
Name _____	
Address _____	
City _____ State _____ Zip _____	
Prices & specifications subject to change without notice. *Mail order prices; F.O.B. factory.	
CL-516	

AUGUST 1974 VOLUME 6, NUMBER 2

Popular Electronics

WORLD'S LARGEST-SELLING ELECTRONICS MAGAZINE

FEATURE ARTICLES

HIRSCH-HOUCK LABS TESTS THE NEW "PREMIUM" CASSETTE TAPES	Julian D. Hirsch	39
A USER'S GUIDE TO MOBILE CB ANTENNAS	W. J. Evezia	51
A GUIDE TO CMOS OPERATION	Walter G. Jung	61
<i>How they are used in linear applications</i>		
HOW TO SET UP A HOME TV SERVICE SHOP	Art Margolis	75
TIPS ON KIT BUILDING	John T. Frye	84

CONSTRUCTION STORIES

THE SCOPEWRITER	Gary Steinbaugh	33
<i>Unique character generator displays alphanumeric on any oscilloscope</i>		
BUILD A LARGE-PORT SPEAKER SYSTEM	David B. Weems	43
<i>High-efficiency enclosure uses novel reflector system</i>		
ADD A 10-MINUTE "BEEPER" TO YOUR DIGITAL CLOCK	Henry Olsen	48
<i>A useful addition to any ham shack</i>		
MEASURE RPM OF ROTATING ELEMENTS WITH THE IC PHOTO TACHOMETER	Adolph A. Mangieri	54
R-F TRANSISTOR TESTER	Daniel Metzger	58
<i>Checks upper frequency limit of bipolar transistors</i>		

COLUMNS

STEREO SCENE	Ralph Hodges	22
<i>Speakers and rooms</i>		
CB SCENE	Len Buckwaite	86
<i>Lightning and the CB boater</i>		
TEST EQUIPMENT SCENE	Leslie Solomon	88
<i>Grid-dip meters</i>		
SOLID STATE	Lou Garner	89
<i>Using surplus diodes</i>		
HOBBY SCENE	Editorial Staff	98

PRODUCT TEST REPORTS

KENWOOD MODEL KR-5340 4-CHANNEL RECEIVER	64
TANDBERG MODEL 3341X STEREO TAPE DECK	65
ROYCE MODEL 1-408 HAND-HELD CB TRANSCEIVER	66
RCA MODEL WT-540A LEAKAGE CURRENT TESTER	67
DIGITAL CONCEPTS MODEL CX-100 ELECTRONIC CLOCK KIT	68

DEPARTMENTS

EDITORIAL	Art Salsberg	4
<i>Our "New Look"</i>		
LETTERS		6
NEW PRODUCTS		12
NEW LITERATURE		16
NEWS HIGHLIGHTS		27
ELECTRONICS LIBRARY		99

POPULARELECTRONICS, August 1974, Volume 6, Number 2. Published monthly at One Park Avenue, New York, NY 10016. One year subscription rate for U.S., U.S. Possessions and Canada, \$6.98; all other countries, \$8.98. Second class postage paid at New York, NY and at additional mailing offices. Authorized as second class mail by the Post Office Department, Ottawa, Canada and for payment of postage in cash. Subscription service and Forms 3579; P.O. Box 2774, Boulder, CO 80302.

POPULAR ELECTRONICS Including ELECTRONICS WORLD, Trade Mark Registered. Indexed in the Reader's Guide to Periodical Literature. Copyright © 1974 by ZIFF-DAVIS PUBLISHING COMPANY. All rights reserved.

Ziff-Davis also publishes Boating, Car and Driver, Cycle, Flying, Modern Bride, Popular Photography, Skiing, and Stereo Review.

Forms 3579 and all subscription correspondence should be addressed to POPULAR ELECTRONICS, Circulation Dept., P. O. Box 2774, Boulder, CO 80302. Please allow at least eight weeks for change of address. Include your old address, as well as new—enclosing, if possible, an address label from a recent issue.

Editorial contributions must be accompanied by return postage and will be handled with reasonable care; however, publisher assumes no responsibility for return or safety of artwork, photographs, models, or manuscripts.

EDGAR W. HOPPER
Publisher

ARTHUR P. SALSBERG
Editorial Director

LESLIE SOLOMON
Technical Editor

JOHN R. RIGGS
Managing Editor

EDWARD I. BUXBAUM
Art Director

ALEXANDER W. BURAWA
Associate Editor

ANDRE DUZANT
Technical Illustrator

ELLEN S. FINKELSTEIN
Editorial Assistant

LEN BUCKWALTER
LOU GARNER
JULIAN D. HIRSCH
RALPH HODGES
WALTER G. JUNG
MILTON S. SNITZER
Contributing Editors

JOSEPH E. HALLORAN
Advertising Director

JOHN J. CORTON
Advertising Sales

MADELEINE LITTMAN
Advertising Service Manager

PEGI McENEANEY
Executive Assistant

STANLEY NEUFELD
Associate Publisher

FURMAN H. HEBB
Group VP, Electronics & Photo

ZIFF-DAVIS PUBLISHING COMPANY
Popular Electronics

Editorial and Executive Offices
One Park Avenue New York, New York 10016
212-725-3500

William Ziff, President

W. Bradford Briggs, Executive Vice President

Hershel B. Sarbin, Senior Vice President,

Secretary, and Treasurer

Philip Sine, Senior Vice President

Phillip T. Heffernan, Vice President, Marketing

Frank Pomerantz, Vice President, Creative Services

Arthur W. Butzow, Vice President, Production

Edward D. Muhfeld, Vice President, Aviation

and Automotive Divisions

Irwin Robinson, Vice President, Travel Division

George Morrissey, Vice President

Sydney H. Rogers, Vice President

Sidney Holtz, Vice President

Lawrence Sporn, Vice President, Circulation

Midwestern Office

The Pattis Group, 4761 West Touhy Ave.,
Lincolnwood, Illinois 60644, 312 679-1100
GERALD E. WOLFE, GEORGE B. MANNION

Western Office

9025 Wilshire Boulevard,
Beverly Hills, California 90211
213 273-8050; BRAdshaw 2-1161
Western Advertising Manager. BUD DEAN

Japan: James Yagi

Oji Palace Aoyama: 6-25, Minami Aoyama
6 Chome, Minato-Ku, Tokyo 407-1930/6821



Editorial

OUR "NEW LOOK"

How sweet it is! After yearning over the years for an opportunity to work within the framework of a magazine of traditional size, here we are, at last, with a spanking new, big format. Would you believe the page size is about 59% larger than what we had before?

What does it mean to you, the reader? First, you will enjoy improved graphics and readability—schematics that are no longer disjointed due to page-size limitations, advertising cards (bless them) that don't act as manila dividers, and artistic effects (including color) that are more pleasing to the eye.

No doubt some ecologically oriented readers will wonder why we changed now, with the reputed paper shortage. The answer to that is simple. Most magazine paper today is produced for use with offset printing presses, which is what we are now using. Prior to this, POPULAR ELECTRONICS was printed by the letterpress process, which promises to go the way of the auk except for special purposes. Further, we recognized that a shift to a larger size was imminent as electronic circuits became increasingly complex, thereby requiring more page space to present larger schematics. As computer technology sifts down to consumer levels, with lower prices and increased availability of components, we anticipate the complexity of schematic diagrams to increase. In essence, we have looked into the future and POPULAR ELECTRONICS is ready for it!

But our new look is more than physical or visual. We've gathered together the most authoritative electronics columnists in the field to bring you exciting, useful information in specific areas. For example, you will soon be reading new columns on DX listening, ham radio, and TV servicing. These will be in addition to our regular columns on high fidelity, CB radio, test instruments and solid-state devices and circuits. Each columnist is expert in his respective field, deeply involved for many years in his specialty. Adding the new columns is a bonus for readers, made possible by the additional editorial space provided by the larger format.

We will welcome your comments on the change we have just made on this, our 239th monthly issue. Also, why not let us know which articles you liked best and what you'd like to see covered in future issues.

Art Salsberg



The publisher has no knowledge of any proprietary rights which will be violated by the making or using of any items disclosed in this issue.

Fresh from the Factory. Yet These Cars Should Be Recalled.



Because they're missing something.
Like an ignition system built for today's driving.

Factory electronic ignitions were okay for yesterday. (All they do is eliminate the points and condenser, you know.) But today...with fuel shortages, the ever-growing cost of maintenance, power-robbing smog control devices, etc....there's a crying need for something better.

That something better is a Delta Capacitive Discharge Ignition System...the low-cost "now" system that really makes sense. Means up to 20% better gas mileage. 75% fewer tune-ups. Three to 10 times longer plug life. Instant starts...even at -40°. Better acceleration and performance. Easy to install on any automobile engine, too; even goes on in minutes right over the factory electronic system with no rewiring.

Delta Capacitive Discharge Ignition Systems...extra energy to beat the energy shortage. Available in two models; Mark Ten CDI, or Mark Ten B. Priced as low as \$34.95 in kit form. Use coupon to order today!



DELTA PRODUCTS, INC.

P.O. Box 1147, Dept. PE
Grand Junction, Colo. 81501
303-242-9C00

Please send me free literature.
Enclosed is \$ _____ Ship ppd. Ship C.O.D.
Please send: _____ Mark Ten B assembled @
\$64.95 ppd. _____ Mark Ten B Kit @ \$49.95 ppd.
(12 volt negative ground only _____ Standard Mark
Ten assembled, @ \$49.95 ppd. _____ 6 Volt: Neg.
Ground Only _____ 12 Volt: Specify _____ Pos. Ground
_____ Neg. Ground _____ Standard Mark Ten Deltakit*
@ \$34.95 ppd. (12 Volt Positive or Negative Ground
Only)

Car Year _____ Make _____

Name _____

Address _____

City/State _____ Zip _____

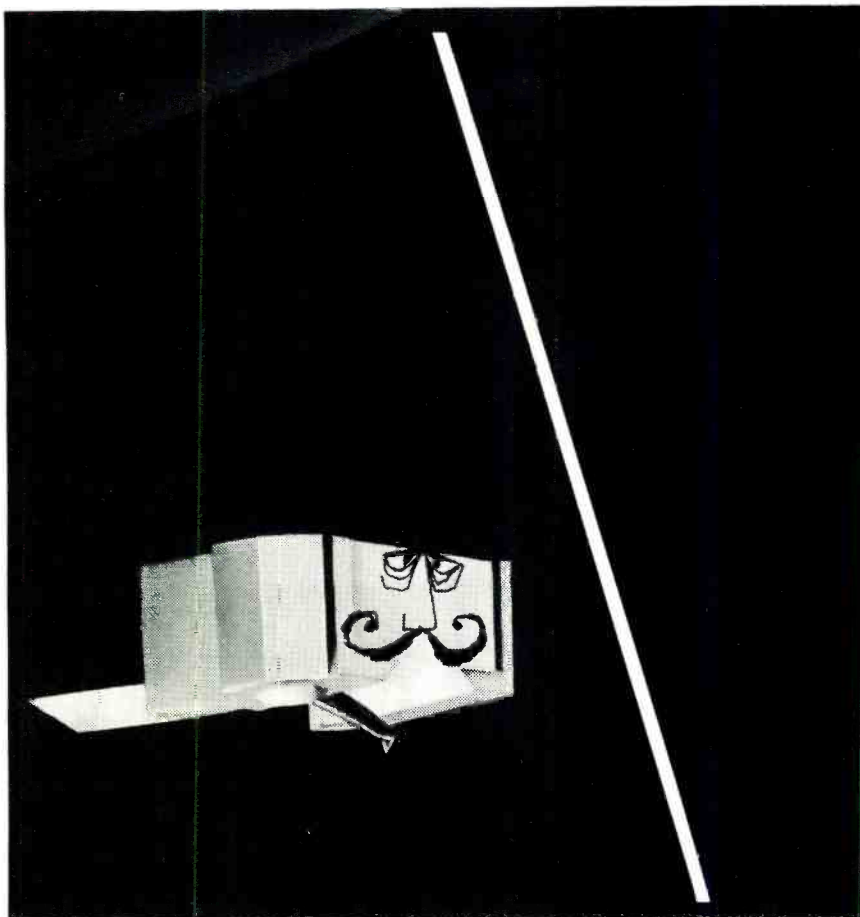

Wolves in cheaps clothing.

Design charlatans around the world have found a lucrative business in selling spurious replacement styli. And because Shure phono cartridges are asked for by more knowledgeable hi-fi enthusiasts than any other cartridges, our styli seem to be imitated more than any others. Now, flattery notwithstanding, Shure design engineers see red when they see these impostors, because they know that

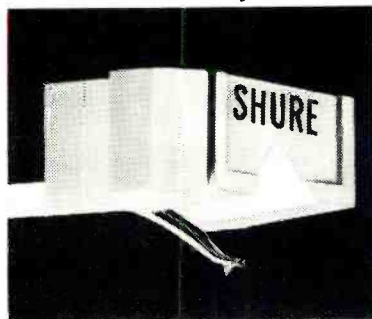

the performance of your Shure cartridge *absolutely* depends upon the *genuine* Shure stylus assembly — so to protect your investment and to insure the original performance of your Shure cartridge, insist on the real thing: Look for the name SHURE on the stylus grip (as shown in the photo, left) and the words, "This Stereo Dynetic® stylus is precision manufactured by Shure Brothers Inc." on the box.

Shure Brothers Inc.
222 Hartrey Ave., Evanston, Ill. 60204
In Canada: A. C. Simmonds & Sons Limited



CIRCLE NO. 37 ON READERS SERVICE CARD

www.americanradiohistory.com

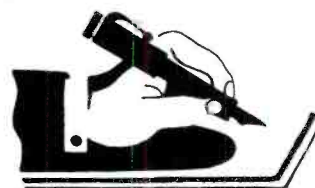

Letters

USING ASCII IN HAM RADIO

In "ASCII Keyboard and Encoder" (April 1974), it was stated that the ASCII system can be used for ham radio operation. However, it appears that the keyboard characters and layout and the necessary changes in the circuit would be different from the ASCII format normally used by hams. In addition, some simple series-parallel and parallel-series conversion circuits would be needed to interface with normal ham equipment.

Do you have any specific information we hams can use to alter the basic design to bring it closer to our requirements?

ROBERT A. LUFF, W3GAC
Gaithersburg, Md.

The author replies: You refer to a five-level Baudot code, not ASCII. The former is obsolete. There are two ways the keyboard could be used with Baudot: You could redefine the key matrix using the bottom three bits of the encoder for the least-significant two bits of the Baudot code and slightly rework the upper circuitry to generate the most significant two bits. The alternative is to add a code-converting ROM to the output of the keyboard. This is preferable because stock keytops and standard layout (with little reworking) can be used. Two ROM's might be needed.

Parallel-series conversion is an easy task. The simplest arrangement would be to use a 555 timer driving a 74165 shift register. A better method for both directions at once would be to use a UART, such as Signetics' 2536, Texas Instruments' TMS-6011, or Western Digital's TR1402A.

More information on the Baudot code and the conversion process using ROM's appears in my TTL Cookbook available from Howard W. Sams & Co.—Don Lancaster.

NEW "EARPHONE" LAW IN FLORIDA

Please advise your readers that, as of January 1, 1974, it is against the law in the State of Florida to drive with an earphone or other listening device covering or inserted in the ear. I would assume that this law also covers the single "boom" microphone combinations now becoming popular with CB'ers. The sole exception to the new Florida law is for an officer (police) while on duty and only when it is essential to the performance of his duty.

As an ambulance driver/attendant, I applaud this law. Drivers cannot hear our si-

POPULAR ELECTRONICS

rens now with air conditioning going, windows closed, and radios blaring. Ear-phones and headsets only add to their deafness to our warning sirens.

R.A. HOLSTE
Orlando, Fla.

SOME WORDS ON REVERSE POLISH NOTATION

As an engineer and owner of an HP-35 pocket calculator, I was amazed that Mr. Frye failed to mention (in his "Buying and Using a Pocket Calculator," May 1974) the one important difference between the Hewlett-Packard calculators and all other pocket calculators currently available. The H-P's use Lukasiewicz (or "reverse Polish") notation and an operational stack, while other calculators use algebraic notation. Polish notation and an operational stack is the most efficient way to evaluate an expression.

KENNETH NOTT
Rensselaer Polytechnic Institute
Troy, N.Y.

You are correct. The H-P's are the only portable calculators to use Lukasiewicz notation, and this notation (plus the use of an operational stack) is the most efficient method of evaluating a mathematical expression.

HOW TO BLANK LEADING ZERO

The clock/calendar chip, CT-7001, sold

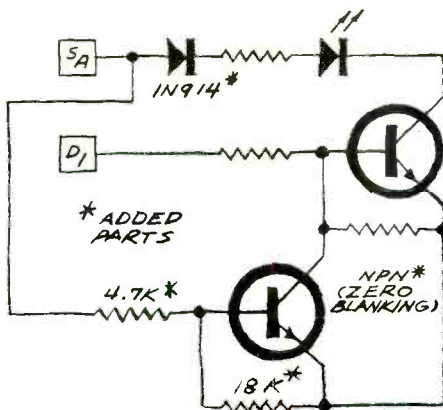

by several mail-order houses advertised in POPULAR ELECTRONICS is a very versatile device. Thus, it was disappointing to discover that the leading zero was not blanked, spoiling the appearance of the display. Having worked out an inexpensive addition to interface the circuit to blank out the leading zero, I thought your readers might be interested.

My add-on circuit (see schematic) consists of one transistor (the same as the driver) two resistors, and a 1N914 diode. Any segment output from the chip can be used except "B" and "C"—which would also blank out the "1"—and "G" (not used for the zero).

WILLIAM E. SCHOEN
Holland, Pa.

ASCII IS NOT A MACHINE LANGUAGE

As a computer science major, I read with interest "ASCII Keyboard and Encoder" (April 1974). However, I must take exception with the statement that ASCII is a machine language. Technically, ASCII is a bit representation of alphanumeric and control information. A machine language, by contrast, is either the internal representation of the opcodes or the external form of the machine's assembly language, depending on who is giving the definition.

DANIEL RUSSELL

MAKING FULL USE OF ALL THE GATES

In "Alarm System for the Popular Electronics Low Cost Digital Clock" (December 1973), the diagram shows one 7404 hex inverter, one 7402 quad 2-input NOR gate, and one 7430 8-input positive NAND gate.

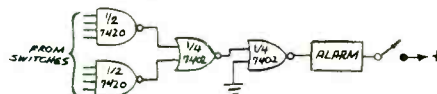

Half of the 7402 is not used. To make full use of all gates, replace the 7430 with a 7420 dual 4-input positive NAND gate, and use the 7402 as shown in my diagram.

JEFF JOHNSON
Rochester, Minn.

WALL-SIZED TV-ONLY \$15⁹⁵

NOW due to a newly developed optical manufacturing technique, you can construct a projector capable of projecting a TV image up to a GIANT 5'x 6' onto a wall or a movie screen.

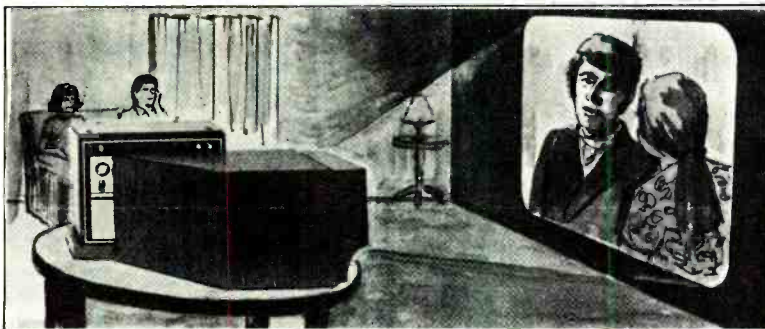

- It works in conjunction with your transistor portable television, any size picture tube up to 15". In full color when used with a color TV set.
- Requires no electrical connection to TV and may be removed in seconds for normal TV viewing.
- Can be assembled in one evening. No electrical or optical knowledge is necessary.
- Kit contains detailed plans, complete instructions, and precision lens system. You supply wood or cardboard, and mirror (obtainable locally for approx. \$1.00).

**GUARANTEED
TO WORK**

**COMPLETE KIT
(including lens)**

\$15.95

SPECIAL BONUS!

Order within the next 10 days and receive "IDEAS FOR YOUR HOME THEATER" FREE!

LAWRENCE A. MYERS CO.

540 Frontage Road, Suite 341, Northfield, Ill. 60093

Please send _____ complete TV projector kit(s) including lens. I enclose \$15.95 plus 55¢ postage & handling for each one. (Illinois residents add 80¢ sales tax, each)

Check M.O. Cash, sent by registered mail

Name _____

Address _____

City _____ State _____ Zip _____

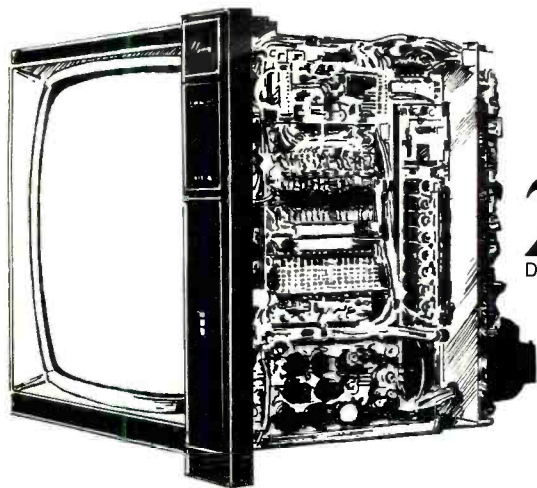

You get the same
25" hobby-kit color
DIAGONAL TV from three
different schools.



You get
this designed-
for-learning
25" color TV only
DIAGONAL
with NRI training.

No other home-study school gives you a TV like the one you build with NRI's Master Course in Color TV/Audio servicing. Some schools give you three or four plug-in sub-assemblies off the production line to put together a commercial set. Others give you a hobby-kit bought from outside sources. And because neither type was originally designed to train people for TV servicing, lessons and experiments must be "retro-fitted" to the set as it comes.

That's why we went to the trouble to engineer our own, exclusive solid-state TV. It's the only way a student can (1) get the feel of typical commercial circuitry, (2) learn bench techniques while building a complete set from the "ground" up, (3) perform over 25 "inset" experiments during construction, and (4) end up with a beautiful 25" diagonal solid-state color TV with wood-grain cabinet and all the modern features for top performance. Nobody else can give you this combination of advantages because nobody else invested the time and money to design a set with learning in mind.



More know-how per dollar

That's what it all boils down to, the quality of training you get for the money you spend. In our 60-year history, almost a million students have come to NRI and we're fully approved for the G.I. Bill. We must be teaching something right.

Some of those "right" things are bite-size lessons to ease understanding and speed learning... personal grading of all tests, with comments or explanations where needed... a full-time staff of engineer/instructors to help if you need it... plenty of "real-life" kits and experiments to give you hands-on training... and fully professional programs oriented to full- or part-time career needs.

NRI passes the savings on to you

This unique TV doesn't cost you more... it costs you less, because NRI engineering eliminates the extra cost of buying from an outside source. NRI training also costs less because we sell only by mail. No salesmen. We pass the savings along to you in the form of lower tuition fees, extras like the TV cabinet (another \$140 with other courses) and a solid state radio you learn on as you build, plus the actual instruments you'll need to service TVs... triggered sweep oscilloscope, integrated circuit TV pattern generator, and digital multimeter. You can pay as much as \$800 more for a similar course and not get a nickel's worth extra in training and equipment.

Widest choice of career opportunities

NRI offers not one, but five excellent TV/Audio servicing courses so you can tailor your training to your budget. Or, you can study other opportunity fields like Computer Electronics, Communications, Aircraft or Marine Electronics, Mobile Radio, and more. Free catalog describes them all, showing lesson plans, equipment and kits, and career opportunities. There's no obligation and no salesman will ever call, so send for your copy today. See for yourself why NRI experience, selection, and exclusives give you something no other school can.

If card is missing, write to:



NRI SCHOOLS
McGraw-Hill Continuing Education Center
3939 Wisconsin Avenue,
Washington, D.C. 20016



New Products

Additional information on new products covered in this section is available from the manufacturers. Either circle the item's code number on the Reader Service Card or write to the manufacturer if the address is given.

3M INTRODUCES NEW LINE OF AUDIO TAPES

A line of audio tapes for the most discriminating audiophiles is now being marketed by the 3M Company under the Scotch brand "Classic" name. The new tapes are said to have more brilliant high-frequency response, excellent low-frequency response, and a higher overall output than previous 3M tapes. The line includes tapes in the popular open-reel, cassette, and 8-track cartridge formats. Each format is said to provide improved performance. The cassette's performance, it is claimed, will be particularly well received. Recorders without a CrO₂ switch (and even those with it, but in the off position) will produce high frequencies superior to low-noise ferric-oxide tapes and low frequencies significantly superior to CrO₂ tapes, according to a company spokesman. Suggested retail prices are \$4.35 for a C-60 cassette; \$5.00 for an 8-track, 90-minute cartridge, and \$12.45 for a 90-minute open-reel tape.

CIRCLE NO. 70 ON READERS SERVICE CARD

ONKYO AUTOMATIC 4-CHANNEL RECEIVER

The latest AM/stereo FM receiver in Onkyo's lineup, the Model TS-500, is described as a fully automatic 4-channel unit.



The heart of the receiver is a logic and analog computer-type circuit that automatically senses the CD-4, SQ, or QS signal coming from the tuner, turntable, or tape deck. The circuit analyzes the signal and automatically routes it to the built-in CD-4 demodulator or appropriate matrix decoder. The receiver is designed to accommodate 2-channel programs and programs in the SQ, QS (RM), and CD-4 (discrete) 4-channel formats. With all four channels driven simultaneously into 8-ohm

loads, output power is specified at 20 watts/channel (rms) over a frequency range of 20 Hz to 20,000 Hz. In the strapped-stereo mode, the amplifier is rated at 50 watts/channel (rms) into 8-ohm loads, both channels driven. Distortion is rated at 0.5 percent, while IM distortion is 0.4 percent. Retail price is \$749.95.

CIRCLE NO. 71 ON READERS SERVICE CARD

POMONA 36-kV CRT TEST PROBE

An advanced version of the self-contained CRT high-voltage test probe with built-in meter has been announced by Pomona Electronics. The model 4000 probe is designed to test all color and monochrome TV receivers with anode voltages up to 36 kV. Small enough to fit into a tube caddy, the probe can be used to make HV adjustments in the home without the need for extra test equipment. Simply connect the ground and touch the probe end to the anode connection; then read the voltage on the meter. Retail price is \$24.95 at most electronics parts distributor outlets.

CDE HAM ANTENNA ROTOR SYSTEM

The Ham II amateur beam rotor system from Cornell Dubilier Electronics Corp. is designed to accommodate antennas and beams with a maximum of 7 sq ft (0.65 sq m) of wind area. The system provides a full

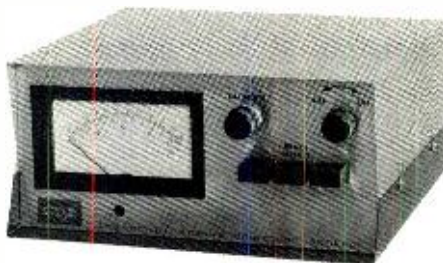

360° range of rotation, while a panel meter indicates accurate positioning. The Ham II has a wedge braking system that is operated independently of the CW and CCW directional controls. (The directional controls will not function until the brake is removed.) An independent brake release is specifically designed to minimize the effects of torsional forces caused by rapid deceleration of large antennas and beams. The bell housing containing the rotor's motor is of cast aluminum to provide complete weather protection. The high-torque motor has a stall-torque rating of 1000 in.-lb to turn the antenna even under severe wind and ice-loading conditions.

CIRCLE NO. 72 ON READERS SERVICE CARD

KINGS ELECTRONICS STRAIN-RELIEF BOOT FOR SMALL COAXIAL CONNECTORS

Junctions between coaxial cable and small, lightweight r-f connectors can now be made fatigue-resistant with a new elastic boot developed by Kings Elec-

tronics Co., Inc. Specifically intended for use with Kings K-grip Jr. cable connectors when mated with RG-174, 122, 58, and 59 cable, the "Flexiboot" protects the cable at the point where it enters the connector and acts as a strain relief. The Flexiboot comes in five different colors to simplify cable identification in multi-cable systems.

CIRCLE NO. 73 ON READERS SERVICE CARD

SANSUI INTEGRATED STEREO AMPLIFIER

The Sansui Electronics Corp. Model AU-6500 stereo amplifier can handle two sets of speaker systems simultaneously. It features high- and low-cut filters, a muting control, and a loudness compensation

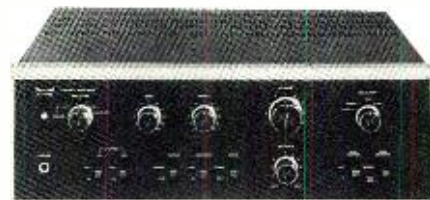

switch. Total harmonic and IM distortion are stated at less than 0.1 percent. The equalized direct-coupled amplifier has a bandwidth of 5 Hz to 40,000 Hz and an input capacity of 300 mV rms. The AU-6500 amplifier permits independent operation of its preamplifier and power-amplifier sections. Power output is specified at 94 watts IHF. Retail price of the Sansui Model AU-6500 stereo amplifier is \$259.95.

CIRCLE NO. 74 ON READERS SERVICE CARD

ROBINS BULK MAGNETIC TAPE ERASER

For erasing every type of magnetic tape, including digital cassettes up to 1/4-in. (6.35-mm) wide, Robins Industries is marketing a new universal bulk eraser that carries UL and CSA approvals. The hand-held Model R24017 eraser is designed primarily for the consumer market for erasing open-reel, cassette, and 8-track cartridge recording tapes, but it is also suited to computer and other commercial applications. A convenient handle permits moving the eraser easily across any reel or cartridge, obliterating the recording in a matter of seconds and eliminating the need for winding and rewinding the tape. The eraser is 2.25 lb (about 1 kg), while retail price is \$26.50.

CIRCLE NO. 75 ON READERS SERVICE CARD

MALLORY ULTRASONIC INTRUSION ALARM

A new ultrasonic intrusion alarm that is both an area and a perimeter protection device is currently being marketed by Mallory Distributor Products Co. as their Model CA3. The alarm employs such features as special circuitry that guards against false tripping by line transients and insects and the capability of using a variety of accessories for virtually any security need. The system features a horn alerting device, a selector switch that can be set for im-

NEW! Build and test circuits as fast as you can think! No soldering or patch cords!

Plug in...wire...modify...build...test



UNIQUE NEW
SNAP/LOCK DESIGN



without soldering for as little as \$3.00

Flexible new Continental Specialties QT SOCKETS® and BUS STRIPS are a fast, easy breadboarding system with unique SNAP/LOCK that lets you add or remove as many QTs as you need instantly. Now you can test ICs, transistors, resistors, capacitors and more. Just plug in, and connect with solid #22 AWG hook up wire... no soldering is needed! No more shorts! No more burnt fingers! No special patch cords! And you can use QTs again and again! QTs come in different sizes, starting as low as \$3 for QT Sockets and \$2 for Bus Strips. Order yours today!

plus, four new completely assembled PROTO BOARDS...

PAT. PENDING

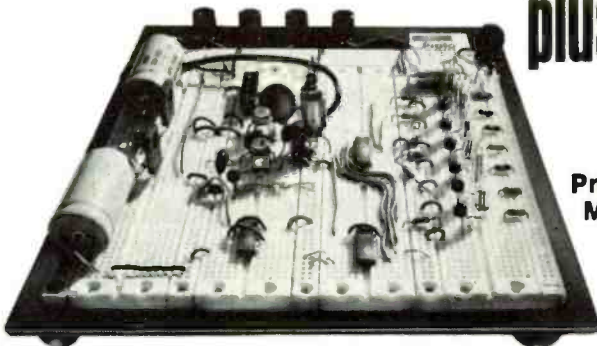

Proto Board Model No.	14 Pin DIP Capacity	Size (L" x W")	Price (U.S. only)
101	10	5.8" x 4.5"	\$29.95
102	12	7.0" x 4.5"	\$39.95
103	24	9.0" x 6.0"	\$59.95
104	32	9.5" x 8.0"	\$79.95

Four new Continental Specialties Proto Boards, made from combinations of QT Sockets and Bus Strips let you make all circuit and power interconnections with common solid #22 wire, while power distribution busses make wiring a snap. Aluminum base plates offer solid work surfaces and perfect ground plane. Rubber feet prevent scratching. Each Proto Board features one or more 5-way binding posts to tie into system or power supply ground. All are compatible with ICs (digital or linear), in TO5s, DIP packs and discrete components. Each is assembled and ready-to-use.

Order today — or send for free selection guide, with applications, photos, specs and more.



Continental Specialties Corp.

325 East St., Box 1942
New Haven, CT 06509
Telephone (203) 624-3103

CANADA: Available thru Len Finkler, Ltd., Downsview, Ontario

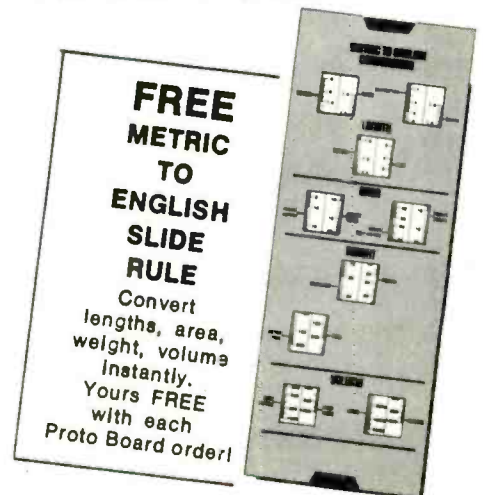

Charge it on your BankAmericard, American Express or Master Charge.

CIRCLE NO. 9 ON READERS SERVICE CARD

Get Less For Your Money.

Yes, we said less. HP's 3 1/2-digit probe multimeter gives you less of the things you'd rather do without. Less worry about knob settings because this unique digital multimeter has AUTO ranging, AUTO zeroing and AUTO polarity. Less weight and bulk... at a scant seven ounces including a rechargeable NiCad* battery, it's fully self-contained and fits in the palm of your hand. Less chance for error because the easy-to-read digital readout is right at the test point. This easy-to-use probe multimeter is so advanced that it's practically fool-proof... yet it costs only \$310*. But get the full story on all the features and benefits you *do* get from HP's 970A probe multimeter... and from its companion scope mentioned elsewhere on this page.

*Domestic U.S.A. price only.

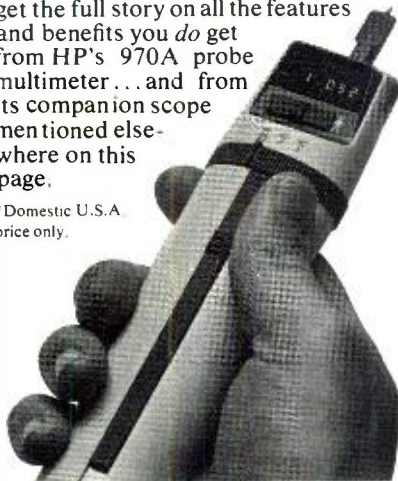

HEWLETT  PACKARD

Sales and service from 172 offices in 65 countries.
1501 Page Mill Road, Palo Alto, California 94306

094-45

PE8/74

Tell me more about your

probe multimeter, scope.

Name _____

Dept. _____

Company _____

Address _____

City _____

State _____ Zip _____

Hewlett-Packard Co.
1501 Page Mill Rd.
Palo Alto, California 94306

CIRCLE NO. 17 ON READERS SERVICE CARD

14

mediate sounding or delayed sounding, an on/off switch for horn alert or silent alarm, remote reset connections, loop connectors for perimeter protection, and a response control that can be adjusted for the length of time movement must occur before the alarm trips. These controls allow the owner to customize the intrusion warning system to his needs. For complete details regarding CA3 alarm system, contact your local Mallory distributor.

LISSON PORTABLE PROBE-TYPE TESTER

The new Versi-Probe multifunction tester from Lisson Electronics provides rapid fault analysis in both digital and analog circuits and is said to eliminate the need for costly test equipment. The compact battery-powered probe can perform many tests now requiring an expensive oscilloscope. It employs a combination of audio and LED indicators to test DTL and TTL circuits, RS232 and CCITT interfaces, communications loops and VF circuits, as well as for testing components. The Versi-Probe has a 1-megohm input impedance, 2-MHz bandwidth, and 50-volt (maximum) peak input specification. Retail price is \$59. CIRCLE NO. 76 ON READERS SERVICE CARD

SCOTT 70-WATT/CHANNEL STEREO RECEIVER

H.H. Scott's Model R77S is a new 70-watt/channel, AM/stereo FM receiver. An all-new MOSFET FM front end replaces the previous FET design to improve sen-



sitivity at all signal levels. The i-f section employs double, 6-pole LC filters to steepen the limiting curve and increase selectivity from 40 to 70 dB, while a phase-locked-loop multiplex section provides a 60-dB S/N ratio in the stereo mode. The new phono preamp circuitry has a high overload threshold and is said to improve the S/N ratio of the phono stages with the cartridge in use. The 70-watt output rating per channel is continuous into 8 ohms from 20 to 20,000 Hz with less than 0.5 percent distortion (both channels driven). Power into 4 ohms is 110 watts/channel. Retail price is \$599.90. CIRCLE NO. 77 ON READERS SERVICE CARD

CHEMTRONICS SILICONE HEAT SINK GEL

A new heat sink compound for use on solid-state electronic equipment has been announced by Chemtronics. Designated the SL-1, the new zinc-oxide-filled silicone gel is said to be ideally suited to heat-transfer applications. Thermal conductivity is rated at 0.428 BTU/ft 2°F/ft. Other im-

portant characteristics of the compound include a high dielectric strength of 500 volts/mil a low dissipation factor of less than 0.005, and capability of withstanding temperatures between -65° F (-53.8° C) and 400° F (205° C). A 1-ounce (28.35 g) squeeze tube contains enough compound for several dozen transistors. Retail price is \$2.15.

CIRCLE NO. 78 ON READERS SERVICE CARD

JVC 8-TRACK CARTRIDGE RECORDER FEATURES AUTOMATIC NOISE REDUCTION

JVC America, Inc., recently introduced what may well be the world's first 8-track record/playback deck with built-in automatic noise-reduction circuitry. In addition to



the noise reduction circuit, the deck has a special fast-forward switch, a pause control, two professional-style VU meters, and two record-level controls. The Model 1245 deck also has selectable automatic program repeat and permits the cartridge eject mechanism to be operated manually or automatically. Retail price of the deck is \$249.95.

CIRCLE NO. 79 ON READERS SERVICE CARD

PANASONIC PUBLIC-SAFETY BAND RECEIVER

The model 1100 five-band portable receiver capable of tuning police, fire, continuous weather, and TV audio broadcasts tops Panasonic's new line of Tech Series portable receivers. The receiver is designed to operate mainly on batteries but has a built-



in power supply that permits it to be line powered. Its coverage includes the uhf/vhf high and vhf low PS bands. Featured are a battery-condition/tuning meter, band selector switch and band indicator, directional AM antenna, telescoping vhf/FM antenna, separate uhf antenna, and 2-hour timer that automatically shuts off the re-

POPULAR ELECTRONICS

ceiver. Controls are provided for power, afc (for FM), squelch, separate bass and treble, loudness, and the timer. Jacks provided include outputs for external-speaker/earphone, multiplex, and recording. Supplied with the receiver are a detachable (adjustable) shoulder strap, earphone, ac power cord, and four D cells at a suggested retail price of \$169.95.

CIRCLE NO. 80 ON READERS SERVICE CARD

PTS ELECTRONICS ALIGNMENT TOOL SET

Recently added to the PTS Electronics, Inc., line of TV-related products is the company's Dura-Seven alignment tool set. This seven-piece glass-filled polymer plastic set includes all the popular alignment tool sizes commonly needed for electronics work. The kit retails for \$2.95.

CIRCLE NO. 81 ON READERS SERVICE CARD

SHURE VOICE-ACTIVATED GAIN CONTROLLER

The Shure Brothers Model M625 Voicegate can be used to combat most of the background noises that plague multiple-microphone tape recording and public address installations. This voice-activated gain controller installs between the microphone and mixer. It attenuates the microphone's output by about 16 dB until



the mike is excited by voice, when it almost instantaneously boosts the mike's output signal to unity gain. This allows all mikes to be on when needed, without ambient noise pickup, danger of feedback, and the need to continuously adjust gain. The circuit can distinguish between human voices and unwanted background noises; attenuate gain below unity until the input signal exceeds a predetermined trigger level; turn on virtually instantaneously without pops, clicks, or switching transients; and hold gain at unity for any predetermined time (from 0.5 to more than 30 seconds) following the final voice sound. Retail price is \$120.

CIRCLE NO. 82 ON READERS SERVICE CARD

SHAKESPEARE CB ANTENNAS

Shakespeare Company's Style 4038 "Thundertwins" antennas offer Citizens Banders a bumper-mounting co-phased whip combination with three-section assembly. The fiberglass antennas are end-

fed half-wave, center loaded. An exclusive Shakespeare Diplexer harness makes each 76-in (1.93-m) antenna act like it is 18-ft. (5.49-m) long. The Thundertwins sell for \$74.50 complete with dual mounts and harness.

CIRCLE NO. 83 ON READERS SERVICE CARD

HALLICRAFTERS SSB/CW TRANSCEIVER

The new Hallicrafters Model FPM-300 Mark II transceiver provides complete coverage for SSB and CW operation on the 80-, 40-, 20-, 15-, and 10-11-meter domestic and international amateur radio bands. This is a complete fixed-station or mobile amateur radio system that can be operated from 12-volt dc or 117/234-volt ac power



sources. Only an antenna and key or microphone are needed to place the transceiver in operation. The single-conversion transmitter and receiver employs a 9-MHz i-f to insure superior image rejection. The transmitter's audio circuit levels are controlled by a compressor to handle a wide range of signal levels. The operator has a choice of VOX or PTT operation on SSB and semi-automatic break-in on CW. A built-in 25-kHz crystal-controlled oscillator provides an accurate frequency reference for dial calibration. Also featured are a six-pole, 2.1-kHz-wide, 9-MHz crystal lattice filter and product detector with crystal-controlled bfo for maximum stability. Price is \$625.

CIRCLE NO. 84 ON READERS SERVICE CARD

ESS BOOKSHELF SPEAKER SYSTEM

The ESS AMT 5 bookshelf speaker system employs a new Heil "power ring" tweeter that has a 16-fold miniaturized diaphragm mounted in a lightweight fiber holder. This driver operates with an air "squeezing" principle that is claimed to provide incredible sound purity. Frequencies beyond 1500 Hz are reproduced by the "power ring" air-motion transformer tweeter, while lower frequencies are reproduced by a 12-in. (30.5-cm) acoustic suspension cone-type woofer. A multi-stage crossover is said to assure virtually perfect blending in the critical midrange. A three-position brightness switch on the rear of the enclosure permits high-frequency adjustments to be made to suit different listening environments. Power-handling capability is rated at 150 watts peak. Frequency range of the system extends from 40 Hz to 24,000 Hz. Retail price of the system is \$189.

CIRCLE NO. 85 ON READERS SERVICE CARD

Get Less For Your Money.

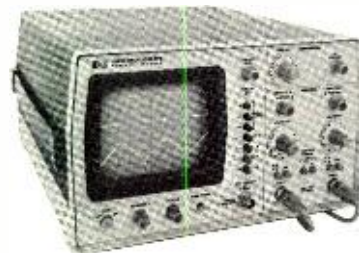

Less reason for those squinting, guessing, knob-twisting measurements with HP's bright, full 5-inch diagonal display. Choose HP's new dual-channel, 15 MHz scope and you'll get all the sensitivity, accuracy and big-scope conveniences you're likely to need. That means less wasted time because the scope is so easy to use. Less weight lifting because it checks out at a mere 15 pounds. And less downtime because the scope meets HP's most rigorous quality standards—and it's backed by HP's worldwide service and support organization. Best of all, it costs less—much, much less—than you might think. Just \$695*. Get all the information on this great buy—and on HP's revolutionary new probe multimeter discussed elsewhere on this page. Send in the coupon today.

*Domestic U.S.A. price only.



Sales and service from 172 offices in 65 countries.
1501 Page Mill Road, Palo Alto, California 94306

02/74

PE8/74

Tell me more about your

scope, probe multimeter.

Name _____

Dept. _____

Company _____

Address _____

City _____

State _____ Zip _____

Hewlett-Packard Co.
1501 Page Mill Rd.
Palo Alto, California 94306

CIRCLE NO. 18 ON READERS SERVICE CARD

FREE

McIntosh CATALOG and FM DIRECTORY

Get all the newest and latest information on the new McIntosh Solid State equipment in the McIntosh catalog. In addition you will receive an FM station directory that covers all of North America.



MX 113

FM/FM STEREO - AM TUNER AND PREAMPLIFIER

SEND TODAY!

McIntosh Laboratory, Inc.
East Side Station P.O. Box 96
Binghamton, N.Y. 13904
Dept. PE

NAME _____
ADDRESS _____
CITY _____ STATE _____ ZIP _____

If you are in a hurry for your catalog please send the coupon to McIntosh.
For non rush service send the *Reader Service Card* to the magazine.

CIRCLE NO. 25 ON READERS SERVICE CARD

Cuts the high cost of metric conversion!

Summit's little electronic MCC does 36 U.S.-metric—metric-U.S. conversions and is a 5-function calculator with memory as well. Its instant accuracy really cuts conversion costs. Rechargeable; includes AC adapter/charger; 1-year warranty.

Only \$79⁹⁵

At your dealer, or order direct:



Summit International Corporation

A subsidiary of Trans Atlas Corporation
P.O. Box 15736 / 180 West 2590 South, Salt Lake City, Utah 84115 U.S.A.
Phone (801) 486-7255 / Telex 388 443 Summit SLC

CIRCLE NO. 41 ON READERS SERVICE CARD

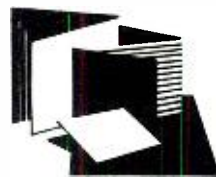

New Literature

SWAN AMATEUR RADIO CATALOG

The "World of Amateur Radio" is the title of a new 20-page catalog from Swan Electronics. The catalog gives features, specifications, and prices on the company's line of transceivers, linear amplifiers, fixed and mobile antennas, and compatible accessories for the ham radio enthusiast. Highlighted are three transceivers, 2-meter FM mobile and base transceivers, 6-meter units featuring SSB/AM/CW operation, and the company's line of High-Q fixed and mobile antennas. Address: Swan Electronics Corp., 305 Airport Rd., Oceanside, CA 92054.

IR TRANSISTOR SUBSTITUTION GUIDE

A handy pocket-sized universal transistor crossover chart is now available from the Semiconductor Division of IRC. Listed on the guide's chart are more than 250 IR and competitive part numbers, permitting the user to quickly select the proper IR transistor that replaces those made by other major manufacturers. The chart lists 48 Sylvania, 45 RCA, 45 GE, and 76 Motorola transistors and their IR replacements. Copies of Chart No. JD-608 can be obtained by writing to: Semiconductor Division, International Rectifier Corp., 233 Kansas St., El Segundo, CA 90245.

SHURE SOUND EQUIPMENT CATALOG

Titled "The Premier Family of Stereo Sound Reproducers," Shure Brothers; catalog No. AL210N fully describes and lists prices of the company's entire current line of phono cartridges. Also described are such accessories as cartridge styli, stylus force gauge, sound preamplifier, tonearms, headphone amplifier, and private-listening sound system. The 14-page catalog includes a two-page "Replacement Stylus Chart" foldout. Address: Shure Brothers Inc., 222 Hartrey Ave., Evanston, IL 60204.

BAYNTON TEST EQUIPMENT CATALOG

Listed in the new 64-page test equipment catalog (No. 38) from Baynton Electronics are specifications and prices for hundreds of test instruments. Oscilloscopes, pulse generators, multimeters, signal generators, Q meters, frequency converters, and dozens of other types of instruments are fully described. Address: Baynton Electronics, 2709 North Broad St., Philadelphia, PA 19132.

The new Mallory CA3 Intrusion Alarm.

Reliable.

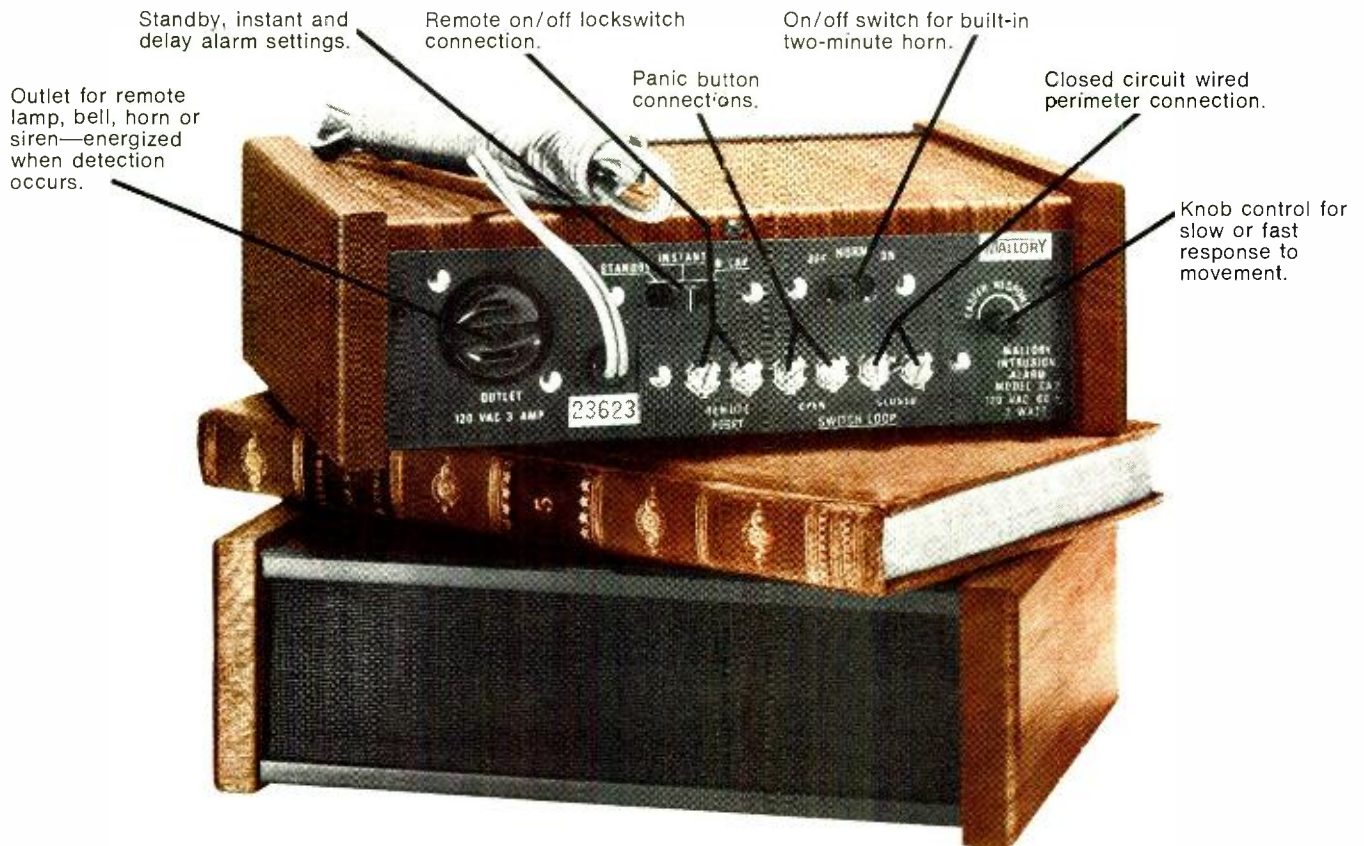

(And inconspicuous.)

This area-and-perimeter device creates and transmits an ultrasonic wavelength field for detection up to a distance of 20 feet. And because of its modern design and walnut-grain finish, the CA3 is attractive and inconspicuous enough to pass as a radio or stereo tuner.

Virtually any movement by an intruder (or a break in the perimeter circuit) activates the built-in horn and the remote outlet for two minutes. An automatic

reset handles the possibility of a new or renewed intrusion. And special CA3 circuitry guards against false alarms from line transients and insects. A variety of companion indoor or outdoor accessory devices is available.

The Mallory CA3 Ultrasonic Intrusion Alarm. From the manufacturer of the most complete line of do-it-yourself security products. Another sound reason to see your Mallory distributor today.

MALLORY

MALLORY DISTRIBUTOR PRODUCTS COMPANY

a division of P. R. MALLORY & CO. INC.
Box 1284, Indianapolis, Indiana 46206; Telephone: 317-261-1501

Batteries • Capacitors • Controls • Security Products • DURATAPE • Resistors • Semiconductors • SONALERT • Switches • Timing Devices and Motors

DURACELL® DURATAPE® and SDNALERT™ are registered trademarks of P. R. Mallory & Co. Inc.

The better the the better you'

And
you can
get started
for just
\$10.

COMPU-TRAINER

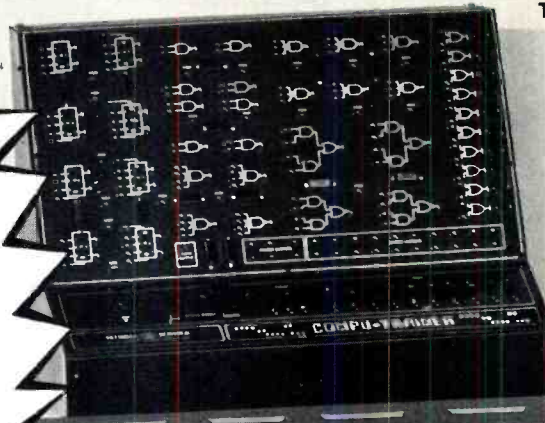

TUBE & TRANSISTOR
TESTER



SOLID STATE
OSCILLOSCOPE



DIGITAL
MULTIMETER

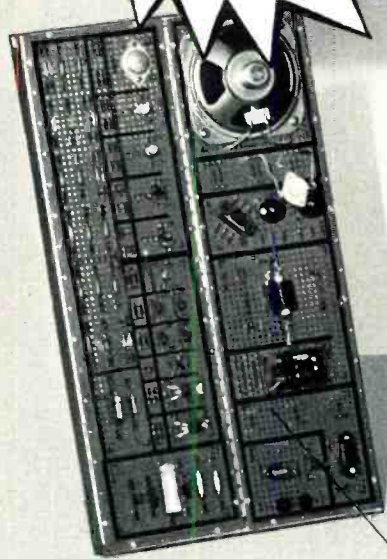

ELECTRO - LAB

NTS DIGITAL GR-2000 SOLID STATE
COLOR TV WITH 315 SQ. IN. PICTURE
AND VARACTOR DIGITAL TUNING

TROUBLESHOOTER
VOM

Only \$10 down gets you into any NTS Home-Study Courses in Electronics.* Just \$10 that can lead to a top-dollar job, a big, bright career in electronics.

As an NTS student, you'll acquire the experience and know-how that comes with first hand training on NTS "pro" equipment. Equipment you'll build and keep. Our courses include equipment like the 5" solid-state oscilloscope, a transistor and tube-tester, a vector monitor scope, 74 sq. in. B&W TV, or a solid-state stereo AM-FM receiver. The unique

new **NTS Digital GR-2000 Color TV** with first-ever features like silent varactor diode tuning; digital channel selection, digital clock, an option at additional cost; and big 315 sq. in. ultra rectangular screen. This is just a sampling of the kind of better equipment that gets you better equipped for the electronics industry.

By following the easy-to-read NTS lessons, you learn the theory behind these tools of the trade. You'll learn and develop skill and confidence fast.

*Not including Advanced Color TV Servicing

equipment will be equipped.

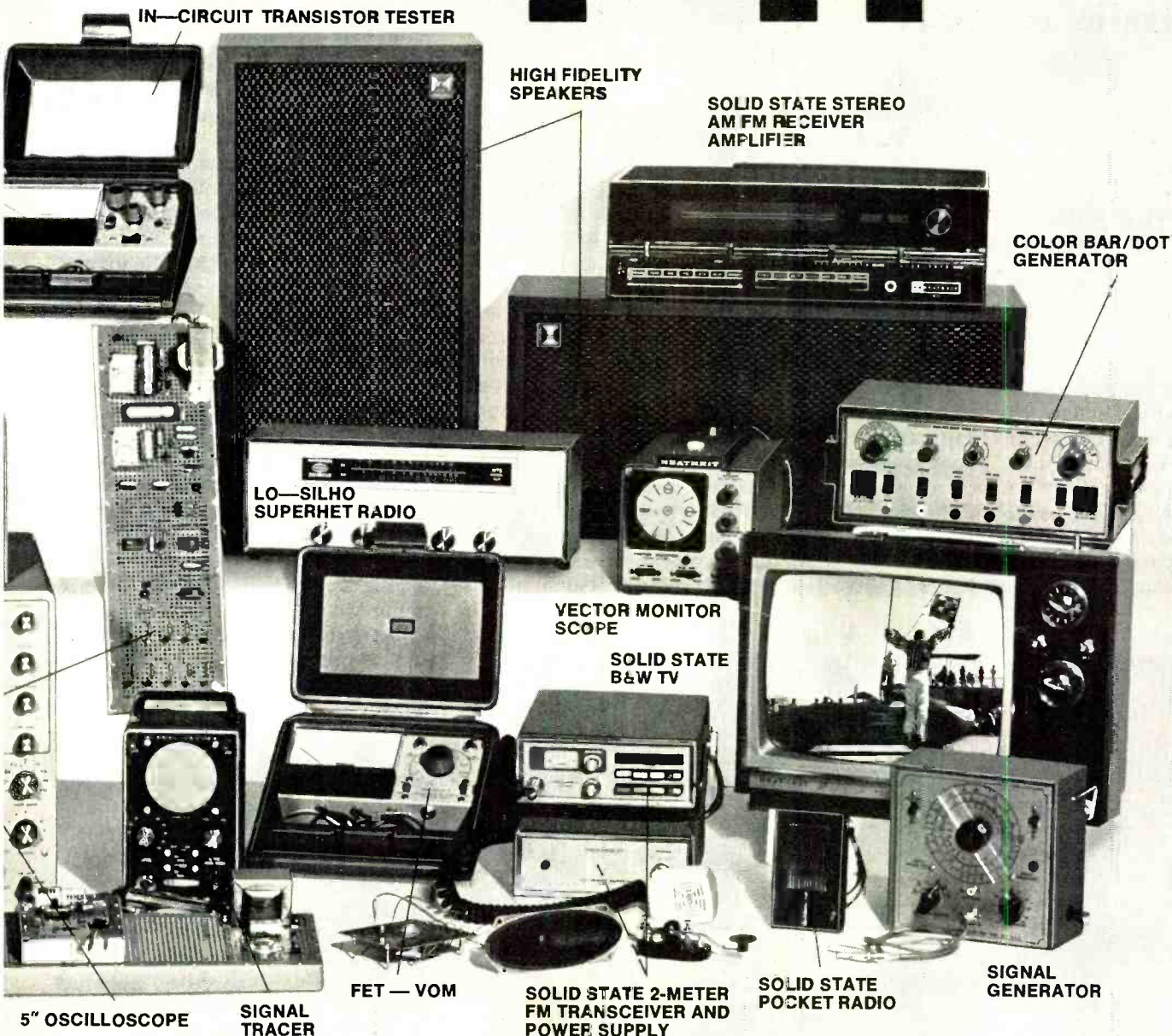

Choose from 12 NTS Electronics Courses, including Color TV and B&W TV Servicing, Electronics and Computer Technology, Electronics Communications & FCC, and Industrial & Automation Electronics. All courses can provide you excellent opportunities to expand your career in the exciting world of electronics! So get started right now by checking the coupon and mailing it today.

Classroom Training at Los Angeles. You can take classroom training at Los Angeles in sunny Southern California. NTS occupies a city block with over

a million dollars in facilities devoted exclusively to technical training. Check box in coupon.

Approved for Veteran Training. Accredited Member: National Association of Trade & Technical Schools; National Home Study Council

NATIONAL TECHNICAL SCHOOLS

TECHNICAL-TRADE TRAINING SINCE 1905
Resident & Home Study Schools
4000 South Figueroa St., Los Angeles, Calif. 90037

the other one outside. Keep room furnishings from obstructing the speakers. If you've succeeded in all this, a mono signal switched from one to the other should sound much the same. If it doesn't, the mid- and high-frequency level controls on the speakers can sometimes be used to make effective adjustments.

Third, if one or more walls are stiffer than the others, always put the speakers against the stiffer walls. If this is impossible, use an adjacent wall. Try hard to avoid putting a speaker opposite (i.e., facing) a stiff wall, because

this will inevitably give rise to the fierce resonant condition known variously as a "standing wave," *eigentone*, or simply "room mode."

The Eigentone Structure. Average-size rooms have dimensions corresponding to the wavelengths (and their multiples and fractions) of musical frequencies. For example, the frequency of 56.5 Hz has a wavelength (in air) of about 20 feet. When a speaker at one end of a 20-foot room emits that tone steadily, each wave races down the room, is reflected by the far wall,

and arrives back at the speaker precisely in phase with the speaker's output a full cycle later. This serves to strengthen the loudness of the tone in the room considerably, at the expense of all other tones within that octave. If we drop the tone an octave in frequency, to about 28.2 Hz, essentially the same thing happens. (See Fig. 1 on previous page.)

The insidious thing about a room mode is that it reinforces only one tone of an octave. All other tones arrive back at the speaker out of phase, in varying degrees, with its immediate output, so a certain amount of *anti*-reinforcement (cancellation) occurs. The audible effect, with an organ pedal working its way steadily down the scale, might be something like: fine, okay, a noticeable weakening, almost nothing, a little stronger, a veritable sonic earthquake, and then a decline again.

Both the reinforcements and the cancellation are due to the same cause — a large, highly reflective surface at some distance from the speaker. This is the reason for the cautionary note about placing a speaker opposite a stiff wall. Such a wall will be an excellent reflector, whereas a flimsy wall might absorb or pass most of the sound energy, leaving little to make the return trip. On the other hand, putting the speaker against the stiff wall will reinforce (by the megaphone effect) *all* the bass frequencies without giving rise to serious resonances. (There will probably be at least one *measurable* resonance, however, occurring over the relatively short sound-path length between the woofer and the wall immediately behind. But if so, this would be unavoidable no matter which wall was used.)

Any of a room's dimensions—even the diagonals between corners—can give rise to an audible resonant mode, at specific frequencies. The sum total of all the modes of which a room is capable is sometimes called its "eigentone structure." A simple eigentone structure can actually be calculated by dividing 565 by each room dimension in feet. This will give the *lowest* frequency capable of exciting each dimension into resonance. Then multiplying that frequency by 2, 3, 4, etc., gives the higher harmonics, which might also be involved. Frequencies above about 200 Hz can safely be ignored. Wavelengths have then become so short that numerous resonant interactions constantly take place, resulting in a "clutter" of random phase interferences throughout the room.

soundcaster



■ **AM Broadcaster**

Use any AM radio to hear cassette recordings.

■ **FM Converter**

Hear your portable FM radio through your car or home radio speakers.

■ **TV Converter**

Your TV will produce concert hall sound when used with Soundcaster.

How would you like to own your own radio station? Now you can, with the new electronic miracle, Soundcaster. It is one of the most amazing products of the electronic age.

What is Soundcaster? It is a transmitting device, which will broadcast the sound of your cassette player, T.V., or FM radio over an AM frequency between 1500 and 1600 KC. All you have to do is plug the Soundcaster into the earphone jack of any sound device, and you can use your car radio or AM/FM stereo to make the sound of your portables fuller and richer than you ever imagined... All without wires or connections. It's really amazing! Soundcaster can be used in your home, in your car, or anywhere. It makes the sound of even the tinniest cassette or FM portable as full and rich as an expensive sound system.

Amaze your friends.... Play your own pre-recorded "radio shows" over any AM radio, anytime. Simply record your voice, music, or any program material, on a cassette, and broadcast it with Soundcaster. Order your Soundcaster today so you can start "Soundcasting" tomorrow!

ONLY **\$12⁹⁵**

**BUY WITH CONFIDENCE
30 DAY MONEY-BACK GUARANTEE**

Gray Matter Inc., 565 Fifth Avenue,
Dept. PB-695, New York, N.Y. 10017

Please rush me _____ amazing Soundcasters
@ \$12.95 plus 50¢ shipping and handling.

SAVE! Order TWO for only \$23.95 plus 80¢ shipping and handling.

SAVE MORE! Give as gifts! Order FOUR for only \$39.95 plus \$1.50 shipping and handling.

Enclosed is check or money order for \$ _____
(N.Y. residents add sales tax)

PRINT NAME _____

ADDRESS _____

CITY _____ STATE _____ ZIP _____

World's Smallest Radio Station

- Battery operated
- Attaches easily & quickly
- No wires or connections needed
- No more tinny sound
- No tools necessary

This simple invention does the trick

- Q. Is the Soundcaster a portable unit?
- A. Definitely yes! Soundcaster weighs only 4 ounces and will fit in the palm of your hand. It requires no electric outlet because it is powered by a standard 9 volt battery. It needs no permanent connections so you can take it anywhere.
- Q. Will it work on foreign as well as domestic portables?
- A. Soundcaster is compatible with any sound device with a standard earphone jack.
- Q. What is the frequency response of the Soundcaster?
- A. 200 Hz to 10 KHZ, ±3DB.
- Q. Is the broadcasting frequency adjustable?
- A. Yes, the minimum tuning range is 1500 KHZ to 1600 KHZ.
- Q. Will I get much distortion?
- A. No, less than 1% at 1KHz.
- Q. Will it work in my car?
- A. You won't believe your ears! Soundcaster will turn your car into a concert hall. Just plug it into your FM portable or cassette player and you'll be amazed.

And the clutter tends to average out in the end.

If all this seems very formidable, perhaps you can take heart from the following: (1) It's extremely unlikely that all the possible modes of a room will give audible trouble. The formation of a mode depends, among many other things, on the stiffness of the reflecting wall, the ability of the speaker to reproduce the offending tone in the first place, and even whether or not the tone corresponds closely to a note on the musical scale. (2) A resonant mode is a local condition that won't be heard everywhere in the room. Moving yourself or the speakers to another location often gets rid of it. (Although this can also, of course, create others). The most persistent modes are likely to be those occurring between parallel walls, and particularly between the speaker wall and the surface opposite, against which you'll probably be sitting. So if you follow the above rules in placing the speakers, you'll have given yourself the best chance of avoiding trouble. Other modes are probably not worth trying to predict in advance. Deal with them as they occur, walking around the room to locate the spots where they are least audible, and moving you listening position or the speakers as much as necessary in the direction of these quiet areas.

Incidentally, the rationale behind the "ideal" room proportions given earlier is that they will serve to distribute the resonant modes evenly throughout the low-frequency spectrum. If standing waves seem hopeless in a particular room, choosing another with proportions more closely approximating the ideal may very well help and could certainly be tried.

Mids And Highs. The effect of the listening room on mid and high frequencies has to do with the sound absorption — or lack of it — the room presents at those frequencies. The absorption usually comes from the furnishings. Bare plaster and uncarpeted floors absorb little sound; a totally empty room usually "rings" like a tile bathroom whenever a noise is made in it. The addition of carpets, drapes, upholstered furniture, and other soft, porous materials subdues the room by soaking up rather than reflecting the impinging sound energy. Shortly, the snarling, reverberant quality disappears, and speech and music become clearer and more intelligible. The highest frequencies are usually affected first. Thicker materials in greater quan-

Inside each of our 4-channel cartridges

AT12S
\$64.95

AT15S \$100.00 ■ AT20SL \$175.00

AT14S
\$75.00

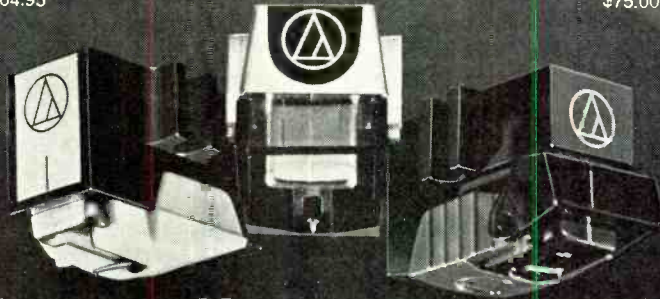

lurks a Dual Magnet stereo cartridge waiting to please you.

Our sophisticated four-channel cartridges* are also stereo cartridges at heart. Very good ones. With ruler flat response, outstanding stereo separation (especially above 1 kHz where it counts), and truly impressive high frequency tracking.

All these advantages are as important to good stereo as they are essential to CD-4. And they can be achieved

only by paying very close attention to detail. And using only the best. Like a genuine Shibata stylus. Nothing less. The results are good for any record... whether stereo, matrix, or discrete 4-channel. But you should really hear for yourself. Write today for our dealer list. No matter how many channels you want to hear best.

*U.S. Pat. Nos: 3,720,796; 3,761,647
†Shibata stylus Pat. No. 3,774,918



audio-technica®

AUDIO-TECHNICA U.S., INC., Dept. 84P, 33 Shilawsee Ave., Fairlawn, Ohio 44313
In Canada: Superior Electronics, Inc.

CIRCLE NO. 4 ON READERS SERVICE CARD

Who Says Audiophile Components have to be Expensive?

No one really says so, but most people think so. The SAE Mark XXX Stereo Preamplifier and Mark XXXIB Stereo Power Amplifier offer the highest engineering excellence and quality parts available at a moderate price.

To find out what makes these units the most sought after components, fill out the coupon and mail today.

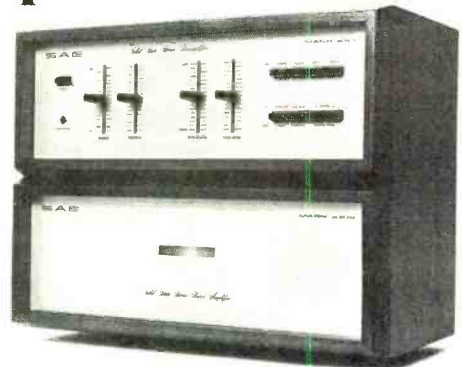

SAE
*Components
for the
Connoisseur*

SAE, Inc., Electronics Division (574)
P.O. Box 60271, Terminal Annex, Dept. PE-874
Los Angeles, California 90060

Gentlemen:

Please rush free information on the Mark XXX and Mark XXXIB by return mail.

Name

Address

City State Zip

The Ultimate in Ignition Systems!
 ★ **ELIMINATES BREAKER POINTS.**
 Perfect Timing and Dwell never change!

★ **Eliminates Tune-ups.**
 Never wears out or needs any Maintenance.



★ **The Most Advanced "OPTO-ELECTRIC SYSTEM"**

- The Allison Breakerless System eliminates the Points and Condenser, replacing them with an Opto-Electronic Trigger, using a Light-Emitting Diode and Phototransistor. Also completely eliminates wiper-arm "friction" wear. The only "TRUE" Electronic Ignition ... that you can install for under \$100. Gives 40-times more Timing Accuracy than ANY system using mechanical Breaker-Points! Unlimited RPM. Smoother running. (No timing fluctuation as with Magnetic units). Unaffected by Temperature, Moisture, or Vibration! All Solid-State Components. Easier Starting under any condition! Increased Horsepower. Sparkplugs last longer. Perfect timing increases engine Efficiency and Gas Mileage up to 30%!
- **Quick and Easy Installation!**
- ★ **Tested and Proven reliability.**

Only **\$49.95** ● **SATISFACTION GUARANTEED!**
 ● Complete. ● **1-YEAR FACTORY WARRANTY.**
 (State Make, Year, Engine Size). (Calif. Res. add Tax).

● **CONVERT YOUR "C-D" UNIT TO BREAKERLESS!**
 "TRIGGER-UNIT" ONLY \$34.95

★ **Send Postcard for FREE BROCHURE Today.**
ALLISON AUTOMOTIVE CO.
 P. O. Box 881-P, TEMPLE CITY, CAL. 91780

CIRCLE NO. 1 ON READERS SERVICE CARD

LARGE-LARGE DISCOUNTS LOW - LOW PRICES

NATIONALLY ADVERTISED STEREO EQUIPMENT AT LOWEST PRICES!

TURNABLES * SPEAKERS * RECEIVERS
 AMPLIFIERS * TAPE RECORDERS

WRITE FOR QUOTE ON
 NATIONALLY ADVERTISED BRANDS OF STEREO COMPONENTS. SATISFACTION GUARANTEED!

Clifford's
HI-FI WHOLESALERS
 231 W. COURT ST.
 Kankakee, Illinois 60901
 (815)-939-7868

CIRCLE NO. 8 ON READERS SERVICE CARD

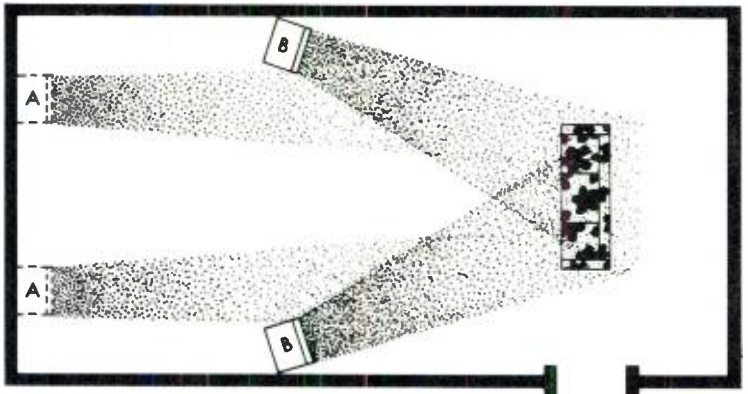

Fig. 2. "Toeing in" the speakers and moving them from locations A to locations B increases the level of high-frequency energy at the listening area. Precise positioning depends on room-mode activity.

ties begin to reach down into the mid-range, and may ultimately have some effect on the upper bass region.

Absorption problems generally come in two varieties. The first is that of the overly "live" room, which imparts a harsh, piercing, glaring quality to the sound. The usual diagnosis for this condition is too little absorption overall, and the cure is finding the time and money to install more "padding," with the greatest emphasis on large expanses of hitherto untreated surface (bare walls, for example).

The second problem involves an absence of the sparkle and "liveliness" contributed by the highest audible frequencies. The sound may be dull, and in extreme cases "murky." A room that exhibits these characteristics is frequently called "dead," and the trouble is usually attributed to too much high-frequency absorption. Actually, in more instances than not, the problem is too little mid-frequency absorption. (A truly "dead" room sounds extremely good with recorded music, although it is not very satisfactory for live performances.) A little explanation is in order here.

Room reflections appear to do very little in supporting frequencies from about 8,000 Hz up. These extreme highs are fragile. Even the molecular friction of their passage through air takes a surprisingly rapid toll. As a result, what we hear of them is largely the energy that has traveled *directly* from tweeter to ear. Whether the room is live or absorptive makes little difference — unless, of course, something has been done to obstruct the tweeter.

Mid-frequencies, of course, are augmented by room reflections. Should they get too much support, they'll simply mask the highs into un-audibility, which results in "muddy" sound. The best remedy, as in the case

of any live room, is more absorption at the appropriate mid-frequencies.

Intelligent acoustical treatment involves a close study of materials and their absorptive properties at various frequencies. This will have to wait for a later column. But in the interim there are a couple of simple tricks that frequently help with murky sound. The first, especially effective when the speakers are directional at the high frequencies and tend to "beam" them straight forward, is simply to "toe" the speakers in — to angle them directly at your listening position, as in Fig. 2, instead of placing them flat against the wall. This arrangement is fairly popular in Europe for several reasons. In the U.S., however, it seems to violate some sanctified principle of decor.

Second, try getting yourself closer to the speakers, or the speakers closer to you. In long rooms where speakers and listeners face each other across the large dimension, it's often possible to bring the speakers forward along the side (long) walls (Fig. 2 again). This means that the sides of the cabinets will be against either wall, with the frequently unsightly backs exposed to view. This can't be helped, however. Besides, the scheme confers several other benefits. The woofer will now be right next to the wall, which often does away with the woofer-to-nearest-reflecting-wall resonance mentioned earlier. Also, the freedom of forward-and-back positioning sometimes provides a creative means of dealing with other persistent room modes.

I've had such good luck with side-wall placement of speakers that I'm tempted to recommend it to everyone. But the fact is that it just won't work in some rooms, either locating the speakers too far apart for good stereo, or involving other complications in some cases.

NEWS HIGHLIGHTS

Color TV Anniversary

Just over twenty years ago commercial color television was born as an industry. The initial sets were bulky 15-inch console receivers with a suggested retail price of \$1000. By the beginning of this year, the total color sets in use stood at an impressive 52.6 million. From practically zero in 1954, color TV grew to the point where two out of every three U.S. households in 1973 had at least one color set. By 1980, this penetration is expected to reach 90 per cent.

New Process for "Noiseless" Disc Recordings

A new disc-recording technique which is said to offer a solution to both tape-hiss carry-over and record surface noise has been announced by dbx, Inc. The decoding of the disc would be done at the point of playback either by an add-on decoder or by decode circuitry built into consumer preamps and receivers (as with the Dolby B system for tapes). Claimed advantages to the listener include: preservation of the full dynamic range of the original musical material, complete rejection of the inherent surface noise of the record medium, and substantial reduction of the perceived loudness of random clicks and pops in playback.

EIA to Furnish New Solid-State Color Sets to Schools

Schools participating in the 1974 EIA Service Technician Development Program will be supplied new solid-state color-TV sets to replace their older inventory of mostly tube-type sets. Sixteen schools geographically spaced across the U.S. will present 23 sessions in 1974, as part of the six-year-old Service Technician Development Program. Attending the schools will be more than 500 high school vocational and industrial arts teachers who will, in turn, present classes in consumer electronic servicing to more than 2500 students in the next school year.

An LSI Linear IC for CD-4 Demodulation

An LSI linear integrated circuit for the purpose of CD-4 discrete record demodulation has been announced by QuadraCast Systems. This IC performs all the demodulation functions required as well as all the necessary circuits for a high-quality, low-noise phono preamp. The subsystems include: wide-range preamp, high-gain FM limiter, phase-locked loop FM detector, carrier detec-

tor, an indicator, expander system, front-to-back differencing circuit, output buffer amplifier, and internal reference supply. Two of these IC's together with a handful of discrete components make a low-cost, high-quality 4-channel demodulator. The devices are being distributed by the Industrial Division of Matsushita Electric Corp., 200 Park Ave., New York, N.Y. 10017.

Flameproof Resistors For Safety

A new line of flameproof film resistors has been introduced by RCA Parts and Accessories Division. The resistors won't flame or short under the most severe overloads, according to the company. There are 61 standard resistance values, ranging from 10 ohms through one megohm in ½-watt, 1-watt, and 2-watt ratings.

\$1-Million Anti-Ham Lawsuit

A group of neighbors in Yorktown Heights, New York, filed suit against a radio amateur, charging interference with TV, radio and/or telephone receptions, invasion of privacy, mental anguish, et al. The defendant's system is said to have line filters in ac lines to both the exciter and linear to minimize r-f interference. It's estimated that the ham, who's retired on a police pension, will have to spend over \$3,000 to defend himself. The Harmonic Hill Radio League, Box 73, Katonah, New York 10536, set up a bank account to accept donations to be used to offer financial assistance to W20VC.

Overseas Tape "Letter" Mailing Requirements

Sound cassettes and three-inch open reels sent *overseas* in Post Office-approved plastic mailers must now be enclosed in an envelope. The 3-inch x 4¼-inch plastic mailers are still fine for domestic mailing, but fall short of the 3½ x 5½ minimum parcel size established recently for international mailing.

Will U.S. Recapture the Radio Market?

According to Lester Hogan, president of Fairchild Camera and Instrument, the U.S. will recapture the AM/FM radio market from Japan. Fairchild Camera and Instrument is currently working on a one-chip AM/FM radio to prove the feasibility of this type of device. This chip along with increased sales to eastern European countries should increase the use of U.S. IC's in the radio market.

CIE graduate builds two-way radio service business into \$1,000,000 electronics company!

How about YOU? Growth of two-way transmitters creates demand for new servicemen, field and system troubleshooters. Licensed experts can make big money. Be your own boss, build your own company. And you don't need a college education.

Two-way radio is booming. There are already nearly seven million two-way transmitters for police cars, fire department vehicles, taxis, trucks, boats, planes, etc., and Citizens Band uses. And the number keeps growing by the thousands every month. Who is going to service them? You can – if you've got the know-how!

Why You'll Earn Top Pay

One reason is that the United States Government doesn't permit anyone to service two-way radio systems unless he's *licensed* by the FCC (Federal Communications Commission).

Another reason is that when two-way radio men are needed, they're *really* needed! A two-way radio *user* must keep those transmitters operating at all times. And, they *must* have their frequency modulation and plate power input checked at regular intervals by licensed personnel to meet FCC requirements.

As a licensed man, working by the hour, you would usually charge at least \$5.00 per hour, \$7.50 on evenings and Sundays, plus travel expenses.

Or you could set up a regular monthly retainer fee with each customer. Your fixed charge might be \$20 a month for the base station and \$7.50 for each mobile station. Studies show that one man can easily maintain at least 135 stations – averaging 15 base stations with 120 mobiles! This would add up to at least \$12,000 a year.



Edward J. Dulaney, Scottsbluff, Nebraska, (above and at right) earned his CIE Diploma in 1961, got his FCC License and moved from TV repairman to lab technician to radio station Chief Engineer. He then founded his own two-way radio business. Now, Mr. Dulaney is also President of D & A Manufacturing, Inc., a \$1,000,000 company building and distributing two-way radio equipment of his own design. Several of his 25 employees are taking CIE courses. He says: "While studying with CIE, I learned the electronics theories that made my present business possible."

Be Your Own Boss

There are other advantages, too. You can become your own boss – work entirely by yourself or gradually build your own fully staffed service company. Of course, we can't promise that you will be as successful as Ed Dulaney, or guarantee that you'll establish a successful two-way radio business of your own, but the opportunities for success are available to qualified, licensed men in this expanding field.

How To Get Started

How do you break in? This is probably the best way:

1. Without quitting your present job, learn enough about electronics fundamentals to pass the Government FCC exam and get your Commercial FCC License.
2. Then get a job in a two-way radio service shop and "learn the ropes" of the business.
3. As soon as you've earned a reputation as an expert, there are several ways you can go. You can move *out* and start signing up and servicing your own customers. You might become a franchised service representative of a big manufacturer and then start getting into two-way radio sales.

Cleveland Institute of Electronics has been successfully teaching Electronics for over 37 years. Right at home, in your spare time, you learn Electronics step by step.

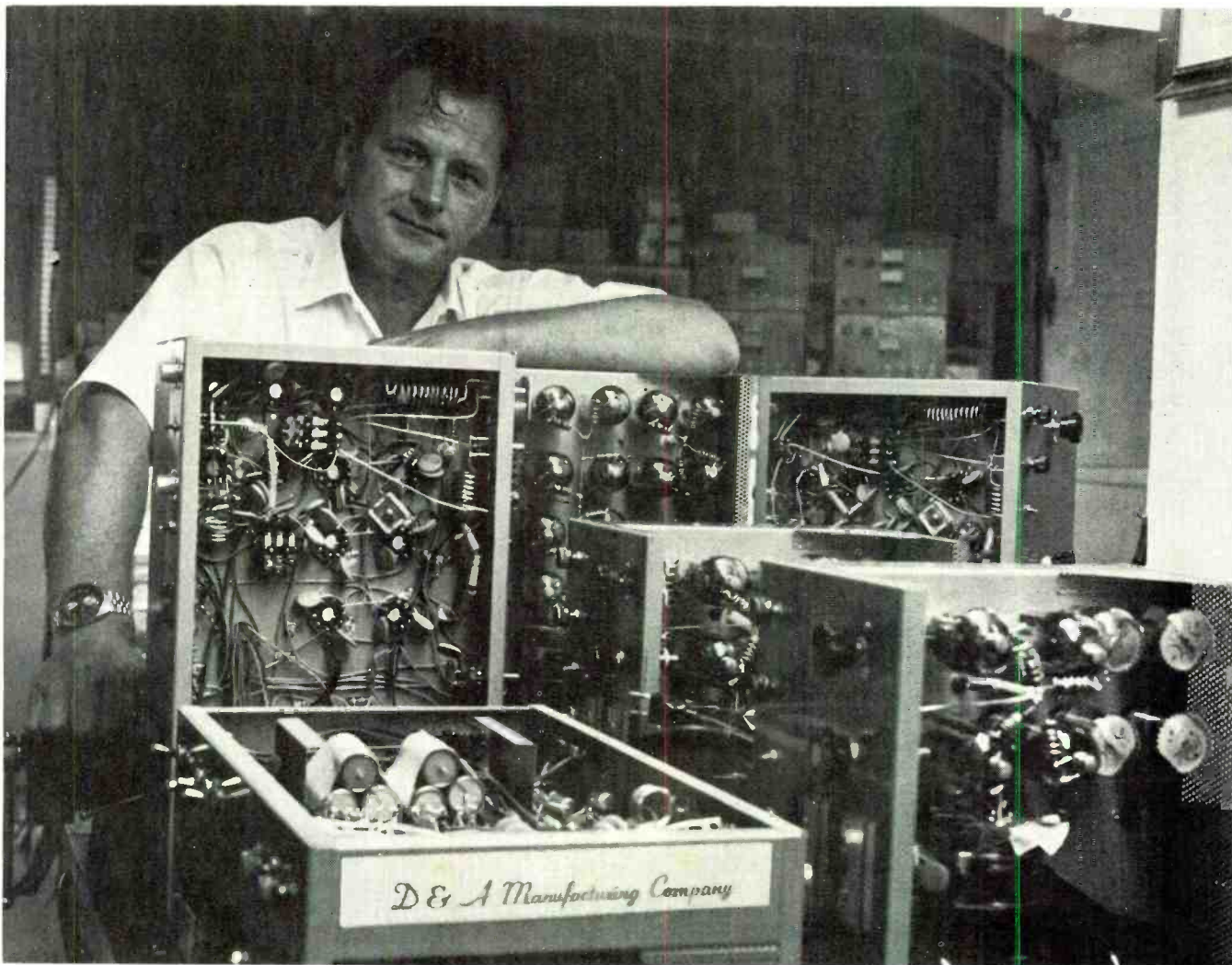

CIE's AUTO-PROGRAMMED® Lessons remove the roadblocks by using simple, concise examples. You learn in small, compact steps — each one building on the other!

You'll learn not only the fundamentals that apply to all electronics design and servicing, but also the specific procedures for installing, troubleshooting, and maintaining two-way mobile equipment.

You Get Your FCC License... or Your Money Back!

By the time you've finished your CIE course, you'll be able to pass the FCC License exam. A recent survey of 787 CIE graduates reveals that better than 9 out of 10 CIE grads passed the FCC License exam. That's why we can offer our famous Money-Back Warranty: when you complete any CIE licensing course, you'll be able to pass your FCC exam or be entitled to a full refund of all tuition paid. This warranty is valid during the completion time allowed for your course. You get your FCC License — or your money back!

It's Up To You

Mail the reply card for two FREE books, "Succeed in Electronics" and "How To Get A Commercial FCC License." For your convenience, we will try to have a representative call. If card has been removed, mail coupon or write: Cleveland Institute of Electronics, Inc., 1776 E. 17th St., Cleveland, Ohio 44114.

APPROVED UNDER G. I. BILL

All CIE career courses are approved for educational benefits under the G.I. Bill. If you are a Veteran or in service now, check box for G.I. Bill information.



CIE Cleveland Institute of Electronics, Inc.

1776 East 17th Street, Cleveland, Ohio 44114
Accredited Member National Home Study Council

Please send me your two FREE books:

1. Your book on "How To Get A Commercial FCC License."
2. Your school catalog, "Succeed in Electronics."

I am especially interested in:

<input type="checkbox"/> Electronics Technology	<input type="checkbox"/> Electronic Communications
<input type="checkbox"/> Broadcast Engineering	<input type="checkbox"/> Industrial Electronics
<input type="checkbox"/> First Class FCC License	<input type="checkbox"/> Electronics Engineering
<input type="checkbox"/> Electronics Technology with Laboratory	

Name _____ (Please Print)

Address _____

City _____

State _____ Zip _____ Age _____

Veterans & Servicemen: Check here for G. I. Bill information

PE-61

We'd like to help you recognize real high fidelity.



With the profusion of music systems available, it's often quite difficult to select real high fidelity. Comparing the sounds of different brands may seem to be a sensible procedure, yet it can be mighty confusing.

So, we're giving you one way to recognize real high fidelity. Just look for the seal of the Institute of High Fidelity. It's your assurance that the product you select is de-

signed by manufacturers dedicated to produce natural sound.

Manufacturers whose equipment carries this seal are committed to the ideals of high performance in the reproduction of sound.

Become an expert in choosing high fidelity. Look for the seal of the Institute of High Fidelity. It will help you eliminate the confusion from the profusion.

INSTITUTE OF HIGH FIDELITY, INC.

516 Fifth Avenue, New York, N.Y. 10036

Breakthrough Project!

Now you can convert any oscilloscope to display alphanumeric with this unique under \$50 character generator



the "Scopewriter"

BY GARY STEINBAUGH

WE HAVE all been fascinated, at one time or another, by those video displays in banks and airline offices that print out alphanumeric information received from a central computer. Now you can have your own character generation system at low cost. With it, you can communicate with a fellow hobbyist over the telephone lines. Your messages to each other can be printed out on a standard oscilloscope CRT. And, if you're a ham, character-coded messages can be sent and received over the air, with CRT printout. The system can also be an inexpensive boon for the deaf and mute, of course.

The "Scopewriter" will display any of 64 different characters in a message up to 32 characters long on a common CRT. (It can be used with a TV screen,

but the application is somewhat more complex.) The Scopewriter uses large-scale integrated circuits so it is easy to build and it can be very simply connected to the scope's Y-axis input. Although it uses switch addressing, it will accept conventional ASCII keyboard inputs. (See "ASCII Keyboard and Encoder," April 1974.)

It is not necessary to use the Scopewriter with special display oscilloscopes because of the sweep and blanking techniques employed. The scope's internal sweep supplies horizontal deflection while a ramp generation circuit supplies vertical deflection to form a raster. When the logic indicates a space, the ramp is disconnected and the scanning dot is rapidly deflected beyond the top of the screen. The resulting vertical traces are very



CONSTRUCTION PROJECT

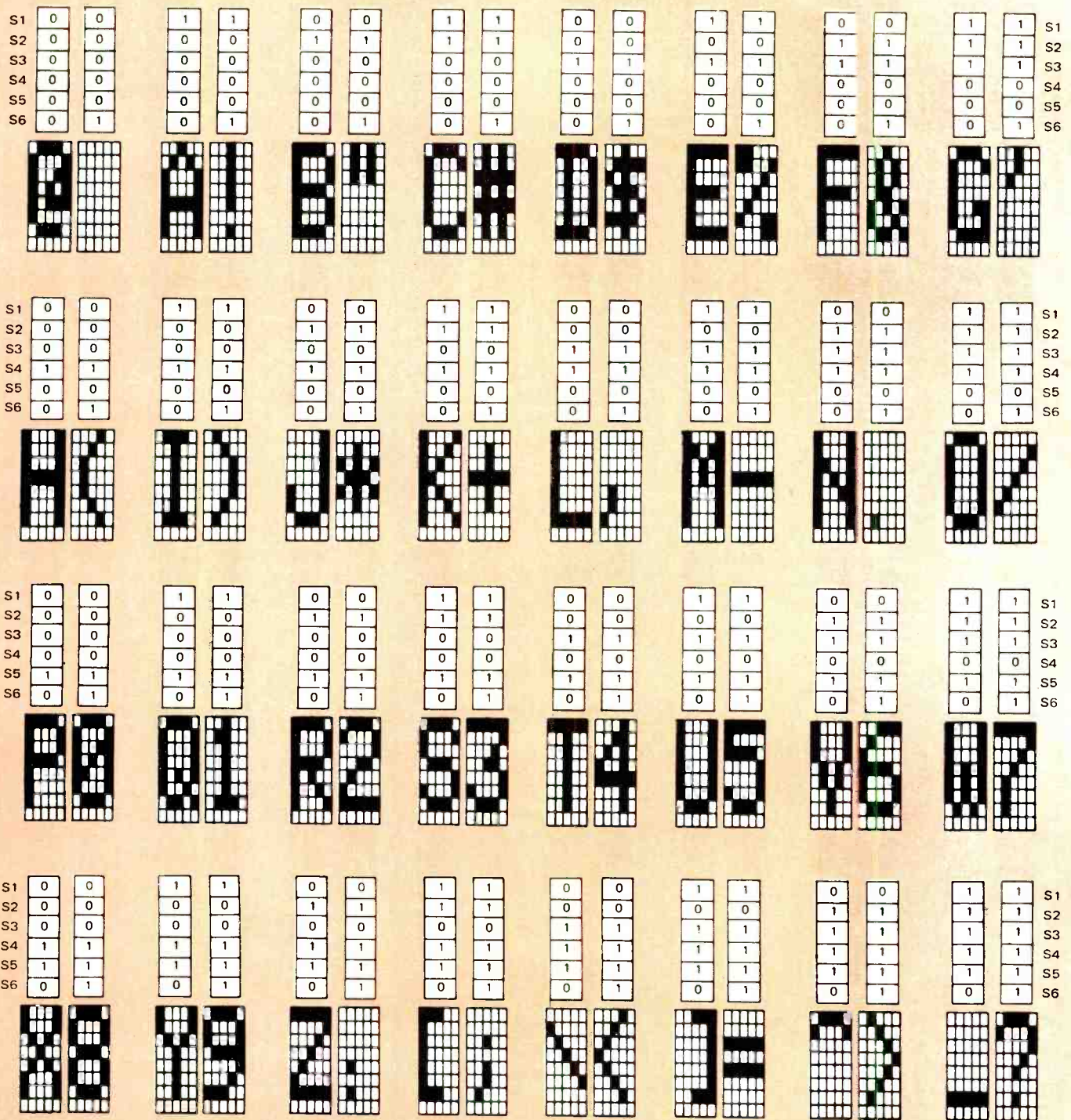

Fig. 2. The 64 characters that can be generated and the required ASCII inputs.

and can't be changed. However, they can be read out when desired. The 64 alphanumeric characters are stored in the form of a matrix of five columns and seven rows (an eighth row is not used). The columns appear as five output lines which are switched through their respective seven rows by three input lines and a row decoder. An additional six input lines and a character decoder select one of the 64 characters.

The 64 characters and the required

ASCII inputs are shown in Fig. 2. Figure 3 shows the internal arrangement of the ROM.

Circuit Operation. The complete schematic of the Scopewriter is shown in Fig. 4. Two NOR gates (formed by portions of IC1), in conjunction with C1, R3, and R4 form the 25-kHz oscillator. The oscillator output drives two flip-flops (IC2) to produce a 3-bit binary count. The latter is connected to the

character generator (IC6, pins 21, 22, and 23) to run the ROM outputs through their seven rows in the proper sequence.

The sawtooth generator is made up of Q1, C3, and R13. The base of Q1 is driven by a pair of transmission gates (TG6 and TG7), arranged as an AND gate. (The transmission gates are in IC4 and IC5.) The AND gate is driven by the 3-bit binary counter. The voltage across C3 increases until it is shorted

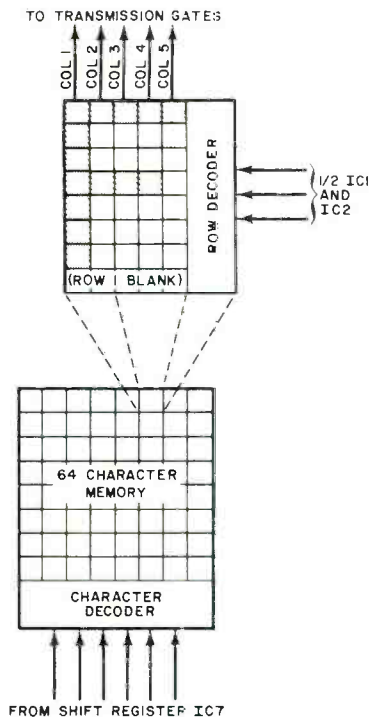

Fig. 3. Diagram showing internal arrangement of the character generator read only memory (IC6).

by Q1 on the eighth binary count. The cycle then repeats to produce the sawtooth waveform.

The output of the last IC2 flip-flop triggers a divide-by-8 counter (IC3) which is connected so that it resets itself on the seventh count, producing a divide-by-5 counter. The five outputs of IC3 turn on TG1 through TG5, which are connected to the five ROM outputs, to provide the output code one column at a time.

The six character inputs to the ROM are supplied by shift register IC7. Resistors R5 and R6 through R11 and capacitor C2 provide the correct conditions for the shift register. The latter is analogous to six long tubes, each capable of holding a string of 32 binary 1's and 0's. When triggered by a clock pulse, each tube takes in a new bit (either 1 or 0) while pushing one bit out the other end. A write recirculate switch (S3) connects the end of each

tube to its input so that none of the bits is lost. Instead they flow around, forming a memory for the message.

The clock pulses come from the divide-by-6 counter (IC3) through S1 and 1/4 IC1 when a character is completed. The clock pulse can also come from switch S2 through the debounce circuit made up of two sections of IC1. Pushbutton switch S2 is used to enter a message one character at a time.

Construction. Although the circuit can be assembled using point-to-point wiring, the use of a pc board, such as that shown in Fig. 5, is recommended. This illustration also shows the component layout. Use a low-power soldering iron and fine solder and be sure to install the jumpers where indicated. Observe the notch code for positioning IC's and the polarity markings on electrolytic capacitors. The use of sockets for the IC's is also recommended. All

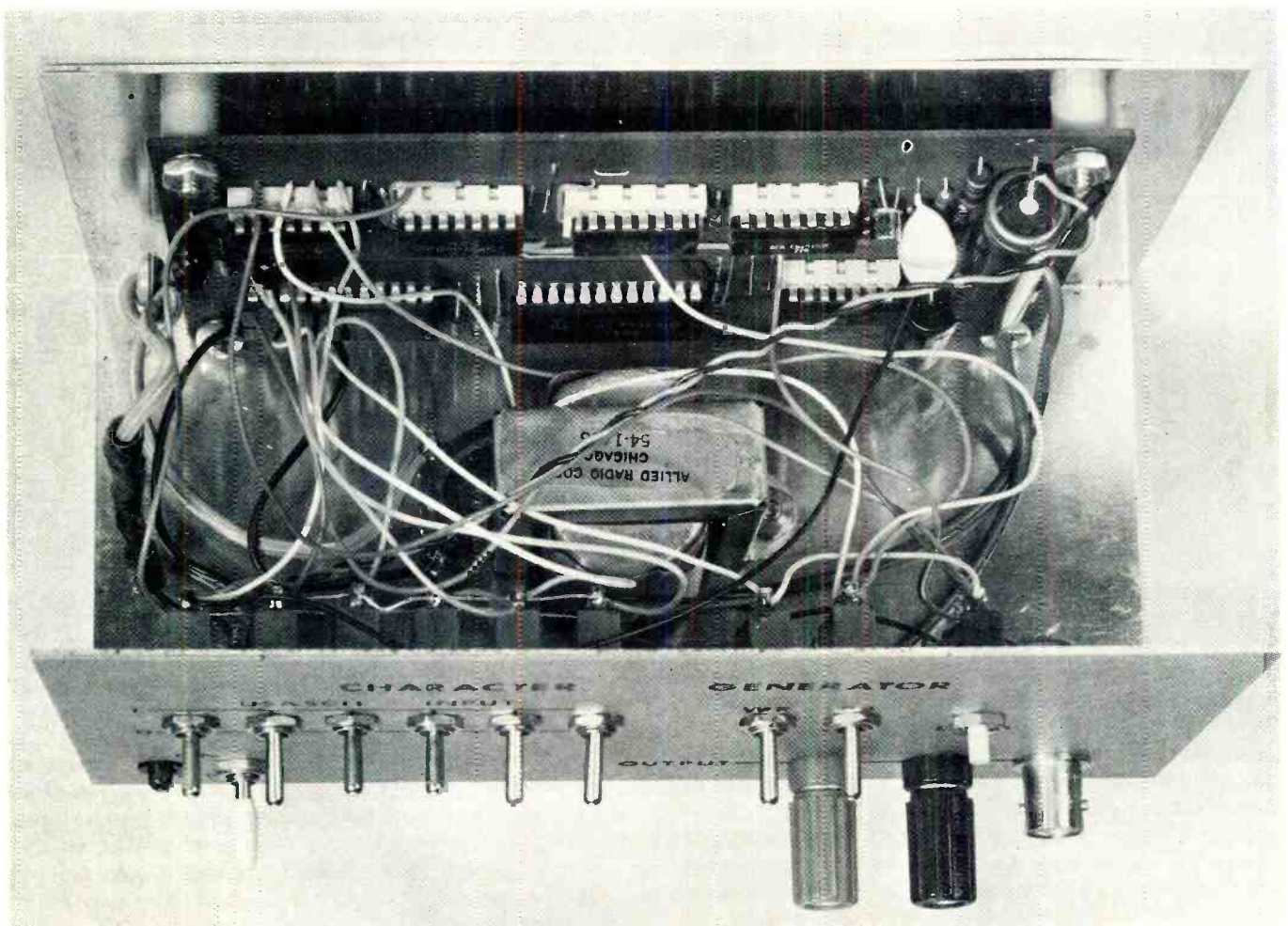

This photo shows how the prototype of the character generator was assembled.

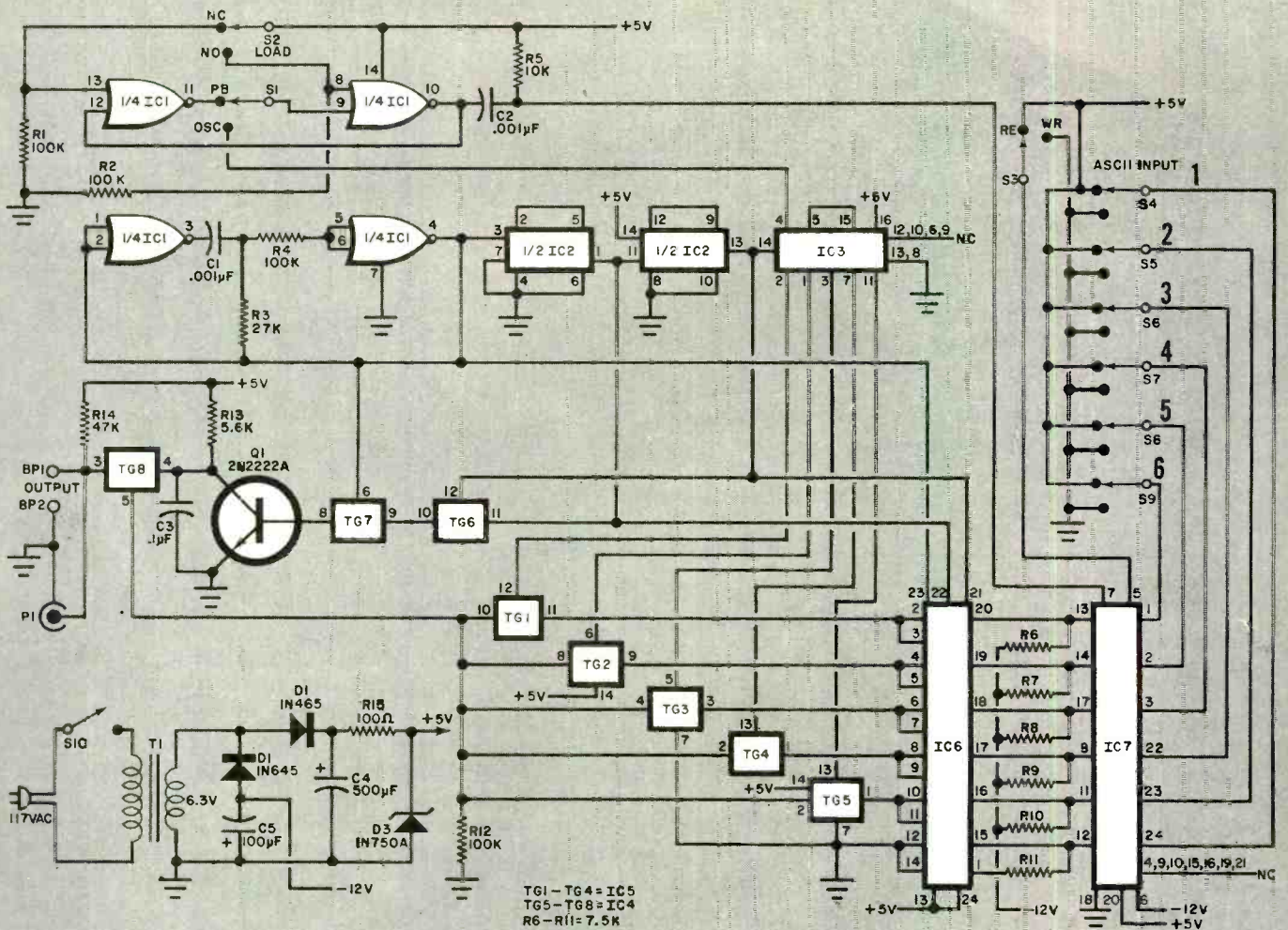

PARTS LIST

- BP1, BP2—5-way binding post (red and black)
- C1, C2—0.001- μ F, 50-volt Mylar capacitor
- C3—0.1- μ F, 50-volt, Mylar capacitor
- C4—500- μ F (or larger), 15-volt electrolytic capacitor
- C5—100- μ F (or larger), 15-volt, electrolytic capacitor
- D1, D2—1N645 silicon rectifier diode
- D3—1N750A, 4.7-volt, $\frac{1}{2}$ -watt zener diode
- IC1—4001 CMOS quad 2-input NOR gate
- IC2—4013A CMOS dual D flip-flop
- IC3—4022A CMOS divide-by-8 counter
- IC4, IC5—4016A CMOS quad bilateral switch (transmission gate)
- IC6—TMS2501NC ROM character

- generator (Texas Instruments)
- IC7—TMS3112NC hex 32-bit static shift register (Texas Instruments)
- PI—BNC connector (optional)
- Q1—2N2222A transistor
- R1, R2, R4, R12—100,000-ohm, $\frac{1}{4}$ -watt resistor
- R3—27,000-ohm, $\frac{1}{4}$ -watt resistor
- R5—10,000-ohm, $\frac{1}{4}$ -watt resistor
- R6-R11—7500-ohm, $\frac{1}{4}$ -watt resistor
- R13—5600-ohm, $\frac{1}{4}$ -watt resistor
- R14—47,000-ohm, $\frac{1}{4}$ -watt resistor
- R15—100-ohm, $\frac{1}{2}$ -watt resistor
- S1, S3-S9—Dpst toggle switch (miniature)
- S2—Spdt momentary-action pushbutton switch

- S10—Spst switch
 - T1—Filament transformer; sec: 6.3 V, 0.6A (Allied Radio 6K32HF or similar)
 - Misc.—LED and current-limiting resistor (optional), suitable chassis, line cord, spacers, mounting hardware, press-on type, rubber feet (4), etc.
- Note—The following are available from Systems West, Inc., 900 Dartmouth Dr., NE, Albuquerque, NM 87106: pc board (SWPC) at \$4.95; electronics kit with pc board and semiconductors (SWE) at \$49.95; complete kit including prepunched case at \$79.95; assembled unit (1-year warranty) at \$99.95; compatible ASCII keyboard at \$39.95.

Fig. 4. This is complete schematic, including power supply, of the Scopewriter.

though they are protected against damage due to static buildup, it is good practice to handle them as little as possible and insert them as the last step in construction.

The photograph shows the front panel of the prototype. Mount the ASCII input switches (S4-S9) in a row, with the top positions marked 1 and the bottom position 0. An optional LED

power-on indicator can be mounted on the front panel. (Use a current-limiting resistor for the LED.)

The transformer can be located in any convenient part of the enclosure.

Although both binding posts and a BNC connector were used for the output on the prototype, either one or some other type of terminal can be used.

Testing and Operation. Connect BP1 to the scope vertical input and BP2 to the scope ground. (If you use the BNC connector, the proper connections will be made automatically.) Turn on the scope and set the horizontal sweep for about 10 ms. When the Scopewriter is turned on, a line should appear on the CRT with random characters below it. Adjust the sweep

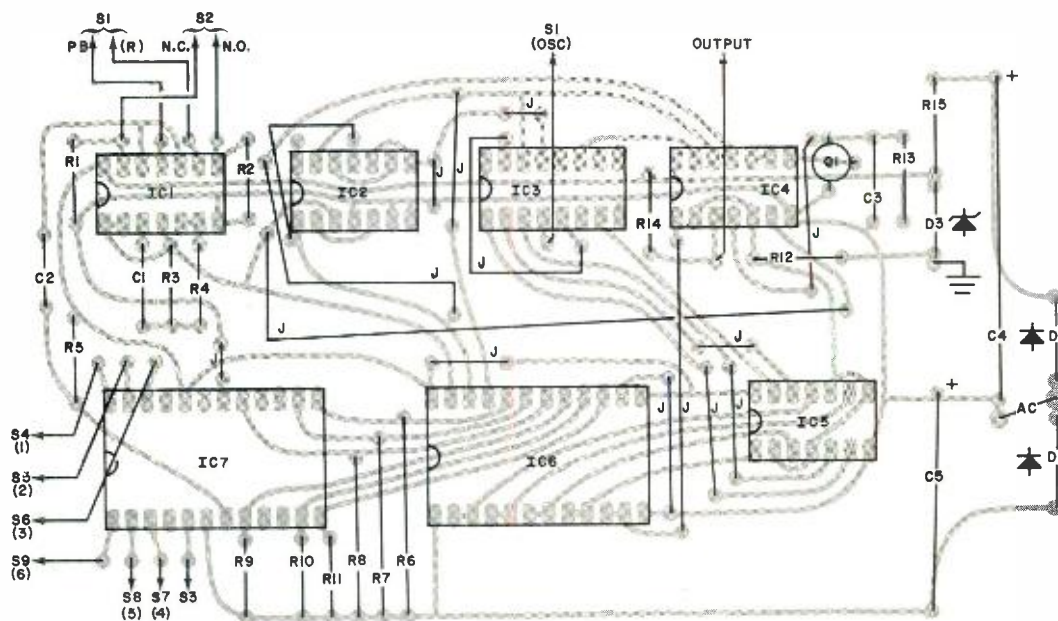
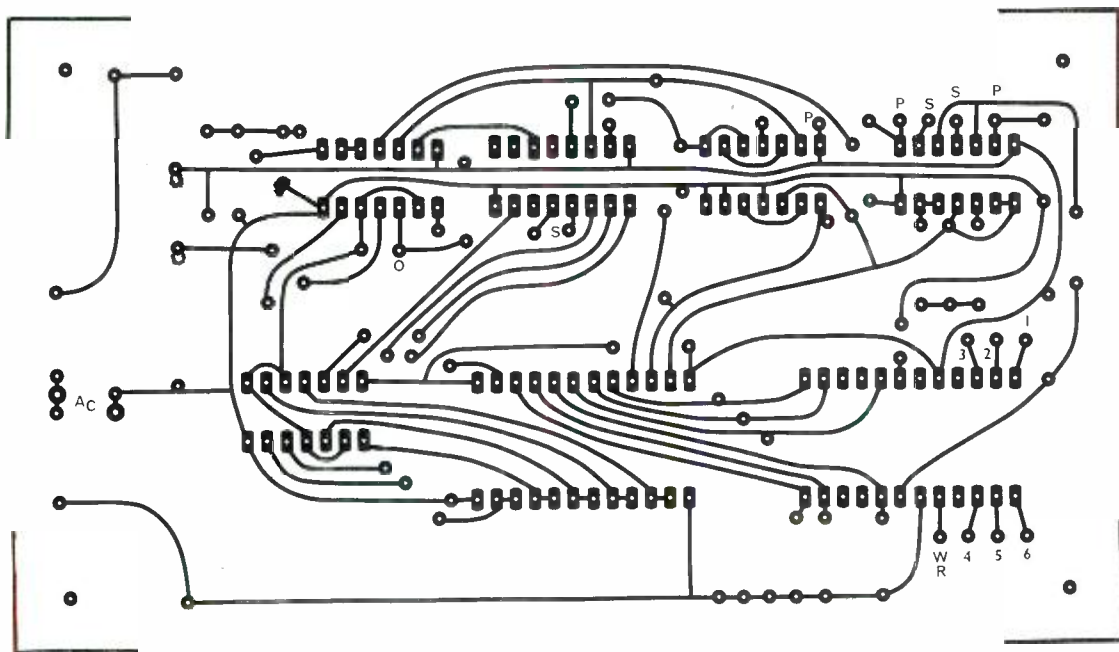

Fig. 5. Though the Scopewriter can be assembled on perforated board, a printed circuit board is recommended. Actual-size foil pattern is at top, component layout shown beneath it.

vernier so that the characters are stationary, and adjust the scope's intensity control so that the blanking lines are not too prominent. Use the scope's vertical gain to vary the character height.

To enter a message, perform the following steps, using the ASCII character coding shown in Fig. 2. Note that the six-element code starts with 6 (S9) on the left and proceeds to 1 (S4) on the right.

1. Place the switches in the 100000 position. This should produce a blank.
2. Set S1 (PB/OSC) on OSC.
3. Set S3 (WR/RE) on WR. This clears the memory.
4. Set S1 to PB.

5. Insert a code on the ASCII switches for some specific character and press S2 (LOAD) to enter the code into the memory. You can insert up to 32 characters, including blanks.

6. Place S3 on RE.
7. Place S1 on osc. The message should appear on the CRT. Adjust the horizontal sweep/sync to position the message.

Should you notice a mistake in spelling within the message, perform the following steps to erase the wrong character and insert the correct one.

1. Set S1 to PB. One of the characters (or spaces) will appear repeated across the face of the CRT.
2. Operate the LOAD switch to step

through the message until the desired character appears.

3. Set the ASCII input switches for the correct character.

4. Set S3 to WR.
5. Depress the LOAD switch to insert the correct character. Note that the next character in the message appears.
6. Set S3 to RE.
7. Set S1 to osc. The entire corrected message should now appear.

Conclusion. The breakthrough project presented here is only the beginning of a variety of projects that POPULAR ELECTRONICS will present in this area, using read-only-memories for display purposes. ♦



Hirsch-Houck Labs TESTS THE NEW 'PREMIUM' CASSETTE TAPES

A CASSETTE deck is no better than the tape used in it. Hence, it is not surprising that tape manufacturers are continually improving their products to keep pace with, or even get ahead of, the steady improvements made in the recorders themselves.

Currently, a number of "premium" cassette tapes are available to tape recordists. Since they are priced higher than "standard" tapes, it is normal to ask what practical sonic advantages they have.

To find an answer to the question, we tested several of these tapes, from different manufacturers, on a single high-quality cassette recorder. The relative performances of the tapes should be valid in any machine, though the specific results we obtained would probably not be duplicated on any other make of recorder.

Tapes Tested. We did not attempt to test every "high-velocity" or "low-noise" tape on the market. The ones we chose are representative of the available premium-grade cassettes. As a control, we used an Audio Magnetics cassette marketed for audio-visual

applications in schools under the name "AV Educator." This tape is similar in its bias requirements to the few standard hi-fi tapes we have been able to identify.

The tapes arbitrarily chosen for testing were:

Brand	Model
Ampex	363
BASF	LHSM
Capitol	2
Memorex	MRX2
TDK	SD
TDK	ED

The Ampex 363 is a chromium-dioxide tape which was included to provide a second frame of reference (All American-made CrO₂ cassettes use Dupont Crolyn[®] tape and have similar magnetic properties.) The other tapes are all ferric-oxide, high-output types, though the new TDK ED is modified with magnetite which is said to improve its magnetic qualities.

The recorder's "regular" bias was optimized for the test's control tape, while its CrO₂ bias was correct for the Ampex tape. The bias was not changed throughout the tests.

Our purpose was to find as many dif-

By Julian D. Hirsch

ferences and similarities as possible between the various tapes when operated under identical conditions in the same tape deck. We measured the record/playback frequency response at a level of 0 dB on the recorder's meter and at levels of -10 dB, -20 dB, and -30 dB. The playback harmonic distortion was measured with recorded levels of -3 dB, 0 dB, and +3 dB and at frequencies of 100 Hz and 1000 Hz. (We also tested at 5000 Hz, but the results were so nearly alike that we discarded them.)

The S/N ratio, relative to the playback level of a 1000-Hz signal recorded at 0 dB, was measured with an IEC (ANSI "A") weighting characteristic to exclude the effects of hum and inaudible low-frequency noise. The recorder's Dolby noise-reduction system was not used during these tests.

The 1000-Hz recording level required for a 3-percent distortion in the playback signal was measured, since the final S/N ratio is determined by the 3-percent THD point rather than by the recorder's meter indications.

Finally, we measured the playback output from each tape after it had been recorded to a 0-dB level, comparing it to the output from a Dolby standard level tape (200 nano-webers/meter flux).

It should be emphasized that a cassette recorder must be biased specifically for the tape in use. A tape with different magnetic properties will generally not give the same frequency response. Therefore, we could not expect, nor did we obtain, a "flat" response from any of the tapes except the standard AV and CrO₂ tapes for which the machine was biased.

A high-energy tape will usually require more bias than a standard tape. It will also have an exaggerated high-frequency response if it is under-biased. We were looking for differences between tapes rather than their actual performance in the test tape deck. Hence, this did not unduly concern us.

What The Measurements Revealed. The frequency response curves clearly demonstrate that, with cassette recorders and tapes, there is no such thing as a frequency response. The actual response is a function of recorded level since the recording pre-emphasis leads eventually to tape saturation at low and high frequencies with increasing input level. This is seen principally as a rolloff of the highs at the higher recording

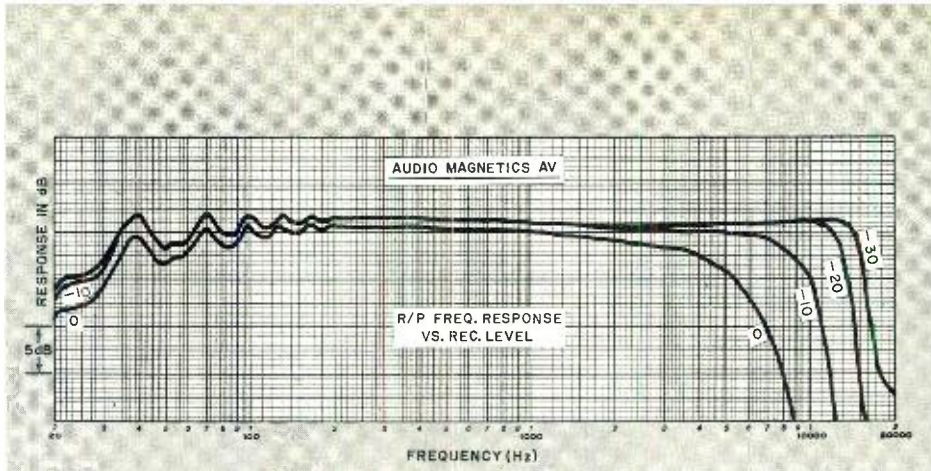

levels. With most tapes, it also shows up as a slight desensitization at middle frequencies and a drop of several decibels at the lower frequencies at maximum recording level.

Cassette recorder frequency response is usually measured at -20dB, but the curves for every tape show a substantial improvement at the high end when the level is reduced to -30 dB. We did not go any lower because we wanted to avoid the influence of noise on the measurements.

These curves suggest that the frequency response of a cassette deck varies continuously with program level. This is a startling concept for people who are accustomed to thinking of frequency response as a fixed characteristic. Nevertheless, this is exactly what happens. A good tape should preserve the dynamics and frequency response of the original program. Thus, the degree to which the frequency response is influenced by level should be one indicator of a tape's quality.

To compare the tapes, we listed the drop in response at 8000 Hz caused by a level shift from -10 dB to 0 dB, the drop at 12,000 Hz with an increase from -20 dB to -10 dB, and the drop at 15,000 Hz with an increase from -30 dB to -20 dB. By summing the decibel figures, we could draw some

conclusions as to the high-frequency recording qualities of the tapes. Not surprisingly, the standard AV tape showed the greatest change, and the CrO₂ tape was the least affected. Although the other ferric-oxide tapes showed distinct differences and could be ranked in this test, we would hesitate to draw sweeping conclusions from the ranking order.

The TDK SD tape was somewhat better than the AV tape. The Capitol 2 and MRX2 were about equal to each other and slightly better than the SD tape. The BASF LH and TDK ED tapes headed the list.

The differences between tapes that rated close to each other were too small to be really significant, but there was no doubt that the TDK ED was the best of the ferric-oxide tapes in this respect; it also carries the highest price. However, the CrO₂ tape (which carries the highest price among tapes tested) out-pointed the TDK ED tape by about the same margin as the latter had over the bottom-ranking AV tape. This could have been because a different recording level was selected within the recorder in the CrO₂ mode. So the difference may not be as dramatic as it appears to be.

Adding the effect of the low-frequency response change over a level shift from -30 dB to 0 dB did not

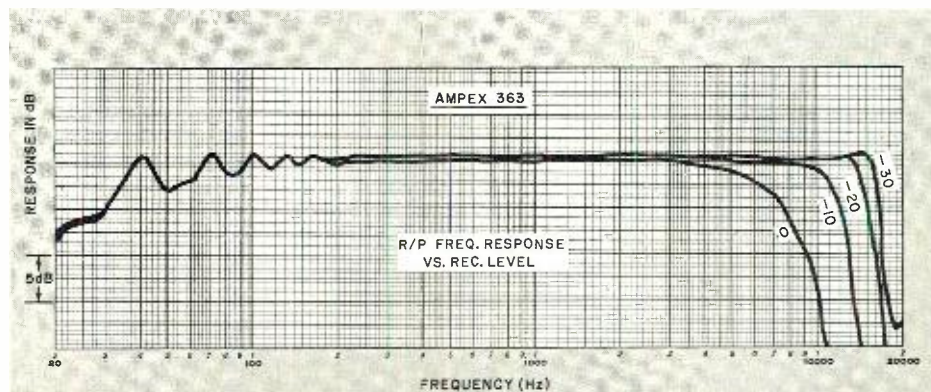

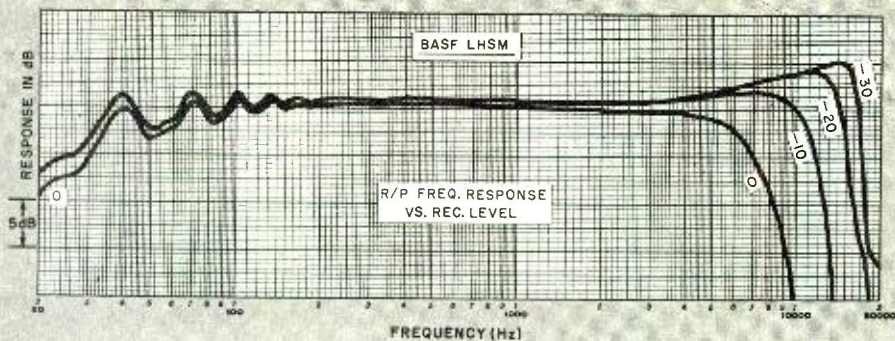

change the rank order of the tapes. The CrO₂ tape was the only one whose low and middle frequency responses were not affected by recording level. The AV and MRX2 displayed more change, while the other tapes were closely grouped between these extremes.

Another point of difference was the 100-Hz distortion at a +3-dB recording level. The Capitol 2 and BASF LH exhibited less distortion than the MRX2 and AV tapes, while the TDK SD and ED had the lowest distortion of the ferric-oxide tapes. The exception, again, was the CrO₂ tape, which had less than half the distortion of the TDK SD. The latter was the best of the ferric-oxide tapes used in this test.

The S/N ratio measurements revealed only minor differences in the tapes. The TDK and MRX2 tapes were slightly better than the AV, Capitol 2, and BASF LH tapes, but the difference from "best" to "worst" was only 2.5 dB. It is not fair to include CrO₂ tape in this comparison since the recording and playback equalization are switched with the bias to obtain the best S/N ratio. This gives it a 2.5-dB advantage over the best ferric-oxide tapes.

From the manufacturers' viewpoints, there are doubtlessly numerous weaknesses in this type of limited

test program. This is why we caution against drawing unwarranted conclusions. For one thing, it is possible that, by optimizing the recording bias for each tape, the results might be affected. We would not expect any major shifts, but most of the tapes were so close in these measurements that even a minor change in high-frequency response could affect their standing. Possibly a different recorder, whose head required either more or less recording equalization than that of the tape deck used would also alter the standings. On the other hand, most consumers have no choice of recording bias (except as provided by a switch on some deck models) and would, therefore, be powerless to optimize their equipment for any particular tape.

How The Tapes Sounded. Since many of the measured differences between the tapes were so slight as to be inconclusive, or at least open to question, the next step was to record music on these tapes and listen for differences during playback. We used phonograph records with considerable energy in the highest octave, as well as in the middle and low-frequency ranges. For these tests, we used the recorder's Dolby noise reduction system, since we wished to

minimize the effect of noise level on apparent frequency response.

A selection was recorded onto each tape without disturbing the setting of the recording level controls and played back for an A-B comparison with the disc. Average levels on the recorder's meter (about -3 dB) were used initially, followed by an increase to 0 dB. If the sound quality warranted it, we also recorded at +3 dB, which was the full-scale meter deflection.

In this test, most of the tapes sounded slightly "bright" due to being underbiased. Interestingly, this effect was not nearly as prominent as the curves would suggest. Evidently, this was due to the rather high average program levels we were using. Most of the tapes rolled off appreciably at the top end, leaving a residual brightness in only the low-level passages.

This test produced no major surprises, although it tended to confirm our suspicion that the minor differences in tape ranking based on tape saturation effects were insignificant in practice. The AV tape (which, after all, is not represented as a "high-fidelity music" tape) had a hazy quality at -3 dB, with an obvious loss of definition on high-frequency transients. At 0 dB, the sound took on a blurred quality. However, by reducing the recording level to -10 dB, the sound was quite good.

Since the operating bias for the TDK SD is only slightly higher than for most standard tapes, it was operating nearly at its optimum point. The results were impressive, with essentially "perfect" sound quality at -3 dB and 0 dB. The only difference between the playback and the incoming signal was a minute dulling of the attack on high-frequency transients. Clearly attributable to tape saturation, this effect was audible to some degree with all the test tapes at the levels we were using.

The other ferric-oxide tapes sounded surprisingly similar to each other. They were all bright sounding, but very clean, at -3 dB. With a slight correction from the amplifier's tone control, this could be converted to a virtually perfect sound. The correct approach, of course, would be to increase the tape recorder's bias to flatten out the response.

At 0 dB, there was no significant deterioration of quality. But at +3 dB, the change was marked. Our first impression was of a brighter sound, which seems contrary to expectations. Further listening revealed that a layer

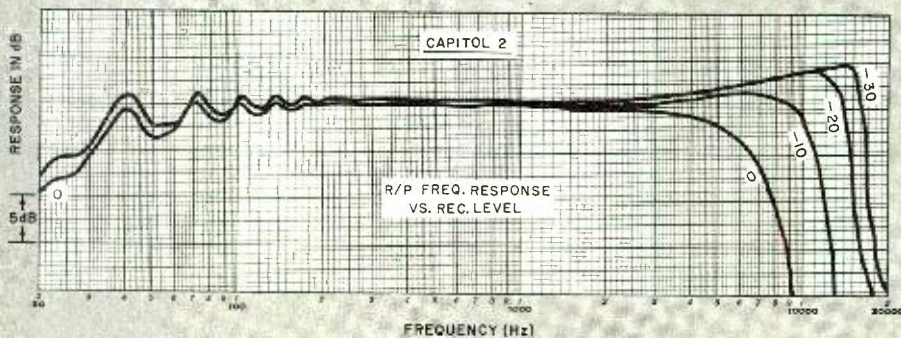

of sonic "fizz" (background noise) had been added to the music. This was the audible effect of high-frequency intermodulation products, which fell in the middle frequency range. The noise has the effect of making the overall sound appear to be bright.

The CrO₂ tape generally sounded much like the better ferric-oxide tapes. Any differences that existed were in its favor; but in this test, they were slight.

In Conclusion. Combining the results of our measurements and listening tests, we must conclude that CrO₂ tape used in a recorder designed to exploit the tape's qualities has clear advantages in distortion, S/N ratio, and resistance to tape saturation. The fact that this superiority is not always audible is a testimonial to the state of the art in cassette recorders and tapes, whose quality, in many cases, is better than the programs most people

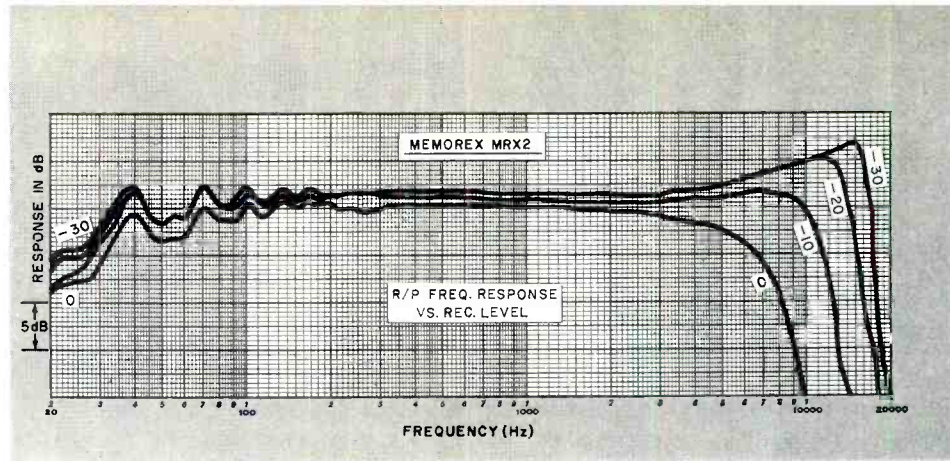

to matching the sound of the other tapes.

There is an obvious lesson to be learned from our tests. To make the best recordings, use the best tape you can get. It is probably no coincidence that TDK ED and most CrO₂ tapes are relatively expensive. On the other hand, it is comforting to know that if your budget cannot accommodate

(perhaps 3 dB or so), and our own preference would be to continue recording at a level that would be used with standard tapes. This must be determined for each recorder, since there is no standardization between their meter indications and the actual level recorded on the tape. Unless you are attempting to wring out the last decibel of S/N ratio, the true benefits of a high-energy tape can best be realized by letting its extra dynamic range accommodate those brief transients that might otherwise contribute to the background haze of an over-recorded cassette. This will also permit you to extract the greatest amount of the high-frequency response built into these tapes.

Since most tape decks cannot readily have their bias settings changed by the average recordist, we suggest that you follow the manufacturer's recommendations for suitable tapes, unless you find another kind more pleasing to your ears. The slight added brightness of a premium tape in a standard-biased deck is not unpleasant and may even help to compensate for some of the recorder's limitations. Since all CrO₂ tapes have the same bias requirements, you are less likely to go wrong in selecting a tape if you use chromium-dioxide tapes, assuming that your recorder has a CrO₂ switch to effect proper bias and equalization. ♦

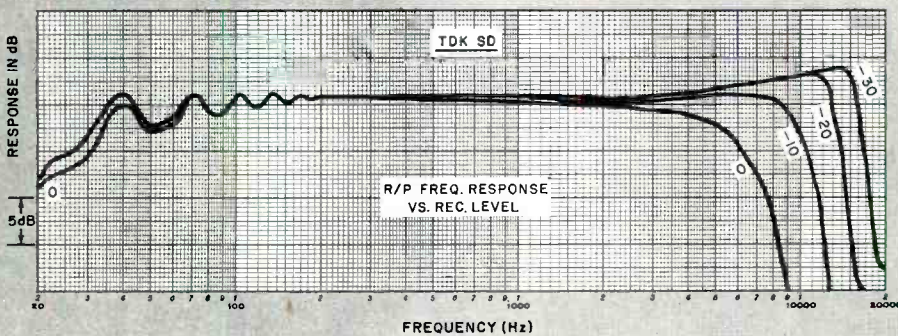

choose to record on those tapes.

Among the ferric-oxide tapes, TDK ED and BASF LH seem to outperform the others, even if only slightly, in almost every respect. Previous experience with Maxell UD (not tested in this study) suggests that it would also rank with these two tapes with respect to the characteristics we evaluated. The other premium-grade tapes are very close to the top two or three. We would have difficulty justifying a ranking order because each tape had some points of superiority and others where it was somewhat inferior. Interestingly, the TDK SD tape was the only one of the premium tapes capable of delivering its best performance with standard bias levels.

Although the AV tape was included principally to show up the superiority of a premium tape for music recording, no apologies need be made for its performance. It was as good as any "standard" tape we have used. At lower recording levels, it came close

them, you could use any of the other tapes and 99.9 percent of the time there would be no audible differences in the sound.

What about recording levels? Obviously, the tapes that are less easily saturated can be recorded at a higher level without unpleasant side effects. The manufacturers make a point of emphasizing this in their promotional literature. However, the extra "head room" of these tapes is not great

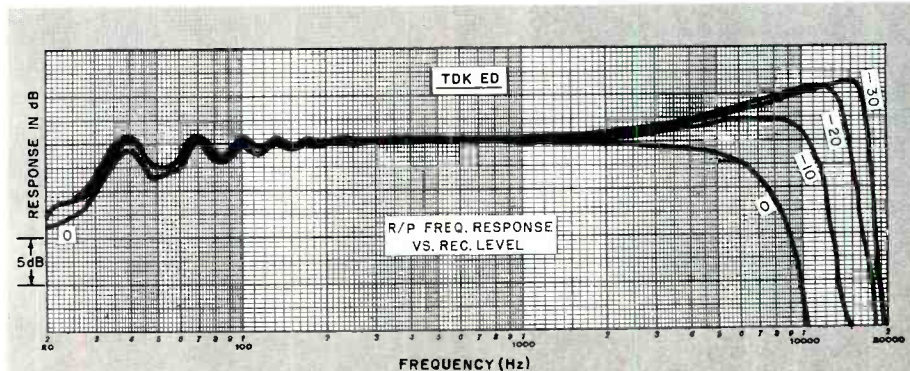

Build a Large-Port Speaker System

High-efficiency ported enclosure features novel high-frequency reflector system

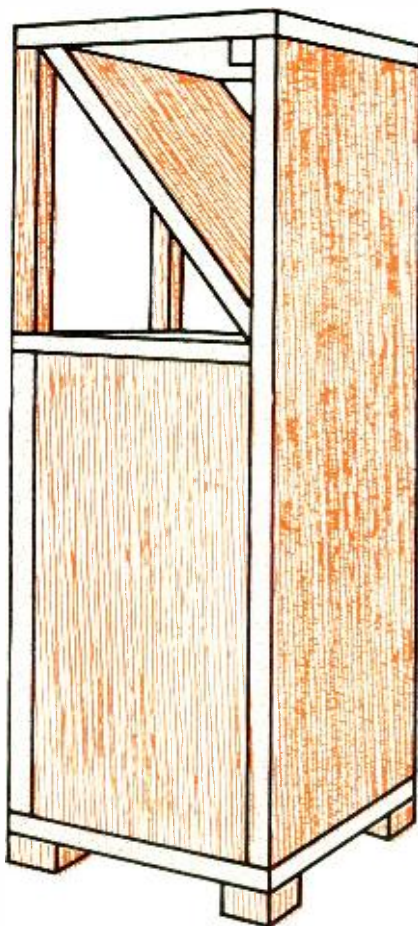

BY DAVID B. WEEMS

IN 1971, an article in a British hi-fi magazine described a speaker enclosure called a "large-port reflex." Its most distinctive feature was the non-uniform cross-section of its port, formed in two parts by a pipe and a cavity. The dimensions of the latter were determined by the distance between the bottom of the cabinet and the floor, making the feet a functional part of the enclosure.

Another unusual feature of the system was the orientation of the speaker: it faced upward. Two kinds of reflectors were suggested: a diffuser for omnidirectional high frequencies, or a

simple 45° reflector board. Especially recommended was the flat reflector for its stable stereo image.

American Version. The enclosure described in these pages is based on the British speaker system — with some important modifications. One questionable aspect of the 45° reflector board was that it, in common with most other small floor-standing speaker sys-

tems, projected the high-frequency beam horizontally below normal ear level in the listening area. The reflector in our speaker system is tipped back 3° to make a 48° angle with the speaker board.

Tipping back the reflector rotates the high-frequency beam upward from the horizontal by 6°. This may not make an earthshaking difference, but it does put the center of the beam about 36 inches (91.44 cm) above floor level at a distance of 10 feet (3.05 m) from the speaker system. This is about right for a seated listener.

A piece of glass, backed by resilient foam plastic, provides maximum efficiency in our system. However, if you want more dispersion, you can substitute a dome-shaped radiator, such as a hub cap from a sub-compact car or a sealed-beam headlight. If you use your imagination, you can get just about any reflection pattern you want. But avoid

reflectors with loose parts that can add buzzes or rattles to your sound system.

Because of the horizontal orientation of the speaker in the enclosure, large and heavy cones can be deflected by gravity. Hence, an 8-inch speaker is probably the largest practical size for this enclosure. In Americanizing the large-port reflex system, therefore, we selected an inexpensive Lafayette Model SK-138 three-way 8-inch (20.32 cm) speaker. According to the published specifications, this speaker can handle up to 30 watts of peak power; yet, it can be driven by much less power. The combination of compact size and the high efficiency of the reflex system makes this speaker a good choice for low-powered amplifiers and small rooms.

Construction. The total cost of your speaker system can vary considerably, depending on your choice of materials. The wood members are so small, however, that you can probably build the entire enclosure from scraps of lumber on hand if you are a wood worker. Just one word of advice: don't skimp on nails or glue.

The first step in construction is to cut all ¾" (1.9-cm) plywood or particle board panels, except the reflector panel that requires special fabrication, to the sizes specified in the Bill of Materials (see also Fig. 1). Once this is done, cut a 7 5/16" (18.6-cm) hole for the speaker in the appropriate panel, centering it between the sides and 4 ¾" (12.1 cm) from the front of the panel.

Next, cut a hole in the center of the bottom panel to fit the tube obtained. If you cannot find a 3 5/8" (9.21-cm) inner-diameter tube (try a carpet dealer), you can make a 3¼" × 3¼" (8.26 cm × 8.26 cm) square hole and make a wood port. (The four pieces for this port should be ½" to ¾" [1.27 to 1.9 cm] thick and stand 6¼" [15.88 cm] above the top surface of the bottom panel. Glue and nail the parts together and mount the port on end over the cutout, using glue and nails.) If you use a cardboard tube, run a bead of glue around one end and fit the tube into the hole flush with the bottom of the panel.

Meanwhile, drill holes in the back panel for the tweeter control and a two-lug screw-type terminal board. Measuring down from the top edge of the panel strike lines 3/8" (0.95 cm) and 9½" (24.13 cm) on the outside surface and 10 ¾" (27.3 cm) across the inside surface of the panel. Spot three equally spaced 1/8" (0.32 cm) holes along the outer surface lines. Then liberally coat

one surface of a 9¼" × ¾" × ¾" (23.5 cm × 1.9 cm × 1.9 cm) pine cleat with glue and nail it, with its top edge flush with the inside line, to the panel.

Strip away ¼" (0.62 cm) of insulation from the conductors at both ends of a 12" (30.5 cm) length of lamp cord, and separate the cord for a distance of about 3" (7.62 cm) at both ends. Pass the conductors at one end through the appropriate holes and solder them to the lugs on the terminal board. Mount the terminal board to the rear of the back panel with small wood screws. Screw in the contacts and fill the voids around the screws and lugs with caulking compound or Dow Corning Silastic® silicone cement to insure an air-tight seal.

You can now assemble the basic enclosure box by gluing and nailing together the front, back, and side panels as shown in Fig. 2. Use only screw-type or ring-shank nails for this operation. Then follow this by gluing and nailing into place the speaker mounting board and bottom panel (assuming the glue around the tube has set by this time). Attach a 1" (2.54 cm) foot to each corner of the box with wood screws. Do not substitute another size foot, or you will change the tuned frequency of the enclosure.

The only part of construction that requires special care is the cutting of the angles on the reflector board. This panel should make a 48° angle with the speaker board and a 42° angle with the rear panel. At the top end of the reflector, the panel will make another 48° angle with the enclosure's top panel, where it will be permanently joined with glue and screws. Hence, you need a 13"-long (33 cm-long) board that is cut to a 48° angle at one end and a 42° angle at the other end.

The only practical way of making the angled cut is with a table saw. First, tilt the saw blade to an angle of 42° and make a trial cut with scrap lumber. Measure the angle with a protractor and make any required tilt adjustments. (Note: Once the saw blade is tilted exactly 42°, it should not be touched. Both angled cuts will be performed with blade in this position.)

Once you are satisfied that the blade is properly tilted, make the 42° cut (this will normally yield a 48° edge). To get a 42° edge, you must rotate the board 90° before passing it through the saw. Do not forget to allow for saw blade thickness when making the angled cuts; the overall point-to-point length of the reflector board should be 13" (33 cm). (If you do not have a table



Grille cloth goes around body of enclosure. Bottom bumper must extend no lower than tops of enclosure's feet.

BILL OF MATERIALS

- 1—Lafayette* Model SK-138 speaker (Stock No. 21E1860W: \$18.95 plus shipping on 5 pounds)
- 1—Package Lafayette* fiberglass insulation; enough for two enclosures (Stock No. 21E15014; \$1.75 plus shipping on $\frac{3}{4}$ pound)
- 1— $27\frac{1}{2}$ " \times $10\frac{3}{4}$ " \times $\frac{3}{4}$ " plywood or particle board for back
- 1— $16\frac{3}{4}$ " \times $10\frac{3}{4}$ " \times $\frac{3}{4}$ " plywood or particle board for front
- 2— $16\frac{3}{4}$ " \times 9 " \times $\frac{3}{4}$ " plywood or particle board for sides
- 1— 13 " \times $10\frac{3}{4}$ " \times $\frac{3}{4}$ " plywood or particle board for reflector (see text)
- 2— $10\frac{3}{4}$ " \times $10\frac{1}{2}$ " \times $\frac{3}{4}$ " plywood or particle board for top and bottom
- 1— $10\frac{3}{4}$ " \times $9\frac{3}{4}$ " \times $\frac{3}{4}$ " plywood or particle board for speaker board
- 4— 2 " \times 2 " \times 1 " pine for feet
- 1— 36 " length of $1\frac{1}{2}$ " \times $\frac{3}{4}$ " pine for bumper
- 1— 48 " long piece of $\frac{3}{4}$ " \times $\frac{3}{4}$ " pine for cleats and top support
- 1— 36 " long piece of $\frac{3}{4}$ " molding for trim
- Screws— $1\frac{1}{2}$ " flathead wood for feet (4); $1\frac{1}{4}$ " flathead wood for back (6); 1 " flathead wood for reflector board and glass (20); 1 " panhead sheet metal for speaker installation (4)
- 1—Box $1\frac{1}{4}$ " ring-shank or screw-type nails
- Misc.—Glue; 12 " \times 12 " \times $\frac{1}{8}$ " resilient foam plastic; mirror clips (4); $\frac{3}{8}$ " wide \times $\frac{3}{16}$ " thick adhesive-backed foam weather stripping; 1 yard grille cloth; trim to match top;

EDITOR'S NOTE

This is the first article in POPULAR ELECTRONICS to "go metric." For the time being, until lumber yards and hardware manufacturers convert to metric units, we will continue to give the "conventional" units, with metric units following in parentheses. Hence, dimensioned diagrams will bear both types of units, while Parts Lists and Bills of Materials will specify parts in "conventional" units.

7" long \times $3\frac{9}{16}$ " inner-diameter cardboard tubing (see text); cabinet finishing materials; screw-type terminal board; lamp cord; caulking compound or Dow Corning Silastic[®] cement; inside corner braces (4); $1\frac{1}{2}$ " finishing nails for trim and bumper; etc.

*Lafayette Radio Electronics, 111 Jericho Turnpike, Syosset, NY 11791.

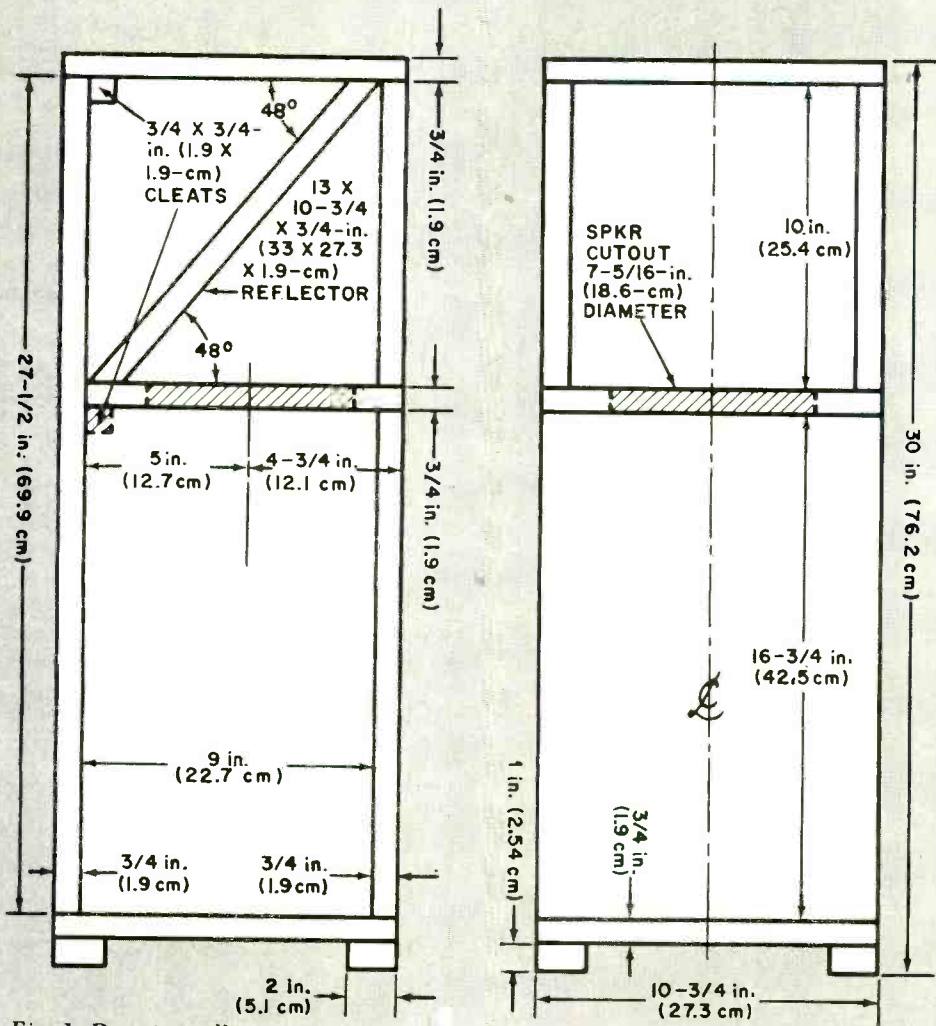
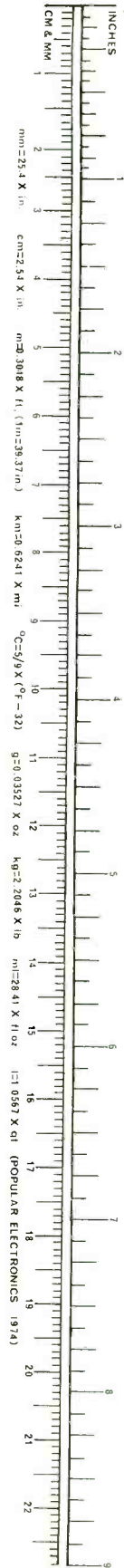

Fig. 1. Drawings illustrate how enclosure goes together and details of reflector assembly.



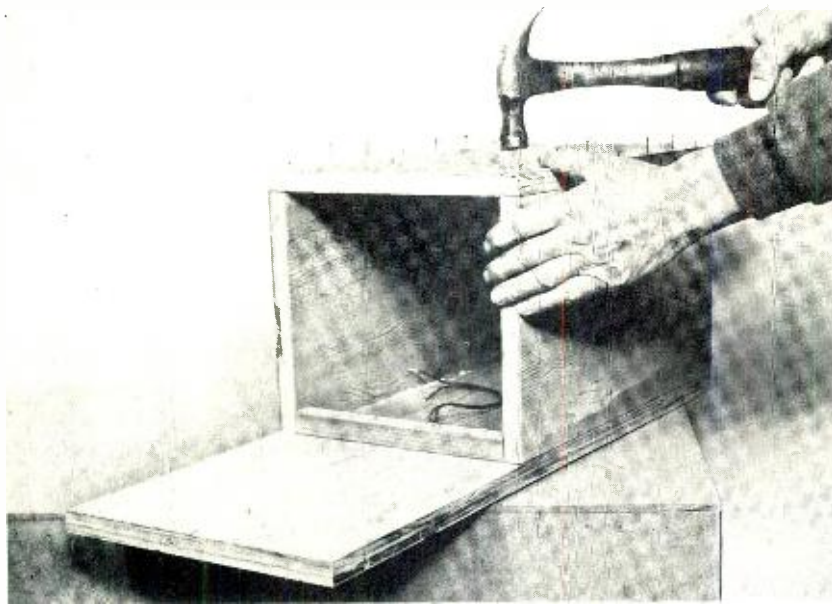

Fig. 2. Basic box is assembled with glue and nails. Don't skimp on the glue.

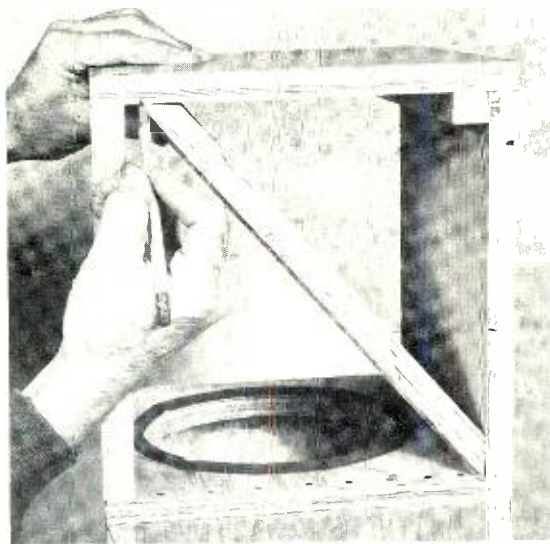

Fig. 3. With top panel temporarily in place, strike leading-edge line of reflector.

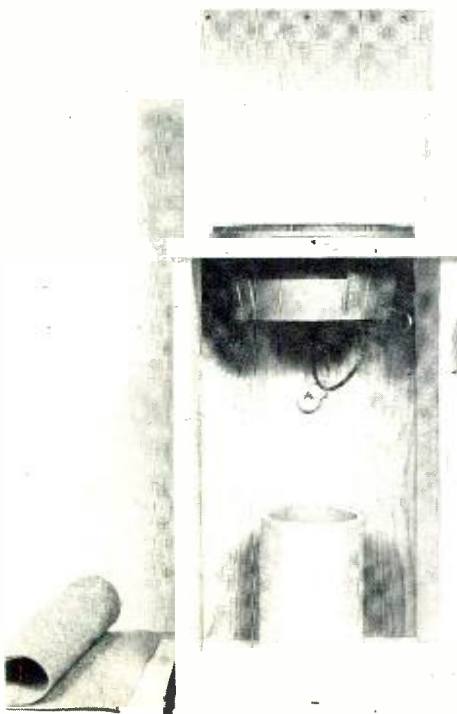

Fig. 4. Speaker faces upward. The terminal board and tweeter control are mounted on rear.

saw available and cannot get a lumberyard to make the cuts, you might want to substitute another kind of reflector, perhaps one suspended from the back or top panels of the enclosure.)

Attach the two front corner posts to the top panel with inside corner braces, and glue and nail the top cleat to the bottom of the top plate parallel to but $\frac{3}{4}$ " (1.9 cm) from the rear edge. Set the top on the enclosure and hold the reflector panel in its proper position so that you can mark a line where the latter's leading edge meets the bottom surface of the top panel. (See Fig. 3.) Drill three or four shank holes through the reflector panel's top edge to permit screws to enter the top panel at a 90° angle. Glue the top edge of the reflector panel and use 1" (2.54 cm) flathead wood screws to fasten it to the top panel along the struck line.

While the glue is setting, prepare and install a gasket for the speaker. One of the easiest gaskets to use is a piece of $\frac{3}{8}$ "-wide by $\frac{3}{16}$ "-thick (0.92 cm-wide \times 0.48 cm-thick) adhesive-backed foam weather stripping. Set the speaker in the opening, and mark the locations of the mounting screws. Drill pilot holes for the screws. Then, when you cut the weather stripping, make half-circle cutouts where the holes are so that the screws do not catch on the foam and damage the seal. Trim the gasket carefully so as to leave no gaps where the ends meet, else the tuning of the enclosure will be affected.

Tack 1" (2.54 cm) or thicker of acoustical damping material to the inside walls of the enclosure. Then cut some loose pieces and drop them around the pipe so they cover the bottom of the box. Next, solder the conductors at the free end of the lamp cord to the lugs on the speaker, and identify with paint or nail polish the terminal board screw that goes to the positive lug of the speaker. Install the tweeter control on the back panel, and mount the speaker in its cutout. (See Fig. 4 where the front panel is shown removed for clarity.) Use panhead sheet metal screws for fastening down the speaker.

Final Construction. At this time it is a good idea to check that everything is working properly. Then complete and install the reflector assembly as follows:

Glue a sheet of $\frac{1}{8}$ "-thick (0.32 cm-thick) resilient foam plastic to the reflector board and mount on this a 10" \times 8" (25.4 cm \times 20.32 cm) sheet of win-

dow glass with the aid of four mirror clips and four 1" (2.54 cm) wood screws as shown in Fig. 5. Most mirror clips are designed to accommodate a 1/8"-thick (0.32 cm-thick) piece of glass; so, you might have to shim each clip with wood or hard plastic.

Temporarily mount the reflector assembly with a single screw in the middle of the back panel. Place the speaker system (or systems if you are assembling a stereo pair) in its permanent listening position and check the high-frequency coverage. If you want wider dispersion, you can unscrew the reflector assembly and replace the glass with a convex reflector as mentioned earlier. Look for a flattish dome that will not reflect the highs back onto the speaker.

When you mount the reflector assembly, use no glue. (You may need easy access to the speaker in the future.) Just sink three screws through the back panel into the top cleat, three more into the reflector panel, and eight more through the corner braces into the front corner posts and top of the speaker board. (See Fig. 6.)

In Fig. 7 are shown two views of the speaker system just prior to finishing. At this point, you should break all sharp edges with medium-grit sandpaper. Then sand and stain the top panel, after first attaching the trim around the raw exposed edges. Paint the front and side panels and the corner posts flat black. The enclosure's feet can be painted black or stained.

After the stain and paint have dried, stretch and staple the grille cloth around the enclosure. Finish up by attaching the bottom bumper, made from sanded and stained 1 1/2" x 3/4" (3.81 cm x 1.9 cm) pine, with finishing nails. This bumper should come flush with the bottom panel; under no circumstances should it extend to the floor.

In Use. Place the speaker system or systems on a carpeted floor for best results. If after a listening test you note a tendency toward boominess, try different room locations if possible. You might also try stuffing a small wad of fiberglass insulation into the pipe at the bottom of the enclosure. (No disassembly is necessary. Just tip back the enclosure and insert the insulation.) Theoretically, this is not the best place to put damping material, but in a finished system it is the most convenient. And it appears to be quite effective. ♦

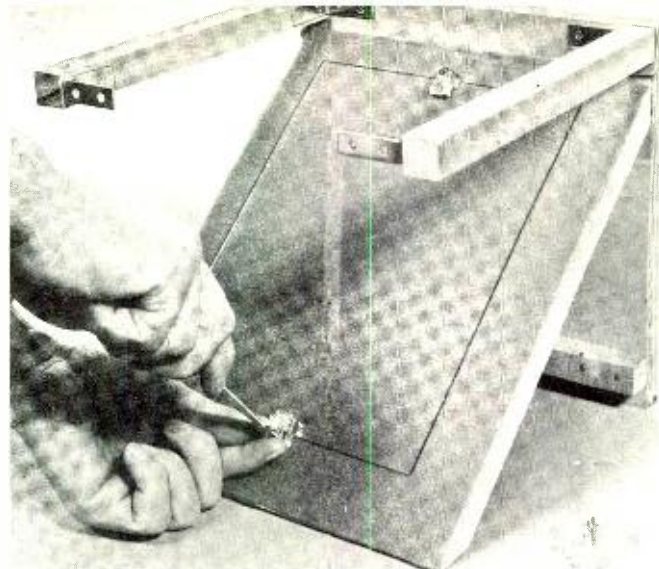

Fig. 5. After gluing foam padding, mount sheet glass reflector with mirror clips. Note weather stripping gasket around the speaker cutout.

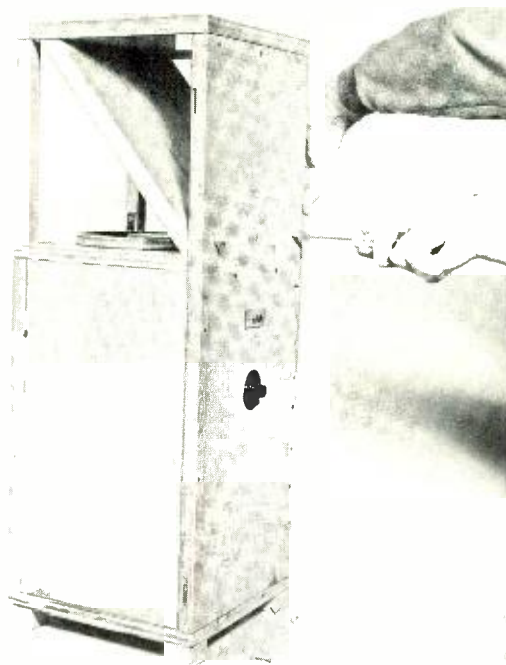

Fig. 6. Top and reflector assembly are fastened to enclosure with wood screw but no glue to provide access in the future.

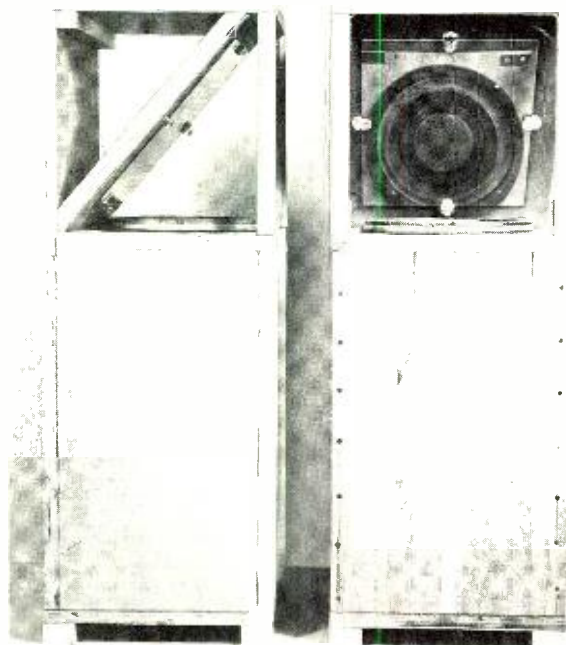
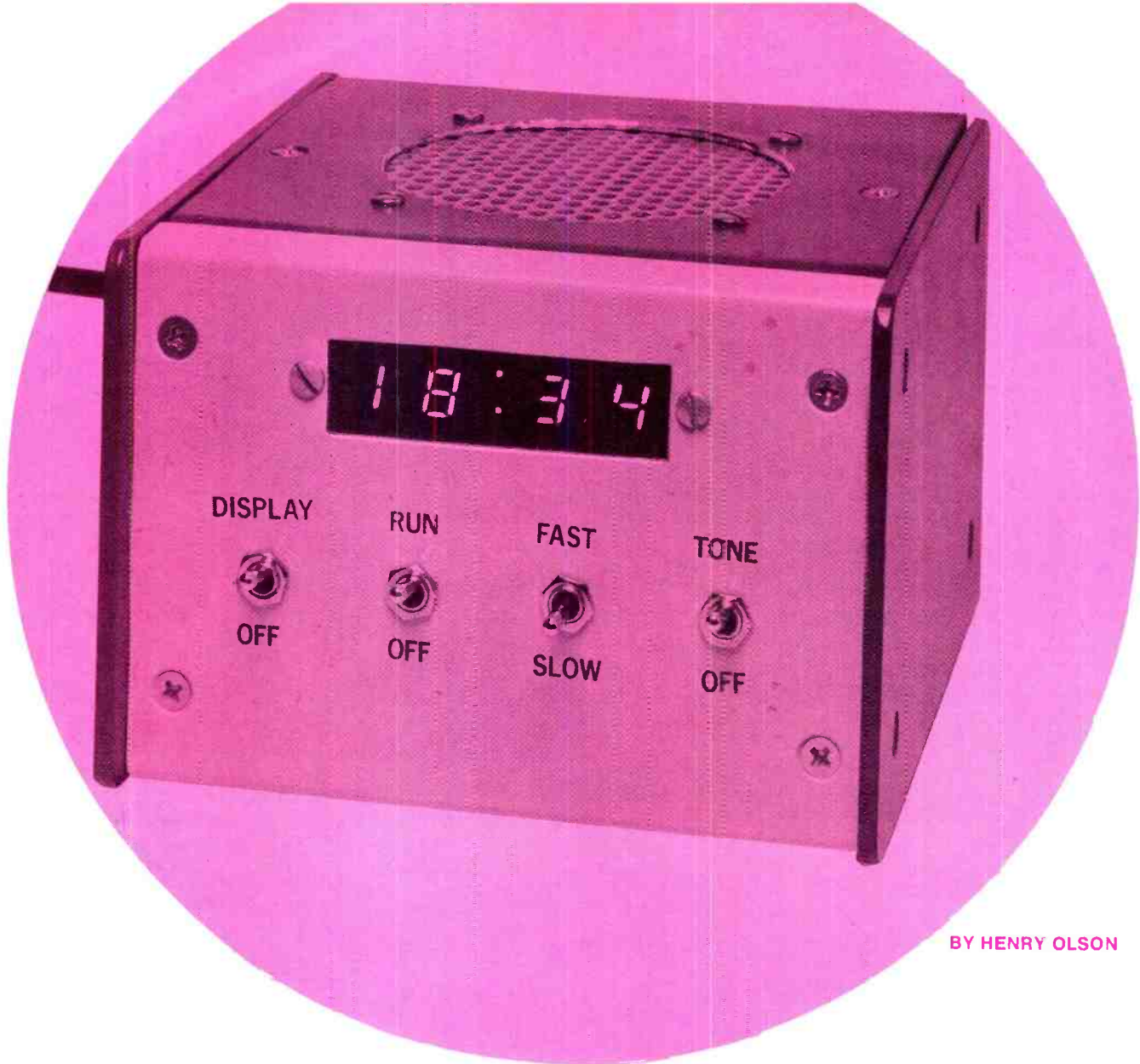

Fig. 7. Completely assembled but unfinished speaker system from front and side.



BY HENRY OLSON

“An amateur station shall be identified . . . at intervals not to exceed 10 minutes. . .” FCC Rules and Regulations, Part 97.87 (a)

ADD A 10-MINUTE “BEEPER” TO YOUR DIGITAL CLOCK

EVERY amateur radio operator knows that FCC rules require that he identify his station every 10 minutes. He also has to log the time of every contact he makes. Both requirements can be easily met if he has a clock with a beeper to give him an audible signal every 10 minutes.

With today's digital “clock-on-a-chip” IC's, building the clock is not difficult. A typical circuit (using an MM5314 IC which costs about \$10) is shown in Fig. 1. The “Digital Clock-Calendar” project published in this magazine in November 1973 could also be used. These are 24-hour clocks, which can be set for GMT, normally used by hams.

With a suitable clock available, the ham operator then needs a way to obtain a 10-minute signal from the clock to drive a

POPULAR ELECTRONICS

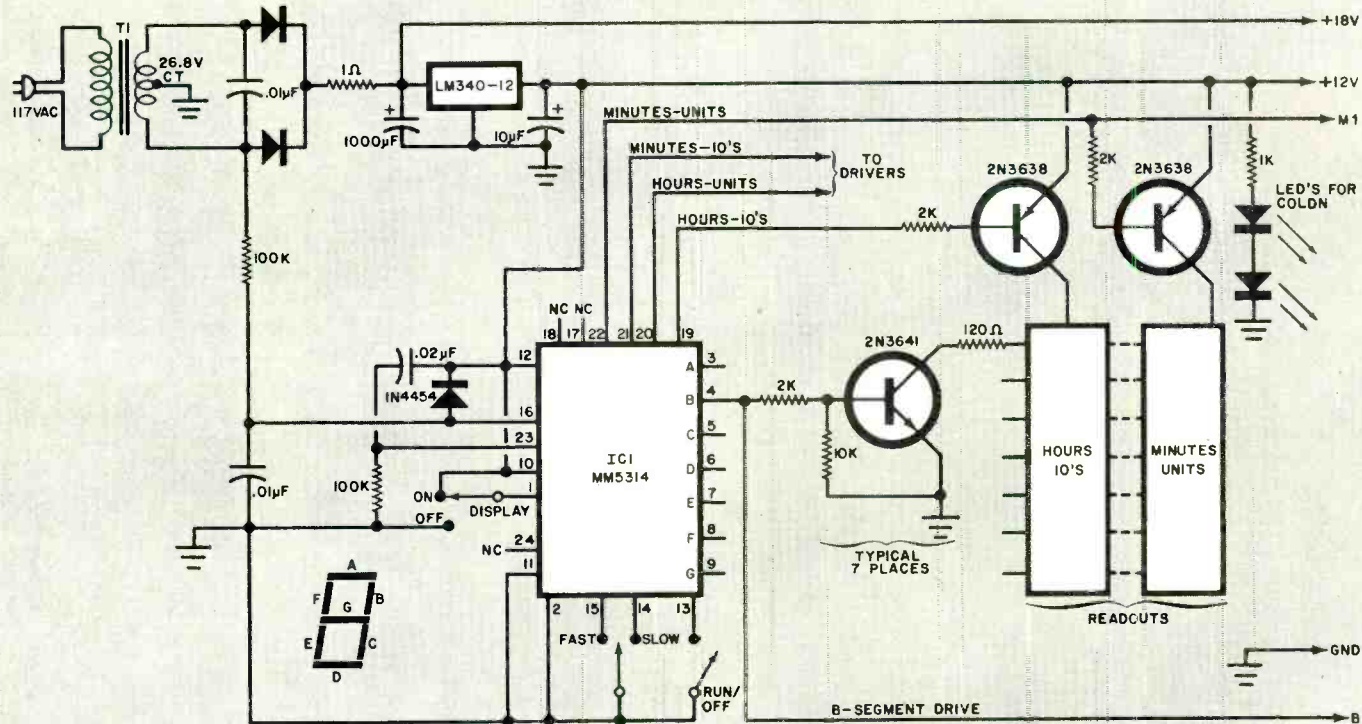

Fig. 1. A basic 24-hour digital clock circuit using an MM5314 IC. Other digital clock circuits could be used with the beeper. Note that only the units-of-minutes driver signal and the readout B-segment signal are used to drive the beeper circuit. If interference is too bad, an r-f decoupling filter can be used.

beeper at the proper identification intervals. Such a circuit is shown in Fig. 2.

How It Works. To understand how the beeper works, it is necessary to examine the way the clock generates the driving signals for a seven-segment readout. The logic that is required to operate the readout is shown in Fig. 3. Note that, in the column for the B segment, the signal changes from the high state to the low state at the count of five. It is that change in states that is used to drive the beeper.

Processing the signal for the beeper requires the use of three IC's because the output of the clock chip is multiplexed. (Drive signals for segments are actually on at all times but display is controlled by digit drivers.) The logic circuit for demultiplexing the signals (Fig. 2) is built up of CMOS IC's with the same pin configurations and functions as their 7400-TTL counterparts.

Elements G, H, I, J, and K form a latch circuit. To assure that the B segment of only the ones of minutes is clocked into the latch, two one-shot (delay) multivibrators (A with B and C with D) are used to

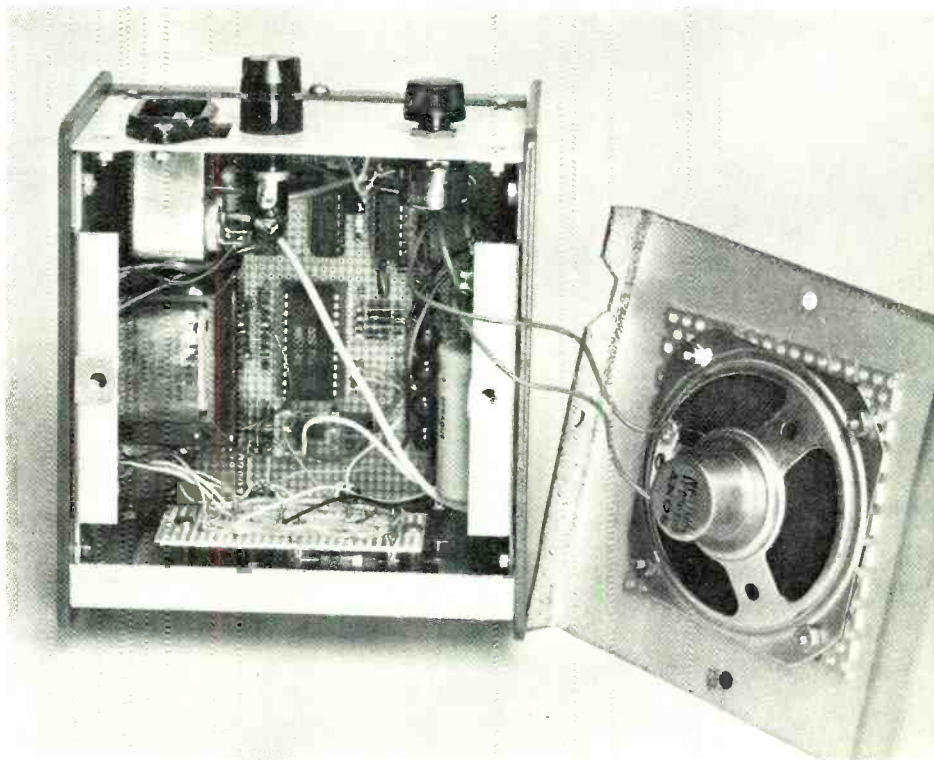
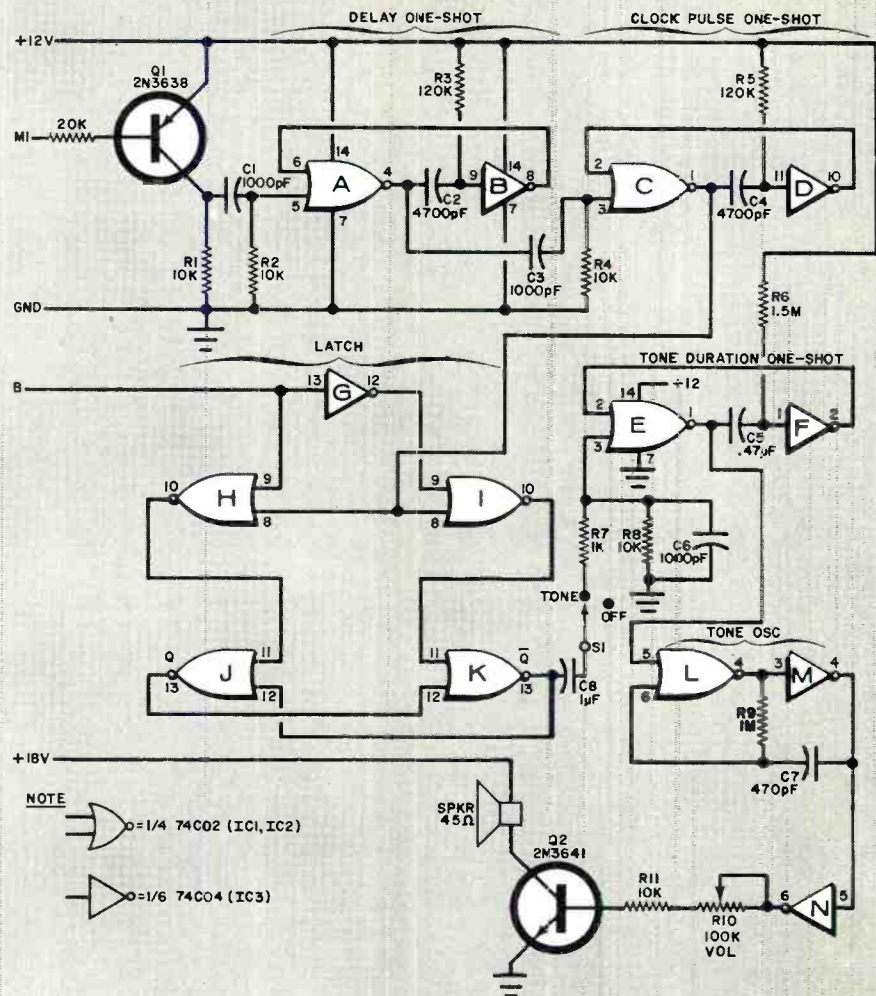

Photo shows internal arrangement of the prototype.

PARTS LIST

- C1, C3, C6—1000-pF capacitor
- C2, C4—4700-pF capacitor
- C5—0.47- μ F capacitor
- C7—470-pF capacitor
- C8—1- μ F capacitor
- IC1, IC2—74C02 CMOS quad 2-input NOR
- IC3—74C04 CMOS hex inverter
- Q1—2N3638 transistor
- Q2—2N3641 transistor
- R1, R2, R4, R8, R11—10,000-ohm resistor
- R3, R5—120,000-ohm resistor
- R6—1.5-megohm resistor
- R7—1000-ohm resistor
- R9—1-megohm resistor
- R10—100,000-ohm potentiometer
- S1—Spst switch

Fig. 2. The beeper circuit uses CMOS equivalents of conventional TTL chips. Inputs are units of minutes (M1), and minutes readout of B segment. The beep occurs on 4/5 transition.



shorten the width of the pulse wave form.

Since the latch is similar to a conventional flip-flop, it has both a Q and a not-Q output. That is, if a 1 is present on the B-data input (when the clock is at 0), then a 1 will be held on the Q output after the clock input changes to a 1. The not-Q output is held at 0.

By using the not-Q output of the latch, the level change when the minutes digit changes from 4 to 5 is from 0 to 1. This step output is differentiated by the following RC network and turns on the tone-duration one-shot (elements E and F). The output of the one-shot then activates the 1-kHz tone oscillator (elements L and M) for about one-half second. The tone burst is buffered and used to drive a small speaker through transistor Q2.

Construction. Since the clock is to be used in a ham station, with a high r-f environment, it should be enclosed in a metal case. For the prototype, the author used a Moduline P-355 case. If interference is too bad, an r-f decoupling filter (Corcom 6EF2) can be used in the power line where it enters the metal chassis. An equivalent job of

line filtering can be obtained by using ferrite beads and feedthrough capacitors.

The composite digital clock and beeper can be assembled on perforated board using sockets for the IC's. In the clock circuit, six digits can be used by adding two more readouts and another pair of LED's for the extra colon.

Operation. Plug the clock into the power line and turn on the DISPLAY switch, the TONE switch, and the RUN switch. Leave the FAST/SLOW switch on the center position. The four readouts will indicate some time and the center colon should be lit.

Using the FAST/SLOW switch, cycle the clock through its 24-hour sequence, noting that the beeper works each time the minute readout goes from 4 to 5. Set the volume of the beeper as desired.

Again using the FAST/SLOW switch, set the clock one minute ahead of the correct time (preferably using WWV). When the clock just indicates the hour, turn it off, wait for the hour tone to sound on WWV and then turn the clock on.

When you are not using the clock to time ham transmissions, turn off the beeper. ♦

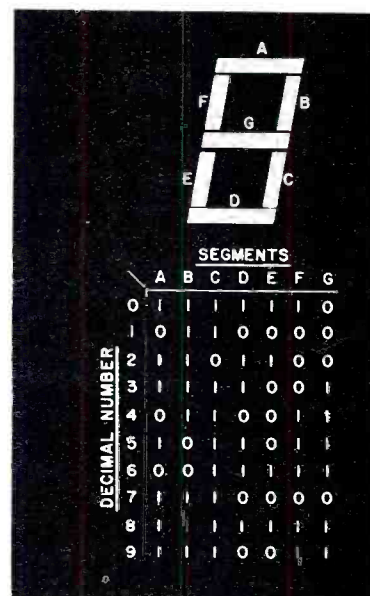

Fig. 3. Signals required for each digit of a 7-segment readout.

A USER'S GUIDE TO MOBILE CB ANTENNAS

Where to mount the antenna and how it performs

MANY CB'ERS are under the misguided impression that they can mount an antenna anywhere on a car and it will work to the best of its ability. But they soon become frustrated when they cannot reach their base stations or fellow mobiles just a mile or two down the road. Assuming the transmitter is performing properly, the problem in such a situation could very well be in the antenna.

Just about every CB'er knows that an antenna can be mounted on a vehicle's roof, trunk lid, fender, or bumper. However, many people do not realize that the antenna's physical location on the vehicle is often critical in maintaining station-to-station contact.

Some Technical Facts. Simply defined, an antenna is a device that radiates or receives electromagnetic energy known as radio waves. When designed for mobile work, all CB antennas are some multiple of one-quarter wave ($\lambda/4$) in length. For example, a 27-MHz, Class D CB antenna, if cut to one full wavelength, would be 36 feet. So, if λ is 36 ft, $\lambda/4$ would be 9 ft. or 108 in., which is exactly the length of the whips used by many CB'ers on their cars.

So far, we have discussed only half the antenna story. The basic antenna (of any type) is a $\lambda/2$ element. Therefore, for the $\lambda/4$ antenna to operate properly, a ground plane is required to serve as the missing quarter wavelength. In mobile applications, the vehicle's body becomes the ground plane and is the image of the $\lambda/4$ antenna (see Fig. 1).

Although it is a favorite topic among CB'ers, when they refer to "antenna gain" they are usually discussing beam antennas at fixed base stations rather than the vertical mobile whip. Antenna gain is defined by John Markus in his *Electronics and Neucleonics Dictionary* as "the effectiveness of a directional antenna compared to a standard non-directional antenna." The key word here is *directional*.

Theoretically, when an antenna is mounted in the center of a ground plane—such as an automobile's roof—it radiates equally well in all directions. In practice, however, this is not the case.

It is possible to mount two antennas one-quarter wavelength apart and feed power to them in such a way that their signals add to each other, and a directional beam will be obtained. This is

so-called "co-phasing". Proper signal addition depends on the phase relationship between the two antennas. Hence, the type of coaxial cable feeding the antennas (which changes the impedance match) as well as physical spacing is critical.

Antenna Specialists Co. markets a phasing harness that does a creditable job of co-phasing antennas. It is made of combinations of RG59/U, RG11/U, and RG8/U coax. Pairing two types improves the impedance match. AS also makes a three-position control box

while their electrical lengths are optimized for resonance.

A number of manufacturers produce top-, center-, and base-loaded tunable and fixed-tuned antennas, as well as continuously tunable antennas for CB use. Naturally, you choose the one that gives the best performance for the type of vehicle on which you intend to use it. As a rule, top-loaded antennas provide the best radiation pattern in the plane of the vehicle. The center-loaded antenna is optimum for average ground resistance; by placing the loading coil at the center of the antenna instead of at the base, the radiation resistance is increased, although a larger coil must be used.

Bear in mind that any movement of the top- or center-loaded antenna that changes its position with relation to the ground plane, as when a vehicle is in motion, changes radiation efficiency. If the antenna is made stiff enough to remain upright at highway speeds, it becomes susceptible to severe damage from low-hanging tree branches and anything else that gets in its way. In general, the base-loaded antenna remains stable under most conditions and is less susceptible to damage.

Tuning the Antenna. Most antennas designed for a specific frequency are pretuned at the factory and little adjustment is necessary. But if tuning is required, an r-f wattmeter or VSWR bridge should be used.

To tune the antenna, first connect it to the transmitter through the VSWR bridge. Power the transmitter and observe the bridge to determine the for-

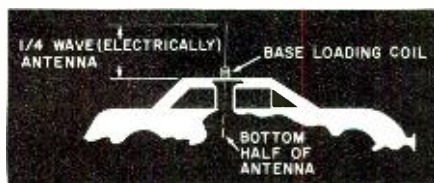

Fig. 1. Loading antenna improves impedance match and shortens length. Automobile provides ground plane and bottom half of the antenna.

that switches the phase of the feed signal to provide 2 dB gain in the forward and rear directions and 1 dB gain to both sides.

In mobile work, co-phased antennas operate best on large vans or motor homes where there is adequate room for the 9-ft spacing between antennas and the ground plane is large and flat.

Returning to the single whip, we find that these antennas are usually used in mobile installations because they require very little space and are easy to install. By using loading coils, the physical length of the whips is kept short,

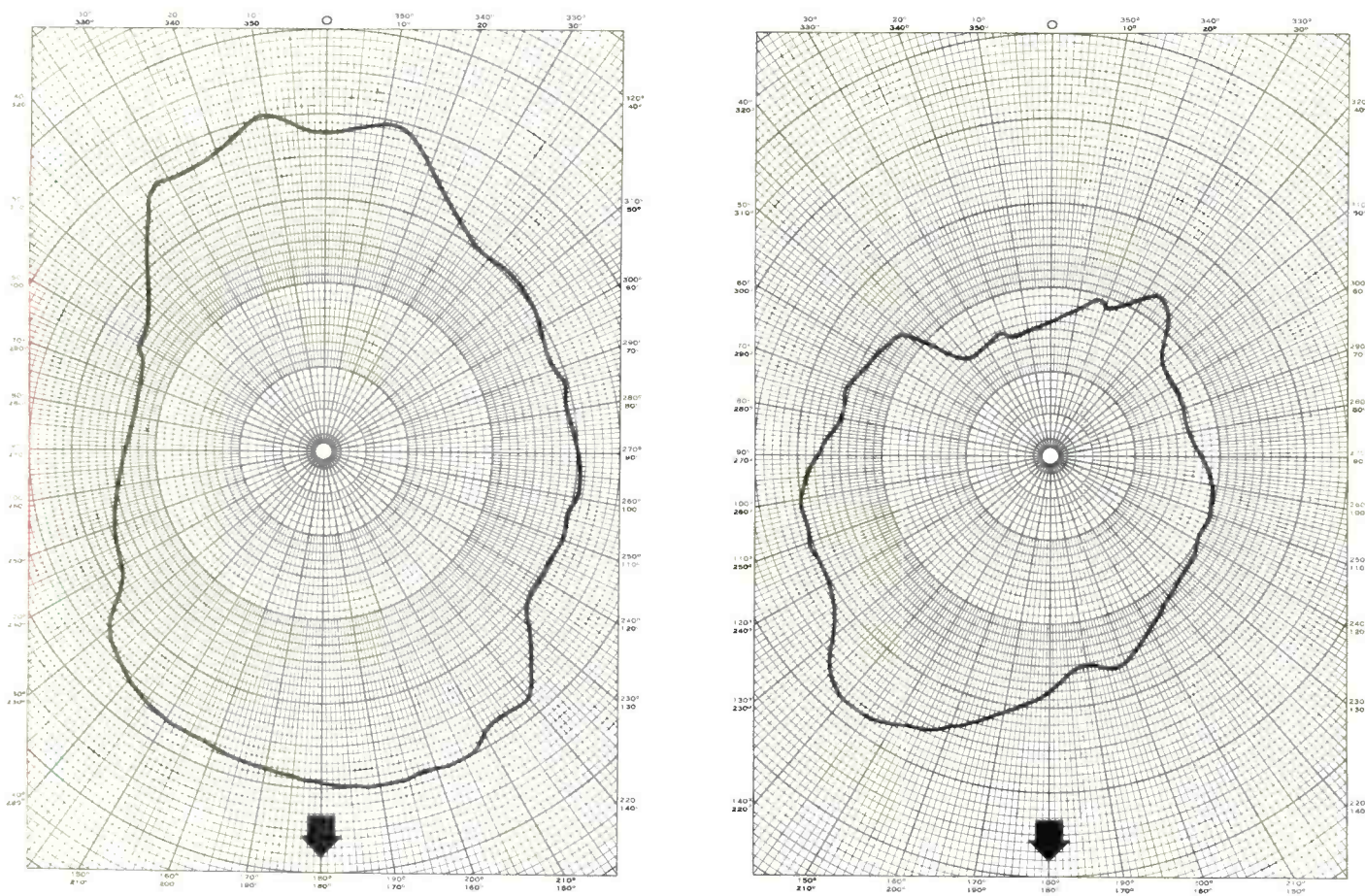

Fig. 2. Typical horizontal radiation patterns when a vertical whip antenna is mounted on the roof (at

ward and reverse power or SWR figures. If the VSWR is greater than 1.5:1, determine the direction of the required adjustment by moving the whip up or down in its mount or by changing taps on the tunable coil. Once you know how the adjustment must be made, adjust the antenna until the lowest SWR is obtained. (You can shorten stainless steel whips by scoring them with a file or grinding wheel and using heavy-duty pliers to snap off the unwanted pieces.)

Where to Put the Antenna. As mentioned earlier, the location of the antenna on a vehicle has considerable effect on performance because the vehicle's body influences the radiation and reception patterns. As Fig. 2 illustrates, the wave patterns for a $\lambda/4$ vertical whip mounted on a car's roof, rear deck, and rear bumpers are significantly different.

If a 9-ft unloaded whip and a base-loaded antenna are mounted in the center of a car's roof, the 9-ft whip will be the better performer. Also, a 9-ft whip mounted on the rear deck usually outperforms the roof-mounted base-loaded antenna. But a bumper-

mounted 9-ft whip will come out second best because the roof-mounted antenna radiates evenly in all directions.

With a small drill, file, screwdriver, and silicone grease, almost any CB'er can install a mobile antenna. For example, to roof mount (or rear-deck mount) one of Hy-Gain's new "Hellcat" antennas, you need to drill only a $3/8$ -in. to $3/4$ -in. hole. The base of this antenna is held firmly in place by taking up evenly on two adjustment screws (see Fig 3).

Trunk-lip mounts are even easier to handle; just two screws are required and no drilling is needed. The lip mount is connected to a clamp or strap that fastens around a bumper. For ball-type mobile antenna bases, the manufacturer usually provides easy-to-follow templates that give proper spacing and size of the bolt and cable connector holes.

The absence of a ground plane on non-metal vehicles and bikes is a pesky problem for the CB'er. A short marine-type antenna is recommended for

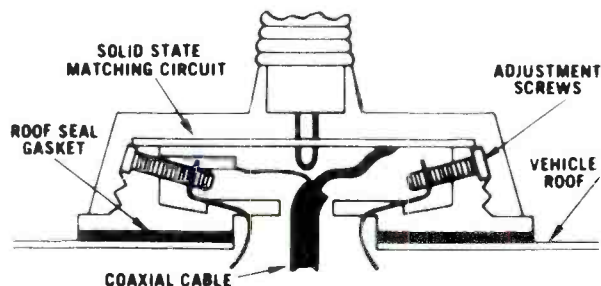
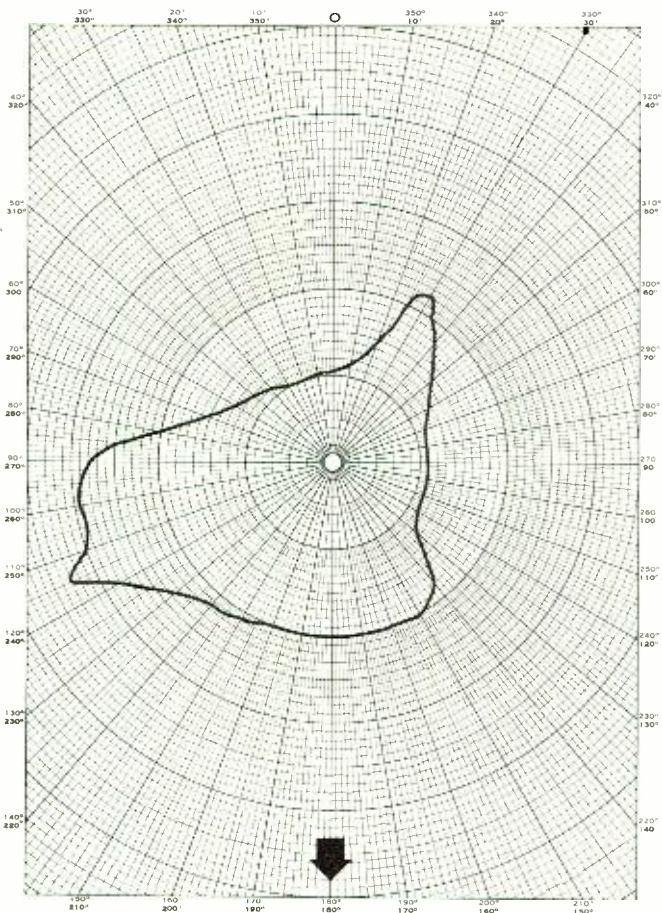

Fig. 3. Hy-Gain Electronics Corp.'s Hellcat 1 rooftop mount (right) is securely clamped to the automobile by two adjustment screws (above).





left), on rear deck (center), and on rear bumper (right).

motorcycles. Many are designed to work without a ground plane, and they are short enough not to interfere with bike operation. Special ground-plane kits, containing strips of self-adhering aluminized tape, are available for use in installations on fiberglass cars and campers.

One word about gutter mounts: they are available but are not recommended as permanent installations since the gutters on many new cars are not strong enough to hold an antenna. Magnetic mounts make superior temporary installations. They hold whips firmly at highway speeds and work equally well on roof tops and trunk decks. Of course, to use them, the vehicle must have a steel body.

Troubleshooting the Antenna.

There are a few simple procedures CB'ers can use if antenna trouble is encountered. The quickest and best method of troubleshooting is to insert a VSWR bridge of the proper frequency and power range between the transmitter and the antenna. If the SWR is less than 1.5:1, the antenna is functioning properly, indicating that the trouble is in the transmitter.

If a bridge is not available, an ohmmeter can be used to troubleshoot the antenna. If you are using a base-loaded, shunt-fed (grounded) antenna, remove the coil from its mount and unplug the coax only at the transceiver end. Next, connect the ohmmeter across the cable connector. If you get an open-circuit indication, so far everything is fine. Now, short the cable at the antenna mount; the meter should read zero resistance. If either of these criteria is not met, the cable should be checked for breaks and/or shorts, and the mount should be checked for improper connections.

When you replace the coil in its mount, the meter should again indicate a short circuit (zero resistance). If it does not, the coil is either open and defective, or there is no connection at the base of the antenna.

For top- or center-loaded (ungrounded) $\lambda/4$ antennas, the cable and mount assembly test procedure is the same. However, when the antenna is replaced in the mount assembly, the meter should continue to indicate an open circuit until a deliberate short is made from whip to ground. An ohmmeter connected across the ends of

any top- or center-loaded coil should indicate zero resistance (short). If it does not, the coil is defective.

Noisy Transceivers. Noise can seriously affect the range of a two-way radio system. So, antenna cables should be kept as short as possible and routed away from engines, gauges, electrical wiring, and other sources of interference. Local "noise" that emanates from alternators, spark plugs, ignition system, and other electrically operated devices can be significantly reduced by using suppression kits; by making sure all connections are tight; and by seeing to it that all metallic parts in the vehicle are positively bonded.

Noise from passing vehicles, or static caused by atmospheric conditions, can be removed by a preamplifier and noise eliminator installed in the antenna circuit. The noise pulses are amplified and blanking pulses are mixed with them to neutralize the noise. The preamp gives the receiver added selectivity and sensitivity which improves overall receiver performance.

Base-loaded antennas have better noise performance than the 9-ft whip or top-loaded types. Since one end of the loading coil is grounded, a direct path exists to ground for unwanted noise.

Communication Range. While communication between fixed stations separated by 20 miles or more is not uncommon, the range between base and mobile stations is usually 5 to 10 miles, and between mobiles it is 1 to 5 miles. It is important to understand that there are no absolute figures that specify just how far a CB radio signal will travel.

The groundwave range is governed primarily by terrain—hills, valleys, buildings, etc.—plus about 10 percent due to atmospheric diffraction. Other factors, such as weather, operating frequency, type of equipment, modulation percentage, noise, and the relative height of the transmitting antenna with respect to the receiving antenna, also affect the range.

Unusual weather, such as temperature inversions, often form tropospheric "ducts" that sometimes enable CB'ers to communicate over distances of up to 100 miles or so. When nature provides the conditions that permit it, such long-range communication is legal. However, using sky waves for DX'ing violates FCC regulations, which sets a 150-mile maximum range. ♦

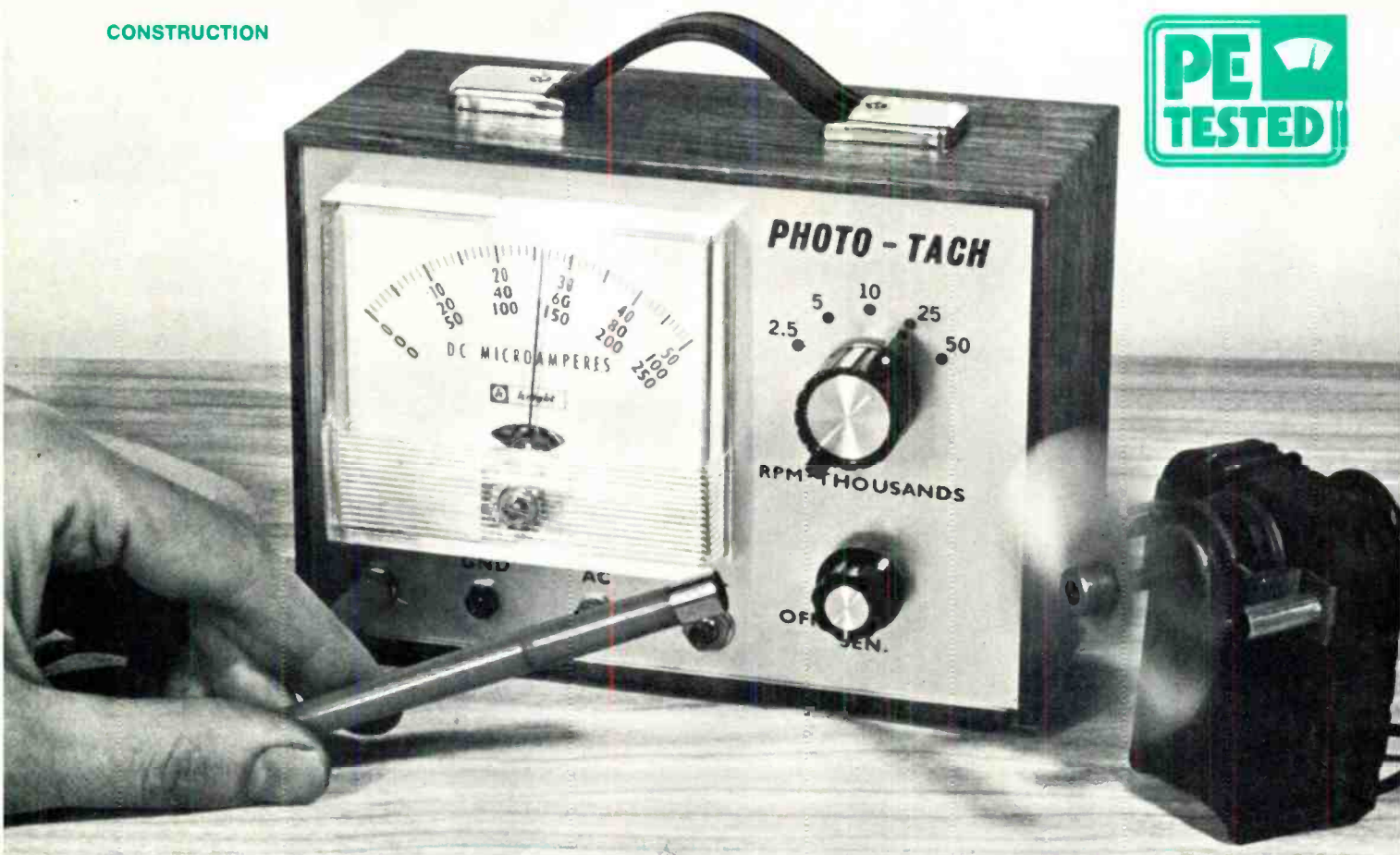

MEASURE RPM OF ROTATING ELEMENTS WITH THE IC PHOTO TACHOMETER

*Battery-operated device gives accurate readings
up to 50,000 rpm without physical contact.*

BY ADOLPH A. MANGIERI

IF YOU service the numerous motor-driven appliances and tools found in the home, shop, or factory, consider building this photo tachometer. By recording normal rotational speeds for comparison with later measurements, you can easily detect the effect of worn gear trains or motor brushes and gauge improvement of performance after repairs. With no mechanical coupling required, the Photo-Tach measures the rpm of any type of rotating element, including miniature high-speed, low-power motors. You can also use the Photo-Tach as an analog frequency meter,

useful for checking inverters and auxiliary ac generators.

Operated in either the incident or reflected light mode, the Photo-Tach includes five ranges up to 50,000 rpm. A plug-in light probe, using a high-speed photo-transistor, facilitates speed measurements. Using low-cost, high-performance IC's, the battery-operated tachometer features high accuracy and stability. The schematic diagram is shown in Fig. 1.

How It Works. Light pulses striking photo-transistor *Q1* produce voltage pulses at the input of operational am-

plifier *IC1*, connected as a Schmitt trigger which produces a sharply squared output pulse for each input pulse. Resistors *R3* and *R4* provide positive feedback and also determine the input voltage hysteresis or dead-band. This prevents the tach from responding to noise components of the main signal and rejects the small 120-Hz modulation of 60-Hz incandescent light sources. Input high-pass filter, *C1-R2*, favors response to fast-changing light signals.

Output pulses from *IC1* are differentiated by *C6-R6* forming voltage spikes which are applied to the trigger input

terminal (2) of timer IC2, connected as a monostable. When a negative-going trigger pulse drives pin 2 below one-third V_{cc} , the timer delivers a precise output pulse V_o at pin 3. Output pulse duration, independent of supply voltage, depends on timing capacitor C7 and a timing resistor selected by range switch S1. Output pulses V_o pass through diode D1 and energize FET constant-current source Q2-R17, producing constant-amplitude pulses across R7. Diode D1 blocks the small residual voltage when V_o is low. Constant-duration pulses of constant amplitude are averaged by meter M1

which responds linearly to the repetition rate of input light pulses.

Potentiometer R16 adjusts the input sensitivity while capacitor C11 dampens meter pointer vibration at low (2500) rpm. With a pulse duty cycle of near one-third at full scale, meter overrange is within safe limits.

Construction. Assemble the Phototach in a 3"×4½"×6½" metal case. In the prototype, perf board construction was used but you can make a printed circuit board using the foil pattern shown in Fig. 2. Use sockets for IC1, IC2, and Q2, and use short, heavy

buses on the circuit board as common tie points to avoid ground loops. Install bypass capacitors C3 and C4 close to their IC1 pins. Wire R16 so that its resistance is zero with the control set counterclockwise. Voltage-range multiplier resistor R10 is, preferably 1% tolerance.

Connect the supply minus to case (ground). Tape over any unused pins of the IC sockets and carefully observe correct installation of the IC's. Remove the meter dial card and mark the additional scales using dry transfers (see photograph). Otherwise, mark rpm range switch S1 with multipliers

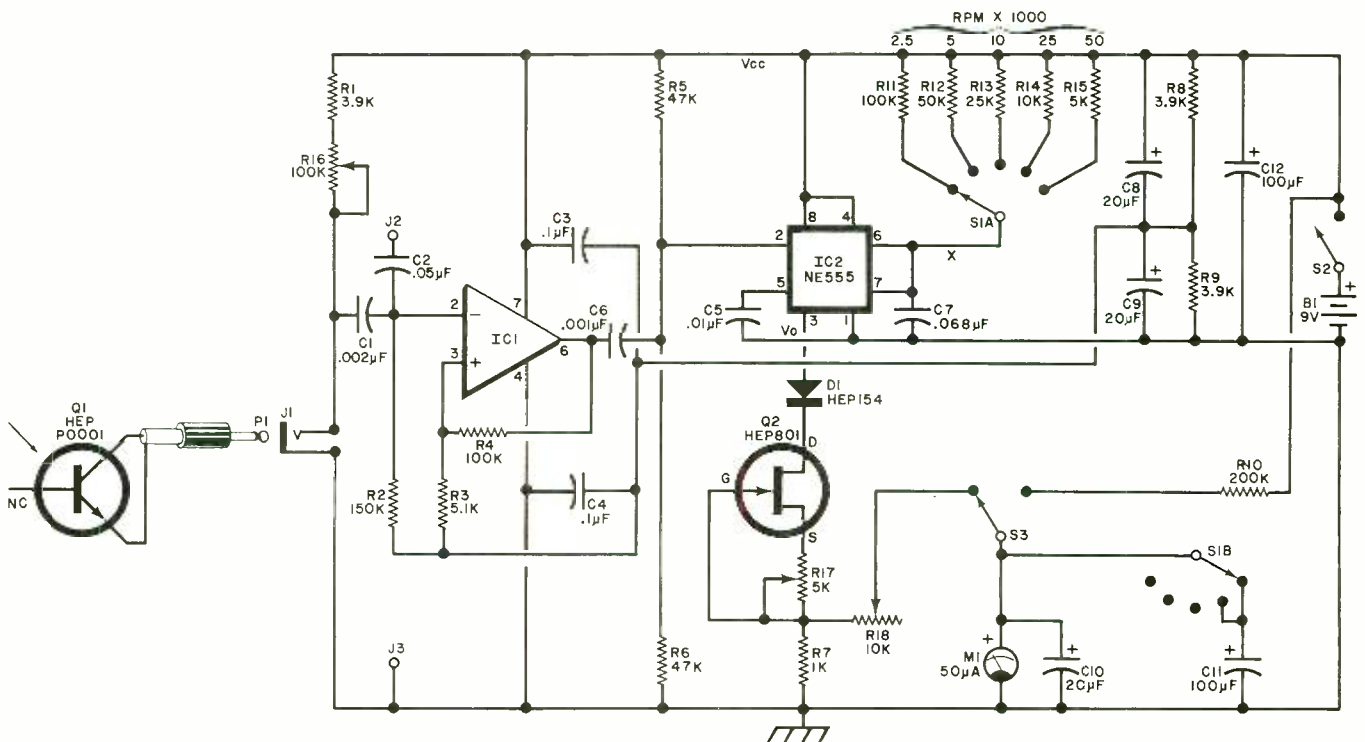

PARTS LIST

- B1—9-volt battery (Burgess 2U6 or equiv.)
- C1—0.002- μ F 10% ceramic disc capacitor
- C2—0.05- μ F ceramic disc capacitor
- C3, C4—0.1- μ F ceramic disc capacitor
- C5—0.01- μ F ceramic disc capacitor
- C6—0.001- μ F 10% ceramic disc capacitor
- C7—0.068- μ F 10% Mylar capacitor
- C8, C9, C10—20- μ F 15-V electrolytic capacitor
- C11, C12—100- μ F, 15-V electrolytic capacitor
- D1—Silicon diode (HEP 154 or equiv.)
- IC1—Operational amplifier (HEP C6052P or 741C)
- IC2—555 timer IC
- J1—Miniature phone jack
- J2, J3—Phone tip jack (one red, one black)
- M1—0-50-microampere dc meter
- P1—Miniature phone plug

- Q1—Photo transistor (HEP P0001, HEP 312, or equiv.)
- Q2—N-channel JFET (HEP 801 or equiv.)
- R1, R8, R9—3900-ohm, ½-watt 5% resistor
- R2—150,000-ohm, ½-watt 10% resistor
- R3—5100-ohm, ½-watt 10% resistor
- R4—100,000-ohm, ½-watt 10% resistor
- R5, R6—47,000-ohm, ½-watt 5% resistor
- R7—1000-ohm, ½-watt 5% resistor
- R10—200,000-ohm, ½-watt 1% resistor
- R11—100,000-ohm resistor
- R12—50,000-ohm resistor
- R13—25,000-ohm resistor
- R14—10,000-ohm resistor
- R15—5000-ohm resistor
- R16—100,000-ohm audio taper potentiometer, with spst switch S2. (Radio Shack 271-1727 or equiv.)
- R17—5000-ohm trimmer (Radio Shack 271-217)

- R18—10,000-ohm trimmer (Radio Shack 271-218)
- S1—Dp, 5-pos. shorting switch (Centralab PA-1002 or equiv.)
- S2—Spst switch (on R16)
- S3—Sp, 2-circuit momentary pushbutton switch
- Misc.—Transistor socket: DIP sockets (2); metal case 4½"×6½"×3" (Vector W30-66-46B or equiv.); P-pattern perforated board; knobs (2); battery clip; miniature shielded cable; flea clips (Vector T42-1 or equiv.) hardware; etc.
- Note: If you choose to use a printed circuit board, an etched, undrilled board (# Phototach 874) is available for \$3.95, postpaid, from Techniques Inc., 235 Jackson St., Englewood, NJ 07631. New Jersey residents please add 5% sales tax.

Fig. 1. The light pulses at Q1 are squared up in IC1 and turn on precision monostable IC2. Constant-current output pulses through Q2 are averaged by the meter as rpm. Five ranges permit testing up to 50,000 rpm.

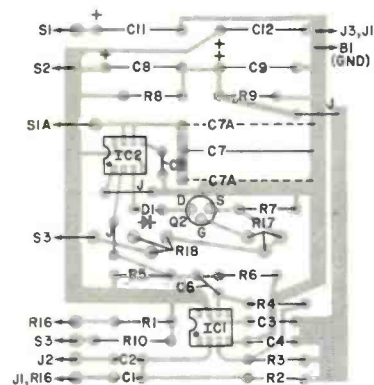
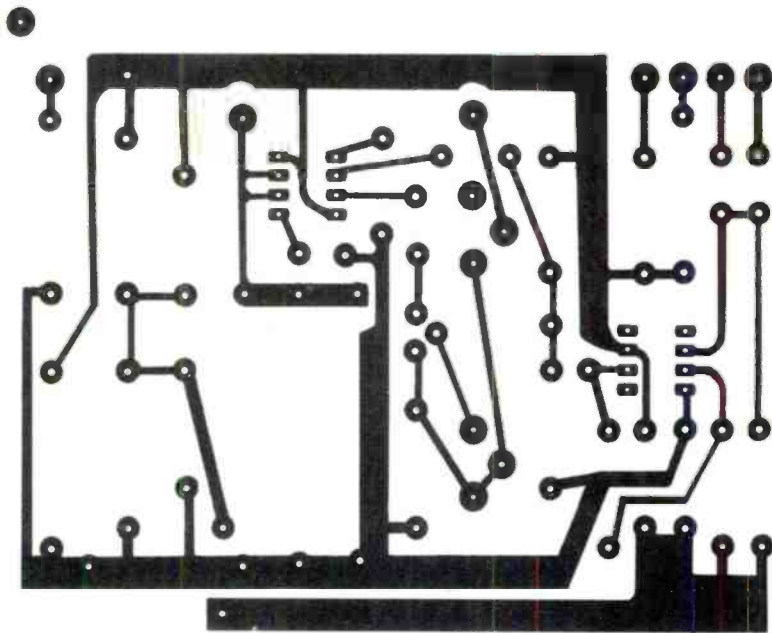

Fig. 2. Though the prototype of the tachometer was assembled on perforated board, it is convenient to use a printed circuit board. C7A is two 0.033 capacitors if this is preferred to one 0.068. (See Parts List to order board.)

of the 0-50 scale. Do not connect a meter protector across *M1*.

Mount the meter, range switch *S1*, sensitivity control *R16*, battery test switch *S3*, probe input jack *J1*, ac input connector *J2*, and the ground connector *J3* on the front panel as shown in the photographs.

For photo-transistor *Q1*, use either a glass lens (HEP P0001) or plastic lens (HEP 312). Clip off or insulate the unused base lead of the P0001 transistor. Connect the outer braid of a three- to four-foot length of miniature shielded cable to the emitter of *Q1* and center conductor to collector. Make sure the braid is connected to the grounding side of the P1-J1 combination. Install *Q1* within an opaque plastic tube, such as the barrel of a ballpoint pen. Position the lens about one-quarter inch from the tip of the probe. Install battery *B1* on the back plate of the cabinet.

Calibration and Checkout. Set *R17* and *R18* to mid-position and *S1* to 2500 rpm, then connect a dc voltmeter across *R7*. This test voltmeter input resistance should be at least 50,000 ohms on the selected voltage range. Disconnect wire "X" from the rotor of switch *S1A*. Operate sensitivity control *S3* and observe battery end-point voltage on *M1*, read as 0-10 volts dc. End-point voltage should be near 6.6 volts or less. If the voltage is above 7 volts, use a 12-volt battery for *B1* (made up of eight AA cells connected in series). The additional supply voltage accommodates a FET (*Q2*) having a pinch-off voltage above 3 volts.

Breadboard the calibration circuit shown in Fig. 3, which supplies a

120-Hz signal (equivalent to 7200 rpm) and connect to jacks *J2* and *J3*. Set *S1* to 10,000 rpm, close *S2* and adjust *R18* until *M1* indicates 7200 rpm. With accurate range resistors, all ranges are simultaneously calibrated to high accuracy. You can use a signal generator to calibrate, check, or trim rpm ranges provided frequencies can be set to high accuracy, as with a frequency counter. Multiply frequency by sixty to obtain equivalent rpm.

Next, check rejection of the small 120-Hz modulation of incandescent light sources. Insert the probe in *J1* and aim the probe at a 50- or 75-watt lamp at distances of two inches to three feet while varying *R16* (sensitivity control) over its range. If *M1* does not remain at zero under all conditions, increase input hysteresis by increasing *R3* to 8200 or 12,000 ohms. If further remedy is required (not likely), reduce *R2* to 100,000 or 82,000 ohms and/or reduce *C1* to 0.001 μ F.

Connect a 1500-ohm potentiometer (set for minimum resistance) in series with the plus lead of *B1*. Connect the calibrating signal to *J2* and *J3*. Increase the potentiometer resistance until *M1* drops to 7100 rpm or about 1% lower. Depress pushbutton switch *S* and observe battery end-point voltage on *M1*, read as 0-10 volts dc. End-point voltage should be near 6.6 volts or less. If the voltage is above 7 volts, use a 12-volt battery for *B1* (made up of eight AA cells connected in series). The additional supply voltage accommodates a FET (*Q2*) having a pinch-off voltage above 3 volts.

Applications. In the incident-light mode of operation, the rotating element whose rpm is to be checked chops or gates the light traveling directly from a light source to the probe. This provides a noise-free, large-signal input to the tach. A reflectorized handy light with a 50- to 100-watt lamp proved a most convenient light source but you can use a desk lamp, drop cord, or a flashlight.

Position the light source about two feet behind the blades of an operating electric fan. Hold the probe near the front of the fan, aimed at the lamp. Advance *R16* until *M1* shows a steady and maximum indication. Observe that *R16* can be varied over much of its range while *M1* remains steady. For a fan with four blades, divide indicated rpm by four, etc.

To check the speed of a drill, construct a light chopper using a three-

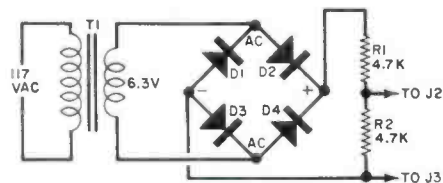
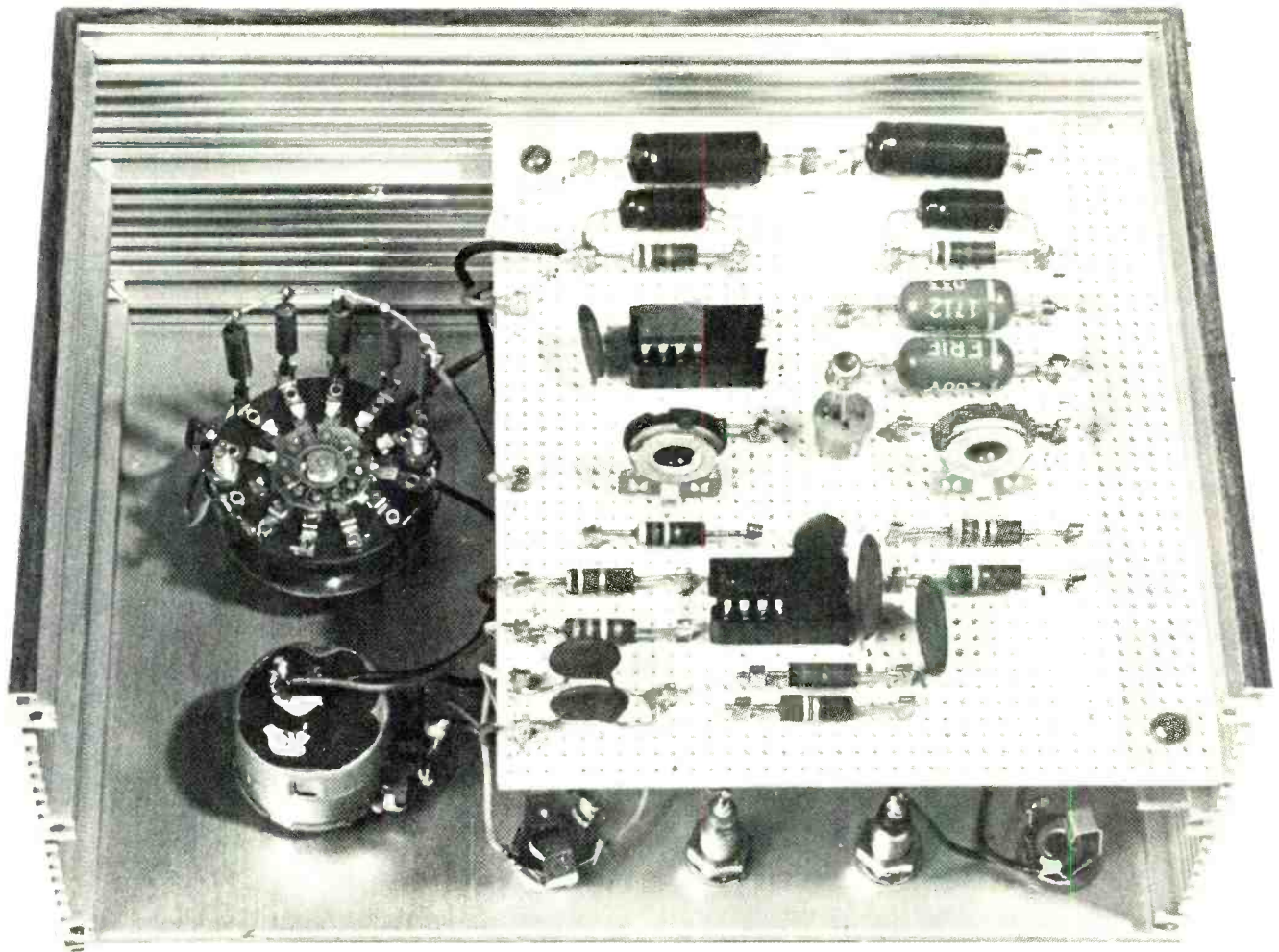

Fig. 3. Calibration circuit delivers a 120-Hz signal equivalent to 7200 rpm. Multiply frequency by 60 to obtain the equivalent speed.



Photograph of prototype, assembled using a perforated board, shows how parts were assembled in chassis. The arrangement of the front panel is shown in the title photo.

inch diameter cardboard disc. Cut out a $\frac{3}{4} \times \frac{3}{4}$ light gate at the edge and chuck the disc in the drill using a machine screw. To check motors having various shaft sizes, attach a light chopper disc to a suitable wheel, shaft collar, or knob. The spokes of a large pulley can serve as a light chopper.

In the reflected-light mode, the sensor views light reflected from contrasting surfaces. If surface reflectivity is excessively uneven due to rust spots, discolorations, or other irregularities, a reflected-light pulse may contain excessive noise. This will be recognized as a very high and erratic indication on the meter. Involving two directions of light travel, the reflected-light mode may require rigging of probe or light source, or both, to maintain steady indications.

To check the speed of a motor having a half-inch shaft or larger, wrap a strip of electrician's tape (cloth friction type, not glossy surface vinyl) around the shaft. Place the band on a shaft flat if possible. Place a strip of white sur-

gical adhesive tape lengthwise across the band. Or, paint a white strip using fast-dry flat paint. Rig the probe horizontally about one inch from the shaft facing the band.

For the flatted shaft with white strip on the flat, hold the light source directly above the shaft at a distance of about 8 to 12 inches. For the round shaft, hold the lamp about 6 inches above the end of the probe handle. Advance *R16* and verify that the meter indication remains steady over some portion of pot rotation, proving adequate light input. For motors having smaller shafts, attach a reflective disc to a suitable wheel or knob. Paint half of the disc flat black and the balance flat white. Fan speed can be checked by this method provided the fan blades are clean and uniform in appearance. By sighting the running fan from several angles, you can pick a suitable direction to aim the probe. Particularly with very small fans, a slightly twisted blade can result in a missed light pulse.

Meter-pointer vibration becomes apparent below 400 rpm. In this case, include a second light gate or reflective surface and divide indicated rpm by two, etc. Position additional light gates or reflective surfaces in an approximately symmetrical pattern.

Keep tabs on the normal running speeds of appliances and tools for later comparisons. Use speed measurements to isolate problems between motor and drive train and observe effect of repairs. Speed measurements on major heavy-duty appliances such as washers and dryers can forewarn you of progressive wear which may lead to motor overload and possible fire hazards.

The tachometer can be used as a low-range frequency meter to check frequencies from about 10 to 800 Hz. Inject one or two volts ac into jacks *J2* and *J3* and divide indicated rpm by 60. Also, by connecting *J2* and *J3* to a scope, you can observe input to the tach as you vary lighting and sensitivity settings. ♦

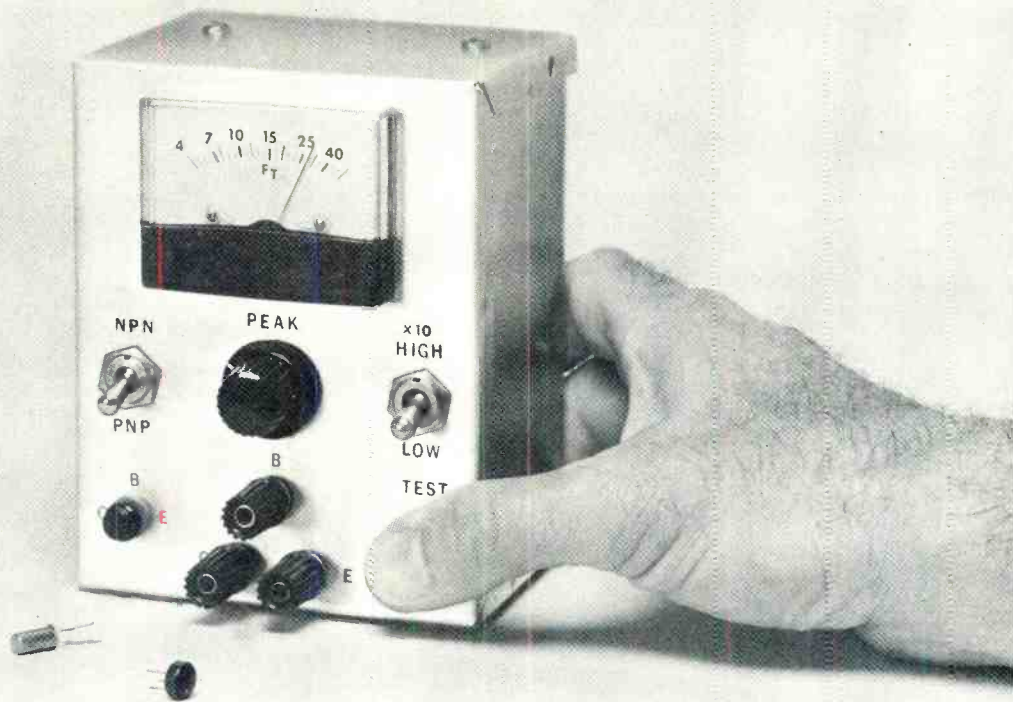

R-F TRANSISTOR TESTER

Checks upper frequency limit of bipolar transistors

BY DANIEL METZGER

CHECKING out an r-f transistor on a "standard" tester is as tricky as testing a high-voltage TV tube on the corner-drugstore machine. When the indicator reads "good," the device can still be bad.

Unfortunately, most transistor testers perform dc checks only. They indicate the device's beta (amplification) and, in some cases, leakage current. Few check performance at radio frequencies, however, which is an essential parameter if you're troubleshooting a transistorized front end.

The important characteristic here is the transistor's cutoff frequency, f_T . As the frequency increases, a transistor's amplifying capability drops rapidly. Above f_T , there is no gain at all, and the transistor just doesn't work. You can check your transistors' f_T to determine if they will operate satisfactorily at r-f by building the circuit shown

in Fig. 1. (For more about the importance of f_T , see the box on page 59.)

How It Works. The circuit is essentially an emitter-follower amplifier whose input impedance varies with the f_T of the transistor. The input impedance is then used as one leg of a voltage divider, and the output voltage, as indicated on the meter, is a function of f_T .

The $Q1$ circuit is a conventional Colpitts oscillator running at 1 MHz on the LOW range and 10 MHz on the HIGH range of $S1$. A signal of approximately 6 volts p-p is applied to the left end of resistor $R6$. Resistors $R4$ and $R5$ provide base bias for $Q2$, the transistor being tested. Either $L3$ or $L4$ forms a tuned circuit with $C6$ and the input capacitance of the transistor being tested. With $C6$ tuned to resonance, the reactance of the transistor's C_{in} ,

which would otherwise load the signal, is cancelled.

The input impedance of the base of $Q2$ is essentially beta times the emitter resistance. This emitter resistance is $R7$ in parallel with the effective resistance of the metering circuit. Emitter resistance varies with the setting of the calibrate control, but should be near 400 ohms. If a transistor having an f_T of 17 MHz is checked on the 1-MHz range, it will have a beta of $f_T/f = 17/1 = 17$. The base input resistance of the transistor will then be:

$$r_b = \beta r_e = 17(400) = 6800 \text{ ohms}$$

The 6-volt p-p input signal is the voltage divided by $R6$ and r_b to produce a 3-volt p-p signal at the base (and also at the emitter) of $Q2$. Diodes $D1$ and $D2$ rectify this signal, but since each diode requires about 0.6 volt before it begins to conduct, only about 1.8 volts dc appears across $C10$.

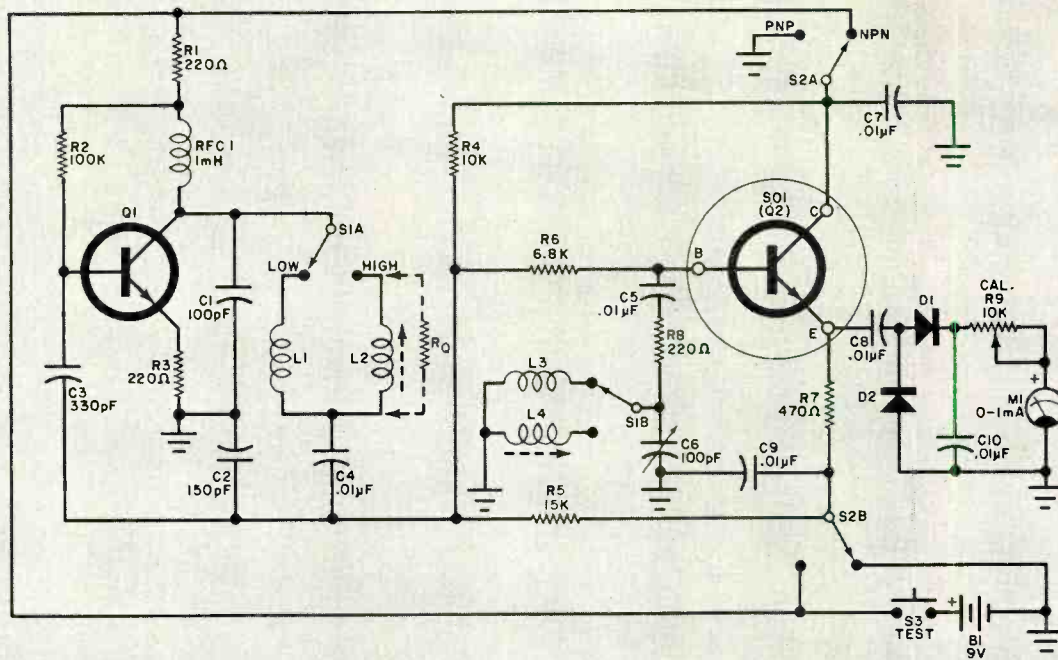

PARTS LIST

- B1—9-volt battery
- C1—100-pF disc capacitor
- C2—150-pF disc capacitor
- C3—330-pF disc capacitor
- C4,C5,C7-C10—0.01- μ F disc capacitor
- C6—100-pF variable capacitor
- D1,D2—Silicon signal diode (1N914 or similar)

- L1,L3—400- μ H inductor
- L2,L4—25 turns No. 26 enamel wire, close-wound on $\frac{1}{4}$ -in. slug-tuned form
- M1—0-1-mA dc meter movement
- Q1—Transistor (2N4124 or similar)
- Q2—Transistor under test
- R1,R3,R8—220-ohm, $\frac{1}{2}$ -watt resistor
- R2—100,000-ohm, $\frac{1}{2}$ -watt resistor

- R4—10,000-ohm, $\frac{1}{2}$ -watt resistor
- R5—15,000-ohm, $\frac{1}{2}$ -watt resistor
- R6—6800-ohm, $\frac{1}{2}$ -watt resistor
- R7—470-ohm, $\frac{1}{2}$ -watt resistor
- R9—10,000-ohm trimmer potentiometer
- RQ—3300-to-33,000-ohm resistor (see text)
- SO1—Transistor socket
- S1,S2—Dpdt toggle switch
- S3—Spst normally open pushbutton switch

Fig. 1. The transistor being tested (Q2) is connected to socket SO1. Transistor Q1 is an r-f oscillator which supplies a signal to Q2. Frequency is changed by switching reactances.

Construction. Almost any type of construction can be used. The prototype was built up on a small piece of perforated board. However, keep in mind that the tester operates in the r-f range, so all leads must be as short as possible.

The test socket (SO1) and all controls and switches (except for R9) are mounted on the front panel. The bat-

tery is supported by a mounting clip. Coils L2 and L4 are mounted on a small metal bracket so that their screwdriver adjustments can be easily reached.

On the prototype, three five-way binding posts were connected to SO1 and mounted on the front panel to facilitate testing using clip leads to connect to the transistor.

Calibration. Calculations such as those given above and in the box can be extended to apply to a range of f_T values and a calibration chart for the low range of the meter can be constructed as shown in Fig. 2. Other values of R6, R7, and signal frequency can be used to alter the range of the instrument, but care should be taken to ensure that betas higher than 50 will

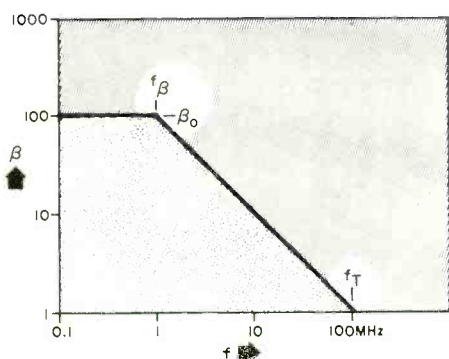

WHAT IS f_T ?

The cutoff frequency (sometimes also called gain-bandwidth product) is the frequency at which the current gain (h_{fe}) drops to unity. For frequencies lower than f_T , h_{fe} increases linearly at a rate of 6 dB per octave. (The beta doubles as the frequency is halved.) The rise in beta continues until the low-frequency beta (β_0) is reached at the beta cutoff frequency (f_β) as shown in the diagram. Notice that, for any frequency above f_β , the product of current gain and operating frequency is constant and equal to f_T . Hence, the name gain-bandwidth product for f_T .

Calculating h_{fe} at any frequency when f_T is known is a simple matter if this relationship is kept in mind. For example, if a transistor having an f_T of 200 MHz is to be used in a 27-MHz amplifier, its effective beta is f_T divided by f or $200/27 = 7.4$.

To find the frequency at which beta will begin to drop below its full low-frequency value, the procedure is reversed. Thus, in the example above, if the transistor has a low-frequency beta of 150, it will begin to drop at $200/150 = 1.33$ MHz.

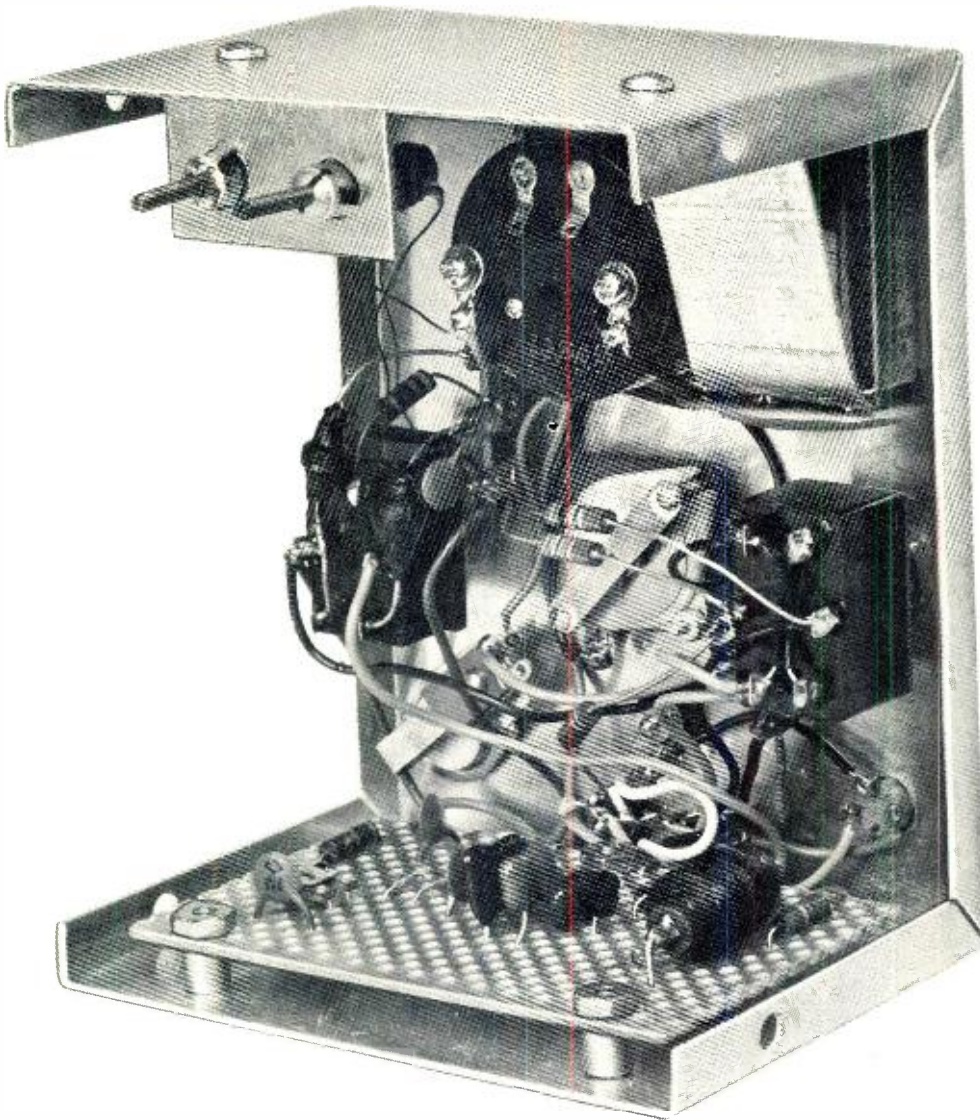

This photograph shows how prototype was assembled. Be sure to use short lead lengths to avoid r-f interference.

always drive the meter above full scale. This is because many transistors have a low-frequency beta not much higher than 50 and they would otherwise read low on the f_T scale.

To calibrate the instrument, a high-beta transistor with an f_T specification above 250 MHz is inserted in test socket $SO1$ with range switch $S1$ on LOW. The author used a 2N4124 with a

measured low-frequency beta of 200. The beta of the transistor is known to be 200 at 1 MHz, giving an I_m of 1.3 mA as shown in the last line of Fig. 2. A 3-mA meter is then inserted in series with the instrument's meter, and $R9$ is adjusted for 1.3 mA. The low range of $S1$ is now calibrated. Use $C6$ to set the meter pointer at maximum.

To calibrate the high range, it is

necessary to insure that $Q1$ is really oscillating at 10 times the low frequency (10 MHz in this case). This can be determined by using a grid-dip meter, a high-frequency oscilloscope, or a frequency counter.

Finally, the output of the oscillator (junction of $R4$ and $R6$) must be checked with an r-f voltmeter and trimmed if necessary to keep the r-f output constant in both the high and low ranges. The trimming is accomplished by placing a resistor (RQ) across $L1$ or $L2$ and choosing its value so that the r-f voltmeter reads the same on both ranges. The resistor effectively lowers the Q of the coil and reduces the oscillator output on the range for which it is inserted. The value of RQ may be from 3300 to 33,000 ohms, depending on the difference in Q between the two coils. The calibration for the high range is simply 10 times the low range. ♦

FIG. 2. SAMPLE CALIBRATION CHART

f_T MHz	β	r_{in} Ohms	v_c Volts (p-p)	V_{C10} Volts	I_m mA
4.2	4.2	1.67 K	1.2	0	0
7.0	7	2.8 K	1.7	0.5	0.15
10	10	4.0 K	2.2	1.0	0.30
17	17	6.8 K	3.0	1.8	0.55
30	30	12 K	3.8	2.6	0.79
50	50	20 K	4.5	3.3	1.00
>250	200	80 K	5.5	4.3	1.30

A GUIDE TO CMOS OPERATION

*How CMOS devices are used
in linear applications*

BY WALTER G. JUNG

Contributing Editor

WHAT are the important characteristics of the basic CMOS inverting stage (amplifier)? First, it has the inherent simplicity of consisting essentially of just two transistors. It has a high input impedance; its output swing goes to the limits of the supply; and the stage can be biased so that the output is centered at half of the supply when the input is half of the supply ($\frac{1}{2}V_{DD}$). These characteristics make the CMOS amplifier ideal for use in digital circuits, where it is widely used, operating in the switching mode. But, how about using it in linear applications?

Actually, the same characteristics make CMOS equally usable in linear circuits. It is only necessary to add a biasing resistor and an input capacitor, as shown in Fig. 1. The CMOS then becomes a class A linear amplifier.

How does this stage bias itself? The answer lies in the $\frac{1}{2}V_{DD}$ balance point. Resistor R_b forms a direct dc feedback path from output to input. Any tendency for the output to drift high or low is fed back to the input, and the amplifier automatically corrects the drift. The stage then stabilizes its own bias point with the output at the same po-

tential as the input balance threshold. Since the gate does not draw any appreciable current, there is no drop in R_b . This effect of a zero gate current permits the use of a very high resistance for R_b (22 megohms or higher). As a straightforward block of gain without ac feedback, the circuit of Fig. 1 has many uses.

The characteristics of this stage of gain are shown in Fig. 2. Although these curves are for a CA3600E, other CMOS inverters behave in a similar fashion. Note that the stage gain increases as the supply voltage is lowered, but the bandwidth is reduced. With higher supply voltages, the gain decreases and the bandwidth increases. To get high gain and wide bandwidth, cascaded stages must be operated at the higher supply.

Linearity Considerations. While the CMOS amplifying stage has the unique property of providing an output swing to the limits of the supply, this feature requires special consideration in linear applications. The transfer characteristic of a CMOS stage becomes quite nonlinear (compressed) at

the extremes of the output swing. For digital use, this is not too important; but for linear amplifiers it is, if high-level outputs are desired. Plainly speaking, the best linearity is obtained at about the center third of the swing. Beyond that, distortion rises rapidly.

While high-level nonlinearity does limit the usefulness of the basic stage, the problem can be overcome by using negative feedback as shown in Fig. 3. Here, an input resistor, R_i , is used in addition to the biasing resistor, R_f . The stage then becomes a feedback amplifier. Gain is set by the ratio of the values of R_f and R_i , which can be varied to obtain different gains. The benefits of feedback are most evident at low gains, where feedback is greatest (as in Fig. 3, where the gain is unity).

This stage no longer has high input impedance. It is, in fact, the same as the value chosen for R_i . Capacitor C_i provides input coupling and C_o is for output coupling. A feedback such as this can provide gains up to 10 with distortion less than 1% near full output. For higher gains, stages can be cascaded, with the overall gain being the product of the gains of individual stages.

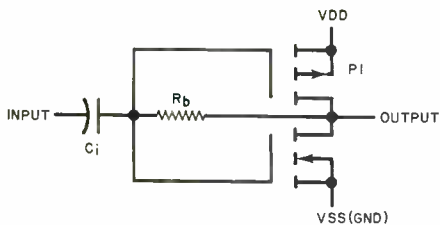

Fig. 1. A CMOS inverter biased for linear operation.

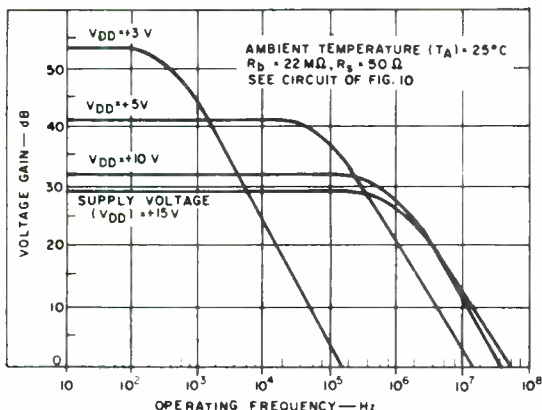

Fig. 2. Gain and bandwidth of RCA CMOS inverter vary with supply voltage.

Oscillator Circuits. Amplifier stages are an integral part of various types of oscillators. With the multiple stages of CMOS inverters available in the CD4007AE and CA3600E types, or in the hex inverters, a wide range of different types of oscillators can be built.

For example, the sine-wave oscillator shown in Fig. 4 is easy and economical to build. This is a Wien-bridge type of oscillator which uses two inverting stages cascaded to give overall positive feedback. The R_1C_1 and R_2C_2 combinations (with A_1) form the "bridge". Stage A_2 provides gain to overcome the loss in the Wien network. Diodes D_1 and D_2 provide agc action to stabilize the output level. Since A_2 has a gain of 3, the circuit has both a high- and a low-level output. Ideally, the resistors and capacitors should be matched, but 5% components will usually work. When possible, use low-value capacitors and high-value resistors. This allows the use of mica capacitors (with their excellent characteristics) for the timing capacitors. The circuit will work over a fairly broad range of supply voltage, but the optimum is a supply of about 10 volts. Trim R_5 for lowest distortion, but don't go too low or the circuit may fail to start reliably.

An oscillator circuit that is even more attractive in performance and simplicity is the triangle/square-wave oscillator shown in Fig. 5. It uses three CMOS inverters. The first, A_1 is an integrator, and the other two are for a

Schmitt-type level sensor. When two inverters such as A_2 and A_3 are cascaded, they have a very high gain. Therefore, it doesn't take much change in the input to A_2 to drive A_3 either full on or full off. This small level change is centered about A_2 's $1/2V_{DD}$ threshold. Resistors R_1 and R_2 divide the input at R_2 so that A_2 switches at a fraction of the output. So the resistors actually set upper and lower thresholds, between which the circuit can be made to oscillate.

Stage A_1 is an integrator whose time constant is set by R_3 and C_1 . When the output at square-wave 1 is high, the output of A_1 decreases on a ramp pattern to form the triangle wave. At the lower threshold, the Schmitt trigger reverses states and the output of A_1 increases on the upward ramp. Thus, the A_1 integrator is made to oscillate between the two thresholds, generating a

Fig. 4. Wien bridge sine-wave oscillator uses a pair of conventional CMOS inverters.

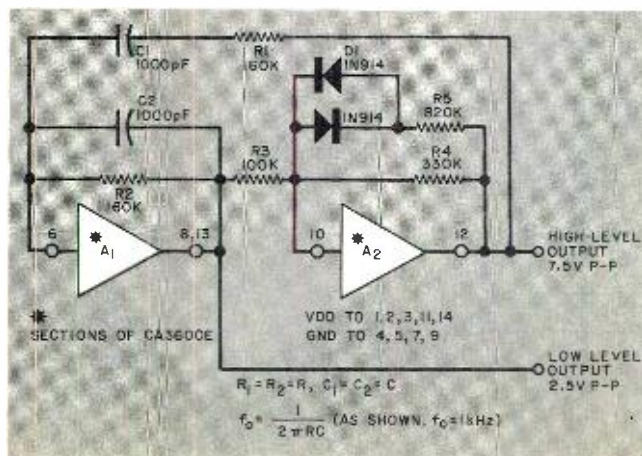

very linear triangle wave due to the negative feedback. The triangle waveform is also buffered by the gain in A_1 . The two square-wave outputs are 180° out of phase.

For simplicity, R_1 is made twice the value of R_2 . This makes the time of one oscillation period twice R_3C_1 . Due to the extremely low CMOS input current, the value of R_3 can be very high. Consequently, the value of C_1 can be very small and it can be of good quality (such as a Mylar type). The capacitor should be nonpolar.

The circuit in Fig. 5 makes an excellent source of stable waveforms and its period is independent of supply voltage. Timing periods into the minutes range can be obtained with reasonable component values. It makes a good fixed-frequency oscillator, but it can also be tuned by varying C_1 in decades and using a potentiometer in series

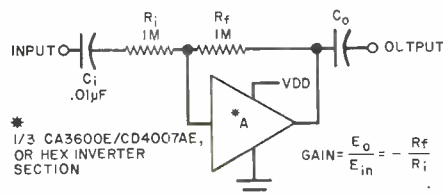

Fig. 3. Adding four components makes a simple feedback amplifier. The ratio of the values of the fixed and variable resistances will determine the frequency range.

Function Generators. The schematic of a CMOS function generator is shown in Fig. 6. This circuit generates triangle, sawtooth, square, and pulse waveforms. By adding a pair of rectifiers (D_1 , D_2) in series with the timing resistors, control of the duty cycle is achieved by making the up (t_1) and down (t_2) times of the



Product Test Reports

KENWOOD MODEL KR-5340 4-CHANNEL RECEIVER (A Hirsch-Houck Labs Report)

Ten watts per channel—less than 0.8% distortion

at 20,000 Hz and 10 watts output. At 1000 Hz, THD was less than 0.15 percent, and typically 0.06 percent, from 0.1 to 17 watts, while IM distortion was 0.3 percent over a power range of 0.1 watt to 10 watts.

The input sensitivity for 10 watts output was 96 volts (AUX) and 1.6 mV (PHONO). Hum and noise level was 72.5 dB down through each input. The phono preamplifiers overloaded at a very high 145-mV input.

The tone controls had a maximum boost or cut of about 8 dB. This represents good design for a low-powered amplifier that could easily be driven into distortion if large amounts of tone control boost were available. The loudness compensation boosted both the low and high frequencies at reduced volume settings.

The RIAA phono equalization was extremely accurate, within ± 0.25 dB from 30 Hz to 15,000 Hz. Unlike most amplifiers and receivers, the phono equalization in the KR-5340 was affected only slightly by the inductance of the cartridge. Only a 2- to 3-dB reduction in output at 15,000 Hz was observed with the popular cartridges we used.

The FM tuner had an IHF usable sensitivity of $2.0 \mu\text{V}$ in mono and attained 50 dB of quieting with an input of only $3.0 \mu\text{V}$. The automatic stereo switching threshold was $5 \mu\text{V}$, and a 50-dB S/N ratio in stereo required $32 \mu\text{V}$ of input signal.

The FM distortion at $1000 \mu\text{V}$, rated at 0.5 percent in mono and 0.8 percent in stereo, tested out considerably better than these figures. At $1000 \mu\text{V}$, the S/N ratio also surpassed the 63-dB specified rating, measuring 69.5 dB in mono and 67 dB in stereo.

The capture ratio was 1.4 dB, and AM rejection was 60 dB. Image rejection was 54 dB, while alternate-channel selectivity was 60 dB. The

THE Model KR-5340 is the lowest priced 4-channel receiver in the Kenwood Electronics line. The AM/stereo FM receiver's amplifiers are rated at 10 watts/channel with less than 0.8 percent distortion into 8 ohms, all channels driven simultaneously. Flipping a switch "straps" the amplifiers to provide 25 watts/channel into 8-ohm loads in the 2-channel mode.

Built into the receiver are RM and SQ decoding matrices, while the four AUX inputs can be used with an accessory CD-4 demodulator for playing discrete 4-channel records.

The FM tuner section features Kenwood's "DSD" (Double Switching Demodulator) for improved stereo performance and has a detector output. The output anticipates a 4-channel discrete FM broadcasting system — if the FCC ever gets around to approving one.

This is a fairly large receiver, measuring $21 \frac{7}{8}$ in. by $14 \frac{3}{16}$ in. by $6 \frac{5}{16}$ in. It weighs 32 pounds.

The retail price of the Model KR-5340 receiver is \$420.

Laboratory Measurements. With all four channels driven simultaneously at 1000 Hz into 8-ohm loads, the outputs of the amplifiers clipped at 16.5 watts/channel. Driving only the

two front channels brought the output power up to 18.7 watts/channel. This increased to 22.5 watts into 4 ohms and decreased to 11.9 watts into 16 ohms. When the front and rear channels were strapped in the 2-channel mode, the maximum output was 41.5 watts/channel into 8 ohms.

Our distortion measurements were made in the 4-channel mode, with only two channels driven. From 20 Hz to 20,000 Hz, and for outputs between 1 watt and 10 watts/channel, the distortion varied only slightly with power or frequency. It was typically less than 0.1 percent, measuring about 0.06 percent in the midrange at 1 watt and reaching a maximum of 0.25 percent

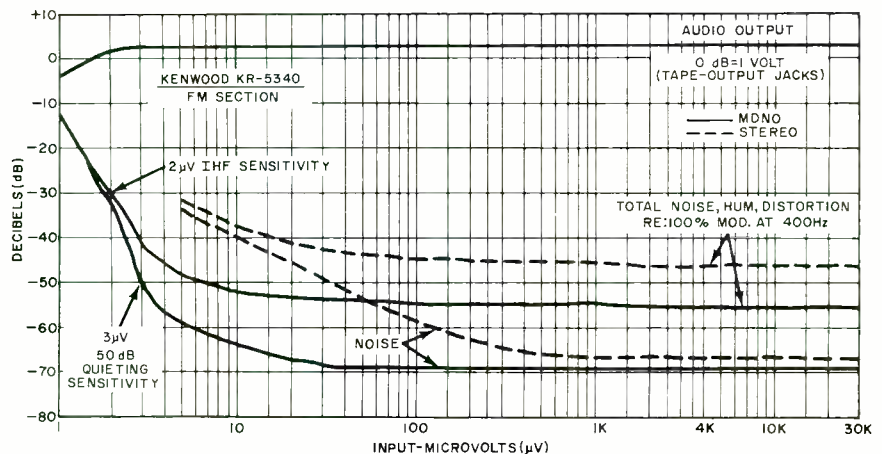

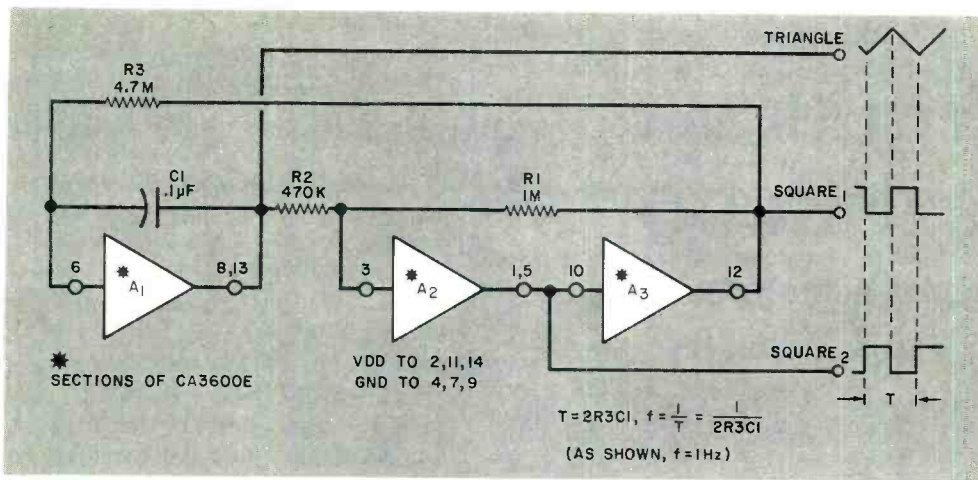

Fig. 5. Three CMOS inverters are used to create a triangle/square-wave oscillator.

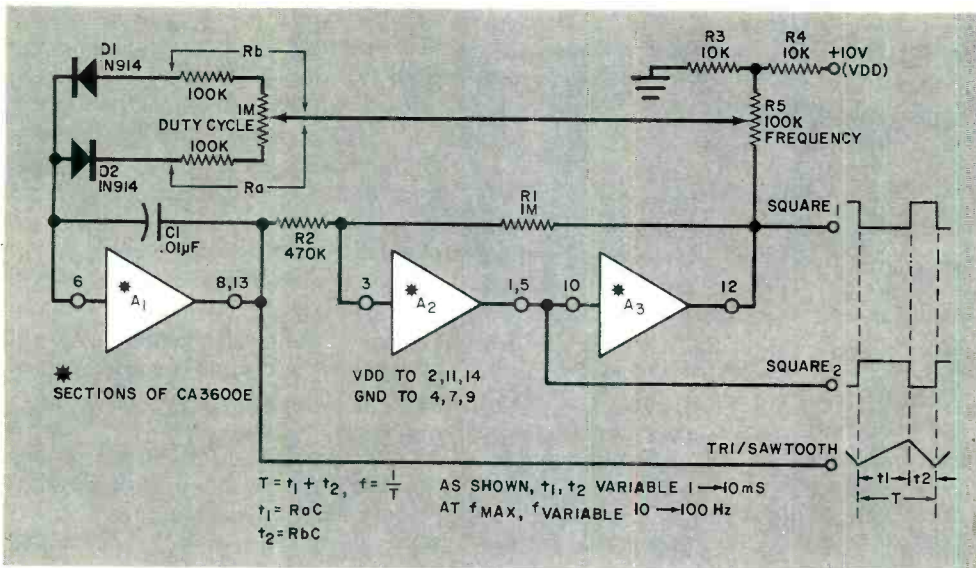

Fig. 6. CMOS function generator for triangle, sawtooth, pulse, and square waves.

ramp unequal. Time t_1 is $RaC1$, while t_2 is $RbC1$. In this case, the timing resistor is a fixed 100 kilohms plus the portion of the duty-cycle potentiometer which is connected to both legs of the circuit. The potentiometer can be used to adjust the Ra -to- Rb ratio over a range of 10 to 1, yielding a 10-to-1 variation in the duty cycle. To vary the frequency, only a portion of the square-wave output is fed back. The amount is varied by $R5$, and the frequency can be varied over a 10:1 range.

There are many other oscillator and timing circuits that can be designed using CMOS, but we haven't space to show them all here. We suggest you consult the manufacturer's literature for details.

The transistors in the CD4007AE and CA3600E CMOS arrays can, of course, be used individually or in combination to build many custom circuits. In the CA3600E, there are three sets of matched complementary transistors. They are also matched so that all p types match one another—as do the n types. For example, in the CA3600E, $P1$

and $P2$ are matched for offset voltage to within ± 4 mV. The n units are matched within ± 30 mV. This matching can be used to advantage in various types of circuits.

FET-Input Op Amp. If you've experimented with op amps, you may have been stymied by the requirements for "input bias current." The literature says that it is ideally zero, but getting the input down to the picoampere range can be a pretty complicated and expensive process. One solution is to use a matched pair from a CA3600E as the input to any standard op amp, as shown in Fig. 7. The matched p-type units are used as source followers, buffering the differential inputs to the op amp. This reduces the input current to the 15-picoampere level. Since the matched pair adds an additional input offset voltage, it may be necessary to use the offset adjustment of the 741 to trim the net offset. Resistors $R1$ and $R2$ should be matched for best results. Other general characteristics of the 741 remain unchanged.

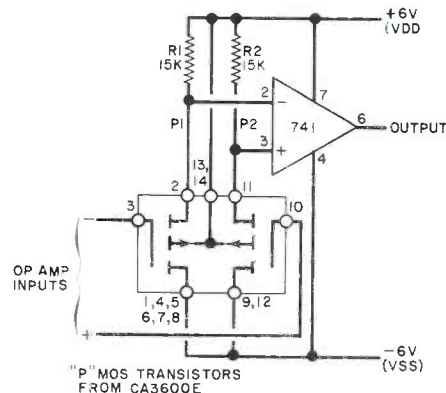
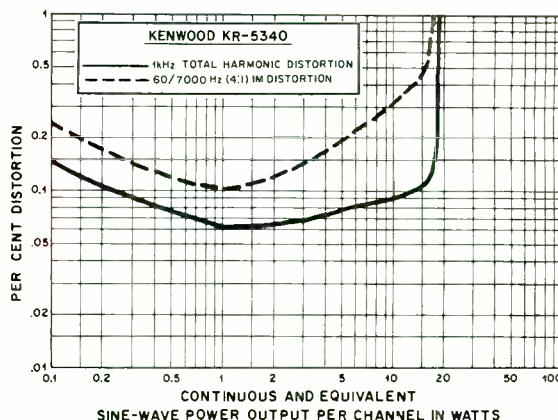
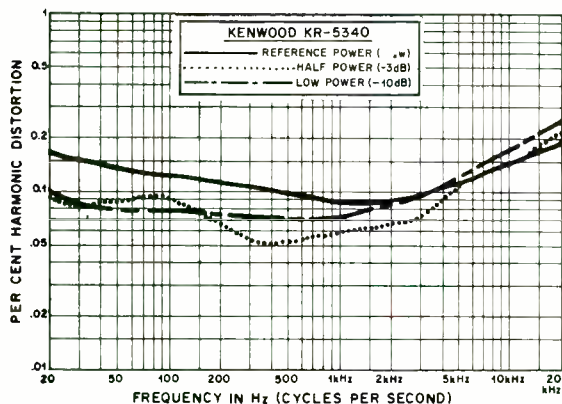

Fig. 7. Converting an op amp to a FET input using a CMOS array.

This circuit must be used with total supply voltages equal to or less than the CA3600E's 15-volt maximum. Also, if the gate input leads can ever see voltages in excess of V_{DD} or V_{SS} , some series resistance (10 k) must be added for protection.

Zero-input-current op amps can be used as long-period timers, sample-and-hold circuits, or anywhere that an absolute minimum of loading is required on the signal source.



19-kHz pilot carrier suppression was a good 61 dB.

In stereo FM, the frequency response was exceptionally flat, down only 1 dB at 30 Hz and 15,000 Hz. Channel separation was also outstanding, averaging 40 dB over most of the audible frequency range and better than 30 dB over the full measurement range of 30-15,000 Hz. (The FM section of this receiver has no interstation-noise muting circuit.)

The AM frequency response was down 6 dB at 70 Hz and 3700 Hz.

User Comment. By concentrating on the essentials and leaving out some of the "frills" (such as interstation noise muting and multiple speaker outputs), Kenwood has been able to produce a 4-channel receiver at a price that is competitive with

medium-priced stereo receivers. Even better, it has retained the traditional Kenwood quality, evidenced by the overall finish of the receiver, the smoothness of its controls, and the

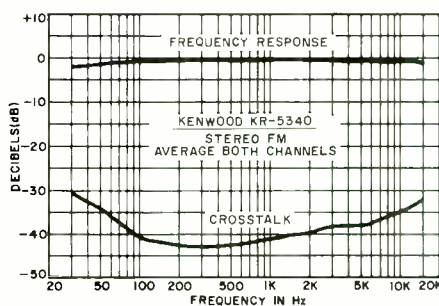

excellent electrical performance of its tuner and amplifier sections.

As with almost all 4-channel receivers with decoding matrices, the KR-5340 has no form of "logic" to en-

hance the rather limited separation of a basic matrix decoder. Nevertheless, it manages to produce an excellent "surround sound" effect with practically any quadrasonic disc. (The RM and SQ characteristics are able to decode any commercially produced 4-channel matrixed disc.) The receiver does a fine job of synthesizing four channels of sound from 2-channel programs.

Upgrading the KR-5340 with an external accessory "logic" SQ decoder or a CD-4 demodulator is as simple as plugging in a couple of cables. Hence, obsolescence is not built in. Even considered as just a stereo receiver, the KR-5340 manages to hold its own quite well against competitively priced receivers with its clean and ample audio system.

CIRCLE NO. 65 ON READERS SERVICE CARD

TANDBERG MODEL 3341X STEREO TAPE DECK (A Hirsch-Houck Labs Report)

Single-motor transport with three speeds

AMONG open-reel stereo tape decks, the Series 3300X may well be the finest single-motor recorders available, as well as the least expensive in the Tandberg line. The Model 3341X, the quarter-track version most widely distributed in the U.S., operates at speeds of 7½, 3¾, and 1½ ips and can handle reels of up to 7 in. diameter. (Each spindle has an integral reel lock.)

The retail price of the Tandberg Model 3341X stereo tape deck is \$430.

General Description. Tape motion in the 3341X is controlled by a single operating lever, a Tandberg feature for many years. For fast forward or rewind, the lever is moved to the right or left. Pulling it toward the front of the deck places the tape in normal forward motion, while pushing it toward



the rear releases the reel brakes for easier tape loading. There is also a separate instantaneous STOP/START lever, sometimes called a "pause" control.

The RECORD interlock button is located at some distance from the tape transport's lever, making it virtually impossible to go into the recording mode accidentally. In addition, individual recording buttons for the two channels allow quarter-track mono recording or a "flying-start" transition from playback to record, without going through STOP.

The two INPUT LEVEL slide controls affect both LINE and MIC inputs. The microphones plug into front-panel jacks and mix with the LINE inputs (on the rear of the deck). However, the level control is common to both sources.

The two level meters are illuminated during record. They do not monitor the playback level, which is fixed. A small "S-ON-S" switch connects the playback output of either channel to the recording input of the other channel for making sound-on-sound recordings. Individual buttons connect either line output to the source or

playback signal for off-the-tape monitoring. If only one button is pressed, a quarter-track mono playback signal appears at both outputs.

Laboratory Measurements. The playback response, with Ampex standard-alignment tapes, was ± 1 dB from 50 Hz to 15,000 Hz at $7\frac{1}{2}$ ips and ± 2 dB from 50 Hz to 7500 Hz at $3\frac{3}{4}$ ips. With Maxell UD tape for which the deck is biased, the overall record/playback frequency response at $7\frac{1}{2}$ ips was 32 to 22,500 Hz. At $3\frac{3}{4}$ ips, it was still an impressive ± 2 dB from 32 to 20,000 Hz. And at $1\frac{1}{8}$ ips, tradition-

ally relegated to voice recording, the response was flat within ± 2 dB from 42 to 11,000 Hz.

ally relegated to voice recording, the response was flat within ± 2 dB from 42 to 11,000 Hz.

At the LINE inputs, 140 mV was needed for a 0-dB recording level. The MIC input gain automatically adjusts itself to the impedance of the microphone over a very wide range to maintain optimum S/N and overload characteristics. With a 600-ohm

source, about 0.5 mV was needed for a 0-dB level. (The meters are fast-acting peak-reading types.) Playback output from a 0-dB recording was 1.43 volts. The reference 3-percent THD level was attained at 0 dB with the two higher speeds, and at -3 dB at $1\frac{1}{8}$ ips. Applying IEC weighting (similar to the ANSI "A" characteristic) for a better correlation with subjective effects, the corresponding S/N figures were 65.6 dB, 64.0 dB, and 52.5 dB. There was no measurable increase in noise through the MIC inputs at 600 ohms.

Resistance to flutter at the two higher speeds was excellent, compar-

ably fast (about 110 seconds for 1800-ft reels).

User Comment. The sonic performance of the Tandberg Model 3341X deck was virtually flawless. With FM tuner interstation hiss as a test signal, we listened for changes between the input and output signals. At $7\frac{1}{2}$ ips, the only difference was a slight bass alteration. (Most of the response variation at that speed occurs below 300 Hz.) At $3\frac{3}{4}$ ips, there was a trace of added brightness, corresponding to the broad emphasis of 2 or 3 dB in the 15,000-Hz region. At $1\frac{1}{8}$ ips, the loss of response above 11,000 Hz could be heard as a dulling of the noise. The same bass alteration could be heard at all three speeds.

With FM music programs, even the lowest speed generally gave perfect results. Playback was indistinguishable from the incoming signal. The STOP/START function, we were pleased to note, was free of the transient "wow" that afflicts many tape-recorder "pause" controls.

Summarizing, this is an outstanding tape deck. With the 3341X, it would seem to us that Tandberg has carried the single-motor transport to its peak of refinement. Further improvements would include, we expect, a change to three motors.

CIRCLE NO. 66 ON READERS SERVICE CARD

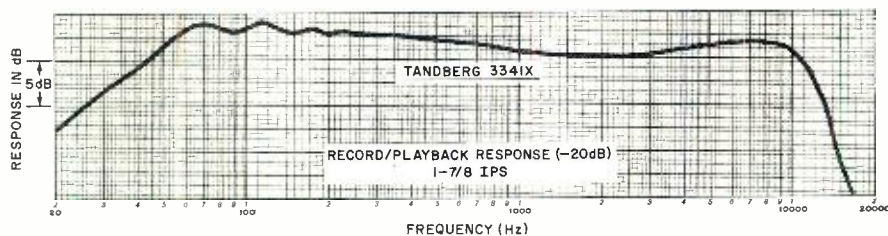

able to many of the better three-motor transports. At $7\frac{1}{2}$ ips, it was only 0.075 percent, including wow. It increased to 0.09 percent at $3\frac{3}{4}$ ips. And at $1\frac{1}{8}$ ips, it was 0.17 percent, which is comparable to that of a good cassette deck.

Tape handling was smooth and gentle, although like all single-motor transports, the "fast" speeds were not

ROYCE MODEL 1-408 HAND-HELD CB TRANSCEIVER

Five watts and six channels in hand-held package



HAND-HELD CB transceivers — often referred to as "walkie-talkies" — have become popular communication devices in the field where external power is not available and where complete portability is desired. In addition to their conventional rigs, Royce Electronics has a wide variety of walkie-talkies, ranging in power from 100 mW to 5 watts and varying in features and the number of channels available.

The top of the Royce Line of walkie-talkies is the Model 1-408, a six-channel rig. Power is obtained from eight AA cells. The transmitter has an input power rating of 5 watts. A special battery-saving feature allows the power to be reduced to 2 watts merely by flipping a switch. This lower power in most cases will be adequate for short-range communication.

If rechargeable batteries are installed in the transceiver, a connector on the side of the unit's case will ac-

commodate a battery charger. Also, the transceiver can be externally powered from any 12- to 14-volt dc source capable of delivering the required current. (Royce makes an accessory ac power supply, the Model 2-048, for line-powering the walkie-talkie. This optional supply retails for \$40.)

Other features include a call-alert setup that is keyed by a tone from another transmitter to get the attention of the unit's operator; adjustable squelch; external speaker jack for receiver and PA use; built-in speaker that doubles as a microphone; jack for an external mike; and a 60-in. telescoping antenna (with provision for an external 50-ohm antenna).

The Model 1-408 retails for \$110, including crystals for only Channel 11, carrying case, shoulder strap, and earphone. The unit measures $9\frac{1}{4}$ " \times $3\frac{1}{8}$ " \times $2\frac{1}{2}$ " and weighs just slightly more than 2 pounds.

The Receiver. The receiver is a superheterodyne, single-conversion design. It employs an r-f stage that converts the incoming signal for driv-

ing the 455-kHz, two-stage i-f strip. Selectivity is obtained from three i-f transformers and a ceramic bandpass filter, the latter located in the emitter circuit of the first i-f stage.

Adjacent-channel rejection was 20 dB on the low and 40 dB on the high sides of the selected channel. The overall bandpass at the 6-dB points was 400 to 2500 Hz. The sensitivity, rated at 1 μ V for 10 dB (S+N)/N, checked out to be closer to 0.5 μ V with 30 percent modulation at 1000 Hz. Image rejection was 20 dB — better than usually obtained with single conversion.

The squelch threshold range was 0.7 to 35 μ V. The agc had little effect below 10 μ V. Above that, the a-f output held to within 2 dB with a 60-dB (10 to 10,000 μ V) r-f input change. A 100- μ V signal was required to produce an S9 meter deflection.

A full-time automatic noise limiter (anl) is included, but it was not too effective. This is not necessarily a bad thing inasmuch as the signal levels encountered under usual operating conditions will override the noise.

With PA operation, the a-f output from a class-B stage was 3 watts (7 percent distortion at the start of clipping) at 1000 Hz into an 8-ohm load. Distortion on receive was slightly greater.

Transmitter. Separate crystals are required for each transmit and receive channel. The transmit crystal-oscillator signal is applied to the driver for the r-f output-power amplifier. The output of this amplifier is coupled to the antenna through a multi-section network and a loading coil. The external-antenna connection is made at the output of the network from which the power meter's reading is obtained. As usual, the driver and power amplifier are collector-modulated.

The automatic modulation control (amc) system is an amplified feedback affair that controls the bias — and thus the gain — of the first speech amplifier. R-f power reduction is accomplished by decreasing the collector voltage of the driver stage.

Operating at the 5-watt input level,

the carrier output into a 50-ohm dummy load was just slightly less than 3 watts at a total transceiver current drain of 400 mA with a supply voltage of 12 volts. Peak current with modulation was 600 mA. On receive, the drain was only 50 mA. Using a 13.8-volt supply, as would be the case if the walkie-talkie were used in a car, the output was 4 watts. Operating on "battery save," the output was slightly less than 1.5 watts at 12 volts. (The transceiver can also be operated at 9 volts, in which case, the output becomes 0.5 watt and receiver sensitivity is down somewhat.

Modulation was excellent, with exceptional performance by the amc, which limited the modulation to 100 percent on the positive-going and about 90 percent on the negative-going peaks (no carrier breakup). Good waveform was observed, and distortion held to within 10 percent. Splatter at the adjacent channel with 10 dB of compression was better than 40 dB down. Otherwise, the response was 600 to 5500 Hz at the 6-dB points.

CIRCLE NO. 67 ON READERS SERVICE CARD

RCA MODEL WT-540A LEAKAGE CURRENT TESTER

Checks appliances and equipment for ground faults

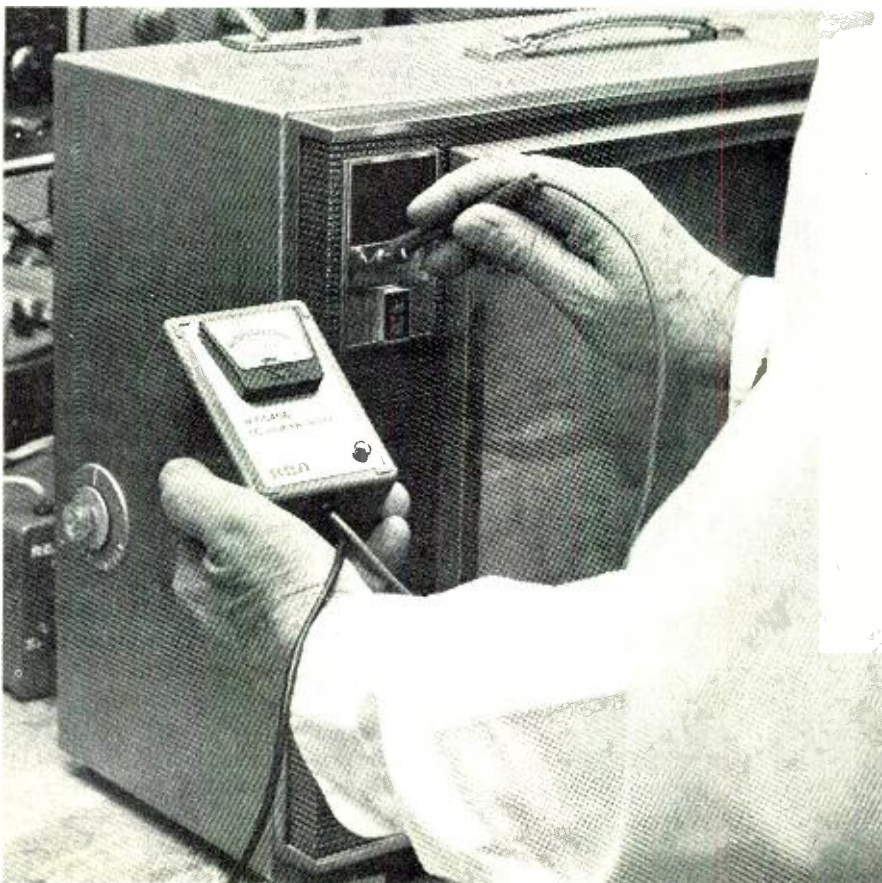

THE THREE-WIRE ac line cord on electrical appliances must be credited with saving many lives, even if the possible "victims" were never aware of the fact. When a three-wire system is used in an electrical appliance, the third, or green, wire is connected to the metal case or chassis of the appliance and electrical ground at the wall outlet. In the event that the "hot" lead from the power line comes adrift and makes contact with the metal chassis, the presence of the third wire trips the circuit breaker or pops the ac line fuse, removing the potential hazard.

To be sure, there are still a considerable number of two-wire appliances in use, including kitchen aids, power tools, electrical fixtures, TV and radio receivers and even some industrial equipment. Those that are "double-insulated" can be considered safe, but other two-wire appliances that are not double-insulated are potential hazards.

To protect appliance users from accidental electrocution, Underwriters Laboratories (UL) and American National Standards Institute (ANSI) have established the maximum leakage current permitted between an appliance and ground. Using a circuit having a 1500-ohm noninductive impedance, shunted by a 0.14- μ F capacitance, the recommended maximum

leakage current is 0.5 mA (0.75 mA in certain cases).

The RCA Model WT-540 ac leakage tester, available from RCA dealers for \$29.50, is just the device needed for making leakage measurements. This easy-to-use instrument has no batteries, switches, or other controls. All you do is connect the test leads between the frame of the appliance and ground. One probe has a needle-sharp tip to permit it to penetrate through dirt, grease, oxide, paint, or other coating to make a good electrical contact with the metal frame.

There is only one meter scale. It is color-coded to provide at-a-glance indications of safe and unsafe leakage currents. The recommended maximum leakage points are clearly indicated on the scale.

A special test clip is provided for making the one simple check that in-

sures that the meter is operating properly. This test clip also provides a means for determining which of the two socket connectors is hot and which is ground.

As an added safety feature, an internal fuse is provided to protect the instrument from damage should the leads contact an appliance that is either shorted or has extremely high leakage. If the fuse should blow, a front-panel lamp indicates that an unsafe level exists.

User Report. After confirming that the leakage tester was operating correctly, we first checked the washer and dryer in our cement-floored basement. It showed that leakage in these appliances was nonexistent. (Both are on three-wire circuits.)

We next checked all of the test instruments and power tools on our

workbench and all the power tools in our garage, especially any that had metal knobs or metal control setscrews. We then proceeded to check every electrical appliance in our home, paying careful attention to such items as hi-fi gear, TV receivers, and kitchen appliances. Everything checked out fine.

As a final test, we inserted a deliberate short circuit in an old communications receiver. The leakage tester immediately registered the existence of an electrical hazard.

After using the leakage tester for a couple of weeks, we are convinced that it is one of the most important pieces of test equipment that has come along in recent years. We recommend that every service technician and electronics experimenter add one to his inventory of test gear.

CIRCLE NO. 68 ON READERS SERVICE CARD

DIGITAL CONCEPTS MODEL CK-100 ELECTRONIC CLOCK KIT

Tells time and date at a glance

HAVING assembled a number of digital electronic clocks from kits, we were not exactly enthusiastic about building another when the \$68 (plus \$18 for the C-31 cabinet) Digital

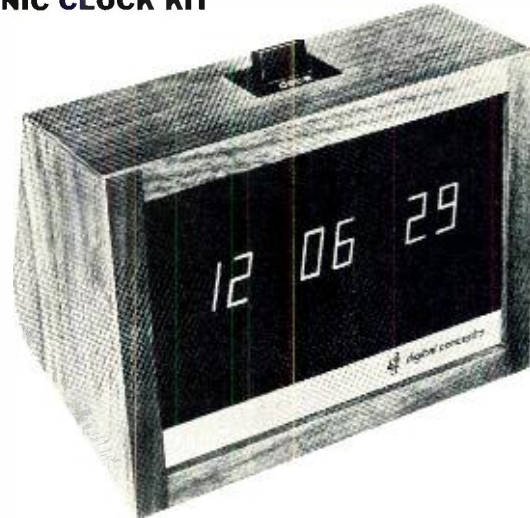

Concepts Model CK-100 clock kit arrived. However, after opening the carton and spending a couple of hours assembling this kit, we have had some second thoughts.

To start with, Digital Concepts has come up with a different concept in kit assembly. Each step in their excellent manual is clearly explained, and the few components that are to be installed in each step are packaged in their own individual envelope. This means that, instead of hunting through a large pile of components for one particular item, everything for a given step is right there in front of you. With this type of setup, it is hard to imagine anyone going wrong, not even the novice kit builder.

High-quality components are used in this clock kit. The display consists of six large seven-segment gas-discharge readouts whose bright

orange glow can be clearly seen from quite a distance away. The ends of each readout segment appear to be joined to the adjacent segments. Hence, the display is almost continuous.

The clock's circuit employs a single MOS/LSI chip with transistor interface between the IC and high-voltage gas readouts. The system is designed to display date and time separately, or time with date on demand (the latter by pressing a pushbutton switch on the top of the cabinet). The time and date setting switches are hidden under the rear of the clock and are not visible.

In assembling the clock, the only tools needed are a low-wattage soldering iron, a screwdriver, and a pair of diagonal cutters. Digital Concepts supplies everything else needed.

CIRCLE NO. 69 ON READERS SERVICE CARD

COLLECTORS!

**Here's how to enjoy
Old-Time Radios—
A fascinating hobby!**





VINTAGE RADIO tells you how to collect valuable old radios, and is the standard reference for collectors. Over 1,000 pictures. 263 pages, \$6.95 hard-cover, \$4.95 handbook.

S. GERNBACK'S 1927 RADIO ENCYCLOPEDIA is your deluxe illustrated technical book on early radio. 175 pages, \$12.95 hard-cover, \$9.95 handbook.

RADIO COLLECTOR'S GUIDE is your data book with 50,000 facts, 1921-1932. 264 pages, \$3.95.

MOST-OFTEN-NEEDED RADIO DIAGRAMS gives circuits of 600 models, 1926-1938. 240 pages, \$7.00.

SEND CHECK TODAY to Vintage Radio, Dep't P, Box 2045, Palos Verdes Peninsula, CA. 90274
Postage Paid. Ten Day Guarantee, Calif. add 6%.

	\$
	\$
	\$
	\$
	\$
TOTAL	\$

NAME _____
STREET _____
CITY _____ ST _____ ZIP _____

COLLECTORS!

CIRCLE NO. 45 ON READERS SERVICE CARD

Hobby and special interest books that make self-instruction easier

EASI-GUIDE TO INDOOR HOME REPAIRS

by Forest H. Belt, John Statzer, and Melba Statzer

If you only knew how to fix the little things that can go wrong in a home, you'd save a mint. This book shows you how. Simple terms and explanations and step-by-step photographs show how to solve the irritating plumbing, plastering, and furniture problems that face homeowners in kitchens, bathrooms, utility rooms, and bedrooms. 128 pages, softbound.

No. 21073 \$3.50

EASI-GUIDE TO SMALL GASOLINE ENGINES

by Forest H. Belt and Callton E. Taylor

The minor gasoline engine repairs and adjustments that are needed to keep lawnmowers, tillers, snow plows, and chain saws in good operating condition can be done easily by any homeowner who follows the simple yet detailed instructions and photographs given here. The book covers repair and operation of both two- and four-cycle engines. 144 pages, softbound.

No. 21095 \$3.50

METRICS FOR THE MILLIONS

by Rufus P. Turner

Here is an essential reference manual for all who will be affected by the coming change-over from our present system of measuring to the metric system. Each of the various metric units is covered, and examples show how to convert from U.S. to metric and from metric to U.S. 96 pages, softbound.

No. 21036 \$3.50

TAPE RECORDERS—HOW THEY WORK 3rd Edition

by Charles G. Westcott and Richard F. Dubbe, revised by Norman Crowhurst

An easy-to-grasp explanation of tape recorders that is equally popular with owners and repair technicians. Updated and revised to include the latest techniques and equipment. Explains principles; covers mechanisms and components; describes types of recorders; gives test procedures. Numerous illustrations and charts. 240 pages, softbound.

No. 20989 \$5.50

MODERN RECORDING TECHNIQUES

by Robert E. Runstein

In explaining the intricacies of recording pop music, this book fills a gap that has been neglected or overlooked. It is of particular value to the recording engineer since it covers equipment, controls, and operating techniques currently in use in recording studios. 368 pages, softbound.

No. 21037 \$9.95

ABC'S OF ZENER DIODES

by Rufus P. Turner

Zener diodes are increasingly more important in the automotive electronics field and in metal-oxide-semiconductor technology. Regardless of your connection with the electronics industry, this book will increase your knowledge of zener diodes in terms of their fundamentals, functions, and their many possible applications. 96 pages, softbound.

No. 21045 \$3.95

HI-FI STEREO SERVICING GUIDE 2nd Edition

by Robert G. Middleton

Anyone servicing a-m tuners, fm tuners, stereo-multiplex units, and audio amplifiers can gain valuable service direction and assistance from this guide. It also covers hi-fi speaker installations, system evaluation, troubleshooting, and methods of verifying test equipment performance. 104 pages, softbound.

No. 21075 \$4.50

PRINCIPLES OF ILLUMINATION

by John E. Traister

A thorough coverage of the subject, including defining the measurements used for lighting, the different types of lamps available, design techniques, and cost analysis of specific types of lighting. Covers practically every application for lighting. 176 pages, softbound.

No. 20973 \$9.95

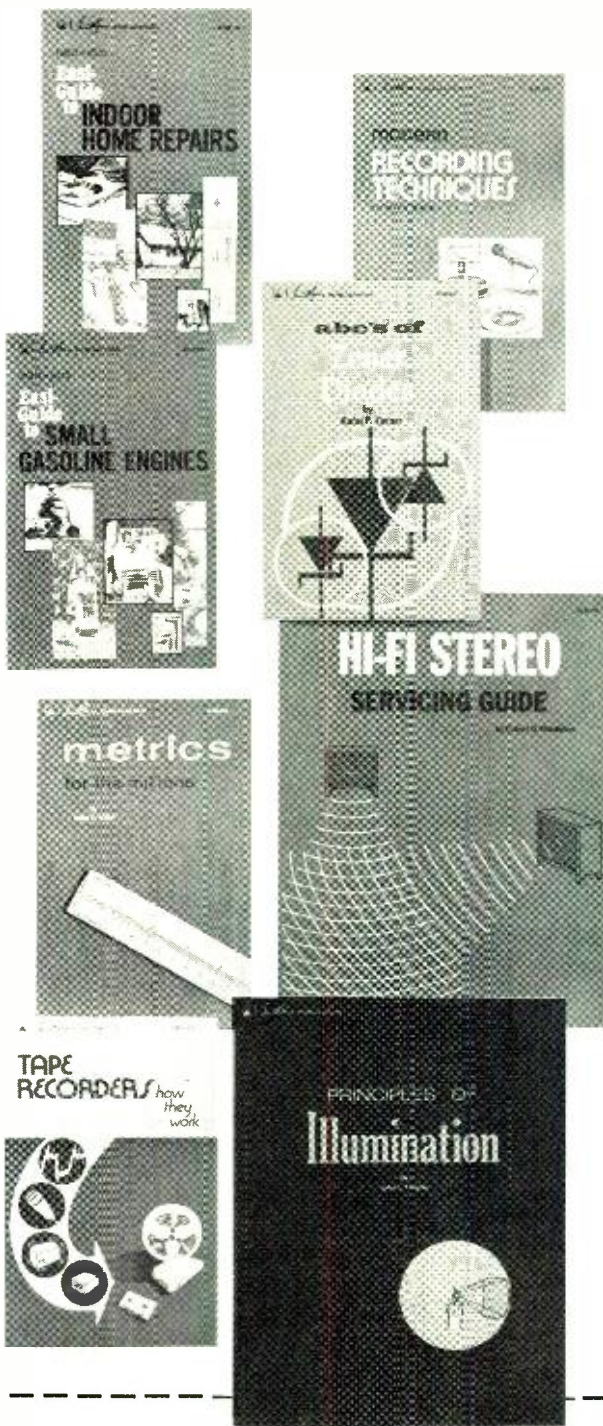

HOWARD W. SAMs & CO., INC.
4300 West 62nd Street,
Indianapolis, Indiana 46206

Order from your electronics parts distributor, or mail to Howard W. Sams & Co., Inc.

Send books checked at right. \$ enclosed. Please include sales tax where applicable.

- 21073
- 21095
- 21036
- 20989
- 21037
- 21045
- 21075
- 20973

Send FREE 1974 Sams Book Catalog 007146

Name _____

Address _____

City _____ State _____ Zip _____

PE 084

If you can use any of these tools...



**You could build
this Bell & Howell
25-inch diagonal
color TV with
digital features!**

It's just part of a fascinating learn-at-home program in electronics from Bell & Howell Schools!

Simulated TV picture

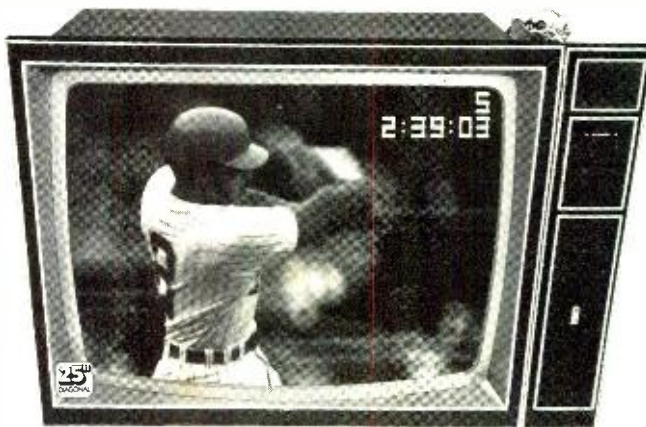

If you're handy with a set of tools, you may already have some of the skills you'll need to build Bell & Howell's color TV... the TV with digital features! This program is the perfect way to discover the exciting field of digital electronics... and best of all, you can do it all at home, in your spare time. Get free information now about this first-of-a-kind learn-at-home program prepared for you by skilled instructors at Bell & Howell Schools.

Discover a new way to spend your spare time hours on evenings and weekends

Even if you have no prior background in electronics, you'll find digital electronics a fascinating world to explore. You'll enjoy spending hours reading about the new systems of digital circuitry, performing experiments to test what you learn, and building your own advanced color TV. It's completely absorbing, and you're spending your spare time learning something new that could open up extra income opportunities for you.

Find out all about electronics equipment and how it works

Once you complete this learn-at-home program, you'll have the specialized skills to service color TVs plus the knowledge that you can apply to repair a variety of home electronic equipment. And because this new Bell & Howell Schools' program includes the study of digital circuitry, you'll be among the first with professional home training in digital electronics, a field that's growing in importance every day.

No electronics background necessary

We start you off with the basics. You'll receive a special Lab Starter Kit with your first lesson so that you can get immediate "hands on" experience to help you better understand newly-learned electronics principles. Later, you'll use your knowledge and learn valuable skills as you build the color TV. You can take full advantage of our toll-free phone-in assistance service throughout the program and also our in-person "help sessions" held in 50 cities at various times throughout the year where you can "talk shop" with your instructors and fellow students. You learn valuable skills in electronics through experiments and testing as you build this advanced-design color TV.

You build and work with a revolutionary color TV

Discover the technology behind such extraordinary features as channel numbers that flash on the screen, an on-screen digital clock that flashes the time in easy-to-read numbers, and an automatic pre-set channel selector that allows intermixing of VHF and UHF channels in any sequence. You'll enjoy probing into advanced performance features like silent all-electronic tuning,

Black Matrix picture tube, "state of the art" integrated circuitry, and the 100% solid-state chassis that makes possible a brighter sharper picture with long life and dependability.

You also build Bell & Howell's exclusive Electro-Lab® electronics training system

You get valuable experience performing experiments and later testing your TV with a digital multimeter, solid-state "triggered sweep" oscilloscope, and design console you build yourself.

The skills you learn can lead to part-time income or a new career in a business of your own

While many of our students do not ask for employment assistance, it is available. We will help you look for a job in a field of electronics that best fits your interests and abilities. Of course, no assurance of income opportunities can be offered. One thing you can be certain of: no better or more practical at-home training in electronics is available anywhere.

Channel numbers that flash on the screen

Digital clock that flashes on the screen

Automatic pre-set channel selector

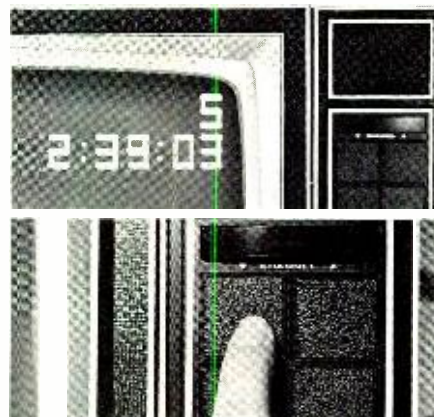

Find out more about this fascinating program... mail the card today for full details, free!

This Bell & Howell Schools' program is approved by the state approval agency for Veterans' Benefits. Please check the box on the card for free information.

If card has been removed, write:
An Electronics Home Study School
DEVRY INSTITUTE OF TECHNOLOGY

667



ONE OF THE
BELL & HOWELL SCHOOLS

4141 Belmont Chicago Illinois 60641

don't miss...

the next issue of the magazine that gives you the most exciting build-it-yourself projects anywhere.

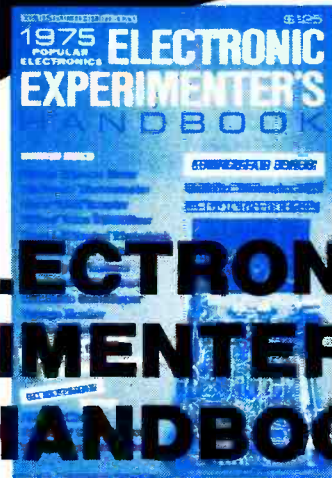

ELECTRONIC EXPERIMENTER'S HANDBOOK

You can always count on ELECTRONIC EXPERIMENTER'S HANDBOOK. Published twice each year by the editors of Popular Electronics, it's the one publication that helps you get it together . . . with a score of build-it-yourself projects.

The next all-new edition, 1975 Winter, goes on sale nationally September 19, 1974.

It will again be packed with features and articles and complete lab-tested instructions that are sure to guarantee successful hours and months of mind absorbing projects for fun and practicality.

This offer is being made to readers of the HANDBOOK and POPULAR ELECTRONICS Magazines only.

Regular price is \$1.25; mail order price \$1.60. You can reserve your copy now at this special pre-publication price of only \$1 by completing the Reservation Form and returning it promptly along with your remittance. The 1975 Winter ELECTRONIC EXPERIMENTER'S HANDBOOK will be mailed to you on or before publication date from first-off-the-press copies.

YOU CAN RESERVE YOUR COPY NOW AT THE SPECIAL MONEY-SAVING PRE-PUBLICATION PRICE OF ONLY \$1.00 POSTPAID.

PRE-PUBLICATION RESERVATION FORM ▶

Electronic Experimenter's Handbook, Ziff-Davis Service Division, 595 Broadway, N.Y., N.Y. 10012.

Enclosed is \$1.00. Please reserve my copy of the 1975 Winter ELECTRONIC EXPERIMENTER'S HANDBOOK at this special pre-publication price, to be mailed to me from first-off-the-press copies on or before September 19, 1974. PE-874

Print Name _____

Address _____

City _____

State _____

Zip _____

PLEASE ENCLOSE PAYMENT WITH ORDER

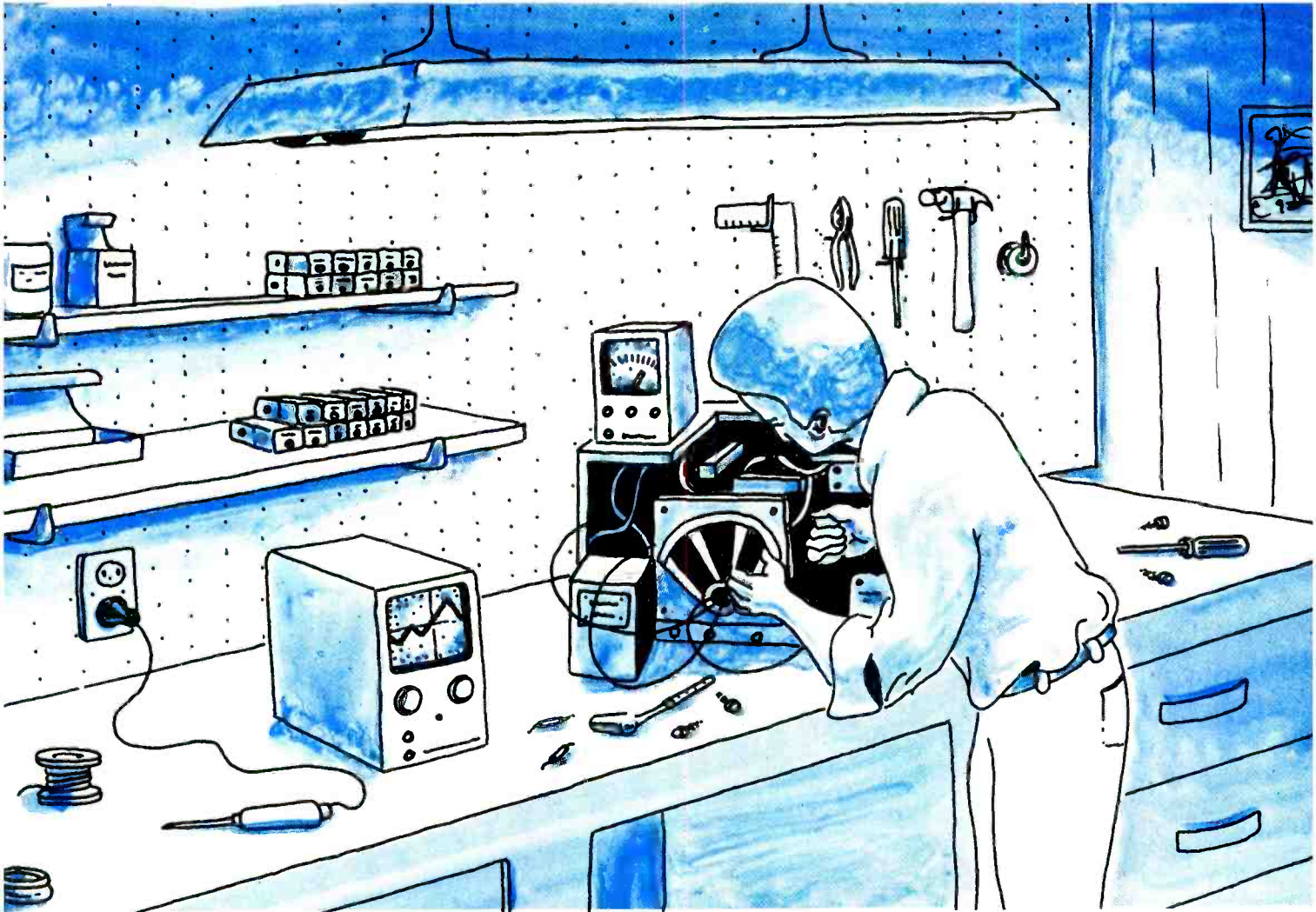

How to set up a

BY ART MARGOLIS

HOME TV SERVICE SHOP

Helpful hints on getting started and the equipment you will need

EVERY year, thousands of electronics technicians and hobbyists get into part-time TV receiver servicing. Many quickly build up a business that justifies opening their own service shops on a full-time basis, and new careers are launched. Perhaps you can become one of the success stories.

You might start out in part-time servicing by working for a full-service shop, in which case, you will not have to make a capital investment. But if you are more ambitious and plan to go it alone, you will most certainly need a minimum number of parts, tools,

and test equipment. Even so, the initial investment is surprisingly small—in the neighborhood of \$50—for starting a business in these times.

Before you embark on part-time TV servicing, bear three things in mind. First, in some localities you need a licence to repair TV receivers; comply with the law. Next, a TV receiver operates on potentially hazardous voltages and has a high vacuum in its picture tube; use your head and follow sensible service precautions. Finally, a small percentage of TV troubles requires great technical skill and lots of



Here is how the author, equipped with a four-wheel dolly, easily carries a large color TV and his tube caddy from the house to the service van.

expensive test equipment to repair. If you can, make a deal with a full-time service shop that is equipped to tackle the jobs you cannot handle.

Your workshop requires replacement tubes, tools, chemicals, assorted parts, and test equipment if you are to work effectively. Let us discuss the minimum requirements that will help you fix a healthy percentage of TV repair jobs you might be called upon to perform.

WEEKEND WORKSHOP INVENTORY LIST

The following items, in addition to a high-impedance multimeter, will see the weekend serviceman through a great majority of TV receiver repairs.

Vacuum Tubes: 3A3C/3AW2/3B2; 6BK4/6CJ3/6CL3; 6DW4; 6CG7/6FQ7; 6GH8A; 6JE6/6LQ6

Hand Tools: Diagonal cutters; longnose pliers; 30-watt soldering iron; long thin screwdriver; Phillips screwdriver; socket wrenches; flashlight; jumper wire with alligator clips at both ends

Chemicals: Tuner/contact cleaner; corona dope

Assorted Parts: Rosin-core (60/40) solder; cheater cord; 4-ampere circuit breaker; fuses; #47 pilot lamps; 1-ampere silicon diode; 20- μ F, 450-volt electrolytic capacitor; electrical tape

Test Equipment: Heavy-duty degaussing coil; hand mirror; incandescent-lamp continuity tester; neon-lamp tester

Replacement Tubes. Before color TV and solid-state electronics arrived on the scene, almost any electronics man could look at a tube-type receiver, analyze the symptoms, pull out the indicated tubes, check them at his local drug store, and identify the bad ones. Once identified, the bad tubes were quickly replaced. The receiver worked again.

In many cases, you can still do the same thing, although now it would be advisable to buy replacement tubes at a supply house and save at least 50 percent of the list price.

If you are doing a few calls a week, it is worth your while to carry some tubes with you. As time goes by and demands increase, you can add to your tube list until you have a satisfactory caddy of the most often needed tubes in your area. As shown in the Weekend Workshop Inventory List, only six vacuum tubes are listed. These are the most often needed tubes for the beginning serviceman. Their suggested list prices add up to about twice what they should cost you if purchased from a supply house.

Hand Tools. The main hand tools you must have for TV servicing and repair are the eight listed. You must be able to take apart a TV chassis and reassemble it, and you must also be able to remove and replace soldered-in components and adjust powdered iron cores without damaging them.

Only the most basic tools are mentioned in the Inventory List. Most of these you probably already have from your experimenting and hobby days.

1. A Lazy Susan tool holder on the service bench makes a place to hold a lot of things and also keeps them in their proper places.

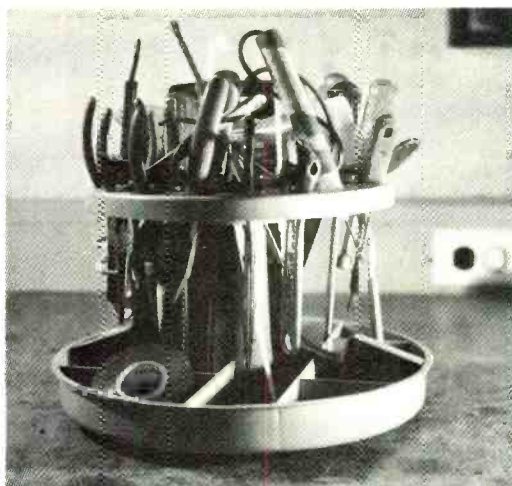

2. Conventional, Philips-head, and hex-head drivers are all needed for the common job of removing the back of the television set.

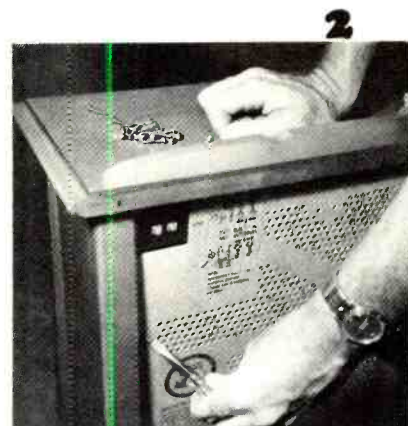

3. A can of freezing solution sprays suspect capacitors and transistors as a test. If suspect heats during the freeze, the symptom will disappear temporarily.

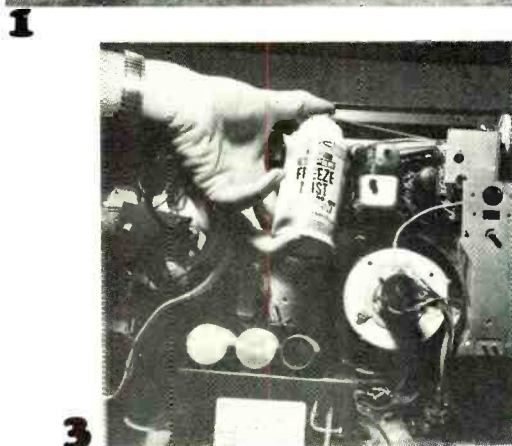

4. To test resistances and voltages in hard-to-manage places, tube socket adapters are handy. They are made for every conceivable socket including those for CRT's.

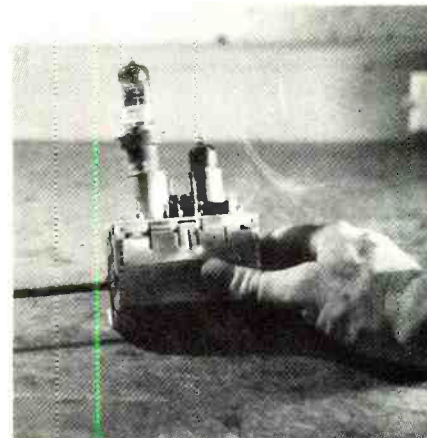

5. A low-wattage iron is a must when working on a printed circuit board. A large iron gives too much heat and can loosen foil, burn holes, or damage semiconductors.

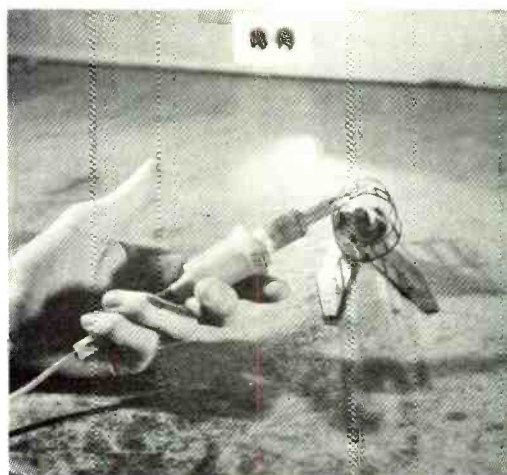

6. Ordinary neon tester allows you to check ac line voltage and r-f voltage around the HV cage.

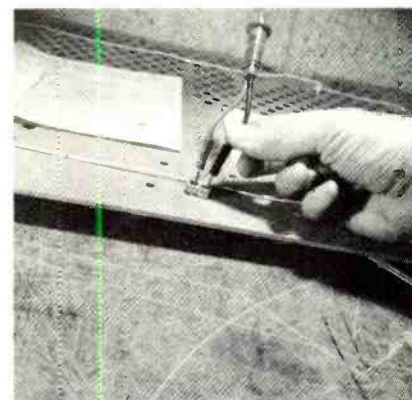

7. A quick way to check out a dead heater string is with a filament checker. It also tests odd tubes like CRT's.

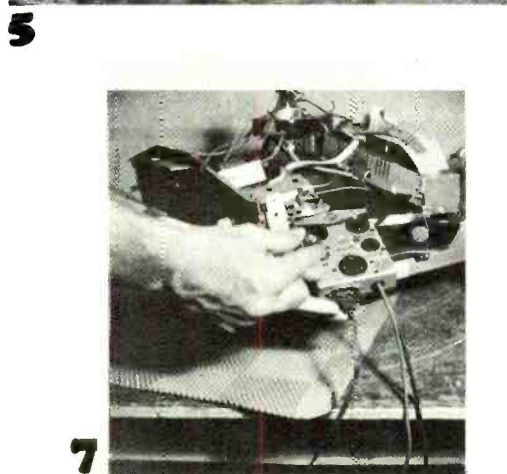

8. Fuses come in many shapes and sizes, including these chemical fuses. Try to have a representative set of fuses on hand at all times.

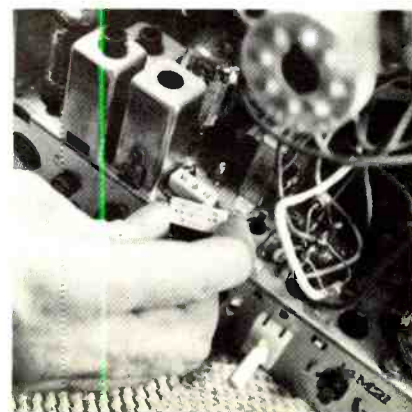

Chemicals & Assorted Parts. Most of the time, you need only two chemicals in TV servicing work. These are tuner cleaner and high-voltage dope, the latter to reinsulate sections where the high voltage has begun to leak.

There are many types of chemicals available to aid in TV repair work, but you can manage without them. However, if you do any appreciable amount of work, each item has a definite time-saving purpose. So, you might consider adding them to your inventory as you begin to show a profit in your servicing.

Although it is not on our list, a can of aerosol freezing spray is the first "extra" chemical you should consider. It is excellent for tracking down capacitor and transistor troubles resulting from heat buildup. Simply spray the suspected component; if normal service is resumed, the cooled component is bad and must be replaced.

In the assorted parts category, the only three you must have are a cheater cord, a roll of solder, and electrical tape. Should-have items include a 1-ampere silicon rectifier, 4-ampere circuit breaker, fuses, several #47 pilot lamps, and a 20-microfarad/450-volt electrolytic capacitor. These are all common failure items that you will find get consumed quickly during servicing.

Test Equipment. It would be nice to own all of the test equipment a full-time service shop has, but you can get by with just a few basic items. While it is true that all the fancy gear will save a lot of time on the job, you will have to weigh this against the hundreds of dollars needed for the fancy gear.

Aside from your high-impedance VOM, you need a heavy-duty degaussing coil for color TV servicing, a simple neon-lamp tester for line and high voltages, a continuity tester, and a hand mirror.

The degaussing coil is a must when working on color-TV receivers for making purity adjustments and setting up for convergence adjustments. Degaussing coils are inexpensive items that are well worth the few dollars investment.

A tube tester is an important test instrument in TV servicing. But you do not have to own one. Most drug stores and electronics parts supply houses have tube testers that can be used free of charge. Testing transistors is another matter. Testers are not available in the places you would ordinarily find tube testers. However, you need not have an elaborate tester at your disposal. Since junction condition of transistors and diodes is a good indication of the device's operating condition, an ohmmeter can be used to check transistors and other solid-state devices. Make sure to use a current-limiting resistor in series with the meter's "hot" test lead.

Service Library. One of the most important tools a TV serviceman can have is a library consisting of schematics and manufacturer service manuals. The

MAKING THE JUMP TO FULL-TIME SERVICING

You may find that after a period of time servicing TV receivers on weekends, you can earn more money and have a large enough clientele to go into the business full-time. If you find yourself in this condition, you will undoubtedly want to know what types of parts and equipment you will need for full-time servicing. So, we have provided the following list to get you started:

TUBES FOR CADDY

1G3/1B3	6EJ7/EF184	10CW5
1V2	6EM7/6EA7	10GN8
1X2/1X2A	6EW6	11KV8
(3)3A3C/3AW2/3B2	(2)6FQ7/6CG7	12AT7/ECC81
3AT2	6GF7A	12AU7/ECC82
5U4GB/5AS4	(3)6GH8A	12AX7/ECC83
6AQ5/6HG5	6GU7	12BH7A
6AU6A	6GY6/6GX6	12BX7/12BV7/12DQ7
6AW8A	6HM5/6HA5	13GF7A
6AX4GTB	(2)6JE6/6LQ6	15KY8A
(2)6BK4C/6EL4A	6JC6A	17AY3
6BL8/ECF80	6JS6C	17BE3/17BZ3
6BZ6	6JU8A	17BF11
6BZ7/6BQ7A	6JW8/ECF802	17JZ8
6CB6A/6CF6	6KT8	21GY5
6CD6GA	6KZ8	22BW3
6CG8A	6LB6	24JE6C
6CJ3/6DW4/6CL3	6SN7GTB	33GY7A
6DQ6/6GW6	6U8/6AX8/	38HE7
6DX8/ECL84	6KD8/5KD8	42KN6
6EA8	8AW8A	
	8FQ7/8CG7	

Note: Numbers in parentheses indicate quantity required. No parenthetical numbers indicate only one required.

RESISTORS

Ohms/Watts	Ohms/Watts	Ohms/Watts
10/a,b,c,d	500/d	22k/a,b,c
15/a	1k/a,b,c,d	22k/a,c
22/c	1.5k/a,c,d	33k/a,b
27/a	2.2k/a,b,c	39k/b
47/a,b,c	2.5k/d	47k/a,b,c
50/d	2.7k/a,b	68k/a,b
75/d	3k/d	100k/a,b,c
82/c	3.3k/a,b,c	150k/a,b
100/a,b,c,d	4k/d	220k/a
150/a,c	4.7k/a,b,c	270k/a,b
175/d	5k/d	330k/a
220/a,b,c	5.6k/d	470k/a,b
250/d	6.8k/a,c,d	1M/a,b
270/c	7.5k/d	2.2M/a
330/a,c	8.2k/a,c,d	3.3M/a
400/d	10k/a,b,c,d	4.7M/a
470/a,b,c	15k/a,b,c,d	10M/a

Note: k=1000; M=1,000,000; a=½ watt; b=1 watt; c=2 watts; d=10 watts.

NON-POLARIZED CAPACITORS

600-V Mylar Paper	500-V Silver Mica
0.001 μF	10 pF
0.002 μF	33 pF
0.003 μF	47 pF
0.004 μF	68 pF

0.01 μ F	100 pF
0.02 μ F	220 pF
0.047 μ F	270 pF
0.1 μ F	330 pF
0.25 μ F	470 pF
	560 pF
	0.001 μ F

50-V Ceramic Disc

0.001 μ F
0.002 μ F
0.005 μ F
0.01 μ F
0.02 μ F
0.05 μ F
0.1 μ F

1000-V Ceramic Disc

220 pF
330 pF
470 pF
680 pF
0.001 μ F
0.005 μ F
0.01 μ F

ELECTROLYTIC CAPACITORS

10-V	25-V	50-V	150-V	450-V
4.7 μ F	2 μ F	10 μ F	10 μ F	2 μ F
10 μ F	4.7 μ F	22 μ F	20 μ F	4 μ F
33 μ F	10 μ F	47 μ F	40 μ F	10 μ F
47 μ F	22 μ F	100 μ F	60 μ F	20 μ F
100 μ F	47 μ F	220 μ F	50/30 μ F	40 μ F
220 μ F	100 μ F	470 μ F	80/50 μ F	60 μ F
	220 μ F	1000 μ F		
	470 μ F	2200 μ F		
	1000 μ F			
	2200 μ F			

Note: All capacitors are axial-lead type.

MISCELLANEOUS ITEMS

Solder (rosin core)	Assorted hardware
Freezing solution	Rabbit-ears antenna
Yoke loosening solution	& replacement elements
Tuner/contact cleaner	Silicon power rectifiers
Heat sink compound	Circuit breakers
Plastic repair kit	Pilot lamps
Cabinet repair kit	Assorted transistors
Cements and glues	Fuses
Corona dope	Ac plugs & line cords
Plastic and glass cleaner	Cheater cords
Alligator clips	Soldering iron tips
Fish paper	High-voltage tape
Insulating spaghetti	Plastic tape
Focus rectifier	300-ohm twin lead
Interlock receptacles	Coaxial cable
"S" type fuse clips	

TOOLS

Diagonal cutters	Flashlight
Longnose pliers	Tube socket adapter
Soldering aid	Tube pin straightener
Soldering iron	Prepared jumper wires
Soldering gun	Control knobs
Wire stripper	Hacksaw
Assorted screwdrivers	Hammer
Tweezers	Cold chisel
Spintites	Center punch
Reamer	Allen wrenches
Socket wrenches	3-to-2 ac plug adapter
Hot-tube puller	Extension cord
File	Alignment tools
Adjustable wrench	Long pickup tool
Slip-jaw pliers	Cheater cords
Heat sink	Adjustable light

Equipment dolly	Magnifying glass
Mirror with stand	Inspection mirror (dental type, preferably illuminated)
Staple gun	Electric drill
Pop riveter	C clamps
Crimping tool and connectors	Vise
Lazy Susan Tool caddy	Workbench

TEST EQUIPMENT

Tube tester
In-circuit transistor tester
CRT tester
Continuity tester
Neon-lamp tester for HV & r-f tests
Filament tester
High-impedance multimeter & HV probe
R-f/i-f/video/audio signal injector
B & K Analyst or Sencore Sweep Analyzer
Oscilloscope & high-impedance probe
Bias power supply
Color bar/pattern generator
Sweep-marker generator
Heavy-duty degaussing coil

investment for these items is very small when equated with the amount of time and effort they can save on a service call. When you attempt to repair a receiver and get stuck, it is time to get out the appropriate schematic and use it like a road-map to trace out circuitry.

The manufacturer is the least expensive source of service notes for his TV receivers. Most of the time, manufacturers will be happy to supply schematics for a fee of 50¢ or \$1. There are other sources from which schematics and service notes can be obtained. Two of them are Howard W. Sams and Tab Books.

After each call, file the schematic in a service library near your workbench. Chances are that you will be called upon to repair this same model receiver in the future.

A good schematic is a well-marked diagram. Every time you find a trouble, circle the component or connection that is the cause of it. Do not be afraid to write on the schematic peculiar symptoms and other pertinent information that will save you time in the future where the symptoms are the same.

You can build up your service library gradually, starting with the service manuals for the most common manufacturer models and series in your service area. If you have to resort to buying \$2 or \$3 worth of schematics to get the one you want for a given receiver, add the cost onto the repair bill. ♦

Why a Sylvania home training program may be

your best investment for a rewarding career in electronics

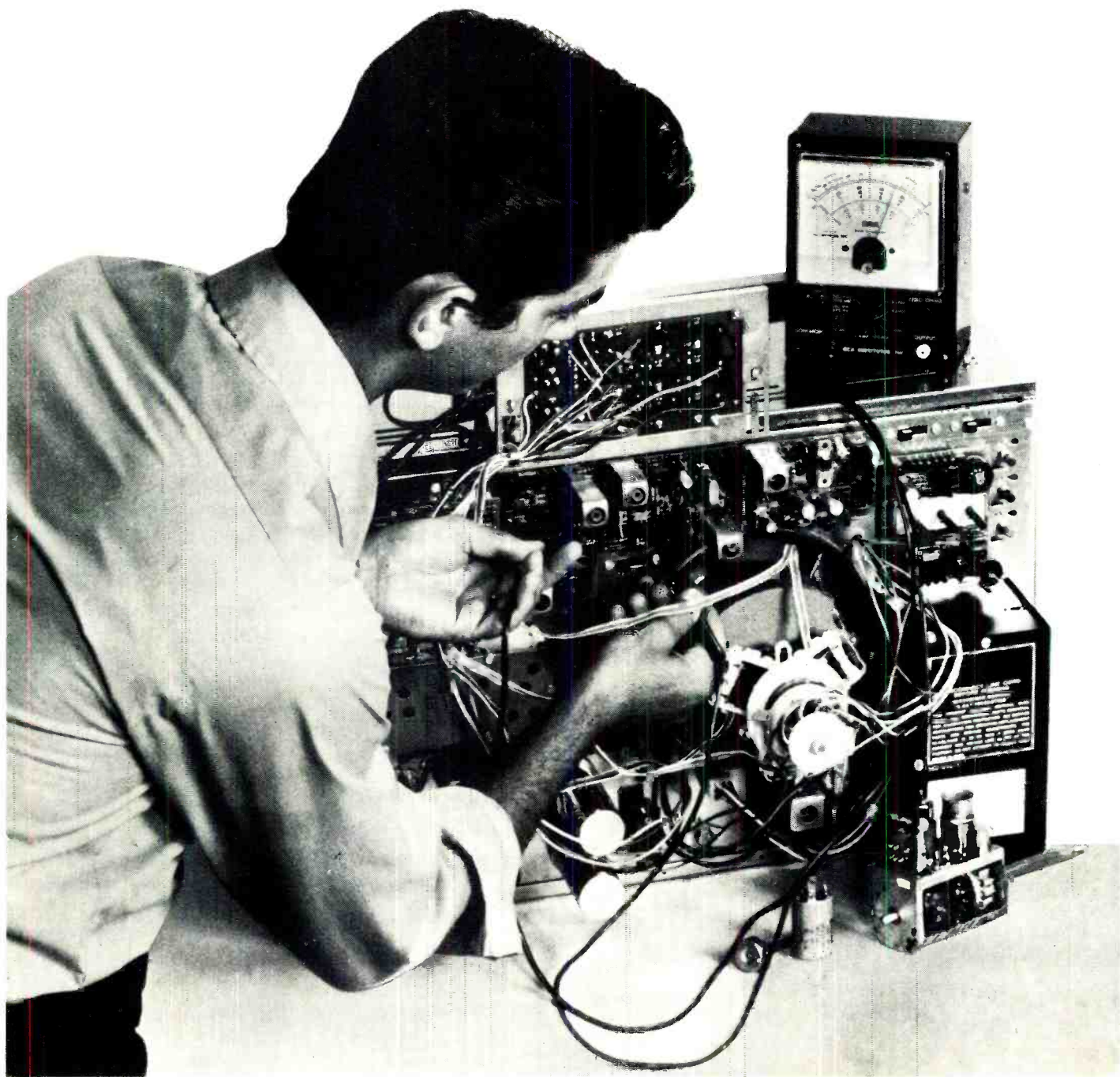

1 LEADER IN ELECTRONICS TRAINING

Over the years, Sylvania Resident Schools have trained thousands of men and women for key positions in the electronics field. Now, through Sylvania Home Training, you can receive the same high-quality career training at home. In your spare time. While you hold your present job. Remember, this training is designed with one purpose in mind — to give you the background you need to land the electronics job you really want!

2 AUTOTEXT TEACHES YOU ELECTRONICS RAPIDLY, EASILY.

AUTOTEXT, offered exclusively by Sylvania, is the proven step-by-step method of home training that can help you learn the basics of electronics quickly and easily.

3 CASSETTE SYSTEM

This innovative learning-by-hearing approach is a special option that adds an extra dimension to AUTOTEXT. It's almost like having an instructor in your own home. As you play the cassette tapes, you'll have an instructor guiding you through your AUTOTEXT lessons. Explaining the material as you read it. Going over schematics with you, reinforcing the basic electricity and electronics study materials with you. Everything you need to know to get you started towards a highly regarded position as an electronics technician — all in an easy-to-understand, conversational tone.

4 SPECIALIZED ADVANCED TRAINING

For those already working in electronics or with previous training, Sylvania offers advanced courses. You can start on a higher level without wasting time on work you already know.

5 PERSONAL SUPERVISION THROUGHOUT

All during your program of home study, your exams are reviewed and your questions are answered by Sylvania instructors who become personally involved in your efforts and help you over any "rough spots" that may develop.

6 HANDS-ON TRAINING

To give practical application to your studies, a variety of valuable kits are included in many programs. In Sylvania's Master TV/Radio Servicing Program, you will actually build and keep an all solid-state black and white TV set, and a color TV set. You also construct an oscilloscope which is yours to keep and use on the job.

7 FCC LICENSE TRAINING — MONEY BACK AGREEMENT

Take Sylvania's Communications Career Program — or enter with advanced standing and prepare immediately for your 1st, 2nd, or 3rd class FCC Radio Telephone License examinations. Our money-back agreement assures you of your money

back if you take, and fail to pass, the FCC examination taken within 6 months after completing the course.

8 CONVENIENT PAYMENT PLANS

You get a selection of tuition plans. And, there are never any interest or finance charges.

SEND ATTACHED POSTAGE PAID CARD TODAY! FREE DESCRIPTIVE BOOK YOURS WITHOUT OBLIGATION!

Sylvania Technical Systems, Inc.

If reply card is detached send this coupon

SYLVANIA TECHNICAL SCHOOL

Home Study 694-408-0

909 Third Avenue
New York, N.Y. 10022

Please send me FREE illustrated career catalog. I understand that I am under no obligation.

Name _____

Address _____

City _____

State _____ Zip _____

Age _____

Veterans: Check here

GTE SYLVANIA

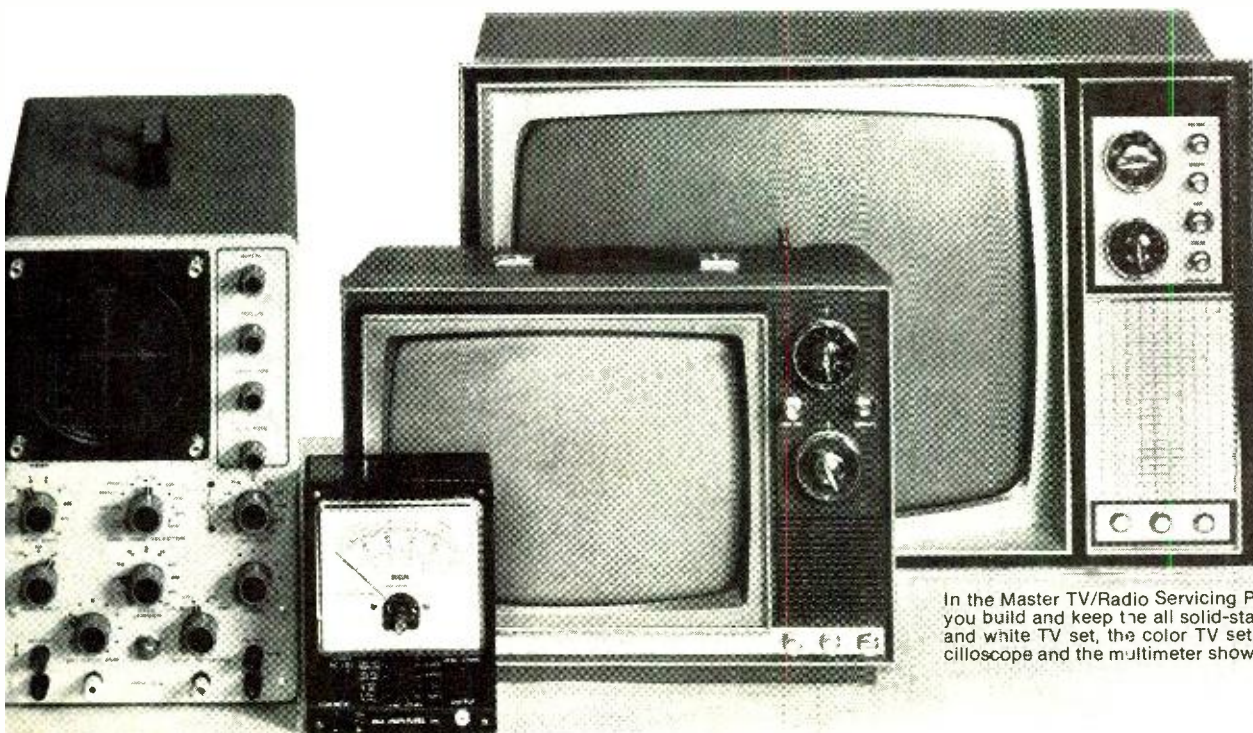

In the Master TV/Radio Servicing Program, you build and keep the all solid-state black and white TV set, the color TV set, the oscilloscope and the multimeter shown above.



Tips On Kit Building

By John T. Frye, W9EGV, KHD4167

SUMMER was bustin' out all over, and Barney's pursed lips were chirping a merry imitation of a robin as he entered the service department, where he found Mac, his employer, placing a kit-type frequency counter back in its case.

"There," Mac said with grim satisfaction, "that's another abused kit straightened out. Kit manufacturers spend countless hours of time and hundreds of thousands of dollars trying to make the assembly of their kits foolproof, but it's impossible to turn out anything some clod can't foul up by ignoring instructions."

"You've put together a bunch of them, haven't you?"

"I estimate that, from the time I ordered that first 5" oscilloscope kit from a tiny Heath ad in *Radio News*, I've put together well over a hundred kits. They were made by such manufacturers as Heath, Eico, Knight, Archer, and ranged in complexity from simple resistance boxes to color TV receivers, laboratory oscilloscopes, and SSB transceivers."

"I notice the kits you put together almost always seem to work the first time you turn them on. They exceed the advertised specs in performance, and they keep working without trouble for many years. You got a secret?"

"No secret, just a fair amount of savvy I've acquired from my own mistakes. Believe me, I've made lots of them, and I've also learned from straightening out botched-up kits like that counter over there on the bench. From this painfully acquired experience, I've distilled a set of rules for myself that I follow faithfully in putting together any kit, large or small."

A Set of Rules. "Wouldst share your wisdom with your miserable slave, O Master?"

"I wouldst. *First, plan the assembly location carefully.* Ideally it should insure privacy, but at least it should be out of the traffic pattern and especially away from the patter of little feet. Kids

and kits don't mix. Have lots of good light available. One light source should be movable so you can direct it into hard-to-see spots from various angles. If you don't have an adjustable bench light or a swiveling high-intensity lamp, you can make do with a good flashlight. At least a couple of outlets should be near at hand for your soldering iron and the lamps. Keep in mind you're going to drop some of the small parts or they will slip from your pliers and sail clear across the room. That's why working over a shag carpet is strictly a no-no. If you need convincing, you'll get it the first time you try to find a tiny germanium diode or a 1/8" setscrew in the pile. A bare floor or a short-napped rug is best.

"Remember most kits will require several sessions to complete, and you don't want to have to pack everything away between sessions. So you need a large portable working surface that can be shoved back in a corner, with everything left on top just as it is, at the end of each session. A large square of hardboard on top of a card table works fine for all but the heaviest kits. The hardboard protects the top of the table from scratches and soldering iron burns; and, if the card table is needed, you can carefully lift off the hardboard and contents and slide it under the bed — if your wife will let you!

"*Next, open the kit carefully, find the manual, and study it.* Is the kit unit-packaged, with all the parts for a single portion packaged together, or are the parts packaged simply by types: resistors, capacitors, hardware, etc.? Are there any parts that require special care in handling? What is the general plan of construction? Do you do the pc boards first and then assemble them onto a mainframe and do the final wiring, or must some of the mainframe wiring be done before the boards are mounted? Will auxiliary equipment be needed in alignment and calibration: batteries, VTVM's, signal generators, short reset-time

pulse generators, 'scopes? If so, you can be arranging ahead of time to secure those you do not have.

"*Locate, identify, and — if the kit is not unit-packaged — store in separate, easily accessible containers each group of parts.* Even if the kit is unit packaged, I go through each unit and locate and identify the parts and then put them back in their individual cartons until the assembly of that unit is called for. I prefer 7-oz. insulated disposable cups over the conventional muffin pans for storing the parts. Costing less than one cent each, these cups are lighter, deeper, easily labeled, and reusable. If you knock over a single cup, you simply scoop up the parts and put them back; but if you knock over a muffin pan, you've got 'pied' parts!"

"All that takes a lot of time," Barney objected. "I'm always in a hurry to get started."

"I know," Mac nodded his understanding, "but in the long run it saves both time and mistakes. You can often order a missing part and have it there by the time you need it. If the time you can devote to the kit is very limited and it is a large kit (such as a color TV), your warranty may well run out before you miss a part needed in final assembly. But the chief advantage of this checkoff is that it makes you thoroughly familiar with the appearance of all the parts you'll be using. Some will be like nothing you've ever seen before. Others will be distinguished from each other by subtle, but important differences. For example, you may have screws identical in size, length and threads but with different head types.

"I use a different cup for each category of screw, even though I have only two or three of one type. I do the same with nuts and lockwashers, and I label, with a pencil, each cup as to its contents. I separate capacitors by type, voltage, and capacitance when there is any danger of getting them mixed up. Quite often you will have a great many of the same type and voltage but a different capacitance. I may place all of these in a single cup. I like to use a block of molded plastic to hold resistors that I separate by wattage, tolerance, and resistance value. Once you've separated the high wattage and close tolerance resistors from the rest, you usually have a great many 1/2-watt, 10% tolerance units left. I've found it helps to cluster these by decimal resistance values: I stick all

those up to 100 ohms in one group, those from 100 to 1000 ohms in another group, those from 1000 to 10000 ohms in another group, and so on. This allows me to select the proper resistor in a hurry. Let me hasten to add that after I have selected a resistor by banding, I always check it with an ohmmeter just before I install it. Rarely do I find a resistor out of its indicated tolerance, but it has happened. Quite often I find — in time — that I've made a mistake in reading the color coding.

"Finally, I'm especially careful with such parts as IC's, transistors, meters, and coils. The less you handle coils, the better, especially if they are pretuned. IC's and transistors never have their leads stuck into the plastic holding the resistors, even though they have apparently been shipped in this fashion. That shipping material is a special conductive type free of the static electrical charges that lurk in many plastics — charges that can easily destroy an IC or transistor.

"Follow instructions to the letter. Strangely enough, the tyro is much less likely to sin in this regard than is the experienced technician. The latter seems to think following step-by-step instructions is somehow beneath him and that he can wire a kit faster and more expertly just by following the diagram. That's the kind of mistake I used to make. Now I do precisely as I'm told, and I get along much better. I try to cut component leads and wires as close to specified lengths as possible, and I've made up a couple of simple little gadgets that help. One is just a plastic card, such as a discarded credit card, that I've cut in stairstep notches so that the distance from each notch to the opposite side of the card is a distance often needed in measuring lead length. The other is a portion of a yardstick with a little butt plate on one end and a clamp to hold the end of the wire. I shove the end of the wire against the butt plate and hold it with the clamp while I stretch it out along the rule and cut it at the right distance. This beats trying to hold the component, a ruler, and a pair of dikes all at the same time.

"Try to do a professional job of soldering. Nothing is more important in kit assembly. Common errors include applying the heat of the iron to the solder instead of the joint; using so much heat the foil is lifted off the board; using so little heat that the flux is not evaporated making a cold solder

joint; using too much solder; and trying to work with a dirty, untinned iron. If inexperienced in soldering, read and reread the manual instructions in this regard and then make a few practice joints before you start on the kit. Study the joints on a commercially soldered board and try to imitate them. Try hard!

"Work carefully and methodically. Check off each operation as it is performed to avoid missing one — which is easy to do. Avoid the need for unsoldering, which is hard on components and the pc board. To do this, watch especially for the correct polarity of diodes and electrolytic capacitors and for the proper arrangement of transistor leads. You may have to put in six transistors in which the center lead was bent away from the flat surface of the transistor, but the seventh transistor may require this lead to be bent toward that surface. And never plug in IC's or transistors until you're told to do so. They may easily be damaged by other operations performed on the board.

"Do not work too long at a time. It hard to quit when things are going well, but errors multiply rapidly when you're tired.

"Check your work when told to do so and recheck it at the end of each session. Use good light and an optical magnifier. Look for incorrect placement of parts, solder bridges, cold solder joints, and loose bits of wire. Incidentally, when clipping off leads from the soldered board, I put the board on its side and hold a paper cup in front of the lead as I clip it. This gathers the leads neatly for dumping into a wastebasket instead of allowing them to fly all over the room — possibly into an eye. The duller the diagonal cutters, the farther these clippings sail. When you're satisfied with the unit, store it where it will not be damaged while you do the next one.

"Check the finished kit carefully before turning it on. Be sure and make any suggested resistance checks. Even if none are suggested, I always check the resistance from a rectifier output to ground and compare this with the diagram. I'm not much for the technique described as 'tuning up for maximum smoke.'

"Perform all preliminary adjustments, alignment, and calibration exactly as instructed and in the order prescribed. Do this, even though you don't understand the reason. It is a very important rule." ♦

((P)) PACE GUARANTEES PERFORMANCE SERVICE



Scan the Bands from your Pocket!

- WEATHER ALERTS
- POLICE MESSAGES
- FIRE ALARMS
- MARINE CALLS
- BUSINESS ACTION

Shown with
optional rubber
antenna



"SCANMATE 150"
only \$109.95
plus crystals

Miniature, precision, 4 channel scanning receiver. Fits right in your pocket to keep you informed on the business or public safety communications in your area. Important weather alerts and other messages keep you informed up to the minute. Long-life NICAD or dry cells (not supplied) may be used, optional accessory plug-in antenna and remote ear/speaker jack give the most versatile monitor receiver performance.

((P))
PACE
TWO-WAY RADIO SPECIALISTS

SIGN OF QUALITY

PACE COMMUNICATIONS
DIVISION OF PATHCOM, INC.
24049 S. FRAMPTON AVE.
HARBOR CITY, CA 90710

Name _____

Street _____

City _____

Frequency or type of Monitor needed:

CIRCLE NO. 32 ON READERS SERVICE CARD

free

The "NEW LOOK" 1975 LAFAYETTE Radio Electronics CATALOG

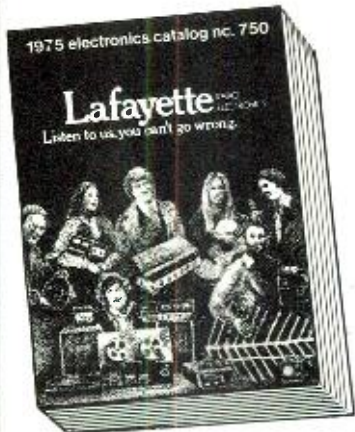

The ONLY Nationally Distributed Full-line Catalog with a Major Showing of the Newest NAME-BRAND electronics products for 1975.

**FREE
SEND TODAY**

SAVE on exclusive Lafayette Products plus MAJOR BRANDS

• Stereo and 4-Channel Systems • Tape Equipment • Car Stereo • CB and Ham Gear • Police/Public Service Receivers • Antennas • Cameras • TV • PA and Test Equipment • Musical Instruments and Amplifiers • Books • Electronic Calculators • Security Systems • PLUS PARTS, TUBES, BATTERIES, HARDWARE, MORE!

Lafayette

Listen to us, you can't go wrong.

Dept. 35084

Lafayette Radio Electronics
111 Jericho Tpke., Syosset, L.I., N.Y. 11791

Send me your FREE 1975 Catalog

Name Apt.

Street

City State

Zip

Send a 1975 Catalog to my friend

Name Apt.

Street

City State

Zip

CIRCLE NO. 23 ON READERS SERVICE CARD
86

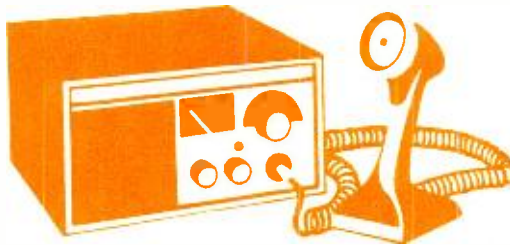

CB Scene

By Len Buckwalter

LIGHTNING AND THE CB BOATER

LIGHTNING strikes somewhere on the earth, says the Weather Bureau, about 100 times every second. It's spawned by some 1800 thunderstorms always raging about the planet. If you live in California or Oregon there's little cause for alarm because almost no lightning hits a thin strip of the West Coast from Washington State to the Mexican border. But if you reside almost anywhere else in the country, electrical storms will strike on 20 to 100 days out of each year. It's especially heavy up and down the Atlantic seaboard, around the Great Lakes and along the Gulf coast. Right now, during the dog days of July and August, the heavenly wrath is at its most intense.

What's it got to do with CB? Plenty, if you're one of the huge fleet of 300,000 CB'ers who use the two-way radio aboard a boat. At home you can hide under a (well-grounded) brass bed when thunder rumbles, but aboard a boat the exposure index is embarrassingly high. That CB marine antenna you mounted topside is not only a high point on the boat, but often the loftiest metal item from stem to stern. And it's a combination of metal and height that a stroke of lightning finds most irresistible. Your antenna is a beckoning finger tempting a bolt from the blue.

If you're struck, the results can be unusual, to say the least. A Virginia man, according to the *Guinness Book of World Records*, lost his eyebrows and big toe nail (only). A while back on Long Island Sound, one amazed boat-owner actually saw a shaft of lightning strike his boat while he was some distance away. Later, when he inspected for damage he discovered

everything shipshape, except for one item; the strike had melted his marine toilet!

It can be argued that your CB antenna is a veritable magnet for lightning, but a direct hit on a small boat is uncommon. Sheer luck may assure you a lifetime of safety, as it did for Ben Franklin when he performed his famous kite-flying stunt in a thunderstorm. Not so lucky were a half-dozen or so other experimenters around the world who tried to duplicate the identical feat. They were all killed. But as a result of Franklin's risky sport, we now have a way of converting a CB antenna from an instrument of destruction, to a protective shield.

Antenna As Lightning Rod. The reason is that a CB antenna easily serves as an excellent lightning rod without harming its original function. It's based on the well-known principle that once lightning is drawn to a high

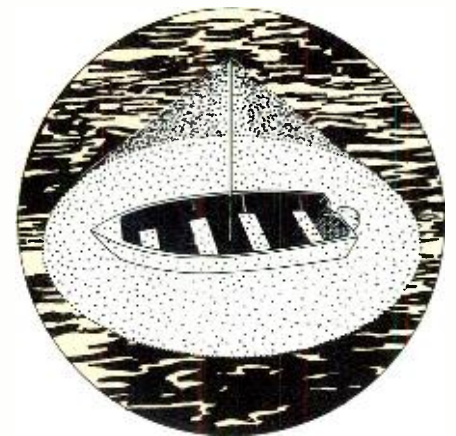
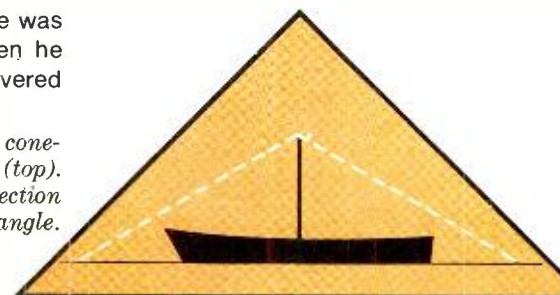

Fig. 1. Antenna protects cone-shaped space above boat (top).

Fig. 2. Cone of protection encloses a 60-degree angle.



POPULAR ELECTRONICS

point it seeks the easiest path to "ground", in this case, the water. If there's a wood hull in between, the bolt can rampage through it, exploding moisture into steam as it expends its awesome energy. Where electrical cabling lies along the path, the wires help duct the discharge, but might melt from the heavy wattage. If you can give the bolt a low-resistance path to ground through conductors of ample size, you'll vastly reduce lightning's potential for death and destruction. Let's start at the top.

First, be sure the tip of your CB antenna is the highest point on your boat. (CB antennas made for marine operation usually rise between 8 to 18 feet.) Height will attract a stroke that would otherwise hit you or some other part of the boat's structure. It also raises the "cone of protection," a tent-like area that encircles and covers the boat. When a storm cloud sends down an exploratory "leader", an electrical "streamer" rises from the ground to create an ionized path for the main stroke to follow. If these preliminary discharges occur in the vicinity of your boat, they are lured by the antenna tip away from objects inside the cone of protection. Though it's invisible, you can easily figure out where the cone lies. Estimate your antenna height above the water line, say 25 feet. Double that dimension (50 feet, in this example) and you have a good idea of how far the cone extends in every direction from the antenna. Note (Fig. 1) that the outline is that of a cone; to find what falls within this electrical tepee, draw an imaginary line from the antenna tip out to that horizontal dimension on the water line. You'll want the antenna high enough to keep all objects inside the cone. Another way to measure the cone is shown in Fig. 2.

The next important consideration is checking for a good path to ground. The shaft of the antenna leads the flow down to the next leg of the grounding circuit, formed by the shield of the coaxial lead. Although the antenna itself is "hot" for 27-MHz signals, it is nearly always "dc-grounded." The manufacturer places a loading coil or matching transformer at the antenna base which acts as a short-circuit to lightning. Lightning currents, therefore, are conducted through the coaxial cable shield down to the CB transceiver. In many instances this is a danger point in a CB marine installation. After a strike, currents travel from

the coaxial shield to the radio chassis, then through the negative, or ground, side of the boat's electrical system. There is considerable risk because that ground may be fine for the dc supply powering your rig, but not good enough for lightning careening down the coaxial transmission line toward the water.

Ground Bonding. Thus, the next major step: Interconnect any large metal masses—handrails, prop shaft, rudder, and engine—with heavy copper braid or No. 8 copper wire. Be sure to include the radio chassis, usually done on the rear apron at a grounding screw or terminal. Keep any ground wires as short and curve-free as possible. (The latter prevents coils that could increase impedance and power dissipation at that point.) You don't have to include every small object made of metal, just large masses, to prevent dangerous side flashes that might jump from one metal surface to the next.

Once the ground-bonding is accomplished, decide if you have a good termination to the water. In many instances, it automatically happens if the boat engine, rudder or other partly submerged metal was strapped into the grounding system. If you don't have metal of at least one square foot in contact with the water, consider installing a ground plate below the water line. We don't mean the classic ground plate for boats—a massive sheet of copper nailed over a huge area underneath the hull—but one of the newer types that are a fraction of the size. They're made of 1/2-inch porous bronze, measure a mere 6" x 2" and furnish a good electrical contact for discharging current harmlessly into the water.

Consider, too, a lightning arrestor sold for coaxial cable to introduce an added measure of protection. If you install the arrestor just before the line enters the cabin, you can connect a ground wire at the arrestor then connect the other end of the ground wire to submerged metal. One advantage is that a lightning stroke travelling down the coaxial shield will see somewhat lower resistance (and impedance) because of a shorter, straighter ground run. Another benefit of the arrestor is that it contains tiny air gaps between the shield and inner conductor. These might reduce interference and possible damage to a transceiver's front end by discharging precipitation static

CALECTRO®

DIGITAL
DISPLAYS AND
LOGIC

ATTENTION
HOBBYISTS!

BUILD THIS
DIGITAL
COUNTER/ L.E.D.
DISPLAY
KIT.





Everything needed to build a complete decade counter (0-9) including a printed circuit board. Operates from a 5 Volt D.C. supply. Can be used in hundreds of applications.



See your nearby CALECTRO distributor for all the most popular digital displays and integrated circuits. Also, get your copy of the new CALECTRO DIGITAL PROJECTS HANDBOOK!





GC ELECTRONICS
Division of Hydrometals, Inc.
Rockford, Illinois 61101 U.S.A.



CIRCLE NO. 15 ON READERS SERVICE CARD

that can be created by a nearby storm.

There's an excellent reason for installing a coaxial lightning arrestor if you regularly remove your CB transceiver after each boating day (to prevent theft) or for servicing. In removing the transceiver, you may also destroy any connection to ground between the CB antenna and the water, thus increasing the risk of damage if lightning strikes while the transceiver is not in place. The coaxial arrestor, which remains permanently in the line, keeps your "lightning rod" safely connected to ground at all times. ♦

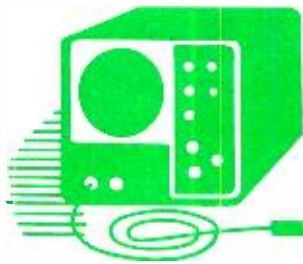

Test Equipment Scene

By Leslie Solomon

GRID-DIP METERS

ONE of the least known and used pieces of test equipment is the grid-dip meter. The question running through many readers' minds right now (especially newcomers to electronics) is "Just what the heck is a grid-dip meter? For that matter, what is a grid dip?"

To start with, the name originated in the early days of radio, when tubes (those glass things that get hot) ruled the roost. It was discovered that the current in the control grid (which, in semiconductor terms, performs somewhat the same function as the base of a transistor) in a self-excited oscillator was very sensitive to resonance in nearby tuned circuits. This current would decrease (dip) as the external circuit was tuned to the frequency of the one-tube oscillator.

Modern grid-dip meters use either bipolar or FET oscillators (or tunnel diodes) and have several plug-in coils for various overlapping frequency bands. They also include some form of meter readout and an accurately calibrated tuning control. Most are battery powered so that they can be used in any location. And what it does is to indicate the dip in its own oscillator grid (or base) current when an external resonant circuit is tuned to the oscillator frequency.

How many times do you have a need to check a resonant r-f circuit. Well, maybe not many, but the grid-dip meter is also useful in checking capacitances, inductances, the Q of a circuit, bandwidths, antennas, transmission lines, crystals, and filters. It can also be used as a single-source monitor or a field-strength meter.

Measuring Resonant Frequency.

The classical use of the grid-dip meter is to measure the resonant frequency of tuned circuits—such as those in TV receivers, FM or AM radios, ham or CB rigs, and radio-control systems. In this case it is not necessary to have the

equipment supplied with power. All you need is access to the coil in the circuit. The coil of the dip meter is placed close to the coil being checked and the meter is tuned until it gives an indication. The tuning capacitor dial of the meter then indicates the frequency. (Of course, the dip meter's dial can be adjusted for very accurate frequency indications by using a signal generator, receiver, and/or frequency counter.) This is about the only way you can determine whether or not a coil is correctly tuned. It's possible that somebody mistuned it by "tightening up that loose screw."

The resonance of an antenna can be checked by using the grid-dip meter on a straight section of the antenna. If you use a long-wire antenna, simply connect one end of it to ground through a 1- or 2-turn loop. Then couple the dip meter to the loop and measure the frequency.

To check the electrical length of a transmission line, leave the far end open and put a 1-turn loop across the near end. Use the dip meter to determine the lowest frequency. This will be the frequency at which the line is a quarter of a wavelength long. These are only a few of the uses for the grid-dip meter in testing antennas. You will find others.

Checking Circuit Elements.

Suppose you want to know the resonant frequency of an unmarked r-f choke. Simply place the choke close to the meter coil and adjust the frequency control. You can measure the self-resonant frequency of any coil by using this technique.

To check the value of an unknown capacitor, connect the capacitor across a known inductance coil. Measure the resonant frequency of the combination and use the expression $C = 25,400/(f^2L)$, where C is in picofarads, L is in microhenries, and f is in megahertz. To determine the dis-

tributed capacitance of the coil, do the same as above, omitting the capacitor.

The process can also be reversed to find the inductance of an unknown coil. In this case, couple the coil to a capacitor of known value and measure the frequency on the grid-dip meter. Use the same equation as above but solve for L instead of C.

Suppose you wanted to find the easiest way to set the slug on a coil when looking for a particular inductance value. One way is to find the desired dip-meter frequency by solving the expression $f = \sqrt{25,400/LC}$. Once you determine the frequency (or if you already know it), set the grid-dip meter to that frequency and adjust the slug in the coil until the meter dips.

Aligning a Radio. How would you align a battery-operated radio without a battery—or an ac radio without the line cord connected? Using a grid-dip meter, you start at the last transformer and couple the dip meter to it. Adjust the slugs (or capacitors) for a dip at the selected i-f frequency. Then work your way back to the antenna, checking each tuned circuit in the same way. When you get to the local oscillator, set the main tuning dial to about 1500 kHz. Set the grid-dip meter to this frequency minus the i-f (usually 455 kHz). This comes out to 1045 kHz. Now couple the dip meter to the oscillator coil and adjust the coil for 1045 as indicated by a dip on the meter.

You can even use the grid-dip meter as an outboard local oscillator coupled to a receiver antenna. The meter is then the beat oscillator for listening to sideband operation. Or, key the grid-dip meter for a code-practice oscillator or use it as a Q multiplier.

In the area of TV servicing, you can use a grid-dip meter to check all the tuning circuits and also as a marker generator when using a sweeper. In this case, couple the dip meter to a 2- to 3-turn coil with one end grounded and the other end coupled through a 0.01- μ F capacitor to the signal input to the receiver. With the dip meter, you can check traps in a TV i-f strip.

A grid-dip meter can be used by hams to neutralize an amplifier without the power being turned on. You can also check for parasitics by probing the circuits and looking for odd dips on the meter.

In Closing. So that's the grid-dip meter and what it can do—at the test workbench, in the ham or CB shack, and in the servicing field. ♦

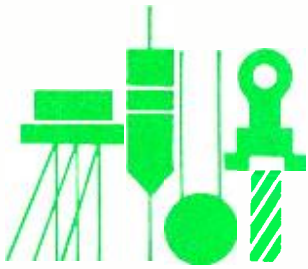

Solid State

By Lou Garner

USING SURPLUS DIODES

IF YOU'RE a typical electronics hobbyist, whether a circuit experimenter or project builder, chances are you have a fair sized collection of various diodes and rectifiers tucked away in a Mason jar, cigar box, or similar container. These may be surplus devices from earlier projects, leftovers from bargain package assortments, or units salvaged from discarded equipment. Despite your collection, however, you probably buy new devices each time you start a project, except for those relatively rare occasions when a stock unit is *exactly* the type number specified in your schematic.

Your diode collection may include low-power germanium units, silicon devices, selenium rectifiers, and, perhaps, even high-voltage stacks or full-wave bridge assemblies. But regardless of type, size, or electrical specifications, your accumulated diodes share a common characteristic — inactivity. Unfortunately, unlike rare wines and delicate cheeses, diodes do not necessarily improve with age.

Perhaps you've felt that diodes can be used only as detectors in receivers and as rectifiers in power supplies. In actual fact, the diode, though the simplest of solid-state components, is an extremely versatile device.

With a little imagination, you can put your surplus diodes to work in a variety of interesting and useful circuits. Several of many possibilities are illustrated in Figs. 1 and 2. In each circuit, diode specifications are not critical provided peak reverse voltage and maximum current ratings are observed.

Use the arrangement illustrated in Fig. 1(A) to minimize dc electrical contact sparking, thus prolonging contact life and reducing electrical noise that may interfere with nearby electronic equipment. The diode offers high resistance to the normal flow of current, but serves as a spark-suppressing short to the back-voltage that develops when the contacts open. This technique may be used in most low voltage dc applications, including thermostat, relay and switch contact protection. Virtually any standard diode is suitable for this application, although low-forward-resistance types are preferred. If the diode becomes warmish in use, it indicates you need a larger (higher current rating) device, but several identical units may be connected in parallel in place of a single larger diode.

A similar technique can be used to suppress dc motor brush sparking, and with similar advantages — longer brush life and less electrical noise. As shown in Fig. 1(B), the diode is simply connected across the motor's terminals with the polarity indicated. This technique is a good one to remember when working with equipment using small dc motors, such as portable tape recorders and record players.

The simple dc polarity tester circuit given in Fig. 1(C) may be assembled in several different versions. For low-impedance applications, such as checking battery voltages and low-voltage power supplies, simply connect a diode in series with a suitable low-current incandescent lamp. You may have to add a current-limiting series resistor if the tested voltage(s) is higher than the lamp's rating. In use, the lamp lights when correct dc polarity is present between the tested points, remains dark with zero voltage or reversed polarity.

A more sensitive version of the polarity tester suitable for a wide range of voltages and high-impedance circuit applications can be assembled by replacing the lamp bulb with a magnetic headphone (1000 ohms or so). Here, a sharp click in the headphone indicates correct polarity or lack of voltage.

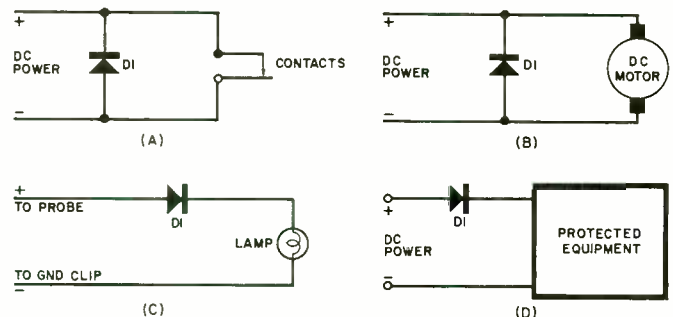

Fig. 1. Some diode applications: (A) contact arc suppressor; (B) motor spark suppressor; (C) polarity tester; and (D) polarity reversal protector.

Although you might expect to find a rectifier in ac line-powered equipment, the use of one with battery powered gear may seem superfluous, so the circuit shown in Fig. 1(D) could cause a "double take." Believe it or not (with suitable apologies), though, this arrangement makes good sense. Many types of solid-state equipment can be seriously damaged if dc power is connected with reverse polarity, whether through circuit fault or improper installation. A series rectifier used as shown serves to void such damage. With correct polarity, the rectifier acts as a virtual short, supplying power to the equipment. If the source polarity is reversed, the rectifier acts as an open circuit, preventing current flow and protecting the equipment. When using this technique, make sure that your rectifier is capable of handling the equipment's current drain.

If you use a soldering iron instead of a soldering gun, the circuit illustrated in Fig. 2(A) will help you to do your bit for the energy shortage. *S1* is a pressure-sensitive normally closed spst switch, *D1* a line voltage rectifier

**Communications
Engineering**

**Aeronautical
& Navigational**

**Television
Engineering**

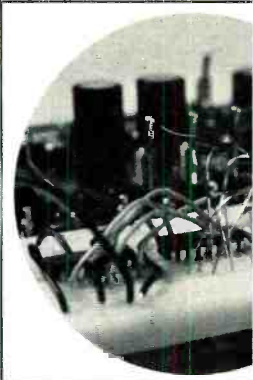

**Automatic
Control
Engineering**

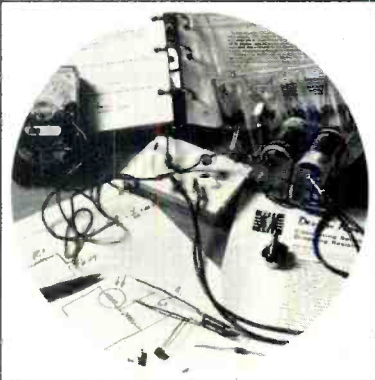

**Missile &
Spacecraft
Guidance**

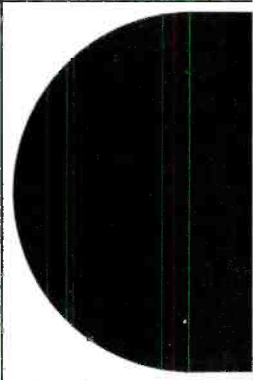

**Radar &
Sonar
Engineering**

**Digital
Communications**

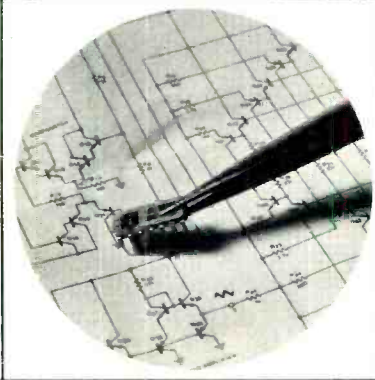

**Industrial
Electronic**

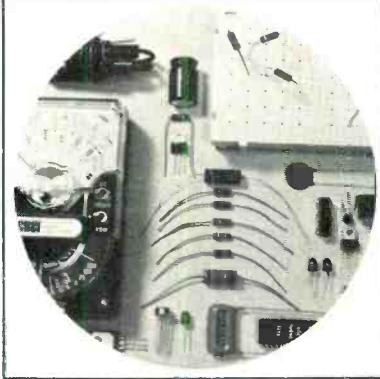

**Microwave
Engineering**

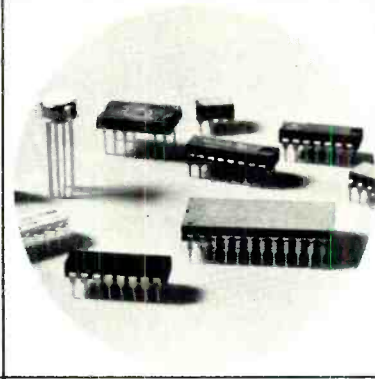

**Satellite
Communicat**

**Cable
Television
Engineering**

**Electronic
Engineering
Technology**

**Nuclear
Instrumentation
& Control**

**Special Prog
for Electro
Engineer**

ADVANCED ELECTRONICS CAREER TRAINING AT HOME

If you are too busy to go to college to learn advanced electronics, CREI brings college level training to you. CREI programs give you practical engineering training that you can apply in your work to move ahead to higher paying jobs. And CREI lets you specialize in exactly the area of electronics you want. You have a choice, depending on your qualifications, of 18 different programs.

Not only are CREI programs college-level but arrangements are available for you to earn college credit applicable to advanced degrees.

Computer
Engineering

Only CREI offers you a choice of 18 programs in advanced electronics

For over 45 years CREI programs have been recognized by leading technical organizations as effective home study training in advanced electronics.

NEW OPTIONAL LAB PROGRAM

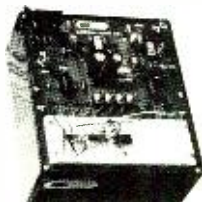

CREI now offers a supplementary ELECTRONIC DESIGN LABORATORY PROGRAM to make learning advanced electronics easier and to give you actual experience to use in your work. Only CREI offers this complete college type laboratory program. You learn to actually design electronic circuits. At the same time you get extensive experience in tests and measurements, breadboarding, prototype building and other areas important to your career.

Qualifications to Enroll. To qualify for enrollment in a CREI program, you must be a high school graduate (or equivalent). You should also be working in electronics or have previous training in this field.

Send for FREE book. If you are qualified, send for CREI's newly published book describing your career opportunities in advanced electronics. This full color book is filled with facts about career opportunities for you.



Accredited Member, National Home Study Council

CREI, Dept. E1208-E
3939 Wisconsin Avenue
Washington, D. C. 20016

Rush me your FREE book describing my opportunities in advanced electronics. I am a high school graduate.

Name _____ Age _____

Address _____

City _____ State _____ ZIP _____

If you have previous training in electronics, check here

Employed by _____

Type of Present Work _____

Veterans and servicemen, check here for G. I. Bill information

CREI

**CAPITOL
RADIO
ENGINEERING
INSTITUTE**

A Division of McGraw-Hill
Continuing Education Co.
3939 Wisconsin Avenue,
Washington, D. C. 20016

Electronic
Systems
Engineering

Nuclear
Engineering
Technology

Special Programs
for
Non Electronic
Engineers



**spend a dime,
save a mint.**

Invest a dime. Send for our catalog. We'll prove to you that you can have selection and convenience and still get a great price for the finest hifi gear.

For an immediate free copy of our new 64-page catalog, including pull-out "Hifi Primer" section, mail the coupon below to the location nearest you. Please print.



**Midwest
Hifi**

**Wholesale
and Mail
Order Division**

1626 Ogden Ave. (US 34), Downers Grove, Ill. 60515
3309 E. Carpenter Frwy. (Texas 183), Irving, Tex. 75062

NAME _____
ADDRESS _____
CITY/STATE _____ ZIP _____ (PE4-08)

CIRCLE NO. 30 ON READERS SERVICE CARD



**NEW FREE
CATALOG OF
CIRCUIT DESIGN
& BREADBOARDING
EQUIPMENT!**

**NOW . . . TEST NEW
CIRCUIT IDEAS, I.C.'S,
DISCRETE COMPONENTS WITH NO SOLDERING!**

Circuit Design's new catalog has everything you need to take you from circuit concept to working hardware in minutes. Featured items include the great SK-10 socket for solderless circuit design and testing, the NEW SK-20 socket (only \$2.75) for smaller circuits, the versatile Digi Designer (in kit form or assembled), a new Op-Amp Designer, plus power supplies, pulse generators, digital logic courses, plug-in socket boards, and much more.

Write today for your free copy.

CIRCUIT DESIGNS, INC.

P.O. Box 24, Shelton, Conn. 06484

Exclusive mail order dist. for E&L Instruments.

with a 1 amp or larger rating (depending on the wattage of your soldering iron). The switch is mounted on the soldering iron's stand in such a way that it is held open when the iron is in place, closing when the iron is picked up. In operation, the rectifier is in series with the iron's heating element when the iron is in place on its stand, reducing the power supplied, but keeping the iron comfortably warm. When the iron is picked up for use, S1 closes, shorting D1 and applying full power, heating the iron to working temperature in a couple of seconds.

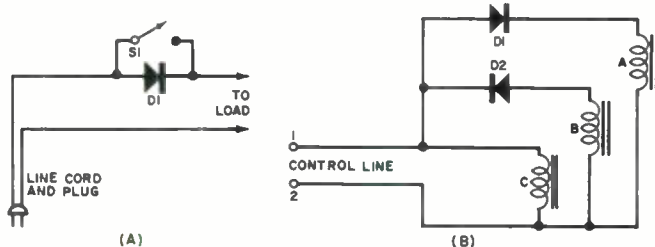

Fig. 2. Circuit (A) shows use of diode in a dual level power control; (B) is simple remote control.

This basic circuit may be used in a variety of other applications where a dual power level is needed. For example, it could be used with heating elements, some types of dc motors, and with incandescent lamps. A photographer, typically, might find it handy for operating his photofloods at reduced intensity while arranging his model and light placement, switching to full output when ready to snap his photo. Here, S1 could be a standard toggle switch.

An interesting remote control circuit featuring simple diodes is given in Fig. 2(B). If the dc control voltage is applied with terminal "1" positive, "2" negative, devices A and C are actuated. If the control voltage polarity is reversed, devices B and C are actuated. The controlled units may be any non-polarized dc-operated devices, including relays, solenoids, lamps, or alarm generators. Device C is optional, of course, and may be omitted if only two controlled units are needed.

Reader's Circuit. Fascinated by Thomas Fox's *Early Warning Storm Forecaster* (POPULAR ELECTRONICS, September, 1973, pgs. 31-34), reader Richard Andre (58-06 43rd Avenue, Woodside, NY 11377) decided to assemble his own model. Unable to obtain all of the listed components in his area, he substituted general replacement transistors for the devices specified in the original design. Less than ecstatic with the results, Richard applied a little of that ingenuity so typical of POP'tronics' readers, redesigning the original circuit for improved sensitivity. His revised circuit is illustrated in Fig. 3.

Referring to the schematic diagram, Richard replaced the two-stage complementary amplifier in the original version with a Signetics type 555 timer, IC1. Otherwise, the circuit arrangement is similar to that used in Fox's design.

As in the original version, the circuit depends for its operation on the accumulation of a voltage charge on capacitor C1 by static noise bursts received from an external AM radio receiver and applied through jack J1 and rectifier diode D1. When C1's charge builds up, both SCR1 and the timer circuit (IC1) are triggered to "on" (conducting) states, with the SCR applying power to the Sonalert (SA) to develop an audible alarm signal and the 555 IC furnishing power to indicator lamp I1 for a visual

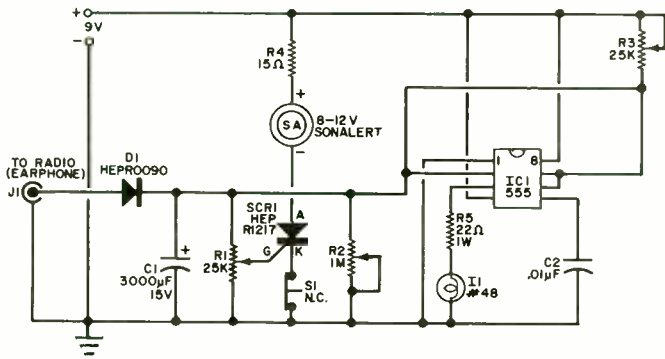

Fig. 3. A reader's version of the low-cost Stormcaster project using a 555 IC timer.

alarm. Since the SCR, once fired, will continue to conduct, S1 is provided as a reset switch, serving to open the SCR's cathode circuit momentarily when depressed, turning off the alarm if C1's charge has dropped to a low enough value.

In practice, potentiometers R1, R2 and R3 must be adjusted for optimum performance and the desired level of sensitivity. This is accomplished by connecting the instrument to the earphone jack of a small AM receiver tuned to a station-free point near the low-frequency end of the broadcast band, volume at near maximum. Artificial "static" is then created by switching a soldering gun off and on rapidly in the vicinity of the receiver for preliminary adjustments. Later, final adjustments for nearby or distant storm detection, as preferred, are made when there are known thunderstorms in your vicinity. Normally, R2 is first set to maximum resistance, with R1 adjusted to achieve desired sensitivity. Afterwards, R2 and R3 are adjusted for best operation.

Manufacturer's Circuit. One of several schematics given in the 12-page data bulletin for the TBA 800 IC, the audio amplifier circuit shown in Fig. 4 may be used in a variety of practical applications. Typically, it might be used as the audio section of a radio receiver or TV set, or in an intercom, signal tracer, record player, booster amplifier, low-power musical instrument amplifier, or power megaphone.

Manufactured by the SGS-ATES Semiconductor Corporation (435 Newtonville Ave., Newtonville, MA 02160), the TBA 800 is a monolithic power amplifier in a 12-lead quad inline plastic package. Integral external cooling tabs permit 2.5 watts output without an external heatsink and 5 watts output using a relatively small heat sink, such as an area of copper on a PC board. With a maximum rating of 30 volts and a peak output current of 2 amperes, the device can be used over a wide range of supply voltages (5-30 volts). It features high efficiency (70% at 4 watts output), very low harmonic distortion and no cross-over distortion.

According to SGS-ATES, the amplifier circuit shown is capable of delivering 5 watts to its 16-ohm loudspeaker load when operated on a 24-volt dc power supply. An 80-millivolt signal is required for maximum output. The circuit's 3-dB frequency response is from 40 Hz to 20 kHz.

For maximum performance, the manufacturer recommends the use of a suitable heat sink but, as indicated previously, this can be a small grounded area of copper on a PC board soldered to the TBA 800's large tabs.

NOW A PROFESSIONAL BURGLAR-FIRE ALARM SYSTEM YOU CAN INSTALL YOURSELF.

ONLY 149.95

Save hundreds of dollars in alarm installation and monthly service charges. The EICO SS-500 "install-it-yourself" burglar-fire alarm system offers you the kind of professional protection you have been looking for, at a price you can afford. The SS-500 has been designed on the EICO "Expandability Concept" that enables you to "add-on" protection to meet your own special needs. Before you purchase any security system, we suggest you read the EICO Security Handbook and see how easy EICO makes it to "Do-it-Yourself."

FREE EICO CATALOG/SPECIAL OFFER!

Security handbook (Reg. \$2.95) only \$1.50 with this ad. Includes a catalog on EICO Security Systems, Test Instruments, Stereo, Hobby Kits and name of nearest distributor. For catalog only, check reader service card or send 50¢ for first class mail service.

EICO, 283 Malta Street, Brooklyn, N.Y. 11207

CIRCLE NO. 12 ON READERS SERVICE CARD

It's about time!

DISPLAYS:
MONTH
DAY
HOUR
MINUTE
SECONDS

MITS presents the DC 100
An alarm — to wake you — (plus a snooze alarm).
An automatic timer — (to turn on the coffee;
to turn off the radio, etc.)
12 OR 24 HOUR MODE — (specify which).

MITS INC. "Creative Electronics"
Warranty: 1 year on assembled units, 90 days on kits

SIZE: 3"x5-3/5"x5-1/10"
PRICES: Kit \$79.95
Assembled \$99.95

Enclosed is a Check for \$ _____

or BankAmericard # _____

or Master Charge # _____

Credit Card Expiration Date _____ Kit

Include \$5.00 for Postage and Handling Assembled

Model DC-100; 12 Hour 24 Hour

Please send information on Entire MITS Line.

NAME _____

ADDRESS _____

CITY _____

STATE & ZIP _____

MITS / 6328 Linn, N.E., Albuquerque, New Mexico 87138 505/265-7553 Telex # 660401

CIRCLE NO. 26 ON READERS SERVICE CARD



SUPER CB TALK POWER!

What gives Johnson CB two-way radios their "extra sock" for longer range? Built-in Electronic Speech Compression, that's what! It's the kind of engineering you expect from U.S.-made Johnson radios . . . backed by a full 1-year parts and labor warranty with over 700 service centers nationwide.

PRICES START AT UNDER \$100!
SEND COUPON FOR FREE CATALOG!



E. F. Johnson Co.

Dept. PE Waseca, Minn. 56093

Name _____

Address _____

City _____ State _____ Zip _____

In Canada: A. C. Simmonds & Sons, Ltd.

CIRCLE NO. 33 ON READERS SERVICE CARD

GREAT MOMENTS

..... in electrical history



... the day each budding electronics buff bumps into Mueller Clips and forms a lifelong friendship. "Mueller Clips are to men what safety pins are to women," wrote A. E. Rose of Canadian Westinghouse Company Limited, in a recent fan letter we treasure most in our 60-year collection. Think you can find the 1001st use for our supergadgets for quick, temporary electrical connections? At Jobbers everywhere.

Write factory for FREE sample clips and catalog.

Mueller Electric Co.

1600V East 31st Street • Cleveland, Ohio 44114

Device/Product News. If you're with the service and repair bit, you'll be pleased to learn that the International Rectifier Corporation (233 Kansas St., El Segundo, CA 90245) has introduced a new line of original equipment transistors for all major Japanese entertainment products. The line, packaged in a special kit, consists of the 24 transistor types most often specified by the manufacturers of Japanese stereo systems, tape recorders, TV sets and other electronic products. This news is doubly interesting because, according to Don Prescott, IR's Manager of Distributor Sales, Japanese-built models accounted for 28 per cent of all TV sets sold in the U.S. last year.

Motorola Semiconductor Products Inc. (Box 20924, Phoenix, AZ 85036) has announced a number of interesting new products, including a new series of high-power plastic transistors, a pair of medium-power Darlingtons, a family of full-wave bridge rectifiers, and an exciting new IC counter.

Assembled in the type 199 plastic package, Motorola's three new power transistors are silicon *npn* devices with dissipation ratings of 80 watts and gain-bandwidth product specifications of 5 MHz. All three devices are rated at 5-A dc continuous collector current, 10-A peak. Designated types 2N6497, 2N6498, and 2N6499, they have V_{ce0} ratings of 250, 300, and 350 volts dc, respectively, and are especially well suited for inverter and ignition system as well as general-purpose applications.

With maximum ratings of 40 volts, 500 mA, and 625 mW free-air dissipation, Motorola's new 2N6426 and 2N6427 Darlington transistors are *npn* devices packaged in the popular TO-92 plastic case. With a typical noise figure of only 3.0 dB, the 2N6426 has a minimum gain of 30,000, the 2N6427 a minimum gain of 20,000, both at 10-mA dc. You'll want to consider these for your high-gain medium-voltage applications, for their prices are competitive with those of earlier lower voltage Darlingtons.

Utilizing the same dice as the popular and time tested 1N4000 rectifier series, Motorola's new MDA100 series of full-wave bridge rectifiers are ideal for most medium-level power supply applications. Encapsulated in miniature plastic cases, they are rated for a full output of 1.5 A at 55° ambient. Their PRV ratings range from 50 volts for the MDA100 to 1 kV for the MDA110.

Fig. 4. General-purpose 5-watt audio amplifier uses single IC. A small area of copper on the pc board acts as a heat sink for the IC.

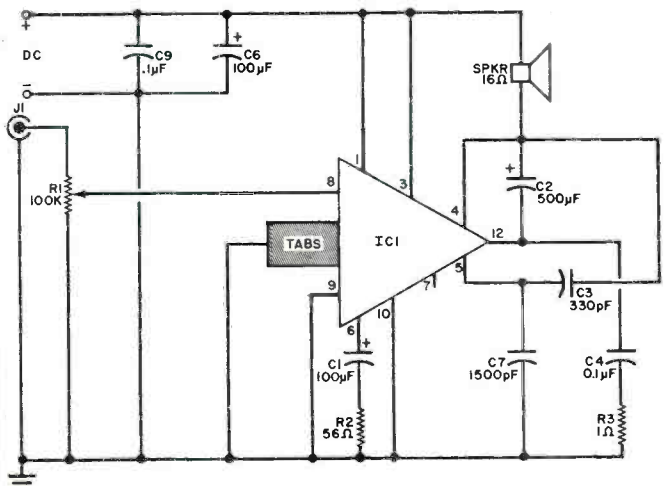

Anything that can be converted into a clock frequency of up to 5MHz — revolutions per minute, dollars, meters, farads, picas, chains, pounds, volts, mils, furlongs, or whatever — can be counted with Motorola's new McMOS 3-digit decade counter, the MC14553. It can count up to 999 and provides an overflow for cascading devices to obtain higher counts. Outputs are multiplied BCD data to input a display driver, and are TTL compatible. Assembled in a 16-pin ceramic DIP, the basic circuit consists of three negative-edge triggered BCD counters synchronously cascaded. A quad-latch output at each counter holds the data, which is time-division multiplexed, providing one BCD number or digit at a time. Digit-select outputs provide display control. Possible applications for the MC14553 include instrumentation counters, clock displays, digital meters, and whatever a fertile mind can imagine.

Fairchild Semiconductor Components (464 Ellis Street, Mountain View, CA 94042) is in there swinging for the market. In addition to announcing substantial price reductions on one hundred and one TTL ICs, the firm has introduced a number of new devices, including a line of voltage regulators and low-cost numeric displays.

The new voltage regulators, designated the 78L series, are three-terminal monolithic ICs. Available in either TO-92 plastic or TO-39 metal can packages, and with either 5% or 10% tolerance ratings, the 78L series devices are all fixed positive voltage types. Standard voltages for the TO-92 units are 2.6, 5, 6.2, 12 and 15 volts, and for the TO-39 versions, 5, 12, and 15 volts.

Fairchild's new low-cost display is a 1/2-inch LED device available in either a common anode (FND-500) or common cathode (FND-507) format. Both types are compatible with Fairchild's monolithic driver circuits, the 9368 for the FND-500 and the 9370 for the FND-507, and both also interface directly with MOS logic. The 7-segment display digits require only 5 mA average drive current per segment and a 3-volt power supply, permitting their operation from bipolar logic supplies. For desk top calculator applications, only 2 mA average drive current (per segment) is needed. Designed specifically for use in competitively priced consumer, industrial and commercial applications, the units are legible at distances of up to 20 feet.

Not to be left out, good old RCA (Solid State Division, Box 3200, Somerville, NJ 08876) is celebrating new additions to its own family of semiconductor devices, including a vhf power transistor and 21 new COS/MOS ICs.

Identified as RCA type 41042, the new vhf power transistor can deliver 80 watts peak envelope power (PEP) at 136 MHz. Intended for use in AM amplifiers operating in the 118 to 136 MHz band, the device is an epitaxial silicon npn planar transistor with overlay emitter-electrode construction. Supplied in the HF-44 package, the 41042 can provide 20 watts cw power with a 13-volt dc supply, and 80 watts PEP with a 26-volt supply, withstanding the infinite load mismatch at the 80-watt PEP level. *Hams — take note!*

Ranging from simple gates to complex functions, and including four second-source types, RCA's twenty-one new COS/MOS IC's feature such devices as a 256-bit static RAM and a variety of gates, counters, oscillators, comparators, inverters and decoders. Detailed information on the devices may be obtained by writing to RCA at the address given above. ♦

COMING UP IN THE SEPTEMBER Popular Electronics

The Super-Power Stereo Amplifier
200 watts/channel into 8 ohms

The Voice Scrambler
Provides secrecy in communications

Primer on Single Sideband
How SSB works for CB, amateur radio, etc.

Directory of Mobile CB Transceivers
What's available and what they can do

Basic Digital Logic Circuits
Beginning of a digital electronics course

Thyristor-Controlled Photoflash Units

**English-Language Shortwave
Broadcasts for Fall**

Digiviewer II
State indicator to check in-circuit DIP IC's

**EVERYTHING YOU
WANTED TO KNOW
ABOUT CD IGNITION
SYSTEMS BUT DIDN'T
KNOW WHOM TO ASK.**

Send for FREE Tiger booklet (20 pages) which answers all your questions.

Name _____

Address _____

City _____

State _____ Zip _____

CLIP OUT THIS AD AND SEND TO—

TRI-STAR CORP.
P. O. Box 1727 Dept. E
Grand Junction, Colo. 81501

ATTENTION: CB'ers

FREE

ECHO CATALOG

The Most Widely Accepted CB Equipment Catalog of Its Kind! Everything you need in one place!



Mail This Coupon TODAY!

Full of bargains on communications, electronics, and other special equipment.

ECHO COMMUNICATIONS, INC.

Cedarburg, Wis. 53012
PHONE 414 377-5050

Please send me free catalog today.

NAME _____

ADDRESS _____

CITY _____

STATE _____

ZIP _____

CIRCLE NO. 13 ON READERS SERVICE CARD

SAVE!

MONEY • TIME • FREIGHT

QUALITY STEREO EQUIPMENT AT LOWEST PRICES.

YOUR REQUEST FOR QUOTATION RETURNED SAME DAY.

FACTORY SEALED CARTONS—GUARANTEED AND INSURED.

SAVE ON NAME BRANDS LIKE:

A.D.C.	KLH
A.R.	SHURE
DYNACO	KOSS
SONY	FISHER

AND MORE THAN 50 OTHERS BUY THE MODERN WAY BY MAIL—FROM

illinois audio

Department 217S
12 East Delaware
Chicago, Illinois 60611
312-664-0020

CIRCLE NO. 19 ON READERS SERVICE CARD

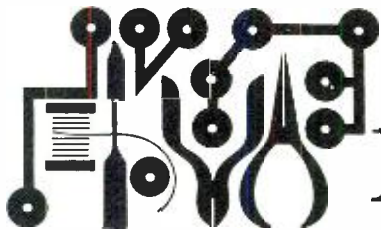

Hobby Scene

Neon Lamp on a Transistor Switch

Q. I would like to operate a neon lamp from a transistor switch. I have heard that there is a way to do this using low-voltage (therefore low-cost) silicon switching transistors. Do you know of such a circuit?

A. You can't just stick a neon lamp in series with a conventional transistor since the high voltage required for the neon would "pop" the transistor. However, you can use the circuit

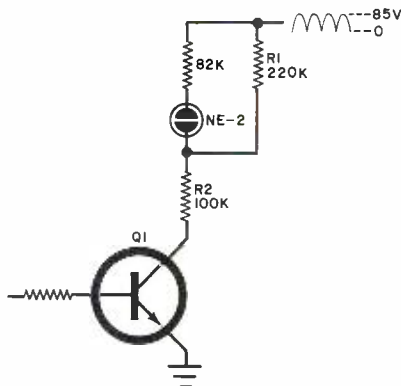

shown here. Resistors *R1* and *R2* are selected so that the drop across *R2* is safe for the transistor and the drop across *R1* is less than the striking voltage of the neon lamp. When the base of *Q1* is grounded, the lamp is off. A positive base signal turns on *Q1* and the lamp. A 25-volt transistor and an 85-volt half-wave supply are needed.

Needs Negative Supply

Q. I have an IC system that uses a +15-volt dc power supply. Now I want to include one IC that requires a -15-volt supply, but I don't want to make a separate power supply. There must be a simple way of getting the negative voltage. Any suggestions?

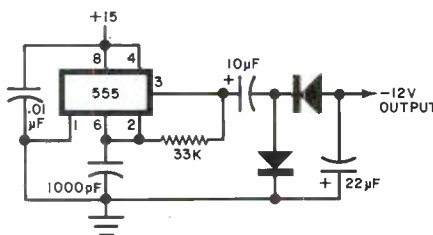

A. The circuit shown here is suggested by NASA. The 555 oscillator

works at about 20 kHz and supplies a voltage-doubling rectifier. You can get between 40 and 50 milliamperes from this circuit.

Warbling Tone Generator

Q. I need a circuit for a warbling tone generator to drive an audio amplifier.

A. The circuit shown here, using two unijunction transistors should do the job. The low-frequency sawtooth generated by *Q1* modulates the high-frequency tone generated by *Q2*. The output should feed into a high-impedance amplifier.

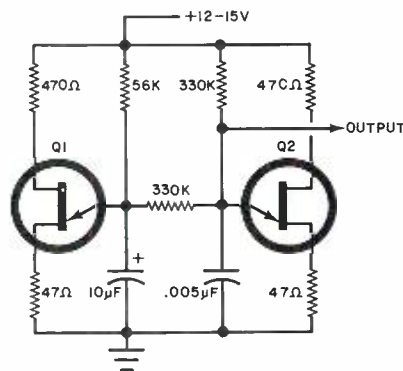

Current Booster for Op Amp

Q. I would like to use a particular op amp circuit to drive a relay. Unfortunately, the op amp will deliver only a few milliamperes, and the relay requires close to 100 mA. Is there a simple current booster I could use?

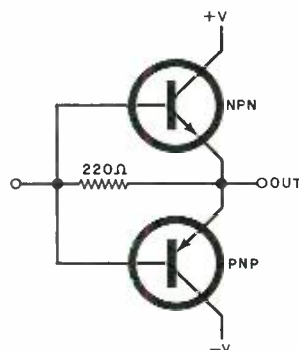

A. Using only a pair of transistors and one resistor, the circuit shown here can deliver up to 100 mA to an op amp load without harming the op amp. Most any type of standard transistor will do.



Electronics Library

TROUBLESHOOTING SOLID-STATE AMPLIFIERS

By Ben Gaddis

A review of basic transistor a-f and r-f amplifier circuits begins this book. Alpha, beta, gamma, and other specifications are discussed from the technician's viewpoint, relying on only basic algebra. Bias stabilization is then described, with details of temperature compensation and emitter "swamping" with fixed resistances and thermistors. Then general methods of trouble-shooting, concentrating on signal tracing and voltage, resistance, and capacitance measurement techniques are covered. Methods of testing individual transistors in and out of circuit are also described.

Published by Tab Books, Blue Ridge Summit, PA 17214 256 pages. \$7.95 hard cover; \$4.95 soft cover.

SO YOU WANT TO BE A HAM, Sixth Edition

by Robert Hertzberg, W2DJJ

This book is intended to get beginners of all ages off to the right start in the fascinating hobby of amateur radio. It also serves as an invaluable reference for the old timer. The entire field of amateur radio is encompassed in this volume, from the various types of licenses and the requirements and procedures for obtaining them to painless methods for learning the code. This book covers the value of kit building and the practical knowledge and experience gained in assembly. Completely updated chapters are devoted to receivers, transmitters, mobile equipment, test equipment, and antenna systems.

Published by Howard W. Sams & Co., Inc., 4300 West 62 St., Indianapolis IN 46268. Soft cover. 189 pages. \$5.50.

AN INTRODUCTION TO ELECTRICAL CIRCUIT THEORY

By G. Williams

This introductory book covers the basic theory of electrical circuits. It follows the modern philosophy of developing basic circuit laws, theorems, and methods of analysis using circuits containing only dc sources and resistances. It then introduces capacitance and inductance, dc transient response of circuits, response of circuits to steady-state ac stimulation, and special analytical techniques based on phasors and complex numbers. Steady-state ac cir-

for only \$19.95* this ugly little space-age device makes your FM/AM mobile stereo sound like it's always parked near the radio station

*suggested list price

model ASC 100
stereo x-pander

as **ascom**® electronic products
Division of CRION INDUSTRIES, INC., 12435 Euclid Ave., Cleveland, Ohio 44106
Export: 2203 Shames Drive, Westbury, L.I. New York 11590
Canada: A. C. Simmonds & Sons, Ltd.

CIRCLE NO. 3 ON READERS SERVICE CARD

SINGLE SIDEBAND

Sidebander II, SSB/AM

Sidebander III, SSB

SBE "sideband" equipment—gives highest legal talk power—25W in, 12W out p.e.p.

Real get-through punch! Like adding a 3 element beam to a good AM set.

Use upper and lower sidebands, enjoy 46 channel equivalent.

Three SBE, performance-proved SSB transceivers: Console and the two shown here for mobile. Sidebander II provides both SSB and AM operation. Sidebander III is SSB only. Both sets are 23 channel types, are synthesized so require no crystals—both operate at 25W peak power on SSB—have switchable USB or LSB—"Clarifier"—Squelch—Noise limiter—RF gain control—Panel monitor meter—PA provisions. Both sets supplied w/ quality dynamic mic. w/ coil cord/ 4 cond. plug.

WRITE FOR DESCRIPTIVE BROCHURE

LINEAR SYSTEMS, INC. 220 Airport Blvd. Watsonville, CA 95076

CIRCLE NO. 24 ON READERS SERVICE CARD

cuit analysis ends with a consideration of the laws and theorems in the frequency domain and a discussion of the complex power relationships.

Published by Barnes & Noble Books, 10 East 53 St., New York, NY 10022. Soft cover. 209 pages. \$7.95

SEMICONDUCTOR DATA HANDBOOK, Second Edition

The latest edition of this handbook is divided into three sections: index and interchangeability guide, product selector guides, and product specification sheets.

The index and interchangeability guide offers General Electric's replacements for most popular 1N, 2N, 3N, 4N, and house-number semiconductor devices. The selector guide contains summary information on all GE semiconductors, including optoelectronic, SCR, triac, UJT, rectifier, transistor, and GE-MOV™ varistor devices. And, as its name implies, the specification sheet section lists detailed specs for all GE products listed.

Published by General Electric Semiconductor Products Dept., Electronics Park Bldg #7, Mail Drop 49, Syracuse, NY 13201. Soft cover, 1484 pages. \$4.95.

ELECTRONICS MARKET PLACE

NON-DISPLAY CLASSIFIED: COMMERCIAL RATE: For firms or individuals offering commercial products or services. \$1.60 per word (including name and address). Minimum order \$16.00. Payment must accompany copy except when ads are placed by accredited advertising agencies. Frequency discount; 5% for 6 months; 10% for 12 months paid in advance. **READER RATE:** For individuals with a personal item to buy or sell, \$1.00 per word (including name and address.) No minimum! Payment must accompany copy. **DISPLAY CLASSIFIED:** 1" by 1 column (2-1/4" wide), \$200.00. 2" by 1 column, \$400.00. 3" by 1 column, \$600.00. Advertiser to supply cuts. For frequency rates, please inquire.

GENERAL INFORMATION: First word in all ads set in bold caps at no extra charge. All copy subject to publisher's approval. All advertisers using Post Office Boxes in their addresses **MUST** supply publisher with permanent address and telephone number before ad can be run. Advertisements will not be published which advertise or promote the use of devices for the surreptitious interception of communications. Closing Date: 1st of the 2nd month preceding cover date (for example, March issue closes January 1st. Send order and remittance to **POPULAR ELECTRONICS**, One Park Avenue, New York, New York 10016, Attention: Hal Cymes.

FOR SALE

FREE! bargain catalog. Fiber optics. LED's, transistors, diodes, rectifiers, SCR's, triacs, parts. Poly Paks, Box 942, Lynnfield, Mass. 01940.

GOVERNMENT Surplus Receivers. Transmitters, Snooperscopes, Radios, Parts, Picture Catalog 25 cents. Meshna, Nahant, Mass. 01903.

LOWEST Prices Electronic Parts. Confidential Catalog Free. KNAPP, 3174 8th Ave. S.W., Largo, Fla. 33540.

ELECTRONIC PARTS, semiconductors, kits. FREE FLYER. Large catalog \$1.00 deposit. BIGELOW ELECTRONICS, Bluffton, Ohio 45817.

FYROTECHNICAL chemicals, casings, fuse, supplies. Listings—50 cents, with samples—\$1.00. Westech, RFD, Logan, Utah 84321.

RADIO—T.V. Tubes—36 cents each. Send for free catalog. Cornell, 4213 University, San Diego, Calif. 92105.

AMATEUR SCIENTISTS, Electronics Experimenters, Science Fair Students... Construction plans—Complete, including drawings, schematics, parts list with prices and sources... Robot Man — Psychedelic shows — Lasers — Emotion/Lie Detector — Touch Tone Dial — Quadraphonic Adapter — Transistorized Ignition — Burglar Alarm — Sound Meter... over 60 items. Send 25 cents coin (no stamps) for complete catalog. Technical Writers Group, Box 5994, University Station, Raleigh, N.C. 27607.

METERS—Surplus, new, used, panel or portable. Send for list. Hanchett, Box 5577, Riverside, CA 92507.

WE SELL CONSTRUCTION PLANS. TELEPHONE: Answering Machine, Speakerphone, Carphone, Phonevision, Auto Dialer, Touch Button Dialer, Central Dial System. TELEVISION: \$35.00 Color Converter, Video Tape Recorder. \$25.00 Camera. HOBBYIST: Electron Microscope, 96 Hour Tape Music System, Ultrasonic Dishwasher, Radar-Oven, Plans \$4.95 each. NEW ITEM: \$75. Electronic Pocket Calculator, \$7.50. COURSES: Telephone Engineering \$39.50. Detective Electronics \$22.50. Integrated Circuit Engineering, \$49.50. NEW SUPER HOBBY CATALOG plus year's subscription to Electronic New Letter AIRMAILED \$1.00. Don Britton Enterprises, 6200 Wilshire Blvd., Los Angeles, Calif. 90048.

JAPAN HONG KONG DIRECTORY. World products information, \$1.00 today. World Trade Inquiries, Hillyard, Washington 99207.

SCOPES, meters, test equipment, military and industrial surplus. Send 25 cents for 'Bargain Bulletin'. Lawrence Instruments, P.O. Box 744, Sunbury, Pa. 17801.

TEST EQUIPMENT, Aerospace-Laboratory Grade. Request your needs: will mail appropriate catalogs (we have 24 catalog categories). Only for engineers, Businesses, Schools and advanced Technicians. Goodheart, Box 1220PE, Beverly Hills, Calif. 90213.

WAVEFORM GENERATOR KIT 8038 Function Generator IC Producing Sine, Square, Triangular Waveforms, \$10.95 PPD. 8038 IC, \$6.75 each PPD. PHOTOLU ME CORPORATION, 118 East 28th Street, New York, NY 10016.

LOOKING FOR A NEW CHALLENGE?
... then build a TV camera!



ONLY SOLID-STATE CAMERA AVAILABLE IN KIT FORM IN FACTORY ASSEMBLED COMPLETE KIT WITH VIDEO TUBES ONLY \$199.99 POSTPAID DELIVERY ANYWHERE IN U.S.A., CANADA AND MEXICO. OPTIONAL AUDIO SUBCARRIER \$18.95. WRITE OR PHONE NOW FOR COMPLETE CATALOG OF KITS, PARTS AND PLANS. (901) 587-3371

1301 BROADWAY **ATV Research** DANVER, MASS. 01923

DIGITAL ELECTRONICS: Complete schematics, parts lists, theories — Discrete Component Digital Clock, \$3.00 — Sound Sensitive Switch, \$1.50. Increase technical competence, hobby skills — Complete Course in Digital Electronics is highly effective, \$10.00. Free literature. DYNASIGN, Box 60A7, Wayland, Mass. 01778.

MECHANICAL, ELECTRONIC devices catalog 10 cents. Greatest Values — Lowest Prices. Fertik's, 5249 "D", Philadelphia, Pa. 19120

SOUND SYNTHESIZER KITS—Surf \$11.95, Wind \$11.95, Wind Chimes \$16.95, Electronic Songbird \$6.95, Musical Accessories, many more. Catalog free. PAIA Electronics, Box J14359, Oklahoma City, OK 73114.

BURGLAR-FIRE alarm components, hardware. Free catalog—information. Silmar, 133 S.W. 57 Ave., Miami, Florida 33144.

FREE CATALOG. Parts, circuit boards for POPULAR ELECTRONICS projects. PAIA Electronics, Box C14359, Oklahoma City, OK 73114.

ALTAJ ELECTRONIC BARGAINS



CLOCK CHIP BONANZA

Brand new National Clock Chips. A complete digital clock in one DIP. Best prices anywhere. WITH SPECS.

MM5314 — 24 PIN DIP. 6 digits 12 or 24 Hrs. \$6.95

MM5316 — Alarm Clock, 40 Pin. For fluorescent or liquid crystal readouts. \$9.95



OPCOA SLA-1C Color LED Readout. .33 In. Character. Like MAN-1 but easier to read. Has two decimal points to form a colon. Perfect for use with clock chips like our MM5314. Special \$1.95 ea.

LIQUID CRYSTAL READOUT

4 Digit Unit. Used in wristwatches. #AEO-129 same as in Jan '74 Popular Electronics article. New with socket \$9.95

PRIME TTL DIP IC'S

7400 — \$.23	7447 — \$.95	74123 — \$.99
74S00 — \$.49	7448 — \$.95	74145 — \$.89
7402 — \$.23	7450 — \$.23	74150 — \$1.39
7404 — \$.25	7453 — \$.23	74151 — \$.89
74S04 — \$.49	7472 — \$.39	74153 — \$1.19
7406 — \$.44	7473 — \$.39	74154 — \$1.59
7408 — \$.23	74H73 — \$.49	74157 — \$1.19
7407 — \$.29	7474 — \$.44	74164 — \$1.69
7409 — \$.29	7475 — \$.69	74165 — \$1.49
7410 — \$.23	7476 — \$.44	74174 — \$1.89
7416 — \$.49	7483 — \$.89	74175 — \$1.95
7420 — \$.23	7486 — \$.39	74180 — \$.99
7427 — \$.35	7490 — \$.89	74181 — \$3.50
7430 — \$.25	7491 — \$.95	74S181 — \$4.50
7432 — \$.30	7492 — \$.89	74182 — \$.95
7437 — \$.49	74107 — \$.44	74192 — \$1.39
7438 — \$.49	74109 — \$.59	74193 — \$1.39
7439 — \$.65	74121 — \$.44	74197 — \$1.25
7442 — \$.77		
7445 — \$.95		

CORE MEMORY SPECIAL

4K X 16

Original Cost Over \$400

Brand New by Ampex. Units were mfg. in 1973 and are state of the art, ultra fast memories. Imagine, 65,536 bits of core in a plane only 10 x 10 in. square. These will store 4096 16 bit words. With drawings. Best memory buy in USA!

\$39.95 ea.

COMPUTER GRADE ELECTROLYTICS

Factory fresh, brand new prime units.

140,000 MFD 15 WVDC by GE	\$2.95
20,000 MFD 15 WVDC by Mallory	\$1.75
1,000 MFD 75 WVDC by GE	\$.99

4.000 MHZ OSCILLATOR MODULE

Miniature, 1 x 1 1/2 x 1/2 in. Only thing needed is to apply voltage. Brand New. Original cost \$20. Our price \$2.95

THIS MONTH'S SPECIALS

LM309K — \$1.49 • 741C — \$.39 (MINI DIP) •	
NE567 — \$2.95	
P1103 — 1024 Bit Ram. New by Intel — \$5.95	
2N3391A — NPN Silicon Transistor. Ultra high Beta 4/\$1	

JUMBO LED LAMPS

Red Like MV5024 — 6/\$1.00
Green Like MV5222 4/\$1.00
Yellow Like MV5322 — 4/\$1.00

SELENIUM SOLAR CELLS

1/2 in. square. With Leads. For solar powered projects. 5 for \$1

RTL IC'S BY MOTOROLA

Brand New. These are getting hard to find.
MC724P—\$.77 MC789P—\$.77 MC790P—\$.89

TERMS: Check or M.O.
No C.O.D. Add 10% to help cover Postg. and Handling.

ALTAJ ELECTRONICS
P. O. Box 38544
Dallas, Texas 75238

COMPARE OUR LOW PRICES
AND FAST SERVICE

FREE INFORMATION:

Learning more about a product that's advertised or mentioned in an article in this month's issue is as simple as one, two, three. And absolutely free.

1 Print or type your name and address on the attached, postage-paid card.

2 Circle the number(s) on the card that correspond to the number(s) at the bottom of the advertisement or article for which you want more information.

(Key numbers for advertised products also appear in the Advertisers' Index.)

3 Simply mail the postage-paid card.

POPULAR ELECTRONICS ZE8746

NAME _____

ADDRESS _____

CITY _____ **STATE** _____ **ZIP** _____

(Zip Code must be included to insure delivery.) (Void after Oct. 31, 1974)

1. Have you ever taken a home study course in electronics?

Yes No

2. Would you consider taking one? Yes No

1 2 3 4 5 6 7 8 9 10 11 12 13 14 15
16 17 18 19 20 21 22 23 24 25 26 27 28 29 30
31 32 33 34 35 36 37 38 39 40 41 42 43 44 45
46 47 48 49 50 51 52 53 54 55 56 57 58 59 60
61 62 63 64 65 66 67 68 69 70 71 72 73 74 75
76 77 78 79 80 81 82 83 84 85 86 87 88 89 90

POPULAR ELECTRONICS ZE8745

NAME _____

ADDRESS _____

CITY _____ **STATE** _____ **ZIP** _____

(Zip Code must be included to insure delivery.) (Void after Oct. 31, 1974)

1. Have you ever taken a home study course in electronics?

Yes No

2. Would you consider taking one? Yes No

1 2 3 4 5 6 7 8 9 10 11 12 13 14 15
16 17 18 19 20 21 22 23 24 25 26 27 28 29 30
31 32 33 34 35 36 37 38 39 40 41 42 43 44 45
46 47 48 49 50 51 52 53 54 55 56 57 58 59 60
61 62 63 64 65 66 67 68 69 70 71 72 73 74 75
76 77 78 79 80 81 82 83 84 85 86 87 88 89 90

POPULAR ELECTRONICS ZE8744

NAME _____

ADDRESS _____

CITY _____ **STATE** _____ **ZIP** _____

(Zip Code must be included to insure delivery.) (Void after Oct. 31, 1974)

1. Have you ever taken a home study course in electronics?

Yes No

2. Would you consider taking one? Yes No

1 2 3 4 5 6 7 8 9 10 11 12 13 14 15
16 17 18 19 20 21 22 23 24 25 26 27 28 29 30
31 32 33 34 35 36 37 38 39 40 41 42 43 44 45
46 47 48 49 50 51 52 53 54 55 56 57 58 59 60
61 62 63 64 65 66 67 68 69 70 71 72 73 74 75
76 77 78 79 80 81 82 83 84 85 86 87 88 89 90

FREE INFORMATION:

First Class
Permit No. 217
Clinton, Iowa

BUSINESS REPLY MAIL

No postage necessary if mailed in the United States

POSTAGE WILL BE PAID BY

Popular Electronics

P.O. Box 2905
Clinton, Iowa 52732

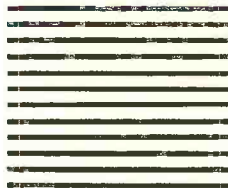

First Class
Permit No. 217
Clinton, Iowa

BUSINESS REPLY MAIL

No postage necessary if mailed in the United States

POSTAGE WILL BE PAID BY

Popular Electronics

P.O. Box 2905
Clinton, Iowa 52732



First Class
Permit No. 217
Clinton, Iowa

BUSINESS REPLY MAIL

No postage necessary if mailed in the United States

POSTAGE WILL BE PAID BY

Popular Electronics

P.O. Box 2905
Clinton, Iowa 52732



THE MOST IMPORTANT DISCS IN YOUR ENTIRE COLLECTION!

Stereo Testing! Spectacular Sound!

The New Standard In Stereo Testing!

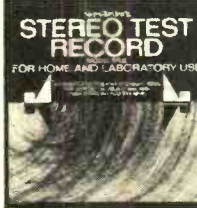

Model SR12 Stereo Test Record

The most complete . . . most sophisticated . . . most versatile test disc available today. Whether you're an avid audiophile who'll settle for nothing but peak performance from his stereo components . . . a casual listener who'd like more insight into the challenging world of stereo reproduction . . . or a professional technician who needs precise standards for lab testing . . . the SR12 is a must for your record collection.

Make These Important Stereo Checks By Ear . . . Frequency response. Separation. Cartridge tracking. Channel balance. Hum and rumble. Flutter. Cartridge Anti-skating adjustment. "Gun shot test" for stereo musician's "A." Equal-tempered Chromatic octave. Guitar-tuning notes.

and speaker phasing. speed. Multi-purpose

7 Critical Professional Test Equipment Checks. The SR12 is also a highly efficient design and measurement tool. Recorded levels, frequencies, etc., have been controlled to laboratory tolerances for use with oscilloscope chart recorder, output meter, intermodulation-distortion meter and flutter meter.

The Most Spectacular Sound Exhibition Of Stereo Fidelity Ever Available On One Disc And Cassette!



Stereo Demonstration Record And Cassette

The result of two years of intensive research in the sound libraries of Deutsche Grammophon Gesellschaft, Connoisseur Society, Westminster and Cambridge. The editors of Stereo Review have selected those excerpts that best demonstrate the many aspects of the stereo reproduction of music. It's the greatest variety of sound ever included on a single disc or cassette.

Electrifying Experience in Listening. A series of independent demonstrations designed to show many aspects of musical sound and its reproduction. Self-sufficient capsule presentations are arranged in a contrasting and pleasing order, isolated and pointed up to give you a basis for future critical listening.

Wide Range of Demonstrations. Techniques of separation and multiple sound sources. Acoustic depth. The ambience of a concert hall. Sharp contrasts of dynamics. Crescendo and diminuendo. Very high and very low pitched musical sounds. Polyphony (two or more melodies going on at once) with both similar and contrasting instruments. Tonal qualities of wind, string and percussion instruments. Sounds of ancient instruments. Sounds of oriental instruments. The singing voice both classically trained and untrained. Plus a large sampling of finger snapping, hand clapping, foot stamping and other musical and percussive sounds.

Booklet discusses and describes each selection.

A Remarkable Listening Experience For Stereo Headphone Owners!



Binaural Demonstration Record

Binaural recording recreates the directions, distances, and even the elevations of sounds better than any other recording method. The super-realism of binaural recording is accomplished by recording the acoustical input for each ear separately, and then playing it back through stereo headphones. Thus the sound intended for the left ear cannot mix with the sound for the right ear, and vice versa. The sound reaching each ear is exactly the same as would have been heard at the live scene.

"Max"—Genie of Binaural Recording. A specially constructed dummy head duplicates the human head as an acoustical absorber and reflector of sound. Super-precision capacitor microphones installed in Max's ears picked up exactly what each human ear would hear. The result is a demonstration of phenomenal recorded sound. 45 minutes of sound and music of startling reality. You'll marvel at the eerie accuracy with which direction and elevation are recreated as you embark on a street tour in binaural sounds—Sounds of the City. Trains. Planes and Ships . . . a Basketball game, a Street Parade, a Steel Fabrication Plant. The Bird House at the Zoo—all demonstrating the incredible realism of binaural sound reproduction. Then, musical performances transport you to the concert hall for a demonstration of a wide variety of music. Selections total 23 minutes, and include examples of jazz, organ and chamber music.

Records are \$5.98 Each — Cassette \$6.98, Postpaid

HERE'S HOW TO ORDER

CASH: Mail your order along with your name, address and correct remittance.

CHARGE . . . Your American Express or BankAmericard account! Mail your order, name, address and credit card number. You will be billed at the price indicated above.

**MAIL ALL ORDERS TO — RECORDS, ZIFF-DAVIS SERVICE DIVISION,
595 BROADWAY, NEW YORK, N.Y. 10012.**

Outside U.S.A. records and cassette are \$8.00 each

DISCOUNT PRICES

B & K, SENCORE, LEADER and RCA
Test Equipment
RAYTHEON, ICC/MULLARD Tubes
TELEMATIC Test Jigs

Free Catalog

FORDHAM RADIO SUPPLY CO., INC.
558 Morris Ave. • Bronx, N.Y. 10451

CALCULATOR OWNERS: Use your +—X÷ calculator to compute square roots, cube roots, sin(x), cos(x), tan(x), arcsin(x), arccos(x), arctan(x), logarithms, exponentials, and more! Quickly, Accurately, Easily! Send today for the IMPROVED AND EXPANDED EDITION of the first and best calculator manual—now in use throughout the world... only \$2.00. Unconditional money-back guarantee—and FAST service! Mallmann Optics and Electronics, Dept. 18A, 836 South 113, West Allis, Wisconsin 53214.

WE SELL MONEY MAKING CONSTRUCTION MANUALS!—Reclaim refined GOLD and SILVER for EXCELLENT full time or part time money!—Color Catalog 25 cents—Airmailed 50 cents. Creative Products, Dept. PE-874, 8415 Lofland, Houston, Texas 77055.

BUGGED??? New locator finds them fast. Write, Clifton, 11500-L N.W. 7th Avenue, Miami, Florida 33168.

TELEPHONE "BUGGED"? Countermeasures Brochure \$1.00. Negeye, Drawer 547, Pennsboro, W. VA 26415.

ELECTROSLEEP, acupuncture. Catalog of 200 more projects free. Cimarron Labs, G-13060 Center Rd., Clio, Michigan 48420.

HEAR POLICE/FIRE Dispatchers! Catalog shows exclusive directories of "confidential" channels, receivers. Send 10 cent stamp. Communications, Box 56-PE, Commack, N.Y. 11725.

FIREWORKS NEWS—Magazine Covering Commercial—Display Fireworks, Sources, Construction, Pyrotechnical Supplies, Fuse, Literature. Free Catalogs/Book list With Subscription! Calendar Year \$9.00 "1974" Fireworks Buyers' Guide" \$5.95. Pyro Press, Box 12010N, Lexington, Kentucky 40511.

CONVERT any television to sensitive, big-screen oscilloscope. Only minor changes required. No electronic experience necessary. Illustrated plans. \$2.00. Sanders, Dept. A-33, Box 92102, Houston, Texas 77010.

DIGITAL IC Manual—Latest Edition—1500 types by types/diagram number, \$3.95. 32—function digital computer kit—IC, transistors, instructions, \$14.00. IC applications manual—numerous circuits—Analog/Digital, \$3.95. Electronics, P.O. Box 127, Hopedale, Mass. 01747.



PAIA HAS... modular SYNTHESIZER KITS

demo record \$1.00 free catalog

PAIA ELECTRONICS, INC.
BOX P14369, OKLAHOMA CITY, OK 73114

YOU WILL SAVE BIG MONEY! Surplus, Clearouts, Bankruptcy, Inventory, Deals. Catalog \$1 (redeemable). ETCOA Electronics, Box 741, Montreal, H3C 2V2, U.S. Inquiries.

ELECTRONIC Parts wholesale. Catalog 10 cents. Donlyn Electronics, P.O. Box 15421, Phoenix, Arizona 85060.

BURGLAR-FIRE alarm supplies and information. Free catalog. Protecto Alarm Sales, Box 357-G, Birch Run, Michigan 48415.

FREE CATALOG. IC's, Puts, Transducers, Thermocouples, Led's, Transistors, Circuit Boards, parts. Chaney's, Box 15431, Lakewood, Colo. 80215.

AUTHENTIC, INSTRUMENTED, FLYING ROCKETS for casual or serious experimenters. Over 80 scale original, multi-stage or ready-to-fly models. Solid-propellant engines for safe, electric launch system liftoffs up to 2,500 feet. Measure altitude, temp, inversions, more. Real telemetry, electronic tracking, aerial still and movie photography with super-miniaturized equipment. New, detailed tech manual and full-color catalog. 25 cents from ESTES INDUSTRIES, Dept. 18Z, Penrose, Colo. 81240.

LOW NOISE RESISTORS—carbon film. Brand new as low as 2-1/4 cents each. Components Center-PE Box 134, N.Y., N.Y. 10038.

CRYSTALS, Scanners, \$3.88, include make and frequency. G Enterprises, P.O. Box 461PC, Clearfield, UT 84015.

ELECTRONIC TEST INSTRUMENT CATALOG—160 illustrated pages list over 5,000 new, used and reconditioned test instruments — 600 manufacturers. Send \$2.50 refundable with first purchase. Tucker Electronics, P.O. B. 1050, Garland, Texas 75040.

CONSTRUCTION PLANS: Laser \$2.00. Rocket Tracking Transmitter... \$2.00. Space Monitor-Missile Tracker... \$2.00. Free Catalog. Electro-Research, P.O. Box 20285, Ferndale, Michigan 48220.

CD IGNITIONS, VHF/UHF monitors, crystals, CB radios. Southland, Box 3591-B, Baytown, Texas 77520.

FREE CATALOG, Kits, Components, audio equipment. Electronic Supply Pacs, Box 175, Floral Park N.Y. 11001.

PRACTICAL Applications of Digital IC's. 100's of tips, circuits, projects, on TTL. 443pp \$19.95. Money Back Guarantee, GEA, P.O. Box 285, Northfield, Ohio 44067.

WEATHER SATELLITE pictures of your own. Can be constructed for \$100.00. \$2.00 for plans to: Weather, P.O. Box 362, Tupelo, Miss. 38801.

ALPHA/THETA BRAINWAVE biofeedback instruments. Analog instruments from \$125; digital processing systems from \$225. BioScan, Box 14168-E, Houston, Texas 77021.

SURPRISE! Build inexpensively, the most Unusual Test Instruments, Futuristic Gadgets using Numerical Readouts! Catalogue Free! GBS, Box 100A, Green Bank, West Virginia 24944.

COMPLETE CONSTRUCTION PLANS—TELEPHONE: Schematics, Answering Device, Automatic Dialer, Call Diverter, Conference Bridge, Central Dial Exchange, Remote Control, Speakerphone, Teletink Burglar Alarm, \$3.00 each. **ELECTRONIC:** Biofeedback Conditioner, Horticulture Stimulator, Multifrequency Encoder Network (Speeds telephone calling 100%), \$5.00 each. **DODECAHEDRON Speaker Enclosure \$7.50.** **PRECISION Stenciling Device \$2.00.** One year subscription: Telephone-Electronics Newline \$3.00. Correspondence Course: Telecommunications \$24.95. Teletronics Company of America, P.O. Box 3486, Los Angeles, California 90028.

PARANOID???... Surveillance Countermeasure Equipment Catalog \$1.00. SECURITY, Box 671, Westwood, New Jersey 07675.

EXPERIMENTERS! Send \$10.00 for postpaid "Grab Bag" of assorted electronic goodies. Satisfaction guaranteed. Aeroparts, Box 1492, International Airport, Del Rio, Texas 78840.

SCOTCH TAPE—2400' on 7" reel boxed, may have music. 12 for \$14 POSTPAID—free list—WIDE RESPONSE, 6114P SANTA MONICA BLVD., HOLLYWOOD, CA. 90038.

ELECTRONIC IGNITION: Capacitor, transistor, pointless. Auburn sparkplugs. Information 10 cents. Anderson Engineering, Epsom, N.H. 03234.

LASER DIODE, 6W, GaAs: \$10.25; 8038 WAVEFORM GENERATOR: \$5.95; INTEL 1103: \$3.00; CATALOG 10 cents. **ELECTRONIC DISCOUNT SALES,** 138 N. 81st St., Mesa, Arizona 85207.

MULTI-TRACE Digital Logic Analyzer, Operates with any oscilloscope. \$19.95. DBS, Box 381, Madison, Alabama 35758.

LEARN DIGITAL ELECTRONICS 4 VOLUME 443pp set Practical Applications of Digital Integrated circuits—\$19.95. Theory plus experiments. GEA, Inc., PO Box 285, Northfield, Ohio 44067.

DIAGRAMS, Servicing Information, Television-Radio, \$1.95. Publications, 1760 Balsam, Highland Park, Illinois 60035.

WHOLESALE Scanners, CB, Crystals, Directories, SSB/AM, Catalog 25 cents. G—Enterprises, Box 461P, Clearfield, Utah 84015.

VOLTMETER MEMORY Adapter remembers last voltage measurement. Details: Richard Blair, Box 42, El Jebel, CO 81628.

PLAY PING PONG ON YOUR TV. You've seen them everywhere—now have your own! Plans \$3.50. D. Duncan, 20650 Runnymede, Canoga Park, Calif. 91306.

THE CALCULATOR HANDBOOK 127 pages. Practical Applications: Hints, Tricks, Metric Conversions, Powers, Roots, Interest, Business, Investing, School. Satisfaction Guaranteed! \$1.65. Techniplan, Box 51A, Baldwin, New York 11510.

POWER SUPPLY plans, precision regulated 9 to 12vdc, 2 amps. \$5.00. Airborne Systems, Box 1175, Hartford, Conn. 06101.

PRINTED CIRCUIT TECHNIQUES FOR THE HOBBYIST. Ferric chloride "suspension etching"; cutting epoxy glass; screen printing, etc. Booklet \$2.00. Trumbull, 833 Balra Dr., El Cerrito, Ca. 94530.

ELECTRONIC ORGAN KITS, KEYBOARDS and many components. Independent and divider tone generators. All diode keying. I.C. circuitry. Supplement your Artisan Organ, 35 cents for catalog. DEVTRONIX ORGAN PRODUCTS, Dept. C., 5872 Amapola Dr., San Jose, Calif. 95129.

For
faster
service

USE
ZIP
CODE

on
all
mail

COMPUTER / DATA INPUT KEYBOARD



Honeywell 8 bit binary coded board, 56 keys, alphanumeric and computer symbols. Built in TTL decoder. 13 1/2" x 5 1/4"

STOCK NO. F5119

\$47.50 ea, 2/90.00

Many request for a transformer capable of powering a 250 watt amplifier, have prompted us to locate this beauty. Good for up to 450 watts continuous service, 64 volts ct, @ 6 A., 18 volts ct @ 8 A., 32 volts @ 6 A., and 400 volts @ 1.150 A.

STOCK NO. F9905 11.95 ea. 2/22.00 5/50.00



3 1/2 DIGIT LIQUID CRYSTAL DISPLAY



Actual size.

This is the Liquid Crystal Display specified in the Jan. POPULAR ELECTRONICS article, "Build This Digital Wrist Watch". Comes complete with socket, and data, plus reprint of above article.

STOCK NO. F5192 \$19.75

DIGIVAC 7 SEGMENT FLUORESCENT READOUT



Tung-Sol DT1704B, 9 pin, electrically similar to G.E. Y4075 Blue-green color. We supply 9 pin socket, 1.2 volts Fil., 25 to 50 volts anode. Makes all digits and 14 letters.

STOCK NO. J5140, with data. \$2.65 ea. 2/5.00, 6/14.00



DELTA ELECTRONICS CO.

BOX 1, LYNN, MASSACHUSETTS 01903

Phone (617) 388-4705

CIRCLE NO. 10 ON READERS SERVICE CARD

INTERNATIONAL ELECTRONICS UNLIMITED

TTL

7400	\$.22 ea.
7401	.25 ea.
7402	.25 ea.
7403	.25 ea.
7404	.25 ea.
7405	.27 ea.
7406	.55 ea.
7408	.29 ea.
7409	.29 ea.
7410	.22 ea.
7413	.95 ea.
7420	.22 ea.
7425	.39 ea.
7430	.25 ea.
7432	.38 ea.
7437	.50 ea.
7438	.35 ea.
7440	.22 ea.
7441	1.25 ea.
7442	1.15 ea.
7445	.89 ea.
7446	1.05 ea.
7447	1.20 ea.
7448	1.50 ea.
7453	.75 ea.
7454	.45 ea.
7460	.20 ea.
7472	.45 ea.
7473	.55 ea.
7474	.55 ea.
7475	.95 ea.
7476	.55 ea.
7490	.99 ea.
7491	1.40 ea.
7492	1.05 ea.
7493	1.05 ea.
74107	.55 ea.
74121	.65 ea.
74123	.89 ea.
74150	1.10 ea.
74151	1.05 ea.
74153	1.45 ea.
74154	1.75 ea.
74164	1.95 ea.
74177	.95 ea.
74193	1.65 ea.
74198	2.50 ea.

All above are DIP. Data sheets supplied on request. Add \$.50 per data sheet for items less than \$1.00 each.

LINEAR CIRCUITS

301	Hi performance amp mini-DIP, TO-5	\$.35 ea.
309K	5 V 1A regulator TO-3	1.75 ea.
311	Hi perf. voltage comparator mini DIP, TO-5	1.25 ea.
319	Hi-speed dual comparator DIP	1.85 ea.
324	Quad op amp DIP	1.89 ea.
339	Quad comparator DIP	2.10 ea.
340T	Positive voltage regulator (6V, 12V) TO-220	2.25 ea.
351	Dual peripheral driver mini DIP	.39 ea.
380	2 Watt audio amp DIP	1.49 ea.
550	Precision voltage regulator DIP	.95 ea.
555	Timer mini DIP	1.25 ea.
565	Phase locked loop DIP	2.49 ea.
566	Function generator mini DIP	2.95 ea.
709	Operational ampl. TO-5 or DIP	.45 ea.
741	Comp. op amp mini DIP, TO-5	.45 ea.
747	Dual 741 op amp TO-5 or DIP	.95 ea.
748	Freq adj 741 mini DIP	.45 ea.
3900	Quad amplifier DIP	.65 ea.
3905	Precision timer DIP	.75 ea.
8039	Voltage controlled oscillator DIP	5.95 ea.
75452	Dual peripheral driver mini DIP	.49 ea.
75491	Quad. seg. driver for LED DIP	.49 ea.
75492	Hex digit driver DIP	.69 ea.

Data sheets supplied on request. Add \$.50 per data sheet for items less than \$1.00 each.

MCD 2	Opto isolator - diodes	\$1.19 ea.
MCT 2	Opto isolator - transistor	.89 ea.

LED DISPLAYS

MAN1 type	Red 7 segment .270"	\$3.95 ea.	4/13.95
MAN2 type	Red dot matrix .350"		5.95 ea.
MAN3M type	Red 7 segment .127"	1.75 ea.	4/4.85
MAN5 type	Green 7 segment .270"	4.75 ea.	4/15.75
MAN7 type	Red 7 segment .270"		1.95 ea.
MAN8 type	Yellow 7 segment .270"	5.50 ea.	4/18.95

CALCULATOR CHIPS

5001 LSI
40 pin, 12 digit display & calculate, add, subtract, multiply, divide, fixed decimal at 0, 2, 3, or 4 with data \$3.95

5002 LSI
40 pin, 12 digit, similar to 5001 except designed for battery powered operation with data \$8.95

CLOCK CHIPS

MM5312
24 pin, any readout, 4 digit 1 pps output BCD with data \$8.95 ea.

MM5314
24 pin LED-incandescent readout, 6 digit with data \$10.95 ea.

MEMORIES

1101	256 bit RAM MOS	\$1.98 ea.
7489	64 bit RAM TTL	2.95 ea.
5260	1024 bit RAM MOS	6.95 ea.

TRANSISTOR SPECIALS

Hi voltage power transistors. Prime quality - typically 40 beta at 50 MHz - 10 watt 1 amp max - TO-5
 NPN 400 volt \$2.45 ea.
 NPN 300 volt 1.20 ea.
 NPN 200 volt .75 ea.
 Transistor grab bag
 Untested PNP & NPN TO-18 epoxy
 Guaranteed 50% usable 20/\$1.00

ON ORDERS OVER \$25.00 DEDUCT 10%

All items are new, unused surplus parts - tested functional. Satisfaction is guaranteed. Shipment will be made via first class mail - postage paid - in U.S., Canada and Mexico within three days from receipt of order. Minimum order - \$5.00. California residents add sales tax.

(408) 659-4773

INTERNATIONAL ELECTRONICS UNLIMITED
P.O. BOX 1708 MONTEREY, CALIF. 93940 USA

HIGH FIDELITY

DIAMOND NEEDLES and Stereo Cartridges at Discount prices for Shure, Pickering, Stanton, Empire, Grado and ADC. Send for free catalog. LYLE CARTRIDGES, Dept. P, Box 69, Kensington Station, Brooklyn, New York 112 8.

WANTED

QUICKSILVER, Platinum, Silver, Gold, Ores Analyzed. Free Circular. Mercury Terminal, Norwood, Mass. 02062.

TUBES

RADIO & T.V. Tubes—36 cents each. Send for free Catalog. Cornell, 4213 University, San Diego, Calif. 92105.

RECEIVING & INDUSTRIAL TUBES, TRANSISTORS. All Brands - Biggest Discounts. Technicians, Hobbyists, Experimenters - Request FREE Giant Catalog and SAVE! ZALYTRON, 469 Jericho Turnpike, Mineola, N.Y. 11501.

TUBES receiving, factory boxed, low prices, free price list. Transletronic, Inc., 1306 40th Street, Brooklyn, N.Y. 11218A, Telephone: 212-633-2800.

"TUBES ANTIQUE" Send your want list. P.O. Box 5570, Compton, Calif. 90224.

CASH PAID FOR WE300B, WE350B, WE349A, WE339A, Amplifier 91A, 81A, 59A, WE Drivers and Horns. Contact: M. Takabe, 303 Fifth Avenue, N.Y.C. (212) 679-1970.

TUBES "Oldies", latest. Lists free. Steinmetz, 7519 Maplewood, Hammond, Indiana 46324.

MOVIE FILMS

8MM-SUPER 8-16MM MOVIES! Biggest Selection! Lowest Prices! Free Catalog! Cinema Eight, Box PE, Chester, Connecticut 06412.

ELECTRICAL SUPPLIES & EQUIPMENT

PLATING Equipment, Portable Platers, Supplies and "Know-How." Build your own tanks for nickel, chrome, etc. Easy-to-install PVC liners. Rectifier components—all sizes. Schematics, parts lists, formulas, operating instructions for all plating. Guaranteed to save you 25%-75%. Some good units for sale. Write for details. Platers Service Company, 1511-PE Esperanza, Los Angeles, Calif. 90023.

TAPE AND RECORDERS

RENT 4-Track open reel tapes—all major labels—3,000 different - free brochure. Stereo-Parti, 55 St. James Drive, Santa Rosa, Ca. 95401.

1930-1962 Radio Programs. Reels, \$1.00 Hour! Cassettes, \$2.00 Hour! Mammoth Catalog, \$1.25. AM Treasures, Box 192F, Babylon, N.Y. 11702.

CASSETTES

Plain white cassette labels, Moreico cassette cleaners, famous brand cassettes. Metal or fiberglass 10" reels. (Send for tape discount sheets!)

Quantity		1-9	10-99	100	1000
Cassette Labels (Multiples of 10)			.02	.015	.01
Moreico Cassette Cleaner		.65	.60	.55	.50
Scotch Cassette SC90HE		2.72 (Buy 2, GET ONE FREE)			
10" Fiberglass Reels, Used		50	40	35	25
10" Metal, NAB Hole, Used		1.00	1.00	.90	.70
Plus Postage by Weight and Zone				Minimum Order: \$5.00	

SAXITONE TAPE SALES
1776 COLUMBIA ROAD, N.W.
WASHINGTON, D.C. 20009

16,000 OLD RADIO SHOWS on tape. Catalog \$2.00, supplement 50 cents (refundable). Hart Enterprises, 1329H George Washington, Richland, WA 99352.

TOOLS

WRAP TOOL \$1.00, Wire, Panels. Xycon, Box 9341, Phoenix, AZ 85020.

GOVERNMENT SURPLUS

GOVERNMENT Surplus. How and Where to Buy in Your Area. Send \$2.00. Surplus, Headquarters Bldg., Box 30177-PE, Washington, D.C. 20014.

ELECTRONIC Equipment and Parts. Big 36 page Free Catalog. Send for your copy today! Fair Radio Sales, Box 1105-P, Lima, Ohio 45802.

MANUALS for Govt Surplus radios, test sets, scopes. List 50 cents (coin). Books, 7218 Roanne Drive, Washington, D.C. 20021.

ELECTRONIC gadgets and parts. Send for free bulletin. Aeroparts, International Airport, Box 1492, Del Rio, Texas 78840.

CIRCLE NO. 21 ON READERS SERVICE CARD

Planning to move?

Let us know 8 weeks in advance so that you won't miss a single issue of **POPULAR ELECTRONICS**.

Attach old label where indicated and print new address in space provided. Also include your mailing label whenever you write concerning your subscription. It helps us serve you promptly.

Write to: P.O. Box 2774, Boulder, CO 80302, giving the following information:

- Change address only.
 Extend subscription. Enter new subscription.
 1 year \$6.98
 Payment enclosed (1 extra BONUS issue)
 Bill me later

AFFIX LABEL

If you have no label handy, print OLD address here.

please print

name

address

city

state

zip-code

0885

If you have no label handy, print OLD address here.

please print

name

address

city

state

zip code

Add'l postage: \$2 per year outside U.S., its poss. & Can. 104

UHF AFC TV TUNER with six channel memory selection. Send for details and time-saving converter applications. Versitronics Co., Box 872 - Roger Williams, Highland Park, Illinois 60035.

ASTRO MIKE, makes long distance recordings of conversations and other sounds quickly and easily. May be used to pick up sounds up to 1/2 mile away. Send \$29.95 to: Executive Room, 3624 Rogero Road, Jacksonville, Florida 32211. No C.O.D.s.

LIQUID crystal digital wristwatch display. Includes instructions for building your own. Identical display used in high priced wristwatches. Could also be used in projects requiring 4-digit display. \$12.95 each. Limited quantity. Tricounty Winslow, Box 5885, Grand Central Station, New York, N.Y. 10017.

A BIT OF SERIAL MEMORY MAKES CENTS!!! Plan available for experimenter shift register tester. Write for complete catalog of digital, analog, microcomputer plans! M.P. Publishing Co., Box 378-A, Belmont, Massachusetts 02178.

PROTECT your vehicles from theft, against "hot wiring", etc., with Auto Guard. Fits all cars. Instructions included. Residents continental U.S.A. only. \$6.95 (add 6% tax in Calif.) Ck. or M.O. Whitesell Sales, 245 Woodlawn, Chula Vista, Calif. 92010.

PLANS AND KITS

TRIGGER SWEEP GENERATOR—improve your low cost scope by adding solid state trigger sweep. Complete kit, \$20.00 PPD. Information Free. PHOTOLUMINE CORPORATION, PO Box 139, New York, N.Y. 10016.

TESLA COIL—40" SPARKS! Plans \$7.50. Information 75 cents. Huntington Electronics, Box 2009-P, Huntington, Conn. 06484.

REUSEABLE PC layout kit—1000 + opaque 1x pads (IC, Xister, donuts, tape) on transparent sheets. Art sheet included. 2x Available. \$4.98. Flynnco, Box 32187, Mpls., Minn. 55432.

LED digital clock kit. Parts tested complete with case. Lowest price anywhere \$34.85. LEDtronics, Box 357, Neosho, Missouri 64850.

BUILD YOUR OWN 8K COMPUTER! Plans and parts now available. Details \$2.00. HPA, P.O. Box 21, Ettrick, Virginia 23803.

EDUCATIONAL KITS, Electronics Components: Fast Service; Low Prices; Catalog: W.O.A.S., Box 322, Lakeside, Calif. 92040.

SOLID STATE SYSTEMS, INC. now has a wider selection of LED displays, lower prices. Now available are:

- ★ 7-segment numeric displays in 3 colors
- ★ Resistor packages for each display
- ★ 9-digit calculator displays

Catalog Number	Description	Character Height	Color	Price Each					Grouping code
				1-49	50-99	100-499	500-999	1000-up	
21-00001	OPCOA SLA-1, 7-Segment, 15mA, left decimal	0.33"	Red	2.00	1.85	1.70	1.55	1.40	10
11-48001	Pkg of 8 current limiting resistors for SLA-1	----	----	.36	.32	.28	.24	.20	16
21-10001	OPCOA SLA-11, 7-Segment, 40mA, left decimal	0.33"	Green	2.00	1.85	1.70	1.55	1.40	10
21-20001	OPCOA SLA-21, 7-Segment, 40mA, left Decimal	0.33"	Yellow	2.00	1.85	1.70	1.55	1.40	10
11-58001	Pkg. of 8 current limiting resistors for SLA-11 & -21	----	----	.36	.32	.28	.24	.20	16
24-00002	OPCOA SLA-2, ±1, 15mA	0.33"	Red	2.00	1.85	1.70	1.55	1.40	10
11-44002	Pkg. of 4 current limiting resistors for SLA-2	----	----	.20	.17	.14	.12	.10	16
24-10001	OPCOA SLA-12, ±1, 40mA	0.33"	Green	2.00	1.85	1.70	1.55	1.40	10
24-20001	OPCOA SLA-22, ±1, 40mA	0.33"	Yellow	2.00	1.85	1.70	1.55	1.40	10
11-54002	Pkg. of 4 current limiting resistors for SLA-12 & -22	----	----	.20	.17	.14	.12	.10	16
23-00011	OPCOA SLA-1C, 7-Segment with Colon, 15mA	0.33"	Red	2.30	2.15	2.00	1.85	1.70	10
11-49011	Pkg. of 9 current limiting resistors for SLA-1C	----	----	.40	.36	.32	.28	.24	16
23-10011	OPCOA SLA-11C, 7-segment with Colon, 40mA	0.33"	Green	2.30	2.15	2.00	1.85	1.70	10
23-20011	OPCOA SLA-21C, 7-Segment with Colon, 40mA	0.33"	Yellow	2.30	2.15	2.00	1.85	1.70	10
11-59011	Pkg. of 9 current limiting resis. for SLA-11C & -21C	----	----	.40	.36	.32	.28	.24	16
21-00007	OPCOA SLA-7, 7-segment, 20mA, left decimal	0.33"	Red	1.50	1.40	1.30	1.20	1.10	10
11-48007	Pkg. of 8 current limiting resistors for SLA-7	----	----	.36	.32	.28	.24	.20	16
24-00009	OPCOA SLA-9, ±1, 20mA	0.33"	Red	1.50	1.40	1.30	1.20	1.10	10
11-44009	Pkg. of 4 current limiting resistors for SLA-9	----	----	.20	.17	.14	.12	.10	16
21-00008	OPCOA SLA-8, 7-segment, 20mA, left decimal	0.33"	Red	1.50	1.40	1.30	1.20	1.10	10
11-48007	Pkg. of 8 current limiting resistors for SLA-8	----	----	.36	.32	.28	.24	.20	16
24-00010	OPCOA SLA-10, ±1, 20mA	0.33"	Red	1.50	1.40	1.30	1.20	1.10	10
11-44009	Pkg. of 4 current limiting resistors for SLA-10	----	----	.20	.17	.14	.12	.10	16
21-10008	OPCOA SLA-18, 7-segment, 40mA, left decimal	0.33"	Green	1.50	1.40	1.30	1.20	1.10	10
11-58008	Pkg. of 8 current limiting resistors for SLA-18	----	----	.36	.32	.28	.24	.20	16
24-10010	OPCOA SLA-20, ±1, 40mA	0.33"	Green	1.50	1.40	1.30	1.20	1.10	10
11-54010	Pkg. of 4 current limiting resistors for SLA-20	----	----	.20	.17	.14	.12	.10	16
21-20008	OPCOA SLA-28, 7-segment, 40mA, left decimal	0.33"	Yellow	1.50	1.40	1.30	1.20	1.10	10
11-58008	Pkg. of 8 current limiting resistors for SLA-28	----	----	.36	.32	.28	.24	.20	16
24-20010	OPCOA SLA-30, ±1, 40mA	0.33"	Yellow	1.50	1.40	1.30	1.20	1.10	10
11-54010	Pkg. of 4 current limiting resistors for SLA-30	----	----	.20	.17	.14	.12	.10	16
21-00003	OPCOA SLA-3H, 7-segment, 30mA, right decimal	0.77"	Red	5.50	5.10	4.70	4.30	3.90	10
11-48003	Pkg. of 8 current limiting resistors for SLA-3H	----	----	.36	.32	.28	.24	.20	16
21-20003	OPCOA SLA-23H, 7-segment, 30mA, right decimal	0.77"	Yellow	5.50	5.10	4.70	4.30	3.90	10
11-58003	Pkg. of 8 current limiting resistors for SLA-23H	----	----	.36	.32	.28	.24	.20	16
24-00004	OPCOA SLA-4H, ±1, 30mA, right decimal	0.77"	Red	5.50	5.10	4.70	4.30	3.90	10
11-45004	Pkg. of 5 current limiting resistors for SLA-4H	----	----	.24	.21	.18	.15	.12	16
24-20004	OPCOA SLA-24H, ±1, 30mA, right decimal	0.77"	Yellow	5.50	5.10	4.70	4.30	3.90	10
11-55004	Pkg. of 5 current limiting resistors for SLA-24H	----	----	.24	.21	.18	.15	.12	16
29-00125	OPCOA 9B125, 9-digit calculator display	0.125"	Red	10.00	9.25	8.50	7.75	7.00	10
29-10125	OPCOA G9B125, 9-digit calculator display	0.125"	Green	10.00	9.25	8.50	7.75	7.00	10

All resistors in packages are supplied for operation with 5V TTL supply.
All items with the same grouping code may be combined for quantity pricing.

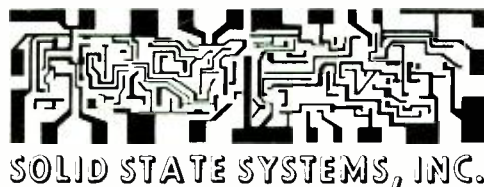

WRITE: SOLID STATE SYSTEMS, INC.
P. O. BOX 617
COLUMBIA, MISSOURI 65201

PHONE (TOLL FREE)
800-325-2595 & 800-325-2981



LED

- MV108 Visible red SPECIAL5 for \$1.00
- MV50 type red emitting6 for 1.00
- MAN 3 type\$1.45 ea.—3 or more 1.00
- MAN 4 type2.25 ea.—3 or more 2.00

TTL

8000 SERIES

7400—\$.23	7451— .27	74157— 1.55	8090—\$.35
7401— .23	7453— .27	74161— 1.65	8091— .55
7402— .23	7454— .40	74163— 2.50	8092— .55
7403— .23	7470— .45	74164— 2.50	8093— .55
7404— .25	7472— .41	74165— 2.50	8094— .55
7405— .24	7473— .47	74166— 1.75	8095— .55
7406— .50	7474— .47	74170— 3.00	8096— .55
7407— .50	7475— .90	74173— 1.75	8097— .55
7408— .25	7476— .47	74176— .85	8098— .55
7409— .25	7480— .50	74177— .85	8121— .90
7410— .23	7482— 1.75	74180— 1.05	8123— 1.60
7411— .30	7483— 1.15	74181— 3.75	8130— 2.25
7413— .89	7485— 1.10	74182— 1.00	8200— 2.70
7416— .45	7486— .47	74190— 1.50	8210— 3.25
7417— .45	7489— 3.00	74192— 1.50	8214— 1.60
7418— .25	7490— 1.00	74193— 1.50	8220— 1.60
7420— .23	7491— 1.15	74194— 1.50	8280— .75
7421— .27	7492— .95	74195— 1.05	8288— .90
7423— .32	7493— .95	74199— 2.75	8520— 1.20
7425— .27	7494— .97		8551— 1.75
7426— .31	7495— .95		8554— 2.70
7427— .32	7496— .95	C/MOS	8570— 1.00
7429— .40	74100— 1.50	CD 4001— .65	8600— .85
7430— .33	74107— .47	CD 4002— .65	8810— .75
7432— .26	74121— .55	CD 4009— 1.50	8812— 1.10
7437— .45	74122— .47	CD 4010— .65	8820— 1.50
7438— .50	74123— 1.05	CD 4011— .65	8822— 2.70
7440— .23	74125— .60	CD 4012— .65	8830— .60
7441— 1.10	74126— .90	CD 4013— 1.60	8831— 2.70
7442— 1.05	74141— 1.15	CD 4016— 1.50	8832— 2.70
7443— 1.10	74145— 1.15	CD 4023— .65	8836— .60
7444— 1.15	74150— .95	CD 4025— .65	8837— 1.50
7445— 1.10	74151— 1.20	CD 4027— 1.35	8838— 1.50
7446— 1.25	74153— 1.50	CD 4030— .65	8880— 1.35
7447— \$1.25	74154— 1.20		
7448— 1.25	74155— 1.30		
7450— .25	74156— 1.30		

ALL DIP PACKAGES

20% DISCOUNT FOR 100 PIECES COMBINED ORDER

SPECIALS

74015 for \$1.00	MM500H\$1.25 each
74115 for \$1.00	MM503H\$1.25 each
74405 for \$1.00	MM504H\$2.00 each
74703 for \$1.00	MM506H\$1.25 each
74723 for \$1.00	MM507H\$1.25 each
74863 for \$1.00	MM5016H\$1.75 each
LM309K 5V 1A regulator\$1.25 each
723 Regulator\$.50 each
741 operational Amp\$.39 each
LM 311 — comparators\$1.00 each
NE 565 Phase Locked Loop	DIP OR TO-5 \$2.00 each
NE 566 Function Generator	MINI DIP OR TO-5 \$2.00 each
NE 567 Tone Decoder	MINI DIP OR TO-5 \$2.00 each
7489 64 bit RAM TTL	\$2.75 each
8223 Programmable ROM	\$4.50 each

LINEAR

LM 300 Pcs V Reg (super 723)	TO-5	\$.85
LM301 Hi performance AMPL	TO-5 or MINI DIP	.40
LM302 Voltage Follower	TO-5	.85
LM305 Positive Voltage Regulator	TO-5	1.00
LM307 Op AMP (super 741)	TO-5 or MINI-DIP	.40
LM308 Micro Power Op Amp	TO-5 or MIN-DIP	1.15
LM309H 5V Regulator	TO-5	1.15
LM309K 5 V 1A Regulator	TO-5	1.70
LM311 Hi perf. Voltage Comparator	TO-5 or MINI-DIP	1.15
LM380 2 Watt Audio AMPL	DIP	1.60
LM709 Operational AMPL	TO-5 or DIP	.40
LM711 Dual Differential Comparator	DIP	.39
LM723 Voltage Regulator	DIP	.65
LM739 Dual Hi Performance Op AMP	DIP	1.15
LM741 Comp. Op AMP	TO-5 or MINI-DIP	.55
LM747 Dual 741 Op AMP	TO-5 or DIP	.90
LM1458 Dual Comp. Op. Amp	MINI-DIP	.85
LM3900 Quad Amplifier	DIP	.65
LM3905 Precision Timer	MINI-DIP	.95
LM7524 Core Memory Sense AMPL	DIP	1.75
LM7525 Core Memory Sense AMPL	DIP	.90
LM7535 Core Memory Sense AMPL	DIP	.90
LM9601 Retriggerable One Shot	DIP	.75
LM75451 Dual Peripheral Driver	MINI-DIP	.49
LM75452 Dual Peripheral Driver	MINI-DIP	.49
LM75453 (LM351) Dual	MINI-DIP	.65

Satisfaction guaranteed. All items are fully tested.

\$5.00 Minimum order. FIRST CLASS MAIL — NO EXTRA CHARGE

California residents — add 6% sales tax.

WHOLESALE OUTLETS — Write for special discounts:

JAMES

Electronics

P.O. Box 822 BELMONT, CA. 94002

(415) 592-8097

CIRCLE NO. 22 ON READERS SERVICE CARD

PERSONALS

MAKE FRIENDS WORLDWIDE through international correspondence. Illustrated brochure free. Hermes, Berlin 11, Germany.

SECRET LOANS!

Borrow by mail in absolute privacy. Up to \$3000 from reputable company—founded 1897. No interviews. No co-signers. No mortgages. For full details write:

Dial Finance Co., Dept. 3800
418 Seventh St., Des Moines, Iowa 50309

RECORDS

OLDIES. 45rpm. Free Catalog. Corry's Record Shop, Box 335TL, Mason, Ohio 45040.

THE ENDLESS OCTAVE Auditory Illusion Record. AMAZING! Explanation included. Sent \$3.48. P. O. Box 176, Palo Alto, CA 94302.

BOOKS

FREE catalog aviation/electronic/space books. Aero Publishers, 329PE Aviation Road, Fallbrook, California 92028.

FREE book prophet Elijah coming before Christ. Wonderful bible evidence. Megiddo Mission, Dept. 64, 481 Thurston Rd., Rochester, N.Y. 14619.

BOOKS—thousands titles, bargains. Catalog Free. Cassiano, 92-27 New York Blvd., Jamaica, New York 11433.

UNUSUAL BOOKS! Catalogue Free! International Imports, Box 7789PE, Atlanta, Georgia 30309.

LEARN RADIO ANNOUNCING! Books, Magazines: DeeJay, Box 1355-C, Sioux Falls, South Dakota 57101.

POPULAR ELECTRONICS INDEXES. Detailed and complete subject indexes now available to both 1972 and 1973 magazines. Hundreds of subject references to help you quickly find that special project, article, or product test. 1972 and 1973 editions \$1.00 each. INDEX, box 2228. Falls Church, VA. 22042.

INSTRUCTION

LEARN ELECTRONIC ORGAN SERVICING at home all makes including transistor. Experimental kit—trouble-shooting. Accredited NHSC, Free Booklet. NILES BRYANT SCHOOL, 3631 Stockton, Dept. A, Sacramento, Calif. 95820.

LEARN WHILE ASLEEP. Hypnotize! Strange catalog free. Auto-suggestion, Box 24-2D, Olympia, Washington 98501.

DEGREE IN ELECTRONICS through correspondence. Free catalog. Grantham, 2000 Stoner Avenue, Los Angeles, California 90025.

INTENSIVE 5 week course for Broadcast Engineers. F.C.C. First Class license. Florida Engineering Incorporated, 52 S. Palm Ave., Sarasota, Florida 33577.

SHORTCUTS To Success! Highly Effective, Profitable Short Courses (75 Choices). Study At Home. Diploma Awarded. Our 29th Year. Free Literature. CIEE-D. Box 20345, Jackson, Miss. 39209.

F.C.C. EXAM MANUAL

PASS FCC EXAM'S Memorize, study—"Test Answers" for FCC 1st and 2nd class Radio Telephone licenses. Newly revised multiple-choice questions and diagrams cover all areas tested in FCC exams plus "Self-Study Ability Test"—\$9.95 postpaid. Money-back Guarantee.

TESTS ANSWERS FOR FCC FIRST AND SECOND CLASS COMMERCIAL LICENSE

COMMAND PRODUCTIONS P.O. BOX 26348-P
RADE ENGINEERS BUILDING SAN FRANCISCO, CALIF. 94126

DEGREE Program in Electronics Engineering. Our 29th Year! Free literature. Cook's Institute, Dept. 13, Box 20345, Jackson, Miss. 39209.

EARN College Degrees at home. Many subjects. Florida State Christian University, P.O. Box 1674, Fort Lauderdale, Florida 33302.

SCORE high on F.C.C. Exams... Over 300 questions and answers. Covers 3rd, 2nd, 1st and even Radar. Third and Second Test, \$14.50; First Class Test, \$15.00. All tests, \$26.50. R.E.I., Inc., Box 806, Sarasota, Fla. 33577.

DIGITAL:THEORY,DESIGN,
CONSTRUCTION

LOGIC NEWSLETTER

SAMPLE COPY \$1.00
LOGIC NEWSLETTER
POB 252
WALDWICK,N.J. 07463

FCC LICENSE Q&A. Cassette recorded. Radio License Training, 1060D Duncan, Manhattan Beach, Calif. 90266.

SELF-STUDY CB RADIO REPAIR COURSE. THERE'S MONEY TO BE MADE REPAIRING CB RADIOS. This easy-to-learn course can prepare you for a career in electronics enabling you to earn as much as \$16.00 an hour in your spare time. For more information write: CB Radio Repair Course, Dept. PE-8, 15S. Overmyer Dr., Oklahoma City, Okla. 73127.

LEARN ELECTRONICS at home. FCC license, Communications Electronics, Satellite Communications. Free Catalog, Genn Tech., 5540 Hollywood Bv., Los Angeles, Calif. 90028.

LEARN design techniques. Electronics Monthly Newsletter. Digital, linear construction projects, design theory and procedures. Sample copy \$1.00. Valley West, Box 2119-B, Sunnyvale, California 94087.

FASTEST AND EASIEST way to a top paying engineering career. Free literature. Technology International 933 Kifer Street, Sunnyvale, California 94086.

REPAIRS AND SERVICES

CALCULATORS, pocket, repaired \$14.95. Major parts extra. Send postpaid to: Rainbow Electronics, 4158 Greeby St., Phila., PA 19135.

MUSICAL INSTRUMENTS

30% DISCOUNT name brand musical instruments. Free Catalog. Freepoint Music, 455N, Route 110, Melville, N.Y. 11746.

WHOLESALE! Professional Guitars, PA Systems, Altac Speakers, 240W RMS Amplifiers. Free Catalog, Carvin, Escondido, Calif. 92028.

30%+DISCOUNT. Name Brand Musical Instruments. Free Catalog. Continental Music, Dept. H, P.O. Box 3001, Garden City, New York 11530.

GUITAR STRINGS! Major brands. Lowest Prices. Free Price List. Write: Scorpio Music, Box 129, Plainfield, Vermont 05667.

BUSINESS OPPORTUNITIES

I MADE \$40,000.00 Year by Mailorder! Helped others make money! Start with \$15.00—Free Proof. Torrey, Box 318-N, Ypsilanti, Michigan 48197.

FREE CATALOGS. Repair air conditioning, refrigeration. Tools, supplies, full instructions. Doolin, 2016 Canton, Dallas, Texas 75201.

MAILORDER MILLIONAIRE helps beginners make \$500 weekly. Free report reveals secret plan! Executive (1K8), 333 North Michigan, Chicago 60601.

PIANO TUNING LEARNED QUICKLY AT HOME! Tremendous field! Musical knowledge unnecessary. GI approved. Information free. Empire School, Box 450327, Miami 33145.

FREE Secret Book "2042 Unique Proven Enterprises." Fabulous "Little Knowns." Work home! Haylings-BH, Carlsbad, California 92008.

\$200.00 DAILY In Your Mailbox! Your opportunity to do what mail-order experts do. Free details. Associates, Box 136-J, Holland, Michigan 49423.

\$49.95 Telephone Answering Machine! Your cost \$33.50! Details: Palomar, Box 17384EB, Jacksonville, Florida 32216.

wanted

CITIZENS BAND
DEALER-DISTRIBUTORS

Send this Ad to:

PAL ELECTRONICS CO.

P. O. Box 778 • Westminster, Ca. 92683

EARN \$15,000 annually plus. Full year trial plan Import-Mailorder business. Postcard brings details: Northeast Imports, Box 121PE8, Fremont, N.H. 03044.

MAKE \$100.00 or more weekly sparetime. Samples, starter's kit. \$1.00 (refundable) Oyewole, Box 4577, N.Y. 10017.

POPULAR ELECTRONICS

POLY PAKS BLUE RIBBON Policy
INCLUDES

20-Years of Business INTEGRITY
20-Years of Money-Back GUARANTEES
20-Years of Economy! LOWEST PRICES!
48-HR. SERVICE

20-WATT STEREO AMP

Featuring solid state circuitry throughout, with printed circuit construction, 10 watts "peak" audio power per channel. Handsome walnut veneer grain with chrome trim escutcheon. With provisions for separate escutcheon mounting items as STEREO HEADPHONES, TREBLE, BASS, BALANCE, VOLUME controls, separate PHONO AND AUXILIARY with separate OFF-ON POWER switches. Chassis size 1 1/2 x 3 x 2". Separate rear plate has right and left speaker phono type jacks, with convenience power outlet for tape of phono and Auxiliary inputs for using amplifier with tape decks, and other equipment. Separate external cables for stereo phono connections, 6-ft. power cord, separate ON-OFF light indicator, and automatic turntable power plug with handsome set of knobs. Wt. 2 lbs. **16.95**

20-WATT STEREO AM-FM-MULTIPLY

Only **\$39.95**

20-WATT STEREO AM-FM-MULTIPLY

60-WATT AM-FM-MULTIPLY

Same as above except amp heavy-duty stereo 60 watt unit. **\$59.95**

\$14.95

Same as item #1 except rect. parts may be missing.

7-SEGMENT LED Readouts

MAN-1, MAN-3, SLA-1, 704, 707, MAN-4, MAN-6, SLA-3H

By Litronix. ** By Opcon, equal to MAN-1 or MAN-4 specs. Color - RED or Green. ** Yellow

(All "LED" TYPES)

Type	Char.	Each	Special
MAN-1	.27	\$3.75	3 for \$9.
MAN-3	.12	1.69	3 for \$3.
MAN-4	.19	2.50	3 for \$6.

REFLECTIVE BAR TYPES

707*	.33	2.50	3 for \$6.
704*	.33	2.50	3 for \$6.
SLA-1**	.33	2.10	3 for \$5.
SLA-3**	.70	4.95	3 for \$13.
SLA-11**	.33†	3.50	3 for \$10.
SLA-21**	.33††	3.95	3 for \$10.

LED MITY DIGIT "DCM'S"

Scientific Devices "Digital Counting Modules," outperform any other DCM on the market today. More features than ever before! Not gaseous, not incandescent, not nixie but the modern LED. Choose from such famous manufacturers as Monsanto's MAN-1, MAN-4, Litronix's 707 and 704, Opcon's SLA-1 (the last 4 having character heights of 0.33 at no extra charge). Each kit includes 3x2" p.c. board with fingers for a FREE edge connector, side-mounting dip socket, LED readout of your choice, resistors, 3 IC's, and Molex connectors 707's - 33 h. Litronics booklet. INCLUDES P.C. EDGE CONNECTOR - FREE!

Buy 3 - Take 10% Only **\$9.99**

READOUT Char. Maker
MAN-1 1.27 h. Monsanto
MAN-4 1.9 h. Monsanto (this ELIMINATES SOLDERING YOUR IC'S)
707's - 33 h. Litronics
704's - 33 h. Litronics
SLA-1's - 33 h. Opcon * Pin-for-pin MAN-1. ** Pin-for-pin MAN-4. elec. char.

SANKEN HYBRID AUDIO POWER AMPS

Used extensively in hi-fi systems, tape decks, FM tuners, record players, stereo components, musical instruments, P.A., etc. All amplifiers, flat within 1/2 db from 10 to 100,000. Each unit properly heat-sinked, with heavy-duty connecting tie lug connections. Single-ended pushpull output. Power supply required 24VDC. Output to 8 ohms. Order by Stock No.

BRAND NEW LOWEST PRICES

GENERAL ELECTRIC 3-WATT AUDIO AMP **\$2.50**

Delivers 4.5 watts continuous, 10 watts peak, with heat sinks; micro-mini size; 3/4 x 1/2 x 1/2". 9 to 30V supply. High sensitivity. 8 to 16 ohms.

Migr's Type Watts Sale
SI-1010Y 10 \$ 8.88
SI-1012 25 18.88
SI-1050E 50 29.95

POCKET CALCULATOR \$6.95 KEYBOARD

Only **\$6.95**

For hand-held units, properly multiplexed for chip CT5001, 2, 12 or Mostek 5010-12. 16 feather-touch keys, by FLEX-KEY.

Calculator Basics

MAKE YOUR OWN CALCULATORS WITH OUR LOW PRICED

6 & 8 DIGIT POCKET CALCULATOR BASIC KITS

Your Choice **\$16.95**

BASIC KIT #1 - includes case, all-function Flex Key Keyboard, Cal Tech CT5002 calculator chip, 9-digit Antex LED display with built-on individual magnifiers, plus sheets.

BASIC KIT #2 - same as Basic #1 except calculator chip is National 8-digit MM5726.

BASIC KIT #3 - same as Basic #1 except calculator chip is National 6-digit MM5736 and 75492.

WRIST WATCH Only \$19.95

LIQUID CRYSTAL DISPLAY

*3-1/2 digit, 7 segment
*Only 1-1/16 x 11/16 x 1/4"

See POPULAR ELECTRONICS (Jan., 1974) for building your own electronic digital wristwatch using the Liquid Crystal Display (LCD) as its basic. Easy to see, 3 1/2 LED's. Visibility increases with ambient light. Difficult face, as LED's, thus smaller package. Chip contains chrome spring face plate. Size of display in holder: 1-1/16 x 11/16 x 1/4". Operating freq. 32 hertz; and cell. Uses the new and latest CMOS micro-circuitry. We include copy of write up from PE magazine.

NATIONAL BUY ANY 3 - TAKE 10% LINEAR OP AMPS

LM-300 POS V.R. (super 723) TO-5	.91
LM-301 Hi-performance op amp (A)	.41
LM-302 Voltage follower TO-5	.91
LM-305 Pos. voltage Reg. TO-5	1.19
LM-307 Super 741 op amp (A)	.41
LM-308 HI-Q fet type op amp TO-5	1.19
LM-309H 5V Volt-Regulator TO-5	1.19
LM-309K 5V Volt-Reg. 1 Amp TO-5	1.65
LM-310 Voltage Follower TO-5	1.25
LM-311 Hi-per. Volt. Comp. (A)	1.19
LM-319 HI-speed Dual Comp. DIP	1.50
LM-320 MINUS 5, 12 or 24V V.R. TO-3	1.50
LM-339 Quad Comparator, DIP	2.50
LM-323 Quad (4-71's in DIP)	2.50
LM-350 Dual peripheral driver	.41
LM-370 AGC Squeelch op amp, TO-5	1.19
LM-373 AM-FM 55B I.A.D. TO-5	3.50
LM-374 AM-FM 55 I.V.A.D TO-5	3.50
LM-377 Dual 2-watt audio amp	1.00
LM-380 2-watt audio amplifier TO-5	1.69
LM-381 Low noise dual pre amp DIP	1.95
LM-382 Low noise dual pre amp DIP	1.95
LM-703 RF-IF amp, TO-5	.55
LM-704 Operational amplifier (A)	.36
LM-710 Differential amplifier (A)	.45
LM-711 Dual Differential Amp (A)	.36
LM-723 Voltage Regulator (A)	.69
LM-725 Instrument Op Amp	.95
LM-723 Differential Video	1.75
LM-741 Freq. Comp. 709 (A)	.41
LM-741CV Mini DIP 741C	.45
LM-747 Dual 741 (A)	.89
LM-748 Freq. adjustable 741C (A)	.44
LM-303 Stereo pre amp DIP	.95
LM-1304 FM Stereo Multiplexer	1.25
LM-1307 FM Multi. Stereo Dem. DIP	.91
LM-3028 Differential RF/IF amp	1.50
LM-3900 Quad "curtain mirror" amp	2.50
LM-4250C Programmable op amp	2.50
LM-75451 Dual peripheral driver	.44
LM-75453 Dual peripheral driver	.44
LM-75492 Hex digit driver, 250ma, DIP 1.85	

(A) TO-5, Dip or mini Dip

LINEAR Op Amps

531 HI slow rate op-amp (TO-5)	\$2.50
532 Micro power 741 (TO-5)	2.50
533 Micro power 709 (TO-5)	2.50
536 FET input op amp (TO-5)	2.95
550 Precision 723 voltage reg. (DIP)	1.17
555 Times 2 u Seconds to 1-hr. (A)	1.25
556 5 Times faster than 741C	2.10
558 Dual 741 (DIP)	1.00
560 Phase lock loops (DIP)	2.95
561 Phase lock loops (DIP)	2.95
562 Phase lock loops (DIP)	2.95
565 Phase lock loops (A)	2.95
566 Function generator (TO-5)	2.95
567 Tone decoder (A)	2.95
7022 Hi-grain, DC amp (TO-5)	2.49
704 TV sound IF system	1.50
711C Dual diff. comp (A)	.33
723C Voltage regulator (A)	.69
741CV Freq. comp 709 (Mini DIP)	.44
748C Freq. adj. 741C (A)	.44
753 Gain Block	1.75
739-739 Dual stereo preamp	1.98
741-741 Dual 741C (TO-5)	.89
741CV 5-Watt voltage regulator	1.00
ULN2300P Op amp with SCR	1.00
CA3065 Video Audio system	1.00
CA4195 Dual 15V Tracking V.R.	2.50
4136 Quad 741's (DIP)	1.95
RC-2556 Dual 555's	2.25

(A) TO-5 or DIP Buy any 3 - Take 10%

Inflation-Fighting ECONOMY IC PRICES

Brand New OVER 1,000,000-PC INVENTORY

Buy 3 or more. 10% discount

Type	Sale	Order by type number	Spec sheets on request	"ONLY" Buy 100 - Take 20%	Buy 100 - Take 20%				
SN7400	\$0.30	SN7432	.55	SN7471	.55	SN7408	.95	SN74160	1.95
SN7401	.30	SN7437	.55	SN7472	.50	SN7412	.95	SN74161	1.75
SN7402	.30	SN7438	.55	SN7473	.55	SN7413	.95	SN74163	1.95
SN7403	.30	SN7440	.30	SN7474	.55	SN7414	.95	SN74164	1.95
SN7404	.35	SN7441	1.40	SN7475	1.00	SN7415	.60	SN74165	2.10
SN7405	.35	SN7442	1.50	SN7476	.65	SN7416	.95	SN74166	2.05
SN7406	.45	SN7443	1.50	SN7477	.95	SN7417	1.20	SN74173	2.50
SN7407	.45	SN7444	1.50	SN7478	.95	SN7418	1.20	SN74175	3.20
SN7408	.35	SN7445	1.50	SN7479	.65	SN7419	1.20	SN74176	2.10
SN7409	.35	SN7446	1.65	SN7480	.65	SN7420	1.20	SN74177	2.10
SN7410	.30	SN7447	1.45	SN7481	1.25	SN7421	1.25	SN74178	2.10
SN7411	.35	SN7448	1.50	SN7482	.99	SN7422	1.95	SN74180	1.20
SN7412	.35	SN7449	1.50	SN7483	1.25	SN7423	1.20	SN74181	3.95
SN7413	.95	SN7450	.30	SN7484	.55	SN7424	1.55	SN74182	1.20
SN7414	.30	SN7451	.30	SN7485	3.50	SN7425	1.50	SN74183	2.50
SN7420	.30	SN7453	.30	SN7486	1.49	SN7426	1.61	SN74185	1.95
SN7421	.55	SN7455	.55	SN7487	1.35	SN7427	.95	SN74186	1.98
SN7422	.35	SN7462	.35	SN7488	1.35	SN7428	1.35	SN74189	1.95
SN7425	.50	SN7464	.30	SN7489	1.35	SN7429	1.35	SN74195	1.28
SN7430	.30	SN7465	.50	SN7490	1.35	SN7430	1.35	SN74196	2.50
				SN7491	1.35	SN7431	1.55	SN74197	2.50
				SN7492	1.35	SN7432	1.55	SN74198	2.58
				SN7493	1.35	SN7433	1.55	SN74200	9.95
				SN7494	1.35	SN7434	1.55		
				SN7495	1.35	SN7435	1.55		
				SN7496	1.35	SN7436	1.55		
				SN74100	1.65	SN7437	1.55		
				SN74107	.70	SN7438	1.55		

* "DIP" Packages

LOWEST PRICES ON NATIONAL "CALCULATOR CHIPS"

CT5001	12-Digits, 40 Pin	\$6.50	3 for \$18.	Similar to Mostek 5001.
CT5002	9-Volt version of 5001	8.50	3 for \$24.	Outperforms Texas 8-digit TM1802. A 40-pin DIP.
CT5005	12-Digits, 28-Pin	9.95	3 for \$27.	Adds multiples, subtracts, and divides. Use with 7-segment readouts, Nixies, and LED's. DATA SHEETS
MM5725	8-Digits, 4-Funct. LED	6.95	3 for \$18.	
MM5736	6-Digits, 28-Pin, 9V	4.95	3 for \$12.	

IC'S FOR EXPERIMENTERS

Money Back Guarantee! Factory Marked **\$1.00**

SN7400	20 for \$1.	SN7490	5 for \$1.
SN7404	20 for \$1.	SN74107	10 for \$1.
SN7413	5 for \$1.	SN74121	10 for \$1.
SN7422	5 for \$1.	SN74123	10 for \$1.
SN7444	5 for \$1.	SN74150	3 for \$1.
SN7445	5 for \$1.	SN74154	5 for \$1.
SN7446	5 for \$1.	SN74181	3 for \$1.
SN7447	5 for \$1.	SN74192	5 for \$1.
SN7448	5 for \$1.	SN74193	5 for \$1.
SN7472	10 for \$1.	SN74199	3 for \$1.
SN7473	10 for \$1.		
SN7474	10 for \$1.		
SN7475	10 for \$1.		

Includes factory-good, rejects & defects, who knows at these prices!

INTEGRATED CIRCUIT SOCKETS

Buy Any 3	14-Pin, DIP	\$.45
Take 10%	16-Pin, Side Mount	1.00
Discount!	TO-5, 8 or 10-Pin	.29
	14-Pin, Wire Wrap	.60c
	16-Pin, Wire Wrap	.89c

Terms: add postage. Rated: net 30
Phone Orders: Wakefield, Mass. (617) 245-3829
Retail: 16-18 Del Carmine St., Wakefield, Mass. (off Water Street) C.O.D.'S MAY BE PHONED

156 CATALOG on Fiber Optics, 'IC's, Semi's, Parts

POLY PAKS
P.O. BOX 942E, LYNNFIELD, MASS. 01946

MAKE \$500 month mailorder! Free Report. Fiddes, Box 1242, Glen Burnie, Maryland 21061.

HIGHLY PROFITABLE ONE-MAN ELECTRONIC FACTORY

Investment unnecessary. Knowledge not required, sales handled by professionals. Postcard brings facts about this unusual opportunity. Write today! **Barta-DH**, Box 248, Walnut Creek, CA 94597.

EARN \$25.00—\$100.00 daily. Immediate earnings. Beginners kit. \$1.00 (refundable) Turner, Box 553, N.Y. 10472.

START SMALL, highly profitable electronic production in your basement. Investment, knowledge unnecessary. Postcard brings facts. **Barta-CH**, Box 248, Walnut Creek, California 94597.

\$75.00 WEEKLY typing, sewing. Details 25 cents. Volken, 4-5285 Vedder Rd., Sardis, B.C. U.S. Inquiries.

EMPLOYMENT OPPORTUNITIES

ELECTRONICS/AVIONICS EMPLOYMENT OPPORTUNITIES. Report on jobs now open. Details FREE. Aviation Employment Information Service, Box 240E, Northport, New York 11768.

TREASURE FINDERS

FAMILY FUN! OUTDOOR ADVENTURE! Find valuable coins and treasure with world famous metal detectors. Free illustrated booklet. Detectron. Dept. PE, Box 243, San Gabriel, Calif. 91778.

MAGAZINES

MAGAZINE SUBSCRIPTIONS at lowest prices available anywhere. Magazine House, Box 390E, Millwood, N.Y. 10546.

INVENTIONS WANTED

CASH-ROYALTIES for patented, unpatented inventions. Global Marketing Service, 2354-P Telegraph, Oakland, California 94612.

INVENTORS: Protect your ideas! Free "Recommended Procedure". Washington Inventors Service, 422T Washington Building, Washington, D.C. 20005.

PATENT Searches including Maximum speed, full airmail report and closest patent copies. Quality searches expertly administered. Complete secrecy guaranteed. Free Invention Protection forms and "Patent Information." Write Dept. 9, Washington Patent Office Search Bureau, Benjamin Franklin Substation, P.O. Box 7167, Washington, D.C. 20044.

FREE PAMPHLET: "Tips on Safeguarding Your Invention." Write: United States Inventors Service Company, 706-T Carry Building, Washington, D.C. 20005.

INVENTORS! Either we will sell your Invention before you or anyone else does, or we will pay you a cash bonus. Get Free Invention Evaluation and information: Write Gilbert Adams Organization, Invention Brokerage, Dept. 20, 80 Wall St., New York, NY 10005.

FILE your own patent application. Complete information and materials. Write: Inventor's Guide, 468-R, Goodspeed Road, Virginia Beach, Virginia 23451.

FREE "DIRECTORY OF 500 CORPORATIONS Seeking New Products." For information regarding Development, Sale, Licensing of your patented/unpatented invention, write for FREE "INVENTOR'S KIT NO. A-73, RAYMOND LEE ORGANIZATION, 230 Park Avenue, New York, N.Y. 10017.

INVENTORS! Don't sell or license your Invention until you receive our offer. Eagle Development Company, Dept. P, 82 Wall St., New York, N.Y. 10005.

INVENTORS! FREE BROCHURE LISTING 1,000 CORPORATIONS which may be interested in your invention. Many well-known Manufacturers have engaged us to locate new products. For FREE brochure and information regarding the promotion of your invention contact: Wall Street Invention Brokerage, Dept. 53-8, 78 Wall Street, N.Y. 10005.

RUBBER STAMPS

RUBBER address stamps. Free catalog. 45 type styles. Jackson's, Box 443G, Franklin Park, Ill. 60131.

SLA-37 segment LED readouts .77" numbers. 45 Ma/seg., red or yellow \$7.50

MINIATURE TRIM POTS 5K, 10K, 20K, 25K, 50K, 100K, \$7.5 3/\$2.00

MULTI-TURN TRIM POTS Similar to Bourns 3010 style 3/16" x 5/8" x 1 1/4" 50, 100, 500, 2000, 5000, 10,000 and 20,000 ohms. \$1.50 ea. 3/\$4.00

PRINTED CIRCUIT BOARD 4 1/2" x 6 1/2" single sided fiber glass board, 1/16" thick, un-etched \$4.00 ea. 5/\$1.75

NIXIE TUBES Similar to Raytheon 8650 tubes, with socket & data sheet \$2.25 3/\$6.00

NSN 33—3 DIGIT LED ARRAY, MAN-3 SIZE (12") INTERNALLY MULTIPLEXED AND DRIVEN BY 7448 \$1.95 EA.

VERIPAX PC BOARD This board is a 1/16" single sided paper epoxy board, 4 1/2" x 6 1/2" (standard veripax). DRILLED and ETCHED which will hold up to 21 single 14 pin IC's or 8, 16 or LSI DIP IC's with busses for power supply connections. Is also etched for 22 pin connector \$5.25

FLV 100 VISIBLE LED \$5.00
ME-4 IR LED \$5.00
MCD-2 OPTO-ISOL \$9.00
GREEN GAP OSL-16 LED \$5.00
RED GAP OSL-3 LED \$5.00
14 PIN DIP SOCKETS \$4.00

10 WATT ZENERS 3.9, 4.7 OR 5.6 V \$7.5 EA
4 WATT ZENERS 3.9, 5.6, 6.8 OR 12 V \$3.0 EA

PRV	1A	3A	12A	50A
100	.06	.11	.30	.80
200	.07	.16	.35	1.15
400	.09	.20	.50	1.40
600	.11	.25	.70	1.80
800	.15	.35	.90	2.20
000	.20	.45	1.10	2.60

REGULATED MODULAR POWER SUPPLIES + -15VDC AT 100 ma, 115VAC INPUT \$19.95
5VDC AT 1A, 115VAC INPUT \$19.95

IN 4148 14/\$1.00

Terms: FOB Cambridge Mass. Send check or Money Order. Include Postage. Minimum Order \$3.00



SOLID STATE SALES

P.O. BOX 74A SOMERVILLE, MASS. 02143 TEL (617) 547-4005

RELIABLE EAST COAST SEMICONDUCTOR PRODUCTS

2N256 PNP GE TO-3	\$.50
2N404 PNP GE TO-5	4/\$1.00
2N1137B PNP GE TO-3	\$.95
2N1016A NPN Si TO-82	\$ 1.95
2N2226 NPN Si TO-82	\$ 2.50
MPS3393 NPN Si TO-92	4/\$1.00
2N3866 NPN Si TO-5	\$.75
2N2369 NPN Si TO-18	5/\$1.00
2N3767 NPN Si TO-56	\$.70
2N2222 NPN Si TO-18	5/\$1.00
2N3025 NPN Si TO-3	\$ 1.00
2N5296 NPN Si TO-220	\$.50
2N6109 PNP Si TO-220	\$.55
2N4898 PNP Si TO-66	\$.60
MJ2252 NPN Si TO-66	\$.90
2N3638 PNP Si TO-5	5/\$1.00
2N2218A NPN Si TO-5	4/\$1.00

6V 30 UF TANT. 5/\$1	
20V 4.7UF TANT. 5/\$1	
12V 10UF ELECT. 5/\$1	
50V 100UF ELECT. \$4.00	
25V 30UF ELECT 4/\$1.00	

1103 1024 bit RAM	\$6.25
NEC 6003 2048 bit RAM	\$9.50
1101 256 bit RAM	\$2.75
8225 64 bit-write RAM	\$2.75
8223 PROGRAMMABLE ROM	\$6.25

Conductive Elastometer low profile calculator keyboard. A 2 3/4" x 3 1/4" x 1/2" flex key. 19SK-6 keyboard having 0-9, +, -, x, /, =, K+C buttons with off, on switch. \$6.00

74L00—5C	7473—48
7400—24	7474—48
7401—24	7475—80
7402—24	7476—52
7403—24	7480—65
7404—26	7483—1.10
7405—26	7486—48
7406—43	7489—3.00
7407—50	7490—83
7408—27	7491—1.30
7410—24	7492—85
7411—30	7493—85
7412—45	7495—99
7413—85	7496—95
7416—48	74107—50
7417—48	74121—60
7420—24	74123—1.00
7422—30	74125—1.40
7426—30	74126—1.40
7427—55	74150—1.15
7430—24	74151—95
7432—30	74153—1.10
7437—60	74154—1.65
7438—50	74157—1.25
7440—24	74163—1.60
7441—15	74164—2.05
7442—100	74165—2.05
7445—15	74173—1.80
7446—1.25	74176—1.80
7447—1.25	74177—1.80
7448—1.30	74181—3.95
7450—24	74192—1.50
7451—30	74193—1.45
7472—40	74195—1.00
	75491—1.10

Similar to 8038C IC Voltage controlled oscillator, as featured in Oct. 73 P.E. they have sine, square and triangular outputs good to 1MHz. Two of them can be used to make an FM generator...\$9.95

74C 02	\$.75
74C 10	\$.65
74C 157	\$2.15
74C 165	\$3.50
CD 4001	\$.65
CD 4002	\$.65
CD 4009	\$1.50
CD 4010	\$.65
CD 4011	\$.65
CD 4012	\$.65
CD 4013	\$1.60
CD 4016	\$1.25
CD 4022	\$2.25
CD 4023	\$.65
CD 4025	\$1.50
CD 4027	\$1.35
CD 4030	\$.65

MAN-3 LED READOUTS	\$1.75
MAN-4 LED READOUTS	\$2.50

PRV	2A	6A
200	.95	1.25
400	1.15	1.50
600	1.35	1.75

5311—CLOCK CHIP 6 DIGIT BCD HOLD COUNT, OUTPUT STROBE \$8.50
5314—CLOCK CHIP 6 DIGIT HOLD COUNT, OUTPUT STROBE \$8.50
5316—ALARM CLOCK CHIP \$13.95

Injection laser—a single diode 6W, 25A Ga As unit similar to RCA 40859 \$10.95

SANKEN AUDIO POWER AMPS
Si 1010 Y 10 WATTS \$ 7.95
Si 1025 E 25 WATTS \$18.88
Si 1050 E 50 WATTS \$29.95

TIS 73 N FET \$5.00
2N4891 UJT \$5.00
ER900 TRIGGER DIODES 4/\$1.00

LM 309K 5V 1A REGULATOR	\$1.80
723—40 +40V REGULATOR	\$.75
LM 300H REGULATOR POSITIVE	\$.90
LM 320—5 or -15V REGULATOR	\$1.75
LM 376—V to 37V POS REG.	\$1.25
741A or 741C OP AMP	\$.47
709C OPER AMP	\$.47
DUAL 709 DUAL OP AMP	\$1.25
101 OPER AMP, HI PERFORM	\$.75
LM 308 OPER AMP, LOW POWER	\$1.15
747—DUAL 741	\$.85
536—FET INPUT OPER AMP	\$2.90
537—PRECISION OP AMP	\$2.50
LM 3900—QUAD OP AMP	\$.75
LM 324—QUAD 741	\$2.20
560—PHASE LOCK LOOP	\$2.95
561—PHASE LOCK LOOP	\$2.95
565—PHASE LOCK LOOP	\$2.95
567—TONE DECODER	\$2.95
703—RF-IF AMP	\$.65
LM 370—AGC SQUELCH AMP	\$1.15
555—2 μs—2 HR. TIMER	\$1.20
3822—TRANSISTOR ARRAY	\$.95
LM 380—2W AUDIO AMP	\$1.75
LM 377—2W STEREO AUDIO AMP	\$3.25
LM 381—STEREO PREAMP	\$1.75
LM 382—DUAL AUDIO PREAMP	\$1.95
LM 311—HI PER. COMPARATOR	\$1.15
LM 319—DUAL HI SPEED COMP.	\$1.50
LM 339—QUAD COMPARATOR	\$1.95

PRV	1A	10A	25A	1.5A	6A	35A
100	.40	.70	1.30	.40	.50	1.20
200	.70	1.10	1.75	.60	.70	1.60
400	1.10	1.60	2.60	1.00	2.0	2.20
600	1.70	2.30	3.00			3.00

325 Elm St., Cambridge, Mass.

ABOUT YOUR SUBSCRIPTION

Your subscription to POPULAR ELECTRONICS is maintained on one of the world's most modern, efficient computer systems, and if you're like 99% of our subscribers, you'll never have any reason to complain about your subscription service.

We have found that when complaints do arise, the majority of them occur because people have written their names or addresses differently at different times. For example, if your subscription were listed under "William Jones, Cedar Lane, Middletown, Arizona," and you were to renew it as "Bill Jones, Cedar Lane, Middletown, Arizona," our computer would think that two separate subscriptions were involved, and it would start sending you two copies of POPULAR ELECTRONICS each month. Other examples of combinations of names that would confuse the computer would include: John Henry Smith and Henry Smith; and Mrs. Joseph Jones and Mary Jones. Minor differences in addresses can also lead to difficulties. For example, to the computer, 100 Second St. is not the same as 100 2nd St.

So, please, when you write us about your subscription, be sure to enclose the mailing label from the cover of the magazine—or else copy your name and address exactly as they appear on the mailing label. This will greatly reduce any chance of error, and we will be able to service your request much more quickly.

DELUXE MAGAZINE CASES

Designed Exclusively for
POPULAR ELECTRONICS

The ideal way to save your valuable copies, keep them well protected and make it easy for you to refer to any issue at any time. Both decorative and attractive enough to enhance the decor of any room, each case holds a full year's copies. Constructed of reinforced fiberboard, these durable cases are covered in a rich-textured leatherette. The gold embossed back adds to its elegance and makes each case a welcome addition to your bookshelf or cabinet.

Magazine cases are available for any of your favorite magazines. They're only \$4.50 each, 3 for \$12.50, in any combination of titles ordered. Add 50c per case for postage and handling. Outside U.S.A. add \$1.00 per case ordered.

CHARGE YOUR AMERICAN EXPRESS OR BANKAMERICARD ACCOUNT

Ziff-Davis Pub. Co., Dept. 23, 1 Park Ave., N.Y. 10016

My remittance in the amount of \$ _____ is enclosed. Please send magazine cases for the titles indicated below.

CHARGE: AMERICAN EXPRESS BANKAMERICARD

Account # _____

Signature _____

TITLE	QUANTITY
_____	_____
_____	_____

Check One:
 All Black Maroon Back, Black Sides

Print Name _____

Address _____

City _____ State _____ Zip _____

REAL ESTATE

BIG...FREE...CATALOG! Over 2,500 top values in FARMS, RANCHES, RECREATIONAL LANDS, BUSINESSES, TOWN and COUNTRY HOMES in 39 states coast to coast! Over 4,100 PHOTOS! UNITED FARM AGENCY, 612-EP, West 47th St., Kansas City, MO 64112.

SPORTS ACTION FILMS

MID-SUMMER FILM SPECIALS — The '72 Olympic Games In Color — \$12.95 each PPD — Competitive Sports (Standard 8 or Super 8); Track & Field (Standard 8); Aquatics (Standard 8 — may be shown on Dual 8 projector); Gymnasts (B&W, Super 8, \$6.50) — each a separate 200' reel, 1973 NFL Superbowl, Super 8, B&W, \$6.00; Standard 8, Color, \$12.95 each (save \$3.00). Forman-Frazier Championship Fight — formerly \$16.95 per 200' reel — out they go at \$13.95 each, Color, Super or Standard 8. Order right now — no limit while quantities last. All lab packed fresh, new prints. SPORTLITE, Elect-8 Dept., 20 North Wacker, Chicago, IL 60606.

PLASTICS

CASTOLITE pours like water, hardens like glass without heat. Crystal clear, colors. Embed flowers, seashells, mementos, anything. Make fine gifts. Form flexible molds over any pattern, size. Reproduce your own designs in plastics, candlewax, metal, plaster, cement. Send 10 cents for illustrated Literature. Profitable. CASTOLITE, Dept. 74J/PE, Woodstock, Ill. 60098.

HYPNOTISM

SLEEP learning. Hypnotic method. 92% effective. Details free. ASR Foundation, Box 7566EG, Fort Lauderdale, Florida 33304.

FREE Hypnotism. Self-Hypnosis. Sleep Learning Catalog! Drawer H400, Ruidoso, New Mexico 88345.

AMAZING self-hypnosis record releases fantastic mental power. Instant results! Free trial. Write: Forum (AAB), 333 North Michigan, Chicago 60601.

MISCELLANEOUS

WINEMAKERS: Free Illustrated catalog yeasts, equipment. Sempex, Box 12276P, Minneapolis, Minn. 55412.

CATALOGS! Receive many! Catalog Directory \$1.00. Box 33098, District Heights, Md. 20028.

SAVE GAS. Professionally maintain your car. Use ignition analyzer adapter with your oscilloscope. Complete instructions and diagnostic manual \$5.00. Assembled unit \$19.95. JJ Industries, Box 62, Stamford, Conn. 06904.

SAVE up to 20% on gas mileage! Buy the best electronic system in the country. Duke Engineering Co., 51 Granger St., Dorchester, Mass. 02122.

SPECIAL interest records available, produced by the editors of the world's leading special interest magazines. Send for free catalog. Record Catalog CL, Ziff-Davis Publishing Co., One Park Avenue, New York, N.Y. 10016.

Popular Electronics

AUGUST 1974

ADVERTISERS INDEX

READER SERVICE NO.	ADVERTISER	PAGE NUMBER
1	Allison Automotive Co.	26
2	Altaj Electronics	100
3	Antenna Specialists Co.	99
4	Audio Technica U.S., Inc.	25
	Bell & Howell Schools	70, 71, 72, 73
	CREI Capitol Engineering Institute	90, 91, 92, 93
6	Circuit Designs, Inc.	94
7	Cleveland Institute of Electronics	28, 29, 30, 31
8	Clifford's Hi-Fi Wholesalers	26
9	Continental Specialties Corp.	13
10	Delta Electronics Co.	103
11	Delta Products, Inc.	5
12	EICO	95
13	Echo Communications, Inc.	98
14	Edmund Scientific Co.	110
15	GC Electronics	99
16	GTE Sylvania	80, 81, 82, 83
46	Gray Matter, Inc.	24
5	Heath Company	2
17	Hewlett-Packard Co.	14
18	Hewlett-Packard Co.	15
19	Illinois Audio	98
20	Institute of High Fidelity, Inc.	32
21	International Electronics Unlimited	104
22	James Electronics	106
33	Johnson Co., E.F.	96
23	Lafayette Radio Electronics	86
24	Linear Systems, Inc.	99
25	McIntosh Laboratory, Inc.	16
26	MITS Inc.	95
27	Mallory Distributor Products Company	17
28	Metal Circuit Systems Corporation	THIRD COVER
29	Meyers Co., Lawrence A.	7
30	Mid-West Hi-Fi Wholesale & Mail Order Division	94
31	Mueller Electric Co.	96
	NRI Schools	8, 9, 10, 11
	National Technical Schools	18, 19, 20, 21
32	Pace Communications	85
34	Poly Paks	107
35	S A E, Inc.	25
36	Sams & Co., Inc., Howard W	69
37	Shure Brothers Inc.	6
38	Solid State Sales	108
39	Solid State Systems, Inc.	105
40	Southwest Technical Products Corporation	23
41	Summit International Corporation	16
42	Technics by Panasonic	FOURTH COVER
43	Tri-Star Corporation	97
	U.S. Pioneer Electronics Corp.	SECOND COVER, 1
45	Vintage Radio	68

CLASSIFIED ADVERTISING . . . 100, 103, 104, 106, 108, 109

CLASSIFIED ADVERTISING ORDER FORM

Please refer to heading on first page of this section for complete data concerning terms, frequency discounts, closing dates, etc.

1	2	3	4	5
6	7	8	9	10
11	12	13	14	15
16	17	18	19	20
21	22	23	24	25
26	27	28	29	30
31	32	33	34	35

_____ Words @ \$1.00 (Reader Rate) = \$ _____
@ \$1.60 (Commercial Rate)

Insert _____ time(s) Total Enclosed \$ _____

NAME _____

ADDRESS _____

CITY _____ STATE _____ ZIP _____

Signature _____

WORD COUNT: Include name and address. Name of city (Des Moines) or of state (New York) counts as one word each. Zip Code numbers not counted. (Publisher reserves right to omit Zip Code if space does not permit.) Count each abbreviation, initial, single figure or group of figures or letters as a word. Symbols such as 35mm, COD, PD, A.C., etc., count as one word. Hyphenated words count as two words.

PE-874

LIVE IN THE WORLD OF TOMORROW...TODAY!

(And our FREE CATALOG is packed with exciting and unusual ecological & physical science items—plus 4,500 finds for fun, study or profit . . . for every member of the family.)

A BETTER LIFE STARTS HERE



12v WIND-POWERED GENERATOR

Cheapest continuous source of electricity available! Attach to 12v truck batt. (not incl) and get free electricity from the wind. Needs only 7 mph wind — 15 amps output in 23 mph wind; double the watt-hour output of ordinary radio chargers. Perfect remote area and alternate energy source. Big 6' propeller (Albers Air-foil princ.) turns 200w generator; governor prevents overcharging/action. Price includes packing & shipping.

No. 19,189AV . . . (10'-145 LB.) . . . \$425.00 Ppd.

3-CHANNEL COLOR ORGAN KIT

Easy to build low-cost kit needs no technical knowledge. Completed unit has 3 bands of audio frequencies to modulate 3 independent strings of colored lamps (i.e. "lows" — reds, "middles" — greens, "highs" — blues. Just connect hi-fi, radio power lamp etc. & plug ea. lampstring into own channel (max, 300w ea.). Kit features 3 neon indicators, color intensity controls controlled individ SCR circuits; isolation transformer; custom plastic housing; instr.



Stock No, 41,831AV . . . \$17.50 Ppd.

"FISH" WITH A GIANT MAGNET

Fascinating fun, and sometimes very profitable! Tie a line of our 3½-pound Magnet drop it overboard in bay, river, lake or ocean. Troll it along the bottom. Your "treasured" haul can be outboard motors, anchors, other metal valuables. Five-pound Magnet is war surplus — Alnico V Tye that cost the Government twice our price. It lifts over 40 pounds on land much greater weights under water!

Stock No. 70,570AV 3½ lbs. . . \$11.50 Ppd.
Stock No, 60,215 AV 1½ lbs. . . \$ 6.50 Ppd.

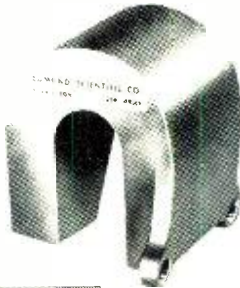

ON-TIME BIOFEEDBACK MONITOR

New—measures & records % of tng. time spent producing alpha/theta! Electronic scoring device to observe exact degree of progress in alpha-theta prod'n. for greater relaxation, concentration. Deluxe sensitive instrument gives reliable audio & visual feedback of alpha/theta brainwaves. Tracking time (0-20 min.) of alpha or theta rhythm generated is switch-controlled. Other innovative features incl. artifact inhibitor (no muscle interference). 12 lb.



No. 1652AV . . . (15x10x6") . . . \$349.50 Ppd.

NEW! KIRLIAN PHOTOGRAPHY KIT!

Experiment in the fascinating new field of "Kirlian" electrophotography — images obtained on film without camera or lens by direct recording of electric charge transmitted by animate & inanimate objects. Each "aura" differs — animate aura said to change corresponding to physical changes. Kit incl. portable darkroom, double transformer isolated from power source; instrs.



Stock No. 71,933AV . . . \$49.95 Ppd.
"HIGH VOLTAGE PHOTOGRAPHY" by H.S. Dakin
No. 9129AV . . . (60-PG. PPBK BK.) . . . \$5.00 Ppd.

GET A CHARGE FROM THE SUN!

Our 12V Solar Battery Charger, like those used aboard satellites but redesigned for broad usage, allows direct conversion of light-to electricity. Compact panel put on a boat can automatically charge its 12V battery over entire daylight period; no power drain at night. Use anywhere a trickle charge is needed (trans. radios, etc.). Terrific value, it comprises thirty ½V silicon solar cells in series w/ a diode. Cap.: 30 Watt-hrs, a wk. approx.

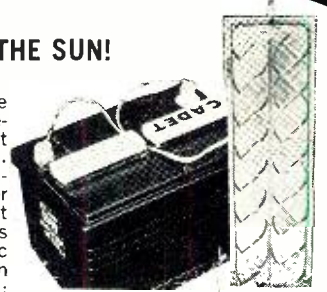

Stock No, 71,971AV . . . \$89.95 Ppd.

MAIL COUPON FOR GIANT FREE CATALOG!

164 PAGES! MORE THAN 4,500 UNUSUAL BARGAINS!

Completely new catalog. Packed with all kinds of unusual bargains. Exciting new categories. Many new items. 100's of charts, illustrations. Many hard-to-get war-surplus bargains. Enormous selection of telescopes, microscopes, binoculars, magnets, ecological and unique lighting items, kits, parts, and so forth, for hobbyists, experimenters, workshops. Simply mail coupon or write for free Catalog "AV."

EDMUND SCIENTIFIC CO.
300 Edscorp Bldg., Barrington, N. J. 08007

Name _____
Address _____
City _____ State _____ Zip _____



COMPLETE & MAIL WITH CHECK OR M.O.

EDMUND SCIENTIFIC CO.
300 Edscorp Building, Barrington, N.J. 08007

How Many	Stock No.	Description	Price Each	Total

PLEASE SEND CATALOG "AV"

MERCHANDISE TOTAL \$ _____
ADD HANDLING CHARGE: \$1.00 ON ORDERS UNDER \$5.00; 50c ON ORDERS OVER \$5.00
TOTAL \$ _____



I enclose check
 money order for \$ _____
NAME _____
ADDRESS _____
CITY _____ STATE _____ ZIP _____

METAL CIRCUIT SYSTEMS CORPORATION

Presents

AN ELECTRONIC BREAKTHROUGH

Convert Your

IDEAS TO REALITY
IN MINUTES



Can Be Produced
In Micrologic To
440 Volts High Amperage
AC and DC Currents.

A trial package of
3 type MCS-102 boards
(1-4"x6" and 2-3"x4") will
be sent to you for \$9.97.

**EXPERIMENT NOW WITH
THIS GREAT NEW MATERIAL**

METAL CIRCUIT SYSTEMS CORPORATION
P. O. Drawer 2226 Houston, Texas 77001
Gentlemen:
Enclosed is \$_____ for _____ trial packages
of 3 type MCS-102 circuit board material at \$9.97
each. Also enclose an information booklet about the
material and ways to use it.

Name: _____
Street: _____
City _____ State _____ Zip _____

Our Houston based corporation, Metal Circuit Systems, has produced a revolutionary non-conducting metal sheet for printed circuitry. To make a simple circuit or a complex multi-layer breadboard you draw or scribe your design directly on the surface of the material, type MCS-101, which instantly renders a working circuit. Because only pressure is necessary there is substantial savings in time, materials, and labor. For mass production, a punch press or letter press can be used. Without using a new board, circuits can be erased for making new designs. A more economical version type MCS-102 for direct wiring purposes rather than printed circuitry is available. Since the metal sheet is non-conducting, components and wiring can be spot soldered at random totally independent from adjacent areas of the board.

CIRCLE NO. 28 ON READERS SERVICE CARD

Introducing our new speakers. They stubbornly maintain their neutrality.

We call them *the Neutrals*. And that's how we designed them — to be neutral, as free of coloration as possible. Because Technics is convinced neutrality is the key to great speaker performance.

Unfortunately, many speaker designers feel that they have to add coloration to give their systems "personality" or "presence." But Technics believes that adding coloring is wrong because it permanently compromises fidelity. And that the best way to introduce special tone emphasis is with the tone controls on your amp or receiver. So you can control it.

Technics speakers achieve their unusually high degree of neutrality without using gimmicks. Instead, they use drivers of proven design. Like phenolic-ring tweeters, dome-center cone supertweeters, cone-type midranges, and air-suspension woofers. Expertly matched with specially

tailored crossover networks. And then precisely positioned in fully sealed enclosures.

Model	T-200	T-300	T-400	T-500
Freq. Resp.: free field	44-18kHz ± 3dB -10dB at 35Hz	40-20kHz ± 3dB -10dB at 30Hz	38-20kHz ± 3dB -10dB at 28Hz	35-20kHz ± 3dB -10dB at 25Hz
Dispersion: on axis-1m.	120° at 10,000 Hz	160° at 10,000 Hz	180° at 10,000 Hz	180° at 10,000 Hz
Power: minimum	10 watts	10 watts	10 watts	10 watts
max. music	100 watts	100 watts	100 watts	100 watts
max. 400Hz	40w-5 min.	50w-5 min.	90w-5 min.	100w-5 min.
Sensitivity: 3,000 cu. ft.	10w = 90dB SPL	10w = 90dB SPL	10w = 92dB SPL	10w = 92dB SPL
Drivers: woofer	10"	10"	12"	2-10"
midrange		3"	5"	5"
tweeter	1 1/4"	2"	3 1/2"	2-1 1/4"
supertweeter			2-2"	2-2"
Controls: normal / -3dB	tweeter	tweeter midrange	tweeter midrange	tweeter midrange
Enclosure: oiled walnut	H-21 3/4" W-12"	H-24 3/4" W-13 3/4"	H-27" W-15"	H-29" W-18 3/4"
fully sealed	D-10 1/2"	D-12 1/2"	D-13 3/4"	D-14 1/2"

Each of the four Technics *Neutrals* has an impressive roster of specifications. The most important ones are stated in the chart. And in terms that make the numbers meaningful.

Stop in at your dealer and experience Technics neutrality. The more you listen to it, the more you'll appreciate why we're so stubborn about maintaining it.

The Neutrals. The concept is simple. The execution is precise. The performance is outstanding. The name is Technics.

FOR YOUR TECHNICS DEALER, CALL FREE 800 447-4700. IN ILLINOIS, 800 322-4400.



Grille available in brown or blue.

Technics

by Panasonic

CIRCLE NO. 42 ON READERS SERVICE CARD