

The Cassette Tape Recording Medium

Popular Electronics

JUNE 1974/FIFTY CENTS

A FIRST!

How To Make Double-Sided PC Boards

Projects:

Single-IC Weather
Receiver
CMOS Microlab
FET VU Meter

Features:

Solid-State Photocells
for Hobbyists
Understanding Transistor
Circuit Characteristics

Test Reports:

- Sony STR-7045
Stereo FM/AM Receiver
- Dual 701 Automatic
Single-Play Turntable
- HM Electronics
310 VOM
- Antenna Specialists
PS/CB Translator
- Tag Electronics

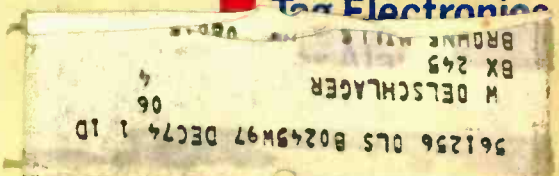

NOW you can train at home building a NEW 25" DIAGONAL Solid State Color TV engineered by NRI for learning and trouble-shooting

So much better for learning TV servicing than any hobby kit, because NRI designed and created it as an educational tool.

Unlike hobby kits which are designed for creating a TV set as the end product, NRI built its exclusive 25" Diagonal Solid State Color TV kit as a real training kit. You can introduce and correct defects . . . for trouble-shooting and hands-on experience in circuitry and servicing. The kits include a wide-band oscilloscope, color bar crosshatch generator, transistorized volt-ohmmeter and other valuable equipment that can soon have you earning \$5 to \$7 an hour servicing color sets in your spare time.

Handsome woodgrain cabinet, at no extra cost. (Offered only by NRI)

New square-cornered Sylvania picture tube

100% solid state chassis

6-position detented UHF channel selector



Modular construction with plug-in circuit boards

Automatic degaussing

Automatic fine tuning

Automatic color control

Automatic tint control

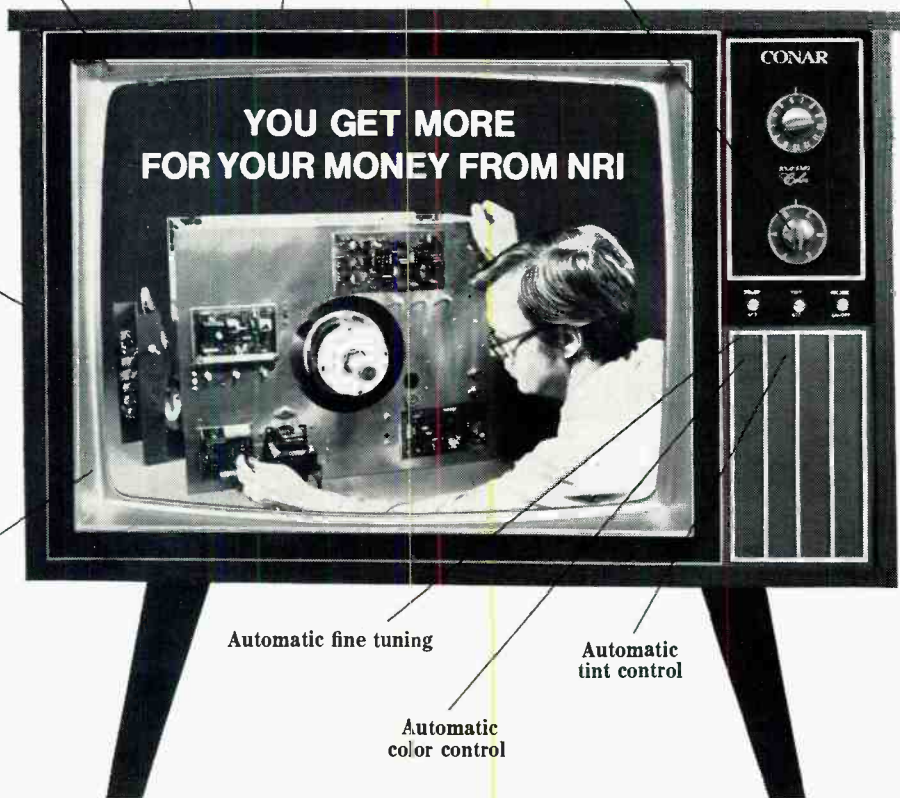

NRI FIRSTS make learning Electronics fast and fascinating—to give you priceless confidence

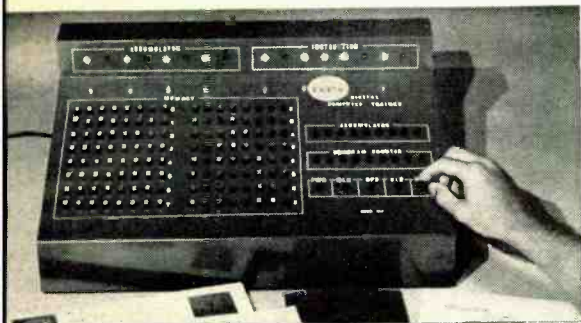

FIRST to give you a complete programmable digital computer, with memory, you build yourself... to learn organization, operation, trouble-shooting and programming. This remarkable computer is one of ten training kits you receive with the new NRI Complete Computer Electronics Course.



FIRST to give you true-to-life experiences as a Communications Technician. Every fascinating step you take in NRI Communications training, including circuit analysis of your own 15-watt, phone/cw transmitter, is engineered to help you prove theory and later apply it on the job. Studio equipment operation and trouble shooting become a matter of easily remembered logic.



FIRST to give you completely specialized training kits engineered for business, industrial and military Electronics Technology. Shown is your own training center in solid-state motor control and analog computer servo-mechanisms. Telemetering circuits, solid-state multivibrators and the latest types of integrated circuits are included in your course.

The NRI color TV and digital computer kits are the latest in a long line of "firsts" for NRI. For more than fifty years, NRI has been providing unique 3-dimensional home-study training that has helped hundreds of thousands of students reach their goals quickly and easily.

What NRI provides is a combination of kits and bite-size texts that give you hands-on experience while you are learning. The texts average only 40 pages each, and they are fully illustrated. You are taken step-by-step from the first stages into the more advanced theory and techniques... with an expert instructor ready at all times to provide valuable guidance and personal attention. (The level of personal attention provided is more than you would receive in many classrooms.) Once you've grasped the fundamentals, you move with confidence and enthusiasm into new discoveries in the fascinating world of electronics.

You start out with NRI's exclusive Achievement Kit, containing everything you need to get moving fast. Lessons have been specifically written so that experiments build upon one another like stepping stones. You can perform a hundred experiments, build hundreds of circuits... as you learn to use the professional test equipment provided, building radios and TV sets, transmitter or computer circuits. It's the priceless "third dimension" in NRI training... practical experience.

Train with the leader—NRI

Compare training kits, texts, techniques and overall training... and you'll find that you get more for your money from NRI. Whatever your reason for wanting more knowledge of Electronics, NRI has an instruction plan that will meet your needs. Choose from major programs in Advanced Color TV Servicing, Complete Computer Electronics, Industrial Electronics and the other special courses designed to meet specific needs. With NRI home training, you can learn new skills while you're still working at your present job... and turn yourself into the man in demand.

GET FACTS ABOUT GI BILL

If you have served since January 31, 1955, or are in service now, check GI line on postage-free card.

Send for free NRI catalog

MAIL THE POSTAGE-FREE CARD FOR THE FREE NRI CATALOG IN THE FIELD OF YOUR CHOICE. YOU WILL BE UNDER NO OBLIGATION. NO SALESMAN WILL CALL.

If the card has been used, write direct to:



NRI TRAINING
3939 Wisconsin Ave.
Washington, D.C. 20016

Popular Electronics

WORLD'S LARGEST-SELLING ELECTRONICS MAGAZINE

FEATURE ARTICLES

- 27 HOW TO MAKE DOUBLE-SIDED PC BOARDS** *Alexander W. Burawa*
Easy procedure to make professional-quality boards.
- 33 AN INTRODUCTION TO THE CASSETTE** *Scott Waverly*
The most popular tape recording medium offers many advantages.
- 48 SOLID-STATE PHOTOCELLS FOR HOBBYISTS,** *Part 1. L. George Lawrence*
Understanding light-sensitive semiconductors.
- 64 TRANSISTOR SELECTION GUIDE FOR EXPERIMENTERS** *Jon L. Turino*
Knowing characteristics speeds and improves designs.
- 69 SOME USEFUL TIPS ON BUILDING AN ELECTRONIC KIT** *John T. Frye*
Good assembly techniques help avoid trouble later.

CONSTRUCTION STORIES

- 40 BUILD THE CMOS MICROLAB** *Don Lancaster*
For learning and breadboarding digital logic.
- 45 A HIGH-VALUE ELECTROLYTIC CAPACITOR METER** *John D. Richard*
Checks capacitance from 10 to 100,000 microfarads.
- 52 BUILD A TAPE RECORDER/AMPLIFIER FET VU METER** *Robert E. Berglas*
For accurate signal-level monitoring.
- 58 TWO SINGLE-IC AM RECEIVER PROJECTS**
THE SIMPLEST AM/WWV RECEIVER
AN FAA WEATHER RECEIVER
Carl C. Drumeller
Michael S. Robbins
Both use unique, new ZN414 integrated circuit.
- 67 9 USES FOR THE 99¢ WONDER** *Joe A. Rolf*
Simple circuits for the 703 IC amplifier.

ZIFF-DAVIS PUBLISHING COMPANY

Popular Electronics
Editorial and Executive Offices
One Park Avenue, New York, New York 10016
212-725-3500

William Ziff, President
W. Bradford Briggs, Executive Vice President
Hershel B. Sarbin, Senior Vice President, Secretary, and Treasurer

Philip Sine, Senior Vice President
Phillip T. Heffernan, Vice President, Marketing
Frank Pomerantz, Vice President, Creative Services
Arthur W. Butzow, Vice President, Production
Edward D. Muhlfeld, Vice President, Aviation Division
Irwin Robinson, Vice President, Travel Division

George Morrissey, Vice President
Sydney H. Rogers, Vice President
Sidney Holtz, Vice President
Lawrence Sporn, Vice President, Circulation

POPULAR ELECTRONICS, June 1974, Volume 5, Number 6. Published monthly at One Park Avenue., New York, NY 10016. One year subscription rate for U.S., U.S. Possessions and Canada, \$6.00; all other countries, \$8.00. Second class postage paid at New York, N.Y. and at additional mailing offices. Authorized as second class mail by the Post Office Department, Ottawa, Canada and for payment of postage in cash. Subscription service and Forms 3579: P.O. Box 2774, Boulder, CO 80302. Editorial offices for manuscript contributions, reader inquiries, etc.: One Park Ave., New York, NY 10016.

POPULAR ELECTRONICS Including ELECTRONICS WORLD, Trade Mark Registered. Indexed in the Reader's Guide to Periodical Literature.

Copyright © 1974 by ZIFF-DAVIS PUBLISHING COMPANY. All rights reserved.

POPULAR ELECTRONICS

EDGAR W. HOPPER
Publisher
ARTHUR P. SALSBERG
Editorial Director
MILTON S. SNITZER
Editor
LESLIE SOLOMON
Technical Editor
JOHN R. RIGGS
Managing Editor
EDWARD I. BUXBAUM
Art Director

ALEXANDER W. BURAWA
Associate Editor
ANDRE DUZANT
Technical Illustrator
ELLEN S. FINKELSTEIN
Editorial Assistant
LEN BUCKWALTER
LOU GARNER
JULIAN D. HIRSCH
RALPH HODGES
WALTER G. JUNG
Contributing Editors

JOSEPH E. HALLORAN
Advertising Director
JOHN J. CORTON
Advertising Sales
MADELEINE LITTMAN
Advertising Service Manager
PEGI MCENEANEY
Executive Assistant
STANLEY NEUFELD
Associate Publisher
FURMAN H. HEBB
Group V.P., Electronics & Photo

THE SCENES

- 12 STEREO SCENE** *Ralph Hodges*
New speaker designs.
- 24 HOBBY SCENE** *Editorial Staff*
- 81 SOLID STATE** *Lou Garner*
Interpreting schematic diagrams.
- 85 CB SCENE** *Len Buckwalter*
Who repairs CB rigs?
- 88 TEST EQUIPMENT** *Leslie Solomon*
Checking antenna efficiency.

PRODUCT TEST REPORTS

- 70 SONY MODEL STR-7045 STEREO RECEIVER**
- 76 DUAL MODEL 701 SINGLE-PLAY AUTOMATIC TURNTABLE**
- 78 ANTENNA SPECIALISTS MODEL MON-41 VHF CONVERTER**
- 79 HM ELECTRONICS MODEL HM-310 VOM PLUS**
- 80 TAG ELECTRONICS WATER ALARM**

DEPARTMENTS

- 6 EDITORIAL** *Milton S. Snitzer*
The Home "Pay TV" Connection
- 8 LETTERS**
- 22 NEWS HIGHLIGHTS**
- 94 NEW PRODUCTS**
- 97 NEW LITERATURE**
- 98 ELECTRONICS LIBRARY**

COMING NEXT MONTH

- Build an ESP Test Machine*
- 4-Channel Tape Recorders*
- Electronic Music Keyboards*
- Low-Cost Metal Locator*

Midwestern Office
The Patis Group, 4761 West Touhy Ave.,
Lincolnwood, Illinois 60464, 312 679-1100
GERALD E. WOLFE, GEORGE B. MANNION

Western Office
9025 Wilshire Boulevard, Beverly Hills, California 90211
213 273-8050; BRadshaw 2-1161
Western Advertising Manager, BUD DEAN

Japan: James Yagi
Oji Palace Aoyama; 6-25, Minami Aoyama
6 Chome, Minato-Ku, Tokyo 407-1930/6821

Ziff-Davis also publishes Boating, Car and Driver, Cycle, Flying, Modern Bride, Popular Photography, Skiing, and Stereo Review.

Forms 3579 and all subscription correspondence should be addressed to POPULAR ELECTRONICS, Circulation Department, P.O. Box 2774, Boulder, CO 80302. Please allow at least eight weeks for change of address. Include your old address, as well as new—enclosing, if possible, an address label from a recent issue.

Editorial contributions must be accompanied by return postage and will be handled with reasonable care; however, publisher assumes no responsibility for return or safety of art work, photographs, models, or manuscripts.



Member Audit Bureau
of Circulations





Editorial

By Milton S. Snitzer, Editor

THE HOME "PAY-TV" CONNECTION

Is there a pay-TV connection in your future? If so, will it be via a pay-per-program cable connection or an over-the-air decoder attached to your antenna input. Right now there are only some 50,000 home TV receivers reported to be hooked up for pay-per-program cable TV; and none for over-the-air subscription TV (STV). But the picture will probably change in the near future.

A major battle is in progress between "free"-TV lobbyists and pay-TV advocates, with the FCC sandwiched between them. If all stops were pulled in favor of pay TV, "free" TV would doubtlessly be seriously wounded. Since this cannot be permitted (if only because a substantial portion of the population cannot afford to pay directly for the luxury of TV), a compromise must be effected. Thus, the FCC must play King Solomon, an unenviable task.

An advancement on the side of pay TV was recently demonstrated by Blonder-Tongue of its "BTVision," a system that encodes and decodes over-the-air subscription TV (UHF) signals. It has won FCC approval for a 35-mile transmitting range. A decoder attached to the subscriber's standard TV set unscrambles both visual and audio signals and, interestingly, is said to provide hi-fi sound to an upper range of 15,000 Hz, as well as stereo capability.

Cable TV is already somewhat entrenched, of course, with about 7.8 million homes wired for cable or community antenna connections. It also has the big plus of providing service in areas where broadcast TV is not readily received. On the negative side, cable TV faces the costly task of tearing up sidewalks and roadways in many large cities in order to bury cables.

Aside from pure entertainment purposes, cable TV has a big potential in providing communications terminals in the home. The cables can carry frequencies from 3 Hz to 270 MHz, with bi-directional capability. Keyboards can be used to provide inputs, and characters can be generated for CRT display. All of this makes possible services such as remote-sensing burglar and fire alarms, time-sharing of computers for banking and shopping, hard-copy printing, and many more. So the cost and bother of running cable underground for pay TV could well be worth it in the long run.

At present, the FCC places constraints on all pay-TV programming and restricts cross-ownership. The former limits the attractiveness of programs that require a monthly charge plus a charge for each program selected. And the latter intensifies broadcast network attacks on pay TV.

We hope that programming and technical challenges will be met satisfactorily before "all out" efforts are made in pay TV. Otherwise, we face a setback similar to California's abortive STV experiment that was ended by a state referendum in 1964.

Essential Electronic Servicing Help from Sams

Here are seven extremely helpful books that can make a serviceman's work much easier. Five of them are just off the press, one is a new second edition, and one came out in '73. It'll pay you to check them out.



VIDEO TAPE RECORDERS
By Harry Kybett

This basic text on the fast-growing field of helical vid's contains information seldom found in service manuals, which only cover specific models. It explains the fundamentals of video tape recording; describes electronic circuits and mechanical systems in currently available machines; lists basic problems encountered and their solutions; and presents recent developments in the field. 352 pages, softbound.

No. 21024 \$8.95

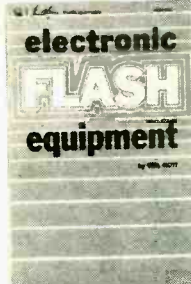

ELECTRONIC FLASH EQUIPMENT
By Verli Molt

A fully informative book on the use of flash/strobe equipment, the problems sometimes encountered, and the service information needed to overcome those problems. Its information on the basic flash unit, flash tubes, triggering circuits, power sources, storage, and service can save you time and frustration. 112 pages, softbound.

No. 21020 \$4.50

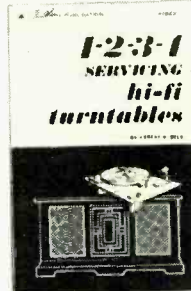

1-2-3-4 SERVICING HI-FI TURNTABLES
By Forest H. Bell

Greatly simplifies understanding of the mechanisms in terms of four divisions: record changers by sections, assemblies within sections, breakdown of assemblies, and mechanical parts. The following chapters cover specifics for each type of drive system, tone arm and turntable. In addition, problem diagnosis—locating, isolating, and pinpointing faults is explained so that servicing can be accomplished quickly and easily. 192 pages, softbound.

No. 21032 \$4.95

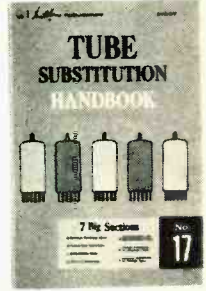

TUBE SUBSTITUTION HANDBOOK, 17th Edition
By the Howard W. Sams Engineering Staff

Quick and accurate information for making suitable substitutions when exact replacements are not available. Lists over 18,000 replacements in seven sections: American receiving and picture tubes, industrial tubes, cross-reference of subminiature tubes, communications and special tubes, cross-reference between American and foreign tubes. 96 pages, softbound.

No. 21007 \$1.95

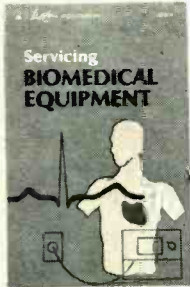

SERVICING BIOMEDICAL EQUIPMENT
By Elliott S. Kanter

Introduces the biomedical technician to the specialized types of electronic and electromechanical devices used in present-day hospitals. Describes test procedures, service and maintenance techniques, and safety factors of centrifuges, electrocardiographs, defibrillators, monitoring devices, oxygen and vacuum devices. 160 pages, softbound.

No. 21011 \$5.50



COLOR-TV SERVICING GUIDE 2nd Edition
By Robert G. Middleton

This guide uses color photos of symptoms of circuit defects as they appear on the picture-tube screen. If the serviceman follows these picture clues and uses proper troubleshooting methods, he can service sets correctly and in less time. Covers both tube and solid-state circuits. 112 pages, softbound.

No. 20990 \$4.95

ELECTRONIC SECURITY SYSTEMS

By Leo G. Sands

The principle and operation of the various electronic devices used for industrial and home security systems are covered in detail. Chapters on: scope and application, switches and relays, sensors and encoders, indicators and alarms, electrical and electronic control and alarm circuits, security communication and systems installation, closed-circuit tv, transmission media. 416 pages, hardbound.

No. 23205 \$5.95



CIRCLE NO. 24 ON READER SERVICE CARD



HOWARD W. SAM'S & CO., INC.
4300 W. 62nd St., Indianapolis, Ind. 46206

Order from your Electronics Parts Distributor, or mail to Howard W. Sams & Co., Inc.

Send books checked at right, \$ _____ enclosed. Please include sales tax where applicable. Canadian prices slightly higher.

Send FREE 1974 Sams Book Catalog.

Name _____ 21024
 21020
 21032
 21007
 21011
 20990
 23205

Address _____
 City _____ State _____ Zip _____

PE 064

**PACE...((p))
GUARANTEES
PERFORMANCE
SERVICE**



**For
Outdoor
Safety**



**HAND HELD
CB TRANSCEIVERS**
from \$29.95 to \$94.95

- Reliable range
- Dependable performance
- Versatile operation

PACE has a complete choice for CB Hand Held transceivers to work with your mobile, base or other hand held units for any type of radio communications need. For "safety sake" as well as fun, your outdoor activity should include a "PACE in your POCKET."

WRITE PACE FOR FREE
CITIZEN TWO-WAY RADIO GUIDE
OR STOP BY YOUR LOCAL...

...SIGN OF QUALITY



PACE COMMUNICATIONS
DIVISION OF PATHCOM INC.
24049 S. FRAMPTON AVE., HARBOR CITY, CA 90710

Name _____
Street _____
City _____

CIRCLE NO. 22 ON READER SERVICE CARD

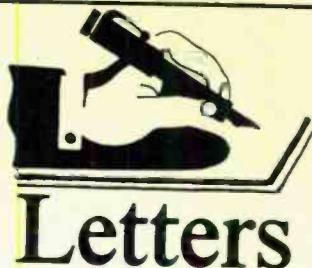

Letters

SILASTIC® IS DOW CORNING TRADEMARK

In "Single-LED Transceiver" (March 1973) the Silastic® trademark was incorrectly credited to General Electric. Silastic® is a registered trademark of Dow Corning Corp. It is used by us to identify, among other things, our line of adhesive/sealant products. We note that the mark has been correctly capitalized and appears with the registered symbol as we prefer. We request that in the future our Silastic® trademark be used correctly and that Dow Corning be indicated as the owner of the mark.

T.H. PEARSON
Legal Department
Dow Corning Corp.
Midland, Mich.

MORE RANGE FROM LED TRANSCEIVER

In "Single LED Transceiver" (March 1974), the efficiency of the system could be improved by doing a bit of rearranging. Although the LED's output is high in frequency, it can still be reflected by shiny surfaces, such as the cases of the AA cells. Hence, some of the strength of the received and transmitted signals will be lost. Moving the battery holder to another location and installing a matte black shield around the light path would increase range and clarity in both operating modes.

DAVID W. PAUL
Charlottesville, Pa.

BATTERY TAKES ON OSCILLOSCOPE

In "Are Your Speakers In Phase?" (March 1974), the author insists upon using an expensive oscilloscope to check speaker phasing. The use of a 1.5-volt battery is easier and cheaper. Connect the battery across the speakers' terminals while observing the direction of cone travel. The connections that cause both cones to move in the same direction indicate proper phasing.

RICK THOMPSON
Lanagan, Mo.

You are correct when dealing with drivers that have relatively long cone travels (not all have such easily detectable travels) and when it is a simple matter to remove the grille cloth

to "get at" the speakers. If you have a scope, however, it is easy to determine, with absolute accuracy, the phasing of any two speakers—and this is the whole point of Mr. Weems' article.

OPEN AND CLOSED ARE TRANSPOSED

In "Diode and Switch Box Makes Soldering Iron Doubly Useful" (Tips & Techniques, March 1974), I believe the terms "open" and "closed" are transposed in the text.

RICHARD M. PAC
Hampton, N.H.

You are correct. With the switch closed, full power will be delivered to the soldering iron; with it open, only half power would be delivered.

WANTS TO TAKE CET EXAM

Where can I inquire about taking the Certified Electronic Technician examination mentioned in the July 1973 News Highlights column?

ROB CAVE
Houston, Texas

Write to IS CET, 1715 Epo Lane, Indianapolis, IN 46224 for information on when and where the CET exams are given.

ANOTHER R/C EQUIPMENT SUPPLIER

In the "R/C Equipment Manufacturer" table published in "How To Get Started In Radio Control Modeling" (February 1974), I forgot to mention Cannon Electronics, 13400-26 Saticoy St., N. Hollywood, CA 91605. Readers interested in R/C modeling should add this name to their supplier list.

FRED MARKS
Gaithersburg, Md.

FET SHOULD BE N-CHANNEL

In my article "Automatic Photo Enlarger Controller" (p 51, April 1974), Q1 should be shown as an n-channel FET, not p-channel.

JOSEPH GIANELLI
Queens Village, NY

TRY LOWERING THE SUPPLY VOLTAGE

Anyone who has built the "Deluxe Frequency Standard" (January 1974) and is having trouble getting the 1-MHz crystal to oscillate should try reducing the supply voltage. My circuit would oscillate only with voltages between 4.2 and 4.8 volts. Therefore, three 1.5-volt cells should be used to power the circuit. Alternatively, a pair of dropping resistors will permit the battery described to provide the necessary supply voltage.

RANDY MOODSPAUGH
Clarksburg, W. Va.

HP: THE STANDARD OF COMPARISON IN TEST EQUIPMENT

Know your frequency... precisely.

\$249* 10 Hz to 80 MHz.

Professional caliber gear with the precision of a seven digit LED readout at an unusually low price. The HP 5381A features a high-stability internal time base, 25 mV sensitivity, a three-position attenuator switch, external oscillator input and ratio measurement capability. All packed in a rugged metal, dust-free case.

\$450* 10 Hz to 225 MHz.

HP's 5382A Counter. All the features of the 5381 to 225 MHz. Plus an eight digit readout. Also, available with a

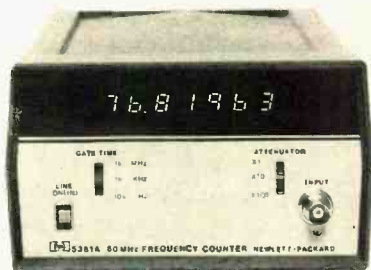

temperature compensated crystal oscillator (\$100*). Both instruments are backed by the full HP guarantee.

*Domestic USA prices only

02402

- Please mail me complete information on your new low-cost precision counters. (No salesman will call.)
- Please have a sales engineer telephone me.

Name _____

Address _____

City _____

State _____

Zip _____

Phone _____

HEWLETT  PACKARD

Sales and service from 172 offices in 65 countries.
1501 Page Mill Road, Palo Alto, California 94304

CIRCLE NO. 14 ON READER SERVICE CARD

The editors' choice: Heathkit Digital Design Color TV!

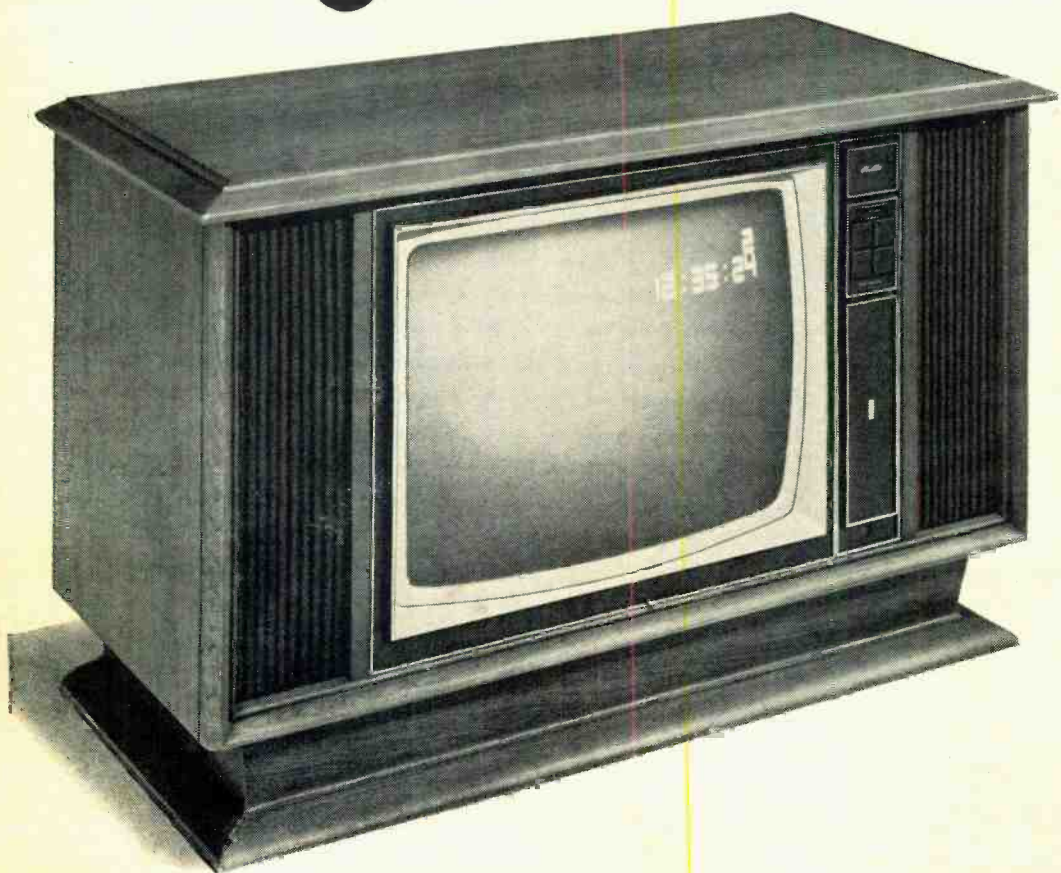



At **ELEMENTARY ELECTRONICS** they said: "The fact is, today's Heathkit GR-2000 is the color TV the rest of the industry will be making tomorrow

... there is no other TV available at any price which incorporates what Heath has built into their latest color TV."

The **FAMILY HANDYMAN** reviewer put it this way: "The picture quality of the GR-2000 is flawless, natural tints, excellent definition, and pictures are steady as a rock. It's better than any this writer has ever seen. Changing channels is uncannily silent, thanks to the varactor tuner, which does away with chunky old-fashioned switches. The visual channel readout ends squinting from across the room forever. Finally, the clock is a great gadget—a pleasure to have, at the least."

POPULAR SCIENCE pointed out "more linear IC's improved vertical sweep, regulators that prevent power supply shorts, and an industry first: the permanently tuned I.F. filter."

The **RADIO-ELECTRONICS** editors said Heathkit Digital Design TV has "features that are not to be found in any other production color TV being sold in the U.S.:

"On-screen electronic digital channel readout... numbers appear each time you switch channels or touch the RECALL button... On-screen electronic digital clock... an optional low cost feature... will display in 12- or 24-hour format... Silent all-electronic tuning. It's done with uhf and vhf varactor diode tuners... Touch-to-tune, reprogrammable, digital channel selection... up to 16 channels, uhf or vhf... in whatever order you wish..."



there's no need to ever tune to an unused channel. *LC IF amplifier* with fixed ten-section *LC IF bandpass filter* in the IF strip... eliminates the need for critically adjusted traps for eliminating adjacent-channel and in-channel carrier beats. No IF alignment is needed ever. *Touch volume control*... when the remote control is used... touch switches raise or lower the volume in small steps."

POPULAR ELECTRONICS took a look at the 25-in. (diagonal) picture and said it "can only be described as superb. The Black (Negative) Matrix CRT, the tuner and IF strip, and the video amplifier provide a picture equal to that of many studio monitors..."

Furthermore, the Heathkit GR-2000 is an easier kit-form TV to build. **POPULAR ELECTRONICS** pointed out that "Each semiconductor has its own socket and there are 12 factory-fabricated interconnecting cables... The complete color adjustments can be performed in less than an hour."

To sum up, **POPULAR ELECTRONICS** concluded its study by stating, "In our

view, the color TV of the future is here — and Heath's GR-2000 is it!"

Why not see what the experts have seen? The Heathkit Digital Design Color TV—without question the most remarkable TV available today.

Mail order price for chassis and tube, \$649.95*. Remote Control, \$79.95*, mail order. Clock, \$29.95* mail order. Cabinets start at \$139.95*. (Retail prices slightly higher.)

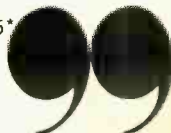

Send for your FREE '74 Heathkit Catalog—world's largest selection of electronic kits

HEATHKIT ELECTRONIC CENTERS

Units of Schlumberger Products Corporation
Retail prices slightly higher.

ARIZ.: Phoenix; CALIF.: Anaheim, El Cerrito, Los Angeles, Pomona, Redwood City, San Diego (La Mesa), Woodland Hills; COLO.: Denver; CONN.: Hartford (Avon); FLA.: Miami (Hialeah), Tampa; GA.: Atlanta; ILL.: Chicago, Downers Grove; IND.: Indianapolis; KANSAS: Kansas City (Mission); KY.: Louisville; LA.: New Orleans (Kenner); MD.: Baltimore, Rockville; MASS.: Boston (Wellesley); MICH.: Detroit; MINN.: Minneapolis (Hopkins); MO.: St. Louis; NEB.: Omaha; N.J.: Fair Lawn; N.Y.: Buffalo (Amherst), New York City, Jericho (L.I.), Rochester, White Plains; OHIO: Cincinnati (Woodlawn), Cleveland, Columbus; PA.: Philadelphia, Pittsburgh; R.I.: Providence (Warwick); TEXAS: Dallas, Houston; WASH.: Seattle; WIS.: Milwaukee.



Heath Company, Dept. 10-6
Benton Harbor, Michigan 49022

HEATH
Schlumberger

Please send FREE Heathkit Catalog.

Name _____

Address _____

City _____ State _____ Zip _____

Prices & specifications subject to change without notice.

*Mail order prices; F.O.B. factory. CL-517R

CIRCLE NO. 5 ON READER SERVICE CARD

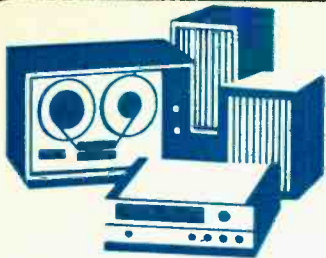

Stereo Scene

By Ralph Hodges

HARDLY a year begins without someone announcing a revolutionary way to build loudspeakers. And hardly a year ends without that same vaunted speaker design finding oblivion in some patent attorney's "inactive" files. But last year was different. After long periods of quiet gestation, three genuinely new speaker principles burst into public consciousness and proved themselves worthy of serious attention.

The Magneplanar Design. First of all, a company called Magnepan developed the Magneplanar speaker, presently marketed by Audio Research Corp. (the company that makes very expensive vacuum-type amplifiers). Several other distributors are due shortly. From outward indications, the Magneplanar could have been conceived as an antidote to the ills of the electrostatic speaker, which are, alas, legion. One of the prime difficulties is that very high voltages are the lifeblood of electrostatics. Special power supplies are required to keep the charges on the conductors; and suitable transformers must follow the power amplifiers to step up the output voltages. At best, all this merely adds to the cost of the speakers. But there are also some practical problems.

Electrostatics are rather inefficient; and amplifiers that don't like large capacitive loads (or transformers) don't work well with them. Because of the high voltages involved, electrostatics are subject to arcing when large diaphragm excursions occur. (Sometimes this takes place with a vicious snap, followed

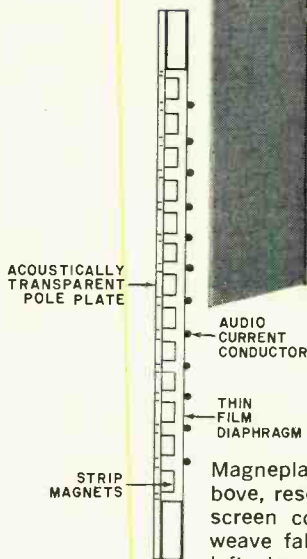
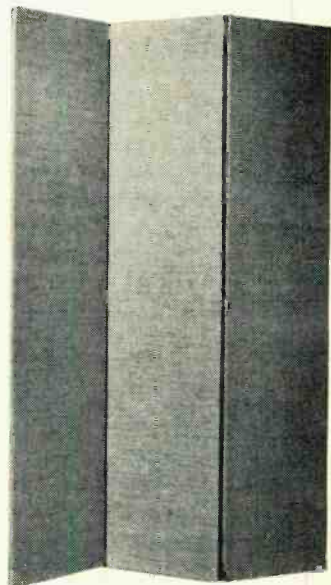

Magneplanar speaker, above, resembles a folding screen covered in loose-weave fabric. Diagram at left shows how it works.

by a general sonic disorientation as the speaker tries to recover its composure.) High voltages are also responsible for the "corona" effect, in which the static charges that drive the speaker simply bleed off through the atmosphere, to the further detriment of efficiency. This problem is at its worst on humid days. When the air quality is "unsatisfactory," as we say in New York, electrostatics act as pollution precipitators. Their charged surfaces grab particles of dust, smoke, grime, grease—almost anything light enough to

New Speaker Designs

Replacing semiconductors takes guidance.

And here it is.

Our new Semiconductor Product Guide.

It's *the* cross-reference for entertainment replacement semiconductors.

Transistors, zener diodes, diodes, high-voltage rectifiers, light emitting diodes, color crystals, integrated circuits, field-effect transistors . . . they're all here. With one of ours you can replace 265 on the average.

And with every one of ours you get Mallory performance and reliability.

Get your Semiconductor Product Guide at your Mallory distributor's today. With a guide like this you can't go wrong.



MALLORY

MALLORY DISTRIBUTOR PRODUCTS COMPANY

a division of P. R. MALLORY & CO. INC.
Box 1284, Indianapolis, Indiana 46206; Telephone: 317-636-5353

CIRCLE NO. 20 ON READER SERVICE CARD

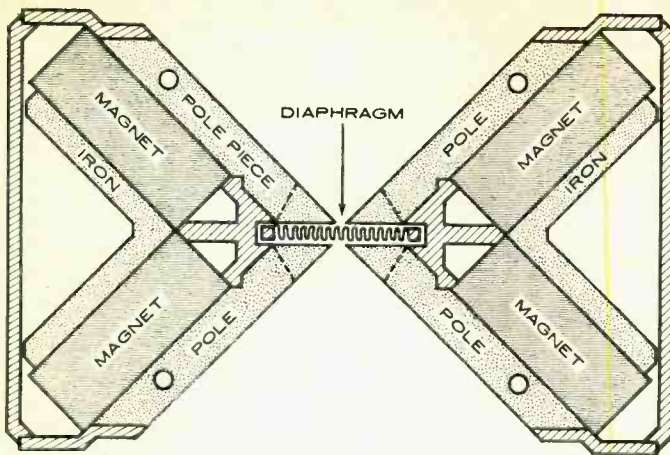

Top view of the Heil driver. The pole pieces are actually formed of horizontal plates that make an acoustical lens near the diaphragm at center.

linger in the air—and wear them as a coating that is difficult to remove.

If this seems like a brief against electrostatics, it's not meant to be. Many users have enjoyed years of delight and rapture from their precise, sparkling (or sometimes silky) sound. There is even progress reported in the curbing of their foibles. In particular, the Dayton Wright outfit has sealed electrostatic drivers away from the problematic atmosphere with acoustically transparent plastic film. Also, models offered by Crown International incorporate some departures from the norm, said to promote more even distribution of static charges over the various surfaces.

But back to the Magneplanar. As his point of departure, Jim Winey, its inventor, dropped the electrostatic principle but retained the physical configuration. The speakers are tall, rectangular, and very shallow. They contain Mylar diaphragms adjacent to stationary plates with perforations to emit sound. But they are dynamic devices. The fixed plates support, and act as pole pieces for, an arrangement of flat bar magnets, while the diaphragms carry a continuous pattern of fine wire that serves as a voice coil. Since it is not actually a coil, however, a purely resistive load is claimed, presenting virtually no reactance to the amplifier. As for the amplifier, it drives the speaker directly, with comparatively modest voltages that don't encourage sparks, leakage, or contamination.

Not all of the electrostatic's failings are cured by the Magneplanar principle. Efficiency is still relatively low; and, like electrostatics, the Magneplanars suffer somewhat from acoustical cancellation be-

tween front and back radiations, which affects bass response. As a result, the radiating areas have to be large to generate substantial acoustic output at low frequencies. The available models are fully as large as many of the full-range electrostatic systems that are popular today.

The Heil Twist. Not long after the Magneplanar's introduction, a man by the name of Oskar Heil managed to interest a small speaker company, ESS, in his idea for making film-diaphragm speakers smaller and more efficient. Heil demonstrated a flaccid rectangular diaphragm gathered into vertical folds, like a narrow, hanging curtain. Large magnetic structures flanked the cur-

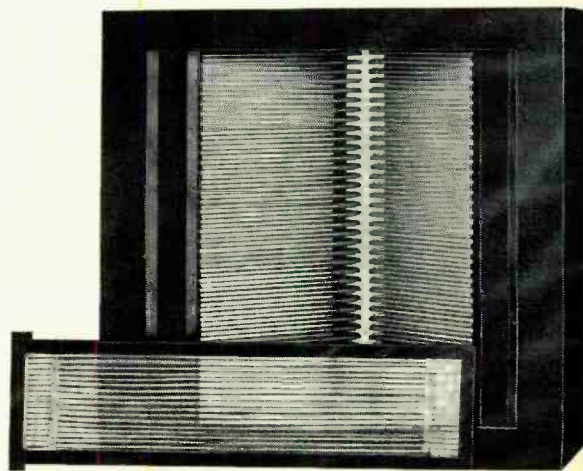

The two-piece ESS/Heil driver. Diaphragm assembly has been removed and laid on its side in front of the magnetic structure.

THERE'S A BETTER WAY TO GO.



Energy shortages tell us we have to change our driving style. Now! It doesn't mean we have to go back to horse and buggy days. But it does mean we have to make every drop of gas give us the most go for our money. Anyone with horse sense knows that a well-tuned car gets better mileage, and in times of fuel shortages, better mileage means a lot.

The Mark Ten B Capacitive Discharge System keeps your car in better tune so it burns less gas. Using Mark Ten B is more than horse sense. It's the smart move under the hood, helping a nation survive an energy crisis and keeping you on the road. Delta Mark Ten. The best way to go.



CIRCLE NO. 9 ON READER SERVICE CARD

DELTA PRODUCTS, INC.

P.O. Box 1147, Dept. PE
Grand Junction, Colo. 81501
(303) 242-9000

Please send me free literature.
Enclosed is \$_____ Ship ppd. Ship C.O.D.
Please send: _____ Mark Ten B assembled @ \$59.95 ppd. _____ Mark Ten B Kit @ \$44.95 ppd. (12 volt negative ground only) _____ Standard Mark Ten assembled, @ \$44.95 ppd. _____ 6 Volt: Neg. Ground Only _____ 12 Volt: Specify _____ Pos. Ground _____ Neg. Ground _____ Standard Mark Ten Deltakit® @ \$29.95 ppd. (12 Volt Positive or Negative Ground Only)

Car Year _____ Make _____

Name _____

Address _____

City/State _____ Zip _____

tain at either edge, distributing a magnetic field throughout its width.

Heil's thesis was that "squeezing motions" exerted on the air were more efficient propagators of acoustic energy than the back-and-forth excursions of conventional cone or film diaphragms. The way he got the diaphragm to squeeze air is slightly reminiscent of the Magneplanar approach. Again a "voice-coil" grid is used, this time made of foil stripes applied to the sides of each fold. The signal current from the amplifier runs up one stripe and down the other, causing the stripes to move left or right, but alternate stripes move in opposing directions. As a result, the folds on one side of the diaphragm draw together, expelling air; on the opposite side, they open up, sucking air in. At each reversal of current, the roles of the diaphragm sides also reverse. Heil called this a "meandering" motion; and it works.

The first Heil/ESS speaker system, the amt-1 became available in the early months of 1973. It is a hybrid, employing a Heil tweeter and a conventional cone woofer, since the magnet structures for a woofer-size Heil diaphragm would be much too massive to be practical.

ESS has been grappling with designs for a Heil woofer ever since. The latest configuration also squeezes air, by means of an upright column of rigid plastic-foam plates that apply a bellows action. The moving plates are interleaved with stationary surfaces and are driven by an arrangement of long vertical rods connected to a conventional voice-coil/magnet assembly underneath. (A push-pull version with voice coils above and below is also under serious consideration.)

To look at the device, you'd expect it to clatter like a weaver's loom in operation. However, a preliminary model was demonstrated to the public in June of 1973, and the most apt description of what was heard then would be "potent." Furthermore, the small size of the driver (described as a "cannister just large enough to contain a regulation NFL football") spoke well for Heil's claim of high efficiency.

The Ohm Approach. The third of the new speakers is practically a testament of faith by speaker designer Martin Gersten to an idea proposed by the late Lincoln Walsh, who unveiled the first working—and reportedly terrible sounding—prototype to

an unadmiring world some years ago. To explain the Walsh principle, we'd best go back to the familiar stone-in-a-pond analogy of sound propagation. Remember the pond and its spreading circles of concentric ripples? Then imagine that we could grasp the water at the very point where the stone entered and pull the entire surface upward like a table cloth. This would create a steep-sided cone, pointing up, with ring-like vibrations descending down the sides—a pretty fair conceptual description of the Walsh/Ohm speaker.

The Walsh principle reasons, correctly, that it's impossible to make a speaker cone behave like a perfect piston at all audio frequencies (unless, of course, you make the cone so small that it has no low-frequency output). So why not encourage the cone to break up into controlled vibratory modes, and let the resulting trains of pulses agitate the air as they pass downward through the cone surface? With the proper cone material, this should permit a single large cone to serve for all frequencies. Since there would be no attempt to damp out local vibrations in the cone structure (on the contrary; local vibrations are *wanted*), the thing could theoretically



The insides of an Ohm F (foreground) speaker system, with larger Model A in background.

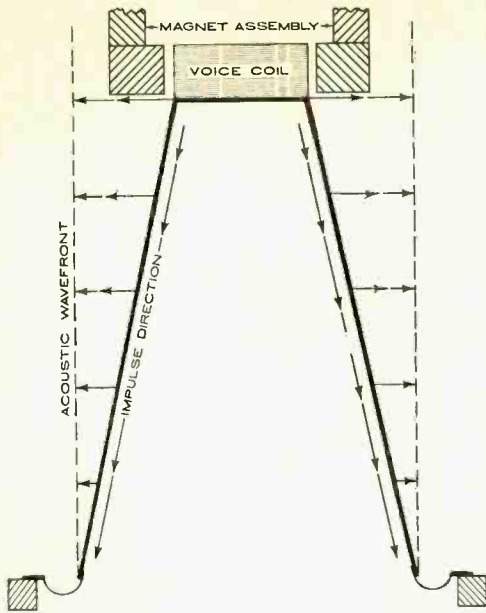

The voice coil of the Ohm/Walsh speaker system sends trains of impulses down through cone material. Slope of cone is designed to propagate cylindrical, in-phase wavefront.

be made efficient at high frequencies as well as at low.

Detractors spoke up immediately. How, they demanded, could you stop the vibrations once they got started? What would keep them from reaching the bottom of the cone and then bouncing right back again, just as wavelets in a pond do when they encounter the shore? Mechanical damping is out; and electrical damping through the voice coil at the top of the cone is impossible. The coil just initiates cone motion, rather than controlling it as in conventional speakers.

There being no easy answers to these questions, Gersten and his associates at Ohm Acoustics apparently didn't look for any. They just slogged away at the problems empirically, trying to get the Walsh principle to work. Their final answer was a two-piece cone, beginning in titanium near the voice coil and ending in aluminum (Ohm Model A) or paper (Ohm Model F). More recently, the paper sections of some Ohm F's have acquired sheathings of metal foil. The combination of materials evidently afforded low damping at the top of the cone and higher damping near the bottom, which allowed the Ohm

designers some latitude in adjusting the behavior of the cone.

The result is a lively, yet pleasantly homogeneous, treble end and more-than-ample bass. In fact, the bass is almost the system's undoing. It can be grotesquely heavy at times, requiring some drastic equalization. But when the conditions are right, the Ohm speakers produce a clear, eerily soundless impact that goes straight to the kidneys.

Ultimate Solutions? After so many mis-carriages, it is a pleasure to be able to report real progress in the area of speaker design. But I don't want to suggest that any kind of ultimate solution is at hand. These new speaker designs take a different tack to achieve a desired end result.

As sound radiators, they still have directional properties that are governed by their physical construction.

The Magneplanar, like its electrostatic brethren, is highly directional unless its diaphragm is sectioned to provide small radiating areas. The Heil tweeter, which is already small, and the Walsh/Ohm speaker, a circular source, are essentially omnidirectional in the horizontal plane (which is good or bad, depending on where you stand in the dispersion controversy). None of them offers any consistent resemblance to the directional properties of the various symphony-orchestra instruments, if that is an important speaker criterion.

Efficiency is another consideration. The Heil looks good in this respect, but the Magneplanar is on the low side. The Ohm A is reported at least 6 dB lower in efficiency than the average acoustic-suspension design. This calls for a quadrupling of amplifier power to get equivalent sound levels—a heavy tax on even the largest amplifiers.

Finally, and perhaps most significantly, the histories of these designs show that they haven't been much easier to coax into high-fidelity performance than their cone predecessors.

The main difficulty facing new speaker designs is that people can't agree on what a speaker should do to create a sense of sonic reality. Therefore, they can't design for it in advance.

On the brighter side, this is a trio of interesting departures that illustrate there is more than one way to skin a cat in achieving electro-mechanical hi-fi. ♦

From Cleveland Institute of Electronics

learn by doing!

Perform more than 200 exciting experiments with CIE's fascinating **ELECTRONICS LABORATORY PROGRAM!**

Put theory... into practice



You get your own 161-piece electronics laboratory... with authentic electronic components used by industry!

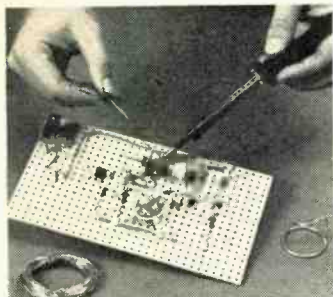

You learn how to construct circuits and connect them with a soldering iron, which is part of your CIE laboratory equipment. This "hands on" experience is extremely valuable in applying what you learn.

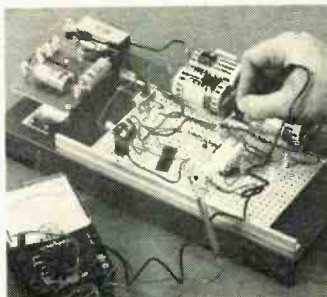

Testing and troubleshooting are an important part of your learning experience. Included in your laboratory is a precision "multimeter" to diagnose electrical and electronic troubles quickly and accurately.

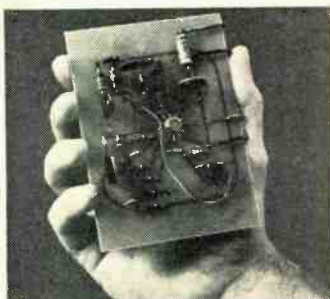

Modern space-age components like this IC (integrated circuit) are professional quality and can be used again and again in many of your projects. Lesson by lesson, piece by piece your knowledge grows!

Prepare now for a high income career in Electronics...the Science of the Seventies.

Electronic miracles are changing today's world with breathtaking speed.

And with this growth in electronics technology has come a brand new need... a demand for thousands of electronics technicians, trained in theory and practice to build the products, operate them and service them during the Seventies.

Don't just wait for something to "happen" in your present job. Get ready now for a career you'll really enjoy with a good income and plenty of opportunity for advancement.

Experience with experiments is your best teacher

"Hands on" experience helps to reinforce basic theory. When you learn by doing, you discover the "how" as well as the "why." You'll find out for yourself the right way as well as the wrong way to use electronic components. How to construct your own circuits, to discover trouble spots and learn how to fix them. And with CIE's special Auto-Programmed® Lessons, you learn faster and easier than you'd believe possible.

CIE's fascinating course, Electronics Technology with Laboratory, teaches you Electronics by making it work before your eyes. And you do it yourself, with your own hands.

Importance of FCC License and our Money-Back Warranty

Many important jobs require an FCC License and you must pass a Government licensing exam to get one.

But, a recent survey of 787 CIE graduates reveals that better than 9 out of 10 CIE grads passed the FCC License exam.

That's why we can offer this famous Money-Back Warranty: when

you complete our Laboratory Course, which provides FCC License preparation, you'll be able to pass your FCC exam or be entitled to a full refund of all tuition paid. This warranty is valid during the completion time allowed for your course.

You get your FCC License — or your money back!

You'll have high paying job opportunities

Electronics is still young and growing. In nearly every one of the new exciting fields of the Seventies you find electronics skills and knowledge are in demand. Computers and data processing. Air traffic control. Medical technology. Pollution control. Broadcasting and communications. With a CIE Diploma and an FCC License you can choose the career field you want... work for a big corporation, a small company or even go into business for yourself.

Here's how two outstanding CIE students carved out new careers: After his CIE training, Edward J. Dulaney, President of D & A Manu-

facturing, Inc., Scottsbluff, Nebraska, moved from TV repairman to lab technician to radio station chief engineer to manufacturer of electronic equipment with annual sales of more than \$500,000. Ed Dulaney says, "While studying with CIE, I learned the electronics theories that made my present business possible."

Marvin Hutchens, Woodbridge, Virginia, says: "I was surprised at the relevancy of the CIE course to actual working conditions. I'm now servicing two-way radio systems in the Greater Washington area. My earnings have increased \$3,000. I bought a new home for my family and I feel more financially secure than ever before."

Send now for 2 FREE BOOKS

Mail the reply card or coupon for our school catalog *plus* a special book on how to get your FCC License. For your convenience, we will try to have a representative call. If coupon is missing, write: Cleveland Institute of Electronics, Inc., 1776 E. 17th St., Cleveland, Ohio 44114. Do it now!



Approved
under
G. I. Bill

All CIE career courses are approved for educational benefits under the G.I. Bill. If you are a Veteran or in service now, check box for G.I. Bill information.

CIE Cleveland Institute of Electronics, Inc.
1776 East 17th Street, Cleveland, Ohio 44114
Accredited Member National Home Study Council

Please send me your two FREE books:

1. Your illustrated school catalog, "Succeed in Electronics."
2. Your book, "How to Get a Commercial FCC License."

I am especially interested in: Electronics Technology with Laboratory
 Electronics Technology Industrial Electronics
 Electronic Communications First Class FCC License
 Broadcast Engineering Electronics Engineering

Name _____ Age _____
(PLEASE PRINT)

Address _____

City _____ State _____ Zip _____

Veterans and Servicemen: Check here for G.I. Bill information.

PE-59

CIRCLE NO. 6 ON READER SERVICE CARD



News Highlights

Navy Amateur Station Will Operate During Convention

On-the-air amateur radio facilities will be provided by the Chief of Naval Operations (CNO) Amateur Radio Station, K4NAA, during the Armed Forces Communications and Electronics Association (AFCEA) convention at the Sheraton-Park Hotel in Washington, DC, June 11 to 13, 1974. The station will be operational from 1000 to 1800 EDT daily with two positions on the 10- through 80-meter radio phone and CW bands. Licensed radio amateurs throughout the world are invited to establish contact. A specially designed QSL card will be sent to acknowledge all contacts. Amateurs desiring to utilize the K4NAA facilities will be required to show their original FCC license in accordance with Article 97.83 of the FCC Rules and Regulations. A facsimile or photostatic copy cannot be honored. All enthusiasts are invited to visit the K4NAA exhibit.

More Electronic Ignitions for Cars

With Chrysler leading the way with standard-equipment electronic ignition systems in their cars, other car makers don't intend to be outdone. For example, Raytheon and Texas Instruments are pushing hard to get their own versions of an electronic ignition system in other makers' autos. Raytheon has booked about a million dollars in orders from Ford for such a system including a \$100,000 developmental contract. Not to be outdone, TRW Inc. and Lumenition Ltd., of London have concluded an agreement in which TRW Electronics will make and market Lumenition's patented opto-electronic ignition system under an exclusive world-wide license. This is a solid-state system that operates on the basis of an interrupted infrared light beam.

Sales of Albums, Tapes Expected to Increase 70 Percent by 1982

With the current reduction in the availability of vinyl used in making phonograph records, the recorded music industry is taking positive steps to ensure a continuation of the spiraling trend in sales. According to a New York market research firm, there is a projected rise from a 1972 sales level of \$2 billion, to \$3 billion by 1980 and to \$3.4 billion by 1982. Figures for 1972 point out that companies released about 5200 new long-playing record albums and about 4500 new tape albums. It is expected that industry will release less material, using better quality repertoires recorded by proven artists in order to reduce record returns. Also, people will be using their recorded music facilities more because of the gasoline shortage.

Speeding Up or Slowing Down Cassette Recorded Speech

A patent for an electronic method of speeding up and slowing down recorded speech on ordinary audio cassettes has been granted and assigned to Cambridge Research and Development Group. The rate of speech playback can be controlled at will by the user and ranges from less than 90 words per minute to more than 450 words per minute without altering tone or pitch. Two major Japanese tape recorder manufacturers, Mansushita (Panasonic) and Sony, have signed non-exclusive license agreements to manufacture and market the invention.

NEW! Build and test circuits as fast as you can think! No soldering or patch cords!

Plug in...wire...modify...build...test

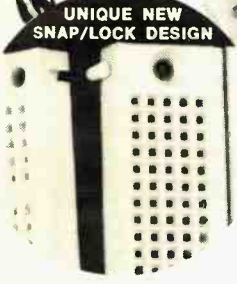
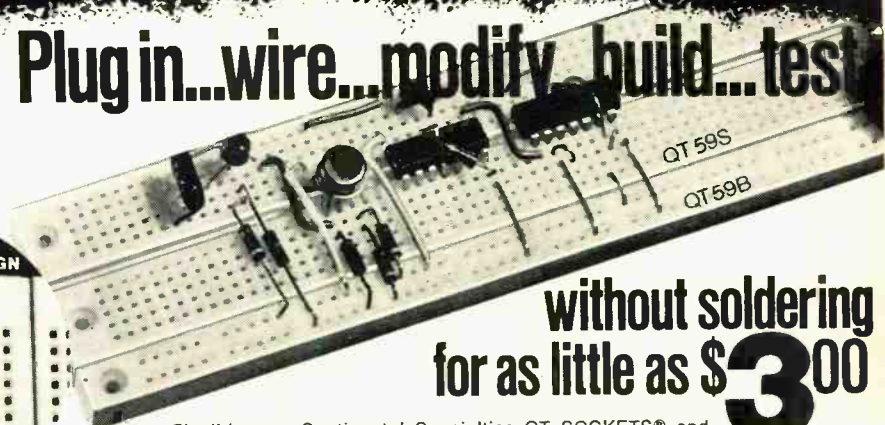

without soldering
for as little as \$3⁰⁰

Flexible new Continental Specialties QT SOCKETS® and BUS STRIPS are a fast, easy breadboarding system with unique SNAP/LOCK that lets you add or remove as many QTs as you need instantly. Now you can test ICs, transistors, resistors, capacitors and more. Just plug in, and connect with solid #22 AWG hook up wire... no soldering is needed! No more shorts! No more burnt fingers! No special patch cords! And you can use QTs again and again! QTs come in different sizes, starting as low as \$3 for QT Sockets and \$2 for Bus Strips. Order yours today!

plus, four new completely assembled PROTO BOARDS...

PAT. PENDING

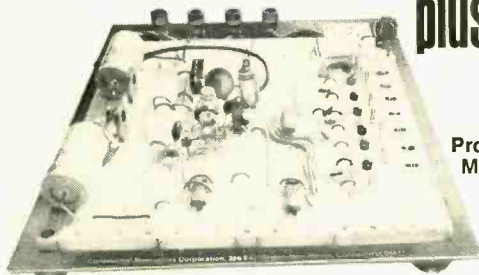

Proto Board Model No.	14 Pin DIP Capacity	Size (L" x W")	Price (U.S. only)
101	10	5.8" x 4.5"	\$29.95
102	12	7.0" x 4.5"	\$39.95
103	24	9.0" x 6.0"	\$59.95
104	32	9.5" x 8.0"	\$79.95

Four new Continental Specialties Proto Boards, made from combinations of QT Sockets and Bus Strips let you make all circuit and power interconnections with common solid #22 wire, while power distribution busses make wiring a snap. Aluminum base plates offer solid work surfaces and perfect ground plane. Rubber feet prevent scratching. Each Proto Board features one or more 5-way binding posts to tie into system or power supply ground. All are compatible with ICs (digital or linear), in TO5s, DIP packs and discrete components. Each is assembled and ready-to-use.

Order today — or send for free selection guide, with applications, photos, specs and more.



Continental Specialties Corp.
325 East St., Box 1942
New Haven, CT 06509
Telephone (203) 624-3103

CANADA: Available thru Len Finkler, Ltd., Downsview, Ontario

FREE METRIC TO ENGLISH SLIDE RULE

Convert lengths, area, weight, volume instantly.

Yours FREE with each Proto Board order!

CIRCLE NO. 7 ON READER SERVICE CARD

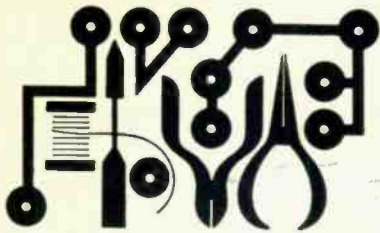

Hobby Scene

Trouble on the Line?

Q. We use a gas-powered 117-volt, 60-Hz generator in our summer cottage. However, digital clocks don't keep the correct time, turntables produce wow, and, generally, I suspect that our "60 Hz" is not 60 Hz. How can I find out?

A. Try this (limited) frequency measuring circuit. All diodes are ordinary silicon recti-

fiers. First, plug the circuit into the commercial 117-volt ac line, which is usually very close to 60 Hz. The circuit will respond to frequencies from 0 to 100 Hz on the 0 to 1 meter scale. Set the potentiometer so that the meter reads 0.6 mA (60 Hz). Now use the circuit on your cottage supply; and, if the reading isn't the same, make the necessary adjustments in the generator's speed. The circuit can also be used at home.

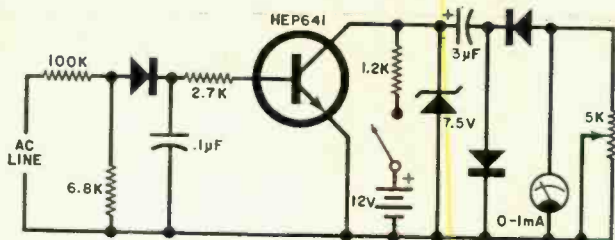

Recharging a Dry Cell

Q. I keep hearing that 1.5-volt dry cells can be recharged. Is this true and, if so, do you have a schematic for a charging circuit?

A. It has been claimed that the circuit below works on charging any kind of 1.5-volt cell. One person says, in fact, that he has charged a flashlight cell a dozen times! It seems that pulsating dc works a lot better than either ac or pure dc in this case. The charging potential is about 3½ volts and current is about 30 mA.

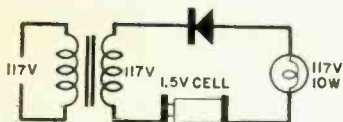

Correction

In this column, in the March issue, the Touch Alarm Circuit should show the emitter of the HEP51 connected to the positive and the relay between the collector and ground.

Soldering Iron for PC Work

Q. The only soldering iron I have is rated at 75 watts. I know that this is too much for pc work, so is there any way I can make a new tip, etc., so that I can use the iron that I have?

A. About the best way to do this is to insert a silicon diode in series with the power line to the iron. Get a diode that has a large enough current rating (in amperes) to take the iron. Then the iron will run at half power and will be "cool" enough for board work. Keep the tip sharp and clean.

Another trick is to wrap some heavy, bare copper wire around the tip, and use the loose end for fine pc soldering.

Have a problem or question on circuitry, components, parts availability, etc.? Send it to the Hobby Scene Editor, POPULAR ELECTRONICS, One Park Ave., New York, NY 10016. Though all letters can't be answered individually, those with wide interest will be published.

3 REASONS WHY YOU SHOULD BUY YOUR CALCULATOR FROM 'THE BIG T'

1. YOU GET THE BEST PRICE ... but what happens later when you want an improved model? At Tucker you can trade-up - just like a used car.

CORVUS 310 HAND-HELD PORTABLE 6 function (+, -, x, ÷, %, square root) with automatic constant, 8 digit readout, floating decimal and negative sign and many features.

With disposable batteries ... \$59.95
 Disposable batteries & AC ... 64.95
 Rechargeable batteries & recharger 69.95



CORVUS 322 HAND-HELD PORTABLE WITH MEMORY

- 5 function (+, -, x, ÷, %) with memory
- Floating decimal, floating negative sign, 8 digit display
- Automatic constant of all functions
- Rechargeable battery pack including recharger

\$79.95

2. Guarantees ... 30 day money-back guarantee... One year repair or replace guarantee and THEN TUCKER will repair any unit **after** the warranty expires for only \$9.95 (excluding any shipping and excessive damage)

CORVUS 305 DESK-TOP CALCULATOR WITH CLOCK & CALENDAR

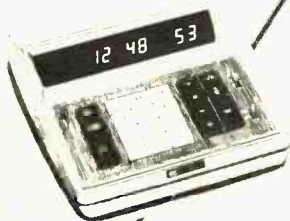

full 7 function (+, -, x, ÷, %, square root and reciprocal) with 10 digit readout, selectable 2-4 or floating decimal, automatic, constant and many features. But when the 305 isn't being used as a calculator it's a digital clock and calendar that keeps perfect time as long as it's plugged in.

Model 305 \$99.95
 Model 300 w/o clock 84.95

3. Convenience ...

You can order by mail and use your Bank cards or American Express with up to 12 months to pay. You can talk to a salesman toll free anytime - just call 800-527-4642.

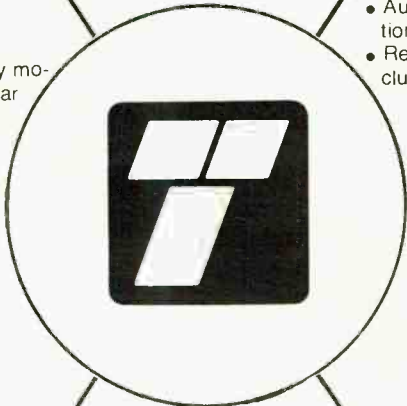

ADD \$2.75 TO EACH ORDER FOR SHIPPING.

Send check, money order, Bank Americard No., Mastercharge No. or American Express No. to: (Residents of Texas, Illinois, New Jersey & California include 5% sales tax)



TUCKER
 ELECTRONICS • COMPANY

P.O. Box No. 1050C
 Garland, Texas 75040

FOR RUSH ORDERS CALL TOLL-FREE 800-527-4642 (In Texas call 214-348-8800)

CIRCLE NO. 30 ON READER SERVICE CARD

TESTING!

with MITS lab quality test equipment

One



SG 1900—The Audio Sweep Generator provides the capabilities of both a fixed frequency (CW) and a sweep generator in a laboratory quality instrument. Modes include CW, linear sweep, and log sweep with a sweep time of 10 milliseconds to 100 seconds. Waveforms are sine, square, and triangle. The range is from 1 Hz to 100 KHz. The output has fixed attenuation levels of 0, 20, and 40 dB \pm 1 dB, as well as continuously variable attenuation.
Prices: Kit \$119.95 Assembled \$149.95

Two



WG 1700—The Waveform Generator/Frequency Counter is well suited to a wide variety of test work. Six carrier waveforms (sine, triangle, square, ramp, sawtooth, and pulse) and three internal AM or FM modulator waveforms (sine, triangle, and square) are featured. The carrier frequency range is 1 Hz to 1.5 MHz in twelve overlapping ranges; the modulator waveform frequency range is 100 Hz to 150 KHz in six overlapping ranges. Both outputs are buffered for low output impedance. The unit also accepts external AM or FM modulating signals. The frequency counter with adjustable sensitivity measures the waveform generator output frequency and frequency of external signals from 1 Hz to over 10 MHz, with input impedance of 100K ohms.
Prices: Kit \$199.95 Assembled \$249.95

Three



DV 1600—The 2-1/2 digit Digital Voltmeter is a perfect companion for MITS' other fine test equipment. Features include full scale measurement of alternating and direct current in five ranges from .1 ma to 1 amp, measurement of AC and DC voltage in four ranges to 1000 volts, and measurement of ohms in six ranges to 10 megohms. The resolution in low ranges for voltage is 10 mv; for current, 10ua; and for resistance, 1 ohm. The DC accuracy is \pm 5% and the AC accuracy is \pm 1%. Other features include autopolarity and 100% overrange capability on all ranges, which effectively doubles full-scale capability.
Prices: Kit \$ 89.95 Assembled \$129.95

Four



ICT 1800—The Integrated Circuit Tester is ideal for testing digital integrated circuits and for breadboarding IC's while developing circuits. The eighteen LED indicators show the status of the IC under test. The internal 5 volt 1 amp power supply, which has overtemperature and overcurrent shutdown capabilities, is also available for external use. The cross bar switch allows complete programming of the IC under test. Other features include an internal two speed clock, single step capability, and four each remote outputs and inputs.
Prices: Kit \$119.95 Assembled \$169.95

Plus

ICT 1810—The Operational Amplifier Tester with fast, simple GO/NO GO test capability tests operational amplifiers for gain, stability, input offset voltage, and input bias current in a dynamic operating environment. A single LED indicates IC status.

Prices: Kit \$29.95 Assembled \$39.95

Power Sale

PS 500—The 5 Volt Power Supply, which has overtemperature and overcurrent shutdown capability, is an ideal unit to power TTL, DTL, and other IC's. Features include load regulation at 0.8% and line regulation at 0.005%. Output voltage is 5 volts \pm .2 volt.

Prices: Kit ~~\$29.95~~ \$19.95 WHILE THEY LAST!

Warranty: Full two-years warranty on assembled units, ninety days on kits.
*Prices subject to change without notice. Available from your local Olson Electronics Dealer.

MITS INC.

"Creative Electronics"

6328 Linn, N.E., Albuquerque, New Mexico 87108
505/265-7553 Telex Number 660401

Enclosed is a Check for \$ _____
 or BankAmericard # _____
 or Master Charge # _____
 Credit Card Expiration Date _____ Kit
 Include \$5.00 for Postage and Handling Assembled
 SG1900 WG1700 DV1600 ICT1800 ICT1810 PS500
 Please Send Information on Entire MITS Line.
 NAME _____
 ADDRESS _____
 CITY _____
 STATE & ZIP _____
MITS/ 6328 Linn, N.E., Albuquerque, New Mexico 87108 505/265-7553 Telex # 660401

CIRCLE NO. 19 ON READER SERVICE CARD

these circles as you can *without crossing lines*. If necessary, reroute lines to obtain the maximum number of interconnects, but pay careful attention to the schematic when you do this.

Use a *red* pencil to interconnect the remaining circles. You can cross the black but *not* the red lines in this step. And do not forget to use the two-color scheme while plotting your progress on the schematic's tracing paper.

You will find that, in a circuit as complex as the Flip's, no amount of rerouting will permit all circles to be interconnected without breaking the line-crossing rule. However, the interconnections can be made by alternating between the red and black patterns, as shown in Fig. 2. Wherever the lines alternate between the patterns, indicate these points with small circles.

When you are finished, check your drawing against the schematic. Then count the red lines. If there are very few, you can opt for a single-sided board, wiring in jumpers for the red lines. On the other hand, many red lines indicate the need for a double-sided board.

If size is of little importance in your project, you can proceed directly to the pencil layout phase of the design procedure. But if you want the board to be as small as possible, you must rearrange your drawing to satisfy this objective. You might have to try several arrangements before settling on the most compact one. This will prove the most time-consuming part of the design procedure, especially with your first few projects. But with a little practice, you will soon acquire an instinct for arrangements.

The Flip's conductor pattern that yields the most compact layout is shown in Fig. 2.

Pencil Layout. You are now going to make a pencil layout of the etching guides, scaling it to the sizes of the components you will be using in the project. Since, from Fig. 2, you already have a rough idea of component arrangement, choose a point at which to start your pencil layout. It is convenient to start with an IC or transistor pad.

As good a place as any to start in our example is the *IC1-IC4* group of pads. Count the vertical red lines, black lines, and alternating-pattern circles between each IC. Then count the horizontal lines and circles between the *IC1/IC4* and *IC5/IC8* groups of pads. Make a list of your counts. Such a list for Fig. 2 might look like:

IC1-IC2: 1R 3B 0C IC5-IC6: 0R 3B 1C
 IC2-IC3: 3R 2B 0C IC6-IC7: 2R 2B 0C
 IC3-IC4: 1R 3B 0C IC7-IC8: 1R 2B 0C
 IC1/IC4-IC5/IC8: 6R 6B 5C

The R, B, and C mean red, black, and circle. Close examination reveals that the circle in the *IC5-IC6* entry does not interfere with the lines between the IC's and can be disregarded. Similarly, the two red lines in the *IC6-IC7* entry do not interfere with each other; they can be counted as one line.

Armed with your list, draw on graph-paper-backed tracing paper the IC-pad circles. It is a good idea to work in a 2:1 scale to avoid possible confusion. Pay strict attention to component-lead spacing.

Once the IC-pad circles are properly located and spaced, write X2 BOTTOM in black pencil on the bottom of the tracing paper. Next to this, in red pencil, write TOP. These references tell you that the scale is 2:1 and that the black and red lines in the pattern you are about to draw refer to the bottom and top etching guides, respectively.

Working very carefully, transfer all of the pattern information contained in your rear-

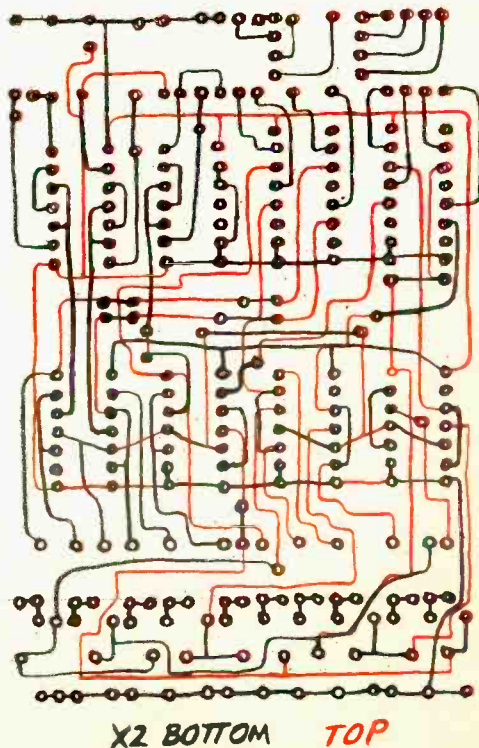

Fig. 2. Rearrange conductor pattern, using two colors, to obtain minimum-size layout.

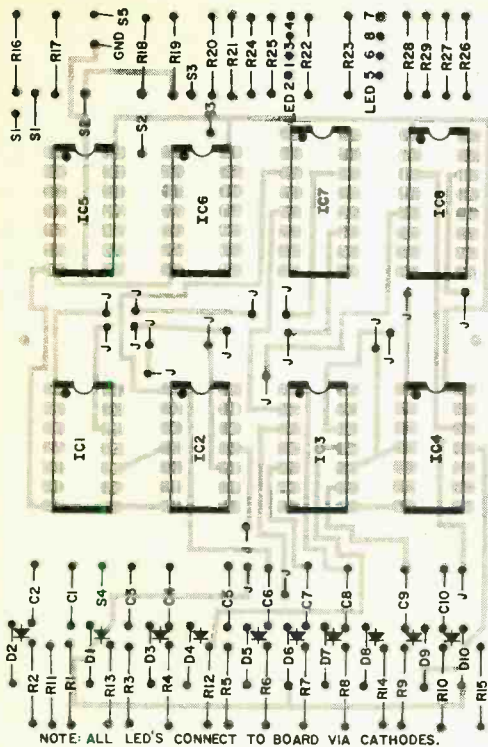

Fig. 3. Indicate exact location and orientation of each component on layout diagram.

ranged composite drawing to the tracing paper on which you drew the IC-pad circles. Use the two-color scheme. You do not have to be very neat, but you must be accurate. Our drawing in Fig. 2 shows the minimum-size arrangement of the schematic in Fig. 1 and is accurately sized to the components used in the Flip, although it is shown reduced to conserve space.

As you become expert in laying out double-sided pc etching guides, you will also learn to combine the rough and finished pencil layouts into one accurately scaled drawing operation. But until you gain familiarity, it is best to perform the two steps separately.

Place another sheet of tracing paper over your pencil layout. On this, indicate all component locations and orientations and all points where feedthroughs are to be used. The component-placement guide for the Flip, indicated on the top etching guide, is shown in Fig. 3. The J's indicate the feedthrough points.

Again, carefully check your work against the schematic. It is essential that you catch errors before proceeding to the finished etch-

ing guide steps. Experience has revealed that you will be more alert if you allow several hours, preferably overnight, of rest between finishing the layout and checking it out.

Exposure Masks. To compose the actual-size etching guides that will be used as exposure masks with presensitized pc blanks, use drafting aids and tapes obtained only from pc materials suppliers. You will need clear Mylar® film (designed for pc work) on which to compose the guides. Also, have handy an X-acto® knife and graph and tracing paper, and work in a well-lighted area.

Measure the length and width of your pencil layout, and divide these figures in half. You now know the sizes of your etching guides and the size of your working area. Add one inch all around; then cut two pieces of Mylar film and one piece of tracing paper to the latter dimensions.

Tape down a piece of Mylar film on a sheet of 10-division/inch graph paper. Very carefully lay out on it the bottom etching guide's pattern (black lines in your pencil layout) with the appropriate drafting aids and tape. To do this, you must *first turn over your pencil layout* to properly view and lay out the bottom etching guide. When you turn over the layout, carefully realign it on its graph-paper backing and put aside the components placement guide. Divide all spacings in half, and transfer the circles and black lines to the film.

When the bottom guide pattern has been transferred, flip over the film and pencil layout. Carefully realign them on their re-

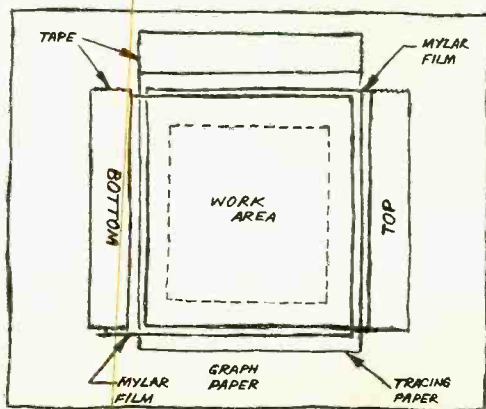

Fig. 4. Set up work area on graph paper. Tape down and identify Mylar film so that sheets open alternately to left and right.

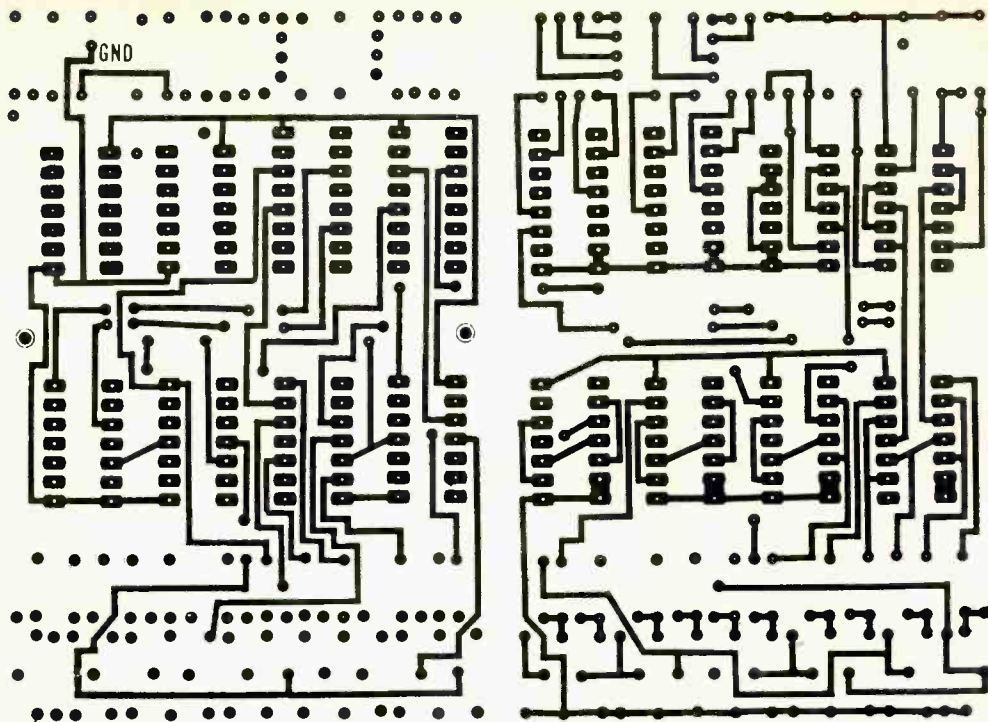

Fig. 5. Double-sided etching guides for Flip are shown from the foil sides.

spective sheets of graph paper. When you tape down the bottom etching guide, do so along only one edge to allow it to swing open to the left or right and write **BOTTOM** on the tape. Follow this with the blank Mylar film, taping it along the opposite edge and writing **TOP** on the tape. Finish up with the tracing paper taped to permit it to swing toward the top. (See Fig. 4 for details.)

Set the bottom etching guide in place. Burnish down the bottom etching guide pattern with a blunt instrument. (A Popsicle stick or tongue depressor will do nicely.) Burnishing is necessary to seat the drafting aids and tapes on the film. Apply firm strokes, but not so firm that they shift the aids or tapes.

Swing the blank Mylar film into place on the bottom etching guide, but not the tracing paper. Very carefully repeat *all* pads from the bottom etching guide on the blank film. Pay special attention to alignment. Then slip the tracing paper between the two sheets of film. It will prevent any black-on-black confusion from cropping up, while allowing a clear view of the bottom etching guide. Now, complete the top etching guide by interconnecting the appropriate

circles indicated in the red pencil layout. Burnish down the drafting aids and tapes.

Remove both guides from the graph paper and place them artwork-side-up in front of you. Apply to the bottom of each a strip of Scotch[®] Magic transparent tape. Follow by using a ball-point pen to write the project's name, **FOIL SIDE**, and **TOP** and **BOTTOM** on the respective guides.

Set aside the top etching guide. Then use a crow-quill pen and India ink to fill in all transparent component-lead holes in the pads of the bottom etching guide. The filled-in holes will provide for a small registration error between the top and bottom pattern when the board is etched and drilled. If these holes are not filled in, it is possible that drilling might remove too much copper from misregistered copper pads.

You now have etching guides that can be used just as they are to expose positive-resist pc blanks. But if you are using negative-resist blanks, the guides must be reversed. This is a simple process that is easily accomplished with a reversing-film kit available from some pc materials suppliers.

The etching guides for the Flip are shown in Fig. 5. For component placement and orientation, refer back to Fig. 3.

Exposing the Blank. To expose a presensitized pc blank with double-sided board masks, start by carefully aligning the two masks, back-to-back, and taping them together so that they cannot shift. Working in a safe-lighted area, tape the mask pair down on a presensitized pc blank. Then drill two or more small holes through both masks and the blank. Use holes in the pattern. Remove the masks and replace the blank in its light-tight shipping container.

Cut off the heads of as many small wire brads as you have holes drilled. Select brads that are just large enough to fit into the drilled holes with the absolute minimum of play without binding. File flat the cut ends of the brads.

Place a sheet of flat black art paper on a block of rigid polystyrene foam (available from florists and plastics specialty shops). Go back to safe lighting after separating the exposure masks. Place the presensitized

blank through which the holes were drilled over the paper-covered foam block and fill each hole with a brad. Press down on the brads until only about $\frac{1}{8}$ inch protrudes above the surface of the blank.

Align the holes in the appropriate exposure mask with the protruding brads and force the mask flat against the blank. Place a sheet of glass over the whole assembly, pressing down only until the exposure mask is in intimate contact with the blank. Expose the blank according to the manufacturer's directions.

Switch back to safe lighting and remove the glass and mask. Remove the blank, handling it only by its edges, and immediately flip it over. Remove the brads from the foam block. Then place the flipped-over blank on the paper-topped block and replace the brads in the holes. Follow the procedure outlined above to set up and expose the second side of the blank. Make absolutely certain that the second exposure mask is properly oriented.

When both sides of the blank have been exposed, develop the blank according to the manufacturer's instructions. Then, after inspecting the developed blank to check that the exposure has taken, etch away the unwanted copper.

Final Steps. The etched board (it is a board once etching has taken place) can now be trimmed to size and all holes can be drilled. Drill from the top of the board, keeping the tool perpendicular to the board's surface. Check frequently for proper hole alignment in the top and bottom copper pads.

After drilling all holes, refer to your component placement guide and immediately solder into place the feedthroughs. Solder both sides of the board; then clip away the excess wire as close as possible to the board. Mount the components in their respective locations, soldering their leads to the foil pattern on both sides of the board. (Note: Because the holes in homemade boards are not plated-through, you must solder to the patterns on both sides of the board. This means that you cannot use IC and transistor sockets that do not provide top-of-the-board access to their leads. If you wish to use sockets, substitute Molex Soldercons®.)

You have now designed and fabricated your own double-sided pc board. Good luck on your next project. ◆

PC MATERIALS SUPPLIERS

Following is a partial list of manufacturers and suppliers of materials for use in making double-sided pc boards. Included are summaries of items available from each.

Bishop Graphics, Inc. (7300 Radford Ave., North Hollywood, CA 91605): Quantity sales of drafting aids and tapes, precision graphed glass and film, polyester drafting film, etc. (Send 50¢ for Technical Manual & Catalog No. 105.) Also available are no-etch "Circuit Zaps."

GC Electronics (400 S. Wyman St., Rockford, IL 61101): Small-quantity sales of drafting aids and tapes, layout film, developing and etching trays, photoresist chemicals, etchant, pc blanks, exposure frame, kits. (Send 50¢ for Printed Circuit Handbook No. FR-161 for complete instructions on how to make single-sided pc boards. Handbook includes listing of complete line of pc materials available.)

Kepro Circuit Systems Inc. (3630 Scarlet Oak Blvd., St. Louis, MO 63122): Pc blanks, photoresist chemicals, etchant, photo layout kit (includes tapes and drafting aids), all-in-one kits, photoreversing (film) kit.

Techniques Inc. (235 Jackson St., Englewood, NJ 07631): All types of drafting and fabrication kits, etchant, photoresist chemicals, pc blanks, tools, reversing film kit, etc.

Vector Electronic Co., Inc. (12460 Gladstone Ave., Sylmar, CA 91342): Direct positive photoresist kits, double-clad pc blanks, drafting aids, chemicals.

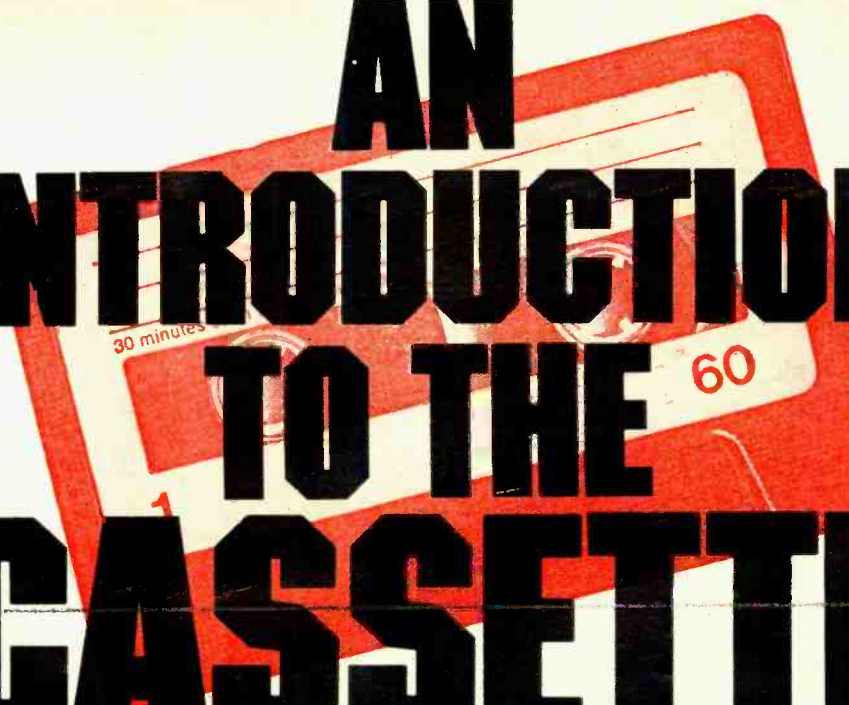

AN INTRODUCTION TO THE CASSETTE

*How it differs from other formats
and the advantages it offers the recordist*

BY SCOTT WAVERLY

CASSETTES are currently the most popular tape medium for audio recording purposes. To place the cassette into proper perspective, let us first examine competitive systems.

The home recording enthusiast has available to him three basic, non-interchangeable tape systems. The first and longest lived is the traditional open-reel system. The second is the reel-to-reel closed-system cassette. And the third is the eight-track cartridge. Since cassette tapes, like the eight-track cartridge tapes, are enclosed in small plastic containers, they are often inappropriately referred to as "cartridges." For clarity, let us restrict the term "cartridge" to the eight-track tape format.

Cassettes are actually miniature versions of the open-reel format with the main differences being that tape and "reels" are housed in a sealed plastic container and track widths are only half that of standard open-reel tapes. The plastic container, measuring roughly $4'' \times 2\frac{1}{2}'' \times \frac{1}{2}''$, offers two

advantages over conventional open-reel tapes. First, storage is simplified. Secondly, the sealed container necessitates that the tape be moored to the hub reels, which eliminates the bother of having to thread the tape every time the recorder is loaded.

Like conventional open-reel tapes, cassettes can record and play back up to four separate tracks. Unlike open-reel tapes, however, they are only slightly more than $\frac{1}{8}$ -in. wide and are designed to travel at a tape speed of only $1\frac{1}{2}$ ips. In contrast, most open-reel tapes travel at a speed of $7\frac{1}{2}$ or $3\frac{3}{4}$ ips.

Eight-track cartridges are physically much larger than cassettes, measuring about $5\frac{1}{4}'' \times 3\frac{3}{8}'' \times \frac{3}{8}''$. They are designed to run at a tape speed of $3\frac{3}{4}$ ips, and tape width is $\frac{1}{8}$ in. The tape is treated with a special lubricant that permits it to be pulled out from the inside of a fully-wound tape pack, passed across the recorder's heads, and then taken up on the outside of the tape pack. Thus, there is only one "reel" in a cartridge, and it serves both feed and take-up functions.

INTRODUCTION TO THE CASSETTE

CONTINUED

The ends of the tape are joined together to make a continuous, unbroken loop.

Which of these three incompatible tape systems is best for you is a personal decision. If hands-off convenience in playing tapes is your chief criterion, the overall ranking would be eight-track cartridge first, cassette second, and open-reel third. On the other hand, if high-fidelity sound is your main objective, the order would be exactly the reverse.

Speeds & Tracks. To see what the cassette is up against, let us compare it to a studio master recorder. The latter uses "half-track" stereo heads so that each of the two channels occupies a full one-half of the standard $\frac{1}{4}$ -in. track width. It also operates at a tape travel speed of 15 ips. In quantitative terms, the width of each of its tracks is 0.08 in. The track width of the ordinary quarter-track tape machine is 0.043 in., while the width for a cassette is 0.022 in.

Every time track width is cut in half, about 3 dB is lost in signal-to-noise ratio (S/N), mostly in hiss products. Going from the track width of the master to the track width of the cassette, you have two such halvings. The total loss is 6 dB S/N. But you are not finished with losses yet, because speed also affects the S/N; every time you halve the speed, you also lose about 3 dB S/N. Three halvings (from 15 ips to $1\frac{1}{4}$ ips) adds up to almost 9 dB. Add the track width and tape speed losses together, and you have almost 15 dB S/N losses between the studio master and cassette tape.

If the professional machine has an impeccable 65-dB S/N figure, the cassette machine would come in at 50 dB S/N at most—about the background hiss level of a none-too-good FM tuner. This is assuming the unlikely proposition that the cassette recorder's electronic circuits are as sophisticated and noise-free as those of a studio machine.

The end of our difficulties is not in sight yet. At 15 ips, each cycle of a 15,000-Hz flute overtone will occupy 0.001 in. of tape. It is easy enough to design tape recorder

heads to record and play back a signal with a 1-mil (0.001-in.) wavelength. But at the cassette's low speed, one second's worth of the same signal must be compacted into $1\frac{1}{4}$ in. of tape, yielding a wavelength of 0.000125 in. Making heads that will resolve that short a wavelength is a challenge. Amazingly, thanks in no small part to special oxides developed specifically for cassette use, such resolution has been achieved.

Tapes for Cassettes. The magnetic tape used in cassettes consists of three basic parts. It starts with a polyester backing material that, in a typical C-60 cassette, is about as thick as that used for 3600-ft open-reel tapes. On this backing is a thin coating, generally on the order of 0.0002-in. thick, of magnetic particles (the oxide). The oxide is held to the backing by a flexible glue known as the "binder."

The standard magnetic material used in cassettes, cartridges, and open-reel tapes is gamma-ferric oxide, a crystalline, needle-shaped material whose length ranges from about 4 to 10 times its diameter. There are "high-energy" cassette tapes "doped" with cobalt to provide a somewhat higher output and better high-frequency response. Chromium dioxide tapes also yield high performance but require changes in the deck's record level, bias current and equalization (usually via a switch built into the deck). Today's best ferric-oxide tapes have a frequency response curve similar to that of chromium-dioxide tapes.

Tape & Machine. The recorder adjustments referred to above represent a series of compromises between the desirable goals: low distortion, high S/N, and extended high-frequency response. Unless you are technically familiar with tape recorder circuits, there is not much you can do to optimize the compromise made at the factory for your specific recorder and a particular type of tape. But understanding the interrelation of the three factors may explain why one brand of tape seems to work best on your machine.

Low-distortion recording is made possible by adding an ultrasonic (say 80-kHz) current known as "bias" to the audio signal that is actually recorded on the tape. Up to a point, increasing the bias current level increases both the playback and output of the tape, thus bettering the S part of the S/N. It also lowers the distortion. Unfortu-

nately, however, the bias level that produces maximum undistorted output at low frequencies has the effect of partially erasing the high-frequency signals.

Lowering the bias level would aid in recording and reproducing highs, but at the cost of greater overall distortion. In general, open-reel recorders are slightly over-biased, while cassette decks may be slightly under-biased, which explains why cassettes ordinarily reveal slightly higher distortion at a 0-VU record level than do open-reel decks. Even so, a considerable treble loss in recording is incurred in cassettes. This must be compensated for in advance by boosting the high frequencies before they reach the tape, a process known as "equalization". On a typical cassette deck, it might amount to about 12 dB pre-emphasis at 10,000 Hz.

The treble pre-emphasis causes no problems as long as the musical energy at 10,000 Hz is about 12 dB below the record level that reads 0 VU on the meter, which is most of the time. When the music hits a lot of high-frequency signal energy, the tape is going to be driven into distortion.

Cassette tapes that have a built-in high sensitivity for the treble range require less pre-emphasis to achieve flat response. Thus, chromium-dioxide tape is much less prone to distortion. Unfortunately, it requires about a 4 dB increase in bias current and a higher record level to be maximized. If your machine is not equipped to provide these, a premium ferric-oxide tape that uses smaller particles and packs more of them into every inch for improved S/N is best.

Advantages of Cassettes. While the cassette does not equal the open-reel tape format in flexibility and fidelity, it has several advantages to recommend it for home entertainment use. First of all, it is a convenient and easy-to-store format that requires little space.

With modern noise-reduction circuitry (Dolby and others), the inherently low S/N figures of the early days of the cassette have been improved by as much as 10 dB. Frequency ranges have been extended by new tape formulations and better electronics. In the machines themselves, voltage regulation in the capstan motor drive circuits has considerably reduced wow and flutter.

In all, the cassette is a viable tape medium for all but the most critical listener, who might opt for open-reel's editing ease, special effects, etc. ♦

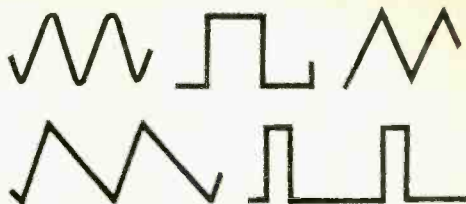

0.1 Hz. to 100 KHz.



For only \$39.95

Our new FG-2 Function Generator kit gives you all five of the most useful waveforms for design and testing at one fourth the cost of previous similar instruments. Thanks to improved IC's the FG-2 now features amplitude stability of ± 1 db over any range, Sine wave distortion of less than 1% from 20 Hz. to 20,000 Hz. and an output of 4.0 Volts peak-to-peak with adjustable offset. The offset selector lets you put the positive peak, negative peak, or the center of the waveform on DC ground. The DC coupled circuit keeps the waveforms in exactly the same position no matter what the level control setting.

Gray impact plastic case 5" x 6" x 2". 115 Volts 60 cycle power supply included.

FG-2 Function Generator Kit
shipping weight 3.0 lbs. \$39.95 + postage.

GET OUR

NEW 1974 CATALOG

listing this and other unique kits

"FREE"

by simply circling our number
on the reader service card.



**SOUTHWEST TECHNICAL
PRODUCTS CORPORATION**

DEPT. PE

219 W. Rhapsody, San Antonio, Texas 78216

CIRCLE NO. 27 ON READER SERVICE CARD

The better the the better you

And
you can
get started
for just
\$10.

COMPU-TRAINER

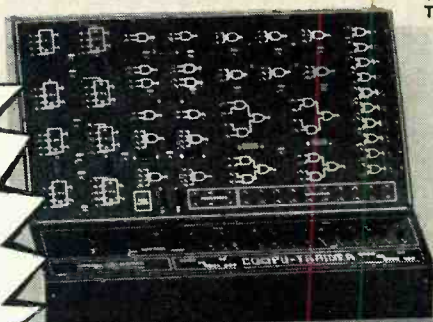

TUBE & TRANSISTOR
TESTER



SOLID STATE
OSCILLOSCOPE

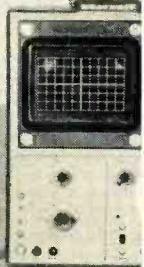

DIGITAL
MULTIMETER

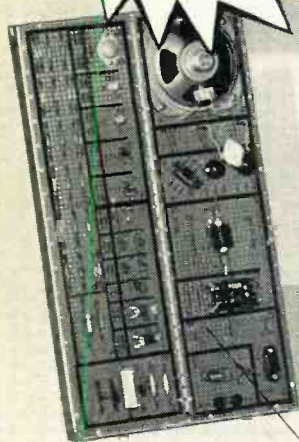

ELECTRO-LAB

NTS DIGITAL GR-2000 SOLID STATE
COLOR TV WITH 315 SQ. IN. PICTURE
AND VARACTOR DIGITAL TUNING

TROUBLESHOOTER
VOM

Only \$10 down gets you into any NTS Home-Study Courses in Electronics.* Just \$10 that can lead to a top-dollar job, a big, bright career in electronics.

As an NTS student, you'll acquire the experience and know-how that comes with first hand training on NTS "pro" equipment. Equipment you'll build and keep. Our courses include equipment like the 5" solid-state oscilloscope, a transistor and tube-tester, a vector monitor scope, 74 sq. in. B&W TV, or a solid-state stereo AM-FM receiver. The unique

new NTS Digital GR-2000 Color TV with first-ever features like silent varactor diode tuning; digital channel selection, digital clock, an option at additional cost; and big 315 sq. in. ultra rectangular screen. This is just a sampling of the kind of better equipment that gets you better equipped for the electronics industry.

By following the easy-to-read NTS lessons, you learn the theory behind these tools of the trade. You'll learn and develop skill and confidence fast.

*Not including Advanced Color TV Servicing

equipment will be equipped.

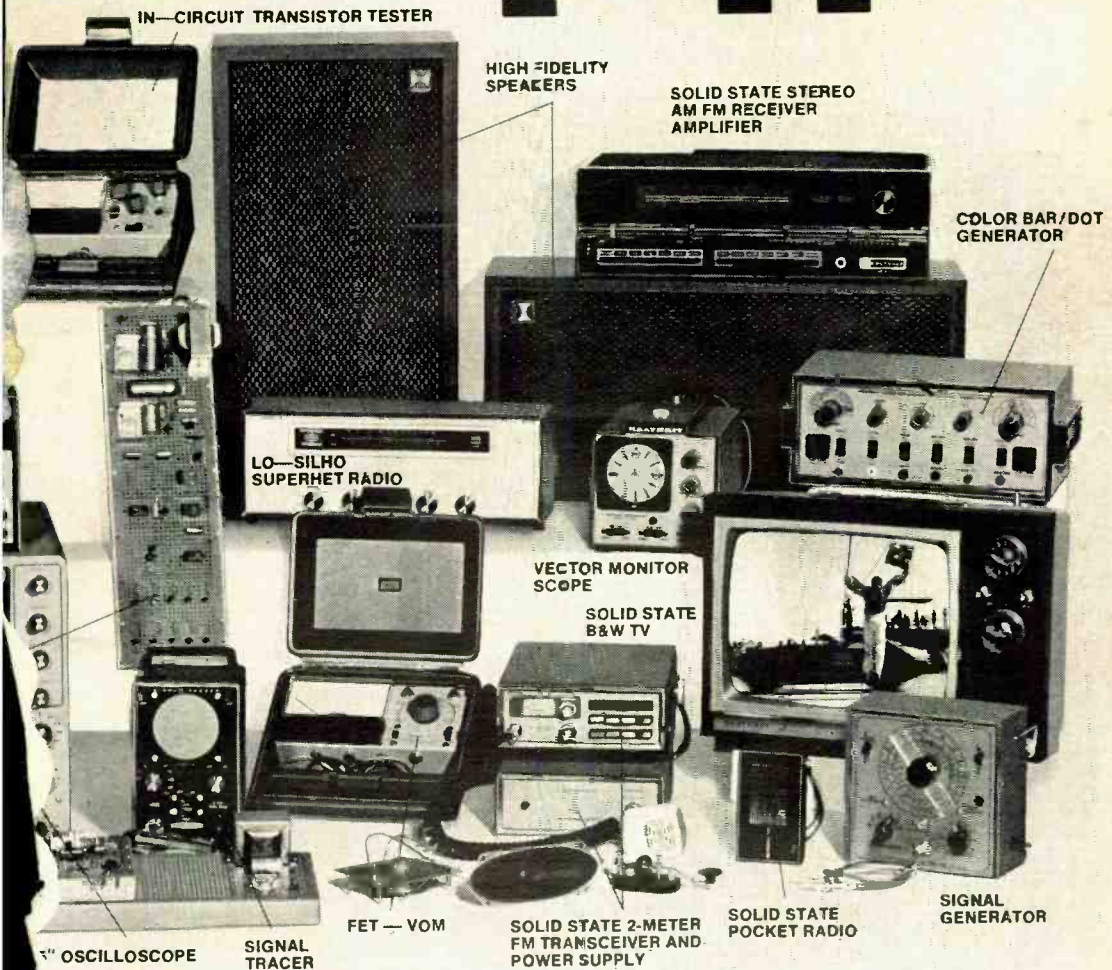

Choose from 12 NTS Electronics Courses, including Color TV and B&W TV Servicing, Electronics and Computer Technology, Electronics Communications & FCC, and Industrial & Automation Electronics. All courses can provide you excellent opportunities to expand your career in the exciting world of electronics! So get started right now by checking the coupon and mailing it today.

Classroom Training at Los Angeles. You can take classroom training at Los Angeles in sunny Southern California. NTS occupies a city block with over

a million dollars in facilities devoted exclusively to technical training. Check box in coupon.

Approved for Veteran Training. Accredited Member: National Association of Trade & Technical Schools; National Home Study Council

NATIONAL TECHNICAL SCHOOLS
 TECHNICAL-TRADE TRAINING SINCE 1905
 Resident & Home Study Schools
 4000 South Figueroa St., Los Angeles, Calif. 90037

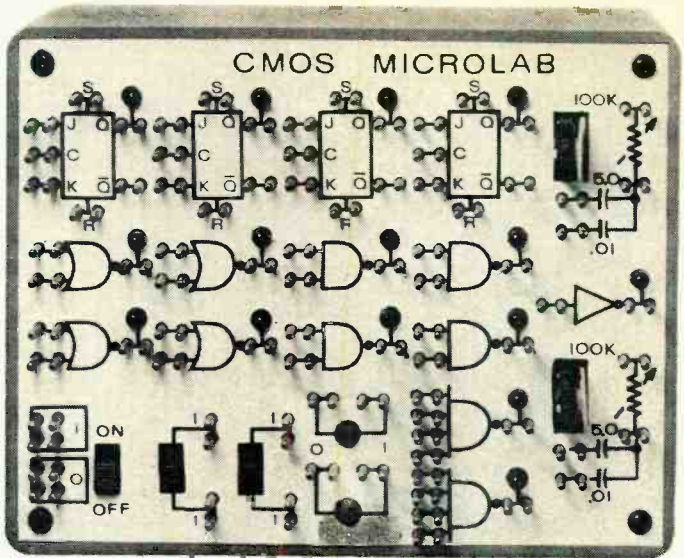

**BUILD
THE**

CMOS MICROLAB

Teach or learn digital logic . . .

Breadboard or test digital circuits . . .

With this state-of-the-art CMOS system

BY DON LANCASTER

EXPERIMENTING is an important part of the learning process, so anyone interested in understanding digital logic will want to have this CMOS Microlab to gain practical experience. It contains four JK/RS flip-flops, four NOR gates, six NAND gates and an inverter/TTL driver. Each section has all terminals available on the front panel and they can be easily interconnected with a solder-free push-on patchcord system. Each logic block also has its own LED to indicate the state of the block. The Microlab can be constructed for about \$35, is battery powered and fits in a 5" by 7" by 2" box.

The logic functions are controlled by two bounceless slide switches and two bounceless pushbuttons. Two RC networks provide for visual rate or oscilloscope rate (mid-audio) clocks, astables, monostables, and pulse networks. The single inverter can be used as a source or sink for 8 mA, making

the system compatible with TTL, DTL, RTL, PMOS, or other CMOS units. Four additional TTL unity-fanout outputs are also available.

A feature of the Microlab, for learning purposes, is that making the wrong connections between units cannot cause any damage. Also, if a connection that is not too important is forgotten, the circuit anticipates what the experimenter is trying to do and tries to provide a response anyway. For instance, without external connections, all unused logic blocks are turned off; and gates with only one input automatically convert to inverters. A flip-flop without J and K connections tries to toggle; without R and S connections, direct inputs are disabled.

About the Circuit. There are 21 independent circuits in the Microlab. Only one of
(Continued on page 42)

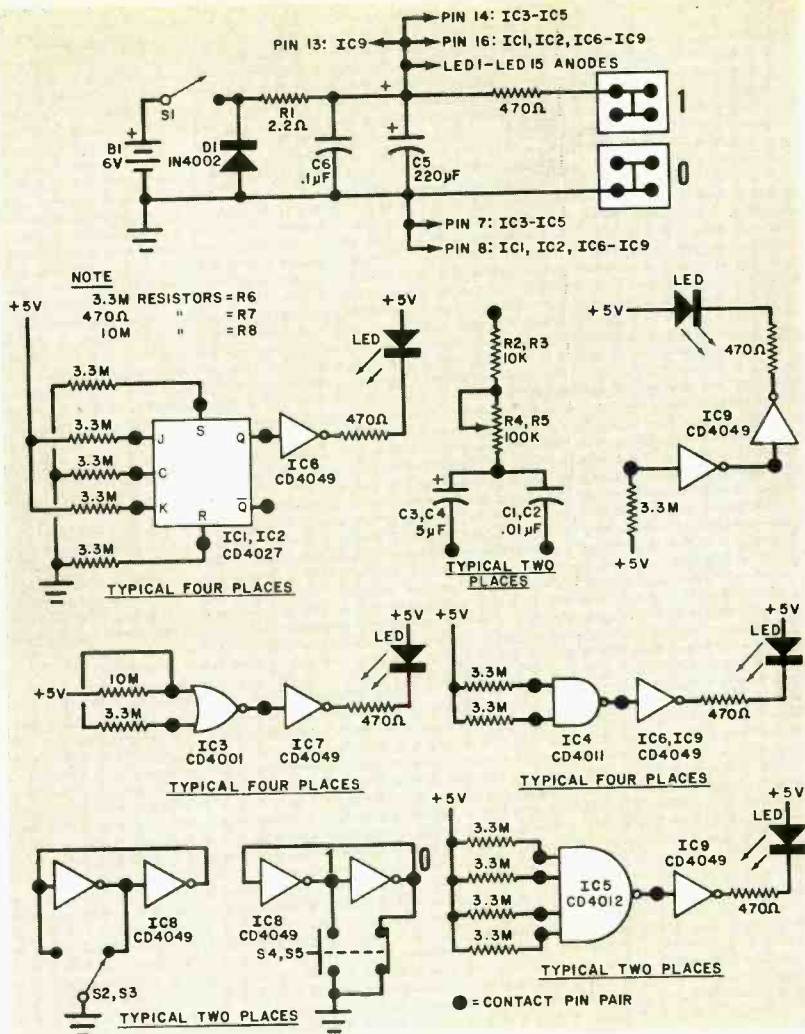

Fig. 1. One of each type of logic block is shown. Power supply is at top.

PARTS LIST

- B1—Four 1.5-VD cells
 C1, C2—0.01- μ F Mylar capacitor
 C3, C4—5- μ F aluminum electrolytic (not tantalum)
 C5—220- μ F, 6-volt electrolytic capacitor
 C6—0.1- μ F, 10-volt disc capacitor
 D1—1N4002 silicon power diode (or similar)
 IC1, IC2—CD4027, MC14027 (CMOS dual JK/RS flip-flop)
 IC3—CD4001 (CMOS quad NOR gate)
 IC4—CD4011 (CMOS quad NAND gate)
 IC5—CD4012 (CMOS dual NAND gate)
 IC6-IC9—CD4049 (CMOS hex inverter)
 LED—0.2" diameter light-emitting diode (15 required)
 R1—2.2- or 2.7-ohm, 1/2-watt resistor
 R2, R3—10,000-ohm, 1/4-watt resistor
 R4, R5—100,000-ohm upright trim potentiometer (Piher Mfg. or similar)
 R6—3.3-megohm, 1/4-watt resistor (40 required)

- R7—470-ohm, 1/4-watt resistor (16 required)
 R8—10-megohm, 1/4-watt resistor (4 required)

- S1—Spst slide switch
 S2, S3—Spdt slide switch
 S4, S5—Spdt pushbutton switch, non-shorting
 Misc.—Pins (0.093" diameter, Bead Chain or Molex R93-12, 168 required); terminals (Molex 02-09-1118 or 02-08-1101); suitable plastic case (Nobex 875); front cover (matched to pc board); mounting hardware; quad D-cell holder (Keystone 200); heat-shrinkable tubing; stranded hookup wire; etc.

Note: The following are available from Southwest Technical Products, 219 W. Rhapsody, San Antonio, TX 78216: pc board, etched and drilled, at \$8.75; complete kit of all parts (except for D cells) at \$34.95, plus postage for 3 lb. Actual-size pc foil patterns and component installation diagrams are free on request.

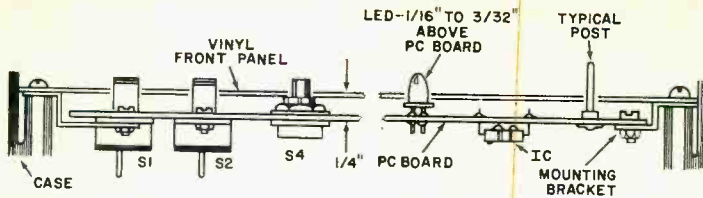

Fig. 2. Mounting details and component spacing for circuit board.

each type is shown in Fig. 1. The power supply, which is common to all, is also shown.

Note that each circuit has a pin connector (dark circle) at each active input or output. This actually indicates a pair of solderless push-on connectors. Each circuit (except for the 0-1 switches) also has its own inverter-LED driver. The two pushbutton switches are made bounceless by a pair of inverters arranged as a set-reset flip-flop.

A high resistance is used on the active inputs (connected either to ground, the supply, or another input) so that the LED is off if a block is unused. It also converts a gate into an inverter if only one input is used and changes a flip-flop into a binary divider if only the clock input is connected.

Four D cells are used for power. Since each LED uses about 7 mA, several hundred hours of operation can be obtained from one set of batteries. With such low power consumption, ordinary D cells work better than the more expensive alkaline types. Reverse polarity protection is provided by diode *DI*.

Construction. The circuit board is double-sided, preferably with plated-through holes. Foil patterns and component layout diagrams are available *free* from the source given in the Parts List.

Assemble the five switches, the LED's and posts as shown in Fig. 2. Note that only the LED's, the two thumbwheel potentiometers, and the 168 connecting pins are mounted on one side of the board. Install the resistors, capacitors, and the diode on the other side of the board, along with the Molex IC terminals (if used). Do not install the IC's at this time.

Be sure that all connecting pins are cleanly soldered to the non-component side of the board and that they are square to the board. Keep in mind that the pins must pass cleanly through the mating holes on the front panel. When installing the LED's note that the flat side of the LED goes to the inverter and current-limiting resistor. If one of the

LED's leads is longer than the other, the longer one is the anode and goes to the positive supply.

Install the LED's so that they are about 1/16" or 3/32" above the board. If you have trouble soldering under the LED, first solder it in place with a slightly higher spacing. Then heat the pins from the underside of the board while pushing the LED into final position. Remember also that the LED's must fit into a mating hole on the front panel.

The power supply should be assembled next and connected to the pc board with the four pins marked "1" at +5 volts and the four "0" pins at ground.

Now make up the push-on interconnecting wires as shown in Fig. 3. Crimp and solder each end of the flexible stranded hookup wire to a connector. You will want about 24 of these wires, varying in lengths from 6" to 10". After they are fabricated, slip heat-shrinkable tubing over the joints between the connectors and wire so that the wire, solder joint, and connector are covered. You can use the ceramic portion of a soldering iron for the heat source. Pre-condition each connector by slipping it on and off a pin several times until it works freely.

For the following steps, connect a milliammeter across power switch *S1*. If the current ever exceeds 7 mA per LED (when lit) stop and check the circuit.

Install *IC7* (hex inverter) and *IC3* (quad

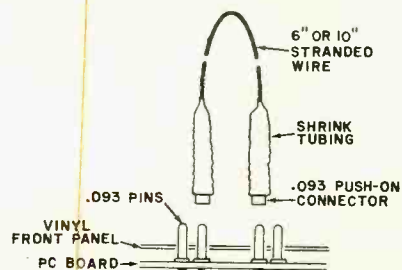

Fig. 3. How to make interconnecting jumpers. Make up about 24 of them.

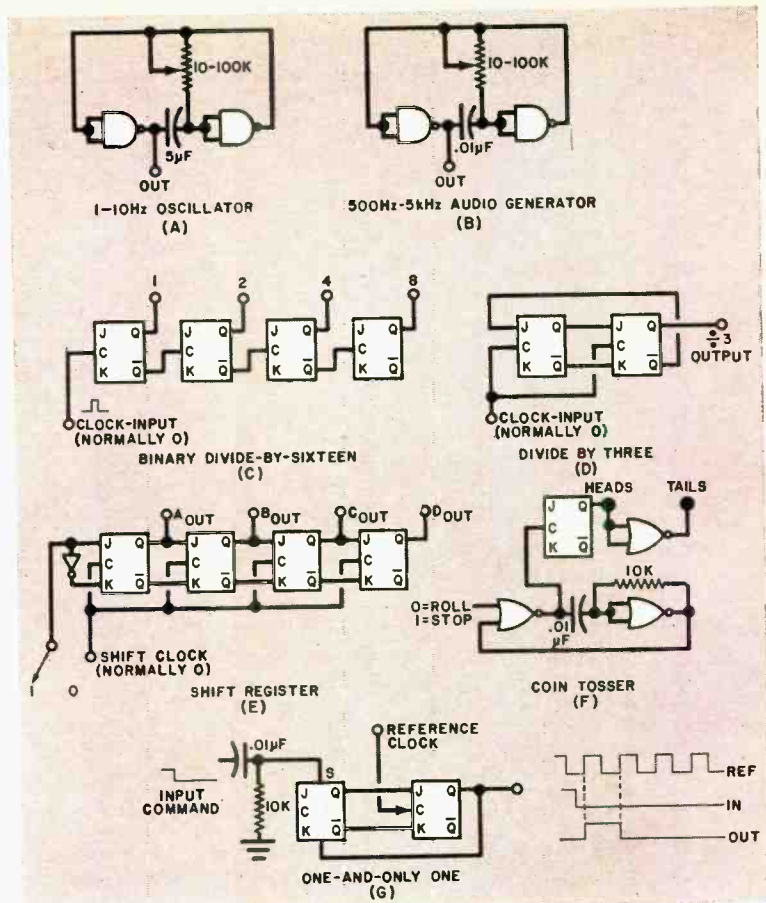

Fig. 4. Some examples of the circuits that can be built up using the Microlab. There are many others, of course, that will be of interest.

NOR gate) noting the notch-and-dot code on the IC and on the component installation drawing.

Connect one end of a test cable to one of the "0" points on the lower left corner of the board. Touch the other end of the cable to all four pins at each NOR gate. The associated LED should come on when the contact is made.

Next install IC5 (dual NAND gate) and IC9 (hex inverter), observing the notch-and-dot code. Again, touching the "0" lead to each of the input pins should cause the associated LED to light.

Install IC6 (hex inverter) and IC4 (quad NAND gate), and repeat the test with the "0" lead.

Install the remaining hex inverter and check the operation of the four "0" and "1" bounceless switches by using them as the driving signals for one of the gates.

Install IC1 and IC2 (dual flip-flop). At this point, it is advisable to build the low-frequency oscillator shown in Fig. 4A, using a pair of NAND gates and one of the time-constant circuits. When this is done, you will note that the LED associated with each NAND gate blinks on and off at a frequency dependent on the setting of the potentiometer.

Using a long test lead, connect one of the NAND-gate outputs to the "C" input of the first (left side) flip-flop. The associated LED will blink on and off at half of the oscillator rate. Connect the not-Q output of that flip-flop to the "C" input of the next flip-flop and note that its associated LED blinks at half rate. Repeat this procedure with the final two flip-flops, noting that each flip-flop LED blinks at half the rate of the preceding one. (Actually you will be building the divide-by-16 circuit shown in Fig. 4C.)

WHY CMOS?

Devices for digital logic circuits are constantly being improved. Today, just about the best type of logic, operating at a reasonable speed, is the CMOS family (Complementary Symmetry Metal Oxide Semiconductor). What makes CMOS so good? There are three main reasons.

First, CMOS requires very little power from the supply—in the nanowatt range if the switching speed is low. This property of CMOS is due to the fact that the inputs are essentially open circuits. They only sense voltage variations, so that there is simply a low-impedance path, either to the positive supply or ground, but never both. Thus, they don't draw current from the preceding stage, nor do they feed current back from the supply.

Secondly, CMOS does not require complicated circuit designs. The power supply can be anywhere between 3 and 18 volts, without regulation or exceptional bypassing. What's more, since all inputs are voltage-sensing one logic block can easily drive 50, 100, or more inputs. Worries about fan-out, fan-in, and loading are thus eliminated. The open-circuit inputs provide many possibilities for de-

signing pulse-shaping circuits or astable, monostable, and Schmitt triggers—all using large-value resistors and small-value capacitors. Unlike most other types of logic, CMOS logic can be triggered with either polarity of the initiating pulse. The latter can be a negative pulse from the supply or a positive pulse from ground). This feature is useful in designing oscillators, contact conditioners, pulse generators, and time-interval generators. And the number of components used in these circuits is low. For example, only one resistor and one capacitor are needed for a free-running oscillator.

The third big plus for CMOS is its exceptional noise performance. It generates no large spikes during switching. Since it switches at one half of the supply voltage, any noise less than 40 to 45% of the supply is generally ignored. In addition, CMOS rise and fall times are usually slower than its transition times, so that noise is attenuated instead of being passed on to the following logic stage.

Right now, CMOS is not the cheapest type of logic; but, at \$2 for a dual JK/RS flip-flop and \$1 for a quad gate, it is competitive for most applications.

You can now connect the output of any flip-flop to any of the inputs of any of the gates or the inverter and note that the associated LED goes on and off in step with the input signal.

Using the Microlab. Some basic logic circuits for "starters" are shown in Fig. 4. An astable oscillator, using a pair of NAND gates is shown in Fig. 4A. With the 5- μ F capacitor, the rate can be varied from about one to 10 per second. This can be observed on the associated LED's. Changing the capacitor to 0.01 μ F makes an oscillator whose frequency ranges from 500 Hz to about 5 kHz.

A conventional four-stage binary counter is made as shown in Fig. 4C and the states are readily shown by the LED at each flip-flop. If you use the low-speed oscillator as the clock input, you can watch the progression. Figure 4D is a divide-by-three counter, while Fig. 4E demonstrates the operation of a shift register.

An elementary game can be built using the "heads/tails" circuit of Fig 4F. The on/off gating can use one of the switches

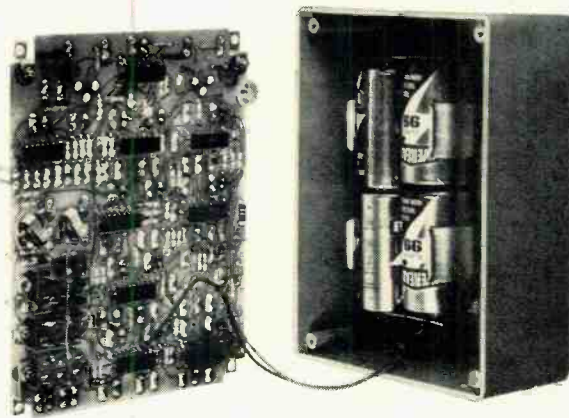

The photo shows the back of Microlab circuit board as it is attached to power supply.

at the bottom of the board. The very useful "one-and-only-one" circuit in Fig. 4G produces one whole cycle when the switch command is executed.

For a test sequencer, use the inverter as a TTL output with a fanout of five or more. For more TTL outputs, parallel the inputs of one NOR gate. ♦

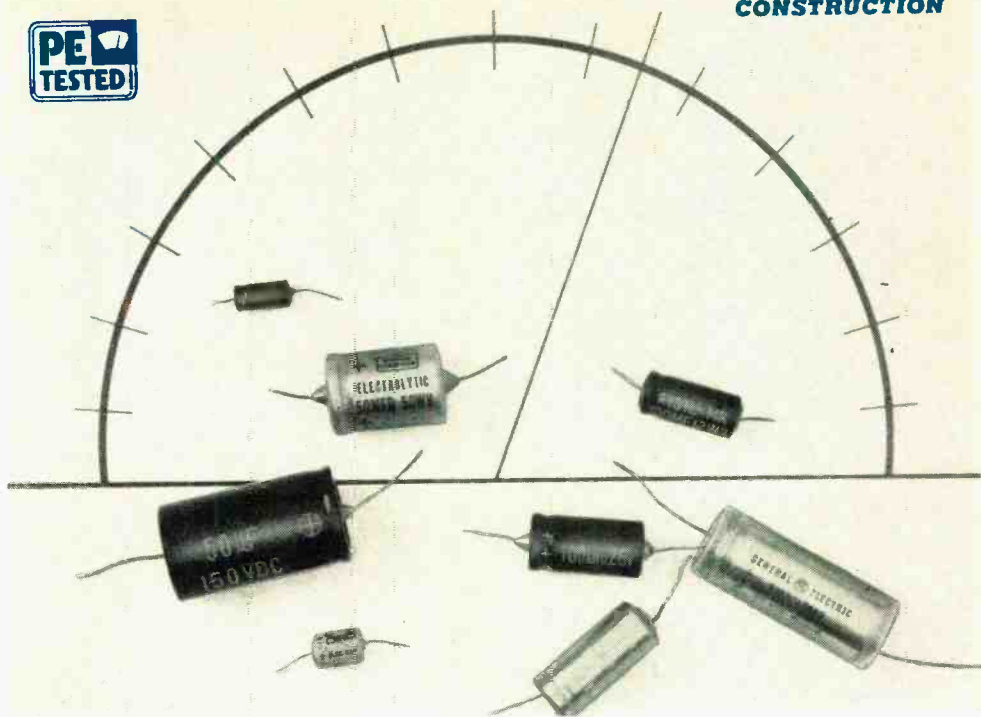

A HIGH-VALUE **ELECTROLYTIC CAPACITOR METER**

*Checks capacitance from 10 to
100,000 microfarads and indicates leakage*

BY JOHN D. RICHARD

THE ACTUAL values of many electrolytic capacitors are sometimes different from those marked on the cases. More often, the values are illegible due to ink blurring, obliteration, etc. These are only two of

the problems the experimenter faces in using electrolytics.

Among others, how do you apply a polarizing voltage to make sure the electrolyte in the capacitor is "formed" and that the unit is really operating properly? How do you tell whether or not an electrolytic capacitor is leaking? There are, of course, costly test instruments that can be used to solve these problems. But the expense

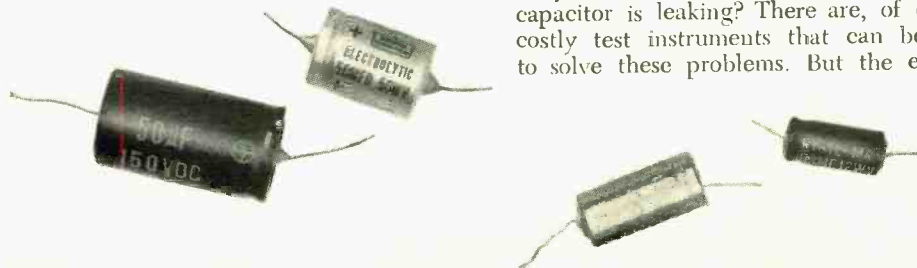

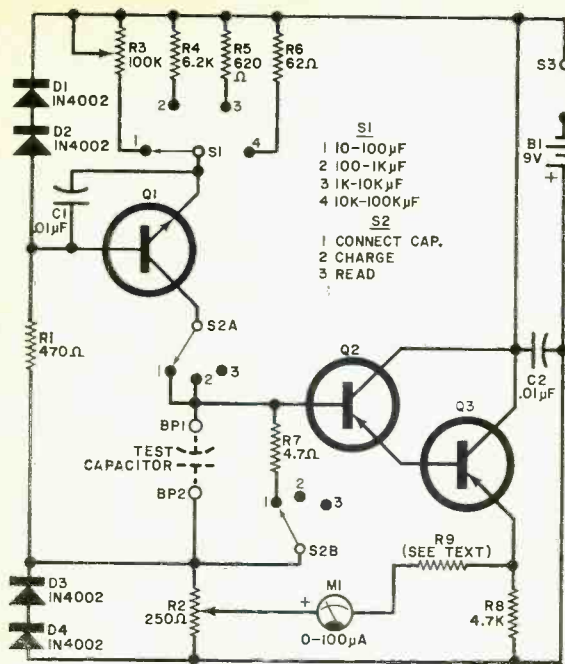

PARTS LIST

- B1—9-volt battery
 BP1, BP2—Five-way binding post (one red, one black)
 C1, C2—0.01- μ F capacitor
 D1-D4—1N4002 diode
 M1—0-100- μ A meter (see text)
 Q1—HEP735 transistor
 Q2, Q3—Any general-purpose silicon pnp transistor
 R1—470-ohm, 10%, $\frac{1}{4}$ -watt resistor
 R2—250-ohm miniature potentiometer
 R3—100,000-ohm miniature potentiometer
 R4—6200-ohm, 2%, $\frac{1}{4}$ -watt resistor
 R5—620-ohm, 2%, $\frac{1}{4}$ -watt resistor
 R6—62-ohm, 2%, $\frac{1}{4}$ -watt resistor
 R7—4.7-ohm, 10%, $\frac{1}{4}$ -watt resistor
 R8—4700-ohm, 10%, $\frac{1}{4}$ -watt resistor
 R9—See text
 S1—One-pole, four-position rotary switch
 S2—Two-pole, three-position rotary switch
 S3—Spst switch
 Misc.—Suitable metal chassis, perforated board, knobs, battery holder and connector, mounting hardware, etc.

Fig. 1. The constant-current source charges unknown capacitor and the meter circuit reads voltage level.

of precise measurements is not always warranted because electrolytics have relatively broad tolerances.

At a low cost, you can build the electrolytic capacitor meter described here and get the information you need. It measures capacitance values from 10 to 100,000 microfarads in four ranges with an accuracy of 10%. It will form the capacitor, and it will indicate if there is too much leakage.

About the Circuit. As shown in Fig. 1, the meter circuit is in two sections: a constant-current source consisting of Q1 and a high-resistance voltmeter circuit consisting of Q2, Q3 and M1.

When the unknown capacitor is connected between BP1 and BP2 (positive side to BP2), switch S2 is first placed in position 1 to discharge the capacitor through R7. Then S2 is moved to position 2, and the constant-current source starts to put a charge on the unknown capacitor. The voltage across it increases linearly with time and is measured by the meter circuit. The voltage increase (in volts per second) is equal to the current (in amperes) from Q1 divided by the capacitance in farads. Thus, with 1 ampere and 1 farad, the voltage increases at a rate of 1 volt per second. The ratio remains constant so that the voltage increases 1 volt per second for currents of 1 μ A, 10

μ A, 100 μ A and capacitances of 1 μ F, 10 μ F, 100 μ F, respectively.

In this capacitance meter, a charge is applied to the unknown capacitor for 5 seconds and then the voltage on the meter is read. (Full-scale deflection is 5 V.) Thus, if the constant current is 100 μ A and the meter indicates full scale after 5 seconds, the value of the capacitor is 100 μ F. Larger values of capacitance will produce lower voltage indications.

The amount of current supplied by Q1 is determined by the setting of S1. In position 4, the current is 10 mA; in position 3, 1000 μ A; in position 2, 100 μ A; and in position 1, 10 μ A. Resistor R3 is a preset potentiometer because the leakage current in Q1 may cause the required current to be slightly different from the calculated value. (Also because the low forward current results in a small voltage drop across the base-emitter junction.) Tests have shown that, once R3 is set, the collector current will remain constant at 10 μ A.

Transistors Q2 and Q3 form a Darlington pair having a very high input resistance. The emitter load, R8, carries about 1 mA when the potential across it is 5 volts. Meter M1 uses a series resistor (R9) of a value (50 kilohms minus the meter resistance) such that the meter will indicate full scale when 5 V is applied to the combination.

Because there is a voltage drop between the base of $Q2$ and the emitter of $Q3$, binding post $BP2$ is raised above ground by diodes $D3$ and $D4$. However, in practice it was found that the voltage across the two diodes was slightly higher than that across $R8$, so the positive side of the meter is connected to potentiometer $R2$ so that the meter can be zeroed.

Capacitors $C1$ and $C2$ remove any tendency of the circuit to oscillate on range 4 when long test leads are used on the binding posts.

Construction. The circuit can be assembled on perforated board and enclosed in a suitable metallic case. Put the three switches, meter, and binding posts on the front panel. Be sure to identify the switches and their positions properly. The power supply is a conventional 9-volt battery mounted in its own holder.

Adjustment. To set $R3$, place $S1$ in position 1 and $S2$ in position 3. Connect a 10- μA dc meter between the collector of $Q1$ and the positive side of the battery. Set $R3$ for maximum resistance and then turn on the power.

Carefully reduce the value of $R3$ until

the test meter indicates 10 μA . Do not allow too much current to flow or the transistor or meter may be damaged.

Fixed resistors $R4$, $R5$, and $R6$ should provide the correct currents. However, for greater accuracy, small trimmer potentiometers may be substituted—10,000, 1000, and 100 ohms respectively. Then adjust the potentiometers to get 100 μA , 1 mA, and 10 mA respectively.

With the circuit adjusted, and with no test capacitor attached to the binding posts, replace the wiring and adjust $R2$ to obtain a zero indication on $M1$.

If desired, $M1$ and $R9$ can be replaced with an external dc voltmeter having a 5-volt scale and at least a 10,000-ohm/volt input resistance. In this case, connect the positive lead of the external meter to the rotor of $R2$ and the negative lead to the junction of $R8$ and the emitter of $Q3$.

Operation. With an unknown electrolytic capacitor connected to $BP1$ (minus) and $BP2$ (positive), place $S1$ for the desired range position and set $S2$ to position 1. Wait a couple of seconds for the unknown to be fully discharged. Then turn on the power ($S3$).

Observing the sweep-second hand of a clock or watch, place $S2$ in position 2 for five seconds and note that $M1$ indicates up-scale. At the end of the 5-second interval, place $S2$ in position 3 and read the meter. The capacitance can be found by using the conversion scale shown in Fig. 2 and the setting of $S1$. If you are using the external 5-volt dc voltmeter, use the conversion scale shown in Fig. 3.

If the capacitor being tested has not been used for some time, it is advisable to give it several charging runs on the capacitance meter before making the actual measurements. This permits the electrolyte to form so that the capacitor settles down at its final value.

Some readers may feel that the test capacitor will start to discharge through its own leakage resistance or because of the base current through $Q2$ when $S2$ is in position 3. In practice, it has been found that modern electrolytic capacitors will provide a meter reading that is steady enough to get a good indication. If the capacitor being tested has excessively low leakage resistance, the meter indication will start to fall rapidly; but it will still be possible to get the initial indication. \diamond

Fig. 2. Use the conversion scale at left for readings on $M1$ as shown in Fig. 1.

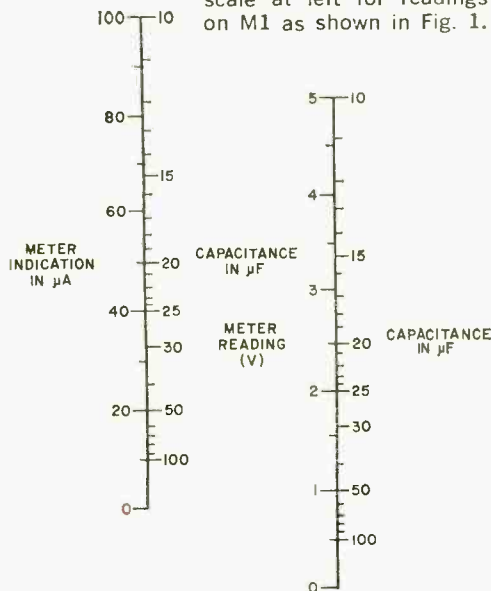

Fig. 3. Conversion scale for external 5-V meter.

SOLID-STATE PHOTOCELLS for HOBBYISTS PART 1



WHAT GOES ON INSIDE LIGHT-SENSITIVE SEMICONDUCTORS?

BY L. GEORGE LAWRENCE

THE ELECTRONICS experimenter who has not tried his hand at using semiconductor photocells is missing a lot. Applications range from simple light meters and noiseless audio controls to amateur star trackers with sensitivities of 0.001 foot-candle. There is even a new kind of photocell material that stores a picture capable of being projected on a screen like any 35-mm slide.

To use photocells, however, you have to know something about what they are and how they work. Unlike phototubes, in which electrons move in a vacuum or gas, photocells are light-sensitive devices, in which electrons move in a solid material. There are two basic types of photocells: photovoltaic cells, which generate a current when stimulated by light, and photoconductive cells, which simply vary in resistance with variations in incident light. The latter require some form of electrical excitation. Photodiodes and phototransistors are devices which use their light-sensing properties in special circuit applications.

Photovoltaic Cells. One of the more versatile, low-cost devices for the hobbyist to use is the selenium photovoltaic cell. (Solar cells are of the same type in that they convert light into electricity.) Relays, meters, and the like can be driven directly by these cells. Because their response to light is quite low, for a light source above 7250 angstroms, colored gelatin filters (as in photography) can be used to alter the spectral response.

Silicon photovoltaic cells are more expensive than selenium units, but the former

have higher power outputs. Although the spectrum sensitivities of the two types overlap, silicon is a superb converter of both visible light and infrared. Silicon cells can be energized by inexpensive GaAs light-emitting diodes (LED's).

In general, photovoltaic cells can be operated in either the photoresistive or self-generating mode. In the latter case (Fig. 1), a current-bucking circuit can be used to offset the cell's quiescent current in a battery-bridge arrangement. This also improves cell sensitivity. Photovoltaic cells are widely used in camera aperture controls, light meters, spectrophotometers, position sensors, and other light-dependent circuits.

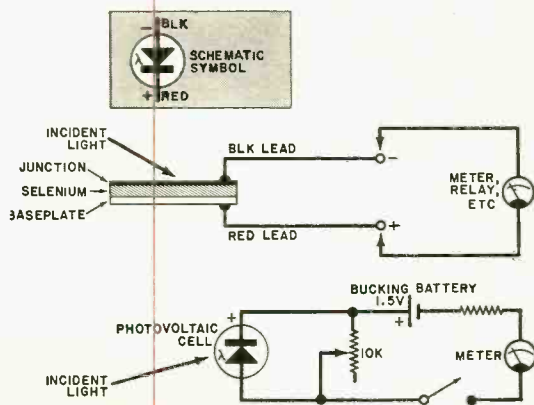

Fig. 1. Self-generating photovoltaic cell can drive a low-power meter or relay. With current bucking through a battery and potentiometer (bottom) the circuit has an artificial null under quiescent conditions for better stability and improved sensitivity.

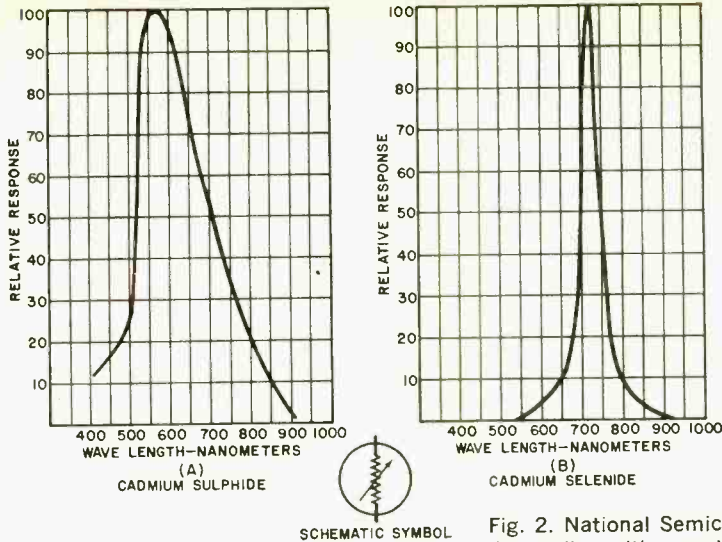

Fig. 2. National Semiconductor photoconductive cells, with spectral responses at left.

Photoconductive Cells. photoconductive cells are best described as light-sensitive resistors. When they are not illuminated by a light source, their resistance is high; but when struck by light, the resistance drops. They require dc or ac excitation, and their sensitivity to light is determined by the type of photoconductive material used.

Photoconductive cells can be used as shunt or series variable resistors. Figure 2A, for example, shows the spectral response of a cadmium-sulphide photoconductive cell whose highest response range is between 525 and 750 nanometers. The response curve for a cadmium-selenide cell (Fig. 2B) is very steep, since the cell responds pri-

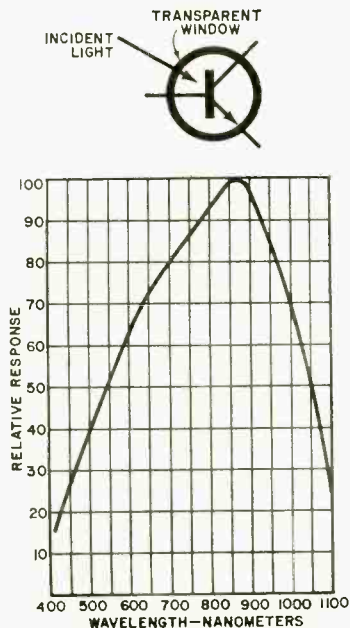

Fig. 3. Spectral response of silicon phototransistor is very wide and fast. Device has one stage of amplification built in.

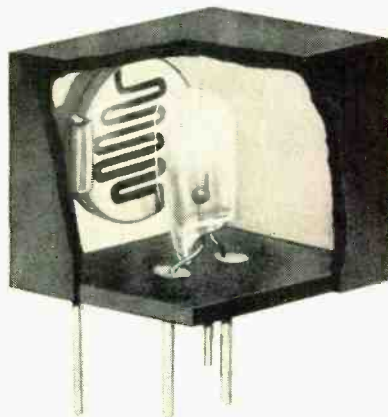

Fig. 4. Photoconductive cell and lamp in light-tight package. (National Semiconductor).

marily to light in the red and near-infrared regions. The speed of response of the CdSe cell to light fluctuations is about 10 times faster than that of the CdS cell (0.001 ms as compared to 0.01 ms).

Diodes and Transistors. Silicon photodiodes and phototransistors are either n- or

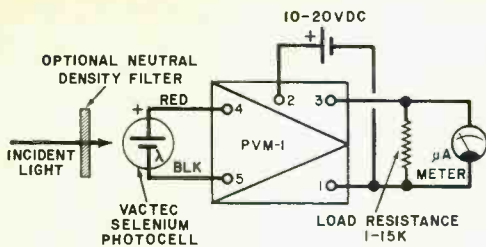

Fig. 5. Photocell voltage multiplier (Model PVM-1 by Vactec) increases the sensitivity of the selenium photovoltaic cell at left.

p-junction devices. Silicon photodiodes have excellent stability and an extremely high speed of response (typically from 10 to 0.1 microseconds). However, their sensitivity is not as high as that of photoconductive cells; and they usually require transistor amplifiers to boost their outputs.

The standard phototransistor has one stage of built-in amplification. As shown in Fig. 3, the spectral response is excellent and there are no dark or light "memory" effects which impair performance. In most industrial and hobby applications, silicon phototransistors can handle loads up to 50 mA with good gain.

Integrated Types. Modules containing light sources and integrated-circuit photocells are becoming increasingly popular. An example is shown in Fig. 4. The effective resistance of the cell is determined by the brightness of the lamp. Typical "on" resistance is 500 ohms, with an "off" resistance of 10 megohms. The ratio of on/off resistance permits the design of noiseless audio potentiometers, modulated gain controls and similar circuits. The lamp has a low thermal inertia and low operating current (15 mA at 10 V). Photodetector lamp assemblies can be used as L-attenuators in both audio and

r-f circuits since the photocell's inductance is very low and it is essentially resistive.

An example of an IC photocell amplifier is Vactec's Type PVM-1 (Fig. 5). Large voltage changes can be obtained with high local resistance. Frequency response from dc to 15 kHz can be obtained with small-area cells. The unit shown in Fig. 5 can be used as a photometer with a sensitive microammeter—without concern for meter resistance. Two units can be used in a bridge-connected photometer. The IC device also allows construction of novel electro-optical microphones, where light reflected from a mirror mounted on a diaphragm is directed onto a photocell.

Another Vactec amplifier module is the Type PAM-1. It contains a matched selenium photocell and a high-gain operational amplifier and can easily detect light intensities of 0.001 foot candles. These characteristics make it ideal for use in astronomy.

Image-Storing Photocells. Many photoelectric cells have what is called a "light-history effect" (hysteresis, fatigue, memory). After exposure to high light intensities, a cell has lower conductance but higher slope. Darkness results in higher conductance and lower slope. Many efforts have been made to use the phenomenon in special cell arrays to store a complex optical or photographic image for reproduction.

A breakthrough was achieved in 1972 when Sandia Laboratories introduced its "Cerampic" image storer, which is now manufactured by the Honeywell Company. As shown in Fig. 6, the Cerampic consists of a thin transparent ferroelectric ceramic plate (PLZT) with a photoconductive layer on one side. Transparent electrodes are then overlaid on the photoconductive layer and the other side of the ceramic. The ceramic plate is one inch in diameter and about the thickness of a postcard (0.0123 inch).

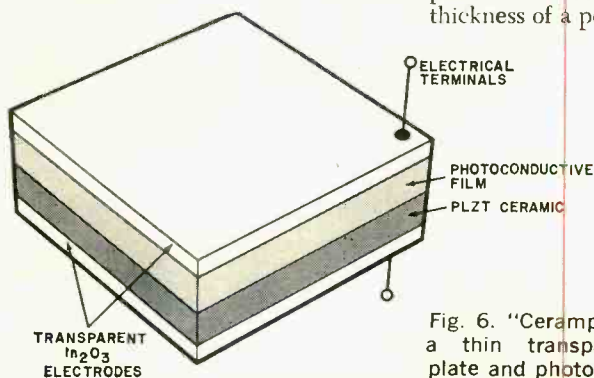

Fig. 6. "Cerampic" image-storing device has a thin transparent ferroelectric ceramic plate and photoconductive layer on one side.

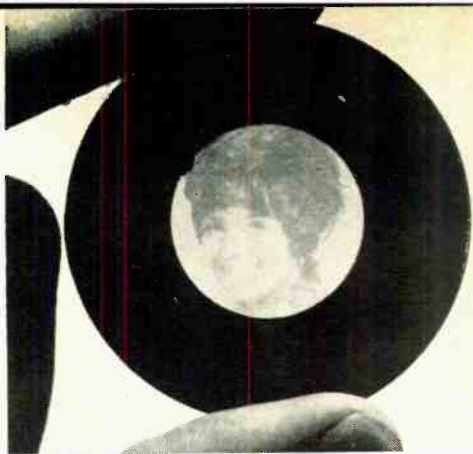

Fig. 7. Photographic image stored in Sandia Cerampic is ready for projection like slide.

An optical image, typically derived from a projected photographic negative, can be stored with acceptable quality, as shown in Fig. 7. The black/white contrast can be as high as 500 to 1.

This relatively simple device needs no chemical developers or fixatives and the image can be projected like any slide or transparency. The developers of Cerampic feel that it should be possible to form and erase images in raster patterns at rates up to 15,000 lines per second, thus permitting the display of TV-like images.

Photocell Tests. In applying silicon and selenium photovoltaic cells, it is important to know something about a given cell's electrical capabilities.

Specification sheets for the photocell

should always be consulted for information on voltage, resistance and power ratings. While actual power outputs can be determined by using simple formulas, complexities tend to arise where frequency-response tests are involved. For example, cells that respond slowly may cut off at, say, 1 kHz and will not respond to light modulations of any intensity above this range.

A photocell's frequency response can be determined by using equipment such as that shown in Fig. 8. In this arrangement, a light-emitting GaAs diode (GE Type LED-9) is mounted in a light-tight enclosure with the photocell. The output of the cell is displayed on an oscilloscope. Drive is furnished by a square-wave generator connected to a suitable audio amplifier. The latter's output transformer modulates the LED through a blocking capacitor. A 6-volt battery and 68-ohm resistor furnish the diode bias.

Ideally, waveforms displayed on the scope should resemble the square-wave generator's output at any given frequency. However (especially with old photocells), it will be noticed that the cell may modify the wave-shape. This can be attributed to capacitive, inductive, or other loss factors. Note that GaAs diodes are very fast modulators (up to about 100 MHz), but the energy is concentrated into a very narrow optical band. As shown in the insert in Fig. 8, the band peaks at 0.9 microns and allowances must be made for this power in the test setup.

Next month, in Part 2 of this article, we will cover circuits and applications for photocells. ♦

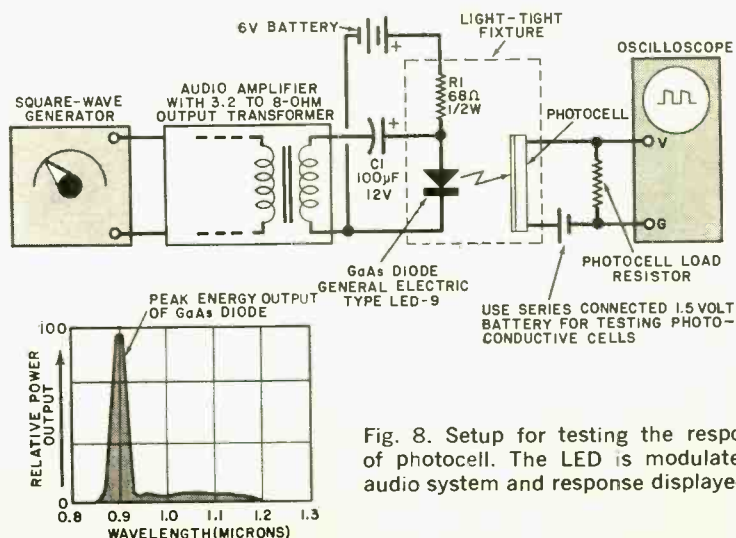

Fig. 8. Setup for testing the response time of photocell. The LED is modulated by the audio system and response displayed on CRT.

*For accurate
signal-level
monitoring,*



BUILD A TAPE RECORDER/AMPLIFIER FET VU METER

BY ROBERT E. BERGLAS

TOO much gain in recording a tape will result in saturation and overload and lead to severe signal distortion. For this reason, tape recorders nowadays often include VU (volume unit) meters that the recordist uses to monitor the signal while setting the deck's gain controls for desirable levels.

A VU meter is a carefully calibrated and damped ac voltmeter designed to provide readings that correspond to the *average* (rms) audio signal level at any instant. The movement's ballistics do not respond to momentary signal-level peaks that would otherwise cause pointer overshoot and give false readings.

Since a VU meter indicates only the average level of the signal being recorded, it is possible that the signal contains many short-duration, high-level transients that cause

distortion. The pointer might remain in the "safe" area of the meter scale. To compensate for this, good recording practice dictates that the recordist set his recording level controls so that the average signal level indicated by the meter's pointer is substantially below the overload point—say, -10 or -12 dB. This provides a safety margin for momentary transients.

The VU meter described here can be used by anyone who wants to add truly accurate metering to his tape recorder. Audio buffs can also add this meter to amplifiers to monitor output levels and the points where overloads occur.

About the Circuit. Because a VU meter has a low-impedance, low-sensitivity movement, wiring it directly into a circuit would place an excessive load on a tape recorder's

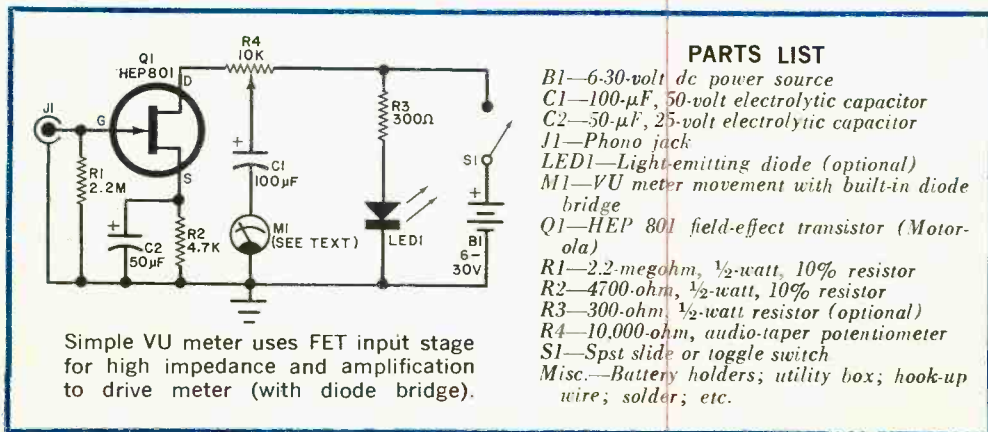

PARTS LIST

- B1—6-30-volt dc power source
- C1—100- μ F, 50-volt electrolytic capacitor
- C2—50- μ F, 25-volt electrolytic capacitor
- J1—Phono jack
- LED1—Light-emitting diode (optional)
- M1—VU meter movement with built-in diode bridge
- Q1—HEP 801 field-effect transistor (Motorola)
- R1—2.2-megohm, $\frac{1}{2}$ -watt, 10% resistor
- R2—4700-ohm, $\frac{1}{2}$ -watt, 10% resistor
- R3—300-ohm, $\frac{1}{2}$ -watt resistor (optional)
- R4—10,000-ohm, audio-taper potentiometer
- S1—Spst slide or toggle switch
- Misc.—Battery holders; utility box; hook-up wire; solder; etc.

or an amplifier's output stage. The circuit shown in the schematic, however, provides both high input impedance and signal amplification.

The FET VU meter is basically a field-effect transistor (*Q1*) amplifier whose input impedance is 2.2 megohms. The circuit is designed to be powered from any source with an output ranging from 6 to 30 volts dc. Frequency response is roughly ten times the range normally encountered in audio work.

Meter *M1* in the schematic is a basic VU movement with a built-in diode-bridge circuit. Resistor *R3* serves as a current limiter for power-on light-emitting diode indicator *LED1*. If you wish, you can eliminate the *LED1/R3* circuit without affecting the circuit's operation.

Since the circuit is so simple, just about any method of construction can be used when building it. Just make sure to install the polarized components properly and go easy on the heat when soldering *LED1* and *Q1* into place.

Installation and Calibration. The FET VU meter can be connected to any high-

level signal point in the recording amplifiers so long as it is after the recording-level controls. (For amplifier hookup, tie the VU meter's input directly to the amplifier's output terminals. The high input impedance of the VU meter will not affect the normal operation of the amplifier.)

To calibrate the FET VU meter, make several recordings, slightly increasing the recording level for each. (Make a note of each recording-level control setting.) While listening carefully to the playback of the recordings, note the control level at which you just begin to hear distortion. This setting corresponds to a 0-dB reading on the VU meter's scale. With the recorder on this setting, play a tape and adjust *R4* in the VU meter's circuit until *M1*'s pointer indicates 0 dB.

You will need an oscilloscope to calibrate the VU meter when it is used to monitor the output of an amplifier. Connect both scope and VU meter to the amplifier's output terminals. Then feed into the amplifier a 1000-Hz sine-wave signal. Advance the amplifier's volume control setting until you just begin to observe distortion in the signal viewed on the oscilloscope screen. Adjust *R4* for a 0-dB pointer indication. ♦



They put a rotary engine in a car. We put a cam shaft in a turntable. For the same reason.

The reason? To make it quieter, smoother, more reliable.

The basic record changer mechanism—like the automobile's piston engine—has been a fairly reliable device that has served with some success for many years. But the very action of the engine—or the changer—produces constant vibration and strong, sudden movements that can ultimately wear it out.

Now we have alternatives. For cars, the Wankel rotary engine. And for record players, the sequential cam shaft drive mechanism used in BSR's finest automatic turntables.

Its even rotating motion programs the complex automatic functions of the BSR 710 and 810 smoothly and without noisy and potentially harmful quick starts and stops, without slamming metal against metal. And because the cam gears are mounted on a carefully machined central shaft, they are all but impossible to put out of alignment by rough handling or constant use.

The result: consistent care-free performance, and good music. With the BSR 710/X and 810/X Transcription Series Total Turntables.



BSR

BSR (USA) LTD.
BLAUVELT, NEW YORK 10913

CIRCLE NO. 4 ON READER SERVICE CARD

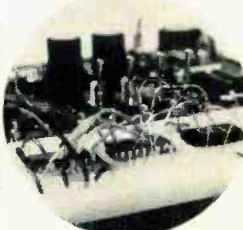
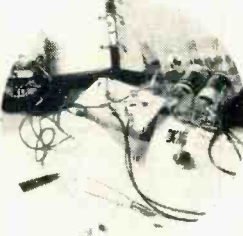
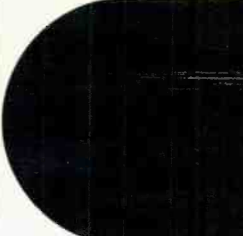
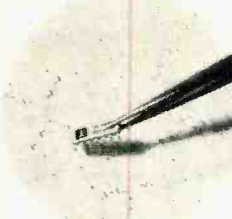
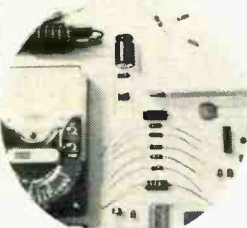
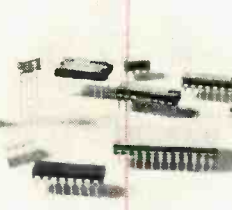
<p>Communications Engineering</p>	<p>Aeronautical & Navigational</p>	<p>Television Engineering</p>	
<p>Automatic Control Engineering</p>		<p>Missile & Spacecraft Guidance</p>	
<p>Radar & Sonar Engineering</p>	<p>Digital Communications</p>		<p>Industrial Electronics</p>
	<p>Microwave Engineering</p>		<p>Satellite Communications</p>
<p>Cable Television Engineering</p>	<p>Electronic Engineering Technology</p>	<p>Nuclear Instrumentation & Control</p>	<p>Special Programs for Electronic Engineers</p>

ADVANCED ELECTRONICS CAREER TRAINING AT HOME

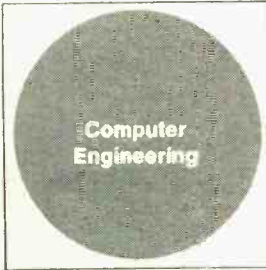

If you are too busy to go to college to learn advanced electronics, CREI brings college level training to you. CREI programs give you practical engineering training that you can apply in your work to move ahead to higher paying jobs. And CREI lets you specialize in exactly the area of electronics you want. You have a choice, depending on your qualifications, of 18 different programs.

Not only are CREI programs college-level but arrangements are available for you to earn college credit applicable to advanced degrees.

Only CREI offers you a choice of 18 programs in advanced electronics

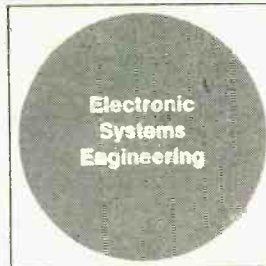

For over 45 years CREI programs have been recognized by leading technical organizations as effective home study training in advanced electronics.

NEW OPTIONAL LAB PROGRAM



CREI now offers a supplementary ELECTRONIC DESIGN LABORATORY PROGRAM to make learning advanced electronics easier and to give you actual experience to use in your work. Only CREI offers this complete college type laboratory program. You learn to actually design electronic circuits. At the same time you get extensive experience in tests and measurements, breadboarding, prototype building and other areas important to your career.

Qualifications to Enroll. To qualify for enrollment in a CREI program, you must be a high school graduate (or equivalent). You should also be working in electronics or have previous training in this field.

Send for FREE book. If you are qualified, send for CREI's newly published book describing your career opportunities in advanced electronics. This full color book is filled with facts about career opportunities for you.

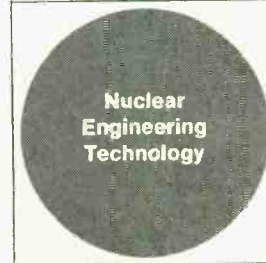

Accredited Member, National Home Study Council

CREI, Dept. E1206E
3939 Wisconsin Avenue
Washington, D. C. 20016

Rush me your FREE book describing my opportunities in advanced electronics. I am a high school graduate.

Name _____ Age _____

Address _____

City _____ State _____ ZIP _____

If you have previous training in electronics, check here

Employed by _____

Type of Present Work _____

Veterans and servicemen, check here for G. I. Bill Information

CREI
CAPITOL
RADIO
ENGINEERING
INSTITUTE

A Division of McGraw-Hill
Continuing Education Co.
3939 Wisconsin Avenue,
Washington, D. C. 20016

TWO SINGLE-IC AM RECEIVER PROJECTS

1

THE SIMPLEST AM/WWV RECEIVER

BY CARL C. DRUMELLER

BELIEVE it or not, there really is a receiver small enough to fit into your ear. At least the vital components—active elements, r-f amplifiers, detector, and agc—are small enough. All of these components are in the ZN414 linear integrated circuit.

With the ZN414 and only eight outboard components, including battery and power switch, you can make an AM BCB receiver that will perform at a level distinctly out of the toy or novelty class. Alternatively, by adding a few more components, you can use the same chip to tune in the WWV or CHU time-signal stations. In fact, there are dozens of specialized radio applications in which this new IC can be used.

Simplest AM Receiver. Perhaps the sim-

plest application for the ZN414 is the AM receiver shown schematically in Fig. 1. With

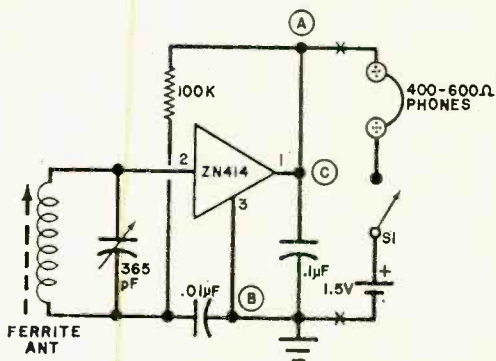

Fig. 1. With this simple AM receiver, local stations can be brought in easily, clearly.

ABOUT THE ZN414

Imagine an IC that has a very high input impedance, three r-f amplifiers, and transistor detector stage—all in one tiny TO-18 package with only three leads. (See opposite.) What we have just described is a versatile linear IC called the ZN414, made by Ferranti Electronic Components Division in Britain. Now available in the U.S., this IC offers the hobbyist and experimenter a whole new approach to radio experimentation.

The ZN414 is housed in just about the smallest package you are likely to see for transistors, let alone IC's. Its three-lead format makes the device a cinch to work with. Those three leads are for the input, output, and a ground that is common to both. Although the circuit configuration is unknown to us, we do know that it contains 10 transistors.

A list of its technical specifications reveals just how versatile is the ZN414. The circuit is designed to amplify incoming signals ranging in frequency from 150 kHz to 3 MHz. Its detector responds to AM signals within that range. The IC has a remarkable degree of automatic gain control (agc). And the best is yet to come: the ZN414 is capable of delivering a power gain of 110 dB!

While Ferranti specifies the ZN414's frequency range as being 150 kHz to 3 MHz, the IC has been operated successfully at a frequency as high as 7 MHz. Quite possibly, the top frequency limit will go even higher than that.

The power considerations for the ZN414 are on a par with its technical specifications. The chip draws a mere 0.5 mA from power sources ranging be-

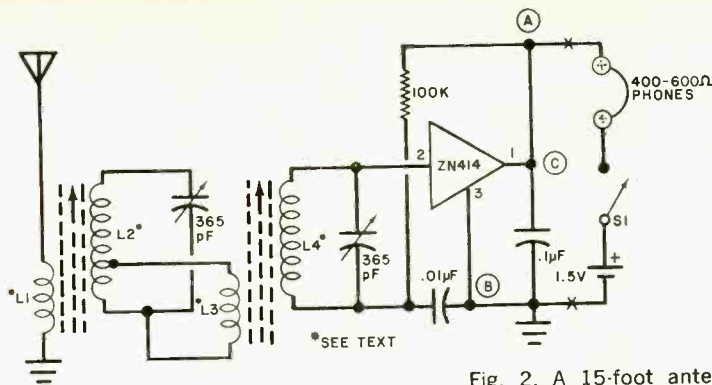

Fig. 2. A 15-foot antenna and tuning coils convert the circuit to receive station WWV.

a circuit as simple as this, it is almost impossible for anything to go wrong. In fact, a prototype receiver worked beautifully the first crack out of the barrel. Local stations came in with superb clarity and adequate volume through the headphone.

Because of the outstanding action of the IC's built-in agc circuit, tuning the receiver was a bit unusual. You expect to hear a jumble of stations. But when you tune to the frequency of any one station, the station's carrier affects the agc in such a way that total sensitivity drops enough to eliminate off-frequency stations.

Time-Signal Receiver. With only a few more parts than needed for the AM receiver, you can build a 2.5-MHz time-signal-only receiver to pick up WWV. The schematic

for the receiver is shown in Fig. 2. With this circuit, a 15-ft length of wire serving as the antenna provided good reception of the WWV signal.

Coils *L2* and *L4* are standard 30- μ H units with adjustable ferrite cores. For *L2*, however, the coil must be tapped 10 turns from the bottom to provide a tie-on point for *L3*. Coils *L1* and *L3* each consist of 10 turns of insulated wire wound around *L2* and *L4*, respectively.

When building the receiver, there are a few points about the ZN414 IC that must be kept in mind. Any device with a power gain of 110 dB requires careful layout of the components to prevent feedback. Hence, keep the tuning assembly (including *L1* through *L4*) isolated from the other components in the circuit. In the circuits in Figs.

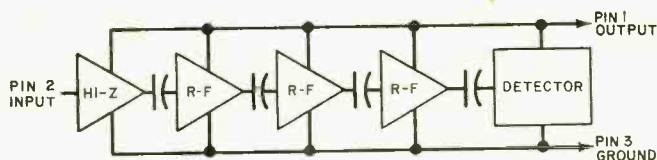

tween 1.2 and 1.6 volts. (Ferranti recommends that the IC be powered from a 1.3-volt source.) With this low-voltage source, the ZN414 can drive headphones with impedances ranging from 400 to 600 ohms without the need for audio amplification. To drive a speaker, the IC's output can be easily capacitively coupled to the input of an amplifier to provide sufficient driving power.

While the agc action of the ZN414 is directly dependent upon the load imped-

ance (hence the need for relatively high impedance phones), a capacitor can be used to isolate the two. With the capacitor between the IC and load, strong agc action will be observed.

If you would like to experiment with the IC, you can start with the projects described here. By special arrangement, the ZN414 IC's are available to POPULAR ELECTRONICS readers for \$5 each (plus 50¢ postage) from Ferranti Electric, Inc., East Bethpage Rd., Plainview, NY 11803.

1 and 2, the age action in the IC is highly dependent on the resistance of the headphones; so, use phones with impedances of 400 to 600 ohms.

When tuning the time-signal-only receiver, the variable capacitors are used for coarse adjustments, while the slugs in *L2* and *L4* are used for fine tuning. Adjust them for the strongest, clearest reception of the WWV signal.

Making A Good Thing Better. You can improve the performance of the receivers with two simple modifications. The first is the use of a voltage-regulator circuit that permits the receivers to operate safely from a 9-volt transistor battery. The second isolates the IC's age circuit from dependency on the impedance of the phones or an amplifier into which the receiver's signal is fed. Both modifications are shown in Fig. 3. The lettered points connect to the same points in Figs. 1 and 2. The "X" marks in the receiver schematics indicate that, with the modifications in place, the phones, power switches, and battery must be disconnected.

Just about any silicon transistor (npn variety) can be used in the voltage-regulator circuit in Fig. 3. Use the potentiometer to adjust the voltage between pins 1 and 3 of the ZN414 to roughly 1.3 volts (the level recommended by Ferranti). If you wish, once the pot has been set to provide the proper voltage, you can remove it from the circuit and replace it with an appropriate-value resistor.

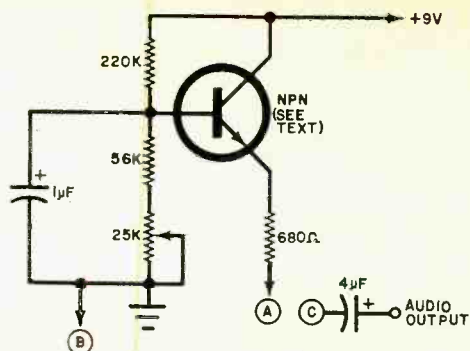

Fig. 3. Receiver performance is improved with voltage regulation and agc isolation.

More Ideas. By letting your imagination run free, you can visualize many other applications for the ZN414. For example, how about using the IC as a fixed-tuned i-f amplifier on 1.75 MHz and precede it with a simple 2-to-54-MHz converter for short-wave listening? Or how about deliberately introducing some r-f feedback that would allow the IC to oscillate for demodulating SSB transmissions? You might even try replacing the LC resonant circuit ahead of the IC with a series-resonant crystal to obtain selectivity suitable for CW reception.

You can see that the ZN414 IC is one of the most versatile building blocks offered to the experimenter in recent years. We predict that readers will find dozens of applications for this versatile device once they become acquainted with it. ♦

2 AN FAA WEATHER RECEIVER

BY MICHAEL S. ROBBINS

MORE than 50 Federal Aviation Administration stations throughout the United States transmit weather information valuable to travelers and others on the ground. Continuously repeated transcribed broadcasts on the FAA channels give wind speed and direction, ceiling, visibility, temperature, dew point, and barometric pressure for

airports and air-travel routes, the latter often corresponding to highway routes.

The station identifications given on the FAA channels consist of two or three letters in tone-modulated code. The rest of the broadcasts are spoken. A partial list of the FAA weather stations is given in the table.

You can build a compact, portable FAA

weather receiver with the aid of the Ferranti ZN414 linear integrated circuit. In tests, this receiver provided good reception (with its built-in antenna) within a 125-mile radius of station IGD in Inglewood, Calif.

About the Circuit. The receiver's circuit, shown schematically in Fig. 1, operates in a tuned-radio-frequency (trf) mode. MOS-FET transistor *Q1* serves as the r-f amplifier stage, while the Ferranti one-chip radio IC (*IC1*) provides more gain, agc, and detection. The audio amplifier, *IC2*, delivers 0.25 watt of power to the speaker. Ferrite-core broadcast-band antenna coil *L1* and three 455-kHz i-f transformers (*T1-T3*) with extra capacitors tune the receiver to

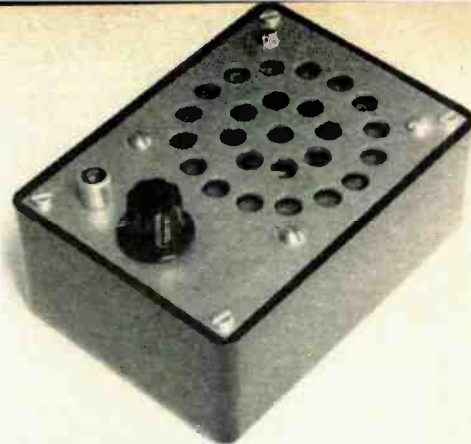

Front of receiver has holes drilled for antenna jack, speaker, and sensitivity control.

FAA WEATHER STATIONS

Location	Frequency (kHz)	Identification			
Arizona			Billings	400	LKO
Papago	326	---	Missoula	308	MSO
Ryan	338	---	Great Falls	371	GT
Arkansas			Nebraska		
Little Rock	353	---	Omaha	320	OM
California			New Jersey		
Oakland	362	EZB	Newark	379	EWR
Fresno	344	FCH	New Mexico		
Inglewood	332	IGD	Roswell	305	ROW
Red Bluff	338	PBT	New York		
Colorado			Elmira	375	ELM
Trinidad	329	TAD	NYC (see Newark)		
District of Columbia			North Carolina		
Washington	332	DC	Raleigh	350	LEI
Florida			North Dakota		
Jacksonville	344	JA	Jamestown	365	HAW
Pensacola	326	PNS	Ohio		
St. Petersburg	388	AM	Cleveland	344	CLE
Miami	365	MF	Columbus	391	CMH
Tallahassee	379	TL	Cincinnati	335	LUK
Idaho			Oklahoma		
Boise	359	BO	Oklahoma City	350	OKC
Illinois			Tulsa	375	DW
Chicago	350	ME	Oregon		
Kansas			Pendleton	341	PDT
Wichita	332	IC	Redmond	368	OBT
Maine			Portland	332	SVY
Bangor	344	SRX	South Carolina		
Massachusetts			Charleston	329	CH
Boston	382	SEW	Tennessee		
Michigan			Nashville	304	BN
Detroit	388	DT	Memphis	371	TS
Sault Ste. Marie	400	SSM	Texas		
Traverse City	365	TV	Fort Worth	365	FT
Minnesota			Midland	326	MA
Hibbing	356	RRY	Vermont		
Missouri			Burlington	323	BTV
St. Louis	338	LM	Virginia		
Kansas City	359	DO	Roanoke	371	ROA
Montana			Washington		
Miles City	320	HTN	Spokane	365	MZS
			Seattle	362	SEA

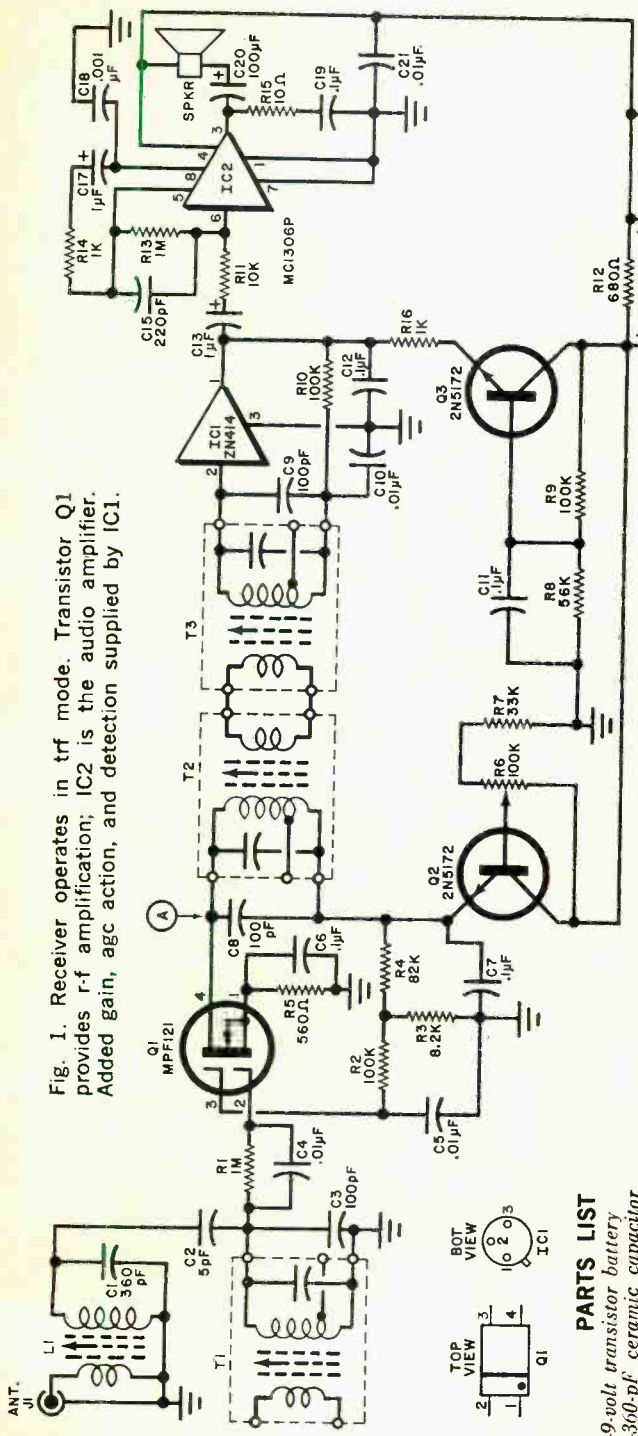

Fig. 1. Receiver operates in trf mode. Transistor Q1 provides r-f amplification; IC2 is the audio amplifier. Added gain, agc action, and detection supplied by IC1.

PARTS LIST

- B1—9-volt transistor battery
- C1—360-pf ceramic capacitor
- C2—5-pf ceramic capacitor
- C3, C8, C9—100-pf ceramic capacitor
- C4, C5, C10, C21—0.01-μF, 16-volt ceramic capacitor
- C6, C7, C11, C12, C19—0.1-μF, 12-volt ceramic capacitor
- C13, C17—1-μF, 16-volt electrolytic capacitor
- C14, C16, C20—100-μF, 16-volt electrolytic capacitor
- C15—220-pf ceramic capacitor
- C18—0.001-μF ceramic capacitor.
- IC1—Ferranti ZN414 (see page 59 for ordering details)
- IC2—MC1306P (Motorola) integrated circuit
- J1—Phono jack
- L1—Transistor radio antenna coil (Philmore No. FF-15 or similar; approximately 480 μH)
- Q1—MPF 121 (Motorola) or MEM 621 (General Instrument Corp.) dual-gate MOSFET
- Q2, Q3—2N5172 transistor
- R1, R13—1-megohm, ¼-watt resistor
- R2, R9, R10—100,000-ohm, ¼-watt resistor
- R3—82,000-ohm, ¼-watt resistor
- R4—82,000-ohm, ¼-watt resistor
- R5—560-ohm, ¼-watt resistor
- R6—100,000-ohm miniature potentiometer
- R7—33,000-ohm, ¼-watt resistor
- R8—56,000-ohm, ¼-watt resistor
- R11—10,000-ohm, ¼-watt resistor
- R12—680-ohm, ¼-watt resistor
- R14, R16—1000-ohm, ¼-watt resistor
- R15—10-ohm, ¼-watt resistor
- S1—Spst switch (part of R6)
- SPKR—Miniature speaker (8-, 16-, 45- or 100-ohm impedance)
- T1, T2, T3, T4, T5, T6, T7, T8—Transformer

T1-T3—Miniature 455-kHz i-f transformer, yellow core, (available in Radio Shack 273-1383 assortment or individually from Mouser Corp., 11511 Woodside Ave., Lake-side, CA 92040 as Part No. 801F101) Misc.—4" x 2 7/8" x 1 7/8" Bakelite utility box with metal cover (Calcraft No. J4-725 or similar), perforated board and solder clips, battery connector, spacers control knob, hookup wire, solder, machine hardware, etc.

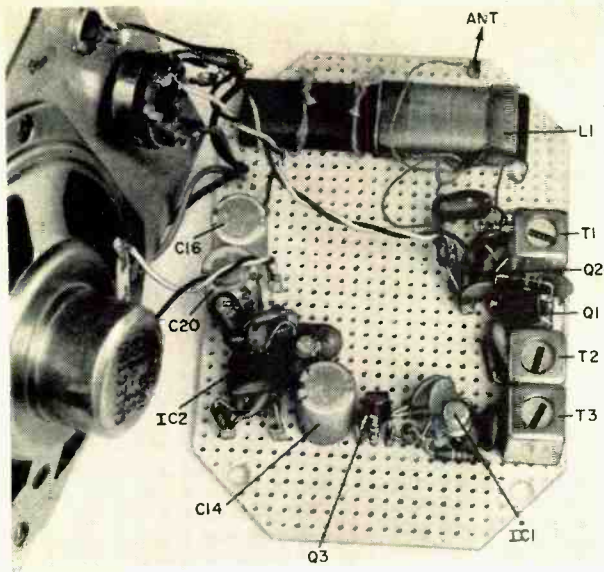

Fig. 2. Follow parts layout shown in photo to minimize the chance of oscillations occurring.

the 300-400-kHz band. However, although the system covers the entire band, it is basically a single-frequency receiver.

Construction. The entire receiver can be assembled on a 3 $\frac{3}{4}$ -in. by 2 $\frac{3}{4}$ -in. piece of perforated board with holes spaced on 0.1-in. centers. Parts placement is not critical, but the general layout shown in Fig. 2 should be followed to avoid oscillations.

All components are mounted on the metal plate of the utility box. Hence, you must drill a number of holes through the plate to allow the speaker's sound to escape. Also, four holes are needed for speaker and board assembly mounting, and mounting must be made for sensitivity control *R6* and antenna jack *J1*. Although a 2 $\frac{1}{2}$ -in. speaker is shown in Fig. 2, a smaller speaker would leave enough panel space for three access holes over the slugs of the i-f transformers to facilitate tuning. Use three spacers and appropriate hardware to mount the speaker and board assembly on the metal plate. The battery can be sandwiched between the spacer and the wall of the utility box to keep it firmly in place.

Tune-Up. Initial tune-up of the receiver is accomplished as follows: Clip a short antenna to point *A* in Fig. 1. Set sensitivity control *R6* to minimum, and adjust the slugs in *T3* and then *T2* for maximum sound output from the speaker on the desired FAA weather channel. You may hear some air

navigation stations in addition to the weather broadcast.

Connect the antenna to *J1*. Then set *R6* to maximum sensitivity or as high as needed to hear the station. Adjust *L1* and *T1* for maximum signal while reducing the sensitivity. Remove the external antenna and readjust *L1* and *T1* through *T3* for best results with only the built-in ferrite antenna. The antenna coil is directional; so, rotate the receiver for best results. ♦



Photo shows how perforated board, with the components, is attached to the front panel.

TRANSISTOR SELECTION GUIDE FOR EXPERIMENTERS

*Understanding transistor circuit
characteristics eliminates
trial-and-error approach*

BY JON L. TURINO

SELECTING a transistor for a specific circuit application involves considerably more than just picking a device at random and using trial and error to determine whether or not it will work. Proper device selection requires that the ratings and parameters of a transistor be known and that the importance of these characteristics in the application be understood.

As readers doubtlessly know, the bipolar transistor is normally forward biased from base to emitter and reverse biased from base to collector (Fig. 1). In the active mode of operation for the transistor, a small change in base current, I_b , results in a much larger change in collector current, I_c . Transistors also have two other modes of operation—cut off and saturated. In the cut-off mode, only leakage current flows through the transistor. In the saturated mode, maximum current flows, limited only by the external components. Even though we use a transistor primarily in the active mode, we can illustrate many parameters much more clearly by considering the cut-off and saturated modes.

Parameters and Characteristics. Here are ten transistor characteristics that should be taken into account when a device is being selected (or when a circuit is being designed

around it). Refer to the proper drawings in Fig. 2 for pictorial definitions of the parameters.

(1) V_{CB0} : This is the collector-to-base breakdown voltage in the reverse-bias condition. If the collector-to-base voltage is

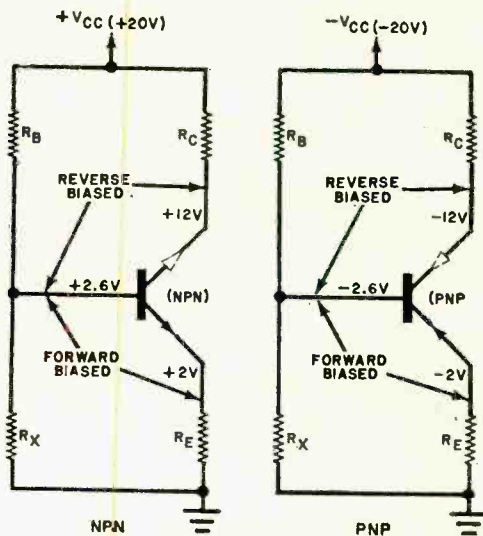

Fig. 1. Reverse and forward biasing requirements are shown for npn and pnp transistors.

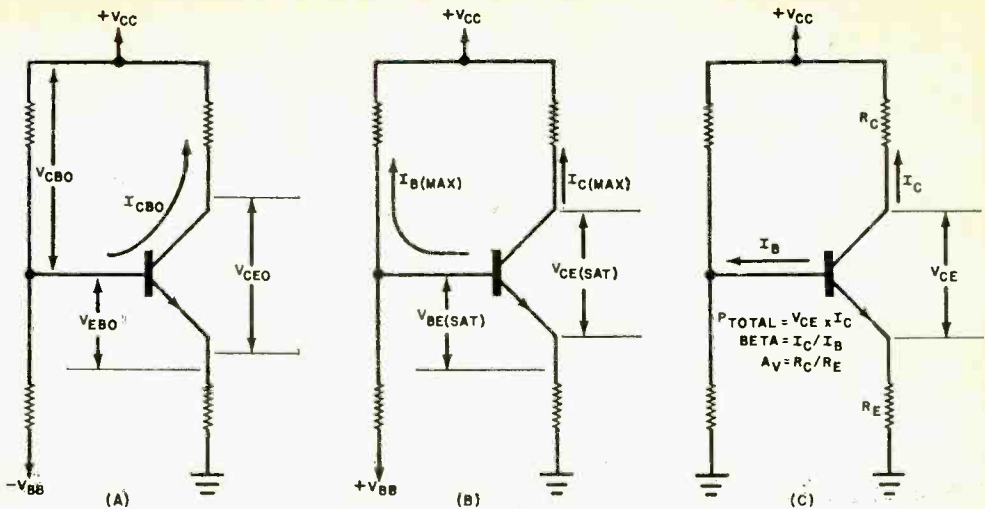

Fig. 2. Transistor is shown cut off (A), saturated (B), and in normal mode (C).

allowed to exceed the breakdown value, the transistor may be destroyed. Always select a transistor whose V_{CBO} rating exceeds the highest voltage expected to exist in the circuit between the base and collector.

(2) V_{EBO} : This is the emitter-to-base breakdown voltage in the reverse-bias condition. If this value is exceeded, the transistor may be permanently damaged; so, select a transistor whose V_{EBO} exceeds the maximum voltage that will exist in the base-to-emitter circuit. (In most "small-signal" analog circuits, the base-emitter voltage seldom exceeds about 0.8 volt in either the forward or the reverse directions. Hence, if this parameter is not specified, it will normally not be cause for concern.)

(3) V_{CEO} : This is the maximum allowable voltage from collector to emitter with the transistor reverse biased (cut off). The V_{CEO} of the transistor should exceed the power supply voltage if the transistor is to operate safely. Alternatively, the supply voltage for the circuit should be maintained at less than the V_{CEO} .

(4) I_{CBO} : This is the leakage current from collector to base when the transistor is reverse biased. This parameter is of major importance because it increases rapidly with increases in transistor temperature. It can affect the biasing of the transistor stage and, if excessive, cause increasingly large current flow that can result in "thermal runaway", ultimately leading to destruction of the transistor. Select a transistor whose I_{CBO} is less than 0.001 times the normally expected collector current. (Usually, silicon transis-

ters have very small I_{CBO} ratings. Nevertheless, it is wise to double check.)

(5) $V_{CE(SAT)}$: This is the voltage from collector to emitter when the transistor is conducting maximum current and further increase in base current will result in no further increase in collector current. This voltage is the minimum potential that must be maintained between emitter and collector if transistor action is to continue. It is usually specified as a specific current, $I_{C(SAT)}$, and should not exceed the power supply voltage minus the peak-to-peak expected collector voltage swing.

(6) $V_{BE(SAT)}$: This is the base-to-emitter voltage when the transistor is saturated. It is usually specified at a specific current, $I_{B(SAT)}$, and is important primarily in switching circuits, although it does affect the biasing of analog circuits.

(7) $I_{B(MAX)}$: This is the absolute maximum base current that can safely flow into the transistor. Care must be taken to insure that the circuit will not cause base current in excess of $I_{B(MAX)}$ to flow, and, conversely, the $I_{B(MAX)}$ rating of a device must always exceed the maximum expected base current.

(8) $I_{C(MAX)}$: This is the absolute maximum collector current that can safely flow in the transistor. If it is exceeded, the device is likely to destruct. The $I_{C(MAX)}$ rating should exceed the maximum value of collector current that can ever flow in the circuit.

(9) P_{TOTAL} : The total (maximum) power that a transistor can safely dissipate should never be exceeded. The actual power in a circuit is equal to $V_{CE} \times I_C$ when the transis-

tor is biased in the active mode. (The base-emitter voltage and current also contribute to total power, but they are usually negligible with respect to $V_{CE} \times I_C$.) In most circuits, it is wise to choose a device whose P_{TOTAL} rating is $2(V_{CE} \times I_C)$.

(10) H_{FE} : This is the current gain of the transistor when in the common-emitter configuration (shown in Figs. 1-3) and is usually referred to as the transistor's beta (β). Beta is defined as the ratio of collector current to base current ($\beta = I_C/I_B$) and is one of the most important of a transistor's parameters. It determines the achievable circuit gain and the required biasing resistor values. It might be specified as a range of values (10 to 100) or as a set of values at specific collector currents (50 @ 1 mA, 20 @ 10 mA, etc.). To select a beta value for a given transistor, calculate the value of collector current required in the circuit and the base current available. In any circuit like that shown in Fig. 2C, beta must exceed the ratio R_C/R_E but must not be so large as to allow the transistor to saturate. In a new design, the minimum beta is the most critical parameter, since the biasing can be tailored for any specific value.

Using The Parameters. The circuit shown in Fig. 3 should help in tying together all of the seemingly unrelated parameters. With this circuit, we will illustrate an actual design procedure and demonstrate how each parameter relates to the design.

Let us assume that we need a circuit with

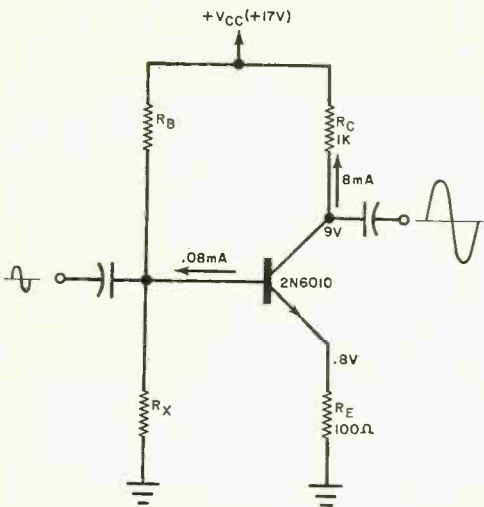

Fig. 3. This diagram shows how the various parameters are used in designing a circuit.

a voltage gain of 10 and a peak-to-peak output swing of 12 volts across a 1000-ohm resistor (R_E). We calculate R_E as being $1000/10$, or 100 ohms. (Since voltage gain $A_v = R_C/R_E$, $R_E = R_C/A_v$.)

There will be 12 volts peak-to-peak across R_C and 1.2 volts p-p across R_E . So that $V_{CE(SAT)}$ does not affect the circuit, add 3 or 4 more volts to the required total potential from the power supply. Make V_{CC} equal to $12 + 1.2 + 3.8$, or 17 volts. With a V_{CC} supply voltage of 17 volts and $R_C + R_E$ equal to 1100 ohms, the maximum collector current will be 17 volts/1100 ohms, or 15.45 mA. With the transistor properly biased, there will be about half of this value (about 8 mA) of collector current. V_{CE} will be 17 volts - (8 mA \times 1100 ohms) = 8.2 volts. Total circuit power, then, is 8.2 volts \times 8 mA = 65.6 mW.

Now specify a value of 100 for the transistor's beta. At this point, we can select a transistor with the following minimum characteristic values:

$V_{CE(SAT)}$	17 V	$V_{BE(SAT)}$	1.5 V
V_{CEO}	17 V	$I_{B(MAX)}$	0.15 mA
V_{EBO}	0.5 V	$I_{C(MAX)}$	15.45 mA
V_{CBO}	8 μ A	P_{TOTAL}	65.6 mW
$V_{CE(SAT)}$	2 V	Beta	100

$V_{CE(SAT)}$ and $V_{BE(SAT)}$ are not critical; $I_{B(MAX)} = I_{C(MAX)}/\text{Beta}$.

You now have enough information to begin looking through a transistor manual for an npn transistor with parameter values on the safe side of those listed above. Let us assume that you settle on a 2N6010 transistor with the following characteristics:

V_{CBO}	50 V	$V_{BE(SAT)}$	1 V
V_{CEO}	17 V	$I_{B(MAX)}$	8 mA
V_{EBO}	5 V	$I_{C(MAX)}$	800 mA
I_{CBO}	10 nA	P_{TOTAL}	500 mW
$V_{CE(SAT)}$	0.25 V	Beta	100 @ 10 mA

A comparison of these characteristics with our circuit requirements reveals that the 2N6010 transistor will more than adequately meet our needs. All that is necessary now is to compute the correct values of R_B and R_X using conventional means, and to check out the circuit.

There is a lot of leeway in the selection of a proper transistor for a circuit. The more conservatively rated the transistor is for a specific application, the better the probability of the circuit operating almost forever. When it is necessary to select a replacement transistor, just analyze the circuit for its important parameters and select a new device whose characteristics fit the requirements. \diamond

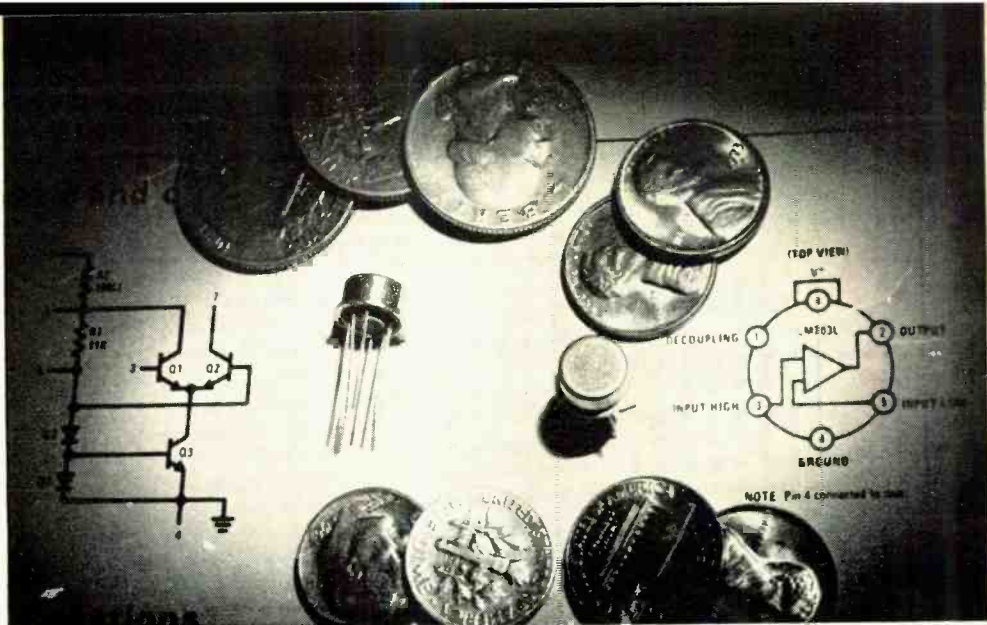

FOR EXPERIMENTERS

9 USES for the 99c WONDER

Tested experimenter circuits that can be built with the 703 monolithic amplifier.

BY JOE A. ROLF

A BUCK doesn't go very far these days. But it will still buy a lot of electronics. For example, for just 99¢, the readily available 703 integrated circuit (an emitter-coupled i-f/r-f amplifier) can be used in a multitude of circuits that require a minimum of parts.

The 703 is a highly stable, limited-gain chip that can be made to operate at frequencies of up to 150 MHz. Its efficient

internal biasing system is easy to use and reduces power supply requirements and stage decoupling demands. For a buck, it's an experimenter's dream.

With this in mind, we present the following nine projects you can build around this popular IC. Three of the projects can be used alone; the remaining six can be used for experimenting or as add-ons to existing electronic devices.

High-Input-Impedance Amplifier. This circuit, shown in Fig. 1, will deliver up to 20 mW of audio output power at the secondary of T2. With a power gain of 30 dB, this circuit can be used as a high-gain preamplifier, a driver amplifier, or a low-power output stage. The transformers provide impedance matching. As such, they

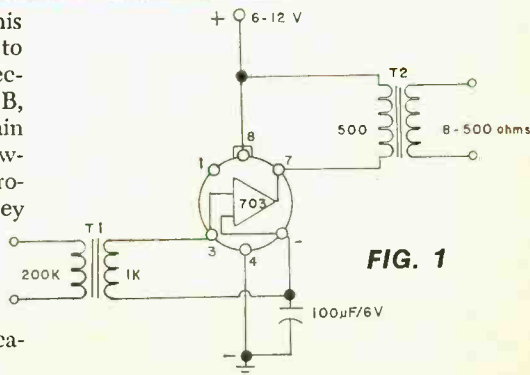

FIG. 1

can be selected to suit the specific application intended for the circuit.

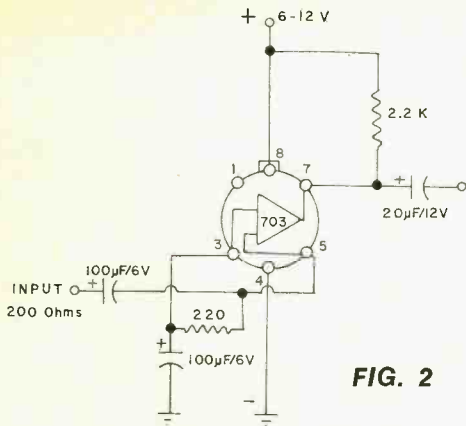

FIG. 2

RC-Coupled A-F Amplifier. With only two resistors and three capacitors, the 703 becomes a high-gain RC-coupled audio amplifier as shown in Fig. 2. The 2200-ohm output resistor can be replaced by 2000-ohm headsets or an output transformer (see Fig. 1 for hookup). Note that the input impedance of this amplifier is low—only about 200 ohms.

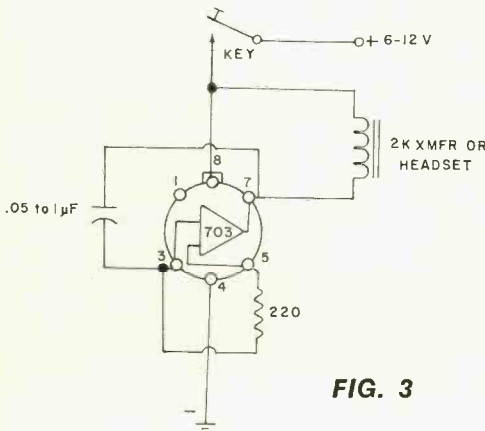

FIG. 3

Code Practice Oscillator. The code practice oscillator circuit shown in Fig. 3 is another minimum-component project. The output can be a small transformer for feeding a small speaker, or it can be a headset load. The frequency of the tone is determined by the value of the feedback capacitor. To make an oscillator with a "warble," use two capacitors of different values and switch one in and out of the circuit. For an electronic siren, connect a 4700-10,000-ohm resistor between pin 8 of the 703 IC and the key and a 100-200-µF capacitor from pin 7 to pin 4.

455-kHz I-F Amplifier. In Fig. 4 is shown the schematic of a 455-kHz i-f amplifier made from four readily available components. By cascading several of these high-gain i-f amplifiers, you can make a complete i-f strip for use in a receiver project. The internal bias and limited-gain features of the 703 reduce the need for decoupling when several stages are cascaded.

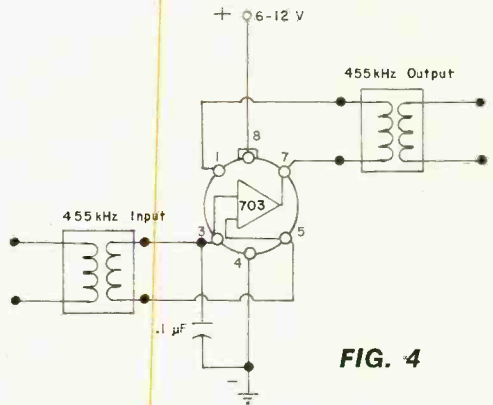

FIG. 4

R-F Amplifier. The Fig. 5 r-f amplifier, designed to operate from 500 kHz to 100 MHz, has its input and output circuits tuned by LC networks. As shown in the short accompanying table, the value of C in both cases must be selected for the frequency range desired. The tuning capacitors should be small trimmers to permit tuning for maximum response at a given frequency.

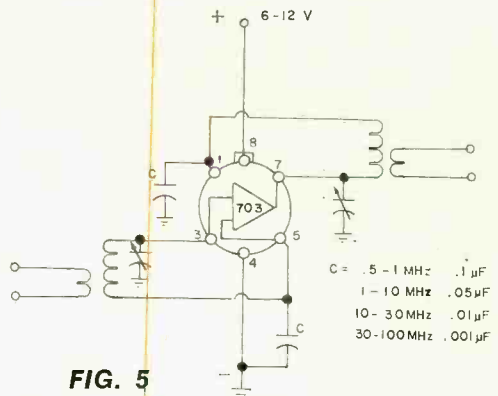

FIG. 5

Crystal Oscillator. A 1-30-MHz crystal oscillator is easy to build when using a 703 IC (see Fig. 6). The values of C1, C2, and L are determined by the crystal and the operating frequency. Capacitor C2 is

the most critical component; it must be selected to provide just enough feedback for stable operation. Inductor L is used for bias decoupling and, in some cases, can be replaced with a 220-ohm resistor.

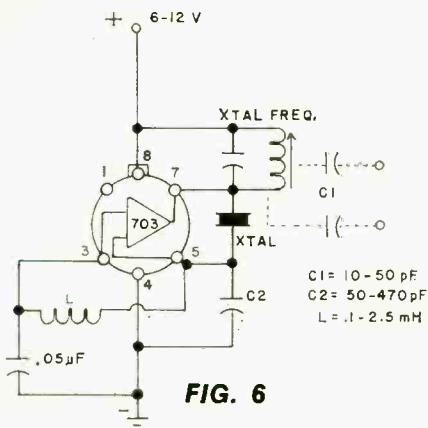

FIG. 6

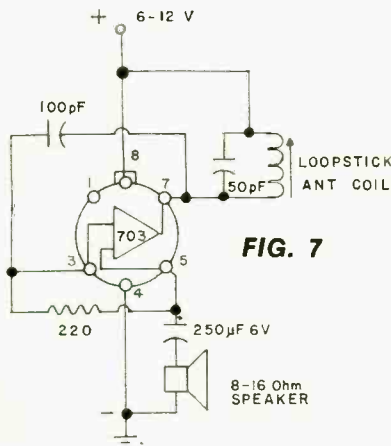

FIG. 7

AM Wireless Microphone. The wireless microphone in Fig. 7 is designed to transmit voice signals by radio up to about 100 ft to an AM broadcast receiver. Here, the 703 IC is used as an oscillator and audio amplifier. Only a small transistor radio speaker is needed as a microphone. For use as a phono-oscillator, replace the speaker with a 50,000:1000-ohm transformer, and connect the high-impedance winding to the phono cartridge.

27-MHz CB Converter. With the circuit shown in Fig. 8, you can listen to CB calls on your AM broadcast-band receiver. The 27-MHz CB signals picked up by the antenna are converted in this circuit to a range of frequencies your BCB receiver

can accommodate. The IC in this case functions as a reflex converter, operating both as a mixer and a local crystal-controlled oscillator. The circuit is simple to build and get to working if care is taken with layout and component leads are kept short. For improved selectivity and sensitivity, you can add the r-f amplifier circuit shown in Fig. 5 to the output of the converter.

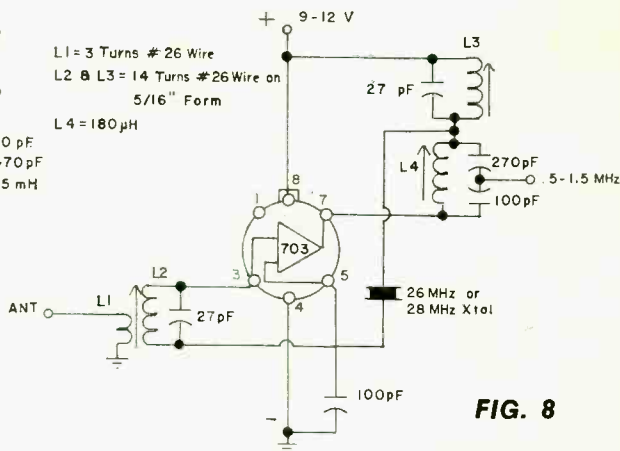

FIG. 8

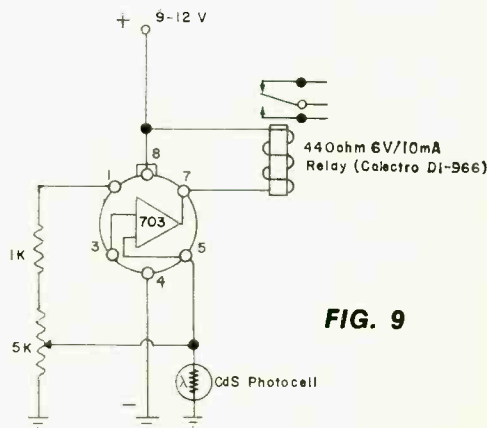
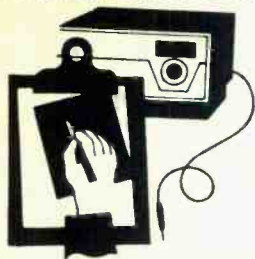

FIG. 9

Photoelectric Control. The 703 IC can even be used as a dc amplifier as demonstrated by the photoelectric control shown in Fig. 9. This circuit has a 5000-ohm sensitivity control potentiometer that permits you to "tune" it to respond to a suitable light source 5 to 10 ft away. A small, sensitive relay must be used to drive whatever signaling load you desire. The current drain for this circuit is very small, making the photoelectric control ideal for battery operation.



Product Test Reports

SONY MODEL STR-7045 STEREO RECEIVER (A Hirsch-Houck Labs Report)



THE MEDIUM-PRICED (\$349.50) Sony Model STR-7045 AM/stereo FM receiver provides the essential features and performance quality of the company's top-priced receivers at only a minor sacrifice of tuner sensitivity and audio output power. With both channels driven simultaneously, the receiver is rated to deliver 30 watts/channel into 8-ohm loads at all frequencies between 20 and 20,000 Hz.

The IIF FM tuner sensitivity is rated at $2.6 \mu\text{V}$, with a 1.5-dB capture ratio and a 70-dB signal-to-noise (S/N) ratio. In stereo FM, the rated channel separation is 38 dB at 400 Hz. Tuner distortion is specified at only 0.2 percent in mono and 0.5 percent in stereo.

The **SPEAKER SELECTOR** switch in the receiver has positions for **REMOTE**, **MAIN**, and **BOTH** sets of speaker systems simultaneously. An **OFF** position silences the speakers to permit private headphone listening via a jack located on the receiver's front panel. The **BASS** and **TREBLE** controls, each a concentric pair, provide for independent control of the tone in each channel. The **MODE** switch permits selection of stereo operation in both the normal and reversed left-to-right orientations, the sum of both channels to both speakers, or either input channel to both speakers.

For program selection, a combination of a three-position lever switch and a rotary

switch are used. The upper and lower positions of the lever select the **PHONO** and **AUX** inputs, respectively. With the lever in the center position, the input source is selected by the **FUNCTION** switch that has positions for **FM** (automatic stereo or mono), **AM** and **AUX 2**. This arrangement, for some time featured by Sony, simplifies selection of the most commonly used program sources, using only the lever switch.

Another lever switch controls the tape monitoring function, two others are used for switching in and out the **HIGH CUT** filter and **FM MUTING**, and a final one is the **POWER** on/off switch.

Laboratory Measurements. Driving both channels of the receiver into 8-ohm loads with a 1000-Hz input signal, the audio amplifiers clipped at 38.5 watts/channel. Into 4 ohms, the power was 53.5 watts/channel, while into 16 ohms, it was 24.8 watts/channel.

The 1000-Hz THD was unusually low,

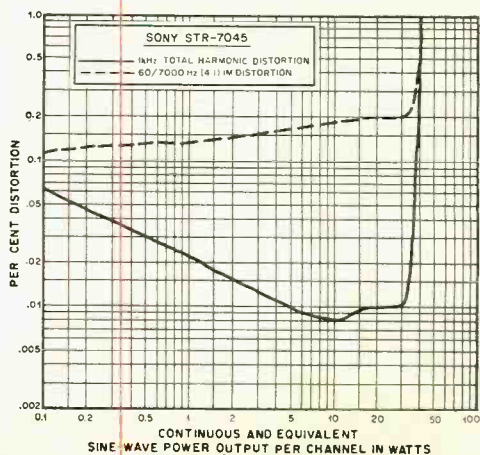

compared to other receivers in the STR-7045's price range—and even some much more expensive receivers. From a mere 0.065 percent at 0.1 watt, it fell to about 0.01 percent between 5 and 30 watts output and reached only 0.1 percent at 38 watts output.

The IM distortion, starting from 0.1 percent at 0.1 watt, increased to 0.2 percent at 30 watts and 0.5 percent at 40 watts. The absence of crossover distortion can be judged from the fact that the IM distortion was less than 0.2 percent at all power levels from 30 watts down to a mere 1 milliwatt!

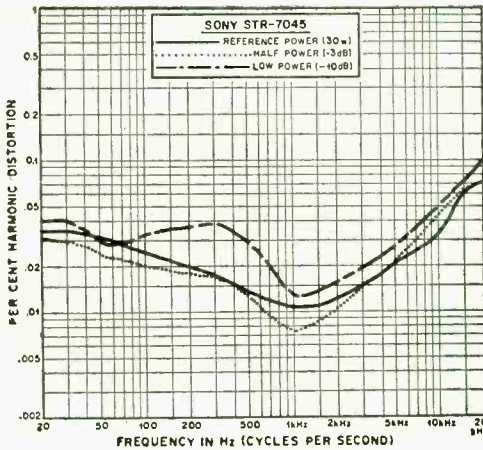

Sony's conservative power ratings were emphasized by the fact that at the rated 30 watts/channel (or less), the THD was under 0.1 percent at any frequency from 20 to 20,000 Hz and was typically about 0.02 percent.

The amplifier could be driven to 10 watts output by a 65-mV signal through the AUX input or a 0.8-mV signal through the PHONO input. The corresponding noise levels were a very low -75 dB and -74 dB. Phono overload occurred at a comfortably high 82-mV input, in spite of the preamplifier's high gain.

The bass tone control had a sliding inflection point, from about 150 to 600 Hz, depending on the control setting. The treble control affected frequencies greater than approximately 1500 Hz. The loudness compensation boosted both low and high frequencies, and the MCH CVT filter had a 6-dB/octave slope, with a -3-dB point at 4500 Hz.

The RIAA phono equalization was accurate to within ± 0.5 dB from 30 Hz to 15,000 Hz. Like most phono preamps, its response was affected somewhat by the inductance of the phono cartridge connected to the receiver's input. This had the effect of reducing the response by 1 dB at 5000 Hz, 2 dB at 10,000 Hz, and 2.5 to 4 dB at 20,000 Hz, depending on the cartridge used. These values are fairly typical of the behavior of most modern amplifiers and receivers.

The FM tuner exhibited an IHF sensitivity of $3.1 \mu\text{V}$ and reached a 50-dB quieting in mono at $4 \mu\text{V}$, with 1.6 percent THD at that input. In stereo, 50 dB of quieting occurred at $43 \mu\text{V}$, with only 0.5 percent THD. The ultimate S/N ratio at $1000 \mu\text{V}$ was 74 dB in mono and 71 dB in stereo. FM distortion at $1000 \mu\text{V}$ was 0.05 percent in mono (probably the residual level of our signal generator) and 0.24 percent in stereo.

In the stereo FM mode, the frequency response was within ± 1 dB from 40 Hz to

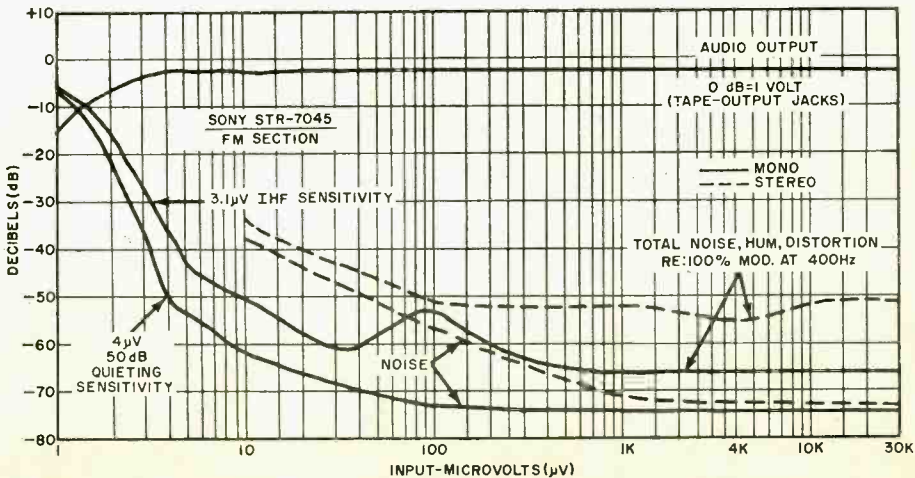

**NEW FROM
BELL & HOWELL
SCHOOLS...**

**THE REVOLUTIONARY
25-INCH DIAGONAL
DIGITAL
COLOR TV
YOU ACTUALLY
BUILD YOURSELF!**

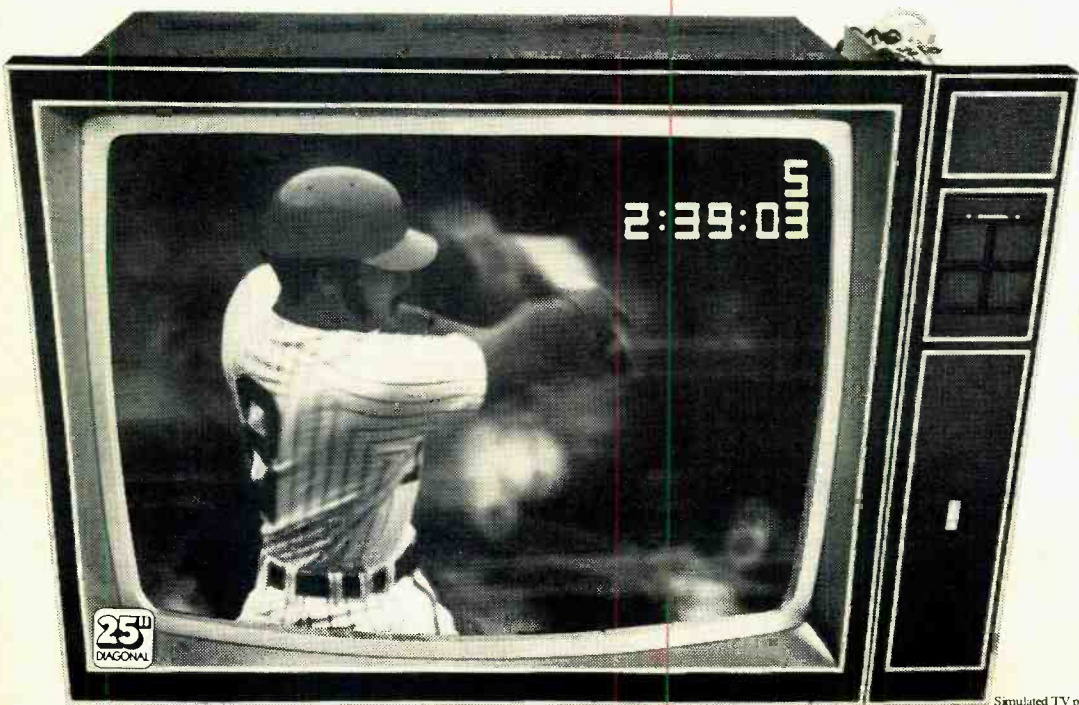

Simulated TV picture



"Electro-Lab" is a registered trademark of the Bell & Howell Company.

Simulated TV picture

Build one of today's most advanced color TV's as part of a complete learn-at-home program! It's an enjoyable way to discover the exciting field of digital electronics!

Digital electronics is a fascinating world to explore! It's an expanding technology that's changing not only our clocks, wristwatches and pocket calculators, but now, color TV!

By building Bell & Howell's big-screen color TV with digital features, you'll learn about this exciting field first hand. And you'll take special pride in this remarkable TV because you built it yourself!

You work with a color TV that's ahead of its time... with revolutionary features like:

Channel numbers that flash on the screen

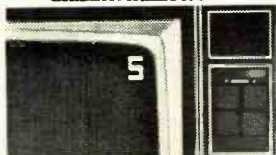

Wait until you see channel numbers that actually flash on the screen! You can even pre-set how long you want them to stay on before fading.

Automatic pre-set channel selector

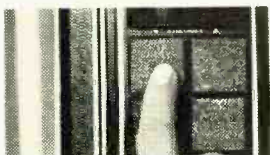

With just the push of a button, your favorite channels come on in the sequence you pre-set. All "dead" channels are skipped over. You can even intermix UHF and VHF channels!

Digital clock that flashes on screen



Imagine pushing a button and seeing the correct time on your TV screen! The hours, minutes and seconds appear in clear, easy-to-read digital numbers.

What's more, Bell & Howell's color TV has silent, all-electronic tuning, "state-of-the-art" integrated circuitry, the advanced Black Matrix picture tube for a brighter, sharper

picture and a 100% solid-state chassis for longer life and dependability.

You need no prior electronics background!

We start you off with the basics. You'll receive a special Lab Starter Kit with your first lesson so that you can get immediate "hands on" experience to help you better understand newly-learned electronics principles. Later, you'll use your new knowledge and learn valuable skills as you build the color TV. You can take full advantage of our toll-free phone-in assistance service throughout the program and also our in-person "help sessions" held in 50 cities at various times throughout the year where you can "talk shop" with your instructors and fellow students.

You also build Bell & Howell's exclusive Electro-Lab electronics training system



Includes building the three professional instruments you'll need to test the TV and perform fascinating electronics experiments.

The digital multimeter (pictured here), solid-state "triggered sweep" oscilloscope and design console make up one of the very best sets of electronics training equipment available today.

The skills you learn could lead to part-time income—perhaps a business of your own!

Bell & Howell Schools' at-home training program could lead to new income opportunities, full or part time. No better or more practical at-home training in electronics is available anywhere! While many of our students do not ask for employment assistance, it is available. Of course, no assurance of income opportunities can be offered.

Mail the postage-free card today!

This Bell & Howell Schools' program is approved by the state approval agency for Veterans' Benefits. Please check the appropriate box on the card for free information.

If card has been removed, write:
An Electronics Home Study School
DEVRY INSTITUTE OF TECHNOLOGY



BELL & HOWELL SCHOOLS

4141 Belmont, Chicago, Illinois 60641

599R5

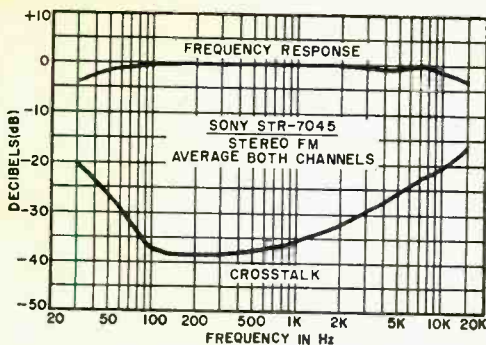

11,500 Hz. It was down 3.5 dB at 30 Hz and 15,000 Hz. Channel separation was 38 dB at middle frequencies and exceeded 20 dB between 30 Hz and 10,500 Hz. It was 16 dB at 15,000 Hz.

In all other respects, the FM tuner acquitted itself very well. Capture ratio was 1.6 dB at 30 and 15,000 Hz, and image rejection was a very good 86 dB. Alternate-channel selectivity was at least 59 dB above and 64.5 dB below the signal frequency. Accurate measurements were prevented by the receiver's mild, but nondefeatable, afc which

Circle No. 65 on Reader Service Card

DUAL MODEL 701 SINGLE-PLAY AUTOMATIC TURNTABLE (A Hirsch-Houck Labs Report)

THE Model 701 single-play automatic turntable from Dual features an automatically regulated direct-drive system. Its motor, turning at a selectable speed of 33½ or 45 rpm, eliminates the need for idler wheels and belts. The low speed assures that all rumble is well below audible frequencies and is very low in amplitude.

The dc motor in the turntable employs Hall-effect devices in its electronic feedback and driving circuits. These not only maintain a constant average speed, they also reduce to a very low level the instantaneous variations that cause "wow" and "flutter."

Externally, the 701 appears to be similar to the top-of-the-line Dual Model 1229 record changer. Its tonearm is nearly identical, with only a slight change in the gimbal pivot structure and a new counterweight design. Adjusted to balance the tonearm, the latter has an independently supported weight within its outer shell. This is the equivalent of two mechanical filters that "tune out" the tonearm/cartridge resonance and the lower resonant frequency of the turntable chassis and mounting system.

caused it to "lock onto" the interfering signal before the interference actually occurred. The threshold for FM muting and stereo switching was 7 μ V. The AM tuner had a typically limited frequency response that was down 6 dB at 100 and 3500 Hz.

User Comments. If one were to characterize the receiver in a single word, it would have to be "clean". Attractive, functional styling, coupled with a minimum of external complexity, is accompanied by extraordinarily low distortion over the full frequency range (and a very respectable power capability). FM tuner distortion is comparable to the residual levels in today's finest laboratory signal generators.

The published ratings of the STR-7045, good as they are, do not do justice to this fine receiver. The numerically unimpressive IHF sensitivity actually is no disadvantage unless one is located 100 miles from an FM transmitter, whereas image rejection, selectivity, and very low distortion allow the receiver to cope with typical suburban and urban listening conditions.



A stylus force gauge on the pivot structure is calibrated from 0 to 3 grams in increments of 0.1 gram up to 1.5 grams and 0.25 gram from 1.5 to 3 grams. The anti-skating compensation dial has two calibration scales (for conical and elliptical styli) that correspond to the tracking force in use. The cartridge mounts in a plastic insert, the latter supplied with a plastic jig that accurately locates the stylus for minimum tracking error.

The cueing lever raises and lowers the tonearm under damped control. Two levers—one for speed selection and the other to

control STOP/START—control the operating functions of the turntable. The turntable can be operated manually simply by lifting the pickup from the arm rest. Picking up the tonearm starts the motor; returning it to the arm rest shuts off the motor. However, it is not necessary to manually return the arm to the rest at the end of manual play. The tonearm automatically lifts at the end of play and returns to rest, shutting off the motor.

The vernier speed-trim control (operates on both speeds) has a nominal range of 8 percent. The under side of the 12-in., 6-lb 10-oz platter has stroboscope markings that can be viewed through an internal mirror system.

The Dual Model 701 automatic turntable, complete with dustcover and wooden base, retails for \$400.

Laboratory Measurements. In our lab, the 701's wow was the lowest we have yet to measure in a turntable. The 0.03-percent reading we obtained probably represents the residual wow on our test record. Flutter was slightly higher. The 0.07-percent figure we measured consisted of higher frequency (around 200 Hz) components that were

relatively less audible than would be the case with most other turntables.

In our tests, the vernier control could be varied by +5.5 and -7.6 percent about the nominal frequency, changing less than 0.6 percent with extreme line-voltage variations of from 90 to 140 volts ac. The platter reached its operating speed in 2 to 3 seconds after the START lever was operated, but total cycling time between operating the lever and the beginning of play was on the order of 6 to 7 seconds.

Rumble was also the lowest we have ever measured on a turntable. Unweighted (NAB) rumble was -41 dB, including both lateral and vertical components, and -45 dB with vertical rumble cancelled out by paralleling the outputs of the cartridge. With RRL relative audibility weighting, rumble was -66 dB—some 6 to 10 dB lower than that found in most of the finest turntables we have tested. This is largely due to the direct-drive system (the platter sits directly on the motor's spindle), since the basic rumble frequency is about 0.5 Hz, and its harmonics are well below the lowest audible frequency.

The tracking error of the tonearm was as

Affordable, portable function generator. \$149⁹⁵

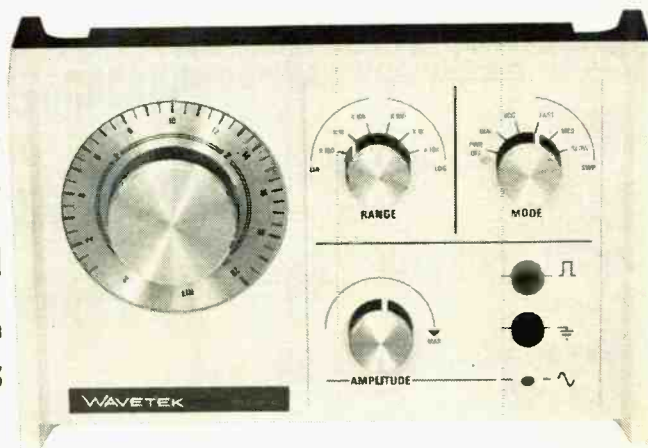

We've built ultra-sophisticated function generators that sell for nearly two thousand dollars. But the Model 30 may be our greatest achievement. An under-\$150 function generator that can do all this: 2Hz to 200 KHz frequency range; sine, square, triangle outputs; linear and logarithmic sweep. Because it's battery operated, the Model 30 can be used anywhere, with complete line isolation. (A rechargeable power supply kit is available for line operation.) Because it's only \$149.95, everyone can afford to buy one. How can you function without it?

WAVETEK®
P.O. Box 651, San Diego, Calif. 92112
TWX 910-335-2007, Tel. (714) 279-2200

CIRCLE NO. 31 ON READER SERVICE CARD

low as a pivoted arm of its length could be: not more than 0.25°/in. of radius. The tracking force dial calibration was unusually accurate, within 0.1 gram of the scale reading over most of its range. At the 1-gram setting, where we operated the 701 during most of our tests, the error was less than 0.05 gram!

We noted an apparent discrepancy in the two anti-skating scales, since the red (conical) scale appeared to give more accurate compensation with our Shure V-15 Type III cartridge than did the white scale. However, since the difference between the two settings

was about 0.25 gram, and even the "worst" was far more accurate than almost any other anti-skating calibration we have seen on a tonearm, this is really not a serious matter.

User Comment. In almost every respect, the Dual 701 surpassed just about every other record player—manual or automatic—that we have tested. Its operation is as simple and foolproof as could be desired, and its electrical and mechanical silence is uncanny. During operation, whether playing or cycling, not a whisper can be heard from the player, nor a click from the speakers.

Circle No. 66 on Reader Service Card

ANTENNA SPECIALISTS MODEL MON-41 VHF CONVERTER

NOW YOU can monitor any of three Public Safety broadcast bands through the receiver portion of a CB transceiver with the aid of a device recently developed by Antenna Specialists Co. Called the "Translator", it converts Public Safety broadcast frequencies to 27.065 MHz for reception on Channel 9 in the Citizens Band.

Three Translator Models are available, each capable of providing monitoring facilities on any two channels within their respective bands. The Model MON-40 covers the 30-50-MHz vhf low band, while the MON-41 (the one we used for our tests) covers the 148-174-MHz vhf high band. Coverage of the 450-470-MHz uhf band is provided by the Model MON-42. The two vhf models retail for \$40 each, and the uhf model sells for \$45. These prices include mobile mounting brackets but not crystals for the desired channels.

How It Works. The MON-41 employs a MOSFET r-f amplifier and mixer. The r-f circuits are adjusted to provide uniform response within the required frequency range. The heterodyning signal fed into the mixer comes from a crystal-controlled local oscillator, the frequency of which is multiplied to provide a 27.065-MHz difference frequency to be fed to the CB transceiver.

Although the Public Safety communication systems employ frequency modulation (FM), they can still be "demodulated" by an AM CB receiver through a process known as "slope detection". The signal is tuned toward the edge of the receiver's i-f selectivity curve where the response simply "slopes"



down in a rather linear fashion. This makes the FM signal "look" like an AM signal to the detector. (This method is satisfactory only for narrow-band FM, the type employed by these particular services.)

The point where the receiver's i-f selectivity starts to drop and its slope changes varies from receiver to receiver. Hence, provisions are included in the Translator to move its crystal frequency to create up to about a 10-kHz shift in the injector signal.

Operation. The Translator has three push-button switches. Two of these select the desired channel crystal. The third controls power to the converter and transfers the CB receiver's input between the CB antenna and output of the Translator. When power is on, a light-emitting diode glows and indicates that the CB antenna is disconnected.

Operation is simple. All that need be done is to depress the pushbutton for one of the two channels, set the CB transceiver to Channel 9, and turn on the power to the Translator.

While listening to Public Safety broadcasts, it is still possible to monitor CB Chan-

nel 9. R-f leakage around the antenna-changeover section of the on/off switch accomplishes this. However, the overall sensitivity of the setup will be reduced for the CB signal. We discovered that, in this case, detection of a regular CB Channel-9 signal would require an input of about 100 μ V. Normal Channel-9 reception requires that the Translator be switched off. The converter must also be switched off for reception on any of the other CB channels.

With respect to the latter, if a CB transmission is attempted when the Translator is on, shunt-connected diodes in the converter's output circuit protect it from damage by r-f energy. Without these protective diodes, the Translator's output is connected directly to the CB transmitter's output and keying the latter would destroy the former's output circuit. Nor should damage occur to the CB transceiver's output circuitry in the event the transmitter is keyed while its output is connected to the output of the Translator. The converter's output is designed to

present an SWR of less than 2:1 to the CB rig.

To obtain the best reception with a particular CB rig, the frequency of the Translator's crystal must be adjusted accordingly. This requires removal of the converter's cover and adjusting the related trimmer capacitor while listening to the desired signal. In some cases, this might require fast action because PS transmissions are usually brief in duration and at intermittent periods. Where available, the transceiver's "delta tune" control may also prove useful to clarify the signal.

Performance. When used with several different transceivers, the Translator performed satisfactorily on our local police broadcast channels and the National Weather Service broadcasts. If you are in a good signal area, particularly where relatively high antennas are involved at the transmitter or receiver, good reception can be expected within normal local communication ranges.

Circle No. 67 on Reader Service Card

HM ELECTRONICS MODEL HM-310 VOM PLUS

YOU probably think all VOM's are easily identifiable by their black plastic cases, large meter movements, and capabilities of measuring voltage, resistance, and current. Well, have another look. While it is true that, at first glance, the HM Electronics, Inc., Model HM-310 VOM looks like any other multimeter, have a closer look. This \$60 three-in-one test instrument can measure voltage, resistance, and current. But it also has built-in facilities for measuring capacitance and checking transistors.

As a VOM, the multimeter has seven dc voltage ranges from 120 mV to 600 V full-scale at a sensitivity of 100,000 ohms/volt; four ranges for ac voltage from 6 to 600 V full-scale at a sensitivity of 10,000 ohms/volt; direct current ranges (four in all) from 120 μ A to 300 mA full-scale, plus a 12-A range; and three resistance ranges (RX1, RX1K, and RX0.1M). A dB range from -20 to +58 is also provided.

The first new function built into the instrument is the capacitance measuring facility that uses line voltage as the measurement source. It has two ranges: 0-0.01 and 0-0.2 μ F full-scale. Measurements can be made from either 50- or 60-Hz lines, since separate scales for each are provided on the meter face.



As a transistor tester, the instrument checks alpha from 0 to 0.9965 and beta from 0 to 285. Collector-to-base leakage current is checked in two ranges at 12 and 48 μ A full-scale for both npn and pnp transistors.

The accuracy on all dc ranges is 3 percent of full-scale, while on ac it is 4 percent. The meter movement has an anti-parallax mirrored scale to reduce reading errors. The movement has a 7.5- μ A full-scale sensitivity, and it is protected against overload damage by a pair of silicon diodes.

The HM-310 multimeter measures 6 in. by 5 in. by 2½ in. Its carrying handle can be swung back to serve as a tilt stand on the service bench and in the field. Three bat-

teries (two 1.5-volt and one 22.5-volt) provide the power needed for all ranges except when making capacitance measurements. A pair of conventional red and black test leads is provided, while a front-panel heavy-duty transistor socket is used for making the semiconductor tests.

Optional extras for the HM-310 VOM include a 30-kV dc probe for high-voltage TV receiver measurements, a 3-kV and a 6-kV ac probe, and a carrying case.

Circle No. 68 on Reader Service Card

TAG ELECTRONICS WATER ALARM

ALTHOUGH water is a necessity for human existence, there are times when water can become too much for human suffering—like when it starts filling up basements and boats. If that is your problem, cheer up. Tag Electronics, Inc., is marketing a Water Alarm that is in all likelihood one of the most convenient moisture/liquid detectors around.

The Water Alarm is built into a black plastic box that measures 6¼ in. by 3¾ in. by 2 in. Its all solid-state circuitry, powered by a pair of conventional alkaline D cells, drives a small but strident horn whenever the alarm trips due to the presence of moisture at a pair of metal contacts mounted flush with the bottom of the box.

The Water Alarm is an all-in-one unit. It has no switches, requires no wiring, and does not have to be mounted on a wall. Four small extruded bumps at the corners support the box (and metal contacts that serve as the sensor) off any normally damp floor.

When a moisture path exists between the sensor contacts, the alarm trips and the horn sounds. The blast is continuous for a short time. It then cycles on and off for about 10 hours if fresh alkaline cells are used. Since there are no switches or other controls to get at, the only way to shut off the alarm is to pick it up off the wet floor. This breaks the moisture path between the sensor contacts and resets the alarm. (The current drain on standby is almost zero, so that a pair of alkaline D cells should last about a year; less if the alarm is periodically tripped.)

We tested the Water Alarm by placing a moistened fingertip across the sensor contacts. The horn sounded immediately. Then

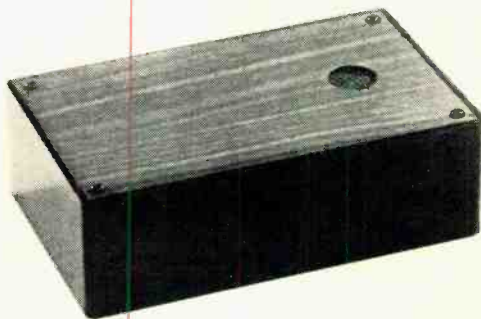

we field tested it by placing it on a back porch. Sure enough, when it began to rain, the horn sounded. But where we really wanted (and needed) it was in the bilge of our small, outboard-motor boat. We hoped the alarm would signal the presence of water in the boat long before we had to abandon ship. It did, and we got the pump going in time to prevent a salvage operation.

(Note: If you have an inboard-powered boat and are planning to use the Water Alarm, mount the box above-deck and run a length of ordinary line cord with the ends exposed between box sensor contacts and bilge. The buzzing contacts on the horn should not be used in a gasoline-fume-filled atmosphere. Tag will supply a 10-ft. cable for inboard-motor boat use.)

All in all, the alarm is a handy item to have around the house, boat, or shop. Its purchase price of \$15 is far less than the damage that can be caused by not knowing that water is building up. You will still have to "man the pumps," but at least you will man them before considerable damage can be inflicted by the water.

Circle No. 69 on Reader Service Card



Solid State

By Lou Garner

FROM TIME TO TIME, we have received complaints from experimenters who assembled projects using circuits published in manufacturers' application notes but have been unable to obtain satisfactory performance. In many cases, the difficulties were traced to interpretation of the published schematic diagram.

By definition, a schematic diagram shows only the *scheme* of a circuit's wiring. Symbols, rather than pictorial reproductions, are used for components and devices, with interconnecting lines to show the wiring. When dealing with basic circuits, rather than specific equipment designs, engineers frequently omit unnecessary frills in the interest of clarity. After all, a basic schematic is easier to draw than a complete wiring diagram.

The practice is not new. Back in the years B.T. (before transistors), design engineers and technicians often simplified their vacuum-tube schematic diagrams by eliminating "obvious" connections. Typically, the power supply would be omitted, with a simple arrow pointing to "B+." Often, the filament wiring was not shown, as everyone capable of reading a schematic knew that the tube filaments had to be connected for the circuit to function. This led to simpler and less intricate diagrams, while retaining all the information needed to understand and duplicate the circuit.

Quite often, basic (as opposed to complete) schematics are used by semiconductor manufacturers when publishing IC data sheets and application notes. Terminal numbers may be omitted because a particular device is available in several different packages—DIP, TO, flat pack—and, while the basic circuit connections are unchanged, the terminal numbers vary, depending on which version of the device is used in the circuit. Power supply connections may be omitted because these are obvious on the terminal

diagram given in the data sheet. Supply voltages may be omitted because these are not critical within the device's maximum ratings or because the circuit is intended to use a "standard" voltage (5, 6, 9 or 12 volts). Similarly, resistor wattage ratings and capacitor types seldom are specified unless critical. The person using the diagram is expected to use some judgement; and, certainly, he wouldn't expect to find a 20-watt wirewound resistor in a micropower op-amp or low-level digital circuit.

Unfortunately, not everyone reading or using published schematics understands this practice. If a wiring connection is not shown (even though it obviously must be included for the circuit to work), the user may simply assume that it is not present or, in fact, it is not essential to circuit operation. This misunderstanding can lead to such interesting situations as a *powerless* audio amplifier.

The differences between a complete schematic *wiring* diagram as might be found, say, in a magazine construction article, and a basic schematic are illustrated in Figs. 1 and 2, respectively. Both are diagrams of a square-wave oscillator using one section of a National Semiconductor type LM124 quad op-amp IC. Although both contain the same basic information, the simpler diagram might be misinterpreted by a less experienced hobbyist.

Interpreting Schematic Diagrams

Referring to Fig. 1, note that all circuit details are shown, including device terminal numbers, the power supply (battery *B1*), power connections to IC terminals 4 and 11, and a spst on-off switch (*S1*). The LM124 may be used on supply voltages of 3 to 30 volts, so a standard 6-volt battery could be used for *B1*. Since relatively little power is involved, $\frac{1}{4}$ - or $\frac{1}{2}$ -watt resistors can be employed, and *C1* could be a ceramic, Mylar, or tubular paper capacitor.

In contrast, the simpler circuit given in Fig. 2 is the type one might find in a manufacturer's application note. Here, pin numbers are not identified, since these depend on which section of the quad amp is to be used. A power source is not shown; and the power connections to the op amp itself are omitted, since these two terminals are common to all four units and, in any case, are clearly identified on the data sheet's terminal diagram. Despite the omissions, the simpler diagram contains the same basic information as Fig. 1 and could be used just as easily by an engineer, technician, or experienced hobbyist.

Both complete and basic schematics are shown in this column, from time to time. Generally, to avoid possible copy errors and to insure clarity, we show all diagrams in the same form as given in the *original* source, whether it was a data sheet, manufacturer's application note, reference manual, or reader's letter.

When working with basic schematics, the following tips are helpful:

1. Refer to the device's data sheet for terminal connections.
2. Remember that most circuits require a power source. If no power connections are shown on the schematic, check the device's terminal diagram.
3. If supply voltages are not specified, check

the data sheet for maximum ratings and use a mid-range value below the maximum.

4. If resistor wattage ratings are not indicated, consider the power levels involved. As a general rule, low-wattage resistors ($\frac{1}{4}$ or $\frac{1}{2}$ watt) may be used with most low-level IC's.

5. Capacitor values generally are given in microfarads unless otherwise specified.

6. If a split power source is indicated, either on the diagram or on the device data sheet, remember that the center tap is connected to circuit ground. A typical value for an op amp circuit, might be ± 15 volts. Such a specification means that a split or dual dc power source is required, furnishing 15 volts on *either* side of the common ground terminal.

Reader's Circuit. Responding to the call for circuits in our March column, Richard K. Brush (165 Leslie Ave., #2, Salt Lake City, UT 84115) submitted the buffer amplifier/differentiator circuit illustrated in Fig. 3. Richard suggests the circuit as an improved and more versatile design than the basic differentiator circuit described by Leslie Solomon in his "Test Equipment Scene" for November, 1972. The new circuit is suitable for checking sine waves for distortion; but it has the advantage of offering several different RC time constants, permitting its application over a broader range of test frequencies. In addition, the circuit may be used as a straight buffer amplifier for more general tests.

In operation, half of a 558 dual op amp (*IC1*) serves as a buffer amplifier; the second half (*IC2*) is a differentiator. Switch *S1* selects the capacitor value (*C1*) used for differentiation, with *R3* providing a fine control over the RC time constant. Potentiometer *R1* acts as the input level control,

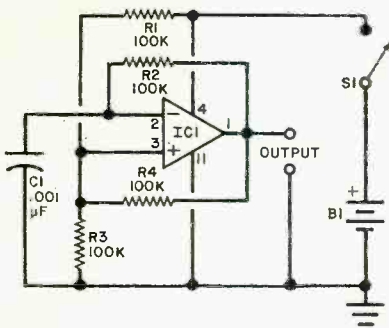

Fig. 1. Schematic with all circuit details, including terminal numbers and power supply.

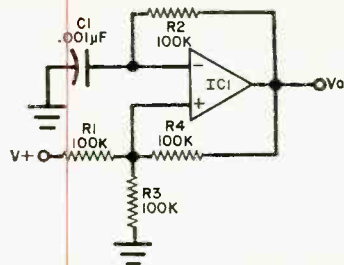

Fig. 2. Simplified diagram of same circuit as Fig. 1, as it is used in application notes.

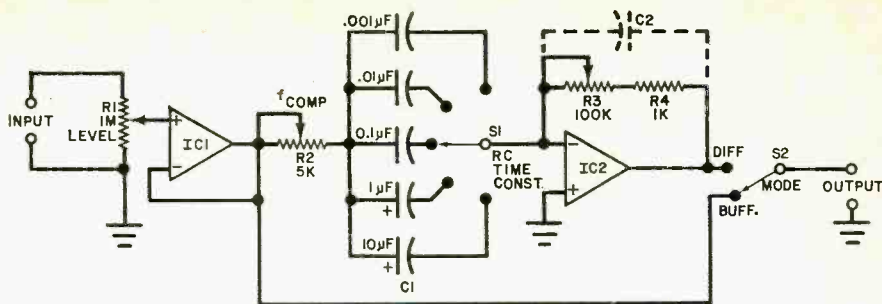

Fig. 3. Simplified buffer amplifier/differentiator has several RC time constants.

while S2 is used to select the preferred mode of circuit operation (either buffer or differentiation). Potentiometer R2 provides adjustable frequency compensation to insure optimum performance.

Any of several available versions of the 558 may be used when duplicating Richard's circuit. This device is essentially a pair of 741 op amps in a single package. Check the data sheet of the specific type for terminal connections. The 558 normally requires a split power source, and a dual 9-volt supply was used in the original model.

Richard recommends the use of *log* taper potentiometers for R2 and R3. He writes, further, that compensation capacitor C2, although suggested in op amp literature, is not needed in this particular circuit.

What's in a Type Number? Unless my memory bank has dropped a few bytes somewhere, it was Shakespeare who wrote: "What is in a name? That which we call a rose by any other name would smell as sweet." Today, we feel inclined to paraphrase the Bard of Avon with our own version: "What's in a Type Number? The same device by any other type number will work as well." Our feelings were crystallized recently by a letter from reader Joseph Arrigo (2008 64th St., Brooklyn, NY 11204) who mildly chastised us for featuring an RCA type HC1000 in a circuit diagram in the January column. Reader Arrigo complained that we should have specified another device. Actually, the HC1000 was specified correctly, for it was the type listed in the original source, and is (or was) an RCA device. But Joseph is also correct, in that the nearest equivalent to the HC1000 in RCA's general replacement line is the KD2131 power module.

This apparent confusion in type numbers results from the practice of most manufac-

turers of offering essentially the same device with different type numbers to the OEM (commercial), industrial, military, and replacement/hobbyist markets. True, there may be minor differences in specified characteristics, temperature ratings, tolerances, or packaging, but the same basic device (from a circuit viewpoint) often may be obtained with any of several different type numbers. The practice is confused even more when an identical device (electrically) is offered by several different manufacturers.

A good example is the popular 555 timer IC. It is offered by various manufacturers under the following type numbers: NE555V (Signetics, Intersil and Fairchild); LM555-CN (National); MC1455P1 (Motorola); LS555 (Lithic Systems); RC555DN (Raytheon). Several of these firms offer slightly different versions. Raytheon, typically, offers the device as the RC555T and RM555T, both of which are identical except for maximum temperature range, and both of which are in a round metal case. The RC555DN is identical to the RC555T, but is in an 8-pin DIP rather than a metal case.

In some cases, different versions of a device are identified by letter suffixes appended to the basic type number. Siliconix, for example, offers five versions of its L144 triple op amp, types L144AL, L144AP, L144BL, L144BP, and L144CJ. Here, the "A" suffix indicates the device is rated for military applications over a temperature range of -55 to $+125^{\circ}\text{C}$, the "B" suffix indicates the unit is suitable for industrial applications from -20 to $+85^{\circ}\text{C}$, and the "C" suffix is for a commercial device for use from 0 to $+70^{\circ}\text{C}$. The "L" suffix identifies the device in a TO-86 flat pack, the "P" suffix in a TO-116 DIP, and the "J" suffix in a plastic DIP. From, this, we can identify the L144CJ as a type L144 triple op amp in a plastic DIP rated for commercial tempera-

ture ranges. Except for the maximum temperature ratings and packaging, however, all five versions of the LI44 are identical as far as internal circuitry is concerned.

If you're not yet thoroughly confused, there's more. Instead of changing suffixes, some manufacturers change the basic type number to identify identical devices with different temperature ratings. National Semiconductor's LM124 quad op amp, discussed earlier, is rated for applications over the range -55 to $+125^{\circ}\text{C}$. The version intended for applications in the -25 to $+85^{\circ}\text{C}$ range is the LM224, while the 0 to $+70^{\circ}\text{C}$ version is the LM324. To these three basic numbers are added letter suffixes to identify packaging—"N" for a molded DIP, "D" for a cavity style DIP, and "F" for a flat pack. Crazy, man!

Device/Product News. In a move to expand its markets, the Intel Corporation (3065 Bowers Ave., Santa Clara, CA 95051) has announced plans to produce a family of complex CMOS circuits for consumer, industrial and commercial applications. The first circuits in volume production form a versatile, two-chip watch system capable of driving either dynamic scattering or field-effect liquid crystal displays. Manufactured using an advanced silicon-gate, ion-implanted complementary MOS technology, the two-chip watch system consists of the 5801 oscillator/divider circuit and a decoder/driver circuit available in two versions: the 5201, which features hours, minutes and seconds on-command readout, and the 5202, which displays conventional hours and minutes. The 5801 operates with an external quartz crystal, dividing a 32-kHz oscillator signal down to 64 Hz and, at the same time, generating a 1024-Hz output to drive an external converter. In the 5201 or 5202, the 64-Hz input is divided further to 1 Hz and then counted and decoded into seconds, minutes and hours. Average current drains are $5.0 \mu\text{A}$ for the 5801 at 1.4 volts and $0.5 \mu\text{A}$ for the 5201 or 5202 at 15 volts. Sample units in flat packages are offered at \$27.50 for the 5801/5201 set and \$25.00 for the 5801/5202 pair.

RCA's Solid State Division (Route 202, Somerville, NJ 08676) has introduced a new 4-decade divide-by-N COS/MOS counter that should be of interest to experimenters working with digital circuits. Designated type CD4059AD, the device is believed to be the first of its type to use LSI techniques

to permit all four decades to be accommodated on a single chip. Operating on 3 to 15 volts, and with TTL drive capability, the new counter can be programmed to divide a clock frequency by any number from 3 to 15,999. Three mode-select controls are provided for programming flexibility. The CD4059AD is a 24-lead ceramic DIP.

If you're planning an electronic thermometer or temperature control, you'll be interested in a new device now available from the National Semiconductor Corporation (2900 Semiconductor Drive, Santa Clara, CA 95051). An IC temperature transducer (LX5600) the device comprises a temperature sensor, stable voltage reference, and an operational amplifier fabricated on a single monolithic chip. The LX5600's output is a voltage directly proportional to temperature in degrees Kelvin. With the internal op amp set for zero gain, the output is 10 millivolts per $^{\circ}\text{K}$, but almost any desired scale factor can be obtained by adjusting the op amp's gain by means of external resistors. If required, the op amp also can be used as a comparator in which the output will switch as the temperature traverses a preset value, making the device useful as an on/off temperature controller. With an internal shunt voltage regulator, the LX5600 can be operated over a wide range of d.c. supply voltages. Two versions are available from National: the LX5600 with an accuracy of $\pm 8\%$ and the LX5600A, with an accuracy of $\pm 4\%$. Both versions are offered in 4-lead TO-5 cases.

Working with memory circuits? If so, you should be interested in a new random access memory recently introduced by Motorola Semiconductor Products, Inc. (P. O. Box 20924, Phoenix, AZ 85036). Designated type MC10143L, the new RAM is a 16-bit multiport register file capable of reading 4 bits and/or writing 2 bits simultaneously. An LSI device, the memory unit has a complexity equivalent to 110 gates. The access time to any four bits is 10 nanoseconds. With a total storage of 16 bits, the MC10143L is organized as 8 words by 2 bits. Among its operating features is the ability to access any two 2-bit words for read operation while writing a third word, permitting two read and a write operations at the same time. Write operations also can be made prior to, simultaneously with, or after read operations. With ECL outputs and a power dissipation of 610 mW., the MC10143L is supplied in a 24-pin ceramic DIP. ◆



CB Scene

By Len Buckwalter, KQA5012

WHEN your modulation's mushy or the r-f won't reach out, who will restore your rig to mint condition? Should you try your own hand at the repair, take the set back to the dealer, or start searching through the yellow pages? Judging by the state of CB service, you might have to try a combination of these routes. Electronic appliances for the home are often backed by local factory service and independent repair shops, but CB service may be hard to come by.

Sometimes there's little choice about *who* is to repair the set. If you ever receive the infamous FCC pink slip—a notice of technical violation—you are directed by law to have the problem solved by, or under the supervision of, the holder of a commercial radiotelephone ticket (First or Second Class). When he is through, he must fill out and sign a report that's returned to the FCC.

Do-It-Yourself Repairs. More likely, you will discover equipment trouble much earlier than an FCC monitor because other stations quickly tell you about audio distortion or a signal that's drifting beyond their receiver's bandwidth. When this happens, the regulations offer considerable leeway about the repairs you can do yourself, without professional help. The crucial item that's off-limits to the do-it-yourself repairman is the "frequency-determining" element of the circuit. This is considered to be the crystal-oscillator stage in the transmitter. Thus you have access, without a commercial license, to about 80 percent of the transceiver's circuitry, mostly in the receiver. The rules are vague about what you can do in the transmitter *output* stage; but the FCC says no ticket is required if the circuit was designed so that adjustments or tests done during servicing, installation, or maintenance will not result in off-frequency operation, ex-

cessive power, overmodulation, excessive harmonics, or spurious emissions. That mouthful is really saying that any CB'er may tune up his transmitter output into an antenna without taking it to a two-way radio shop. We've never heard of a test case about needing a license to replace parts in a transmitter output stage. Chances are you'd run little risk with factory-approved components. It would take a sizable mistake in values to cause all those circuit evils mentioned earlier.

Back to the Dealer. But assume you are neither sufficiently skilled nor equipped to cope with a faulty transceiver. If your set is still in warranty, you'd naturally take it back to the dealer. But CB dealers or repair stations aren't on every street corner. There's a good chance you will have to pack up the set and mail it to the factory. Here the news is good and bad. The in-warranty set will be fixed, but you may not see it for six or eight weeks. The same is true for sets beyond warranty, but the chances are excellent that your transceiver will be fixed properly and at a reasonable price. Manufacturers have the advantage of personnel who work on your model regularly and can often fix it faster than an independent shop. A manufacturer is also highly motivated to offer service, even if it's only a break-even proposition, to back up his product.

In checking with one major company that deals through mail-order distribution,

Who Repairs CB Rigs?

I learned you can return a defective set and expect to have it back in about three weeks (probably not counting mailing time). When the set is not under warranty, the company lets the customer state, in advance, a maximum price for the repair. This avoids an unacceptably large bill. You can also take an ailing set to this chain's local retail outlets where the purchase was made. One store manager reports he employs no full-time service personnel, but has a technician who appears at the store every Thursday. If the trouble is easy and obvious, he'll fix it on the spot. Otherwise, there's a waiting period of several weeks for replacement parts.

One of the least satisfactory routes to CB repair in many locations is a local two-way radiotelephone shop which repairs police, taxi and related services. This month's column, in fact, was triggered by the contemptuous remarks by one such shop-owner that appeared recently in a serviceman's journal. The writer said there was intense interest in CB repair, but he refused this work for several reasons: few CB'ers, he said, come into the shop until they have so misadjusted their sets that they won't work at all; when they do come in, they expect him to correct the problem quickly at a small charge, if any; and most CB customers take up too much time just "visiting" and trying to get useful knowledge free of cost.

Although this man probably kicks his dog, too, there's some justification in his complaints. In a conversation with another technician, one who specializes in marine repair, I heard more reasonable arguments. A typical CB set, he said, is in the \$100 category and his hourly rate is \$18 (recently raised from \$15) for professional two-way repair. Despite CB's low initial

cost, he argues, it's a complex piece of equipment that can take two or three hours of troubleshooting. The question he raises: How can you tell a customer it may cost \$56 to repair a \$100 set? He suggested that a CB owner send the set back to the factory or seek a CB specialist, if one is near by. This shop-owner had raised a servicing problem that now plagues the electrical and electronics industry; the cost of service is uncomfortably close to the original price tag.

Easy-To-Fix Troubles. The brightest side of the CB service picture, thanks to the near-elimination of vacuum tubes and the timely death of the vibrator power supply, is that most trouble isn't inside the chassis. As in the appliance industry, where most service calls are caused by "the plug not inserted into the wall outlet", many troubles are easily fixed by anyone. Some tips on what to do before you pull the chassis:

Don't trust the first report of a faulty signal. The other operator, even if he's electrically skilled, may be unable to tell the difference between bad circuits and difficult propagation conditions. Also, the reporter's set, not yours, may be defective. Listen to your signal on another set, or get several reports under different conditions of range and terrain.

The input and output cables of a CB set bear the most mechanical brunt in daily service. If you hear reports that your transmitter is intermittent, start by suspecting the mike cable. It's weakest points occur where the cable joins the connector on the set's front panel and its entry into the microphone. Each time you grab the mike, those areas are slightly strained until the day arrives when a tiny wire inside the cable fractures. As the ends brush each

FREE McIntosh CATALOG and FM DIRECTORY

McIntosh Laboratory, Inc.
East Side Station P.O. Box 96
Binghamton, N.Y. 13904
Dept. 16-5

**SEND
TODAY!**

NAME _____

ADDRESS _____

CITY _____ STATE _____ ZIP _____

Get all the news and latest information on the new McIntosh Solid State equipment in the McIntosh catalog. In addition you will receive an FM station directory that covers all of North America.



MX 113

AM FM/STEREO TUNER PREAMPLIFIER

CIRCLE NO. 18 ON READER SERVICE CARD

other, audio acts in sporadic fashion. Sometimes you can grab the cable, squeeze it near the connector and get yourself back on the air!

Vibration in an automobile can loosen coaxial connectors where they attach to the rear of the set or at the bottom of the antenna. These cables operate at very low impedance—approximately 50 ohms—which means it doesn't take much contact resistance to drop power. Regularly check the tightness of these fittings. If you spot any sign of corrosion, shine them with "crocus cloth", a handy item stocked in many hardware stores. It's a reddish paper (impregnated with jeweler's rouge) that restores the factory shine to plugs and other metal fittings.

Although relays are often electronic these days, or sealed against air, they're still a major troublemaker in CB equipment. When you hear an erratic or delayed changeover between send and receive, it's probably time to dress the contacts. An excellent way to clean contacts without changing their shape (a design factor) is with an ordinary business card. Insert the card between the contacts, gently press the contacts together, then draw the card through with a wiping action. Repeat above and below the movable contacts.

If your crystal selector switch no longer operates in a positive fashion (receiver audio is intermittent or the transmitted signal won't stay constant), apply a good grade of TV tuner spray to the wafers and rotate the channel knob several times while the contacts are still wet. Apply some cleaner to the volume and squelch controls, too.

A fuse may blow merely because it's tired. Before pulling the chassis, replace a defective fuse once to see if it blows again. Only then should you suspect deeper trouble.

If audio on both send and receive is fuzzy, don't plunge into the audio amplifier. In mobile operation, a paper-cone speaker takes terrible abuse from the hot-air blast of a car heater or oven-like temperatures inside the vehicle on a summer day. A replacement speaker often restores the audio sparkle.

These tactics should take care of most CB afflictions. Only when the simple measures fail will you need further help from frequency counters and holders of commercial tickets. ♦

EXAMINE ANY TAB BOOK ON 10-DAY FREE TRIAL!

BRAND-NEW BOOKS...JUST PUBLISHED

- Getting The Most Out of Your Electronic Calculator—Solves just about any everyday math problem you'll encounter. 1st truly modern math course—using the calculator vs pencil & paper. Scores of practical examples. 228 p. \$4.95.
- Auto Stereo Service & Installation—Save \$ by installing your own 8-track or cassette system! 240 p., 245 ill. \$5.95.
- Don't Look at the Camera—Shortcuts to Television Photography & Filmmaking—228 p., 46 ill. \$9.95.
- Practical Test Instruments You Can Build—204 p., 157 ill. \$4.95.
- Modern Guide to Auto Tuneup & Emission-Control Svcs.—240 p., 124 ill. \$4.95.
- Ques & Ans. About Tape Recording—264 p., 103 ill. \$5.95.
- Modern Comm's Switching Systems—276 p., 171 ill. \$17.95.
- Simplified Computer Programming—The Easy RPG Way—240 p., 115 ill. \$5.95.
- Commercial FCC License Handbook—444 p., 150 ill.—\$5.95.
- Modern Applications of Linear IC's—276 p., illus. \$12.95.
- Radio Production Techniques—204 p., 86 ill. \$12.95.
- How to Prepare a Prod. Budget for Film & Video Tape—\$12.95.
- Cassette Tape Recorders—204 pp.—over 160 ill.—\$4.95.
- Miniature Proj. For Elect. Hobbyists—168 p., ill.—\$3.95.
- Experimenting With Electronic Music—103 pp.—\$4.95.
- Electrical Wiring & Lighting for Home/Office—204 pp.—\$4.95.
- FM Stereo/Quad Receiver Servicing Man—192 p., 120 ill. \$4.95.
- Electronic Measurements Simplified—252 pp., ill.—\$4.95.
- Solid-State Circuits Guidebook—252 pp., 177 ill.—\$5.95.

A UNIQUE CONCEPT IN KITS—TAB ELECTRONIC BOOK KITS

For the price of a kit alone, you get an appropriate projects book—PLUS a complete kit to help you start building and learning.

- Audio Mixer, \$7.95 5-Watt Hi-Fi Amplifier, \$9.95 Electronic Fortune Teller, \$4.95 AM Wireless Mike, \$6.95 Electronic Touch Switch, \$6.95 Garage Light Control, \$9.95 Audio Signal Generator/Injector, \$5.95 Low Voltage DC Power Supply, \$4.95 Slide Tester, \$5.95 High Power Lamp Dimmer, \$4.95 20W 4-Channel "Quad" Ampl. \$19.95 Electric Siren, \$4.95 Intrusion Alarm, \$7.95 Tunable Organ, \$9.95.

BEST SELLERS...INVALUABLE TO ALL IN ELECTRONICS

- 10-Min Test Techniques For PC Svcing.—216pp., 114 ill.—\$4.95
- TV Bench Servicing Techniques—228 pp., 177 ill.—\$4.95
- How To Be A Ham—Incl Latest FCC Rules—192 p., 34 ill.—\$3.95
- 125 Typical Elect. Cir. Analyzed & Repaired—208 pp.—\$4.95
- Handbook of Semiconductor Circuits—448 pp.—\$5.95
- Everyman's Guide to Auto Maintenance—192 p., 144 ill.—\$4.95
- Introduction to Medical Electronics—272 pp., 126 ill.—\$6.95
- MATV Systems Handbook—176 pp., 91 ill.—\$4.95
- Trbshgt. Solid-State Wave Gen./Shaping Cir.—192 p.—\$4.95
- Pictorial Guide to CB Rad. Inst. & Rep.—256 p., ill.—\$4.95
- Understanding & Using the VOM & EVM—192 p., ill.—\$4.95
- Mobile Radio Handbook—192 pp., 203 ill.—\$4.95
- Pictorial Guide to Color TV Circ. Trouble—256 pp.—\$4.95
- Acoustic Techniques for Home & Studio—208 p., ill.—\$4.95
- Understanding & Using the Oscilloscope—256 p., ill.—\$4.95
- Basic Audio Systems—272 pp., 203 ill.—\$4.95
- The Complete Mini-Bike Handbook—320 pp., 145 ill.—\$5.95
- Pictorial Guide to Color TV Circ. Trouble—256 pp.—\$4.95
- Dictionary of Electronics—420 pp., 487 ill.—\$3.95
- Marine Electronics Handbook—192 pp., 121 ill.—\$4.95
- FM Repeater Circuits Handbook—305 pp., 182 ill.—\$6.95
- Basic Electronic Circuits Simplified—352 pp., 170 ill.—\$5.95
- How to Read Electronic Circuit Diagrams—192 p., ill.—\$4.95
- 4-Channel Stereo From Source to Speaker—hardback—\$6.95
- Basic Math Course for Electronics—152 pp., ill.—\$4.95
- Basic Electricity & Beginning Electronics—256 pp.—\$4.95
- Computer Technician's Handbook—480 pp., 400 ill.—\$7.95
- Small Appliance Repair Guide—224 pp., 400 ill.—\$4.95
- How to Repair Small Gas Engines—256 pp., ill.—\$4.95
- Electric Motor Test & Repair—160 pp.—hardback—\$6.95
- How to Build Solid-State Audio Circuits—320 pp., ill.—\$5.95
- RTTY Handbook—320 pp., 230 ill.—\$6.95
- Des. & Maint. CATV & Small TV Studio—256 p.—HB—\$12.95
- How to Become a Radio Disc Jockey—256 pp.—HB—\$7.95
- IC Projs. for Amateur & Experimenter—192 p., 105 ill.—\$4.95
- Stereo/Quad Hi-Fi Print's & Projects—192 p., ill.—\$4.95
- Pulse & Switching Circuits—256 pp., 184 ill.—\$4.95
- Using Electronic Testers for Auto Tune-up—256 pp.—\$4.95
- Digital Electr.: Prin's & Practice—288 p., 191 ill.—\$5.95
- How to Repair Home & Auto Air Conditioners—208 pp.—\$4.95
- Basic Color Television Course—420 pp., 300 ill.—\$5.95
- Fire & Theft Security Systems—176 pp., over 100 ill.—\$4.95
- CB Radio Operator's Guide—224 pp., ill.—\$4.95
- New IC FET Print's. & Projects—160 p., 60 ill.—\$3.95

ALL-IN-ONE COLOR & B&W TV SCHEMATIC/SERVICING MANUALS

Each vol. contains complete service data, parts lists, full-size schematics, and all other info needed. Each 8 1/2 x 11", 196-212 pp. Each only \$4.95 unless otherwise marked. COLOR TV: Adm. Vol. 1, \$5.95 Vol. 2, G-E Vol. 1 Jap. Vol. 1 Vol. 2 Vol. 3 Vol. 4, \$5.95 Vol. 5, \$5.95 Magnavox Vol. 1 Vol. 2 Motorola Vol. 1 Vol. 2 Philco RCA Vol. 1, \$5.95 Vol. 2, \$5.95 Sylvania Vol. 1 Vol. 2 Zenith Vol. 1 Vol. 2 Vol. 3 Serv. Modular Rec'v. Vol. 1 Vol. 2 B & W TV: Adm. G-E Jap. Magnavox Motorola Philco RCA Sylvania Zenith

SEE THESE HELPFUL BOOKS AT YOUR PARTS DISTRIBUTORS' OR CLIP THIS AD AND order on FREE 10-DAY Trial, or attach payment and save postage. Fully guaranteed or money back! Pa. add 6% tax. Foreign 10% (P.E. 64)

TAB BOOKS

BLUE RIDGE SUMMIT, PA. 17214

CIRCLE NO. 28 ON READER SERVICE CARD

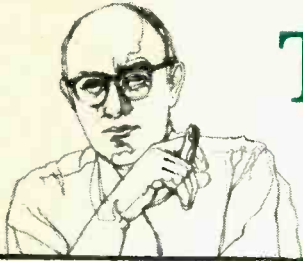

Test Equipment Scene

By Leslie Solomon, Technical Editor

MOST of the equipment we talk about in this column is for use on the workbench. However, there are important pieces of test gear that find a lot of use "out in the field." This is especially true if you are concerned with CB—a not unimportant area of electronics these days.

The name of the game in CB is, of course, to get the most out of the rig (whether it is base or mobile). Since the FCC Rules preclude any messing around with the portion of the transmitter that determines frequency, all that is left is the audio section and the antenna. We'll consider the latter first.

Most people seem to buy antennas by "name." That is, they know somebody who has a such-and-such antenna and it works fine; or they have heard glowing reports, about an antenna "on the air." But, after procuring the same antenna, the user finds that it doesn't do for him what it did for others. That's when the questions start.

For mobile use, it appears that the old-fashioned, rather long (Army style) whip antenna is giving way to relatively small, hard-to-spot loaded dipoles. The switch may be due to looks or utility; but whichever one is selected, the important thing is to mount it properly. In some cases of course, the antenna location is determined by the vehicle (using the fender hole for the broadcast whip, for example).

However, if there is a choice of mounting sites, the "polar diagram" of the antenna/car

combination should be considered. This means that the radiation pattern of the antenna is modified by the large metal mass of the vehicle and it is possible to get a better signal in one direction than another. To check this out, use a field-strength meter.

Field-Strength Meter. This is essentially a crystal set tuned to the CB frequency with a meter readout. The induced r-f from the transmitter is rectified by the semiconductor crystal and the amount of current flow (which depends on the amount of r-f present at the small whip antenna that feeds the crystal set) is indicated on the meter.

Thus, with the antenna temporarily mounted on the vehicle (with a good ground plane to work against), the field-strength meter is carried around the vehicle at some constant radius and the amount of field strength picked up is noted. A definite pattern will usually be found; and the pattern can be changed by trying other mounting locations. With the antenna on the right-rear fender, for example, there may be a major lobe across the vehicle over the left-front fender. The best location is, obviously, a matter of choice; but a circular pattern is usually preferred for general all-round coverage. On the other hand, it may be better to have a pattern that provides a stronger signal when a station is approached than when it is being left behind.

All of this illustrates why base station antennas are mounted up in the air (in the clear) with a good built-in ground. The radiation pattern is circular. Of course, beam antennas are another matter, since they are designed to produce a single-lobed pattern to be effective in one direction only.

The same CB crystal set that is used to determine the radiation pattern can also be used to check the modulation if a pair of headphones is substituted for the meter. In this way, speech clarity and distortion due to overmodulation can be checked.

Checking Antenna Efficiency

Standing Wave Ratios. When a transmitter, transmission line, and antenna are all properly matched, the transmitter will deliver optimum power to the antenna and (hopefully) radiate the signal properly. The instruction manuals for most rigs explain how to "tune" the transmitter to the antenna and some "how-to-do-it" antenna information. However, it is still good to know just how much power is going to waste and how much is actually getting off the antenna.

This is done by measuring the standing wave ratio (SWR). An SWR meter can be built using the schematic shown here. Start

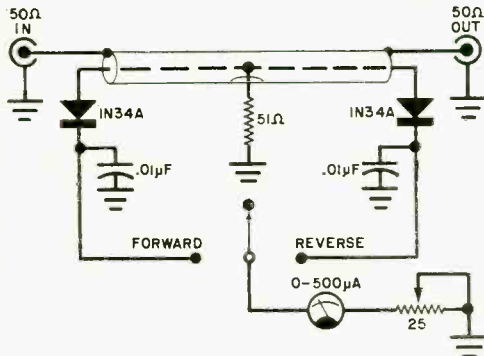

with a 4½" piece of RG-58A/U coaxial cable and a similar length of ½" copper tubing. Remove the outer jacket and braid from the coax, leaving only the insulation and the inside lead. Locate the center of the cable and gently cut away the insulation so that a 51-ohm, ½-watt resistor can be soldered to the center conductor—but don't solder it on yet.

Make a hole in the copper tubing so that the resistor lead can pass through the tubing and connect to the center conductor. Slide the copper tubing over the coax until the two center points line up and solder the resistor to the center conductor. You can use a pair of r-f connectors at each end of the copper tubing to connect it between the transmitter and the antenna (both assumed to be 50 ohms).

To use the device, connect it between the transmitter and antenna, apply power to the transmitter and set the switch to the FORWARD position. Adjust the potentiometer for a full-scale meter reading. Setting the switch to REVERSE will show the reflected power. It should be near zero, to indicate a good match. If it is far upscale, power is being wasted in the radiating system. Consult the instruction manuals for the transmitter and for the antenna to find the procedures for reducing SWR. ♦

JUNE 1974



The great new

Super Scanner

It scans 360° in milliseconds with 5.75 dB gain. Or beams an 8.75 dB gain signal where and when you want it—instantaneously. (Otherwise, it's just another beautiful base antenna.)



MODEL MS 119 Super Scanner electronic beam antenna with control console.

the antenna specialists co.

Division of ORION INDUSTRIES, INC.
12435 Euclid Ave., Cleveland, Ohio 44106
Export: 2200 Shames Dr.,
Westbury, L.I., New York 11590
Canada: A. C. Simmonds & Sons, Ltd.

CIRCLE NO. 3 ON READER SERVICE CARD



FREE

1974 LAFAYETTE CATALOG 740

Ready Now!

Your Complete Electronics Buying Guide

- Stereo/Hi-Fi Components • CB Transceivers & Walkie-talkies • PA Systems • Tools & Test Equipment
- Police/Fire Monitor Receivers • Antennas • Photography Equipment • Ham Gear • Books, Parts, and More!

Send Today!

Lafayette Radio Electronics
P.O. Box 10, Dept. 35064
Syosset, L.I., N.Y. 11791

35064

NAME _____

ADDRESS _____

CITY _____

STATE _____ ZIP _____

CIRCLE NO. 17 ON READER SERVICE CARD

Why a Sylvania home training program may be

your best investment for a rewarding career in electronics

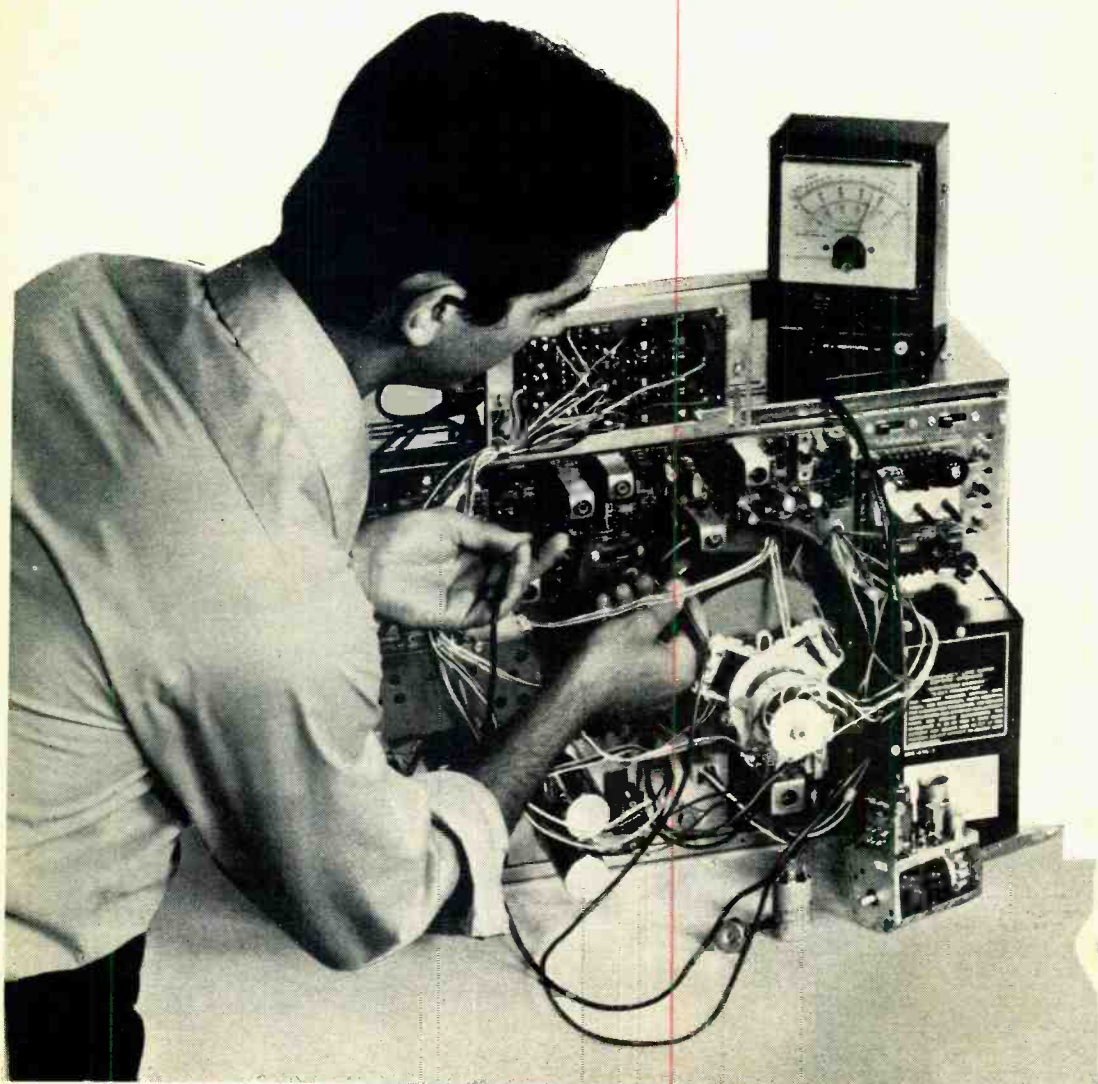

1 LEADER IN ELECTRONICS TRAINING

Over the years, Sylvania Resident Schools have trained thousands of men and women for key positions in the electronics field. Now, through Sylvania Home Training, you can receive the same high-quality career training at home. In your spare time. While you hold your present job. Remember, this training is designed with one purpose in mind — to give you the background you need to land the electronics job you really want!

2 AUTOTEXT TEACHES YOU ELECTRONICS RAPIDLY, EASILY.

AUTOTEXT, offered exclusively by Sylvania, is the proven step-by-step method of home training that can help you learn the basics of electronics quickly and easily.

3 CASSETTE SYSTEM

This innovative learning-by-hearing approach is a special option that adds an extra dimension to AUTOTEXT. It's almost like having an instructor in your own home. As you play the cassette tapes, you'll have an instructor guiding you through your AUTOTEXT lessons. Explaining the material as you read it. Going over schematics with you, reinforcing the basic electricity and electronics study materials with you. Everything you need to know to get you started towards a highly regarded position as an electronics technician — all in an easy-to-understand, conversational tone.

4 SPECIALIZED ADVANCED TRAINING

For those already working in electronics or with previous training, Sylvania offers advanced courses. You can start on a higher level without wasting time on work you already know.

5 PERSONAL SUPERVISION THROUGHOUT

All during your program of home study, your exams are reviewed and your questions are answered by Sylvania instructors who become personally involved in your efforts and help you over any "rough spots" that may develop.

6 HANDS-ON TRAINING

To give practical application to your studies, a variety of valuable kits are included in many programs. In Sylvania's Master TV/Radio Servicing Program, you will actually build and keep an all solid-state black and white TV set, and a color TV set. You also construct an oscilloscope which is yours to keep and use on the job.

7 FCC LICENSE TRAINING — MONEY BACK AGREEMENT

Take Sylvania's Communications Career Program — or enter with advanced standing and prepare immediately for your 1st, 2nd, or 3rd class FCC Radio Telephone License examinations. Our money-back agreement assures you of your money

back if you take, and fail to pass, the FCC examination taken within 6 months after completing the course.

8 CONVENIENT PAYMENT PLANS

You get a selection of tuition plans. And, there are never any interest or finance charges.

SEND ATTACHED POSTAGE PAID CARD TODAY! FREE DESCRIPTIVE BOOK YOURS WITHOUT OBLIGATION.

If reply card is detached send this coupon

SYLVANIA TECHNICAL SCHOOL	
Home Study	694-406-0
909 Third Avenue	
New York, N.Y. 10022	
Please send me FREE illustrated career catalog. I understand that I am under no obligation.	
Name	_____
Address	_____
City	_____
State	_____ Zip _____
Age	_____
Veterans: Check here <input type="checkbox"/>	

Sylvania Technical Systems, Inc.

GTE SYLVANIA

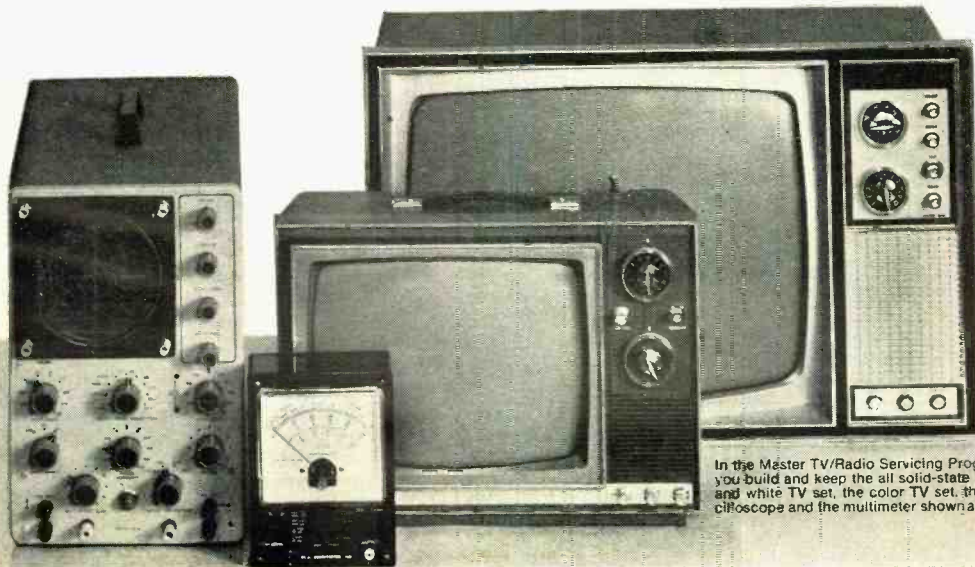

In the Master TV/Radio Servicing Program, you build and keep the all solid-state black and white TV set, the color TV set, the oscilloscope and the multimeter shown above.

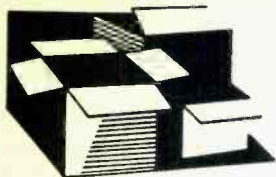

New Products

Additional information on new products covered in this section is available from the manufacturers. Either circle the item's code number on the Reader Service Card inside the back cover or write to the manufacturer at the address given.

LAFAYETTE FULL-LOGIC DECODER

The Lafayette Radio Electronics Model SQ-W decoder with Variblend is said to be the most advanced wave-matching full-logic SQ decoder available for playing 4-channel SQ discs and FM broadcasts. The decoder provides the highest front-to-rear and left-to-right separation of SQ-encoded material. In addition, two Composer circuits are built in for restoring all other 4-channel encoded (matrixed) discs to their original quadrasonic format and deriving 4-channel sound from conventional 2-channel programs. The decoder is designed to be used with a system consisting of four amplifier channels and four speaker systems. List price is \$99.95.

Circle No. 70 on Reader Service Card

BSR TELEPHONE ANSWERING DEVICE

The Phone Butler 1000 telephone answering device and home message center from BSR Electronics, Inc., is the first electronic device of its kind designed for both office and home use. It is shipped with a professionally pre-recorded answering message, but personal messages can be recorded via a condenser microphone built into the tape deck. The Phone Butler can record up to 30 messages on a special cassette, and a Message Waiting indi-

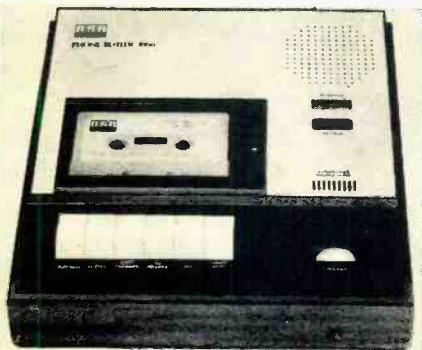

icator lamp illuminates whenever a call has been taped. The unit is factory set to answer after three rings, but it can be user-adjusted to respond after up to five rings. A bonus function is the device's ability to act as an electronic "bulletin board" for in-home messages. Retail price is \$99.95.

Circle No. 71 on Reader Service Card

KEYSTONE BATTERY HOLDER LINE

Keystone Electronics Corp. is marketing a new line of battery holders designed to withstand shock and vibration. Styles are available to accommodate all standard carbon, alkaline, lithium, magnesium, and mercury batteries in the AAA, AA, C, D, and 9-volt sizes. All sizes in the line are available in both steel and aluminum. When installed in the snap-fit clips, the batteries are held under spring tension at a constant pressure to assure low-resistance contact. Steel holders have steel contacts, while aluminum holders have nickel-plated brass contacts.

Circle No. 72 on Reader Service Card

PIONEER HIGH-POWER STEREO RECEIVER

U.S. Pioneer Electronics Corp. Model SX-1010 is designed for the audiophile who wants the flexibility and performance specifications of sep-



arate tuner and integrated amplifiers, combined with the convenience of a single multipurpose component. Conservatively rated at 100 watts continuous power per channel (both channels driven into 8-ohm loads) the receiver is designed to deliver full power at less than 0.1 percent THD at all audio frequencies from 20 Hz to 20,000 Hz. The receiver can handle three pairs of speaker systems. (Price is \$699.95.)

Circle No. 73 on Reader Service Card

EDMUND SCIENTIFIC KIRLIAN PHOTO KIT

A whole new photographic field is now possible with Edmund Scientific's Stock No. 71,938 Kirlian photography kit. The kit ionizes the gases emitted by all living things, as well as inorganic matter, making possible the photographing of these gaseous "halos". Kirlian photography obtains images on film without a camera or lens by direct recording of the electronic charge transmitted by animate and inanimate objects. Each photographed aura differs from another, and animate auras are said to change with physical changes. Thus, one can measure bioplasmic state changes because the electrophotographic image makes

visible the bioplasma as it relates to a particular condition during a given time period. The kit includes a portable darkroom. Retail price is \$49.95.

Circle No. 74 on Reader Service Card

DATA TECHNOLOGY 4-DIGIT DMM

A 4-digit (10,000 count) multimeter that can operate from line or battery power has been introduced as the Model 45 by Data Technology Corp. The high-resolution instrument is particularly applicable for tuning precision



power supply and amplifier circuits. It has five ac and dc voltage ranges with 10- μ V resolution, six resistance ranges with 10-milli-ohm resolution, and five each direct and alternating current ranges with 10-nA resolution. The instrument will operate for 10 to 12 hours on fully charged batteries. Power consumption is 3 watts, and the 7-segment display measures 0.33" high. The calibration chart is silk-screened inside the case so that it cannot be mislaid. Price is \$399.

Circle No. 75 on Reader Service Card

AKAI OPEN-REEL TAPE RECORDERS

The Model GX-600D tape recorder, from AKAI America, Ltd., features a two-speed, three-motor tape deck, GX glass and crystal tape heads, and 10 $\frac{1}{2}$ " reel capacity. The Model GX-600DB has the same features, plus a built-in Dolby noise reduction system. Both models also have sound-on-sound, line/microphone mixing, dual monitoring, automatic stop, and pause control with automatic release. Technical specifications include better than 56 dB S/N, less than 0.07 percent wow and flutter at 7 $\frac{1}{2}$ ips, 30-23,000-Hz frequency range, less than 0.7 percent distortion at 7 $\frac{1}{2}$ ips, and 7 $\frac{1}{2}$ - and 3 $\frac{3}{4}$ -ips operating speeds. Retail price of the Model GX-600D is \$625, while the Model GX-600DB sells for \$725.

Circle No. 76 on Reader Service Card

HEATH SMALL-ENGINE TUNE-UP METER

Now the weekend tinkerer can set up his garden tractor, lawnmower, motorcycle, trail bike, snowmobile, etc., with the same accuracy obtainable on a V-8 engine with the aid of the Heath Company's Model CM-1045 small-engine tune-up meter. The instrument is designed for use on 4-cylinder and 2- and 4-cycle engines. It tests voltage, resistance, dwell, continuity, and

NOW A PROFESSIONAL BURGLAR-FIRE ALARM SYSTEM YOU CAN INSTALL YOURSELF.



Save hundreds of dollars in alarm installation and monthly service charges. The EICO SS-500 "install-it-yourself" burglar-fire alarm system offers you the kind of professional protection you have been looking for, at a price you can afford. The SS-500 has been designed on the EICO "Expandability Concept" that enables you to "add-on" protection to meet your own special needs. Before you purchase any security system, we suggest you read the EICO Security Handbook and see how easy EICO makes it to "Do-it-Yourself."

FREE EICO CATALOG/SPECIAL OFFER!

Security handbook (Reg. \$2.95) only \$1.50 with this ad. Includes a catalog on EICO Security Systems, Test Instruments, Stereo, Hobby Kits and name of nearest distributor. For catalog only, check reader service card or send 50¢ for first class mail service.

EICO, 283 Malta Street, Brooklyn, N.Y. 11207



CIRCLE NO. 10 ON READER SERVICE CARD

Now... the most enjoyable, do-it-yourself project of your life—a Schober Electronic Organ!

You'll never reap greater reward, more fun and proud accomplishment, more benefit for the whole family than by assembling your own Schober Electronic Organ.



You need no knowledge of electronics, woodwork or music. Schober's complete kits and crystal-clear instructions show you — whoever you are, whatever your skill (or lack of it) — how to turn the hundreds of quality parts into one of the world's most beautiful, most musical organs, worth up to twice the cost of the kit.

Five superb models, with kit prices from \$500 to around \$2,000, each an authentic musical instrument actually superior to most you see in stores.

Get the full story FREE by mailing the coupon TODAY for the big Schober color catalog, with all the fascinating details!

The Schober Organ Corp., Dept. PE-55
43 West 61st Street, New York, N. Y. 10023

- Please send me Schober Organ Catalog.
 Enclosed please find \$1.00 for 12-inch L.P. record of Schober Organ music.

NAME _____
ADDRESS _____
CITY _____ STATE _____ ZIP _____

CIRCLE NO. 25 ON READER SERVICE CARD



SUPER CB TALK POWER!

What gives Johnson CB two-way radios their "extra sock" for longer range? Built-in Electronic Speech Compression, that's what! It's the kind of engineering you expect from U.S.-made Johnson radios . . . backed by a full 1-year parts and labor warranty with over 700 service centers nationwide.

PRICES START AT UNDER \$100!
SEND COUPON FOR FREE CATALOG!



E. F. Johnson Co.

Dept. PE Waseca, Minn. 56093

Name _____

Address _____

City _____ State _____ Zip _____

In Canada: A. C. Simmonds & Sons, Ltd.

CIRCLE NO. 33 ON READER SERVICE CARD

ABOUT YOUR SUBSCRIPTION

Your subscription to POPULAR ELECTRONICS is maintained on one of the world's most modern, efficient computer systems, and if you're like 99% of our subscribers, you'll never have any reason to complain about your subscription service.

We have found that when complaints do arise, the majority of them occur because people have written their names or addresses differently at different times. For example, if your subscription were listed under "William Jones, Cedar Lane, Middletown, Arizona," and you were to renew it as "Bill Jones, Cedar Lane, Middletown, Arizona," our computer would think that two separate subscriptions were involved, and it would start sending you two copies of POPULAR ELECTRONICS each month. Other examples of combinations of names that would confuse the computer would include: John Henry Smith and Henry Smith; and Mrs. Joseph Jones and Mary Jones. Minor differences in addresses can also lead to difficulties. For example, to the computer, 100 Second St. is not the same as 100 2nd St.

So, please, when you write us about your subscription, be sure to enclose the mailing label from the cover of the magazine—or else copy your name and address exactly as they appear on the mailing label. This will greatly reduce any chance of error, and we will be able to service your request much more quickly.

in many cases permits checking the entire ignition system of a small engine without tearing down the engine to get at the ignition points behind the flywheel. A built-in tachometer, with 0-3000- and 0-15,000-rpm ranges, employs a snap-on inductive pickup. Price of the kit is \$39.95.

Circle No. 5 on Reader Service Card

MITS AUDIO SWEEP GENERATOR

The Model SG 1900 audio sweep generator from MITS has the capabilities of both a fixed-frequency (CW) generator and a sweep gen-



erator. It is fully adjustable (10 ms to 100 s) in its logarithmic and linear sweep modes. The generator eliminates the need of hand-plotting response data points by providing an instantaneous oscilloscope or oscillograph display of the performance of the equipment under test. The instrument simplifies setting up tape recorder bias and aligning head azimuth and provides an easy means of checking line and load regulation and output impedance-versus-frequency for power supplies. Other uses include testing room and speaker box acoustics, phase-locked loops, SSB filters, and telecommunications equipment. List price is \$119.95 in kit form, \$149.95 factory wired.

Circle No. 78 on Reader Service Card

TECHNICS DIRECT-DRIVE TURNTABLE

By eliminating such motion-transmitting and speed-reducing devices as belts, idler wheels, and gears in the Technics Model SL-1200 direct-drive turntable, Panasonic has reduced wear, vibration, wow, and flutter. Operating speeds are provided for 33 $\frac{1}{3}$ and 45 rpm play. This is supplemented by a pitch control that has a separate ± 5 percent electrical adjustment range for each speed. Wow and flutter are less than 0.03 percent, while rumble is specified at better than -70 dB (DIN B rating). Retail price is \$279.95.

Circle No. 79 on Reader Service Card

EDSYN DESOLDERING TOOL

The new deluxe Soldapullit, Part No. DS017, from Edsyn has such new and improved features as low-friction plunger with floating seal ring, high-impact one-piece main barrel, extra-strong low-friction return shaft, and easy exhaust control valving that slows the vacuum stroke for delicate desoldering. Retail price is \$9.95.

Circle No. 80 on Reader Service Card

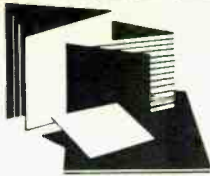

New Literature

GE SEMICONDUCTOR CROSS REFERENCE GUIDE

The new No. 451.104 Semiconductor Interchangeability & Cross Reference Guide from General Electric lists more than 6000 semiconductor types. The 44-page guide includes listings for 1N, 2N, 3N, and popular industry house numbers with cross references to either an exact GE type or a suggested replacement. Address: General Electric Co., Semiconductor Products Dept., Electronics Park, Bldg. #7, Mail Drop 49, Syracuse, NY 13201.

METROLOGIC 1974 LASER CATALOG

Listed and described in the March 1974 Research and Education Products catalog from Metrologic are dozens of basic laser items and optics kits and accessories. The 16-page catalog contains complete details, including prices, on such diverse items as He-Ne laser tubes, modulated lasers, power supplies, optics kits aimed at every level from beginner to advanced researcher, laser power meters and detectors, and much more. Address: Metrologic Instruments, Inc., 143 Harding Ave., Bellmawr, NJ 08030.

BROOKSTONE HARD-TO-FIND TOOLS CATALOG

There are literally hundreds of hand tools and instruments of all descriptions fully described in the First 1974 Edition A catalog available from the Brookstone Co. The tools listed are generally in the "hard-to-find" category, many of which will prove of interest to the electronics professional, hobbyist, and experimenter. Address: Brookstone Co., 15 Brookstone Bldg., Peterborough, NH 03458.

RCA AUDIO POWER AMPLIFIERS BOOKLET

RCA's No. APA-550 "Audio Power Amplifiers" booklet (40¢ each) will prove of interest to anyone who wants to know how audio power amplifiers are designed. The booklet discusses classes of operation, drive requirements, effects of operating conditions on circuit design, and basic circuit configurations. In a more technical vein, it focuses on output power, rating methods, basic power-dissipation relationships, thermal-stability requirements, effects of large phase shifts and excessive drive, and short-circuit protection. Address: RCA Solid State Div., Somerville, NJ 08876.

JUNE 1974



spend a dime, save a mint.

Invest a dime—send for our catalog. We'll prove to you that you *can* have selection and convenience and still get a great price.

For an immediate free copy of our 32 page catalog, mail the coupon below to the location nearest you. Please print.



Midwest Hifi

Wholesale & MAIL ORDER DIVISION

2455 Wisconsin Ave., Downers Grove, Ill. 60515
3309 E. J W Carpenter Frwy., Irving, Tex. 75062

NAME _____
ADDRESS _____
CITY/STATE _____ ZIP _____ (PE4-06)

CIRCLE NO. 21 ON READER SERVICE CARD

EVERYTHING YOU WANTED TO KNOW ABOUT CD IGNITION SYSTEMS BUT DIDN'T KNOW WHOM TO ASK.

Send for *FREE* Tiger booklet (20 pages) which answers all your questions.

Name _____
Address _____
City _____
State _____ Zip _____

CLIP OUT THIS AD AND SEND TO—

TRI-STAR CORP.

P. O. Box 1727 Dept. E
Grand Junction, Colo. 81501

CIRCLE NO. 29 ON READER SERVICE CARD

The Ultimate in Ignition Systems!
★ ELIMINATES BREAKER POINTS. ★
Perfect Timing and Dwell never change!

- Never wears out or needs any Maintenance.
- Eliminates Tune-ups.

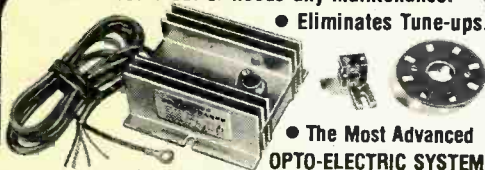

• The Most Advanced
OPTO-ELECTRIC SYSTEM

• The Allison Breakerless System eliminates the Points and Condenser, replacing them with an Opto-Electronic Trigger, using a Light-Emitting Diode and Phototransistor. The only "TRUE" Electronic Ignition! Gives 40 times more Timing Accuracy than ANY system using mechanical Breaker-Points! Unlimited RPM. Smoother running... (No timing fluctuation as with Magnetic units). Unaffected by Temperature, Moisture, or Vibration! All Solid-State Components. Easier Starting under any condition. Increased Horsepower. Sparkplugs last longer. Perfect timing increases engine Efficiency and Gas Mileage up to 30%!

Quick and Easy Installation! Tested and Proven reliability.

- Only **\$49.95**
 - **SATISFACTION GUARANTEED!**
 - **1-YEAR FACTORY WARRANTY!**
- (State Make, Year, Engine Size). (Calif. Res. add Tax).
- CONVERT YOUR "C-D" UNIT TO BREAKERLESS!
 "TRIGGER-UNIT" ONLY \$34.95
 - Send Postcard for **FREE BROCHURE** Today.

ALLISON AUTOMOTIVE CO.

P.O. Box 881-P, TEMPLE CITY, CAL. 91780

CIRCLE NO. 1 ON READER SERVICE CARD

SAVE!

MONEY • TIME • FREIGHT

QUALITY STEREO EQUIPMENT AT LOWEST PRICES.

YOUR REQUEST FOR QUOTATION RETURNED SAME DAY.

FACTORY SEALED CARTONS—GUARANTEED AND INSURED.

SAVE ON NAME BRANDS LIKE A.D.C.

DYNACO

A.R.

KLH

FISHER

KOSS

SHURE

SONY

AND MORE THAN 50 OTHERS
 BUY THE MODERN WAY
 BY MAIL—FROM

illinois audio

12 E. Delaware Place
 Chicago, Illinois 60611
 312-664-0020

CIRCLE NO. 15 ON READER SERVICE CARD



Electronics Library

BASIC AUDIO SYSTEMS

by Norman H. Crowhurst

This authoritative book covers sound systems for every application, both indoors and out. It is an introduction to the electronic aspects of sound, written for the technician who wants to install amplifiers in a church without distortion or feedback, the hi-fi fan who plans to install his own well-matched 2- or 4-channel stereo system, and the industrial technician who wants a PA system that can be heard by all employees.

Published by *Tab Books, Blue Ridge Summit, PA 17214. 240 pages. \$7.95 hard cover; \$4.95 soft cover.*

DIGITAL COMPUTER CONCEPTS

by Vester Robinson

A self-teaching, programmed course on the basic principles of digital computers, this book is geared to the beginner. The text format presents the big picture first, then drops back to the fundamental principles and builds back up to a complete operational computer system. The basic principles of what a computer does, how it does it, functional sections of a system, how each section functions, storage of information, retrieval of information, basic programming, and timing synchronization are discussed. Mathematics is kept to a minimum, while visualization of computer actions is emphasized.

Published by *Reston Publishing Co., Inc., P.O. Box 547, Reston, VA 22090. 295 pages. \$7.95 hard cover; \$5.95 soft cover.*

MODERN TELEVISION SYSTEMS

Including a Master Index to Common Television Troubles, this new book is perhaps the most up-to-date working tool available to the professional TV serviceman. It covers every aspect of both monochrome and color TV receivers. Fully detailed explanations cover every basic circuit of the receiver, how it functions and probable troubles. Covered are signal tracing methods, all current test equipment, alignment precautions, and numerous examples for localizing malfunctions accurately and quickly.

Published by *Prentice-Hall, Inc., Englewood Cliffs, NJ 07632. Hard cover. 463 pages. \$15.95.*

ELECTRONICS MARKET PLACE

NON-DISPLAY CLASSIFIED: COMMERCIAL RATE: For firms or individuals offering commercial products or services. \$1.60 per word (including name and address). Minimum order \$16.00. Payment must accompany copy except when ads are placed by accredited advertising agencies. Frequency discount: 5% for 6 months; 10% for 12 months paid in advance. **READER RATE:** For individuals with a personal item to buy or sell, \$1.00 per word (including name and address.) No minimum! Payment must accompany copy. **DISPLAY CLASSIFIED:** 1" by 1 column (2 5/8" wide), \$200.00. 2" by 1 column, \$400.00. 3" by 1 column, \$600.00. Advertiser to supply cuts. For frequency rates, please inquire.

GENERAL INFORMATION: First word in all ads set in bold caps at no extra charge. All copy subject to publisher's approval. All advertisers using Post Office Boxes in their addresses **MUST** supply publisher with permanent address and telephone number before ad can be run. Advertisements will not be published which advertise or promote the use of devices for the surreptitious interception of communications. Closing Date: 1st of the 2nd month preceding cover date (for example, March issue closes January 1st. Send order and remittance to **POPULAR ELECTRONICS**, One Park Avenue, New York, New York 10016, Attention: Hal Cymes.

FOR SALE

FREE! bargain catalog. Fiber optics, LED's, transistors, diodes, rectifiers, SCR's, triacs, parts. Poly Paks, Box 942, Lynnfield, Mass. 01940.

GOVERNMENT Surplus Receivers, Transmitters, Snooperscopes, Radios, Parts. Picture Catalog 25¢. Meshna. Nahant, Mass. 01908.

LOWEST Prices Electronic Parts. Confidential Catalog Free. **KNAPP**, 3174 8TH Ave. S.W., Largo, Fla. 33540.

ELECTRONIC PARTS, semiconductors, kits. **FREE FLYER**. Large catalog \$1.00 deposit. **BIGELOW ELECTRONICS**. Bluffton, Ohio 45817.

RADIO—T.V. Tubes—36¢ each. Send for free catalog. Cornell, 4213 University, San Diego, Calif. 92105.

AMATEUR SCIENTISTS, Electronics Experimenters, Science Fair Students . . . Construction Plans—Complete, including drawings, schematics, parts list with prices and sources . . . Robot Man — Psychedelic shows — Lasers — Emotion/Lie Detector — Touch Tone Dial—Quadasonic Adapter—Transistorized Ignition—Burglar Alarm—Sound Meter . . . over 60 items. Send 25¢ coin (no stamps) for complete catalog. Technical Writers Group, Box 5994, University Station, Raleigh, N.C. 27607.

METERS—Surplus, new, used, panel or portable. Send for list. Hanchett, Box 5577, Riverside, CA 92507.

PYROTECHNICAL chemicals, casings, tools, fuse, literature, supplies. Catalog—50¢, with samples—\$1.00. Westech, Box 593, Logan, Utah 84321.

WE SELL CONSTRUCTION PLANS. TELEPHONE: Answering Machine, Speakerphone, Carphone, Phonevision, Auto Dialer, Touch Button Dialer, Central Dial System. **TELEVISION:** \$35.00 Color Converter, Video Tape Recorder. \$25.00 Camera. **HOBBYIST:** Electron Microscope, 96 Hour Tape Music System, Ultrasonic Dishwasher, Radar-Oven. Plans \$4.95 each. **NEW ITEM:** \$75. Electronic Pocket Calculator, \$7.50. **COURSES:** Telephone Engineering \$39.50. Detective Electronics \$22.50. Integrated Circuit Engineering, \$49.50. **NEW SUPER HOBBY CATALOG** plus year's subscription to Electronic New Letter **AIRMAILED \$1.00**. Don Britton Enterprises. 6200 Wilshire Blvd., Los Angeles, Calif. 90048.

JAPAN HDNG KONG DIRECTORY. World products information. \$1.00 today. World Trade Inquiries, Hillyard, Washington 99207.

SCOPES, meters, test equipment, military and industrial surplus. Send 25¢ for "Bargain Bulletin". Lawrence Instruments, P.O. Box 744, Sunbury, Pa. 17801.

TEST EQUIPMENT, Aerospace-Laboratory Grade. Request your needs; will mail appropriate catalogs (we have 24 catalog categories). Only for Engineers, Businesses, Schools and advanced Technicians. Goodheart, Box 1220PE, Beverly Hills, Calif. 90213.

WAVEFORM GENERATOR KIT 8038 Function Generator IC Producing Sine, Square, Triangular Waveforms, \$10.00. Write for catalog. Photolume Corporation, 118 East 28th Street, New York, N.Y. 10016.

LOOKING FOR A NEW CHALLENGE?

... then build a TV camera!



ONLY SOLID-STATE CAMERA AVAILABLE IN KIT FORM OR FACTORY ASSEMBLED. COMPLETE KIT WITH WIDICON TUBE ONLY \$ 66.00. POSTPAID DELIVERY ANYWHERE IN USA, CANADA and MEXICO. OPTIONAL AUDIO SUBCARRIER \$18.95. WRITE or PHONE NOW FOR COMPLETE CATALOG OF KITS, PARTS and PLANS. DIAL 402-987-3771.

1301 BROADWAY **ATV Research** DAKOTA CITY, NEBR. 68731

DIGITAL ELECTRONICS: Complete schematics, parts lists, theories—Discrete Component Digital Clock, \$3.00—Sound Sensitive Switch, \$1.50. Increase technical competence, hobby skills—Complete Course in Digital Electronics is highly effective, \$10.00. Free literature. **DYNASIGN**, Box 60A7, Wayland, Mass. 01778.

SOUND SYNTHESIZER KITS—Surf \$11.95, Wind \$11.95, Wind Chimes \$16.95, Electronic Songbird \$6.95, Musical Accessories, many more. Catalog free. **PAIA Electronics**, Box J14359, Oklahoma City, OK 73114.

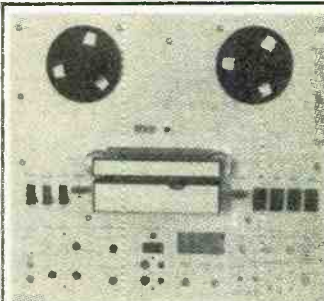

KLH TAPE DECK

New in factory cartons. 3 head, 3 motor-solenoid operated. Part of their \$699 unit. No electronics, but panel cut for all controls. Walnut case

included. Controls include Automatic Rewind, Search, Pause, Fast forward, Reverse, Play, and speed control, (3.75 & 7.5"). Tape counter. Wt. 37 lbs. 14 1/2" x 15 1/4". Ideal for custom installation.

STOCK NO. F5180 \$79.00

3 1/2" LIQUID CRYSTAL WRIST WATCH DISPLAY



The AEO129 Liquid Crystal Display specified in Jan. '74 **POPULAR ELECTRONICS** article! Build This Electronic Digital Wristwatch.

We supply reprint of article, and data sheets.

STOCK NO. B 5192 With Socket \$19.75

MINIMUM ORDER \$5.00. Include sufficient postage; excess refunded. Send for latest 56 page catalog with exciting values.



DELTA ELECTRONICS CO.

BOX 1, LYNN, MASSACHUSETTS 01903

CIRCLE NO. 8 ON READER SERVICE CARD

**Led Readouts with Internal Logic
Space Savers! Everything on one Dip.**



This is the best readout buy of 1974. Brand new, factory fresh T.T. #TIL306 readouts. These contain the equivalent of 1-Man-1 Led readout 1-7490, 1-7475, 1-7447 plus current limiting resistors. Imagine, a complete digital counting system with readout in one 16 PIN Dip. Regular catalog price on these is \$22.00 ea. Our price \$8.95 with specs. Quantity limited — Sold on a first come basis.

Led lamps at new lower prices

Jumbo red — Large like MV5024 — 6 for \$1
Jumbo green — Large like MV5222 — 4 for \$1
Jumbo yellow — Large like MV5322 — 4 for \$1
SPECIAL: Miniature red lamps like MV-50, but better. 8 for \$1

RTL IC's by Motorola

Brand new. These are getting hard to find. Best price anywhere
MC724-P — \$ 77 MC789P — \$ 77 MC790P — \$ 89

Calculator chip — Moslek MK5011 — Improved CT5001 — \$5.95 with specs

**New Low Prices
PRIME DIP TTL IC'S**

7400 — \$ 23	7427 — \$ 35	74H73 — \$ 49	74151 — \$ 89
74500 — \$ 49	7430 — \$ 23	7483 — \$ 89	74154 — \$1.59
7402 — \$ 23	7437 — \$ 49	7486 — \$ 39	74157 — \$1.79
7404 — \$ 25	7438 — \$ 49	7490 — \$ 89	74164 — \$1.19
74504 — \$ 49	7439 — \$ 65	7491 — \$ 95	74165 — \$1.49
7407 — \$ 29	7442 — \$ 77	7492 — \$ 89	74174 — \$1.95
7408 — \$ 23	7447 — \$ 95	74121 — \$ 49	74181 — \$3.50
7409 — \$ 29	7448 — \$ 95	74123 — \$ 95	74192 — \$1.39
7410 — \$ 23	7473 — \$ 39	74150 — \$1.39	74193 — \$1.39
	7474 — \$ 39		

IC Breadboard Panel

Removed from computers. Consists of an Augat panel with 210 14 pin wirewrap sockets. Also has 44 — MV-50 Led lamps. Board has also 2 oscillators, one is a CTS — Knights unit at 4.000000 MHz, and the other is 2.000 MHz \pm .1% tuning fork osc. Both are set up to work on 5v DC. There is also a Beckman 10v reg. IC. Original cost on these units was \$750. Our price is \$12.50 ea.

Send
Check or M. D.
Add 10 % for Pstg.
and handling

ALTAJ ELECTRONICS

P. O. Box 28592A
Dallas, Texas 75228

Bargain flyer (10c),
Free with order,
No C.D.D.

Texas Residents. Add 5% State Sales Tax.

CIRCLE NO. 2 ON READER SERVICE CARD

MECHANICAL, ELECTRONIC devices catalog 10¢. Greatest Values —Lowest Prices. Fertik's, 5249 "D", Philadelphia, Pa. 19120.

BURGLAR-FIRE alarm components, hardware. Free catalog—information. Silmar, 133 S.W. 57 Ave., Miami, Florida 33144.

DISCOUNT PRICES

B & K, SENCORE, LEADER Test Equipment
RAYTHEON, ICC/MULLARD Tubes

TELEMATIC Test Jigs

Free Catalog

FORDHAM RADIO SUPPLY CO. INC.
558 Morris Ave., Bronx, N.Y. 10451

FREE CATALOG. Parts, circuit boards for POPULAR ELECTRONICS projects. PAIA Electronics, Box C14359, Oklahoma City, OK 73114.

YOU SAVE BIG MONEY! Surplus, Clearouts, Bankruptcy, Inventory, Deals. Catalog \$1 (redeemable). ETCOA Electronics, Box 741, Montreal, H3C 2V2. U.S. Inquiries.

ELECTRONIC Parts wholesale. Catalog 10¢. Donlyn Electronics, P.O. Box 15421, Phoenix, Arizona 85060.

FREE Catalog lists resistors, tubes, transistors, rectifiers, condensers, tools, tuners, etc. Hytron Hudson, Dept. PE, 2818 Kennedy Blvd., Union City, N.J. 07087.

BURGLAR-FIRE alarm supplies and information. Free catalog. Protecto Alarm Sales, Box 357-G, Birch Run, Michigan 48415.

ELECTRONIC ORGAN KITS, KEYBOARDS and many components. Independent and divider tone generators. All diode keying. I.C. circuitry. Supplement your Artisan Organ. 35¢ for catalog. DEVTRONIX ORGAN PRODUCTS, Dept. C, 5872 Amapola Drive, San Jose, Calif. 95129.

FREE CATALOG. IC's, Puts, Transducers, Thermocouples, Led's, Transistors, Circuit Boards, parts. Chaney's, Box 15431, Lakewood, Colo. 80215.

AUTHENTIC, INSTRUMENTED, FLYING ROCKETS for casual or serious experimenters. Over 80 scale original, multi-stage or ready-to-fly models. Solid-propellant engines for safe, electric launch system liftoffs up to 2,500 feet. Measure altitude, temp. inversions, more. Real telemetry, electronic tracking, aerial still and movie photography with super-miniaturized equipment. New, detailed tech manual and full-color catalog. 25¢ from ESTES INDUSTRIES Dept. 18X, Penrose, Colo. 81240.

**PAIA SYNTHESIZER
KITS**



- Models
priced from
\$139 -

**LIKE TO HEAR IT?
NEED TO KNOW MORE?**

10 minutes of far out sounds
created with the PAIA Synthesizer
now on a demo record... 75¢ - , Catalog free

PAIA ELECTRONICS, INC.

BOX P14359, OKLAHOMA CITY, OK 73114

CALCULATOR OWNERS: Use your + - \times \div calculator to compute square roots, cube roots, sin(x), cos(x), tan(x), arccsin(x), arccos(x), arctan(x), logarithms, exponentials, and more! Quickly, Accurately, Easily! Send today for the IMPROVED AND EXPANDED EDITION of the first and best calculator manual—now in use throughout the world . . . only \$2.00. Unconditional money-back guarantee—and FAST service! Mallmann Optics and Electronics, Dept. 15A, 836 South 113, West Allis, Wisconsin 53214.

BUGGED??? New locator finds them fast. Write, Clifton, 11500-L N.W. 7th Avenue, Miami, Florida 33168.

TELEPHONE "BUGGED"? Countermeasures Brochure \$1.00. Negeye, Drawer 547, Pennsboro, W. VA 26415.

ELECTROSLEEP, acupuncture. Catalog of 200 more projects free. Cimarron Labs, G-13060 Center Rd., Clio, Michigan 48420.

WE SELL MONEY MAKING CONSTRUCTION MANUALS!—Reclaim refined GOLD and SILVER for EXCELLENT full time or part time money!—Color Catalog 25¢—Airmailed 50¢. Creative Products, Dept. PE-674, 8415 Lofland, Houston, Texas 77055.

HEAR POLICE/FIRE Dispatchers! Catalog shows exclusive directories of "confidential" channels, receivers. Send 10¢ stamp. Communications, Box 56-PE, Commack, N.Y. 11725.

FIREWORKS NEWS—Magazine Covering Commercial—Display Fireworks, Sources, Construction, Pyrotechnical Supplies, Fuse, Literature. Free Catalogs/Booklist With Subscription! Calendar Year \$9.00 "1974" Fireworks Buyers' Guide" \$5.95. Pyro Press, Box 12010N, Lexington, Kentucky 40511.

$\frac{1}{2}$ WATT Resistors all values 2¢. Minimum \$2.00. Lectronic, Box 1067, Southgate, Michigan 48195.

CONVERT any television to sensitive, big-screen oscilloscope. Only minor changes required. No electronic experience necessary. Illustrated plans. \$2.00. Sanders, Dept. A-33, Box 92102, Houston, Texas 77010.

BIOFEEDBACK. Professional instruments: Electroencephalophone, Galvanic Skin Response. J&J, 8102E, Bainbridge, WA 98110.

DIGITAL IC Manual—Latest Edition—1500 types by types/diagram number, \$3.95. 32—function digital computer kit—IC, transistors, instructions, \$14.00. IC applications manual—numerous circuits—Analog/Digital, \$3.95. Electronics, P.O. Box 127, Hopedale, Mass. 01747.

NOW AVAILABLE FROM SOLID STATE SYSTEMS, INC. LOW-COST FIELD EFFECT TRANSMISSIVE AND/OR REFLECTIVE LIQUID CRYSTAL AC DISPLAY

DESCRIPTION

Only one liquid crystal display provides excellent contrast and readability in diffused light: FELIX. Field Effect Liquid Crystal from Illico.

FELIX liquid crystal displays produce superior optical properties than other liquid crystal systems because of their bi-level characteristic. The Felix display system has two distinct optical states, so that display segments are fully off at 3 volts and completely on at 7 volts.

Bi-level refers to the two levels of optical activity present in specially organized liquid crystals. In the quiescent state, the level is referred to as a 90° rotation of the plane of polarized light. That is, when a liquid crystal organized in this manner is inserted between a polarizer and an analyzer which are parallel, the light transmission will be at a minimum. The other level of the bi-level system is zero degrees rotation of the plane of polarized light, which occurs upon the application of a well defined voltage, giving maximum transmission.

Extremely low voltage threshold provides full compatibility with TTL and MOS devices. The power consumption of the ON segment is less than 1/2 microwatt.

DIMENSIONS

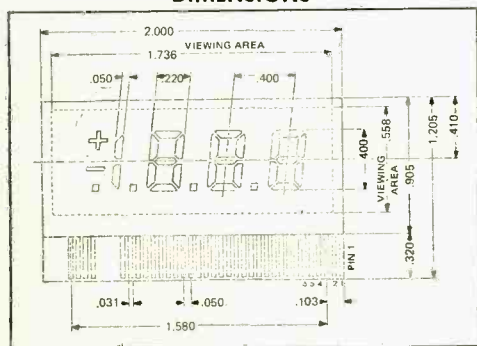

ASSEMBLED COUNTING BOARDS

Completely assembled and tested counting board, consisting of above display and connector, three decade to 7-segment-decoder (7448), seven AC pulse drive generators (7486), and tin plated glass-epoxy PC board with edge connector pattern is available as part number 94-06051.

PRICES

Catalog Number	Description	1-4	5-9	10-24	25 Up
94-06051	Complete Assembly	15.50	14.50	13.50	12.50
84-06051	Display & Connector Only	9.75	9.00	8.25	7.50

FEATURES

- ★ Excellent contrast in ambient light
- ★ Field effect
- ★ Wide temperature range
- ★ Low voltage operation (7 volts)
- ★ Extremely low power consumption
- ★ Transmitted or reflected light displays
- ★ Operates 60–10 KHz
- ★ Pluggable

TYPICAL INTERFACING CIRCUITRY

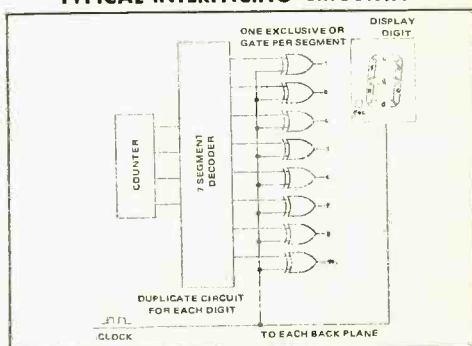

PIN CONNECTIONS

PIN	SEGMENT	PIN	SEGMENT
1.	...	21.	b
2.	...	22.	g
3.	b	23.	c
4.	g	24.	d
5.	c	25.	B.P.
6.	d	26.	e
7.	B.P.	27.	f
8.	e	28.	a
9.	f	29.	DEC.
10.	a	30.	1
11.	DEC.	31.	DEC.
12.	b	32.	-
13.	g	33.	+
14.	c	34.	B.P.
15.	d	35.	...
16.	B.P.	36.	...
17.	e	37.	...
18.	f	38.	...
19.	a	39.	...
20.	DEC.	40.	...

SEND YOUR ORDER TO:

SOLID STATE SYSTEMS, INC.
P. O. BOX 617
COLUMBIA, MISSOURI 65201

OR PHONE (TOLL FREE):

800-325-2595 & 800-325-2981

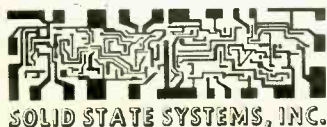

SOLID STATE SYSTEMS, INC.

CIRCLE NO. 32 ON READER SERVICE CARD

PROFESSIONAL Record Cleaner eliminates dust and static. Only available from Canada. \$4.50 postpaid. Dept. P, P.O. Box 5207 Stn. B., Victoria, Canada. U.S. Inquiries.

CD IGNITIONS, VHF/UHF monitors, crystals, CB radios. Southland, Box 3591-B, Baytown, Texas 77520.

CRYSTALS, Scanners, \$3.88, include make and frequency. G Enterprises, P.O. Box 461PC, Clearfield, UT 84015.

LINEAR IC's, most types available, send for free list. Semi-Lin Enterprises, P.O. Box 992, Santa Ana, Calif. 92702.

ELECTRONIC TEST INSTRUMENT CATALOG—160 illustrated pages list over 5,000 new, used and reconditioned test instruments—600 manufacturers. Send \$2.50 refundable with first purchase. Tucker Electronics, P.O.B. 1050, Garland, Texas 75040.

LOW NOISE RESISTORS—carbon film. Brand new as low as 2¼ cents each. Components Center-PE, Box 134, N.Y., N.Y. 10038.

DIAGRAMS, Service Information, Radio-Television, \$2. Specify manufacturer, model. Publications, 1760 Balsam, Highland Park, Ill. 60035.

POWER SUPPLY Assembly Manual. Completely illustrated. +5 v regulated, 0-2 amp capacity, metered. Etched P-C Board available. Manual \$3.00. P-C Board \$6.00. Meltech, Drawer G-26506, Raleigh, N.C. 27611.

NE555V: \$1.10, 8038 Waveform Generator: \$6.95, 1103 (1024 Bit Ram): \$4.50, DG200BA Analog Switch: \$3.25, 2N6084 RF Pwr: \$10.50, 74181 Alu: \$3.75. Catalog: 10¢. Electronic Discount Sales, 138 N. 81st St., Mesa, Arizona 85207.

CONSTRUCTION PLANS: Laser . . . \$2.00. Rocket Tracking Transmitter . . . \$2.00. Space Monitor-Missile Tracker . . . \$2.00. Free Catalog. Electro-Research, P.O. Box 20285, Ferndale, Michigan 48220.

P.C. BOARDS—Artwork, Negatives, Fabrication—Fast prototype service. B&S Circuitry, 6573 Allatoona Place, Morrow, GA 30260.

FREE CATALOG. Kits, Components, audio equipment. Electronic Supply Pacs, Box 175, Floral Park, N.Y. 11001.

ELECTRONIC parts discount catalog—25¢. Electronic Liquidators, Box 401, Longwood, Florida 32750.

SURPRISE! Get the most unusual Numerical Readout Project Plans Catalog: FREE!! GBS, Box 100AA, Green Bank, West Virginia 24944.

MAXIMUM Tire Life. Details \$1.00. H. Weiner, 50 Reservoir Avenue, Jersey City, New Jersey.

FIRSTPHONE—4 Tests, formulas, aids, etc. Guaranteed! \$10. Engineer, DWR 570, Mars, PA. 16046.

FREE! Diodes and catalog! BDI ELECTRONICS, 11 Revere, Tappan, New York 10983.

TV GAMES—Ping Pong, Space War, Cat and Mouse, many others. Instructions, schematics, kits. SP Electronics, Box 5, Prospect Heights, Illinois 60070.

MELLOTRONS—ARP synthesizers. Lowest prices. Dan Keen, Dept. E., 219 19th Street, Avalon, N.J. 08202.

SEMICONDUCTORS, components unusual items, discount prices, catalog 20 cents. Seaboard International Electronics, Box 906, Clute, Texas 77531.

AUTOMATIC telephone recording and debugging equipment. Top quality. Lowest wholesale prices. Viking International, Box 632E2, Newhall, California 91322.

ALPHA/THETA BRAINWAVE biofeedback instruments. Analog instruments from \$125; digital processing systems from \$225. BioScan, Box 14168-E, Houston, Texas 77021.

FREE SAMPLE IC breadboard. Send self addressed stamped envelope to ETEC Electronics Co., PO Box 402, San Luis Obispo, CA 93406.

WEATHER SATELLITE pictures of your own. Can be constructed for \$100.00. \$2.00 for plans to: Weather, P. O. Box 362, Tupelo, Miss. 38801.

FREE! Giant catalog. Semiconductors, IC's, Parts. Crown Electronics, 501 Baldwin Avenue, Lodi, N.J. 07644.

PRACTICAL Applications of Digital IC's. 100's of tips, circuits, projects, on TTL. 443pp \$19.95. Money Back Guarantee, GEA, P.O. Box 285, Northfield, Ohio 44067.

HIGH FIDELITY

DIAMOND NEEDLES and Stereo Cartridges at Discount prices for Shure, Pickering, Stanton, Empire, Grado and ADC. Send for free catalog. LYLE CARTRIDGES, Dept. P, Box 69, Kensington Station, Brooklyn, New York 11218.

DERIVE 4 channel sound from your present stereo without any expensive devices. Send \$1.00 for easy instructions to: Surround Sound, 96 Home St., Somerset, N.J. 08873.

WANTED

QUICKSILVER, Platinum, Silver, Gold, Ores Analyzed. Free Circular. Mercury Terminal, Norwood, Mass. 02062.

TUBES

RADIO & T.V. Tubes—36¢ each. Send for free Catalog. Cornell, 4213 University, San Diego, Calif. 92105.

RECEIVING & INDUSTRIAL TUBES, TRANSISTORS. All Brands—Biggest Discounts. Technicians, Hobbyists, Experimenters—Request **FREE** Giant Catalog and **SAVE!** ZALYTRON, 469 Jericho Turnpike, Mineola, N.Y. 11501.

TUBES "Oldies", latest. Lists free. Steinmetz, 7519 Maplewood, Hammond, Indiana 46324.

TUBES receiving, factory boxed, low prices, free price list. Transletronic, Inc., 1306 40th Street, Brooklyn, N.Y. 11218A, Telephone: 212-633-2800.

CASH Paid for obsolete receiving tubes WE300B, WE350B, WE252A, WE310A, WE274A, WE262B, WE284D, RCA45, RCA50, and Movie Theatre we amplifier models 91B, 86F. Contact: M. Takabe, 303 Fifth Avenue, N.Y.C. (212) 679-1970.

TAPE AND RECORDERS

RENT 4-Track open reel tapes—all major labels—3,000 different—free brochure. Stereo-Parti, 55 St. James Drive, Santa Rosa, Ca. 95401.

1930-1962 Radio Programs. Reels, \$1.00 Hour! Cassettes, \$2.00 Hour! . . . Mammoth Catalog, \$1.00. AM Treasures, Box 192F, Babylon, N.Y. 11702.

CASSETTES

PLAIN WHITE CASSETTE LABELS, NORECO CASSETTE CLEANERS, PAPER MAILER BOXES—HOLDS NORECO-TYPE PLASTIC BOX, FAMOUS BRAND CASSETTES, "LIKE NEW" 100% METAL OR FIBERGLASS REELS. SEND FOR OPEN REEL AND CASSETTE DISCOUNT CATALOG. QUANTITY 1-9 10-99 100 1000

CASSETTE LABELS (Multiples of 10)	.02	.15	.01
NORECO CASSETTE CLEANER	.65	.60	.55
SCOTCH CASSETTE SC90HE	2.72 (BUY 2, GET ONE FREE)	.50	.40
100% FIBERGLASS REELS, USED	.50	.40	.35
100% METAL, NAB HOLE, USED	1.00	1.00	.90
PLUS POSTAGE BY WEIGHT AND ZONE MINIMUM ORDER \$5.00			

SAXITONE TAPE SALES 1776 COLUMBIA ROAD, N.W. WASHINGTON, D.C. 20009

16,000 OLD RADIO SHOWS on tape. Catalog \$2.00, supplement 50¢ (refundable). Hart Enterprises, 1329H George Washington, Richland, WA 99352.

MUSICASSETTE: Low price high quality wide selection. Lists Free. Thomas Tang, TTM PO Box 313, Hong Kong.

NATIONAL LINEAR OP AMPS

Buy any 3 — Take 10%

LM-300	POS V.R. (super 723) TO-5	\$.91
LM-301	Hi-performance op amp (A)	.91
LM-302	Voltage follower TO-5	.91
LM-304	Neg. Voltage Regulator TO-5	1.19
LM-305	Pos. Voltage Reg. TO-5	1.19
LM-307	Super 741 op amp (A)	.41
LM-308	Hi-Q fet type op amp TO-5	1.19
LM-309H	5V Volt-Regulator TO-5	1.19
LM-309K	5V Volt-Reg. 1 Amp TO-3	1.85
LM-310	Voltage-Follower TO-5	1.25
LM-311	Hi-perf. Volt. Comp. (A)	1.19
LM-315	Hi-speed Dual Comp. DIP	1.50
LM-320	MINUS 5, 12 or 24V V.R. TO-3, 50	1.50
LM-322	Precision Timer	1.75
LM-329	Quad Comparator, DIP	1.75
LM-324	Quad (4-741's in DIP)	2.50
LM-350	Dual peripheral driver	.41
LM-370	AGC Squelch op amp, TO-5	1.19
LM-371	RF, IF op amp, TO-5	1.25
LM-373	AM-FM SSB I.A.D. TO-5	3.50
LM-374	AM-FM 5S IVAD TO-5	3.50
LM-377	Dual 2-watt audio amp	3.00
LM-380	2-Watt audio amplifier TO-5	1.69
LM-381	Low noise dual pre amp DIP	1.95
LM-382	Low noise dual pre amp DIP	1.95
LM-703	RF-IF amp, TO-5	.55
LM-709	Operational amplifier (A)	.41
LM-710	Differential amplifier (A)	.45
LM-711	Dual Differential Amp (A)	.36
LM-723	Voltage Regulator (A)	.69
LM-725	Instrument Op Amp	1.75
LM-733	Differential Video	1.75
LM-741	Freq. Comp. 709 (A)	.41
LM-741CV	Mini DIP 741C	.45
LM-747	Dual 741 (A)	.89
LM-748	Freq. adjustable 741C (A)	.89
LM-1303	Differential Video DIP	.95
LM-1305	FM Multi. Stereo Dem. DIP	1.25
LM-1307	FM Multi. Stereo Dem. DIP	.91
LM-13028	Differential RF/IF amp	1.50
LM-13009	Quad "current mirror" amp	.95
LM-4250C	Programmable op amp	2.50
LM-75451	Dual peripheral driver	.44
LM-75453	Dual peripheral driver	.44
LM-75492	Quad seg. driver, LED (DIP)	1.65
LM-75492	Hex. driver, 250ma, D11.85	1.65

(A) TO-5. Dip or mini Dip

LINEAR Op Amps

3 FACTORY GUARANTEED MADRID FACTORY TESTED BUY ANY 3 — TAKE 10%

531	Hi slew rate op amp (TO-5)	\$2.50
532	Micro power 741 (TO-5)	2.50
533	Micro power 709 (TO-5)	2.50
536	FET input op amp (TO-5)	2.95
550	Precision 723 voltage reg. (DIP)	1.17
555	Timer 2 u Seconds to 1 hr. (A)	1.25
556	5 Times faster than 741C	2.10
558	Dual 741 (A)	1.00
560	Phase lock loops (DIP)	2.95
561	Phase lock loops (DIP)	2.95
562	Phase lock loops (DIP)	2.95
565	Phase lock loops (A)	2.95
566	Function generator (TO-5)	2.95
567	Tone decoder (A)	2.95
702	Micro-gram, DC amp (TO-5)	.95
704	TV sound IF system	1.50
711C	Dual diff. comp (A)	.33
723C	Voltage regulator (A)	.69
741CV	Freq. comp 709 (Mini DIP)	.44
748C	Freq. adj. 741C (A)	.75
753	Gain Block	1.75
739-739	Dual stereo preamp	1.98
741-741	Dual 741C (TO-5)	.89
PA265	5-Watt voltage regulator	1.00
UL123	00M Op amp with 500	1.00
CA3065	Video Audio system	1.00
4136	Quad 741's (DIP)	1.95

(A) TO-5 or DIP dual in line pak

WRIST WATCH LIQUID CRYSTAL DISPLAY

*3-1/2 digit, 7 segment
*Only 1-1/16 x 11/16 x 1/4"

\$19.95



Calculator Basics



MAKE YOUR OWN CALCULATORS WITH OUR BASIC LOW PRICED BASIC KITS

8-DIGIT LED Basic Kit #1 \$19.95
Includes Case, Keyboard (by Flex-Key), CT-5002 Calculator chip for 8 digits, your choice of three 3-digit readouts, sheets.

6-DIGIT LED Basic Kit #2 \$19.95
Includes Case, Keyboard (by Flex-Key), National MM758 Calculator Chip for 6 digit indication, two 74841 segment drivers, one 7482 2 digit driver, two 3-digit readouts at your choice, sheets.

See POPULAR ELECTRONICS (Jan. 1974) for building your own electronic digital wristwatch using the Liquid Crystal Display (LCD) as its basic. Easy to see, 3 1/2 digit display, requires less than 1/1000 of power as LEDs. Visibility increases with ambient light. Difficult reading of LEDs in light. Pulses SECONDS in center of display. NO NEED OF TRANSISTOR-RESISTOR interface, as LEDs, thus smaller package. Chip contains holder, tiny connecting terminals, and "slide-in-place chrome spring face plate". Size of display in holder: 1 1/16 x 11/16 x 3/4". Operating freq. 32 hertz. 45-microampere of power. Operates from 1.5V hearing aid cell. View the new and latest CMOS microcircuits. We include copy of write up from PE magazine.

LED 7-SEGMENT Readouts

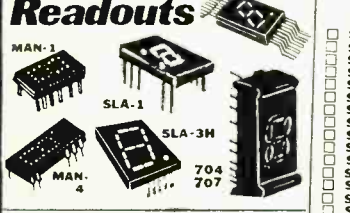

(All "LED" TYPES)

Type	Char.	Each	Special
MAN-1	.27	\$3.75	3 for \$9.
MAN-3	.12	1.49	3 for \$4.
MAN-4	.19	2.50	3 for \$6.

POLY PAKS SMASHES IC PRICES

Factory Marked Order by type number! Speed sheets on request "ONLY" Buy 100 — Take 20%

SN7400	.30	SN7432	.55	SN7471	.55	SN74108	.95	SN74161	1.95
SN7401	.30	SN7437	.55	SN7472	.50	SN74112	.95	SN74163	1.98
SN7402	.30	SN7440	.55	SN7473	.55	SN74113	.95	SN74164	2.95
SN7403	.30	SN7441	1.40	SN7474	.55	SN74114	.95	SN74165	2.10
SN7404	.35	SN7442	1.50	SN7476	.65	SN74121	.60	SN74166	2.08
SN7405	.35	SN7443	1.50	SN7478	.95	SN74122	.95	SN74173	2.50
SN7406	.45	SN7444	1.50	SN7478	.95	SN74123	1.20	SN74174	2.20
SN7407	.55	SN7445	1.50	SN7480	.65	SN74125	.71	SN74175	3.26
SN7408	.55	SN7446	1.65	SN7482	1.25	SN74126	.71	SN74176	2.10
SN7409	.35	SN7447	1.45	SN7483	1.25	SN74129	4.50	SN74177	2.10
SN7410	.35	SN7448	1.50	SN7485	1.41	SN74140	1.25	SN74178	2.10
SN7411	.35	SN7449	.30	SN7485	1.41	SN74145	1.55	SN74180	3.20
SN7413	.95	SN7451	.30	SN7486	.55	SN74148	4.50	SN74181	3.95
SN7415	.55	SN7453	.30	SN7490	3.50	SN74150	1.61	SN74182	1.20
SN7416	.55	SN7454	.30	SN7491	1.35	SN74152	4.95	SN74185	2.50
SN7417	.55	SN7454	.30	SN7492	1.35	SN74155	1.60	SN74192	1.98
SN7420	.30	SN7460	.55	SN7493	1.35	SN74156	2.10	SN74193	1.98
SN7421	.55	SN7461	.35	SN7494	1.35	SN74158	1.55	SN74194	1.98
SN7422	.35	SN7462	.35	SN7495	1.35	SN74159	1.55	SN74195	1.28
SN7423	.55	SN7463	.30	SN7496	1.35	SN74157	1.55	SN74196	2.80
SN7426	.55	SN7466	.50	SN7496	1.35	SN74158	1.55	SN74197	2.60
SN7430	.30	SN7470	.50	SN74106	.95	SN74160	1.95	SN74198	2.68
				SN74107	.70			SN74200	9.95

REFLECTIVE BAR TYPES

707*	.33	2.50	3 for \$6.
704*	.33	2.50	3 for \$6.
SLA-1**	.33	2.10	3 for \$5.
SLA-3**	.70	4.95	3 for \$13.
SLA-11**	.33†	3.50	3 for \$10.
SLA-21**	.33††	3.95	3 for \$10.

*By Litronix. **By Opcon, equal to MAN-1 or MAN-4 specs. Color - RED. †Green. ††Yellow

IC'S FOR EXPERIMENTERS

Money Back Guarantee! Factory Marked! **\$1.00** Includes factory-good, rejects & defects, who knows at these prices!

SN7400	... 20 for \$1.	SN7447	... 5 for \$1.	SN74121	... 10 for \$1.
SN7404	... 20 for \$1.	SN7448	... 5 for \$1.	SN74123	... 10 for \$1.
SN7413	... 5 for \$1.	SN7473	... 10 for \$1.	SN74154	... 5 for \$1.
SN7441	... 5 for \$1.	SN7474	... 10 for \$1.	SN74181	... 3 for \$1.
SN7442	... 5 for \$1.	SN7475	... 5 for \$1.	SN74192	... 5 for \$1.
SN7444	... 5 for \$1.	SN7490	... 5 for \$1.	SN74193	... 5 for \$1.
SN7445	... 5 for \$1.	SN74107	... 10 for \$1.		

CLOCK CHIPS ON A "DIP"

ANY CHIP **\$8.88**

MMS311	6-digit 28-Pin	8.88
MMS312	6-digit 24-Pin	8.88
MMS313	6-digit 28-Pin	8.88
MMS314	6-digit 24-Pin	8.88
MMS316	4-digit 40-Pin	13.50

Alarm

CALCULATOR CHIPS ON A "DIP"

Similar to Mostek 5001. Outperforms Texas 8-digit TMS1802. A 40-pin DIP. Adds, multiplies, subtracts, and divides. Use with 7-segment readouts, Nixies, and LEDs.

CT5001	12-digits 40-Pin	\$6.95
CT5002	9 Volt version of 5001	8.88
CT5005	2, 12-digits 28-Pin	9.95

with 3-function memory.

SANKEN HYBRID AUDIO POWER AMPS

Mfr's Type Watts Sale

SI-10110	10	\$ 8.88
SI-1025E	25	18.88
SI-1050E	50	29.95

Used extensively in hi-fi systems, tape decks, FM tuners, record players, stereo components, musical instruments, P.A., etc. All amplifiers, flat within 1/2 db from Hz to 100,000. Each unit properly heat-sunked, with heavy-duty connecting the lug connections. Single-ended push-pull output. Power supply required 24VDC. Output to 8 ohms. Order by Stock No.



POCKET CALCULATOR KEYBOARD

For hand-held units, properly multiplexed for chip CT-5001, 2, 12 or Mostek 5010-12, 18 feather-touch keys, by FLEX-KEY.

Only \$6.95
3 for \$18.



BRAND NEW LOWEST PRICES

GENERAL ELECTRIC 3-WATT AUDIO AMP \$2.50

3 for \$6.00

Delivers 3 watts continuous, 10 watts peak. With heat sinks; micro-mini size; 3x8x1 1/2"; 9 to 30V supply. High sensitivity: 1 to 16 ohms. For mono and stereo phonos, tape, FM, AM, TV, servo.



POLY PAKS

Terms: add postage Rated: net 30
Phone Orders: Wakefield, Mass. (617) 245-3829
Retail: 16-18 Del Carmine St., Wakefield, Mass.
(off Water Street) C.O.D.'S MAY BE PHONED

P.O. BOX 942 E
Lynnfield, Mass. 01940



DELUXE
MAGAZINE CASES
Designed Exclusively for
POPULAR ELECTRONICS

The ideal way to save your valuable copies, keep them well protected and make it easy for you to refer to any issue at any time. Both decorative and attractive enough to enhance the decor of any room, each case holds a full year's copies. Constructed of reinforced fiberboard, these durable cases are covered in a rich-textured leatherette. The gold embossed back adds to its elegance and makes each case a welcome addition to your bookshelf or cabinet.

Magazine cases are available for any of your favorite magazines. They're only \$4.50 each, 3 for \$12.50, in any combination of titles ordered. Add 50¢ per case for postage and handling. Outside U.S.A. add \$1.00 per case ordered.



CHARGE YOUR AMERICAN EXPRESS OR BANKAMERICARD ACCOUNT



Ziff-Davis Pub. Co., Dept. 23, 1 Park Avenue, New York 10016

My remittance in the amount of \$_____ is enclosed. Please send magazine cases for the titles indicated below.

CHARGE: American Express BankAmericard

Account # _____

Signature _____

TITLE PE-674 QUANTITY

Check One: All Black Maroon Back, Black Sides

Print Name _____

Address _____

City _____ State _____ Zip _____

PAYMENT MUST ACCOMPANY ORDER

PLANS AND KITS

ADVANCED DIGITAL CLOCK kit, calendar 256 note alarm tone, incorporated timer controls auxiliary AC load. Free details. Clocks, 337 Colledge, Hol and, Michigan 49423.

POWER SUPPLY PLANS; precision regulated 9 to 12vdc, 2 amps, \$5.00. Airborne Systems, Box 1175, Hartford, Connecticut 06101.

NEW INVENTION, DYNAMIC TRANSISTOR TESTER. SIMULATION PRINCIPLE, identifies whether unknown transistor is Silicon or Germanium; VHF, HF or LF; NPN or PNP. OUT AND INCIRCUIT GOOD—BAD TEST. Kit \$32.00, wired \$39.50, information 20¢. SUJITRON, 145a Church Street, Toronto, M5B1Y4, Canada. U. S. inquiries.

COMPLETE CONSTRUCTION PLANS—TELEPHONE: Answering device, conference bridge, auto-dialer, central dial exchange. \$4.00 each. DODECAHEDRON speaker cabinet. \$2.50 T.E.L. (Telephone Electronics Newsline) subscription \$2.50. Teletronics Company of America, P.O. Box 362, Agoura, California 91301.

EXCELLENT Electronic Auto Burglar Alarm System. Plans \$2.00, Kit \$39.95. Byron Nelson, Route 1, Box 232 #8, Kingsville, Texas 78363.

\$5 Complete plans plus special part for 100 watt, 20-40 MHZ base linear. Information S.A. S. E. and 10¢. Aldato Enterprises, Box 81, Thorold, Ontario, Canada L2V 3Y7.

MOVIE FILMS

8MM-SUPER 8-16MM MOVIES! Biggest Selection! Lowest Prices! Free Catalog! Cinema Eight, Box PE, Chester, Connecticut 06412.

TOOLS

WRAP Tool \$1.00, Wire, Panels. Xycon, Box 9341, Phoenix, AZ. 85020.

ELECTRICAL SUPPLIES AND EQUIPMENT

PLATING Equipment, Portable Platers, Supplies and "Know-How." Build your own tanks for nickel, chrome, etc. Easy-to-install PVC liners. Rectifier components—all sizes. Schematics, parts lists, formulas, operating instructions for all plating. Guaranteed to save you 25%-75%. Some good units for sale. Write for details. Platers Service Company, 1511-PE Esperanza, Los Angeles, Calif. 90023.

GOVERNMENT SURPLUS

GOVERNMENT Surplus. How and Where to Buy in Your Area. Send \$2.00. Surplus Information, Headquarters Bldg., Box 30177-PE, Washington, D.C. 20014.

ELECTRONIC Equipment and Parts. Big 36 page Free Catalog. Send for your copy today! Fair Radio Sales, Box 1105-P, Lima, Ohio 45802.

MANUALS for Govt Surplus radios, test sets, scopes. List 50¢ (coin). Books, 7218 Roanne Drive, Washington, D.C. 20021.

ELECTRONIC gadgets and parts. Send for free bulletin. Aeroparts, International Airport, Box 1492, Del Rio, Texas 78840.

PERSONALS

MAKE FRIENDS WORLDWIDE through international correspondence. Illustrated brochure free. Hermes, Berlin 11, Germany.

INVENTIONS WANTED

CASH-ROYALTIES for patented, unpatented inventions. Global Marketing Service, 2354-P Telegraph, Oakland, California 94612.

INVENTORS: Protect your ideas! Free "Recommended Procedure." Washington Inventors Service, 422T Washington Building, Washington, D.C. 20005.

PATENT Searches including Maximum speed, full airmail report and closest patent copies. Quality searches expertly administered. Complete secrecy guaranteed. Free Invention Protection forms and "Patent Information." Write Dept. 9, Washington Patent Office Search Bureau, Benjamin Franklin Substation, P.O. Box 7167, Washington, D.C. 20044.

FREE PAMPHLET: "Tips on Safeguarding Your Invention." Write: United States Inventors Service Company, 708-T Carry Building, Washington, D.C. 20005.

INVENTORS! Either we will seal your Invention before you or anyone else does, or we will pay you a cash bonus. Get Free Invention Evaluation and information: Write Gilbert Adams Organization, Invention Brokerage, Dept. 20, 80 Wall St., New York, NY 10005.

FILE your own patent application. Complete information and materials. Write: Inventor's Guide, 468-R, Goodspeed Road, Virginia Beach, Virginia 23451.

FREE "DIRECTORY OF 500 CORPORATIONS Seeking New Products." For information regarding Development, Sale, Licensing of your patented/unpatented invention, write for FREE "INVENTOR'S KIT NO. A-73, RAYMOND LEE ORGANIZATION, 230 Park Avenue, New York, N.Y. 10017.

DO-IT-YOURSELF

BURGLAR ALARM SYSTEM—Do It Yourself. Installed in minutes. Free literature. Emrad Corporation, P.O. Box 1341, Kokomo, Indiana 46901.

LIGHT EMITTING DIODES		TRANSISTORS SPECIALS		5311—Clock Chip featuring BCD, hold count and output strobe . . . \$8.50		C. MOS (Diode Clamped)	
WRD 14B Photo		2N1137B PNP TO-3 GE . . . \$.95		5314—Clock Chip 6 digit readout hold count . . . \$8.50		CD 4001 . . . \$.65	
Darlington		2N2222 NPN Si TO-92 5/1.00		5316—Alarm Clock Chip . . . \$33.95		CD 4002 . . . \$.65	
ML-3 GAP VIS. LED . . . \$.75		2N3137 NPN Si TO-5 . . . 4/\$1.00				CD 4008 . . . \$1.50	
MCD-2 Opto. Isolator . . . \$.90		2N1605 NPN GE TO-5 . . . 5/\$1.00				CD 4011 . . . \$.65	
ME4 IR LED's		MPS3393 NPN Si TO-106				CD 4012 . . . \$.65	
GREEN GAP OS-16 LED . . . \$.90						CD 4013 . . . \$1.00	
		2N2218T NPN Si TO-5 4/\$1.00				CD 4016 . . . \$1.50	
74100 . . . \$.50	7476 . . . \$.52	2N2677 NPN Si TO-68 . . . \$.70				CD 4023 . . . \$.65	
7400 . . . \$.24	7480 . . . \$.65	MPS 3391A NPN Si TO-92 . . . \$1.00				CD 4027 . . . \$1.35	
7401 . . . \$.24	7486 . . . \$1.10					CD 4030 . . . \$.65	
7402 . . . \$.24	7486 . . . \$.48	2N3866 NPN Si TO-5 . . . 5/\$1.00				CD 4030 . . . \$1.35	
7403 . . . \$.24	7489 . . . \$3.00	2N6109 NPN Si TO-220 . . . \$.55				CD 4030 . . . \$.65	
7404 . . . \$.26	7490 . . . \$.85	2N5296 NPN Si TO-220 . . . \$.55				74C157 . . . \$2.15	
7405 . . . \$.26	7491 . . . \$1.30	2N4898 NPN Si TO-66 . . . \$.60				74C165 . . . \$3.50	
7407 . . . \$.50	7492 . . . \$.85	M12522 NPN Si TO-66 . . . \$.90				4022 . . . \$2.25	
7408 . . . \$.27	7493 . . . \$.85	2N3055 NPN Si TO-3 . . . \$1.00					
7410 . . . \$.24	7495 . . . \$.99						
7411 . . . \$.30	7496 . . . \$.95	SLA-3 7 Segment LED Readout 77" Numbers 45 MA 1 Seg. Red or Yellow . . . \$7.50					
7412 . . . \$.45	74107 . . . \$1.00						
7413 . . . \$.85	74121 . . . \$.60						
7416 . . . \$.48	74123 . . . \$1.00						
7417 . . . \$.24	74125 . . . \$1.40						
7420 . . . \$.24	74126 . . . \$1.40						
7422 . . . \$.30	74150 . . . \$1.15						
7426 . . . \$.30	74151 . . . \$.95						
7427 . . . \$.35	74154 . . . \$1.65						
7430 . . . \$.24	74157 . . . \$1.25						
7432 . . . \$.52	74164 . . . \$2.05						
7437 . . . \$.60	74165 . . . \$2.05						
7438 . . . \$.50	74173 . . . \$1.80						
7440 . . . \$.24	74176 . . . \$1.80						
7441 . . . \$1.15	74177 . . . \$1.80						
7442 . . . \$1.00	74192 . . . \$1.50						
7445 . . . \$1.25	74193 . . . \$1.80						
7446 . . . \$1.25	74195 . . . \$1.00						
7447 . . . \$1.25	75451 . . . \$1.00						
7448 . . . \$1.30	75452 . . . \$1.00						
7450 . . . \$.24	75491 . . . \$1.10						
7451 . . . \$.30	8210 . . . \$1.50						
7472 . . . \$.40	8211 . . . \$1.50						
7473 . . . \$.48	8220 . . . \$1.50						
7474 . . . \$.48	8520 . . . \$1.75						
7475 . . . \$.80	LM351 . . . \$1.00						

VERIPAX PC BOARD	
This board is a 1/16" single sided paper epoxy board 4 1/2" x 6 1/2" (standard veripax) DRILLED and etched, which will hold 21 single 14 pin IC's, or 8,16 or LSI DIF IC's with busses for power supply connections. It is also etched for a 22 pin connector. \$5.25 3/\$14.50	
10 Watt Zeners	
3-9, 4.7 or 5.6V	\$7.5 ea.

FULL WAVE BRIDGES	
PRV 2A	6A
200	.95 1.25
400	1.15 1.50
600	1.35 1.75

Silicon Power Rectifiers	
PRV 1A	3A 12A 50A
100	.06 .11 .30 .85
200	.07 .16 .35 1.25
400	.09 .20 .45 1.50
600	.11 .30 .70 2.00
800	.15 .40 .85 2.30
1000	.20 .55 1.10

TRIACS		SCR's	
PRV 1A	10A 25A	1.5A	6A
100	.40 .70 1.30	.40	.50
200	.70 1.10 1.75	.60	.70
400	1.10 1.60 2.60	1.00	1.20
600	1.70 2.30 3.00		

NSN 33-3 Digit LED Array, MAN-3 Size Internally Multiplexed and Driven By 7448 \$3.50
Send Check or Money Order. Include Postage.
Minimum Order \$3.00. Rated Companies 30 Days Net
Send \$2.00 for our latest catalog featuring transistors and rectifiers

SOLID STATE SALES

THE RELIABLE EAST COAST SEMICONDUCTOR SURPLUS HOUSE

POST OFFICE BOX 74A SOMERVILLE, MASS. 02143 TEL. (617) 547-4005

CIRCLE NO. 26 ON READER SERVICE CARD

INSTRUCTION

LEARN ELECTRONIC ORGAN SERVICING at home all makes including transistor. Experimental kit—trouble-shooting. Accredited NHSC, Free Booklet. **NILES BRYANT SCHOOL**, 3631 Stockton, Dept. A, Sacramento, Calif. 95820.

LEARN WHILE ASLEEP, Hypnotize! Strange catalog free. Auto-suggestion, Box 24-ZD, Olympia, Washington 98501.

DEGREE IN ELECTRONICS through correspondence. Free catalog. Grantham, 2000 Stoner Avenue, Los Angeles, California 90025.

INTENSIVE 5 week course for Broadcast Engineers. F.C.C. First Class license. Radio Engineering Incorporated, 52 S. Palm Ave., Sarasota, Florida 33577.

SHORTCUTS TO Success! Highly Effective, Profitable Short Courses. (75 Choices). Study At Home. Diploma Awarded. Our 29th Year. Free Literature. CIEE-D, Box 20345, Jackson, Miss. 39209.

EXAM MANUAL

F.C.C. MANUAL

PASS FCC EXAMS! Memorize, study — Tests—Answers for FCC 1st and 2nd class Radio-telephone licenses. Newly revised multiple-choice questions and diagrams cover all areas tested in FCC exams.—plus— "Self-Study Ability Test." \$9.95 postpaid. Moneyback Guarantee.

COMMAND PRODUCTIONS P.O. BOX 26348-P
RADIO ENGINEERING DIVISION SAN FRANCISCO, CALIF. 94126

DEGREE Program in Electronics Engineering. Our 29th Year! Free literature. Cook's Institute, Dept. 13, Box 20345, Jackson, Miss. 39209.

EARN College Degrees at home. Many subjects. Florida State Christian University, P.O. Box 1674, Fort Lauderdale, Florida 33302.

JUNE 1974

DIGITAL THEORY DESIGN, CONSTRUCTION

LOGIC NEWSLETTER

SAMPLE COPY \$1.00
LOGIC NEWSLETTER
POB 252
WALDWICK, N.J. 07463

SCORE high on F.C.C. Exams . . . Over 300 questions and answers. Covers 3rd, 2nd, 1st and even Radar. Third and Second Test, \$14.50; First Class Test, \$15.00. All tests, \$26.50. R.E.I., Inc, Box 806, Sarasota, Fla. 33577.

LEARN design techniques. Electronics Monthly Newsletter. Digital, linear construction projects, design theory and procedures. Sample copy \$1.00. Valley West, Box 2119-B, Sunnyvale, California 94087.

MUSICAL INSTRUMENTS

30% DISCOUNT name brand musical instruments. Free Catalog. Freeport Music, 455N, Route 110, Melville, N.Y. 11746.

WHOLESALE! Professional Guitars, PA Systems, Altec Speakers, 240W RMS Amplifiers. Free Catalog, Carvin, Escondido, Calif. 92028.

30% + DISCOUNT. Name Brand Musical Instruments. Free Catalog. Continental Music, Dept. H, P.O. Box 3001, Garden City, New York 11530.

REAL ESTATE

FREE . . . NEW . . . 280-PAGE SUMMER CATALOG! Describes and pictures hundreds of farms, ranches, town and country homes, businesses coast to coast! Specify type property and location preferred. UNITED FARM AGENCY, 612-EP, West 47th St., Kansas City, Mo. 64112.

Planning to move?

Let us know **6 to 8 weeks** in advance so that you won't miss a single issue of **POPULAR ELECTRONICS INCLUDING ELECTRONICS WORLD**

Attach old label where indicated and print new address in space provided. Also include your mailing label whenever you write concerning your subscription. It helps us serve you promptly.

Write to: P.O. Box 2774, Boulder, Colo., 80302, giving the following information.

- Change address only.**
 Extend subscription. **Enter new subscription.**
 (1) 5 yrs. \$21 (2) 3 yrs. \$15 (3) 1 year \$6
 Payment enclosed (1 extra issue per yr. as a BONUS)
 Bill me later.

If you have no label handy, print OLD address here.

name _____ please print
 address _____
 city _____
 state _____ zip-code _____

← AFFIX LABEL →

name _____ please print 0883
 address _____
 city _____ state _____ zip _____
Add'l postage: \$2 per year outside U.S., its possessions & Canada

BUSINESS OPPORTUNITIES

I MADE \$40,000.00 Year by Mailorder! Helped others make money! Start with \$15.00—Free Proof. Torrey, Box 318-N, Ypsilanti, Michigan 48197.

FREE CATALOGS. Repair air conditioning, refrigeration. Tools, supplies, full instructions. Doolin, 2016 Canton, Dallas, Texas 75201.

MAILORDER MILLIONAIRE helps beginners make \$500 weekly. Free report reveals secret plan! Executive (1K6), 333 North Michigan, Chicago 60601.

PIANO TUNING LEARNED QUICKLY AT HOME! Tremendous field! Musical knowledge unnecessary. GI approved. Information free. Empire School, Box 450327, Miami 33145.

\$2000.00 MONTHLY selling information by mail. Ropchan, Box 161X, Saginaw, Oregon 97472.

FREE Secret Book "2042 Unique Proven Enterprises." Fabulous "Little Knowns." Work home! Haylings-BH, Carlsbad, California 92008.

DO SIMPLE ADDRESSING—Mailing. Receive \$12.95 orders. Keep \$8.00 profit. Details Free. Quality, Box 9-ZD, East Rockaway, N.Y. 11518.

START SMALL, highly profitable electronic production in your basement. Investment, knowledge unnecessary. Postcard brings facts. Barta-CF, Box 248, Walnut Creek, California 94597.

\$200.00 DAILY In Your Mailbox! Your opportunity to do what mail-order experts do. Free details. Associates, Box 136-J, Holland, Michigan 49423.

TELEPHONE answering machine manufacturer is looking for dealers. Our high-fidelity unit takes 90 messages. It can even ask questions from callers! Retail Value \$225. For limited time anyone can buy one sample at factory cost for only \$78. Telephonic, 4880 49th Street North, St. Petersburg, Florida 33709.

MAKE \$1.00 PER SALE selling engraved metal Social Security plates. FREE SALES KIT. Engravaplates, Box 10460-200, Jacksonville, Fla. 32207.

EARN \$15,000 annually plus. Full year trial p'an Import-Mailorder business. Postcard brings details: Northeast Imports, Box 121PE5, Fremont, N.H. 03044.

\$49.95 Telephone Answering Machine! Your cost \$33.50! Details: Palomar, Box 17384EB, Jacksonville, Florida 32216.

HIGHLY PROFITABLE

ONE-MAN ELECTRONIC FACTORY

Investment unnecessary, knowledge not required, sales handled by professionals. Postcard brings facts about this unusual opportunity. Write today!
Barta-DF, Box 248, Walnut Creek, CA 94597.

\$178.00 WEEKLY. Work one hour daily. Free brochure. FAS, Box 13703-A, San Antonio TX, 78213.

EMPLOYMENT OPPORTUNITIES

ELECTRONICS/AVIONICS EMPLOYMENT OPPORTUNITIES. Report on jobs now open. Details FREE. Aviation Employment Information Service, Box 240E, Northport, New York 11768.

TREASURE FINDERS

FAMILY FUN! OUTDOOR ADVENTURE! Find valuable coins and treasure with world famous metal detectors. Free illustrated booklet. Detection, Dept. PE, Box 243, San Gabriel, Calif. 91778.

TIRED OF DIGGING UP TRASH? The all new "Coinshooter" rejects bottle caps, tin foil, nails and shallow trash. Detects gold, silver, coins and jewelry. FREE LITERATURE. D-TEX ELECTRONICS, Box 451-P, Garland, Texas 75040.

AUTHORS' SERVICES

AUTHORS WANTED BY NEW YORK PUBLISHER

Leading book publisher seeks manuscripts of all types: fiction, non-fiction, poetry, scholarly and juvenile works, etc. New authors welcomed. For complete information, send for free booklet P-56. Vantage Press, 516 W. 34 St., New York 10001

wanted

Citizens Band

DEALER-DISTRIBUTORS

SEND THIS AD TO:

PAL ELECTRONICS CO.
P. O. BOX 778 • WESTMINSTER, CA. 92683

Popular Electronics

JUNE 1974

ADVERTISERS INDEX

READER SERVICE NO.	ADVERTISER	PAGE NO.	READER SERVICE No.	ADVERTISER	PAGE NO.
1	Allison Automotive Co.	98	18	McIntosh Laboratory, Inc.	86
2	Altaj Electronics	100	19	MITS Inc.	26
3	Antenna Specialists Co., The	89	20	Mallory Distributor Products Company	13
4	BSR (USA) Ltd	53	21	Midwest Hifi Wholesale & Mail Order Division	97
	Bell & Howell Schools	72, 73, 74, 75		NRI Training	SECOND COVER, 1, 2, 3
	CREI Capitol Radio Engineering Institute	54, 55, 56, 57		National Technical Schools	36, 37, 38, 39
6	Cleveland Institute of Electronics	18, 19, 20, 21	22	Pace Communications	8
7	Continental Specialties Corp.	23	23	Poly Paks	103
8	Delta Electronics Co.	99	24	Sams & Co., Inc., Howard W.	7
9	Delta Products, Inc.	15	25	Schober Organ Corp., The	95
10	EICO	95	26	Solid State Sales	105
12	Edmund Scientific Co.	108	32	Solid State Systems, Inc.	101
13	GTE Sylvania	90, 91, 92, 93	27	Southwest Technical Products Corporation	35
5	Heath Company	10, 11	28	TAB Books	87
14	Hewlett Packard	9	16	Technics by Panasonic	FOURTH COVER
15	Illinois Audio	98	29	Tri-Star Corp.	97
33	Johnson Co., E.F.	96	30	Tucker Electronics Company	25
17	Lafayette Radio Electronics	89	31	Wavtek	77
	CLASSIFIED ADVERTISING				99, 100, 102, 104, 105, 106, 107

SPORTS ACTION FILMS

SHOP BY MAIL—SAVE TIME, ENERGY AND \$\$\$\$\$! Get what you want . . . make your selections from current Columbia, Castle and Sportlite Films catalogs, only 25¢ each (coins or stamps, please). **JUNE SPECIAL:** Indy "500" Super 8 Color Films, 1962 thru 1970, each a separate 200' reel, only \$14.95 each PPD. Because of demand, indicate 1st and 2nd choice of years. **SPORTLITE**, Elect-6 Dept., Box 500, Speedway, Indiana 46224.

RECORDS

OLDIES. 45rpm. Free Catalog. Corny's Record Shop, Box 335TH, Mason, Ohio 45040.

RUBBER STAMPS

RUBBER address stamps. Free catalog. 45 type styles. Jackson's, Box 443G, Franklin Park, Ill. 60131.

BOOKS

FREE catalog aviation/electronic/space books. Aero Publishers, 329PE Aviation Road, Fallbrook, California 92028.

FREE book prophet Elijah coming before Christ. Wonderful bible evidence. Megiddo Mission, Dept. 64, 481 Thurston Rd., Rochester, N.Y. 14619.

BOOKS—thousands titles, bargains. Catalog Free. Cassiano, 92-27 New York Blvd., Jamaica, New York 11433.

POPULAR ELECTRONICS INDEXES. Detailed and complete subject indexes now available to both 1972 and 1973 magazines. Hundreds of subject references to help you quickly find that special project, article, or product test. 1972 and 1973 editions \$1.00 each. **INDEX**, Box 2228, Falls Church, Va. 22042.

UNUSUAL BOOKS! Catalogue Free! International Imports, Box 7798PE, Atlanta, Georgia 30309.

PLASTICS

CASTOLITE pours like water, hardens like glass without heat. Crystal clear, colors. Embed flowers, seashells, mementos, anything. Make fine gifts. Form flexible molds over any pattern, size. Reproduce your own designs in plastics, candlewax, metal, plaster, cement. Send 10¢ postage for illustrated profitable facts and figures. **CASTOLITE**, Dept. 74G/PE, Woodstock, Ill. 60098.

HYPNOTISM

SLEEP learning. Hypnotic method. 92% effective. Details free. ASR Foundation, Box 7566EG, Fort Lauderdale, Florida 33304.

FREE Hypnotism. Self-Hypnosis. Sleep Learning Catalog! Drawer H400, Ruidoso, New Mexico 88345.

AMAZING self-hypnosis record releases fantastic mental power. Instant results! Free trial. Write: Forum (AA6), 333 North Michigan, Chicago 60601.

MISCELLANEOUS

WINEMAKERS: Free illustrated catalog yeasts, equipment. Semplex, Box 12276P, Minneapolis, Minn. 55412.

CATALOGS! Receive many! Catalog Directory \$1.00. Box 33098, District Heights, Md. 20028.

CLEAN, Perpetual automotive power! Information, Development—\$10. Bridgman, Box 284, Enid, Oklahoma 73701.

INCREASE GAS mileage 20%! Powerspark installs without tools. Send \$9.95 today—guaranteed! Powerspark, 350 Thompson #221-C, Ann Arbor, Michigan 48108.

SAVE GASOLINE. Anti-siphon unit for standard filler pipes. Easy installation. Only \$2.00 ppd. Monitor, Box 825, Toledo, Ohio 43696.

LIVE IN THE WORLD OF TOMORROW... TODAY!

A BETTER LIFE STARTS HERE

HE-NE LASERS ... \$99.50 UP!

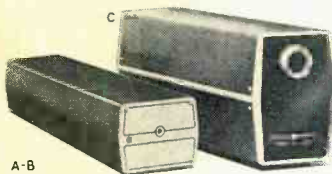

A-B
 (B) 1.0mW... (as above) = \$79.073AV
 (C) 4.0mW... 0.8 Beam Dia., 1.1 mRad Diverg. = \$79.079AV (3.9x5.5x15.6") \$465.00 Ppd.

Top quality Spectra Physics lasers feature TEM00 mode, internal mirror plasma tubes w/ 10,000 hr life, self-starting cold aluminum cathodes, low noise & ripple, guaranteed output power stability and more for demanding lab work. 18-mo. mfr. wty. 115v AC (A) 0.5mW... 0.88 Beam Dia., 1mRad Diverg. = \$99.50 Ppd. = \$79.070AV (2.6x8.5x14.8")

NEW! KIRLIAN PHOTOGRAPHY KIT!

Experiment in the fascinating new field of "Kirlian" electrophotography—images obtained on film without camera or lens by direct recording of electric charge transmitted by animate & inanimate objects. Each "aura" differs from another—animate aura said to change corresponding to physical changes. \$50 Kit gives everything needed except film, including portable darkroom, double transformer isolated from power source; complete instructions. Stock No. 71,938AV \$49.95 Ppd.



GET A CHARGE FROM THE SUN!

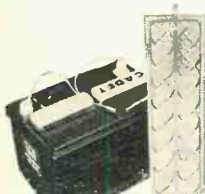

Our 12V Solar Battery Charger, like those used aboard satellites but redesigned for broad usage, allows direct conversion of light-to-electricity. Compact panel put on a boat can automatically charge its 12V battery over entire daylight period; no power drain at nite. Use it anywhere a trickle charge is needed (trans. radios, etc.). Terrific value, it comprises thirty 1/2V silicon solar cells in series w/ a diode. Cap.: 30 Watts. hrs. a wk., approx.

Stock No. 71,971AV \$89.95 Ppd.

(And our FREE CATALOG is packed with exciting and unusual ecological & physical science items—plus 4,500 finds for fun, study or profit... for every member of the family.)

KNOW YOUR ALPHA FROM THETA!

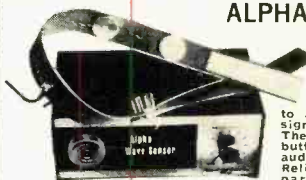

For greater relaxation, concentration, listen to your Alpha-Theta brainwaves. Ultra-sensitive electrode headband slips on/off in seconds—eliminates need for messy creams, etc. Attached to amplifier, filters brainwaves, signals beep for ea. Alpha or Theta wave passed. Monitoring button simulates Alpha sound; audio & visual (L.E.D.) feedback. Reliable, easy-to-use unit—comparable to costlier models.

Completely safe. Comprehensive instruction booklet. No. 1635AV... (8x3x4"; 24 oz.) \$128.00 Ppd.
 (LOW COST "STARTER" UNIT) No. 71,809AV \$49.95 Ppd.

3-CHANNEL COLOR ORGAN KIT

Easy to build, low-cost kit needs no technical knowledge. Completed unit has 3 bands of audio frequencies to modulate 3 independent strings of colored lamps (i.e. "lows"—reds, "middles"—greens, "highs"—blues. Just connect hi-fi, radio, power lamp etc. & plug ea. lamp string into own channel (max. 300w ea.). Kit features 3 neon indicators, color intensity controls, controlled individ. SCR circuits; isolation transformer; custom plastic housing; instr.



Stock No. 41,831AV \$17.50 Ppd.

SUPER 6" SPACE CONQUEROR



Superb Astro-nomical Reflector—reveals faint stars of nearly 13th magnitude, split double stars separated by less than 1 sec. of arc. Features aluminum overcoated 6" f/8 ground polished Pyrex® parabolic mirror accurate to 1/4 wave. 4x F1.6X automatic finder, 4 eyepieces—48X Kellner, 1/2" Ø6X, 1 1/4" 192X Ramsden's, & a Barlow to double or triple power—rack & pinion focusing mount. 47 1/4" aluminum tube. Electric clock drive w/ manual slow-motion control. Setting circles. Heavy-duty equatorial mount. Pedestal base. No. 85,086AV... (5hp. Wt. 68 lbs.) \$259.50 F.O.B. 6" WITHOUT CLOCK DRIVE No. 85,187AV \$222.50 F.O.B. 4 1/4" REFLECTOR (48X to 275X) No. 85,105AV \$115.00 F.O.B. 4 1/4" REFLECTOR W/CLOCK DRIVE No. 85,107AV \$149.95 F.O.B. 3" REFLECTOR (60X to 180X) No. 85,050AV \$36.95 Ppd.

MAIL COUPON FOR GIANT FREE CATALOG!

180 PAGES • MORE THAN 4,500 UNUSUAL BARGAINS!

Completely new '74 Catalog. Packed with huge selection of telescopes, microscopes, binoculars, magnets, magnifiers, prisms, photo components, ecology and Unique Lighting items, parts, kits, accessories—many hard-to-get surplus bargains. 100's of charts, illustration. For hobbyists, experimenters, schools, industry.

EDMUND SCIENTIFIC CO.
 300 Edscorp Building, Barrington, N. J. 08007
 Please rush Free Giant Catalog "AV"

Name _____
 Address _____
 City _____ State _____ Zip _____

COMPLETE & MAIL WITH CHECK OR M.O.

EDMUND SCIENTIFIC CO.
 300 Edscorp Building, Barrington, N.J. 08007

How Many Stock No.	Description	Price Each	Total

PLEASE SEND GIANT FREE CATALOG "AV" MERCHANDISE Total _____

ADD HANDLING CHARGE: \$1.00 ON ORDERS UNDER \$5.00; 50c ON ORDERS OVER \$5.00

I enclose check TOTAL \$ _____
 money order for \$ _____



30 DAY MONEY-BACK GUARANTEE
 YOU MUST BE SATISFIED OR RETURN ANY PURCHASE IN 30 DAYS FOR FULL REFUND

NAME _____
 ADDRESS _____
 CITY _____ STATE _____ ZIP _____

CIRCLE NO. 12 ON READER SERVICE CARD

Popular Electronics

READER SERVICE

Here's an easy and convenient way for you to get additional information about products advertised or mentioned editorially (if it has a reader service number) in this issue. Just follow the directions below... and the material will be sent to you promptly and free of charge.

1

On the attached postage-free card, print or type your name and address on the lines indicated.

2

Circle the number(s) that corresponds to the key number(s) at the bottom or next to the advertisement or editorial mention that is of interest to you. (Key numbers for advertised products also appear in the Advertisers' Index.)

3

Simply cut out the card and mail. No postage required.

FREE INFORMATION

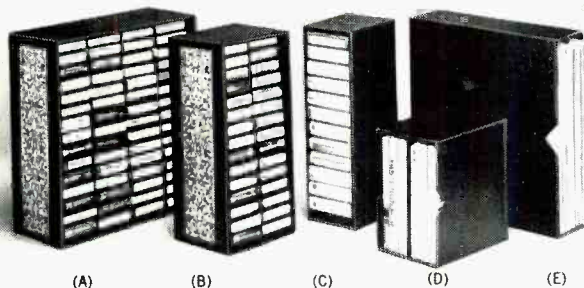

(A) (B) (C) (D) (E)

A COMPLETE SET OF MATCHED STORAGE CASES

Here's the ideal solution to the problem of keeping all your records and tapes stored neatly, safely, conveniently and attractively. A complete set of matched storage cases, designed by the editors of STEREO REVIEW magazine, for your records and all your tapes: cassette, cartridge and 7" reel. Now you can keep them side-by-side on your bookshelf or cabinet, easy to identify and readily available.

These cases are sturdily constructed and covered in a handsome leatherette. The outer case is elegantly embossed in gold and comes in your choice of three popular decorator colors—black, brown and green—so that they lend themselves readily to the decor of any room.

STEREO REVIEW large capacity storage cases are just what you've been looking for—they're the ideal solution to keeping your records and tapes neatly stored for easy use.

(A) 60-unit cassette case. 13½" high x 12⅝" deep x 5½" wide. \$15.95 each; 3 for \$45.00.

(B) 30-unit cassette case. 13½" high x 6½" deep x 5½" wide. \$11.95 each; 3 for \$33.00.

(C) 12-unit 8-track cartridge case. 13¼" high x 6½" deep x 4¼" wide. \$7.95 each; 3 for \$22.00.

Units A, B and C have titled compartments to prevent spillage and include pressure sensitive labels for titling.

(D) 6-unit 7" reel case. 8" high x 7½" deep x 5" wide. Holds reels in original boxes. \$5.25 each; 3 for \$15.00.

(E) 20-unit 12" record case. 13¼" high x 12½" deep x 3½" wide. Holds records in original jackets. \$5.95 each; 3 for \$17.00.

HERE'S HOW TO ORDER

Send your order to Ziff-Davis Publishing Co., Dept 23, One Park Ave., N.Y., N.Y. 10016. Be sure you identify the type of case ordered and indicate your color choice for the back of the case—black, green or brown (sides in black only). Print your name and address clearly and enclose the amount indicated above for the units being ordered PLUS an additional 50c per unit for postage and handling. Outside U.S.A. add \$1.00 per unit ordered.



CHARGE YOUR STORAGE CASE ORDERS TO YOUR AMERICAN EXPRESS OR BANKAMERICARD ACCOUNT



Mail your order, name, address and credit card number. You will be billed for the amount indicated above.

Our most expensive turntable has direct drive. So does our least expensive.

When Technics introduced direct drive, we set new standards for turntable performance. That's why we use direct drive exclusively in all Technics turntables.

No other system measures up to direct drive. Wow and flutter are less than 0.03% WRMS. And rumble is down to -65dB (DIN A) and -70dB (DIN B).

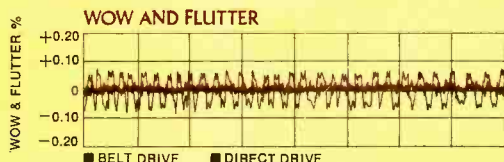

Our DC motor has no noise- or static-producing brushes and virtually none of the hum normally found in AC motors. It reaches playing speed in half a revolution and has electronic speed control that prevents speed changes due to line fluctuations.

All Technics turntables have illuminated stroboscopes, cast aluminum platters and variable pitch controls. The SL-1200 also has a precision tone arm, viscous damped cueing and low-capacitance 4-channel phono cables.

So does the SL-1100A but with a heavier platter, bigger motor and longer tone arm.



And the SP-10 is for those who insist on choosing their own tone arm.

No matter which Technics turntable you choose, you get the finest drive system that money can buy. But don't take our word for it. Read the reviews.* And you'll agree.

The concept is simple. The execution is precise. The performance is outstanding. The name is Technics.

*SP-10: Audio, 8/71; Stereo Review, 9/71.
SL-1100A: Stereo Review, 7/73; High Fidelity, 9/73.

200 PARK AVE., N.Y., N.Y. 10017 FOR YOUR NEAREST
AUTHORIZED TECHNICS DEALER, CALL TOLL FREE
800 447-4700. IN ILLINOIS, 800 322-4400.

Technics

by Panasonic



CIRCLE NO. 16 ON READER SERVICE CARD