

ELECTRONICS IN MODERN SOUND STUDIOS

Popular Electronics

APRIL 1974/FIFTY CENTS

NEW! SIMPLIFIED!

ASCII KEYBOARD AND ENCODER

• Build for Under \$40

Santa Clara
Central Library



**"WALKIE TALKIES"
FOR EVERYONE**

**UNDERSTANDING
DECIBELS**

CONSTRUCTION PROJECTS

- GFI Anti-Electrocution Device
- 99 Sec/Min Interval Timer

SPECIAL TEST REPORT

HEATHKIT'S DIGITAL
25" COLOR TV!

- Channel/Time Readout



**NRI “hands-on” training in
Television, Communications,
Electronics and Computers
can give you as much
as 2 years of on-the-job
experience.**

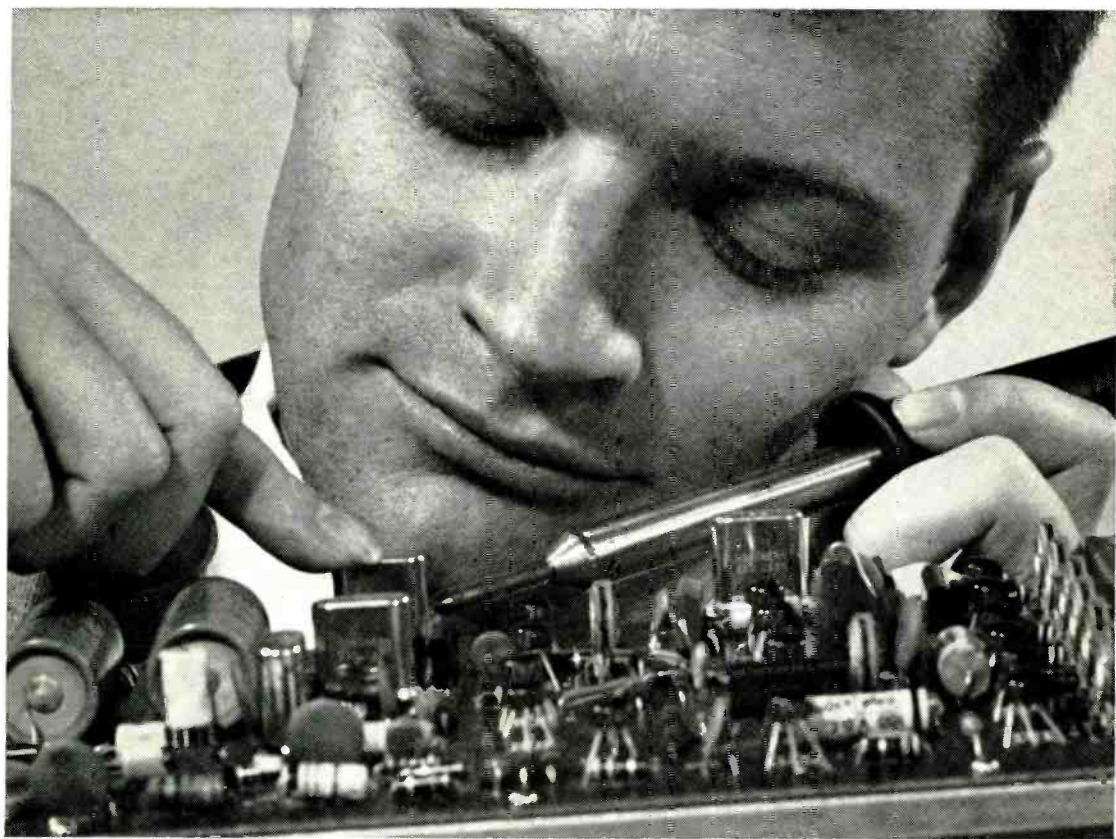

EARN YOUR FCC LICENSE – OR YOUR MONEY BACK

NRI Communications training programs will qualify you for a First Class Commercial Radiotelephone License issued by the FCC. If you fail to pass the FCC examinations for this license after successfully completing an NRI Communications course we will, on request, refund in full the tuition you have paid. This agreement is valid for the period of your active student membership and *for six months* after completion of your training. No school offers a more liberal FCC License agreement.

Experience is still your best teacher

...here's how you get it with unique NRI training at home



NRI Achievement Kit is educator-acclaimed and the original "starter" kit in home study training. Imitated but never duplicated, this kit is designed and personalized for you and your training objective. It has one purpose — to get you started quickly and easily.



"Bite-Size" Texts average an easily-digested 40 pages of well-illustrated, scientifically prepared subject matter in the course of your choice. Questions in each book are carefully hand-graded and returned to you with helpful instructional notes. You get unlimited personal help from the day you enroll.

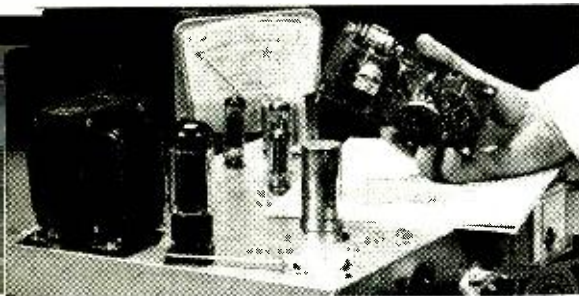

Designed-For-Learning Equipment

Like this phone-cw transmitter (Kit #7 in the Communications course) is engineered from chassis up to demonstrate principles you must know. NRI does not use modified hobby kits for training, but the finest parts money can buy, professionally and educationally applied.

Ask any teacher, job counselor, engineer, technician or prospective employer about the need for practical application of theory in Electronics. He'll tell you Electronics is as much a "hands-on" profession as dentistry or chemistry. That's how you learn at home with NRI. You prove the theory you read in "bite-size" texts, by actual experimentation with the type of solid-state, transistor and tube circuits you'll find on the job today — *not* hardware or hobby kits. You introduce circuit defects, analyze results, discover quickly the kind of trouble-shooting and design techniques that will make you employable in Electronics.

Train with the leader — NRI

NRI lab equipment is designed from chassis up for effective, fascinating training — not for entertainment. The fact that end results are usable, quality products is a bonus. In Communications, for example, you build and analyze, stage by stage, your own 25-watt phone/cw transmitter. It's suitable for use on the 80-meter amateur band, if you have an interest in ham radio. In TV-Radio Servicing your practical training gives you your choice of monochrome or color TV sets. All training equipment is included in the low tuition — you pay nothing extra. Discover for yourself the ease, excitement and *value* of NRI training. Mail postage-free card today for new NRI Catalog . . . or use the coupon below. No obligation. No salesman will call on you. NATIONAL RADIO INSTITUTE, Washington, D.C. 20016.

APPROVED UNDER NEW GI BILL

If you have served since January 31, 1955, or are in service now, check GI line on postage-free card or in coupon.

MAIL THIS COUPON IF CARD IS GONE



NATIONAL RADIO INSTITUTE

Washington, D.C. 20016

1-043

Please send me your new NRI Catalog. I understand no salesman will call and there is no obligation.

Name _____ Age _____

Address _____

City _____ State _____ Zip _____

Check for facts on new GI Bill

ACCREDITED MEMBER NATIONAL HOME STUDY COUNCIL

Popular Electronics

WORLD'S LARGEST-SELLING ELECTRONICS MAGAZINE

FEATURE ARTICLES

- 35 WALKIE-TALKIES: SOMETHING FOR EVERYONE** *Herb Friedman*
What's available from milliwatts to 5 watts.
- 59 A GUIDE TO CMOS OPERATION, Part 2.** *Walter G. Jung*
Practical applications of CMOS in logic circuits
- 65 ELECTRONICS IN MODERN SOUND STUDIOS** *Craig Anderton*
New methods create higher fidelity and unusual recordings.
- 76 QUIZ: WHAT DO YOU KNOW ABOUT RESISTORS?** *Robert P. Balin*
- 86 WHY USE A TRIAC** *Leslie Solomon*
- 87 ELECTRONICS AND THE ENERGY CRISIS** *John T. Frye*
- 94 UNDERSTANDING DECIBELS** *George Board*

CONSTRUCTION STORIES

- 27 ASCII KEYBOARD AND ENCODER** *Don Lancaster*
A low-cost, fully professional unit that's easy to build.
- 32 Q MULTIPLIER BOOSTS SW SELECTIVITY & GAIN** *Joe A. Rolf*
- 41 HOW TO MAKE CUSTOM METERS FROM SALVAGED PARTS** *Robert Koval*
- 44 ELIMINATE RISK OF FATAL ELECTRIC SHOCK
WITH THE GROUND FAULT INTERRUPTER** *C. C. Lo*
- 47 BUILD A PRECISION SECONDS/MINUTES INTERVAL TIMER** *John D. Collin*
- 51 AUTOMATIC PHOTO ENLARGER CONTROLLER** *Joseph Giannelli*
Save time and supplies—eliminate guesswork.
- 69 BUILD A SHIRT-POCKET METRONOME** *A. A. Mangieri*
Audible count of 40 to 220 beats per minute.
- 71 VOLTAGE INDICATOR USING LED'S** *Calvin R. Graf*

ZIFF-DAVIS PUBLISHING COMPANY

Popular Electronics
Editorial and Executive Offices
One Park Avenue, New York, New York 10016
212-725-7405

William Ziff, President
W. Bradford Briggs, Executive Vice President
Hershel B. Sarbin, Senior Vice President, Secretary, and Treasurer
Philip Sine, Senior Vice President
Phillip T. Heffernan, Vice President, Marketing
Frank Pomerantz, Vice President, Creative Services
Arthur W. Butzow, Vice President, Production
Edward D. Muhlfeld, Vice President, Aviation Division
Irwin Robinson, Vice President, Travel Division
George Morrissey, Vice President
Sydney H. Rogers, Vice President
Sidney Holtz, Vice President
Lawrence Sporn, Vice President, Circulation

POPULAR ELECTRONICS, April 1974, Volume 5, Number 4. Published monthly at One Park Ave., New York, NY 10016. One year subscription rate for U.S., U.S. Possessions and Canada, \$6.00; all other countries, \$8.00. Second class postage paid at New York, N.Y. and at additional mailing offices. Authorized as second class mail by the Post Office Department, Ottawa, Canada and for payment of postage in cash. Subscription service and Forms 3579: P.O. Box 2774, Boulder, CO 80302. Editorial offices for manuscript contributions, reader inquiries, etc.: One Park Ave., New York, NY 10016.

POPULAR ELECTRONICS Including ELECTRONICS WORLD, Trade Mark Registered. Indexed in the Reader's Guide to Periodical Literature.

Copyright © 1974 by ZIFF-DAVIS PUBLISHING COMPANY. All rights reserved.

EDGAR W. HOPPER
Publisher
ARTHUR P. SALSBERG
Editorial Director
MILTON S. SNITZER
Editor
LESLIE SOLOMON
Technical Editor
JOHN R. RIGGS
Managing Editor
EDWARD I. BUXBAUM
Art Director

ALEXANDER W. BURAWA
Associate Editor
ANDRE DUZANT
Technical Illustrator
ELLEN S. FINKELSTEIN
Editorial Assistant
LEN BUCKWALTER
JOHN T. FRYE
LOU GARNER
RALPH HODGES
WALTER G. JUNG
Contributing Editors

JOSEPH E. HALLORAN
Advertising Director
JOHN J. CORTON
Advertising Sales
MADELEINE LITTMAN
Advertising Service Manager
PEGI McENEANEY
Executive Assistant
STANLEY NEUFELD
Associate Publisher
FURMAN H. HEBB
Group VP, Electronics & Photo

THE SCENES

- 12 STEREO SCENE** *Ralph Hodges*
- 24 HOBBY SCENE**
- 97 CB SCENE** *Len Buckwalter*
- 99 TEST EQUIPMENT SCENE** *Leslie Solomon*
- 101 SOLID STATE** *Lou Garner*

PRODUCT TEST REPORTS

- 77 HEATHKIT MODEL GR-2000 DIGITAL COLOR TV RECEIVER WITH OPTIONAL REMOTE CONTROL AND CLOCK**
- 81 SANSUI MODEL QRX-3500 4-CHANNEL RECEIVER**
- 84 CARINGELLA MODEL TCG-1 SEMICONDUCTOR CURVE TRACER**
- 85 MICRO ELECTRONIC SYSTEMS MINI DRILL**

DEPARTMENTS

- 6 EDITORIAL** *Milton S. Snitzer*
The CB Pleasure Seekers
- 8 LETTERS**
- 22 NEWS HIGHLIGHTS**
- 96 TIPS & TECHNIQUES**
- 106 NEW LITERATURE**
- 112 ELECTRONICS LIBRARY**
- 114 NEW PRODUCTS**

COMING NEXT MONTH

A 9-Band Audio Equalizer for Stereo
What to Look for in a Shortwave Receiver
"Flip"—A New CMOS Game Computer

Midwestern Office
The Pattis Group, 4761 West Touhy Ave.,
Lincolnwood, Illinois 60464, 312 679-1100
GERALD E. WOLFE, GEORGE B. MANNION

Western Office
9025 Wilshire Boulevard, Beverly Hills, California 90211
213 273-8050; BRADSHAW 2-1161
Western Advertising Manager, BUD DEAN

Japan: James Yagi
Oji Palace Aoyama; 6-25, Minami Aoyama
6 Chome, Minato-Ku, Tokyo 407-1930/6821

Ziff-Davis also publishes Boating, Car and Driver, Cycle, Flying, Modern Bride, Popular Photography, Skiing, and Stereo Review.

Forms 3579 and all subscription correspondence should be addressed to POPULAR ELECTRONICS, Circulation Department, P.O. Box 2774, Boulder, CO 80302, Please allow at least eight weeks for change of address. Include your old address, as well as new—enclosing, if possible, an address label from a recent issue.

Editorial contributions must be accompanied by return postage and will be handled with reasonable care; however, publisher assumes no responsibility for return or safety of art work, photographs, models, or manuscripts.





Editorial

By Milton S. Snitzer, Editor

THE CB PLEASURE SEEKERS

Want to chat about anything in any part of the world over radio for any length of time? Get a ham license! Want the no-test privilege of transmitting brief, personal or business messages up to 150 miles away ("I'm stuck in traffic, hold dinner till I contact you again")? Get a CB license!

But it doesn't work out this way. The CB bands have become "party lines," with attendant clogging of channels. Linear power amplifiers manufactured for use in the 10-meter ham band are being used for the 11-meter band to soup up CB rigs so that they exceed the legal 5-watt input limit. Result? TV interference and bottling up local CB channels at a great distance away.

Abuses are rampant. Millions of CB'ers are not covered by an FCC license, depriving the government of revenue and inviting users to work CB illegally by not having call letters that must be used when transmitting.

Who is responsible for the misuse of the Citizens Radio Service? Heaviest blame must rest with the FCC for not covering the loopholes that existed when the service was initiated. Without a policing force that would match our standing army or some hard-nosed checks and balances, it should have been obvious that the pleasure of hobby use would win out over limited communication privileges. Even type acceptance (see "CB Scene," March 1974) of Class-D CB transmitters, adopted only recently, could have been required of manufacturers many years ago.

Sure there have been violation fines imposed here and there. But they've been minuscule in percentage. The FCC has witnessed blatant violations of its Part 95 of FCC Rules with hardly a raised eyebrow (or at least without a mailed fist).

With the proposed Class-E CB service planned to supplement, not supplant Class D, some of these problems will be alleviated by the opening of more communication channels and virtual elimination of "skip." But with brisk sales of CB rigs expected to continue, some of the problems—idle chatting, no call letters, etc.—will continue and eventually result in busy channels once again.

What's the solution? CB'ers who want to clean up the service for their own good could start by getting licenses, using callsigns, limiting lengths and types of conversations and ceasing transmission beyond legal limits. There is certainly great value remaining in CB—sending important personal and business messages, reporting local traffic conditions to persons engaged in furnishing this information to the public, requesting routing directions or any other assistance needed in transit (food, lodging, etc.), communicating emergencies involving safety of life or property, and much more. Free the channels and everyone will benefit.

There's a wealth of enjoyment and information in Sams books for the hobbyist.

One or more of the eight shown here could be right down your alley.

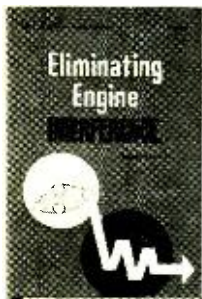

ELIMINATING ENGINE INTERFERENCE, 2nd Edition
By John D. Lenk

Explains how to eliminate or reduce troublesome interference caused by auto, boat or other engines in mobile communications receivers. Covers solid-state circuits and includes wiring diagrams for major autos. Analyzes and discusses squelch and noise-limiter circuits, commercial suppression kits, shielding kits, and electronic circuits that can be added to the receiver. 128 pages, softbound.
No. 21004 \$4.50



QUESTIONS AND ANSWERS ABOUT AUTO TAPE UNITS
2nd Edition
By Leo G. Sands

A handy, easy-to-follow guide to understanding the operation of auto tape units. Using a question-and-answer format, it provides information on the circuitry, installation, trouble-shooting, and maintenance of auto tape players, cartridges, and cassettes. 96 pages, softbound.
No. 21002 \$3.50



QUESTIONS AND ANSWERS ABOUT NOISE IN ELECTRONICS
By Courtney Hall

Explains, in easy Q & A format, the situations that cause noise in electronics. Provides a clear understanding of noise characteristics and the measurement peculiarities associated with them. Examples and tables of solutions save time and effort for the reader. 96 pages, softbound.
No. 21022 \$3.95



ABC'S OF CITIZENS BAND RADIO
3rd Edition
By Len Buckwalter

This easy-to-understand text covers the principles of operation, regulations, setup, and operating of CB radio equipment. Illustrations and schematics show how to obtain an FCC license, and set up and operate the equipment with efficiency. 128 pages, softbound.
No. 21021 \$3.95

TAPE RECORDING FOR THE HOBBYIST, 3rd Edition
By Arthur Zuckerman

Everything you need to know to get the most from your tape recorder. The book discusses the advantages, disadvantages, maintenance, and repair of the different types of machines and microphones available. It also covers their many uses, ranging from recorded letters to sound effects and video tape recording. 192 pages, softbound.
No. 21016 \$4.95



ELECTROSTATICS HANDBOOK
By Charles Green

An introduction to one of the great natural forces — electrostatic electricity. You learn its fundamentals firsthand by building educational and entertaining demonstration projects. Each chapter in the book includes groups of projects that cover different aspects of electrostatic electricity generation, detection, and use. 128 pages, softbound.
No. 21023 \$4.25



5-MINUTE ELECTRONIC PROJECTS
By Len Buckwalter

While each project can be created in just minutes, in total the book provides many hours of pleasure. It presents, in complete detail, dozens of projects that can be made with simple tools and inexpensive components. The projects start with simple demonstrations and grow progressively more complex, enabling you to learn by building. 96 pages, softbound.
No. 20968 \$3.95



LED CIRCUITS & PROJECTS
By Forrest M. Mims III

The recently developed and fast-growing field of uses for light emitting diodes (LED) is graphically presented in this highly readable book. Following an introduction to the theory of LEDs, the book covers the many varied LED circuits and applications. Chapters cover installation, operating hints, multi-color LEDs, diode laser theory, and much more. 176 pages, softbound.
No. 21006 \$4.95

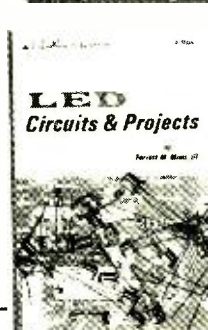

PE 044



HOWARD W. SAMS & CO., INC.
4300 W. 62nd St., Indianapolis, Ind. 46206

Order from your Electronics Parts Distributor, or mail to Howard W. Sams & Co., Inc.

Send books checked at right. \$ enclosed. Please include sales tax where applicable. Canadian prices slightly higher.

Send FREE 1974 Sams Book Catalog.

- 21004
- 21002
- 21022
- 21021
- 21016
- 21023
- 20968
- 21006

Name _____

Address _____

City _____ State _____ Zip _____

CIRCLE NO. 34 ON READER SERVICE CARD

New—Low Distortion
**COMPRESSOR
 expander**



Restore the original dynamic range of your music— increase your stereo separation, OR make your own background music with our new compressor-expander kit. Our circuit uses an electronic gain control integrated circuit for fast attack, slow release type operation with none of the lags and distortion found in the old photocell lamp controlled circuits. Expansion beginning level and compression beginning signal levels are adjustable. Up to 20 db of expansion and 40 db of compression are available with less than 1.0% THD under worst case conditions. Typically less than .05% under most operating conditions. Frequency response of 2 Hz to 100,000 Hz. Self contained power supply. Connects to preamp output, or to "Tape Monitor" jacks if available.

EX-1 Kit.3.0 lbs. \$29.95

REVERB ADAPTOR

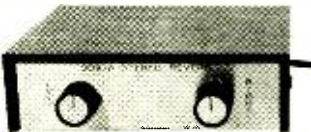

Put more life into your music with this self powered stereo reverb adaptor system. The reverb circuit electronically simulates the longer reverberation time of a large hall, giving your music more life and realism. Separate spring units and controls for each channel may be used with any stereo system by connecting the adaptor between the amplifier and pre-amp.

No. 239 Reverb Adapter Kit with two spring units
 Shipping Weight 5½ lbs. \$38.50

Circle the reader service card number below for a FREE copy of our latest catalog.



**SOUTHWEST TECHNICAL
 PRODUCTS CORPORATION**

DEPT. PE

219 W. Rhapsody, San Antonio, Texas 78216

CIRCLE NO. 30 ON READER SERVICE CARD



Letters

CHECK THE LEGALITY

California limits the use of "siren" devices such as the "Electronic Siren" (December 1973) in unauthorized vehicles. California readers of POPULAR ELECTRONICS should be made aware that sirens cannot be legally used as the alerting devices in automobile burglar alarm systems in this state. We appreciate your interest in other types of auto theft warning systems as contributing towards a reduction in vehicle thefts.

WARREN M. HEATH
 Commander, Engineering Section
 Dept. of California Highway Patrol
 Sacramento, Calif.

We are sorry that the limited space we had for the story precluded our inserting the usual admonition to the reader to check with his state motor vehicle department on the legality of using a siren sound in an auto theft alarm system. We hope this belated warning will rectify the situation.

WANTS TO KNOW ABOUT TESLA

In school and on the radio, I have been hearing a lot about Nikola Tesla. So far, all I have been able to find out is where he lived and how great an inventor he was. I would like to know a lot more about him. Can you tell me where to look?

JIM HERRICK
 Kent, Ohio

Nikola Tesla is among the most famous men in electrical science. Hence, it should be easy to find detailed information on his life and contributions. A good place to start is the encyclopedia. Even more information can be found in your local library.

WRONG SIDE UP

I was so fascinated by the "Logidex" (November 1973) that I decided to build one for myself and another for a friend. To do a really professional job, I had the boards professionally made. I was frustrated when the circuit boards I had ordered turned out to be the mirror image of what they should have been. I suspect that someone goofed because the etching and

NEW! Build and test circuits as fast as you can think! No soldering or patch cords!

Plug in...wire...modify...build...test

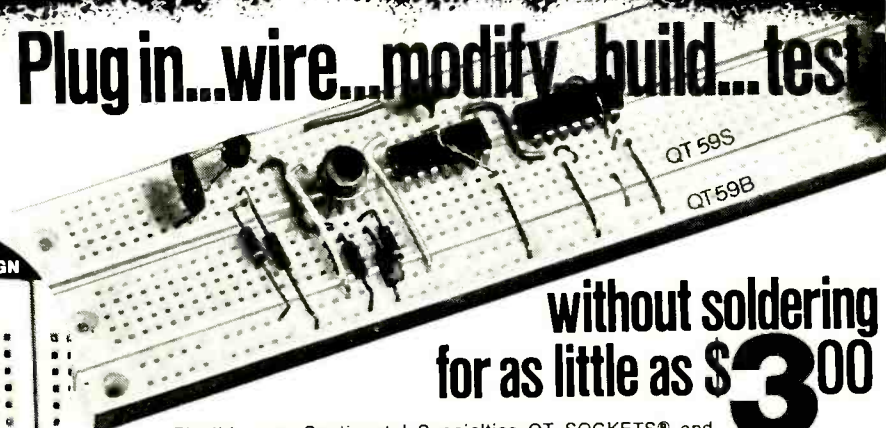

**UNIQUE NEW
SNAP/LOCK DESIGN**

without soldering for as little as \$3⁰⁰

Flexible new Continental Specialties QT SOCKETS® and BUS STRIPS are a fast, easy breadboarding system with unique SNAP/LOCK that lets you add or remove as many QTs as you need instantly. Now you can test ICs, transistors, resistors, capacitors and more. Just plug in, and connect with solid #22 AWG hook up wire... no soldering is needed! No more shorts! No more burnt fingers! No special patch cords! And you can use QTs again and again! QTs come in different sizes, starting as low as \$3 for QT Sockets and \$2 for Bus Strips. Order yours today!

plus, four new completely assembled PROTO BOARDS...

PAT. PENDING

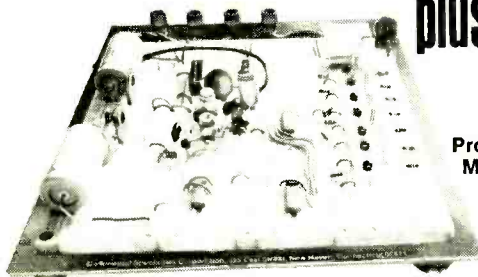

Proto Board Model No.	14 Pin DIP Capacity	Size (L" x W")	Price (U.S. only)
101	10	5.8" x 4.5"	\$29.95
102	12	7.0" x 4.5"	\$39.95
103	24	9.0" x 6.0"	\$59.95
104	32	9.5" x 8.0"	\$79.95

Four new Continental Specialties Proto Boards, made from combinations of QT Sockets and Bus Strips let you make all circuit and power interconnections with common solid #22 wire, while power distribution busses make wiring a snap. Aluminum base plates offer solid work surfaces and perfect ground plane. Rubber feet prevent scratching. Each Proto Board features one or more 5-way binding posts to tie into system or power supply ground. All are compatible with ICs (digital or linear), in TO5s, DIP packs and discrete components. Each is assembled and ready-to-use.

Order today — or send for free selection guide, with applications, photos, specs and more.



Continental Specialties Corp.

325 East St., Box 1942
New Haven, CT 06509
Telephone (203) 624-3103

CANADA: Available thru Len Finkler, Ltd., Downsview, Ontario

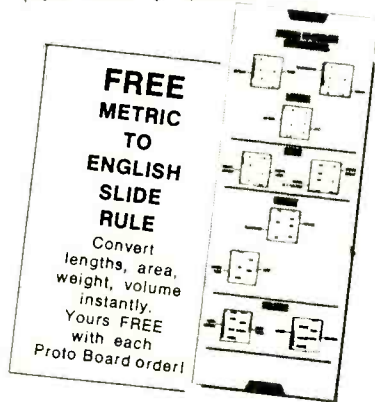

CIRCLE NO. 9 ON READER SERVICE CARD

HOW TO INCREASE YOUR EARNING CAPACITY IN JUST 6 WEEKS



Here's how our Digital Circuit Design course helped Mr. Wright: "... your course helped me immeasurably. I recently applied for a new position and got it. Your special training is now helping me fulfill my responsibilities on the job."

**Learn advanced CIRCUIT THEORY
in your spare time; without higher math!**

THE CENTER understands and anticipates your needs for working in electronics today. Our courses get results for you quickly, with convenient home study. All courses are 100% tax deductible. You take no risks. You receive everything on a 5 day FREE TRIAL basis. Decide your future, act today!

SEND FOR FREE INFORMATION TODAY!

Send me complete information on the following:

Digital Circuit Design IC Logic Design Power Supply Design
 MOS/FET & J/FET Circuit Design UJT Circuit Design

Name _____ Age _____

Street _____

City _____ State _____ Zip _____



Dept. PE474

Phone: 513/296-1020
2876 CULVER AVENUE
DAYTON, OHIO 45429

CIRCLE NO. 7 ON READER SERVICE CARD

drilling guide shown in the story was given from the component-side view.

DOUG EDMONDS
Independence, Ore.

In the process of reproduction, the foil pattern did, unfortunately get printed the wrong way.

ADVERTISEMENT CAUSES CONCERN

On page 93 of the January 1974 issue, there is an advertisement for the sale of POPULAR ELECTRONICS indexes from an outside source. I sincerely hope that this does not mean the demise of the publication of PE's own cumulative index in the December issues.

D.H. POMEROY
Manchester, N.H.

Rest assured that we will not cease the publication of our cumulative index. However there seems to be some confusion about the "outside source" index offered in the ad. To clarify, the two indexes are different. Our index is a compilation of Tables of Contents for the year. The outside-source index is a "working" reference, going into greater depth and detail.

BATTLE OF THE BATTERIES

Because my company manufactures electronic watches and clocks, the article "Build Your Own Electronic Digital Wristwatch" in the January 1974 issue was of great interest to me. I must, however, take issue with the recommendation of using a hearing-aid battery in the watch. Watch and hearing-aid cells are often identical in dimensions, but there are significant differences that make interchanging the two rather risky.

By design, a battery for watch use is built to supply a minuscule constant current for as long as two years. A hearing-aid cell, however, is designed to supply currents many times greater for a few weeks. The result is that the use of a hearing-aid cell in an electronic watch could result in a much shortened battery life—or worse yet, destruction of the interior of the watch from leaking electrolyte. Even if the A-H ratings of the two types of battery are the same, different sealing techniques, barrier materials, and electrolytes are often used.

JAMES L. BECK
Vice President of Engineering
Integrated Microsystems Inc.
Mountain View, Calif.

In essence, a hearing-aid battery is not designed for use in an electronic watch. However, the S-14 battery specified is inexpensive and easy to obtain. Also, in watches that we have been operating since September 1973, no damage or sign of potential damage has occurred.

—Bill Green, Alpha Electronics

Build yourself a better car!

Build an ArcherKit™ from Radio Shack

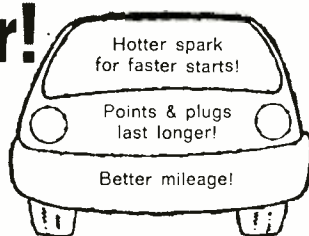

"After an hour or so of driving we noted that the engine was acting the way it did two years and 20,000 miles ago . . . a definite improvement in performance. Acceleration, specifically, was much improved." **Popular Electronics, May, '73**

Radio Shack's Deluxe Capacitive Discharge Ignition puts more "Go" in every gallon! It delivers 50% more spark power for faster acceleration and more complete combustion. That means you get better gas mileage, and your points and plugs will last 3 to 10 times longer. An in/out button lets you make instant performance comparisons with your old ignition. And it makes tuneups easier. The thorough step-by-step manual makes it easy for even a first-time kit builder to assemble and install—no wires to cut. Improves any 12-volt negative ground vehicle. #28-3203.

Deluxe, High-Intensity Timing Light Kit



Tune-up aid for any engine. For full power & economy. Bright flash is visible even in daylight! #28-4016.

1995 With All Cables

Retail prices may vary at individual stores.



FREE '74 CATALOG 375
AT YOUR NEARBY STORE OR
MAIL THIS COUPON

180 Pages . . . Full Color! Hi-Fi, CB, Kits,
Recorders, Antennas, Parts, More!

PLEASE
PRINT
CLEARLY

Name _____ Apt. # _____
Street _____
City _____ State _____ ZIP

ArcherKit

by

Radio Shack®

and ALLIED RADIO STORES
A TANDY CORPORATION COMPANY
P. O. Box 1052, Fort Worth, Texas 76107

CIRCLE NO. 27 ON READER SERVICE CARD



Stereo Scene

By Ralph Hodges

NEW YORK City's Consumer Protection Law Regulation 36 ("... Disclosures in the Sale of Home Audio Equipment") went into effect on October 17, 1973. It is still too early (in mid-January 1974) to judge what the law's long-term influence will be, but at least no one can call it a lax or unspecific directive. Among its requirements are: *minimum* amplifier power to be specified in continuous sine-wave rms watts per channel, with all channels driven to rated output simultaneously; impedance to be 8 ohms; rated power to be available over a bandwidth of at least 60 to 10,000 Hz; total harmonic distortion to be less than 1 percent at all power levels up to rated. If a manufacturer or retailer chooses to employ another power rating system as well, he is free to do so, as long as the above information also appears "clearly and conspicuously," *and* as long as the performance specified is "obtainable . . . when the equipment is operated by the consumer in the usual or normal manner without the use of extraneous aids."

Aside from a quibble on the correct technical usage of rms (see box on page 14), there is little in the document that is open to broad interpretation. New York clearly means to clean up the audio retail industry by making a "uniform basis of comparison" among competing brands available. If that basis is a little rigorous for all types of equipment (pocket transistor radios can either claim 0.15 watt continuous—150 milliwatts would look better—or keep quiet about power), the asking price will (or should) balance things out.

Consumer Protection Law Regulation 36 is a direct fallout from hearings begun by the Federal Trade Commission several years ago, at which a number of representatives of industry groups (principally the EIA or Electronic Industries Association and the Institute of High Fidelity or IHF) and

members of the audio press testified. The object of the hearings was to examine the chaos in amplifier power rating systems used regularly in product advertising, with the possible aim of disallowing some of the flagrantly unrealistic or meaningless ones.

What they stumbled on, of course, was the well-known quagmire of trying to correlate audible phenomena with measurable parameters. In the end, finding none of the existing rating systems completely definitive (in view of the testimony), the FTC devised its own, the particulars of which were announced in a revised, "final" form in late 1973. A mild uproar ensued, with the result that the FTC has been challenged to show that it has not overstepped its charter as a *rule-enforcing* agency and become, in this instance, a *rule-making* one. At the moment, the issue is still being debated.

Various Rating Systems. Why all the controversy over establishing a few uniform guidelines for the hapless consumer? It's a long and complicated story. We might as well begin by exploring the differences between the current FTC proposal and the rating systems espoused by the EIA and IHF. The IHF standard (IHF-A-201) was promulgated in 1966 as an updating of a previous standard from some years before. The EIA standard (EIA RS-234-B) came out in early 1971—virtually coincident with the first FTC hearings—as a display of solidar-

Legislating Power Output Claims

TESTING!

with MITS lab quality test equipment

One



SG 1900—The Audio Sweep Generator provides the capabilities of both a fixed frequency CW and a sweep generator in a laboratory quality instrument. Modes include CW, linear sweep, and log sweep with a sweep time of 10 milliseconds to 100 seconds. Waveforms are sine, square, and triangle. The range is from 1 Hz to 100 KHz. The output has fixed attenuation levels of 0, 20, and 40 dB \pm 1 dB, as well as continuously variable attenuation.
Prices: Kit \$119.95 Assembled \$149.95

Two



WG 1700—The Waveform Generator/Frequency Counter is well suited to a wide variety of test work. Six carrier waveforms (sine, triangle, square, ramp, sawtooth, and pulse) and three internal AM or FM modulator waveforms (sine, triangle, and square) are featured. The carrier frequency range is 1 Hz to 1.5 MHz in twelve overlapping ranges; the modulator waveform frequency range is 100 Hz to 150 KHz in six overlapping ranges. Both outputs are buffered for low output impedance. The unit also accepts external AM or FM modulating signals. The frequency counter with adjustable sensitivity measures the waveform generator output frequency and frequency of external signals from 1 Hz to over 10 MHz, with input impedance of 100K ohms.
Prices: Kit \$199.95 Assembled \$249.95

Three



DV 1600—The 2-1/2 digit Digital Voltmeter is a perfect companion for MITS' other fine test equipment. Features include full scale measurement of alternating and direct current in five ranges from .1 ma to 1 amp, measurement of AC and DC voltage in four ranges to 1000 volts, and measurement of ohms in six ranges to 10 megohms. The resolution in low ranges for voltage is 10 mv; for current, 10 μ A; and for resistance, 1 ohm. The DC accuracy is \pm 5% and the AC accuracy is \pm 1%. Other features include autopolarity and 100% overrange capability on all ranges, which effectively doubles full-scale capability.
Prices: Kit \$ 89.95 Assembled \$129.95

Four



ICT 1800—The Integrated Circuit Tester is ideal for testing digital integrated circuits and for breadboarding IC's while developing circuits. The eighteen LED indicators show the status of the IC under test. The internal 5 volt 1 amp power supply, which has overtemperature and overcurrent shutdown capabilities, is also available for external use. The cross bar switch allows complete programming of the IC under test. Other features include an internal two speed clock, single step capability, and four each remote outputs and inputs.
Prices: Kit \$119.95 Assembled \$169.95

Plus

ICT 1810—The Operational Amplifier Tester with fast, simple GO/NO GO test capability tests operational amplifiers for gain, stability, input offset voltage, and input bias current in a dynamic operating environment. A single LED indicates IC status.

Prices: Kit \$29.95 Assembled \$39.95

Power Sale

PS 500—The 5 Volt Power Supply, which has overtemperature and overcurrent shutdown capability, is an ideal unit to power TTL, DTL, and other IC's. Features include load regulation at 0.8% and line regulation at 0.005%. Output voltage is 5 volts \pm .2 volt.

Prices: Kit ~~\$29.95~~ \$19.95 WHILE THEY LAST!

Warranty: Full two-years warranty on assembled units, ninety days on kits.
* Prices subject to change without notice. Available from your local Olson Electronics Dealer.

MITS INC.

"Creative Electronics"

6328 Linn, N.E., Albuquerque, New Mexico 87108
505/265-7553 Telex Number 660401

Enclosed is a Check for \$ _____
or BankAmericard # _____
or Master Charge # _____
Credit Card Expiration Date _____ Kit
Include \$5.00 for Postage and Handling Assembled
 SG1900 WG1700 DV1600 ICT1800 ICT1810 PS500
 Please Send Information on Entire MITS Line.

NAME _____
ADDRESS _____
CITY _____
STATE & ZIP _____
MITS/ 6328 Linn, N.E., Albuquerque, New Mexico 87108 505-265-7553 Telex = 660401

CIRCLE NO. 21 ON READER SERVICE CARD

DOES RMS POWER EXIST?

A brief time ago there was a short-lived flurry in the audio press about the expression "watts rms," which has long been the nomenclature for continuous-power output in many manufacturers' literature. "There is no such thing!" it was hotly asserted, and there was a general deploring of loose standards and sloppy thinking in the industry. Well, I have heard that rms power does exist, at least as a concept, but it is of no interest to the audiophile. What we're concerned with is watts computed from rms voltage, which is a much easier concept to understand.

Way back when electricity had just emerged from Leyden jars, it was desired to find a way of expressing ac voltages that would compare them with dc in respect to work-doing potential. The following means was hit upon. A dc current was passed through a resistor and the heat generated was measured. Any ac current that generated the same amount of heat passing through the resistor was then considered to have the

same effective voltage as the dc. Shortly it was discovered that the "dc equivalent voltage" of alternating current could be calculated by the rms (root-mean-square) method, which consisted of squaring all the instantaneous voltage values of the ac, computing the mean, and then extracting the square root. Thus rms voltage was born.

Power output is determined in the laboratory by the formula $P=E^2/R$, where E is the rms voltage and R is the load resistance. The rms "power," as the critics point out, is a misnomer, although probably a harmless one. The real curiosity is that "rms power" has come to mean, in audio, the same thing as "continuous sine-wave power." The rms voltage of a half cycle of a sine wave could easily be calculated, so the expression implies nothing about the continuity of the power output (music power is also calculated from rms voltage); nor does it suggest sine-wave signals in any way, except in that almost everyone knows the rms voltage of a sine wave is 0.707 of its peak value. But as long as rms means the same thing to everybody, we're probably all right.

ity with the IIF, and possibly as a demonstration of the industry's willingness to adopt self-regulatory policies in the face of impending government controls. Both standards are very similar, and they differ significantly from the FTC's only on seemingly minor points:

(1) The FTC proposal calls for amplifiers to be tested with a line voltage of 117 volts. The EIA specifies 120 volts, and offers an extensive study showing that the vast majority of the population has at least that much or more voltage available at the wall socket. Testing with 120 volts would theoretically provide an increase in power output of somewhat less than 10 percent; so would a slight modification of the equipment's power transformer. So this is a minor point; but, in my view, the EIA wins it on the basis of its documentation, provided this era of 10 percent brownouts hasn't negated the 1966 study of line voltage. The IIF also calls for 120 volts.

(2) The IIF standard specified that the amplifier be preconditioned before testing by being operated at 10 percent of its rated output for one hour. The EIA follows suit. The FTC proposal calls for 30 percent of rated output for the same period. I am told that continuous operation at 30 percent

of capacity is approaching the condition under which typical amplifiers generate—and thus must dissipate—the most heat. In other words, after an hour of such conditioning there may not be a working amplifier left to test. This point could become a serious bone of contention, or it might just fade away.

(3) Both the EIA and the IIF standards describe a supplementary measuring procedure for rating short-term power-output capability—essentially the IIF's controversial "music" or "dynamic" power system. The FTC proposal recognizes no such system, specifying only continuous power.

The first two conflicts, although they have taken on the proportions of large issues for the moment, are resolvable because all equipment will be treated equally by whatever uniform standards are finally adopted. Point three is not so easily dealt with, because it poses the question of what exactly is "useful" power for an audio amplifier, and will therefore affect design philosophy as well as (possibly) the final cost.

IIF music power, for those who are not aware of the particulars, is usually measured in exactly the same way as continuous power. A steady sine-wave signal is applied to the inputs of the amplifier, the maximum

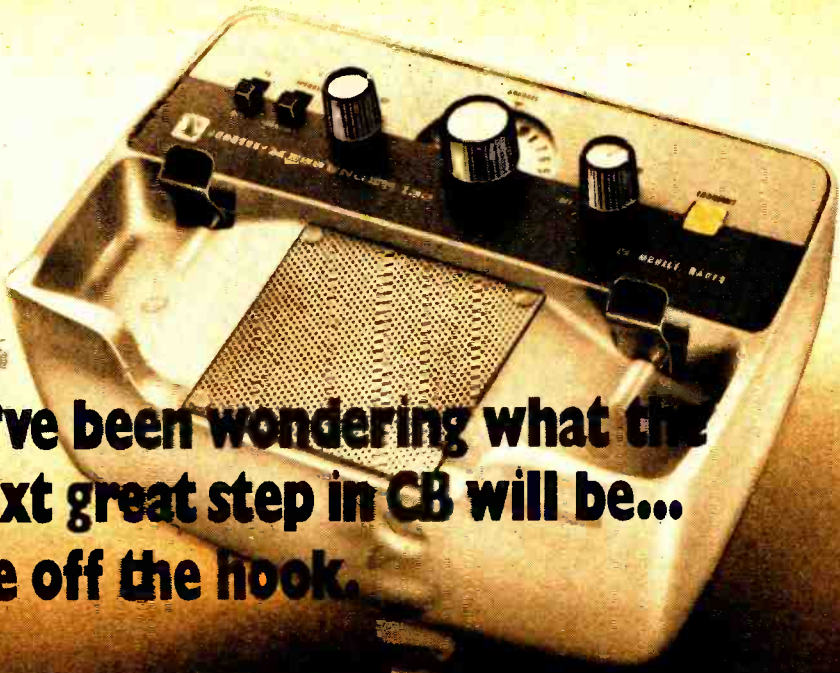

**if you've been wondering what the
next great step in CB will be...
you're off the hook.**

Messenger 130... so radically new in design and performance that citizens band radio will never be the same again. Inside this prestigious "radiotelephone" package is a unique all solid-state chassis that provides unparalleled operating advantages. From handset reception clarity... to automatic speaker silencing for private listening... this is truly an innovation in CB mobile radio performance. An innovation that's available only from your E. F. Johnson dealer.

Messenger® 130

CB mobile radio will never be the same again.

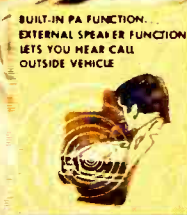

E. F. Johnson Co.

Waseca, Minnesota 56093

Excellence through half a century of experience.

rms output voltage at rated distortion is measured, squared, and divided by the resistance of the load to give the watts of output. However, the voltage provided by the power supplies of many amplifiers begins to drop rapidly as soon as a large output is required of the device, and when it finally stabilizes, it is often at a significantly lower value than it was under idle conditions. This results in a lower power-output measurement (continuous power, that is). Now, what the proponents of a music-power rating originally argued to the IIF was that the maximum output voltage of an amplifier, even if it lasts for only an instant under continuous-power testing, is significant for musical reproduction (and therefore of benefit to consumers) because music signals do not impose a steady drain on the amplifier's reserves, and thus don't drag down power-supply voltage as drastically. In other words, the maximum voltage of the supply, although unavailable for steady sine waves at full power output, is available for many types of music signal at "normal" listening levels, and thus deserves a rating.

It got one, even though it has been an occasional source of embarrassment for many, including the IIF, ever since. Ignoring audible consequences for the moment, the accepted method of measuring music power has always seemed suspicious. As noted above, it is basically the same as a continuous-power measurement, except that a highly regulated power supply that can hold maximum voltage under drain is substituted for the supply the amplifier will be sold with. Not only does this look bad, it could be interpreted as a violation of Regulation 36 (no "extraneous aids"). So many people, myself included, were pleased when first the U.S. government and then New

York City decided to ignore music power completely. But was it the right decision?

Power Ratings. Recently I participated in a listening session designed to determine whether music power can audibly benefit sound reproduction, and if so, how. (The session was an unofficial part of an IIF program now under way to devise new evaluation standards for all types of audio equipment.) These preliminary tests were carried out with an amplifier having two power supplies that could be interchanged at will. One was highly regulated so that almost no combination of load and demand could affect the voltage it provided. The other, although it exhibited the same voltage as the first supply under continuous power measurement, had a considerably higher voltage when idling. (That is, its music power rating was significantly higher than its continuous-power rating; the first supply had identical music- and continuous-power ratings.) It might also be mentioned that this second power supply was appreciably smaller and less expensive than the first.

I approached this session with ill-concealed skepticism, having always associated music power with very brief sonic phenomena (the first instant of a cymbal crash, for example)—probably too brief to be heard. However, I had failed to take into account the great variety of steady-state musical sounds that have periodic spikes in their waveforms—little glitches that can often be coped with quite handily by a power supply that would collapse quickly under sine-wave drive. I can't go into the full details of our results here. They are too sketchy to be conclusive, and they fail to consider the *duration* of music-power availability, which is probably at least as important as its mea-

FREE McIntosh CATALOG and FM DIRECTORY

McIntosh Laboratory, Inc.
East Side Station P.O. Box 96
Binghamton, N.Y. 13904
Dept. 16-5

**SEND
TODAY!**

NAME _____

ADDRESS _____

CITY _____ STATE _____ ZIP _____

Get all the news and latest information on the new McIntosh Solid State equipment in the McIntosh catalog. In addition you will receive an FM station directory that covers all of North America.



MX 113

AM FM/FM STEREO TUNER PREAMPLIFIER

CIRCLE NO. 20 ON READER SERVICE CARD

POPULAR ELECTRONICS

sured or calculated maximum value." (On that point, a Crown DC 300A in my possession not long ago proved to be able to play 22 seconds of recognizable music at reasonable levels *after being turned off*. With supply capacitors like that, the difference between music power and continuous power becomes practically insignificant.) But as slender as it is, the evidence I heard during that session has convinced me that I was wrong about music power. So, perhaps, were New York and the Federal Trade Commission.

This is the trouble with trying to legislate amplifier power: complex subjective phenomena are too difficult to pin down with measuring instruments and armchair philosophizing about what they should measure. With this trouble comes a danger, which was well expressed by one of the people present at the listening session. All performance standards, he said, should be designed to point the way toward improvement of the breed in its actual application (i.e., music listening). If not, manufacturers will ultimately be selling—and consumers paying for—"improved" products that only seem improved when tested by some complicated piece of lab gear. For example, highly regulated (stiff) power supplies have often been touted as being a desirable design feature. However, such a supply could come off a poor second when compared to an inexpensive, poorly regulated power supply that happens to better the stiffer supply in *music power*. Consider also the 60-to-10,000-Hz bandwidth demanded by New York's Regulation 36. Any pocket transistor radio with an amplifier boasting appreciable output at those frequency extremes would simply be wasting battery power since its speaker could never hope to reproduce them.

Lest I give the impression that I am against consumer safeguards in the area of audio equipment, let me applaud the FTC and the New York Consumer Affairs Dept. for chasing "instantaneous peak power" and other such abuses from the marketplace, and for bringing about a new uniformity in advertised amplifier specifications. My only concern is with the future, which will inevitably be built upon what is decreed today. Our best defense against expensive engineering with no audible benefit still rests with an informed consumership that recognizes the need for standards and also their limitations. ♦

PACE ((P)) GUARANTEES PERFORMANCE SERVICE



For Safety Sake



CB 10-2
only \$69.95 with Ch. 9



- SMALLEST SIZE AND LOW COST
- FULL 5 WATT TRANSCEIVER
- MOBILE, BASE OR PORTABLE

Here's the travel companion you don't want to leave behind. Call on Channel 9 for highway assistance anywhere in the U.S.A. Add other channels to communicate for fun and convenience after receiving your FCC license.

WRITE PACE FOR FREE
CITIZEN TWO-WAY RADIO GUIDE
OR STOP BY YOUR LOCAL...

...SIGN OF QUALITY



PACE COMMUNICATIONS
DIVISION OF PATHCOM INC.
24049 S. FRAMPTON AVE., HARBOR CITY, CA 90710

Name _____

Street _____

City _____

CIRCLE NO. 24 ON READER SERVICE CARD

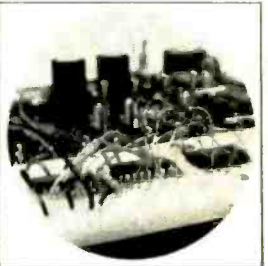
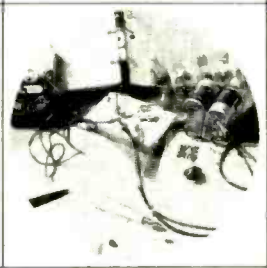
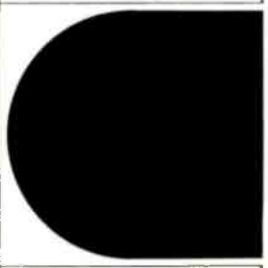
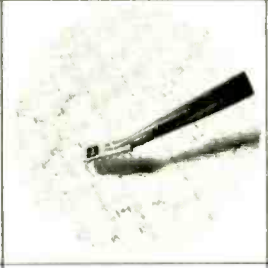
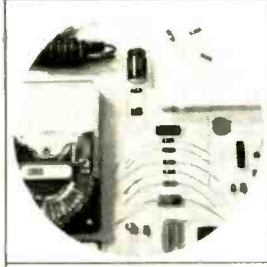
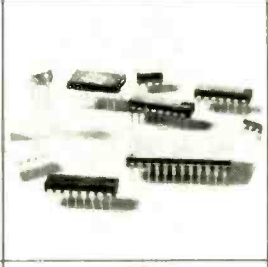
<p>Communications Engineering</p>	<p>Aeronautical & Navigational</p>	<p>Television Engineering</p>	
<p>Automatic Control Engineering</p>		<p>Missile & Spacecraft Guidance</p>	
<p>Radar & Sonar Engineering</p>	<p>Digital Communications</p>		<p>Industrial Electronics</p>
	<p>Microwave Engineering</p>		<p>Satellite Communications</p>
<p>Cable Television Engineering</p>	<p>Electronic Engineering Technology</p>	<p>Nuclear Instrumentation & Control</p>	<p>Special Programs for Electronic Engineers</p>

ADVANCED ELECTRONICS CAREER TRAINING AT HOME

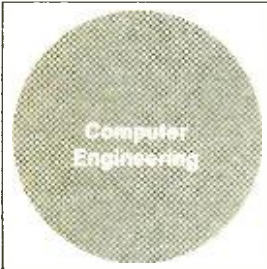

If you are too busy to go to college to learn advanced electronics, CREI brings college level training to you. CREI programs give you practical engineering training that you can apply in your work to move ahead to higher paying jobs. And CREI lets you specialize in exactly the area of electronics you want. You have a choice, depending on your qualifications, of 18 different programs.

Not only are CREI programs college-level but arrangements are available for you to earn college credit applicable to advanced degrees.

Only CREI offers you a choice of 18 programs in advanced electronics



For over 45 years CREI programs have been recognized by leading technical organizations as effective home study training in advanced electronics.

NEW OPTIONAL LAB PROGRAM



CREI now offers a supplementary ELECTRONIC DESIGN LABORATORY PROGRAM to make learning advanced electronics easier and to give you actual experience to use in your work. Only CREI offers this complete college type laboratory program. You learn to actually design electronic circuits. At the same time you get extensive experience in tests and measurements, breadboarding, prototype building and other areas important to your career.



Qualifications to Enroll. To qualify for enrollment in a CREI program, you must be a high school graduate (or equivalent). You should also be working in electronics or have previous training in this field.

Send for FREE book. If you are qualified, send for CREI's newly published book describing your career opportunities in advanced electronics. This full color book is filled with facts about career opportunities for you.



Accredited Member, National Home Study Council

CREI, Dept. E1204E
3939 Wisconsin Avenue
Washington, D. C. 20016

Rush me your FREE book describing my opportunities in advanced electronics. I am a high school graduate.

Name _____ Age _____

Address _____

City _____ State _____ ZIP _____

If you have previous training in electronics, check here

Employed by _____

Type of Present Work _____

Veterans and servicemen check here for G. I. Bill information

CREI

**CAPITOL
RADIO
ENGINEERING
INSTITUTE**

A Division of McGraw-Hill
Continuing Education Co.
3939 Wisconsin Avenue,
Washington, D. C. 20016



News Highlights

Advent to Begin Full-Scale Production of Projection TV

Some 88,000 additional square feet has been leased by the Advent Corp. to provide for the manufacture of Videobeam™ projection color TV systems. Production is initially scheduled at 5000 sets per year; estimated capacity for the new facilities is 10,000 sets per year on a single-shift basis. Initial deliveries from the new facilities are scheduled for late April. The system, which sells for \$2500, receives conventional TV programs or other video sources and displays them on a screen 4¼ feet high by 5¾ feet wide. The floor-standing receiver/-projector is positioned 8 feet from the screen.

Britain's Booming Hi-Fi Market

In spite of Britain's economic woes, the country is now one of the fastest-growing export markets for audio electronics of all kinds. Sales of hi-fi tuners, amplifiers and receivers there increased by an estimated 60 percent in the last year, a faster rate of growth than in most other countries, and imports accounted for a dominant share of the increase. Imports to Britain now account for 70 percent of the \$42 million British hi-fi electronics market. Japan is by far the biggest source of imports, but the US, West Germany, Denmark, the Netherlands and other Western European countries make a large contribution. Above are among the conclusions of a new report by a British company specializing in market research.

New Small, Low-Profile Readouts



A new "flat pack" vacuum fluorescent readout, the Digivac 2000, has been developed by the Tung-Sol Division of Wagner Electric Corp. The 2000 is available in a rectangular, low-profile package and its low-voltage, low-current requirements make it compatible with all MOS IC logic units. The readouts come in either one- or three-digit packages with flexible language (alpha/numerical-symbolic). The cathodoluminescent readout has a broad color spectrum, which, with filters, offers virtually any visible hue.

EIA Requests Phase IV Exemption for Semiconductors

A petition to exempt semiconductors and related devices from Phase IV regulation has been filed with the government by the Electronic Industries Association's Solid State Products Division. EIA pointed out that the semiconductor industry has been characterized by declining prices and increased productivity resulting in non-inflationary behavior. The government was told that the price elasticity of semiconductors and the industry's continued technological advancement are self-regulating factors which will insure future non-inflationary behavior.

Take a leaf from the Mallory Money Tree and save on famous Mallobins.[®]

Our Mallobin benchtop organizers are worth many times their modest cost in keeping electronic components neatly sorted, labeled, protected and ready for use. Now, you can save on buying them, too. For

instance, this PTC semiconductor Mallobin organizer can be purchased at a special discount at your Mallory Distributor. Just present the Mallory Money Tree coupon below.



MALLORY

MALLORY DISTRIBUTOR PRODUCTS COMPANY
 a division of P. R. MALLORY & CO. INC.
 Box 1284, Indianapolis, Indiana 46206; Telephone: 317-636-5353

Batteries • Capacitors • Controls • Security Products • DURATAPE[®] • Recorders • Resistors • SEMICONDUCTORS • SONALERT[®] • Switches • Timers



DURATAPE[®] and SONALERT[®] are registered trademarks of P. R. Mallory & Co. Inc.

Money Tree Coupon

This coupon valid through Sept. 1, 1974. Only one coupon valid on each purchase. This coupon not valid where prohibited or taxed by law. Coupon does not apply to sales tax, if applicable.

TO MALLORY DISTRIBUTOR

This coupon redeemable for \$1.00 credit towards the purchase of any Mallory products or \$1.00 in cash provided it is tendered to Mallory Distributor Products Company, a division of P. R. Mallory & Company Inc., Indianapolis, Indiana prior to Oct. 1, 1974. Invoices showing purchase of Mallobin organizers sufficient to cover coupon must be shown on request.

Worth
\$100
 OFF
 on any purchase of any Mallory Mallobin organizer at a Mallory Distributor.

PE-44

CIRCLE NO. 22 ON READER SERVICE CARD

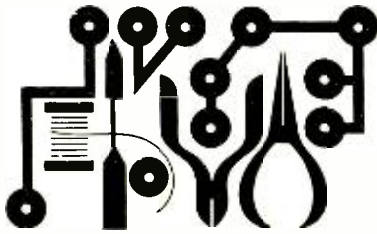

Hobby Scene

Checking on the Energy Crisis

Q. *With the utilities cutting their power due to the energy crisis, I keep wondering just what my line voltage is. However, my VOM is needed for other purposes—besides it is difficult to read minor changes in the power-line voltage. What would you suggest?*

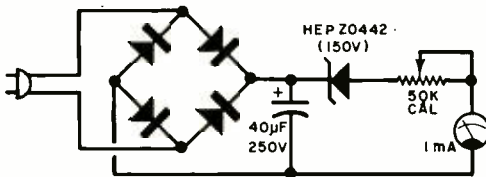

A. Try the 115-to-125-volt power line monitor shown above. Calibration is performed by using an accurate ac meter. The scale on the 1-mA meter can be redrawn to fit. Any type of silicon rectifier diode can be used in the bridge.

CB Antenna for the Camp

Q. *During the summer, I want to use my CB rig in camp. However, I don't want to take my base-station antenna along since transporting that metal monster would present a problem. Isn't there some reasonably efficient antenna I can use that would go in the trunk of the car?*

A. There are several ways you can solve this problem. One is to use one of those small commercial whips that do not take up much room and can easily be put in a car trunk. You can also make up a really small antenna by constructing a dipole out of two 104-inch lengths of wire (any type, including conventional electrical "zip" cord that has been separated into two independent lines) and some ordinary antenna insulators. Use a length of 72-ohm coaxial line as the feeder to the rig. The slight mismatch between the 72-ohm antenna and transmission line and

the nominal 50-ohm output of the conventional CB rig will not make much difference. The coaxial cable is soldered across the center insulator, while the two end insulators can be suspended from anything that sticks up high enough above the ground so that passing people will not run into them.

Turning on a Tone Generator

Q. *I have built several audio oscillators, some for code practice, and some for door alarms. The only problem I have is connecting them to a remote switch of some type so that the tone generator can be turned on with the application of a signal. Any ideas on this?*

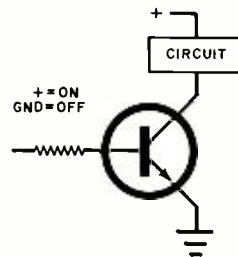

A. The circuit shown here is a simple series switch using an npn transistor. Disconnect the power source from the circuit common and connect the collector to the ground of the circuit. Connect the emitter to the power supply common. When the base of the switching transistor receives a positive-going signal, it saturates and turns on the audio oscillator. The base resistor can be any value from 1000 ohms up. If you want to have some fun, try connecting this circuit to various points in a digital countdown chain.

Have a problem or question on circuitry, components, parts availability, etc.? Send it to the Hobby Scene Editor, POPULAR ELECTRONICS, One Park Ave., New York, NY 10016. Though all letters can't be answered individually, those with wide interest will be published.

THERE'S A BETTER WAY TO GO.



Energy shortages tell us we have to change our driving style. Now! It doesn't mean we have to go back to horse and buggy days. But it does mean we have to make every drop of gas give us the most go for our money. Anyone with horse sense knows that a well-tuned car gets better mileage, and in times of fuel shortages, better mileage means a lot.

The Mark Ten B Capacitive Discharge System keeps your car in better tune so it burns less gas. Using Mark Ten B is more than horse sense. It's the smart move under the hood, helping a nation survive an energy crisis and keeping you on the road. Delta Mark Ten. The best way to go.



DELTA PRODUCTS, INC.

P.O. Box 1147, Dept. PE
Grand Junction, Colo. 81501
(303) 242-9000

Please send me free literature.

Enclosed is \$ _____ Ship ppd. Ship C.O.D.

Please send: Mark Ten B assembled @ \$59.95 ppd. Mark Ten B Kit @ \$44.95 ppd. (12 volt negative ground only) Standard Mark Ten assembled. @ \$44.95 ppd. 6 Volt: Neg. Ground Only 12 Volt: Specify Pos. Ground Neg. Ground Standard Mark Ten Deltakit* @ \$29.95 ppd. (12 Volt Positive or Negative Ground Only)

Car Year _____ Make _____

Name _____

Address _____

City/State _____ Zip _____

CIRCLE NO. 11 ON READER SERVICE CARD

THE RIGHT PICKERING CARTRIDGE FOR YOUR EQUIPMENT IS THE BEST CARTRIDGE MONEY CAN BUY.

They feature low frequency tracking and high frequency tracing ability!*

DISCRETE 4 CHANNEL

UV-15 2400 Q
DCF 2400

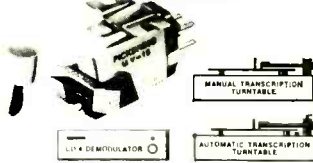

UV-15 2000 Q
DCF 2000

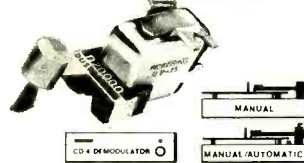

STEREO AND MATRIX

XV-151200E
DCF 1200

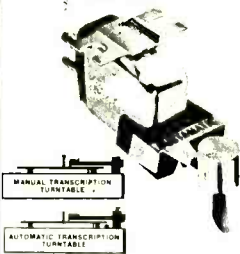

XV-15750E
DCF 750

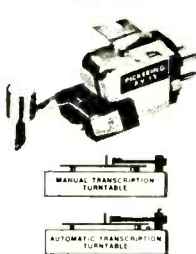

XV-15400E
DCF 400



XV-15350
DCF 350



XV-15200E
DCF 200

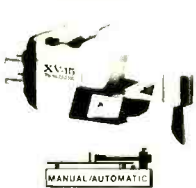

XV-15150
DCF 150



XV-15140E
DCF 140

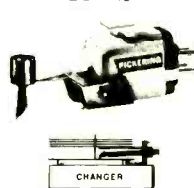

XV-15100
DCF 100

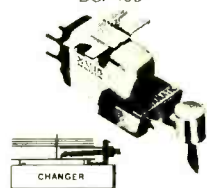

Pickering offers you "The Best of Both Worlds" in DISCRETE 4-channel and in STEREO cartridges. These cartridges have been specifically designed and engineered not only to peak specifications and performance characteristics, but also to achieve total compatibility with *your music system* to help you get the most out of it.

Only Pickering has developed a way for you to be absolutely certain you select the "right" cartridge for *your music system*. We did it first for STEREO by developing our Dynamic Coupling Factor rating system—DCF for short—which identifies pick-up performance in terms of a quantitative measurement. The value of a DCF rating lies not only in its merit to define low frequency tracking ability but also in its measure as an index of *high frequency* (8 to 50 kHz) *tracing ability*. Pickering's DCF-rated pick-ups have exceptional *high frequency tracing characteristics*, vital for both STEREO and DISCRETE 4-channel performance. The Pickering cartridge exactly

"right" for maximum performance with your equipment is simple to select because of this rating method.

Now, Pickering is also applying application engineering techniques and DCF ratings to its DISCRETE cartridges. They fulfill the stringent requirements necessitated by the sophisticated nature of discrete discs.

So, whether STEREO or DISCRETE is your preference, choose from "The Best of Both Worlds" the Pickering cartridge exactly right for your equipment.

For further information write to Pickering & Co., Inc., Dept. E 101 Sunnyside Blvd., Plainview, New York 11803

**traceAbility—T.M.*



"for those who can hear the difference"

CIRCLE NO. 25 ON READER SERVICE CARD

AT LAST!



A low-cost, fully professional ASCII KEYBOARD AND ENCODER you can build



Using only two IC's, this simple-to-build alphanumeric system can be your springboard to many sophisticated applications

BY DON LANCASTER

MANY advanced electronic projects start with an alphanumeric keyboard. The difficulty is in finding one that is reasonable in cost, reliable in use, and equipped with the proper 7- or 8-bit parallel ASCII code. (See box.) This is particularly true if it is

to be used with computer circuits, a calculator, ham RTTY equipment, video titling, etc. Commercial keyboards of this type are very expensive and hard to find. Surplus keyboards are limited in availability and usually have encoders and keytops that may

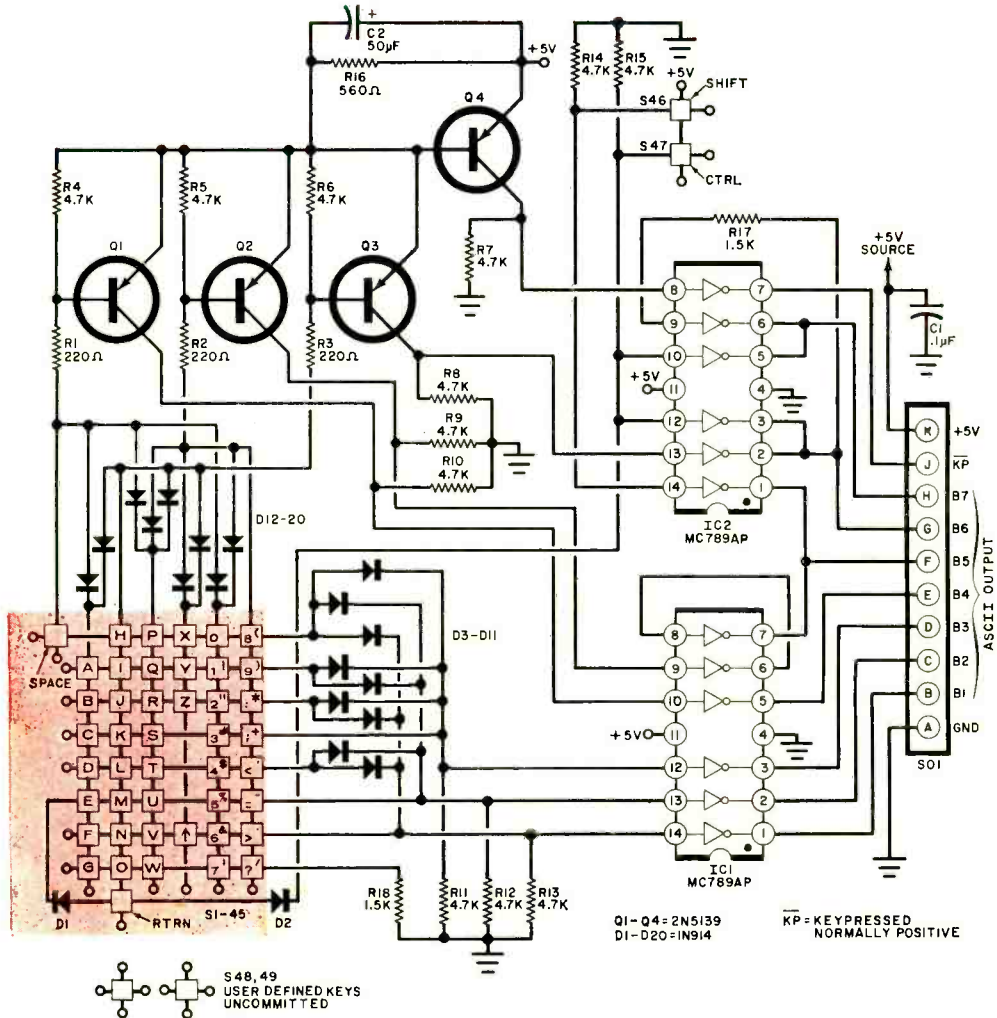

Fig. 1. The 48 keys are arranged in a 6-by-8 matrix as shown in block at lower left. The encoder, Q1 through Q4 and IC1 and IC2, provides the proper output.

PARTS LIST

C1—0.1- μ F, 10-volt disc ceramic capacitor
 C2—50- μ F, 10-volt electrolytic capacitor
 D1-D20—1N914 diode
 IC1, IC2—MC789AP hex inverter (no substitute)
 Q1-Q4—2N5139 transistor
 R1-R3—220-ohm, $\frac{1}{4}$ -watt resistor
 R4-R15—4700-ohm, $\frac{1}{4}$ -watt resistor
 R16—560-ohm, $\frac{1}{4}$ -watt resistor
 R17, R18—1500-ohm, $\frac{1}{4}$ -watt resistor
 S1-S49—Keyswitches (Mechanical Enterprises LFW-CT)
 SO1—Socket (Molex 09-52-3103)

Misc.—Keypots (two-shot molded) (shift and return are $1\frac{1}{2}$ width); spacebar with equalizer and #2-56 mounting hardware; pc board (see text); #6 mounting hardware; solder; etc.

Note—The following are available from Southwest Technical Products, 219 W. Rhapsody, San Antonio, TX 78216: actual-size pc foil patterns and component installation diagram free on request; pc board, etched and drilled #Kb at \$17.50; complete kit of all parts #KBC at \$39.50 plus postage for 3 lb.

not be compatible with modern circuits.

Here is a brand-new, fully professional, alphanumeric typewriter-style keyboard that you can build yourself for less than \$40 and uses only two IC's (readily available) for its integral ASCII encoder and debouncer. Thus, it's both simple to build and inexpensive. The output is directly compatible with TTL, DTL, RTL, CMOS, and PMOS integrated circuits.

The 49 keys provide all the upper-case alphabet, numbers, punctuation, spacing, and transparent or control commands. Two of the keys are uncommitted, which means they can be used for any purpose, either with or without the rest of the encoder circuit. Except for some punctuation which is seldom used, the design follows very closely the ANSI keyboard. It is easily made compatible with such popular industrial equipment as the ASR-33 Teletype®.

High-reliability modular keyswitches duplicate the full typewriter travel and tactile feedback. The two-shot molded keytops are identical to those found on quality office typewriters. The spacebar has an equalizer so that it travels smoothly, regardless of where it is depressed. Power needs are +5 volts at under 100 mA.

About the Circuit. The 48 single-contact, normally open keys are arranged in a matrix 8 keys high by 6 keys wide (Fig. 1). Some of the little-used keys are omitted from the matrix. When a key is depressed, it shorts the wires beneath it.

The "8" side of the matrix goes to a diode encoder (D3-D11) and an integrated circuit (½ of IC1) that generates the least significant three bits of the ASCII code (B1, B2, and B3).

The "6" side of the matrix goes to a diode encoder (D12-D20) and transistors (Q1-Q4) that sense which section of the matrix has been selected by a key. When any key is pressed, the signal is sensed by Q4 and passed on to IC2 as a key-pressed output, while Q1 through Q3 set up the upper, or most significant, four bits of the code, producing B4, B5, B6, and B7. Key actuation is logically combined with a shift key and a control key to handle the machine commands and the punctuation-numeral shifts.

The spacebar and carriage return key do two things at once. Space is a "shifted zero," while carriage return is a "control M." The spacebar is electrically the same as any other key. The eighth ASCII bit can be optionally

picked up with an external IC parity generator (such as a 74180); but this feature is seldom used in experimental or small-scale circuits. Capacitor C2 provides a delay of a few milliseconds so that the code is up and valid before the key-pressed common signal is sent.

Construction. The complete keyboard is assembled on a single, double-sided pc board. Since the two foil patterns are too large to be reproduced here, they are available *free* from the source given in the Parts List.

Adequate mechanical support for the board is essential. It should be backed with a similar-size blank board (or an insulating layer) mounted on a metal plate. The best operation angle is with a slight slope down from the top—about 10 or 15 degrees. If more response is needed on the spacebar, booster springs can be added to each equalizer post.

Testing. Ground terminal A of SO1 and connect a 100-mA meter to the +5-volt line. Briefly connect the metered 5-volt line to terminal K of SO1 and note that there is a current of about 30 mA.

Connect a dc voltmeter (5-volt range) to terminal J of SO1 and note that there is a high level there. If it is low, recheck the key matrix for shorts.

Using the ASCII code as a guide, depress

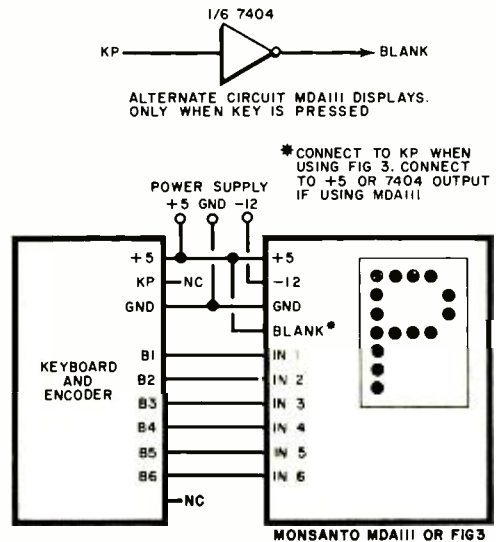

Fig. 2. One possible output display for the keyboard uses a Monsanto MDA111 readout

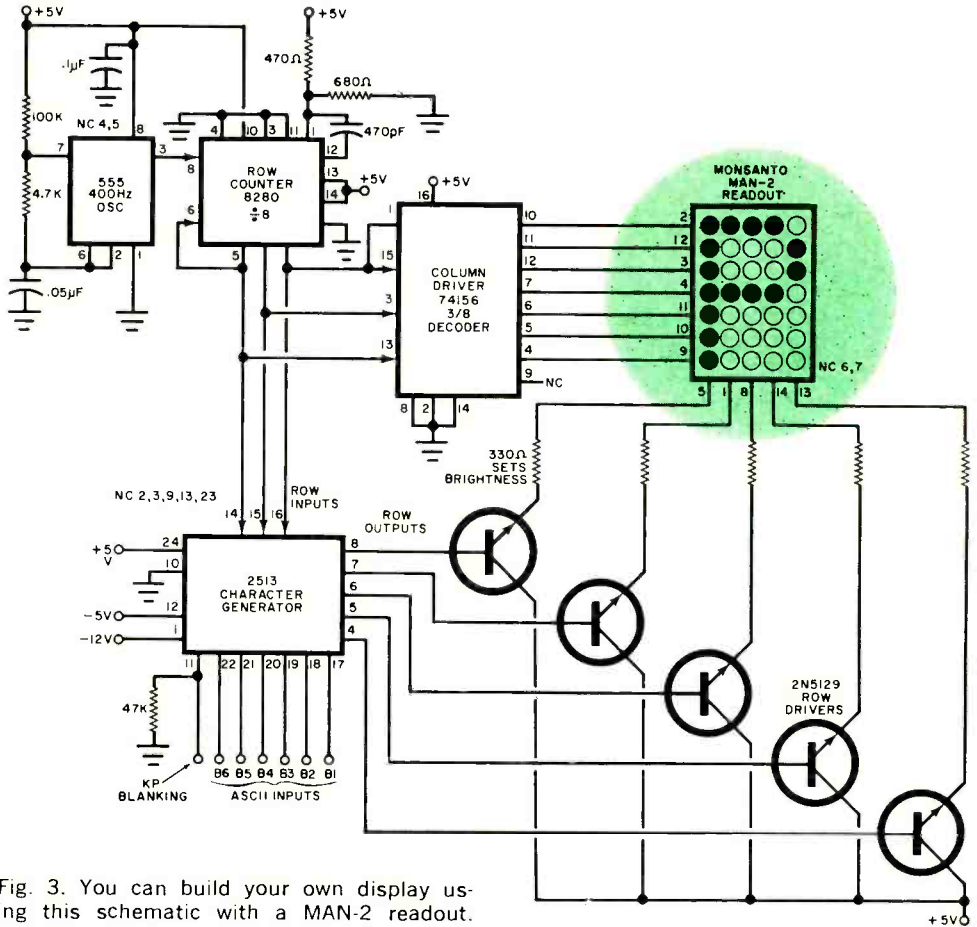

Fig. 3. You can build your own display using this schematic with a MAN-2 readout.

one key at a time and check for the correct output code at the B1 through B7 outputs of SO1. If you have access to an instrument that "speaks" ASCII, you can make an actual use test.

Use. The keyswitches are inherently low in noise and, combined with the delay in C2, provide enough debouncing for the majority of experimental applications. Only the leading edge of the key-pressed command is debounced. This leading edge should be used to enter data into the system. A more sophisticated system might use an 8-bit latch to store the entire code word until the rest of the circuit could use it.

The key-pressed output is normally high and drops to ground if one or more keys are pressed. Codes other than ASCII can be created by rewiring the pc board. The parallel code output can be converted to

serial form by using a shift register such as a 74165 or 2536 UART.

The two uncommitted keys (S48 and S49) can be tied to the encoder for extra commands or used separately for local or remote controlling.

Obviously, the keyboard has to be connected to something else to make it useful. For example, a Monsanto MDA111 alphanumeric display can be connected to the keyboard as shown in Fig. 2. To make your own single-character display (at lower cost), build the circuit shown in Fig. 3.

Some immediate and obvious applications of this one-character computer terminal are as a touch-typing teaching aide; as a means of communication for a deaf or handicapped person; as a pre-school lettering and spelling machine; for keyboard monitoring; for film annotation; as a secure communications loop (with bits of the ASCII code scrambled and

BIT NUMBERS																
								0	0	0	0	1	1	1	1	
								0	0	1	0	1	0	1	0	1
b7	b6	b5	b4	b3	b2	b1	COLUMN	0	1	2	3	4	5	6	7	
↓	↓	↓	↓	↓	↓	↓	ROW ↓									
			0	0	0	0	0	NUL	DLE	SP	0	@	P	\	p	
			0	0	0	1	1	SOH	DC1	!	1	A	Q	a	q	
			0	0	1	0	2	STX	DC2	"	2	B	R	b	r	
			0	0	1	1	3	ETX	DC3	#	3	C	S	c	s	
			0	1	0	0	4	EOT	DC4	\$	4	D	T	d	t	
			0	1	0	1	5	ENO	NAK	%	5	E	U	e	u	
			0	1	1	0	6	ACK	SYN	&	6	F	V	f	v	
			0	1	1	1	7	BEL	ETB	'	7	G	W	g	w	
			1	0	0	0	8	BS	CAN	(8	H	X	h	x	
			1	0	0	1	9	HT	EM)	9	I	Y	i	y	
			1	0	1	0	10	LF	SUB	*	:	J	Z	j	z	
			1	0	1	1	11	VT	ESC	+	;	K	[k	{	
			1	1	0	0	12	FF	FS	,	<	L	\	l		
			1	1	0	1	13	CR	GS	-	=	M]	m	}	
			1	1	1	0	14	SD	RS	.	>	N	^	n	~	
			1	1	1	1	15	SI	US	/	?	O	-	o	DEL	

WHAT IS ASCII?

ASCII is a standard 8-bit information interchange code, which is used with virtually every computer and data base system. It is essential as an input to such integrated-circuit character-generation systems as the Signetics 2513. ASCII is a machine language. It should not be confused with such programming languages as "Basic," "Fortran," "PLI," "APL," etc. All of the alphanumeric communications between machines using any of these programming languages are really nothing but a group of ASCII coded commands.

The eighth bit of the code is often a 1 all the time, though some systems use the eighth bit for parity or error testing. The remaining seven bits provide 128 possible different codes or characters. Of these, 32 are allocated for the upper-case alphabet and some are often used for punctuation. Another 32 are used for numbers, spacing, and other punctuation. Assigned but very rarely used is a third group of 32 for lower-case alphabet

and little-used punctuation. Finally, the remaining 32 possible codes are "transparent" or machine commands, called control or CTRL commands. They never appear in print, but they handle the sequencing of machinery at both ends. A carriage return (CR) is a typical machine command. If only upper case alphanumeric are needed, only six of the eight bits of the code are used. This is called the ASCII-6 code.

The complete code is shown above. The first four bits are read from the left—the remaining three from the top. For instance "H" is 100-1000. A carriage return command is 000-1101, and a 7 is 011-0111. Note that the bottom four number bits are identical to the four-bit binary (BCD) code. By the same token, if the serial form of the ASCII is used with a start bit and two stop bits added, the result is the 11-bit Teletype code such as that used on an ASR-33.

ASCII can be used in parallel form (all bits at once) or serial form (one bit at a time, least, or B1 significant bit first.)

inverted on either end); or as an annunciator or electronic catalog.

On a more ambitious scale, the keyboard can be used as a computer timesharing terminal, either in commercial service or for home or school. The keyboard, with a simple parallel-to-series converter, forms half of

an ASR-33 Teletype at a very reasonable cost.

Other applications include programmable calculators, ham RTTY transmission, videotape and TV titling and annotation, electronic editing and page composition, and data search and retrieval systems. ♦



MULTIPLIER

BOOSTS SW SELECTIVITY & GAIN

Add this low-cost accessory to your shortwave receiver and enjoy more stations with greater clarity

BY JOE A ROLF

IF YOU are using a typical medium-priced shortwave receiver, chances are you need more gain and better selectivity to separate the stations on the crowded SW bands. Before you make the decision to trade in your receiver for a newer, "hotter" one, consider adding a Q multiplier; it is relatively inexpensive and just might save you a lot of money.

The reason most medium-priced SW re-

ceivers are far from ideal for serious SW listening is that they are designed with i-f bandwidths of between 5 kHz and 10 kHz. This is okay for good performance on the relatively uncluttered AM broadcast band, but on shortwave, where stations operate almost on top of each other, such a broad i-f bandwidth is often less than satisfactory. So, for a receiver that lacks a narrow i-f bandwidth, the Q multiplier can prove a

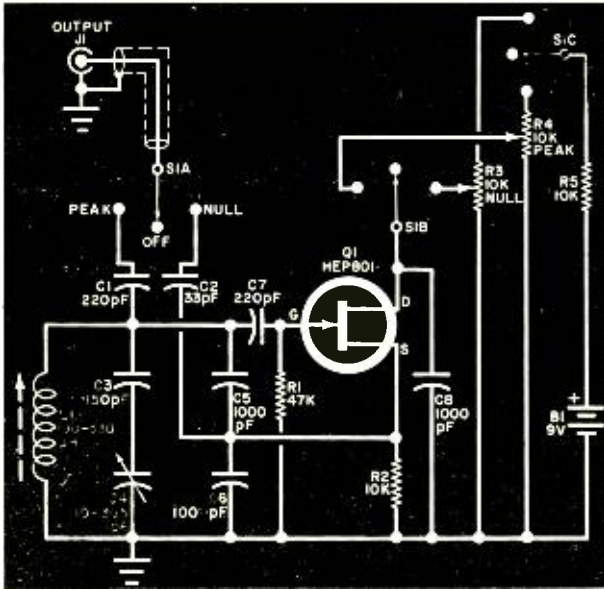

Fig. 1. The circuit is essentially a Colpitts oscillator which is adjusted by R3, R4.

PARTS LIST

B1—9-volt battery
 C1, C7—220-pF polystyrene capacitor
 C2—33-pF polystyrene capacitor
 C3—150-pF polystyrene capacitor
 C4—10-365-pF tuning capacitor (Archer No. 272-1341, or equivalent)
 C5, C6—1000-pF polystyrene capacitor
 C8—1000-pF ceramic disc capacitor
 J1—Phono jack
 L1—190-330- μ H miniature adjustable choke (J.W. Miller No. 4565, or equivalent)

Q1—HEP801 (Motorola) field-effect transistor
 R1—47,000-ohm, $\frac{1}{4}$ -watt resistor
 R2, R5—10,000-ohm, $\frac{1}{4}$ -watt resistor
 R3, R4—10,000-ohm miniature potentiometer (Mallory No. MLC14L or similar)
 S1—Three-pole, three-position non-shorting rotary switch (Calectro No. E2-168 or similar)
 Misc.—Metal chassis box; printed circuit or perf board with solder clips; battery connector; phono jack (for receiver); phono plugs (2); shielded cable; etc.

valuable accessory for shortwave tuning.

The Q multiplier described here is designed around a single field-effect transistor to provide the equivalent gain of an extra i-f stage. Additionally, it doubles as a bfo. Best of all, it can be built for less than \$20.

Theory of Operation. The schematic diagram of the Q multiplier is shown in Fig. 1. The circuit consists of a simple 455-kHz Colpitts oscillator that can be adjusted in and out of oscillation by R3 and R4. A field-effect transistor is used for Q1 to provide a high impedance to the tuned circuit consisting of L1 and C3 through C6.

When the circuit oscillates, the Q (selectivity) of the tuned circuit is determined primarily by the components used. However, when the oscillator is adjusted to a regenerative point just below oscillation, component losses are offset by feedback,

and the selectivity rises to many times the normal value. If the oscillator (Q multiplier) were connected in parallel with a 455-kHz i-f transformer in a receiver, the selectivity of the transformer would also be greatly increased.

In Fig. 2 is shown a typical i-f response curve for a medium-priced SW receiver and the effect a Q multiplier has on selectivity. The i-f bandpass of the receiver is reduced to a fraction of the original by the Q multiplier. Since the multiplier is tunable, it can be used to peak any signal in the original bandwidth.

By connecting the Q multiplier in a slightly different manner, the i-f response can be left unaltered except for a very sharp adjustable notch. Used in this manner, the circuit can tune out or null unwanted signals.

Since both the peak and the null functions are desirable, the Q multiplier has been designed to operate in either mode, simply

by flipping selector switch *SI*. A small 365-pF tuning capacitor (*C4*), trimmed by *C3*, tunes the circuit across the receiver's i-f bandpass. When neither the peaking nor nulling function is needed, the Q multiplier can also be switched out of the circuit and the receiver is on its own.

Construction. The Q multiplier can be assembled in any metal chassis box large enough to accommodate it. A box with a front-panel area measuring roughly 2½" high by 3½" wide and a depth of about 4", such as the Archer No. 270-251 from Radio Shack, will be suitable.

Since the circuit of the Q multiplier is very simple, perforated phenolic board and solder clips can be used for mounting most of the parts. Alternatively, you can design and make your own printed circuit board.

Mount *B1* on the bottom of the chassis, close to the rear wall. On the rear wall itself goes *J1*. The front panel should have mounted on it *NULL* and *PEAK* controls *R3* and *R4*, *MODE* switch *SI* (with appropriate position legends), and *TUNE* capacitor *C4*. Coil *L1* should be mounted on the board assembly in such a manner that its slug adjustment is readily accessible.

To simplify hookup to your receiver, it is a good idea to mount a phono jack on its rear apron and use a length of shielded cable to interconnect the jack and first i-f transformer as shown in Fig. 3. (Note: ground this cable only at the jack.)

Finally, solder phono plug to the ends of a length of Belden No. 8421, or equivalent, low-capacitance shielded cable. This cable should be as short as possible, preferably less than 24 inches.

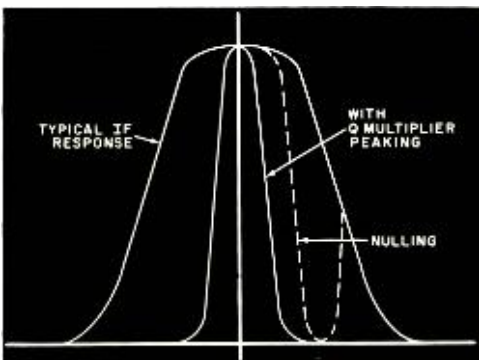

Fig. 2. Waveforms show effect of Q multiplier on i-f response of medium-priced receiver.

In Use. To put the Q multiplier into operation, connect it to the receiver with the shielded cable. Turn on your receiver and tune to a quiet spot on the AM broadcast dial. Set the Q multiplier to *PEAK*. With *C4* (*TUNE*) set to mid-position and *PEAK* control *R4* fully clockwise, tune *L1* until you hear a signal. If the Q multiplier is tuned to the receiver's i-f, the signal will be heard continuously across the AM band, with a beat note when you tune across a broadcast

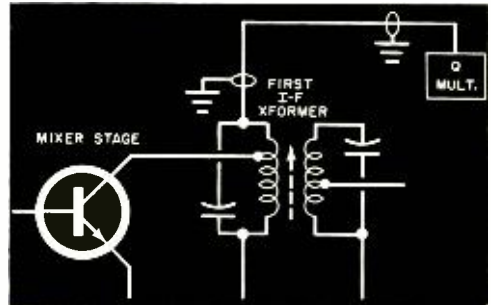

Fig. 3. Diagram shows how to connect the Q multiplier into your receiver using coax.

station. In this mode, the Q multiplier can be used as a bfo.

Switch to *NULL* and rotate the *TUNE* knob until a signal is again heard with the *NULL* control fully clockwise. (The setting of *C4* in the *NULL* and *PEAK* positions of the *MODE* switch will be slightly different, in which case it may be necessary to make a compromise adjustment of *L1* to get both to fall as near the center of the *TUNE* capacitor's setting as possible.) Finally, set the Q multiplier to a point below oscillation and peak the i-f transformer to which it is connected as needed.

It takes a little practice to learn how to use a Q multiplier efficiently if this is the first time you have used one. Adjusting the *PEAK* control clockwise increases selectivity and decreases i-f bandwidth. Greatest selectivity occurs just before oscillation, indicated by a ringing sound when the receiver is tuned across a signal.

When in *NULL*, the notch is made sharper as the *NULL* control is turned clockwise, and a very noticeable drop in signal will be heard when the Q multiplier is tuned to an unwanted signal. A little practice at the controls will enable you to peak or null any signal you hear for best reception. ♦

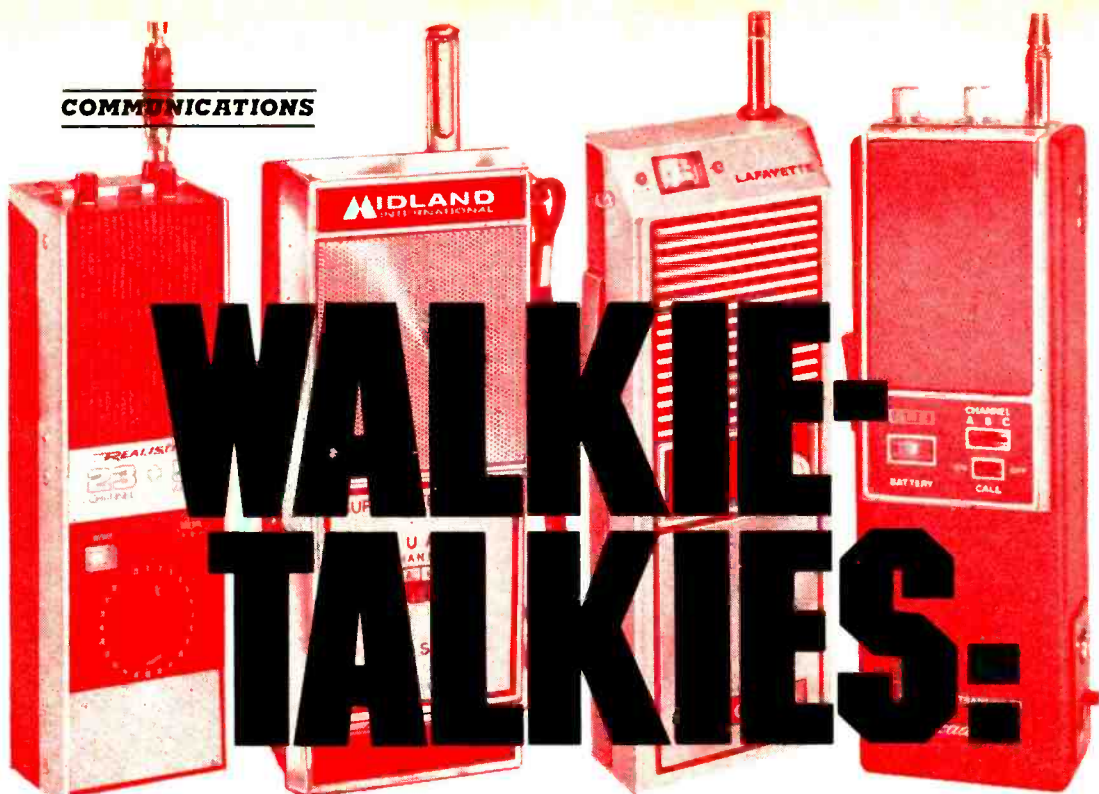

SOMETHING FOR EVERYONE

BY HERB FRIEDMAN

CHILDREN eagerly look forward to getting a toy walkie-talkie for Christmas or birthday presents. To their big brothers, those walkie-talkies aren't toys but indispensable units for things like relaying football plays from the stands to the high-school teams. On the top of the heap with much better w-t's are the CB'ers involved in REACT and Rescue Team programs where the compact communicators can prove invaluable over relatively short distances. And outside workers have adopted the w-t as their principal "no-wire" communication system.

The CB walkie-talkie which began life as a plaything for children has grown into the most popular communication device of the day. The reason for the popularity of the relatively low cost w-t that operates on the CB frequencies is due to there being a model almost tailor-made for any applications. Whether you are looking for a cheap present for a child, a tone-controlled radio tripper device for woodland photography, or a pocketful of power for search-and-rescue operations, there is a CB w-t to fill your need.

Low-Cost W-T's. The basic CB walkie-talkie, priced at less than \$20, is usually a three- or four-transistor device with a super-regenerative receiver and a simplified single-frequency, crystal-controlled transmitter. Its power input is generally stated at a nominal 100 mW, making it license-free (anyone can use it), although the actual input might be as low as 20 mW, providing a dependable range of only two or three city blocks.

The superregenerative receiver, noted for a sensitivity almost the equal of a good superheterodyne receiver, is also noted for its poor selectivity. The less-than-\$20 w-t might well receive every signal frequency on the Citizens Band, regardless of the frequency to which it is tuned. Still, the least expensive w-t does make a desirable gift for children. But for more serious work, one inevitably must look to more expensive models.

Moving up the ladder to the \$25-\$50 range, you will find 100-mW models that are really useful. Featuring superhet receivers and fully modulated 100-mW transmitters, these w-t's serve a very useful purpose
(Continued on page 40)



This important job (and its big income) is reserved for a qualified electronics technician. It can be you!

It's a fact. There are *thousands* of jobs like this one available *right now* for skilled electronics technicians. What's more, these men are going to be in even *greater* demand in the years ahead. But how about you? Where do you fit into the picture? Your opportunity will never be greater... so act *now* to take advantage of it. The first step? Learn electronics fundamentals... develop a practical understanding of transistors, trouble-shooting techniques, pulse circuitry, micro-electronics, computers and many other exciting new developments in this growth field. Prepare yourself now for a job with a

bright future... unlimited opportunity with lasting security... prestige and a steadily growing paycheck.

Cleveland Institute of Electronics courses have been stepping stones to good jobs in electronics for thousands of ambitious men. Why not join them? You can learn at home, in your spare time, and tuition is remarkably low. Read the important information on the facing page. Then fill out and mail the reply card or coupon today. We'll send you all the details and for your convenience, we will try to have a representative call. Act now... and get your high-paying job just that much sooner.

How You Can Succeed In Electronics ... Select Your Future From Seven Career Programs

The "right" course for your career

Cleveland Institute offers not one, but seven different and up-to-date Electronics Home-Study Programs. Look them over. Pick the one that is "right" for you. Then mark your selection on the reply card or coupon and mail to-day. In a few days you will have the complete details.

1A. Electronics Technology

A comprehensive program covering Automation, Communications, Computers, Industrial Controls, Solid-State Devices, and preparation for a 1st Class FCC License.



1B. Electronics Technology with Laboratory

Includes all areas of Course 1A including 1st Class FCC License preparation. In addition, student receives 161-piece Electronics Laboratory and 17 "lab" lessons for "hands-on" experience.

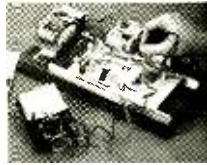

2. Broadcast Engineering

Here's an excellent studio engineering program which will get you a 1st Class FCC License. Now includes Video Systems, Monitors, FM Stereo Multiplex, Color Transmitter Operation and Remote Control.



3. First Class FCC License

If a 1st Class FCC ticket is your goal, this streamlined program will do the trick and enable you to maintain and service all types of transmitting equipment.

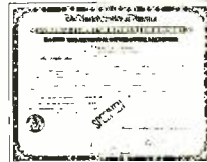

4. Electronic Communications

Mobile Radio, Microwave and 2nd Class FCC preparation are just a few of the topics covered in this "compact" program. Highly recommended for jobs with telephone companies.



5. Industrial Electronics & Automation

This exciting program includes many important subjects such as Instrumentation, Solid-State Devices used in Pulse, Digital and power controls.



6. Electronics Engineering

A college-level course for men already working in Electronics... covers Steady-State and Transient Network Theory, Solid-State Physics and Circuitry, Pulse Techniques, Computer Logic and Mathematics through Calculus.



An FCC License... or your money back!

The CIE courses described here will prepare you for the FCC License specified. In fact, we are so certain of their effectiveness we offer this Money Back Warranty when you complete any CIE licensing course you'll be able to pass your FCC exam or be entitled to a full refund of all tuition paid. This warranty is valid during the completion time allowed for your course. You get your FCC License or your money back.

CIE's AUTO-PROGRAMMED Lessons help you learn faster and easier

Cleveland Institute uses the new programmed learning approach. Our Auto-Programmed Lessons present facts and concepts in small, easy-to-understand bits... reinforce them with clear explanations and examples. Students learn more thoroughly and faster through this modern, simplified method. You, too, will absorb... retain... advance at your own pace.

Employment Assistance available for all CIE students... at no extra cost

Once enrolled with CIE you will get a bimonthly listing of high-paying, interesting jobs available with top companies throughout the country. Many CIE graduates hold such jobs with leading companies like American Airlines, AT&T, General Electric, General Telephone and Electronics, IBM, Motorola, Penn Central Railroad, Raytheon, RCA, Westinghouse and Xerox... to name a few.

CIE Lessons are continually up-dated

All lesson books and materials from CIE are continually revised or replaced according to the current needs of industry and the rapidly advancing and changing state of the art.

Approved Under G.I. Bill

All CIE career courses are approved for educational benefits under the G.I. Bill. If you are a Veteran or in service now, check box for G.I. Bill information.

CIE Cleveland Institute of Electronics, Inc.

1776 East 17th Street, Cleveland, Ohio 44114
Accredited Member National Home Study Council

Mail coupon for 2 FREE BOOKS

Cleveland Institute of Electronics, Inc.

1776 East 17th Street, Cleveland, Ohio 44114

Please send me your two FREE books:

1. Your school catalog, "Succeed in Electronics"
2. Your book on "How To Get a Commercial FCC License"

I am especially interested in:

- | | | |
|---|--|--|
| <input type="checkbox"/> Electronics Technology | <input type="checkbox"/> Broadcast Engineering | <input type="checkbox"/> Electronic Communications |
| <input type="checkbox"/> Electronics Technology with Laboratory | <input type="checkbox"/> First Class FCC License | <input type="checkbox"/> Industrial Electronics & Automation |
| | <input type="checkbox"/> Electronics Engineering | |

Name _____ Age _____
(please print)

Address _____

City _____ State _____ Zip _____

Veterans and Servicemen:

Check here for G.I. Bill information

PE-57

CIRCLE NO. 8 ON READER SERVICE CARD

for short-range work. The transmitter and receiver sections are crystal controlled, and some means is provided for easily changing crystals.

The receiver generally contains an r-f preamplifier and a 455-kHz i-f amplifier. The i-f section can provide as much selectivity as can be expected of an inexpensive 5-watt base or mobile CB rig. Models near the top of the price range often feature an extra stage of i-f amplification, or a ceramic or mechanical filter, for more selectivity to yield performance that approaches that of the better single-conversion 5-watt transceivers.

Unlike the superregen w-t's that usually use small 9-volt batteries with average lives of 2-4 hours, the low-cost superhet w-t uses some type of "penlight" battery, whether it is throw-away or rechargeable being left up to the user. Depending on the type of battery used, you can expect anywhere from 20 to 50 hours of dependable service before it must be replaced or recharged.

A full 100-mW input power w-t will have a reliable range of about one mile in open country, less in areas where the terrain is interrupted by hills, buildings, etc. One important advantage of these units is that they can be used at relatively short range without overloading the receiver; higher powered models generally overload at close range.

While there is usually no need for multi-frequency capability, it is conceivable that you might have to communicate with two or more systems operating on different frequencies. The higher-priced 100-mW models (\$35 and up) can give you two or three switch-selectable channels, and they often include some form of tone signalling system to get the monitor's attention. Another feature you get is a "talk-power" modulator, with speech clipping or compression similar to that found in 5-watt rigs.

The 5-Watt W-T. When you need long-range communication from a hand-held device, you need lots of power to get through. Consequently, you will find w-t's with transmitter power inputs ranging from 1 to 5 watts. Power input definitely determines the price you will have to pay for a unit; so, the cost differences between models usually represent transmitter input power rather than differences in operating features. (Any w-t with a power input in excess of 100 mW must be operated under a CB license.)

Except for the "stripped" models in the \$50 price area, most high-power CB w-t's have features you would expect to find in quality mobile equipment, starting with a power input jack that permits operation from an ac-operated power supply. All models have squelch controls, antenna jacks, ear-phone jacks, and S/r-f meters that double as battery-condition indicators. Some models have only a battery-condition indicator.

The circuits in the high-power units are often identical to those used in higher quality base and mobile CB rigs. Receiver sensitivity is generally 1 μ V or better, while selectivity can be 50 dB or greater between channels.

Depending on total cost (high-power w-t's ranging from \$50 to almost \$200), you might have a choice of three to 23 channels coverage. In most cases, 23-channel models are supplied with all crystals. (You pay for all whether you need them or not.) One 23-channel model is presently available on a build-up basis; you purchase only the crystals you want as you go along.

For w-t's with less than 23-channel coverage, you add a channel at a time. The usual two crystals, one for transmit and the other for receive, are required.

As a general rule, the higher power models have some type of "talk power" booster. Though the high-power w-t's provide extended range, they also prove a decided convenience for short-range work when portability is a prime requirement. The length of antennas used with CB w-t's can run up to and beyond 4 ft. Hence, one of the most convenient accessories to have is a loaded whip antenna whose total length is 12 in. to 18 in. Their short length easily adapts the w-t to belt or shoulder-strap carrying use.

Unfortunately, loaded whips have very low efficiency. When used on a 100-mW unit, the signal might not make it the length of a city block. (Transmit losses are many times greater than receiver losses.) But with a loaded whip on a 3- or 5-watt w-t, there is still plenty of power available—more than enough to cover a large office building, school, stadium, or playground.

A secondary advantage of the loaded whip is that the reduction of output signal power makes the w-t less prone to front-end "jamming" caused by signal overloads. Of course, the loaded whip cuts down maximum range. So, when you need maximum range, you can always switch back to the regular whip. ♦

HOW TO MAKE CUSTOM METERS FROM SALVAGED PARTS

TEST INSTRUMENTS

Surplus D'Arsonval movements are easily converted to special-purpose voltmeters and ammeters

BY PROF. ROBERT KOVAL

WITH the switch to digital logic and numeric readout devices in modern test equipment, the surplus market is becoming glutted with D'Arsonval meter movements. Actually, the availability of these parts is a boon to the electronics experimenter because the going prices for the movements are often only a small fraction of what he would have to pay if purchased from an industrial supply house.

Most surplus meter movements can be refurbished and custom designed to suit just about any metering need imaginable. The process is relatively simple.

Preliminary Steps. Because the meter movement is from a surplus parts store, the first task is to clean away all dirt and other foreign matter from the case. This can be done with warm water and soap. For tough, greasy build-ups, try using some rubbing alcohol.

Once cleaned, carefully disassemble the movement (Fig. 1). Then inspect the movement to determine whether or not any resistors have been installed. Since you need only the basic movement for the next step, any resistors you find can be discarded.

Now, get out your VOM, a 2-megohm potentiometer, and a 1.5-volt dry cell with holder. Wire up the circuit shown in Fig. 2, but do not install the battery in its holder until after you adjust the pot for maximum resistance. Connect the battery and slowly adjust the setting of the pot to obtain exactly full-scale pointer deflection on the meter movement. (Note: Temporarily replace the old meter scale to locate the full-scale position.) Since the meter under test is in series with the VOM, both units carry the same magnitude of current. Hence, the VOM's reading is the full-scale current sensitivity of the meter movement.

At this point, the resistance of the meter

Fig. 1. The first step is to disassemble and clean the surplus meter.

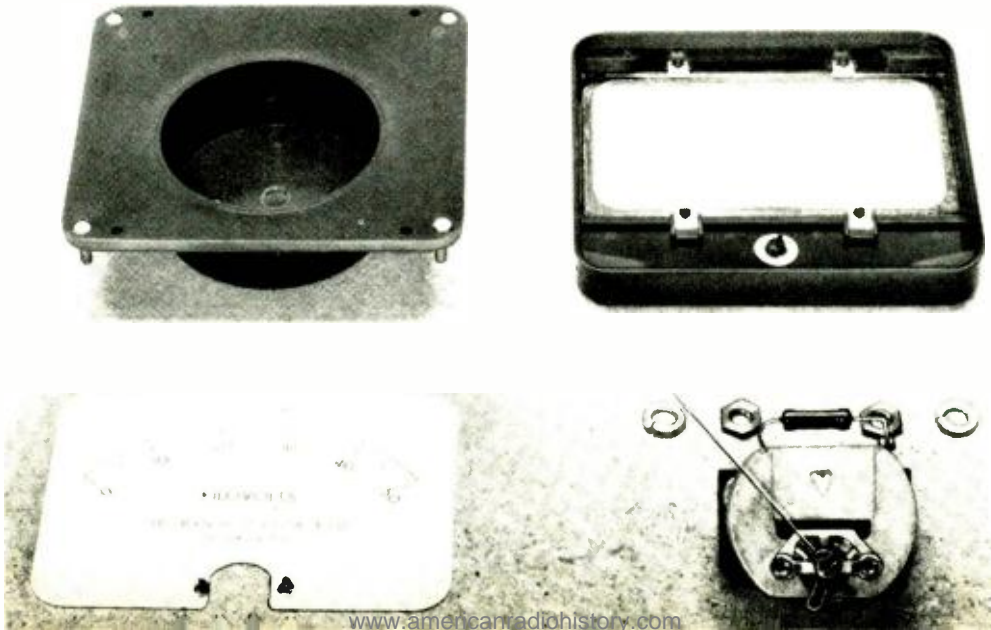

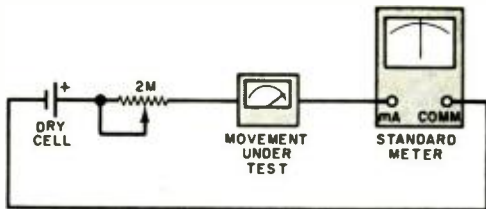

Fig. 2. Use this setup (with VOM and 1.5-V cell) to check movement's full-scale value.

movement (R_m) must be determined. Do not use an ohmmeter to measure the movement's resistance; the current supplied by the ohmmeter could easily damage the movement beyond repair. A method has been developed for calculating R_m using only the basic movement, two resistors of known value, and a 1.5-volt dry cell. The circuit hookup is shown in Fig. 3. Series resistor R_{ser} should have a value large enough to permit I_1 to fall within the upper third of the scale. As a guide for choosing R_{ser} , use Ohm's law. Assume the dry cell to be delivering 1.5 volts, and work this against the basic movement's full-scale current sensitivity. A fixed precision resistor would be ideal for R_{ser} . The value of R_{sh} should be 1/10 or 1/20 the value of R_{ser} . You can determine I_1 and I_2 from the meter's scales. Calculate R_m as follows:

$$R_m = \frac{R_{ser} \times R_{sh} \times (I_1 - I_2)}{R_{ser} \times I_2 + R_{sh} (I_2 - I_1)}$$

You now have enough information to custom-design a voltmeter or ammeter.

The Custom Voltmeter. It is usually convenient to customize a meter movement in such a manner that it retains the same numeric sequence on the original meter scales to obviate the necessity of relabeling the scales. However, this is not absolutely

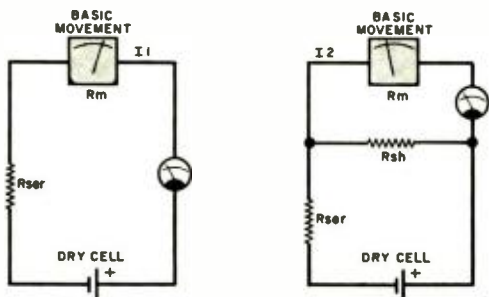

Fig. 3. Simple circuits for determining the resistance of the original meter movement.

necessary if you do not mind the task of removing the old and applying new legends.

Since the meter movement shown in Fig. 1 has a numeral 50 at its full-scale index, let us design a voltmeter with a 0.5-volt range. Assume that $50 \mu\text{A}$ is needed to deflect the pointer to full scale and that R_m is 2090 ohms. To calculate the value of the multiplier resistor (R_{mult}) for any given voltage range (V_r), use the following equation:

$$R_{mult} = (V_r \times 1/I_m) - R_m$$

In the equation, R_m is the basic movement's resistance (2090 ohms in our example), V_r is the voltage range desired (0.5 V full-scale), and $1/I_m$ is the reciprocal of the current needed to obtain full-scale pointer deflection ($1/0.00005$). Hence, $R_{mult} = (5 \times 1/0.00005) - 2090 = 97,910$ ohms.

As illustrated in the above example, a 97,910-ohm resistor will yield a 0.5-volt range when connected in series with the basic meter movement. To change ranges,

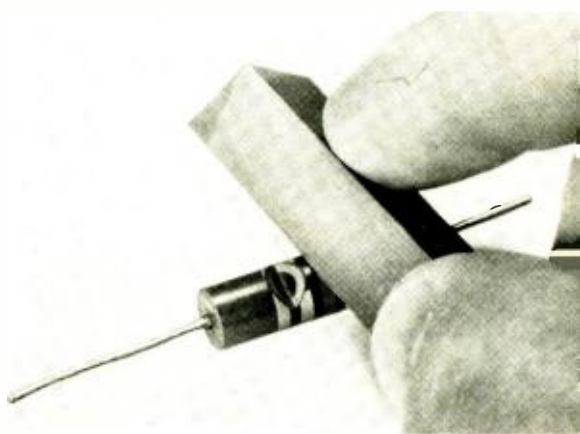

Fig. 4. The resistance of an ordinary carbon resistor can be trimmed by using a file.

simply substitute the desired full-scale figure for V_r in the equation. If you want multi-range capability, calculate R_{mult} for each range desired and use a rotary switch for range selection.

Very likely, the value calculated for R_{mult} will not be readily available from the commercial selections listed. Do not let this deter you. It is a simple matter to arrange two or more resistors in series/parallel hookups to yield the required ohmic value. Alternatively, you can "trim" an ordinary carbon resistor to the proper resistance with the aid of a file (see Fig. 4). Select a fixed resistor of slightly lower value than required. For example, if you need 97,910

ohms, a standard 91,000-ohm carbon resistor can be used. Use an ohmmeter to verify that it is indeed less than 97,910 ohms; a 10-percent tolerance resistor can go as high as 100,100 ohms, a useless figure for the trimming procedure.

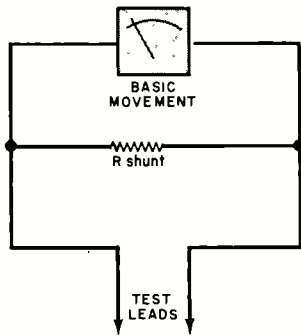

Fig. 5. The basic setup to be used for determining shunt resistor for an ammeter.

Use a resistance bridge or an ohmmeter to monitor your progress as you cut into the resistor with the corner of a triangular file. Work very carefully so as not to trim away too much of the composition resistance material and end up with a value too high for your needs. When the resistor is trimmed to the proper value, liberally coat the notch with coil dope to seal out moisture. This will assure a constant resistance under changing humidity conditions.

The multiplier resistor can be mounted inside or outside the meter's case. A tag indicating the range and units can then be affixed to the meter face. Make it large enough to completely cover the original legend.

The Custom Ammeter. A custom ammeter can be designed around the basic meter movement with much the same ease encountered when making the voltmeter. The

RESISTANCE PER UNIT LENGTH OF COPPER WIRE AT 25° C			
Gauge	Ohms per 1000 ft.	Gauge	Ohms per 1000 ft.
18	6.510	30	105.2
20	10.35	32	167.3
22	16.46	34	266.0
24	26.17	36	423.0
26	41.62	38	672.6
28	66.17	40	1069.0

basic hookup is shown in Fig. 5. The equation to use for determining the resistance of the shunt resistor is:

$$R_{shunt} = \frac{R_m \times I_m}{I_{max} - I_m}$$

Maximum current I_{max} is the desired full-scale current the meter is to indicate; I_m is the current required to deflect the meter's pointer to full-scale; and R_m is the resistance of the basic movement.

Assume that you want a range of 0-50 mA and that R_m and I_m remain the same as in the voltmeter example given above. Then, R_{shunt} would be equal to $(2090 \times 0.00005) / (0.05 - 0.00005)$, or 2.092 ohms. Again, if a different range or ranges are desired, the maximum current wanted would be inserted into the equation as I_{max} . A switching arrangement would be used to provide several ranges.

The value of R_{shunt} will normally be very low, sometimes on the order of only a fraction of an ohm. In cases where its value would be too low to be conveniently trimmed with a file, you will have to wind your own shunt resistors. Enamel-coated copper wire



Fig. 6. A hand-wound shunt resistor. Next the assembly is protected with a coil dope.

can be used as the resistive element, while the resistor form can be any high-value resistor (1 megohm will do). Wire gauges and the resistance they yield are given in the Table. A hand-wound shunt resistor assembly is shown in Fig. 6. After winding the wire onto the resistor body and soldering the wire's ends to the resistor's leads, coat the assembly with coil dope.

As with the voltmeter, the ammeter's shunt resistor can be mounted inside or outside of the meter's case. Also, be sure to label the meter face with the range and unit for which it is designed. To check out your ammeter, connect it in series with a VOM and current source; both meters should indicate the same magnitude of current. ♦

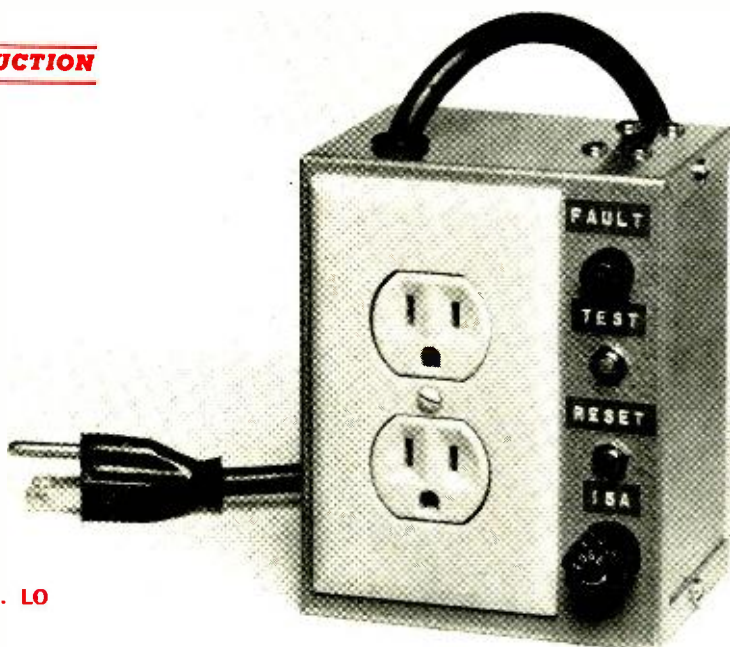

BY C. C. LO

ELIMINATE RISK OF FATAL ELECTRIC SHOCK WITH THE GFI

The ground fault interrupter automatically removes power when it senses leakage current

HAVE YOU ever used a power tool outdoors while standing on wet ground? Do you have a swimming pool with electrical equipment (or an ac radio) nearby? How about using an electric lawn mower on a damp lawn on a hot day and taking your shoes off? Every time you let your body make good contact with a ground (whether it is the earth itself or a pipe or other metal object that is grounded) and, at the same time, use a power tool or other electric equipment, you expose yourself to a possible electric shock which can be fatal if the current is sufficiently high and you can't let go in time.

That's why many people today are using ground fault interrupters (GFIs) on their

electrical equipment. There are commercial devices available, but you can build your own GFI easily and at low cost. The GFI is connected between the power line and the appliance. The device described here senses ground (leakage) currents of about 2 mA and automatically turns off the primary power within 30 milliseconds. This provides protection at a sufficiently low current and in a sufficiently short time to prevent serious shock injury. Of course, if the leakage current occurs, the apparatus is shut down, whether someone is touching it or not.

Circuit Operation. The main sensing element of the ground-fault interrupter (see Fig. 1) is transformer *T1*. It consists of a

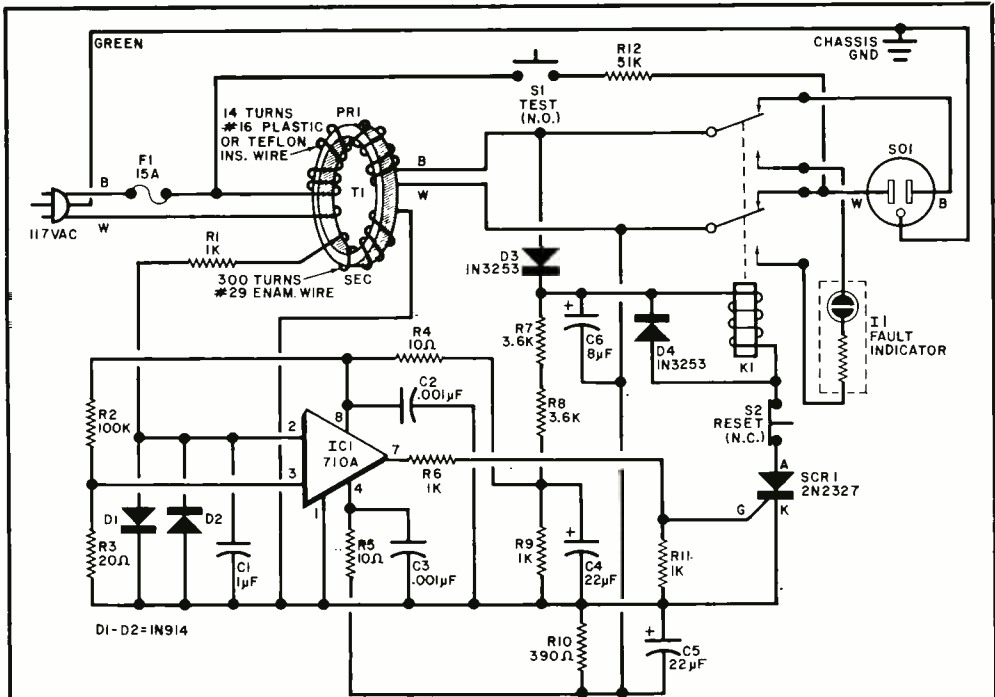

Fig. 1. When the secondary of T1 senses an imbalance in the two power-line feeds, the difference is amplified and turns on SCR1, which cuts the power to the socket.

PARTS LIST

C1—1- μ F, 15-volt, Mylar capacitor
 C2, C3—0.001- μ F ceramic disc capacitor
 C4, C5—22- μ F, 15-volt miniature electrolytic capacitor
 C6—8- μ F, 450-volt electrolytic capacitor
 D1, D2—1N60 diode or similar
 D3, D4—1N914 diode or similar
 F1—15-ampere fuse and holder
 I1—Neon indicator light (117 volts)
 IC1—Voltage comparator (710A or similar)
 K1—Dpdt relay, 120-V dc, 11-mA coil rating, Allied Control Co. Type BO-6D (100 Relay Rd., Plantsville, CT 06497) or Allied Electronics Corp. part No. KN105-2C-120D.
 R1, R6, R9, R11—1000-ohm, $\frac{1}{2}$ -watt resistor
 R2—100,000-ohm, $\frac{1}{2}$ -watt resistor
 R3—20-ohm, $\frac{1}{2}$ -watt resistor

R4, R5—10-ohm, $\frac{1}{2}$ -watt resistor
 R7, R8—3600-ohm, 2-watt resistor
 R10—390-ohm, $\frac{1}{2}$ -watt resistor
 R12—51,000-ohm, $\frac{1}{2}$ -watt resistor
 S1—Spst normally open pushbutton switch
 S2—Spst normally closed pushbutton switch
 SCR1—2N2327, HEPR1004, or similar
 SO1—Single or dual three-way socket
 T1—See text
 Misc.—Suitable chassis (3" x 4" x 5") (Bud CU-2105-A or similar), perf board and terminals, mounting hardware, plastic washers (2), three-lead power cord, rubber grommet for line cord, press-on type, etc.
 Note—The following are available from C. C. Lo, P. O. Box 975, El Cerrito, CA 94530: toroid for T1 at \$4.00, complete transformer at \$9.50, postage paid.

ferrite core with the two power lines wound around it to form the primary windings and a secondary winding of #29 enameled wire. The transformer does not respond to power consumed by the load but is extremely sensitive to unequal currents in the two power lines. This would be the case if there were leakage to ground through any device plugged into SO1. The transformer compares the current in the two sides of the line and, if they are not the same, induces a voltage in the secondary winding.

If there is no leakage, and no voltage in the secondary of T1, the power supply goes through the contacts of relay K1. When there is a voltage induced in the secondary of T1, it is compared in IC1 to a reference voltage applied to pin 3. When the generated voltage, applied to pin 2, is high enough, the output of IC1 drives the gate of SCR1 positive so that it turns on and energizes the relay. This cuts off the power line and turns on the fault indicator lamp. Since SCR1 is powered by a rectified and filtered

HOW MUCH CURRENT

The amount of current that the human body can withstand varies from one person to another. Generally, at a frequency of 60 Hz, current above 0.5 mA produces some sensation. At 10 or 20 mA, voluntary muscle control may be lost and the person is unable to let go of the current-carrying object. Slightly above that, the victim's chest muscles contract and breathing stops as long as the current persists. The equivalent 2-mA level required to trip the ground-fault interrupter described here is below the dangerous level for an average person, including a child. It is essential to mention that, while the ground-fault interrupter will protect a person from current flowing from the appliance through him to ground, it will not protect him if he gets directly across the power line. This must be avoided at all times.

Component layout of the prototype. The perforated board is mounted on the chassis with two 1½-in. aluminum standoffs, and the same two holes are used for output socket.

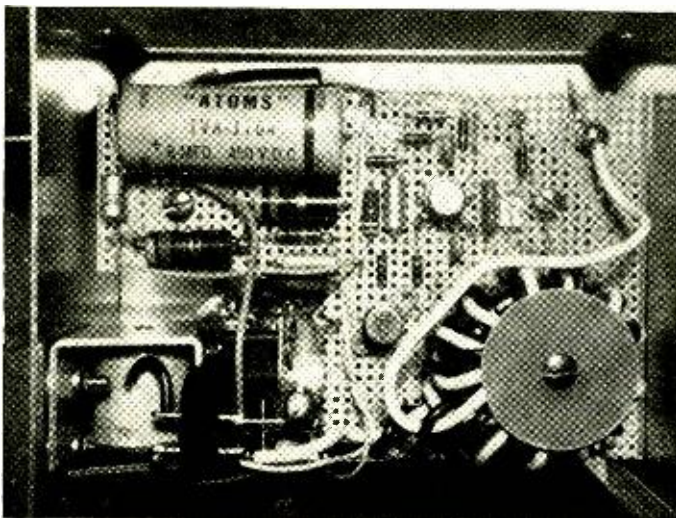

dc, it remains on until the reset pushbutton (S2) is operated. The fault that caused the power-line imbalance must then be corrected before the protection system is enabled again.

Resistor *R12* and test switch *S1* are included to produce a low current imbalance (about 2 mA) and should be operated before each use of the system to be sure that it is operating properly. After testing, of course, the reset button must be pushed.

Construction. The circuit can be assembled very easily on perf board and mounted in any suitable chassis. The test and reset

switches, fault indicator light, and fuse should be mounted on the front panel. If the chassis is metal, be sure that no part of the circuit is contacting the chassis. Also be sure that the ground lead of *SO1* and the green lead of the three-way power line are connected to the metal chassis.

The relay specified has 10-ampere (1200-watt) contact ratings, which should be sufficient for most purposes. If higher contact ratings are required, be sure that the current required by the relay coil is below 20 mA and above 5 mA.

The core of the transformer is a Ferroxcube K300501-3E. Wind 300 turns of #29 enameled wire through the toroid to form the secondary, leaving long lead ends. Then cover this winding with a layer of plastic insulating tape. To form the primary, use a twisted pair of #16 plastic or Teflon insulated wires and wind 14 turns through the

toroid and over the secondary winding. The finished transformer can be supported on the perf board with a long screw and a pair of large insulated (plastic) washers.

Use. Be sure to perform the operating test by depressing the test button and noting that the relay operates and the fault indicator lamp comes on. Then press the reset switch.

The circuit shown here is for three-wire electrical systems—which everyone should have. However, two-wire appliances can be plugged into the fault interrupter to take advantage of its protection. ♦

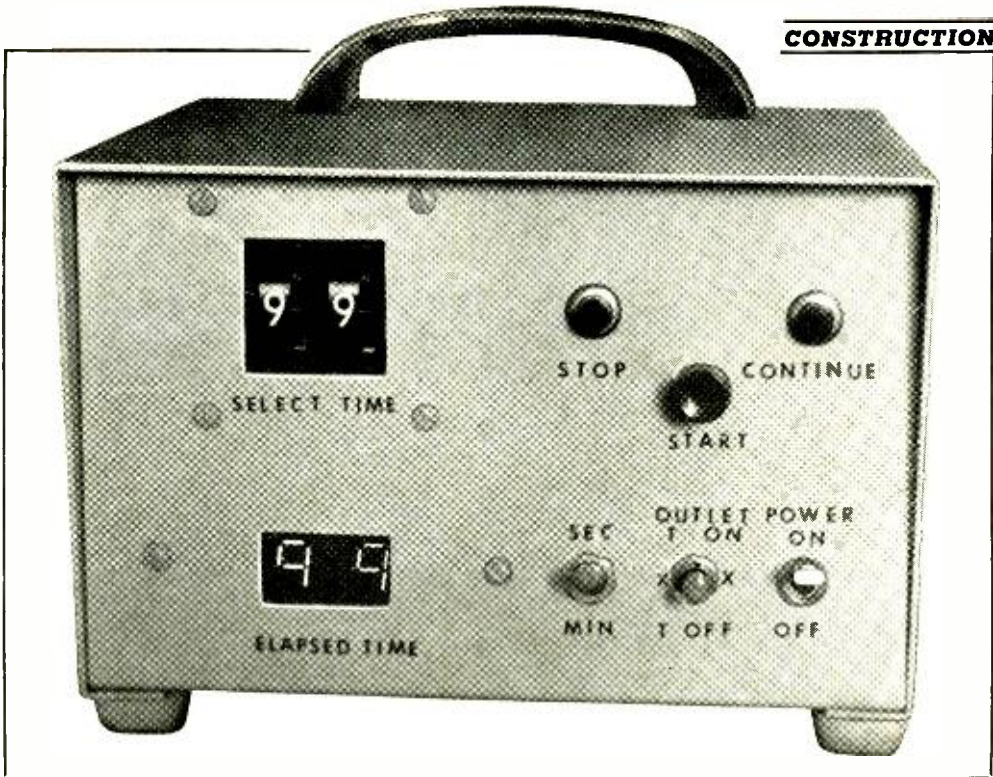

BUILD A PRECISION SECONDS/MINUTES INTERVAL TIMER

Digital readout provides accurate on or off timing to 99 seconds or 99 minutes for powering

117-volt equipment

BY JOHN D. COLLIN

TIMERS of one sort or another are fairly common around the house today (on radios, blenders, etc.), but most of them are relatively "rough" when it comes to the accuracy of the interval. This timer provides precise increments of time either in seconds or minutes from 1 to 99, with digital readout. The timer can be set to turn the controlled device either off or on after the se-

lected elapsed time. It makes a valuable accessory in the photo darkroom and can also be used in adult and children's games. Other practical applications include control of kitchen appliances, radios, or TV's. The timing interval can be stopped at any point and reset or allowed to continue. You can extend the time if desired.

With the relay specified in the Parts List,

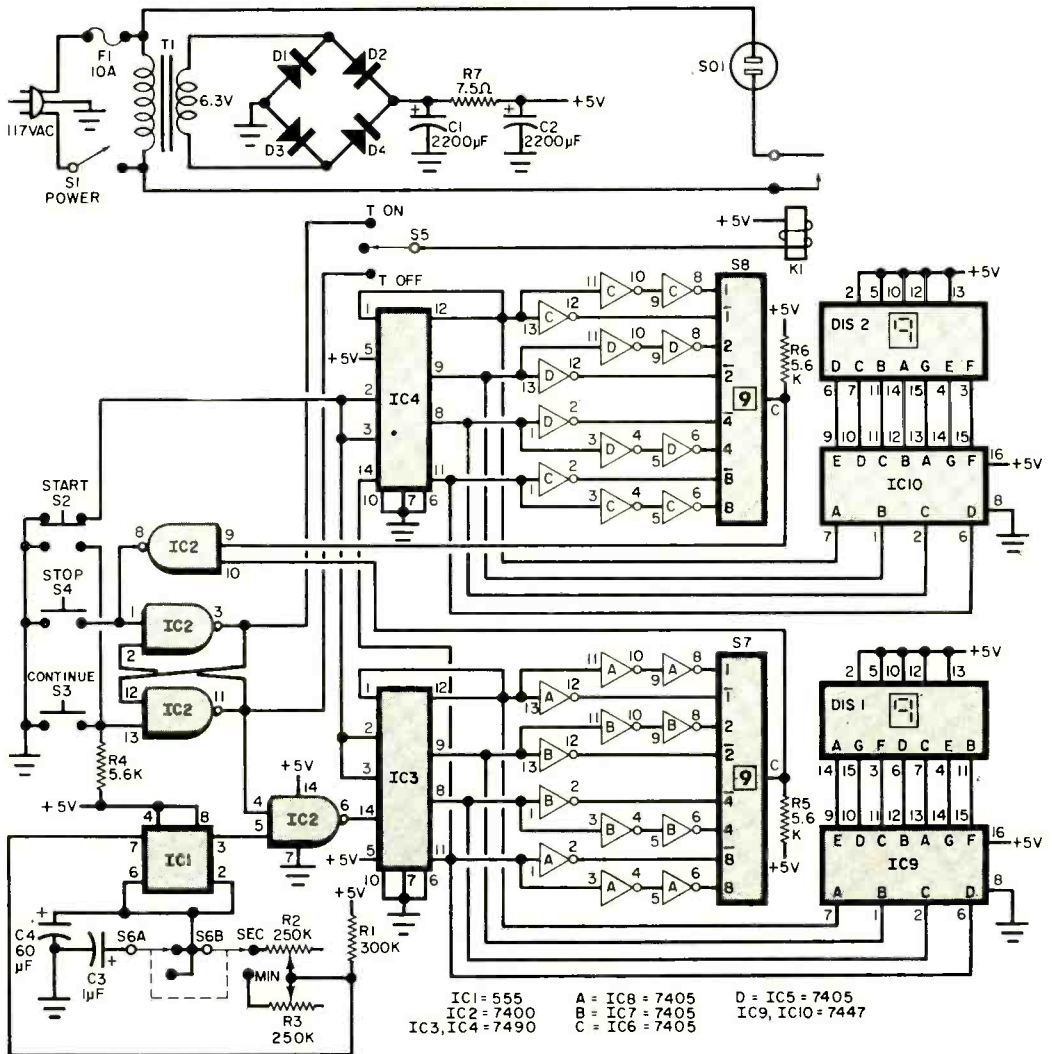

Fig. 1. The basic timing interval is generated by IC1, while IC3 and IC4 are decade counters. The displays are driven by IC9 and IC10. Thumbwheel switches S7 and S8 form a value detector for individual numeric selections.

PARTS LIST

C1, C2—2200- μ F, 10-volt electrolytic capacitor
 C3—1- μ F, 10-volt electrolytic capacitor
 C4—60- μ F, 10-volt electrolytic capacitor
 D1-D4—Silicon rectifier diode
 DIS1, DIS2—7-segment display (Poly-Pak 92CU1299 or similar)
 F1—10-ampere fuse and holder
 IC1—555 timer IC
 IC2—7400 IC
 IC3, IC4—7490 IC
 IC5-IC8—7405 IC
 IC9, IC10—7417 IC
 KI—Spst relay; coil: 6 V at 10mA; contacts: 115 V ac at 3 A (Calectro D1-966 or similar)

R1—300,000-ohm, $\frac{1}{4}$ -watt resistor
 R2, R3—250,000-ohm potentiometer
 R4-R6—5600-ohm, $\frac{1}{4}$ -watt resistor
 R7—7.5-ohm, 2-watt resistor
 S1—Spst slide or toggle switch
 S2—Spdt pushbutton switch
 S3, S4—Spst pushbutton switch
 S5—Spdt, center off, slide or toggle switch
 S6—Dpdt slide or toggle switch
 S7, S8—10-position thumbwheel switch (1, 2, 4, 8 and complements inputs—usually found at electronic surplus houses)
 T1—Transformer; secondary: 6.3 V, 1.2 A
 Misc.—Suitable chassis (LMB-564 or similar), line cord, spacers, terminal strips, mounting hardware, etc.

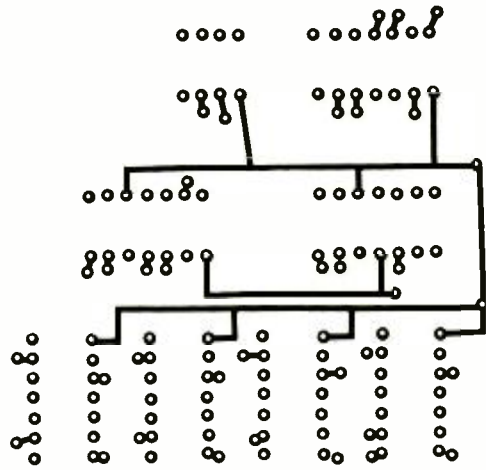
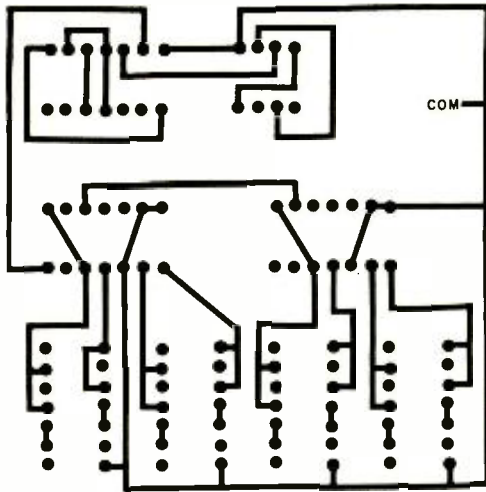
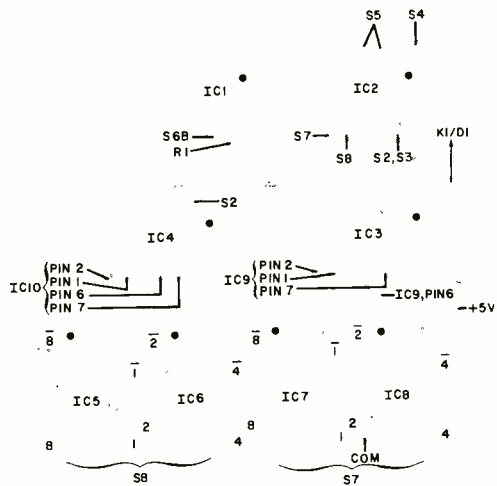

Fig. 2. The counter circuits are mounted on a double-sided pc board whose foil patterns are shown above. Components, however, mount on only one side, as shown at right.



the timer can be used with any 117-volt device drawing less than 3 amperes. If more power is required, an external relay or an SCR or triac circuit can be used.

About the Circuit. The basic timing interval is generated in *IC1*, a 555 timer (Fig. 1). Switch *S6* is used to select seconds or minutes, and *R2* sets the timing for seconds. *R3* for minutes. The clock pulses are applied to two series decade counters, *IC3* and *IC4*, through one gate of four-gate *IC2*. Two of the gates are used as a set-reset flip-flop that serves two purposes: to control the clock pulses to *IC3* in accordance with the positions of *S2*, *S4*, *S3*, *S7*, and *S8*; and to energize relay *K1* at the proper time.

The outputs of decade counters *IC3* and *IC4* drive conventional seven-segment decoders (*IC9* and *IC10*) and associated read-

outs, *DIS1* and *DIS2*, respectively. These outputs also feed the thumbwheel switches, *S7* and *S8*. The latter form a value detector for individual numeric selections. Their mechanical wafers and sliders connect corresponding weights of the binary inputs (from the decade counters) and their complements to a common output. Each decimal selection requires both polarities of a 4-bit BCD value. For example, to detect a decimal 7, the BCD switch input must equal 0111 and its complement 1000. The common output of the switch remains at logic 0 until all logic 1 input requirements are satisfied.

As the decade counters continue with their count, the inputs to the thumbwheel switches eventually satisfy both numeric selections and turn on the fourth gate of *IC2*. The output of this gate then goes low, and

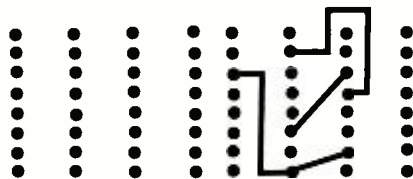
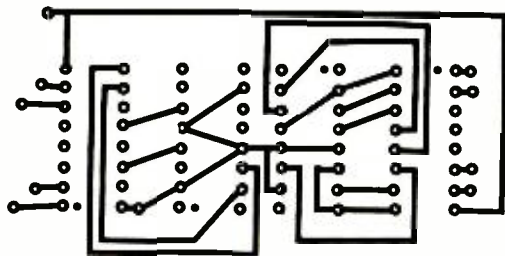
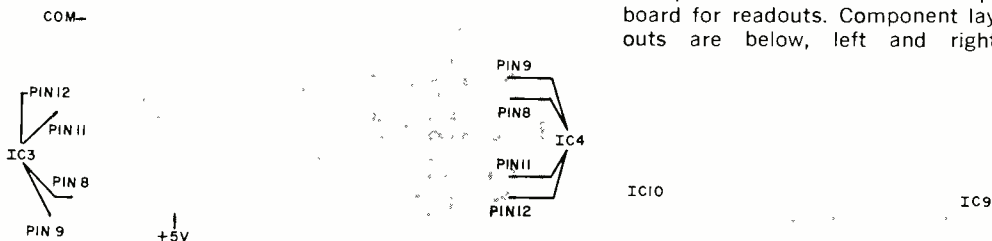

Fig. 3 Above, left and right, are foil patterns for double-sided pc board for readouts. Component layouts are below, left and right.



the circuit shuts down the clock gate to stop the count. New values of thumbwheel selection will not affect the clock gate.

Due to the internal construction of the thumbwheel switches, the decade counter outputs must be isolated from the switch. This is provided by IC5 through IC8, which have open collector circuits. TTL hex inverters with active pull-ups are not suitable for this application because their outputs are not predictable when tied together.

The relay is connected by S5 to either side of the set-reset circuit formed by the two sections of IC2. In one position of S5, the relay is activated during the timing period; in the other position, it is activated when the system times out.

Construction. The circuit can be assembled on perf board or on a double-sided pc board, using the foil pattern shown in Fig. 2. IC sockets are optional. Note that the readouts and associated decoders are mounted on a separate board (Fig. 3) so that they can be installed in the chassis with the digits visible through a hole in the front panel.

Mount the controls, readouts, potentiometers, etc. on the front and back panels as shown in the photos.

Adjustment. Connect a conventional household electric clock, with a sweep second hand to S01. Put S5 on OUTLET ON and S6 on SEC. Set the thumbwheel switches to 90 and turn on the power. It is best to have the clock second hand at 12, but if it isn't, note its exact position. Depress the START pushbutton and allow the timer to run to 90, noting that the readouts keep count. At the end of 90 seconds, the clock will stop. Compare the clock indication to the readout. They should be indicating 90 seconds, but the clock will be off. Readjust R2 and repeat the timing procedure until both the clock and the readout indicate 90. Once this has been done, lock the shaft of R2 so that it can't be moved accidentally to throw off the calibration.

With S6 in the MIN position, calibrate R3 in the same way as R2 was set. This will take some time, so use some small minute values as displayed on the thumbwheel switches. ♦



Mounted on the back panel are the power outlet, the fuse, and adjustments R2 and R3.

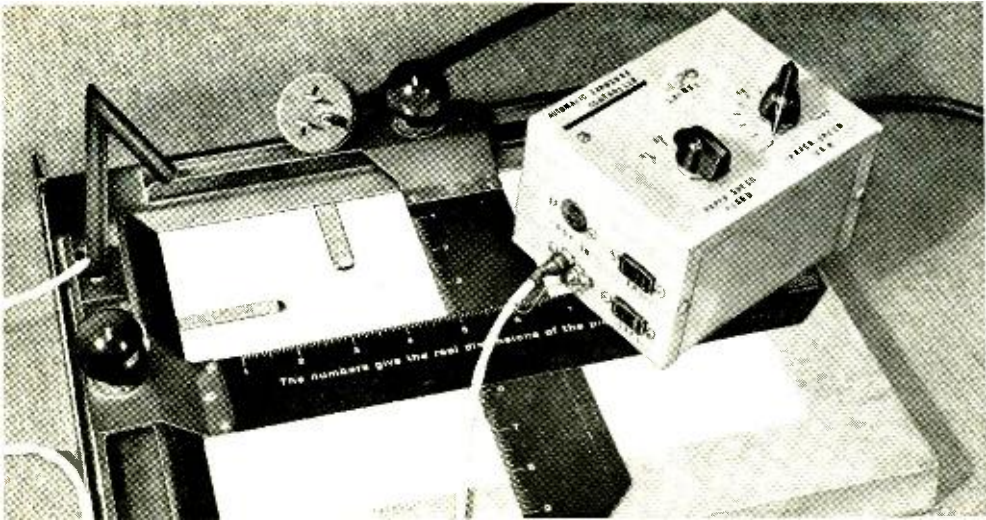

AUTOMATIC PHOTO ENLARGER CONTROLLER

SELECTS THE PROPER EXPOSURE TIME AND
CUTS DOWN ON PHOTO PAPER WASTE

BY JOSEPH GIANNELLI

IF you're presently making photographic enlargements using a light meter, a gray scale, test strips, or some other such device, you'd probably welcome a simple pushbutton device that automatically selects the correct exposure and exposes your print for precisely the correct time. Well, with this automatic exposure controller, you can have such a device for a great deal less than you would have to pay for a professional unit.

The controller is a new device for the amateur photographer. A search through camera catalogs and visits to photo suppliers will quickly reveal that the only thing remotely resembling this device is the simple light meter—and the resemblance is remote indeed. You can build the automatic exposure controller for about \$17. (*Heart of the device is a timer IC, the Signetics NE555 discussed in detail in a previous issue and widely used in timing circuits.*—Editor)

How It Works. The sensor used in the controller (*LDRI* in Fig. 1) is sensitive to the entire visible spectrum, adapting the system to color printing and multi-contrast paper. It is mounted on the edge of the easel where it "looks" down at the photographic paper and picks up the reflected

light from a large area of the projected image the moment **EXPOSE** pushbutton switch *S2* is depressed. A certain resistance value for a given light level is then established by *LDRI*. This resistance, coupled with *C3*, determines the on time of the enlarger lamp plugged into *SO2* to extinguish.

Field effect transistor *Q1* increases the input resistance at pin 6 of *IC1*, allowing larger resistance swings for *LDRI* with smaller capacitance values for *C3*, *C4*, and *C5*. This eliminates the need of inherently leaky electrolytics for these capacitors but requires that low-leakage Mylar units be used in the fixed paper speed circuit.

When pushbutton switch *S2* is depressed, a negative-going trigger pulse is applied to pin 2 of *IC1*, sending the output at pin 3 to the high state. This, in turn, energizes *K1* and turns on the enlarger lamp plugged into *SO2*. The initiation of the expose trigger also opens up the IC's discharge circuit at pin 7, allowing the *C3*, *C4*, or *C5* (whichever is switched into the circuit via *S3*) voltage to rise through *LDRI* as a function of the reflected light level seen by the *LDR*.

The voltage continues to rise at pin 6, where it is compared with an intrinsic control voltage; that appearing at pin 5 of *IC1* (equal to 0.667 the supply voltage). When

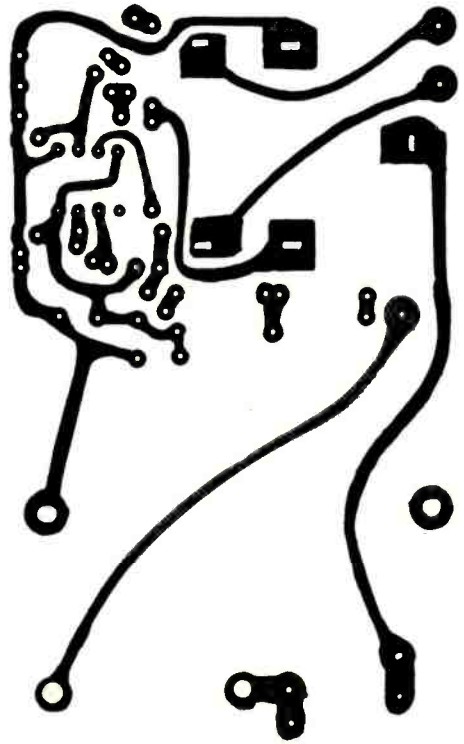
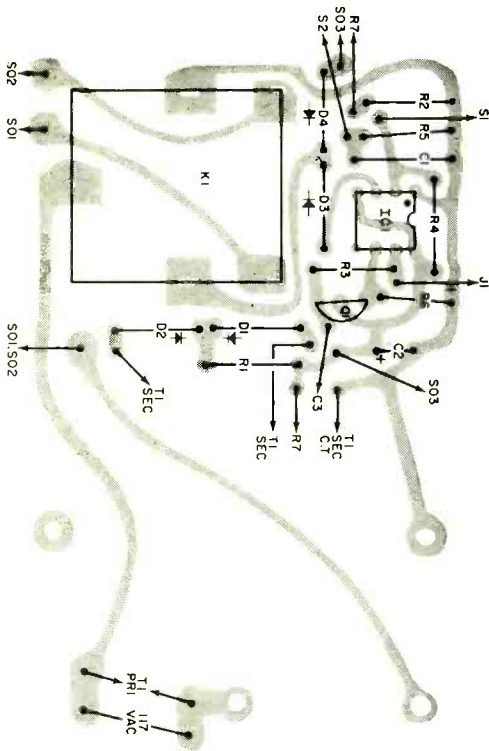

Fig. 2. Foil pattern for PC board is at right, component layout shown at left.

tremely linear in its performance. With the components specified, the timing range is from 1 second to more than 2 minutes, which more than covers the various paper speeds. Furthermore, the system is insensitive to line voltage variations.

Construction. For the sake of neatness and convenience, it is suggested that you assemble the controller on a PC board (see Fig. 2 for etching and drilling guide and components placement diagram). The prototype was assembled with two PC boards; one for the main circuitry and the other for the bulky C3, C4, and C5 capacitors. However, you can obviate the need for the capacitor board by joining one lead of each capacitor in common, slipping a length of insulated spaghetti over the common lead, and soldering this lead to the hole marked C3 on the main board. The free leads of C3, C4, and C5 can now be soldered directly to their respective S3 lugs.

Aside from the normal precautions to be taken with any solid-state circuit, assembling and wiring the PC board is simple. (If you elect to use perforated phenolic board construction, it is suggested that you use a

socket with IC1; do not solder directly to the IC pins.)

Mount J1, R7, SO1-SO3, and S1-S3 on the top half of the case, and route the line cord through a grommet-lined hole as shown in Figs. 3 and 4. Connect the earth-ground (green) power cord wire to one of the mounting lugs of T1 and case ground. (Note: In the prototype, no power switch was used. But the use of S1, mounted to the case top and connected in series with the black power line lead and F1, is recommended.)

(Continued on page 58)

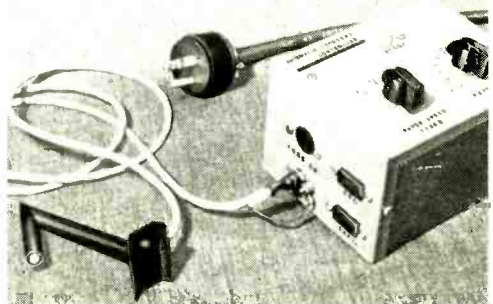
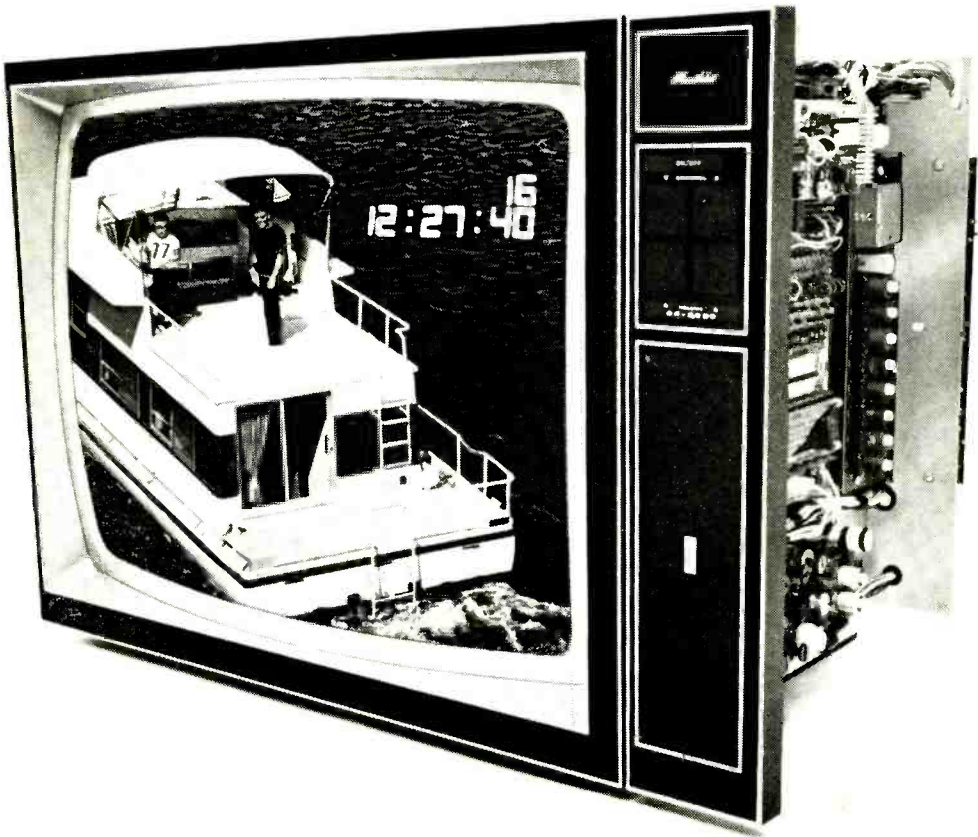

Fig. 3. Overall view of controller. Bracket which holds the LDR sensor is extreme left.

Heathkit® Digital Color TV...

Digital technology comes to TV with the new Heathkit GR-2000 Color TV.

It has on-screen channel numbers and a digital clock . . . programmable digital channel selection, all electronic varactor tuning, and an IF that never needs alignment! So advanced, it's like nothing you've ever seen before.



tomorrow's TV design today!

The Heathkit GR-2000 Digital Color TV has electronic on-screen readout that puts channel number and an optional digital clock into the picture. Change channels, or touch the "recall" button and you have instant, highly visible station identification.

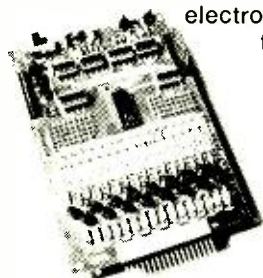

Digital logic circuitry selects channels. You program up to 16 stations, in any sequence, for automatic recall — intermix UHF with VHF, even repeat a station in the cycle. You'll never switch through a "dead" channel again. A solid-state UHF-VHF varactor tuner takes the place of the noisy mechanical "thunker", corroding contacts, humming motors and mechanical linkages. It's completely silent and never needs cleaning.



Yet another "first" is the unique fixed-filter IF amplifier that never needs instrument alignment! The picture retains its brilliance and clarity year after year, without periodic IF servicing. And you get truly superior reception, even in urban areas where the high density of stations causes adjacent channel interference.



The 100% solid-state chassis uses more integrated circuits than any other TV around. The 25" (diagonal) matrix picture tube is the most advanced available. There's even a volume controlled hi-fi output jack, so you can reproduce TV audio through your separate amplifier.

Plus, the Heathkit Digital Color TV comes with a complete complement of self-service

instruments. And a service manual that shows you how to use them all.

The Heathkit GR-2000 Digital TV is also an easier kit-form TV to build. More modular circuit boards, plus more prefabricated wiring harnesses and cables, hold point-to-point connections to a minimum. It may well be the most rewarding kit-building experience of your life.

You can order the Heathkit GR-2000 Digital Color TV with the optional on-screen digital clock (it can be set for 4- or 6-digit readout), ultrasonic digital remote control, and any of four beautiful factory assembled and finished cabinets. Mail order price for chassis and tube, \$649.95. Remote Control, \$79.95 mail order. Clock, \$29.95 mail order. Cabinets start at \$139.95. (Retail prices slightly higher).

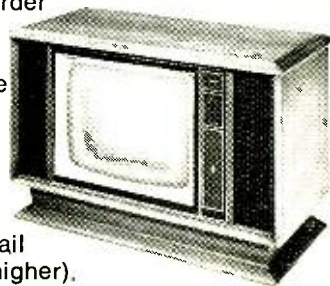

Send the attached card for your FREE HEATHKIT CATALOG describing the amazing new Heathkit Digital Color TV in detail. If card has been removed, write: Heath Company, Dept. 10-4, Benton Harbor, Mich. 49022.



HEATHKIT ELECTRONIC CENTERS

Units of Schlumberger Products Corporation

ARIZ.: Phoenix; CALIF.: Anaheim, El Cerrito, Los Angeles, Pomona, Redwood City, San Diego (La Mesa), Woodland Hills; COLO.: Denver; CONN.: Hartford (Avon); FLA.: Miami (Hialeah), Tampa; GA.: Atlanta; ILL.: Chicago, Downers Grove; IND.: Indianapolis; KANSAS: Kansas City (Mission); KY.: Louisville; LA.: New Orleans (Kenner); MD.: Baltimore, Rockville; MASS.: Boston (Wellesley); MICH.: Detroit; MINN.: Minneapolis (Hopkins); MO.: St. Louis; NEB.: Omaha; N.J.: Fair Lawn; N.Y.: Buffalo (Amherst), New York City, Jericho, L.I., Rochester, White Plains; OHIO: Cincinnati (Woodlawn), Cleveland, Columbus; PA.: Philadelphia, Pittsburgh; R.I.: Providence (Warwick); TEXAS: Dallas, Houston; WASH.: Seattle; WIS.: Milwaukee.

CIRCLE NO. 5 ON READER SERVICE CARD

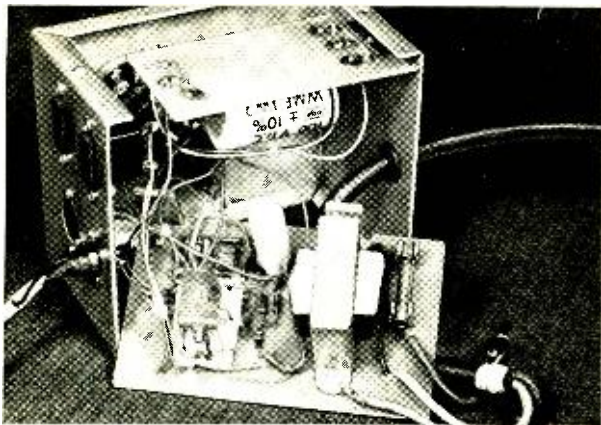

Fig. 4. Photo shows inside of prototype chassis with bottom removed and board detached.

Details for fabricating the cell bracket for *LDR1* are shown in Fig. 5. Use only solderable brass or copper tubing. You can make the cell holder as shown, cutting and soldering it as required. Alternatively, you can fill the tubing with dry sand or slide into it a tubing bender spring and heat the tubing just enough to permit its bending without crumpling. Either method should yield the same results with respect to orientation over the photographic paper when the bracket is mounted on the easel.

After drilling and deburring the cable exit hole and soldering the tubing to the modified Leica easel adaptor, spray the entire assembly with flat black paint. When the paint dries, slip the two conductors of the shielded cable up the tubing and solder them to the leads of the LDR. Slip the LDR, with enough filler around it to hold it in place, into the tubing. Solder a spade lug to the cable shield at each end and a phono plug to the insulated conductors at the end of the cable that goes to the control box.

At this point, the entire system should be assembled, minus *R2*. Tack solder a 10-megohm resistor across the lugs of *J1* and a 10,000-ohm potentiometer across the points marked *R2* on the PC board. Set the pot to its midpoint. Plug the line cord into an ac outlet and your enlarger lamp into *SO2*. Set *R7* to its minimum-resistance position, turn on *S1* and momentarily depress *S2*. Time out the cycle. Then set *R7* to its maximum-resistance position, depress *S2*, and time out the cycle. If there is not a 2:1 ratio between this and the first position of *R7*, adjust the tacked-in potentiometer until you get this ratio.

Turn off the power, unplug the line cord and enlarger lamp cord, and unsolder the 10-meg resistor and pot (do not disturb the latter's setting). Use an ohmmeter to measure the pot's resistance and select a fixed resistor of a value close to your reading for *R7*, soldering it in the appropriate location on the PC board. Then assemble the case. The controller is now ready to use in your darkroom.

Making A Print. It is now necessary only to determine the settings of the **FIXED** and **VARIABLE PAPER SPEED** controls for the types of paper you are using. Place the LDR bracket to look at an area of interest, avoiding hot spots, and simply make a small enlargement at different settings of the controls. Use low numbers for lighter and high numbers for darker areas. Record the best

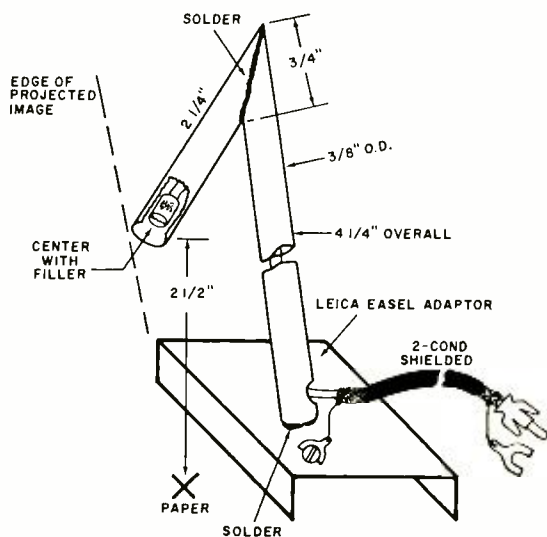

Fig. 5. Details of the cell bracket which holds LDR. Tubing is brass or copper, obtainable in hobby stores, and painted black.

setting on your package of paper. This setting is now always used for that paper, regardless of the magnification and film density. A new setting will be required for other grades of paper.

If Kodak Polycontrast paper is used, the controller will automatically adjust for filters and the inherent paper speed change, using only one setting.

Although the controller has the potential for discerning colors and their varying densities, no color prints were made with it at this time. ♦

A GUIDE TO CMOS OPERATION

PART 2

BY WALTER G. JUNG, Contributing Editor

HERE ARE PRACTICAL APPLICATIONS OF CMOS IN LOGIC CIRCUITS

HAVING considered the basics of CMOS operation in Part 1, last month, we can move on to the use of CMOS in circuits that provide the various logic functions. These run the gamut from simple gates and flip-flops to registers, arithmetic units, and even memories. Space does not permit our going into detail on all of the circuits, but we will be able to get an idea of how the low-order functions operate. Most of them can actually be assembled using either the CD4007AE or CA3600E for experimentation.

Inverters and Buffers. The basic inverting function is a natural for CMOS. In fact, the CD4007AE and CA3600E contain three inverters in one package with pin connections as shown in Fig. 1A. Note that there are three pins for V_{DD} and three for the ground.

A noninverting buffer can be made by cascading two inverters as shown in Fig. 1B. However, note that in the second stage of this circuit, sections B and C are connected in parallel. This allows them to function as a single stage with twice the output drive—a neat trick to remember. This paralleling of like stages can be done with as many CMOS sections as necessary, as long as they are in the same package. With the CD4007AE or CA3600E, up to 3 sections can be connected in parallel as shown in Fig. 1C.

Paralleling can be used in digital or

linear applications. A single CD4007AE section can handle up to 2.5 mA of output current with a 10-volt supply; 3 sections boost the output to 7.5 mA. This is valuable in driving TTL with CMOS; for example, three CD4007AE sections with a 5-volt supply will drive four low-power TTL stages. When driving into CMOS from TTL, however, be sure to add a pull-up resistor (about 4700 ohms) to the 5-volt supply.

NOR and OR Functions. The gate structure of CMOS logic is as interesting as the basic amplifier and is almost as uniquely simple. It involves interconnections of p and n transistors to perform the required logic. Figure 2A shows how simple it is to construct a NOR (or OR) gate. In the NOR gate, if either input is high, the out-

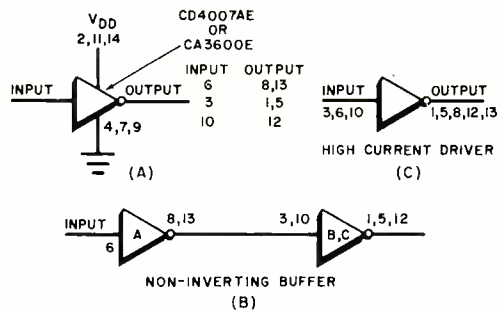

Fig. 1. Using the CMOS as a triple inverter (A), a noninverting buffer (B), and (C) as high-current driver with units in parallel.

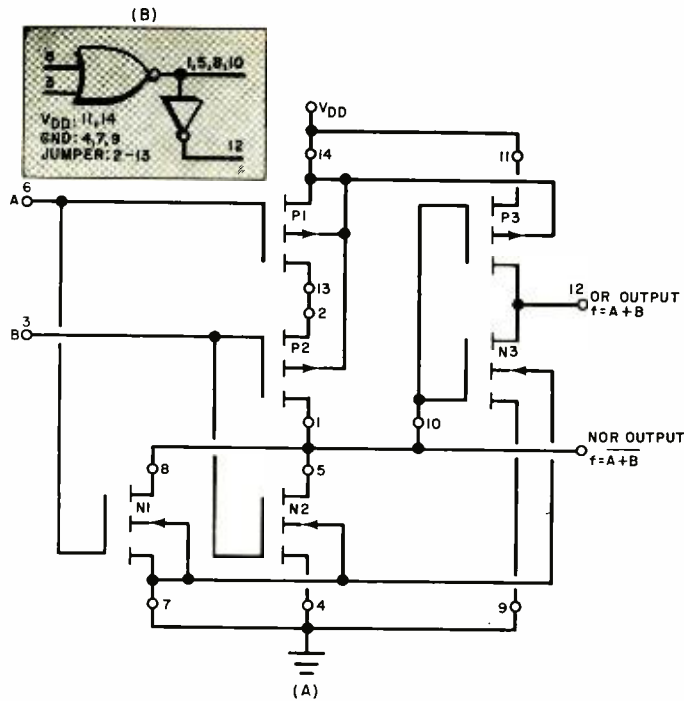
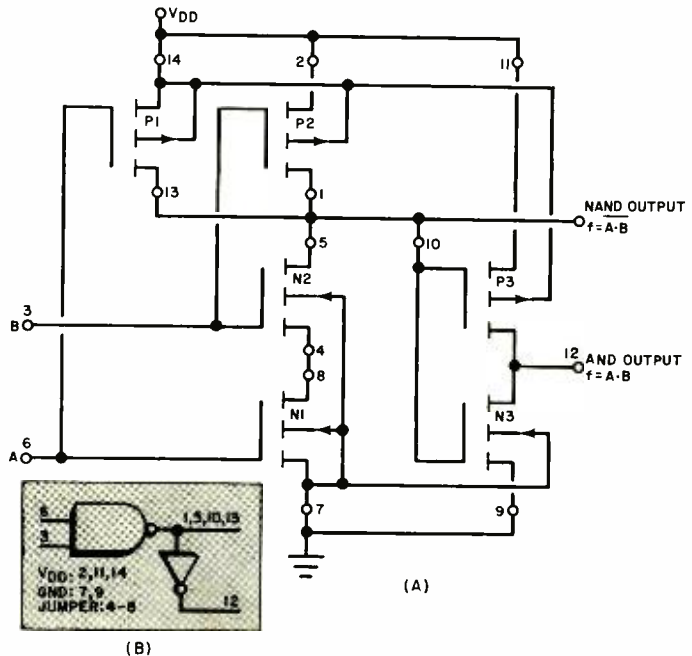

Fig. 2. A CD4007AE or CA3600E can be interconnected as shown to create NOR or OR logic (A). Symbol is at (B).

Fig. 3. The interconnections for a NAND or AND circuit are similar to those in Fig. 2, with units upside down. Symbol is at (B).



put will be low. If both inputs are low, the output is high. The NOR logic is performed by $P1$, $P2$, $N1$, $N2$. If either the A or B input is high, $N1$ or $N2$ is held low by the low on resistance of $N1$ (or $N2$). Also, during a high input, either $P1$ or $P2$ is off, so there is no series path to V_{DD} . But suppose both inputs are low. Then, both $P1$

and $P2$ are on and $N1$ and $N2$ are off. The output is pulled high to V_{DD} by the low on resistances of $P1$ and $P2$ in series. With only 4 transistors, this circuit performs the NOR function; and it can be wired up easily using the pin connections shown.

By adding a third stage as shown in Fig. 2A, a 2-input OR/NOR gate is ob-

tained. The logic symbol for the complete gate is shown in Fig. 2B.

Two-input gates are by no means the limit. NOR gates with three, four, or more inputs, can be built by stacking more p units in series and adding more complementary n units in parallel. In fact, the CD4007A data sheet shows an example of a 3-input NOR. However, beyond 3 inputs, or for a number of gates, it is better to use units already manufactured—of which there are several. The CD4001AE, for example, is a quad, two-input NOR; the CD4002AE is a dual, four-input NOR; and the CD4025AE is a triple, three-input plus inverter. By examining the schematics of these devices, it can be seen that more inputs are added by building on the basic gate of Fig. 2A.

NAND and AND Functions. NAND logic is also very simply created by interconnecting p- and n-channel transistors. The NAND function means that, if both inputs are high, the gate output is low. If either input is low, the output is high. This is shown in Fig. 3A.

Note that this circuit is somewhat similar to the NOR gate with the series and parallel devices "turned upside down." The series-connected units, $N1$ and $N2$, are both on when A and B are high. Consequently, the output is low only when this is true. If either A or B is low, the series $N1$ - $N2$ path is broken. Also, a low on either A or B means that $P1$ or $P2$ is on, so the output is high. With the pin numbers shown, either a CD4007AE or CA3600E can be used for this gate. To get an AND function, add the $P3/N3$ inverter. The logic is in Fig. 3B.

As with the NOR gate, more inputs can be added by stacking more series n units and more shunt p units. For example, the CD4007A data sheet also shows a 3-input

NAND. For multiple circuits, however, there are devices that will serve the purpose without stacking. The CD4011AE is a quad, two-input NAND; CD4012AE is a dual four; and CD4023AE has triple, three-input capability.

While these basic multiple gates offer either NAND or NOR logic as they stand, AND/OR functions can be obtained by using inverters. Having both NAND and NOR logic readily available greatly simplifies logic designs since it isn't necessary to invert to use only one type of gating (often necessary with TTL or DTL, which use NAND logic).

Transmission Gates. The logic functions we have discussed so far are really just variations on the basic inverter. For counting and storage elements, a new type of CMOS is used—one which has no counterpart in other types of logic. This is the transmission gate, a basic building block which is used in flip-flops, counters, shift registers, and memories.

As its name implies, a transmission gate is used to transmit or block a signal. Its circuit is quite simple, as shown in Fig. 4A.

To form a transmission gate, p- and n-channel transistors are connected in parallel and placed in series with the signal to be controlled. Since a CMOS transistor is really a voltage-controlled resistor, a transmission gate uses this property to switch both devices to a low-resistance state when on and a high-resistance state when off. This is effectively an electronic switch whose state is controlled by the drive to the gates of the transistors. Transmission gates are bilateral switches, which means they can pass signals in either direction, so either signal terminal can be used for an input or output.

Since p and n units require opposite polarities on the gates to be on or off simul-

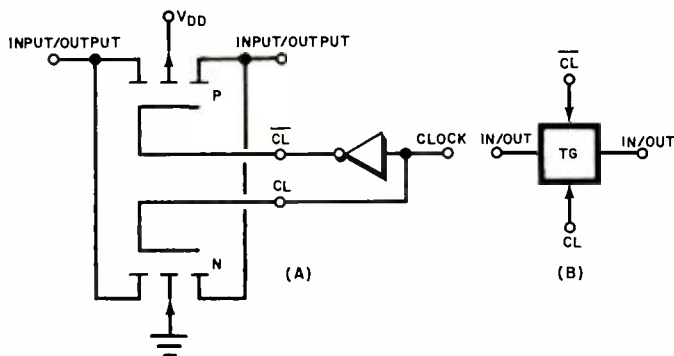

Fig. 4. A CMOS transmission gate (TG) has both pass transistors on or off together when driven by clock signals (A). The logic diagram is at (B).

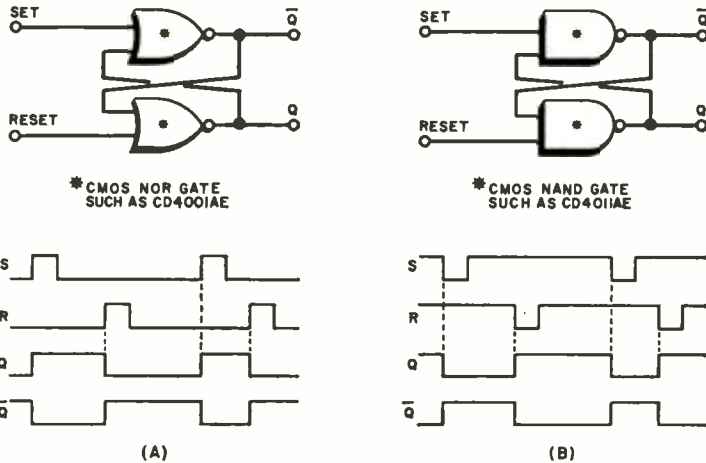

Fig. 5. Cross-coupled NOR gates respond to positive-going input signals (A) while cross-coupled NAND gates respond to negative-going.

taneously, a transmission gate requires a two-phase (push-pull) gate drive. This is usually obtained from a single clock (control) line with an inverter. In both the actual circuit (Fig. 4A) and the symbolic equivalent (Fig. 4B), the gate is on when the clock is high and off when the clock is low.

Latching (RS) Flip-Flop. The simplest form of flip-flop is the latch or RS (set/reset) device; and it can be made by cross-connecting a pair of gates—either NOR or NAND depending on the input triggering requirements. The general function of a latching flip-flop is to store the information commanded by the last active input pulse. NOR gates respond to positive input pulses. Thus, the circuit shown in Fig. 5A changes state when the set and reset lines alternately go high. This flip-flop can be made by cross-coupling any two CMOS NOR gates. Since there are two gates, the outputs are complementary.

Sometimes, negative-going inputs are available to store input timing information with a latch flip-flop. Rather than invert these negative inputs to drive a NOR latch, it is simpler to use a NAND latch as shown in Fig. 5B. The function of this circuit is exactly the same except that its inputs are sensitive to negative-going transitions. This latch can be made up of any two CMOS NAND gates, and it also has complementary outputs. For both the NOR and NAND latch-input flip-flop functions, there are also standard devices which offer multiple cir-

cuits. The CD4043AE is a quad NOR latch, and the CD4044AE is a quad NAND latch. Both of these units have built-in transmission gates which can be used to enable the output.

Type D Flip-Flops. Using latching flip-flops and transmission gates in a master/slave arrangement, the type D flip-flop is clocked, meaning that its outputs do not respond to input data until the clock line goes from low to high. A typical CMOS type D flip-flop is the CD4013AE as shown in Fig. 6.

The key to the operation of this flip-flop is the transmission gates, which are controlled by the clock input. There are two sets of gates, driven in opposition. In the master section, data is entered and held, then transferred into the slave section when the clock line goes from low to high. The slave (output) section has separate set and reset inputs which can be used to latch it upon application of a high input, regardless of the state of the clock.

JK Flip-Flop. The standard CMOS JK flip-flop is the CD4027AE, a dual device with set and reset capability. This flip-flop circuit is similar to the type D, with additional gating for the J and K inputs. Like the CD4013, the CD4027 changes states synchronously with the positive transition of the clock pulse. It also has set and reset inputs, which override the clock and respond to high-level inputs. The CD4027AE is useful in counters, registers,

and control circuits and will typically clock at 8 MHz with a 10-volt supply.

Counters and Registers. There are many CMOS high-order devices. They are multiple stages of the basic CMOS functions and many of them are MSI or LSI. Circuits with large component density are ideally suited to CMOS because its all-transistor circuit allows high packing densities.

There are a number of multiple-stage counters available. The CD4024AE is a 7-stage unit, allowing counts up to 128, with buffered taps at each of the seven stages. A common line resets all stages together. The CD4040AE is similar, but has twelve stages (counts up to 4096). Fourteen stages are available in the CD4020AE, which counts up to 16,384.

A watch can be made with the CD4045AE, a 21-stage counter, which can count to 2,097,152. It also has output pulse shaping for motor drive and a stage for an oscillator. With this one device, it is possible to have a crystal-controlled source with 1-second outputs.

There are a number of CMOS registers with various input/output formats. The CD4015AE is a 4-stage device; CD4014AE has 8 stages; and CD4006AE 18 stages. The versatile CD4034AD is an 8-stage register which can be used serial in and parallel out, parallel in and out, bidirectionally, and either synchronously or asynchronously.

Display Decoders and Drivers. To use with the counters and registers, a number of display drivers and decoders are available. The most basic are the CD4026A and CD4033A, decade counters with seven-segment decoders. Outputs can be inter-

faced to LED and other popular 7-segment displays with a high-current buffer.

The low-power display to go with low-power CMOS is the liquid-crystal type, and there are several decoder/driver combinations which can drive liquid-crystal displays directly. The CD4054AE is the basic unit, a 4-line input (with latches) and display drivers. The CD4055AE is a BCD input unit with 7-segment decoder and drivers. The CD4055AE is a BCD input unit with 7-segment decoder and drivers. The CD4056AE is basically the same, but it has a latch with strobe on each input line.

Other CMOS Variations. What has been described so far are the basic elements of the RCA 4000A COS/MOS line. RCA was a pioneer in the field and the 4000A series is now manufactured by many other companies. However, in addition to the 4000A devices, several manufacturers offer their own highly useful versions of CMOS logic elements.

Motorola Semiconductor has a very broad line of CMOS devices—both 4000A types and its own variety. Motorola's CMOS line (which it calls MeMOS) is similar in concept to those we have discussed but they have a greater power supply range. Military devices (denoted by an AL suffix) operate from 3 to 18 V and the CL or CP types operate from 3 to 16 V at -40 to $+85^{\circ}\text{C}$. The numbering of the 4000A devices is slightly different—the 4007A, for instance, is Motorola's type MC14007AP.

In addition to the MC14000 series, Motorola has an MC14500 series, with many special features. The most interesting devices are in the MSI category. For instance the MC14517CP is a dual, 64-

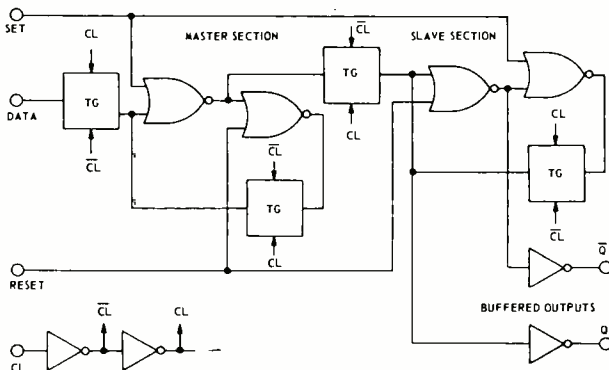
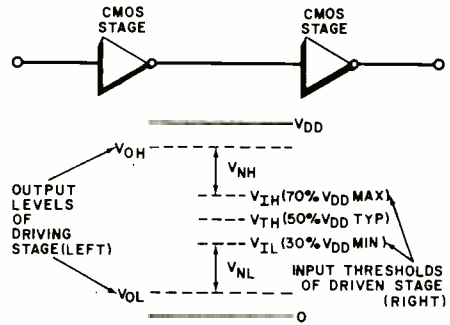

Fig. 6. Block diagram of one section of an RCA CD4013AE COS/MOS type D flip-flop unit.

CMOS NOISE IMMUNITY

In Part 1 of this article we mentioned the fact that CMOS stages switch at approximately half of the supply voltage. This transfer characteristic and the fact that the high and low logic levels approach the values of the supplies provide the very high noise immunity that is typical of CMOS. Typically the noise immunity is specified as 45% of V_{DD} .

Noise immunity is basically the difference between the high and low states of the output voltages and the high and low states of the input thresholds. This is shown graphically in the accompanying sketch. In general, an output voltage (V_{OH}) greater than the next stage's high input threshold (V_{IH}) guarantees that the driven stage will recognize the input level as a valid high level and switch properly. Similarly, an output low voltage (V_{OL}) lower than the stage's low input threshold (V_{IL}) guarantees recognition of a valid low level. The difference between the actual V_{OH} and necessary V_{IH} is the high-state noise margin (V_{NH}) since a noise pulse of this amplitude can exist without disturbing the validity of a one logic



state. In like manner, the difference between V_{OL} and V_{IL} is the low-state noise margin (V_{NL}).

The highest noise margins (V_{NH} and V_{NL} , maximum) occur when V_{OH} approaches V_{DD} , V_{OL} approaches 0, and V_{IH} and V_{IL} are nearly centered between V_{DD} and 0. These factors are all characteristic of CMOS stages. V_{OH} and V_{OL} are typically within 10 mV of V_{DD} and 0, and the input thresholds are centered around $\frac{1}{2}V_{DD}$. CMOS noise margins at room temperature are typically 45% of V_{DD} —at a minimum, 30%. This makes the worst-case upper and lower input thresholds 30% and 70% of the supply.

stage shift register, with taps at 16, 32, 48, and 64 bits. The MC14511CP is a BCD-to-7-segment latch/decoder/driver which can supply up to 25 mA of output current. The MC14514CL and MC14515CL are combination 4-bit latches and 4-line to 16-line decoders.

An interesting counter set is the MC14522CP and MC14526CP, BCD and binary (respectively) programmable "divide-by-N" counters. The BCD unit can divide by 1 to 999 at up to 5 MHz.

The standard monostable is also available in the MC14528CP, a dual one-shot. Its two sections can be triggered with either pulse edge, and pulse width is set by external resistance and capacitance.

National Semiconductor has two CMOS lines—one a 4000A series and the other a series with "74-type" pin configurations. The latter, the much broader of the two lines, are pin-for-pin functional equivalents of 7400 TTL. In this, a 74C00 is a quad 2-input NAND gate just as is a 7400. The rest of the series is the same, including gates, inverters, flip-flops, counters, registers, decoders, and so on. The line is still

being expanded. All 74C outputs are designed to drive two 74L loads, making interfacing easy.

National's MM4600A series is equivalent to the 4000A CMOS lines for -55 to 125°C operation; and the MM5600A line is for -25 to 70°C . So, the National part number for a CD4007AE is MM5607AN.

Harris Semiconductor has made a unique contribution to CMOS technology with its process of "dielectric isolation" which yields both higher speed and even lower power than regular CMOS. Harris also has 4000A types as well as its own proprietary devices. All are made with the D1-CMOS process. The 4000A devices are designated simply as HD-4000 types. For instance, an HD1-4007-9 is a 4007A in a ceramic package. The other Harris series is the HD4800; and it includes buffers, flip-flops, transmission gates, etc.

Summary. We have covered the important aspects of the operation and application of CMOS IC's. The important thing now is for the reader to try them in his own circuits and come up with new ideas. ♦

ELECTRONICS IN MODERN SOUND STUDIOS

HOW ELECTRONICS HAS REFINED AND ADDED NEW
DIMENSIONS TO THE ART OF SOUND RECORDING

BY CRAIG ANDERTON

ELECTRONICS has changed the professional recording studio just as it has changed many other specialized areas over the past few years. Much of the increased sophistication in sound can be traced to a corresponding sophistication in electronics in general. Specifically, linear and digital integrated circuits have opened up an entirely new era in the art of recording, making possible machines that create sounds which attract listener attention and save precious time and money in the studio.

It is interesting to look into a modern recording studio. By comparing the relatively unsophisticated studio of only a decade ago

to a modern studio, one can get an inkling of what the studio of the future is likely to be.

Inside a Typical Studio. Before discussing what is new, let us review the basics of studio recording. The heart of the whole process is usually a tape system that can record 16 independent tracks of audio information. This independence allows individual tracks to be electronically adjusted to provide the best possible effect. Sometimes the sound engineer will erase one track to get a better performance from a musician while leaving the other tracks alone.

In this modern studio at RCA Records, the audio engineers can alter, electronically, studio size and reverberation time to obtain desired effects.



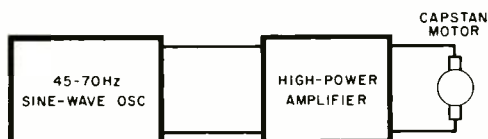

Fig. 1. A sine-wave oscillator and amplifier circuit control speed of tape recorder motor.

To end up with the final stereo master, the 16 tracks, each individually optimized for best level and tonal balance, are mixed down into a 2-track machine. Just to accomplish this basic function requires sophisticated electronics, usually found only in sound studios, for both recording and playing back. Limiters are used to keep audio signal peaks from overdriving the tape recorder by electronically keeping the signal level within a range that can be handled by the recorder. Panpots are used to place the signal "source" at a position anywhere between the extreme left and extreme right of a stereo "spread." Artificial reverberation might be used to provide a realistic depth to the signal that the studio acoustics may lack. And equalizers can be used to cut or boost any tonal range, making thin basses full, strident voices mellow, and dull sounds bright.

In addition to the specialized devices, a studio requires monitor amplifiers and speakers, cueing devices, microphone preamplifiers, etc. Working together, these various items make up a basic studio.

New Sound Machines. Since studio time is expensive (\$100-\$150 per hour), it is no wonder that the promise of electronics to do a better and faster job has led to the rapid acceptance of a number of innovative de-

VICES. The new devices either modify the sounds of existing instruments and voices to produce a novel effect, or solve a particular problem.

The pitch problem is only one area in which electronics has helped. For example, suppose someone records a piano and a voice track in the studio and, a week later, decides to overdub an electronic organ that is not quite in tune with the piano. Before electronic speed control, the out-of-tune organ might have been put on with the hope that no one would notice the discrepancy, or the organ was retimed and the overdub was remade, neither approach being satisfactory. With speed control, however, the recording engineer can now adjust the speed of the entire 16-track master tape until the pitch of the old track exactly matches the tuning of the new instrumental overdub. If the track is slightly higher in pitch than the instrument to be overdubbed, a slight reduction in the recorder's speed can bring the two into line.

There are two other popular applications to which speed control can be put. If a selection drags a bit, the whole number can be sped up by a small but noticeable amount; conversely, too fast a tempo can be dealt with by slowing down the recorder. Secondly, with drastic speed changes, instruments become almost unrecognizable. Slowed-down drums can sound like thunder, while a sped-up guitar's sound resembles the sounds produced by a harpsichord. Hence, speed control can be used to introduce special effects.

Since most tape recorder motors use the 60-Hz power-line frequency as a reference for speed, speed controls are basically variable-frequency devices. They consist of a variable sine-wave oscillator feeding a high-power, heavy-duty power amplifier, the output of which is used to drive the motor (see Fig. 1). It should be noted that too great a speed deviation can strain a recorder motor, causing it to heat or stall. This restricts the maximum deviation in frequency to about ± 25 percent, which is satisfactory for all but the most unusual effects.

Phasing, defined as the sound produced by playing back two identical signals at the same time with a slight time difference between them, is another example of electronics making a tough job easy. The composite signal acquires a very popular "spacey" type of sound due to the subtle phase and frequency changes that occur. This process



Many tracks are equalized, enhanced and mixed electronically to make master tape.

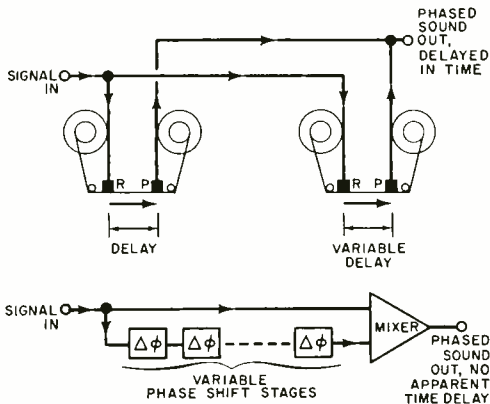

Fig. 2. Phasing (to get "spacey" effects) was formerly accomplished by running the signal through two tape decks, with different delays (top diagram). Now, a series of electronic stages with variable shifts accomplishes same thing (bottom diagram).

formerly required the use of two tape decks, one with variable speed to produce variable time delays, and could be done only during mixdown since recording the signal was a prerequisite to any processing.

Now, electronic phasing units accomplish virtually the same thing by cascading a series of phase-shifting stages. As the phase shifts, the signal picks up a simulated time delay which, combined with the original un-

shifted signal present at the input of the phasing unit, produces phased sound at the output (see Fig. 2). This avoids tying up an extra machine and setting up a variable-speed system and offers the advantage of being able to be used while the musician is recording. Also, this helps the engineer by reducing the number of tasks to be accomplished during mixdown, while permitting the musician to tailor his playing to the effect.

A close but considerably more complex relative of the phasing unit is a device called the "digital delay line" (DDL). It consists of an analog-to-digital (a/d) converter, a large number of shift registers, and a digital-to-analog (d/a) converter. The a/d converter (see Fig. 3) changes the analog signal at the input of the DDL into a binary, or digital, signal that is then shifted many times to pick up a small but useful time delay on the order of a few hundred milliseconds. The d/a converter then changes the delayed digital coded signal back into an analog signal that is identical to the signal at the input but delayed in time.

A DDL unit has many uses. It can produce the phasing effect. It can produce an echo or "reverb" effect without using the usual tape process or mechanical springs. It can also multiply the sound of an instrument. To accomplish the last, a violin re-

A typical professional mixing console such as those employed in modern recording studios.



(All photos courtesy of RCA Records)

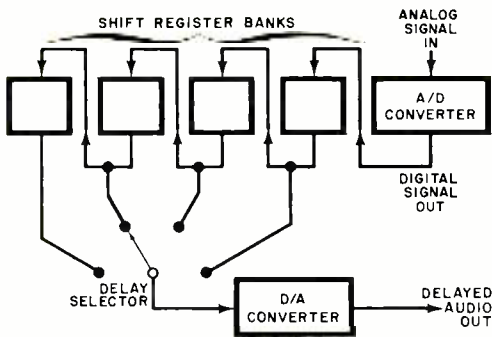

Fig. 3. Schematic of digital delay line that is used for phasing and effects such as reverb.

corded through a slight time shift of, say, 5 ms, sounds like two violins. Recording the composite sound into one track of a 16-track recorder and playing the new track back through a DDL again yields a sound like four violins. Repeating the process, it is possible to create an entire string section from one violin, one DDL, and a multi-track tape recorder.

The problem of leakage between adjacent microphones in a studio is yet another event that lends itself to solution through electronics. A device called the "Kepex" effectively cancels leakage by being, in effect, an expander with a programmable threshold level. All signals below the threshold are attenuated by a controllable amount of up to 60 dB, while signals above the threshold are left untouched (see Fig. 4). Some studios use a Kepex for each of the 16 recorder tracks to control leakage. Other applications for the Kepex include eliminating excessive reverberation in a room and eliminating objectionable outside sounds such as air conditioning, sirens, etc.

Silencers. Tape hiss has always been a problem in the studio. Many techniques have been used to cut back on noise: running a tape at 30 ips instead of 15 ips, while expensive on the tape bill, helps to some extent. So does using tapes with special oxide formulations. High-output microphones help by improving the overall signal-to-noise ratio. But nothing does quite so much to cut out tape hiss as the Dolby™ noise reduction system (and other related systems) that electronically controls the recorded signal to minimize noise. The Dolby system boasts the highs during recording to bring low-level passages above the ambient noise. During playback, the system

compresses the signal to restore the dynamic range—but without the noise. Several other companies, among them dbx and Burmens, have also developed noise reduction systems that help in cleaning up a record.

Looking To The Future. In the recording industry, new advances are almost immediately put to practical use. The exploitation of digital equipment and techniques is just one example. Some control boards now use switching logic to replace the traditional patching system found in older consoles.

Various programmable expansion and compression devices are now available. So are digital accessories like timers and tuning standards. Some manufacturers are even perfecting a computerized mixing console. Such a console allows the programming of fade-outs, fade-ins, stereo image placement, and so on. There is no doubt that extensive automation will be a key to studio work in the future.

Another trend to watch is the tendency for people to build their own 4- or 8-track studios at home rather than pay the going rate for 16-track recorder time. Several consumer-oriented companies like Teac are making home-studio oriented 4-channel synchronizable tape decks and relatively inexpensive (less than \$2000) mixing consoles.

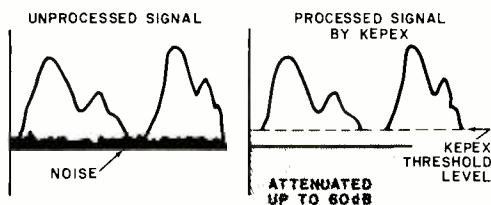

Fig. 4. Waveforms show how Kepex device effectively cancels leakage between mikes.

There are a few catches to having advanced studio equipment available. For one thing, just to use it properly requires the services of an engineer with equal musical and electronics knowledge. There is also a shortage of people capable of maintaining the highly complex equipment in peak operating order. Considering the high cost of studio time and the fact that many studios are booked around the clock, equipment down-time must be kept to an absolute minimum. Hence, the extra automation comes at the expense of more to learn and more to maintain. ♦



Build a **Shirt-Pocket METRONOME**

PROVIDES PRECISION AUDIBLE COUNT OF
40 to 220 BEATS PER MINUTE

BY A. A. MANGIERI

THE ubiquitous 555 IC is proving to be the answer to many timing problems. Here, for example, it is used as the heart of a precision shirt-pocket electronic metronome having an adjustable range from 40 to 220 beats per minute. It costs less than \$5 to build.

About the Circuit. The timer (IC1) is operated as an astable oscillator whose per-

iod is determined by capacitor *CI* and timing resistors *R1* through *R3*. When the voltage across *CI* reaches $\frac{2}{3}$ of V_{cc} , *CI* discharges rapidly through *R1* and the internal circuit of the IC to $\frac{1}{3}$ of V_{cc} , and then the cycle repeats. With the IC trigger terminal (pin 2) connected as shown, the IC re-triggers itself to initiate the next cycle.

The output of IC1 (pin 3) is a pulse which drives a small speaker voice coil

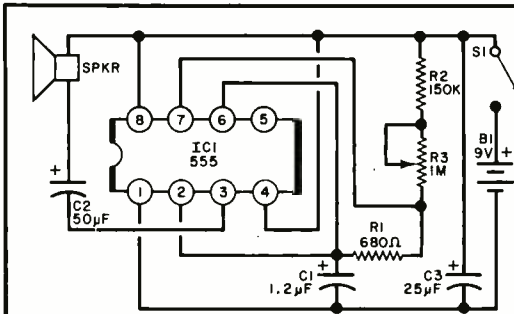

PARTS LIST

- B1*—9-volt transistor battery
- C1*—1.2- μ F, 12-volt disc capacitor (see text)
- C2*—50- μ F, 15-volt electrolytic capacitor
- C3*—25- μ F, 15-volt electrolytic capacitor
- IC1*—555 IC timer
- R1*—680-ohm, $\frac{1}{2}$ -watt resistor
- R2*—150,000-ohm, $\frac{1}{2}$ -watt resistor (see text)
- R3*—1-megohm miniature linear-taper potentiometer
- S1*—Spst slide switch
- SPKR*—Miniature speaker
- Misc.*—Case, perf board, IC socket, push-in terminals, battery clip, knob, etc.

The clock rate, generated by IC1 is determined by C1 and the associated resistors. A small speaker converts the current pulses to audible clicks.

through coupling capacitor C2. Using small resistance values for R1 and large values for R2 and R3 produces brief pulses at moderate time intervals, with potentiometer R3 determining the repetition rate.

Since the trigger levels of the IC depend on the ratio of some "on-the-chip" resistors, timing is not affected by changes in the supply voltage. Also, because the 555 delivers sufficient current, a much higher audio vol-

ume will result than in the conventional UJT approach.

Construction. Using a socket for IC1, the complete circuit can be assembled on a small piece of perf board and installed in almost any type of chassis. The prototype, as shown in the photos, was built in a plastic transistor radio case.

The metronome should deliver 40 to 220 beats per minute, so set R3 at maximum resistance and pick a capacitance for C1 that will provide slightly less than 40 beats per minute. This is done by using five 0.22- μ F disc capacitors and padding them until the desired 40 beats is obtained. Then set R3 to minimum resistance and pick a resistance for R2 that will provide slightly more than 220 beats. You can count the beats over a 5- or 10-second interval.

The impedance of the speaker limits the peak current surges through the output stage transistors. The prototype has been used with six-inch speakers having only several ohms of resistance and also with a 16-ohm speaker. So pick a speaker that will fit the selected enclosure.

Use a dial scale on R3, and calibrate it at the most frequently used rates. For photographic work, make the one-per-second beat calibration the most accurate.

Application. Turn on the metronome and adjust R3 for the desired beat rate. After S1 is first turned on, a few moments will elapse before the first click is heard while the dc voltage levels become established. Replace the battery when the audio level drops below a satisfactory level. The average current drain is about four milliamperes, so battery life should be long. ♦

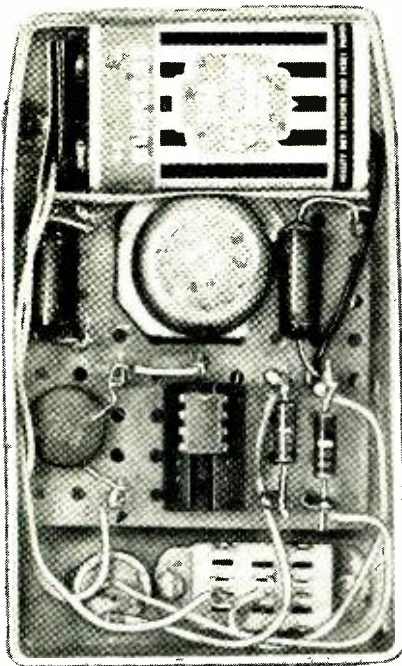

Photo shows how author's prototype, using perf board, fits in transistor radio case.

VOLTAGE INDICATOR USING LED'S

*Two light-emitting diodes indicate
polarity and level of voltage*

BY CALVIN R. GRAF

A SIMPLE dc voltage polarity indicator that can also reveal the presence of ac voltages and provide a rough estimate of ac and dc voltage levels is a handy item to have on a workbench. As shown in the schematic diagram, such an instrument can be built from very few components, making your investment minimal.

The polarity indicator provides testing capability for ac and dc voltages between 1.5 and 150 volts. This range covers just about every voltage level you are likely to encounter in solid-state electronics, the automotive field, and the standard 117-volt ac line power that is so important to modern electronics.

Light-emitting diodes *LED1* and *LED2* indicate both the polarity and level of voltages under test. For dc voltages, only one LED will illuminate, while ac voltages will turn on both LED'S. (When both LED'S come on, it is a sure indication that ac is present.) Level indication is a function of the value of the series resistance (*R1* through *R4*) switched into the circuit via rotary range switch *S1*. Resistor *R1* is always in the circuit, limiting the current through the LED'S to about 30 mA on the 5-volt range. As *S1* is rotated through the 12-, 24-, and 150-volt positions, resistors *R2*, *R3*, and *R4*, respectively, add to *R1* to maintain a safe current limit (20 to 30 mA) through the LED'S.

Polarity indication is a function of which of the LED'S illuminates and the manner in which the test probes are connected to the unknown voltage buses. To illustrate, assume that the red (+) test probe were connected to the "high" bus and the black (-) test probe were connected to the "low" bus. Under these conditions, *LED1* would illuminate, indicating that the red

test probe is indeed touching the high bus. If the probes were transposed so that red is touching low and black is touching high, *LED2* would come on to indicate that the black probe is connected to high. (For ac voltage indications, no matter how the test probes are connected to the buses, both LED'S would illuminate.)

Use LED'S rated at 50 mA or greater forward current. Two good choices are Motorola's HEP P2000 and P2003 LED'S, both of which are rated at 50 mA.

To use the polarity/level indicator, always start with *S1* in the "off" position. Connect the test probes to the buses of the unknown voltage and switch to the 150-volt range. If neither LED glows, proceed down-range until you see one or both LED'S glow. Stop at the first range that yields an indication. If you switch to a lower range, you might pass excessive current through the series circuit and destroy one or both LED'S.

With practice, you will learn not only how to determine polarity and the range into which test voltages fall, but you will also get the knack of refining voltage level readings within each range by the intensity of the glow. ♦

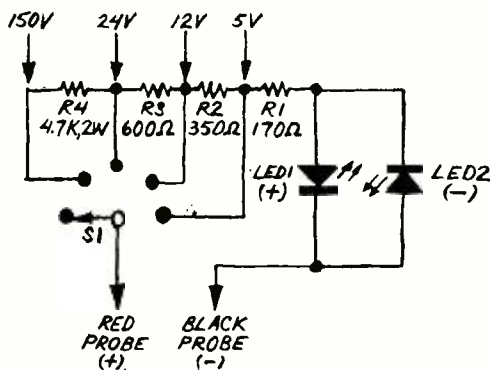



Ken Fransen is using his electronics training where it really counts.

Helping to save lives in the U.S. Coast Guard.

It's up to Ken to keep sophisticated electronics communications equipment in top condition.

He's part of our lifesaving team. We count on Ken and need more people like him.

You may or may not have electronics training. If, like Ken, you have training, we'll put you to work fast, on a rewarding job with responsibility and challenges. If you don't have training, we'll train you.

Say your experience goes no further than building a crystal radio set. If you have an aptitude for electronics and qualify, we'll guarantee you 25 to 38 weeks of school and turn you into a seasoned professional who'll be able to troubleshoot the most complex electronics equipment. You'll study everything from theory and principle to practical application.

Those of you who already know your way around electronics systems may qualify for our advanced promotion program. After only ten weeks, you'll be promoted immediately to a higher pay grade (up to 2nd class petty officer with pay of over \$400 a month, plus food, housing and medical care). And you may qualify for even more advanced training.

Either way, your job as a Coast

Guard electronics technician will give you a broad range of experience. Using the most modern diagnostic tools, you'll maintain, repair and calibrate the latest electronics equipment, including LORAN transceivers, computer controlled transmitters, solid state equipment and AM, FM and SSB transceivers.

You might even qualify to help design, test and evaluate new equipment or prototype models in our research laboratories, or work on cesium and rubidium atomic clocks.

You'll be doing plenty for yourself, too. The training alone is worth thousands of dollars, and the skills you learn can lead to valuable, sought-after jobs in both the Coast Guard and civilian life.

What's more, the Coast Guard offers you a combination of pay and benefits most private companies can't match. (For more about our package of benefits, read the attached card.)

Find out more about a rewarding career in electronics. Mail us the card today.

**Help others/Help yourself.
Join the lifesavers.
The Coast Guard.**

WHAT DO YOU KNOW ABOUT RESISTORS?

BY ROBERT P. BALIN

The electronics technician and hobbyist must know a great deal about resistors. Besides being able to read the resistor color code, they should be able to identify some of the common applications of resistors, know how to use a resistance bridge, and know how to combine resistors to obtain a desired equivalent resistance or power rating.

To test your knowledge of resistors, see how many of the following problems you can solve. The numbers on the problems correspond to numbers on the diagrams below. The answers are at the bottom of the page.

1. The color code on the axial-lead resistor shown indicates that it has a rating of how many ohms and what tolerance percentage?

2. The color code on the radial-lead resistor

shown indicates that it has a rating of how many ohms and what tolerance percentage?

3. 4. 5. What is the function of the resistor (R) in each of these three circuits?

6. If the bridge circuit shown is balanced when the adjustable resistor is set for 60 ohms, what is the value of the unknown resistor, R_x ?

7. If a 500-ohm, 5-watt resistor and a 500-ohm, 10-watt resistor are connected in series, the combination is the equivalent of a resistor of how many ohms and what wattage rating?

8. 9. 10. What is the total equivalent resistance between points A and B for each of these three circuits? All of the resistors are identical and rated at 6 ohms.

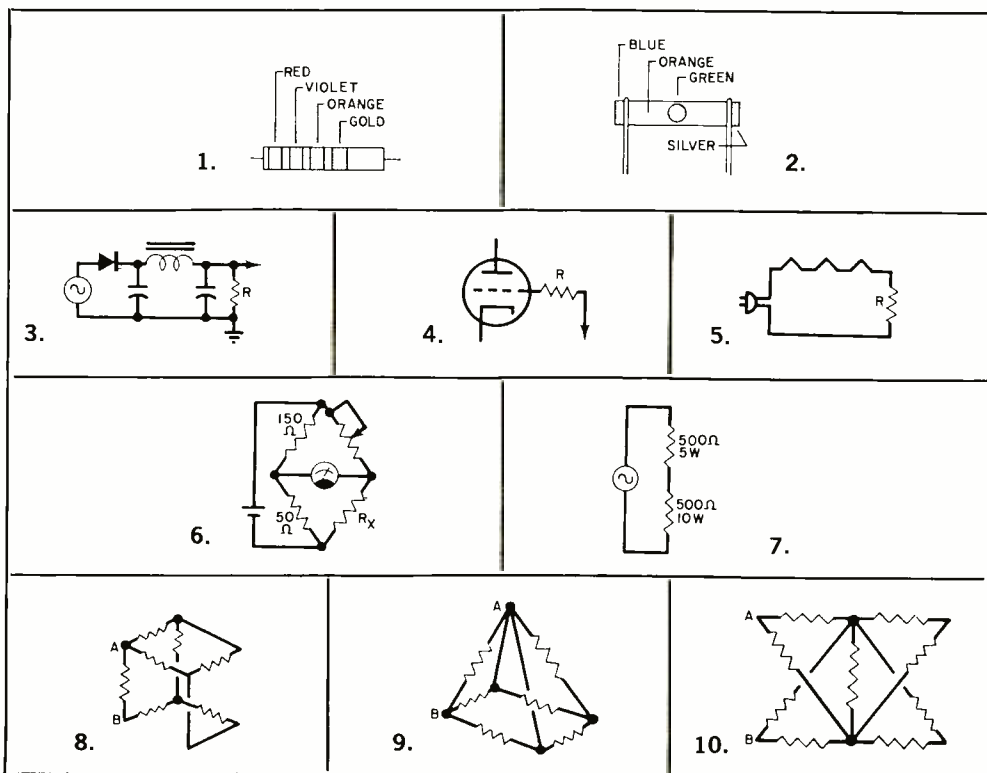

1. 27,000 ohms, $\pm 5\%$ 6. 20 ohms
 2. 3.6 megohms, $\pm 10\%$ 7. 1000 ohms, 10 watts
 3. Bleeder 8. 4 ohms
 4. Parasitic suppressor 9. 2 ohms
 5. Ballast or dropper 10. 6 ohms

ANSWERS



Product Test Reports

HEATHKIT MODEL GR-2000 DIGITAL COLOR TV RECEIVER WITH OPTIONAL REMOTE CONTROL AND CLOCK

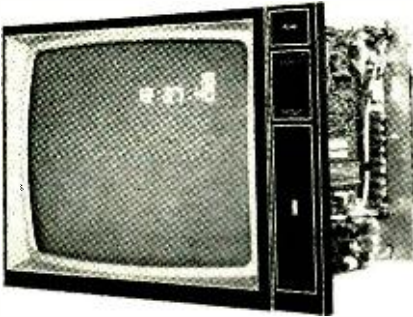

IT HAS been a long time since anything novel as far as electronics is concerned has been introduced to the color TV receiver market. Advertised "new" models are really mostly older models with cosmetic changes and perhaps a minor alteration or two in the circuitry. But now there really is something new in color TV receivers: digital, non-mechanical tuning is just one innovation. You can find it in the Heathkit Model GR-2000 color TV receiver chassis kit that retails for \$650. For another \$80 and \$30, respectively, you can add the convenience of wireless remote control and a 6-digit, 12/24-hour clock accessory.

The receiver features a digital read-out display of the selected vhf or uhf channel on the picture tube screen (also used for displaying the time); an i-f system that uses a filter, factory preset for optimum response—without traps—while having a response curve that rivals the best systems currently available; and a black-matrix, ultra-rectangular CRT with 25-in. diagonal measurement.

For kit builders who do not wish to "custom install" the GR-2000, four handsome floor-standing cabinets, from \$140 to \$180, are available to house the chassis. Style choice of Early American, Mediterranean and Contemporary, constructed of hardwoods or oak solids and veneers, with metal hardware, simplifies matching to any de-

cor. All cabinets accept a second speaker.

Technical Features. The TV tuner employs variable-capacitance (Varactor) diodes as the tuning elements. The capacitance of these diodes is determined by an applied dc voltage so that, when used with an appropriate inductance, they can be used to tune a circuit to eliminate moving parts.

The tuning system is shown in Fig. 1. The circuit begins with a 2-Hz clock oscillator (*Q217* and *Q218*) whose output pulses are gated into a four-bit up/down counter (*IC202*), depending on which latching gate formed by sections of *IC201* is turned on by its respective front-panel touch switch. The counter produces 16 binary numbers and can be commanded to continue in either the up or the down mode.

The four-bit output is applied to *IC203*, a 16-line decoder. Only one of the 16 outputs is low at any given clock interval, the other outputs remaining high. The low cycles around the 16 outputs, depending on the input count. Let us assume that output 1 is low while all others are high. Each *IC203* output drives a separate transistor (*Q201-Q216*). Only *Q201*, connected to the low 1 output, is turned off and *Q202-Q216* are saturated and act as closed switches, shorting their respective diode anodes to ground.

The Varactor tuning voltage for each channel is derived from the setting of preset tuning controls *R276-R293* which are calibrated for each tuner via *R294*. The tuning voltage at the rotor of each preset control is fed via isolating resistors *R213-R246* and diodes *D249-D264* to the tuning voltage input in the tuner. Only *Q201* is cut off so the positive voltage from *R213*, the only "on" circuit, passes through *D249* to the tuner. Simultaneously, the other diodes

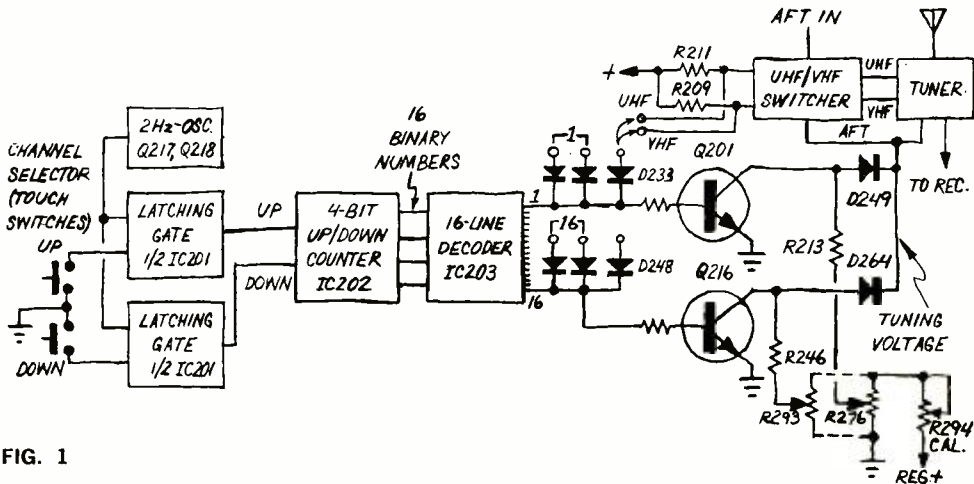

FIG. 1

are automatically reverse biased. As the low output of IC203 cycles with channel selection, each transistor in turn is "opened" while all others are saturated. Hence, IC203 automatically selects the preset Varactor tuning voltage for each channel.

Each channel-selecting transistor circuit has provisions for vhf or uhf strapping. When the selected channel is uhf, strapping automatically develops a voltage drop across R211, which causes the vhf/uhf switcher module to apply the correct voltage to the tuner to convert it to uhf for that selection. The switcher also accepts the automatic fine tuning (aft) voltage and applies it to the Varactor input of the tuner to which the channel-control voltage is applied.

The preselected channels, totalling 16 in all, can be any combination of vhf and/or uhf channels in your viewing area. The same channel can even be programmed into more than one selection slot.

The basic circuit for the digital channel readout system is shown in Fig. 2. (Lacking a mechanically operated tuner, the GR-2000 has no control-panel channel indicator.) The vhf/uhf channel numbers automatically appear at any preset position on the TV screen whenever the channel is changed or when the channel number is called for by the user. The seven-segment display differs from other such displays in that the segments overlap each other at their extremities to produce unbroken figures. The channel identifier can be programmed to remain on over a period of time ranging from a few seconds to 1½ minutes.

The display chip (IC301) is a CMOS device that generates numerical characters on demand. It uses the horizontal and ver-

tical pulses for timing. The 4.5-MHz gated oscillator that forms the "clock" for the character generator is gated only when the horizontal and vertical pulses are simultaneously present. The horizontal pulses are fed directly into IC301, while the vertical pulses arrive via a gate and time-delay circuit. The delay keeps the vertical gate on for the programmed-in period, after which the gate opens, no vertical pulses appear at IC301, and the digit display disappears. The time delay is activated automatically with channel up/down or recall signals.

Facilities are provided in IC301 for generating either a 4- or a 6-digit display when using the optional Model GRA-2000-1 clock module, or to display either the channel number and time or the channel number only. Each time or channel digit is generated in accordance with the IC301 inputs from the tuner or optional clock. The IC output is passed through a display/dot switch to emitter follower Q221. Three chroma amplifiers accept the red, green, and blue video from the receiver, while the luminance signal is inserted via transistor Q426. Transistor Q427, in parallel with the luminance input, accepts the numeric display or dots for parallel display on the CRT screen. Potentiometer R445 determines the brightness of the digital display.

The optional clock module accepts the digit address code from IC301 and uses it to generate the time's numeric characters.

Positioning controls for both the horizontal and vertical directions enable the user to place the digital display almost anywhere on the TV screen.

The dot generator (not illustrated) consists of conventional digital logic using the

horizontal and vertical pulses as timing to generate the pattern required. The output of the dot generator is passed to Q221 through the display/dots switch.

The unique bandpass filter used in the video i-f module is a predistorted transitional gaussian design made up of ten sections. This computer-designed module is enclosed in a double-shielded enclosure and never requires adjustment. When coupled with its associated amplifiers, it creates an i-f that is at least the equal of most top-of-the-line performance for commercial color TV receivers.

There are no tunable traps in this unique filter-type video i-f amplifier. The curve skirts are very steep on both sides immediately above the picture carrier and below the chroma carrier. This means that the 10-to-15-dB "comeback" problem typical of the conventional trap is nonexistent in the GR-2000 and, hence, no "herringbone" patterns will appear in the picture.

Remote Control Option. The main option for the GR-2000 is the GRA-2000-6 TV Remote Control which consists of two sections—a hand-held ultrasonic transmitter and a two-part ultrasonic receiver that is mounted in the receiver.

The hand-held transmitter has four finger-operated rocker switches that provide the eight signals that turn the TV receiver on and off, adjust the audio volume (increase and decrease), change TV channels (up and down), and give complete control of both tint and color intensity. A touch on either the volume or channel selector control will also recall the digital on-screen channel number or time readout. The usable range

is at least 20 feet. The single-transistor transmitter is powered by a conventional 9-volt battery and is enclosed in a beige plastic case.

The two-part ultrasonic receiver, which is mounted in the TV chassis, senses the eight ultrasonic signals through a microphone concealed in the front panel of the set. The circuit of the receiver uses 28 transistors, 12 IC's, and 8 diodes. One portion detects the signal presence, and the second "remembers" what was remotely commanded.

The color and tint circuits each have an 8-bit up/down counter, an associated clock-pulse latching gate, and a digital-to-analog converter. The volume control circuit consists of a 4-bit up/down counter, an associated clock-pulse latching gate, and a digital-to-analog converter with additional circuits for controlling an ac power on/off relay.

When installed in the GR-2000, the remote control is paralleled with the similar elements in the receiver.

User Report. The receiver is assembled in module fashion. First come the 20 glass-epoxy circuit boards. (Each board is packed with its own components so that there can be no errors.) Assembling the boards is easy if the excellent instructions in the manual are followed. Each step is clearly identified and there are sufficient illustrations to satisfy even the most fastidious assembler.

Once the boards are complete, the receiver subchassis is assembled, with other elements following. Total time taken for our assembly of the receiver was 52 hours. If this seems a little long, we must point out that we were not racing against time and took some care to make sure that the as-

FIG. 2

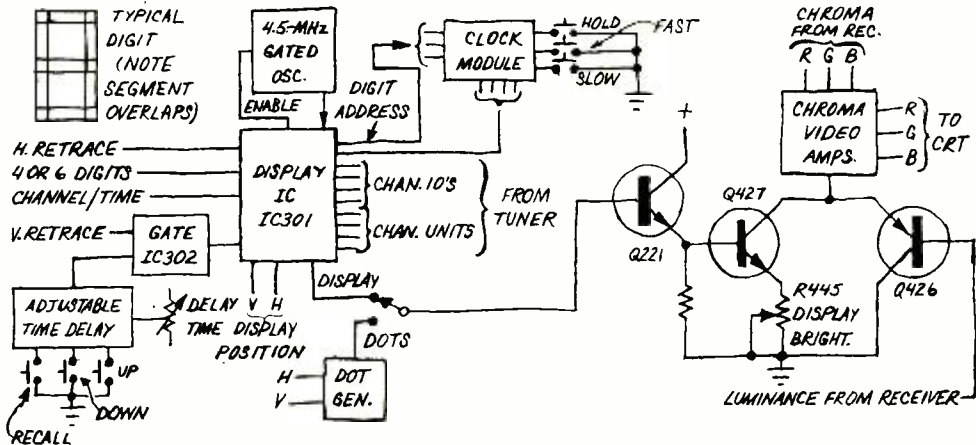

sembly, when complete, would work properly—a procedure that we find usually pays good dividends.

The receiver contains 19 IC's (33 if the remote control and clock are included) and 71 transistors. Each semiconductor has its own socket and there are 12 factory-fabricated interconnecting cables. The 25-in. CRT is enclosed in a sturdy Magna-Shield metal container with the circuit elements mounted on the rear apron. The preset tuning controls, remote control, readout board, convergence board, and clock module are all mounted on a slide-out service drawer, which is mounted beside the CRT enclosure.

Once the set is completely assembled, it can be converged. For the GR-2000, convergence is far easier than with most color sets. The built-in dot generator produces rock-steady, *small* dots that make adjustment much easier. The complete color adjustments can be performed in less than one hour. The tuner and i-f circuits are preset in the factory and require no alignment.

Programming the channels is simply a matter of determining which channels will be most frequently used, and in what order. There is a choice of any 16 channels—high or low vhf and uhf. The same channel can also be programmed to appear in more than one selected position.

The CRT-displayed channel identifier is programmed at the same time. This on-screen identifier is used because the set does not have a mechanical front end. The digital readout appears automatically when the channel is changed or when the volume is turned down by pressing the appropriate switch on the receiver or remote control. The channel number display can be set to remain on for a few seconds or as long as 1½ minutes. It can also be set to be displayed at all times; its brightness can be adjusted; and it can be adjusted to appear anywhere on the CRT screen.

The clock module also fits in the slide-out drawer and is provided with the usual pushbutton controls. The time display can be set to provide either four or six digits, and it appears just below and at the same time as the channel identifier.

The picture obtained on the GR-2000 can only be described as superb. The Black (Negative) Matrix CRT, the tuner and i-f strip, and the video amplifier provide a pic-

ture equal to that of many studio color monitors. (We used the GR-2000 with a broadband log-period antenna and coaxial transmission line, in a good signal area.) Blacks are intense and vivid and high-frequency outlines are very clean with no evident ringing. The color "fit" is excellent and the overall chroma spans the range from a light pastel to excessive coloration. The i-f produces no herringbones, no adjacent-channel interference, and no moiré patterns. Best of all, no more alignments.

The touch-switch system of tuning and sound control takes some "getting used to." To change channels, for example, the front panel (or remote) touch switch is operated for either up or down. Since there is no mechanical movement involved, the channels skip by quite rapidly. The key to the operation is just to *touch* the switch and then release it—a procedure that one adjusts to quickly. In the remote mode, changing the audio level has a similar operation. When the sound is reduced to a minimum, the set will go off if the switch is touched again. Touching the switch for increased sound, will turn it back on and start to raise the volume.

The GR-2000 has an "instant-on" feature, which means the CRT heater is on all the time, making the picture available as soon as the set is turned on—without warm-up. Instant-on also permits the remote control module to remember all of the previous settings (being digital, the settings are lost if power is removed) and the digital clock is supplied with power so that it keeps time when the set is not in use. There is a master on-off switch which can be used to turn off the power completely.

We have taken a close look at the solid-state circuits used in the GR-2000 and were pleased to find that they use all of the latest IC's. Digital logic experimenters will find many fascinating circuits to analyze—and possibly modify for other uses. The remote control itself has more IC's and transistors than some complete TV sets.

This outstanding, large-screen TV receiver combines peerless reception, anticipated ultra-reliability (due to the elimination of mechanical switching and solid-state design) and all the optional convenience features one could wish for (electronic digital clock, remote control, and "hi-fi" audio tap). In our view, the color TV of the future is here—and Heath's GR-2000 is it!

Circle No. 5 on Reader Service Card

SANSUI MODEL QRX-3500 4-CHANNEL RECEIVER (A Hirsch-Houck Labs Report)

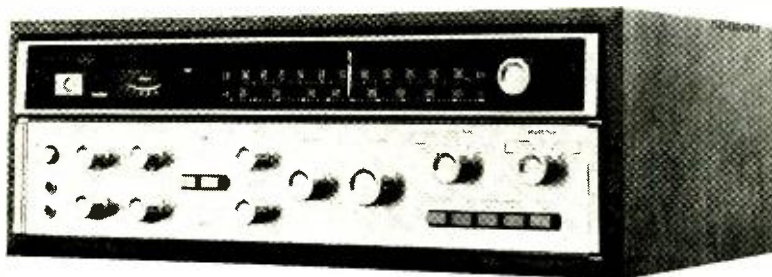

THE Model QRX-3500 4-channel stereo receiver is one of the new line of products made by Sansui which uses their Vario-Matrix (a logic controller that enhances the stereo separation inherent in the QS system). The Vario-Matrix compares the phases of the two input channels and controls the matrix coefficients to accentuate separation without "pumping" or other audible side effects encountered with other decoding systems.

The receiver's amplifiers are rated at 15 watts/channel into 8-ohm loads with all channels driven (22 watts when only one channel is driven). The power amplifiers are direct-coupled right out to the speaker outputs. Thorough protection against damage to the output transistors is provided by fuses, electronic circuits, and a relay that disconnects the speakers in the event of a short circuit or other malfunction.

The FM tuner has a rated 2.2- μ V IHF sensitivity, better than 25 dB of midrange stereo separation, and less than 0.4 and 0.6 percent distortion in mono and stereo, respectively. Most other tuner specifications reflect a good-quality tuner that is easily able to meet the needs of the vast majority of listeners.

The receiver measures 20 $\frac{1}{2}$ in. wide by 13 $\frac{3}{16}$ in. deep by 7 $\frac{1}{2}$ in. high. It weighs about 41 pounds, including wood cabinet. The front panel, its upper third dominated by a black-out dial window, is finished in satin gold with matching control knobs.

Separate bass and treble controls, each with 11 detented positions, are provided for the front and rear channels. The front and rear channels can be separately balanced left to right, and the filters operate on all four channels. There is also a front-to-rear balance control. A master volume control

permits all four channel gains to be adjusted simultaneously.

The FUNCTION switch establishes the operating mode from among 2 CH, SQ SYNTHESIZER, QS REGULAR MATRIX with both SURROUND and HALL characteristics (each supplying different amounts of rear left-to-right separation), PHASE MATRIX for SQ-encoded discs, and DISCRETE. Illuminated legends to the left of the dial scales identify the mode in use.

Another SELECTOR switch establishes the program source in use from among PHONO, FM AUTO, FM MONO, AMI, and two 4 CH AUX.

Pushbutton switches are provided for switching in and out of use loudness compensation, FM muting, and tape monitoring for any of three tape recorders (one 2-channel and two 4-channel decks). Completing the front-panel features are separate headphone jacks for front and rear channels and a pushbutton power switch.

The rear apron of the receiver contains the inputs and outputs. The 2-channel tape monitoring jacks are paralleled by a DIN connector. Spring-loaded insulated terminals are used for the speaker and antenna hook-

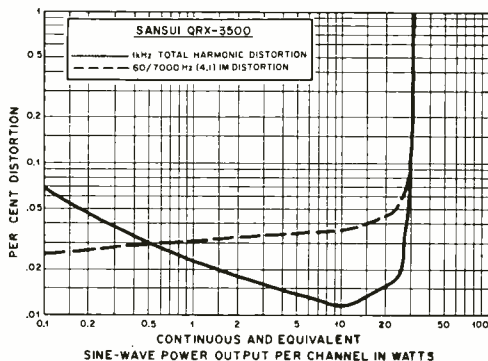

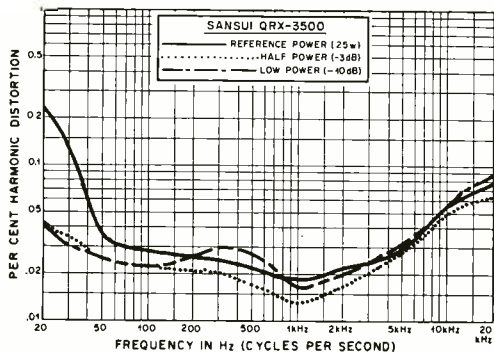

ups. There is also a socket for an optional remote-control accessory, the Model QBL-100 (\$35), that consists of a "joystick" balance control and a volume control for the 4-channel setup. One of the two ac outlets provided is switched. An input voltage selector plug adapts the receiver to line voltages between 100 and 240 volts ac. The ferrite AM antenna pulls out about 2 in. from the receiver; it does not rotate or pivot.

The retail price of the Sansui Model QRX-3500 4-channel receiver is \$500.

Laboratory Measurements. With all four channels driven at 1000 Hz into 8-ohm loads, the output clipped at 24.2 watts/channel. Driving only two channels, the available power rose to 29 watts/channel. With 4-ohm loads, the power jumped to 41 watts, while into 16-ohm loads it was 12 watts/channel. Our subsequent measurements were made with two channels driven into 8-ohm loads.

The 1000-Hz total harmonic distortion

was 0.023 percent at 1 watt, 0.012 percent at 10 watts, and 0.1 percent at 30 watts. Using 25 watts/channel as a reference power output, the THD was 0.23 percent at 20 Hz and less than 0.08 percent between 45 and 20,000 Hz. At half power or less, the distortion was less than 0.88 percent between 20 and 20,000 Hz and was typically less than 0.03 percent.

To drive the amplifiers to 10 watts output, an input of 92 mV on AUX or 1.45 mV on PHONO was required. The S/N ratio through any input was a very good 75 dB referred to 10 watts. Phono overload was at 120 mV, exceptionally high. RIAA equalization was accurate within ± 0.5 dB over the defined 30-to-15,000-Hz range (actually the full 20-to-20,000-Hz measurement range).

The tone-control characteristics were good, with a sliding turnover frequency on the bass controls and a hinged characteristic on the treble controls. The filters had gradual 6-dB/octave slopes, and their responses were down 3 dB at 120 and 3000 Hz. The loudness contours were boosted at low and high frequencies when the volume level was reduced.

The FM tuner's usable IHF sensitivity was $2.6 \mu\text{V}$. A 50-dB S/N ratio was measured at $3.6 \mu\text{V}$ (with 1.35 percent THD). The ultimate distortion, at a $1000\text{-}\mu\text{V}$ input, was 0.16 percent in mono (0.36 in stereo)—well below the specified values. The ultimate S/N ratio was 73.5 dB in mono and 63 dB in stereo. The automatic transition from stereo to mono took place gradually as the input was reduced from $40 \mu\text{V}$ to $25 \mu\text{V}$, and the FM muting threshold was $12 \mu\text{V}$.

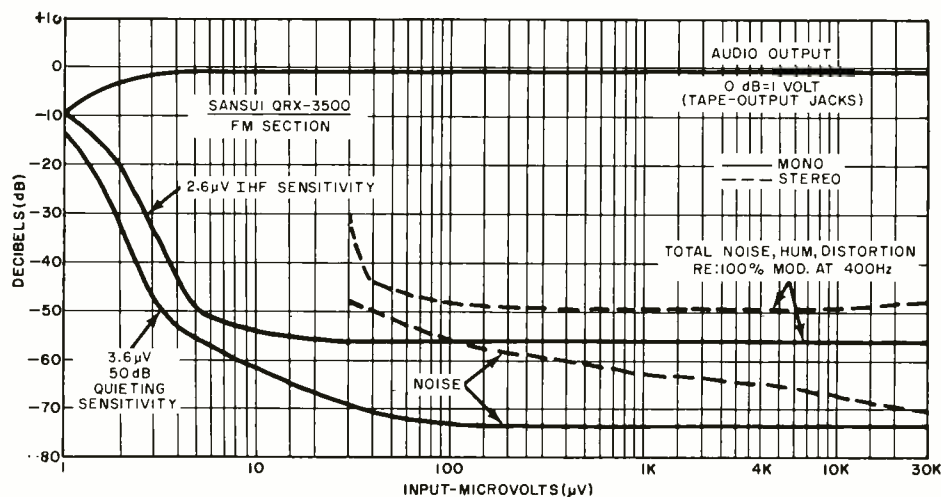

The FM capture ratio was 1.75 dB, and AM rejection was 49 dB. Image rejection was better than rated, measuring 77 dB. The receiver proved to be slightly better than its rated 50-dB alternate-channel selectivity figure, measuring 51.5 dB on one side of the signal and 65 dB on the other side.

The stereo FM frequency response was ± 1 dB from 30 Hz to 15,000 Hz, and 19-

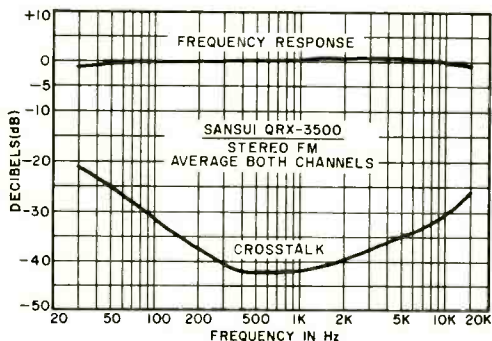

kHz pilot-carrier leakage was 69.5 dB down. Channel separation was better than 21 dB from 30 Hz to 15,000 Hz and exceeded 40

dB through a wide range of middle frequencies. The AM frequency response was down 6 dB at 50 and 3300 Hz.

Although most of our evaluation of the Vario-Matrix was done by ear, we checked its separation with a QS-encoded Sansui test record. On the sides, the front-to-rear separation was 7 to 10 dB, and across the front and rear, respectively, it was 12 and 14 dB. Across the diagonals, it was 15 to 20 dB, and from the center of each side to the opposite center or to any corner it was 10 to 20 dB.

User Comments. Judged by its published specifications, the QRX-3500 might appear to be a fairly low-powered receiver. As our tests show, however, it is rated most conservatively. It can actually deliver about 100 watts of total continuous power. Similarly, although the tuner ratings are modest, sensitivity is more than adequate, and the low distortion is comparable to that of some very expensive separate-component tuners. As the very low distortion demonstrates, the audio amplifiers are among the cleanest we have found in any receiver.

The Vario-Matrix proved to be a fascinating and impressive device. With QS-en-

Now that the AT 12S with genuine Shibata stylus is here... all other stereo cartridges over \$50 are obsolete!

Better performance from existing stereo records, and ideal operation of any CD-4 discrete playback system is all yours when you select an **audio-technica** four channel cartridge.

Now four models, including the new AT12S at only

\$49.95 suggested retail. All with genuine Shibata tips that permit response to 45,000 Hz and above, while minimizing record wear and offering superb tracking. Write today for free literature and list of **audio-technica** dealers nearest you.

 **audio-technica.**

AUDIO-TECHNICA U.S., INC., Dept. 44P, 1655 W. Market Street, Fairlawn, Ohio 44313
CIRCLE NO. 3 ON READER SERVICE CARD

coded discs, it produced virtually "discrete" 4-channel sound with none of the sudden cutting off of sound from one speaker by the action of a gain-riding logic system. With SQ discs, the system was almost as good—not as good as the latest full-logic SQ decoders, but strikingly better than other receivers equipped with the basic SQ matrix.

We most appreciated the QS SYNTHESIZER that gave better "4-channel" sound from 2-

channel programs than we have gotten from 4-channel records played through ordinary matrix decoders. Any matrix decoder can create an "ambience" enhancement via the rear speakers from 2-channel material, but this is usually totally lacking in solid directionality. In contrast, the Vario-Matrix creates four distinctly different channels from two and does it in a way that most of the time does not sound awkward or excessively artificial.

Circle No. 65 on Reader Service Card

CARINGELLA MODEL TCG-1 SEMICONDUCTOR CURVE TRACER

AS THE electronics experimenter and service technician begin to use more sophisticated solid-state devices, he must look beyond simple go/no-go semiconductor testers. At this time, he usually investigates curve tracing and its advantages, especially the capability of testing a great variety of semiconductor devices both in and out of the circuit. And, in using a curve tracer he becomes familiar with operating parameters of semiconductor devices. Of course, a curve tracer must be used in conjunction with an oscilloscope, on the screen of which are displayed the curves.

One such tracer is the Model TCG-1 made by Caringella Electronics, Inc. It is a fine example of a well-designed and easy-to-use curve tracer. The price of the TCG-1 in kit form is \$80; wired, it is \$100.

How It Is Used. The TCG-1 tracer is used with almost any type of ac or dc oscilloscope. It features two collector voltage modes: one of ± 10 volts operating at 550 Hz provides a flicker-free conventional family of five curves display, and the other of ± 200 volts is for checking voltage breakdowns. A built-in step generator produces a total of ten base-current steps (five positive and five negative) that allows both npn and pnp transistors to be tested consecutively without having to touch control settings or flipping switches to change polarity.

A three-position lever switch permits the selection of either of two test sockets or a set of three color-coded binding posts (into which test leads are plugged) for out-of-circuit and odd-based transistor tests.

The beta of the transistor under test is indicated on a clearly marked front-panel control after making a simple CRT adjustment. To eliminate guesswork, a built-in



calibrator is used to set up the scope's vertical and horizontal amplifier channels.

The instrument measures 6 in. high by 4 in. wide by 2½ in. deep. It has an attractive two-tone case with a brushed aluminum front panel. The adjustable carrying handle doubles as a tilt bench stand.

We have been using the curve tracer for several months now. In comparing it to another (more expensive) semiconductor curve tracer, we have found that the TCG-1 is more comfortable to use, primarily because of its ease of oscilloscope calibration and the capability of testing both types of transistors without having to switch around. All in all, this is a good, reliable test instrument accessory that should see a lot of use by the serious experimenter or the busy service technician involved in solid-state circuitry.

Circle No. 66 on Reader Service Card

MICRO ELECTRONIC SYSTEMS MINI DRILL

LAYING out and etching a printed circuit board is not difficult once you know how to go about it. But the trouble starts for most of us when we have to drill the considerable number of holes, sometimes several hundred in an IC project, required for component mounting. These holes are usually very small in diameter, necessitating the use of somewhat fragile No. 61 and No. 64 bits. Unfortunately, most of us own 1/4-in. or 3/8-in. hand drills that were never designed for the delicate touch needed when working with pc-type bits. The result is usually the destruction of one bit after another as each snaps or twists under the pressure of the drill. In extreme cases, the bit might break and damage the pc board beyond repair.

If you have gone this route and are considering chucking the whole idea of pc boards in favor of point-to-point wiring, don't make a hasty decision. We recently obtained a Mini-Drill made by Micro Electronic Systems Inc. that promises to solve pc drilling woes. It costs only \$17.50 and comes with a chuck tool, four AA cells, and a 0.03937-in. bit that is ideal for pc mounting holes. The battery-powered drill measures only 1 1/2 in. in diameter and 7 in. in length. It weighs a negligible few ounces; so, it is easy to handle and maneuver and reduces operator fatigue to a minimum.

The chuck of the Mini-Drill is designed to accommodate drill bit sizes ranging from 0.8 mm to 1.4 mm (0.0135 in. to 0.0551 in.), which just about covers the entire range of hole sizes you will ever need for pc work. Although the drill is usually battery powered, it can also be operated from a 6-volt, 600-mA source (available as optional Model AD-660 accessory).



In use, the Mini-Drill is comfortable to handle. Having made several test runs, each consisting of 100-plus holes, we can honestly say that there is virtually no user fatigue. The bit pierces easily through phenolic, polyester, and G-10 epoxy pc board. Although we didn't time ourselves during a test run in which we drilled 250 holes, one after the other, we would estimate that the entire job didn't consume more than ten minutes. We didn't bend or break one drill bit in well over a thousand holes drilled. (We were lucky to average 25 holes per bit with our clumsy hand drill during similar test runs.)

Circle No. 67 on Reader Service Card

Planning to move?

Let us know **6 to 8 weeks in advance** so that you won't miss a single issue of **POPULAR ELECTRONICS INCLUDING ELECTRONICS WORLD**

Attach old label where indicated and print new address in space provided. Also include your mailing label whenever you write concerning your subscription. It helps us serve you promptly.

Write to: P.O. Box 2774, Boulder, Colo., 80302, giving the following information.

Change address only.

Extend subscription. Enter new subscription.

(1) 5 yrs. \$21 (2) 3 yrs. \$15 (3) 1 year \$6

Payment enclosed (1 extra issue per yr. as a BONUS)

Bill me later.

If you have no label handy, print OLD address here.

name _____ please print _____

address _____

city _____

state _____ zip-code _____

AFFIX LABEL

name _____ please print _____ 0881

address _____

city _____ state _____ zip _____

Add'l postage: \$2 per year outside U.S., its possessions & Canada

WHY USE A TRIAC?

BY LESLIE SOLOMON, Technical Editor

THE USE of the triac in various power control systems may not be particularly innovative; but, in looking at the circuit, one tends to wonder just why a triac was used instead of some other component—or components. Many hobbyists are not really that familiar with the triac.

Since a triac can be considered to be a second-generation silicon controlled rectifier, it is necessary to understand how the latter works before getting into details on the former. An SCR is a four-layer pnpn semiconductor device having three electrodes—cathode, anode, and gate. With a forward bias (positive voltage on the anode, cathode connected to common), an SCR should behave like a conventional diode. In that case, current would flow through the junction and through any load in series.

However, the construction of an SCR is such that current cannot flow through the junction unless both the anode and gate are simultaneously positive with respect to the cathode. As soon as this happens, the SCR conducts fully, after which the signal on the gate no longer has any effect. Thus, if pure dc (rectified and filtered) is used as the power source, the SCR will not turn off as long as the anode voltage is applied.

But in most SCR circuits, either raw ac or rectified but not filtered dc is applied to the SCR. This means that only the positive half cycle has any effect on the SCR since the negative half cycle reverse biases the SCR and can't be used (see sketch A). The amount of power controlled by the SCR depends on how long the positive voltage is allowed to remain on the anode, thus supplying current to the load. The SCR turns off automatically when its anode voltage drops to zero.

If the SCR is turned on late in the positive half cycle (sketch B), only a small amount of current is available for the load; but when the gate signal is used to turn the SCR on earlier in the positive half cycle, the current through the load is increased. Keep in mind that the SCR turns off at each zero crossing and must be retriggered in each positive half cycle. Varying the triggering is usually the job of a phase-shift network which drives the gate (a circuit found quite commonly in home light dimmers, power tool controllers, etc.).

Obviously, no matter how early in each positive half cycle the SCR is triggered, the best it can do is pass half of the available power in each cycle—hardly a profitable arrangement. To remedy the situation, bridge rectifiers are sometimes used for full-wave rectification. (The negative half cycle gets "folded up" to become a positive half cycle.) This approach permits using more of the available power; but the rectifiers cost money too.

Now back to the triac, which is essentially a pair of SCR's connected as shown in sketch C, with just one common gate for the two junctions. But the two junctions are, so to speak, back-to-back so that the other two terminals can't be marked anode and cathode. Instead they are called simply Main Terminal 1 and Main Terminal 2 (MT1 and MT2).

Unlike the SCR, the triac can conduct on both halves of the cycle—with MT1 positive on one half cycle and MT2 positive on the other half cycle. Thus the triac can deliver more power than a single SCR, without a special power supply circuit. ♦

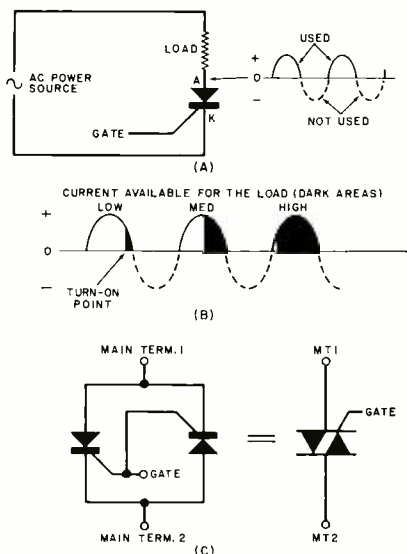



Electronics And the Energy Crisis

By John T. Frye, W9EGV, KHD4167

WHEN Barney entered the service department, blinking from the bright April sunshine, he found Mac frowning in concentration and scribbling on a note pad.

"Writing a spring poem, Boss?" the youth asked flippantly.

"Hardly," Mac replied. "I'm preparing a brief on the electronics industry's place in the sun during the long-haul energy crisis. As things have been going, I'm afraid the loudly squeaking wheels—truckers, commercial aviation, farmers, owners of private planes, teachers, boat owners, etc.—are going to get most of the grease, or oil, and leave little for the rest of us who do not have a government department, a strong union, or a powerful Washington lobby to open the spigot for us.

"Electronics is so all-pervasive in our society, it plays such a quiet but essential part in our lives, that it's easy to take its services for granted and forget that it, too, must have its fair share of energy to continue and expand those services. *Unlike most other industries, electronics returns many-fold every caloric it consumes!* It has played and will continue to play a major role on three fronts in the energy crisis: (1) the locating of new sources of present forms of energy, (2) the conservation of all forms of energy, and (3) the development and control of new kinds of energy."

Locating New Energy Sources. "I guess electronics helps locate new oil and gas fields, huh?"

"You guess right. If all the oil wells discovered through the use of electronics were suddenly taken out of production and we had left only those wells brought in guessing or using a divining rod, we would have only a small fraction of the 17 million barrels of oil we consume daily in this country. While electronics plays an essential part in most

forms of modern geophysical prospecting, it is the heart of the seismic type on which the oil industry spends many millions of dollars each year in field work and laboratory research.

"You know how this works: explosive charges are detonated in shot holes drilled in the earth, and the refracted or reflected shock waves are picked up by special chart-drawing receivers in the vicinity. The accurate measuring of the times that elapse between the detonation and the reception of the ground-travelling waves at several receiver points indicates the presence of anticlines, salt domes, and faults beneath the surface, formations expected to be oil-bearing. In underwater prospecting from a surface vessel, detonating charges are often replaced by bursts of compressed air. When new oil fields are discovered, you can bet that electronics will have pointed the finger."

Conservation of Energy. "How does electronics conserve energy?"

"Dozens of ways. First, let's talk about what electronics has already done to save electrical energy in the home, office, and industry. Replacement of tube-type radios, TV receivers, and hi-fi sets with semiconductor equipment has saved up to 80% of the energy consumed by these entertainment devices. The same goes for computers and calculators. And don't forget the saving in the huge air-conditioning energy requirements for keeping those early tube-type computers cool. The replacement of older energy-consuming relays with newly developed semiconductor products is just getting off the ground in the telephone industry, and in the future this will represent a very substantial saving in energy. Humidity sensors that automatically shut off clothes dryers when the clothes are dry, rather than at the end of an arbitrary, energy-wasting time

interval, are already saving both gas and electricity.

"But more is on the way. IC microprocessors will be used to monitor and program heating, lighting, and air-conditioning in office buildings and factories of the future. By tailoring these quantities precisely to actual needs—for example, lighting only areas actually occupied by people and maintaining a uniform temperature during all seasons—it is estimated a 30% saving in energy can be achieved. Back in the home, electronic equipment will calculate the total heat produced by an oven from turn-on and eliminate the need for wasteful preheating. You'll be glad to know the electronics industry is constantly scrutinizing its own uses of energy and trying to make savings. Core memories in computers will be replaced with semiconductor circuits; CMOS logic circuits will be substituted for TTL."

"How about transportation? Don't tell me electronics can't help save some energy there."

"It most assuredly can, and this is very important because transportation consumes 24.8% of all the energy we use, making its consumption second only to that of industry, which takes 37.3%. Actually, electronics is already doing a good job of conserving fuel used in cars. A good electronic ignition system can add up to 2 miles per gallon over a period of time by eliminating misfires and providing stable ignition timing that does not change because of wear. Automatic speed control devices can increase mileage 20% on highway travel. It's claimed that the substitution of electronic fuel injection for carburetion can, on average, increase mileage in stop-start driving from 4 to 16 miles per gallon. All in all, Floyd Kvamme of National Semiconductor says that electronics can provide up to 40% savings in automobile fuel.

"Don't forget that the car of the future is going to come equipped with an on-board computer to provide separate digital readouts for the speedometer, gas gauge, electric clock, tachometer, etc. At the same time, as we have discussed before, this computer will provide, by means of pulse modulation, exactly the amount of power—no more and no less—needed for braking, steering, window control, windshield wiping, and other mechanical jobs. It will do this over the single-cable wiring system that will replace the rat's nest of wiring found in today's cars. The saving in dc power from the bat-

tery, of course, means a saving in fuel required to recharge that battery. But that brings me to my 'invention' that I was working on when you came in."

"What invention?" Barney asked.

"A really accurate miles-per-gallon digital readout meter controlled by the on-board computer. All we need to do is provide that computer with two inputs from digital sensors, one of which will indicate distance travelled per unit of time and another which will indicate gasoline consumed per identical unit of time. The computer will sample inputs from both the flowmeter installed in the gas line and the speedometer at very short time intervals, compare them, and provide a constantly updated digital readout in miles per gallon."

"Hey, I like that!" Barney exclaimed. "It certainly would be a vast improvement over those so-called mileage meters that are nothing more than intake manifold pressure indicators. That thing would really give religion to some of our lead-footed brethren, especially if you modified the readout to indicate cost-per-mile for the high-priced fuel we're going to be using."

Mac grinned as he nodded agreement. "All of us would be better drivers if we were made instantly and irrefutably aware of the effect of our driving performance on fuel consumption—and our pocketbooks. The installation of such meters on all cars would probably do more to save gasoline than would all the dire predictions and exhortations coming out of Washington. And there would be other advantages. You'd not need to take the salesman's word about the gas mileage you could expect from the car he was trying to sell you. It would be right there on the dash in little glowing numbers at any speed you chose to drive; furthermore, after you got a tune-up, if you couldn't see an immediate improvement in gas mileage, you could ask some very pointed questions of the mechanic."

New Forms of Energy. "You said something about how electronics would help with the development and control of new forms of energy," Barney pointed out.

"That's right. Electronics really shines in the areas of precise measurement, tireless monitoring, remote control, almost instantaneous communication, adjusting output to demand, and elephant-like memory. No matter what kind of energy source we use in the future—whether it is solar energy

from sun farms in the Southwest or from circling satellites, breeder reactors, 'laser energy' resulting from continuous controlled nuclear fusion triggered by a laser beam, shale oil extraction, the gasification of coal, or some as yet undreamed of source—all of these functions of electronics will be sorely needed to design the hardware for the new energy source, to harness and control its output, and to make sure that it does no harm to man or his ecological environment."

"Well," Barney observed, "you've done a pretty good job of convincing me that electronics is the key to man's survival during the approaching period of exhaustion of the earth's supply of fossil energy. It helps him locate and extract fossil energy deposits still left, it's absolutely essential to stretching those supplies as far as they will go, and it's the best hope of discovering and using new sources of energy. Depriving the electronics industry of the energy it needs to do the work it is already doing and to expand its potential would be suicidally short-sighted. How could energy-alloting bureaucrats fail to understand that?"

"Never underestimate the ability of a bureaucrat or a politician to overlook something until it is forcefully pointed out to him by a powerful lobby or voting block," Mac warned. "Electronics has no voice of its own because it speaks through the languages of medicine, science, industry, entertainment, research, computation, and communication. There are some who will not appreciate the contribution of electronics to our way of living until pace-maker-stimulated hearts quit beating, space vehicles never leave the launching pad, or TV and radio sets go dead."

"You don't really expect that to happen, do you?"

"Not unless we continue the policy of greasing only the wheels that squeak the loudest. In our highly organized, specialized, and interdependent society, it's difficult to judge the essentiality of any segment. Certainly, you can't base that judgment on which group bellows the loudest when it is asked to conserve energy. Some of the gears in our society are large and some are small, but remove any one gear and the whole clock stops. This is no time for any one group to claim it should not be asked to join in energy conservation on the grounds that its work is absolutely essential to the welfare of the whole nation. ♦

EVERYTHING YOU WANTED TO KNOW ABOUT CD IGNITION SYSTEMS BUT DIDN'T KNOW WHOM TO ASK.

Send for *FREE* Tiger booklet (20 pages) which answers all your questions.

Name _____

Address _____

City _____

State _____ Zip _____

CLIP OUT THIS AD AND SEND TO—

TRI-STAR CORP.

P. O. Box 1727 Dept. E
Grand Junction, Colo. 81501

CIRCLE NO. 31 ON READER SERVICE CARD



FREE

1974 LAFAYETTE CATALOG 740

Ready Now!

Your Complete Electronics Buying Guide

- Stereo/Hi-Fi Components • CB Transceivers & Walkie-talkies • PA Systems • Tools & Test Equipment
- Police/Fire Monitor Receivers • Antennas • Photography Equipment • Ham Gear • Books, Parts, and More!

Send Today!

Lafayette Radio Electronics
P.O. Box 10, Dept. 35044
Syosset, L.I., N.Y. 11791

NAME _____ 35044

ADDRESS _____

CITY _____

STATE _____ ZIP _____

CIRCLE NO. 19 ON READER SERVICE CARD

Train at home on NTS equipment like this:

NTS Audio Electronics Servicing

Know tweeters, woofers and baffles—sound distortion, amplification and control—public address and music systems. Kits you build and keep include Heath 60-watt stereo receiver, twin speakers, Volt-Ohmmeter, digital meter, in-circuit transistor tester, solid-state pocket radio.

**AM-FM Solid-State
60-Watt Stereo Receiver
and Twin Speakers**

Digital Multimeter

NTS color and b&w tv servicing

Build the largest and most advanced solid-state color TV. A 315 sq. in. ultra-rectangular matrix picture tube, Varactor Diode Tuner, Electronic Character Generator and more. Or build B&W TV with cabinet. Both TV's feature "instant on" Automatic Fine Tuning, solid-state design, and more. Other kits you build and keep: Solid-State Pocket Radio, Troubleshooter, AM/SW Radio, Volt-Ohmmeter, Color Bar/Dot Generator, Electronic Tube and Transistor Tester, TV Vector Monitor Scope and 5-inch Oscilloscope. Send card or coupon for all new color catalog and full details today.

**NTS/GR2000
solid-state color TV
315 sq. in. picture**

**Solid-state
B&W TV
74 sq. in.
picture**

**Electronic Tube
and Transistor Tester**

**Signal
Generator
Color Bar
Generator**

**TV Vector
Monitor Scope**

**FET
Volt-Ohmmeter**

Compu-Trainer

NTS Automation and Computer Electronics

Master computer servicing technology as you build this solid-state Compu-Trainer—an NTS exclusive! Duplicates circuit technology of giant computers in industry, do your own wiring, patch-cording, assembly. Other kits you build and keep: 5-inch wide-band solid-state oscilloscope, FET Volt-Ohmmeter, Electro-Lab.

**Solid-State
Oscilloscope**

**Transceiver
and
Power Supply**

NTS Electronic Communications

Earn your FCC First-Class Radio-Telephone License. Prepare for the test by building your own amateur phone 2-Meter FM Transceiver. NTS gives you the exact skills the FCC requires. Other kits you build and keep: fully transistorized Volt-Ohmmeter and regulated power supply.

Project Method Training — "heart" of the NTS system.

NTS Project Method Training is a better way to learn electronics. With easy-to-follow lessons, comprehensive kit manuals, large fold-out charts and more, you'll build advanced equipment while you learn electronics principles and applications. You'll learn how components work, why they work, what to do when they don't work. In short, you'll use your mind *and* your hands to develop ability and confidence. This is why the NTS Project Method is such an invaluable part of your program.

NTS gives you confidence-building extras!

- Job Getting Manual
- Advice On Starting A Business
- Answers To On-The-Job Questions
- Illustrated Electronics Dictionary
- Mechanics & Science Bulletins

NATIONAL TECHNICAL SCHOOLS

Technical-Trade Training Since 1905
Resident & Home Study Schools

4000 SOUTH FIGUEROA ST., LOS ANGELES, CA. 90037

Feel at home on jobs like these:

NTS builds your confidence with more solid training in Solid-State

NTS Training on professional solid-state equipment prepares you for many careers — in many consumer, commercial and industrial fields. If television is your chosen field, you could join a first class TV repair center, start a shop of your own, or specialize in industrial applications of television such as security system installation. And other electronic fields are continuing to grow, revolutionizing industry and communications, even reshaping our own lives. Opportunities are opening in home entertainment areas, commercial audio systems, mobile communications,

computer servicing, industrial controls and many other service technician areas. Yes, this is truly "The Age of Electronics." Your NTS training and the equipment you receive prepare you for these exciting careers wherever electronic technicians are needed. Start now! Build your confidence along with new skills in electronics. You may start earning extra money even before you graduate! Check your course on the card or coupon and mail today! No obligation. No salesman will call.



Master Technician: Communications Electronics



Master Technician:
Industrial Electronics



Master Technician:
Home Entertainment Electronics

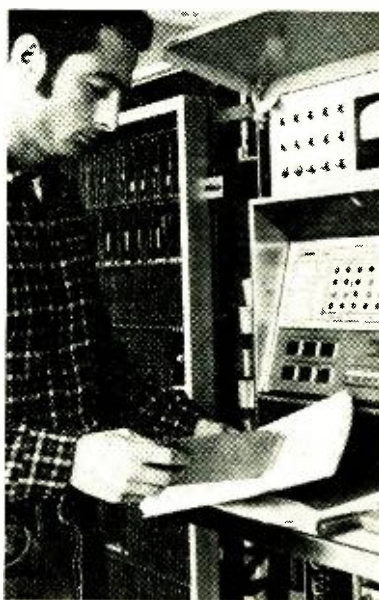

Master Technician:
Computer Electronics

Classroom training at Los Angeles

You can take classroom training at Los Angeles in sunny Southern California. NTS occupies a city block with over a million dollars in facilities devoted exclusively to technical training. Check box in coupon.

Approved for Veteran Training

Accredited Member: National Association of Trade and Technical Schools; National Home Study Council.

Please rush Free Color NTS Guide To Careers In Electronics and Sample Lessons, plus information on course checked below. No obligation. No salesman will call.



National Technical Schools
Technical-Trade Training Since 1905
Resident & Home Study Schools
4000 So. Figueroa St.
Los Angeles, Ca. 90037

NTS guide
to careers in
Electronics

- Master Course in Color TV Servicing
- Color TV Servicing (For Qualified Technicians)
- Master Course in B&W TV & Radio Servicing
- Master Course in Electronic Communications
- Practical Radio Servicing
- FCC License Course
- Master Course In Electronics Technology
- Automation & Industrial Electronics
- Computer Electronics
- Basic Electronics
- Audio Electronics Servicing
- Audio Technology for Qualified Technicians

Dept. 205-044

NAME _____ AGE _____

ADDRESS _____

CITY _____

STATE _____ ZIP _____

- Check if interested in Veteran Training under new G.I. Bill.
- Check if interested ONLY in Classroom Training at Los Angeles.

Understanding

HERE ARE SOME SIMPLE RULES OF THUMB THAT

LEARNING to understand the decibel—really understanding it—can be very confusing. Actually, a decibel is nothing more than the logarithm of the ratio of two power levels; but the problem gets complex when the term is used in such diverse areas as antenna gain or microphone voltage. As a result, the only people who toss off decibel ratings with apparent confidence are salesmen and others who have memorized the values without knowing what they really mean.

Actually, understanding decibels requires just a slight amount of general knowledge and two simple rules of thumb. There is no “higher” math involved. The basic expression is

$$G_{dB} = 10 \log_{10} (P_2/P_1)$$

The power ratio has no units since the two powers cancel each other.

The output power, P_2 , is some multiple of the input power, P_1 . For example, with a power ratio of 2 and an input power of 5 watts, the output power is twice the input, or 10 watts. This power ratio of 2 expressed in decibels is 3 dB. (The output is 3 dB greater than the input.) The input power, then, is usually the starting point or reference level to which the output power is compared. Knowing the reference level defines what the dB measures.

The concept of reference level is not found only in the use of decibels. Voltages are usually referenced to one volt. Multiples of one volt can then be used to define all voltage levels. Similarly, the power ratio in decibels defines the power level in multiples of the reference level. The difference is that the reference for voltage is one volt, while the reference for dB could be any defined power or just an arbitrary test input.

These references are usually understood for each type of measurement. Typically, in measuring acoustical energy, 10^{-12} watt/cm² is used as a reference. In antenna measurements, everything is compared to a simple

dipole. Hopefully, if the reference is not standard, it is abbreviated as a letter following the dB value. Audio power, dBm, is referenced to 1 milliwatt. Other common references are dBW (1 watt reference) and dBn (thermal noise). There is no set rule for the derivation of these abbreviations; they are originated for special cases.

Why Are They Used? The beauty of using the decibel system is that decibel figures can be added (as can any logarithm) rather than multiplied, as must be done with regular gain figures. The circuit gains in dB from one stage to the next can simply be added or subtracted from the input reference level. For example, assume that a microphone has an output of 0.00001 mW (-50 dBm) which is attenuated by a factor of 1/10 (-10 dB) in the cable to the amplifier. The amplifier has a power gain of 10,000,000,000 (100 dB). The output of the amplifier can be found in one of two ways:

$$(1) 0.00001 \text{ mW} \times 1/10 \times 10,000,000,000 = 10,000 \text{ mW} = 10 \text{ W}$$

$$(2) -50 \text{ dBm} - 10 \text{ dB} + 100 \text{ dB} = 40 \text{ dBm} = 10 \text{ W}$$

Using the dB figures requires an additional step to convert the answer to watts, but the rest of the calculation is much easier. The numbers are of a more manageable size and addition is easier than multiplication.

Any signal level or known characteristic can be used as a reference as long as it is related to power. The power measurements, however, are seldom taken directly. That would require a calorimeter or a direct-reading wattmeter. Usually the voltage or current through a known resistance is measured and the power is calculated from

$$P = V^2/R = I^2R = VI$$

Input and Output Resistances. The power ratio is simplified when both the input and output resistances are equal. By cancelling the like resistance terms, it is only necessary

Decibels

BY GEORGE BOARD

MAKE IT EASY TO USE AND UNDERSTAND dB's

to measure voltage or resistance and square it to obtain the power ratio. The logarithm of the voltage ratio squared is twice the logarithm of the voltage ratio unsquared. Thus,

$$G_{dB} = 20 \log_{10} V_2/V_1$$

The special case of having equal input and output resistances is not unusual. Equipment requiring many signal interconnections usually has input and output resistances of 50 ohms. In such a system, the formula $20 \log_{10} V_2/V_1$ is always usable in finding the dB gain.

Instant chaos develops if the input and output resistances are not equal. The voltage ratio squared would then not be equivalent to the power ratio. In this case the power ratio must be calculated using the proper resistance values.

Rules of Thumb. Knowing what decibel ratings are, the next thing to learn is how they are used. When a salesman says, "Instead of the beam, why not get this new kW rig," he knows that the beam antenna gain in dB cannot be directly compared to the power ratio between your old transmitter and a kilowatt. To figure out what he means, using algebra and logarithm tables, would take too long and making a guess is difficult with decibels. Being logarithmic, they don't increase in a normal fashion. A power ratio of 5, for instance, represents 7 dB, but increasing the ratio to 10 only increases the decibels by 3. So some rules of thumb are useful.

The first rule of thumb pertaining to the decibel scale is that adding 3 dB doubles the power ratio. (The factor is actually 1.9953 . . . , but doubling is close enough.) Thus the gain represented by 6 dB is twice that of 3 dB just as a gain of 58 dB is twice that of 55 dB. Similarly, a gain of 55 dB is half that of 58 dB and -3 dB is a power ratio of one half.

If powers of two were so easy to remem-

ber, things would be easy. But it wouldn't be worth the effort to figure out that 30 dB is 10 times 3 dB for a power ratio of 2^{10} .

The second rule of thumb is that each 10 dB represents a power-of-ten change in the power ratio. Or, add 10 dB for each zero in the power ratio. If the power ratio is less than one, subtract 10 dB for each zero, including the zero to the left of the decimal. A ratio of 1000 is 30 dB (3 zeros), and a ratio of 0.001 is -30 dB (3 zeros).

Combining the counting of zeros and the multiples of two, the simplified system expands to provide a handy reference for all decibel levels. A power ratio of 20,000 is 40 dB (4 zeros) plus 3 dB for the factor of two, totalling 43 dB. Half (-3 dB) of 100 (20 dB) is 50; so 50 is 20 dB minus 3 dB or 17 dB. Interpolating, 0.0001875 is between 0.0001 (-40 dB) and 0.0002 (-37 dB). But the number is much closer to 0.0002, so it must be -38 dB. A closer figure could only be obtained by using logarithm tables and many calculations.

The two rules of thumb for power ratios can also be used for voltage ratios. Remember that the voltage ratio in dB is $20 \log_{10} V_2/V_1$ and the power ratio is the square of the voltage ratio. Thus a power ratio of 16 (12 dB) is the same as a voltage ratio of 4. Now, 4 would be 6 dB as a power ratio—one half of the 12 dB for 16. So, the voltage ratio in dB is twice what the rules for the power ratio would make it. In other words, a voltage ratio of 2 is 6 dB, 4 is 12 dB, and 0.01 is -40 dB.

Summary. (1) Adding decibels is like multiplying power ratios. (2) The reference level must be known. (3) The voltage ratio in dB (resistances equal) is twice what the power ratio would be. (4) Doubling the power ratio adds 3 dB (6 dB for the voltage ratio). (5) Multiplying the power ratio by 10 adds 10 dB (20 dB for the voltage ratio). ♦

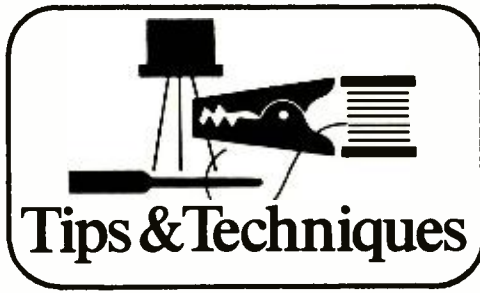

CORK SLAB AND STRAIGHT PINS MAKE DANDY BREADBOARD

One of the fastest and least expensive methods for breadboarding electronic circuits can be had with a slab of close-grain cork and some of those straight pins in your wife's sewing basket. Perhaps the best cork base to use is the self-adhering variety that can be purchased from any hardware store. Place it on a nonconducting surface when breadboarding a circuit. To lay out the circuit, push the component leads into the cork. The leads will be readily accessible for tack soldering. Use straight pins for solder terminals and lugs where several wires are to be joined in common. You will find that the cork base can be used many times before replacement is required. Also, it is a good idea to use only a low-wattage soldering iron for the tacking operations. —Robert Oliver

SPACER PREVENTS EXCESSIVE HEAT FROM DAMAGING PRINTED CIRCUIT BOARD

Before soldering power-handling components like resistors and axial-lead inductors and diodes to a printed circuit board, it is good practice to space them away from the board's surface by a small distance. This is an expedient that will obviate excessive heat damage to the board should the component fail during operation and overheat. A piece of scrap phenolic board, plastic, or wood measuring about 1/16 in. thick by about 3/4 in. at its widest will do fine. Taper one end of the spacer to permit easy insertion and removal. The spacer goes between component and board. When soldering is complete, it is removed. —Richard A. Walton

HOW TO DEAL WITH TARNISH ON UHF AND BNC CONNECTORS

Uhf and BNC connectors removed from surplus equipment are often tarnished by oxidation to the point where poor electrical contact results. The easiest and most effective way to clean away the tarnish is to dip the connectors into jewelry cleaner. This cleaning solution works equally well on gold- and silver-plated connectors and contacts; so, it can be used on pc board edge connectors, rotary switches, tran-

sistor and IC sockets, etc.

—Steven R. Flick

RESISTOR AIDS IN TRANSMISSION LINE CONTINUITY TESTS

Many of today's antenna arrays contain no folded dipole and, therefore, exhibit an open circuit when the conventional continuity test is performed. Hence, a continuity test of the transmission line cannot be made with an ohmmeter. However, by placing a 100,000-ohm resistor across the transmission line terminals at the antenna, one can check the continuity of the line at any time. The resistor will not interfere with antenna operation due to the relatively low impedance of the antenna at r-f. —Thomas A. Singletary

DUMMY LOAD AND SPEAKER FOR AMPLIFIER TESTING

If you do a lot of amplifier testing, you will find that it's convenient to have on hand a dummy load and a test speaker. The load con-

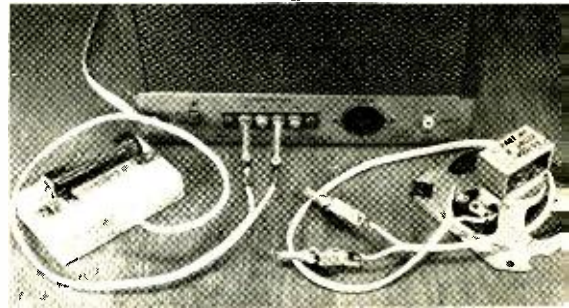

sists of an 8-ohm 50-watt resistor mounted on a block of wood with an 18-in. length of zip cord terminated with two alligator clips. The clips are much more convenient than spade lugs or raw wire ends, and you should not chisel on the length of the zip cord. You may want to tip the amplifier over for access to the under-chassis area so the long zip cord is a necessity. It's also useful to have on hand a test speaker. Use any 5- or 6-in. speaker to which you have attached an 18-in. length of zip cord terminated again with the convenient alligator clips. —Lewis A. Harlow

TIPS WANTED

Do you have a "tip" or "technique" that might help your fellow readers? It may be worth money to you. Send it in (about 100 words, with a rough drawing and/or clear photograph, if needed) and you'll receive payment if accepted. Amount depends on originality and practicality. Material not accepted will be returned if accompanied by a stamped, self-addressed envelope. Send material to: Tips and Techniques Editor, POPULAR ELECTRONICS, 1 Park Ave., New York, NY 10016.

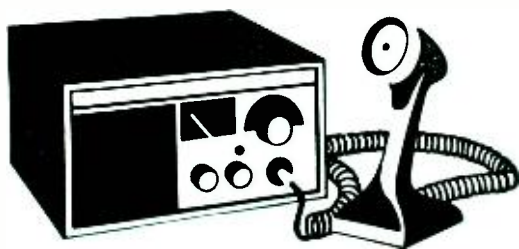

CB Scene

By Len Buckwalter, KQA5012

A REMARKABLE number of accessories—from field-strength and SWR meters, to coaxial switches and antennas—are nearly interchangeable between CB and amateur radio. So it's no surprise that CB, the younger medium, leans heavily on the tools and technology of ham radio. Latest item to bridge the gap is the *phone patch*. It is an attachment to a telephone that can send your CB voice by landline to just about any other phone in the world. In reverse fashion, you can speak on a phone and be heard by a mobile CB station on the road. Since the number of manufacturers offering phone patches is increasing, it's timely to consider just what this accessory offers a CB operator. About three manufacturers now make patches in the \$20 category.

Phone patching has been done for years on the ham bands for several reasons. It enables thousands of servicemen to place low-cost phone calls from overseas posts to the folks back home. In a typical case, the soldier goes to a station on his military base and asks the operator to contact a stateside ham close to the soldier's home. After radio contact is accomplished, the U.S. ham turns on his patch and feeds the soldier's voice into the landline. The advantage is no charge for the transoceanic hop by ham radio—only for toll charges within the U.S. Phone patching is also enjoyed by scientists on expeditions to remote parts of the globe. Finally, patching provides vital communications for victims of natural disasters when phone lines are knocked out.

That last category holds the most promise for CB phone patching. If you're on the scene of an emergency, you (or anyone else) can speak directly from your car to police, civil defense or other authorities by telephone. Of course you could do the same without a patch by asking a base station to

make the call for you, but the patch is vastly more efficient. You speak directly with the party on the phone line without the verbal repetition and misunderstanding possible with a go-between.

How It Works. You can see how the whole system works in Fig. 1. Let's say the CB'er at an accident scene wants to speak by telephone to a distant party. He first contacts another CB'er known to have a base station fitted with a patch. The operator on base responds by dialing the phone number and turning on his patch.

When the party at the other end of the line answers, the base operator lets the two parties speak directly with each other. The only difference between talking on a patch and an ordinary phone is that only one person talks at a time. In actual operation, though, you can speak quite normally and be only faintly aware of the send-receive switching. After a few moments it has the feeling of an ordinary phone call. During one test I witnessed, voices went back and forth with normal intelligibility, even though the mobile CB'er was in a moving car. Only when the car moved out of normal communicating distance did quality deteriorate.

Installing a phone patch isn't difficult if you're willing to remove the CB set from

Patches Come to CB

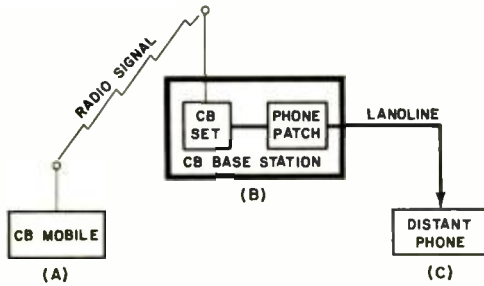

Fig. 1. How phone patch works. Mobile CB (A) talks directly to any phone (C) by going through base station and patch at (B).

its cabinet and locate tie-in points. There are usually two circuit connections (Fig. 2): a shielded cable to the microphone input; and a pair of wires to the loudspeaker. With these cables in place, the CB loudspeaker feeds incoming voices (from over the air) into the telephone line. The

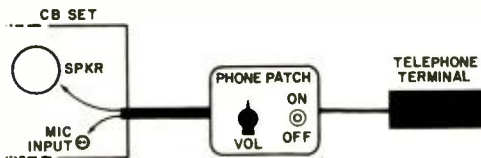

Fig. 2. Diagram of how a phone-patch installation is connected at CB base station.

telephone signal reaches the microphone input so the landline voice goes out over the air. The circuit inside the phone patch typically has a transformer to match various impedances, provides a method for adjusting audio levels, and has a disconnect switch.

The Technicalities. What does Ma Bell have to say about all this? The situation surrounding attachments to the phone line is not yet completely resolved. During decades of ham patching, the phone company looked the other way. Speculation has it that hams deliver a valuable public service to men in uniform and stopping the practice could cause bad feelings toward the phone company. Other observers believe that phone patching actually generates *more* revenue for the company by encouraging servicemen to make calls they'd never consider under normal toll rates. The company, at least, gains revenue on the stateside part of the circuit.

The legal tide changed in 1968 when a

private manufacturer won a momentous decision against the phone company. In the celebrated Carterfone case, the FCC declared the Bell System too restrictive about attachments to the line. The result of that decision was an outpouring of accessories that do everything from answering the phone and recording messages, to diverting incoming calls to another number or dialing preset numbers at the touch of a button. It's estimated that more than 6 million telephone answerers have already been sold and the end is nowhere in sight. It's common knowledge that just about all of these accessories can be connected directly to the phone line. The phone patch between a CB set and the phone line connects the same way. However, the phone company demands that any attachment be connected to its line through an interconnect device. Bell argues that its device protects the line against interference and other disturbances. There is a charge, though, for using an interconnect (installation fee and monthly rental).

A phone patch can be an excellent addition for CB clubs and other groups bent on rendering public service, especially when normal communications are disrupted or aren't available in the field. At little cost, a patch provides communications with fewest intrusions in between. ♦



"I'd suggest the next signals you transmit to the YL of yours be RIP."



Test Equipment Scene

By Leslie Solomon, Technical Editor

ALTHOUGH we, as serious electronics experimenters and service technicians, have access to the latest in test equipment, quite often our needs are one step ahead of the available instruments. Take the case of waveform analysis as an example.

Although two-channel scopes are readily available, as are dual-trace converters for single-trace scopes, there are many occasions when even two traces are not enough. This is especially true when observing several signals in a digital counter, aligning an i-f strip, servicing audio systems—any occasion when it is necessary that a number of signals have certain specific and accurate relationships in order for the complete system to operate properly.

Since multiple trace displays are not readily available now, we have cooked up a small circuit that does the job at reasonable cost. Because 5-inch scopes seem to be so popular and since four traces fit nicely on such a scope, the circuit is designed for four traces. (Most of the readers we have contacted on this subject seem to be interested in displaying four traces.) The circuit (Fig. 1) uses CMOS IC's so the power requirements are minimal. Only the circuit is shown—the serious instrument builder can readily design his own pc or perf board layout.

The heart of the 4-channel switcher is the 4016 transmission gate, also known as a quad bilateral switch—which has no equivalent in any other type of logic. Essentially, each transmission gate (TG) consists of a CMOS device that is connected in series with an input signal and the scope. (There are four such gates in a 4016).

Each TG acts as a conventional mechanical switch, in that, when its control element is driven one way, the CMOS device looks like an open circuit; and when the control element is driven the other way, the device looks like a short circuit. Also, like a me-

chanical switch, either end of a TG can be the input or output.

The circuit uses a pair of flip-flops (4013) and a set of two-input NOR gates (4001) used as a decoder and arranged to deliver four independent successive gate signals—one for each input trigger signal (pin 3 of the 4013). Each NOR output turns on its pair of associated TG's in sequence, with only one pair of TG's operating at the same time.

The four audio inputs are passed through their own gain controls and then to one of the four lower TG's. The four outputs are connected to the common summing output through isolation resistors. In this way, each audio channel is sampled successively and presented to the scope.

Each audio TG has an associated bias TG (upper 4016) which is turned on simultaneously. The bias TG's deliver a predetermined dc voltage (set by the associated positioning control) to the summing output. In this way, each channel can be independently positioned on the scope. By keeping the audio input level low and properly spacing the four traces, they will easily fit on a 5-inch scope.

Trigger Source. The 4013 requires a positive going input trigger on pin 3. This can be provided in one of two ways—either in a

4-Channel CRT Viewing

Fig. 1. Just four standard CMOS IC's are used to make a handy four-trace adapter for a single-channel scope.

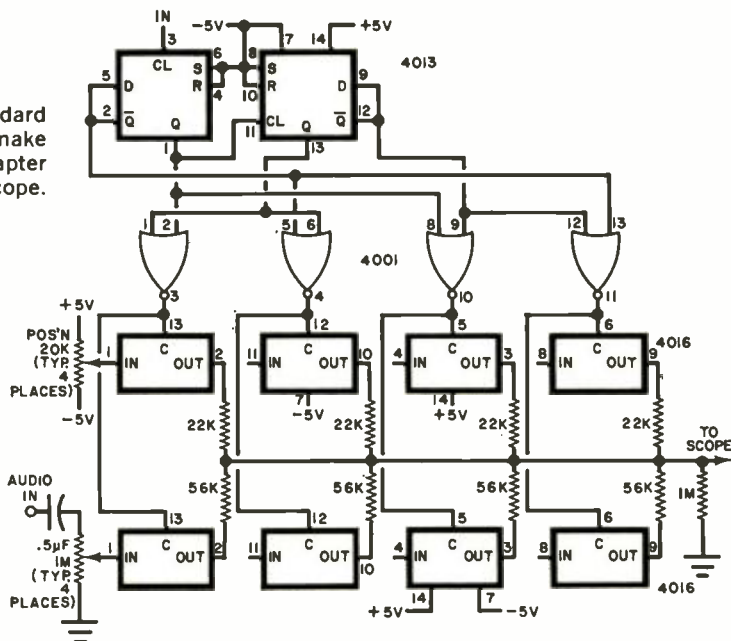

chopped mode or an alternate mode. Both arrangements are shown in Fig. 2.

In Fig. 2A, the chopped mode, a 4009 CMOS chip is arranged as a free-running multivibrator whose frequency is dependent on the value of R and C . The buffered output is connected to pin 3 of the 4013.

For alternate-mode triggering, with one channel for each sweep of the scope CRT, it is necessary to get to the scope's horizontal oscillator and pick off a pulse that occurs

during the retrace. (The particular scope that we used had such an output provided on the rear apron.) The way in which this pulse is processed to drive the flip-flops depends on the pulse from the scope. In our case, we had a 2-volt negative-going pulse from the scope. The circuit is shown in Fig. 2B. Another transistor will provide phase inversion if necessary.

Keep in mind that, in the alternate mode, the four traces will follow each other in time. Thus they will be dimmer than usual. However, we found that there was enough brightness left in the scope intensity control to compensate.

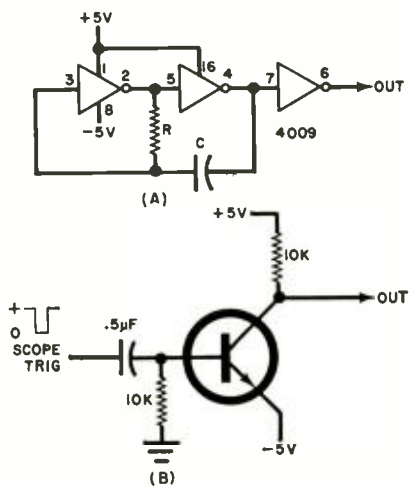

Fig. 2. Chopped mode of triggering uses a CMOS oscillator (A). Simpler circuit (B) is for alternate trigger.

Generating Sync Pulse. Figure 3 shows one approach to generating a sync pulse for

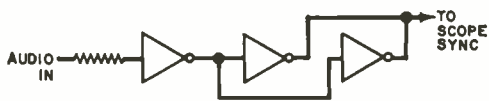

Fig. 3. Three CMOS inverters are used to make a sync generator for four-channel trace. Output inverters are in parallel.

the scope. Here, the selected audio channel is coupled into an inverter (4009) through an isolation resistor, and the output is taken from a pair of inverters in parallel to provide a hettier output signal to drive the scope sync. ♦



Solid State

By Lou Garner

IF YOU'RE not using MOS (metal oxide semiconductor) devices as yet, there's a good chance you'll be doing so in the near future. Not only are these devices being specified more frequently in experimenter and hobbyist projects, they are being used in ever increasing numbers in commercial, industrial and consumer products. Typically, you'll find MOS devices in digital wrist-watches, clocks, counters and calculators—in hi-fi equipment, receivers, and TV sets—and in much of the electronic control and safety equipment installed in new automobiles.

Certainly, MOS technology has much to recommend it compared to more familiar and older techniques. MOS devices have extremely low power consumption (in the nanowatt range for some circuit functions), high input impedances, high noise immunity, wide supply voltage tolerances, liquid crystal readout compatibility, minute leakage currents (often specified in picoamperes), and fantastic versatility. MOS techniques, for example, can be used for the fabrication of discrete devices, such as individual field effect transistors (known, variously, as MOSFET's or IGFET's), multiple device arrays, and both MSI and LSI circuits as well as standard IC's. They are easily adapted to the manufacture of either linear or digital circuits.

There are, basically, three general types of MOS devices: PMOS (p-channel), NMOS (n-channel), and CMOS (complementary or complementary-symmetry, a combination of both p- and n-channel devices on a single substrate).

Regardless of type, virtually all MOS devices utilize a very thin film of oxide insulation between their control (gate) and output (source/drain) electrodes. Because of this, MOS devices are inherently sensitive to damage by electrostatic discharges,

despite the fact that most commercial units incorporate input protection networks to minimize accidental damage. Excessive static discharges can break through the oxide film and cause such failures as shorted or leaky input protection diodes, shorted or open gates, open circuit paths, and a degradation of device characteristics. With improper handling, such failures can occur before a device is actually used in a circuit.

For maximum safety and minimum damage, then, it's best to adopt special handling methods when working with these versatile devices. The following procedures, suggested by the National Semiconductor Corporation (2900 Semiconductor Drive, Santa Clara, CA 95051) in their *National 74C Times*, should enable you to get the MOST from your MOS:

1. The leads of MOS devices should be kept in contact with conductive materials to avoid the buildup of static charges when handled. Manufacturers generally use special containers lined with conductive films for packaging, transporting and storing MOS devices. *In no case should MOS devices be inserted into polystyrene plastic foam or other high dielectric materials.* (So that's what happened to my expensive MOS alarm clock circuit!)

2. MOS devices and/or circuit boards containing MOS units *should not be inserted into or removed from circuits with power "on"* because transient voltage spikes may cause permanent damage.

3. *Do not apply signal voltages to the*

Using MOS Devices

with the signal removed, $L1$ is de-energized and $L2$ energized.

In practical installations, the input switching signal can be obtained from various sources, depending on the required control function. Typically, the signal could be derived from a thermistor bridge for temperature indication or heater control or, in another case, from a photoresistive cell for annunciator, burglar alarm, or safety control applications.

The final circuit, Fig. 3, can be used as a high-speed, low-level ac static switch or, with a time-variable pulse generator furnishing the input signal, as an ac proportional control. In effect, the circuit is the SCR "equivalent" of a bi-directional triac control, but with the advantage of being able to handle load currents from as little as 1 mA to as much as 1 A. In contrast, most commercial triacs require a minimum load current of 30 mA for turn-on and as much as 150 mA for latch-on.

In operation, the application of a positive signal of 2 to 3 mA to $SCR1$'s gate causes

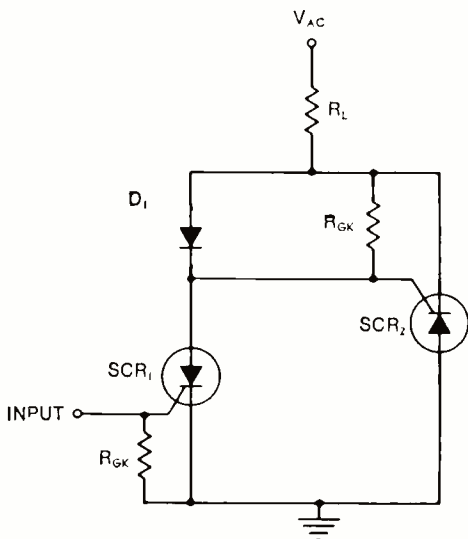

Fig. 3. SCR triac replacement circuit.

this device to switch on during positive half-cycles, energizing load RL . During negative half-cycles, $SCR2$ is energized by $SCR1$'s reverse anode current, which is blocked by diode $D1$ and forced to flow into $SCR2$'s gate, thus again energizing the load and providing full bi-directional performance.

Relatively few parts are required for circuit assembly. $SCR1$ is type AA109, $SCR2$, type AA102, and $D1$, type UT113. The gate-

cathode resistors (R_{GK}) are 1000-ohm, $\frac{1}{2}$ -watt types.

The basic circuit is designed to operate on a standard 117-volt ac source at from 60 Hz to 20 kHz. It may be used as an ac static switch by applying a dc voltage to the input (enough to supply 2 to 3 mA), positive with respect to circuit ground, or as a proportional control by applying positive-going time-variable pulses. The control pulses may be obtained from any variable frequency PUT or UJT oscillator circuit.

Device/Product News. Shades of *Star Trek!* According to an item in *MONOgram*, a publication issued by Interdesign, Inc. (1255 Reanwood Ave., Sunnyvale, CA 94086), R. W. Enterprises (P.O. Box 735, Independence, IA 50644) is now marketing a digital alarm clock which will obey an oral command to "shut up." In operation, the clock first tries to awaken you with a soft beep-beep-beep. If you want to snooze a little longer, you just tell it to be quiet—a grunt, yell, or even a cuss word will work. The clock, obedient to your wishes, then shuts its alarm off and tries again five minutes later. Naturally, the clock is solid state, with all the electronic circuitry contained on a single IC chip.

Intended for reference oscillator and clock applications, two new crystal oscillators have been introduced by Motorola Semiconductor Products Inc. (P.O. Box 20924, Phoenix, AZ 85036). Featuring a choice of complementary sine-wave, single-ended MTTL, and complementary MECL outputs from a single MSI IC chip, each device comprises a voltage regulator, an oscillator, an amplifier/automatic gain control, a sine-to-MECL translator, and a MECL-to-TTL translator. The only external components required to produce a highly stable oscillator are a series-mode crystal, two bypass capacitors, and, of course, a power supply. Output voltages range from 800 mV p-p (no load) to 500 mV p-p at full load. Type MC12060/12560 is intended for operation from 100 kHz to 2.0 MHz, while type MC12061/12561 covers the 2.0-to-20.0-MHz range. Both types are offered in 16-pin ceramic DIP's.

RCA's Solid State Division (Route 202, Somerville, NJ 08876) has introduced a new device which should be of interest to serious experimenters and hams: an AM radio receiver IC.

Designated type CA3123E, RCA's linear

radio receiver subsystem provides an r-f amplifier, i-f amplifier, mixer, oscillator, age detector, and voltage regulator on a single chip. Designed for use in superhet AM radio receivers, the new device is supplied in a 14-lead dual-in-line plastic package.

If you're an advanced experimenter, student, or ham working with uhf and vhf circuits, you should be interested in two new offerings from the Amperex Electronic Corporation (Hicksville Division, Hicksville, NY 11802)—a series of uhf amplifier modules and a 50-watt r-f power transistor.

Consisting of three units, Amperex's new uhf amplifier modules are designed for operation in the 380-512-MHz band on 12.5-volt power supplies. Designated types BGY22, BGY23 and BGY24, the devices can furnish output powers of 2.5, 7, and 17 watts, respectively. The BGY22 requires 50 mW drive power while the BGY23 and BGY24 each requires 2.5 watts. If desired, the BGY22 can be used as a driver for either the BGY23 or BGY24. The only external matching required to use these modules are 50-ohm input and output lines. The units are offered with either ceramic or plastic caps.

GE's Semiconductor Products Department (Electronics Park, Building 7, Mail Drop #49, Syracuse, NY 13201) has introduced two sets of inexpensive, matched LED/detector pairs for use in interrupter applications. Each pair consists of a gallium arsenide LED and a silicon detector housed separately in side-looking TO-92 plastic packages. Type H17A1 features a transistor detector, while type H17B1 employs a Darlington detector. The new units may be used for such applications as level detectors, counters, position sensing, etc.

Reader Idea. If you are looking for a novel chess set, reader Richard A. Picard has this suggestion: obtain some translucent chess pieces and drill out a small portion at the bottom, just large enough to accommodate a small low-voltage pilot lamp or LED. Insert the light and attach it to a two-terminal electrical connector which will form the new bottom of the piece. Then drill a hole in the middle of each square of a checkerboard, just large enough to accommodate a socket matching the connector on the chess piece. Wire all of the sockets to a common low-voltage supply. If the chessmen are clear, you can use lights of two different colors. If they are already tinted, clear lights can be used. ♦

FOR A SOUND INVESTMENT You Need Sound Advice...

1974 STEREO DIRECTORY & BUYING GUIDE

Listen to this . . . and you'll hear better! It features all the latest information on stereo systems and components—Amplifiers • Tuners • 4-Channel Components • Receivers • Hi-Fi Compacts • Changers and Turntables • Speaker Systems • Phono Cartridges and Arms • Cassette, Cartridge and Open Reel Tape Machines and Microphones • Raw Tape and Accessories. More than 1500 products in all—listed by manufacturer, each with model number, complete specifications, descriptions and price—PLUS—How to select equipment—authoritative guides on judging stereo and quadrophonic components.



Tells you what to look for, what to avoid, how to decide what's best at a price you can afford.

TAPE RECORDING & BUYING GUIDE — 1973 Summer

WITH THE WORLD OF TAPE IN FAST-FORWARD, HOW CAN YOU KEEP UP?

All the changes and advances in the tape market could make your head spin and reel. Relax. Unwind.



Here's the magazine that unsnarls the facts . . . the 1973 Summer Edition of TAPE RECORDING & BUYING GUIDE. It records all the changes, choices and facts you need to make a clear-cut buying decision. Complete directories and buying guides compare products feature by feature, cost by cost — Reel-to-Reel Tape Machines • Cassette Tape Machines • 8-Track Tape Machines • 4-Channel Components • Special features — How Magnetic Tape is made • How to Tape a Symphony in Quadriphonics • The Status of 4-Channel Sound and much more! If the fast-forward world of tape has you going around in circles, STOP. Order your copy now, only \$1.50.

ZIFF-DAVIS SERVICE DIVISION—Dept. W
595 Broadway, New York, N.Y. 10012

Please send the following:

- 1974 STEREO DIRECTORY & BUYING GUIDE, \$1.50
- 1973 TAPE RECORDING & BUYING GUIDE—Summer, \$1.50

In U.S.A., add 35c per copy for postage and handling.
Outside U.S.A., copies are \$2.50 each.

TOTAL ENCLOSED \$ _____ PE-474

print name _____

address _____

city _____

state _____ zip _____

— PAYMENT MUST BE ENCLOSED WITH ORDER —



New Literature

SAMS BOOK CATALOG

Contained in the 88 pages that make up this new catalog are more than 400 book listings (hard and soft cover) from Howard W. Sams. Of particular interest are the numerous listings for audio and hi-fi, electricity and electronics, communications and computers. In fact, the electronics-related books occupy the lion's share of the catalog. Address: Howard W. Sams & Co., Inc., 4300 West 62 St., Indianapolis, IN 46268.

HEATHKIT GENERAL CATALOG FOR 1974

Included in the 1974 Heathkit catalog are color TV receivers, the latest in audio/hi-fi equipment, marine gear, communication gear, automotive test devices, test equipment, etc. Many of the items listed and fully described are accompanied by full-color photos of the finished project. Address: Heath Co., Benton Harbor, MI 49022.

NBS METRIC SYSTEM BOOKLET

Publication of a new consumer booklet that outlines the essential details of the metric system of measurement has been announced by the

National Bureau of Standards. The 16-page "What About Metric" booklet was written to give consumers the few terms and relationships they need to use the metric system and relate it to the system they have been accustomed to using. The booklet is largely two-color illustrations and a minimum of text. It gives visual comparisons and simple illustrations. Copies are available for 80¢ each from: Supt. of Documents, U.S. Govt. Printing Office, Washington, DC 20402. Specify NBS Consumer Information Series 7 or GPO stock No. 0303-01191.

GILFER SWL'ING CATALOG

"The World of SWL'ing" is the title of the latest catalog from Gilfer Associates, Inc. It lists and fully describes many items of interest to beginner and old-timer alike—receivers, pre-selectors, antennas and antenna matchers, headphones, etc. Also listed are a Franklin 24-hour wall clock and a digital electronic six-digit 12/24-hour desk clock. Address: Gilfer Associates, Inc., P.O. Box 239, Park Ridge, NJ 05676.

SWTPC PRODUCT CATALOG

Featured in the latest Southwest Technical Products catalog are kits ranging from hi-fi equipment to electronic music devices, test gear, and light displays. Each item listed is fully described and is accompanied by a photo and full technical description. Address: Southwest Technical Products Corp., 219 W. Rhapsody, San Antonio, TX 78216.

JOHN WILEY BOOK ORDER CATALOG

A new catalog that lists and describes 19 electronics engineering books is available from John Wiley. Except for the cover, the entire catalog

Do your stereo system a favor— **UPGRADE!**

Convert your System from Ceramic to Magnetic Cartridge with Pickering's new preamplifier.

You'll appreciate this easy, low cost method for getting so much more out of your stereo system. Use it to help get real hi fi from your system.

SPECIFICATIONS FOR THE PP-1 PREAMPLIFIER:

Input Impedance:	47,000 ohms
Gain @ 1 kHz:	38 dB
Frequency Response RIAA	
30-15000 Hz:	±2 dB
Signal to Noise Ratio:	60 dB Min.
Crosstalk:	Better than 60 dB
Rumble Filter:	Attenuates rumble frequencies a minimum of 15 dB

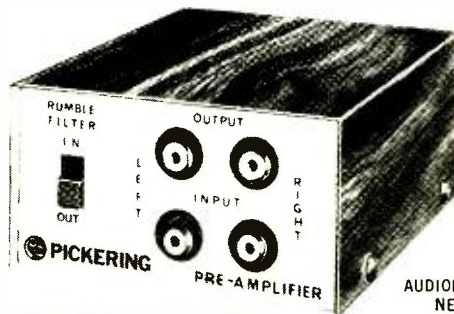

PICKERING

"for those who can hear the difference"

AUDIOPHILE
NET
\$29.95

For further information write Pickering & Co., Inc., Dept. E, 101 Sunnyside Boulevard, Plainville, New York 11803

CIRCLE NO. 36 ON READER SERVICE CARD

is divided into 20 post card order forms (no postage necessary). Address: John Wiley & Sons, Inc., 605 Third Ave., New York, NY 10016.

IEEE STANDARDS CATALOG

This new catalog lists more than 350 standards publications by subject as well as in numerical sequence. Included in the new set of listings are the many American National Standards published by IEEE. Address: IEEE Standards Dept., 345 East 47 St., New York, NY 10017.

GR GUIDE TO COAXIAL COMPONENTS

Components and accessories for high-frequency applications (to 9 GHz) are described in a 32-page pamphlet from General Radio. Included are detailed specifications for general-purpose and precision 50-ohm and 75-ohm connectors, adapters, attenuators, terminations, coupling elements, cables, air lines, and a unique low-cost r-f bridge. Address: General Radio, 300 Baker Ave., Concord, MA 01742.

SANYO CONSUMER ELECTRONICS CATALOG

The complete line of Sanyo consumer items is described in a new 52-page booklet. Full-color photos, descriptions, and important features are outlined for such items as color and mono-

chrome TV receivers; portable and clock radio receivers; tape recorders; stereo systems (2- and 4-channel); and automotive radios and stereo equipment. Address: Sanyo Electric Inc., 1200 W. Artesia Blvd., Compton, CA 90220.

RCA LINEAR IC REPLACEMENT GUIDE

An updated "Linear IC Direct-Replacement Guide" (No. CRG-110A) is available from RCA Solid State Division. It includes the solid-state devices of 13 industry manufacturers and reflects the change in RCA linear-IC type designations. To simplify the recognition of second-source IC's in the linear line, type numbers have been changed to include the exact source manufacturer's type number, except for the CA prefix and package identification suffix letters. (Address: Box 3200, Somerville, NJ 08876).

MAXELL TAPE GUIDE

Maxell Corp. of America dealers have a 24-page Tape Guide that tells the complete story about magnetic recording tapes. It describes how tapes are manufactured for specific recording devices and provides a basic understanding of recording bias, record and playback equalization, etc. (Address: 130 W. Commercial Ave., Moonachie, NJ 07074).



They put a rotary engine in a car. We put a cam shaft in a turntable. For the same reason.

The reason? To make it quieter, smoother, more reliable.

The basic record changer mechanism—like the automobile's piston engine—has been a fairly reliable device that has served with some success for many years. But the very action of the engine—or the changer—produces constant vibration and strong, sudden movements that can ultimately wear it out.

Now we have alternatives. For cars, the Wankel rotary engine. And for record players, the sequential cam shaft drive mechanism used in BSR's finest automatic turntables.

Its even rotating motion programs the complex automatic functions of the BSR 710 and 810 smoothly and without noisy and potentially harmful quick starts and stops, without slamming metal against metal. And because the cam gears are mounted on a carefully machined central shaft, they are all but impossible to put out of alignment by rough handling or constant use.

The result: consistent care-free performance, and good music. With the BSR 710/X and 810/X Transcription Series Total Turntables.



BSR (USA) LTD.
BEAUREVIEW, NEW YORK 10913

CIRCLE NO. 4 ON READER SERVICE CARD

DIGITAL COLOR

Bell & Howell Schools introduces an amazing new color TV featuring channel numbers and digital clock that flash on the screen and automatic channel selector!

Now you can build and keep a color television that's ahead of its time!

You've seen TV's that swivel, TV's with radios built in, TV's small enough to stuff in a suitcase and TV's that have remote control.

But now comes a color television with features you've *never* seen before. Features now possible as a result of the new applications of digital electronics... features that make Bell & Howell's new 25-inch diagonal digital color TV ahead of its time! Like...

Channel numbers that flash big and clear right on the screen. An on-screen digital clock that flashes the time in hours, minutes and seconds with just the push of a button. An automatic channel selector that you pre-set to skip over "dead" channels and go directly to the channels of your choice.

And to insure highest quality performance, this new TV has silent, all-



electronic tuning, "state-of-the-art" integrated circuitry, Black matrix picture tube for a brighter, sharper picture and 100% solid-state chassis for longer life and dependability.

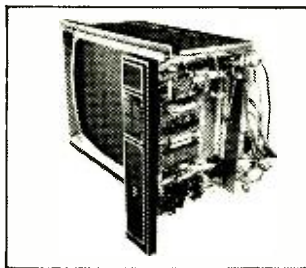

Perform fascinating experiments with the exclusive Electro-Lab[®] electronics training system. It's yours to build and keep!

Designed exclusively for our students, this new Bell & Howell Electro-

Simulated TV picture

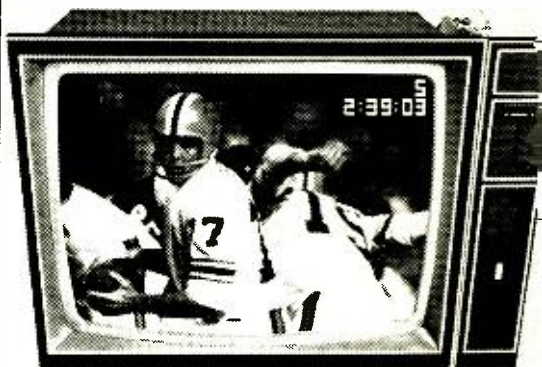

You build and keep this revolutionary new Bell & Howell 25" diagonal digital color TV! Mail the postage-free card today for complete details, free!

Lab gives you up-to-date "tools of the trade", including instruments you can use professionally after you finish the program.

A new digital multimeter that measures voltage, current and resistance and displays its findings in big, clear numbers. Far more accurate and readable than conventional "needle pointer"

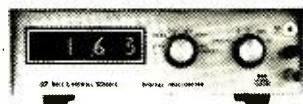

meters that require guesswork and interpretation.

The solid-state "triggered sweep" oscilloscope is a "must" for accurate analysis of digital circuitry. Includes DC wide-band vertical amplifier and "triggered sweep" feature to lock in signals for easier observation.

The design console is a valuable device for setting up and examining circuits without soldering! Features patented modular connectors, AC power supply and transistorized dual range DC power supply.

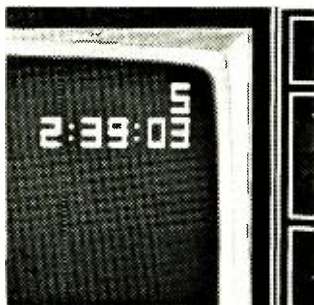

R TV IS HERE!

Build it yourself... the perfect way to learn all about the exciting field of digital electronics!

It's part of a complete at-home program!

Imagine spending your spare time actually building your own 25-inch diagonal digital color TV! It's a project you can work on right in your home. You'll enjoy the challenge... exploring the new systems of digital circuitry and performing experiments to test what you learn.

There's no travelling to classes, no lectures to attend, and you don't have to give up your job or paycheck just because you want to get ahead. When you finish this new Bell & Howell Schools program, you'll have the skills you need plus a great color TV to keep and enjoy for years!



Digital electronics is changing our lives!

There's a lot more to digital electronics than just the numbers! True, that's what you see on more and more products like digital calculators, clocks and watches. But behind the numbers lies a fantastic technology that's creating higher standards of accuracy and dependability. The versatility of digital electronics has begun another industrial revolution. Its growth and applications are giving us new and better ways of doing things and spectacular products like this new Bell & Howell digital color TV!

You need no prior electronics background!

We start you off with the basics. You'll receive a special Lab Starter Kit with your first lesson so that you can get immediate "hands on" experience to help you better understand newly-learned electronics principles. Later, you'll use your new knowledge and learn valuable skills as you build the digital color TV. You can take advantage of our toll-free phone-in assistance service throughout the program and also our in person "help sessions" held

in major cities throughout the year where you can "talk shop" with your instructors and fellow students.

Pick up valuable skills in electronics that could lead to extra income, full or part time... perhaps a business of your own!

Once you complete this new at-home program from Bell & Howell Schools, you'll have the specialized skills to service not only color TV's but a variety of today's most modern home entertainment electronics equipment. These skills could open up new income opportunities for you, full or part time. Get the complete story on this exciting, learn-at-home program... the world's first color TV course employing digital electronics technology! No better or more practical at-home training in electronics is available anywhere!

Mail card today for full details, free!

If card has been removed, write:
An Electronics Home Study School
of BELL & HOWELL INSTITUTE OF TECHNOLOGY

BELL & HOWELL SCHOOLS
2141 Bell & Howell Drive, Chicago, Illinois 60641

Bell & Howell Labs is a registered trademark of the Bell & Howell Company.

597791

NOW A PROFESSIONAL BURGLAR-FIRE ALARM SYSTEM YOU CAN INSTALL YOURSELF.

ONLY 139.95!



Save hundreds of dollars in alarm installation and monthly service charges. The EICO SS-500 "install-it-yourself" burglar-fire alarm system offers you the kind of professional protection you have been looking for, at a price you can afford. The SS-500 has been designed on the EICO "Expandability Concept" that enables you to "add-on" protection to meet your own special needs. Before you purchase any security system, we suggest you read the EICO Security Handbook and see how easy EICO makes it to "Do-it-Yourself."

FREE EICO CATALOG/SPECIAL OFFER!

Security handbook (Reg. \$2.95) only \$1.50 with this ad. Includes a catalog on EICO Security Systems, Test Instruments, Stereo, Hobby Kits and name of nearest distributor. For catalog only, check reader service card or send 25¢ for first class mail service.

EICO, 283 Malia Street, Brooklyn, N.Y. 11207



CIRCLE NO. 12 ON READER SERVICE CARD



Free!

New 14th
Edition of
the Midwest
Hifi Catalog!

Save on stereo! Buy direct from us and you save money with our high-volume prices on more than 100 name brands. Order from the branch nearest you.

Midwest Hifi Wholesale & MAIL ORDER DIVISION

2455b Wisconsin Ave, 3309 E. J W Carpenter Frwy,
Downers Grove, Ill 60515 Irving, Tex 75062

PE

NAME

ADDRESS

CITY/STATE

ZIP

CIRCLE NO. 23 ON READER SERVICE CARD



Electronics Library

UNDERSTANDING AND USING THE OSCILLOSCOPE

by Clayton Hallmark

Presupposing no prior knowledge whatever on the part of the reader, this book tells how to set up any type of oscilloscope, calibrate it, and use it for small- and large-signal voltage, frequency, phase, time, response, gain, modulation percentage, and a host of other applications. It covers scope construction, sweep circuits, time-base circuitry, sync circuits, blanking and unblanking, probes, how and why of linearity, checks for distortion within a scope, intensity modulation, interpretation of Lissajous figures, direct and indirect phase measurement, and electronic switching for dual-trace displays. Covered also are special-purpose devices in which CRT's are used.

Published by Tab Books, Blue Ridge Summit, PA 17214. 256 pages. Hard cover \$7.95; soft cover \$4.95.

ELECTRONIC TROUBLESHOOTING: A MANUAL FOR ENGINEERS AND TECHNICIANS

by Clyde N. Herrick

The theory of electronics is kept to a minimum with emphasis on troubleshooting techniques. A broad spectrum of topics has been chosen for instruction, including AM and FM broadcast radio receivers, stereo/hi-fi equipment, tape recorders, color and monochrome TV receivers, TV cameras, tape recorders, radio transmitters, electronic organs, digital computers, etc. Solid-state circuit analysis and testing are stressed, as are the standard and specialized test equipment needed for troubleshooting today's electronic equipment.

Published by Reston Publishing Co., Inc., P.O. Box 547, Reston, VA 22090. Hard cover. 306 pages. \$15.95.

QUESTIONS AND ANSWERS ABOUT NOISE IN ELECTRONICS

by Courtney Hall

Why is noise important? What is "shot" noise? How can noise figures be measured using a sig-

nal generator? These and many more pertinent questions are answered in this book for the engineer, technician, and experimenter. The Q & A approach provides a quick basic understanding of noise characteristics and noise measurement techniques for practical applications in electronics. Discussed are white, pink, man-made, atmospheric, and galactic noises and their importance. Next come discussions on thermal and shot noise, noise bandwidth, special considerations for noise, S/N ratio, noise figure, etc.

Published by Howard W. Sams & Co., Inc., 4300 West 62 St., Indianapolis, IN 46268. Soft cover. 96 pages. \$3.95.

ELECTRONICS FOR MODERN COMMUNICATIONS

by George A. Angerbauer

If you are seeking an amateur or a commercial FCC license, this book contains the latest information that you need to prepare for taking the licensing exam. It presents all of the material in a step-by-step method, progressing from basic simple concepts to the more complex ones, while establishing a valuable continuity from one element to the next. Material included on transistors and other solid-state devices reflects the latest FCC questions asked. The questions following most chapters have

been compiled in full accordance with the latest FCC Study Guide Revisions. Hundreds of drawings illustrate all of the material throughout the book.

Published by Prentice-Hall, Inc., Englewood Cliffs, NJ 07632. Hard cover. 662 pages. \$15.95.

ILLUSTRATIONS IN APPLIED NETWORK THEORY

by F.E. Rogers

Although this book is intended for intermediate college-level engineering courses, its math level rarely rises above simple algebra and trigonometry. The text emphasizes the importance of natural frequencies that correspond to the poles and zeros of synthesis specification through illustration of their roles in time and frequency domains, in specification of characteristics at real frequencies, and the behavior of amplifiers with various feedback arrangements. The reader is introduced in simple ways to the indefinite admittance matrix as a nodal-voltage analysis tool and the basis of Darlington's transfer function procedure for a terminated-reactance two-port network, to the scattering coefficient, and to the concept of a scattering matrix.

Published by Crane, Russak & Co., Inc., 52 Vanderbilt Ave., New York, NY 10017. Hard cover. 228 pages. \$11.75.



MAKING "WAVES"

CADENCE—the musical instrument speakers

Making better, clearer, amplified sound waves is the **THING** Cadence does . . . better than anything else in the industry. Cadence Speakers are built to withstand heat from sustained notes at a high power level and the vibrations and stresses which are continually placed upon them. Cadence is guaranteed **one full year** at the power level specified. This proven speaker family has been selected by the manufacturers of most of the world's fine amplified music instruments.

If making beautiful, clear sound waves is your thing, ask for **CADENCE SPEAKERS**.

For complete information and the name of your Cadence Dealer, write:



UTAH ELECTRONICS DIVISION
Utah-American Corporation
1124 East Franklin Street
Huntington, Indiana 46750

CIRCLE NO. 32 ON READER SERVICE CARD



New Products

Additional information on new products covered in this section is available from the manufacturers. Either circle the item's code number on the Reader Service Card inside the back cover or write to the manufacturer at the address given.

TI SLIDE-RULE CALCULATOR

A new full-function slide-rule calculator from Texas Instruments Inc. costs only \$169.95. The Model SR-50 calculator features an easy-to-use algebraic keyboard with circuitry that permits numbers and functions to be entered in the same order as they are written. It performs the four basic arithmetic functions, reciprocals, squares, square roots, nth powers, nth roots, factorials, trigonometric and hyperbolic functions (sine, cosine, tangent), inverse trig and hyperbolic functions, common and natural log functions, and e^x . Answers to problems are calculated to 13 significant digits, with the answer automatically converted to scientific notation when it exceeds 10^{10} or is less than 10^{-10} .

Circle No. 68 on Reader Service Card

SCHOBER BASIC POWER AMPLIFIER

The Model TR-3 basic power amplifier from Schober Organ Corp. is offered in both stereo and mono versions at outputs of 70 watts/channel. Unusual features include push-pull operation of all stages and direct coupling throughout. At a steady-state 70 watts into 8 ohms, the power bandwidth is 5 to 40,000 Hz ± 0.5 dB. THD is less than 0.1 percent, and IM distortion is less than 0.07 percent. Sensitivity can be set



with a special control so that only 150 mV is needed at the input for full output power. The Model TR-3D 2-channel kit sells for \$194.90; the Model TR-3M mono kit sells for \$142. A model TCK-3 mono-to-stereo conversion kit is also available for \$59.20.

Circle No. 69 on Reader Service Card

TRIPLETT "3-IN-1" TESTER KIT

Triplett Corporation's versatile new Model 615 VOM for appliance, industrial, commercial, and residential maintenance jobs is now available in kit form. The Model 615-K kit provides a single package containing the Model 615 VOM, the Model 20-A clamp-on ac ammeter adapter, the Model 101 ac line separator, 48-in. test leads, a 6-ft thermocouple probe, alligator clips, batteries, and instruction manual—all in a rugged carrying case that is lined with shock-isolating plastic form. (Price is \$180).

Circle No. 70 on Reader Service Card

BSR 12-OCTAVE FREQUENCY EQUALIZER

The Model FEW-3 frequency analyzer from BSR Electronics Inc. covers 12 full octaves with 24 individual controls for complete and pre-

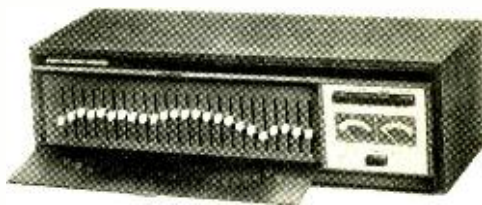

cise adjustment of each of two stereo channels. It is equipped with two VU meters for use with calibrated sound level meters. Unlike other equalizers, it is designed to permit convenient equalization while making a recording. Distortion is less than 0.007 percent and noise is 80 dB down. A translucent flip-down front panel protects the slide controls from accidental movement that would upset the equalization.

Circle No. 71 on Reader Service Card

LAFAYETTE 4-WAY SPEAKER SYSTEM

The Lafayette Radio Electronics Corp. top-of-the-line floor-standing speaker system (stock No. 21-0505411WX) has a nominal impedance of 8 ohms and will handle 100 watts of input power. The four-speaker, four-way system is housed in a 5.4-cu ft acoustic-suspension enclosure. Its overall frequency range is 18 to 22,000 Hz, with crossovers at 400, 900, and 7000 Hz. The driver complement includes a 15-in. woofer with 12-lb magnet structure, 8-in. midrange driver with 2½-lb magnet structure, 5-in. upper midrange driver with 2-lb magnet structure, and 2-in. direct-radiator super tweeter. Separate high, upper-midrange, and lower-mid-

range controls are provided for tailoring the system's response to the listening environment. (Price is \$199.95).

Circle No. 72 on Reader Service Card

CLEGG HAND-HELD 2-METER TRANSCEIVER

A new solid-state portable 2-meter FM transceiver designed to provide the ham with reliable performance at low price (\$289) is available

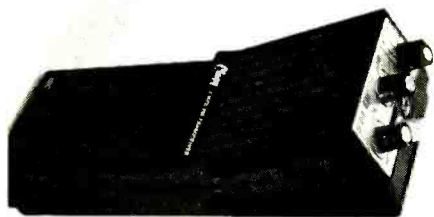

from the Clegg Division of International Signal and Control Corp. The Model HT-146 transceiver meets all FCC type-acceptance requirements. It is a 2-watt, five-channel unit that draws only 5 mA of standby current. The receiver section features single conversion, a crystal filter, and solid-state T/R switching. Plug-in crystals make channel changing fast and easy. Jacks for external microphone, speaker, and earphone are included along with a BNC antenna connector and a heliflex antenna. The transceiver measures 8 $\frac{3}{8}$ in. by 3 $\frac{1}{8}$ in. by 1 $\frac{1}{8}$ in. and weighs about 1 lb 10 oz.

Circle No. 73 on Reader Service Card

EDMUND SCIENTIFIC BIOFEEDBACK MONITOR

A portable biofeedback system, the "Biosone" (No. 71,809) is available for only \$49.95 from Edmund Scientific Co. It picks up alpha and theta brainwaves and provides an audio signal for monitoring their increase and decrease. The Biosone contains narrow-band filters that isolate the brainwaves and a high-gain, low-noise amplifier with a 5- μ V sensitivity. The unit includes stethoscope earphones, a headband with permanent electrodes, a neckband that eliminates the need to hold the unit, electrode cream, complete instructions, and a one-year warranty.

Circle No. 74 on Reader Service Card

DATA TECHNOLOGY DMM MEASURES C

A new 3 $\frac{1}{2}$ -digit bench-type digital multimeter that measures ac and dc voltages, resistance,

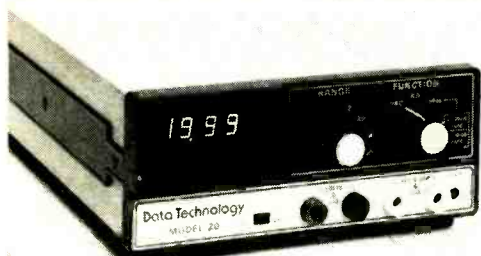

APRIL 1974

SAVE!

MONEY • TIME • FREIGHT

QUALITY STEREO EQUIPMENT AT LOWEST PRICES.

YOUR REQUEST FOR QUOTATION RETURNED SAME DAY.

FACTORY SEALED CARTONS—GUARANTEED AND INSURED.

SAVE ON NAME BRANDS LIKE A.D.C.



DYNACO

A.R.

KLH

FISHER

KOSS

SHURE

SONY

AND MORE THAN 50 OTHERS
BUY THE MODERN WAY
BY MAIL—FROM

illinois audio

12 E. Delaware Place
Chicago, Illinois 60611
312-664-0020

CIRCLE NO. 17 ON READER SERVICE CARD

THE ONE WORD
FOR PERFORMANCE AND
RELIABILITY IN
ELECTRONIC
IGNITION
JUDSON

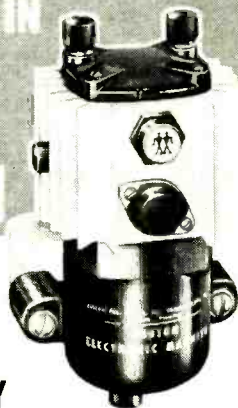

YOU CAN HAVE
TOMORROW'S
IGNITION ON
YOUR CAR TODAY

Don't accept "as good as" there are none.

Write Today for Literature

JUDSON
RESEARCH AND MFG. CO
CONSHOHOCKEN PA. 19428



CIRCLE NO. 18 ON READER SERVICE CARD

and capacitance has been introduced by Data Technology Corp. The Model 20 DMM is said to be the first precision, easy-to-use capacitance meter that sells for less than \$300. It has a resolution of 1 pF and an accuracy of 2 percent of reading. There are four dc voltage ranges (to 2000 V) with 1-mV resolution and 0.1-percent accuracy; four ac voltage ranges (also to 2000 V) with 1-mV resolution and 0.5-percent accuracy; and four resistance ranges with 1-ohm resolution and 0.2-percent accuracy. The instrument consumes 3.5 watts of power and employs 3/4-in. Sperry gas-discharge readouts. (Price is \$269).

Circle No. 75 on Reader Service Card

PIONEER OPEN-REEL TAPE DECK

The U.S. Pioneer Electronics Corp. Model RT-1020 tape deck is a three-motor/three-head unit that features a 2/4-channel stereo playback head. The 15- and 7 1/2-ips deck will accom-



modate professional 10 1/2-in. tape reels. It offers unique two-step equalizer and three-step bias selection that permits its use with all available tape formulations. The deck will record and play back in the standard 2-channel/4-track stereo format. Additionally, the playback head permits playback of discrete 4-channel stereo tapes.

Circle No. 76 on Reader Service Card

ESS STEREO PREAMPLIFIER

The ESS Stereo Preamplifier has harmonic and intermodulation distortion figures of 0.0075 and 0.005 percent, respectively. Noise is down



100 dB in the high-level section, 96 dB in the tone control section, and 80 dB (referenced to a 10-mV, 1000-Hz input signal) in the phono preamplifier section. The bandwidth and frequency response in the high-level section at ± 0.025 dB is 10 to 40,000 Hz, becoming 2 to 2,000,000 Hz at ± 1.0 dB. In the tone control section, the response is 10 to 25,000 Hz ± 0.025 dB or 2 to 150,000 Hz ± 1.0 dB. And in the phono preamp section, it is ± 0.25 dB from the RIAA curve, 20-20,000 Hz.

Circle No. 77 on Reader Service Card

XCELITE METRIC DRIVER SET

A compact convertible hex socket screwdriver set, the Model PS-90MM, manufactured precisely to metric dimensions is now available from Xcelite Inc. The set includes eight hex socket drivers plus the company's original "piggyback" torque amplifier handle that slips over the tops of the midget tools to provide longer reach and greater driving power. Hex tip drivers on the 4-in. long shanks range in size from 0.89 mm to 5.0 mm. The drivers and handle are supplied in a flexible plastic see-through case with integral molded-in snap lock.

Circle No. 78 on Reader Service Card

REGENCY HAND-HELD MONITOR/SCANNER

The introduction of a hand-held, four-channel scanning monitor receiver—the Model ACT-P-4II—has been announced by Regency Electronics, Inc. The compact receiver features pushbutton control for each of its four frequencies, fast/slow scan operation, and stop-scan for listening to any one channel. It has a telescoping antenna and external provisions for powering from an optional ac power supply and battery charging accessory. (Price is \$119, plus crystals).

Circle No. 79 on Reader Service Card

COLE-FLEX AEROSOL SOLVENT & CLEANER

The all-purpose CD-240 solvent and cleaner from Cole-Flex Corp. is most effective on printed circuits, pc boards, and general bench use. It is said to have no flash or fire point, low residue, low toxicity, good solvency, and excellent electrical properties. The spray will leave no visible effect on most materials and insulations commonly found in the electronics/electrical industries, with the exception of polystyrene. (Price is \$2.10).

Circle No. 80 on Reader Service Card

SONY CASSETTE DECK

The new Sony Model TC-129 stereo cassette deck available from Superscope offers many features for a \$149.95 unit. In its design, are Sony's Ferrite head for extended life, automatic shut-off at tape's end in both the record and



playback modes, a tape selector switch for selecting the proper equalization for standard and chromium dioxide tape, illuminated dual VU meter, and straight-line record level controls. Other features include a built-in dust cover, three-digit tape counter, locking pause control, a stereo headphone jack, and a walnut base.

Circle No. 81 on Reader Service Card

GOLD LINE MULTI-BAND ANTENNA COUPLER

The Model GLC 1079 multi-band antenna coupler from Gold Line allows you to use the standard radio antenna in your car to monitor the 20-70-MHz, 148-174-MHz, and 250-470-MHz bands (with the appropriate receiver) as well as the AM and FM broadcast bands. The coupler installs, via two cables provided, between the antenna and receiver being used. The receiver's antenna input plugs into or screws onto the appropriate connector mounted on the coupler's housing. (Price is \$12.95).

Circle No. 82 on Reader Service Card

TECHNICS BY PANASONIC RECEIVER

The Model SA-6700X Technics by Panasonic 4-channel AM/stereo FM receiver generates 92 watts of total continuous rms power when all four channels are driven simultaneously into 8-ohm speakers. The receiver offers a 1.8- μ V FM sensitivity. Built into the receiver is a multi-function oscilloscope that visually displays signal distribution in all channels simultaneously.

Circle No. 83 on Reader Service Card

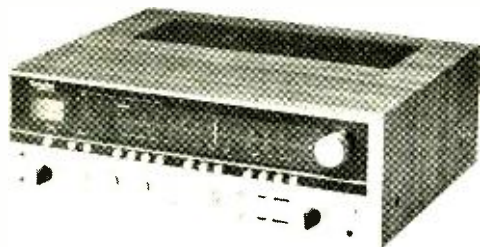

NEW FREE CATALOG OF CIRCUIT DESIGN & BREADBOARDING EQUIPMENT!

NOW . . . TEST NEW CIRCUIT IDEAS, I.C.'S, DISCRETE COMPONENTS WITH NO SOLDERING!

Circuit Design's new catalog has everything you need to take you from circuit concept to working hardware in minutes. Featured items include the great SK-10 socket for solderless circuit design and testing, the NEW SK-20 socket (only \$2.75) for smaller circuits, the versatile Digi Designer (in kit form or assembled), a new Op-Amp Designer, plus power supplies, pulse generators, digital logic courses, plug-in socket boards, and much more.

Write today for your free copy.

CIRCUIT DESIGNS, INC.

P.O. Box 24, Shelton, Conn. 06484
Exclusive mail order dist. for E&L Instruments.

CIRCLE NO. 13 ON READER SERVICE CARD

JUST OUT!

FORGET THE 1973 YEARBOOK OF Consumer Electronics 1974



YEARBOOK OF CONSUMER ELECTRONICS 1974

By Forest H. Belt

Here is in-depth coverage of the latest developments in consumer electronics, done in magazine style. Nearly 30 separate articles cover such subjects as: quadraphonic music systems, color-tv, hi-fi cassettes, decks, home video recordings, security alarms, CB radio, police scanners, pocket calculators, and much more. Includes special service technicians section. A timely and valuable book for technical and non-technical readers alike. 96 pages, softbound.

No. 21029

\$2.50



Howard W. Sams & Co., Inc. PE X44
4300 W. 62nd St., Indianapolis, Ind. 46206

Order from your Electronics Parts Distributor, or mail to Howard W. Sams & Co., Inc.

I enclose \$2.50 (add sales tax where applicable) for Yearbook of Consumer Electronics, 1974. Canadian prices slightly higher.

Name _____
Address _____
City _____ State _____ Zip _____

CIRCLE NO. 35 ON READER SERVICE CARD

ELECTRONICS MARKET PLACE

NON-DISPLAY CLASSIFIED: COMMERCIAL RATE: For firms or individuals offering commercial products or services, \$1.60 per word (including name and address). Minimum order \$16.00. Payment must accompany copy except when ads are placed by accredited advertising agencies. Frequency discount: 5% for 6 months; 10% for 12 months paid in advance. **READER RATE:** For individuals with a personal item to buy or sell, \$1.00 per word (including name and address.) No minimum! Payment must accompany copy. **DISPLAY CLASSIFIED:** 1" by 1 column (2 5/8" wide), \$200.00. 2" by 1 column, \$400.00. 3" by 1 column, \$600.00. Advertiser to supply cuts. For frequency rates, please inquire.

GENERAL INFORMATION: First word in all ads set in bold caps at no extra charge. All copy subject to publisher's approval. All advertisers using Post Office Boxes in their addresses **MUST** supply publisher with permanent address and telephone number before ad can be run. Advertisements will not be published which advertise or promote the use of devices for the surreptitious interception of communications. Closing Date: 1st of the 2nd month preceding cover date (for example, March issue closes January 1st. Send order and remittance to **POPULAR ELECTRONICS**, One Park Avenue, New York, New York 10016, Attention: Hal Cymes.

FOR SALE

FREE! bargain catalog. Fiber optics, LED's, transistors, diodes, rectifiers, SCR's, triacs, parts. Poly Paks, Box 942, Lynnfield, Mass. 01940.

GOVERNMENT Surplus Receivers, Transmitters, Snooperscopes, Radios, Parts, Picture Catalog 25¢. Meshna, Nahant, Mass. 01908.

LOWEST Prices Electronic Parts. Confidential Catalog Free. **KNAPP**, 3174 8TH Ave. S.W., Largo, Fla. 33540.

ELECTRONIC PARTS, semiconductors, kits. **FREE FLYER**. Large catalog \$1.00 deposit. **BIGELOW ELECTRONICS**, Bluffton, Ohio 45817.

RADIO—T.V. Tubes—36¢ each. Send for free catalog. Cornell, #213 University, San Diego, Calif. 92105.

AMATEUR SCIENTISTS, Electronics Experimenters, Science Fair Students . . . Construction Plans—Complete, including drawings, schematics, parts list with prices and sources . . . Robot Man — Psychedelic shows — Lasers — Emotion/Lie Detector — Touch Tone Dial—Quadrasonic Adapter—Transistorized Ignition — Burglar Alarm—Sound Meter . . . over 60 items. Send 25¢ coin (no stamps) for complete catalog. Technical Writers Group, Box 5994, University Station, Raleigh, N.C. 27607.

METERS—Surplus, new, used, panel or portable. Send for list. Hanchett, Box 5577, Riverside, CA 92507.

PYROTECHNICAL chemicals, casings, tools, supplies, fuse, literature. Giant, illustrated catalogue/handbook includes formulas, instructions—50¢, with samples—\$1.00. Westech, Box 593, Logan, Utah 84321.

WE SELL CONSTRUCTION PLANS. TELEPHONE: Answering Machine, Speakerphone, Carphone, Phonevision, Auto Dialer, Touch Button Dialer, Central Dial System. **TELEVISION:** \$35.00 Color Converter, Video Tape Recorder. \$25.00 Camera. **HOBBYIST:** Electron Microscope, 96 Hour Tape Music System, Ultrasonic Dishwasher, Radar-Oven. Plans \$4.95 each. **NEW ITEM:** \$75. Electronic Pocket Calculator, \$7.50. **COURSES:** Telephone Engineering \$39.50. Detective Electronics \$22.50, Integrated Circuit Engineering, \$49.50. **NEW SUPER HOBBY CATALOG** plus year's subscription to Electronic New Letter **AIRMAILED \$1.00**. Don Britton Enterprises, 6200 Wilshire Blvd., Los Angeles, Calif. 90048.

JAPAN HONG KONG DIRECTORY. World products information. \$1.00 today. World Trade Inquiries, Hillyard, Washington 99207.

SCOPES, meters, test equipment, military and industrial surplus. Write for free "Bargain Bulletins". Lawrence Instruments, P.O. Box 744, Sunbury, Pa. 17801.

TEST EQUIPMENT, Aerospace-Laboratory Grade. Request your needs; will mail appropriate catalogs (we have 24 catalog categories). Only for Engineers, Businesses, Schools and advanced Technicians. Goodheart, Box 1220PE, Beverly Hills, Calif. 90213.

LED READOUT BONANZA!
Compare prices and you will buy from us!

MAN-1 type readout. .27 inch character size Left decimal point Uses 7447 driver. 14 pin style — \$2.50 ea.

MAN-3A type readout. .12 inch character size. Right decimal point. Uses 7448 driver — 0.95¢

Three digit readout. In one dip. Has 3 MAN-3 type readouts. Internally multiplexed. Designed for calculators, etc. Right decimal point. Like DL-33 — (3 digits) \$2.95.

OPCOA SLA-1 readout. Electrically like MAN-1 except has larger digit size. 33 inch character. 14 pin style. Uses 7447 driver. Segments consist of bar, rather than dots. Much easier to read. Left decimal — \$1.75 ea.

LOOKI OPCOA SLA-17 readout. Same as SLA-1 but **Green!** Like MAN-5 Uses 7447 A Driver. Left decimal point — \$2.95 ea

OPCOA SLA-1C. Color readout for use in digital clocks. Has either left or right decimal — \$2.50 ea

Jumbo red led lamps. Large like MV5024 5 for \$1.00
Jumbo green led lamps. Like MV5222. 3 for \$1.00

Prime TTL DIP IC'S			
7400 - 25¢	7438 - 49¢	7483 - 89¢	74121 - 49¢
7402 - 25¢	7439 - 69¢	74H73 - 49¢	74151 - 89¢
7404 - 25¢	7442 - 89¢	7483 - 89¢	74154 - \$1.95
7407 - 30¢	7445 - 89¢	7486 - 39¢	74164 - \$1.95
7408 - 25¢	7447 - 95¢	7490 - 95¢	74165 - \$1.50
7410 - 25¢	7448 - 95¢	7491 - 95¢	74174 - \$1.95
7427 - 35¢	7473 - 39¢	7492 - 95¢	74181 - \$3.50
7430 - 25¢	7474 - 49¢		74182 - 95¢
7437 - 49¢			74192 - \$1.39
			74193 - \$1.39

Prime TTL DIP IC'S

Calculator chip, with Memory, Outperforms CT5005 — \$8.95
LM309-R 5V regulator — \$1.75 + 741C mini dip — \$ 49
Phase lock loop. NE 567V mini dip — \$2.50

TTL and Linear Assortment. Contains 1/2 pound (Approximately 200 pieces) mixed TTL and Linear IC's untested, includes logic gates, Flip flops, counter FM detectors chroma demod IC's, etc. Marked and unmarked, with some spec sheets — \$3.95.

Plastic transistor assortment manufactured by T.I., contains NPN and PNP silicon, TO-92 case, many useable units. We have more than we can test, 100 piece assortment — \$1.49
New for 74! 4 bags for \$5.00.

SPECIAL OFFER

On every \$15.00 order, choose \$1.00 worth of free merchandise.

ALTAJ ELECTRONICS
P.O. Box 28592
Dallas, Texas 75228

Terms: Check or Money Order. No COD. Add 10% of order to help cover postage and handling. Bargain flyer 10¢ free with order. Cashiers check and money order will speed up delivery.

BUILD YOUR OWN SPACE-AGE TV CAMERA

ONLY KNOWN SOLIDSTATE CAMERA KIT! Ideal for experimentation, home, education, industry, etc. • High quality • Backed by over 100 years of Aik & Field testing • Fully Guaranteed • Converts to any TV set without modification • Simply plug constructed camera into Model XT1A, Series D camera with video. \$149.95 (postpaid anywhere in USA & Canada, less with our like \$119.95!)

PHONE OR WRITE FOR CATALOG.
DIAL 468-9137X

Many other kits, parts and plans available including camera kits, locust-dell, cells, video tapes, color parts, audio subcarrier kit, etc.

ATV Research DAKOTA CITY, NEBR. 68721

DIGITAL ELECTRONICS: Complete schematics, parts lists, theories — Discrete Component Digital Clock, \$3.00—Sound Sensitive Switch, \$1.50. Increase technical competence, hobby skills—Complete Course in Digital Electronics is highly effective, \$10.00. Free literature. DYNASIG, Box 60A7, Wayland, Mass. 01778.

MECHANICAL, ELECTRONIC devices catalog 10¢. Greatest Values —Lowest Prices. Fertik's, 5249 "D", Philadelphia, Pa. 19120.

CD IGNITIONS, VHF/UHF monitors, crystals, CB radios. Wholesale. Southland, Box 3591-B, Baytown, Texas 77520.

CIRCLE NO. 1 ON READER SERVICE CARD

WAVEFORM GENERATOR KIT 8038 Function Generator IC Producing Sine, Square, Triangular Waveforms, \$10.00. Write for catalog. Photolume Corporation, 118 East 28th Street, New York, N.Y. 10016.

SURPLUS electronic parts and pieces. Monthly picture flyer free. Startronics, Box 17127, Portland, Oregon 97217.

BURGLAR-FIRE alarm components, hardware. Free catalog—information. Silmar, 133 S.W. 57 Ave., Miami, Florida 33144.

DISCOUNT PRICES

B & K, SENCORE, LEADER Test Equipment
RAYTHEON, ICC/MULLARD Tubes
TELEMATIC Test Jigs

Free Catalog

FORDHAM RADIO SUPPLY CO. INC.
558 Morris Ave., Bronx, N.Y. 10451

FREE CATALOG. Parts, circuit boards for POPULAR ELECTRONICS projects. PAIA Electronics, Box C14359, Oklahoma City, OK 73114.

YOU SAVE BIG MONEY! Surplus, Clearouts, Bankruptcy, Inventory, Deals. Catalog \$1 (redeemable). ETCOA Electronics, Box 741, Montreal, H3C 2V2. U.S. Inquiries.

ELECTRONIC Parts wholesale. Catalog 10¢. Donlyon Electronics, P.O. Box 15421, Phoenix, Arizona 85060.

FREE Catalog lists resistors, tubes, transistors, rectifiers, condensers, tools, tuners, etc. Hytron Hudson, Dept. PE, 2818 Kennedy Blvd., Union City, N.J. 07087.

SOUND SYNTHESIZER KITS—Surf \$11.95, Wind \$11.95, Wind Chimes \$16.95, Electronic Songbird \$6.95, Musical Accessories, many more. Catalog free. PAIA Electronics, Box J14359, Oklahoma City, OK 73114.

AUTHENTIC, INSTRUMENTED, FLYING ROCKETS for casual or serious experimenters. Over 80 scale original, multi-stage or ready-to-fly models. Solid-propellant engines for safe, electric launch system liftoffs up to 2,500 feet. Measure altitude, temp. inversions, more. Real telemetry, electronic tracking, aerial still and movie photography with super-miniaturized equipment. New, detailed tech manual and full-color catalog. 25¢ from ESTES INDUSTRIES Dept. 18V, Penrose, Colo. 81240.

PAIA SYNTHESIZER KITS



Models priced from
\$139

**LIKE TO HEAR IT?
NEED TO KNOW MORE?**
10 minutes of far out sounds
created with the PAIA Synthesizer
now on a demo record... 75¢... Catalog free

PAIA ELECTRONICS, INC.

BOX P14359, OKLAHOMA CITY, OK 73114

WHOLESALE Scanners, CB., Crystals, Directories, SSB/AM, Catalog 25¢. G—ENTERPRISES, Box 461P, Clearfield, Ut. 84015.

LASER parts catalog, 60¢. Moynihan, 107 North Brighton, Atlantic City, New Jersey 08401.

BURGLAR-FIRE alarm supplies and information. Free catalog. Protecto Alarm Sales, Box 357-G, Birch Run, Michigan 48415.

FREE CATALOG. IC's, Puts, Transducers, Thermocouples, Led's, Transistors, Circuit Boards, parts. Chaney's, Box 15431, Lakewood, Colo. 80215.

APRIL 1974

3-15 VOLT 0.1% REGULATORS ON A CIRCUIT BOARD

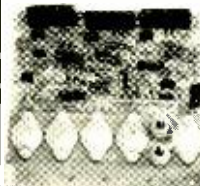

Board contains 3 15 volt regulators. 2 rated at 3 amps & 1 @ 6 amps, all @ 0.1%. At 5 & 10 amps, reg. is 0.5%. Comes with common +, easily isolated or changed to common -. Ideal for circuits requiring \pm - 15 volts. Board contains 5 2N5878 150 watt silicon NPN transistors. 4 used in regulators & 1 spare.

2 regulators have electronic crowbar over voltage control, and all are short circuit protected. Precision resistors and capacitors used thruout. Best regulators we've seen, all for less than the price of the power transistors. With data sheet and circuit diagram. 6" x 6"
STOCK NO. F5169 \$11.95 ea. 2/21.00.

TRANSFORMERS

(Ideal for above regulators)

14 V. 3 A.	3 lbs	F9793	2.75	2/5.00
34 V ct 5A.	5 lbs	F9448	4.75	2/9.00
32 Vct 2 A.	3 lbs	F9743	4.00	3/11.00

COMPUTER GRADE CAPACITORS

MFD.	VOLTS	STOCK	PRICE
8500	55	F2221	1.50 6/8.00
4000	50	F2189	1.50 6/8.00
3750	75	F2116	1.75 6/9.00

MINIMUM ORDER \$5.00. Include sufficient postage; excess refunded. Send for latest 56 page catalog with exciting values.



DELTA ELECTRONICS CO.

BOX 1, LYNN, MASSACHUSETTS 01903

ELECTRONIC ORGAN KITS, KEYBOARDS and many components. Independent and divider tone generators. All diode keying. I.C. circuitry. Supplement your Artisan Organ. 35¢ for catalog. DEVTRONIX ORGAN PRODUCTS, Dept. C, 5872 Amapola Drive San Jose, Calif. 95129.

CALCULATOR OWNERS: Use your $+ - \times \div$ calculator to compute square roots, cube roots, $\sin(x)$, $\cos(x)$, $\tan(x)$, $\arcsin(x)$, $\arccos(x)$, $\arctan(x)$, logarithms, exponentials, and more! Quickly, Accurately, Easily! Send today for the IMPROVED AND EXPANDED EDITION of the first and best calculator manual—now in use throughout the world... only \$2.00. Unconditional money-back guarantee—and FAST service! Mallmann Optics and Electronics, Dept. 14A, 836 South 113, West Allis, Wisconsin 53214.

BUGGED??? New locator finds them fast. Write, Clifton, 11500-L N.W. 7th Avenue, Miami, Florida 33168.

PROJECT TV image life size! Construction plans: \$2.00. Macrovision, Box 14197, San Francisco, CA 94114.

TELEPHONE "BUGGED"? Countermeasures Brochure \$1.00. Negeye, Drawer 547, Pennsboro, W. VA 26415.

JAPANESE TRANSISTORS, Wholesale Prices, Free Catalog. West Pacific Electronics, Box 25837, W. Los Angeles, CA 90025.

ELECTROSLEEP, acupuncture. Catalog of 200 more projects free. Cimarron Labs, G-13060 Center Rd., Clio, Michigan 48420.

DIGITAL logic trainers. Digital and analog modules. LED displays. Scientific Measurements, 2945 Central, Wilmette, Illinois 60091.

WE SELL MONEY MAKING CONSTRUCTION MANUALS!—Reclaim refined GOLD and SILVER for EXCELLENT full time or part time money!—Color Catalog 25¢—Airmailed 50¢. Creative Products, Dept. PE-474, 8415 Lofland, Houston, Texas 77055.

HEAR POLICE/FIRE Dispatchers! Catalog shows exclusive directories of "confidential" channels, receivers. Send 10¢ stamp. Communications, Box 56-PE, Commack, N.Y. 11725.

Atlantic CB INVENTORY

SALE



EXCLUSIVE 3-CHANNEL,
6-WATT HAND-HELD
SSB / AM CB
TRANSCEIVER
MIDLAND MODEL 13-778
ATLANTIC CB PRICE—

Original
List Price
\$230.95

\$99⁹⁵

FEATURES INCLUDE: 6-Watts P.E.P., 3-Watts AM. Dual Circuitry Provides AM, SSB Transmission. DeLuxe Dual Conversion, Super-Heterodyne Receiver. Combination SSB Clarifier-AM Delta Tuning. Exclusive IF Noise Blanker Circuit. Separate Speaker and Microphone. Convenient Battery Condition Meter. 3 Integrated Circuits, plus 2 FETs. Operates on 3 Modes: Standard AM, Upper Sideband (USB) and Lower Sideband (LSB), on Three Pre-Selected DB Channels. Plug-In Transmit and Receive Crystals for Channels 5, 11 and 17 Factory installed. Provides 9 Possible Combinations. Can be used In Car or Home, with Optional Accessories.

U. S. ORDERS SEND
CHECK OR MONEY OR-
DER—WE WILL PAY ALL
HANDLING CHARGES!

CIRCLE NO. 2 ON READER SERVICE CARD

Atlantic CB

7748 CLEMENTS ROAD.

WYNCOTE, PA 19099

TEL: 455-5300 (215)

FIREWORKS NEWS—Magazine Covering Commercial—Display Fireworks, Sources, Construction, Pyrotechnical Supplies, Fuse, Literature. Free Catalogs/Book list With Subscription! Calendar Year \$9.00 "1974" Fireworks Buyers' Guide" \$5.95. Pyro Press, Box 12010N, Lexington, Kentucky 40511.

AIRCRAFT TYPE HEADSET with tube loaded mike for CB walkie-talkies only \$9.95, literature 25¢ refundable. Dept. P4 Campbell & Company, Box 91654, L.A., Calif. 90009.

1/2 WATT Resistors all values 2¢. Minimum \$2.00. Lectronix, Box 1067, Southgate, Michigan 48195.

90 WATTS peak stereo amp, build for less than \$90.00. Plans \$6.50, specs \$1.00. Cole's Consultants, 7090 Madera, Goleta, Calif. 93017.

NEW and Surplus electronics dealers. List \$2.00. Kin's Electronics, Route 3, Upper Sandusky, Ohio 43351.

MEASURE Things Accurately! Numerically! Digitally! Numerical Readout Projects Catalog: Free! GBS, Box 100K, Green Bank, West Virginia 24944.

ALPHASYNC biofeedback metronome for relaxation, meditation. \$10.95 postpaid. Guaranteed. Lawson Electronics, Box 711, Poteet, TX 78065.

ORAKE and Swan Receivers, Transmitters, Transceivers, Accessories. New Boxed 1974 models, trade-in's taken. S'ep Electronics, P.O. Box 100, Otto, North Carolina 28763.

PLANS: Logic tester, Multimeter, electronic dice power supplies; \$1.50 each. MCT, 4510 Stinson Blvd., Col. Hgts., MN 55421.

TRANSISTOR-TESTER Build in 10 minutes for pennies. Will test transistors, diodes, fuses, tube-filaments, shorts, broken-circuits and many more other parts. How to build and use instructions, \$1. William Morgan, Bruce, Miss. 38915.

IC's, Semiconductors, parts. Catalog free. Davis Associates, 16 Grove, Londonderry, N.H. 03053.

ALPHA/THETA BRAINWAVE biofeedback instruments: Analog instruments from \$125; digital processing systems from \$225. BioScan, Box 14168-E, Houston, Texas 77021.

BIOFEEDBACK. Professional instruments: Electroencephalophone, Gavanic Skin Response. J&J, 8102E, Bainbridge, WA 98110.

AUTOMATIC telephone recording and debugging equipment. Electronic car ignition systems. Top quality. Lowest wholesale prices. Viking International, Box 632E, Newhall, California 91321.

1974 ELECTRONIC Computer Knowledge. Electronic Computer Code; Electronic Computer Math; Electronic Computer Punched Card. For only \$1.98 each, all 3 for \$3.98. C. Code, Box 343, Mohegan Lake, N.Y. 10547.

ALPHA WAVE Monitors—free brochure. MedLab, Box 31035, San Francisco, CA 94131.

USED Tape Readers. List. LaTorre, 45 Ellis Ave., Northport, N.Y. 11768.

LOW NOISE RESISTORS—carbon film. Brand new as low as \$2.25 each. Components Center-PE, Box 134, N.Y., N.Y. 10038.

CONVERT any television to sensitive, big-screen oscilloscope. Only minor changes required. No electronic experience necessary. Illustrated plans. \$2.00. Sanders, Dept. A-33, Box 92102, Houston, Texas 77010.

CONVERTERS: Any voltage from -30 to +30 volts from a +5 volts source. Maximum 5 watts, \$28.00 each. Write your requirement and send bank check or money order to IMI, Box 97, Ballardvale Station, Andover, MA 01810.

FREE! Giant catalog. Semiconductors, IC's, Parts. Crown Electronics, 501 Baldwin Avenue, Lodi, N.J. 07644.

BABY TUNING FORKS—for personal or oscillator usage. A-440 or C-523.3 \$3.00 each postpaid. McNeil, 5150 Belleview Rd., Cincinnati, Ohio 45242.

METRIC CONVERTOR. Plastic, longlasting slide rule converts U.S. to Metric measurements. Contains conversion tables to four decimals. \$3.95. Metrivoter, Box 225H, Dayton, Ohio 45401.

THE CALCULATOR HANDBOOK 127 pages practical applications, short cuts, algorithms. \$1.25 plus 39¢ postage and handling. Techniplan, Box 51A, Baldwin, New York 11510.

SURPRISE! Unusual Numerical Readout Projects Catalogue including sample plan: \$1.00. GBS, Box 100T, Green Bank, West Virginia 24944.

FREE CATALOG—Stereo Components—TV's, Radios, Tape Recorders, CB Equipment. People's World, 11044 Rennard Street, Philadelphia, Pa. 19116.

HEATHKIT, EICO, RCA and Stereo Equipment. Fantastic bargains, \$25.00 color TV, not junk. Moving sell out. Must dispose entire workshop. Radio, Test, Stereo Equipment bargains. For catalog send \$1.00 to 127 Park View, Apt. 207, Los Angeles, California 90057.

MAILORDER CONCERNS. We have electronic components for sale. Low prices! BDJ Electronics, 16 Horn, Orangeburg, New York 10962.

HIGH FIDELITY

DIAMOND NEEDLES and Stereo Cartridges at Discount prices for Shure, Pickering, Stanton, Empire, Grado and ADC. Send for free catalog. LYLE CARTRIDGES, Dept. P, Box 69, Kensington Station, Brooklyn, New York 11218.

SAVE 50%. Build your own speaker systems featuring Norelco, Eminence and CTS. Famous brands from world's largest speaker factories at lowest wholesale prices. Write for 176 page catalog for speakers and electronic accessories. McGee Radio Company, 1901 McGee Street, Kansas City, Missouri 64108.

WANTED

QUICKSILVER, Platinum, Silver, Gold, Ores Analyzed. Free Circular. Mercury Terminal, Norwood, Mass. 02062.

CAPACITORS WANTED: Computer-Grades, Tantalums, Mylars, Discs.—Cash Paid—National Electronics Supply, Dept. P1, 7231-B Garden Grove Blvd., Garden Grove, Calif. 92641.

LED 7-SEGMENT Readouts

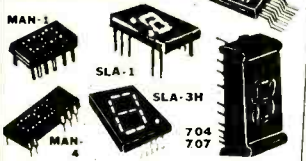

(All "LED" TYPES)

Type	Char.	Each	Special
MAN-1	.27	\$3.75	3 for \$9.
MAN-3	.12	1.49	3 for \$3.
MAN-4	.19	2.50	3 for \$6.
704*	.33	2.50	3 for \$6.
704**	.33	2.50	3 for \$6.
SLA-1**	.33	2.50	3 for \$6.
SLA-3**	.70	5.95	3 for \$15.
SLA-11**	.331	4.95	3 for \$12.

*By Litronix. **By Opcon, equal to MAN-1 or MAN-4 specs. Color - RED, Green.

LED SPECIAL #1
Includes RED LED's, jumbo, mediums, small, miniature, micro-mini, in upright & axial leads. Includes INVERTER. RED, too! All brand new & guaranteed!

10 for \$1.50
3 Kits - Take 10%

LED SPECIAL #2
Includes GREEN LED's, jumbo, mediums & miniature, upright. Brand new, guaranteed.

3 for \$1.50
3 Kits - Take 10%



Money-Back GUARANTEE on all items

BUY ANY 3 — TAKE 10%
LINEAR FACTORY GUARANTEED

Op Amps

- 531 Hi slew rate op-amp (TO-5) \$2.50
 - 532 Micro power 741 (TO-5) 2.50
 - 533 Micro power 709 (TO-5) 2.50
 - 536 FET input op amp (TO-5) 2.95
 - 550 Precision 723 voltage reg. (DIP) 1.17
 - 555 Timer 2 to Seconds to 1-hr. (A) 1.25
 - 556 5 Times faster than 741C (A) 2.10
 - 558 Dual 741 (A) 1.00
 - 560 Phase lock loops (DIP) 2.95
 - 561 Phase lock loops (DIP) 2.95
 - 562 Phase lock loops (DIP) 2.95
 - 565 Phase lock loops (A) 2.95
 - 566 Function generator (TO-5) 2.95
 - 567 Tone decoder (A) 2.95
 - 702C Hi-grain. DC amp (TO-5)49
 - 703C RF-IF, amp, 14 ckt's (TO-5)69
 - 704 TV sound IF system 1.50
 - 709C Operational amp (A)47
 - 710C Differential amp (A)47
 - 711C Dual diff. comp (A)47
 - 723C Voltage regulator (A)75
 - 733 DiV. Video Amp 1.75
 - 741C Frequency compensator 709 (A)44
 - 741CV Freq. comp 709 (Mini DIP)49
 - 747C Dual 741C (A)69
 - 748C Freq. adj. 741C (A)69
 - 753 Gain Block 1.75
 - 739-739 Dual stereo preamp 1.98
 - 741-741 Dual 741C (TO-5)89
 - PA265 5-watt voltage regulator 1.50
 - ULN2300M Op amp with SCR 1.50
 - CA3065 Video Audio system 1.05
 - 75451 Dual peripheral driver44
 - 75453 Dual peripheral driver44
 - 75491 Quad seg driver for LED readouts 1.65
 - 75492 Hex driver w/col. out 250 ma. 1.85
- For LED readouts (A) TO-5 or DIP dual in line pak. **FACTORY MARKED**

BRAND NEW LOWEST PRICES
GENERAL ELECTRIC 3-WATT AUDIO AMP 3 for \$6.00
Delivers 3 watts continuous, 10 watts peak, with heat sinks; micro-mini size; 3x3x1 1/2"; 9 to 40V supply. High sensitivity, 8 to 16 ohms. For mono and stereo phonos, tape, FM, AM, TV, servo.



POLY PAKS SMASHES IC PRICES

OVER 1,000,000-PC INVENTORY
"DIP" PICKUPS
LIMITED OFFER!
Buy 3 or more, 10% discount

Factory Marked Order by type number! See sheets on request "ONLY"

Type	Sale	Buy 100 —	Take 20%
SN7400	\$0.24	SN74732	.35
SN7401	.24	SN74737	.49
SN7402	.24	SN74738	.52
SN7403	.24	SN7440	.24
SN7404	.26	SN7441	1.19
SN7405	.26	SN7442	1.12
SN7406	.49	SN7443	1.12
SN7407	.45	SN7444	1.25
SN7408	.27	SN7445	1.19
SN7409	.28	SN7446	1.29
SN7410	.24	SN7447	1.29
SN7411	.24	SN7448	1.35
SN7413	.89	SN7450	.27
SN7415	.49	SN7451	.31
SN7416	.49	SN7453	.31
SN7417	.49	SN7454	.43
SN7420	.24	SN7455	.50
SN7421	.55	SN7456	.27
SN7422	.31	SN7462	.35
SN7425	.31	SN7464	.43
SN7426	.33	SN7465	.43
SN7430	.24	SN7470	.36
SN7471	.55	SN7472	.41
SN7473	.49	SN7473	.49
SN7474	.49	SN7474	.49
SN7475	.85	SN7475	.85
SN7476	.53	SN7476	.53
SN7478	.65	SN7478	.65
SN7480	.65	SN7480	.65
SN7481	1.25	SN7481	1.25
SN7482	.99	SN7482	.99
SN7483	1.15	SN7483	1.15
SN7486	.49	SN7486	.49
SN7489	3.10	SN7489	3.10
SN7490	.85	SN7490	.85
SN7491	1.35	SN7491	1.35
SN7492	.85	SN7492	.85
SN7493	.85	SN7493	.85
SN7494	1.05	SN7494	1.05
SN7495	1.00	SN7495	1.00
SN7496	1.00	SN7496	1.00
SN74106	.95	SN74106	.95
SN74107	.51	SN74107	.51
SN74108	.95	SN74108	.95
SN74112	.69	SN74112	.69
SN74113	.95	SN74113	.95
SN74114	.95	SN74114	.95
SN74121	.69	SN74121	.69
SN74123	1.05	SN74123	1.05
SN74125	1.45	SN74125	1.45
SN74126	1.45	SN74126	1.45
SN74139	1.25	SN74139	1.25
SN74140	2.50	SN74140	2.50
SN74145	1.19	SN74145	1.19
SN74148	4.50	SN74148	4.50
SN74150	1.00	SN74150	1.00
SN74151	4.95	SN74151	4.95
SN74152	1.95	SN74152	1.95
SN74153	4.95	SN74153	4.95
SN74154	1.39	SN74154	1.39
SN74155	1.29	SN74155	1.29
SN74156	1.45	SN74156	1.45
SN74157	1.45	SN74157	1.45
SN74158	1.45	SN74158	1.45
SN74161	1.85	SN74161	1.85
SN74163	1.75	SN74163	1.75
SN74164	2.10	SN74164	2.10
SN74165	2.10	SN74165	2.10
SN74166	1.85	SN74166	1.85
SN74173	1.85	SN74173	1.85
SN74174	2.20	SN74174	2.20
SN74175	2.60	SN74175	2.60
SN74176	1.85	SN74176	1.85
SN74177	1.85	SN74177	1.85
SN74179	1.85	SN74179	1.85
SN74180	1.10	SN74180	1.10
SN74181	4.10	SN74181	4.10
SN74182	1.05	SN74182	1.05
SN74185	2.50	SN74185	2.50
SN74192	1.85	SN74192	1.85
SN74193	1.50	SN74193	1.50
SN74194	1.55	SN74194	1.55
SN74195	1.25	SN74195	1.25
SN74196	1.25	SN74196	1.25
SN74197	1.10	SN74197	1.10
SN74198	2.35	SN74198	2.35
SN74200	9.95	SN74200	9.95

IC'S FOR EXPERIMENTERS

Money Back Guarantee! Factory Marked! \$1.00

SN7400	20 for \$1.	SN7476	10 for \$1.
SN7401	20 for \$1.	SN7477	5 for \$1.
SN7413	5 for \$1.	SN74107	10 for \$1.
SN7441	5 for \$1.	SN74121	10 for \$1.
SN7444	5 for \$1.	SN74123	10 for \$1.
SN7445	5 for \$1.	SN7454	5 for \$1.
SN7446	5 for \$1.	SN7481	5 for \$1.
SN7447	5 for \$1.	SN7492	5 for \$1.
SN7473	10 for \$1.	SN7493	5 for \$1.
SN7474	10 for \$1.	SN7494	5 for \$1.
SN7475	5 for \$1.	SN74193	5 for \$1.

Includes factory good, rejects & defects, who knows at these prices!

CLOCK CHIPS ON A "DIP"

ANY CHIP \$8.88

MM5311	6-digit 28-Pin	8.88
MM5312	4-digit 24-Pin	8.88
MM5313	6-digit 28-Pin	8.88
MM5314	6-digit 24-Pin	8.88
MM5316	4-digit 40-Pin	13.50 Alarm

1-MM5316, DIGITAL ALARM FACTORY FALLOUT — \$1.49



Only \$39.95
20-WATT STEREO AM-FM-MULTIPLEX

- 20-watt Solid State Amplifier!
- All Solid State, Printed Circuitry!
- 4 Speaker Systems! Slide Rule Dial!
- All Purpose, All Family System!

The most unusual HI-FI stereo buy of 1974. A unit that has so many unique and different functions, makes it the finest system of its kind at the usual Poly Pak economy prices. Features: 4-speaker system, built-in FM antenna, record player jacks on separate panel. Another external panel consists of provisions for external FM and AM antenna, "satellite" speakers to provide 4-speaker ground, jacks for connecting a tape recorder to radio tuner or phono of systems to record. Lower inputs for connecting tape deck that will play back thru the internal amplifier for systems. AC jack for phono power connection. RED, GREEN and CLEAR indicators for Phono, AM, and FM respectively. Includes red indicator on front panel for STEREO indicator. Has separate input to plug into mike, guitar and other musical instruments as well as another jack for plugging in a pair of stereo headphones.

Has the following controls on front panel, PHONO-STEREO-AM-FM, MONO, FM STEREO, GUITAR, TAPE, MIKE, master control switch, LOUDNESS, BALANCE, TREBLE, BASS controls, with power ON-OFF rocker switch, and AFC ON-OFF. Designed for all audio-philes to use as wall unit in DEN or FAMILY ROOM, or control unit by easy chair in family room, or for those who wish to design their own console or modular system. With 6 ft. 115 VAC cord and plug. Only 13 x 7 x 3 1/2" deep. No escutcheon, but we include template for one, plus diagram. Shpg. wt. 3 lbs. With knobs.



8-TRACK CAR RADIO STEREO 3 for \$24
TAPE TRANSPORT 8.88

8-Track tape transport with complete stereo playback system, less audio amplifier. Operates at 12 VDC Wow & flutter proof. Use 739 preamp & ready to go. Uses 8-track tape. Wt. 3-lbs.

CALCULATOR CHIPS ON A "DIP"

Similar to Mostek 5001. Outperforms Texas 8-digit TMS1802. A 40-pin DIP. Adds, multiplies, subtracts, and divides. Use with 7-segment readouts. Sixes, and LED's.

CT5001	12-digits 40-Pin	8.95
CT5002	9 Volt version of 5001	8.88
CT5005	12-digits 28-Pin	9.95 with 3-function memory.

POCKET CALCULATOR KEYBOARD

For hand-held units, properly multiplexed for chip CT-5001, 2, 12 or Mostek 5010-12. 18 feather-touch keys, by FLEX-KEY. 3 for \$18.

Terms: add postage. Rated: net 30
Phone Orders: Wakefield, Mass. (617) 245-3829
Retail: 16-18 Del Carmine St., Wakefield, Mass. (off Water Street) C.O.D.'S MAY BE PHONED
POLY PAKS P.O. BOX 942 E. Lynnfield, Mass. 01940

CIRCLE NO. 26 ON READER SERVICE CARD

PLANS AND KITS

ELECTRONIC Slot Machine type game. Plans \$5.00. KAB, 1923 Fern, Royal Oak, Michigan 48073.

FUN Kits novel, entertaining, educational. Build electronic touch switch, audio a.arm, digital clock, others. Send for free flyer. ADVENT ELECTRONICS, Dept. PE, P.O. Box 252, Lafayette Hill, PA 19444.

COMPLETE CONSTRUCTION PLANS—TELEPHONE: Answering device, conference bridge, auto-dialer, central dial exchange. \$1.00 each. DODECAHEDRON speaker cabinet. \$2.50. Telephonics Company of America, P.O. Box 362, Agoura, California 91301.

TV GAMES—Ping Pong, Space War, Cat and Mouse, many others. Instructions, schematics, kits. SP Electronics, Box 5, Prospect Heights, Illinois 60070.

NEW!

**CONVERT TV TO
6 FT. WIDE SCREEN!**

Easy Do-It-Yourself Kit

Project a giant 5'x6' picture onto wall or screen. B&W/Color. Kit contains detailed plans, Inst., and Precision Lens System. Only \$15.95 ppd., or write for Free illustrated details.

**The Macrocoma Co., Dept. DDE
Washington Crossing, PA 18977**



Guaranteed to Work!

TUBES

RADIO & T.V. Tubes—36¢ each. Send for free Catalog. Cornell, 4213 University, San Diego, Calif. 92105.

RECEIVING & INDUSTRIAL TUBES, TRANSISTORS. All Brands—Biggest Discounts. Technicians, Hobbyists, Experimenters—Request **FREE** Giant Catalog and **SAVE!** ZALYTRON, 469 Jericho Turnpike, Mineola, N.Y. 11501.

TUBES "Oldies", latest. Lists free. Steinmetz, 7519 Maplewood, Hammond, Indiana 46324.

SAVE money on parts and transmitting-receiving tubes, foreign-domestic. Send 25¢ for giant catalog. Refunded first order. United Radio Company, 56-P Perry Street, Newark, N.J. 07105.

TUBES receiving, factory boxed, low prices, free price list. Transleteronic, Inc., 1306 40th Street, Brooklyn, N.Y. 11218A, Telephone: 212-633-2800.

CASH Paid for obsolete receiving tubes WE300B, WE350B, WE252A, WE310A, WE274A, WE262B, WE284D, RCA45, RCA50, and Movie Theatre w amplifier models 91B, 86F. Contact: M. Takabe, 303 Fifth Avenue, N.Y.C. (212) 679-1970.

TAPE AND RECORDERS

RENT 4-Track open reel tapes—all major labels—3,000 different—free brochure. Stereo-Parti, 55 St. James Drive, Santa Rosa, Ca. 95401.

1930-1962 Radio Programs. Reels, \$1.00 Hour! Cassettes, \$2.00 Hour! . . . Mammoth Catalog, \$1.00. AM Treasures, Box 192F, Babylon, N.Y. 11702.

WHOLESALE PRICES CASSETTES

PLAIN WHITE CASSETTE LABELS, NORELCO CASSETTE CLEANERS, PAPER MAILER BOXES** HOLDS NORELCO-TYPE PLASTIC BOX, FAMOUS BRAND CASSETTES, "LIKE NEW" 10 1/2" METAL OR FIBERGLASS REELS. SEND FOR OPEN REEL AND CASSETTE DISCOUNT CATALOG.

*QUANTITY	1-9	10-99	100	1000
CASSETTE LABELS (Multiples of 10)		.02	.15	.01
NORELCO CASSETTE CLEANER	.65	.60	.55	.50
*NORELCO PAPER MAILER BOXES	.30	.025	.022	.02
10 1/2" FIBERGLASS REELS, USED	.50	.40	.35	.25
10 1/2" METAL HUB HOLE, USED	1.00	1.00	.90	.70

**PLUS POSTAGE BY WEIGHT AND ZONE MINIMUM ORDER. \$5.00
SAXITONE TAPE SALES 1776 COLUMBIA ROAD, N.W.
 WASHINGTON, D.C. 20009

PERSONALS

MAKE FRIENDS WORLDWIDE through international correspondence. Illustrated brochure free. Hermes, Berlin 11, Germany.

BUGGED??? . . . Detectors locate hidden transmitters. Literature 25¢. Security, Box 671, Westwood, N. J. 07675.

MOVIE FILMS

8MM-SUPER 8-16MM MOVIES! Biggest Selection! Lowest Prices! Free Catalog! Cinema Eight, Box PE, Chester, Connecticut 06412.

TOOLS

WRAP Tool \$1.00, Wire, Panels. Xycon, Box 9341, Phoenix, AZ. 85020.

TREASURE FINDERS

FREE—Valuable Treasure Finder catalog sent by return mail. Find Coins, Rings, Gold, Silver, Metals, Relics. Write today. JETCO, Dept. CPE, Box 26669, El Paso, Texas 79926.

FREE FACT-FILLED CATALOG. World's largest line of metal detectors. Models as low as \$49.50 and up. Two year Guarantee. Three factory locations, U.S. and Canada, plus over 1,000 dealers and 35 Service Centers from coast to coast. No finer instruments made at any price. Budget terms. Write: White's Electronics, Inc., Rm# 391, 1011 Pleasant Valley Road, Sweet Home, Oregon 97386.

FAMILY FUN! OUTDOOR ADVENTURE! Find valuable coins and treasure with world famous metal detectors. Free illustrated booklet. Detectron, Dept. PE, Box 243, San Gabriel, Ca. 91778.

MUSICAL INSTRUMENTS

30% DISCOUNT name brand musical instruments. Free Catalog. Freeport Music, 455N, Route 110, Melville, N.Y. 11746.

WHOLESALE! Professional Guitars, PA Systems, Altec Speakers, 240W RMS Amplifiers. Free Catalog, Carvin, Escondido, Calif. 92028.

30% + DISCOUNT. Name Brand Musical Instruments. Free Catalog. Continental Music, Dept. H, P.O. Box 3001, Garden City, New York 11530.

REAL ESTATE

FREE . . . BIG . . . 264-PAGE . . . CATALOG! Describes and pictures hundreds of farms, ranches, town and country homes, businesses coast to coast! Specify type property and location preferred. UNITED FARM AGENCY, 612-EP, West 47th St., Kansas City, Mo. 64112.

EMPLOYMENT INFORMATION

IMPROVE your job opportunity potential. Professionally written resumes. Samples, \$3.00. Dept. PE. Cullen Associates, 30 West Washington, Chicago, Ill. 60602.

EMPLOYMENT OPPORTUNITIES

ELECTRONICS/AVIONICS EMPLOYMENT OPPORTUNITIES. Report on jobs now open. Details FREE. Aviation Employment Information Service, Box 240E, Northport, New York 11768.

LIGHT EMITTING DIODES		TRANSISTORS SPECIALS		5311—Clock Chip featuring BCD hold count and Out. put Strobe \$11.50		C/MOS (DIODE CLAMPED)	
MRD 148 Photo Darlington	\$.75	2N1137B PNP TO-3 GE	\$.95	5314—Clock Chip, 6 Digit readout hold count and Output Strobe	\$9.50	CD 4001	\$.65
W/2 Photo Transistor	\$.80	2N2222 NPN Si TO-92	\$1.00	ASCI! Encoded Terminal Keyboards	\$60.00	CD 4062	\$.65
MCT-2 Opto. Isolator	\$.90	2N3137 NPN Si TO-5	4 \$1.00	14 Pin IC Sockets	\$.40	CD 4009	\$.50
OSL-3 GAP V15. LED	\$.50	2N1605 NPN GE TO-5	5 \$1.00	Printed circuit board 4 1/2" x 6 1/2"		CD 4010	\$.65
MCD-2 Opto. Isolator	\$.90	MP53393 NPN Si TO-106	4 \$1.00	double sided fiber glass board 1 1/16" thick, unetched.	\$60 ea. 5 \$2.50	CD 4011	\$.65
MCA-2-30 Photo Relay	\$.90	2N2218T NPN Si TO-5	4 \$1.00	Miniature Trim Pots		CD 4012	\$.65
ME4 IR LED	\$.50	2N3767 NPN Si TO-66	4 \$.70	5K, 10K, 20K, 25K, 50K, 100K	\$.75 3 \$2.00	CD 4013	\$.60
GREEN GAP OSL-16 LED	\$.90	2N3772 NPN Si TO-3	\$.125	FULL WAVE BRIDGES		CD 4016	\$.50
		2N3866 NPN Si TO-5	\$.75	PRV 2A 6A		CD 4018	\$.65
		2N6109 PNP Si TO-220	\$.55	200 .95 1.25		CD 4019	\$.65
		2N5296 NPN Si TO-220	\$.50	400 1.15 1.50		CD 4030	\$.65
		2N4898 PNP Si TO-66	\$.60	600 1.35 1.75		LM 309K 5V	
		MJ2522 NPN Si TO-66	\$.60			1 Amp Regulator	\$.25
		2N3055 NPN Si TO-3	\$.100			741 OPER. AMP	\$.47
						709 OPER. AMP	\$.47
						723 Regulator	\$.75
						703RF 1F Amp	\$.80
						565 Phase Lock Loop	\$.29
						567 Tone Decoder	\$.29
						560 Phase Lock Loop	\$.29
						568 Phase Lock Loop	\$.29
						536 FET Input Oper Amp	\$.25
						537 Precision 741	\$.25
						747 Dual 741	\$.125
						LM308 Oper Amp	\$.15
						101 Oper Amp	\$.75
						741A Oper Amp	\$.47
						320-5V Reg.	\$.175
						320-15V Reg.	\$.175
						748 Oper Amp	\$.90
						LM370 AGC Squelch Op. Amp	\$.125
						LM380 2 Watt Amp	\$.175
						LM372 2 Watt Stereo IC 14 Pin Dip	\$.395
						LM319 Dual HiSpeed Comparator	\$.50
						LM382 5T rrd Preamp	\$.175
						555-US-2 HR. TIMER	\$.40
						LM3900-Quad Op. Amp	\$.149
						3822-Trans Array	\$.95
						LM311-Comparator	\$.50
						501-VIDEO AMP	\$.100
						711-DUAL COMPARATOR	\$.47
						LM300-REGULATOR	\$.125
						CONDUCTIVE ELASTOMETER LOW PROFILE CALCULATOR KEYBOARD A 234x31xk2	
						FILE KEY 19 SK-6 KEYBOARD HAVING 0-9 *	
						K.C. BUTTONS WITH OFF. ON SWITCH \$6.50	
						Terms: FOB Cambridge, Mass. Send Check or Money Order. Include Postage Minimum Order \$3.00. Rated Companies 30 Days Net Send \$2.00 for our latest catalog featuring transistors and rectifiers	

SOLID STATE SALES

Post Office Box 74A Somerville, Mass. 02143 Tel. (617) 547-4005

CIRCLE NO. 29 ON READER SERVICE CARD

WANTED: Ham Radio Oper./Instr. Boys resident Camp. Please write: Camp Winadu, 1 Patchin Place, N.Y., N.Y. 10011.

SALES Representatives needed by Car-Home-Boat 8-Track Stereo Distributor. Write: Soundsonic Electronics, 428 Springfield Avenue; Berkeley Heights, New Jersey 07922.

TRANSMITTER SECTION HEAD with at least five years experience in performing and supervising short wave broadcast operations. Main duties will include two 100 Kw transmitters and several curtain antennas. Experience in supervising and working with a multiracial staff desirable. Church related short wave station in Ethiopia. Position to be filled June, 1974. Applications to: The Station Director, Radio Voice of the Gospel, P.O. Box 654, Addis Ababa, ETHIOPIA.

OVERSEAS EMPLOYMENT OPPORTUNITIES FOR RADIO TECHNICIANS. A few positions available to qualified persons. Experience in installing and servicing radio equipment with thorough knowledge in solid state, UHF and VHF equipment. Frequent travel involved. Starting salary approximately \$10,500. Quarters, educational and other allowances payable when residing overseas, depending on post of assignment. Submit written application (SF 171) to Officer Employment Branch, Employment Division, U.S. Department of State, Washington, D. C. 20520.

STUDIO PROJECT SUPERVISOR with at least 3 years experience in installation, maintenance and operation of radio and recording equipment duties include up-keep of several recording studios and transmitting outfit at a church related short wave station in Ethiopia. Position to be filled May, 1974. Applications to: The Station Director, Radio Voice of the Gospel, P. O. Box 654, Addis Ababa, ETHIOPIA.

GOVERNMENT SURPLUS

GOVERNMENT Surplus. How and Where to Buy in Your Area. Send \$2.00. Surplus Information, Headquarters Bldg., Box 30177-PE, Washington, D.C. 20014.

ELECTRONIC Equipment and Parts. Big 36 page Free Catalog. Send for your copy today! Fair Radio Sales, Box 1105-P, Lima, Ohio 45802.

MANUALS for Govt Surp'ns radios, test sets, scopes. List 50¢ (coin). Books, 7218 Roanne Drive, Washington, D.C. 20021.

INVENTIONS WANTED

CASH-ROYALTIES for patented, unpatented inventions. Global Marketing Service, 2420-P 77th, Oakland, California 94605.

INVENTORS: Protect your ideas! Free "Recommended Procedure". Washington Inventors Service, 422T Washington Building, Washington, D.C. 20005.

PATENT Searches including Maximum speed, full airmail reprint and closest patent copies. Quality searches expertly administered. Complete secrecy guaranteed. Free Invention Protection forms and "Patent Information," Write Dept. 9, Washington Patent Office Search Bureau, Benjamin Franklin Substation, P.O. Box 7167, Washington, D.C. 20044.

FREE PAMPHLET: "Tips on Safeguarding Your Invention." Write: United States Inventors Service Company, 708-T Carry Building, Washington, D.C. 20005.

INVENTORS! Either we will sell your Invention before you or anyone else does, or we will pay you a cash bonus. Get Free Invention Evaluation and information: Write Gilbert Adams Organization, Invention Brokerage, Dept. 20, 80 Wall St., New York, NY 10005.

FILE your own patent application. Complete information and materials. Write: Inventor's Guide, 468-R, Goodspeed Road, Virginia Beach, Virginia 23451.

FREE "DIRECTORY OF 500 CORPORATIONS Seeking New Products." For information regarding Development, Sale, Licensing of your patented/unpatented invention, write for FREE "INVENTOR'S KIT NO. A-73, RAYMOND LEE ORGANIZATION, 230 Park Avenue, New York, N.Y. 10017.

ABOUT YOUR SUBSCRIPTION

Your subscription to POPULAR ELECTRONICS is maintained on one of the world's most modern, efficient computer systems, and if you're like 99% of our subscribers, you'll never have any reason to complain about your subscription service.

We have found that when complaints do arise, the majority of them occur because people have written their names or addresses differently at different times. For example, if your subscription were listed under "William Jones, Cedar Lane, Middletown, Arizona," and you were to renew it as "Bill Jones, Cedar Lane, Middletown, Arizona," our computer would think that two separate subscriptions were involved, and it would start sending you two copies of POPULAR ELECTRONICS each month. Other examples of combinations of names that would confuse the computer would include: John Henry Smith and Henry Smith; and Mrs. Joseph Jones and Mary Jones. Minor differences in addresses can also lead to difficulties. For example, to the computer, 100 Second St. is not the same as 100 2nd St.

So, please, when you write us about your subscription, be sure to enclose the mailing label from the cover of the magazine—or else copy your name and address exactly as they appear on the mailing label. This will greatly reduce any chance of error, and we will be able to service your request much more quickly.

BUSINESS OPPORTUNITIES

I MADE \$40,000.00 Year by Mailorder! Helped others make money! Start with \$15.00—Free Proof. Torrey, Box 318-N, Ypsilanti, Michigan 48197.

FREE CATALOGS. Repair air conditioning, refrigeration. Tools, supplies, full instructions. Doolin, 2016 Canton, Dallas, Texas 75201.

MAILORDER MILLIONAIRE helps beginners make \$500 weekly. Free report reveals secret plan! Executive (1K4), 333 North Michigan, Chicago 60601.

PIANO TUNING LEARNED QUICKLY AT HOME! Tremendous field! Musical knowledge unnecessary. GI approved. Information free. Empire School, Box 450327, Miami 33145.

\$2000.00 MONTHLY selling information by mail. Ropchan, Box 161X, Saginaw, Oregon 97472.

FREE Secret Book "2042 Unique Proven Enterprises." Fabulous "Little Knowns." Work home! Haylings-BH, Carlsbad, California 92008.

DO SIMPLE ADDRESSING—Mailing. Receive \$12.95 orders. Keep \$8.00 profit. Details Free. Quality, Box 9-2D, East Rockaway, N.Y. 11518.

IMPORT-MAILORDER OPPORTUNITY. Risk free trial basis. Details: Northeast Imports, Box 111PE3, Fremont, New Hampshire 03044.

\$940 equiv entitlement to Vet's. Details \$2.00; NOE, P.O. Box 749, Cypress, Calif. 90630.

START SMALL, highly profitable electronic production in your basement. Investment, knowledge unnecessary. Postcard brings facts. Barta-CD, Box 248, Walnut Creek, California 94597.

\$200.00 DAILY In Your Mailbox! Your opportunity to do what mail-order experts do. Free details. Associates, Box 136-J, Holland, Michigan 49423.

HIGHLY PROFITABLE ONE-MAN ELECTRONIC FACTORY

Investment unnecessary, knowledge not required, sales handled by professionals. Postcard brings facts about this unusual opportunity. Write today! Barta-DD, Box 248, Walnut Creek, CA 94597.

\$178.00 WEEKLY. Work one hour daily. Free brochure. FAS, Box 13703-A, San Antonio, TX 78213.

PLASTICS

CASTOLITE pours like water, hardens like glass without heat. Crystal clear, colors. Embed flowers, seashells, momentos, anything. Make fine gifts. Form flexible molds over any pattern, size. Reproduce your own designs in plastics, candle wax, metal, plaster, cement. Profitable. Illustrated Manual and Catalog Only 50¢. CASTOLITE, Dept. 74D/PE, Woodstock, Ill. 60098.

RESORTS AND TRAVEL

BERTH & Partnership in 155 ft. 3-masted Barquentine for \$10,700. Join in Europe, assist conversion then help sail on 2-year Adventure & Business World Voyage. Write: R. Bruderer, IYC, Box 149 Broadway, NSW Australia 2007.

BOOKS

FREE catalog aviation/electronic/space books. Aero Publishers, 329PE Aviation Road, Fallbrook, California 92028.

FREE book prophet Elijah coming before Christ. Wonderful bible evidence. Megiddo Mission, Dept. 64, 481 Thurston Rd., Rochester, N.Y. 14619.

BOOKS—thousands titles, bargains. Catalog Free. Cassiano, 92-27 New York Blvd., Jamaica, New York 11433.

RUBBER STAMPS

RUBBER address stamps. Free catalog. 45 type styles. Jackson's, Box 443G, Franklin Park, Ill. 60131.

HYPNOTISM

SLEEP learning. Hypnotic method. 92% effective. Details free. ASR Foundation, Box 7566EG, Fort Lauderdale, Florida 33304.

FREE Hypnotism. Self-Hypnosis. Sleep Learning Catalog! Drawer H400, Ruidoso, New Mexico 88345.

AMAZING self-hypnosis record releases fantastic mental power. Instant results! Free trial. Write: Forum (AA4), 333 North Michigan, Chicago 60601.

INSTRUCTION

LEARN ELECTRONIC ORGAN SERVICING at home all makes including transistor. Experimental kit—trouble-shooting. Accredited NHSC, Free Booklet. NILES BRYANT SCHOOL, 3631 Stockton, Dept. A, Sacramento, Calif. 95820.

LEARN WHILE ASLEEP, Hypnotize! Strange catalog free. Auto-suggestion. Box 24-2D, Olympia, Washington 98501.

DEGREE IN ELECTRONICS through correspondence. Free catalog. Grantham, 2000 Stoner Avenue, Los Angeles, California 90025.

Popular Electronics

APRIL 1974

ADVERTISERS INDEX

READER SERVICE No.	ADVERTISER	PAGE NO.
1	Altaj Electronics	118
2	Atlantic CB	120
3	Audio Technica U.S., Inc	83
4	BSR (USA) Ltd	107
	Bell & Howell Schools	108, 109, 110, 111
	CREI Capitol Radio Engineering Institute	18, 19, 20, 21
7	Center for Technical Development, Inc., The	10
13	Circuit Designs, Inc	117
8	Cleveland Institute of Electronics	36, 37, 38, 39
9	Continental Specialties Corp	9
10	Delta Electronics Co	119
11	Delta Products, Inc	25
12	EICO	112
14	Edmund Scientific Co	126
15	GTE Sylvania	127, 128
5	Heath Company	54, 55, 56, 57
17	Illinois Audio	115
33	Johnson Co., E.F.	15
18	Judson Research and Mfg. Co	115
CLASSIFIED ADVERTISING		

READER SERVICE No.	ADVERTISER	PAGE NO.
19	Lafayette Radio Electronics	89
20	McIntosh Laboratory Inc	16
21	MITS Inc	13
22	Mallory Distributor Products Company	23
23	Midwest Hifi Wholesale & Mail Order Division	112
	National Radio Institute	SECOND COVER, 1, 2, 3
	National Technical Schools	90, 91, 92, 93
24	Pace Communications	17
25	Pickering & Co.	26
36	Pickering & Co.	106
26	Poly Paks	121
27	Radio Shack and Allied Radio Stores	11
34	Sams & Co., Inc., Howard W	7
35	Sams & Co., Inc., Howard W	117
29	Solid State Sales	123
30	Southwest Technical Products Corporation	8
16	Technics by Panasonic	FOURTH COVER
31	Tri-Star Corp.	89
	U.S. Coast Guard	72, 73, 74, 75
32	Utah Electronics Division	113
CLASSIFIED ADVERTISING		

INTENSIVE 5 week course for Broadcast Engineers. F.C.C. First Class license. Radio Engineering Incorporated, 52 S. Palm Ave., Sarasota, Florida 33577.

SHORTCUTS To Success! Highly Effective, Profitable Short Courses. (75 Choices). Study At Home. Diploma Awarded. Our 27th Year. Free Literature. CIEE-D, Box 10634, Jackson, Miss. 39209.

DEGREE Program in Electronics Engineering. Our 27th Year! Free literature. Cook's Institute, Dept. 13, Box 10634, Jackson, Miss. 39209.

DIGITAL:THEORY,DESIGN,
CONSTRUCTION

LOGIC NEWSLETTER

SAMPLE COPY \$1.00
LOGIC NEWSLETTER
POB 252
WALDWICK,N.J. 07463

SCORE high on F.C.C. Exams . . . Over 300 questions and answers. Covers 3rd, 2nd, 1st and even Radar. Third and Second Test, \$14.50; First Class Test, \$15.00. All tests, \$26.50. R.E.I., Inc, Box 836, Sarasota, Fla. 33577.

EARN College Degrees at home. Many subjects. Florida State Christian University, P.O. Box 1674, Fort Lauderdale, Florida 33302.

TELEVISION Home Study Course, 13 lessons, complete with four monochrome—color Servicing Manuals, 832 pages, only \$13.95. Publications, 1760 Balsam, Highland Park, Illinois 60035.

HOME ENTERTAINMENT (FILMS)

ORDER A COMPLETE SET of NFL SUPER BOWL Color Films, Standard 8 or Super 8 at \$15.95 each PPD, or \$7.95 each B&W. Order 1967 & 1968 (Lombardi); then the glory years from 1969 thru 1973—each a separate 200' reel. **BASEBALL SPECIAL:** Includes '72 World Series and '72 All Star Game (just released) at \$15.95 each PPD Color; \$7.95 each B&W, Standard 8 or Super 8. Castle, Columbia, or Sportlite Catalog, 25¢ each. **SPORTLITE,** Elect-4 Dept., Box 500, Speedway, Indiana 46224.

MISCELLANEOUS

WINEMAKERS: Free illustrated catalog yeasts, equipment. Semplex, Box 12276P, Minneapolis, Minn. 55412.

ORGANIC liqueurs—easy, economical—at home. Send \$1.00 for catalogue. Receive free organic ingredients for one quart liqueur. Magnus Enterprises, 5902 West Siegfried, Milwaukee 53214.

CATALOGS! Receive many! Catalog Directory \$1.00. Box 33098, District Heights, Md. 20028.

YOUR LOW COST Classified or Display Classified Ad in these columns will be seen and read regularly by America's largest audience of Electronics Professionals and Hobbyists. Check rates and terms noted on first page of this section; then send copy and payment as indicated in order to be certain of inclusion in next available issue.

LIVE IN THE WORLD OF TOMORROW...TODAY!

A BETTER LIFE STARTS HERE

He-Ne LASERS FROM \$99.50!



Edmund quality. TEMoode, cold cathode for long life. Completely self-contained unit; solid state power supply; 110v AC. 0.3mW min—**GREAT GENERAL PURPOSE LASER**: 1.2mm beam dia., 2.0mRad beam Diverg. Stock No. 79.051AV

.....\$99.50 Ppd.
ANCE LAB LASER: 1.2mm beam dia., 1.0mW min—**HI-PERFORMANCE LASER**: 1.0mm beam dia., 0.8mRad beam Diverg. Stock No. 79.052AV\$325.00 Ppd.

"FISH" WITH A GIANT MAGNET

Fascinating fun, and sometimes very profitable! Tie a line to our 3½-pound Magnet—drop it overboard in bay, river, lake or ocean. Trawl it along the bottom. Your "treasured" haul can be outdoor motors, anchors, other metal valuables. Five-pound Magnet is war surplus—Alnico V Type that cost the Government twice our price. It lifts over 40 pounds on land—much greater weights under water!



Stock No. 70.570AV 3½ lbs. \$11.50 Ppd.
 Stock No. 60.215AV 1½ lbs. \$ 6.50 Ppd.



130 EXPERIMENTS IN OPTICS...

and photography! Optix® Experiments Kit is a complete optical & photography lab for 130 exciting experiments. Lets you recreate the periscope, telescope, microscope, kaleidoscope! Build a 35-mm reflex camera with interchangeable lens system! Make, develop photographic film! Enjoy the fun and fascination of having your own optics lab. Fully illustr 112-pg manual, 8½x11", clearly explains usage of this stimulating kit's 114 precision engineered components.

Stock No. 71.646AV\$22.50 Ppd.



MAIL COUPON FOR GIANT FREE CATALOG!

180 PAGES • MORE THAN 4,500 UNUSUAL BARGAINS!

Completely new '74 Catalog. Packed with huge selection of telescopes, microscopes, binoculars, magnets, magnifiers, prisms, photo components, ecology and Unique Lighting items, parts, kits, accessories—many hard-to-get surplus bargains, 100's of charts, illustration. For hobbyists, experimenters, schools, industry.

EDMUND SCIENTIFIC CO.
 300 Edscorp Building, Barrington, N. J. 08007
 Please rush Free Giant Catalog "AV"

Name _____
 Address _____
 City _____ State _____ Zip _____

COMPLETE & MAIL WITH CHECK OR M.O.

EDMUND SCIENTIFIC CO.
 300 Edscorp Building, Barrington, N.J. 08007

How Many	Stock No.	Description	Price Each	Total

PLEASE SEND GIANT FREE CATALOG "AV" MERCHANDISE Total
 ADD HANDLING CHARGE: \$1.00 ON ORDERS UNDER \$5.00; 50c ON ORDERS OVER \$5.00

I enclose check money order for \$ _____ TOTAL \$ _____



NAME _____
 ADDRESS _____
 CITY _____ STATE _____ ZIP _____

CIRCLE NO. 14 ON READER SERVICE CARD

Printed in U.S.A.

(And our FREE CATALOG is packed with exciting and unusual ecological & physical science items—plus 4,500 finds for fun, study or profit . . . for every member of the family.)

KNOW YOUR ALPHA FROM THETA!

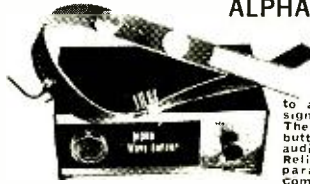

For greater relaxation, concentration, listen to your Alpha-Theta, brainwaves. Ultra-sensitive electrode headband slips on off in seconds—eliminates need for messy creams, etc. Attached to amplifier, filters brainwaves, signals beep for ea. Alpha or Theta wave passed. Monitoring button simulates Alpha sound; audio & visual (L.E.D.) feedback. Reliable, easy-to-use, unit—comparable to costlier models. Completely safe. Comprehensive instruction booklet.

No. 1635AV(8x3x4"; 24 oz.)\$124.50 Ppd.
 No. 71.809AV.....(LOW COST "STARTER" UNIT).....\$49.95 Ppd.

3-CHANNEL COLOR ORGAN KIT

Easy to build low-cost kit needs no technical knowledge. Completed unit has 3 bands of audio frequencies to modulate 3 independent strings of colored lamps (i.e. "lows"—reds, "middles"—greens, "highs"—blues. Just connect hi-fi, radio, power lamp etc. & plug ea. lamp string into own channel (max. 300w ea.). Kit features 3 neon indicators, color intensity controls, controlled individ SCR circuits; isolation transformer; custom plastic housing; instr.



Stock No. 41.831AV\$17.50 Ppd.

SEE THE STARS, MOON, PLANETS CLOSE UP!



3" ASTRONOMICAL REFLECTING TELESCOPE

60 To 180 Pwr. Famous Mt. Palomar Type
 See the rings of Saturn, the fascinating planet Mars, Seas and Craters of the Moon, Star Clusters in detail. New improved, aluminized and overcoated 3" diameter f/10 primary mirror, ventilated cell. Equatorial mount with locks on both axes. Equipped with 60x finder telescope, hardwood tripod. Included FREE VALUABLE "HOW TO USE YOUR TELESCOPE" book; "STAR CHART"

Deluxe 3" Reflector Telescope 5¼" Stock No. 85.050AV\$36.95 Ppd.
 Stock No. 80.162AV \$66.50 Ppd. Refl. Telescope (5¼x to 270x)
 6" Reflector Telescope Stock No. 85.187AV\$222.50 FOB
 6" Reflector W/ Electric Clock Drive No. 85.086AV.....\$259.50 FOB

Popular Electronics

READER SERVICE

Here's an easy and convenient way for you to get additional information about products advertised or mentioned editorially (if it has a reader service number) in this issue. Just follow the directions below... and the material will be sent to you promptly and free of charge.

1

On the attached postage-free card, print or type your name and address on the lines indicated.

2

Circle the number(s) that corresponds to the key number(s) at the bottom or next to the advertisement or editorial mention that is of interest to you. (Key numbers for advertised products also appear in the Advertisers' Index.)

3

Simply cut out the card and mail. No postage required.

FREE INFORMATION

DELUXE MAGAZINE CASES

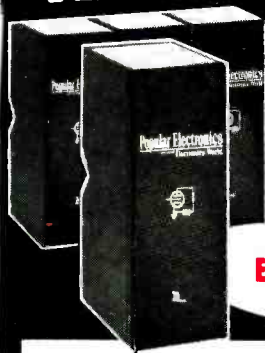

*Designed
Exclusively for*
**POPULAR
ELECTRONICS**

It's the new look in magazine cases! The ideal way to save your valuable copies, keep them well-protected and make it easy for you to refer to any issue at any time. Both decorative and attractive to enhance the decor of any room—each case is designed to hold a full year's copies.

Sturdily constructed to guard your magazines against soiling and tearing, these durable cases are covered in a rich-textured leatherette. They are available in either all black or attractive maroon back with black sides. The gold-embossed back adds to its

elegance and makes each case a welcome addition to your book shelf or cabinet.

Magazine cases are available for any of your favorite magazines. They're only \$4.50 each, 3 for \$12.50 in any combination of titles ordered. Add 50¢ per case for postage and handling. Outside U.S.A. add \$1.00 per case ordered.

HERE'S HOW TO ORDER

Send your order to Ziff-Davis Publishing Company, Dept. 721-A, One Park Ave., New York, N.Y. 10016. Be sure to indicate the titles of the magazines for which cases are being ordered. Specify your color choice for Popular Electronics cases which are available in either all black or maroon back with black sides. Colors for other cases are determined by the respective magazine publishers. Print your name and address clearly and enclose the amount indicated above for the number of cases being ordered PLUS an additional 50¢ per case for postage and handling. Outside U.S.A. add \$1 per case ordered.



AN EXTRA SERVICE FOR YOU—
CHARGE YOUR ORDER TO YOUR
AMERICAN EXPRESS OR
BANKAMERICARD ACCOUNT.



Mail your order, name, address and credit card number. You will be billed for the amount indicated above.

Our most expensive turntable has direct drive. So does our least expensive.

When Technics introduced direct drive, we set new standards for turntable performance. That's why we use direct drive exclusively in all Technics turntables.

No other system measures up to direct drive. Wow and flutter are less than 0.03% WRMS. And rumble is down to -65dB (DIN A) and -70dB (DIN B).

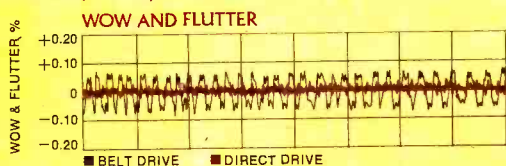

Our DC motor has no noise- or static-producing brushes and virtually none of the hum normally found in AC motors. It reaches playing speed in half a revolution and has electronic speed control that prevents speed changes due to line fluctuations.

All Technics turntables have illuminated stroboscopes, cast aluminum platters and variable pitch controls. The SL-1200 also has a precision tone arm, viscous damped cueing and low-capacitance 4-channel phono cables.

So does the SL-1100A but with a heavier platter, bigger motor and longer tone arm.

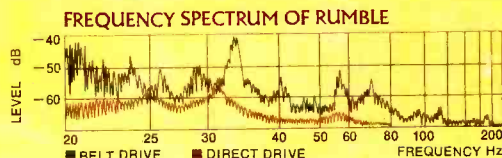

And the SP-10 is for those who insist on choosing their own tone arm.

No matter which Technics turntable you choose, you get the finest drive system that money can buy. But don't take our word for it. Read the reviews.* And you'll agree.

The concept is simple. The execution is precise. The performance is outstanding. The name is Technics.

*SP-10: Audio, 8/71; Stereo Review, 9/71.
SL-1100A: Stereo Review, 7/73; High Fidelity, 9/73.

200 PARK AVE., N.Y., N.Y. 10017 FOR YOUR NEAREST AUTHORIZED TECHNICS DEALER, CALL TOLL FREE 800 447-4700. IN ILLINOIS, 800 322-4400,

Technics

by Panasonic



CIRCLE NO. 16 ON READER SERVICE CARD