

Pitch Standards for Electronic Music

# Popular Electronics

JANUARY 1974/FIFTY CENTS

**PE TESTED** EXCLUSIVE!

## Build this ELECTRONIC DIGITAL WRISTWATCH

- Easy Construction
- Low Cost



DESIGN YOUR OWN

## Bass Reflex HI-FI Speakers

## Electronic Projects For Your Car

HOW TO BUILD

## Lamp-Readout VU Indicator

## Microphones for CB'ers & Hams

## Test Reports:

- Onkyo TX-555 Receiver
- EPI Microtower II Speaker
- International IC-500 FET VOM
- SBE 18CB CB Transceiver
- EL Instrument

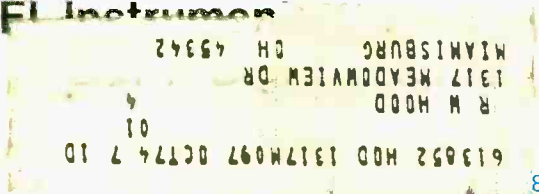

# NOW you can train at home building a NEW 25" DIAGONAL Solid State Color TV engineered by NRI for learning and trouble-shooting

*So much better for learning TV servicing than any hobby kit, because NRI designed and created it as an educational tool.*

Unlike hobby kits which are designed for creating a TV set as the end product, NRI built its exclusive 25" Diagonal Solid State Color TV kit as a real training kit. You can introduce and correct defects . . . for trouble-shooting and hands-on experience in circuitry and servicing. The kits include a wide-band oscilloscope, color bar crosshatch generator, transistorized volt-ohmmeter and other valuable equipment that can soon have you earning \$5 to \$7 an hour servicing color sets in your spare time.

**Handsome woodgrain cabinet, at no extra cost. (Offered only by NRI)**

**New square-cornered Sylvania picture tube**

**100% solid state chassis**

**6-position detented UHF channel selector**



**Modular construction with plug-in circuit boards**

**Automatic degaussing**

**Automatic fine tuning**

**Automatic tint control**

**Automatic color control**

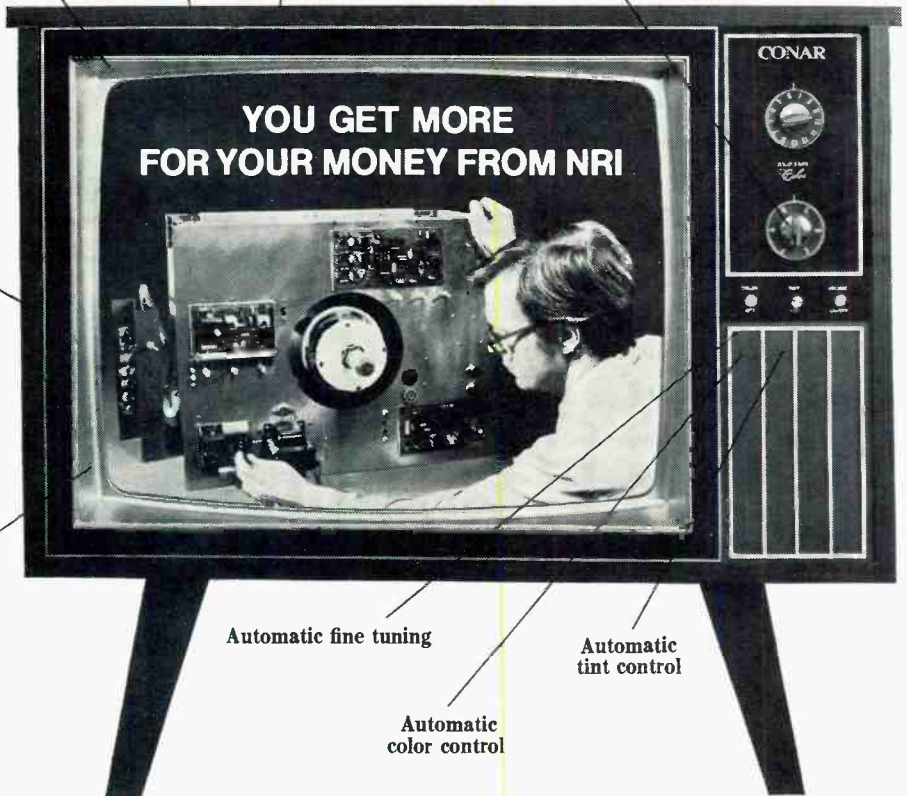



# NRI FIRSTS make learning Electronics fast and fascinating—to give you priceless confidence

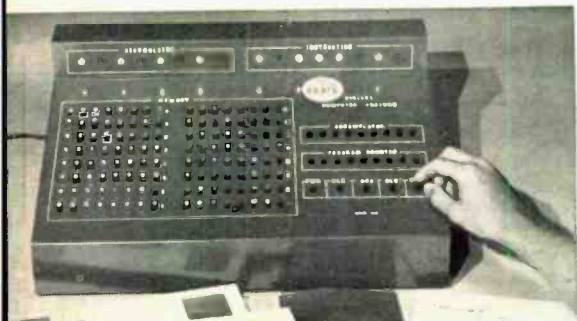

**FIRST** to give you a complete programmable digital computer, with memory, you build yourself... to learn organization, operation, trouble-shooting and programming. This remarkable computer is one of ten training kits you receive with the new NRI Complete Computer Electronics Course.

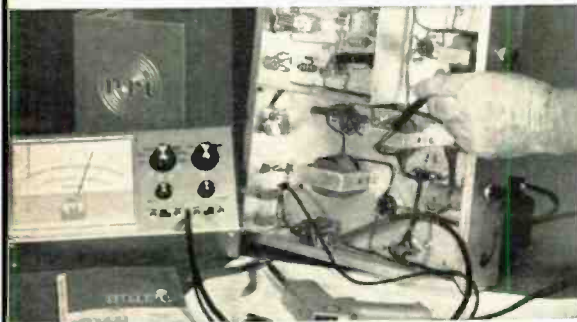

**FIRST** to give you true-to-life experiences as a Communications Technician. Every fascinating step you take in NRI Communications training, including circuit analysis of your own 15-watt, phone/cw transmitter, is engineered to help you prove theory and later apply it on the job. Studio equipment operation and trouble shooting become a matter of easily remembered logic.



**FIRST** to give you completely specialized training kits engineered for business, industrial and military Electronics Technology. Shown is your own training center in solid-state motor control and analog computer servo-mechanisms. Telemetering circuits, solid-state multivibrators and the latest types of integrated circuits are included in your course.

JANUARY 1974

The NRI color TV and digital computer kits are the latest in a long line of "firsts" for NRI. For more than fifty years, NRI has been providing unique 3-dimensional home-study training that has helped hundreds of thousands of students reach their goals quickly and easily.

What NRI provides is a combination of kits and bite-size texts that give you hands-on experience while you are learning. The texts average only 40 pages each, and they are fully illustrated. You are taken step-by-step from the first stages into the more advanced theory and techniques... with an expert instructor ready at all times to provide valuable guidance and personal attention. (The level of personal attention provided is more than you would receive in many classrooms.) Once you've grasped the fundamentals, you move with confidence and enthusiasm into new discoveries in the fascinating world of electronics.

You start out with NRI's exclusive Achievement Kit, containing everything you need to get moving fast. Lessons have been specifically written so that experiments build upon one another like stepping stones. You can perform a hundred experiments, build hundreds of circuits... as you learn to use the professional test equipment provided, building radios and TV sets, transmitter or computer circuits. It's the priceless "third dimension" in NRI training... practical experience.

## Train with the leader—NRI

Compare training kits, texts, techniques and overall training... and you'll find that you get more for your money from NRI. Whatever your reason for wanting more knowledge of Electronics, NRI has an instruction plan that will meet your needs. Choose from major programs in Advanced Color TV Servicing, Complete Computer Electronics, Industrial Electronics and the other special courses designed to meet specific needs. With NRI home training, you can learn new skills while you're still working at your present job... and turn yourself into the man in demand.

### GET FACTS ABOUT GI BILL

If you have served since January 31, 1955, or are in service now, check GI line on postage-free card.

## Send for free NRI catalog

MAIL THE POSTAGE-FREE CARD FOR THE FREE NRI CATALOG IN THE FIELD OF YOUR CHOICE. YOU WILL BE UNDER NO OBLIGATION. NO SALESMAN WILL CALL.

If the card has been used, write direct to:



**NRI TRAINING**  
3939 Wisconsin Ave.  
Washington, D.C. 20016

3



## THINK OF IT AS THE BEST TESTER in your bag. Only \$299

Now you can get a high performance Model 8000A Digital V.O.M. from Fluke, America's foremost maker of quality digital multimeters, especially designed for TV, radio, stereo and audio service. No other digital V.O.M. gives you the resistance range to check breakers and switches, the high resolution voltage to look at emitter base and other transistor voltages, excellent ac accuracy and full accuracy with a 30 second warm-up.

Measures in 26 ranges 100 $\mu$ V to 1200 V, 0.1  $\mu$ A to 2A, and 100 milli $\Omega$  to 20 meg $\Omega$  with a basic dc accuracy of 0.1%. Full year guarantee. Low cost options include rechargeable battery pack, print output, deluxe test leads, HV, RF & 600-amp ac current probes, carrying case, and rack mount. Unique self zero eliminates offset uncertainty. Electronics securely mounted in high-impact case. Service centers throughout U.S., Canada, Europe and Far East for 48-hour turn-around repair.

P.O. Box 7428, Seattle, Washington 98133.

Get all the details from your nearest Fluke sales office.  
Dial toll-free 800-426-0361 for address of office nearest you.



CIRCLE NO. 31 ON READER SERVICE CARD

JANUARY 1974

9

ver: CONN.: Hartford (Avon); FLA.: Miami (Hialeah); GA.: Atlanta; ILL.: Chicago; Downers Grove; IND.: Indianapolis; KANSAS: Kansas City (Mission); KY.: Louisville; LA.: New Orleans (Kenner); MD.: Baltimore; Rockville; MASS.: Boston (Wellesley); MICH.: Detroit; MINN.: Minneapolis (Hookins); MO.: St. Louis; N.J.: Fair Lawn; N.Y.: Buffalo (Amherst), New York City, Jericho; L.I.: Rochester; OHIO: Cincinnati (Woodlawn), Cleveland, Columbus; PA.: Philadelphia, Pittsburgh; R.I.: Providence (Warwick); TEXAS: Dallas, Houston; WASH.: Seattle; WIS.: Milwaukee.



Please send FREE Heathkit Catalog.  
Enclosed is \$\_\_\_\_\_, plus shipping  
 Please send model(s) \_\_\_\_\_  
Name \_\_\_\_\_  
Address \_\_\_\_\_  
City \_\_\_\_\_ State \_\_\_\_\_ Zip \_\_\_\_\_  
\*Mail order prices; F.O.B. factory. CL-492R

CIRCLE NO. 12 ON READER SERVICE CARD

JANUARY 1974

11

JANUARY 1974

13

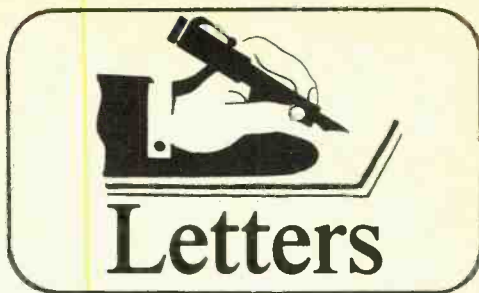
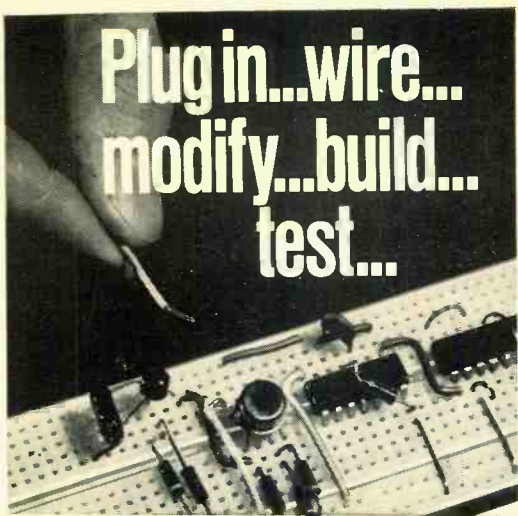

**MORE HAZARDS AT THE WORKBENCH**

"How To Avoid Workbench Hazards" (September 1973) included a statement implying that the minimum current through the heart that could cause ventricular fibrillation in individuals is 10 to 20 microamperes. This latter value might be lower than those actually observed in cases involving humans. Addressing

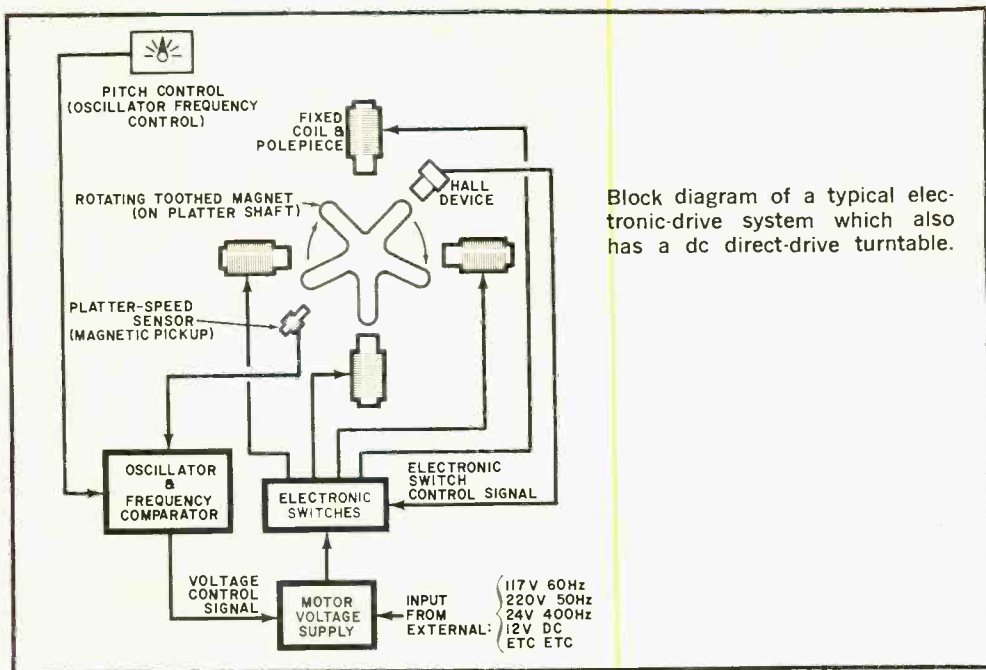
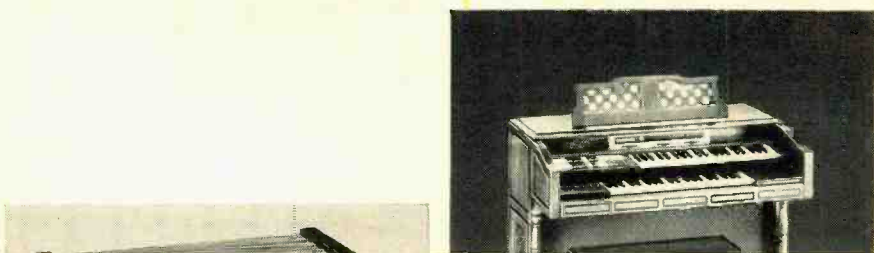

Block diagram of a typical electronic-drive system which also has a dc direct-drive turntable.

to a magnetic pickup, similar to a tape head, which then produces a series of output pulses. The frequency of these is compared with a reference frequency in the oscillator or from the ac line. If their relationship is incorrect, the electronic drive's output voltage is adjusted appropriately.

The dc drive motor is advantageous mainly in that it can produce adequate driving torque at slower rotating speeds than can an ac motor. This means less motor vibration and, hence, lower rumble. It should be noted though that, strictly speaking, there is no such thing as a dc motor. All motors require periodic reversal of their magnetic field, and the traditional way of doing this when the power source is dc is by having a commutator on the rotating motor shaft and a set of "brushes" which contact the commutator. This kind of dc motor was used in Sony's (now discontinued) TTS-3000, which, predictably, required brush replacement every once in a while.

**The Electronic Commutator.** The thing that has made dc motors practical for use in turntables was what has been called (after its discoverer) the Hall effect. The device that now bears his name is a control device, like an adjustable resistor, through which the passage of current is varied ac-

ording to the intensity of the magnetic field impinging on it. Unlike a magnetic sensor, which is responsive only to the *change* in a magnetic field (thus having no response to a constant or dc field), a Hall device is equally responsive to all frequencies of magnetic reversal as well as to a constant magnetic field. Placed next to the opposite rotating magnets of a dc motor, a pair of Hall-effect devices can control the output from an electronic drive in such a way as to provide electronic commutation of the motor windings, obviating the need for brushes.

This is the arrangement used to drive Pioneer's PL-61 turntable, with a slow-speed (330 rpm) dc motor that puts motor vibration (and any rumble from it) at a totally inaudible 5 Hz. That is not, however, as low in frequency as it is possible to get the rumble. It can be dropped to an almost-absurd 1/2 Hz by going to *direct* drive.

In a direct-drive turntable, there is no speed-reduction linkage between the drive motor and the platter. They are one and the same moving part. This accomplishes several very desirable things. It completely eliminates the motor and any intermediate drive elements as sources of rumble. It virtually guarantees that there can be no flutter, because there is nothing



rotating fast enough to cause rapid speed variation. And it reduces maintenance to a simple matter of periodic platter-spindle cleaning and lubrication. There are no pulleys or idlers to keep clean, no belts to fray or deteriorate, and no high-speed bearings to wear out within your lifetime. In other words, with minimal maintenance and perhaps an occasional part replacement in the electronic drive circuit, a direct-drive turntable can be expected to deliver peak performance for as long as you want to keep it. That hardly sounds like the kind of product a manufacturer would want to sell, but it looks as if every progressive turntable manufacturer is going to town with direct drive (including Pioneer, whose direct-drive model is PL-51).

At least one, Sony, has announced a model (PS-2251) that uses a direct-drive ac motor with a gear-tooth servo control of speed. All of the others listed in current catalogs use dc motors for direct drive, and many of them use Hall devices in a dual role—for servo control as well as winding commutation. In the Dual 701, for instance, two Hall devices are placed in proximity to the radial-finned rotor magnets (which are part of the platter bearing) and as the

magnets pass the devices, they in turn control solid-state switches to route the dc supply voltage to the appropriate motor coils. At the same time, the current passing through each Hall device in turn is compared with a reference current at any given moment, and if they differ, indicating that the motor magnet is not in exactly the position it should be at the moment, the electronic drive automatically supplies more or less motor drive voltage to bring the speed to the correct value.

The Technics by Panasonic SP-10, also a dc direct-drive model, is unusual in that it does not use Hall devices for commutation. Instead, it has a set of magnetic pickups—similar to those used for speed sensing in some other turntables—to “read” the platter position from a toothed wheel on it and thus to control the functions of the switching transistors. The same pickups also control the servo function, which in this case is represented by deviations of a 50-kHz oscillator-generated control signal.

All of which suggests that there are any number of ways of accomplishing the same end. In the case of electronic drive, the end does justify the rather complicated means. ♦

## Now that the AT 12S with genuine Shibata stylus is here... all other stereo cartridges over \$50 are obsolete!

Better performance from existing stereo records, and ideal operation of any CD-4 discrete playback system is all yours when you select an **audio-technica** four channel cartridge.

Now four models, including the new AT12S at only

 **audio-technica**®



\$49.95 suggested retail. All with genuine Shibata tips that permit response to 45,000 Hz and above, while minimizing record wear and offering superb tracking. Write today for free literature and list of **audio-technica** dealers nearest you.

AUDIO-TECHNICA U.S., INC., Dept. 14P, 1655 W. Market Street, Fairlawn, Ohio 44133  
**CIRCLE NO. 35 ON READER SERVICE CARD**



# News Highlights

## FCC Proposes More Liberal CB Antenna Rules

The FCC has released a Proposed Notice of Rule Making which would increase the maximum antenna height allowed for Class D Citizens Band stations from 20 feet to 60 feet. The new rules would permit installations where: "The highest point of the antenna or its supporting structure does not exceed 60 feet above ground level and the highest point does not exceed one foot in height above the established airport elevation for each 100 feet of horizontal distance from the nearest point of an airport runway."

## Electronic Wristwatches Spur Need for Quartz Crystals

With an estimated half million electronic watches (digital and non-digital) sold in 1973 and perhaps 4 million such watches due to be sold this year and 8 million in 1975, there is a squeeze on some of the suppliers of components for these watches. These large figures are predicated on lowering of watch prices, just as happened with pocket calculators. The quartz crystals used in the watches are said to be in short supply and some crystal manufacturers are a little leery about expanding their facilities as long as the prices for the watches remain at fairly high levels. Another thing preventing mass production of the crystals is the fact that several different frequencies are being called for. Although the most common is 32.768 kHz, there are also calls for 16-kHz, 30-kHz and 50-kHz crystals.

## Bullets and Transceivers

According to the Department of Justice, two police officers—one in Miami and the other in Seattle—put transceiver radios in the same pocket in which they were also carrying loose pistol ammunition. In both cases, one round of ammunition exploded in the officer's pocket. The Law Enforcement Standards Laboratory found that, when loose ammunition makes contact with transceiver recharging studs, one of two things happens: If the cartridges are new and clean, providing firm electrical contact, they will simply discharge the radio battery. On the other hand, if the cartridges are dirty, making poor electrical contact, rapid generation of heat will occur. This detonates the bullet primer within a few seconds. The solution suggested was for police officers to carry and store cartridges separately from transceivers and batteries.

## Guidelines for Safe Use of Lasers

Schools and industry can get guidance for the safe use of lasers from a new American National Standard designed to help laser users protect students, workers and bystanders from injury. The new Standard spells out the safety rules for lasers operating at essentially any wavelength or pulse duration. It defines control measures and provides technical information on measurements, calculations and biological effects. The standard is designated ANSI Z136.1-1973 and is



titled "Safe Use of Lasers." Copies are available at \$9 each from the American National Standards Institute, 1430 Broadway, New York, NY 10018.

### CBS Labs to Market Sony's 4-Channel Broadcast Encoder

An arrangement has been concluded through which CBS Laboratories Professional Products Dept. will distribute the Sony Encoder/Mixer exclusively in the U.S. and Canada. While an encoder is not needed to broadcast SQ™ quadrasonic records in ordinary two-channel stereo, the new encoder greatly expands the broadcaster's quadrasonic capability by allowing transmission of 4-channel discrete recordings and 4-channel live programs. The signals produced are matched to the SQ decoders incorporated in many brands of quadrasonic home receivers.

### REACT's Comments on Class E CB Proposal

The FCC has proposed to establish 40 Class E Citizens Radio channels on the frequency of 224 to 225 MHz. REACT has urged that the new service be brought into being as quickly as possible. Without knowing details of specific rules, current REACT thinking is along these lines: 1) Class D operations would continue without change; 2) all REACT teams would be encouraged to monitor the Class E emergency channel; 3) Class E monitoring would be entirely optional with existing teams; and 4) new teams might be chartered for either Class D or Class E operations, or for operation in both Class D and Class E bands.

**The Mark Ten B Capacitive Discharge Ignition System keeps your car in tune ... and everyone knows that a well-tuned car gets better mileage, requires less maintenance, runs longer and better, and helps in the quest for cleaner air.**



... Just ask Detroit

CIRCLE NO. 5 ON READER SERVICE CARD

**Order your Mark Ten B today! Please send me free literature.**

Enclosed is \$ \_\_\_\_\_  Ship ppd.  Ship C.O.D.  
 Please send \_\_\_\_\_ Mark Ten B, assembled, @ \$59.95 ppd. \_\_\_\_\_ Mark Ten B Kit @ \$44.95 ppd.  
 (12 Volt Negative Ground Only) \* \_\_\_\_\_ Standard Mark Ten, assembled @ \$44.95 ppd.  
 6 Volt: Neg. Ground Only \_\_\_\_\_ 12 Volt: Specify \_\_\_\_\_ Pos. Ground \_\_\_\_\_ Neg. Ground  
 \_\_\_\_\_ Standard Mark Ten Deltakit® @ \$29.95 ppd. (12 Volt Positive or Negative Ground Only)  
 Car Year \_\_\_\_\_ Make \_\_\_\_\_

Name \_\_\_\_\_  
 Address \_\_\_\_\_  
 City/State \_\_\_\_\_ Zip \_\_\_\_\_

**DELTA PRODUCTS, INC.**  
 Dept. PE - P.O. Box 1147 - Grand Junction,  
 Colo. 80501 (303) 242-9000

**Born Smart?**

**The Navy  
will make it  
pay off.**





## If you've got what it takes, the Navy can challenge you with over \$17,000 worth of advanced training in electronics or nuclear power.

The New Navy offers high school graduates a challenge with a future. And if you're qualified to meet the challenge, you can get training and experience that puts you ahead of the pack in the exciting fields of nuclear power or electronics.

These special Navy programs are tough. And besides the technical training, you'll have your share of the unglamorous chores. Everybody does. But the rewards and your personal satisfaction make it all worthwhile. Learning to operate and maintain the Navy's sophisticated electronic systems or nuclear power plants will give you skills you can use for a lifetime.

And as a sailor, you'll see the

world while you're still young. You'll make new friends. And get higher pay than any sailor in history.

Get all the details from your local Navy Recruiter. Or mail the coupon below. Or call toll-free 800-841-8000 anytime.

### Be someone special in the new Navy.

463

TO: Captain Robert W. Watkins, USN  
Navy Opportunity Information Center  
P.O. Box 2000, Pelham Manor, N.Y. 10803

Please send more information on:  Advanced Electronics Program  
 Nuclear Power Program  Other Navy career opportunities.

If you really don't want to wait, call 800-841-8000 toll-free (24 hours a day, seven days a week). In Georgia, call 800-342-5855. Call collect: In Alaska—272-9133. In Hawaii—533-1871.











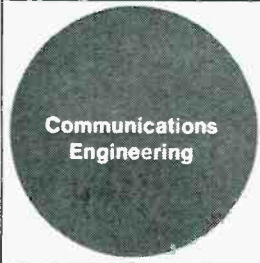

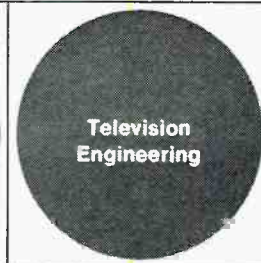
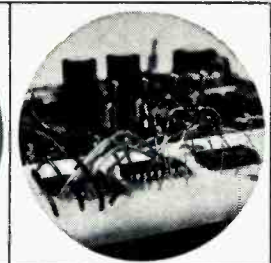
Name \_\_\_\_\_ Date of Birth \_\_\_\_\_  
(Please Print)

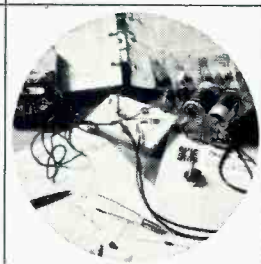
Address \_\_\_\_\_

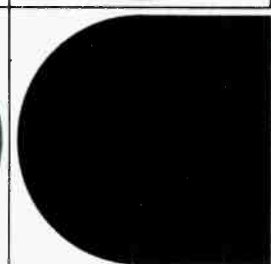
City \_\_\_\_\_ Phone \_\_\_\_\_

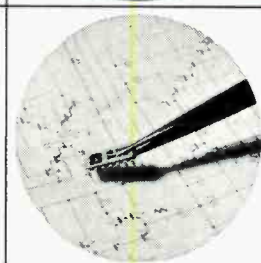
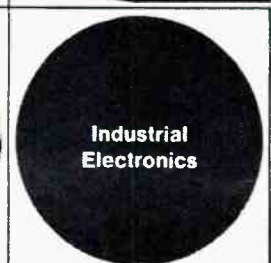
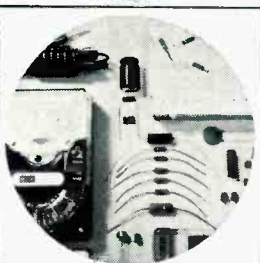
State \_\_\_\_\_ Zip \_\_\_\_\_

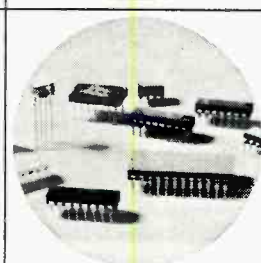
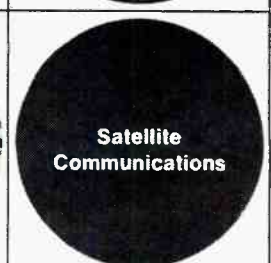
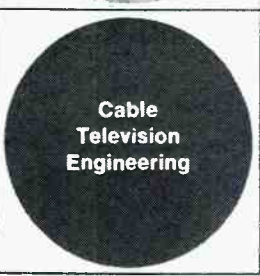
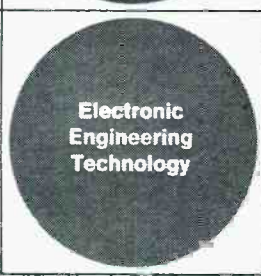

 <p><b>Communications Engineering</b></p>	 <p><b>Aeronautical &amp; Navigational</b></p>	 <p><b>Television Engineering</b></p>	
 <p><b>Automatic Control Engineering</b></p>		 <p><b>Missile &amp; Spacecraft Guidance</b></p>	
 <p><b>Radar &amp; Sonar Engineering</b></p>	 <p><b>Digital Communications</b></p>		 <p><b>Industrial Electronics</b></p>
	 <p><b>Microwave Engineering</b></p>		 <p><b>Satellite Communications</b></p>
 <p><b>Cable Television Engineering</b></p>	 <p><b>Electronic Engineering Technology</b></p>	 <p><b>Nuclear Instrumentation &amp; Control</b></p>	 <p><b>Special Programs for Electronic Engineers</b></p>



#### ADVANCED ELECTRONICS CAREER TRAINING AT HOME

Computer  
Engineering

If you are too busy to go to college to learn advanced electronics, CREI brings college level training to you. CREI programs give you practical engineering training that you can apply in your work to move ahead to higher paying jobs. And CREI lets you specialize in exactly the area of electronics you want. You have a choice, depending on your qualifications, of 18 different programs.

Not only are CREI programs college-level but arrangements are available for you to earn college credit applicable to advanced degrees.

## Only CREI offers you a choice of 18 programs in advanced electronics

Electronic  
Systems  
Engineering

For over 45 years CREI programs have been recognized by leading technical organizations as effective home study training in advanced electronics.

#### NEW OPTIONAL LAB PROGRAM



CREI now offers a supplementary ELECTRONIC DESIGN LABORATORY PROGRAM to make learning advanced electronics easier and to give you actual experience to use in your work. Only CREI offers this complete college type laboratory program. You learn to actually design electronic circuits. At the same time you get extensive experience in tests and measurements, breadboarding, prototype building and other areas important to your career.

**Qualifications to Enroll.** To qualify for enrollment in a CREI program, you must be a high school graduate (or equivalent). You should also be working in electronics or have previous training in this field.

**Send for FREE book.** If you are qualified, send for CREI's newly published book describing your career opportunities in advanced electronics. This full color book is filled with facts about career opportunities for you.

Nuclear  
Engineering  
Technology

Special Programs  
for  
Non Electronic  
Engineers



Accredited Member, National Home Study Council

CREI, Dept. E 1201 E  
3939 Wisconsin Avenue  
Washington, D. C. 20016

Rush me your FREE book describing my opportunities in advanced electronics. I am a high school graduate.

Name \_\_\_\_\_ Age \_\_\_\_\_

Address \_\_\_\_\_

City \_\_\_\_\_ State \_\_\_\_\_ ZIP \_\_\_\_\_

If you have previous training in electronics, check here

Employed by \_\_\_\_\_

Type of Present Work \_\_\_\_\_

Veterans and servicemen, check here for G. I. Bill information

**CREI**  
**CAPITOL  
RADIO  
ENGINEERING  
INSTITUTE**

A Division of McGraw-Hill  
Continuing Education Co.  
3939 Wisconsin Avenue,  
Washington, D. C. 20016

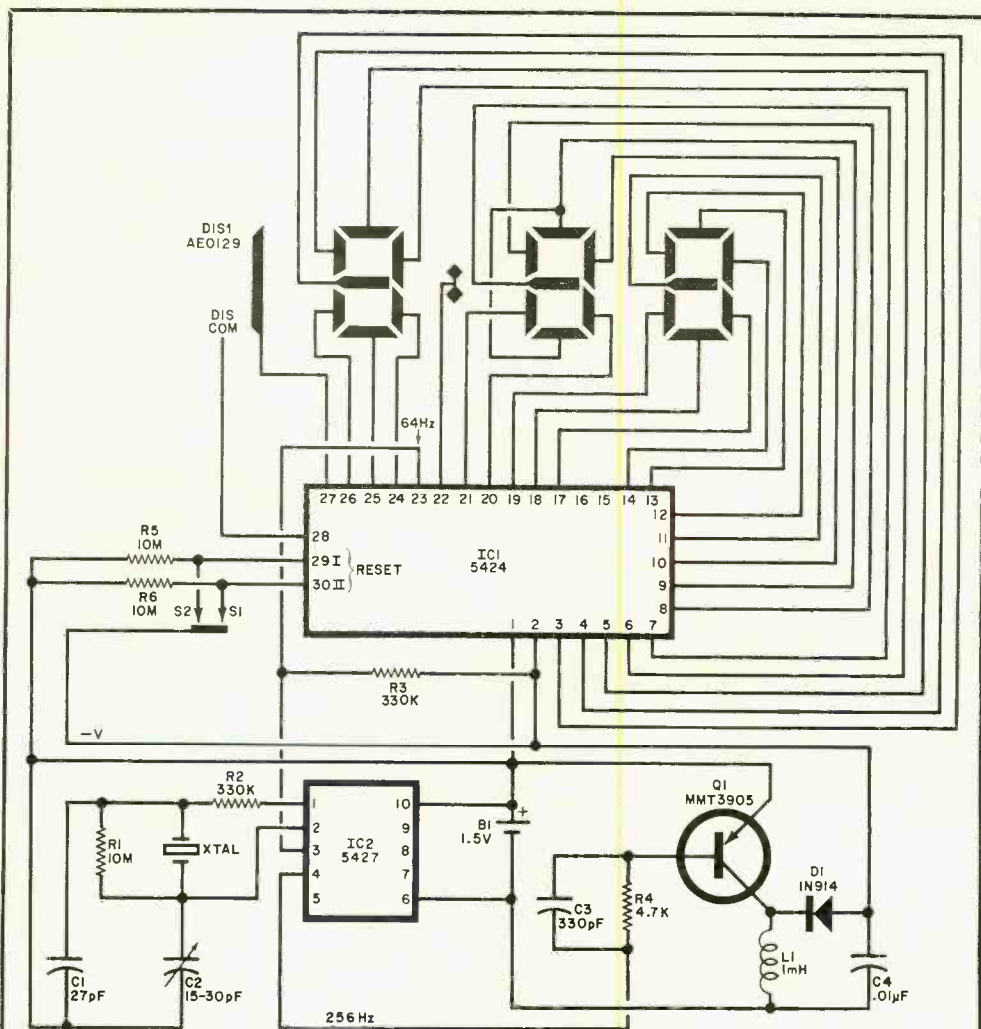

### PARTS LIST

B1—1.5-volt hearing-aid cell (S-41 or similar)  
 C1—27-pF miniature capacitor  
 C2—15-30-pF miniature trimmer capacitor (Johnson 9410-2)  
 C3—330-pF miniature capacitor  
 C4—0.01- $\mu$ F miniature capacitor  
 DIS1—Liquid crystal display with socket SO1 (AE0129 or RCA 8047R)  
 D1—1N914 or 1N4148 diode  
 IC1—5424 4-digit decoder/driver (Solid State Scientific)  
 IC2—5427 time base (Solid State Scientific)  
 L1—1-mH miniature coil  
 Q1—Miniature transistor (Motorola MMT 3905)  
 R1, R5, R6—10-megohm,  $\frac{1}{8}$ -watt resistor

R2, R3—330,000-ohm,  $\frac{1}{8}$ -watt resistor  
 R4—4700-ohm,  $\frac{1}{8}$ -watt resistor  
 S1, S2—See text  
 SO1—Socket (part of DIS1)  
 XTAL—32,768-Hz 28° C miniature crystal (Reeves-Hoffman)  
 Misc.—Brass strip (0.01"), thin spaghetti tubing, black tape, case, etc.  
 Note—The following are available from Alpha Electronics, P. O. Box 1005, Merritt Island, FL 32952: complete kit (DWK-1) less case, band, and battery at \$69.90, plus \$2 for postage and insurance; etched and drilled PC board (DW-1) at \$6.00, plus 50¢ postage; case (DWC-1) without band at \$10, postpaid.

Fig. 1. Integrated circuit IC2 contains the crystal oscillator and provides 64 Hz to drive IC1 (the decoder) and 256 Hz for the voltage converter, Q1. S1 and S2 set time.



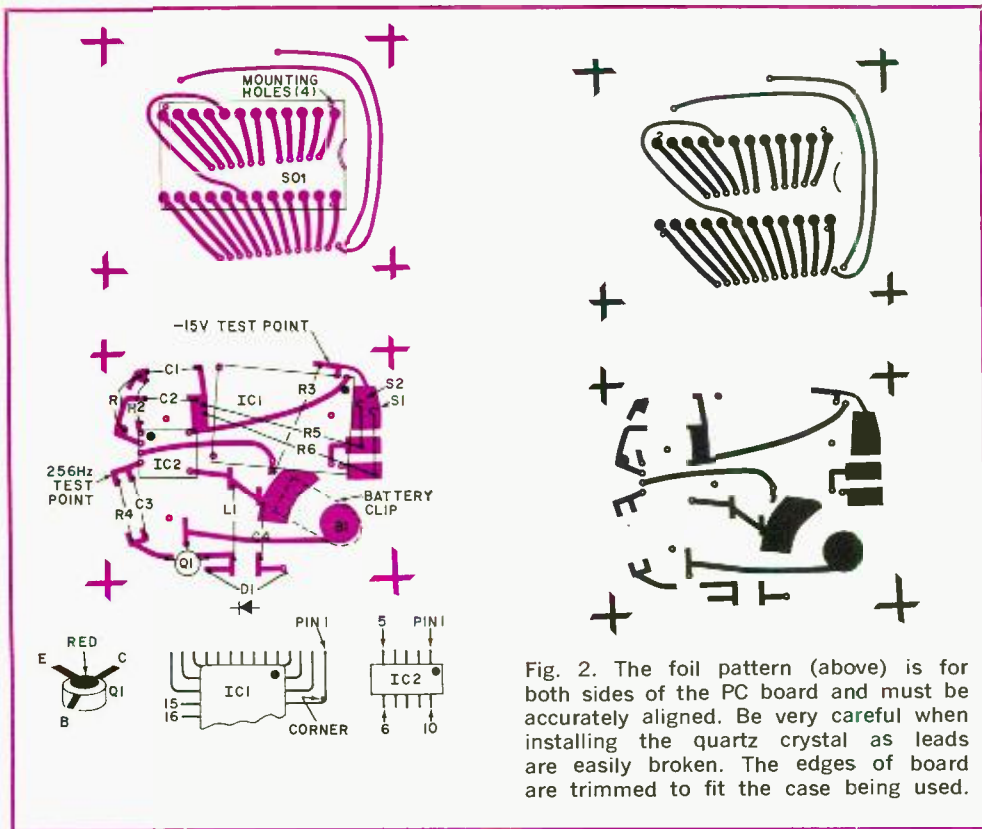

Fig. 2. The foil pattern (above) is for both sides of the PC board and must be accurately aligned. Be very careful when installing the quartz crystal as leads are easily broken. The edges of board are trimmed to fit the case being used.

First, the LCD requires less than 1/1000 of the power needed to illuminate an LED, thus contributing to the life of the battery. The visibility of the LCD increases with ambient light, whereas the LED is difficult to read in bright daylight. (Of course, the LCD can't be read without some light, but neither can most conventional watches.) Due to the optical properties of the scattering type of LCD, the display has to be tilted slightly for clear visibility, but this has been found to be no problem since the wrist is always turned to tell the time on a wristwatch. Electronically, the LCD does not require the transistor-resistor interface needed for an LED, which permits the design of a much smaller package.

**Construction.** To achieve the small size necessary for the wristwatch, it is necessary to use a thin, double-sided PC board. A foil pattern and component layout are shown in Fig. 2.

In assembling the watch, use a low-power soldering iron—preferably one whose tip is grounded. Also, use very fine solder. If you

do not have a slender tip on your iron, wrap some bare copper wire around the tip you have and shape the other end into a chisel point, using the point for the soldering tip. Before starting any work on the PC board, make sure that the foil pattern is thoroughly clean. If necessary, use a household cleaner on the foil. Once the board is clean, do not touch the foil with the fingers. It is especially important that the foil associated with display socket SO1 not be touched, so always handle the board by the edges.

Socket SO1 is the first component installed. Do not remove the thin metal spring cover from the socket. Handling it gently, install the socket as shown in Fig. 2, with the curved end adjacent to the curve mark on the foil so that the four small corner pegs fit into their holes. Holding the socket tight to the board (pins make only surface contact with the foil pattern), turn the board over and gently fuse the four plastic corner pegs using the low-power iron.

To make the unit as small as possible, some unconventional component mounting

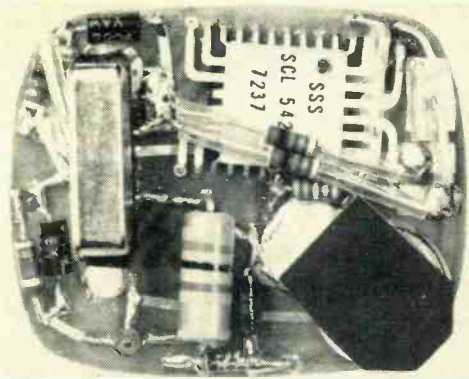

Photo of the prototype shows how closely the components fit on the PC board. Note the use of thin spaghetti on crystal-resistor leads.

methods are used. The only holes drilled in the board are those for *SO1*, the two IC's, and two feedthrough holes used to connect the foil pattern on one side, with their mates on the other.

Note that all components are attached to elongated copper foil pads. In soldering the components to the pads, coat the latter with generous amounts of solder.

The leads on the capacitors, resistors, coil *L1*, diode *D1*, and transistor *Q1* should be bent down from the points where they come out of the components. Then bend them out 90 degrees so they are parallel

### HOW IT WORKS

Integrated circuit *IC2* is a 9-stage binary ripple counter which also includes an inverter used as the crystal-controlled oscillator. The crystal is cut for 32,768 Hz so that the output at pin 3 is 64 Hz. Integrated circuit *IC1* is specifically designed for 12-hour time-keeping. It processes the 64-Hz output of *IC2* to deliver a decoded 7-segment output suitable for driving the liquid crystal display without an interface circuit.

Integrated circuit *IC2* operates from the 1.5-volt hearing-aid cell, but *IC1* and the display operate best with about -15 volts. To avoid the use of more cells to increase the voltage, transistor *Q1* is used as an "up converter." The 256-Hz output at pin 4 of *IC2* turns *Q1* on for about 15 microseconds. During this time, current flows through *L1* building up a magnetic field. When the trigger pulse stops, the collapsing magnetic field builds up a large ringing voltage across *L1*. This voltage is rectified by diode *D1* and stored in capacitor *C4*. The dc voltage measured at this point (using a high-input-impedance voltmeter) is about 15 volts, enough to drive *IC1* and the LCD.

with the body. They should be positioned as they are mounted with their leads clipped the correct length to reach the pads. Carefully tin each component lead since they are installed by solder reflow.

Trimmer capacitor *C2* is installed next, by clipping its leads as required and soldering the leads to the pads.

Install the other components, except for *R3*, *R5*, *R6*, the two IC's and the crystal. The components mounted about the outer edge of the board should not protrude past the edge. The anode lead of *D1* and the emitter lead of *Q1* are bent down, inserted through their pad holes, and soldered on both sides of the board. Be sure that all leads are clipped short and that there are no solder bridges.

Cut pins 15 and 16 from *IC1* (see Fig. 2) and cover the bottom of *IC1* with black tape to insulate the metal body from the foil underneath. Bend the other leads as shown in Fig. 2 so that, when the IC is in position with the black dot in the proper corner, it can be installed in its holes. Make sure that the IC is flat to the board and solder the leads to their pads on the underside (display socket) of the board. Pins 1, 2, 23, 29, and 30 are soldered on the top of the board. Using a sharp nail clipper, make all leads flush with the board.

Clip leads 5, 7, 8, and 9 from *IC2*. The black dot indicates pin 1. Cover the bottom with black tape. Position *IC2* and solder the leads to their pads making sure that the IC is flat on the board.

Install resistor *R3* with a short lead soldered to the pad below *IC1* and the other lead through thin spaghetti tubing to the pad on the other side of *IC1*. Place a length of spaghetti over one lead of *R5* and solder this end to the pad between the two IC's. Put the body of *R5* across *IC1* (in physical contact to reduce height) and slide a length (long enough to reach from the resistor body to the other *R5* pad) of spaghetti onto the other *R5* lead. Do not clip off the excess lead length. Bend the lead and solder the "elbow" to its pad. Slide a short length of spaghetti over the remaining lead and bend the tip into a small "hook" (Fig. 3A) over the -15-volt pad. This hook will act as time-setting switch *S2*. Use the same procedure with *R6* to form *S1*. Since these switches are used to set the time, make sure that the hooks do not make contact with the -15-volt pad until they are deliberately depressed.

Make the battery clip using some 0.01-inch thick brass sheet with the dimensions shown in Fig. 3B. Tin the large pad adjacent to C4 and the underside of the small lip on the clip. Solder the clip to the pad and cover the top side of the clip with black tape.

The board should now be complete except for the insertion of the liquid crystal display and the quartz crystal. Completely check the board for proper component installation and make sure there are no protruding lead ends or solder bridges. Also be sure that, where necessary, leads are soldered on both sides of the board. Be sure no component extends beyond the edge of the board.

Turn the board over and very carefully slide the thin steel spring cover from S01. Be very careful with any mechanical manipulations as the socket contacts are not soldered to the board. Insert the liquid-crystal display in the socket so that the narrow "1" display is nearest the notch on the socket. The display has a shoulder so that it fits into the socket properly. While holding light finger pressure on the display, slide the thin steel cover over the display from the notched end of the socket, until it is properly seated.

The quartz crystal is mounted so that it is touching IC2 with as short leads as possible. Use a small piece of black tape on the

underside of the crystal and short lengths of thin spaghetti over the leads. Solder carefully in place. At this point, the watch is completely assembled and ready for testing and time setting.

Install the 1.5-volt hearing-aid cell under its clip with the positive side down to the board. The display should indicate some digits, and the colon should pulsate at a 1-Hz rate.

**Time Setting.** To set the time, use an insulated thin wand and depress spring hook S1 to set the hours—clock will continue to count. When S1 and S2 are depressed simultaneously, the minutes will advance, and the clock will not count. If only S2 is depressed, the count will hold and the seconds (not displayed) will reset to zero. When S2 is released, the count will resume. Make sure that, after depressing, both hooks come up from the -15-volt pad.

A frequency counter can be used to check the 256-Hz test point shown in Fig. 2. Trimmer capacitor C2 is used to set the exact frequency. If you do not have a counter, allow the watch to run to determine its accuracy and adjust C2 accordingly. This will have to be repeated (like any conventional spring watch) until it keeps time correctly.

**Final Assembly.** Select a suitable case for the watch and trim (file) the board to fit with the display near the lens. Use care in installing the board in the case since the display can be damaged by undue pressure. Once the board fits the case, use black paint to cover the metal surrounding the display. Use black tape over the top of the PC board. Place a small piece of tape over the top of the quartz crystal and make sure that the top of the battery clip is still covered with tape.

The S-41 cell recommended is a conventional hearing-aid type and should operate the watch for 8 months to one year. The timekeeping accuracy is dependent on the quartz crystal, whose frequency is calibrated at 82° F. At temperatures from 64° F to 100° F, there is little effect on the crystal oscillator's frequency. The liquid-crystal display will not operate below 50° F or above 130° F. When worn on the wrist, however, even in winter, the temperature of the watch would probably not be outside these limits. ♦

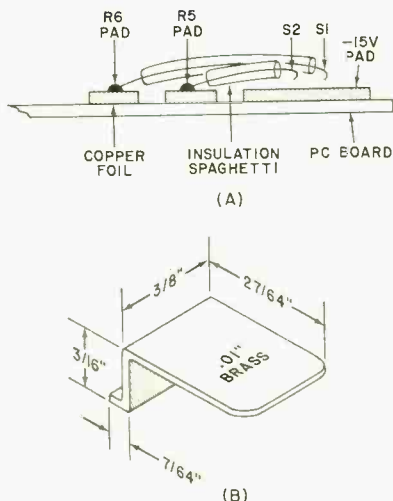

Fig. 3. Time-setting "hooks" are shown in (A). The hooks should clear the negative pad when not depressed. The cell clip is shown at (B) and is made of 0.01" brass sheeting.



# **Design Your Own** **BASS** **REFLEX** **HI-FI** **SPEAKER** **SYSTEMS**

## **PART 1. BASIC PRINCIPLES**

*There's renewed interest in this high-efficiency enclosure design. Here's how it works.*

**BY DAVID B. WEEMS**

**T**HE BASS reflex loudspeaker enclosure has always had some theoretical advantages over the closed box that has dominated, for so many years, speaker system design. The bass reflex makes use of the back wave from the loudspeaker to increase the bass output in the octave above speaker resonance. The port also reduces low-frequency distortion by damping the speaker cone, and the air in the port can undergo large vibrations without the distortion associated with large cone excursions.

One disadvantage of the reflex is that, as a tuned system, it requires correct tuning if it is to operate according to theory. Reflex design charts are available, of course, but they sometimes appear to give conflicting recommendations. And tuning instructions are often confusing to follow. To analyze this situation, it is necessary first to review how the ported box of a bass reflex system operates.

**How It Works.** The bass reflex enclosure is a form of Helmholtz resonator (named for the nineteenth century physicist who

first studied such a resonator). Helmholtz discovered that any enclosure with a single hole in it will resonate at some frequency that is determined by the compliance of the interior air and the inertance of the air in the opening. Inside air compliance varies directly with the air volume, while port inertance varies inversely with port size.

Comparing the mechanical elements of the Helmholtz resonator to a resonant electrical circuit, the enclosure's volume represents capacitance, the port inductance. (Fig. 1). If a resonant circuit is altered by increasing the capacitance, the inductance must be decreased to maintain resonance at the same frequency. The mechanical analogy of this is that as the volume of the Helmholtz resonator is increased, (increasing capacitance) the port area must be increased (to decrease inductance) to obtain the same tuning frequency.

The mechanical "circuit" can be tuned just as surely by choosing a certain port area and varying the enclosure's volume. The volume of the box can be reduced by the simple expedient of partially filling it

with some solid material. Enlarging a finished enclosure is nigh impossible; it is usually more practical to build a box with the desired volume and tune the port to the box.

Adding a loudspeaker to the box complicates the situation because the speaker, like the box, exhibits a single frequency at which the mass of the cone resonates with the compliance of the cone's suspension. This free-air resonance is measured with the speaker suspended in mid-air. Modern loudspeakers tend to have heavier cones and higher compliance than early high-fidelity speakers and, so, lower resonant frequencies.

If a low-frequency test is run on an un-baffled speaker, there will be a noticeable vigorous cone vibration at its resonant frequency. This excessive vibration tends to accentuate sounds with frequencies at or near this resonance, even though the rise in impedance restricts the power transfer from amplifier to speaker. Resonance, which increases conversion efficiency, can produce a peak output of up to 15 dB.

When a loudspeaker is installed in a simple closed box, the resonance moves up in frequency because the stiffness of the air in the box is added to that of the cone's suspension. But if a hole just the right area to tune the box to the speaker's free-air resonance is cut into the box, some interesting

things happen. The main resonance disappears, and two new resonances emerge, one above and one below the original resonant frequency of the speaker. An impedance curve of the speaker/box combination has a double hump, with a trough between the peaks, as shown in Fig. 2. For any bass reflex system, the three critical frequencies are at the  $f_1$  lower peak,  $f_2$  trough, and the  $f_3$  upper peak. If the box is tuned to the speaker's free-air resonance ( $f_r$ ), trough frequency  $f_2$  is the same as  $f_r$ .

The behavior of the loudspeaker/enclosure combination is similar to that produced when two tuned electrical circuits are closely coupled. The more tightly the two are coupled, the greater the spread between the two resonances. In the bass reflex, the degree of coupling is inversely proportional to the size of the box. Small boxes produce tightly coupled circuits with a wide spread between them; large boxes produce more loosely coupled combinations with a narrow spread between the peaks.

While we can compare the resonances in a tuned box to those of two tuned electrical circuits, this does not tell us what is happening to the speaker or the air in the box. At the port resonance, the air in the box vibrates easily at its natural resonance. The mass of the port air, vibrating on the air "spring" in the box, damps the cone so that it hardly moves. At resonance, the output is mainly from the port, which has a  $90^\circ$  phase difference to that of the cone.

At lower frequencies, the air in the box acts progressively "stiffer." Finally, at the lower critical frequency, the air in the box and the air in the port move as if all were connected in series with the cone (Fig. 3). As the cone, largely undamped at this frequency, moves in, the air in the port moves out. The port radiation is  $180^\circ$  out of phase with the cone radiation. This, coupled with the normal drop in cone output below resonance, produces a frequency response curve that falls off rapidly at 18 dB/octave below the cutoff frequency. The cut-off frequency should be set low enough to give a satisfactory bass response.

At frequencies above port resonance, the reactance of the port air increases with the frequency of the air pulses, just as the inductance of a coil reacts to increasing frequency of an electric current. At some point, the increase in reactance makes the enclosure act like a sealed box. The upper critical frequency of a ported box is higher than

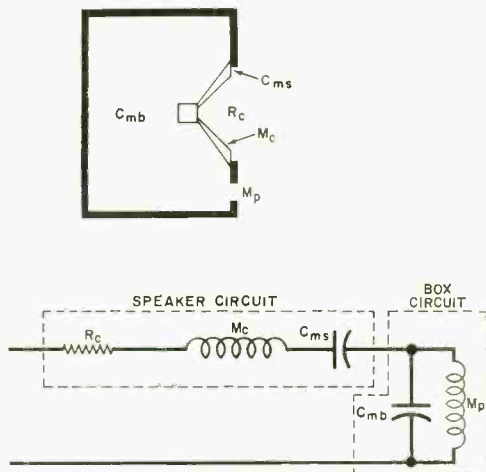

Fig. 1. Electrical analog of a loudspeaker in ported box. (Radiation resistance of the port is omitted here to simplify box circuit.)  $R_c$  is mechanical resistance of air load and suspension system.  $M_c$  is mass of cone, voice coil and air load.  $C_{ms}$  is compliance of cone suspension.  $C_{mb}$  is compliance of air in the box, and  $M_p$  is inductance of air in port.

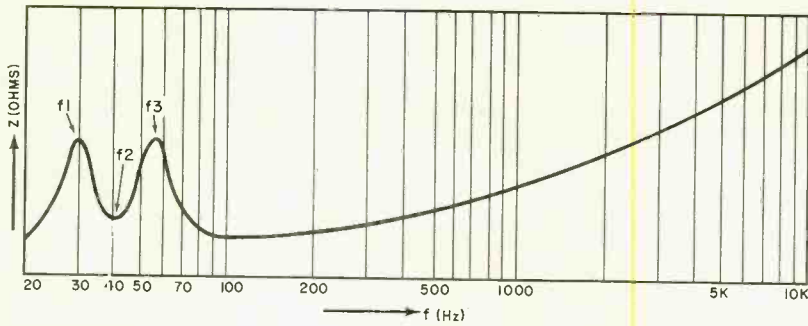

Fig. 2. Typical impedance curve of a speaker in a bass reflex enclosure. Three critical frequencies are easily identified by two peaks and valley. The rise in impedance at high frequencies is due to voice coil inductance.

would be the frequency of the single system resonance if the port were closed. At the upper resonance, the port air is exactly in phase with the cone, and the compliance of the box air must be shared by the two vibrating pistons, the cone and "plug" of air in the port. This increases the pressure on the back of the cone over that of the simple box, raising the resonant frequency.

**Enclosure Size.** One of the most important decisions to make in designing a ported enclosure is how large the box is to be. In the early days of hi-fi, this question was solved rather easily. With a port area equal to the cone's effective cone area, one chose from a design chart that enclosure volume that would tune the box to the speaker's free-air resonance. This method yielded large enclosures even when speakers had much stiffer cones than those used today. For example, a 12-in. speaker with an effective cone area of 78 sq in. and a bass resonance of 75 Hz would require an enclosure volume of 6 cu ft. But if the bass resonance were 30 Hz, a common value today, a 78-sq-in. port would require a volume of 25 cu ft.

A 25-cu-ft volume would not only be impractical, but it would probably not be an effective value for a reflex enclosure. Since the degree of coupling between a speaker and an enclosure varies inversely with box size, an enclosure that is too large cannot adequately load the speaker. In this situation, one might just as well close the port and make the box an infinite baffle.

One way to inspect the degree of coupling between an enclosure and a speaker is to run an impedance curve such as those shown in Fig. 2 and Fig. 4. The speaker in Fig. 4 has a free-air resonance of 45 Hz,

and the two enclosures (with volumes of 1300 and 8600 cu in.) are tuned to that frequency. Note the depth of the troughs between the twin impedance peaks. The close coupling of the small box has much greater effect on the speaker impedance at resonance than does the loose coupling of the larger box.

Another way to compare the two boxes is in the spread between the resonances as represented by the ratio of the upper to the lower critical frequency. In the 1300-cu-in. enclosure, the frequencies are 94 and 21 Hz, a ratio of 4. In the 8600-cu-in. box, the ratio of the peaks is 65:32, or about 2.

The degree of coupling and its symptoms, the depth of the impedance valley and the critical frequency ratio, are determined by the ratio of the speaker compliance to the compliance of the air in the box ( $C_{ms}/C_{mb}$ ). In the 1950's, it was typical to make this ratio equal to or lower than 1. The relatively stiff speakers of that time were fitted into boxes with a compliance equal to or greater than that of the speaker. Now, the ratio is nearly always greater than 1, sometimes much greater. It is not necessary—or even desirable—to make the box compliance equal to or greater than that of the speaker.

For a typical high-quality speaker, if the  $C_{ms}/C_{mb}$  ratio is made equal to about 1.41, system response will be flat down to about the frequency of the speaker's free-air resonance. If the desired  $C_{mb}$  is known, the correct volume can be determined from a box compliance chart. (For more detailed information, see "Closed Box Speaker System Design," June and July 1973.)

To determine the  $C_{ms}/C_{mb}$  ratio of a speaker/box combination, measure the speaker's free-air resonance and denote this



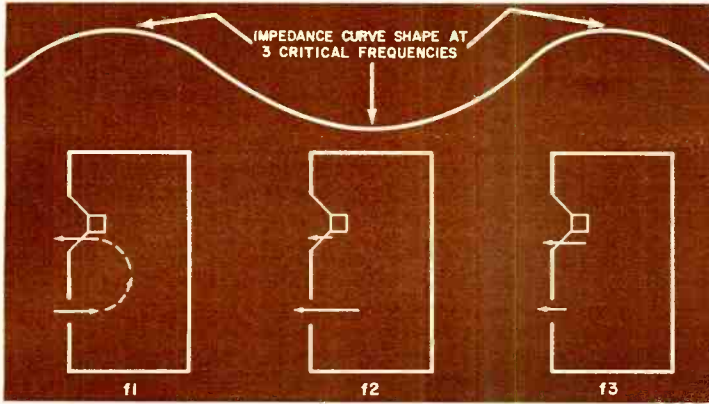

Fig. 3. Behavior of cone and port air at three critical frequencies. Lengths of arrow are rough indication of relative outputs from each.

$f_r$ . Install the speaker in the unvented box, and measure system resonance  $f_{rs}$ . The compliance ratio can then be found:

$$C_{ms}/C_{mb} = (f_{rs}/f_r)^2 - 1.$$

James F. Novak, Chief Engineer at Jensen Sound Laboratories, developed an optimum-volume concept for ported enclosures that was based on a  $C_{ms}/C_{mb}$  ratio of 1.44. This volume produces a critical-frequency ratio,  $f_3/f_1$ , of 3.13. Novak states that A.N. Thiele has done some excellent work on the optimum volume concept with a more exact solution for the optimum-compliance ratio, which turns out to be 1.414, and adds that

modern high-compliance speakers will operate satisfactorily at higher ratios—that is, in smaller boxes.

This is fortunate because even with a  $C_{ms}/C_{mb}$  ratio of 1.414, a typical high-compliance 12-in. speaker can sometimes require a cabinet volume of 10 to 15 cu ft. In most home situations, the theoretical optimum volume for a large speaker is of no more than academic interest.

There is one way to combine optimum volume with compact enclosures: Use a small woofer. A typical optimum volume for an 8-in. high-compliance woofer would be

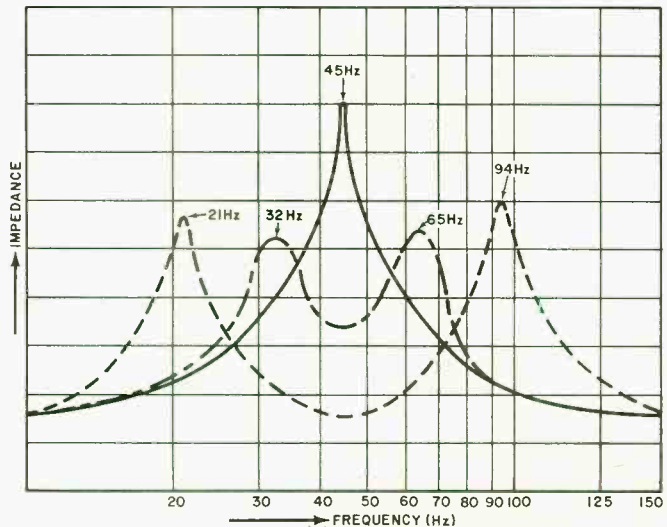

Fig. 4. The effect of enclosure size on the impedance curve of a speaker. The solid curve is the impedance of the speaker alone, while the dashed curve is the impedance of the speaker in a small, 1300-cu-in. enclosure. Dot-dash curve is impedance of speaker (free air resonance of 45 Hz) in 8600-cu-in. box.

about 2 cu ft; for a 6-in. speaker, it would be perhaps 0.75 down to 0.5 cu ft or less. Small woofers vary greatly in effective cone area due to their different suspension widths.

For large woofers, the enclosure volume should be as large as practical, assuming that it is below the optimum value. Unless some measurements are made to estimate the compliance ratio, the results will be unpredictable. Here are some examples of how box requirements vary between speakers produced by a single manufacturer:

If a Jensen Model 11 (12-in.) speaker is installed in a 1.15-cu-ft box, the bass cutoff occurs at 60 Hz. Jensen's Models 7 and 8 (both 8-in. speakers) offer a bass cutoff at 50 Hz in the same box, making them better choices for that box size. If more space is available, enough to double the volume of the box, the 12-in. speaker offers essentially flat response down to 45 Hz. However, one sometimes runs into the law of diminishing returns. A Jensen Model 9 (12-in.) speaker cuts off at 50 Hz in a 2.3-cu-ft box, but when the volume is increased to 4 cu ft, the low end is extended by only about 5 Hz, down to 45 Hz.

Even though theoretical considerations are ignored, one should try to avoid the kind of problem situation where the enclosure size can degrade the sound. This is most

likely to occur when the upper critical frequency is too high. If it is near 100 Hz, the reproduction of male voices may be boomy. A serious 100-Hz boom in a completed enclosure is difficult to treat except by closing the port; the boom will still be present, but the frequency will be lower. Also, the bass roll-off of speakers in a closed box occurs at the rate of 12 dB/octave instead of 18 dB/octave. Because of the necessity of keeping the upper impedance peak as low in frequency as possible and the sharp roll-off that is characteristic of reflex systems, compact ported enclosures require low-resonance woofers just as certainly as do compact sealed boxes.

The final word on reflex enclosure size is: When in doubt, make it larger. The deficiencies of oversize boxes are subtle ones, such as reduced speaker loading and impaired transient response. Boxes that are too small not only limit the low-frequency range, they also put the upper resonance in a critical region of the response band. The average ear will forgive speakers in too-large boxes but never speakers in too-small boxes.

**Enclosure Shape.** Various enclosures can be used, if necessary, but it is desirable to have the three dimensions unequal (but with a ratio of not greater than 3:1). These precautions eliminate the cube-shaped box that can develop standing waves, and the long narrow box that would act as a resonant pipe.

The nomograph in Fig. 5 is based on a dimension ratio of 1:1.44:2.08. This nomograph shows the correct dimensions for producing a desired volume. To use it, first find the correct volume; then lay a straight-edge across the chart at right angles to the vertical lines. For large enclosures, the correct dimensions can be read to the nearest inch. For example, if you want to build a 6-cu-ft enclosure, put the straight-edge at 6 cu ft and read the dimensions at the points where it intersects the vertical lines, in this case, 31½" x 21¾" x 15". Take care to note that these are the *inside* dimensions. The enclosure panels would be made somewhat larger, depending on the thickness of the panel material, to provide an internal volume of 6 cu ft.

This completes part one. In the second part of this series of two articles devoted to the bass reflex speaker system, the stress will be on practical construction details. ♦

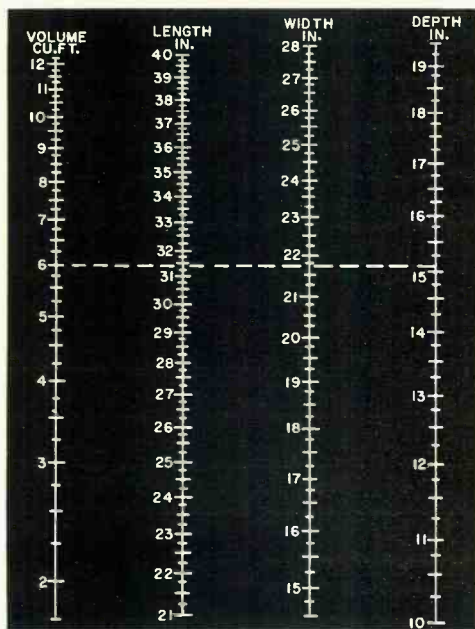

Fig. 5. This optimum dimension nomograph by E. G. Lescault is based on 1:1.44:2.08 ratio.

# ELECTRONIC MUSIC PITCH STANDARDS

*Including the construction of a  
voltage-controlled oscillator with memory*

BY DON LANCASTER

ANY electronic music system has to generate either a number of different tones or one or more tone producers have to be shifted around to get a desired tone sequence. Before we can look at how we produce tones, we have to ask some pretty basic questions: What is pitch? How stable must the tones be? What are their frequencies? And so on.

*Pitch* is the psychological perception of the *frequency* of a tone, just as *loudness* is the psychological perception of the *amplitude* of a tone. Since pitch is an "in the head" type of thing, it's affected by loudness, the presence of other notes, room acoustics, your particular mood, and a dozen other things. So, we really can't generate a pitch directly. All we can do is generate a note of a given frequency, amplitude, and stability, and hope that the final effect in the listener's head is the one we are after or at least close to it. Thus, our pitch generation problem is really one of

making one or a group of related tone frequencies available.

There are two types of perceived frequencies. One is called *absolute pitch*, or the actual value as perceived in so many hertz or cycles per second. The other is the *relative pitch* or the frequency relationship between a certain note and a note played either with it or immediately before. Fortunately for music in general, very few people care about or can tell an absolute pitch, and it is only the *relative* relationship between notes on a frequency ratio basis that really matters. Thus, if *all* the notes produced change their absolute frequency slowly with time, very few listeners will notice. This also lets us move up and down a musical scale to get a different overall effect or to add variety or depth to a composition.

A pitch generator is a circuit or system that makes available several notes of different frequencies. It does this in such a way

The ARP Model 2500 electronic music synthesizer.

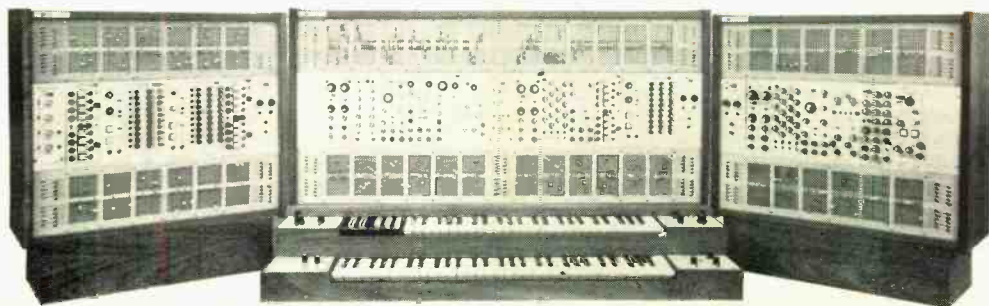



that the frequency ratio relationships can be combined to get an overall effect that at least the composer, and hopefully his listeners, will consider "music."

Theoretically, we could use any group of tones of any stability we like. This might be fine for special effects, music soundtracks, and TV commercials, but there are certain things that get in the way of using a more or less random selection of tone frequencies. The three most important are: the physical characteristics of the ear and hearing, the traditions and music that went before in the mind of the listener, and, finally, whether the electronic musical instrument you are building is going to be used either with other instruments or in an attempt to synthesize their sounds. While you as a composer can select any group of tones you like, you may not have very many listeners if your selection violates basic physical properties of the ear or goes completely against the cultural grain of your intended listeners.

**What the Ear Likes To Hear.** There are several characteristics of the ear that set up the basic ground rules. These are pretty much independent of the listener's cultural or musical heritage.

The first of these is that the ear is *not* a linear device. It works on a logarithmic basis both for the perception of pitch and for loudness. For instance, the sound energy of a whisper added to another whisper gives an apparent doubling of loudness. The same amount of energy added to a shout gives very little if any added loudness perception. What counts is the *change* in the amount of energy received, not on a "how much is it?" linear basis, but on a "how

much is it in relation to what we have already?" log basis.

This, of course, gives us the familiar decibel or log relationship where a change in loudness of one decibel (around 10% amplitude or 20% power) is about the smallest change we can normally detect.

The same type of log relationship applies to pitch as well as loudness. It's very easy to spot a 10-hertz frequency difference as you go from 40 hertz to 50 hertz, since the *percentage* or relative change in frequency is so great. If you go from 4000 to 4010 hertz, the frequency difference between the two is still 10 hertz, but the *percentage* change is so small that a trained ear could just barely detect it.

So, our notes have to be spread out on an exponential or log basis, in order that the frequency difference between the low notes is low and the frequency difference between high notes is higher—perhaps maintaining the same percentage change between successive notes over the scale. Thus, any scheme to make all the notes equally spaced in frequency is doomed to failure because the ear just doesn't work that way. The notes would end up much too far apart at the low end and too cramped together at the high end to allow very much meaningful to be done with them. Any reasonable pitch generator has to spread out the high notes and cramp together the low ones. The type of scale that best fits the ear's characteristics turns out to be one where each successive tone is an equal percentage or constant ratio higher in frequency. This is called an *equally tempered* scale, and produces tones that appear to be just as far apart in the low register as in the high.

**TABLE 1—STANDARD FREQUENCIES FOR TWELVE-NOTE EQUALLY TEMPERED MUSICAL SCALE**

Octave Number	Note (in hertz)											
	C	C#	D	D#	E	F	F#	G	G#	A	A#	B
0*	16.351	17.324	18.354	19.445	20.601	21.827	23.124	24.499	25.956	27.500	29.135	30.867
1	32.703	34.648	36.708	38.891	41.203	43.654	46.249	48.999	51.913	55.000	58.270	61.735
2	65.406	69.296	73.416	77.782	82.407	87.307	92.499	97.999	103.83	110.00	116.54	123.47
3	130.81	138.59	146.83	155.56	164.81	174.61	184.99	195.99	207.65	220.00	233.08	246.94
4	261.62	277.18	293.67	311.13	329.63	349.23	369.99	391.99	415.31	440.00	466.16	493.88
5	523.25	554.36	587.33	622.25	659.26	698.46	739.99	783.99	830.61	880.00	932.32	987.76
6	1046.5	1108.7	1174.7	1244.5	1318.5	1396.9	1479.9	1567.9	1661.2	1760.0	1864.7	1975.5
7	2093.0	2217.5	2349.3	2489.0	2637.0	2793.8	2959.9	3135.9	3322.4	3520.0	3729.3	3951.1
8	4186.0	4434.9	4698.6	4978.0	5274.0	5587.7	5919.9	6271.9	6644.9	7040.0	7458.6	7902.1

\*Octave zero is very seldom used.  
This scale applies to most musical instruments except the piano.

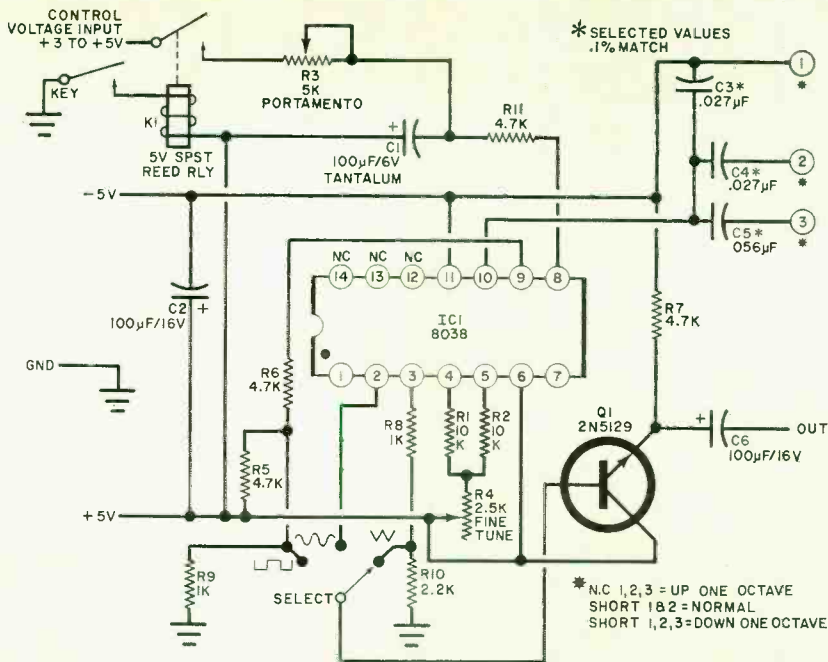

Fig. 1. Voltage controlled oscillator has memory to hold notes after key release.

### A VCO WITH MEMORY

The vco or voltage controlled oscillator circuit described in the October issue (p. 37) gave us a very low-cost, extremely stable way of generating simultaneous sine, square and triangle waves. By the way, the temperature stability is such that around 20 degrees F are needed for a 1-cent change in frequency. Supply sensitivity is about 10 cents per volt, so a reasonably regulated supply is recommended.

Figure 1 shows how we add memory to the basic circuit and provide an emitter follower output to handle the nor-

mally high output impedance of the sine wave generator section.

The sample-hold circuit on the input uses a reed relay and a tantalum capacitor. It remembers what key was pressed after it is released so that the envelope generating circuit still has a note to work on during the decay portion of the note. Pins 1, 2 and 3 add capacitance or remove it so that the vco has to work only over a two-octave range, greatly easing the control voltage and stability problems. Note that a reasonably regulated 10-, 12-, or 15-volt supply is needed. Figure 2 shows the control voltages to apply for the various notes. Potentiometer R3 controls the *portamento*.

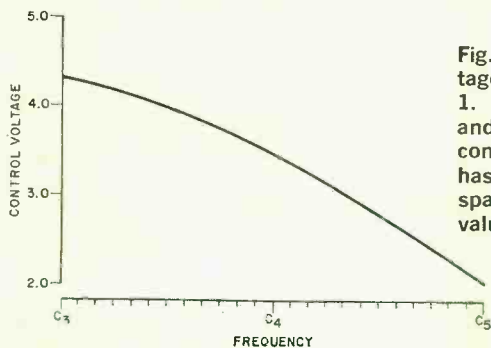

Fig. 2. Typical variation of control voltage vs frequency for the circuit in Fig. 1. The vco by itself is extremely linear and is related to the difference between control input and positive supply. Curve has to be suitably "bent" to fit the log-spaced, equally tempered notes. The exact values can be calculated by using Table II.

**Beats.** Since the ear has to be nonlinear to accommodate such a wide range of tone frequencies and amplitudes, it reacts to two tones sounded at once by producing the sum and difference frequencies. The difference between two tones is called a *beat*. Beats of a very few hertz or fractions of a hertz are normally considered a pleasant sensation or a *consonant* sound. Beats higher in frequency may often be perceived as a “wrong” sound, called a *dissonance*.

Beats can be perceived even with two low-level sine waves. When tones have a more elaborate *timbre* (harmonic and overtone structure), the ear will also beat the harmonics of the tones against each other, generating a wide range of different beat frequencies. The overall result depends on how strong these beats are and where they lie in frequency.

**Intervals.** The characteristic of the ear to mix and multiply tones together has led to some fundamental and important musical ratios called *intervals*. Just about anyone can tell when two notes are of identical pitch, particularly if they have an identical overtone or harmonic structure and if the fundamental is strong.

Two notes of identical frequency played together are said to be in *unison*. If they are absolutely identical in frequency and phase and coming from the same source, you won't be able to tell there are two tones at all. They sound like one. If the tones differ slightly in frequency or phase, you get a *chorus* effect which adds *warmth* to the tone. This is why a group of violins in an orchestra sounds much richer than does a single violin. Of course, if the two tones get too far apart in frequency, the notes become dissonant or *out of tune*.

The 1:1 frequency ratio is very easy to spot. The next easiest ratio is a 2:1 frequency spread between two notes. If the notes have a complex harmonic structure, the beats between harmonics will minimize as you hit exactly a 2:1 ratio. Even with pure sine waves at low amplitudes, there is something “special” about this 2:1 relationship to the ear. This interval is called an *octave* because in one system of music there are eight notes before the frequency is doubled.

It turns out that the ear “likes” to hear or finds musically pleasant, any tone ratio that consists of *small whole numbers*. Another important interval is called the *fifth*, and its

frequency ratio is 3:2. As the number ratios get larger, the tones tend toward sadness and then to dissonance.

A *scale* can be based entirely on fifths. For instance, we can start with a note, arbitrarily called C. We can find a new note at a 3:2 ratio above it, and call this G. We can find a new note at a 3:2 ratio above G. This will be in the next octave, but we can divide it down by two to put it between C and G. It may be called D. D will be  $(1/2) (3/2) (3/2) C$  or a ratio of  $(9/8)$ . A fifth above D will be  $(3/2) (9/8) = (27/16)$  above C. We call this A, and so on. When we have generated all the notes, we have a seven-note scale in the *key* of C. The notes in order turn out to be C,D,E,F,G,A,B, and finally back to C one octave higher. This is called a *chromatic scale* or *Pythagorean tuning*.

The space between E and F and the space between B and C are only about half that of the other intervals. The other intervals are called *whole tone* steps, while the narrow ones are called *semitone* intervals. It became logical to add new semitone intervals between the other notes, so five new keys are added between the others, and called C# (or C sharp), D#, F#, G#, and A#. The scale then consists of twelve notes of one semitone each. This allows the playing of *minor* or generally sadder tonal sequences as well as the *major* or brighter, happier tonal sequences.

This is a fine scale as long as everyone is willing to play in the key of C. But certain instruments have a range that favors other starting points. Every time you pick a different key or starting point, you generate 12 new notes. Some of these new notes are so close to the others it doesn't matter; others are so far apart and so bad that they are called *wolves*.

To make a long story short, a compromise approximation has to be made, one that ends up with a reasonable number of notes per octave, but that sounds almost as good as the chromatic scale, yet lets each instrument play in its own key as needed.

To an engineer, the solution is obvious—use twelve notes and space each one an equal percentage above the one below, exactly fitting what the ear likes to hear. It took musicians centuries to get around to the same conclusion. The result is called the *equally tempered 12-note scale*. To standardize usage around the western world, the center C was called *middle C*, and the A above



middle C was eventually standardized to a frequency of 440 hertz. The notation was also standardized. The lowest note is called C<sub>0</sub> at 16.35 hertz. The first octave continues C<sub>#0</sub>, D<sub>0</sub> . . . . B<sub>0</sub>, and the next octave starts at C<sub>1</sub> and so on. Middle C turns out to be C<sub>4</sub> at 261.6 Hz and the standard pitch A above middle C is A<sub>4</sub> at 440 hertz. Table I shows all the notes of the equally tempered scale with 12 notes per octave.

Mathematically, if you are going to double something by multiplying it by itself twelve times, the basic interval must be the twelfth root of two, or 1.0595. This is roughly six percent. Since you might like to design your own way of generating tones in this sequence, Table II lists the twelfth-root-of-two ratios and some number series that *approximate* the ratios. Note that the twelfth root of two is an irrational number—in no way will you generate it exactly.

**How Stable?** The equally tempered scale then provides a reasonable approximation to all the individual chromatic scales and lets us play Western music with only twelve notes per octave. Our next question should be how accurate must our approximation to each note be? Also, how stable does our electronic instrument have to be?

We've already found out that an absolute drift by a small amount of all the notes together really doesn't matter too much unless you get too far off. What really matters is the relative change between notes.

The interval between any two successive notes is called a semitone, and corresponds to roughly a 6% change in frequency. We obviously have to be much better than this. It's convenient to break the semitone interval down into 100 parts, and call each 1/100th of a semitone a *cent*. A 1-cent change in frequency is a change of 0.0595 percent, or roughly 0.06% or 600 parts per million.

Under carefully controlled conditions, certain musicians can sometimes spot a cyclical variation of a few cents in pitch. So, a good criterion for any electronic musical instrument is to set and hold the pitch to within one cent of its design value; perhaps a note or two could be off by twice this without too much harm, so long as the overall average worked out to under one cent.

#### Must We Use Western Music Standards?

The obvious answer to this is, "no, but. . . ."

**TABLE II—SOME PROPERTIES OF THE EQUALLY TEMPERED 12-NOTE SCALE**

Note	Ratio	Series A	Series B
C	1.0000	232	478
C#	1.0595	219	451
D	1.1225	207	426
D#	1.1892	195	402
E	1.2599	184	379
F	1.3348	176	358
F#	1.4142	164	338
G	1.4983	155	319
G#	1.5874	146	301
A	1.6818	138	284
A#	1.7818	130	268
B	1.8877	123	253
C	2.0000	116	239

From the fundamental physical properties of the ear, we should use a scale that is related by octave intervals, and we should use a scale of equal tempering. These are pretty much independent of cultural musical heritage. This leaves several choices.

You can use the traditional 12-note equally tempered scale and the traditional rules of composition and chording and end up with musical sequences that are more or less in the traditional heritage of western music. You also will be able to play with and synthesize tones of the conventional musical instruments this way.

Or, you can use the 12-note equally tempered scale *without* the traditional rules of the game. You treat every note as an equal and do your own thing. This is called *well tempered* composition and it does go back a way and has had limited success.

Or, you can change the number of notes per octave but keep equal tempering and octave relationships. Up to 31 notes per scale have been used, and a 31-note scale easily accommodates eastern musical instruments (such as the Indian sitar) as well as conventional. There are some ground rules for these exotic scales. Today, the hardware to generate them really isn't too bad, but the keyboards get rather complex and hard to play.

Finally, you can say that everything everyone else has ever done in music is wrong and go out and do your own thing, using completely unstructured or random tonal sequences. While this can generate some interesting compositions and is quite useful for special effects, for a steady diet of this sort of thing, you might have to end up renting your listeners by the hour. Synthesizing or accompanying a traditional instrument will also be rather tricky. ♦

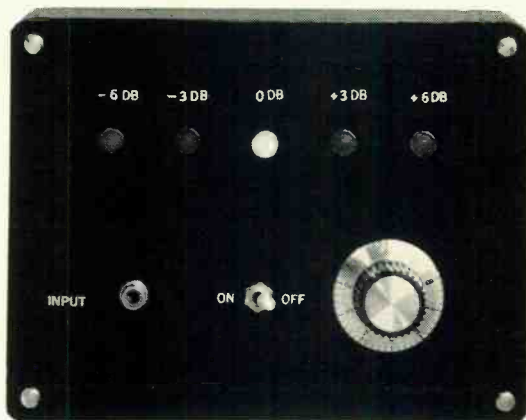

*Audio recording  
simplified with  
discrete lamp  
indicators*

# Lamp- Readout VU Meter



BY HERB COHEN

ONE of the biggest headaches involved in making an audio recording is keeping track of the signal level as indicated by a bouncing VU meter needle (or needles if you are recording in stereo). This requires close visual monitoring of the meter. By using the lamp-readout level indicator described here, you can simplify the process considerably since the indicators are positive and can be seen from a considerable distance.

Five lamps are mounted in a row, indicating -6, -3, 0, +3, and +6 dB. The lamp in the center has a clear jewel, the negative-dB indicators are green, and the positive lamps are red.

**About the Circuit.** As shown in the diagram, the circuit consists of a bank of programmable unijunction transistors ( $Q1$  through  $Q5$ ) used as comparator switches. Their gates are reverse biased by the voltage drop across  $D6$ .

The audio signal is applied to  $J1$  (with level set by  $R20$ ). It is rectified by  $D7$  and  $D8$  and filtered by  $C4$ , which also determines the rate of change of the lamps. Transistor  $Q7$  converts the rectified signal

into a current which pulls down the gates of the unijunction transistors to turn them on and illuminate their respective lamps. Which lamp is turned on is determined by the settings of potentiometers  $R6$ ,  $R11$ ,  $R15$ ,  $R18$ , and  $R23$ . Transistor  $Q6$  acts as a constant-current preload for the gate line to preset the firing level and increase the sensitivity of  $Q7$ .

Diode  $D5$  isolates the filtered portion of the power supply from the unfiltered section. This allows the lamps to be turned off when the gate goes off.

**Construction.** Since the operation of the circuit is not critical, any type of construction can be used—perf board or printed circuit board. All components except the lamps, input jack and controls can be mounted on the board. For stereo operation, two VU indicators are needed.

**Calibration.** Before turning on the power, set potentiometers  $R6$ ,  $R11$ ,  $R15$ ,  $R18$ , and  $R23$  so that their movable contacts are toward the associated fixed resistors. Set  $R20$  at its maximum.

Turn on  $S1$  and rotate  $R6$  to the oppo-





# ELECTRONICS CROSSWORD PUZZLE

BY JAMES R. KIMSEY

## ACROSS

1. Special direct-current generator.
5. Space between two electrodes.
7. Specific electrode in a transistor.
9. Paid notice (abbr).
10. Luminous discharge of electricity.
12. Symbolized by X.
15. Sphere of interest or activity.
16. Grate.
17. Possess.
18. Mineral spring resort.
20. Natural vegetable gum, similar to rubber, used principally as insulation for wires and cables.
24. Bypass, coupling, or tuning.
27. Greek letter designating the ratio of the circumference of a circle to its diameter.
28. Magazine executive (abbr).
30. A bolt accessory.
31. Semiconductor using the field effect.

## DOWN

1. Type of cable used with some printed circuit connectors.
2. Type of current that is a nonuniform electron flow, which varies periodi-

- cally but does not reverse its direction.
  3. Resistance to motion.
  4. Organ of hearing.
  5. Gallium.
  6. An attenuator.
  8. Color with a slight shade or stain.
  9. Type of reversible current (abbr).
  11. Hybrid ring (2 words).
  13. Remove data stored on magnetic tape.
  14. A continuously reversing change in the magnitude of a given force.
  19. Two of a kind (abbr).
  21. Expressed or carried on without words or speech.
  22. Storage space immediately below the roof.
  23. Mass-audience communication system (abbr).
  24. A metal shield, placed around some components.
  25. Type of control (abbr).
  26. To place a binary cell in the one state.
  29. Physician (abbr).
- (Solution on page 103.)

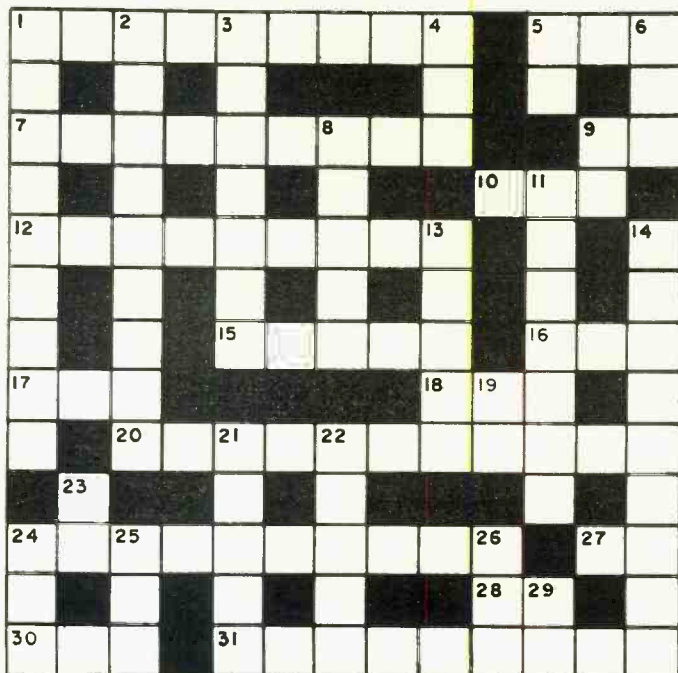

# 10Mhz 3" Triggered Sweep Scope ... 1/3 the size of comparably performing scopes



Model  
1431

**\$400<sup>00</sup>**

only 4<sup>3</sup>/<sub>4</sub>"  
high

It's a lightweight 13 pounds in your hand with heavy-weight wideband scope performance on your bench or jobsite. Only 35 nanosecond rise time, 10 millivolts/division sensitivity and 19 calibrated auto or triggered sweep speeds from 0.5 usec/cm to 0.5 sec/cm with 5X magnification. Pushbutton selected sync modes include internal, external, pos and neg slope, and TV horizontal and TV vertical with exclusive TV sync separator. If you've been waiting to buy a portable scope until you could get all the features you'll ever need at a price you want to pay, you've been waiting for the B&K Precision Model 1431. See your distributor or write Dynascan Corporation.

**B&K** PRODUCTS OF  
**DYNASCAN**

1801 W. Belle Plaine Ave.  
Chicago, IL 60613 • (312) 327-7270

CIRCLE NO. 33 ON READER SERVICE CARD

**“Learn an honest trade,”  
“and you’ll never have to**





# my old man used to say, knuckle under to any man.”

(A TRUE STORY)

Bill De Medio of Conshohocken, Pa., has it made.

At 23, he's a licensed master electrician. The top of a trade where there aren't enough good men to go around.

But more important, Bill's his own boss and calls his own shots.

“I just went into my own business. And even before the sign on my truck was dry, I got my first big job.

“The contractor for a new group of houses asked me to do all the wiring. And there's bound to be a lot more work from him and other builders.

“If it wasn't for my ICS training as an electrician, I'd still be in some dead-end job — hating what I was doing, taking orders from everyone, and never getting any thanks for it.

“As a master electrician, you're the boss on the job — even when you're working for someone. You get respect, good money, and like my old man said, you don't have to take baloney from anyone.”

### **The right combination for success**

Bill De Medio has the right combination for success. He's in a growing field. And he has good training for it. You could, too.

Especially if you're interested in one of the fast-growing careers where ICS concentrates its training. Like Electrician. Engineer-

ing. Automotive Mechanic. TV Repair & Servicing. Drafting. Air Conditioning. (Check your choice on attached card.)

### **Ideal way to learn**

As an ICS student, you study at home, on your own schedule. You waste no time traveling to and from class. And you never have to miss a paycheck.

But you're never alone. Skilled instructors are always ready to help you.

If you ever have doubts or problems or just want to talk to your instructor, you can call ICS from anywhere, Toll-free.

### **ICS training works**

More than 8,500,000 men and women have turned to ICS for career training in the past 80 years.

Government agencies, unions and some of America's top corporations (including Ford, U.S. Steel, Mobil, Alcoa, Pan Am, GE, Motorola and RCA) use ICS courses in their own training programs.

### **Free demonstration lesson**

If you want your job to give you more (more money, more day-to-day satisfaction, and more future) send for our career guide booklets and free demonstration lesson.

Remember, it's your life. You might as well make the most of it.

**ICS**

*We'll show you a better way to earn a living.*

*At 23, Bill De Medio has more freedom, more security, and gets more respect than guys twice his age. (Photograph by Frank Cowan.)*

If card is missing, write for free career booklets to: International Correspondence Schools, Scranton, Pa. 18515 ©1973 ICS

# MICROPHONES

## for CB'ers and Hams

*How they work  
and which one to choose*

BY RICHARD HUMPHREY

**T**HERE are microphones for every conceivable purpose in two-way voice communications: and their costs range from a few dollars to several thousand. However, like the practical (and necessary) zipper, the microphone is so familiar that many CB'ers and amateurs don't give enough attention to the selection and use of this vital component in their setup.

**The Carbon Mike.** While it was not the first type of microphone to be used, the carbon microphone is generally regarded to be the "granddaddy" of them all. (Bell's early electromagnetic microphone was quite similar to today's controlled-magnetic mike.) Perfected by Edison for the telephone, the carbon mike was used by Fessenden and Collins in early experiments in voice modulation and was burnt out by the hundreds by Poulson in modulating high-frequency spark transmitters.

A carbon mike changes the varying pressures of sound waves into electrical waves by using a diaphragm connected so that the pressure waves alternately compress and



This Electro-Voice microphone for mobile use has a ceramic element and a cardioid pickup pattern. It is noise-cancelling in operation.



A Shure carbon mobile mike with a high output and a moderate price. The same design comes with controlled-reluctance cartridge.

decompress loosely packed carbon granules in a capsule or "button." Placing a voltage in series with this carbon-granule variable resistor results in a varying current in the microphone circuit.

Single-button carbon microphones have a limited frequency response so the diaphragms are made to have a natural resonance around 800 Hz (the approximate center of the speaking voice range). They have a relatively high hiss level since there is always a slight current passing through the carbon granules and they are prone to packing. A gentle tap against the heel of the hand is usually enough to separate the granules. (*Never* tap or pound a carbon mike with the mike switch on.)

The double-button carbon mike uses a diaphragm positioned between two buttons of carbon granules. As in most other types, the diaphragm is stretched to the point where its natural resonance is far above the normal hearing range.

Though there are some minor problems involved in using a carbon mike (the necessity of having it in a vertical or nearly vertical position and using a source of voltage and a transformer to match the low impedance of the mike to the higher input impedance of an audio amplifier), you will find that the high output and cutting quality are very readable. The carbon mike is light, sturdy, and inexpensive and has a range of 250 to 3500 Hz.

**Crystal Microphones.** Another microphone with good communications qualities is the crystal mike. Its bright, scratchy sound will take the signal through a lot of mud. However, despite its moderate cost and fairly high output, the crystal mike is almost entirely for use with base stations since it is sensitive to extremes of temperatures and humidity. A few hours in a closed automobile on an August afternoon will probably ruin a crystal mike.

Crystal microphones convert sound energy to electrical energy by changing physical stress to an electrical potential due to the piezoelectric effect. One type, the cellular, consists of two wafers of Rochelle salt cemented together (Fig. 1). A second type, the most popular, uses a diaphragm connected to a single crystal wafer. The diaphragm type has the higher output, while the cellular type has a flatter response. The frequency responses of both are fairly wide; their outputs have high impedance; and they are the least expensive (with the possible exception of carbon mikes).

The ceramic microphone was the result of the search to find a mike with the characteristics of the crystal microphone but without its fragility and sensitivity to high temperatures and humidities. The wafer is made of a ceramic which has been doped with barium titanate or a similar substance and polarized by impressing a dc voltage across it. The ceramic wafer has the same piezoelectric qualities as does a crystal and

Dynamic base-station microphone by Electro-Voice with the grip- or touch-to-talk feature.





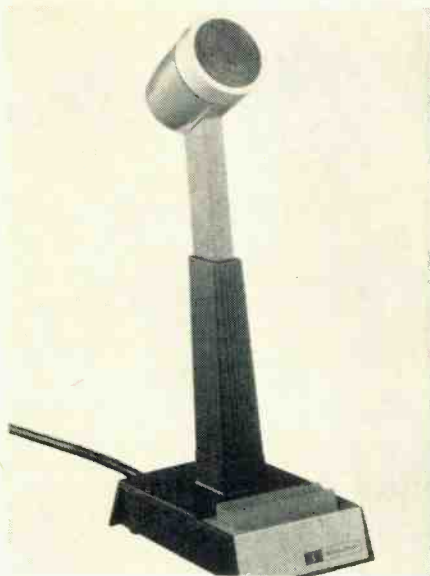

The Shure controlled-reluctance microphone which was designed for base-station uses.

is relatively insensitive to heat and humidity.

The frequency response of a ceramic mike is quite similar to that of a crystal mike. The output is high impedance, but the output level is lower than that of the crystal mike. The ceramic unit is low in price and is by far the most popular mobile microphone.

**Dynamic Microphones.** The dynamic mike runs a close second to the ceramic in mobile equipment. It has a fairly uniform response, tends to cancel background noise, is light and rugged, and isn't affected by extremes in temperature and humidity. The output is moderately low and is at a low impedance.

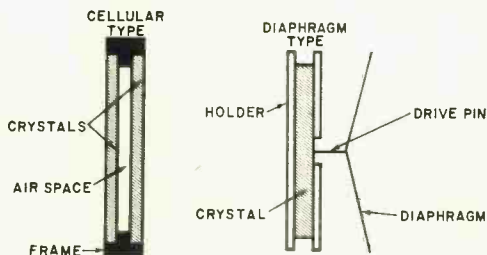

Fig. 1. The cellular or bi-morph type of crystal element has fairly flat response. The diaphragm type has a somewhat higher output and is the kind more generally used.

The dynamic mike can be compared quite literally to a dynamic loudspeaker operating in reverse. As a matter of fact, some walkie-talkie transceivers use a dynamic speaker as a combination loudspeaker and microphone. The sound waves move the diaphragm, which then moves a coil of wire suspended in a magnetic field creating the electrical energy (Fig. 2).

In one respect, the controlled-reluctance (or controlled-magnetic) microphone is similar to the dynamic in that it has a magnet and a coil of wire. In the controlled-reluctance mike, however, the coil is stationary and an "armature" in a magnetic field is moved within the coil by the action of the diaphragm. One interesting feature of the controlled-reluctance mike is that the wire coil can be wound to match any impedance.

The controlled-reluctance microphone was developed originally for the military and theoretically combines the characteristics of the dynamic and ceramic mikes. It is being used more and more as a communications mike.

The unidirectional or cardioid pattern in a microphone pickup is generally the best for communications work since it reduces sound from the back and sides of the mike. In addition, it is sometimes necessary and desirable to have noise-cancelling features,

The Turner transistorized ceramic microphone which has a gain of approximately 30 dB.



POPULAR ELECTRONICS

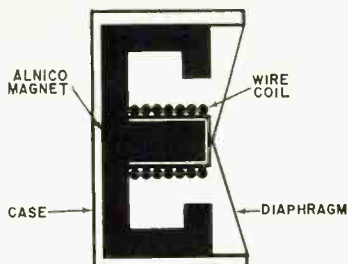

Fig. 2. Sound waves striking diaphragm in a dynamic mike make wire coil vibrate in magnetic field creating electrical output.

especially in mobile installations where the environment is noisy.

**Summing Up.** The microphones with built-in transistorized preamps are undoubtedly of value where high audio gain is needed. Do not use excessive gain, however, or you will overload the audio section.

Authorities seem to agree that the bulk of the intelligibility of the human voice is roughly between 300 and 3000 Hz. There are two schools of thought as to the best way of accommodating this range in voice communications. One side favors a mike with a full response, letting the transmitter do the frequency limiting. The idea in this case is

to present the rig with as good an audio quality as possible at the outset. The other side says to pick a microphone with a response of about 300 to 3000 Hz to begin with, on the basis that there is no point in having something that isn't going to be used anyway.

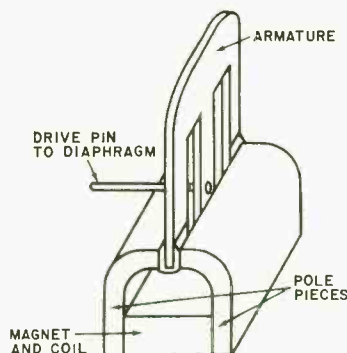

Fig. 3. In the controlled-reluctance microphone, the wire coil is stationary and the armature (actuated by diaphragm and drive pin) vibrates within the permanent magnet gap.

Since the microphone is the backbone of any voice communications system, examine your needs carefully, and then get the best you can afford. ♦

## INDUSTRIAL NOISE LEVELS

In an effort to protect industrial workers against the hazards of excessive noise where they work, the government issued a modification of the Walsh-Healey Public Contracts Act some time ago. The idea is to prevent irritation as well as permanent hearing loss when a worker is exposed to excessive noise levels for long periods of time. Other effects of loud noise are cranial bone vibration, blurred vision and weakened muscular structure.

The permissible noise exposures as read on a sound level meter with an "A" weighting response are as follows:

Duration per day (hours)	Sound levels (dBA) slow response
8	90
6	92
4	95
3	97
2	100
1½	102
1	105
½	110
¼ or less	115

Some idea of the sound levels encountered are the following:

Effect	dB	Source
Extreme danger	155	Rifle blast, close-up jet engine, nearby siren
	140	Shotgun blast (to shooter), drag strip (near starting line), nearby jet engine
	120	Jet airport, some electronic music, rock drill
Probable permanent hearing loss	115-125	Drop hammers, chipping hammers
	110-115	Planers, routers, sheet metal speed hammers
	90-100	Subway, weaving mill, paper-making machine
	90-95	Screw machines, punch press, riveter, cut-off saw
Possible damage	80-95	Spinners, looms, lathes

# NOISE & INTERFERENCE FILTER FOR SHORTWAVE RECEIVER

## Construction of a simple, inexpensive active audio filter

HIGH-GRADE voice communication requires an audio frequency range (band) of from 330 Hz to about 3000 Hz. If some degradation of the voice tone can be tolerated, a narrower band of, say, 500 to 2000 Hz is possible. On the other hand, if a wider bandwidth is allowed, noise and adjacent signals can make the voice difficult to hear or understand. Many inexpensive and moderately priced communications receivers have insufficient selectivity—too wide a band—to provide optimum performance. To improve selectivity would generally require extensive modification, but a good audio

filter can help considerably if it is used at the receiver's output.

With the availability of high-quality, low-cost operational amplifiers, active filters are generally the least expensive and easiest type to build for operation at low audio frequencies. Active filters differ from passive filters in that the former employ active elements, usually op amps, to obtain the desired filter response. One very effective type of active filter is the "voltage-controlled voltage source" (VCVS). It is the construction of a VCVS filter that we will be discussing.

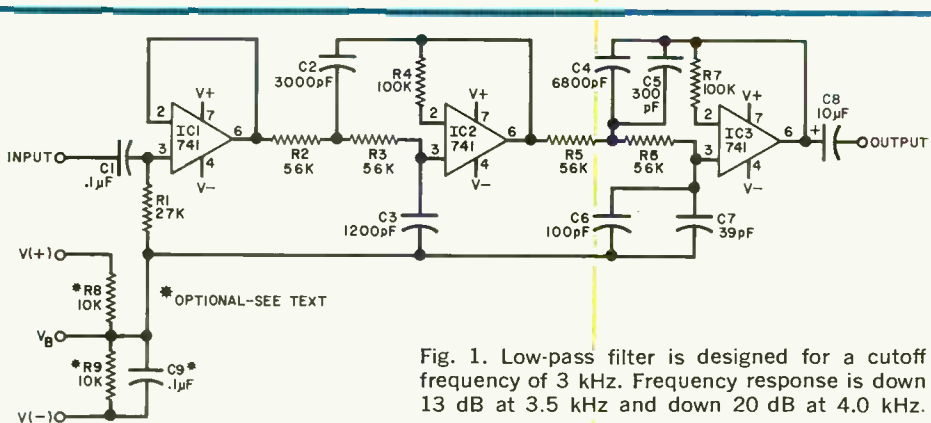

Fig. 1. Low-pass filter is designed for a cutoff frequency of 3 kHz. Frequency response is down 13 dB at 3.5 kHz and down 20 dB at 4.0 kHz.

### PARTS LIST

C1, C9—0.1- $\mu$ F Mylar capacitor  
 C2—3000-pF, 5% capacitor  
 C3—1200-pF, 5% capacitor  
 C4—6800-pF, 5% capacitor  
 C5—300-pF, 5% capacitor  
 C6—100-pF, 5% capacitor  
 C7—39-pF, 5% capacitor  
 C8—10- $\mu$ F, 25-volt electrolytic capacitor  
 IC1-IC3—741 op amp integrated circuit  
 R1—27,000-ohm, 10% resistor

R2, R3, R5, R6—56,000-ohm, 5% resistor

R4, R7—100,000-ohm, 10% resistor

R8, R9—10,000-ohm, 10% resistor

Misc.—Printed circuit board or perforated phenolic board, sockets, and flea clips; solder; mounting hardware; etc.

Note: The following items are available from Northwest Engineering Co., 801 Duchess, Bothell, WA 98011: printed circuit board No. AF-07-PCB for \$2.50; complete kit of parts (No. AF-07K) for \$8.25. Include shipping costs for 3 oz and 10 oz respectively.



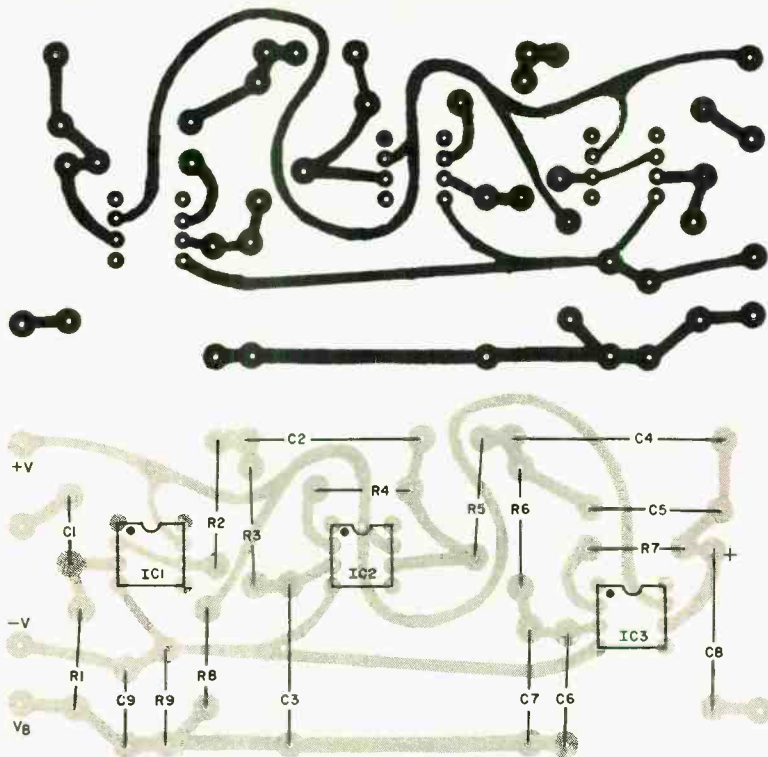

Fig. 2. Actual-size foil pattern (above) and component layout guide.

**Theory of Operation.** The schematic diagram of the VCVS active filter is shown in Fig. 1. A high-impedance buffer circuit made up of  $IC1$ ,  $R1$ , and  $C1$  drives  $IC2$  and  $IC3$  which form a four-pole active filter. The filter was designed so that resistors  $R2$ ,  $R3$ ,  $R5$ , and  $R6$  are all of the same value. As long as all four resistors have the same value, changing that value changes the cutoff frequency but has no effect on the shape of the filter's response. The values of the resistors can be calculated from the equation:  $R = (168,000)/F$ , where  $F$  is the desired cutoff frequency in kilohertz.

To adequately control the shape of the filter's response, all frequency-controlling elements ( $C1$ - $C7$ ,  $R2$ ,  $R3$ ,  $R5$ , and  $R6$ ) should have a 5-percent tolerance. With the values specified in the Parts List and given on the schematic diagram, the filter's cutoff frequency will be 3 kHz.

The filter can be operated from a single power supply with between 6 and 30 volts output if assembled as shown. Single power supply operation requires the use of  $R8$  and  $R9$  to provide the necessary bias voltage to operate the op amps ( $IC1$ - $IC3$ ) and  $V_b$  is not used. If two supplies (or a dual) are

used, their outputs can range from a low of  $\pm 3$  volts to a high of  $\pm 15$  volts; in this case, the filter can be built without  $R8$ ,  $R9$ , and  $C9$  and  $V_b$  is common.

**Construction and Use.** Owing to the fact that integrated circuits are used in the VCVS active filter, printed circuit board assembly is recommended. (An actual-size etching and drilling guide and a components installation diagram are given in Fig. 2.) However, if sockets or Molex "Soldercons" are used, the filter can readily be assembled on perforated phenolic board.

The filter can be used wherever voice-band filtering is required. For shortwave receivers, the headphone output can be used to drive the filter, with the filter driving a standard high-impedance headset. Alternatively, the filter can be permanently installed between the detector and the audio output amplifier in the receiver.

Another possibility would be to use the filter to limit the frequency range of a microphone's output before modulation in a transmitter. This effectively concentrates more of the available output power into the critical 300-3000-Hz voice band.  $\diamond$

# Build your own Bell & Howell solid-state 25-inch diagonal color TV!

It's an enjoyable way to learn valuable skills in the exciting new field of *digital electronics* and also get a brand-new color TV you build yourself!  
For free information, mail the postage-free card today!

## Enjoy the personal satisfaction of building your own color TV

It's not an ordinary accomplishment. You can take pride in it because you did it all yourself. And you'll find *digital electronics* a fascinating world to explore. It's an absorbing way to spend your spare time... tinkering with the equipment... reading up on electronic principles... and finding out how they work in practice.

## Not just a kit—a complete at-home learning program in home entertainment electronics

Skilled instructors at Bell & Howell Schools have carefully prepared a program that starts you off with the basics and guides you smoothly through the course with step-by-step instructions. You'll enjoy the challenge of learning something new that could lead to extra income opportunities for you.

## Attend special "help sessions" ... talk to your instructors in person

A unique advantage of your learn-at-home program is the "help session." Scheduled regularly at Bell & Howell Schools and in cities around the country, these informal seminars give you face-to-face, personal assistance from our instructors. You'll meet other students and enjoy talking shop.

## Master the most up-to-date solid-state and digital technology

As color TV moves closer toward total solid-state, and as the more accurate and reliable digital systems begin to appear in home entertainment gear, you'll be thoroughly familiar with the most

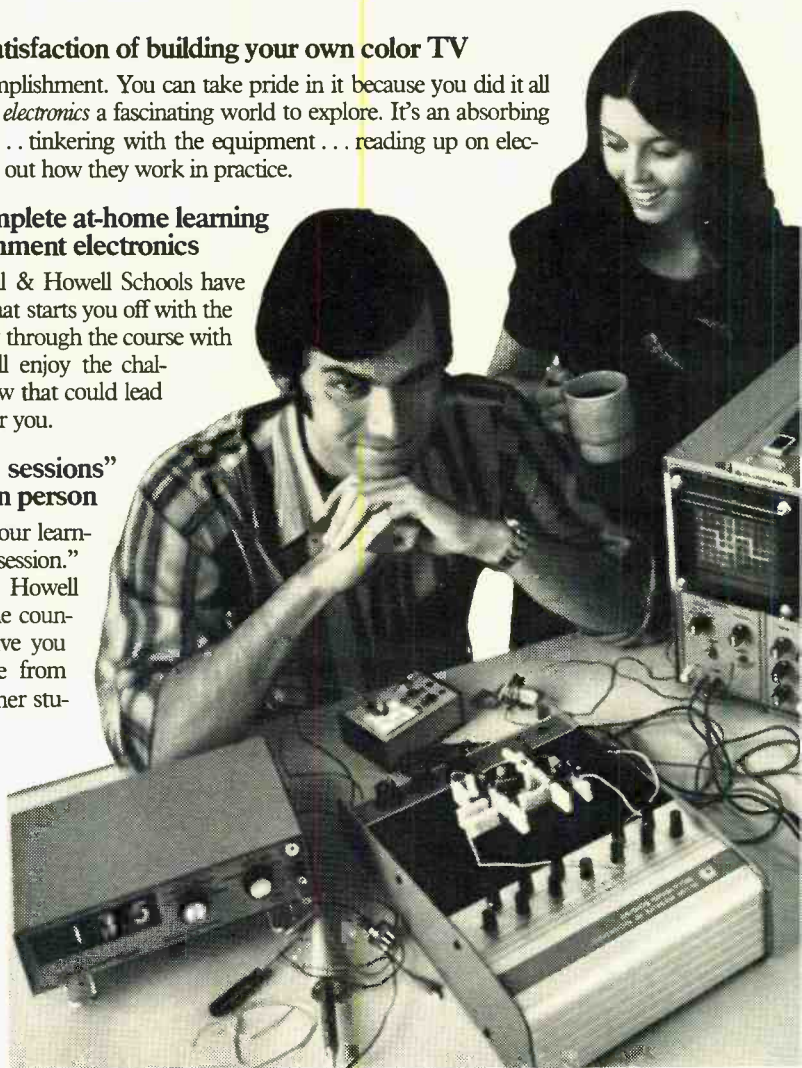

Advanced troubleshooting techniques for these sophisticated circuits.

**Digital electronics is growing everyday – and you can cash in on it!**

Digital clocks and pocket calculators are already on the market. Soon, everything from speedometers to stereos to kitchen stoves will have digital readout and control systems in place of conventional dials and needles. During your program, you can gain the know-how to build, service or repair this new digital equipment, part-time or full-time!

**You also build and keep the NEW Electro-Lab® electronics training system**

Three professional instruments . . . a digital multimeter, design console and solid-state oscilloscope designed exclusively for Bell & Howell students . . . provide you with necessary practical experience during your program. It's the equipment you need to successfully analyze and master the principles of today's digital technology.

**Earn extra income part-time or get ready for your own service business**

We'd like to tell you more about this fascinating *digital electronics* program – and how it can lead to a promising future – full or part-time. Mail the attached card today and get all the facts.

**NEW from Bell & Howell Schools . . . first time ever offered!**

When you build your color TV, we include a complete volume on the "Guidelines For Starting Your Own Repair Business." It gives you all the basics including setting up shop, basic bookkeeping and income tax, small business legal requirements and customer relations. It's just another way we can help people get going in electronics.

**FOR FREE INFORMATION, MAIL CARD TODAY!**

If the card has been removed, write: **An Electronics Home Study School  
DEVRY INSTITUTE OF TECHNOLOGY**

**BELL & HOWELL SCHOOLS**  
1141 Belmont, Chicago, Illinois 60641

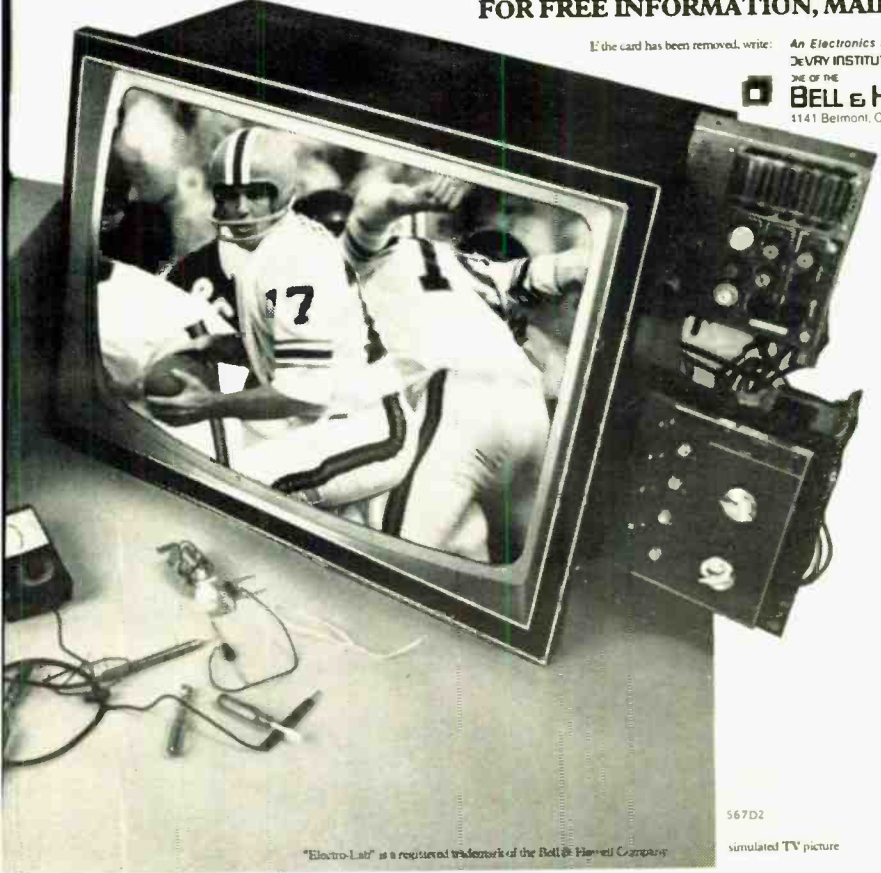

"Electro-Lab" is a registered trademark of the Bell & Howell Company

S67D2

simulated TV picture





# THREE-WAY POWER SUPPLY

*Two 0-15 volts at 750 mA and one 50 volts at 1 ampere supplies have both voltage and current limiting.*

BY J. R. LAUGHLIN

**H**ERE IS a power supply package incorporating a number of features which make it not only unique but extremely useful. First of all, the package includes three separate power supplies. Two of these are identical and are designed to supply independent operating voltages for transistor and integrated circuits—one can be used as the positive supply, the other negative. Each has an output capability of up to 15 volts at 0.75 ampere, and the adjustable output voltage is regulated to 0.1% or better. These two supplies are completely isolated from

one another, which makes it possible to stack them for higher output voltage or to operate them at different ground levels. (Parallel operation of the two supplies is not recommended since the very least voltage difference between them causes undesirable interaction between the two.) The supplies are generously over-rated and can be operated at maximum capacity on a continuous basis without overheating.

The third supply is similar to the other two except that it has a higher output voltage and current capabilities. This supply is also

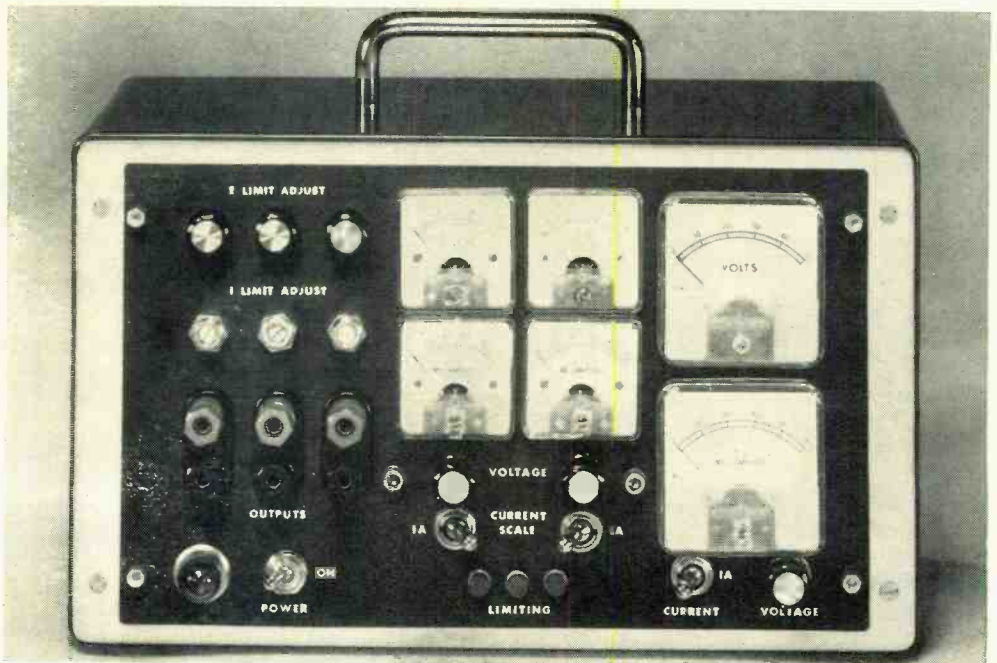

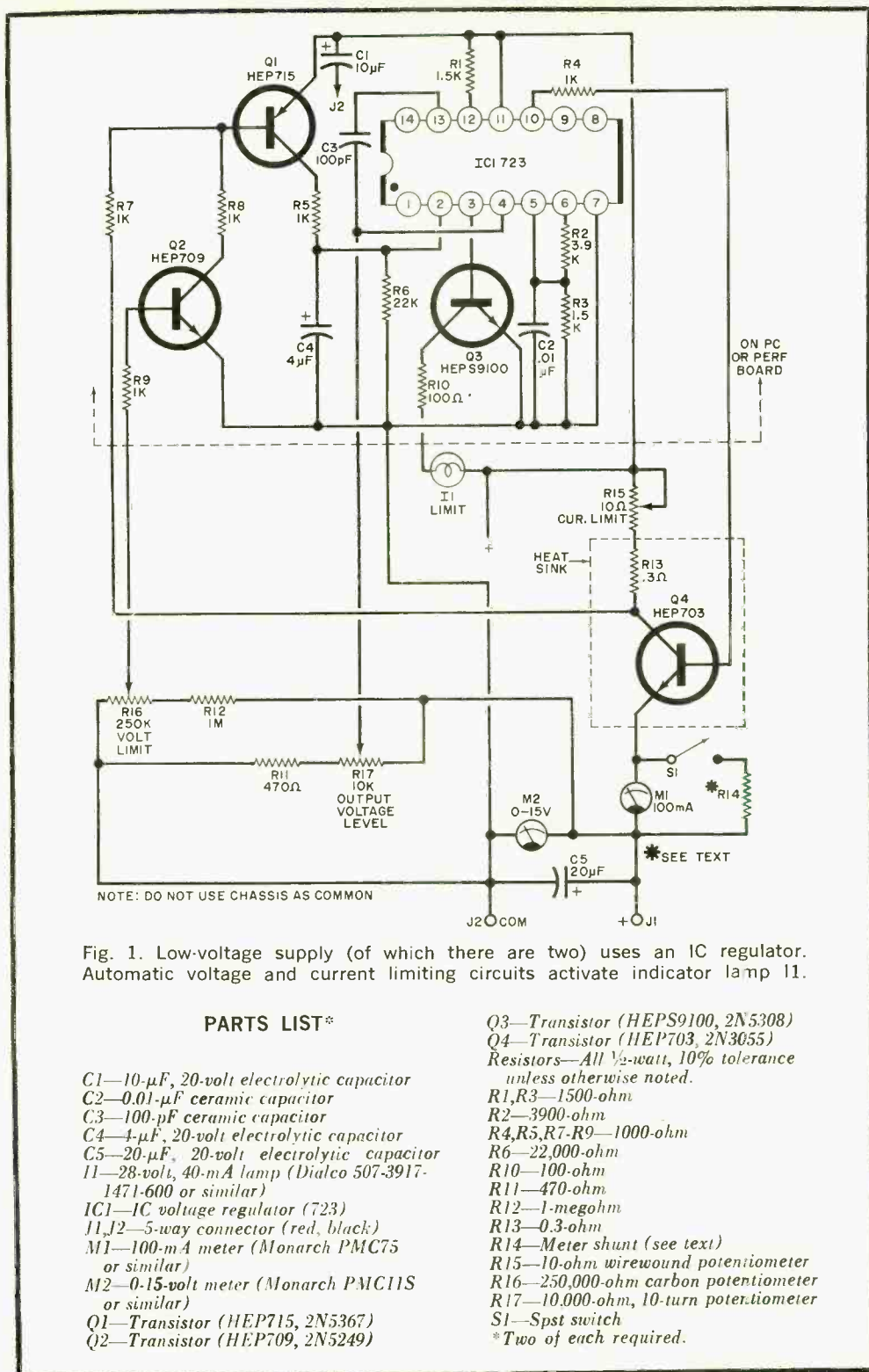

Fig. 1. Low-voltage supply (of which there are two) uses an IC regulator. Automatic voltage and current limiting circuits activate indicator lamp I1.

### PARTS LIST\*

- C1—10- $\mu$ F, 20-volt electrolytic capacitor
- C2—0.01- $\mu$ F ceramic capacitor
- C3—100-pF ceramic capacitor
- C4—4- $\mu$ F, 20-volt electrolytic capacitor
- C5—20- $\mu$ F, 20-volt electrolytic capacitor
- I1—28-volt, 40-mA lamp (Dialco 507-3917-1471-600 or similar)
- IC1—IC voltage regulator (723)
- J1, J2—5-way connector (red, black)
- M1—100-mA meter (Monarch PMC75 or similar)
- M2—0-15-volt meter (Monarch PMC11S or similar)
- Q1—Transistor (HEP715, 2N5367)
- Q2—Transistor (HEP709, 2N5249)

Q3—Transistor (HEPS9100, 2N5308)

Q4—Transistor (HEP703, 2N3055)

Resistors—All  $\frac{1}{2}$ -watt, 10% tolerance unless otherwise noted.

R1, R3—1500-ohm

R2—3900-ohm

R4, R5, R7-R9—1000-ohm

R6—22,000-ohm

R10—100-ohm

R11—470-ohm

R12—1-megohm

R13—0.3-ohm

R14—Meter shunt (see text)

R15—10-ohm wirewound potentiometer

R16—250,000-ohm carbon potentiometer

R17—10,000-ohm, 10-turn potentiometer

S1—Spst switch

\*Two of each required.

very well regulated, is adjustable, and will supply up to 50 volts at one ampere. The lower limit of voltage output is approximately 8 V. This characteristic is intrinsic in the design. No attempt was made to incorporate an adjust-to-zero output capability because of the added complexity and lack of need to operate very near zero. (The minimum output of the other two supplies is about 1.5 V). This supply is handy for performing odd jobs in conjunction with the circuit under test, such as powering a small motor, heater, etc. or part of the circuit that requires higher power. It can also be used as a battery charger at 24 or 36 volts.

All three supplies have adjustable current-limiting circuits and output-voltage limiting capability. The current limiting can prevent destructive conditions in case of accidental shorting or overloading of a circuit. This feature also lends itself to operation of the supplies as constant-current sources, with the current level being adjustable over a wide range. Over-voltage limit-

goes on when either current or over-voltage limiting occurs.

**Circuit Operation.** The two low-voltage supplies are identical, using an integrated circuit as the regulating device (Fig. 1). The IC drives a power transistor, Q4, to provide the output current. The IC contains a very stable voltage-reference source and a sensitive error-detecting amplifier. Regulation is accomplished by comparing the output to the reference and any discrepancy is corrected by the error amplifier. Adjustment of the output voltage is accomplished by varying the amount of the output that is fed back to the error amplifier (pin 4) through R17. The reference voltage is on pin 6 of the IC. It is divided by R2 and R3 and applied to the second input to the error amplifier (pin 5).

Current output level is monitored by Q1 with feedback through R7. The setting of R15 determines the amount of feedback. When the feedback is sufficient for Q1 to turn on, a signal is supplied to pin 2 of the

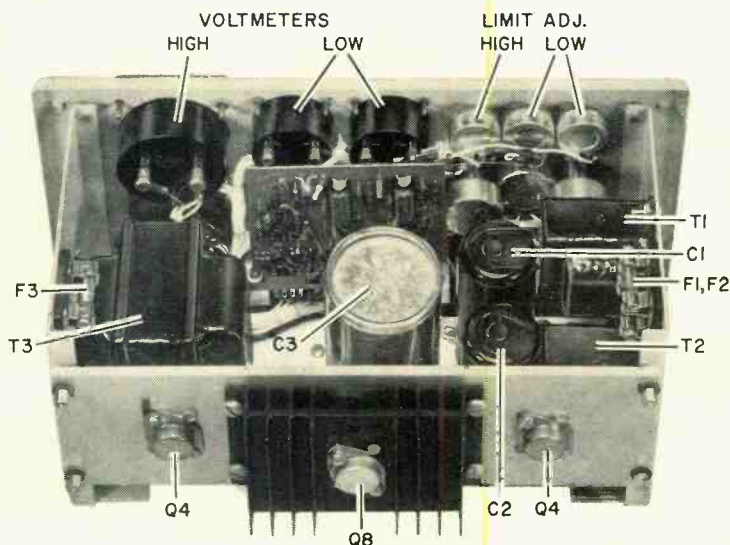

Photo shows arrangement of the components in prototype of triple power supply. The three electronic regulators are mounted on a double-sided circuit board.

ing was added as a result of the destruction of IC's due to adjustment of previous supplies to too high a voltage level.

Each supply has its own meters for continuously monitoring its voltage and current output so there is no need to switch back and forth. The current meters are dual-range due to the wide range of currents available. Each supply also has an indicator light that

integrated circuit to adjust the output.

Voltage output is monitored by Q2 with feedback through R9. The setting of R16 determines the amount of feedback and when it is sufficient to turn on Q2, Q1 also turns on, supplying the limiting signal to the IC. Whenever this signal is supplied to the IC, it sends a signal to the base of Q3, which turns on limiting indicator II.



Instead of an IC, the high-voltage supply uses transistors throughout (Fig. 2). The voltage reference is provided by zener diode D2. Comparison of the reference to the output level from R15 is made by Q2. The current output is monitored by Q4 with feedback determined by R17. If Q4 is

turned on, Q5 is turned on to change the output (through Q3) and also to turn on Q6 and energize the indicator light. Voltage output is monitored by Q7 with feedback from R16. When Q7 turns on, Q4 turns on as for current limiting.

Conventional transformer and full-wave

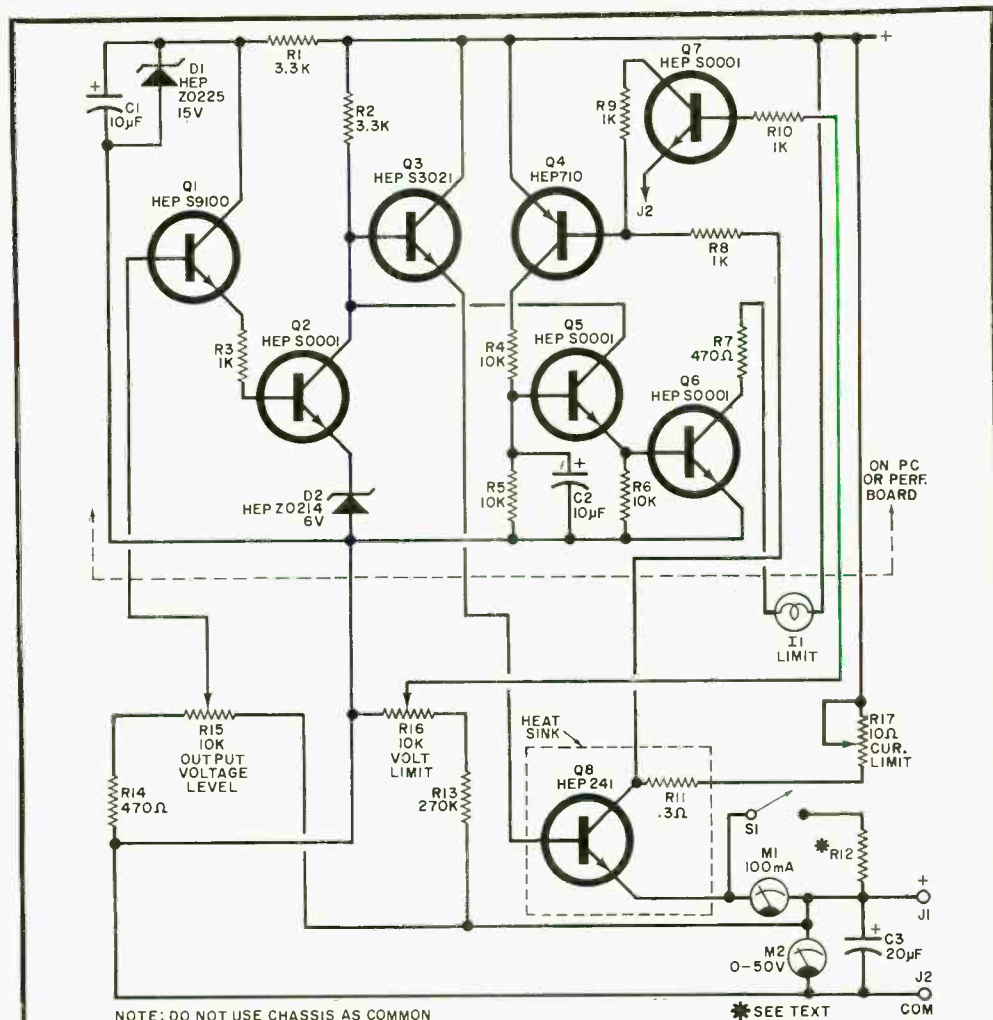

Fig. 2. The 50-volt supply is all-transistor and also has current and voltage limiting.

### PARTS LIST

- C1, C2—10-µF, 20-volt electrolytic capacitor
- C3—20-µF, 50-volt electrolytic capacitor
- D1—15-volt zener diode (HEP Z0225)
- D2—6-volt zener diode (HEP Z0214)
- I1—28-volt, 40-mA lamp (Dialco 507-3917-1471-600 or similar)
- J1, J2—5-way connector (red, black)
- Q1—Transistor (HEP S9100, 2N5303)
- Q2, Q5-Q7—Transistor (HEP S0001, 2N5550)
- Q3—Transistor (HEP S3021, MPSU03)
- Q4—Transistor (HEP 710, 2N5400)
- Q8—Transistor (HEP 241, 2N5069)

Resistors—All ½-watt, 10% tolerance unless otherwise noted.

- R1, R2—3300-ohm
- R3, R8-R10—1000-ohm
- R4-R6—10,000-ohm
- R7—470-ohm, 1-watt
- R11—0.3-ohm
- R12—Meter shunt (see text)
- R13—270,000-ohm
- R14—470-ohm
- R15—10,000-ohm, 10-turn potentiometer
- R16—10,000-ohm carbon potentiometer
- R17—10-ohm wirewound potentiometer
- S1—Spst switch

rectifier circuits are used to power each supply as shown in Fig. 3. The individual transformers provide complete isolation between the supplies. Note that each supply is independent and their commons are not connected to chassis ground.

**Construction.** Any type of enclosure can be used for the three-way supply. A photo of the interior of the prototype is shown on page 64. In this case a Bud CU-7127 cabinet was used and the bottom plate was constructed of  $\frac{3}{16}$ " aluminum, drilled for the three large capacitors. The power supply rectifiers were mounted on their own small board under the bottom plate. In the prototype a two-sided PC board was used for the electronics of all three supplies. The board was mounted in an 18-pin double readout card connector. It might be preferable to assemble each regulator on a separate board for ease of construction, installation, and future maintenance.

The rear-panel heat sink should be made of aluminum at least  $\frac{1}{8}$ " thick and preferably  $\frac{1}{4}$ ". The output transistor for the high-voltage supply was mounted on a separate heat sink attached to the rear panel to increase the surface area.

The current meters require shunts for 1-ampere operation ( $R12$  and  $R14$ ). These shunts can be wound easily by hand using #28 enameled copper wire and a 1-watt carbon resistor (any value) for the form. Of course, shunts can be purchased for most high-quality meters, but it is possible to wind the shunts for less expensive models.

The ammeter shunts should be mounted directly from the ammeter terminals to the shunt switch terminals. The 0.3-ohm resistors ( $R11$  and  $R13$ ) can be mounted on the bases of the transistor sockets.

The  $C5$  capacitors in the low-voltage supplies and  $C3$  in the high-voltage supply should be mounted directly on the output binding post behind the front panel. Use tie-points to hold  $R11$  and  $R12$  in the low-voltage supplies and  $R13$  and  $R14$  in the high-voltage supply.

**Checkout.** Check the rectifier circuits before connecting all the rest of the circuits. If the rectifiers are all right, connect the regulator circuits.

It is strongly suggested that, when first testing the high-voltage supply, a Variac (or similar source) be used to provide a low voltage input at the start.

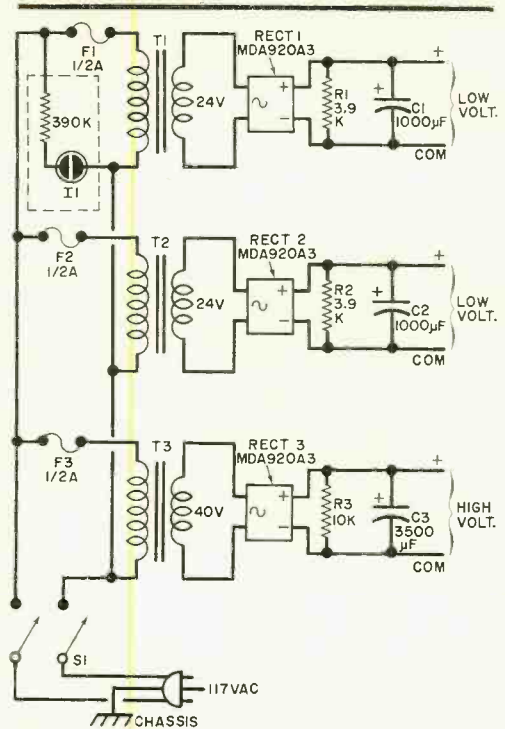

Fig. 3. The three independent power supplies are conventional bridge-rectifier circuits.

#### PARTS LIST

- $C1, C2$ —1000- $\mu F$ , 50-volt electrolytic capacitor
- $C3$ —3500- $\mu F$ , 75-volt electrolytic capacitor
- $F1-F3$ — $\frac{1}{2}$ -ampere 3AG fuse and holder
- $I1$ —117-volt neon lamp assembly
- $RECT1-RECT3$ —MDA920A-3 bridge rectifier
- $R1, R2$ —3900-ohm, 2-watt resistor
- $R3$ —10,000-ohm, 1-watt resistor
- $S1$ —Dpst switch
- $T1, T2$ —Transformer, 24-V, 1-A (Triad F46X or similar)
- $T3$ —Transformer, 40-V, 1-A (Triad F92A or similar)
- Misc.—Suitable cabinet (Bud CU7127 or similar), aluminum panel  $\frac{3}{16}$ " thick (Bud PA3102 or similar), heat sink 3" x 4" x 1", mounting hardware, line cord, power transistor insulators, terminal strips, capacitor mounts, knobs, etc.

An oscilloscope should be used to detect any tendency of the supplies to oscillate. This should be done at several current and voltage output levels. Regulation can be observed by using various values of load resistors on the supplies. The low-voltage supplies should regulate to within about 0.2% or better from zero to full load. The current-limiting circuit will hold the output current to a preadjusted level regardless of the value of the load. ♦

# SIMPLE TESTERS FROM "JUNKBOX" PARTS

BY JOSEPH E. TAYLOR

**G**OOD test equipment can cost quite a bit of money; but if you are just interested in having some relatively simple items and have a well-stuffed "junkbox," you can put together a few really useful circuits.

The basic systems described here include an audio generator, which can also be keyed to make a code-practice oscillator; a simple transistor quality checker for either audio or r-f; an r-f oscillator that can be used to align either BCB radios or their i-f's; and an audio amplifier that can serve as a useful audio section for almost any experiment requiring a loudspeaker. Assembled from discarded semiconductor radio parts, these circuits can be put to many uses.

**Audio Oscillator.** Shown in Fig. 1, this circuit consists of an npn and a pnp transistor. With the values shown, it will produce a mid-range audio tone. If sockets are used for the transistors, plugging a suspect transistor in the appropriate socket will produce an audio tone if the transistor is good.

A conventional Morse code key can be connected in series with the positive supply (at J1) and, with S1 turned on and a speaker connected to the output, you have a code-practice oscillator. You can use this oscillator to check any type of audio amplifier by starting at the speaker and working back.

OLD TRANSISTOR RADIO PARTS  
CAN MAKE: **AUDIO OSCILLATOR**  
**CRYSTAL OSCILLATOR**  
**A-F/R-F AMPLIFIER**

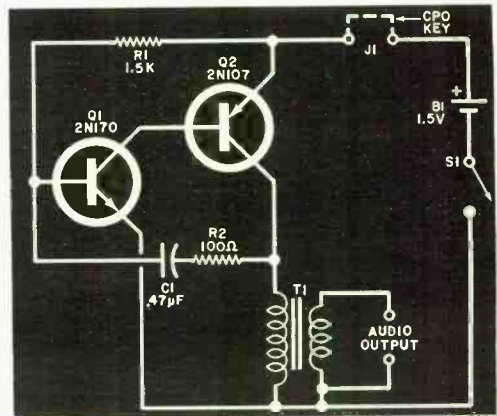

## PARTS LIST

- B1—1.5-volt C or D cell
- C1—0.47- $\mu$ F capacitor
- J1—Phono connector (optional)
- Q1—2N170 transistor
- Q2—2N107 transistor
- R1—1500-ohm,  $\frac{1}{4}$ -watt resistor
- R2—100-ohm,  $\frac{1}{4}$ -watt resistor
- S1—Spst switch
- T1—Miniature audio output transformer
- Misc.—Battery holder, transistor socket (2), perf board and clips, mounting hardware.

Fig. 1. Simple audio generator can also be used as code-practice oscillator or audio transistor tester by substitution.



**Crystal Oscillator.** A simple crystal oscillator is shown in Fig. 2. The crystal (ob-

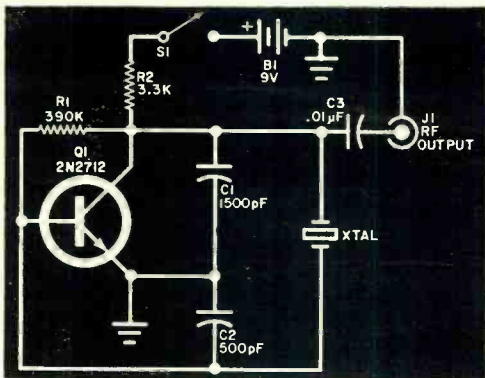

### PARTS LIST

- B1—9-volt battery
- C1—1500-pF mica capacitor
- C2—500-pF mica capacitor
- J1—Binding post
- Q1—2N2712 transistor
- R1—390,000-ohm resistor
- R2—3300-ohm resistor
- S1—Spst switch
- XTAL—228-kHz crystal
- Misc.—Battery holder and connector, transistor socket, crystal socket, PC or perf board, mounting hardware.

Fig. 2. This crystal oscillator can be used as a BCB i-f aligner with harmonics usable across the whole broadcast band.

tainable from any crystal supplier) should operate at about 228 kHz. The harmonics of this oscillator can be used in receiver alignment. For example, the second harmonic, which falls at 456 kHz, can be used for i-f alignment. A short wire antenna will serve to inject this signal into the radio being checked. For dial calibration, the upper harmonics come in handy. For example, there are harmonics at 1368 and 1596 kHz for aligning the high end of the dial, while the harmonic at 684 kHz is useful for the low end.

**Audio Amplifier.** The circuit shown in Fig. 3 is a conventional high-gain audio amplifier having a selection of one or two inputs. The input at jack J2 is for conventional audio, while the input at J1 is for an r-f demodulator probe (also shown in Fig. 3). This composite circuit can be used to check a radio from the antenna input through the final audio section.

**Construction.** The circuits can be assembled either individually or combined on either perf board or printed circuit board. They can all be mounted in a common chassis with pertinent switches and connectors on the top. As each element is constructed, it should be tested before final installation in the chassis. ♦

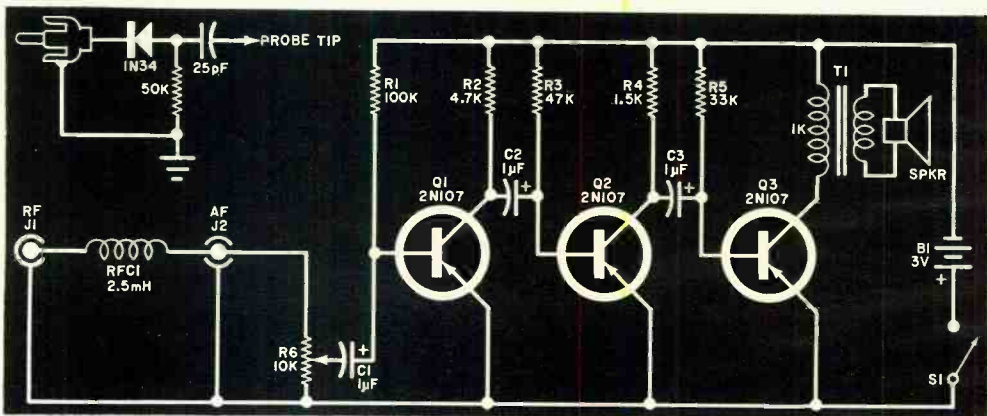

### PARTS LIST

- B1—3-volt battery (2 AA, C, or D cells)
- C1-C3—1-μF, 10-volt electrolytic capacitor
- J1, J2—Phono connector
- Q1-Q3—2N107 transistor
- R1—100,000-ohm, ½-watt resistor
- R2—4700-ohm, ½-watt resistor
- R3—47,000-ohm, ½-watt resistor
- R4—1500-ohm, ½-watt resistor
- R5—33,000-ohm, ½-watt resistor

- R6—10,000-ohm miniature potentiometer
- RFC1—2.5-mH r-f choke
- S1—Spst switch
- T1—1000-ohm primary miniature output transformer
- Misc.—Battery holder, PC or perf board, mounting hardware.
- For probe: 50,000-ohm, ¼-watt resistor; 25-pF capacitor; 1N34 diode; shielded cable; phono connector.

Fig. 3. Three-transistor audio amplifier can have either audio (J2) or r-f (J1) inputs.

# THREE PROJECTS FOR YOUR CAR

- LIGHTS-ON REMINDER
- SPARK-MISS ANALYZER
- WIPER PULSER

BY LOUIS F. CASO

**N**OW that summer is only a memory and winter has become firmly entrenched, it's time for you to catch up on those automotive jobs you've been putting off for a "rainy day." While you're about the usual mechanical jobs in preparing your car for next summer's fun, give some thought to putting together the three electronic devices described in these pages. They will make your driving easier and safer, and add to your car's trade-in value.

**Lights-On Reminder.** Referring to Fig. 1, power to this circuit is supplied only when the ignition is turned on. It comes from the car's electrical system, routing through the normally closed contacts of relay *K2*. The light level at which the system triggers can be preset by adjusting potentiometer *R5*.

The resistance of photocell *PCI* varies with changes in light "seen" by the PC. As darkness approaches, *PCI*'s resistance

Fig. 1. The lights-on circuit reminds the driver, either by the visual or audible alarm, that level of outside light is sufficiently low to require headlights, if ignition is on.

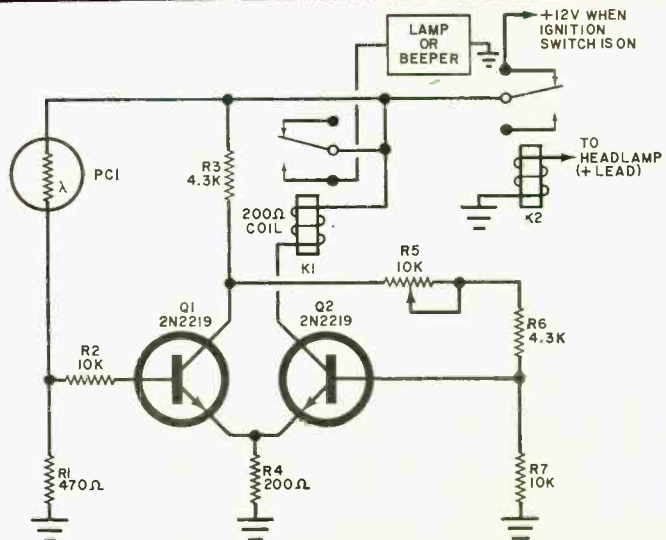

increases. At some point, this increase is sufficiently high to bias off  $Q1$ , thereby triggering  $Q2$  into saturation. When this happens,  $K1$  energizes and powers a warning lamp or beeper.

Now, when you see the lamp come on or hear the beeper, you switch on the headlights. In doing so, you apply power to  $K2$ , opening its contacts and disabling the power line to the circuit. As long as the headlight switch is on, no power will be delivered to the reminder circuit.

The circuit was designed for use in any car with a 12-volt, negative-ground electrical system. Under bright ambient-light conditions, it draws only 3 mA, while in total darkness the drain is 15 mA (exclusive of the power drawn by the relays).

For proper operation,  $PC1$  should be mounted in a tube about 3 in. long with the inside painted flat black. This assembly can be mounted, facing outward, atop

the dashboard or behind the rear seats of an automobile.

**Spark-Miss Analyzer.** This device (see Fig. 2) will go a long way toward helping you maintain your car and track down ignition problems. It is easy to build and employs a very simple register circuit.

Clock pulses for the analyzer are generated by  $I1$  located near, but not touching, the ignition wire of the spark plug to be checked. The lamp is mechanically coupled to  $PC1$  with a piece of light-tight heat-shrinkable tubing. Each time the plug under test is fired, the lamp will light, raising and lowering the resistance of  $PC1$ . This rise and fall in resistance is seen by the base of  $Q1$ , where it is converted into a series of pulses that drive the divide-by-16 circuit made up of  $FF1$  through  $FF4$ . This divider register is necessary to reduce the pulse frequency from about 800 pulses/minute to about 12.5

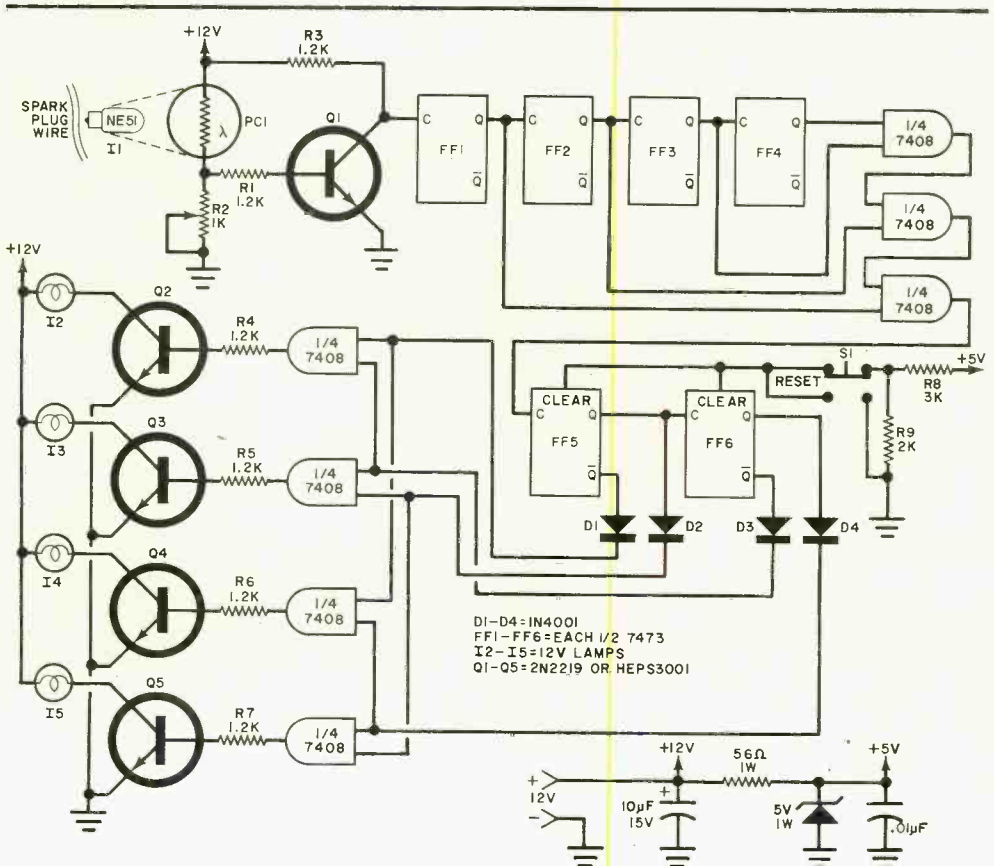
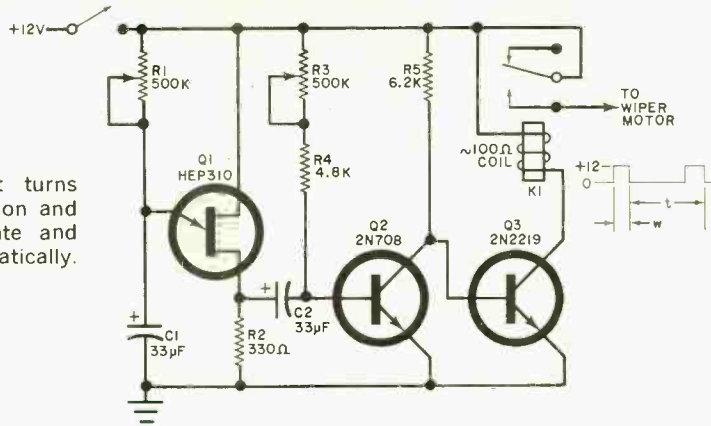

Fig. 2. The spark-miss analyzer shows when automobile plugs are firing properly.



Fig. 3. Pulser circuit turns the windshield wipers on and off at the desired rate and length of time, automatically.



pulses/minute so that they can easily be seen.

Passing through a series of AND gates, the pulses are then applied to FF5 and FF6, which, in turn, toggle on and off another series of AND gates and driver transistors to provide power to the indicators consisting of 12 through 15. With the arrangement shown, 12-15 will light sequentially at even time intervals when the 11/PCI assembly is brought close to a spark plug wire. Transistors Q2-Q5 are drivers for the indicator lamps.

The analyzer can be powered by any mobile electrical system that delivers 12 volts dc and is referenced to a negative ground when the power supply shown is used. The supply delivers 12 volts to the input and indicator circuits and 5 volts to the IC elements.

The light-tight 11/PCI assembly should be fastened to one end of a long wooden probe, with the leads going back to the circuit proper via a two-conductor cable. The insulated (wood) probe serves as a shock preventive device when the analyzer's probe is being moved around near high-voltage spark plug lines.

To use the analyzer, simply connect its power cable to the car's electrical system and momentarily depress RESET switch S1 to clear the register. Bring the probe near the spark plug wire; if the plug is firing normally, 12-15 will fire sequentially. Before moving to the next plug, momentarily depress S1. (Note: S1 should be pressed every time the analyzer is first powered and when a new plug is to be tested to clear the register.)

**Windshield-Wiper Pulser.** Very often while driving your car, it rains just enough to require a sweep of the windshield wipers once every 10 seconds or so. Turning on and off the wiper switch at such intervals can be inconvenient and dangerous while driving, whereas to allow the wipers to run continuously will only wear out the blades. The circuit in Fig. 3 does the switching on and off of the wipers automatically, freeing you to concentrate on your driving.

When power is applied to the circuit, C1 charges to the firing level of Q1. At this point, Q1 avalanches and discharges C1 through R2 to initiate the cycle. This pulse is then coupled through C2 to fire Q2 which, in turn, fires Q3. When Q3 switches into conduction, it energizes K1. With the relay's contacts closed, power is applied to the wiper motor only for the pulse width duration ( $w$ ) shown in the waveform. The wipers make one sweep every time Q1 fires. (Note: In some cars, the wiper motor is "hot" as soon as the ignition is turned on, requiring the circuit to ground to be completed to turn on the motor. Check your car's hookup before wiring the circuit. If you find the ground-completion hookup, connect K1's contacts to the ground of the pulser circuit.)

The cycle repeats every  $t$  seconds, the duration of the time period being determined by the value of R1. Potentiometer R3 can be adjusted to change pulse width  $w$  to determine the length of time K1 remains energized during the cycle. Both controls can be adjusted to get the timing and duration desired. ♦

# APPLICATIONS FOR THE IC "TIME MACHINE"

*Some interesting circuits using  
the 555 timer-on-a-chip*

BY WALTER G. JUNG

Contributing Editor

IN THE November 1973 issue of POPULAR ELECTRONICS ("The IC Time Machine," p 54), we discussed the basic operation of the 555 integrated circuit timer chip. Now that we understand the principles, let's see how some practical applications work.

Below, and on following pages, are five interesting and useful circuits that are easily built. Note the wide range of areas in which these circuits can be used.

Of course, the story of the IC "time machine" is by no means complete with these applications. We have barely scratched the

surface with the circuits given here, but we hope that we have suggested some new ideas that will be useful in designing new projects.

In a case like this, the best approach to new circuit design is to understand fully the internal workings of the IC itself and know just what the inputs and outputs are at each pin. Then let the imagination go to work. The best way to do this is to make a "breadboard" and play with the IC, using different connections and varying the external components.

## A WARBLE ALARM CIRCUIT

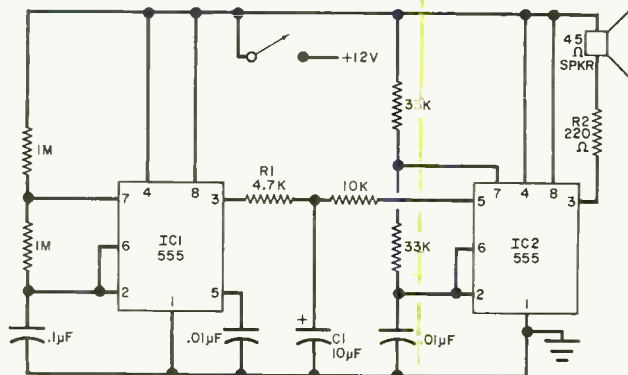

The warble alarm circuit shown on the opposite page uses two 555 IC's as an audio attention getter. The first 555, IC1, oscillates at a frequency slightly below 10 Hz. Its rectangular output is filtered by R1C1 to produce a triangle wave, which in turn is used to frequency modulate IC2. The latter is operated at approximately 1 kHz and is modulated at a 5-Hz rate.

The output current of the 555 IC is sufficient to drive a small speaker and R2

is used to prevent excessive loading, but the audible level of the tone produced is still quite noticeable. The exact frequency, rate, and deviation of the circuit can be easily modified to produce almost any type of warble sound desired. The on-off control is most efficiently achieved by interrupting the supply line so as to minimize standby power. The switch can be relay contacts or some other means of applying power when an alarm condition is sensed.

## SCHMITT TRIGGER OR BISTABLE BUFFER

Aside from its basic use in timing functions, the 555 IC can be applied to advantage in other switching circuits. One example is the Schmitt trigger circuit shown here. In this circuit, the two comparator inputs (pins 2 and 6) are tied together and biased at half of the applied dc voltage through the voltage divider made up of R1 and R2. Since the upper comparator (pin 6) will trip at  $\frac{2}{3}$  of the applied dc and the lower one at  $\frac{1}{3}$  of the applied voltage, the bias provided by resistors R1 and R2 is centered within the comparators' trip limits.

A sine-wave input of sufficient amplitude to exceed the reference levels causes the internal flip-flop to be set and reset. In this way, it creates a square wave at the output. As long as R1 is equal in value to R2, the 555 will be automatically biased correctly for almost any supply voltage. Note that the output waveform (as shown in the diagram above) is 180 degrees out of phase with the applied input sine wave. Because of the 555's high output current capability, this circuit can be used to good purpose as a signal shaper/buffer circuit.

Such a circuit can also find application if you have a sine-wave-only audio generator and you would also like to have a simultaneous square-wave output. The major advantage of this circuit is that,

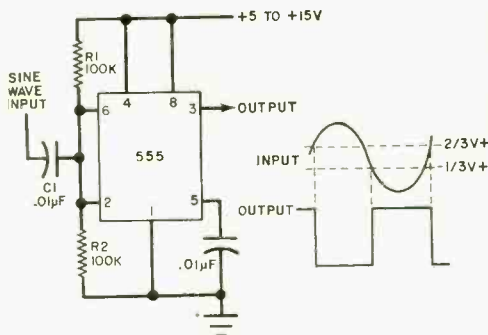

unlike a conventional multivibrator type of squarer, which divides the incoming frequency in half to square it, the Schmitt trigger simply squares the input frequency without changing the frequency. A circuit of this type can easily be installed within almost any audio generator.

**Inverting Bistable Buffer.** By modifying the input time constant of the circuit shown above (reducing the value of input capacitor C1 to 0.001 microfarad, for example) so that input pulses will be differentiated, the arrangement can also be used as either a bistable device or to invert pulse waveforms. In the latter case, the fast time constant of the combination of C1 with R1 and R2 causes only the edges of the input pulse or rectangular waveform to be passed. These pulses set and reset the flip-flop; and a high-level, inverted output is the result.

(More on next page)



## SQUARE-WAVE OSCILLATOR

A conventional astable circuit using a 555 IC does not normally produce a symmetrical output waveform. However, square waves can be obtained from a 555 by using the simple circuit shown here.

The asymmetry of a conventional astable circuit is a result of the fact that the charging and discharging time constants are not equal. If the timing capacitor can be charged and discharged through the same (or equivalent) resistance value, the symmetry can be restored.

In the circuit shown here, capacitor  $C1$  is charged through  $R1$  and  $R2$  and it is discharged through  $R2$ . If  $R1$  is made very small in resistance compared to  $R2$ , then both time constants will be reduced so that they depend essentially on  $R2$  and  $C1$ .

The frequency of operation ( $f$ ) of this circuit is approximately equal to 1.43 divided by the product of  $R2$  and  $C1$ . The frequency is of course independent of the supply voltage.

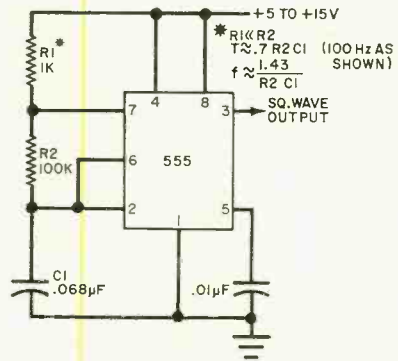

## OUTPUT DRIVE CONSIDERATIONS

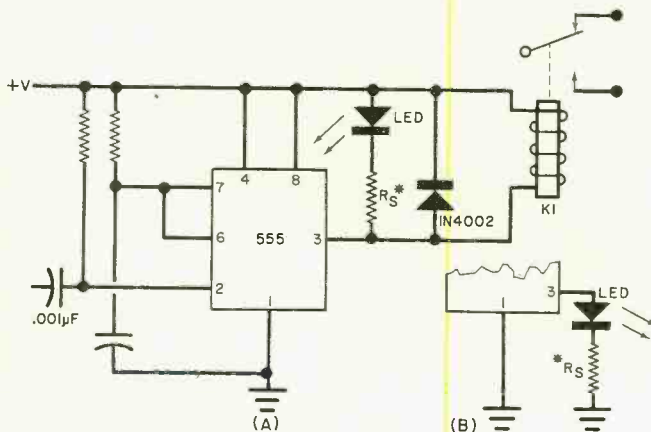

\*SELECT FOR DESIRED LED CURRENT. +5V USE 150Ω, +15V USE 680Ω

The 555 timer IC can provide up to 200 mA of output current in either its high or low state. However, this value should not be considered too strictly since some types of loads have a voltage limitation. If, for example, the 555 is used with a 5-volt supply to drive TTL logic, the output current is limited to much less than 200 mA because of the required input voltage for the following TTL stage. Since TTL output stages are normally specified for 0.4 volt at rated cur-

rent, a more realistic maximum output current for the 555 is 5 mA, which is far less than the 200 mA specified.

Other types of loads, such as incandescent lamps, relays or light-emitting diodes are not as critical in terms of voltage and they can be driven by using the circuit shown above. Depending on the logic involved in the application, these types of loads can be connected from pin 3 to either +V or ground. In a timer such as that shown in (A) above, the output

(pin 3) is normally at the ground potential and goes high during the timing interval. Therefore, a LED connected as shown at left will be on when pin 3 is low, and it will go off when pin 3 is high (during the timing cycle).

Since a 555 can operate over a wide dc supply range and a light-emitting diode requires about 1.6 volts, a series resistor ( $R_s$ ) is used to drop the excess voltage and limit the LED current.

Relays can be driven as shown in this circuit by selecting a relay that is compatible with the applied dc. Of course,

it will have to have the contact arrangement desired. Since the 555 has a healthy current output, the relay selected need not be particularly sensitive.

This permits relays rated at 12 volts and 100 mA to be used. The diode across the relay coil is used to prevent the back emf from damaging the IC chip. If the current demand is not too high, both an LED and a relay can be used at the same time.

The connections shown at (B) are for the opposite type of logic where the LED is normally off and is pulsed on.

## WIDE-RANGE PULSE GENERATOR

The most sophisticated of the 555 applications described here is the wide-range pulse generator, whose circuit is shown below.

This general-purpose pulse generator consists of an astable oscillator ( $IC1$ ) whose output frequency can be varied over a 10:1 range by potentiometer  $R1$  (frequency control). Range selection is made by  $S1$ , with five ranges from 0.1 Hz to 10 kHz. Tantalum capacitors are used for the two lower ranges, while Mylar capacitors should be used for the upper ranges. The output of  $IC1$  feeds  $S2$ , which can be used to select either

internal or external signals for  $IC2$ , a monostable circuit.

Integrated circuit  $IC2$  is a monostable generator whose output is a pulse with a width that can be varied over a range of 10 to 1 by changing  $R2$ . Switch  $S3$  provides five ranges from 100 microseconds to 10 seconds. The output of the latter stage consists of positive-going pulses whose frequency (rate) and width can be set to almost any desired values. If the external mode of triggering  $IC2$  is selected, almost any negative-going pulse can be applied to the external trigger input.

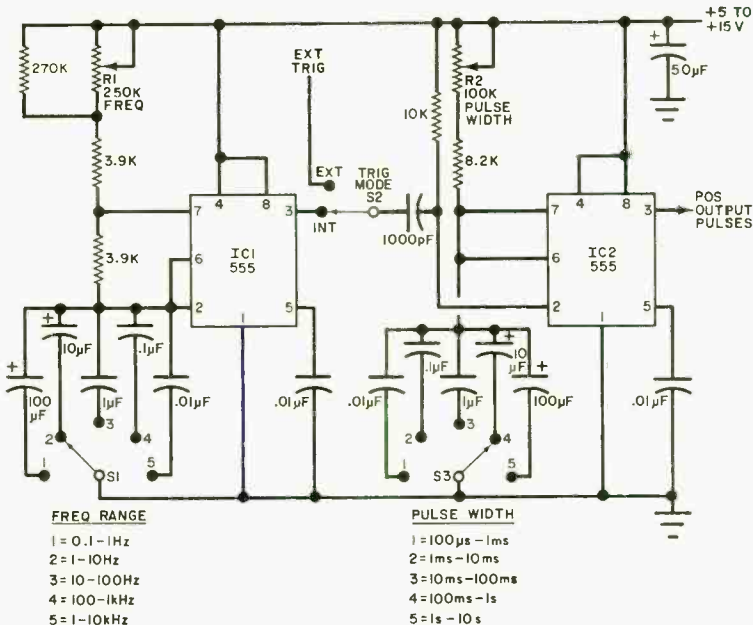





# Ken Fransen is using his electronics training where it really counts.

## Helping to save lives in the U.S. Coast Guard.

It's up to Ken to keep sophisticated electronics communications equipment in top condition.

He's part of our lifesaving team. We count on Ken and need more people like him.

You may or may not have electronics training. If, like Ken, you have training, we'll put you to work fast, on a rewarding job with responsibility and challenges. If you don't have training, we'll train you.

Say your experience goes no further than building a crystal radio set. If you have an aptitude for electronics and qualify, we'll guarantee you 25 to 38 weeks of school and turn you into a seasoned professional who'll be able to troubleshoot the most complex electronics equipment. You'll study everything from theory and principle to practical application.

Those of you who already know your way around electronics systems may qualify for our advanced promotion program. After only ten weeks, you'll be promoted immediately to a higher pay grade (up to 2nd class petty officer with pay of over \$400 a month, plus food, housing and medical care). And you may qualify for even more advanced training.

Either way, your job as a Coast

Guard electronics technician will give you a broad range of experience. Using the most modern diagnostic tools, you'll maintain, repair and calibrate the latest electronics equipment, including LORAN transceivers, computer controlled transmitters, solid state equipment and AM, FM and SSB transceivers.

You might even qualify to help design, test and evaluate new equipment or prototype models in our research laboratories, or work on cesium and rubidium atomic clocks.

You'll be doing plenty for yourself, too. The training alone is worth thousands of dollars, and the skills you learn can lead to valuable, sought-after jobs in both the Coast Guard and civilian life.

What's more, the Coast Guard offers you a combination of pay and benefits most private companies can't match. (For more about our package of benefits, read the attached card.)

Find out more about a rewarding career in electronics. Mail us the card today.

**Help others/Help yourself.  
Join the lifesavers.  
The Coast Guard.**

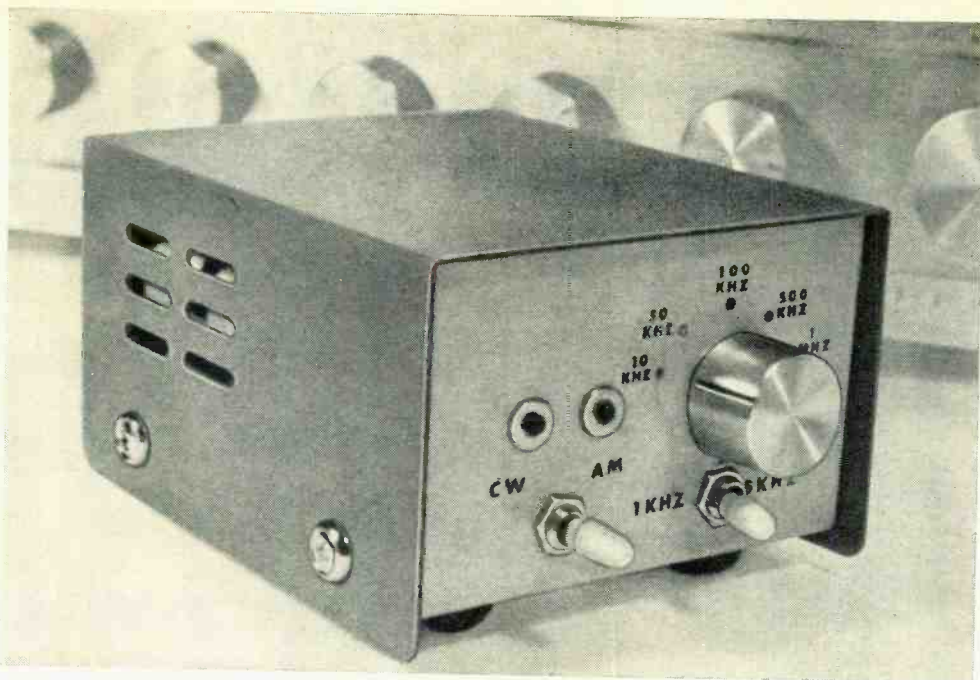

## BUILD A **DELUXE** **FREQUENCY STANDARD**

*One crystal and four TTL devices produce  
seven crystal-controlled calibration frequencies*

BY JOE A. ROLF, K5JOK

**F**OR the shortwave listener, a precision frequency standard is an important accessory for locating the exact frequency of a hard-to-get station. Hams need a calibration oscillator to take the guesswork out of determining where they are in the band. And the electronics experimenter or technician finds many uses for a frequency standard, from calibrating a receiver to using it as a precision timing source.

The deluxe frequency standard described here can be used for all of these purposes since it provides highly accurate AM or CW signals at 1, 5, 10, 50, 100, and 500 kHz and at 1-MHz intervals to well above 50 MHz. It is small in size, battery operated, and easy to build.

The compactness, versatility, and accuracy of the standard are a result of the use of readily available, economy-priced TTL

integrated circuits. The standard (Fig. 1) uses one 7404 hex-inverter and three 7490 decade dividers as a master 1-MHz oscillator that can be calibrated to WWV. A divider chain generates six sub-frequencies.

The master-oscillator, digital-divider approach to a frequency standard provides extreme accuracy on all frequencies since digital dividers always divide by a fixed number. For instance, if the 1-MHz master oscillator is tuned to within 10 Hz of WWV at 20 MHz, it will be within 0.5 Hz at 1 MHz and 0.0005 Hz at 1 kHz. This represents an accuracy of 0.00005%.

Three of the inverters in IC2 form the master oscillator; IC2A and IC2B generate a crystal-controlled 1-MHz signal that can be precisely tuned by C1, and IC2C provides isolation. Three 7490 IC's (IC1, IC3, and IC4) divide by 2 and then by 5 to

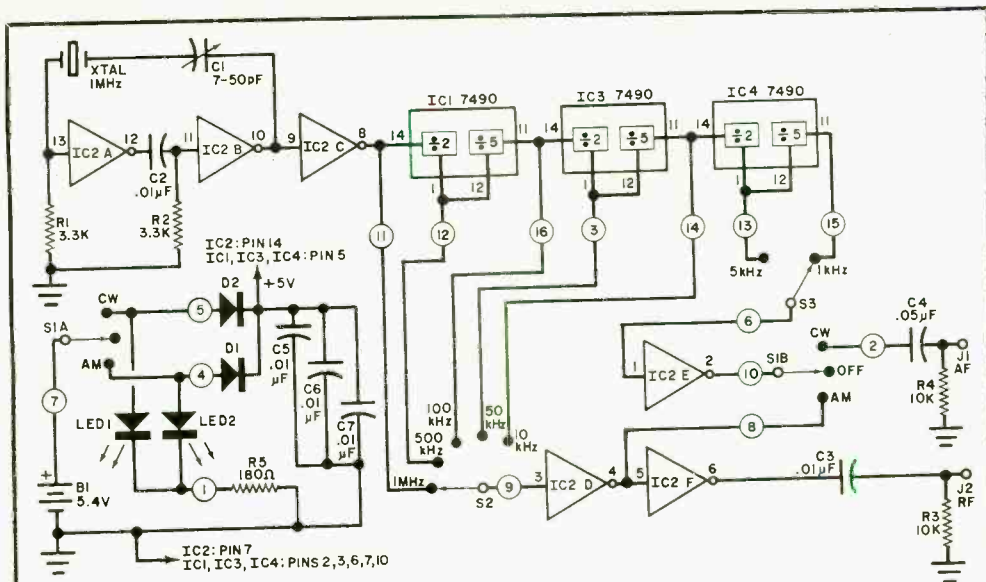

### PARTS LIST

B1—5.4-volt mercury battery (Mallory TR-134 or similar)  
 C1—7.50-pF midjet trimmer capacitor (Arco #403, Calectro A1-246 or similar)  
 C2, C3, C5-C7—0.01- $\mu$ F, 25-volt disc capacitor  
 C4—0.05- $\mu$ F, 12-volt disc capacitor  
 D1, D2—0.2-A, 25-PRV diode (1N4444, 1N4450, 1N914 or similar)  
 IC1, IC3, IC4—7490 decade divider  
 IC2—7404 hex inverter  
 J1, J2—Miniature pin jack (GC 33-216, Smith 223 or similar)  
 LED1, LED2—Miniature light emitting diode

R1, R2—3300-ohm,  $\frac{1}{4}$ -watt resistor  
 R3, R4—10,000-ohm,  $\frac{1}{4}$ -watt resistor  
 R5—180-ohm,  $\frac{1}{4}$ -watt resistor  
 S1—Miniature 2pdt. center off, toggle switch (Alco MST-205N, Calectro E2-129 or similar)  
 S2—5-position, miniature rotary switch, non-shorting (Calectro E2-163 or similar)  
 S3—S-pdt miniature toggle switch (Alco MTS-115D, Calectro E2-122 or similar)  
 XTAL—1-MHz crystal (PR Type Z-9 HC6/U Holder or similar)  
 Misc.—Suitable cabinet, rubber feet (4), spacers, mounting hardware, etc.

Fig. 1. Two inverters are used as crystal oscillator. A series of three 7490 divider IC's count down to 1 kHz. The low-frequency dividers can modulate higher frequencies.

provide the sub-frequencies. Switch S2 selects the proper output points in the divider chain and feeds the signal to two inverters for shaping and output.

All outputs above 10 kHz can be modulated at 5 kHz or 1 kHz as selected by S1 and S2. Switch S3 selects the 1- or 5-kHz outputs, while S1 selects either J1 for an audio output or the input of IC2F to modulate the high-frequency output.

Switch S1 is a center-off toggle switch that selects either the AM or CW mode. Mode indication is given by two LED indicators located on the front panel. Diodes D1 and D2 serve to isolate the LED's from one another in the selector switch circuit.

**Construction.** Printed circuit board construction should be used for ease of wiring and compactness. Details on the board are shown in Fig. 2. The photos show the board assembly and the completed unit.

Trimmer capacitor C1 is mounted by soldering two small perf-board terminals to the board and then soldering the capacitor terminals to these so that the adjusting screw is located just behind the rear edge of the board. A hole with grommet in the rear panel will provide access to this control.

Carefully solder the crystal in place and trim the pins protruding below the board. The battery is secured with a small cable tie and pad and carefully soldered to leads from the board. Since the calibrator will normally be used only for short intervals, battery replacement should be infrequent. Use  $\frac{3}{8}$ " spacers to mount the board to the case.

Put the controls and LED's on the front panel and J1 and J2 on the rear apron. Use plastic cement to hold the LED's in place. Drill a hole for access to C1. Be sure to clip all unused terminals of S2 flush with



the switch wafer. For appearance and neatness, bundle wires from the PC board with small wraps of masking tape.

**Operation.** Put *S1* in the AM and then the CW positions, and note that the appropriate LED illuminates. Set the mode switch to CW and the output selector switch to 1 MHz. Using a shortwave receiver and a short piece of wire connected to *J2*, determine that there is a signal from the calibrator every 1 MHz on the receiver. Place *S3* to either 1 or 5 kHz and set the mode switch to AM. The signal should now be tone modulated at 1 or 5 kHz.

To calibrate, tune to WWV at either 10, 15, or 20 MHz and set the calibrator for a 1-MHz CW output. Carefully adjust *C1* with an insulated screwdriver to zero beat with WWV. As you approach the zero beat, tune very carefully to get the best possible calibration. By listening carefully or ob-

Shown below is assembled board module with front-panel switches wired in; two wires at bottom go to input and output jacks on rear panel. Battery fastens down with cable tie.

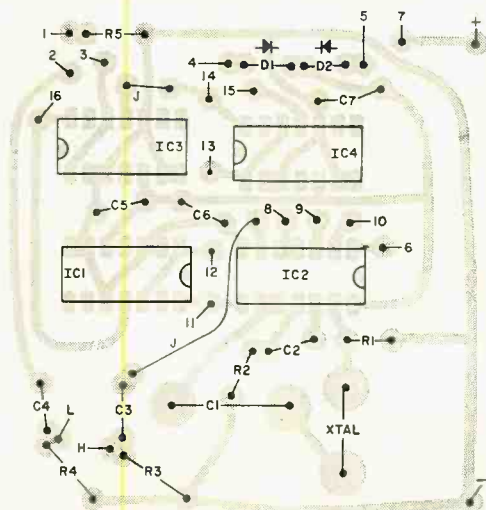
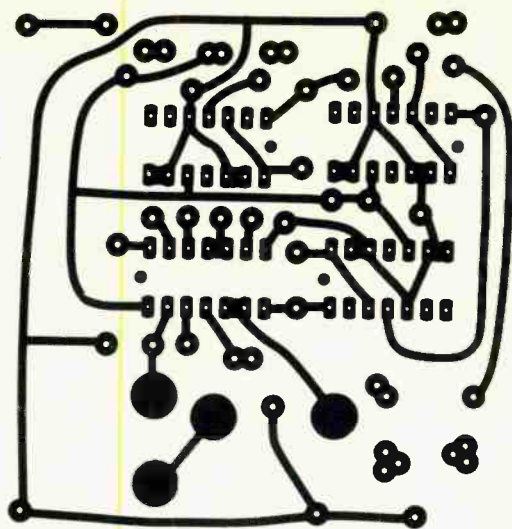
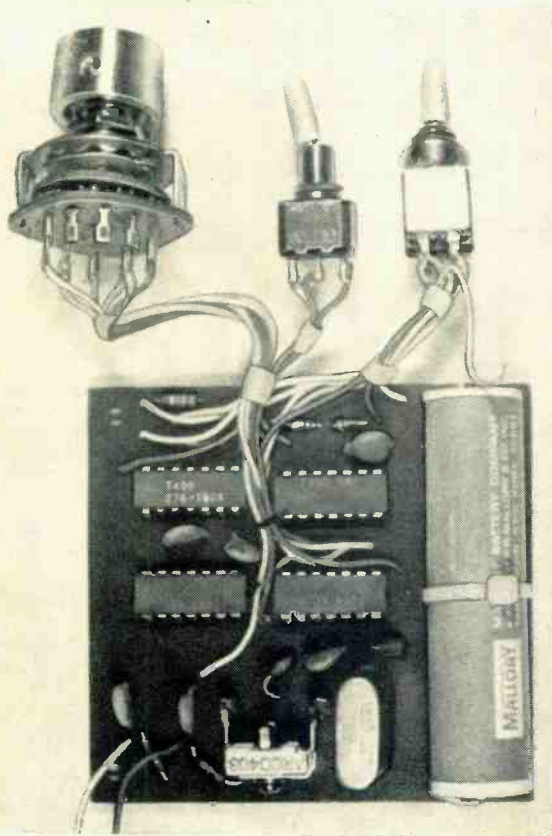

Fig. 2. Actual-size etching guide is shown at top. On component-placement guide above, numbered points connect to panel controls.

serving the receiver's S meter, you can set the standard within a few cycles.

A short piece of wire connected to the output terminal is sufficient to provide strong marker signals through 50 MHz. You can locate 1-MHz points by first turning the selector switch to that position and, by stepping down successively, identify 500-, 100-, 50- or 10-kHz points either as a carrier or as a tone-modulated signal. For a 1- or 5-kHz output, connect a short piece of wire to *J1* and turn the mode switch to CW. Major calibration points can be taken from *J2* simultaneously by setting the selector switch to the desired position. ♦



# Development of a Modern ECG

By John T. Frye, W9EGV, KHD4167

**B**ARNEY came shivering into the service department, blowing on his cold-numbed fingers to warm them, and found Mac, his employer, examining a long strip of 2½" wide cross-ruled paper with a magnifying glass.

"I'll bite; what's that?" Barney demanded.

"It's an electrocardiogram I ran on my long-suffering guinea pig wife last evening," Mac explained. "As you know, I'm growing increasingly interested in medical electronics and recently signed up for Hewlett-Packard's *ECG Study Course*, for which I must have access to an electrocardiograph. Dr. Brown was good enough to lend me his Sanborn Model 51 Viso-Cardiette portable ECG that he acquired back when he hung out his shingle. That's it in the mahogany case over there on the end of the bench. While the instrument is more than twenty years old, it is excellently engineered and still functions beautifully."

"How does the heart make this squiggly little line?" Barney asked, picking up the strip of paper and looking at the tracing.

"You're looking at an amplitude-vs-time graph of the voltage generated by a beating heart and picked up at various points on the surface of the body. Heart beats are initiated by rhythmic pulses of electrical current generated by a bit of specialized tissue called the *S-A Node* located in the upper portion of the right atrium. This tiny current spreads over the entire heart, proceeding from cell to cell in a toppling-domino type of action. As the current reaches a cell, that cell 'depolarizes' and contracts. The interior of a resting cell is about 90 millivolts negative with respect to the exterior, but when stimulated by the spreading current from the *S A Node*, this polarity reverses and the interior briefly becomes about 20 millivolts positive with respect to the exterior. Then the cell 're-polarizes' to its former resting state.

"As a cell depolarizes, it creates a tiny voltage that triggers the depolarization of its neighbor; and so the electrical action initiated by the *S-A Node* spreads over the atria, down through the septum between the ventricles, thence to the endocardium, or lining, of the ventricles, and finally out through the muscular ventricular heart walls to the surface. On this journey the depolarization wave of a normal heart follows a certain predictable path at various predictable speeds so that the accompanying muscular contractions of the various chambers of the heart are properly timed for most effective pumping action.

"At any particular moment, the voltage produced by this depolarization wave has both amplitude and direction—in short, it is a vector quantity. As such, it must be 'viewed' from more than one angle to determine its direction and maximum amplitude. This viewing is performed by the electrocardiograph, ECG, or EKG (after the German spelling). The travelling wave of depolarization voltage does not stop when it reaches the surface of the heart but continues on through the body tissue to the surface, where it can be detected through electrodes in contact with the skin going to sensitive electrical instruments.

"The first practical ECG instrument was developed in 1903 by a Dutchman named Einthoven. It consisted of a very thin gold-plated quartz fiber suspended between the poles of a powerful magnet. When the ends of this fiber were connected to electrodes on the surface of the body, the picked-up heart voltages sent current through the conductive 'string' that produced electromagnetic fields which reacted with the permanent field of the magnet and caused the string to move one way or the other, depending on which way the current was momentarily flowing through the fiber. An optical system magnified these motions and

they were reproduced on a moving strip of photographic paper by a special camera. This 'string galvanometer ECG' was very delicate and hard to adjust, and it has been completely superseded by the amplifier type that is portable, rugged, easy to use, and more accurate."

**An Amplifier Type ECG.** "I assume that one on the bench is an amplifier type."

"Right. It consists essentially of a vacuum tube differential amplifier that boosts up thousands of times the tiny difference in voltages presented to its two inputs by the body electrodes; of a rugged D'Arsonval movement galvanometer similar to the ones used in our meters but of a much heavier, stiffer construction and having, instead of a pointer, an arm carrying a heated stylus attached to its moving coil; and of a paper transport system that moves a special coated paper over a knife-edge and beneath the stylus at a speed of exactly 25 mm per second. The greatly amplified voltage is fed to the galvanometer coil that responds by moving the heated stylus up and down over the horizontally moving paper stretched taut over the knife edge. With no voltage present, the stylus rides in the center of the paper. A depolarization wave moving towards a positive electrode moves the stylus up on the paper; a wave going the other way moves it down. Heat from the stylus produces a continuous black marking on the heat-sensitive coating of the moving paper."

"With the paper sliding under the stylus at 25 mm/s, you can tell how much time elapses between any two points on the tracing," Barney observed.

"Yes. Each small square on the paper is a mm on a side; so the distance between two adjacent vertical lines represents .04 second."

"How do you measure voltage?"

"You inject a standardizing calibration pulse of exactly 1 mV amplitude into the input of the amplifier by momentarily pushing a button on the ECG panel and adjust the amplifier gain until this square-topped pulse is exactly ten small squares tall; then the distance between two adjacent horizontal lines represents .1 mV. All electrocardiograms are properly made with this standardization. Each fifth horizontal and vertical line is made heavier for convenience in measuring."

"Where do you attach the electrodes?"

"Normally one labelled *RL* goes to the right leg, *LL* to the left leg, *RA* to the right arm, and *LA* to the left arm. A fifth suction-type electrode *C* is attached to various positions on the chest. Wires from all electrodes connect to the ECG through a plug-in cable. The *RL* electrode goes to ground, and combinations of the other electrodes are selected by a rotary switch on the panel of the ECG and are connected to the input of the amplifier.

"Each such combination of electrodes is called a 'lead' and is designated by number, letters, or a combination of letters and numbers. Recordings from twelve such leads constitute a standard electrocardiogram, although other combinations and placement of electrodes are occasionally used. Einthoven used three bipolar leads called I, II, and III. Lead I teamed a positive *LA* with a negative *RA*. Lead II combined a positive *LL* with a negative *RA*. Lead III attached *LL* to the positive amplifier terminal and *LA* to the negative terminal.

"Now we also have the augmented unipolar limb leads: *aVR*, *aVL* and *aVF*, in which a single limb electrode is attached to the positive terminal of the ECG amplifier and the remaining two are tied together to form a 'neutral' electrode and attached to the negative terminal. *aVR* has the *RA* positive, *aVL* has *LA* positive, and *aVF* has *LL* positive. Finally we have the *V* leads in which all three limb electrodes are tied together to form a neutral 'central terminal' and the suction cup electrode *C* is successively attached to six different positions on the chest, starting to the right of the sternum in the fourth interspace and proceeding across the sternum and then down and to the left around the apex of the heart to the mid-axillary line. Each such position of *C* constitutes a different lead, and these are called *V1*, *V2*, *V3*, *V4*, *V5*, and *V6*."

"What's this little button above the paper viewing window and this switch marked 'Insto'?" Barney asked, looking at the panel of the ECG.

"The button marks the top of the paper when depressed. You use it to mark each section of the serially recorded electrocardiogram with a code of long and short marks so you can tell, after the strip is cut into twelve pieces for mounting, which piece displays a recording of which lead. The 'Instomatic Switch' is closed when



switching leads so that the amplifier adjusts instantly to the different dc potentials existing between electrodes of the different leads. Otherwise, when you switch leads, the stylus is likely to be knocked clear off the paper and stay there for up to thirty seconds before returning to center.

"But let me describe how I make an electrocardiogram on the Viso-Cardiette: I start the paper, close the insto switch, move the lead selector to I, open the Insto switch, push the 1 mV standard switch, hit the marker button once to make a short dash, close the Insto switch, move the lead selector to II, open the Insto switch, push the 1 mV switch, hit the marker button twice, etc., right on through leads III, aVR, aVL, and aVF to V. From here on I do not have to change the lead selector, but I must move the C electrode to a new position for each different V lead, and I still must operate the Insto switch, the marker button, and the 1 mV switch for each lead. Since I only want about six seconds worth of each lead, I am busier than the performer on one of those keep-the-plates-spinning circus acts."

"Are modern ECG's much different from this one?"

**Modern ECG's.** "I'll say! Sanborn became a subsidiary of Hewlett-Packard in 1961 and formed the basis of H-P's Medical Electronics Division; so let me tell you about the H-P Model 1515A ECG Phone Terminal to show you how far one company has gone with this equipment in about twenty-five years. The 1515A is, first, a three-channel recorder having three instant-warm-up solid state amplifiers driving three high-fidelity galvanometers and recording three leads simultaneously. Here's a picture of it and a sample of the recording it makes. All twelve standard leads are recorded in four sets of three leads each. Lead switching, operation of the Insto switch, marker identification of lead sets, and standardization are all performed automatically. You simply connect the electrodes (there are separate electrodes for all six V leads), press a button, and in ten seconds you have a complete 12-lead electrocardiogram."

"But there's more. The recording can be simultaneously sent over an ordinary telephone circuit to a computer system that digitalizes the data by taking hundreds of samples a second of the ECG signal. This

data is stored in the computer memory, analyzed, and compared with hundreds of thousands of other ECG's. Then, in less than a minute, the computer sends a print-out back to the patient site containing many significant amplitude, duration, and vector axis measurements together with a classification of the electrocardiogram as normal, atypical, borderline, or abnormal. By performing many tedious, necessary measurements for the cardiologist, the computer provides him with guidelines he can combine with information from auscultation, enzyme studies, X-rays, angiograms, cardiac catheterization, and experience to arrive at a diagnosis in 1/5 to 1/3 the time it would otherwise take."

"What's this about a 'high fidelity galvanometer'?"

"Ideally the stylus position should change

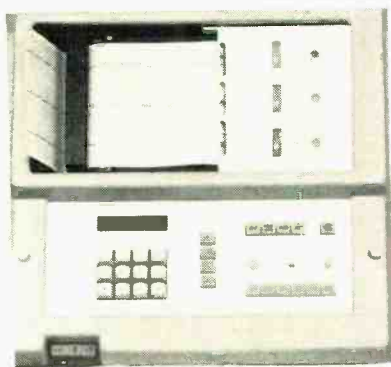

Panel view of Hewlett-Packard's Model 1515A three-channel ECG machine.

in a linear fashion with respect to applied voltage. With the ordinary galvanometer this doesn't quite happen because of frictional drag between stylus and paper and flexing of the mechanical coupling between stylus and rotor. H-P has largely overcome this 'hysteresis distortion' with a rigid coupling and a feedback system that senses the rotor position and forces the stylus to move to where it should be. As a result, H-P's new ECG's reproduce often significant fine detail of heart voltage waveforms with a fidelity approaching that of a scope. Furthermore, these new instruments include features that insure the patient against electrical shock hazard.

"Let me wind up by saying that with 160 million electrocardiograms being run annually world wide—70 million in the U.S.—busy cardiologists need all the help they can get. ♦

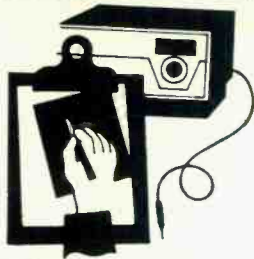

# Product Test Reports

## ONKYO MODEL TX-555 AM/STEREO FM RECEIVER (A Hirsch-Houck Labs Report)



**T**HE Onkyo Model TX-555 AM/stereo FM receiver is rated at 37 watts/channel with both channels driven simultaneously into 8-ohm loads. Its 20-20,000-Hz frequency response is specified at less than 0.3 percent distortion. The FM tuner has correspondingly good specifications. It contains a FET front end and a six-element ceramic i-f filter for selectivity.

The upper half of the receiver's front panel is dominated by a large black dial face into which is set a relative-signal-strength tuning meter. A large tuning dial is also set into the dial window. The dial and meter are green lighted when either of the tuners is in use; when the PHONO or AUX inputs are in use, the meter is darkened. When a stereo broadcast is received, a red STEREO light comes on.

The lower half of the front panel contains all level, balance, and tone controls (each concentric for the two channels); switches; and a headphone jack. Six pushbutton switches control high- and low-cut filters, loudness compensation, stereo/mono mode, tape monitoring, and FM muting. The rotary selector switch has positions for AM, FM (mono), FM (auto), PHONO, AUX 1, and AUX 2 input sources.

The various inputs and outputs, including a DIN connector in parallel with the main tape recording input and output jacks, are located on the rear apron. One set of tape recording outputs is controlled by the re-

ceiver's volume and tone controls (but cannot be used when monitoring off the tape). Also on the rear apron are 300- and 75-ohm FM antenna inputs, a LOCAL connection (for attenuating the input signal when the receiver is close to an FM transmitter), a pivoted AM ferrite antenna, a terminal for a long-wire external AM antenna, and one switched and one unswitched ac accessory outlets. Finally, there are output and line fuses.

The receiver can drive two pairs of speakers, singly or in combination. All speakers can be silenced for headphone listening. The power amplifiers are direct-coupled, and a 10-second delay after power is turned on prevents transients from reaching the speakers during warm-up.

The TX-555 receiver is list priced at \$400. It carries a 3-year parts replacement, 2-year labor guarantee.

**Laboratory Measurements.** The receiver delivered 46.5 watts/channel into 8 ohms at 1000 Hz at the clipping point. Into 4 ohms, the output was 65.5 watts, while into 16 ohms it was 28 watts/channel. The 1000-Hz harmonic distortion was less than 0.1

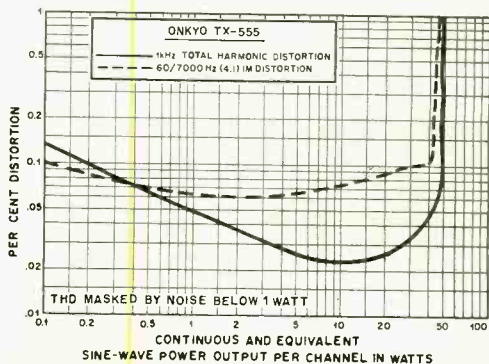

percent—typically 0.02 to 0.05 percent—from 0.2 watt to almost 50 watts/channel. IM distortion was under 0.1 percent from less than 0.1 watt to more than 40 watts.

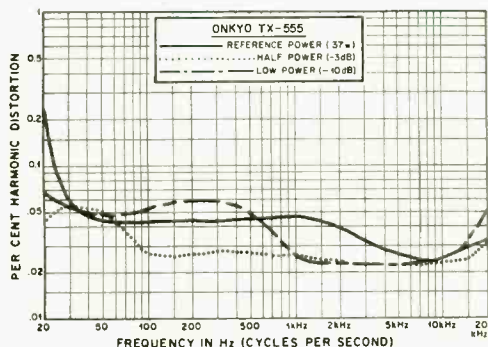

At the rated 37 watts/channel (or lower power levels), the harmonic distortion was 0.02 to 0.06 percent from 20 Hz to 20,000 Hz, except for a rise to 0.2 percent at 20 Hz with full power. The high-level (AUX) inputs required 59 mV to drive the amplifier to a 10-watt output, with a 72.5-dB S/N ratio. Through the phono inputs, 1.4 mV was needed for a 10-watt output, with a 65-dB S/N ratio. The receiver had an exceptional phono dynamic range, with the preamplifiers able to handle up to 185 mV without distortion.

The RIAA phono equalization was within  $\pm 0.5$  dB of the ideal response from 30 Hz to 15,000 Hz. The tone controls had a moderate—but adequate—range. A boost of about 10 dB and a cut of about 15 to 20 dB were available at the frequency extremes. The bass control varied the “turnover” fre-

quency so that at settings less than half the maximum only frequencies below 200 Hz were affected. At full boost or cut, the control action began at about 400 Hz.

The loudness compensation provided a moderate boost at low and high frequencies with reduced volume control settings and did not have the undesirable heavy sound of most such circuits. The filters had gradual 6-dB/octave slopes, with the response down 3 dB at about 4000 and 60 Hz.

The FM tuner had a  $2.8\text{-}\mu\text{V}$  IHF sensitivity (slightly higher than the rated  $1.8\text{ }\mu\text{V}$ ), but the steep limiting curve produced a listenable 50-dB S/N ratio with only  $2.5\text{ }\mu\text{V}$  of input signal. The FM distortion was about 0.2 percent in mono and about 0.85 percent in stereo at 100 percent modulation. The ultimate quieting was 71.5 dB in mono and 70 dB in stereo. The automatic stereo switching threshold was 25 to  $30\text{ }\mu\text{V}$ .

In the stereo FM mode, the frequency response was +2.5 dB/-1.5 dB from 30 Hz to 15,000 Hz. Channel separation was better than 20 dB from 30 Hz to 15,000 Hz and exceeded 30 dB from 63 Hz to 4200 Hz.

The FM capture ratio was 2.2 dB, with an AM rejection of 50 dB. The image rejection was an excellent 86.5 dB in the audio outputs. Apparently, the receiver has a small amount of non-defeatable afc action, which prevented our making an accurate alternate-channel selectivity measurement. But it is evident that the selectivity is good. The AM frequency response was slightly better than average, being down 6 dB at 4000 Hz, with a steep attenuation of higher frequencies that effectively eliminated the

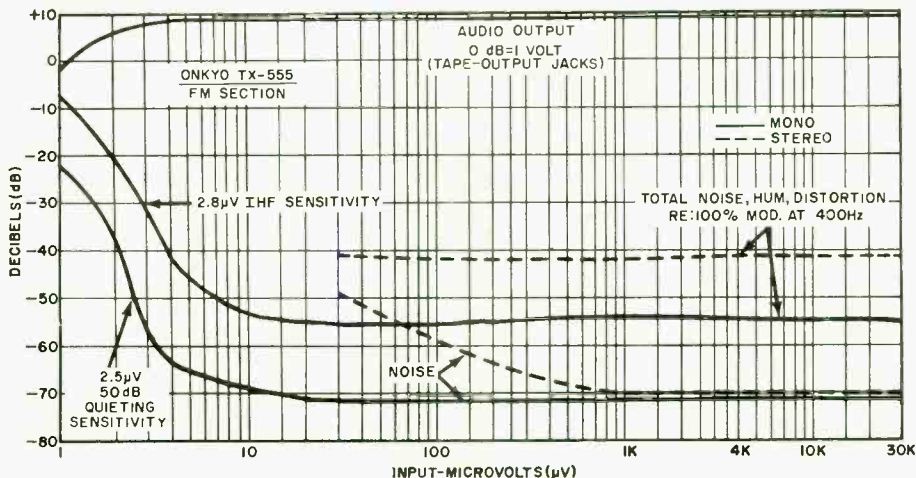



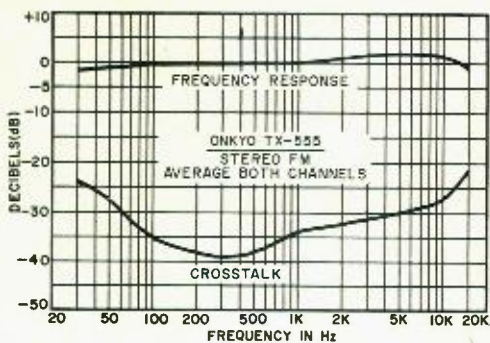

10,000-Hz interstation whistle that plagues many AM tuners.

**User Comments.** Although the measured

Circle No. 65 on Reader Service Card

performance of the TX-555 receiver was excellent in all important respects, the true quality of this receiver can be appreciated only by living with it. For example, the knob and panel markings are easy to read at a glance, a human factor often overlooked by equipment designers. Tuning was not critical, and the FM muting action was one of the best we have encountered. There was no trace of modulation or noise when tuning on or off a signal, nor did we hear any clicks or thumps.

In combining fine electrical performance with tasteful styling, plus an attention to small details that are so often overlooked, Onkyo has created in the TX-555 a receiver of which they can justly be proud. We could not fault the receiver in any respect.

### EPI MICROTOWER II SPEAKER SYSTEM (A Hirsch-Houck Labs Report)

**T**HE EPI Microtower II is a compact floor-standing column-type speaker system. It stands 33½" high and occupies an area 8½" square. Near the top, mounted on opposite walls of the enclosure, are two 4" cone drivers. The other two sides of the column each contain a 1" concave "inverted dome" tweeter, similar to those used in most other EPI speaker systems.

The 4" drivers are back-loaded by the column, with most of the energy below about 150 Hz radiating from a slot that extends completely around the base of the column. EPI describes the system as using the "organ-pipe" principle in which three resonant modes of the pipe are used to augment the bass output of the small woofers, with damping supplied by glass fiber filling.

At 3000 Hz, there is a crossover to the tweeters. The horizontal dispersion of the system is very wide, although it obviously varies somewhat with frequency. In normal use, most of the sound reaching the listener is first reflected from one or more room surfaces; so, the system has the essential qualities of an omnidirectional speaker system. EPI rates the low-frequency cutoff of the Microtower II at 40 Hz. The tweeters are claimed to have a strong response to at least 18,000 Hz, with very good dispersion out to 13,000 Hz.

The Microtower II is supplied in a walnut finished enclosure. It retails for \$120.



**Laboratory Measurements.** The composite frequency response of the speaker system, measured in a live room and corrected for port radiation at low frequencies and the microphone response at high frequencies, was very uniform (within  $\pm 1.5$  dB) from 80 Hz to 1000 Hz. The lower frequencies rolled off at about 8 dB/octave, with no significant resonant peaks or irregularities. A slight dip of 3 to 4 dB at 1500 Hz was followed by a very smoothly rising response

to beyond 15,000 Hz with less than 1 dB of irregularity and a total variation of 8 dB over this range. The overall output variation of  $\pm 6.5$  dB from 40 Hz to 20,000 Hz represents fine performance, especially for a speaker system in the Microtower II's price range.

The bass distortion, with a 1-watt drive level, began to increase below 70 Hz (where it was 2 percent), reaching 5 percent at 47 Hz and 10 percent at 35 Hz. The limitations of the small woofers were apparent when we attempted to push the speaker to a constant 90-dB SPL output at a distance of 1 meter. The distortion rose very rapidly below 80 Hz at that rather high sound level to 5 percent at 72 Hz and 10 percent at 70 Hz.

System impedance was between 8 and 20 ohms from 20 Hz to 3000 Hz. It fell off to about 4 ohms between 7000 and 20,000 Hz. The efficiency was moderately high as compared to that of popular acoustic-suspension speakers, with somewhat less than 1 watt of driving power needed to produce a 90-dB SPL at middle frequencies. The tone-burst response was excellent, with virtually no start-up delay, overshoot, or ringing. Even a 5000-Hz square wave was reproduced in recognizable form, although there was obvious ringing superimposed on the square wave. (Note: In the tone-burst photos, the upper waveform is the input and the lower waveform is the output.)

**General User Comments.** The speaker system had an audible quality consistent with its measured response. It had a "bright" sound, with no apparent midrange coloration and a satisfying, if not powerful, bass response. Initially, we operated the speakers with the tweeters facing forward (as suggested by EPI), but in our bright listening room a better balance was obtained with one of the woofers facing forward.

The simulated "live-versus-recorded" listening comparison confirmed our listening judgement. The extreme top end was over-bright with a tweeter facing us but was virtually perfect with a woofer facing front. We detected a slightly "boxy" mid-range sound when comparing the system to the original sound source it was reproducing, although this was not apparent in ordinary listening tests. A slight boost of about 4 dB in the 1500-Hz region with an octave-band equalizer corrected this condition. As an accurate reproducer of music, we would rate the Microtower II "A—" —if the necessary correction at 1500 Hz is made, that rating would become an "A". We suspect that an amplifier with a midrange control (as well as the usual bass and treble controls) would satisfactorily modify the mid-range response as well as did our octave-band equalizer.

Although the low bass was not powerful, by comparison to some larger or more conventional speakers in its price class, it was

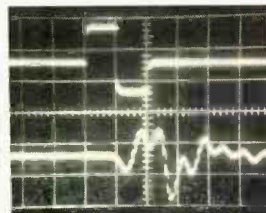
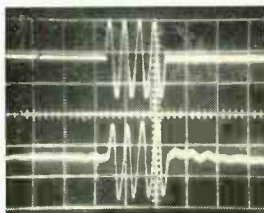
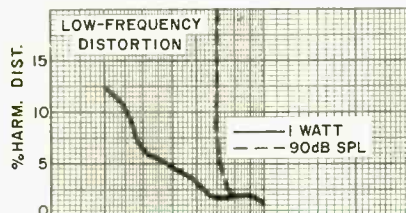
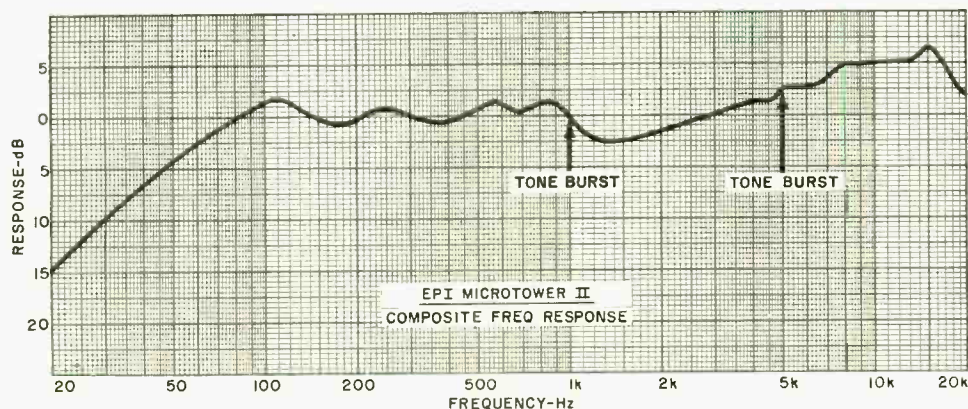



by no means lacking in the Microtower II. Subjectively, the system has an "all there" quality. It can play at fairly loud listening levels without strain. But it should not be expected to compete with larger systems in sheer sound power output.

All in all, the EPI Microtower II is one of

Circle No. 66 on Reader Service Card

the better sounding speaker systems in its price range. Its essentially omnidirectional sound character is rarely found in \$120 speaker systems. Also, we know of no other speaker system that occupies only 72 sq in. of floor space whose sound can compare with this one.

## INTERNATIONAL COMPONENTS MODEL IC-500 FET VOM

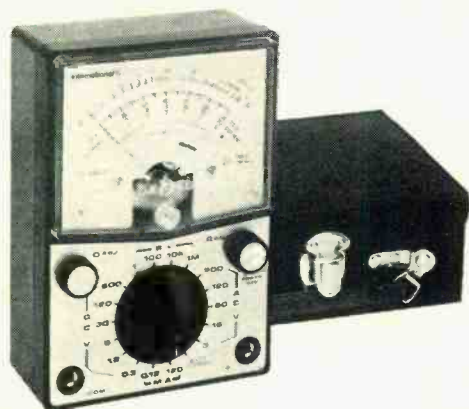

**T**HE old notion that VOM's are good only for making approximate measurements suddenly evaporated when we recently received a new multimeter in the mail. Upon first opening the box in which it came, the International Components Corp.'s Model IC-500 FET multimeter appeared to be neither more nor less than any other VOM. After reading the operating manual and performing some preliminary tests with the IC-500 VOM, our view underwent a radical change.

This 5 in. by 3½ in. by 2 in. lightweight VOM has 17 basic ranges and includes a zero-center function that can be used for checking voltages of unknown polarity and for making null settings. Input resistance on the dc ranges is 10 megohms, while the impedance on the ac ranges is 10,000 ohms/volt. Accuracy is specified at 3 percent on dc and 4 percent on ac.

The Model IC-500 FET multitester retails for \$55.

**General Description.** There are six dc voltage ranges: 0.3, 1.2, 6, 30, 120, and 600 volts full-scale. The five ac voltage ranges provided are: 3, 12, 60, 120, and 600 volts full-scale. Four resistance ranges

(X1, X100, X10k, and X1M) and two dc current ranges (0.12 and 120 mA full-scale) round out the range/function complement. The function switch also has a test position for which there is a small green scale on the meter movement to indicate battery condition.

Two batteries are required for the VOM. One is a conventional 9-volt transistor battery, while the other is a 1.5-volt C cell. Also provided with the VOM is a Model DCVX-2 probe that doubles the dc ranges and runs the input resistance up to 20 megohms. This increases the number of ranges available to a grand total of 23, which includes the standard 17 plus the six additional.

As can be guessed, the sensitivity and very high input resistance is due to the use of FET's. Protection for the VOM's input circuit is provided by a diode should the instrument be accidentally used to test voltages beyond its capability. The meter itself is protected by a back-to-back silicon-diode arrangement.

The meter scale is printed in three colors: green for resistance, black for dc voltage and current, and red for ac voltage. Together with an anti-parallax mirror behind the pointer on the meter scales, this greatly eases scale reading and interpretation.

Four accessories are available for use with the instrument. The Model IC-HV probe permits voltage measurements of up to 30,000 volts dc. The Model IC-DCX probe enables measurements of up ten times the magnitude normally permitted on the built-in ranges. The IC-RF probe can be used for ac measurements between 500 kHz and 250 MHz, and the TP-1 probe can be used for temperature measurements from -50° C to 200° C.

**User Comments.** We have been using the instrument for several weeks now and have come to the conclusion that it is an excellent



VOM. Treated to the usual rough handling, including a couple of drops to a hard floor from our bench top, it has survived, with no effect on its accuracy.

The compact size of the instrument made it ideal for slipping into a coat pocket or tucking away in a small niche on our test bench. On service trips, the sturdy carrying case, compartmentalized to accept both the

meter and test leads with extra probe, further protected the VOM from the hazards other meters normally encounter.

We like the idea of the slip-on insulated alligator clips provided with the VOM. Switching from probe tips to alligator clips takes no time at all. And because both tips and clips are available, there is hardly a job this instrument will not handle.

Circle No. 67 on Reader Service Card

## LINEAR SYSTEMS MODEL SBE-18CB TRANSCEIVER

The Linear Systems Model SBE-18CB is a 23-channel single-sideband-only transceiver. As such, it can be manufactured and sold at relatively lower cost (\$290 for the SBE-18CB) than most SSB/AM rigs. Also, this is a compact, lightweight rig, measuring 8¾ in. by 5¾ in. by 2 in. and weighing just 3¾ pounds. The transceiver is not restricted to mobile service; with an ac power supply accessory, it can be used for base station operation.

The rig has the usual SSB transceiver features. Choice of either upper or lower sideband can be had at the flip of a switch. On-the-nose frequency control is obtained with a clarifier control that operates on both transmit and receive. A noise blanker can be switched in or out. An illuminated meter indicates signal strength in S units and relative transmitter output power. And there are r-f and a-f gain controls, plus an adjustable squelch. Public address service is available with an external speaker. Operated from a 12-volt dc power source, the transmitter has a PEP input of 15 watts.

Three slide-type switches are used for: NOISE BLANKER on/off; CB/PA service; and USB/LSB operation. A channel selector dial is back-lighted at only the channel position in use. (Only the odd-numbered channels are



marked on the dial.) The channel-9 position is red lighted, while all other channels show up in white. A red lamp comes on when the transmitter is activated.

**Technical Notes.** We did not receive an operating manual or schematic diagram with our test unit, so our technical notes are limited to outward observations.

Channel selection and frequency control are obtained by means of a crystal frequency synthesizer that provides a heterodyning signal against the received signal to produce a 7.8-MHz i-f. A crystal band-pass sideband filter at the i-f provides the unwanted-sideband rejection for SSB. The high-frequency i-f allows good image rejection to be obtained. And since a crystal filter at this i-f can be made satisfactory for

# FREE McIntosh CATALOG and FM DIRECTORY

McIntosh Laboratory, Inc.  
East Side Station P.O. Box 96  
Binghamton, N.Y. 13904  
Dept. 16-5

**SEND  
TODAY!**

NAME \_\_\_\_\_

ADDRESS \_\_\_\_\_

CITY \_\_\_\_\_ STATE \_\_\_\_\_ ZIP \_\_\_\_\_

Get all the news and latest information on the new McIntosh Solid State equipment in the McIntosh catalog. In addition you will receive an FM station directory that covers all of North America.



**MX 113**

AM FM/FM STEREO TUNER PREAMPLIFIER

CIRCLE NO. 16 ON READER SERVICE CARD

SSB use, there is no need to go to a second, lower-frequency conversion for the required selectivity (as is usually done). The mixer is preceded by an r-f stage that enhances both the sensitivity and image (or other unwanted-signal) rejection.

The bfo for carrier reinsertion at the product detector is crystal controlled. Switching between the upper and lower sidebands is accomplished in the usual manner. Instead of changing the heterodyning and bfo frequencies to place the signal at one side or the other of the sideband filter, the frequency-controlling system places the heterodyning frequency at the low side of the signal on USB operation and at the high side for LBS. An advantage of this arrangement is that the bfo (carrier oscillator) frequency always remains at the same side of the filter. This allows the latter to be more easily optimized for the best unwanted-sideband suppression while retaining the desired bandpass.

AM signals can also be received by the SBE-18CB transceiver. To do this, the clarifier control can be adjusted for zero-beat with the AM carrier.

On transmit, the bfo and microphone signals are combined at the balanced modulator which, with the same sideband filter used on receive, produces the suppressed carrier SSB signal. This is mixed with the synthesized frequencies to produce the on-channel signal that goes to the r-f driver and linear output amplifier. An output network at the linear amplifier provides harmonic attenuation and matching to a nominal load of 50 ohms.

**Measurements.** Performance measurements on our test rig produced the following results:

*Receiver:* sensitivity was 0.3  $\mu\text{V}$  for 10 db (S + N)/N; unwanted-sideband suppression was -80 dB at 1000 Hz; overall bandpass was 400-2700 Hz at 6 dB; unwanted signal rejection image was down 60 dB, and all other unwanted signals were down a minimum of 50 dB; adjacent-channel desensitization was -55 dB for 3 dB of desensitization; agc threshold was approximately 3  $\mu\text{V}$ , with a 5-dB a-f output change with 70 dB r-f input change (3-10,000  $\mu\text{V}$ ); impulse noise peaks of 40 dB above a 0.1- $\mu\text{V}$  signal were reduced by the noise blanker to inaudibility; a-f output at 1000 Hz into 8 ohms was 2 watts at 3 percent distortion and 2.5 watts with 7 percent distortion at the onset of clipping.

*Transmitter:* PEP output was 9.5 watts (at 13.8 V), with third-order distortion products 25 dB below maximum single-tone output; unwanted-sideband suppression was the same as on receive, and carrier suppression was -50 dB; overall frequency response was 300 to 2800 Hz at 6 dB. Frequency tolerance at the center position of the clarifier control was within  $\pm 50$  Hz. The clarifier's range was  $\pm 1100$  Hz.

On receive, the current drain was 250 mA. On transmit, the drain was 1.5 A. In both cases, the supply voltage was 13.8 volts dc.

The excellent results given above indicate the SBE-18CB provides the fine performance to be expected from a good SSB rig.

Circle No. 68 on Reader Service Card

## EL INSTRUMENTS MODEL DD1-K DIGI-DESIGNER

**E**XPERIMENTING with readily available TTL digital integrated circuits is both educational and entertaining—the latter, up to a point. The fun goes out of it when one finds oneself working around a maze of sockets to which are made a “rat’s nest” of interconnections. The problem is further compounded by the fact that digital IC’s require a power source, some form of “clock” to toggle them, and a “readout” system to indicate the states of the logic signals. It is no wonder that many people who begin experimenting in digital electronics with the greatest enthusiasm rapidly lose interest as circuit complexity increases.

Well, if you fall into the category we have just described, despair not. EL Instruments appears to have just the thing to put the fun back into digital experimenting. It is their Model DD1-K “Digi-Designer” kit, a sort of all-inclusive bread-boarding/experimenting instrument that retails for \$50. (A factory wired unit, the Model DD1-A, is available for \$95.) The DD1-K contains a regulated 5-volt power supply (for TTL IC’s, of course); a switch-selectable frequency clock oscillator circuit that operates in six decade ranges from 1 Hz to 100 kHz—with complementary outputs, no less; a unique gaint socket that

accommodates a number of IC's and transistors in solderless plug-in fashion; a pair of bounceless pushbutton pulsers and four logic-1/logic-0 slide switches; and four buffered monitor logic lamps. All components furnished in the kit are of a quality normally associated with commercial gear—which the Digi-Designer was originally intended to be.

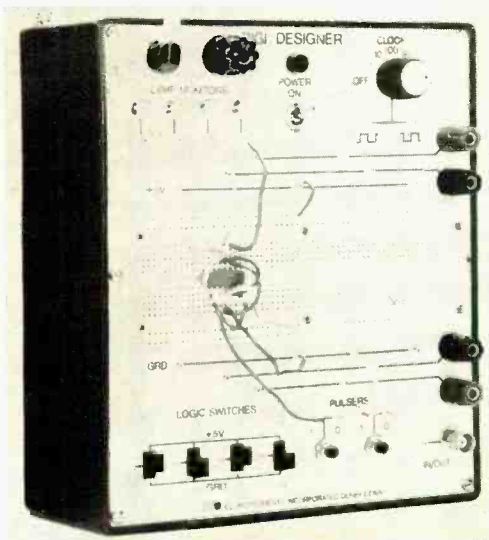

**Assembling the Kit.** Our kit went together in about 4½ hours of relatively easy work. The heavy-gauge metal front panel supports the entire electronics package that makes up the instrument, with the bulk of the components mounted on a large PC board. A separate small PC board is provided for the lamp and monitor circuits, while a third board accommodates the pulser circuits. As with all PC work, we made certain that we used a narrow-tipped, low-wattage soldering iron; we suggest you do the same if you decide to build the Digi-Designer Kit.

**After Assembly.** Once we had the kit assembled and checked out for any wiring faults, our immediate aim was to put it to work checking a TTL countdown circuit. Because the kit uses the special bread-boarding socket, all interconnects went faster than we had expected.

We can heartily recommend the Digi-Designer to anyone interested in digital experimenting, whether for curiosity or for serious study and design work.

Circle No. 69 on Reader Service Card

# Now Available!

The **Popular Electronics**  
INCLUDING **Electronics World**

# INDEX

PUBLISHED FOR THE FIRST TIME

NOW...you can find the information you want quickly and easily in these detailed and complete Indexes, each covering a full year of POPULAR ELECTRONICS Magazines (12 issues). Hundreds of subjects, titles, and brand names arranged for clear, fast reference. An ideal companion to your magazine collection - and essential for the audiophile, gadgeteer, ham, and service technician.

Both the 1972 and 1973 Indexes have been prepared in cooperation with the Editors of POPULAR ELECTRONICS Including ELECTRONICS WORLD. Indexes for both 1972 and 1973 are available at only \$1.00 per copy, postpaid. Each Index covers a full year of 12 issues.

Order your copies of these valuable and informative Indexes now!

## INDEX

Box 2228, Falls Church, Virginia, 22042

Enclosed please find \$\_\_\_\_\_ for the following Indexes at \$1.00 each, postpaid: PE-174

\_\_\_\_\_ copies --- 1972 Index

\_\_\_\_\_ copies --- 1973 Index

Print Name: \_\_\_\_\_

Address: \_\_\_\_\_

City \_\_\_\_\_ State \_\_\_\_\_ Zip \_\_\_\_\_

Please enclose full payment with order. Make checks payable to INDEX.



Use it all as you get ready for a new career:

# \$1,500.00 WORTH OF TWO-WAY RADIO ELECTRONIC COMMUNICATIONS EQUIPMENT

Bell & Howell Schools announces a new learn-at-home program in two-way radio that gives you "hands on" experience with commercial-grade equipment! For free information mail the postage-free card today.

You need "hands on" experience with a real, commercial-band FM transceiver and actual commercial-grade test equipment -- to take full advantage of growing opportunities in electronic communications.

Two-way radio communications is a healthy growth area in electronics. And it's lucrative. Almost two million commercial two-way radio systems now serve as vital communications links for trucks, planes, boats and taxis. And the FCC requires each system to have its equipment serviced regularly by a licensed technician. That's where you come in. But you need career-oriented training -- plus your FCC license.

Knowing how to put an amateur radio kit together won't help when you're "on the job" -- servicing two-way radio systems for aircraft or advising trucking companies about their land-mobile communications system. For that, you need "hands on" experience with the real thing. This unique new Bell & Howell Schools learn-at-home program gives you just that. You can work with the equipment by attending one of our special "help sessions" or by dropping by one of the Bell & Howell resident schools. If neither of these plans is convenient, you can have the equipment shipped to your home in return for a \$100 deposit, which is refundable when you return the equipment.

Find out more about this exciting new Bell & Howell Schools program. There's no obligation.

**For free information,  
mail attached card today!**

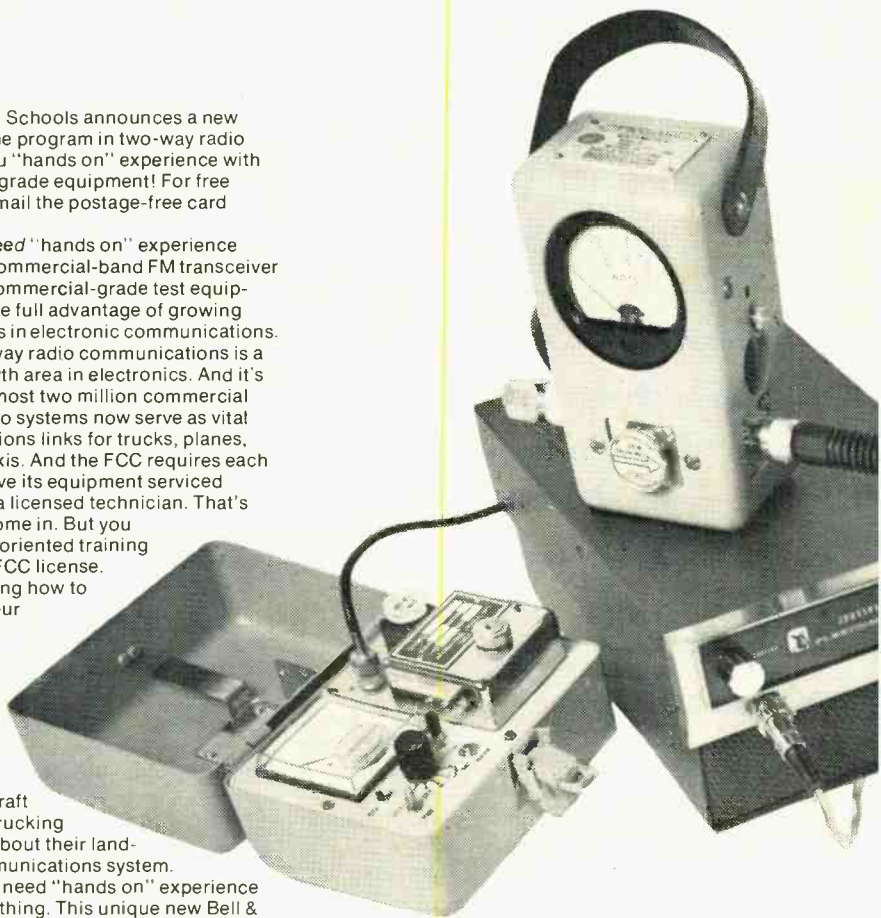

# Let Bell & Howell Schools help you get ready for an exciting career in the business of your own in two-way radio electronic communications!

Bell & Howell Schools has helped thousands of people prepare for careers—and businesses of their own—in electronics. You can have absolute confidence in the thorough training you get.

Expert instructors at Bell & Howell Schools plan each program to answer a single question: "What qualifications will you need to take advantage of *actual career opportunities* in electronics?" They then build each program to give you those exact qualifications.

To get ready for a business of your own in two-way radio, you need: 1) career-oriented training; 2) FCC license; 3) "hands on" experience with commercial-grade equipment. Bell & Howell Schools now offers this new at-home training program that gives you all three. See FCC License Warranty on attached card.)

### JUST LOOK AT ALL THE EQUIPMENT YOU'LL WORK WITH DURING YOUR TRAINING PROGRAM WITH BELL & HOWELL SCHOOLS!

**Commercial-Band FM Transceiver**... exactly the kind of two-way radio you'll service throughout your career.



**Deviation Meter**... model favored by many working technicians to check modulation of transmitted signal.

**Frequency Meter**... highly sensitive instrument used to check signal frequency within precise tolerances established by government standards.

**Power Output Meter**... meter used almost universally by trained and licensed technicians to check power output—or wattage—of signal.

**Alignment Generator**... a custom-designed unit you use to generate test signals for transceiver alignment.

### FCC REGULATIONS GIVE YOU THE OPPORTUNITY TO START YOUR OWN BUSINESS!

The Federal Communications Commission requires that all commercial two-way communications systems be checked and serviced by a licensed technician at regular intervals.

As a Bell & Howell Schools graduate, you'll have the technical know-how you need. With your FCC license, you could go out and eventually build your own business—signing contracts with companies that use two-way radio. FCC regulations could mean security and regular income for you!

### BELL & HOWELL SCHOOLS OFFERS YOU THESE SPECIAL ADVANTAGES:

**Help Sessions** Scheduled regularly at the Bell & Howell Schools and in many other cities throughout the U.S. and Canada. Top instructors give you personal help and expert advice.

**National Career Placement Center** Helps you locate a job in the field of electronics that fits your background and interests. Use this unique service *any time* after you complete your program—and throughout your new career.

**Veterans' Benefits** We are approved by the state approval agency for Veterans' Benefits.

**Student Financial Aid** We are an eligible institution under the Student Loan Program.

### EXCLUSIVE ELECTRO-LAB® ELECTRONICS TRAINING SYSTEM!

To make sure you get practical experience with instruments used daily by professionals, we've integrated into your program three precision instruments you assemble yourself:

**Design Console** Use this to rapidly "breadboard" circuits without soldering.

**Oscilloscope** Offers bright, sharp screen images, 3-way jacks for leads, plugs.

**Transistorized Meter** Registers current, voltage and resistance.



### DETACH AND MAIL POSTAGE-FREE CARD TODAY! OR WRITE:

An Electronics Home Study School  
DEVRY INSTITUTE OF TECHNOLOGY  
ONE OF THE

**BELL & HOWELL SCHOOLS**  
4141 Belmont, Chicago, Illinois 60641

531

\*Electro-Lab is a registered trademark of the Bell & Howell Company

# FLAG-POLE HAM ANTENNA

**Construction**

*Vertical helix disguised as a flag pole produces good results*

BY ROLAND J. McMAHAN

**W**HEN we moved to our new house, my usually gentle and permissive wife issued an unusual ultimatum: "Please do not put up a spider web of antennas around our new home." For a moment, my world reeled; 40 years of spider webs—uh, amateur radio—had taught me that a good antenna is the first requirement of a good station.

I ruminated for a while, rejecting the idea of an antenna camouflaged to look like a lightning rod in a location where lightning rods are a rarity. A flag pole? We're patriotic enough to have had one at our last location, so I was sure my wife wouldn't object. Now, I became obsessed with the idea of designing a flagpole antenna.

**Trial and Error.** The various handbooks cover vertical antennas very well—except for the helix, which is probably the easiest to build, consisting of a half-wave length of wire wound on a form. Convinced that this was the design I needed, I wound 70 ft. of #12 insulated stranded wire on a 6-ft. length of 1½-in. inner diameter rigid plastic pipe. The turns stayed in place; so, I drilled a hole at each end of the pipe and passed the wires through them to secure the coil.

The turns stayed in place well without cement—at least until the antenna-ground system was resonating on the 40-meter band, at which time about 20 turns suddenly dropped a foot and completely demolished my work up to that time. Too late, I realized that I should have taped the turns at about 12-in. intervals.

I checked the resonant frequency of the antenna-ground system with a dip meter and verified the frequency with my calibrated receiver. (The depth of the dip gives an indication of the Q of the system. The resonant frequency will change by 0.2-0.4 MHz when the antenna is raised to its perch atop a flag pole; it did with mine.)

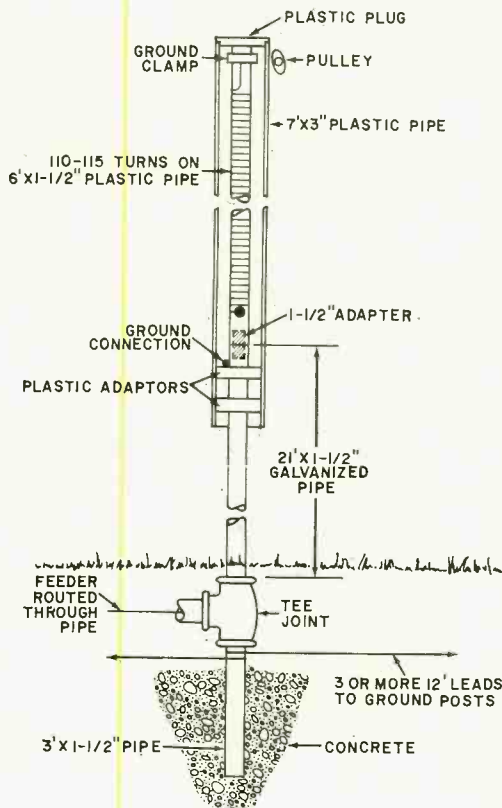

My first effort, running the antenna to a loop around my dip oscillator coil and then to the ground I intended to use, gave a high-Q dip at about 6 MHz. Removing turns of wire sometimes raised and at other times seemed to lower the resonant frequency. Adding a ground-type clamp as a top-loading capacitance connected to the antenna at the top seemed to make the antenna behave better.

I removed turns until the wire on the form was only 60 ft. A high-Q dip appeared at 6.4 MHz—still far too low. I decided to



try the antenna indoors and far off resonance because I wasn't sure yet how much difference raising the antenna would make. So, with the antenna and ground connected to my transceiver, I had to increase the loading adjustment and got the plate current to increase from 100 mA to 200 mA. The point of maximum field strength and minimum plate current occurred at the same plate tank tuning setting—an indication of low SWR.

With the antenna sitting on a table and leaning against a wall, I received an S7 from Seattle, some 300 miles away. On transmit, power to the antenna system was about 80 watts. I removed a few more turns until the oscillator indicated a dip at 7.1 MHz (this was later verified). Now minimum loading caused a broad tuning, flat plate current of slightly more than 200 mA. I tuned for maximum field strength indication and received some S8 reports.

**Finalizing the Design.** Now I decided to try out my antenna outside, feeding it with a 50- or 75-ohm line. Fitting a plastic adaptor into the lower end of the plastic pipe form, I screwed the antenna into an

iron coupling on a 3-ft. iron pipe and planted the pipe in the ground. One lead of a length of flat ac power cord ran to the antenna, and the other I clamped to the pipe and to a wire about 30 ft. long which terminated in a pipe in the ground.

Now the frequency was 7.4 MHz; too high. However, I tried the system out and received an S7 from a ham aboard a ship some 1000 miles away. Adding some turns and mounting the antenna on a 21-ft. length of galvanized iron pipe, with the feed line running down the center of the pipe, I raised the antenna and leaned the pipe against the roof of the house to minimize capacitance problems. The antenna checked out 0.2 MHz higher than it was when on the ground.

That antenna went up and came down so many times that our neighbors must have thought I was signaling with my flag pole. Eventually, I got the antenna to resonate at 7.1 MHz. Readings of S9 became common, and I got an S6 from one of the Japanese Islands on 40 meters. Using the third harmonic and with no changes to the antenna, I logged an S9 from Germany—no mean feat in Idaho. ♦

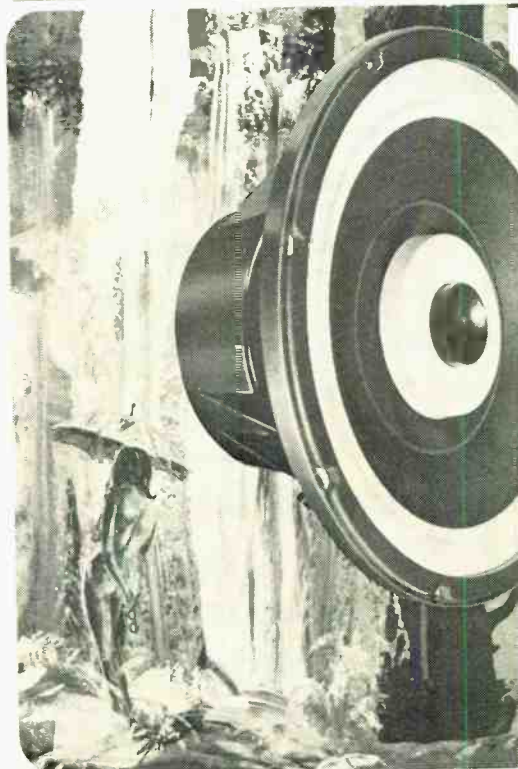

**utah PRESENTS**

# Cascade

**MOST POWERFUL, MOST  
EPIC PRODUCTION EVER!**

This is the one you will want to see and hear. It is the most powerful die-cast High Fidelity speaker series ever produced by Utah. Its name is CASCADE... the totally new co-axial speaker line. It has the largest magnets ever and larger voice coils to handle more power for a longer time. Cloth rolls enhance bass performance. The rigid die-cast frame is designed for maximum structural length, and it can be mounted to either the front or rear of the baffle board. Your choice of 2-way or 3-way models in 8" and 12" sizes, some with co-axially mounted compression tweeters. Your ticket to the powerful CASCADE performance can be hurried along by writing us for complete information.

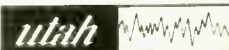

**UTAH ELECTRONICS**  
HUNTINGTON, INDIANA 46750

**CIRCLE NO. 29 ON READER SERVICE CARD**



# Solid-State

By Lou Garner

**J**ANUARY is a wonderful month! It gives us a chance to forget the past and make resolutions for the future. It also gives us an opportunity to hazard some guesses about things to come. We seem to enjoy predicting as much as we do the other aspects; and we'd like to share with you some of our "electronic" predictions for 1974. To wit, there will be:

- *A substantial drop in the prices of digital electronic watches* from the present hundreds of dollars.
- *Comparable reductions in the prices of digital electronic clocks.* We expect these to be competitive in price with better-quality mechanical clocks before 1974 draws to a close.
- *LED's at prices comparable to those of miniature incandescent lamps in small quantities.* True, 9¢ LED's are available now, but only in million-lot production quantities. We anticipate a substantial drop in retail prices as well in coming months.
- *The introduction of control-function IC's as stock items.* Although currently available only as custom designs, these would be suitable for use in alarm and control systems, and would complement the digital and linear IC's now available through distributor outlets.
- *The development of one or more new solid-state transducers,* perhaps for automotive applications. One roadblock to the extensive use of electronics in vehicles is the

lack of suitable transducers. We feel sure American engineering know-how will eliminate this problem soon.

- *The introduction of low-cost (about \$100) preprogrammed business calculators.* These would be designed specifically to handle standard business calculations, such as percentages, interests, mortgage pay-offs, and similar problems. Perhaps two of three models will be offered, each programmed for specific business areas, such as real estate, insurance, and so on.
- *Digital electronic test instruments, such as VOM's and frequency meters, at prices comparable to those of instruments using moving-coil meter movements.* We feel the day is not far distant when there will be less than a 20% difference between the prices of digital readout and meter readout instruments with similar performance specifications.
- *Development of a new semiconductor manufacturing technique or a refinement in current techniques* which will improve quality, increase yield rates, and lower costs.
- *The announcement of an unusual new solid-state device.* The "prophecy computer" is a little fuzzy on this one, but it may be a new microwave device, or perhaps even a LED with bilateral switch characteristics, providing the equivalent of a semiconductor "neon" lamp.

That's it for our 1974 predictions. Next January, we'll tote up the score, using our jim-dandy electronic calculator.

## Predictions for 1974

**Circuit Sources.** Assembling a digital clock? Planning an audio project? Designing a hearing aid or test amplifier? Working on a new piece of test equipment? Regardless of the project you are planning, there's a good chance you can find just the circuit you need by referring to the literature published by major semiconductor manufacturers. Often, practical circuits are included as

part of individual device specification bulletins. In some cases, circuits are given in general application notes. In other cases, practical designs will be found in books, booklets, and brochures published by manufacturers. Typical examples of the circuits featured in manufacturers' literature are described below.

A useful digital clock circuit is shown in Fig. 1—a general-purpose alarm clock providing a 24-hour display. This schematic was abstracted from the 6-section data sheet for the S1736 MOS digital clock IC, published by American Microsystems, Inc. (3900 Homestead Road, Santa Clara, CA 95051). Featuring 117-volt ac operation and requiring but a single S1736, the circuit may be used to drive a commercial liquid-crystal display or, if preferred, a Tung-Sol type DT1704 tube display.

Featuring the LM381 low-noise dual preamplifier IC, the audio preamp circuits illustrated in Fig. 2 were taken from National Semiconductor's data and application bulletins for this device. The circuits require a minimum of external components and may be used independently or, if preferred, incorporated into more elaborate audio preamplifier designs.

With two completely independent ampli-

fiers in a single 14-pin DIP, the LM381 is ideal for stereo and quadraphonic applications. A dual short-circuit-protected internal power supply decoupler-regulator permits device operation on single-ended sources of from 9 to 40 volts dc, while providing 120-dB supply rejection and 60-dB channel separation.

If you are looking for a high power output circuit to use in a PA or musical instrument amplifier, you might consider the one given in Fig. 3. Described in RCA's Application Note AN-4474 (RCA Solid State Division, Route 202, Somerville, NJ 08876), this design has a nominal 100-watt rating, but can furnish a maximum output of up to 200 watts. It requires a dual 23-volt, medium-current (10 A) dc power supply, has an input impedance of 1800 ohms and may be coupled directly to a loudspeaker's voice coil.

If test instruments are your bag, you should be interested in the Wien bridge oscillator in Fig. 4. The schematic was abstracted from Application Bulletin A005 for the type 8007 operational amplifier IC. Published by Intersil, Inc. (10900 N. Tantau Ave., Cupertino, CA 95014), the 6-page bulletin also features a number of other useful circuits, including log and antilog am-

Fig. 1. Circuit of a general-purpose alarm clock which provides a 24-hour display. It uses American Microsystems' S1736 MOS IC chip.

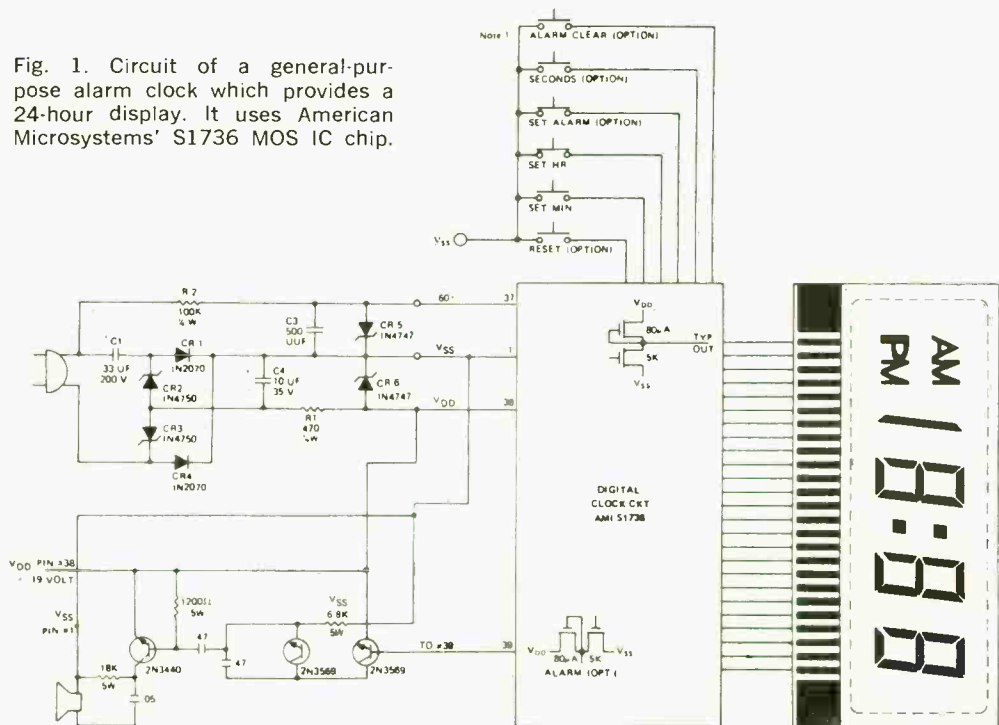



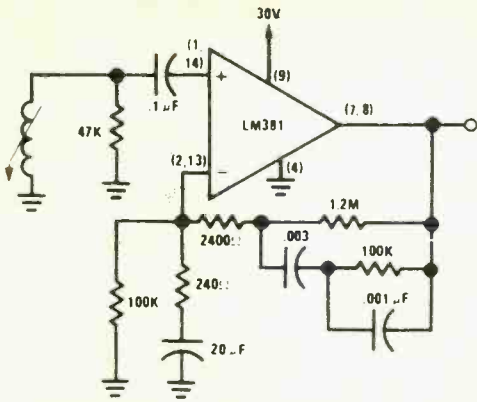

Typical Magnetic Phono Preamp.

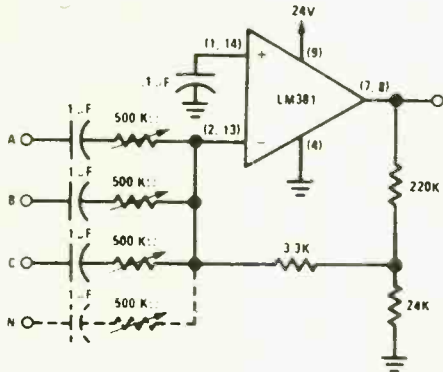

Audio Mixer

Fig. 2. Circuits shown here are suggested by National Semiconductor for using their LM381, a low-noise dual preamplifier IC.

plifiers, both inverting and non-inverting peak detectors, sample and hold circuits, and a high-impedance buffer amplifier.

According to Intersil, the Wien bridge oscillator is capable of supplying good-quality

sine-wave signals at frequencies up to and beyond 100 kHz, depending on the values chosen for the bridge network. The basic oscillator circuit may be used alone as a tone source in other equipment, or, if preferred, combined with a buffer output stage and suitable dc power supply to form a bench audio signal generator. Switch selectable or continuously variable bridge components may be used to provide other than a single-frequency output, if needed by the user's application.

**Device/Product News.** If there's an electronic musical instrument project in your future, you'll be pleased to learn that American Microsystems, Inc. has released advance details on a new rhythm generator. Designated type S8890, the new unit is an LSI counter-ROM intended for applications in electronic organs, music synthesizers, and similar instruments. The device comprises an internal oscillator, a 6-bit counter, and a ROM that drives nine rhythm instruments as well as a seven-segment sequence count display. It can furnish up to 10 rhythm patterns per instrument. Supplied in a 40-pin DIP, the S8890 is designed for operation on a 12-volt dc source.

Motorola Semiconductor Products, Inc. (P. O. Box 20912, Phoenix, AZ 85036) has introduced two new devices which should be of particular interest to experimenters and hobbyists: a new MOSFET intended for use in highly sensitive smoke detection applications and an analog-to-digital (A/D) IC suitable for control and digital instrument designs. Identified as the MFE824, the new MOSFET is a depletion-enhancement mode (Type B) n-channel silicon device with a reverse gate current figure of only 1.0 pA max at a  $V_{GS}$  of 10 volts dc. With a maximum drain current of 30 mA

Fig. 3. A 100-watt bridge amplifier circuit; it uses a pair of RCA's HC1000 hybrid amplifier IC chips.

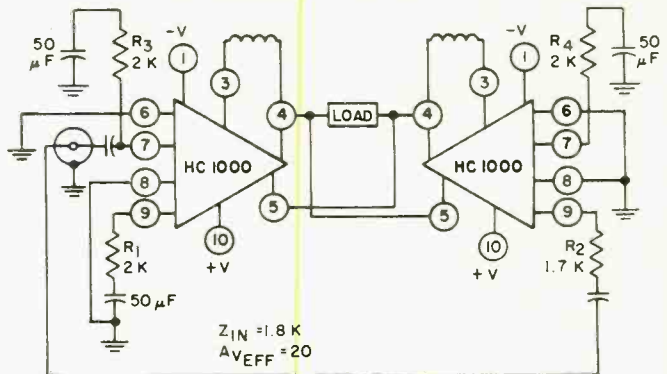

and a maximum drain-source voltage rating of 20 volts, the MFE824 is supplied in a standard TO-18 package. Motorola's new A/D control device combines a wide-band operational amplifier and a high-speed dual-threshold comparator in a single 16-pin DIP. Designated type MC1507/1407, the new device can be used in conjunction with a pair of MC74193 counters to produce an inexpensive high-speed tracking A/D converter.

Power supply designers and builders should be interested in a new family of seven blow-out-proof voltage regulators now available from Silicon General, Inc. (7382 Bolsa Ave., Westminster, CA 92683). The new devices are offered in both TO-3 and TO-5 packages. Each unit in the family, the SG7800/140 Series, can supply in excess of 1 A at nominal voltages of 5, 6, 8, 12, 15, 18 and 24 volts.

RCA (Solid State Division, Route 202, Somerville, NJ 08876) also is in there pitching to the power supply builder with a new 2-to-32-volt, high-current, high-voltage, adjustable voltage regulator, the type HC4100.



Fig. 5. GE has two new high-current SCR's.

The new power hybrid module features a 5-A current rating, adjustable current fold-back protection, remote sensing capability, and remote shutoff, supplying a continually adjustable output voltage regulated to within 0.2% (typ.). The input voltage capability is 43 volts. With a maximum power dissipation of 62.5 watts, the HC4100 is supplied in an 8-pin TO-3 type hermetic package.

Working with high power inverters (isn't everybody?)? Then you'll want to take a look at General Electric's (Semiconductor Products Dept., Building #7, Mail Drop

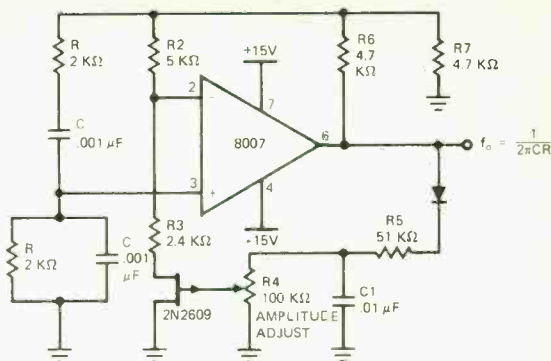

Fig. 4. Schematic of a Wien bridge oscillator using intersil's type 8007 op amp IC.

49, Electronics Park, Syracuse, NY 13201) new high current SCR's, types C364 and C365. Rated at 275 A rms with forward and reverse blocking voltages to 600 volts, the units, Fig. 5, are designed primarily for power switching in the 1- to 10-kHz range. Featuring GE's amplifying-gate and a 10- $\mu$ s turn-off time, the C364/C365 devices are offered in  $\frac{1}{2}$ " PRESS-PAK cases.

Thus concludes our Solid-State story for this month . . . and a HAPPY NEW YEAR to one and all.  $\blacklozenge$

### SOLUTION TO CROSSWORD PUZZLE (see p. 46)

A	M	P	L	I	D	Y	N	E		G	A	P
C		U		N			A			A		A
C				C			L					A
O				S			R					A
R				E			A					V
D				T			I					I
I				I			A					R
O				W			N					R
N				G			U					C
				P			A					T
C				C			A					P
A				O			I					O
N				U			T					N



# YOU'LL BE DYNAMITE!

Build your own CIE color TV!

Learn Electronics!

Create a new  
career!

Enjoy a whole  
new life style!

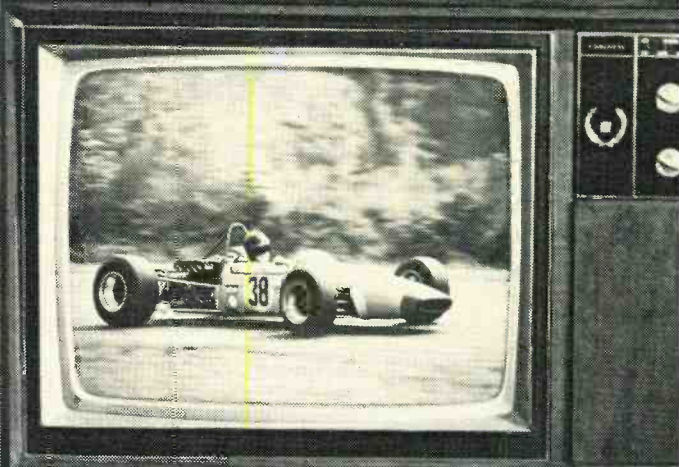

Mail the postage-  
free card today  
for free information.

Television reception is simulated.



Imagine what your friends will say when they see your new solid-state 25-inch diagonal CIE color TV — and find out you built it yourself!

## Learn Electronics this new enjoyable way.

When you learn Electronics with CIE, you not only get to build your own solid-state color TV (worth \$599.95), you acquire a knowledge of Electronics that can open up a whole new world of exciting, high-paying opportunities in a broad selection of career fields!

## You also get to work with your own CIE Experimental Electronics Lab.

In addition to building your own solid-state TV, you get to perform hundreds of fascinating electronics experiments and projects with your own 161-piece CIE Electronics Laboratory. The lab includes electronics testing gear and dozens of the same components you'd use in your own electronics business or in a key industry job. You actually apply what you learn in the most enjoyable and practical way possible.

## You can use your new skills to become your own boss or to make big money in business and industry.

Look around you — everything is "going electronic"! Electronic equipment is the heart of today's entertainment and communications industries. It's the "nerve system" of our newest office buildings, manufacturing plants, transportation systems, financial institutions, hospitals — even the newest super-

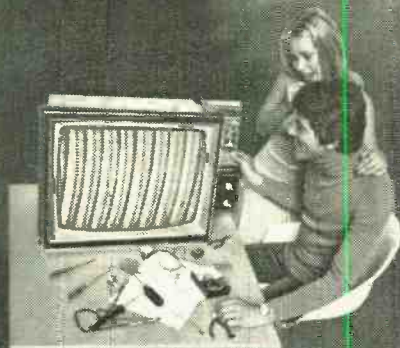

markets. Your electronics skills and knowledge will put you among the elite in this continuing technical revolution! According to a U.S. Office of Education Bulletin, 25 Technical Careers You Can Learn in 2 Years Or Less, "The demand for people with technical skills is growing twice as fast as for any other group, while jobs for the untrained are rapidly disappearing."

## CIE has trained thousands of men like you.

CIE's special AUTO-PROGRAMMED® Lessons are designed to make learning easier — even if you've never done anything more complicated than wiring a lamp. And when you've completed your course, you'll be prepared to take the Government FCC License exam — a must for top paying jobs in such fields as broadcasting. Best of all — you learn it all at home, in your spare time, while you go right on picking up your regular paycheck.

If you are in the service or are a veteran, check the box on the attached reply card for complete information on educational benefits under the G.I. Bill.

## Detach the postage-paid reply card and mail it today for complete FREE information!

If the card has been removed, write to:

**CIE** Cleveland Institute of Electronics, Inc.

1776 E. 17th St., Cleveland, Ohio 44114  
Accredited Member National Home Study Council

CIRCLE NO. 4 ON READER SERVICE CARD

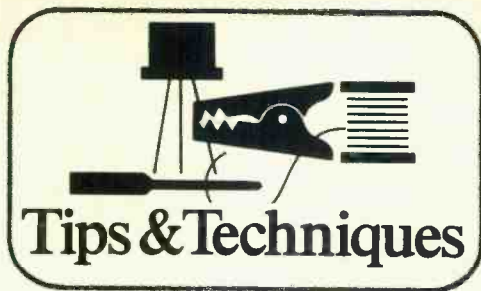

## Tips & Techniques

### COLORED POLYESTER FILM MAKES INEXPENSIVE LED DISPLAY FILTER

An attractive color-matched filter and protective window for LED and incandescent numeric displays can be made from an inexpensive item that you can buy in almost any art supply store. Called Rubylith or Amberlith, the polyester film material is available in deep red, orangy amber, and deep green. The red can be used with good effect with LED displays, while any color can be used with the incandescent display. To use this material, cut it to a size large enough to fit the window cutout of your project plus about  $\frac{1}{4}$  in. on all sides to permit mounting. Run a bead of plastic cement around the perimeter of the film and fix the film into place. Note that the colored non-reflective side should face away from the display.

—William A. Russo

### A QUICK-FIX APPROACH TO SPLICING COAXIAL CABLE

Having to splice together two lengths of coaxial cable isn't one of the more pleasant jobs an experimenter must face, but the task can be made considerably easier with the aid of 5-minute epoxy cement and a length of heat-shrinkable tubing. Begin the operation by first preparing the ends of the coax to be joined as shown in the drawing. Slip a 2" length of heat-shrinkable

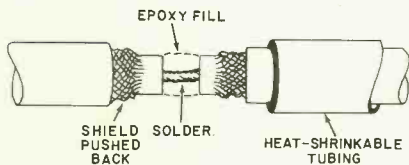

tubing over one of the cables. Solder together the inner conductors of the cable and coat them with epoxy cement, building up the coat to the thickness of the inner insulator. Let the cement set for five or more minutes. Then push together the two shields, overlapping slightly, and tack solder. Push the heat-shrinkable tubing over the joint and heat to seal. Finish the job with a couple of turns of electrical tape over the ends of the tubing. —Pete Walton, VE3FEZ

### BLUNT INSTRUMENT SEPARATES BRAID WITHOUT CUTTING OR NICKING WIRES

The braided-wire outer conductors of most coaxial cables are very fine and easily damaged if a sharp tool like a knife is used to separate them when preparing to install a connector. A safer tool to use is a small screwdriver. Another tool that can be used to good advantage for this job is a soldering tool like those supplied with soldering guns; use the un-notched end to "comb" loose the fine wires. By using the right tool for the job, you will end up with

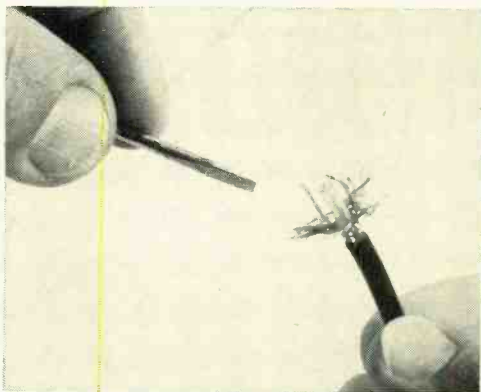

a much more professional-looking connection and chances of a loose or broken wire accidentally shorting against the inner conductor will be virtually nil. —Marshall Lincoln

### GET PC BOARD BLANK CLEANER FROM PHOTO SUPPLY HOUSE

Before applying the resist, most people clean the copper surface of their PC board blanks with an abrasive scouring powder that leaves a surface over which it is difficult to apply the resist evenly. A better cleaner, 28-percent acetic acid (not glacial acetic acid, which is too strong), can be obtained from any photography supply house. Add to the bottle of acetic acid a half teaspoon of table salt and gently shake until the salt has completely dissolved. Now, wearing rubber gloves, wet a large wad of cotton with the solution and rub the copper surface vigorously until it is clean. Thoroughly rinse the PC blank under running water and pat dry with a lint-free cloth. —Garry H. Barnett

#### TIPS WANTED

Do you have a "tip" or "technique" that might help your fellow readers? It may be worth money to you. Send it in (about 100 words, with a rough drawing and/or clear photograph, if needed) and you'll receive payment if accepted. Amount depends on originality and practicality. Material not accepted will be returned if accompanied by a stamped, self-addressed envelope. Send material to: Tips and Techniques Editor, POPULAR ELECTRONICS, 1 Park Ave., New York, NY 10016.





# CB Scene

By Matt P. Spinello, KHC2060

**T**HE new year having arrived, it is time for all CB'ers to make some resolutions to better the hobby. Here are a few that have been put off for far too long:

1. Radio amateurs and CB operators should unite in programs of public service and emergency communications. This will require cooperation from both sides, but once the program is under way, the two services can aid each other and civic authorities in a really effective way.

2. Let's work toward cooperation on another level. Hams can be of enormous help to CB'ers who are interested in getting an amateur radio ticket. Perhaps we can make hams amicable enough to set up more theory and code classes to teach all of our compatriots who want to move up to higher power communications.

3. All CB clubs should make it a firm policy to find more effective methods of policing their own areas. Let's get those who abuse the privilege of operating on the CB channels off those channels so that the rest of us won't have to suffer.

4. It's time we all added more volunteer projects to club activities, including first aid instruction and emergency standby teams on call at a moment's notice.

Sound too optimistic? Look at it this way: If all of the resolutions mentioned above were put into effect, most of the present entanglements that bind the Citizens Band would be eliminated. Amicable relationships with other CB'ers, hams, emergency and civic services, and the community at large will go a long way toward erasing the bad public relations that have been heaped upon us in the past.

A few of the resolutions we have outlined appeared as predictions in the column we wrote for this magazine in January 1964. Maybe now that we "resolve" rather than "predict," they will come to pass.

**Full Time Communicators.** The array of CB gear available to the CB'er today can make the man (or lady) at the mike the most well-equipped local communicator in the world. As a licensed Citizens Radio operator, he can be in direct contact with his office, home, another mobile station, the police or fire department, or virtually any telephone in the world. And he can do all this without leaving his automobile.

The hobby aspects of monitoring the Public Service bands cannot be denied, as witnessed by the increased sale of scanning monitor receivers in recent years. The arrival of such monitors has brought about a new service convenience for the serious channel 9 emergency monitor. REACT personnel found definite advantages in the ability to monitor (in addition to channel 9) area police, sheriff, weather, and fire frequencies by means of receivers that automatically tune in as many as eight frequencies in half a second.

Applications for scanning monitors are nearly limitless. When emergencies are announced which indicate a lost child, a drunk driver, or a community-wide disaster, REACT and ALERT teams are quick to volunteer their collective services to the authorities. A motorist who reports to REACT a disabled vehicle in the wee hours, requesting police assistance or a tow, can rest assured that help is on the way as soon as the monitor has reported the trouble by telephone.

Miniature solid-state transceivers and monitors, combined with a multitude of ac-

## The Full-Time Communicator



**STATEMENT OF OWNERSHIP, MANAGEMENT AND CIRCULATION (Act of August 12, 1970: Section 3685. Title 39. United States Code).**

1. Title of publication: Popular Electronics including Electronics World.

2. Date of filing: October 1, 1973.

3. Frequency of issue: Monthly.

4. Location of known office of publication: One Park Avenue, New York, New York 10016.

5. Location of the headquarters or general business offices of the publishers: One Park Avenue, New York, New York 10016.

6. Names and addresses of publisher, editor, and managing editor: Publisher, Edgar W. Hopper, One Park Avenue, New York, New York 10016; Editor, Milton S. Snitzer, One Park Avenue, New York, New York 10016; Managing Editor, John R. Riggs, One Park Avenue, New York, New York 10016.

7. Owner: Ziff-Davis Publishing Company, One Park Avenue, New York, N.Y. 10016. 1. William Ziff, One Park Avenue, New York, N.Y. 10016 2. Dirk S. Brady, Charles Housman, Jules I. Whitman, Trustees F/B/O Dirk Ziff et al, 16 Ervilla Drive, Larchmont, N.Y. 10538.

8. Known bondholders, mortgagees, and other security holders owning or holding 1 percent or more of total amount of bonds, mortgages or other securities: NONE.

9. For optional completion by publishers mailing at the regular rates (Section 132.121, Postal Service Manual). 39 U. S. C. 3626 provides in pertinent part: "No person who would have been entitled to mail matter under former section 4359 of this title shall mail such matter at the rates provided under this subsection unless he files annually with the Postal Service a written request for permission to mail matter at such rates."

In accordance with the provisions of this statute, I hereby request permission to mail the publication named in Item 1 at the reduced postage rates presently authorized by 39 U. S. C. 3626.

William L. Phillips, Assistant Treasurer

11. Extent and nature of circulation:

	Average No. Copies Each Issue During Preceding 12 Months	Actual Number of Copies of Single Issue Published Nearest to Filing Date
A. Total No. Copies printed, (Net Press Run) .....	461,318	447,598
B. Paid Circulation		
1. Sales through dealers and carriers, street vendors and counter sales .....	54,262	52,300
2. Mail subscriptions .....	324,682	313,884
C. Total paid circulation .....	378,944	366,184
D. Free distribution by mail, carrier or other means		
1. Samples, complimentary, and other free copies .....	7,761	7,693
2. Copies distributed to news agents, but not sold .....	72,328	71,650
E. Total distribution (Sum of C and D) .....	459,033	445,527
F. Office use, left-over, unaccounted, spoiled after printing .....	2,285	2,071
G. Total (Sum of E & F—should equal net press run shown in A) .....	461,318	447,598

I certify that the statements made by me above are correct and complete. William L. Phillips, Asst. Treas.

cessory items and short, highly effective mobile antennas for vehicle operation and directional beam antennas for base station effectiveness, took the CB'er out of the 1960's and launched him into the 1970's. The emergency monitor can easily equip his base station with the necessary communication links: CB transceiver, Public Service monitor, and telephone. He could duplicate the capability in his mobile station with an under-dash CB transceiver, miniature PS monitor, and phone patch to base.

Monitor receivers, once bulky items, have been reduced small enough to be battery operated and to fit into a shirt pocket. Some even have built-in scanning circuits. Now, the serious monitor can literally carry Public Service transmissions with him wherever he goes. Twenty-three channel hand-held CB transceivers have become a firm reality. Combining a hand-held CB rig and a scanning monitor comprises a fairly complete system for the monitor afoot.

The devoted monitor who stays tuned to CB frequencies late into the evening can appreciate the advantages of taking his full-time system from room to room and even outside where he will be away from his base station and mobile rig. More often than not, an important request for assistance seems to hit the air when a monitor who has been glued to his shack all evening decides to take a short sandwich and coffee break or whatever. With full-time monitoring equipment, he won't miss such a call.

The battery-operated combination of equipment can serve the emergency rescue team on foot as well. All can be kept informed of rescue progress by monitoring individually from the field with a minimum exchange of communications. A battery-operated, cordless telephone linked to the team leader or a central point could serve as the final link to complete the communications system.

Now you know how you can become a full-time communicator with the glittering array of gear currently available. It is obvious that you can communicate from the hip in 1974. What may not be obvious is that some people feel that this is only the beginning. What will the CB scene be like in 1984? Look back over the past ten years and you can make an educated guess. ♦



# Test Equipment Scene

By Leslie Solomon, Technical Editor

**M**OST of us have hobbies related to electronics other than slaving over a hot test bench. For example, some are hams, some are CB'ers, others dabble in audio, and still others play with radio control. Our little thing recently has been with shortwave listening because we inherited a shortwave receiver of dubious value. After repairing it, we became fascinated with the prospects and spent many evenings tuning over the various bands and listening to English-language broadcasts from many countries.

What does all this have to do with test equipment? Well, we discovered that the main problem in using our shortwave receiver was that it had only so-so dial calibration so that we could never find the station whose frequency was called out in the SWL frequency lists. This left us with two options if we were to continue to pursue our new-found hobby: either sink some dough into a better receiver or do something about the one we had. We decided on the latter and the way we corrected the situation should be of interest to others who have some test equipment and a not-too-good SW receiver.

All you need is an r-f signal generator connected to a frequency counter. Using the SWL frequency guide, tune the generator to the desired frequency using the counter. Then apply audio modulation to the generator and tune the receiver to that tone.

We've had good success with the scheme and have located many countries. Of course the idea is very simple and many other hobbyists may be using it already. But you never know and we thought it was worth passing along.

**A Bit on Scopes.** We are so used to thinking of our scopes as non-loading, "infinite-input-impedance" devices (though

somewhere we read in the manual that it was 1 megohm at 35 pF) that we almost never question it when making waveform measurements.

However, let's stop for a moment and consider the actual input impedance. When considering dc, the input impedance is the 1 megohm specified. However, in the case of ac, things are a little different because then the capacitive reactance comes into play. If you really want to see just how high in frequency your scope can go before the display drops to nothing, plug the value of your scope's input capacitance into the  $1/(2\pi FC)$  equation for capacitive reactance and watch how fast the input impedance drops as the frequency goes up. In this way, you will understand one of the limitations of your scope and discover the importance of a good compensated (10:1) probe.

**About Components.** We frequently get inquiries about the various types and sizes of resistors and capacitors. Usually, the reader has to replace a defective part in a commercial test instrument or is constructing an instrument himself. The following examination of the attributes of these components will hopefully provide some answers to recurring questions.

**Capacitors.** A typical query is: what is the significance, in a circuit, when a capacitor is specified as a mica, ceramic, paper, or plastic-film? What are the purposes and uses of the various types of electrolytics? A mica capacitor is used

## Some Odds and Ends

when there are high voltages involved, where stability under temperature or electrical stress are concerned, and where long life is required. Essentially, they consist of a metal foil and mica "sandwich" encapsulated in a plastic package. Mica capacitors have low leakage current and a small dissipation factor. They are usually available from about 1 pF to 0.1  $\mu$ F with tolerances from 1 to 20 percent. They have no polarity preference.

A ceramic capacitor consists of a ceramic disc coated on both sides with metal and with connecting leads secured to the metal. There are two types: a low-loss, low-dielectric-constant type and a high-dielectric-constant type. Low-loss types have leakages approaching 1000 megohms and are used in high-frequency circuits. The high-dielectric-constant types have high capacitance values in small sizes. Capacitance values range from about 100 pF to 0.1  $\mu$ F and typical tolerance is from +100% to -20% of marked value. They can change values with variations in temperature, applied dc and frequency and are used only where an exact value is not required—such as for coupling or bypassing.

Paper capacitors were widely used in vacuum-tube circuits because of their low manufacturing cost and broad range of values (400 pF to 50  $\mu$ F). They can also withstand high voltages. However, their leakage currents are high and tolerances are poor. Most paper capacitors are cylindrical and consist of a metal-impregnated paper sandwich with axial leads. Because some type of oil, wax, etc. is used to soak the paper, these capacitors can "dry out" with time. Some paper capacitors have a special oil-filled interior to enable them to withstand very high voltages.

A plastic-film capacitor is almost the same as a paper except that a sheet of Mylar, Teflon, or polyethylene is used as the dielectric. This enables the capacitor to be used at temperatures up to almost 200°C. Capacitance values range from 500 pF to about 10  $\mu$ F.

There are two types of electrolytics—aluminum and tantalum. These two materials are used because they form oxides having very high dielectric strengths. The oxide is used as the dielectric between two sheets of metal. Between the foils is an electrolytic solution soaked in paper. This serves as an extension of the non-oxidized

metal foil. The side of the foil without the oxide forms the negative terminal and the other side (positive) *must* be connected to the positive side of the circuit. If you connect an electrolytic backward, chemical action will rupture the oxide and destroy the capacitor. In the larger values, the oxide layer is very thin so the rated dc voltage is very low. Electrolytics come in capacitance values from 1 to 500,000  $\mu$ F, but they have a leakage resistance of about 1 megohm or less.

A non-polar electrolytic has the oxide on both sides of the foil so polarity indications are not used. However, the capacitance-to-volume ratio is reduced by about half, making this type of capacitor twice the size of a polarized unit of the same value.

**And Then Resistors.** While we think of a fixed resistor as having "so many ohms" as determined by Ohm's law, it is important to remember that many fixed resistors exhibit a change in resistance with frequency due to stray capacitance. The resistance can drop to a fraction of its specified value when used in circuits above about 10 MHz. On the other hand, some resistors look like inductors at some frequency and can have a far higher effect on ac than is expected.

The most common resistor is the carbon composition type, having values ranging from 1 to 22 megohms at tolerance from 5 to 20%. Their temperature coefficients are relatively large. Power ratings run up to two watts.

Wirewound resistors are usually more accurate than carbons. Tolerances range from 0.01 to 1%, from 1 ohm to 1 megohm. Power ratings can go as high as 200 watts. You can get special-alloy wirewounds with tolerances as low as 0.0005%.

Metal-film resistors can come up to 10,000 megohms. They have high accuracy and low TC. With metal film for the resistance element, noise is low, making them ideal for use in low-level amplifiers.

Carbon-film resistors use a deposited film of carbon rather than metal. This produces lower tolerances, but smaller values of resistance. The carbon film has a slight negative coefficient of resistance.

So, when you design and build your own test equipment or are replacing a part in a piece of commercial gear, it isn't just a case of soldering in any old resistor or capacitor. ♦



# A Pair of "De-Shockers"

*Harmlessly discharge  
high-voltage electrostatic charges*

BY BYRON G. WELS

**D**ID you ever shuffle across a nylon carpet, touch a ground, and—ZAP!—get jolted by an electrostatic discharge? Sure you have, and so have countless other people who have walked across carpets or slid across vinyl car seats. In most cases, it isn't the electrical charge that gets you but the small quick burn that is caused by the spark during discharge. So, the obvious way to avoid being zapped is to make the spark jump from some inanimate object instead of your tender fingertip. Shown in the drawings are two methods you can adopt.

You can make a portable de-shocker with the aid of a clear-plastic ballpoint pen body (the type with a metal ferrule girdling its center), a miniature NE-51H neon lamp, and a small steel bearing or BB. Unscrew the pen and remove and discard the cartridge and spring. Bend one lead of the lamp so that it points straight up and slip the lamp into the point end of the pen body. With the lead sticking out of the point hole, epoxy cement the bearing or BB in place, making certain that good electrical contact exists between the lamp lead and bearing. After the cement sets, assemble the pen, looping the free lamp lead over the metal ferrule.

To test the de-shocker wand, hold it with one finger on the ferrule and scuff across a carpet to build up a good static charge. Then touch the bearing against the mounting screw of an electrical wall plate. If the wand is properly assembled and you have built up a good charge, the lamp will flash as the charge harmlessly dissipates and you'll never feel a thing—except maybe relief.

The de-shocker can also be built into an existing electrical outlet. For this, you will have to determine if enough room exists in the switch box you select. Next, you will need a metal wall plate. Determine where on the wall plate you can mount an NE-211

neon lamp you'll be using so that it doesn't interfere with or contact the wall switch. Drill a  $\frac{3}{8}$ " hole in this location and deburr it. Slip into the hole a  $\frac{3}{8}$ " grommet. Solder to one lead of the lamp a spade lug; then slip the lamp into the grommet (the fit will be tight enough to obviate the need for mounting hardware). Solder one lamp lead to the wall plate.

For proper operation, the wall plate must be completely insulated from the wallbox. To do this, apply electrical tape around the perimeter of the plate. Squeeze the spade lug's prongs together just enough to make it stay put on the mounting screw. Under the head of the mounting screw, place a shoulder fiber washer, on the other side a flat fiber washer. Follow this with the spade lug, and finish up by fastening the wall plate to the outlet box.

Now, whenever you shuffle across a carpet, simply touch the wall plate. The lamp will flash, and the charge you built up will harmlessly dissipate. ♦

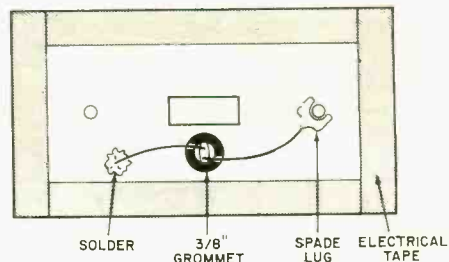
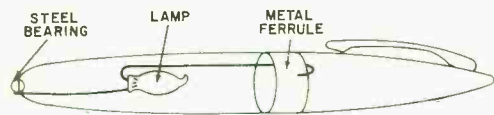

Ball-point pen de-shocker (top) and a de-shocker made from an insulated wall plate.

## ABOUT YOUR SUBSCRIPTION

Your subscription to POPULAR ELECTRONICS is maintained on one of the world's most modern, efficient computer systems, and if you're like 99% of our subscribers, you'll never have any reason to complain about your subscription service.

We have found that when complaints do arise, the majority of them occur because people have written their names or addresses differently at different times. For example, if your subscription were listed under "William Jones, Cedar Lane, Middletown, Arizona," and you were to renew it as "Bill Jones, Cedar Lane, Middletown, Arizona," our computer would think that two separate subscriptions were involved, and it would start sending you two copies of POPULAR ELECTRONICS each month. Other examples of combinations of names that would confuse the computer would include: John Henry Smith and Henry Smith; and Mrs. Joseph Jones and Mary Jones. Minor differences in addresses can also lead to difficulties. For example, to the computer, 100 Second St. is not the same as 100 2nd St.

So, please, when you write us about your subscription, be sure to enclose the mailing label from the cover of the magazine—or else copy your name and address exactly as they appear on the mailing label. This will greatly reduce any chance of error, and we will be able to service your request much more quickly.

## Planning to move?

Let us know **6 to 8 weeks in advance** so that you won't miss a single issue of **POPULAR ELECTRONICS INCLUDING ELECTRONICS WORLD**

Attach old label where indicated and print new address in space provided. Also include your mailing label whenever you write concerning your subscription. It helps us serve you promptly.

Write to: P.O. Box 2774, Boulder, Colo., 80302 giving the following information.

If you have no label handy, print OLD address here.

name	please print
address	
city	
state	zip-code

AFFIX LABEL

Change address only.

Extend subscription.  Enter new subscription.

(1)  5 yrs. \$21 (2)  3 yrs. \$15. (3)  1 year \$6

Payment enclosed (1 extra issue per yr. as a BONUS)

Bill me later.

0878

name \_\_\_\_\_ please print

address \_\_\_\_\_

city \_\_\_\_\_ state \_\_\_\_\_ zip \_\_\_\_\_

Add'l postage: \$1 per year outside U.S., its possessions & Canada.

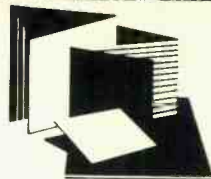

## New Literature

### EDMUND SCIENTIFIC HAS 1974 CATALOG

Every member of the family, including craft and hobby enthusiasts, gardening and workshop buffs, serious students and youngsters will find something special in the 1974 edition of Edmund Scientific Company's catalog. Listed in catalog No. 741's illustrated pages are more than 4500 items that range from toys and games to photography and optics items to scientific and electronic gear. Prominently featured in the listing are helium-neon lasers and accessories and light show devices such as a visual effects projector, UV lamps, and Edmund's own "Music Vision" color organ. There are many items of interest for the electronics hobbyist. Address: Edmund Scientific Co., 380 Edscorp Bldg., Barrington, NJ 08007.

### EXPANDED CATALOG FROM BROOKSTONE

A new 68-page catalog of high-quality, hard-to-find tools and shop devices has been issued by the Brookstone Co. The unique collection of items described and illustrated includes unusual craftsman's hand tools and small power tools. Of particular interest to the electronics enthusiast are the line of traditional and special-purpose pliers and cutters, screw and nut holders (which can also be used as heat sinks), a micro soldering station that has everything needed for tackling modern miniaturized circuit assembly projects, a terminal kit, and lots more. Address: Brookstone Co., 15 Brookstone Bldg., Peterborough, NH 03458.

### RCA PHOTODETECTOR BROCHURE/WALL CHART

A new brochure/wall chart that covers their solid-state silicon photodetectors is available from RCA Electronic Components. Titled "RCA Silicon Photodetectors," brochure No. OPT-112 provides quick comparison data for RCA single-element and quadrant-type p-i-n photodiodes, avalanche photodiodes, photo-voltaic diodes and photodetector-preamplifier modules. Address: RCA Electronic Components, Harrison, NJ 07029.

### SYLVANIA IC REPLACEMENT GUIDE

A new IC replacement guide published by the Electronic Components Group of CTE Syl-

vania, Inc. cross-references more than 1700 linear and digital devices to the equivalent Sylvania devices. A separate section in the guide lists part numbers used by 25 domestic manufacturers of home entertainment equipment and the ECG types that replace them. The guide also provides replacement information for imported IC's. More than 75,000 solid-state devices are cross-referenced in a separate master catalog. Both IC guide and master semiconductor replacement catalog are available from: Sylvania electronic components distributors or by writing to Electronic Components Group, GTE Sylvania Inc., One Stamford Plaza, Stamford, CT 06904.

#### J.W. MILLER COIL REPLACEMENT GUIDE

A comprehensive 100-page radio and TV coil replacement guide with cross-reference directory is available from the J.W. Miller Division of Bell Industries. Replacement guide No. 174 lists some 30,000 replacement coils for 375 manufacturers' names listed. The guide is a complete and authoritative coil replacement listing for all known domestic and foreign color and monochrome TV receivers and auto and home radio receivers. Address: Bell Industries, J.W. Miller Div., 19070 Reyes Ave., Compton, CA 90224.

#### MOUNTAIN WEST ALARM CATALOG

The new No. M-73 alarm equipment catalog from Mountain West Alarm Supply Co. features 80 pages of illustrated and described security alarm systems and accessories. Listed are full systems, detectors of all types, controls, annunciators, dialers, remote controls, locks, books, etc. Major categories include intrusion systems; fire systems; and infrared, ultrasonic, closed-circuit TV, switch, heat, and smoke alarm devices and systems. Address: Mountain West Alarm Supply Co., 4215 N. 16 St., Phoenix, AZ 85016.

#### CALECTRO HANDBOOK

In 72 pages of their Calectro Handbook No. FR-73-C, GC Electronics has managed to pack in a surprisingly complete listing of their product line, how-to information in text format, an Ohm's law calculator, and a section devoted to seven projects you can build. In the audio/hi-fi line are such items as microphones, speakers (raw and in enclosures), adapters and cable assemblies, etc. For the experimenter, there are solid-state devices, passive devices (resistors and capacitors), relays, switches, transformers, tools, PC items, and much more. Also featured are test meters and chassis boxes. The handbook can be obtained by sending 50¢ to: GC Electronics, Div. of Hydrometals, Inc., 400 S. Wyman St., Rockford, IL 61101.

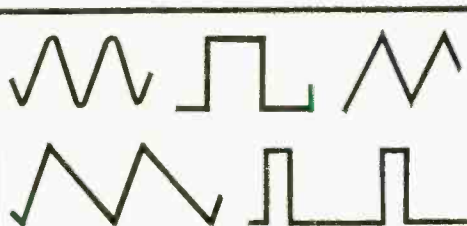

0.1 Hz. to 100 KHz.



For only \$39.95

Our new FG-2 Function Generator kit gives you all five of the most useful waveforms for design and testing at one fourth the cost of previous similar instruments. Thanks to improved IC's the FG-2 now features amplitude stability of  $\pm 1$ db over any range, Sine wave distortion of less than 1% from 20 Hz. to 20,000 Hz. and an output of 4.0 Volts peak-to-peak with adjustable offset. The offset selector lets you put the positive peak, negative peak, or the center of the waveform on DC ground. The DC coupled circuit keeps the waveforms in exactly the same position no matter what the level control setting.

Gray impact plastic case  $5\frac{1}{4} \times 6\frac{1}{4} \times 2\frac{1}{2}$ . 115 Volts 60 cycle power supply included.

FG-2 Function Generator Kit  
shipping weight 3.0 lbs. \$39.95 + postage.

GET OUR

## NEW 1974 CATALOG

listing this and other unique kits

"FREE"

by simply circling our number  
on the reader service card.



SOUTHWEST TECHNICAL  
PRODUCTS CORPORATION

DEPT. PE

219 W. Rhapsody, San Antonio, Texas 78216

CIRCLE NO. 26 ON READER SERVICE CARD



# NOW A PROFESSIONAL BURGLAR-FIRE ALARM SYSTEM YOU CAN INSTALL YOURSELF.

ONLY 129.95



Save hundreds of dollars in alarm installation and monthly service charges. The EICO SS-500 "install-it-yourself" burglar-fire alarm system offers you the kind of professional protection you have been looking for, at a price you can afford. The SS-500 has been designed on the EICO "Expandability Concept" that enables you to "add-on" protection to meet your own special needs. Before you purchase any security system, we suggest you read the EICO Security Handbook and see how easy EICO makes it to "Do-it-Yourself."

## FREE EICO CATALOG/SPECIAL OFFER!

Security handbook (Reg. \$2.95) only \$1.50 with this ad. Includes a catalog on EICO Security Systems, Test Instruments, Stereo, Hobby Kits and name of nearest distributor. For catalog only, check reader service card or send 25¢ for first class mail service.

EICO, 283 Malta Street, Brooklyn, N.Y. 11207



CIRCLE NO. 9 ON READER SERVICE CARD

# CALECTRO® DIGITAL DISPLAYS AND LOGIC

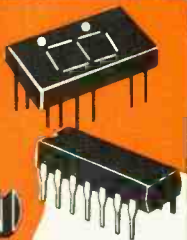

## ATTENTION HOBBYISTS!

**BUILD THIS  
DIGITAL  
COUNTER/ L.E.D.  
DISPLAY KIT.**



Everything needed to build a complete decade counter (0-9) including a printed circuit board. Operates from a 5 Volt D.C. supply. Can be used in hundreds of applications.

See your nearby CALECTRO distributor for all the most popular digital and integrated circuits. Also

get your copy of the new CALECTRO DIGITAL PROJECTS HANDBOOK!



**GC ELECTRONICS**

Division of Hydrometals, Inc.  
Rockford, Illinois 61101 U.S.A.

CIRCLE NO. 10 ON READER SERVICE CARD

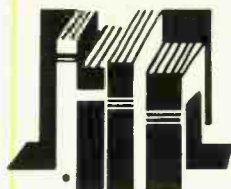

## Electronics Library

### TRANSISTOR PROJECTS, Volume 1 INTEGRATED CIRCUIT PROJECTS, Volume 1

by Forrest M. Mims, III

Both of these illustrated booklets feature projects that are prefaced with informative "How It Works" sections and concluded with supplementary project information that will enable the reader to expand upon the basic projects. Transistor Projects has 12 educational projects, including a metronome, amplifier, electronic siren, and electronic thermometer.

Published by Radio Shack, 2617 West 7 St., Fort Worth, TX 76107. Both volumes 96 pages, soft covers. Each volume \$1.25.

### GUIDE TO BROADCASTING STATIONS

This pocket-sized book of SW radio station listings is based on information provided by the various monitoring services of the British Broadcasting Corporation. It lists thousands of stations by frequency, geographic location, transmitter power, and the most likely time of year a particular frequency will be in use. All SW broadcasters are listed, including internationals, tropicals, regionals, domestics, etc. Medium-wave listeners will be interested in the detailed lists of all European broadcasters from 151 to 1612 kHz.

Available from Gilfer Associates, Inc., P.O. Box 239, Park Ridge, NJ 07656. Soft cover. 202 pages. \$2.50.

### PICTORIAL GUIDE TO TAPE RECORDER REPAIRS

by Forest H. Belt

Step-by-step text and 320 photos in this book show how to successfully disassemble, clean, troubleshoot, repair mechanisms and electronics, and reassemble all types of tape recorders after post-repair checkout. Included in this all-in-one handbook are home tape decks, reel-to-reel stereo decks, mono and stereo cassette decks, 4-channel machines, dictation recorders, Dolby systems, 8-track auto players, and more.

Published by Tab Books, Blue Ridge Summit, PA 17214. 256 pages. \$7.95 hard cover, \$4.95 soft cover.

**FUNDAMENTALS FOR ELECTRONICS,**  
Third Edition

by Matthew Mandl

This comprehensive volume provides broad and deep coverage of circuits, signals, and entire systems. Basic circuitry is illustrated and discussed from the standpoint of operational characteristics and applications to overall systems. All mathematics required for a working knowledge of signal analysis is covered early in the book. The text treats signals and spectra, modulation and sidebands, signal generation and shaping, r-f and i-f amplification, a-f and video amplification, AM and FM detection, monochrome and color TV modulation and detection, filters and transmission lines, microwave principles, and antenna systems.

Published by Prentice-Hall, Inc., Englewood Cliffs, NJ 07632. Hard cover. 628 pages. \$13.95.

**COLOR TELEVISION PRINCIPLES AND SERVICING**

by Howard & Marvin Bierman

Featuring a full-color section to illustrate common color faults, this book first maps out the entire color TV receiver in block diagram format and details the function of each section. Then specific circuits are analyzed with key input and output waveforms shown. Wherever possible, color circuits are compared with similar monochrome circuits to simplify understanding. Tube and solid-state arrangements are used to show the full variety of receiver circuitry. A complete chapter is devoted to the three-gun picture tube, its accessories, and special adjustment procedures required.

Published by Hayden Book Co., Inc., 50 Essex St., Rochelle Park, NJ 07662. Soft cover. 158 pages. \$4.95.

**RADIO TRANSMITTER PRINCIPLES AND PROJECTS, First Edition**

by Edward M. Noll, W3FQJ

Devoted entirely to the subject of radio transmitters, this is an excellent book for communications technicians, hams, experimenters, and people studying for the various grades of amateur and commercial FCC license exams. The text covers electron devices and describes hybrid transmitter circuits. Later DSB and SSB generation and circuits are discussed, followed by separate chapters devoted to amplifiers/mixers and IC's. The final three chapters cover vhf circuits, frequency modulation, and transmitter testing. Each chapter begins with basic principles and advances to more detailed information. Projects included in the book give the radio amateur an opportunity to build his own gear.

Published by Howard W. Sams & Co., Inc., 4300 West 62 St., Indianapolis, IN 46268. Soft cover. 320 pages. \$6.95.

# AUTO AIDS

Do-It-Yourself—Save Time, Money, Gas.

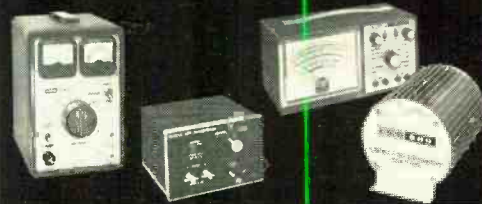

**EICO 1064** Dual purpose Battery Eliminator and Charger incorporating an extra low ripple filter circuit. Ideal for servicing, and powering 6-12 volt auto and marine equipment. Kit \$64.95 Wired \$84.95

**EICO 888** Portable Universal Engine Analyzer. Keeps your car or boat engine in tip-top shape. Complete with "How-to-Use" tune-up and troubleshooting manual. Kit \$54.95 Wired \$79.95

**EICO 1080** 200 watt Solid State Power Inverter and Battery Charger. Converts 12 volts DC to 117V. AC current. For use in cars, mobile homes and boats to operate recorders, appliances, etc. Kit \$44.95 Wired \$59.95

**EICO 889** Solid State C-D Ignition System adds power to any engine. Boosts gas mileage up to 20%. Points and spark plugs last up to 5 times longer, instant cold weather starting. Kit \$29.95 Wired \$39.95

**FREE 32 PAGE EICO CATALOG**

For latest catalog on EICO Test Instruments, Stereo, EICOCRAFT Projects, Environmental Lighting, Burglar/Fire Alarm Systems, and name of nearest EICO Distributor, check Reader Service Card or send 25c for First Class mail service.

EICO, 283 Malta Street, Brooklyn, N.Y. 11207 

**CIRCLE NO. 34 ON READER SERVICE CARD**



# Free!

New 12th Edition of the Midwest Hifi Catalog!

Save on stereo! Buy direct from us and you save money with our high-volume prices on more than 100 name brands. Order from the branch nearest you.

## Midwest Hifi

**Wholesale & MAIL ORDER DIVISION**

2455b Wisconsin Ave.      3309 E. J W Carpenter Frwy,  
Downers Grove, Ill 60515      Irving, Tex 75062

PE

NAME \_\_\_\_\_

ADDRESS \_\_\_\_\_

CITY/STATE \_\_\_\_\_ ZIP \_\_\_\_\_

**CIRCLE NO. 18 ON READER SERVICE CARD**



## New Products

Additional information on new products covered in this section is available from the manufacturers. Either circle the item's code number on the Reader Service Card inside the back cover or write to the manufacturer at the address given.

### SOUNDCRAFTSMEN PREAMPLIFIER/EQUALIZER

Continuous visual monitoring of input-to-output balance and overload warning using LED's are exclusive features of the Soundcraftsmen Model PE2217 preamplifier. In addition there are discrete 10-octave equalizers for each channel and pushbutton patching for control flexibility with safety-interlocked buttons to prevent

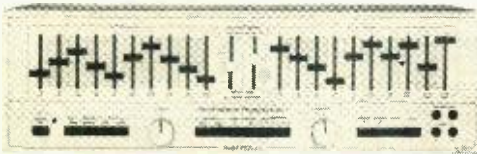

inadvertent program destruction. A total of 39 separate front-panel control functions provide maximum convenience and versatility in hook-up and usage of virtually any combination of related components. Equalization control is  $\pm 12$  dB for each of the 10 octaves. Dual main outputs are provided for scope, bi-amp, 4-channel hookup, or other special applications. S/N ratio is 90 dB; THD and IM distortion are less than 0.02 percent; and frequency range is 10 to 100,000 Hz.

Circle No. 70 on Reader Service Card

### SANYO DOLBY SYSTEM CASSETTE DECK

Among the features built into Sanyo's new Model RD 4250 high-performance cassette deck is a Dolby Noise Reduction System that minimizes tape hiss. Other features include super ferrite heads, large VU recording level meters, and a servo-drive tape transport designed to provide 99.8 percent speed accuracy. The deck has a tape counter, seven-button control function, automatic stop, and adjustable equalization for high-energy tapes. Two microphone, two stereo-line, and one stereo-headphone outputs are also provided.

Circle No. 71 on Reader Service Card

### E.F. JOHNSON MINI CB TRANSCEIVER

The E.F. Johnson Company's recently announced hand-held Messenger 180 portable CB transceiver is designed for single-channel operation with a 1.5-watt output signal. The American-made rig is compact and rugged, built of materials designed to take the abuse a portable radio is subject to and still get the message through. Only two controls are used: an on/off switch combined with the volume control and a squelch-adjust control. Built into the rig is a telescoping whip antenna. The radio can be ordered with a variety of accessories, including a leather case and holster, penlight rechargeable or standard batteries, a heavy-duty rechargeable battery pack, and several battery chargers.

Circle No. 72 on Reader Service Card

### ADVENT SPEAKER SYSTEM

The Advent/2, a new low-cost speaker system designed for unprecedented performance-per-dollar, has been announced by Advent Corp. Housed in a molded thermoplastic cabinet, it employs drivers normally associated with systems of twice this one's cost. The system has an acoustic-suspension woofer and two direct-radiator tweeters, arranged in an acoustic array that provides maximum dispersion with no interference effects between drivers. System resonance is specified at 58 Hz. The nominal crossover point is 1500 Hz, and the impedance is 8 ohms. The recommended minimum driving power for the Advent/2 is 10 watts.

Circle No. 73 on Reader Service Card

### ELECTRONIC TOOL "QUICK DRAW" DESOLDERER

A fast, one-hand-operated desoldering tool, dubbed the "Quick Draw," is available from Electronic Tool Co. Completely thumb-oper-

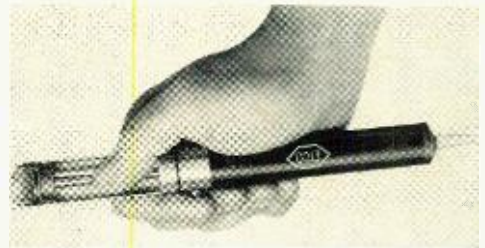

ated, the tool is said to be the fastest desoldering tool available. Its high suction power removes solder from terminal strips, component leads, standard and miniature wiring, and circuit boards without effort when used with a soldering iron or gun. The all-metal suction tool is internally chromium plated to prevent solder clog or build-up. Its Teflon nozzle is designed for extra long life; when worn, it is easily and inexpensively replaced.

Circle No. 74 on Reader Service Card



## EICO UNIVERSAL ENGINE ANALYZER

Now you can tune up and troubleshoot automotive engines the professional electronic way with Eico's new Model 888 solid-state universal engine analyzer. The 888 can be used to check voltage, engine rpm, dwell angle, current, resistance, spark output, and diode/leakage. It can be used for 6- and 12-volt electrical systems and for 4-, and 6-, and 8-cylinder engines. The analyzer works equally well with both negative- and positive-ground systems. In all, some 30 engine and wiring tests can be performed with the analyzer, aided all the way by a comprehensive troubleshooting manual supplied with the instrument. Ten large, easy-to-read scales on the 6-in. meter movement are keyed to the tests being conducted. The self-powered instrument is available both factory wired and in kit form.

Circle No. 75 on Reader Service Card

## TWO NEW SCOPES FROM HEWLETT-PACKARD

Featuring characteristics normally found only in lab scopes, two new low-cost 15-MHz oscilloscopes from Hewlett-Packard are priced for the technician market. The single-channel Model



1221A and dual-channel Model 1220A have deflection factors of from 2 mV/cm to 10 mV/cm, making them useful for basic analyses of audio, video, and logic applications and for such low-level uses as measuring FM i-f performance and the outputs from magnetic phono cartridges and tape heads. Triggered sweep, 8 x 10-cm CRT display (with internal anti-parallax graticule), X10 expander, pushbutton beam finder, TV sync separator, matched vertical and horizontal amplifiers, and more are standard. Being solid-state in design, the scopes weigh a mere 15 pounds each. The Model 1220A has alternate and chop modes for its dual-channel display.

Circle No. 76 on Reader Service Card

## GC INTRODUCES DIGITAL DISPLAYS & IC's

A complete assortment of digital displays (read-outs), logic, and TTL integrated circuits has been introduced by the Calectro Division of GC Electronics. The digital counter/LED display kit (Cat. No. J4-950) includes everything needed to build a complete decade counter.

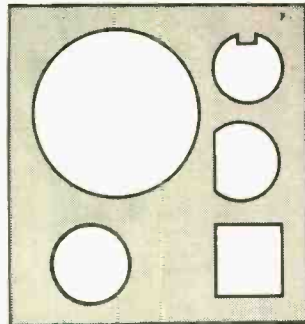

## Put more punch in your work.

With a Greenlee Chassis Punch you can punch clean, true holes in seconds. Round, square, key or D. In 16-ga. metal, hard rubber, plastic or epoxy. Available at radio and electronics parts dealers. Write for catalog E-730. Greenlee Tool Co, 1764 Columbia Ave., Rockford, Ill. 61101.

## GREENLEE TOOL CO

A Unit of Ex-Cell-O Corporation 

CIRCLE NO. 11 ON READER SERVICE CARD



FREE

1974 LAFAYETTE CATALOG 740

Ready Now!

### Your Complete Electronics Buying Guide

- Stereo/Hi-Fi Components • CB Transceivers & Walkie-talkies • PA Systems • Tools & Test Equipment
- Police/Fire Monitor Receivers • Antennas • Photography Equipment • Ham Gear • Books, Parts, and More!

Send Today!

**Lafayette Radio Electronics**  
P.O. Box 10, Dept. 35014  
Syosset, L.I., N.Y. 11791

35014

NAME \_\_\_\_\_

ADDRESS \_\_\_\_\_

CITY \_\_\_\_\_

STATE \_\_\_\_\_ ZIP \_\_\_\_\_

CIRCLE NO. 15 ON READER SERVICE CARD

**EVERYTHING YOU  
WANTED TO KNOW  
ABOUT CD IGNITION  
SYSTEMS BUT DIDN'T  
KNOW WHOM TO ASK.**

*Send for FREE Tiger booklet (20 pages) which answers all your questions.*

Name \_\_\_\_\_

Address \_\_\_\_\_

City \_\_\_\_\_

State \_\_\_\_\_ Zip \_\_\_\_\_

CLIP OUT THIS AD AND SEND TO—

**TRI-STAR CORP.**

P. O. Box 1727 Dept. E  
Grand Junction, Colo. 81501

**CIRCLE NO. 27 ON READER SERVICE CARD**

**SAVE!**

**MONEY • TIME • FREIGHT**

🎵 QUALITY STEREO EQUIPMENT  
AT LOWEST PRICES.

🎵 YOUR REQUEST FOR QUOTA-  
TION RETURNED SAME DAY.

🎵 FACTORY SEALED CARTONS—  
GUARANTEED AND INSURED.

🎵 SAVE ON NAME BRANDS LIKE:  
A.D.C. KOSS KLH DYNACO  
A.R. FISHER SHURE SONY

AND MORE THAN 50 OTHERS

BUY THE MODERN WAY BY MAIL—

FROM



Department 873 12 East Delaware  
Chicago, Illinois 60611 312-664-0020

**CIRCLE NO. 13 ON READER SERVICE CARD**

From this can be built such impressive projects as a digital clock, digital poker or dice game, digital stop watch, and many others. Also introduced was a series of TTL IC's promised by the company to be the most comprehensive line of TTL devices readily available to the hobbyist.

Circle No. 77 on Reader Service Card

**MIT'S LAB-QUALITY DVOM**

A low-cost laboratory-quality digital multimeter is available from MITS, Inc., as the Model DVM 1600. It is designed to measure alternating and direct currents in five ranges from 0.1



mA to 1 A; ac and dc voltages in four ranges from 1 V to 1000 V; and resistance in six ranges from 100 ohms to 10 megohms—all figures stated in full-scale for each function. Resolution on the low ranges for voltage is 10 mV, for current is 10 mA, and for resistance is 1 ohm. Dc voltage accuracy is  $\pm 0.5$  percent. All other measurements are accurate to  $\pm 1$  percent. Input resistance on dc V is 10 megohms, while input impedance on ac V is 1 megohm. Also featured are auto polarity indication, regulated power supply, 100-percent overrange capability, and large Sperry gas-discharge readouts.

Circle No. 78 on Reader Service Card

**HEATH 15-MHz OSCILLOSCOPE KIT**

The Heath Company's new Model 10-104 oscilloscope (available only in kit form) features all-solid-state circuitry, triggered sweep, and dc-15-MHz bandwidth. The vertical sensitivity of 10 mV/cm and 12 calibrated vertical attenuator positions of up to 50 V/cm accommodate a broad range of input signal levels. Any of 22 calibrated time bases from 2 s/cm to 0.2  $\mu$ s/cm (X5 magnifier for maximum sweep of 40 ns/cm) can be selected to provide accurate frequency measurements. The horizontal amplifier accepts external inputs of from dc to 1 MHz. A built-in calibrator circuit in the scope provides accurate frequency and amplitude signals that can be used during calibration or anytime the accuracy of the instrument is to be checked out.

Circle No. 79 on Reader Service Card

**LAFAYETTE RADIO DELUXE AM/FM TUNER**

The Model LT-D10 deluxe AM/stereo FM tuner from Lafayette Radio Electronics has a

built-in Dolby Noise Reduction System to allow the listener to take advantage of the increasing number of FM stations that are broadcasting Dolby-encoded signals. Other features include a phase-locked loop in the multiplex section, dual-gate MOSFET's in the front end, and IC's in the i-f section—all designed to yield the best possible performance. The front panel has two tuning meters, controls for Dolby on/off, AM/FM, stereo/mono, MPX filter, FM mute, dial light dimmer, and tape output jack. On the rear panel are variable- and fixed-level outputs, FM detector output for 4-channel FM adapter (when available), internal AM and FM antennas, external AM and FM antenna binding posts, ac convenience outlet, and a switch to select 75- $\mu$ s or 25- $\mu$ s Dolby deemphasis.

Circle No. 80 on Reader Service Card

### TELEDYNE AM/SSB CB TRANSCEIVER

The new Teledyne Model RA-510 23-channel CB transceiver from Olson Electronics features



operation on both AM and SSB. The transmitter has 8 watts of effective output power on SSB and 3.5 watts minimum on AM. The receiver has dual conversion, a low-noise r-f stage, an r-f gain control, agc, and other convenience features. Sensitivity is specified at better than 0.2  $\mu$ V for 10-dB (S + N)/N. The rig comes with a mobile mounting bracket, push-to-talk microphone with coiled cord, ac and 12-volt dc positive- or negative-ground power cord, and crystals for all channels.

Circle No. 81 on Reader Service Card

### ELECTRO-VOICE CARDIOID MICROPHONE

The Electro-Voice Model 671 is a new ball type, single-D cardioid microphone that is designed to emphasize low frequencies when used close up for high-quality sound reinforcement in public address and recording applications. A new head design and an exclusive diaphragm provide wide, linear response at all angles of incidence for high gain-before-feedback in sound reinforcement applications. Off-axis coloration is virtually eliminated. A newly designed and extremely effective shock absorber in the head assembly isolates the transducer assembly from mechanical noises. The mike uses the broadcast standard A3M-type connector, and the matching tapered cable plug becomes a part of the mike's silhouette. A locking device keeps the switch on when desired. Hi- or lo-Z impedance is selectable at the connector.

Circle No. 82 on Reader Service Card

JANUARY 1974

# free BA 1974 catalog



276 PAGE  
RADIO, TV &  
ELECTRONICS  
CATALOG

Your Buying Guide for  
Everything in Electronics  
Stereo, Hi-Fi, TV's,  
Radios, Tape Recorders,  
CB, Kits, Tools, Books,  
and Electronic Parts.

WRITE FOR  
IT TODAY!

## burstein-applebee

DEPT. PE 3199 MERCIER ST.  
KANSAS CITY, MO. 64111

NAME \_\_\_\_\_

ADDRESS \_\_\_\_\_

CITY \_\_\_\_\_

STATE \_\_\_\_\_ ZIP \_\_\_\_\_

## PRINTED CIRCUITS

FAST — EASY  
with DATAK's

## DIRECT ETCH SET

EASY—patterns rub down directly on the copper board and connect with rub-down lines or tapes supplied.

FAST—safe new etchants will etch a 2 oz. copper board in 30 minutes.

ACCURATE— $\pm .002$ " print tolerance so parts and connectors mate with no errors.



Circuit Made With ER-1

COMPLETE ER-1 SET contains hundreds of dry transfer DIP, flatpack, TO-5, IC, and transistor patterns;  $\frac{1}{8}$ " and  $\frac{1}{16}$ " etch resist tapes; 4 copper clad boards;  $\frac{1}{4}$  lb. dry etch; tray and instructions. \$4.95 ppd.

IN STOCK AT ALLIED AND OTHER DISTRIBUTORS  
WRITE FOR FREE CATALOG listing this and many other dry transfer marking sets.

The DATAK Corporation

65 Seventy-first Street • Guttenberg, New Jersey 07093

CIRCLE NO. 7 ON READER SERVICE CARD



# ELECTRONICS MARKET PLACE

**NON-DISPLAY CLASSIFIED: COMMERCIAL RATE:** For firms or individuals offering commercial products or services, \$1.60 per word (including name and address). Minimum order \$16.00. Payment must accompany copy except when ads are placed by accredited advertising agencies. Frequency discount: 5% for 6 months; 10% for 12 months paid in advance. **READER RATE:** For individuals with a personal item to buy or sell, \$1.00 per word (including name and address.) No minimum! Payment must accompany copy. **DISPLAY CLASSIFIED:** 1" by 1 column (25/8" wide), \$200.00. 2" by 1 column, \$400.00. 3" by 1 column, \$600.00. Advertiser to supply cuts. For frequency rates, please inquire.

**GENERAL INFORMATION:** First word in all ads set in bold caps at no extra charge. All copy subject to publisher's approval. All advertisers using Post Office Boxes in their addresses **MUST** supply publisher with permanent address and telephone number before ad can be run. Advertisements will not be published which advertise or promote the use of devices for the surreptitious interception of communications. Closing Date: 1st of the 2nd month preceding cover date (for example, March issue closes January 1st. Send order and remittance to Hal Cymes. **POPULAR ELECTRONICS**, One Park Avenue, New York, New York 10016.

## FOR SALE

**FREE!** bargain catalog. Fiber optics, LED's, transistors, diodes, rectifiers. SCR's, triacs, parts. Poly Paks, Box 942, Lynnfield, Mass. 01940.

**GOVERNMENT** Surplus Receivers, Transmitters, Snooperscopes, Radios, Parts, Picture Catalog 25¢. Meshna, Nahant, Mass. 01908.

**LOWEST Prices** Electronic Parts. Confidential Catalog Free. KNAPP, 3174 8TH Ave. S.W., Largo, Fla. 33540.

**ELECTRONIC PARTS**, semiconductors, kits. **FREE FLYER.** Large catalog \$1.00 deposit. **BIGELOW ELECTRONICS**, Bluffton, Ohio 45817.

**CONVERT** any television to sensitive, big-screen oscilloscope. Only minor changes required. No electronic experience necessary. Illustrated plans. \$2.00. Relco-A33, Box 10563, Houston, Texas 77018.

**AMATEUR SCIENTISTS**, Electronics Experimenters, Science Fair Students . . . Construction Plans—Complete, including drawings, schematics, parts list with prices and sources . . . Robot Man — Psychedelic shows — Lasers — Emotion/Lie Detector — Touch Tone Dial—Quadrasonic Adapter—Transistorized Ignition—Burglar Alarm—Sound Meter . . . over 60 items. Send 25¢ coin (no stamps) for complete catalog. Technical Writers Group, Box 5994, University Station, Raleigh, N.C. 27607.

**RADIO**—T.V. Tubes—36¢ each. Send for free catalog. Cornell, 4213 University, San Diego, Calif. 92105.

**METERS**—Surplus, new, used, panel or portable. Send for list. Hanchett, Box 5577, Riverside, CA 92507.

**PYROTECHNICAL** chemicals, casings, tools, supplies, fuse, literature. Giant, illustrated catalogue/handbook includes formulas, instructions—50¢, with samples—\$1.00. Westech, Box 593, Logan, Utah 84321.

**WE SELL CONSTRUCTION PLANS. TELEPHONE:** Answering Machine, Speakerphone, Carphone, Phonevision. Auto Dialer, Touch Button Dialer, Central Dial System. **TELEVISION:** \$35.00 Color Converter, Video Tape Recorder. \$25.00 Camera. **HOBBYIST:** Electron Microscope, 96 Hour Tape Music System, Ultrasonic Dishwasher, Radar-Oven. Plans \$4.95 each. **NEW ITEM:** \$75. Electronic Pocket Calculator, \$7.50. **COURSES:** Telephone Engineering \$39.50. Detective Electronics \$22.50, Integrated Circuit Engineering, \$49.50. **NEW SUPER HOBBY CATALOG** plus year's subscription to Electronic New Letter **AIRMAILED \$1.00.** Don Britton Enterprises. 6200 Wilshire Blvd., Los Angeles, Calif. 90048.

**JAPAN HONG KONG DIRECTORY.** World products information. \$1.00 today. World Trade Inquiries, Hillyard, Washington 99207.

**SCOPES**, meters, test equipment, military and industrial surplus. Write for free "Bargain Bulletins". Lawrence Instruments, P.O. Box 744, Sunbury, Pa. 17801.

**TEST EQUIPMENT**, Aerospace-Laboratory Grade. Request your needs: will mail appropriate catalogs (we have 24 catalog categories). Only for Engineers, Businesses, Schools and advanced Technicians. Goodheart, Box 1220PE, Beverly Hills, Calif. 90213.

## BUILD YOUR OWN SPACE-AGE TV CAMERA



**ONLY KNOWN SOLIDSTATE CAMERA KIT!** Ideal for experimenters, hobby, education, industry, etc. \* High quality \* Backed by over 10 years of lab & field testing \* Fully Guaranteed \* Connects to any TV set without modification \* Step-by-step construction manual \* Model X-1A, Series D complete with vidicon \$149.50 postpaid anywhere in USA & Canada (less vidicon tube \$116.95pp)

PHONE OR WRITE FOR CATALOG.

DIAL 402-867-3771

Many other kits, parts and plans available including stereo kits, focus-free cells, vidicon tubes, const. plans, radio subcarrier kit, etc.  
1301 BROADWAY **ATV Research** DAKOTA CITY, NEBR. 68731

**MECHANICAL, ELECTRONIC** devices catalog 10¢. Greatest Values—Lowest Prices. Fertik's, 5249 "D", Philadelphia, Pa. 19120.

**FREE** Catalog lists resistors, tubes, transistors, rectifiers, condensers, tools, tuners, etc. Hytron Hudson, Dept. PE, 2818 Kennedy Blvd., Union City, N.J. 07087.

**DIGITAL ELECTRONICS:** Complete schematics, parts lists, theories—Discrete Component Digital Clock, \$3.00—Sound Sensitive Switch, \$1.50. Increase technical competence, hobby skills—Complete Course in Digital Electronics is highly effective, \$10.00. Free literature. DYNASIGN, Box 60A7, Wayland, Mass. 01778.

## FREE CATALOG UP TO 50% OFF COMPARABLE KITS\*

•BUY DIRECT •SAVE \$\$\$

**FREE** Catalog—Electronic Kits—Amplifiers—Preamps—Psychedelic Strobes—Burglar Alarms—Digital Tachometer—More: Free Catalog. SWTPC, Box A32040, San Antonio, Tex. 78284.

**IGNITION SYSTEMS:** Capacitor, Transistor. Information 10¢. Anderson Engineering, Epsom, N.H. 03239.

**AUTHENTIC, INSTRUMENTED, FLYING ROCKETS** for casual or serious experimenters. Over 80 scale original, multi-stage or ready-to-fly models. Solid-propellant engines for safe, electric launch system liftoffs up to 2,500 feet. Measure altitude, temp. inversions, more. Real telemetry, electronic tracking, aerial still and movie photography with super-miniaturized equipment. New, detailed tech manual and full-color catalog. 25¢ from ESTES INDUSTRIES Dept. 18S, Penrose, Colo. 81240.

**WE SELL CONSTRUCTION MANUALS—GOLD** Recovery Unit—SILVER Recovery Unit—Alternator Adapter (provides 120 volts in your car!)—Infrared Scope—Inverter (12 volts DC to 120 volts AC)—Electronic Insect Trap—Burglar Alarm—X-Ray Fluoroscope—Chemical Formulary. Manuals \$5.00 each. **HIGHLY PROFITABLE Business Courses!**—"How To Start and Operate Your Own SILVER Recovery Business!"—"The Manual of PRECIOUS Metals" courses \$9.95 each—illustrated color catalog, 25¢—Airmailed 50¢—Creative Products, 8415 Lofland, Dept. PE-174, Houston, Texas 77055.

**SOUND SYNTHESIZER KITS**—Surf \$11.95, Wind \$11.95, Wind Chimes \$16.95, Electronic Songbird \$6.95, Musical Accessories, many more. Catalog free. PAIA Electronics, Box J14359, Oklahoma City, OK 73114.

# PAIA

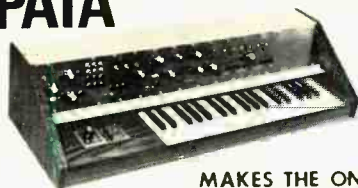

**MAKES THE ONLY  
SYNTHESIZER KITS**

models priced from \$139 — free brochure and catalog

**PAIA ELECTRONICS, INC.**

**BOX P14359, OKLAHOMA CITY, OK 73114**

**WHOLESALE** Scanners, CB., Crystals, Directories, SSB/AM, Catalog 25¢. G—ENTERPRISES, Box 461P, Clearfield, Ut. 84015.

**LOGIC Probe** \$9.95. Free bargain catalog. Electro, 4201 Irving Park, Chicago, Illinois 60641.

**CD IGNITIONS, VHF/UHF monitors, crystals, CB radios.** Wholesale. Southland, Box 3591-B, Baytown, Texas 77520.

**WAVEFORM GENERATOR KIT 8038** Function Generator IC Producing Sine, Square, Triangular Waveforms. \$10.00. Write for catalog. Photolume Corporation, 118 East 28th Street, New York, N.Y. 10016.

**NEW FM Deviation Meters** \$75.00. Free Information. Write: ECM, 412A N. Winbach, Evansville, Indiana 47711.

## DISCOUNT PRICES

**B & K, SENCORE, LEADER Test Equipment**  
RAYTHEON, ICC/MULLARD Tubes  
TELEMATIC Test Jigs

**Free Catalog**

**FORDHAM RADIO SUPPLY CO. INC.**  
558 Morris Ave., Bronx, N.Y. 10451

**SURPLUS** electronic parts and pieces. Monthly picture flyer free. Startronics, Box 17127, Portland, Oregon 97217.

**BURGLAR-FIRE** alarm components, hardware. Free catalog—information. Simar, 133 S.W. 57 Ave., Miami, Florida 33144.

**CALCULATOR OWNERS:** Use your  $+ - \times \div$  calculator to compute SQUARE ROOTS, Trigonometric Functions, Logarithms, Exponentials, and more! Quickly, Accurately, Easily! Send today for the improved and expanded edition of the first and best calculator manual—sold throughout the world . . . only \$2.00. Absolutely Unconditional Money-Back Guarantee—and FAST service! Mallman Optics and Electronics, Dept.-10A, 836 South 113, West Allis, Wisconsin 53214.

**HEAR POLICE/FIRE Dispatchers!** Catalog shows exclusive official directories of "confidential" channels, receivers. Send 8¢ stamp. Communications, Box 56-PE, Commack, N.Y. 11725.

**FREE CATALOG.** Parts, circuit boards for POPULAR ELECTRONICS projects. PAIA Electronics, Box C14359, Oklahoma City, OK 73114.

**FACTORY OUTLET**—Auto Quadraphonic, Stereo Tape and FM systems from \$15. Dealer lists \$1. BIDCO, 565E McMurray, McMurray, Pa. 15317.

**WHOLESALE** burglar alarm supplies. Catalog \$1.00 (refundable). 110V. ELECTRICITY from your auto. Plans \$3.00. Ellin, 161-E Bonad, Chestnut Hill, Mass. 02167.

**YOU SAVE BIG MONEY!** Surplus, Clearouts, Bankruptcy, Inventory, Deas. Catalog \$1 (redeemable). ETCOA Electronics, Box 741, Montreal, H3C 2V2. U.S. Inquiries.



**GREGORY ELECTRONICS**  
Reconditioned & Used  
FM 2-WAY RADIO SAVINGS  
Send for New Catalog

You Save **WITH THIS AD ONLY**  
**\$44**



## MOTOROLA SPECIAL EXCELLENT CONDITION

**X71GJT-1190B.** 12 volts, 100 watts, full transistor power supply. 2 freq. 40-50 MHz transmit, 3 freq. receive (dual freq. 40-50 MHz, single freq. 30-40 MHz) with dual front end for simultaneous receive.

Including accessories.  
Bench checked.

Reg. **\$228**  
**Now \$184**



**GREGORY ELECTRONICS CORP.**

249-P Rt. 46, Saddle Brook, N. J. 07662  
Phone: (201) 489-9000

**CT5005:** \$11.95, Laser Diodes: \$5.95, IC's (Digital, Linear), Readouts, Free Catalog. ELECTRONIC DISCOUNT SALES, 138 N. 81st Street, Mesa, Arizona 85207.

7400 IC's at fantastic prices. Minimum order 100 Per Type 100% GUARANTEED. 7400 .20¢, 7402 .20¢, 7404 .25¢, 7413 .80¢, 7446 \$1.00, 7447 \$1.05, 7453 .20¢, 7473 .50¢, 7490 \$1.05, 74121 .55¢, 74192 \$1.65. Many other types in stock. Check with order. Phone: (212) 966-2227.

**ELECTRONIC Parts** wholesale Free Catalog. Donlyn Electronics, P.O. Box 15421, Phoenix, Arizona 85060.

**WHOLESALE** catalog electronic components—25 cents. National Electronic Supply, Box 15015, Long Beach, Calif. 90815.

**EXTRUDED** aluminum panels to dress up your projects. Brushed finish, gold and clear anodized, easily machined. Send for drawings and specs. D&J, Box 587, North Attleboro, Mass. 02761.

## The Soft Touch : ELECTRONIC TOUCH SWITCH by ARM



Completely Solid State - No Moving Parts  
100 Watt Cp. - Great For Wall or Lamp Sw.  
Contains: 5 Transistors, 1 Triac, 3 Diodes  
12 Resistors, 4 Capacitors, Face Plate  
PC Board, Hardware, Complete Instr.  
Kit-7.95, Assembled-9.95 postpaid - Pa.  
Res. Add 6% Sales Tax - 60 day guarantee

**ARM ELECTRONICS, BOX 765, PITTSBURGH, PA. 15260**

**BURGLAR-FIRE** alarm supplies and information. Free catalog. Protecto Alarm Sales, Box 357-G, Birch Run, Michigan 48415.

**SPEEDOMETER, Tachometer;** Accurate electronic numerical readouts; Either simplified plan: \$4.00; GES, Box 100PE, Green Bank, West Virginia 24944.

**POLICE, Fire, Sheriff, Hi-Lo-UHF** crystals, scanners. \$3.95 send make of radio and freq. Marko, 2028 W. Central, Toledo, Ohio 43606.



**LIGHT EMITTING DIODES**

MRD 148 Photo Darlington	\$ .75
MT2 Photo Transistor	\$ .80
MCT-2 Opto. Isolator	\$ .90
OSL-3 GAP VIS. LED	\$ .59
MCD-2 Opto. Isolator	\$ .90
MCA-2-30 Photo Relay	\$ .90
ME4 IR LED's	\$ .59
GREEN GAP OSL-16 LED	\$ .50

7400	.28	7483	1.25
7401	.28	7486	.50
7402	.28	7490	1.50
7403	.28	7491	1.25
7404	.33	7492	.75
7405	.30	7493	1.30
7406	.50	7494	1.30
7407	.50	7495	1.30
7408	.32	7496	1.10
7410	.28	74107	.75
7411	.22	74121	.70
7412	.40	74123	1.10
7413	.85	74125	1.50
7416	.50	74126	1.50
7417	.50	74145	1.00
7422	.28	74151	1.25
7423	.32	74153	1.00
7426	.35	74154	1.95
7427	.35	74159	1.50
7430	.28	74162	2.20
7437	.60	74165	2.00
7438	.55	74176	1.95
7440	.50	74177	1.95
7441	1.50	74192	1.95
7442	1.25	74193	1.75
7446	1.50	74195	1.75
7447	1.50	74195	1.75
7448	1.50	75452	1.00
7450	.50	75491	1.10
7472	.50	8211	1.50
7473	.60	8220	1.50
7474	.60	8520	1.50
7475	1.00	8520	1.75
7476	.75	(SP380)	.95
7480	.70	LM351	1.00

**VERIPAX PC BOARD**

This board is a 1 1/16" single sided paper epoxy board 4 1/2" x 6 1/2" (standard veripax) DRILLED and etched, which will hold 23 single 14 pin IC's, or 8 16 or 151 DIP IC's with busses for power supply connections. It is also etched for a 22 pin connector. \$5.25 3/\$14.50

**TRANSISTOR SPECIALS**

2N2222 NPN Si TO-92 30V .8A SW 250MHZ 80HFE5	\$1.00
2N3137 NPN Si TO-5 .6 20 .5 70	500 4 \$1.00
2N1605 NPN GE TO-5 15W 24V JA 14	125 5 \$1.00
MPS3393 NPN Si TO-106 25 .1 3 .2	200 4 \$1.00
2N404 PNP GE TO-5 25 .2 .15 12	40 4 \$1.00
2N3767 NPN Si TO-66 80 4. 20. 10	80 70
2N3772 NPN Si TO-3 150W 60V 30A .2	30 \$1.25
2N3866 NPN Si TO-5 5 30 RF Power	S 75
2N6109 PNP Si TO-220 36W 40V 4A .8	60 50c
2N5296 NPN Si TO-220 36W 40V 4A .8	60 50c
2N4898 PNP Si TO-66 25W 40V 4A 40	46 5 60
MJ2251 NPN Si TO-66 10W 225V .5A 10	40 5 70
2N3055 NPN Si TO-3 115W 100V 15A .2	44 \$1.00

SLA-3 7 Segment LED Readout 77" Num- bers 45 ml 1 Seg. \$7.95

INJECTION LASER-A SINGLE DIODE 6W. 25A GaAs UNIT SIMILAR TO RCA 40859 \$10.95

MAN-4 LED READOUT \$3.50  
MAN-3 LED READOUT \$2.95

**CAPACITORS**  
6V 30 UF TANT .5 \$1.00  
20V 4.7 UF TANT .5 \$1.00  
12V 10 UF ELECT. 3 \$1.00  
50V 100 UF ELECT. .40

1103 1024 BIT RAM \$ 7.25  
NEC6003 2048 BIT RAM 14.50  
1101 256 BIT RAM 3.25  
8225 64 BIT MEMORY 3.50

DUAL TAPERED COS PHOTO CELL USED FOR OPTICAL ALIGNMENT WITH A SINGLE PLANE LENSE (Not Included) \$ .95

SIMILAR TO 8038 IC VOLTAGE-CONTROLLED OSCILLATOR AS FEATURED IN P.E. OCT 73. THEY HAVE SINE, SQUARE AND TRIANGULAR OUTPUT GOOD TO 1 MHz \$9.95

NIXIE TUBE RAYTHEON 8650 WITH SOCKET AND DATA SHEET \$2.25 3/\$6.00

**FULL WAVE BRIDGES**  
PRV 2A 1 6A  
200 .95 1.25  
400 1.15 1.50  
600 1.35 1.75

**Silicon Power Rectifiers**  
PRV 1A 3A 12A 50A  
100 .06 .11 .30 .85  
200 .07 .16 .35 1.25  
400 .09 .20 .45 1.50  
600 .11 .30 .70 2.00  
800 .15 .40 .85 2.30  
1000 .20 .55 1.10 2.75

**TRIACS**  
PRV 1A 10A 25A 1.5A 6A  
100 .40 .70 1.30 .40 .50  
200 .70 1.10 1.75 .60 70  
400 1.10 1.60 2.60 1.00 1.20  
600 1.70 2.30 3.00

TIS-73 N CHANNEL F.E.T. \$6.60  
2N 4891 UJT \$5.00  
ER 900 TRIGGER DIODE 4/1.00

5311—Clock Chip, 6 Digit hold count and Output Strobe \$11.95  
5314—Clock Chip, 6 Digit readout hold count and Output Strobe \$9.50

ASCII Encoded Terminal Keyboards \$60.00  
14 Pin IC Sockets 3 \$1.00

Printed circuit board 4 1/2" x 6 1/2" double sided fiber glass board 1/16" thick, unetched. \$6.00 ea. 5/\$2.50

Miniature Trim Pots 5K, 10K, 20K, 25K, 50K, 100K \$ .75 3/\$2.00

LM 309K 5V 1 Amp Regulator \$2.25  
741 OPER. AMP \$ .47  
709 OPER. AMP \$ .47  
723 Regulator \$ .75  
709RF 1F Amp \$ .80  
CA3065 FM TV Amp \$1.35  
565 Phase Lock Loop \$2.95  
567 Tone Decoder \$2.95  
560 Phase Lock Loop \$2.95  
561 Phase Lock Loop \$2.95  
747 Dual 741 \$1.25  
537 Precision 741 \$2.50  
540 70W Power Driver \$2.04  
747 Dual 741 \$1.25  
LM308 Oper Amp \$1.95  
101 Oper Amp \$1.75  
741A Oper Amp \$ .47  
320-5V Reg. \$1.75  
320-15V Reg. \$1.75  
748 Oper Amp \$ .90  
LM370 AGC Squelch Op. Amp \$1.25  
LM380 2 Watt Amp \$1.75  
2 Watt Stereo IC 14 Pin Dip \$3.95

CONDUCTIVE ELASTOMETER LOW PROFILE CALCULATOR KEYBOARD. A 2 3/4"x3 3/4"x1 1/2" FLEX KEY. 19 SK-6 KEYBOARD HAVING 0-9, \*, K-C BUTTONS WITH OFF. ON SWITCH. \$6.50

Terms: FOB Cambridge, Mass.

Send Check or Money Order. Include Postage.  
Minimum Order \$3.00 Send \$2.00 for our latest catalog featuring Rated companies 30 days net Transistors and Rectifiers

**SOLID STATE SALES**

Post Office Box 74A Somerville, Mass. 02143 Tel. (617) 547-4005

CIRCLE NO. 24 ON READER SERVICE CARD

**DIGITAL** and analog computer modules. LED numeric display kits. FREE LITERATURE. Scientific Measurements, 2945 Central, Wilmette, Illinois 60091.

**CITIZENS BAND EQUIPMENT**—Discount Prices—Free list. CRS Communications, 2271 Morris Ave., New York, N.Y. 10453.

FREE Catalog. Reeds, Tantalums, Transistors, PUTS, LEADS, Parts. Chaney, Box 15431, Lakewood, Colo. 80215.

**ELECTRONIC ORGAN KITS, KEYBOARDS** and many components. Independent and divider tone generators. All diode keying. I.C. circuitry. Build any type or size organ desired. Supplement your Artisan Organ. 25¢ for catalog. DEVTRONIX ORGAN PRODUCTS, Dept. C, 5872 Amapola Drive, San Jose, Calif. 95129.

**BRAIN WAVE MONITOR** Biosone BF-20 Alpha Biofeedback Instrument. \$34.95 complete. Not a kit. Fully Guaranteed. For information write. BIO-LOGIC DEVICES, INC., Dept. A, 888 Seventh Avenue, New York, New York 10019.

**COBRA-21** and trunk mount ant. 23 channel CB radio. All for \$139.95. Shipping paid. Save over \$23.00. Send bank check or money order to RC Electronics, 17 Haller Ave., Wallingford, CT 06492.

FREE BOOK about Digital Logic and Computers, and how you can design and build your own. EEW, Box 8204-CB, Pittsburgh, PA 15217.

**BIOFEEDBACK.** Professional instruments: Electroencephalophone, Galvanic Skin Response. J&J, 8102-E, Bainbridge, WA. 98110.

**SEMICONDUCTORS,** Components, Unusual items, discount prices, catalog 20¢. Seaboard International Electronics, P.O. Box 906, Clute, Texas 77531.

**ALPHA/THETA** brainwave biofeedback instruments. Analog systems from \$125; digital processing from \$225. BioScan, Box 14168-E, Houston, Texas 77021.

**POLICE SCANNERS,** C.B. radios, at discount prices. Kits—cat. 25¢. Krystal Kits, 2202 S.E. 14th, Bentonville, Arkansas 72712.

**AUTOMATIC** telephone recording and debugging equipment. Electronic car ignition systems. Top quality. Lowest wholesale prices. Viking International, Box 632, Newhall, California 91321.

FREE CATALOG: Lowest prices. Quality Electronics Parts, all types. Great for hobbyists, experimentalists, etc. I-TRONICS, Box 29, East Rockway, New York 11518.

**SEMICONDUCTORS,** Parts, Kits. Free catalog, Grab Bag, special \$1.00. Davis Associates, 16 Grove, Londonderry, N.H. 03053.

**BURGLAR ALARM SYSTEM**—Do it Yourself installed in minutes. Free Literature. Emrad Corporation, P.O. Box 1341, Kokomo, Indiana 46901.

**NI-CADS,** size AA, Guaranteed, 50¢ each, post paid; Goodcase, P.O. Box 195, Brookfield, Ill. 60513.

**PLANS AND KITS**

**ANTIGRAVITY DEVICE.** Brochure rushed free. AGD, Box 3062-ZD, Bartlesville, Oklahoma 74003.

**FREE KIT CATALOG**

Why does every major College, University, Technical School, Research & Development Center buy from us? Because we have the highest quality and lowest prices. Free Catalog. SWTPC, Box H32040, San Antonio, Tex. 78284.

**VOICE** Activated Switch 25¢, completed kit includes Microphone, \$2.50. Lectronix, Box 42, Madison Heights, Michigan 48071.



**NEW!** **CONVERT TV TO 6 FT. WIDE SCREEN!** 

**Easy Do-It-Yourself Kit**

Project a giant 5'x6' picture onto wall or screen. B&W/Color. Kit contains detailed plans, Inst., and Precision Lens System. Only \$12.95 ppd., or write for Free illustrated details. The Macrocoma Co., Dept. DAE Washington Crossing, PA 18977

**Guaranteed to Work!**

## HIGH FIDELITY

DIAMOND NEEDLES and Stereo Cartridges at Discount prices for Shure, Pickering, Stanton, Empire, Grado and ADC. Send for free catalog. All merchandise brand new and factory sealed. LYLE CARTRIDGES, Dept. P, Box 69, Kensington Station, Brooklyn, New York 11218.

SAVE 50%. Build your own speaker systems featuring Norelco, Eminence and CTS. Famous brands from world's largest speaker factories at lowest wholesale prices. Write for 176 page catalog for speakers and electronic accessories. McGee Radio Company, 1901 McGee Street, Kansas City, Missouri 64108.

## WANTED

QUICKSILVER, Platinum, Silver, Gold, Ores Analyzed. Free Circular. Mercury Terminal, Norwood, Mass. 02062.

## ELECTRICAL SUPPLIES AND EQUIPMENT

PLATING Equipment, Portable Platers, Supplies and "Know-How." Build your own tanks for nickel, chrome, etc. Easy-to-install PVC liners. Rectifier components—all sizes. Schematics, parts lists, formulas, operating instructions for all plating. Guaranteed to save you 25%-75%. Some good units for sale. Write for details. Platers Service Company, 1511-PE Esperanza, Los Angeles. Calif. 90023.

## TUBES

RADIO & T.V. Tubes—36¢ each. Send for free Catalog. Cornell, 4213 University, San Diego, Calif. 92105.

RECEIVING & INDUSTRIAL TUBES, TRANSISTORS. All Brands—Biggest Discounts. Technicians. Hobbyists. Experimenters—Request FREE Giant Catalog and SAVE! ZALYTRON, 469 Jericho Turnpike, Mineola, N.Y. 11501.

TUBES "Oldies", latest. Lists free. Steinmetz, 7519 Maplewood, Hammond, Indiana 46324.

SAVE money on parts and transmitting-receiving tubes, foreign-domestic. Send 25¢ for giant catalog. Refunded first order. United Radio Company, 56-P Perry Street, Newark, N.J. 07105.

TUBES receiving, factory boxed, low prices, free price list. Translateronic, Inc., 1306 40th Street, Brooklyn, N.Y. 11218A, Telephone: 212-633-2800.

TUBES, ANTIQUE—Send list. P.O. Box 5570, Compton, Calif. 90224.

## TAPE AND RECORDERS

RENT 4-Track open reel tapes—all major labels—3,000 different—free brochure. Stereo-Parti, 55 St. James Drive, Santa Rosa, Ca. 95401.

**USED SCOTCH MAGNETIC TAPE**

1800 FOOT, 7 INCH REEL, 1 MIL POLYESTER, ±150, BULK ERASED (NO BOX), 99¢, PLUS 10% FOR SHIPPING & HANDLING (MINIMUM ORDER 10 REELS). "LIKE NEW" EMPTY 10 1/2 INCH REELS: FIBERGLASS, 3/8" CENTER HOLE, 50¢. ALUMINUM, NAB 3" CENTER HOLE, \$1.00—BOTH CHEAPER IN LARGER QUANTITIES—ALL PLUS POSTAGE BY WEIGHT & ZONE. (INCREDIBLE BARGAINS ON NEW, FAMOUS BRAND TAPES & CASSETTES)



**SAXITONE TAPE SALES**  
1776 Columbia Rd., N.W. Washington, D.C. 20009

## BURROUGHS DIGITAL COUNTERS

 BURROUGHS Series C2506 decade counters with memory. Available 4,5,6, and 7 digits. NIXIE tube readouts. Complete 25 Mhz counter. All you need is power supplies for NIXIE tubes, (200 Vdc, and Vcc(E.O Vdc). Basic unit for all counters, frequency meters, clocks, thermometers, DVMs etc. With 5 pages of data.

STOCK NO. J5134 4 digits (C2506-4) 32.00  
STOCK NO. J5135 5 digits (C2506-5) 39.00  
STOCK NO. J5136 6 digits (C2506-6) 47.50  
STOCK NO. J5137 7 digits (C2506-7) 52.00

Also available without NIXIES. Write for info.

## TUNG-SOL DIGIVAC FLUORESCENT READOUT TUBE

 TUNG-SOL DT 1704B, 7 segment vacuum fluorescent. 9 pin miniature socket included. Blue-green display. Electrically similar to G.E. Y 4075. With data sheets.

STOCK NO. J5140 2.65 ea. 2/5.00 6/14.00

## COMPUTER GRADE CAPACITORS

74,000 mfd	10 vdc	Stk. J2118	1.75	6/9.00
110,000 mfd	15 vdc	Stk. J2352	2.25	5/10.00
9000 mfd	50 vdc	Stk. J2353	2.25	5/10.00
3750 mfd	75 vdc	Stk. J2116	1.75	6/9.00

MINIMUM ORDER \$5.00. Include postage. Excess refunded. Send for new large catalog.



**DELTA ELECTRONICS CO.**

BOX 1, LYNN, MASSACHUSETTS 01903

## CIRCLE NO. 8 ON READER SERVICE CARD

1930-1962 Radio Programs. Reels, \$1.00 hour! Cassettes, \$2.00 hour! Send \$1.00 for mammoth catalog . . . with hour samples, \$2.00. AM Treasures, Box 192F, Babylon N.Y. 11702.

SCOTCH TAPES. Discounts! Catalog 10¢. Tower, Box 33098, District Heights, Md. 20028.

## PERSONALS

MAKE FRIENDS WORLDWIDE through international correspondence. Illustrated brochure free. Hermes, Berlin 11, Germany.

BUGGED??? . . . Electronic Detector locates hidden transmitters. Literature 25¢. Security Devices, Box 671, Westwood, New Jersey 07675.

## GOVERNMENT SURPLUS

GOVERNMENT Surplus. How and Where to Buy in Your Area. Send \$2.00. Surplus Information, Headquarters Bldg., Box 30177-PE, Washington, D.C. 20014.

ELECTRONIC Equipment and Parts. Big 36 page Free Catalog. Send for your copy today! Fair Radio Sales, Box 1105-P, Lima, Ohio 45802.

JEeps, TRUCKS, Cars from \$31.50 . . . Airplanes, Typewriters, Clothing, Multimeters, Transceivers, Oscilloscopes, Photographic Electronics Equipment . . . 100,000 Surplus Bid Bargains Direct From Government Nationwide Typically Low as 2¢ on Dollar! Complete Sales Directory and Surplus Catalog \$1.00 (Deductible First \$10 Order From Included Catalog). U.S. Surplus Disposal, 2200 Fuller 601B-PEL, Ann Arbor, Michigan 48105.

MANUALS for Govt Surplus radios, test sets, scopes. List 50¢. Books, 7218 Roanne Drive, Washington, D.C. 20021.

## MOVIE FILMS

8MM-SUPER 8-16MM MOVIES! Biggest Selection! Lowest Prices! Free Catalog! Cinema Eight, Box PE, Chester, Connecticut 06412.

**IC****FACTORY FIRSTS**

NATIONALLY KNOWN BRANDS

SATISFACTION GUARANTEED

DIGITAL TTL	
7400N	32c
7401N	32c
7402N	32c
7403N	32c
7404N	32c
7405N	35c
7406N	52c
7407N	32c
7408N	36c
7409N	36c
7410N	32c
7411N	35c
7413N	63c
7416N	50c
7417N	50c
7418N	36c
7420N	32c
7423N	75c
7426N	36c
7430N	32c
7437N	51c
7438N	51c
7440N	51c
7441N	\$1.45
7442N	\$1.20
7445N	\$1.52
7446N	\$1.30
7447N	\$1.30
7448N	\$1.35
7450N	32c
7451N	32c
7453N	32c
7454N	32c
7459N	32c
7460N	32c
7470N	36c
7472N	40c
7473N	52c
7474N	52c
7475N	85c
7476N	85c
7480N	74c
7482N	\$1.02
7483N	\$1.58
7486N	60c
7489N	\$4.50
7491N	\$1.37
7490N	85c
7492N	85c
7493N	85c
7494N	\$1.20
7495N	\$1.20
7496N	\$1.20
7497N	\$1.20
7498N	\$1.80
7499N	\$2.78

**PRICES SLASHED**

Discounts offered in quantities of 100 pcs TTL in mixed lots.

**LINEAR INTEGRATED CIRCUITS**

N5588V MiniDIP	95¢	723C DIP	\$1.15
N5658A DIP	\$3.57	741C MiniDIP	60c
N567V MiniDIP	\$3.57	747C DIP	\$1.10
N5588V MiniDIP	95c	748C MiniDIP	60c
709C MiniDIP	44c	Quantity Discounts	

**GENERAL PURPOSE SILICON TRANSISTORS**

2N3638	20c	10/51.65	2N5134	15c	10/51.25
2N3638A	22c	10/51.80	2N5137	18c	10/51.50
2N3641	23c	10/52.00	2N5138	15c	10/51.25
2N5643	23c	10/52.00	2N5139	15c	10/51.25
2N5133	15c	10/51.25	2N3055	\$1.00	10/59.50

**1 AMP SILICON RECTIFIERS**

IN4003	200PIV	10/51	100/57	1M/55r
IN4005	600PIV	9/51	100/58	1M/561
IN4007	1000PIV	6/51	100/510	1M/583

**SILICON SIGNAL DIODES**

1N4148	(1N914 equiv.)	10/51	100/54	1M/535
--------	----------------	-------	--------	--------

**MOLEX IC SOCKET PINS**

1000/\$8.20	200/\$1.80	300/\$2.60	500/\$4.20	700/\$5.80
-------------	------------	------------	------------	------------

**INTEGRATED CIRCUIT SOCKETS**

14 PIN DIP SOLDER	45c	16 PIN DIP SOLDER	50c
14 PIN WIRE WRAP	55c	16 PIN WIRE WRAP	60c

**C.O.D. ORDERS ACCEPTED FOR SAME DAY SHIPMENT**

CALL 218-681-6674

Free Catalog—Large Quantity Discounts—Orders Less Than \$10.00 Add 25c—Others Postpaid

**PRICE PACESETTER FOR QUALITY IC'S**

BOX 126K THIEF RIVER FALLS, MN56701

**CIRCLE NO. 36 ON READER SERVICE CARD**

**ELECTRONICS** Genius? Know your electronics I.Q. Self scoring exams rushed. \$3.00 Omicron, Dept. 101B, Box 10219, Albuquerque, New Mexico 87114.

**DIGITAL THEORY, DESIGN, CONSTRUCTION****LOGIC NEWSLETTER**

SAMPLE COPY \$1.00  
LOGIC NEWSLETTER  
POB 252  
WALDWICK, N.J. 07463

**SCORE** high on F.C.C. Exams . . . Over 300 questions and answers. Covers 3rd, 2nd, 1st and even Radar. Third and Second Test, \$14.50; First Class Test, \$15.00. All tests, \$26.50. R.E.I., Inc, Box 806, Sarasota, Fla. 33577.

**LICENSE-AID** formula chart. Formulas you should be able to work with before sitting for Second and First class FCC license exams. \$7.00 each. License-Aid, Box 1497, Moultrie, Georgia 31768.

**NEW!** "RADIOTELEPHONE EXAM MANUAL." First, Second, Radar, Third Classes with multiple-choice Questions, Answers, Diagrams, Formulas, Rules, Regulations. Recap from actual FCC material. "SCORE HIGH" memorize, pass phone exams. \$15.00. "ACT NOW!" Evaluation Research Hill, Dept-ER3, Box-19A56, Ahsokie, North Carolina 27910.

**LEARN** Electronics College level communications, FCC license, Broadcast Engineering, Satellite Communications. Home study. Free brochure. GTI, 5540 Hollywood Bv., Hollywood, Calif. 90028.

**INVENTIONS WANTED**

**CASH-ROYALTIES** for patented, unpatented inventions. Global Marketing Service, 2420-P 77th, Oakland, California 94605.

**FREE** "Directory of 500 Corporations Seeking New Products." For information regarding development, sale, licensing of your patented/unpatented invention. Write: Raymond Lee Organization, 230-GR Park Avenue, New York City 10017.

**PATENT** Searches including Maximum speed, full airmail report and closest patent copies. Quality searches expertly administered. Complete secrecy guaranteed. Free Invention Protection forms and "Patent Information," Write Dept. 9, Washington Patent Office Search Bureau, Benjamin Franklin Substation, P.O. Box 7167, Washington, D.C. 20044.

**INVENTORS:** Protect your ideas! Free "Recommended Procedure". Washington Inventors Service, 422T Washington Building, Washington, D.C. 20005.

**FREE PAMPHLET:** "Tips on Safeguarding Your Invention." Write: United States Inventors Service Company, 708-T Carry Building, Washington, D.C. 20005.

**INVENTORS!** Either we will sell your Invention before you or anyone else does, or we will pay you a cash bonus. Get Free Invention Evaluation and information: Write Gilbert Adams Organization, Invention Brokerage, Dept. 20, 80 Wall St., New York, NY 10005.

**HOW TO FILE** your own patent. Inventor's Guide, 468-H Goodspeed Road, Virginia Beach, Virginia 23451.

**PLASTICS**

**CASTOLITE** pours like water, hardens like glass without heat. Crystal clear, colors. Embed flowers, seashells, moments, anything. Make fine gifts. Form flexible molds over any pattern, size. Reproduce your own designs in plastics, candle wax, metal, plaster, cement. Profitable. Illustrated Manual and Catalog Only 50¢. CASTOLITE, Dept. 4A/PE, Woodstock, Ill. 60098.

**INSTRUCTION**

**LEARN ELECTRONIC ORGAN SERVICING** at home all makes including transistor. Experimental kit—trouble-shooting. Accredited NHSC, Free Booklet. NILES BRYANT SCHOOL, 3631 Stockton, Dept. A, Sacramento, Calif. 95820.

**LEARN WHILE ASLEEP,** Hypnotize! Strange catalog free. Auto-suggestion, Box 24-ZD, Olympia, Washington 98501.

**DEGREE IN ELECTRONICS** through correspondence instruction. G.I. Bill approved. Free catalog. Grantham, 2000 Stoner Avenue, Los Angeles, California 90025.

**INTENSIVE** 5 week course for Broadcast Engineers. F.C.C. First Class license. Radio Engineering Incorporated, 52 S. Palm Ave., Sarasota, Florida 33577.

**SHORTCUTS** To Success! Highly Effective, Profitable Short Courses. (75 Choices). Study At Home. Diploma Awarded. Our 27th Year. Free Literature. CIEE-D, Box 10634, Jackson, Miss. 39209.

**F.C.C. EXAM MANUAL**

**PASS FCC EXAMS!** Memorize, study — "Tests-Answers!" for FCC 1st and 2nd class Radio-telephone licenses. Newly revised multiple-choice questions and diagrams cover all areas tested in FCC exams—plus — "Self-Study Ability Test." \$9.95 postpaid. Moneyback Guarantee.

COMMAND PRODUCTIONS  
RADIO ENGINEERING DIVISION  
P.O. BOX 26348-P  
SAN FRANCISCO, CALIF. 94126



**DEGREE** Program in Electronics Engineering. Our 27th Year! Free Literature. Cook's Institute, Dept. 13, Box 10634, Jackson, Miss. 39209.



## 12-DIGIT "CALCULATOR CHIP"

WAS \$12.95

CT5001 Chip  
**\$6.95**

3 for \$18.

Similar to Mostek 5001. Outperforms Texas 8-digit TMS1402. A 10-pin DIP. Adds, multiplies, subtracts and divides. Use with 7-segment readouts, switches, and LEDs. We include schematics, instructions to build calculator.

CT5002-9: Full version of above — \$8.88  
CT5005: Same as above with MEMORY — \$14.95

## LED MY DIGIT "DCM'S" \$9.99

Scientific Devices' "Digital Counting Modules" outperform any other DCM on the market today. More features than ever before! Not gaseous, not incandescent, not nixie but the modern LED. Choose from such famous manufacturers as Monsanto's MAN-1, MAN-3, Litronix 707 and 704, Opco's SLA-1 (the last 4 having character heights of 0.33" at no extra charge). Each kit includes "ix2" p.c. board with lingers for a FREE edge connector, side-mounting dip socket, LED readout of your choice, resistors, 3 10% and Moslex connectors and booklet. INCLUDES P.C. EDGE CONNECTOR — FREE!

\* Pin-for-pin MAN-1. \*\* Pin-for-pin MAN-1.

## WEST COAST MAKER OF LED'S

- 4-MV5054 Jumbo red lens, red lite, TO-18 \$1.00
- 1-MV5222 Jumbo green lens, green lite, TO-18 1.00
- 1-MV5322 Jumbo yellow lens, yellow lite, TO-18 1.98
- 4-MV5080 Micro red dome red lite, TO-18 1.00

## LITRONIX-OPCOA-MAN "7-SEGMENT" LED Readouts

All fit 14-pin IC sockets. All 7-segments. MAN Series "all LED" and made by well-known West Coast mfg. Others: Reflective Bar type made by OPCOA and LITRONIX. The Reflective Bar types are low-cost versions of the MAN's except .33 character height! If one LED blows you lose a segment. MAN's you DO NOT! All readouts 0-9-0 numerals, plus letters and decimal. \* Opcoa and Litronix products pin-for-pin readouts. \*\* For MAN-1 MAN-1. All 5V TTL compatible.

ALL LED READOUTS — TYPE	character	Size	Color Display	Dec. mal	Miss	Driver	Each	Special
<input type="checkbox"/> MAN-1 equal	.27	Red	Yes	20	SN7447	\$4.50	3 for \$12.	
<input type="checkbox"/> MAN-1A equal*	.27	Red	Yes	20	SN7447	4.95	3 for \$13.	
<input type="checkbox"/> MAN-3 equal	.115	Red	Yes	10	SN7448	2.50	3 for \$6.	
<input type="checkbox"/> MAN-3A equal*	.115	Red	Yes	10	SN7448	2.50	3 for \$6.	
<input type="checkbox"/> MAN-3M equal*	.127	Red	Yes	10	SN7448	2.50	3 for \$6.	
<input type="checkbox"/> MAN-3 equal	.115	Red	***	10	SN7448	1.95	3 for \$5.	
<input type="checkbox"/> MAN-3M equal*	.127	Red	Yes***	10	SN7448	1.95	3 for \$5.	
<input type="checkbox"/> MAN-4 equal*	.190	Red	Yes	15	SN7448	3.25	3 for \$9.	
<input type="checkbox"/> MAN-4 equal*	.190	Red	Yes***	15	SN7448	2.75	3 for \$8.	

### "REFLECTIVE LITE BAR" (Segment LED Readouts)

<input type="checkbox"/> 707** (MAN-1)	.33	Red	Yes	20	SN7447	3.25	3 for \$9.
<input type="checkbox"/> 704** (MAN-4)	.33	Red	Yes	20	SN7448	3.25	3 for \$9.
<input type="checkbox"/> SLA-1** (MAN-1)	.33	Red	Yes	20	SN7447	3.25	3 for \$9.
<input type="checkbox"/> SLA-2 + - 1	.33	Red	No	15	SN7447	3.25	3 for \$9.
<input type="checkbox"/> SLA-3H Giant	.70	Red	Yes	20	SN7447	6.50	3 for \$18.
<input type="checkbox"/> SLA-11C** (MAN-5.33)	Green	Yes	40	SN7447	4.95	3 for \$12.	
<input type="checkbox"/> SLA-12** ± 1	.33	Green	No	40	SN7447	3.50	3 for \$9.

\* Red epoxy case, others clear. \*\* Litronix and Opcoa's pin-for-pin equals and electrical specs as MAN-1 or MAN-4. \*\*\* LED "dot" missing.

## SIGNETIC & NATIONAL EQUALS ON NATIONAL OP AMPS

Buy Any 3 — Take 10%  
\* FACTORY GUARANTEED

Type	Description	Sale
LM-305	Pos. V. reg.	
LM-307	Super 741	\$1.49
LM-308	Hi-Q FET type op amp	1.50
LM-309H	SV 200 mil V. reg.	1.50
LM-309K	SV 1-amp V. reg. (TO-3)	2.25
LM-370	AGC squelch op amp	1.29
LM-380	2-watt audio amplifier	1.45
536	FET input op amp (TO-5)	1.95
558	Dual 741 (TO-5)	3.95
560	Phase lock loops (DIP)	1.00
561	Phase lock loops (DIP)	2.95
562	Phase lock loops (DIP)	2.95
565	Phase lock loops (DIP)	2.95
566	Phase lock loops (A)	2.95
567	Phase lock loops (TO-5)	2.95
709C	Tone decoder (A)	2.95
723C	Operational amp (A)	2.95
741C	Voltage regulator (A)	.49
741CV	Freq. comp. 709 (A)	.95
739-739	Dual stereo preamp	.49
7559	Digit driver for LED's (DIP)	1.98
7559Z	Segment driver for LED's (DIP)	2.50

## NATIONAL EQUALS ON "DIGITAL CLOCK on a CHIP"

as low as \$9.95

Any "Chip" \$9.95

\* With Money Back Guarantee

Mfrs #	Description	Sheet	Sale
<input type="checkbox"/> 5311	28-pin, ceramic, any readout, 6-digits: A-B-D		\$12.88
<input type="checkbox"/> 5312	24-pin, ceramic, any readout, 4-digits: C-D		\$ 9.95
<input type="checkbox"/> 5313	28-pin, ceramic, any readout, 6-digits: A-C		\$ 9.95
<input type="checkbox"/> 5314	24-pin, plastic, LED and incandescent readouts, 6-digits: A-B		\$12.88

Code: A—Hold Counts C—1 PPS Output B—Output Strobe. D—BCD

## NATIONAL MM5316 EQUAL "ALARM CLOCK ON A CHIP"

14.95

MOS 40-pin IC. 4-Digit display, time, seconds, alarm & sleep, 7-segment devices, 12 or 21 alarm setting. Operates from 3 to 29 volts, has seconds provisions, with instant press of button. With 5-pages of tech. info., plus applications.

## 8-TRACK CAR RADIO STEREO TAPE TRANSPORT \$8.88

8-Track tape transport with complete stereo playback system less audio amplifier. Operates off 12VDC. VMC Wax & flutter proof. Use 739 preamp & ready to go. Uses 8-track tape. Wt. 3-lbs.



## INTEGRATED CIRCUIT SOCKETS

<input type="checkbox"/> 14-Pin, DIP	\$.45
<input type="checkbox"/> 14-Pin, Wire Wrap	.50
<input type="checkbox"/> 14-Pin, Side Mount	1.00
<input type="checkbox"/> 16-Pin, DIP	.50
<input type="checkbox"/> TO-5, 8 or 10-Pins	.29

\* Buy Any 3 Take 10% Discount!

## HI-FI 1" SQUARE MINI METERS

<input type="checkbox"/> Balancing, Stereo, tape, amps.	3 for \$3.75
<input type="checkbox"/> VU, rms mix, plus 3 minus 20 db.	
<input type="checkbox"/> VU, front mix, plus 3 minus 20 db.	\$1.49



Terms: add postage. Rated: net 30. Wakefield, Mass. (617) 245-3829

Phone Orders: 16-18 Del Curme St., Wakefield, Mass. (off Water Street) C.O.D.'S MAY BE PHONED

## POLY PAKS

P.O. BOX 942 E. Lynnfield, Mass. 01940

## Lowest Prices Largest Selection TTL IC's

Type	Sale	SN7437	55	SN7472	50	SN74112	95	SN74163	1.95
<input type="checkbox"/> SN7400	\$0.30	SN7438	55	SN7473	55	SN74113	95	SN74164	2.95
<input type="checkbox"/> SN7401	.30	SN7440	30	SN7474	55	SN74114	95	SN74165	2.20
<input type="checkbox"/> SN7402	.30	SN7441	1.40	SN7475	1.00	SN74121	60	SN74166	2.05
<input type="checkbox"/> SN7403	.30	SN7442	1.50	SN7476	65	SN74122	95	SN74173	2.50
<input type="checkbox"/> SN7404	.35	SN7443	1.50	SN7478	95	SN74123	1.20	SN74174	3.20
<input type="checkbox"/> SN7405	.35	SN7444	1.50	SN7480	65	SN74125	71	SN74175	2.20
<input type="checkbox"/> SN7406	.45	SN7445	1.50	SN7481	1.25	SN74126	71	SN74176	2.10
<input type="checkbox"/> SN7407	.55	SN7446	1.65	SN7482	99	SN74139	1.25	SN74177	2.10
<input type="checkbox"/> SN7408	.55	SN7447	1.45	SN7483	1.25	SN74140	1.25	SN74179	2.10
<input type="checkbox"/> SN7410	.30	SN7448	1.50	SN7485	1.45	SN74152	4.95	SN74180	1.20
<input type="checkbox"/> SN7411	.35	SN7451	30	SN7486	1.55	SN74158	4.50	SN74181	4.90
<input type="checkbox"/> SN7413	.95	SN7451	30	SN7489	4.50	SN74150	1.61	SN74182	2.00
<input type="checkbox"/> SN7415	.55	SN7453	30	SN7490	1.49	SN74151	1.25	SN74185	2.50
<input type="checkbox"/> SN7416	.55	SN7454	30	SN7491	1.45	SN74152	1.95	SN74186	2.50
<input type="checkbox"/> SN7417	.55	SN7455	55	SN7492	1.35	SN74156	1.95	SN74189	1.95
<input type="checkbox"/> SN7420	.30	SN7460	30	SN7493	1.35	SN74155	2.10	SN74194	1.95
<input type="checkbox"/> SN7421	.55	SN7461	35	SN7494	1.35	SN74156	1.55	SN74195	1.25
<input type="checkbox"/> SN7422	.35	SN7462	30	SN7495	1.35	SN74157	1.55	SN74196	2.50
<input type="checkbox"/> SN7425	.50	SN7463	50	SN7496	1.35	SN74158	1.55	SN74197	2.50
<input type="checkbox"/> SN7426	.36	SN7465	50	SN74106	95	SN74158	1.55	SN74198	2.65
<input type="checkbox"/> SN7430	.30	SN7470	50	SN74107	70	SN74160	1.95		
<input type="checkbox"/> SN7432	.35	SN7471	55	SN74108	95	SN74161	1.95		

\* Factory Marked \* Money Back Guarantee Buy 100 — Take 20%

## GENERAL ELECTRIC 3-WATT AUDIO AMP \$2.50

Delivers 3 watts continuous, 10 watts peak. With heat sinks; micro-mini size; 3x3x2 1/2"; 9 to 30V supply. High sensitivity, 8 to 16 ohms. For mono and stereo phonos, tape, FM, AM, TV, servo.



CIRCLE NO. 22 ON READER SERVICE CARD



<b>NATIONAL MOS</b>		<b>CT5005</b>		<b>7400 TTL</b>	
DYNAMIC shift registers		CALCULATOR ON A CHIP		DIP	
MM502	dual 50 bit 1.25	This chip has a full four function memory. Memory is controlled by four keys: M (adds entry to memory), M (subtract entry from memory), CM (clear memory—without clearing rest of registers), RM (read memory or use as entry).			
MM506	dual 100 bit 1.75				
MM5006	dual 100 bit 1.50	• 12 DIGIT DISPLAY AND CALC.			
MM5013	1024 bit 2.00	• FIXED DECIMAL AT 0, 1, 2, 3, 4, OR 5			
MM5016	512 bit 1.50	• CLEARING ZERO SUPPRESSION			
STATIC shift registers		• SEVEN SEGMENT MULTIPLEXED OUTPUT			
MM504	dual 16 bit 1.50	• TRUE CREDIT SIGN DISPLAY			
MM505	dual 32 bit 1.75	• SINGLE 28 PIN CHIP			
MM550 dual differential analog switch		Chip and data—\$14.95			
2.50		Data only—1.00 (refundable)			
<b>KEYBOARD Telephone</b>		7476—70			
Ten push buttons (0-9) touch-tone, encoding, programming devices. Easy for panel mounting.		7480—65			
		7483—1.30			
\$5.95		7486—80			
Size: 3X2½"1"		7489—4.75			
MV-50 red emitting 10-40ma @ 2V .25		7492—1.15			
MV-4 High Power Red 2.95		7493—1.15			
MV-108 Visible red 5-70ma @ 2V .30		7499—1.25			
		74107—70			
<b>TRIAC 2HG344 600V 1.00</b>		74154—2.50			
NE531 op amp 10-5 \$2.00		74192—2.50			
NE561 phase lock loop DIP 3.25		74193—1.50			
NE565 phase lock loop 10-5 3.25		74195—1.10			
NE566 function generator 10-5 4.00		<b>LINEARS</b>			
NE567 tone decoder 10-5 4.00		LM100—\$ 1.00			
<b>DM880 (Sperry DD700 202) 7 segment high voltage nixie driver—\$1.75</b>		LM309H—75			
All IC's are new and fully tested, leads are plated with gold or solder. Orders for \$5 or more will be shipped prepaid. Add 35¢ for smaller orders. California residents add sales tax. IC orders are shipped with 24 hrs. COD's may be phoned in \$10. minimum. Money back guarantee. P.O. Box J. Carmichael, California 95608 (916) 966-2111		LM309K—1.00			
<b>BABYLON ELECTRONICS</b>		NE560—3.25			
<b>CIRCLE NO. 2 ON READER SERVICE CARD</b>		NE565—1.10			
		709—45			
		710—40			
		711—40			
		723—1.00			
		LM330D (audio amp) 1.75			
		<b>CMOS</b>			
		CD4001—5.75			
		CD4002—75			
		74C00—75			
		CD4012—75			
		CD4023—75			

## BUSINESS OPPORTUNITIES

**I MADE \$40,000.00 Year by Mailorder!** Helped others make money! Start with \$15.00—free Proof. Torrey, Box 318-N, Ypsilanti, Michigan 48197.

**FREE CATALOGS.** Repair air conditioning, refrigeration. Tools, supplies, full instructions. Doolin, 2016 Canton, Dallas, Texas 75201.

**MAILORDER MILLIONAIRE** helps beginners make \$500 weekly. Free report reveals secret plan! Executive (1K1), 333 North Michigan, Chicago 60601.

**PIANO TUNING LEARNED QUICKLY AT HOME!** Tremendous field! Musical knowledge unnecessary. GI approved. Information free. Empire School, Box 327, Miami 33145.

**\$2000.00 MONTHLY** selling information by mail. Ropchan, Box 161X, Saginaw, Oregon 97472.

**SILVER RECOVERY DEALERS WANTED!**—Earn \$24,000.00 by second year!—No Investment!—No Risk!—Equipment Provided!—Our manual "How To Start and Operate Your Own Silver Recovery Business" gives complete details!—Manual only \$9.95—Limited Offer!—Creative Products, 8415 Lofland, Dept. PE-14, Houston, Texas 77055.

**FREE Secret Book "2042 Unique Proven Enterprises."** Fabulous "Little Knowns." Work home! Haylins-BH, Carlsbad, California 92008.

**HIGHLY PROFITABLE**

## ONE-MAN ELECTRONIC FACTORY

Investment unnecessary, knowledge not required, sales handled by professionals. Postcard brings facts about this unusual opportunity. Write today! Barta-DA, Box 248, Walnut Creek, CA 94597.

**START SMALL,** highly profitable electronic production in your basement. Investment, knowledge unnecessary. Postcard brings facts. Barta-CA, Box 248, Walnut Creek, California 94597.

## TREASURE FINDERS

**FREE—Valuable Treasure Finder catalog** sent by return mail. Find Coins, Rings, Gold, Silver, Metals, Relics. Write today. JETCO, Dept. CPE, Box 26669, El Paso, Texas 79926.

**FREE FACT-FILLED CATALOG.** World's largest line of metal detectors. Models as low as \$49.50 and up. Two year Guarantee. Three factory locations, U.S. and Canada, plus over 1,000 dealers and 35 Service Centers from coast to coast. No finer instruments made at any price. Budget terms. Write: White's Electronics, Inc., Rm# 391, 1011 Pleasant Valley Road, Sweet Home, Oregon 97386.

**FIND BURIED TREASURE** eight transistorized models \$19.95 to \$119.95, modular interchangeable heads, full view motors, FREE Catalog, Solidtronics Corporation-PE 41, Tennent, N.J. 07763.

**FAMILY FUN! OUTDOOR ADVENTURE!** Find valuable coins and treasure with world famous metal detectors. Free illustrated booklet. Detectron, Dept. PE, Box 243, San Gabriel, Calif. 91778.

## MUSICAL INSTRUMENTS

**30% DISCOUNT** name brand musical instruments. Free Catalog. Freepoint Music, 455N, Route 110, Melville, N.Y. 11746.

**WHOLESALE!** Professional Guitars, PA Systems, Altec Speakers, 240W RMS Amplifiers. Free Catalog, Carvin, Escondido, Calif. 92028.

## BOOKS

**FREE catalog aviation/electronic/space books.** Aero Publishers, 329PE Aviation Road, Fallbrook, California 92028.

**FREE book prophet Elijah** coming before Christ. Wonderful bible evidence. Megiddo Mission, Dept. 64, 481 Thurston Rd., Rochester, N.Y. 14619.

**STEPS TO CHRIST—50¢** and self-addressed shipping label to New Worlds Unlimited, P.O. Box 62, Ridgecrest, Calif. 93555. Postage and applicable tax included.

## RUBBER STAMPS

**RUBBER** address stamps. Free catalog. 45 type styles. Jackson's, Box 443G, Franklin Park, Ill. 60131.

## HYPNOTISM

**SLEEP** learning. Hypnotic method. 92% effective. Details free. ASR Foundation, Box 7566EG, Fort Lauderdale, Florida 33304.

**FREE Hypnotism.** Self-Hypnosis. Sleep Learning Catalog! Drawer H400, Ruidoso, New Mexico 88345.

**AMAZING** self-hypnosis record releases fantastic mental power. Instant results! Free trial. Write: Forum (AA1), 333 North Michigan, Chicago 60601.

## PRINTING

**FREE literature, business cards, letterheads, rubber stamps.** Geer's, 111 North Drive, Ottawa, Ohio 45875.

# Popular Electronics

JANUARY 1974

## ADVERTISERS INDEX

READER SERVICE NO.	ADVERTISER	PAGE NO.
35	Audio Technica U.S., Inc	17
33	B&K, Dnyascan Corporation	47
	Bell & Howell Schools	58, 59, 60, 61, 94, 95, 96, 97
3	Bose	28
4	CIE Cleveland Institute of Electronics	104, 105, 106, 107
	CREI Capitol Radio Engineering Institute	22, 23, 24, 25
6	Continental Specialties Corporation	8
7	Datak Corporation, The	121
8	Delta Electronics Co	125
5	Delta Products, Inc.	19
36	Digi-Key	126
9	EICO	116
34	EICO	117
14	Edmund Scientific Co	134
31	Fluke	9
10	GC Electronics	116
11	Greenlee Tool Co	119
	Gregory Electronics Corp	123
12	Heath Company	10, 11
13	Illinois Audio	120
CLASSIFIED ADVERTISING		

READER SERVICE NO.	ADVERTISER	PAGE NO.
	International Correspondence Schools	48, 49, 50, 51
15	Lafayette Radio Electronics	119
16	McIntosh Laboratory, Inc	91
17	MITS Micro Instrumentation & Telemetry Systems, Inc	27
18	Midwest Hi-Fidelity Wholesalers & Mail Order Division	117
	NRI Training	SECOND COVER, 1, 2, 3
	National Technical Schools	130, 131, 132, 133
20	Olson Electronics	15
22	Poly Paks	127
23	Radio Shack and Allied Radio Stores	7
32	Shure Brothers, Inc	FOURTH COVER
24	Solid State Sales	124
25	Solid State Systems, Inc	135 thru 150
26	Southwest Technical Products Corporation	115
27	Tri-Star Corp	120
	U.S. Coast Guard	76, 77, 78, 79
	U.S. Navy	20, 21
28	United Audio Products, Inc	13
29	Utah Electronics	99
		122, 123, 124, 125, 126, 128, 129

### SPORTS ACTION FILMS

**SPEND YOUR CHRISTMAS \$\$\$**—Order **SPORTLITE** Films. Action packed NFL Super Bowl '73; '72 World Series; '72 Baseball All Stars; '72 Olympics (Aquatics, track & field, gymnasts, competitive sports)—each a separate 200 foot reel; Color, \$14.95 each; B&W, \$7.95 each PPD. 1973 Indianapolis "500", Super 8, 200', \$15.95; Ali-Norton; Foreman-Frazier—\$16.95 Each, Color; \$8.50 Each B&W. 24-page catalog, 25¢. **SPORTLITE FILMS**, Dept., Elect., Box 500, Speedway, Indiana 46224.

### RESORTS AND TRAVEL

**BERTH & Partnership** in 155 ft. 3-masted Barquentine for \$10,700. Join in Europe, assist conversion then help sail on 2-year Adventure & Business World Voyage. Write: R. Bruderer, IYC, Box 149 Broadway, NSW Australia 2007.

### REAL ESTATE

**FREE . . . NEW . . . BIG . . . SPRING CATALOG!** Describes and pictures hundreds of farms, ranches, town and country homes, businesses coast to coast! Speciy type property and location preferred. UNITED FARM AGENCY, 612-EP, West 47th St., Kansas City, Mo. 64112.

### EMPLOYMENT INFORMATION

**EXCITING** Overseas jobs. Directory \$1.00. Research Associates, Box 889-E, Belmont, California 94002.

### MAGNETS

**MAGNETS.** All types. Specials-20 disc, or 10 bar, or 2 stick, or 8 assorted magnets, \$1.00 Magnets, Box 192-H, Randallstown, Maryland 21133.

### MISCELLANEOUS

**WINEMAKERS:** Free illustrated catalog yeasts, equipment. Semplex, Box 12276P, Minneapolis, Minn. 55412.

**YOUR LOW COST** Classified or Display Classified Ad in these columns will be seen, read and responded to regularly by America's largest audience of Electronics Professionals and Hobbyists. Check out the rates and terms noted on the first page of this section. Then, send copy and payment to: Hal Cymes, Classified Advertising Manager, POPULAR ELECTRONICS, One Park Avenue, New York, New York 10016. Your ad will be included in the next available edition!

### 1974 Communications Handbook



Everything you want to know—need to know—about Citizens' Band, Amateur Radio, Shortwave Listening. The world's most complete guide to communications. Designed to help you get greater value, greater enjoyment out of every minute you spend with your equipment.

Order by number from  
Ziff-Davis Service Division,  
595 Broadway, N. Y., N.Y. 10012.

Enclose an additional 35c per copy for postage and handling. Outside USA all magazines are \$2.50 per copy, postpaid.

1974 #84 \$1.25  
1973 #80 \$1.25  
1972 #70 \$1.25

**PAYMENT MUST BE ENCLOSED WITH ORDER**

# Changes come fast in electronics.

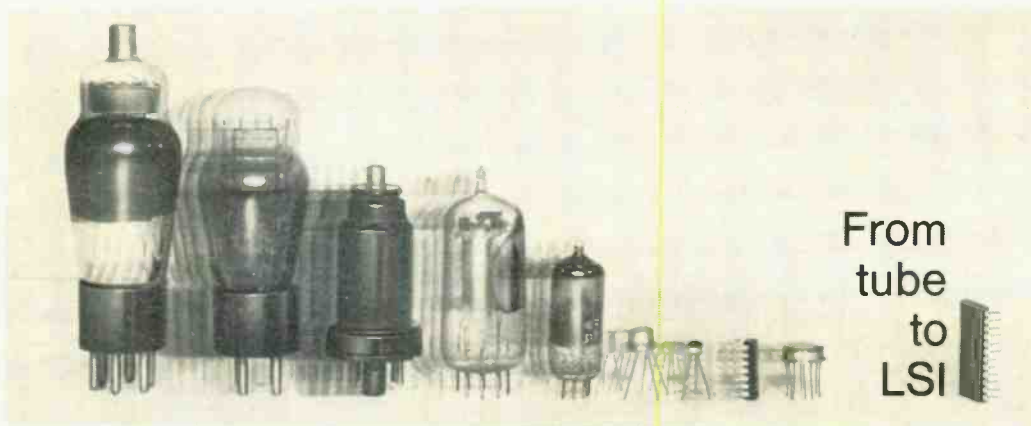

From  
tube  
to  
LSI

Take a look at the race in circuit technology. In the 1960's the tubes at the left made way for the transistors at the right. Today, transistors are surpassed by the large scale integrated circuit (LSI) at the far right. This circuit, less than a quarter inch square, replaces over 6000 transistors!

There's big money to be made by the men who stay ahead of this technology race. Put yourself

ahead with NTS Home Training! You get the latest, most advanced equipment (at no extra cost). More solid-state units, and more advanced technology. Plenty of training with integrated circuits, too! As an NTS graduate, you enter a world of electronics you're familiar with. You have a thorough working knowledge of solid-state circuitry. You're ready to tackle bigger jobs at higher pay!

## NTS COLOR AND B & W TV SERVICING

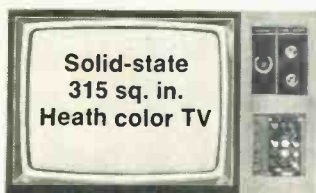

Build and keep the largest, most advanced color TV made! Over-all solid-state design, ultra-rectangular screen, matrix picture tube, built-in self-servicing features, "Instant On," A.F.T., solid-state, 24-channel detent UHF/VHF power tuning, and much more! Also build and keep AM-SW Radio, Solid-State Radio, FET Volt-Ohmmeter, and Electronic Tube Tester. Learn trouble-shooting, hi-fi stereo, multiplex systems, radio, color and B & W TV servicing.

Learn sophisticated solid-state circuitry as you build this B & W TV receiver. Lo-Silho "Superhet" Radio, FET Volt-Ohmmeter, Solid-State Radio, Electronic Tube Checker, and Signal Generator. TV

and all other equipment are yours to keep.

Solid-state B & W TV, 74 sq. in. picture (cabinet included)



## NTS ELECTRONICS & COMPUTER TECHNOLOGY

Build and keep this exclusive NTS Compu-Trainer. It teaches you the

Solid-state Compu-Trainer 14 integrated circuits replace 198 transistors!

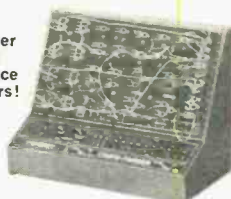

same principles used in million-dollar systems. Contains 14 inte-

grated circuits! All Solid-State! You perform all wiring and patchcording. No shortcuts. No pre-wired circuit boards. Your training is complete! Also receive an FET Volt-Ohmmeter and a 5" wide-band Solid-State Oscilloscope.

## NTS ELECTRONICS COMMUNICATIONS

Gain the prestige and earning power of owning an F.C.C. First Class Radio-Telephone License. Two comprehensive NTS courses cover the big opportunity field of transmitting and receiving.

You build and keep 14 kits, including this amateur phone 6-meter VHF Transceiver, NTS's exclusive 6-transistor Solid-State Radio, and a fully transistorized Volt-Ohmmeter. Also, learn 2-way radio, Citizens-Band microwaves, and radar.

5-watt AM transmitter/receiver



POPULAR ELECTRONICS



# NTS Home Training puts you in the lead.

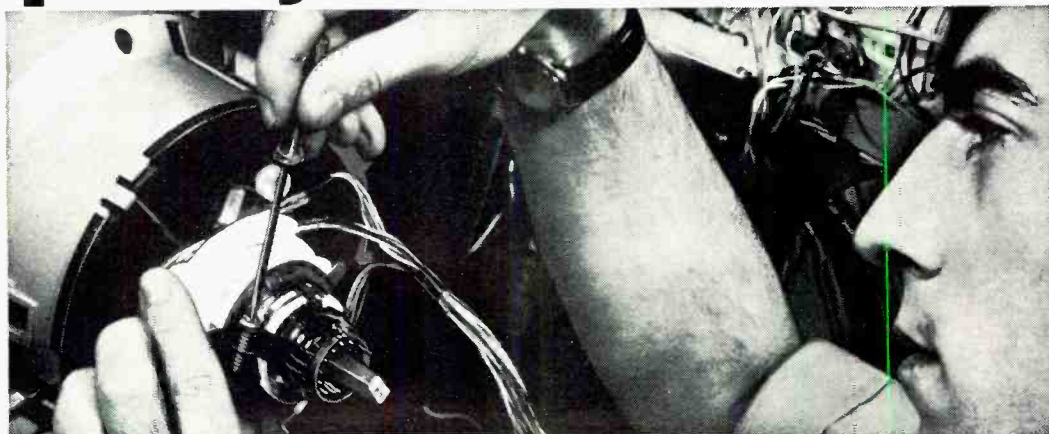

## NTS INDUSTRIAL & AUTOMATION ELECTRONICS

Automation is the future of industry and you can play an important part! Learn industrial controls by training on the NTS Electro-Lab (a complete workshop). You also build and operate this 5" Solid-State oscilloscope. And you perform experiments that involve regulating motor speeds, temperature, pressure, liquid level, and much more. All equipment is yours to keep.



decks, stereo multiplex component systems, and more! Set up a spectacular music system. Learn about

Build and keep this famous Heath Stereo Receiver and Speakers.



sound distortion, amplification and control, loud-speaker baffles, problems of system installation, etc. Included is Volt-Ohmmeter, In-Circuit Transistor Tester, and Solid-State

Radio. Prepare yourself for great opportunities in the Home Entertainment Industry!

## CLASSROOM TRAINING AT LOS ANGELES

You can take classroom training at Los Angeles in sunny Southern California. NTS occupies a city block with over a million dollars in technical facilities. Check box in coupon below.

## NATIONAL TECHNICAL SCHOOLS

WORLD-WIDE TRAINING SINCE 1905  
Resident & Home Study Schools  
4000 S. Figueroa Street  
Los Angeles, California 90037

## APPROVED FOR VETERAN TRAINING

Accredited Member: National Association of Trade and Technical Schools; National Home Study Council.

Dept. 205-014

Big, Colorful NTS Guide to new opportunities in Electronics. Yours FREE!



NATIONAL TECHNICAL SCHOOLS  
4000 S. Figueroa Street  
Los Angeles, California 90037

Please rush me FREE Color NTS Electronics Guide & FREE lesson, plus information on course checked at right. No obligation. No salesman will call.

- MASTER COURSE IN COLOR TV SERVICING
- COLOR TV SERVICING (FOR ADVANCED TECHNICIANS)
- MASTER COURSE IN B&W TV & RADIO SERVICING
- MASTER COURSE IN ELECTRONIC COMMUNICATIONS
- PRACTICAL RADIO SERVICING
- FCC LICENSE COURSE
- MASTER COURSE IN ELECTRONICS TECHNOLOGY
- AUTOMATION & INDUSTRIAL ELECTRONICS
- COMPUTER ELECTRONICS
- BASIC ELECTRONICS
- AUDIO ELECTRONICS SERVICING

NAME \_\_\_\_\_ AGE \_\_\_\_\_

ADDRESS \_\_\_\_\_

CITY \_\_\_\_\_

STATE \_\_\_\_\_ ZIP \_\_\_\_\_

- Check if interested in Veterans Training under new G.I. Bill.
- Check if interested ONLY in Classroom Training at Los Angeles

# LIVE IN THE WORLD OF TOMORROW... TODAY!

## A BETTER LIFE STARTS HERE

### ELECTRONIC DIGITAL STOPWATCH

Most precise, error-free timer ever! Obsoletes mechanical stop-watches. Not only clocks to 1/100 sec. w/inst. big bright readout, but times unlimited no. of intervals while clocking overall event. Time 2 or more participants simultaneously! Solid state; unchangeable accuracy ( $\pm 0.001\%$ ) w/6 running digits always shown clearly under any conditions; quartz crystal gives lifetime reliability. Incls. 4 "C" batts., leather case (\$12.50 val.) 2-yr. warranty. Stock No. 1645AV.. (16-oz.).. \$195.00 Ppd.

### "FISH" WITH A MAGNET

Go treasure hunting on the bottom! Fascinating fun & sometimes profitable! Tie a line to our powerful new specially designed 150 lb. pull Magnet—drop it overboard in bay, river, lake or ocean. Trawl it along bottom—your "treasured" haul can be outboard motors, anchors, other metal valuables. Has 6 stacked ceramic magnets. Lifts more than 150 lbs. and water! No. 71.135AV ..... (31/4x3 3/4") ..... \$16.50 Ppd.  
75-LB. PULL (1 LB. W/3 CERAMIC MAGNETS) No. 71.150AV ..... (1-11/16x3 3/4") ..... \$10.25 Ppd.



### KNOW YOUR ALPHA FROM THETA!

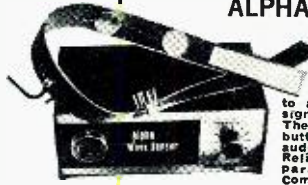

For greater relaxation, concentration, listen to your Alpha-Theta brainwaves. Ultra-sensitive electrode headband slips on/off in seconds—eliminates need for messy creams, etc. Attach'd to amplifier, filters brainwaves, signals beep for ea. Alpha or Theta wave passed. Monitoring button simulates Alpha sound; audio & visual (L.E.D.) feedback. Reliable, easy-to-use unit—comparable to costlier models. Completely safe. Comprehensive instruction booklet.

No. 1635AV ..... (8x3 1/4" x 2 1/2") ..... \$128.00 Ppd.  
No. 71.809AV ..... (LOW COST "STARTER" UNIT) ..... \$49.95 Ppd.

### 3-CHANNEL COLOR ORGAN KIT

Easy to build low-cost kit needs no technical knowledge. Completed unit has 3 bands of audio frequencies to modulate 3 independent strings of colored lamps (i.e. "lows"—reds, "middles"—greens, "highs"—blues. Just connect hi-fi, radio, power lamp etc. & plug ea. lamp string into own channel (max. 300W ea.). Kit features 3 neon indicators, color intensity controls, controlled individ SCR circuits; isolation transformer; custom plastic housing; instr. Stock No. 41,831AV ..... \$17.50 Ppd.



### 130 EXPERIMENTS IN OPTICS...

and photography! Optix® Experiments Kit is a complete optical & photography lab for 130 exciting experiments. Lets you recreate the periscope, telescope, microscope, kaleidoscope! Build a 35-mm reflex camera with interchangeable lens system! Make, develop photographic film! Enjoy the fun and fascination of having your own optics lab. Fully illustr 112-pg manual, 8 1/2 x 11", clearly explains usage of this stimulating kit's 114 precision engineered components. Stock No. 71.646AV ..... \$22.50 Ppd.

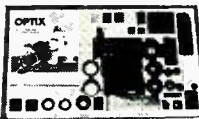

SEE THE STARS, MOON, PLANETS CLOSE UP!

### 3" ASTRONOMICAL REFLECTING TELESCOPE



60 To 180 Pwr. Famous Mt. Palomar Type See the rings of Saturn, the fascinating planet Mars. Seas and Craters of the Moon. Star Clusters in detail. New improved, aluminized and overcoated 3" diameter f/10 primary mirror; vented cell. Equatorial mount with locks on both axes. Equipped with 60x finder telescope, hardwood tripod. Included FREE: VALUABLE "HOW TO USE YOUR TELESCOPE" book; "STAR CHART" Stock No. 85.050AV ..... \$36.95 Ppd.  
4 1/4" Reflector Telescope (65x to 270x) Stock No. 85.105AV ..... \$115.00 FOB  
4 1/4" Reflector Telescope with Clock Drive Stock No. 85.107AV \$149.95 ppd.  
6" Reflector Telescope Stock No. 85.187AV ..... \$222.50 FOB  
6" Reflector W/(Electric) Clock Drive No. 85.086AV... \$259.50 FOB

### MAIL COUPON FOR GIANT FREE CATALOG!

180 PAGES • MORE THAN 4,500 UNUSUAL BARGAINS!

Completely new '74 Catalog. Packed with huge selection of telescopes, microscopes, binoculars, magnets, magnifiers, prisms, photo components, ecology and Unique Lighting Items, parts, kits, accessories—many hard-to-get surplus bargains. 100's of charts, illustration. For hobbyists, experimenters, schools, industry.

EDMUND SCIENTIFIC CO.  
300 Edscorp Building, Barrington, N. J. 08007  
Please rush Free Giant Catalog "AV"

Name \_\_\_\_\_  
Address \_\_\_\_\_  
City \_\_\_\_\_ State \_\_\_\_\_ Zip \_\_\_\_\_

### COMPLETE & MAIL WITH CHECK OR M.O.

EDMUND SCIENTIFIC CO.  
300 Edscorp Building, Barrington, N.J. 08007

How Many	Stock No.	Description	Price Each	Total

PLEASE SEND  GIANT FREE CATALOG "AV" MERCHANDISE Total

ADD HANDLING CHARGE: \$1.00 ON ORDERS UNDER \$5.00; 50c ON ORDERS OVER \$5.00

I enclose  check  money order for \$ \_\_\_\_\_ TOTAL \$ \_\_\_\_\_

NAME \_\_\_\_\_  
ADDRESS \_\_\_\_\_  
CITY \_\_\_\_\_ STATE \_\_\_\_\_ ZIP \_\_\_\_\_



CIRCLE NO. 14 ON READER SERVICE CARD



# SOLID STATE SYSTEMS, INC.

800 N. PROVIDENCE RD. (314) 443-3673 TWX 910-760-1453  
COLUMBIA, MISSOURI 65201

Dear Customer:

We are pleased to offer you this Winter 1973 Edition of our complete parts catalog. Those of you that have received previous catalogs will want to take notice of the new items that have been added. For instance, we are now carrying a full range of 5% type RCR resistors in addition to the 10% resistors we have always stocked. We hope to continue our trend toward these additions so that we can more completely serve your needs.

As our company has grown and the number of orders per day has increased, it has become necessary to request that certain items be ordered in exact multiples of five or ten. This allows us to prepackage many items and process each order with greater speed and accuracy. We ask that our customers pay particular attention to this ordering feature as this will save time consuming correspondence for both of us.

Those of you that have been with us since our inception will be familiar with our policy of 24 hour service and we want to again emphasize that we stress this policy to all our employees. We know how frustrating long delays can be when you are waiting for your order and we have built our reputation on FAST SERVICE and the stocking of only FIRST RUN, FACTORY TESTED COMPONENTS. We guarantee to replace any defective items if you will call or write for a Return Authorization.

Other features to note are our Toll Free Lines to our Order Desk (open 7 a.m. to 9 p.m. Monday through Friday and 8 a.m. to 4 p.m. on Saturday) and our offer of free data sheets for all our integrated circuits and readouts. A special column on the order blank has been provided for this request. You will also notice the use of grouping code numbers throughout the catalog. All items with like grouping codes may be combined for quantity pricing.

We would like to express our appreciation to those of you who have continued to support us and offer new readers an invitation to try our parts and services. We are getting better and stronger every day.

Sincerely,

Lynette Caskey  
General Manager

### SHIPPING CHARGES

If your merchandise total is between:

SPECIAL CHARGES		STANDARD CHARGES	
COD .....	\$1.00 - additional	\$ 0.00 - \$ 4.99 .....	add ..... \$1.00
Air Mail .....	\$0.50 - additional	\$ 5.00 - \$24.99 .....	add ..... \$0.75
Postal Insurance .....	\$0.25 - additional	\$ 25.00 - \$49.99 .....	add ..... \$0.50
Special Delivery .....	\$0.75 - additional	\$ 50.00 - \$99.99 .....	add ..... \$0.25
		\$100.00 and up .....	NO CHARGE

Above charges include shipping via First Class or UPS (your choice), and insurance for all domestic shipments.

**ORDER DESK (TOLL FREE): 800-325-2595 & 800-325-2981**  
**MON. - FRI. 7 AM - 9 PM SAT. 8 AM - 4 PM**

PRICES SUBJECT TO CHANGE WITHOUT NOTICE  
©COPYRIGHT 1973, SOLID STATE SYSTEMS, INC.  
PRINTED IN USA





# CERAMIC DISC CAPACITORS

Solid State Systems offers a complete selection of Ceramic Disc Capacitors for a wide range of applications from high voltage RF to low voltage transistor Circuitry. PLEASE NOTE: In order to maintain our low prices, we must request that you order in exact multiples of 10 per item; you may, however, mix all different types of ceramic capacitors for quantity pricing.



Sprague type 5HK ceramic disc capacitors offer high capacity in a minimum space. All type 5HK capacitors have a tolerance of -20%, +80%. Voltage rating is 1000VDC for values up to and including 0.01 $\mu$ F; and 500VDC for 0.015 $\mu$ F and higher.

Catalog Number	Capacitance	10-90	100-240	250-490	500-990	1000-up	Grouping Code
72-10369	1000 pF	.10	.09	.08	.07	.06	4
72-15369	1500 pF	.10	.09	.08	.07	.06	4
72-20369	2000 pF	.10	.09	.08	.07	.06	4
72-22369	2200 pF	.10	.09	.08	.07	.06	4
72-33369	3300 pF	.10	.09	.08	.07	.06	4
72-47369	4700 pF	.10	.09	.08	.07	.06	4
72-50369	5000 pF	.10	.09	.08	.07	.06	4
72-68369	6800 pF	.10	.09	.08	.07	.06	4
72-10469	0.010 $\mu$ F	.10	.09	.08	.07	.06	4
72-15463	0.015 $\mu$ F	.10	.09	.08	.07	.06	4
72-20463	0.020 $\mu$ F	.11	.10	.09	.08	.07	4
72-25463	0.025 $\mu$ F	.11	.10	.09	.08	.07	4
72-40463	0.040 $\mu$ F	.20	.18	.16	.14	.12	4
72-50463	0.050 $\mu$ F	.20	.18	.16	.14	.12	4
72-10563	0.1 $\mu$ F	.35	.32	.29	.26	.23	4



Sprague type TG low voltage ceramic disc capacitors with a rating of 100VDC are ideal for use in transistorized circuits. All units have a  $\pm 20\%$  tolerance.

Catalog Number	Capacitance	10-90	100-240	250-490	500-990	1000-up	Grouping Codes
73-50342	0.005 $\mu$ F	.10	.09	.08	.07	.06	4
73-10442	0.01 $\mu$ F	.11	.10	.09	.08	.07	4
73-20442	0.02 $\mu$ F	.11	.10	.09	.08	.07	4
73-25442	0.025 $\mu$ F	.12	.11	.10	.09	.08	4
73-30442	0.03 $\mu$ F	.12	.11	.10	.09	.08	4
73-50442	0.05 $\mu$ F	.20	.18	.16	.14	.12	4
73-10542	0.1 $\mu$ F	.26	.23	.20	.17	.14	4



Centralab type UK miniature ceramic discs offer minimum space occupancy on transistorized boards where large capacitance in a small volume is required. Tolerance: 3WVDC types, guaranteed minimum value; all others -20%, +80%.

Catalog Number	Capacitance	10-90	100-240	250-490	500-990	1000-up	Grouping Code
84-10415	.01 $\mu$ F, 16V	.10	.09	.08	.07	.06	4
84-22421	.022 $\mu$ F, 25V	.15	.14	.13	.11	.10	4
84-10509	.1 $\mu$ F, 10V	.12	.11	.10	.09	.08	4
84-20509	.2 $\mu$ F, 10V	.20	.18	.16	.14	.12	4
84-47503	.47 $\mu$ F, 3V	.25	.22	.19	.16	.13	4
84-10603	1.0 $\mu$ F, 3V	.25	.22	.19	.16	.13	4
84-22603	2.2 $\mu$ F, 3V	.30	.27	.24	.21	.18	4



Sprague type 5GA ceramic disc capacitors have low self-inductance of silvered flat-plate design for high by-pass efficiency. All type 5GA capacitors have a tolerance of  $\pm 20\%$ , and 1000VDC ratings.

Catalog Number	Capacitance	10-90	100-240	250-490	500-990	1000-up	Grouping Code
71-50069	5 pF	.10	.09	.08	.07	.06	4
71-75069	7.5 pF	.10	.09	.08	.07	.06	4
71-10169	10 pF	.10	.09	.08	.07	.06	4
71-12169	12 pF	.10	.09	.08	.07	.06	4
71-15169	15 pF	.10	.09	.08	.07	.06	4
71-20169	20 pF	.10	.09	.08	.07	.06	4
71-22169	22 pF	.10	.09	.08	.07	.06	4
71-25169	25 pF	.10	.09	.08	.07	.06	4
71-27169	27 pF	.10	.09	.08	.07	.06	4
71-30169	30 pF	.10	.09	.08	.07	.06	4
71-33169	33 pF	.10	.09	.08	.07	.06	4
71-39169	39 pF	.10	.09	.08	.07	.06	4
71-50169	50 pF	.10	.09	.08	.07	.06	4
71-56169	56 pF	.10	.09	.08	.07	.06	4
71-68169	68 pF	.10	.09	.08	.07	.06	4
71-75169	75 pF	.10	.09	.08	.07	.06	4
71-82169	82 pF	.10	.09	.08	.07	.06	4
71-10269	100 pF	.10	.09	.08	.07	.06	4
71-12269	120 pF	.10	.09	.08	.07	.06	4
71-15269	150 pF	.10	.09	.08	.07	.06	4
71-18269	180 pF	.10	.09	.08	.07	.06	4
71-20269	200 pF	.10	.09	.08	.07	.06	4
71-22269	220 pF	.10	.09	.08	.07	.06	4
71-25269	250 pF	.10	.09	.08	.07	.06	4
71-27269	270 pF	.10	.09	.08	.07	.06	4
71-30269	300 pF	.10	.09	.08	.07	.06	4
71-33269	330 pF	.10	.09	.08	.07	.06	4
71-36269	360 pF	.10	.09	.08	.07	.06	4
71-39269	390 pF	.10	.09	.08	.07	.06	4
71-47269	470 pF	.10	.09	.08	.07	.06	4
71-50269	500 pF	.10	.09	.08	.07	.06	4
71-56269	560 pF	.10	.09	.08	.07	.06	4
71-68269	680 pF	.10	.09	.08	.07	.06	4
71-75269	750 pF	.10	.09	.08	.07	.06	4
71-82269	820 pF	.10	.09	.08	.07	.06	4
71-10369	1000 pF	.10	.09	.08	.07	.06	4
71-12369	1200 pF	.10	.09	.08	.07	.06	4
71-15369	1500 pF	.10	.09	.08	.07	.06	4
71-18369	1800 pF	.10	.09	.08	.07	.06	4
71-20369	2000 pF	.10	.09	.08	.07	.06	4
71-22369	2200 pF	.10	.09	.08	.07	.06	4
71-25369	2500 pF	.10	.09	.08	.07	.06	4
71-27369	2700 pF	.10	.09	.08	.07	.06	4
71-30369	3000 pF	.10	.09	.08	.07	.06	4
71-33369	3300 pF	.10	.09	.08	.07	.06	4
71-39369	3900 pF	.10	.09	.08	.07	.06	4
71-47369	4700 pF	.10	.09	.08	.07	.06	4
71-50369	5000 pF	.10	.09	.08	.07	.06	4
71-10469	0.01 $\mu$ F	.11	.10	.09	.08	.07	4
71-20469	0.02 $\mu$ F	.12	.11	.10	.09	.08	4



SOLID STATE SYSTEMS, INC. P.O. BOX 773  
COLUMBIA, MISSOURI 65201

# ELECTROLYTIC CAPACITORS

These aluminum electrolytic capacitors offer an unexcelled combination of high performance, high stability, low leakage current and long shelf life in a package ideally suited for operation in coupling, by-passing and filtering functions with typical operating life of 10 years.

**PLEASE NOTE:** In order to keep our costs at minimum and maintain our low prices, we must request that you order in EXACT multiples of 10 per item. However, you may mix all electrolytic capacitors for quantity pricing.

- \* Operating Temperature Range: -30°C to +85°C.
- \* Maximum OC Working Voltage: Rated for continuous duty at 85°C.
- \* Capacitance Tolerance Measured at 120 Hz and 25°C Ambient Temperature: -10%, +100%.
- \* Maximum Leakage Current: According to formula:  

$$I (\mu A) = 0.02 \times C \times V.$$
- \* Lead Pull Test: Units will withstand steady pull of 5 lbs. (2.5 lbs. for radial leads) applied to the lead, axially, for a period of 5 minutes.
- \* Life Test: After 1000 hours at rated voltage and temperature of 85°C, the capacitance will be no less than 85% nor more than 120% of the initial value and leakage current will not exceed the maximum given above.

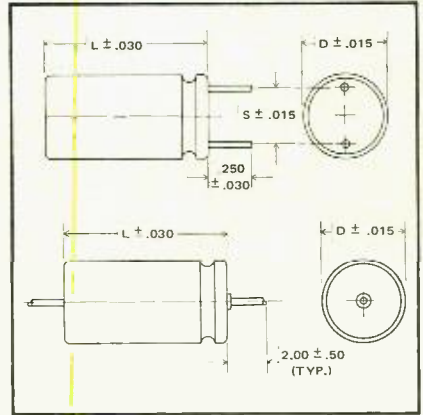

## PHYSICAL DIMENSIONS & PRICE LISTING

AXIAL LEADS			RADIAL LEADS				Capacitance $\mu Fd$	Working DC Volts	Surge DC Volts	PRICE EACH					Grouping Code
Catalog Number	Dimensions "D" "L"	Lead Dia.	Catalog Number	Dimensions "D" "L" "S"	Lead Dia.	10- 90				100- 240	250- 490	500- 990	1000- up		
37-10609	.205 0.488	.020	38-10609	.205 0.413 .079	.020	1	10	13	.10	.09	.07	.06	5		
37-10621	.205 0.488	.020	38-10621	.205 0.413 .079	.020	1	25	32	.11	.10	.09	.08	5		
37-10633	.205 0.488	.020	38-10633	.205 0.413 .079	.020	1	50	63	.12	.11	.10	.09	5		
37-22609	.205 0.488	.020	38-22609	.205 0.413 .079	.020	2.2	10	13	.10	.09	.08	.07	5		
37-22621	.205 0.488	.020	38-22621	.205 0.413 .079	.020	2.2	25	32	.11	.10	.09	.08	5		
37-22633	.244 0.492	.024	38-22633	.244 0.417 .098	.020	2.2	50	63	.12	.11	.10	.09	5		
37-33609	.205 0.488	.020	38-33609	.205 0.413 .079	.020	3.3	10	13	.10	.09	.08	.07	5		
37-33621	.205 0.488	.020	38-33621	.205 0.413 .079	.020	3.3	25	32	.11	.10	.09	.08	5		
37-33633	.244 0.492	.024	38-33633	.283 0.417 .098	.020	3.3	50	63	.12	.11	.10	.09	5		
37-47609	.205 0.488	.020	38-47609	.205 0.413 .079	.020	4.7	10	13	.10	.09	.08	.07	5		
37-47621	.205 0.488	.020	38-47621	.205 0.413 .079	.020	4.7	25	32	.11	.10	.09	.08	5		
37-47633	.323 0.622	.024	38-47633	.283 0.417 .098	.020	4.7	50	63	.12	.11	.10	.09	5		
37-10709	.205 0.488	.020	38-10709	.205 0.413 .079	.020	10	10	13	.10	.09	.08	.07	5		
37-10721	.244 0.492	.024	38-10721	.244 0.417 .098	.020	10	25	32	.11	.10	.09	.08	5		
37-10733	.323 0.622	.024	38-10733	.323 0.512 .138	.020	10	50	63	.12	.11	.10	.09	5		
37-22709	.244 0.492	.024	38-22709	.244 0.417 .098	.020	22	10	13	.10	.09	.08	.07	5		
37-22721	.323 0.622	.024	38-22721	.323 0.520 .118	.020	22	25	32	.13	.12	.11	.10	5		
37-22733	.402 1.024	.024	38-22733	.402 0.768 .197	.024	22	50	63	.18	.17	.16	.15	5		
37-33709	.244 0.492	.024	38-33709	.244 0.417 .098	.020	33	10	13	.10	.09	.08	.07	5		
37-33721	.323 0.622	.024	38-33721	.323 0.520 .118	.020	33	25	32	.13	.12	.11	.10	5		
37-33733	.402 1.024	.024	38-33733	.402 0.787 .197	.024	33	50	63	.20	.19	.17	.16	5		
37-47709	.323 0.622	.024	38-47709	.323 0.417 .138	.020	47	10	13	.11	.10	.09	.08	5		



**SOLID STATE SYSTEMS, INC.** P.O. BOX 773  
COLUMBIA, MISSOURI 65201



AXIAL LEADS			RADIAL LEADS				Capacitance μFd	Working DC Volts	Surge DC Volts	PRICE EACH					Grouping Code		
Catalog Number	Dimensions "D" "L"		Lead Dia.	Catalog Number	Dimensions "D" "L" "S"					Lead Dia.	10- 90	100- 240	250- 490	500- 990		1000- up	
37-47721	.402	1.004	.024	38-47721	.402	0.512	.197	.020	47	25	32	.15	.14	.13	.12	.11	5
37-47733	.520	1.240	.031	38-47733	.520	0.807	.236	.024	47	50	63	.19	.18	.17	.16	.14	5
37-10809	.323	0.622	.024	38-10809	.323	0.512	.138	.020	100	10	13	.12	.11	.10	.09	.08	5
37-10821	.402	1.004	.024	38-10821	.402	0.787	.197	.024	100	25	32	.18	.17	.16	.15	.14	5
37-10833	.520	1.240	.031	38-10833	.520	1.240	.236	.031	100	50	63	.27	.25	.23	.21	.19	5
37-15809	.402	1.004	.024	38-15809	.402	0.524	.197	.020	150	10	13	.17	.16	.15	.14	.13	5
37-15821	.402	1.024	.024	38-15821	.520	0.787	.236	.024	150	25	32	.24	.23	.21	.20	.18	5
37-15833	.638	1.260	.031	38-15833	.638	1.260	.295	.031	150	50	63	.36	.34	.32	.30	.28	5
37-22809	.402	1.004	.024	38-22809	.402	0.571	.197	.024	220	10	13	.13	.12	.11	.10	.09	5
37-22821	.520	1.240	.031	38-22821	.520	0.807	.236	.024	220	25	32	.25	.24	.22	.21	.19	5
37-22833	.717	1.240	.031	38-22833	.638	1.555	.295	.031	220	50	63	.37	.35	.32	.30	.27	5
37-33809	.402	1.004	.024	38-33809	.402	0.768	.197	.024	330	10	13	.20	.19	.18	.17	.16	5
37-33821	.520	1.240	.031	38-33821	.520	1.240	.236	.031	330	25	32	.26	.24	.22	.20	.18	5
37-33833	.717	1.811	.031	38-33833	.717	1.772	.295	.031	330	50	63	.54	.50	.46	.42	.38	5
37-47809	.402	1.004	.024	38-47809	.402	0.768	.197	.024	470	10	13	.24	.23	.21	.20	.18	5
37-47815	.520	1.240	.031	38-47815	.520	0.984	.236	.031	470	16	20	.25	.24	.22	.21	.19	5
37-47821	.638	1.240	.031	38-47821	.630	0.984	.295	.031	470	25	32	.26	.24	.22	.20	.18	5
37-47827	.717	1.240	.031	38-47827	.638	1.555	.295	.031	470	35	44	.35	.33	.31	.29	.27	5
37-47833	.717	1.949	.031	38-47833	.717	1.909	.295	.031	470	50	63	.64	.60	.55	.51	.46	5
37-68809	.520	1.240	.031	38-68809	.520	1.004	.236	.031	680	10	13	.31	.29	.27	.25	.23	5
37-68821	.717	1.260	.031	38-68821	.638	1.575	.295	.031	680	25	32	.42	.39	.36	.33	.30	5
37-10909	.520	1.240	.031	38-10909	.638	1.004	.295	.031	1000	10	13	.41	.38	.35	.32	.29	5
37-10915	.638	1.240	.031	38-10915	.638	1.260	.295	.031	1000	16	20	.45	.42	.39	.36	.33	5
37-10921	.717	1.437	.031	38-10921	.717	1.393	.295	.031	1000	25	32	.50	.47	.43	.40	.37	5
37-10927	.717	1.949	.031	38-10927	.717	1.969	.295	.031	1000	35	44	.67	.63	.58	.54	.49	5
37-15915	.717	1.457	.031	38-15915	.638	1.575	.295	.031	1500	16	20	.42	.39	.36	.33	.30	5
37-22915	.717	1.594	.031	38-22915	.717	1.752	.295	.031	2200	16	20	.56	.53	.49	.46	.42	5

## TRANSFORMERS

Three Stancor filament transformers are now available for a variety of power supply circuit applications. All three have 117 volts, 50/60 Hz primaries and center-tapped secondaries with lead terminations. All secondary voltages ±3%. Units designed and built to meet the requirements of EIA for electrical tolerances, dielectric strength, temperature rise and construction. All are insulated with class A materials; (105°C maximum operating temperatures).

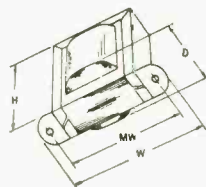

## DIMENSIONS & PRICE LISTING

Catalog Number	Stancor Part Number	Secondary		Dimensions				Wt. Lbs.	1- 49	50- 99	100- 499	500- 999	1000- up	Grouping Code
		Volts	Amps	H	W	D	MW							
11-06134	P-6134	6.3	1.2	1 5/8	2 7/8	1 7/8	2 3/8	0.8	3.00	2.75	2.50	2.00	1.50	7
11-08384	P-8384	12.6	1.0	2	3 1/4	1 3/4	2 13/16	0.9	3.25	3.00	2.75	2.25	1.75	7
11-08180	P-8180	25.2	1.0	2	3 1/4	2 1/8	2 13/16	1.4	3.25	3.00	2.75	2.25	1.75	7



SOLID STATE SYSTEMS, INC.

P.O. BOX 773  
COLUMBIA, MISSOURI 65201

# RESISTORS

Solid State Systems presents standard 5% and 10% tolerance Stackpole & Allen-Bradley type RCR hot molded fixed composition resistors which meet all requirements of MIL-R-39008. These resistors have established reliability to 0.001% failure rate per 1000 hours of operation at maximum ambient temperature of 70°C as symbolized by the fifth color band on the body of the resistor.

- \* Maximum Ambient Operating Temperature: 70°C.
- \* Available Values: All 84 standard 10%, and all 167 standard 5% values from 2.7Ω to 22MΩ.
- \* Unexcelled low noise characteristics.
- \* Utmost uniformity in dimensions due to exclusive molding process.
- \* All leads tin plated to meet MIL-STD-202, Method 208 requirements.
- \* Permanent color codes which are immune to scrubbing with all commercially used flux solvents.

Within the limitations shown in price table below, all values of ¼ and ½ watt resistors may be combined for quantity pricing. All Resistors must be ordered in exact multiples of 5 per value.



COLOR	FIRST DIGIT	SECOND DIGIT	MULTIPLIER	TOLERANCE	RELIABILITY LEVEL*
Silver	--	--	-----	±10%	-----
Gold	--	--	0.1	±5%	-----
Black	0	0	1	-----	-----
Brown	1	1	10	-----	1%
Red	2	2	100	-----	0.1%
Orange	3	3	1,000	-----	0.01%
Yellow	4	4	10,000	-----	0.001%
Green	5	5	100,000	-----	-----
Blue	6	6	1,000,000	-----	-----
Violet	7	7	-----	-----	-----
Gray	8	8	-----	-----	-----
White	9	9	-----	-----	-----

\* RELIABILITY LEVEL: Percent failure per 1000 hrs.

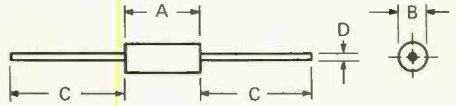

Catalog Number	Multiples of 5 Per Value		Multiples of 10 Per Value		Grouping Code
	5 & up	50-950 & up	1000-9000 & up	10,000 & up	
From Table I	.05	.040	.035	.03 .025	3
From Table II	.08	.065	.055	.045 .040	3

Wattage	Dimension In Inches			
	A	B	C	D
¼	0.250±0.015	0.090±0.008	1.500±0.125	0.025±0.002
½	0.375±0.031	0.140±0.008	1.500±0.125	0.033±0.002

TABLE I: STANDARD 10% VALUES AND CATALOG NUMBERS

Resistance	Catalog Number		Resistance	Catalog Number		Resistance	Catalog Number		Resistance	Catalog Number	
	¼ Watt	½ Watt		¼ Watt	½ Watt		¼ Watt	½ Watt		¼ Watt	½ Watt
			100	11-10207	12-10220	10K	11-10407	12-10420	1.0M	11-10607	12-10620
			120	11-12207	12-12220	12K	11-12407	12-12420	1.2M	11-12607	12-12620
			150	11-15207	12-15220	15K	11-15407	12-15420	1.5M	11-15607	12-15620
			180	11-18207	12-18220	18K	11-18407	12-18420	1.8M	11-18607	12-18620
			220	11-22207	12-22220	22K	11-22407	12-22420	2.2M	11-22607	12-22620
2.7	11-27007	12-27020	270	11-27207	12-27220	27K	11-27407	12-27420	2.7M	11-27607	12-27620
3.3	11-33007	12-33020	330	11-33207	12-33220	33K	11-33407	12-33420	3.3M	11-33607	12-33620
3.9	11-39007	12-39020	390	11-39207	12-39220	39K	11-39407	12-39420	3.9M	11-39607	12-39620
4.7	11-47007	12-47020	470	11-47207	12-47220	47K	11-47407	12-47420	4.7M	11-47607	12-47620
5.6	11-56007	12-56020	560	11-56207	12-56220	56K	11-56407	12-56420	5.6M	11-56607	12-56620
6.8	11-68007	12-68020	680	11-68207	12-68220	68K	11-68407	12-68420	6.8M	11-68607	12-68620
8.2	11-82007	12-82020	820	11-82207	12-82220	82K	11-82407	12-82420	8.2M	11-82607	12-82620
10	11-10107	12-10120	1000	11-10307	12-10320	100K	11-10507	12-10520	10M	11-10707	12-10720
12	11-12107	12-12120	1200	11-12307	12-12320	120K	11-12507	12-12520	12M	11-12707	12-12720
15	11-15107	12-15120	1500	11-15307	12-15320	150K	11-15507	12-15520	15M	11-15707	12-15720
18	11-18107	12-18120	1800	11-18307	12-18320	180K	11-18507	12-18520	18M	11-18707	12-18720
22	11-22107	12-22120	2200	11-22307	12-22320	220K	11-22507	12-22520	22M	11-22707	12-22720
27	11-27107	12-27120	2700	11-27307	12-27320	270K	11-27507	12-27520			
33	11-33107	12-33120	3300	11-33307	12-33320	330K	11-33507	12-33520			
39	11-39107	12-39120	3900	11-39307	12-39320	390K	11-39507	12-39520			
47	11-47107	12-47120	4700	11-47307	12-47320	470K	11-47507	12-47520			
56	11-56107	12-56120	5600	11-56307	12-56320	560K	11-56507	12-56520			
68	11-68107	12-68120	6800	11-68307	12-68320	680K	11-68507	12-68520			
82	11-82107	12-82120	8200	11-82307	12-82320	820K	11-82507	12-82520			



SOLID STATE SYSTEMS, INC. P.O. BOX 773 COLUMBIA, MISSOURI 65201

TABLE II: STANDARD 5% VALUES AND CATALOG NUMBERS

Resistance	Catalog Number		Resistance	Catalog Number		Resistance	Catalog Number		Resistance	Catalog Number	
	¼ Watt	½ Watt		¼ Watt	½ Watt		¼ Watt	½ Watt		¼ Watt	½ Watt
			100	13-10207	14-10220	10K	13-10407	14-10420	1.0M	13-10607	14-10620
			110	13-11207	14-11220	11K	13-11407	14-11420	1.1M	13-11607	14-11620
			120	13-12207	14-12220	12K	13-12407	14-12420	1.2M	13-12607	14-12620
			130	13-13207	14-13220	13K	13-13407	14-13420	1.3M	13-13607	14-13620
			150	13-15207	14-15220	15K	13-15407	14-15420	1.5M	13-15607	14-15620
			160	13-16207	14-16220	16K	13-16407	14-16420	1.6M	13-16607	14-16620
			180	13-18207	14-18220	18K	13-18407	14-18420	1.8M	13-18607	14-18620
			200	13-20207	14-20220	20K	13-20407	14-20420	2.0M	13-20607	14-20620
			220	13-22207	14-22220	22K	13-22407	14-22420	2.2M	13-22607	14-22620
			240	13-24207	14-24220	24K	13-24407	14-24420	2.4M	13-24607	14-24620
2.7	13-27007	14-27020	270	13-27207	14-27220	27K	13-27407	14-27420	2.7M	13-27607	14-27620
3.0	13-30007	14-30020	300	13-30207	14-30220	30K	13-30407	14-30420	3.0M	13-30607	14-30620
3.3	13-33007	14-33020	330	13-33207	14-33220	33K	13-33407	14-33420	3.3M	13-33607	14-33620
3.6	13-36007	14-36020	360	13-36207	14-36220	36K	13-36407	14-36420	3.6M	13-36607	14-36620
3.9	13-39007	14-39020	390	13-39207	14-39220	39K	13-39407	14-39420	3.9M	13-39607	14-39620
4.3	13-43007	14-43020	430	13-43207	14-43220	43K	13-43407	14-43420	4.3M	13-43607	14-43620
4.7	13-47007	14-47020	470	13-47207	14-47220	47K	13-47407	14-47420	4.7M	13-47607	14-47620
5.1	13-51007	14-51020	510	13-51207	14-51220	51K	13-51407	14-51420	5.1M	13-51607	14-51620
5.6	13-56007	14-56020	560	13-56207	14-56220	56K	13-56407	14-56420	5.6M	13-56607	14-56620
6.2	13-62007	14-62020	620	13-62207	14-62220	62K	13-62407	14-62420	6.2M	13-62607	14-62620
6.8	13-68007	14-68020	680	13-68207	14-68220	68K	13-68407	14-68420	6.8M	13-68607	14-68620
7.5	13-75007	14-75020	750	13-75207	14-75220	75K	13-75407	14-75420	7.5M	13-75607	14-75620
8.2	13-82007	14-82020	820	13-82207	14-82220	82K	13-82407	14-82420	8.2M	13-82607	14-82620
9.1	13-91007	14-91020	910	13-91207	14-91220	91K	13-91407	14-91420	9.1M	13-91607	14-91620
10	13-10107	14-10120	1000	13-10307	14-10320	100K	13-10507	14-10520	10M	13-10707	14-10720
11	13-11107	14-11120	1100	13-11307	14-11320	110K	13-11507	14-11520	11M	13-11707	14-11720
12	13-12107	14-12120	1200	13-12307	14-12320	120K	13-12507	14-12520	12M	13-12707	14-12720
13	13-13107	14-13120	1300	13-13307	14-13320	130K	13-13507	14-13520	13M	13-13707	14-13720
15	13-15107	14-15120	1500	13-15307	14-15320	150K	13-15507	14-15520	15M	13-15707	14-15720
16	13-16107	14-16120	1600	13-16307	14-16320	160K	13-16507	14-16520	16M	13-16707	14-16720
18	13-18107	14-18120	1800	13-18307	14-18320	180K	13-18507	14-18520	18M	13-18707	14-18720
20	13-20107	14-20120	2000	13-20307	14-20320	200K	13-20507	14-20520	20M	13-20707	14-20720
22	13-22107	14-22120	2200	13-22307	14-22320	220K	13-22507	14-22520	22M	13-22707	14-22720
24	13-24107	14-24120	2400	13-24307	14-24320	240K	13-24507	14-24520			
27	13-27107	14-27120	2700	13-27307	14-27320	270K	13-27507	14-27520			
30	13-30107	14-30120	3000	13-30307	14-30320	300K	13-30507	14-30520			
33	13-33107	14-33120	3300	13-33307	14-33320	330K	13-33507	14-33520			
36	13-36107	14-36120	3600	13-36307	14-36320	360K	13-36507	14-36520			
39	13-39107	14-39120	3900	13-39307	14-39320	390K	13-39507	14-39520			
43	13-43107	14-43120	4300	13-43307	14-43320	430K	13-43507	14-43520			
47	13-47107	14-47120	4700	13-47307	14-47320	470K	13-47507	14-47520			
51	13-51107	14-51120	5100	13-51307	14-51320	510K	13-51507	14-51520			
56	13-56107	14-56120	5600	13-56307	14-56320	560K	13-56507	14-56520			
62	13-62107	14-62120	6200	13-62307	14-62320	620K	13-62507	14-62520			
68	13-68107	14-68120	6800	13-68307	14-68320	680K	13-68507	14-68520			
75	13-75107	14-75120	7500	13-75307	14-75320	750K	13-75507	14-75520			
82	13-82107	14-82120	8200	13-82307	14-82320	820K	13-82507	14-82520			
91	13-91107	14-91120	9100	13-91307	14-91320	910K	13-91507	14-91520			



SOLID STATE SYSTEMS, INC.

P. O. BOX 773  
COLUMBIA, MISSOURI 65201



# INTEGRATED CIRCUITS & DIODES

Catalog Number	Description	Any Quantity Per Item (Mix)			Multiples of 10 Per Item (Mix)		Grouping Code
		1-99	100-999	1000 Up	100-990	1000-9990	
7400	Quad 2-Input Pos. NAND Gate	.34	.32	.30	.28	.26	1
7401	Quad 2-Input Pos. NAND Gate with D/C Outputs	.34	.32	.30	.28	.26	1
7402	Quad 2-Input Pos. NOR Gate	.34	.32	.30	.28	.26	1
7403	Quad 2-Input Pos. NAND Gate with D/C Outputs	.34	.32	.30	.28	.26	1
7404	Hex Inverter	.36	.34	.32	.30	.28	1
7405	Hex Inverter with D/C Outputs	.36	.34	.32	.30	.28	1
7406	Hex Inverter Buffer/Driver with D/C 30V Outputs	.56	.53	.50	.47	.44	1
7407	Hex Buffer/Driver with D/C 30V Outputs	.56	.53	.50	.47	.44	1
7408	Quad 2-Input Pos. AND Gate	.38	.36	.34	.32	.30	1
7409	Quad 2-Input AND Gate with D/C Outputs	.38	.36	.34	.32	.30	1
7410	Triple 3-Input Pos. NAND Gate	.34	.32	.30	.28	.26	1
7411	Triple 3-Input Pos. AND Gate	.34	.32	.30	.28	.26	1
7413	Dual NAND Schmitt Trigger	.60	.57	.54	.51	.48	1
7416	Hex Inverter Buffer/Driver with D/C 15V Outputs	.54	.51	.48	.45	.42	1
7417	Hex Buffer/Driver with D/C 15V Outputs	.54	.51	.48	.45	.42	1
7418	Triple 3-Input OR Gate	.38	.36	.34	.32	.30	1
7420	Dual 4-Input Pos. NAND Gate	.34	.32	.30	.28	.26	1
7421	Dual 4-Input Pos. AND Gate	.34	.32	.30	.28	.26	1
7423	Expandable Dual 4-Input Pos. NOR Gate W/Strobe	.84	.80	.76	.72	.68	1
7425	Dual 4-Input Pos. NOR Gate	.54	.51	.48	.45	.42	1
7426	Quad 2-Input High Voltage NAND Gate	.40	.37	.34	.31	.28	1
7430	8-Input Pos. NAND Gate	.34	.32	.30	.28	.26	1
7437	Quad 2-Input Pos. NAND Buffer	.56	.53	.50	.47	.44	1
7438	Quad 2-Input Pos. NAND Buffer with D/C Outputs	.56	.53	.50	.47	.44	1
7440	Dual 4-Input Pos. NAND Buffer	.34	.32	.30	.28	.26	1
7441	BCD-To-Decimal Decoder/Driver	1.73	1.64	1.55	1.46	1.37	1
7442	BCD-To-Decimal Decoder	1.34	1.27	1.20	1.13	1.06	1
7443	Excess-3-To-Decimal Decoder	1.34	1.27	1.20	1.13	1.06	1
7444	Excess-3-Gray-To-Decimal Decoder	1.34	1.27	1.20	1.13	1.06	1
7445	BCD-To-Decimal Dec./Dr. with D/C HV Outputs	1.71	1.62	1.53	1.44	1.35	1
7446	BCD-To-Seven-Segment Decoder/Driver, 30V Outputs	1.34	1.27	1.20	1.13	1.06	1
7447	BCD-To-Seven-Segment Decoder/Driver, 15V Outputs	1.30	1.23	1.16	1.09	1.02	1
7448	BCD-To-Seven-Segment Decoder/Driver	1.44	1.37	1.29	1.22	1.14	1
7450	Exp. Dual 2-Wide 2-Input AND-OR-INVERT Gate	.34	.32	.30	.28	.26	1
7451	Dual 2-Wide 2-Input AND-OR-INVERT Gate	.34	.32	.30	.28	.26	1
7453	Exp. 4-Wide 2-Input AND-OR-INVERT Gate	.34	.32	.30	.28	.26	1
7454	4-Wide 2-Input AND-OR-INVERT Gate	.34	.32	.30	.28	.26	1
7459	Dual 2-Wide 2-3-Input AND-OR-INVERT Gate	.34	.32	.30	.28	.26	1
7460	Dual 4-Input Expander	.34	.32	.30	.28	.26	1
7470	Gated J-K Flip-Flop	.46	.43	.40	.37	.34	1
7472	J-K Master-Slave Flip-Flop	.40	.38	.36	.34	.32	1
7473	Dual J-K Master-Slave Flip-Flop	.52	.49	.46	.43	.40	1



**SOLID STATE SYSTEMS, INC.** P.O. BOX 773  
COLUMBIA, MISSOURI 65201

Catalog Number	Description	Any Quantity Per Item (Mix)			Multiples of 10 Per Item (Mix)		Grouping Code
		1-99	100-999	1000 Up	100-990	1000-9990	
7474	Dual D-Type Edge-Triggered Flip-Flop	.52	.49	.46	.43	.40	1
7475	Quadruple Bistable Latch	.80	.76	.72	.68	.64	1
7476	Dual J-K Master-Slave Flip-Flop W/Preset & Clear	.58	.55	.52	.49	.46	1
7480	Gated Full Adder	.80	.76	.72	.68	.64	1
7482	2-Bit Binary Full Adder	1.10	1.05	1.00	.95	.90	1
7483	4-Bit Binary Full Adder (Look Ahead Carry)	1.72	1.64	1.56	1.48	1.40	1
7485	4-Bit Magnitude Comparator	1.58	1.51	1.44	1.37	1.30	1
7486	Quad 2-Input Exclusive-OR Gate	.60	.57	.54	.51	.48	1
7489	(8225) 64-Bit Random Access Memory	5.00	4.75	4.50	4.25	4.00	1
7490	Decade Counter	.85	.80	.75	.70	.65	1
7491	8-Bit Shift Register	1.48	1.41	1.34	1.27	1.20	1
7492	Divide-By-Twelve Counter	.85	.80	.75	.70	.65	1
7493	4-Bit Binary Counter	.85	.80	.75	.70	.65	1
7494	4-Bit Shift Register (Parallel-In, Serial-Out)	1.32	1.26	1.20	1.14	1.08	1
7495	4-Bit Right-Shift Left-Shift Register	1.32	1.26	1.20	1.14	1.08	1
7496	5-Bit Shift Register	1.32	1.26	1.20	1.14	1.08	1
74100	Dual 4-Bit Bistable Latch	1.80	1.70	1.60	1.50	1.40	1
74104	Gated J-K Master-Slave Flip-Flop	.70	.67	.64	.61	.58	1
74105	Gated J-K Master-Slave Flip-Flop	.70	.67	.64	.61	.58	1
74107	Dual J-K Master-Slave Flip-Flop	.54	.51	.48	.45	.42	1
74121	Monostable Multivibrator	.60	.57	.54	.51	.48	1
74122	Retriggerable Monostable Multivibrator W/Clear	.74	.71	.68	.65	.62	1
74123	Dual Retriggerable Monostable Multivibrator W/Clear	1.30	1.20	1.10	1.00	.90	1
74141	BCD-To-Decimal Decoder/Driver	1.75	1.66	1.57	1.48	1.39	1
74145	BCD-To-Decimal Dec./Dr. with O/C HV Outputs	1.50	1.43	1.36	1.29	1.22	1
74150	16-Line-To-1-Line Data Selector/Multiplexer	2.00	1.85	1.70	1.55	1.40	1
74151	8-Line-To-1-Line Data Selector/Multiplexer	1.30	1.24	1.18	1.12	1.06	1
74153	Dual 4-Line-To-1-Line Data Selector/Multiplexer	1.70	1.60	1.50	1.40	1.30	1
74154	4-Line-To-16-Line Decoder/Demultiplexer	2.75	2.55	2.35	2.05	1.85	1
74155	Dual 2-Line-To-4-Line Decoder/Demultiplexer	1.56	1.49	1.42	1.35	1.28	1
74156	Dual 2-Line-To-4-Line Decoder/Demultiplexer	1.46	1.39	1.31	1.23	1.16	1
74157	Quad 2-Input Data Selector/Multiplexer	1.56	1.48	1.39	1.31	1.23	1
74158	Quad 2-Input Data Selector/Multiplexer with O/C	1.56	1.48	1.39	1.31	1.23	1
74160	Synch. 4-Bit Decade Counter W/Asynch. Clear	1.56	1.48	1.39	1.31	1.23	1
74161	Synch. 4-Bit Binary Counter W/Asynch. Clear	2.10	2.00	1.90	1.80	1.70	1
74162	Synch. 4-Bit Decade Counter W/Synch. Clear	2.10	2.00	1.90	1.80	1.70	1
74163	Synch. 4-Bit Binary Counter W/Synch. Clear	2.10	2.00	1.90	1.80	1.70	1
74164	8-Bit Shift Register (Serial-In, Parallel-Out)	2.10	2.00	1.90	1.80	1.70	1
74165	8-Bit Shift Register (Parallel-/Serial-In, Serial-Out)	2.96	2.82	2.67	2.52	2.37	1
74166	8-Bit Shift Register (Parallel-/Serial-In, Serial-Out)	2.20	2.09	1.98	1.87	1.76	1
74180	8-Bit Odd/Even Parity Generator/Checker	1.30	1.23	1.16	1.09	1.02	1
74181	High Speed Arithmetic/Logic Unit	5.20	4.90	4.60	4.30	4.00	1
74182	Look-Ahead Carry Generator	1.26	1.19	1.12	1.05	.98	1
74192	Presetable Synch. Decade Up/Down Counter	2.10	2.00	1.90	1.80	1.70	1
74193	Presetable Synch. 4-Bit Binary Up/Down Counter	2.10	2.00	1.90	1.80	1.70	1
74198	8-Bit Shift Register	3.10	2.95	2.80	2.65	2.50	1
74199	8-Bit Shift Register	3.10	2.95	2.80	2.65	2.50	1



SOLID STATE SYSTEMS, INC.

P.O. BOX 773  
COLUMBIA, MISSOURI 65201

# SCHOTTKY TTL

Catalog Number	Description	Any Quantity Per Item (Mix)			Multiples of 10 Per Item (Mix)		Grouping Code
		1-99	100-999	1000 Up	100-990	1000-9990	
74S00	Quad 2-Input Pos. NAND Gate	.88	.84	.79	.75	.70	1
74S01	Quad 2-Input Pos. NAND Gate with O/C Outputs	.88	.84	.79	.75	.70	1
74S02	Quad 2-Input Pos. NOR Gate	.88	.84	.79	.75	.70	1
74S03	Quad 2-Input Pos. NAND Gate with O/C Outputs	.88	.84	.79	.75	.70	1
74S04	Hex Inverter	1.00	.95	.90	.85	.80	1
74S05	Hex Inverter with O/C Outputs	1.00	.95	.90	.85	.80	1
74S08	Quad 2-Input Pos. AND Gate	.88	.84	.79	.75	.70	1
74S09	Quad 2-Input AND Gate with O/C Outputs	.88	.84	.79	.75	.70	1
74S10	Triple 3-Input Pos. NAND Gate	.88	.84	.79	.75	.70	1
74S11	Triple 3-Input Pos. AND Gate	.88	.84	.79	.75	.70	1
74S15	Triple 3-Input Pos. AND with O/C Outputs	.88	.84	.79	.75	.70	1
74S20	Dual 4-Input Pos. NAND Gate	.88	.84	.79	.75	.70	1
74S21	Dual 4-Input Pos. AND Gate	.88	.84	.79	.75	.70	1
74S22	Dual 4-Input Pos. NAND Gate with O/C Outputs	.88	.84	.79	.75	.70	1
74S40	Dual 4-Input Pos. NAND Buffer	1.00	.95	.90	.85	.80	1
74S50	Exp. Dual 2-Wide 2-Input AND-OR-INVERT Gate	.88	.84	.79	.75	.70	1
74S51	Dual 2-Wide 2-Input AND-OR-INVERT Gate	.88	.84	.79	.75	.70	1
74S60	Dual 4-Input Expander	.88	.84	.79	.75	.70	1
74S64	4-2-3-2-Input AND-OR-INVERT Gate	.88	.84	.79	.75	.70	1
74S65	4-2-3-2-Input AND-OR-INVERT Gate with O/C Outputs	.88	.84	.79	.75	.70	1
74S73	Dual J-K Master-Slave Flip-Flop	1.82	1.73	1.63	1.54	1.44	1
74S74	Dual D-Type Edge-Triggered Flip-Flop	1.82	1.73	1.63	1.54	1.44	1
74S76	Dual J-K Master-Slave Flip-Flop W/Preset & Clear	1.82	1.73	1.63	1.54	1.44	1
74S78	Dual J-K Master-Slave Flip-Flop W/Preset & Clear	1.82	1.73	1.63	1.54	1.44	1
74S107	Dual J-K Master-Slave Flip-Flop	1.82	1.73	1.63	1.54	1.44	1
74S112	Dual J-K Edge-Trig. F-F W/Sep. Clock & Clear	1.82	1.73	1.63	1.54	1.44	1
74S113	Dual J-K Edge-Trig. F-F W/Sep. Clock	1.82	1.73	1.63	1.54	1.44	1
74S114	Dual J-K Edge-Trig. F-F W/Common Clock & Clear	1.82	1.73	1.63	1.54	1.44	1
74S140	Dual 4-Input Pos. NAND Buffer/Line Driver	1.00	.95	.90	.85	.80	1

## LINEAR IC'S

NE501A	Video Amplifier	2.99	2.82	2.66	2.49	2.32	1
NE526A	Analog Voltage Comparator	3.59	3.38	3.17	2.95	2.74	1
NE531V	High Slew-Rate Operational Amplifier	3.20	3.04	2.88	2.72	2.56	1
NE536 T	FET Input Operational Amplifier	7.31	6.88	6.45	6.02	5.59	1
NE540 L	Power Driver	2.16	2.04	1.92	1.80	1.68	1
SE540 L	Power Driver	4.48	4.20	3.92	3.64	3.36	1
NE550A	Precision Voltage Regulator	1.30	1.23	1.16	1.09	1.02	1
NE555V	Timer	1.10	1.05	1.00	.95	.90	1
NE560B	Phase Locked Loop	3.57	3.36	3.15	2.94	2.73	1
NE561B	Phase Locked Loop	3.57	3.36	3.15	2.94	2.73	1
NE562B	Phase Locked Loop	3.57	3.36	3.15	2.94	2.73	1
NE565A	Phase Locked Loop	3.57	3.36	3.15	2.94	2.73	1
NE566V	Function Generator	3.57	3.36	3.15	2.94	2.73	1



**SOLID STATE SYSTEMS, INC.**

P.O. BOX 773  
COLUMBIA, MISSOURI 65201



Catalog Number	Description	Any Quantity Per Item (Mix)			Multiples of 10 Per Item (Mix)		Grouping Code
		1-99	100-999	1000 Up	100-990	1000-9990	
NE567V	Tone Decoder Phase Locked Loop	3.57	3.36	3.15	2.94	2.73	1
N5111A	(ULN2111) FM Detector and Limiter	.90	.86	.82	.78	.74	1
N5556V	Operational Amplifier	2.10	1.95	1.80	1.65	1.50	1
N5558V	Dual Operational Amplifier	1.00	.95	.90	.85	.80	1
N5596A	Balanced Modulator-Demodulator	1.87	1.77	1.66	1.56	1.46	1
$\mu$ A709CV	Operational Amplifier	.50	.47	.44	.41	.38	1
$\mu$ A710CA	Differential Voltage Comparator	.50	.47	.44	.41	.38	1
$\mu$ A711CA	Dual Voltage Comparator	.55	.52	.49	.46	.43	1
$\mu$ A723CA	Precision Voltage Regulator	1.00	.95	.90	.85	.80	1
$\mu$ A733CA	Differential Video Amplifier	1.90	1.80	1.70	1.60	1.50	1
$\mu$ A741CV	High Performance Operational Amplifier	.80	.75	.70	.65	.60	1
$\mu$ A747CA	Dual Operational Amplifier	1.10	1.04	.98	.92	.86	1
$\mu$ A748CV	High Performance Operational Amplifier	.80	.75	.70	.65	.60	1
LM335	5V, 600 mA Voltage Regulator	2.85	2.72	2.64	2.55	2.46	1
LM336	12V, 500 mA Voltage Regulator	3.85	3.66	3.46	3.27	3.06	1
LM337	15V, 450 mA Voltage Regulator	4.05	3.70	3.51	3.31	3.12	1

## DIODES

1N270	Germanium Switching Diode	.15	.14	.13	.12	.11	2
1N4001	1 Amp, 50 PRV Rectifier Diode	.10	.09	.08	.07	.06	2
1N4002	1 Amp, 100 PRV Rectifier Diode	.11	.10	.09	.08	.07	2
1N4003	1 Amp, 200 PRV Rectifier Diode	.13	.12	.11	.10	.09	2
1N4004	1 Amp, 400 PRV Rectifier Diode	.14	.13	.12	.11	.10	2
1N4005	1 Amp, 600 PRV Rectifier Diode	.15	.14	.13	.12	.11	2
1N4006	1 Amp, 800 PRV Rectifier Diode	.17	.16	.14	.13	.12	2
1N4007	1 Amp, 1000 PRV Rectifier Diode	.20	.18	.16	.14	.12	2
1N4148	Silicon Switching Diode	.10	.09	.08	.07	.06	2
1N746A	3.3V, 400 mW Zener Diode	.25	.22	.19	.16	.13	2
1N747A	3.6V, 400 mW Zener Diode	.25	.22	.19	.16	.13	2
1N748A	3.9V, 400 mW Zener Diode	.25	.22	.19	.16	.13	2
1N749A	4.3V, 400 mW Zener Diode	.25	.22	.19	.16	.13	2
1N750A	4.7V, 400 mW Zener Diode	.25	.22	.19	.16	.13	2
1N751A	5.1V, 400 mW Zener Diode	.25	.22	.19	.16	.13	2
1N752A	5.6V, 400 mW Zener Diode	.25	.22	.19	.16	.13	2
1N753A	6.2V, 400 mW Zener Diode	.25	.22	.19	.16	.13	2
1N754A	6.8V, 400 mW Zener Diode	.25	.22	.19	.16	.13	2
1N755A	7.5V, 400 mW Zener Diode	.25	.22	.19	.16	.13	2
1N756A	8.2V, 400 mW Zener Diode	.25	.22	.19	.16	.13	2
1N757A	9.1V, 400 mW Zener Diode	.25	.22	.19	.16	.13	2
1N758A	10V, 400 mW Zener Diode	.25	.22	.19	.16	.13	2
1N759A	12V, 400 mW Zener Diode	.25	.22	.19	.16	.13	2

All IC's are supplied in 8-, 14-, 16-, or 24-pin DIP (Dual-in-line) plastic or ceramic package except for NE536, NE540 and SE540, which come in TO-5 package. Voltage Regulators LM335, LM336, and LM337 are supplied in TO-3 (Diamond) package.

We give FREE data sheets upon request, so ask for those data sheets that you NEED, even for those listed IC's that you are not buying.



**SOLID STATE SYSTEMS, INC.**

P.O. BOX 773  
COLUMBIA, MISSOURI 65201

# DUAL-IN-LINE IC SOCKETS

Solid State Systems now offers you the most complete line of Dual-In-Line integrated circuit sockets from such leaders as Cambion<sup>®</sup>, and Micro Plastic, Inc. Virtually every combination of Tin or Gold plated, Solder or Wire-Wrap type in both glass-filled Nylon or Diallylptalate for IC's from 6- to 40-pins is now available from a single source. As it is our policy, you may of course, combine different sockets with the same grouping code to obtain quantity pricing.

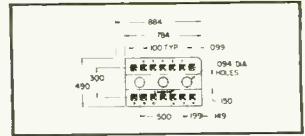

Sockets keyed "Diallyl" in table below have body material of fiberglass-reinforced Diallylptalate usable over -50°C to 125°C temperature range. Sockets keyed "Nylon" have body material of glass-reinforced Nylon usable over 0°C to 75°C temperature range.

All contact materials are phosphor bronze. All tin plated pins have a minimum of 300 micro-inches of electro deposited tin and all gold plated pins have a minimum of 20 micro-inches of hard gold over nickel or copper.

**PLEASE NOTE:** Due to our method of packaging, all sockets must be ordered in multiples of 5 per item.

Catalog Number	Number of Pins	Color	Pin Plating	Material	Type	Unit Price					Grouping Code
						5-45	50-95	100-495	500-995	1000-up	
41-37714	6	Blue	Tin	Diallyl	Solder-Tab	.29	.26	.22	.19	.16	6
41-37713	6	Blue	Gold	Diallyl	Solder-Tab	.32	.28	.24	.21	.17	6
41-38814	6	Blue	Tin	Diallyl	Wire-Wrap	.34	.30	.26	.23	.19	6
41-38813	6	Blue	Gold	Diallyl	Wire-Wrap	.37	.33	.28	.24	.20	6
41-37724	8	Blue	Tin	Diallyl	Solder-Tab	.32	.28	.24	.21	.17	6
41-37723	8	Blue	Gold	Diallyl	Solder-Tab	.34	.30	.26	.23	.19	6
41-38824	8	Blue	Tin	Diallyl	Wire-Wrap	.29	.26	.22	.19	.16	6
41-38823	8	Blue	Gold	Diallyl	Wire-Wrap	.32	.28	.24	.21	.17	6
41-37774	14	Red	Tin	Nylon	Solder-Tab	.32	.28	.24	.21	.17	6
41-37773	14	Red	Gold	Nylon	Solder-Tab	.37	.33	.28	.24	.20	6
31-01014	14	Black	Gold	Nylon	Solder-Tab	.43	.38	.33	.28	.23	6
41-37884	14	Blue	Tin	Diallyl	Solder-Tab	.52	.46	.40	.34	.28	6
41-37883	14	Blue	Gold	Diallyl	Solder-Tab	.60	.53	.46	.40	.33	6
31-02014	14	Black	Gold	Nylon	Wire-Wrap	.53	.47	.41	.35	.29	6
41-38974	14	Blue	Tin	Diallyl	Wire-Wrap	.52	.46	.40	.34	.28	6
41-38973	14	Blue	Gold	Diallyl	Wire-Wrap	.55	.49	.42	.36	.30	6
41-37784	16	Red	Tin	Nylon	Solder-Tab	.34	.30	.26	.23	.19	6
41-37783	16	Red	Gold	Nylon	Solder-Tab	.41	.36	.31	.27	.22	6
31-01016	16	White	Gold	Nylon	Solder-Tab	.49	.43	.37	.32	.26	6
41-37894	16	Blue	Tin	Diallyl	Solder-Tab	.52	.46	.40	.34	.28	6
41-37893	16	Blue	Gold	Diallyl	Solder-Tab	.60	.53	.46	.40	.33	6
31-02016	16	White	Gold	Nylon	Wire-Wrap	.58	.52	.45	.38	.32	6
41-38984	16	Blue	Tin	Diallyl	Wire-Wrap	.55	.49	.42	.36	.30	6
41-38983	16	Blue	Gold	Diallyl	Wire-Wrap	.60	.53	.46	.40	.33	6
41-37874	18	Blue	Tin	Diallyl	Solder-Tab	.60	.53	.46	.40	.33	6
41-37873	18	Blue	Gold	Diallyl	Solder-Tab	.65	.58	.50	.43	.35	6
41-38954	18	Blue	Tin	Diallyl	Wire-Wrap	.81	.72	.62	.53	.44	6
41-38953	18	Blue	Gold	Diallyl	Wire-Wrap	.94	.83	.72	.62	.51	6
41-37854	22	Blue	Tin	Diallyl	Solder-Tab	.65	.58	.50	.43	.35	6
41-37853	22	Blue	Gold	Diallyl	Solder-Tab	.71	.63	.54	.46	.38	6
41-38924	22	Blue	Tin	Diallyl	Wire-Wrap	1.17	1.04	.90	.77	.63	6
41-38923	22	Blue	Gold	Diallyl	Wire-Wrap	1.30	1.15	1.00	.85	.70	6
41-51534	24	Red	Tin	Nylon	Solder-Tab	1.25	1.11	.96	.82	.68	6
41-51533	24	Red	Gold	Nylon	Solder-Tab	1.38	1.22	1.06	.91	.75	6
41-37904	24	Blue	Tin	Diallyl	Solder-Tab	1.25	1.11	.96	.82	.68	6
41-37903	24	Blue	Gold	Diallyl	Solder-Tab	1.38	1.22	1.06	.91	.75	6
41-38964	24	Blue	Tin	Diallyl	Wire-Wrap	1.33	1.18	1.02	.87	.72	6
41-38963	24	Blue	Gold	Diallyl	Wire-Wrap	1.46	1.29	1.12	.96	.79	6
41-37834	28	Blue	Tin	Diallyl	Solder-Tab	1.98	1.75	1.52	1.30	1.07	6
41-37833	28	Blue	Gold	Diallyl	Solder-Tab	2.27	2.01	1.74	1.48	1.22	6
41-38904	28	Blue	Tin	Diallyl	Wire-Wrap	1.43	1.27	1.10	.94	.77	6
41-38903	28	Blue	Gold	Diallyl	Wire-Wrap	1.56	1.38	1.20	1.02	.84	6
41-37914	36	Blue	Tin	Diallyl	Solder-Tab	2.21	1.96	1.70	1.45	1.19	6
41-37913	36	Blue	Gold	Diallyl	Solder-Tab	2.47	2.19	1.90	1.62	1.33	6
41-38934	36	Blue	Tin	Diallyl	Wire-Wrap	2.21	1.96	1.70	1.45	1.19	6
41-38933	36	Blue	Gold	Diallyl	Wire-Wrap	2.47	2.19	1.90	1.62	1.33	6
41-37664	40	Blue	Tin	Diallyl	Solder-Tab	1.20	1.06	.92	.79	.65	6
41-37663	40	Blue	Gold	Diallyl	Solder-Tab	1.30	1.15	1.00	.85	.70	6
41-38854	40	Blue	Tin	Diallyl	Wire-Wrap	1.20	1.06	.92	.79	.65	6
41-38853	40	Blue	Gold	Diallyl	Wire-Wrap	1.30	1.15	1.00	.85	.70	6



**SOLID STATE SYSTEMS, INC.** P.O. BOX 773 COLUMBIA, MISSOURI 65201

# IC INTERFACE HARDWARE

## COMPONENT SOCKET ADAPTERS

Cambion Component Socket Adapters provide versatility of component plugging for your discretes. Two models are available for both 14- and 16-pin sockets.

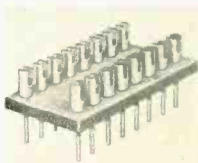

## IC INSERTION-EXTRACTION TOOL

This handy tool properly positions the integrated circuit for insertion or extraction. Securely grips IC between the leads and under the body with clothespin-like action. Practically any dual in-line IC with 14 or 16 leads aligned on .300" centers can easily be inserted or extracted regardless of tight packaging and without damage to the fragile IC leads.



## INTEGRATED SOCKET STRIP

Cambion's Integrated Socket Strips provide high density packaging of dual-in-line integrated circuits. The Integrated Socket has 0.025" tin-plated square wire-wrap pins aligned, double-column (40 pins per column), on 0.300" centers (.100" grid). As many as five dual-in-line packages can be mounted per integrated socket strip. The socket pins are replaceable, if damaged, and can be ordered separately.

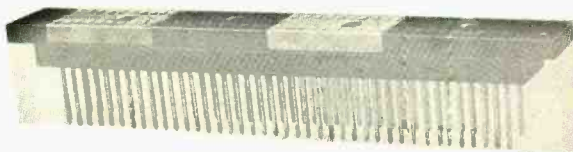

## BATTERY HOLDERS

Cambion's new molded battery holders offer users many advantages, not the least of which is the corrosion resistant, molded glass-filled nylon body.

Models are now available for both C size and D size batteries. They have tinned phosphor bronze contacts and built-in shock and vibration retainers which assure dependable, non-shorting service under the most severe environmental and operating conditions.

These strong individual holders interlock with each other, by a unique design, which permits building sturdy single unit assemblies for any multiple of batteries required, for either series or parallel hook-up. Truly high density packaging!



## HAND WIRE-WRAPPING TOOL

Cambion's new pocket-size wire-wrapping tool is for hand wrapping No. 30 AWG wire on a .025" square wrapost. It is ideal for making field modifications, building small systems in the laboratory, teaching, for the hobbyist, and for other non-production wrapping applications.



The wrap is made by inserting pre-stripped wire in the end of the tool in either of the offset holes until the insulation comes in contact with the tool. The end of the wire is bent back, in a "V" shape to secure the wire in the tool and the insulated portion is then bent at right angles to the axis of the tool. Now the center of the tool is placed over the center of the wrapost and lowered to the level where the connection is to be made; it is turned by hand until all the stripped wire has been wrapped around the post.

A modified wrap . . . one where the insulation portion of the wire is wrapped for about one and a half turns around the post before the regular wrap . . . can be made by permitting the insulation to turn with the first one and a half turns of the tool.

Performance of wire-wrapped connections made with this tool is excellent with high strip strengths and gas tight corners achieved.

## PRICE LISTING

Catalog Number	Description	1-24	25-49	50-99	100-249	250-up	Grouping Code
43-37253	14-Pin Component Adapter	1.10	1.00	.90	.80	.70	27
43-37283	16-Pin Component Adapter	1.20	1.10	1.00	.90	.80	27
43-37390	IC Insertion/Extraction Tool	1.40	1.30	1.20	1.10	1.00	27
43-28000	Molded Size "C" Battery Holder	.45	.41	.37	.33	.29	27
43-28010	Molded Size "D" Battery Holder	.45	.41	.37	.33	.29	27
43-10004	Integrated IC Socket Strip	4.75	4.50	4.00	3.75	3.50	27
43-18160	Hand Wire-Wrapping Tool	2.00	1.90	1.80	1.70	1.60	27



**SOLID STATE SYSTEMS, INC.** P.O. BOX 773  
COLUMBIA, MISSOURI 65201



# READOUTS

A wide choice of 7-segment and  $\pm 1$  overflow Incandescent and LED Readouts are now available from Solid State Systems for practically any type of application. PLEASE NOTE: All displays may be combined for quantity pricing.

## INCANDESCENT DISPLAYS

The Series 90 MINITRON<sup>®</sup> readout is a miniature direct viewed incandescent filament display, housed in a standard metal 16-pin dual-in-line package with a hermetically sealed front lens. These units operate from 5 volt TTL supply and are fully compatible with TTL decoder driver, 7447, without the need for any external current limiting resistors. The current drain at 5VDC is only 8mA per segment with a design life of 50,000 hours. Due to white-light characteristics of this display, filtering by means of virtually any color is possible without sacrificing sharpness of the character displayed.

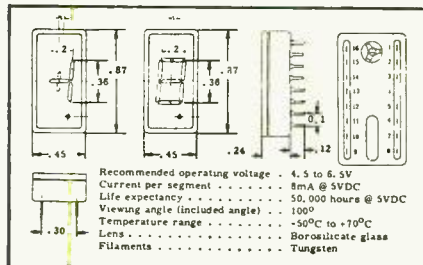

## LED DISPLAYS

Figures 1 through 8 below provide physical characteristics of all LED displays.

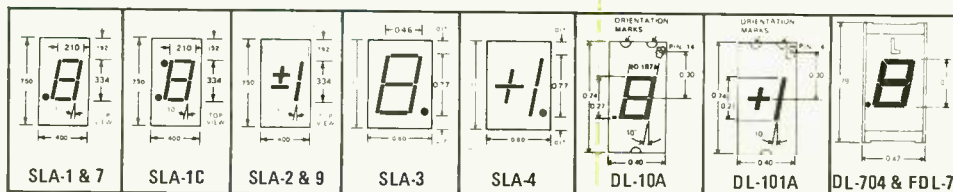

## PRICE LISTING FOR ALL DISPLAYS

Catalog Number	Description	1-49	50-99	100-499	500-999	1000-up	Grouping Code
21-00001	Opcoa SLA-1, 7-segment LED display	4.50	4.25	3.75	3.40	3.00	10
11-48001	Pkg. of 8 current limiting resistors for SLA-1	.36	.32	.28	.24	.20	16
23-00011	Opcoa SLA-1C, 7-segment LED display W/colon	4.75	4.50	4.00	3.65	3.25	10
11-49011	Pkg. of 9 current limiting resistors for SLA-1C	.40	.36	.32	.28	.24	16
24-00002	Opcoa SLA-2, $\pm 1$ LED display	4.50	4.25	3.75	3.40	3.00	10
11-44002	Pkg. of 4 current limiting resistors for SLA-2	.20	.17	.14	.12	.10	16
21-00003	Dpcoa SLA-3, 7-segment LED display	7.75	7.50	7.00	6.75	6.50	10
11-48003	Pkg. of 8 current limiting resistors for SLA-3	.36	.32	.28	.24	.20	16
24-00004	Dpcoa SLA-4, $\pm 1$ LED display	7.75	7.50	7.00	6.75	6.50	10
11-45004	Pkg. of 5 current limiting resistors for SLA-4	.24	.21	.18	.15	.12	16
21-00007	Dpcoa SLA-7, 7-segment LED display	3.50	3.25	3.00	2.75	2.50	10
11-48007	Pkg. of 8 current limiting resistors for SLA-7	.36	.32	.28	.24	.20	16
24-00009	Dpcoa SLA-9, $\pm 1$ LED display	3.50	3.25	3.00	2.75	2.50	10
11-44009	Pkg. of 4 current limiting resistors for SLA-9	.20	.17	.14	.12	.10	16
16-00010	Litronix DL-10A, 7-segment LED display	4.95	4.75	4.50	4.25	4.00	10
11-48010	Pkg. of 8 current limiting resistors for DL-10A	.36	.32	.28	.24	.20	16
16-00101	Litronix DL-101A, $\pm 1$ LED display	4.95	4.75	4.50	4.25	4.00	10
11-48101	Pkg. of 4 current limiting resistors for DL-101A	.20	.17	.14	.12	.10	16
16-00704	Litronix DL-704, 7-segment LED display	2.50	2.25	2.00	1.75	1.50	10
11-48704	Pkg. of 8 current limiting resistors for DL-704	.36	.32	.28	.24	.20	16
16-00007	Litronix FDL-7, 7-segment LED display	3.25	3.00	2.75	2.50	2.25	10
11-48007	Pkg. of 8 current limiting resistors for FDL-7	.36	.32	.28	.24	.20	16
39-00760	Luminetics, 7-segment incandescent display	3.00	2.75	2.50	2.25	1.90	10
39-00160	Luminetics, $\pm 1$ incandescent display	3.00	2.75	2.50	2.25	1.90	10



**SOLID STATE SYSTEMS, INC.**

P.O. BOX 773  
 COLUMBIA, MISSOURI 65201



# PUSH-BUTTON SWITCHES

## DESCRIPTION

The Series LM switches are new, low-bounce miniature mechanical switches. Switching contact is achieved by moving a gold wire beam spring into the vee formed by the conical points of the two gold-plated contact rods.

These solder-mounted switches are ideal for use on circuit boards and can be wave soldered along with the other circuit components.

These reliable, low-priced units are designed for use in hand-held devices, such as miniature electronic calculators. These can be mounted on centers as close as one-half inch.

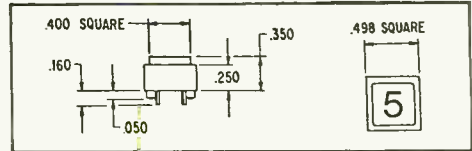

## PRICE LISTING

Catalog Number	1-49	50-99	100-499	500-999	1000-up	Grouping Code
Choose from Table Below	.45	.41	.37	.33	.29	24

## LEGENDS AVAILABLE

Catalog Number	Legend	Catalog Number	Legend	Catalog Number	Legend	Catalog Number	Legend	Catalog Number	Legend	Catalog Number	Legend
65-32000	"0"	65-32101	"C"	65-32112	"RM"	65-32123	"RESET"	65-32207	"G"	65-32218	"R"
65-32001	"1"	65-32102	"CE"	65-32113	"CM"	65-32124	"STOP"	65-32208	"H"	65-32219	"S"
65-32002	"2"	65-32103	"+"	65-32114	"D"	65-32125	"RUN"	65-32209	"I"	65-32220	"T"
65-32003	"3"	65-32104	"-"	65-32115	" $\sqrt{X}$ "	65-32126	"ENTER"	65-32210	"J"	65-32221	"U"
65-32004	"4"	65-32105	"X"	65-32116	"X <sup>2</sup> "	65-32127	"AUTO"	65-32211	"K"	65-32222	"V"
65-32005	"5"	65-32106	" $\frac{1}{X}$ "	65-32117	"1/X"	65-32201	"A"	65-32212	"L"	65-32223	"W"
65-32006	"6"	65-32107	"="	65-32118	" $\pi$ "	65-32202	"B"	65-32213	"M"	65-32224	"X"
65-32007	"7"	65-32108	" $\pm$ "	65-32119	"%"	65-32203	"C"	65-32214	"N"	65-32225	"Y"
65-32008	"8"	65-32109	" $\frac{1}{=}$ "	65-32120	"ON"	65-32204	"D"	65-32215	"O"	65-32226	"Z"
65-32009	"9"	65-32110	" $\pm$ M"	65-32121	"OFF"	65-32205	"E"	65-32216	"P"		
65-32100	"."	65-32111	"-M"	65-32122	"SET"	65-32206	"F"	65-32217	"Q"		

# ONE CHIP CALCULATORS & CLOCK CHIP

The CT5001 is a single MOS chip containing all of the logic necessary for a 12 digit calculator with display type readout. Multiplexed seven segment outputs enable operation with LED's, incandescent, and fluorescent or gas discharge tubes with a minimum of external components. The unit is packaged in a 40 lead DIP.

The CT5005 is a single MOS chip with all the logic necessary for a twelve-digit four function calculator with an extra storage register for memory or constant application. Capability includes +, -, x, and  $\div$  as well as a memory register for storage of internal values or four function constant capability. Multiplexed seven segment outputs enable operation with LED, incandescent, fluorescent or gas discharge displays with a minimum of external display interface components. The unit is packaged in a 28 lead DIP.

The CT7001 is an extremely versatile MOS/LSI digital clock/calendar circuit. The chip incorporates an automatic 28/30/31 day calendar; 12/24 hour clock AND 24 hour alarm; 10-minute snooze alarm; and clock radio feature.

The CT7001 can operate from either a 50/60 Hz line frequency or an external 100.8 KHz signal. If battery back-up is provided, the CT7001 will continue to operate during power outages by virtue of an on-chip 50/60 Hz backup counter. The CT7001 Digital Clock/Calendar Integrated Circuit is available in 28-Pin Dual-in-line package.

## PRICE LISTING

Catalog Number	Description	1-4	5-9	10-24	25-up	Grouping Code
63-05001	Four function calculator IC	7.50	7.00	6.00	5.50	25
63-05005	Four function calculator IC with memory	13.50	12.60	11.70	10.80	25
63-07001	Digital clock/calendar IC	13.50	12.60	11.70	10.80	25
60-05157	Set of data sheets for CT5001, CT5005 & CT7001	.50	-----	-----	-----	26

**PLEASE NOTE:** Complete kits of all parts and boards for each of the above calculators and clock/calendar will be available by early December. Please write or call for further details.



**SOLID STATE SYSTEMS, INC.**

P.O. BOX 773  
COLUMBIA, MISSOURI 65201

**CIRCLE NO. 25 ON READER SERVICE CARD**  
Printed in U.S.A.



# Popular Electronics

## READER SERVICE

Here's an easy and convenient way for you to get additional information about products advertised or mentioned editorially (if it has a reader service number) in this issue. Just follow the directions below... and the material will be sent to you promptly and free of charge.

### 1

On the attached postage-free card, print or type your name and address on the lines indicated.

### 2

Circle the number(s) that corresponds to the key number(s) at the bottom or next to the advertisement or editorial mention that is of interest to you. (Key numbers for advertised products also appear in the Advertisers' Index.)

### 3

Simply cut out the card and mail. No postage required.

## FREE INFORMATION

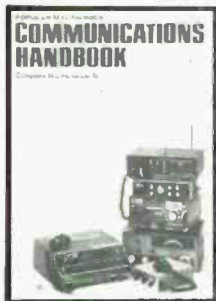

### 1974 COMMUNICATIONS HANDBOOK

Here is everything you want to know — need to know — about Citizens' Band, Amateur Radio, Shortwave Listening.

#### DON'T TURN A DIAL

In fact don't even buy a dial or anything else until you've checked out the 1974 Communications Handbook. Whatever your radio specialty — whether you're an old hand or just getting started — this vital "how-to" guide will help you get greater value, greater enjoyment out of every minute you spend with your equipment.

**CITIZENS BAND** — What it is, how it is used, how to get a license, how to set up your station, Business Radio Service, Single-Sideband CB. PLUS three handy buyers' catalogs: 1. A major listing of all known 5-watt input CB transceivers complete with detailed technical specifications, photographs, and pricing. 2. Complete line of CB accessories. 3. Selected CB antennas.

**AMATEUR RADIO** — A true inside view of the excitement, the novelty, the worldwide interest in this fascinating and fast-growing hobby. How to apply for a novice license: how to train and qualify; how to set up your rig; latest trends including 2-meter FM & slow-scan TV. PLUS: Illustrated Ham Equipment Directory, including slow-scan TV.

**SHORTWAVE LISTENING** — Starts right out with a look at what's ahead for SWL's in 1974, followed by important articles on the how's and why's of reporting and verifications, how to choose and use SWL equipment. You'll get all of the shortwave bands around the world plus a list of leading DX clubs and take a look at some interesting SWL QSL cards. There's also a complete BUYER'S GUIDE with full specs on all known general coverage SW receivers. And that's still not all! ...

#### SPECIAL BONUS

Includes "Shortwave DX'ing," "Public Weather Broadcast Frequencies," changes in Marine Communications, and a Directory of all monitor receivers for picking up police, fire, and public service broadcasts.

So to make sure you come through "Loud and Clear" in 1974, get your copy of the 1974 COMMUNICATIONS HANDBOOK today!

#### HERE'S HOW TO ORDER

Send your order to Ziff-Davis Service Division, Dept. CH, 595 Broadway, New York, N.Y. 10012. Print your name and address clearly, specify "1974 COMMUNICATIONS HANDBOOK," enclose \$1.25 plus 35c for postage and handling. (Outside U.S.A. copies are \$2.50 each, postpaid.)



SSB-ers:

increase talk power, cut "splatter"



Our 444 base station microphone not only gives you increased talk power, but cuts "splatter" (and QRM complaints) to an absolute minimum! It has superbly tailored response, with sharp cutoffs below 300 and above 3,000 Hz and a rising response characteristic for maximum intelligibility. The 444's rugged, reliable Controlled Magnetic element has been proved in safety communications, and other tough professional communications applications. It delivers a clean signal to the transmitter at levels as high as crystal units! (And, unlike crystal and ceramic units, the element is totally immune to the effects of temperature and humidity.) The 444 also features an adjustable height stand that makes for comfortable "ragchewing" sessions, an optional-locking bar for push-to-talk or VOX operation, and a practically indestructible Armo-Dur® case. Write:

Shure Brothers Inc.,  
222 Hartrey Ave. Evanston, Ill. 60204

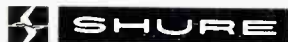

CIRCLE NO. 32 ON READER SERVICE CARD