

# Popular Electronics

INCLUDING **Electronics World**

## **THE NEW, FAST-CHARGE BATTERIES** How They Work

Julian Hirsch Discusses

## **ADVANCES IN SQ 4-CHANNEL DECODERS**

## **LOGIDEX-AN ELECTRONIC GAME FOR ALL SEASONS**

How To Build An

## **ELECTRONIC COMBINATION LOCK**

Construct A

## **LOW-DISTORTION, 5-WATT AUDIO AMPLIFIER**

**TEST REPORTS:** JVC VP-100 Stereo Preamp  
Crown DC-300A Power Amplifier  
Active Beta-3 Auto Antenna  
Heath IC-2009 Pocket Calculator  
Pace Model 10-2 CB Transceiver

# **BUILD A**



# **DIGITAL CLOCK-CALENDAR**

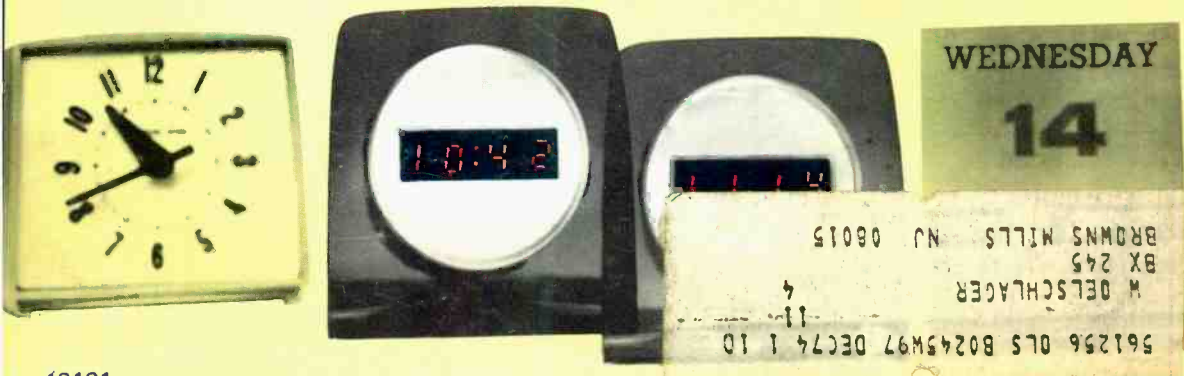

# NOW you can train at home building a NEW 25" DIAGONAL Solid State Color TV engineered by NRI for learning and trouble-shooting

*So much better for learning TV servicing than any hobby kit, because NRI designed and created it as an educational tool.*

Unlike hobby kits which are designed for creating a TV set as the end product, NRI built its exclusive 25" Diagonal Solid State Color TV kit as a real training kit. You can introduce and correct defects . . . for trouble-shooting and hands-on experience in circuitry and servicing. The kits include a wide-band oscilloscope, color bar crosshatch generator, transistorized volt-ohmmeter and other valuable equipment that can soon have you earning \$5 to \$7 an hour servicing color sets in your spare time.

Handsome woodgrain cabinet, at no extra cost. (Offered only by NRI)

New square-cornered Sylvania picture tube

100% solid state chassis

6-position detented UHF channel selector



Modular construction with plug-in circuit boards

Automatic degaussing

Automatic fine tuning

Automatic tint control

Automatic color control

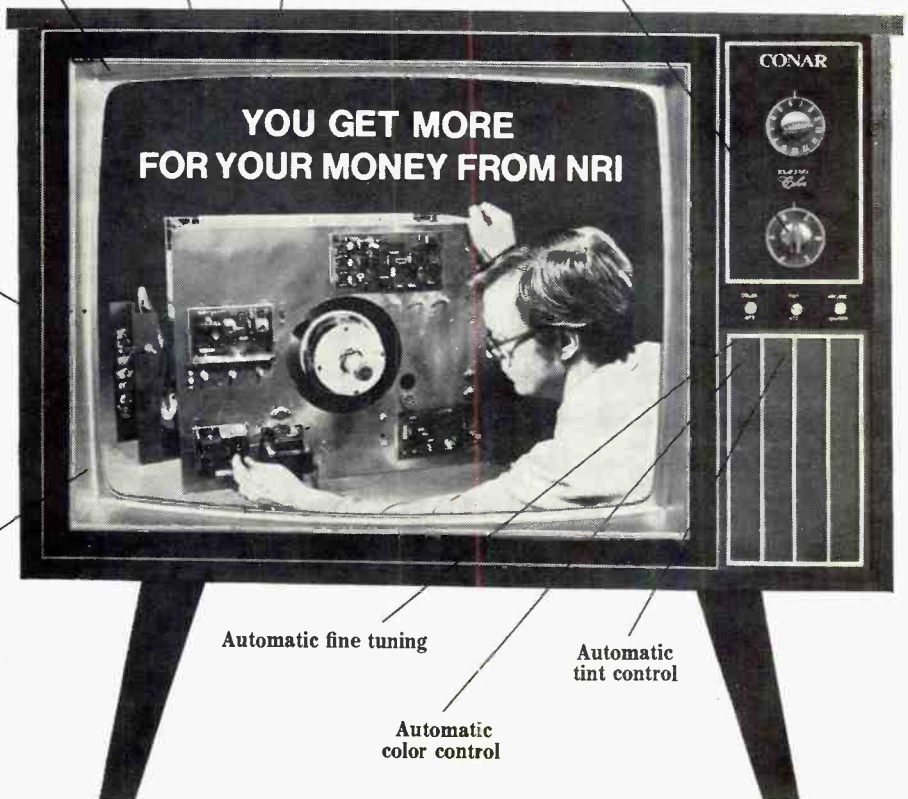



# NRI FIRSTS make learning Electronics fast and fascinating—to give you priceless confidence



**FIRST** to give you a complete programmable digital computer, with memory, you build yourself... to learn organization, operation, trouble-shooting and programming. This remarkable computer is one of ten training kits you receive with the new NRI Complete Computer Electronics Course.



**FIRST** to give you true-to-life experiences as a Communications Technician. Every fascinating step you take in NRI Communications training, including circuit analysis of your own 15-watt, phone/cw transmitter, is engineered to help you prove theory and later apply it on the job. Studio equipment operation and trouble shooting become a matter of easily remembered logic.



**FIRST** to give you completely specialized training kits engineered for business, industrial and military Electronics Technology. Shown is your own training center in solid-state motor control and analog computer servo-mechanisms. Telemetering circuits, solid-state multivibrators and the latest types of integrated circuits are included in your course.

The NRI color TV and digital computer kits are the latest in a long line of "firsts" for NRI. For more than fifty years, NRI has been providing unique 3-dimensional home-study training that has helped hundreds of thousands of students reach their goals quickly and easily.

What NRI provides is a combination of kits and bite-size texts that give you hands-on experience while you are learning. The texts average only 40 pages each, and they are fully illustrated. You are taken step-by-step from the first stages into the more advanced theory and techniques... with an expert instructor ready at all times to provide valuable guidance and personal attention. (The level of personal attention provided is more than you would receive in many classrooms.) Once you've grasped the fundamentals, you move with confidence and enthusiasm into new discoveries in the fascinating world of electronics.

You start out with NRI's exclusive Achievement Kit, containing everything you need to get moving fast. Lessons have been specifically written so that experiments build upon one another like stepping stones. You can perform a hundred experiments, build hundreds of circuits... as you learn to use the professional test equipment provided, building radios and TV sets, transmitter or computer circuits. It's the priceless "third dimension" in NRI training... practical experience.

## Train with the leader—NRI

Compare training kits, texts, techniques and overall training... and you'll find that you get more for your money from NRI. Whatever your reason for wanting more knowledge of Electronics, NRI has an instruction plan that will meet your needs. Choose from major programs in Advanced Color TV Servicing, Complete Computer Electronics, Industrial Electronics and the other special courses designed to meet specific needs. With NRI home training, you can learn new skills while you're still working at your present job... and turn yourself into the man in demand.

### GET FACTS ABOUT GI BILL

If you have served since January 31, 1955, or are in service now, check GI line on postage-free card.

## Send for free NRI catalog

MAIL THE POSTAGE-FREE CARD FOR THE FREE NRI CATALOG IN THE FIELD OF YOUR CHOICE. YOU WILL BE UNDER NO OBLIGATION. NO SALESMAN WILL CALL.

If the card has been used, write direct to:



**NRI TRAINING**

3939 Wisconsin Ave.  
Washington, D.C. 20016

# Popular Electronics

WORLD'S  
LARGEST-SELLING  
ELECTRONICS MAGAZINE

INCLUDING **Electronics World**

## FEATURE ARTICLES

- 35** ADVANCES IN SQ QUADRAPHONIC MATRIX DECODERS  
*Julian D. Hirsch*
- 47** COMPONENTS FOR ELECTRONIC MUSIC SYSTEMS *Don Lancaster*  
*Tone generators, keyboards, and voicing techniques.*
- 54** THE IC "TIME MACHINE" *Walter G. Jung*  
*Versatile 555 chip has many applications.*
- 67** THE NEW FAST-CHARGE BATTERIES *Adolph A. Mangieri*  
*Ni-Cd cells are easily recharged. Lithium non-rechargeable batteries also are new.*
- 91** MOTOROLA'S 1974 COLOR TV RECEIVERS *John T. Frye*
- 98** SILICON SOLAR CELLS *Joseph H. Wujek*  
*How they work and where they are used.*

## CONSTRUCTION STORIES

- 29** BUILD A DIGITAL CLOCK-CALENDAR *W. L. Green*  
*Seven-segment readout of time and day.*
- 38** MAKE LOW-COST MONO/STEREO HEADPHONES *Marshall Lincoln*
- 44** AUDIO POWER AMPLIFIER *Michael S. Robbins*  
*No output transformer or capacitor.*
- 51** SIMPLE ELECTRONIC COMBINATION LOCK *Joe A. Rolf*
- 62** REDUCING TVI ON 6-, 10-, and 11-METER BANDS *R. L. Winklepleck*  
*Simple antenna filter does the job.*
- 63** LOGIDEX—AN ELECTRONIC GAME FOR ALL SEASONS *Howard L. Nurse*
- 71** TAPE RECORDER CONTROL OF SLIDES *J. W. Sharp*
- 72** ENLARGER EXPOSURE CALCULATOR *Adolph A. Mangieri*

ZIFF-DAVIS PUBLISHING COMPANY  
Popular Electronics Including Electronics World  
Editorial and Executive Offices  
One Park Avenue, New York, New York 10016  
212 679-7200

William Ziff, President  
W. Bradford Briggs, Executive Vice President  
Hershel B. Sarbin, Senior Vice President, Secretary, and  
Treasurer  
Philip Sine, Senior Vice President  
Phillip T. Heffernan, Vice President, Marketing  
Frank Pomerantz, Vice President, Creative Services  
Arthur W. Butzow, Vice President, Production  
Edward D. Muhlfield, Vice President, Aviation Division  
Irwin Robinson, Vice President, Travel Division  
George Morrissey, Vice President  
Sydney H. Rogers, Vice President  
Sidney Holtz, Vice President  
Lawrence Sporn, Vice President, Circulation

POPULAR ELECTRONICS Including ELECTRONICS WORLD, November, 1973, Volume 4, Number 5. Published monthly at One Park Ave., New York, NY 10016. One year subscription rate for U.S., U.S. Possessions and Canada, \$6.00; all other countries, \$7.00. Second class postage paid at New York, N.Y. and at additional mailing offices. Authorized as second class mail by the Post Office Department, Ottawa, Canada and for payment of postage in cash. Subscription service and Forms 3579: P.O. Box 2774 Boulder, CO 80302. Editorial offices for manuscript contributions, reader inquiries, etc.: One Park Ave., New York, NY 10016.

POPULAR ELECTRONICS Including ELECTRONICS WORLD is indexed in the Reader's Guide to Periodical Literature.

Copyright © 1973 by ZIFF-DAVIS PUBLISHING COMPANY. All rights reserved.

POPULAR ELECTRONICS Including Electronics World



**EDGAR W. HOPPER**  
*Publisher*  
**ARTHUR P. SALSBERG**  
*Editorial Director*  
**MILTON S. SNITZER**  
*Editor*  
**LESLIE SOLOMON**  
*Technical Editor*  
**JOHN R. RIGGS**  
*Managing Editor*  
**EDWARD I. BUXBAUM**  
*Art Director*

**ALEXANDER W. BURAWA**  
*Associate Editor*  
**ANDRE DUZANT**  
*Technical Illustrator*  
**ELLEN S. FINKELSTEIN**  
*Editorial Assistant*  
**JOHN T. FRYE**  
**LOU GARNER**  
**J. GORDON HOLT**  
**WALTER G. JUNG**  
**MATT P. SPINELLO**  
*Contributing Editors*

**JOSEPH E. HALLORAN**  
*Advertising Director*  
**JOHN J. CORTON**  
*Advertising Sales*  
**MADELEINE LITTMAN**  
*Advertising Service Manager*  
**STANLEY NEUFELD**  
*Associate Publisher*  
**FURMAN H. HEBB**  
*Group Vice President*  
*Electronics and Photographic*

## THE SCENES

- 12 STEREO SCENE** *J. Gordon Holt*
- 26 HOBBY SCENE**
- 103 SOLID-STATE** *Lou Garner*
- 107 CB SCENE** *Matt P. Spinello*
- 110 TEST EQUIPMENT SCENE** *Leslie Solomon*

## PRODUCT TEST REPORTS

- 80 HEWLETT-PACKARD MODEL 970A DIGITAL MULTIMETER**
- 82 JVC AMERICA, INC., MODEL VP-100 STEREO PREAMPLIFIER**
- 84 CROWN MODEL DC-300A POWER AMPLIFIER**
- 86 PACE MODEL 10-2 CB TRANSCEIVER**
- 88 ACTIVE BETA-3 BCB AUTO ANTENNA**
- 89 HEATHKIT MODEL IC-2108 DESK CALCULATOR AND MODEL IC-2009 POCKET CALCULATOR KITS**

## DEPARTMENTS

- 6 EDITORIAL** *Milton S. Snitzer*  
*Skyrocketing Solid-State*
- 8 LETTERS**
- 18 NEWS HIGHLIGHTS**
- 97 TIPS & TECHNIQUES**
- 116 NEW PRODUCTS**
- 118 NEW LITERATURE**
- 120 ELECTRONICS LIBRARY**

## COMING NEXT MONTH

*Special Section on Hi-Fi  
and Quadraphonics*  
*Experiments with Shortwave Receivers*  
*Electronics in Cameras*  
*Build a Universal Op Amp Tester*

Midwestern Office  
The Pattis Group, 4761 West Touhy Ave.,  
Lincolnwood, Illinois 60644, 312 679-1100  
GERALD E. WOLFE, DICK POWELL  
DICK GOVATSKI, MANLEY LUDWIG

Western Office  
9025 Wilshire Boulevard, Beverly Hills, California 90211  
213 273-8050; BRADSHAW 2-1161  
Western Advertising Manager, **BUD DEAN**

Japan: James Yagi  
Oji Palace Aoyama; 6-25, Minami Aoyama  
6 Chome, Minato-Ku, Tokyo 407-1930/6821

Ziff-Davis also publishes Boating, Car and Driver, Cycle, Flying, Modern Bride, Popular Photography, Skiing, and Stereo Review.

Forms 3579 and all subscription correspondence should be addressed to POPULAR ELECTRONICS Including ELECTRONICS WORLD, Circulation Department, P.O. Box 2774, Boulder, CO 80302. Please allow at least eight weeks for change of address. Include your old address, as well as new—enclosing, if possible, an address label from a recent issue.

Editorial contributions must be accompanied by return postage and will be handled with reasonable care; however, publisher assumes no responsibility for return or safety of art work, photographs or manuscripts.



Member Audit Bureau  
of Circulations





# Editorial

By Milton S. Snitzer, Editor

## SKYROCKETING SOLID-STATE

The 1970-1971 recession has passed as far as semiconductor sales are concerned. Thanks, in part, to the surging consumer market, 1972 sales of semiconductors for just two companies, Texas Instruments and Motorola, were a combined total of \$2.1 billion. If the performance during the second half of 1973 matches that of the first half, these two companies will beat 1972 by \$500 million. Other companies, new and old, are also enjoying swollen semiconductor sales.

To keep our readers abreast of the overwhelming number of new semiconductor devices and applications regularly announced (many of which find their way into construction projects in this magazine) we are expanding our solid-state coverage.

Effective with this issue, both Walter Jung and Lou Garner will be covering solid-state developments, each from a different vantage point.

Walter Jung, who was authoring our monthly "Solid-State Scene," is now focusing on exciting solid-state devices that are being applied now with increasing frequency. His "Solid-State Perspective" will dig into the "why and how it works" of semiconductors, with tutorial and state-of-the-art articles for beginners and heavy doses of "hands on" material for more advanced hobbyists and experimenters. Read his first, "The IC Time Machine," in this issue. Jung, by the way, has contributed dozens of articles to both the popular and professional electronics press, presented many technical papers to engineering societies, and recently completed the text for *The IC Op Amp Cookbook*, an area in which he has special interest and expertise.

Lou Garner, after about a one-year hiatus (which was preceded by an unbroken line of regular editorial contributions to this magazine since Vol. 1, No. 1 in October 1954) has returned to write his "Solid-State" column (originally "Transistor Topics"). His excellent technical credentials, which include work on development of the first wideband oscilloscope offered in kit form, his long lines of communication with device manufacturers, and his keen wit (which usually surfaces in writing around Christmas time) will undoubtedly be welcomed by old followers and new readers. More than a half-dozen books carry his byline, including what is believed to be the first elementary text on transistors (*Transistors and Their Applications*) in 1953. Read his renewed column, which leads off with a lively discussion on availability of parts, followed by new devices and practical circuits.

With this team, we feel confident that the world of transistors, integrated circuits, etc. will become more meaningful to our readers with each succeeding issue.

# When you want the very best stereo without paying the highest price

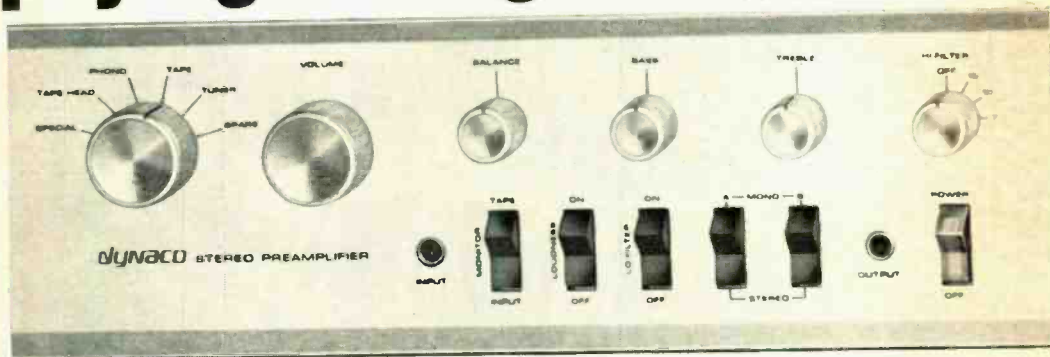

PAT-4 Preamplifier

## BUILD A DYNAKIT

The experts agree that Dynakit's deliver pure performance that match the most costly components. A few evenings of your time brings you substantial savings with unparalleled listening satisfaction. It's easy, fun and educational. Advanced engineering, with functional simplicity which is a hallmark of Dynaco's designs, add a special satisfaction for you who appreciate excellence.

It's much easier to build a Dynakit. Thoroughly proven circuits, supplied preassembled and tested on fiberglass etched circuit boards, leave only the mechanical assembly and interconnection to you. Detailed step-by-step instructions with easy-to-follow pictorial diagrams clearly show every connection. In high fidelity stereo or 4-channel sound there is no match for Dynakit value.



A-25  
Loudspeakers



SCA-80Q  
Amplifier



AF-6  
AM-FM Tuner

***Dynaco INC.*** Division Tyco  
3060 Jefferson St., Phila., Pa. 19121  
Also available in Canada  
from Dynaco of Canada, Ltd.

**DYNACO INC.**  
3060 Jefferson St., Phila., Pa. 19121

PE11

Gentlemen:

Please send new 1973 full color Dynaco catalog.

Name \_\_\_\_\_

Address \_\_\_\_\_

City \_\_\_\_\_ State \_\_\_\_\_ Zip \_\_\_\_\_

CIRCLE NO. 10 ON READER SERVICE CARD



# MOW

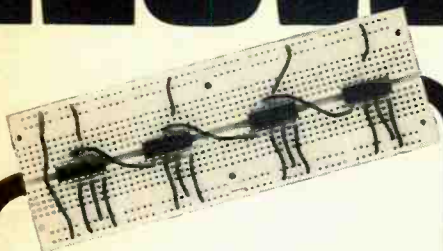

... TEST  
**NEW CIRCUIT IDEAS,  
I.C.'s, DISCRETE COMPONENTS  
WITH NO SOLDERING!**

Only **\$17.75** The E&L SK-10 SOCKET

Just plug in ¼ watt resistors, ceramic capacitors, diodes, I.C.'s, transistors and more, and your circuit is built! No soldering! No special patch cords needed. All components reusable! Interconnect with any sold #22 gage wire.

- Nickel/silver terminals — low contact resistance
- Low insertion force
- Initial contact characteristics beyond 10M insertions
- Vertical and horizontal interconnecting matrices
- Handles wide range of wire leads from .015" to .032"

### MONEY-BACK GUARANTEE

Try it with absolutely no risk for 5 days. If not satisfied, return your SK-10 socket and get a full refund. Trying is believing. How can you go wrong? Send check or M.O. today!

- Add 50¢ for postage and handling
- 25% deposit for C.O.D.'s

Ask for FREE IDEA-PACKED,  
ILLUSTRATED CIRCUIT DESIGN  
CATALOG.



**E&L INSTRUMENTS, INCORPORATED**  
61 First Street, Derby, Conn. 06418

**CIRCLE NO. 12 ON READER SERVICE CARD**

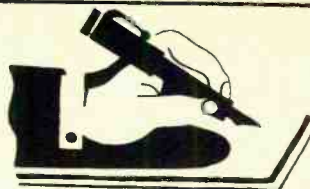

## Letters

### IN REBUTTAL

Mr. Holt's answer to Patrick Mullin in the August 1973 "Stereo Scene" concerning amplifier damping seems to leave out one important aspect of amplifier/loudspeaker relationships. All dynamic low-frequency loudspeakers have a low-frequency resonant point. This frequently can be related to the  $Q$  of the speaker system. If the diaphragm of the speaker is not substantially damped, the  $Q$  will be high and, therefore, the impedance of the system will be high at resonance.

Audio amplifiers—especially solid-state ones—transfer maximum power into a low impedance. If the impedance at resonance is many times greater than the average impedance of the system, less power will be transferred at the low-frequency resonant point, causing the speaker to be in a less controlled state. Since the low-frequency resonant peak is virtually the low-frequency limit of a speaker's low-end capability, it is rather a function of the speaker's damping or  $Q$  than the damping factor of the amplifier. The more power that a speaker can accept at resonance from an amplifier determines how clean the entire system can sound.

STEPHEN POTURALSKI  
Isostatic Audio Systems  
Tonawanda, N.Y.

### TAKES EXCEPTION TO "CB SCENE"

I find your July "CB Scene" incredibly ill-informed. If a foreigner may be permitted to make an observation on your domestic scene, I feel that the thoughts attributed to Dean Burch are naive, to say the least. If Mr. Burch really said: "I don't know what is so . . . interesting about finding out what kind of outfit a guy has or is listening to . . ." then I can't believe for one minute that he has talked with Sen. Goldwater or any other ham.

The variety of public service ham radio has provided the world over is almost endless. Sure, CB can do some of the same sort of thing, sometimes more efficiently than can hams. But the two services work very well together in their individual public service roles.

If Mr. Burch is going to be allowed to express his thoughts on the subject of ham radio,

I feel it only behooves you to let someone who knows what he's talking about have equal time.

DAVE BENNETT.  
VE7AZG/XM11-3545  
Surrey, B.C., Canada

The "CB Scene" to which you refer was about Citizens Band Radio. On the CB band, chit-chat about the type of gear or power that the sender is using is not really important; for hams it is. The CB band is for business, emergencies, and similar messages. Perhaps, Mr. Burch's remarks about Senator Goldwater were misplaced in that article. We do not know whether Mr. Goldwater uses CB as efficiently as he does the ham bands, but the two services should not be confused. Both have their place when properly used.

### MEASURING RMS VOLTAGE OF SQUARE WAVES

It was incorrectly stated in the March 1973 edition of "Mac's Service Shop" that a dynamometer is needed for measuring the rms voltage of a square wave. A good approximation of the rms voltage can be obtained without a dynamometer. The amplitude of a square-wave voltage is equal to the rms voltage, provided that its duty cycle is 0.5 and there is no dc component.

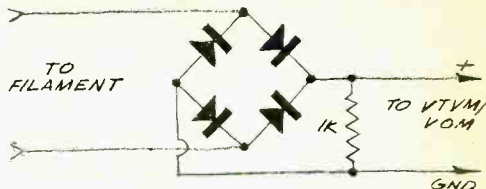

The rms voltage can be measured with an oscilloscope. However, measurements with an ac meter require a correction factor that must be determined for a given meter. To determine the correction factor, measure a square wave of known amplitude. The percentage difference between the reading and the actual half-amplitude p-p value will be the correction factor.

Shown in the drawing is a simple circuit for use with a dc VTVM or VOM that permits the rms voltage of a square wave to be read directly from the dc scale with no correction factor. The resistor is there to insure sufficient loading of the rectifier bridge for proper biasing of the diodes.

E. HAMILTON  
St. Louis, Mo.

### MILITARY TECHNICAL MANUAL SOURCE

From time to time, a number of readers have asked in the "Letters" column for infor-

## Electro-Voice Condenser Microphones Meet the test

(and please the testers).

Hirsch-Houck Laboratories (reporting in the May, 1973 *Popular Electronics*) said, in part, "Best of all, their sound quality has a range and smoothness that we have not previously found except in much more expensive mikes".

And *Consumer Guide* magazine (Vol. 31) rated the E-V electret condenser microphones "Best Buys" on the basis of their tests.

Further proof that you can get studio-quality sound at moderate prices with an E-V electret condenser microphone. Prices start at \$39.75, suggested retail. See and hear them today at your E-V dealer. Or write for your useful FREE guide to the use of Electro-Voice condenser microphones. It has helpful information for every tape recording enthusiast.

a **Gulton**  
COMPANY

ELECTRO-VOICE, INC., Dept. 1132P  
630 Cecil St., Buchanan, Mich. 49107

**Electro-Voice®**

More U.S. recording studios use Electro-Voice microphones than any other brand.

CIRCLE NO. 14 ON READER SERVICE CARD

Plug in...wire...  
modify...build...  
test...

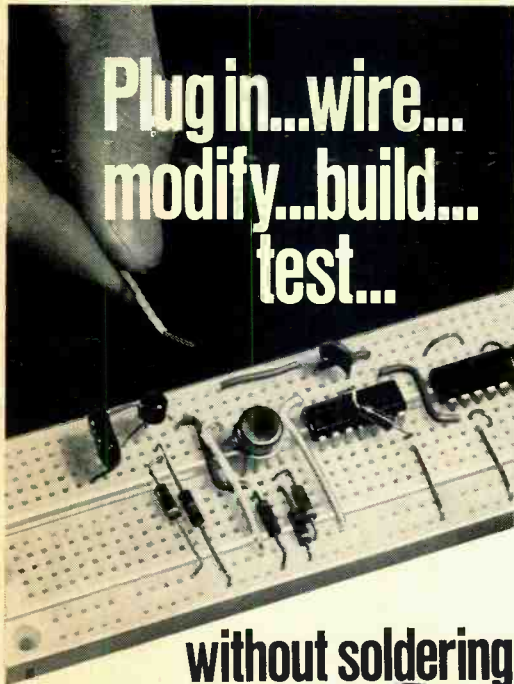

without soldering  
for as little as \$3<sup>00</sup>

Introducing QT SOCKETS™ and BUS STRIPS, a flexible new breadboarding system with unique SNAP/LOCK that lets you expand or contract your project by simply snapping together as many QTs as you need. Test ICs, transistors, resistors, capacitors and more. Just plug in, connect with solid #22 AWG hook up wire — no

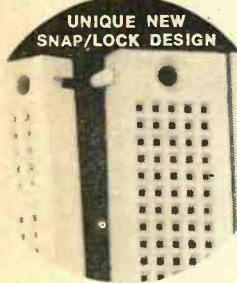

UNIQUE NEW  
SNAP/LOCK DESIGN

soldering needed! Re-use QTs again and again. No more shorting or burnt fingers! No special patch cords! Available in 10 different sizes, starting as low as \$3 for QT Sockets, \$2 for Bus Strips.

### FREE SELECTION GUIDE

Write or phone today for application and product photos, drawings, specs, socket sizes and ordering information.

#### Continental Specialties Corporation

325 East St., New Haven, CT Tel 203/624-1811

CIRCLE NO. 7 ON READER SERVICE CARD

mation on where they could obtain technical manuals for various types of military test equipment. Well, after some research, I have located an address to which they can write, requesting the order number and price of the test equipment TO desired: SAAMA/SANSTD, Kelly A.F.B., TX 78241. Bear in mind that this address is valid for test equipment TO's only.

WILLIAM R. MEREDITH  
Madison, Wisc.

### THYRISTOR TESTER UPDATED

After having built the "Thyristor Tester" (July 1973), I realized that it omitted a sometimes very critical test for SCR's. It is often necessary to gate an SCR with a dc voltage and remove the gate. Many SCR's that check good in all other respects will not continue to function when the gate is removed.

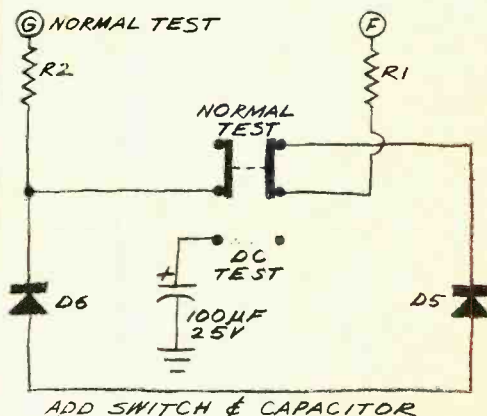

To update my project, I installed a 100- $\mu$ F capacitor into the positive gate. This requires switching out the negative-gate indicating LED, else the capacitors will charge and turn on both LED's.

RONALD B. STEAR  
Lake Charles, La.

### WANTS TO BUY "DISTORTIONLESS PREAMP"

In "Build a Distortionless Audio Preamplifier" (June 1972), a kit supplier was specified. Unfortunately, when I finally got around to making out my order, I was informed by the supplier that they no longer carry the kit. I would like to know if any readers who have this kit, wired or otherwise, would like to sell it.

DEAN M. KUEHN  
100 Pleasant Dr.  
Box 338  
Waunakee, WI 53597

Interested readers please write directly to Mr. Kuehn. ♦





## Stanton. Benchmark for an Industry.



### Stanton's 681A is the Calibration standard to recording engineers such as Robert Ludwig.

Whatever the requirements for recording and playback, Stanton's Series 681 cartridges are the Calibration Standard. And there is a 681 model engineered specifically for each of these critical applications. That's why Stanton is truly the Benchmark for the industry.

**The Stanton 681A — For Cutting Head Calibration.** With Stanton's Model 681A, cutting heads can be accurately calibrated with the cartridge, for it has been primarily designed as a calibration standard in recording system checkouts. Frequency response is factory calibrated to the most rigid tolerances and the flattest possible response is assured for precise alignment of recording channels.



**The Stanton 681EE—for Critical Listening.**

Stanton's Model 681EE is designed for low-distortion tracking with minimum stylus force, regardless of the recorded velocity or the distance of the groove from the disc center. High compliance, low mass and low pressure assure perfect safety even on irreplaceable records.

All Stanton Calibration Standard cartridges are guaranteed to meet the specifications with exacting limits. Their warranty comes packed with each unit—the calibration test results for that individual cartridge.

For complete information and specifications write Stanton Magnetics, Inc., Terminal Drive, Plainview, L.I., New York.



All Stanton cartridges are designed for use with all two- and four-channel matrix derived compatible systems.

**CIRCLE NO. 29 ON READER SERVICE CARD**



# Stereo Scene

By J. Gordon Holt

**N**OT too long ago, I was discussing preamplifiers with an audiophile friend and the subject of a particular solid-state preamp came up. I liked it, I said, because with the tone controls set for "flat," it was the closest thing I had found for under \$500 to the ideal "straight wire with gain." He did *not* like it.

"Why not?" I asked, having my own reasons for agreeing with him, but curious to know whether he concurred. "Because they never seem to do what I want them to do," was the reply. And there, in a nutshell, was my own reaction to them.

At first glance, though, a preamp such as this *should* be able to do quite a bit, for instead of the usual two controls, one for bass, one for treble, it has *five* "tone" controls, each affecting a different part of the audio spectrum. Neither is there any question about those controls working as they are supposed to. They do exactly what the manufacturer claims they do: Each raises or lowers its particular segment of the audio spectrum, producing as nice-looking a peak or dip in the response as one could wish.

So, what's the matter with them? Two things: Because there are only five of them, they do not always affect the frequency

ranges which need correction in typical recordings or in loudspeakers (though in most instances, the broad ranges available are satisfying). And because the center frequency of the lowest-frequency control is at 60 Hz, the control has little effect on the 40-Hz range where many recordings and loudspeakers are deficient or overly endowed. I'll put it this way: The lowest control is a "boom" control, when what is often needed is a "thud" control.

"Well," you might ask, "Those five controls must be of more value than the two on most other preamps!" Generally, yes, but not necessarily.

Let's revert to basics for a moment, and raise the question of what tone controls are supposed to do anyway. If your answer is "To control tone, of course," you are not being as snide as you think. That *is* what they're for. And in most experts' books, tone and equalization are two different things.

Although one might be hard-put to find a definition this explicit, the word "tone" in a hi-fi context implies "balance." That is, balance between bass and treble. Thus, the classic tone control is a device which, by raising or lowering the output of a major portion of the audio range (relative to the rest of the range), changes the over-all balance of the sound. To an unsophisticated listener, the sound can be made "richer" either by rolling off most of the high frequencies or by boosting most of the low frequencies. To the more enlightened ear of an audiophile, treble cut does *not* sound like bass boost, nor vice versa, and that is why audiophile equipment has separate controls for the bass and the treble ranges.

**Poor vs. Good Controls.** Here, though, is where we start getting into the business of poor tone controls versus good tone con-

## Tone Controls and Equalizers

# Introducing the new **BOSE 901 and 501 Series II** **Direct/Reflecting® Speaker Systems**



***BOSE 901 SERIES II***

***BOSE 501 SERIES II***

## A New Listening Experience by **BOSE**®

For information on new BOSE products and a list of local dealers, write  
BOSE Corp., Dept. EP, The Mountain, Framingham, Mass., 01701.

**CIRCLE NO. 4 ON READER SERVICE CARD**



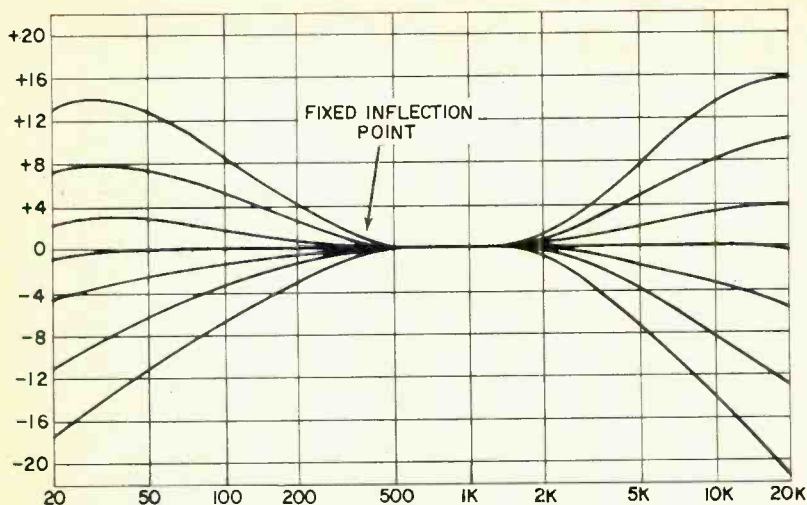

Fig. 1. Family of curves for variable-slope (fixed-inflection) tone controls.

controls. (Purists will argue that *any* tone controls are bad because, even in their "flat" positions, they tend to muddy up the sound a bit, and besides, if your loudspeakers and pickup are good enough and you always play good recordings you shouldn't need tone controls anyway.) What, then, should a *good* tone control do?

If it is a bass control, it should control bass. If it is a treble control it should control treble. And nothing else! It's the "nothing else" that's the hooker there, for the most common failing of poor tone control systems is that they have a marked affect on the middle range of frequencies which is neither bass nor treble. That this should *not* occur is the first requisite of good tone controls.

In most tone control designs, the "hinge points"—the frequencies above and below which the controls vary the response—are chosen to be just below and just above 1,000 Hz. Typically, the points are at 500 and 2,000 Hz, which are equidistant from 1,000 Hz. Turning up the bass control, for example, causes the whole range below 500 to tilt upwards by degrees until, with the control full up, the tilt is at its steepest. The boosting is however rarely allowed to continue to below 30 Hz. If it did, the system would tend to overload because of the presence of excessively strong subsonic frequencies, most of which comprise nothing but turntable rumble. Turning the bass control down simply tilts the low-end response downwards below the hinge point, and the treble control has the same effects *above*

the treble hinge point (Fig. 1). This type of tone-control system is commonly called a variable-slope system (because the slope of the correction curves is adjustable), and is useful *solely* for correcting for tonal imbalances in the program material.

The other type of tone-control system in common use (although less common than the variable-slope variety) is what is known as the variable-turnover or variable-inflection type. As its name implies, this has no fixed hinge points, and the *slope* of the boost or cut curves remains essentially the same (Fig. 2). With either tone control set near (but not at) its flat position, the variable-inflection control affects only the extreme low or high-frequency part of the audio spectrum. Thus, advancing the bass control to, say, 5 degrees above flat may introduce 3 dB of boost at 30 Hz, 1 dB at 5 Hz, and nothing above that. Such a tone control can be used to trim the extreme low- or high-end portions of the audio spectrum as desired, without affecting the over-all balance of the sound. But the further each control is turned away from flat, the more its effect extends toward the middle-frequency range and hence the more effect it has on the *balance* of the sound. It should be obvious which is the more useful kind of control system.

**Limitations of Both Types.** Both have their limitations, though. Figure 3 shows the over-all frequency response of a hypothetical (although by no means atypical) commercial recording, played through a system

# Replacing semiconductors takes guidance.

## And here it is.

Our new Semiconductor Product Guide.

It's *the* cross-reference for entertainment replacement semiconductors.

Transistors, zener diodes, diodes, high-voltage rectifiers, light emitting diodes, color crystals, integrated circuits, field-effect transistors . . . they're all here. With one of ours you can replace 265 on the average.

And with every one of ours you get Mallory performance and reliability.

Get your Semiconductor Product Guide at your Mallory distributor's today. With a guide like this you can't go wrong.



**MALLORY**

**MALLORY DISTRIBUTOR PRODUCTS COMPANY**

a division of P. R. MALLORY & CO. INC.

Box 1284, Indianapolis, Indiana 46206; Telephone: 317-636-5363

**CIRCLE NO. 22 ON READER SERVICE CARD**

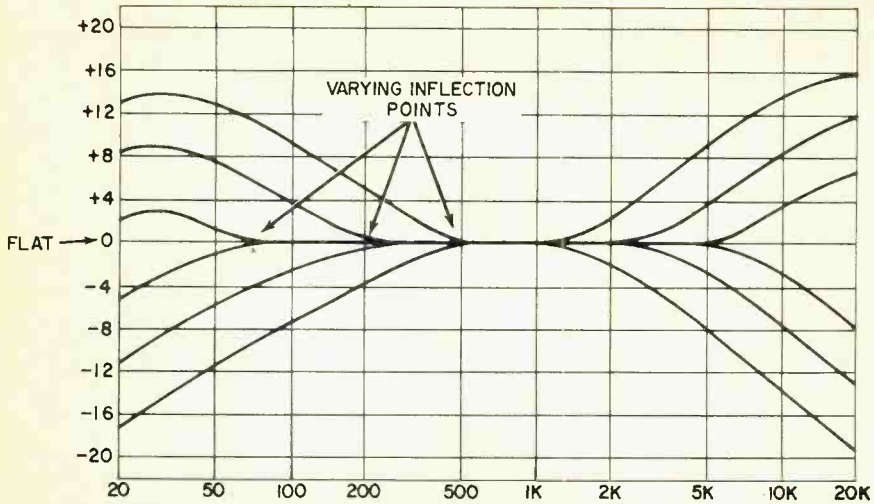

Fig. 2. Family of curves for variable-inflection tone-control system. Note that at maximum and minimum settings, both types of control have same effect.

with a mild mid-bass peak (which isn't unusual either). Let's look at the mid-bass peak first. The peak will make the sound boomy, so it *would* be nice to get rid of it, if possible. Either kind of bass control that we've discussed will do the trick rather well, if turned below flat by an appropriate amount. But look what happens then to the deep-bass range below 60 Hz. Since this range was not peaked to begin with, but was equal in output to most of the rest of the audio spectrum, turning down *either* kind of bass control will reduce its level relative to the middle range. In killing the boom, we will have also killed much of the deep-bass range.

Consider now the upper-middle-range peak that the recording director added to the recording in order to make it sound more "hi-fi" on cheap phonographs. Again, we can get rid of that rather effectively by turning down our treble control, but we do so at the same cost as before; the range *above* it then becomes excessively attenuated. This is why I am inclined to snicker to myself whenever I see a record critic excusing a case of recorded shrillness or boominess with the admonition that "it's easily remediable with your tone control." It isn't. Response deviations affecting only the range between the extreme low and the extreme high frequencies are in fact *not* prop-

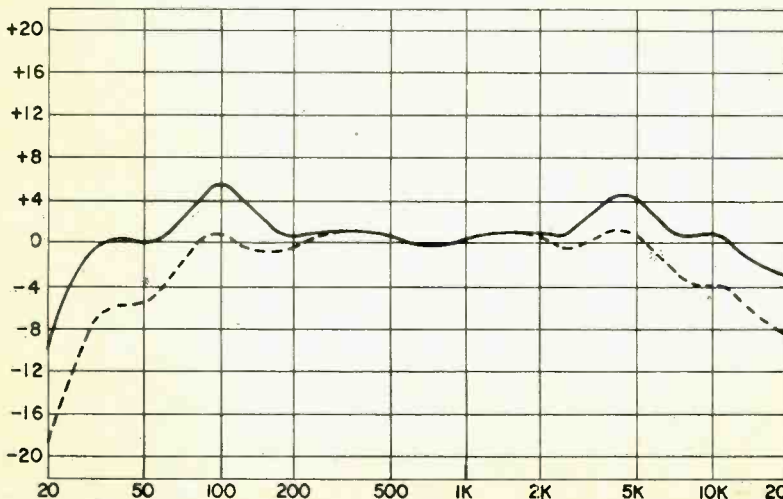

Fig. 3. Solid line shows response with mid-bass speaker or room peak and high recording peak. Dashed line shows effect of variable-inflection control.



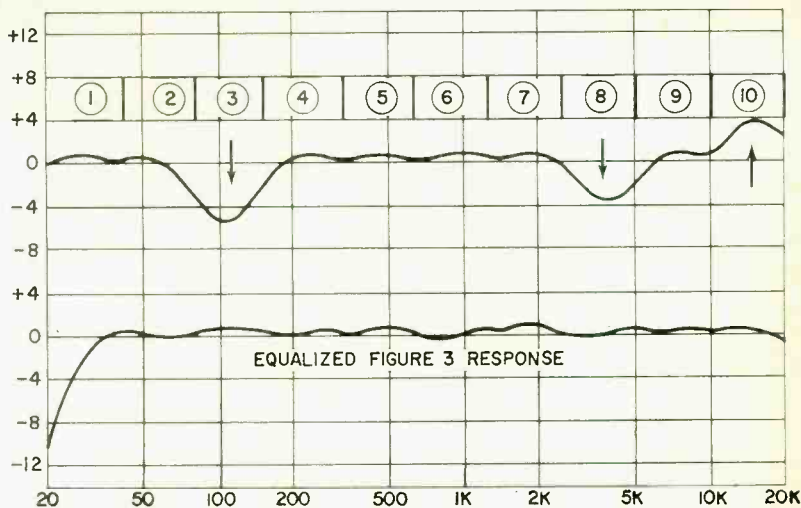

Fig. 4. How equalizers are used to correct the high and low peaks in Fig. 3.

erly remediable with tone controls; they need the ministrations of an "equalizer."

**Use of an Equalizer.** To the audio engineer, an equalizer is anything which affects frequency response, and thus includes tone controls. In audiophile parlance, though, the term equalizer applies to a specific kind of tone control that allows you to vary the response of portions of the audio spectrum between the extreme low or extreme high ranges without affecting either of those ranges. The preamp I was discussing with my friend was equipped with such an equalizer, although of a rather rudimentary kind. Some of the costlier varieties divide the audio spectrum into as many as 10 bands, each about an octave wide, and assign each band its own "volume control." The Soundcraftsmen, for example, has controls affecting individually the ranges from 20 to 40, 40 to 80, and 80 to 160 Hz. The uppermost of these could most effectively eliminate the boom peak from Fig. 3, while the 2560-5120 control would do a nice job of de-shrilling the recording, and neither correction would affect the rest of the audio spectrum in any way.

Multi-band equalizers like this can in fact do almost as good a job of "environmental equalization"—matching a system to the room acoustics—as do the devices made specifically for that purpose, most of which sell for several times the price. A very sharp response deviation involving a narrow range of frequencies may or may not be correct-

able with an equalizer, depending on the severity of the deviation and on whether or not it happens to fall right on the center of one of the controlled bands, but such equalizers are far more efficacious than any conventional tone-control system for controlling frequency-response-related system problems. (See Fig. 4)

They have other applications, too. They can correct, to a respectable fare-thee-well, for the flaccid or overly lean bass performance from a speaker/amplifier damping incompatibility. The ones offering individual control of each channel (some have the controls ganged) allow a truly critical listener to undo much of the havoc wreaked on commercial recordings by overly creative recording directors, who are often moved to add shrillness to the violins (in the left channel only) or excess "fatness" to the double-basses (right channel only). Equalizers can be used, preferably by measurement rather than by ear, to restore the correct playback equalization to older recordings, including 78's, that were made prior to the industry standardization of the RIAA curve, and can also do a very nice job of cleaning up some of the extraneous noises on older recordings. And if you happen to be a live-tape-recording enthusiast who must record in less-than-perfect auditoriums, a good equalizer with comprehensive control facilities can often make the difference between an outstanding recording and a miserable dud. But then, that's another story. ♦

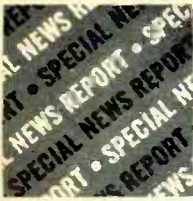

# News Highlights

## Electronics and Wristwatches

The big news at the recent convention of the Retail Jewelers of America in New York City was the emergence of the electronic wristwatch. Such a watch uses a quartz crystal for high accuracy, an integrated circuit for frequency countdown, and a light-emitting diode or liquid crystal digital number readout. At least 500,000 electronic watches are expected to be sold this year, compared to about 15,000 last year. Currently retailing for \$150 and up to around \$300, an industry spokesman speculated that prices could drop to around \$100 next year. Already available for under \$100 is an electronic watch that uses a regular analog (dial and hands) readout. It was estimated by Harry Weisberg, director of MOS IC technology at RCA, that by 1980 the watch industry will be producing 100 million electronic wristwatches, some selling for as little as \$25. Watch manufacturers have either already introduced electronic watches or are hard at work designing them now. So, it is predicted that the U.S. will challenge the Swiss in the watch market. One new display that we have seen is used by Gruen in their new electronic watches. These use a new type of liquid crystal display which has a high contrast black background for improved legibility.

## U.S. Color TV Sets to be Sold Overseas

In a reversal of the trend in which Japanese TV sets are widely sold in the U.S., at least two U.S. set makers are offering their products overseas. Motorola recently signed an agreement with Aiwa Co., Ltd. to sell Quasar sets in Japan in competition with Japanese manufacturers. The emphasis will be on large-screen consoles rather than portables. The receivers will sell for \$750 to \$1250, at which prices they will cost about the same as Japanese-built consoles. In a related development, RCA color sets are to be sold in the Far East. The company recently signed up a distributor on Taiwan. Again the emphasis is on 25-in. consoles with remote control.

## Timer IC Chip Off to a Big Start

Not long ago, Signetics introduced a low-priced IC timer chip, the 555. Proving to be extremely popular, other manufacturers (Exar, Intersil, Motorola, National and Raytheon) soon climbed on the bandwagon. Signetics priced the chip at 75 cents each in 100-up quantities. It is estimated that some 200,000 to 700,000 units are being shipped every month. At an average selling price of 60 cents, this amounts to a \$3 million annual market. Some of the manufacturers have already introduced a dual model of the timer, including two separate timers on the same chip. Prices for these are running at \$1.25 to \$1.50 in 100-up quantities.

## New Videotelephone Design

At the recent Hanover Fair, Siemens demonstrated a new videotelephone design which is said to be ready for production. This device is

a further development of the first European videotelephone for dial operation which was first shown by Siemens in 1967 and has been in use since 1971 for a trial service between the Deutsche Bundespost in Darmstadt and the manufacturer in Munich. The new phone is characterized by a larger screen (5 x 5½ in.), improved picture quality and simplified operation. It uses the internationally proposed standard video bandwidth of 1 MHz and is fully compatible with the U. S. standard.

### Philco Portable TV's to be Serviced at Home

Purchasers of 18- and 19-inch Philco portable color TV sets can now have all in-warranty service work performed in their own homes. The company has begun offering a parts and service option that expands the standard warranty policy requiring all Philco portable TV's to be delivered to the agent's shop for servicing. The "in home" service option carries a suggested retail price of \$9.95. The company is also extending its second-year warranty option—at a suggested retail price of \$69.95—on all solid-state color consoles.

### High-Speed Facsimile System

A new high-speed facsimile system that can transmit a standard sized document over both telephone lines and through satellite communications in less than 15 seconds was introduced by Comfax Communications Industries (New York, N. Y.). The time required for the new system is ten times faster than most commonly employed techniques. Electronic Associates, Inc. (West Long Branch, N. J.) has been licensed to manufacture, market and service the new unit and is expected to have the first of the new devices in production during the last half of this year.

**The Mark Ten B Capacitive Discharge Ignition System keeps your car in tune ... and everyone knows that a well-tuned car gets better mileage, requires less maintenance, runs longer and better, and helps in the quest for cleaner air.**



**... Just ask Detroit and the E.P.A.**

**CIRCLE NO. 5 ON READER SERVICE CARD**

**Order your Mark Ten B today! Please send me free literature.**

Enclosed is \$ \_\_\_\_\_  Ship ppd.  Ship C.O.D.  
 Please Send: \_\_\_\_\_ Mark Ten B @ \$59.95 ppd. \_\_\_\_\_ Mark Ten B Kit @ \$44.95 ppd.  
 Car Year \_\_\_\_\_ Make \_\_\_\_\_  
 Name \_\_\_\_\_  
 Address \_\_\_\_\_  
 City \_\_\_\_\_  
 State \_\_\_\_\_ Zip \_\_\_\_\_



**DELTA PRODUCTS, INC.**

Dept. PE - P.O. Box 1147 - Grand Junction, Colo. 80501  
 (303) 242-9000



# Bill Stewart, B.S. in Civil Engineering.

# Officer in the Nuclear Navy.

LTJG Stewart, University of Kentucky  
selected in 1969 for the Navy's

*He is already qualified to operate and maintain  
one of over 100 Navy Nuclear Propulsion Plants.*

In 1973, the Navy will accept about 500 outstanding college graduates like Bill Stewart for its Nuclear Propulsion Officer Program. Each one of these young men will have an incomparable opportunity to become a leader in the Nuclear Navy.

For its Nuclear Program, the Navy wants only men who can master advanced technology. While they do not necessarily have to be engineers, many of them will be. They must have a solid foundation in mathematics and



physics. They must demonstrate superior ability. High standards limit selection opportunity to only the most qualified candidates.

If you qualify, you will spend a solid year learning all aspects of nuclear propulsion plant theory and operation. All of this training will build upon your ability to solve difficult problems through the application of fundamental engineering principles.

While this program is tough, the Navy pays well for the kind of ability and dedication that is

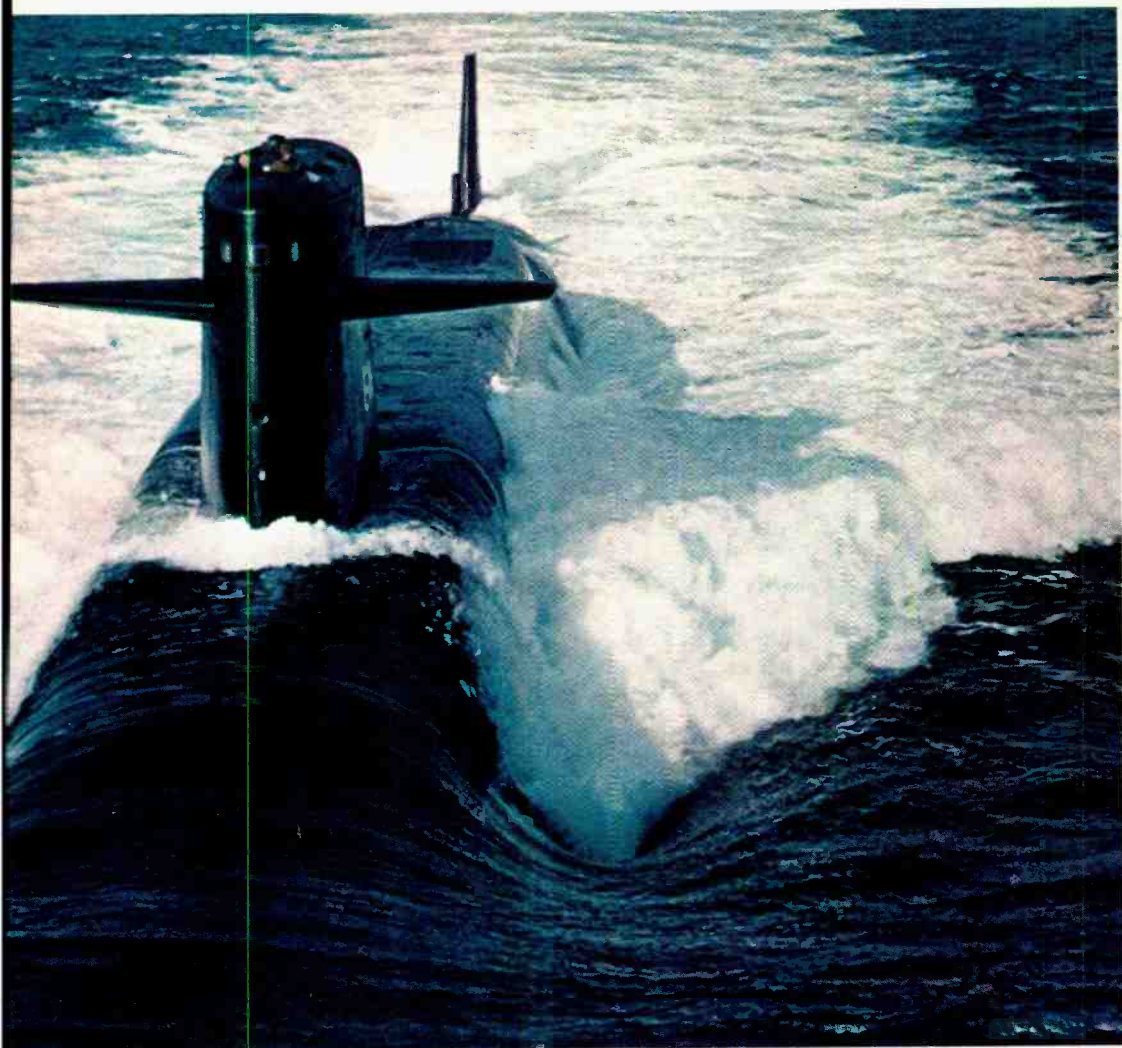

'68, is one of only 429 officer candidates  
Nuclear Propulsion Program.

required. Starting salary in the Nuclear Program is comparable with salaries given to junior executives by private companies; and career advancement is rapid. There are many other benefits, including, of course, the opportunity to see much of the world.

If you think you have the abilities and desire to become a leader in nuclear engineering, call the Nuclear Desk, toll-free, 800-841-8000.

A nuclear-trained officer will contact you and answer your questions about the program.

Do something special with your life.

431

TO: LTJG William Stewart, USN  
Navy Opportunity Information Center  
P.O. Box 2000, Pelham Manor, N. Y. 10803

Yes, I'm interested in becoming a Nuclear Propulsion Officer Candidate. Please send me more information on the Nuclear Program as it applies to:

nuclear-powered submarines.     nuclear-powered surface ships.

If you really don't want to wait, call us toll-free, 800-841-8000. In Georgia, call 800-342-5855. Call collect: in Alaska - 272-9133, in Hawaii - 533-1871.

Name \_\_\_\_\_ Date of Birth \_\_\_\_\_

Address \_\_\_\_\_ City \_\_\_\_\_

State \_\_\_\_\_ Zip \_\_\_\_\_ Phone \_\_\_\_\_

College \_\_\_\_\_ Major \_\_\_\_\_ Class of \_\_\_\_\_

**Be someone special in the Nuclear Navy.**





# NTS Home-Training in Electronics was the start of something big for James Gupton

## **An NTS Graduate**

James A. Gupton Jr. graduated from National Technical Schools with a diploma in TV & Radio Servicing. Today, he's a mighty important man in the world of Electronics!

Research associate with a major electronics corporation; author of numerous articles in electronics magazines; an inventor with five patent applications to his credit. In the field of electro-optics, he has perfected a revolutionary phosphor deposition technique for cathode ray tubes.

Quite a list of accomplish-

ments for a man who began his career with an NTS diploma and a job in TV & Radio servicing.

## **Any student can succeed**

James Gupton is certainly an exceptional NTS graduate. He proves there's nothing to keep a determined man from becoming a success in Electronics. As he himself says, "Any student, properly motivated, can succeed in Electronics through home-training."

Every NTS Electronics Course is specially designed to keep you motivated from the time you

start building your first test instrument until you're ready to plug-in your solid-state Color TV or other advanced electronics equipment.

## **Exciting "Project Method" Training**

NTS Project Method Training is the best way to learn electronics.

You build advanced equipment while you learn Electronics principles and applications.

Each week brings new excitement when you actually see the progress you've made.



# NTS builds self-confidence.

For a man to become successful, like James Gupton, he must have confidence in himself.

As an NTS graduate you have this confidence. Your training is practical and thorough. You know Electronics from the bottom up. You enter a world of Electronics you're familiar with.

And if you have the drive and determination of a man like James Gupton, there are no limits on your success!

(James Gupton's address available upon request).

## NTS COLOR TV SERVICING



Solid-state  
315 sq. in.  
Heath Color TV

Build and keep the largest, most advanced color TV made! Over-all solid-state design, ultra-rectangular screen, matrix picture tube, built-in self-servicing features, "Instant On," A.F.T., solid-state, 24-channel detent UHF/VHF power tuning, and much more! Also build and keep AM-SW Radio, solid-state Radio, FET Volt-Ohmmeter, and Electronic Tube Tester. Learn trouble-shooting, hi-fi, stereo, multiplex systems, radio, color and B&W TV servicing.

## NTS B&W TV SERVICING

Learn sophisticated solid-state circuitry as you build this B&W TV Receiver, Lo-Silho "Superhet" Radio, FET Volt-Ohmmeter, solid-state Radio, Electronic Tube

Solid-state  
B&W TV,  
74 sq. in.  
picture  
(cabinet  
included)



Checker, and Signal Generator. TV and all other equipment are yours to keep.

## NTS ELECTRONIC & COMPUTER TECHNOLOGY

Solid-state  
Compu-Trainer  
14 integrated  
circuits  
replace 198  
Transistors!

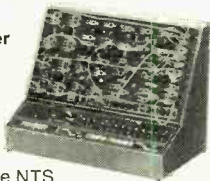

Build and keep this exclusive NTS Compu-Trainer. It teaches you the same principles used in million-dollar systems. Contains 14 integrated circuits! All solid-state! You perform all wiring and patchcording. No shortcuts. No pre-wired circuit boards. Your training is complete! Also receive a FET Volt-Ohmmeter and a 5" wide-band solid-state Oscilloscope.

## NTS ELECTRONIC COMMUNICATIONS

Gain the prestige and earning power of owning and F.C.C. First Class Radio-Telephone license. Two comprehensive NTS Courses cover the big opportunity field of transmitting and receiving.



5-watt AM  
Transmitter/  
Receiver

You build and keep 14 kits, including this amateur phone 6-meter VHF Transceiver, NTS's exclusive 6-transistor solid-state Radio, and a fully transistorized Volt-Ohmmeter. Also, learn 2-way radio, Citizens Band Microwaves, and radar.

## NTS INDUSTRIAL & AUTOMATION ELECTRONICS

Automation is the future of industry, and you can play an important part! Learn industrial controls by training on the NTS Electro-Lab (a complete workshop). You also build and operate this 5" solid-state

oscilloscope. And you perform experiments that involve regulating motor speeds, temperature, pressure, liquid level, and much more. All equipment is yours to keep.



All solid-state!

## NTS AUDIO ELECTRONICS SERVICING

Learn sound theory — how it works in home radio, car tape decks, stereo multiplex component systems, and more! Set up a spectacular music system. Learn about sound distortion, amplification and control, loud-speaker baffles, problems of system installation, etc.

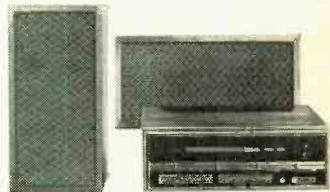

Build and keep this famous Heath Stereo Receiver and Speakers

Included is Volt-Ohmmeter, In-Circuit Transistor Tester and solid-state Radio. Prepare yourself for great opportunities in the Home Entertainment Industry!

## CLASSROOM TRAINING AT LOS ANGELES

You can take classroom training at Los Angeles in sunny Southern California. NTS occupies a city block with over a million dollars in technical facilities. Check box in coupon below.

## APPROVED FOR VETERAN TRAINING

Accredited Member: National Association of Trade and Technical Schools; National Home Study Council.

## NATIONAL TECHNICAL SCHOOLS

World-Wide Training Since 1905  
Resident & Home Study Schools  
4000 S. Figueroa St., Los Angeles, Ca. 90037

Dept. 205-113

Big, Colorful NTS Guide to new opportunities in Electronics. Yours FREE!

NATIONAL TECHNICAL SCHOOLS  
4000 S. Figueroa Street  
Los Angeles, California 90037

Please rush me FREE Color NTS Electronics Guide & FREE lesson, plus information on course checked at right. No obligation. No salesman will call.

- MASTER COURSE IN COLOR TV SERVICING
- COLOR TV SERVICING (FOR ADVANCED TECHNICIANS)
- MASTER COURSE IN B&W TV & RADIO SERVICING
- MASTER COURSE IN ELECTRONIC COMMUNICATIONS
- PRACTICAL RADIO SERVICING
- FCC LICENSE COURSE
- MASTER COURSE IN ELECTRONICS TECHNOLOGY
- AUTOMATION & INDUSTRIAL ELECTRONICS
- COMPUTER ELECTRONICS
- BASIC ELECTRONICS
- AUDIO ELECTRONICS SERVICING

NAME \_\_\_\_\_ AGE \_\_\_\_\_

ADDRESS \_\_\_\_\_

CITY \_\_\_\_\_

STATE \_\_\_\_\_ ZIP \_\_\_\_\_

- Check if interested in Veterans Training under new G.I. Bill.
- Check if interested ONLY in Classroom Training at Los Angeles

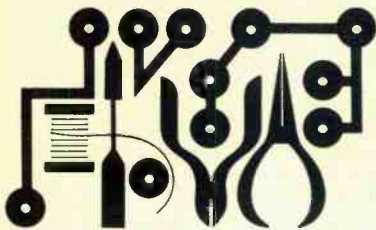

# Hobby Scene

## Solid-State Supply Problems.

**Q.** For the second time, my solid-state power supply has gone dead when I turned it on. There is absolutely nothing wrong with either the circuit or the components, yet both times the rectifier was gone. It is of the correct rating for the supply. What do I do?

**A.** When you first turn on a power supply (solid-state only) the large-valued filter capacitor looks like a dead short until it starts charging. Although solid-state rectifiers can take this kind of current, it is best to either insert some resistance in series to limit the current flow or to use a circuit like that shown here. The power supply is turned on as slowly as the capacitor is charged through  $R1$ . The higher the value

Have a problem or question on circuitry, components, parts availability, etc.? Send it to the Hobby Scene Editor, POPULAR ELECTRONICS Including Electronics World, One Park Ave., New York, NY 10016. Though all letters can't be answered individually, those with wide interest will be published.

of  $R1$ , the longer the turn-on time. This circuit is especially effective in audio power amplifiers.

## Low-cost Power Supply

**Q.** What's a good low-cost, general-purpose bench power supply—preferably using commonly available parts?

**A.** The circuit below can deliver between 5 and 16 volts at up to about 2 amperes. You can select the range by choosing the value of  $R1$ . Use an npn power transistor and heat sink for  $Q2$  and any high-gain npn signal transistor for  $Q1$ . Also, use at least 1-A rectifier diodes. The transformer can be any filament type from 16 volts or so up to say 24 volts. You can always juggle  $R1$  to make the voltage suitable. The addition of a d-c voltmeter across the output jacks, and a suitable current meter in series with the positive lead can convert this simple supply into a good bench instrument.

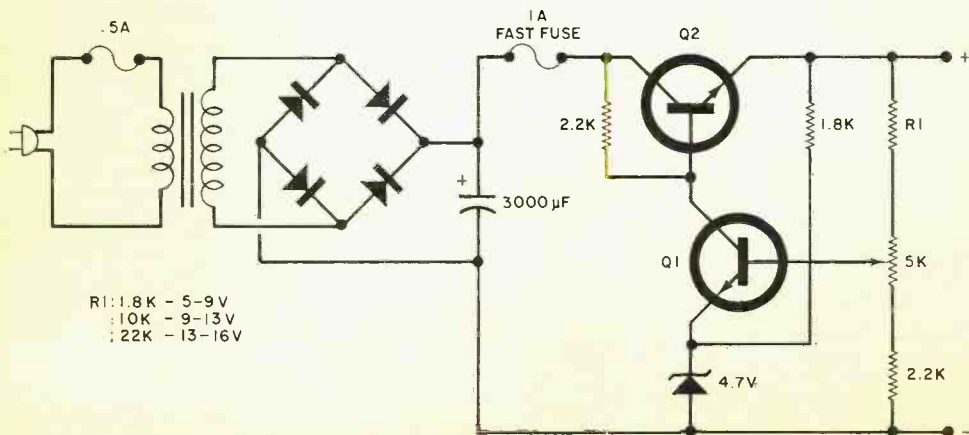
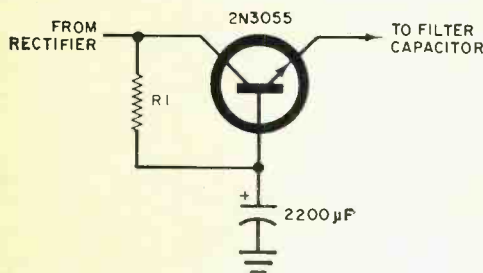

# Introducing the expensive digital multimeter that doesn't cost a lot.

The B&K Precision Model 281. A solid-state, lab-quality portable instrument that measures AC/DC voltage, current and resistance.

The state-of-the-art Model 281 shows readings on a large, clear, 2½-digit numeric display. It also has positive over-range and reverse-polarity indication. There's no need to switch leads. You can reverse polarity at the flick of a switch.

Model 281 readings are faster and more accurate than analog-type meters. Unlike hard-to-see needle indicators, you can read the large, illuminated numerals—including the decimal point—from a distance.

Featured are 26 ranges: five DC voltage, 100mV to 1000V, with 1% accuracy and 10 megohms input impedance; five AC voltage, 100mV to 1000V RMS, five DC current, 100  $\mu$ A to 1A; five AC current, 100  $\mu$ A to 1A; and six resistance, 10 ohms to 10 megohms.

With built-in protection, the 281 can't be harmed by overload. And for safety's sake, it has a three-line AC grounded cord.

Everything about the 281 says expensive—except the price.

Call your B&K distributor.

Or write Dynascan Corporation.

Very good equipment  
at a very good price. **B&K**

# \$169<sup>95</sup>

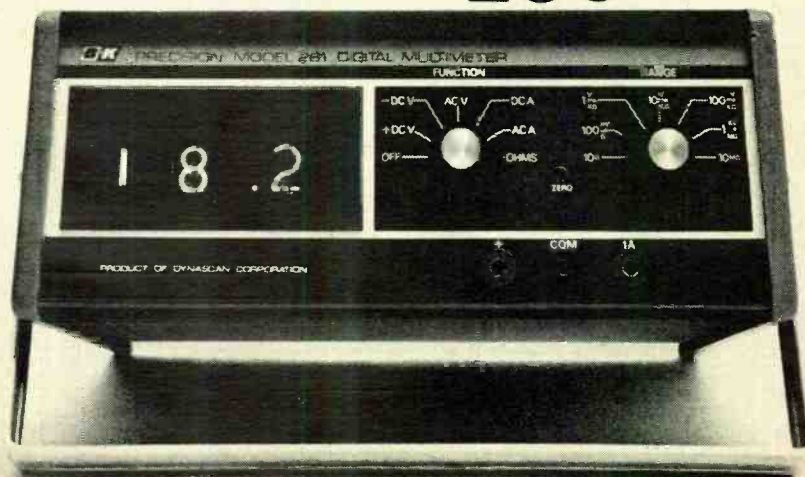

Product of Dynascan Corporation, 1801 West Belle Plaine Avenue, Chicago, Illinois 60613

CIRCLE NO. 2 ON READER SERVICE CARD



# MITS... makes the answer twice as easy.

Soon the world will be calculated by the metric system.

**The MITS 941M** handheld calculator converts to metric instantly — accurately — electronically.



## 41 FUNCTIONS

**LENGTH**  
in. → cm.  
cm. → in.  
ft. → m.  
m. → ft.  
yd. → m.  
m. → yd.  
mi. → km.  
km. → mi.

**VOLUME**  
in<sup>3</sup> → cm<sup>3</sup>  
cm<sup>3</sup> → in<sup>3</sup>  
ft<sup>3</sup> → m<sup>3</sup>  
m<sup>3</sup> → ft<sup>3</sup>  
yd<sup>3</sup> → m<sup>3</sup>  
m<sup>3</sup> → yd<sup>3</sup>  
mi<sup>3</sup> → km<sup>3</sup>  
km<sup>3</sup> → mi<sup>3</sup>

**AREA**  
in<sup>2</sup> → cm<sup>2</sup>  
cm<sup>2</sup> → in<sup>2</sup>  
ft<sup>2</sup> → m<sup>2</sup>  
m<sup>2</sup> → ft<sup>2</sup>  
yd<sup>2</sup> → m<sup>2</sup>  
m<sup>2</sup> → yd<sup>2</sup>  
mi<sup>2</sup> → km<sup>2</sup>  
km<sup>2</sup> → mi<sup>2</sup>

**LIQUID**  
oz. → cc.  
cc. → oz.  
qt. → liter  
liter → qt.  
gal. → liter  
liter → gal.

**MASS**  
lb. → kg.  
kg. → lb.  
oz. → gm.  
gm. → oz.

**TEMPERATURE**  
°F → °C  
°C → °F

**ARITHMETIC**  
+ - × ÷ %

**The MITS 908M** handheld calculator offers 8 functions (addition, subtraction, multiplication, division, square root, square, percentage, and reciprocal) and a handful of features.

## MEMORY can be used as:

- a constant
- a temporary storage
- register
- an accumulator

## Fixed and floating decimal (operators choice)

- Chain and mixed operations
- 8 digit readout — bright LED display
- 100% American made
- Algebraic entry system

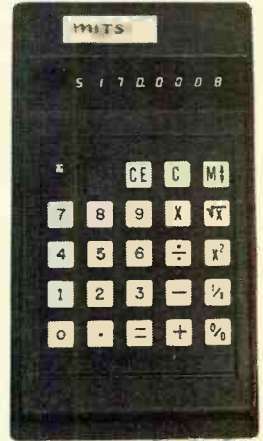

## Special Readouts

- Negative result
- Entry overflow
- result overflow
- low battery
- Math error

**SIZE** 5-3/4" x 3-1/4" x 1-1/2"

**908M PRICES\*** Assembled ..... \$129.95  
Kit ..... \$99.95

\*Prices subject to change without notice.

## FULL OPERATION MEMORY.

**Raises numbers to integral powers.**

- Chain calculation
- Full floating decimal
- Leading and trailing zero suppression
- True credit balance
- Algebraic entry system
- 8 digit read out

**INDICATORS** Sign • Low battery • Overflow • Math error

**941M PRICES\*** Assembled ..... \$149.95  
Kit ..... \$129.95

**SIZE** 146.05mm x 82.55mm x 38.10mm  
(5-3/4" x 3-1/4" x 1-1/2")

\*Prices subject to change without notice.

## ACCESSORIES

AC adapter for 117 VAC operation ..... \$6.95  
Carrying case (leatherette) ..... \$5.95

## WARRANTY

Full two-year warranty on assembled models, including parts and labor; on kit models; ninety-day warranty on parts.

• Available from your local Olson Electronics Dealer.

**MITS**  
**Micro Instrumentation & Telemetry Systems, Inc.**

6328 Linn, N.E., Albuquerque, New Mexico 87108  
505/265-7553 Telex Number 660401

Enclosed is a Check for \$ \_\_\_\_\_  
or  BankAmericard # \_\_\_\_\_  
or  Master Charge # \_\_\_\_\_  
Credit Card Expiration Date \_\_\_\_\_ Accessories  
Include \$5.00 for Postage and Handling  AC Adapter  
Model # \_\_\_\_\_  Kit  Assembled  Carrying Case

Please Send Information on Entire MITS Line.

NAME \_\_\_\_\_  
ADDRESS \_\_\_\_\_  
CITY \_\_\_\_\_  
STATE & ZIP \_\_\_\_\_

**MITS/** 6328 Linn, N.E., Albuquerque, New Mexico 87108 505/265-7553 Telex # 660401

CIRCLE NO. 21 ON READER SERVICE CARD

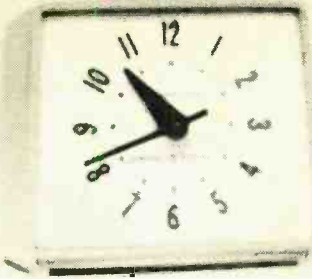

*New IC chip  
does double  
duty in  
this small  
clock with  
calendar*

# **BUILD A DIGITAL CLOCK-CALENDAR**



**T**HERE are lots of electronic digital clocks around, but how often do you see one that's a clock and a calendar too? In this low-cost (under \$50) clock, the time is displayed (using easily visible LED's) for eight seconds and the date for two seconds. Two discrete LED's separate the hours and minutes. During time display both are lit to form a colon, but only the lower one is lit during date display to separate the day and month.

The project takes full advantage of the small size and low power consumption of a "clock-on-a-chip" MOS IC. The total volume is less than 5 cubic inches and it can be operated from the ac power line or an internal or external source of dc.

The prototype was built as a desk model and four digits were used since, for most applications, knowledge of seconds is not required. It is housed in a satin-finished aluminum can, 2" in diameter and 3" deep. An 1/8" thick piece of smoked plastic, bent to support the clock at an easy viewing angle, gives the clock a modern appearance.

A slightly larger container (perhaps square or rectangular) could be used if six digits were required.

The 60-Hz power line is stepped down to the required 12-volt operating level in an outlet-mounted transformer. The clock's accuracy was found to be nearly 0.0003% when averaged over a period of several days. To get greater accuracy, it would be necessary to use a stable crystal-controlled time base instead of the 60-Hz power line for the time base. (This might be the case if six digits were used to display the seconds.) For portable use of the clock, a one-IC 60-Hz oscillator can be used for the clock reference.

Bear in mind that the only red indicators permitted in motor vehicles are danger warning devices. This rules out the use of the red LED's supplied with the kit. However, yellow and green LED displays are now available from experimenter sources such as Poly Paks at reasonably low unit-quantity prices. These can be used in motor vehicles. Some of the small incandescent displays will

*By W. L. Green*



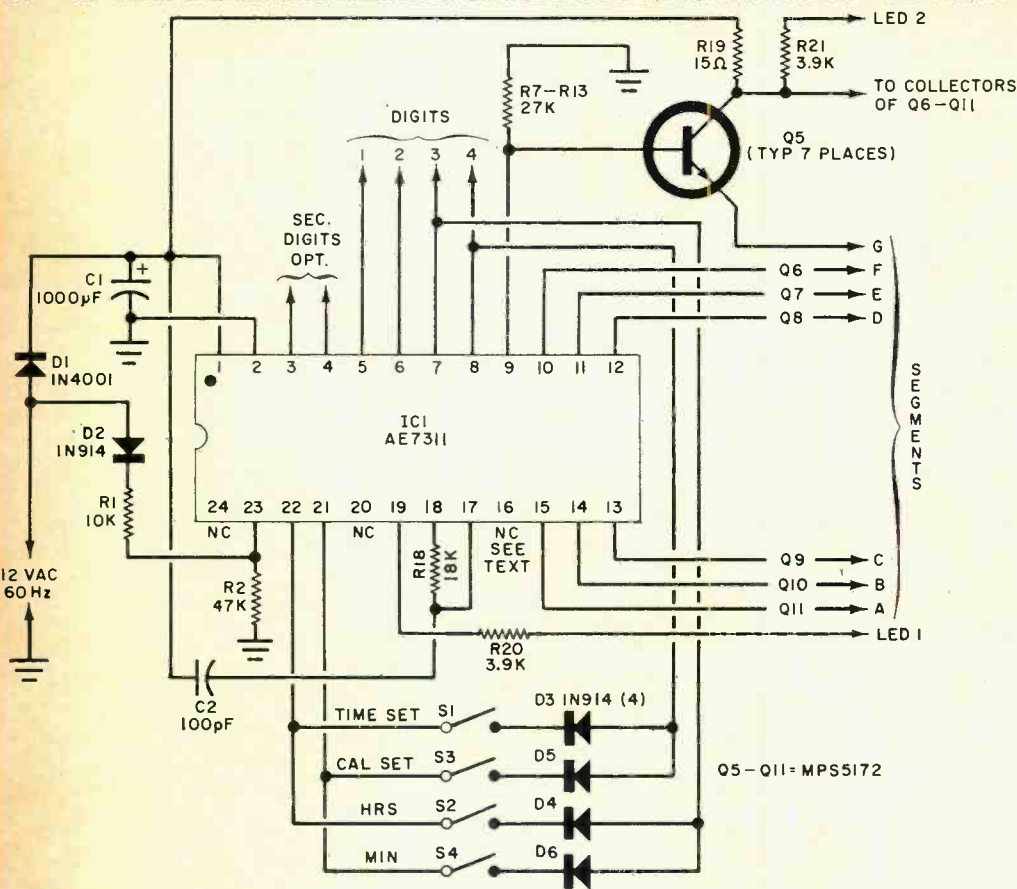

### PARTS LIST

- C1—1000- $\mu$ F, 15-volt electrolytic capacitor
- C2—100-pF capacitor
- D1—1N4001 diode
- D2-D6—1N914 diode
- DIS1-DIS4—Seven-segment LED digit display (FND70244 or similar; also, see text)
- IC1—AE7311 integrated circuit
- LED1, LED2—Discrete display (MLED-50 or similar)
- Q1-Q11—MPS5172 transistor
- R1—10,000-ohm resistor
- R2—47,000-ohm resistor

- R3-R13—27,000-ohm resistor
  - R14-R17—4700-ohm resistor
  - R18—18,000-ohm resistor
  - R19—15-ohm resistor
  - R20, R21—3900-ohm resistor
  - S1-S4—Spst normally open miniature push-button switch
  - Misc.—Suitable enclosure, red transparent plastic, wire, tubing, grommet, 12-volt transformer, hardware, etc.
- Note—The following are available from

also work satisfactorily in a vehicle, as their high current consumption is no particular problem. The power to the display should be supplied through the ignition switch to minimize the drain on the battery when the engine is off. Also, when used in an automobile, suitable filtering and regulation may be employed to prevent noise spikes from the electrical system from interfering with the MOS logic. In other portable applications a source of dc power between 11 and 14 volts is required.

**Construction.** The circuits of the clock are shown in Figs. 1 and 2. The use of a PC board is recommended. The foil patterns shown in Fig. 3 are for a four-digit clock. Etched and drilled boards for this as well as for a six-digit clock are available as noted in the Parts List.

In assembling parts on the boards, be sure to observe proper polarities on semi-conductors and capacitors. Don't forget the jumpers. When you come to the IC, first remove the black conductive sponge from



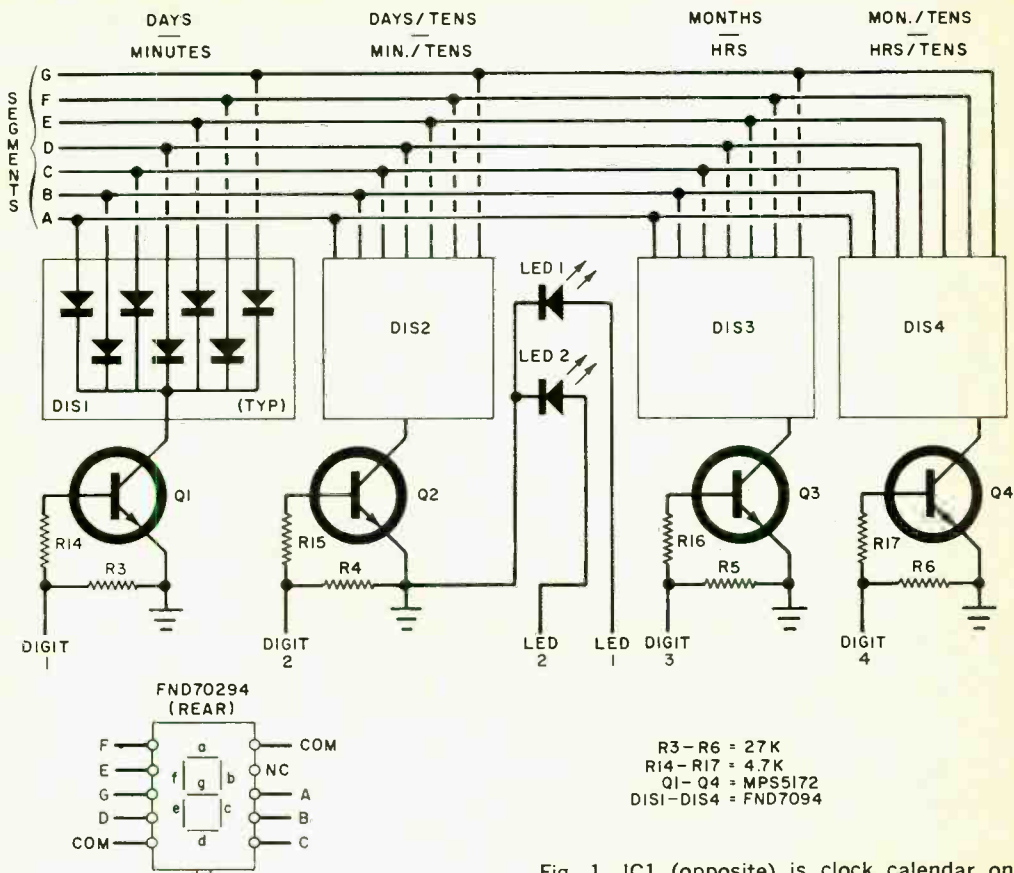

Fig. 1. IC1 (opposite) is clock calendar on a chip. The displays are seven-segment LED's with two discrete LED's to separate numbers.

Alpha Electronics, Box 1005, Merritt Island. FL 32952: etched and drilled PC boards for four digits (CC-4) at \$4.00; for six digits (CC-6) at \$4.50; complete kit except for case and transformer (CCK) at \$49.50; display digits (FND70244) at \$3.50 per digit; integrated circuit (AE7311) at \$25; integrated circuit (MC1455) at \$1.50; aluminum can and cover (CCCA1) at \$2.50; battery eliminator supply at \$4.50; all postpaid.

the pins of the IC. Be sure to locate the pins properly in the board and use a grounded, low-power soldering iron. Do not use a soldering gun. Handle the IC with care since a static discharge could ruin the chip.

Three components (C1, R20, and R2) are installed on the foil side of the PC board to keep the size of the board to a minimum. Install these three components after the IC is soldered in place. The row of pads along the edge of the PC board on which the transistors are mounted and the row of

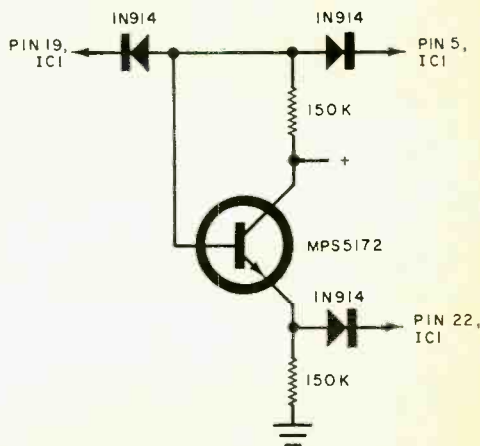
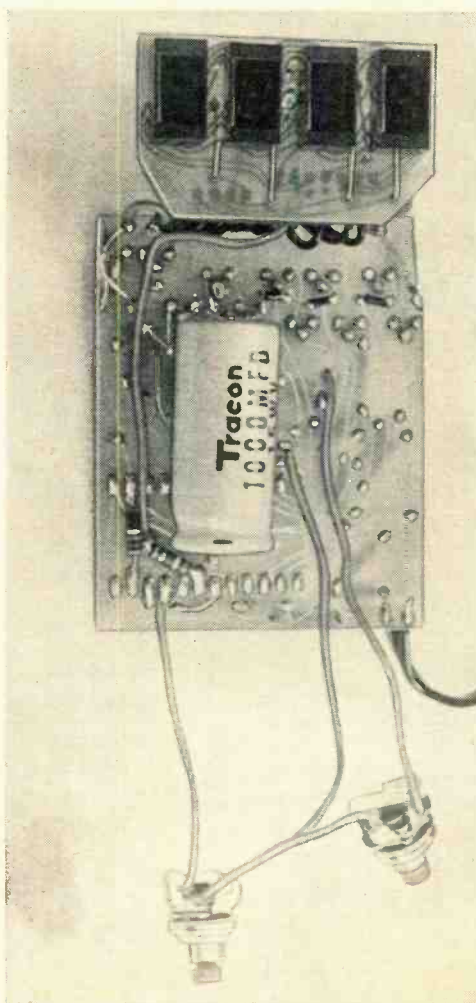
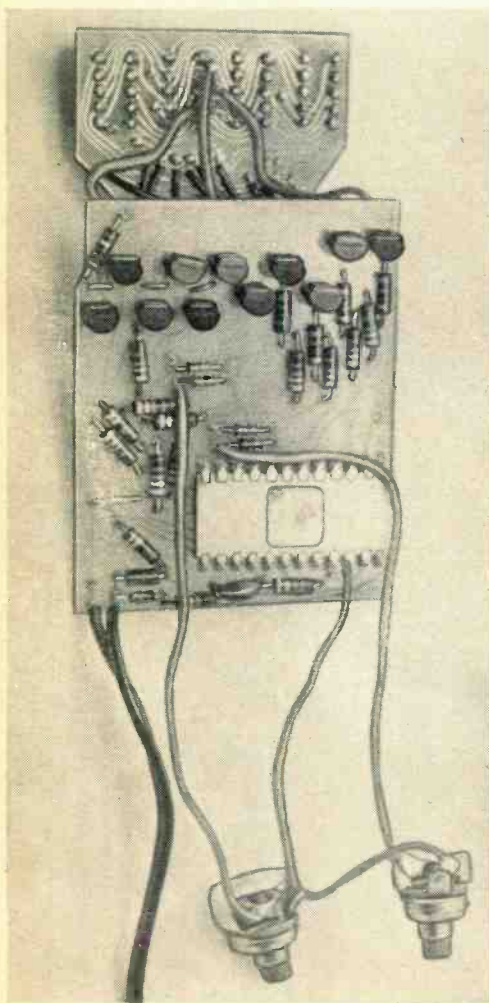

Fig. 2. Basic circuit can be modified with above if 24-hour clock display is desired.

pads on one edge of the display board do not have drilled holes. The connections between the boards will be made later with short, insulated wires as shown in the photos.

Install the jumpers on the display board and either the second or third display digit. The grooves on one narrow edge of the digits go toward the row of pads. Install the two discrete LED's with their cathodes (wide lead) in the two holes marked with a "C". They should be pushed into the board until their tops are flush with the top of the digit already installed. Solder them in place. Install the remaining digits and solder them in place. Tin the pads on the edges of the main and display boards.

In a suitable enclosure, cut a  $\frac{1}{2}$ " by  $1\frac{1}{2}$ " slot in the front cover for the display. Attach (with epoxy) a piece of red plastic behind the opening. Punch holes in the back of the enclosure for the time and date set switches and the power supply cord. Identify the switch locations as to their functions with press-on lettering. After making the necessary mounting brackets for the boards, solder insulated wires between the two boards, noting that the rows of pads match, with the main board component side up and the display board foil side up. The two leads to *LED1* and *LED2* and between the common circuits on each board are made as shown in Fig. 3. The wiring to the switches is also shown in Fig. 3.



Photos show how the two boards are wired together with jumpers soldered to pads on the board edges. Setting switches are wired two on one side and two on other.

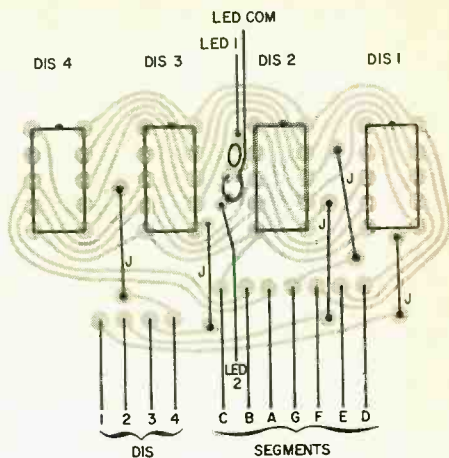
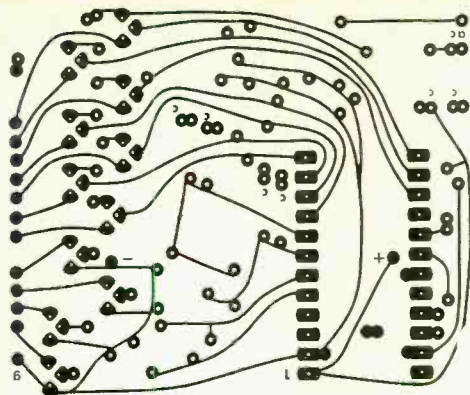
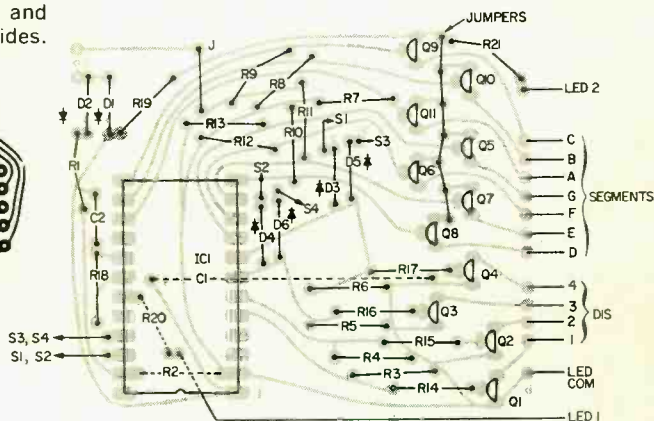
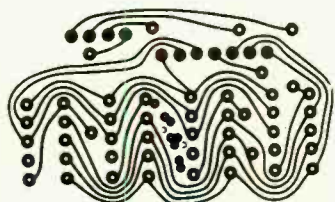

Fig. 3. Above and below are the foil patterns with layouts right. Jumpers between Q9, Q11, Q6, and Q8 alternate between board sides.



### HOW IT WORKS

The only parts of the circuit not on the single IC are the LED drivers and associated resistors, the timing capacitor and resistor for the multiplexer, the mechanical switches and diodes for time and date setting, and the clock reference oscillator. The 60-Hz reference is shaped and divided by *D2*, *R1*, and *R2* to provide the master clock signal, which is counted, multiplexed and decoded for application to the display in a seven segment format.

A pulse which is generated once every 24 hours by the tens-of-hours time counter, is applied to the input of the date counters. The day portion of the date counter supplies one pulse every 31 days, which is fed to the months counter, incrementing the month display automatically. The day and date can be externally and independently set by operation of switches *S1* to *S4*. The switches are isolated by diodes *D3* to *D6*. The time and date set input lines on the IC are encoded allowing a minimum number of pins on the IC. The signal on pin 19 of *IC1* alternates from a high state when the time is displayed to a low state when the data is displayed. This signal

drives *LED1* in the display to provide the colon or single dot.

The two resistors (*R20*, *R21*) in series with *LED1* and *LED2* are for current limiting. Transistors *Q1-Q4* return the common cathodes of the LED digits to ground when the information supplied to each digit's anode is correct for that digit. (This type of display operation is called multiplexing and allows fewer interconnects from IC to display, as well as lower current consumption.) Transistors *Q5-Q11* switch the display supply voltage off and on by command of the IC's segment outputs. The logic to switch from time to date display and back is also provided in the chip.

One additional pin is provided on the IC to blank the display. (thus reducing battery drain) when operated from a non-automotive battery supply. When pin 16 of *IC1* is connected to the positive of the power supply, the display is disabled. The clock can be operated on a 50-Hz power line if a diode is connected with its cathode to pin 21 and its anode to pin 5 of *IC1*. Twenty-four hour display of time can also be obtained if the circuit shown in Fig. 2 is used.



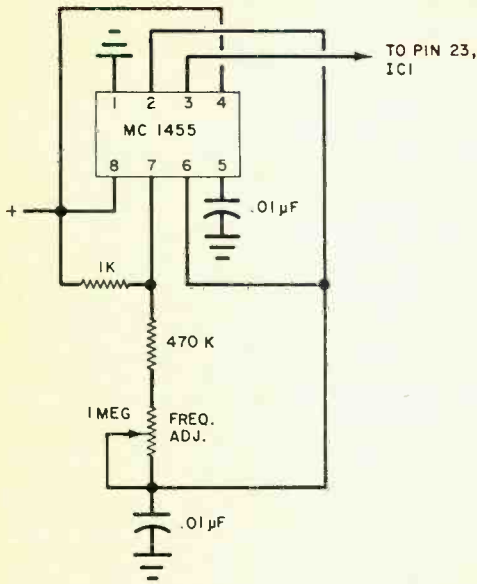

Fig. 4. Outboard clock is used for vehicle operation. Timing is set by using a counter.

The outlet-mounted transformer you use may be from a 9-volt, 150-mA battery eliminator power supply. The unit must be disassembled and the diodes and filter capacitor and resistors, if any, removed. Reconnect the cord directly across the secondary of the transformer and put the case back on. Install a grommet in the hole in the clock housing and run the cord from the transformer through it. Solder the cord to the main PC board.

**Checkout and Use.** When the power supply is plugged into the wall outlet, the display should show four eights, separated by a colon in the middle. To match the clock to WWV or another source, depress the TIME SET button when the time is at 00 seconds. This will start the clock counting. Depress the CALENDAR SET button, hold it down, and press the HOURS button to set the month and the MINUTES button to set the day. Release the CALENDAR SET button. The calendar is set first because the time resets to a.m. if it is in p.m. when the day is reset.

Now depress and hold the TIME SET button, and depress the HOURS button to set the hour and tens of hours, and the MINUTE button to set the minutes. The tens of minutes digit is set by depressing the HOURS and MINUTES buttons together, while holding the TIME SET button.

If all is working properly, the time should

be displayed for eight seconds and the date for two seconds. At midnight, the day should switch to the next day. For months with less than 31 days, depress the CALENDAR SET button and the MINUTES button until the correct day and month are displayed. This must be done before noon on the day following the last day of the preceding month. Also, when setting the hour when the 12-hour mode is used, remember that, to have the date advance properly at midnight, the hour must be set either to a.m. or p.m. Since no a.m./p.m. indicator is used, the best way to determine whether the time is a.m. or p.m. is to set the day on the calendar, then the time. If a.m., stop before 12 is displayed, or after it is first displayed for p.m.

If an enclosure such as that in the prototype is used, a plastic stand for it can be made by cutting a piece of plastic to size. Cut a hole for the face, and polish all edges with sandpaper and lamb's wool. Scribe a center line on the side of the plastic which will be on the inside. Heat the plastic, being careful not to overheat it, and bend to the proper angle. Small rubber pads may be cemented on the bottom.

If operation from a dc power source is required, construct the oscillator shown in Fig. 4. Connect the output from it to pin 23 on the IC. The power for the oscillator can be the same as that used for the main board. Adjust the oscillator's frequency to 60 Hz using a scope (60-Hz Lissajous pattern) or a frequency counter. If neither of these is available, the oscillator can be adjusted by trial and error, until the clock keeps the proper time.

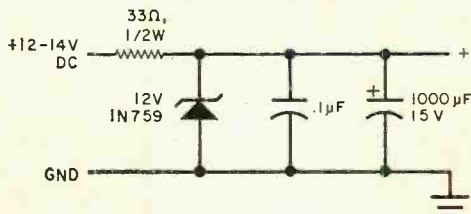
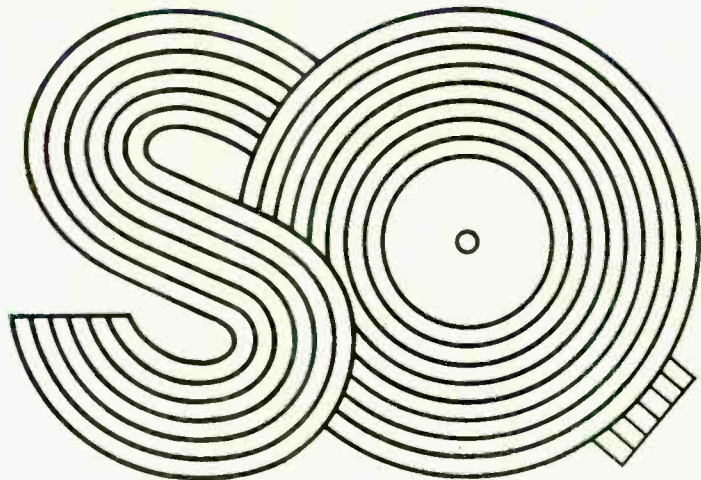

Fig. 5. Filtered power supply for vehicle use.

When the clock is used in a car or boat, use the filter-regulator circuit shown in Fig. 5. If batteries have short life or are rechargeable, increase resistor  $R_{19}$  to 100 ohms to reduce the drain on the batteries and use the display on-off switch previously mentioned. The larger resistor will dim the display slightly. ♦

# ADVANCES IN



## QUADRAPHONIC MATRIX DECODERS

*How they work and what's new*

BY JULIAN D. HIRSCH, Hirsch-Houck Laboratories

**S**INCE 4-channel matrixed phonograph records made their debut several years ago, a number of matrix systems have been proposed, only to quickly fade into obscurity. It is clear that to be successful a particular matrix must not only perform well, it must also find favor with one or more major producers. Failure to meet the latter requirement has caused some otherwise worthy matrixing proposals to disappear from the scene.

The CBS SQ™ matrix now incorporated in virtually every piece of 4-channel hardware sold in the United States owes much of its popularity to the wide availability of SQ-encoded discs. In the 4-channel marketplace, it is the SQ-encoded disc that currently dominates.

**A Reasonable Solution.** Matrixing offers a reasonable solution to the formidable task of recording four high-fidelity program channels in a standard stereo record groove and recovering them during playback, while

maintaining compatibility with stereo and monophonic playback with standard stereo phono cartridges. This sounds like an impossible task and, in a strict sense, it is. Nevertheless, through a variety of ingenious electronic and psychoacoustic techniques, it is possible to come remarkably close to achieving the desired effect.

In a matrixed 4-channel recording, each stereo channel contains a composite of all four primary program channels. For example, the left channel of the encoded record can be described by the equation:  $L_T = aL_F + bR_F + cL_B/\alpha + dR_B/\beta$ . The  $L_T$  signal corresponds to the left channel output of a stereo pickup playing the record, and  $L_F$ ,  $R_F$ ,  $L_B$ , and  $R_B$  represent the left and right, front and back channels. The right channel,  $R_T$ , is encoded similarly.

An infinite variety of matrices are possible, since coefficients  $a$ ,  $b$ ,  $c$ , and  $d$  can have any value from 0 to 1, and the  $\alpha$  and  $\beta$  phase angles can each be anything between  $+180^\circ$  and  $-180^\circ$ . The designers

of the SQ system have chosen coefficients of 1, 0, -0.7, and 0.7, with  $\alpha$  and  $\beta$  phase angles of  $90^\circ$  and  $0^\circ$ , respectively.

On an SQ disc,  $L_T = L_F + 0.7 L_R / -90^\circ + 0.7 R_B$ , and  $R_T = R_F + 0.7 L_R + 0.7 R_B / 90^\circ$ . When an SQ disc is played in 2-channel stereo, each channel contains the corresponding front channel program, plus both back channels at a 3-dB lower level. One of the back channels is shifted  $90^\circ$  in phase. Since there is no blending of the front channels, a fully separated stereo program is heard, with all four original program channels represented.

For 4-channel playback, the  $L_T$  and  $R_T$  signals are processed by an SQ decoding matrix. Each channel is split into two parts and recombined with appropriate phase shifts and level modification to form four output channels. The outputs of the basic SQ decoding matrix only approximate the original four channels. The front channels are identical to the  $L_T$  and  $R_T$  programs. That is, when the back speakers of an SQ playback system are silenced, the full program is still heard in stereo through the front speakers. The signals fed to the back

speakers are  $L_B + 0.7 L_F / 90^\circ - 0.7 R_F$  and  $R_B + 0.7 R_F / -90^\circ + 0.7 L_F$ .

It is obvious that the playback matrix blends each of the original back channels with a portion of both front channels, reduced in level by 3 dB and with one of them shifted by  $90^\circ$ . The key feature of the basic SQ system is that it maintains full normal stereo separation between the two front channels and between the two back channels. On the other hand, there is only 3 dB of separation between the front and back on each side and across the diagonals.

It might appear, then, that the 4-channel effect would be severely diluted by the separation characteristics of the SQ system. Fortunately, the phase shifts, combined with appropriate recording techniques, produce a pleasing "surround-sound" effect with many recordings. It is undeniable, however, that considerable vagueness exists in the placement of the sound image. In particular, a center-front signal appears equally in both front channels and is down only 3 dB in both back speakers. The result is an amorphous spa-

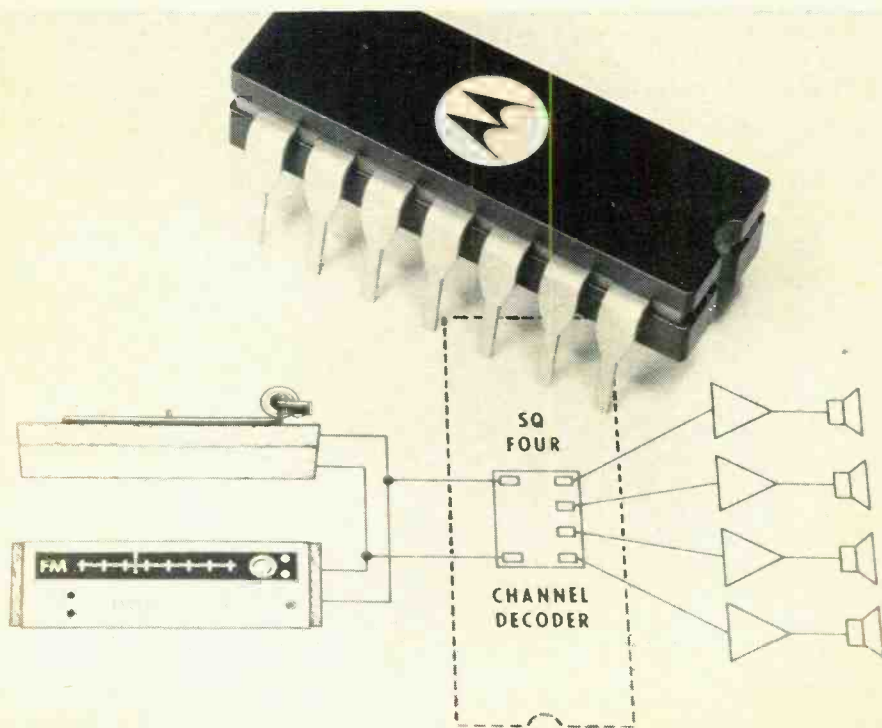

Motorola Semiconductor's monolithic four-channel decoder IC. The part is available to equipment manufacturers as MC1312 for home equipment and MC1313 for auto units.



tial pattern surrounding the listener, but with little or no specific directionality.

**The Logic Systems.** The subjective separation of the SQ decoding matrix can be enhanced by the application of a so-called "logic" system. For example, when a comparison of the front channel program levels with those of the back channels shows a predominance of front channel energy, a variable gain circuit can be used to momentarily reduce the back channel levels (or vice versa if the back channels predominate). The effect is an increase in the apparent front-to-back separation, typically from the normal 3 dB to about 10 dB. As with any dynamic variable gain system, the attack and decay time constants must be carefully chosen so that the gain change is not heard as such but only as a more positive directionality.

The basic SQ decoding matrix is used in some low-priced amplifiers and receivers, but most of the better-quality components incorporate some form of front-to-back logic. Its use is almost always stated in the equipment specifications.

A more advanced form of logic, referred to as "full logic" or "wave-matching logic," provides a more or less uniform separation of 15 to 20 dB in all directions. In the special case where a signal is intended to be present in only one channel, the full-logic system can be effective, producing an essentially "discrete" effect. More usually, however, there are some signals present in all four channels, and it is possible under some conditions to hear a sudden level drop in one channel as one of the others becomes dominant. With a combination of carefully chosen time constants and a skillful job of recording, these side effects can be minimized and often rendered inaudible. It must be realized that no logic system can produce any significant separation enhancement when all channels are in full use.

**SQ Decoders and IC's.** Early SQ decoders used discrete components exclusively. The basic matrix was quite simple and inexpensive, costing typically about \$50 or less as an "add-on" unit, but even the front-to-back logic system could double the cost of the decoder. The first commercial "full-logic" decoder to come on the market, the Sony Model SQD-2000 (since replaced by the SQD-2020), was a very complex device containing more than 100 semicon-



The Sony SQD-2020 full-logic decoder unit is now replacing the SQD-2000, the first commercially available full-logic decoder.

ductors and sporting a price tag of about \$300.

Recognizing that SQ decoding circuits could be made as IC's at a considerable cost saving, Motorola embarked on a program to develop such IC's under license from CBS. The first device was a basic SQ decoding matrix (MC1312); with the addition of a few external components, the IC forms an effective SQ decoder. It is interesting to note that Motorola suggests the addition of two blending resistors to reduce the left-to-right separation in the front and back channels. This reduction, not sufficient in itself to impair audible separation, has the desirable effect of increasing the front-to-back separation, partially correcting one of the limitations of the SQ system.

Concurrently, Motorola was working on IC's to replace the prohibitively expensive discrete circuits of the full-logic system. These have been made available to manufacturers for some time, although they have not yet appeared in a significant percentage of the commercial 4-channel equipment delivered to consumers.

The Motorola MC1315 IC combines the front-to-back logic and wave-matching logic systems on a single chip that requires only a handful of external components. An interesting feature of the IC is its "dimensional control," a single potentiometer that varies the amount of logic control action. A bright, acoustically hard room requires a maximum amount of logic control for the most discrete sound, but in a less reverberant environment, the logic action might become audible. With the dimension control, the user can adjust the logic action to suit the listening environment, the specific disc, and his own listening tastes.

The outputs of the MC1315 control the

channel gains through the MC1314 "power transfer module." The MC1314 is essentially a 4-channel variable-gain amplifier that operates under the control voltage outputs of the MC1315. The MC1314 also requires only a few external components, principally four potentiometers.

Three of the potentiometers control the balance between the  $L_F$ - $R_F$ ,  $L_B$ - $R_B$ , and front-to-back axes. The fourth control is a unique advantage of the Motorola IC system. Normally a 4-section potentiometer would be needed to control all channel gains simultaneously. This is an expensive component, and it is difficult to maintain reasonably good tracking between the channel gains as the control is varied over a wide range. The control-voltage vs gain characteristics of the MC1314 are carefully matched between channels so that a single-section pot can vary its gain over an 80-dB range, with an error between channels of not more than 1 dB.

The potential advantages of IC logic in SQ decoders can best be appreciated by the fact that three IC's, 28 capacitors, eight resistors, and five single-section pots can replace the more than 100 transistors and hundreds of passive components used in the original full-logic SQ systems. At press time, the all-IC decoders have not reached the market, but it is likely that they will have made their appearance by the time you read this. A substantial price reduction can be expected, bringing the advantages of full logic to a wider segment of the hi-fi population. (*We have also learned that Sony is working on their own IC chips for SQ demodulation.*—Editor)

**The Consumer's Standpoint.** It is difficult to be dogmatic about the necessity of advanced logic systems. Our experience in listening to a large number of SQ discs with decoders of all types has convinced us that the basic SQ matrix, while better than a 2-channel playback system, is not able to do justice to the capabilities of the SQ system. A full-logic decoder, on the other hand, can produce startlingly "discrete" effects, and only with certain combinations of listening positions and program material can its control action be detected.

The partial (front-to-back) logic system falls between these limits, although it is priced closer to the basic matrix than to the full-logic decoders built around discrete components. With a large part of available program material in which the 4-channel effect is used to supply a sense of ambience and a general "surround-sound" effect, a partial-logic system can sound about as good as a full-logic system. Without an A-B comparison between the two, it is unlikely that most people would be aware of the limitations of the partial-logic system. Conversely, when full-logic action is available, one frequently discovers that specific instruments or voices appear distinctly at one corner of the room instead of occupying a diffused, general area.

Our conclusion is that some form of logic control is virtually necessary for satisfactory SQ reproduction. However, the final choice between full or partial logic, or for any future advances in these areas, must be made on the basis of economics and personal taste. ♦

---

## MAKE LOW COST MONO/STEREO HEADPHONES

Lightweight earphones for private listening can be made from a pair of those earpieces that come with portable radios and tape recorders and some inexpensive materials. A length of spring steel wire and large-diameter plastic sleeving make up the headband. The only other materials you need are epoxy cement for fastening the earpieces to the headband wire, a mono or stereo cable with appropriate connector, and electrical tape to wrap around the soldered connections and serve as a cable strain relief. The whole assembly goes together as shown in the photo. For mono, the earpieces are wired in parallel; for stereo, wire them to separate cables.

—Marshall Lincoln



# Are you playing your records or ruining them?

If you're like most music listeners, you never think about your records after putting them on your record player.

You just sit back and enjoy the music.

Chances are you'd be less relaxed if you knew that your records might be losing something with every play.

Like the high notes.

It's something to think about. Especially when you consider how many hundreds or even thousands of dollars you have invested in your record collection. And will be investing in the future.

## What happens during play.

Even the cheapest record changer can bring its tonearm to the record and lift it off again. But what happens during the twenty minutes or so of playing time is something else.

The stylus is responding with incredible speed to the roller-coaster contour of the stereo grooves. This action recreates all the music you hear, whether it's the driving energy of a rock band or the richness of a symphony orchestra.

The higher the frequency of the music, the more rapidly the contours change, and the sharper the peaks the stylus has to trace. If the stylus bears down too heavily, it won't go around those soft vinyl peaks. Instead, it will lop them off. The record will look unchanged, but your piccolos will never sound quite the same. Nor will Jascha Heifitz.

## It's all up to the tonearm.

What does it take for the stylus to travel

the obstacle course of the stereo groove without a trace that it's been there? It takes a precision tonearm. One that can allow today's finest cartridges to track optimally at low pressures of one gram or less. For flawless tracking, the tonearm should be perfectly balanced with the weight of the cartridge, and must maintain the stylus pressure equally on each side wall of the stereo groove. And in order to maintain this equal pressure during play, the tonearm must not introduce any drag. This requires extremely low friction pivot bearings.

There is much more to the design and engineering of tonearms and turntables. But this should be sufficient to give you the idea.

## Dual: the music lovers' preference.

By now you probably understand why serious music lovers won't play their precious records on anything but a precision turntable. And the most serious of these people, the readers of the leading music magazines, buy more Duals than any other make of quality turntable.

If you would like to know more about Dual turntables, we'll send you lots of interesting literature, including an article on how to buy a turntable, and reports by independent test labs. Or better yet, just visit your franchised United Audio dealer and ask for a Dual demonstration. You will never have to worry about your records again.



United Audio Products, Inc., 120 So. Columbus Ave., Mt. Vernon, N.Y. 10553

Exclusive U.S. Distribution Agency for Dual.

**CIRCLE NO. 32 ON READER SERVICE CARD**



# PUT IT ALL TOGETHER

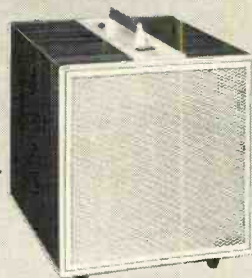
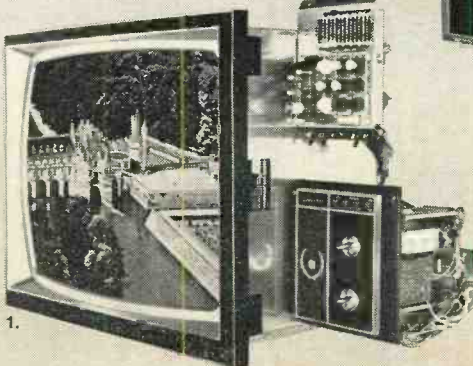
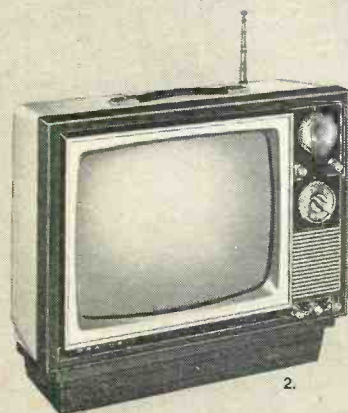

# Build Heathkit quality electronics and create a whole house full of personal accomplishments. Plus you'll often save considerably over the cost of comparable products, then save again because Heathkit designs include built-in self-service features.

Heathkit building is unbelievably easy. In fact, we stake our reputation on the idea that you can build any kit you see on these pages. Even if you have never assembled a kit product before. All you need are conventional hand tools and a soldering iron. The assembly manuals tell you how and when to use them — step-by-step from start to successful completion.

And of course every kit is backed up by the Heath Plain Language Warranty and our pledge that — whatever the problem, whatever the reason — "we won't let you fail".

**1. GR-900 25V Color Television** . . . . . \$599.95\* (less cabinet)  
The most advanced circuitry Heath has ever offered. Push-button power tuning locks-in on any 12 preselected UHF channels, all VHF stations. Along with the largest color screen in the industry, you get angular tint control to reduce flesh-tone change between channels, instant on, automatic fine tuning, adjustable tone control, hi-fi audio output jacks, and exclusive Heath self-service built-ins. Shipping weight, 125 lbs.

**2. NEW GR-104C Portable Black & White TV** . . . . . \$299.95\*  
Now the ultimate portable TV has positive detent tuning on all 72 UHF channels as well as VHF. All solid-state circuitry, plus brilliant 12V shell bond picture tube puts black & white entertainment anywhere. Plugs into wall outlet, or runs from 12-volt DC automotive system with adapter included — or becomes completely self-contained with optional rechargeable battery-pack base. Mailing weight, 35 lbs. Optional GRA-104-3 battery pack 42.95\*, 9 lbs. Outdoor Sun Shield 1.95\*, 1 lb.

**3. NEW GD-1003 Electronic Air Purifier** . . . . . \$139.95\*  
An easy-to-build 3-evening project. Removes 99% of airborne pollen and 95% of all other contaminants. Has 2-stage electronic operation; washable collector cell; replaceable charcoal filter; 2-speed fan; attractive walnut and gold finish. Purifies air in 20' x 20' room in minutes. Mailing weight, 46 lbs.

**4. NEW AS-1039 Ultra-efficient Speaker System** . . . . . \$44.95\*  
Just 5 watts drives it to booming volume. Uses 8-in. woofer in vented bass reflex enclosure and exponential rectangular horn tweeter with separate level control. Response, 70 to 15,000 Hz. Impedance, 8 ohms. Maximum input 25 watts. Walnut-tone vinyl covered cabinet and green, brown and gold grille board shipped assembled. Measures 21" H x 12" W x 10½" D. Mailing weight, 28 lbs.

**5. NEW AS-1042 Acoustic Suspension Speaker** . . . . . \$34.95\*  
Uses 8" long throw woofer and 3½" shallow cone/dome tweeter for flat frequency response from 40 to 18,000 Hz. External high-frequency control tailors the "highs" to your environment. Requires as little as 10 watts, can handle up to 25. 8 ohms impedance. Walnut-tone vinyl covered cabinet and brown and black grille board shipped pre-assembled. Measures 19" H x 10" W x 8¼" D. Mailing weight, 22 lbs.

**6. NEW GD-3209A Deluxe Garage Door Opener** . . . \$139.95\*  
Ultra-quiet, ultra-reliable screw drive system that you can build and install over a weekend. All electronics shipped

pre-assembled. Has ½-hp motor, automatic safety reversing plus adjustable slip clutch, automatic time delay light, external adjusting knobs for up/down travel. Includes 1 transmitter. GD-3209B, same as above with 2 transmitters, 154.95\*. Mailing weight, 66 lbs. For jamb & pivot doors and GDA-3209-2 adapter, 14.95\*, 7 lbs.

**7. NEW AD-1013 4-Channel Audio-Scope** . . . . . \$199.95\*  
A sophisticated solid-state oscilloscope designed for monitoring the home audio system. Displays stereo or 4-channel signals for separation, phasing, relative strength, multipath reception, center tuning, etc. Has exclusive triggered sweep for stable, jitter-free trace. Designed to complement Heathkit AR-1500 Receiver. Mailing weight, 19 lbs. AR-15 and AJ-15 owners, add ARA-15-1 adapter, 24.95\*, 1 lb.

**8. NEW GD-1018 Solid-state Lamp Dimmer** . . . . . \$7.95\*  
Controls lamp brightness from full illumination through mood-setting dimness to complete invisibility. For single and multiple lamps not exceeding 300 watts total. Extends filament life, eliminates the need for costly 3-way bulbs. A great starter kit. Can be assembled easily in 1 evening. Mailing weight, 2 lbs.

**9. NEW CM-1045 Small-engine Tune-up Meter** . . . . . \$39.95\*  
Solid-state tach/dwell/volt/ohm meter for all 2 and 4 cycle engines, 1 through 4 cylinders. In many cases permits checking entire small-engine ignition without tearing down flywheel assembly. Built-in tachometer has handy snap-on inductive pickup, reads from 0-3000, 0-15000 rpm. Completely portable, uses 3 1.5-volt batteries (not supplied). Mailing weight, 5 lbs.

**10. NEW HD-1234 Coaxial Switch** . . . . . \$9.95\*  
A neat accessory for the amateur radio enthusiast. Designed to switch one RF source to any one of several antennas or RF loads while grounding the unused outputs. Two switches can be used to switch up to four antennas/loads to four different components. Standing wave ratio is 250 MHz, 1.1:1 max. Power capability is 1000 W (2000W PEP). Mailing weight, 2 lbs.

**11. NEW GD-600 Photoelectric Lamp Switch** . . . . . \$5.00\*  
Low-cost home protection in a simple, enjoyable kit. Solid-state circuitry turns light on at dusk, turns it off at dawn. Adjustable sensitivity control sets switch to operate at various levels of light and darkness. Can be used with single or multiple lamps not exceeding 300 watts total. Easy, single circuit board design can be assembled in 1 evening. Mailing weight, 1 lb.

## Visit your nearest Heathkit Electronic Center... or send for FREE catalog

**HEATHKIT ELECTRONIC CENTERS** — ARIZ.: Phoenix; CALIF.: Anaheim, El Cerrito, Los Angeles, Pomona, Redwood City, San Diego (La Mesa), Woodland Hills; COLO.: Denver; CONN.: Hartford (Avon); FLA.: Miami (Hialeah); GA.: Atlanta; ILL.: Chicago, Downers Grove; IND.: Indianapolis; KANSAS: Kansas City (Mission); MD.: Baltimore, Rockville; MASS.: Boston (Wellesley); MICH.: Detroit; MINN.: Minneapolis (Hopkins); MO.: St. Louis; N.J.: Fair Lawn; N.Y.: Buffalo (Amherst), New York City, Jericho, L.I., Rochester; OHIO: Cincinnati (Woodlawn), Cleveland; PA.: Philadelphia, Pittsburgh; R.I.: Providence (Warwick); TEXAS: Dallas, Houston, WASH.: Seattle; WIS.: Milwaukee.



World's largest selection of electronic kits

<b>HEATH COMPANY, Dept. 10-11</b> Benton Harbor, Michigan 49022		<b>HEATH</b> <b>Schlumberger</b>	
<input type="checkbox"/> Please send FREE Heathkit Catalog.			
Enclosed is \$ _____, plus shipping.			
<input type="checkbox"/> Please send model(s) _____.			
Name _____			
Address _____			
City _____		State _____	Zip _____
* Mail order prices; F.O.B. factory.			CL-481R

**CIRCLE NO. 16 ON READER SERVICE CARD**

- **SMALL SIZE**
- **LOW POWER**
- **LOW DISTORTION**

# AUDIO POWER AMPLIFIER

BY MICHAEL S. ROBBINS

**O**UTPUT transformer-less (OTL) audio amplifiers are almost as old as audio power transistors. But if an audio amplifier is also output capacitor-less (OCL), several

advantages are gained. Presented here is an excellent OTL/OCL hi-fi amplifier designed to deliver 3 to 5 watts rms output power to an 8-ohm load. Its frequency response is a

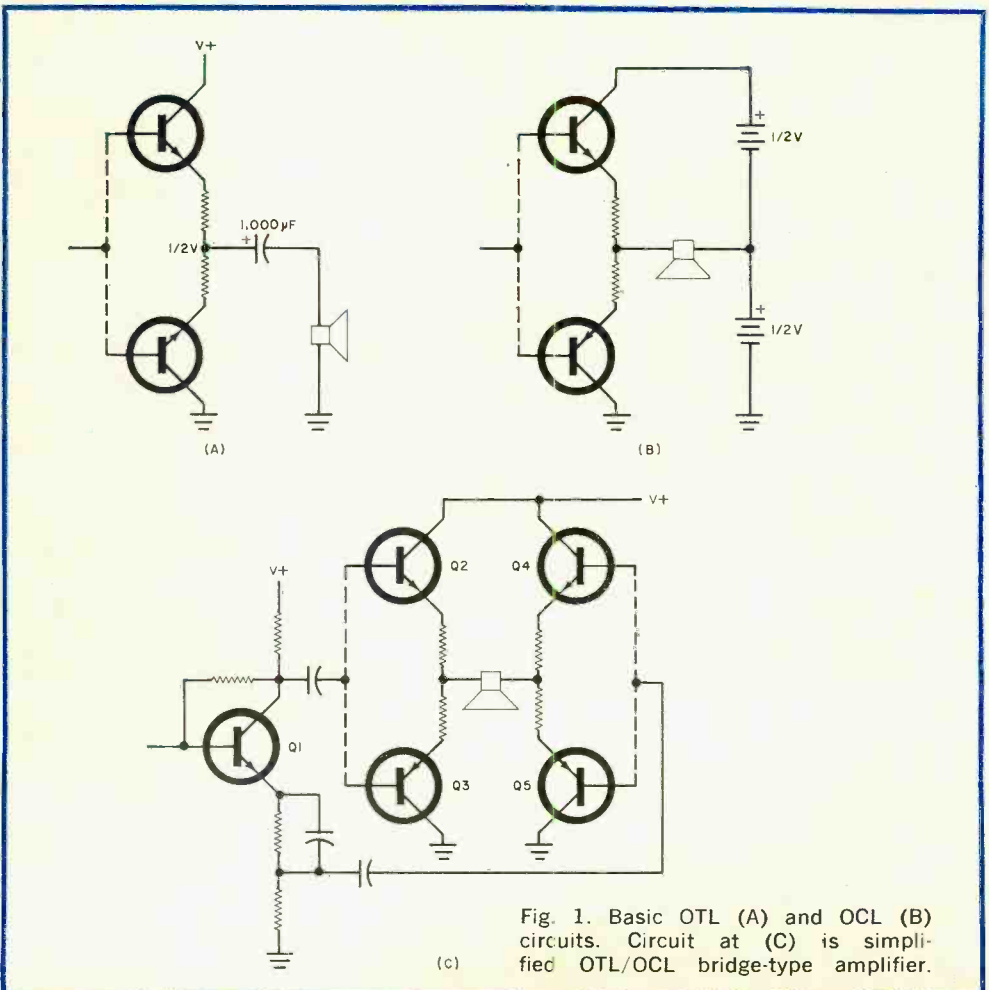

Fig. 1. Basic OTL (A) and OCL (B) circuits. Circuit at (C) is simplified OTL/OCL bridge-type amplifier.



flat  $\pm 0.5$  dB from 10 Hz to 20,000 Hz, and its total harmonic distortion, measured at a 1-watt output level, is less than 0.2 percent. Input sensitivity is 150 mV rms for full output.

State-of-the-art linear IC's are employed in the amplifier, reducing the outboard components required to a bare minimum. The whole amplifier, minus the power transformer, fits neatly on a 3"  $\times$  2" PC board.

**Theory of Operation.** A typical OTL stage is shown in Fig. 1A. The transistors and current-limiting resistors form a voltage divider across the power supply voltage. This results in a dc potential that is equal to half the power supply voltage that appears between the output and ground. To prevent this voltage from appearing across the speaker, a very large coupling capacitor is usually used as a dc blocker. Detrimental side effects

of this capacitor include decreased low-frequency response, phase shift, etc.

One way to eliminate the output capacitor is shown in Fig. 1B. This method is called "split-supply" and is often used in high-power amplifiers. A big disadvantage of the circuits shown in Figs. 1A and 1B is that the audio output potential (peak) across the speaker is limited to half the supply voltage. Therefore, the output power of these circuits can be no greater than a fourth of the output power of the circuit shown in Fig. 1C.

The Fig. 1C circuit illustrates a simplified bridge-type OCL amplifier. Transistor Q1 is a phase splitter, used to drive each half of the bridge amplifier. Since Q2 and Q5 conduct only when Q3 and Q4 are cut off, and vice versa, the maximum speaker output voltage is practically equal to the supply voltage.

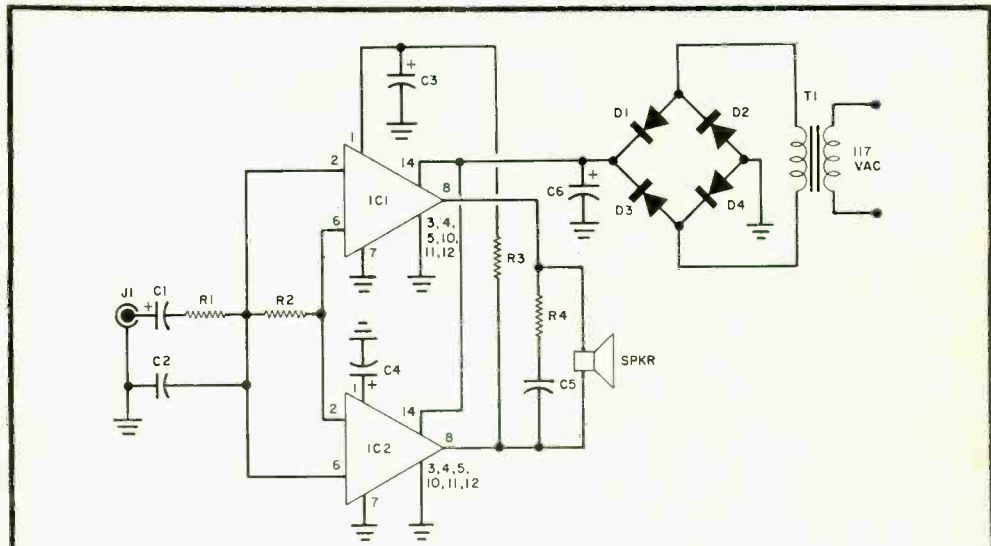

#### PARTS LIST

- C1—10- $\mu$ F, 25-volt electrolytic capacitor
- C2—100-pF ceramic capacitor
- C3, C4—10- $\mu$ F, 16-volt electrolytic capacitor
- C5—0.1- $\mu$ F, 25-volt ceramic capacitor
- C6—500- $\mu$ F, 25-volt electrolytic capacitor
- D1-D4—1N4001 rectifier diode
- IC1, IC2—LM380N integrated circuit (National)
- J1—Phono jack
- R1—100,000-ohm,  $\frac{1}{2}$ -watt resistor
- R2—470,000-ohm,  $\frac{1}{2}$ -watt resistor
- R3—2200-ohm,  $\frac{1}{2}$ -watt resistor (usually not required)

- R4—2.7-ohm,  $\frac{1}{2}$ -watt resistor
  - T1—12-volt, 1-ampere filament transformer
  - Misc.—Printed circuit board; heat sink made from 0.04-in. thick copper (see text); etc.
- Note: The following items are available from Caringella Electronics, Inc., P.O. 327, Upland, CA 91786: Etched and drilled printed circuit board, No. AMP-1PC for \$4.95; complete kit of above parts, No. AMP-1K for \$19.95 plus \$1.50 shipping and handling in U.S.A. (California residents, please add 5% sales tax.)

Fig. 2. Schematic diagram of a practical OTL/OCL hi-fi amplifier using IC's.

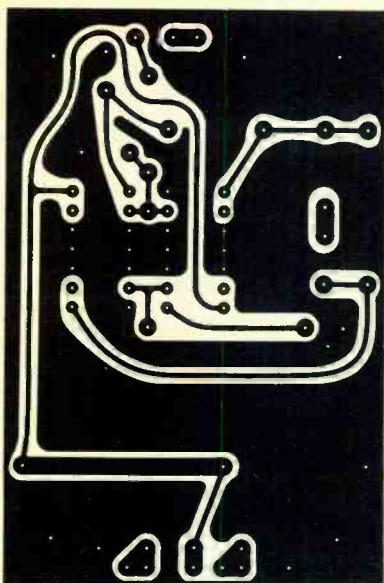

The circuits shown in Fig. 1 are provided for illustration purposes only and should not be used for actual amplifiers. A number of components have been omitted, including those required for proper biasing. A practical amplifier schematic diagram—our hi-fi OTL/OCL amplifier—is shown in Fig. 2. The transistors and most of their allied components have been replaced by a pair of power operational amplifiers. The differential input stage of each IC provides both an inverting and a non-inverting input. By connecting the inverting input of one IC to the non-inverting input of the other, no phase splitter is needed.

Capacitor C2 limits the high-frequency response of the amplifier to the audio range. Without C2, the amplifier is flat to about 200,000 Hz and could draw excessive current when amplifying high-frequency noise.

The gain of the amplifier is determined by the value of R2. With the value shown, about 150 mV will drive the amplifier to full output. By substituting a small 500,000-ohm potentiometer for R2, you can make your own sensitivity adjustments. However, if a potentiometer is used, shield its leads.

As with most direct-coupled amplifiers, a small dc offset voltage appears across the output. Resistor R3 (usually not required) is used to adjust the bias on IC1 and maintain the offset at a minimum.

The power supply shown in Fig. 2 will provide about 17.5 volts dc at 1 ampere. At this voltage, the amplifier will deliver about 3 watts of rms power to the 8-ohm speaker

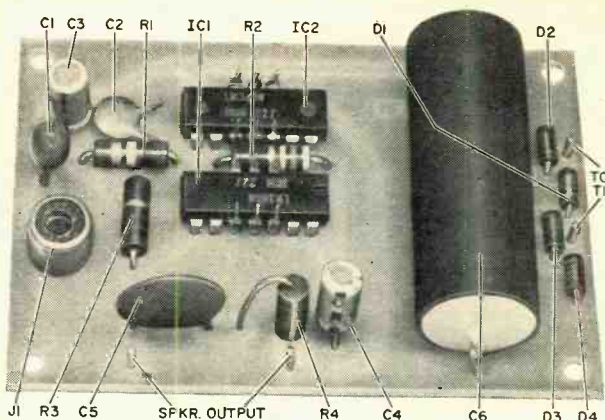

Fig. 3. PC foil pattern and photo of parts layout.

—more than enough to drive an efficient speaker in a bass-reflex enclosure. By increasing the supply potential to 22 volts, however, the amplifier will deliver about 5 watts rms to the load. (Note: Do not go beyond 22 volts; this is the absolute maximum for the IC's.) A 12-volt battery or power supply will provide about a 1-watt output from the amplifier.

**Construction.** The complete amplifier, minus power transformer T1, can be assembled on a printed circuit board, the etching and drilling guide and component placement for which are shown in Fig. 3. Note the large ground areas used for shielding and heat sinking. If the amplifier is to be used with a 12-volt dc power supply, additional heat sinking is not required, and pins 3, 4, 5, 10, 11, and 12 of both IC's should be soldered to the PC board.

Assuming that you will be operating the amplifier at 17.5 or 22 volts dc, pins 3, 4, 5, 10, 11, and 12 should be carefully bent up-

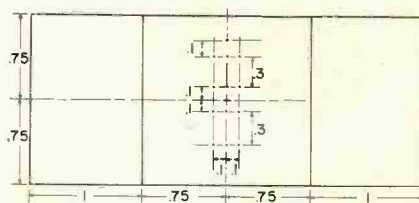

Fig. 4. Mechanical details of IC heat sink.

ward and fitted into the holes in the heat sink (see Fig. 4 for details on how to make the heat sink) and soldered in place. Be sure to solder a short bare copper wire from the hole next to pin 11 of IC2 on the heat radiator to the hole in the PC board. ♦

# COMPONENTS FOR ELECTRONIC MUSIC SYSTEMS

*Tone generators, keyboards,*

*and voicing techniques.*

**BY DON LANCASTER**

ANY electronic musical instrument can be viewed from a systems standpoint. Many of the features common to electronic musical instruments are shown in the block diagram of Fig. 1. This instrument could be an electronic organ, a synthesizer, or a computer-type composer. For the moment, let's just consider it as a "system" and take a closer look.

All electronic musical instruments begin with a means for generating tones. Next comes control of the presence of the tones and the formation of the *envelope*, or attack/sustain/decay characteristic, of the note. This is followed by a suitable alteration of the tone's harmonic content to obtain a particular *voicing* that will make it more interesting to the ear. Finally, the tone is amplified and delivered to either a live audience or to a tape recorder. If desired, along the way, special effects like amplitude and frequency variations, noise, echo, transients, or spectrum translation can be thrown in.

Instruments that generate only one tone at a time are termed *monophonic*, while those that have a multiple-tone capability are called *polyphonic* instruments. Through the use of a tape recorder, complex tonal structures can be built up with a monophonic instrument, not on a real-time basis.

**Tone Generation.** Tones can be generated either through the use of digital or analog circuits. One possible analog system provides for a separate oscillator for every note and ideally for every *voicing*, or *timbre*, of every note. Another analog method employs a *voltage-controlled oscillator* (vco) that can be set to any desired tone simply by presetting the proper input voltage level. Besides being movable in pitch, this latter analog method offers an easy way to do glides and sweeps, vibrato (FM), and random variations in the produced tones.

One approach to digital tone generators starts with the needed notes at the upper end of the musical range. Twelve notes are used if the traditional equally tempered scale is desired, but as many as 31 notes per octave are sometimes used in modern compositions. Binary dividers then provide octave-related 2:1 frequencies, generating as many tones as are needed. Each flip-flop divides the input frequency exactly in half; the entire audio spectrum down to the low bass notes can be readily generated in this manner.

A modern refinement starts with a single crystal in the 2-MHz region and derives all of the upper division notes by repeated divisions. This results in a fixed-



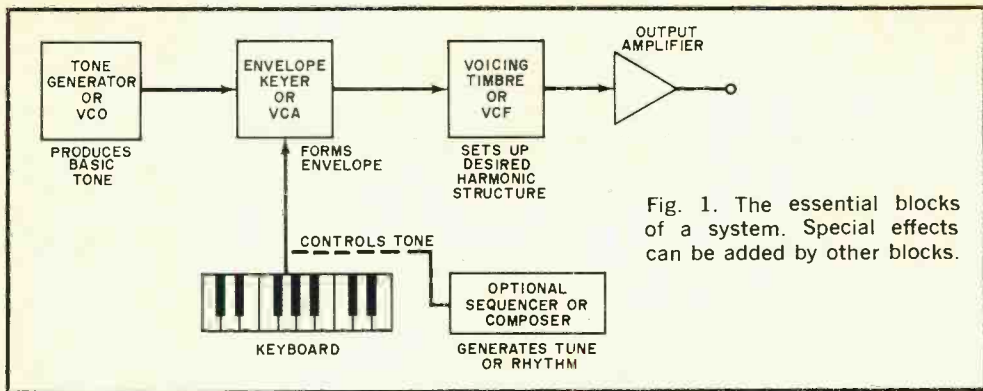

Fig. 1. The essential blocks of a system. Special effects can be added by other blocks.

tuned, permanently accurate instrument if crystal control is used. A single pitch adjustment is needed if a variable oscillator is used.

Another digital method starts with the 16th, 32nd, or 64th harmonic of the desired note. It then runs through a memory circuit that converts the harmonic samples of the note into an overall desired shape. At the same time, voicing is performed by the replication method. A final digital technique uses a computer or an elaborate memory and sequencer to perform all operations, specifying the voicing, tonal characteristics, frequency, and envelope simultaneously.

With most pitch systems, tones are generated in whatever waveshape is handy—usually a sine, square, or triangle wave. Occasionally, white or pink noise or some other structure is used. Only in the replication voicing systems does the generated tone look like what is ultimately desired. Simple sine, square, and sawtooth waves sound uninteresting. To give them color and appeal, voicing or timbre circuits are used.

**Tone Controllers.** Once tones are generated, a way is needed to control them so that only the notes wanted appear at the output. A keyboard is one type of on/off controller. Notes can also be digitally or computer controlled, in which case a *composer, sequencer, or rhythm box* is used.

In *direct* keyboards, the notes go through the keyboard's contacts. This is a traditional (translate "obsolete") route that can lead to crosstalk problems and may require many contacts for elaborate systems. It also greatly restricts the permissible envelope of the notes produces. The *indirect* keyboard, on the other hand, employs an electronic *keyer* or *voltage-controlled am-*

*plifier* (vca) controlled by the keyboard which, in turn, shapes and turns on and off the pitch envelope. The keyboard or controller works only with dc voltages that do not interact with each other and are readily combined, expanded, and controlled. Mechanically simple single-contact keys can be used in the keyboard, and things can be electronically expanded to whatever degree of control is desired.

**Special Effects.** Special effects introduced into the keyboard have to do with making the keys sensitive to pressure or velocity so that loudness can be controlled as well as the duration. In single-voiced systems, a memory must be provided after the key is released. In analog systems, a *sample-and-hold*, or *boxcar*, circuit is used, while in digital systems a latch-type memory is used.

Once the key is released, the decay portion of the note usually continues. The circuit must "remember" what note it is generating during the entire decay time; otherwise, the note would stop abruptly.

Coupling systems form another special effect, permitting one key to perform several functions simultaneously. Traditional organ couplers were used to add extra ranks of pipes to the voicing. The electronic equivalent allows the use of voicing associated with one keyboard or another or permits the addition of one octave higher or lower voices. In synthesizers, coupling can be added to gain chords, for scale translation, and to provide multiple voicing.

The keyer, or vca, turns the notes on and off in a precisely controlled manner. It is very important that the keyer change only the loudness of the waveshape and not distort it as a function of the desired output loudness. So, the keyer must always be-

have as a bipolar, electronically variable linear resistor—or as at least a two-quadrant multiplier. Keyers must be transparent to the tonal effects run through them.

If a note were simply turned on and off, it would sound phony and have some objectionable contact noise on the leading edge. The note that is allowed to build up rapidly (but not suddenly) and die down rapidly (but not instantaneously), as in Fig. 2A, would be about the very least acceptable. The rise time of the note is called the *attack*; its dwell time across the top is the *sustain*; and the drop-off at the end is the *decay*. Each of these times can be varied to obtain any desired sounds, ranging from a faithful imitation of a traditional instrument to “science-fiction” scores.

In Fig. 2B, the attack is rapid but not instantaneous. The sustain time is zero, and the decay time is very long. This is a form

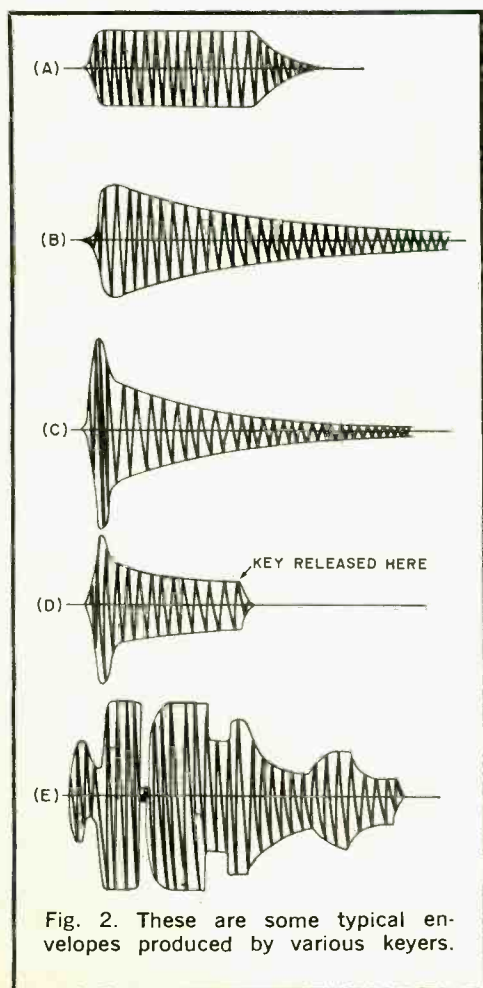

Fig. 2. These are some typical envelopes produced by various keyers.

of percussion that is greatly enhanced if the keyboard initiates the action but does not determine how long it lasts. A refinement is added in Fig. 2C to gain realism. When a bell is first struck, its sound is very loud, rapidly dropping off to a much lower level. Finally, there is the same long decay of the percussion sound. All that has been done is to reshape the initial fallback, giving it a very fast decay time. If the bell were repeatedly struck, each individual strike would be distinctly heard, while repeated strikes with an envelope like that in Fig. 2B would be indistinct.

A piano-type action where the decay continues gradually until the key is released, then suddenly drops to zero, is shown in Fig. 2D. This is called *snubbing*, and the final time interval is called the snubbing or damping time.

The envelopes shown in Fig. 2A through Fig. 2D are easily accomplished by adding diodes, capacitors, and resistors between the kever and the keyboard. More parts are needed for the more complex envelopes. In Fig. 2E is shown the envelope obtained with an “unlimited” controller. The latter permits the generation of any waveshapes at all multiple attacks, sustains, echoes, etc. This can be done with computer control or with various special programmable envelope generators. Both techniques are very complex and costly when used with polyphonic instruments.

At this point, the keyed tones have the correct frequency and envelope shape, but they are still in the form in which they were generated—square, sine, or sawtooth waves. To obtain the desired sound, the waveshape itself must be altered. This is accomplished with voicing, or timbre, circuitry.

**Voicing.** The quality of a note is determined by both its fundamental frequency and its harmonic content. For instance, a flute tone is predominantly fundamental with a little bit of second harmonic; a string tone is an ordered series of harmonics similar to a sawtooth; and a horn is essentially the same thing run through a resonant acoustical circuit so that certain harmonics are emphasized.

In general, voicing circuits can provide all notes with an identical harmonic structure, leading to an electronic or synthesizer sound. The harmonic structure can also be varied with frequency to yield a tonal structure more like most conventional musical

## AN ELECTRONIC BELL

Traditional twin-T and bridged-T bell circuits suffer from stability problems and are difficult to design. Here we show a better way of doing things. Push the RING button and the bell sounds.

Coarse frequency is controlled by the capacitors which must be kept nearly identical in value for best results. Fine tuning is accomplished with R1 and R2. The decay time is controlled by R3.

This same circuit is useful as a high-Q filter. Send the signal in at point X and take it out at point Y. The response is bandpass, and the Q is controlled by R3. Gain is controlled by R4. Unlike practically all other active filters, none of the parameters in this circuit interact. The Q, frequency, and gain are pretty much independent of each other and are simple factors in the design.

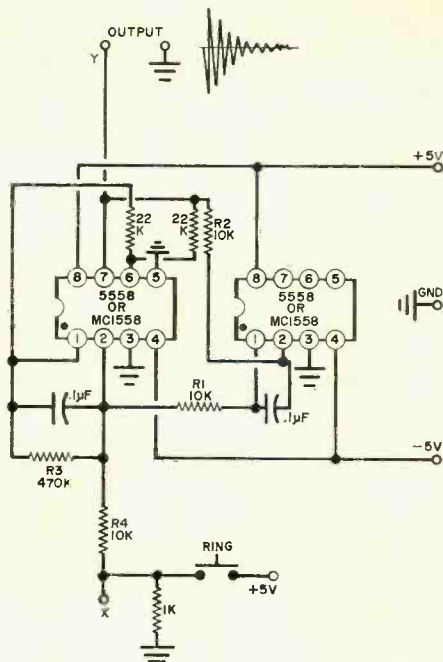

instruments. The phase of the harmonic is not too important, but its amplitude is. There are four general ways of building up the desired harmonic content—or timbre—of the tone:

In the *additive* method, fundamental frequency sine waves and the desired harmonics are added together in the proper proportions.

In the *subtractive* (formant) method, one starts with a waveshape that contains all of the harmonics. Then the harmonics are selectively removed, attenuated, or emphasized to obtain the desired effect. A linear sawtooth is an excellent choice because all the harmonics are present. The sawtooth can also be converted linearly back to a square wave by subtracting one-half of a sawtooth of double the frequency from it.

In the *nonlinear* method, diodes or other nonlinear devices are used to generate new harmonics for suitable alteration. This method is limited to monophonic systems because intolerable distortion would result in polyphonic systems.

In the *replication* method, something akin to a "picture" of the desired waveshape is used, set up on a mask via slide potentiometers or in a computer memory.

In many synthesizers, *voltage-controlled* (active) *filters* (vcf's) are used to empha-

size or attenuate harmonics selectively. This is a variation of the formant or subtractive method.

Special effects added after voicing can include echo and reverberation, frequency translation, etc. Frequency translation is done with sideband techniques and electronic multiplication. Control of gain and high-level amplification completes the electronic musical instrument.

More exotic sounds require more complex systems. For example, the voicing can be allowed to change throughout the envelope's time, perhaps letting the higher harmonics decay faster than the lower ones. Again, vcf is usually needed. Multiple voicing can be used for choral or unison effects. Two or three independent, but almost identical, voices are essential for piano-like sounds. Other complications can be introduced by making the overtone structure of the voice nonharmonic, as is the case with some stiff piano strings. Voicing can also be amplitude-dependent. Buzzes and sympathetic resonances can also be added.

Sometimes the voicing and envelope shaping are interchanged; other times they are part of the same circuit. The essential thing is to get the *product* of the desired envelope and timbre in an undistorted manner. ♦



# SIMPLE ELECTRONIC COMBINATION LOCK

*As an electronic lock, or as a game,  
this system is hard to beat*

BY JOE A. ROLF

**T**HIS space-age combination lock defies deception! Even the great escape artist Houdini, were he alive today, would probably back away from this lock before trying to open it. You can easily duplicate it for fun or practical use for less than \$20.00.

The lock is opened by pushing a correct combination of five pushbuttons in the proper sequence. There are 30,240 possible combinations and the odds of randomly selecting the proper one are better than three million to one. The only key that will work is a five-digit code carried in the owner's head; and, unless this combination is completed in ten seconds, the lock forgets what it has been told. Power is required only after the first correct digit has been selected.

**How It Works.** The circuit of the lock is shown in Fig. 1. It consists of a two-transistor timer ( $Q1, Q2$ ) and an SCR sequence detector. Five pushbuttons ( $S6$  through  $S10$ ) are used for the combination and five more ( $S1$  through  $S5$ ) defeat the circuit if they are operated.

Switch  $S6$ , which can be any of the ten buttons on the panel, is the first digit of the combination. Depressing this switch

momentarily charges capacitor  $C1$  and turns on  $Q1$  and  $Q2$  for approximately ten seconds.

Switch  $S7$  is the second digit of the combination. When  $S7$  is depressed,  $SCR1$  fires and applies voltage to  $R3$ . This furnishes a triggering voltage to fire  $SCR2$  when  $S8$  is depressed. The sequence continues through  $S9$  and  $S10$  until the relay driver ( $Q3$ ) is turned on.

An indicator lamp ( $I1$ ) can be included to show that the correct combination has been selected. The entire combination must be completed in the proper sequence in about ten seconds or the circuit automatically turns off. Then the sequence must be started again.

If any of the pushbuttons that are not part of the combination ( $S1-S5$ ) are operated, capacitor  $C1$  is discharged and the circuit is turned off. The combination can be changed at any time by changing the physical positions of the ten switches.

Of course, the design can be changed to use fewer than ten switches, with a consequent lowering of the total number of combinations. If you use only 4 buttons, for instance, with 2 digits in the combination, the total number of possible combinations is only 12. With 8 buttons and using 4 for



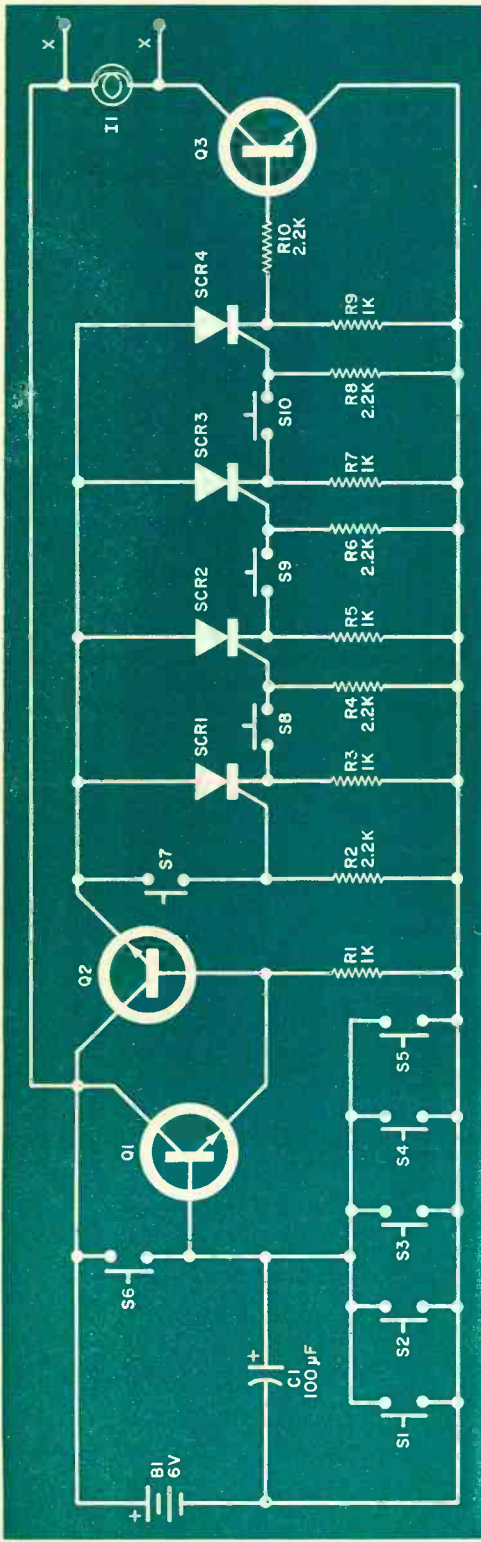

the combination, 1680 combinations are possible.

**Construction.** The circuit can be assembled on a PC board such as that shown in Fig. 2 or on a perf board. In the prototype, a 3-3-3-1 matrix of pushbuttons was mounted on the cover of a 4" by 4" by 2" aluminum box with the last switch (*S10*) containing a light. The PC board was bolted to the bottom cover of the box with a short cable connecting the board to the switches to permit easy service and change of combinations.

A second box of the same size was used to hold four series-connected alkaline penlite cells.

You may prefer to use smaller pushbutton switches which could be assembled to be mounted in a standard surface or wall junction box. This assembly could be located away from the PC board and battery with a 16-conductor 22-gauge shielded cable con-

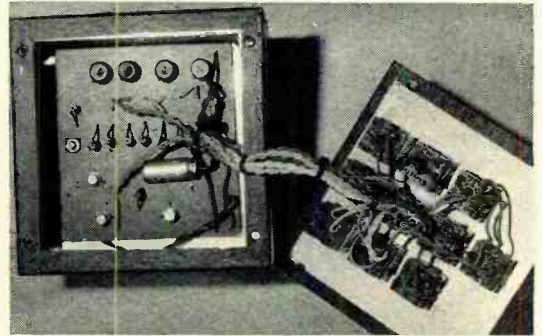

Photo shows how prototype of lock was wired.

### PARTS LIST

- B1—6-volt supply (see text)
  - C1—100- $\mu$ F, 15-volt electrolytic capacitor
  - I1—6-volt, 75-mA lamp (optional)
  - Q1-Q3—Transistor (GE-20, HEP 53, or similar)
  - R1, R3, R5, R7, R9—1000-ohm resistor
  - R2, R4, R6, R8, R10—2200-ohm resistor
  - SCR1-SCR4—Silicon controlled rectifier (GE-C6U, HEP320, or similar)
  - S1-S10—Single-pole, normally open pushbutton switch (*S10* can be illuminated)
  - Misc.—Aluminum utility box (BUD AU-1083 or similar), battery holders, mounting hardware, interconnecting cable, etc.
- Note—Electrically operated locks are available for almost any application from most large building supply and hardware outlets. The exact model you choose will depend on the application. One major manufacturer is the Trine Co., which offers a variety of models at prices from \$12.75 up.

Fig. 1. Five of ten switches make up combination. Others will open circuit.

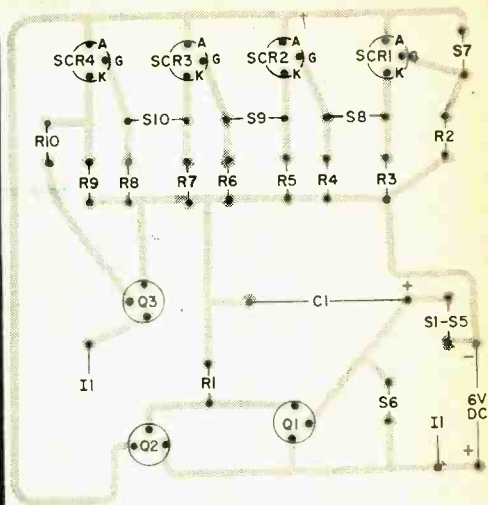
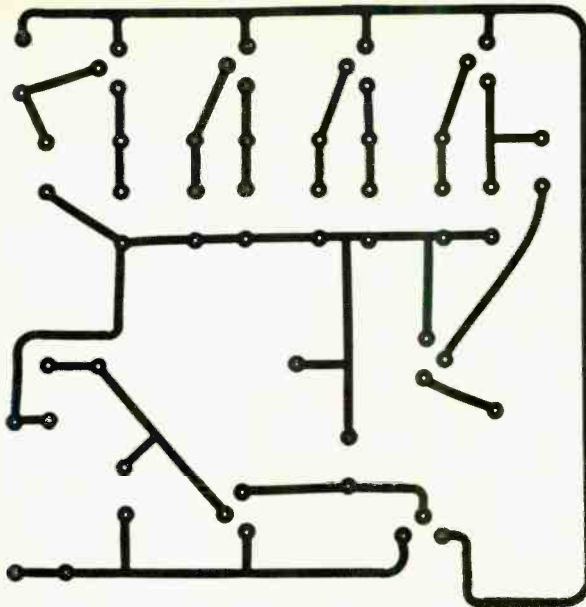

Fig. 2. You can use the foil pattern at left to make up a printed circuit or assemble components on perf board.

necting the components. The distance can be as much as 20 or 30 feet. Be sure to use shielded cable to prevent the lock from opening at odd times due to electrical noise pickup on the long cable run.

To operate a door lock, connect an external control relay across the points marked "X" in Fig. 1. Any single-pole, normally open, 6-volt dc relay can be used as long as it requires less than 0.2 amperes to energize the coil and the contacts can handle the lock current. For this purpose, the Potter & Brumfield KA5-DY or Guardian 200 relays are suitable.

**Power Supply.** One difficulty encountered when using an electronic lock is what to do about the power supply. If you use the ac power line, a power failure on the line can keep you locked out of the house. On the other hand, batteries go dead.

With the lock described here, since power is required only for short periods, a set of alkaline D cells will give satisfactory service if replaced frequently. Better yet, a 6-volt lantern battery can be used to provide service for several months of normal usage.

If you really want to be safe, you can build the simple float charger circuit shown in Fig. 3. This will keep the lantern battery well charged and will also provide power if the battery fails. If you use a 6-volt dc lock, you can also eliminate problems caused by ac outage.

**Troubleshooting.** To check out the timer, connect a voltmeter between the emitter of Q2 and the negative battery terminal. Momentarily depressing S6 should give a 6-volt indication for about ten seconds. Depressing one of S1 through S5 during this interval should cause the indication to go to zero.

Next measure the voltage across R3 after depressing S6 and S7 in proper sequence.

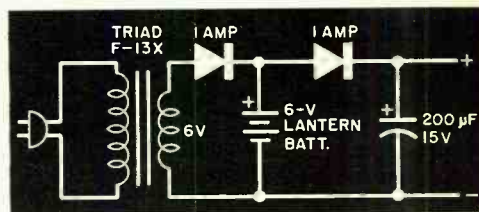

Fig. 3. Supply to protect against ac failure.

Voltage should appear at this point for about ten seconds. Repeat measurements across R5, R7, and R9, after depressing the proper buttons in sequence. In this manner, you can quickly determine which portion of the circuit is not working. A malfunction can usually be traced to a wiring mistake or a bad solder joint.

One final point, write down the combination you choose and store it away somewhere—just in case you should forget. Otherwise, you will have a lock that will be very difficult to open. ♦



# the IC “time machine”

BY WALTER G. JUNG  
Contributing Editor

*Once you understand how the  
555 IC timer works, there are many  
fascinating projects you can build*

ONE might think that the number of “standard” IC building blocks would be limited since, by definition, a standard device is one which is usable in a wide variety of applications. However, just in the last year or so, a new type of IC has shown definite signs of becoming a standard. Interestingly enough, this category of device was not represented previously by an IC specifically designed to fulfill its function. This chip is the “555” IC timer, a versatile, self-contained timing control circuit with the capability of astable (free-running) or monostable (one-shot) operation over a wide range of pulse widths from microseconds to minutes. Furthermore, it operates from a single wide-range power supply (+4.5 to +16 V), and, as another bonus, has an output current of 200 mA.

Timing functions can of course be realized by other IC techniques, such as digital or op-amp multivibrators. However, when high-current loads are to be driven or single-supply operation is a must, both of these

methods can be unattractive due to the number of components required. The picture changed, though, when Signetics introduced the first IC timer, the NE555, an 8-pin commercial device with a price tag in the range of \$1. The 555 has quickly established itself and is now available from a number of sources. There are also dual versions now on the market.

The usefulness of the 555 is enhanced by its impressive performance specifications. Consider, for instance, its initial timing accuracy, which is typically within 1% of the calculated value. This degree of accuracy is good for supply voltages of +5 or +15 V, since the 555 by design provides an output pulse width that is independent of the supply voltage. This means you needn't be concerned with regulated supplies to maintain stability. In addition, once it is set up, a 555 will hold its pulse width. For instance, pulse-width variation is typically only 0.005% per degree C of temperature change—which is quite stable. In

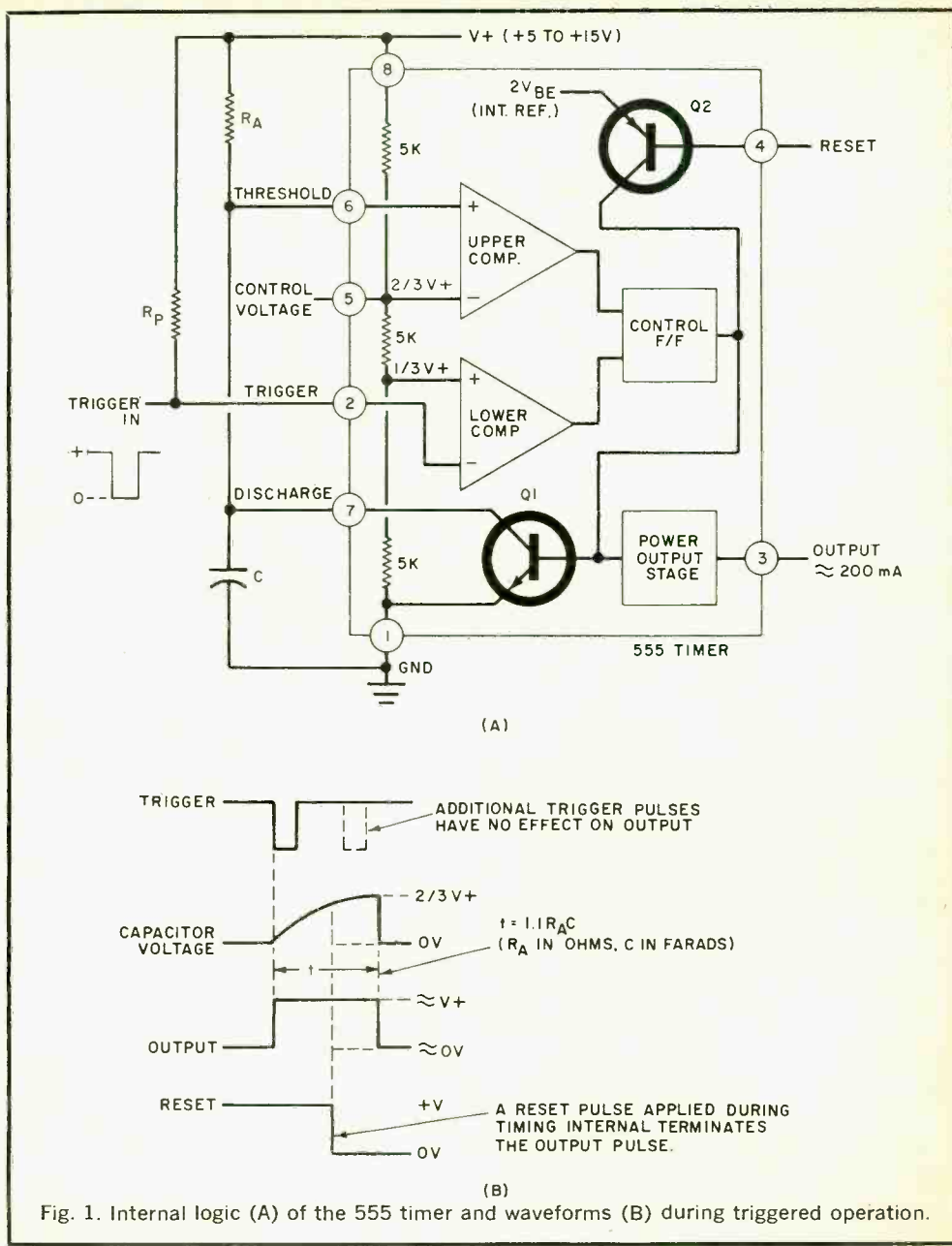

Fig. 1. Internal logic (A) of the 555 timer and waveforms (B) during triggered operation.

fact, the 555 can be considered to be temperature independent over the modest temperature environments of experimental projects. (This is true of course if the  $R$  and  $C$  timing components are also temperature stable.)

**What Makes the Timer Tick.** Knowing the basic principle of what it does, a look inside a 555 is helpful in determining how

it works and how to use it most effectively. The block diagram in Fig. 1A shows the 555's functional components and its basic mode of operation—as a triggered one-shot timer. The internal circuit, while actually fairly complex, has a minimum of external connections (8 pins).

The circuit provides the functions of control, triggering, level sensing, and discharge, with a power output stage which

delivers a high-level gate (near the  $V+$  level) for the duration of the timing interval. Yet the complete timing operation is determined by only two external components, resistor  $R_A$  and capacitor  $C$ .

**Monostable Mode.** In the standby state, the control flip-flop holds  $Q1$  on, clamping timing capacitor  $C$  to ground. In this state, the output (pin 3) is at ground level. The internal bias divider composed of three 5000-ohm resistors provides bias voltages of  $2/3 V+$  and  $1/3 V+$  to the upper and lower limit comparators, respectively. These two levels determine the voltage thresholds which, in turn, determine the timing interval.

Since the lower comparator is biased at  $1/3 V+$ , it stays in its standby state as long as the trigger input (pin 2) is held high (greater than  $1/3 V+$ ) by  $R_p$ . When pin 2 goes low, the lower comparator sets the flip-flop, turning off  $Q1$ , and the output

goes to its high state (near  $V+$ ). Since capacitor  $C$  is now unclamped, it charges exponentially (through  $R_A$ ) toward  $V+$ . After a period of time equal to  $1.1R_A C$ , the voltage across  $C$  reaches  $2/3 V+$ , which is the threshold of the upper comparator (pin 6). At this time, the upper comparator resets the flip-flop, which turns on  $Q1$ , discharging  $C$  to zero and returning the output to the low (standby) state.

The 555 monostable timing sequence is shown in Fig. 1B. In addition to the basic operation described above, there are two other points of interest. One is that any additional input triggers (shown dotted in Fig. 1B) during the timing interval will not affect the output. That is, once triggered, the cycle will time out regardless of a subsequent trigger. Trigger pulse duration should be less than the output pulse width. This can be accomplished by differentiation, which also improves noise immunity.

A second point is that the reset function, when activated by a low-level input at pin 4, turns on  $Q1$  and terminates the output pulse. The output is held low as long as pin 4 is low. The use of the reset input is optional. If not used, pin 4 should be tied to  $V+$  to avoid possible triggering from noise.

The 555's interesting feature of an output pulse width that is independent of supply voltage comes about from the fact that the timing voltage reference ( $2/3 V+$ ) and the charging rate of  $C$  are both proportional to the supply voltage. Consequently, variations in the supply affect both in a manner that cancels changes in the time interval.

Note also that the upper threshold voltage is made available at pin 5. This allows external control of pulse width if desired. If this feature is not used, it is recommended that pin 5 be bypassed to ground with a small (0.01 microfarad) capacitor to prevent noise problems.

**Triggered Monostable.** A triggered monostable circuit is shown in Fig. 2A. It includes the  $R1C1$  network, which prevents any possibility of mistriggering on positive edges. Values for  $R1$  and  $C1$  are not critical. Values for  $R_A$  and  $C$  are selected from the timing chart shown in Fig. 2B. For best performance, there are several guidelines that should be followed concerning  $R_A$  and  $C$ . Stay within the range of resist-

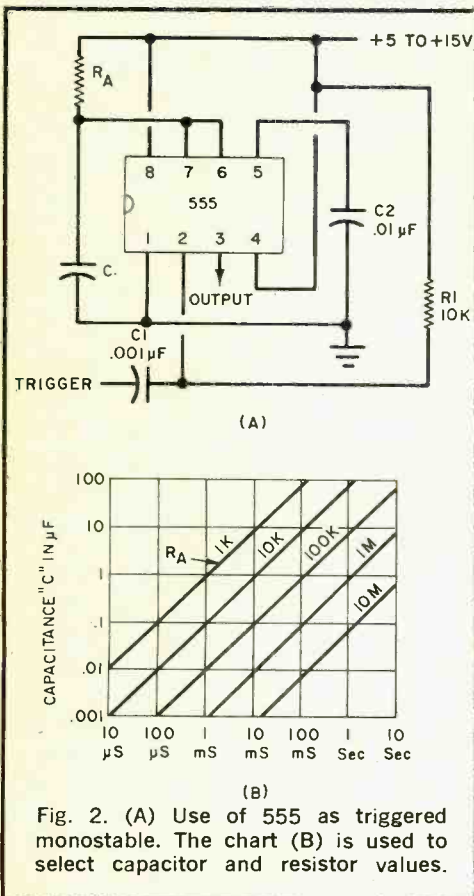
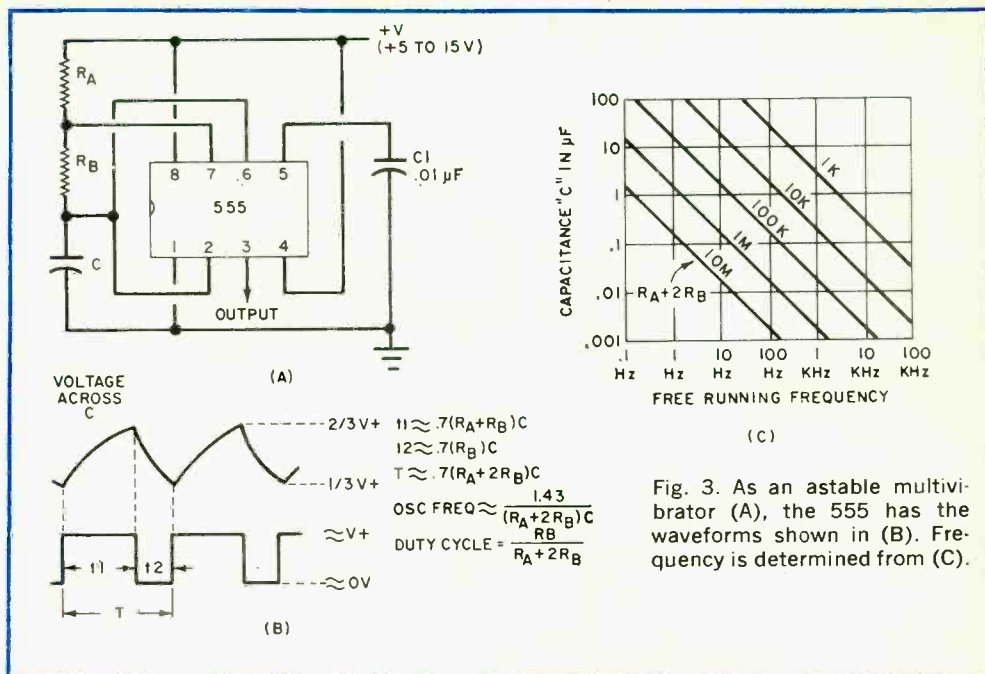

Fig. 2. (A) Use of 555 as triggered monostable. The chart (B) is used to select capacitor and resistor values.





ances shown, and avoid the use of large-value electrolytics if possible since they tend to be leaky. Leakage is, of course, more of a problem with long timing periods (large values of C), a "fact of life" which limits the upper range of timing. If electrolytic capacitors are necessary, tantalums should be used because of their low leakage. Voltage derating will also help minimize leakage current. With timing components of good quality, the 555 will provide accurate, stable pulses.

**Astable Mode.** The second basic operating mode of the 555 is as an astable multi-vibrator (Fig. 3A). Here the timing resistance is split into two sections,  $R_A$  and  $R_B$ , with the discharge transistor (pin 7) connected to the junction. Upon start up, C charges toward  $V+$  through  $R_A$  and  $R_B$  until the charge reaches  $2/3 V+$ , which triggers the upper comparator. The capacitor then starts to discharge toward ground through  $R_B$  until the charge reaches  $1/3 V+$ , when the lower comparator triggers. This starts a new charge cycle.

The capacitor is charged and discharged between the limits of  $2/3 V+$  and  $1/3 V+$ , as shown in Fig. 3B. The output state is, as before, high during the charge cycle and low during discharge. Timing equations for this mode are somewhat more

complex (Fig. 3B). However, values for the resistances and capacitance can be chosen by using Fig. 3C. Since the capacitor is charged by two timing resistors and discharged by only one, the output waveform is asymmetrical, not square.

Times  $t1$  and  $t2$  (and thus the frequency) are independent of  $V+$ , as in the monostable circuit.

**Types and Sources.** Type numbers for 555 timers from the various manufacturers are: Signetics, NE555V; National, LM555CN; Motorola, MC1455P1; Lithic Systems, LS555; Fairchild, NE555V; Intersil, NE555V. These are all single, 8-pin minidip devices.

Dual 555 units are: Signetics, NE556A; Exar, XR-2556CP; Lithic Systems, LS555-2. The Signetics and Exar devices are 14-pin dual inline units, while the Lithic Systems unit is 16-pin, with pins arranged identically to two "vertically stacked" 555's.

The following are available from Circuit Specialists Co., P.O. Box 3047, Scottsdale, AZ 85257: NE555V at \$1.25; LS555-2 at \$1.80. All prices are for individual units and postpaid.

*(We are planning some interesting applications and construction projects using the 555 timer chip. These will appear in upcoming issues; watch for them.—Ed.)* ♦

# CREI—the only home-study college-level training

## and now

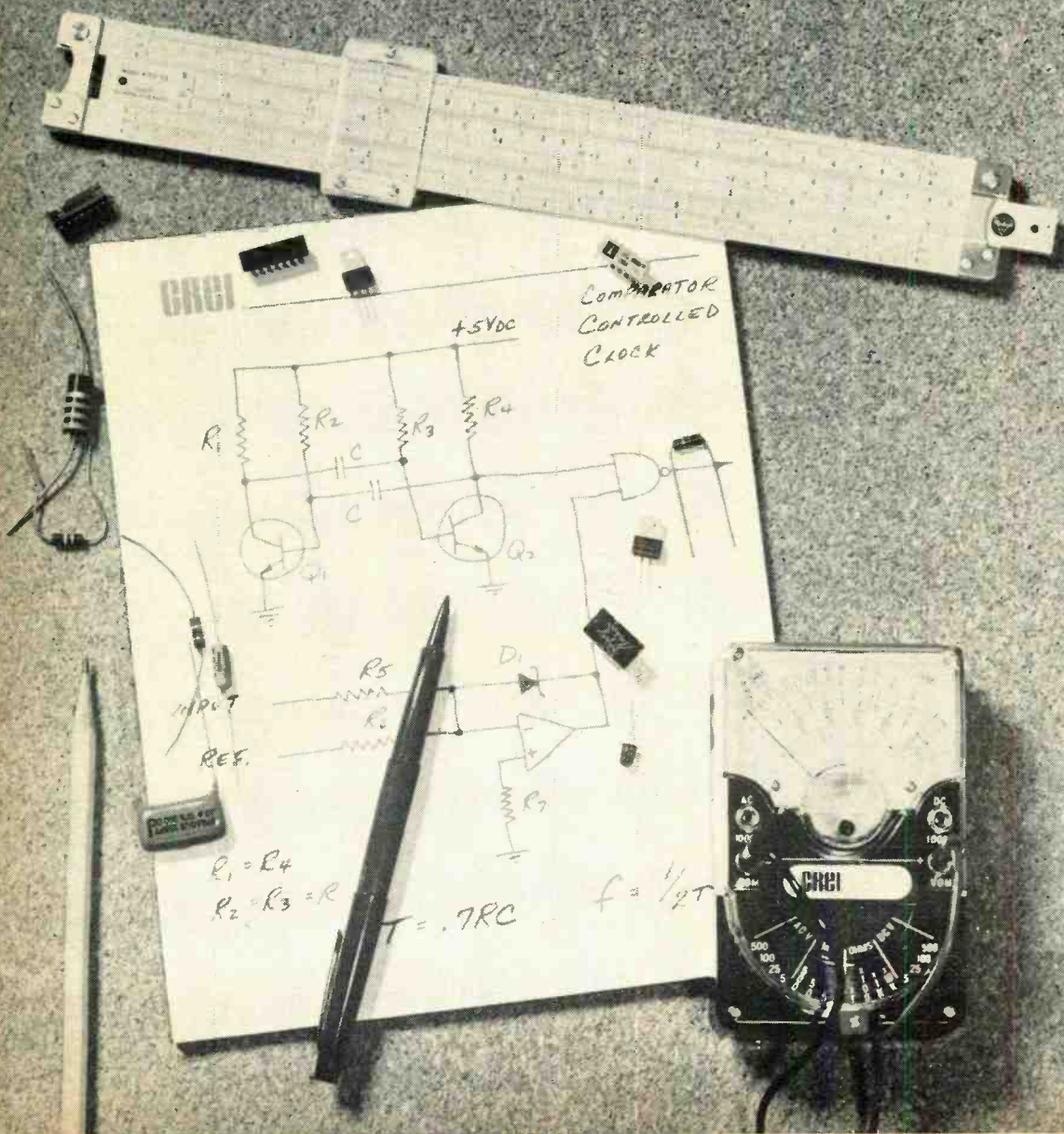



# program which gives you in electronic circuit design

## only CREI offers you a complete college-level Electronic Design Laboratory to speed your learning

**Electronic circuit design**—source of all new development in the application of electronics to new products and services. Without this skill, we would be unable to monitor the heartbeat of men in space. Without it, the computer revolution would never have occurred. And we would have yet to see our first TV show. Yet, *only CREI teaches electronic circuit design at home.*

### ELECTRONIC CIRCUIT DESIGN

A key skill which paces our nation's progress in countless fields—from pollution control to satellite tracking to modern medicine to exploring the ocean's depths. And beyond. A skill which *you* must have to move to the top in advanced electronics.

### CREI programs open up new worlds of opportunity for you.

In addition to electronic circuit design, CREI provides you with a full advanced electronics education in any of thirteen fields of specialization you choose. Communications, computers, space operations, television, nuclear power, industrial electronics—to mention just a few of the career fields for which CREI training is qualifying. With such preparation, you will have the background for a career which can take you to the frontiers of the nation's most exciting new developments. And around the world.

### This free book can change your life. Send for it.

If you are a high-school graduate (or equivalent) and have previous training or experience in electronics, then you are qualified to enroll in a CREI program to move you ahead in advanced electronics.



Send now for our full-color, eighty page book on careers in advanced electronics. In it, you will find full facts on the exciting kinds of work which CREI programs open up to you. And full facts on the comprehensive courses of instruction, the strong *personal* help, and the professional laboratory equipment which CREI makes available to you. All at a surprisingly low tuition cost.

### And when you have it, talk with your employer about it.

Tell him you're considering enrolling with CREI. He'll undoubtedly be happy to know you are planning to increase your value to him. *And he may offer to pay all or part of your tuition cost.* Hundreds of employers and government agencies do. Large and small. Including some of the giants in electronics. *If they are willing to pay for CREI training for their employees, you know it must be good.*

**Send for Advanced Electronics today. You'll be glad you did.**



CREI Dept. E1211D  
3939 Wisconsin Avenue  
Washington, D.C. 20016

Rush me your FREE book describing my opportunities in advanced electronics. I am a high school graduate.

Name \_\_\_\_\_ Age \_\_\_\_\_

Address \_\_\_\_\_

City \_\_\_\_\_ State \_\_\_\_\_ ZIP \_\_\_\_\_

If you have previous training in electronics, check here

Employed by \_\_\_\_\_

Type of Present Work \_\_\_\_\_

Veterans and servicemen, check here for G. I. Bill information

# CREI

**CAPITOL  
RADIO  
ENGINEERING  
INSTITUTE**

WASHINGTON, D.C. 20016





# REDUCING TVI ON 6-, 10-, and 11-Meter Bands

*Simple antenna filter  
does the job*

BY R. L. WINKLEPLECK

**T**HAT old bug-a-boo, TVI, is a never ending problem on and near the vhf bands. Dozens of filter designs have been described and most of them help to a degree.

Here's a filter that is easy to build and, because input and output are at opposite ends of the filter, it produces good attenuation of the unwanted frequencies. As shown in the schematic, the filter consists of only two stock coils and a variable capacitor and its performance is excellent. The insertion loss is under 1 dB and the 3-dB bandwidth is just a little over 2 MHz on six meters and 5 to 6 kHz on ten and eleven meters.

Construction is fast and easy. The coils and coax fittings are soldered to a sheet of copper flashing or a piece of copper-faced circuit board. This assembly is then fitted into a 3" by 5" by 7" metal enclosure which has been drilled to accept the input and output connectors and the capacitor shaft. The

three mounting nuts hold the assembly in the box. Use the full 3-inch length of the coils, unwinding  $\frac{1}{2}$  inch from each end. Solder one end of each coil to the capacitor and the opposite ends to the copper sheet. Position the coils so that the center terminals of the coax fittings can be soldered to the coils  $1\frac{1}{2}$  turns from their ground ends.

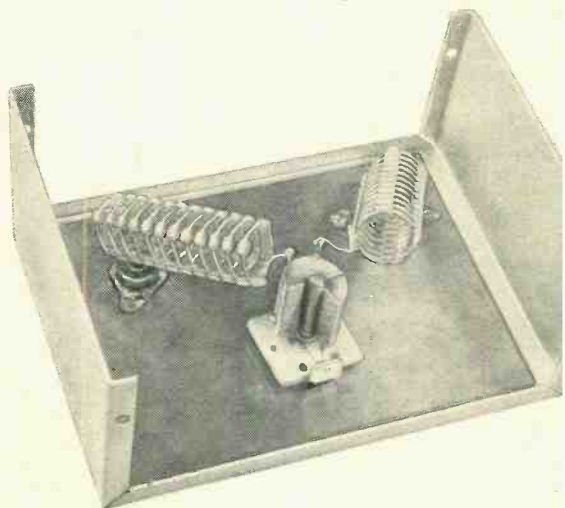

Three components are mounted on copper foil.

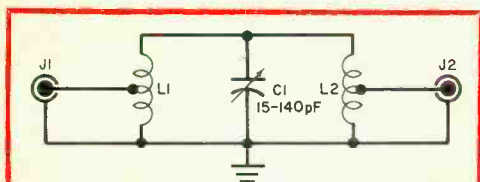

### PARTS LIST

- C1*—15-140-pF variable capacitor (Hammarlund HF-140 or similar)
- L1, L2*—Coil (Barker & Williamson 3009)
- J1, J2*—Coax connector
- Misc.*—3" x 5" x 7" metal enclosure, 4 $\frac{1}{2}$ " x 6 $\frac{1}{2}$ " flashing copper or PC board, knob, press type, etc.

Simple tuned filter consists of two stock coils and a variable capacitor.

The photo shows the arrangement, which places the coils so that there is little or no inductive coupling between them.

Placed in series with the antenna to the transmitter, the filter is tuned for maximum output or, more accurately, for minimum reflected power as indicated by an SWR bridge between the filter and the transmitter. If you move very far on any band, re-tuning the filter will peak up your signal. ♦

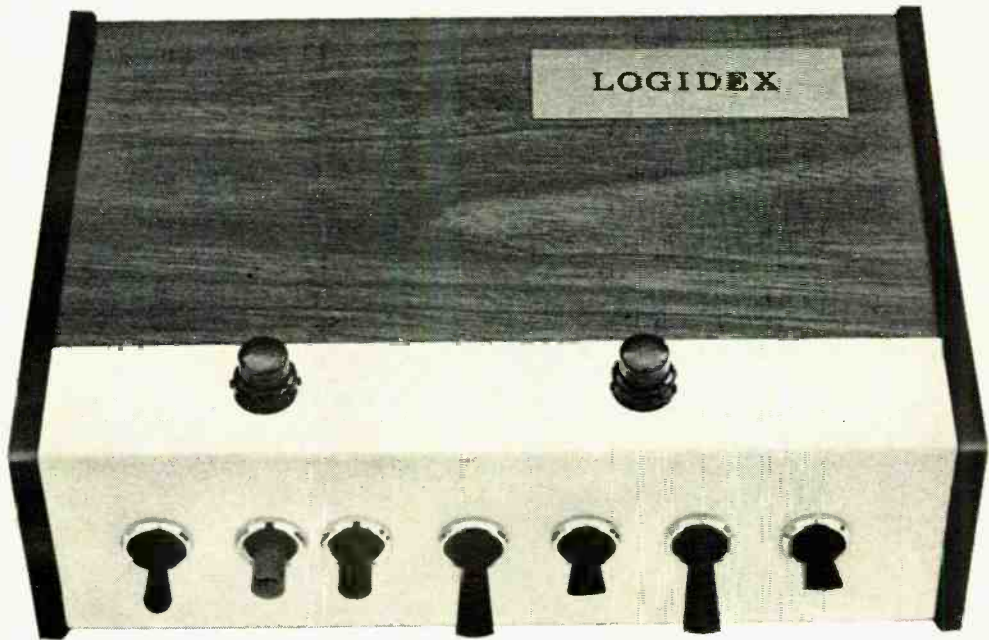

# LOGIDEX



**AN ELECTRONIC GAME FOR ALL SEASONS**

*Flashing light game for all ages uses digital logic*

BY HOWARD L. NURSE

**C**HILDREN are fascinated by switches and flashing lights, while adults are attracted to games of chance. Here is an electronic game you can build which bridges the gap and can be enjoyed by persons of all ages.

We call the game "Logidex," a combination of logic and dexterity, both of which are required to win the game.

The table describes some ways in which the Logidex can be used. The games are based on a player's ability to logically de-

code an unknown four-bit binary number as rapidly as possible with an array of four switches. Each time the player succeeds in finding the number with a correct combination of "up" and "down" game switches, a red light flashes for four seconds. After four seconds, the player presses the red switch to generate a new random number, and plays again. This sequence, which was initially started by pressing the green switch, continues for thirty seconds, as timed by a green flashing light.

CHASSIS  
CIRCUIT  
BOARD

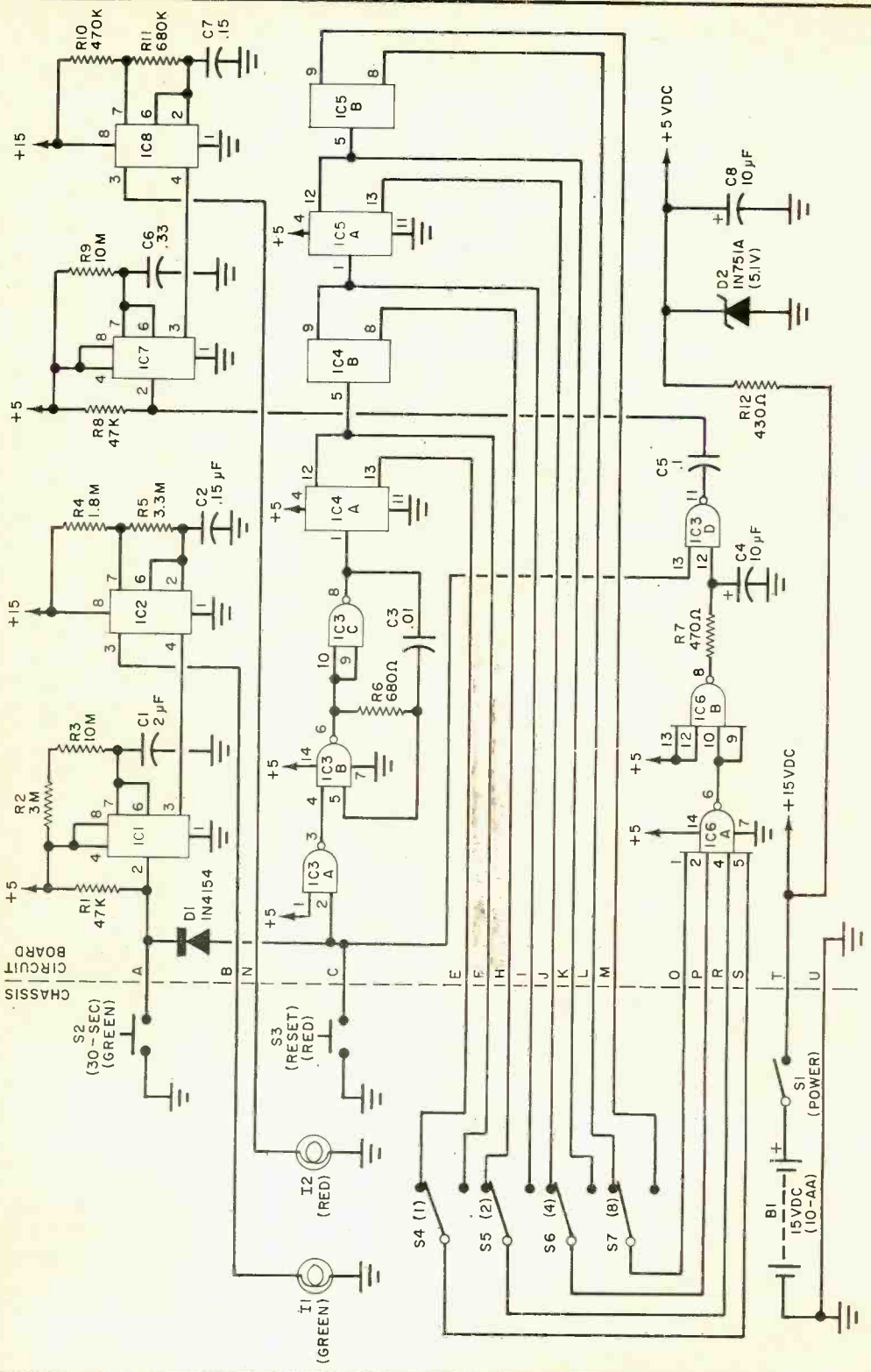



## PARTS LIST

- B1—AA cell (10)  
 C1—2- $\mu$ F, 200-volt capacitor (Sprague  
 "Orange Drop" or similar)  
 C2, C7—0.15- $\mu$ F, 100-volt capacitor (Sprague  
 "Orange Drop" or similar)  
 C3—0.01- $\mu$ F disc capacitor  
 C4, C8—10- $\mu$ F, 30-volt electrolytic capacitor  
 C5—0.1- $\mu$ F disc capacitor  
 C6—0.33- $\mu$ F, 100-volt capacitor (Sprague  
 "Orange Drop" or similar)  
 D1—Diode (1N4154 or similar)  
 D2—5.1-volt, 1N751A zener diode  
 I1, I2—12-volt, 60-mA lamp (red and green)  
 IC1, IC2, IC7, IC8—NE555V integrated circuit  
 IC3—SN7400/SN74L00N (see text)  
 IC4, IC5—SN7473/SN74L73N (see text)  
 IC6—SN7420/SN74L20N (see text)  
 R1, R8—47,000-ohm,  $\frac{1}{4}$ -watt, 10% resistor  
 R2—3-megohm,  $\frac{1}{4}$ -watt, 10% resistor  
 R3, R9—10 megohm,  $\frac{1}{4}$ -watt, 10% resistor  
 R4—1.8 megohm,  $\frac{1}{4}$ -watt, 10% resistor  
 R5—3.3 megohm,  $\frac{1}{4}$ -watt, 10% resistor  
 R6—680-ohm,  $\frac{1}{4}$ -watt, 10% resistor  
 R7—470-ohm,  $\frac{1}{4}$ -watt, 10% resistor  
 R10—470,000-ohm,  $\frac{1}{4}$ -watt, 10% resistor  
 R11—680,000-ohm,  $\frac{1}{4}$ -watt, 10% resistor  
 R12—430-ohm,  $\frac{1}{4}$ -watt, 10% resistor  
 S1—Spst switch  
 S2, S3—Spst, normally open pushbutton  
 switch (red and green)  
 S4-S7—Spdt switches (bathandle type)  
 Misc.—Battery holders, cabinet (Ten-Tec  
 JW-8), mounting hardware, etc.

Fig. 1. The game consists of four portions: a 30-second timer and flasher, a clock, a ripple counter, and a 4-second timer-flasher.

Fig. 2. Actual-size foil pattern and component installation. Observe all polarities.

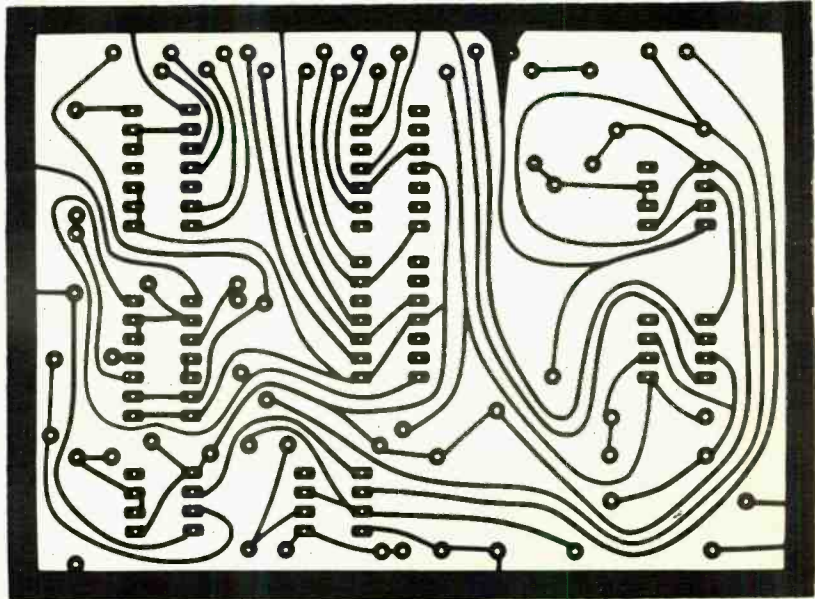

**How It Works.** The schematic for Logidex is shown in Fig. 1. The circuit can be divided into functional blocks as follows: a thirty-second timer and flasher (*IC1, IC2*); clock oscillator (*IC3B* and *C*); counter (*IC4, IC5*); qualification logic (*IC6, IC3D*); and four-second timer and flasher (*IC7, IC8*). In addition there are the power supply and the controls.

Pressing the green switch (*S2*) causes the

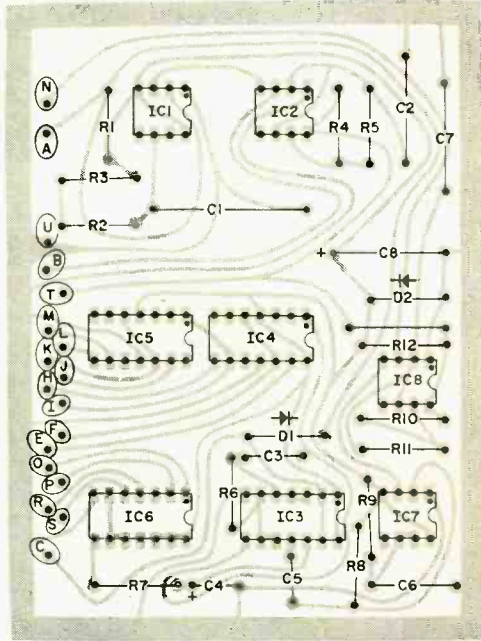

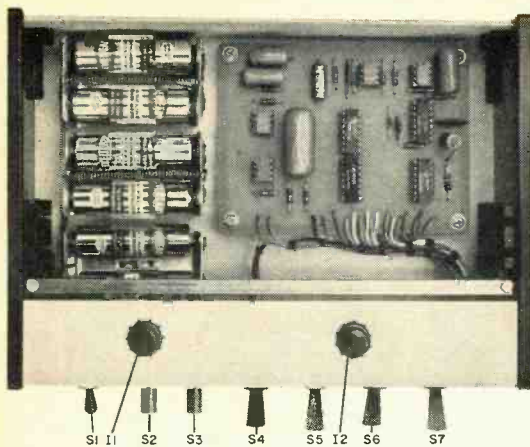

Use large bathandle-type switches for easy operation. Switch S1 and lamp I1 are green, while switch S2 and lamp I2 are red colored.

### GAMES TO PLAY

Game	Rules
Logi-Peg	<ol style="list-style-type: none"> <li>1. Use a cribbage board with pegs. Assign one peg to each player.</li> <li>2. Each player advances his peg one hole per win during his thirty-second play period.</li> <li>3. Play last "round" after one player reaches end.</li> <li>4. Player to advance farthest after all players have had an equal number of turns wins.</li> </ol>
Logi-Sum	<ol style="list-style-type: none"> <li>1. Assign a number (any number, including Roman numerals) to each switch.</li> <li>2. Player must sum the "up" switches after each win.</li> <li>3. First player to exceed a pre-determined total (such as 100) wins.</li> </ol>
Logi-Lette	<ol style="list-style-type: none"> <li>1. Draw a circle and divide it into 16 sections, numbering the sections from 0 to 15.</li> <li>2. Assign the game switches the numbers 1, 2, 4, and 8.</li> <li>3. Each player chooses one numbered section of the circle.</li> <li>4. One player plays Logidex and sums the "up" switches.</li> <li>5. The player whose chosen section number corresponds to the score wins.</li> </ol>

thirty-second timer to start and also enables the clock to oscillate for an unknown number of cycles. The clock oscillates at approximately 50 kHz, so that many cycles pass while the switch is pressed. The red switch (S3) also enables the oscillator, but it is isolated from the thirty-second timer by diode *D1*.

The clock output (from *IC3C*) is used to trigger a four-bit ripple counter (*IC4,IC5*). Both the normal and inverted outputs from each stage of the counter are wired to switches so that one throw of each switch will always have a logic 1 connected to it.

When the switches have been toggled to the correct positions, all four inputs to *IC6A* are at a logic 1. The output from *IC6B* goes high under this condition, passes through a low-pass filter (*R7,C4*) to remove noise transients, and triggers the four-second timer and flasher. Integrated circuit *IC3D* allows the circuit to function only during normal play and inhibits the output of the qualification logic when the clock is causing the counter to operate.

The power supply consists of ten AA batteries with a zener regulator for the IC supplies.

**Construction.** The circuit can be constructed on a printed circuit board such as that shown in Fig. 2. The assembly of the prototype is shown in the photos. Note that the lamp connections from points B and N on the circuit board are routed separately from the main harness. This routing is necessary to isolate the fifteen-volt flash signals from the sensitive flip-flop inputs and outputs. Be sure to unscrew the lamps while soldering the sockets to prevent costly damage to the filaments.

When selecting components, keep in mind that high impedances are present in the timing circuits, so low-leakage capacitors are necessary for *C1* and *C6*. Sprague "Orange Drop" capacitors were used for *C1, C2, C6,* and *C7* to stabilize the flash rates and timing.

While standard TTL logic gates (such as SN7400) can be used, low-power logic (such as SN74L00) is recommended to conserve power and prolong battery life. When using an SN7400 instead of an SN74L00 for *IC3*, it is necessary to lower the values of *R6* and *R7* to 220 ohms and *R12* to 120 ohms, 2W. Logic speed, which is reduced when using low-power gates, is not a critical consideration in this application. ♦

# THE NEW FAST-CHARGE BATTERIES

STATE OF THE ART



*Ni-Cd cells and logic charging circuit  
provide big extras for portable equipment*

**BY ADOLPH A. MANGIERI**

IMAGINE being able to recharge a cold walkie-talkie battery pack or a newly discharged and warm battery in your cordless power tool in just 15 minutes without having to wait for the batteries to reach room temperature first. Safe fast charges over a wide temperature range or under heavy duty cycle is now possible with General Electric's new "PowerUp-15" rechargeable nickel-cadmium battery.

**The PowerUp-15.** Specifically designed for 15-minute fast recharging, the PowerUp-15 is a secondary rechargeable, reseal-

able-vent nickel-cadmium battery. Its electrodes are porous sintered nickel plates that contain active materials deposited by nickel and cadmium salts. The positive electrode contains nickel hydroxide that reduces to nickelous hydroxide during discharge. The negative electrode contains cadmium that reduces to cadmium hydroxide during discharge. The electrodes are separated by a porous insulator that is saturated with an alkaline solution of potassium hydroxide. Charging causes the electrode materials to revert to their original states. A resealable vent mechanism functions as a safety valve



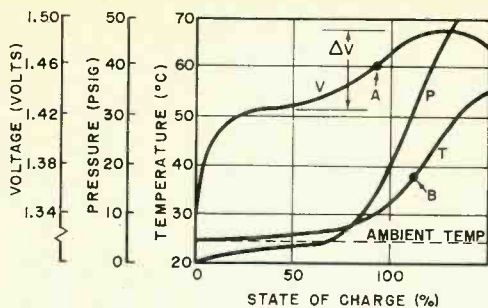

Fig. 1. Charger is set to cut off at point A.

when cell pressure rises excessively.

A nickel-cadmium cell delivers 1.25 volts during most of its discharge cycle; the voltage drops off rapidly as the cell approaches exhaustion. The cell's open-circuit potential is about 1.45 volts immediately following charging and settles down to 1.35 volts after standing for a while. Capable of

safely accepting fast charges at the 4C rate and provided with liberal overcharge tolerance, the PowerUp-15 can be charged 1000 or more times. (In expressing charge rates, C numerically equals the cell's rated ampere-hour capacity. The 1C and 4C charge rates for a 1 A-h battery are 1 A and 4 A, respectively. Charge rates of 1C or greater are considered fast.)

**Fast-Charging Ni-Cd Batteries.** The cell conditions during charge that greatly affect cell life are excessive temperature that degrades the separator and excessive cell pressure that causes venting and the gradual loss of chemicals. In Fig. 1 are shown typical cell voltage, pressure, and temperature characteristics of a sealed cell charging at the 1C rate with the cell initially at room temperature.

Up to 80 percent charge, cell voltage,

## LITHIUM CELLS PROVIDE HIGH

**A** PRIMARY or non-rechargeable battery, the lithium Eternacell recently introduced by Power Conversions delivers about 2.8 volts/cell during discharge. The characteristics of the D Eternacell, with several primary and one secondary cell, are shown in Fig. A. Unlike other cells, the voltage of the Eternacell increases slightly during the

earlier portion of the discharge cycle. With continuous discharge, the cell exhibits remarkably constant voltage during most of the period.

Its higher cell voltage a contributing factor, the Eternacell also provides the highest energy per unit volume and weight of all currently available cells. The manufactur-

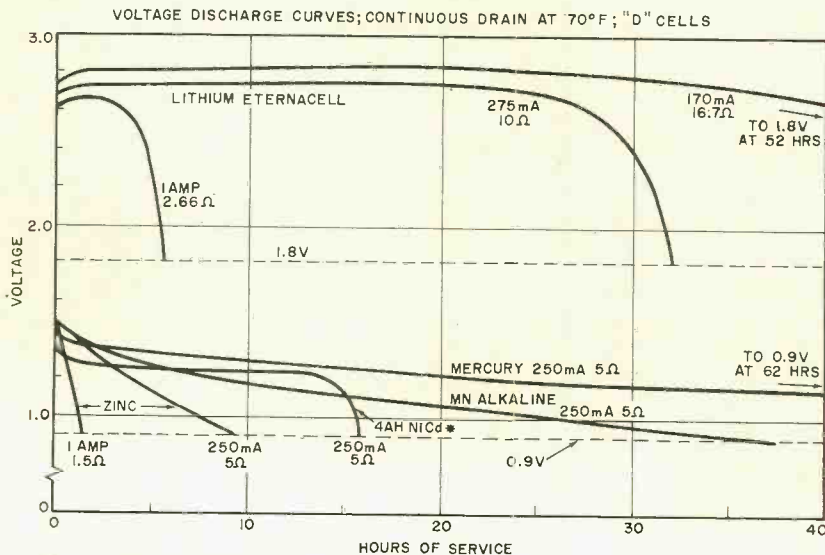

\* NiCd RECHARGEABLE; ALL OTHERS NON RECHARGEABLE

Fig. A. Characteristics of Eternacell compared to other battery types.

pressure, and temperature rise slowly as most of the charging current is expended in forcing the electrode materials into their charged states. As charging continues to 100 percent and beyond into overcharge, cell pressure and temperature rapidly rise as the charging current expends itself in generating oxygen gas at the positive electrode and heating the cell. Excess cadmium at the negative electrode prevents the generation of hydrogen there.

Oxygen migrates through the separator to the negative electrode where it electrochemically recombines with the chemical system. Cell voltage rises rapidly near 100 percent charge. It peaks, then drops, in overcharge.

At the conventional 0.1C overnight charge rate, oxygen recombination proceeds smoothly and cell temperature and pressure stabilize at low and safe levels.

Although the fast-charge cell is designed for efficient oxygen recombination—which extends the allowable overcharge—continuous overcharging results in cell venting. Occasional venting is harmless, but repeated venting results in the cell's drying out and its ultimate failure. Excessive cell temperatures weaken the separator and result in internal short circuits.

Because a cell can be placed on charge in any state of discharge and at various initial cell temperatures, it is the task of the fast charger to monitor cell conditions and automatically cut off the fast charge before a cell vents or its internal temperature becomes excessive. Continually sensing cell conditions, fast chargers might use voltage cutoff (VCO), temperature cutoff (TCO), or the new voltage/temperature cutoff (VTCO) system developed by General Electric for use with their PowerUp-15

## ENERGY PER UNIT VOLUME

er's comparison of cell energy of the primary D cell at a 1-A drain is shown in Fig. B. Note that the Eternacell can provide more than 30 times the energy of a carbon-zinc cell and more than three times the energy of a mercury-zinc cell at high

discharge rates. The energy comparisons narrow somewhat at lower drain currents. At 250 milliamperes, the Eternacell delivers about 22 watt-hours. Similarly, carbon-zinc cells supply about 3 watt-hours. Actual values depend on cell quality and end-point voltage.

The Eternacell is a member of the lithium battery family that includes both primary and secondary batteries. Lithium is a very soft silver-white light metal that readily reacts with or dissolves in water to form lithium hydroxide and rapidly oxidizes in the presence of oxygen. Lithium has the greatest tendency of all metals to give up electrons, and it has the highest oxidation potential, which accounts for the higher cell voltage. The Eternacell uses an organic electrolyte.

Packaged in six cell sizes that outwardly resemble carbon-zinc cells, Eternacell batteries include the Model 550 D cell rated at 8 A-h at 250 mA drain; Model 660 C cell rated at 3A-h at 100 mA drain, Model 440 (0.54" × 1.31") rated at 1 A-h at 15 mA drain, a 7/8" × 1 5/16" model rated at 1.2 A-h at 50 mA, and a 6-volt model rated at 0.8 A-h at 50 mA.

The Eternacell ideally powers electronic instruments, communication gear, emergency equipment and lighting, photography equipment, and other devices whose major power sources are primary cells. ♦

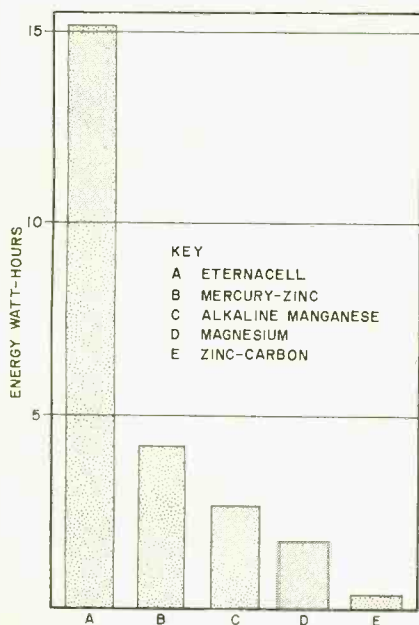

Fig. B. Manufacturer's comparison of cell energy of primary D battery at a 1-A drain.

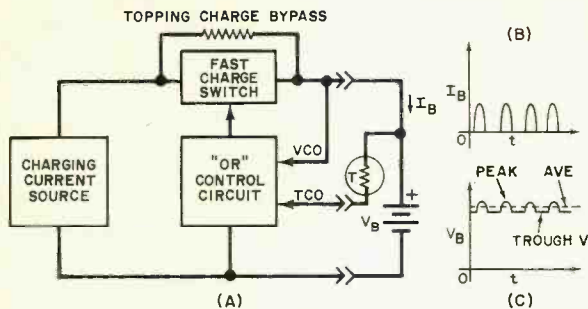

Fig. 2. Block diagram of three-conductor voltage/temperature cutoff battery/charger system.

cells. A comparison among the various systems readily reveals the superiority of the VTCO system.

**VCO and TCO.** Fast chargers that use VCO rely on the fast rising portion of the voltage profile near 100 percent charge. The charger can be set to cut off when battery potential rises to 1.46 volts/cell (point A in Fig. 1). This setting is well below the peak point, insuring cutoff, and sufficiently high to insure near full charge.

The voltage profile shifts upward at both higher charge rates and lower cell temperatures. The cell reaches 1.46 volts too early in the charge period and is undercharged. On the other hand, the profile is lowered and flattened at higher ambient temperatures and at lower charge rates. The cell can be grossly overcharged before reaching 1.46 volts at cutoff. The shifting voltage profile greatly complicates charger design by requiring critical temperature compensation of the voltage cutoff point.

Cells for the VCO system are designed to optimize the delta-V voltage. The cells must be specially processed, graded, and matched for similar voltage profiles that are repeatable throughout cell life.

Fast charge systems that employ TCO rely on the fast rising temperature profile encountered in overcharge. The temperature sensor can be a thermostat or a thermistor installed within the battery pack (as is the case with the PowerUp-15). The fast charger can be set to cut off when battery temperature reaches point B (38° C) on the profile. As might be expected, the profile shifts markedly, depending upon initial cell temperature charge-rate variations, battery self-heating, heat-transfer rates, and other factors.

A particularly adverse situation occurs at low cell or ambient temperatures where

the profile is shifted well downward. The battery can be grossly overcharged long before the sensor reaches 38° C. Additionally complicating matters, oxygen recombination in a cold battery is very slow, cell pressure rises rapidly, and venting occurs.

Unlike the VCO system where cutoff often occurs near 100 percent charge at relatively low rise in cell temperature, the TCO system runs the cell into overcharge and necessarily raises the cell temperature to the cutoff point. As a result, the TCO system can impose close tolerances on charger design, place restrictions on operation, and limit the charge rate to 2C maximum. Again, specially processed and graded cells are required for high reliability.

**The VTCO System.** Developed by General Electric, the new VTCO and PowerUp-15 battery system overcomes the major limitations of prior systems. The VTCO system combines both temperature and voltage cutoff, allowing either to effect the cutoff. When mated with the VTCO charger and operated at room temperature, the PowerUp-15 battery can be charged to 90 percent capacity in 15 minutes at the 4C rate. Operation at high duty cycles and wider temperature range is possible, and costly cell processing and critical charger design are avoided.

The arrangement of a three-conductor VTCO battery/charger system is shown in Fig. 2. (An alternative two-wire system includes a thermostat sensor installed inside the cell pack and connected in series with the battery.) The charger current source is usually rectified dc. The fast-charge current switch can be a relay, power transistor, or SCR. A bypass resistor shunts the fast-charge current and supplies a "topping" charge at the 0.1C rate, adding the final 10 percent of cell capacity when the battery is



left connected to the charger. A thermistor is buried in the cell pack, accounting for the third conductor.

The heart of the VTCO system is the control circuit that is set to cut off the charger's high rate when either cell temperature rises to 120° F or when the potential rises to 1.5 volts/cell, the maximum limits for the PowerUp-15. Control circuit logic compares both signals in an OR circuit, giving preference to the strongest indicator of cell condition.

With unfiltered rectified ac as the charging source, the cell current flows in pulses with intervals of zero current as shown in Fig. 2B. This must be considered in sensing battery voltage. One method senses peak battery voltage with a peak voltage detector. However, the peak voltage varies with line voltage and charging current. Also, line noise can prematurely trip the

VCO system. A second method uses average battery voltage sensing by filtering the voltage signal. This method is immune to line noise, but it still responds to line voltage and charging current variations.

The recommended method for use with the PowerUp-15 is called "trough voltage" sensing. The trough voltage is merely the flat portion of the battery voltage waveform shown in Fig. 2C. It corresponds to the open-circuit battery voltage during zero battery current. Trough voltage sensing provides the best indication of the charge.

Combined with VTCO at the 4C rate and trough sensing, the PowerUp-15 provides a reasonably economical and reliable high-duty-cycle battery/charger system. PowerUp-15 cells are manufactured in 10 sizes ranging from the miniature 1/3AA rated at 100 mA-h capacity at 100 mA drain to the D cell rated at 3.5 A-h at a 3.5-A drain. ♦

## TAPE RECORDER CONTROL OF SLIDES

BY J. W. SHARP

**S**YNCHRONIZING the change mechanism of a slide projector with a tape recording is not a new idea, but the devices most often used for the purpose are cumbersome and expensive. By eliminating the power source, transformers, control relay, and signal amplification, it is possible to build a palm-size slide/tape synchronizer for about \$5. Not only will it operate a slide projector's slide changer, but it will also supply the impulse for prerecording the control signal onto one track of a magnetic recording tape.

In the record function (see schematic), *J1* patches to the auxiliary input of the tape track to be used for slide control, and *J2* patches to parallel the slide-change contacts of the remote switch. By operating *S1*, a 60-Hz square wave (derived from clipping diodes *D1* and *D2* and limiting resistor *R1*) is applied to the recorder's input. The signal level is 0.8-0.9 volt over a changer control potential range of 8 to 28 volts.

For slide control, *J1* patches to the speaker output of the channel you are using for this purpose, leaving *J2* connected as above. A 60-Hz signal from the recorder passes through the normally closed contacts of *S1* and *I1* and goes to trigger diodes *D3* and *D4*. The diodes permit only the voltage peaks to reach the gate of triac *Q1*, causing the latter to conduct and operate

the changer mechanism in the projector.

So few parts are used in the slide/tape sync box that almost any method of assembly will suffice. The diodes can be sorted into matched pairs from a germanium bargain assortment with the aid of an ohmmeter and 1000-ohm resistor. The triac specified for *Q1* has its MT2 terminal common to its TO-5 case. Since there is no heat problem, a short piece of No. 22 stranded wire clamped under a small heat sink will provide a convenient third lead.

The slide projector will require another phono jack—either on the remote control box or on the projector itself—wired in parallel with the changer switch's contacts. But first make certain that the control potential does not exceed 28 volts and is isolated from the power line. ♦

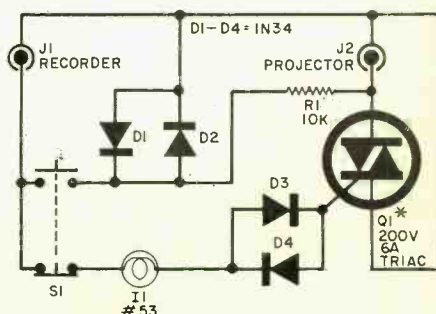

# ENLARGER EXPOSURE CALCULATOR

*Direct indication  
of exposure time  
and image contrast*

ANY well-equipped darkroom should include an enlarger exposure calculator. Its use can practically eliminate costly paper loss and greatly reduce darkroom time by eliminating test strips. Both exposure time and image contrast are directly indicated on a large, easily read back-lit dial. A variable sensitivity control calibrates the calculator accounting for projection paper speed and mode of operation.

Constructed at low cost and with performance exceeding that of available devices, this calculator uses a linear high-speed remote CdS light sensor in a dc comparator bridge. A very high-gain op amp driving an LED fully on or off sharply detects bridge balance with precise repeatability. Voltage changes have no effect on dial readout.

**Circuit Operation.** As shown in Fig. 1, potentiometer *R9* forms two arms of a variable ratio bridge. Linear high-speed sensor *LDRI* forms the third arm and *R8* and *R1* are the fourth. Potentiometer *R9* is calibrated in exposure time in seconds while *R8* is used to calibrate the calculator. Operating open-loop, op amp *IC1* senses bridge voltage through lowpass filter *CIR2*. As *R9* is rotated through bridge balance or null, *LED1* lights up when pin 2 of *IC1* goes negative and vice versa. Because *IC1* has very high gain, only slight movement of *R9* about the null point effects turn-on or turn-off of *LED1* resulting in accurate and repeatable detection of the trip point.

Markings on the dial of *R9* are similar to those of a comparator bridge. Since *LDRI* is highly linear over the light range of interest, the dial of *R9* is calibrated using re-



BY ADOLPH A. MANGIERI

sisters substituting for *LDRI* and forming known ratios with *R1*. A split zener supply provides the op amp supply voltage. Potentiometer *R10* adjusts the op amp bias current, though the op amp input offset voltage (a few millivolts) has negligible effect on the bridge balance point. A three-wire line eliminates stray fields which would otherwise degrade sharpness of the trip point depending on direction of ac plug insertion.

**Construction.** All components except *T1* are assembled on the panel of a 3" by 4½" by 6½" metal case. Begin by cutting a 2¾" diameter disc from ¼-in. clear plastic sheet. Ream the center hole to ¼ inch and mount the disc on a drill or arbor to true up the edge. Cement the disc to a knob using a ¼-inch rod to insure alignment. Install *R9* and the disc dial on the panel and mark the window cutout. Make the cutout ¼ inch high and arced over eighty degrees of the dial face. Temporarily install the circuit board on spacers and locate the hole position for a rubber grommet which supports lamp *I1* on the board. Use shoulder washers to insulate jack *J1* from the panel.

Assemble the circuit board as shown in Fig. 2, using flea clips and point-to-point wiring. Use a socket for *IC1*. Capacitors *C1* and *C2* are installed below the board at the IC socket. Defer installation of *R6* and *R7* if you have substituted for transformer *T1*. Potentiometer *R9* may have any value from 10,000 to 50,000 ohms. Make the window pane a bit larger than the window cutout using translucent red plastic. Mark an opaque vertical center index line on the pane and drill a 0.071-inch hole near the upper





end. Using clear epoxy, cement the LED in the hole on the bottom side of the pane. Solder a length of twisted phono wire, less shield, to LED leads with the red wire to LED anode.

Connect the right-hand lug of *R8*, as viewed from the rear with terminals down, to resistor *R1*. Connect the right-hand lug of *R9*, similarly viewed, to the other end of *R1*. Install *T1* and a lug strip for the line cord at one end of the case. You may add a separate spst switch ahead of *T1* in one of the ac line wires.

Connect both the circuit ground and line ground to the metal case. Install a battery compartment made of sheet aluminum.

Mount the photo sensor (*LDR1*) between two pieces of thin plastic or phenolic sheet so that the light-sensitive face of *LDR1* fits through a suitable hole in the upper sheet. Paint the top piece white. Use a length of miniature shielded and jacketed mike cable for the connecting cable. Insulate the connections to *LDR1* with bits of vinyl tape and run the center wire to *R2* through *PL1* and *J1*.

**Checkout and Calibration.** Connect *R6* to the circuit using clip leads with a dc milliammeter in series. Unplug *IC1* and insert the ac line cord. If necessary, alter the value of *R6* to obtain a current of about 70 mA. Measure the ac voltage across *I1* and alter the value of *R7*, if required, to obtain a voltage of preferably 1.5 volts but not in excess of 2 volts.

Install *IC1* with power off, observing proper direction of installation. With the photo sensor unplugged, *S1* off, and *R8* set to maximum resistance, adjust *R10* very slowly to the setting where *LED1* initially lights up. If this cannot be done, increase *R4* or *R5* as required by about 1000 ohms to bring *R10* within adjustment range.

The dial of *R9* is calibrated by plugging in resistors having a known ratio with bridge arm *R1*. Use either fixed resistors or a potentiometer set to required values connected to a phone plug with short leads. Ground the instrument to eliminate stray pickup. Jumper the two wired lugs of *R8* insuring zero resistance. Plug 10,000 ohms into *J1* and turn *S1* on. Adjust *R9* to the point where *LED1* first lights up. Mark the dial above the index line as the 1-second index.

Similarly, use 20,000 ohms for the 2-second index, 30,000 ohms for the 3-second index, and so forth, up to 200,000 ohms for

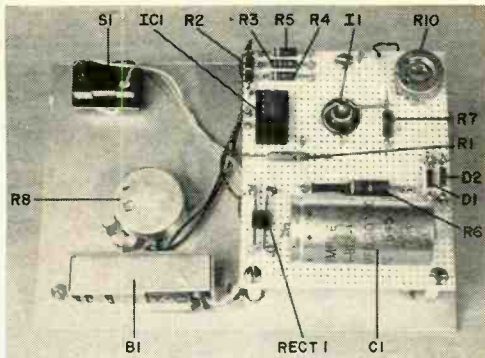

Fig. 2. The circuit can be built on a perf board as shown here. Lamp *I1* illuminates the "seconds" dial through the hole in the front panel. *LED1* is built into the window panel as it is shown in the lead photograph.

the 20-second index. Spot additional indices in 5-second intervals to 50 seconds (500,000 ohms) and at 10-second intervals to 100 seconds (1 megohm). Half-second indices between 1 and 10 seconds may be linearly interpolated or spotted using suitable resistances. Remove the dial and label it using dry transfers. Plug 100,000 ohms into *J1* and replace the dial for LED turn-on at 10 seconds. Remove the jumper from *R8*.

**Application.** If darkroom receptacles lack a ground wire, determine direction of plug insertion as follows and color-code both plug and receptacle. Set *R8* to maximum resistance and turn *S1* on. At room light level, invert or cover the sensor with sheets of paper so that dial readout is at least ten seconds. Try the line cord both ways. Use that direction which produces a sharp and sudden turn-on of *LED1* as *R9* is slowly rotated. Turn off all darkroom light when using the calculator. At very low light levels, check for possible contribution of light from the dial itself by placing a blackened cardboard tube from a 35-mm film carton over the sensor.

Correct settings of calibration potentiometer *R8* for projection papers in use are obtained by means of a test print. Using a negative of average contrast and content, make the best possible test print conventionally. Let us assume that the best print was exposed for ten seconds at f/8 lens aperture.

For the integrated light method, use a three-inch square ground-glass plate as a light scatterer. With enlarger settings un-

disturbed, place the sensor at the center of the projected image. Turn *S1* on and set *R9* to ten seconds. Hold the light scatterer up to the lens and adjust *R8* slowly until *LED1* first turns on. Rock *R9* slightly to verify turn-on at ten seconds and trim *R8* if required. Record *R8* setting and paper data. To use the calculator, and at any print magnification and lens aperture, set *R8* as previously recorded, use the light scatterer, and rotate *R9* to the point of *LED1* turn-on. Expose for the indicated time at the selected aperture.

If you cannot calibrate *R8* (advanced to its limit) open up the lens one (or even two) full stops and try again for ten seconds readout on *R9*. In using such calibration settings, you would naturally close down one (or two) full stops from any selected measuring aperture to compensate before exposing. Or, you may use one-half (or one-fourth) of the indicated exposure and expose at the measuring aperture. Record the mode you have selected along with *R8* settings and paper type.

Next, the spot method takes a single measurement at the brightest portion of the projected image (print shadows). To calibrate *R8* for this mode, place the sensor at print shadows and *R9* at ten seconds. Adjust *R8* for ten seconds readout on *R9* with lens aperture set to that of the test print. In use, merely set *R8* as recorded, place the sensor at print shadows, select any lens aperture, and turn *R9* to the point of lamp turn-on for the required exposure time.

Negative contrast is related to the brightness range of the projected image. To measure contrast, place the sensor at the brightest portion of the image. Set *R9* to one second. Adjust lens aperture and/or *R8* for indicator turn-on at one second. Rock *R9* to check. Then move the sensor to the darkest portion of the image and adjust *R9* to a second and always higher indication. If the second reading is 12 seconds, the contrast is 12:1 or merely 12. Contrasts of 8 to 15 print well on normal contrast paper but you should make up your own grading system since contrast also depends on print development time.

You can readily conceive of other modes of operation and applications. By installing the sensor in a probe or handle, you can take measurements from printboxes and ground-glass viewing screens. Depending on your needs, you can interpret the 10-second index as 0.1, 1, or 100 seconds. ♦

We will document the fact we make more models of Monitoradio (Scanners) than all other names combined—our satisfied users number more police departments, more fire departments, more CD units—in fact, just more happy customers, plain or fancy, than all competitors put together—we believe it's because we try to be the difference with innovative engineering delivered to you at a price you prefer to pay—for example:

## our NEW 10 CHANNEL Hi/Lo/U 3 BAND ACTION RADIO

**\$169<sup>00</sup>**

suggested list price.



Available at your favorite retailer now from—

© 1973 *Regency*

the people who produced  
the world's first transistor radio

7707 Records Street, Indianapolis, Indiana 46226  
CIRCLE NO. 27 ON READER SERVICE CARD

# Build your own Bell & Howell solid-state 25-inch diagonal color TV!

It's an enjoyable way to learn new skills that could launch you on a brand-new career in electronics!

For free information, mail postage-free card today!

Get free information now about this complete electronics program you can enjoy at home in your spare time. It's prepared for you by skilled instructors at Bell & Howell Schools.

## Discover a new way to spend your spare-time hours on evenings and weekends

You'll find electronics a fascinating world to explore! You'll enjoy spending your spare time tinkering with the equipment . . . reading up on electronics principles . . . finding out how they work in practice . . . learning something new that could lead to a new career!

## Find out all about electronics equipment and how it works

You can apply your new skills to stereo systems . . . FM-AM radios . . . phonographs . . . tape recorders. You master the most *up-to-date* solid-state circuitry. In fact, you'll be able to work with almost *any* type of home entertainment electronic equipment — even some not on the market yet!

## Learn by doing . . . one step at a time

With this program you first learn basic principles in the text. Then you apply them to your "hands on" project so you fully understand how they work. You learn each principle *by doing* . . . one step at a time. You walk before you run.

## Consider these important facts about the color TV set you build

This Bell & Howell Color TV has an ultra-rectangular tube and a 25-inch picture measured diagonally — a full 315 square inches of viewing area! The circuitry is modular solid-state — individual plug-in circuit boards make servicing easier. And the built-in self-service components are located on the back — where they're easier to get at!

## Talk to your instructors in person . . . get expert help and guidance when you need it

If you'd like some personal advice at any point in your program, you can arrange



"Electro-Lab" is a registered trademark of the Bell & Howell Company.



to attend a "help session" and talk over special problems with a qualified Bell & Howell Schools instructor.

### Find out how to earn extra income part-time — or start your own business!

We'd like to tell you how this fascinating program could lead to extra income part-time, a new career or a business of your own. Mail the card now so that our Bell & Howell Schools representative can bring you all the facts. No obligation.

### You build and keep the exclusive Electro-Lab® electronics training system

As part of your program you build a design console, oscilloscope, and transistorized meter. The Electro-Lab gives you practical experience with instruments used daily by professionals. You not only *build* these three precision instruments, you continue to *use* them throughout the balance of your program and in your career.

### Plus . . . you start out with your own Laboratory Starter Kit

With your very first lesson, you get a volt-ohm-meter (VOM) with design panels, modular connectors, experimental parts and battery power source. This Laboratory Starter Kit gives you immediate "hands on" experience right from the start!

If card has been removed, write:

An Electronics Home Study School  
DEVRY INSTITUTE OF TECHNOLOGY



ONE OF THE  
**BELL & HOWELL SCHOOLS**  
4141 Belmont, Chicago, Illinois 60641

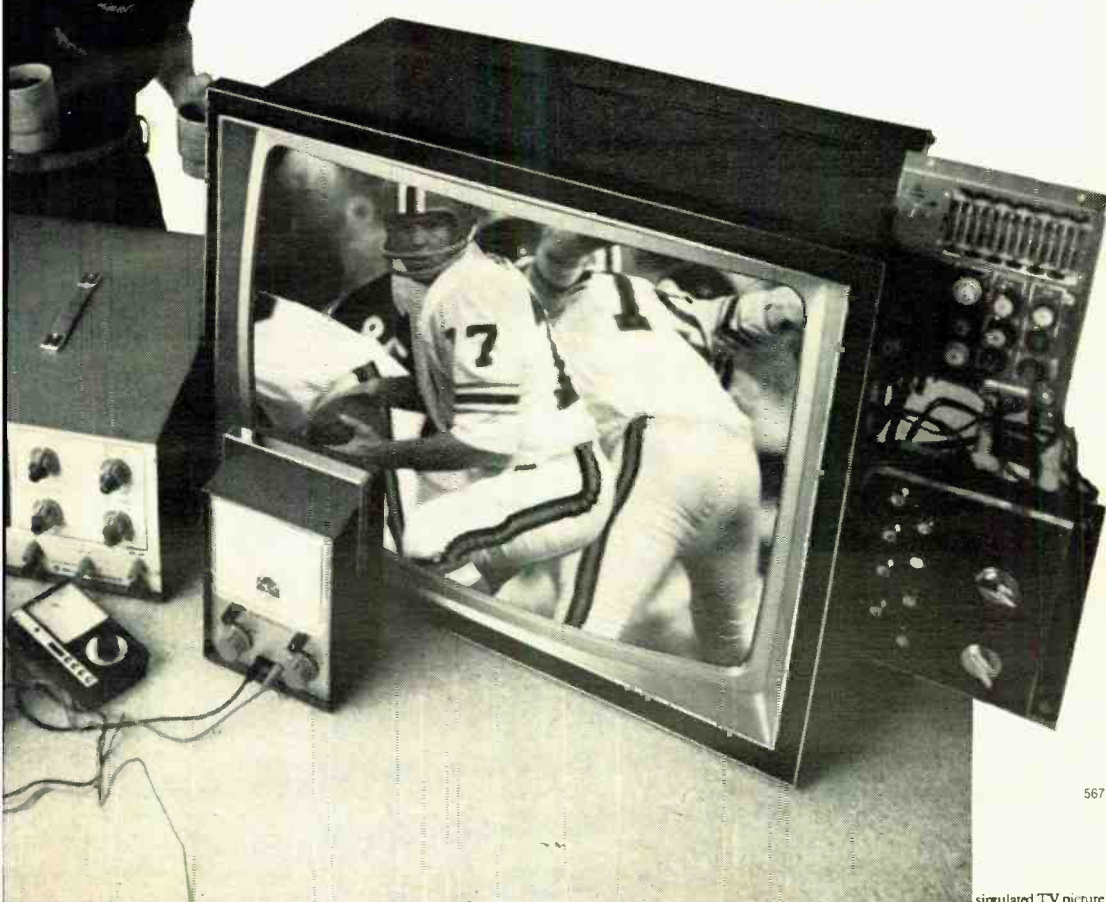

567

simulated TV picture

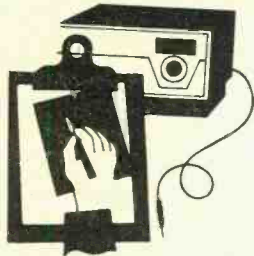

# Product Test Reports

## HEWLETT-PACKARD MODEL 970A DIGITAL MULTIMETER

**W**E recently observed a result of the quiet revolution in test equipment design that has been taking place at the Hewlett-Packard labs. Until one of HP's representatives visited us with the company's futuristic Model 970A digital multimeter, our thinking about DMM's was along the lines of chunky bench-type instruments. The HP 970A, hardly larger than a conventional oscilloscope demodulator probe, certainly changed this view, as well as others.

Contained within its ultra-miniature (for a complete DMM) 6½ in. long by 1¾ in. oval diameter case are all the electronics for a full 3½-digit display, automatic ranging on ac and dc volts and resistance, automatic zeroing, automatic decimal location, and a rechargeable nickel-cadmium battery pack. The 970A weighs less than 7 ounces and fits easily in the palm of the hand.

In action, the instrument left no doubt that it was worthy of bearing the name of a company that has built its reputation on top-quality commercial electronic gear. Nor did it take long to convince us that this DMM is at least the equal of many bulky bench-type instruments.

The new DMM carries a list price of \$275, which is roughly the middle of the price range for most 3½-digit service-type digital multimeters on the market. For this price, the buyer gets the DMM with its built-in battery pack, an ac recharger, a zippered, leather-type case that has a belt clip for convenient carrying, a sun shield for field service use, three different test probes, and a rugged plastic storage case that is compartmentalized to accept all of these items.

**About The Instrument.** The HP 970A digital multimeter employs a seven-segment light-emitting diode cluster. Integral to the cluster are decimal points.

There are only three switches with which

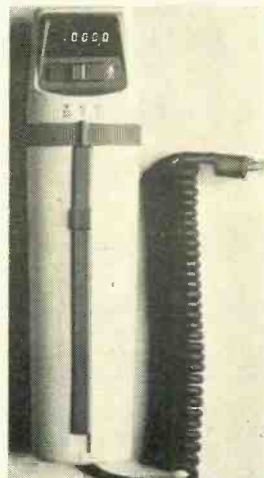

a user must concern himself when using the DMM. The power switch has off, momentary-on (press the switch plate, and the instrument is powered for as long as you want it to be; release the switch, and power disconnects), and constant-on positions. The function switch, operated by moving a flexible plastic band encircling the instrument's case, has positions for dc volts, ac volts, and resistance in kilohms. The last switch is rather unique in that it can be used to flip over the display so that the readings can be made in both the right-side-up and upside-down positions.

The automatic-ranging circuit operates on all three functions built into the 970A. There are five ranges for each function. On both the ac and dc voltage functions, coverage is from 0.1 volt full-scale to 500 volts full-scale. Input impedance on ac is 10 megohms, and input resistance on dc is 10 megohms, shunted by less than 30 pF. Accuracy on dc is better than 1 percent, while on ac it varies with frequency from 2 percent between 45 Hz and 1 kHz to 5 percent between 1 kHz and 3.5 kHz. The maximum



input on both ac and dc is 500 volts. The resistance function's ranges cover from 1000 ohms full-scale to 20 megohms full-scale; test current is less than 10 mA.

Supplied with the instrument are three test probes that plug into an articulated connector hinged to the top rear of the instrument case. The 2½-in. pointed probe is used for most work, the 2½-in. concave probe is for use on test points and wire-wrap terminals, and the 5-in. probe is for reaching down into deep recesses. Only the points and plug-in ends of the probe are bare metal. The bodies are insulated. The connector will also accept a standard banana plug test cable. The ground lead is a coiled-cord cable that exits the DMM from the bottom end and terminates in an alligator clip.

The test probe connector is pivot hinged to the back of the instrument case in such a way that it can be set at almost any angle between almost closed to full open. This means that the business end of the probe can be positioned right in the same viewing plane with the display system, permitting both the display and test point to be viewed simultaneously. When the instrument is not in use, the test probe connector folds flat against the back of the case.

The battery pack provided with the 970A

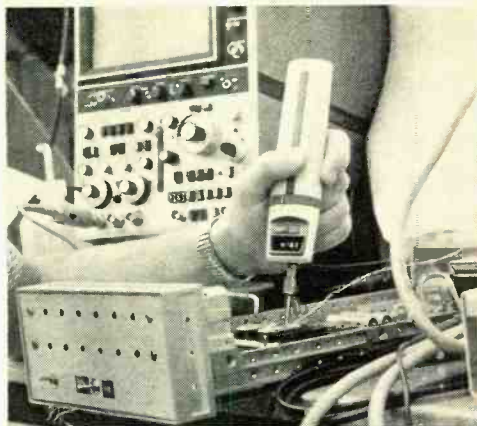

Readout display is reversible for easy use.

will provide some 2000 measurements when the instrument is operated in the momentary-on mode of the power switch. In continuous-on, the DMM will operate for about 2½ hours before the battery pack needs recharging. For those people who anticipate a lot of work on a regular basis, HP is making available an optional back-up HP 97001A rechargeable battery pack for \$25. Recharging the battery is an overnight (about 14-hour) process.

**How It Performed.** Over the past few years, we have tested quite a number of digital test instruments. We have to score the HP 970A DMM highest for quality, ease of use, and just plain handiness. During our tests, the instrument performed admirably and was well within specifications. (We missed the current measuring capability, but by the time you read this, the HP 97002A ac/dc current shunt bench cradle that will convert the 970A to a bench instrument should be available for \$45.)

The bright, easy-to-read LED display was very convenient when working in and around chassis, and having the display in front of our eyes certainly made a world of difference compared to the traditional touch-and-look-up procedure. The automatic ranging and polarity functions really proved their worth many times over during the past couple of weeks. It will be hard to go back to the manual way.

Since the HP 970A is touted as a "very rugged instrument," we subjected it to our standard drop test—with some trepidation because of its apparent frailness. We need not have bothered worrying. Dropped from a 3-ft height, it came through the test with-

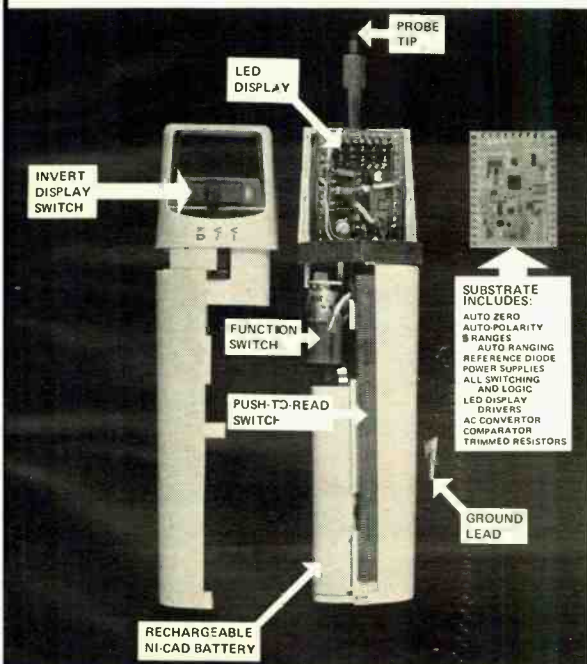

Cutaway view shows basic parts of the meter.



out so much as a scuff mark. The instrument case is molded high-impact plastic, with built-in stress reliefs. Subjected to unusually rough treatment, the stress points give to prevent any real damage. Just snap it back together, and the instrument is no worse for wear.

There can be little doubt that we really like this DMM. There is only one drawback. Owing to its compact size, it makes an at-

tractive theft item. If you don't watch it carefully, it might find its way into some one else's pocket.

The HP 970A will not replace our much larger bench-type DMM, which is an invaluable instrument for bench work. Nor was it intended for that purpose. Its primary attraction will be among the many field-service technicians and others who work away from a test bench.

Circle No. 65 on Reader Service Card

## JVC AMERICA, INC., MODEL VP-100 STEREO PREAMPLIFIER (A Hirsch-Houck Labs Report)

**T**HE JVC America Model VP-100 "Laboratory Series" preamplifier features an expanded version of the graphic equalizer (or multi-band tone control) that has been a feature of JVC amplifiers and receivers for several years. This S.E.A. (Sound Effect Amplifier), as JVC terms it, operates in seven different frequency ranges to provide a nearly infinite number of variable frequency-response characteristics.

About half of the front panel of the VP-100 is devoted to the seven vertical S.E.A. slide-pot controls. Their center frequencies are 40 or 60 Hz (selected by an adjacent pushbutton switch), 150, 400, 1000, 2400, 6000, and 15,000 Hz. Each slide control is slightly detented at 2-dB intervals, indicating the level change being introduced at the center frequency of the control. The overall range of each S.E.A. slide control is  $\pm 10$  dB.

Just to the right of the S.E.A. controls is a lever switch that bypasses the S.E.A. system, permitting an instantaneous comparison of the controls' effects with a flat frequency response. Three similar switches provide a 20-dB volume reduction for temporary interruptions, switch tape monitoring for two separate tape decks, and a unique "pink-noise" test signal. More about this later.

Another lever switch to the left of the S.E.A. controls is used for power on/off and the three switched ac convenience outlets located on the rear apron of the preamp. There are two additional unswitched outlets that are always powered.

Three control knobs occupy the top right of the VP-100's panel. The first selects the operating mode—stereo, both normal and reversed, and either left or right inputs or their sum through both outputs. Next is the input selector, with positions for micro-



phones of medium impedance between 10,000 and 50,000 ohms, PHONO 1 and 2, TUNER, and AUX 1 and 2. Finally, there is the volume control. Channel balance is controlled by a horizontal slide pot located below the volume control; it, too, has a detent at its center position.

The "pink-noise" generator is a built-in test facility that is useful for testing speaker phasing and adjusting the level balance between drivers in a multi-speaker system. It supplies a random-noise signal with a frequency response that is shaped for equal energy in each frequency octave. Pink noise is heard as a smooth hissing or rushing sound that reveals system response irregularities much more readily than the brighter sounding "white" noise. White noise has equal energy for each frequency and, therefore, emphasizes the higher-frequency octaves.

Moving the three-position lever switch down replaces the usual program with in-phase pink noise at the two outputs. In the up position, the outputs are driven out-of-phase by the noise signal.

The difference in sound character between the in-phase and out-of-phase conditions is instantly audible, providing a quick check of speaker phasing. All preamplifier controls, including the S.E.A., are effective on the noise signals so that with a little practice one can balance the system's fre-

quency response more effectively than with most musical program material.

On the rear apron of the preamplifier are located all its input and output connectors. Ten screwdriver-adjustable controls are used to set the levels of each input channel (except the mikes) individually. There are two pairs of outputs, one at a fixed level, and the other adjustable by another pair of screwdriver controls. One of the two groups of tape-recorder jacks is paralleled by a DIN connector.

The JVC Model VP-100 preamplifier is housed in a black metal cabinet that measures 18 in. by 5½ in. by 11½ in. Suggested list price is \$260.

**Laboratory Measurements.** The maximum output voltage of the VP-100 was almost 7 volts into an open circuit, 6 volts into 50,000 ohms, and 3.85 volts into 10,000 ohms. We used a 50,000-ohm load during our tests, since few power amplifiers have a lower input impedance.

The 1000-Hz harmonic distortion was 0.03 percent at a 1-volt output, rising smoothly to 0.19 percent at 5 volts. It was not significantly higher at the frequency extremes, measuring about 0.25 percent at 20 and 20,000 Hz with a 5-volt output. The IM distortion was about 0.065 percent up to 1 volt, increasing to 0.52 percent at 5 volts.

The input sensitivity for a 1-volt output was 0.11 volt (AUX), 1 mV (PHONO), and 1.2 mV (MIC). The noise levels were among the lowest we have ever measured in a preamplifier: 95 dB below 1 volt on the high-level inputs and 93 dB below 1 volt on the phono inputs. Phono overload occurred at a very high 120-mV input level, and the MIC inputs overloaded at 130 mV.

The S.E.A. response curves conformed to the manufacturer's specifications. Each control, especially at its intermediate setting,

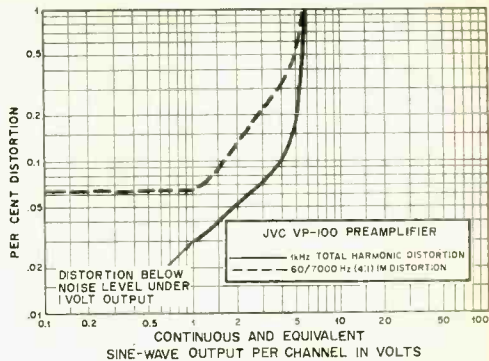

affected a broad range of frequencies; when several were used, the average volume level could be altered by several decibels. Their action was sharper and better defined at the maximum control settings, with less effect at the far-removed frequencies.

The RIAA phono equalization was within  $\pm 2$  dB from 30 Hz to 15,000 Hz, and the MIC response was within  $\pm 0.5$  dB from 25 Hz to 20,000 Hz. The preamp has a built-in subsonic filter with an 18-dB/octave slope which reduces the response at 20 Hz by about 3 dB. Noting that the individual channel-level adjustments used relatively high impedance (220,000 ohms) controls, we checked their effect on high-frequency response at the  $-6$ -dB settings, which would be the worst-case condition. The effect was negligible, with a 0.7-dB reduction at 10,000 Hz and a 2-dB loss at 20,000 Hz.

**User Comments.** With respect to its electrical performance, the VP-100 is clearly a top-ranking preamplifier. The rarely offered ability to match *all* inputs for level and channel balance is a much-appreciated nicety, as is the generous number of ac outlets, both switched and unswitched. And the characteristics of the basic preamp circuits, with their low noise and distortion and high overload points, are excellent.

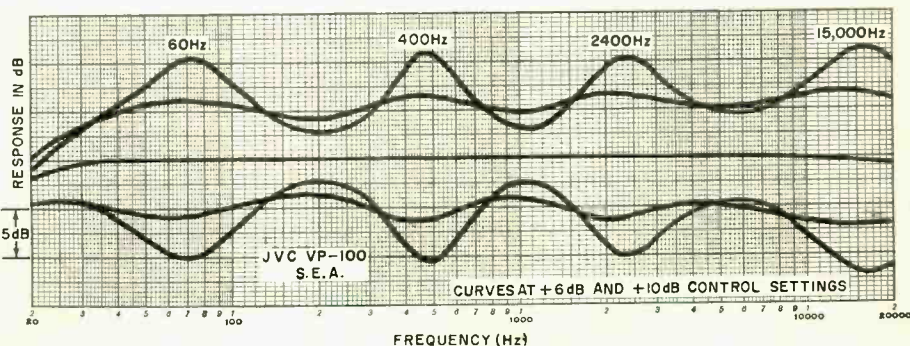

The absence of the usual filters and loudness compensation circuits is also noteworthy. The reason, of course, is that the S.E.A. can perform both functions at least as effectively as most separate controls. As a result, the VP-100 is even more versatile than its front-panel controls would suggest.

As we see it, the VP-100 is probably not for the audio neophyte or casual user who would prefer to set controls according to a "cookbook" formula and let the preamp (or its designers) do his thinking for him. While it would still do a fine job, much of its potential performance could be wasted

by such use. This impression is reinforced by JVC's "Laboratory Series" designation.

The combination of so many control functions into the seven S.E.A. slide pots places the responsibility for optimum adjustment squarely on the user. It is really impractical to set the controls according to some preconceived response curve and assume that all is well. This preamplifier should be adjusted by ear. Provided you know what you want to hear, and trust your own listening judgment, the VP-100 will give you a better chance of realizing your expectations than any comparably priced audio component.

Circle No. 66 on Reader Service Card

### CROWN MODEL DC-300A POWER AMPLIFIER (A Hirsch-Houck Labs Report)

**T**HE NEW Crown International Model DC-300A power amplifier is a thoroughly redesigned version of the company's well-known Model DC-300 amplifier. It has major improvements in its output circuit protection and even lower distortion than the DC-300. The new amplifier is designed for professional rack mounting and, hence, has a front panel that measures 19 in. by 7 in. The depth of the amp is 9 $\frac{3}{4}$  in., and overall weight is 45 pounds.

The only front-panel controls on the amplifier are the two channel sensitivity controls and a heavy-duty power switch with a built-in "power-on" indicator. Heavy-duty binding posts are used for the speaker outputs, and standard  $\frac{1}{4}$ -in. phone jacks are used for the signal inputs. Most of the rear of the amplifier is occupied by the 1000-watt power transformer and the large finned heat sinks.

The gain of each channel is supplied by a single integrated-circuit operational amplifier. Each output stage consists of eight 150-watt-dissipation power transistors (increased from four in the DC-300). Elaborate protection circuits prevent damage to the amplifier under any load impedance from short circuit to full open circuit, including when the amplifier is used with reactive loads. There are no output fuses as were used in the DC-300. The amplifier is direct-coupled from its inputs to the speakers and is designed to exclude all transient thumps from the outputs when the power is turned on or off.

Although the DC-300A is rated at 150 watts/channel into 8-ohm loads, its clipping point is rated at 190 watts/channel, and by



the IHF dynamic power rating system, it can be called a 420-watt (at 8 ohms) power amplifier. Some 14 graphs in the very complete operation manual that accompanies the amplifier fully define its performance. The DC-300A delivers its maximum power to 2.5-ohm loads, but it can operate with *any* type of load with no ill effects other than a reduction in maximum output power.

Measurement of the distortion in the amplifier cannot be accomplished with any unmodified laboratory equipment, since its rated distortion is lower than anything now available. Using filters to further reduce the distortion of their audio generators, the Crown people have been able to demonstrate that the DC-300A's distortion approaches 0.0001 percent under some conditions. The amplifier can be converted to monophonic operation, delivering about 650 watts of power into 4- or 8-ohm loads, by a simple internal jumper connection. Its other performance specifications are essentially unchanged in the mono mode.

The Crown International Model DC-



300A power amplifier retails for \$695. An optional walnut cabinet is \$37.

**Laboratory Measurements.** The output of the amplifier clipped at 185 watts/channel, with both channels driven into 8-ohm loads. Into 4 ohms, the output was 325 watts/channel, and into 16 ohms, it was 102 watts/channel. Our standard reference output of 10 watts was obtained with a 0.43-volt input, and 1.75 volts drove the amplifier to full power. The noise was 88 dB below 10 watts, or 1000 dB below rated power. (Crown's rating of -110 dB noise is based on a measurement in a 20,000-Hz band and is consistent with our wide-band measurement.)

We used 180 watts/channel as a reference full power output. Although this is slightly higher than Crown's ratings, we found that the distortion of the amplifier did not significantly change with power or frequency until the clipping point was reached. At 180 watts, the total harmonic distortion (THD) was about 0.02 percent over most of the audio-frequency range. It was a maximum of 0.08 percent at 20,000

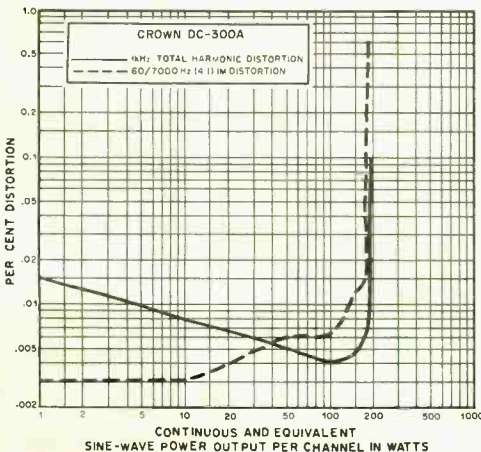
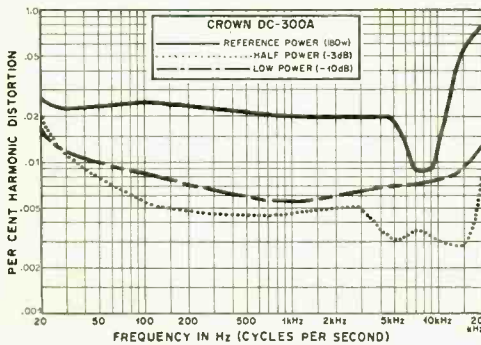

**free**  
**1974 Olson®**  
**240 big page**  
**catalog**



**93**  
**FAMOUS**  
**BRANDS!**  
**240**  
**BIG PAGES!**  
**MANY**  
**IN FULL**  
**COLOR!**

**SAVE on the NEWEST**  
**and BEST in famous-**  
**name product lines . .**

**A superstore of electronics at your fingertips**  
• Stereo/4-Channel Sound Systems • Tape Records and Accessories • Radios • Phonos • Kits • Amateur and Shortwave Gear • Citizens Band • Antennas • Police/Fire VHF-UHF Radios • Electronic Calculators and Timepieces • Security • Test Equipment • 1000's of Parts, Tubes, Batteries, Wire, Hardware

**Exclusive TELEDYNE and OLSON Audio Products**

**mail this coupon today**

**free**

**Olson Electronics** Dept. IN  
260 S. Forge St., Akron, Ohio 44327

Send me my FREE 1974 Olson Catalog

Name \_\_\_\_\_ Apt. \_\_\_\_\_

Street \_\_\_\_\_

City \_\_\_\_\_ State \_\_\_\_\_ Zip \_\_\_\_\_

Send a Catalog to my friend

Name \_\_\_\_\_ Apt. \_\_\_\_\_

Street \_\_\_\_\_

City \_\_\_\_\_ State \_\_\_\_\_ Zip \_\_\_\_\_

**CIRCLE NO. 24 ON READER SERVICE CARD**

Hz and was typically between 0.003 and 0.01 percent over the entire audio range at half power or less.

At 1000 Hz, the harmonic distortion was less than the noise level at most usable power outputs, with readings of 0.015 percent at 1 watt, 0.004 percent at 100 watts, and 0.0045 percent at the rated 150 watts. The intermodulation (IM) distortion was the residual of the test equipment on hand; about 0.003 percent up to 10 watts, increasing to 0.012 percent at 150 watts. The "crossover" distortion effect of most amplifiers is totally absent from the DC-300A (whose IM distortion remains very small at the lowest power levels, measuring a maximum of 0.014 percent at about 3 mW output).

The frequency response of the amplifier was as flat as our test instruments from 5 Hz to about 20,000 Hz. It was down 0.6 dB at 50,000 Hz and down 3 dB at 170,000 Hz. At the low end, the amplifier's response is actually flat to dc (zero frequency). In spite of the high power capability of the amplifier—it can deliver 40 volts to an 8-ohm load—the dc offset volt-

age across the load was an almost unmeasurable 3 mV.

**User Comments.** As engineers, we were highly impressed with the conservative design and almost literally unmeasurable distortion of the DC-300A amplifier. Even more impressive, and probably of greater significance to most users, is its ruggedness and immunity to the usual hazards of operation that cause otherwise satisfactory amplifiers to self-destruct.

Not only does the DC-300A handle the very low impedances of some speakers, or of several pairs of speakers in parallel, but it is not fazed by reactive loads or even by a complete short circuit across its outputs. We tried every abuse we could, including shorting the speaker terminals, with no result more serious than to draw some impressive sparks at the shorting points. Although the amplifier gets very hot with sustained full-power operation, its thermal overload breaker opens long before any damage can result. In normal use, even with the lowest efficiency speakers, the amplifier does not get even warm to the touch.

Circle No. 67 on Reader Service Card

## PACE MODEL 10-2 CB TRANSCEIVER

**T**HE PACE Model 10-2 AM Citizens Band mobile transceiver is designed to meet the needs for channel-9 emergency operation and provide two additional channels for specific operation between base and mobile or mobile-to-mobile units where only occasional contacts are required. In other words, this is a three-channel rig for those people who require something less than all-channel operational capability, but where emergency preparedness is to be included. And at \$70 retail, made possible by the omission of unnecessary frills such as a meter, PA operation, delta tune, etc., the 10-2 is very economical.

This is an extremely compact CB rig, measuring just 6¼" by 4¾" by 1¾". Its overall weight is 2½ pounds. The compact size permits easy installation in tight quarters when used in mobile service. In spite of its size, however, the 10-2's performance is excellent as evidenced by a measured receiver sensitivity of 0.35  $\mu$ V for 10 dB (S + N)/N at 30 percent modulation and 1000 Hz, adjacent-channel selectivity of 50 dB with a 6-dB bandpass of 6000 Hz, 0.35-500  $\mu$ V adjustable squelch threshold, 3.75 watts output at 13.8 volts dc, etc.



**The Receiver.** The receiver employs an r-f stage and mixer with single conversion to a 455-kHz i-f. Selectivity is obtained primarily with a ceramic bandpass filter located ahead of two transformer-coupled i-f stages. Image rejection is only 10 dB, which is about par for one conversion to 455 kHz. However, problems in this regard are not likely to arise inasmuch as the image is on the low-frequency side of the CB range where little activity is found. Other spurious-signal responses were approximately 50 dB down.

A diode detector also provides age action

which, with an input signal variation of 80 dB (1-10,000  $\mu$ V), held the a-f output to within 11 dB, a 7.5-dB change occurring at 1-10  $\mu$ V (20 dB), leaving only a 3.5-dB a-f change above 10  $\mu$ V of input. The age also controls the squeelch. An automatic noise limiter is a series gate type that functions full time and does an adequate job.

The a-f system employs two amplifier stages with a push-pull class-B output stage. As is customary, this setup also increases the microphone output level and modulates the transmitter. A jack is provided for using an external speaker in place of the speaker mounted in the rig.

The overall a-f response was found to be 670 to 2550 Hz at the 6-dB points, with a rolloff at the low-frequency end. Coupled with the upper frequency response, this ensures good crisp quality for maximum intelligibility. Up to 3 watts of a-f output into an 8-ohm load was obtained with slight clipping at less than 10 percent distortion at 1000 Hz. A good output of 2.5 watts was available with a 0.5- $\mu$ V r-f input signal.

**The Oscillators.** Individual crystal-controlled oscillators are used for the receiver and the transmitter. Each has three crystal positions. Crystals for only channel 9 operation are supplied with the unit. A receive and a transmit crystal are required for each of any of the two other channels to be selected by the customer. These are optional extras.

Since only one crystal is involved for either mode of operation, the overall frequency tolerance can be more readily maintained. For channel 9 we measured the tolerance at about 0.0024 percent while powering the 10-2 rig from a 13.8-volt dc source. Operated from a 12-volt source, the frequency dropped 80 Hz (from 27.065.645 Hz); but where such a voltage variation is encountered with attendant frequency change during mobile operation, this is of little consequence as far as AM is concerned.

**The Transmitter.** Following the transmitter's crystal oscillator are a driver and the power-output amplifier, both of which are collector-modulated. The power amplifier output circuit is a triple-pi section for harmonic and other spurious-signal attenuation and for matching to a nominal 50-ohm load.

At just slightly less than 100 percent mod-

**now 9**

**midget driver sets**

**for double duty**

**on dozens of popular screws & nuts**

Three new assortments have joined Xcelite's family of "Compact Convertibles." Each an Xcelite "original." No-where will you find such a variety of sizes and types in a midget set, for driving slotted, Phillips, Allen, Scrulox®, hex, and clutch head screws. And hex nuts.

All of professional quality, precision made of finest materials. All doing "double duty" with torque amplifier handle that slips over color-coded midget tools for longer reach, greater driving power. Each easily identifiable on the bench or in the service kit thru Xcelite's exclusive, optically clear, plastic "show case" that closes securely with positive snap-lock.

*nationwide availability through local distributors*

**NEW!**

**PS130** 3 slot tip, 2 Phillips screwdrivers, 5 nutdrivers

**PS140** 4 slot tip, 3 Phillips screwdrivers, 3 nutdrivers

**PS6** 3 slot tip, 3 Phillips screwdrivers

**PLUS** PS88, PS120, PS7, PS89, PS44 and PS-TR-1 with varying selections of screwdrivers and nutdrivers

REQUEST FREE CATALOG.



XCELITE INC. • 20 BANK ST., ORCHARD PARK, N. Y. 14127  
Send General Catalog No. 171 with information on Midget Driver Sets.

name \_\_\_\_\_

address \_\_\_\_\_

city \_\_\_\_\_

state & zone \_\_\_\_\_

In Canada contact Charles W. Pointon, Ltd.

**CIRCLE NO. 34 ON READER SERVICE CARD**



ulation, the waveform at 1000 Hz was good, with less than 7.5 percent distortion. With 10 dB of clipping at the maximum modulation point, the distortion held to within 15 percent. Some crossover at the negative peaks was observed during clipping, but with operation at normal voice-frequency levels under this condition, splat-

ter into the adjacent channel was 40 to 50 dB down.

Current drain on receive was about 110 mA at 13.8 volts with no signal, 625 mA on transmit, and 1.3 A with modulation. The 11-16-volt dc line is fuse-protected, and an L-type line filter here minimizes transient noises and voltage spikes from the vehicle.

Circle No. 68 on Reader Service Card

### ACTIVE BETA-3 BCB AUTO ANTENNA

**M**OBILE antennas for receiving the AM and/or FM broadcasting bands are generally fender-mounted telescoping whips or fine wire dipoles built into the vehicle's windshield. Most of these antennas are compromises and as such suffer from drawbacks not common to the stationary antennas used with home receivers.

Telescopic antennas are prone to damage by wind, low-hanging tree branches, low garage doors, car washes, and just plain vandalism. The wire dipole built into a windshield, at first glance, appears to be a fine idea, but it also suffers from inherent drawbacks. It can be too directional to suit the conditions encountered in normal driving; as cars twist and turn on roads, stations keep popping in and out with irksome regularity. But don't despair because there is a very acceptable solution to the problems encountered with most mobile antennas.

The "solution" we recently found was a new antenna imported from Germany. Called the Beta-3 active antenna by its maker, it is distributed in the U.S. by Active Antenna Co. at \$22.50. In its small plastic base is a transistorized two-channel amplifier, which is coupled to a short 15-in. stainless-steel whip antenna element.

The active antenna is designed to operate at frequencies between 150 kHz and 25 MHz (which includes AM broadcasting) and the FM broadcast band between 88 MHz and 108 MHz. The manufacturer claims a 10-15-dB gain over a conventional whip antenna on the AM and shortwave bands, while the gain figure is claimed to be 7 to 10 dB on the FM band.

The improved performance is based on the concept of integrating the actual antenna directly with a solid-state amplifier, thereby yielding a high signal-to-noise ratio. Built into the antenna are separate amplifiers for the AM/SW bands and the FM band. Each amplifier has associated filter networks to reduce interaction between

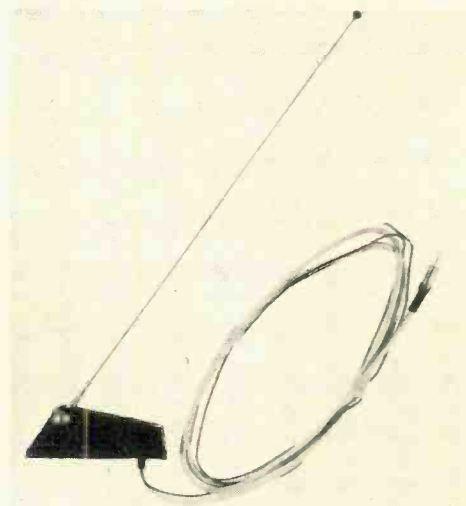

them. The operating amplifier requires between 6 and 12 volts dc at a 10-mA current drain. These demands are easily met by connecting the active antenna to the electrical system of a car, truck, camper, etc.

The antenna can be installed almost anywhere on a vehicle or boat as far away from engine ignition noise as the vehicle will permit. The short antenna element can be tilted to compensate for areas in which the field signal strength is excessive—especially useful if you happen to do most of your driving in large urban areas where local powerful transmitters have a tendency to "swamp" the system. As an added touch, the antenna element is easily removable from its pivot mount if a vehicle must be left in an unsupervised place, thus obviating the possibility of vandalism.

The antenna is supplied with a length of coaxial cable to which is affixed a connector that mates with the antenna input jacks found on auto radios. A length of flexible power cable is also provided for hooking up the electrical system of the vehicle.

We found no difficulty whatever in installing the antenna on our car, following carefully the installation instructions provided with the antenna. We had to drill two small holes to accommodate the permanent-installation mounting screws. The antenna's plastic base contains a rubber gasket for weather-sealing.

Living in a large urban area as we do, we rarely experience any reception problems. But, being a salt-water fisherman—a hobby we pursue quite actively—we often find ourselves in areas where radio reception is pretty bad. With the Beta-3, reception far

from the big city was greatly improved. As a test, we swapped the Beta-3's coax with our old fender-mounted whip's coax for an A-B comparison. The advantages of using the Beta-3 left no room for doubting that the active antenna is far superior to ordinary passive antennas.

Incidentally, if you live in an area plagued by vandalism, you might consider replacing your old antenna with the Alpha-3 active antenna. This little gem, retailing for \$26, is camouflaged to look—and work—like a rear-view mirror housing. It has all of the characteristics of the Beta-3.

Circle No. 69 on Reader Service Card

### HEATHKIT MODEL IC-2108 DESK CALCULATOR and MODEL IC-2009 POCKET CALCULATOR KITS

IT SEEMS almost every retail establishment these days provides a choice of a dozen or more electronic calculators at enticingly low prices. The calculators come in all sizes and shapes, ranging from large ac-operated desk models to ultra-compact battery-powered pocket portables. Some models lack the basic amenities, while others go overboard with features most of us are not likely to use enough to justify their extra cost.

A good compromise calculator for ordinary use would be a four-function unit with a built-in "constant" memory. It would be as easy to operate as a Touch-Tone telephone, have a numeric display system of no less than eight digits, and contain a decimal locator. Overflow, excessive-entry, and true credit balance indicators and a clear-entry key that permits the removal of an erroneous entry without wiping out previous calculations would also be considered "basic" in a utilitarian calculator. All of these features are integral to a pair of new calculator kits recently introduced by the Heathkit people.

Heath's new calculator kits include the Model IC-2108 ac-powered desk-top unit and the Model IC-2009 battery-powered pocket portable. These kits retail for \$80 and \$92.50, respectively. The only optional item available is the ICA-2009-1 Naugahyde carrying case for the pocket portable; it retails for \$3.95.

**Similarities and Differences.** The desk-top Model IC-2108 is built into a molded plastic case. The keyboard panel is sloped for comfortable operation and ready access



to all keys and switches. Arranged above the keys, and sloped at a comfortable viewing angle, is an eight-digit readout system and an overflow, excess-entry, and credit balance indicator. The readouts themselves are extra-large  $\frac{3}{4}$ " seven-segment gas-discharge types that glow a brilliant orange. A pair of rocker switches allows the choice of floating decimal or fixed 2- or 4-place decimal location.

The IC-2009 pocket portable can be powered from its built-in AA-size nickel-

cadmium rechargeable cells or line operated with the aid of the battery charger/ac adapter that comes with the kit (instead of being offered as an option). The eight-digit (also with overflow, excess-entry, and credit balance indicator) readout system consists of a single light-emitting diode array. Character size for the red numerals is roughly  $\frac{3}{4}$ " for a high degree of readability.

Since the IC-2009 is a battery-powered unit, it contains two special features that we would like to see used on all portable calculators. The first is that its power switch is recessed in the case and requires sufficient force for operation to prevent turn-on by any but deliberate means. So, you can safely put the calculator in your briefcase or a drawer without having to worry about battery run-down. The second feature is an ingenious display shut-down system that really conserves battery power. This system disables the power to the readout system—but *not* the logic circuitry—should an entry not be made in 15 or 20 seconds after the last was made. The display fades, leaving only the center bar of the center digit lighted to indicate that power is still applied. The display can be restored simply by depressing the "D" (display) key or continuing with the calculations. When the battery pack is ready for recharging, an "L" (low) lights up on the overflow indicator.

Aside from the size, shape, powering requirements, and readout device differences between the two calculators, there is also a marked difference in their respective keyboards. In the IC-2108 desk model, each key is a separate switching element that must be individually mounted and soldered to the keyboard PC board. Key travel is comparable to professional calculators. Neither the keys nor the power and constant switches need be mounted and sol-

dered to a PC board for the IC-2009 pocket calculator; the whole thing comes as a factory-wired assembly, ready for installation. Key travel is not as far, but it is very positive and has a reassuring audible click when contact is made.

There are also differences in the operation of the two keyboards. For example, let us say that you have the problem  $8 \times 3 \div 6 + 7 - 8 = 3$ . With the IC-2108, you would depress each number and function key exactly as shown in the problem. However, when using the IC-2009, the keys would have to be depressed as follows:  $8 \times 3 \div 6 + = 7 + = 8 - = 3$ . If you were to attempt to enter the  $- 8$  before operating the  $+ =$  key, the answer would be negative and incorrect. This might at first appear to be an awkward way to do things, but one soon becomes accustomed to it.

**Assembling the Kits.** As with any assembly project with IC's, a low-wattage, fine-point soldering iron is a must when assembling the calculator kits. Also, since the LSI chips used in the calculators are MOS devices, special care must be exercised when handling and installing the IC's. However, the handling is not so special that the average kit builder cannot tackle it successfully—especially when he has the well-written, illustrated Heathkit assembly manuals to guide him.

Total assembly time for each of the kits was the same: about 8 hours in each case. We practiced the same kind of care we do with all IC projects and encountered no difficulties with either component mounting or lead soldering to the closely spaced conductor patterns on the PC boards. Nor did we have any problems with solder bridges when we used our "PC-type" soldering pencil.

Circle No. 70 on Reader Service Card

## FREE McIntosh CATALOG and FM DIRECTORY

McIntosh Laboratory, Inc.  
East Side Station P.O. Box 96  
Binghamton, N.Y. 13904  
Dept. 16-5

**SEND  
TODAY!**

NAME \_\_\_\_\_

ADDRESS \_\_\_\_\_

CITY \_\_\_\_\_ STATE \_\_\_\_\_ ZIP \_\_\_\_\_

CIRCLE NO. 20 ON READER SERVICE CARD

Get all the news and latest information on the new McIntosh Solid State equipment in the McIntosh catalog. In addition you will receive an FM station directory that covers all of North America.



**MX 113**

AM FM/FM STEREO TUNER PREAMPLIFIER

POPULAR ELECTRONICS Including Electronics World





# Motorola's 1974 Color TV Receivers

By John T. Frye, W9EGV, KHD4167

"I SEE you're at it again," was Barney's early morning greeting to Mac, his employer, who was sitting at a back bench literally covered with pictures, service manuals, press releases, and other manufacturer's literature, all bearing the name of "Motorola" or that company's distinctive emblem: a heavily shaded, stylized black "M" within a circle.

"Yes," Mac replied; "now that we've boned up on Zenith and RCA color sets, I think it's time we studied the 1974 offerings of another leading manufacturer, Motorola. The first thing that impresses me, naturally, is the serviceability of these color sets. As I'll explain later, that's no accident. But first let's back off and take a panoramic view of the whole color line.

**The Entire Line.** "By my count Motorola offers 37 color TV receivers that include one each of 12", 14", 16", and 17" portables; two 18" portables; five 19" portables; three 21" table models; three 23" consoles; eight 25" Quasar II consoles that are solid-state except for four chassis tubes; eleven 25" Quasar consoles that are all solid-state; and one unique 21" table model that can be switched to receive either the NTSC color system we use in this country or the PAL system used in Europe. All models have 'Insta-Matic' color tuning in which the push of a single button automatically balances color hue, intensity, brightness, and contrast and activates the automatic tuning. All console models except one 23" use black-matrix, negative-guard-band picture tubes, and this type of tube can also be had in two of the 19" portables.

"The 'Satellite Remote Control' is available on one 19", one 21", and eight 25" models. The mechanical ultrasonic transmitter has only two buttons that turn the set on and off, select a desired vhf or uhf channel

(except for the 19" portable which selects only vhf channels), and adjust the volume. This simplified control is possible because the Insta-Matic circuitry of the chassis maintains a stable color picture when changing channels. The vhf tuners are of the type that permits pre-set fine tuning, and the solid-state uhf tuner comes in four versions in different models: 70-detent-click, continuous, pushbutton, and varactor tuned. In the pushbutton type, up to five uhf channels can be set up for pushbutton selection just as you set up a car radio."

"The thing that impresses me," Barney interrupted, "is that 'Works in a Drawer' solid-state chassis that pulls out from the front of the set on guides. You can have the whole chassis right there in front of you, with the picture in plain view, while you probe around with a diddle stick or tap components to locate an intermittent connection. A Motorola service technician told me 94% of the components in these sets are mounted on plug-in modules, or 'panels,' as he calls them. Even tuners plug in, and anyone who has had to unwire an easily damaged, easily misaligned tuner and wire in another in cramped quarters to see if that is the trouble knows what a blessing a plug-in tuner can be. He says Motorola sets use up to ten panels and that the most expensive, the Electronic Power Supply Module, costs the customer only \$18 on an exchange basis."

**Electronic Power Supply Module.** "That power supply, introduced in the 1972 models, is one of the most interesting engineering features of these sets," Mac commented. "Essentially it transforms rectified 60-Hz current into 15,750-Hz pulses that are applied to the primary of a lightweight 'fly-back' transformer whose secondary then furnishes seven different 15,750-Hz ac

voltages that are rectified to produce positive and negative voltages for powering the chassis and heating the filament of the CRT, as well as high-frequency ac for heating pilot lamps.

"Dc through the primary is turned on at a 15,750-Hz rate by a switching transistor switched by a square-wave input. This input originates as pulses from an oscillator locked in sync to the horizontal sweep circuit. These pulses pass through a shaper that transforms them into square waves and thence to a driver stage to the switching transistor. This switching transistor is turned on only when the positive-going portion of the square wave is present at its input. How long it remains on, and consequently how much power is delivered to the primary, depends on the duration of this positive portion of the square wave.

"This affords a means of power and volt-

creases to an unsafe level. An SCR samples the emitter resistor voltage of the switching transistor. If an overload causes this voltage to rise above a pre-set level, the SCR fires and shortcircuits the square-wave input of the switching transistor, preventing it from turning on. The SCR continues to conduct and keep the switching transistor off until all power is removed by turning the set's on/off switch off momentarily. The SCR then becomes non-conductive and allows the power supply to operate when turned on."

"I'd think that kind of power supply would have lots of advantages."

"It does. First, there is isolation of the chassis from the AC line. It regulates for line voltage changes in the same way it regulates for power demand changes. The powdered-iron core of the high-frequency transformer is much lighter than the heavy

Photo shows a comparison of the Motorola "JA" electronic power supply (near right) used in the Quasar sets and the previously used power supply. The new unit weighs about 1 $\frac{3}{4}$  pounds as compared to 13 pounds for the original iron-core power supply.

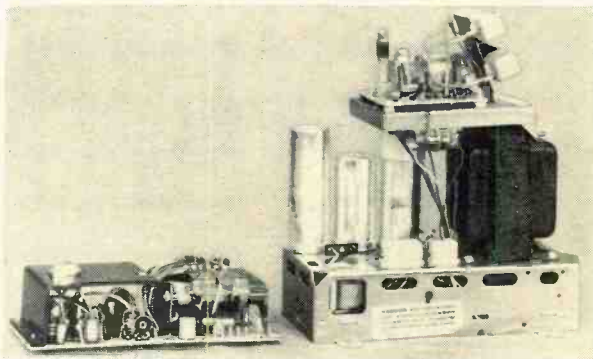

age regulation. Suppose you increase the brightness and so the load demand on the secondary. This drops all secondary voltages. A sensing winding on the secondary passes this voltage drop to a voltage-regulating transistor whose resulting changed output is passed to the shaper stage. There it widens the square wave delivered to the driver and thence to the switching transistor. The resulting longer on time of this switch delivers more power to the primary and brings the voltage of the secondary windings back up to where they were before the brightness was advanced. A decrease in power demand in the secondary has the opposite effect: it causes the VR transistor to narrow the square wave put out by the shaper and so reduce power in the primary and voltage in the secondary.

"Still another feature is automatic shut-down of the power supply if the load in-

creases to an unsafe level. At the higher frequency, filter capacitors are substantially smaller in both size and capacitance."

**Dual System Sets.** "How about that set that operates on both the NTSC and the PAL systems?"

"That's the ZX600JW Model obviously intended for people who globe-trot and don't want to have to buy a new TV set every time they cross the pond. It covers all NTSC channels, all PAL uhf channels, and eight PAL vhf channels. PAL channels 2, 11, and 12 are out of the receiver tuning range. The chassis includes both 4.5-MHz (NTSC) and 5.5-MHz (PAL) sound i-f and color processing circuits for both systems of transmission. Switching diodes, controlled by a PAL-NTSC switch on the front panel, activate the appropriate circuit. Tuners,

# IF YOU HAVE STEREO, YOU ALREADY OWN HALF A 4-CHANNEL SYSTEM! ADD THE 2nd HALF FOR 164.95. BY REALISTIC®.

Save 17.45 off our "each" prices for everything you need to move up to true quadraphonic sound!

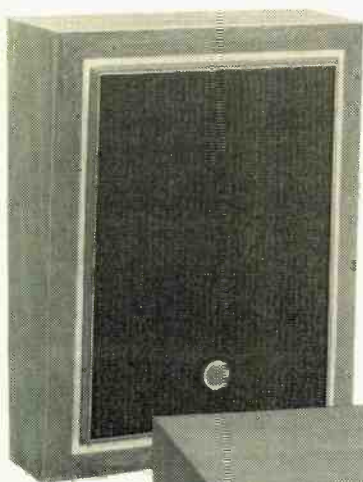

Baffle/Speakers  
With Walnut  
Enclosures



24-Watt Stereo  
Amplifier



SQ-II 4-Channel  
Decoder

SQ-II Decoder Alone 39<sup>95</sup>

Your stereo components are ready and waiting for easy updating to 4-channel. Our SQ-II Decoder unscrambles all matrixed 4-channel records, tapes and FM broadcasts and even gives a 4-channel effect to regular stereo. Add it, and our SA-175B Amplifier

plus two deluxe Baffle/Speakers to your system, and hear sound from front and rear, left and right—the way you hear actual "live" music. Simple hookup, no internal rewiring. Get a demonstration at any of 2000 Radio Shack stores in all 50 states!

Now Playing at Over 2000 Stores in ALL 50 States

Price may vary at individual stores.



**FREE '74 CATALOG** 282

AT YOUR NEARBY STORE OR  
MAIL THIS COUPON

180 Pages . . . Full Color! Hi-Fi, CB, Kits,  
Recorders, Antennas, Parts, More!

PLEASE  
PRINT  
CLEARLY

Name \_\_\_\_\_ Apt. # \_\_\_\_\_

Street \_\_\_\_\_

City \_\_\_\_\_ State \_\_\_\_\_ ZIP

**REALISTIC®**

by

**Radio Shack®**

and ALLIED RADIO STORES

A TANDY CORPORATION COMPANY

P.O. Box 1052, Fort Worth, Texas 76107

CIRCLE NO. 26 ON READER SERVICE CARD



part of the video i-f, the audio output, and the deflection circuits are common to both systems. To change from one system to the other, you simply push the PAL-NTSC switch and fine tune the desired channel. This initial fine tuning is necessary because of the difference in channel allocations in the two systems. For example, in the PAL system the video carrier, chroma carrier, and sound carrier frequencies of channel 3 are respectively 55.25 MHz, 59.68 MHz, and 60.75 MHz. In the NTSC system, they are, for channel 2, 55.25 MHz, 58.83 MHz, and 59.75 MHz. Here is the service manual on this cosmopolitan TV receiver. I think you'll find it technically very interesting, even if you never expect to service one."

**Serviceability.** "Okay, but you said you'd tell me why the serviceability of Motorola color sets is no accident."

"That's right. I'm always interested in the basic philosophy of the manufacturer of any product, and we have a rare opportunity to examine the Motorola philosophy through a speech delivered by Edward P. Reavey, Jr., Vice President & General Manager of the Consumer Products Division of Motorola, Inc., to the American Management Association in September, 1971. Let me read you a few excerpts from it:

"Change is taking place throughout the land . . . There are early warnings that an anti-materialistic mood could be building. More Americans appear to be interested in meeting their basic needs as easily and inexpensively as possible. . . . Many are moving away from the big shiny cars to small cars. . . . There's less interest in big TV-stereo combinations and more demand for smaller sets. People want reliability and serviceability from their cars and TV sets. . . . The product [they buy] often costs less than the service performed on that product. . . . People are angry. Mad. Sore. . . . This is what consumerism is all about, gentlemen—service.

"For too long, service has been treated as a dingy back-room operation in too many companies. Top management has paid little or no attention to this part of the business. . . . We have been so busy building new and better products . . . that we simply have not learned how to serve the customer. . . . Top management had better find out where the service department is located, who runs it, and how well he runs it. . . . The head of service should

be a part of top management. In my company, he is. My service manager is a vice president. Service requires that kind of authority and visibility today. We "think" service from the design of the color TV until the ultimate consumer tells us he is happy with our product. . . . I am completely convinced that success and even survival of a company in the 1970's and 1980's will depend upon how well that company serves the consumer.'

"There was lots more to the speech," Mac said, laying the paper aside, "in which he tells what Motorola has been doing about improving service to their customers. This does not stop with improving the serviceability of their sets with the module concept—which they pioneered in 1967—and with the 'Works in a Drawer' idea. He is opposed to what he calls 'cosmetic consumerism' in which a token attempt is made to placate the consumer with 'plastic programs announced with great fan-fare.' Such programs include the listing of a trouble phone, an expensive media campaign, and the appointment of a vice president of consumer affairs. As Mr. Reavey points out, 'When an angry customer contacts you, it's just possible you've already lost him as a future buyer, no matter how rapidly and efficiently you respond to his call for help.'

"So, according to Mr. Reavey, Motorola has been trying to anticipate complaints. They tested a program of phoning purchasers of Quasar TV sets to see if the owner was satisfied with his purchase. If not, they went out and saw to it that he was. Mr. Reavey himself began dropping into consumers' homes as he went about his business. He took along a service manager, and if the Motorola customer had a problem, the service manager fixed it. Public reaction to these programs was about the same as would be evoked by the advent of the millennium!"

"I can well imagine," Barney exclaimed. "But that sounds as though someone might have been listening to us after all. I've heard you say a hundred times that it is downright stupid not to have a good technician play a major role in the design of a color receiver; and how many times have I seen you pick up the telephone and make sure that a set we'd fixed was working satisfactorily?"

"All that proves," Mac said with a grin, "is that a really good idea is seldom the property of one person!"

Mail the Card Today!

# FREE

Find All Your Electronic Needs  
In One Complete Book



468  
PAGES

The World's Largest  
Consumer Electronics Catalog

Featuring Everything In Electronics for:

• HOME • INDUSTRY • LABORATORY

All From One Source—All From One Catalog!

- Stereo Hi-Fi • The Latest in 4-Channel Stereo
- CB Equipment • Ham Gear • Test Equipment
- Tools • PA & Intercom Systems • TV • Radios
- Musical Instruments • Cameras • Auto Accessories
- Tape Recorders • Tubes, Books, Parts
- and Much More!

Mail This Card Today for a Friend

### STORE LOCATIONS

NEW YORK	PENNSYLVANIA	GEORGIA
NEW JERSEY	MARYLAND	INDIANA
CONNECTICUT	OHIO	VIRGINIA
MASSACHUSETTS	ILLINOIS	MISSOURI
WISCONSIN	MINNESOTA	

LAFAYETTE RADIO ELECTRONICS  
P.O. Box 10  
Syosset, L.I., N.Y. 11791

Please Send the FREE CATALOG 740 35113

Name \_\_\_\_\_  
 Address \_\_\_\_\_  
 City \_\_\_\_\_ State \_\_\_\_\_ Zip \_\_\_\_\_

MAIL THIS  
CARD TODAY



# FREE!

LAFAYETTE  
CATALOG 740

35113

Name \_\_\_\_\_  
 Address \_\_\_\_\_  
 City \_\_\_\_\_  
 State \_\_\_\_\_  
 Zip \_\_\_\_\_

MAIL THIS  
CARD TODAY



# FREE!

LAFAYETTE  
CATALOG 740

35113

Name \_\_\_\_\_  
 Address \_\_\_\_\_  
 City \_\_\_\_\_  
 State \_\_\_\_\_  
 Zip \_\_\_\_\_

Mail This Card Today For Your

# FREE

1974 LAFAYETTE CATALOG 740

## 468 Pages



- Stereo Hi-Fi • CB Equipment • Test Equipment • Musical Instruments • Ham Gear • PA Systems • Cameras • Auto Accessories • Tools • Books • Parts • and Much More!

### SATISFACTION GUARANTEED OR MONEY REFUNDED

#### LAFAYETTE Leads The Way In 4 CHANNEL STEREO Components



LR-4000



Micro 23  
CB 2-Way Radio



Dyna-Com  
Walkie-Talkies



Musical  
Instruments &  
Accessories

#### Do A Friend A Favor . . .

Have a friend interested in hi-fi or electronics? Send us his name and address and we will send him his own personal copy of the 1974 LAFAYETTE Catalog 740.

## FREE! Mail the Card Today!

# LAFAYETTE

## RADIO ELECTRONICS

P.O. BOX 10  
SYOSSET, L.I., N.Y. 11791

PLACE  
STAMP  
HERE

# LAFAYETTE

## RADIO ELECTRONICS

P.O. BOX 10  
SYOSSET, L.I., N.Y. 11791

PLACE  
STAMP  
HERE



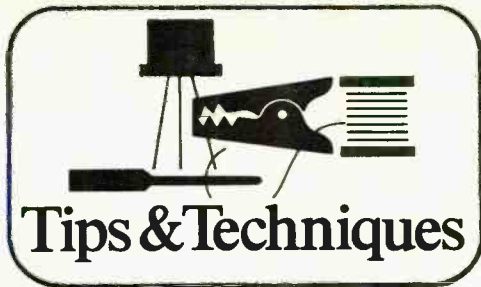

## Tips & Techniques

### COMMERCIAL BREADBOARDING SOCKETS SIMPLIFY ELECTRONICS EXPERIMENTING

The typical breadboard and all it conjures up to old timers has always been the mainstay of the electronics experimenter. The earliest ones were contrivances of lumber and nails. After

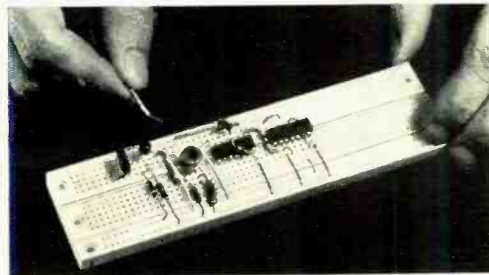

that came "pegboard" and spring clip arrangements. More recently, some equipment manufacturers have been making exotic breadboarding devices that relieve the experimenter of having to assemble his own. The Continental Specialties Corp. (325 East St., New Haven, CT 06511) QT, for quick-test, Sockets are prime examples of what we experimenters are switching over to. They range in price from \$2 to \$12.50 for the one shown in the photo and are worth every cent if you are as avid an experimenter as I am.

—J. Pina

### WIRE NUTS AND MACHINE HARDWARE MAKE EXCELLENT EMERGENCY BINDING POSTS

Here's a tip you might try when you need binding posts without the "five-way" action. Hunt up some #6 machine hardware, solder lugs, shoulder and flat fiber washers and as many wire nuts as you need binding posts. Into the open end of each wire nut, epoxy a machine nut. Meanwhile, slip onto a machine screw a locking-type solder lug and shoulder fiber washer and fit this assembly into the binding post mounting hole, following it with a flat fiber washer and another machine nut. Tighten securely. Mount similar assemblies in the remaining binding post holes. When the epoxy sets, screw on the wire nuts and you're ready to go. Your binding posts won't accept banana plugs or tip probes, but they'll be ideal for spade lugs and wire wraps.

—Michael A. Bandemer

### THICK-TIP FELT MARKERS INCREASE COLOR-CODE RANGE

When more colors are needed than are available for a color-coded cable harness, use a thick-tip permanent felt marking pen to increase the color range. To use the marker, first straighten out the length of the wire needed and run a stripe along the insulation from end to end. Then slowly roll the wire over to make a spiral band, drawing the marker along the insulation. Since permanent marker ink is not opaque, it is best if you confine yourself to the lighter colors in insulation, such as white, yellow, light gray, etc. Also, if you have several different color markers, you can really expand the color-coding line and go to three and even four colors (on the same wire) when many conductors are needed.

—Herbert C. Wottle

### MAKE YOUR OWN LOW-COST INSPECTION MAGNIFIER

A handy work light and close-up inspection magnifier for working with small electronic parts and assemblies can be made from an ordinary "high-intensity" desk lamp and a read-



ing magnifying lens as shown in the photo. The magnifying glass readily mounts to the lamp's shade with the aid of machine hardware and a small metal L bracket. Since some of these lamps have small lightweight bases, a potential tipping-over problem can be circumvented by mounting to its bottom a heavy weight, such as those used with rabbit-ears antennas.

—Marshall Lincoln

### TIPS WANTED

Do you have a "tip" or "technique" that might help your fellow readers? It may be worth money to you. Send it in (about 100 words, with a rough drawing and/or clear photograph, if needed) and you'll receive payment if accepted. Amount depends on originality and practicality. Material not accepted will be returned if accompanied by a stamped, self-addressed envelope. Send material to: Tips and Techniques Editor, POPULAR ELECTRONICS Including Electronics World, 1 Park Ave., New York, NY 10016.

# SILICON SOLAR CELLS

*What makes them work;  
where they are used*

BY JOSEPH H. WUJEK

THE photoelectric effect that takes place in certain materials has long been known. However, it was not exploited in semiconductors until the mid-1950's when Bell Laboratories produced a solar cell, a device that converts the sun's energy into electrical energy. Then, as semiconductor technology expanded, improvements in solar-cell performance followed.

Although solar cells employ diverse materials, in this article we will discuss only the silicon device. Because of its high efficiency, stability, and reliability, silicon has become the most important and widely used material in solar cell technology.

**Physical Principles.** Before expanding in detail the characteristics of the silicon solar cell, let us review the physics involved in its operation to get a better understanding of the device's characteristics. Figure 1 shows a pn junction that is similar in principle to a simple semiconductor diode. While the events occurring in the junction are like those of an ordinary diode, several important differences in construction should be noted.

If useful application of the device as a solar cell is to be made, the surface area must be as large as possible to permit it to "see" the maximum amount of sunlight.

However, recognizing that silicon is an easily damaged brittle material, a surface area of roughly 2 cm on each side ( $0.8'' \times 0.8''$ ) was chosen. A means for drawing off the electrical energy generated by the cell was required; so, leads were attached to each side of the junction, with care taken to minimize the area used for connections on the "sun side" to avoid obscuring the sunlight from the active portion of the device. Then, to reduce the cell's resistivity, thin metallic "fingers" or grids are often used on the active surface, while the other side may be entirely metallized.

Depending upon the spectrum (wavelength characteristic) of the excitation light and the physical properties of the cell, electron-hole pairs are generated and a voltage appears across the terminals. If a resistance is placed across the terminals and the voltage and current for various loads are measured, the voltage-current (V-I) characteristic for the cell can be determined. A typical V-I plot for a commercial 2-x-2-cm silicon cell is shown in Fig. 2. (Note: the silicon solar cell has a negative temperature coefficient of 2 mV/°C; its output decreases by approximately 2 mV for each 1°C rise in temperature.)

**Performance Characteristics.** To predict the performance of a solar cell, we must rely on spectral response measurements which state the cell's output as a function of the wavelength of the incident light for

a given brightness. Energy is inversely related to wavelength (the higher the energy, the shorter the wavelength). The spectral response of the cell, as well as the spectral output information of the sun, enable us to predict the cell's performance.

In Fig. 3 is given the spectral response of a silicon solar cell. The wavelength is stated in angstroms (Å), equal to  $10^{-10}$  meter, or  $10^{-4}$  micron. The visible portion of the spectrum extends from 4000 Å (ultraviolet) to 7000 Å (infrared). The curve plot is given in terms of percent of peak (normalized) short-circuit current for a constant light intensity (flux). The curve's shape remains the same over a broad range of flux levels, although the short-circuit current increases with increasing flux. To find the total output of the cell, the function must be integrated, yielding the area under the curve.

The curve is statistical in nature. It is a measure of the number of electrons that are excited into the conduction band of the p-n junction. At the right, no output is obtained until the energy is increased to about 11,000 Å—which corresponds to the 1.1 eV of energy required to "trigger" the mechanism in silicon. The presence of excess electrons lowers this threshold somewhat so that some output appears at energies slightly below 11,000 Å.

As the energy is increased, more electrons are dislodged because an electron given additional energy can also collide with other



Fig. 1. Cross section of silicon solar cell shows its similarity to simple pn junction.

Fig. 2. Voltage-current characteristic for a silicon solar cell at 20°C with noon sun at right angles.

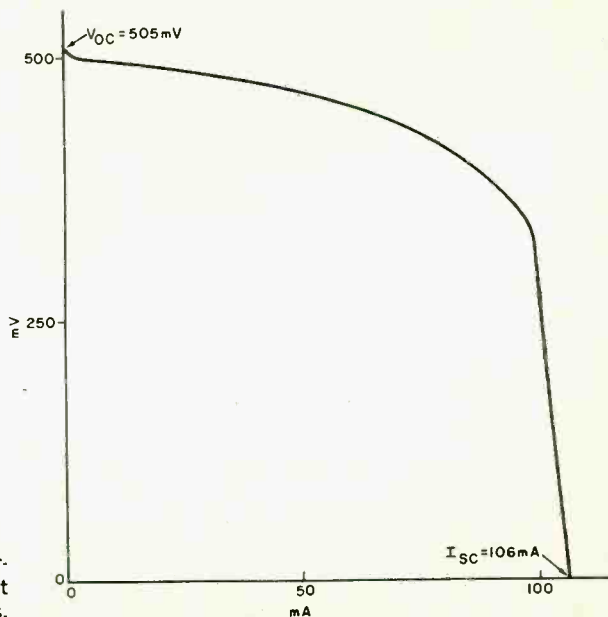



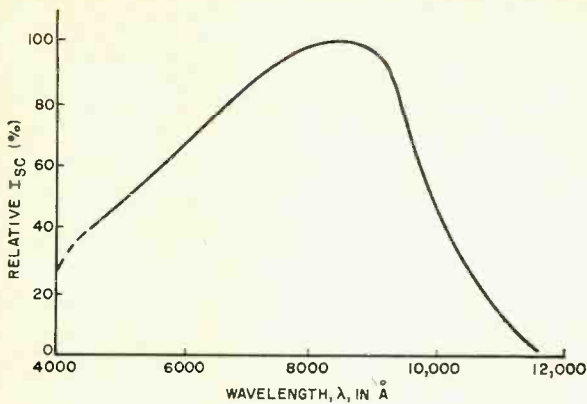

Fig. 3. The spectral response of a silicon solar cell in terms of peak short-circuit current for a constant light intensity (flux).

electrons and transfer some of its energy, yielding additional electrons. If the energy is increased beyond a certain limit, the output decreases. This is due to the bluish-purple color of the silicon-dioxide passivation layer on the top of the cell; this layer filters the light in this energy region so that the junction does not "see" as much light. A further increase in energy would ultimately destroy or at least degrade the cell with X-rays.

The information given in Fig. 3 is useless unless something of the nature of the spectrum associated with the sun is known if the cell is to be excited. The relative spectral output of the sun, as viewed at the earth's surface, is shown in Fig. 4. The dips are due to atmospheric absorption of certain wavelengths.

The flux from the sun observed at the earth's surface depends upon the geographic location, time of year, and time of day, as well as local atmospheric and elevation conditions. For most of the U.S., the peak flux is 80-90 mW/sq cm, measured for clear-sky conditions at solar noon. For standardization, most workers in the field use

the so-called air-mass zero (A.M.-0) flux, 140 mW/sq cm, based on measurements performed in high-altitude balloons and solar simulators. The peak earth-surface flux at noon for the above conditions corresponds to an air mass of 1 (A.M.-1). For times other than noon, the air mass is greater than 1, with an attendant decrease in flux. This effective increase in air mass, as well as the change in the incident angle of the sun throughout the day, cause variations in the output of a stationary terrestrial solar array.

The output current of a solar cell decreases as the angle of incidence of the sun changes from perpendicular to the cell. This roll-off is shown in Fig. 5. The "best" angle for mounting an array of solar cells will depend on geographic location, time of year, and time of day. A sun-tracking mechanism can be used to rotate the cells and at the same time vary the array's tilt to keep the sunlight perpendicular to the plane of the cells. Earth satellites use this scheme, although it is more common for them to have cells that "look" in all directions simultaneously. In Fig. 6 is shown a satellite of the latter category; so long as it is not oriented in an end-on attitude or is eclipsed behind the earth, power will be generated by the array.

For the most part, cells supplied by U.S. manufacturers are either rectangular ( $1 \times 2$  cm) or square ( $2 \times 2$  cm), although other

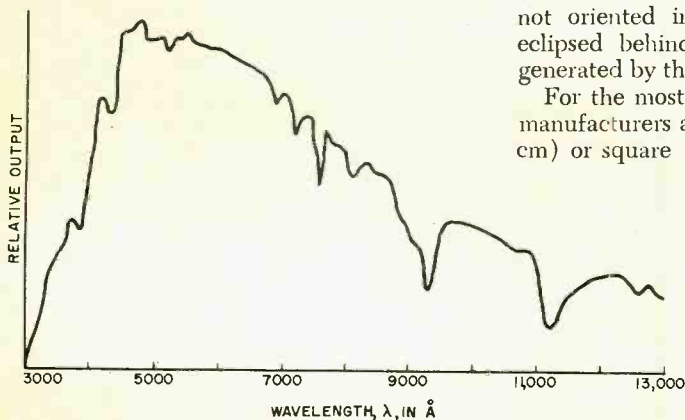

Fig. 4. Relative spectral output of the sun viewed at surface of the earth.

sizes and shapes are also manufactured. For example, Fig. 7 shows cells made by IRC. They have more than 95 percent of their surface area active. (Electrical contacts occupy a small fraction of the area.)

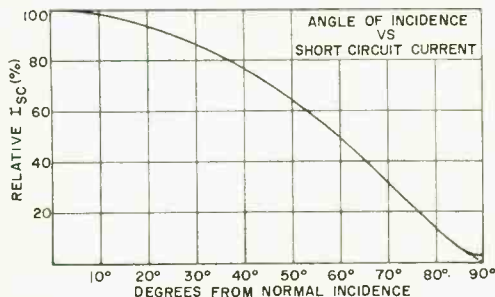

Fig. 5. Plot of change in the short-circuit current as the angle of incidence is altered.

Most silicon solar cells have an efficiency of 8 to 11 percent. (At 90 mW/sq cm of sunlight, a 2-x-2-cm cell will have a 26-36-mW output.) The peak output also depends on the load.

Since the individual solar cell has an output of about 0.5 V, cells must be interconnected in series and parallel configurations to raise the voltage and current, respectively, to the load's demands. To prevent one series string from driving current into another string, isolation diodes are used. These diodes are particularly important when sunlight is reduced or cut off from a string. If the diodes were not present, the shadowed string would appear as an ordinary diode across the unshadowed cells, reducing the voltage and perhaps destroying the cells by drawing excessive current. Diodes can also be used to protect individual cells in an array.

**Types & Applications.** Centralab Semiconductor manufactures a standard array that provides up to 6 watt-hours a day. The panels can be had at nominal outputs of 4.7, 7, 14, 16.5, or 28 volts at a nominal 1-watt output. The array's area is 5½ x 6¾ in., and weight is about 2 lb. Panels such as these are used to power weather recorders, snow-depth recorders, and pipe-line monitors.

Centralab, along with Heliotek and International Rectifier Corp., furnish most of the silicon solar cells manufactured in the U.S. Although some panels are available as standard items, most of the arrays made by these companies are to customer speci-

cations. Individual cells are also supplied for user-designed arrays.

An example of what can be done in designing an array is the FRUSA (Flexible Rolled-Up Solar Array) developed by Hughes Aircraft Co. The system (Fig. 8) consists of two 16-x-5½-ft. solar panels on which are mounted a total of 34,500 2-x-2-cm cells. The mounting medium is du Pont's Kapton® film, and a 0.006-in. glass cover protects the cells. Fabricated in this manner, the arrays are flexible and can be rolled up in window-shade fashion on a 10-in. diameter cylinder. The 1500-watt, 28-volt system was designed for satellite applications.

The FRUSA system represents an improvement of 300 percent/lb ratio over space power systems developed in the past. Hughes engineers are hopeful that the FRUSA concept will find application in powering electrically propelled spacecraft in interplanetary exploration.

A proposal for building solar-powered stations has been advanced by E.L. Ralph of Heliotek. He points out the need for developing new sources of power to alleviate the fossil fuel shortages that are bound to occur. These stations would consist of great quantities of solar concentrators to reflect the sunlight to the solar cell over a broad range of solar angles. Ralph be-

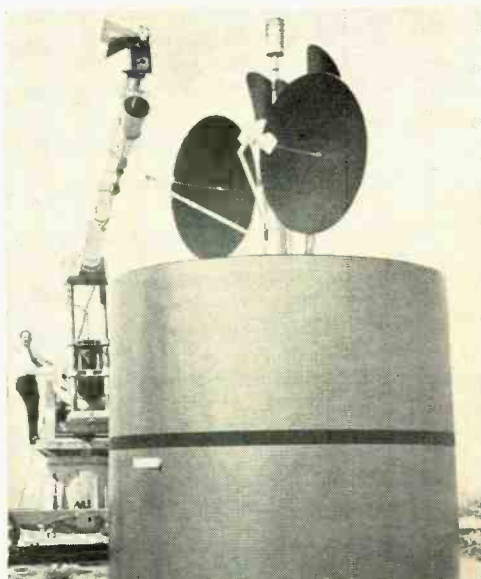

Fig. 6. Intelsat 4 communication satellite showing the solar cells that are mounted around circumference. By contrast, the Sky Lab satellite which is in orbit uses flat panels.

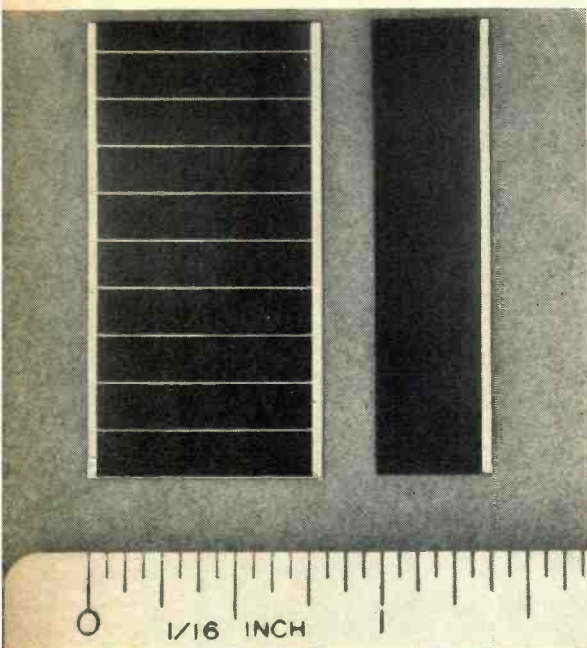

Fig. 7. IRC silicon cells occupy 95 percent of the surface; contacts make up the rest.

believes that such a system could be built at a cost of between \$2000 and \$10,000 per kilowatt for small power stations and as little as \$1000 for large stations. The prospects of such installations is appealing since solar energy costs nothing and maintenance would be only a small effort when compared to present-day fossil-fuel stations.

Less exotic, but no less important perhaps, are other applications of solar cells. With the growing emphasis on preservation of our natural resources, the migratory habits of wildlife are of considerable interest. Schemes for implanting tiny transmitters in birds and sea otters have been discussed; they would be powered by small solar arrays attached to the subject. Information gathered in these studies is of fundamental importance in preserving the well-being of the species.

With travel by automobile gaining in popularity in the U.S., the need to provide emergency roadside call boxes also grows. In those areas that are remote from power lines, solar cell powered call boxes could provide the means for furnishing this needed service. Even in those areas where power lines are accessible, solar power might prove economical.

The development over the past several

years of low-powered complementary symmetry MOS circuits enables designers to produce circuits that perform complex functions at power levels in the microwatt region. With high-density packaging made possible by large-scale integration (LSI) technology, these circuits, when combined with small batteries and solar-cell chargers, could provide new products that up to now were not feasible. Portable instruments, consumer products, and marine navigational aids are among the major product areas where this new technology is likely to appear.

To the interested amateur, solar cells are available from most of the major mail-order electronics supply houses. A variety of interesting circuits and gadgets can be built from these components, using the information contained in this article and manufacturer data sheets for the cells.

Beyond furnishing power to recharge batteries, the cells can be used as sunlight sensors to power relays or drive transistors. Used with small batteries, recharge capability is provided for activities in remote locations for back-packing campers, on small boats, and the like.

The solar energy, radiated to the earth's surface, is of the order of  $10^{16}$  kW-hr/yr. This enormous source of energy is too plentiful to be overlooked. Solar cells will undoubtedly continue to provide a means for tapping this vital source. ♦



Fig. 8. Panel of solar cells for a Hughes FRUSA (Flexible Rolled-up Solar Array).





# Solid-State

By Lou Garner

**B**ACK in the dim and ancient days of World War II, one small manufacturer published a tongue-in-cheek specifications sheet covering a strange and wonderful substance known as **unobtainium**, which was described as "material we need and wish we had, but can't get."

Judging from the letters I've received, a number of our readers must feel that many of the newer and more exotic devices announced by semiconductor manufacturers are fabricated from this same rare material, for the question asked most often by experimenters and hobbyists, their appetites whetted by an intriguing circuit, is *where can I buy the new xxxxx device?*

While most reputable manufacturers do not announce new devices until they are able to supply production units, device availability from an individual's viewpoint may depend on a number of factors, the least of which are his desires and willingness to buy. If you're a senior design engineer with a major equipment manufacturer having a potential requirement for thousands or millions of the new device, for example, chances are you can get test units virtually overnight simply by calling either the manufacturer or his local representative. If you're an experimenter wishing to buy one or two units for a pet project, on the other hand, your chances of getting a device may range from good to nearly zero, depending on the manufacturer's policies and his distribution set-up.

When you're planning a construction project, then, or designing a new circuit, you'll find it worthwhile to select your solid-state devices on the basis of relative availability. The following guide should help.

(1) Devices offered as part of a general purpose or replacement line are generally the easiest to find. Usually blister packaged, pre-priced and sold from self-service racks, such lines are handled by virtually every

parts distributor catering to walk-in across-the-counter customers. Some larger distributors stock two, three, or more different lines, while the smaller outlets generally offer but a single line. Typical are Motorola's HEP program, RCA's SK line, Sylvania's ECC devices, GE's X-line, IR's general replacement line, Mallory's PTC devices, Sprague's Q-Mart products, the Calectro line, Workman's WEP, Semitron's devices and Radio Shack's Archer line.

(2) Standard devices produced by the major semiconductor manufacturers as off-the-shelf stock items offered through *both* industrial and general broad-line parts distributors are readily available, although there may be a time lag of up to several months after a new device is announced before it is available from distributor stocks. Occasional shortages may be encountered due to production problems or unexpected volume orders. Typical of the devices in this category are the general line products produced by RCA, GE, Motorola, and International Rectifier.

(3) Depending on your location, devices manufactured by medium and larger firms which sell *exclusively* through franchised industrial distributors are generally available, but their purchase may require special efforts on the part of the buyer. Included in this category are products from Amperex, Delco, Hewlett-Packard, Litronix, Signetics, Siliconix, Dickson, Raytheon, National Semiconductor, Fairchild, ITT Semiconductor, TI, General Instrument, Monsanto, Harris Semiconductor, Unitrode, Clairex, Crystal-

## Semiconductor Availability

onics, Westinghouse, and Precision Monolithics. Few, if any, of these firms will sell directly to individuals, so your chances of obtaining a specific device will depend on your proximity to an industrial distributor handling the line as well as upon the distributor's willingness, in turn, to make an "across-the-counter" sale. Some industrial distributors are quite cooperative in this regard, but others will sell only to established firms and government agencies. A few don't even have facilities for servicing "walk-in" customers, handling all sales by telephone. If you need a device manufactured by a firm selling *only* through franchised industrial distributors, then, first obtain the name and address of your nearest local distributor, either by checking the "Yellow Pages" of your phone book, contacting the manufacturer's local representative (if known), or writing or calling the manufacturer and asking for a list of his distributors. If possible, write your request on a firm, agency or school letterhead. Call your nearest outlet first and, if he refuses to sell the device you need, contact other (out-of-town) distributors handling the line. Some of these firms will accept mail orders.

(4) Some special devices may be purchased direct from the manufacturer(s) in unit quantities, even by individual experimenters. Typical of the firms accepting direct orders are Analog Devices, Burr-Brown Research, and Exar Integrated Systems. Most are small-to-medium-size firms and their direct order policy may change as they grow in size or establish a national distributor network. There may be a "mini-

num order" requirement, usually from ten to twenty-five dollars, if the firm offers low-cost devices. Device availability is excellent and generally "off-the-shelf," but you'll have to send payment with order, including postage and sales tax (if applicable). Post Office money orders or certified checks are preferred to personal checks if you want to insure prompt shipment.

(5) Foreign made devices are next to impossible to obtain unless the manufacturer has an aggressive U.S. importer/distributor or unless they are included as part of a general line, such as the *Archer*, Semitron or WEP programs. Some are stocked by the more progressive mail order distributors, but availability is spotty. If you need such devices, and can't find them offered in a general replacement line, your best bet is to write to two or three broad-line mail order distributors or to the manufacturer's importer/agent (if known).

(6) Custom and semi-custom devices designed and fabricated especially for OEM (original equipment manufacturers) or military applications also are hard to find. Some are available to individuals directly from manufacturers under special circumstances, as, for example, when ordered by a consulting engineer working on a prototype design for an OEM client or government agency, but prices are likely to be on the high side, and future identical devices may not be available unless the semiconductor manufacturer receives a substantial production contract.

(7) Finally, high-performance, high-power and extremely high-frequency devices, as

Fig. 1. Motorola's MC3302, a new quad comparator IC.

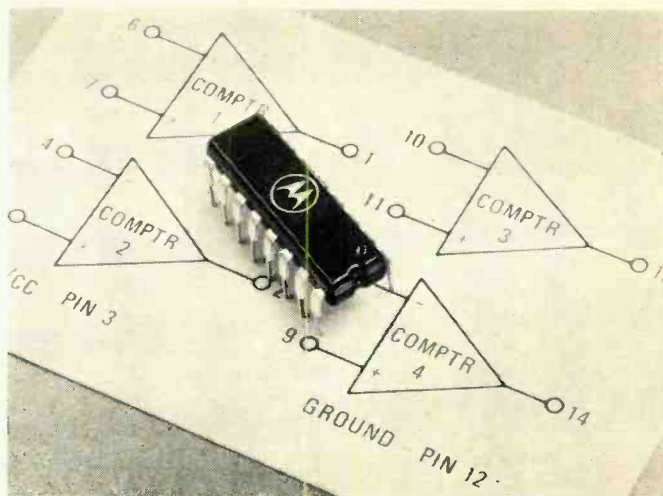

well as some LSI units and memory arrays, while available, may be beyond the reach of most experimenters and hobbyists due to their high cost, which can range up to several hundred dollars *per unit*.

**Device/Product News.** RCA's Solid State Division (Route 202, Somerville, NJ 08876) has introduced a number of interesting new devices, including a family of integrated thyristor/rectifiers, a low-noise uhf/MATV transistor, three medium-power uhf transistors, and several microwave power transistors. Most are available direct from franchised distributors or factory stock.

Intended for use in TV horizontal-deflection circuits, RCA's integrated thyristor/rectifiers (ITR's), types 41017 through 41023, are all-diffused, power integrated circuits that incorporate a silicon controlled rectifier and a silicon rectifier on a common pellet. These new devices may be used for beam deflection in color and monochrome TV picture tubes with deflection angles up to 114°, and can supply as much as 7 millijoules of stored energy to the deflection yoke. Types 41017 through 41019 are used as bipolar switches to control

horizontal yoke current during the beam trace interval, while types 41020 through 41023 are used as commutating switches to initiate trace-retrace switching.

From deep in the sunny southwest, Motorola Semiconductor Products, Inc. (P.O. Box 20912, Phoenix, AZ 85036) has announced several exciting new additions to their product lines, including a low-cost quad comparator IC, a family of light-activated thyristors, two new LED drivers, and a high-speed MOS dual clock driver. All the devices are in production and available off-the-shelf from franchised full-line Motorola distributors.

Designed for industrial and consumer applications requiring a number of differential voltage comparators, Motorola's new IC, type MC3302, Fig. 1, packs four independent voltage comparators into a single DIP. Suitable for operation on single-ended power sources, the device requires a *total* current of only 1.5 mA (max) at a  $V_{cc}$  of 5.0 to 28 volts dc. Each comparator features a voltage gain of 30,000, an input bias current of only 30 nA (approx.), and an input offset voltage of 3 mV. The outputs are TTL compatible.



## MAKING "WAVES"

**CADENCE—the musical instrument speakers**

Making better, clearer, amplified sound waves is the **THING** Cadence does... better than anything else in the industry. Cadence Speakers are built to withstand heat from sustained notes at a high power level and the vibrations and stresses which are continually placed upon them. Cadence is guaranteed **one full year** at the power level specified. This proven speaker family has been selected by the manufacturers of most of the world's fine amplified music instruments.

If making beautiful, clear sound waves is your thing, ask for **CADENCE SPEAKERS**. For complete information and the name of your Cadence Dealer, write:



**UTAH ELECTRONICS DIVISION**  
Utah-American Corporation  
1124 East Franklin Street  
Huntington, Indiana 46750

**CIRCLE NO. 33 ON READER SERVICE CARD**



Motorola's new line of annular, light-activated thyristors are available in both plastic and metal packages, Fig. 2. Types MLS101 through MLS105 are plastic TO-92 versions, while types MLS201 through MLS205 are in metal TO-18 packages. Both versions have peak reverse blocking voltages of 15 to 200 volts. Forward rms current for the MLS101 series is 250 mA and, for the MLS201 series, 400 mA. Peak forward surge current for both series is 5 A. Providing up to several kV isolation between the controlling and controlled circuits, these devices may be used in solid-state relay, sensing, detection, opto-logic control, card reading/counting/sorting, and photo-coupling applications in addition to conventional control and driving circuits.

Intended for operation directly from MOS calculator chips and other MOS logic, Motorola's new LED display drivers are offered in quad and hex versions. The quad-segment driver, type MC75491, has both collector and emitter outputs and can sink or source up to 50 mA. The MC75492 hex driver, with collector outputs only, can sink up to 250 mA. Featuring high-gain Darlington driver transistors and single-chip construction, both linear devices are capable of interfacing with a wide range of calculator chips and LED displays, and both are supplied in 14-pin DIP's.

TI's new Schottky TTL dual voltage-controllable oscillator IC, type SN54S/

74S124, is a self-starting, free-running, dual symmetrical square-wave generator which can be used as a stable clock generator in digital systems or in phase-locked loops. The oscillator's center frequency is established by a single external component, either a crystal or a capacitor. Typical center frequencies range from 0.12 Hz to 85 MHz. If a capacitor is used to set the center frequency, the instantaneous frequency can be shifted by applying an external control voltage at either or both of two voltage-sensitive inputs. One input sets the frequency range, while the other controls the output frequency +75% or -35% from the center frequency. Suitable for operation on a 5-volt dc supply, the dual oscillator is offered in a 16-pin plastic or ceramic DIP.

Designated types TIS126, TIS128, and TIS129, TI's new vhf/uhf transistors feature high transition frequency and low collector-base capacitance as well as high guaranteed power gain. Minimum  $f_T$  values are 600 MHz (TIS126), 650 MHz (TIS128), and 800 MHz (TIS129). Capacitance ratings are 0.36 pF, 0.3 pF, and 0.9 pF for the TIS126, TIS128 and TIS129, respectively, while minimum power gain for each is 10 dB at 850 MHz. The TIS126 is intended for applications through vhf as a mixer and non-agg amplifier, the TIS126 as a vhf/uhf common-base amplifier, and the TIS129 primarily as a vhf/uhf oscillator. All three are in TO-18 plastic packages. ♦

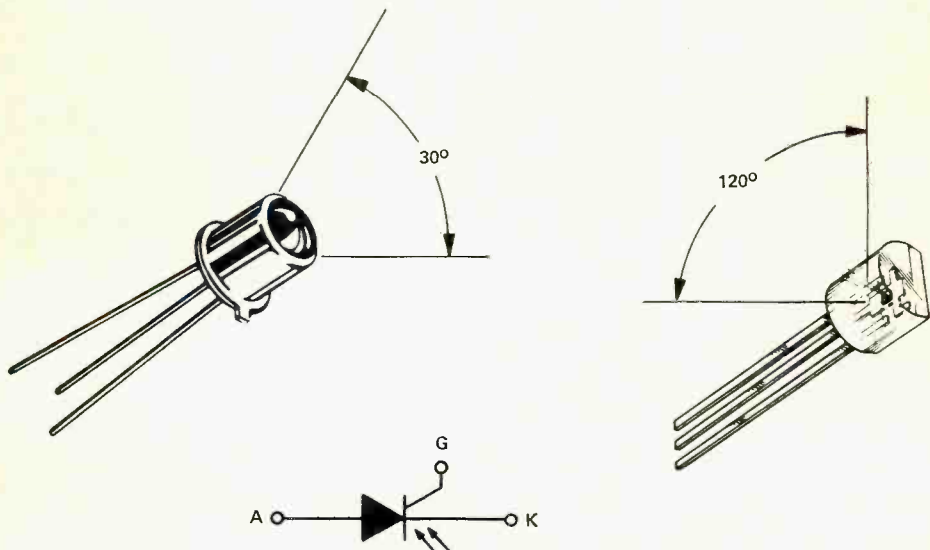
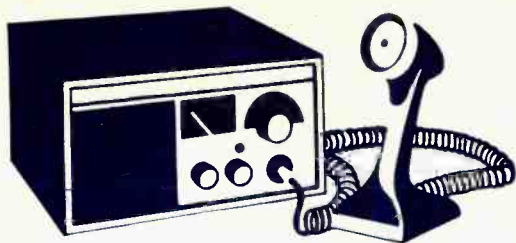

Fig. 2. Packages and view angles of new light-activated thyristors.



# CB Scene

By Matt P. Spinello, KHC2060

**F**OR the last four years, mostly single-handedly, Arnie Timm, KDT1009, has promoted the Quit Skip QSL Club (QSQC) nationally. He has corresponded with hundreds of CB clubs and individuals. He even purchased advertising space to encourage the concept of "Lawful CB Radio Nationwide."

Unlike countless individuals and so-called national organizations that seemingly vanished during Citizens Radio's early years (taking with them CB'ers hard-earned dollars in return for fancy proposals and promises of national representation), Arnie asks only for active support.

Simply stated, QSQC looks to individual CB'ers to pledge support and adherence to the FCC Rules and Regulations and to send "Quit Skip" QSL cards through the mail—never on the air. In fact, when skip cards are received, bearing code names and/or encouragement to make contact beyond the legal 150 mile limit, Arnie ships them off to the FCC office nearest their point of origin, hoping that the Commission will keep an ear tuned in the same direction.

KDT1009 admits that his project has a long way to go before he will be satisfied that the idea has been accepted and employed effectively by CB'ers through the U.S. and Canada. "We've had too many 'joiners' who jump on board just to be a member of another organization—especially one that doesn't cost anything." Arnie needs individuals in every state who will help spread the word and seek out legal operators who will promote the concept of shared, legal operations on all 23 Citizens Radio channels.

Operating from his Wisconsin base as the "chapter of origin", Arnie continues to promote the establishment of sub-chapters in each state where a volunteer heads the operation by exchanging Quit Skip QSL's in

his area. If, for example, 100 QSL's are exchanged with interested operators who, in turn, exchange similar cards with 10 others, the pyramid builds, spreading the word.

One certainly sensible requirement for fronting a sub-chapter of the Quit Skip QSL Club is that all units must exchange reports every 60 days so that an evaluation of conditions, progress and setbacks can be made and new directions taken where necessary. One of Arnie's most active sub-chapters is directed by Randy Gregg, KCP0461, Minneapolis, Minn. Both Arnie and Gregg admit to waves of discouragement along a difficult road, but they continue to hold QSQC together by taking new approaches to the problem. Quit skip rubber stamps are recommended for use by sub-chapters (frequently seen stamped on the reverse of skip cards in retaliation), as are personalized QSQC QSL cards. Randy continually busies himself with objective proposals to sub-chapters with suggested ways and means of handling on-air problems. Arnie continues to produce reams of material on the subject, stating what he feels should be done about current problems.

In addition to Wisconsin and Minnesota, the Quit Skip QSL Club has established sub-

## Lawful CB Radio Nationwide



**We Stock What  
We Catalog**

**Allied  
Electronics**  
ENGINEERING MANUAL  
& PURCHASING GUIDE

**Special Offer!** \$5.00 VALUE Only \$1.00 to readers of Popular Electronics

**TECHNICAL INFORMATION:** Complete information on all items. Both electrical properties and physical dimensions. **ALL ITEMS IN STOCK:** Highest percentage of order filling in the country on standard and stock items. A guaranteed shipment program covering thousands of popular and hard-to-get items. **NEW FROM COVER TO COVER:** The only up to date annual in the electronics field. Allied has a reputation for delivery! Three key locations for immediate delivery. If you see it in our Engineering Manual & Purchasing Guide, it's because we've got it ready for your use! **THE MOST WIDELY USED BOOK IN THE COUNTRY!**

Enclosed is my \$1.00 to cover cost of shipping  
Cat. 910-9999-6

Allied Electronics Corporation  
2400 W. Washington Blvd., Chicago, Ill. 60612

Name \_\_\_\_\_

Address \_\_\_\_\_

City \_\_\_\_\_ State \_\_\_\_\_ Zip \_\_\_\_\_

**ALLIED ELECTRONICS**

A DIVISION OF TANDY CORPORATION

chapters in Illinois, Kentucky, California, Alabama, Indiana, Iowa, Massachusetts, Missouri, Colorado, Connecticut, Michigan, N. Carolina, Maryland, Georgia, Maine, Rhode Island, Kansas, New York, S. Dakota, and Pennsylvania. "We're a long way from having all 50 states," says Arnie, "and sometimes chapters report in once or twice and then are never heard from again."

He goes on, "You can look the other way, close your eyes, plug your ears, for just so long, and then you get tired of playing monkey. You have to fight. Tempers will rise, arguments will blossom—many will hate you. But talk is cheap.

"Idle chit-chat rescues no lost child and discloses no severe destruction of life through storm or accident, but it is interference during base-to-mobile contact attempts. If your adult adequacy impels you to speak out against outlaw tactics, if you believe in a method advocating an ultimate lawful trend, please write."

The address is Arnie Timm, KDT1009, 649 N. Eau Claire St., Mondovi, WI 54755. Interested CB'ers can help him promote "lawful CB radio nationwide" by carrying the banner in their own areas.

**TVI—The Season and the Reason.** There is probably no fate worse than finding an irate television viewer pounding on your door during football season (especially when he's heftier than some of the players) and claiming that your transmissions are interrupting his Sunday afternoon football game. And it had better stop by the end of half-time, or else!

Television interference is not seasonal; it can occur any time as a result of a number of conditions. However, a Midwest CB'er who is glad that "the Pack is back," would prefer not to have the team marching on his door, supported by a parade of townspeople prepared to move him, his rig, and his home to another state. Our correspondent's main question is what to do when you have been charged with appearing on neighborhood television screens visually as a series of hashmarks and audibly with call-sign and a one-sided conversation.

The Federal Communications Commission receives approximately 10,000 to 11,000 TVI complaints a year. They generally respond to a complainant by forwarding him information on how to eliminate the interference. The "accused" is not usually notified on the first round of inquiries. How-



GREGORY ELECTRONICS  
Reconditioned & Used  
FM 2-WAY RADIO SAVINGS  
Partial List—Send for New Catalog

**Motorola  
Special**



X71GJT-1190B,  
40-50 MHz, 12 volt,  
100 watts, "T"  
power, 2 freq. TX.,  
3 freq. RX.,

In excellent  
condition —  
Including  
accessories  
**\$228**



**The General Electric  
Message Mate**

Personal pocket voice receiver, with sel-call-150-162 MHz, 162-174 MHz. Specify freq. with order. Charger inc. with nickel-cadmium model. Ask about low band.

**\$78**  
less reeds  
With new mercury  
battery ... **\$68**



**GREGORY ELECTRONICS CORP.**  
249 F Rt. 46, Saddle Brook, N.J. 07642  
Phone: (201) 489-9000

CIRCLE NO. 15 ON READER SERVICE CARD



ever, should the Commission receive a barrage of complaints about the same operator, they will ask the licensee to have his system checked.

Television receiver manufacturers could eliminate the problem by installing the necessary filter at the time of manufacture. But manufacturers feel it is unfair to burden everybody with the additional cost of special circuitry and design which would benefit only a relatively small group. Therefore, in the small percentage of instances where interference is caused by insufficient rejection of strong unwanted signals by the receivers, manufacturers, dealers, and servicing people have worked out procedures to eliminate the problem.

In the majority of cases, the cure *can* be applied to the TV receiver. That does not mean that the CB transceiver is never at fault. It is recommended that the CB licensee familiarize himself thoroughly with the whole of Section 95.97 and Part 95, dealing with TVI and transmitter adjustments. The wise operator will also want to procure a copy of the 3-page report, FE Bulletin #6a, *CRS Interference Problems and Suggested Solutions*, from the FCC Field Engineering Bureau, Washington, DC 20554,

before facing the problem of interference.

Of course, a little personal public relations never hurts. The guy who pounds on your front door can cause you a lot of unnecessary grief, even if it is his receiver that is at fault. To eliminate the possibility of neighborhood petitions to hack your antenna down to the ground, take you to court, and place highly visible marks on your body, offer to help.

Indicate first that you were not aware you were quarterbacking his football game. (You weren't, were you?) Don't tell him the trouble is in his TV receiver. Suggest that he contact the FCC. Volunteer to help him solve the problem on the basis of what measures the Commission suggests. Let the Commission inform him that the problem could very well be in his receiver. Then, and only then, should you take your time, talent, and tools to his house to install what he will tell the neighbors is "a little whatsis that does the trick." Then you are the hero, without pain.

If it turns out (heaven forbid) that it really is your CB system that is involved in the game of the week, pay your dues. Hire a licensed expert to work out the problem. There's more than one way to be a hero! ♦



Think of it as the best tester  
in your bag. Only \$299

Now you can get a high performance Model 8000A Digital V.O.M. from Fluke, America's foremost maker of quality digital multimeters, especially designed for TV, radio, stereo and audio service. No other digital V.O.M. gives you the resistance range to check breakers and switches, the high resolution voltage to look at emitter base and other transistor voltages, excellent ac accuracy and full accuracy with a 30 second warm-up.

Measures in 26 ranges 100 $\mu$ V to 1200 V, 0.1  $\mu$ A to 2A, and 100 milliohms to 20 megohms with a basic dc accuracy of 0.1%. Full year guarantee. Low cost options include rechargeable battery pack, printer output, deluxe test leads, HV, RF & 600-amp ac current probes, carrying case, and rack mount. Unique self zero eliminates offset uncertainty. Electronics securely mounted in high-impact case. Service centers throughout U.S., Canada, Europe and Far East for 48-hour turn-around repair.

P. O. Box 7428, Seattle, Washington 98133.

Get all the details from your nearest Fluke sales office.  
Dial toll-free 800-426-0361 for address of office nearest you.



CIRCLE NO. 35 ON READER SERVICE CARD



# Test Equipment Scene

By Leslie Solomon, Technical Editor

**D**URING a recent round-table discussion on test equipment, I made the suggestion that the use of a scope in making digital measurements was not as reliable as the use of a logic probe. Most of the guys jumped on me because they said most electronic experimenters have scopes, but very few have logic probes. This is probably true. In which case, it is necessary to use the scope—but this means that the user should be aware of some possible pitfalls regarding scopes and digital circuits.

Of course, a scope can be used to observe a digital waveform, particularly when you have multi-traces that can check cause-and-effect waveforms. However, there is a problem here and it has to do with digital logic states.

Most of us are aware of the two basic logic states: a 0 or low state and a 1 or high state. But this is not the whole story. Digital signals can exist in three states: 0, 1, and an undefined (wrong) state. In TTL circuits, for example, these states come out to be 0.4 volt for 0, 2.4 volts for 1 and somewhere in between. When the signal is in that undefined state, the TTL won't work. Digital logic doesn't care about absolute values. It works only on the prescribed 0 and 1 triggering thresholds. If the 0 voltage is slightly above 0.4, the circuit may not switch to 0. If the 1 level is slightly below 2.4 volts, the circuit may not go high. Of

course, if the 0 level is below 0.4 and the 1 level is above 2.4, all is well. It is that hazy area between the two levels that causes problems.

What does this have to do with using a scope to check the circuit? Well, the scope displays the absolute voltage with respect to time; and if the vertical isn't well calibrated at both the 0 and 1 levels for the logic you are testing, you can't tell for sure what you are measuring. It is also recommended that you use a dc scope.

Of course, once you pass the first input logic, you can be pretty certain that the remaining circuits trigger OK. But, you never know about changes in component values that can cause an undefined state to exist. A logic probe on the other hand, does not display waveforms, but indicates their existence above and below the correct triggering levels with some form of visual or audible signal.

This brings up another point about testing TTL circuits. When using a probe to follow a square-wave signal through a circuit, you may come to a point where a particular portion will not trigger on, even though the trigger signal has sufficient amplitude and decent rise and fall times. The IC's may be perfectly all right, the trouble is something else.

If you assume a logic circuit where one TTL is driving another TTL, the output circuit inside the first IC is a transistor to ground (most TTL's use the totem-pole type of output) and an emitter input on the second TTL, both electrically interconnected through the PC foil pattern. If the first IC output is in a low state, it means that its output transistor to ground is saturated, making its output pin (connected to that transistor's collector) about 5 or 10 ohms to ground. This means that the emitter input of the second IC is also at this

## Scopes & Probes for Digital Testing

very low resistance to ground since they are connected through the foil. Unfortunately, most present digital trigger generators do not deliver enough output to overcome this low resistance and produce a trigger threshold. So keep this in mind when troubleshooting TTL and try to rig things to remove low signals when testing a particular input.

**Hi-Fi AM.** An audio service technician recently asked why he can't align his BCB AM tuner for more than 4-kHz audio range, despite the fact that he has quite good equipment and knows his business. It took quite a lot pondering, but we came up with an interesting approach.

A typical AM detector is shown in the accompanying sketch. The rectified audio

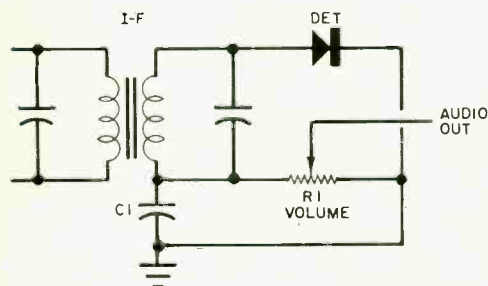

appears across  $R1$  while  $C1$  bypasses the unwanted r-f to ground. Unfortunately, this network also determines the audio response of the detector. The time constant of  $RIC1$  is long compared to the time for one r-f cycle (at the i-f), but short when compared to an audio cycle.

For example, if the i-f is 456 kHz, one i-f constant is  $TC = 1/f(\text{MHz})$  or  $1/0.456$  which equals 2.19 microseconds. If  $R1$  is a 250,000-ohm pot and  $C1$  is 100 pF, their time constant is  $0.250(100)$  or 25 micro-

seconds. The capacitor discharges through  $R1$  in half the time for one audio cycle ( $1/2f$ ) and the time required to discharge  $C1$  is  $5(RIC1)$  in seconds. Thus  $1/2f$  equals  $5RIC1$  and  $f$  equals  $1/(10RIC1)$ . The answer comes out to 4000 Hz. This then is the highest audio frequency that  $C1$  will allow to pass without distortion.

To increase the upper end response, the time constant of  $RIC1$  must be reduced. For example; changing  $R1$  to 10,000 ohms provides a frequency of 10 kHz. This is an example of where test equipment can only go so far and human ingenuity has to take over.

**In Defense of the Nixie.** We have been hearing a lot lately about the superiority of the 7-segment single-plane readout over the Nixie® tube. Admittedly most people prefer the easy-to-read, single-plane, 7-segment readout to the in-and-out numerical display of the older gas tube. However, there is a place where the Nixie tube has proven superiority. This is in the so-called "analog effect" that occurs in some types of digital measurements, usually in the right-hand digit.

Assume that a particular measurement is fluctuating around a 4 as the last digit. Out of 200 samples, possibly 150 would be a 4, approximately 30 would be 3, and about 20 would be 5. With a Nixie tube, the 4 would glow brightly while the 3 and 5 would glow dimly. This display would clearly show the analog effect. Now let us take a look at a 7-segment display under the same conditions. Although an approximate 4 is being measured, the display will show a 9 with a tail (3, 4, and 5 combined) as the 3, 4, and 5 all try to be displayed at the same time. Not only is the analog effect removed, the final digit is in error. ♦

## Planning to move?

Let us know 6 to 8 weeks in advance so that you won't miss a single issue of **POPULAR ELECTRONICS INCLUDING ELECTRONICS WORLD**

Attach old label where indicated and print new address in space provided. Also include your mailing label whenever you write concerning your subscription. It helps us serve you promptly.

Write to: P.O. Box 2774, Boulder, Colo., 80302, giving the following information.

Change address only.

Extend subscription.  Enter new subscription.

(1)  5 yrs. \$21 (2)  3 yrs. \$15 (3)  1 year \$6

Payment enclosed (1 extra issue per yr. as a BONUS)

Bill me later.

If you have no label handy, print OLD address here.

name \_\_\_\_\_ please print

address \_\_\_\_\_

city \_\_\_\_\_

state \_\_\_\_\_ zip-code \_\_\_\_\_

AFFIX LABEL

name \_\_\_\_\_ please print 0782

address \_\_\_\_\_

city \_\_\_\_\_ state \_\_\_\_\_ zip \_\_\_\_\_

Add'l postage: \$1 per year outside U.S., its possessions & Canada.



From Cleveland Institute of Electronics

# learn by doing!

Perform more than 200 exciting experiments  
with CIE's fascinating **ELECTRONICS  
LABORATORY PROGRAM!**

Put theory... into practice



# You get your own 161-piece electronics laboratory... with authentic electronic components used by industry!

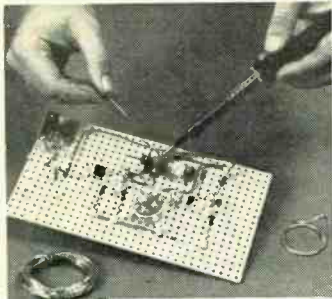

You learn how to construct circuits and connect them with a soldering iron, which is part of your CIE laboratory equipment. This "hands on" experience is extremely valuable in applying what you learn.

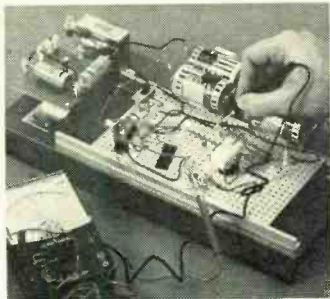

Testing and troubleshooting are an important part of your learning experience. Included in your laboratory is a precision "multimeter" to diagnose electrical and electronic troubles quickly and accurately.

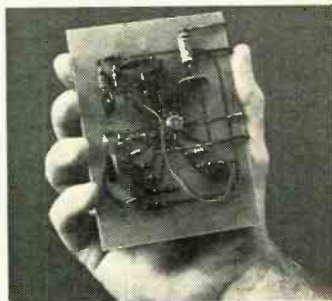

Modern space-age components like this IC (integrated circuit) are professional quality and can be used again and again in many of your projects. Lesson by lesson, piece by piece your knowledge grows!

## Prepare now for a high income career in Electronics...the Science of the Seventies.

Electronic miracles are changing today's world with breathtaking speed.

And with this growth in electronics technology has come a brand new need... a demand for thousands of electronics technicians, trained in theory and practice to build the products, operate them and service them during the Seventies.

Don't just wait for something to "happen" in your present job. Get ready now for a career you'll really enjoy with a good income and plenty of opportunity for advancement.

### Experience with experiments is your best teacher

"Hands on" experience helps to reinforce basic theory. When you learn by doing, you discover the "how" as well as the "why." You'll find out for yourself the right way as well as the wrong way to use electronic components. How to construct your own circuits, to discover trouble spots and learn how to fix them. And with CIE's special Auto-Programmed® Lessons, you learn faster and easier than you'd believe possible.

CIE's fascinating course, Electronics Technology with Laboratory, teaches you Electronics by making it work before your eyes. And you do it yourself, with your own hands.

### Importance of FCC License and our Money-Back Warranty

Many important jobs require an FCC License and you must pass a Government licensing exam to get one.

But, a recent survey of 787 CIE graduates reveals that better than 9 out of 10 CIE grads passed the FCC License exam.

That's why we can offer this famous Money-Back Warranty: when

you complete our Laboratory Course, which provides FCC License preparation, you'll be able to pass your FCC exam or be entitled to a full refund of all tuition paid. This warranty is valid during the completion time allowed for your course.

You get your FCC License — or your money back!

### You'll have high paying job opportunities

Electronics is still young and growing. In nearly every one of the new exciting fields of the Seventies you find electronics skills and knowledge are in demand. Computers and data processing. Air traffic control. Medical technology. Pollution control. Broadcasting and communications. With a CIE Diploma and an FCC License you can choose the career field you want... work for a big corporation, a small company or even go into business for yourself.

Here's how two outstanding CIE students carved out new careers: After his CIE training, Edward J. Dulaney, President of D & A Manu-

facturing, Inc., Scottsbluff, Nebraska, moved from TV repairman to lab technician to radio station chief engineer to manufacturer of electronic equipment with annual sales of more than \$500,000. Ed Dulaney says, "While studying with CIE, I learned the electronics theories that made my present business possible."

Marvin Hutchens, Woodbridge, Virginia, says: "I was surprised at the relevancy of the CIE course to actual working conditions. I'm now servicing two-way radio systems in the Greater Washington area. My earnings have increased \$3,000. I bought a new home for my family and I feel more financially secure than ever before."

### Send now for 2 FREE BOOKS

Mail the reply card or coupon for our school catalog *plus* a special book on how to get your FCC License. For your convenience, we will try to have a representative call. If coupon is missing, write: Cleveland Institute of Electronics, Inc., 1776 E. 17th St., Cleveland, Ohio 44114. Do it now!



Approved  
under  
G. I. Bill

All CIE career courses are approved for educational benefits under the G. I. Bill. If you are a Veteran or in service now, check box for G. I. Bill information.

**CIE** Cleveland Institute of Electronics, Inc.  
1776 East 17th Street, Cleveland, Ohio 44114  
Accredited Member National Home Study Council

Please send me your two FREE books:

1. Your illustrated school catalog, "Succeed in Electronics."
2. Your book, "How to Get a Commercial FCC License."

I am especially interested in:  Electronics Technology with Laboratory  
 Electronics Technology  Industrial Electronics  
 Electronic Communications  First Class FCC License  
 Broadcast Engineering  Electronics Engineering

Name \_\_\_\_\_ Age \_\_\_\_\_  
(PLEASE PRINT)

Address \_\_\_\_\_

City \_\_\_\_\_ State \_\_\_\_\_ Zip \_\_\_\_\_

Veterans and Servicemen: Check here for G. I. Bill information.

PE-52

CIRCLE NO. 6 ON READER SERVICE CARD



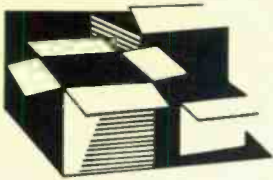

## New Products

*Additional information on new products covered in this section is available from the manufacturers. Either circle the item's code number on the Reader Service Card inside the back cover or write to the manufacturer at the address given.*

### MICRO/ACOUSTICS CD-4 PHONO CARTRIDGE

The Model QDC-1 phono cartridge from Micro/Acoustics Corp. is designed to provide unexcelled stereo playback and to reproduce CD-4 discs when equipped with a special Quadra-Point™ stylus. The cartridge is available with three stylus configurations: the QDC-1q with Quadra-Point, QDC-1e with 0.0002 x 0.0007-in. elliptical, and QDC-1s 0.0005-in. spherical stylus. The cartridge body is identical in all three models, and stylus assemblies are interchangeable.

Circle No. 71 on Reader Service Card

### VOLTRONIX SOLID-STATE IGNITION SYSTEM

The new low-cost Voltronix solid-state ignition from General Products is said to eliminate tune-ups for over 50,000 miles. The system greatly reduces point current and voltage, eliminating point wear. The compact system delivers maximum gas mileage and quicker cold-weather starts. One model is designed to fit all makes of domestic and imported cars. Designed for the do-it-yourselfer, the Voltronix ignition system can be installed in any vehicle in 15 minutes.

Circle No. 72 on Reader Service Card

### AVANTI MOBILE CB ANTENNAS

Available in 4- and 6-ft models, the Avanti "Hippo" mobile antennas with high power potential are topped with tunable tips. Both antennas feature an ABS molded covering that hermetically seals the coil against moisture to minimize noise and maximize performance. The tunable tips permit adjustment for the lowest possible VSWR. The 4-ft Model AV-324 handles 250 watts, while the 6-ft Model AV-326 handles 350 watts.

Circle No. 73 on Reader Service Card

### NORTRONICS TAPE HEAD CLEANER KIT

"Every Head Needs Cleaning," a unique and economical kit designed specifically to keep

magnetic tape heads clean in cassette, 8-track cartridge, and open-reel recorders and players, has been introduced by the Record Care Division of Nortronics Co., Inc. The Catalog No. QM-9 kit contains a 3-ounce can of aerosol spray cleaner, 6-in. long cotton QM-Tips, and instructions for maintaining tape equipment in proper operating condition.

Circle No. 74 on Reader Service Card

### ANTENNA SPECIALISTS' "BIG MOMMA III"

Big Momma III, a tough and resilient rooftop version of the popular Big Momma CB antennas, is now available from Antenna Specialists Co. The Model M-412 antenna is unconditionally guaranteed not to burn out regardless of operating conditions and features a heavy-duty oversized loading coil with virtually unlimited reserve power handling ability. A new professional style shock spring and heavier gauge whip contribute to Big Momma III's rugged new appearance and performance. The whip is copper and nickel plated for cool operation. And the antenna is easily removable for avoiding obstructions.

Circle No. 75 on Reader Service Card

### HEATHKIT 2-METER FM TRANSCEIVER

A kit-form 2-meter FM transceiver has been introduced by Heath Co. as their Model HW-202. Its solid-state, 10-watt circuitry is designed



to operate into an infinite VSWR without failure. Front-panel pushbutton switches independently select six transmit and six receive frequencies over a 1-MHz segment between 143.9 and 148.3 MHz. Reception sensitivity is 0.5  $\mu$ V or less for 12 Sinad, or 15 dB quieting. The output power at the speaker is typically 2 watts at less than 3 percent THD. Included in the kit are a gimbal mounting bracket, push-to-talk microphone, and 12-volt dc hookup cable.

Circle No. 76 on Reader Service Card

### ADC HIGH-DEFINITION SPEAKER SYSTEM

The Audio Dynamics Corp. is currently marketing their Model XT 10 low-cost bookshelf speaker system. The XT 10 has a wide, flat frequency range and high power handling capacity. It is said that the speaker system's wide



dispersion and outstanding transient response make the XT 10 an exceptionally accurate transducer, capable of extremely realistic performance in either stereo or 4-channel use. The XT 10 employs three drivers in a two-way system.

Circle No. 77 on Reader Service Card

#### CHANNEL MASTER VHF/UHF TV ANTENNAS

Channel Master is marketing a new series of vhf/uhf crossfire antennas incorporating con-linear elements and specially designed corner reflectors to provide superior performance, particularly on the lower uhf channels. The antenna comes in eight "Ultra-Hi Crossfire" models. The uhf section has been engineered to avoid interference with the rest of the antennas so that it delivers very high gain without diminishing the performance of the vhf crossfire. There are two special models designed for areas that require only moderate vhf gain but very high nhf gain.

Circle No. 78 on Reader Service Card

#### TWO NEW BSR-McDONALD TURNTABLES

Two new automatic turntables have been introduced by BSR-McDonald. The Model 310 A/XE is a "Total Turntable," including a base and dustcover and equipped with an ADC K-8E elliptical-stylus magnetic cartridge. It has a viscous-damped cue/pause control, jam-proof tonearm, adjustable anti-skating, and automatic tonearm lock. The Model 260/X, also a Total Turntable, is the lowest-priced complete changer module that includes a magnetic cartridge.

Circle No. 79 on Reader Service Card

#### BOZAK "RHAPSODY" SPEAKER SYSTEM

The Rhapsody Model B-401 is the newest in a series of loudspeaker systems introduced by R.T. Bozak Manufacturing Co. Its compact three-way floor-standing design is expressly for listeners who seek big sound in a limited space. A 12-in. extended-travel, high-compliance woofer produces remarkably full bass for its size, while an isolated midrange speaker and a pair of tweeters yield clear and smooth midrange and treble reproduction.

Circle No. 80 on Reader Service Card

#### JERROLD TV/FM COUPLER

A new Yagi coupler, the Model YC-75-FM, from Jerrold efficiently combines the output of an FM antenna with the output of a broadband TV antenna. Matched to 75 ohms, the coupler is ideal for MATV systems using broadband head-end amplifiers. The coupler can also be used to couple both a TV receiver and an FM tuner or receiver to a common coaxial feed with minimal loss to either. The new couplers provide two separate signal paths: One path passes the entire FM band and attenuates all other frequencies by about 20 dB. The other passes all uhf and vhf channels and attenuates the FM band by about 10 dB.

NOVEMBER 1973



## New UNGAR All-Purpose Soldering Kit #7070

Pro Kit Designed for Hobbyists

An economical, yet complete soldering kit, with 3 thread-on tips... ideal for most electronic kit assembly and medium duty repair. But that's just the beginning.

### Versatility; A Modular System

Only Ungar gives you *Maximized Versatility*: Tips — heater units — even handles are interchangeable and available in an optimum variety of configurations. "Custom-make" your iron: for PC work simply add a #537 heater to your kit. Tackle virtually every job by simple component change

— not the whole tool. (Our brand new catalog has all details plus a handy application guide... at local electronic retailers).

### Rugged, Durable Quality Too

Perfectly balanced handle of hi-strength plastic, comfort-cork grip, stainless steel heat deflector and flexible 2 wire, integral cord — all UL listed, backed by Ungar's guarantee of excellence.

### Get the Finest Tool Available!

Versatility, high quality, low cost plus a complete selection of accessories and production aids... the reason more pros in service, repair, R&D and production demand Ungar. It's at your local electronic retailer for only about \$6... all accessories and our new catalog is there too.

*Argyle socks and wild ties you may still get. This hint coupon may help. Let us know where you put it and what the results were. Ungar*



Division of Eldon Industries, Inc.  
233 East Manville Compton, California 90220 (213) 774-5950

**CIRCLE NO. 31 ON READER SERVICE CARD**

Honey, I could sure use a Xmas Day gift like the Ungar #7070 Soldering Kit. Hint! Hint!



only about \$6 too!

## The great new **Super Scanner**

It scans 360° in milliseconds with 5.75 dB gain. Or beams an 8.75 dB gain signal where and when you want it—instantaneously. (Otherwise, it's just another beautiful base antenna.)

MODEL MS-119 Super Scanner electronic beam, incl. control console — sugg. price, \$995

**the antenna specialists co.**

Division of ORION INDUSTRIES, INC.  
12435 Euclid Ave., Cleveland, Ohio 44106  
Export: 2200 Shames Dr.,  
Westbury, L.I., New York 11590  
Canada: A. C. Simmonds & Sons, Ltd.

CIRCLE NO. 1 ON READER SERVICE CARD

## ABOUT YOUR SUBSCRIPTION

Your subscription to POPULAR ELECTRONICS is maintained on one of the world's most modern, efficient computer systems, and if you're like 99% of our subscribers, you'll never have any reason to complain about your subscription service.

We have found that when complaints do arise, the majority of them occur because people have written their names or addresses differently at different times. For example, if your subscription were listed under "William Jones, Cedar Lane, Middletown, Arizona," and you were to renew it as "Bill Jones, Cedar Lane, Middletown, Arizona," our computer would think that two separate subscriptions were involved, and it would start sending you two copies of POPULAR ELECTRONICS each month. Other examples of combinations of names that would confuse the computer would include: John Henry Smith and Henry Smith; and Mrs. Joseph Jones and Mary Jones. Minor differences in addresses can also lead to difficulties. For example, to the computer, 100 Second St. is not the same as 100 2nd St.

So, please, when you write us about your subscription, be sure to enclose the mailing label from the cover of the magazine—or else copy your name and address exactly as they appear on the mailing label. This will greatly reduce any chance of error, and we will be able to service your request much more quickly.

## New Literature

### TEAC TAPE RECORDING BOOKLET

A guide to increased tape recorder performance and service life is being offered by Teac. The 24-page "Expanding the Art of Tape Recording" booklet describes how various accessories or extensions to a tape recorder are engineered to increase productivity and usefulness. Also described in the booklet are microphone and impedance matching devices, service accessories, special effects devices, timer and remote control items, reels and reel adapters, as well as a comprehensive troubleshooting chart. Address: Teac Corp. of America, 7733 Telegraph Rd., Montebello, CA 90640.

### LAFAYETTE RADIO 1974 CATALOG

Available now from Lafayette Radio is their 1974 catalog (No. 740) which lists 2- and 4-channel stereo, CB, amateur radio, and test equipment, among other items of interest to consumers and commercial users alike. Other listings include such items as cameras and photographic equipment, marine gear, automotive accessories, tools, books, microscopes, and telescopes. In all, more than 20,000 Lafayette and brand-name items are listed and described. Address: Lafayette Radio Electronics, Dept. PR, Box 10, Syosset, NY 11791.

### ALLIED ELECTRONICS 1974 CATALOG

A prime feature of the 1974 Allied Electronics catalog (No. 740) is the inclusion of engineering drawings for the electrical components listed. All physical dimensions and electrical properties of components are given. Among the items are semiconductors, vacuum tubes, a host of passive components, relays, connectors, and hardware. Test equipment, intercoms, power supplies, sound systems, chemicals, books, tools, and much more make up the remainder of the listings. Copies of Catalog No. 740 can be obtained for \$1 each from: Allied Electronics, 2400 W. Washington Blvd., Chicago, IL 60612.

### NEW AUDIOTEX CATALOG FROM GC

Everything necessary for the proper care and maintenance of sound equipment, a complete assortment of security alarms and accessories, and antennas and installation hardware are



included in the new Audiotex No. FR-73-A catalog available from GC Electronics. The 68-page catalog lists more than 570 items, accompanied by illustrations, descriptions, and prices, including nearly 50 new ones to the Audiotex line. Address: GC Electronics, Div. of Hydrometals, Inc., 400 South Wyman, Rockford, IL 61101.

### HITACHI "MAXI-FI" BOOKLET

Hitachi's latest 2- and 4-channel audio components are described and illustrated in a new 40-page "Maxi-Fi Booklet," which gives complete descriptions for eight receivers, 10 speaker systems, nine tape decks for cassettes and 8-track cartridges. Also described are integrated amplifiers, an FM tuner, turntables, headphones and accessories, and a collection of music centers and compact stereo systems. A master chart in the back of the booklet makes it easy to analyze and compare performance and specifications on all components and systems. Address: Consumer Relations Dept., Hitachi Sales Corp. of America, 48-50 34 St., Long Island City, NY 11101.

### MICRO SWITCH "USES UNLIMITED" BULLETIN

Micro Switch has issued the 49th edition of the Honeywell division's "Uses Unlimited" publication, an eight-page quarterly published for engineers and technicians which reports on a variety of useful and unusual switch applications. Issue No. 49 describes eight applications, four new products, and three ideas sent in by readers. Address: Micro Switch, a Division of Honeywell Inc., 11 W. Spring St., Freeport, IL 61032.

### GTE SYLVANIA TV PIX TUBE GUIDE

The Electronic Tube Division of GTE Sylvania Inc. has published a new edition of their TV picture tube interchangeability guide. It lists more than 325 color tubes that can be replaced by 62 Sylvania types and 495 monochrome tubes that can be replaced by 155 Sylvania types. All part numbers are cross-referenced to their Sylvania counterparts in alphanumeric order. Address: GTE Sylvania Inc., One Stamford Forum, Stamford, CT 06904.

### JENSEN "UNITARY" SPEAKERS BROCHURE

Jensen Sound Labs has announced availability of a new brochure that fully describes their complete line of "Unitary" high-fidelity speakers. Described are eight speaker models that lend themselves to build-in and build-your-own-system applications. A handy reference guide on the design and construction of loud-speaker enclosures is included in the brochure. Address: Jensen Sound Laboratories, 4310 Trans World Rd., Schiller Park, IL 60176.



## 12 REASONS YOUR CAR NEEDS TIGER CDI

Instant starting in any weather - Eliminates tune-ups - Increases gas mileage - Increases horsepower 15% - Improves acceleration and performance - Spark plugs last up to 70,000 miles - Reduces engine maintenance expense - Amplifies spark plug voltage to 45,000 volts - Maintains spark plug voltage to 10,000 RPM - Reduces exhaust emissions - Dual ignition switch - An Unconditional LIFETIME GUARANTEE - Installs in 10 minutes on any car with 12 volt negative ground - No rewiring - Most powerful, efficient and reliable Solid State Ignition made.

SATISFACTION GUARANTEED or money back.

TIGER 500 assembled . . . . . \$49.95  
TIGER SST assembled . . . . . 39.95  
TIGER SST Simpli-Kit . . . . . 29.95  
Post Paid in U.S.A.

Send check or money order with order to:

**Tri-Star Corporation**

Dept. W, P. O. Box 1946  
Grand Junction, Colorado 81501

DEALER INQUIRIES INVITED

CIRCLE NO. 30 ON READER SERVICE CARD

# free BA 1974 catalog

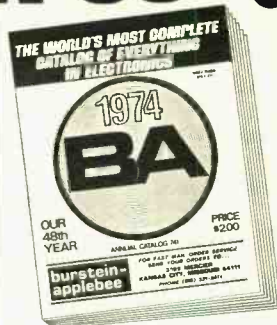

276 PAGE  
RADIO, TV &  
ELECTRONICS  
CATALOG

Your Buying Guide for  
Everything in Electronics  
... Stereo, Hi-Fi, TV's,  
Radios, Tape Recorders,  
CB, Kits, Tools, Books,  
and Electronic Parts.

WRITE FOR  
IT TODAY!

**burstein-applebee**

DEPT. PE 3199 MERCIER ST.  
KANSAS CITY, MO. 64111

NAME \_\_\_\_\_

ADDRESS \_\_\_\_\_

CITY \_\_\_\_\_

STATE \_\_\_\_\_ ZIP \_\_\_\_\_



# Why pay retail for hifi?

Buy direct from us, and you save money with our high-volume prices on more than 100 name brands. Order from the branch nearest you to save time and money on freight.

Send for our free catalog.



## Midwest Hifi Wholesale

& MAIL ORDER DIVISION

2455b Wisconsin Ave., 3309 E. J W Carpenter Frwy,  
Downers Grove, Ill 60515 Irving, Tex 75062

CIRCLE NO. 23 ON READER SERVICE CARD

**Free!**  
**1973 Eico Catalog**  
**OVER 200 INSTRUMENTS • KIT & WIRED!**

NEW! TR-410 Solid State Triggered Sweep Scope  
NEW! 300C "Clamp-On" Current Tester  
NEW! TD-8 8 Track Stereo Tape Deck  
NEW! SS-200 "Time Delay" Burglar Alarm System  
NEW! ASA-300 Electronic Siren Auto Alarm

Build all-professional Eico Kits and save up to 50%. The more you know about electronics, the more you'll appreciate Eico. Over 2500 local Eico dealers offer you all the top brands, personal technical counsel, fast off-the-shelf service. Free catalog includes Test Equipment, Stereo, Eico-craft Projects, Burglar/Fire Alarm Systems and name of nearest Eico distributor, check reader service card or send 25¢ for first class mail service.

EICO, 283 Malta St., Brooklyn, N.Y. 11207  
Leadership in creative electronics since 1945

CIRCLE NO. 11 ON READER SERVICE CARD



## Electronics Library

### CRC STANDARD MATHEMATICAL TABLES, 21st Edition

Edited by Samuel M. Selby

This is one of the most valuable and concise basic reference books available for scientists, mathematicians, and engineers. New and vital information has been added to this latest edition, especially in the area of combinational analysis which now includes excellent reference sections on continued fractions and undetermined equations. Featured are tables and expository sections covering such topics as circular and hyperbolic trigonometry, the algebra of sets, determinants and matrices, integral tables, and solutions to linear and partial differential equations. Also included are Laplace, Fourier, and Z transforms, vector analysis, and much more.

Published by CRC Press, Inc., 18901 Cranwood Pkwy., Cleveland, OH 44128. Hard cover. 720 pages. \$5.95.

### SEMICONDUCTOR LOGIC & SWITCHING CIRCUITS, Second Edition

by S.L. Oppenheimer

This book attempts to fill the gap that exists between the many excellent textbooks on linear semiconductor circuits and those on computers. The text is design oriented. It starts off with Boolean algebra and logic functions and rules. It goes on to waveshaping techniques, semiconductor switches and logic circuits, discrete regenerative switching, integrated logic and regenerative circuits, and finishes up with an applications section. This new edition has been written to reflect the changes made in logic and switching technology.

Published by Charles E. Merrill Publishing Co., Columbus, OH 43216. Hard cover. 289 pages. \$10.95.

### BASIC PRINCIPLES OF ELECTRONICS

by Vester Robinson

This book traces the history of electronics from the discovery of current flow to the present while developing the principles of electronics. It develops the basic theories of solid-state electronics in sufficient detail to prepare the student for more advanced courses. Basic coverage of

silicon controlled rectifiers, tunnel diodes, cryosars, lasers, and masers is included; and the development of microelectronics from the small tube to large-scale integration is traced. Detailed review exercises are provided at the end of each chapter.

Published by Reston Publishing Co., Inc., Box 547, Reston, VA 22090. Hard cover 356 pages. \$12.95.

### RCA RECEIVING TUBE MANUAL RC-29

This new edition of a popular receiving tube manual contains ratings and characteristics data on more than 1400 receiving, industrial, and monochrome and color picture tubes. The text explains the basic principles of operation, significant electrical characteristics, circuit applications, and testing of various types of electron tubes. At the rear of the book is a section that features 35 tube circuits of interest to hobbyists, students, technicians, and engineers. Each circuit is accompanied by a parts list and circuit description. The manual also has an extensive Applications Guide, Resistance-Coupled Amplifier Charts, and an index.

Published by RCA Electronic Components, 415 S. Fifth St., Harrison, NJ 07029. Soft cover. 752 pages. \$2.50.

### GUIDE TO ELECTRONIC MEASUREMENTS AND LABORATORY PRACTICE

by Stanley Wolf

This book introduces electrical laboratory techniques, electrical components, and the language of electrical measurements. It describes the principles of operation of electrical measuring instruments and includes specific instructions as to how to properly select and use them. The book is useful to readers in a variety of technical disciplines since no background in electrical science is assumed.

Published by Prentice-Hall, Inc., Englewood Cliffs, NJ 07632. Hard cover. 494 pages. \$4.95.

### FOUR-CHANNEL SOUND

by Leonard Feldman

For those people interested in how 4-channel sound systems operate, this book presents a comprehensive and up-to-date discussion of this new form of musical reproduction. It explains how 4-channel sound operates and the reasons for using it and discusses early and new matrix techniques for 4-channel discs. Chapters are devoted to sound on tape, discrete records, and FM broadcasting. The final two chapters explain how to convert to 4-channel sound and select new equipment. An appendix is included to acquaint the reader with new terms related to quadratics.

Published by Howard W. Sams & Co., Inc., 4300 West 62 St., Indianapolis, IN 46268. Soft cover. 144 pages. \$4.50.

NOVEMBER 1973

## SAVE ON Brand Name Audio Components

BY MAIL

### Write Today for Our FREE Wholesale Audio Catalog

\*DIXIE, one of the largest stereo wholesalers, fills all your orders promptly. At prices actually LOWER than "Discounters". See our exciting new Wholesale Price Catalog, or write for quotes. Choose the famous brand stereo equipment and accessories you desire. Everything shipped factory-sealed.



### DIXIE HI-FI WHOLESALE

5600 Second St., N.E., Washington, D.C. 20011

Please rush me your FREE Wholesale Audio Catalog and complete information. I understand there is no obligation.

Name

Address

City  State  Zip

Phone:  1-202-635-4900  PE-11

CIRCLE NO. 9 ON READER SERVICE CARD

## SAVE!

MONEY • TIME • FREIGHT

QUALITY STEREO EQUIPMENT AT LOWEST PRICES.

YOUR REQUEST FOR QUOTATION RETURNED SAME DAY.

FACTORY SEALED CARTONS—GUARANTEED AND INSURED.

SAVE ON NAME BRANDS LIKE:  
A.D.C. KOSS KLH DYNACO  
A.R. FISHER SHURE SONY

AND MORE THAN 50 OTHERS

BUY THE MODERN WAY BY MAIL—

FROM

**ia**  
illinois audio

Department 873 12 East Delaware  
Chicago, Illinois 60611 312-664-0020

CIRCLE NO. 17 ON READER SERVICE CARD



# ELECTRONICS MARKET PLACE

**NON-DISPLAY CLASSIFIED: COMMERCIAL RATE:** For firms or individuals offering commercial products or services, \$1.60 per word (including name and address). Minimum order \$16.00. Payment must accompany copy except when ads are placed by accredited advertising agencies. Frequency discount: 5% for 6 months; 10% for 12 months paid in advance. **READER RATE:** For individuals with a personal item to buy or sell, \$1.00 per word (including name and address.) No minimum! Payment must accompany copy. **DISPLAY CLASSIFIED:** 1" by 1 column (25/8" wide), \$200.00. 2" by 1 column, \$400.00. 3" by 1 column, \$600.00. Advertiser to supply cuts. For frequency rates, please inquire.

**GENERAL INFORMATION:** First word in all ads set in bold caps at no extra charge. All copy subject to publisher's approval. All advertisers using Post Office Boxes in their addresses **MUST** supply publisher with permanent address and telephone number before ad can be run. Advertisements will not be published which advertise or promote the use of devices for the surreptitious interception of communications. Closing Date: 1st of the 2nd month preceding cover date (for example, March issue closes January 1st. Send order and remittance to Hal Cymes. **POPULAR ELECTRONICS** Including **ELECTRONICS WORLD**, One Park Avenue, New York, New York 10016.

## FOR SALE

**FREE!** bargain catalog. Fiber optics, LED's, transistors, diodes, rectifiers, SCR's, triacs, parts. Poly Paks, Box 942, Lynnfield, Mass. 01940.

**GOVERNMENT** Surplus Receivers. Transmitters, Snooperscopes, Radios, Parts, Picture Catalog 25¢. Meshna, Nahant, Mass. 01908.

**LOWEST** Prices Electronic Parts. Confidential Catalog Free. **KNAPP**, 3174 8TH Ave. S.W., Largo, Fla. 33540.

**ELECTRONIC PARTS**, semiconductors, kits. **FREE FLYER**. Large catalog \$1.00 deposit. **BIGELOW ELECTRONICS**, Bluffton, Ohio 45817.

**CONVERT** any television to sensitive, big-screen oscilloscope. Only minor changes required. No electronic experience necessary. Illustrated plans. \$2.00. **Relco-A33**, Box 10563, Houston, Texas 77018.

**AMATEUR SCIENTISTS**, Electronics Experimenters, Science Fair Students . . . Construction Plans—Complete, including drawings, schematics, parts list with prices and sources . . . Robot Man — Psychedelic shows — Lasers — Emotion/Lie Detector — Touch Tone Dial—Quadronor Adapter—Transistorized Ignition —Burglar Alarm—Sound Meter . . . over 60 items. Send 25¢ coin (no stamps) for complete catalog. Technical Writers Group, Box 5994, University Station, Raleigh, N.C. 27607.

**RADIO—T.V.** Tubes—36¢ each. Send for free catalog. **Cornell**, 4213 University, San Diego, Calif. 92105.

**METERS**—Surplus, new, used, panel or portable. Send for list. **Hanchett**, Box 5577, Riverside, CA 92507.

**PYROTECHNICAL** chemicals, casings, tools, supplies, fuse, literature. Giant, illustrated catalogue/handbook includes formulas, instructions—50¢, with samples—\$1.00. **Westech**, Box 593, Logan, Utah 84321.

**WE SELL CONSTRUCTION PLANS. TELEPHONE:** Answering Machine, Speakerphone, Carphone, Phonevision. Auto Dialer, Touch Button Dialer, Central Dial System. **TELEVISION:** \$35.00 Color Converter, Video Tape Recorder. \$25.00 Camera. **HOBBYIST:** Electron Microscope, 96 Hour Tape Music System, Ultrasonic Dishwasher, Radar-Oven. Plans \$4.95 each. **NEW ITEM:** \$75. Electronic Pocket Calculator, \$7.50. **COURSES:** Telephone Engineering \$39.50. Detective Electronics \$22.50, Integrated Circuit Engineering, \$49.50. **NEW SUPER HOBBY CATALOG** plus year's subscription to Electronic New Letter **AIRMAILED \$1.00**. Don Britton Enterprises, 6200 Wilshire Blvd., Los Angeles, Calif. 90048.

**ANTIGRAVITY**, experiment and theory, Rushed—\$2.00. U.S. inquiries. **Intertech 7A1**, Box 5373, Station-F, Ottawa, Canada.

**JAPAN HONG KONG DIRECTRY.** World products information. \$1.00 today. World Trade Inquiries, Hillyard, Washington 99207.

**BUILD YOUR OWN SPACE-AGE TV CAMERA**

ONLY KNOWN SOLID-STATE CAMERA KIT! Ideal for experimenters, home, education, industry, etc. • High quality • Backed by over six years of job & field testing • Fully Guaranteed • Connects to any TV set without modification • Priority ship construction manual • Model X116, Series D complete with vidicon \$169.50 (postpaid anywhere in USA & Canada (less vidicon tube \$116.95pp))

PHONE or WRITE for CATALOG.  
DIAL 402-987-3771

Many other kits, parts and plans available including starter kits, focus-defl. coils, vidicon tubes, const. plans, audio subcarrier kit, etc.

**1301 BROADWAY ATV Research DAKOTA CITY, NEBR. 68731**

**NATIONAL MOS**  
DYNAMIC shift registers—5  
MM502 dual 50 bit 1.25  
MM506 dual 100 bit 1.75  
MM506 dual 100 bit 1.50  
MM5013 1024 bit 2.00  
MM5016 512 bit 1.50

STATIC shift registers  
MM504 dual 16 bit 1.50  
MM505 dual 32 bit 1.75  
MM550 dual differential analog switch 2.50

**KEYBOARD General Telephone**  
Ten push buttons (0-9) touch-tone, encoding, programming devices. Easy for panel mounting.  
\$5.95  
Size: 3x2 1/2" x 1 1/2"

MV-50 red emitting 10-40ma @ 2V .25  
MV-4 High Power Red 2.95  
MV-10B Visible red 5-70ma @ 2V .30

**CT5005**  
CALCULATOR ON A CHIP  
This chip has a full four function memory. Memory is controlled by four keys, HM (adds entry to memory), JM (subtract entry from memory), CM (clear memory—without clearing rest of registers), RM (read memory or use as entry).

12 DIGIT DISPLAY AND CALC. • FIXED DECIMAL AT 0.1, 2, 3, 4, OR 5  
• LEADING ZERO SUPPRESSION  
• SEVEN SEGMENT MULTIPLEXED OUTPUT  
• TRUE CREDIT SIGN DISPLAY  
• SINGLE 28 PIN CHIP  
Chip and data—\$14.95  
Data only—1.00 (refundable)

1101/2501  
256 BITx1 MOS memory \$2.56

**MAN 1**  
Popular 7 segment diffused LED. Dual in line 14 pin package of displaying all digits and nine distinct letters.  
\$4.00 each

**7400 TTL DIP**

7400	.....	\$.35
7401	.....	.35
7402	.....	.35
7403	.....	.35
7404	.....	.35
7405	.....	.35
7413	.....	1.75
7410	.....	.35
7420	.....	.35
7430	.....	.35
7440	.....	.35
7441	.....	1.60
7442	.....	1.30
7446	.....	1.75
7448	.....	1.15
7450	.....	.35
7451	.....	.35
7453	.....	.35
7454	.....	.35
7460	.....	.35
7472	.....	.50
7473	.....	.65
7474	.....	.70
7476	.....	.70
7480	.....	.65
7483	.....	1.30
7486	.....	.75
7489	.....	4.75
7492	.....	1.15
7493	.....	1.15
7495	.....	1.25
74107	.....	.70
74154	.....	2.50
74192	.....	2.50
74193	.....	1.50
74195	.....	1.10

**TRIAC 2N6344** 600V BA 100-220 \$1.90

NE531 op amp T0-5 3.25  
NE561 phase lock loop DIP \$2.00  
NE565 phase lock loop T0-5 3.25  
NE566 function generator T0-5 4.00  
NE567 tone decoder T0-5 4.00

**LED FL 100** Special !!! .35 each  
Ten or more, 2.50  
3.50 for ten  
29.95 for 100

**LINEARS**

LM100	.....	1.00
LM309H	.....	.75
LM309K	.....	2.00
NE556	.....	1.00
NE560	.....	3.25
741(MINI DIP)	.....	.45
747	.....	1.10
709	.....	.45
710	.....	.40
711	.....	.40
723	.....	1.00
LM380(audio amp)	.....	1.75

**MB880 (Sperry DD700 202)** 7 segment high voltage nixie driver—\$1.75

All IC's are new and fully tested, leads are plated with gold or solder. Orders for \$5 or more will be shipped prepaid. Add 35¢ for smaller orders. California residents add sales tax. IC orders are shipped with 24 hrs. minimum. Money back guarantee.  
P.O. Box 3 Carmichael, California 95608  
**BABYLON ELECTRONICS** (916) 966-2111

**CMOS**

CD4001	.....	.75
CD4002	.....	.75
CD4003	.....	.75
CD4012	.....	.75
CD4023	.....	.75

**MECHANICAL, ELECTRONIC** devices catalog 10¢. Greatest values—Lowest Prices. Fertik's, 5249 "D", Philadelphia, Pa. 19120.

**SURPLUS** electronics for everyone. Free catalog. U.S. inquiries. **ETCO**, 464 McGill, Montreal, Canada.

**DIGITAL ELECTRONICS!** Complete schematics, parts lists, theories—Discrete Component Digital Clock, \$3.00—Sound Sensitive Switch, \$1.50. Increase technical competence, hobby skills—Complete Course in Digital Electronics is highly effective, \$10.00. Free literature. **DYNASIGN**, Box 60A7, Wayland, Mass. 01778.

**SCOPES**, meters, test equipment, military and industrial surplus. Write for free "Bargain Bulletins". **Lawrence Instruments**, P.O. Box 744, Sunbury, Pa. 17801.

**MECHANICAL, ELECTRONIC** devices catalog 10¢. Greatest values—Lowest Prices. Fertik's, 5249 "D", Philadelphia, Pa. 19120.

**SURPLUS** electronics for everyone. Free catalog. U.S. inquiries. **ETCO**, 464 McGill, Montreal, Canada.

**DIGITAL ELECTRONICS!** Complete schematics, parts lists, theories—Discrete Component Digital Clock, \$3.00—Sound Sensitive Switch, \$1.50. Increase technical competence, hobby skills—Complete Course in Digital Electronics is highly effective, \$10.00. Free literature. **DYNASIGN**, Box 60A7, Wayland, Mass. 01778.

CIRCLE NO. 3 ON READER SERVICE CARD



FREE Catalog lists resistors, tubes, transistors, rectifiers, condensers, tools, tuners, etc. Hytron Hudson, Dept. PE, 2218 Kennedy Blvd., Union City, N.J. 07087.

## FREE CATALOG UP TO 50% OFF COMPARABLE KITS\*

• BUY DIRECT • SAVE \$\$\$

FREE Catalog — Electronic Kits — Amplifiers — Preamps — Psychedelic Strobes — Burglar Alarms Digital Tachometer — More: Free Catalog. SWTPC, Box A32040. San Antonio, Tex. 78284.

**IGNITION SYSTEMS:** Capacitor, Transistor. Information 10¢. Anderson Engineering, Epsom, N.H. 03239.

**AUTHENTIC, INSTRUMENTED, FLYING ROCKETS** for casual or serious experimenters. Over 80 scale original, multi-stage or ready-to-fly models. Solid-propellant engines for safe, electric launch system liftoffs up to 2,500 feet. Measure altitude, temp. inversions, more. Real telemetry, electronic tracking, aerial still and movie photography with super-miniaturized equipment. New, detailed tech manual and full-color catalog. 25¢ from ESTES INDUSTRIES, Dept. 18Q, Penrose, Colo. 81240.

**TTL IC, Semiconductors, parts discount.** Price List, 10¢. Totelek, Box 222, Goodyear, Arizona 85338.

**WE SELL CONSTRUCTION MANUALS—**GOLD Recovery Unit—SILVER Recovery Unit—Alternator Adapter (provides 120 volts in your car!)—Infrared Scope—Inverter (12 volts DC to 120 volts AC)—Electronic Insect Trap—Burglar Alarm—X-Ray Fluoroscope—Chemical Formulary. Manuals \$5.00 each. **HIGHLY PROFITABLE Business Courses!**—“How To Start and Operate Your Own SILVER Recovery Business!”—“The Manual of PRECIOUS Metals” courses \$9.95 each—illustrated color catalog, 25¢—Airmailed 50¢—Creative Products, 8415 Loffland, Dept. 1173, Houston, Texas 77055.

**ELECTRONIC ORGAN KITS, KEYBOARDS** and many components. Independent and divider tone generators. All diode keying. I.C. circuitry. Build any type or size organ desired. Supplement your Artisan Organ. 25¢ for catalog. DEVTRONIX ORGAN PRODUCTS, Dept. C. 5872 Amapola Dr., San Jose, Calif. 95129.

**DIGITAL SPEEDOMETER** with numeric readout. Plans \$4.50. KIMTRON, Box 80134, Chamblee, Georgia 30341.

**ELECTRONIC COMPONENTS** for mailorder concerns. I.C.'s, CAP's, Switches, Light Ass. Write or call for samples. Windsor Dist. Co., 46 Cadman Pl. W., Bklyn, N.Y. 11201. (212) 624-7038.

**FIREWORKS NEWS Magazine** Covers Commercial-Display Fireworks, Sources, Construction, Literature. Pyrotechnical Supplies. Free Catalog! Pyro Press, Box 12010(N113), Lexington, Kentucky 40511.

# PAIA



**MAKES THE ONLY  
SYNTHESIZER KITS**

models priced from \$139 — free brochure and catalog

**PAIA ELECTRONICS, INC.**  
BOX #14359, OKLAHOMA CITY, OK 73114



### CALCULATOR / TOUCH TONE ENCODER KEYBOARD

Ten digits, 4 arithmetic functions plus 4 other keys & on-off switch. Can be used with any calculator chip. Ideal for touch tone encoders. 2 3/4" x 3 1/4" x 1/2". Gold plated contacts. Life over 1 million cycles.

STOCK NO. F5112 \$7.95 2/15.00



### STEREO AMPLIFIER

Complete stereo amplifier on 2" x 7" board. Two watts per channel. Tone, volume and balance controls. Requires 12 volts AC or 15 volts DC. Also usefull as foundation for intercom. With Data.

STOCK NO. F5113 \$9.50 ea. 2/17.50

### COMPUTER GRADE CAPACITORS

MFD	VOLTS	STOCK	PRICE
150,000	10	F2254	2.25 ea 5/10.00
48,000	25	F2337	2.25 ea 5/10.00
3500	55	F2221	1.50 ea 6/8.00
3750	75	F2116	1.75 ea 6/9.00
4500	100	F2344	3.50 ea 4/13.00

Include postage. Excess refunded. **MINIMUM ORDER, \$3.00.** Write for new 56 page catalog.



## DELTA ELECTRONICS CO.

BOX 1, LYNN, MASSACHUSETTS 01903  
617-388-4705

**CIRCLE NO. 8 ON READER SERVICE CARD**

**WHOLESALE** Scanners, CB., Crystals, Directories, SSB/AM, Catalog 25¢. G—ENTERPRISES, Box 461P, Clearfield, Ut. 84015.

**LOGIC Probe** \$9.95. Free bargain catalog. Electro, 4201 Irving Park, Chicago, Illinois 60641.

**CD IGNITIONS, VHF/UHF monitors, crysta's, CB radios.** Wholesale. Southland, Box 3591-B, Baytown, Texas 77520.

**BRAIN WAVE MONITOR** Biosone BF-20 Alpha Biofeedback Instrument. \$34.95 complete. Not a kit. Fully Guaranteed. For information write. BIO-LOGIC DEVICES, INC., Dept. A, 888 Seventh Avenue, New York, New York 10019.

## DISCOUNT PRICES

**B & K, SENCORE, LEADER Test Equipment**  
RAYTHEON, ICC/MULLARD Tubes  
TELEMATIC Test Jigs

### Free Catalog

**FORDHAM RADIO SUPPLY CO. INC.**  
558 Morris Ave., Bronx, N.Y. 10451

**SOUND SYNTHESIZER KITS**—Surf \$11.95, Wind \$11.95, Wind Chimes \$16.95, Electronic Songbird \$6.95, Musical Accessories, many more. Catalog free. PAIA Electronics, Box J14359, Oklahoma City, OK 73114.

**BIOFEEDBACK.** Professional Instruments: Electroencephalophone, Galvanic Skin Response. J&J, 8102-E, Bainbridge, WA 98110.

**WAVEFORM GENERATOR KIT 8038** Function Generator IC Producing Sine, Square, Triangular Waveforms, \$10.00. Write for catalog. Photolum Corporation, 118 East 28th Street, New York, N.Y. 10016.

**NEW FM Deviation Meters** \$75.00. Free Information. Write: ECM, 412A N. Winbach, Evansville, Indiana 47711.

**TELEPHONE RECORDING** equipment. Starts recorder automatically. Top quality. Absolutely lowest wholesale prices. Free details. Viking International, Box 632, Newhall, California 91321.

LIGHT EMITTING DIODES	
MRD 14B Photo Darlington	\$.75
FLV 100 VIS. LED	\$.59
MT2 Photo Transistor	\$.50
MCT-2 Opto. Isolator	\$1.00
MCD-2 Opto. Isolator	\$1.00
MCA-2-30 Photo Relay	\$1.95
MV5026 VIS LED	\$.65
ME4 IR LED's	\$.59
GREEN GA OSL-3 LED	\$1.25
RED GA OSL-3 LED	.95

7400	.50	7460	.28
7401	.28	7465	.35
7402	.28	7472	.50
7403	.28	7473	.60
7404	.33	7474	.50
7405	.30	7475	1.00
7406	.50	7476	.75
7408	.32	7483	1.25
7410	.28	7486	1.50
7411	.32	7490	1.50
7412	.40	7492	1.30
7413	.85	7493	1.30
7416	.94	7494	.50
7417	.50	7495	1.30
7420	.28	74121	.70
7422	.32	74123	1.10
7426	.35	74125	1.50
7430	.28	74126	1.50
7437	.60	74151	1.25
7438	.55	74153	1.50
7440	.28	74159	1.50
7441	1.50	74164	2.50
7442	1.25	74165	2.20
7446	1.50	74176	1.95
7447	1.50	74177	1.95
7448	1.50	74193	.75
7450	.28	74195	1.75
7451	.28	8211	1.50
7452	.28	8240	1.50

### VERIPAX PC BOARD

This board is a 1/16" single sided paper epoxy board 4 1/2" x 6 1/2" (standard veripax) DRILLED and etched, which will hold 21 single 14 pin IC's, or 8,19, or LSI DIP IC's with buses for power supply connections. It is also etched for a 22 pin connector. \$5.25 3/\$14.50

TRANSISTOR SPECIALS	
2N3584 NPN Si TO-66 35W 250V 2A 10MHz/100Hfe	\$1.50
2N3137 NPN Si TO-5 .6 20 .5 70 500 4/\$1.00	
MP53393 NPN Si TO-92 .3 25 1.190 2 4/\$1.00	
2N1605 NPN GE TO-5 .15W 24V .1A 14 125 5/\$1.00	
2N5324 PNP GE TO-3 60W 250V 10A 20 35 \$1.50	
2N1015D NPN Si TO-82 150W 200V 7.5A .025 10 \$1.45	
2N3772 NPN Si TO-3 150W 60V 30A 2 30 \$1.25	
2N3866 NPN Si TO-5 S 30 RF Power	\$ .75
2N6109 PNP Si TO-220 36W 40V 4A 8 60 50c	
2N5296 NPN Si TO-220 36W 40V 4A 8 60 55c	
2N4898 PNP Si TO-66 25W 40V 4A 40 46 \$ .60	
MJ2251 NPN Si TO-66 10W 225V 5A 10 40 \$ .70	
2N3055 NPN Si TO-3 115W 100V 15A 2 44 \$1.00	

SLA-3 7 Segment LED Readout 77" Num- bers 45 ma 1 Seg. \$9.95

Data-Kit 707 direct replacement for MAN-1 LED seven segment Reouts \$3.75

MAN-4 LED READOUT \$3.50  
MAN-3 LED READOUT \$2.95

CAPACITORS	
6V 30 UF TANT	\$.50
20V 4.7 UF TANT	\$.50
12V 10 UF ECT.	\$.50
50V 100 UF ELECT.	.40

1103 1024 Bit RAM \$8.00  
NEC6003 2048 Bit RAM \$14.50  
1101 256 Bit RAM \$4.00  
8225 64 BIT MEMORY \$4.00

T R I A C S	
PRV 1A 10A 15A 20A <sup>0</sup>	
100 .40 .70 1.00 1.20	
200 .70 1.10 1.50 1.60	
300 .90 1.35 1.90 2.00	
400 1.10 1.60 2.30 2.40	
500 1.50 2.00 2.70 2.80	

NIXIE TUBE  
RAYTHEON 8754 WITH SOCKET  
AND DATA SHEET \$2.25 3/\$6.00

FULL WAVE BRIDGES	
PRV 2A 1A 6A	
200   .95   1.25	
400   1.15   1.50	
600   1.35   1.75	

Silicon Power Rectifiers	
PRV 1A 3A 12A 50A	
100 .06 .11 .30 .85	
200 .07 .16 .35 1.25	
400 .09 .20 .45 1.50	
600 .11 .30 .70 1.30	
800 .15 .40 .85 2.30	
1000 .20 .55 1.10 2.75	

Silicon Control Rectifiers	
PRV 1.5A 6A 10A 70A	
100 .40 .50 .60 3.50	
200 .60 .70 .80 6.50	
400 1.00 1.20 1.30 9.50	
600     1.70 11.00	

715 73 N Channel FET \$ .75  
2N4851 UJT \$1.00  
ER900 Trisger Diode .4 \$1.00

5311—Clock Chip, 6 Digit hold count and Output Strobe \$11.95  
5314—Clock Chip, 6 Digit readout hold count and Output Strobe \$9.95

ASCII Encoder  
Terminal Keyboards \$60.00

14 Pin Wire Wrap Sockets \$5.50

Printed circuit board 4 1/2" x 6 1/2" double sided fiber glass board 1/16" thick, unetched. \$60 ea. \$2.50

MULTI-TURN TRIM POT'S  
Similar to Bourns 3010 style 50, 100, 500, 2K, 5K, 10K & 20K ohms. \$2.00 3/\$5.50

PA234 1 Watt Audio Amps	\$.125
LM 309K SV 1 Amp Regulator	\$.225
741 Precision AMP	\$.50
Dual 709	.95
723 Regulator	\$.75
TVK 200 2 high power 723	\$1.00
703RF 1F Amp	\$.30
CA3085 FM TV Amp	\$.18
565 Phase Lock Loop	\$.85
567 Tone Decoder	\$.325
560 Phase Lock Loop	\$.125
561 Phase Lock Loop	\$.325
536 FET Input Oper Amp	\$.325
747 Precision 741	\$.90
450 70W Power Driver	\$2.04
747 Dual 741	\$.125
LM3085 Oper Amp	\$.18
101 Oper Amp	\$.75
741A Oper Amp	\$.60
320-5V Reg.	\$.25
320-15V Reg.	\$.225
424-Zero Voltage Switch	\$.125
748 Oper Amp	\$.90
PA 264 Regulator	\$.125

Terms: FOB Cambridge, Mass.

Send Check or Money Order. Include Postage. Minimum Order \$3.00. Send \$2.00 for our latest featuring Transistors and Rectifiers. Rated companies 30 days net.

# SOLID STATE SALES

Post Office Box 74A Somerville, Mass. 02143 Tel. (617) 547-4005

## CIRCLE NO. 28 ON READER SERVICE CARD

**FREE** Color Codes, Digital Logic Charts. Send 8¢ stamp. Electronics, Box 278, Cranbury, N.J. 08512.

**SURPLUS** electronic parts and pieces. Monthly picture flyer. Startronic, Box 17127, Portland, Oregon 97217.

**BURGLAR-FIRE** alarm components, hardware. Free catalog—information. Silmar, 133 S.W. 57 Ave., Miami, Florida 33144.

**COMBINATION** Lock Alarm System. Theory, schematics, installation tips. \$2.00. DATRON, Box 26456, Denver, Colorado 80226.

**SEND PICTURES BY TELEPHONE**, wire, or radio: Complete Western Union surplus facsimile transceivers, checked out, \$14 each, two for \$25, shipping collect. Shop manual \$3.80 postpaid. Johnston, 1808 Pomona, Las Cruces, New Mexico 88001.

**CALCULATOR OWNERS:** Use your + - x ÷ calculator to compute SQUARE ROOTS, Trigonometric Functions, Logarithms, Exponentials, and more! Quickly, Accurately, Easily! Send today for the first and best calculator manual—sold throughout the world—only \$2.00. Absolutely Unconditional Money-Back Guarantee—and FAST service! Mallman Optics and Electronics, Dept.-9A, 836 South 113, West Allis, Wisconsin 53214.

**NUMERIC** Displays. Low cost gas, led. Free catalog. Caltronnix Electronics, Box 1318, Grand Prairie, Texas 75050.

**DIGITAL** and analog computer modules. LED numeric display kits. **FREE LITERATURE.** Scientific Measurements, 2945 Central, Wilmette, Illinois 60091.

**FREE CATALOG**—tremendous electronics bargains. American, Box 4192L, Mountain View, California 94040.

**FREE** Catalog. Reeds, Tantalums, Transistors, PUTS, LEADS, Parts. Chaney, Box 15431, Lakewood, Co'o. 80215.

**HEAR POLICE/FIRE** Dispatchers! Catalog shows exclusive official directories of "confidential" channels, receivers. Send 8¢ stamp. Communications, Box 56-PE, Commack, N.Y. 11725.

**ALPHA/THETA BRAINWAVE BIOFEEDBACK INSTRUMENTS.** M.O.E., Dept. 3, Box 2693, Santa Cruz, CA 95063.

**ALPHA/THETA** Brainwave biofeedback instruments. Analog systems from \$135; digital processing from \$265. BioScan, Box 14168-E, Houston, Texas 77021.

**FREE CATALOG.** Parts, circuit boards for POPULAR ELECTRONICS projects. PAIA Electronics, Box C14359, Oklahoma City, OK 73114.

**SEMICONDUCTORS,** components, unusual items, lowest prices. Catalog 20¢. Seaboard International Electronics, Box 906, Clute, Texas 77531.

**POWER SUPPLY**—Operate your CB Two-Way or vehicle tape player from house current. 1 Yr Guar. Made in USA. \$19.95 plus tax and \$1.00 Shipping. Interspace General Inc., 1561 West 132nd St., Gardena, Calif. 90249.

**FREE** Parts Flyer! Phase Seventy, Box 475PE, Marysville, Washington 98270.

**COMPLETE** alphabetical index to Popu'ar Electronics. Volume 1 (1954)-December, 1973. \$3.00 ppd. Portable Power, Box 13, Flushing, N.Y. 11352.

**BURGLAR-FIRE** alarm supplies and information. Free catalog. Protecto Alarm Sales, Box 357-G, Birch Run, Michigan 48415.

### TEKTRONIX OSCILLOSCOPES AT SURPLUS PRICES

1st price: Tested for sweep, deflection & good CR tube.  
2nd price: Overhauled and Calibrated. ("OH(C'd)")

502A dual beam, dc-1 mhz. 100 v/cm. 50 ns/cm. \$500, \$375.  
515: to 15 mhz. 100 mv/cm. 40 ns/cm. \$280, \$320.  
515A: later model. 50 mv/cm and up. \$390, \$430.  
524AD TV scope. 10 mhz. 15 mv. 100 ns. markers. \$340, \$425.  
535/CA: 2-trace 15 mhz w/cal. delay; 50 mv. 20 ns. \$560, \$645.  
535A/CA: is later model. \$670, \$755.  
RM35A/CA rack mtg version of 535A. W/cabinet. \$560, \$645.  
536/T B B: Ordinary 11 mhz or X-Y scope. 10x10 cm. \$350, \$450.  
545/CA 24 mhz 2-trace w/cal. delay. OH(C'd) \$695.  
545A/CA is later model of above. \$775, \$860.  
RM45A/CA rack mtg version of above, w/cabinet. \$725, \$805.  
551: 2 L's; 33 mhz 2-beam. 6 mv/cm. 20 ns/cm. \$550, \$635.  
581A/82: 80 mhz 2-trace. 10 mv/cm. 10 ns/cm. \$890, \$975.  
585/82 adds calib. variable delay to above. OH(C'd) \$1095.  
RM85A/82 rack-mtg version, later model. \$1050, \$1145.  
P6006 de-33 mhz 10X probes are extra. \$20.  
Other plug-ins, other Tek items, H.T. scopes, spectrum-analyzer plug-ins, cameras in Catalog Category 24.  
Many other category catalogs. Ask for your needs!  
For Receivers, see our ads in CQ, 73, & Ham Radio.  
We also buy!

R. E. Goodheart Co., Inc., Box 1220, Beverly Hills, CA 90213



## PLANS AND KITS

**ANTIGRAVITY DEVICE.** Brochure rushed free. AGD, Box 3062-ZD, Bartlesville, Oklahoma 74003.

## FREE KIT CATALOG

Why does every major College, University, Technical School, Research & Development Center buy from us? Because we have the highest quality and lowest prices. Free Catalog. SWTPC, Box H32040, San Antonio, Tex. 78284.

**PROFESSIONAL Burglar Alarm System.** Complete Plans \$2.00. Southwest Plans, Box 447, Garland, Texas 75040.

**ELECTRONIC KITS:** A new free service is now being offered by "Land Kits." It consists of a comprehensive catalog of over two hundred kits and an updating service to bring new kits to its readers as they become available to the market. Each kit has been researched to bring the beginner or the engineer the best choice available. Send for your FREE catalog. Write to: Land Kits, 9R Franklin St., Lynn, Mass. 01902.

**BUILD A "MINI-PUTER"**—Smaller than a pack of cigarettes, perfect gift for the person that has everything! LED's flicker as they "compute" random yes or no answer. Kit includes: wire, solder—1 ea. G-10 fiberglass etched and drilled board, I.C., UJT, 9V battery, battery clip. **CUSTOM MOLDED CASE**—2 ea. LED's, capacitors, push button switches (enclosed)—5 ea. 5% resistors. **EASY ILLUSTRATED INSTRUCTIONS.** \$7.95 Postpaid. **MONEY BACK GUARANTEE.** The Electric Farm, R.F.D. 1, Anna, Illinois 62906.

**CONSTRUCTION PLANS:** 4-digit tachometer with 10 rpm resolution; low-cost frequency counter; crystal time-base for digital clocks makes it portable, for car, or boat. All plans \$5. DIGI-DEC, 342 SE 32nd, Portland, Oregon 97214.

**AUTOMATIC GARAGE DOOR OPENER.** Complete building, installation plans. ADC, Box 114, Roslyn Heights, New York 11577.

## HIGH FIDELITY

**DIAMOND NEEDLES** and Stereo Cartridges at Discount prices for Shure, Pickering, Stanton, Empire, Grado and ADC. Send for free catalog. All merchandise brand new and factory sealed. **LYLE CARTRIDGES,** Dept. P, Box 69, Kensington Station, Brooklyn, New York 11218.

**STEREO SPECTRUM,** the money saver for hifi buyers, write us, Box 1818, Miami Beach, Florida 33139.

**SAVE 50%.** Build your own speaker systems featuring Norelco, Eminence and CTS. Famous brands from world's largest speaker factories at lowest wholesale prices. Write for 176 page catalog for speakers and electronic accessories. McGee Radio Company, 1901 McGee Street, Kansas City, Missouri 64108.

## WANTED

**QUICKSILVER,** Platinum, Silver, Gold, Ores Analyzed. Free Circular. Mercury Terminal, Norwood, Mass. 02062.

## ELECTRICAL SUPPLIES AND EQUIPMENT

**PLATING** Equipment, Portable Platers, Supplies and "Know-How." Build your own tanks for nickel, chrome, etc. Easy-to-install PVC liners. Rectifier components—all sizes. Schematics, parts lists, formulas, operating instructions for all plating. Guaranteed to save you 25%-75%. Some good units for sale. Write for details. Platers Service Company, 1511-PE Esperanza, Los Angeles, Calif. 90023.

NOVEMBER 1973

## TUBES

**RADIO & T.V. Tubes**—36¢ each. Send for free Catalog. Cornell, 4213 University, San Diego, Calif. 92105.

**RECEIVING & INDUSTRIAL TUBES, TRANSISTORS.** All Brands—Biggest Discounts. Technicians, Hobbyists, Experimenters—Request **FREE** Giant Catalog and **SAVE!** ZALYTRON, 469 Jericho Turnpike, Mineola, N.Y. 11501.

**TUBES "Oldies",** latest. Lists free. Steinmetz, 7519 Maplewood, Hammond, Indiana 46324.

**SAVE** money on parts and transmitting-receiving tubes, foreign-domestic. Send 25¢ for giant catalog. Refunded first order. United Radio Company, 56-P Perry Street, Newark, N.J. 07105.

**TUBES** receiving, factory boxed, low prices, free price list. Transletronic, Inc., 1306 40th Street, Brooklyn, N.Y. 11218A, Telephone: 212-633-2800.

## GOVERNMENT SURPLUS

**GOVERNMENT** Surplus. How and Where to Buy in Your Area. Send \$2.00. Surplus Information, Headquarters Bldg., Box 30177-PE, Washington, D.C. 20014.

**ELECTRONIC** Equipment and Parts. Big 36 page Free Catalog. Send for your copy today! Fair Radio Sales, Box 1105-P, Lima, Ohio 45802.

**GOVERNMENT SURPLUS.** Complete sales directory \$1.00. Surplus Publications, Box 26062Z, Los Angeles, Calif. 90026.

**MANUALS** for gov't surplus radios, test sets, scopes, teletype. List 50¢. Books, 7218 Roanne Drive, Washington, D.C. 20021.

**JEEPS, TRUCKS,** Cars From \$31.50 . . . Airplanes, Typewriters, Clothing, Multimeters, Transceivers, Oscilloscopes, Photographic Electronics Equipment . . . 100,000 Surplus Bid Bargains Direct From Government Nationwide Typically Low as 2¢ on Dollar! Complete Sales Directory and Surplus Catalog \$1.00 (Deductible First \$10 Order From Included Catalog). U.S. Surplus Disposal, 2200 Fuller 601B-PEL, Ann Arbor, Michigan 48105.

## BOOKS

**FREE** catalog aviation/electronic/space books. Aero Publishers, 329PE Aviation Road, Fallbrook, California 92028.

**FREE** book prophet Elijah coming before Christ. Wonderful bible evidence. Megiddo Mission, Dept. 64, 481 Thurston Rd., Rochester, N.Y. 14619.

## TAPE AND RECORDERS

**RENT** 4-Track open reel tapes—all major labels—3,000 different—free brochure. Stereo-Parti, 55 St. James Drive, Santa Rosa, Ca. 95401.

### SCOTCH MAGNETIC TAPE (USED)

~150, 1800 FT. 7 INCH REEL, 1 MIL POLYESTER, RECORDED ONCE, BULK ERASED (NO BOX), 99¢. PLUS 10% SHIPPING & HANDLING (MIN. ORDER \$10.00); SLIGHTLY USED 10 1/2 INCH FIBERGLASS REELS, 3/8" HOLE, 50¢ EACH, PLUS SHIPPING BY WEIGHT AND ZONE.



### SAXITONE TAPE SALES

1776 Columbia Rd., N.W. Washington, D.C. 20009

**RECORD** 8TRK cartridges with any player. Instructions, \$2.00. C. Faust, Rancocas, New Jersey 08073.

**1930-1962** Radio Programs on reels, \$1.00 hour! Cassettes, \$2.00 hour! Send \$1.25 for huge catalog and hour samples. AM Treasures, Box 192F, Babylon, N.Y. 11702.

**SCOTCH TAPES.** Discounts! Catalog 10¢. Tower, Box 33098, District Heights, Md. 20028.



## DO-IT-YOURSELF

**DIGITAL** projects with numeric readout: Speedometer, Human reaction time tester, Detroit automobile sobriety tester, Thermometer, DVOM, Frequency counter. Plans \$5.00 each, Literature 25¢. GBS, Box 100, Green Bank, West Virginia 24944.

**CONVERT TV** to 6-ft. wide screen! B&W/Color. Do-It-Yourself—easy! Kit, instructions, lens, \$12.95 ppd. Free illustrated details. MACROCOMA, PE-11, Washington Crossing, Penna. 18977.

## PERSONALS

**MAKE FRIENDS WORLDWIDE** through international correspondence. Illustrated brochure free. Hermes, Berlin 11, Germany.

**BUGGED???** . . . Electronic Detector locates hidden transmitters. Literature 25¢. Security Devices, Box 671, Westwood, New Jersey 07675.

## INVENTIONS WANTED

**CASH-ROYALTIES** for patented, unpatented inventions. Global Marketing Service, 2420-P 77th, Oakland, California 94605.

**FREE** "Directory of 500 Corporations Seeking New Products." For information regarding development, sale, licensing of your patented/unpatented invention. Write: Raymond Lee Organization, 230-GR Park Avenue, New York City 10017.

**PATENT** Searches including Maximum speed, full airmail report and closest patent copies. Quality searches expertly administered. Complete secrecy guaranteed. Free Invention Protection forms and "Patent Information." Write Dept. 9, Washington Patent Office Search Bureau, Benjamin Franklin Substation, P.O. Box 7167, Washington, D.C. 20044.

**INVENTORS:** Protect your ideas! Free "Recommended Procedure". Washington Inventors Service, 422T Washington Building, Washington, D.C. 20005.

**FREE PAMPHLET:** "Tips on Safeguarding Your Invention." Write: United States Inventors Service Company, 708-T Carry Building, Washington, D.C. 20005.

**INVENTORS!** Either we will sell your Invention before you or anyone else does, or we will pay you a cash bonus. Get Free Invention Evaluation and information: Write Gilbert Adams Organization, Invention Brokerage, Dept. 20, 81 Wall St., New York, NY 10005.

**MR. INVENTOR:** Ideas and inventions urgently needed by manufacturers. Product development assistance and quality patent searches. Financial assistance plan if required. Write: Charles S. Prince, Invention Consultant, 509-E 5th Avenue, New York City 10017.

## INSTRUCTION

**LEARN ELECTRONIC ORGAN SERVICING** at home all makes including transistor. Experimental kit—trouble-shooting. Accredited NHSC, Free Booklet. NILES BRYANT SCHOOL, 3631 Stockton, Dept. A, Sacramento, Calif. 95820.

**LEARN WHILE ASLEEP,** Hypnotize! Strange catalog free. Auto-suggestion, Box 24-ZD, Olympia, Washington 98501.

**ASSOCIATE DEGREE IN ELECTRONICS** through correspondence instruction. G.I. Bill approved. Free catalog. Grantham, 1509 N. Western, Hollywood, California 90027.

**INTENSIVE** 5 week course for Broadcast Engineers. F.C.C. First Class license. Radio Engineering Incorporated, 52 S. Palm Ave., Sarasota, Florida 33577.

**SHORTCUTS** To Success! Highly Effective, Profitable Short Courses. (75 Choices). Study At Home. Diploma Awarded. Our 27th Year. Free Literature. CIEE-D, Box 10634, Jackson, Miss. 39209.

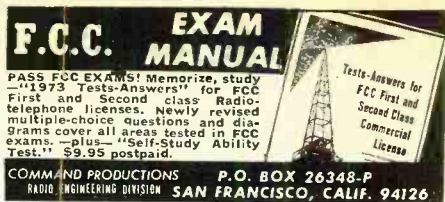

**F.C.C. EXAM MANUAL**  
PASS FCC EXAMS! Memorize, study "1973 Tests-Answers" for FCC First and Second class Radio-telephone licenses. Newly revised multiple-choice questions and diagrams cover all areas tested in FCC exams.—plus—"Self-Study Ability Test." \$9.95 postpaid.  
COMMAND PRODUCTIONS  
RADIO ENGINEERING DIVISION  
P.O. BOX 26348-P  
SAN FRANCISCO, CALIF. 94126

**TAPE RECORDING COURSE:** Taught by studio engineers. Free Information. NNA, Box 721R, Rye, New York 10580.

DIGITAL THEORY DESIGN,  
CONSTRUCTION

## LOGIC NEWSLETTER

SAMPLE COPY \$1.00  
LOGIC NEWSLETTER  
POB 252  
WALDWICK, N.J. 07463

**SCORE** high on F.C.C. Exams . . . Over 300 questions and answers. Covers 3rd, 2nd, 1st and even Radar. Third and Second Test, \$14.50; First Class Test, \$15.00. All tests, \$26.50. R.E.I., Inc, Box 806, Sarasota, Fla. 33577.

**DEGREE** Program in Electronics Engineering. Our 27th Year! Free Literature. Cook's Institute, Dept. 13, Box 10634, Jackson, Miss. 39209.

**ELECTRONICS** Genius? Know your electronics I.Q. Self scoring exams rushed. \$3.00 Omicron, Dept. 101B, Box 10219, Albuquerque, New Mexico 87114.

**FCC** Phone Exams. First, Second, Radar, Third, \$5.00: Actual FCC study material listing, \$1.00: ERH, Dept. R3, Box-19A56, Ahsokie, N. Carolina 27910.

## BUSINESS OPPORTUNITIES

**I MADE** \$40,000.00 Year by Mailorder! Helped others make money! Start with \$15.00—Free Proof. Torrey, Box 318-N, Ypsilanti, Michigan 48197.

**\$200.00 DAILY** in Your Mailbox! Your opportunity to do what mail-order experts do. Free details. Associates, Box 136-J, Holland, Michigan 49423.

**FREE CATALOGS.** Repair air conditioning, refrigeration. Tools, supplies, full instructions. Doolin, 2016 Canton, Dallas, Texas 75201.

**START SMALL,** highly profitable electronic production in your basement. Investment, knowledge unnecessary. Postcard brings facts. Barta-CY, Box 248, Walnut Creek, California 94597.

**MAILORDER MILLIONAIRE** helps beginners make \$500 weekly. Free report reveals secret plan! Executive (1K11), 333 North Michigan, Chicago 60601.

**PIANO TUNING LEARNED QUICKLY AT HOME!** Tremendous field! Musical knowledge unnecessary. GI approved. Information free. Empire School, Box 327, Miami 33145.

**FREE SECRET BOOK** "2042 Unique, Proven Enterprises." Beat inflation with fabulous, successful "Little Knowns." Work home! Haylings-B3, Carlsbad, Calif. 92008.

## HIGHLY PROFITABLE ONE-MAN ELECTRONIC FACTORY

Investment unnecessary, knowledge not required, sales handled by professionals. Postcard brings facts about this unusual opportunity. Write today! Barta-DY, Box 248, Walnut Creek, CA 94597.

**\$2000.00 MONTHLY** selling information by mail. Ropchan, Box 5341X, Sherman Oaks, Calif. 91413.

# KRONOS WITH "TIME BASE"\*

Cabinet 6" x 5 1/4" x 6"

CHOOSE YOUR READOUT

Type	LED	Charac.	Sale
KR-101	MAN-3	.12	\$47.
KR-102	MAN-1	.27	47.
KR-103	MAN-4	.19	47.
KR-104	Nixie*	.45	47.
KR-105	707†	.33	47.
KR-106	704†	.33	47.
KR-107	SLA-1†	.33	47.
KR-108	Same as SLA-1 but GREEN.	as†	47.

\* "MAN" LED readouts are "all LEDs" but the Litronix 707 and Optoca SLA-1, like the MAN-1, are of the reflective bar segment technique, the 704 is the reflective bar version of the MAN-4. The Nixie tube is a 7-segment device as others.

• 12 or 24-hr clock, 6-digits!

Scientific Devices introduces the new any LED Kronos digital clock. That's right, you can choose the "ALL-LED" Man-1, Man-3, and Man-4, and the new reflective bar types with the larger digits, at only one price, \$47. This is a Scientific Device first! We even have the GREEN LED readouts at a slightly extra cost. We have more options for \$19.95 we have available as an extra option to Naval Observatory your clock, or making it an all-purpose all-duty unit. For indoor and outdoor activity. This "TIME BASE" is the simplest on the market today with the help of one of the largest time base manufacturers for the famous digital wrist watches. Therefore, current drain is negligible, not like other cumbersome types. It's easy to construct, easy to slip into the Kronos of your choice and connect with easy instructions. Its overall design is simple and easy to construct. The kit is complete with famous black and white TEN-TEC cabinet, plus all accessories with booklets. Features include 3 setting controls, 1-hour per second, 1-minute per second, and hold button.

CRYSTAL TIME BASE \$19.95 FOR ANY KRONOS

Includes precision crystal, time-base IC, pc board & accessories with info.

\$47. Any Type Clock less time-base

• With TIME BASE \$64.95

- Now two clocks in one!
- For 12VDC & 110VAC!
- Now adaptable to boats, planes & cars too!

## WORLD FAMOUS SEMI-KON Dollar Stretchers

- 20-HEAT SINKS for all types of TO5 trans, makes 'em high power!
- 2-2N5296 3S WATT NPN TRANSISTORS, for NE540 \$1.
- 2-2N6109 40-WATT PNP PLASTIC TRANSISTORS, for NE540 \$1.
- 40-1TT MICRO MINI RECTIFIERS silicon porcelain to 1KV\* \$1.
- 30-WORLD'S SMALLEST RECT. & zeners, 1W, assorted volts\* \$1.
- 40-BENDIX 25 WATT "pellet" transistors, silicon\* \$1.
- 2-2N5036 HI-PWR plastic trans 100 Vceo, 7 amp 35 watts \$1.
- 4-RCA 2N3600 NPN, UHF transistors, tv-fm, TO-18, 1000mc \$1.
- 1-300V PLASTIC POWER TAP transistors, 6A \$1.

### "EYE C" SPECIAL ECONOMY BARGAINS!

- 10-555 HOBBY TIMER special, in the mini DIP pak\* \$1.
- 10-NATIONAL 301 and 307 HOBBY OP AMP SPECIAL TO5\* \$1.
- 15-NATIONAL SYNTHETIC TTL dip special, all marked\* \$1.
- 3-1-WATT AUDIO AMPLIFIERS, Westinghouse, TO-5 \$1.
- 15-709 FLAT PAK OP AMPS, 100% good \$1.
- 50-710-711 flip flop COMPARATORS, untested \$1.
- 4-DUAL 709, dip pak, op amps, untested \$1.
- 5-7474D triggered flip-flops, dip, no test \$1.
- 2-1101 256 BIT ram special, dip, no test \$1.
- 5-SN7447 7-Seg. decoder-driver fallouts \$1.
- 40-TO-5 Case 536, 540, 568, 567, 741\* \$1.
- 5-MOS REGISTERS, 5013-17, mini dips, no-test \$1.
- 5-MOS REGISTERS, 501-6, etc., TO-5, no-test \$1.
- 5-SN7440M, RC10-Nixie driver, DIP\* \$1.
- 10-LINEAR AMPS, 709, 710, 711, 741, TO-5 \$1.
- 10-709 LINEAR AMPS, 741's too, DIP'S\* \$1.
- 5-HOBBY MEMORY CELLS, SN7481, up to 16-cell, DIP\* \$1.
- 10-RCA 7400, 7401, 7402, 7403, 7404, 7405, DIP'S \$1.
- 5-723 VOLTAGE REGULATORS, TO-5, case\* \$1.
- 4-PHASE LOCK LOOPS, hobby 566, 560, 561\* \$1.
- 10-MINI DIPS phase lock loops, 709, 741, 301, 307, hobby\* \$1.
- 2-VOLTAGE REGULATORS, LM309K, hobby, TO-3\* \$1.
- 10-5IGNETIC OP AMP, 531, 533, 536, 550, 555, DIP'S, TO-5 \$1.
- 1-5311-14 CLOCK ON A CHIP, 4-or-6 digit, 24-or-28-pin\* \$1.
- 1-CALCULATOR ON A CHIP, hobby, exp. 40-pin, specs\* \$1.
- 4-DECADE COUNTER, hobby special, SN7490, DIP pak\* \$1.
- 1-7516 CHARACTER GENERATORS, hobby, for MAN 2\* \$1.
- 1-2513 CHARACTER GENERATOR, Hobby for MAN-2\* \$1.

\*Untested, guaranteed satisfaction

### SUPER/ECONOMY \$1 PARTS "DOLLAR STRETCHERS"

- 10-LARGE BACKLOG RELAYS, 24V, unmarked, 2 lbs. \$1.
- 1-AC/DC CONVERTER, 110 to 9V, 180 ma for ch'gers, Nicad. \$1.
- 2-2.5V MICRO MINI BULBS with lens, bayonet \$1.
- 2-GUARDIAN 12VDC type 1205 DPDT 10 amps. cont. \$1.
- 2-SOLENOID 24VDC type 1 x 3/8 x 3/8, Str. 50k 1/2", w/plunger \$1.
- 4-LINE CORDS, 18-2, black, molded plug, 15VAC \$1.
- 15-NE-2 LAMPS, neon, for 100's applications \$1.
- 1-115VAC RELAY, DPST, 10 amp cost. 2 x 2 x 2 1/2" \$1.
- 100-MOLEX SOCKET connectors, for IC's, etc. \$1.
- 2-CINCH EDGE CONNECTORS, type fits .015 board, 30 cont. \$1.
- 10-TEXAS INST type silicon resistors 1-ohm to 10K, 1/4" \$1.
- 10-POINTER KNOBS, push-on, black, fluted, 1/4" shafts \$1.
- 4-MIKES, xtal, only 1" diameter, 2 lugs \$1.
- 4-CONTROL DATA BOARDS, 100's parts, w/plugs \$1.
- 15-TRANSISTOR SOCKETS, for pnp & npn transistors \$1.
- 2-GLASS P.C. BOARDS, 6 x 6 \$1.
- 1-TTL FILAMENT XFMR, 115V/160 to 5V @ 120 ma \$1.
- 4-CHERRY MICRO-MICRO switches w/1 af, 2 1/4 x 1/4 x 1/2" \$1.
- 5-MINI HANDY TOGGLE SWITCHES, 11 VAC, 3 amps, with wire \$1.
- 10-RELAYS, crystal can, micro's, 12-24V, unmarked \$1.
- 10-SELENIUM RECTIFIERS, 65 mil, for ac de sets, Only 3/4" sq \$1.
- 10-SLIDE SWITCHES, SPDT, DPST, DPDT, 115V/160, 3A \$1.
- 10-ALLEN BRADLEY MICRO MINI 1/2 watt resistors, asst. \$1.
- 30-POWER RESISTORS, 3-to-25W, square, vitreous, asst. vals. \$1.
- 10-MICRO REED SWITCHES, 1 1/2" long, transistor work \$1.
- 1-525. SURPRISE PAK, resistors, caps, transistors, etc. \$1.
- 50-TERMINAL STRIPS, 1-to-8 screw & tie lugs \$1.
- 30-SQUARE DISCS, 85mm, to 0.1mf, space-savers \$1.
- 75-PRE-FORMED DISCS, condensers, printed circuit \$1.
- 60-TUBE SOCKETS, receptacles, plugs, audio, etc. \$1.
- 100-PREFORMED RESISTORS, 1/2 watt, printed circuit \$1.
- 50-COILS & CHOKES, if, rf, ant, peaks, osc, parasitic \$1.
- 60-PRECISION RESISTORS, 1/2, 1, 2, 1 & 2w, 1% asst. vals. \$1.
- 60-TUBOID RESISTORS, 10 to 5mf, to 1k, molded top \$1.
- 30-POLYSTYRENE CONDS, finest caps made, asst. values \$1.
- 10-PANEL SWITCHES, 110VAC, micro, rotary, thermal, slide \$1.
- 10-VOLUME CONTROLS, to 1 meg, duals too, some w/switch \$1.
- 40-MICRO-MINI RESISTORS, 1 to 100 ohm to 1 meg, 5% \$1.
- 40-MICRO-MINI CONDENSERS, to .05mf erafall \$1.
- 5-IBM COMPUTER BOARDS, trans, caps, res, coils, etc. \$1.
- 10-ELECTROLYTIC CONDS, PP's, & tubular, 2 & 3 sect. too \$1.
- 6-TRIMMER POTS, 100, 500, 2K, 5K, 10K, 25K, 1/2w, 1 meg \$1.
- 10-MICRO POTS w/ knobs, 1/5w, 1/5w, 1/5w, 100k, 1 meg \$1.
- 30-YELLOW PACKET MYLARS, assorted values & sizes \$1.
- 10-POWER TRANSISTOR SOCKETS, for TO-3, asst. types \$1.
- 64-PLASTIC TRANSISTORS TO-18, printed circuit \$1.

- 1-PHOTO TRANSISTOR, with darlington amp filter, lens \$1
- 1-PHOTO TRANSISTOR, with darlington amp, 2N5777, GE \$1
- 1-PHOTO CELLS, Claxrex, pancake, 30K-70 ohms \$1

- 10-1N52 GERMANIUM UHF diode, clip-in type\* \$1.
- 5-5CR5 7-AMP TO20, 6-12-24 prv, power tab \$1.
- 10-MOS FETS, 3N187, 3N200, 3N128, TO-18, Fairchild\* \$1.
- 5-5CR5 & TRIACS up to 25 amps, 6-12-24 prv. studs to \$1.
- 2-2N3819, Texas, N channel, 6500 umho TO-18 \$1.
- 2-2N5 FET UNFUNCTIONS, plastic TO-18, 52 famous digital wrist \$1.
- 5-2N107, GE, most commonly used pnp, germanium \$1.
- 50-SILICON, glass rectifiers, computer, axial leads \$1.
- 50-GERMANIUM, glass rectifiers, signal, axial leads \$1.
- 5-2N170, GE, RF, germanium, npn transistors, TO-18, 2251 \$1.
- 6-3AMP 1000 PIV, epoxy, submini, silicon rectifiers\* \$1.
- 30-500MVA ZENERS, axial, 4, 6, 9, 10, 12V rectifiers \$1.
- 4-2N3055, HOBBY, 40W npn silicon transistors, TO-3 \$1.
- 30-3AMP RECTIFIERS, silicon, epoxy, asst. V. axial \$1.
- 1-2N3055 npn 100W, 15A, 10V transistor \$1.
- 5-ER900 TRIGGER DIODES, for SCRs \$1.
- 2-FET'S 2N5457 N channel 5000 umhos, TO-92 plastic \$1.
- 10-1N914 fast switch diodes, silicon, 4 nanosecond \$1.
- 2-1N4007, GE, 1N4001, 1N4002, 1N4003, 1N4004, 1N4005, 1N4006, 1N4007, 1N4008, 1N4009, 1N4010, 1N4011, 1N4012, 1N4013, 1N4014, 1N4015, 1N4016, 1N4017, 1N4018, 1N4019, 1N4020, 1N4021, 1N4022, 1N4023, 1N4024, 1N4025, 1N4026, 1N4027, 1N4028, 1N4029, 1N4030, 1N4031, 1N4032, 1N4033, 1N4034, 1N4035, 1N4036, 1N4037, 1N4038, 1N4039, 1N4040, 1N4041, 1N4042, 1N4043, 1N4044, 1N4045, 1N4046, 1N4047, 1N4048, 1N4049, 1N4050, 1N4051, 1N4052, 1N4053, 1N4054, 1N4055, 1N4056, 1N4057, 1N4058, 1N4059, 1N4060, 1N4061, 1N4062, 1N4063, 1N4064, 1N4065, 1N4066, 1N4067, 1N4068, 1N4069, 1N4070, 1N4071, 1N4072, 1N4073, 1N4074, 1N4075, 1N4076, 1N4077, 1N4078, 1N4079, 1N4080, 1N4081, 1N4082, 1N4083, 1N4084, 1N4085, 1N4086, 1N4087, 1N4088, 1N4089, 1N4090, 1N4091, 1N4092, 1N4093, 1N4094, 1N4095, 1N4096, 1N4097, 1N4098, 1N4099, 1N4100, 1N4101, 1N4102, 1N4103, 1N4104, 1N4105, 1N4106, 1N4107, 1N4108, 1N4109, 1N4110, 1N4111, 1N4112, 1N4113, 1N4114, 1N4115, 1N4116, 1N4117, 1N4118, 1N4119, 1N4120, 1N4121, 1N4122, 1N4123, 1N4124, 1N4125, 1N4126, 1N4127, 1N4128, 1N4129, 1N4130, 1N4131, 1N4132, 1N4133, 1N4134, 1N4135, 1N4136, 1N4137, 1N4138, 1N4139, 1N4140, 1N4141, 1N4142, 1N4143, 1N4144, 1N4145, 1N4146, 1N4147, 1N4148, 1N4149, 1N4150, 1N4151, 1N4152, 1N4153, 1N4154, 1N4155, 1N4156, 1N4157, 1N4158, 1N4159, 1N4160, 1N4161, 1N4162, 1N4163, 1N4164, 1N4165, 1N4166, 1N4167, 1N4168, 1N4169, 1N4170, 1N4171, 1N4172, 1N4173, 1N4174, 1N4175, 1N4176, 1N4177, 1N4178, 1N4179, 1N4180, 1N4181, 1N4182, 1N4183, 1N4184, 1N4185, 1N4186, 1N4187, 1N4188, 1N4189, 1N4190, 1N4191, 1N4192, 1N4193, 1N4194, 1N4195, 1N4196, 1N4197, 1N4198, 1N4199, 1N4200, 1N4201, 1N4202, 1N4203, 1N4204, 1N4205, 1N4206, 1N4207, 1N4208, 1N4209, 1N4210, 1N4211, 1N4212, 1N4213, 1N4214, 1N4215, 1N4216, 1N4217, 1N4218, 1N4219, 1N4220, 1N4221, 1N4222, 1N4223, 1N4224, 1N4225, 1N4226, 1N4227, 1N4228, 1N4229, 1N4230, 1N4231, 1N4232, 1N4233, 1N4234, 1N4235, 1N4236, 1N4237, 1N4238, 1N4239, 1N4240, 1N4241, 1N4242, 1N4243, 1N4244, 1N4245, 1N4246, 1N4247, 1N4248, 1N4249, 1N4250, 1N4251, 1N4252, 1N4253, 1N4254, 1N4255, 1N4256, 1N4257, 1N4258, 1N4259, 1N4260, 1N4261, 1N4262, 1N4263, 1N4264, 1N4265, 1N4266, 1N4267, 1N4268, 1N4269, 1N4270, 1N4271, 1N4272, 1N4273, 1N4274, 1N4275, 1N4276, 1N4277, 1N4278, 1N4279, 1N4280, 1N4281, 1N4282, 1N4283, 1N4284, 1N4285, 1N4286, 1N4287, 1N4288, 1N4289, 1N4290, 1N4291, 1N4292, 1N4293, 1N4294, 1N4295, 1N4296, 1N4297, 1N4298, 1N4299, 1N4300, 1N4301, 1N4302, 1N4303, 1N4304, 1N4305, 1N4306, 1N4307, 1N4308, 1N4309, 1N4310, 1N4311, 1N4312, 1N4313, 1N4314, 1N4315, 1N4316, 1N4317, 1N4318, 1N4319, 1N4320, 1N4321, 1N4322, 1N4323, 1N4324, 1N4325, 1N4326, 1N4327, 1N4328, 1N4329, 1N4330, 1N4331, 1N4332, 1N4333, 1N4334, 1N4335, 1N4336, 1N4337, 1N4338, 1N4339, 1N4340, 1N4341, 1N4342, 1N4343, 1N4344, 1N4345, 1N4346, 1N4347, 1N4348, 1N4349, 1N4350, 1N4351, 1N4352, 1N4353, 1N4354, 1N4355, 1N4356, 1N4357, 1N4358, 1N4359, 1N4360, 1N4361, 1N4362, 1N4363, 1N4364, 1N4365, 1N4366, 1N4367, 1N4368, 1N4369, 1N4370, 1N4371, 1N4372, 1N4373, 1N4374, 1N4375, 1N4376, 1N4377, 1N4378, 1N4379, 1N4380, 1N4381, 1N4382, 1N4383, 1N4384, 1N4385, 1N4386, 1N4387, 1N4388, 1N4389, 1N4390, 1N4391, 1N4392, 1N4393, 1N4394, 1N4395, 1N4396, 1N4397, 1N4398, 1N4399, 1N4400, 1N4401, 1N4402, 1N4403, 1N4404, 1N4405, 1N4406, 1N4407, 1N4408, 1N4409, 1N4410, 1N4411, 1N4412, 1N4413, 1N4414, 1N4415, 1N4416, 1N4417, 1N4418, 1N4419, 1N4420, 1N4421, 1N4422, 1N4423, 1N4424, 1N4425, 1N4426, 1N4427, 1N4428, 1N4429, 1N4430, 1N4431, 1N4432, 1N4433, 1N4434, 1N4435, 1N4436, 1N4437, 1N4438, 1N4439, 1N4440, 1N4441, 1N4442, 1N4443, 1N4444, 1N4445, 1N4446, 1N4447, 1N4448, 1N4449, 1N4450, 1N4451, 1N4452, 1N4453, 1N4454, 1N4455, 1N4456, 1N4457, 1N4458, 1N4459, 1N4460, 1N4461, 1N4462, 1N4463, 1N4464, 1N4465, 1N4466, 1N4467, 1N4468, 1N4469, 1N4470, 1N4471, 1N4472, 1N4473, 1N4474, 1N4475, 1N4476, 1N4477, 1N4478, 1N4479, 1N4480, 1N4481, 1N4482, 1N4483, 1N4484, 1N4485, 1N4486, 1N4487, 1N4488, 1N4489, 1N4490, 1N4491, 1N4492, 1N4493, 1N4494, 1N4495, 1N4496, 1N4497, 1N4498, 1N4499, 1N4500, 1N4501, 1N4502, 1N4503, 1N4504, 1N4505, 1N4506, 1N4507, 1N4508, 1N4509, 1N4510, 1N4511, 1N4512, 1N4513, 1N4514, 1N4515, 1N4516, 1N4517, 1N4518, 1N4519, 1N4520, 1N4521, 1N4522, 1N4523, 1N4524, 1N4525, 1N4526, 1N4527, 1N4528, 1N4529, 1N4530, 1N4531, 1N4532, 1N4533, 1N4534, 1N4535, 1N4536, 1N4537, 1N4538, 1N4539, 1N4540, 1N4541, 1N4542, 1N4543, 1N4544, 1N4545, 1N4546, 1N4547, 1N4548, 1N4549, 1N4550, 1N4551, 1N4552, 1N4553, 1N4554, 1N4555, 1N4556, 1N4557, 1N4558, 1N4559, 1N4560, 1N4561, 1N4562, 1N4563, 1N4564, 1N4565, 1N4566, 1N4567, 1N4568, 1N4569, 1N4570, 1N4571, 1N4572, 1N4573, 1N4574, 1N4575, 1N4576, 1N4577, 1N4578, 1N4579, 1N4580, 1N4581, 1N4582, 1N4583, 1N4584, 1N4585, 1N4586, 1N4587, 1N4588, 1N4589, 1N4590, 1N4591, 1N4592, 1N4593, 1N4594, 1N4595, 1N4596, 1N4597, 1N4598, 1N4599, 1N4600, 1N4601, 1N4602, 1N4603, 1N4604, 1N4605, 1N4606, 1N4607, 1N4608, 1N4609, 1N4610, 1N4611, 1N4612, 1N4613, 1N4614, 1N4615, 1N4616, 1N4617, 1N4618, 1N4619, 1N4620, 1N4621, 1N4622, 1N4623, 1N4624, 1N4625, 1N4626, 1N4627, 1N4628, 1N4629, 1N4630, 1N4631, 1N4632, 1N4633, 1N4634, 1N4635, 1N4636, 1N4637, 1N4638, 1N4639, 1N4640, 1N4641, 1N4642, 1N4643, 1N4644, 1N4645, 1N4646, 1N4647, 1N4648, 1N4649, 1N4650, 1N4651, 1N4652, 1N4653, 1N4654, 1N4655, 1N4656, 1N4657, 1N4658, 1N4659, 1N4660, 1N4661, 1N4662, 1N4663, 1N4664, 1N4665, 1N4666, 1N4667, 1N4668, 1N4669, 1N4670, 1N4671, 1N4672, 1N4673, 1N4674, 1N4675, 1N4676, 1N4677, 1N4678, 1N4679, 1N4680, 1N4681, 1N4682, 1N4683, 1N4684, 1N4685, 1N4686, 1N4687, 1N4688, 1N4689, 1N4690, 1N4691, 1N4692, 1N4693, 1N4694, 1N4695, 1N4696, 1N4697, 1N4698, 1N4699, 1N4700, 1N4701, 1N4702, 1N4703, 1N4704, 1N4705, 1N4706, 1N4707, 1N4708, 1N4709, 1N4710, 1N4711, 1N4712, 1N4713, 1N4714, 1N4715, 1N4716, 1N4717, 1N4718, 1N4719, 1N4720, 1N4721, 1N4722, 1N4723, 1N4724, 1N4725, 1N4726, 1N4727, 1N4728, 1N4729, 1N4730, 1N4731, 1N4732, 1N4733, 1N4734, 1N4735, 1N4736, 1N4737, 1N4738, 1N4739, 1N4740, 1N4741, 1N4742, 1N4743, 1N4744, 1N4745, 1N4746, 1N4747, 1N4748, 1N4749, 1N4750, 1N4751, 1N4752, 1N4753, 1N4754, 1N4755, 1N4756, 1N4757, 1N4758, 1N4759, 1N4760, 1N4761, 1N4762, 1N4763, 1N4764, 1N4765, 1N4766, 1N4767, 1N4768, 1N4769, 1N4770, 1N4771, 1N4772, 1N4773, 1N4774, 1N4775, 1N4776, 1N4777, 1N4778, 1N4779, 1N4780, 1N4781, 1N4782, 1N4783, 1N4784, 1N4785, 1N4786, 1N4787, 1N4788, 1N4789, 1N4790, 1N4791, 1N4792, 1N4793, 1N4794, 1N4795, 1N4796, 1N4797, 1N4798, 1N4799, 1N4800, 1N4801, 1N4802, 1N4803, 1N4804, 1N4805, 1N4806, 1N4807, 1N4808, 1N4809, 1N4810, 1N4811, 1N4812, 1N4813, 1N4814, 1N4815, 1N4816, 1N4817, 1N4818, 1N4819, 1N4820, 1N4821, 1N4822, 1N4823, 1N4824, 1N4825, 1N4826, 1N4827, 1N4828, 1N4829, 1N4830, 1N4831, 1N4832, 1N4833, 1N4834, 1N4835, 1N4836, 1N4837, 1N4838, 1N4839, 1N4840, 1N4841, 1N4842, 1N4843, 1N4844, 1N4845, 1N4846, 1N4847, 1N4848, 1N4849, 1N4850, 1N4851, 1N4852, 1N4853, 1N4854, 1N4855, 1N4856, 1N4857, 1N4858, 1N4859, 1N4860, 1N4861, 1N4862, 1N4863, 1N4864, 1N4865, 1N4866, 1N4867, 1N4868, 1N4869, 1N4870, 1N4871, 1N4872, 1N4873, 1N4874, 1N4875, 1N4876, 1N4877, 1N4878, 1N4879, 1N4880, 1N4881, 1N4882, 1N4883, 1N4884, 1N4885, 1N4886, 1N4887, 1N4888, 1N4889, 1N4890, 1N4891, 1N4892, 1N4893, 1N4894, 1N4895, 1N4896, 1N4897, 1N4898, 1N4899, 1N4900, 1N4901, 1N4902, 1N4903, 1N4904, 1N4905, 1N4906, 1N4907, 1N4908, 1N4909, 1N4910, 1N4911, 1N4912, 1N4913, 1N4914, 1N4915, 1N4916, 1N4917, 1N4918, 1N4919, 1N4920, 1N4921, 1N4922, 1N4923, 1N4924, 1N4925, 1N4926, 1N4927, 1N4928, 1N4929, 1N4930, 1N49



**IC****PRICES  
SLASHED****FACTORY FIRSTS  
NATIONALLY  
KNOWN  
BRANDS  
SATISFACTION GUARANTEED**

DIGITAL TTL	
7400N	32c
7401N	32c
7402N	32c
7403N	32c
7404N	35c
7405N	35c
7406N	52c
7407N	52c
7408N	36c
7409N	36c
7410N	32c
7411N	32c
7412N	50c
7413N	63c
7414N	50c
7415N	50c
7416N	35c
7420N	32c
7422N	35c
7426N	36c
7430N	32c
7437N	51c
7438N	51c
7440N	32c
7441N	\$1.45
7442N	\$1.20
7445N	\$1.62
7446N	\$1.30
7447N	\$1.35
7448N	32c
7449N	32c
7450N	32c
7451N	85c
7453N	32c
7454N	32c
7455N	32c
7460N	32c
7470N	36c
7472N	40c
7473N	52c
7474N	52c
7475N	52c
7476N	60c
7480N	74c
7482N	\$1.02
7483N	\$1.58
7486N	60c
7489N	\$4.50
7491N	\$1.37
7490N	85c
7492N	85c
7493N	85c
7494N	\$1.20
7495N	\$1.20
7496N	\$1.20
74107N	55c
74121N	70c
74122N	72c
74155N	\$1.11
74141N	\$1.61
74150N	\$1.56
74152N	\$1.20
74153N	\$1.58
74154N	\$2.25
74156N	\$1.46
74156N	\$1.17
74157N	\$1.56
74158N	\$1.56
74160N	\$1.95
74161N	\$1.95
74162N	\$1.20
74163N	\$1.95
74164N	\$1.95
74165N	\$2.48
74166N	\$2.03
74180N	\$1.20
74181N	\$3.38
74182N	\$1.17
74192N	\$1.80
74193N	\$1.80
74198N	\$2.78
74199N	\$2.78

Discounts offered in quantities of 100 pcs TTL in mixed lots.

**LINEAR INTEGRATED CIRCUITS**

MS558V MiniDIP	95c	723C DIP	\$1.15
NE565A DIP	\$3.57	741C MiniDIP	.60c
NE567V MiniDIP	\$3.57	747C DIP	\$1.10
MS58V MiniDIP	95c	748C MiniDIP	.60c
709C MiniDIP	44c	Quantity Discounts	

**GENERAL PURPOSE SILICON TRANSISTORS**

2N3638	20c	10/\$1.65	2N5134	15c	10/\$1.25
2N3638A	22c	10/\$1.80	2N5137	18c	10/\$1.50
2N3641	23c	10/\$2.00	2N5138	15c	10/\$1.25
2N3643	23c	10/\$2.00	2N5139	15c	10/\$1.25
2N5133	15c	10/\$1.25	2N3055	\$1.00	10/\$9.50

**1 AMP SILICON RECTIFIERS**

1N4003 200PIV	10/\$1	100/\$7	1M/\$51
1N4005 600PIV	9/\$1	100/\$8	1M/\$61
1N4007 1000PIV	6/\$1	100/\$10	1M/\$83

**SILICON SIGNAL DIODES**

1N4148 (1N914 equiv.)	10/\$1	100/\$4	1M/\$35
-----------------------	--------	---------	---------

**MOLEX IC SOCKET PINS**

100/\$1.00	200/\$1.80	300/\$2.60	500/\$4.20	700/\$5.80
1000/\$8.20 ea	addn	1000/\$7.50		

**INTEGRATED CIRCUIT SOCKETS**

14 PIN DIP SOLDER	45c	16 PIN DIP SOLDER	50c
14 PIN WIRE WRAP	55c	16 PIN WIRE WRAP	60c

**C.O.D. ORDERS ACCEPTED FOR SAME DAY SHIPMENT**

CALL 218-981-6674

Free Catalog—Large Quantity Discounts—Orders Less Than \$10.00 Add 25c—Others Postpaid

PRICE PACESETTER FOR QUALITY IC'S

BOX 126K THIEF RIVER FALLS, MN56701

**CIRCLE NO. 36 ON READER SERVICE CARD**

**SILVER RECOVERY Dealers WANTED!**—Earn \$24,000.00 by second year!—No investment!—No Risk!—Equipment Provided!—Our manual "How To Start and Operate Your Own Silver Recovery Business" gives complete details!—Manual only \$9.95—Limited Offer!—Creative Products, 8415 Lofland, Dept. 113, Houston, Texas 77055.

**YOUR IDEAS** are worth big money. Exciting new book tells secrets. Free details. Neotak (PEA), 19309 Revere, Detroit, MI 48234.

**TIRED OF NO MONEY??** Get Going! Instant Success! Small Investment brings \$30,000.00 per year or more! Write: Wyllins, 22 Sheppard Lane, Smithtown, N.Y. 11787.

**MOVIE FILMS**

**8MM-SUPER 8-16MM MOVIES!** Biggest Selection! Lowest Prices! Free Catalog! Cinema Eight, Box PE, Chester, Connecticut 06412.

**MAGNETS**

**MAGNETS.** All types. Specs-20 disc, or 10 bar, or 2 stick, or 8 assorted magnets, \$1.00. Magnets, Box 192-H, Randallstown, Maryland 21133.

**PLASTICS**

**CASTOLITE** pours like water, hardens like glass without heat. Crystal clear, colors. Embed flowers, seashells, momentos, anything. Make fine gifts. Form flexible molds over any pattern, size. Reproduce your own designs in plastics, candle wax, metal, plaster, cement. Profitable. Illustrated Manual and Catalog Only \$1.00. CASTOLITE, Dept. 73M/PE, Woodstock, Ill. 60098.

**RUBBER STAMPS**

**RUBBER** address stamps. Free catalog. 45 type styles. Jackson's, Box 443G, Franklin Park, Ill. 60131.

**SPORTS ACTION FILMS**

**CHRISTMAS GIFT SPECIAL**—Pro Sports Films Instant Replay: '72 NFL Super Bowl, '72 World Series, '72 NHL Stanley Cup Hockey, '72 NBA Championship and Ali-Norton first bout—each a separate film in regular or Super 8mm. Color, \$14.95 each or 2 for \$29.00 PPD. Offer expires December 1, 1973. Write for Discount Sports Films Catalog, 25¢. SPORTLITE, Elect. Dept. 500, Speedway, Ind. 46224.

**HYPNOTISM**

**SLEEP** learning. Hypnotic method. 92% effective. Details free. ASR Foundation, Box 7566EG, Fort Lauderdale, Florida 33304.

**FREE** Hypnotism, Self-Hypnosis. Sleep Learning Catalog! Drawer H400, Ruidoso, New Mexico 88345.

**EMPLOYMENT INFORMATION**

**EXCITING** Overseas jobs. Directory \$1.00. Research Associates, Box 889-E, Belmont, California 94002.

**EMPLOYMENT OPPORTUNITIES**

**ELECTRONICS/AVIONICS EMPLOYMENT OPPORTUNITIES.** Report on jobs now open. Details FREE. Aviation Employment Information Service, Box 240E, Northport, New York 11768.

**STAMPS**

**88 COUNTRIES—ONLY 10¢!** Worth \$5.00 at catalog prices!! Incredible collection of genuine postage stamps from 88 different countries—from Afghanistan to Zambia, North to South Pole! British, French, Portuguese, Spanish Colonies, Old 19th Century, New Issues, Moon and Outer Space stamps, etc. All for only 10¢! Also, other exciting stamps to examine free. Buy any or none; return balance, cancel service anytime. Plus Wonderful Free Catalog. H. E. HARRIS, Dept. SS-62, Boston, Mass. 02117.

**PRINTING**

**FREE** Literature, Business cards, letterheads, Rubber stamps. Geer's, 111 North Drive, Ottawa, Ohio 45875.

**TREASURE FINDERS**

**FREE**—Valuable Treasure Finder catalog sent by return mail. Find Coins, Rings, Gold, Silver, Metals, Relics. Write today. JETCO, Dept. CPE, Box 26669, El Paso, Texas 79926.

**TREASURE FINDER** locates buried gold, silver, coins, treasures. 6 powerful models. \$19.95 up. Instant financing available. Write or call for free catalog. Phone (713) 682-2728 day or night. Dealer inquiries invited. Relco, Dept. A-33, Box 10839, Houston, Texas 77018.

**FREE FACT-FILLED CATALOG.** World's largest line of metal detectors. Models as low as \$49.50 and up. Two year Guarantee. Three factory locations, U.S. and Canada, plus over 1,000 dealers and 35 Service Centers from coast to coast. No finer instruments made at any price. Budget terms. Write: White's Electronics, Inc., Rm# 391, 1011 Pleasant Valley Road, Sweet Home, Oregon 97386.

**FIND BURIED TREASURE** eight transistorized models \$19.95 to \$119.95, modular interchangeable heads, full view motors, FREE Catalog, Solidtronics Corporation PE 38, Tennent, N.J. 07763.



# Popular Electronics

INCLUDING **Electronics World**

NOVEMBER 1973

## ADVERTISERS INDEX

READER SERVICE NO.	ADVERTISER	PAGE NO.
	Allied Electronic	108
1	Antenna Specialists Co., The	118
2	B & K Division, Dynasean Corporation	27
3	Babylon Electronics	122
	Bell & Howell Schools	76, 77, 78, 79
4	Bose	13
	Burstein-Applebee Co.	119
	CREI Capitol Radio Engineering Institute	58, 59, 60, 61
6	Cleveland Institute of Electronics	112, 113, 114, 115
7	Continental Specialties Co	10
8	Delta Electronics Co	123
5	Delta Products, Inc	19
36	Digi-Key	128
9	Dixie Hi-Fidelity Wholesalers	121
10	Dynaco Inc	7
11	EICO	120
12	E & L Instruments, Incorporated	8
13	Edmund Scientific Co	130
14	Electro-Voice, Inc	9
35	Fluke	109
15	Gregory Electronics Corp	108
16	Heath Company	40, 41, 42, 43

READER SERVICE NO.	ADVERTISER	PAGE NO.
17	Illinois Audio	121
18	Lafayette Radio Electronics	95, 96
20	McIntosh Laboratory, Inc	90
21	MITS Micro Instrumentation & Telemetry Systems, Inc	28
22	Mallory & Co., Inc., P.R.	15
23	Midwest Hi-Fi Wholesale & Mail Order Division	120
	National Radio Institute	SECOND COVER, 1, 2, 3
	National Technical Schools	22, 23, 24, 25
24	Olson Electronics	85
25	Poly Paks	127
26	Radio Shack and Allied Radio Stores	93
27	Regency	75
19	Shure Brothers Inc	FOURTH COVER
28	Solid State Sales	124
29	Stanton Magnetics Inc	11
30	Tri-Star Corporation	119
	U.S. Navy	20, 21
31	Ungar	117
32	United Audio Products, Inc	39
33	Utah Electronics Division	105
34	Xcelite, Inc	87

CLASSIFIED ADVERTISING ..... 122, 123, 124, 125, 126, 128, 129

### REAL ESTATE

**FREE . . . BIG . . . 264-PAGE FALL CATALOG!** Describes and pictures hundreds of farms, ranches, town and country homes, businesses coast to coast! Specify type property and location preferred. UNITED FARM AGENCY, 612-EP West 47th St., Kansas City, Mo. 64112.

### MUSICAL INSTRUMENTS

**30% DISCOUNT** name brand musical instruments. Free Catalog. Freeport Music, 455N, Route 110, Melville, N.Y. 11746.

**WHOLESALE!** Professional Guitars, PA Systems, Aitec Speakers, 240W RMS Amplifiers. Free Catalog, Carvin, Escondido, Calif. 92028.

### MISCELLANEOUS

**WINEMAKERS:** Free illustrated catalog yeasts, equipment. Semplex, Box 12276P, Minneapolis, Minn. 55412.

**STOP BURGLARS THE EASY WAY!** Affix authentic "Protected by Electronics Sentry Alarm" decals to auto windows, doors and windows of home, retail stores, vending machines, etc. Whether you have an alarm or not—thieves stay away! Only \$1.00 for each set of two. J. Ross, 80-34 Kent Street, Jamaica, N. Y. 11432, Dept. PE.

**YOUR Classified or Display Classified Ad** in these columns will be seen, read and regularly responded to by America's largest audience comprising Electronics Professionals and Hobbyists. Cost is low, results high (most advertisers repeat 12 times each year). Send copy and payment now to address indicated at beginning of **ELECTRONICS MARKET PLACE**.

# LIVE IN THE WORLD OF TOMORROW...TODAY!

## A BETTER LIFE STARTS HERE

### DIGITAL COMPUTER LOGIC LAB

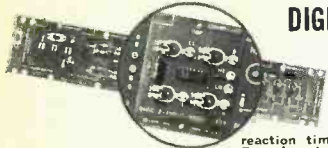

Fascinating new way to learn computer types, binary systems, truth tables, logic. Make ring counter, shift register and binary counters. Play with reaction timer, electronic coin flipper. Experiment with memory, counting & arithmetic circuits. 4 assembled module circuits (clock, solid-state NAND gates, flip-flop, display), 20 patch cords for 100's of circuits—23 computer experiments. No electronic know-how needed! 74 pg. illustr. manual explains all. Req. 6v batt. (not incl.)

Stock No. 71,403AV ..... \$39.75 Ppd.

### KNOW YOUR ALPHA FROM THETA!



For greater relaxation, concentration, listen to your Alpha-Theta brainwaves. Ultra-sensitive electrode headband slips on/off in seconds—eliminates need for messy creams, etc. Atch'd to amplifier, filters brainwaves, signals beep for ea. Alpha or Theta wave passed. Monitoring button simulates Alpha sound; audio & visual (L.E.D.) feedback. Reliable, easy-to-use unit—comparable to costlier models. Completely safe. Comprehensive instruction booklet.

No. 1635AV ..... (8x3x4", 24 oz.) ..... \$124.50 Ppd.  
No. 71,809 ..... (Low Cost "Starter" Unit) ..... \$49.95 Ppd.

### "FISH" WITH A MAGNET



Go treasure hunting on the bottom! Fascinating fun & sometimes profitable! Tie a line to our powerful new specially designed 150 lb. pull Magnet—drop it overboard in bay, river, lake or ocean. Trawl it along bottom—your "treasured" haul can be outboard motors, anchors, other metal valuables. Has 6 stacked ceramic magnets. Lifts more than 150 lbs. under water!

No. 71,135AV ..... (31/4x37/8") ..... \$16.50 Ppd.  
75-LB. PULL (1 LB.) W/3 CERAMIC MAGNETS ..... \$10.25 Ppd.  
No. 71,150AV ..... (5-11/16x3 1/4")

### 3-CHANNEL COLOR ORGAN KIT

Easy to build low-cost kit needs no technical knowledge. Completed unit has 3 bands of audio frequencies to modulate 3 independent strings of colored lamps (i.e. "lows"—reds, "middles"—greens, "highs"—blues. Just connect hi-fi, radio, power lamp etc. & plug ea. lamp string into own channel (max. 300w ea.). Kit features 3 neon indicators, color intensity controls, controlled individ SCR circuits; isolation transformer; custom plastic housing; instr.

Stock No. 41,831AV ..... \$17.50 Ppd.



### 130 EXPERIMENTS IN OPTICS...

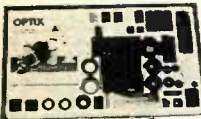

and photography! Optix® Experiments Kit is a complete optical & photography lab for 130 exciting experiments. Lets you recreate the periscope, telescope, microscope, kaleidoscope! Build a 35-mm reflex camera with interchangeable lens system! Make, develop photographic film! Enjoy the fun and fascination of having your own optics lab. Fully illustr 112-pg manual, 8 1/2x11", clearly explains usage of this stimulating kit's 114 precision engineered components.

Stock No. 71,646AV ..... \$22.50 Ppd.

SEE THE STARS. MOON, PLANETS CLOSE UP!

### 3" ASTRONOMICAL REFLECTING TELESCOPE



60 To 180 Pwr. Famous Mt. Palomar Type See the rings of Saturn, the fascinating planet Mars, Seas and Craters of the Moon, Star Clusters in detail. New improved, aluminized and overcoated 3" diameter f/10 primary mirror, ventilated cell. Equatorial mount with locks on both axes. Equipped with 60x finder telescope, hardwood tripod. Included FREE: VALUABLE "HOW TO USE YOUR TELESCOPE" book; "STAR CHART".

Stock No. 85,050AV ..... \$34.95 Ppd.  
Deluxe 3" Reflector Telescope 4 1/4" Reflector Telescope (45x to 270x)  
Stock No. 80,162AV ..... \$62.50 Ppd. Stock No. 85,105AV ..... \$110.00 FOB  
4 1/4" Reflector Telescope with Clock Drive Stock No. 85,107AV ..... \$145.00 Ppd.  
6" Reflector Telescope Stock No. 85,187AV ..... \$215.00 FOB  
6" Reflector W/ (Electric) Clock Drive No. 85,086AV ..... \$249.50 FOB

## MAIL COUPON FOR GIANT FREE CATALOG!

164 PAGES • MORE THAN 4,500 UNUSUAL BARGAINS!

Completely new '74 Catalog. Packed with huge selection of telescopes, microscopes, binoculars, magnets, magnifiers, prisms, photo components, ecology and Unique Lighting items, parts, kits, accessories—many hard-to-get surplus bargains. 100's of charts, illustration. For hobbyists, experimenters, schools, industry.

**EDMUND SCIENTIFIC CO.**  
300 Edscorp Building, Barrington, N. J. 08007  
Please rush Free Giant Catalog "AV"

Name \_\_\_\_\_  
Address \_\_\_\_\_  
City \_\_\_\_\_ State \_\_\_\_\_ Zip \_\_\_\_\_

### COMPLETE & MAIL WITH CHECK OR M.O.

#### EDMUND SCIENTIFIC CO.

300 Edscorp Building, Barrington, N.J. 08007

How Many	Stock No.	Description	Price Each	Total

PLEASE SEND  GIANT FREE CATALOG "AV" MERCHANDISE Total

ADD HANDLING CHARGE: \$1.00 ON ORDERS UNDER \$5.00; 50c ON ORDERS OVER \$5.00

TOTAL \$ \_\_\_\_\_

I enclose  check  
 money order for \$ \_\_\_\_\_

NAME \_\_\_\_\_

ADDRESS \_\_\_\_\_

CITY \_\_\_\_\_ STATE \_\_\_\_\_ ZIP \_\_\_\_\_



CIRCLE NO. 13 ON READER SERVICE CARD

Printed in U.S.A.

POPULAR ELECTRONICS Including Electronics World

Electrify your friends  
for one full year with  
Christmas subscriptions to  
**Popular Electronics**  
INCLUDING **Electronics World**

Save now with these special Christmas rates

**FIRST GIFT \$6.00**  
**SECOND GIFT \$5.00** (save \$1.00)  
**EACH ADDITIONAL GIFT \$4.00**  
(save \$2.00 on each)

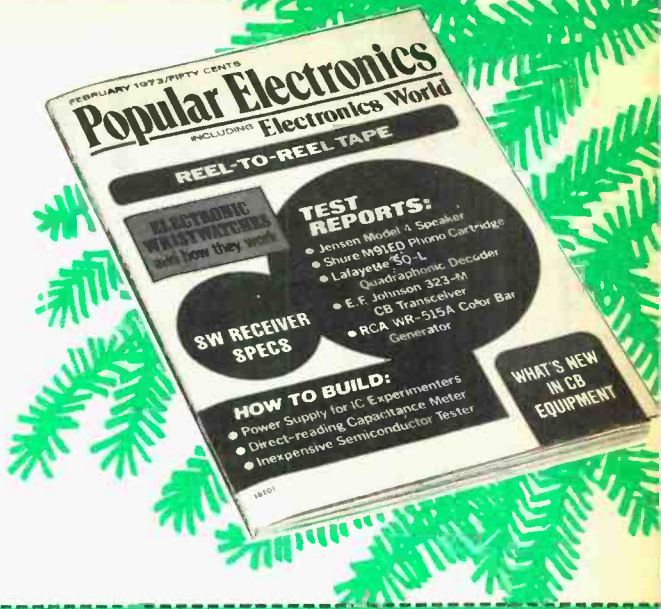

Say Merry Christmas with a gift subscription to **Popular Electronics** 2066  
INCLUDING **Electronics World**

Please send a 12-month subscription of  
POPULAR ELECTRONICS INCLUDING ELECTRONICS WORLD as my gift to:

name \_\_\_\_\_

address \_\_\_\_\_

city \_\_\_\_\_ state \_\_\_\_\_ zip \_\_\_\_\_

Gift card to read: \_\_\_\_\_

name \_\_\_\_\_

address \_\_\_\_\_

city \_\_\_\_\_ state \_\_\_\_\_ zip \_\_\_\_\_

Gift card to read: \_\_\_\_\_

Enter or  Renew my present subscription  Please bill me later  I enclose \$

For postage outside U.S., its possessions and Canada, add \$1 for each subscription.

First gift \$6.00, second gift \$5.00, each additional gift \$4.00

Print additional names on separate sheet of paper and  
mail with this card in an envelope.

name \_\_\_\_\_

address \_\_\_\_\_

city \_\_\_\_\_ state \_\_\_\_\_ zip \_\_\_\_\_

Gift card to read: \_\_\_\_\_

MY NAME \_\_\_\_\_

address \_\_\_\_\_

city \_\_\_\_\_ state \_\_\_\_\_ zip \_\_\_\_\_

Gift card to read: \_\_\_\_\_

Say Merry Christmas with a gift subscription to **Popular Electronics** 2066  
INCLUDING **Electronics World**

Please send a 12-month subscription of  
POPULAR ELECTRONICS INCLUDING ELECTRONICS WORLD as my gift to:

name \_\_\_\_\_

address \_\_\_\_\_

city \_\_\_\_\_ state \_\_\_\_\_ zip \_\_\_\_\_

Gift card to read: \_\_\_\_\_

name \_\_\_\_\_

address \_\_\_\_\_

city \_\_\_\_\_ state \_\_\_\_\_ zip \_\_\_\_\_

Gift card to read: \_\_\_\_\_

Enter or  Renew my present subscription  Please bill me later  I enclose \$

For postage outside U.S., its possessions and Canada, add \$1 for each subscription.

First gift \$6.00, second gift \$5.00, each additional gift \$4.00

Print additional names on separate sheet of paper and  
mail with this card in an envelope.

name \_\_\_\_\_

address \_\_\_\_\_

city \_\_\_\_\_ state \_\_\_\_\_ zip \_\_\_\_\_

Gift card to read: \_\_\_\_\_

MY NAME \_\_\_\_\_

address \_\_\_\_\_

city \_\_\_\_\_ state \_\_\_\_\_ zip \_\_\_\_\_

Gift card to read: \_\_\_\_\_

Send  
no  
money.  
Just  
fill in  
and  
mail the  
postpaid  
card.



# Make your friends one year happier with a Christmas subscription to Popular Electronics

INCLUDING **Electronics World**  
**FIRST GIFT \$6.00** **SECOND GIFT \$5.00** (save \$1.00)  
**EACH ADDITIONAL GIFT \$4.00**  
 (save \$2.00 on each)



FIRST CLASS  
 Permit No. 906  
 Boulder, Colo.

## BUSINESS REPLY MAIL

NO POSTAGE NECESSARY IF MAILED IN THE UNITED STATES

POSTAGE WILL BE PAID BY

**Popular Electronics**  
 INCLUDING **Electronics World**

P.O. Box 2774  
 Boulder, Colorado 80302

---

---

---

---

---

---

---

---

FIRST CLASS  
 Permit No. 906  
 Boulder, Colo.

## BUSINESS REPLY MAIL

NO POSTAGE NECESSARY IF MAILED IN THE UNITED STATES

POSTAGE WILL BE PAID BY

**Popular Electronics**  
 INCLUDING **Electronics World**

P.O. Box 2774  
 Boulder, Colorado 80302

---

---

---

---

---

---

---

---

*Send no money.  
 Just fill in the other side of the postpaid card. We'll bill you later.*

# Popular Electronics

INCLUDING Electronics World

## READER SERVICE

Here's an easy and convenient way for you to get additional information about products advertised or mentioned editorially (if it has a reader service number) in this issue. Just follow the directions below... and the material will be sent to you promptly and free of charge.

# 1

On the attached postage-free card, print or type your name and address on the lines indicated.

# 2

Circle the number (s) that corresponds to the key number (s) at the bottom or next to the advertisement or editorial mention that is of interest to you. (Key numbers for advertised products also appear in the Advertisers' Index.)

# 3

Simply cut out the card and mail. No postage required.

## FREE INFORMATION

### 1974 ELECTRONIC EXPERIMENTER'S HANDBOOK Winter Edition



*Helps you get it together... with a score of build-it-yourself projects.*

You can count on Electronic Experimenter's Handbook. It's by the Editors of Popular Electronics Including Electronics World. With features and articles and complete lab-tested instructions that guarantee successful hours and months of mind-absorbing projects for fun and practicality.

Think of the money you can save by building a HAND-HELD ELECTRONIC CALCULATOR—with six, nine or twelve digit read-out that will do the job for you. Or, how about an ALL AMERICAN SPORTS AMPLIFIER which will bring in distant stations not affected by TV blackouts of your favorite teams' games. Or, a DIGITAL LOGIC TRAINER—the "Baby Computer" which performs 32 functions and teaches Boolean algebra.

There's a dozen and a half other brain-teasers including THE DRUMMER BOY, a low-cost rhythm section you can build for yourself • THE MUSCLE WHISTLER—listen to your biceps do their thing with simple, easy-to-build circuit • LOW-VOLTAGE REMOTE POWER CONTROL—avoid safety problems and costly rewiring by building this circuit • THE CHARGE NOW—this unit will recharge any nickel-cadmium or alkaline AA, C, or D cell • VHF FREQUENCY CONVERTER—if you enjoy monitoring the various bands • RUGGED AUTO EMERGENCY FLASHER—providing reliable protection for your camper, trailer or other oversized vehicles • CRYSTAL CALIBRATOR FOR THE HAM AND SWL—provides accurate frequency checks 25 and 100 kHz apart • TESTING POWER SUPPLIES—this simple circuit is designed to be used with your TVM or VTVM and will work with supplies of 5 or more volts • ELECTRO-CHEMICAL HYGROMETER—a low-cost unit which measures ambient relative humidity and gives you metered "proof" of why you feel so uncomfortable! Don't miss this latest issue with its many exciting build-it-yourself projects.

### HERE'S HOW TO ORDER

Send your order to Ziff-Davis Service Division, Dept. EEH, 595 Broadway, New York, N.Y. 10012. Print your name and address clearly, specify "1974 ELECTRONIC EXPERIMENTER'S HANDBOOK—Winter Edition," enclose \$1.25 plus 35c for postage and handling. (Outside U.S.A. copies are \$2.50 each, postpaid.)

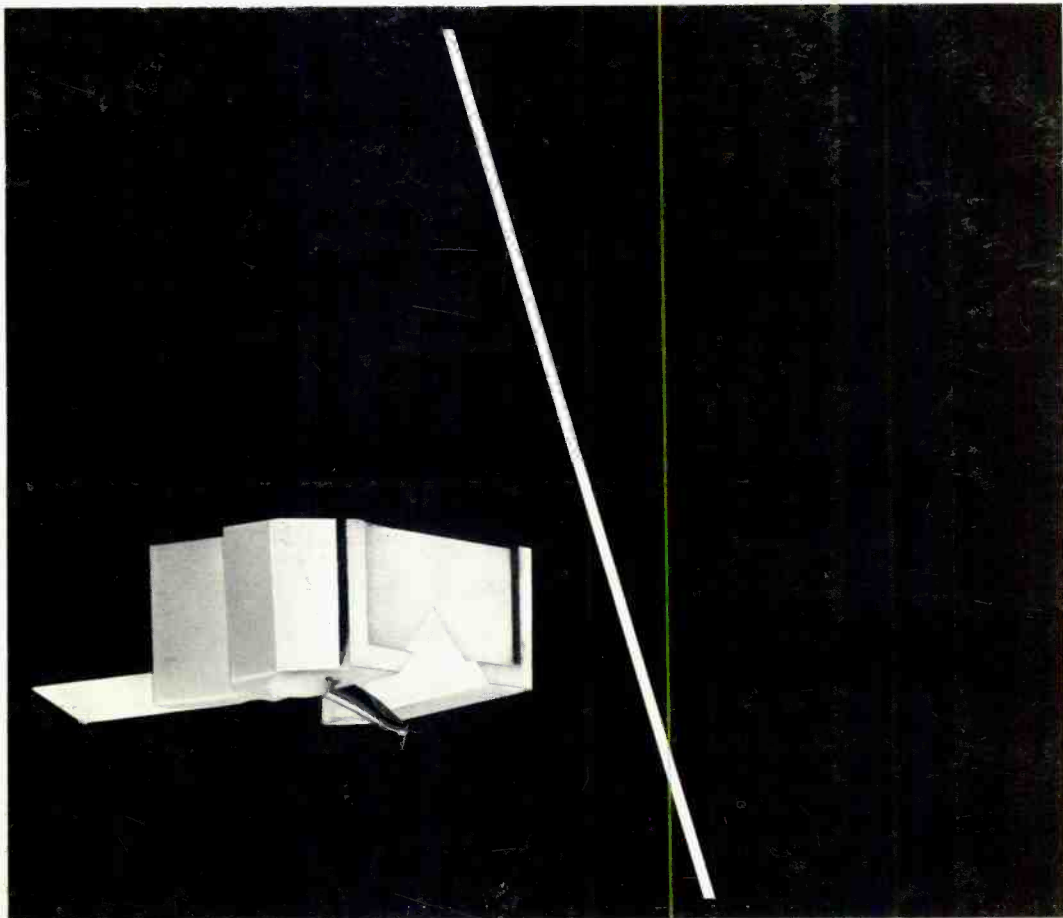

## The three dollar bill.



The stylus shown above is phony. It's represented as a replacement stylus for a Shure cartridge, and although it looks somewhat authentic, it is, in fact, a shoddy imitation. It can fool the eye, but the critical ear? Never! The fact is that the Shure Quality Control Specialists have examined many of these impostors and found them, at best, to be woefully lacking in uniform performance — and at worst, to be outright failures that simply do not perform even to minimal trackability specifications. Remember that the performance of your Shure cartridge depends upon the stylus, so insist on the real thing. Look for the name SHURE on the stylus grip (as shown in the photo, left) and the words, "This Stereo Dynetic® Stylus is precision manufactured by Shure Brothers Inc." on the box.

Shure Brothers Inc.  
222 Hartrey Avenue, Evanston, Illinois 60204



CIRCLE NO. 19 ON READER SERVICE CARD