

Popular Electronics

INCLUDING **Electronics World**



BREAKTHROUGH!

Build the Super Audio Sweep Generator

Tape Recording:

HOW TO ADD

- Overload Protection
- Sound Activated "On"

Communications:

- CB Accessory Roundup
- A Battery-less AM Portable

Plus:

- Intro to Electronic Music
- Make a Polaroid IC Timer
- Color-TV CRT Saver Project

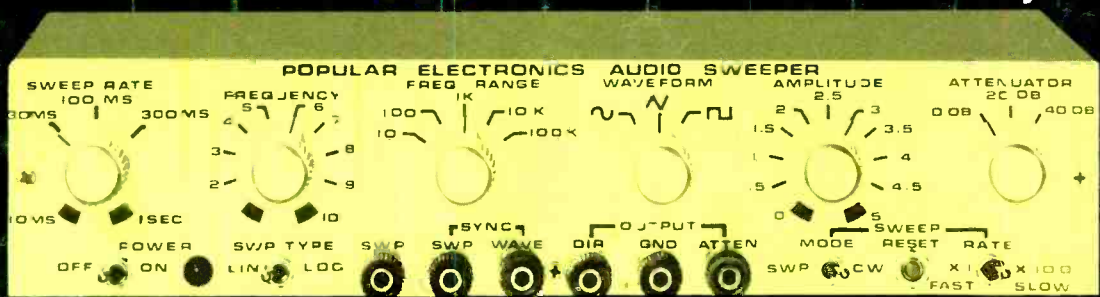

Product Test Reports:

- KLH Model 52 Stereo Receiver
- Akai Model 4000DS Ta
- RCA WV-529A Volt-oh
- Realistic TRC-46 CB T
- James C-8600 Electronic Thermometer

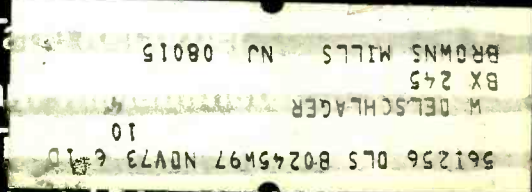

firsts

make learning
Electronics at home
fast and fascinating –
give you priceless
confidence.

Some NRI **firsts** in training equipment



first to give solid state 25" diagonal color TV, 5" wide band oscilloscope, color bar generator and other professional equipment engineered specifically for education. You work directly on the receiver as you build it, discovering the practical aspects of TV servicing as you create a handsome new color console. Only NRI includes an attractive woodgrain cabinet without extra charge.



first to give you a unique, exciting digital computer *with memory* built especially for home training. You learn organization, troubleshooting, operation, programming as you build and use it. Performs the same functions as commercial computers. Lessons stress computer repair. You conduct a hundred experiments, build hundreds of circuits. A solid-state TVOM is included among ten training kits.

NRI's "discovery" method is the result of over half a century of leadership simplifying and dramatizing training at home

The FIRSTS described below are typical of NRI's half century of leadership in Electronics home training. When you enroll as an NRI student, you can be sure of gaining the in-demand technical knowledge and the priceless confidence of "hands-on" experience sought by employers in Communications, Television-Radio Servicing and Industrial and Military Electronics. Everything about NRI training is designed for your education . . . from the much-copied, educator-acclaimed Achievement Kit sent the day you enroll, to "bite-size" well-illustrated, easy to read texts programmed with designed-for-learning training equipment.

YOU GET YOUR FCC LICENSE OR YOUR MONEY BACK

There is no end of opportunity for the trained man in Electronics. You can earn \$6 or more an hour in spare time, have a business of your own or qualify quickly for career positions in business, industry, government. And if you enroll for any of five NRI courses in Communications, NRI prepares you for your FCC License exams. *You must pass* or NRI refunds your tuition in full. No school offers a more liberal money-back agreement. The full story about NRI leadership in Electronics training is in the new NRI Catalog. Mail postage-free card today. No salesman is going to call.

NATIONAL RADIO INSTITUTE, Washington, D.C. 20016 (In Canada write: NRI Rep., 330 Progress Ave., Scarborough, Ont.)

APPROVED UNDER NEW GI BILL If you have served since January 31, 1955, or are in service, check GI line on postage-free card.

designed from chassis up for your education

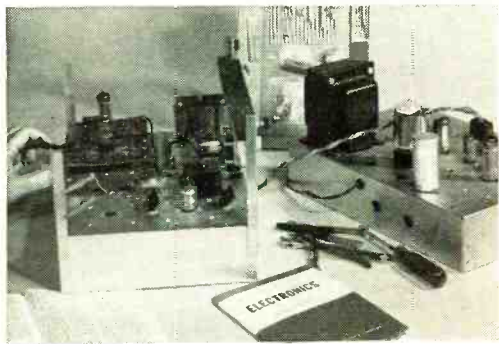
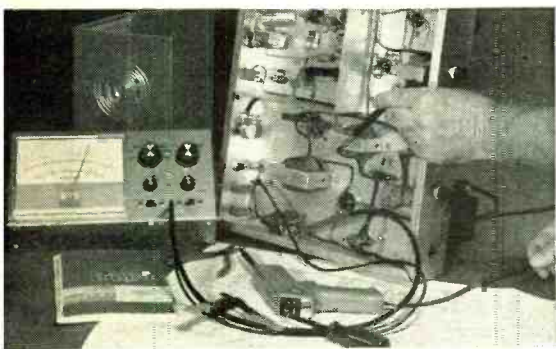

first to give you true-to-life experiences as a communications technician. Every fascinating step you take in NRI Communications training, including circuit analysis of your own 15-watt, phone/cw transmitter, is engineered to help you prove theory and later apply it on the job. Studio equipment operation and troubleshooting become a matter of easily remembered logic.

first to give you completely specialized training kits engineered for business, industrial and military Electronics. Shown above is your own training center in solid state motor control and analog computer servo-mechanisms. Telemetry circuits, solid-state multi-vibrators, and problem-solving digital computer circuits are also included in your course.

Popular Electronics

WORLD'S
LARGEST-SELLING
ELECTRONICS MAGAZINE

INCLUDING

Electronics World

FEATURE ARTICLES

- 35 INTRODUCTION TO ELECTRONIC MUSIC** Don Lancaster
What it is and how to get started with it.
- 47 ACCESSORIES FOR YOUR CB RIG** Richard Humphrey
- 51 ANTENNAS FOR CB'ERS AND HAMS, Part 2** Carl C. Drumeller
Some unusual antennas and variations.
- 64 ADDITIONAL FUNCTIONS FOR YOUR POCKET CALCULATOR**
Edward C. Priest
- 65 THE EASY WAY TO MAKE PC BOARDS** William T. Reubal
The photopositive method is simple.
- 72 THOSE WILD HAMS OF THE 1920'S** Charles C. Hay
They made their own components.
- 89 ABOUT THE NEW RCA COLOR TV RECEIVERS** John T. Frye
- 92 DO YOU KNOW YOUR BIPOLAR TRANSISTORS?** Lothar Stern
- 107 CHARLES P. STEINMETZ** David L. Heiserman

CONSTRUCTION STORIES

- 29 BUILD THE SUPER AUDIO SWEEP GENERATOR** George deLucenay Leon,
Jon D. Paul, and Luis E. Rico
Low-cost instrument has log and linear sweep.
- 38 AUDIO-VISUAL CMOS TOY** Joseph G. Gaskill
- 44 VERSATILE TAPE RECORDER CONTROL** Marshall Lincoln
Add new flexibility to your old recorder.
- 50 PICTURE-TUBE TESTER AND REJUVENATOR** William R. Shippee
- 56 A TAILOR-MADE ZENER DIODE** James E. McAllister
Variable-voltage zener using a transistor.
- 62 HOW TO BUILD "FREE-POWER" RADIOS** Terry L. Lyon
- 70 IC PHOTO DEVELOPMENT TIMER** Robert Marchant

ZIFF-DAVIS PUBLISHING COMPANY
Popular Electronics Including Electronics World
Editorial and Executive Offices
One Park Avenue, New York, New York 10016
212 679-7200

William Ziff, President
W. Bradford Briggs, Executive Vice President
Hershel B. Sarbin, Senior Vice President, Secretary, and Treasurer
Philip Sine, Senior Vice President
Phillip T. Heffernan, Vice President, Marketing
Frank Pomerantz, Vice President, Creative Services
Arthur W. Butzow, Vice President, Production
Edward D. Muhlfeld, Vice President, Aviation Division
Irwin Robinson, Vice President, Travel Division
George Marrissey, Vice President
Sydney H. Rogers, Vice President
Sidney Holtz, Vice President
Lawrence Sporn, Vice President, Circulation

POPULAR ELECTRONICS Including ELECTRONICS WORLD, October, 1973, Volume 4, Number 4. Published monthly at One Park Ave., New York, NY 10016. One year subscription rate for U.S., U.S. Possessions and Canada, \$6.00; all other countries, \$7.00. Second class postage paid at New York, N.Y. and at additional mailing offices. Authorized as second class mail by the Post Office Department, Ottawa, Canada and for payment of postage in cash. Subscription service and Forms 3579: P.O. Box 2774 Boulder, CO 80302. Editorial offices for manuscript contributions, reader inquiries, etc.: One Park Ave., New York, NY 10016.

POPULAR ELECTRONICS Including ELECTRONICS WORLD is indexed in the Reader's Guide to Periodical Literature.

Copyright © 1973 by ZIFF-DAVIS PUBLISHING COMPANY. All rights reserved.

POPULAR ELECTRONICS Including Electronics World

EDGAR W. HOPPER
Publisher
ARTHUR P. SALSBERG
Editorial Director
MILTON S. SNITZER
Editor
LESLIE SOLOMON
Technical Editor
JOHN R. RIGGS
Managing Editor
EDWARD I. BUXBAUM
Art Director

ALEXANDER W. BURAWA
Associate Editor
ANDRE DUZANT
Technical Illustrator
ELLEN S. FINKELSTEIN
Editorial Assistant
JOHN T. FRYE
J. GORDON HOLT
RICHARD HUMPHREY
WALTER G. JUNG
MATT P. SPINELLO
Contributing Editors

JOSEPH E. HALLORAN
Advertising Director
JOHN J. CORTON
Advertising Sales
MADELEINE LITTMAN
Advertising Service Manager
STANLEY NEUFELD
Associate Publisher
FURMAN H. HEBB
Group Vice President
Electronics and Photographic

THE SCENES

- 12** STEREO SCENE *J. Gordon Holt*
- 26** HOBBY SCENE
- 98** CB SCENE *Matt P. Spinello*
- 102** TEST EQUIPMENT SCENE *Leslie Solomon*
- 104** SOLID-STATE SCENE *Walter G. Jung*

PRODUCT TEST REPORTS

- 80** KLH MODEL FIFTY-TWO AM/STEREO FM RECEIVER
- 83** AKAI MODEL 4000DS TAPE RECORDER
- 85** RCA MODEL WV-529A MULTIMETER
- 86** REALISTIC MODEL TRC-46 AM/SSB CB TRANSCEIVER
- 88** JAMES MODEL C-8600 ELECTRONIC THERMOMETER

DEPARTMENTS

- 6** EDITORIAL *Milton S. Snitzer*
The Fork in the Road
- 8** LETTERS
- 18** NEWS HIGHLIGHTS
- 97** TIPS & TECHNIQUES
- 109** NEW LITERATURE
- 110** ELECTRONICS LIBRARY
- 111** OUT OF TUNE
("A 5-Watt Current-Carrier Transmitter," June 1973)
- 116** NEW PRODUCTS

COMING NEXT MONTH

How the SQ Quadraphonic Matrix Works
Two New High Performance Batteries
Build an OCL/OTL Hi-Fi Amplifier
Integrated Circuit Timers

Midwestern Office
The Pattis Group, 4761 West Touhy Ave.,
Lincolnwood, Illinois 60644, 312 679-1100
GERALD E. WOLFE, DICK POWELL
DICK GOVATSKI, MANLEY LUDWIG

Western Office
9025 Wilshire Boulevard, Beverly Hills, California 90211
213 273-8050; BRadshaw 2-1161
Western Advertising Manager, BUD DEAN

Japan: James Yagi
Oji Palace Aoyama; 6-25, Minami Aoyama
6 Chome, Minato-Ku, Tokyo 407-1930/6821

Ziff-Davis also publishes Boating, Car and Driver, Cycle, Flying, Modern Bride, Popular Photography, Skiing, and Stereo Review.

Forms 3579 and all subscription correspondence should be addressed to POPULAR ELECTRONICS Including ELECTRONICS WORLD, Circulation Department, P.O. Box 2774, Boulder, CO 80302, Please allow at least eight weeks for change of address. Include your old address, as well as new—enclosing, if possible, an address label from a recent issue.

Editorial contributions must be accompanied by return postage and will be handled with reasonable care; however, publisher assumes no responsibility for return or safety of art work, photographs or manuscripts.





Editorial

By Milton S. Snitzer, Editor

THE FORK IN THE ROAD

The outcome of pending rulings on frequency allocations for hams and CB'ers and on standards for quadrasonic FM broadcasts can change the course of equipment design for the future.

In the past, we have seen the adoption of stereo FM broadcast standards and the introduction of the Citizens Radio Service. We have also witnessed the results of these advances in the avalanche of equipment that has been made available to the public.

This is a healthy, ongoing process that **often takes years** of industry and FCC efforts before coming to fruition. (Of course, many changes never get past the proposal stage). Looking up the road, we see serious consideration now being given to a variety of matters that will affect electronics hobbyists.

For example, the proposed Class E Citizens Radio Service, initiated as far back as February 1971, appears to be heading toward a decision, since acceptance of comments was closed September 20. (See "CB Scene" in our September 1973 issue.) Should the FCC act favorably on opening up a portion of the 220-225-MHz amateur band to CB'ers, you can be sure that a myriad of adaptors and units covering the Class E band will be made available. However, even a decision favorable to CB won't result in an instantaneous stocking of dealers' shelves with new equipment since considerable manufacturing/distribution lead time is needed. Additionally, Class D will not be obsolete.

Further, the ham community is outraged by the possibility of losing part of the amateur radio spectrum, and it is putting up strong (and influential) opposition to usurping the ham portion of 220 MHz. They point out that crowding by 2-meter FM'ers on the 144-MHz band makes the 220-MHz band a likely one for hams to move to in the future. So we're not yet sure if we have reached the fork in that road.

Hi-fi buffs, too, are anxiously awaiting results of pending proposals before the FCC on quadrasonic broadcasting. There are some ten proposals on hand, including a few that emanated from other countries. One system, the Dorren Quadraplex System, submitted to the FCC in May 1971, is a discrete 4-channel broadcast system that would require a change in FCC regulations. In contrast, a matrix system does not require such a change. However, its channel isolation cannot match a discrete system's separation. Several years may well go by before the FCC makes a firm decision on this matter. But when it does, you may be sure that a big decoder market will develop.

There is no need to hold our breaths until the fork in the road is taken. These matters are always churning and it would be foolish to wait out possible turns of events. Since there is no way of knowing when—if at all—they will be effected, we would only be depriving ourselves of considerable enjoyment from equipment that will not be obsolete.

Another introductory offer to new members of the ELECTRONICS AND CONTROL ENGINEERS' BOOK CLUB

	404/445 ELECTRONIC CIRCUITS MANUAL by J. Markus Pub. price, \$19.75 Club price, \$15.75		286/515 INTEGRATED CIRCUITS: A Basic Course for Engineers and Technicians by R. G. Hibberd Pub. price, \$9.95 Club price, \$8.45
	637/458 DESIGNING WITH TTL INTEGRATED CIRCUITS by Texas Instruments Inc. Pub. price, \$18.50 Club price, \$13.50		100/810 MOS/LSI DESIGN AND APPLICATION by Carr & Mize Pub. price, \$18.50 Club price, \$13.50
	404/437 SOURCEBOOK OF ELECTRONIC CIRCUITS by J. Markus Pub. price, \$19.75 Club price, \$14.75		313/059 HANDBOOK OF SEMI-CONDUCTOR ELECTRONICS, 3/e by P. Hunter Pub. price, \$27.50 Club price, \$21.50
	259/607 COMMUNICATION SYSTEM ENGINEERING HANDBOOK by D. H. Hamsher Pub. price, \$29.50 Club price, \$22.50		287/341 STANDARD HANDBOOK OF ENGINEERING CALCULATIONS by T. G. Hicks Pub. Price, \$18.50 Club Price, \$14.25
	491/364 THE DESIGN OF DIGITAL SYSTEMS by J. B. Peatman Pub. price, \$15.50 Club price, \$11.75		124/035 HANDBOOK OF PHYSICS, 2/e by Condon and Odishaw Pub. price, \$34.75 Club price, \$14.95
			571/422 ELECTRONIC FUNDAMENTALS FOR TECHNICIANS by R. L. Shrader Pub. price, \$11.95 Club price, \$9.25
			649/170 OPERATIONAL AMPLIFIERS by Tabey, Graeme & Huelsman Pub. price, \$15.00 Club price, \$11.50
			209/731 STANDARD HANDBOOK FOR ELECTRICAL ENGINEERS, 10/e by Fink and Carroll Pub. price, \$32.50 Club price, \$24.95

ANY ONE
of these great professional books
for only **\$1.00**

VALUES FROM \$9.95 to \$34.75

Special \$1.00 bonus book comes to you with your first club selection

Save time and money by joining the
Electronics and Control Engineers' Book Club



HERE is a professional club designed specifically to meet your day-to-day engineering needs by providing practical books in your field on a regular basis at below publisher prices.

How the Club operates: Basic to the Club's service is its publication, the *Electronics and Control Engineers' Book Club Bulletin*, which brings you news of books in your field. Sent to members without cost, it announces and describes in detail the Club's featured book of the month as well as alternate selections which are available at special members' prices.

When you want to examine the Club's feature of the month, you do nothing. The book will be mailed to you as a regular part of your Club service. If you prefer one of the alternate selections—or if you want no book at all for that month—you notify the Club by returning the convenient card enclosed with each *Bulletin*.

As a Club member, you agree only to the purchase of four books over a two-year period. Considering the many books published annually in your field, there will surely be at least four that you would want to own anyway. By joining the Club, you save both money and the trouble of searching for the best books.

MAIL THIS COUPON TODAY

ELECTRONICS AND CONTROL ENGINEERS' BOOK CLUB
582 Princeton Road, Highstown, N.J. 08520

Please enroll me as a member of the Electronics and Control Engineers' Book Club and send me the two books indicated below. I am to receive the bonus for just \$1.00, and my first selection at the special Club price shown. These books are to be shipped on approval, and I may return them both without cost or further obligation. If I decide to keep the books, I agree to purchase as few as four books during the next two years at special Club prices (at least 15% below list).

Write Code No. of
bonus book
here

Write Code No. of
first selection
here

Name _____

Address _____

City _____

State _____ Zip _____

E33229

CIRCLE NO. 16 ON READER SERVICE CARD

Get deeper into your music.

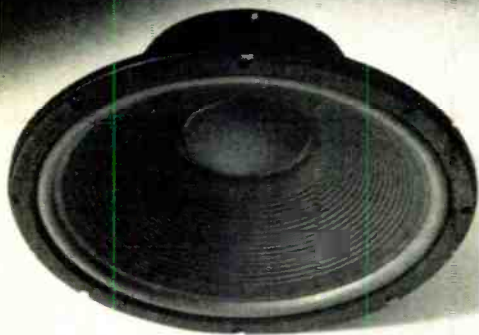

A hefty rib-reinforced 133 square inch cone with a super-compliant surround. A solid 15" cast aluminum frame. A 4-inch edgewound copper voice coil on a highly heat resistant aluminum coil form. A massive 18 lb. magnetic structure. Precision engineering and construction inside and out.

Add it all up, and you've got Altec's new 411-8A Dynamic Force acoustic suspension woofer. A dynamite low frequency speaker that delivers the deepest bass you've ever felt.

If you'd like to know how to custom build a complete Altec professional speaker system or how to add the bass power of the 411-8A to your present system, write for your free copy of the 411-8A Assembly Instructions today.

We guarantee it'll be deeply appreciated by your music.

1515 S. Manchester, Anaheim, Calif. 92803

ALTEC

The sound of experience.

CIRCLE NO. 2 ON READER SERVICE CARD



Letters

GETS MORE LIFE OUT OF CARBON-ZINCS

The "Rechargeable Alkaline Battery" (November 1972) was interesting, but I find it very expensive to use in comparison to carbon-zinc batteries. In most of my low-current drain equipment—pocket portable radios and an intercom—I get longer service from my carbon-zincs.

I think the lifespan of carbon-zinc batteries after recharging is underestimated. I have recharged my flashlight batteries for years. I also have a multimeter with carbon-zinc cells that have stood up for more than four years; they get recharged about once a year and are still okay.

HAROLD P. HAFFA
Waterloo, Iowa

Obviously, rechargeable alkaline batteries are not your cup of tea. Except for those in your flashlight (and your letter doesn't say how long they last), the batteries in seldom-used portable radios, intercoms, and multimeters might indeed be more economical if carbon-zincs were used. The alkalines shine in heavy duty and constant-drain service where carbon-zincs just can't hack it, such as in flashlights, lanterns, toys, etc. But if you prefer carbon-zincs, who are we to deter you?

IN THIS CORNER, WEIGHING . . .

After reading Bill Kennedy's letter ("Letters," August 1973), I felt compelled to take issue with him. In the first place, "How To Select an Electronic Organ" (June 1973) was about *electronic* organs. The Hammond B-3 is an *electric*, rather than *electronic*, organ, generating its tones by electromechanical means.

Secondly, the B-3 was in great favor with professional organists, not because of its musical superiority, but because of its reliability over the then tube-type instruments available. In recent years, the swing has been toward the infinitely more flexible and musically satisfying electronic organ.

K.R. RENSRAW
Minneapolis, Minn.

K.R. (and all you others who have written in to refute Bill Kennedy's claims), you and

Bill can fight it out in the arena of your own choosing. We'll supply the gloves, you supply the sweat.

LEND A HELPING HAND

We have a small radio club in the Philippines where we train indigent enthusiasts in the field of electronics. The club is encountering some financial difficulty in purchasing radio equipment here. We would like to appeal to POPULAR ELECTRONICS readers for help. We urgently need test equipment, ham gear, surplus gear, and old magazines. We would greatly appreciate any help your readers can give us.

RODOLFO B. DEL ROSARIO
Chairman, Calaca Radio Club
16 Scout Taulon St.
Diliman, Quezon City, Philippines

Anyone who wishes to contribute to a good cause, please send to Rodolfo at the address given above.

ANOTHER PE SCIENCE FAIR WINNER

I wish to belatedly thank you for your articles on laser modulation (May and November 1970) for the help they gave me on my Science Fair project that placed first in the physics category at the state level. A laser beam can

be internally (as in your articles) or externally modulated. I chose to externally modulate the beam by means of a modified Michelson interferometer. However, instead of the mirrors being stationary, they are moved by transducers that cause a phase shift in the light. Since the amount of movement is proportional to the voltage applied to the transducers, the phase shifts are also proportional. When the two beams recombine, amplitude modulation occurs.

MARVIN MOSER
Hoffman, Minn.

Congratulations, Marvin. We're happy to have been of help. By the way, whatever happened to the Tesla coil and oatmeal-box crystal radio Science Fair projects of bygone days?

SORRY, BUT WE GOOFED

Referring to the SSB Citizens Band Transceiver Directory in the August 1973 issue, I note a discrepancy in your listing for the Tele-dyne (Olson) RA-510 transceiver. In the Power Supply column, the listing should have been "ac/dc."

WALT CORRIGAN
Olson Electronics, Inc.
Fort Worth, Texas

Sorry for the inconvenience our goof has caused anyone.



They put a rotary engine in a car. We put a cam shaft in a turntable. For the same reason.

The reason? To make it quieter, smoother, more reliable.

The basic record changer mechanism—like the automobile's piston engine—has been a fairly reliable device that has served with some success for many years. But the very action of the engine—or the changer—produces constant vibration and strong, sudden movements that can ultimately wear it out.

Now we have alternatives. For cars, the Wankel rotary engine. And for record players, the sequential cam shaft drive mechanism used in BSR's finest automatic turntables.

Its even rotating motion programs the complex automatic functions of the BSR 710 and 810 smoothly and without noisy and potentially harmful quick starts and stops, without slamming metal against metal. And because the cam gears are mounted on a carefully machined central shaft, they are all but impossible to put out of alignment by rough handling or constant use.

The result: consistent care-free performance, and good music. With the BSR 710/X and 810/X Transcription Series Total Turntables.



BSR

BSR (USA) LTD.
BLAUVELT, NEW YORK 10913

CIRCLE NO. 3 ON READER SERVICE CARD

If you've ever said...

"There must be a better

Send for a free Career Guidance Booklet that could start you on the road to success in a rewarding new career.

It happens to all of us, sooner or later. No matter what kind of job we have.

One day, it suddenly strikes home that we're going to have to work for a living, the rest of our lives. And most of us are horrified at the thought of forever being locked into the jobs we now hold.

"Surely," we tell ourselves, "there must be a way to earn enough extra dollars each month to balance the family budget. Surely, there must be

a way to get the kind of position where you don't have to worry about job security."

"Surely," in other words, "there must be a better way to earn a living!"

If you, too, have been thinking these same thoughts, you'll find one of our free Career Guidance Booklets very helpful at this time. We invite you to send for one.

Your free booklet will describe the opportunities for higher income and greater job security you might ex-

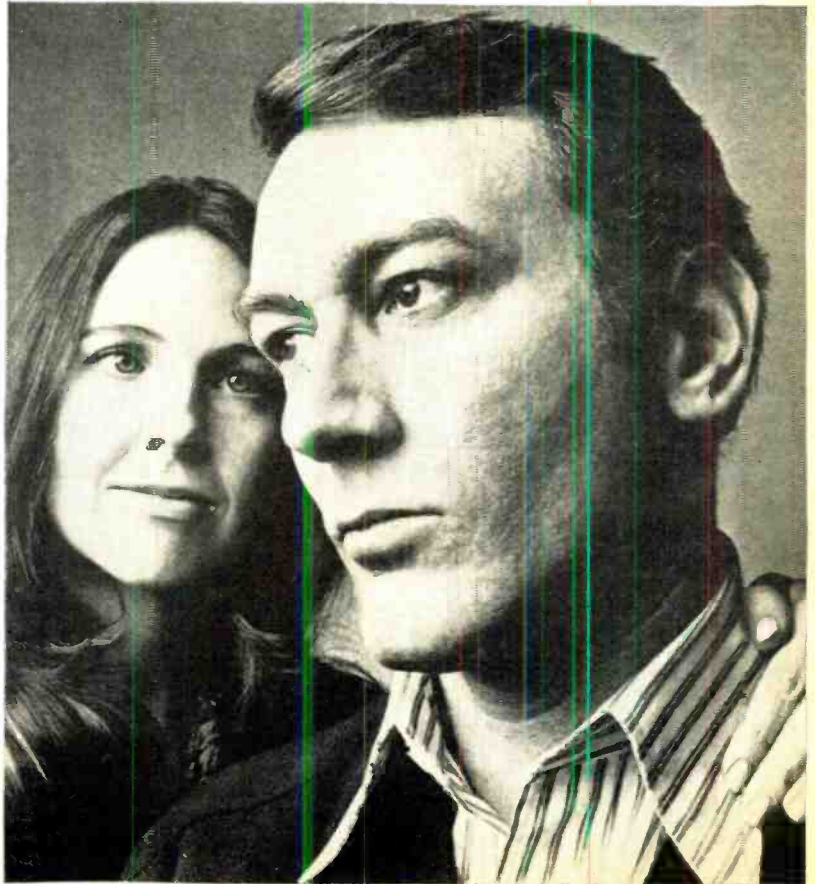

way to earn a living..”

pect in one of the career fields listed on the coupon below. It will also explain why ICS can prepare you for this new career field...right in your own home...in your spare time...regardless of your education or past experience.

In addition, you will receive a free "Demonstration Lesson" that lets you see for yourself why preparing for a more rewarding career—the ICS way—may be a lot easier than you think.

Please bear in mind, as you check off your career choice on the coupon below, that ICS has a long and distinguished record of success. In fact, more than 8,500,000 men and women have turned to ICS for career training, since 1891.

Major corporations use ICS Career Training

ICS has provided training programs for various divisions and branches of companies like Ford; U.S. Steel; Chrysler; Mobil; DuPont; etc.

ICS Career Training is approved for Veterans and Servicemen under the new G.I. Bill, and is Accredited by the Accrediting Commission of the National Home Study Council.

Now it's your turn to discover how ICS training can start you in a rewarding new profession. Just fill in the coupon and mail for your free Career Guidance Booklet and free "Demonstration Lesson."



Mail coupon for Free

Career Guidance Booklets and Free "Demonstration Lesson."

These free Career Guidance Materials are yours without obligation. They will help you find out what you should know about the career field of your choice. They will also let you see for yourself why preparing for a more rewarding career—the ICS way—may be easier than you think.



ICS International Correspondence Schools XA671T
Scranton, Pennsylvania 18515

Please send me a free Career Guidance Booklet, and a free "Demonstration Lesson" for the field I have checked below. I understand that I am under no obligation.

- | | |
|--|---|
| <p>Air Conditioning/
Refrigeration & Heating</p> <p><input type="checkbox"/> Air Conditioning/
Refrigeration Technician</p> <p><input type="checkbox"/> Heating Specialist</p> <p>Engineering</p> <p><input type="checkbox"/> Mechanical <input type="checkbox"/> Civil</p> <p><input type="checkbox"/> Chemical <input type="checkbox"/> Industrial</p> <p><input type="checkbox"/> Electrical-Electronics</p> <p><input type="checkbox"/> Surveying & Mapping</p> <p>TV Servicing</p> <p><input type="checkbox"/> Color TV Technician</p> <p><input type="checkbox"/> Stereo/Hi-Fi Specialist</p> <p><input type="checkbox"/> CATV/MATV Specialist</p> <p>Electronics</p> <p><input type="checkbox"/> Electronics Technician</p> <p><input type="checkbox"/> Specialized programs in
Computer Servicing,
Communications/
Broadcasting, CATV</p> <p><input type="checkbox"/> FCC Licensing</p> <p>Automotive</p> <p><input type="checkbox"/> Master Mechanic</p> <p><input type="checkbox"/> Air Conditioning Specialist</p> <p><input type="checkbox"/> Body Rebuilding Specialist</p> <p><input type="checkbox"/> Diesel/Gas Mechanic</p> <p>Drafting</p> <p><input type="checkbox"/> General Drafting</p> <p><input type="checkbox"/> Specialized Drafting</p> | <p><input type="checkbox"/> Architecture</p> <p>Electrician</p> <p><input type="checkbox"/> Master Electrician</p> <p><input type="checkbox"/> Practical Electrician</p> <p><input type="checkbox"/> Interior Decorating
& Design</p> <p><input type="checkbox"/> Airline-Travel Training</p> <p>Computer Programming</p> <p><input type="checkbox"/> Programming Concepts</p> <p><input type="checkbox"/> COBOL <input type="checkbox"/> System 360</p> <p><input type="checkbox"/> Fortran IV</p> <p><input type="checkbox"/> Secretarial</p> <p>Accounting</p> <p><input type="checkbox"/> Business Accounting</p> <p><input type="checkbox"/> CPA Training</p> <p><input type="checkbox"/> Income Tax Specialist</p> <p>Motel/Hotel Management</p> <p><input type="checkbox"/> Motel Management</p> <p><input type="checkbox"/> Club, Restaurant
Management</p> <p><input type="checkbox"/> Hotel Executive</p> <p>Business Management</p> <p><input type="checkbox"/> Executive Management</p> <p><input type="checkbox"/> Industrial/Production
Management</p> <p><input type="checkbox"/> High School
For those who want to earn
ICS High School Diploma</p> |
|--|---|
- Check here for special information, if age 16 or under

Miss _____
Mrs. _____
Mr. _____ Age _____
Address _____ Apt. _____
City _____ State _____ Zip _____

Approved for Veterans' Training. Eligible Institution under the Guaranteed Student Loan Program. Accredited Member National Home Study Council. Canadian residents use coupon address for service from ICS Canadian, Ltd. In Hawaii: 931 University Ave., Honolulu, Hawaii 96814



Stereo Scene

By J. Gordon Holt

PERHAPS the major difference between a true audiophile and a music listener who owns a high-fidelity system is that the audiophile is often not fully satisfied with the sound of his system. And much of the time, it is the loudspeakers that provide the major measure of dissatisfaction. Sometimes this is because they may not, in fact, be very good. In many cases, though, the loudspeakers aren't really the source of the annoyances that lead to dissatisfaction, but are instead being unjustly accused. Here are a few of the more common reasons for the difficulty.

Room Placement. This is the most frequent cause of poor—excessive or thin—bass performance from loudspeakers of better-than-passable quality. Even the best systems differ widely in the efficiency of their bass radiation into the room, and their placement in the room can determine whether the over-all performance is excellent or whether a typically efficient bass radiator will become boomy or be sparse and dry-sounding.

Speaker systems can be—and often are—placed almost anywhere in a listening room. In 2-channel stereo setups, corner and along-a-wall placement schemes have become traditional, but more recently omnidirectional speaker systems have provided incentives for other placement schemes. In 4-channel sound setups, the

speakers again become corner located, or they are placed in such a manner that they define a roughly square or rectangular listening area. The aim in either case has always been to preserve or enhance binaural “spread” (and front-to-rear balance in 4-channel setups). Speaker systems can also be placed at any height between floor level and the ceiling.

There are two basic principles to remember in placing conventional speakers for best bass. First, the closer they are to a

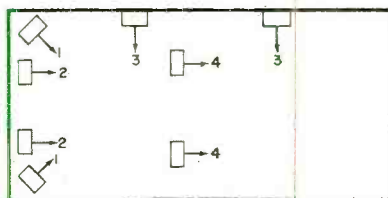

Fig. 1. Speaker placements at floor level. (1) Maximum bass, severest standing waves. (2) Excellent bass, moderate standing waves. (3) Moderate bass, and smoother response. (4) Has fairly thin bass, smooth response.

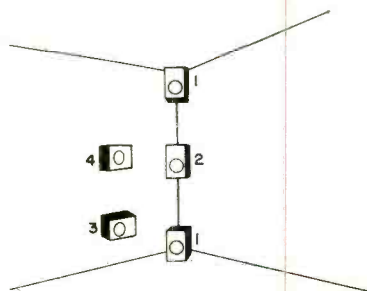

Fig. 2. Some speaker placements on a wall. Numerical designations are same as Fig. 1.

Loudspeaker Problems



the Sansui AU9500: hottest-selling integrated amplifier in the field.

Here's the power amplifier that not only boasts 85 hefty wats per channel, but also boasts a host of other fantastic features. It's designed and made for people who want only the best—and are willing to pay for it. And, judging by the way the AU9500 is selling, there must be a lot of those folks around.

The new Sansui AU9500 is the most advanced stereo product we make. It's superior performance characteristics include total harmonic distortion and intermodulation distortion below 0.1% throughout the entire audio spectrum and well beyond. Power bandwidth is extremely wide (5-40,000Hz) and RMS true power, conservatively rated, is 85 wats per channel into 8 ohms.

Among the many exciting features of the AU9500 are a wide variety of conveniences, such as a 4-channel adaptor switch, for QS, SQ, or CD-4 add-on units, the ability to handle up to four tape decks, and provision for tape-to-tape dubbing. Triple tone controls allow even the fussiest listener to adjust the AU9500's response to his taste.

As eye-catching as it is functional, the AU9500's elegant front-panel styling is a standout in any audio display. And it has two counterparts, the AU7500 and AU6500, which offer many of the same features, the same quality engineering and manufacturing, but slightly less power. All three are powerful, quality units that are unequalled for fine high fidelity reproduction.



SANSUI ELECTRONICS CORP.

Woodside, New York 11377 • Gardena, California 90247

SANSUI ELECTRIC CO., LTD., Tokyo, Japan • Sansui Audio Europe S. A., Antwerp, Belgium

CIRCLE NO. 35 ON READER SERVICE CARD

room corner, the more efficiently they will radiate bass into the room and the more they will tend to excite standing-wave resonances in the room. (See Figs. 1 and 2.) In rooms of small size, standing waves affect the middle-bass range which, in proper proportion, gives the sound its fatness and body, and in excess makes it boomy. In large rooms, of 15 by 20 feet or more in size, standing waves are likely to affect mainly the deeper bass, below about 50 Hz. Since they are related to room dimensions, standing waves occur at certain discrete frequencies, and the result is a series of peaks in the response (Fig. 3). So while their utilization can help to fill out bass, it may also produce uneven bass response.

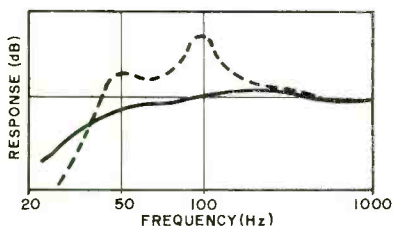

Fig. 3. Condition of maximum (but peakiest) bass may produce less apparent deep bass.

The improved bass radiation that corner placement brings about is likely to be uniform over the entire bass range, which is of course desirable. Thus, optimum placement will often have to be a compromise between radiation efficiency and a modicum of bass peakiness.

Second principle: The more pronounced a speaker's mid-bass output, the less audible its deep-bass range will seem to be when listening to musical material. (This phenomenon, which is purely psychoacoustical, does *not* show up when listening to an oscillator being swept through the bass range, as the ear has time to adjust its perceptual sensitivity as the system's output changes.) For this reason, speaker placement right in a corner, where maximum deep bass will be radiated into the room, may actually make the sound seem to have *less* deep bass, because of the effect of pronounced standing-wave resonances at higher bass frequencies. Again, it is best to hit a compromise.

In many rooms, corner placement produces too much and too-peaky bass. The best location is usually at or near the junction between two surfaces—typically a wall

and the floor or ceiling. Ceiling placement is often better, as the highs are not blocked by furniture, and the multiple reflections from the bare ceiling produce a more spacious sound. In rectangular rooms, locating speakers against one of the longer walls will give smooth low-end response but sometimes not enough of it. Don't instantly dismiss as impossible an apparent thinning of bass when you move the speakers, though. Many of us have grown accustomed to excessive bass, and may need some readjustment of values to appreciate the improved quality (range and detail) that may accompany a diminution in the *quantity* of the bass. Live with the new sound for a few days before changing the speaker positions again.

The Impossible Room. Some rooms just don't seem to want to support any low end at all, while others tend to excessive bass almost regardless of where you place your speakers. Small L-shaped rooms are typically poor bass-supporters, as are ones with angled ceilings. Square rooms tend to be bassy and peaky because both dimensions cause standing waves at the same frequencies. Cube-shaped rooms of practical (for the home) size are difficult for the same reason. Despite such handicaps, you can often find at least one pair of speaker locations where performance will be satisfactory, if not great. Otherwise, you have three alternatives. Rebuilding the room along acoustical principles is one, but is hardly practical for most of us. The choice between the other two alternatives—replacing the speakers or buying a good equalizer—depends on the relative cost.

To be effective for low-end control, an equalizer should have separate controls covering the 20-to-40-Hz range and the 40-to-80-Hz range. (Even-narrower-range control is better, but can be prohibitively expensive. Altec's Acusta-Voice equalizer costs in the \$1,000 class.) Suitable home-type equalizers like the Soundcraftsmen 20-12 and the SAE Mark Seven cost around \$300 and up, but this may still be less money than it would take to replace your speakers with different ones, even if you were allowed a liberal trade-in on your present ones. Equalizers offering octave-wide control bands (as do the Soundcraftsmen and the SAE) can't do much about the sharp resonances of standing waves, but they can allow you to correct any fairly broad

From Mits: New digital test equipment professional lab quality at shop cost.

Model 1700 Waveform Generator/Frequency Counter

Kit \$139.95 Assembled \$199.95



WAVEFORM GENERATOR: • 6 carrier waveforms including sine, triangle, square, ramp, saw tooth and pulse. Frequency range — from 1Hz to 1.5MHz in 12 overlapping ranges. • 3 internal AM or FM modulator waveforms including sine, triangle, and square. Frequency range — 100HZ to 150KHZ in 6 overlapping ranges. Has ability to accept external AM or FM modulator signals. • 3 amplitude controls carrier only, modulator only or modulated carrier.

FREQUENCY COUNTER: • Measures frequency of the WFG output or frequency of external signals from 1Hz to over 10MHz. • 4 digit display of .55 inch Sperry gas discharge type. (same as

DVM) • Adjustable sensitivity. • Has flashing overrange indication. • Features an event counter which can be used for external signals. • Input impedance — greater than 100K ohms. • External input clamped at ± 10 volts. • Sampling period — 1 second for Hz ranges, .1 second for Kiloherzt and Megahertz ranges. • Integrated circuit electronics construction.

POWER REQUIREMENTS: SPECIFY 115 OR 230 VAC. 60 Hz, 25 WATTS.

Model 1600 Digital Voltmeter

Kit \$89.95 Assembled \$129.95



FUNCTIONS: 1. AC Volts 4 Ranges from 1 volt to 1000 volts

2. DC Volts

3. AC Current } 5 Ranges from .1ma to 1 amp

4. DC Current

5. Ohms-6 Ranges from 100 ohms to 10 megohms

RESOLUTION: (low ranges) Voltage-10mv • Current-10ma • Resistance-1 ohm

ACCURACY: DC Volts $\pm .5$ • All others $\pm 1\%$

INPUT IMPEDANCE: DC Volts — 10 megohms • AC Volts — 1 megohm

SAMPLE RATE: 5 per second **POWER REQUIREMENTS:** Specify 115 or 230 VAC, 50/60 Hertz, 20 Watts.

• 2-1/2 digits of large .55" Sperry gas discharge display • Can be read from up to 40 feet away in direct sunlight • Integrated circuit technology throughout • Auto polarity feature automatically displays polarity and magnitude w/o probe reversal • Regulated power supply • 100% overrange capability on all ranges

ITC-1800 Integrated Circuit Tester

Kit \$119.95 Assembled \$169.95

SPECIFICATIONS: • 18 LED indicators show status of IC under test • Internal 5 volt 1 amp power supply. Internal 2 speed clock • Single step capability • Cross bar switch allows complete programming of IC under test • 4 remote outputs • 4 remote inputs
Detailed instruction manual (includes diagrams of all common digital IC's)

SIZE: 8" x 9" x 3-1/2" **POWER:** 50/60Hz 115 VAC 8 watts **WEIGHT:** 9 lbs.

The ICT-1800 is ideal for testing digital integrated circuits. It also may be used to breadboard ICs while developing circuits. The ICT-1800 is as indispensable for testing ICs as the vacuum tube tester was for testing vacuum tubes.

mits

Micro Instrumentation & Telemetry Systems, Inc.

6328 Linn, N.E., Albuquerque, New Mexico 87108
505/265-7553 Telex Number 660401

Enclosed is a Check for \$ _____

or BankAmericard # _____

or Master Charge # _____

Credit Card Expiration Date _____

Include \$5.00 for Postage and Handling

Model # _____ Kit Assembled

Please Send Information on Entire MITS Line.

NAME _____

ADDRESS _____

CITY _____

STATE & ZIP _____

MITS/ 6328 Linn, N.E., Albuquerque, New Mexico 87108 505/265-7553 Telex # 660401

CIRCLE NO. 25 ON READER SERVICE CARD

aberrations. One could also consider the five-band BSR-Metrotec equalizer, at \$99.95 for minimizing peaky response, brightening extreme highs or boosting low bass.

We mentioned that some speakers are heavier, some thinner, at the bottom than others. If you elect to try new speakers, what you want are ones that tend in the opposite direction from your present ones. A suitable choice may solve your problem, but it is more likely that the end result will be better if you equalize; for instead of merely improving the situation, or even overshooting it and ending up with an error in the opposite direction, equalization allows you to zero-in on the bass balance you want.

Equalizers are like atomic energy though: they have great potential for evil as well as for good. Improperly used, an equalizer can completely mess up the sound of the best system, so use with discretion. This means that, if you don't feel the urgent need to elevate or depress any other part of the audio spectrum (other than the bass), don't. Leave all controls flat except those that are correcting for your bass problem.

Phasing. A common cause of bass thinness is misphasing of the loudspeakers. Proper phasing is such a basic requirement for good stereo that some instruction manuals don't even mention it, assuming that everyone knows about it. The result is that the inexperienced audiophile runs a 50-50 chance of ending up with his speakers out of phase.

When speakers are misphased, one's cone will be moving outward while the other's cone is drawing in. When one is trying to produce an air-pressure wave in the room, the other will be sucking the pressure wave back in again, and the result is that bass tones, which call for large air-pressure changes, never make it out to the rest of the room. The cones tend to cancel instead of augmenting one another.

Phasing is easily checked either visually or acoustically. The visual check involves nothing more than seeing that each wire starting at each GND or zero tap at the amplifier follows straight through to each minus terminal on the speakers. In the case of zip cord, you can do this either by following the tiny molding-seam ridge along the edge of one of the wires of the pair, or by observing the fact that some pairs have one conductor colored copper and the other silver. The acoustical method involves plac-

ing both speakers face to face and about an inch apart, feeding some bassy program material to them with the system set for *mono* (A+B) mode, and then disconnecting one speaker. If the volume of the bass *increases* when one speaker is turned off, the phasing is wrong, and the connections to either speaker (*not* both) should be reversed.

Shrillness. This is often the sign of a poor loudspeaker, but there's an easy way of telling with reasonable certainty whether most of the problem is speaker-related or whether something else in the system is causing it.

First, listen for surface noise from discs. If this varies in pitch, from plops through ticks to spitting sounds, your speakers are free from severe treble peaks and the shrillness must be coming from somewhere else. If all the surface noise seems to have much the same pitch, tune between two FM stations and observe whether or not *that* hiss seems to have the same pitch as the surface-noise ticks. If it does, the speakers are probably peaky. Reduce the settings of their tweeter controls or, if that's not possible or doesn't help, get rid of them. If FM hiss seems peak-free, the speakers are okay but the pickup needs upgrading.

Suppose nothing indicates peaks. Then, chances are the trouble is odd-order harmonic distortion, possibly in the power amplifier but more likely in the preamp.

The ear is extremely sensitive to odd-order harmonics (odd multiples of the fundamental frequency), and even amounts of it that look absurdly low on paper (0.05% and less) are perceptible to an acute ear as a slight hardening of the sound.

If your transducers are peak-free, though, about the *only* thing that can cause shrillness at listening levels below loudspeaker overload is the electronics. So if that's your problem, try a better amplifier or preamplifier, or both.

Poor Stereo. This covers a multitude of sins, from lack of center fill between speakers, through vague or wandering stereo images, to excessively restricted listening area and overly critical channel-balance adjustment. The most common cause of any or all of these malaises is irregular frequency response, which need not necessarily show up as response peaks. *Dips* in the response can do it, without adding unduly noticeable colorations to the sound. Unfortunately,

these usually *are* the fault of the loud-speakers. High-frequency beaming or phase interference between spatially separated drivers in each speaker will produce poor imaging and a restricted listening area.

Out-of-phase speakers can cause any of the aforementioned "poor stereo" symptoms too, so check that possibility if you haven't already. Also, try changing the angles of the speakers relative to your listening area, toeing them slightly inward or outward (symmetrically) to change the patterns of interference. You may not achieve perfect stereo imaging (it isn't on all recordings anyway), but it should be possible to get satisfactory results from virtually any speaker pair. If you don't know it already, though, you should understand that it is impossible to get ideal stereo performance from a pair of nonidentical speaker systems.

Incidentally, poor treble dispersion can be improved at moderate cost by the addition of wide-angle "hang-on" tweeters.

Other Speaker Problems. Sometimes an inherently good speaker system will show a persistent tendency toward overly taut or somewhat loose, heavy bass no matter where you place it in a room. If this isn't a case of the impossible room, it may be due to incompatibility between the amplifier and the speakers. Some speakers are designed to allow for a modicum of bass resonance to take place, in order to support full low end. If these speakers are used with amplifiers having high power capacity and very high damping factor, the speakers will be *over* damped, with resulting thin, dry bass. Conversely, an amplifier of inadequate power and/or too-low damping will allow the system to resonate too much, resulting in poorly controlled bass performance. Equalization can help this situation, but it is best coped with by proper amplifier/speaker selection.

In Case of Defeat. If you've tried all these suggestions and you're still unhappy with the sound of your speakers, you still have several alternatives open to you. You can hire a good custom-installation specialist to come and help out; you can start from scratch with a completely new system of components recommended by someone you know whose judgement in such matters you trust; or you can admit to yourself that your taste in sound is either too demanding or too bizarre to ever be wholly satisfied. ♦

If You Work In Electronics:

GRANTHAM OFFERS YOU College-Level Training and a college degree.

Electronic Circuit Design, Engineering Analysis (including mathematics thru calculus), Classical and Solid-State Physics, Engineering Design, etc., etc., are all part of the Grantham home-study degree program in Electronics Engineering.

(Regardless of what you may have read in another school's ad. Grantham does teach college-level circuit design by home study.)

By adding college-level home training and a college degree to your experience, you can *move up* to greater opportunities in electronics.

Grantham offers the A. S. E. T. degree by correspondence. After earning this degree, you may continue with additional correspondence plus a one-week residential seminar and certain transfer credits, to earn the B. S. E. T. degree. Then, the B. S. E. E. is available through further residential attendance.

GRANTHAM SCHOOL OF ENGINEERING

1505 N. Western Ave., Hollywood, CA 90027

● Telephone (213) 462-1411 ●

Established in 1951 — G.I. Bill approved.

Mail the coupon below for free bulletin.

Grantham School of Engineering PE-10-73

1505 N. Western Ave., Hollywood, CA 90027

I have been in electronics for _____ years. Please mail me your free bulletin which gives details concerning your electronics degree programs.

Name _____ Age _____

Address _____

City _____ State _____ Zip _____

CIRCLE NO. 17 ON READER SERVICE CARD





News Highlights

Computerized Traffic Control Signs

New York State has announced that it will install a computerized system that would guide and inform motorists along a 30-mile heavily traveled corridor. This includes the Long Island Expressway in New York City's Queens borough and adjoining Nassau and Suffolk Counties on Long Island. Cost of the system is expected to be \$11 million and it will take three years for the electronic sensors and flashing message boards to be put into place. The boards will indicate the heaviest traffic areas and will notify motorists to take one of the half dozen parallel roads. Hopefully traffic will be eased on what has been called "the world's longest parking lot."

SQ Quadraphonic Logic IC Introduced

One of the highlights of the recent Consumers Electronics Show was the introduction by Columbia Records of the SQ logic integrated circuit system. The IC's were developed jointly by CBS Labs and Motorola's semiconductor division. With discrete components, SQ logic equipment requires a complex network of over 400 separate electronic parts. So great economies are expected to be realized by turning to IC's. The IC's are available to SQ licensees, which now include almost 80 of the world's audio equipment brands. A list of SQ disc releases distributed at the Show indicates over 240 albums are available from 21 record companies. The Sony Corp., too, is said to have introduced SQ IC's, including a low-cost, full-logic chip, and is also marketing the chips to hardware licensees.

World's Smallest Solid-State Lamp

The world's smallest solid-state lamp produces invisible light and is dwarfed by the head of a match. Developed by General Electric's Miniature Lamp Products Dept., the new lamp is an infrared light-emitting diode measuring only $\frac{1}{20}$ of an inch in diameter. The lamp's small size will make it useful in applications requiring small center-to-center spacing on printed circuit boards. Such uses include paper-tape and retail-merchandise price-tag readers, and other photo-detection systems. The lamp is housed in a $\frac{1}{8}$ -in. long metal and ceramic cylinder topped by a dome-like glass lens. It sells for \$2.64 in sample quantities.

Stereophonic Baseball in Japan

Adding to the excitement of watching baseball games in Japan is a newly installed stereophonic sound system. The sound-effects audio system, valued at \$23,000, is being used at the Heiwadai Baseball Stadium at Fukuoka in southern Japan. The system consists of six power amplifiers with a total power rating of 720 watts, one mixer, one tape recorder, eighteen outdoor speaker systems, and three parabolic-type microphones. The sounds of a grounder, a runner sliding, hit and caught balls, and the voice of the umpire are amplified and fed to the speakers. The equipment was installed by Pioneer Electronic Corp., Tokyo.

RCA Receives Certification on C/MOS

NASA has granted line certification to RCA for the production of complementary symmetry MOS integrated circuits, called COS/MOS by the company. The manufacturer's plant at Findlay, Ohio becomes the first production facility to receive NASA line certification as well as previous certification granted by the Defense Electronics Supply Center.

Post Office Honors Invention of Transistor

Have you seen the new transistor stamp yet? The transistor was honored recently by the U. S. Postal Service with the issuance of a commemorative stamp. The one being issued is one of four stamps in a Progress in Electronics series. The 8-cent transistor stamp depicts an electronic printed circuit, and the others depict Marconi's spark coil, Lee DeForest's audion tube, and electronic components used in broadcasting.

Alarm System Prevents TV Set Theft

A tamper-proof burglar alarm system tailored for use in individual rooms of motels and hotels is available from Forward Detection Systems, Danvers, Mass. Called "TV Guard," the new solid-state electronic system is already preventing thefts of color TV sets which are easily removed from motel rooms and readily sold in the streets. The device detects when any set wired into the system is unplugged. A light on the control panel located at the registration desk indicates in which room the unplugging occurred, thus permitting the desk clerk to take appropriate action promptly.

The Mark Ten B Capacitive Discharge Ignition System keeps your car in tune ... and everyone knows that a well-tuned car gets better mileage, requires less maintenance, runs longer and better, and helps in the quest for cleaner air.



... Just ask Detroit and the E.P.A.

Order your Mark Ten B today! Please send me free literature.

Enclosed is \$ _____ Ship ppd. Ship C.O.D.
Please Send: _____ Mark Ten B Kit @ \$59.95 ppd. _____ Mark Ten B Kit @ \$44.95 ppd.

Car Year _____ Make _____

Name _____

Address _____

City _____

State _____

Zip _____



DELTA PRODUCTS, INC.

Dept. PE - P.O. Box 1147 - Grand Junction, Colo. 81501
(303) 242-9000

Bill Stewart, B.S. in Civil Engineering. Officer in the Nuclear Navy.

LJTG Stewart, University of Kentucky
selected in 1969 for the Navy's

*He is already qualified to operate and maintain
one of over 100 Navy Nuclear Propulsion Plants.*

In 1973, the Navy will accept about 500
outstanding college graduates like Bill Stewart
for its Nuclear Propulsion Officer Program.
Each one of these young men will have an
incomparable opportunity to become a leader
in the Nuclear Navy.

For its Nuclear Program, the Navy wants
only men who can master advanced technology.
While they do not necessarily have to be
engineers, many of them will be. They must
have a solid foundation in mathematics and



physics. They must demonstrate
superior ability. High standards
limit selection opportunity to only
the most qualified candidates.

If you qualify, you will spend
a solid year learning all aspects of
nuclear propulsion plant theory
and operation. All of this training
will build upon your ability to solve difficult
problems through the application of fundamental
engineering principles.

While this program is tough, the Navy pays
well for the kind of ability and dedication that is



'68, is one of only 429 officer candidates Nuclear Propulsion Program.

required. Starting salary in the Nuclear Program is comparable with salaries given to junior executives by private companies; and career advancement is rapid. There are many other benefits, including, of course, the opportunity to see much of the world.

If you think you have the abilities and desire to become a leader in nuclear engineering, call the Nuclear Desk, toll-free, 800-841-8000. A nuclear-trained officer will contact you and answer your questions about the program.

Do something special with your life.

TO: LTJG William Stewart, USN, Building 157, Fourth Floor
Washington Navy Yard, Washington, D.C. 20374.

355

Yes, I'm interested in becoming a Nuclear Propulsion Officer Candidate. Please send me more information on the Nuclear Program as it applies to:

- nuclear-powered submarines.
 nuclear-powered surface ships.

If you really don't want to wait, call us toll-free, 800-841-8000. In Georgia, call 800-342-5855. Call collect: in Alaska—272-9133, in Hawaii—533-1871.

Name _____ Age _____
Address _____ City _____
State _____ Zip _____ Phone _____
College _____ Major _____ Class of _____

Be someone special in the Nuclear Navy.

Changes come fast in electronics.



From
tube
to
LSI

Take a look at the race in circuit technology. In the 1960's the tubes at the left made way for the transistors at the right. Today, transistors are surpassed by the large scale integrated circuit (LSI) at the far right. This circuit, less than a quarter inch square, replaces over 6000 transistors!

There's big money to be made by the men who stay ahead of this technology race. Put yourself

ahead with NTS Home Training! You get the latest, most advanced equipment (at no extra cost). More solid-state units, and more advanced technology. Plenty of training with integrated circuits, too! As an NTS graduate, you enter a world of electronics you're familiar with. You have a thorough working knowledge of solid-state circuitry. You're ready to tackle bigger jobs at higher pay!

NTS COLOR AND B & W TV SERVICING

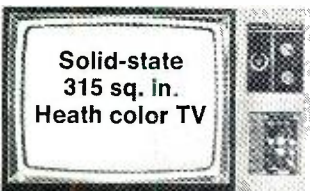

**Solid-state
315 sq. in.
Heath color TV**

Build and keep the largest, most advanced color TV made! Over-all solid-state design, ultra-rectangular screen, matrix picture tube, built-in self-servicing features, "Instant On," A.F.T., solid-state, 24-channel detent UHF/VHF power tuning, and much more! Also build and keep AM-SW Radio, Solid-State Radio, FET Volt-Ohmmeter, and Electronic Tube Tester. Learn trouble-shooting, hi-fi, stereo, multiplex systems, radio, color and B & W TV servicing.

Learn sophisticated solid-state circuitry as you build this B & W TV receiver. Lo-Silho "Superhet" Radio, FET Volt-Ohmmeter, Solid-State Radio, Electronic Tube Checker, and Signal Generator. TV

and all other equipment are yours to keep.

**Solid-state
B & W TV,
74 sq. in.
picture
(cabinet
included)**



NTS ELECTRONICS & COMPUTER TECHNOLOGY

Build and keep this exclusive NTS Compu-Trainer. It teaches you the

**Solid-state
Compu-Trainer
14 integrated
circuits replace
198 transistors!**

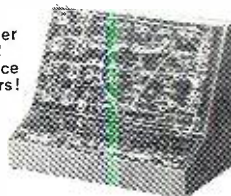

same principles used in million-dollar systems. Contains 14 inte-

grated circuits! All Solid-State! You perform all wiring and patchcording. No shortcuts. No pre-wired circuit boards. Your training is complete! Also receive an FET Volt-Ohmmeter and a 5" wide-band Solid-State Oscilloscope.

NTS ELECTRONICS COMMUNICATIONS

Gain the prestige and earning power of owning an F.C.C. First Class Radio-Telephone License. Two comprehensive NTS courses cover the big opportunity field of transmitting and receiving.

You build and keep 14 kits, including this amateur phone 6-meter VHF Transceiver, NTS's exclusive 6-transistor Solid-State Radio, and a fully transistorized Volt-Ohmmeter. Also, learn 2-way radio, Citizens Band microwaves, and radar.

**5-watt AM
transmitter/
receiver**

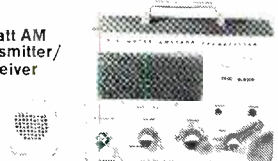

NTS Home Training puts you in the lead.

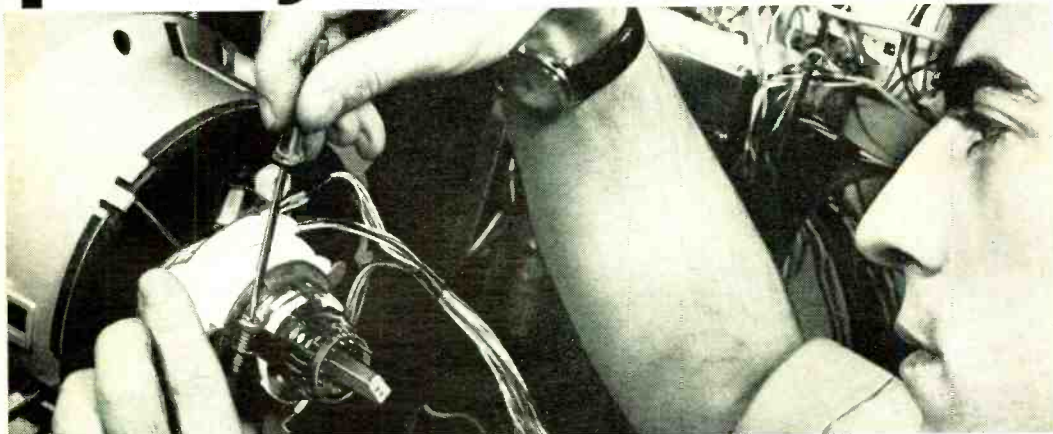

NTS INDUSTRIAL & AUTOMATION ELECTRONICS

Automation is the future of industry and you can play an important part! Learn industrial controls by training on the NTS Electro-Lab (a complete workshop). You also build and operate this 5" Solid-State oscilloscope. And you perform experiments that involve regulating motor speeds, temperature, pressure, liquid level, and much more. All equipment is yours to keep.

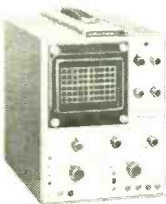

NTS AUDIO ELECTRONICS SERVICING

Learn basic sound theory—how it works in home radio, car tape

decks, stereo multiplex component systems, and more! Set up a spectacular music system. Learn about



Build and keep this famous Heath Stereo Receiver and Speakers.

sound distortion, amplification and control, loud-speaker baffles, problems of system installation, etc. Included is Volt-Ohmmeter, In-Circuit Transistor Tester, and Solid-State

Radio. Prepare yourself for great opportunities in the Home Entertainment Industry!

CLASSROOM TRAINING AT LOS ANGELES

You can take classroom training at Los Angeles in sunny Southern California. NTS occupies a city block with over a million dollars in technical facilities. Check box in coupon below.

NATIONAL TECHNICAL SCHOOLS

WORLD-WIDE TRAINING SINCE 1905
Resident & Home Study Schools
4000 S. Figueroa Street
Los Angeles, California 90037

APPROVED FOR VETERAN TRAINING

Accredited Member: National Association of Trade and Technical Schools; National Home Study Council.

Big, Colorful NTS Guide to new opportunities in Electronics. Yours FREE!



NATIONAL TECHNICAL SCHOOLS
4000 S. Figueroa Street
Los Angeles, California 90037

Please rush me FREE Color NTS Electronics Guide & FREE lesson, plus information on course checked at right. No obligation. No salesman will call.

- MASTER COURSE IN COLOR TV SERVICING
- COLOR TV SERVICING (FOR ADVANCED TECHNICIANS)
- MASTER COURSE IN B&W TV & RADIO SERVICING
- MASTER COURSE IN ELECTRONIC COMMUNICATIONS
- PRACTICAL RADIO SERVICING
- FCC LICENSE COURSE
- MASTER COURSE IN ELECTRONICS TECHNOLOGY
- AUTOMATION & INDUSTRIAL ELECTRONICS
- COMPUTER ELECTRONICS
- BASIC ELECTRONICS
- AUDIO ELECTRONICS SERVICING

Dept. 205-103

NAME _____ AGE _____

ADDRESS _____

CITY _____

STATE _____ ZIP _____

- Check if interested in Veterans Training under new G.I. Bill.
- Check if interested ONLY in Classroom Training at Los Angeles

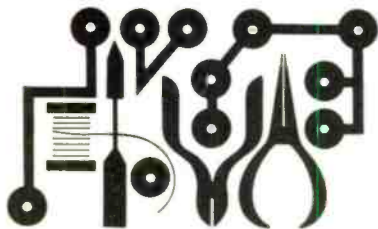

Hobby Scene

Need a Null Indicator

Q. *I need a good null indicator for my Wheatstone bridge.*

A. Try the circuit shown here. The two inputs drive the op amp to either extreme,

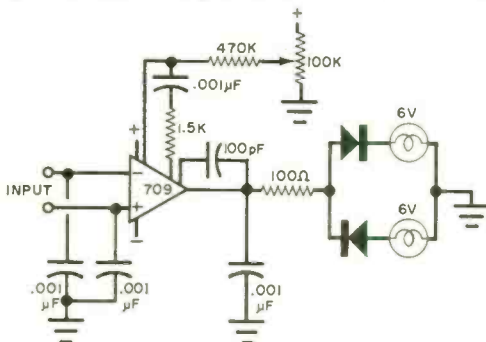

with one low-current lamp coming on when the bridge is on one side of null and the other when the bridge is on the other side of the null. Short the two inputs together to adjust the potentiometer until the lamps just go out. This adjusts the offset.

Op Amp Problems

Q. *Many of your projects use op amps and often you do not even give the pin numbers. Where does the average guy, who doesn't live in a big city, get these op amps and why don't you identify the pins?*

A. These are common questions. First, turn to the back of this magazine and look at the various solid-state "surplus" dealers advertised there. You will note that all kinds of IC's are available—most at really low prices. If you do a lot of experimenting, you should send for their catalogs.

About the pins, many op amps come in one of three kinds of packages, the familiar 14-pin DIP, an 8-pin DIP, and a round case having 8 or 10 leads. Because, in most cases, each pin configuration is different, we cannot publish the pin connections since we don't know what kind your op amp has.

Local Audio Interference

Q. *What can I do about some local radio stations that keep coming in on my audio equipment?*

A. What you may be experiencing is rectification in the transistor junction or between the grid and cathode in tubes. Essentially, then you have a crystal-set receiver. There are many approaches to quieting such amplifiers, including the use of ferrite beads (the best way, but such beads are hard to find) or filters such as the one shown here. The use of shielded cables will also help.

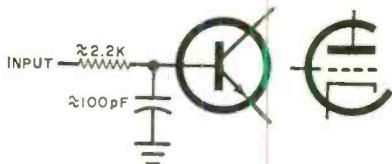

Simple Scope Probe

Q. *Can you describe a simple probe that I can use with my scope to enable me to see the modulation on my CB rig right from the antenna.*

A. The probe below works at frequencies into the r-f range. Use a short length of flexible coaxial cable to couple to the scope. Any high-frequency diode can be used. Coupling to the probe is made through a small loop. Mount the complete probe in a small metal tube.

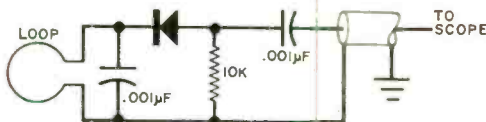

Have a problem or question on circuitry, components, parts availability, etc.? Send it to the Hobby Scene Editor, POPULAR ELECTRONICS Including Electronics World, One Park Ave., New York, NY 10016. Though all letters can't be answered individually, those with wide interest will be published.

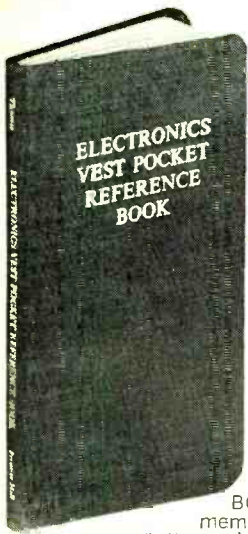

Now—the handiest book
on electronics you'll ever own—

The Electronics Vest Pocket Reference Book

—yours for only 99¢!

And you'll also receive a FREE, no-risk Membership
in The Electronics Book Service.
(No obligation ever to buy ANY minimum number of books.)

When the ELECTRONICS VEST POCKET REFERENCE BOOK was first offered to members of the ELECTRONICS BOOK SERVICE, they gobbled it up in unprecedented quantities. No other offering had ever been so well received. So great was its acceptance, in fact, that we became convinced that everyone in the field of electronics should have a copy of Harry Thomas's handy compendium of indispensable information—have it on his desk or bench, or in his pocket, at all times. So we have made special arrangements with the publisher to let you have a copy of ELECTRONICS VEST POCKET REFERENCE BOOK for just 99¢—when you accept a no-risk, trial membership in the *Electronics Book Service*—a unique and practical way to advance your career . . . add to your income . . . and enjoy your hobby.

In the pages of the ELECTRONICS VEST POCKET REFERENCE BOOK you'll find tables, lists, formulas, laws—all sorts of information and material necessary to anyone, novice or expert, who works with electronic or electrical equipment, in any branch of its technology.

Packed full of vital material and indispensable information, ELECTRONICS VEST POCKET REFERENCE BOOK explains and illustrates principles that are applicable in all branches of electronics. Whatever you're looking for, you'll *quickly* find it in this handy reference tool—simply by reaching into your vest pocket and flipping a few pages. It's as simple as that. There's hardly a page in this book that doesn't contain illustrative material of some kind. You'll find scores of equations, formulas, charts, graphs, and diagrams—all of which help to make the printed information absolutely clear. A separate box in this advertisement gives you a bare *outline* of the contents of the ELECTRONICS VEST POCKET REFERENCE BOOK—but only when you see it for yourself will you realize just how *continually* valuable it can be to you.

And it's yours for only 99¢!

Fill in and return the coupon below—*today*—and we'll send the REFERENCE BOOK to you at once. As a Charter Member of the Electronics Book Service—on this free trial basis—the 99¢ is your *only* financial commitment. You have *no further cost or obligation*. You need purchase no other books. However, if you decide to buy any book you're especially interested in, you are entitled to the special Member's discount of no less than 15% off the list price of the book! Even if you never buy another book, you'll still be informed regularly about books that can be yours at generous savings—books written by some of the most knowledgeable men in the field, on such phases of electronics as the following:

THE ELECTRONICS VEST POCKET REFERENCE BOOK IS DIVIDED INTO SIX SECTIONS:

- I. **Electronics Laws and Formulas:** Ohm's Law; Resonance in AC Circuits; How to Calculate Decibels; Radar Band Codes and Frequencies; TV Channel Frequencies; others.
- II. **Constants, Standards, Conversion:** International System of Units (SI); Physical and Electrical Conversion Factors; Electronic Constants, Multiples, and Sub-Multiples; others.
- III. **Symbols, Components, Codes:** Electronic Circuit and Component Symbols; Summary of Resistor Types; Diode Symbols, Characteristics and Applications; Coaxial Cable Types and Sizes; others.
- IV. **Mathematics, Mechanics, Charts:** Computer Number Codes; Number Functions; Powers of Numbers; Four Place Log Tables; Twist Drill Sizes; others.
- V. **Circuits, Instruments, Measurements:** Common DC Bridges; Common AC Bridges; Fuse Data; Basic Rectifier Transistor Test Circuits; others.
- VI. **Microwave Hardware and Micro-electronics:** Screws, Bolts, Nuts and Washers; Transducer Types; Date Display Devices; Thermistor Types and Sizes; others.

• AC and DC Circuits and Measurements • Transistor Circuit Analysis • Color TV Servicing • Electric and Electronic Circuits • Frequency Modulation Receivers • Electronic Switching Circuits • Electron Devices and Circuits • Special Purpose Transistors • Electronic Tests and Measurements • Solid State TV Systems

—plus many other guides, including handbooks and data books, to circuitry, radio, TV and electronic equipment, and math and physics of electronics, and all related areas of significance to you.

In an area in which novelty today is old hat tomorrow, there is no better way to keep on top of the changing technology—no more practical way for you to build an electronics library of permanent value to you—at your own pace and in line with your own special interests.

Start saving now!

Just mail the coupon below to get your copy of the ELECTRONICS VEST POCKET REFERENCE BOOK for only 99¢—and to receive all the benefits of membership in the Electronics Book Service on a FREE trial basis. Every month, you will receive an Advance Bulletin describing the current selection in detail. With the Bulletin you will also receive a Refusal Card, which you simply return if you do not want the current Club choice. Otherwise, the book will be sent to you about four weeks later. Don't wait another day for this valuable, money-making knowledge. *Send the coupon*

Electronics Book Service, Dept. 6651-M1(8)
 Englewood Cliffs, New Jersey 07632
 Please enroll me in Electronics Book Service on a free-trial basis. I am to receive all announcements, free of charge, and will be entitled to full privileges as a Member without obligation to buy any specific number of club selections.
 As my first selection under this trial membership, send me the ELECTRONICS VEST POCKET REFERENCE BOOK for only 99¢.
 Name _____
 Address _____
 City _____ State _____ Zip _____

CIRCLE NO. 32 ON READER SERVICE CARD

Introducing the new BOSE 901 and 501 Series II Direct/Reflecting® Speaker Systems



BOSE 901 SERIES II

BOSE 501 SERIES II

A New Listening Experience by **BOSE**®

For information on new BOSE products and a list of local dealers, write BOSE Corp., Dept. EP, The Mountain, Framingham, Mass., 01701.

Build the Super Audio Sweep Generator

PROVIDES LOG
AND LINEAR SWEEP.
DELIVERS 1 Hz TO
100 kHz SINE, TRIANGLE,
SQUARE WAVEFORMS AT A
BREAKTHROUGH LOW COST



BY GEORGE deLUCENAY LEON,
JON D. PAUL, AND LUIS E. RICO

ONE of the most valuable pieces of audio test equipment is the audio sweep generator. Unfortunately, it is not widely used because heretofore only costly professional instruments contained the desirable functions and accuracy: a logarithmic function which eliminates tedious point-by-point frequency plots, a frequency range extending virtually flat to beyond 20 kHz, calibrated attenuators, and high stability. Now, you can build the "Super Sweeper" audio sweep generator and have a laboratory-quality instrument for about the same you would expect to pay for a common audio signal generator *without* the sweep function.

Also, the Super Sweeper sacrifices nothing as a conventional wide-range audio signal generator. Its controls can be set to provide any frequency- and amplitude-adjustable square, sine, or triangle waveform for signal tracing or what have you.

The overall block diagram for the Sweeper is shown in Fig. 1, with the various blocks referring to the schematics in Figs. 2 through 6. Rather than go through a lengthy stage-by-stage discussion of how the Sweeper works, we will be concentrating on calibration procedures and how to use the instrument.

Construction. For ease of assembly, we recommend the use of a PC board. Due to the complexity of the board, the foil pattern is not shown here. A foil pattern and component layout (included in the step-by-step instructions) or a completed board are available from the source in the Parts List. Mount the following switches and control potentiometers on the Sweeper's front panel: SWEEP RATE (R4), FREQUENCY (R33), FREQUENCY RANGE (S4), WAVEFORM (S5), AMPLITUDE (R60), ATTENUATOR (S7), SWEEP MODE (S2), RESET (S8), SWP TYPE (S3), and SWEEP RATE (S1). Also locate on the front panel the PILOT lamp and the six binding posts for the outputs. All other controls are to be mounted on the PC board.

You can use any type of chassis that suits your fancy. However, if you're looking for a professionally pre-drilled and screened chassis/cabinet, you can get one from the same company specified in the Parts List as the kit supplier.

Calibration. Using a VTVM and an oscilloscope, perform the calibration of the Super Sweeper as outlined in the Table. The procedure given will yield a frequency calibration accurate to within 10 percent.

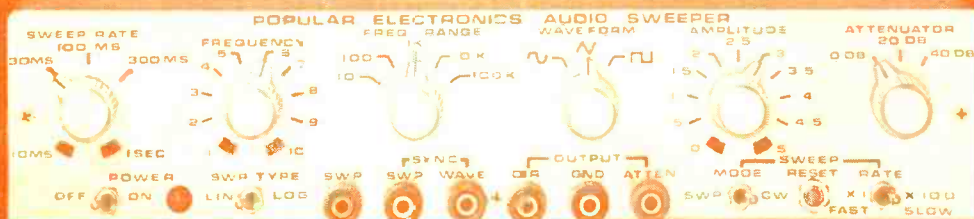

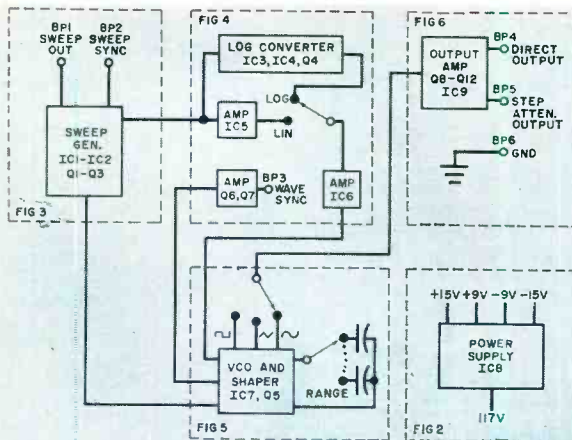

Fig. 1. Overall block diagram showing signal flow in the Sweeper. Blocks are given in detail in other figures.

PARTS LIST

BP1-BP6—Five-way binding post
 C1,C12—1- μ F, 50-volt, 10% Mylar capacitor
 C2—100- μ F, 15-volt, 10% tantalum capacitor
 C3,C23,C24—0.01- μ F, 50-volt disc capacitor
 C4,C14—100-pF, 50-volt disc capacitor
 C5,C17,C18—0.001- μ F, 50-volt disc capacitor
 C6,C11—0.1- μ F, 50-volt, 10% Mylar capacitor
 C7,C8,C19,C20—15- μ F, 20-volt tantalum capacitor
 C9—910-pF, 100-volt, 10% mica capacitor
 C10—0.01- μ F, 50-volt, 10% Mylar capacitor
 C13—10- μ F, 25-volt, 10% tantalum capacitor
 C15,C16—1000- μ F, 25-volt electrolytic capacitor
 C21—150-pF, 50-volt disc capacitor
 C22—3.3-pF, 50-volt, 10% disc capacitor
 C25—5-pF, 50-volt, 10% disc capacitor
 D1-D6,D9-D12—1N914 or 1N4148 signal diode
 D7,D8—1N4001 50-volt rectifier diode
 F1— $\frac{1}{4}$ -A 3-AG fuse and holder
 IC1,IC3-IC6—741 op amp IC
 IC2,IC9—301A op amp IC
 IC7—Function generator IC (Intersil ICL8038CC)
 IC8—Voltage regulator IC (Raytheon RC4194TK)
 LED1—Light emitting diode (Monsanto MV5023)
 Q1,Q10—2N4250 transistor
 Q2,Q3,Q6,Q7,Q11—2N3642 transistor
 Q4—2N4955 dual npn transistor (Fairchild)
 Q5—MPF.111 n-channel FET (Motorola)
 Q8,Q9—2N5210 transistor
 Q12—2N3645 transistor
 R1—2400-ohm, $\frac{1}{4}$ -watt, 5% resistor
 R2,R36—1000-ohm trimpot
 R3,R16—5600-ohm, $\frac{1}{4}$ -watt, 5% resistor
 R4—500,000-ohm, log taper potentiometer
 R5,R53—3900-ohm, $\frac{1}{4}$ -watt, 5% resistor
 R6,R41—2000-ohm trimpot
 R7—1800-ohm, $\frac{1}{4}$ -watt, 5% resistor
 R8,R17,R26,R29,R52—4700-ohm, $\frac{1}{4}$ -watt, 5% resistor
 R9,R20,R42—4020-ohm, 1% resistor
 R10,R25,R32—5010-ohm, 1% resistor
 R11,R13,R61—10,000-ohm, $\frac{1}{4}$ -watt, 5% resistor
 R14—3300-ohm, $\frac{1}{4}$ -watt, 5% resistor

R15—8600-ohm, $\frac{1}{4}$ -watt, 5% resistor
 R18,R27,R31—5000-ohm trimpot
 R19,R56—22,600-ohm, 1% resistor
 R21—100-ohm, 1% resistor
 R22,R51—82,000-ohm, $\frac{1}{4}$ -watt, 5% resistor
 R23—10,000-ohm trimpot
 R24—330,000-ohm, $\frac{1}{4}$ -watt, 5% resistor
 R28,R30,R35,R37—10,000-ohm, 1% resistor
 R33—10,000-ohm, linear taper potentiometer
 R34—1100-ohm, 1% resistor
 R38,R39—100,000-ohm trimpot
 R40—4750-ohm, 1% resistor
 R43,R62—15,000-ohm, $\frac{1}{4}$ -watt, 5% resistor
 R44,R58—100,000-ohm, $\frac{1}{4}$ -watt, 5% resistor
 R45,R49—22,000-ohm, $\frac{1}{4}$ -watt, 5% resistor
 R46—33,000-ohm, 1% resistor
 R47—120,000-ohm, $\frac{1}{4}$ -watt, 5% resistor
 R48—30,000-ohm, $\frac{1}{4}$ -watt, 5% resistor
 R50—6800-ohm, $\frac{1}{4}$ -watt, 5% resistor
 R54—680-ohm, $\frac{1}{2}$ -watt, 5% resistor
 R55—71,500-ohm, 1% resistor
 R57—68,000-ohm, $\frac{1}{4}$ -watt, 5% resistor
 R59—2200-ohm, $\frac{1}{4}$ -watt, 5% resistor
 R60—1000-ohm, linear taper potentiometer
 R63—39,000-ohm, $\frac{1}{4}$ -watt, 5% resistor
 R64—100-ohm, $\frac{1}{4}$ -watt, 5% resistor
 R65,R66—1500-ohm, $\frac{1}{4}$ -watt, 5% resistor
 R67,R68—51-ohm, $\frac{1}{4}$ -watt, 5% resistor
 R69—6200-ohm, $\frac{1}{4}$ -watt, 5% resistor
 R70,R72,R73—620-ohm, $\frac{1}{4}$ -watt, 5% resistor
 R71—62-ohm, $\frac{1}{4}$ -watt, 5% resistor
 R74—560-ohm, $\frac{1}{4}$ -watt, 5% resistor
 R75—20,000-ohm, 1% resistor
 S1,S2—Dpdt miniature toggle switch
 S3—Spdt miniature toggle switch
 S4—5-position, 1-pole shorting rotary switch
 S5,S7—3-position, 1-pole shorting rotary switch
 S6—Spst miniature toggle switch
 S8—Spst normally open pushbutton switch
 T1—Transformer; secondary: 12 V at 150 mA
 Misc.—Suitable chassis, mounting hardware, wire, solder, etc.
 Note—The following are available from:
 MITS, 6328 Linn, N.E. Albuquerque, NM 87108: PC board at \$6.00; step-by-step instructions, including lot pattern and component layout at \$3.00; complete kit, including board, instructions, and enclosure, \$119.95; complete unit assembled, \$149.95.

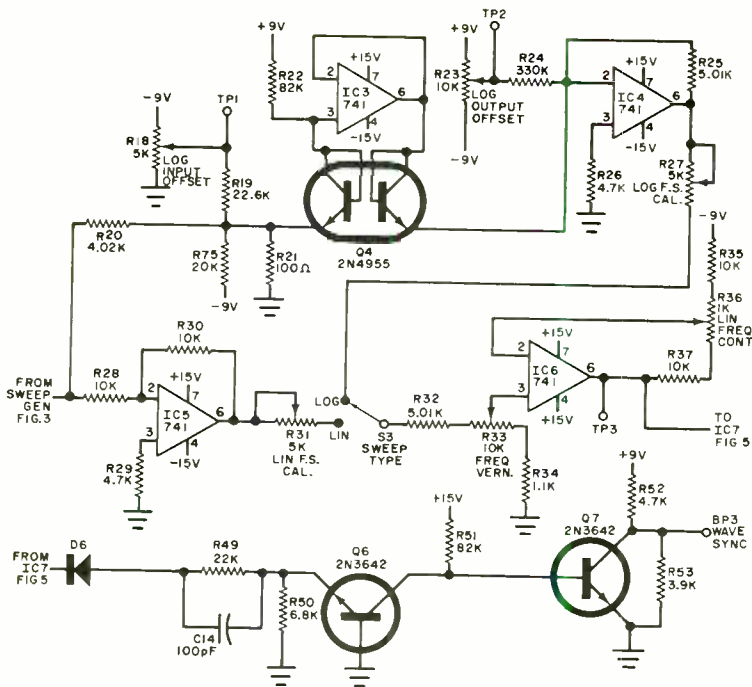

Fig. 4. Converter circuit shapes the linear sweep into logarithmic waveform, since second half of Q4 has current flow proportional to the exponent of applied voltage. IC4 converts the current to voltage. S3 selects either the linear or logarithmic output.

controls will now have no effect on the Sweeper's output. When the WAVEFORM switch is set to sine, BP4 (OUTPUT DIR) will supply a 0-5-volt rms sine wave at 600 ohms impedance. In the triangle and square positions of the WAVEFORM switch, the output at BP4 will have a peak voltage variable between 0 and 7 volts. The BP5 (OUTPUT ATTN) binding post will have the same open-circuit output as the direct output when the ATTENUATOR switch is set for 0 dB. In the 20-dB position, the output will be 1/10 of the direct output, while in the 40-dB position it will be down to 1/100. Loads (or short circuits) on either of these

outputs will have no effect on the other.

The output frequency can be set at any point from 1 Hz to 100 kHz by adjusting the FREQ RANGE switch and FREQUENCY control. The SYNC WAVE output (BP3) provides a 4-volt, positive-going square wave for sync or counter use.

Refer to Fig. 7 for setting up a sweep display. In the sweep mode, the output voltages and waveforms are the same as they are in the CW mode, but the frequency is swept from nearly zero up to the frequency set by the FREQ RANGE switch and FREQUENCY control. The SWEEP RATE control varies the time for a full sweep from 10 ms

Fig. 5. The vco uses one LSI IC to generate sine, triangle, or square wave output. The chip is reset from the sweep generator. Switch S4 selects range.

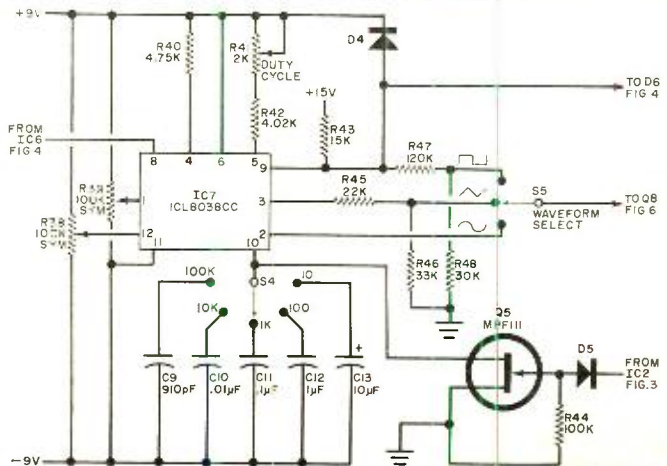

PROJECT EVALUATION (Hirsch-Houck Labs Report)

In our tests, the Super Sweeper easily met or surpassed all of its performance specifications. In fact, the rated accuracy and response uniformity of our laboratory-grade test equipment was not adequate to verify the "flatness" of the Sweeper's output. However, it left us with no doubts as to the capabilities of this versatile instrument.

The uniformity of output in the CW mode was within ± 0.1 dB from 5 Hz to 100 kHz. Using an oscilloscope, we judged that the output rose to +0.8 dB at 1 Hz, although this involved some guesswork. In the sweep mode, we recorded the output on a General Radio 1521-B Graphic Level Recorder, whose rated flatness is comparable to that of the Sweeper. The chart calibration was not synchronized in frequency with the swept signal, but it showed a total variation of less than 0.25 dB over the full 100-kHz sweep in the linear mode. The logarithmic sweep was almost perfectly flat up to and beyond 60 kHz (on the 100-kHz range); and the output then dropped about 0.5 dB as the sweep continued to 100 kHz. Using less than the maximum sweep capability of the unit, the flatness was generally well within 0.1 dB.

The maximum output voltage (sine) was 5.3 volts into an open circuit, dropping to 2.6 volts with a 600-ohm load.

The attenuator error at 1000 Hz was -0.1 dB at the 20-dB setting and -1 dB at the 40-dB setting.

The harmonic distortion (sine wave output) varied with frequency. The lowest reading, 1.0%, was measured at 20 Hz, and the highest, 1.9% to 2.0%, was in the range between 100 and 1000 Hz. Over the audio range, the average distortion was about 1.5%. Of course, one would not use this instrument for making distortion measurements of high-quality amplifiers: it is principally a tool for frequency response measurements.

The frequency calibrations proved to be surprisingly accurate. The error was typically less than 3% and at only one point did it even approach the 10% figure specified.

The square and triangle waves appeared to be good, judging from a visual examination on an oscilloscope. The square-wave rise time was approximately 2 microseconds.

The logarithmic sweep, a virtual necessity for meaningful audio measurements, is rarely found—even on generators costing many times the price of this one. The lack of a logarithmic frequency calibration is a minor inconvenience, but an external marker generator can be mixed with the output of the Sweeper; and once the calibration has been made for a commonly used frequency range (such as up to 20 kHz), it should remain valid for a long time without further checks.

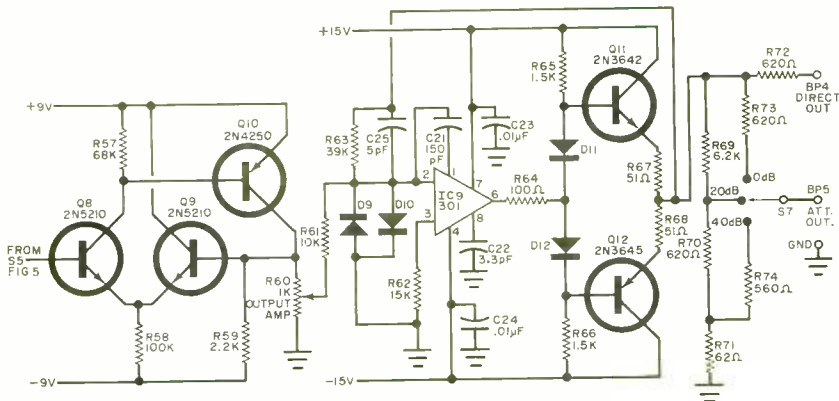

Fig. 6. In the output stage, Q8, Q9, and Q10 form a unity gain buffer, whose output is applied to amplitude control R60 and is then amplified by IC9. Transistors Q11 and Q12 provide high output current. A three-step attenuator is made up of R69 to R74 with amount of attenuation selected by S7. Output impedance is 600 ohms.

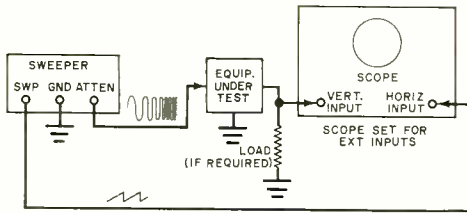

Fig. 7. This is setup for hooking the sweeper to the gear under test and to a scope (preferably dc). Sweep rate is adjusted to correct value by observing output on scope.

ALIGNMENT PROCEDURE

CONTROL/SETTING	OBSERVE	ADJUST	DESIRED
POWER/on	IC8-5	—	+15 ±3 V
SWP/lin	IC8-case	—	-15 ±3 V
	IC8-6	—	+9 ±0.1 V
	IC8-1	—	-9 ±0.1 V
SWP MODE/SWP	SWP out	R2	1-s sweep time
SWP RATE/X1			(1 Hz)
SWP RATE/1 sec			
As above with	SWP out	R6	10-ms sweep time
SWP RATE/10 ms			(100 Hz)
FREQ RANGE/10K	OUTPUT	R36	30-90-Hz output
FREQUENCY/10	DIR		
SWEEP RESET/in			
As above with	OUTPUT	R31	10-kHz output
SWEEP MODE/CW	DIR		
SWEEP RESET/out			
As above with	OUTPUT	R41	Equal time for
WAVEFORM/square	DIR		both states of
SWEEP MODE/CW			square wave
As above with	As	R38	Minimum distur-
WAVEFORM/sine	above	R39	tion (on sine
FREQ RANGE/1K		R41	wave)
FREQUENCY/5			
SWP TYPE/LOG	TP1	R18	-5 V
SWEEP MODE/SWP			
SWEEP RATE/X1			
SWEEP RATE/1 SEC	TP2	R23	-5 V
As above	TP3	R18	Sweep voltage
			should drop 10%
			(middle of trace)
As above with	OUTPUT	R23	30-70-Hz output
FREQ RANGE 10K	DIR		
FREQUENCY/10			
SWEEP RESET/in			
As above with	OUTPUT	R27	10-kHz output
SWEEP MODE/CW	DIR		
SWEEP RESET/out			

Note: All observation points (Column 2) referenced to ground.

to 1 s in the FAST and 1 s to 100 s in the SLOW position. The sweep rate is adjusted to the correct value by observing the output display with an oscilloscope. Sweeping too fast causes the display to smear. Sweeping too slowly will cause a flicker in the display and make observation difficult. The point at which display smearing occurs depends on the bandwidth of the unit being tested and on the sweep width setting.

The linear sweep allows the frequency of any point on the plot to be read directly, since the frequency starts at zero and changes at a constant rate. The only disadvantage of the linear sweep is that only a narrow region of the audio band is shown in detail. Thus, for a 10-kHz sweep, the bass and midrange (20-1000 Hz) are compressed into the first 10 percent of the sweep, with the remaining 90 percent covering the treble response in detail.

The logarithmic sweep solves this problem by devoting equal area to each band of audio. The rate of frequency change with time increases at a constant pace. The log sweep covers two decades, or about six octaves. Notice that the starting point is not dc (zero frequency), but is offset, since the logarithm of zero is minus infinity.

The ability of the sweeper to go as slowly as 100 seconds/sweep permits plots of systems with narrow bandwidths. A graphic chart plotter or an oscilloscope camera will give a permanent record of the response curve.

The audiophile can use the 100-second sweep to detect resonant objects in a room by "playing" the sweeper through his audio system and moving around the room, listening for resonances. When using slow sweeps, the SWEEP RESET pushbutton is handy for restarting the sweep before it is completed. Holding the button down permits synchronizing the sweep manually.

Applications. An audio sweep generator has many applications. For example, it simplifies setting a tape recorder's bias and aligning head azimuth. Line and load regulation and output impedance vs frequency for power supplies can be checked easily. It can also be used to test room and speaker enclosure resonance, microphone-element sensitivity, ultrasonic system response, phase locked loops, SSB filters and telecommunications systems, not to mention the host of all-audio applications. ♦

INTRODUCTION TO ELECTRONIC MUSIC

HOW TO GET STARTED AND WHERE TO LEARN ABOUT IT

BY DON LANCASTER

A QUESTION often asked about electronic music is: What is it? Stated simply, electronic music is the production and modification of audio tonal effects by electronic means. With this basic definition, we really can't go far wrong because everything but a harmonica, a kazoo, or a chamber music group usually gets electronics involved in it somehow.

We prefer to separate music that is modified, deliberately or unintentionally, from instruments that actually produce music by electronic means. Any means of producing an electronic audio tone that isn't intimately associated with a traditional non-electronic musical instrument we would define as an electronic synthesizer.

The difference between electronic organs and Moog-style synthesizers is sometimes a very touchy point for both organists and synthesizer people. No one who follows today's circuitry can doubt that the hardware behind both instruments is rapidly converging toward essentially identical, mostly digital, systems. The distinctions lie more in who uses a given instrument and what the instrument is used for than in its hardware. Electronic organs are aimed at a more or less faithful accompaniment or imitation of classical instruments or traditional pipe organ voices through established musical forms. On the other hand, traditional Moog-style synthesizers are much more unstructured and have more freedom for creating new tonal combinations and new sounds.

Incidentally, many synthesizers are *not* real-time devices. They require tape recording techniques to build up one-note-at-a-time sequences and to multiply single voices. Some computer systems are extremely slow and have to be sped up hundreds or even thousands of times to obtain the desired

audio-frequency range. The latest hardware is getting away from this because being able to do live performances and to play more than a single note at a time from a keyboard are essential for a viable instrument.

Building Up A Library. At the present time, you can't just run out and buy any one book that will tell you all there is to know about electronic music. With the "digital electronic revolution" centered around the 5-cent gate in full swing, things are happening so fast that articles and personal communications, let alone a book, can't even keep up. So, how do you go about building up a good library? There are four routes you can take: subscribing to association newsletters; building up a file of technical papers; reading over and constructing the electronic music projects that appear in this magazine; and, finally, getting your hands on textbooks.

There are at least two electronic music associations. One is called Electronotes, located at 60 Sheraton Dr., Ithaca, NY 14850. Besides publishing a monthly newsletter, the association has a wide variety of technical material, including a good bibliography, and a loan service on rare or hard-to-find material. The cost of all this is \$2 per year.

Another more arty association that concerns itself more with the "new sound" in general, composition techniques, sound recording and distribution, etc., is called Numus West, located at Box 146, Mercer

NOTE TO READERS

We would welcome your comments and questions on electronic music, hardware and non-hardware. Write to POPULAR ELECTRONICS Including Electronics World, One Park Ave., New York, NY 10016.

Island, WA 98040. Numus concerns itself more with people and the end product, while Electronotes is more hardware oriented.

Synthesizer design articles most often appear in the *Journal of the Audio Engineering Society* (60 East 42 St., Rm. 428, New York, NY 10017). Their subscription rate may be a bit steep for you at \$30 per year, but you might try a large university library for copies you can browse through. Some two-dozen electronic music articles have appeared in the *Journal* during the last three years, most of them on digital tone generation techniques.

Detailed measurement and analysis of what traditional musical instruments should sound like show up regularly in the *Journal of the Acoustical Society of America* (335 East 45 St., New York, NY 10017), at \$45 per year. Again, try a large university library or check with Electronotes for loan copies.

Several of the "obvious" places to look rarely or only occasionally have electronic music articles of value. These include the *IEEE Transactions on Audio* (345 East 47 St., New York, NY 10017). And don't overlook *Scientific American* (415 Madison Ave., New York, NY 10017); once every three years or so, they come up with an outstanding article on musical instruments.

Most libraries also have the *Music Index*, a "readers guide" sort of thing that reviews the traditional music magazines and occasionally gets involved with the new sounds.

POPULAR ELECTRONICS has had several electronic music projects in the past. Among them were the "Pitch Reference" (Sept. 1968), "Thumpa-Thumpa Box" (Feb. 1970), "Psych-Tone" (Feb. 1971), and the "Drummer Boy" (July 1971).

There are also many books available. One classic is H.F. Olsen's *Musical Engineering* (McGraw-Hill, 1952). It is now out of print but has been updated by *Music, Physics, and Engineering*, available in paperback for \$3.50 from Dover Publications, 180 Varick St., New York, NY 10014. Another classic is R.H. Dorf's *Electronic Musical Instruments* which sells for \$10 from Radiofile, Box 43 Ansonia Station, New York, NY 10023.

Electronic Organ Handbook, Volumes I and II, are \$5.75 per volume from Howard W. Sams & Co., Inc., 4300 West 62 St., Indianapolis, IN 46268. Tab Books, Blue Ridge Summit, PA 17214, has *Electronic Musical Instruments* by Norman Crowhurst for

\$4.95 in soft cover, and *Electronic Music* by Allen Strange is available from William C. Brown Co., 135 S. Locust, Dubuque, IA 52001 for \$3.95.

Horns, Strings and Harmony by Arthur E. Benade can be obtained for \$1.75 from Doubleday/Anchor Books, 501 Franklin Ave., Garden City, NY 11530. *Piano Tuning and Allied Arts* by William B. White is available from Tuners Supply Co., 88 Wheatland St., Somerville, MA 02145 for \$6.95. It contains a lot of material on piano mechanics. Tuners also has other traditional music books and some parts for build-your-own keyboards.

A *Bibliography of Electronic Music* from the University of Toronto Press sounds like it might be a handy item to have, but its 1967 publication date makes it too old to contain the most modern circuitry.

A number of other books are listed in

MANUFACTURERS OF ELECTRONIC MUSIC EQUIPMENT

Synthesizers and Kits:

- ARP Instruments, 320 Needham St., Newton Highland, MA 02161
 - Buchla Associates, Box 5051, Berkely, CA 94705
 - CBS Laboratories, 1300 E. Valencia St., Fullerton, CA 92631
 - Electronic Music Labs Inc., Box H, Vernon, CT 06080
 - Electronic Music Studios of Amherst Inc., 460 West St., Amherst, MA 01002
 - EL Systems, 3455 Homestead Rd. #59, Santa Clara, CA 95051
 - Ionic Industries, 128 James St., Morristown, NJ 07960
 - Moog Music Inc., P. O. Box 131, Williamsville, NY 14221
 - PAIA Electronics, P. O. Box 14359, Oklahoma City, OK 73114
 - Southwest Technical Products Corp., 219 W. Rhapsody, San Antonio, TX 78216
 - Total Technology, P. O. Box 828, Belmont, CA 94002
 - Electronic Music London Ltd., 49 Deodar Rd., London England, SW15 2NU
- ##### Organs and Kits:
- Artisan Organs, Wheeler St., Arcadia, CA 91006
 - Devtronix Organ Products, 5872 Amapola Dr., San Jose, CA 95129
 - Heath Company, Benton Harbor, MI 49022
 - Newport Organs, 846 Production Place, Newport Beach, CA 92660
 - Schober Organs, 43 W. 61 St., New York, NY 10023

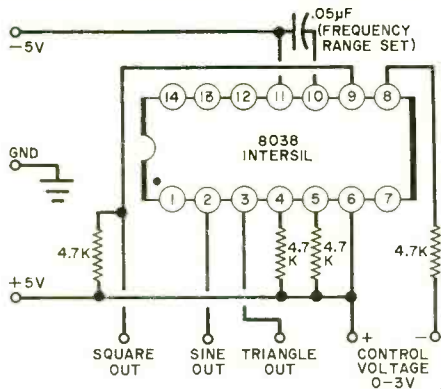
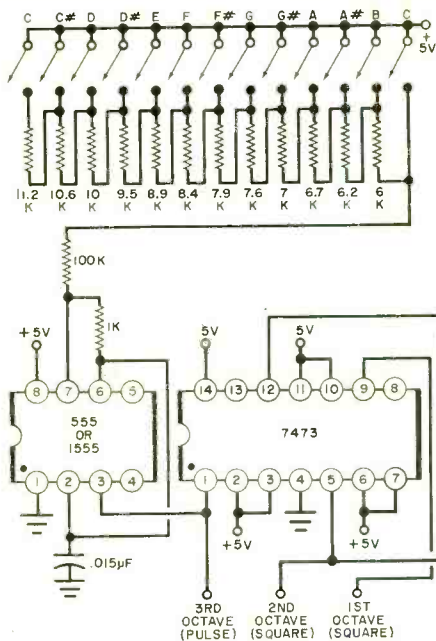

Fig. 2. The simple vco, above, offers sine, square, and triangle waveforms.

Fig. 1. Equally tempered tone generator, left, is inexpensive and can be used to generate 37 notes. Components can be trimmed to tolerances needed; small PC trimmers are the best to use.

TWO PITCH GENERATORS

Here are two very simple, low-cost pitch generator circuits, shown in Fig. 1 and Fig. 2, with which you can experiment. The circuit in Fig. 1 generates square waves. The 555 IC costs only \$1 and is very stable with regard to power supply and temperature variations. By operating the switches, the equally tempered scale will be generated on a one-note-at-a-time basis. You can shift down an octave by *doubling* the value of the timing capacitor, or up an octave by *halving* the capacitor's value. The output level of the generator is 3 volts.

Another monophonic, or single-note, circuit is that shown in Fig. 2. This cir-

cuit generates sine, square, and triangle waveforms. Its parts cost is about \$3. The generator is stable enough for serious music work.

A future article will explain why you should have a logarithmic characteristic to any wide-range vco (voltage-controlled oscillator), and why digital techniques are better in the long run. To change octaves with this generator, once again, you juggle capacitor values. As a vco, the circuit has a 1000:1 range as you vary the input from 0 to 3 volts following the polarity and connections shown. Best stability is obtained near a 3-volt control potential. ♦

the *Whole Earth Catalog*. And Nonesuch Records (15 Columbus Circle, New York, NY 10023) has a set titled *The Nonesuch Guide to Electronic Music* that can be obtained for \$8.94 through your local record store. The set consists of two records and a comprehensive booklet.

We could go on and on with our bibliography, but you get the idea.

The Instrument Makers. Manufacturer trade literature is also a great help and

should become a solid part of your electronic music library. Some of the major synthesizer and organ kit suppliers are listed in the table. You might like to write the companies for catalogs and prices. Depending on the manufacturer and the performance capabilities of his equipment, the instruments range from less than \$100 to more than \$20,000. Of course, there are low-cost, practical ways of doing the same things the very expensive units can. Two examples are described in the box. ♦

AMUSE YOUR CHILD WITH THIS AUDIO-VISUAL CMOS TOY

BY JOSEPH G. GASKILL

THE PURPOSE of any toy is to amuse and entertain a child. This one, using the latest in IC's, has flashing lights and an unusual audible output and will keep a child occupied for hours. It is also an interesting project for the builder.

The toy uses a CMOS IC and the outputs are a series of noises with variable frequency and repetition rates and two lights that flash at a variable rate. A series of interconnected switches is manipulated to create various effects. The toy is powered by batteries to make it safe and, since it requires about 40 mA, six D cells should last for about a year.

How It Works. A simplified schematic of the circuit is shown in Fig. 1, along with a graph for determining frequency of oscillation. The circuit will not "latch up" in any state if it is properly wired. The period can be adjusted from the low microseconds to several tens of seconds and the frequency can be set for values from about 0.25 Hz to 30 kHz. The frequency of the CMOS oscillator is almost completely independent of the power supply; the curves in Fig. 1 are based on empirical data.

The actual circuit is shown in Fig. 2. Both oscillators are contained in *IC1*. Some typical timing components are shown. Switch *S1* either disables the first oscillator or permits it to free-run; and *R1* keeps the input to the NOR gate high when the switch is open. Resistor *R2* is a current-limiting feedback resistor, while *R3* and *R4* and *C1* through *C7* provide the time constant. Capacitor *C1* and resistor *R3* limit the high frequency range. The second oscillator (*IC1C* and *IC1D*) is identical to the first

but is limited in period from about 3 seconds to 100 milliseconds. Both oscillators are gated through *IC2A* to drive *IC2B* and the speaker. Switches *S8* and *S12* are used to disengage either function.

When *S12* is open, there will be a continuous audio tone. With *S12* closed and *S8* open, a low-frequency tone will be heard. The sections of *IC3* form two hex inverter chains which drive the lamps. The lamps are controlled by *S13* and *S14*. Since there is

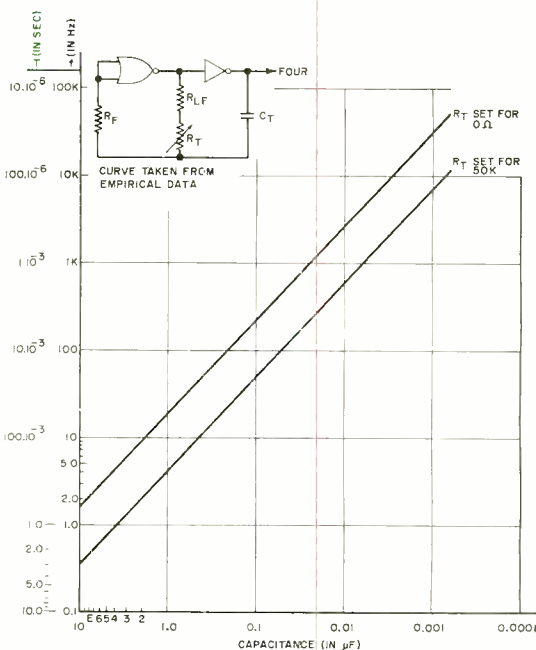

Fig. 1. Capacitance versus frequency or period to determine output of the oscillator.

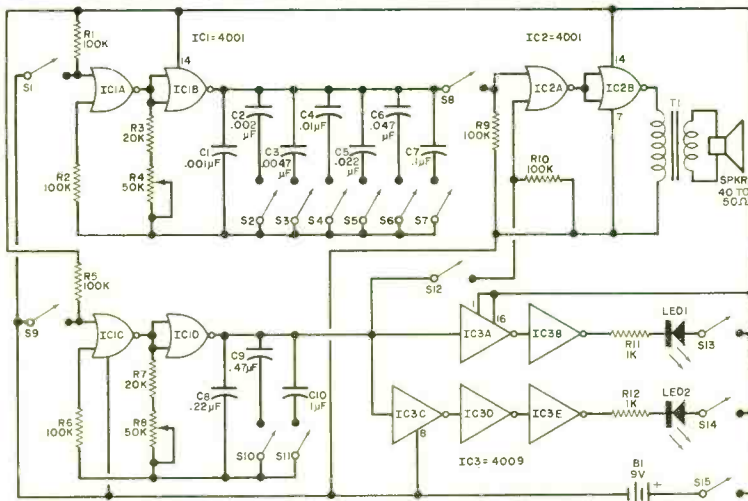

Fig. 2. High-frequency and low-frequency oscillators are mixed to produce audio.

PARTS LIST

B1—9-volt battery (six C or D cells)
 C1—0.001- μ F capacitor
 C2—0.002- μ F capacitor
 C3—0.0047- μ F capacitor
 C4—0.01- μ F capacitor
 C5—0.022- μ F capacitor
 C6—0.047- μ F capacitor
 C7—0.1- μ F capacitor
 C8—0.22- μ F capacitor
 C9—0.47- μ F capacitor
 C10—1.0- μ F capacitor
 IC1, IC2—CMOS 4001 quad 2-input NOR gate (SCL4001AE or similar)

IC3—CMOS 4009 hex inverter (SCL4009AE or similar)
 LED1, LED2—1.7-2.5-volt LED (see text)
 R1, R2, R5, R6, R9, R10—100,000-ohm, $\frac{1}{4}$ -watt resistor
 R3, R7—20,000-ohm, $\frac{1}{4}$ -watt resistor
 R4, R8—50,000-ohm potentiometer
 R11, R12—1000-ohm (max) resistor (see text)
 S1-S15—Spst switch
 T1—Lafayette TR-98 subminiature audio transformer
 Misc.—Chassis, battery clips, colored lens caps for lamps, wire, board, etc.

one more inverter in one chain than in the other, the lamps alternate.

Construction. The circuit can be assembled on either a perf or printed circuit board. There are two precautions to be observed: an MOS device can be destroyed by a static discharge and an IC gate input should not remain unconnected. If an input is allowed to "float", the associated device will remain in its linear region; and if this continues for more than a few seconds (usually), the device will go into thermal runaway. A NOR gate (such as IC1 and IC2) should have its uncommitted inputs tied "low" or in parallel with the other input. (A NAND gate can have its uncommitted inputs tied "high" or to the companion input.) Inverters or buffers (such as IC3) can be tied high or low. It is suggested that sockets be used for these MOS devices and that they not be plugged in until all wiring is complete.

The visual display can be either light

emitting diodes (with R11 and R12 chosen so that 20 mA flow through each diode) or 12-volt, 50-mA pilot lamps (with R11 and R12 not required).

The assembled circuit board should be mounted in a suitable chassis with switches S1 through S15 and the two tone-control potentiometers (R4 and R8) on the front cover. Mount the speaker behind small holes drilled in the front panel.

Operation. Switches S1 and S9 control the operation of their respective audio oscillators, while switches S2 through S7 (with R4) control the frequency of one oscillator and S10 and S11 (with R8) control the other oscillator. The oscillators are gated into the output stages through their associated series switches and S8 and S12. With the power turned on (S15), various configurations of the switches and controls will produce different audio outputs. Switches S13 and S14 control the operation of the visual displays. ♦

IF YOU CAN USE ANY OF THESE TOOLS...

... you can build yourself a Bell & Howell
solid-state 25-inch diagonal color TV...
and maybe build a whole new future
while you're at it!

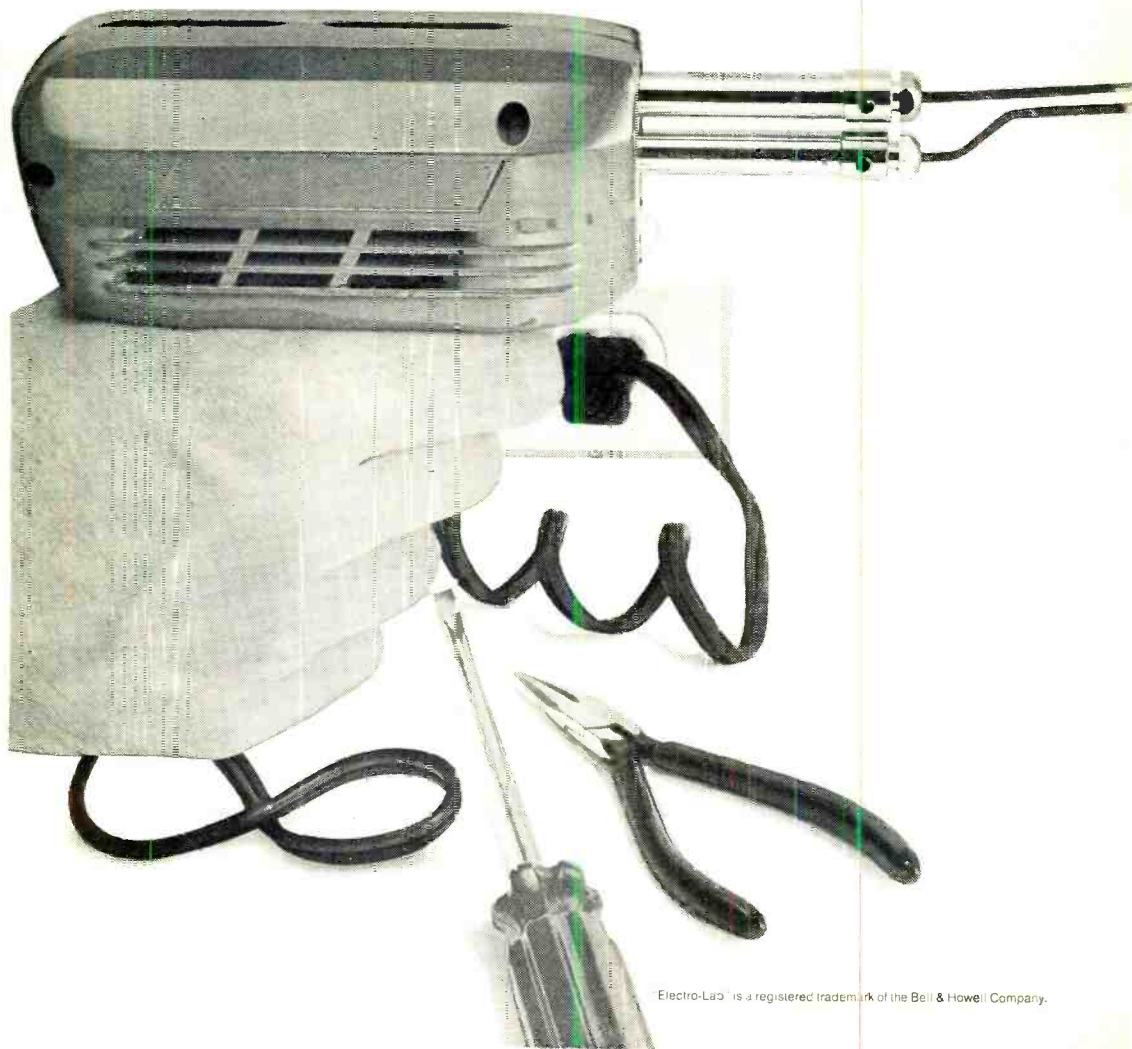

"Electro-Lab" is a registered trademark of the Bell & Howell Company.

If you're already handy with a set of tools, here's a way to pick up a pretty thorough knowledge of electronics: build yourself a solid-state color TV as part of a complete learn-at-home program from Bell & Howell Schools.

This important project gives you valuable "hands on" experience with solid-state circuitry—the kind of *practical* experience you'll need to build a successful career. It's a vital part of your total electronics education.

Once you've completed your program from Bell & Howell Schools, you could have an exciting career opportunity waiting for you in the growing field of home entertainment electronics. You might even end up with a business of your own in color TV servicing.

Fix stereo systems . . . FM-AM radios . . . phonographs . . . tape recorders

With your new skills, you can build and service stereo-hi-fi systems—including FM-AM radios . . . phonographs . . . open reel tape recorders and cassette or cartridge player/recorders. You could even build yourself a complete "home entertainment communications center"—complete with the new gadgetry of cartridge television when it comes out. The skills you build by following this unique program are more than enough to service almost *any* type of home entertainment electronics device.

A complete at-home learning program in home entertainment electronics

Your color TV project is probably the best way for you to learn the most advanced "state of the art" concepts of sophisticated electronics circuitry. It's part of a complete at-home learning program prepared by skilled instructors at Bell & Howell Schools. Mail the postage-free card today so that our representative can bring you all the facts at no obligation.

It doesn't matter if you've never had any training in electronics before. Nobody's going to start throwing "diodes" and "capacitors" at you right off. You start with the basics. You take it one step at a time. You walk before you run. And you'll be amazed at how quickly you start to feel comfortable with things that seemed complicated at the beginning.

Attend special "help sessions" if you like

In case you run into a sticky problem—or you want to discuss your project with an instructor—come in and see us. We've scheduled special "help sessions" regularly at the Bell & Howell Schools and in many other cities throughout the U.S. and Canada. Drop by. Meet an expert instructor in person. Talk over any rough spots with him—and with other students. You'll enjoy the chance to "talk shop."

Master the most up-to-date solid-state circuitry

Solid-state is here to stay. Not just color TV but almost every type of electronic device will eventually move farther and farther in the direction of *total* solid-state circuitry. Get to know the most advanced "trouble-shooting" techniques for these sophisticated circuits. You'll find an almost irresistible demand for your skills.

Why you should know electronics

No matter where you look, the amazing technology of electronics is becoming a bigger and bigger part of the picture. More and more automotive parts and diagnostic instruments are electronic. Many large manufacturing plants use sophisticated electronic systems—controlled by a few skilled electronics technicians. The increasing use of two-way radio . . . the huge promise of cable television . . . the astonishing growth of electronic data processing all open doors to exciting new career opportunities for the man with thorough training in electronics. In fact, the day may come when the man who does *not* have electronic skills will be severely handicapped in many industries.

Why you should get your training from Bell & Howell Schools

Skilled instructors at Bell & Howell Schools—carefully selected for their knowledge, experience and teaching ability—plan each program with the utmost care and attention. Each year, they spend over \$200,000 improving programs to keep them up-to-date with the latest technology. Many Bell & Howell Schools graduates have used their home study training to get started in exciting new careers or businesses of their own in electronics. You could too!

With your first lesson you get . . .

. . . the Laboratory Starter Kit! A volt-ohm-meter (VOM) with design panels, modular connectors, experimental parts and battery power source. Gives you *immediate* "hands on" experience with your very first lesson.

You also build and keep the exclusive Bell & Howell Schools Electro-Lab® electronics training system

To make sure you get practical experience with instruments used daily by professionals, you build yourself a Design Console, an Oscilloscope and a Transistorized Meter (see details at right). These are the three instruments you'll work with constantly—both during your program and thereafter.

CONSIDER THESE ADVANTAGES:

Help Sessions We've scheduled special "help sessions" regularly at the Bell & Howell Schools and in many other cities throughout the U.S. and Canada. Top instructors give you expert advice and you meet other students, too.

National Career Placement Center

When you complete your course, we will help you in your search for a job in a field of electronics that fits your background and interests. Although we cannot guarantee jobs to our graduates, this placement service is available at *any* time after you graduate.

Veterans' Benefits We are approved by the state approval agency for Veterans' Benefits. Check the box for details.

Student Financial Aid We are an eligible institution under the Guaranteed Student Loan Program. Check the box for details.

For Free Information, Mail Card Today!

If card has been removed, write:

An Electronics Home Study School
DEVRY INSTITUTE OF TECHNOLOGY



ONE OF THE
BELL & HOWELL SCHOOLS

4141 Belmont Chicago, Illinois 60641

Detach postage-paid reply card and mail today for Free Information!

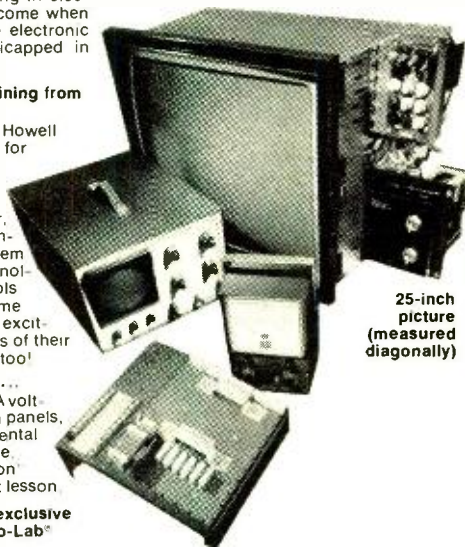

25-inch picture (measured diagonally)

■ **Bell & Howell Solid-State 25-inch color TV.** Ultra-rectangular tube . . . 25-inch picture measured diagonally . . . full 315 square inch viewing area. Solid-state modular circuitry . . . 4 advanced IC's . . . 100 transistors . . . 72 diodes . . . individual plug-in circuit boards. Special UHF/VHF tuning features . . . built-in self-service components.

■ **Design Console** Use this to rapidly "breadboard" circuits without soldering. Equipped with built-in power supply . . . test light . . . speaker . . . patented plug-in modular connectors.

■ **Oscilloscope** Portable 5-inch wide-band oscilloscope offers bright, sharp screen images . . . calibrated for peak-to-peak voltage and time measurements . . . 3-way jacks for leads, plugs, wires.

■ **Transistorized Meter** Combines most desired features of vacuum-tube volt-meter and quality multimeter. Registers current, voltage and resistance measurements on a large, easily-read dial. Features sensitive, 4-inch, jewel-bearing d'Arsonval meter movement.

527R

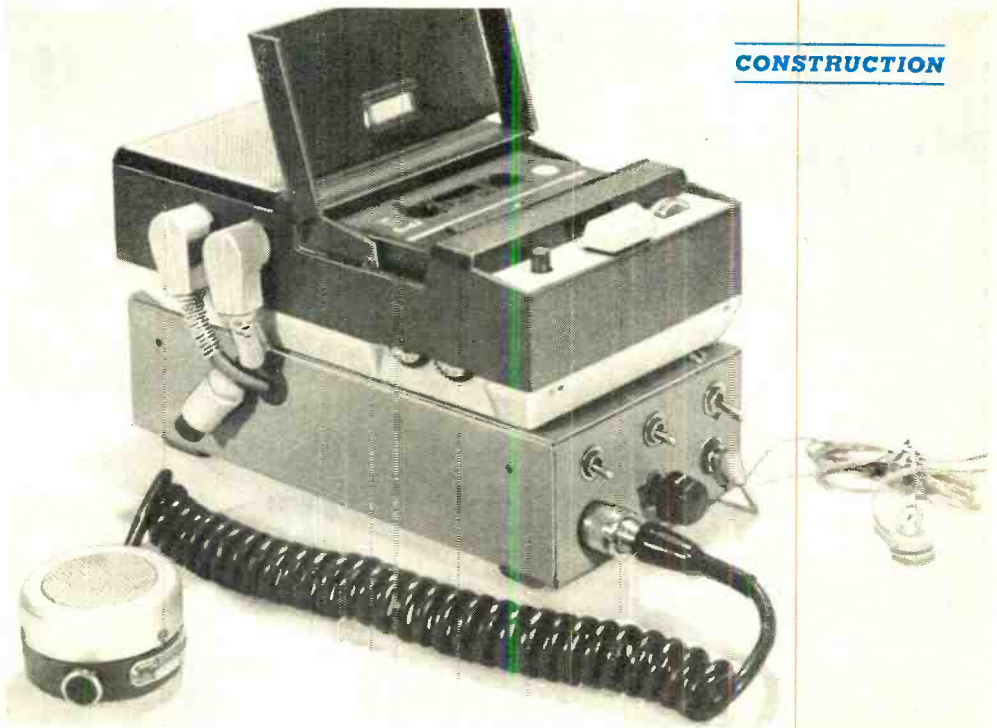

VERSATILE TAPE RECORDER CONTROL

Adds audio compression, squelch-activated start, and earphone amplifier

BY MARSHALL LINCOLN

THERE are many fine tape recorders available and they have all sorts of features to provide better recordings and, at the same time, make the job easier. But, as with most everything, there is usually room for improvement. Here are three "for instance's." Sometimes audio-input level settings are so critical that satisfactory adjustment is difficult. This can be helped by the addition of

an audio compressor to regulate the input. Improvement number 2 is the need for a way to turn the recorder on automatically when a transmission is picked up on a monitor receiver. A squelch-operated relay does this trick. Finally, suppose you want to use earphones to monitor recorded material or listen privately on a recorder that has only a low-level output jack. For this, all that is

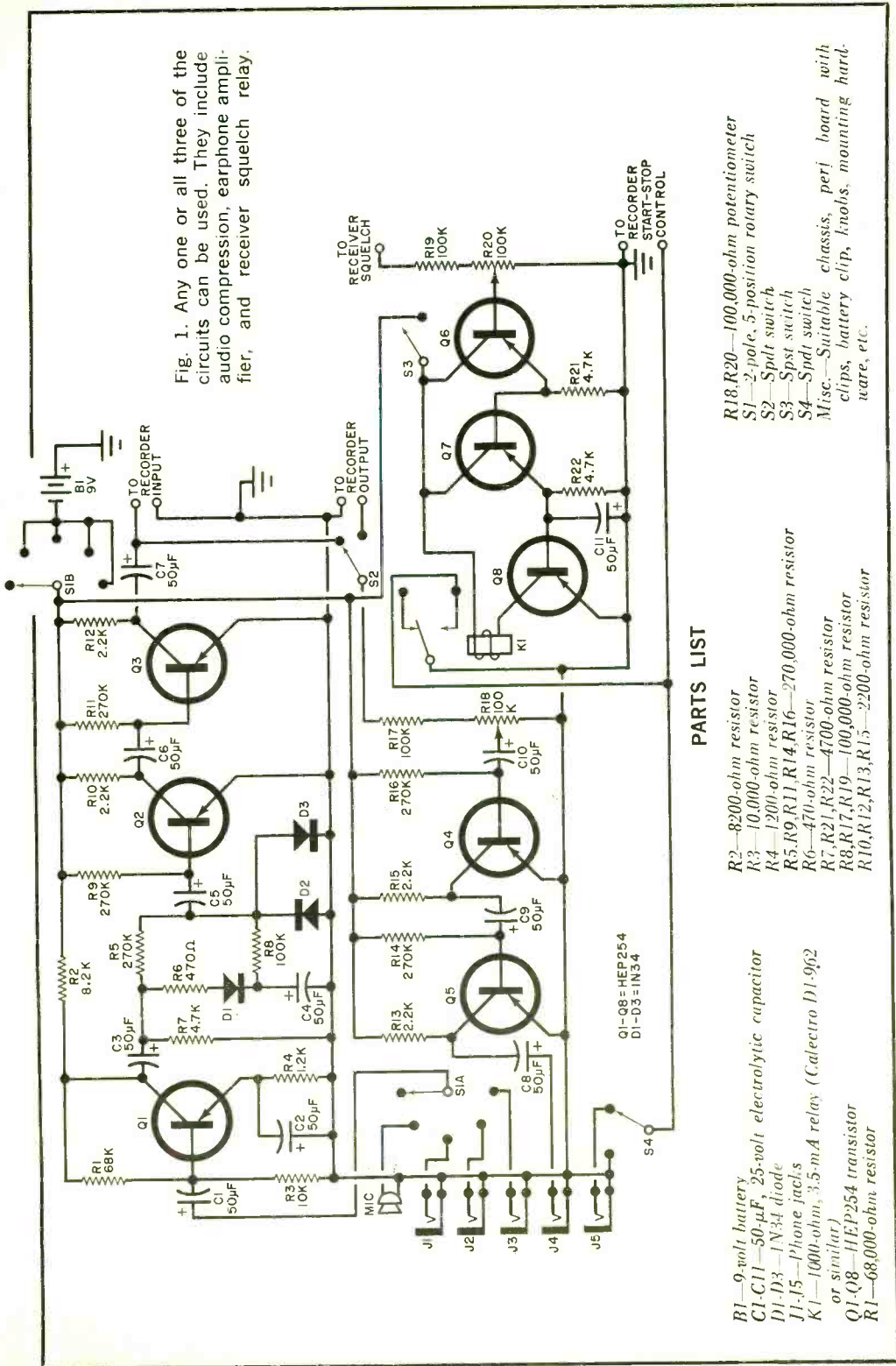

Fig. 1. Any one or all three of the circuits can be used. They include audio compression, earphone amplifier, and receiver squelch relay.

PARTS LIST

- B1—9-volt battery
- C1-C11—50-µF, 25-volt electrolytic capacitor
- D1-D3—1N34 diode
- J1-J5—Phone jacks
- K1—1000-ohm, 3.5-mA relay (Calcraft D1-962 or similar)
- Q1-Q8—HEP254 transistor
- R1—68,000-ohm resistor
- R2—8200-ohm resistor
- R3—10,000-ohm resistor
- R4—1200-ohm resistor
- R5, R9, R11, R14, R16—270,000-ohm resistor
- R6—470-ohm resistor
- R7, R21, R22—4700-ohm resistor
- R8, R17, R19—100,000-ohm resistor
- R10, R12, R13, R15—2200-ohm resistor
- R11—2.2K
- R12—2.2K
- R13—2.2K
- R14—2.70K
- R15—2.2K
- R16—2.70K
- R17—100K
- R18—100K
- R19—100K
- R20—100K
- R21—4.7K
- R22—4.7K

Misc.—Suitable chassis, perf board with clips, battery clip, knobs, mounting hardware, etc.

R18, R20—100,000-ohm potentiometer
 S1—2-pole, 5-position rotary switch
 S2—Spdt switch
 S3—Spdt switch
 S4—Spdt switch

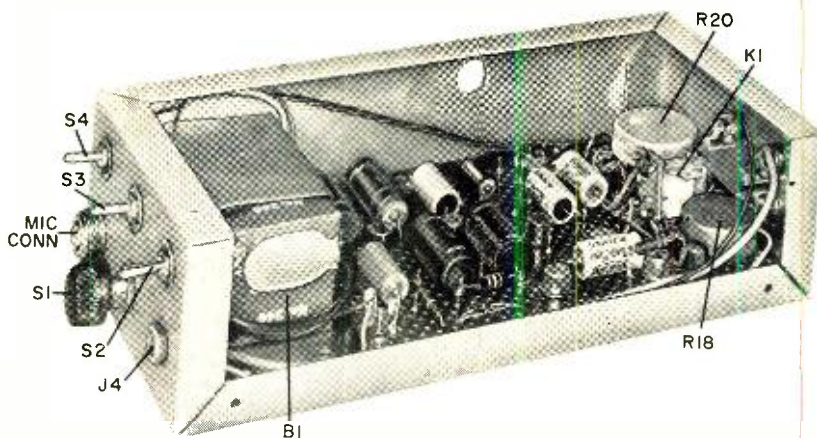

Photo shows layout of the prototype, though any type of chassis can be used.

needed is an additional amplifier to drive the earphones.

Described here are circuits for solving all three of these problems, simply and economically. By using perf-board construction, you can build any one or all three of the circuits (shown in Fig. 1) to upgrade your recorder.

Compressor and Mike Preamp. Transistor *Q1* and its associated components comprise a conventional audio compressor which prevents overdriving of the recorder input by loud sounds such as talking too close to the microphone. Transistors *Q2* and *Q3* can be added to the compressor to provide adequate input level in case your particular recorder requires additional input sensitivity. Either one or both of these additional stages can be omitted.

Receiver Squelch Relay. Transistors *Q6*, *Q7*, and *Q8* drive a 1000-ohm relay (*K1*) to start the recorder whenever a signal is sensed in the squelch or limiter circuit of an FM monitor receiver. Switch *S3* activates this relay circuit and the setting of *R20* determines its sensitivity. Resistor *R19* is connected to the receiver squelch or limiter circuit at a point which goes negative upon receipt of a signal. The exact point will vary among different receivers, but it can be found by switching the monitor receiver to an active channel and checking voltage swings at various points in the limiter and squelch circuits (with a VTVM) to find one with noticeable voltage swing when a signal appears, without degrading receiver performance. When the point is found and the circuit is connected, adjust *R20* until the

relay closes with a readable signal in the receiver, but does not close with a weak, unreadable signal.

Earphone Monitor Amplifier. Two low-level audio amplifier stages (*Q4* and *Q5*) will easily drive earphones from a low-level signal—such as that from an output connector on some recorders intended for feeding the playback signal to an external amplifier. This amplifier also drives the earphones with the output from the compressor and mike preamp (through *S2*) if desired. By using a toggle switch for *S2* with an off position, you can remove the earphone amplifier from the circuit. Potentiometer *R18* is set to produce the desired audio level

Switching Circuits. Switch *S4*, when in the position shown, allows the recorder to be keyed on by either the mike push-to-talk button (through *J5*) or the squelch relay.

Switch *S1* turns on the battery power and selects the desired input. With the switch in position 1 the power is off. Position 2 is for the mike, and positions 3, 4, and 5 are connected to miniature jacks on the rear panel for receivers, telephone pickup coil, or any other convenient device. Jack *J4* should be on the front panel for earphone monitoring.

Construction. The construction shown in the photos illustrates one of many possible ways to assemble such a unit. The enclosure used in the prototype was 4" by 8" by 2", but the size will ultimately be determined by the recorder with which the add-on is to be used. ♦

ACCESSORIES FOR YOUR CB RIG

*Getting the most out of
basic equipment*

BY RICHARD HUMPHREY

THE Citizens Band user long ago supplanted the radio amateur as the darling of the two-way radio communications industry. The modern CB'er has as many—and possibly more—accessories for his base station and mobile rig as the ham had in his heyday.

Complete-function station control panels are probably the ultimate accessory in the CB radio lineup. On the budget end of the price range is Pace's "Base Command," a unit consisting of an SWR bridge, output-power and field-strength meters, a modulation meter with earphone monitoring, and an on-the-air indicator. At the top of the range is Hy-Gain's \$160 "Base Station Control" that has the same features, minus the field strength meter, plus a speaker, receiver preamplifier, microphone compressor/clipper amplifier, coaxial antenna switch with three-antenna capability, phone patch, and many rear-apron convenience outlets and jacks.

The microphone preamp is among the "exotic" items offered to CB'ers. The best of these combine audio compression and clipping in addition to straight amplification. The standard compression circuit employs an automatic gain control (agc) that responds to the average audio power rather than the many sudden peaks in the human voice. This provides more "talk power" into the modulating stage. Clipping chops off those same audio peaks that are usually harmonics of the voice and have very little speech power. While clipping

does distort the voice, the gain in effective audio power more than makes up for the loss. Filtering in the clipper eliminates the radio-frequency harmonics that cause splatter.

Another way of putting more talk power into the transmitter is to restrict the range of voice frequencies to between 500 Hz and 2500 Hz. Small-value coupling capacitors are used in the modulation section to accomplish this by lopping off the power-robbing frequencies below 500 Hz that add little to intelligibility. The 500-2500-Hz range can then be amplified more than is possible if the entire voice frequency range were used. This is one reason why women's voices are usually more "readable" on the air. Prices for speech processors range to a maximum of about \$60; they are made by Hy-Gain, Antenna Specialists, and Gold Line, among others.

The popular transistorized microphones should be included among mike preamps because that is exactly what they are—with the addition of a microphone cartridge, of course. Some do nothing more than amplify the voice signal, while the more expensive ones also incorporate forms of compression and limiting. The only possible shortcoming of these amplifying mikes is that they might produce over-modulation

Solid-State amplifier in SBE/Linear's base station microphone provides 40 dB of gain, uses dynamic element and has weighted base.

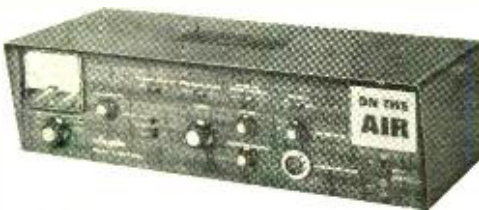

Hy-Gain's total system control console is elaborate, combines several CB accessories.



that causes splatter up and down the band if a heavy hand is used on the gain control. Prices for transistorized mikes range from less than \$20 to more than \$75, and the mikes are available in both base and mobile models. Among the companies marketing these items are Turner, Echo, Shure, Palomar, SBE/Linear Systems, Robyn, Pace, Fanon-Courier, and Electro-Voice.

SOME MAJOR MANUFACTURERS OF CB ACCESSORIES

Ameco/Aerotron, U. S. Hwy. One. N., Raleigh, NC 27608
 Antenna Specialists Co., 12435 Euclid Ave., Cleveland, OH 44106
 Avanti R & D, Inc., 33-37 W. Fullerton Ave., Addison, IL 60101
 Barker & Williamson, Inc., Canal St., Bristol, PA 19007
 R. L. Drake Co., 540 Richard St., Miamisburg, OH 45342
 Echo Communications, Inc., P. O. Box 223, Cedarburg, WI 53012
 Eico, 283 Malta St., Brooklyn, NY 11207
 Electro-Voice, Buchanan, MI 49107
 Estes Engineering Co., 543 W. 184th St., Gardena, CA 90247
 Fanon-Courier, 990 S. Fair Oaks Ave., Pasadena, CA 91105
 Gold Line Connector, Inc., Muller Ave., Norwalk, CT 06852
 Heath Co., Benton Harbor, MI 49022
 Hy-Gain Electronics Corp., 8451 NE Hwy. 6, Lincoln, NE 68501
 E. F. Johnson, Waseca, MN 56093
 Lafayette Radio Electronics, 111 Jericho Turnpike, Syosset, NY 11791
 Linear Systems, Inc. (SBE), 220 Airport Blvd., Watsonville, CA 95076
 Midland Electronics Co., P. O. Box 19032, Kansas City, MO 64141
 Olson Electronics, Inc., 260 S. Forge St., Akron, OH 44308
 Pace/Pathcom, Inc., 24049 S. Frampton Ave., Harbor City, CA 90710
 PAL Electronics Co., 6391 Westminster Ave., Westminster, CA 92683
 Palomar Instrument Co., 563 N. Citracado Pkwy., Escondido, CA 92025
 Radio Shack, 2617 W. Seventh St., Ft. Worth, TX 76107
 Robyn International, Inc., 10901 Northland Dr., Rockford, MI 49341
 Shure Bros., Inc., 222 Hartrey Ave., Evanston, IL 60204
 Ten-Tec, Inc., Hwy. 411 E., Sevierville, TN 37862
 Tram Corp., Lower Bay Rd., Winnisquam, NH 03289
 Turner/Conrac Corp., 909 17th St., NE., Cedar Rapids, IA 52402

Phone Patches. Phone patches were once the exclusive property of the radio amateur. Now, however, it is legal to use one with CB gear.

All there is to a phone patch device is a transformer that matches the output impedance of the CB gear's audio section to the impedance of the telephone line, and a volume control that permits adjusting the signal level to a range that the line can accommodate. Phone patches can be purchased from various outlets for less than \$20 and range on up to almost twice that figure. Built into the more expensive models are an audio-level, or VU, meter. Hy-Gain, Lafayette, and Radio Shack (under the Realistic brand name) make patches aimed at the CB market. Manufacturers of ham gear have more expensive phone patches, and it is possible to pick up a used one by looking around long enough.

Test Equipment. Standing wave ratio (SWR) bridges make the most of the wide variety of test equipment made for CB'ers.



Mobile amplifying mike by Turner is rated at 15 dB gain, is ceramic, has gain control.

Not only do they perform a valuable function, but as with phone patches, they can be found on the ham and used equipment market. An SWR bridge is the easiest instrument to use for checking the efficiency of an antenna system. Its function is to indicate the amount of mismatch between the output of the transmitter and the antenna. The higher the impedance mismatch,

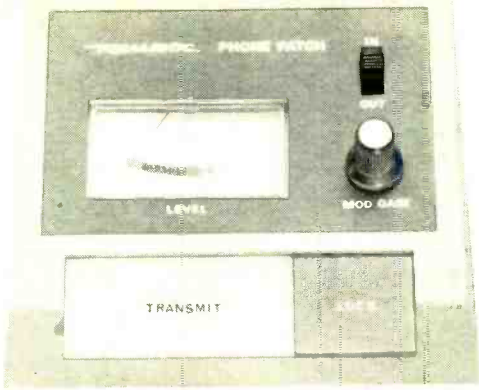

The Radio Shack Realistic phone patch measures $\frac{1}{4} \times 4\frac{3}{4} \times 4$ in., costs about \$20.

the higher the SWR and the lower the efficiency of the antenna system. Anything below 1.5:1 is good; with a reading of 2:1 or higher, too much power is being lost due to mismatch.

SWR bridges come in two basic configurations—individual units and those incorporated into some other piece of test gear. Prices for the former start at less than \$12 and go up to more than \$50. The cost of the combination units runs as high as \$75. SWR bridges for the CB market are made by Radio Shack, Echo, Ten-Tec, Pace, Ameco/Aerotron, Pal, Antenna Specialists, Hy-Gain, Eico, Midland, and Palomar. Radio amateur equipment manufacturers are another source of these units.

An SWR bridge appears in nearly all of the CB "test sets" on the market. In addition, the average test set would include a wattmeter, modulation and field strength meters, a crystal checker, and a basic r-f/a-f signal generator. Prices run as high as \$75, but the equipment is well worth it.



This CB test set by Midland checks anything from crystals to r-f output and efficiency.

Antenna Accessories. Other antenna system accessories come in all shapes, sizes, and colors. There are matchboxes to lower SWR (from less than \$10 to more than \$100) from Avanti, Midland, Echo, Hy-Gain, E.F. Johnson, Gold Line, Antenna Specialists, and Radio Shack. Coaxial switches, for using two or more antennas with a single rig, are made by Lafayette, Gold Line, Midland, Echo, Antenna Specialists, Avanti, and Hy-Gain.

"Co-phasers" that increase the performance of two colinear antenna arrays are made by Hy-Gain and Avanti, while a black box that makes it possible to work two transceivers on one antenna is available from Gold Line. Coaxial lightning arresters are made by Echo, Olson, Lafayette, Hy-Gain, and Gold Line; and dummy loads that



Palomar test set is basically a CB SWR unit with provisions for monitoring your signal.

permit checking a rig without going on the air (all less than \$15) are made by Heath, Gold Line, Lafayette, and Hy-Gain. Field strength meters ranging in price from less than \$10 to \$75 in combination with other test instruments are made by almost every manufacturer of CB equipment. TVI filters (\$6 to \$30) are made by most of the companies already mentioned as well as Drake and B&W. And wattmeters, both separately and in combination with other metered instruments are commonly available from CB dealers.

Exotica. In addition to the more conventional accessories available to the CB'er there are tone-call units made by Pace, Lafayette, E.F. Johnson, and others; \$10-\$50 receiver preamps from Hy-Gain, Ameco/Aerotron, and Antenna Specialists; power supplies that permit a mobile rig to be used as a base station operating from line power; and automobile ignition suppression kits for \$1. (Prices given in this article were gathered before Phase IV.)

PICTURE-TUBE TESTER AND REJUVENATOR

BY WILLIAM R. SHIPPEE

TV picture tubes are expensive—especially the ones for color. If you have one that has seen better days and is getting a bit dim and dark, you can probably add new life to it by using the tester-rejuvenator described here. You will not have the equal of a new tube, but you may be able to keep the old one going for a while.

The circuit shown is used to test the emission of a cathode-ray tube; and if it is low, give the CRT a "shot" to revitalize it. The latter consists of raising the emission of the CRT by increasing the filament voltage. This "boils" the inner electrons of the cathode structure, bringing them to the outside where they can do the most good. The circuit will also remove some cathode/contrl-grid shorts. After using this circuit, a conventional picture-tube brightener can be used if the rejuvenated CRT does not exceed 50% emission as shown on the meter.

Construction. Any type of vacuum-tube transformer can be used for *T1* as long as the high-voltage winding does not exceed 400 volts rms. This winding should deliver at least 50 mA, and the current ratings of the two filament windings should be at least one ampere. The filament windings must be properly phased so that approximately 11.3 volts appear across the series combination. If you don't get 11.3 volts, reverse the connections to one of the filament windings.

The meter should not have a full-scale reading over 50 mA. To calculate the value of *R3* for your particular meter, use Ohm's law to determine the resistance through which 50 mA will flow at the high-voltage dc obtained from the rectifier-filter circuit. As an alternative, you can start with a value of several kilohms and reduce it until the meter indicates exactly full scale. Take care not to contact the high voltage when working with the resistor.

You can connect other sockets to *SO1* to suit your own particular type of tube, using pins 1 and 12 of *SO1* for each of the filaments of the tube and pin 2 switched to each of the control grids of the tube.

Operation. With filament switch *S2* in the **NORMAL** position and pushbutton switch *S3* open, note the meter indication. To rejuvenate the CRT, momentarily depress *S3*. You may note a small arc in the neck of the tube. Release *S3* and note whether the meter indication has increased.

If the meter still indicates low, place *S2* in the **BOOST** position, wait a second for the filament to get hotter, and then depress *S3*. Return the filament switch to **NORMAL** and press the rejuvenate pushbutton a couple of times. The meter should show a marked increase. It may be necessary to repeat this operation several times, but do not leave the filament switch in the **BOOST** position for any length of time.

Remember that, on color tubes, there are usually 3 guns, so an adapter socket must be used with the circuit shown below. ♦

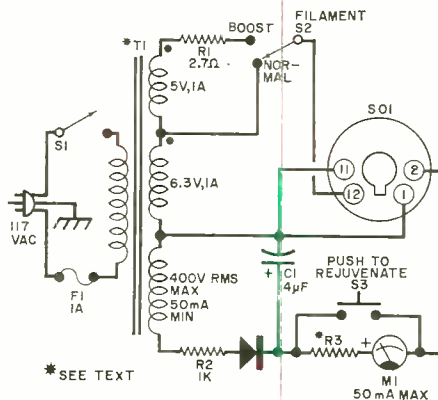

PARTS LIST

- C1*—4- μ F, 600-volt electrolytic capacitor
- D1*—1-A, 800-V silicon rectifier
- F1*—1-A slow-blow fuse and holder
- M1*—50-mA meter (see text)
- R1*—2.7-ohm, 5-watt resistor
- R2*—1000-ohm, 2-watt resistor
- R3*— $\frac{1}{2}$ -watt resistor (see text)
- S1*—Spst switch, 1 A, 117 V
- S2*—Spdt switch, 1 A
- S3*—Spst pushbutton switch, normally open, 600-V contact rating
- T1*—Power transformer; secondaries: 400 V at 50 mA, 6.3 V at 1 A, 5 V at 1 A
- Misc.—Suitable chassis, line cord, CRT socket(s), high-voltage cables for sockets.

ANTENNAS FOR CB'ers & HAMS

PART 2

*Some unusual antenna configurations
are discussed in this second part.*

BY CARL C. DRUMELLER

LAST MONTH, in Part 1 of this article, we dealt with some basic antennas, along with transmission lines and matching. Here we will discuss other related topics and more antenna types.

Antenna Height. The optimum height for a dipole antenna, in any configuration, has been the subject of much conjecture, even dispute. Two factors are to be considered: angle of radiation and efficiency. What is wanted in the prime angle of radiation depends upon the application for which the antenna is intended. For long-range communication, a low angle is desired. For short ranges, a high angle is better. You can get that high angle by placing the antenna less than a quarter-wave above earth (or by using a vertical radiator).

What about those instances where a low antenna would be shielded by surrounding objects? Then it is necessary to compromise. Only experiment can tell which will perform better: high angle with obstructions or low angle with fewer obstructions. As for effi-

ciency, the Collins Radio Co.'s publication "Engineering Compendium, High Frequency Antennas" says, "Most transmitting antennas of resonant dimensions that are elevated at least a quarter-wave above ground are sufficiently close to 100% efficient that their efficiency is seldom of concern."

The Collins booklet also has interesting things to say about receiving antennas. It says that receiver gain is so high and receiver noise figures are so low that highly inefficient receiving antennas are quite acceptable. A gain figure of -42 dB at 2 MHz is quoted as being acceptable. It goes on, "Even buried antennas can give adequate efficiency up to about 15 MHz. For example, a half-wave dipole (with a physical length about half the free-space value), buried to a depth of several feet in good ground is capable of -25 dB efficiency in the 2-MHz to 20-MHz range, relative to a perfect quarter-wave vertical." As an aside, it also states that on east-west paths and under poor propagation conditions, vertical antennas at both ends provide best performance.

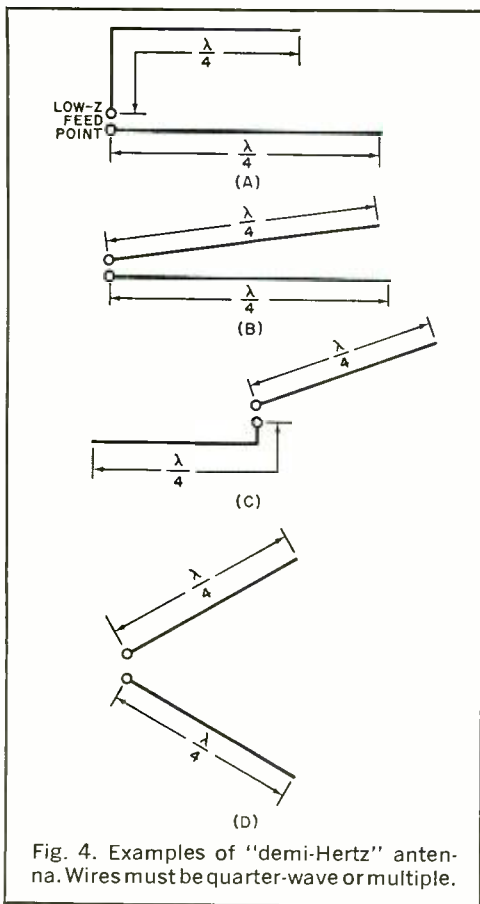

Fig. 4. Examples of "demi-Hertz" antenna. Wires must be quarter-wave or multiple.

In relation to polarization, the same source mentions that reflected waves do not maintain their initial polarization, so vertical-to-vertical or horizontal-to-horizontal antenna configurations become of little consequence.

Loops. Loop antennas have had a long-standing and well-deserved good reputation for receiving purposes. In this application, their size does not seem to be of too great an importance—perhaps for the same reasons mentioned above. Their "gain" is 1.76 dB.

Transmitting loops, though, are quite another matter! Small loops (with a circumference under a half-wave) are difficult to feed with any degree of efficiency. This is one of the few instances in which antenna ohmic resistance is important.

A large loop, especially one having a circumference of a full wave, can be a very good transmitting antenna. Its configuration may be in the form of a square, a delta, or an inverted delta.

Capture effect, the ability of a receiving antenna to extract electromagnetic energy from space, is of small concern in the high-frequency spectrum for reasons already mentioned. Most authorities agree that, unless the physical size of an antenna is reduced to something like 1/10 of its normal size, its capture effect will not be too seriously degraded.

Grounds and Counterpoises. First, let's agree on some nomenclature. Let's say that a ground constitutes actual earth that is reasonably conductive; that a ground plane is made up of either a number of resonant radials or a relatively large solid conductive surface positioned under the antenna and at least a quarter-wavelength above ground; and that a counterpoise has (usually) a number of wires sited under the antenna and relatively close to the ground, with a considerable capacitance to ground. These definitions conform reasonably well with those in general use.

Ground losses can be considerable under certain circumstances. With any form of Marconi antenna, a good ground is needed for reasonable efficiency. Even with Hertz or Fuchs antennas, ground losses mount up when the antenna is sited closer than a tenth-wave above ground. In all instances, vertical antennas are more adversely affected by ground losses than are horizontal ones.

What constitutes a good ground? The station site dictates the answer to that

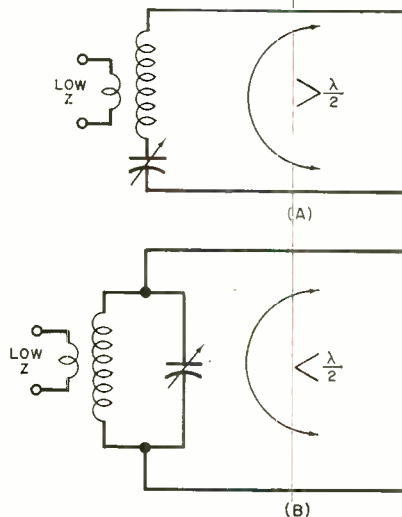

Fig. 5. For loading the "demi-Hertz" antenna, use one of these LC resonant circuits.

question. Ideally, you'd like to have a plane surface of perfect conductivity below your antenna — an unobstructed surface that spreads out a wavelength in all directions. Usually, though, you'd cheerfully compromise on a level bit of land that stays slightly moist and has a water table that maintains a constant position near the surface.

The classic ground, a cold water pipe, is adequate only for serving as the electrical ground for the equipment. It's a poor complement to an antenna system. For that, you need lots of metal with low resistance, either on top of the ground or buried just below the surface. Remember, the purpose of this ground is to permit r-f current to flow with the least impediment. You don't want that current to have to penetrate many inches of dry, high-resistance earth before it reaches a truly conductive path.

How much metal and how placed? If planted in the form of radials branching out from the feedpoint of the antenna/ground system, a minimum of 15 radials is recommended. Often, it is suggested that you make these radials a quarter-wave in length, but if you make them longer, they'll serve better. If you can't manage a quarter-wave concentrate a number of shorter ones around the feedpoint. That's where the r-f current is heavy and where the resistance should be low. It does no harm, and it may do some good (especially if you're short on radials), to plant a number of deeply imbedded ground rods and tie the radials to these. They need not go any deeper than where they'll always be in contact with moist earth.

We have spoken of grounds that form an integral part of an antenna/ground sys-

tem, such as a Marconi. For radiators that stand alone, such as the Hertz and Fuchs types, the operation of the system does not depend on the earth as a component. Instead, it serves as the repository of the "image antenna" and as a source of signal loss. The image antenna is desirable, since it helps form the vertical radiation pattern. But those ground losses are something we'd just as soon do without.

To reduce the losses, you can use a ground plane or a counterpoise. The distinction (which is very small) between the two is a matter of altitude. The ground plane is at least a quarter-wave above ground, while the counterpoise is just above ground. How far the latter is above ground depends on whether you would rather trip or decapitate stray wanderers. Ideally, the counterpoise should have many wires spread out so as to intercept as many as feasible of the electrostatic lines of force emanating from the radiator. Most people compromise with a dimension that is far less than this ideal.

The Demi-Hertz Antenna. This is a term that we coined to describe an antenna that looks as if it started out to be a Marconi and then changed its mind and became a variant of the Hertz. Instead of a ground or a true counterpoise, it has a single wire at a lower height than what is thought of as the "antenna." This portion may be folded back under the antenna, where you would expect to see a counterpoise; or it may be stretched out behind the antenna, as if it formed the other half of a dipole. Figure 4 shows several variations.

As with any Hertz antenna, this has an electrical centerpoint that can be grounded

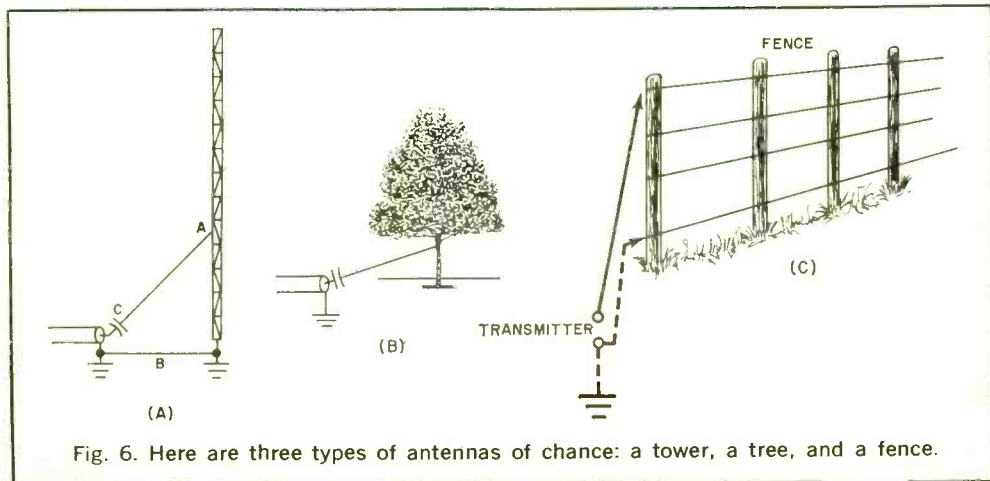

Fig. 6. Here are three types of antennas of chance: a tower, a tree, and a fence.

without disturbing the balance or the action of the system. There is a slight advantage to grounding the centerpoint, as it provides a path for draining off atmospheric charges. But the centerpoint may not always be accessible.

Sometimes this type of antenna is fed by a system involving the use of a resonant circuit to which the transmitter is inductively coupled. The circuit involves the antenna itself so the electrical size of the antenna determines whether the circuit is series-tuned or parallel-tuned. In either case, by experimentally tapping on the inductor, you can find a spot where a ground can be attached without upsetting the circuit (such as detuning or causing a spark). (See Fig. 5.)

Antennas of Chance. There are times when you would like to use some form of radiator other than a conventional antenna system. Many radio amateurs are hesitant to make such a move since they believe that the use of anything but a conventionally designed antenna will endanger their transmitters. Another factor is that they've been told repeatedly that nothing but an antenna of orthodox design can possibly function properly.

Bold experimenters have found that antennas of chance often perform remarkably well. These people can tell you amazing

stories of results achieved from such odd radiators as rain gutters, water towers, barbed wire fences, insulated wire tossed on the ground, etc. An old Signal Corps manual showed how one could tap a wire onto a tree and use it as an antenna. It even gave comparative results to be expected from trees with or without foliage. Figure 6 shows three of the many feasible antennas of chance.

When considering the potentialities of some object you hope to use as a radiator, there is just one general rule. If your transmitter will load into it, either with or without a matching device, go ahead and use it. You may be disappointed (though you shouldn't be since you knew it was a gamble) or you may be delighted. You'll never know until you've tried. All that is needed is to get the r-f current circulating in a conductor. (If you've ever tried to solve a bad problem of TVI, you know that r-f waves need little encouragement to radiate.) If the conductor doesn't have enough resistance to dissipate all of the r-f power in the form of heat, it will radiate the remaining portion. Of course, it helps to have the radiation out in the clear so that it can travel freely.

If an antenna of chance happens to be many wavelengths long, like a wire fence or a stretch of abandoned telephone line,

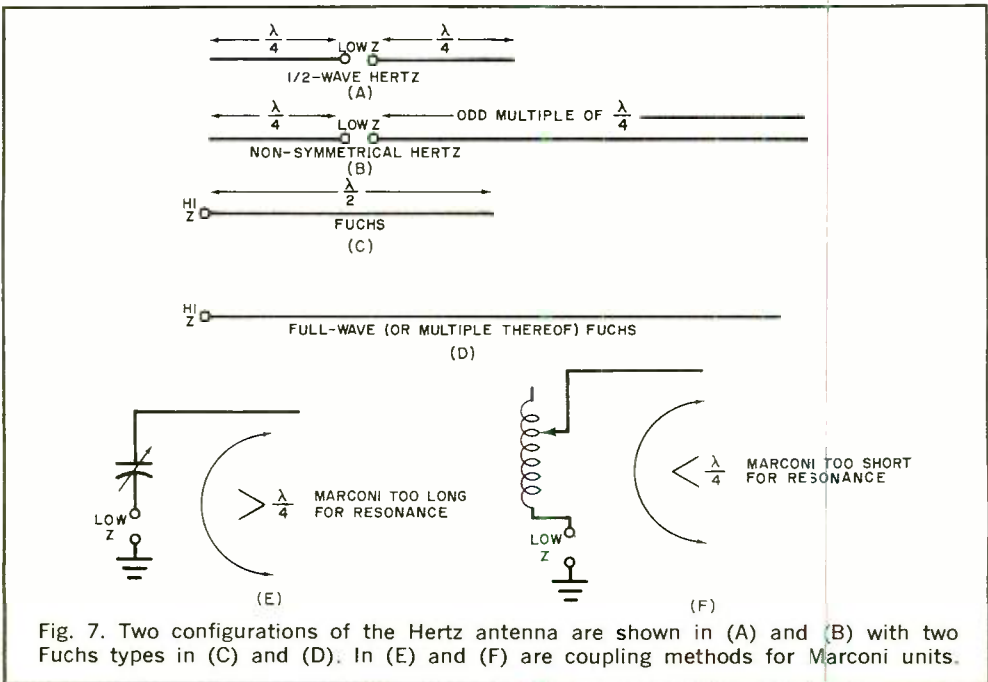

Fig. 7. Two configurations of the Hertz antenna are shown in (A) and (B) with two Fuchs types in (C) and (D). In (E) and (F) are coupling methods for Marconi units.

you will discover two pleasant things. There will be no standing waves on the antenna, since it will perform as a travelling-wave antenna; and it will make a superb receiving antenna, showing a remarkable discrimination against atmospherics. If there is a ground on the antenna a few hundred feet or a few miles down the line, don't worry about it; it may even enhance its radiating capabilities.

In considering unorthodox antennas, keep in mind the sketches shown in Fig. 4. In devising a simple antenna from pieces of wire attached to whatever supports you find, each wire should be a quarter-wave or an odd multiple of a quarter-wave. The two wires need not be of the same length. (One may be three times as long as the other, for example.) All of the arrangements shown in Fig. 4 present a low impedance to the transmitter.

Unless siting factors grossly upset current distribution and cause the feedpoint impedance to deviate from what might be expected, most transmitters sold to radio amateurs will load directly into the antenna without the use of a matching device.

The V-shaped version of the demi-Hertz offers about the most flexible antenna you can imagine. Not only can the legs of the V be of any length (as long as they are an odd multiple of a quarter-wave), but the V can be in either a vertical plane or a horizontal plane—or anything in between. The subtended angle of the V can be anything between 30° and 180°. The height can range from an insulated wire laid on the ground to as high (legally) as you can find supports.

If you can't arrange for the legs to come out at the desired length, a simple coupler such as shown in Fig. 5 will permit the use of just about any conceivable lengths. You will note that the coupler may be in either of two circuits: series tuned for a wire length that comes out too long for a quarter-wave (or odd multiple) in each leg, and parallel tuned for lengths under a quarter-wave.

Your antenna of chance doesn't have to be a wire. In Fig. 6, three unusual radiators are shown, but you can find an almost unlimited number of other objects that can be pressed into service to put your signal on the air. The three illustrations show the simplest form of shunt feed, one in which you experimentally adjust the tap on the radiator until you find a spot that enables

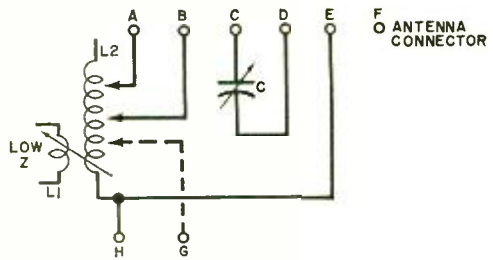

Fig. 8. A flexible type of antenna impedance matching circuit used with various antennas.

the transmitter to load. With a little more effort, you can improvise a gamma match that will provide more flexibility in finding an acceptable loading spot.

Two configurations of the familiar Hertz antenna are shown in Fig. 7. One has the two sections the same length (a quarter-wave or odd multiple each). The other illustrates how one leg can be longer; just so the basic rule concerning quarter-waves is observed. The Fuchs antenna, of which two examples are shown, unlike the Hertz, is voltage-fed. That means it has a high input impedance and therefore demands some sort of matching device to be used with conventional transmitters, all of which have low-impedance outputs.

The Fuchs is perhaps the simplest of all antennas and therefore is the most likely to be encountered in the search for an on-the-spot chance antenna. Although ideally it should be a half-wave or a multiple in length, by juggling the coupler a little, it can be made to work with just about any length. A flexible type of coupler is shown in Fig. 8. Two examples given in Fig. 7 are for Marconi antennas which don't have the conventional quarter-wave or multiple length. Either can be made to present the low impedance required for conventional transmitters.

Conclusions. Radio signals radiate easily, but some radiators are better than others. The difference between a carefully designed radiator and one picked just because it might work may be much less than popular supposition leads one to believe. Don't ever hesitate to use an odd-ball radiator. If you can make your transmitter load into it, it will radiate your signal—perhaps poorly or perhaps better than you dared to hope. You will never know until you have tried. Dare to experiment, explore, and improvise. You will gain experience and satisfaction. ♦

A TAILOR-MADE ZENER DIODE

BY JAMES E. McALISTER

Design your own variable-voltage zener

ZENER diodes are powerful circuit elements (as pointed out in "Design Your Own Voltage Regulator," in the April 1973 issue); unfortunately, they are available only in discrete, fixed values of voltage. In some cases, a variable voltage is needed, and a zener will not suffice. In addition, zeners are not commonly available at levels below about 3 volts. This makes it difficult to design simple 1.5-volt regulators for battery replacement.

With only a handful of components, a transistor equivalent of a zener diode can be built for use in any circuit calling for a zener. The output voltage from the "equivalent zener" is variable and can be adjusted to values down to as low as 1 volt and below.

The circuit, shown in the figure, is quite simple. Transistor *Q1*, begins to conduct when the voltage across *R1* reaches approximately 0.5 volt. This causes *Q2* to conduct, but *Q2* draws only enough current through the load resistor to maintain con-

duction in both *Q1* and *Q2*. The voltage drop across the load resistor is thus the output voltage.

Transistor *Q1* can be almost any silicon pnp transistor, but one with a high current gain is preferable. The parameters of *Q2* are not critical either. The power dissipating capability of the equivalent zener is primarily determined by the power dissipation rating of *Q2*, however, so *Q2* should be selected accordingly. The equivalent zener diode can be used in any circuit where a regular zener would apply.

Resistor *R2* is shown as a variable, but fixed values of resistance may be used if desired. The chart in the figure shows how to determine the resistance for a desired output voltage. Since the voltage does depend to some extent on the characteristics of the transistors, the value of *R2* chosen from the chart may not give the exact desired output, but it will be close. The chart (and the accompanying equation) assumes that *R1* is 4700 ohms. ♦

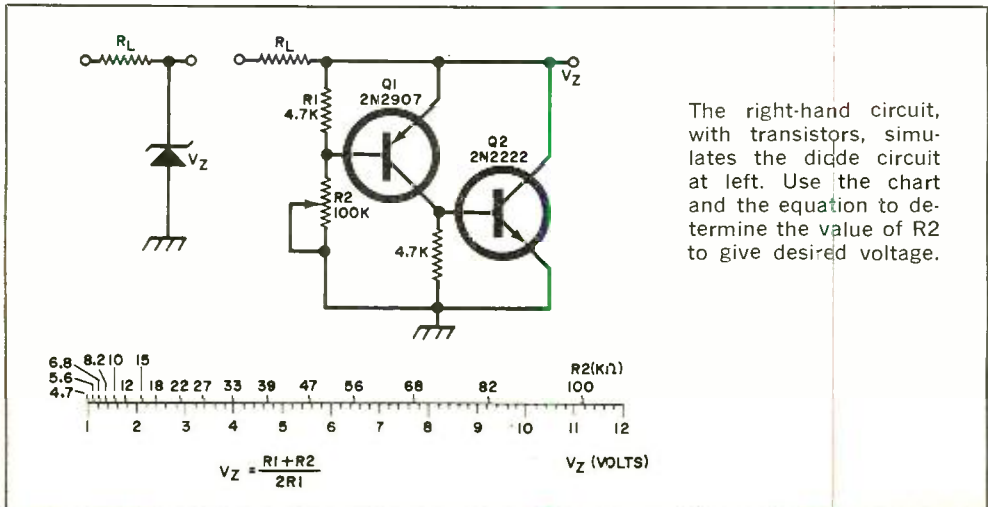

A significant advance in the state-of-the-art

THE PICKERING XV-15/1200E CARTRIDGE

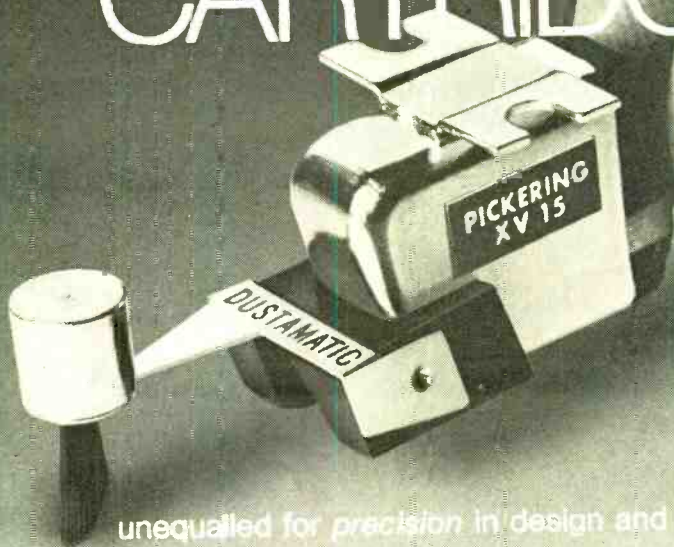

unequaled for precision in design and performance

"PRECISION" is the one word that best characterizes the extraordinary quality of the new Pickering XV-15/1200E cartridge, the culmination of Pickering's 25 years in contributing important technological advances to the manufacture of magnetic cartridges.

Its exceptional design and performance accords it a DCF

(Dynamic Coupling Factor) rating of 1200. Naturally, it delivers 100% Music Power.

This cartridge is for the sophisticate — one who possesses components of such superlative quality that the superiority of the XV-15/1200E is a requirement. \$79.95 audiophile net. Write Pickering & Co., Dept. E, 101 Sunnyside Blvd., Plainview, N.Y. 11803.

SPECIFICATIONS

Frequency Response:	10 Hz to 30 KHz
Nominal Output:	4.4 mV
Channel Separation:	
Nominal:	35 dB
Stylus Tip:	0.0002" x 0.0007" Elliptical Diamond
Tracking Force:	¾ gram, + ½ gram, — ¼ gram



All Pickering cartridges are designed for use with all 2 and 4-channel matrix derived compatible systems.

CIRCLE NO. 30 ON READER SERVICE CARD

CREI—the only home-study college-level training

and now

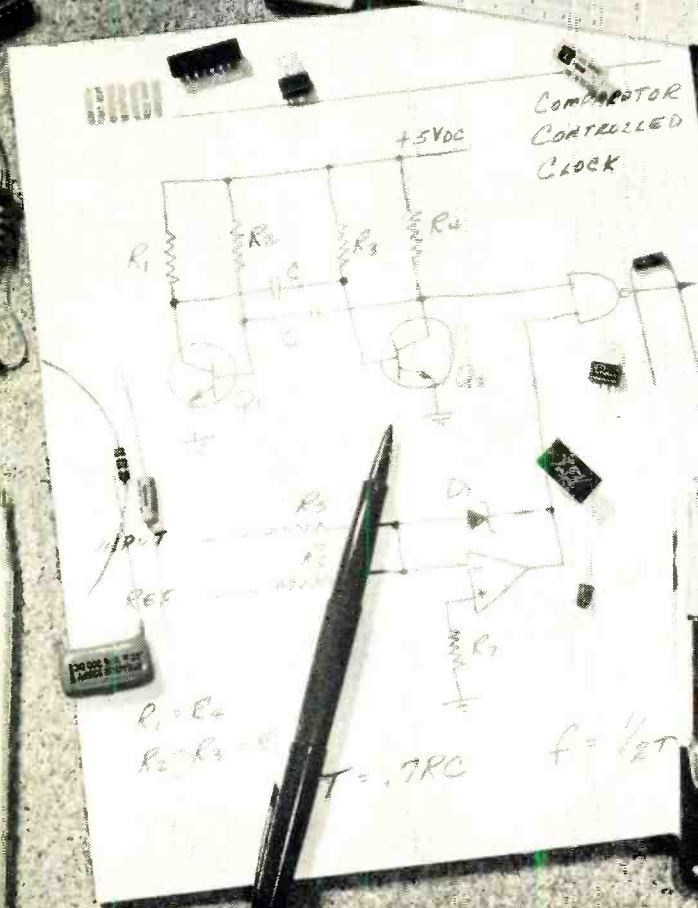
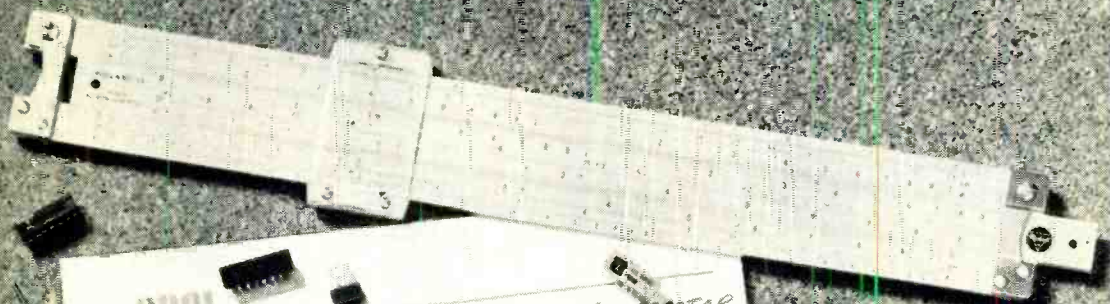

program which gives you in electronic circuit design

only CREI offers you a complete college-level Electronic Design Laboratory to speed your learning

Electronic circuit design—source of all new development in the application of electronics to new products and services. Without this skill, we would be unable to monitor the heartbeat of men in space. Without it, the computer revolution would never have occurred. And we would have yet to see our first TV show. *Yet, only CREI teaches electronic circuit design at home.*

ELECTRONIC CIRCUIT DESIGN

A key skill which paces our nation's progress in countless fields—from pollution control to satellite tracking to modern medicine to exploring the ocean's depths. And beyond. A skill which *you* must have to move to the top in advanced electronics.

CREI programs open up new worlds of opportunity for you.

In addition to electronic circuit design, CREI provides you with a full advanced electronics education in any of thirteen fields of specialization you choose. Communications, computers, space operations, television, nuclear power, industrial electronics—to mention just a few of the career fields for which CREI training is qualifying. With such preparation, you will have the background for a career which can take you to the frontiers of the nation's most exciting new developments. And around the world.

This free book can change your life. Send for it.

If you are a high-school graduate (or equivalent) and have previous training or experience in electronics, then you are qualified to enroll in a CREI program to move you ahead in advanced electronics.

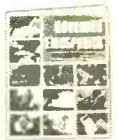

Send now for our full-color, eighty page book on careers in advanced electronics. In it, you will find full facts on the exciting kinds of work which CREI programs open up to you. And full facts on the comprehensive courses of instruction, the strong *personal* help, and the professional laboratory equipment which CREI makes available to you. All at a surprisingly low tuition cost.

And when you have it, talk with your employer about it.

Tell him you're considering enrolling with CREI. He'll undoubtedly be happy to know you are planning to increase your value to him. *And he may offer to pay all or part of your tuition cost.* Hundreds of employers and government agencies do. Large and small. Including some of the giants in electronics. *If they are willing to pay for CREI training for their employees, you know it must be good.*

Send for Advanced Electronics today. You'll be glad you did.

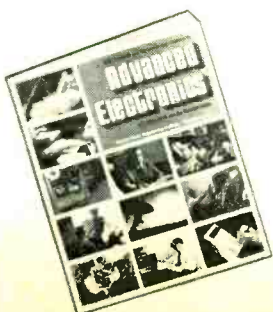

CREI Dept. E1210D
3939 Wisconsin Avenue
Washington, D.C. 20016

Rush me your FREE book describing my opportunities in advanced electronics. I am a high school graduate.

Name _____ Age _____

Address _____

City _____ State _____ ZIP _____

If you have previous training in electronics, check here

Employed by _____

Type of Present Work _____

Veterans and servicemen, check here for G. I. Bill information

CREI

CAPITOL
RADIO
ENGINEERING
INSTITUTE

WASHINGTON, D.C. 20016

www.americanradiohistory.com

HOW TO BUILD “FREE-POWER” RADIOS

Successors to crystal radios use

single high-gain transistor amplifier

BY TERRY L. LYON

EXPERIMENTERS and hams have liked to fool around with battery-less radios since wireless communication was first thought about. Although notable improvements have increased the sensitivity and selectivity of the devices, their performance is limited unless the newest design techniques are used. Described here are three battery-less receivers which have improved gain as a result of the use of a simple transistor amplifier powered by random electrical fields which are everywhere. These circuits, which are relatively inexpensive to build, have higher volume and better reception than a crystal radio.

The first circuit (Fig. 1A) is a broadcast-band receiver and requires the fewest number of components. The circuit in Fig. 1B also tunes the broadcast band but it has increased gain due to a more efficient design. Figure 1C's circuit has improved selectivity and sensitivity due to regeneration, and it is designed to receive short-wave as well as conventional broadcast transmissions.

In the construction, although circuit layout is not critical, it is wise to keep com-

ponent leads short and neat. The antenna and ground leads from the receiver could have various lengths of stranded insulated wire with alligator clips attached for connecting the receiver to large metallic objects.

If some components cannot be located, substitute others with similar characteristics. For example, the tantalum capacitor (C2) can be replaced by an electrolytic with the same specifications. The 1N459 diode can be replaced by another low-power silicon unit with small reverse current characteristics. Likewise, another small-signal, high-gain silicon unit can be used for the 2N3391 npn transistor. A 4700-ohm resistor can be used for *RF*C1. Finally, the crystal earphones can be interchanged with high-impedance magnetic phones with a suitable series capacitor.

Operation. Once the receiver is completed, a tuner dial can be added. Calibration of the dial is accomplished by listening to stations which have a known transmitting frequency or by coupling a variable r-f signal generator to the receiver through

HOW IT WORKS

The noise and signal are separated by coupling the series $L2C3$ resonant circuit to the parallel $L1C1$ resonant circuit. This arrangement functions as a bandpass filter, allowing broadcast information to appear across $L1C1$ while leaving the noise across $L2C3$. When $L1C1$ is adjusted to a standard broadcast frequency, an amplitude-modulated carrier is produced across the tuned circuit. This r-f signal is sent through dc blocking capacitor $C4$ to the base-emitter junction of transistor $Q1$, a common-emitter amplifier.

The transistor is biased by a large value of shunt feedback ($R1$) and its load resistance ($R2$) also has a large value. This arrangement performs several functions. First, the voltage drop across the base-emitter junction is quite small. This allows the junction to detect the incoming signal by changing it to modulated dc. Although the shunt feedback biasing arrangement lowers $Q1$'s input impedance, its emitter current is so small that the input impedance is still very large and does not appreciably load the tuned circuit.

Secondly, the transistor is biased in a region of extremely high gain and some non-linearity. The latter acts to a small degree as an a-gc. When signals get larger, the amplifier's gain is reduced whereas, on weak signals, the gain is large.

The power supply for the transistor derives its energy from the noise obtained across $L2C3$. This noise derives primarily from a 60-Hz field radiated from household wiring, lights, and appliances. The noise is rectified by $D1$ through $D4$ and the resulting dc is filtered by $C2$. Limiting resistor $R2$ connects the supply to the transistor circuit.

Although the three receivers operate in basically the same manner, there are several differences between them. The first two rectify voltage fluctuations (low-frequency noise) appearing across $C3$. The first circuit has a voltage doubling diode arrangement to reduce the number of components. On the other hand, the second circuit utilizes a full-wave bridge rectifier with improved efficiency; but it requires the addition of $C5$, $L2$, and two diodes. Capacitor $C5$ is used to reference the $L1C1$ circuit to ground, which increases the signal and minimizes hum.

The third receiver uses a voltage doubler, however it is connected across the $L2C3$ circuit through $R3$. This arrangement allows high-frequency noise as well as low-frequency noise to be rectified with high efficiency and minimum receiver hum. If a full-wave bridge rectifier were added to this circuit, low-frequency noise would be allowed to pass through $C5$ to produce hum in the earphone. A possible solution is to add another feedback coil, but this might load the tuned circuit and reduce sensitivity and selectivity of the receiver. This receiver also has exchangeable coils so that several bands can be received. Some of the amplified signal in this circuit is returned to the input of $Q1$ by $C6$, $L2$, and $RFC1$. This adds positive feedback and further increases the receiver's gain.

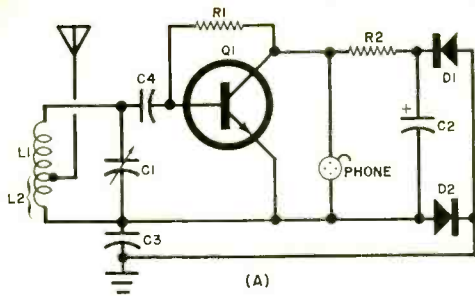

(A)

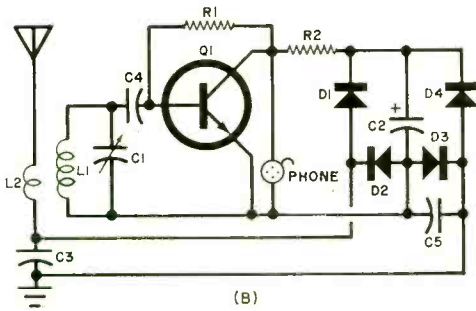

(B)

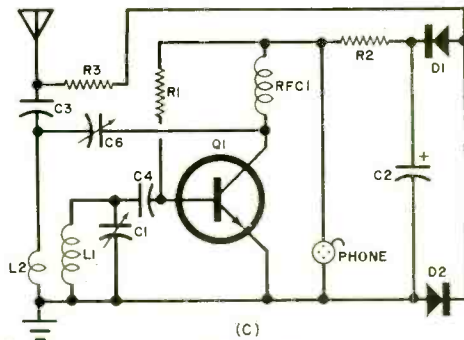

(C)

PARTS LIST

- $C1, C6$ —365-pF variable capacitor
- $C2$ —5- μ F, 50-volt tantalum capacitor
- $C3$ —0.002- μ F ceramic disc capacitor
- $C4, C5$ —0.005- μ F ceramic disc capacitor
- $D1-D4$ —1N459 silicon diode
- $L1$ —Fig. 1A: tapped transistor antenna coil
Fig. 1B: transistor antenna coil
Fig. 1C: see Fig. 2
- $L2$ —Fig. 1B: 15 to 20 turns of #24 enameled wire wound directly over antenna coil.
Adjust turns or reverse leads for optimum performance
Fig. 1C: see Fig. 2
- $Q1$ —2N3391 transistor
- $R1$ —10-megohm resistor
- $R2$ —470,000-ohm resistor
- $R3$ —10,000-ohm resistor
- $RFC1$ —2.5-mH r-j choke

Fig. 1. Three versions of simple single-transistor radios that derive their operating power from the random electrical noise that is usually found in atmosphere.

a suitable antenna. If the receiver is not operating in the specified range, adjust the core of *L1* in the first two circuits or add or remove a few turns from *L1* in the third circuit.

To operate the third circuit (Fig. 1C), advance (counterclockwise) the regeneration control (*C6*) until a slight hiss is heard. The proper position of *C6* depends on the length of the antenna, the receiver coil, and the position of the tuner capacitor (*C1*). However, the receiver may not operate with regeneration at high frequencies, but *C6* will serve to boost the receiver's performance. Shortwave reception is obtained by changing coils in accordance with Fig. 2.

For optimum performance, these receivers require a good earth ground and a large metallic antenna. Water pipes and other low-lying metallic objects make good grounds. The antenna lead can be clipped to a window screen, roof gutter, refrigerator, or similar items. Sometimes just touching the antenna lead with the hand is sufficient to power the receiver. To increase reception, attach a 9-volt battery across *C2*, observing the correct polarity.

For listening to weak signals, connect two earphones in parallel to form a head set. Local stations in the broadcast band may interfere with distant transmissions.

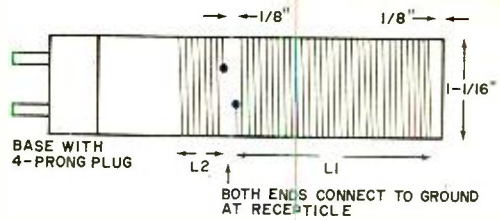

Range	Turns	Wire
540-1500 kHz	L1: 149.6 closewound	#28
	L2: 41.3 closewound	#28
1.5-4.0 MHz	L1: 49.2 even for 2"	#24
	L2: 11.2 even for 7/16"	#24
4.0-11.0 MHz	L1: 18.4 even for 2"	#22
	L2: 4.2 even for 7/16"	#22

All wire is enamel coated, wound on low-loss 1 1/16" diameter forms at least 3 1/2 in. Use plastic pill containers or thin-wall cardboard tubing. Coat with clear lacquer, if desired, to keep wire in place.

Fig. 2. Windings for coils in Fig. 1C.

If so, a series *LC* circuit may be constructed to remove the unwanted station. This circuit connects between the receiver's antenna and ground and is built using a standard antenna coil connected in series with a 365-pF variable capacitor. When this circuit is tuned to the interfering frequency, the latter will be effectively removed. However, the antenna coil must be kept away from *L1*, and the chassis of the capacitor should be connected to ground. ♦

ADDITIONAL FUNCTIONS FOR YOUR POCKET CALCULATOR

BY KNOWING a few simple procedures, you can make your "under-\$100" calculator do functions found only on more expensive models. Positive integral exponents, reciprocals, and square roots, for example, can be done quickly and easily.

The procedure for calculating x^2 , x^3 , or x^n is: enter the number, activate the constant, push the multiply button, and push the equals button $n - 1$ times. For example, to calculate 3.7^3 , you would use the following procedure: (3); (.); (7); (K); (×); (=); (=); (=); (=). Read 693.44.

Reciprocals and other negative integral exponents (x^{-1} , x^{-2} , . . . x^{-n}) can be calculated by entering the number, activating the constant, pushing the divide button, and pushing the equals button $n + 1$ times. For example, 5.2^{-1} would have the following procedure: (5); (.); (2); (K); (÷); (=); (=). Read 0.1923.

The process of finding square roots is a little more complicated, but after doing it a few times, it too is simple and quick. The easiest way to explain it is through an example. To find the square root of 8, first enter 8, then divide by an approximate square root. Try 3. The result should be 2.6666666. Add the approximate square root to this reading. Thus, $2.6666666 + 3 = 5.6666666$. Now divide this by 2. The answer, an approximate square root of 8 is 2.8333333. For greater accuracy repeat the process. Thus, $8/2.8333333 = 2.8235$. Again, add the two together and divide by two: $2.8235 + 2.83333 = 5.6568$. And $5.6568/2 = 2.8284$, a more accurate answer. This, of course, is simply a matter of finding a range and then narrowing the range.

These functions are very handy in electronic calculation. —Edward C. Priest

The Easy Way to Make PC Boards

THE PHOTOPOSITIVE METHOD

SIMPLIFIES PC CONSTRUCTION FOR HOBBYISTS
AND EXPERIMENTERS

BY WILLIAM T. ROUBAL

Fabricating printed circuit boards, believe it or not, is not a fine art that can be mastered by only a talented few. Anyone who isn't "all thumbs" and has patience can master the techniques needed to turn out commercial-quality PC boards. The trick lies in how you go about it and the medium in which you choose to work.

For all but the most basic, least detailed PC layouts, the photosensitive process is best to use. There are basically two types of photosensitive resists available. The most

commonly used—only because it was developed first and received most of the attention—is the negative-type photoresist. The other type, much more convenient for the hobbyist and experimenter to use, is called positive photoresist.

All negative-type photoresists suffer from one inherent drawback. Before you can use them, you must first prepare a negative from your positive artwork. Hence, you are faced with double the work—unless you elect to use a reversing film—because the

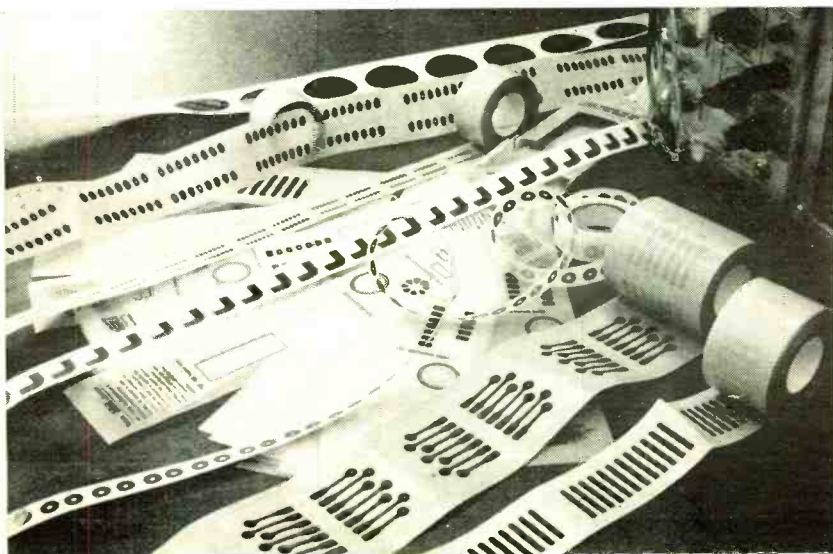

Fig. 1. Opaque transfers and stick-ons are used for making photopositive artwork.

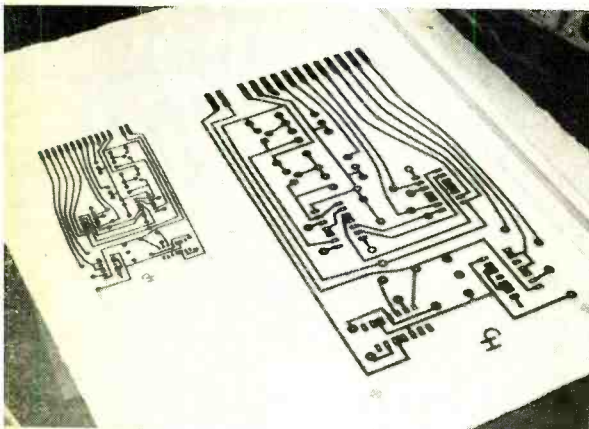

Fig. 2. Twice-size artwork and final photopositive. The final of the photopositive is made from lithographic film. Such procedure requires the use of a darkroom and enlarger.

positive artwork must be converted into a negative if it is to be usable. Additionally, because of the nature of the process, any alterations or corrections must normally be made on your positive, demanding that you make a new negative.

Alternatively, you can use positive-type photoresists and cut your work in half by using the positive artwork directly. What you see in the original artwork is what you'll get when you etch away the copper. Realistically, then, this is the easier way to work.

Positive photoresists differ chemically from negative types. With positive resists, the portions exposed to light are dissolved away during the development process. Another difference lies with the developer itself. Volatile hydrocarbon solvents used with negative resists are expensive and often hard to keep uncontaminated. By contrast, a dilute solution of ordinary household lye, or caustic soda, in water is all you'll need as a developer for the positive resist.

The Artwork. The best way (actually the only realistic way for multi-IC and other finely detailed PC layouts) of preparing your positive artwork is to use sheet Mylar or acetate film and any of the various dry-transfer and/or stick-on patterns available. The film used should be between 0.002 in. and 0.004 in. thick.

It is imperative that all drafting aids be opaque to ultraviolet (UV) light. While electronics-type materials invariably meet this demand, not all brands of dry-transfer

materials will pass the test. Prestape, Chart Pak, and Para Type are quite satisfactory, while Cello-Tak is not opaque enough.

Representative examples of the drafting aids currently on the market are shown in Fig. 1. Commonly available patterns include various-size solder pad "donuts" and "tear drops," edge connectors, right-angle L's and T's, circles and dots, three- and four-lead transistor pads, and all IC pad configurations. Some companies produce dry-transfer patterns, while most make pressure-sensitive stick-ons. The only thing not shown in Fig. 1 is the opaque crepe tape, also available in various widths, you'll need for interconnecting solder pads.

You can obtain the drafting aids in various scales, the most common being 1:1 and 2:1. For most jobs, 1:1 will fill your requirements. If you are working on a very detailed and crowded layout, you might be better off working twice up (2:1 scale) to

STEP-AND-REPEAT ARTWORK

When you must make two or more of the same PC board, you can save considerable time if you make a multiple positive for exposing several blanks at once. The least time-consuming method to use is a "step-and-repeat" process by which your original artwork is duplicated two or more times with the aid of "Trans-O-Paque" (TOP) film.

The TOP film is sensitive to UV light; so, you can safely work in a dimly (incandescent) lighted area. A 25-sheet package of 8 x 10-in. TOP film costs \$13.50. Order it from one of the following Dynachem Corp. outlets:

FAR WEST:

13000 E. Firestone Blvd.
Sante Fe Springs, CA 90670

MIDWEST:

449 Fullerton Ave.
Elmhurst, IL 60126

NEW ENGLAND:

22 B Street
Burlington, MA 01803

SOUTHEAST (NYC to Florida):

234 Dominion Rd.
Vienna, VA 22180

You will need a large vacuum-type exposure frame. Carefully measure your original artwork, add about 1/8 in. to the

simplify the job and give you better control over the work. Working twice up means that you'll have to reduce, by photographic means, your artwork to the proper size; but the extra step is worth it if there's any chance of introducing errors when using the 1:1 aids. Of course, when you work in any scale larger than 1:1, select interconnecting crepe tape to suit the scale. An example of 2:1 artwork is shown in Fig. 2.

Preparing the PC Blank. The copper-clad board that you will use for making a PC board is called a "blank." The copper must be perfectly clean before you attempt to apply the photoresist. Any dirt or oil will prevent the resist from adhering to the copper.

First, cut the blank to shape, allowing about $\frac{1}{4}$ in. extra in length and width. Do *not* make any cutouts that will appear in your finished board at this time. Deburr all

length and width, and use the figures just obtained to cut an opening of the same size in the center of a sheet of aluminum foil. The foil must be large enough to permit only the portion of the film that shows through the cutout to be seen, no matter where on the TOP sheet the mask is placed.

Tape the mask to the inside glass cover of the exposure frame and position and tape your original artwork into the opening. Start at one corner with a UV sunlamp 8 in. away and expose the film through the artwork for about 10 minutes or until all visible yellow areas become transparently clear. Turn off the lamp and slide the film to an adjacent unexposed portion and expose. Repeat until all areas of the film have been used up.

Place the exposed film in a large container along with an open jar of 28-percent ammonia (get from a drug store). Put a cover on the container and develop the film in the ammonia fumes for 20 to 30 minutes in the dark.

When fully developed, the duplicated positive will be a UV-opaque amber color. Allow the ammonia fumes to completely dissipate before taking the developed film into the area where you have your stock of unexposed TOP film.

Your step-and-repeat positive can be used as one large sheet if you have a PC blank large enough to accommodate it. Cut up, it can be used with several medium- and small-size blanks.

cut edges with a medium or fine file. Then clean the copper by light scrubbing with scouring powder and a wet cloth. Thoroughly rinse the blank under running water to remove all traces of grit and immediately blot dry with absorbent paper towels or a lint-free cloth. If the blank is allowed to air-dry, the copper will quickly tarnish. From now on, handle the board only by its edges.

Type AZ-111 positive photoresist (available for \$2/oz postpaid from S&H Electronics, P.O. Box 286, Corvallis, OR 97331) is easiest to apply by the spinning method. Place the blank, copper side down, on a lint-free cloth and affix to its unclad surface a wide strip of masking tape (adhesive on both sides or lay one-sided tape back on itself) as shown in Fig. 3. Now, centrally position the rubber disk of an electric drill sanding attachment over the blank and press it home. Check to see that the tape is firmly bonded to both the blank and the rubber disc. Then chuck the disc/blank assembly in a variable-speed electric hand drill.

Working in a dimly lighted room (make certain that the light is from an incandescent lamp—*not* a fluorescent fixture), up-end the drill assembly and place a few drops or a small puddle of photoresist onto the center of the copper surface (Fig. 4). The amount of resist to use will be governed by the size of the blank. With a little experience, you will quickly learn how much to use for any size blank. Now, quickly brush the resist out toward the blank's edges with a clean artist's brush and up-end the drill assembly over a newspaper-lined wastebasket. Be sure that the blank is several

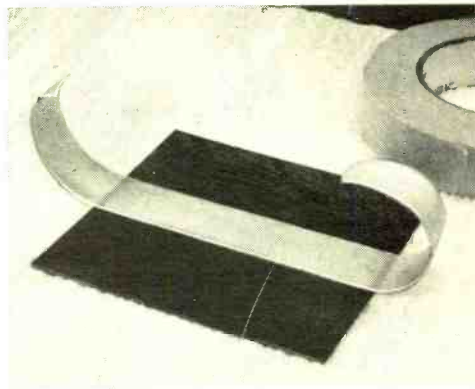

Fig. 3. First step in coating copper by spinning is to adhere masking tape to the back.

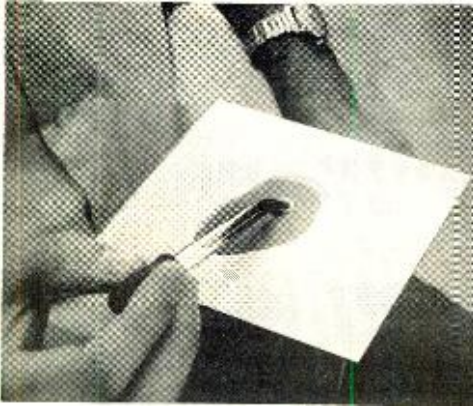

Fig. 4. Once board has been attached to the spinner, pour on AZ-111 positive photoresist.

inches below the open top of the wastebasket; then turn on the drill for 5-8 seconds at a speed of 300-400 rpm (Fig. 5).

Working very carefully so as not to touch or disturb the resist coating, remove the blank from the rubber disc, while still in the darkened area. Place the treated blank in a lightproof, dustproof box or cupboard to dry. Since the resist has a strong odor of solvent, it is best to set the box under a kitchen hood with the exhaust fan on until most of the solvent has dissipated. The blank can also be force-dried by placing it in an oven set at 160°F, with the door open—don't forget to keep the room in darkness—for 10 to 15 minutes.

Exposing & Developing the Blank. When the PC blank is dry and as solvent-free as possible, it's ready to be developed. One test you can use for determining if the blank is ready is to sniff it at close range;

PC BOARD CONSTRUCTION

Step

- A1. Cut and clean PC board
- A2. Coat copper with photoresist (photosensitize)
- A3. Dry
- B1. Prepare artwork (positive)
- B2. Prepare multiple positive (step-and-repeat, optional)
- C. Place sensitized board and positive in exposure frame and expose to ultraviolet light
- D. Develop photoresist
- E. Etch copper
- F. Drill holes
- G. Plate copper (optional)

if you detect only a faint odor of solvent, it's ready. If you mistrust your olfactory sense, lightly press the tip of a finger against the coating at one corner; any tackiness at all indicates that the board isn't ready.

Once you've satisfied yourself that the blank is ready, you can proceed to expose it as follows: Position the positive over the resist-coated surface of the blank. Next, sandwich the assembly between the glass and pressure plate of the exposure frame. (See Fig. 6 for details of how to make a professional-quality vacuum-type frame.) Then expose the positive-masked resist to a 275-watt UV sunlamp for 8 to 10 minutes at a distance of 14 to 18 inches. If you already have a fluorescent UV lamp, feel free to use it. In any case, you'll probably have to experiment a little to determine the optimum exposure time and distance for your setup. Although it is difficult to over-expose the resist, too short an exposure will prevent the resist from dissolving away when you attempt to develop the exposed blank.

Since we've introduced the vacuum-type exposure frame in Fig. 6, let's go into a little more detail. The frame itself is made from ordinary pine lumber. The lumber need not be fancily painted; a single coat of flat black paint will do nicely. Nor are any fancy construction techniques required during assembly. You can make the frame as small or as large as you want it to be (a practical size is 12 in. long by 8 in. wide by about 2 in. (or less) deep. Don't forget to drill the 1/8 in. holes through the platform as indicated; space them on grid centers of about 2 in. apart. And don't forget the island supports. The vacuum tube can be seamless plastic tubing of a size that will provide a friction—not binding—fit for your vacuum cleaner. A foam rubber gasket around the drop lid will increase vacuum efficiency.

The main function of the exposure frame in PC work is to provide a rock-steady system for holding the exposure positive and sensitized blank together and properly registered during the entire exposing time. The vacuum feature is a convenience that comes in handy when you're working with a warped PC blank or an exposure positive that insists upon curling up.

While your blank is being exposed is a good time to mix up a batch of developer. Do this by dissolving about three teaspoonfuls of lye in a quart of water in a shallow

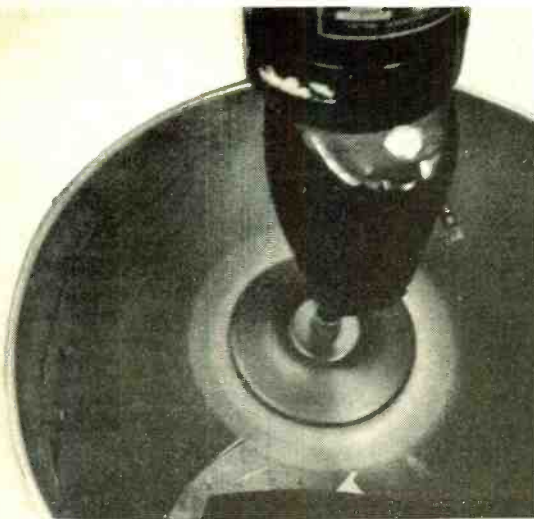

Fig. 5. Thin coat of photoresist is deposited on copper by spinning at moderate speed.

Pyrex or enamelled tray. If you use an enamelled tray, make certain that there are no cracked or chipped areas of the enamel coating. (Warning: Use only household lye that is free of metal particles.)

As soon as the blank is completely exposed, immerse it in the developer solution, resist side up. Rock the tray back and forth to agitate the developer and speed up the developing process. The resist will turn purple and the exposed portions will slowly wash away. (Note: If the caustic solution is too weak, development time will be prolonged, or development will be impossible, indicating that you must increase the concentration of caustic in the bath. Again, experiment until you know the right proportions of lye to water you will need for any given job.)

When all exposed areas on the PC blank are free of resist, remove the blank from the developing bath. Don't just reach in to retrieve the blank; use rubber gloves or plastic tongs. Rinse the blank under gently running water. Then pat the exposed blank dry with absorbent paper towels or a soft cloth.

Etching the PC Board. Submerge the board, copper side up, in the etching solution of your choice. Most people use syrupy ferric chloride for etching. This chemical is fast acting but requires that the board be removed from the bath several times during etching to check the progress of the

chemical action, mainly because ferric chloride is very dark and so dense that it is opaque. You might consider using ammonium persulfate crystals and water, with just a "pinch" of mercuric chloride as a catalyst. (WARNING: Mercuric chloride is highly poisonous; handle it with extreme care.)

During the etching process, the etchant should be continuously agitated to speed up the chemical action. Also, it helps if the etchant starts off warm. To warm ferric chloride, simply immerse its stoppered container in hot water. The ammonium persulfate solution is even easier to warm; just add the crystals and catalyst to hot water (about 150°F).

When the etchant has done its work, use rubber gloves or plastic tongs to remove the PC board from the tray in which it was etched and rinse it off under running tap water. Dry the board. Then remove the remaining resist with a soft cloth dipped into acetone or with very fine steel wool. Trim the board to its exact finished size and drill the component mounting holes.

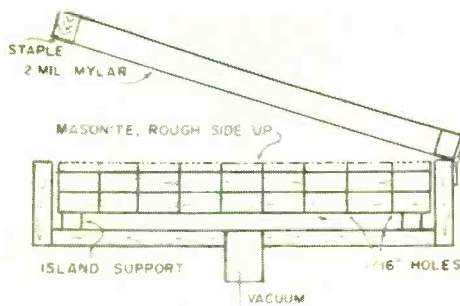

Fig. 6. Building a vacuum exposure frame.

You might consider plating the copper foil after the PC board is trimmed and drilled, using electroless tin solution that requires only one step and does not contain cyanide. Plated copper resists tarnish and corrosion and, more important, serves as a "wetting" agent that greatly facilitates soldering.

Once you've worked with positive resist techniques, it's almost guaranteed that you'll never go back to the negative-resist technique that requires almost double the work to obtain the same results. You'll also save money by using inexpensive household chemicals that keep for a long time and do not require special storing. ♦

IC PHOTO DEVELOPMENT TIMER

IDEAL FOR USE WITH POLAROID CAMERAS

BY ROBERT MARCHANT

PROCESSING film often involves different time intervals, ranging from several seconds to several minutes. This usually means that a couple of commercial timers are required. The electronic circuit shown in Fig. 1, using two low-cost IC's, can be built for less than \$15 and provides almost any selected timing interval with an audible alarm at the end of the period.

Both of the IC circuits are monostable and provide the automatic reset at the end of the timing interval. When S2 is closed, IC1 is triggered, causing its output to go to about 3 volts. Simultaneously, an internal flip-flop is triggered, removing a short circuit across timing capacitor C2. This enables C2 to be charged at a rate determined by the setting of S3, which selects the timing

resistor (R3 or R4). When the voltage across C2 reaches $\frac{2}{3}$ of the supply voltage, an internal comparator operates to reset the flip-flop and short out C2. This drives the output to a low state.

This negative-going output signal activates the Schmitt trigger in IC2, whose output goes to about three volts for about one second. This time is determined by the values of R8 and C3. When this output goes high, audible alarm AI is energized.

The component values given here were selected so that the circuit includes a human reaction factor. Thus the short cycle (15 seconds) is actually about 13 seconds to allow for the pulling and tearing necessary for type 51, 52 and 57 Polaroid film. The two-minute interval is actually

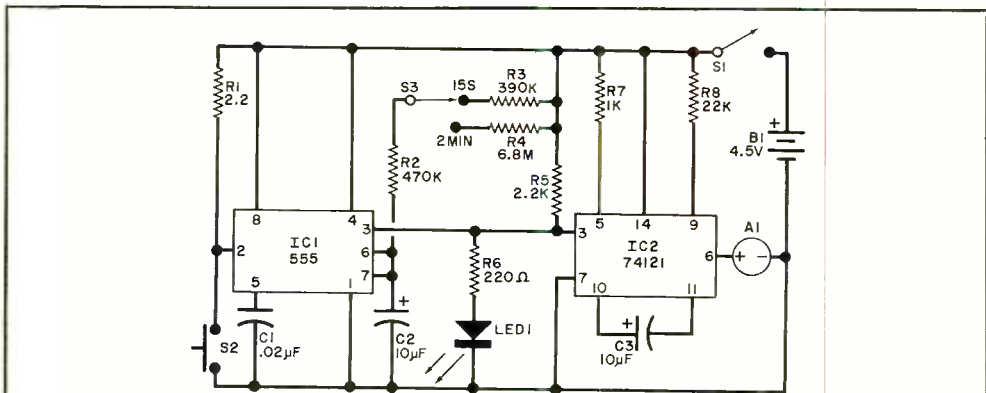

PARTS LIST

A1—Audible alarm (Mallory Sonalert SC628 or similar)
 B1—4.5-volt battery (3 AA cells in series)
 C1—0.02- μ F capacitor
 C2, C3—10- μ F 15-volt electrolytic capacitor
 IC1—555 IC timer
 IC2—74121 IC Schmitt trigger
 LED1—Light-emitting diode (MLED-500) (optional)
 R1, R5—2200-ohm resistor
 R2—470,000-ohm resistor
 R3—390,000-ohm resistor

R4—6.8-megohm resistor
 R6—220-ohm resistor (optional)
 R7—1000-ohm resistor
 R8—22,000-ohm resistor
 S1—Spst switch
 S2—Normally open pushbutton switch
 S3—Spdt switch
 Misc.—Suitable chassis, battery holder, IC sockets (optional), mounting hardware, etc.
 Note—An etched and drilled PC board is available from Robert Marchant, Tartane Rd., Manomet, MA 02345 for \$2 postpaid.

Fig. 1. Timing starts when S2 is depressed. The visual indicator, LED1, is optional.

one minute and 55 seconds and is used for type 46 Polaroid film.

If desired, resistors *R2*, *R3*, and *R4* and switch *S3* can be replaced with a 10-megohm potentiometer with a dial calibrated for varying time intervals.

Construction. The circuit can be assembled on a PC board such as that shown in Fig. 2. Note that *R6* and *LED1* are not shown. They are optional. The LED will turn on during the timing cycle, and its faint red glow will show up easily in a darkroom. Leaving out these two components will not alter the operation of the rest of the circuit.

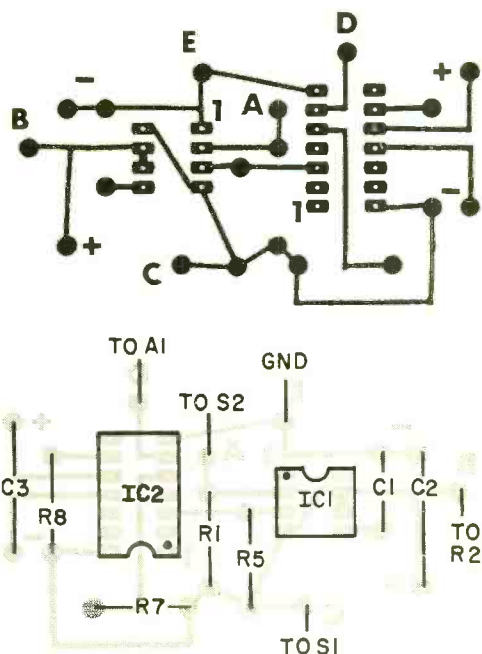

Fig. 2. Construction is best done on a PC board (top) with components as shown below.

The choice of a housing is optional. Use the smallest case possible to accommodate the switches, Sonalert, PC board, and batteries. Mark the 15-second side of *S3* "51, 52, 57" and the 2-minute side "46."

Operation. Turn on the timer with *S1* and allow it to time out in the 15-second setting until the alarm sounds. If there is no alarm, depress *S2*. Place *S3* in the desired position, and depress *S2* to start the timing interval. Successive timing intervals do not require resetting of any controls—just operation of *S2*. ♦

**PACE ((P))
GUARANTEES
PERFORMANCE
SERVICE**



**For
Safety
Sake**

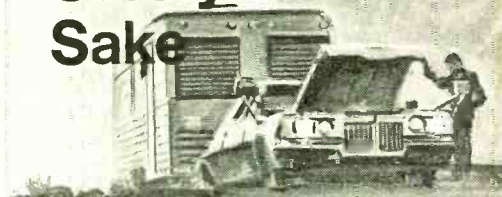

CB 10-2
only \$69.95 with Ch. 9



- SMALLEST SIZE AND LOW COST
- FULL 5 WATT TRANSCEIVER
- MOBILE, BASE OR PORTABLE

Here's the travel companion you don't want to leave behind. Call on Channel 9 for highway assistance anywhere in the U.S.A. Add other channels to communicate for fun and convenience after receiving your FCC license.

WRITE PACE FOR FREE
CITIZEN TWO-WAY RADIO GUIDE
OR STOP BY YOUR LOCAL...

...SIGN OF QUALITY



PACE COMMUNICATIONS
DIVISION OF PATHCOM INC.
24049 S. FRAMPTON AVE., HARBOR CITY, CA 90710

Name _____
Street _____
City _____

CIRCLE NO. 29 ON READER SERVICE CARD

THOSE WILD HAMS OF THE 1920's

- ◆ MADE THEIR OWN COMPONENTS
- ◆ WERE CONFINED TO BELOW 200 METERS
- ◆ DIDN'T TAKE FCC EXAMS

BY CHARLES C. HAY, WØLCE

IT WAS a glorious time to live—back in the 1920's, when radio communication was just beginning to emerge. Only a very few top scientists knew anything about this new medium—and most of the things they “knew” were incorrect. But that didn't deter them from displaying their errors—what they thought were “facts”—in the public press.

One of the notable “facts” that got around was the statement that radio communication was impossible below a wavelength of 200 meters. (For those of you familiar with only hertz, 200 meters is 1500 kHz.) So, Congress dreamed up a radio law that confined all amateur communication to the bands below 200 meters—or above 1500 kHz. The law also specified that all radio stations had to be licensed. Little problem that, since a license was granted upon request and without the applicant having to submit to an examination.

Another part of the law stipulated that only in the big cities were licenses to be granted. Needless to say, since many experimenters lived a long way from the big cities, a lot of transmitters were on the air without the benefit of licenses. Whatever call letters were used were self-assigned.

We Built Our Own Equipment. All of the equipment we early hams used was home-made. There were only two companies in the entire United States that sold radio parts, and their prices were quite steep. For example \$20 would buy a link coupler, while a variable condenser (now called capacitor) went for \$15. So, most of us were forced to build our own equipment.

The usual receiver consisted of a coil of wire wound around an empty oatmeal box;

another coil inside the box was rotated by a lead pencil pushed through the box and both coils. This pair of coils was connected to a fine wire sharpened to a point. The point made contact with the surface of a galena crystal. The body of the crystal was connected to one lead of a pair of headphones, and the other lead of the phones was connected to ground. With a long enough length of wire for the antenna, this contrivance could receive radio signals from as far away as 1000 miles. It needed no outside power since all the power was furnished by the radio waves themselves.

While vacuum tubes were known in the early 1920's (they were used in World War I), they weren't available, except to a very few lucky individuals. Everyone used a tubeless spark transmitter, anyway.

A spark transmitter was easy to build. It required simple materials, like a spark coil from a Model T Ford, a pair of sharpened zinc strips (to act as the spark gap), a telegraph key, and an antenna. By connecting the spark coil through the telegraph key to an automobile battery, and the secondary of the coil through the spark gap to the antenna a guy was in business. When he pressed the key, he drew a lovely spark from the gap. The spark could be received clear across town, if the town wasn't too big, that is.

Although the receiving station had a tuner it wasn't really necessary. Those spark transmitters were the original all-band transmitters. When they came on the air, any nearby receiver, no matter where tuned, would pick them up.

Along Came Tubes. Late in the 1920's, vacuum tubes became available. About the same time, commercial broadcasting reared

its head. People with money could buy broadcast receivers, precipitating the unpopularity of the neighborhood experimenter with his all-wave spark transmitter.

Government regulations, which instituted "silent hours" for Sunday mornings and until 10 o'clock each evening, came into effect. Not that this did much to the experimenter. He usually didn't read government publications, so he knew nothing of the regulations.

At the time the new regulations came into effect, radio communication was administered by the Department of Commerce, which had other things to do besides supply money for radio enforcement. With the absence of enforcement, the young radio experimenter wasn't much troubled. But there were neighborhood relations to consider, and if interference was overdone, the neighbor with his high-priced broadcast set was likely to take the matter up with the offender's parents. This usually resulted in the enforcement of "quiet hours"—if it didn't terminate experimentation altogether.

I was one of the experimenters in the early days of amateur radio. The fact that I could hear broadcasts on my crystal-detector tuner intrigued my parents to the point where they shelled out enough money for a vacuum tube, a Crosley book-condenser and a variable tuner. With these treasures on hand, I was able to build a new-fangled superregenerative receiver.

A by-product of my new receiver was the fact that the superregen was itself a transmitter. It interfered mightily with our neighbor's neutrodvne receiver. But that was a problem between my parents and the neighbor.

The superregen would pick up commercial broadcasts. It was also adept at picking

up amateur transmissions (after my parents had gone to bed, of course). By this time, amateur operators had acquired vacuum tubes. Some of them were even communicating via voice (phone)!

My desire for a tube transmitter could be described as a "consuming passion." But while my parents were deeply interested in broadcasting, the idea of an amateur radio transmitter in the same house left them cold. No money was forthcoming.

I had read of a Chicago ham who had built every part of an amateur radio station. He even built the vacuum tube. So, I thought, anything he could do, I could do. Building the vacuum tube, however, was the big problem. Vacuum tubes grew from Mr. Edison's incandescent lamp. They were large and had four-pronged bases. Making the base was beyond my powers. Fortunately, one of the broadcast set dealers I happened to visit showed me a receiver made in Canada. It used Myers tubes. While the American tubes were descended from a light bulb, the Myers tube was fathered by a cartridge fuse. Now, this was something I could duplicate.

I bought a test tube and from it cut away the lip and closed end. To the body of this 2-inch-long glass cylinder I fused a length of ¼-inch glass tubing over a hole made previously. Then after rolling a strip of copper into a cylinder and soldering to it a length of heavy wire, I slipped the assembly into the glass tube. Next, I wound a coil of wire, much smaller in diameter than the inner diameter of the copper cylinder, soldered to it a length of wire, and slipped the new assembly into the copper cylinder. When I was finished with this step, the wires from both assemblies protruded from opposite ends of the glass tube.

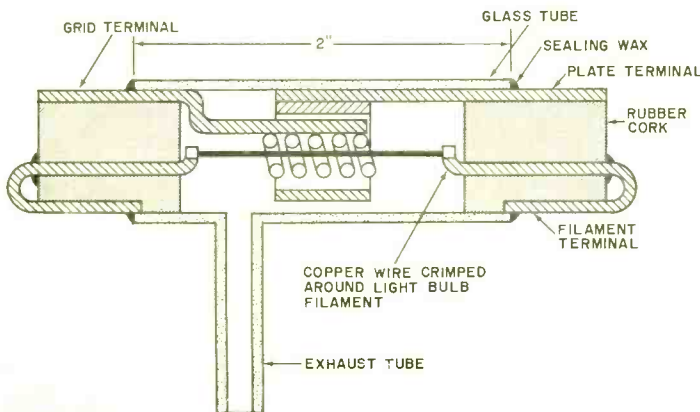

Cross section of the home-made vacuum tube that was put together by the author in early days of ham radio.

Recovering a length of filament wire from a light bulb, I slipped this down the center of the coiled wire. After using rubber stoppers to seal both ends of the glass tube (with the wires protruding, of course), I applied sealing wax to assure an airtight seal. Later, at school, I attached a rubber hose to the 3/4-inch glass tube and used a vacuum pump to evacuate the air until the rubber tubing went flat. The only thing left was to use a blow pipe to seal the 3/4-inch glass tubing.

My first vacuum tube had the filament wire exiting from it through the centers of the rubber stoppers. When power was applied to the filament, it heated up as expected—and so did the stoppers. The vacuum left the tube with a piercing shriek, and a strong smell of burning rubber filled the air.

My next vacuum tube (see drawing) produced better results. Instead of having the heater wire exit the tube, a pair of copper wires, crimped around the heater wire, did the exiting, and all the heat was contained within the tube. This arrangement functioned quite well. In fact, I had three QSO's using the tube before the vacuum got up and slowly walked away.

Condensers and Resistors. There were other components we early hams had to make by hand. Some were easy to make, like tubular bypass condensers. Back then, Hershey chocolate bars were wrapped in real solderable tin foil. This foil, some waxed paper, copper wire, and a soldering iron and solder were all an experimenter needed to make his own condensers.

To make the condenser, we would cut two pieces each of tin foil and waxed paper to 4 inches by 1 inch. After lightly tacking soldering leads to the short edges of the foil, the waxed paper and foil sheets were interleaved with overhangs to obviate any possibility of the plates (or leads) from touching each other when the condenser was assembled. Then the whole was tightly rolled into a cylinder. When finished, the condenser had one lead coming out of the center of the cylinder and one lead to one side. After bending the side lead to line up with the center, the foil was crimped around the leads and soldered. A bit of sealing wax over the soldered foil and along the exposed seam of the waxed paper properly sealed the condenser. A strip of adhesive tape held the whole thing together.

A variable condenser also had to be hand

made. The Crosley book-condenser didn't have enough insulation resistance between its plates. So, 4-inch-square pieces of sheet zinc were cut and fitted into every other sawed groove in a pair of pine guides. An end piece which had sawed grooves that mated with the empty ones in the other assembly had fastened to it the rest of the zinc plates. When the two were meshed, we had a crude variable condenser.

Resistors were more of a problem. The carbon cores from flashlight batteries could be used, but they were rather limited in their resistance. Even when a number of them were connected in series, the resistances obtained were often unsatisfactory. Nor could the resistance be controlled. The way to go was to insert a couple of copper wires through a rubber cap into a bottle half filled with water and change the resistance by varying the depth of the wires in the water. Excitement was added when the water boiled during a transmission.

The Power Supply. The power supply was more difficult to make. Hams with lots of money had dc motor generators to supply their power. Most of us, however, had to find another means of obtaining power. For example, I took a number of copper plates, about 4 inches square, and oxidized one side of each with a blow torch. I drilled a hole through the center of each plate, and, after slipping a rubber tube around a long bolt and insulating the head and nut with rubber from an old inner tube, put the bolt through the stack of plates. When finished, the plates were bolted together, oxide face to bare copper. This rectifying setup, with a couple of my home-made bypass condensers and the coil from an old telegraph sounder made a 117-volt dc plate power supply.

Finally, there came that magic night when my parents were in bed safely asleep. I crept downstairs and assembled the set with a galena crystal where the tube would be. With the headphones tightly over my ears. I moved the variable condenser until I heard another amateur. Then I quickly tuned him in on the superregen.

Taking the galena crystal out and inserting the tube, I fired up my rig and gave him a call. I was lucky. He came back to me, and that was my first QSO, the high point of my life. The QSL card I received from him still hangs on my shack wall, some five decades after it was sent. ♦

EVEN IF THEY NEVER SEE YOUR SLEEK NEW COBRA 135, THEY'LL KNOW YOU HAVE THE BEST.



They'll know by listening. Because you'll send with all the power allowed—15 watts P.E.P. input. Plus the extra authority of 100% modulation with Dynabooast speech compression.

You'll transmit on 23 AM and 46 SSB modes. Two separate transmitters give you the best of each, with overload protection.

Your own ears will confirm what we say. This Cobra has the crispest, cleanest

sound ever. Over 60 dB cross modulation interference rejection completely eliminates bleedover.

Cobra's drift-free Voice Lock lets you locate and lock-in sideband signals over a wide range. Three filters—one crystal, two ceramic—keep adjacent channels under wraps.

And Cobra's noise blanker really punches holes in noise, both AM and SSB.

The control console has everything. Adjustable AM/SSB RF gain control. Backlit RF output/SWR/S meter. 24-hour digital-leaf clock. Illuminated mode selector. And full-function controls.

Both talking and listening, it's the first base station to combine all the features you want in one package. And as for looks—wow!

Ask your CB dealer to show you the best. Cobra 135.

COBRA 135 **AM/SSB** **\$449⁹⁵**

microphone included

Product of Dynascan Corporation, 1801 West Belle Plaine Avenue, Chicago, Illinois 60613

CIRCLE NO. 42 ON READER SERVICE CARD

One of our most successful students wrote this ad!

Harry Remmert decided he needed more electronics training to get ahead. He carefully "shopped around" for the best training he could find. His detailed report on why he chose CIE and how it worked out makes a better "ad" than anything we could tell you. Here's his story, as he wrote it to us in his own words.

By Harry Remmert

AFTER SEVEN YEARS in my present position, I was made painfully aware of the fact that I had gotten just about all the on-the-job training available. When I asked my supervisor for an increase in pay, he said, "In what way are you a more valuable employee now than when you received your last raise?" Fortunately, I did receive the raise that time, but I realized that my pay was approaching the maximum for a person with my limited training.

"Education was the obvious answer, but I had enrolled in three different night school courses over the years and had not completed any of them. I'd be tired, or want to do something else on class night, and would miss so many classes that I'd fall behind, lose interest, and drop out.

The Advantages of Home Study

"Therefore, it was easy to decide that home study was the answer for someone like me, who doesn't want to be tied down. With home study there is no schedule. I am the boss and I set the pace. There is no cramming for exams because I decide when I am ready, and only then do I take the exam. I never miss a point in the lecture because it is right there in print for as many re-readings as I find



Harry Remmert gives his CIE Electronics course much of the credit for starting him on a rewarding career. He tells his own story on these pages.

necessary. If I feel tired, stay late at work, or just feel lazy, I can skip school for a night or two and never fall behind. The total absence of all pressure helps me to learn more than I'd be able to grasp if I were just cramming it in to meet an exam deadline schedule. For me, these points give home study courses an overwhelming advantage over scheduled classroom instruction.

"Having decided on home study, why did I choose CIE? I had catalogs from six different schools offering home study courses. The CIE catalog arrived in less than one week (four days before I received any of the other catalogs). This indicated (correctly) that from CIE I could expect fast service on grades, questions, etc. I eliminated those schools which were slow in sending catalogs.

FCC License Warranty Important

"The First Class FCC Warranty* was also an attractive point. I had seen "Q" and "A" manuals for the FCC exams, and the material had always seemed just a little beyond my grasp. Score another point for CIE.

*CIE backs its courses with this famous Money-Back Warranty: when you complete a CIE license preparation course, you'll be able to pass your FCC exam or be entitled to a full refund of all tuition paid. Warranty is valid during completion time allowed for your course.

"Another thing is that CIE offered a complete package: FCC License and technical school diploma. Completion time was reasonably short, and I could attain something definite without dragging it out over an interminable number of years. Here I eliminated those schools which gave college credits instead of graduation diplomas. I work in the R and D department of a large company and it's been my observation that technical school graduates generally hold better positions than men with a few college credits. A college degree is one thing, but I'm 32 years old, and 10 or 15 years of part-time college just isn't for me. No, I wanted to *graduate* in a year or two, not just *start*.

"When a school offers both resident and correspondence training, it's my feeling that the correspondence men are sort of on the outside of things. I wanted to be a full-fledged student instead of just a tag-a-long, so CIE's exclusive home-study program naturally attracted me.

"Then, too, it's the men who know their theory who are moving ahead where I work. They can read schematics and understand circuit operation. I want to be a good theory man.

"From the foregoing, you can see I did not select CIE in any haphazard fashion. I knew what I was looking for, and only CIE had all the things I wanted.

Two Pay Raises in Less Than a Year

"Only eleven months after I enrolled with CIE, I passed the FCC exams for First Class Radiotelephone License with Radar Endorsement. I had a pay increase even before I got my license and *another* only ten months later.

"These are the tangible results. But just as important are the things I've learned. I am smarter now than I had ever thought I would be. It feels good to know that I know what I know now. Schematics that used to confuse me completely are now easy for me to read and interpret. Yes, it is nice to be smarter, and that's probably the most satisfying result of my CIE experience.

Praise for Student Service

"In closing, I'd like to get in a compliment for my Correspondent Counselor who has faithfully seen to it that my supervisor knows I'm studying. I think the monthly reports to my supervisor and generally flattering commentary have been in large part responsible for my pay increases. My Counselor has given me much more student service than "the contract calls for," and I certainly owe him a sincere debt of gratitude.

"And finally, there is Mr. Tom Duffy, my instructor. I don't believe I've ever had the individual attention in any classroom that I've received from Mr. Duffy. He is clear, authoritative, and spared no time or effort to answer my every question. In Mr. Duffy, I've received everything I could have expected from a full-time private tutor.

"I'm very, very satisfied with the whole CIE experience. Every penny I spent for my course was returned many

For men with prior electronics training . . . Electronics Engineering Course

. . . Covers steady-state and transient network theory, solid-state physics and circuitry, pulse techniques, computer logic and mathematics through calculus. A college-level course for men already working in Electronics.

times over, both in increased wages and in personal satisfaction."

Perhaps you too, like Harry Remmert, have realized that to get ahead in Electronics today, you need to know much more than the "screwdriver mechanics." They're limited to "thinking with their hands" . . . learning by taking things apart and putting them back together . . . soldering connections, testing circuits, and replacing components. Understandably, their pay is limited—and their future, too.

But for men like Harry Remmert, who have gotten the training they need in the fundamentals of Electronics, there are no such limitations. He was recently promoted, with a good increase in income, to the salaried position of Senior Engineering Assistant working in the design of systems to silence submarines. For trained technicians, the future is bright. Thousands of men will be needed in virtually every field of Electronics from two-way mobile radio to computer testing and troubleshooting.

Send for Complete Information — FREE

Many men who are advancing their Electronics career started by reading our illustrated school catalog, "Succeed in Electronics." It tells of the many electronics careers open to men with the proper training. And it tells which courses of study best prepare you for the work you want.

If you're "shopping around" for the training you need to move up in Electronics, this interesting book may have the answers you want. We'll send it to you FREE. With it, we'll also include our other helpful book, "How To Get A Commercial FCC License."

To get both FREE books, just fill out and mail the reply card. For your convenience, we will try to have a representative call. If card is missing, use coupon below.

APPROVED UNDER G.I. BILL

All CIE career courses are approved for educational benefits under the G.I. Bill. If you are a Veteran or in service now, check box for G.I. Bill information.

CIE Cleveland Institute of Electronics, Inc.

1776 East 17th Street, Cleveland, Ohio 44114
Accredited Member National Home Study Council

Cleveland Institute of Electronics, Inc.

1776 East 17th Street, Cleveland, Ohio 44114

Please send me your two FREE books:

1. Your school catalog, "Succeed in Electronics."
2. Your book on "How To Get A Commercial FCC License."

I am especially interested in:

- | | |
|---|--|
| <input type="checkbox"/> Electronics Technology | <input type="checkbox"/> Electronic Communications |
| <input type="checkbox"/> Broadcast Engineering | <input type="checkbox"/> Industrial Electronics |
| <input type="checkbox"/> First Class FCC License | <input type="checkbox"/> Electronics Engineering |
| <input type="checkbox"/> Electronics Technology with Laboratory | |

Name _____ (Please Print)

Address _____

City _____

State _____ Zip _____ Age _____

Veterans & Servicemen: Check here for G. I. Bill information

PE-51

CIRCLE NO. 6 ON READER SERVICE CARD

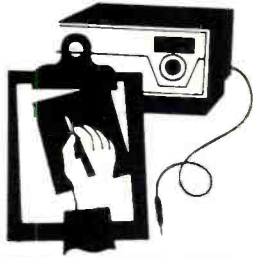

Product Test Reports

KLH MODEL FIFTY-TWO AM/STEREO FM RECEIVER (A Hirsch-Houck Labs Report)

THE KLH Model Fifty-Two is a compact, moderately priced (\$290) stereo receiver that exhibits better than average performance for its price. It is rated to deliver 30 watts/channel continuous output power into 8-ohm loads with both channels driven simultaneously, or 38 watts/channel into 4-ohm loads. The FM tuner's rated sensitivity is $2 \mu\text{V}$. This tuner features a FET "front end," IC limiters in its i-f section, and ceramic filters for improved selectivity. The AM tuner section contains a ceramic filter i-f amplifier.

The tuning dial's window is "blacked out" when power is switched off; when the power is switched on, the AM, FM, and logging scales are illuminated, as are the signal-strength and zero-center tuning meters. Illuminated legends under the dial scales identify the selected input (PHONO, FM, AM, or AUX) and show when a stereo FM transmission is being received. The FM dial is linearly calibrated, with frequencies shown at 2-MHz intervals.

On the front panel of the receiver are a stereo headphone jack and an array of five knobs and seven pushbutton switches. The knobs are used for selecting the input source, operating the bass and treble tone controls

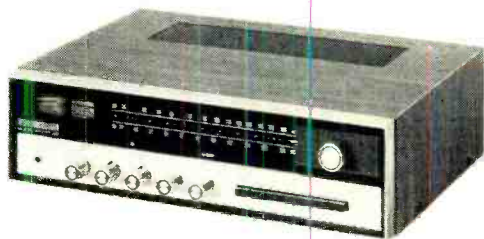

(separate for each channel, with slip clutches to couple them), stereo balance, and adjusting audio volume and turning on and off the receiver. The pushbutton switches operate the loudness compensation for low-level listening, mono/stereo mode selection, tape monitoring, FM muting, high filter, and the two sets of speaker outputs that can be used singly or together.

In the rear of the receiver are the input and output connectors, speaker and line audio fuses, antenna terminals, pivoted AM ferrite rod antenna, and an unswitched ac outlet. Standard screw terminals are used for the MAIN speaker outputs, while the REMOTE speaker hookups are made through conventional phono connectors. A number of speaker systems are fitted with phono jacks that simplify installation. The line cord can be used as an FM antenna for local reception by means of a jumper connection. Opening the jumper connection allows external antennas to be used for FM (a similar jumper is used for AM reception). Each speaker output is protected by a fast-acting 2.8-ampere fuse, a special fuse value available only from KLH, and a 1.5-ampere slow-blow fuse is in the ac power line input.

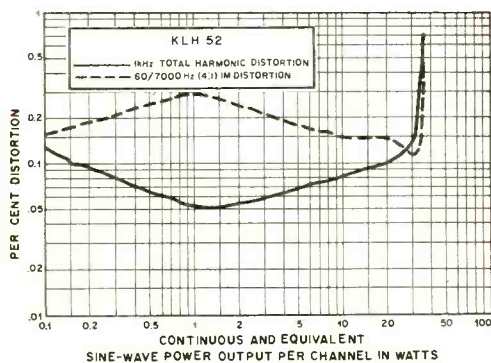

Laboratory Measurements. With both channels driven, the audio amplifiers delivered 33 watts/channel into 8-ohm loads at 1000 Hz at the clipping point. The out-

12 electronics operating and servicing aids from Sams.

LIGHT EMITTING DIODES

by Forrest M. Mims, III

Here is thorough coverage of a fascinating subject, starting with the theory of semiconductor emission, and covering infrared-emitting diodes, visible-light-emitting diodes, and their growing number of commercial applications.

No. 20964 \$4.50

ABC'S OF COMPUTER PROGRAMMING

—2nd Edition

by Allan Lytel & Lawrence Buckmaster

You needn't have an advanced degree in math to understand computer programming. Here, in easy-to-grasp terms, is an explanation of computer arithmetic, numbering systems, binary notation, punched card codes, arithmetic operations, octal numbering, the hexadecimal system codes COBAL and FORTRAN. Anyone interested in working in computer programming or merely in gaining a general knowledge of it, will find this book of value.

No. 20841 \$3.95

NORTH AMERICAN RADIO-TV STATION GUIDE—9th Edition

by Vane A. Jones

The latest expanded edition of this most comprehensive, one-source reference to all commercial broadcasting stations in North America. The guide lists frequencies, call letters, and locations for am, fm, and tv stations.

No. 20957 \$4.50

SOUND SYSTEMS INSTALLERS

HANDBOOK—3rd Edition

by Leo G. Sands

For technicians in commercial sound as well as for those interested in its use, this book gives clear, precise information on installing, operating, troubleshooting, and servicing stationary and mobile systems. Also it suggests the best type of amplifiers, microphones, tuners, speakers, and tape reproducers for use with each system.

No. 20980 \$5.50

ABC'S OF UNIJUNCTION TRANSISTORS

by Courtney Hall

The solid-state unijunction transistor (UJT) makes possible the use of more simplified circuits with significantly fewer components. This text describes all the various types including CUT's and PUT's. Their use in many typical circuits is thoroughly explained for the service technician.

No. 20987 \$3.95

RADIO TRANSMITTER PRINCIPLES AND PROJECTS

by Edward M. Noll, W3FQJ

This helpful gathering of modern transmitter principles, ideas, circuits, techniques, and learn-by-doing projects is of benefit to the student, the practicing technician, the radio amateur, and those studying for FCC license examinations. Covers radio-frequency oscillators, multipliers, and amplifiers; all modes of modulation; all of the important electron devices; and the tuning and testing of transmitters.

No. 24031 \$6.95

EASI-GUIDE TO COLOR TV

by Forest H. Bell

This handy book answers the questions that present or prospective owners most frequently ask about color tv. It shows what to do to get the best color picture, how to save money on repairs, and where and how to buy. Follow its detailed and illustrated tips and you'll get maximum pleasure from your color tv.

No. 20938 \$3.50

EASI-GUIDE TO YOUR AUTOMOBILE

by Forest H. Bell

Shows, in nontechnical language, how and why your car works the way it does—and what you can do to keep it operating well and safely. It covers the car's electrical system, engine, carburetor, brakes, tires, battery, ignition system, maintenance, and safety precautions—things you seldom think about until something does wrong. With illustrations on almost every page, it is extremely easy to follow.

No. 20938 \$3.50

EASI-GUIDE TO CITIZENS BAND RADIO

by Forest H. Bell

If you're considering operating your own personal two-way radio communications system, this book is for you. It covers every phase: FCC rules; how to get a license; equipment you'll need and where to get it; terminology; installation in your car and home; operation and maintenance.

No. 20960 \$3.50

EASI-GUIDE TO BOAT RADIO

by Forest H. Bell

Marine radio is the best—and safest—method of communicating between power boats. This book gives you an above-average knowledge of its operation and use, its installation, maintenance and repair, and its rules and regulations.

No. 20958 \$3.50

EASI-GUIDE TO HI-FI STEREO

by Forest H. Bell

This book can help the reader avoid the mistakes frequently made by seekers of realistic music reproduction. It explains and discusses the maze of equipment variously labeled "hi-fi," "stereo," and "quadraphonic", and finally, guides you in putting together the right equipment for your home music system.

No. 20937 \$3.50

EASI-GUIDE TO SHORTWAVE LISTENING

by Forest H. Bell

In this all-embracing guide to the pleasure of "listening in" on the world via shortwave radio, the author explains—with pictures and nontechnical descriptions, the workings of a shortwave set, the proper equipment to install—and shows what to do and when to do it to get the best reception.

No. 20961 \$3.50

PC 103

HOWARD W. SAM'S & CO., INC.
4300 West 62nd Street, Indianapolis, Indiana 46268

Order from your Electronics Parts Distributor or mail to: Howard W. Sam's & Co., Inc. Send Letters of Credit through _____ enclosed. Please include tax when applicable. <input type="checkbox"/> Send FREE 1974 Sam's Book Catalog.	<table border="0"> <tr><td>20964</td><td>20936</td></tr> <tr><td>20841</td><td>20938</td></tr> <tr><td>20957</td><td>20960</td></tr> <tr><td>20980</td><td>20958</td></tr> <tr><td>20987</td><td>20937</td></tr> <tr><td>24031</td><td>20961</td></tr> </table>	20964	20936	20841	20938	20957	20960	20980	20958	20987	20937	24031	20961
20964	20936												
20841	20938												
20957	20960												
20980	20958												
20987	20937												
24031	20961												

Name _____

Address _____

City _____ State _____ Zip _____

CIRCLE NO. 34 ON READER SERVICE CARD

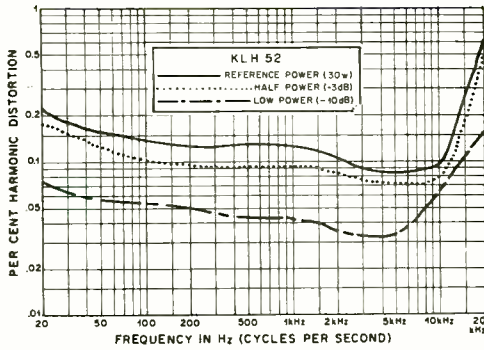

put was 42 watts/channel into 4-ohm loads and 21.5 watts/channel into 16-ohm loads. Harmonic distortion was less than 0.1 percent at all power levels up to 20 watts output and was only 0.15 percent at the rated output of 30 watts. The IM distortion was between 0.13 and 0.3 percent at all power outputs up to about 35 watts.

At the rated 30-watt output, the harmonic distortion was between 0.1 and 0.2 percent between 23 and 14,000 Hz and rose to 0.6 percent at 20,000 Hz. It was slightly lower at half power, typically about 0.1 percent with a maximum of 0.5 percent at 20,000 Hz. At a 3-watt output level, the distortion was much lower: 0.03 to 0.06 percent at most frequencies below 10,000 Hz and only 0.15 percent at 20,000 Hz.

Through the AUX inputs, our standard 10-watt reference power output was obtained with an input level of 0.31 volt and a signal-to-noise (S/N) ratio of 77.5 dB. The PHONO inputs required a 2-mV signal to generate a 10-watt output level with the exceptionally good S/N ratio of 76.5 dB. The phono preamplifier overloaded at a 55-mV input at 1000 Hz, which is a safe figure for any good magnetic cartridge rated at average output levels up to about 5 mV.

The tone control characteristics were hinged at about 1000 Hz and had a maximum control range of about ± 10 dB, which is adequate for almost any practical requirements. The high filter had a gradual 6-dB/octave slope, with the -3-dB response point being located at 2500 Hz. At low volume control settings, the loudness compensation boosted both lows and highs, the latter principally above 10,000 Hz. RIAA phono equalization was accurate within ± 0.5 dB from 50 Hz to 15,000 Hz and was an insignificant 1 dB down at 20 Hz.

The FM tuner surpassed all of its specifications. The IHF sensitivity checked out

at $1.6 \mu\text{V}$, with a 50-dB S/N ratio reached at only $2.5 \mu\text{V}$, and an ultimate quieting of 73 dB at inputs of $100 \mu\text{V}$ or greater. The distortion was approximately the 0.5-percent residual of our signal generator. In the stereo mode, the S/N ratio reached 50 dB at $20 \mu\text{V}$ and 73 dB at $100 \mu\text{V}$.

The FM frequency response was flat within ± 0.5 dB up to about 4000 Hz and dropped off slightly to -2.5 dB at 15,000 Hz. The overall flatness of ± 1.25 dB between 30 Hz and 15,000 Hz is well within industry standard tolerances. The stereo channel separation was very good, measuring a maximum of 47.5 dB at 1000 Hz and exceeding 30 dB between 80 and 15,000 Hz. Leakage of the 19,000-Hz pilot carrier signal into the audio outputs was a very low -76 dB relative to full modulation.

Other measured performance parameters were substantially better than the manufacturer's specifications. Capture ratio was 1.5 dB, image rejection was 68.5 dB, AM rejection was 64 dB, and alternate-channel selectivity was 55 dB. The FM muting came into action smoothly at inputs ranging from $3.5 \mu\text{V}$ to $7 \mu\text{V}$, and the automatic stereo/mono FM switching threshold was $2.8 \mu\text{V}$. The AM tuner's frequency response was flat to about 2000 Hz, was down 6 dB at 4000 Hz, and fell off more at higher frequencies.

User Comments. As the measured performance indicates, the KLH Model Fifty-Two is a very fine receiver. It sounded first rate and operated properly in all respects. Even the AM quality, usually not worthy of comment in the context of high-fidelity sound, was much better than average in its freedom from distortion and its frequency balance.

When the published specifications for

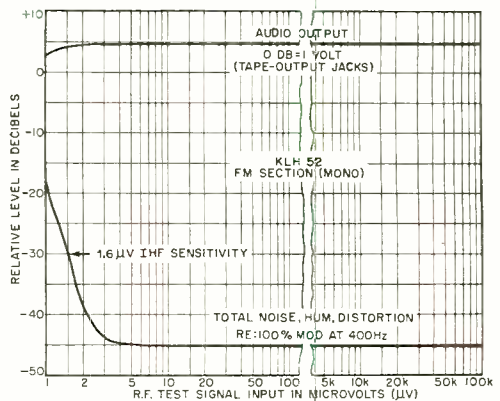

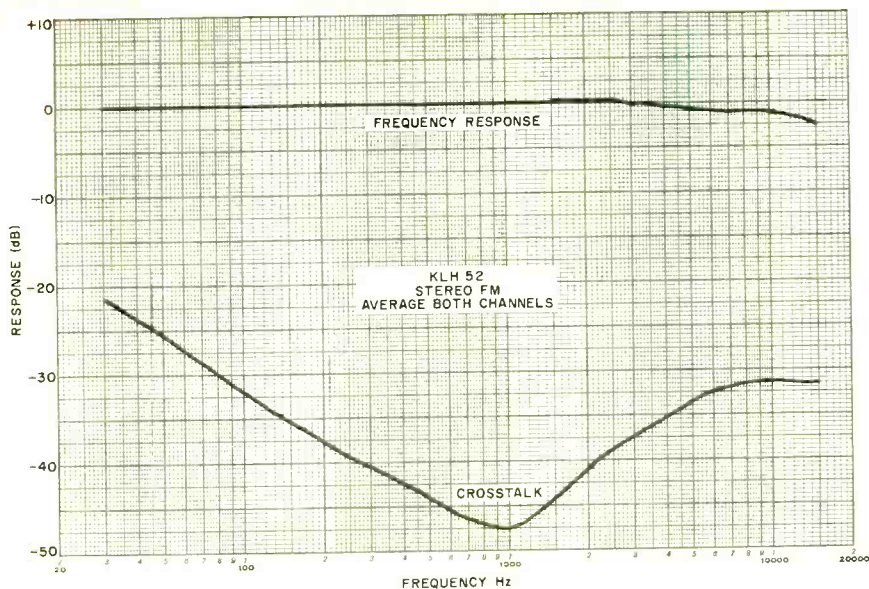

the Model Fifty-Two are compared with those of its competition, it is evident that few, if any, of the others selling for less than \$300 can match the Fifty-Two's combination of high output power, excellent FM sensitivity, and overall performance. This is especially noteworthy because the Model Fifty-Two surpasses every one of its specifications by a comfortable margin.

The operating manual that accompanies the receiver merits special comment. In its 44 pages, the usual installation and setup instruction material is given in better than

average detail. It also contains a wealth of general background information which answers most of the questions on hi-fi system installation that might be raised by a non-technical user. One section of the manual covers a logical step-by-step troubleshooting procedure that should enable anyone to localize the cause of any suspected malfunction, and—if it is not due to an actual defect within the receiver—to correct it. Throughout, the conversational style makes for easy reading, which is a great deal more than can be said for some "manuals" we have seen.

Circle No. 65 on Reader Service Card

AKAI MODEL 4000DS TAPE RECORDER (A Hirsch-Houck Labs Report)

THE Akai Model 4000DS is a compact open-reel tape deck and preamp with above-average performance specifications and operating features for a recorder in its price range of \$300. The deck is a four-track/2-channel stereo and monophonic unit with separate recording and playback heads and preamplifiers. It can accommodate reels up to 7 in. in diameter and has a single-motor transport that provides record/play speeds of 7½ and 3¾ ips.

The tape motion is mechanically controlled by means of a pair of levers, both of which are vertical when tape motion is stopped and the drive mechanism is disengaged. The left lever is turned clockwise to put the tape into normal forward motion; if a separate REC (record) button is pressed,



it can be set to the next clockwise position to permit recording. The second lever is

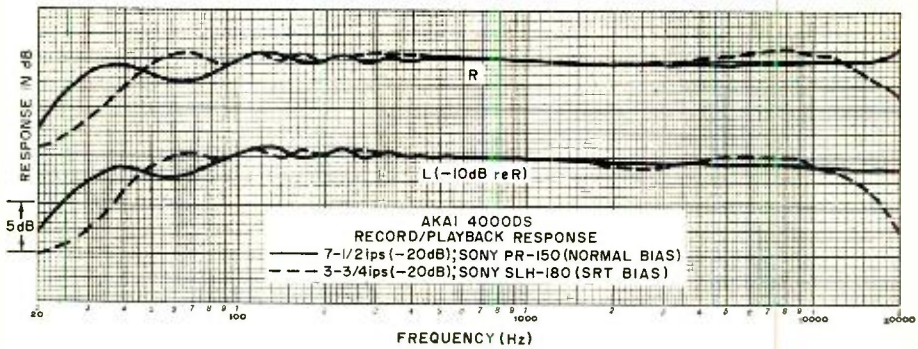

used for the fast-forward and rewind functions; it can be moved to either function only when the other lever is set to the off position. A PAUSE lever instantly halts the tape when it is activated. It locks into position, and pressing a nearby release button restarts tape motion.

The tape loading path is fairly straight, across the heads and between the capstan and a rubber pressure wheel. A small lever, resembling a tape tension arm, can be included in the tape path to provide automatic shutoff of the recorder when the tape runs out. If this feature is not needed, the shutoff lever can be disregarded.

The tape speed is changed from 3¾ to 7½ ips by installing a capstan bushing. When not in use, the bushing is stored on a post near the head cover. On the head cover is a switch for connecting the heads to provide stereo or four-track mono recording.

Along the lower portion of the panel are the electrical controls, including concentric microphone and line input level controls for each channel. The two sources can be mixed. Two illuminated VU meters indicate recording and playback levels. Rocker switches control source/tape monitoring, sound-on-sound recording, equalization for the two tape speeds, and bias for normal or "super-range" tapes. There is a headphone jack for 8-ohm phones and two 5000-ohm mike input jacks. In the rear of the recorder are the line inputs and outputs and a DIN connector.

Laboratory Measurements. The published specifications for the Akai 4000DS deck are extensive and will not be repeated here. Although they are of a caliber usually associated with higher priced decks, our laboratory tests revealed them to be very conservative.

The record/playback frequency response was measured with the Sony PR-150 (normal) and Sony SLH-180 ("super-range") tape formulations. At 7½ ips, the respective frequency response limits within ±3 dB were 23 to 24,000 Hz and 25 to 27,000 Hz. At 3¾ ips, the corresponding figures were 32 to 16,000 Hz and 33 to beyond 20,000 Hz. The playback equalization measured with Ampex test tapes was within ±1 dB of the NAB characteristic at both speeds.

The flutter was about half the rated limits, measuring 0.08 percent at 7½ ips and 0.11 percent at 3¾ ips. The tape speeds were slightly fast (rated ±2 percent). The playback distortion with a 0-VU recording level was less than 1 percent (rated at less than 1.5 percent). A distortion level of 3 percent, used as a reference for S/N measurements, was obtained at about ±10 VU—well off the meter scales. The meters tracked within about 1 dB of the Ampex standard recording levels, and their ballistic characteristics were slightly slower than the standard VU meter characteristic.

The unweighted S/N ratio varied from 52.4 dB with the PR-150 tape at 3¾ ips to 56.5 dB with the SLH-180 tape at 7½ ips.

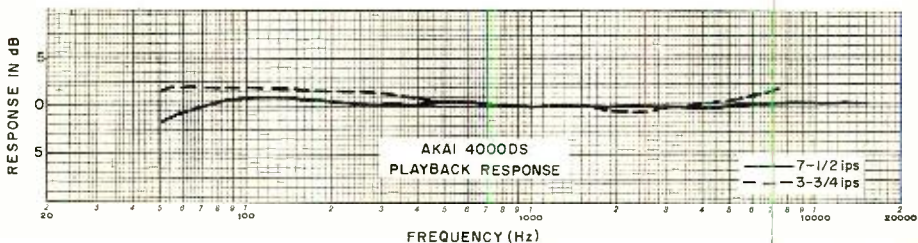

The rated figure is better than 50 dB. The noise increased by only 2.5 dB when recording through the microphone inputs at maximum gain. An input of 44 mV on line or 0.43 mV on mike was needed for a 0-VU recording; the corresponding output was at a fixed level of about 1.2 volts. The headphone output level was quite low and was not adjustable.

The mechanical operation of the recorder was smooth and positive. The PAUSE control introduced an audible start-up "wow." In common with most single-motor tape transports, the "fast" speeds of the 4000DS were rather slow. An 1800-ft reel of tape required four minutes to pass through the machine on fast-forward and about 3½ minutes on rewind.

User Comments. The Akai Model 4000DS recorder offers an excellent level of performance for the money invested. In fact, many recorders at double the 4000DS's price are not significantly better overall, although they might be superior in some specific characteristic.

The value of the 4000DS has apparently been achieved through the elimination of certain "convenience" features, such as the use of a single control to change tape speed and equalization. In return for the minor inconvenience of having to change a capstan bushing (and storing it when not in use) and remembering to select the proper equalization, one can enjoy superb open-reel tape quality in a machine that is priced below the better cassette recorders.

Circle No. 66 on Reader Service Card

RCA MODEL WV-529A MULTIMETER

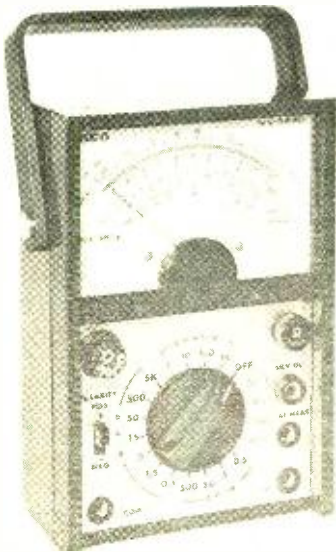

PHYSICALLY small multimeters are the backbone of the electrical and electronic service technician's "tool" box. These small general-utility instruments usually go along on all kinds of service calls where they are used for testing everything from TV receivers to air conditioners. To provide long service life, these instruments must be as rugged as they are electrically practical to bear up under such indignities as being tossed into trucks, tool caddies, and sometimes onto hard floors.

The latest small multimeter to come to our testbench was the RCA Model WV-

529A, available from RCA test equipment distributors for \$53.50. It reflects the image of its very useful predecessors. Its single rotary switch permits a selection of seven dc voltage ranges from 15 to 500 volts rms full-scale at an input resistance of 20,000 ohms/volt. Four ac ranges are provided for 15-500-volt rms full-scale tests with an input impedance of 10,000 ohms/volt and a frequency range of 10 to 100,000 Hz. Four dc ranges (0.5 to 500 mA full-scale), four resistance ranges (RX1 to RX1K), and a decibel scale for making measurements between -10 and +25 dB round out the function/range complement.

The three meter scales are color-coded to provide easy readability and aid in interpreting test results. Resistance measurements are made on the green scale, voltage and current measurements on the black scale, and dB readings on the red scale.

Mechanically, the multimeter measures 6 7/16" by 4 1/8" by 2 1/8" and weighs about a pound. The instrument has a high-impact plastic case into which the meter movement and operating controls are recessed to obviate any damage when it is lying on its front surface. The carrying handle is hinged to provide a convenient tilt stand while the user is making measurements. The taut-band meter movement is diode-protected against damaging overloads. As a further bonus, RCA has designed into the instrument a convenient front-panel polarity reversal switch to eliminate the need for making constant lead transpositions when making mul-

multiple tests. This switch not only makes possible easy measurements of either positive or negative dc voltages, but it also reverses the battery polarity in the resistance function, to permit fast checks on semiconductors.

An optional high-voltage probe, the Model WG-297, in conjunction with a Model WG-442A multiplier resistor, can also be used with the multimeter to extend its high-voltage measuring capability to 50,000 volts.

User Tests. We checked out the WV-529A in accordance with our "standard" VOM test. This consists of dc voltage measurements against our laboratory standard and resistance checks against a series of 0.1-

percent precision resistors. In both tests, the multimeter came within its specified tolerances. It was then subjected to our "drop test" for instruments claiming "high impact resistance" — three feet from the workbench top to a hardwood floor. The instrument survived the test and remained within its voltage and resistance specifications.

One more test was forthcoming—the hardest one. The WV-529A spent two weeks in a service vehicle where it was given a good wringing out and subjected to the usual bumps and shocks that occur during a busy couple of weeks. It survived and performed nobly throughout the period. We feel that this new instrument from RCA is a worth-while addition to the electronics technician's toolbox.

Circle No. 67 on Reader Service Card

REALISTIC MODEL TRC-46 AM/SSB CB TRANSCEIVER

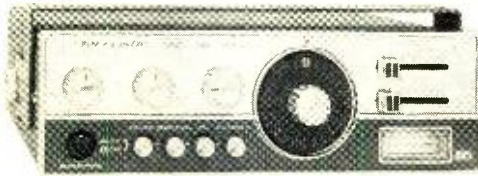

RREALISTIC'S Model TRC-46 is a 23-channel, crystal-synthesized transceiver that offers the Citizens Band user a choice of operation on single sideband (upper or lower) as well as traditional AM. Consequently, the CB'er obtains the superiority of SSB communication, which under equal limitations and conditions can provide a 9-dB advantage over AM. How this is possible is simply explained in an easy-to-understand manner in the operating manual provided with this rig.

Since the TRC-46 is not restricted to SSB operation, it still permits contacts to be made with stations limited to AM operation. In addition, the rig can be used as is, operated from a 117-volt ac line, as a base station, or as a mobile unit when operated from a 12-14-volt dc supply. No separate power is needed for ac operation because the supply is built into the rig and is electronically regulated.

Circuit Details. Bipolar transistors are used in the r-f amplifier/mixer section of the receiver for both the AM and SSB modes. Individual i-f sections and detectors are used for each mode.

Single conversion is employed for SSB, with an 11,275-kHz i-f that ensures fine image rejection (tested out at 90 dB). The SSB sensitivity with this setup was $0.2 \mu\text{V}$ for 10 dB $(S+N)/N$. This i-f section incorporates a 2.1-kHz crystal-lattice filter that provides a 6-dB overall output bandpass of 500 to 2600 Hz, and an unwanted-sideband suppression of at least 80 dB at 1 kHz. The SSB detector is a diode-ring demodulator with upper- or lower-sideband carrier reinsertion obtained from individual crystal-controlled oscillators.

Dual conversion is utilized on AM, with an 11,275-kHz first i-f converted to a 455-kHz i-f where a four-element ceramic filter provides an overall 6-dB bandpass at the receiver output of 450 to 3500 Hz for crisp voice quality, while maintaining an i-f skirt selectivity of at least 70 dB down at the adjacent channel.

A phenomenon not mentioned in our previous reports is desensitization by an undesired adjacent-channel signal that is stronger than the desired one. This is more indication of the overall effective rejection of adverse interference by such a signal. With the TRC-46, the undesired adjacent-channel signal had to be down 30 dB to avoid interference. This is the minimum EIA standard. The AM sensitivity was $0.5 \mu\text{V}$ for 10 dB $(S+N)/N$.

A conventional diode detector and agc are employed in the AM section. The agc was quite flat, allowing only a 4-dB maximum a-f output change with signals above

10 μ V. Under the same conditions, an SSB agc holds the output to within 10 dB.

A noise blanker ahead of the crystal filter is provided for SSB and attenuates impulse noise by about 15 dB. For AM, there is a series-gate a-f and which, although it cut down noise, also dropped the level of weak signals and distorted them.

A common a-f section is engaged for both modes of operation. This ends up with a class-B stage. It is also used for modulating the transmitter as well as for PA operation. Power output is rated at 4 watts with 10 percent distortion, at which point clipping was observed. But with 3.25 watts into 8 ohms, the waveform was good, exhibiting only 4.5 percent distortion at 1000 Hz.

Other Features. A handy feature, particularly in mobile service, is a remote volume control installed in the mike case. This is switched in by a pushbutton on the transceiver. It functions as well for PA operations.

An r-f gain control is furnished to minimize overload and distortion on strong signals. There is also a sensitivity control for the squelch, operating on both AM and SSB. The range was 0.35-1000 μ V. These controls are operated by sliding a lever from one side to the other.

An edgewise meter registered S9 with a 100- μ V SSB signal (1000 μ V on AM). The meter automatically doubles as a relative-output indicator for the transmitter, illuminated in white on receive and switching to red on transmit while varying in brilliance in step with the modulation.

The frequency synthesizer employs 14 crystals and a balanced mixer with a band-pass filter to minimize spurious responses. A clarifier control allows the frequency of both the transmitter and receiver to be shifted (on both AM and SSB) by an amount varying from -650 Hz to +900 Hz about the center frequency which was within 200 Hz on all channels.

The SSB signal is generated by the receiver's demodulator (used as a balanced modulator), SSB filter, and first i-f stage. The signal is then combined at a mixer with the synthesized signal, the result being applied to the r-f amplifier setup, the power amplifier for which includes an output-matching and harmonic-attenuation network with a 50-ohm output impedance. An automatic level control system is included to minimize overdriving the power amplifier. Operating

FREE!

LAFAYETTE 1974 CATALOG 740



Ready
Now!

The World's Largest Consumer Electronics Catalog

Everything In Electronics for Home, Business, Industry

- Stereo/Hi-Fi Components • Musical Instruments and Amplifiers • CB & Ham Equipment • Tools and Test Equipment • Police and Fire Monitor Receivers • Public Address Systems • Photography Equipment • Semiconductors, Books, Parts • Plus Much More!

Your Complete Electronics Buying Guide

Send
Today!

Lafayette Radio Electronics
P.O. Box 10, Dept. 35103
Syosset, L.I., N.Y. 11791

Send FREE 1974 Catalog

35103

NAME _____

ADDRESS _____

CITY _____

STATE _____

ZIP _____

CIRCLE NO. 22 ON READER SERVICE CARD

from a 117-volt ac or a 13.8-volt dc source, the PEP output measured 7.25 watts with third-order distortion products down 25 dB below the peak output. Carrier suppression was a minimum of 50 dB and unwanted sideband suppression was as on receive.

The same r-f section is used for AM with both the driver and power amplifier collector-modulated. The carrier output was 4

watts with 100 percent modulation obtainable with good waveform and 7.5 percent distortion which, with 10 dB of built-in clipping, rose to 10 percent.

The TRC-46 AM/SSB CB transceiver from Radio Shack retails for \$330. This price includes a detachable microphone, mobile mounting hardware, power cables, and a spare fuse.

Circle No. 68 on Reader Service Card

JAMES MODEL C-8600 ELECTRONIC THERMOMETER

ALTHOUGH it isn't strictly a piece of test gear, we found the Model C-8600 electronic thermometer from James Electronics, Inc., so useful that we would like to bring it to the attention of electronics hobbyists and experimenters. This \$40 unit is housed in an attractive walnut-finished case and measures 6¾ in. by 4½ in. by 3½ in. It is powered by a single 1.5-volt D cell and comes with a pair of temperature sensors—one with 18 in. of slender two-conductor cable attached to it and the other located at the end of a similar 15-ft-long cable. The electronic thermometer has provisions built into it for selecting up to three sensors (additional sensors and extension cables are available as options).

The temperature range of the thermometer is calibrated for from -22° F to +122° F and from -30° C to +50° C. There is no need to switch from °F to °C or vice versa since the scales are accurately laid out with reference to each other on the meter face. The probe tips, about the size of the head of a kitchen match, can be immersed in water and most other liquids. Through the use of extension cables, they can be located up to 1000 ft away from the thermometer's electronics package.

Calibration of the thermometer is simple. A conventional meter zero screw is adjusted for pointer position at the upper end of the range, while a potentiometer located on the rear of the instrument is adjusted to set the meter's pointer to -30° C when no probes are plugged into the inputs. No other instruments or test gear are needed for calibration.

Many Uses. We found that the Model C-8600 compares favorably and accurately with a known good mercury bulb thermometer that we have been using for years in our photographic darkroom. Besides enabling us

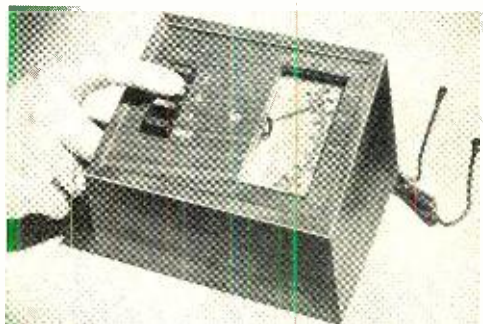

to check the conventional indoor and outdoor temperatures, we were able to keep tabs on the water temperature in our tropical fish aquarium and to check periodically the air conditioners around the house. Other suggested uses include keeping tabs on chicken or fowl incubators, freezer compartments, garage temperatures, attic temperatures, and even the temperatures in a hot-house. On the workbench, we used the probe in contact with transistor heat sinks to monitor the temperatures during long measurement tests.

Maintenance of the electronic thermometer is limited to the replacement of the single D cell. The life of this battery is expected to be about one year if the thermometer is used continuously, and a few years (essentially shelf life) if the thermometer is used intermittently.

The switches used are of the self-cleaning type and no difficulty should be experienced in this area. The cabinet can be cleaned with a damp cloth.

All in all, we found that an electronic thermometer is so generally useful around the house and in the workshop that we feel the James Model C-8600 electronic thermometer to be a worthwhile investment.

Circle No. 69 on Reader Service Card



About the New RCA Color Receivers

By John T. Frye, W9EGV, KHD4167

"IT'S kind of like GM's putting out an El Dorado Cadillac with racing stripes and mag wheels," Mac said.

"What is?" Barney asked, glancing up from the digital clock he was troubleshooting with a logic probe. Mac was perched on a stool thumbing through a great stack of RCA service literature and press releases.

In-line Picture Tube. "I mean it's startling to see RCA, who really made color TV possible over twenty years ago with their shadow-mask, delta-gun, triad-dot picture tube—a tube that became and remained the standard of the industry for almost two decades—coming out with a new tube that has an in-line gun, a spherical mask with cross-braced vertical slits, and color phosphors deposited on the screen in vertical stripes."

"Yeah, I read about RCA's new in-line tube in the July *POPULAR ELECTRONICS*. Why do you suppose RCA jumped into the in-line tube business after all these years of continued success with their reliable delta gun tube?"

"Probably they were like the paratrooper recruit who was being congratulated on having made his first jump. 'I didn't really jump,' he modestly admitted; 'I was pushed.' The Sony Trinitron and GE's Porta Color—to name only two of the in-line tubes—have been very well received in the portable color TV field; so RCA needed to come up with something that would permit it to compete in price and quality. Fortunately, they were able to develop their Precision In-Line tube.

"How many of their sets use this new tube?"

"Only two, so far: a 15" and a 17" portable in the XL-100 line. (That 'XL-100' means the set is 100% solid-state, as are three-fourths of all RCA's color receivers.)

But RCA produces a 19" in-line tube that is being used by other set manufacturers, and a 13" version is in the works. While the tube is ideal for solid-state portable sets, at the present stage of development there are no apparent plans to build it in larger than the 19" version."

"Why is it so hot for portables?"

"It's shorter, lighter, less expensive to manufacture, and requires less chassis circuitry. It has ITC, or Integral Tube Components. That means yoke and neck components are permanently attached to the tube at the factory and are adjusted for optimum static convergence, purity, focus, and white uniformity. There are no dynamic convergence components or adjustments at all, for the tube has what RCA calls 'inherent self-convergence.' That means the setup for a receiver using an in-line tube is almost as simple as that for a black-and-white set. This is made possible by a Precision Static Toroidal (PST) yoke. This yoke has molded plastic rings cemented to each end of the core, and each turn of wire is precisely placed into winding grooves of these rings. When the yoke is accurately positioned at the factory and cemented in place, the convergence stays put. The tube is very little affected by the earth's magnetic field."

"If the yoke goes bad, do you have to throw away the whole tube?"

"No. The yoke is fastened in position with thermoplastic cement that can be heated for removal of the yoke. However, replacement in the field is not practical. The tube should be returned to the factory for installation and adjustment of a new yoke for optimum performance. Actually, PST yoke failure is very unlikely because of its necessarily exact construction. Convergence variations in PST yokes are less than half those observed with saddle yokes."

"I thought other in-line tubes required some dynamic convergence adjustments."

"You're right. The Trinitron has two adjustments; the Porta-Color requires four adjustments. This compares, as you know, with up to twelve dynamic convergence adjustments in the delta-gun tube."

"Are those in-line tubes of the black matrix type with black guard bands surrounding the phosphor stripes?"

"The 17-in. one is. Incidentally, sets with in-line tubes are called 'Acculine' models by RCA. Those that are solid-state in many ways but are not 100% solid-state are called 'XL-Color.' RCA's twelve plug-in circuits are called 'AccuCircuit Modules,' and this name covers both discrete plug-in units and encapsulated plug-in units. When a module fails, it is intended to be replaced with a new one.

RCA calls its black matrix conventional delta-gun tube a 'Super AccuColor' picture tube. This tube is used in all 19", 21" and 25" XL-100 models and in selected 19" XL-Color models. All 25" consoles use the XL-100 chassis. Large-screen XL-100 models have built-in self-regulation features which serve to monitor and compensate for line voltage fluctuations. This feature becomes increasingly important as our straining electrical generating plants have difficulty in maintaining a stable voltage.

"The company offers three new home entertainment centers with Super Accu-Color 25" picture tubes and XL-100 chassis as well as stereo phonographs and built-in 8-track tape players. All have 'Dimensia IV Spacial Sound Enhanced Stereo' which permits extending the conventional stereo sound through phase adjustment circuitry to two optional rear speakers.

"Seventeen different models can be had with remote control that changes channels, adjusts volume, and turns the set on and off. This can be had down to 19" models. A brand-new remote control called 'Instant Electronic Tuning' that employs silent varactor tuning is available this fall on two consoles.

"Many cable TV systems are increasing their capacity beyond 12 vhf channels, and RCA is ready for them with five new 25" XL-100 cable TV receivers. These sets are equipped with shielded tuners and circuitry for receiving up to 24 cable channels or 12 vhf and 12 uhf 'on-air' channels. Note these receivers will receive broadcast signals normally, but they can also receive

extra cable channels without the use of a converter. Furthermore, four of these sets have 'Signal Sensor' remote control that allows you to select any of the 24 channels, adjust the volume, and turn the set on and off."

Barney had picked up some of the literature and was leafing through it. "It looks



The CRT at left is a picture tube used in 1954, in the pioneer days of color TV. At the right is the much more compact 15-in. in-line tube being used in new RCA portables.

to me," he observed, "as though RCA offers twelve XL-Color models, thirty-one XL-100 consoles, five XL-100 CATV receivers, three XL-100 Home Entertainment Centers, and two XL-100 Instant Electronic Tuning models. That makes a total of fifty-three models from which the customer can choose. He certainly should be able to find something he likes."

Some Service Suggestions. "I agree," Mac said. "I was just looking through the service data on the 15" receiver, and I see several service suggestions that could well apply to servicing most new solid-state color receivers. Let me give you some 'instances':

"Always connect the ground lead of a test instrument to the chassis before connecting the positive lead; conversely, always remove the ground lead of a test instrument last.

"Turn off the set before removing or replacing any module on the signal circuit board.

"The line voltage must be removed from the chassis and the +140-volt supply must

be discharged with a 10-ohm, 5-watt resistor before removing or replacing the horizontal or vertical modules.

"If the set is operated with a module removed, to prevent circuit damage from transients, the B-plus supplies to that module must be discharged before replacing the module in its socket. The power supply electrolytic capacitors will maintain almost the full B-plus voltage after the ac power is turned off because there is no 'bleeder' path. As an example, if this receiver is operated with the horizontal oscillator or the vertical sweep module removed, the sync separator transistor may be damaged when either of these modules is replaced, even though the ac power is off.

"Do not bridge electrolytic capacitors since resultant surges may damage solid-state devices.

"All soldering irons used with transistors and IC's should be 25-watt irons grounded so that no voltage will be applied to the solid-state device during the operation. This is to prevent possible damage to the device due to excessive heat or voltage.

"If an ac interlock feature is incorporated in the yoke plug and socket, do not defeat

this interlock feature. Turning on the receiver with the yoke unplugged may do considerable damage.

"Do not arc the high-voltage anode or B-plus voltage to chassis ground. This produces voltage and current transients that can clobber solid-state devices.

"Do not use spray-type chemical troubleshooting aids (especially circuit coolants) in the vicinity of module sockets. Some chemicals used in the manufacture of such aids attack the socket material and cause failures."

"Hey! A couple of those are ones I hadn't thought about," Barney admitted. "They certainly underscore the fact that a technician should be careful about trying to transfer all of his tube-type troubleshooting techniques to the new solid-state stuff. With tubes, you usually have some pyrotechnics to warn you that you've goofed; but a transistor or an IC can give up the ghost very quietly—but just as permanently. In medicine they have a word 'iatrogenic' that refers to a physician-caused illness. It is very easy for an inexperienced technician to produce many 'iatrogenic' troubles in modern solid-state equipment." ♦

NOW! YOU CAN HAVE YOUR OWN PROFITABLE ALARM/SECURITY BUSINESS

Prepare at home without risk to job!

An alarm dealer in California reported in a trade publication that he had installed 200 residential alarm systems in one year with little or no sales effort. "They just kept calling us faster than we could handle them all."

Make no mistake about it, there is great demand for new security and alarm installation businesses everywhere in the U.S.A. Yet, now you can learn everything necessary about the installation and servicing of systems, about getting customers, making estimates, running your business profitably,

right at home in state-approved training that qualifies you either for your business—or a highly-paid position in the alarm industry.

Not only can you make big money—but you can have the personal satisfaction of helping make America a better, safer place.

The course is complete in every way. There are no extras. Even the special professional tools and equipment enough to do your first job are included. Mail coupon for full information, FREE! No salesman will call.



SECURITY SYSTEMS MANAGEMENT SCHOOL

Division of Technical Home Study Schools
Dept. 7246-103 Little Falls, N.J. 07424.

N.J. State Approved Diploma Awarded

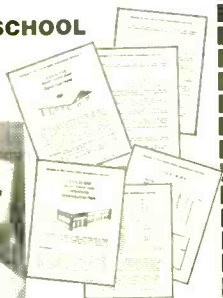

**Security Systems Management School
Div. Technical Home Study Schools
Little Falls, N.J. 07424. Dept 7246-103**

RUSH ME FREE INFORMATION ON OPPORTUNITIES IN THE ALARM AND SECURITY INDUSTRY and about your home training. No obligation! No salesman is to call.

Name _____

Address _____

City _____

State/Zip _____

CIRCLE NO. 39 ON READER SERVICE CARD

DO YOU KNOW YOUR BIPOLAR TRANSISTORS?

CONCLUSION OF A 3-PART SERIES ON BASIC TRANSISTOR THEORY

By **LOTHAR STERN**, Motorola Semiconductor Products Inc.

Newer Processes. Among new techniques, the latest process (see Fig. 15) diffuses controlled-geometry base and emitter regions into the collector layer and covers the entire device with a protective coating of silicon dioxide to eliminate impurity contamination. It permits operation at extremely high frequency, high voltage, and high current and provides good reliability at low cost.

For small-signal, low-frequency transistors, the epitaxial planar structure with annular ring is by far the most widely used. For high-power applications, however, other processes are often employed to optimize characteristics needed for special requirements. Figure 16 shows the most common power-transistor processes.

At very high frequencies, power transistors take on very complex geo-

metries to compensate for current crowding. The latter restricts the emission of charge carriers to the edges of the emitter at high current levels. With rectangular or round emitters, therefore, the center portion of the emitter does not contribute to current emission, but it does add parasitic capacitance which reduces high-frequency response. High-frequency structures, therefore, have very long, thin emitters which may be folded many times to fit within a given base area. (Fig. 17) This greatly increases the ratio of emitter periphery to base area, thereby maximizing the emission-to-capacitance ratio. These extremely complex structures stress present processing technology to its limits, accounting for the rapid increases in prices as frequency capabilities of power transistors go beyond 100 MHz.

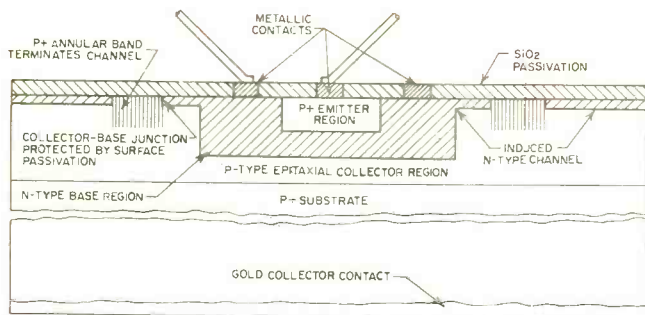
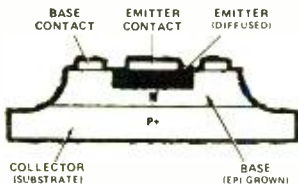

Fig. 15. Latest process is epitaxial planar with annular ring.

EPI-BASE STRUCTURE



Achievable Characteristics

Collector Current – to 50 A
 Breakdown Voltage – to 140 V
 Safe-Operating Area – Excellent
 Current-Gain – Bandwidth – to 10 MHz
 Available Conductivity – NPN, PNP
 Main Feature – Versatility
 Main Application – All

SINGLE-DIFFUSED STRUCTURE

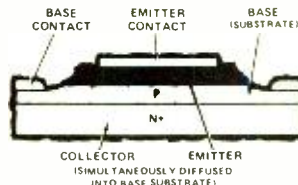

Achievable Characteristics

Collector Current – to 30 A
 Breakdown Voltage – to 140 V
 Safe-Operating Area – Excellent
 Current-Gain – Bandwidth – to 2 MHz
 Available Conductivity – NPN only
 Main Feature – Ruggedness
 Main Application – Power Supply Regulators

TRIPLE-DIFFUSED MESA STRUCTURE

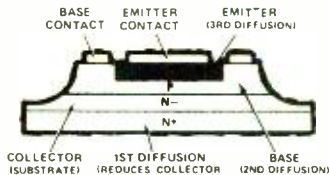

Achievable Characteristics

Collector Current – to 10 A
 Breakdown Voltage – to 1500 V
 Safe-Operating Area – Good
 Current-Gain – Bandwidth – to 10 MHz
 Available Conductivity – NPN only
 Main Feature – High Voltage
 Main Application – TV Deflection

DOUBLE-DIFFUSED STRUCTURE

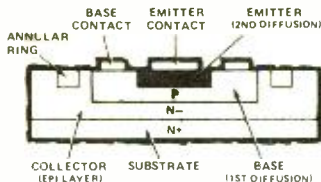

Achievable Characteristics

Collector Current – to 30 A
 Breakdown Voltage – to 200 V
 Safe-Operating Area – Low
 Current-Gain – Bandwidth – to 150 MHz
 Available Conductivity – NPN, PNP
 Main Feature – High Speed
 Main Application – High Speed Switching

Fig. 16 Cross sections of the processes employed in making transistors for power applications, with some characteristics.

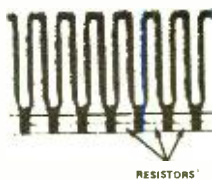
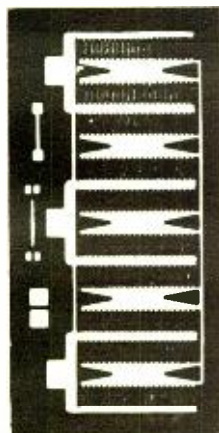

Typical high-frequency transistor structure has INTERDIGITATED geometry. Complex structure is due to large number of separate emitters all interconnected to form a single transistor. Resistor depositions equalize current to the individual emitter areas.

RELATIVE CHARACTERISTICS OF RF STRUCTURES

GEOMETRY	ADVANTAGES	LIMITATIONS
Interdigitated	High emitter periphery to base-area ratio, (≈ 7.0). Low r_b' . Adequate manufacturing experience. Easily balanced with emitter resistors.	Processing critical due to narrow interdigitated fingers. Limited to relatively low currents due to narrow metal stripes.
Overlay	Wider fingers for higher current capability. Reduced manufacturing difficulty.	Higher r_b' and considerable emitter-base parasitic capacitance limits high-frequency response. Relatively low P/A ratio, (≈ 4.0). Emitter balancing difficult.
Network Emitter	Wide metal fingers. Highest P/A ratio, (7.0 to 8.0).	High contact resistance. Emitter balancing difficult. Processing critical.

Fig. 17. At very high frequencies, power transistors take on some very complex geometries to prevent current crowding. Characteristics of structures are at right.

free

OVER 93
FAMOUS-NAME
ELECTRONICS
PRODUCT LINES...
MOST FULL COLOR!

1974 VALUE PACKED Olson® Catalog

SAVE ON EVERYTHING*
IN ELECTRONICS FROM
THE WORLD'S LARGEST
SELECTION OF THE BEST
OF THE FAMOUS-NAME
BRANDS — PLUS
EXCLUSIVE OLSON
VALUES AND SERVICES



Your Complete
electronics buying guide
for home or business...
Over 8,000 Quality-Tested items
fully described and illustrated.

free Send today

Olson. electronics

260 S. FORGE ST.
AKRON, OHIO 44327

Send Me My FREE 1974 Olson Catalog

Name (print) _____

Street _____ Apt. _____

City _____

State _____

Zip

Send a FREE 1974 Olson Catalog to
My Friend

Name (print) _____

Street _____ Apt. _____

City _____

State _____

Zip

for the electronics in your life

NEW 1974 OLSON CATALOG

free

Shop in the comfort of your own home.
Order by mail with complete confidence—
through the catalog or at any of our
stores nationwide.

SAVE ON THE NEWEST AND THE BEST IN FAMOUS-NAME

- Stereo and 4-Channel Sound Systems
- Tape Recorders and Accessories
- Radios
- Phonos
- Kits
- Amateur and Shortwave Gear
- Citizens Band
- Antennas
- Police/Fire VHF-UHF Radios
- Security
- Test Equipment
- Electronic Calculators and Timepieces
- 1000's of Parts, Tubes, Batteries, Wire, Hardware

PLUS exclusive Teledyne and Olson Audio Products



mail this card
today for your
free
catalog



Olson®

the **VALUE** leader since 1931

Stores Nationwide
Check your yellow pages.

PLACE
STAMP
HERE

Olson® electronics Dept.-IM

260 S. Forge St.
Akron, Ohio 44327



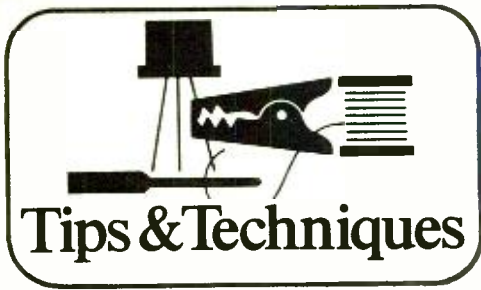

HOW TO ADAPT SAME-TYPE COAX CONNECTORS TO EACH OTHER

Not all electronics hobbyists are aware of the ease with which lengths of coaxial cable equipped with male connectors can be connected in series with each other. The trick is to use a double female connector between the two

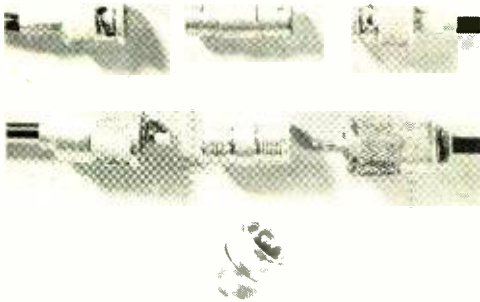

same-type connectors. In the top row of the photo is shown a pair of BNC connectors flanking the UG-914/U adapter that makes short work of connecting them together. The middle row shows a pair of PL-259 connectors and their corresponding PL-258 adapter. The item shown in the bottom row is a double male adapter that can be used to join together a pair of female connectors such as found mounted on chassis. —Marshall Lincoln

WIRE PREVENTS TURNBUCKLE SLIPPAGE

When using a turnbuckle with a guy wire, like as not you'll have to periodically tighten it because the darn things never seem to stay put. They work loose in the slightest breeze. However there is a way to circumvent the loosening problem. All you need is a length of heavy-duty wire (insulated solid electrician's wire or guy wire is excellent). After you tighten the turnbuckle to your satisfaction, simply slip the wire through the rings and center of the turnbuckle. If possible, have the wire long enough to permit it to be wrapped around the guy wire. This fix-it is permanent until you're ready to take down the guy wire, at which time it is easily removed. —Richard Mollentine, WAØKKC

DUAL-PURPOSE SAFETY FLASHER FOR AUTOMOTIVE AND OPEN-PIT USE

The dual-purpose safety flasher shown in the schematic can be used anywhere a hazard or potential hazard exists. With the switch on AUTO, oncoming headlights will illuminate the photocell and trigger the circuit, while in the CONT. mode, the light will flash independent of

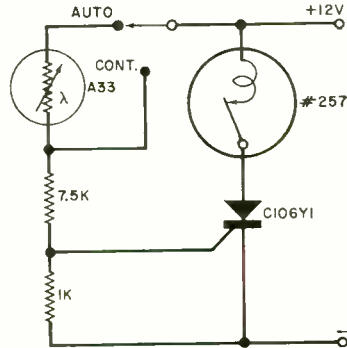

any oncoming light. The switch should be set to AUTO in a disabled car parked on a lonely road to conserve battery power. On a heavily trafficked road or highway where traffic is flowing at high speed, it is safest to put the switch in the CONT. position to provide long-distance warning to oncoming traffic. You can also use the flasher wherever you want to warn pedestrians and motorists of open-pit excavation: leave it in the CONT. mode. —Rudolf F. Graf

ELECTRICIANS' SOLID WIRE BECOMES EMERGENCY SOLDERING GUN TIP

Comes Saturday night and you're at your workbench busily assembling your latest project when the soldering gun tip suddenly parts. You search frantically for a new tip but can't find one, and all the stores are closed. So, what do you do? If you have some 14-gauge or larger solid electrician's house wire handy you can jury-rig a tip that will see you through the emergency. Strip away the insulation and cut the wire to approximately the same length as the original soldering gun tip. Form the wire into a rough tip, fit it into the soldering gun, and you're ready to resume work. The jury-rigged tip won't last long, but it will work until you get to the store to buy new tips. —D.J. Backstrom

TIPS WANTED

Do you have a "tip" or "technique" that might help your fellow readers? It may be worth money to you. Send it in (about 100 words, with a rough drawing and/or clear photograph, if needed) and you'll receive payment if accepted. Amount depends on originality and practicality. Material not accepted will be returned if accompanied by a stamped, self-addressed envelope. Send material to: Tips and Techniques Editor, POPULAR ELECTRONICS including Electronics World, 1 Park Ave., New York, NY 10016.

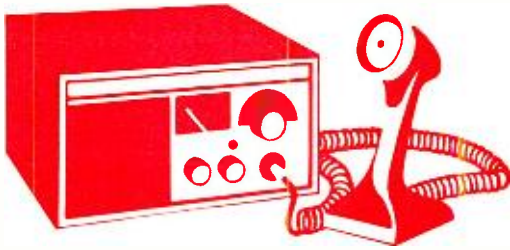

CB Scene

By Matt P. Spinello, KHC2060

IN a letter received at ALERT National Headquarters in Washington, D. C., a San Francisco woman asked: "Just exactly who and what are you people? What do you do? Are you some kind of night patrol?" The inquiry grew out of a situation involving a flat tire the woman experienced at 3:30 a.m. on a one-way bridge. "About 4:00 a.m.," her letter continued, "this white station wagon with a big antenna came toward me. When (the man) stopped and got out of the car. I saw a gold badge on his hat and one on his shirt . . . which set my panicky heart at ease. He threw his hat in his car and donned an orange helmet and a yellow rain jacket, turned on a set of red flashing lights and set them on the roof of his car. For some reason, having seen that badge and full uniform, I felt safe.

"He came over and changed the flat tire, and he was humming and whistling as he worked. He gave me a cigarette and some hot coffee from his thermos. Man alive, he acted like helping people was just another commonplace, everyday experience for him. He was the most cheerful and friendly person I have ever met. I am writing to you to say 'Thank you, Unit 127', for I really appreciated what you did for me."

According to ALERT President Robert Thompson, KLM9374, team members throughout the United States assist people

daily, "acting like helping others was just another commonplace, everyday experience, and in a most cheerful and friendly manner." The San Francisco woman's thanks for assistance by an ALERT team member is one of thousands on file in the association's Washington headquarters. It is considered typical of many letters that are received almost daily.

ALERT, an Affiliated League of Emergency (CB) Radio Teams is 10,000 members strong, represented in all 50 states by its 400 emergency teams. As one of the two largest national emergency organizations in the country, its goals extend far beyond the distribution of decals, arm patches, and paraphernalia that have all too often been the main inducement to join other so-called national organizations, the majority of which have disappeared almost as quickly as they were announced.

In addition to the administration efficiency of its president, Robert Thompson, and his assistant, Diana Helmstetler, another key to ALERT's success is the site of its national headquarters in Washington, D. C. Strategically located to surround itself with federal agencies and national organizations, ALERT offers its membership—and follows through with—a "your-voice-in-Washington" concept. Where other by-the-wayside national CB groups have promised to "take the CB'ers voice to Washington in great numbers," ALERT lives in the shadow of the governing bodies that generate federal law.

A local telephone call, prepared correspondence, or pre-arranged in-person visits to federal agencies by its administrator—on a daily basis if necessary—can more effectively "voice" the needs, objections and/or recommendations of an association of 10,000 Citizens Radio users than can several widely spread exchanges of correspondence over a period of months.

ALERT: National CB Association

Alert's President Bob Thompson is undoubtedly one of the nation's most involved CB'ers. It is common to find him criss-crossing the U. S. visiting ALERT teams, speaking at national association gatherings, and problem-solving at trouble spots. Soft-spoken, but easily riled by negative conditions that threaten the orderly operation of the Citizens Radio Service, Bob admits that ALERT is not without problems—which he accepts as a part of any major organizational undertaking. He is convinced, however, that association in large numbers is what is needed to protect the rights of lawfully operating CB'ers; that a standardization of organizing and operating citizens' emergency teams is essential to effective utilization of team efforts; and that regular exchanges of information regarding how CB teams function as public-service organizations throughout the U. S., how proposed rules changes might affect the licensed CB user, and news specifically of interest to the Citizens Radio Service user, are essential in strengthening the bond between local, state, and national authorities and assistance-minded organizations such as ALERT.

To effectively practice what it proposes, ALERT is in frequent contact with the Federal Communications Commission, keeping abreast of federal attitudes and gathering data for distribution to its membership almost before the ink is dry. In its welcoming letter to new league members, ALERT boasts an established recognition by the FCC and invites members to contact national headquarters in the event they encounter illegal use of the frequencies in their area or find themselves eye-to-eye with FCC credentials at their front door. In any instance, ALERT indicates that it is standing-by and available to help.

ALERT does not limit its inquiries on behalf of its membership (and Citizens Radio users in general) to the FCC. President Thompson has been known to direct his organization's objections and requests for action to President Nixon. Bob is familiar to, and in contact with, Congressmen who are sympathetic to the needs of the CB service.

Local Level. At the local level, ALERT extends an organizational hand to existing CB clubs and/or individuals who wish to utilize Citizens Radio frequencies more effectively, serve where needed with emergency communications and personal assistance, and organize with others who share a



... BUILD YOUR OWN CIRCUIT DESIGNER, WITH ALL THE OUTSTANDING FEATURES OF EXPENSIVE MODELS ... AT A LOW BUDGET PRICE.

THE DIGI DESIGNER

This compact package contains a regulated 5VDC supply, selectable frequency clock, E&L-socket, dual bounce-free pushbuttons (pulsers), 4 slide switches for voltage/ground, plus 4 independent "logic lights" for on/off states of various logic circuitry. Exclusive Breadboarding Pins offer input/output connections to socket, eliminating all soldering. All your circuit components are reuseable. Use any #22 gage solid wire. Send check or M.O. today for your choice of two models.

DD1-K, Kit Form (incl. p.c. boards, all components, instruction manual) **\$59.95**

DD1-A, Assembled, ready for use **\$95.00**

- Add \$1 postage, handling
- 25% deposit on C.O.D.'s

Ask for **FREE IDEA-PACKED, ILLUSTRATED CIRCUIT DESIGN CATALOG.**



E&I INSTRUMENTS, INCORPORATED
61 First St., Derby, Conn. 06418
Telephone: 203/735-8774

CIRCLE NO. 13 ON READER SERVICE CARD

common interest. For purposes of identification, especially when working as a team with Civil Defense, local police and sheriff's departments, and the American Red Cross, ALERT supplies member groups with I.D. cards, wall certificates, decals, bumper stickers, code cards, and assist cards (presented to someone who has been served by an ALERT member). Headquarters also makes available ALERT-identified jackets, T-shirts and jumpsuits.



ALERT CB base station operator Betty Lou Herlihy and her assistant, Ruth Meade, members of the Sandusky, Ohio, ALERT Team 354, know how effectively ALERT can serve at the local level. During the team's participation in "Pumpkin Patrol" (last year's Halloween activity), team members added 17 mobile rigs and 30 volunteers to police communications net; logged 520 collective hours, 1415 miles.

To aid a local group, ALERT furnishes a suggested constitution and by-laws, a monthly newsletter, and national headquarters assistance that can be programmed through ALERT'S computer facilities. It also makes available an ALERT airplane which can be dispatched and used as a communications point or link.

ALERT works with local teams to aid in the organization of statewide ALERT associations which can more closely tie in with national headquarters in Washington. Consideration is also given to the "CB'er of tomorrow." ALERT feels that young adults, properly trained in the use of CB radio, will benefit Citizens Radio and the junior team member when he reaches licensing age. As a result of that commitment, a Junior ALERT Program is offered. Members are divided into two categories: ages 9 to 14 and 14 to 18. A junior member's parents

need not be licensed CB'ers for him to participate in the program, but he must be sponsored by the local adult ALERT team and voted upon for acceptance by the junior team.

The junior team elects its own officers, conducts its own meetings, and is allowed to sit in on senior team meetings to give it a better understanding of the inner workings of the adult group. The junior member has no voting privileges, however, until he reaches the age of 18.

Bi-monthly Publication. To round out its package of services provided to team members, ALERT distributes bi-monthly its official publication, *ALERT 44*, (available to non-members by subscription). The magazine, while prepared mainly for ALERT team members, contains Citizens Radio news, views and comments of interest to all CB'ers or those considering use of CB 2-way radio. A typical issue spotlights such features as *FCC Reports* which may contain questions and answers covering in-depth definitions of various portions of the Rules and Regulations which govern Citizens Radio, a report from the FCC, or an interview with one of its Commissioners. The publication also includes *News Releases*, a *For Your Information* column, *ALERT Team Highlights*, *New ALERT Teams* listings, *Letters to the Editor*, and *ALERT Assistance Reports*. Photographs in each issue, some of them from the field and the rest generated by ALERT Headquarters, are excellent. The cover photo on each issue of *ALERT 44* usually ties in with a feature story.

A close analysis of any issue of *ALERT 44* reveals that the publication serves as the organization's most impressive promotion vehicle. In any given issue, the reader is exposed to 40 or 50 individual assistance reports, volunteer activity, and letters of praise from persons served through team efforts, on and off the air. Several responses extend kudos for help provided by ALERT members, ranging from flat tires that needed changing, to replacing fuel pumps or making necessary arrangements to have an auto pulled from a ditch.

A railroad praised the efforts of ALERT CB'ers in helping clear an intersection and handling communications following a train derailment. Local police, governmental agencies, the Red Cross, and other public-service groups have commended the organ-

ization's team efforts in providing food, clothing, shelter, and a necessary communication link through the use of CB radio in time of disasters—which have included snowstorms, floods, hurricanes, threatening fires, and searches for lost children.

From Maine to Montana, San Diego to Seattle, and Chicago to Cheyenne, the clue to ALERT's continuing success might best be summed up in a word: *organization!* This is one of the primary benefits national headquarters in Washington, D. C. has to offer the individual CB'er interested in helping others. ALERT organizes—locally, statewide, and nationally—public-service-minded CB'ers who, when not actively involved in emergency or community volunteer work, monitor CB's emergency channel 9 coast-to-coast.

ALERT has just barely scratched the surface in organizing the nation's 900,000 licensed Citizens Radio users, but as an association owned and operated by the membership, represented in all 50 states, it maintains a very commendable edge over previous organizational attempts that grabbed the CB'ers money and ran. ALERT is alive and well in these United States and has the statistics to prove it! (For detailed informa-

tion on membership in the ALERT program write: ALERT National Headquarters, Suite 818A, National Press Building, Washington, D. C. 20004.)



"You're welcome, dear. I got a substantial raise so why shouldn't I buy my wife a gift."

Electro-Voice Condenser Microphones Meet the test

(and please the testers.)

Hirsch-Houck Laboratories (reporting in the May, 1973 *Popular Electronics*) said, in part, "Best of all, their sound quality has a range and smoothness that we have not previously found except in much more expensive mikes".

And *Consumer Guide* magazine (Vol. 31) rated the E-V electret condenser microphones "Best Buys" on the basis of their tests.

Further proof that you can get studio-quality sound at moderate prices with an E-V electret condenser microphone. Prices start at \$39.75, suggested retail. See and hear them today at your E-V dealer. Or write for your useful FREE guide to the use of Electro-Voice condenser microphones. It has helpful information for every tape recording enthusiast.

a **Gulton**
COMPANY

ELECTRO-VOICE, INC., Dept. 1032P
630 Cecil St., Buchanan, Mich. 49107

Electro-Voice®

More U.S. recording studios use Electro-Voice microphones than any other brand.

CIRCLE NO. 15 ON READER SERVICE CARD



Test Equipment Scene

By Leslie Solomon, Technical Editor

I HAVE had several letters asking how to connect a digital frequency counter to an r-f source so that frequency measurements can be made. This is an important subject because there may be enough dc voltage present at the source to damage the input of the counter. Also, remember that there may be enough r-f voltage to inflict damage to a high-input-impedance stage. So, in many cases, capacitor coupling to r-f output stages should be avoided. Some typical connections are shown in the accompanying illustration.

In (A), a one- or two-turn link coil is connected to the end of a length of coaxial cable, with the other end of the cable connected to the counter. If the coax is about a quarter of a wavelength long (or more) at the frequency of interest, you should connect a terminating resistor (about 50 to 100 ohms) across the cable at the counter end. The distance between the link coil and the main r-f coil should be enough to cause the counter to indicate. If more signal is required, move the link closer to the main coil. Use the greatest possible distance between the link and the main coil; pick up just enough r-f energy to activate the counter.

If you don't want to, or can't make a close coupling to the main r-f coil (such as in a shielded transmitter), then use either circuit (B) or (C). In both cases, a short pickup antenna is placed close enough to the source's antenna or output tuned circuit to pick up enough signal to activate the counter.

Frequency Counters

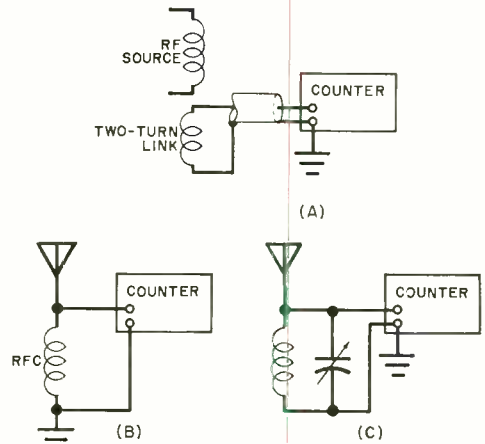

Using a counter in r-f measurements.

In (B), the r-f choke somewhat reduces the effects of stray electrical line noise picked up by the short whip antenna. In (C), the resonant circuit should be tuned to the transmitter frequency, which makes the setup more sensitive to that frequency and, at the same time, reduces the possibility of stray r-f fields influencing the measurements. The last approach is best for r-f transmitters (within the counting range of the digital frequency counter) and can be used for getting a signal directly from the antenna.

If you think that there may be too much r-f power available (which can damage the input stages of the counter), then insert a couple of hundred ohms of resistance in series with the lead going to the counter input and two back-to-back diodes between the counter input and ground. If you use silicon diodes, then any voltage peaks greater than about half a volt will be sliced off, thus protecting the counter.

Counter Frequency Adjustment. While we are on the subject of frequency counters,

let me remind you that frequency counters that use a crystal oscillator as the time base usually have a little frequency adjustment screw somewhere on the rear apron. If it has been some time since you last calibrated your counter (or if you never have and are using it as it came from the manufacturer), now is a good time to set your shortwave receiver to WWV and zero-beat your internal crystal. You paid for accurate frequency measurements so you might as well get them.

To answer those who ask about the meaning of the "plus or minus one count ambiguity" specification usually given in counter literature, it means that, because the input signal and the time base are normally not synchronized, the count being registered depends on the instantaneous relationship between the train of incoming pulses and the start of the gating interval. Thus, at any instant, the display may be incorrect by one count. Obviously, the more pulses counted in a time interval, the smaller the error. If you have the option and you need the accuracy, always use the longest gate interval that your counter has.

Another source of error occurs in the use of an external gate control signal, as in using the counter to perform period, ratio, or time-interval measurements. Any noise present on the gate signal trigger lead will cause the gate to open at strange times, producing an erroneous count. If this is your problem, use long period averaging. When more periods are averaged, the effects of trigger error and the one-count ambiguity are proportionally reduced.

If you have a 30-MHz counter, look at the various front-end pre-scalers now on the market—some in kit form. They can easily be used to extend the range of your low-cost counter out to 100 or 200 MHz, to provide greater versatility.

Fish Story. While out West on a recent vacation, I got to talking with an ichthyologist about sonar, depth finders, fish locators, etc. I discovered that, while most of us know that these ultrasonic devices detect the presence of fish, most of us don't really know why.

Well, it isn't just the fact that a fish is an object and it's there to produce the ultrasonic reflection. It is the discontinuity between the fish's body and the internal air-filled flotation buoyancy bladder that produces the reflection. How about that? ♦

Free!
1973
Eico Catalog
OVER 200 INSTRUMENTS • KIT & WIRED!

NEW! TR-410 Solid State Triggered Sweep Scope
NEW! 300C "Clamp-On" Current Tester
NEW! TD-8 8 Track Stereo Tape Deck
NEW! SS-200 "Time Delay" Burglar Alarm System
NEW! ASA-300 Electronic Siren Auto Alarm

Build all-professional Eico Kits and save up to 50%. The more you know about electronics, the more you'll appreciate Eico. Over 2500 local Eico dealers offer you all the top brands, personal technical counsel, fast off-the-shelf service. Free catalog includes Test Equipment, Stereo, Eico-craft Projects, Burglar/Fire Alarm Systems and name of nearest Eico distributor, check reader service card or send 25¢ for first class mail service.

EICO, 283 Malta St., Brooklyn, N.Y. 11207
 Leadership in creative electronics since 1945



CIRCLE NO. 12 ON READER SERVICE CARD

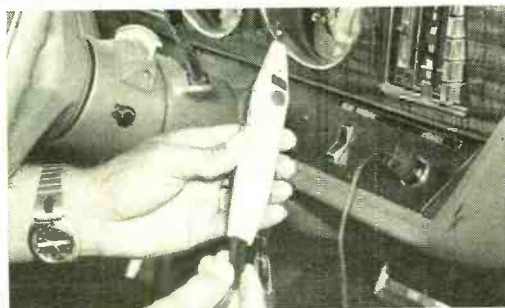

greatest advance in soldering since electricity!

WAHL Cordless SOLDERING IRON

Wahl "Iso-Tip" gives soldering heat in 5 seconds. Lets you solder up to 100 joints* unhindered by cord and plug anywhere! Recharger/converter plugs into 12V cigarette lighter. Safe to use on sensitive components. See your dealer or order direct.

7565 Kit with 12V Auto Charger \$18.95
 7500 Kit with 120V AC Charger \$19.95

(*Depending upon wire size, temperature and atmospheric conditions.)

WAHL CLIPPER CORPORATION Dept. 2
 2902 Locust St. • Sterling, Ill. 61081 (815) 625-6525
CIRCLE NO. 41 ON READER SERVICE CARD

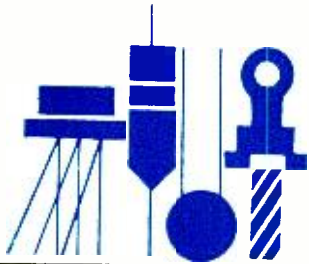

Solid-State Scene

By Walter G. Jung

THE big news this month is that there are some new TTL IC's, several of which will find many uses in experimental projects.

First, there is a new Schottky TTL voltage controlled oscillator recently introduced by Texas Instruments: the SN54S/74S124. The ones with the "54" in the number are military grade units, while the others operate over the commercial temperature range

establishes the tuning frequency range, while the V_{IN} input varies the output frequency +75% or -35% from the nominal center frequency. Both control-voltage inputs are in the range of 0 to +5V.

The enable input is used to start or stop the output pulses and is unique in that it is not a simple gate. The enable circuit includes a synchronizing feature which ensures that the output pulses aren't shortened

Fig. 1. This block diagram shows one section of S124 dual-voltage controlled oscillator as made by TI.

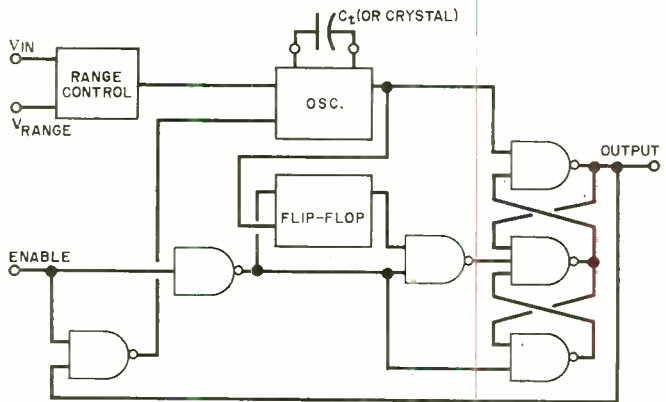

of 0 to 70°C. These IC's are dual, square-wave generators with the capability of operating between frequencies of 0.12 Hz and 85 MHz. A look at some of the operating characteristics show how an S124 can be used.

A block diagram for one section of the device is shown in Fig. 1. There are two control-voltage inputs and an enable input. The center frequency is set by a single (external) capacitor. The V_{RANGE} input es-

or stretched due to gating. The output duty cycle of the S124 is maintained constant at 50% (square wave) over its frequency range, eliminating the need for divide-by-2 circuits to provide a square wave.

For applications not requiring frequency control, an S124 can be operated with a crystal as the frequency determining element, providing a simple and stable clock source anywhere in its basic frequency range.

One natural use of this chip is as the voltage-controlled oscillator component of a phase locked loop. With the broad frequency range capability, the potential applications are numerous—from audio through r-f. Or, as a fixed-frequency clock, it can be used to eliminate the hardware necessary to implement a square-wave source—particu-

New TTL IC's

larly because of the frequencies involved.

Both of these units come in 16-pin, dual inline packages, and the SN74S124N is priced at \$4.22 each.

Dual TTL "One Shot." Virtually anyone who has worked with TTL logic is familiar with the popular 74121 one-shot multivibrator. Texas Instruments has now done the 121 one (or two) better with the introduction of the SN54/74221, a dual version of the 121.

Actually, the 221 is more than twice as good because it includes an additional feature and improved performance characteristics over the 121. The additional feature is an asynchronous "clear" input, which can be used to terminate the output pulse while the one shot is in its timing cycle. In addition, the 221 has a more repeatable output pulse width (from device to device). The output pulse width variation over the full supply and temperature ranges is less than $\pm 0.6\%$ for the SN74221.

The devices come in 16-pin, dual inline packages, and prices start at \$2.33 for the plastic SN74221N.

Dual Peripheral Drivers—New and Old.

An extremely useful device which is perhaps not as well known as other TTL units to the average experimenter is the peripheral driver. That is the name Texas Instruments has applied to their line of dual logic gates (7400 type) combined in a single package with a pair of high-current, medium-voltage transistors. Gate inputs are TTL compatible, but the output transistors can be wired externally for a variety of driving functions—relays, lamps, LED's, small motors, high-power pulsers, and, in general, applications with current ratings up to 300 mA.

The original devices are quite popular in the industry, as evidenced by their availability from a number of other sources. Now, TI has expanded the line by introducing a similar series, SN75460-SN75464, which differ in that the output transistors have a 50-V breakdown rating, while the original devices were rated at 30 V. As shown below, there are a number of different input logic capabilities represented by the various parts, achieved through the use of a different 7400-type input gate structure.

30-V Devices	Logic	50-V Devices (New)
SN75450A*	AND	SN75460*
SN75451A	AND	SN75461
SN75452	NAND	SN75462
SN75453	OR	SN75463
SN75454	NOR	SN75464

*These have 14 pins; others are in 8-pin packages.

Figure 2 is a functional diagram of the basic device for either family (SN75450A or SN75460). This circuit, in a 14-pin pack-

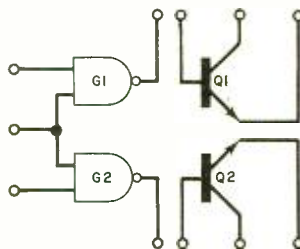

Fig. 2. Functional diagram of dual driver.

age, has floating output transistors which permit a variety of connections to be used. The remaining devices of the series have direct gate-to-base connections, with the transistor emitters tied to ground and the collector emitters available as outputs. This permits

**SEE...
COMPARE
SELECT!!**

SBE

COMPLETE LINE OF
SUPER
C-STAR'S

Console



SSB/AM BASE STATION
SSB, 15W, p.e.p. input. AM, 5W input.
23 channels, no crystals to buy.
115VAC (will operate also from ext. 12V battery).

Catalina



AM MOBILE
23 channels, no crystals to buy.
Supplied w/dynamic mic/coil cord.

Cascade II



**5 WATT
PORTABLE**
6 channels, 5 watts
(reducible to 3W).
Battery operated.
All metal case.
Sturdy!

Sidebander II



SSB/AM MOBILE
SSB, 15W, p.e.p. input.
AM, 5W input. 23 channels,
no crystals to buy. Supplied
w/dynamic mic

WRITE FOR BROCHURE
SBE, 220 Airport Blvd., Watsonville, CA 95076

CIRCLE NO. 33 ON READER SERVICE CARD

GREATEST TV Schematic Bargain EVER Offered
...Complete TV Schematics for less than 5¢ each

8 BIG Volumes
Regular Price \$79.60
...NOW YOURS
for only \$34.95

Covers all Color TV 1960-1968 and 23 Brands B&W from 1965-1968 TV TECH/MATICS

8 GIANT VOLUMES—Covers 99% of Color TV—4 Years B&W

Here are FABULOUS savings on nationally-known TV schematic and service data—on everything you need to fill your vital service data needs for TV receiver produced by more than 20 leading American Manufacturers for 1965, 1966, 1967, and 1968. All diagrams and servicing details are completely authentic. Each year's coverage is bound into two convenient-to-use volumes which open flat to 11" x 29½". Ready to provide you with instant service data at your workbench. Some diagrams as large as 58" x 22".

SERVICE DATA FOR 23 BRANDS—TV TECH/MATICS includes complete schematic diagrams and vital servicing data for every TV receiver produced by more than 20 leading American Manufacturers for 1965, 1966, 1967, and 1968. All diagrams and servicing details are completely authentic. Each year's coverage is bound into two convenient-to-use volumes which open flat to 11" x 29½". Ready to provide you with instant service data at your workbench. Some diagrams as large as 58" x 22".

HERE'S WHAT YOU GET— You receive 8 BIG volumes in all. Included is a clearly detailed and annotated TV schematic diagram for each specific model. You also get complete replacement parts lists, alignment instructions, tube and component location diagrams, plus key waveforms and voltage readings. All the information you need to service over 90% of the TV receivers you'll encounter!

Each volume is organized alphabetically by manufacturer, then numerically by model number. In addition, a handy Chassis Model Finder is bound into each volume. Regular list price for each year's coverage—2 BIG volumes—is \$19.90. All 8 volumes normally sell for \$79.60. Your price is ONLY \$34.95... a savings of nearly \$45.00!

STREAMLINED & CONVENIENT All the information for a given model is contained on two facing sheets. The special bound-leaf format allows pages to lie flat when open. Each volume is organized alphabetically by manufacturer, then numerically by model number. In addition, a handy Chassis Model Finder is bound into each volume. Regular list price for each year's coverage—2 BIG volumes—is \$19.90. All 8 volumes normally sell for \$79.60. Your price is ONLY \$34.95... a savings of nearly \$45.00!

MONEY-BACK GUARANTEE— Order at our risk for FREE 10-day examination. Prove to yourself they are worth many times the price.

CONTENTS

The 8 BIG volumes (2 for each year) cover all black-and-white receivers for model years 1965 through 1968—PLUS Color TV coverage from 1960 through 1968—for these brands: Admiral, Airline, Andrea, Coronado, Curtis, Mathis, Dumont, Electrolume, Emerson, Firestone, General Electric, Hoffman, Magnavox, Motorola, Muntz, Olympic, Packard-Hell, Philco, Philco-Ford, RCA, Victor, Sears Silvertone, Setchell-Carlson, Sonora, Sylvania, Truetone, Westinghouse and Zenith. Publisher's List Price each year \$19.90. Total \$79.60. Special price \$34.95 only while they last!



LARGE PAGES, 15x 11", open flat to 29½x11". Provides complete schematic diagrams.

them to use an 8-pin (can or mini-DIP) package.

These drivers are very handy for high-current loads or loads with voltage supplies greater than the 5-V TTL norm. You might find them useful the next time you run into a TTL interface requirement that can't be met by standard devices.

Dual High-Speed Comparators. Recently, we touched on the basic advantages (primarily speed) that Schottky diode processing provides in TTL IC's. The dual vco mentioned above is a good example. However, Schottky processing is also finding its way into IC's that are not strictly digital in nature. Take, for instance, the device that compares the difference between two analog voltages and delivers a digital output (1 or 0) to indicate the relative states of the inputs. The speed at which a comparator can make an output change in response to an input is its response time. For high system speeds, the faster the response, the better.

Readers familiar with the 710, the first standard comparator, will recall its response time is 40 ns, which is still quite fast.

However, Schottky processing gives a new dimension to speed, as evidenced by the new Signetics dual comparators, the NE521 and NE522. These chips have typical response times of 6 ns and maximum operating speeds of 55 MHz. Both devices have TTL compatible outputs with fanouts of 10 loads, the basic difference being that the 521 has a standard TTL output stage while the 522 is an open-collector version.

Both the NE521 and NE522 are available in 14-pin DIP's (silicone or ceramic) with prices of \$5.75 each, for the silicone versions.

More Information. Write: Texas Instruments Inquiry Answering Service M/S 308, P.O. Box 5012 Dallas, TX 75222

Signetics 811 East Arques Ave. Sunnyvale, CA 94086

Correction. One of those elusive typographical gremlins got into our September column. On page 104, in the last sentence of the paragraph on Raytheon's RC4136 quad op amp, the device was incorrectly listed as the RCA4136P. ◆

Publisher's NO RISK COUPON—MAIL TODAY

List Price each year \$19.90... Total \$79.60. Special price \$34.95 only while they last!

TAB Books, Blue Ridge Summit, Pa. 17214
 I enclose \$34.95. Please send me your complete 8-Vol. Tech/Matics Schematic. Offer postage prepaid... plus my 5 FREE SINGLPAK Manuals.
 Please invoice me for \$34.95 plus postage. Same return privileges.

Name Phone
 Company
 Address
 City State Zip
 Foreign, add 10%. Pa. add 6% sales tax. PE103

CIRCLE NO. 38 ON READER SERVICE CARD

CHARLES P. STEINMETZ- Father of Modern Electrical Engineering

BY DAVID L. HEISERMAN



ON June 2, 1889, Karl Steinmetz stood before a New York customs official. The 24-year-old Swiss-German immigrant's clothing was sloppy, his beard ragged, and on the bridge of his nose were thick spectacles. He also was a hunchback and stood barely four feet tall, physical defects inherited from his father and grandfather. The official's first impulse was to put Steinmetz on the first boat returning to Europe. Fortunately for the world of electrical engineering, Steinmetz, with the aid of a friend and fellow immigrant, persuaded the

official to let him pass through the customs office. The official could never have guessed that in a few short years this untidy hunchback whom he had almost refused entry to the United States would revolutionize twentieth century alternating-current technology.

Steinmetz' first job was with Eikenmeyer & Osterheld, designers and producers of ac motors for streetcars. Lacking training in electrical engineering (his training was in mathematics and mechanical engineering), Steinmetz wound up in the drafting department.

Meanwhile, Eikenmeyer and his engineers were encountering serious problems in fulfilling a large contract. Since no one had yet developed a way to accurately calculate the amount of heating in a motor before the motor was actually built, a lot of time and money was being wasted on trial-and-error experiments. All of the prototype motors the company was making were either too bulky or so small that they quickly burned out.

From Draftsman to Designer. While doing design drawings in the drafting department, Steinmetz began to notice logical relationships between the magnetic properties of the iron in the motors and the amount of heat the motors produced. He developed preliminary equations and motor designs which he showed to Eikenmeyer. Immediately recognizing the value of the work and already running behind schedule, Eikenmeyer decided to gamble on a revolutionary idea. He set up an industrial research and development laboratory. Putting Steinmetz in charge of the facility paid off. Steinmetz went on to perfect his theory of hysteresis losses, worked out equations for designing ac motors, and pulled the company out of debt.

In 1892, Steinmetz presented a paper dealing with his hysteresis losses laws and motor design to the American Institute of Electrical Engineering. A year later, he found himself working for the new General Electric Company in Massachusetts after they had bought out Eikenmeyer & Osterheld. At about the same time, he was completing his work for American citizenship. He Americanized his first name to Charles and took for a middle name his fraternity nickname "Protius." He signed his citizenship papers and last paycheck from Eikenmeyer & Osterheld "Charles Protius Steinmetz."

More Horizons. While working at the new General Electric plant, Steinmetz became involved with problems encountered in long-distance transmission of ac power. He found the graphical methods for designing power transformers and other ac devices too cumbersome and inaccurate for his work. He chucked the whole business and launched into a new line of reasoning that would eventually revolutionize every phase of electrical engineering.

Trained as a mathematician, Steinmetz was familiar with ideas generally held to have no value in the real world. He noted that the use of complex numbers—curiosities at the time—in his ac equations simplified the theoretical ideas and design procedures. Between 1893 and 1897, he used complex numbers as a foundation for completely revamping the world's knowledge of ac theory and design.

His ideas were so new that few engineers understood what he was talking about. Steinmetz found that he had to work harder explaining what he had done than he had in developing the ideas in the first place. His book *Theory and Calculation of Alternating Current Phenomena* (1897) was a failure simply because no one understood it. So was his later *Alternating Current Phenomena*.

Steinmetz made one final attempt. This time, his *Theoretical Elements of Electrical Engineering* was a success. It was adopted all over the world as a standard textbook for college programs in alternating current theory. Then, to give engineers and students a firm footing in the mathematics they would need in their studies and careers, he put together *Engineering Mathematics*, the first book to demonstrate a practical application of complex numbers.

Popular Fame. By the turn of the century, Charles Steinmetz was quite famous among the scientific and engineering communities. The general public, having no real appreciation for lofty engineering theories, heard little about him. However, his third major line of investigation made Steinmetz a very popular figure.

Steinmetz did not realize popular fame was coming his way when he designed the first long-distance (26 miles) ac power transmission system from Niagara Falls to Buffalo, New York. Nor was it the fact that the system worked that brought him into the public spotlight. What happened was

that Steinmetz soon encountered difficulties with lightning that occasionally knocked out the power transmission system.

Rather than guessing at what was happening, Steinmetz decided to learn more about the nature of lightning by building a high-voltage laboratory. The image of this strange-looking little man fussing with gigantic bolts of artificial lightning caught the public's fancy. Steinmetz suddenly was the subject of hundreds of newspaper and magazine articles. He accepted the accolades of the public with humility and good humor, but he did not let this new kind of fame change his life style or keep him from his work.

High-voltage machines were not new at the turn of the century. Other investigators had already built "lightning machines" capable of generating a million volts at several hundred milliamperes. But Steinmetz rightly concluded that the essential characteristics of natural lightning included incredibly high currents with very high voltages. Not wanting to be misled by the low-current effects that characterized existing high-voltage generators, he designed a General Electric high-voltage generator that produced only a few hundred thousand volts at currents in excess of 10,000 amperes!

The first tests with the new machine exhibited some dramatic effects. Instead of merely scorching the outside of a freshly cut piece of timber, the new lightning machine peeled away the bark, split the wood into several steaming-hot pieces, and occasionally blasted the wood into thousands of burning splinters. Although the effect was still feeble compared to natural lightning, the high-current component brought the tests more in line with the real thing.

Tests on commercial lightning rods revealed flaws that were invisible to detection with the million-volt, low-current generators. Finding these flaws explained why some lightning rods sometimes failed. This led Steinmetz to recommend immediate design changes that would make the rods more reliable.

By getting a better understanding of lightning, Steinmetz and his co-workers at General Electric made great strides toward absolute protection of power transmission systems. Although they did not solve all of the problems, their data contributed to the design changes and innovations that make modern power transmission systems safer, more reliable, and practical. ♦

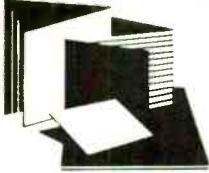

New Literature

TDK GUIDE TO BETTER RECORDINGS

TDK Electronics is offering, free at all dealerships, their new "TDK Guide to Better Recordings" pamphlet. The pamphlet contains a collection of tips and suggestions on how to make professional-quality cassette recordings on any cassette deck. It is designed to answer almost any question and solve most problems encountered by cassette home recordists. Address: TDK Electronics Corp., Eastgate Blvd., Roosevelt Field, Garden City, NY 11530.

DUAL TURNTABLE BROCHURE

Described in six four-color pages is the new Dual Model 701 state-of-the-art automatic turntable—not changer—that features a precision Hall-effect dc motor and special antiresonance filters built into its tonearm. The brochure can be obtained by writing to: United Audio Products, Inc., 120 S. Columbus Ave., Mt. Vernon, NY 10533.

EDMUND SCIENTIFIC CATALOG

Free for the asking is the latest edition of the famous Edmund Scientific Co. catalog, No. 735. Listed and described in this new edition are items of interest to all people, 6 to 80 years of age, male or female. Toys, scientific games and kits, optics, electronic parts and equipment, lasers and light displays, books, arts and crafts equipment, and plants are among the thousands of fascinating items listed. Address: Edmund Scientific Co., 380 Edscorp Bldg., Barrington, NJ 08007.

"HI-PRO" ELECTRONIC PRODUCTS CATALOG

The Ascom Products division of The Antenna Specialists Co. has just released catalog No. SD-569 that features many new accessories designed to improve communications systems performance. Listed are "Translators" that permit CB transceivers to monitor low- or high-band or uhf transmissions on CB channel 9, and preamplifiers that significantly increase the sensitivity of even the best equipment for scanning monitor receivers. Other "high-performance" booster products listed include CB test instruments and speech processors. Address: Ascom Electronic Products, 12435 Euclid Ave., Cleveland, OH 44106.

OCTOBER 1973



NEW

... for the sound buff

HYBRID POWER AMPLIFIERS

With the addition of a few off-the-shelf components, you can easily build your own quality amplifier for record player, tape deck, tuner, P.A. (musical instruments) or intercom system.

USED BY LEADING MANUFACTURERS • 2 YEAR WARRANTY

AVAILABLE IN 3 MODELS:		CHARACTERISTICS:
Power	RMS IHF	• Harmonic Distortion < .05%
1. SI-1010Y	10W 25W	• Bandwidth 20 Hz — 100K Hz
2. SI-1025E	25W 65W	• Flat response within 1/2dB
3. SI-1050E	50W 120W	• Input sensitivity 500 mV

Contact your local electronic component distributor!

AIRPAX™

INTERNATIONAL DIVISION
P.O. Box 8488
Ft. Lauderdale, Fla. 33310

CIRCLE NO. 1 ON READER SERVICE CARD



12 REASONS YOUR CAR NEEDS TIGER CDI

Instant starting in any weather - Eliminates tune-ups - Increases gas mileage - Increases horsepower 15% - Improves acceleration and performance - Spark plugs last up to 70,000 miles - Reduces engine maintenance expense - Amplifies spark plug voltage to 45,000 volts - Maintains spark plug voltage to 10,000 RPM - Reduces exhaust emissions - Dual ignition switch - An Unconditional LIFETIME GUARANTEE - Installs in 10 minutes on any car with 12 volt negative ground - No rewiring - Most powerful, efficient and reliable Solid State Ignition made.

SATISFACTION GUARANTEED or money back.
TIGER 500 assembled \$49.95
TIGER SST assembled 39.95
TIGER SST Simpli-Kit 29.95
 Post Paid in U.S.A.

Send check or money order with order to:

Tri-Star Corporation

Dept. W, P. O. Box 1946
Grand Junction, Colorado 81501

DEALER INQUIRIES INVITED

CIRCLE NO. 40 ON READER SERVICE CARD

109

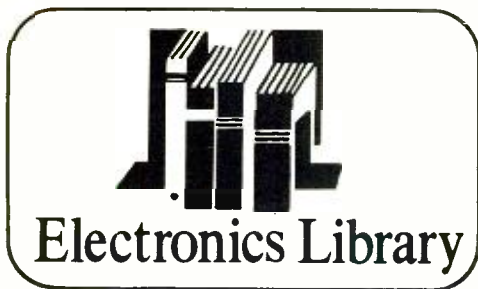

THE RADIO AMATEUR'S HANDBOOK, 50th Edition

Extensive revision and updating have gone into the 1973 edition of the "ham's bible." The areas of solid-state devices, specialized communication techniques, transmitting, and power supplies have been given a rewrite, giving examples of up-to-the-minute information. Among the newly revised sections are digital logic devices, toroidal inductors, h-f antennas, vhf amplifiers, and filter networks. Nearly 100 charts and drawings have been included to help carefully explain all technical facets of communications for the radio amateur.

Published by The American Radio Relay League, Inc., Newington, CT 06111. Soft cover \$4.50, hard cover \$7.50. 704 pages.

ELECTRICAL ENGINEERING PRINCIPLES AND TESTING METHODS

by Rhys Lewis

This book was written for people who are taking courses leading to technician and technologist status in electronics engineering. The contents cover fundamentals of ac and dc circuits, including network theorems, three-phase ac systems, transformers, dc machines, electronic and other amplifiers, and electrical instruments, principles of testing, and testing methods, the latter including the basic essentials of quality control. A number of examination questions are included at the end of each

chapter, and typical (British) exam papers are given at the end of the book.

Published by Barnes & Noble Books, 10 East 53 St., New York, NY 10022. Hard cover. 289 pages. \$12.50.

SOLID-STATE SWITCHING: Discrete and Integrated

by Robert D. Pascoe

While most courses deal with solid-state switching devices via the "black-box" approach, this textbook diverges from that tack by providing the reader with a "hands-on" feeling for IC's by getting "inside" the chips. To accomplish this, it demonstrates the use of discrete and IC components of switching devices, provides a practical approach to the selection of components and the analysis of operating parameters, and allows the reader to build all of the circuitry presented.

Published by John Wiley & Sons, Inc., 605 Third Ave., New York, NY 10016. Hard cover. 205 pages. \$10.95.

DESIGN OF MODERN TRANSISTOR CIRCUITS

by Maurice Yunik

The needs of scientists, engineers, and technicians working in a variety of fields were the primary considerations in the development of this new book. Circuit theory forms the fundamental basis of the book's text where the stress is on terminal properties of transistors, diodes, and FET's to obtain accurate circuit models. These models are, in turn, used to obtain practical design formulas. The comprehensive contents range from the basics of circuit theory to audio power amplifiers.

Published by Prentice-Hall, Inc., Englewood Cliffs, NJ 07632. Hard cover. 365 pages. \$12.00.

SOLID-STATE ELECTRONIC CIRCUITS

by Anthony S. Manera

Offered in this book is a broad, comprehensive coverage of solid-state device theory and asso-

FREE McIntosh CATALOG and FM DIRECTORY

McIntosh Laboratory, Inc.
East Side Station P.O. Box 96
Binghamton, N.Y. 13904
Dept. 16-5

**SEND
TODAY!**

NAME _____

ADDRESS _____

CITY _____ STATE _____ ZIP _____

CIRCLE NO. 24 ON READER SERVICE CARD

Get all the news and latest information on the new McIntosh Solid State equipment in the McIntosh catalog. In addition you will receive an FM station directory that covers all of North America.



MX 113

AM FM/FM STEREO TUNER PREAMPLIFIER

POPULAR ELECTRONICS Including Electronics World

ciated electronic circuit configurations. Utilizing conventional current, the text employs graphical and equivalent circuit analysis methods. Featured are a graphical presentation of differentiation and integration that does not require calculus and an introduction to "y" parameters to cover FET's, hode plots, and operational amplifiers.

Published by McGraw-Hill Book Co., 1221 Ave. of the Americas, New York, NY 10020. Hard cover. 806 pages. \$15.50.

BUILD YOUR OWN HOME & CAR SECURITY (HEP-409)

This timely book was compiled and written for the hobbyist-experimenter and is devoted entirely to the topics of sensors, alarms, and detectors primarily for home and automotive use. Beginning with basic alarm theory, the book contains illustrated construction and installation techniques for 11 safety systems. Each project includes a brief description of the system's function, a schematic diagram, suggested applications, and a complete parts list.

Published by Motorola Semiconductor Products, Inc., Box 2953, Phoenix, AZ 58036. Soft cover. 106 pages. \$1.25.

MARINE SINGLE SIDEBAND

by Donald L. Stoner & Pierre B. Goral

Since marine double sideband must cease by January 1, 1974 and all operations (except the international emergency and calling frequency) on coastal frequencies must be SSB by January 1, 1977, it is not too early for all interested parties to learn details of this changeover and thus ease the transition period of boat owners and radio technicians. The authors cover the elements of SSB circuitry, explain the advantages of SSB, the SSB signal, equipment, propagation forecasts, and related subjects.

Published by Howard W. Sams & Co., Inc., 4300 W. 62nd St., Indianapolis, Ind. 46268. Soft cover. 192 pages. \$5.95.

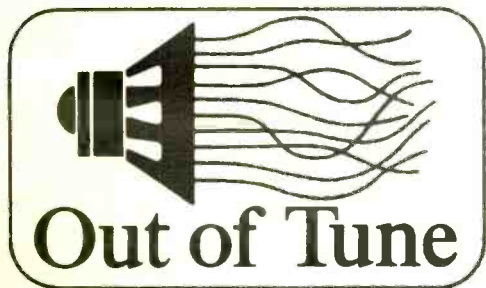

In "A 5-Watt Carrier-Current Transmitter" (p. 34, June 1973), the ground wire of the audio input should be connected to the chassis and the entire chassis earth-grounded.

A down-to-earth, low-math magnetic recording manual



MAGNETIC RECORDING
by Charles E. Lowman
320 pages, \$14.50

"... an authoritative and practical guide to the technology of magnetic recorders... up-to-date circuitry, newest techniques and latest innovations are covered in basic language with a minimum of mathematics and many helpful illustrations."—POPULAR ELECTRONICS

The author, Manager of Instrumentation Technical Writing for the Ampex Corporation, provides long-needed, practical information on the basic principles, applications and operation of magnetic recorders used in such fields as audio and instrumentation recording; broadcast and closed circuit TV; computer data systems, and the latest data on cassette and cartridge recording. This handbook helps you make the correct selection of tape, choose the right recording system, and operate and maintain your equipment at peak efficiency.

BASIC ELECTRONIC INSTRUMENT HANDBOOK

Clyde F. Coombs, Jr., Editor-in-Chief. This book is the first to serve as a general reference to both measurement techniques and instruments for professional engineers and technicians. A practical guide to the proper equipment for any job. 836 pp., 665 illus., \$28.50

ELECTRONIC CIRCUITS MANUAL

by John Markus. For builders of anything electronic, here is quick A-Z access to thousands of up-to-date circuits, complete with values. It also provides the latest international advances in the field and exact sources of additional data. 892 pp., over 3000 illus., \$19.75

SOURCEBOOK OF ELECTRONIC CIRCUITS

by John Markus. A virtual desktop retrieval center, this massive handbook contains over 3000 electronic circuits and component values. Included with each circuit is a concise description of its features, performance and operating data. 888 pp., over 3000 illus., \$18.50

At your bookstore or mail coupon today for

-----10 DAYS' FREE EXAMINATION-----

McGRAW-HILL BOOK COMPANY
1221 Avenue of the Americas, New York, N.Y. 10020

Send me the books checked below for ten days' examination. At the end of that time, I will remit the full price plus tax, postage, and handling costs, or return books and owe nothing.

MAGNETIC RECORDING (388458)—\$14.50

BASIC ELECTRONIC INSTRUMENT HANDBOOK (126151)—\$28.50

ELECTRONIC CIRCUITS MANUAL (404445)—\$19.75

SOURCEBOOK OF ELECTRONIC CIRCUITS (404437)—\$18.50

Name _____

Address _____

City _____ State _____ Zip _____

This offer subject to acceptance by McGraw-Hill and good in U.S. only. 23-PPE-103

CIRCLE NO. 23 ON READER SERVICE CARD

PUT IT ALL TOGETHER

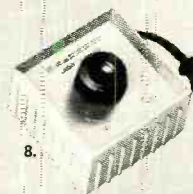
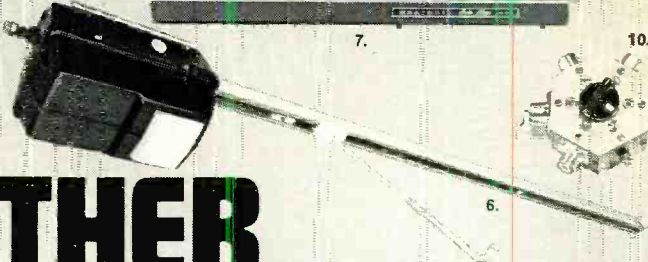
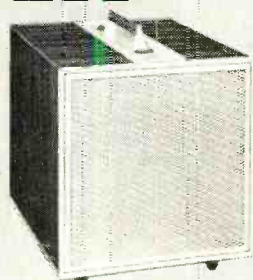
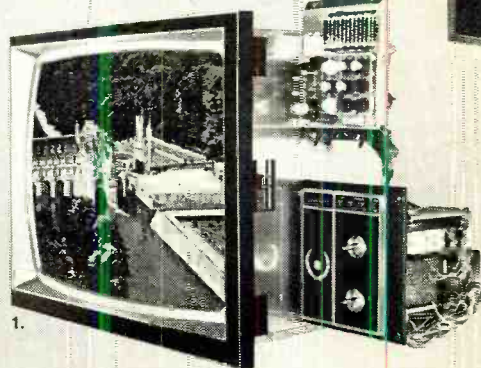
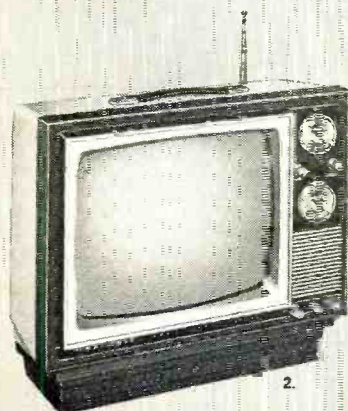

Build Heathkit quality electronics and create a whole house full of personal accomplishments. Plus you'll often save considerably over the cost of comparable products, then save again because Heathkit designs include built-in self-service features.

Heathkit building is unbelievably easy. In fact, we stake our reputation on the idea that you can build any kit you see on these pages. Even if you have never assembled a kit product before. All you need are conventional hand tools and a soldering iron. The assembly manuals tell you how and when to use them — step-by-step from start to successful completion.

And of course every kit is backed up by the Heath Plain Language Warranty and our pledge that — whatever the problem, whatever the reason — “we won't let you fail”.

- GR-900 25V Color Television \$599.95*** (less cabinet)
The most advanced portability Heath has ever offered. Push-button power tuning locks-in on any 12 preselected UHF channels, all VHF stations. Along with the largest color screen in the industry, you get angular tint control to reduce flesh-tone change between channels, instant on, automatic fine tuning, adjustable tone control, hi/hi audio output jacks, and exclusive Heath self-service built-ins. Shipping weight, 125 lbs.
- NEW GR-104C Portable Black & White TV \$129.95***
Now the ultimate portability TV has positive detent tuning on all 72 UHF channels as well as VHF. All solid-state circuitry, plus brilliant 12V shell bond picture tube puts black & white entertainment anywhere. Plugs into wall outlet, or runs from 12-volt DC automotive system with adapter included — or becomes completely self-contained with optional rechargeable battery-pack base. Mailing weight, 35 lbs. Optional GRA-104-3 battery pack 42.95*, 9 lbs. Outdoor Sun Shield 1.95*, 1 lb.
- NEW GD-1003 Electronic Air Purifier \$139.95***
An easy-to-build 3-evening project. Removes 99% of airborne pollen and 95% of all other contaminants. Has 2-stage electronic operation; washable collector cell; replaceable charcoal filter; 2-speed fan; attractive walnut and gold finish. Purifies air in 20' x 20' room in minutes. Mailing weight, 46 lbs.
- NEW AS-1039 Ultra-efficient Speaker System \$44.95***
Just 5 watts drives it to booming volume. Uses 8-in. woofer in vented bass reflex enclosure and exponential rectangular horn tweeter with separate level control. Response, 70 to 15,000 Hz. Impedance, 8 ohms. Maximum input 25 watts. Walnut-tone vinyl covered cabinet and green, brown and gold grille board shipped assembled. Measures 21" H x 12" W x 10 1/2" D. Mailing weight, 28 lbs.
- NEW AS-1042 Acoustic Suspension Speaker \$34.95***
Uses 8" long throw woofer and 3 1/2" shallow cone/dome tweeter for flat frequency response from 40 to 18,000 Hz. External high-frequency control tailors the “highs” to your environment. Requires as little as 10 watts, can handle up to 25. 8 ohms impedance. Walnut-tone vinyl covered cabinet and brown and black grille board shipped pre-assembled. Measures 19" H x 10" W x 8 3/4" D. Mailing weight, 22 lbs.
- NEW GD-3209A Deluxe Garage Door Opener \$139.95***
Ultra-quiet, ultra-reliable screw drive system that you can build and install over a weekend. All electronics shipped

- pre-assembled. Has 1/3-hp motor, automatic safety reversing plus adjustable slip clutch, automatic time delay light, external adjusting knobs for up/down travel. Includes 1 transmitter. GD-3209B, same as above with 2 transmitters, 154.95*. Mailing weight, 66 lbs. For jamb & pivot doors and GDA-3209-2 adapter, 14.95*, 7 lbs.
- NEW AD-1013 4-Channel Audio-Scope \$199.95***
A sophisticated solid-state oscilloscope designed for monitoring the home audio system. Displays stereo or 4-channel signals for separation, phasing, relative strength, multipath reception, center tuning, etc. Has exclusive triggered sweep for stable, jitter-free trace. Designed to complement Heathkit AR-1500 Receiver. Mailing weight, 19 lbs. AR-15 and AJ-15 owners, add ARA-15-1 adapter, 24.95*, 1 lb.
 - NEW GD-1018 Solid-state Lamp Dimmer \$7.95***
Controls lamp brightness from full illumination through mood-setting dimness to complete invisibility. For single and multiple lamps not exceeding 300 watts total. Extends filament life, eliminates the need for costly 3-way bulbs. A great starter kit. Can be assembled easily in 1 evening. Mailing weight, 2 lbs.
 - NEW CM-1045 Small-engine Tune-up Meter \$39.95***
Solid-state tach/dwell/volt/ohm meter for all 2 and 4 cycle engines, 1 through 4 cylinders. In many cases permits checking entire small-engine ignition without tearing down flywheel assembly. Built-in tachometer has handy snap-on inductive pickup, reads from 0-3000, 0-15000 rpm. Completely portable, uses 3 1.5-volt batteries (not supplied). Mailing weight, 5 lbs.
 - NEW HD-1234 Coaxial Switch \$9.95***
A neat accessory for the amateur radio enthusiast. Designed to switch one RF source to any one of several antennas or RF loads while grounding the unused outputs. Two switches can be used to switch up to four antennas/loads to four different components. Standing wave ratio is 250 MHz, 1:1:1 max. Power capability is 1000 W (2000W PEP). Mailing weight, 2 lbs.
 - NEW GD-600 Photoelectric Lamp Switch \$5.00***
Low-cost home protection in a simple, enjoyable kit. Solid-state circuitry turns light on at dusk, turns it off at dawn. Adjustable sensitivity control sets switch to operate at various levels of light and darkness. Can be used with single or multiple lamps not exceeding 300 watts total. Easy, single circuit board design can be assembled in 1 evening. Mailing weight, 1 lb.

Visit your nearest Heathkit Electronic Center... or send for FREE catalog

HEATHKIT ELECTRONIC CENTERS — ARIZ.: Phoenix; CALIF.: Anaheim, El Cerrito, Los Angeles, Pomona, Redwood City, San Diego (La Mesa), Woodland Hills; COLO.: Denver; CONN.: Hartford (Avon); FLA.: Miami (Hialeah); GA.: Atlanta; ILL.: Chicago, Downers Grove; IND.: Indianapolis; KANSAS: Kansas City (Mission); MD.: Baltimore, Rockville; MASS.: Boston (Wellesley); MICH.: Detroit; MINN.: Minneapolis (Hopkins); MO.: St. Louis; N.J.: Fair Lawn; N.Y.: Buffalo (Amherst), New York City, Jericho, L.I., Rochester; OHIO: Cincinnati (Woodlawn), Cleveland; PA.: Philadelphia, Pittsburgh; R.I.: Providence (Warwick); TEXAS: Dallas, Houston; WASH.: Seattle; WIS.: Milwaukee.



World's largest selection of electronic kits

HEATH COMPANY, Dept. 10-10 Benton Harbor, Michigan 49022		HEATH	
<input type="checkbox"/> Please send FREE Heathkit Catalog.		Schlumberger	
Enclosed is \$ _____, plus shipping.			
<input type="checkbox"/> Please send model(s) _____			
Name _____			
Address _____			
City _____ State _____ Zip _____			
* Mail order prices; F.O.B. factory.		CL-481R	

CIRCLE NO. 20 ON READER SERVICE CARD



New Products

Additional information on new products covered in this section is available from the manufacturers. Either circle the item's code number on the Reader Service Card inside the back cover or write to the manufacturer at the address given.

MARANTZ 2/4-CHANNEL RECEIVER

There are too many things to be said about Marantz's new Model 4300 2/4-channel AM/stereo FM receiver to give them all here, but a few of the salient features are: Conservatively rated at 200 watts continuous output power, the receiver develops 40 watts/channel in the 4-channel mode; while in stereo, a bridging circuit delivers 100 watts/channel. Facilities are provided for installing an equalizer between the tuner/preamp and main power amplifier as well as to accept an optional SQ (or other) matrix decoder. The receiver's integral Dolby noise reduction system can improve FM sound quality when listening to Dolby-encoded broadcasts and improve the performance of associated tape equipment by reducing tape hiss.

Circle No. 70 on Reader Service Card

AUDIO-TECHNICA CD-4 PHONO CARTRIDGE

Audio-Technica U.S., Inc., has announced availability of the Model AT12S, newest in their series of phono cartridges designed for use with the CD-4 4-channel disc. Said to be of low mass, wide-range design, the new cartridge shares the patented dual-magnet construction employed in other AT cartridges. Use of the Shibata stylus and a tapered cantilever permits optimum reproduction of CD-4 recordings and offers reduced record wear and improved tracking with stereo and matrixed discs. The AT12S is recommended for use in either manual or high-quality automatic turntables.

Circle No. 71 on Reader Service Card

JENSEN ELECTRONIC TOOL KIT

A new roll pouch kit for electronics technicians has been assembled by Jensen Tools and Alloys. The JK-80 kit contains 25 professional

tools, including many items not usually found in sets of this type: soldering iron; solder aid; wire stripper/cutter; heat sink tweezers; 8" adjustable wrench; hex wrench and spline wrench sets; No's. 1 and 2 Phillips driver blades; $\frac{3}{16}$ " and $\frac{5}{16}$ " regular-slot driver blades; $\frac{3}{16}$ ", $\frac{1}{4}$ ", $\frac{5}{16}$ ", and $\frac{3}{8}$ " nut drivers; two handles for the drivers; No. 0 Phillips and $\frac{3}{32}$ " regular pocket screwdrivers; alignment tool; burnisher; electrician's pocket knife; long-nose, chain-nose, and diagonal pliers; slip-lock pliers and a 6" steel ruler. The roll pouch is made of tough vinyl-coated canvas.

Circle No. 72 on Reader Service Card

UNION CARBIDE "MICROFARAD MANIPULATOR"

A new plastic "Microfarad Manipulator" slide rule that simplifies and consolidates all capacitor calculations into one handy calculator is available for \$1 from the Components Dept. of Union Carbide Corp., P.O. Box 5928, Greenville, SC 29606. One side of the calculator relates capacitance, reactance, resistance, frequency, and dissipation factor, while the other relates ripple voltage, power dissipation, impedance, and resistance. Also included are in./mm and °C/°F converters and a cm/mm/in. ruler. Complete instructions for using the calculator are printed directly on the unit and on its packaging envelope.

SBE 23-CHANNEL AM CB TRANSCEIVER

Linear Systems has announced the addition of the mid-priced, full-feature "Cortez" 23-channel AM CB transceiver to their SBE product line. The Cortez employs a double-conversion design.

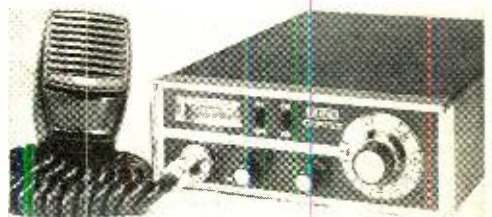

Its "Super Shape" filter provides excellent adjacent-channel rejection to minimize cross-talk. Operational features include a switchable noise limiter, plug-in microphone, PA capability, external speaker jack, and an S-unit/relative-carrier-power meter. The rig comes with a plug-in dynamic mike and a mobile mounting bracket. It can be used in vehicles with either a positive- or negative-ground 12-volt electrical system.

Circle No. 73 on Reader Service Card

KRIS POCKET SCANNING MONITOR

The new Kris, Inc., "Hand-Skan" is a miniature vhf scanning monitor receiver capable of sequentially sampling any four selected frequencies in the 150-170-MHz band. When a signal

is detected, the Hand-Skan locks onto that channel until the transmission ceases, after which it continues to scan until the next signal is received. The monitor is equipped with switches that can be used to "lock out" any unwanted channel. Measuring $6\frac{1}{2}$ " x $2\frac{3}{4}$ " x $1\frac{1}{4}$ " and weighing less than 16 oz, the unit is small and lightweight enough to carry in a coat or hip pocket. Alternatively, it can be conveniently carried on a belt loop in its carrying case.

Circle No. 74 on Reader Service Card

HEATHKIT VHF WATTMETER KIT

An ideal instrument for aligning 2-meter FM gear is the new Heathkit Model HM-2102 vhf wattmeter (available only in kit form). The



wattmeter tests transmitter output power in ranges of 1 to 25 watts and 10 to 250 watts, ± 10 percent of full scale. Its 50-ohm nominal impedance permits placing the unit in transmission lines with little or no loss. In addition, the wattmeter features a built-in SWR bridge with less than 10-watt sensitivity for tuning 2- and 6-meter antennas for proper match.

Circle No. 75 on Reader Service Card

FANON FM WIRELESS MICROPHONE

The battery-powered Fanon Model WFM-1 FM wireless microphone comes equipped with a soft antenna and tuning wand and operates on any open frequency in the FM broadcast band. The mike has a maximum range of up to 100 ft when used in conjunction with an afe-equipped FM receiver. Its highly stable oscillator is designed to provide the minimum of drift. The slim compact mike is hardly larger than most "entertainment-type" professional microphones on the market. The wireless mobile feature comes in handy where cable runs are impractical or dangerous.

Circle No. 76 on Reader Service Card

TDK'S NEW FAMILY OF CASSETTES

New Dynamic and Brilliant lines of TDK Electronics Corp. audio tape cassettes are now available. The two new lines include a total of 14 cassette types in four series, with playing times from 45 minutes to 3 hours. The Dynamic line is designed to meet the needs of all home

Now... the most enjoyable, do-it-yourself project of your life—a Schober Electronic Organ!



You'll never reap greater reward, more fun and proud accomplishment, more benefit for the whole family than by assembling your own Schober Electronic Organ.

You need no knowledge of electronics, woodwork or music. Schober's complete kits and crystal-clear instructions show you — whoever you are, whatever your skill (or lack of it) — how to turn the hundreds of quality parts into one of the world's most beautiful, most musical organs, worth up to twice the cost of the kit.

Five superb models, with kit prices from \$500 to around \$2,000, each an authentic musical instrument actually superior to most you see in stores.

Get the full story FREE by mailing the coupon TODAY for the big Schober color catalog, with all the fascinating details!

The Schober Organ Corp., Dept. PE-52
43 West 61st Street, New York, N. Y. 10023

- Please send me Schober Organ Catalog.
 Enclosed please find \$1.00 for 12-inch L.P. record of Schober Organ music.

NAME _____

ADDRESS _____

CITY _____ STATE _____ ZIP _____

CIRCLE NO. 36 ON READER SERVICE CARD

SAVE ON Brand Name Audio Components

BY MAIL

Write Today for Our FREE Wholesale Audio Catalog

*DIXIE, one of the largest stereo wholesalers, fills all your orders promptly. At prices actually LOWER than "Discounters". See our exciting new Wholesale Price Catalog, or write for quotes. Choose the famous brand stereo equipment and accessories you desire. Everything shipped factory-sealed.

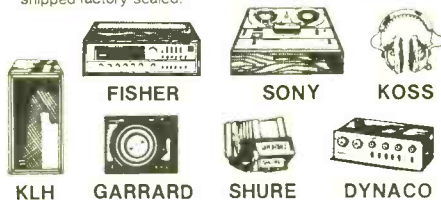

DIXIE HI-FI WHOLESALERS

5600 Second St., N.E., Washington, D.C. 20011

Please rush me your FREE Wholesale Audio Catalog and complete information. I understand there is no obligation.

Name _____

Address _____

City _____ State _____ Zip _____

Phone: 1-202-635-4900 PE-10

CIRCLE NO. 11 ON READER SERVICE CARD

recordists, while the Brilliant line consists of "more-than-equal" premium-quality chromium-dioxide cassettes for use on decks equipped with the proper biasing requirements. Now, cassette recordists can choose from a wide variety of TDK cassette types, choosing the types and formulations that best meet their specific requirements.

Circle No. 77 on Reader Service Card

RADIO SHACK POCKET CALCULATOR

Radio Shack has introduced as their Model EC-200 a new miniature electronic calculator that performs mixed and chain calculations as well as the four basic arithmetic functions. The



calculator features a constant switch, a hooded 8-digit display with built-in automatic cutoff that extends battery life, full floating decimal system, and ac/dc operation. The automatic cutoff feature dissolves the display after 30 seconds; a touch of the D button restores the stored display. The EC-200 calculator comes complete with padded carrying case, ac adapter/battery charger, and instruction booklet.

Circle No. 78 on Reader Service Card

Planning to move?

Let us know 6 to 8 weeks in advance so that you won't miss a single issue of **POPULAR ELECTRONICS INCLUDING ELECTRONICS WORLD**

Attach old label where indicated and print new address in space provided. Also include your mailing label whenever you write concerning your subscription. It helps us serve you promptly.

Write to: P.O. Box 2774, Boulder, Colo., 80302, giving the following information.

Change address only.

Extend subscription. Enter new subscription.

(1) 5 yrs. \$21 (2) 3 yrs. \$15 (3) 1 year \$6

Payment enclosed (1 extra issue per yr. as a BONUS)

Bill me later.

PIONEER CD-4 DISC DEMODULATOR

To help increase the versatility of existing stereo equipment, U.S. Pioneer Electronics Corps. has just released the Model QD-240

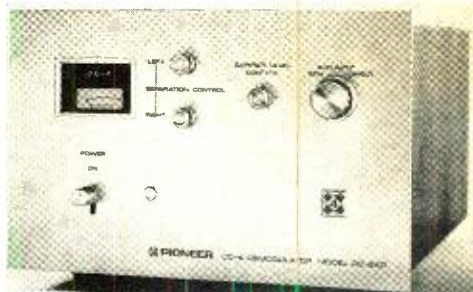

demodulator that reproduces discrete 4-channel sound from CD-4 discs. Separation can be adjusted by means of a pair of controls and a "separation" meter located on the demodulator's front panel. A special test record comes with the unit to allow the user to optimize separation. The QD-240 also features a three-position function switch that permits a choice of 2-channel stereo, 4-channel demodulation, and 4-channel direct. In the 4-channel auto position, switching between 2 and 4 channel is accomplished automatically, while in the direct position, the demodulator's inputs are fed directly to the outputs, bypassing the demodulating circuits.

Circle No. 79 on Reader Service Card

RCA SOLID-STATE HOME TV ANTENNA

A new home TV antenna, called the "Mini-State" by RCA Corp., strongly resembles a miniature flying saucer. It derives its name from its small (21"-diameter) size and its use of special solid-state circuitry to amplify TV signals. The Mini-State is designed to provide superior reception in metropolitan and suburban areas within 35 miles of TV stations. A compact hand-held remote control unit enables the viewer to watch his TV receiver as he rotates the antenna to zero-in on the sharpest

If you have no label handy, print OLD address here.

name _____ please print

address _____

city _____

state _____ zip-code _____

AFFIX LABEL

name _____ please print 0781

address _____

city _____ state _____ zip _____

Add'l postage: \$1 per year outside U.S., its possessions & Canada.

POPULAR ELECTRONICS Including Electronics World

picture. As the internal portion of the antenna revolves, special lights on the remote control indicate the precise location, via compass points, where the antenna is pointing.

Circle No. 80 on Reader Service Card

PAGE SCANNING MONITOR RECEIVER

A programmable two-band uhf/vhf scanning monitor receiver that covers 140-174 MHz and 450-470 MHz simultaneously is now available from the Pace Communications Division of Pathcom Inc. It utilizes a switching network that can be programmed for monitoring any combination of eight channels of the high-band vhf or uhf frequencies. Designated the Scan 216, it holds up to 16 different channels. With simple rear-panel switch controls, the monitor receiver can provide visual readout for up to eight channels at one time.

Circle No. 81 on Reader Service Card

TEAC CASSETTE RECORDER/PLAYER DECK

The Teac Corp. of America Model 450 cassette recorder/player deck has specifications previously unheard of in such equipment. The 450



boasts a wow and flutter of less than 0.07 percent, a -58-dB S/N ratio with the Dolby circuits switched in, and a 30-16,000-Hz frequency range with chromium dioxide tape formulations. The deck features switchable controls for both bias and equalization to permit maximum utilization of all tape formulations and optimum use of its built-in Dolby Noise Reduction system. All controls are on the front to permit shelf placement and operation.

Circle No. 82 on Reader Service Card

SCHURMAN ONE-HAND SOLDERING ADD-ON

Precision one-hand soldering with all popular brand soldering guns has been made possible with the introduction of the "Free-Hand" solder feeder manufactured by Schurman Products. The new add-on is the first solder feeder to offer the time-saving efficiency of one-hand soldering with a device that fits on most existing soldering guns and pistols. It is also the first feeder to fit and work with the natural motion of the hand. The thumb-actu-

free BA 1974 catalog



276 PAGE RADIO, TV & ELECTRONICS CATALOG

Your Buying Guide for Everything in Electronics... Stereo, Hi-Fi, TV's, Radios, Tape Recorders, CB, Kits, Tools, Books, and Electronic Parts.

WRITE FOR IT TODAY!

burstin - applebee

DEPT. PE 3199 MERCIER ST.
KANSAS CITY, MO. 64111

NAME _____
ADDRESS _____
CITY _____
STATE _____ ZIP _____

Why pay retail for hifi?

Buy direct from us, and you save money with our high-volume prices on more than 100 name brands. Order from the branch nearest you to save time and money on freight.

Send for our free catalog.



Midwest Hifi Wholesale & MAIL ORDER DIVISION

2455b Wisconsin Ave. 3309 E. J W Carpenter Frwy,
Downers Grove, Ill 60515 Irving, Tex 75062

CIRCLE NO. 26 ON READER SERVICE CARD

CONTROLLED
QUALITY
CRYSTALS by



CRYSTEK



The "On-Channel" Crystals

FOR

CITIZEN BAND

23 Channels and "Mars"

HAM OPERATORS

Commercial 2-Way

Marine-Monitor

See your Distributor for Speedy
"Zip Certificates"



CRYSTEK

formerly Texas Crystals
Div. of Whitehall Electronics Corp.
1000 Crystal Drive Fort Myers, Florida 33901
4117 W. Jefferson Blvd. Los Angeles, California 90016

CIRCLE NO. 7 ON READER SERVICE CARD

SAVE!

MONEY • TIME • FREIGHT

- ♪ QUALITY STEREO EQUIPMENT AT LOWEST PRICES.
- ♪ YOUR REQUEST FOR QUOTATION RETURNED SAME DAY.
- ♪ FACTORY SEALED CARTONS—GUARANTEED AND INSURED.
- ♪ SAVE ON NAME BRANDS LIKE:
A.D.C. KOSS KLH DYNACO
A.R. FISHER SHURE SONY

AND MORE THAN 50 OTHERS

BUY THE MODERN WAY BY MAIL—

FROM

ia
illinois audio

Department 873 12 East Delaware
Chicago, Illinois 60611 312-664-0020

CIRCLE NO. 21 ON READER SERVICE CARD

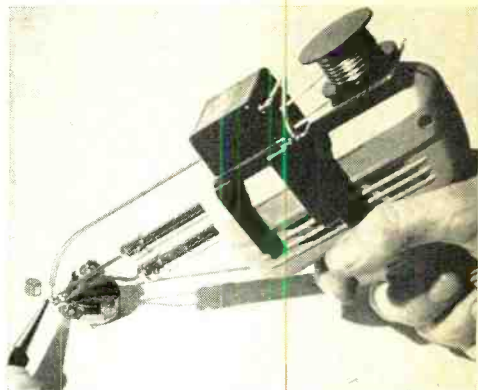

ated feeder trigger positioned on the side of the gun feeds solder at a controlled rate. The trigger can be positioned on either side of the gun for right- and left-hand use. Address: Dept. G, Box 13, Weymouth, MA 02188.

AVANTI DUAL-POLARITY ANTENNA

A new "super power" CB base antenna featuring a 31½-ft. boom has been announced by Avanti R & D. Called the Moonraker 6, it is a 6-element, dual-polarity beam that combines five sets of crossed dipole elements, plus a quad reflector for better rejection and gain. Tunable gamma matching on both the vertical and the horizontal elements handles more than 2000 watts of power, gets the lowest possible SWR, is said to provide excellent lightning protection, and is trouble-free. Specifications include 17 dB gain over the isotropic, 44 dB rejection, 24 dB side rejection, and 1.2:1 VSWR. Address: 33 W. Fullerton Ave., Addison, IL 60101.

DATAPULSE FUNCTION GENERATOR

The Model 400 function generator made by the Datapulse Division of Systron-Donner

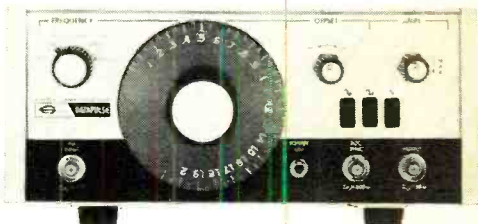

Corp. has a frequency range of 0.02 Hz to 2 MHz; ±2% full-scale dial accuracy; 1000:1 frequency modulation; sine, square, and triangle waveform outputs with less than 1% sine distortion; and open-circuit dc offset variable from -10 V to +10 V. The open-circuit output signal amplitude can be varied up to 20 V p-p (10 V into 50 or 600 ohms). Output impedances of 50 and 600 ohms are available. Address: 10150 W. Jefferson Blvd., Culver City, CA 90230.

POPULAR ELECTRONICS Including Electronics World

ELECTRONICS MARKET PLACE

NON-DISPLAY CLASSIFIED: COMMERCIAL RATE: For firms or individuals offering commercial products or services, \$1.60 per word (including name and address). Minimum order \$16.00. Payment must accompany copy except when ads are placed by accredited advertising agencies. Frequency discount: 5% for 6 months; 10% for 12 months paid in advance. **READER RATE:** For individuals with a personal item to buy or sell, \$1.00 per word (including name and address). No minimum! Payment must accompany copy. **DISPLAY CLASSIFIED:** 1" by 1 column (2 5/8" wide), \$200.00. 2" by 1 column, \$400.00. 3" by 1 column, \$600.00. Advertiser to supply cuts. For frequency rates, please inquire.

GENERAL INFORMATION: First word in all ads set in bold caps at no extra charge. All copy subject to publisher's approval. All advertisers using Post Office Boxes in their addresses **MUST** supply publisher with permanent address and telephone number before ad can be run. Advertisements will not be published which advertise or promote the use of devices for the surreptitious interception of communications. Closing Date: 1st of the 2nd month preceding cover date (for example, March issue closes January 1st. Send order and remittance to Hal Cymes. **POPULAR ELECTRONICS** including **ELECTRONICS WORLD**, One Park Avenue, New York, New York 10016.

FOR SALE

FREE! bargain catalog. Fiber optics, LED's, transistors, diodes, rectifiers, SCR's, triacs, parts. Poly Paks, Box 942, Lynnfield, Mass. 01940.

GOVERNMENT Surplus Receivers, Transmitters, Sniperscopes, Radios, Parts, Picture Catalog 25c. Meshna, Nahant, Mass. 01908.

LOWEST Prices Electronic Parts. Confidential Catalog Free. **KNAPP**, 3174 8TH Ave. S.W., Largo, Fla. 33540.

ELECTRONIC PARTS, semiconductors, kits. **FREE FLYER**. Large catalog \$1.00 deposit. **BIGELOW ELECTRONICS**, Bluffton, Ohio 45817.

CONVERT any television to sensitive, big-screen oscilloscope. Only minor changes required. No electronic experience necessary. Illustrated plans. \$2.00. **Reico-A33**, Box 10563, Houston, Texas 77018.

AMATEUR SCIENTISTS, Electronics Experimenters, Science Fair Students . . . Construction Plans—Complete, including drawings, schematics, parts list with prices and sources . . . Robot Man — Psychedelic shows — Lasers — Emotion/Lie Detector — Touch Tone Dial—Quadrasonic Adapter—Transistorized Ignition — Burglar Alarm—Sound Meter . . . over 60 items. Send 25¢ coin (no stamps) for complete catalog. Technical Writers Group, Box 5994, University Station, Raleigh, N.C. 27607.

RADIO—T.V. Tubes—36¢ each. Send for free catalog. **Cornell**, 4213 University, San Diego, Calif. 92105.

METERS—Surplus, new, used, panel or portable. Send for list. **Hanchett**, Box 5577, Riverside, CA 92507.

PYROTECHNICAL chemicals, casings, tools, supplies, fuse, literature. Giant, illustrated catalogue/handbook includes formulas, instructions—50¢, with samples—\$1.00. **Westech**, Box 593, Logan, Utah 84321.

WE SELL CONSTRUCTION PLANS. TELEPHONE: Answering Machine, Speakerphone, Carphone, Phonevision, Auto Dialer, Touch Button Dialer, Central Dial System. **TELEVISION:** \$35.00 Color Converter, Video Tape Recorder, \$25.00 Camera. **HOBBYIST:** Electron Microscope, 96 Hour Tape Music System, Ultrasonic Dishwasher, Radar-Oven. Plans \$4.95 each. **NEW ITEM:** \$75 Electronic Pocket Calculator, \$7.50. **COURSES:** Telephone Engineering \$39.50. Detective Electronics \$22.50, Integrated Circuit Engineering, \$49.50. **NEW SUPER HOBBY CATALOG** plus year's subscription to Electronic New Letter **AIRMAILED \$1.00**. **Don Britton Enterprises**, 6200 Wilshire Blvd., Los Angeles, Calif. 90048.

ANTIGRAVITY, experiment and theory. Rushed—\$2.00. U.S. inquiries. **Intertech 7A12**, Box 5373, Station-F, Ottawa, Canada.

JAPAN HONG KONG DIRECTORY. World products information. \$1.00 today. World Trade Inquiries, Hillyard, Washington 99207.

TEST EQUIPMENT, Aerospace-Laboratory Grade. Request your needs; will mail appropriate catalogs (we have 24 catalog categories). Only for Engineers, Businessmen. Schools and advanced Technicians. **Goodheart**, Box 1220PE, Beverly Hills, Calif. 90213.

BUILD YOUR OWN SPACE-AGE TV CAMERA



ONLY KNOWN SOLID-STATE CAMERA KIT! Ideal for experimenters, hobbyists, education, industry, etc. • High quality • Backed by over six years of lab & field testing • Fully Guaranteed • Connects to any TV set without modification • Step-by-step construction manual • Model XT-1A, Series D complete with vidicon \$149.50 (postpaid anywhere in USA & Canada (less vidicon wire \$116.95-99))

PHONE OR WRITE FOR CATALOG.
DIAL 402-383-3171

Many other kits, parts and plans available including starter kits, focus-deflect, vidicon, kines, camera, plans and a subcompact kit, etc.

1301 BROADWAY ATV Research DAKOTA CITY, NEBR. 68731

SCOPES, meters, test equipment, military and industrial surplus. Write for free "Bargain Bulletins". **Lawrence Instruments**, P.O. Box 744, Sunbury, Pa. 17801.

MECHANICAL, ELECTRONIC devices catalog 10¢. Greatest Values —Lowest Prices. **Fertik's**, 5249 "D", Philadelphia, Pa. 19120.

SURPLUS electronics for everyone. Free catalog. U.S. inquiries. **ETCO**, 464 McGill, Montreal, Canada.

IC

FACTORY FIRSTS
NATIONALLY KNOWN BRANDS
SATISFACTION GUARANTEED

ITEM	1-99	100-999	DIGITAL TTL	ITEM	1-99	100-999
7400N	32c	28c	7450N	32c	28c	
7401N	32c	28c	7472N	40c	35c	
7402N	32c	28c	7473N	52c	45c	
7403N	32c	28c	7474N	52c	45c	
7404N	35c	31c	7475N	\$1.00	85c	
7410N	32c	28c	7476N	60c	55c	
7420N	32c	28c	7485N	60c	55c	
7430N	32c	28c	7490N	\$1.00	85c	
7440N	32c	28c	7492N	\$1.00	85c	
7441N	\$1.75	\$1.45	7493N	\$1.00	85c	
7442N	\$1.35	\$1.15	7495N	\$1.30	\$1.15	
7447N	\$1.30	\$1.10	74107N	55c	50c	
7451N	32c	28c	74121N	55c	60c	
7453N	32c	28c	*MIXED TTL PRICES			

ITEM	1-99	100-999	LINEAR INTEGRATED CIRCUITS	ITEM	1-99	100-999
709C MINIDIP			60c	10/S 5.50	100/S 51	
723C DIP			\$3.15	10/S 11.50	100/S 100	
741C MINIDIP			60c	10/S 5.50	100/S 66	
748C MINIDIP			80c	10/S 7.50	100/S 70	
558C MINIDIP			\$1.25	10/S 12.00	100/S 110	
NE565A DIP			\$3.57	10/S 30.00		
LM309K To-3			\$2.50	5/S 11.25		

ITEM	1-99	100-999	GENERAL PURPOSE SILICON TRANSISTORS	ITEM	1-99	100-999
2N3638	20c	10/S 1.65	2N5134	15c	10/S 1.25	
2N3638A	22c	10/S 1.65	2N5137	18c	10/S 1.50	
2N3641	23c	10/S 2.00	2N5138	15c	10/S 1.25	
2N3643	23c	10/S 2.00	2N5139	15c	10/S 1.25	
2N5133	15c	10/S 1.25	2N5139	\$1.00	10/S 9.50	

1 AMP SILICON RECTIFIERS

1N4003 200PIV	10/S 11	100/S 7	1M \$53
1N4005 500PIV	9/S 11	100/S 56	1M \$61
1N4007 100PIV	8/S 11	100/S 50	1M \$53

SILICON SIGNAL DIODES

1N4148 (1N914 equiv.)	20/S 11	100/S 4	1M \$35
-----------------------	---------	---------	---------

MOLEX IC SOCKET PINS

100 \$1.00	200 \$1.80	300 \$2.60	500 \$4.20	700 \$5.80
1000 \$8.20	ea addn 1000/\$7.50			

INTEGRATED CIRCUIT SOCKETS

14 PIN DIP SOLDER	45c	16 PIN DIP SOLDER	50c
14 PIN WIRE WRAP	55c	16 PIN WIRE WRAP	60c

DISPLAY DEVICES

5 Volt 7 Segment Tube	\$3.75
Display Kit (Tube) 7447-7475-7490	\$6.15 3/\$17.50
7 Segment Led (Man-I Type)	\$4.00
Display Kit (Led 7447-7475-7490-Resistors)	\$6.40 3/\$18.25

C.O.D. ORDERS ACCEPTED FOR SAME DAY SHIPMENT
CALL 218-681-6674

Free Catalog—Large Quantity Discounts—Orders Less Than \$10.00 Add 25c—Others Postpaid



PRICES SLASHED

DIGI-KEY

PRICE PACESETTER FOR QUALITY IC'S
BOX 126K THIEF RIVER FALLS, MN56701

CIRCLE NO. 10 ON READER SERVICE CARD



GREGORY ELECTRONICS
Reconditioned & Used
FM 2-WAY RADIO SAVINGS
 Partial List—Send for New Catalog

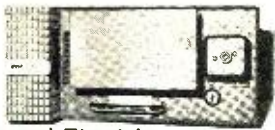

General Electric
 DT03, 150 MHz, transistor
 powered, 5 channel

**FULL DUPLEX MTS
 TELEPHONE UNITS**

12 volt, 25 watts

Less cables,
 ovens & heads **\$195.00**

5 channel manual telephone
 heads available with purchase
 of above units at **\$50.00**
 each



GREGORY ELECTRONICS CORP.

249 P.R. 46, Saddle Brook, N.J. 07642
 Phone: (201) 489-9000

CIRCLE NO. 18 ON READER SERVICE CARD

DIGITAL ELECTRONICS! Complete schematics, parts lists, theories—Discrete Component Digital Clock, \$3.00—Sound Sensitive Switch, \$1.50. Increase technical competence, hobby skills—Complete Course in Digital Electronics is highly effective, \$10.00. Free literature. DYNASIGN, Box 60A7, Wayland, Mass. 01778.

FREE Catalog lists resistors, tubes, transistors, rectifiers, condensers, tools, tuners, etc. Hytron Hudson, Dept. PE, 2218 Kennedy Blvd., Union City, N.J. 07087.

FREE CATALOG
UP TO 50% OFF COMPARABLE KITS*

• **BUY DIRECT • SAVE \$\$\$**

FREE Catalog — Electronic Kits — Amplifiers — Preamps — Psychedelic Strobes — Burglar Alarms Digital Tachometer — More: **Free Catalog**, SWTPC, Box A32040, San Antonio, Tex. 78284.

IGNITION SYSTEMS: Capacitor, Transistor, Information 10¢. Anderson Engineering, Epsom, N.H. 03239.

AUTHENTIC, INSTRUMENTED, FLYING ROCKETS for casual or serious experimenters. Over 80 scale original, multi-stage or ready-to-fly models. Solid-propellant engines for safe, electric launch system liftoffs up to 2,500 feet. Measure altitude, temp. inversions, more. Real telemetry, electronic tracking, aerial still and movie photography with super-miniaturized equipment. New, detailed tech manual and full-color catalog. 25¢ from ESTES INDUSTRIES, Dept. 180, Penrose, Colo. 81240.

FREE CATALOG. Parts, circuit boards for Popular Electronics projects. PAIA Electronics, Box C14359, Oklahoma City, OK 73114.

WAVEFORM Generator Kit \$10.00. Stereo Multiplex Kit \$19.95. Free Kit Catalog. Photolume Corp., Box 139, N.Y., N.Y. 10016

TTL IC, Semiconductors, parts discount. Price List, 10¢. Totelek Box 222, Goodyear, Arizona 85338.

DIGITAL SPEEDOMETER with numeric readout. Plans \$4.50. KIMTRON, Box 80134, Chamblee, Georgia 30341.

WHOLESALE Scanners, CB, Crystals, Directories, SSB/AM, Catalog 25¢. G—ENTERPRISES, Box 461P, Clearfield, Ut. 84015.

+ - × ÷ CALCULATOR OWNERS: Compute **SQUARE ROOTS**, trigonometric functions, logarithms, exponentials, and more! Quickly, accurately, easily! Manual \$2.00. Send today—Unconditional money-back guarantee! Mallmann Optics and Electronics, Dept. 8A, 836 South 113, West Allis, Wisconsin 53214.

FIREWORKS NEWS Magazine Covers Commercial-Display Fireworks, Sources, Construction, Literature, Pyrotechnical Supplies. Free Catalog! Pyro Press, Box 12010(N103), Lexington, Kentucky 40511.

FREE Catalog. Reeds, Tantalums, Transistors, PUTS, LEDES, Parts. Chaney, Box 15431, Lakewood, Colo. 80215.

AUTOMATIC Telephone Recording Monitors. Starts and stops recorder automatically and unattended. Catalog \$1.00. Jack, Box 19422, Sacramento, Calif. 95819.

ELECTRONIC COMPONENTS for mailorder concerns. I.C.'s, CAP's, Switches, Light Ass. Write or call for samples. WIRDSON Dist. Co., 46 Cadman Pl. W., Bklyn, N.Y. 11201. (212) 624-7038.

DIGITAL and analog computer modules. LED numeric display kits. Free Literature. Scientific Measurements, 2945 Central, Wilmette, Illinois 60091.

BURGLAR-FIRE alarm components, hardware. Free catalog—information. Silmar, 133 S.W. 57th Ave. Miami, Florida 33144.

CD IGNITIONS, VHF/UHF monitors, crystals, CB radios. Wholesale. Southland, Box 3591-B, Baytown, Texas 77520.

COLOR TELEVISION ANTENNA (Missile Age slotted Design) (Pat. No. 3577196, 1971) VHF (6 db.)—UHF (12 db.) Encased in rollable decorative plastic. Unroll it, hang it on your living room wall, attic, etc. Order prepaid AIRMAIL from: ANTENNA DESIGN CO., Subcontract Office, 11621 Hughes Ave., NE, Albuquerque, N.M. 87112. Note: Uses no splitter, YOU save \$3.00. Price: \$10. Size: 18" x 48" (unrolled).

LOGIC Probe \$9.95. Free bargain catalog. Electro, 4201 Irving Park, Chicago, Illinois 60641.

CHOKES—(150 watt—air core) for crossover networks, \$5.00 + postage. Reostats, Tantalum capacitors, send for list. Pragmatech Sound, 70 Sheldrake Pl., New Rochelle, N.Y. 10804.

POLICE SCANNERS, C.B. Radios, at discount prices. Kits—Cat., 25¢. Krystal Kits, 2202 S.E. 14, Bentonville, Arkansas 72712.

ELECTRONIC ORGAN KITS, KEYBOARDS and many components. Independent and divider tone generators. All diode keying. I.C. circuitry. Build any type or size organ desired. Supplement your Artisan Organ. 25¢ for catalog. DEVTRONIX ORGAN PRODUCTS, Dept. C, 5872 Amapola Dr., San Jose, Calif. 95129.

EXPERIMENTER supplies, PC chemicals, solder, adhesives, accessories—Free catalog. Technical Services, Box 687P, Arlington, MN 55307.

NEW and Surplus Electronics. 10 Univac boards crowded with Transistors, Diodes, Resistors, Long Leads, \$1. MM5314 Digital Clock Chip, \$12.50. Dual 16VCT 1/2A Transformer, \$3.25. Postpaid order or 8¢ stamp for lists. Tri-Tek, P.O. Box 14206, Phoenix, Arizona 85063.

CMOS, TTL, Linears, LED's. Surplus Bargains. Stamp brings free catalog. Godbout, Box 2673, Oakland Airport, CA 94614.

WE SELL CONSTRUCTION MANUALS—**GOLD** Recovery Unit—**SILVER** Recovery Unit—Alternator Adapter (provides 120 volts in your car!)—Infrared Scope—Inverter (12 volts DC to 120 volts AC)—Electronic Insect Trap—Burglar Alarm—X-Ray Fluoroscope—Chemical Formulary. Manuals \$5.00 each. **HIGHLY PROFITABLE Business Courses!**—"How To Start and Operate Your Own **SILVER Recovery Business!**"—"The Manual of **PRECIOUS METALS!**" courses \$9.95 each—illustrated color catalog, 25¢—Airmailed 50¢—Creative Products, 8415 Loffland, Dept. 103, Houston, Texas 77055.

PAIA

MAKES THE ONLY SYNTHESIZER KITS
models priced from \$139 - free brochure and catalog

PAIA ELECTRONICS, INC.
BOX #14359, OKLAHOMA CITY, OK 73114

SCOTCH 150 STUDIO TAPE—1800' on 7" reel, degaussed and boxed, 12 for \$12. **LOW NOISE CASSETTES** in hard p'astic boxes professional quality-LNC60. 12 for \$11; LNC90, 12 for \$15. **POSTPAID**. Free price list. **WIDE RESPONSE**, 6114-P Santa Monica Blvd., Hollywood, Calif. 90038.

PHOTO BUTTON MACHINE \$29.95. 8D Enterprises, 230-PE Greenwood, Lupton, Arkansas 72354.

FREE CATALOG—Tremendous electronics bargains. Pacific, Box 4192C, Mountain View, California 94040.

NOW buy crystals for Regency, Bearcat, Tennelec and other popular monitor radios at the low prices of \$3.95 each. Also, you can now buy citizen band crystals for \$2.10. Just send the make and model number of the radio along with the desired frequencies to: Penn-Alley Distributors, 310 Penn Street, Hollidaysburg, Pa. 16648. Please send a check or money-order for the amount of the order and 6% state sales tax, to eliminate C.O.D. charges. Allow 3 to 4 weeks for delivery.

BRAIN WAVE MONITOR Biosone BF-20 Alpha Biofeedback Instrument. \$34.95 complete. Not a kit. Fully Guaranteed. For information write. **BIO-LOGIC DEVICES, INC.**, Dept. A, 888 Seventh Avenue, New York, New York 10019.

DISCOUNT PRICES
B & K, SENCORE, LEADER Test Equipment
RAYTHEON, ICC/MULLARD Tubes
TELEMATIC Test Jigs
Free Catalog
FORDHAM RADIO SUPPLY CO. INC.
558 Morris Ave., Bronx, N.Y. 10451

SOUND SYNTHESIZER KITS—Surf \$11.95, Wind \$11.95, Wind Chimes \$16.95, Electronic Songbird \$6.95, Musical Accessories, many more. Catalog free. **PAIA Electronics**, Box J14359, Oklahoma City, OK 73114.

BIOFEEDBACK. Professional Instruments: Electroencephalophone, Galvanic Skin Response. J&J, 8102-E, Bainbridge, WA 98110.

WEATHER EQUIPMENT for hobbyist and professional. Send for **FREE** catalog. Sierra Weather Instrument Corp., P.O. Box 771, Nevada City, CA 95959.

ALPHA/THETA brainwave biofeedback instruments. Analog instruments from \$135; digital processing from \$265. BioScan, Box 14168E, Houston, Texas 77021.

BURGLAR-FIRE ALARMS. Unique, solid state, keyless control unit for home or auto. Total protection. Literature. Kenmore Electronics, Box 715, Forest Hills, NY 11375.

RADIO-TELEVISION Diagrams, 17 Volumes, 2,880 large pages. \$42. value, only \$14.95. Supreme Publications, 1760 Balsam, Highland Park, Illinois 60035.

LOW NOISE RESISTORS—1/4W, 5%, carbon film for 3.5c each. 50 of one value for \$1.25. All 5% values from 10 ohms to 3.3M ohms in stock. Specifications upon request. 75c postage and handling charge per order. Deduct 10% on orders over \$50.00. **COMPONENTS CENTER**, Box 134, N.Y., N.Y. 10038.

<p>NATIONAL MOS DYNAMIC shift registers TO-5 MM502 dual 50 bit 1.25 MM506 dual 100 bit 1.75 MM506 dual 100 bit 1.50 MM5013 1024 bit 2.00 MM5016 512 bit 1.50 STATIC shift registers MM504 dual 16 bit 1.50 MM505 dual 32 bit 1.75 MM550 dual differential analog switch 2.50</p>	<p>CT5005 CALCULATOR ON A CHIP This chip has a full four function memory. Memory is controlled by four keys. +M (adds entry to memory), -M (subtract entry from memory), C (clear memory-without clearing rest of registers), RM (read memory or use as entry). 12 DIGIT DISPLAY AND CALC. FIXED DECIMAL AT 0.1, 2, 3, 4, OR 5 CLEARING ZERO SUPPRESSION SEVEN SEGMENT MULTIPLEXED OUTPUT TRUE CREDIT SIGN DISPLAY SINGLE 28 PIN CHIP Chip and data—\$14.95 Data only—1.00 (refundable) 1101/2501 256 bit x1 MOS memory \$2.56</p>	<p>7400 TTL DIP 7400-----\$.35 7401-----.35 7403-----.35 7404-----.35 7405-----.35 7413-----1.75 7410-----.35 74110-----.50 7420-----.35 7430-----.35 7441-----.35 7441-----1.00 7442-----1.30 7446-----1.75 7448-----1.15 7450-----.35 7451-----.35 7453-----.35 7454-----.35 7460-----.35 7472-----.50 7473-----.65 7474-----.65 7476-----.70 7480-----.65 7483-----1.30 7486-----.80 7489-----4.75 7492-----1.15 7493-----1.15 7495-----1.25 74107-----.70 74154-----2.50 74192-----2.50 74193-----1.50 74195-----1.10</p>
<p>KEYBOARD General Telephone Ten push buttons (0-9) touch-tone, encoding, programming devices. Easy for panel mounting. \$5.95 Size: 3X2 1/2 X 1 1/2"</p>	<p>MAN 1 Popular 7 segment diffused LED. Dual in line 14 pin capable of displaying all digits and nine distinct letters. \$4.00 each only</p>	<p>LINEARS LM100-----\$ 1.00 LM309H-----.75 LM309K-----2.00 NE5556-----1.00 NE5560-----3.25 741(MINI DIP)-----.45 7473-----1.10 709-----.45 710-----.40 711-----.40 723-----1.00 LM380(audio amp) 1.75</p>
<p>TRIAIC 2HG344 600V 8A TO-220 \$1.00 NE531 op amp TO-5 \$2.00 NE561 phase lock loop DIP 3.25 NE566 phase lock loop TO-5 3.25 NE566 function generator TO-5 4.00 NE567 tone decoder TO-5 4.00 CM5880 (Sperry DD700 202) 7 segment high voltage mixie driver-----\$1.75</p>	<p>LED FLUO special!!!! 39 each 3.50 for ten 29.95 for 100 MANEM Each-----\$3.00 Ten or more-----2.50</p>	<p>CMOS CD4001-----\$.75 74C00-----.75 74C01-----.75 CD4012-----.75 CD4023-----.75</p>
<p>All IC's are new and fully tested, leads are plated with gold or solder. Orders for \$5 or more will be shipped prepaid. Add 35c for smaller orders. California residents add sales tax. IC orders are shipped with 24 hrs. COD's may be phoned in \$10. minimum. Money back guarantee. P.O. Box 3 Carmichael, California 95608 BABYLON ELECTRONICS (916) 966-2111</p>		

CIRCLE NO. 4 ON READER SERVICE CARD

PLANS AND KITS

ANTIGRAVITY DEVICE. Brochure rushed free. AGD, Box 3062-ZD, Bartlesville, Oklahoma 74003.

FREE KIT CATALOG

Why does every major College, University, Technical School, Research & Development Center buy from us? Because we have the highest quality and lowest prices. Free Catalog. SWTPC, Box H32040, San Antonio, Tex. 78284.

LATEST vista digital, linear IC, PC Board Kits. Free Flyer. Photolum Corp., Dept. A, Box 139, N.Y., N.Y. 10016.

NT-T Peerless Speaker kits. Danish-engineered 40-20,000 hz systems requiring no tools to assemble, surprisingly little money to buy. Free catalog. Aware, Box 683, La Canada, CA 91011.

"CRYSTAL Set Handbook"—50c. Catalog 25c, refundable. Laboratories, 1477-L, Garden Grove, Calif. 92642.

TESLA COIL—40" SPARKS! Plans! \$7.50. Information 75c. Huntington Electronics, Box 2009-P, Huntington, Conn. 06484.

PROFESSIONAL Burglar Alarm System. Complete Plans \$2.00. Southwest Plans, Box 447, Garland, Texas 75040.

UNIQUE DEVICES: Plans, Kits—Security, Audio, Hobby; Catalog 50c (refundable). Metro-Elco, Box 409, Toledo, Ohio 43692.

SIMPLE Instructions: Tool Speed Control—Drill reversing switch—Light dimmer—\$1.50 each. 12VDC to 115VAC converter, \$3.00. DanRan, Box D, Reno, Nevada 89506.

HIGH FIDELITY

DIAMOND NEEDLES and Stereo Cartridges at Discount prices for Shure, Pickering, Stanton, Empire, Grado and ADC. Send for free catalog. All merchandise brand new and factory sealed. **LYLE CARTRIDGES**, Dept. P, Box 69, Kensington Station, Brooklyn, New York 11218.

STEREO SPECTRUM, the money saver for hifi buyers, write us, Box 1818, Miami Beach, Florida 33139.

WANTED

QUICKSILVER, Platinum, Silver, Gold, Ores Analyzed. Free Circular. Mercury Terminal, Norwood, Mass. 02062.

ELECTRICAL SUPPLIES AND EQUIPMENT

PLATING Equipment, Portable Platers, Supplies and "Know-How." Build your own tanks for nickel, chrome, etc. Easy-to-install PVC liners. Rectifier components—all sizes. Schematics, parts lists, formulas, operating instructions for all plating. Guaranteed to save you 25%-75%. Some good units for sale. Write for details. Platers Service Company, 1511-PE Esperanza, Los Angeles, Calif. 90023.

TUBES

RADIO & T.V. Tubes—36¢ each. Send for free Catalog. Cornell, 4213 University, San Diego, Calif. 92105.

RECEIVING & INDUSTRIAL TUBES, TRANSISTORS. All Brands—Biggest Discounts. Technicians, Hobbyists, Experimenters—Request **FREE** Giant Catalog and **SAVE!** **ZALYTRON**, 469 Jericho Turnpike, Mineola, N.Y. 11501.

TUBES "Oldies", latest. Lists free. Steinmetz, 7519 Maplewood, Hammond, Indiana 46324.

SAVE money on parts and transmitting-receiving tubes, foreign-domestic. Send 25¢ for giant catalog. Refunded first order. United Radio Company, 56-P Perry Street, Newark, N.J. 07105.

TUBES receiving, factory boxed. low prices, free price list. Transleteronic, Inc., 1306 40th Street, Brooklyn, N.Y. 11218A, Telephone: 212-633-2800.

GOVERNMENT SURPLUS

GOVERNMENT Surplus. How and Where to Buy in Your Area. Send \$2.00. Surplus Information, Headquarters Bldg., Box 30177-PE, Washington, D.C. 20014.

ELECTRONIC Equipment and Parts. Big 36 page Free Catalog. Send for your copy today! Fair Radio Sales, Box 1105-P, Lima, Ohio 45802.

JEEPS Typically from \$53.90 . . . Trucks from \$78.40 . . . Boats, Typewriters, Knives, Airplanes, Clothing, Multimeters, Oscilloscopes, Transceivers, Photographic, Electronics Equipment. Wide-variety, condition. 100,000 Bid Bargains direct from government nationwide. Complete sales directory and surplus categories catalog \$1.00 (Deductible on orders from separate included catalog). Surplus Service, Box 820-J, Holland, Michigan 49423.

GOVERNMENT SURPLUS. Complete sales directory \$1.00. Surplus Publications, Box 26062Z, Los Angeles, Calif. 90026.

MANUALS for gov't surplus radios, test sets, scopes, teletype. List 50¢. Books, 7218 Roanne Drive, Washington, D.C. 20021.

BOOKS

FREE catalog aviation/electronic/space books. Aero Publishers, 329PE Aviation Road, Fallbrook, California 92028.

FREE book prophet Elijah coming before Christ. Wonderful bible evidence. Megiddo Mission, Dept. 64, 481 Thurston Rd., Rochester, N.Y. 14619.

UNUSUAL BOOKS! 40 for \$3. Catalogue 10¢. International, Box 7798PE, Atlanta, Georgia 30309.

CLASSIFIED ADVERTISING ORDER FORM

Please refer to heading on first page of this section for complete data concerning terms, frequency discounts, closing dates, etc.

1	2	3	4	5
6	7	8	9	10
11	12	13	14	15
16	17	18	19	20
21	22	23	24	25
26	27	28	29	30
31	32	33	34	35

Words { @ \$1.00 (Reader Rate) }
 { @ \$1.60 (Commercial Rate) }

Insert _____ time(s)

Total Enclosed

\$ _____

NAME _____

ADDRESS _____

CITY _____

STATE _____

ZIP _____

Signature _____

WORD COUNT: Include name and address. Name of city (Des Moines) or of state (New York) counts as one word each. Zip Code numbers not counted. (Publisher reserves right to omit Zip Code if space does not permit.) Count each abbreviation, initial, single figure or group of figures or letters as a word. Symbols such as 35mm, COD, PO, AC, etc., count as one word. Hyphenated words count as two words.

PE473

12-DIGIT "CALCULATOR CHIP"

Similar to Mostek 5001. Outperforms Texas S-8 digit TMS1802. A 10-pin DIP. Adds, multiplies, subtracts, and divides. Use with 7-segment readouts, Nixies, and LEDs. We include schematics, instructions to build calculator.

CT5001 Chip **\$9.95** 3 for \$27.

CT5002-9 Volt version of above — **\$9.95**

CT5005—Same as above with MEMORY — **\$14.95**

CALCULATOR KEYBOARD

\$9.95 3 for \$27

Etched calculator board with holes, as above, less switches ... **\$2.50 Board**

8-TRACK CAR RADIO STEREO TAPE TRANSPORT

Contains complete 8-track stereo recording/playback unit you find in expensive car tape decks. Excellent direct replacement unit if your unit does not function properly. Priced to toss away old, and replace with new. Less amplifier. Design your own hi-fi stereo systems around it. Uses standard 8-track cartridge. With hi-fi stereo tape and all its mechanical parts that go with it. Operates off 12VDC. Automatic track locating and changing plus track indicator output. 3 1/2 ips speed. WOW and FLUTTER less than 0.5%. Metal shield motor reduces motor noise to an inaudible level. Uses separate 739 preamp and is ready to go. Size: 5" x 5" x 2"

\$8.88

Properly etched, drilled, "MULTI-PLATED" with proper diodes. Ready to go! Use with our own CAL TECH'S 5001 chip advertised at \$12.95 or equal to Cal Tech or Mostek chip. Keyboard uses 64 diodes manufactured by OAK printed-circuit low-profile FEATHER TOUCH switches. 0-to-9 in white with black letters, Decimal white with black dot, CE, CL and the J function switches are in blue with white characters. Designed by top maker, Size: 6 1/2" x 4 1/2". All etched connections link to take a 12-pin edge connector.

Cal Tech 5001 12-digit calculator 28-pin DIP for **\$ 9.95**

Keyboard, 5001 "chip", and 12 MAN-3's, specs **\$35.00**

Twelve MAN-3's for above ... **\$17.50**

Twelve MARI-4's for above ... **\$32.00**

Twelve MAN-1's for above ... **\$42.00**

LED MITY DIGIT "DCM'S"

Scientific Devices' "Digital Counting Modules" outperform any other DCM on the market today. Many features than ever before: 10% accuracy, not incandescent, not nixie but the modern LED. Choose from such famous manufacturers as Monsanto's MAN-1, MAN-4, Litronics 707 and 704, Opcoa's SLA-1 (the last 4 having character heights of 0.03 at no extra charge). Each kit includes 15x27 pin board with fingers for a FREE edge connector, self-mounting dip socket, LED readout of your choice, resistors, 10% and 5% resistors, connector, and a FREE SOLDERING YOUR IC'S booklet. INCLUDES P.C. EDGE CONNECTOR — FREE!

Only **\$9.99**

Buy 3 — Take 10%

Char. Maker

MAN-1	27 h. Monsanto
MAN-4	19 h. Monsanto
707*	.33 h. Litronics
704**	.33 h. Litronics
SLA-1*	.33 h. Opcoa

* Pin-for-pin MAN-1, ** Pin-for-pin MAN-1, elec. char. same

OAK FEATHER-TOUCH CALCULATOR KEYBOARD SWITCHES

For RTTY, Teletype, and other data systems, same as used in Keyboard Calculator Chip. Normally Open, 24V 1 amp contacts. Characters and letters instantly changed. 3/4" high. Printed circuit.

Unique Circuits

For Panel Switches

No.	Sale	5*	.49	CE†	.49	+	.49
0*	\$.49	6*	.49	CL†	.49	x†	.49
1*	.49	7*	.49	+	.49	-†	.49
2*	.49	8*	.49	-†	.49		
3*	.49	9*	.49				
4*	.49						

* White top, black numbers.
† Blue top, white characters.

Kit of 17 above switches for keyboard **\$7.50**

LITRONICS-MONSANTO-OPCOA LED Readouts

All full 14-pin IC sockets, 10 to 20 mfd. 5000 numerals, plus letters & decimal. With spec sheets.

Monsanto Equal, MAN-1

MAN-1 Series

735-Diode Array.

MAN-1	27	Red	Yes	SN7447	4.50	3 for \$12
MAN-2*	.32†	Red	Yes	2513	6.50	3 for \$18
MAN-3*	.115	Red	Yes	SN7448	2.25	3 for \$6
MAN-3**	.115	Red	No	SN7448	1.49	3 for \$3.
MAN-4*	.190	Red	Yes	SN7448	2.95	3 for \$8.
MAN-4**	.190	Red	No	SN7448	1.79	3 for \$5.
MAN-5*	.27	Green	Yes	SN7447	6.50	3 for \$18
MAN-8*	.27	Yellow	Yes	SN7447	6.50	3 for \$18

NATIONAL EQUALS ON DIGITAL CLOCK CHIP

Any "Chip" **\$12.88**

*Money Back Guarantee!

Mrs #	Description	Sale	
5311	28-pin, ceramic, any readout, 12,888		*With Spec Sheet!
5312	24-pin, ceramic, any readout, 12,888 4-digits: C-D		
5313	28-pin, ceramic, any readout, 12,888		
5314	24-pin, plastic, LED and incandescent readouts, 6-digits: A-B		*Compare Save!

Code: A—Hold Count. C—1 PPS Output. B—Output Strobe. D—BCD

"REFLECTIVE LITE BAR" (SEGMENT) LED READOUTS! ***** Decimal right or left

LITRONIX 707** (MAN-1)	.33	Red	Yes	SN7447	3.50	3 for \$9.
LITRONIX 704*** (MAN-4)	.33	Red	Yes	SN7448	3.50	3 for \$9.
OPCOA SLA-1** (MAN-1)	.33	Red	Yes	SN7447	3.50	3 for \$9.
OPCOA SLA-1** (MAN-1)	.33	Red	No	SN7447	1.95	3 for \$5.
OPCOA SLA-3H Giant Dixit	.70	Red	Yes	SN7447	8.60	3 for \$24.
OPCOA SLA-2 Plus/Minus/1	.33	Red	No	SN7447	3.50	3 for \$9.
OPCOA SLA-11C (MAN-5)	.33	Green	****	SN7447	4.95	3 for \$13.
OPCOA SLA-12 Plus/Minus/1	.33	Green	—	SN7447	4.95	3 for \$12.

HOBBY EXPERIMENTAL "LED" KORNER

3-MAN-3*	"The claw", some segments missing, hobby use, readout	1.00
1-MAN-4	some segments missing, hobby use, readout	1.00
1-SLA-7	Opcoa's MAN-1, 1-segment missing, hobby use, readout	1.49
1-SLA-7	Opcoa's MAN-1, hobby, some segments missing	1.00
10-LED HOBBY SURPRISE!	asst, typins, no-test	1.00
3-P.C. KIT, MANT, MAN-3, MAN-4	some segments missing	1.49
5-MONSANTO'S Opto Coupler	supplies, asst, nixie, readout	1.00
1-SLA-13H	Opcoa, giant 0.7 character readout, some seg missing	1.49
1-SLA-11	Opcoa, like MAN-1, green, some seg missing, readout	1.49
2-SPERRY SP332	two-digit, factory failures, no test	1.00

POLY PAKS STOCKS "C-MOS" IC CIRCUITS

FACTORY GUARANTEED FACTORY TESTED

531	Hi slow rate op amp (TO-5)	\$2.50
532	Micro power 741 (TO-5)	2.50
533	Micro power 709 (TO-5)	2.50
536	FET input op amp (TO-5)	2.50
537	Precision 741 (TO-5)	2.50
540	70W pwr driver amp (TO-5)	2.50
550	Universal 723 volt reg. (DIP) 1.17	
556	5 Times faster than 741C	1.00
558	Dual 741 (mini DIP)	1.00
560	Phase lock loops (DIP)	3.25
561	Phase lock loops (DIP)	3.25
562	Phase lock loops (DIP)	3.25
563	Phase lock loops (A)	3.25
566	Function Generator (A)	3.25
567	Tone generator (A)	3.25
595	Four quadrant multiplier	3.10
702C	Hi-grain, DC amp (TO-5)	.49
703C	RF-IF, amp, 14 ckts (TO-5)	1.00
704	TV sound IF system	1.50
709C	Operations/comp (A)	.49
709CV	Op amp (mini DIP)	.49
710C	Differential amp (A)	.49
711C	Dual diff. comp (A)	.49
723C	Voltage regulator (A)	.95
733	Diff. Video Amp	1.75
741C	Freq compenator 709 (A)	.49
741CV	Freq, comp 709 (Mini DIP)	.49
747C	Dual 741C (mini DIP)	.49
748C	Freq. adj. 741C (A)	.49
748CV	Freq. adj. 741C (mini DIP)	.49
753	Gain Block	1.75
709-709	Dual 709C (DIP)	1.00
739-739	Dual stereo preamp	1.98
741-741	Dual 741C (A)	1.00
75150	Dual peripheral driver	.88
75154	Dual peripheral driver	.88
745512	Dual line driver	.39
PA265	5-Watt voltage regulator	1.95
ULN2300M	Op amp with SCR	1.50
CAS065	Video 1.25 to system	1.50

(A) TO-5 or DIP dual in line pak

Terms: add postage. Rated: net 30

Phone Orders: Wakefield, Mass. (617) 245-8829

Retail: 6-18 Del Carmine St., Wakefield, Mass. (off Water Street) C.O.D.'S MAY BE PHONED

P.O. BOX 942 E Lynnfield, Mass. 01940

Largest Selection TTL IC's

Lowest Prices

Brand New

*DIP Packages Order by type number! Spec sheets on request "ONLY"

Type	Sale	SN7430	.30	SN7470	.45	SN7410	.55	SN74181	1.65
SN7400	.30	SN7432	.30	SN7472	.35	SN74105	.55	SN74162	1.95
SN7402	.30	SN7437	.60	SN7473	.52	SN74106	1.25	SN74163	1.95
SN7403	.30	SN7440	.30	SN7475	.95	SN74107	.60	SN74164	3.50
SN7404	.35	SN7441	1.40	SN7476	.55	SN74112	1.25	SN74165	3.50
SN7405	.32	SN7442	1.25	SN7477	1.30	SN74113	1.25	SN74174	2.10
SN7406	.35	SN7443	1.35	SN7478	1.30	SN74114	1.25	SN74175	2.10
SN7407	.35	SN7444	1.35	SN7479	.75	SN74121	1.70	SN74176	2.10
SN7408	.35	SN7445	1.35	SN7481	1.15	SN74122	.75	SN74177	2.10
SN7409	.35	SN7446	1.65	SN7482	.95	SN74123	1.20	SN74179	2.10
SN7410	.30	SN7447	1.50	SN7483	1.15	SN74124	1.20	SN74180	1.20
SN7411	.35	SN7448	1.50	SN7484	1.41	SN74139	1.50	SN74181	4.50
SN7413	.35	SN7451	1.35	SN7485	.55	SN74140	.25	SN74182	4.50
SN7415	.35	SN7452	1.35	SN7486	.55	SN74145	1.40	SN74183	2.50
SN7416	.35	SN7453	.35	SN7489	4.25	SN74148	4.50	SN74192	1.95
SN7417	.35	SN7454	.35	SN7490	1.30	SN74151	1.25	SN74193	1.95
SN7420	.30	SN7460	.35	SN7491	1.50	SN74152	1.25	SN74194	1.95
SN7421	.30	SN7461	.35	SN7492	1.10	SN74154	1.95	SN74195	1.95
SN7422	.35	SN7462	.35	SN7493	1.10	SN74156	1.42	SN74196	1.50
SN7425	.30	SN7464	.50	SN7494	1.10	SN74157	1.55	SN74197	2.10
SN7426	.37	SN7465	.50	SN7496	1.10	SN74160	1.95	SN74199	2.65

* Factory Margins

* Money Back Guarantee

Buy 100 — Take 20%

CIRCLE NO. 31 ON READER SERVICE CARD

TAPE AND RECORDERS

RENT 4-Track open reel tapes—all major labels—3,000 different—free brochure. Stereo-Parti, 55 St. James Drive, Santa Rosa, Ca. 95401.

SCOTCH MAGNETIC TAPE (USED)

—150, 1800 FT. 7 INCH REEL, 1 MIL POLYESTER, RECORDED ONCE, BULK ERASED (NO BOX), 99¢ PLUS 10% SHIPPING & HANDLING (MIN. ORDER \$10.00); SLIGHTLY USED 10 1/2 INCH FIBERGLASS REELS, 3/4" HOLE, 50¢ EACH, PLUS SHIPPING BY WEIGHT AND ZONE.



SAXITONE TAPE SALES

1776 Columbia Rd., N.W. Washington, D.C. 20009

RECORD 8TRK cartridges with any player. Instructions, \$2.00. C. Faust, Rancocas, New Jersey 08073.

1930-1962 Radio Programs on reels, \$1.00 hour! Cassettes, \$2.00 hour! Send \$1.25 for huge catalog and hour samples. AM Treasures, Box 192F, Babylon, N.Y. 11702.

UNIQUE introductory offer. A \$22.50 value for \$8.95 on over 300 spoken word audio cassette tapes. Send for special order blank and complete catalog. Send to Superscope Tape Products Division, 455 Fox Street, Dept. PE-1, San Fernando, CA 91340.

SCOTCH TAPES. Discounts! Catalog 10¢. Tower, Box 33098, District Heights, Md. 20028.

DO-IT-YOURSELF

PROFESSIONAL ELECTRONIC PROJECTS—\$1.00 up. Catalog 35¢. PARKS, Box 15201A, Seattle, Wash. 98115.

CONVERT TV to 6-ft. wide screen! B&W/Color. Do-It-Yourself—easy! Kit, instructions, lens, \$12.95 ppd. Free illustrated details. MACROCOMA, PE-10, Washington Crossing, Penna. 18977.

PERSONALS

MAKE FRIENDS WORLDWIDE through international correspondence. Illustrated brochure free. Hermes, Berlin 11, Germany.

BUGGED??? . . . Electronic Detector locates hidden transmitters. Literature 25¢. Security Devices, Box 671, Westwood, New Jersey 07675.

INSTRUCTION

LEARN ELECTRONIC ORGAN SERVICING at home all makes including transistor. Experimental kit—trouble-shooting. Accredited NHSC, Free Booklet. NILES BRYANT SCHOOL, 3631 Stockton, Dept. A, Sacramento, Calif. 95820.

LEARN WHILE ASLEEP, Hypnotize! Strange catalog free. Auto-suggestion, Box 24-ZD, Olympia, Washington 98501.

ASSOCIATE DEGREE IN ELECTRONICS through correspondence instruction. G.I. Bill approved. Free catalog. Grantham, 1509 N. Western, Hollywood, California 90027.

F.C.C. EXAM MANUAL

PASS FCC EXAMS! Memorize, study—1973 Tests—Answers* for FCC First and Second class Radio-telephone licenses. Newly revised multiple-choice questions and diagrams cover all areas tested in FCC exams.—plus—Self-Study Ability Test!—\$9.95 postpaid.

Tests—Answers for FCC First and Second Class Commercial License

COMMAND PRODUCTIONS
RADIO ENGINEERING DIVISION P.O. BOX 26348-P
SAN FRANCISCO, CALIF. 94126

INTENSIVE 5 week course for Broadcast Engineers. F.C.C. First Class license. Radio Engineering Incorporated, 52 S. Palm Ave., Sarasota, Florida 33577.

SHORTCUTS To Success! Highly Effective, Profitable Short Courses. (75 Choices). Study At Home. Diploma Awarded. Our 27th Year. Free Literature. CIEE-D, Box 10634, Jackson, Miss. 39209.

TAPE RECORDING COURSE: Taught by studio engineers. Free information. NNA, Box 721R, Rye, New York 10580.

DIGITAL: THEORY, DESIGN,
CONSTRUCTION

LOGIC NEWSLETTER[®]

SAMPLE COPY \$ 1.00
LOGIC NEWSLETTER
POB 252
WALDWICK, N.J. 07463

SCORE high on F.C.C. Exams . . . Over 300 questions and answers. Covers 3rd, 2nd, 1st and even Radar. Third and Second Test, \$14.50; First Class Test, \$15.00. All tests, \$26.50. R.E.I., Inc, Box 806, Sarasota, Fla. 33577.

DEGREE Program in Electronics Engineering. Our 27th Year! Free Literature. Cook's Institute, Dept. 13, Box 10634, Jackson, Miss. 39209.

NEW! "Revised 1973." Basic: Third, Second. Advanced: Radar, First. Phone Exams. "1000" Questions, Answers, Diagrams, Formulas Taken from actual FCC material. \$7.75. Evaluation Research Hill, Dept-R3, Box 19A56, Ahsoskie, North Carolina 27910.

REPAIRS AND SERVICES

PRINTED Board Design, Fabrication. PCDS, 1610 Melville, Fairfield, CT 06430.

INVENTIONS WANTED

CASH-ROYALTIES for patented, unpatented inventions. Global Marketing Service, 2420-P 77th, Oakland, California 94605.

FREE "Directory of 500 Corporations Seeking New Products." For information regarding development, sale, licensing of your patented/unpatented invention. Write: Raymond Lee Organization, 230-GR Park Avenue, New York City 10017.

PATENT Searches including Maximum speed, full airmail report and closest patent copies. Quality searches expertly administered. Complete secrecy guaranteed. Free Invention Protection forms and "Patent Information," Write Dept. 9, Washington Patent Office Search Bureau, Benjamin Franklin Substation, P.O. Box 7167, Washington, D.C. 20044.

INVENTORS: Protect your ideas! Free "Recommended Procedure", Washington Inventors Service, 422T Washington Building, Washington, D.C. 20005.

FREE PAMPHLET: "Tips on Safeguarding Your Invention." Write: United States Inventors Service Company, 708-T Carry Building, Washington, D.C. 20005.

INVENTORS! Either we will sell your Invention before you or anyone else does, or we will pay you a cash bonus. Get Free Invention Evaluation and information: Write Gilbert Adams Organization, Invention Brokerage, Dept. 20, 81 Wall St., New York, NY 10005.

INVENTORS are invited to join the INTERNATIONAL SOCIETY of INVENTORS, Rosenstrasse 1 Thalwil 8800, Zurich, Switzerland. Request Information.

MR. INVENTOR: Ideas and inventions urgently needed by manufacturers. Product development assistance and quality patent searches. Financial assistance plan if required. Write: Charles S. Prince, Invention Consultant, 509-E 5th Avenue, New York City 10017.

LIGHT EMITTING DIODES	
FLV 100 VIS. LED	\$.59
MT2 Photo Transistor	\$.90
MCT-2 Opto. Isolator	\$1.00
MCD-2 Opto. Isolator	\$1.00
MCA-2-30 Photo Relay	\$1.95
MV5026 VIS LED	\$.65
ME4 IR LED's	\$.59
GREEN GAP OSL-16 LED	\$1.25
RED GAP OSL-3 LED	.95
Hi Intensity Red with Reflector	\$1.25

7400	.30	7453	.30
7401	.30	7454	.30
7402	.30	7460	.30
7403	.30	7465	.35
7404	.35	7472	.50
7406	.50	7473	1.00
7408	.35	7474	.60
7410	.30	7475	1.00
7411	.35	7476	.75
7412	.50	7480	.65
7413	.85	7481	1.25
7416	.50	7481	1.25
7417	.75	7480	1.30
7420	.30	7482	1.20
7422	.35	7493	1.50
7426	.40	7494	1.30
7430	.30	7495	1.30
7438	.60	74121	1.20
7440	.30	74123	1.20
7441	1.50	74151	1.95
7442	1.50	74153	1.95
7446	1.50	74157	1.75
7447	1.50	74161	1.75
7448	1.50	74192	1.95
7450	.30	74193	1.95
7451	.30	74194	2.35
7452	.30		

VERIPAX PC BOARD

This board is a 1 1/2" single sided board epoxy board 4 1/2" x 6 1/2" (standard veripax) DRILLED and etched, which will hold 21 single 14 pin IC's, or 8,15 or LSI DIP IC's with busses for power supply connections. It is also etched for a 22 pin connector. \$5.25 \$31.450

NIXIE TUBE

RAYTHEON R754 WITH SOCKET AND DATA SHEET \$2.25 3/56.00

TRANSISTOR SPECIALS									
2N3137 NPN Si	To-5	6	20	.5	70	500	4/51.00		
2N3584 NPN Si	To-66	35W	250V	2A	10MHZ	100HF	\$1.50		
MP53393 NPN Si	To-92	.3	25	.1	190	.2	4/51.00		
2N1605 NPN GE	To-5	.15W	24V	1A	14	125	5/51.00		
2N5324 PNP GE	To-3	60W	250V	10A	20	35	\$1.50		
2N1015D NPN Si	To-82	150W	200V	7.5A	.025	10	\$1.45		
2N3772 NPN Si	To-3	150W	60V	30A	.2	30	\$1.25		
2N3866 NPN Si	To-5	5	30				RF Power	\$	7.75
2N6109 PNP Si	To-220	36W	40V	4A	.8	60		\$	50c
2N5296 NPN Si	To-220	36W	40V	4A	.8	60		\$	55c
2N4898 PNP Si	To-66	25W	40V	4A	40	46		\$	60
MJ2521 NPN Si	To-66	10W	225V	5A	10	40		\$	5.00
2N3055 NPN Si	To-3	115W	100V	15A	.2	44		\$	17.00

SLA-3 7 Segment LED Readout 77" Num- bers 45 ma 1 Seg. \$9.95

Data-Lit 707 direct replacement for MAN-1 LED seven segment Reouts \$3.75

MAN-4 LED READOUT \$3.50
MAN-3 LED READOUT \$2.95

SV 1 Amp. regulated power supplies. These units are similar to analog devices encapsulated SE905 power supplies \$24.95

1103 1024 Bit RAM \$8.00
NEC6003 2048 Bit RAM \$14.50
1101 256 Bit RAM \$4.00
8225 64 BIT MEMORY \$4.00

TRIACS

PRV	1A	10A	15A	20A
100	.40	.70	1.00	1.20
200	.70	1.10	1.50	1.60
300	.90	1.35	1.90	2.00
400	1.10	1.60	2.30	2.40
500	1.50	2.00	2.70	2.80

Press Fit

FULL WAVE BRIDGES

PRV	2A	6A
200	.95	1.25
400	1.15	1.50
600	1.35	1.75

Silicon Power Rectifiers

PRV	1A	3A	12A	50A
100	.06	.11	.30	.85
200	.07	.16	.35	1.25
400	.09	.20	.45	1.50
600	.11	.30	.70	1.30
800	.15	.40	.85	2.30
1000	.20	.55	1.10	2.75

Silicon Control Rectifiers

PRV	1.5A	6A	10A	70A
100	.40	.50	.60	3.50
200	.60	.70	.80	6.50
400	1.00	1.20	1.30	9.50
600			1.70	11.00

715 73 N Channel FET \$.75
2N4891 UJT \$.50
ER900 Trigger Diode \$4 51.00

New Raytheon
ASCII Encoded
Terminal Keyboards \$60.00

10 Pin Wire Wrap Sockets .50
14 Pin Wire Wrap Sockets .50

Printed circuit board 4 1/2" x 6 1/2" double sided fiber glass board 1 16" thick. unetched. \$5.60 ea. 5 \$2.50

MULTI-TURN TRIM POTS

Similar to Bourins 3010 style 50, 100, 500, 2K, 5K, 10K & 20K ohms. \$2.00 3 \$5.50

PA234 1 Watt Audio Amps \$1.25
LM 309K SV Amp \$1.35

1 Amp Regulator \$2.25
741 OPER. AMP \$.50
Dual 705 Reg. \$.95
723 Regulator \$.75
TVR-2002 high power 723 \$1.00

703RF 1F Amp \$.80
CA3065 FM TV Amp \$1.35
565 Phase Lock Loop \$3.25
567 Tone Decoder \$3.25

560 Phase Lock Loop \$3.25
561 Phase Lock Loop \$3.25
5558 Dual 741 (Mini Dip) .88
536 FET Input Oper Amp \$3.25
537 Precision 741 \$2.50

540 70W Power Driver \$2.04
747 Dual 741 \$1.25
LM308 Oper Amp \$1.05
101 Oper Amp \$.75
741A Oper Amp \$.60

320-15V Reg. \$2.25
424-Zero Voltage Switch \$1.25
748 Oper Amp \$.90

LM 3900 Quad Oper Amp \$1.49
PA 264 Regulator \$1.25

Terms: FOB Cambridge, Mass.
Send check or Money Order. In- clude postage. No C.O.D.'s.

Minimum Order \$3.00
Rated companies 30 days net

Send \$.20 for our latest catalog featuring Transistors and Rectifiers

SOLID STATE SALES

Post Office Box 74A

Somerville, Mass. 02143

Tel. (617) 547-4005

CIRCLE NO. 37 ON READER SERVICE CARD

BUSINESS OPPORTUNITIES

I MADE \$40,000.00 Year by Mailorder! Helped others make money! Start with \$15.00—Free Proof. Torrey, Box 318-N, Ypsilanti, Michigan 48197.

\$200.00 DAILY In Your Mailbox! Your opportunity to do what mail-order experts do. Free details. Associates, Box 136-J, Holland, Michigan 49423.

FREE CATALOGS. Repair air conditioning, refrigeration. Tools, supplies, full instructions. Doolin, 2016 Canton, Dallas, Texas 75201.

MAILORDER MILLIONAIRE helps beginners make \$500 weekly. Free report reveals secret plan! Executive (1K10), 333 North Michigan, Chicago 60601.

PIANO TUNING LEARNED QUICKLY AT HOME! Tremendous field! Musical knowledge unnecessary. GI approved. Information free. Empire School, Box 327, Miami 33145.

FREE SECRET BOOK "2042 Unique, Proven Enterprises." Beat inflation with fabulous, successful "Little Knowns." Work home! Haylings-B2, Carlsbad, Calif. 92008.

HIGHLY PROFITABLE

ONE-MAN ELECTRONIC FACTORY

Investment unnecessary, knowledge not required, sales handled by professionals. Postcard brings facts about this unusual opportunity. Write today! Barta-DEPI, Box 248, Walnut Creek, CA 94597.

BECOME our Mail Order Distributor with \$150 investment. Free brochure. Audit Controls, 141 Brookside Ave., Fair Lawn, NJ 07410.

START SMALL, highly profitable electronic production in your basement. Investment, knowledge unnecessary. Postcard brings facts. Barta-PEM, Box 248, Walnut Creek, California 94597.

\$2000.00 MONTHLY selling information by mail. Ropchan, Box 5341X, Sherman Oaks, Calif. 91413.

SILVER RECOVERY Dealers WANTED!—Earn \$24,000.00 by second year!—No Investment!—No Risk!—Equipment Provided!—Our manual "How To Start and Operate Your Own Silver Recovery Business" gives complete details!—Manual only \$9.95—Limited Offer!—Creative Products, 8415 Lofland, Dept. 103, Houston, Texas 77055.

PARTNERS WANTED—Sound Repair Centers operates stereo repair stores in 3 states. If you are qualified, we'll train you to manage a store of your own. You'll be guaranteed sets to repair, and the tools to repair them. A \$10,000.00—\$25,000.00 investment is required. Call: Donald Bailey, collect, (215) 563-4400.

SECRET mailorder technique. 500% profit. \$1.00. Gallery, Box 48212/7D10, Atlanta 30340.

IMMEDIATE CASH in your spare time. It's easy to sell nationally famous Knapp Shoes. Very high commissions plus bonuses. Your own business with no investment. Free selling and training kit. Lowell Harris, Dept. PE-1, Knapp Center, Brockton, MA 02401.

MOVIE FILMS

8MM-SUPER 8-16MM MOVIES! Biggest Selection! Lowest Prices! Free Catalog! Cinema Eight, Box PE, Chester, Connecticut 06412.

PRINTING

FREE Literature, Business cards, letterheads, Rubber stamps. Geer's, 111 North Drive, Ottawa, Ohio 45875.

RCA COMPUTER BOARDS



New glass epoxy boards, from last computers made by RCA. All kinds of semiconductors, trippots, resistors, capacitors, time delays etc. STOCK NO. F9662 6/5.00, 14/10.00, 22/15.00, all different.

HEAVY DUTY MULTIPLE VOLTAGE REGULATED TRANSFORMER

7 voltages, 15 volts @ 10 A., 36 volts @ 5 A., 10 volts @ 5 A., 20 volts @ 2 A., 36 volts @ 5 A., 42 volts @ 5 A., 36 volts @ 4 A. Resonant primary regulated, (no change in output voltages for up to 20% change in primary). 5 1/4" x 4 1/4" x 6". Complete with regulating capacitor and data for many more uses and voltage combinations.



STOCK NO. F9584 20 lbs. 12.50 ea. 2/22.00

OUR NEW 56 PAGE CATALOG JUST OUT, LOADED WITH NEW AND DIFFERENT ITEMS, NEVER BEFORE AVAILABLE.

Include postage. Excess refunded. MINIMUM ORDER, \$3.00. Write for new 56 page catalog.



DELTA ELECTRONICS CO.

BOX 1, LYNN, MASSACHUSETTS 01903
617-388-4705

CIRCLE NO. 8 ON READER SERVICE CARD

ABOUT YOUR SUBSCRIPTION

Your subscription to POPULAR ELECTRONICS is maintained on one of the world's most modern, efficient computer systems, and if you're like 99% of our subscribers, you'll never have any reason to complain about your subscription service.

We have found that when complaints do arise, the majority of them occur because people have written their names or addresses differently at different times. For example, if your subscription were listed under "William Jones, Cedar Lane, Middletown, Arizona," and you were to renew it as "Bill Jones, Cedar Lane, Middletown, Arizona," our computer would think that two separate subscriptions were involved, and it would start sending you two copies of POPULAR ELECTRONICS each month. Other examples of combinations of names that would confuse the computer would include: John Henry Smith and Henry Smith; and Mrs. Joseph Jones and Mary Jones. Minor differences in addresses can also lead to difficulties. For example, to the computer, 100 Second St. is not the same as 100 2nd St.

So, please, when you write us about your subscription, be sure to enclose the mailing label from the cover of the magazine—or else copy your name and address exactly as they appear on the mailing label. This will greatly reduce any chance of error, and we will be able to service your request much more quickly.

HOME ENTERTAINMENT FILMS

GIVE FILMS THIS CHRISTMAS—join SPORTLITE's Film Club. Send \$1.00 for your catalog today. This entitles you to \$1.00 off on six (6) separate films (color; B&W; Regular 8; Super 8)—your choice from the entire Columbia or Castle catalogs. Offer expires November 30, 1973. Treat yourself, a friend, too! SPORTLITE, Elect Dept., Box 500, Speedway, Ind. 46224.

PLASTICS

CASTOLITE pours like water, hardens like glass without heat. Crystal clear, colors. Embed flowers, seashells, momentos, anything. Make fine gifts. Form flexible molds over any pattern, size. Reproduce your own designs in plastics, candle wax, metal, plaster, cement. Profitable. Illustrated Manual and Catalog Only \$1.00. CASTOLITE, Dept. 73L/PE, Woodstock, Ill. 60098.

HYPNOTISM

SLEEP learning. Hypnotic method. 92% effective. Details free. ASR Foundation, Box 7566EG, Fort Lauderdale, Florida 33304.

FREE Hypnotism. Self-Hypnosis. Sleep Learning Catalog! Drawer H400, Ruidoso, New Mexico 88345.

AMAZING Hypnodisk pulls subjects into Deep Hypnosis!! Instructions! Rushed!! Guaranteed! \$2.00. Hypnodisk, 508 Mourningdove, CM-10, Audubon, Pennsylvania 19407.

RUBBER STAMPS

RUBBER address stamps. Free catalog 45 type styles. Jackson's, Box 443G, Franklin Park, Ill. 60131.

EMPLOYMENT INFORMATION

EXCITING Overseas jobs. Directory \$1.00. Research Associates, Box 889-E, Belmont, California 94002.

EMPLOYMENT OPPORTUNITIES

ELECTRONICS/AVIONICS EMPLOYMENT OPPORTUNITIES. Report on jobs now open. Details FREE. Aviation Employment Information Service, Box 240E, Northport, New York 11768.

STAMPS

88 COUNTRIES—ONLY 10¢! Worth \$5.00 at catalog prices!! Incredible collection of genuine postage stamps from 88 different countries—from Afghanistan to Zambia, North to South Pole! British, French, Portuguese, Spanish Colonies. Old 19th Century, New Issues, Moon and Outer Space stamps, etc. All for only 10¢! Also, other exciting stamps to examine free. Buy any or none; return balance, cancel service anytime. Plus Wonderful Free Catalog. H. E. HARRIS, Dept. SS-62, Boston, Mass. 02117.

100 ALL DIFFERENT Sweden. Only \$1.00. Banknote to: Sjoeborg, PO Box 102, S-28300, Osby, Sweden.

REAL ESTATE

FREE . . . 264-PAGE FALL CATALOG! Describes and pictures hundreds of farms, ranches, town and country homes, businesses coast to coast! Specify type property and location preferred. UNITED FARM AGENCY, 612-EP West 47th St., Kansas City, Mo.

Popular Electronics

INCLUDING **Electronics World**

OCTOBER 1973

ADVERTISERS INDEX

READER SERVICE NO.	ADVERTISER	PAGE NO.
1	Airpax International Division	109
2	Altec	8
3	BSR (USA) Ltd.	9
4	Babylon Electronics	123
	Bell & Howell Schools	40, 41, 42, 43
	Bose	28
	Burstein-Applebee Co.	119
	CREI Capitol Radio Engineering Institute	58, 59, 60, 61
6	Cleveland Institute of Electronics	76, 77, 78, 79
42	Cobra Communications, Dynascan Corporation	75
7	Crystek	120
8	Delta Electronics Co.	128
9	Delta Products, Inc.	19
10	Digi-Key	121
11	Dixie Hi-Fidelity Wholesalers	117
12	EICO	103
13	E & L Instruments, Incorporated	99
14	Edmund Scientific Co.	130
15	Electro-Voice, Inc.	101
16	Electronic & Control Engineers' Book Club	7
32	Electronics Book Service	27
17	Grantham School of Engineering	17
18	Gregory Electronics Corp.	122
20	Heath Company	112, 113, 114, 115
	ICS International Correspondence Schools	10, 11
CLASSIFIED ADVERTISING		121, 122, 123, 124, 126, 127, 128, 129

READER SERVICE NO.	ADVERTISER	PAGE NO.
21	Illinois Audio	120
22	Lafayette Radio Electronics	87
23	McGraw-Hill Book Company	111
24	McIntosh Laboratory, Inc.	110
25	MITS Micro Instrumentation & Telemetry Systems, Inc.	15
26	Midwest Hifi Wholesale & Mail Order Division	119
	National Radio Institute	SECOND COVER, 1, 2, 3
	National Technical Schools	22, 23, 24, 25
28	Olson Electronics	95, 96
29	Pace Communications	71
30	Pickering	57
31	Poly Paks	125
33	SBE	105
34	Sams & Co., Inc., Howard W.	81
35	Sansui Electronics Corp.	13
36	Schober Organ Corp., The	117
37	Solid State Sales	127
38	Tab Books	106
39	Technical Home Study Schools	91
19	Technics By Panasonic	FOURTH COVER
40	Tri-Star Corporation	109
	U.S. Navy	20, 21
41	Wahl Clipper Corporation	103

TREASURE FINDERS

FREE—Valuable Treasure Finder catalog sent by return mail. Find Coins, Rings, Gold, Silver, Metals, Relics. Write today. JETCO, Dept. CPE, Box 26669, El Paso, Texas 79926.

TREASURE FINDER locates buried gold, silver, coins, treasures. 6 powerful models. \$19.95 up. Instant financing available. Write or call for free catalog. Phone (713) 682-2728 day or night. Dealer inquiries invited. Relco, Dept. A-33, Box 10839, Houston, Texas 77018.

FREE FACT-FILLED CATALOG. World's largest line of metal detectors. Models as low as \$49.50 and up. Two year Guarantee. Three factory locations, U.S. and Canada, plus over 1,000 dealers and 35 Service Centers from coast to coast. No finer instruments made at any price. Budget terms. Write: White's Electronics, Inc., Rm# 391, 1011 Pleasant Valley Road, Sweet Home, Oregon 97386.

METAL DETECTORS. Save \$\$\$. Catalog: Detector, Room 1065-W, 102 W. Arrellaga St., Santa Barbara, Calif. 93101.

FIND BURIED TREASURE eight transistorized models \$19.95 to \$119.95, modular interchangeable heads, full view motors, FREE Catalog, Solidtronics Corporation-PE 37, Tennent, N.J. 07763.

MUSICAL INSTRUMENTS

30% DISCOUNT name brand musical instruments. Free Catalog. Freeport Music, 455N, Route 110, Melville, N.Y. 11746.

WHOLESALE! Professional Guitars, PA Systems, Altec Speakers. 240W RMS Amplifiers. Free Catalog, Carvin, Escondido, Calif. 92028.

MISCELLANEOUS

WINEMAKERS: Free illustrated catalog yeasts, equipment. Simplex, Box 12276P, Minneapolis, Minn. 55412.

LIVE IN THE WORLD OF TOMORROW...TODAY!

A BETTER LIFE STARTS HERE

CREATIVE AERONAUTICS FUN KIT



Complete aeronautics lab provides 100 experiments for ages 12 to 50. Learn about air convection, aerodynamics, rel. density, drag, altitude determination. Easily make glider—rubber-powered aileron-controlled plane; 27" wingspan plane w/ wkg. ailerons & elevators; rudder; helium balloon w/ passenger transport; helicopter; air-driven land vehicle; rocket w/ automat. chute recovery. Everything you need for weeks of fun & learning! Incl. 159-pg instr. book.

Stock No. 71.840AV \$15.95 Ppd.

"FISH" WITH A GIANT MAGNET

Go Treasure Hunting On The Bottom! Fascinating fun, and sometimes very profitable! Tie a line to our 5-pound Magnet—drop it overboard in bay, river, lake or ocean. Troll it along the bottom. Your "treasured" haul can be outboard motors, anchors, other metal valuables. Five-pound Magnet is war surplus—Alnico V Type that cost the Government \$50. It lifts over 150 pounds on land—much greater weights under water!

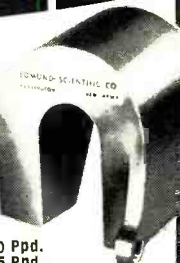

Stock No. 70.571AV \$14.00 Ppd.
 Stock No. 70.570AV 3 1/2 lbs. \$8.75 Ppd.
 Stock No. 60.215AV 1 1/2 lbs. \$5.75 Ppd.

130 EXPERIMENTS IN OPTICS...



and photography! Optix® Experiments Kit is a complete optical & photography lab for 130 exciting experiments. Lets you recreate the periscope, telescope, microscope, kaleidoscope! Build a 35-mm reflex camera with interchangeable lens system! Make, develop photographic film! Enjoy the fun and fascination of having your own optics lab. Fully illustrated 112-pg manual, 8 1/2 x 11", clearly explains usage of this stimulating kit's 114 precision engineered components.

Stock No. 71.646AV \$22.50 Ppd.



MAIL COUPON FOR GIANT FREE CATALOG!

164 PAGES • MORE THAN 4,500 UNUSUAL BARGAINS!

Completely new '74 Catalog. Packed with huge selection of telescopes, microscopes, binoculars, magnets, magnifiers, prisms, photo components, ecology and Unique Lighting items, parts, kits, accessories—many hard-to-get surplus bargains. 100's of charts, illustration. For hobbyists, experimenters, schools, industry.

EDMUND SCIENTIFIC CO.
 300 Edscorp Building, Barrington, N. J. 08007
 Please rush Free Giant Catalog "AV"

Name _____
 Address _____
 City _____ State _____ Zip _____

COMPLETE & MAIL WITH CHECK OR M.O.

EDMUND SCIENTIFIC CO.
 300 Edscorp Building, Barrington, N. J. 08007

How Many	Stock No.	Description	Price Each	Total

PLEASE SEND GIANT FREE CATALOG "AV" MERCHANDISE Total
 HANDLING CHARGE \$1.00*
 TOTAL \$ _____



I enclose check money order for \$ _____
 *50¢ ON ORDERS OVER \$5.00

NAME _____
 ADDRESS _____
 CITY _____ STATE _____ ZIP _____

(And our FREE CATALOG is packed with exciting and unusual ecological & physical science items—plus 4,500 finds for fun, study or profit... for every member of the family.)

KNOW YOUR ALPHA FROM THETA!

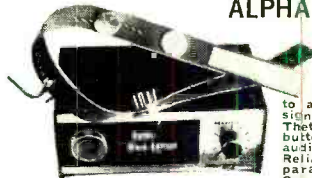

For greater relaxation, concentration, listen to your Alpha/Theta brainwaves. Ultra-sensitive electrode headband slips on/off in seconds—eliminates need for messy creams, etc. Attach'd to amplifier, filters brainwaves, signals beep for ea. Alpha or Theta wave passed. Monitoring button simulates Alpha sound; audio & visual (L.E.D.) feedback. Reliable, easy-to-use unit—comparable to costlier models. Completely safe. Comprehensive instruction booklet.

No. 1635AV (8x3x4"; 24 gr.) \$124.50 Ppd.
 No. 71.809 (Low Cost "Starter" Unit) \$49.95 Ppd.

3-CHANNEL COLOR ORGAN KIT

Easy to build low-cost kit needs no technical knowledge. Completed unit has 3 bands of audio frequencies to modulate 3 independent strings of colored lamps (i.e. "lows"—reds, "middles"—greens, "highs"—blues. Just connect hi-fi, radio, power lamp etc. & plug ea. lamp string into own channel (max. 300W ea.). Kit features 3 neon indicators, color intensity controls, controlled individ SCR circuits; isolation transformer; custom plastic housing; instr.



Stock No. 41.831AV \$17.50 Ppd.

SEE THE STARS, MOON, PLANETS CLOSE UP!



3" ASTRONOMICAL REFLECTING TELESCOPE

60 To 180 Pwr. Famous Mt. Palomar Type. See the rings of Saturn, the fascinating planet Mars, Seas and Craters of the Moon, Star Clusters in detail. New improved, aluminized and overcoated 3" diameter, 1/10 primary mirror, ventilated cell. Equatorial mount with locks on both axes. Equipped with 60x finder telescope; hardwood tripod. Included FREE: VALUABLE "HOW TO USE YOUR TELESCOPE" book; "STAR CHART".

Stock No. 85.050AV \$34.95 Ppd.
 Deluxe 3" Reflector Telescope 4 1/4" Reflector Telescope (45x to 270x)
 Stock No. 80.162AV \$62.50 Ppd. Stock No. 85.105AV \$110.00 FOB
 3 1/4" Reflector Telescope with Clock Drive Stock No. 85.107AV \$145.00 Ppd.
 6" Reflector Telescope Stock No. 85.187AV \$215.00 FOB
 6" Reflector W/ (Electric) Clock Drive Np. 85.086AV \$249.50 FOB

CIRCLE NO. 14 ON READER SERVICE CARD

Printed in U.S.A.

POPULAR ELECTRONICS Including Electronics World

Popular Electronics

INCLUDING Electronics World

READER SERVICE

There's an easy and convenient way for you to get additional information about products advertised or mentioned editorially (if it has a reader service number) in this issue. Just follow the directions below... and the material will be sent to you promptly and free of charge.

2

On the attached postage-free card, print or type your name and address on the lines indicated.

Circle the number(s) that corresponds to the key number(s) at the bottom or next to the advertisement or editorial mention that is of interest to you. (Key numbers for advertised products also appear in the Advertisers' Index.)

3

Simply cut out the card and mail. No postage required.

FREE INFORMATION



DELUXE
MAGAZINE CASES

Designed Exclusively for
POPULAR ELECTRONICS
INCLUDING Electronics World

It's the new look in magazine cases! The ideal way to save your valuable copies, keep them well-protected and make it easy for you to refer to any issue at any time. Both decorative and attractive to enhance the decor of any room—each case is designed to hold a full year's copies.

Sturdily constructed to guard your magazines against soiling and tearing, these durable cases are covered in a rich-textured leatherette. They are available in either all black or attractive maroon back with black sides. The gold-embossed back adds to its

elegance and makes each case a welcome addition to your book shelf or cabinet.

Magazine cases are available for any of your favorite magazines. They're only \$4.50 each, 3 for \$12.50 in any combination of titles ordered. Add 50c per case for postage and handling. Outside U.S.A. add \$1.00 per case ordered.

HERE'S HOW TO ORDER

Send your order to Ziff-Davis Publishing Company, Dept. 721-A, One Park Ave., New York, N.Y. 10016. Be sure to indicate the titles of the magazines for which cases are being ordered. Specify your color choice for Popular Electronic cases which are available in either all black or maroon back with black sides. Colors for other cases are determined by the respective magazine publishers. Print your name and address clearly and enclose the amount indicated above for the number of cases being ordered PLUS an additional 50¢ per case for postage and handling. Outside U.S.A. add \$1 per case ordered.



AN EXTRA SERVICE FOR YOU—
CHARGE YOUR ORDER TO YOUR
AMERICAN EXPRESS OR
BANKAMERICARD ACCOUNT.



Mail your order, name, address and credit card number. You will be billed for the amount indicated above.

The better the turntable the fewer the moving parts. Ours have only one.

The one is the Technics direct drive DC motor. A DC motor to escape wow, flutter and hum. A DC motor that is brushless and spins at $33\frac{1}{3}$ or 45 rpm so it doesn't have the vibration and noise problems of its faster competitors.

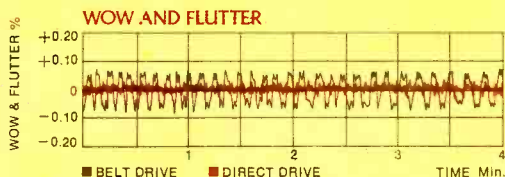

And it has an analog feedback speed control so it never suffers from frequency or voltage fluctuations.

The drive system is just as important as the motor. And direct drive doesn't depend on an idler wheel or belt. They had to go because they show their age and lose their shape. Instead we put the platter right on the motor shaft.

The improvement is obvious . . .

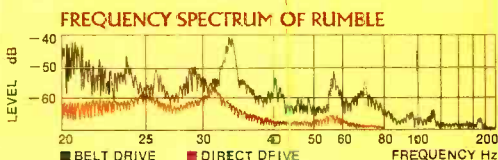

We make three direct drive turntables. The SL-1100A, shown below, comes with a professional-type tone arm, viscous-damped cueing, illuminated stroboscope, variable pitch controls and a dust cover.

The SL-1200 includes most of the same features at a more modest price. And the SP-10 is for those who insist on choosing their own tone arm.

Either way. The concept is simple. The execution is precise. The performance is outstanding. The name is Technics.

Technics

by Panasonic



200 PARK AVE., N.Y., N.Y. 10027
FOR YOUR NEAREST AUTHORIZED
TECHNICS DEALER, CALL TOLL-FREE
800 447-4700. IN ILLINOIS, 800 322-4400.

CIRCLE NO. 19 ON READER SERVICE CARD

www.americanradiohistory.com